

SECTION **FL**  
FUEL SYSTEM

A  
FL  
C  
D  
E  
F  
G  
H  
I  
J  
K  
L  
M

CONTENTS

<b>FUEL SYSTEM</b> .....	2	<b>FUEL TANK</b> .....	7
Checking Fuel Lines .....	2	Removal and Installation .....	7
General Precautions .....	2	REMOVAL .....	7
<b>FUEL LEVEL SENSOR UNIT, FUEL FILTER AND</b>		INSTALLATION .....	9
<b>FUEL PUMP ASSEMBLY</b> .....	3	<b>SERVICE DATA AND SPECIFICATIONS (SDS)</b> .....	10
Removal and Installation .....	3	Standard and Limit .....	10
REMOVAL .....	3		
INSTALLATION .....	6		

## FUEL SYSTEM

PFP:17503

### Checking Fuel Lines

EBS00DTF

Inspect the fuel lines, filler cap, and fuel tank for incorrect attachment, leaks, cracks, damage, loose connections, chafing, and deterioration.

If necessary, repair or replace the faulty parts.

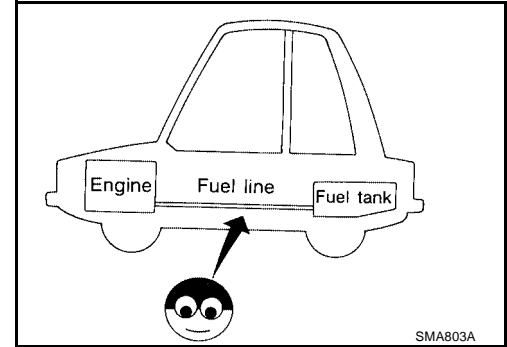

### General Precautions

EBS00DTG

#### **WARNING:**

When replacing the fuel line parts, observe the following:

- Place a "CAUTION: FLAMMABLE" sign in the workshop.
- Do not smoke while servicing the fuel system. Keep open flames and sparks away from the work area.
- Have a CO<sub>2</sub> fire extinguisher in the workshop.

#### **CAUTION:**

Before removing the fuel line parts, use the following procedures:

- Put drained fuel in an explosion-proof container and put the lid on securely.
- Release the fuel pressure from the fuel system. Refer to [EC-56, "FUEL PRESSURE RELEASE"](#) [QG18DE (ULEV)], [EC-637, "FUEL PRESSURE RELEASE"](#) [QG18DE (SULEV)], [EC-1257, "FUEL PRESSURE RELEASE"](#) (QR25DE).
- Disconnect the battery ground cable.
- Always replace the O-ring seals with new ones.
- Do not kink or twist any of the hoses and tubes when installing.
- Do not over tighten the hose clamps to avoid damaging hoses.
- After installation, run the engine and check for fuel leaks at the connections.
- Use only a genuine NISSAN fuel filler cap as a replacement. If an incorrect fuel filler cap is used, the MIL may come on.
- For inspection and installation of EVAP system parts, refer to [EC-33, "System Diagram"](#) [QG18DE (ULEV)], [EC-614, "System Diagram"](#) [QG18DE (SULEV)], [EC-1236, "System Diagram"](#) (QR25DE).
- For inspection and installation of ORVR system parts, refer to [EC-33, "System Diagram"](#) [QG18DE (ULEV)], [EC-614, "System Diagram"](#) [QG18DE (SULEV)], [EC-1236, "System Diagram"](#) (QR25DE).



# FUEL LEVEL SENSOR UNIT, FUEL FILTER AND FUEL PUMP ASSEMBLY

6. Disconnect the fuel pump assembly electrical connector.

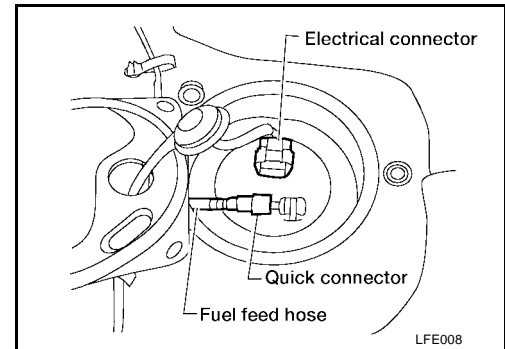

7. Disconnect the fuel feed hose quick connector as follows:

- a. Align the mating marks on the fuel pump outlet and the quick connector.
- b. Hold the quick connector and push in the tabs, then pull out from the fuel pump outlet that is inserted in the quick connector.

**CAUTION:**

- The quick connector can be removed when the tabs are completely depressed. Do not twist the fuel hose more than necessary.
- Do not use any tools to remove the quick connector.

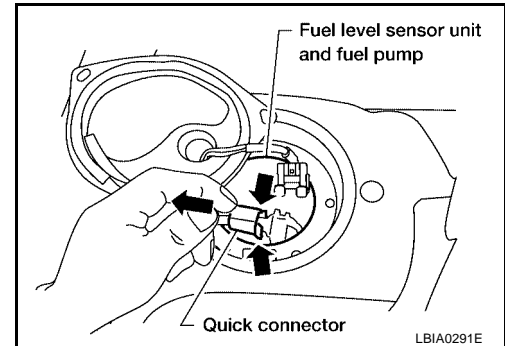

8. Remove the six retainer ring screws.

9. To remove, pull up on the fuel level sensor unit and fuel pump.

**CAUTION:**

Do not damage the arm of the fuel level sensor and fuel tank temperature sensor when removing.

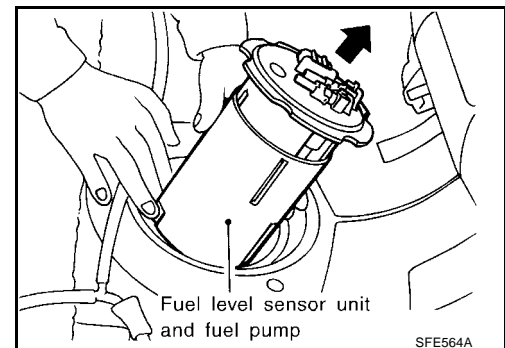

10. Remove the fuel pump as shown in the figure.

- Apply mating marks on the fuel pump and fuel filter for proper alignment for installation.

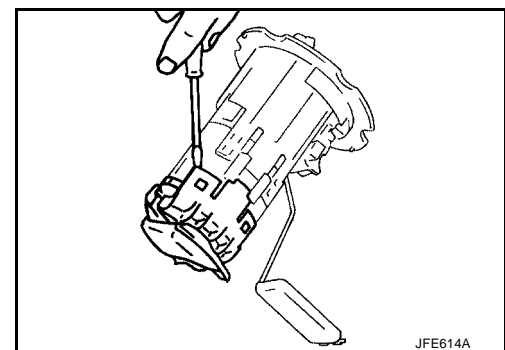

# FUEL LEVEL SENSOR UNIT, FUEL FILTER AND FUEL PUMP ASSEMBLY

11. Disconnect the fuel pump harness connector.

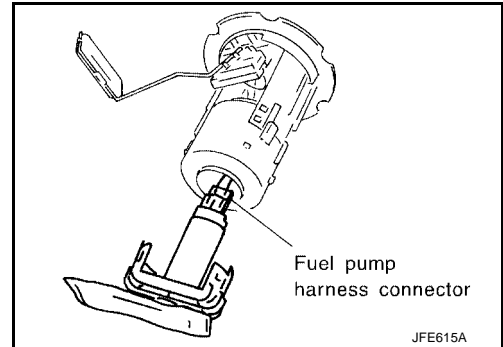

12. Remove the fuel filter from fuel level sensor unit as shown.

- Apply mating marks on fuel filter and fuel level sensor unit for proper alignment for installation.

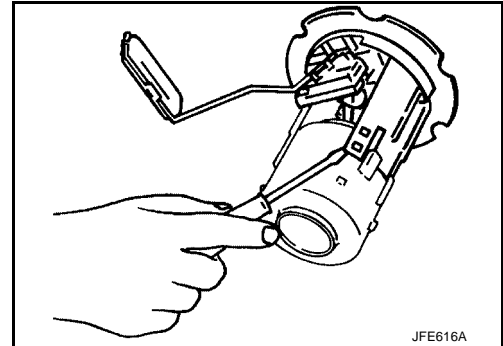

13. Remove the fuel pressure regulator from the fuel filter, if necessary.

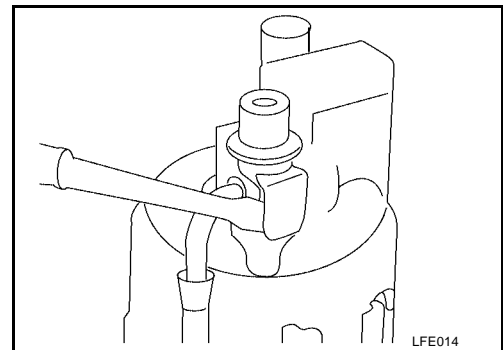

A

FL

C

D

E

F

G

H

I

J

K

L

M

# FUEL LEVEL SENSOR UNIT, FUEL FILTER AND FUEL PUMP ASSEMBLY

## INSTALLATION

Installation is in reverse order of removal.

Connect the quick connector as follows:

1. Align the mating marks on the fuel pump outlet and quick connector for installation.
2. Align the push tabs with the quick connector slots.
3. Insert the fuel pump outlet into the center of the quick connector until you hear a click.

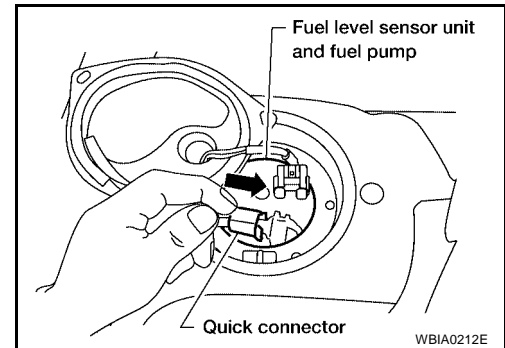

After connecting the quick connector, make sure the connection is fully seated as follows:

1. Pull on the quick connector to make sure it is firmly connected.
2. Apply fuel pressure to the fuel lines by turning the ignition switch ON (without starting the engine). Then check for fuel leaks at the connections.
3. Start the engine and increase the engine speed, verify there are no fuel leaks.

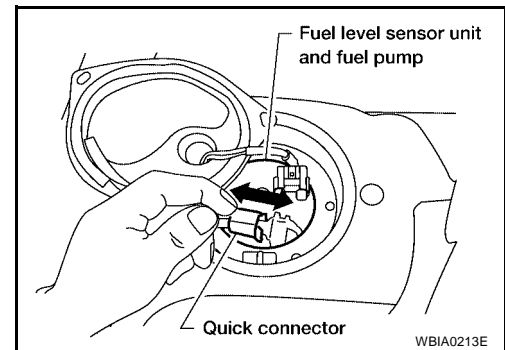

# FUEL TANK

PF17202

## FUEL TANK

### Removal and Installation

EBS00DT1

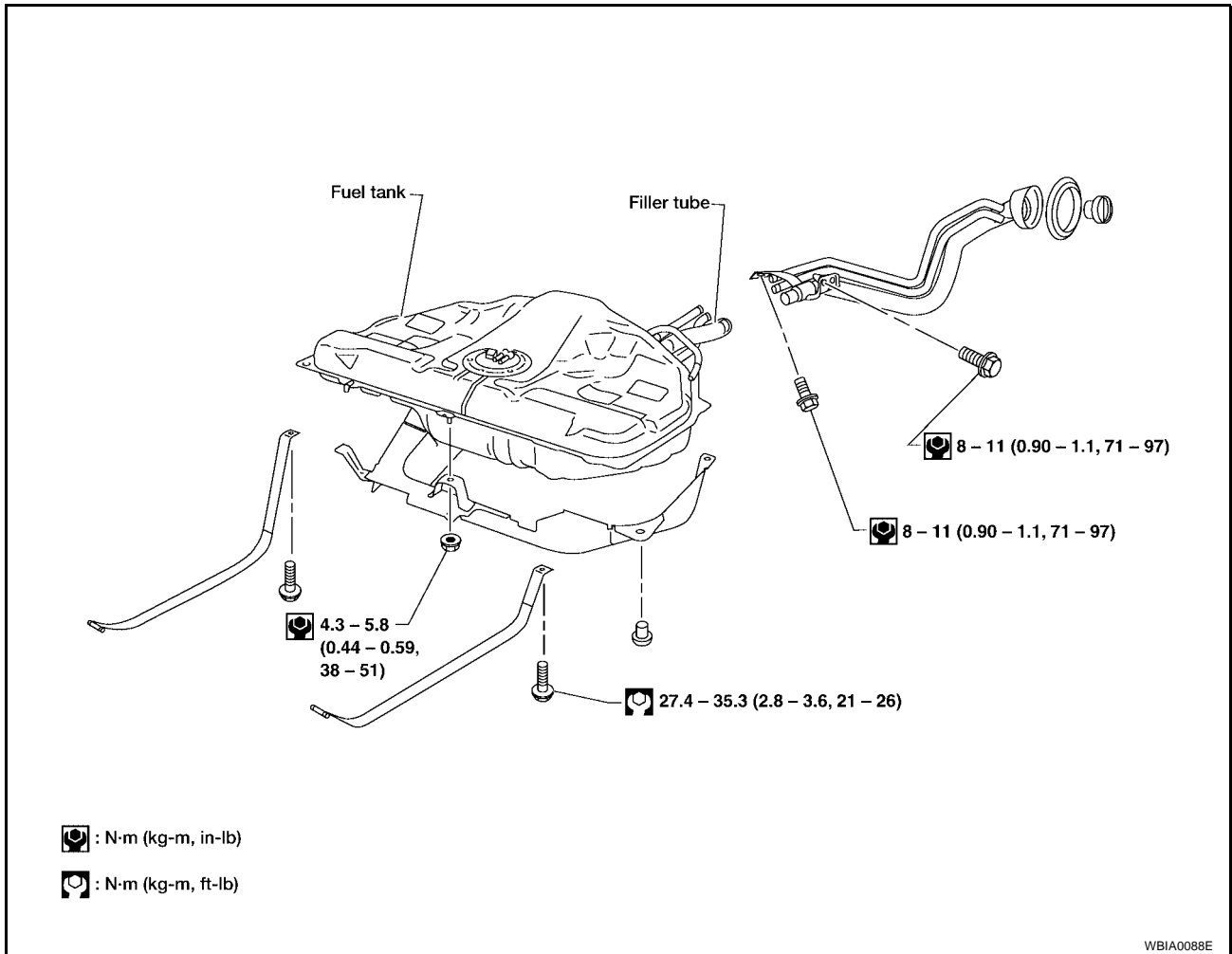

### REMOVAL

1. Release the fuel pressure.  
Refer to [EC-56. "FUEL PRESSURE RELEASE"](#) [QG18DE (ULEV)], [EC-637. "FUEL PRESSURE RELEASE"](#) [QG18DE (SULEV)], [EC-1257. "FUEL PRESSURE RELEASE"](#) (QR25DE).
2. Disconnect the battery ground cable.
3. Open the fuel filler lid and filler cap.
4. Drain the fuel from fuel tank.
5. Remove the rear seat cushion. Refer to [SE-5. "Removal and Installation"](#) .
6. Remove the inspection hole cover located under rear seat.

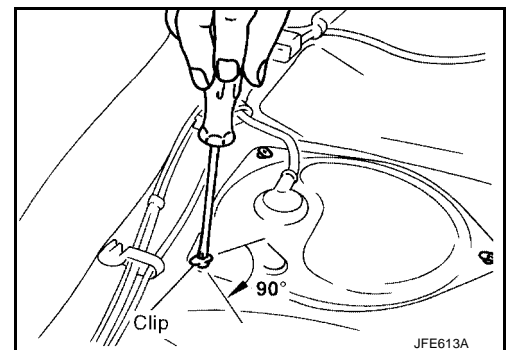

# FUEL TANK

7. Disconnect the fuel pump electrical connector.

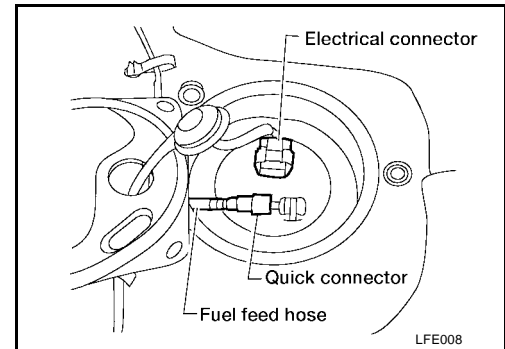

8. Disconnect the fuel feed hose quick connector as follows:

- a. Apply mating marks on the fuel pump outlet and the quick connector for installation.
- b. Hold the quick connector and push in the tabs, then pull out off of the fuel pump outlet that is inserted into the quick connector.

**CAUTION:**

- The quick connector can be removed when the tabs are completely depressed. Do not twist the fuel feed hose more than necessary.
- Do not use any tools to remove the quick connector.

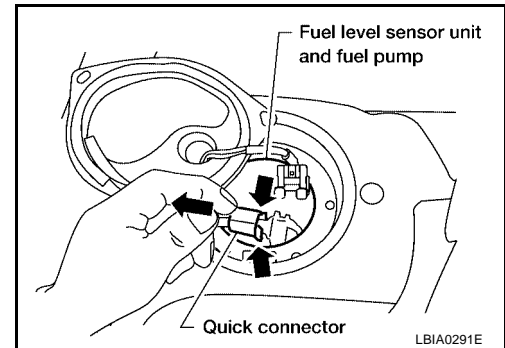

9. Remove the center exhaust tube. Refer to [EX-3, "Removal and Installation"](#).

10. From rear left area of the fuel tank, remove the filler hose, vent hose, and evaporation hoses as shown.

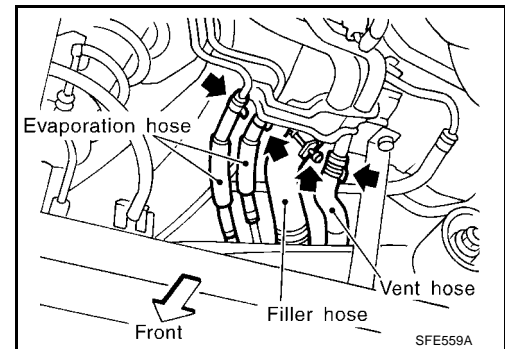

11. Support the fuel tank with a suitable transmission jack as shown.

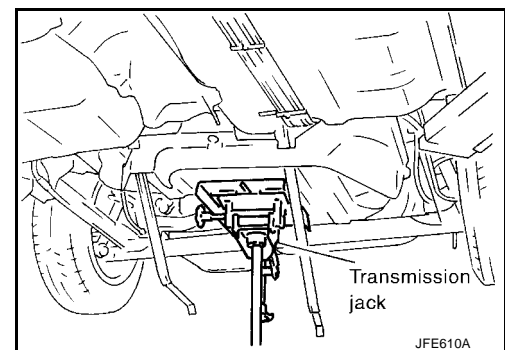

12. Remove the fuel tank mounting band bolts while supporting the fuel tank.



# FUEL TANK

- Lower the fuel tank by 70 - 80 mm (2.76 - 3.15 in), then remove the nuts and clips holding the fuel tank protector, and remove the protector.

- To remove the clips, use pliers to squeeze the extensions as shown by the arrows, and then remove the clip from above.

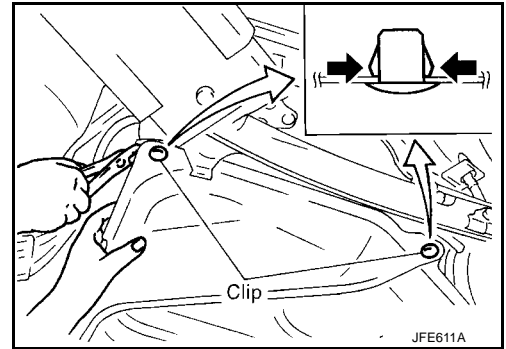

- Remove the fuel tank.

## INSTALLATION

Installation is in the reverse order of removal.  
Connect the quick connector as follows:

- Align mating marks on the fuel pump outlet and the quick connector for correct installation.
- Align the push tabs with the quick connector slots.
- Insert the fuel pump outlet into the center of the quick connector until you hear a click.

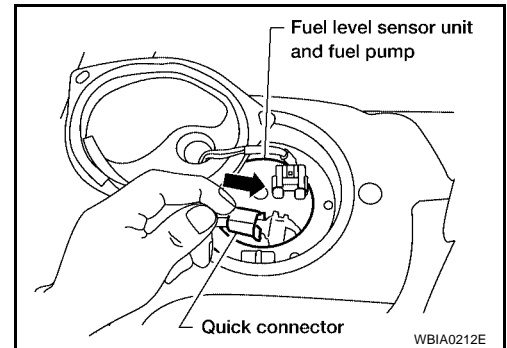

After connecting the quick connector, check that the quick connector is fully seated as follows:

- Pull on the quick connector to make sure it is firmly connected.
- Apply fuel pressure to the fuel lines by turning the ignition switch ON (without starting the engine). Then check for fuel leaks at the hose connections.
- Start the engine and increase engine speed, verify that there are no fuel leaks.

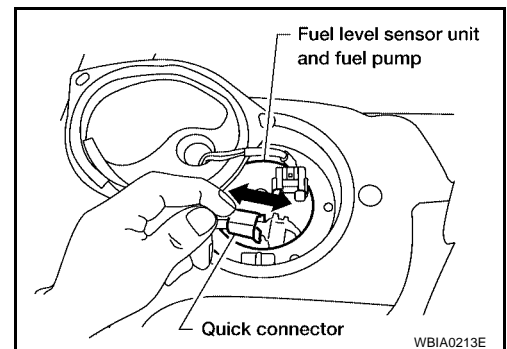

# SERVICE DATA AND SPECIFICATIONS (SDS)

---

## SERVICE DATA AND SPECIFICATIONS (SDS)

PF0:00030

### Standard and Limit

EBS00DTJ

---

Fuel tank capacity	50 ℓ (13 1/4 US gal, 11 Imp gal)
--------------------	----------------------------------

---