

SECTION **EX**
EXHAUST SYSTEM

A
EX
C
D
E
F
G
H
I
J
K
L
M

CONTENTS

PREPARATION	2	EXHAUST SYSTEM	3
Special Service Tool	2	Removal and Installation	3
Commercial Service Tools	2		

PREPARATION

PFP:00002

PREPARATION

Special Service Tool

EBS00DTK

The actual shapes of Kent-Moore tools may differ from those of special service tools illustrated here.

Tool number (Kent-Moore No.) Tool name	Description
KV10114400 (J-38365-A) Heated oxygen sensor wrench	Loosening or tightening front and rear heated oxygen sensors a: 22 mm (0.87 in)

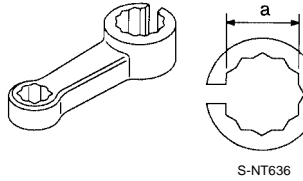

Commercial Service Tools

EBS00DTL

(Kent-Moore No.) Tool name		Description
(J-43897-18) (J-43897-12) Oxygen sensor thread cleaner		Reconditioning the exhaust system threads before installing a new oxygen sensor (Use with anti-seize lubricant shown below.) a: J-43897-18 (18 mm) for zirconia oxygen sensor b: J-43897-12 (12 mm) for titania oxygen sensor
Anti-seize lubricant (Permatex 133AR or equivalent meeting MIL specification MIL-A-907)		Lubricating oxygen sensor thread cleaning tool when reconditioning exhaust system threads

EXHAUST SYSTEM

PFP:20100

EBS00DTM

EXHAUST SYSTEM

Removal and Installation

Refer to the following figures for removal and installation.

QG18DE

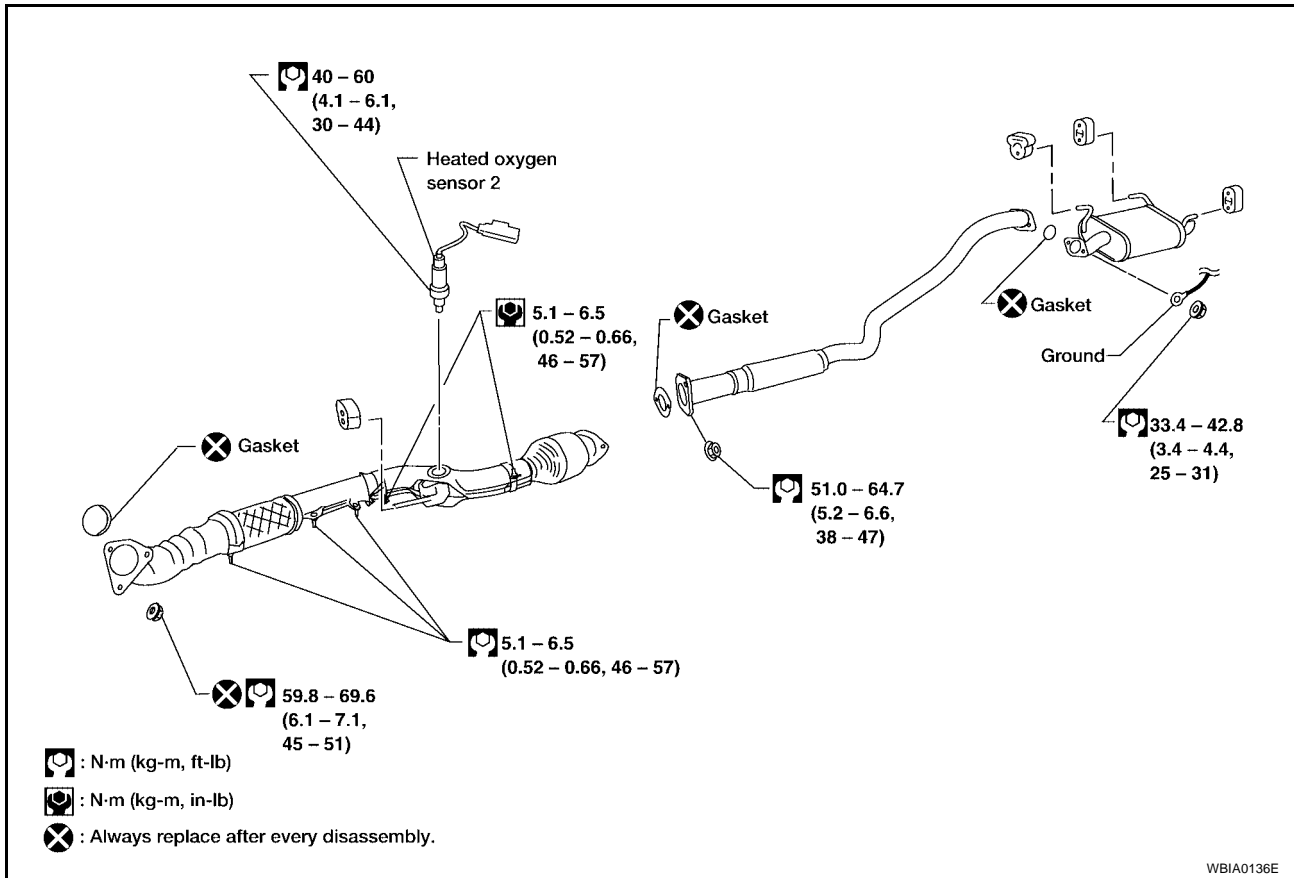

A
EX
C
D
E
F
G
H
I
J
K
L
M

EXHAUST SYSTEM

QR25DE

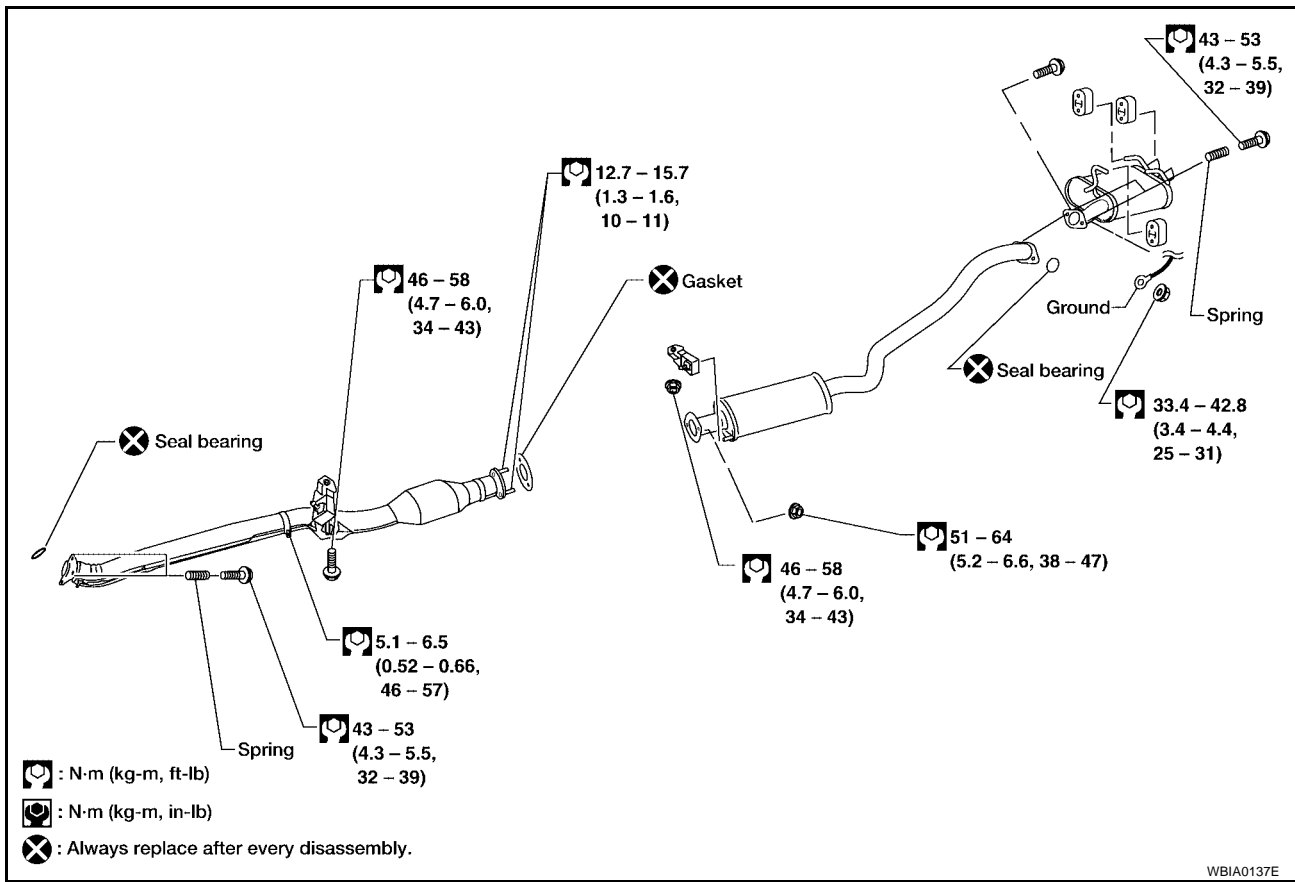

CAUTION:

- Always replace exhaust gaskets with new ones when reassembling.
- For the QR25DE engine, install the front combination seal bearing as shown. Position the conical spring so that the wide end is against the flange as shown.

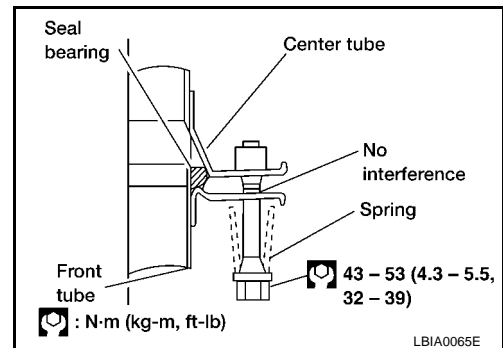

- With engine running, check all tube connections for exhaust gas leaks, and entire system for unusual noises.
- Check to ensure that mounting brackets and mounting insulators are installed properly and free from undue stress. Improper installation could result in excessive noise or vibration.
- Discard any heated oxygen sensor which has been dropped from a height of more than 0.5 m (19.7 in) onto a hard surface such as a concrete floor; replace it with a new one.
- Before installing a new oxygen sensor, clean exhaust system threads using oxygen sensor thread cleaner tool, J-43897-18 or J-43897-12, and apply anti-seize lubricant.
- Do not over-tighten the oxygen sensor. Doing so may cause damage to the oxygen sensor, resulting in the MIL coming on.