

NOISE, VIBRATION, AND HARSHNESS (NVH) TROUBLESHOOTING

NOISE, VIBRATION, AND HARSHNESS (NVH) TROUBLESHOOTING

PF:00003

NVH Troubleshooting Chart

EES000CU

Use the chart below to help you find the cause of the symptom. If necessary, repair or replace these parts.

Symptom		Possible cause and SUSPECTED PARTS																Reference page	
		Out-of-round	Imbalance	Incorrect tire pressure	Uneven tire wear	Deformation or damage	Non-uniformity	Incorrect tire size	DIFFERENTIAL	FRONT AXLE AND FRONT SUSPENSION	REAR AXLE AND REAR SUSPENSION	TIRES	ROAD WHEEL	DRIVE SHAFT	BRAKE	STEERING			
Symptom	TIRES	Noise	x	x	x	x	x	x		x	x	x		x	x	x		Refer to WT-3	
		Shake	x	x	x	x	x		x		x	x	x		x	x		Refer to WT-4	
		Vibration			x				x		x	x			x				Refer to WT-6
		Shimmy	x	x	x	x	x	x	x		x	x		x		x	x		—
		Judder	x	x	x	x	x		x		x	x		x		x	x		—
		Poor quality ride or handling	x	x	x	x	x		x		x	x		x					Refer to WT-6
	ROAD WHEEL	Noise	x	x			x			x	x	x	x		x	x	x		—
		Shake	x	x			x				x	x	x		x	x	x		Refer to WT-6
		Shimmy, judder	x	x			x				x	x	x		x	x	x		—
		Poor quality ride or handling	x	x			x				x	x	x		x				Refer to WT-6
																		Refer to WT-6	
																		Refer to WT-6	
																		Refer to WT-6	
																		Refer to WT-6	
																		Refer to WT-6	

x: Applicable

ROAD WHEEL

ROAD WHEEL

PFP:40300

EES000CV

Inspection

1. Check tires for wear and improper inflation.
2. Check wheels for deformation, cracks and other damage. If deformed, remove wheel and check wheel runout.
- a. Remove tire from wheel and mount wheel on a tire balance machine.
- b. Set dial indicator as shown in the illustration.

Wheel runout (Dial indicator value):

Refer to [WT-6, "Road Wheel"](#) .

3. Check front wheel bearings for looseness.
4. Check front suspension for looseness.

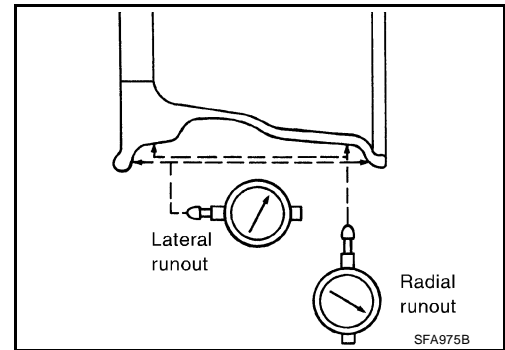

A
B
C
D

WT

F
G
H
I
J
K
L
M

ROAD WHEEL AND TIRE ASSEMBLY

ROAD WHEEL AND TIRE ASSEMBLY

PF0:40300

Balancing Wheels REMOVAL

EES000CW

1. Remove inner and outer balance weights from the road wheel.

CAUTION:

Be careful not to scratch the road wheel during removal procedures.

2. Using releasing agent, remove double-faced adhesive tape from the road wheel.

CAUTION:

Be careful not to scratch the road wheel during removal.

- After removing double-faced adhesive tape, wipe clean traces of releasing agent from the road wheel.

WHEEL BALANCE ADJUSTMENT

- If a tire balance machine has adhesion balance weight mode settings and drive-in weight mode setting, select and adjust a drive-in weight mode suitable for wheels.

1. Set wheel on wheel balancer using the center hole as a guide. Start the tire balance machine.
2. When inner and outer unbalance values are shown on the wheel balancer indicator, multiply outer unbalance value by 1.6 to determine balance weight that should be used. Select the outer balance weight with a value closest to the calculated value and install it to the designated outer position of, or at the designated angle in relation to the road wheel.

CAUTION:

- **Do not install the inner balance weight before installing the outer balance weight.**
- **Before installing the balance weight, be sure to clean the mating surface of the wheel.**

Indicated unbalance value $\times 5/3 =$ balance weight to be installed

Calculation example:

$23 \text{ g (0.81 oz.)} \times 5/3 = 38.33 \text{ g (1.35 oz.)} = 40 \text{ g (1.41 oz.)}$ balance weight (closer to calculated balance weight value)

Note that balance weight value must be closer to the calculated balance weight value.

Example:

$37.4 \text{ g} = 35 \text{ g (1.23 oz.)}$

$37.5 \text{ g} = 40 \text{ g (1.41 oz.)}$

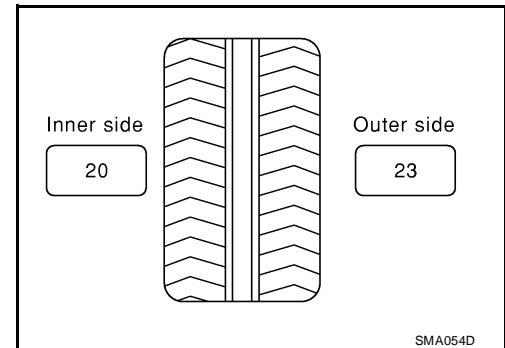

- a. Install balance weight in the position shown.
- b. When installing balance weight to wheels, set it into the grooved area on the inner wall of the wheel as shown so that the balance weight center is aligned with the wheel balancer indication position (angle).

CAUTION:

- **Always use genuine Nissan adhesion balance weights.**
- **Balance weights are not reusable; always replace with new ones.**
- **Do not install more than three sheets of balance weight.**

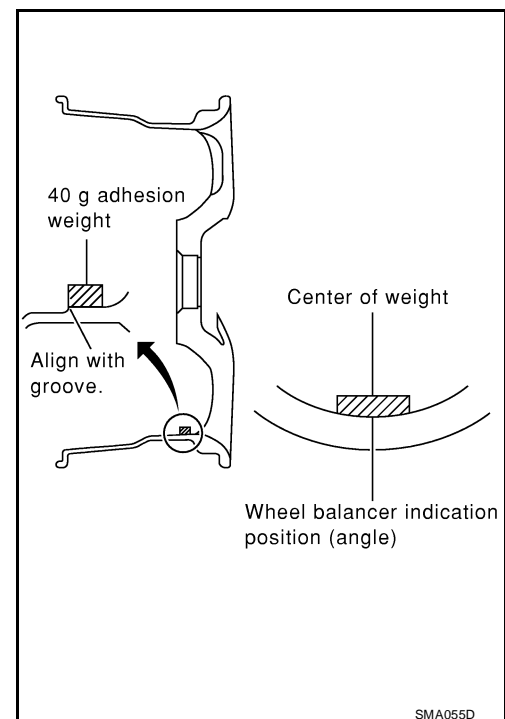

ROAD WHEEL AND TIRE ASSEMBLY

- c. If calculated balance weight value exceeds 50 g (1.76 oz.), install two balance weight sheets in line with each other as shown.

CAUTION:

Do not install one balance weight sheet on top of another.

3. Start wheel balancer again.
 4. Install drive-in balance weight on inner side of road wheel in the wheel balancer indication position (angle).

CAUTION:

Do not install more than two balance weights.

5. Start wheel balancer. Make sure that inner and outer residual unbalance values are 10 g (0.35 oz.) each or below.
 ● If either residual unbalance value exceeds 10 g (0.35 oz.), repeat installation procedures.

Wheel balance (Maximum allowable unbalance):

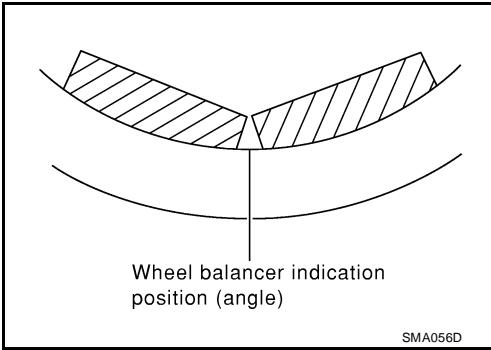

Maximum allowable unbalance	Dynamic (At rim flange)	10 g (0.35 oz.) (one side)
	Static	20 g (0.71 oz.)

Rotation

EES000CX

- Do not include the T-type spare tire when rotating the tires.

CAUTION:

When installing wheels, tighten them diagonally by dividing the work two to three times in order to prevent the wheels from developing any distortion.

Tightening torque of wheel nut :98 - 117 N·m (10 - 12 kg·m, 73 - 86 ft·lb)

A
B
C
D
WT
F
G
H
I
J
K
L
M

SERVICE DATA AND SPECIFICATIONS (SDS)

SERVICE DATA AND SPECIFICATIONS (SDS)

PF0:00030

Road Wheel

EES000CY

Wheel type		Aluminum	Steel	
			Inside	Outside
Maximum radial runout limit	Lateral mm (in)	0.3 (0.012) or less	1.0 (0.039) or less	0.9 (0.035) or less
	Radial mm (in)	0.3 (0.012) or less	0.8 (0.031) or less	0.4 (0.016) or less
Allowable quantity of residual unbalance	Dynamic (On the ear part)	Less than 10 g (0.35 oz) (per side)		
	Static (On the ear part)	Less than 20 g (0.70 oz)		

Tire

EES000CZ

Unit : kPa (kg/cm² , psi)

Tire size	Air pressure	
	Conventional tire	Spare tire
T125/70D14 T125/70D15 T135/80D15 T135/90D15	—	420 (4.2, 60)
P185/65R14 P195/60R15 P195/55R16 P215/45R17	200 (2.0, 29)	—