

SECTION **RAX**  
REAR AXLE

A  
B  
C

RAX

CONTENTS

E

<b>PRECAUTIONS</b> .....	2	Rear Axle Parts .....	5	F
Precautions .....	2	Rear Wheel Bearing .....	5	
<b>PREPARATION</b> .....	3	<b>WHEEL HUB</b> .....	6	G
Special Service Tools .....	3	Components .....	6	
Commercial Service Tools .....	3	Removal .....	6	
<b>NOISE, VIBRATION, AND HARSHNESS (NVH)</b>		Installation .....	7	H
<b>TROUBLESHOOTING</b> .....	4	<b>SERVICE DATA AND SPECIFICATIONS (SDS)</b> .....	9	
NVH Troubleshooting Chart .....	4	Wheel Bearing (Rear) .....	9	
<b>ON-VEHICLE SERVICE</b> .....	5			

I

J

K

L

M

# PRECAUTIONS

## PRECAUTIONS

PF0:00001

### Precautions

EDS0008S

- When installing each rubber part, final tightening must be carried out under unladen condition\* with tires on ground.  
\*: Fuel, radiator coolant and engine oil full. Spare tire, jack, hand tools and mats in designated positions.
- Use flare nut wrench when removing or installing brake tubes.
- After installing removed suspension parts, check wheel alignment.
- Do not jack up at the trailing arm and lateral link.
- Always torque brake lines when installing.

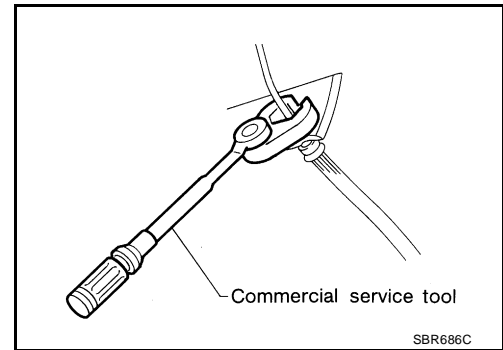

# PREPARATION

## PREPARATION

PFP:00002

### Special Service Tools

EDS0008T

The actual shapes of Kent-Moore tools may differ from those of special service tools illustrated here.

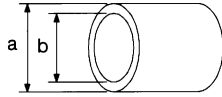
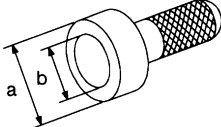
Tool number (Kent-Moore No.) Tool name	Description	
KV40104710 ( — ) Drift	 <p style="text-align: right;">NT474</p>	Install sensor rotor <b>a: 76.3 mm (3.004 in) dia.</b> <b>b: 67.9 mm (3.673 in) dia.</b>
ST3072000 ( — ) Drift	 <p style="text-align: right;">NT115</p>	Install sensor rotor <b>a: 77 mm (3.03 in) dia.</b> <b>b: 55.5 mm (2.185 in) dia.</b>

A  
B  
C  
**RAX**  
E  
F  
G  
H  
I  
J  
K  
L  
M

### Commercial Service Tools

EDS0008U

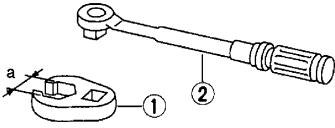
Tool name	Description	
GG94310000 1 Flare nut crowfoot 2 Torque wrench	 <p style="text-align: right;">NT360</p>	Removing and installing brake piping <b>a: 10 mm (0.39 in)</b>

# NOISE, VIBRATION, AND HARSHNESS (NVH) TROUBLESHOOTING

## NOISE, VIBRATION, AND HARSHNESS (NVH) TROUBLESHOOTING

PF0:00003

### NVH Troubleshooting Chart

EDS0008V

Use the chart below to help you find the cause of the symptom. If necessary, repair or replace these parts.

Reference page			<a href="#">RAX-7, "Installation"</a>	<a href="#">RAX-5, "Rear Wheel Beating"</a>	<a href="#">RAX-5, "Rear Wheel Beating"</a>	<a href="#">WT-2, "NVH Troubleshooting Chart"</a>	<a href="#">WT-2, "NVH Troubleshooting Chart"</a>
Possible cause and SUSPECTED PARTS			Improper installation, looseness	Parts interference	Wheel bearing damage	TIRES	ROAD WHEEL
Symptom	REAR AXLE	Noise	x	x		x	x
		Shake	x	x		x	x
		Vibration	x	x		x	
		Shimmy	x	x		x	x
		Judder	x			x	x
		Poor quality ride or handling	x	x	x	x	x

x: Applicable

## ON-VEHICLE SERVICE

PFP:00000

EDS0008W

### Rear Axle Parts

Check axle and suspension parts for excessive play, wear or damage.

- Shake each rear wheel to check for excessive play.
- Retighten all axle and suspension nuts and bolts to the specified torque.

**Tightening torque** : Refer to [RSU-6, "Components"](#) .

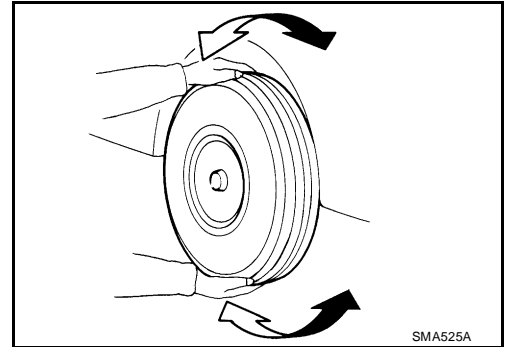

### Rear Wheel Bearing

- Check axial end play.

**Axial end play** : 0.05 mm (0.0020 in) or less

- Check that wheel hub bearings operate smoothly.
- Check tightening torque of wheel bearing lock nut.



**Tightening torque** : 187 - 255 N·m (19 - 26 kg-m, 138 - 188 ft-lb)

- If out of specification or if wheel bearing does not turn smoothly, replace wheel bearing assembly. Refer to [RAX-6, "Components"](#)

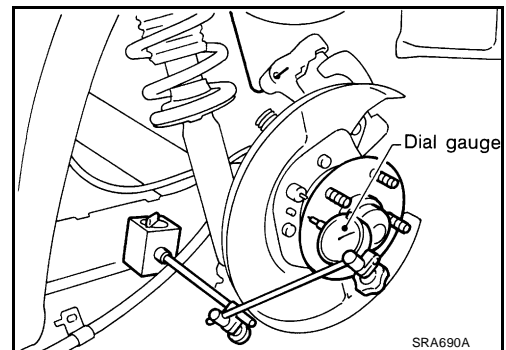

A  
B  
C  
RAX  
E  
F  
G  
H  
I  
J  
K  
L  
M

# WHEEL HUB

PF:43200

EDS0008Y

## WHEEL HUB

### Components

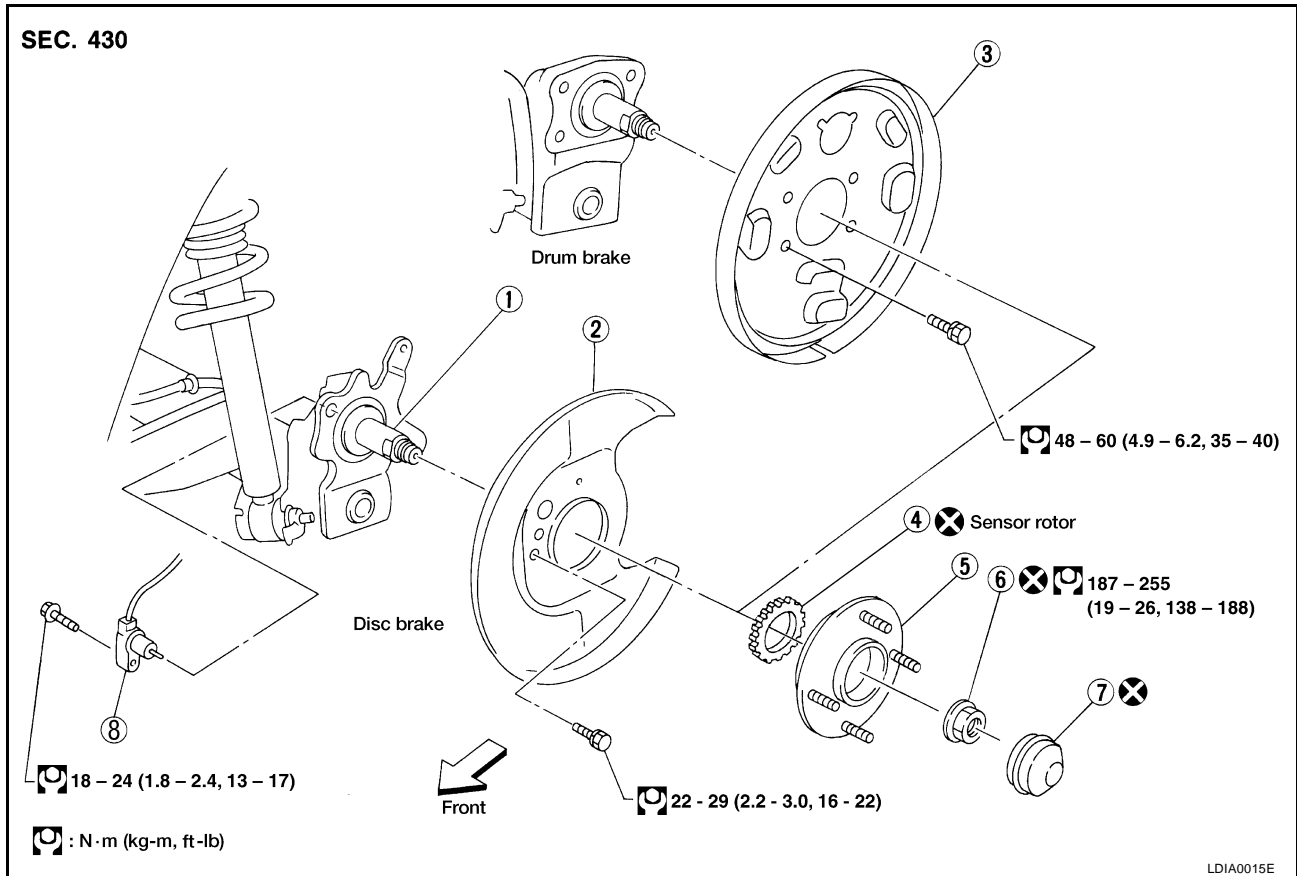

- |                               |                               |                           |
|-------------------------------|-------------------------------|---------------------------|
| 1. Spindle                    | 2. Baffle plate               | 3. Back plate             |
| 4. Sensor rotor (if equipped) | 5. Wheel hub                  | 6. Wheel bearing lock nut |
| 7. Hub cap                    | 8. Wheel sensor (if equipped) |                           |

## Removal

EDS0008Z

### CAUTION:

- Before removing the rear wheel hub assembly, disconnect the wheel sensor from the assembly. Then move it away from the hub assembly. Failure to do so may result in damage to the sensor wires and the wheel sensor becoming inoperative.
- Wheel hub bearing does not require maintenance. If any of the following symptoms are noted, replace wheel hub bearing assembly.
  1. Growling noise is emitted from wheel hub bearing during operation.
  2. Wheel hub bearing drags or turns roughly. This occurs when turning hub by hand after bearing lock nut is tightened to specified torque.

1. Remove brake caliper assembly.
2. Remove wheel bearing lock nut.
3. Remove brake rotor.
4. Remove wheel hub bearing from spindle.

Brake hose does not need to be disconnected from brake caliper.

Suspend caliper assembly with wire so as not to stretch brake hose.

Be careful not to depress brake pedal, or piston will pop out. Make sure brake hose is not twisted.

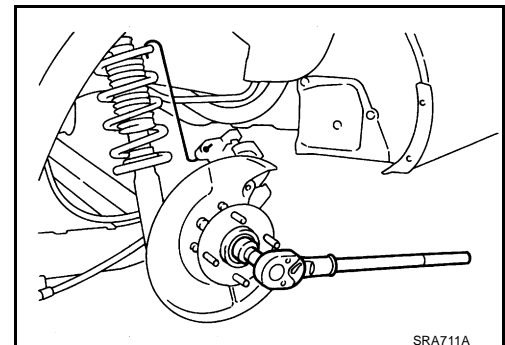

# WHEEL HUB

- Remove the sensor rotor, if equipped, using suitable puller, drift and bearing replacer.

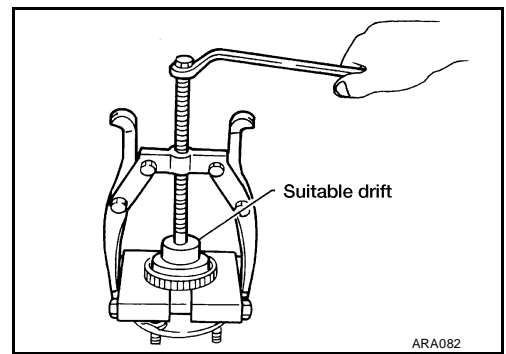

## Installation

- With vehicles equipped with ABS, press-fit sensor rotor into wheel hub bearing using a drift. **Do not reuse sensor rotor. When installing, replace it with a new one.**

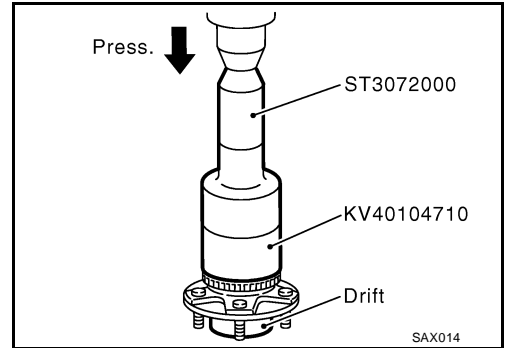

- Press-fit sensor rotor as far as the location shown in figure at right.

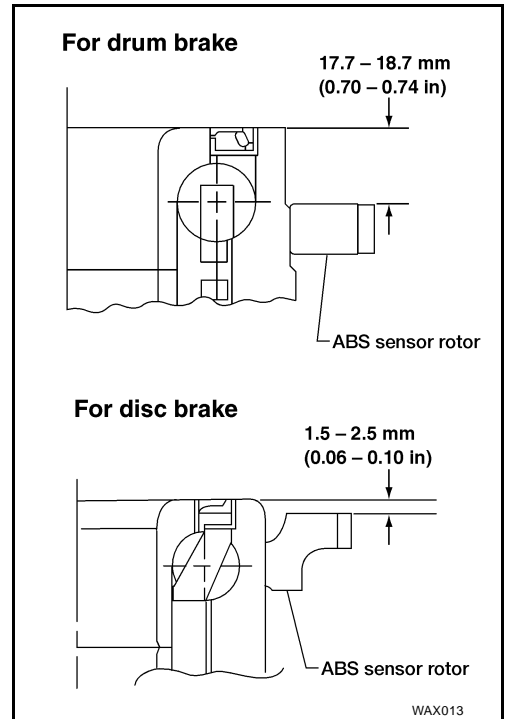

A

B

C

RAX

E

F

G

H

I

J

K

L

M

# WHEEL HUB

- Install wheel hub bearing.
- Tighten wheel bearing lock nut.  
Before tightening, apply oil to threaded portion of rear spindle.  
**Do not reuse wheel bearing lock nut.**



: 187 - 255 N·m (19 - 26 kg·m, 138 - 188 ft·lb)

- Check that wheel bearings operate smoothly.

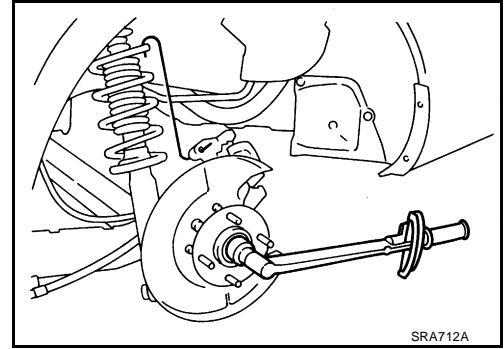

- Check wheel hub bearing axial end play.

**Axial end play** : 0.05 mm (0.0020 in) or less

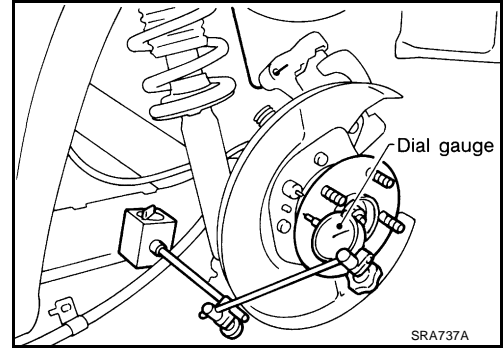

- Clinch two places of lock nut.

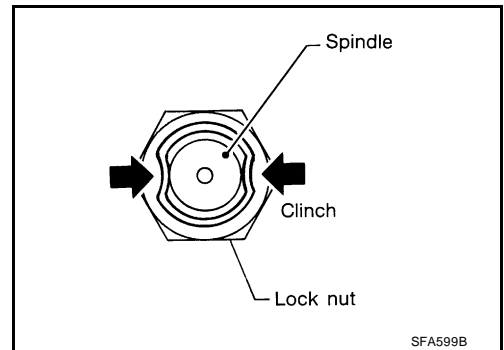

- Install hub cap using a suitable tool.  
**Do not reuse hub cap. When installing, replace it with a new one.**

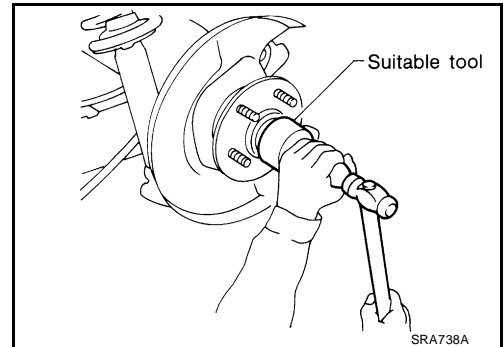



# SERVICE DATA AND SPECIFICATIONS (SDS)

## SERVICE DATA AND SPECIFICATIONS (SDS)

PFP:00030

### Wheel Bearing (Rear)

EDS00091

Wheel bearing axial end play limit mm (in)	0.05 (0.0020) or less
Wheel bearing lock nut tightening torque N·m (kg·m, ft·lb)	187 - 255 (19 - 26, 138 - 188)

A

B

C

RAX

E

F

G

H

I

J

K

L

M

## SERVICE DATA AND SPECIFICATIONS (SDS)

---