

A
B
C

SECTION PS

POWER STEERING SYSTEM

CONTENTS

<p>PRECAUTIONS 2</p> <p> Precautions for Supplemental Restraint System (SRS) "AIR BAG" and "SEAT BELT PRE-TENSIONER" 2</p> <p> Precautions for Steering System 2</p> <p>PREPARATION 3</p> <p> Special Service Tools 3</p> <p> Commercial Service Tool 5</p> <p>NOISE, VIBRATION, AND HARSHNESS(NVH)</p> <p>TROUBLESHOOTING 6</p> <p> NVH Troubleshooting Chart 6</p> <p>ON-VEHICLE SERVICE 7</p> <p> Checking Steering Wheel Play 7</p> <p> Checking Neutral Position on Steering Wheel 7</p> <p> PRE-CHECKING 7</p> <p> CHECKING 7</p> <p> Front Wheel Turning Angle 7</p> <p> Checking Gear Housing Movement 8</p> <p> Checking and Adjusting Drive Belts 8</p> <p> Checking Fluid Level 8</p> <p> Checking Fluid Leakage 8</p> <p> Bleeding Hydraulic System 8</p> <p> Checking Steering Wheel Turning Force 9</p> <p> Checking Hydraulic System 9</p> <p>STEERING WHEEL AND STEERING COLUMN11</p> <p> Components 11</p>	<p> Removal and Installation 11</p> <p> STEERING WHEEL 11</p> <p> STEERING COLUMN 12</p> <p> Disassembly and Assembly 13</p> <p> Inspection 14</p> <p> TILT MECHANISM 14</p> <p>POWER STEERING GEAR AND LINKAGE 15</p> <p> Components 15</p> <p> Removal and Installation 16</p> <p> Disassembly 18</p> <p> Inspection 18</p> <p> BOOT 18</p> <p> TIE-ROD OUTER AND INNER SOCKETS 19</p> <p> Assembly 19</p> <p>POWER STEERING OIL PUMP 21</p> <p> Components 21</p> <p> Pre-Disassembly Inspection 21</p> <p> Disassembly 22</p> <p> Inspection 22</p> <p> Assembly 22</p> <p>SERVICE DATA AND SPECIFICATIONS (SDS) 24</p> <p> General Specifications 24</p> <p> Steering Wheel 24</p> <p> Steering Column 24</p> <p> Steering Gear and Linkage 24</p> <p> Power Steering 25</p>
---	---

A
B
C
D
E
F
PS
H
I
J
K
L
M

PRECAUTIONS

PRECAUTIONS

PF0:00001

Precautions for Supplemental Restraint System (SRS) “AIR BAG” and “SEAT BELT PRE-TENSIONER”

EGS0009V

The Supplemental Restraint System such as “AIR BAG” and “SEAT BELT PRE-TENSIONER”, used along with a front seat belt, helps to reduce the risk or severity of injury to the driver and front passenger for certain types of collision. Information necessary to service the system safely is included in the SRS and SB section of this Service Manual.

WARNING:

- To avoid rendering the SRS inoperative, which could increase the risk of personal injury or death in the event of a collision which would result in air bag inflation, all maintenance must be performed by an authorized NISSAN/INFINITI dealer.
- Improper maintenance, including incorrect removal and installation of the SRS, can lead to personal injury caused by unintentional activation of the system. For removal of Spiral Cable and Air Bag Module, see the SRS section.
- Do not use electrical test equipment on any circuit related to the SRS unless instructed to in this Service Manual. SRS wiring harnesses can be identified by yellow and/or orange harness connectors.

Precautions for Steering System

EGS0009W

- Before disassembly, thoroughly clean the outside of the unit.
- Disassembly should be done in a clean work area. It is important to prevent the internal parts from becoming contaminated by dirt or other foreign matter.
- For easier and proper assembly, place disassembled parts in order on a parts rack.
- Use nylon cloths or paper towels to clean the parts; common shop rags can leave lint that might interfere with their operation.
- Before inspection or reassembly, carefully clean all parts with a general purpose, non-flammable solvent.
- Before assembly, apply a coat of recommended Genuine NISSAN PSF II or equivalent to hydraulic parts. Petroleum jelly may be applied to O-rings and seals. Do not use any grease.
- Replace all gaskets, seals and O-rings. Avoid damaging O-rings, seals and gaskets during installation. Perform functional tests whenever designated.

PREPARATION

PREPARATION

PFP:00002

Special Service Tools

EGS0009X

The actual shapes of Kent-Moore tools may differ from those of special service tools illustrated here.

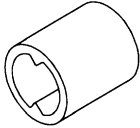
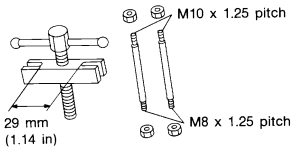
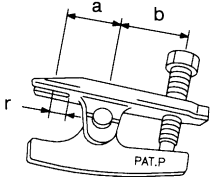
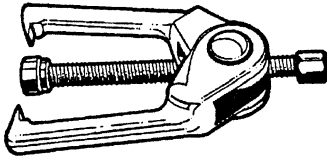
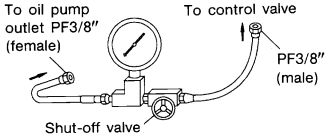
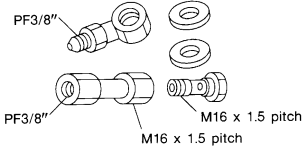
Tool number (Kent-Moore No.) Tool name	Description
KV48101100 (J26364) Torque adapter <div style="text-align: center;">  </div> <p style="text-align: right;">NT169</p>	Measuring pinion rotating torque
ST27180001 (J25726-B) Steering wheel puller <div style="text-align: center;">  </div> <p style="text-align: right;">S-NT544</p>	Removing steering wheel
HT72520000 (J25730-B) Ball joint remover <div style="text-align: center;">  </div> <p style="text-align: right;">NT546</p>	Removing tie-rod and lower ball joint a: 33 mm (1.30 in) b: 50 mm (1.97 in) r: R11.5 mm (0.453 in)
(J-24319-B) Tie rod puller <div style="text-align: center;">  </div> <p style="text-align: right;">LGIA0007E</p>	Remove outer tie rod
KV48103500 (J26357 and J26357-10) Pressure gauge <div style="text-align: center;">  </div> <p style="text-align: right;">S-NT547</p>	Measuring oil pressure
KV48102500 (J33914) Pressure gauge adapter <div style="text-align: center;">  </div> <p style="text-align: right;">S-NT542</p>	Measuring oil pressure

A
B
C
D
E
F
PS
H
I
J
K
L
M

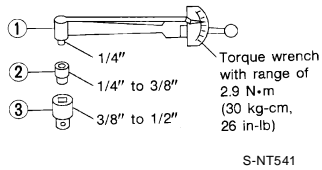
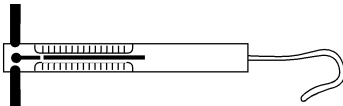
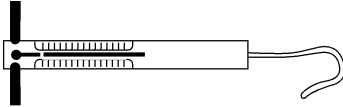
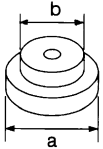
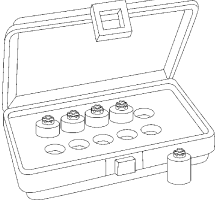

PREPARATION

Tool number (Kent-Moore No.) Tool name	Description
ST3127S000 1 GG91030000 (See J25765-A) Torque wrench 2 HT62940000 (—) Socket adapter 3 HT62900000 (—) Socket adapter	Measuring turning torque 
(J44372) 5-60 Pound pull gauge	Measuring steering wheel turning force  <p style="text-align: center;">WST052</p>
(J44183-A) 20-100 Pound pull gauge	Measuring rack sliding force  <p style="text-align: center;">WST052</p>
ST35300000 (—) Drift	Installing power steering pump oil seal a: 49 mm (1.93 in) dia. b: 41 mm (1.61 in) dia.  <p style="text-align: center;">NT073</p>
(J-44615) Air Bag Master Key Set	Removing and installing accessory air bag bolts.  <p style="text-align: center;">LRS194</p>

PREPARATION

Commercial Service Tool

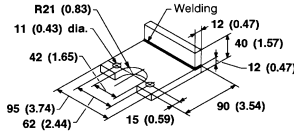
EGS0009Y

Tool number	Description
<p>Power steering pump attachment</p>  <p style="text-align: right;">S-NT179</p>	<p>Disassembling and assembling power steering pump Unit: mm (in)</p>
<p>10 mm Drift</p>  <p style="text-align: right;">LST027</p>	<p>Installing power steering pump snap ring</p>

A
B
C
D
E
F

PS

H
I
J
K
L
M

NOISE, VIBRATION, AND HARSHNESS(NVH) TROUBLESHOOTING

NOISE, VIBRATION, AND HARSHNESS(NVH) TROUBLESHOOTING

PF:00003

NVH Troubleshooting Chart

EGS0009Z

Use the chart below to help you find the cause of the symptom. If necessary, repair or replace these parts.

Symptom		Possible cause and SUSPECTED PARTS	Reference page																						
			Fluid level	Air in hydraulic system	Tie-rod ball joint swinging force	Tie-rod ball joint rotating torque	Tie-rod ball joint end play	Steering gear fluid leakage	Steering wheel play	Steering gear rack sliding force	Drive belt looseness	Improper steering wheel	Improper installation or looseness or tilt lock lever	Mounting rubber deterioration	Steering column deformation or damage	Improper installation or looseness of steering column	Steering linkage looseness	DRIVE SHAFT	AXLE	SUSPENSION	TIRES	ROAD WHEEL	BRAKES		
STEERING	Noise		x	x	x	x	x	x	x	x	x														
	Shake											x	x	x			x	x	x	x	x	x	x	x	x
	Vibration											x	x	x	x		x	x	x	x					
	Shimmy											x	x	x			x	x	x	x	x	x	x	x	x
	Judder													x			x	x	x	x	x	x	x	x	x

x: Applicable

ON-VEHICLE SERVICE

PFP:00000

Checking Steering Wheel Play

EGS000A0

- With wheels in a straight-ahead position, check steering wheel play.

Steering wheel play : 35 mm (1.38 in) or less

- If it is not within specification, check the following for loose or worn components:
 - Steering gear assembly
 - Steering column
 - Front suspension and axle

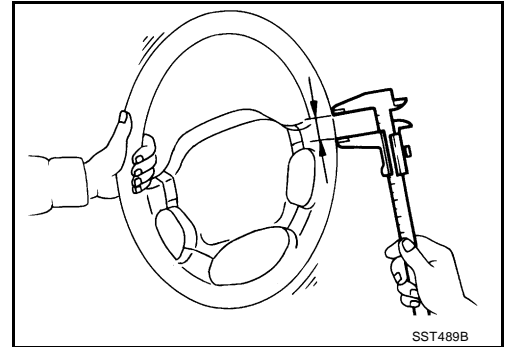

Checking Neutral Position on Steering Wheel

EGS000A1

- Make sure that wheel alignment is correct.

Wheel alignment : Refer to [FSU-6, "Front Wheel Alignment"](#)

- Verify that the steering gear is centered before removing the steering wheel.

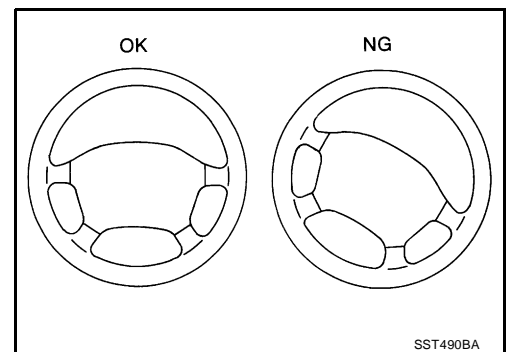

CHECKING

1. Check that the steering wheel is in the neutral position when driving straight ahead.
2. If it is not in the neutral position, remove the steering wheel and reinstall it correctly.
3. If the neutral position is between two teeth, loosen tie-rod lock nuts. Turn the tie-rods by the same amount in opposite directions on both left and right sides.

Front Wheel Turning Angle

EGS000A2

1. Rotate steering wheel all the way right and left; measure turning angle.

Turning angle of full turns : Refer to [FSU-6, "Front Wheel Alignment"](#)

2. If it is not within specification, check rack stroke.

Rack stroke "S" : Refer to [PS-24, "Steering Gear and Linkage"](#)

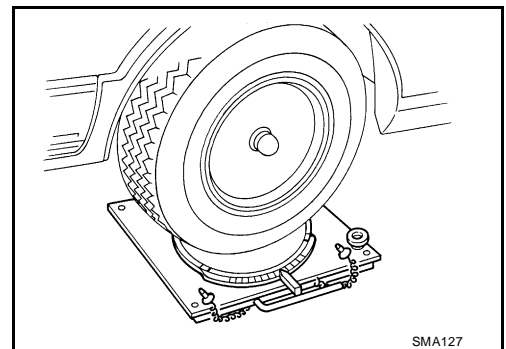

ON-VEHICLE SERVICE

Checking Gear Housing Movement

EGS000A3

1. Check the movement of steering gear housing during stationary steering on a dry paved surface.
 - Apply a force of 49 N (5 kg, 11 lb) to steering wheel to check the gear housing movement.
Turn off ignition key while checking.

Movement of gear housing : ± 2 mm (± 0.08 in) or less

2. If movement exceeds the limit, replace mount insulator after confirming proper installation of gear housing clamps.

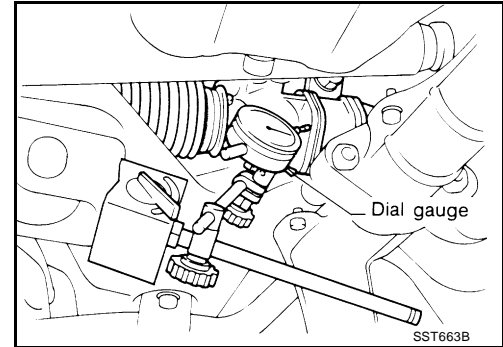

Checking and Adjusting Drive Belts

EGS000A4

Refer to [MA-15, "Checking Drive Belts"](#) (QG18DE), [MA-22, "Checking Drive Belts"](#) (QR25DE).

Checking Fluid Level

EGS000A5

Check fluid level, referring to the scale on reservoir tank.
Use "HOT" range for fluid temperatures of 50 to 80°C (122 to 176°F).
Use "COLD" range for fluid temperatures of 0 to 30°C (32 to 86°F).

CAUTION:

- Do not overfill.
- Recommended fluid is Genuine NISSAN PSF II or equivalent. Refer to [MA-13, "Fluids and Lubricants"](#).

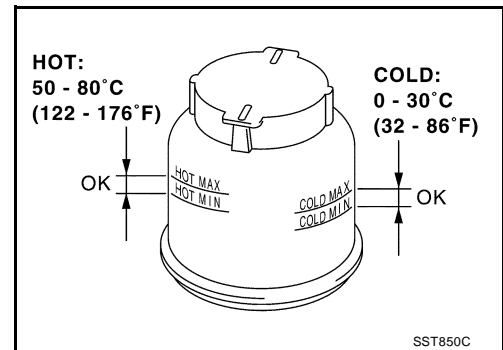

Checking Fluid Leakage

EGS000A6

Check the lines for improper attachment and for leaks, cracks, damage, loose connections, chafing and deterioration.

1. Run engine between idle speed and 1,000 rpm.

Make sure temperature of fluid in oil tank rises to 60 to 80°C (140 to 176°F).

2. Turn steering wheel right-to-left several times.
3. Hold steering wheel at each "lock" position for five seconds and carefully check for fluid leakage.

CAUTION:

Do not hold the steering wheel in a locked position for more than 15 seconds.

4. If fluid leakage at connectors is noticed, shut off engine, then loosen and retighten flare nut.

Do not overtighten connector as this can damage O-ring, washer and connector.

5. If fluid leakage from power steering pump is noticed, check power steering pump. Refer to [PS-21, "Pre-Disassembly Inspection"](#).
6. Check rack boots for accumulation of power steering fluid.

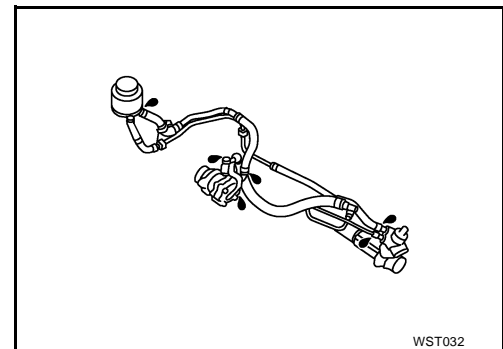

Bleeding Hydraulic System

EGS000A7

1. Raise front end of vehicle until wheels are clear of the ground.
2. Add fluid into oil tank to specified level. Then quickly turn steering wheel fully to right and left and lightly touch steering stoppers.
Repeat steering wheel operation until fluid level no longer decreases.
3. Start engine.
Repeat step 2 above.
 - If any of the following occurs, bleed air again:
 - Air bubbles in reservoir tank

ON-VEHICLE SERVICE

- Clicking noise in oil pump
- Excessive buzzing in oil pump

Fluid noise may occur in the valve or oil pump. This is common when the vehicle is stationary or while turning the steering wheel slowly. This does not affect the performance or durability of the system.

Checking Steering Wheel Turning Force

EGS000A8

1. Park vehicle on a level, dry surface and set parking brake.
2. Start engine.
3. Bring power steering fluid up to adequate operating temperature. [Make sure temperature of fluid is approximately 60 to 80°C (140 to 176°F).]

Tires need to be inflated to normal pressure.

4. Check steering wheel turning force when steering wheel has been turned 360° from the neutral position.

Steering wheel turning force : 39 N (4 kg, 9 lb) or less

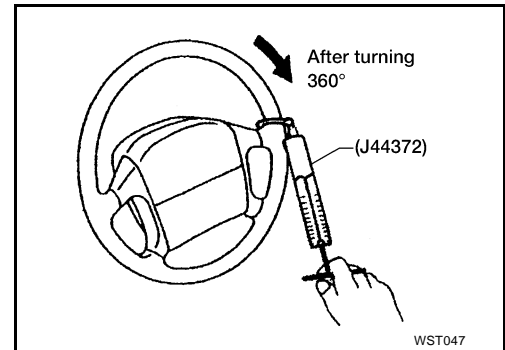

5. If steering wheel turning force is out of specification, check rack sliding force.
 - a. Disconnect steering column lower joint and knuckle arms from the gear.
 - b. Start and run engine at idle to make sure steering fluid has reached normal operating temperature.
 - c. Pull tie-rod slowly to move it from neutral position to ±11.5 mm (±0.453 in) at speed of 3.5 mm (0.138 in)/s. Check that rack sliding force is within specification.

Average rack sliding force (QG18DE models) : 140 - 330 N (14.3 - 33.7 kg, 31.5 - 74.2 lb)

Average rack sliding force (QR25DE models) : 160 - 350 N (16.3 - 35.7 kg, 36.0 - 78.7 lb)

Maximum force deviation : 95 N (9.7 kg, 21.4 lb)

- d. Check sliding force outside the above range at rack speed of 40 mm (1.75 in)/s.

Maximum rack sliding force : Not more than 294 N (30 kg, 66 lb)

Maximum force deviation : 147 N (15 kg, 33 lb)

6. If rack sliding force is not within specification, overhaul steering gear assembly.
7. If rack sliding force is OK, inspect steering column. Refer [PS-14, "Inspection"](#).

Checking Hydraulic System

EGS000A9

Before starting, check belt tension, driving pulley and tire pressure.

1. Set Tool. Open shut-off valve. Then bleed air. Refer to [PS-8, "Bleeding Hydraulic System"](#).
2. Run engine at idle speed or 1,000 rpm.

Make sure temperature of fluid in tank rises to 60 to 80°C (140 to 176°F).

WARNING:

Warm up engine with shut-off valve fully opened. If engine is started with shut-off valve closed, fluid pressure in oil pump increases to maximum. This will raise oil temperature abnormally.

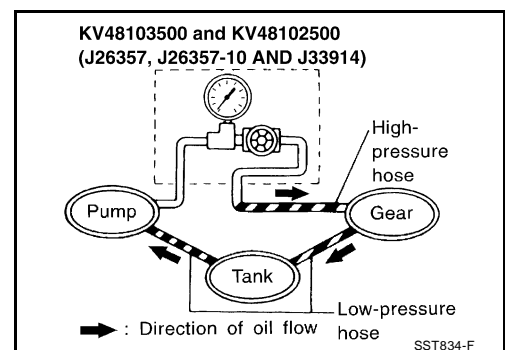

ON-VEHICLE SERVICE

3. Check pressure with steering wheel fully turned to left and right positions with engine idling at 1,000 rpm.

CAUTION:

Do not hold the steering wheel in a locked position for more than 15 seconds.

Oil pump maximum standard pressure

(QG18DE) : 7,649 - 8,238 kPa (78 - 84 kg/cm² ,
1,109 - 1,194 psi)

(QR25DE) : 8,000 - 8,800 kPa (82 - 90 kg/cm² ,
1,160 - 1,276 psi)

- If pressure reaches maximum operating pressure, system is OK.
 - If pressure increases above maximum operating pressure, check power steering pump flow control valve. Refer to [PS-21, "Components"](#) .
4. If power steering pressure is below the maximum operating pressure, slowly close shut-off valve and check pressure again.

CAUTION:

Do not close shut-off valve for more than 15 seconds.

- If pressure increases to maximum operating pressure, gear is damaged. Refer to [PS-16, "Removal and Installation"](#) .
 - If pressure remains below maximum operating pressure, pump is damaged. Refer to [PS-22, "Disassembly"](#) .
5. After checking hydraulic system, remove Tool and add fluid as necessary. Then completely bleed air out of system. Refer to [PS-8, "Bleeding Hydraulic System"](#) .

STEERING WHEEL AND STEERING COLUMN

STEERING WHEEL AND STEERING COLUMN

PFP:48430

Components

EGS000AA

SEC. 484 • 487 • 488

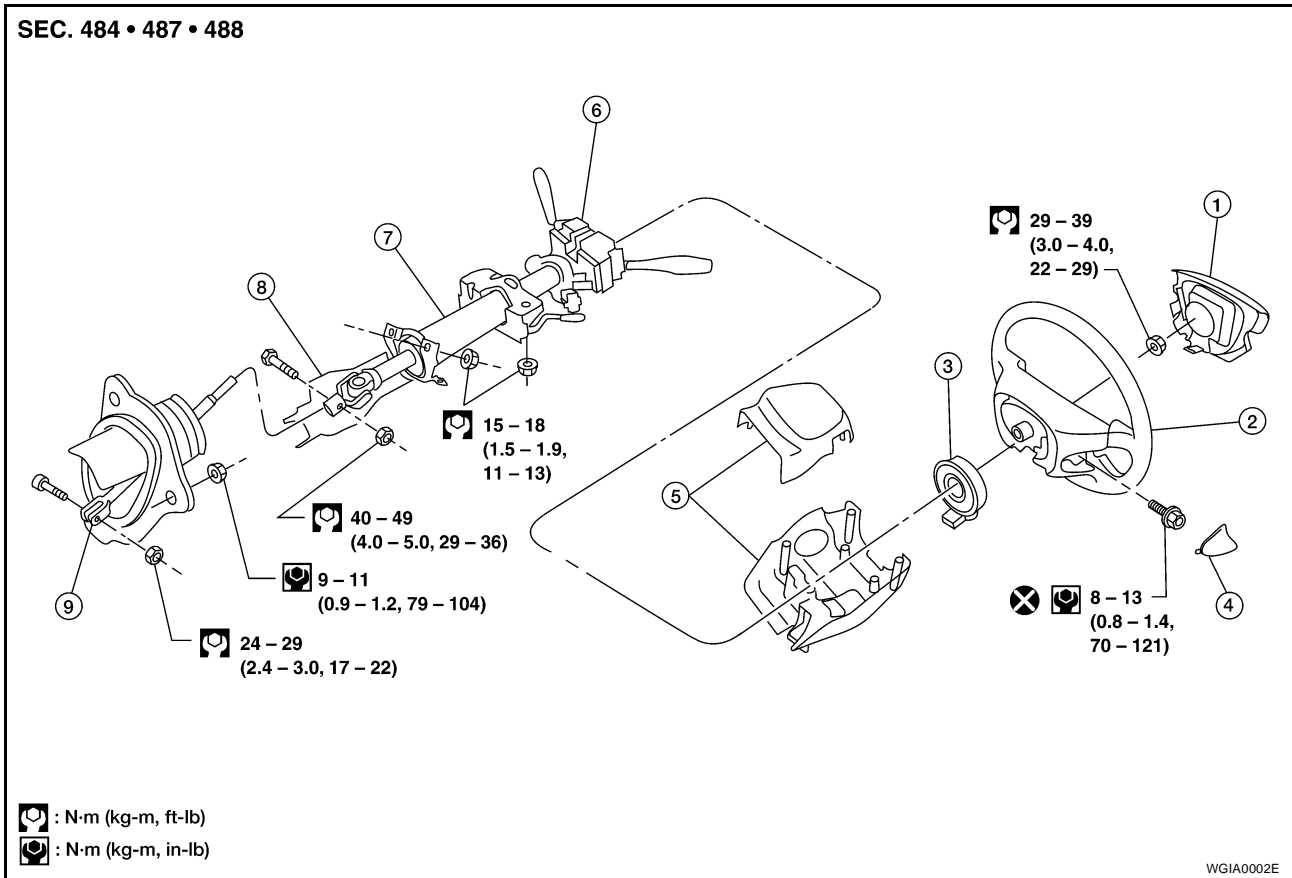

- | | | |
|-----------------------------|--------------------------------|-----------------------|
| 1. Air bag module | 2. Steering wheel | 3. Spiral cable |
| 4. Side lid LH | 5. Column cover | 6. Combination switch |
| 7. Steering column assembly | 8. Steering column lower cover | 9. Lower joint |

CAUTION:

- The rotation of the spiral cable (SRS "Air bag" component part) is limited. If the steering gear must be removed, set the front wheels in the straight-ahead direction. Do not rotate the steering column while the steering gear is removed.
- Remove the steering wheel before removing the steering lower joint to avoid damaging the SRS spiral cable.

Removal and Installation STEERING WHEEL

EGS000AB

1. Remove air bag module.
Refer to [SRS-40, "Removal and Installation"](#).
2. Remove steering wheel mounting nut.
3. Remove steering wheel with Tool.
4. Installation is in the reverse order of removal.

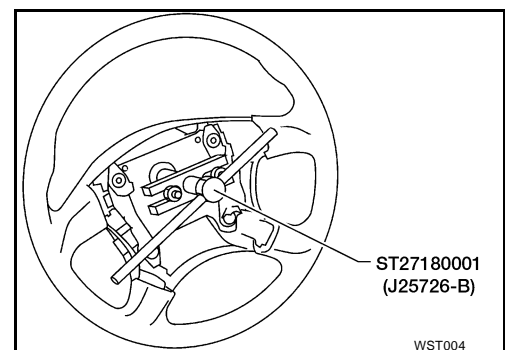

STEERING WHEEL AND STEERING COLUMN

STEERING COLUMN

Removal

CAUTION:

- The rotation of the spiral cable (SRS "Air Bag" component part) is limited. If the steering gear must be removed, set the front wheels in the straight-ahead direction. Do not rotate the steering column while the steering gear is removed.
 - Remove the steering wheel before removing the steering lower joint to avoid damaging the SRS spiral cable.
1. Remove the steering wheel, refer to [PS-11, "STEERING WHEEL"](#).
 2. Removal spiral cable, refer to [SRS-42, "Removal and Installation"](#).
 3. Remove instrument lower panel and dash lower reinforcement panel.
 4. Remove the column covers.
 5. Disconnect electrical connectors from the ignition switch and combination switch.
 6. Remove three screws securing combination switch and remove combination switch.
 7. Remove key interlock cable (A/T models).
 8. Remove the hole cover, then remove bolt from lower joint.
 9. Remove the steering column lower cover.
 10. Remove four nuts securing steering column and remove steering column.

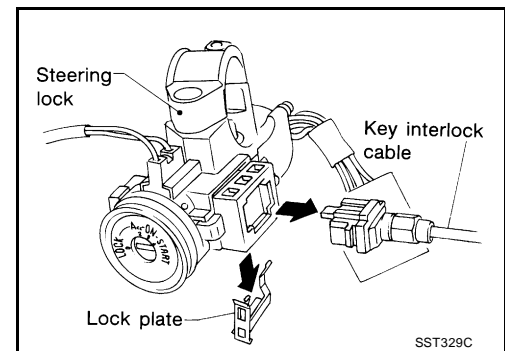

Installation

1. Installation is the reverse order of removal.
- When installing steering column, finger tighten all lower bracket and clamp retaining bolts; then tighten them securely. Do not apply undue stress to steering column.
 - When attaching coupling joint, be sure tightening bolt faces cut-out portion.
- Align slit of lower joint with projection on dust cover. Insert joint until surface A contacts surface B.

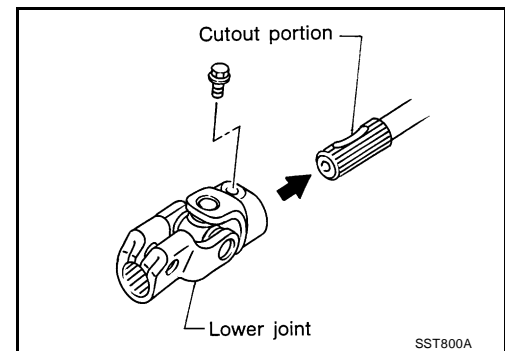

CAUTION:

After installation, turn steering wheel to make sure it moves smoothly. Ensure the number of turns are the same from the straight forward position to left and right locks. Be sure that the steering wheel is in a neutral position when driving straight ahead.

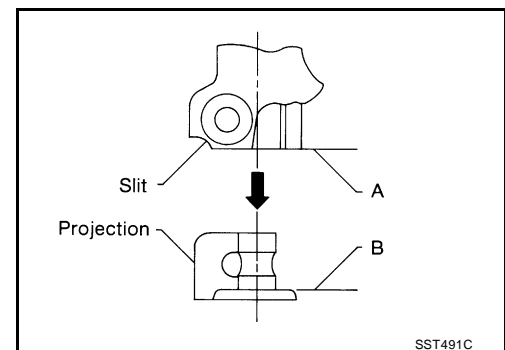

STEERING WHEEL AND STEERING COLUMN

Disassembly and Assembly

EGS000AC

SEC. 484 • 488

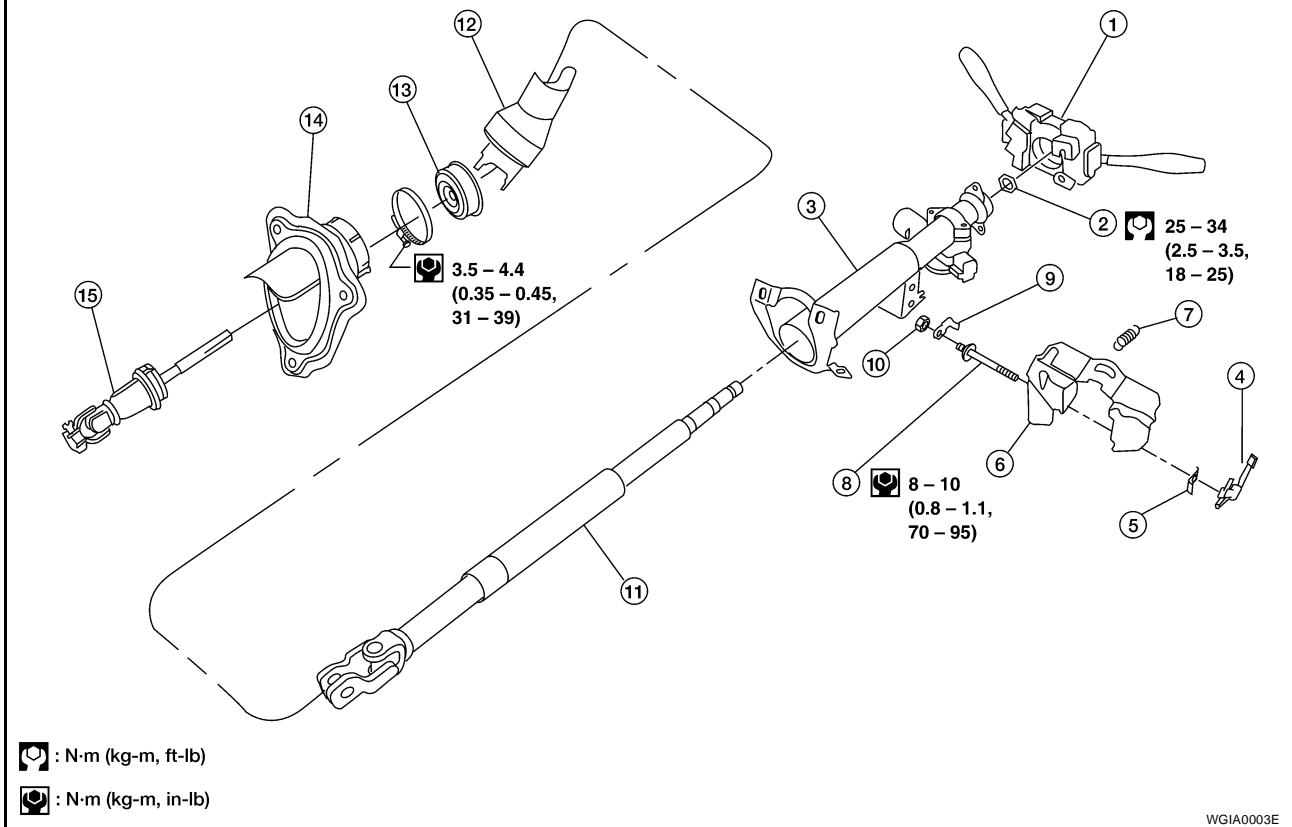

: N·m (kg·m, ft·lb)

: N·m (kg·m, in·lb)

- | | | |
|-----------------------|---------------------------|-------------------------------------|
| 1. Combination switch | 2. Lock nut | 3. Jacket tube assembly |
| 4. Tilt lever | 5. Tilt lever stopper | 6. Steering column mounting bracket |
| 7. Spring | 8. Adjust bolt | 9. Adjust bolt stopper |
| 10. Nut | 11. Column shaft assembly | 12. Steering column lower cover |
| 13. Hole cover seal | 14. Hole cover | 15. Lower joint |

- When disassembling and assembling, unlock steering lock with key.
- Install lock nut on steering column shaft and tighten the nut.

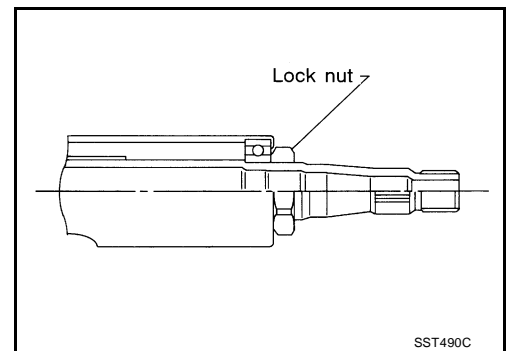

- Steering lock:
 - Break self-shear type screws using a drill or other appropriate tool.

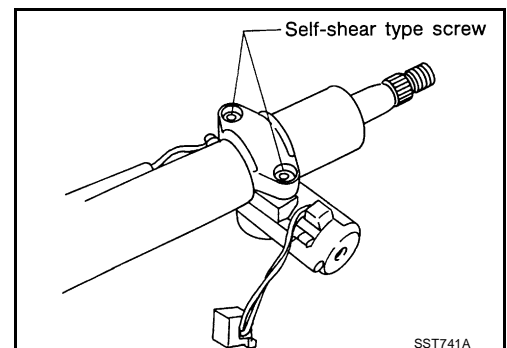

STEERING WHEEL AND STEERING COLUMN

- Install new self-shear type screws, then tighten until screw heads break off.

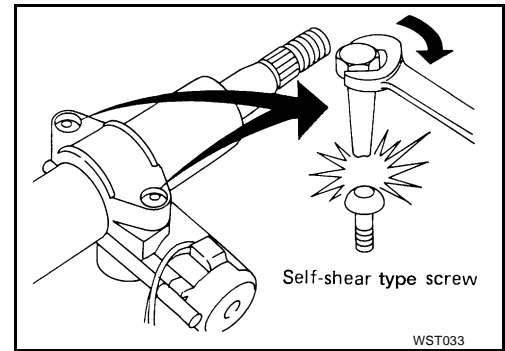

EGS000AD

Inspection

- When steering wheel does not turn smoothly, check the steering column as follows and replace damaged parts.
- Check column bearings for damage or unevenness. Lubricate with recommended multi-purpose grease or replace steering column as an assembly, if necessary.
- Check jacket tube for deformation or breakage. Replace if necessary.
- When the vehicle comes into a light collision, check length "L".

Steering column length "L" : 542 - 544 mm
(21.34 - 21.42 in)

If out of specification, replace steering column as an assembly.

TILT MECHANISM

- After installing steering column, check tilt mechanism operation.

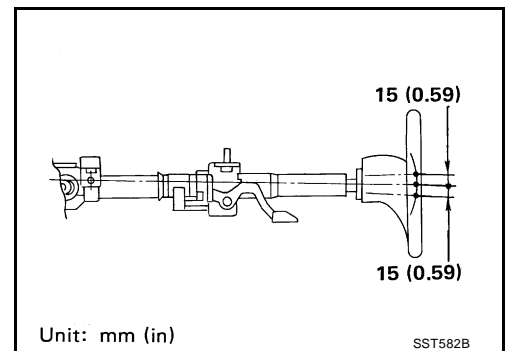
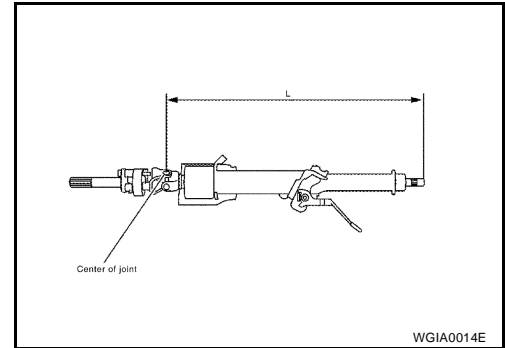

POWER STEERING GEAR AND LINKAGE

POWER STEERING GEAR AND LINKAGE

PF:49001

EGS000AE

Components

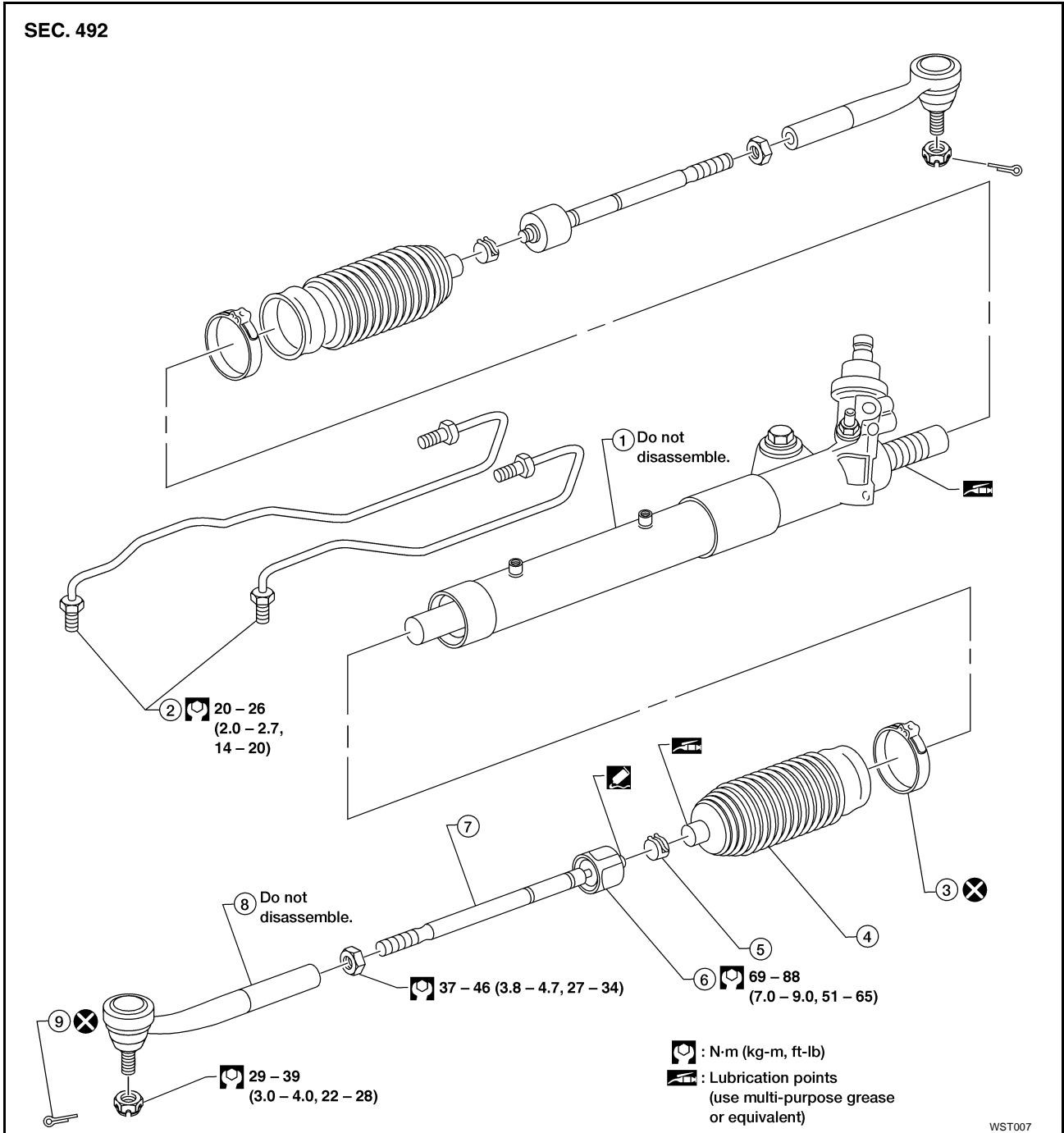

1. Steering gear
4. Dust boot
7. Tie-rod

2. Gear housing tube
5. Boot band
8. Tie-rod outer socket

3. Boot clamp
6. Tie-rod inner socket
9. Cotter pin

POWER STEERING GEAR AND LINKAGE

Removal and Installation

EGS000AF

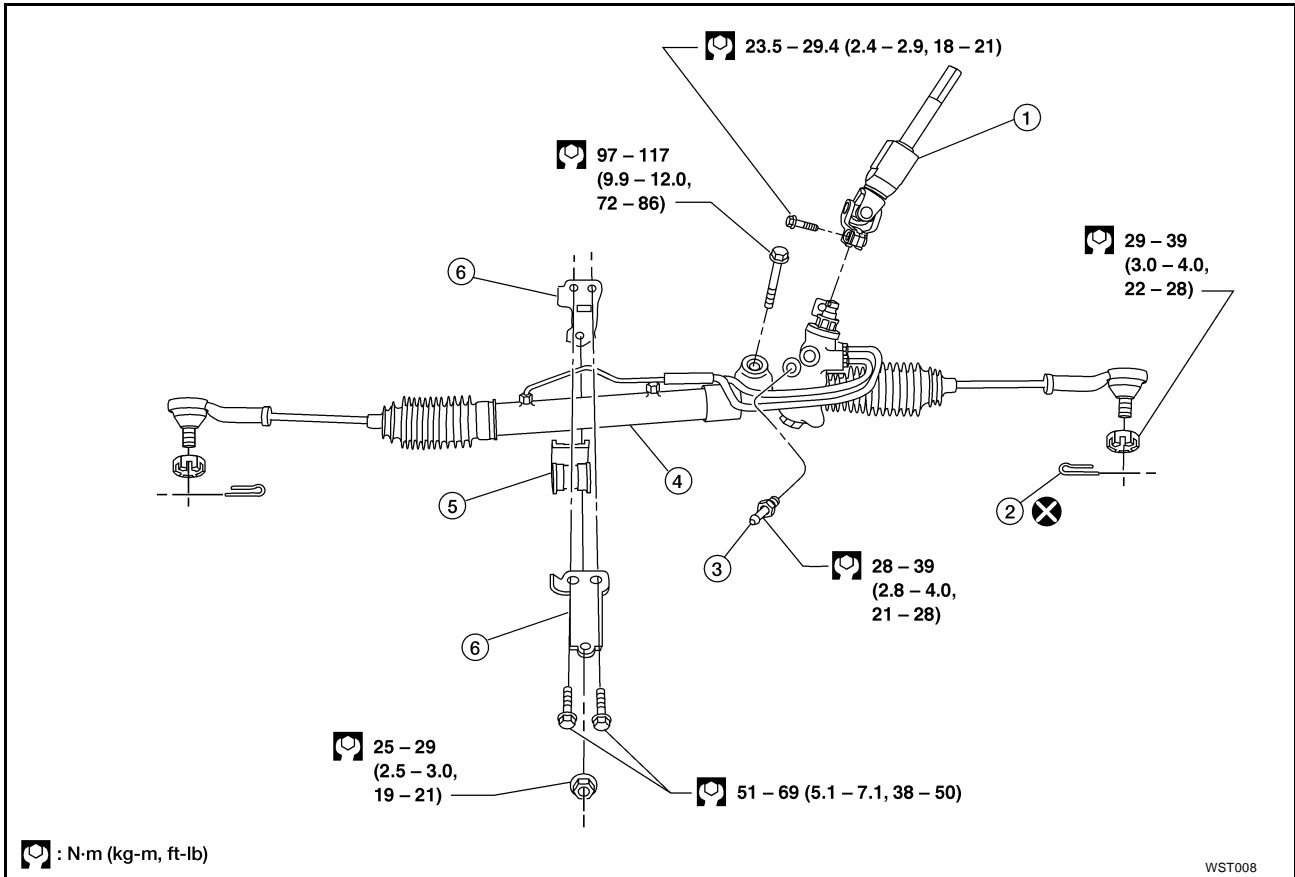

- | | | |
|------------------------------|----------------------------|----------------------------------|
| 1. Lower joint | 2. Cotter pin | 3. Low pressure line fitting |
| 4. Gear and linkage assembly | 5. Rack mounting insulator | 6. Gear housing mounting bracket |

CAUTION:

- The rotation of the spiral cable (SRS "Air bag" component part) is limited. If the steering gear must be removed, set the front wheels in the straight-ahead direction. Do not rotate the steering column while the steering gear is removed.
- Remove the steering wheel before removing the steering lower joint to avoid damaging the SRS spiral cable.

1. Detach tie-rod outer sockets.
2. Disconnect the power steering lines.
3. Disconnect the steering gear lower joint.
4. Position the bracket for the hoses and harness aside.
5. Remove the return line fitting.

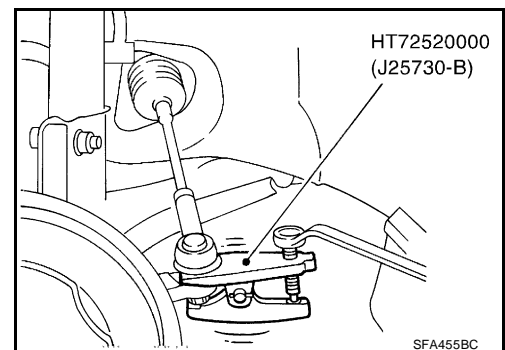

POWER STEERING GEAR AND LINKAGE

- Remove the steering gear mounting bolts.
- Remove the steering gear through the passenger side.

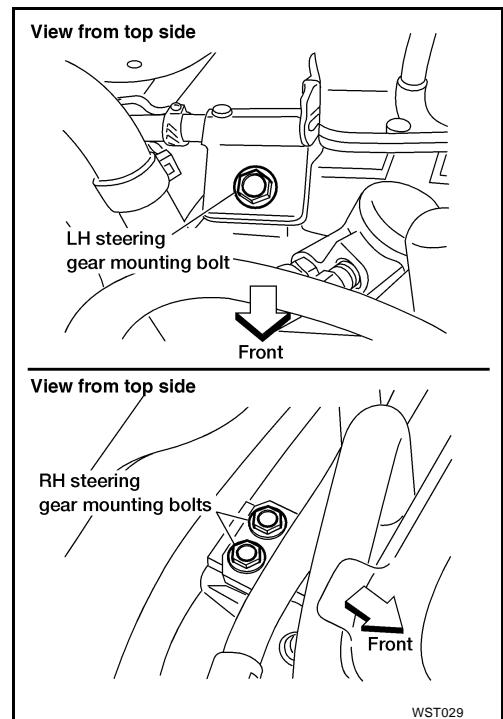

- Installation is the reverse order of removal.
 - Install power steering line connector.
 - Observe specified tightening torque when tightening high-pressure and low-pressure line connectors. Excessive tightening will damage threads of connector or O-ring.

Connector tightening torque

1 Low-pressure side : 28 - 39 N·m (2.8 - 4.0 kg-m, 21 - 28 ft-lb)

2 High-pressure side : 15 - 25 N·m (1.5 - 2.5 kg-m, 11 - 18 ft-lb)

- The O-ring in low-pressure pipe connector is larger than that in high-pressure connector. Take care to install the proper O-ring.
- Initially, tighten nut on tie-rod outer socket and knuckle arm to 29 to 39 N·m (3 to 4 kg-m, 22 to 28 ft-lb). Then tighten further to align nut groove with first pin hole so that cotter pin can be installed.

CAUTION:

Tightening torque must not exceed 49 N·m (5 kg-m, 36 ft-lb).

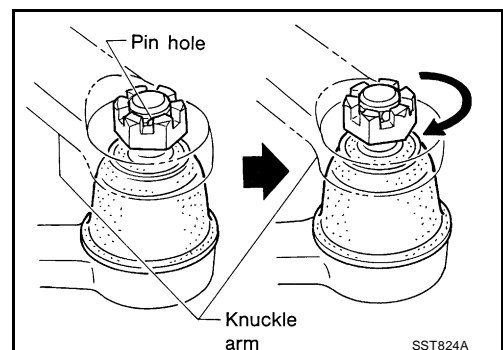
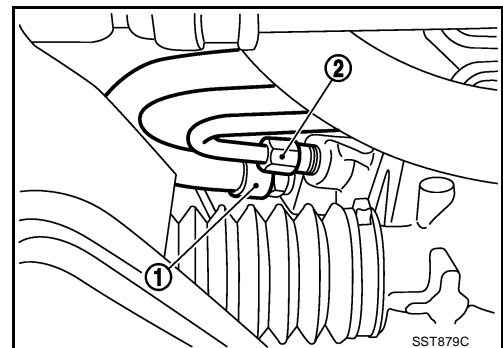

POWER STEERING GEAR AND LINKAGE

- Before removing lower joint from gear, set gear in neutral (wheels in straight-ahead position). After removing lower joint, put matching mark on pinion shaft and pinion housing to record neutral position.
- To install, set left and right dust boots to equal deflection. Attach lower joint by aligning matching marks of pinion shaft and pinion housing.

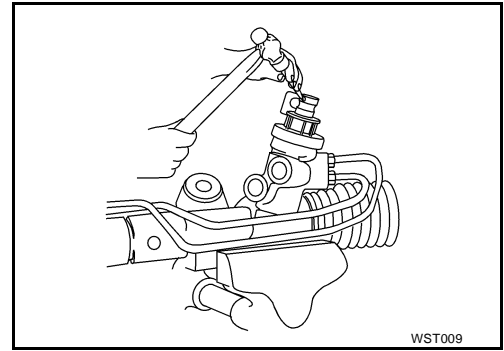

- Tighten gear housing mounting bracket bolts and nut in the order shown.

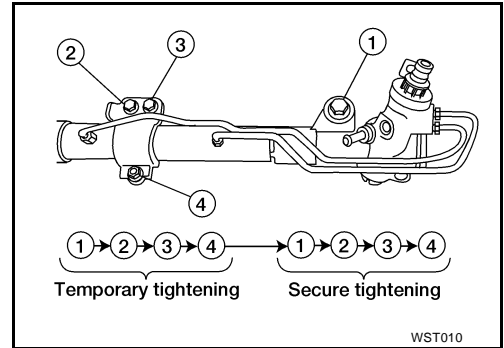

Disassembly

1. Prior to disassembling, measure pinion rotating torque.

Within $\pm 100^\circ$ from the neutral position

Average rotating torque : 0.6 - 1.79 N-m (7 - 18 kg-cm, 6 - 15 in-lb)

Maximum torque deviation : 0.6 N-m (6 kg-cm, 5.2 in-lb)

Except for above measuring range

Maximum rotating torque : 1.9 N-m (19 kg-cm, 17 in-lb)

Maximum torque deviation : 0.65 N-m (7 kg-cm, 6 in-lb)

- If pinion rotating torque is not within the specifications, replace steering gear assembly.
 - Before measuring, disconnect gear housing tube and drain fluid.
 - Use soft jaws when holding steering gear housing. Handle gear housing carefully, as it is made of aluminum. Do not grip cylinder in a vise.
2. Remove tie-rod outer sockets and boots.
 3. Remove tie-rod inner sockets.

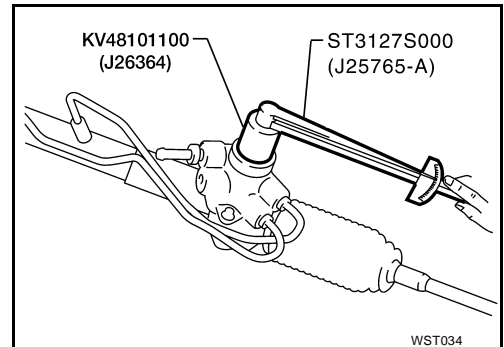

Inspection

Thoroughly clean all parts in cleaning solvent or Genuine DEXRON™ III or equivalent. Blow dry with compressed air, if available.

BOOT

- Check condition of boot. If cracked excessively, replace it.
- Check boots for accumulation of power steering fluid.

POWER STEERING GEAR AND LINKAGE

TIE-ROD OUTER AND INNER SOCKETS

- Check outer and inner ball joints for swinging force "A" and axial end play "C".
Refer to PS-24, "Steering Gear and Linkage" .
- Check outer ball joint for rotating torque "B".
Refer to PS-24, "Steering Gear and Linkage" .
- Check condition of dust cover. If excessively cracked, replace outer tie-rod.

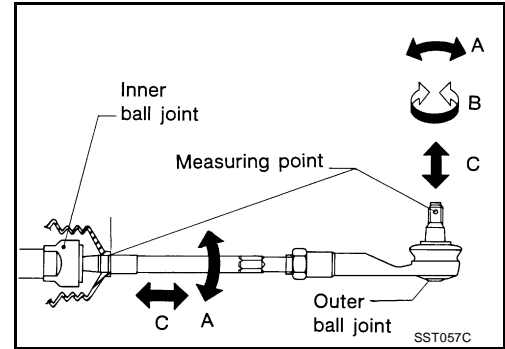

Assembly

1. Install tie-rod inner sockets, dust boots and outer sockets.
Apply locking sealant to inner socket threads.
2. Tighten outer socket lock nut.

Tie-rod length "L" : Refer to [PS-24, "Steering Gear and Linkage"](#) .

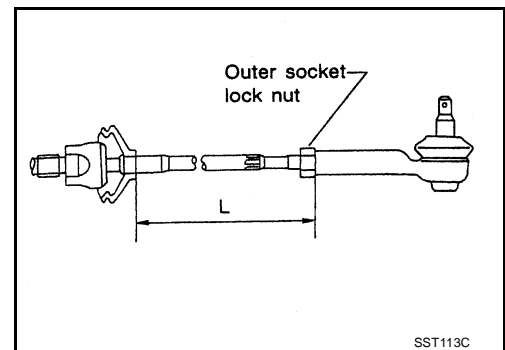

3. Measure rack stroke.

Rack stroke "S" : Refer to [PS-24, "Steering Gear and Linkage"](#) .

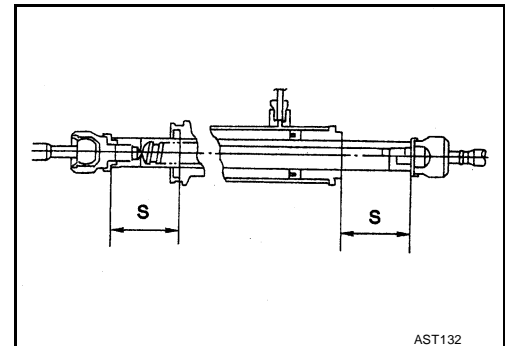

4. Before installing boot, coat the contact surfaces between boot and tie-rod with grease.

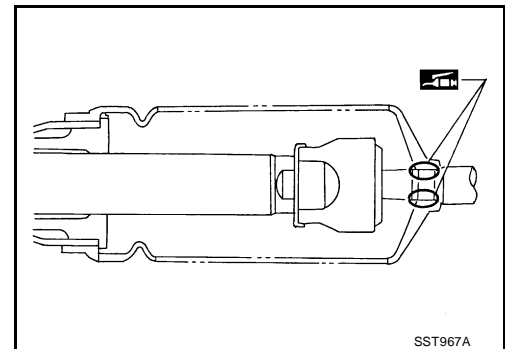

A
B
C
D
E
F
PS
H
I
J
K
L
M

POWER STEERING GEAR AND LINKAGE

5. Install boot clamps.
- Install large boot clamp using suitable tool and crimp securely.
 - Install small boot clamp as shown.

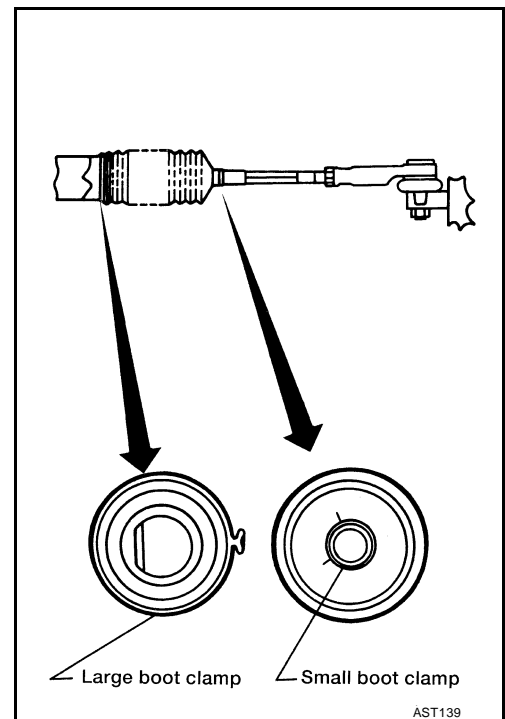

POWER STEERING OIL PUMP

PF:49110

EGS000IK

POWER STEERING OIL PUMP

Components

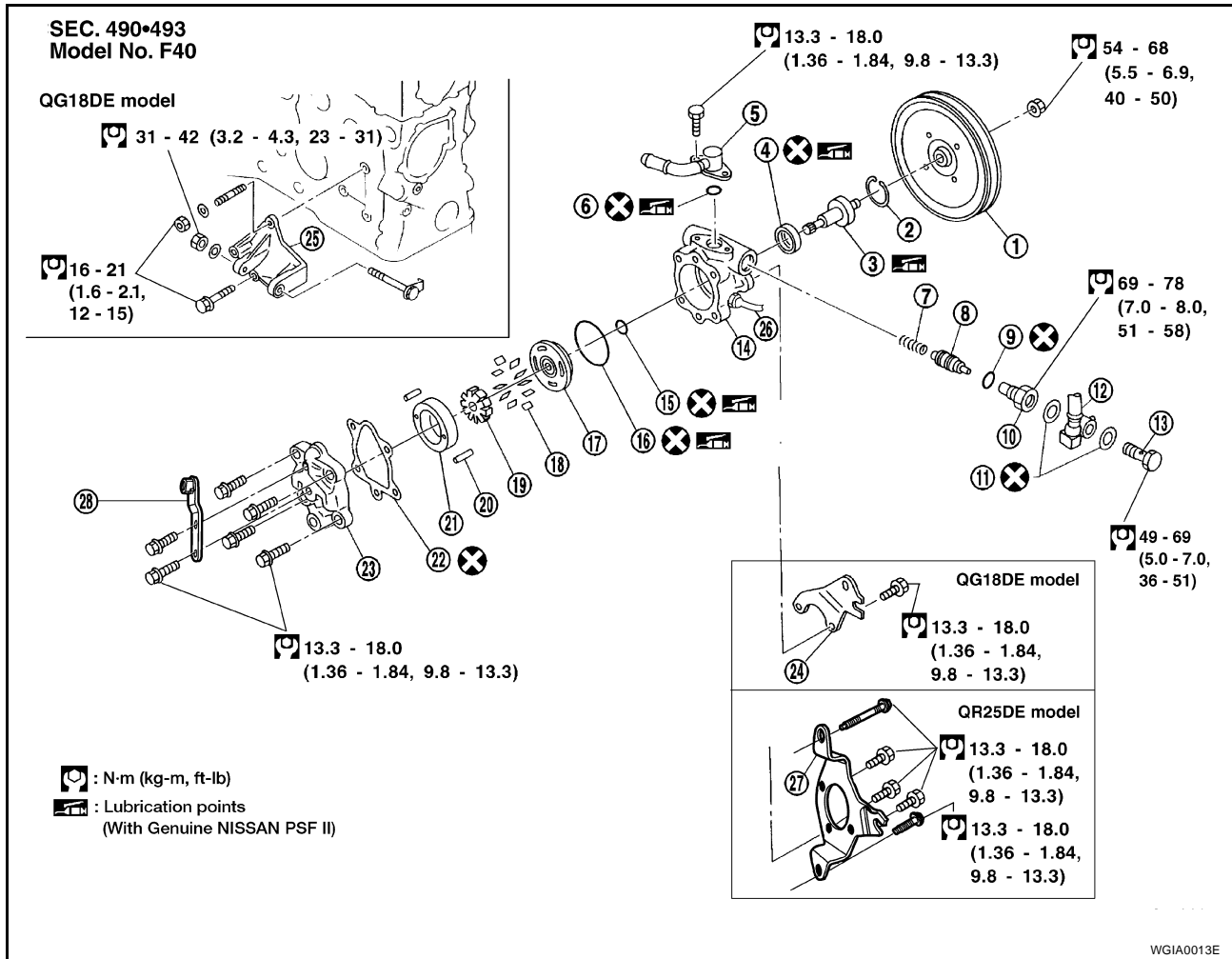

- | | | |
|---------------------------------|------------------------------------|----------------------|
| 1. Pulley | 2. Snap ring | 3. Drive shaft |
| 4. Oil seal | 5. Suction pipe | 6. O-ring |
| 7. Spring | 8. Flow control valve | 9. O-ring |
| 10. Connector | 11. Washer | 12. Joint |
| 13. Connector bolt | 14. Pump case | 15. O-ring |
| 16. O-ring | 17. Front side plate | 18. Vane |
| 19. Rotor | 20. Pin | 21. Cam ring |
| 22. Gasket | 23. Rear cover | 24. Mounting bracket |
| 25. Power steering pump bracket | 26. Power steering pressure switch | 27. Mounting bracket |
| 28. Mounting bracket | | |

Pre-Disassembly Inspection

EGS000IL

Disassemble the power steering oil pump only if the following items are found.

- Fluid leak from any point shown in the figure.
- Deformed or damaged pulley
- Poor performance

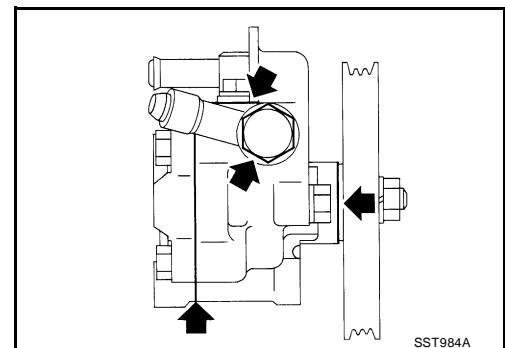

POWER STEERING OIL PUMP

EGS0001M

Disassembly

CAUTION:

- Parts which can be disassembled are strictly limited. Never disassemble parts other than those specified.
- Disassemble in as clean a place as possible.
- Clean your hands before disassembly.
- Do not use rags; use nylon cloths or paper towels.
- Refer to [PS-2, "Precautions for Steering System"](#) .
- When disassembling and reassembling, do not let foreign matter enter or contact the parts.
- Remove snap ring, then draw drive shaft out.
Be careful not to drop drive shaft.

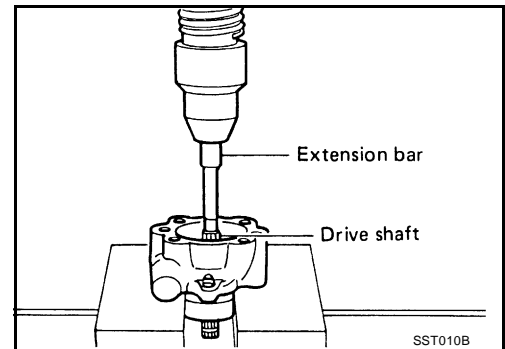

- Remove oil seal.
Be careful not to damage front housing.

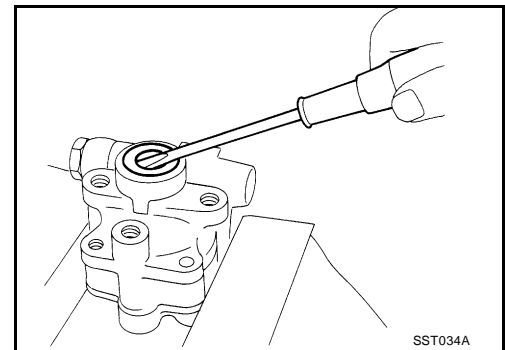

- Remove connector and flow control valve with spring.
Be careful not to drop flow control valve.
Do not disassemble flow control valve.

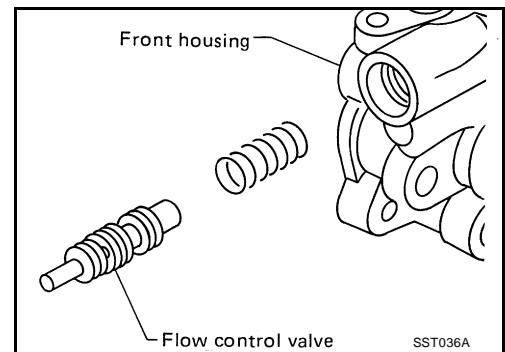

Inspection

EGS0001N

- If pulley is cracked or deformed, replace it.
- If an oil leak is found around pulley shaft oil seal, replace the seal.
- If serration on pulley or pulley shaft is deformed or worn, replace it.

Assembly

EGS0001O

Assemble oil pump, noting the following instructions.

- Make sure O-rings and oil seal are properly installed.
- Always install new O-rings and oil seal.
- Be careful of oil seal direction.

POWER STEERING OIL PUMP

- Cam ring, rotor and vanes must be replaced as a set if necessary.
- Coat each part with Genuine NISSAN PSF II or equivalent when assembling.
- Pay attention to the direction of rotor.

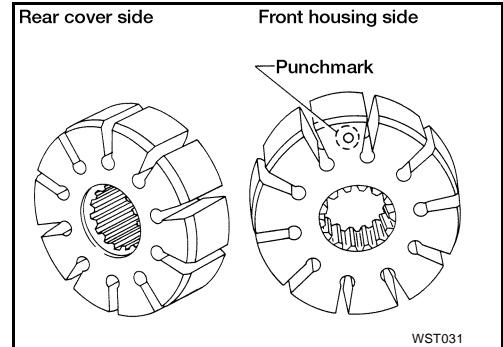

- When assembling vanes to rotor, flat surfaces of vanes must face inside of rotor (rounded surfaces of vanes face cam ring side).

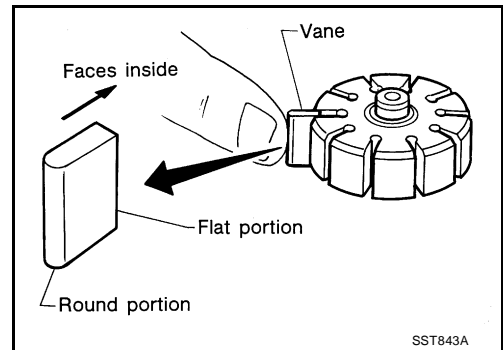

- Insert pin 2 into pin groove 1 of front housing and front side plate. Then install cam ring 3 as shown at left.

Cam ring : D_1 is less than D_2 .

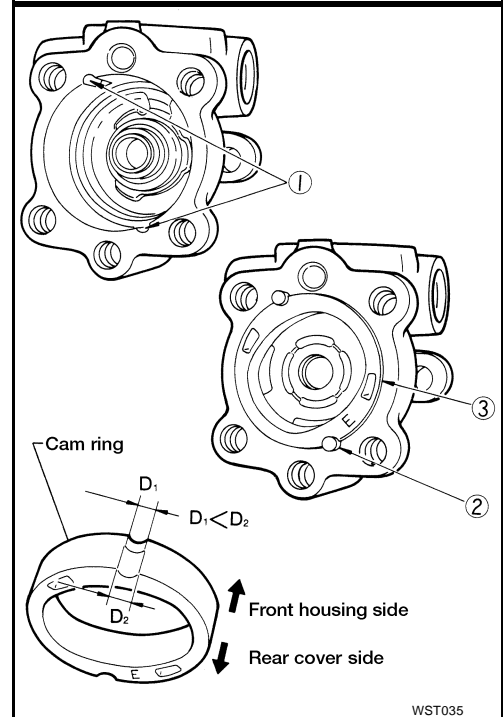

A
B
C
D
E
F
PS
H
I
J
K
L
M

SERVICE DATA AND SPECIFICATIONS (SDS)

SERVICE DATA AND SPECIFICATIONS (SDS)

PF:00030

General Specifications

EGS000AK

Applied model	QG18DE	QR25DE
Steering model	Power steering	
Steering gear type	Rack and Pinion (PR25T)	
Steering overall gear ratio	17.5	15.8
Turns of steering wheel (Lock to lock)	3.01	2.42
Steering column type	Collapsible, tilt	

Steering Wheel

EGS000AL

Applied model	All
Steering wheel axial play mm (in)	0 (0)
Steering wheel play mm (in)	35 (1.38) or less
Movement of gear housing mm (in)	±2 (±0.08) or less

Steering Column

EGS000AM

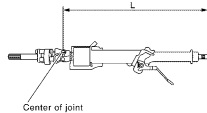

SST855C

Applied model	All
Steering column length "L" mm (in)	542 - 544 (21.34 - 21.42)

Steering Gear and Linkage

EGS000AN



SST867C

Applied model		QG18DE	QR25DE
Steering gear type		Rack and Pinion (PR25T)	
Tie-rod outer socket	Swinging force at cotter pin hole: "A" N (kg, lb)	6.9 - 65.7 (0.66 - 6.59, 1.5 - 14.8)	
	Rotating torque: "B" N-m (kg-cm, in-lb)	0.29 - 2.94 (3.0 - 30.0, 2.6 - 26.0)	
	Axial end play: "C" mm (in)	0.4 (0.016) or less	
	Initial tightening torque N-m (kg-cm, ft-lb)	29 - 39 (3 - 4, 22 - 28)	
	Maximum tightening torque N-m (kg-cm, ft-lb)	49 (5, 36)	
Tie-rod inner socket	Swinging force*: "A" N (kg, lb)	5.9 - 46.1 (0.58 - 4.65, 1.3 - 10.4)	
	Axial end play: "C" mm (in)	0.2 (0.004) or less	
	Initial tightening torque N-m (kg-cm, ft-lb)	29 - 39 (3 - 4, 22 - 28)	
	Maximum tightening torque N-m (kg-cm, ft-lb)	49 (5, 36)	
Tie-rod standard length "L" mm (in)		133.04 (5.238)	136.09 (5.358)

SERVICE DATA AND SPECIFICATIONS (SDS)

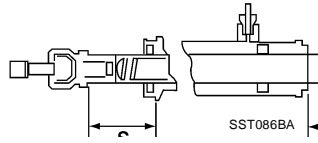

Retainer adjustment Adjusting screw	Initial tightening torque N·m (kg·cm, in·lb)	4.9 - 5.9 (50 - 60, 43 - 52)	
	Retightening torque after loosening N·m (kg·cm, in·lb)	0.2 (2, 1.7)	
	Tightening torque after gear has settled N·m (kg·cm, in·lb)	4.9 - 5.9 (50 - 60, 43 - 52)	
	Returning angle degree	60° - 80°	
Steering gear type		PR25T	
Rack stroke "S" mm (in)		65 (2.56)	58 (2.28)
Pinion gear preload without gear fluid Within ±100° from the neutral position	Average rotating torque N·m (kg·cm, in·lb)	0.6 - 1.79 (7 - 18, 6 - 15)	
	Maximum torque deviation N·m (kg·cm, in·lb)	0.6 (6, 5.2)	
Except above range	Maximum rotating torque N·m (kg·cm, in·lb)	1.9 (19, 17)	
	Maximum torque deviation N·m (kg·cm, in·lb)	0.65 (7, 6)	

*: Measuring point [l: 172 mm (6.77 in)]

Power Steering

EGS000A0

Applied model			QG18DE	QR25DE
Steering gear type			Rack and Pinion (PR25T)	
Pump type			F40	
Rack sliding force N (kg, lb) Under normal operating oil pressure	Range within ±11.5 mm (±0.453 in) from the neutral position at rack speed of 3.5 mm (0.138 in)/s	Average rack sliding force	140 - 330 (14.3 - 33.7, 31.5 - 74.2)	160 - 350 (16.3 - 35.7, 36.0 - 78.7)
		Maximum force deviation	95 (9.7, 21.4)	
	Except for the above range	Maximum rack sliding force	294 (30, 66)	
		Maximum force deviation	147 (15, 33)	
Steering wheel turning force (Measured at one full turn from the neutral position) N (kg, lb)			39 (4, 9) or less	
Fluid capacity (Approximate) ℓ (US qt, Imp qt)			1.0 (1-1/8, 7/8)	
Oil pump maximum pressure kPa (kg/cm ² , psi)			7,649 - 8,238 (78 - 84, 1,109 - 1,194)	8,000 - 8,800 (82 - 90, 1,160 - 1,276)

SERVICE DATA AND SPECIFICATIONS (SDS)
