

**SECTION MA**  
**MAINTENANCE**

A  
B  
C

**CONTENTS**

<p><b>PRECAUTIONS ..... 3</b>                  Precautions for Supplemental Restraint System (SRS) "AIR BAG" and "SEAT BELT PRE-TENSIONER" ..... 3</p> <p><b>PREPARATION ..... 4</b>                  Special Service Tool ..... 4                  Commercial Service Tool ..... 4</p> <p><b>GENERAL MAINTENANCE ..... 5</b>                  Explanation of General Maintenance ..... 5                  General Maintenance ..... 5</p> <p><b>PERIODIC MAINTENANCE ..... 7</b>                  Introduction of Periodic Maintenance ..... 7                  Schedule 1 ..... 7                      EMISSION CONTROL SYSTEM MAINTENANCE ..... 7                      CHASSIS AND BODY MAINTENANCE ..... 9                  Schedule 2 ..... 11                      EMISSION CONTROL SYSTEM MAINTENANCE ..... 11                      CHASSIS AND BODY MAINTENANCE ..... 12</p> <p><b>RECOMMENDED FLUIDS AND LUBRICANTS ..... 13</b>                  Fluids and Lubricants ..... 13                  SAE Viscosity Number ..... 14                  Anti-freeze Coolant Mixture Ratio ..... 14</p> <p><b>ENGINE MAINTENANCE (QG18DE ENGINE) ..... 15</b>                  Checking Drive Belts ..... 15                  Changing Engine Coolant ..... 15                      DRAINING ENGINE COOLANT ..... 15                      REFILLING ENGINE COOLANT ..... 16                      FLUSHING COOLING SYSTEM ..... 17                  Checking Fuel Lines ..... 18                  Changing Air Cleaner Filter ..... 18                  Changing Engine Oil ..... 19                  Changing Oil Filter ..... 20                  Changing Spark Plugs (Double Platinum - Tipped Type) ..... 20                  Checking EVAP Vapor Lines ..... 21</p> <p><b>ENGINE MAINTENANCE (QR25DE ENGINE) ..... 22</b>                  Checking Drive Belts ..... 22                  Changing Engine Coolant ..... 22</p>	<p>    DRAINING ENGINE COOLANT ..... 23                      REFILLING ENGINE COOLANT ..... 23                      FLUSHING COOLING SYSTEM ..... 24                  Checking Fuel Lines ..... 25                  Changing Air Cleaner Filter ..... 25                  Changing Engine Oil ..... 25                  Changing Oil Filter ..... 26                  Changing Spark Plugs (Double Platinum - Tipped Type) ..... 27                  Checking EVAP Vapor Lines ..... 28</p> <p><b>CHASSIS AND BODY MAINTENANCE ..... 29</b>                  Checking Exhaust System ..... 29                  Checking Clutch Fluid Level and Leaks ..... 29                  Checking M/T Oil ..... 29                  Changing M/T Oil ..... 29                  Checking A/T Fluid ..... 30                  Changing A/T Fluid ..... 31                  Balancing Wheels ..... 31                  Tire Rotation ..... 31                  Checking Brake Fluid Level and Leaks ..... 32                  Checking Brake Lines and Cables ..... 32                  Changing Brake Fluid ..... 32                  Checking Disc Brakes ..... 32                      ROTOR ..... 32                      CALIPER ..... 33                      PAD ..... 33                  Checking Drum Brake ..... 33                      WHEEL CYLINDER ..... 33                      DRUM ..... 33                      LINING ..... 34                  Checking Steering Gear and Linkage ..... 34                      STEERING GEAR ..... 34                      STEERING LINKAGE ..... 34                  Checking Power Steering Fluid and Lines ..... 34                      CHECKING FLUID LEVEL ..... 34                      CHECKING LINES ..... 34                  Axle and Suspension Parts ..... 35                  Drive Shaft ..... 36                  Lubricating Locks, Hinges and Hood Latches ..... 36                  Checking Seat Belt, Buckles, Retractors, Anchors</p>
--	---

D  
E  
F  
G  
H  
I  
J  
K

MA

M

---

and Adjusters .....	37	Engine Maintenance (QR25DE) .....	38
<b>SERVICE DATA AND SPECIFICATIONS (SDS) .....</b>	<b>38</b>	BELT DEFLECTION AND TENSION .....	38
Engine Maintenance (QG18DE) .....	38	SPARKPLUGS(DOUBLE PLATINUM-TIPPED)	...
BELT DEFLECTION AND TENSION .....	38		38
SPARKPLUGS(DOUBLE PLATINUM-TIPPED)	...	Chassis and Body Maintenance .....	38
...	38	WHEEL BALANCE .....	38

# PRECAUTIONS

## PRECAUTIONS

PF0:00001

### Precautions for Supplemental Restraint System (SRS) “AIR BAG” and “SEAT BELT PRE-TENSIONER”

ELS00097

The Supplemental Restraint System such as “AIR BAG” and “SEAT BELT PRE-TENSIONER”, used along with a front seat belt, helps to reduce the risk or severity of injury to the driver and front passenger for certain types of collision. Information necessary to service the system safely is included in the SRS and SB section of this Service Manual.

#### **WARNING:**

- To avoid rendering the SRS inoperative, which could increase the risk of personal injury or death in the event of a collision which would result in air bag inflation, all maintenance must be performed by an authorized NISSAN/INFINITI dealer.
- Improper maintenance, including incorrect removal and installation of the SRS, can lead to personal injury caused by unintentional activation of the system. For removal of Spiral Cable and Air Bag Module, see the SRS section.
- Do not use electrical test equipment on any circuit related to the SRS unless instructed to in this Service Manual. SRS wiring harnesses can be identified by yellow and/or orange harness connectors.

A  
B  
C  
D  
E  
F  
G  
H  
I  
J  
K  
MA  
M

MA

# PREPARATION

## PREPARATION

PFP:00002

### Special Service Tool

ELS00098

The actual shapes of Kent-Moore tools may differ from those of special service tools illustrated here.

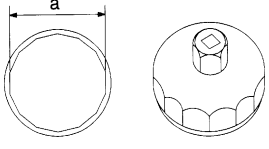
Tool number (Kent-Moore No.) Tool name		Description
KV10115801 (J-37140-A) Oil filter cap wrench	 <p style="text-align: center;">NT375</p>	Removing and installing oil filter <b>a: 64.3 mm (2.531 in)</b>

### Commercial Service Tool

ELS00099

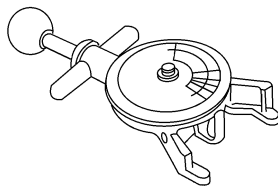
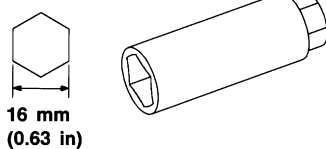
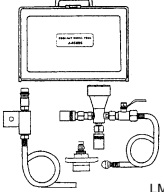
Tool name (Kent-Moore No.)		Description
Belt tension gauge (BT3373-F)	 <p style="text-align: center;">AMA126</p>	Checking drive belt tension of QG18DE engine
Spark plug wrench	 <p style="text-align: center;">16 mm (0.63 in)</p> <p style="text-align: center;">S-NT047</p>	Removing and installing spark plugs
Coolant refill tool (J-45695)	 <p style="text-align: center;">LMA053</p>	For refilling the engine cooling system

# GENERAL MAINTENANCE

## GENERAL MAINTENANCE

PFP:00000

### Explanation of General Maintenance

ELS0009A

### General Maintenance

ELS0009B

General maintenance includes those items which should be checked during the normal day-to-day operation of the vehicle. They are essential if the vehicle is to continue operating properly. The owners can perform checks and inspections themselves or they can have their NISSAN dealers do them.

#### OUTSIDE THE VEHICLE

The maintenance items listed here should be performed from time to time, unless otherwise specified.

Item		Reference page
<b>Tires</b>	Check the pressure including the spare, at least once a month and always prior to a long distance trip. Adjust to the specified pressure if necessary. Check carefully for damage, cuts or excessive wear.	—
<b>Wheel nuts</b>	When checking the tires, make sure no nuts are missing, and check for any loose nuts. Tighten if necessary.	—
<b>Windshield</b>	Clean the windshield on a regular basis. Check the windshield at least every six months for cracks or other damage. Repair as necessary.	—
<b>Tire rotation</b>	Tires should be rotated every 12,000 km (7,500 miles).	<a href="#">MA-31, "Tire Rotation"</a>
<b>Wheel alignment and balance</b>	If the vehicle pulls to either side while driving on a straight and level road, or if you detect uneven or abnormal tire wear, there may be a need for wheel alignment. If the steering wheel or seat vibrates at normal highway speeds, wheel balancing may be needed.	<a href="#">FSU-6, "Front Wheel Alignment"</a> and <a href="#">MA-31, "Balancing Wheels"</a>
<b>Windshield wiper blades</b>	Check for cracks or wear if they do not wipe properly.	—
<b>Doors and engine hood</b>	Check that all doors and the engine hood operate smoothly as well as the trunk lid and back hatch. Also make sure that all latches lock securely. Lubricate if necessary. Make sure that the secondary latch keeps the hood from opening when the primary latch is released. When driving in areas using road salt or other corrosive materials, check lubrication frequently.	<a href="#">MA-36, "Lubricating Locks, Hinges and Hood Latches"</a>
<b>Lamps</b>	Make sure that the headlamps, stop lamps, tail lamps, turn signal lamps, and other lamps are all operating properly and installed securely. Also check headlamp aim. Clean the headlamps on a regular basis.	—

#### INSIDE THE VEHICLE

The maintenance items listed here should be checked on a regular basis, such as when performing periodic maintenance, cleaning the vehicle, etc.

Item		Reference page
<b>Warning lamps and buzzers/chimes</b>	Make sure that all warning lamps and buzzers/chimes are operating properly.	—
<b>Windshield wiper and washer</b>	Check that the wipers and washer operate properly and that the wipers do not streak.	—
<b>Windshield defroster</b>	Check that the air comes out of the defroster outlets properly and in sufficient quantity when operating the heater or air conditioning.	—
<b>Steering wheel</b>	Check that it has the specified play. Be sure to check for changes in the steering condition, such as excessive play, hard steering or strange noises. <b>Free play: Less than 35 mm (1.38 in)</b>	—
<b>Seats</b>	Check seat position controls such as seat adjusters, seat back recliner, etc. to make sure they operate smoothly and that all latches lock securely in every position. Check that the head restraints move up and down smoothly and that the locks (if equipped) hold securely in all latched positions. Check that the latches lock securely for folding-down rear seat backs.	—
<b>Seat belts</b>	Check that all parts of the seat belt system (e.g. buckles, anchors, adjusters and retractors) operate properly and smoothly and are installed securely. Check the belt webbing for cuts, fraying, wear or damage.	<a href="#">SB-7, "Seat Belt Inspection"</a>
<b>Accelerator pedal</b>	Check the pedal for smooth operation and make sure the pedal does not catch or require uneven effort. Keep the floor mats away from the pedal.	—

# GENERAL MAINTENANCE

Item		Reference page
<b>Clutch pedal</b>	Make sure the pedal operates smoothly and check that it has the proper free play.	<a href="#">CL-7, "ADJUSTING CLUTCH PEDAL"</a>
<b>Brakes</b>	Check that the brake does not pull the vehicle to one side when applied.	—
<b>Brake pedal and booster</b>	Check the pedal for smooth operation and make sure it has the proper distance under it when depressed fully. Check the brake booster function. Be sure to keep floor mats away from the pedal.	<a href="#">BR-12, "BRAKE PEDAL HEIGHT"</a> and <a href="#">BR-16, "OPERATING CHECK"</a>
<b>Parking brake</b>	Check that the lever has the proper travel and make sure that the vehicle is held securely on a fairly steep hill when only the parking brake is applied.	<a href="#">PB-2, "Inspection"</a>
<b>Automatic transaxle "Park" mechanism</b>	Check that the lock release button on the selector lever operates properly and smoothly. On a fairly steep hill check that the vehicle is held securely with the selector lever in the "P" position without applying any brakes.	—

## UNDER THE HOOD AND VEHICLE

The maintenance items listed here should be checked periodically (e.g. each time you check the engine oil or refuel).

Item		Reference page	
		QG18DE	QR25DE
<b>Windshield washer fluid</b>	Check that there is adequate fluid in the tank.	—	
<b>Engine coolant level</b>	Check the coolant level when the engine is cold.	<a href="#">CO-8, "CHECKING COOLING SYSTEM FOR LEAKS"</a>	<a href="#">CO-26, "CHECKING RESERVOIR LEVEL"</a>
<b>A/C condenser, radiator and hoses</b>	Check the front of the condenser and radiator and clean off any dirt, insects, leaves, etc., that may have accumulated. Make sure the radiator hoses have no cracks, deformation, deterioration or loose connections.	—	
<b>Brake and clutch fluid levels</b>	Make sure that the brake and clutch fluid levels are between the "MAX" and "MIN" lines on the reservoirs.	<a href="#">MA-32, "Checking Brake Fluid Level and Leaks"</a> and <a href="#">MA-29, "Checking Clutch Fluid Level and Leaks"</a>	
<b>Battery</b>	Check the fluid level in each cell. It should be between the "MAX" and "MIN" lines. Vehicles operated in high temperatures or under severe conditions require frequent checks of the battery fluid level.	—	
<b>Engine drive belts</b>	Make sure that no belt is frayed, worn, cracked or oily.	<a href="#">MA-15, "Checking Drive Belts"</a>	<a href="#">MA-22, "Checking Drive Belts"</a>
<b>Engine oil level</b>	Check the level on the dipstick after parking the vehicle on a level spot and turning off the engine.	—	—
<b>Power steering fluid level and lines</b>	Check the level is between the "MAX" and "MIN" lines on the reservoir with the engine off. Check the lines for improper attachment, leaks, cracks, etc.	<a href="#">MA-34, "Checking Power Steering Fluid and Lines"</a>	
<b>Automatic transaxle fluid level</b>	Check the level on the dipstick after putting the selector lever in "P" with the engine idling.	<a href="#">MA-30, "Checking A/T Fluid"</a>	
<b>Exhaust system</b>	Make sure there are no loose supports, cracks or holes. If the sound of the exhaust seems unusual or there is a smell of exhaust fumes, immediately locate the trouble and correct it.	<a href="#">MA-29, "Checking Exhaust System"</a>	
<b>Underbody</b>	The underbody is frequently exposed to corrosive substances such as those used on icy roads or to control dust. It is very important to remove these substances, otherwise rust will form on the floor pan, frame, fuel lines and around the exhaust system. At the end of winter, the underbody should be thoroughly flushed with plain water, being careful to clean those areas where mud and dirt can easily accumulate.	—	
<b>Fluid leaks</b>	Check under the vehicle for fuel, oil, water or other fluid leaks after the vehicle has been parked for a while. Water dripping from the air conditioner after use is normal. If you should notice any leaks or gasoline fumes are evident, check for the cause and correct it immediately.	—	

# PERIODIC MAINTENANCE

## PERIODIC MAINTENANCE

PFP:00026

### Introduction of Periodic Maintenance

ELS0009C

Two different maintenance schedules are provided, and should be used, depending upon the conditions in which the vehicle is mainly operated. **After 60,000 miles (96,000 km) or 48 months, continue the periodic maintenance at the same mileage/time intervals.**

Schedule 1	Follow Periodic Maintenance Schedule 1 if your driving habits frequently includes one or more of the following driving conditions: <ul style="list-style-type: none"> <li>● Repeated short trips of less than 5 miles (8 km).</li> <li>● Repeated short trips of less than 10 miles (16 km) with outside temperatures remaining below freezing.</li> <li>● Operating in hot weather in stop-and-go "rush hour" traffic.</li> <li>● Extensive idling and/or low speed driving for long distances, such as police, taxi or door-to-door delivery use.</li> <li>● Driving in dusty conditions.</li> <li>● Driving on rough, muddy, or salt spread roads.</li> <li>● Towing a trailer, using a camper or a car-top carrier.</li> </ul>	Emission Control System Maintenance	<a href="#">MA-7, "Emission Control System Maintenance"</a>
		Chassis and Body Maintenance	<a href="#">MA-9, "Chassis and Body Maintenance"</a>
Schedule 2	Follow Periodic Maintenance Schedule 2 if none of the driving conditions shown in Schedule 1 apply to your driving habits.	Emission Control System Maintenance	<a href="#">MA-11, "Emission Control System Maintenance"</a>
		Chassis and Body Maintenance	<a href="#">MA-12, "Chassis and Body Maintenance"</a>

### Schedule 1

#### EMISSION CONTROL SYSTEM MAINTENANCE

ELS0009D

Abbreviations: R = Replace. I = Inspect. Correct or replace if necessary. [ ]: At the mileage intervals only

MAINTENANCE OPERATION		MAINTENANCE INTERVAL								Reference Section - Page or - Content Title		
		Miles x 1,000 (km x 1,000) Months	3.75 (6) 3	7.5 (12) 6	11.25 (18) 9	15 (24) 12	18.75 (30) 15	22.5 (36) 18	26.25 (42) 21	30 (48) 24	QG18DE	QR25DE
Drive belt	NOTE (1)										<a href="#">MA-15, "Checking Drive Belts"</a>	<a href="#">MA-22, "Checking Drive Belts"</a>
Air cleaner filter	NOTE (2)									[R]	<a href="#">MA-18, "Changing Air Cleaner Filter"</a>	<a href="#">MA-25, "Changing Air Cleaner Filter"</a>
EVAP vapor lines										I*	<a href="#">MA-21, "Checking EVAP Vapor Lines"</a>	<a href="#">MA-28, "Checking EVAP Vapor Lines"</a>
Fuel lines										I*	<a href="#">MA-18, "Checking Fuel Lines"</a>	<a href="#">MA-25, "Checking Fuel Lines"</a>
Fuel filter	NOTE (3)										—	

# PERIODIC MAINTENANCE

MAINTENANCE OPERATION		MAINTENANCE INTERVAL								Reference Section - Page or - Content Title	
Perform at number of miles, kilometers or months, whichever comes first.	Miles x 1,000 (km x 1,000)	3.75 (6)	7.5 (12)	11.25 (18)	15 (24)	18.75 (30)	22.5 (36)	26.25 (42)	30 (48)	QG18DE	QR25DE
	Months	3	6	9	12	15	18	21	24		
Engine coolant	NOTE (4)									<a href="#">MA-15, "Changing Engine Coolant"</a>	<a href="#">MA-22, "Changing Engine Coolant"</a>
Engine oil		R	R	R	R	R	R	R	R	<a href="#">MA-19, "Changing Engine Oil"</a>	<a href="#">MA-25, "Changing Engine Oil"</a>
Engine oil filter (Use part No. 15208-65F01, 15208-9E000 or equiv.)		R	R	R	R	R	R	R	R	<a href="#">MA-20, "Changing Oil Filter"</a>	—
Engine oil filter (Use part No. 15208-9E000 or equiv.)		R	R	R	R	R	R	R	R	—	<a href="#">MA-26, "Changing Oil Filter"</a>
Spark plugs (Double PLATINUM-TIPPED type)		Replace every 105,000 miles (169,000 km)								<a href="#">MA-20, "Changing Spark Plugs (Double Platinum - Tipped Type)"</a>	<a href="#">MA-27, "Changing Spark Plugs (Double Platinum - Tipped Type)"</a>
Intake and exhaust valve clearance	NOTE (5)*									<a href="#">EM-50, "Valve Clearance"</a>	—

Abbreviations: R = Replace. I = Inspect. Correct or replace if necessary. [ ]: At the mileage intervals only

MAINTENANCE OPERATION		MAINTENANCE INTERVAL								Reference Section - Page or - Content Title	
Perform at number of miles, kilometers or months, whichever comes first.	Miles x 1,000 (km x 1,000)	33.75 (54)	37.5 (60)	41.25 (66)	45 (72)	48.75 (78)	52.5 (84)	56.25 (90)	60 (96)	QG18DE	QR25DE
	Months	27	30	33	36	39	42	45	48		
Drive belt	NOTE (1)								I*	<a href="#">MA-15, "Checking Drive Belts"</a>	<a href="#">MA-22, "Checking Drive Belts"</a>
Air cleaner filter	NOTE (2)								[R]	<a href="#">MA-18, "Changing Air Cleaner Filter"</a>	<a href="#">MA-25, "Changing Air Cleaner Filter"</a>
EVAP vapor lines									I*	<a href="#">MA-21, "Checking EVAP Vapor Lines"</a>	<a href="#">MA-28, "Checking EVAP Vapor Lines"</a>
Fuel lines									I*	<a href="#">MA-18, "Checking Fuel Lines"</a>	<a href="#">MA-25, "Checking Fuel Lines"</a>
Fuel filter	NOTE (3)									—	—



# PERIODIC MAINTENANCE

MAINTENANCE OPERATION		MAINTENANCE INTERVAL								Reference Section - Page or - Content Title	
Perform at number of miles, kilometers or months, whichever comes first.	Miles x 1,000 (km x 1,000)	33.75 (54)	37.5 (60)	41.25 (66)	45 (72)	48.75 (78)	52.5 (84)	56.25 (90)	60 (96)	QG18DE	QR25DE
	Months	27	30	33	36	39	42	45	48		
Engine coolant	NOTE (4)								R*	<a href="#">MA-15, "Changing Engine Coolant"</a>	<a href="#">MA-22, "Changing Engine Coolant"</a>
Engine oil		R	R	R	R	R	R	R	R	<a href="#">MA-19, "Changing Engine Oil"</a>	<a href="#">MA-25, "Changing Engine Oil"</a>
Engine oil filter (Use part No. 15208-65F01, 15208-9E000 or equiv.)		R	R	R	R	R	R	R	R	<a href="#">MA-20, "Changing Oil Filter"</a>	—
Engine oil filter (Use part No. 15208-9E000 or equiv.)		R	R	R	R	R	R	R	R	—	<a href="#">MA-26, "Changing Oil Filter"</a>
Spark plugs (Double PLATINUM-TIPPED type)		Replace every 105,000 miles (169,000 km)								<a href="#">MA-20, "Changing Spark Plugs (Double Platinum - Tipped Type)"</a>	<a href="#">MA-27, "Changing Spark Plugs (Double Platinum - Tipped Type)"</a>
Intake and exhaust valve clearance	NOTE (5)*									<a href="#">EM-50, "Valve Clearance"</a>	—

**NOTE:**

- (1) After 60,000 miles (96,000 km) or 48 months, inspect every 15,000 miles (24,000 km) or 12 months. Replace the drive belt if found damaged or if the auto belt tensioner reading reaches the maximum limit.
- (2) If operating mainly in dusty conditions, more frequent maintenance may be required.
- (3) Maintenance-free item.
- (4) After 60,000 miles (96,000 km) or 48 months, replace every 30,000 miles (48,000 km) or 24 months.
- (5) If valve noise increases, inspect valve clearance.

Maintenance items and intervals with "\*" are recommended by NISSAN for reliable vehicle operation. The owner need not perform such maintenance in order to maintain the emission warranty or manufacturer recall liability. Other maintenance items and intervals are required.

## CHASSIS AND BODY MAINTENANCE

Abbreviations: R = Replace. I = Inspect. Correct or replace if necessary. L = Lubricate.

MAINTENANCE OPERATION		MAINTENANCE INTERVAL								Reference Section - Page or - Content Title
Perform at number of miles, kilometers or months, whichever comes first.	Miles x 1,000 (km x 1,000)	3.75 (6)	7.5 (12)	11.25 (18)	15 (24)	18.75 (30)	22.5 (36)	26.25 (42)	30 (48)	
	Months	3	6	9	12	15	18	21	24	
Brake lines & cables					I				I	<a href="#">MA-32</a>
Brake pads, rotors, drums & linings (QG18DE)			I		I		I		I	<a href="#">MA-32</a> and <a href="#">MA-33</a>
Brake pads & rotors (QR25DE)			I		I		I		I	<a href="#">MA-32</a>

# PERIODIC MAINTENANCE

MAINTENANCE OPERATION		MAINTENANCE INTERVAL								Reference Section - Page or - Content Title
Perform at number of miles, kilometers or months, whichever comes first.	Miles x 1,000 (km x 1,000) Months	3.75 (6) 3	7.5 (12) 6	11.25 (18) 9	15 (24) 12	18.75 (30) 15	22.5 (36) 18	26.25 (42) 21	30 (48) 24	
Manual transaxle oil or automatic transaxle fluid	NOTE (1)				I				I	<a href="#">MA-29</a> or <a href="#">MA-31</a>
Steering gear & linkage, axle & suspension parts			I		I		I		I	<a href="#">MA-34</a> , <a href="#">MA-35</a>
Tire rotation	NOTE (2)									<a href="#">MA-31</a>
Front drive shaft boots			I		I		I		I	<a href="#">MA-36</a>
Exhaust system			I		I		I		I	<a href="#">MA-29</a>

Abbreviations: R = Replace. I = Inspect. Correct or replace if necessary. L = Lubricate.

MAINTENANCE OPERATION		MAINTENANCE INTERVAL								Reference Section - Page or - Content Title
Perform at number of miles, kilometers or months, whichever comes first.	Miles x 1,000 (km x 1,000) Months	33.75 (54) 27	37.5 (60) 30	41.25 (66) 33	45 (72) 36	48.75 (78) 39	52.5 (84) 42	56.25 (90) 45	60 (96) 48	
Brake lines & cables					I				I	<a href="#">MA-32</a>
Brake pads, rotors, drums & linings (QG18DE)			I		I		I		I	<a href="#">MA-32</a> and <a href="#">MA-33</a>
Brake pads & rotors (QR25DE)			I		I		I		I	<a href="#">MA-32</a>
Manual transaxle oil or automatic transaxle fluid	NOTE (1)				I				I	<a href="#">MA-29</a> or <a href="#">MA-31</a>
Steering gear & linkage, axle & suspension parts			I		I		I		I	<a href="#">MA-34</a> , <a href="#">MA-35</a>
Tire rotation	NOTE (2)									<a href="#">MA-31</a>
Front drive shaft boots			I		I		I		I	<a href="#">MA-36</a>
Exhaust system			I		I		I		I	<a href="#">MA-29</a>

**NOTE:**

- (1) If towing a trailer, using a camper or a car-top carrier, or driving on rough or muddy roads, change (not just inspect) oil (exc. LSD) at every 30,000 miles (48,000 km) or 24 months, and change LSD gear oil every 15,000 miles (24,000 km) or 12 months.
- (2) Refer to "Tire rotation" under the "GENERAL MAINTENANCE" heading earlier in this section.

# PERIODIC MAINTENANCE

ELS0009E

## Schedule 2 EMISSION CONTROL SYSTEM MAINTENANCE

Abbreviations: R = Replace. I = Inspect. Correct or replace if necessary. [ ]: At the mileage intervals only

MAINTENANCE OPERATION		MAINTENANCE INTERVAL								Reference Section - Page or - Content Title		
		Miles x 1,000 (km x 1,000) Months	7.5 (12) 6	15 (24) 12	22.5 (36) 18	30 (48) 24	37.5 (60) 30	45 (72) 36	52.5 (84) 42	60 (96) 48	QG18DE	QR25DE
Drive belt	NOTE (1)									I*	<a href="#">MA-15, "Checking Drive Belts"</a>	<a href="#">MA-22, "Checking Drive Belts"</a>
Air cleaner filter					[R]					[R]	<a href="#">MA-18, "Changing Air Cleaner Filter"</a>	<a href="#">MA-25, "Changing Air Cleaner Filter"</a>
EVAP vapor lines					I*					I*	<a href="#">MA-21, "Checking EVAP Vapor Lines"</a>	<a href="#">MA-28, "Checking EVAP Vapor Lines"</a>
Fuel lines					I*					I*	<a href="#">MA-18, "Checking Fuel Lines"</a>	<a href="#">MA-25, "Checking Fuel Lines"</a>
Fuel filter	NOTE (2)										—	
Engine coolant	NOTE (3)									R*	<a href="#">MA-15, "Changing Engine Coolant"</a>	<a href="#">MA-22, "Changing Engine Coolant"</a>
Engine oil		R	R	R	R	R	R	R	R	R	<a href="#">MA-19, "Changing Engine Oil"</a>	<a href="#">MA-25, "Changing Engine Oil"</a>
Engine oil filter (Use part No. 15208-65F01, 15208-9E000 or equivalent.)		R	R	R	R	R	R	R	R	R	<a href="#">MA-20, "Changing Oil Filter"</a>	—
Engine oil filter (Use part No. 15208-9E000 or equiv.)		R	R	R	R	R	R	R	R	R	—	<a href="#">MA-25, "Changing Engine Oil"</a>
Spark plugs (Double PLATINUM-TIPPED type)		Replace every 105,000 miles (169,000 km)									<a href="#">MA-20, "Changing Spark Plugs (Double Platinum - Tipped Type)"</a>	<a href="#">MA-27, "Changing Spark Plugs (Double Platinum - Tipped Type)"</a>
Intake and exhaust valve clearance)	NOTE (4)*										<a href="#">EM-50, "Valve Clearance"</a>	—

**NOTE:**

Replace the drive belt if found damaged or if the auto belt tensioner reading reaches the maximum limit.

- (1) After 60,000 miles (96,000 km) or 48 months, inspect every 15,000 miles (24,000 km) or 12 months.
- (2) Maintenance-free item.
- (3) After 60,000 miles (96,000 km) or 48 months, replace every 30,000 miles (48,000 km) or 24 months.
- (4) If valve noise increases, inspect valve clearance.

# PERIODIC MAINTENANCE

Maintenance items and intervals with “\*” are recommended by NISSAN for reliable vehicle operation. The owner need not perform such maintenance in order to maintain the emission warranty or manufacturer recall liability. Other maintenance items and intervals are required.

## CHASSIS AND BODY MAINTENANCE

Abbreviations: R = Replace. I = Inspect. Correct or replace if necessary. L = Lubricate.

MAINTENANCE OPERATION		MAINTENANCE INTERVAL								Reference Section - Page or - Content Title
Perform at number of miles, kilometers or months, whichever comes first.	Miles x 1,000 (km x 1,000) Months	7.5 (12) 6	15 (24) 12	22.5 (36) 18	30 (48) 24	37.5 (60) 30	45 (72) 36	52.5 (84) 42	60 (96) 48	
Brake lines & cables			I		I		I		I	<a href="#">MA-32</a>
Brake pads, rotors, drums & linings (QG18DE)			I		I		I		I	<a href="#">MA-32</a> , <a href="#">MA-33</a>
Brake pads & rotors (QR25DE)			I		I		I		I	<a href="#">MA-32</a>
Manual transaxle oil or automatic transaxle fluid			I		I		I		I	<a href="#">MA-29</a> or <a href="#">MA-31</a>
Steering gear & linkage, axle & suspension parts					I				I	<a href="#">MA-34</a> , <a href="#">MA-35</a>
Tire rotation	NOTE (1)									<a href="#">MA-31</a>
Front drive shaft boots			I		I		I		I	<a href="#">MA-36</a>
Exhaust system					I				I	<a href="#">MA-29</a>

**NOTE:**

- (1) Refer to “Tire rotation” under the “GENERAL MAINTENANCE” heading earlier in this section.

# RECOMMENDED FLUIDS AND LUBRICANTS

## RECOMMENDED FLUIDS AND LUBRICANTS

PFP:00000

### Fluids and Lubricants

ELS0009F

QG18DE		Capacity (Approximate)			Recommended Fluids/Lubricants
		US measure	Imp measure	Liter	
Engine oil Drain and refill	With oil filter change	2-7/8 qt.	2-3/8 qt.	2.7	<ul style="list-style-type: none"> <li>● API Certification Mark*1</li> <li>● API grade SG/SH, Energy Conserving II or API grade SJ or SL, Energy Conserving*1</li> <li>● ILSAC grade GF-II &amp; GF-III*1</li> </ul>
	Without oil filter change	2-5/8 qt.	2-1/4 qt.	2.5	
Dry engine (engine overhaul)		3-1/4 qt.	2-3/4 qt.	3.1	
Cooling system (With reservoir)	MT	7-1/8 qt.	5-7/8 qt.	6.7	Genuine NISSAN Anti-freeze coolant or equivalent
	AT	7 qt.	5-7/8 qt.	6.6	
Manual transaxle gear oil	RS5F70A	3-1/8 qt.	2-5/8 qt.	3.0	API GL-4, Viscosity SAE 75W-85
Automatic transaxle fluid	RE4F03B	7-3/8 qt.	6-1/8 qt.	7.0	NISSAN Matic "D" (Continental U.S. and Alaska) or Canada NISSAN Automatic Transmission Fluid*2
Power steering fluid		1-1/8 qt.	7/8 qt.	1.0	Genuine NISSAN PSF II or equivalent*4
Brake and clutch fluid		—	—	—	Genuine NISSAN Brake Fluid*3 or equivalent DOT 3 (US FMVSS No. 116)
Multi-purpose grease		—	—	—	NLGI No. 2 (Lithium soap base)

\*1: For further details, see "SAE Viscosity Number".

\*2: DEXRON™ III/MERCON™, or equivalent may also be used. Outside the continental United States and Alaska contact a NISSAN dealership for more information regarding suitable fluids, including recommended brand(s) of DEXRON™ III/MERCON™ Automatic Transmission Fluid.

\*3: Available in mainland U.S.A. through your NISSAN dealer.

\*4: Genuine NISSAN PSF, Canada NISSAN Automatic Transmission Fluid, DEXRON™ III/MERCON™ or equivalent ATF may also be used.

QR25DE		Capacity (Approximate)			Recommended Fluids/Lubricants
		US measure	Imp measure	Liter	
Engine oil Drain and refill	With oil filter change	4-1/2 qt.	3-3/4 qt.	4.2	<ul style="list-style-type: none"> <li>● API Certification Mark*1</li> <li>● API grade SG/SH, Energy Conserving II or API grade SJ or SL, Energy Conserving*1</li> <li>● ILSAC grade GF-II &amp; GF-III*1</li> </ul>
	Without oil filter change	4-1/4 qt.	3-1/2 qt.	4.0	
Dry engine (engine overhaul)		4-7/8 qt.	4 qt.	4.6	
Cooling system (With reservoir)	MT	7-3/16 qt.	6 qt.	6.8	Genuine NISSAN Anti-freeze coolant or equivalent
	AT	7-1/8 qt.	5-7/8 qt.	6.7	
Manual transaxle gear oil	RS5F51A RS6F51H	2-3/8 qt.	2 qt.	2.3	API GL-4, Viscosity SAE 75W-85
Automatic transaxle fluid	RE4F04B	9.0 qt.	7-1/2 qt.	8.5	NISSAN Matic "D" (Continental U.S. and Alaska) or Canada NISSAN Automatic Transmission Fluid*2
Power steering fluid		1-1/8 qt.	7/8 qt.	1.0	Genuine NISSAN PSF II or equivalent*4
Brake and clutch fluid		—	—	—	Genuine NISSAN Brake Fluid*3 or equivalent DOT 3 (US FMVSS No. 116)
Multi-purpose grease		—	—	—	NLGI No. 2 (Lithium soap base)

\*1: For further details, see "SAE Viscosity Number".

\*2: DEXRON™ III/MERCON™, or equivalent may also be used. Outside the continental United States and Alaska contact an authorized NISSAN dealership for more information regarding suitable fluids, including recommended brand(s) of DEXRON™ III/MERCON™ Automatic Transmission Fluid.

\*3: Available in mainland U.S.A. through your authorized NISSAN dealer.

# RECOMMENDED FLUIDS AND LUBRICANTS

\*4: Genuine NISSAN PSF, Canada NISSAN Automatic Transmission Fluid, DEXRON™ III/MERCON™ or equivalent ATF may also be used.

## SAE Viscosity Number

SAE 5W-30 viscosity oil is preferred for all temperatures. SAE 10W-30 and 10W-40 viscosity oil may be used if the ambient temperature is above -18°C (0°F).

ELS0009G

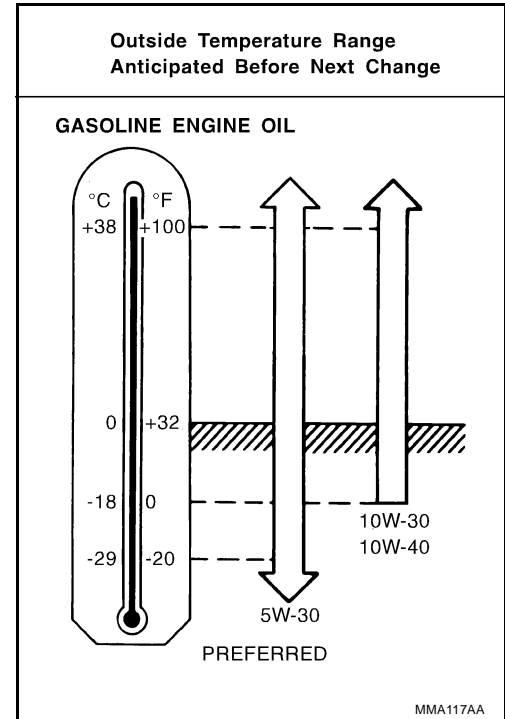

MMA117AA

## Anti-freeze Coolant Mixture Ratio

ELS0009H

The engine cooling system is filled at the factory with a high-quality, year-round, anti-freeze coolant solution. The anti-freeze solution contains rust and corrosion inhibitors. Therefore, additional cooling system additives are not necessary.

### CAUTION:

When adding or replacing coolant, be sure to use only a Genuine NISSAN anti-freeze coolant or equivalent with the proper mixture ratio.

Outside temperature down to:		Genuine NISSAN Anti-freeze Coolant or equivalent	Demineralized water or distilled water
°C	°F		
-35	-30	50%	50%

The use of other types of coolant solutions may damage the engine cooling system.

### Checking Drive Belts

ELS00091

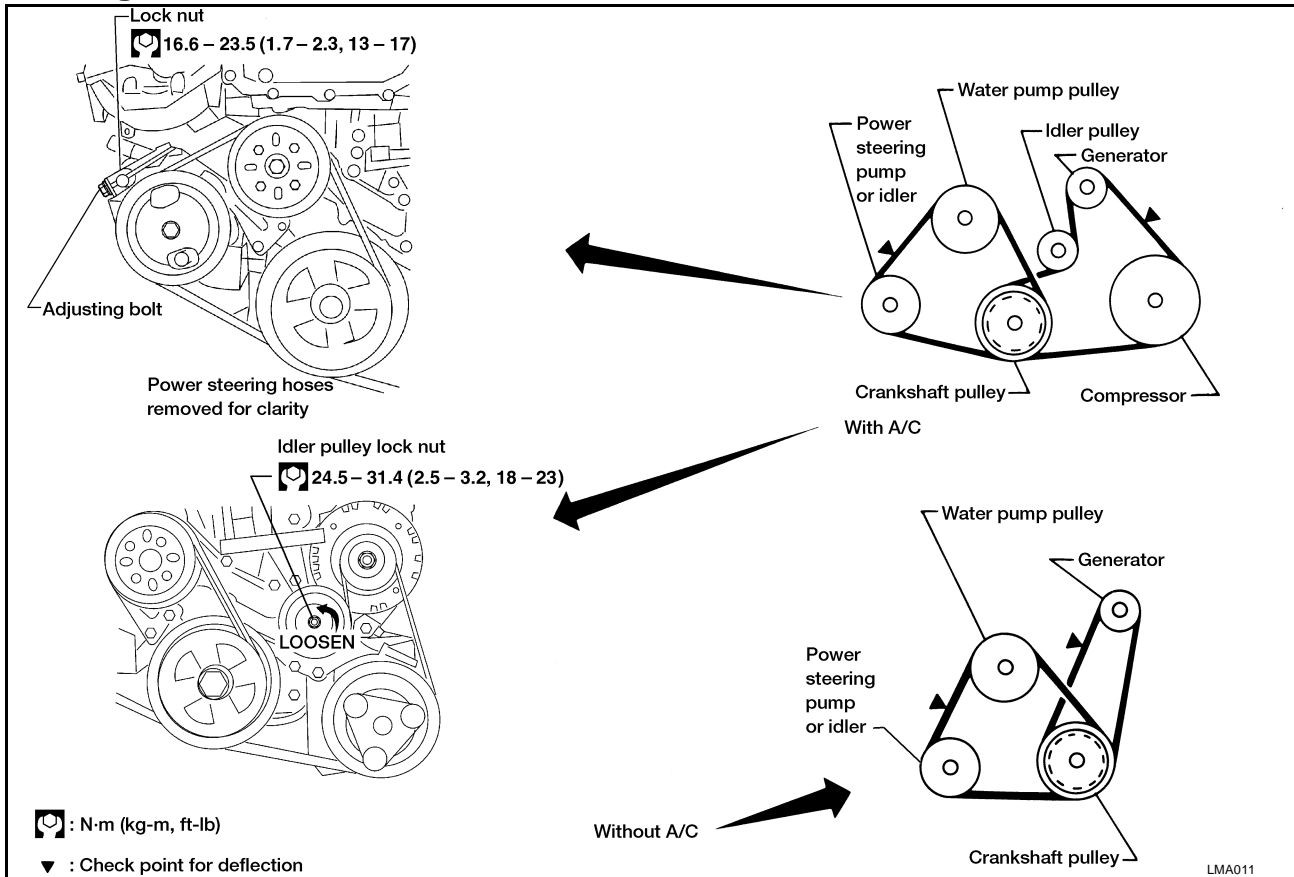

1. Inspect belt for cracks, fraying, wear and oil. If necessary, replace.
  2. Inspect drive belt deflection or tension at a point on the belt midway between pulleys.
    - Check belt tension using Belt Tension Gauge BT3373-F or equivalent. Refer to [MA-38. "Belt Deflection and Tension"](#).
    - Inspect drive belt deflection or tension when engine is cold.
- Adjust if belt deflection exceeds the limit or if belt tension is not within specifications.

### Changing Engine Coolant

ELS000U2

#### **WARNING:**

To avoid the danger of being scalded, never change the coolant when the engine is hot.

#### DRAINING ENGINE COOLANT

1. Set climate control system as follows to prevent coolant from remaining in the system.
  - Turn ignition switch "ON" and set temperature controller to maximum hot position.
  - Wait 10 seconds before turning ignition switch "OFF".

## ENGINE MAINTENANCE (QG18DE ENGINE)

- Open radiator drain plug at the bottom of the radiator, and remove radiator filler cap.

**CAUTION:**

Be careful not to allow coolant to contact drive belts.

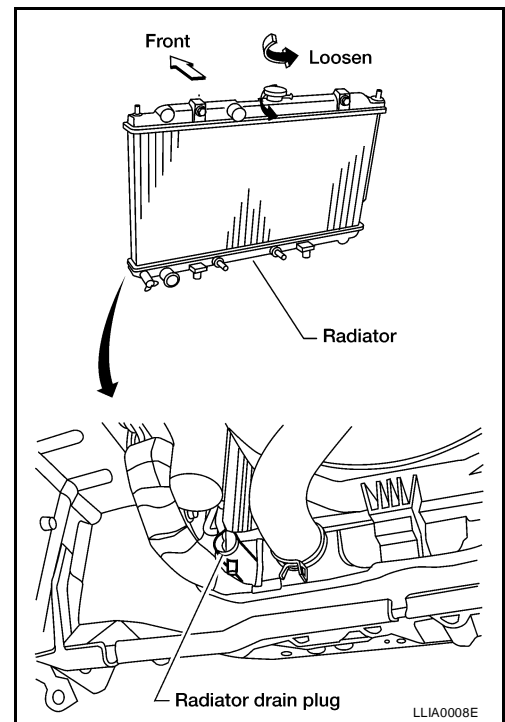

- Remove cylinder block drain plug and air relief plug.

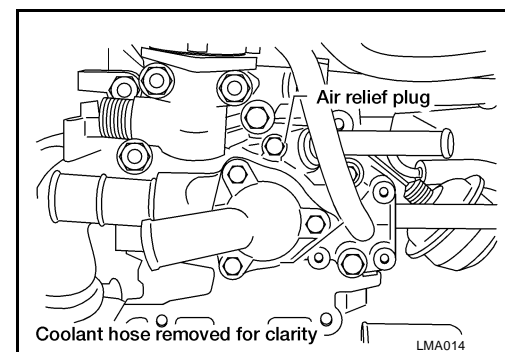
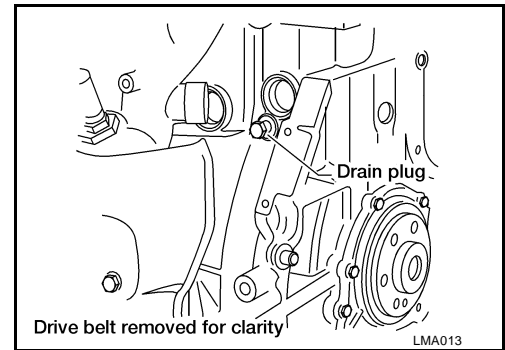

- Check drained coolant for contaminants such as rust, corrosion or discoloration. If contaminated, flush engine cooling system. Refer to [MA-17, "FLUSHING COOLING SYSTEM"](#).

### REFILLING ENGINE COOLANT

- Close radiator drain plug. Install the reservoir tank and cylinder block drain plug, if removed for a total system drain for engine removal or repair.
  - The radiator must be completely empty of coolant and water.
  - Apply sealant to the threads of the cylinder block drain plugs. Use Genuine High Performance Thread Sealant or equivalent. Refer to [GI-44, "Recommended Chemical Products and Sealants"](#)

Cylinder block drain plug : 34.3 - 44.1 N-m (3.5 - 4.5 kg-m, 26 - 32 ft-lb)



## ENGINE MAINTENANCE (QG18DE ENGINE)

2. If disconnected, reattach the upper radiator hose at the engine side.
3. Set the vehicle heater controls to the full HOT and heater ON position. Turn the vehicle ignition ON with the engine OFF as necessary to activate the heater mode.
4. Install the Tool by installing the radiator cap adapter onto the radiator neck opening. Then attach the gauge body assembly with the refill tube and the venturi assembly to the radiator cap adapter.
5. Insert the refill hose into the coolant mixture container that is placed at floor level. Make sure the ball valve is in the closed position.

- **Use Genuine NISSAN Anti-Freeze Coolant or equivalent, mixed 50/50 with distilled water or demineralized water. Refer to MA-14, "Anti-freeze Coolant Mixture Ratio".**

### Coolant capacity (without reservoir tank)

**M/T : 6.0 ℓ (6-3/8 US qt, 5-1/4 Imp qt)**

**A/T : 5.9 ℓ (6-1/4 US qt, 5-1/4 Imp qt)**

**Reservoir tank capacity : 0.7 ℓ (3/4 US qt, 5/8 Imp qt)  
(for MAX level)**

6. Install an air hose to the venturi assembly, the air pressure must be within specification.

**Compressed air supply pressure : 5.7 - 8.5 kPa (5.6 - 8.4 kg/cm<sup>2</sup>, 80 - 120 psi)**

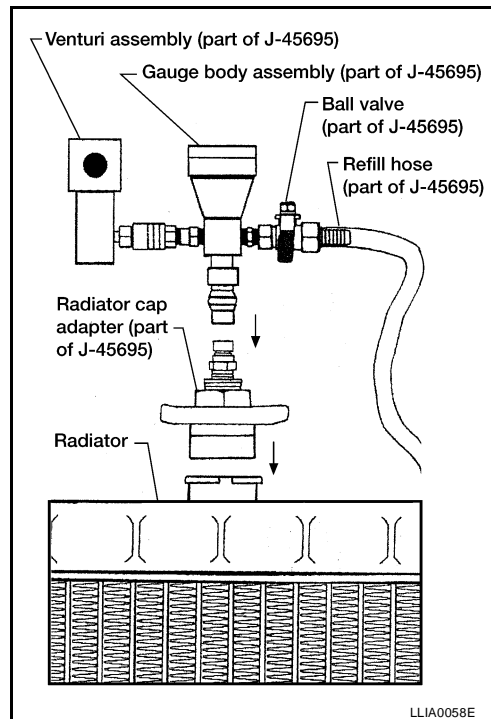

### CAUTION:

**The compressed air supply must be equipped with an air dryer.**

7. The vacuum gauge will begin to rise and there will be an audible hissing noise. During this process open the ball valve on the refill hose slightly. Coolant will be visible rising in the refill hose. Once the refill hose is full of coolant, close the ball valve. This will purge any air trapped in the refill hose.
8. Continue to draw the vacuum until the gauge reaches 28 inches of vacuum. The gauge may not reach 28 inches in high altitude locations, refer to the vacuum specifications based on the altitude above sea level.

<b>Altitude above sea level</b>	<b>Vacuum gauge reading</b>
<b>0 - 100 m (328 ft)</b>	<b>: 28 inches of vacuum</b>
<b>300 m (984 ft)</b>	<b>: 27 inches of vacuum</b>
<b>500 m (1,641 ft)</b>	<b>: 26 inches of vacuum</b>
<b>1,000 m (3,281 ft)</b>	<b>: 24 - 25 inches of vacuum</b>

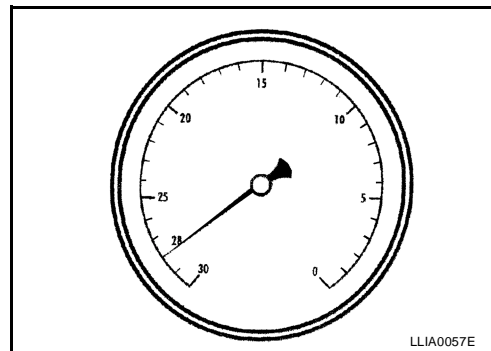

9. When the vacuum gauge has reached the specified amount, disconnect the air hose and wait 20 seconds to see if the system loses any vacuum. If the vacuum level drops, perform any necessary repairs to the system and repeat steps 6 - 8 to bring the vacuum to the specified amount. Recheck for any leaks.
10. Place the coolant container (with the refill hose inserted) at the same level as the top of the radiator. Then open the ball valve on the refill hose so the coolant will be drawn up to fill the cooling system. The cooling system is full when the vacuum gauge reads zero.

### CAUTION:

**Do not allow the coolant container to get too low when filling, to avoid air from being drawn into the cooling system.**

11. Remove the Tool from the radiator neck opening.
12. Fill the cooling system reservoir tank to the specified level. Run the engine to warm up the cooling system and top up the system as necessary before installing the radiator cap.

## FLUSHING COOLING SYSTEM

1. Open air relief plug.

# ENGINE MAINTENANCE (QG18DE ENGINE)

2. Fill radiator with water until water spills from the air relief hole, then close air relief plug. Fill radiator and reservoir tank with water and reinstall radiator cap.
3. Run engine and warm it up to normal operating temperature.
4. Rev engine two or three times under no-load.
5. Stop engine and wait until it cools down.
6. Drain water.
7. Repeat steps 1 through 6 until clear water begins to drain from radiator.

## Checking Fuel Lines

ELS0009K

Inspect fuel lines and tank for improper attachment, leaks, cracks, damage, loose connections, chafing or deterioration.

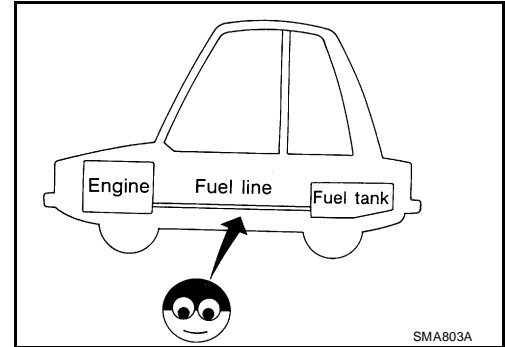

If necessary, repair or replace faulty parts.

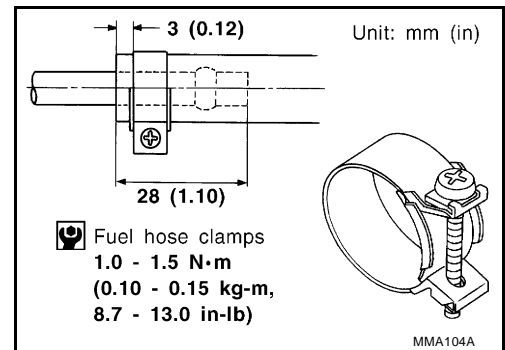

## Changing Air Cleaner Filter

ELS0009L

Unfasten clamps to change air cleaner filter.

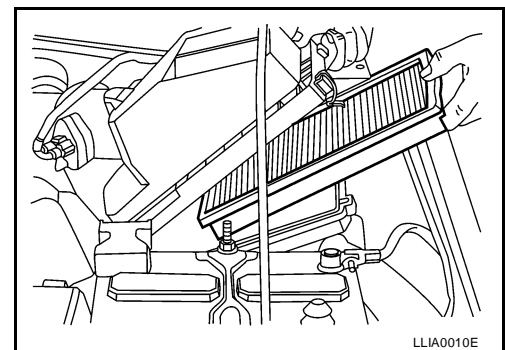

# ENGINE MAINTENANCE (QG18DE ENGINE)

ELS0009M

## Changing Engine Oil

### WARNING:

- Be careful not to burn yourself, as the engine oil is hot.
  - Prolonged and repeated contact with used engine oil may cause skin cancer; try to avoid direct skin contact with used oil. If skin contact is made, wash thoroughly with soap or hand cleaner as soon as possible.
1. Warm up engine, and check for oil leakage from engine components.
  2. Stop engine.
  3. Remove drain plug and oil filler cap.
  4. Drain oil and refill with new engine oil.

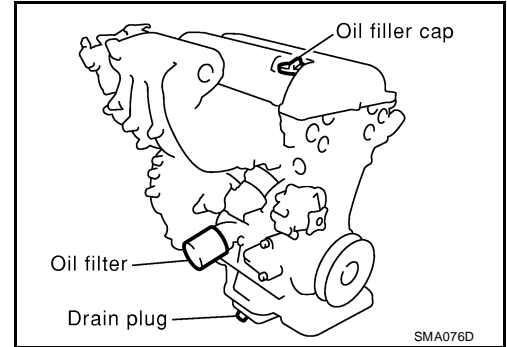

### Oil specification and viscosity

- API Certification Mark
- API grade SG/SH, Energy Conserving II or API grade SJ or SL, Energy Conserving
- ILSAC grade GF-II & GF-III
- Refer to [MA-14](#), "SAE Viscosity Number".



: 29 - 39 N·m (3.0 - 4.0 kg·m, 22 - 29 ft·lb)

### Oil capacity (Approximate):

Unit: ℓ (US qt., Imp qt.)

Drain and refill	With oil filter change	2.7 (2-7/8, 2-3/8)
	Without oil filter change	2.5 (2-5/8, 2-1/4)
Dry engine (engine overhaul)		3.1 (3-1/4, 2-3/4)

### CAUTION:

- Be sure to clean drain plug and install with new washer.

#### Oil pan drain plug



: 29 - 39 N·m (3.0 - 4.0 kg·m, 22 - 29 ft·lb)

- The refill capacity depends on the oil temperature and drain time. Use these specifications for reference only.  
Always use the dipstick to determine when the proper amount of oil is in the engine.

5. Warm up engine and check area around drain plug and oil filter for oil leakage.
6. Stop engine.
7. Check oil level.

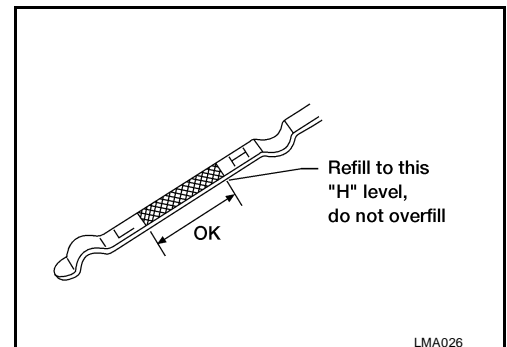

# ENGINE MAINTENANCE (QG18DE ENGINE)

ELS0009N

## Changing Oil Filter

1. Remove oil filter with Tool.

### **WARNING:**

**Be careful not to burn yourself, as the engine and engine oil are hot.**

The filter is a full-flow cartridge type and is provided with a relief valve.

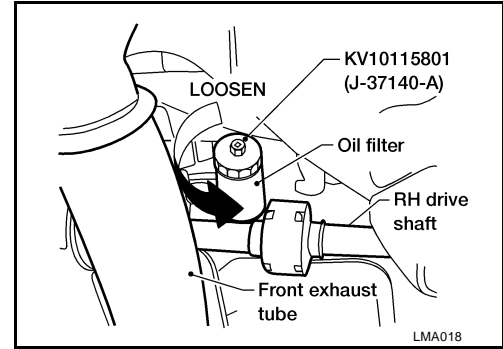

2. Clean oil filter mounting surface on cylinder block. Coat rubber seal of new oil filter with engine oil.

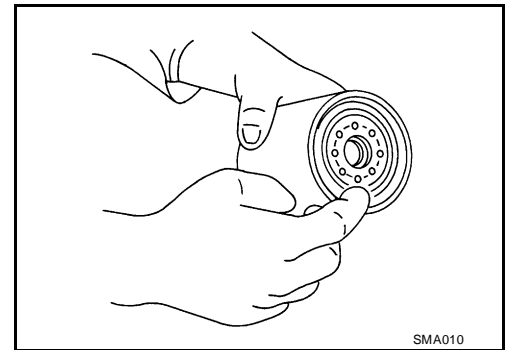

3. Screw in the oil filter until a slight resistance is felt, then tighten an additional 2/3 turn.

4. Add engine oil.

Refer to [MA-19, "Changing Engine Oil"](#).

- Clean excess oil from engine.

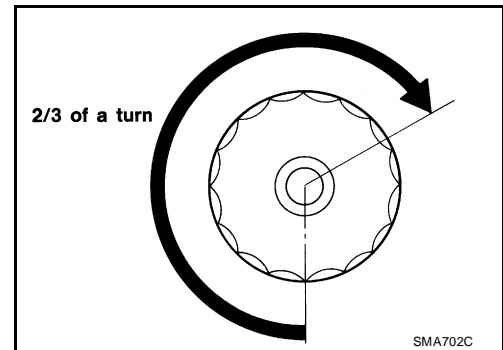

## Changing Spark Plugs (Double Platinum - Tipped Type)

ELS0009O

1. Disconnect ignition coil harness connectors.
2. Remove ignition coils.

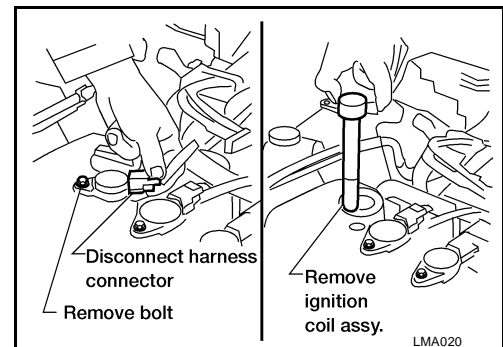

3. Remove spark plugs with spark plug socket.

# ENGINE MAINTENANCE (QG18DE ENGINE)

## Spark plug:

Hot type	PLFR4A-11
Standard type	PLFR5A-11
Cold type	PLFR6A-11

**Gap (Nominal) : 1.1 mm (0.043 in)**

### Use standard type spark plug for normal condition.

The hot type spark plug is suitable when fouling occurs with the standard type spark plug under conditions such as:

- frequent engine starts
- low ambient temperatures

The cold type spark plug is suitable when spark knock occurs with the standard type spark plug under conditions such as:

- extended highway driving
- frequent high engine revolution
- **Do not use a wire brush for cleaning.**
- **If plug tip is covered with carbon, spark plug cleaner may be used.**

**Cleaner air pressure : Less than 588 kPa (6 kg/cm<sup>2</sup>, 85 psi)**

**Cleaning time : Less than 20 seconds**

- **Checking and adjusting plug gap is not required between change intervals.**

4. Install spark plugs.

### Spark plug

 : 20 - 29 N·m (2.0 - 3.0 kg·m, 14 - 22 ft·lb)

5. Install ignition coils.

 : 34.3 - 44.1 N·m (3.5 - 4.5 kg·m, 26 - 32 ft·lb)

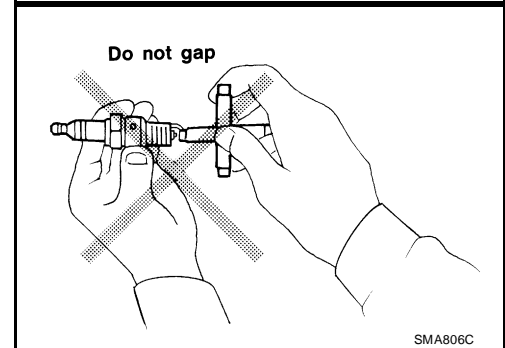
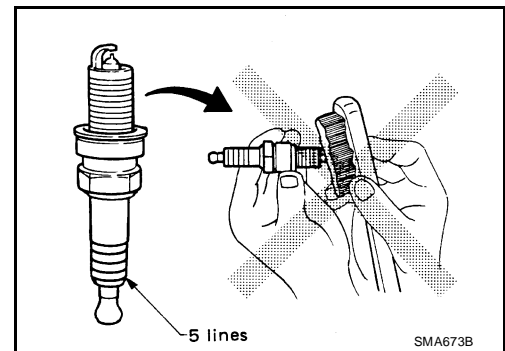

## Checking EVAP Vapor Lines

1. Visually inspect EVAP vapor lines for improper attachment, cracks, damage, loose connections, chafing or deterioration.

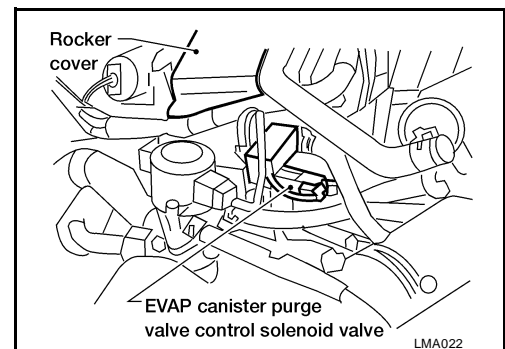

2. Inspect vacuum relief valve of fuel tank filler cap for clogging, sticking, etc.

# ENGINE MAINTENANCE (QR25DE ENGINE)

## ENGINE MAINTENANCE (QR25DE ENGINE)

PF1:10001

### Checking Drive Belts

ELS00090

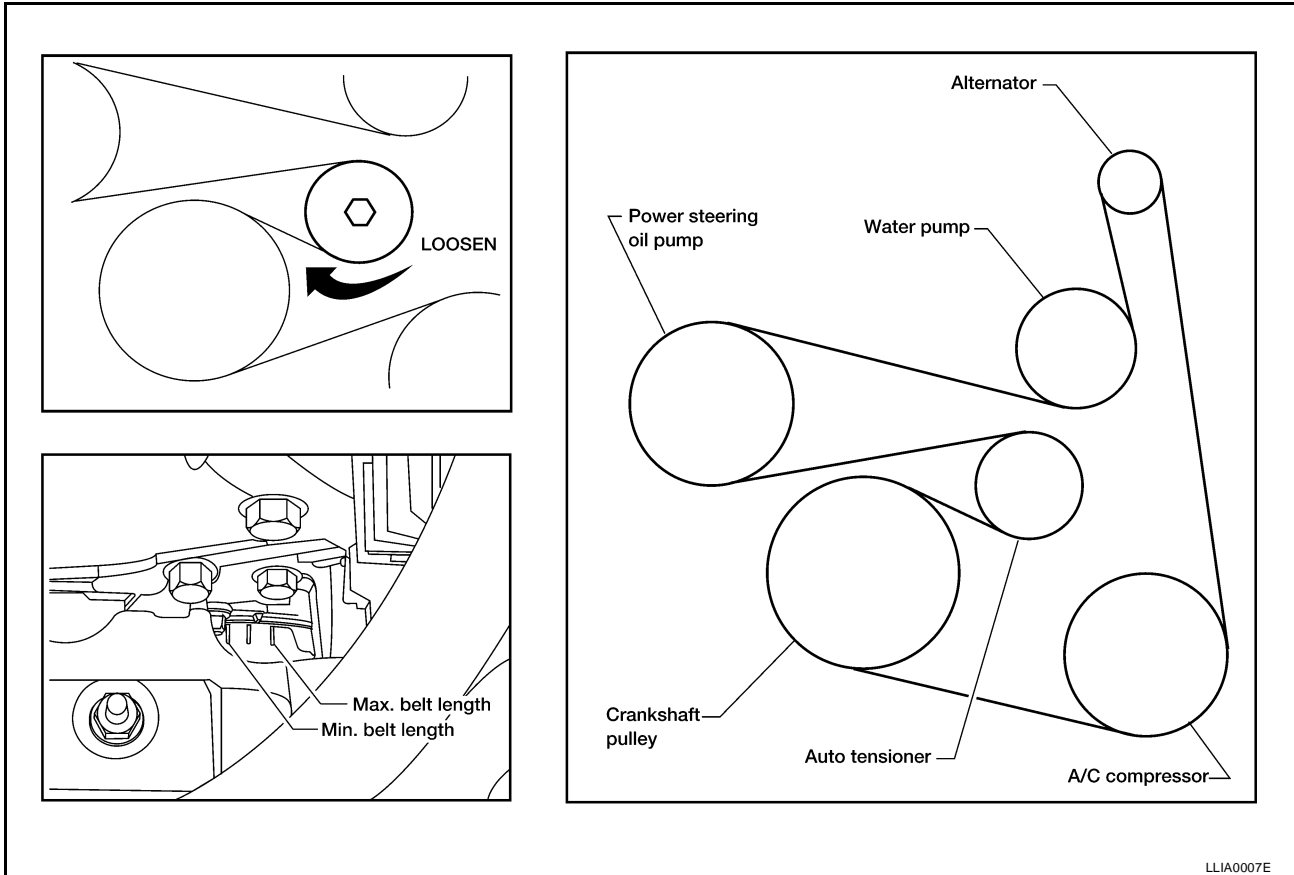

#### NOTE:

On vehicles not equipped with A/C, there is an idler pulley in the position for the drive belt routing.

#### WARNING:

**Be sure to perform when the engine is stopped.**

- Make sure that indicator (single line notch) of each automatic tensioner is within the allowable working range (between three notches).

#### NOTE:

- Check the automatic tensioner indicator when the engine is cold.
- The indicator notch is located on the moving side of the tensioner.
- Visually check entire belt for wear, damage or cracks.
- If the indicator is out of allowable working range or belt is damaged, replace the belt.
- Belt tensioning is not necessary, as it is automatically adjusted by auto belt tensioner.

### Changing Engine Coolant

ELS000U1

#### WARNING:

**To avoid the danger of being scalded, never change the coolant when the engine is hot.**

# ENGINE MAINTENANCE (QR25DE ENGINE)

## DRAINING ENGINE COOLANT

1. Open radiator drain plug at the bottom of the radiator, and remove radiator filler cap.

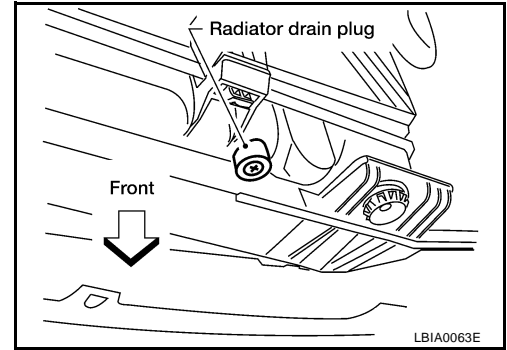

When draining all the coolant in the system, also perform the following two steps:

1. Remove cylinder block drain plug and air relief plug.

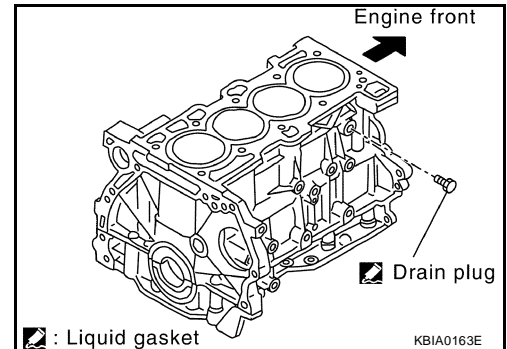

2. Check drained coolant for contaminants such as rust, corrosion or discoloration. If contaminated, flush engine cooling system.  
Refer to [MA-24, "FLUSHING COOLING SYSTEM"](#) .

## REFILLING ENGINE COOLANT

1. Install the radiator drain plug. Install the reservoir tank and cylinder block drain plug, if removed for a total system drain for engine removal or repair.
  - **The radiator must be completely empty of coolant and water.**
  - **Apply sealant to the threads of the cylinder block drain plugs. Use Genuine High Performance Thread Sealant or equivalent. Refer to [GI-44, "Recommended Chemical Products and Sealants"](#)**

**Radiator drain plug : 7.8 - 11.8 N·m (0.8 - 1.2 kg·m , 69 - 104 in·lb)**

**Cylinder block drain plug : 34 - 44 N·m (3.5 - 4.5 kg·m, 25 - 33 ft·lb)**

2. If disconnected, reattach the upper radiator hose at the engine side.
3. Set the vehicle heater controls to the full HOT and heater ON position. Turn the vehicle ignition ON with the engine OFF as necessary to activate the heater mode.

## ENGINE MAINTENANCE (QR25DE ENGINE)

4. Install the Tool by installing the radiator cap adapter onto the radiator neck opening. Then attach the gauge body assembly with the refill tube and the venturi assembly to the radiator cap adapter.
5. Insert the refill hose into the coolant mixture container that is placed at floor level. Make sure the ball valve is in the closed position.

- Use Genuine NISSAN Anti-Freeze Coolant or equivalent, mixed 50/50 with distilled water or demineralized water. Refer to [MA-14, "Anti-freeze Coolant Mixture Ratio"](#).

**Coolant capacity** : M/T 6.1 ℓ (6-1/2 US qt, 5-3/8 Imp qt)  
(Without reservoir tank) A/T 6.0 ℓ (6-3/8 US qt, 5-1/4 Imp qt)

**Reservoir tank capacity (for MAX level)** : 0.7 ℓ (3/4 US qt, 5/8 Imp qt)

6. Install an air hose to the venturi assembly, the air pressure must be within specification.

**Compressed air supply pressure** : 5.7 - 8.5 kPa (5.6 - 8.4 kg/cm<sup>2</sup>, 80 - 120 psi)

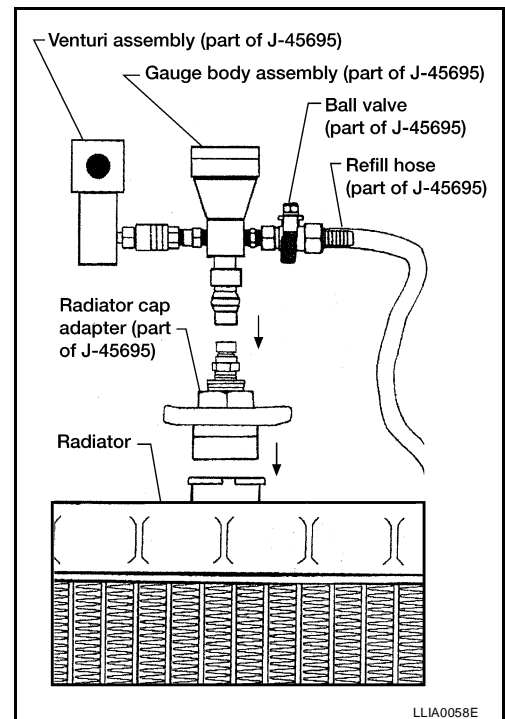

### CAUTION:

**The compressed air supply must be equipped with an air dryer.**

7. The vacuum gauge will begin to rise and there will be an audible hissing noise. During this process open the ball valve on the refill hose slightly. Coolant will be visible rising in the refill hose. Once the refill hose is full of coolant, close the ball valve. This will purge any air trapped in the refill hose.
8. Continue to draw the vacuum until the gauge reaches 28 inches of vacuum. The gauge may not reach 28 inches in high altitude locations, refer to the vacuum specifications based on the altitude above sea level.

Altitude above sea level	Vacuum gauge reading
0 - 100 m (328 ft)	: 28 inches of vacuum
300 m (984 ft)	: 27 inches of vacuum
500 m (1,641 ft)	: 26 inches of vacuum
1,000 m (3,281 ft)	: 24 - 25 inches of vacuum

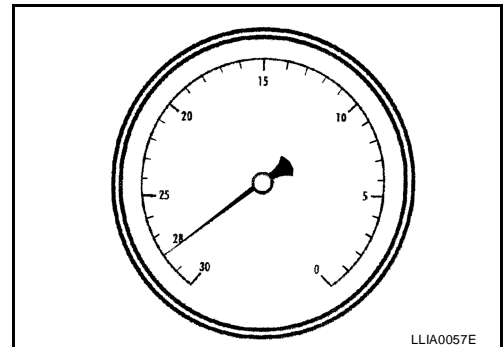

9. When the vacuum gauge has reached the specified amount, disconnect the air hose and wait 20 seconds to see if the system loses any vacuum. If the vacuum level drops, perform any necessary repairs to the system and repeat steps 6 - 8 to bring the vacuum to the specified amount. Recheck for any leaks.
10. Place the coolant container (with the refill hose inserted) at the same level as the top of the radiator. Then open the ball valve on the refill hose so the coolant will be drawn up to fill the cooling system. The cooling system is full when the vacuum gauge reads zero.

### CAUTION:

**Do not allow the coolant container to get too low when filling, to avoid air from being drawn into the cooling system.**

11. Remove the Tool from the radiator neck opening.
12. Fill the cooling system reservoir tank to the specified level. Run the engine to warm up the cooling system and top up the system as necessary before installing the radiator cap.

## FLUSHING COOLING SYSTEM

1. Fill radiator and reservoir tank with water and reinstall radiator cap.
2. Run engine and warm it up to normal operating temperature.



# ENGINE MAINTENANCE (QR25DE ENGINE)

3. Rev engine two or three times under no-load.
4. Stop engine and wait until it cools down.
5. Drain water.
6. Repeat steps 1 through 5 until clear water begins to drain from radiator.

## Checking Fuel Lines

ELS0009S

Inspect fuel lines and tank for improper attachment, leaks, cracks, damage, loose connections, chafing or deterioration.

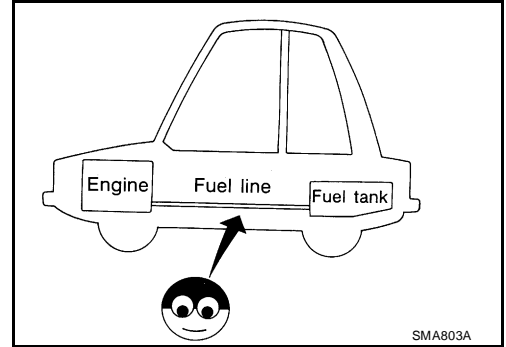

If necessary, repair or replace faulty parts.

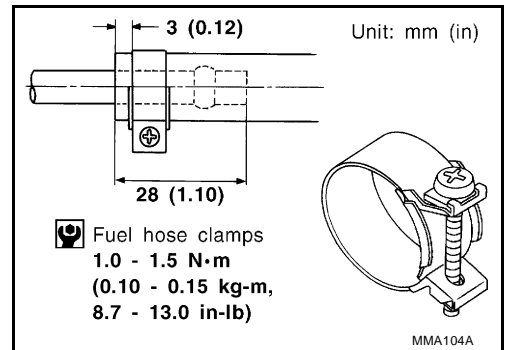

## Changing Air Cleaner Filter

ELS0009T

Unfasten clamps to change air cleaner filter.

- The viscous paper type filter does not need cleaning.

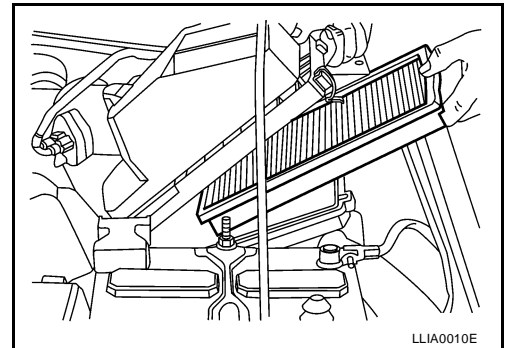

## Changing Engine Oil

ELS0009U

### WARNING:

- Be careful not to burn yourself, as the engine oil is hot.
  - Prolonged and repeated contact with used engine oil may cause skin cancer; try to avoid direct skin contact with used oil. If skin contact is made, wash thoroughly with soap or hand cleaner as soon as possible.
1. Warm up engine, and check for oil leakage from engine components.
  2. Stop engine.
  3. Remove drain plug and oil filler cap.
  4. Drain oil and refill with new engine oil.

### Oil specification and viscosity

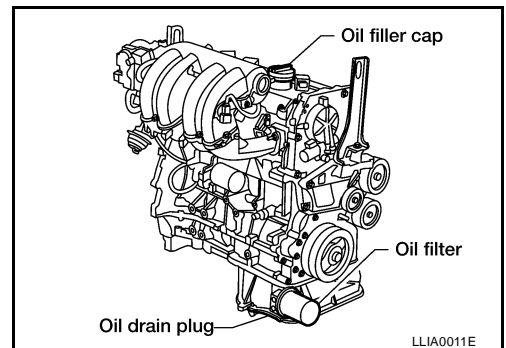

# ENGINE MAINTENANCE (QR25DE ENGINE)

- API Certification Mark
- API grade SG/SH, Energy Conserving II or API grade SJ or SL, Energy Conserving
- ILSAC grade GF-II & GF-III
- Refer to [MA-14, "SAE Viscosity Number"](#) .

## Oil capacity (Approximate):

Unit: ℓ (US qt., Imp qt.)

Drain and refill	With oil filter change	4.2 (4-1/2, 3-3/4)
	Without oil filter change	4.0 (4-1/4, 3-1/2)
Dry engine (engine overhaul)		4.6 (4-7/8, 4)

### CAUTION:

- Be sure to clean drain plug and install with new washer.

#### Oil pan drain plug



: 29 - 39 N·m (3.0 - 4.0 kg·m, 22 - 29 ft·lb)

- The refill capacity depends on the oil temperature and drain time. Use these specifications for reference only.  
Always use the dipstick to determine when the proper amount of oil is in the engine.

5. Warm up engine and check area around drain plug and oil filter for oil leakage.
6. Stop engine.
7. Check oil level.

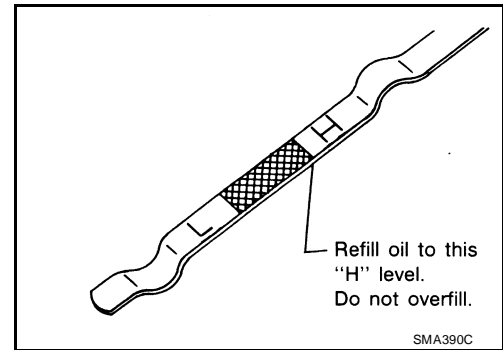

ELS0009V

## Changing Oil Filter

1. Remove oil filter with Tool.

### WARNING:

Be careful not to burn yourself, as the engine and engine oil are hot.

The filter is a full-flow cartridge type and is provided with a relief valve.

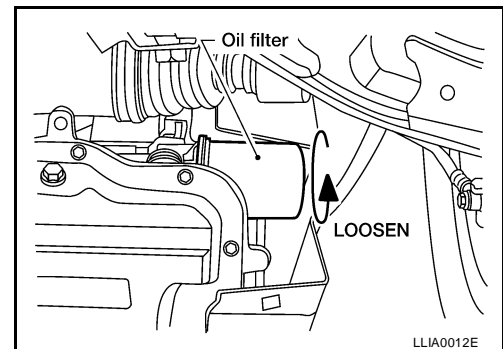

2. Clean oil filter mounting surface on cylinder block. Coat rubber seal of new oil filter with engine oil.

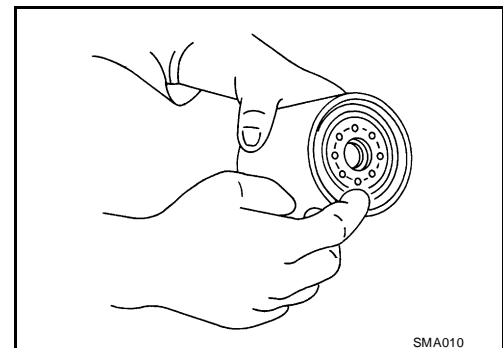

# ENGINE MAINTENANCE (QR25DE ENGINE)

3. Screw in the oil filter until a slight resistance is felt, then tighten an additional 2/3 turn.
4. Add engine oil.

Refer to [MA-25, "Changing Engine Oil"](#).

- Clean excess oil from engine.

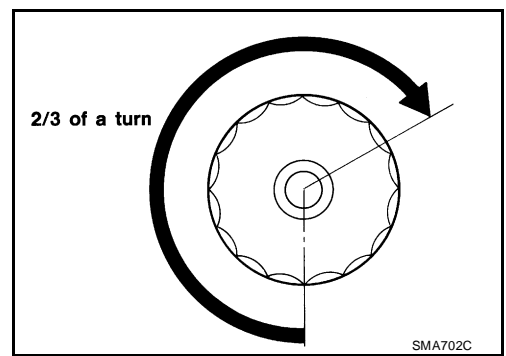

## Changing Spark Plugs (Double Platinum - Tipped Type)

ELS0009W

1. Disconnect ignition coil wires. Remove spark plug coil.

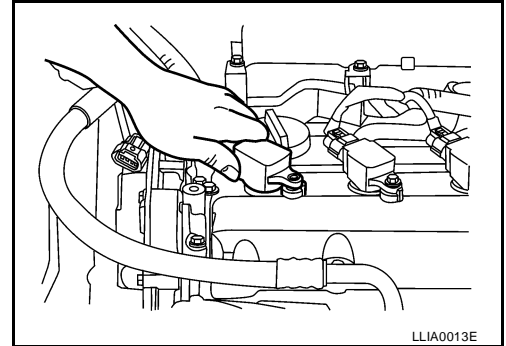

2. Remove spark plugs with spark plug socket.

### Spark plug:

Hot type	PLFR4A-11
Standard type	PLFR5A-11
Cold type	PLFR6A-11

**Gap (Nominal) : 1.1 mm (0.043 in)**

### Use standard type spark plug for normal condition.

The hot type spark plug is suitable when fouling occurs with the standard type spark plug under conditions such as:

- frequent engine starts
- low ambient temperatures

The cold type spark plug is suitable when spark knock occurs with the standard type spark plug under conditions such as:

- extended highway driving
- frequent high engine revolution
- **Do not use a wire brush for cleaning.**
- **If plug tip is covered with carbon, spark plug cleaner may be used.**

**Cleaner air pressure : Less than 588 kPa (6 kg/cm<sup>2</sup>, 85 psi)**

**Cleaning time : Less than 20 seconds**

- **Checking and adjusting plug gap is not required between change intervals.**

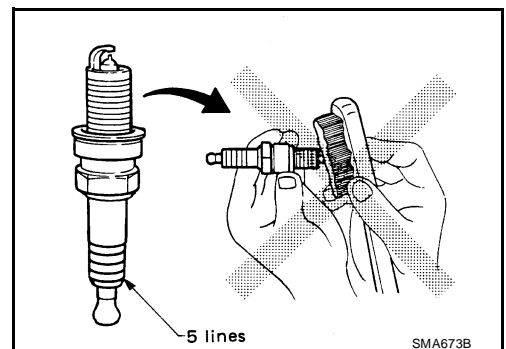

A  
B  
C  
D  
E  
F  
G  
H  
I  
J  
K  
L  
M

MA

M

# ENGINE MAINTENANCE (QR25DE ENGINE)

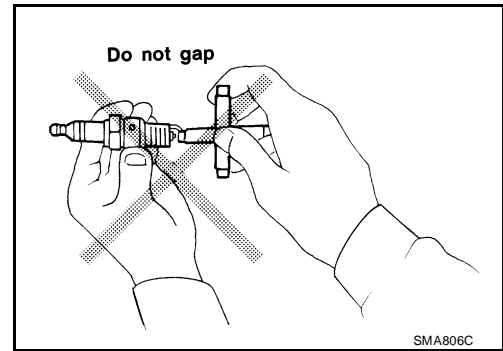

3. Install spark plugs. Reconnect ignition wires according to numbers indicated on them.

## Spark plug



: 20 - 29 N·m (2.0 - 3.0 kg·m, 14 - 22 ft·lb)

## Checking EVAP Vapor Lines

1. Visually inspect EVAP vapor lines for improper attachment, cracks, damage, loose connections, chafing or deterioration.

ELS0009X

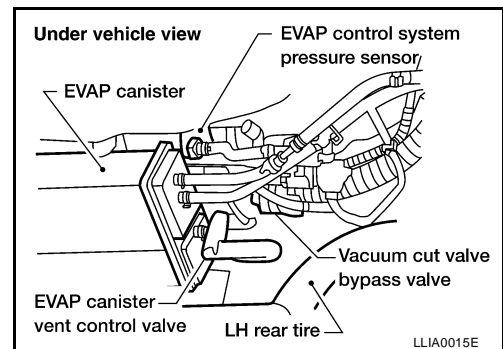
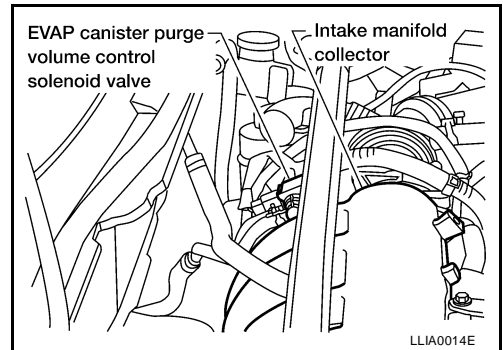

2. Inspect vacuum relief valve of fuel tank filler cap for clogging, sticking, etc. Refer to [EC-1839, "FUEL TANK VACUUM RELIEF VALVE \(BUILT INTO FUEL FULLER CAP\)"](#).

## CHASSIS AND BODY MAINTENANCE

PFP:00000

### Checking Exhaust System

ELS0009Y

Check exhaust pipes, muffler and mounting for improper attachment, leaks, cracks, damage, loose connections, chafing or deterioration.

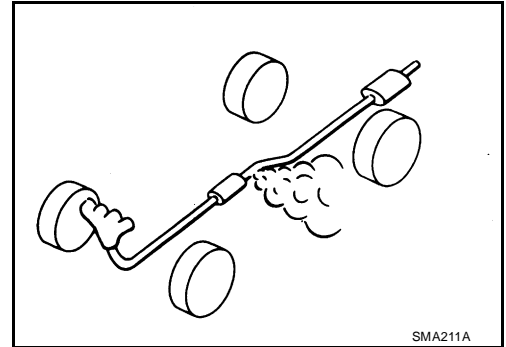

### Checking Clutch Fluid Level and Leaks

ELS0009Z

If fluid level is extremely low, check clutch system for leaks.

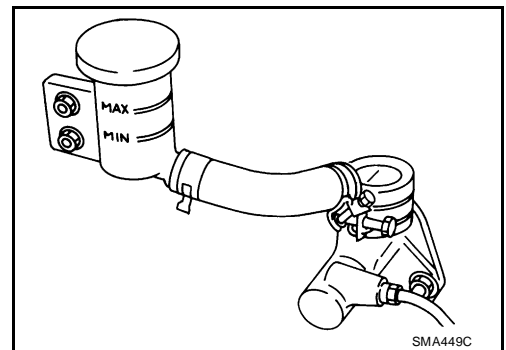

### Checking M/T Oil

ELS000A0

1. Check that oil is not leaking from transaxle or around it.
2. Check oil level.

**Never start engine while checking oil level.**

#### Filler plug



**: RS5F70A (QG18DE)  
10 - 19 N·m (1.0 - 2.0 kg·m, 87 - 173 in·lb)**



**: RS5F51A, RS6F51H, (QR25DE)  
30-39 N·m (3.1-4.0 kg·m, 23-28 lb·ft)**

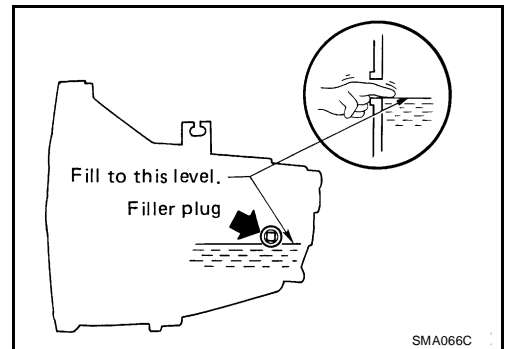

### Changing M/T Oil

ELS000A1

1. Drain oil from drain plug and refill with new gear oil.

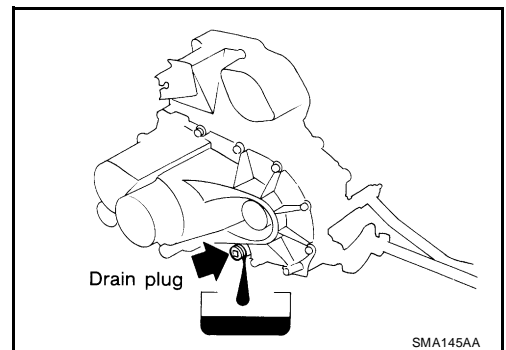

A  
B  
C  
D  
E  
F  
G  
H  
I  
J  
K  
MA  
M

# CHASSIS AND BODY MAINTENANCE

## 2. Check oil level.

**Oil grade** : API GL-4

**Viscosity** : Refer to [MA-14, "SAE Viscosity Number"](#)

**Capacity** : RS5F70A/V (QG18DE)  
3.0 ℓ (3-1/8 US qt, 2-5/8 Imp qt)  
RS5F51A, RS6F51H (QR25DE)  
2.3 ℓ (2-3/8 US qt, 2 Imp qt)

**Drain plug** :



: RS5F70A (QG18DE)  
10 - 19 N·m (1.0 - 2.0 kg·m, 87 - 173 in·lb)



: RS5F51A, RS6F51H (QR25DE)  
30 - 39 N·m (3.1 - 4.0 kg·m, 23 - 28 ft·lb)

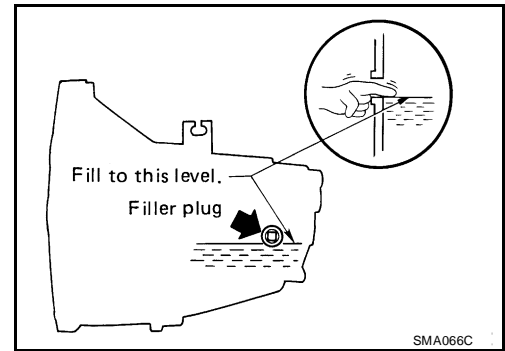

## Checking A/T Fluid

ELS000A2

1. Check for fluid leakage.
2. Warm up engine. Drive vehicle for approximately 5 minutes in urban areas.
3. Check fluid level at fluid temperatures of 50 to 80°C (122 to 176°F) using "HOT" range on dipstick.
  - a. Park vehicle on level surface and set parking brake.
  - b. Start engine and move selector lever through each gear position. Leave selector lever in "P" position.
  - c. Check fluid level with engine idling.
  - d. Remove dipstick and note reading. If fluid level is within **A**, add fluid to the charging pipe. If fluid is within **B**, fluid level is OK.
  - e. Re-insert dipstick into charging pipe as far as it will go.
  - f. Remove dipstick and note reading. If fluid is low, add fluid to the charging pipe.

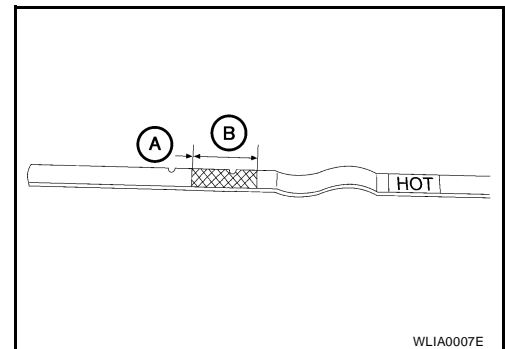

### Do not overfill.

4. Check fluid condition.
  - If fluid is very dark or smells burned, refer to [AT-63, "FLUID CONDITION CHECK"](#). Flush cooling system after repair of A/T.
  - If A/T fluid contains frictional material (clutches, bands, etc.), replace radiator and flush cooler line using cleaning solvent and compressed air after repair of A/T. Refer to [CO-14, "RADIATOR"](#).

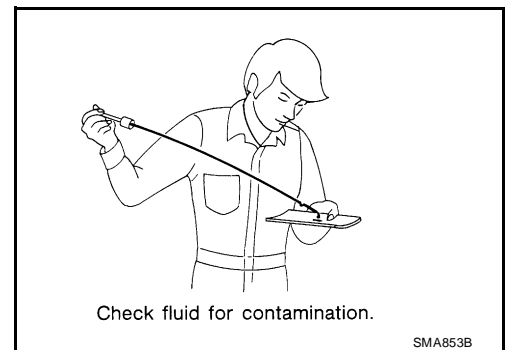

# CHASSIS AND BODY MAINTENANCE

## Changing A/T Fluid

ELS000A3

1. Warm up A/T fluid.
2. Stop engine.
3. Drain A/T fluid from drain plug and refill with new A/T fluid. Always refill same volume with drained fluid.

**Fluid grade** : NISSAN Matic "D" (Continental U.S. and Alaska) or Canada NISSAN Automatic Transmission Fluid. Refer to [MA-13, "Fluids and Lubricants"](#) .

**Fluid capacity (With torque converter)** : RE4F03B (QG18DE) 7.0 ℓ (7-3/8 US qt, 6-1/8 Imp qt)  
RE4F04B (QR25DE) 8.5 ℓ (9 US qt, 7-1/2 Imp qt)

**Drain plug**



: 29 - 39 N-m (3.0 - 4.0 kg-m, 22 - 29 ft-lb)

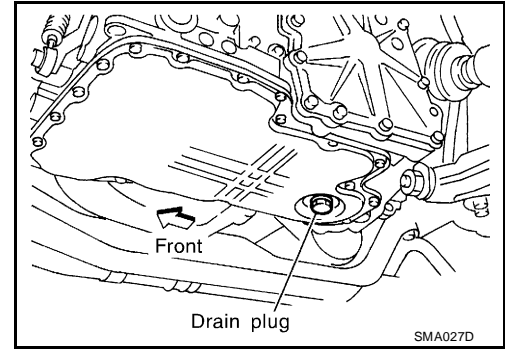

4. Run engine at idle speed for five minutes.
5. Check fluid level and condition. Refer to [MA-30, "Checking A/T Fluid"](#) . If fluid is still dirty, repeat steps 2 through 5.

## Balancing Wheels

ELS000A4

Adjust wheel balance using the road wheel center.

**Wheel balance (Maximum allowable unbalance)** : Refer to [MA-31, "Balancing Wheels"](#) .

## Tire Rotation

ELS000A5

- After rotating the tires, adjust the tire pressure.
- Retighten the wheel nuts when the vehicle has been driven for the first 1,000 km (600 miles) (also in cases of a flat tire, etc.).

**Wheel nuts**



: 98 - 127 N-m (10 - 13 kg-m, 73 - 94 ft-lb)

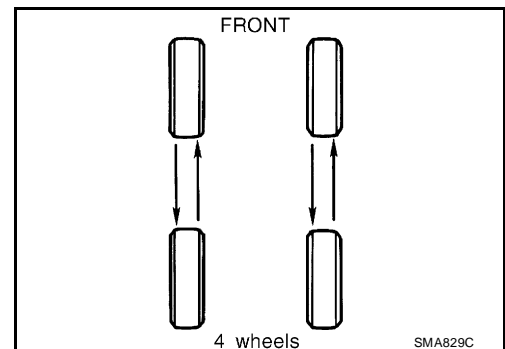

A

B

C

D

E

F

G

H

I

J

K

MA

M

# CHASSIS AND BODY MAINTENANCE

## Checking Brake Fluid Level and Leaks

ELS000A6

- Check fluid level in reservoir tank. It should be between MAX and MIN lines on reservoir tank.
- If fluid level is extremely low, check brake system for leaks.
- Release parking brake lever and see if brake warning lamp goes off. If not, check brake system for leaks.

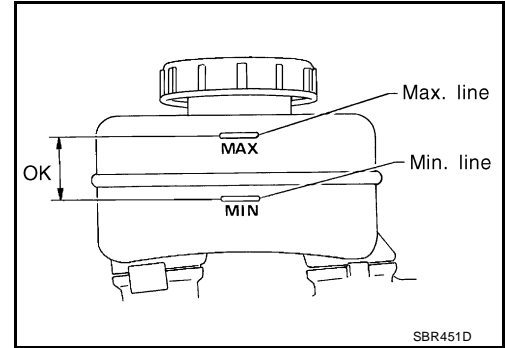

## Checking Brake Lines and Cables

ELS000A7

### CAUTION:

If leakage occurs around joints, retighten or, if necessary, replace damaged parts.

1. Check brake lines (tubes and Hoses) for cracks, deterioration and other damage. replace damaged parts.
2. Check for oil leakage by fully depressing brake pedal while engine is running.

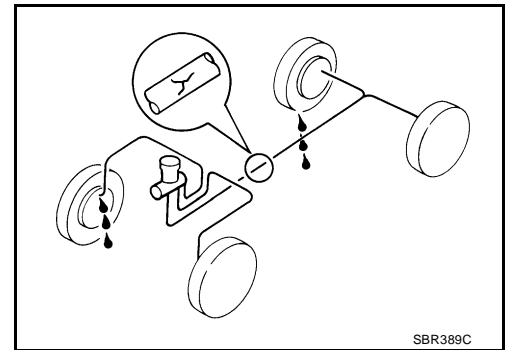

## Changing Brake Fluid

ELS000A8

### CAUTION:

- Refill with new brake fluid "DOT 3".
- Always keep fluid level higher than minimum line on reservoir tank.
- Never reuse drained brake fluid.
- Be careful not to splash brake fluid on painted areas; it may cause paint damage. If brake fluid is splashed on painted areas, wash it away with water immediately.

1. Clean inside of reservoir tank, and refill with new brake fluid.
2. Connect a vinyl tube to each bleeder valve.
3. Drain brake fluid from each air bleeder valve by depressing brake pedal.
4. Refill until brake fluid comes out of each air bleeder valve. Use same procedure as in bleeding hydraulic system to refill brake fluid. Refer to [BR-7, "Bleeding Brake System"](#) .

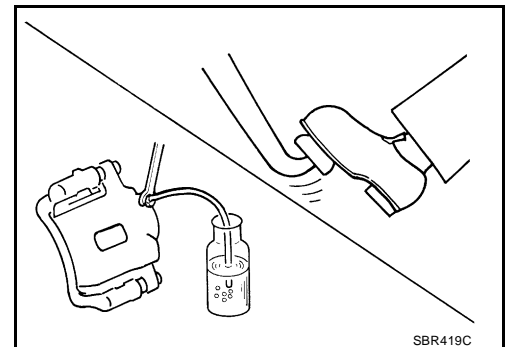

## Checking Disc Brakes

ELS000A9

### ROTOR

Check condition, wear, and damage.

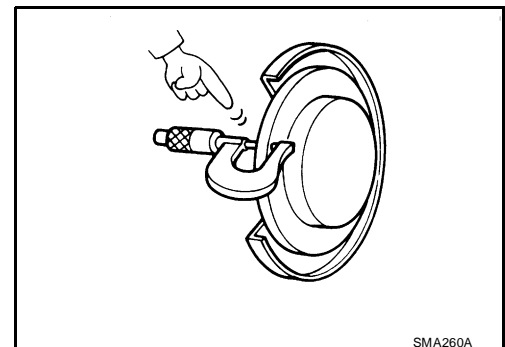



# CHASSIS AND BODY MAINTENANCE

## CALIPER

Check for leakage.

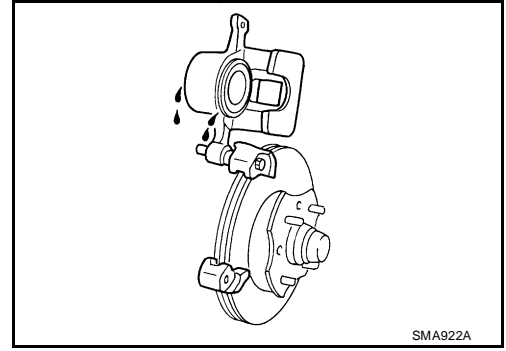

A  
B  
C  
D

## PAD

Check condition and thickness.

**Standard thickness** : Front 11 mm (0.433 in)  
: Rear 10 mm (0.39 in)

**Minimum thickness** : Front 2.0 mm (0.079 in)  
: Rear 2.0 mm (0.079 in)

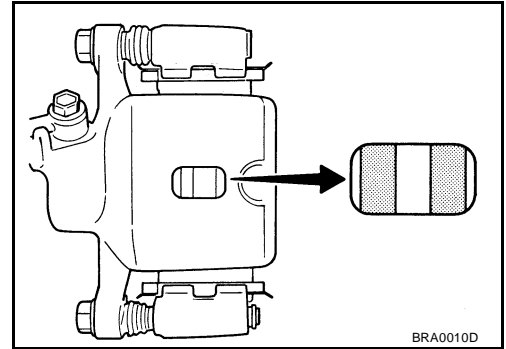

E  
F  
G  
H

## Checking Drum Brake WHEEL CYLINDER

Check operation and for leakage.

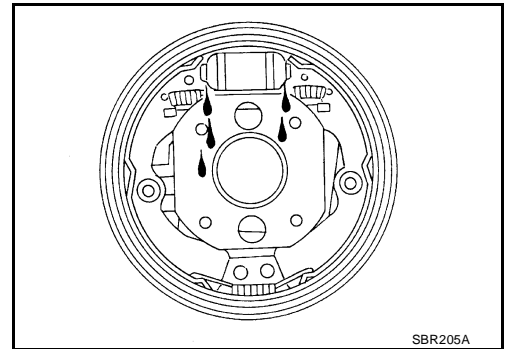

I  
J  
K

## DRUM

Check condition of inner surface.

**Standard diameter** : 203.2 mm (8.000 in)  
**Maximum inner diameter** : 204.5 mm (8.051 in)

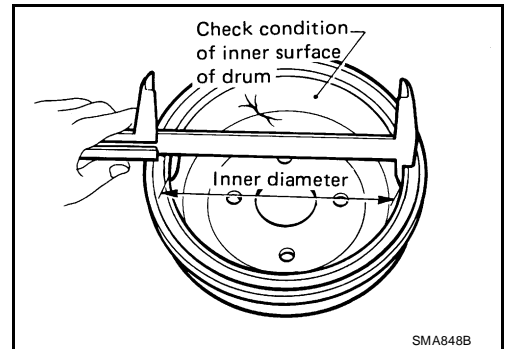

M

MA

# CHASSIS AND BODY MAINTENANCE

## LINING

Measure wear and check for damage.

**Standard thickness** : 4.5 mm (0.177 in)

**Minimum thickness** : 1.5 mm (0.059 in)

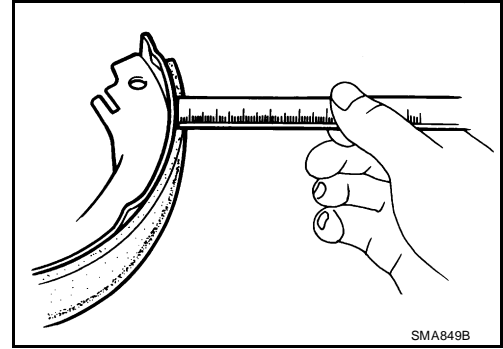

## Checking Steering Gear and Linkage

### STEERING GEAR

- Check gear housing and boots for looseness, damage and grease leakage.
- Check connection with steering column for looseness.

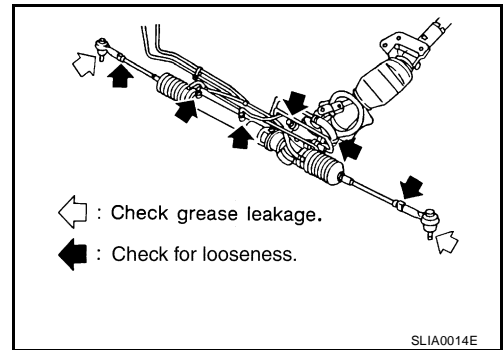

### STEERING LINKAGE

- Check ball joint, dust cover and other component parts for looseness, wear, damage and grease leakage.

## Checking Power Steering Fluid and Lines

### CHECKING FLUID LEVEL

- Check fluid level with engine off.
- Use the correct range of the tank depending on the fluid temperature. Use "HOT" range at fluid temperatures of 50 to 80°C (122 to 176°F). Use "COLD" range at fluid temperatures of 0 to 30°C (32 to 86°F).

### CAUTION:

- Do not overfill.
- Recommended fluid is Genuine NISSAN PSF II or equivalent.

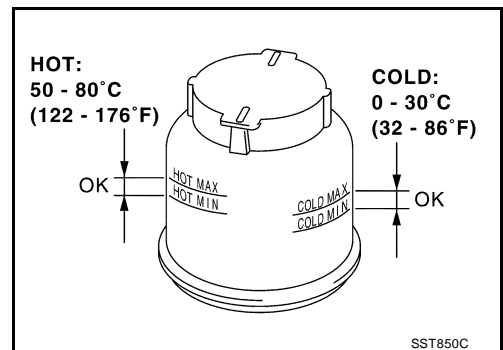

### CHECKING LINES

- Check lines for improper attachment, leaks, cracks, damage, loose connections, chafing and deterioration.
- Check rack boots for accumulation of power steering fluid.

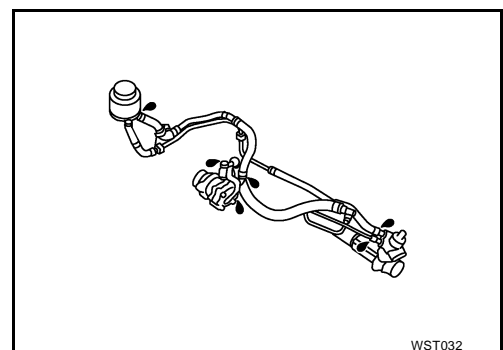

# CHASSIS AND BODY MAINTENANCE

## Axle and Suspension Parts

ELS000AD

Check front and rear axle and suspension parts for excessive play, cracks, wear, or other damage.

- Shake each wheel to check for excessive play.
- Rotate each wheel to check for abnormal noise.
- Check axle and suspension nuts and bolts for looseness.
- Check strut (shock absorber) for oil leakage or other damage.
- Check suspension ball joint for grease leakage and ball joint dust cover for cracks or other damage.

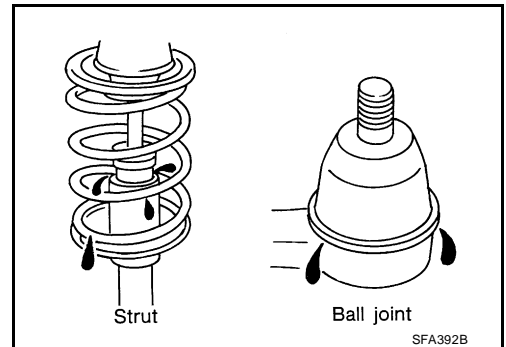
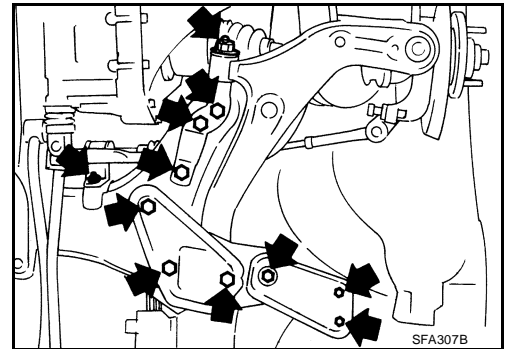
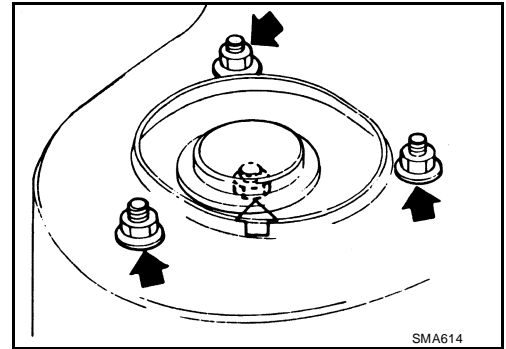
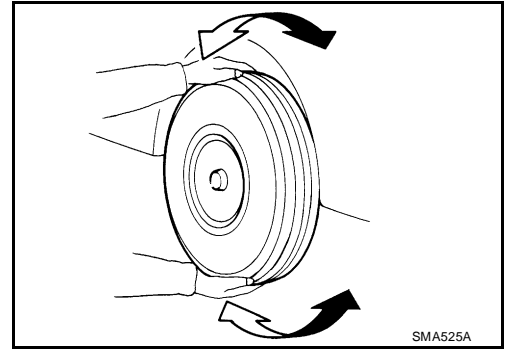

A  
B  
C  
D  
E  
F  
G  
H  
I  
J  
K  
MA  
M

# CHASSIS AND BODY MAINTENANCE

## Drive Shaft

ELS000AE

- Check boot and drive shaft for cracks, wear, damage and grease leakage.

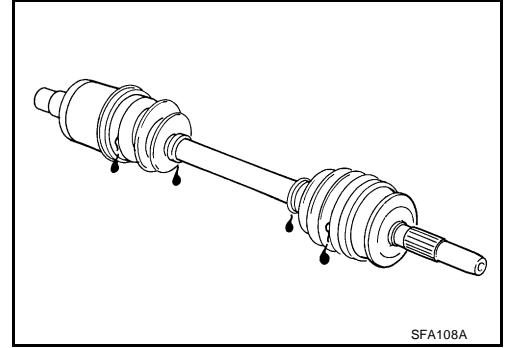

## Lubricating Locks, Hinges and Hood Latches

ELS000AF

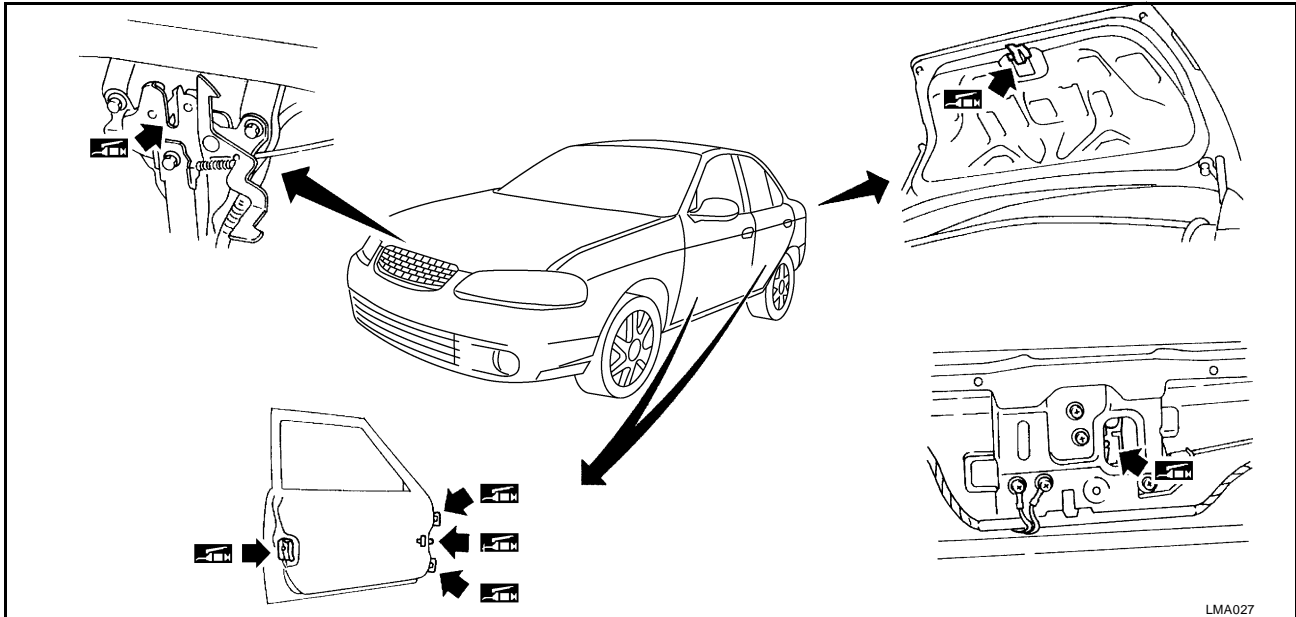

# CHASSIS AND BODY MAINTENANCE

## Checking Seat Belt, Buckles, Retractors, Anchors and Adjusters

ELS000AG

### CAUTION:

- After any collision, inspect all seat belt assemblies, including retractors and other attached hardware (i.e. anchor bolt, guide rail set). Nissan recommends to replace all seat belt assemblies in use during a collision, unless not damaged and properly operating after minor collision. Also inspect seat belt assemblies not in use during a collision, and replace if damaged or improperly operating. Seat belt pre-tensioner should be replaced even if the seat belts are not in use during a frontal collision where the driver and passenger air bags are deployed.
- If any component of seat belt assembly is questionable, do not repair. Replace as seat belt assembly.
- If webbing is cut, frayed, or damaged, replace belt assembly.
- Never oil tongue and buckle.
- Use a Genuine NISSAN seat belt assembly.

For details, refer to "Seat Belt Inspection" in SB section.

### Anchor bolt

 43.1 – 54.9 (4.4 – 5.6, 32 – 40)

 : N·m (kg·m, ft·lb)

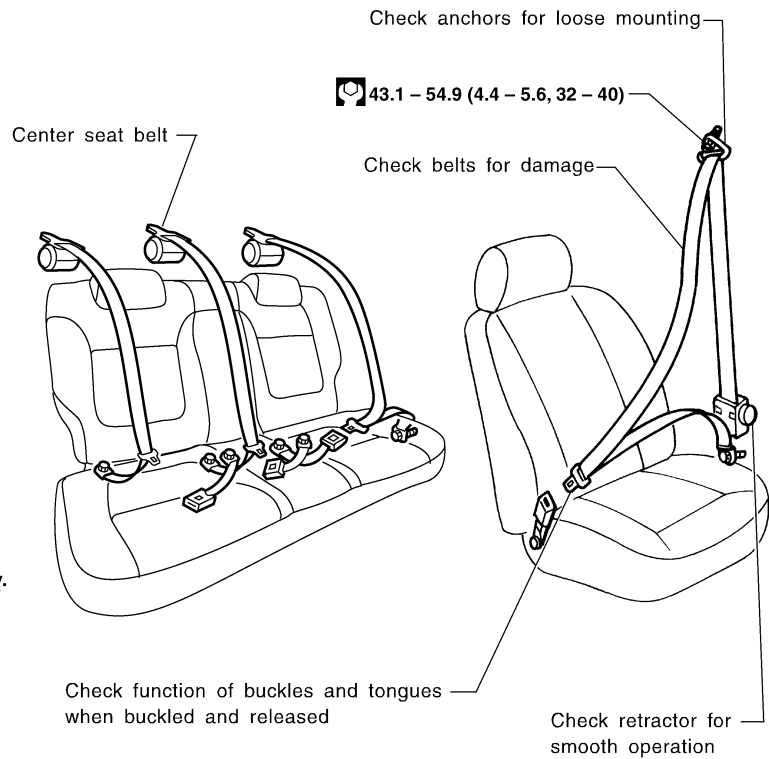

LLIA0020E

A  
B  
C  
D  
E  
F  
G  
H  
I  
J  
K  
L  
M

MA

# SERVICE DATA AND SPECIFICATIONS (SDS)

## SERVICE DATA AND SPECIFICATIONS (SDS)

PF:00030

### Engine Maintenance (QG18DE) BELT DEFLECTION AND TENSION

ELS000AH

Component		Deflection adjustment Unit: mm (in)			Tension adjustment *1 Unit: N (kg, lb)		
		Used Belt		New Belt	Used Belt		New Belt
		Limit	After Adjustment		Limit	After Adjustment	
Generator	With air conditioner compressor	8.1 (0.319)	5.3 - 5.7 (0.209 - 0.244)	4.5 - 5.0 (0.177 - 0.197)	292 (30, 66)	652 - 740 (66.5 - 75.5, 146.6 - 166.4)	789 - 877 (80.5 - 89.5, 177.4 - 197.1)
	Without air conditioner compressor	10.2 (0.402)	6.5 - 7.0 (0.256 - 0.276)	5.5 - 6.1 (0.217 - 0.240)	292 (30, 60)	652 - 740 (66.5 - 75.5, 146.6 - 166.4)	789 - 877 (80.5 - 89.5, 177.4 - 197.1)
Power steering oil pump		7.1 (0.280)	4.4 - 4.9 (0.173 - 0.193)	3.9 - 4.4 (0.154 - 0.173)	196 (20, 44)	495 - 583 (50.5 - 59.5, 111.4 - 131.2)	603 - 691 (61.5 - 70.5, 135.6 - 155.5)
Applied pushing force		98 N (10 kg, 22 lb)			—		

\*1: If the belt tension gauge cannot be installed at check points shown, check belt tension at a different location on the belt.

### SPARK PLUGS (DOUBLE PLATINUM - TIPPED)

Type	Standard	PLFR5A-11
	Hot	PLFR4A-11
	Cold	PLFR6A-11
Plug gap		Nominal: 1.1 mm (0.043 in)

### Engine Maintenance (QR25DE) BELT DEFLECTION AND TENSION

ELS000AI

Tension of drive belts

Auto-adjustment by auto tensioner

### SPARK PLUGS (DOUBLE PLATINUM - TIPPED)

Type	Standard	PLFR5A-11
	Hot	PLFR4A-11
	Cold	PLFR6A-11
Plug gap		Nominal: 1.1 mm (0.043 in)

### Chassis and Body Maintenance WHEEL BALANCE

ELS000AJ

Maximum allowable unbalance	Dynamic (At rim flange) g (oz)	10 (0.35) (one side)
	Static g (oz)	20 (0.71)