

A
CO
C
D
E
F
G
H
I
J
K
L
M

SECTION CO

ENGINE COOLING SYSTEM

CONTENTS

QG18DE	QR25DE
PRECAUTIONS 3	PRECAUTIONS 21
Liquid Gasket Application Procedure 3	Precautions For Liquid Gasket 21
PREPARATION 4	REMOVAL OF LIQUID GASKET 21
Special Service Tools 4	LIQUID GASKET APPLICATION PROCEDURE.. 21
OVERHEATING CAUSE ANALYSIS 5	PREPARATION 22
Troubleshooting Chart 5	Special Service Tools 22
COOLING SYSTEM 7	OVERHEATING CAUSE ANALYSIS 23
Cooling Circuit 7	Troubleshooting Chart 23
ENGINE COOLANT 8	COOLING SYSTEM 25
System Check 8	Cooling Circuit 25
CHECKING COOLING SYSTEM HOSES 8	ENGINE COOLANT 26
CHECKING COOLING SYSTEM FOR LEAKS..... 8	System Check 26
CHECKING RADIATOR 8	CHECKING COOLING SYSTEM HOSES 26
CHECKING RADIATOR CAP 9	CHECKING RESERVOIR LEVEL 26
Refilling Engine Coolant 9	CHECKING COOLING SYSTEM FOR LEAKS... 26
WATER PUMP 10	CHECKING RADIATOR 26
Removal and Installation 10	CHECKING RADIATOR CAP 27
Inspection 11	Refilling Engine Coolant 27
THERMOSTAT AND THERMOSTAT HOUSING 12	WATER PUMP 28
Removal and Installation 12	Removal and Installation 28
Inspection 13	REMOVAL 28
RADIATOR 14	INSPECTION AFTER REMOVAL 29
Removal and Installation 14	INSTALLATION 29
REMOVAL 14	INSPECTION AFTER INSTALLATION 29
INSTALLATION 14	THERMOSTAT AND THERMOSTAT HOUSING 30
Disassembly and Assembly 15	Removal and Installation 30
PREPARATION 15	REMOVAL 30
DISASSEMBLY 15	INSPECTION AFTER REMOVAL 31
ASSEMBLY 16	INSTALLATION 31
Inspection 18	RADIATOR 32
COOLING FAN 19	Removal and Installation 32
Disassembly and Assembly 19	REMOVAL 32
DISASSEMBLY 19	INSTALLATION 32
ASSEMBLY 19	Disassembly and Assembly 33
SERVICE DATA AND SPECIFICATIONS (SDS) 20	PREPARATION 33
Capacity 20	DISASSEMBLY 33
Thermostat 20	ASSEMBLY 34
Radiator 20	Inspection 36

COOLING FAN	37	SERVICE DATA AND SPECIFICATIONS (SDS)	38
Disassembly and Assembly	37	Capacity	38
DISASSEMBLY	37	Thermostat	38
ASSEMBLY	37	Water Control Valve	38
		Radiator	38

PRECAUTIONS

Liquid Gasket Application Procedure

1. Use a scraper to remove all traces of old RTV Silicone Sealant from mating surfaces and grooves. Also, completely clean any oil from these areas.
2. Apply a continuous bead of Genuine RTV Silicone Sealant or equivalent to the mating surfaces. Refer to [GI-44, "RECOMMENDED CHEMICAL PRODUCTS AND SEALANTS"](#).
 - For oil pan, be sure RTV Silicone Sealant diameter is 3.5 to 4.5 mm (0.138 to 0.177 in).
 - For areas except oil pan, be sure RTV Silicone Sealant diameter is 2.0 to 3.0 mm (0.079 to 0.118 in).

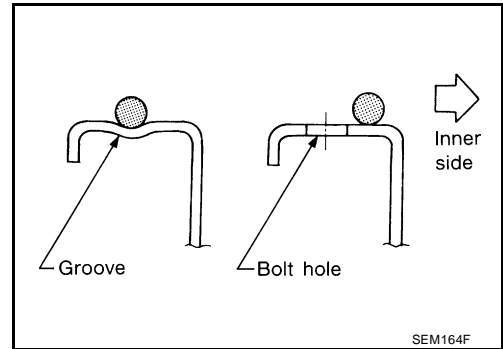

3. Apply RTV Silicone Sealant around the inner side of bolt holes (unless otherwise specified).

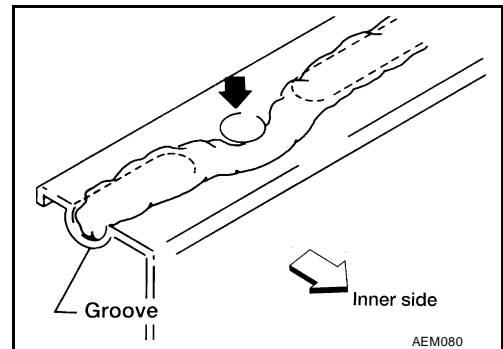

4. Assembly should be done within 5 minutes after coating.
5. Wait at least 30 minutes before refilling the engine with the recommended oil and coolant. Refer to [MA-13, "RECOMMENDED FLUIDS AND LUBRICANTS"](#).

A
CO
C
D
E
F
G
H
I
J
K
L
M

PREPARATION

[QG18DE]



PF0:00002

PREPARATION

Special Service Tools

EBS006BQ

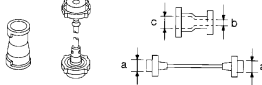
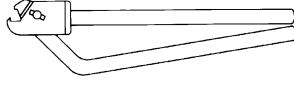
The actual shapes of Kent-Moore tools may differ from those of special service tools illustrated here.

Tool number (Kent-Moore No.) Tool name	Description
EG17650301 (J33984-A) Radiator cap tester adapter  <p style="text-align: right;">NT564</p>	Adapting radiator cap tester to radiator filler neck a: 28 (1.10) via. b: 31.4 (1.236) via. c: 41.3 (1.626) via. Unit: mm (in)
KV99103510 (—) Radiator plate pliers A  <p style="text-align: right;">S-NT224</p>	Installing radiator upper and lower tanks
KV99103520 (—) Radiator plate pliers B  <p style="text-align: right;">S-NT225</p>	Removing radiator upper and lower tanks

OVERHEATING CAUSE ANALYSIS

[QG18DE]

OVERHEATING CAUSE ANALYSIS

PFP:00012

Troubleshooting Chart

EBS006BR

	Symptom		Check items		
Cooling system parts malfunction	Poor heat transfer	Water pump malfunction	Worn or loose drive belt	—	CO
		Thermostat stuck closed	Coolant circulation		
		Damaged fins	Dust contamination or paper clogging		
			Mechanical damage		
	Reduced air flow	Clogged radiator cooling tube	Excess foreign material (rust, dirt, sand, etc.)	—	D
		Cooling fan does not operate	Engine cooling fans		
		High resistance to fan rotation			
		Damaged fan blades			
	Engine runs hot	Damaged radiator shroud	Radiator shroud	—	E
		Improper coolant mixture ratio	Coolant quality, viscosity	—	F
	Poor coolant quality	—		G	
	Insufficient coolant	Coolant leaks	Cooling hose	Loose clamp	H
				Cracked hose	
			Water pump	Poor sealing	I
				Loose	
			Radiator cap	Poor sealing	J
O-ring for damage, deterioration or improper fitting					
Radiator		Cracked radiator tank	K		
		Cracked radiator core			
Reservoir tank	Cracked reservoir tank	L			
	Exhaust gas leaks into cooling system				
Overflowing reservoir tank	Exhaust gas leaks into cooling system	Cylinder head deterioration	M		
		Cylinder head gasket deterioration			

OVERHEATING CAUSE ANALYSIS

[QG18DE]

	Symptom		Check items	
Except cooling system parts malfunction	Over heating engine	Overload on engine	Abusive driving	High engine RPM under no load
				Driving in low gear for extended time
				Driving at extremely high speed
			Powertrain system malfunction	—
			Installed improper size wheels and tires	
			Dragging brakes	
	Improper ignition timing			
	Blocked or restricted air flow	Blocked bumper	—	—
		Blocked radiator grille	Installed car brassiere	
			Mud, debris or paper clogging	
Blocked radiator		Dirty radiator		
Blocked condenser		Dirty condenser		
Blockage in front of radiator	Installed large fog lamp			

COOLING SYSTEM

[QG18DE]

COOLING SYSTEM

PFP:21020

Cooling Circuit

EBS006BS

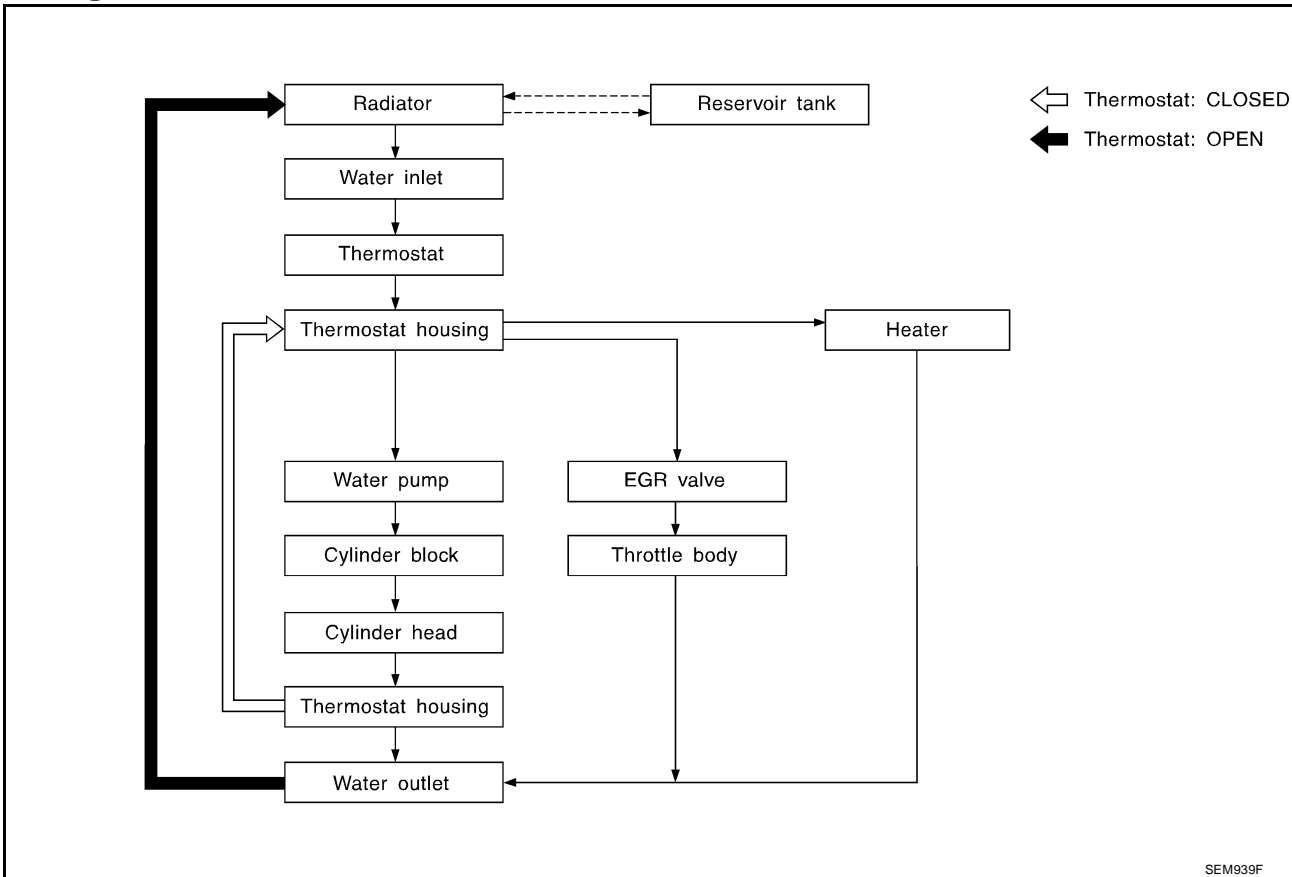

A

CO

C

D

E

F

G

H

I

J

K

L

M

ENGINE COOLANT

System Check

WARNING:

Never remove the radiator cap when the engine is hot. Serious burns could occur from high pressure fluid escaping from the radiator.

Wrap a thick cloth around the cap. Slowly push down and turn it a quarter turn to allow built-up pressure to escape. Carefully remove the cap by pushing down and turning it all the way.

CHECKING COOLING SYSTEM HOSES

Check hoses for the following:

- Improper attachment
- Leaks
- Cracks
- Damage
- Loose connections
- Chafing
- Deterioration

CHECKING COOLING SYSTEM FOR LEAKS

To check for leakage, apply pressure to the cooling system with a tester.

Testing pressure : 157 kPa (1.6 kg/cm² , 23 psi)

CAUTION:

Higher pressure than specified may cause radiator damage.

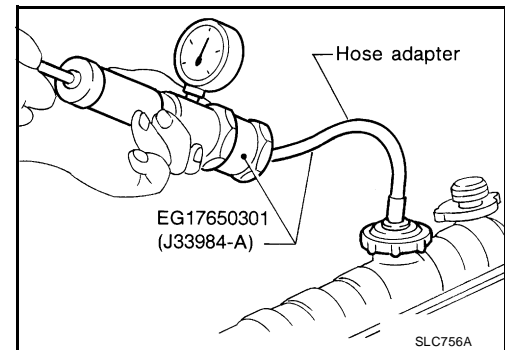

CHECKING RADIATOR

Check radiator for mud or clogging. If necessary, clean radiator as follows.

- Be careful not to bend or damage the radiator fins.
 - When radiator is cleaned without removal, remove all surrounding parts such as cooling fan, radiator shroud and horns. Then tape the harness and connectors to prevent water from entering.
1. Apply water by hose to the back side of the radiator core vertically downward.
 2. Apply water again to all radiator core surfaces once per minute.
 3. Stop washing when clear water flows off of the radiator.
 4. Blow air into the back side of radiator core vertically downward.
 - Use compressed air lower than 490 kPa (5 kg/cm² , 71 psi) and keep distance more than 300 mm (11.8 in).
 5. Blow air again into all the radiator core surfaces once per minute until no water sprays out.

CHECKING RADIATOR CAP

- To check radiator cap, apply pressure to cap with a tester.
Radiator cap relief pressure
Standard : 78 - 98 kPa (0.8 - 1.0 kg/cm² , 11 - 14 psi)
Limit : 59 - 98 kPa (0.6 - 1.0 kg/cm² , 9 - 14 psi)

- Pull the negative pressure valve to open it.
Check that it closes completely when released.

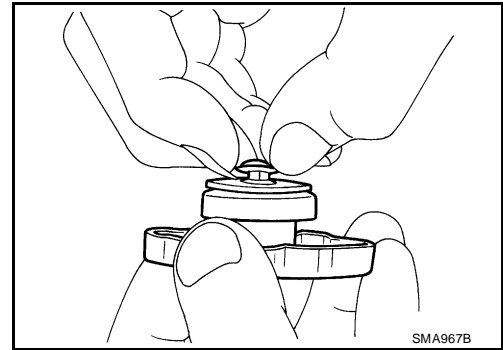
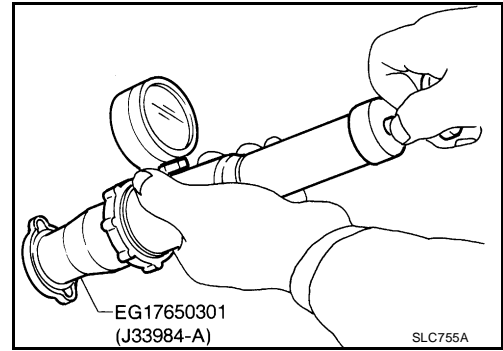

EBS006BU

Refilling Engine Coolant

Changing the engine coolant is part of the required maintenance of the engine. Refer to [MA-16, "REFILLING ENGINE COOLANT"](#).

WATER PUMP

Removal and Installation

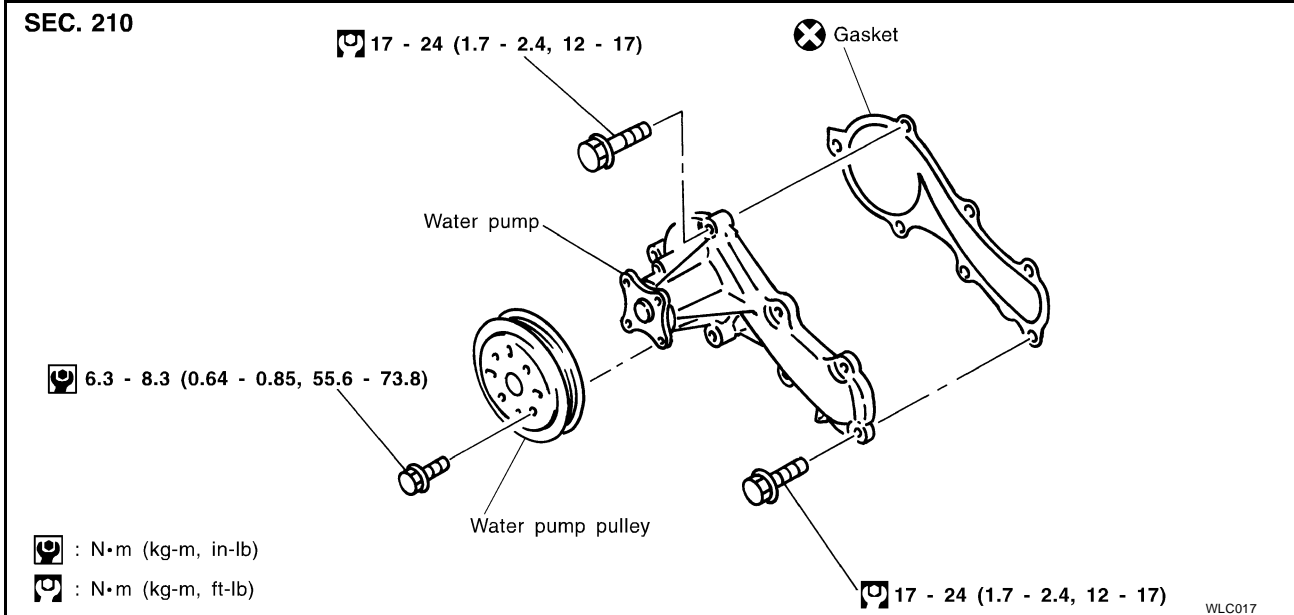

CAUTION:

- When removing water pump assembly, be careful not to get coolant on drive belt.
 - Water pump cannot be disassembled and should be replaced as a unit.
 - After installing water pump, check for leaks using radiator cap tester. Refer to [CO-8, "CHECKING COOLING SYSTEM FOR LEAKS"](#).
1. Drain engine coolant.
Refer to [MA-15, "DRAINING ENGINE COOLANT"](#).

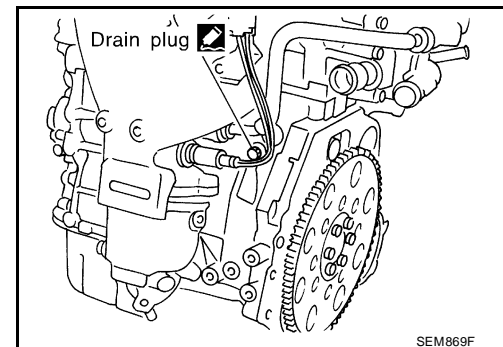
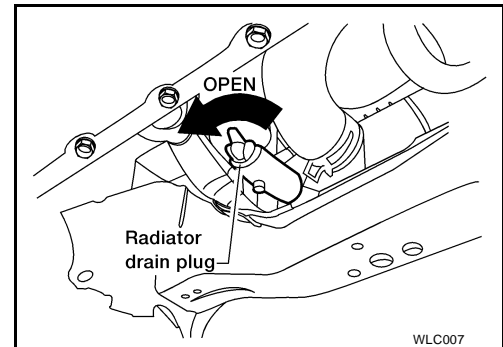

2. Remove front RH wheel.
3. Remove engine side cover.
4. Remove drive belts and idler pulley.
5. Loosen water pump pulley bolts.
6. Remove water pump pulley.

WATER PUMP

[QG18DE]

7. Remove the water pump bolts.
8. Remove the water pump.
 - Remove RTV Silicone Sealant from water pump and mating surface of cylinder block using a scraper.
9. Installation is in the reverse order of removal.
 - When applying RTV Silicone Sealant to mating surface of water pump, use Genuine RTV Silicone Sealant or equivalent. Refer to [GI-44, "RECOMMENDED CHEMICAL PRODUCTS AND SEALANTS"](#) .
 - When filling radiator with coolant, refer to [MA-16, "REFILLING ENGINE COOLANT"](#) .
 - When installing drive belts, refer to [MA-15, "Checking Drive Belts"](#) .

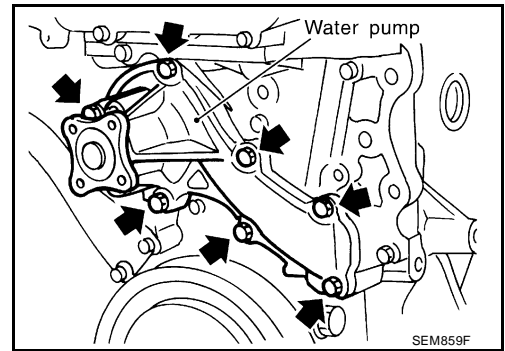

Inspection

1. Rotate water pump shaft, replace the water pump as necessary.
 - **Check body assembly and vane for rust or corrosion.**
 - **Check for rough operation due to excessive end play.**

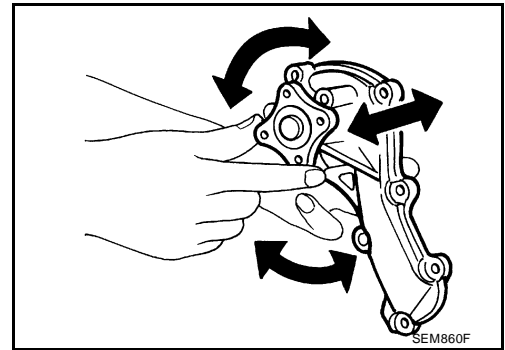

A

CO

C

D

E

F

G

H

I

J

K

L

M

THERMOSTAT AND THERMOSTAT HOUSING

Removal and Installation

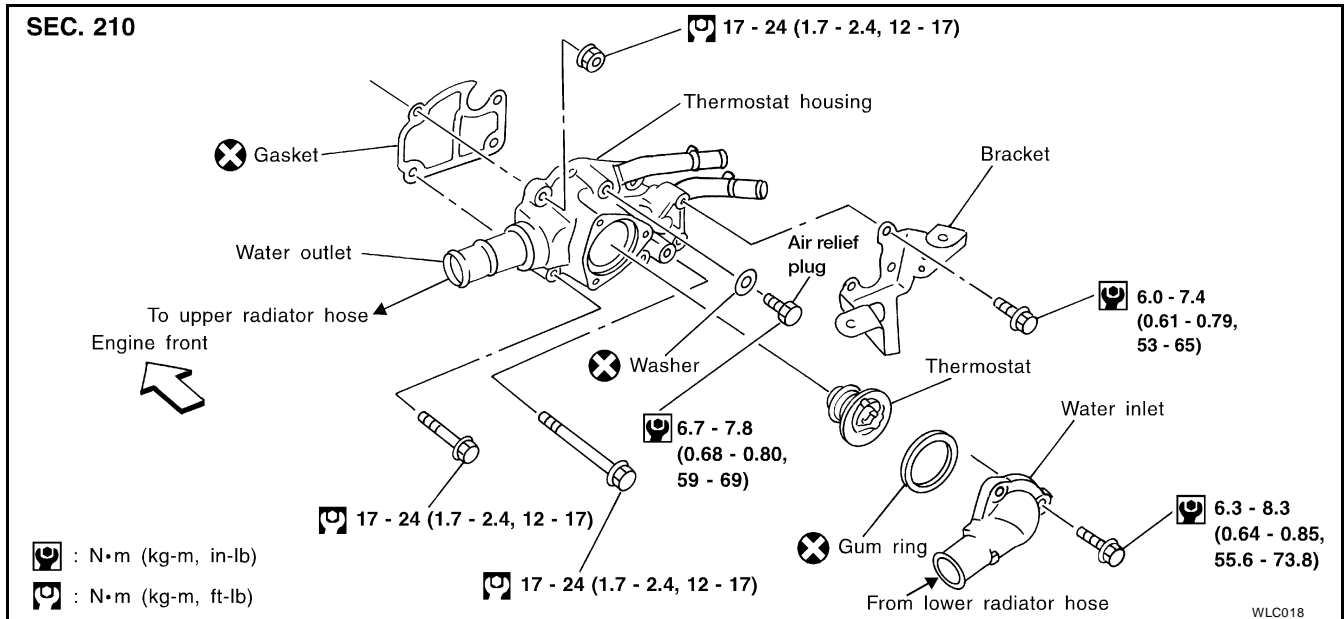

CAUTION:

Be careful not to spill coolant over the engine compartment. Use a rag to absorb any spilled coolant.

1. Drain engine coolant. Refer to [MA-15, "DRAINING ENGINE COOLANT"](#) .
2. Disconnect the lower radiator hose.
3. Remove water inlet thermostat housing, then remove the thermostat.
4. Before installing the thermostat, make sure the gum ring is properly seated around the thermostat.

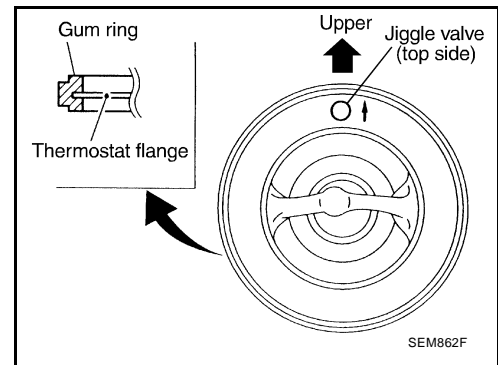

5. Install thermostat with jiggle valve or air bleeder at upper side.
 6. Refill engine coolant. Refer to [MA-16, "REFILLING ENGINE COOLANT"](#) .
- After installation, run engine for a few minutes, and check for any coolant leaks.**

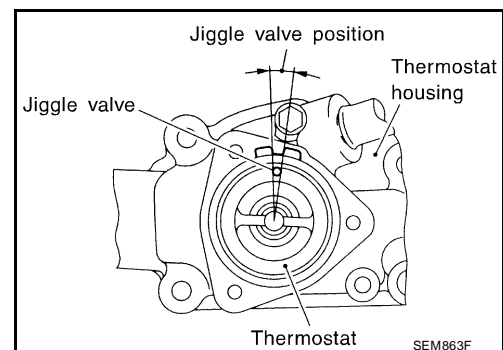

EBS006BY

Inspection

1. Check for valve seating condition at normal room temperature. The valve should seat tightly all the way around. If the valve is warped or stuck open, replace the thermostat.
2. Suspend the thermostat, by a string caught in the closed valve, in boiling water while monitoring the temperature.

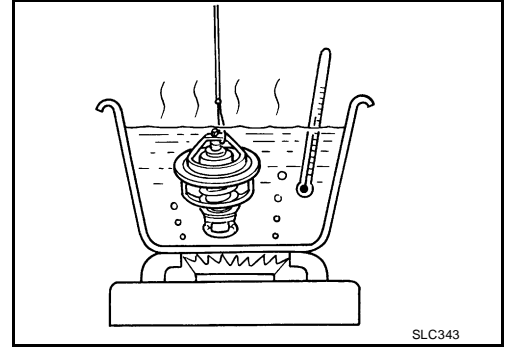

Valve opening temperature °C (°F)	76.5° (170°)
Valve lift mm/°C (in/°F)	More than 9/90° (0.35/194°)

3. Check the temperature at which the valve begins to open and falls from the string. Check the total valve lift when the valve opens completely.
4. Then check if valve closes at 5°C (41°F) below valve opening temperature.

A
CO
C
D
E
F
G
H
I
J
K
L
M

RADIATOR

PF21400

Removal and Installation

EBS006BZ

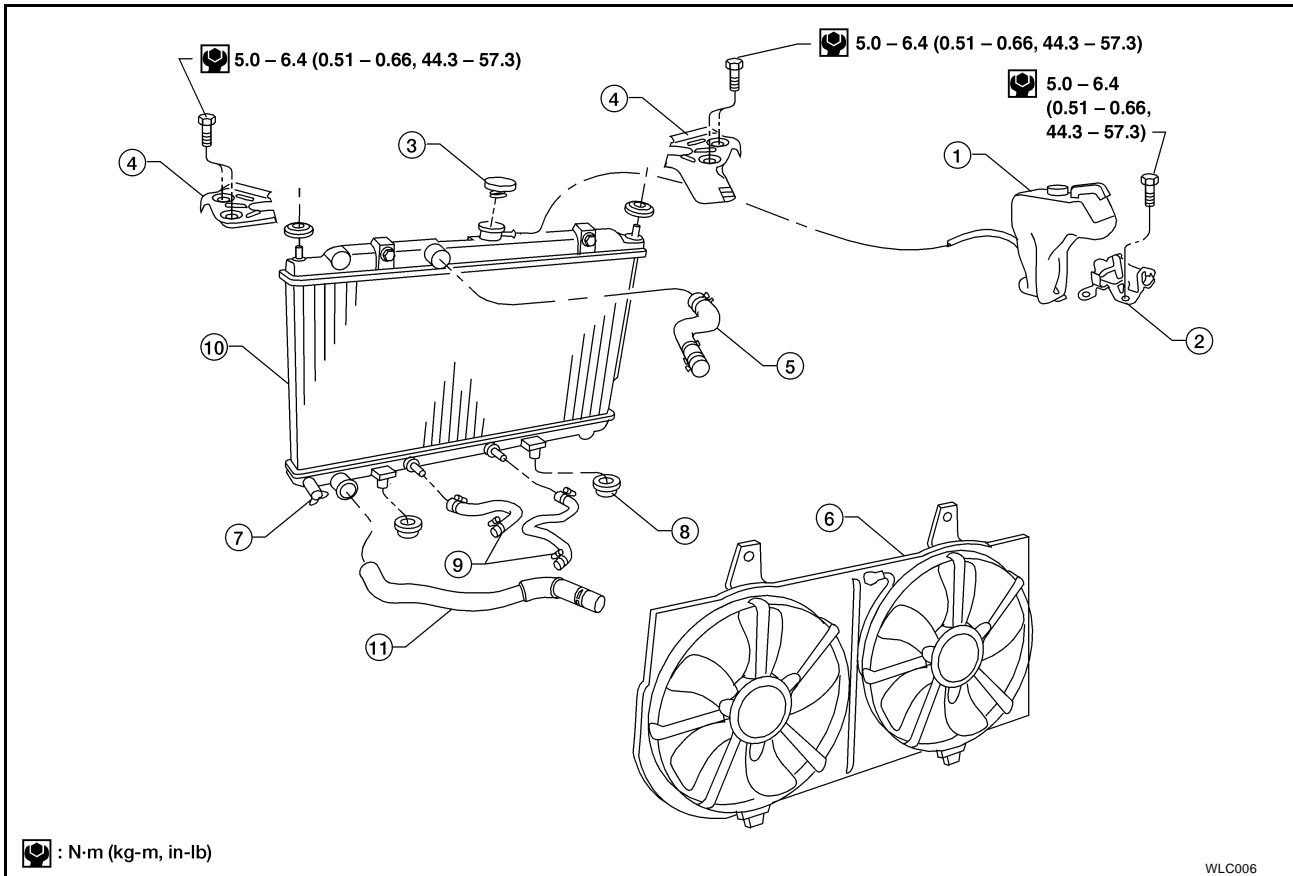

- | | | |
|------------------------|---------------------------|---------------------------------|
| 1. Reservoir tank | 2. Reservoir tank bracket | 3. Radiator cap |
| 4. Mounting bracket | 5. Upper radiator hose | 6. Cooling fans |
| 7. Radiator drain plug | 8. Mounting rubber | 9. Oil cooler hose (A/T models) |
| 10. Radiator | 11. Lower radiator hose | |

WARNING:

Never remove the radiator cap when the engine is hot. Serious burns can occur from high pressure coolant escaping from the radiator. Wrap a thick cloth around the cap. Slowly push down and turn it a quarter of a turn to allow the built-up pressure to escape. Carefully remove the cap by pushing down and turning it the rest of the way.

REMOVAL

1. Drain engine coolant. Refer to [MA-15, "DRAINING ENGINE COOLANT"](#).
2. Remove the air duct and air cleaner assembly.
3. Disconnect the A/T oil cooler hoses (if equipped) and install a blind plug in the hoses to prevent A/T oil loss.
4. Disconnect the upper and lower radiator hoses and mounting bracket.
5. Remove the radiator and radiator fan assembly as one unit.

CAUTION:

Do not damage or scratch the radiator core when removing.

INSTALLATION

1. Installation is in the reverse order of removal.

Disassembly and Assembly

SEC. 214

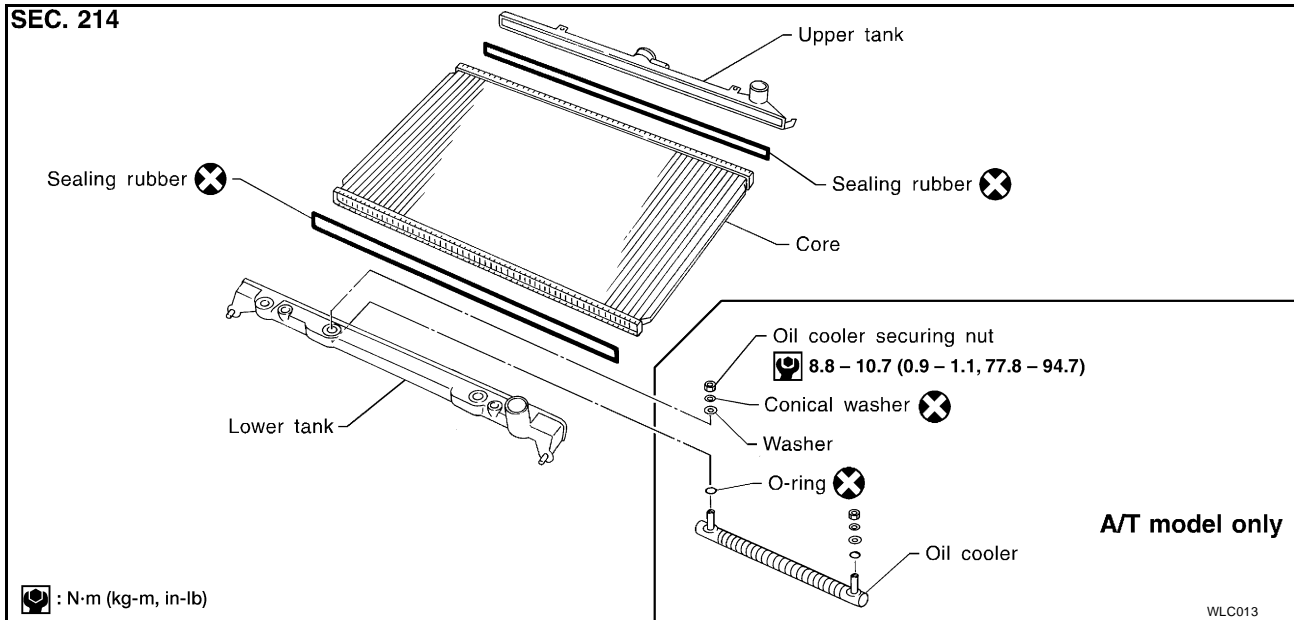

PREPARATION

1. Attach the spacer to the tip of the radiator plate pliers A. Spacer specification: 1.5 mm (0.059 in) thick x 18 mm (0.71 in) wide x 8.5 mm (0.335 in) long.
2. Make sure that when radiator plate pliers A are closed dimension H'' is approx. 7.6 mm (0.299 in).
3. Adjust dimension H'' with the spacer, if necessary.

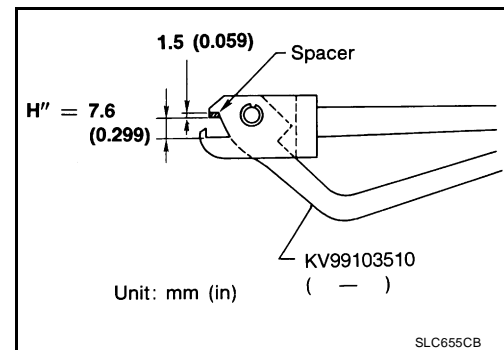

DISASSEMBLY

1. Remove tank with Tool.

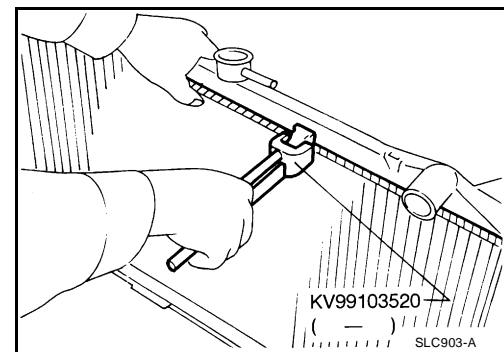

- Grip the crimped edge and bend it upwards so that Tool slips off.

Do not bend excessively.

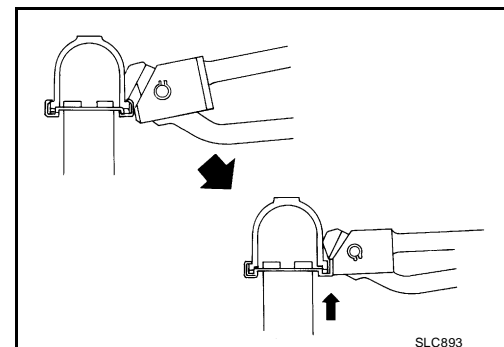

RADIATOR

[QG18DE]

- In areas where Tool cannot be used, use a screwdriver to bend the edge up.
Be careful not to damage tank.

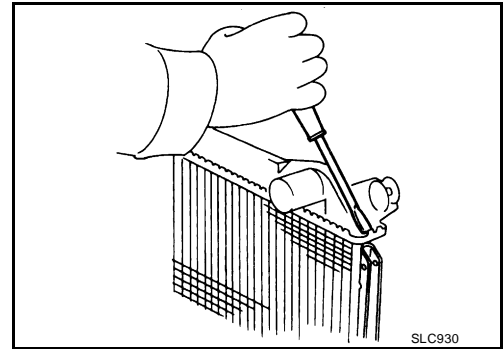

2. Make sure the edge stands straight up.
3. Remove oil cooler from tank (A/T model only).

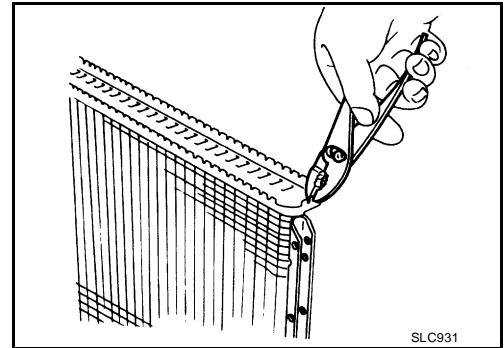

ASSEMBLY

1. Install oil cooler (A/T model only).
- **Pay attention to direction of conical washer.**

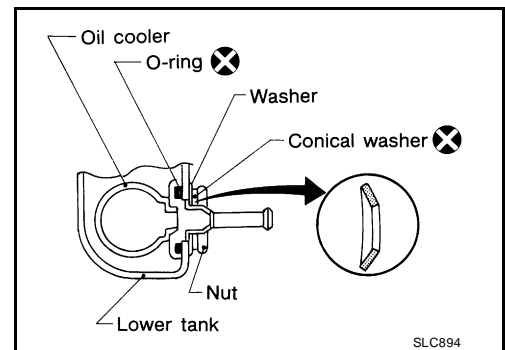

2. Clean contact portion of tank.

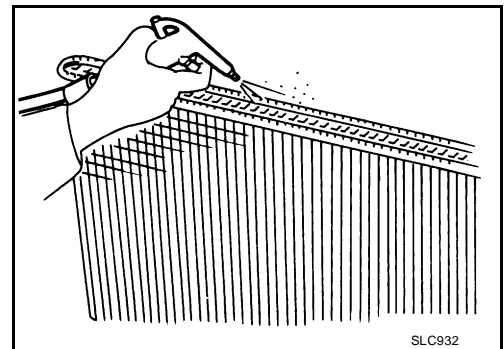

RADIATOR

[QG18DE]

3. Install sealing rubber.
 - Push it in with fingers.
 - Be careful not to twist sealing rubber.

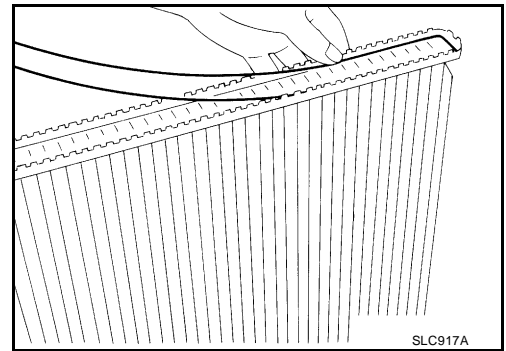

4. Crimp the tank rim in a specified sequence with the Tool.

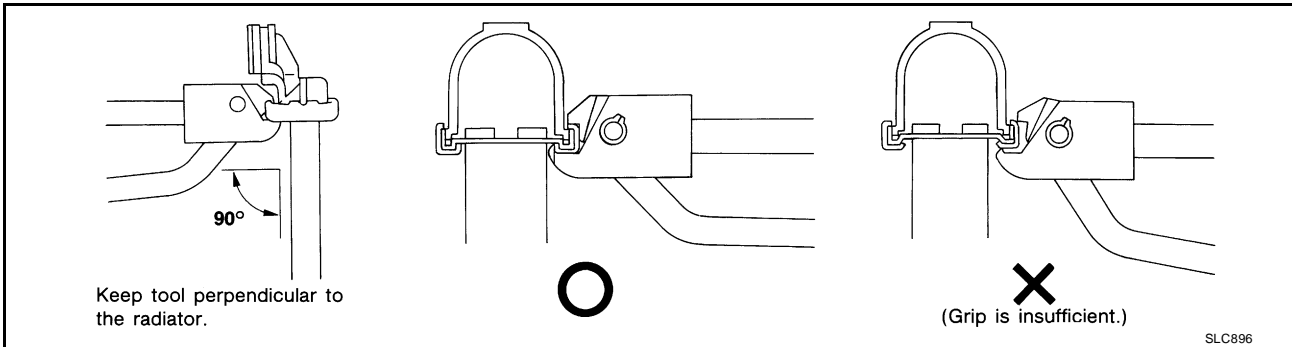
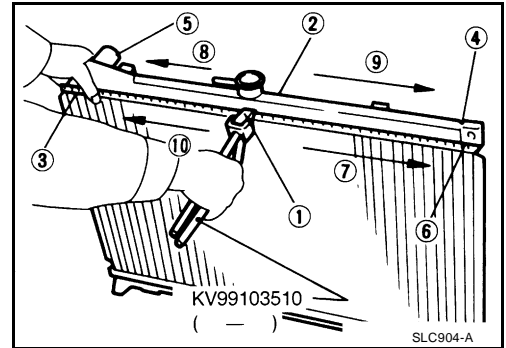

- Use pliers in the locations where the Tool cannot be used.

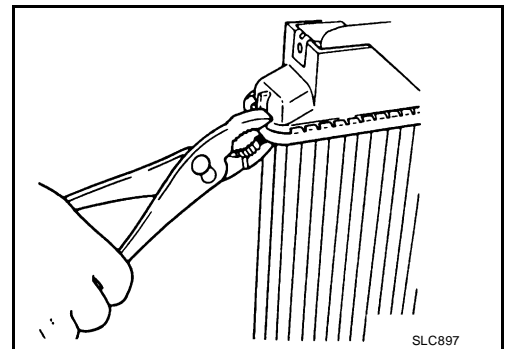

5. Make sure that the tank rim is completely crimped down.
Standard height "H" : 8.0 - 8.4 mm (0.315 - 0.331 in)
6. Check for any coolant leakage. Refer to [CO-8, "CHECKING COOLING SYSTEM FOR LEAKS"](#).

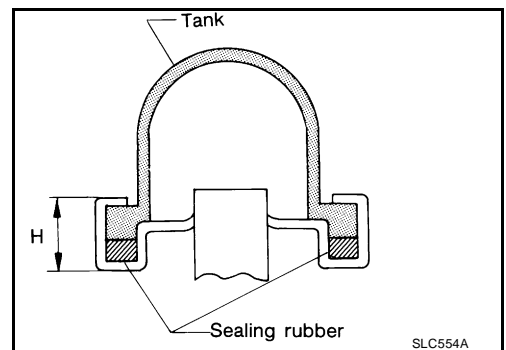

A
CO
C
D
E
F
G
H
I
J
K
L
M

Inspection

1. Apply pressure with Tool.

Specified pressure : 157 kPa (1.6 kg/cm² , 23 psi)

WARNING:

To prevent the risk of the hose coming undone while under pressure, securely fasten it down with a hose clamp.

Attach a hose to the oil cooler as well (A/T model only).

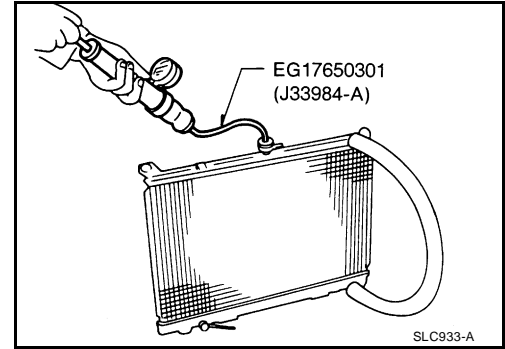

2. Check for leaks in dip tank.

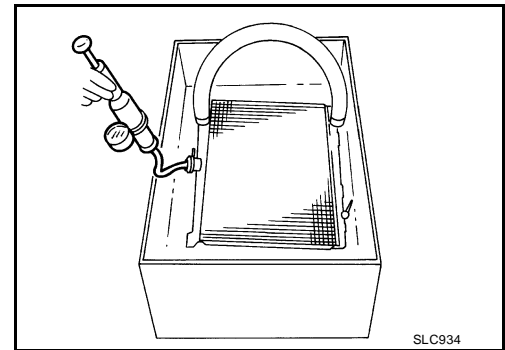

COOLING FAN

Disassembly and Assembly

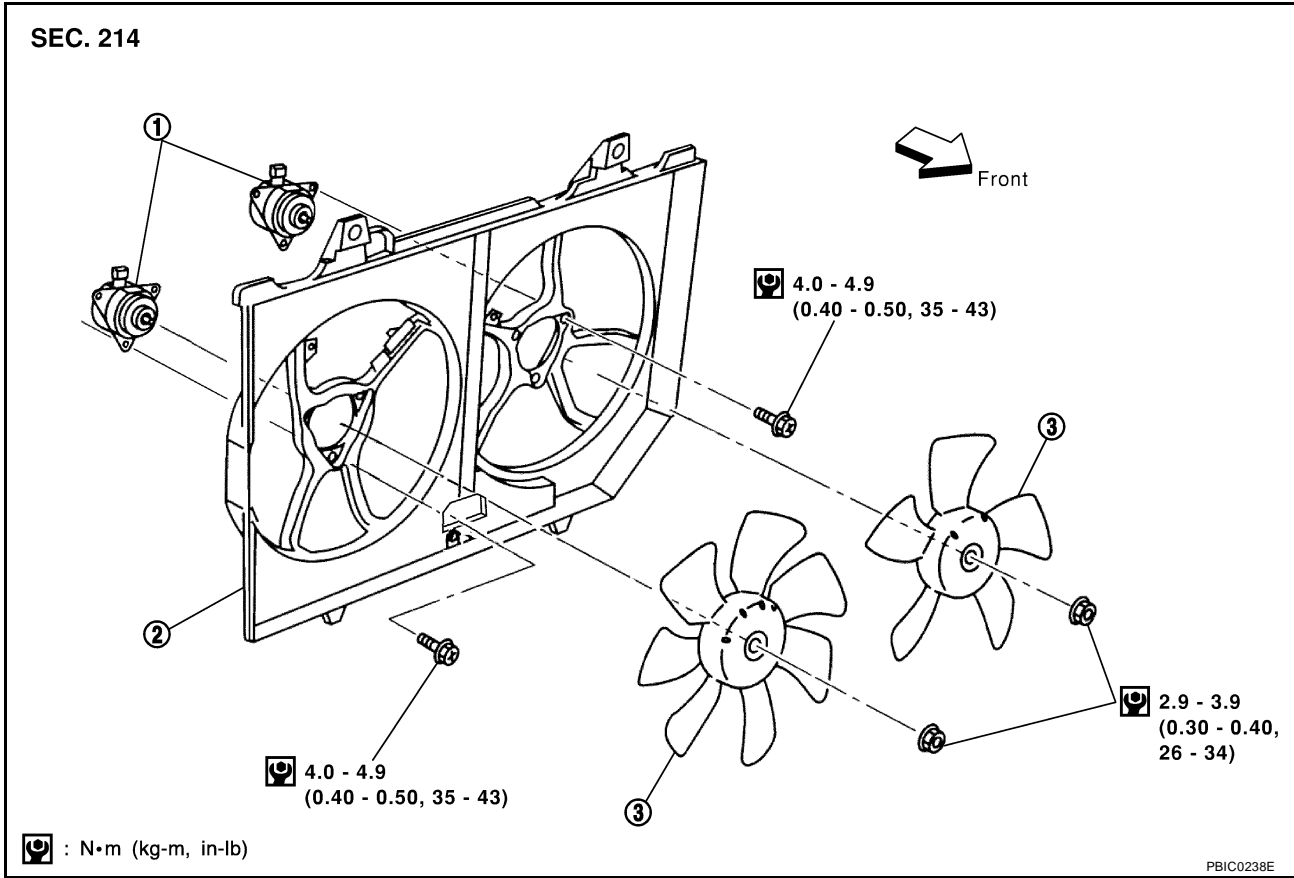

1. Cooling fan motors

2. Cooling fan shroud

3. Cooling fan blades

DISASSEMBLY

1. Remove the radiator and cooling fan assembly. Refer to [CO-14, "Removal"](#).
2. Remove the cooling fan shroud assembly from the radiator.
3. Remove the cooling fan blades from the shroud.
4. Remove cooling fan motors from the shroud.

ASSEMBLY

- Assembly is in the reverse order of disassembly.

SERVICE DATA AND SPECIFICATIONS (SDS)

[QG18DE]

SERVICE DATA AND SPECIFICATIONS (SDS)

PF0:00030

Capacity

EBS00G44

Coolant capacity (without reservoir tank)	A/T	5.9 ℓ (6 1/4 qt.)
	M/T	6.0 ℓ (6 3/8 qt.)
Reservoir tank coolant capacity (at MAX level)		0.7 ℓ (3/4 qt.)

Thermostat

EBS006C3

Valve opening temperature °C (°F)	76.5° (170°)
Valve lift mm/°C (in/°F)	More than 9/90° (0.35/194°)

Radiator

EBS006C4

Unit: kPa (kg/cm², psi)

Cap relief pressure	Standard	78 - 98 (0.8 - 1.0, 11 - 14)
	Limit	59 - 98 (0.6 - 1.0, 9 - 14)
Leakage test pressure		157 (1.6, 23)

PRECAUTIONS

Precautions For Liquid Gasket REMOVAL OF LIQUID GASKET

- After removing the mounting bolts and nuts, disconnect and remove the RTV Silicone Sealant using a seal cutter.

CAUTION:

Be careful not to damage the mating surfaces.

- In areas where the cutter is difficult to use, use a plastic hammer to lightly tap the gasket applied area.

CAUTION:

If for some unavoidable reason a tool such as a flat-blade screwdriver is used, be careful not to damage the mating surfaces.

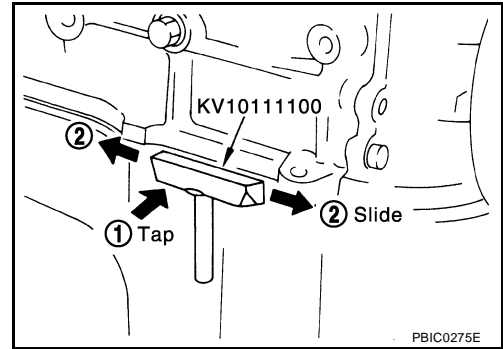

LIQUID GASKET APPLICATION PROCEDURE

- Using a scraper, remove the old RTV Silicone Sealant adhering to the application surface and the mating surface.
 - Remove the RTV Silicone Sealant completely from the groove of the application surface, mounting bolts, and bolt holes.
- Thoroughly clean the application surface and the mating surface to remove adhering moisture, grease and foreign material.
- Attach the RTV Silicone Sealant container to the tube presser. **Use Genuine RTV Silicone Sealant or equivalent. Refer to [GI-44, "RECOMMENDED CHEMICAL PRODUCTS AND SEALANTS"](#).**

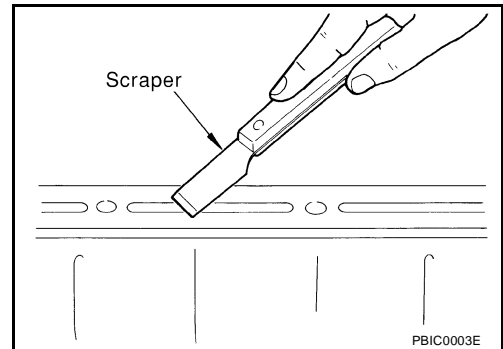

- Apply the RTV Silicone Sealant without breaks to the specified location with the specified dimensions.
 - If there is a groove for the RTV Silicone Sealant application, apply the gasket to the groove.

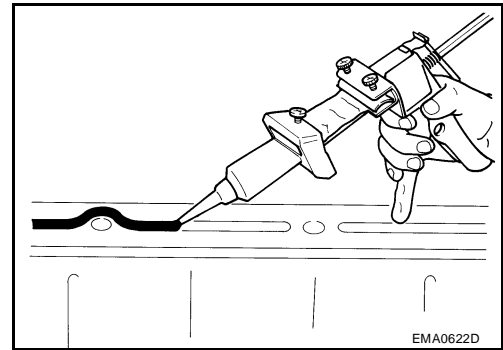

- As for the bolt holes, normally apply the RTV Silicone Sealant inside the holes. Occasionally, it should be applied outside the holes.
- Within five minutes of RTV Silicone Sealant application, install the mating component.
- If the RTV Silicone Sealant protrudes, wipe it off immediately.
- Do not retighten after the installation.
- After 30 minutes or more have passed from the installation, fill the engine with the specified oil and coolant. Refer to [MA-13, "RECOMMENDED FLUIDS AND LUBRICANTS"](#).

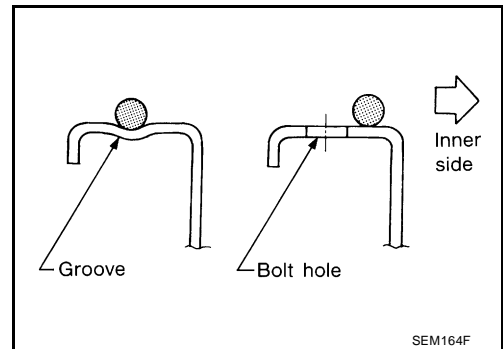

A
C
D
E
F
G
H
I
J
K
L
M

CO

PREPARATION

[QR25DE]

PF0:00002

EBS006C6

PREPARATION

Special Service Tools

The actual shapes of Kent-Moore tools may differ from those of special tools illustrated here.

Tool number (Kent-Moore No.) Tool name	Description
WS39930000 (-) Tube presser	Pressing the tube of liquid gasket
EG17650301 (J33984-A) Radiator cap tester adapter	Adapting radiator cap tester to radiator filler neck a: 28 (1.10) diameter b: 31.4 (1.236) diameter c: 41.3 (1.626) diameter Unit: mm (in)
KV99103510 (-) Radiator plate pliers A	Installing radiator upper and lower tanks
KV99103520 (-) Radiator plate pliers B	Removing radiator upper and lower tanks

OVERHEATING CAUSE ANALYSIS

[QR25DE]

PFP:00012

EBS006C7

OVERHEATING CAUSE ANALYSIS

Troubleshooting Chart

	Symptom		Check items		
Cooling system parts malfunction	Poor heat transfer	Water pump malfunction	Worn or loose drive belt	—	CO
		Thermostat stuck closed	Coolant circulation		
		Damaged fins	Dust contamination or paper clogging		
			Mechanical damage		
	Reduced air flow	Clogged radiator cooling tube	Excess foreign material (rust, dirt, sand, etc.)	—	D
		Cooling fan does not operate	Engine cooling fans		
		High resistance to fan rotation			
		Damaged fan blades			
	Engine runs hot	Damaged radiator shroud	Radiator shroud	—	E
		Improper coolant mixture ratio	Coolant quality, viscosity	—	F
	Poor coolant quality	—		G	
	Insufficient coolant	Coolant leaks	Cooling hose	Loose clamp	H
				Cracked hose	
			Water pump	Poor sealing	I
			Radiator cap	Loose Poor sealing	
Radiator			O-ring for damage, deterioration or improper fitting	J	
			Cracked radiator tank		
		Cracked radiator core			
Reservoir tank		Cracked reservoir tank	K		
Overflowing reservoir tank	Exhaust gas leaks into cooling system	Cylinder head deterioration	L		
		Cylinder head gasket deterioration			

A
C
D
E
F
G
H
I
J
K
L
M

OVERHEATING CAUSE ANALYSIS

[QR25DE]

	Symptom		Check items			
Except cooling system parts malfunction	—	Overload on engine	Abusive driving	High engine rpm under no load		
				Driving in low gear for extended time		
				Driving at extremely high speed		
					Powertrain system malfunction	—
					Installed improper size wheels and tires	
					Dragging brakes	
			Improper ignition timing			
	Blocked or restricted air flow	Blocked bumper	—	—		
		Blocked radiator grille	Installed car brassiere			
			Mud, debris or paper clogging			
Blocked radiator		Dirty condenser				
Blocked condenser		Dirty condenser				
Blockage in front of radiator	Installed large fog lamp					

COOLING SYSTEM

[QR25DE]

PFP:21020

EBS006C8

COOLING SYSTEM

Cooling Circuit

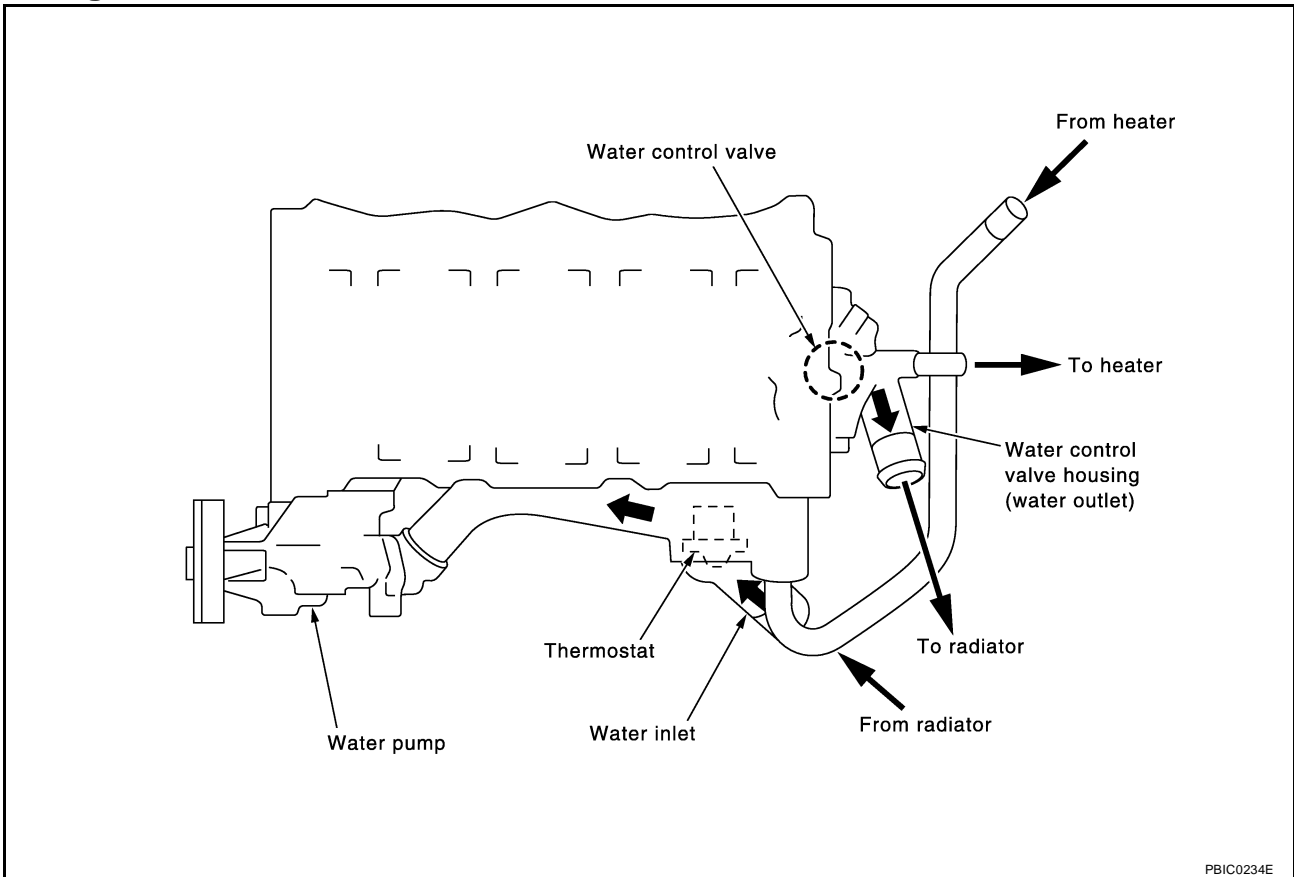

PBIC0234E

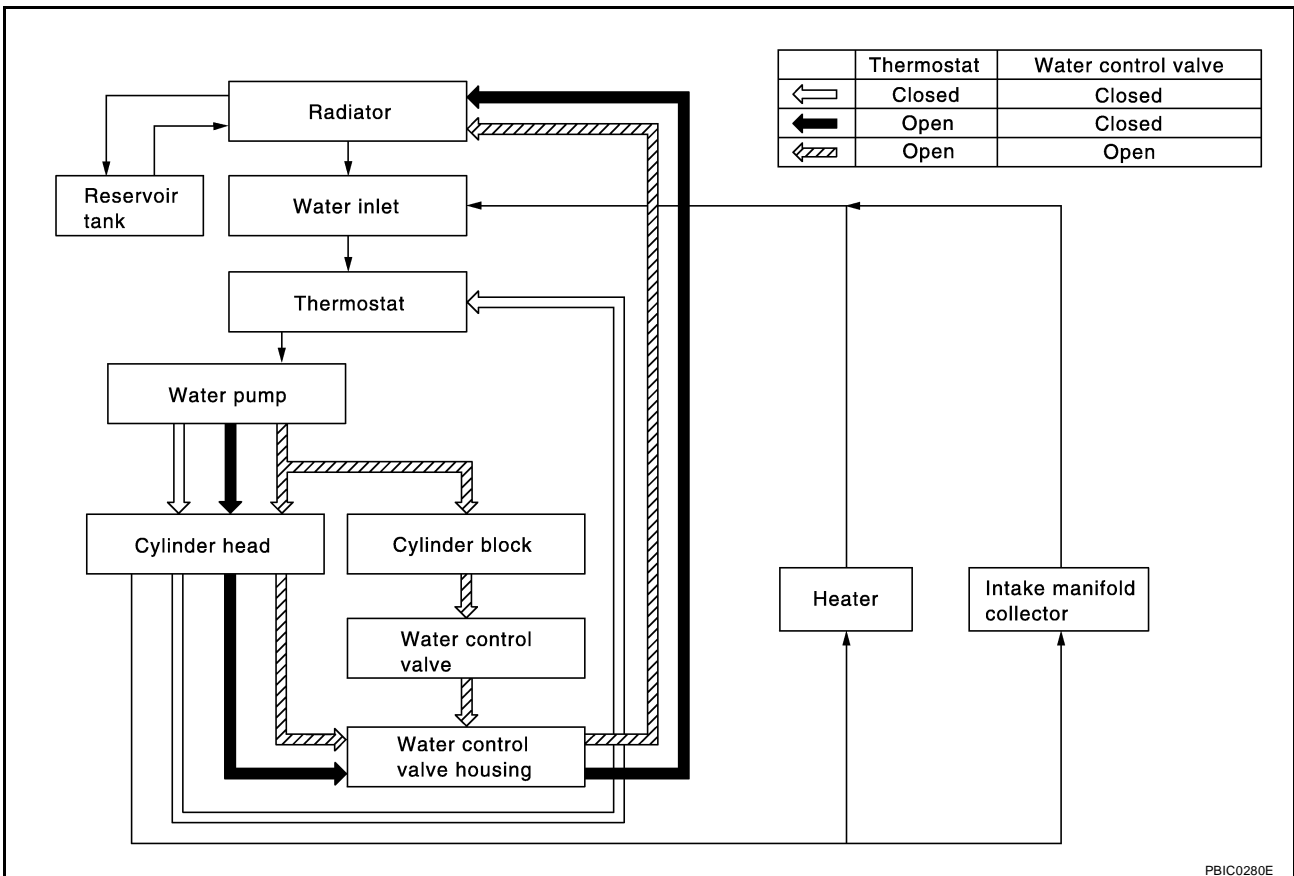

PBIC0280E

ENGINE COOLANT

System Check

WARNING:

Never remove the radiator cap when the engine is hot. Serious burns could occur from high pressure fluid escaping from the radiator.

Wrap a thick cloth around the cap. Slowly push down and turn it a quarter turn to allow built-up pressure to escape. Carefully remove the cap by pushing down and turning it all the way.

CHECKING COOLING SYSTEM HOSES

Check hoses for the following:

- Improper attachment
- Leaks
- Cracks
- Damage
- Loose connections
- Chafing
- Deterioration

CHECKING RESERVOIR LEVEL

- Check if the reservoir tank coolant level is within MIN to MAX when the engine is cool.
- Adjust coolant level if it is too much or too little.

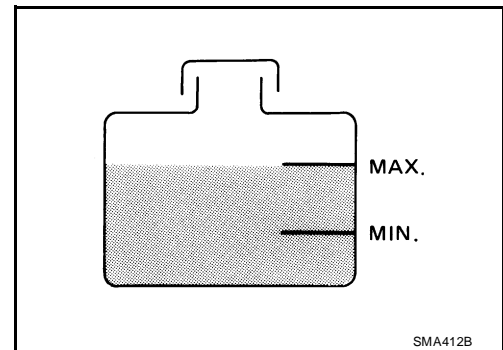

CHECKING COOLING SYSTEM FOR LEAKS

To check for leakage, apply pressure to the cooling system with a tester.

Testing pressure : 157 kPa (1.6 kg/cm² , 23 psi)

WARNING:

Never remove the radiator cap when the engine is hot. Serious burns could occur from high pressure coolant escaping from the radiator.

CAUTION:

Higher pressure than specified may cause radiator damage.

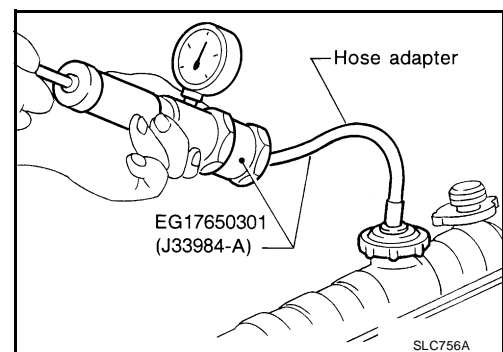

CHECKING RADIATOR

Check radiator for mud or clogging. If necessary, clean radiator as follows.

- Be careful not to bend or damage the radiator fins.
 - When radiator is cleaned without removal, remove all surrounding parts such as cooling fan, radiator shroud and horns. Then tape the harness and connectors to prevent water from entering.
1. Apply water by hose to the back side of the radiator core vertically downward.
 2. Apply water again to all radiator core surfaces once per minute.
 3. Stop washing when clear water flows off of the radiator.
 4. Blow air into the back side of radiator core vertically downward.
 - Use compressed air lower than 490 kPa (5 kg/cm² , 71 psi) and keep distance more than 300 mm (11.8 in).

5. Blow air again into all the radiator core surfaces once per minute until no water sprays out.
6. Check for leakage.

CHECKING RADIATOR CAP

- To check radiator cap, apply pressure to cap with a tester.

Radiator cap relief pressure

Standard : 78 - 98 kPa (0.8 - 1.0 kg/cm² , 11 - 14 psi)

Limit : 59 kPa (0.6 kg/cm² , 14 psi)

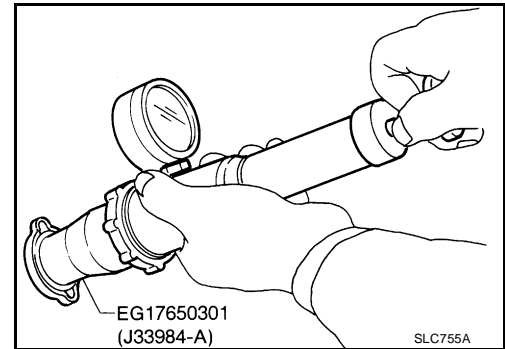

- Pull the negative pressure valve to open it.
- Check that it closes completely when released.

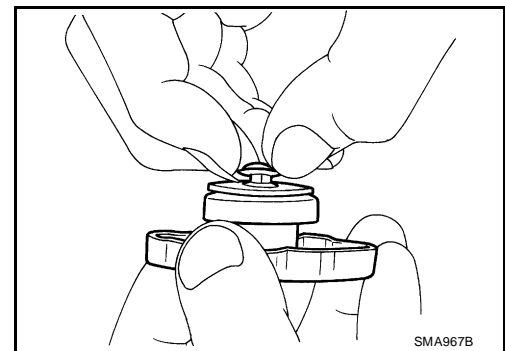

Refilling Engine Coolant

Changing the engine coolant is part of the required maintenance of the engine. Refer to [MA-23, "REFILLING ENGINE COOLANT"](#).

EBS00G46

A
CO
C
D
E
F
G
H
I
J
K
L
M

INSPECTION AFTER REMOVAL

- Visually check that there is no significant dirt or rust on the water pump body and vane.
- Check that there is no play when rotating the vane shaft, and that it turns smoothly when rotated by hand.
- If necessary, replace the water pump as an assembly.

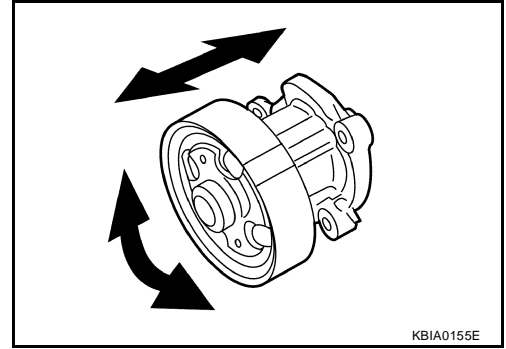

INSTALLATION

Installation is in the reverse order of removal.

NOTE:

When inserting the water pipe end into the thermostat housing, apply coolant to the O-ring seal and install immediately.

INSPECTION AFTER INSTALLATION

After installing the water pump and pipe, check for leaks using the radiator cap tester. Refer to [CO-26, "CHECKING COOLING SYSTEM FOR LEAKS"](#).

A
CO
C
D
E
F
G
H
I
J
K
L
M

THERMOSTAT AND THERMOSTAT HOUSING

PFP:21200

Removal and Installation

EBS006CC

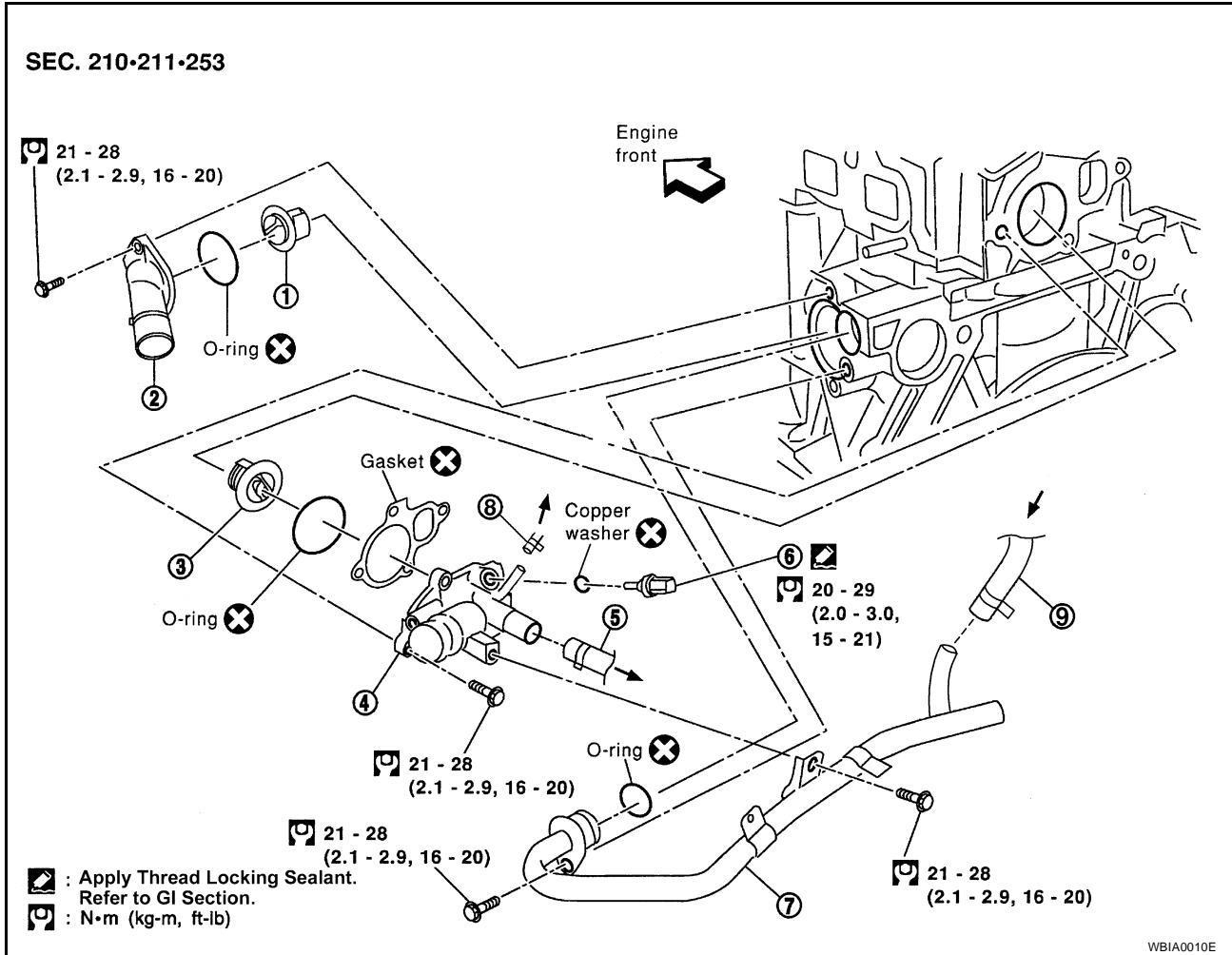

- | | | |
|-------------------------|--------------------------------|---------------------------------|
| 1. Thermostat | 2. Water inlet housing | 3. Water control valve |
| 4. Water outlet housing | 5. Heater hose | 6. Water temperature sensor |
| 7. Heater pipe | 8. Throttle body coolant inlet | 9. Throttle body coolant outlet |

WARNING:

Never remove the radiator cap when the engine is hot. Serious burns could occur from high pressure coolant escaping from the radiator.

CAUTION:

Perform when the engine cold.

REMOVAL

Thermostat

1. Drain engine coolant. Refer to [MA-23, "DRAINING ENGINE COOLANT"](#) .
2. Remove the lower radiator hose from the water inlet housing.
3. Remove the water inlet housing.
4. Remove the thermostat.

Water Control Valve

1. Drain engine coolant. Refer to [MA-23, "DRAINING ENGINE COOLANT"](#) .
2. Remove the upper radiator hose, heater pipe, and heater hose.
3. Remove the water outlet housing.
4. Remove the water control valve.

INSPECTION AFTER REMOVAL

- Place a string so that it is caught in the valve of the thermostat (or water control valve) and suspend it in boiling water. It must be fully immersed in the water.
- The valve opening temperature is the temperature at which the valve plate begins to rise from the top plate causing the thermostat to fall off of the string.
- Continue heating the water and thermostat to check the full-open valve lift distance.

NOTE:

The full-open lift amount standard temperature for the thermostat (water control valve) is the reference value.

- After checking the full-open lift amount, lower the water temperature and check the valve closing temperature.

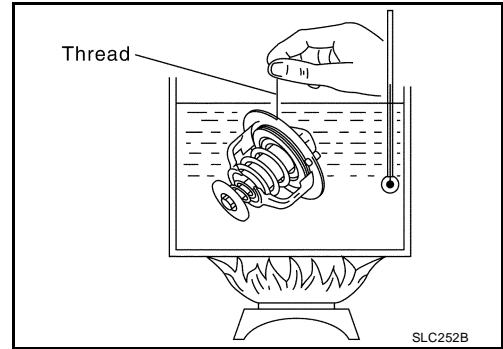

Standard Values

Component	Thermostat	Water control valve
Valve opening temperature	80.5 - 83.5°C (177 - 182° F)	93.5 - 96.5°C (200 - 206°F)
Full-open lift amount	More than 8 mm/ 95°C (0.315 in/ 203 °F)	More than 8 mm/ 108°C (0.315 in/ 226 ° F)
Valve closing temperature	77°C (171°F)	90°C (194° F)

INSTALLATION

- Installation is in the reverse order of removal.

Thermostat and Water Control Valve

- Install the thermostat and water control valve with the whole circumference of each flange fitting securely inside the rubber ring. (The example in the figure shown is the thermostat.)

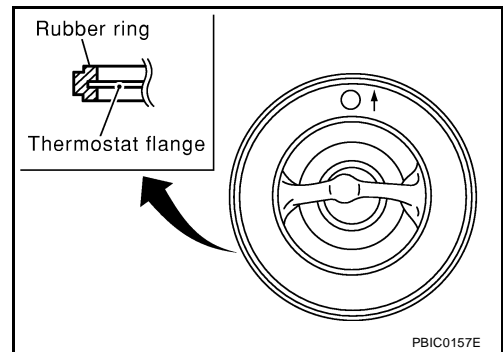

- Install the thermostat with the jiggle-valve facing upwards. (The position deviation may be within the range of $\pm 10^\circ$)
- Install the water control valve with the up-mark facing up and the frame center part facing upwards. The position deviation may be within the range of $\pm 10^\circ$ of vertical.

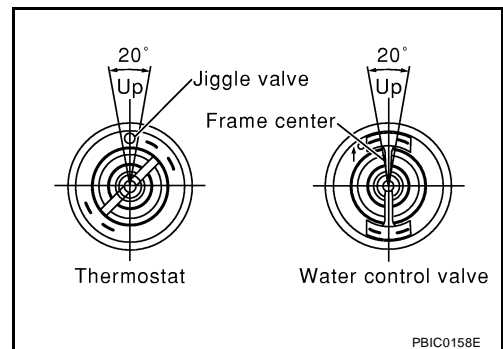

Heater Pipe

- Apply clean coolant to the heater pipe O-ring, and immediately install the heater pipe into the installation holes.

RADIATOR

Removal and Installation

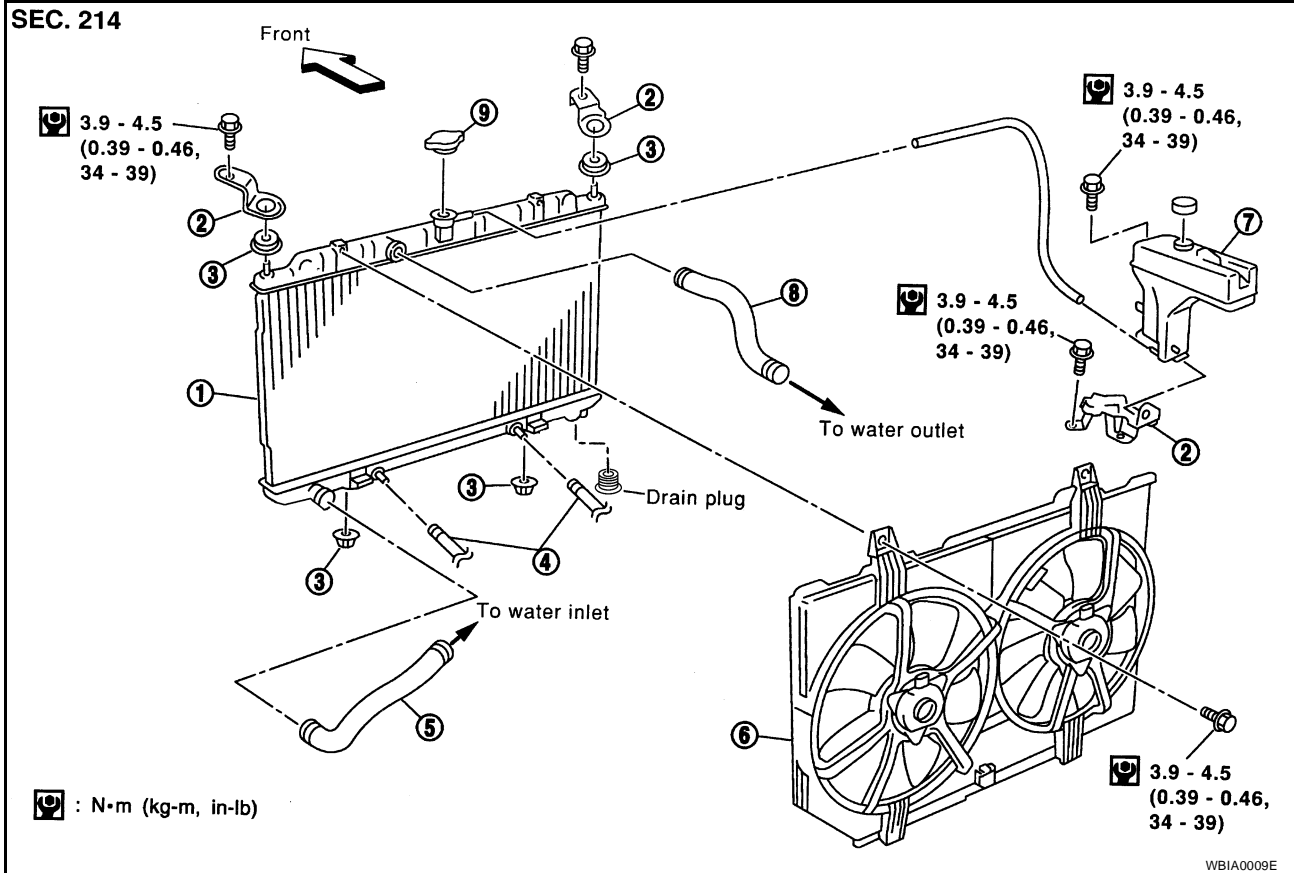

- | | | |
|--------------------------------------|--------------------------|-------------------------|
| 1. Radiator | 2. Bracket | 3. Mounting rubber |
| 4. A/T oil cooler hose (if equipped) | 5. Radiator hose (lower) | 6. Cooling fan assembly |
| 7. Reservoir tank | 8. Radiator hose (upper) | 9. Radiator filler cap |

WARNING:

Never remove the radiator cap when the engine is hot. Serious burns could occur from high pressure coolant escaping from the radiator. Wrap a thick cloth around the cap. Slowly push down and turn it a quarter turn to allow built-up pressure to escape. Carefully remove the cap by pushing down and turning it three-quarters around.

REMOVAL

1. Drain the engine coolant. Refer to [MA-23, "DRAINING ENGINE COOLANT"](#).
2. Remove the air duct with air cleaner assembly.
3. Disconnect A/T oil cooler hoses (if equipped).
 - Install a blind plug to avoid leakage of A/T oil.
4. Disconnect the radiator upper hose, lower hose, and mounting bracket.
5. Remove the radiator and cooling fan assembly

CAUTION:

- Do not damage or scratch radiator core when removing.

INSTALLATION

Installation is in the reverse order of removal.

- After installation, run the engine until it reaches full operating temperature and check for any cooling system leaks. Repair any leaks as necessary.

Disassembly and Assembly

EBS006CE

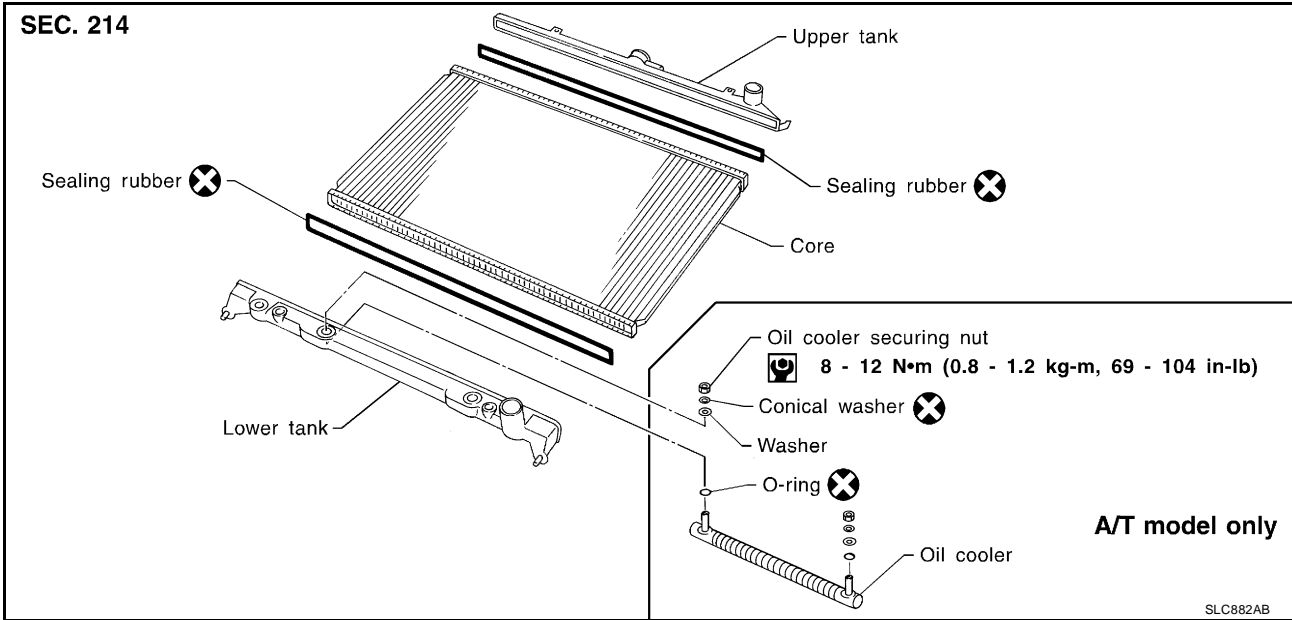

PREPARATION

1. Attach the spacer to the tip of the radiator plate pliers A. Spacer specification: 1.5 mm (0.059 in) thick x 18 mm (0.71 in) wide x 8.5 mm (0.335 in) long.
2. Make sure that when radiator plate pliers A are closed dimension H'' is approx. 7.6 mm (0.299 in).
3. Adjust dimension H'' with the spacer, if necessary.

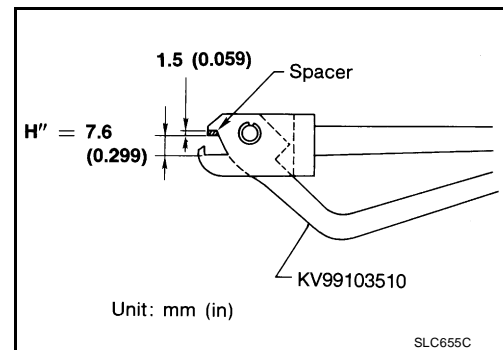

DISASSEMBLY

1. Remove tank with Tool.

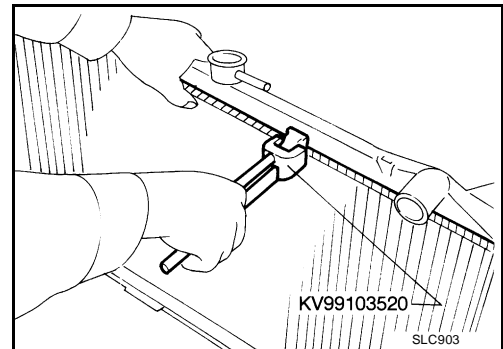

- Grip the crimped edge and bend it upwards so that the Tool slips off.
Do not bend excessively.

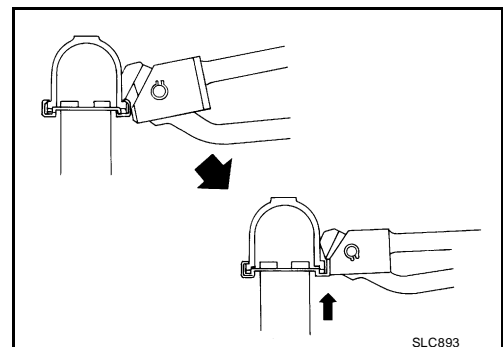

RADIATOR

[QR25DE]

- In areas where Tool cannot be used, use a screwdriver to bend the edge up.
Be careful not to damage tank.

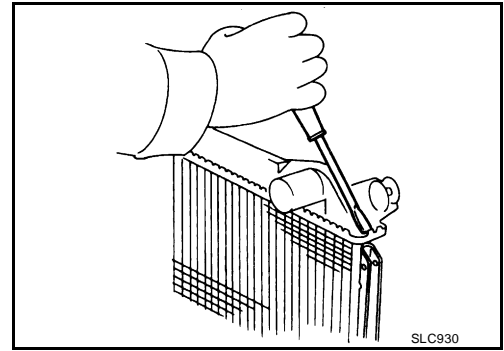

2. Make sure the edge stands straight up.
3. Remove oil cooler from tank (A/T model only).

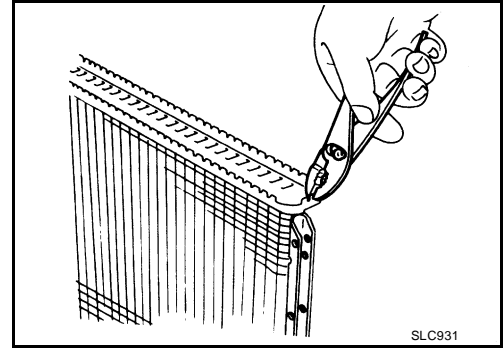

ASSEMBLY

1. Install oil cooler (A/T model only).
 - Pay attention to direction of conical washer.

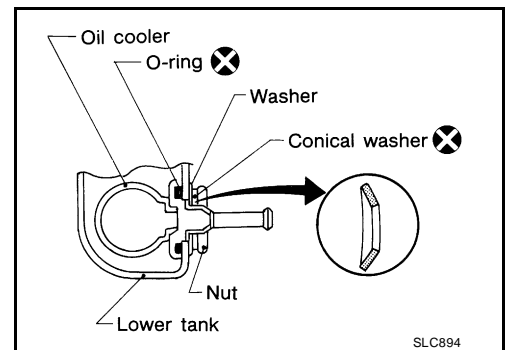

2. Clean contact portion of tank.

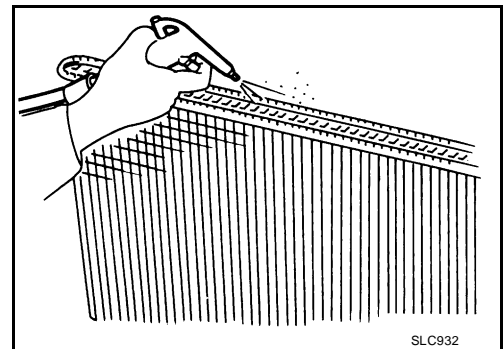

RADIATOR

[QR25DE]

3. Install sealing rubber.
 - Push it in with fingers.
 - Be careful not to twist sealing rubber.

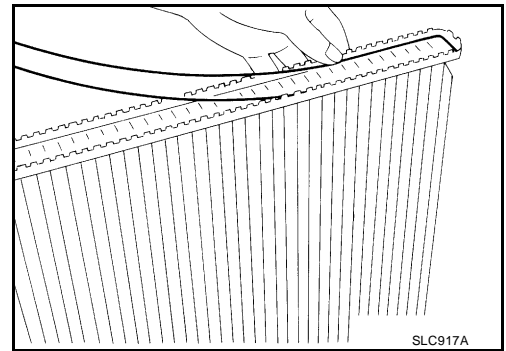

4. Crimp tank in specified sequence with Tool.

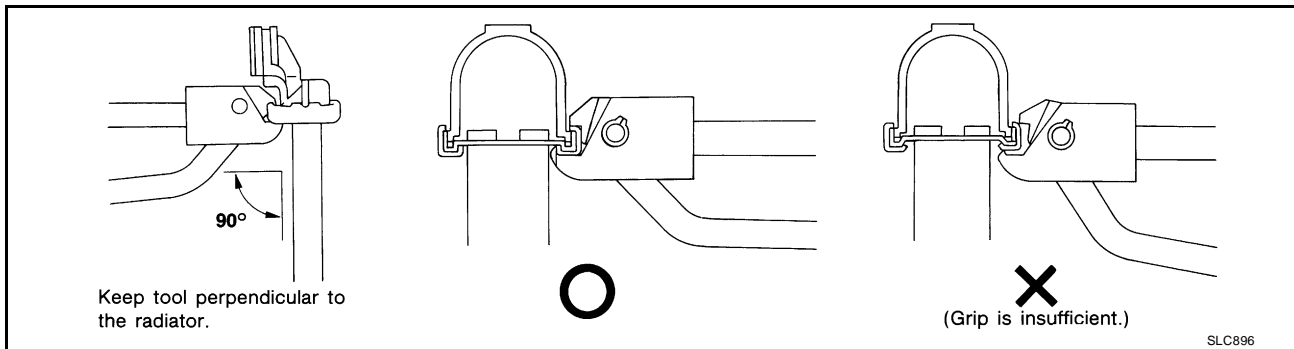
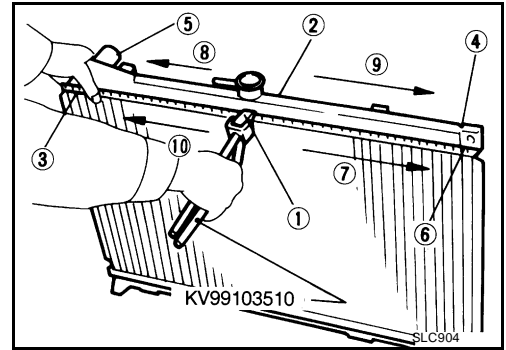

- Use pliers in the locations where Tool cannot be used.

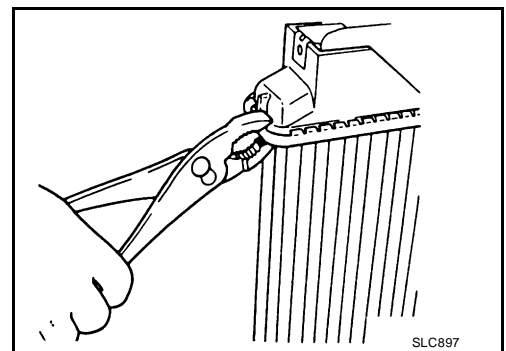

5. Make sure that the rim is completely crimped down.

Standard height "H" : 8.0 - 8.4 mm (0.315 - 0.331 in)

6. Confirm that there is no leakage.

- Refer to [CO-26, "CHECKING COOLING SYSTEM FOR LEAKS"](#) .

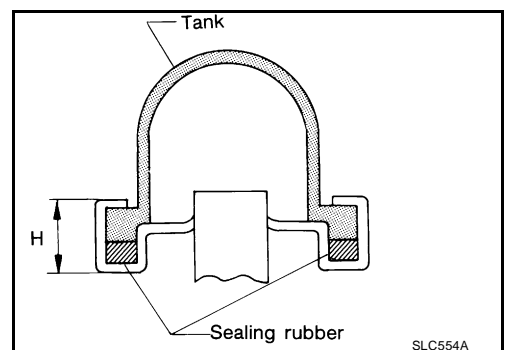

Inspection

1. Apply pressure with Tool.

Specified pressure value : 157 kPa (1.6 kg/cm² , 23 psi)

WARNING:

To prevent the risk of the hose coming undone while under pressure, securely fasten it down with a hose clamp. Attach a hose to the oil cooler as well (A/T model only).

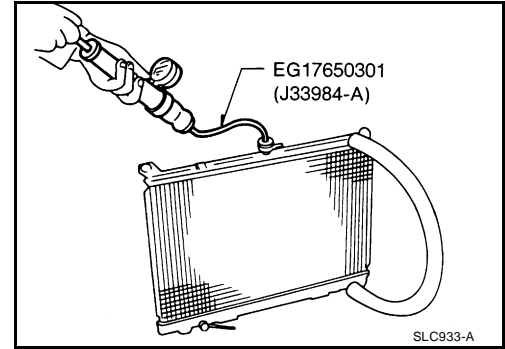

2. Check for leaks in dip tank.

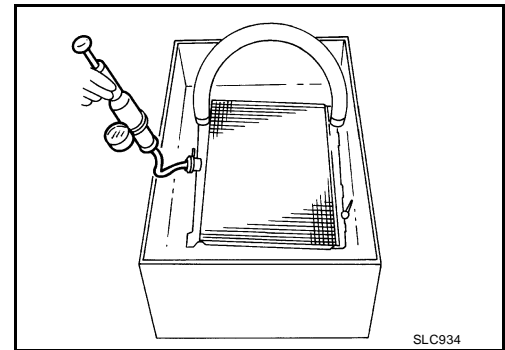

COOLING FAN

Disassembly and Assembly

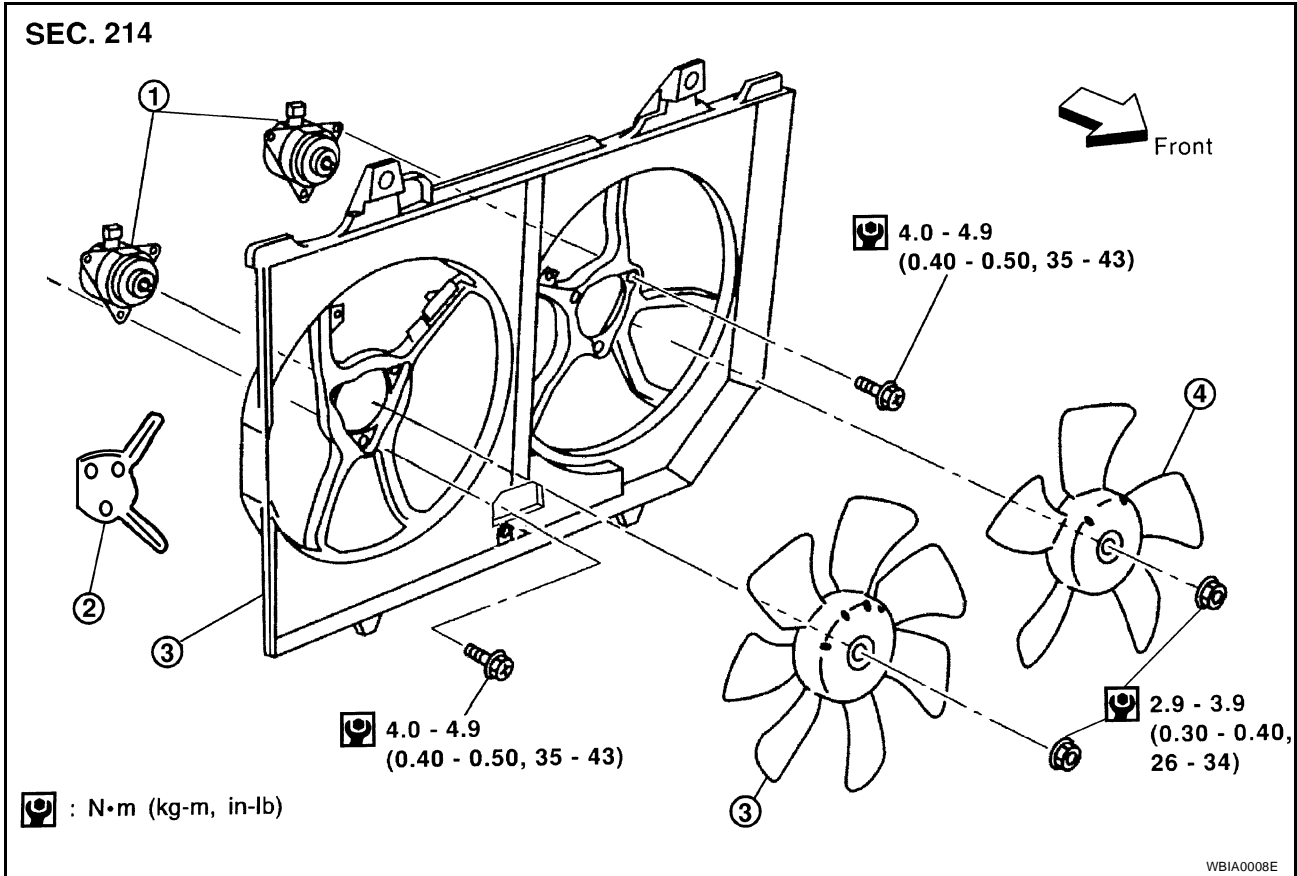

- 1. Cooling fan motor
- 2. Insulator
- 3. Cooling fan shroud
- 4. Cooling fan blade

DISASSEMBLY

1. Remove the radiator and cooling fan assembly. Refer to [CO-32, "REMOVAL"](#).
2. Remove the cooling fan shroud from the radiator.
3. Remove the cooling fan blades from the cooling fan motors.
4. Remove the insulator.
5. Remove the cooling fan motors from the fan shroud.

ASSEMBLY

- Assembly is in the reverse order of disassembly.

SERVICE DATA AND SPECIFICATIONS (SDS)

[QR25DE]

SERVICE DATA AND SPECIFICATIONS (SDS)

PF0:00030

Capacity

EBS006CH

Coolant capacity with reservoir tank (MAX level)	Approximately 6.3 ℓ (6 qt.)
--	-----------------------------

Thermostat

EBS006CI

Valve opening temperature	80.5 - 83.5°C (177 - 182°F)
Valve lift	More than 8 mm / 95°C (0.315 in / 203°F)

Water Control Valve

EBS006CJ

Valve opening temperature	93.5 - 96.5°C (200 - 206°F)
Valve lift	More than 8 mm / 108°C (0.315 in / 226°F)

Radiator

EBS006CK

Unit: kPa (bar, kg/cm², psi)

Cap relief pressure	Standard	78- 98 (0.78- 0.98, 0.8 -1.0, 11-14)
	Limit	59 (0.59, 0.6, 9)
Leakage test pressure		157 (1.57, 1.6, 23)