

SECTION **BRC**

BRAKE CONTROL SYSTEM

A
B
C
D
E

CONTENTS

ABS		BRC
PRECAUTIONS	3	
Precautions for Supplemental Restraint System (SRS) "AIR BAG" and "SEAT BELT PRE-TENSIONER"	3	
Precautions for Brake System	3	
Wiring Diagrams and Trouble Diagnosis	3	
PREPARATION	4	
Commercial Service Tools	4	
DESCRIPTION	5	
Purpose	5	
Operation	5	
ABS Hydraulic Circuit	5	
System Components	6	
System Description	6	
SENSOR	6	
CONTROL UNIT (BUILT-IN ABS ACTUATOR AND ELECTRIC UNIT)	6	
ABS ACTUATOR AND ELECTRIC UNIT	7	
Component Parts and Harness Connector Location	8	
Schematic	9	
Wiring Diagram — ABS —	10	
ON BOARD DIAGNOSTIC SYSTEM DESCRIPTION	14	
Self-diagnosis	14	
FUNCTION	14	
SELF-DIAGNOSIS PROCEDURE	14	
HOW TO READ SELF-DIAGNOSTIC RESULTS (MALFUNCTION CODES)	15	
HOW TO ERASE SELF-DIAGNOSTIC RESULTS (MALFUNCTION CODES)	15	
CONSULT-II	16	
CONSULT-II APPLICATION TO ABS	16	
ECU (ABS CONTROL UNIT) PART NUMBER	16	
MODE	16	
CONSULT-II Inspection Procedure	17	
SELF-DIAGNOSIS PROCEDURE	17	
SELF-DIAGNOSTIC RESULTS MODE	18	
DATA MONITOR PROCEDURE	19	
ACTIVE TEST PROCEDURE	20	
DATA MONITOR MODE	21	
ACTIVE TEST MODE	21	
TROUBLE DIAGNOSIS — INTRODUCTION	22	
How to Perform Trouble Diagnoses for Quick and Accurate Repair	22	
INTRODUCTION	22	
TROUBLE DIAGNOSIS — BASIC INSPECTION ...	23	
Preliminary Check	23	
Ground Circuit Check	25	
ABS ACTUATOR AND ELECTRIC UNIT	25	
GROUND	25	
TROUBLE DIAGNOSIS — GENERAL DESCRIPTION	26	
Malfunction Code/Symptom Chart	26	
WHEEL SENSOR OR ROTOR	27	
Diagnostic Procedure	27	
ABS ACTUATOR SOLENOID VALVE AND SOLENOID VALVE RELAY	29	
Diagnostic Procedure	29	
MOTOR RELAY OR MOTOR	31	
Diagnostic Procedure	31	
LOW VOLTAGE	33	
Diagnostic Procedure	33	
CONTROL UNIT	35	
Diagnostic Procedure	35	
TROUBLE DIAGNOSES FOR SYMPTOMS	36	
Symptom 1. ABS Works Frequently	36	
Symptom 2. Unexpected Pedal Action	36	
Symptom 3. Long Stopping Distance	37	
Symptom 4. ABS Does Not Work	38	
Symptom 5. Pedal Vibration and Noise	38	
Symptom 6. Warning Lamp Does Not Come On When Ignition Switch Is Turned On	39	
Symptom 7. Warning Lamp Stays On When Ignition		

BRC
G
H
I
J
K
L
M

Switch Is Turned On 41

REMOVAL AND INSTALLATION 44

Removal and Installation 44

FRONT WHEEL SENSOR 44

REAR WHEEL SENSOR (REAR DRUM) 44

REAR WHEEL SENSOR (REAR DISC) 45

SENSOR ROTOR 45

ACTUATOR 46

PRECAUTIONS

PFP:00001

Precautions for Supplemental Restraint System (SRS) “AIR BAG” and “SEAT BELT PRE-TENSIONER”

EFS002RU

The Supplemental Restraint System such as “AIR BAG” and “SEAT BELT PRE-TENSIONER”, used along with a front seat belt, helps to reduce the risk or severity of injury to the driver and front passenger for certain types of collision. Information necessary to service the system safely is included in the SRS and SB section of this Service Manual.

WARNING:

- To avoid rendering the SRS inoperative, which could increase the risk of personal injury or death in the event of a collision which would result in air bag inflation, all maintenance must be performed by an authorized NISSAN/INFINITI dealer.
- Improper maintenance, including incorrect removal and installation of the SRS, can lead to personal injury caused by unintentional activation of the system. For removal of Spiral Cable and Air Bag Module, see the SRS section.
- Do not use electrical test equipment on any circuit related to the SRS unless instructed to in this Service Manual. SRS wiring harnesses can be identified by yellow and/or orange harness connectors.

Precautions for Brake System

EFS002RV

- Recommended fluid is brake fluid “DOT 3”.
- Never reuse drained brake fluid.
- Be careful not to splash brake fluid on painted areas.
- To clean or wash all parts of master cylinder, disc brake caliper and wheel cylinder, use clean brake fluid.
- Never use mineral oils such as gasoline or kerosene. They will ruin rubber parts of the hydraulic system.
- Use flare nut wrench when removing and installing brake tube.
- Always torque brake lines when installing.
- Burnish the brake contact surfaces after refinishing or replacing drums or rotors, after replacing pads or linings, or if a soft pedal occurs at very low mileage. Refer to [BR-6, "Brake Burnishing Procedure"](#).

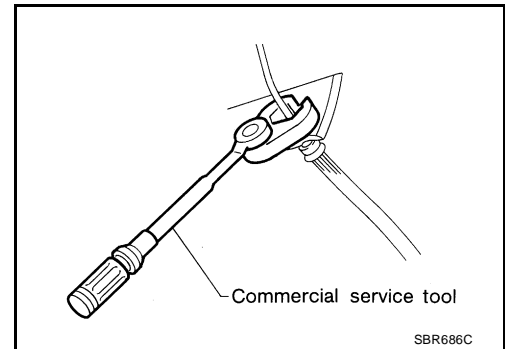

WARNING:

- Clean brake pads and shoes with a waste cloth, then wipe with a dust collector.

Wiring Diagrams and Trouble Diagnosis

EFS002RW

When you read wiring diagrams, refer to the following:

- [GI-13, "How to Read Wiring Diagrams"](#)
- [PG-2, "POWER SUPPLY ROUTING"](#)

When you perform trouble diagnosis, refer to the following:

- [GI-10, "HOW TO FOLLOW TEST GROUPS IN TROUBLE DIAGNOSES"](#)
- [GI-26, "How to Perform Efficient Diagnosis for an Electrical Incident"](#)

PREPARATION

[ABS]

PREPARATION

PF0:00002

Commercial Service Tools

EF002RX

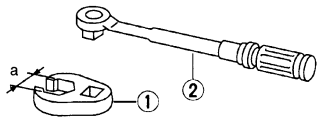
Tool name	Description
<p>1 Flare nut crowfoot 2 Torque wrench</p>  <p>S-NT360</p>	<p>Removing and installing brake piping a: 10 mm (0.39 in)</p>

DESCRIPTION

PFP:00000

Purpose

EFS001EN

The Anti-Lock Brake System (ABS) consists of electronic and hydraulic components. It allows for control of braking force so locking of the wheels can be avoided.

1. Improves proper tracking performance through steering wheel operation.
2. Eases obstacle avoidance through steering wheel operation.
3. Improves vehicle stability.

Operation

EFS001EO

- When the vehicle speed is less than 10 km/h (6 MPH), this system does not work.
- The Anti-Lock Brake System (ABS) has a self-test function. The system turns on the ABS warning lamp for 1 second each time the ignition switch is turned "ON". After the engine is started, the ABS warning lamp turns off. The system performs a test the first time the vehicle reaches 6 km/h (4 MPH). A mechanical noise may be heard as the ABS performs this self-test. This is a normal part of the self-test feature. If a malfunction is found during this check, the ABS warning lamp will stay on.
- While driving, a mechanical noise may be heard during ABS operation. This is a normal condition.

ABS Hydraulic Circuit

EFS001EP

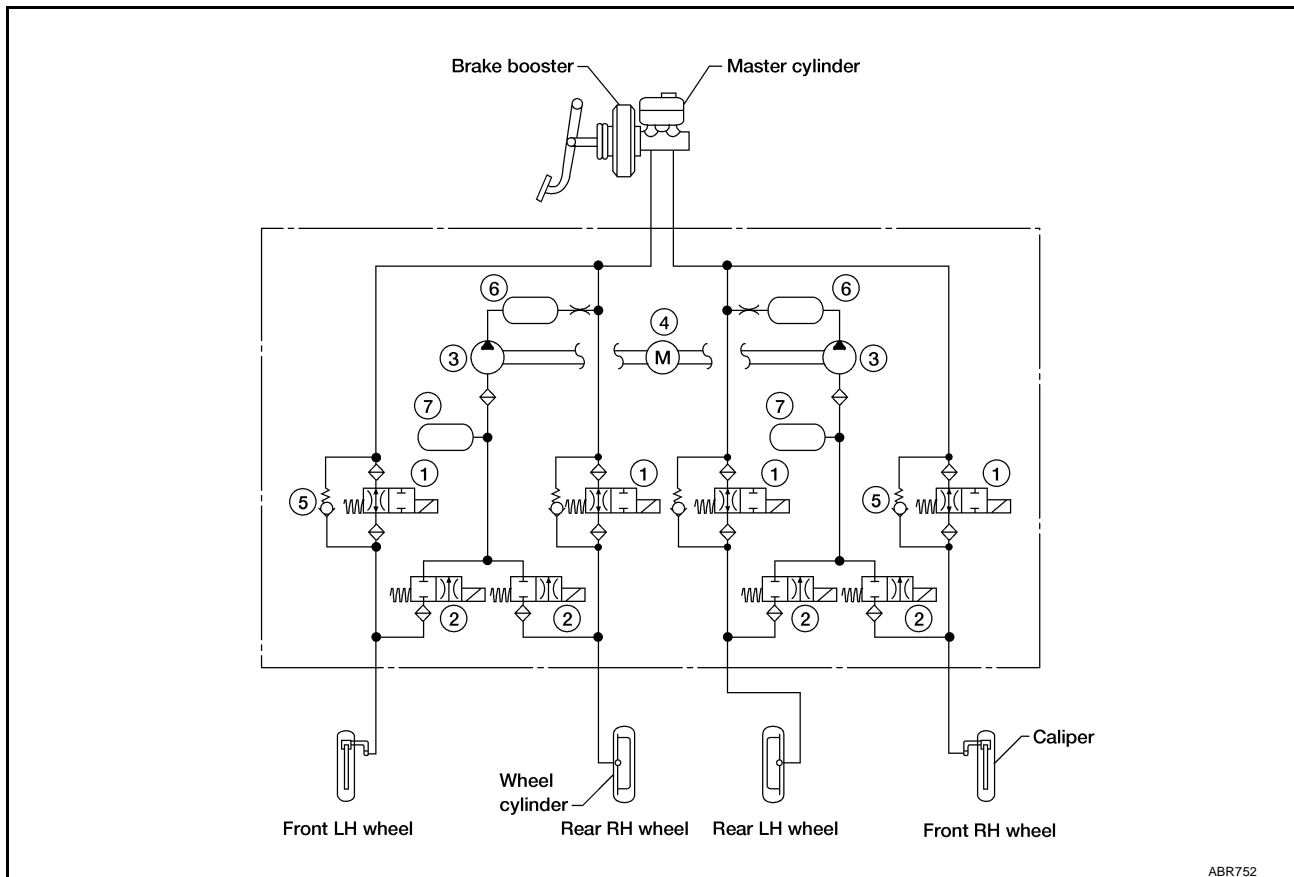

- | | | |
|----------------------------------|--------------------------|-----------|
| 1. Inlet solenoid valve | 2. Outlet solenoid valve | 3. Pump |
| 4. Motor | 5. Bypass check valve | 6. Damper |
| 7. Solenoid valve relay actuator | | |

ABR752

System Components

EFS001EQ

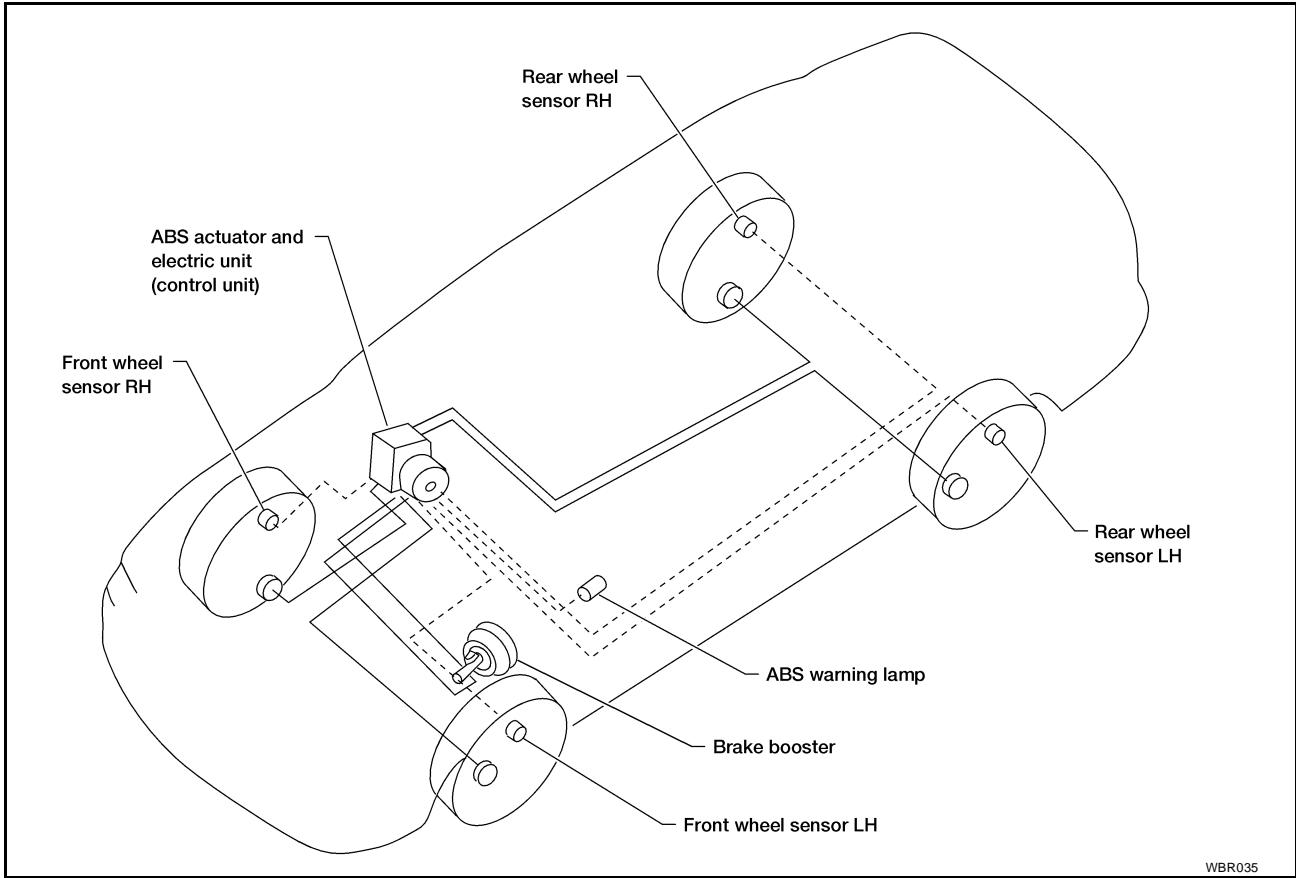

WBR035

System Description
SENSOR

EFS001ER

The sensor unit consists of a gear-shaped sensor rotor and a sensor element. The element contains a bar magnet around which a coil is wound. The front sensors are installed on the front spindles and the rear sensors are installed on the rear spindles. As the wheel rotates, the sensor generates a sine-wave pattern. The frequency and voltage increase(s) as the rotating speed increases.

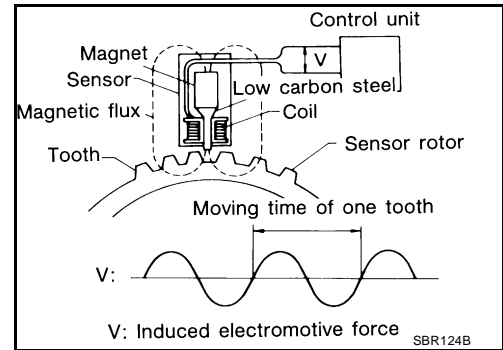

CONTROL UNIT (BUILT-IN ABS ACTUATOR AND ELECTRIC UNIT)

The control unit computes the wheel rotating speed by the signal current sent from the sensor. Then it supplies a DC current to the actuator solenoid valve. It also controls ON-OFF operation of the valve relay and motor relay. If any electrical malfunction should be detected in the system, the control unit causes the warning lamp to light up. In this condition, the ABS will be deactivated by the control unit, and the vehicle's brake system reverts to normal operation. (For control unit layout, refer to [BRC-7, "ABS ACTUATOR AND ELECTRIC UNIT"](#) .)

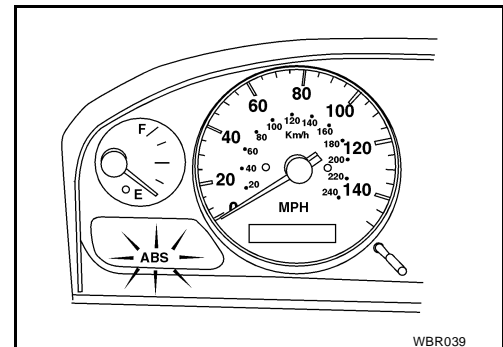

WBR039

ABS ACTUATOR AND ELECTRIC UNIT

The ABS actuator and electric unit contains:

- An electric motor and pump
- Two relays
- Eight solenoid valves, each inlet and outlet for
 - LH front
 - RH front
 - LH rear
 - RH rear
- ABS control unit

This component controls the hydraulic circuit and increases, holds or decreases hydraulic pressure to all or individual wheels. The ABS actuator and electric unit is serviced as an assembly.

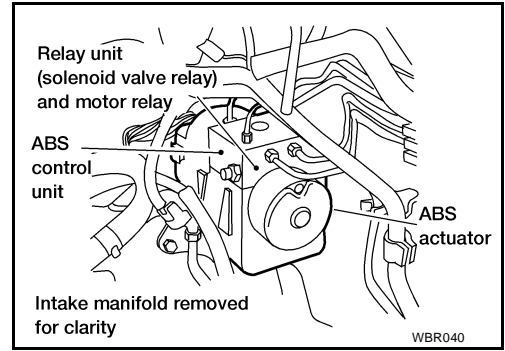

ABS Actuator Operation

		Inlet solenoid valve	Outlet solenoid valve	
Normal brake operation		OFF (Open)	OFF (Closed)	Master cylinder brake fluid pressure is directly transmitted to caliper via the inlet solenoid valve.
ABS operation	Pressure hold	ON (Closed)	OFF (Closed)	Hydraulic circuit is shut off to hold the caliper brake fluid pressure.
	Pressure decrease	ON (Closed)	ON (Open)	Caliper brake fluid is sent to reservoir via the outlet solenoid valve. Then it is pushed up to the master cylinder by pump.
	Pressure increase	OFF (Open)	OFF (Closed)	Master cylinder brake fluid pressure is transmitted to caliper.

A
B
C
D
E
BRC
G
H
I
J
K
L
M

Component Parts and Harness Connector Location

EFS001ES

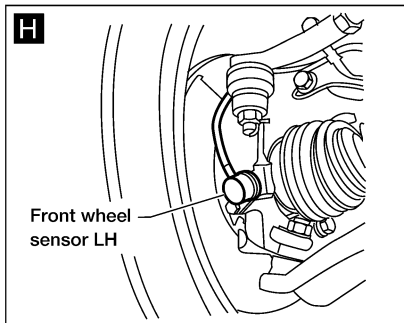
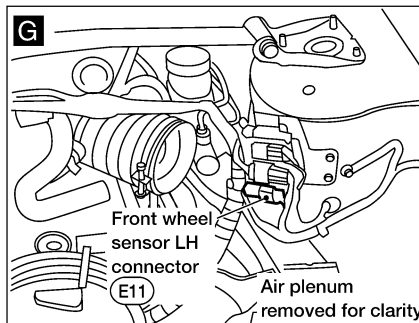
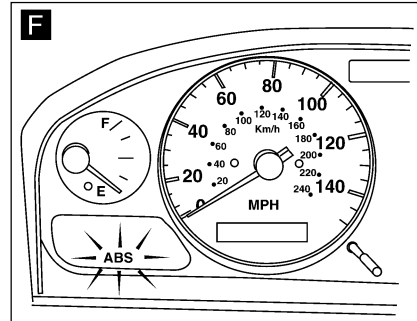
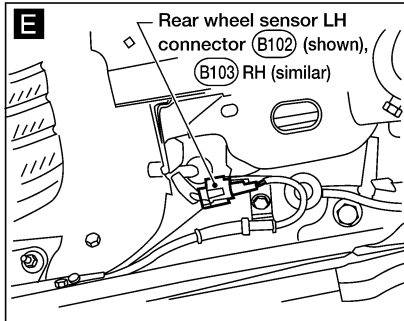
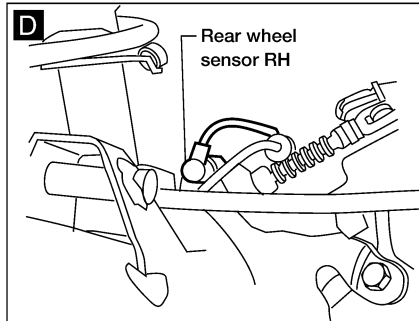
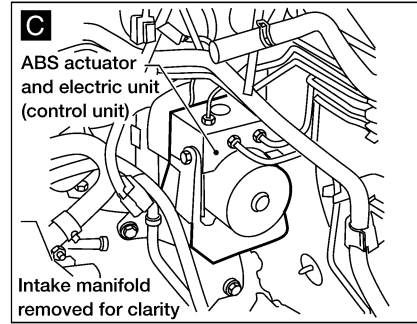
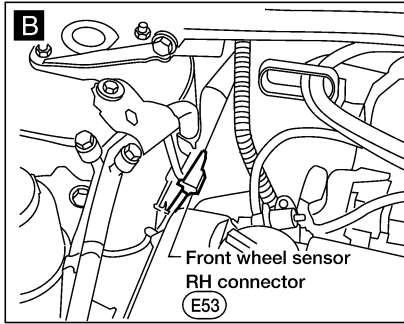
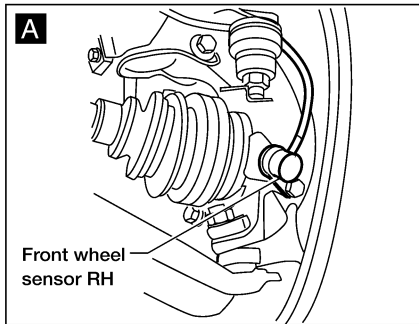
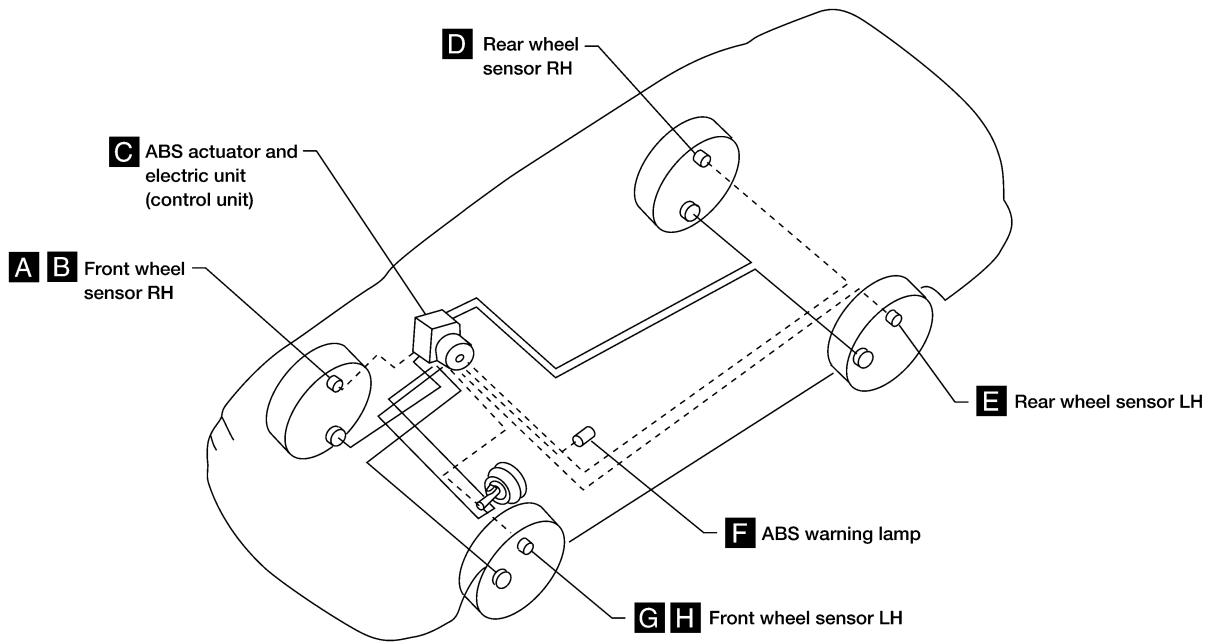

WFIA0039E

Schematic

A
B
C
D
E
BRC
G
H
I
J
K
L
M

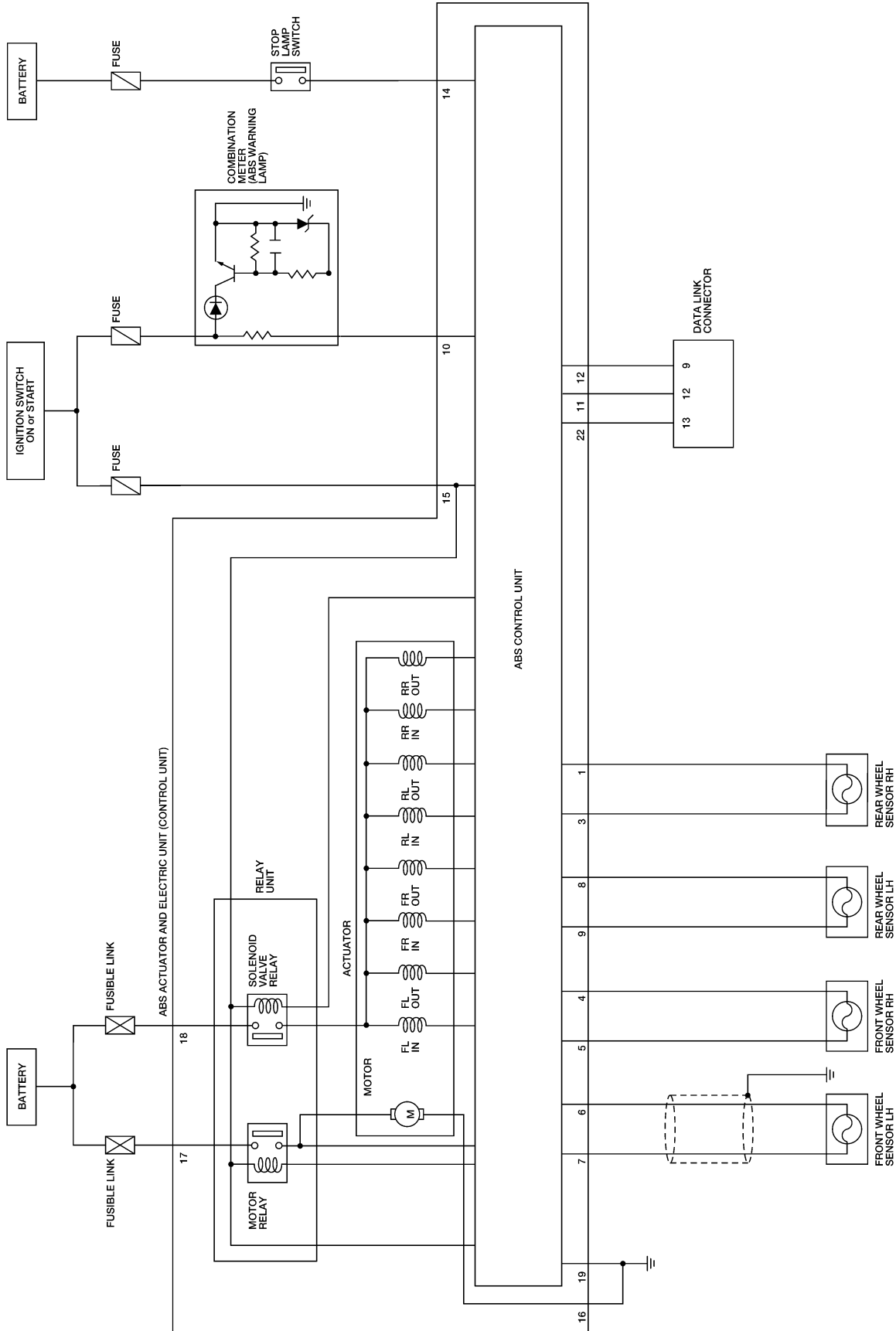

DESCRIPTION

[ABS]

Wiring Diagram — ABS —

EFS001EU

BRC-ABS-01

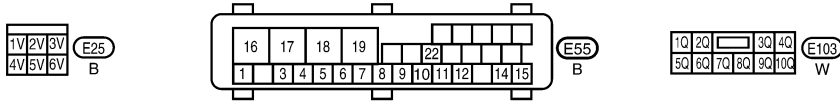
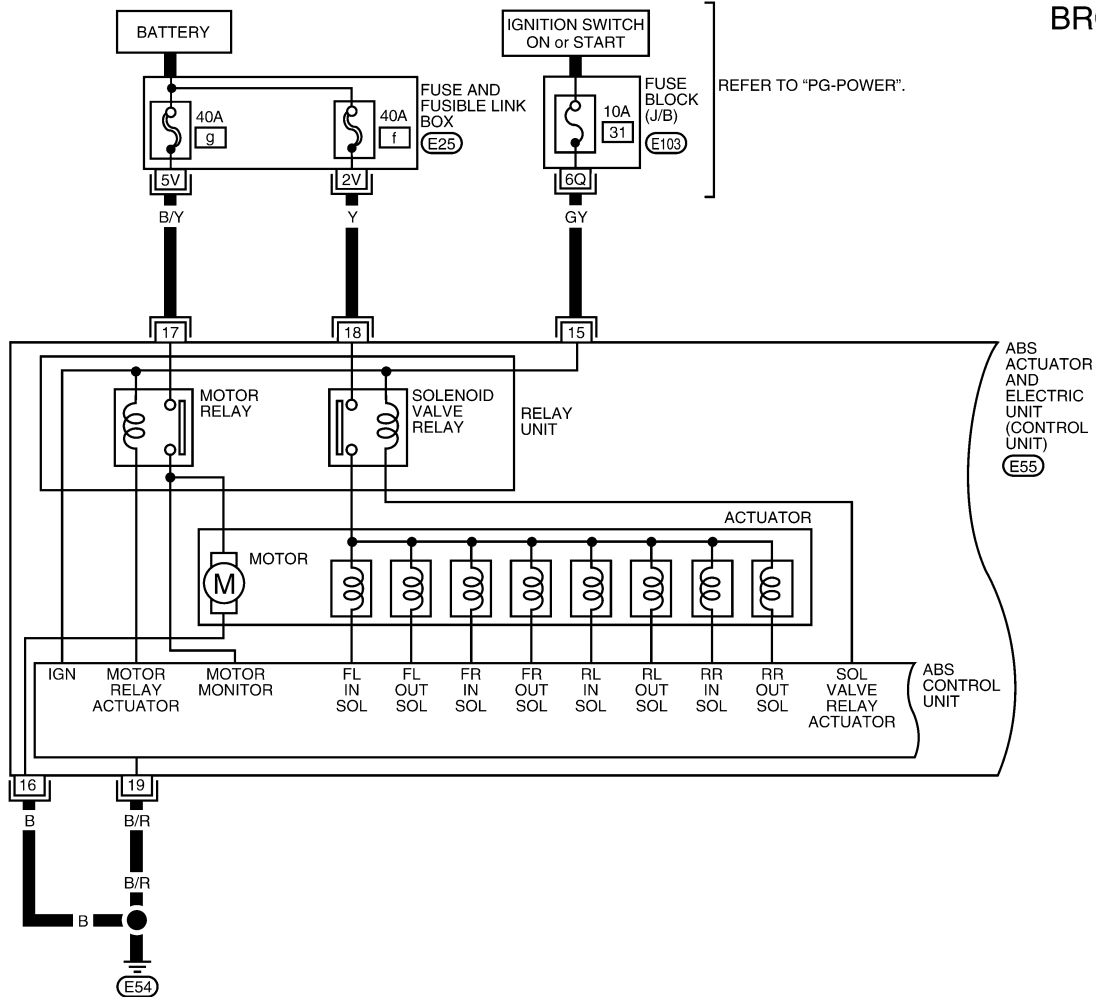

WFWA0002E

ABS ACTUATOR AND ELECTRIC UNIT (CONTROL UNIT)
TERMINALS AND REFERENCE VALUE MEASURED BETWEEN EACH TERMINAL AND GROUND

TERMINAL	WIRE COLOR	ITEM	CONDITION	DATA (DC)
15	GY	POWER SOURCE (FUSE)	IGNITION ON OR START	BATTERY VOLTAGE
16	B	GROUND	—	—
17	B/Y	POWER SOURCE (FUSE)	BATTERY	BATTERY VOLTAGE
18	Y	POWER SOURCE (FUSE)	BATTERY	BATTERY VOLTAGE
19	B/R	GROUND	—	—

LBR071

DESCRIPTION

[ABS]

BRC-ABS-02

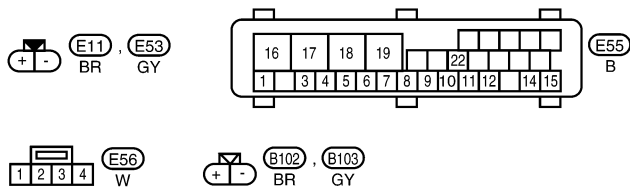
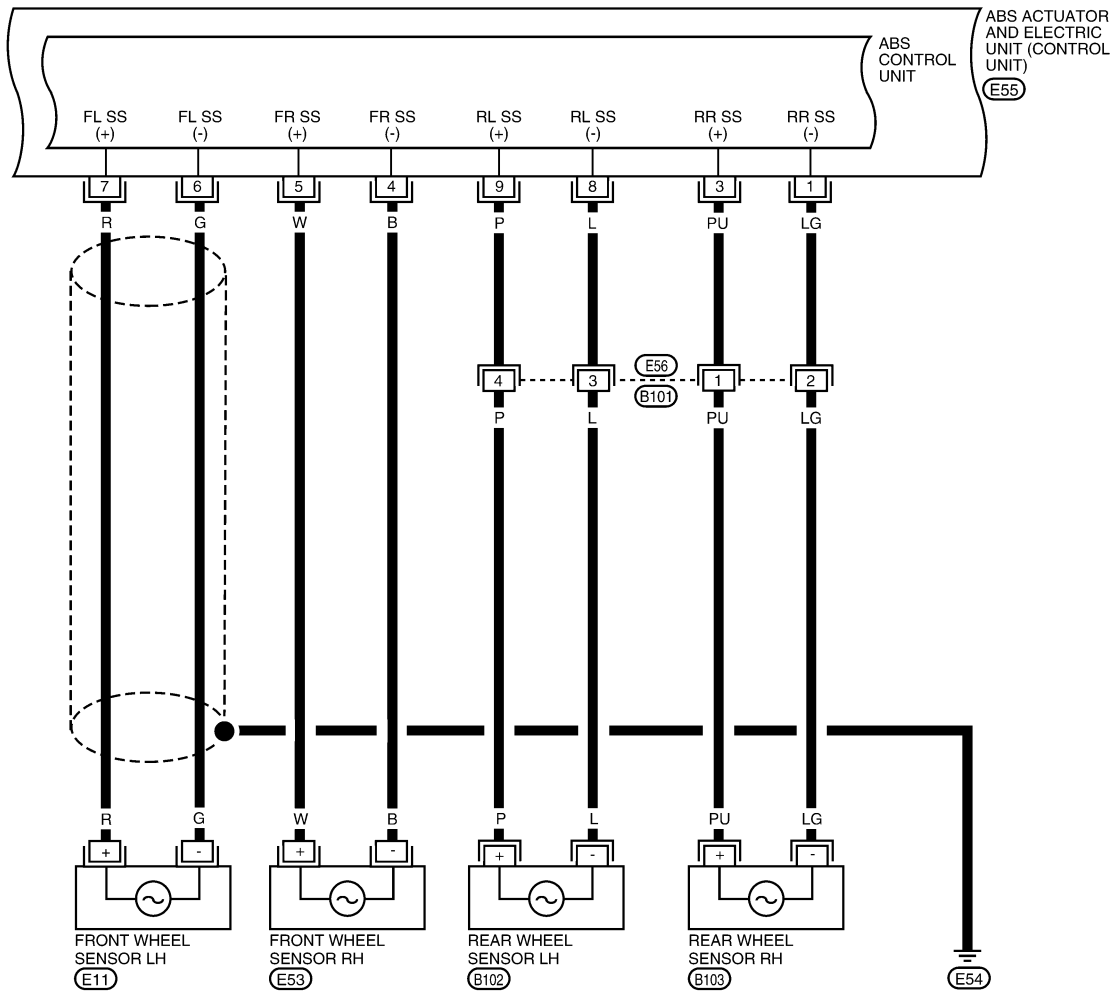

WFWA0004E

ABS ACTUATOR AND ELECTRIC UNIT (CONTROL UNIT)
TERMINALS AND REFERENCE VALUE MEASURED BETWEEN EACH TERMINAL AND GROUND

TERMINAL	WIRE COLOR	ITEM	CONDITION	DATA (DC)
1	LG	REAR WHEEL SENSOR RH	WHEN VEHICLE CRUISES AT 30 KM/H (19 MPH)	PULSE FRONT: APPROX. 190 HZ REAR: APPROX. 190 HZ
3	PU	REAR WHEEL SENSOR RH		
4	B	FRONT WHEEL SENSOR RH		
5	W	FRONT WHEEL SENSOR RH		
6	G	FRONT WHEEL SENSOR LH		
7	R	FRONT WHEEL SENSOR LH		
8	L	REAR WHEEL SENSOR LH		
9	P	REAR WHEEL SENSOR LH		

LBR072

DESCRIPTION

[ABS]

BRC-ABS-03

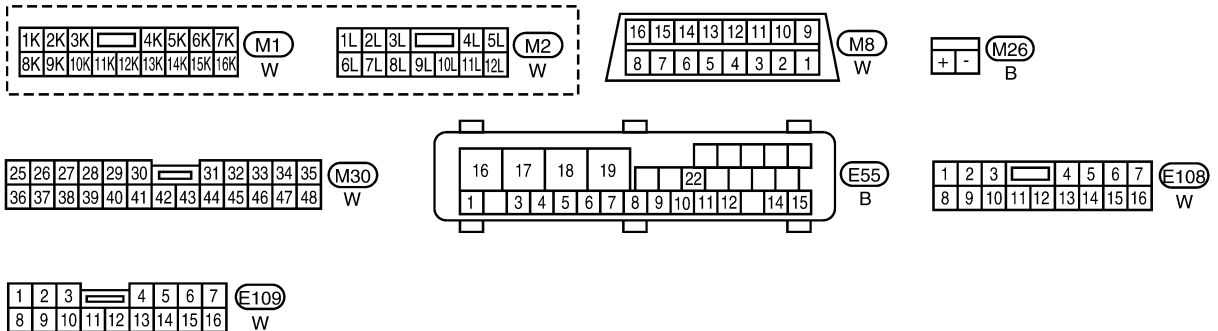
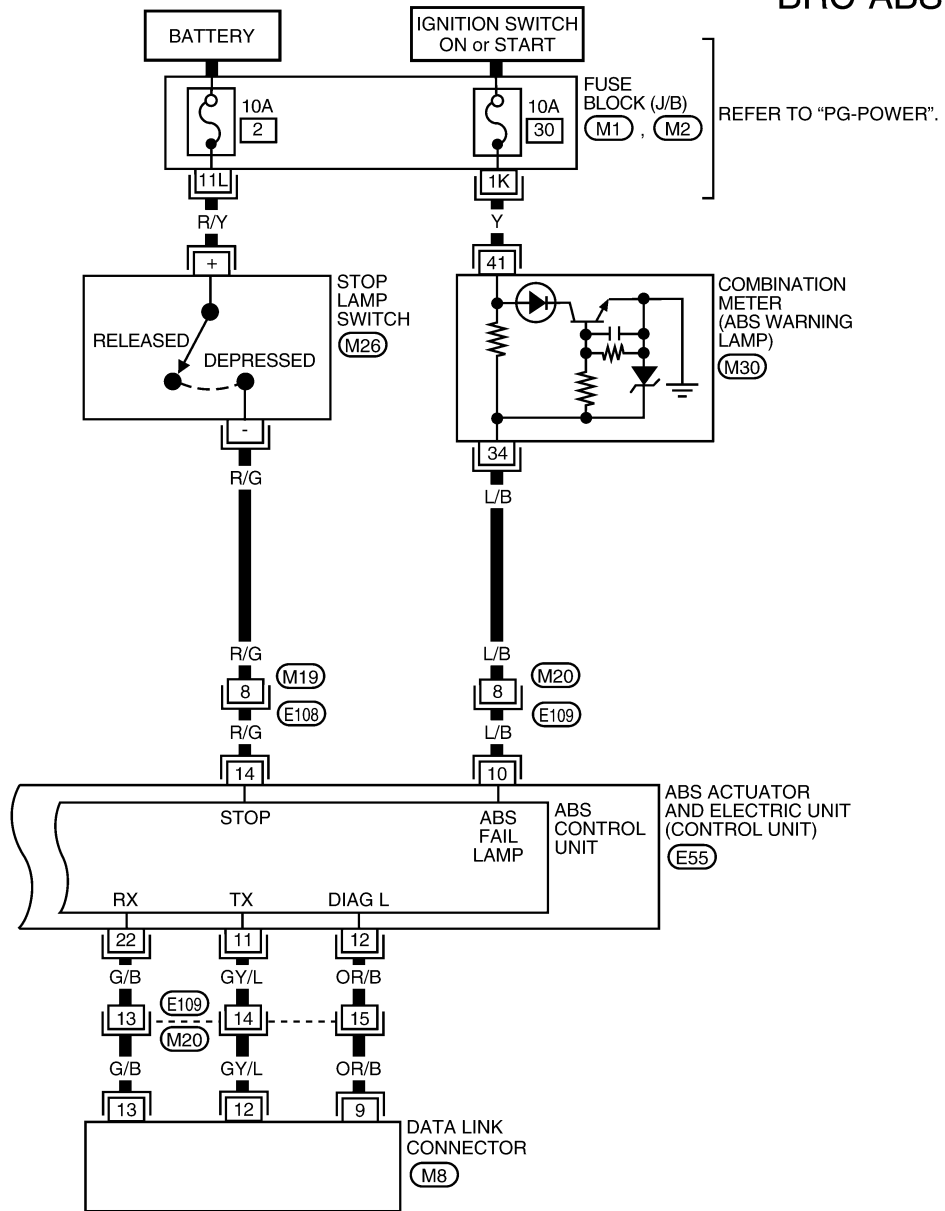

WFWA0006E

DESCRIPTION

[ABS]

ABS ACTUATOR AND ELECTRIC UNIT (CONTROL UNIT)
 TERMINALS AND REFERENCE VALUE MEASURED BETWEEN EACH TERMINAL AND GROUND

TERMINAL NO.	WIRE COLOR	ITEM	CONDITION	DATA (APPROX.)
10	L/B	ABS WARNING LAMP IN COMBINATION METER	WHEN ABS LAMP IS ACTIVE	0V
			WHEN ABS LAMP IS NOT ACTIVE	BATTERY VOLTAGE
11	GY/L	DATA LINK CONNECTOR	—	—
12	OR/B	DATA LINK CONNECTOR	—	—
14	R/G	STOP LAMP SWITCH	WHEN BRAKE PEDAL IS DEPRESSED	BATTERY VOLTAGE
			WHEN BRAKE PEDAL IS RELEASED	0V
22	G/B	DATA LINK CONNECTOR	—	—

A
B
C
D
E
G
H
I
J
K
L
M

BRC

ON BOARD DIAGNOSTIC SYSTEM DESCRIPTION

PFP:00000

Self-diagnosis FUNCTION

EFS001EV

- When a problem occurs in the ABS, the warning lamp on the instrument panel comes on. To start the self-diagnostic results mode, ground the self-diagnostic (check) terminal located on Data Link Connector. The location of the malfunction is indicated by the warning lamp flashing.

SELF-DIAGNOSIS PROCEDURE

1. Drive vehicle over 30 km/h (19 MPH) for at least one minute.
2. Turn ignition switch OFF.
3. Ground terminal 9 of Data Link Connector with a suitable harness.
4. Turn ignition switch ON while grounding terminal 9.
Do not depress brake pedal.

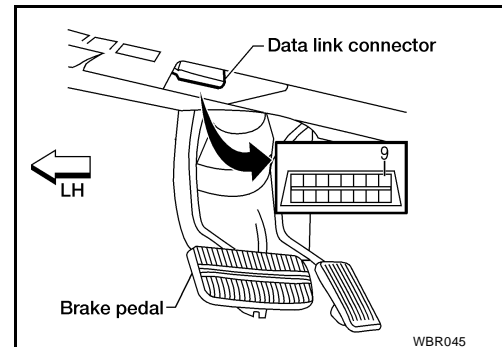

5. After 3.0 seconds, the warning lamp starts flashing to indicate the malfunction code No. (See NOTE.)
6. Verify the location of the malfunction with the malfunction code chart. Refer to [BRC-26, "Malfunction Code/Symptom Chart"](#). Then make the necessary repairs following the diagnostic procedures.
7. After the malfunctions are repaired, erase the malfunction codes stored in the control unit. Refer to [BRC-15, "HOW TO ERASE SELF-DIAGNOSTIC RESULTS \(MALFUNCTION CODES\)"](#).
8. Rerun the self-diagnostic results mode to verify that the malfunction codes have been erased.

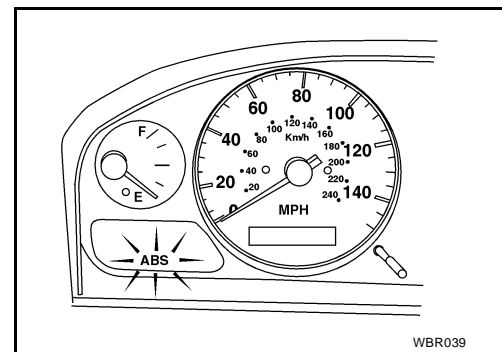

9. Disconnect the check terminal from the ground. The self-diagnostic results mode is now complete.
10. Check warning lamp for deactivation after driving vehicle over 30 km/h (19 MPH) for at least one minute.
11. After making certain that warning lamp does not come on, test the ABS in a safe area to verify that it functions properly.

NOTE:

The indication terminates after 5 minutes. However, when the ignition switch is turned from OFF to ON, the indication starts flashing again.

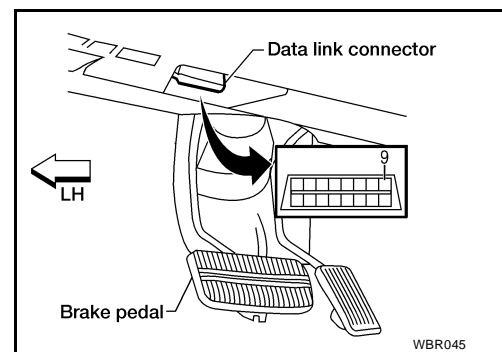

HOW TO READ SELF-DIAGNOSTIC RESULTS (MALFUNCTION CODES)

1. Determine the code No. by counting the number of times the warning lamp flashes on and off.
2. When several malfunctions occur at one time, up to three code numbers can be stored; the latest malfunction will be indicated first.
3. The indication begins with the start code 12. After that a maximum of three code numbers appear in the order of the latest one first. The indication then returns to the start code 12 to repeat (the indication will stay on for five minutes at most).
4. Refer to [BRC-26, "Malfunction Code/Symptom Chart"](#) for a list of malfunction codes.

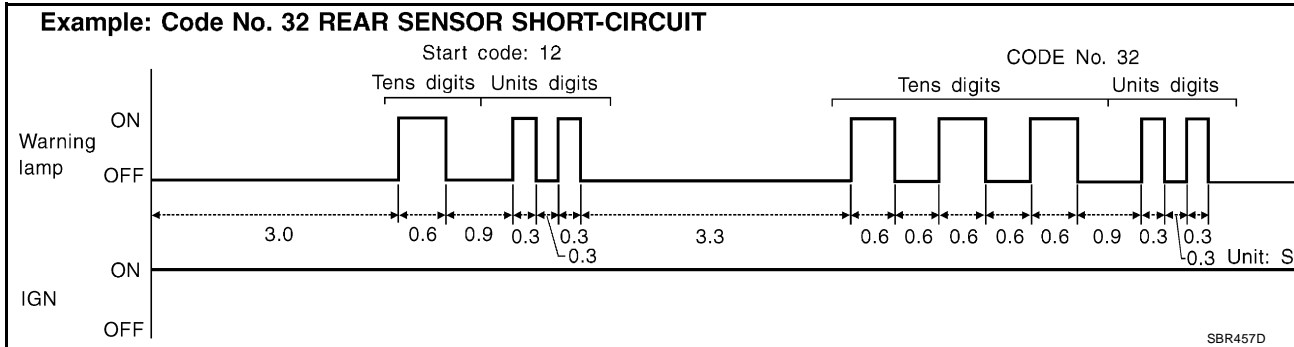

HOW TO ERASE SELF-DIAGNOSTIC RESULTS (MALFUNCTION CODES)

1. Disconnect the check terminal from ground (ABS warning lamp will stay lit).
2. Within 12.5 seconds, ground the check terminal three times. Each terminal ground must last more than 1 second. The ABS warning lamp goes out after the erase operation has been completed.
3. Perform self-diagnosis again. Refer to [BRC-14, "SELF-DIAGNOSIS PROCEDURE"](#). Only the start code should appear, no malfunction codes.

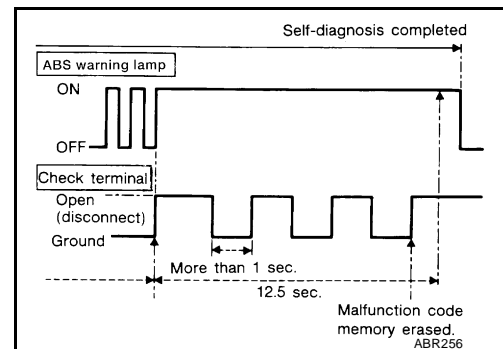

ON BOARD DIAGNOSTIC SYSTEM DESCRIPTION

[ABS]

EFS001EW

CONSULT-II CONSULT-II APPLICATION TO ABS

ITEM	SELF-DIAGNOSTIC RESULTS	DATA MONITOR	ACTIVE TEST
Front right wheel sensor	×	×	—
Front left wheel sensor	×	×	—
Rear right wheel sensor	×	×	—
Rear left wheel sensor	×	×	—
ABS sensor	×	—	—
Stop lamp switch	—	×	—
Front right inlet solenoid valve	×	×	×
Front right outlet solenoid valve	×	×	×
Front left inlet solenoid valve	×	×	×
Front left outlet solenoid valve	×	×	×
Rear right inlet solenoid valve	×	×	×
Rear right outlet solenoid valve	×	×	×
Rear left inlet solenoid valve	×	×	×
Rear left outlet solenoid valve	×	×	×
Actuator solenoid valve relay	×	×	—
Actuator motor relay (ABS MOTOR is shown on the Data Monitor screen.)	×	×	×
ABS warning lamp	—	×	—
Battery voltage	×	×	—
Control unit	×	—	—

×: Applicable

—: Not applicable

ECU (ABS CONTROL UNIT) PART NUMBER MODE

Ignore the ECU part number displayed in the ECU PART NUMBER MODE. Refer to Parts Catalog to order the ECU.

EFS001EX

CONSULT-II Inspection Procedure SELF-DIAGNOSIS PROCEDURE

1. Turn ignition switch OFF.
2. Connect CONSULT-II to Data Link Connector.
3. Start engine.
4. Drive vehicle over 30 km/h (19 MPH) for at least one minute.

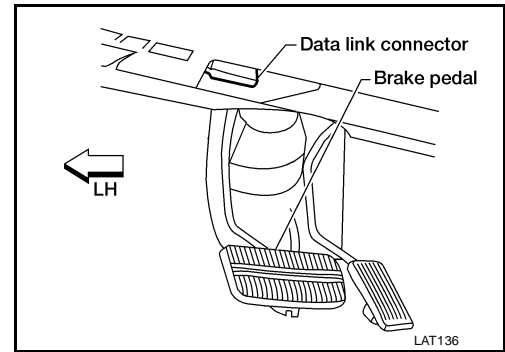

5. Stop vehicle with engine running and touch "START" on CONSULT-II screen.

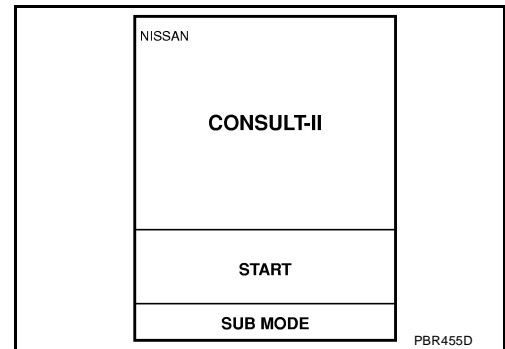

6. Touch "ABS".

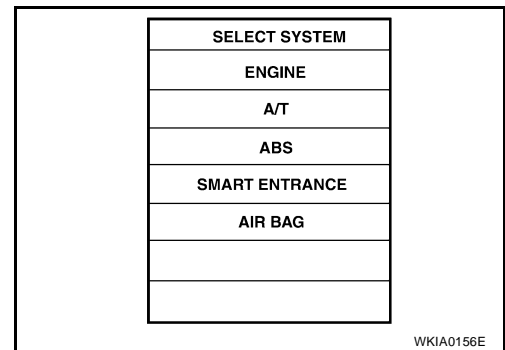

7. Touch "SELF-DIAG RESULTS".
 - The screen shows the detected malfunction and how many times the ignition switch has been turned ON since the malfunction.
8. Make the necessary repairs following the diagnostic procedures.

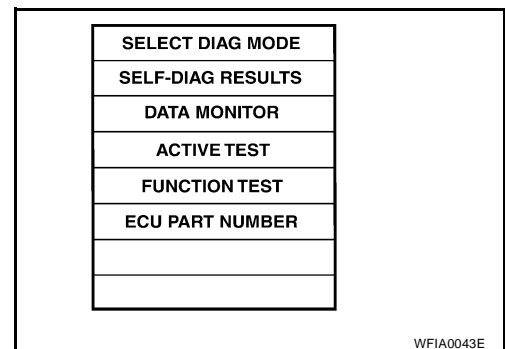

A
B
C
D
E
BRC
G
H
I
J
K
L
M

ON BOARD DIAGNOSTIC SYSTEM DESCRIPTION

[ABS]

9. After the malfunctions are repaired, erase the self-diagnostic results stored in the control unit by touching "ERASE".
10. Check warning lamp for deactivation after driving vehicle over 30 km/h (19 MPH) for at least one minute.
11. Test the ABS in a safe area to verify that it functions properly.

SELF DIAG RESULTS	
FAILURE DETECTED	TIME
FR RH SENSOR [OPEN]	XXX

PBR950C

SELF-DIAGNOSTIC RESULTS MODE

Diagnostic item	Diagnostic item is detected when...	Reference Page
FR RH SENSOR ¹ [OPEN]	<ul style="list-style-type: none"> ● Circuit for front right wheel sensor is open. (An abnormally high input voltage is entered.) 	BRC-27
FR LH SENSOR ¹ [OPEN]	<ul style="list-style-type: none"> ● Circuit for front left wheel sensor is open. (An abnormally high input voltage is entered.) 	BRC-27
RR RH SENSOR ¹ [OPEN]	<ul style="list-style-type: none"> ● Circuit for rear right sensor is open. (An abnormally high input voltage is entered.) 	BRC-27
RR LH SENSOR ¹ [OPEN]	<ul style="list-style-type: none"> ● Circuit for rear left sensor is open. (An abnormally high input voltage is entered.) 	BRC-27
FR RH SENSOR ¹ [SHORT]	<ul style="list-style-type: none"> ● Circuit for front right wheel sensor is shorted. (An abnormally low input voltage is entered.) 	BRC-27
FR LH SENSOR ¹ [SHORT]	<ul style="list-style-type: none"> ● Circuit for front left wheel sensor is shorted. (An abnormally low input voltage is entered.) 	BRC-27
RR RH SENSOR ¹ [SHORT]	<ul style="list-style-type: none"> ● Circuit for rear right sensor is shorted. (An abnormally low input voltage is entered.) 	BRC-27
RR LH SENSOR ¹ [SHORT]	<ul style="list-style-type: none"> ● Circuit for rear left sensor is shorted. (An abnormally low input voltage is entered.) 	BRC-27
ABS SENSOR ¹ [ABNORMAL SIGNAL]	<ul style="list-style-type: none"> ● Teeth damage on sensor rotor or improper installation of wheel sensor. (Abnormal wheel sensor signal is entered.) 	BRC-27
FR RH IN ABS SOL [OPEN, SHORT]	<ul style="list-style-type: none"> ● Circuit for front right inlet solenoid valve is open. (An abnormally low output voltage is entered.) 	BRC-29
FR LH IN ABS SOL [OPEN, SHORT]	<ul style="list-style-type: none"> ● Circuit for front left inlet solenoid valve is open. (An abnormally low output voltage is entered.) 	BRC-29
FR RH OUT ABS SOL [OPEN, SHORT]	<ul style="list-style-type: none"> ● Circuit for front right outlet solenoid valve is open. (An abnormally low output voltage is entered.) 	BRC-29
FR LH OUT ABS SOL [OPEN, SHORT]	<ul style="list-style-type: none"> ● Circuit for front left outlet solenoid valve is open. (An abnormally low output voltage is entered.) 	BRC-29
RR RH IN ABS SOL [OPEN, SHORT]	<ul style="list-style-type: none"> ● Circuit for rear right inlet solenoid valve is shorted. (An abnormally high output voltage is entered.) 	BRC-29
RR LH IN ABS SOL [OPEN, SHORT]	<ul style="list-style-type: none"> ● Circuit for rear left inlet solenoid valve is shorted. (An abnormally high output voltage is entered.) 	BRC-29
RR RH OUT ABS SOL [OPEN, SHORT]	<ul style="list-style-type: none"> ● Circuit for rear right outlet solenoid valve is shorted. (An abnormally high output voltage is entered.) 	BRC-29
RR LH OUT ABS SOL [OPEN, SHORT]	<ul style="list-style-type: none"> ● Circuit for rear left outlet solenoid valve is shorted. (An abnormally high output voltage is entered.) 	BRC-29
ABS ACTUATOR RELAY [ABNORMAL]	<ul style="list-style-type: none"> ● Actuator solenoid valve relay is ON, even if control unit sends off signal. ● Actuator solenoid valve relay is OFF, even if control unit sends on signal. 	BRC-29
ABS MOTOR RELAY [ABNORMAL]	<ul style="list-style-type: none"> ● Circuit for ABS motor relay is open or shorted. ● Circuit for actuator motor is open or shorted. ● Actuator motor relay is stuck. 	BRC-31

ON BOARD DIAGNOSTIC SYSTEM DESCRIPTION

[ABS]

Diagnostic item	Diagnostic item is detected when...	Reference Page
BATTERY VOLT [VB-LOW]	<ul style="list-style-type: none"> Power source voltage supplied to ABS control unit is abnormally low. 	BRC-33
CONTROL UNIT	<ul style="list-style-type: none"> Function of calculation in ABS control unit has failed. 	BRC-35

¹: If one or more wheels spin on a rough or slippery road for 40 seconds or more, the ABS warning lamp will illuminate. This does not indicate a malfunction. Only in the case of the short-circuit (Code Nos. 26, 22, 32 and 36), after repair the ABS warning lamp also illuminates when the ignition switch is turned ON. In this case, drive the vehicle at speeds greater than 30 km/h (19 MPH) for approximately 1 minute as specified in [BRC-14, "SELF-DIAGNOSIS PROCEDURE"](#). Check to ensure that the ABS warning lamp goes out while the vehicle is being driven.

DATA MONITOR PROCEDURE

1. Turn ignition switch OFF.
2. Connect CONSULT-II to Data Link Connector.
3. Turn ignition switch ON.
4. Touch "START" on CONSULT-II screen.

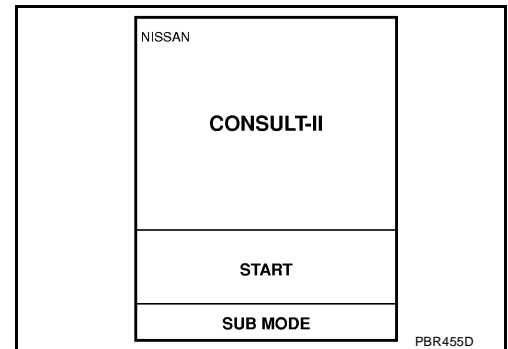

5. Touch "ABS".

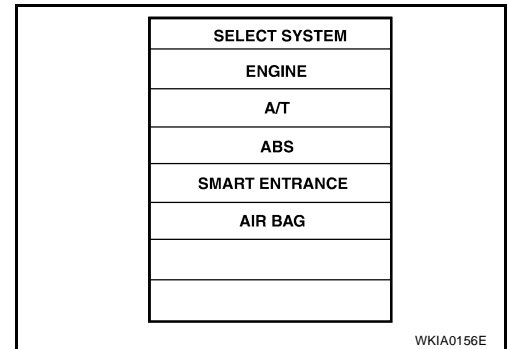

6. Touch "DATA MONITOR".

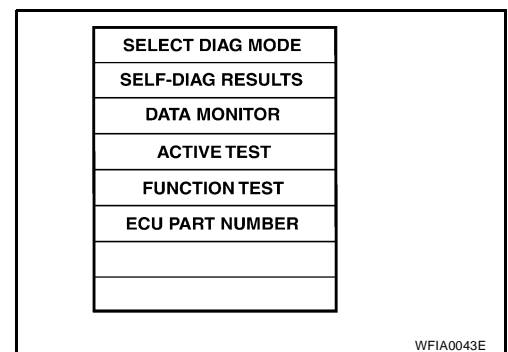

ACTIVE TEST PROCEDURE

- When conducting Active test, vehicle must be stationary.
 - When ABS warning lamp stays on, never conduct Active test.
1. Turn ignition switch OFF.
 2. Connect CONSULT-II to Data Link Connector.
 3. Start engine.
 4. Touch "START" on CONSULT-II screen.

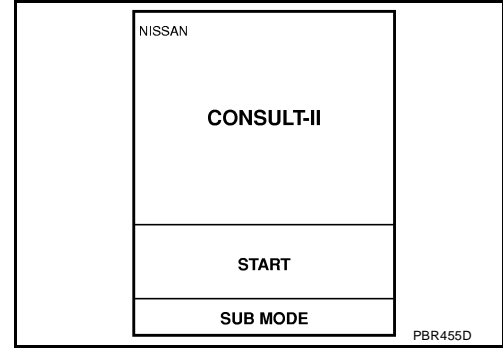

5. Touch "ABS".

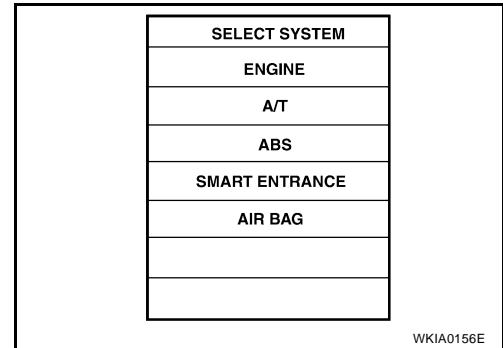

6. Touch "ACTIVE TEST".

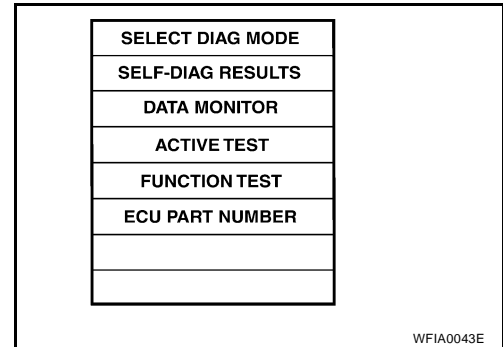

7. Select active test item by touching screen.

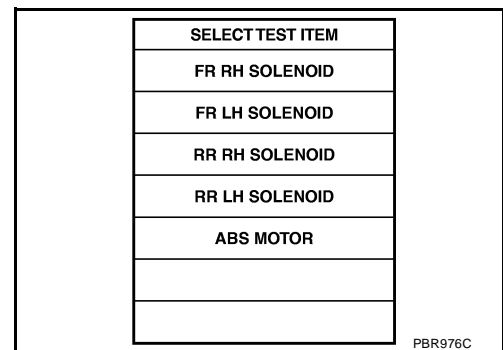

ON BOARD DIAGNOSTIC SYSTEM DESCRIPTION

[ABS]

8. Touch "START".
9. Carry out the active test by touching screen key.

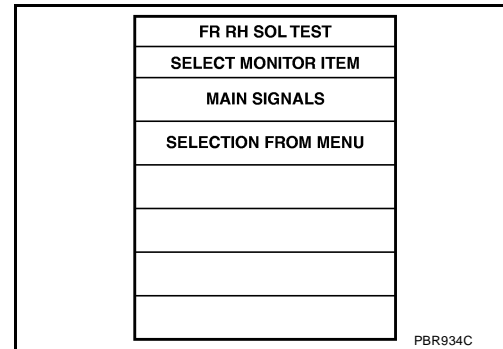

A
B
C
D

DATA MONITOR MODE

MONITOR ITEM	CONDITION	SPECIFICATION
FR LH SENSOR FR RH SENSOR RR LH SENSOR RR RH SENSOR	Drive vehicle. (Each wheel is rotating.)	Wheel speed signal (Almost the same speed as speedometer.)
WARNING LAMP	Ignition switch is ON or engine is running.	ABS warning lamp is turned on: ON ABS warning lamp is turned off: OFF
STOP LAMP SW	Brake is depressed.	Depress the pedal: ON Release the pedal: OFF
MOTOR RELAY	1. Drive vehicle at speeds over 30 km/h (19 MPH) for at least 1 minute. 2. Engine is running.	ABS is not operating: OFF ABS is operating: ON
ACTUATOR RELAY	Ignition switch is ON or engine is running.	Ignition switch ON (Engine stops): OFF Engine running: ON
FR LH OUT SOL FR LH IN SOL FR RH OUT SOL FR RH IN SOL RR LH OUT SOL RR LH IN SOL RR RH OUT SOL RR RH IN SOL	1. Drive vehicle at speeds over 30 km/h (19 MPH) for at least 1 minute. 2. Engine is running.	Operating conditions for each solenoid valve are indicated. ABS is not operating: OFF
BATTERY VOLT	Ignition switch is ON or engine is running.	Power supply voltage for control unit

BRC

E
G
H
I
J
K
L

ACTIVE TEST MODE

TEST ITEM	CONDITION	JUDGEMENT		
FR RH SOL FR LH SOL RR RH SOL RR LH SOL	Engine is running.	Brake fluid pressure control operation		
			IN SOL	OUT SOL
		UP (Increase):	OFF	OFF
		KEEP (Hold):	ON	OFF
		DOWN (Decrease):	ON	ON
ABS MOTOR		ABS actuator motor ON: Motor runs (ABS motor relay ON) OFF: Motor stops (ABS motor relay OFF)		

M

NOTE:

Active test will automatically stop ten seconds after the test starts. (TEST IS STOPPED monitor shows ON.)

TROUBLE DIAGNOSIS — INTRODUCTION

How to Perform Trouble Diagnoses for Quick and Accurate Repair INTRODUCTION

The ABS system has an electronic control unit to control major functions. The control unit accepts input signals from sensors and instantly drives the actuators. It is essential that both kinds of signals are proper and stable. It is also important to check for conventional problems: such as air leaks in booster lines, lack of brake fluid, or other problems with the brake system.

It is much more difficult to diagnose a problem that occurs intermittently rather than continuously. Most intermittent problems are caused by poor electric connections or faulty wiring. In this case, careful checking of suspicious circuits may help prevent the replacement of good parts.

A visual check only may not find the cause of the problems, so a road test should be performed.

Before undertaking actual checks, take a few minutes to talk with a customer who approaches with an ABS complaint. The customer is a very good source of information on such problems; especially intermittent ones. By talking to the customer, find out what symptoms are present and under what conditions they occur. Start your diagnosis by looking for “conventional” problems first. This is one of the best ways to troubleshoot brake problems on an ABS controlled vehicle.

Also check related Service bulletins for information.

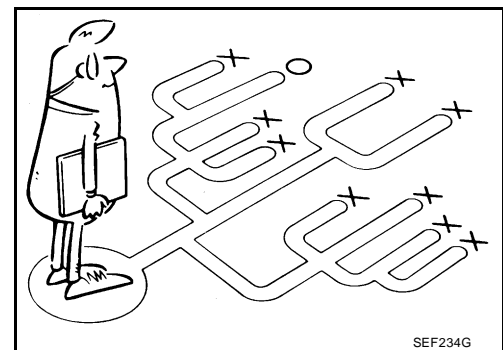
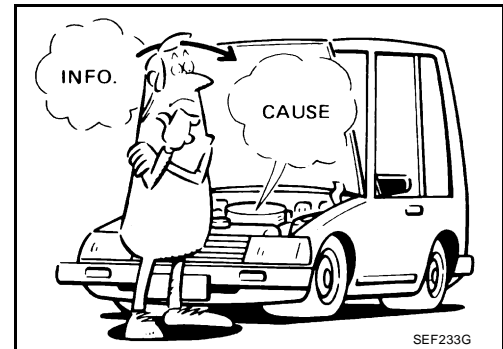

TROUBLE DIAGNOSIS — BASIC INSPECTION

PF0:0000

Preliminary Check

EFS001EZ

1. CHECK BRAKE FLUID

Check brake fluid for contamination.

Has brake fluid been contaminated?

- Yes >> Replace. GO TO 2.
- No >> GO TO 2.

2. CHECK BRAKE FLUID LEVEL

Check brake fluid level in reservoir tank.

Low fluid level may indicate brake pad wear or leakage from brake line.

Is brake fluid filled between MAX and MIN lines on reservoir tank?

- Yes >> GO TO 3.
- No >> Fill brake fluid. GO TO 3.

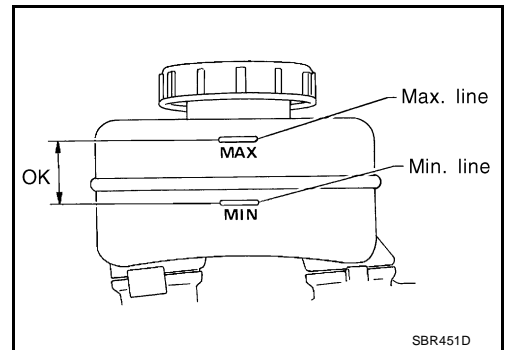

3. CHECK BRAKE LINE

Check brake line for leakage.

Is leakage present at or around brake lines, tubes or hoses or are any of these parts cracked or damaged?

- Yes >> Repair or replace as required. GO TO 4.
- No >> GO TO 4.

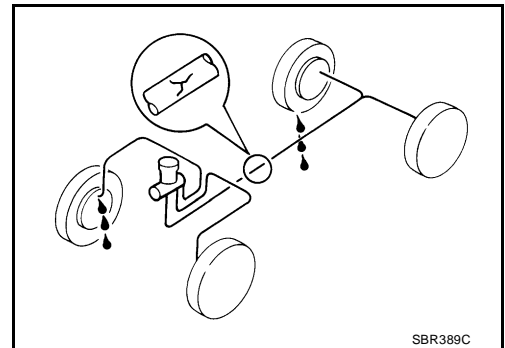

4. CHECK BRAKE BOOSTER OPERATION

Check brake booster for operation. Refer to [BR-16, "OPERATING CHECK"](#) . Also, check air tightness. Refer to [BR-16, "AIRTIGHT CHECK"](#) .

Is brake booster airtight and functioning properly?

- Yes >> GO TO 5.
- No >> Replace. GO TO 5.

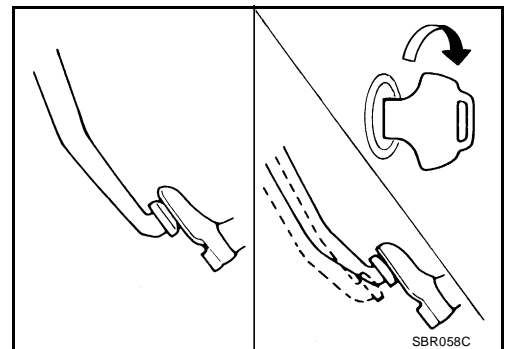

A
B
C
D
E
BRC
G
H
I
J
K
L
M

5. CHECK BRAKE PAD, ROTOR, SHOE AND DRUM

Check brake pad, rotor, shoe and drum.

Refer to [BR-19, "Pad Replacement"](#) , [BR-21, "ROTOR"](#) , [BR-27, "ROTOR"](#) , [BR-34, "LINING"](#) , and [BR-34, "DRUM"](#) .

Are brake pads, rotors, shoes and drums functioning properly?

Yes >> GO TO 6.

No >> Replace.

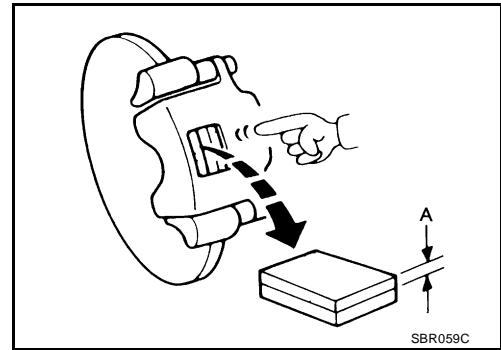

6. RECHECK BRAKE FLUID LEVEL

Check brake fluid level in reservoir tank again.

Is brake fluid filled between MAX and MIN lines on reservoir tank?

Yes >> GO TO 7.

No >> Fill brake fluid reservoir to specification.

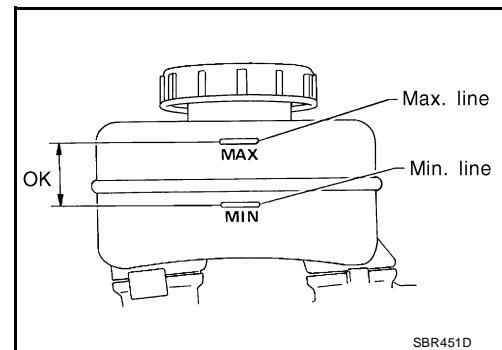

7. CHECK WARNING LAMP ACTIVATION

Check warning lamp activation.

Does warning lamp turn on when ignition switch is turned ON?

Yes >> GO TO 8.

No >> Check fuse, warning lamp bulb and warning lamp circuit.

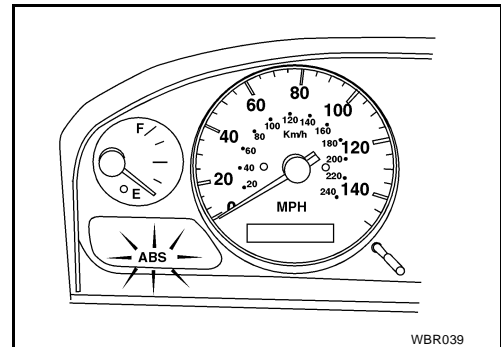

8. CHECK WARNING LAMP DEACTIVATION

Check warning lamp for deactivation after engine is started.

Does warning lamp turn off when engine is started?

Yes >> GO TO 9.

No (with CONSULT-II)>> Refer to [BRC-17, "SELF-DIAGNOSIS PROCEDURE"](#) .

No (without CONSULT-II)>> Refer to [BRC-17, "SELF-DIAGNOSIS PROCEDURE"](#) .

9. DRIVE VEHICLE

Drive vehicle at speeds over 30 km/h (19 MPH) for at least one minute.

Does warning lamp remain off after vehicle has been driven at 30 km/h (19 MPH) for at least one minute?

Yes >> **INSPECTION END**

No (with CONSULT-II)>> Refer to [BRC-17, "SELF-DIAGNOSIS PROCEDURE"](#) .

No (without CONSULT-II)>> Refer to [BRC-17, "SELF-DIAGNOSIS PROCEDURE"](#) .

EFS001F0

Ground Circuit Check

ABS ACTUATOR AND ELECTRIC UNIT GROUND

- Check resistance between ABS actuator and electric unit connector terminals and ground.

Resistance : Approximately 0Ω

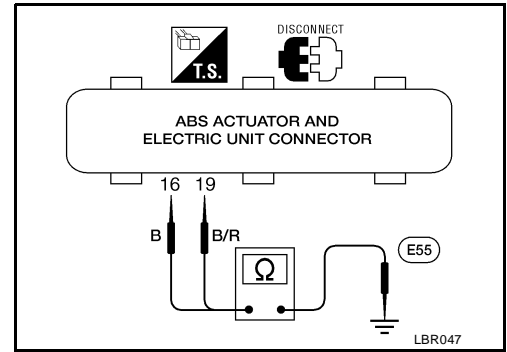

A
B
C
D
E
G
H
I
J
K
L
M

BRC

TROUBLE DIAGNOSIS — GENERAL DESCRIPTION

[ABS]

TROUBLE DIAGNOSIS — GENERAL DESCRIPTION

PF0:0000

Malfunction Code/Symptom Chart

EFS001F1

Code No.	Malfunctioning Part	Reference Page
12	Self-diagnosis could not detect any malfunctions.	—
45	Actuator front left outlet solenoid valve	BRC-29
46	Actuator front left inlet solenoid valve	BRC-29
41	Actuator front right outlet solenoid valve	BRC-29
42	Actuator front right inlet solenoid valve	BRC-29
51	Actuator rear right outlet solenoid valve	BRC-29
52	Actuator rear right inlet solenoid valve	BRC-29
55	Actuator rear left outlet solenoid valve	BRC-29
56	Actuator rear left inlet solenoid valve	BRC-29
25 *1	Front left sensor (open-circuit)	BRC-27
26 *1	Front left sensor (short-circuit)	BRC-27
21 *1	Front right sensor (open-circuit)	BRC-27
22 *1	Front right sensor (short-circuit)	BRC-27
31 *1	Rear right sensor (open-circuit)	BRC-27
32 *1	Rear right sensor (short-circuit)	BRC-27
35 *1	Rear left sensor (open-circuit)	BRC-27
36 *1	Rear left sensor (short-circuit)	BRC-27
18 *1	Sensor rotor	BRC-27
61 *3	Actuator motor or motor relay	BRC-31
63	Solenoid valve relay	BRC-29
57 *2	Power supply (Low voltage)	BRC-33
71	Control unit	BRC-35
Warning lamp stays on when ignition switch is turned ON.	Control unit power supply circuit Warning lamp bulb circuit Control unit or control unit connector Solenoid valve relay stuck Power supply for solenoid valve relay coil	BRC-41
Warning lamp does not come on when ignition switch is turned ON.	Fuse, warning lamp bulb or warning lamp circuit Control unit	BRC-39
Pedal vibration and noise	—	BRC-38
Long stopping distance	—	BRC-37
Unexpected pedal action	—	BRC-36
ABS does not work	—	BRC-38
ABS works frequently	—	BRC-36

- *1: If one or more wheels spin on a rough or slippery road for 40 seconds or more, the ABS warning lamp will illuminate. This does not indicate a malfunction. Only in the case of the short-circuit (Code Nos. 26, 22, 32 and 36), after repair the ABS warning lamp also illuminates when the ignition switch is turned ON. In this case, drive the vehicle at speeds greater than 30 km/h (19 MPH) for approximately 1 minute as specified in [BRC-14](#), "Self-diagnosis". Check to ensure that the ABS warning lamp goes out while the vehicle is being driven.
- *2: The trouble code "57", which refers to a low power supply voltage, does not indicate that the ABS control unit is malfunctioning. Do not replace the ABS control unit with a new one.
- *3: The trouble code "61" can sometimes appear when the ABS motor is not properly grounded. If it appears, be sure to check the condition of the ABS motor ground circuit connection.

WHEEL SENSOR OR ROTOR

Diagnostic Procedure

Malfunction code No. 21, 22, 25, 26, 31, 32, 35, 36 or 18

NOTE:

Wheel position should be distinguished by code No. except code No. 18 (sensor rotor).

1. INSPECTION START

Wheel sensor inspection

>> GO TO 2.

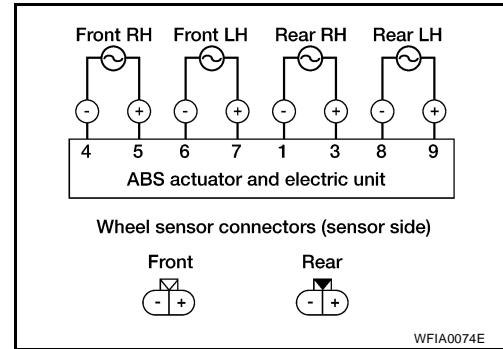

2. CHECK CONNECTOR

1. Disconnect connectors from ABS actuator and electric unit and wheel sensor of malfunction code No. Check terminals for damage or loose connection, then reconnect connectors.

2. Carry out self-diagnosis again.

Does warning lamp activate again?

Yes >> GO TO 3.

No >> **INSPECTION END**

3. CHECK WHEEL SENSOR ELECTRICAL

1. Disconnect ABS actuator and electric unit connector.

2. Check resistance between ABS actuator and electric unit connector E55 (body side) terminals.

Code No. 21 or 22 (Front RH wheel)

Terminals 4 (B) and 5 (W)

Code No. 25 or 26 (Front LH wheel)

Terminals 6 (G) and 7 (R)

Code No. 31 or 32 (Rear RH wheel)

Terminals 1 (LG) and 3 (PU)

Code No. 35 or 36 (Rear LH wheel)

Terminals 8 (L) and 9 (P)

Resistance

Front : 1.45 - 1.85kΩ

Rear : 1.05 - 1.35kΩ

Is resistance within specification?

Yes >> GO TO 5.

No >> GO TO 4.

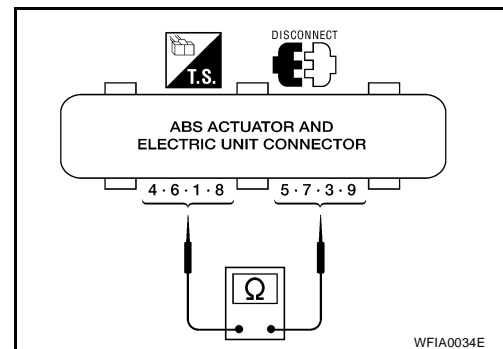

4. CHECK WHEEL SENSOR

Check each sensor for resistance.

Resistance

Front : 1.45 - 1.85k Ω

Rear : 1.05 - 1.35k Ω

Is resistance within specification?

Yes >> Check the following.

- If resistance is within specification range, repair harness or connectors.
- Harness connectors E11, E53, E55, B102, B103
- Harness for open or short between wheel sensor connectors and ABS actuator and electric unit

No >> Replace wheel sensor. Refer to [BRC-44, "Removal and Installation"](#) .

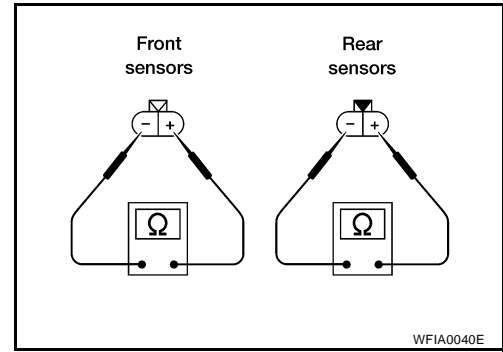

5. CHECK TIRE

Check for inflation pressure, wear and size of each tire. (See NOTE)

Are tire pressure and size correct and is tire wear within specifications?

Yes >> GO TO 6.

No >> Adjust tire pressure or replace tire(s). (See NOTE)

6. CHECK WHEEL BEARING

Check wheel bearing axial end play. (See NOTE)

Is wheel bearing axial end play within specifications? Refer to [FAX-5, "Front Wheel Bearing"](#) , or [RAX-5, "Rear Wheel Bearing"](#) .

Yes >> GO TO 7.

No >> Check wheel bearing. Refer to [FAX-5, "Front Wheel Bearing"](#) , or [RAX-5, "Rear Wheel Bearing"](#) .

7. CHECK SENSOR ROTOR

Check sensor rotor for teeth damage. (See NOTE)

Is sensor rotor free from damage?

Yes >> Check ABS actuator and electric unit pin terminals for damage or the connection of ABS actuator and electric unit harness connector. Reconnect ABS actuator and electric unit harness connector. Then retest.

No >> Replace sensor rotor. Refer to [BRC-45, "SENSOR ROTOR"](#) . (See NOTE)

ABS ACTUATOR SOLENOID VALVE AND SOLENOID VALVE RELAY

PFP:47600

Diagnostic Procedure

EFS001F3

Malfunction code No. 41, 42, 45, 46, 51, 52, 55, 56, 63

1. INSPECTION START

Solenoid valve relay inspection

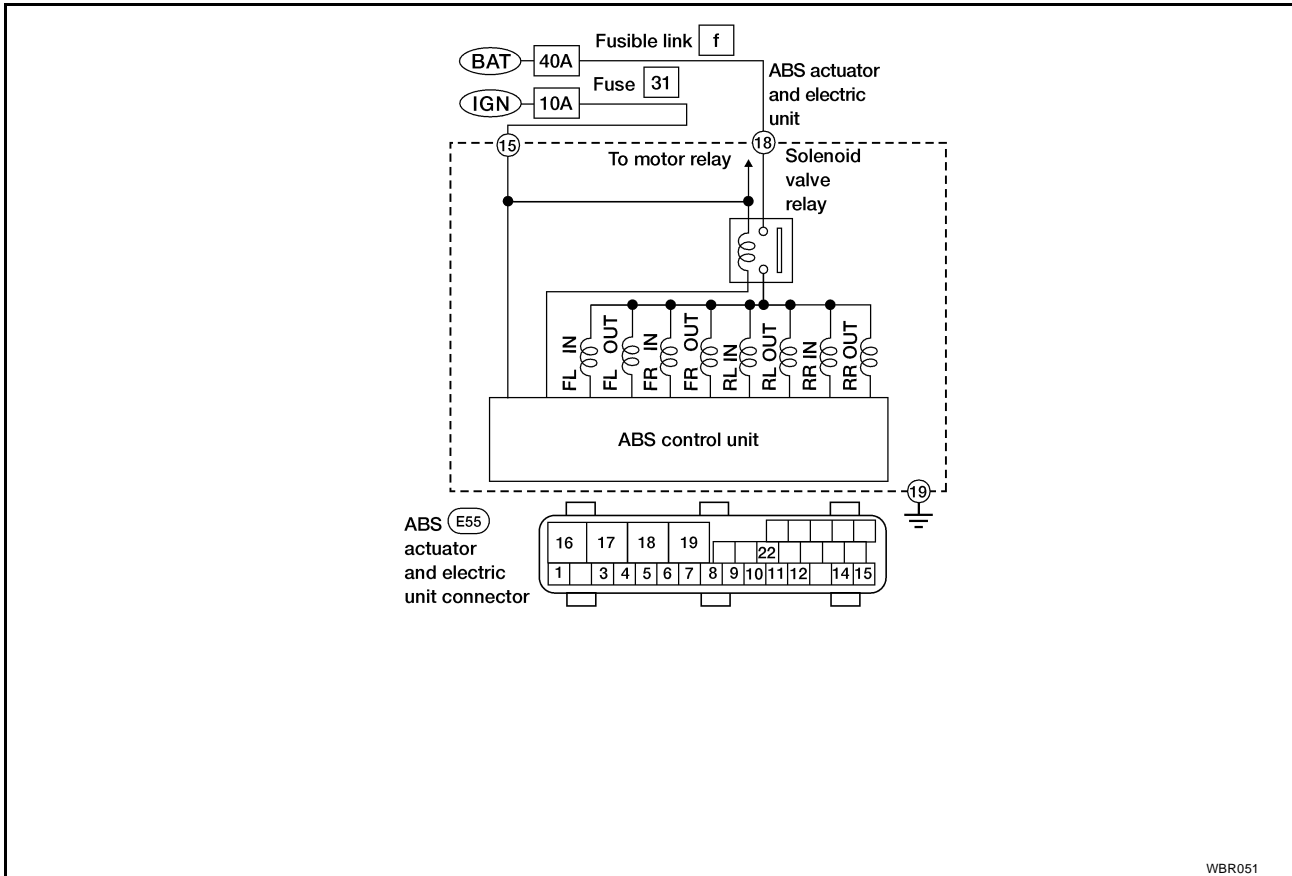

>> GO TO 2.

2. CHECK FUSE

Check 40A fusible link **f** . For fuse layout, refer to [PG-2, "Schematic"](#) .

Is fusible link OK?

- Yes >> GO TO 3.
- No >> GO TO 6.

3. CHECK CONNECTOR

1. Disconnect connector from ABS actuator and electric unit. Check terminals for damage or loose connection. Then reconnect connector.
2. Carry out self-diagnosis again.

Does warning lamp activate again?

- Yes >> GO TO 4.
- No >> **INSPECTION END**

A
B
C
D
E
BRC
G
H
I
J
K
L
M

4. CHECK ABS ACTUATOR AND ELECTRIC UNIT GROUND CIRCUIT

Refer to [BRC-25, "ABS ACTUATOR AND ELECTRIC UNIT GROUND"](#) .

Is ground circuit OK?

- Yes >> GO TO 5.
- No >> Repair harness or connector.

5. CHECK SOLENOID VALVE POWER SUPPLY CIRCUIT

1. Disconnect ABS actuator and electric unit connector.
2. Check voltage between ABS actuator and electric unit connector E55 (body side) terminal 18 (Y) and ground.

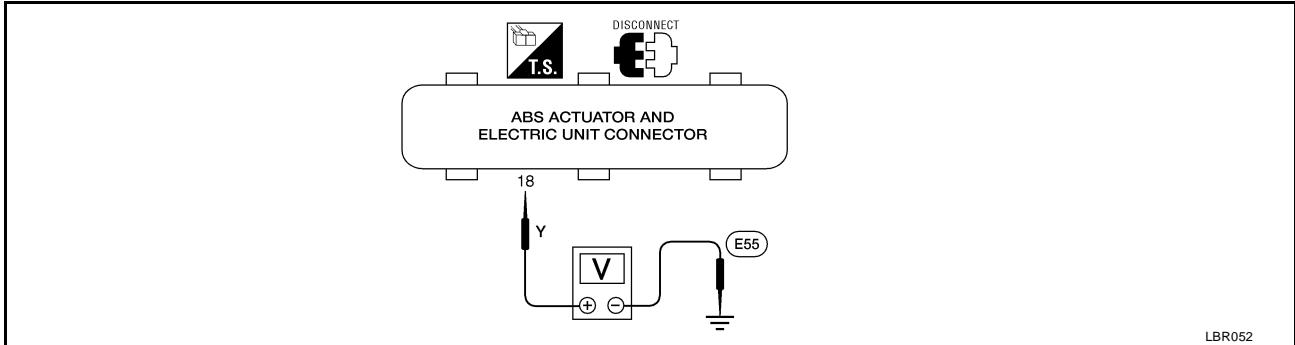

Does battery voltage exist?

- Yes >> Replace ABS actuator and electric unit. Refer to [BRC-46, "ACTUATOR"](#) .
- No >> Check the following.
 - If NG, repair harness or connectors.
 - Harness connector E55
 - Harness for open or short between ABS actuator and electric unit and fusible link.

6. REPLACE FUSE

Replace 40A fusible link f . For fuse layout, refer to [PG-2, "Schematic"](#) .

Does the fusible link blow when ignition switch is turned ON?

- Yes >> GO TO 7.
- No >> **INSPECTION END**

7. CHECK SOLENOID VALVE RELAY POWER SUPPLY CIRCUIT FOR SHORT

1. Disconnect battery cable and ABS actuator and electric unit connector.
2. Check continuity between ABS actuator and electric unit connector E55 (body side) terminal 18 (Y) and ground.

Continuity should not exist.

Does continuity exist?

- Yes >> Check the following.
 - Harness connector E55
 - Harness for short between ABS actuator and electric unit and fusible link.
- No >> Replace ABS actuator and electric unit. Refer to [BRC-46, "ACTUATOR"](#) .

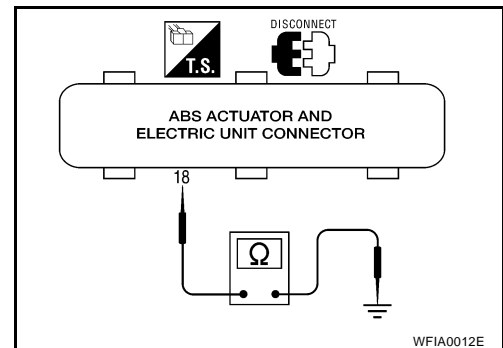

MOTOR RELAY OR MOTOR

Diagnostic Procedure

Malfunction code No. 61

1. INSPECTION START

ABS motor relay inspection

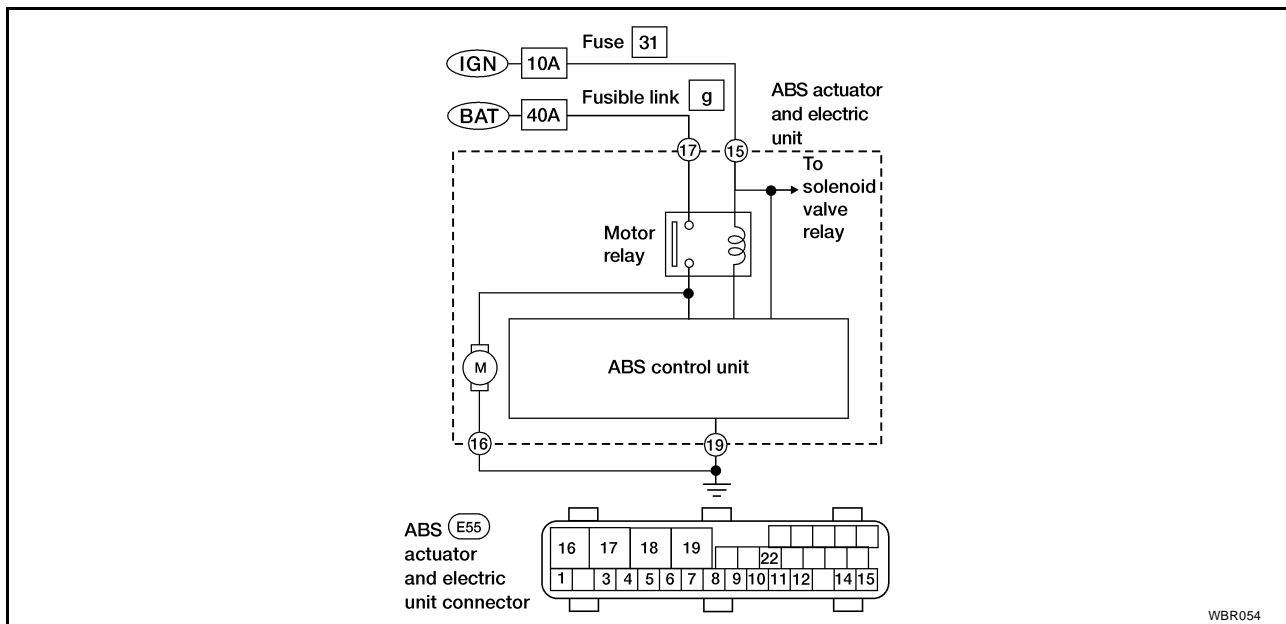

>> GO TO 2.

2. CHECK FUSIBLE LINK

Check 40A fusible link **g**. For fusible link layout, refer to [PG-2, "Schematic"](#).

Is fusible link OK?

- Yes >> GO TO 3.
- No >> GO TO 6.

3. CHECK CONNECTOR

1. Disconnect ABS actuator and electric unit connector. Check terminals for damage or loose connection. Then reconnect connector.
2. Carry out self-diagnosis again.

Does warning lamp activate again?

- Yes >> GO TO 4.
- No >> **INSPECTION END**

4. CHECK ABS ACTUATOR AND ELECTRIC UNIT GROUND CIRCUIT

Refer to [BRC-25, "ABS ACTUATOR AND ELECTRIC UNIT GROUND"](#).

Is ground circuit OK?

- Yes >> GO TO 5.
- No >> Repair harness or connector.

5. CHECK MOTOR RELAY POWER SUPPLY CIRCUIT

1. Disconnect ABS actuator and electric unit connector.
2. Check voltage between ABS actuator and electric unit connector E55 (body side) terminal 17 (B/Y) and ground.

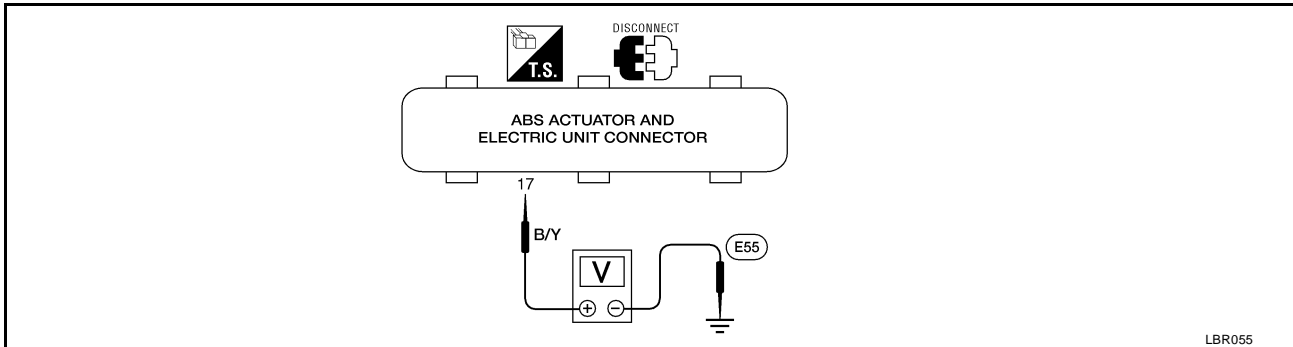

Does battery voltage exist?

- Yes >> Replace ABS actuator and electric unit. Refer to [BRC-46, "ACTUATOR"](#) .
- No >> Check the following.
- Harness connector E55
 - Harness for open or short between ABS actuator and electric unit and fusible link

6. REPLACE FUSIBLE LINK

Replace 40A fusible link **g** . For fuse layout, refer to [PG-2, "Schematic"](#) .

Does the fusible link blow when ignition switch is turned ON?

- Yes >> GO TO 7.
- No >> **INSPECTION END**

7. CHECK ABS ACTUATOR MOTOR POWER SUPPLY CIRCUIT FOR SHORT

1. Disconnect battery cable and ABS actuator and electric unit connector.
2. Check continuity between ABS actuator and electric unit connector E55 (body side) terminal 17 (B/Y) and ground.

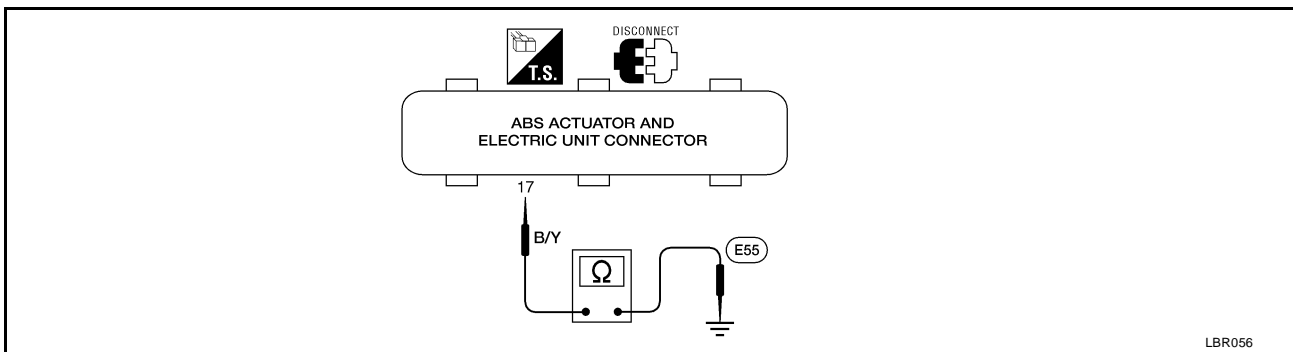

Continuity should not exist.

Does continuity exist?

- Yes >> Check the following.
- Harness connector E55
 - Harness for short between ABS actuator and electric unit and fusible link
- No >> Replace ABS actuator and electric unit. Refer to [BRC-46, "ACTUATOR"](#) .

LOW VOLTAGE

Diagnostic Procedure

Malfunction code No. 57

1. INSPECTION START

ABS actuator and electric unit power supply and ground circuit inspection

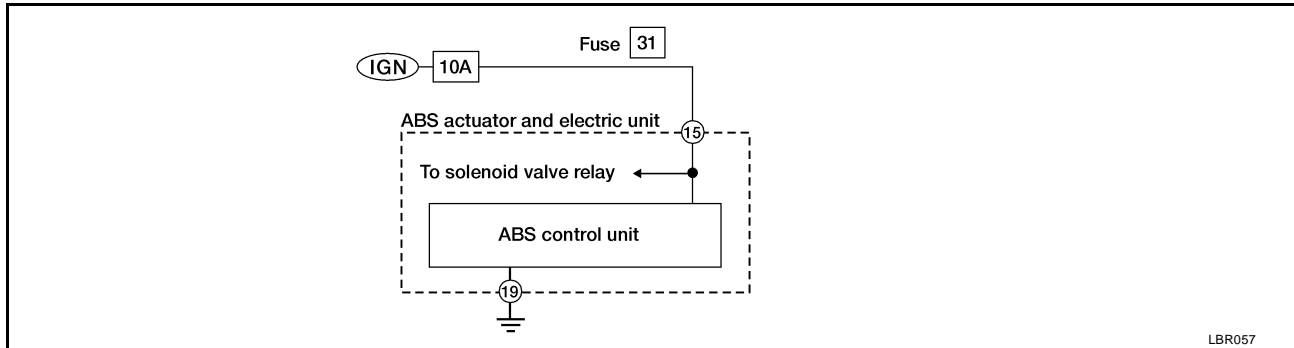

>> GO TO 2.

2. CHECK FUSE

Check 10A fuse No. 31. For fuse layout, refer to [PG-2, "Schematic"](#).

Is fuse OK?

- Yes >> GO TO 3.
- No >> GO TO 6.

3. CHECK CONNECTOR

1. Disconnect ABS actuator and electric unit connector. Check terminals for damage or loose connections. Then reconnect connector.
2. Carry out self-diagnosis again.

Does warning lamp activate again?

- Yes >> GO TO 4.
- No >> **INSPECTION END**

4. CHECK ABS ACTUATOR AND ELECTRIC UNIT GROUND CIRCUIT

Refer to [BRC-25, "ABS ACTUATOR AND ELECTRIC UNIT GROUND"](#).

Is ground circuit OK?

- Yes >> GO TO 5.
- No >> Repair harness or connector.

5. CHECK ABS ACTUATOR AND ELECTRIC UNIT POWER SUPPLY CIRCUIT

1. Disconnect ABS actuator and electric unit connector.
2. Check voltage between ABS actuator and electric unit connector E55 (body side) terminal 15 (GY) and ground.

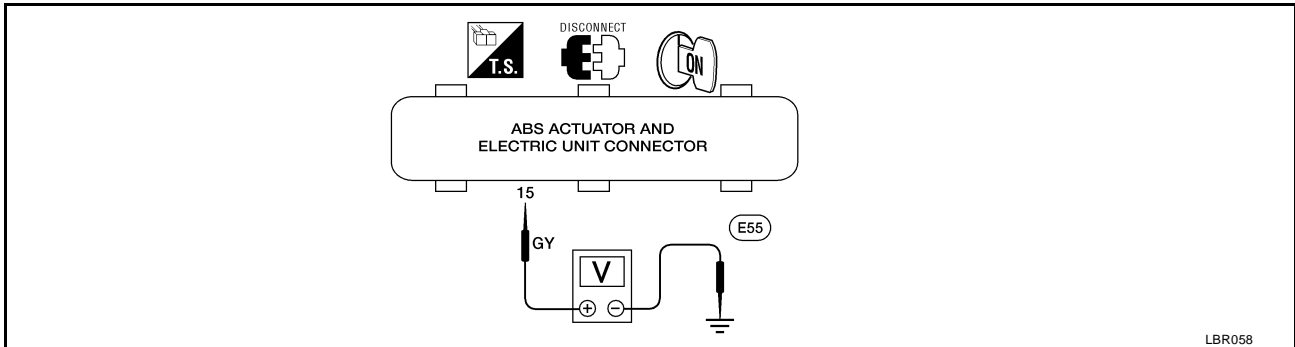

Does battery voltage exist when ignition switch is turned ON?

- Yes >> Replace ABS actuator and electric unit. Refer to [BRC-46, "ACTUATOR"](#) .
- No >> Check the following.
- Harness connector E55
 - Harness for open or short between ABS actuator and electric unit and fuse

6. REPLACE FUSE

Replace 10A fuse 31. For fuse layout, refer to [PG-2, "Schematic"](#) .

Does the fuse blow when ignition switch is turned ON?

- Yes >> GO TO 7.
- No >> **INSPECTION END**

7. CHECK ABS ACTUATOR AND ELECTRIC UNIT POWER SUPPLY CIRCUIT FOR SHORT

1. Disconnect battery cable and ABS actuator and electric unit connector.
2. Check continuity between ABS actuator and electric unit connector E55 (body side) terminal 15 (GY) and ground.

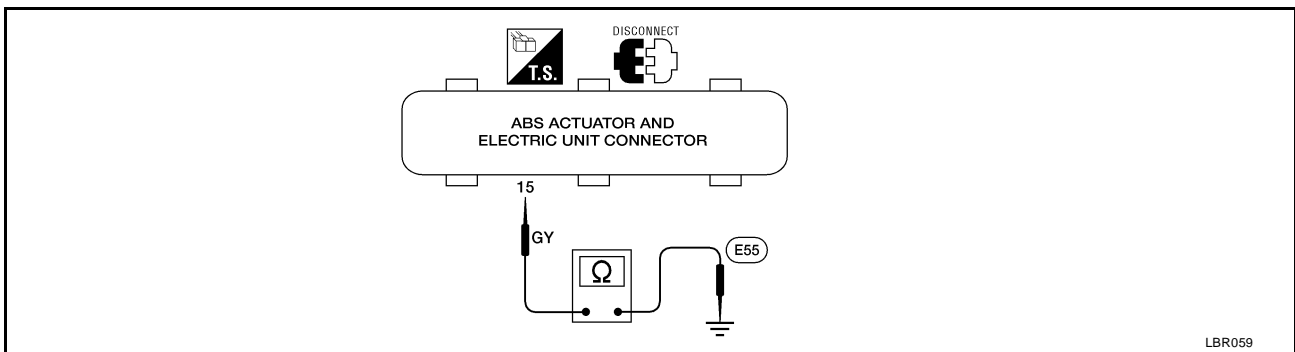

Continuity should not exist.

Does continuity exist?

- Yes >> Check the following.
- If continuity exists, repair harness or connector.
Harness connector E55
 - Harness for short between ABS actuator and electric unit and fuse
- No >> Replace ABS actuator and electric unit. Refer to [BRC-46, "ACTUATOR"](#) .

CONTROL UNIT

Diagnostic Procedure

Malfunction code No. 71

1. INSPECTION START

ABS actuator and electric unit power supply and ground circuit inspection

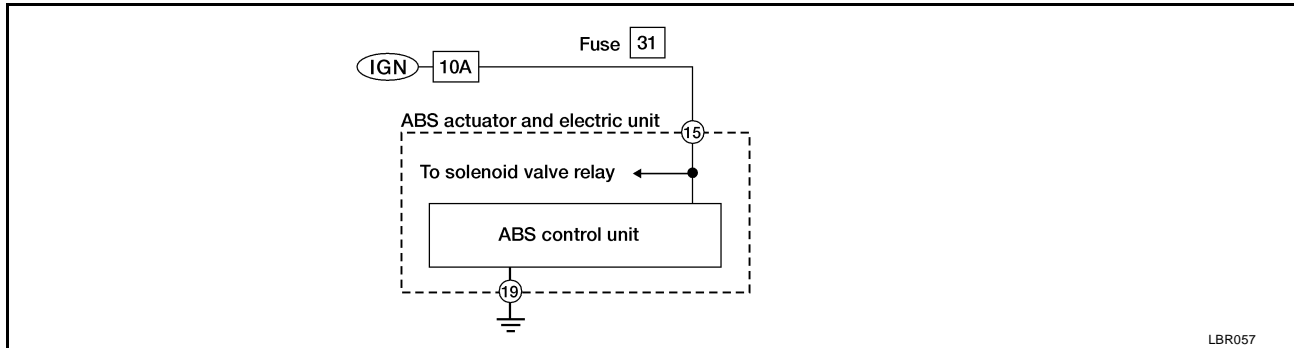

>> GO TO 2.

2. CHECK CONNECTOR

1. Disconnect ABS actuator and electric unit connector.
Check terminals for damage or loose connection. Then reconnect connector.
2. Carry out self-diagnosis again.

Does warning lamp activate again?

- Yes >> GO TO 3.
No >> **INSPECTION END**

3. CHECK ABS ACTUATOR AND ELECTRIC UNIT POWER SUPPLY CIRCUIT

Check voltage. Refer to [BRC-33, "Diagnostic Procedure"](#).

Does battery voltage exist when ignition switch is turned ON?

- Yes >> GO TO 4.
No >> Check the following.
- Harness for open or short between ABS actuator and electric unit and fuse

4. CHECK WARNING LAMP INDICATION

Does warning lamp indicate code No. 71 again?

Yes or No

- Yes >> Replace ABS actuator and electric unit. Refer to [BRC-46, "ACTUATOR"](#).
No >> Inspect the system according to the code No.

TROUBLE DIAGNOSES FOR SYMPTOMS

Symptom 1. ABS Works Frequently

1. CHECK BRAKE FLUID PRESSURE

Check brake fluid pressure distribution.

Refer to [BR-10, "Inspection"](#) .

Is brake fluid pressure distribution normal?

Yes >> GO TO 2.

No >> ● Repair. Then perform Preliminary Check.

- Refer to [BR-11, "Inspection"](#) .

2. CHECK WHEEL SENSOR

1. Check wheel sensor connector for terminal damage or loose connections.

2. Perform wheel sensor check.

Refer to [BRC-27, "Diagnostic Procedure"](#) .

Is wheel sensor mechanism OK?

Yes >> GO TO 3.

No >> Repair.

3. CHECK FRONT AXLE

Check front axles for excessive looseness. Refer to [FAX-5, "Front Wheel Bearing"](#) .

Is front axle installed properly?

Yes >> Go to [BRC-36, "Symptom 2. Unexpected Pedal Action"](#) .

No >> Repair.

Symptom 2. Unexpected Pedal Action

1. CHECK BRAKE PEDAL STROKE

Check brake pedal stroke.

Is brake pedal stroke excessive?

Yes >> Perform Preliminary Check. Refer to [BRC-23, "Preliminary Check"](#) .

No >> GO TO 2.

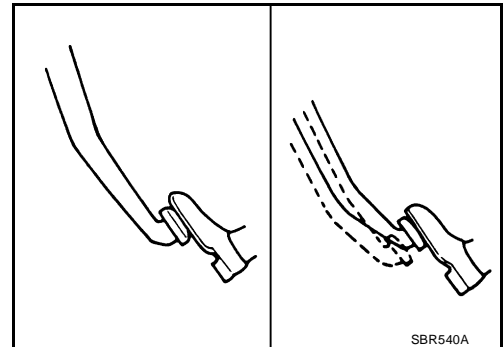

2. CHECK MECHANICAL BRAKE SYSTEM PERFORMANCE

Disconnect ABS actuator and electric unit connector and check whether brake is effective.

Does brake system function properly when brake pedal is depressed?

Yes >> GO TO 3.

No >> Perform Preliminary Check. Refer to [BRC-23, "Preliminary Check"](#) .

3. CHECK WARNING LAMP INDICATION

Ensure warning lamp remains off while driving.

Is warning lamp turned off?

Yes >> GO TO 4.

No (with CONSULT-II)>> Carry out self-diagnosis. Refer to [BRC-17, "SELF-DIAGNOSIS PROCEDURE"](#).

No (without CONSULT-II)>> Carry out self-diagnosis. Refer to [BRC-14, "SELF-DIAGNOSIS PROCEDURE"](#).

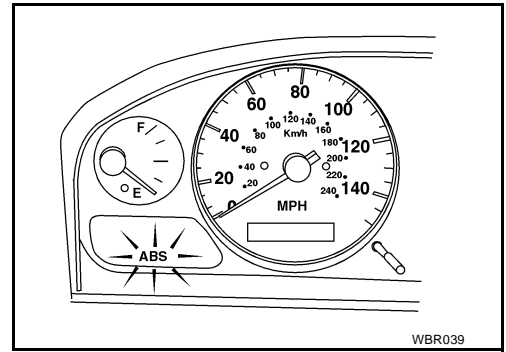

4. CHECK WHEEL SENSOR

1. Check wheel sensor connector for terminal damage or loose connection.
2. Perform wheel sensor check. Refer to [BRC-27, "Diagnostic Procedure"](#).

Is wheel sensor mechanism OK?

- Yes >>
- Check ABS actuator and electric unit pin terminals for damage, or the connection of ABS actuator and electric unit harness connector.
 - Reconnect ABS actuator and electric unit harness connector.
 - Retest.

No >> Repair.

Symptom 3. Long Stopping Distance

EFS001F9

1. CHECK MECHANICAL BRAKE SYSTEM PERFORMANCE

Disconnect ABS actuator and electric unit connector and check whether stopping distance is still long.

Does brake system function properly when brake pedal is depressed?

Yes >> Perform Preliminary Check and air bleeding (if necessary).

No >> Go to [BRC-38, "Symptom 4. ABS Does Not Work"](#).

NOTE:

Stopping distance may be longer for vehicles without ABS when road condition is slippery.

Symptom 4. ABS Does Not Work

EFS001FA

1. CHECK WARNING LAMP INDICATION

Does the ABS warning lamp activate?

Yes or No

Yes (with CONSULT-II)>> Carry out self-diagnosis. Refer to [BRC-17, "SELF-DIAGNOSIS PROCEDURE"](#) .
 Yes (without CONSULT-II)>> Carry out self-diagnosis. Refer to [BRC-14, "SELF-DIAGNOSIS PROCEDURE"](#)

No >> Go to [BRC-36, "Symptom 2. Unexpected Pedal Action"](#) .

NOTE:

ABS does not work when vehicle speed is under 10 km/h (6 MPH).

Symptom 5. Pedal Vibration and Noise

EFS001FB

1. INSPECTION START

Pedal vibration and noise inspection.

>> GO TO 2.

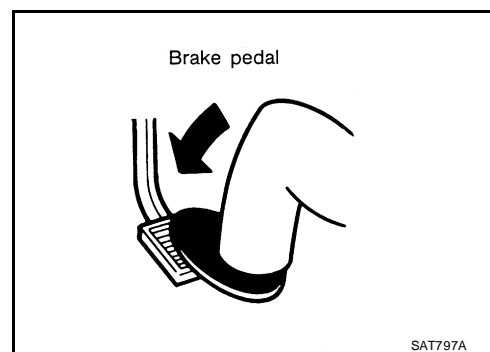
**2. CHECK SYMPTOM**

1. Apply brake.
2. Start engine.

Does the symptom appear only when engine is started?

Yes (with CONSULT-II)>> Carry out self-diagnosis. Refer to [BRC-17, "SELF-DIAGNOSIS PROCEDURE"](#) .
 Yes (without CONSULT-II)>> Carry out self-diagnosis. Refer to [BRC-14, "SELF-DIAGNOSIS PROCEDURE"](#)

No >> Go to [BRC-36, "Symptom 2. Unexpected Pedal Action"](#) .

NOTE:

ABS may operate and cause vibration under any of the following conditions.

- Low friction (slippery) road.
- High speed cornering.
- Driving over bumps and potholes.

Symptom 6. Warning Lamp Does Not Come On When Ignition Switch Is Turned On

EFS001FC

1. INSPECTION START

Warning lamp circuit inspection.

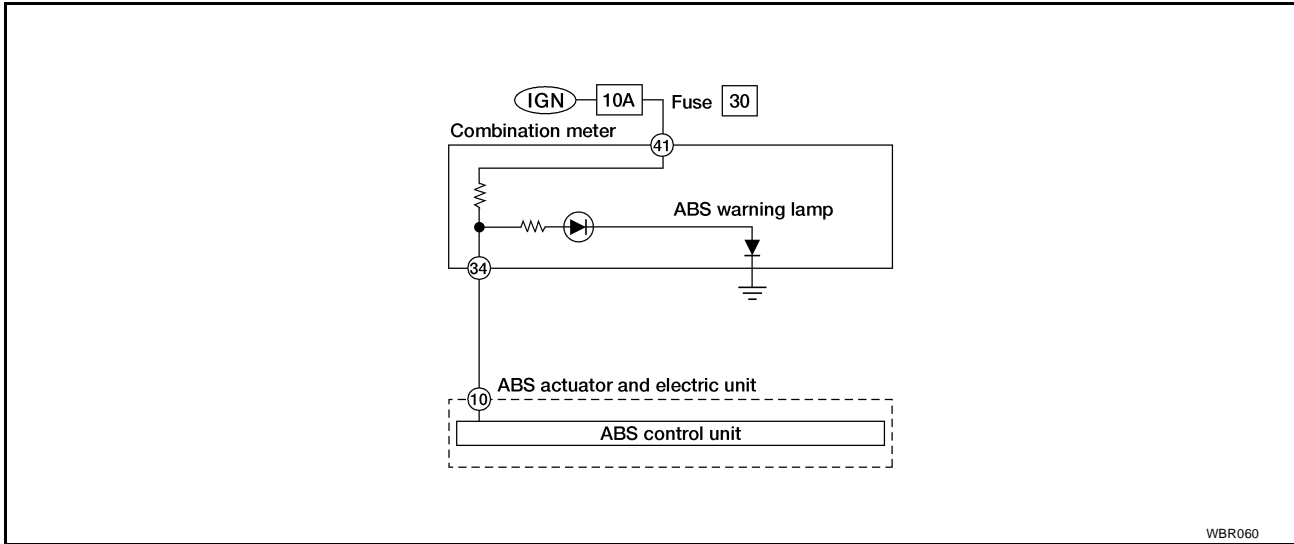

>> GO TO 2.

2. CHECK FUSE

Check 10A fuse No. 30. For fuse layout, refer to [PG-2, "Schematic"](#).

Is fuse OK?

- Yes >> GO TO 4.
- No >> GO TO 3.

3. REPLACE FUSE

Replace 10A fuse No. 30. For fuse layout, refer to [PG-2, "Schematic"](#).

Does the fuse blow when ignition switch is turned ON?

- Yes >> Check wiring for short between fuse and combination meter. Repair as required.
- No >> **INSPECTION END**

4. CHECK WARNING LAMP ACTIVATION

Disconnect ABS actuator and electric unit connector.

Does the warning lamp activate?

- Yes >> Replace ABS actuator and electric unit. Refer to [BRC-46, "ACTUATOR"](#).
- No >> GO TO 5.

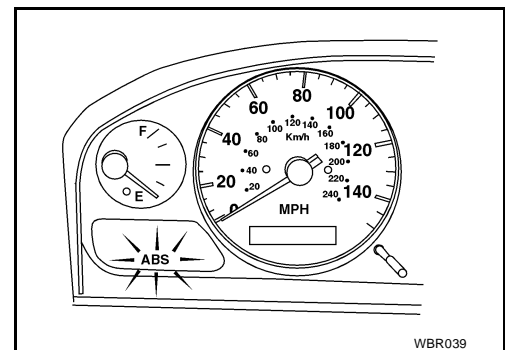

5. CHECK HARNESS FOR SHORT

1. Disconnect ABS actuator and electric unit connector and combination meter connector M30.
2. Check continuity between ABS actuator and electric unit connector E55 (body side) terminal 10 (L/B) and ground.

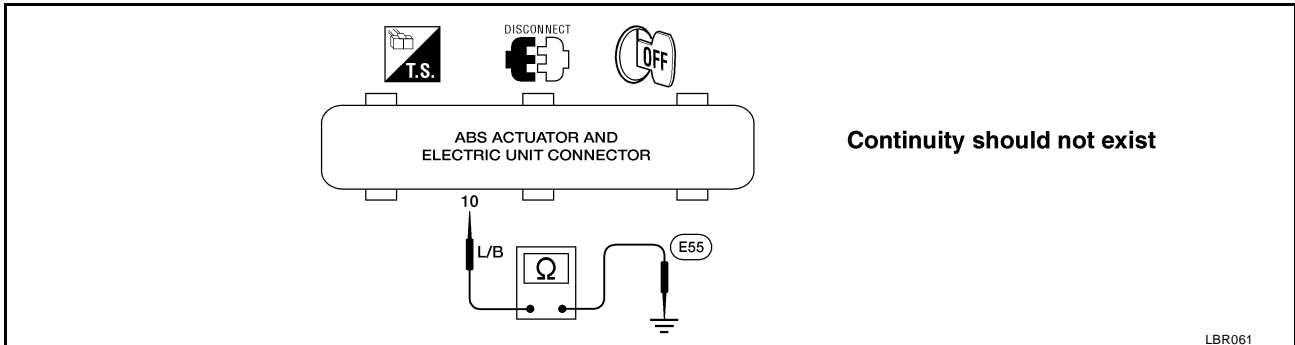

Does continuity exist?

- Yes >> Repair harness or connectors.
- No >> Check combination meter.
 - Refer to [DI-25. "WITH TACHOMETER"](#) .

Symptom 7. Warning Lamp Stays On When Ignition Switch Is Turned On

EFS001FD

1. INSPECTION START

ABS control unit inspection.

>> GO TO 2.

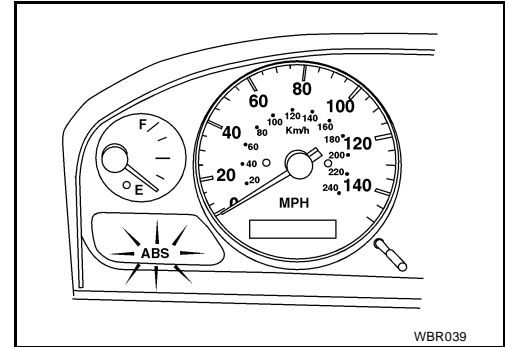

WBR039

2. CHECK FUSE

Check 10A fuse No. 31. For fuse layout, refer to [PG-2, "Schematic"](#).

Is fuse OK?

- Yes >> GO TO 3.
- No >> GO TO 8.

3. CHECK HARNESS CONNECTOR

Check ABS actuator and electric unit pin terminals for damage or bad connection of ABS actuator and electric unit harness connector. Reconnect ABS actuator and electric unit harness connector. Then retest.

Does warning lamp stay on when ignition switch is turned ON?

- Yes >> GO TO 4.
- No >> **INSPECTION END**

4. CHECK ABS ACTUATOR AND ELECTRIC UNIT GROUND CIRCUIT

Refer to [BRC-25, "ABS ACTUATOR AND ELECTRIC UNIT GROUND"](#).

Is ground circuit OK?

- Yes >> GO TO 5.
- No >> Repair harness or connector.

5. CHECK ABS ACTUATOR AND ELECTRIC UNIT POWER SUPPLY CIRCUIT

1. Disconnect ABS actuator and electric unit connector.
2. Check voltage between ABS actuator and electric unit connector E55 (body side) terminal 15 (GY) and ground.

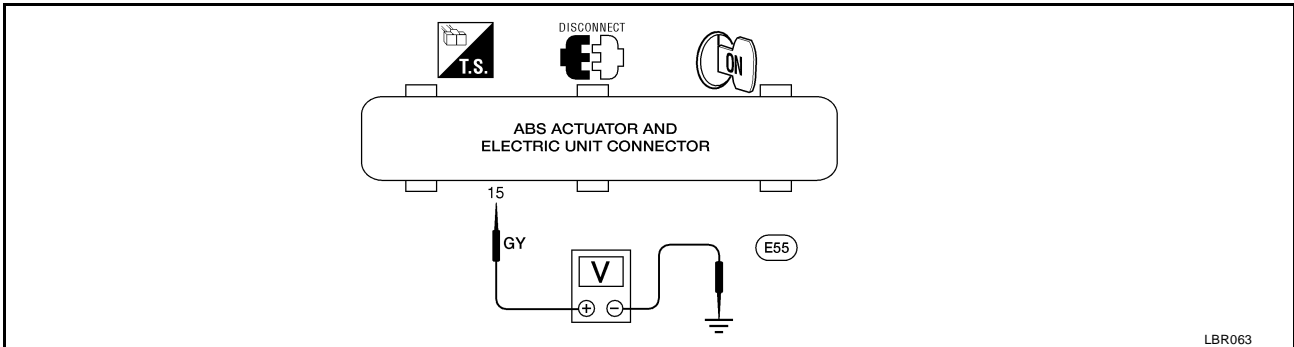

Does battery voltage exist when ignition switch is turned ON?

Yes >> GO TO 6.

No >> Check the following.

- Harness connector E55
- Harness for open or short between ABS actuator and electric unit and fuse

6. CHECK WARNING LAMP

1. Disconnect ABS actuator and electric unit connector.
2. Connect suitable wire between ABS actuator and electric unit connector E55 (body side) terminal 10 (L/B) and ground.

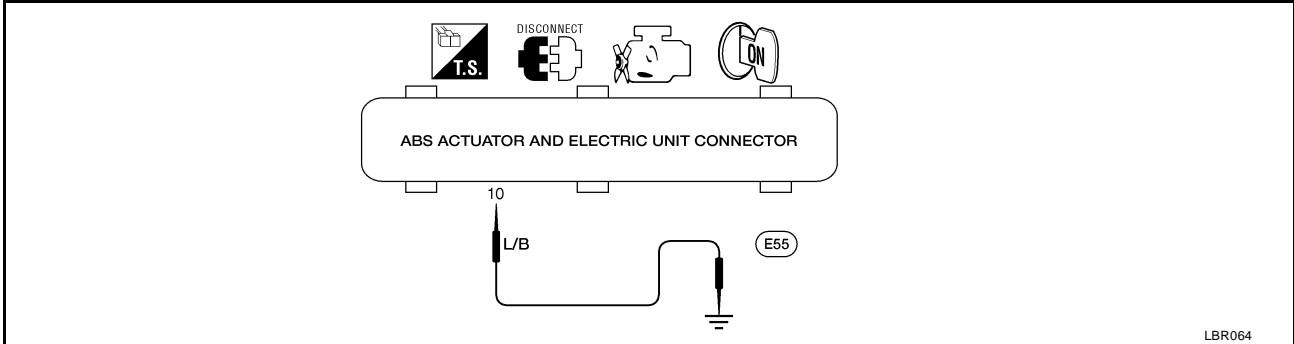

Does the warning lamp deactivate?

Yes >> Replace ABS actuator and electric unit. Refer to [BRC-46, "ACTUATOR"](#).

No >> GO TO 7.

7. CHECK ABS WARNING LAMP CONTROL CIRCUIT FOR OPEN

1. Disconnect combination meter connector M30.
2. Check continuity between combination meter connector M30 (body side) terminal 34 (L/B) and ABS actuator and electric unit connector E55 (body side) terminal 10 (L/B).

NOTE:

Connect positive lead of multimeter to combination meter connector M30 (body side) terminal 34 (L/B) and negative lead to ABS actuator and electric unit connector E55 (body side) terminal 10 (L/B).

Continuity should exist.

Does continuity exist?

- Yes >> Check combination meter.
- Refer to [DI-25, "WITH TACHOMETER"](#).
- No >> GO TO 8.

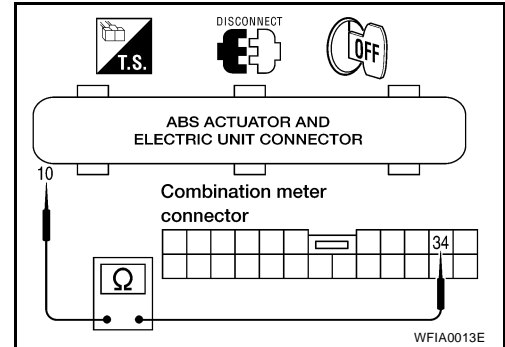

8. REPLACE FUSE

Replace fuse.

Does the fuse blow when ignition switch is turned ON?

- Yes >> GO TO 9.
- No >> **INSPECTION END**

9. CHECK ABS ACTUATOR AND ELECTRIC UNIT POWER SUPPLY CIRCUIT FOR SHORT

1. Disconnect battery cable and ABS actuator and electric unit connector.
2. Check continuity between ABS actuator and electric unit connector E55 (body side) terminal 15 (GY) and ground.

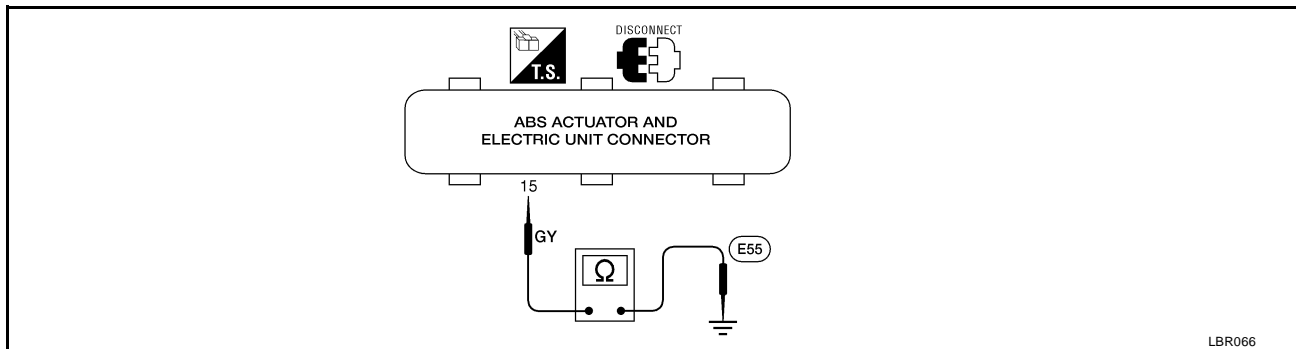

Continuity should not exist.

Does continuity exist?

- Yes >> Check the following.
- Harness connector E55
 - Harness for short between ABS actuator and electric unit and fuse
- No >> Replace ABS actuator and electric unit. Refer to [BRC-46, "ACTUATOR"](#).

REMOVAL AND INSTALLATION

[ABS]

REMOVAL AND INSTALLATION

PFP:00000

Removal and Installation

EFS001FE

CAUTION:

Be careful not to damage sensor edge and sensor rotor teeth. When removing the front or rear wheel hub assembly, disconnect the ABS wheel sensor from the assembly and move it away.

FRONT WHEEL SENSOR

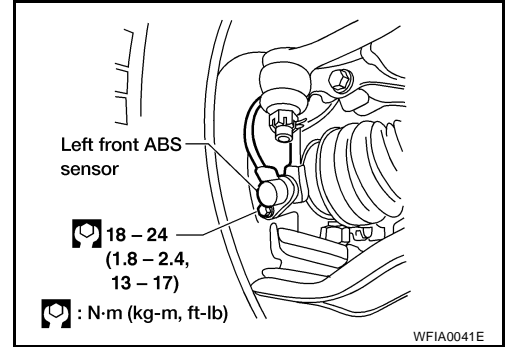

REAR WHEEL SENSOR (REAR DRUM)

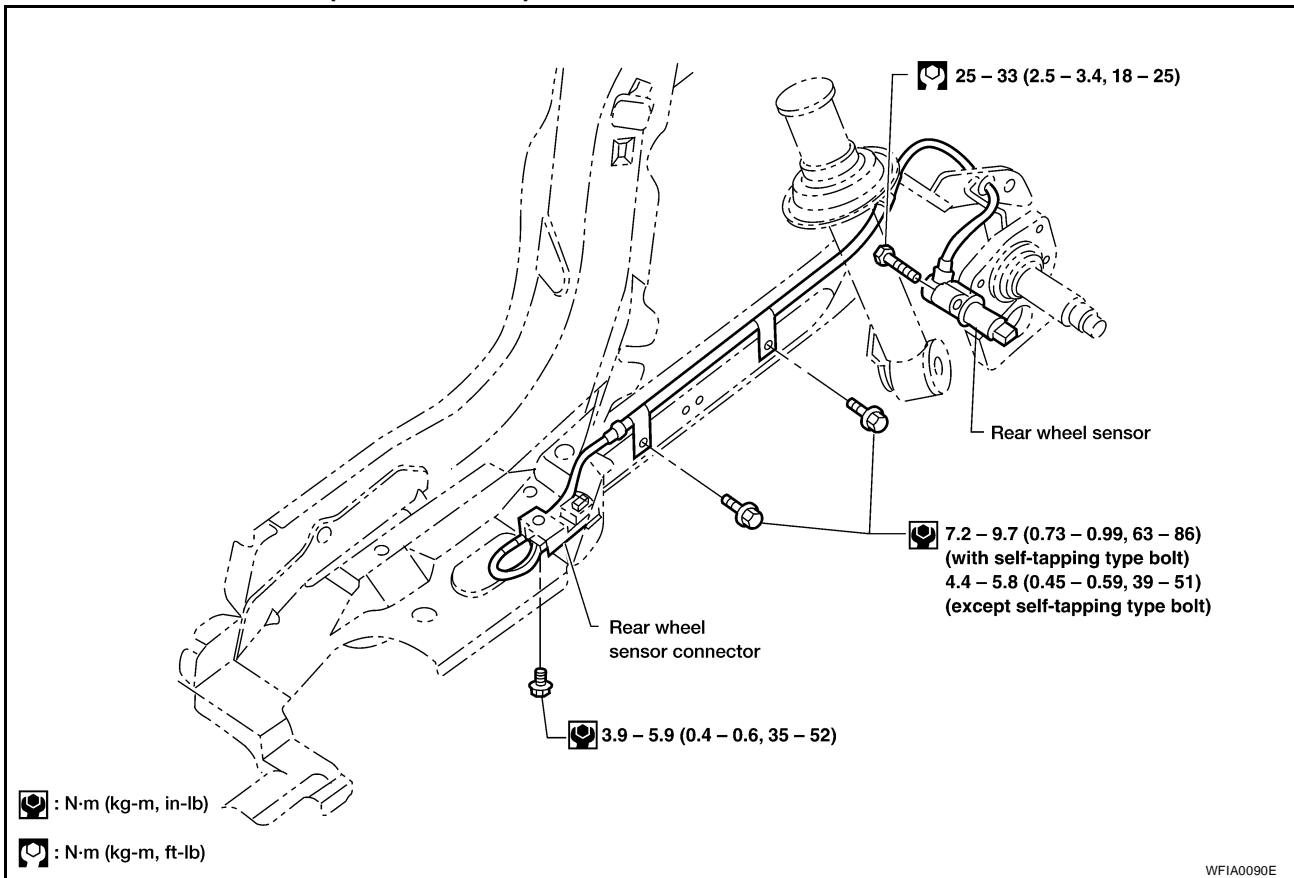

REAR WHEEL SENSOR (REAR DISC)

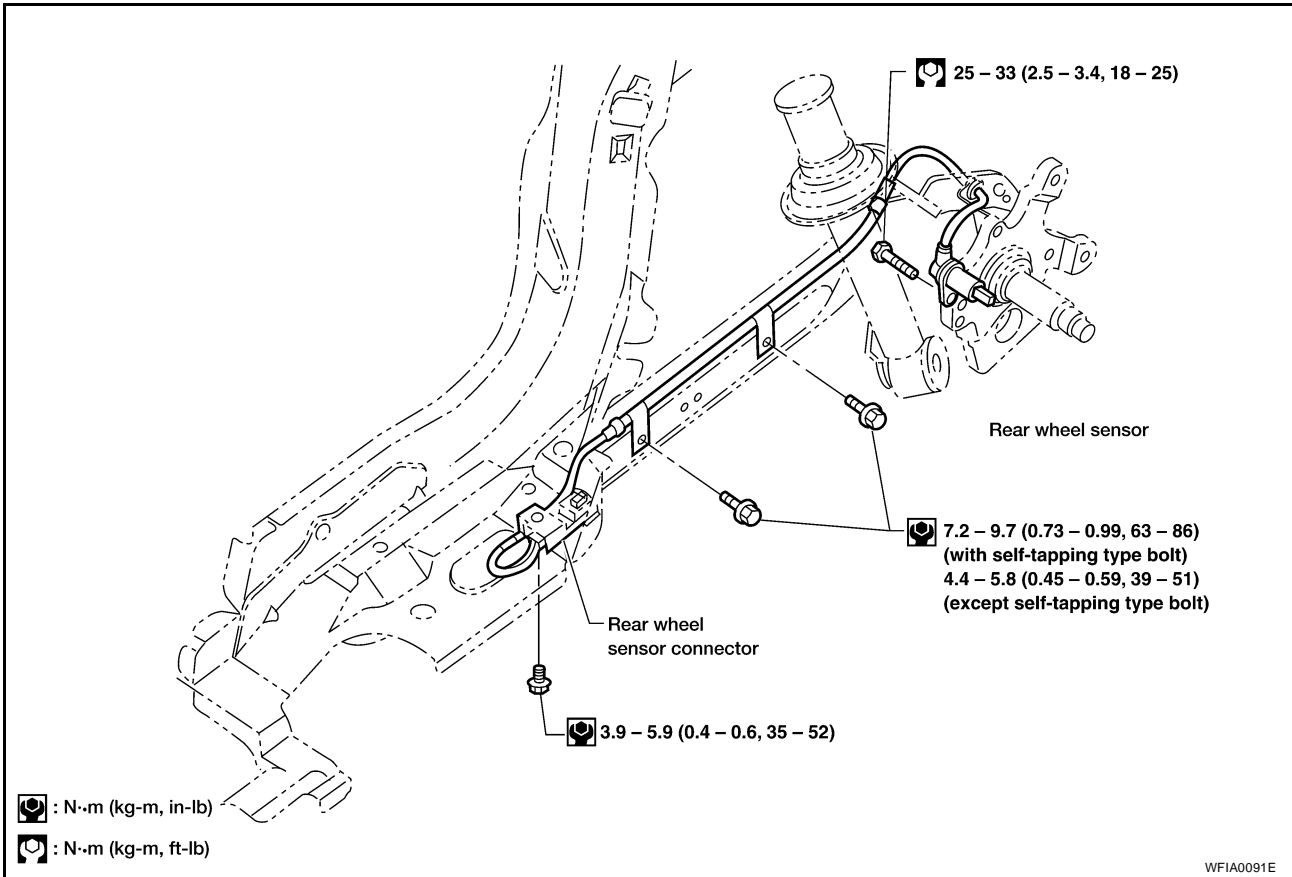

SENSOR ROTOR

Removal

1. Remove the drive shaft or rear wheel hub. Refer to [FAX-16, "Removal"](#), or [RAX-6, "Removal"](#) respectively.

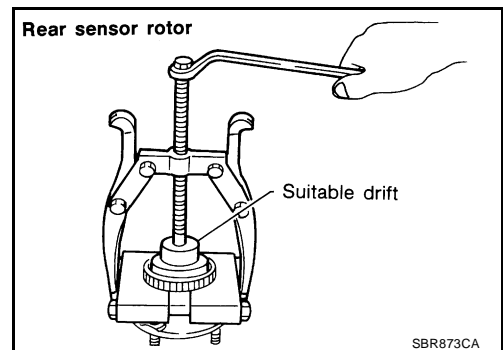
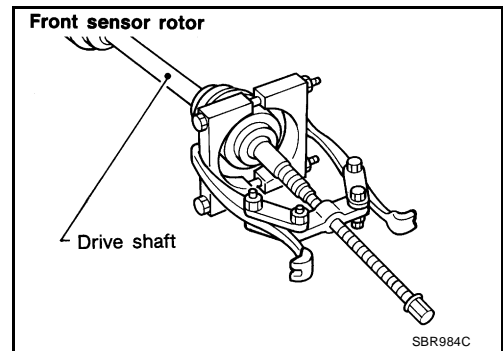

2. Remove the sensor rotor using suitable puller, drift and bearing replacer.

A
B
C
D
E
BRC
G
H
I
J
K
L
M

REMOVAL AND INSTALLATION

[ABS]

Installation

Install the sensor rotor. For front sensor rotor, use hammer and wooden block. For rear sensor rotor, use suitable drift and press.

- Always replace sensor rotor with new one.

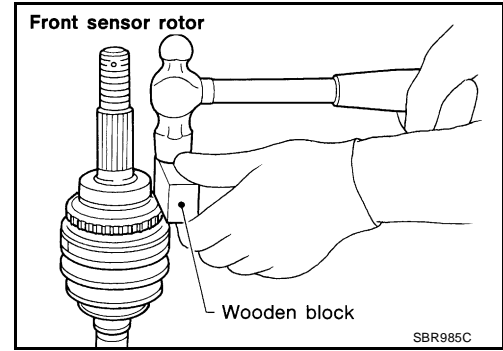

- Pay attention to the dimension of rear sensor rotor as shown in figure.

Dimension h

Rear Disc : 1.5 - 2.5 mm (0.06 - 0.10 in)

Rear Drum : 17.7 - 18.7 mm (0.70 - 0.74 in)

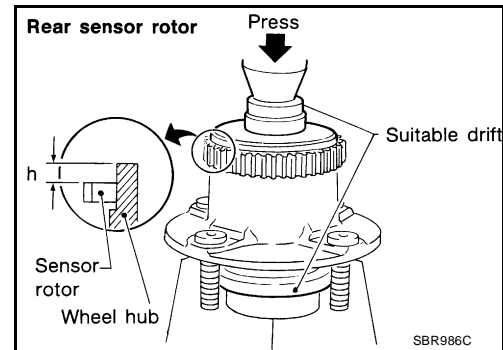

ACTUATOR

SEC. 476

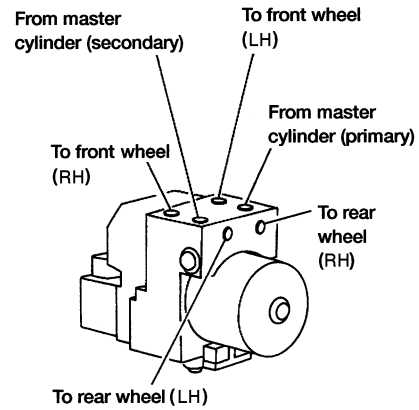
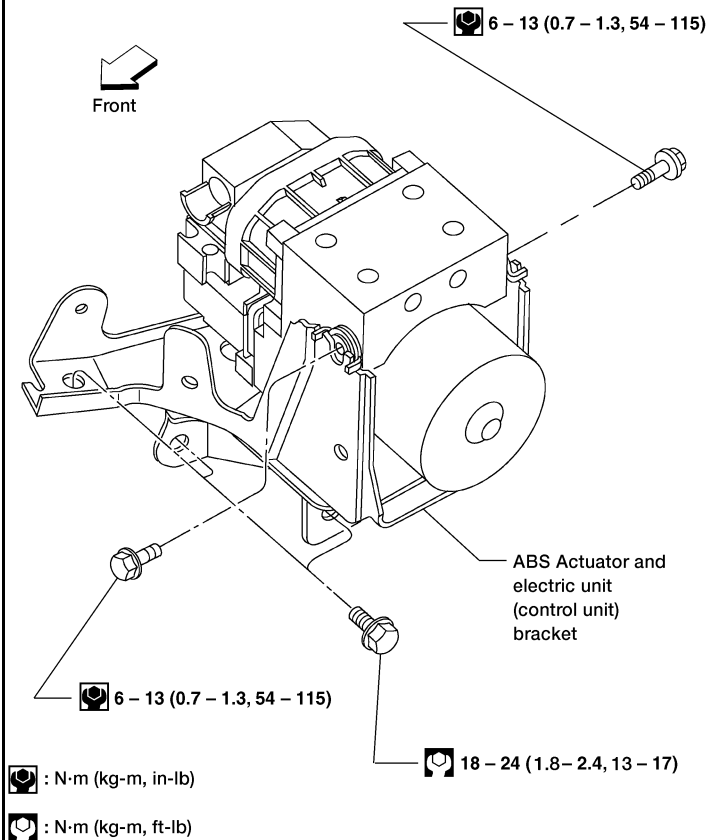

Connector lock

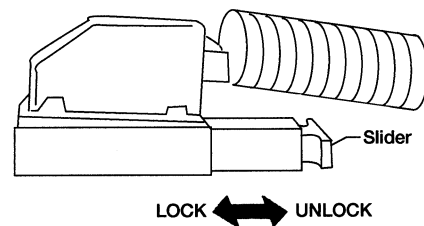

Removal

- Disconnect negative battery cable.
- Drain brake fluid. Refer to [BR-6, "Changing Brake Fluid"](#).
- Remove the A/C high pressure and A/C low pressure lines. Refer to [MTC-87, "Removal and Installation"](#).

REMOVAL AND INSTALLATION

[ABS]

4. Remove strut tower bar (if equipped). Refer to [FSU-5, "Components"](#) .
5. Remove mounting bracket bolts.
6. Disconnect harness connector and brake lines.

A

Installation

1. Connect brake lines temporarily.
2. Tighten bolts.
3. Tighten brake lines.
4. Connect harness connector and negative battery cable.
5. Install strut tower bar (if equipped). Refer to [FSU-5, "Components"](#) .
6. Refill and bleed the brake fluid. Then bleed air. Refer to [BR-7, "Bleeding Brake System"](#) .
7. Install the A/C high pressure and A/C low pressure lines. Evacuate and recharge the A/C system. Refer to [MTC-85, "Evacuating System and Charging Refrigerant"](#) .

B

C

D

E

BRC

G

H

I

J

K

L

M

