

SECTION **BR**  
BRAKE SYSTEM

A  
B  
C  
D  
E

CONTENTS

<p><b>PRECAUTIONS</b> ..... 3</p> <p style="padding-left: 20px;">Precautions for Supplemental Restraint System (SRS) "AIR BAG" and "SEAT BELT PRE-TENSIONER" ..... 3</p> <p style="padding-left: 20px;">Precautions for Brake System ..... 3</p> <p style="padding-left: 20px;">Wiring Diagrams and Trouble Diagnosis ..... 3</p> <p><b>PREPARATION</b> ..... 4</p> <p style="padding-left: 20px;">Commercial Service Tools ..... 4</p> <p><b>NOISE, VIBRATION, AND HARSHNESS (NVH)</b></p> <p><b>TROUBLESHOOTING</b> ..... 5</p> <p style="padding-left: 20px;">NVH Troubleshooting Chart ..... 5</p> <p><b>ON-VEHICLE SERVICE</b> ..... 6</p> <p style="padding-left: 20px;">Checking Brake Fluid Level ..... 6</p> <p style="padding-left: 20px;">Checking Brake Line ..... 6</p> <p style="padding-left: 20px;">Changing Brake Fluid ..... 6</p> <p style="padding-left: 20px;">Brake Burnishing Procedure ..... 6</p> <p style="padding-left: 20px;">Bleeding Brake System ..... 7</p> <p><b>BRAKE HYDRAULIC LINE</b> ..... 8</p> <p style="padding-left: 20px;">Hydraulic Circuit ..... 8</p> <p style="padding-left: 20px;">Removal ..... 8</p> <p style="padding-left: 20px;">Inspection ..... 9</p> <p style="padding-left: 20px;">Installation ..... 9</p> <p><b>DUAL PROPORTIONING VALVE</b> ..... 10</p> <p style="padding-left: 20px;">Inspection ..... 10</p> <p><b>BRAKE PEDAL AND BRACKET</b> ..... 11</p> <p style="padding-left: 20px;">Removal and Installation ..... 11</p> <p style="padding-left: 20px;">Inspection ..... 11</p> <p style="padding-left: 20px;">Adjustment ..... 12</p> <p style="padding-left: 40px;">BRAKE PEDAL HEIGHT ..... 12</p> <p style="padding-left: 40px;">STOP LAMP SWITCH AND ASCD CANCEL SWITCH CLEARANCE ..... 12</p> <p><b>MASTER CYLINDER</b> ..... 13</p> <p style="padding-left: 20px;">Removal ..... 13</p> <p style="padding-left: 20px;">Disassembly ..... 13</p> <p style="padding-left: 20px;">Inspection ..... 14</p> <p style="padding-left: 20px;">Assembly ..... 14</p> <p style="padding-left: 20px;">Installation ..... 15</p> <p><b>BRAKE BOOSTER</b> ..... 16</p> <p style="padding-left: 20px;">On-vehicle Service ..... 16</p> <p style="padding-left: 20px;">OPERATING CHECK ..... 16</p>	<p style="padding-left: 20px;">AIRTIGHT CHECK ..... 16</p> <p style="padding-left: 20px;">Removal ..... 16</p> <p style="padding-left: 20px;">Inspection ..... 16</p> <p style="padding-left: 20px;">OUTPUT ROD LENGTH CHECK ..... 16</p> <p style="padding-left: 20px;">Installation ..... 17</p> <p><b>VACUUM HOSE</b> ..... 18</p> <p style="padding-left: 20px;">Removal and Installation ..... 18</p> <p style="padding-left: 20px;">Inspection ..... 18</p> <p style="padding-left: 20px;">HOSES AND CONNECTORS ..... 18</p> <p style="padding-left: 20px;">CHECK VALVE ..... 18</p> <p><b>FRONT DISC BRAKE</b> ..... 19</p> <p style="padding-left: 20px;">Component ..... 19</p> <p style="padding-left: 20px;">Pad Replacement ..... 19</p> <p style="padding-left: 20px;">Caliper Removal ..... 20</p> <p style="padding-left: 20px;">Caliper Disassembly ..... 20</p> <p style="padding-left: 20px;">Inspection ..... 21</p> <p style="padding-left: 40px;">CALIPER ..... 21</p> <p style="padding-left: 40px;">ROTOR ..... 21</p> <p style="padding-left: 20px;">Caliper Assembly ..... 22</p> <p style="padding-left: 20px;">Caliper Installation ..... 22</p> <p><b>REAR DISC BRAKE</b> ..... 23</p> <p style="padding-left: 20px;">Component ..... 23</p> <p style="padding-left: 20px;">Pad Replacement ..... 24</p> <p style="padding-left: 20px;">Caliper Removal ..... 25</p> <p style="padding-left: 20px;">Caliper Disassembly ..... 26</p> <p style="padding-left: 20px;">Inspection ..... 27</p> <p style="padding-left: 40px;">CALIPER ..... 27</p> <p style="padding-left: 40px;">ROTOR ..... 27</p> <p style="padding-left: 20px;">Caliper Assembly ..... 28</p> <p style="padding-left: 20px;">Caliper Installation ..... 31</p> <p><b>REAR DRUM BRAKE</b> ..... 32</p> <p style="padding-left: 20px;">Components ..... 32</p> <p style="padding-left: 20px;">Removal ..... 32</p> <p style="padding-left: 20px;">Inspection ..... 34</p> <p style="padding-left: 40px;">WHEEL CYLINDER ..... 34</p> <p style="padding-left: 40px;">WHEEL CYLINDER OVERHAUL ..... 34</p> <p style="padding-left: 40px;">DRUM ..... 34</p> <p style="padding-left: 40px;">LINING ..... 34</p> <p style="padding-left: 20px;">Installation ..... 35</p> <p><b>SERVICE DATA AND SPECIFICATIONS (SDS)</b> ..... 36</p>
--	---

BR

G  
H  
I  
J  
K  
L  
M

---

General Specifications .....	36	Drum Brake .....	36
Disc Brake .....	36	Brake Pedal .....	36

# PRECAUTIONS

## PRECAUTIONS

PFP:00001

### Precautions for Supplemental Restraint System (SRS) “AIR BAG” and “SEAT BELT PRE-TENSIONER”

EFS001D3

The Supplemental Restraint System such as “AIR BAG” and “SEAT BELT PRE-TENSIONER”, used along with a front seat belt, helps to reduce the risk or severity of injury to the driver and front passenger for certain types of collision. Information necessary to service the system safely is included in the SRS and SB section of this Service Manual.

#### WARNING:

- To avoid rendering the SRS inoperative, which could increase the risk of personal injury or death in the event of a collision which would result in air bag inflation, all maintenance must be performed by an authorized NISSAN/INFINITI dealer.
- Improper maintenance, including incorrect removal and installation of the SRS, can lead to personal injury caused by unintentional activation of the system. For removal of Spiral Cable and Air Bag Module, see the SRS section.
- Do not use electrical test equipment on any circuit related to the SRS unless instructed to in this Service Manual. SRS wiring harnesses can be identified by yellow and/or orange harness connectors.

### Precautions for Brake System

EFS001D4

- Recommended fluid is brake fluid “DOT 3”.
- Never reuse drained brake fluid.
- Be careful not to splash brake fluid on painted areas.
- To clean or wash all parts of master cylinder, disc brake caliper and wheel cylinder, use clean brake fluid.
- Never use mineral oils such as gasoline or kerosene. They will ruin rubber parts of the hydraulic system.
- Use flare nut wrench when removing and installing brake tube.
- Always torque brake lines when installing.
- Burnish the brake contact surfaces after refinishing or replacing drums or rotors, after replacing pads or linings, or if a soft pedal occurs at very low mileage. Refer to [BR-6, "Brake Burnishing Procedure"](#).

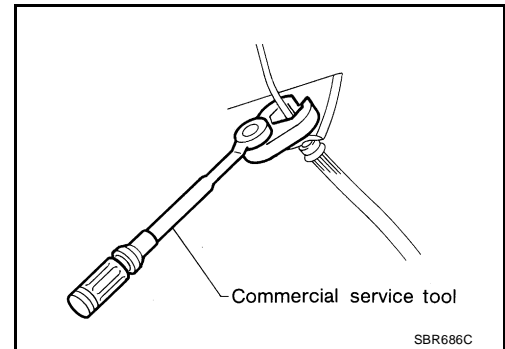

#### WARNING:

- Clean brake pads and shoes with a waste cloth, then wipe with a dust collector.

### Wiring Diagrams and Trouble Diagnosis

EFS001D5

When you read wiring diagrams, refer to the following:

- [GI-13, "How to Read Wiring Diagrams"](#)
- [PG-2, "POWER SUPPLY ROUTING"](#)

When you perform trouble diagnosis, refer to the following:

- [GI-10, "HOW TO FOLLOW TEST GROUPS IN TROUBLE DIAGNOSES"](#)
- [GI-26, "How to Perform Efficient Diagnosis for an Electrical Incident"](#)

# PREPARATION

## PREPARATION

PFP:00002

### Commercial Service Tools

EFS001D6

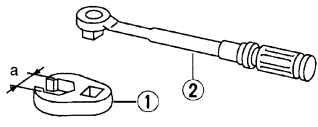
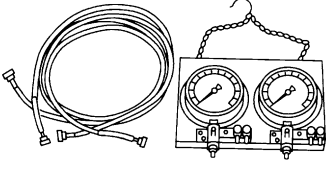
Tool name	Description
<p>1 Flare nut crowfoot 2 Torque wrench</p>  <p>S-NT360</p>	<p>Removing and installing brake piping <b>a: 10 mm (0.39 in)</b></p>
<p>Brake fluid pressure gauge</p>  <p>NT151</p>	<p>Measuring brake fluid pressure</p>

# NOISE, VIBRATION, AND HARSHNESS (NVH) TROUBLESHOOTING

## NOISE, VIBRATION, AND HARSHNESS (NVH) TROUBLESHOOTING

PEP:00003

ES001D7

Use the chart below to help you find the cause of the symptom. If necessary, repair or replace these parts.

Symptom	BRAKE		Possible cause and SUSPECTED PARTS	Reference page
	Noise	Shake		
			Pads - damaged	<a href="#">BR-19</a> , <a href="#">BR-24</a>
			Pads - uneven wear	<a href="#">BR-19</a> , <a href="#">BR-24</a>
			Shims damaged	<a href="#">BR-19</a> , <a href="#">BR-23</a>
	X	X	Rotor imbalance	
		X	Rotor damage	
		X	Rotor runout	<a href="#">BR-21</a> , <a href="#">BR-27</a>
		X	Rotor deformation	
		X	Rotor deflection	
		X	Rotor rust	
		X	Rotor thickness variation	<a href="#">BR-21</a> , <a href="#">BR-27</a>
	X	X	DRIVE SHAFT	<a href="#">FAX-4</a> , "NVH Troubleshooting Chart"
	X	X	AXLE	<a href="#">FAX-4</a> , "NVH Troubleshooting Chart"
	X	X	SUSPENSION	<a href="#">FSU-4</a> , "NVH Troubleshooting Chart"
	X	X	TIRES	<a href="#">FSU-4</a> , "NVH Troubleshooting Chart"
	X	X	ROAD WHEEL	<a href="#">FSU-4</a> , "NVH Troubleshooting Chart"
	X	X	STEERING	<a href="#">PS-6</a> , "NVH Troubleshooting Chart"

X: Applicable

BR

E

D

C

B

A

H

G

J

I

K

L

M

## ON-VEHICLE SERVICE

PFP:00000

### Checking Brake Fluid Level

EFS001D8

- Check fluid level in reservoir tank. It should be between Max and Min lines on reservoir tank.
- If fluid level is extremely low, check brake system for leaks.
- Release parking brake lever and see if brake warning lamp goes off. If not, check brake system for leaks.

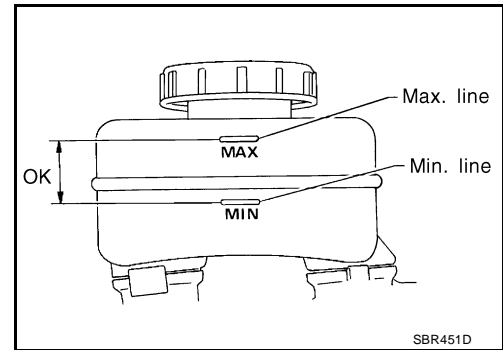

### Checking Brake Line

EFS001D9

#### CAUTION:

If leakage occurs around joints, retighten or, if necessary, replace damaged parts.

1. Check brake lines (tubes and hoses) for cracks, deterioration or other damage. Replace any damaged parts.
2. Check for oil leakage by fully depressing brake pedal while engine is running.

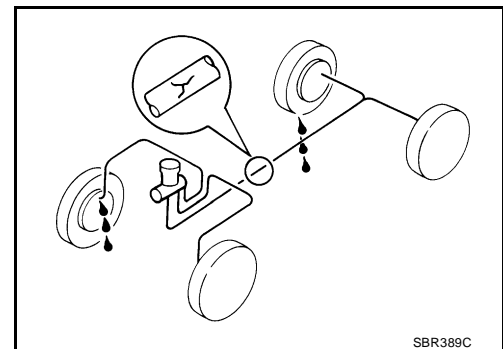

### Changing Brake Fluid

EFS001DA

#### CAUTION:

- Refill with new brake fluid "DOT 3".
- Always keep fluid level higher than minimum line on reservoir tank.
- Never reuse drained brake fluid.
- Be careful not to splash brake fluid on painted areas; it may cause paint damage. If brake fluid is splashed on painted areas, wash it away with water immediately.

1. Clean inside of reservoir tank, and refill with new brake fluid.
2. Connect a vinyl tube to each air bleeder valve.
3. Drain brake fluid from each air bleeder valve by depressing brake pedal.
4. Refill until brake fluid comes out of each air bleeder valve. Use same procedure as in bleeding hydraulic system to refill brake fluid. Refer to [BR-7, "Bleeding Brake System"](#).

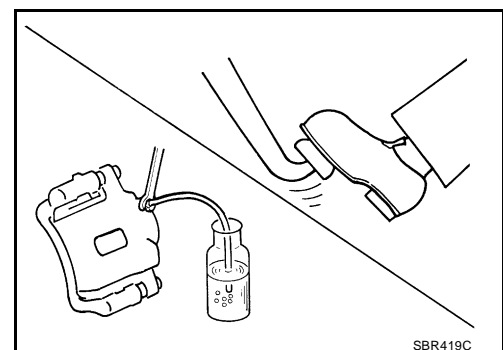

### Brake Burnishing Procedure

EFS001DB

Burnish the brake contact surfaces according to the following procedure after refinishing or replacing drums or rotors, after replacing pads or linings, or if a soft pedal occurs at very low mileage.

#### CAUTION:

Only perform this procedure under safe road and traffic conditions. Use extreme caution.

1. Drive the vehicle on a straight smooth road at 50 km/h (31 MPH).

# ON-VEHICLE SERVICE

2. Use medium brake pedal/foot effort to bring the vehicle to a complete stop from 50 km/h (31 MPH). Adjust brake pedal/foot pressure so that vehicle stopping time equals 3 to 5 seconds.
3. To cool the brake system, drive the vehicle at 50 km/h (31 MPH) for 1 minute without stopping.
4. Repeat steps 1 to 3, 10 times or more to complete the burnishing procedure.

## Bleeding Brake System

EFS001DC

### CAUTION:

- Carefully monitor brake fluid level at master cylinder during bleeding operation.
- Fill reservoir with new brake fluid "DOT 3". Make sure it is full at all times while bleeding air out of system.
- Place a container under master cylinder to avoid spillage of brake fluid.
- For models with ABS, turn ignition switch OFF and disconnect ABS actuator and electric unit connectors or battery ground cable.
- Bleed air in the following order.  
Right rear brake → Left front brake → Left rear brake → Right front brake

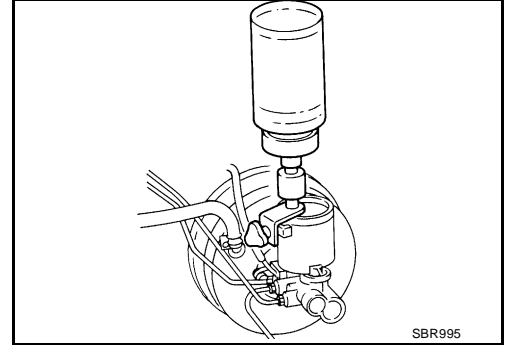

1. Connect a transparent vinyl tube to air bleeder valve.
2. Fully depress brake pedal several times.
3. With brake pedal depressed, open air bleeder valve to release air.
4. Close air bleeder valve.
5. Release brake pedal slowly.
6. Repeat steps 2. through 5. until clear brake fluid comes out of air bleeder valve.
7. Tighten air bleeder valve.

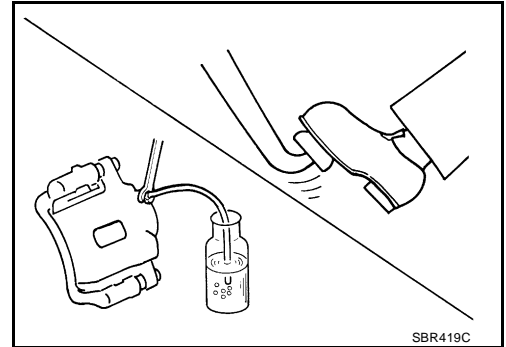

### Torque air bleeder valve

#### Front and rear disc brake

 : 7 - 9 N·m (0.7 - 0.9 kg·m, 61 - 78 in·lb)

#### Rear disc brake

 : 6.9 - 8.8 N·m (0.71 - 0.89 kg·m, 61 - 77 in·lb)

# BRAKE HYDRAULIC LINE

PFP:46210

## BRAKE HYDRAULIC LINE

### Hydraulic Circuit

EFS001DD

Without anti-lock brake system  
(Models with dual proportioning valve built into master cylinder)  
(built-in type)

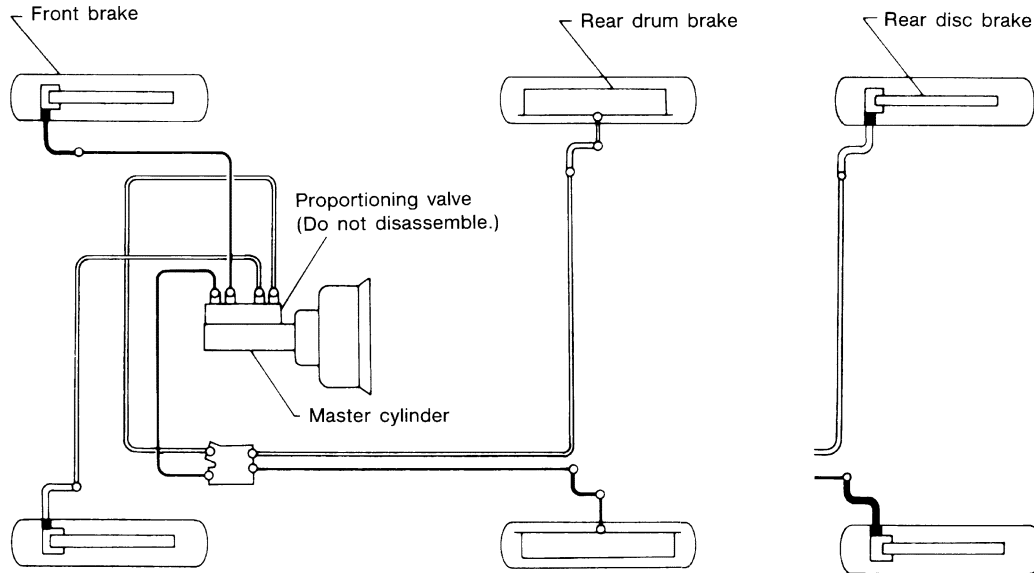

With anti-lock brake system

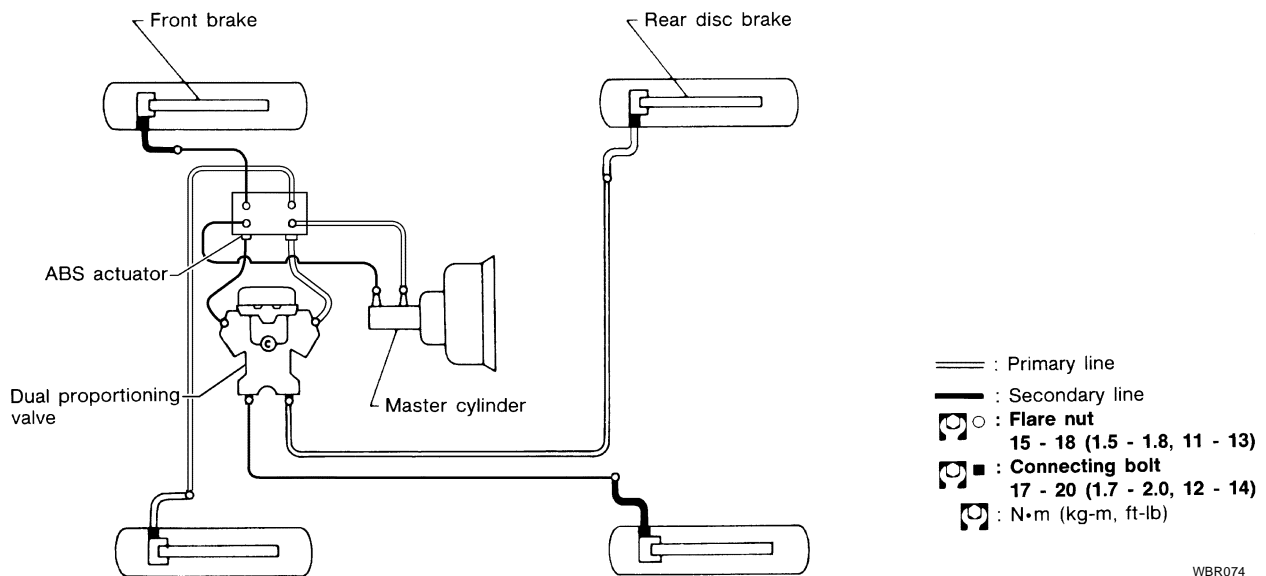

WBR074

## Removal

EFS001DE

### CAUTION:

- Be careful not to splash brake fluid on painted areas; it may cause paint damage. If brake fluid is splashed on painted areas, wash it away with water immediately.
- All hoses must be free from excessive bending, twisting and pulling.



# BRAKE HYDRAULIC LINE

1. Connect vinyl tube to air bleeder valve.
2. Drain brake fluid from each air bleeder valve by depressing brake pedal.
3. Remove flare nut connecting brake tube and hose, then withdraw lock spring.
4. Cover openings to prevent entrance of dirt whenever disconnecting brake line.

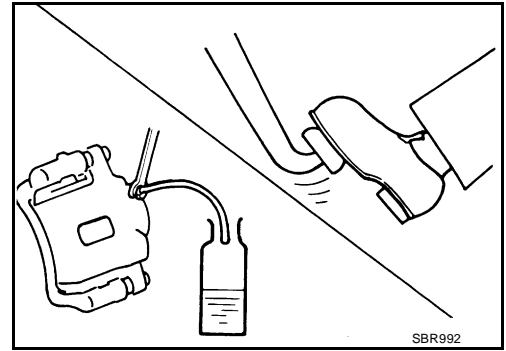

EFS001DF

EFS001DG

## Inspection

Check brake lines (tubes and hoses) for cracks, deterioration or other damage. Replace any damaged parts.

## Installation

### CAUTION:

- Refill with new brake fluid "DOT 3".
  - Never reuse drained brake fluid.
1. Tighten all flare nuts and connecting bolts.

### Specification

#### Flare nut

 : 15 - 18 N·m (1.5 - 1.8 kg·m, 11 - 13 ft·lb)

#### Connecting bolt

 : 17 - 20 N·m (1.7 - 2.0 kg·m, 12 - 14 ft·lb)

2. Refill until new brake fluid comes out of each air bleeder valve.
3. Bleed air. Refer to [BR-7, "Bleeding Brake System"](#).

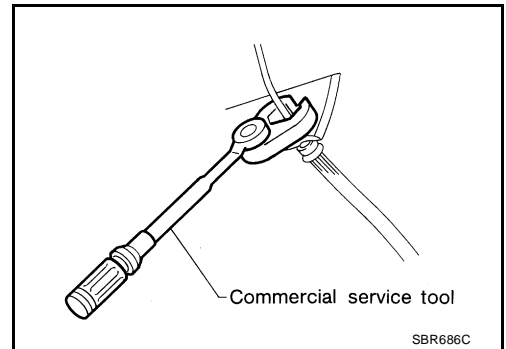

A  
B  
C  
D  
E  
BR  
G  
H  
I  
J  
K  
L  
M

# DUAL PROPORTIONING VALVE

PF:46400

## DUAL PROPORTIONING VALVE

EFS001DH

### Inspection

#### CAUTION:

- Carefully monitor brake fluid level at master cylinder.
  - Use new brake fluid "DOT 3".
  - Be careful not to splash brake fluid on painted areas; it may cause paint damage. If brake fluid is splashed on paint areas, wash it away with water immediately.
1. Connect Tool to air bleeders of front and rear brakes on either LH and RH side.
  2. Bleed air from the Tool.
  3. Check fluid pressure by depressing brake pedal.

Unit: kPa (kg/cm<sup>2</sup>, psi)

Applied model	All QG18DE	QR25DE non-ABS	QR25DE with ABS
Applied pressure (Front brake)	7,355 (75, 1,067)	6,374 (65, 924)	6,374 (65, 924)
Output pressure (Rear brake)	5,099 - 5,492 (52 - 56, 740 - 796)	3,775 - 4,168 (38 - 42, 548 - 604)	4,119 - 4,511 (42 - 46, 597 - 654)

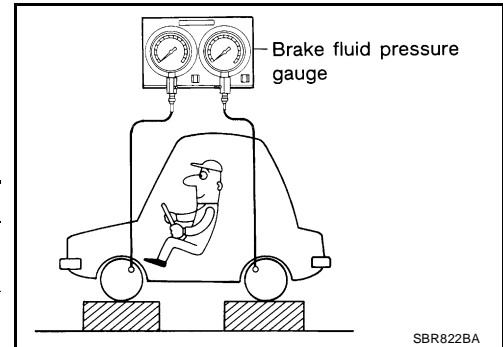

If output pressure is out of specification, replace dual proportioning valve.

4. Bleed air after disconnecting the Tool. Refer to [BR-7, "Bleeding Brake System"](#).

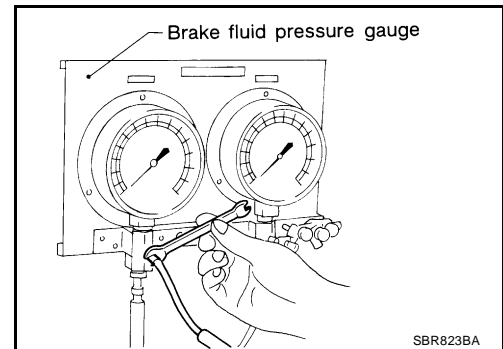

# BRAKE PEDAL AND BRACKET

## BRAKE PEDAL AND BRACKET

PFP:46501

### Removal and Installation

EFS001DI

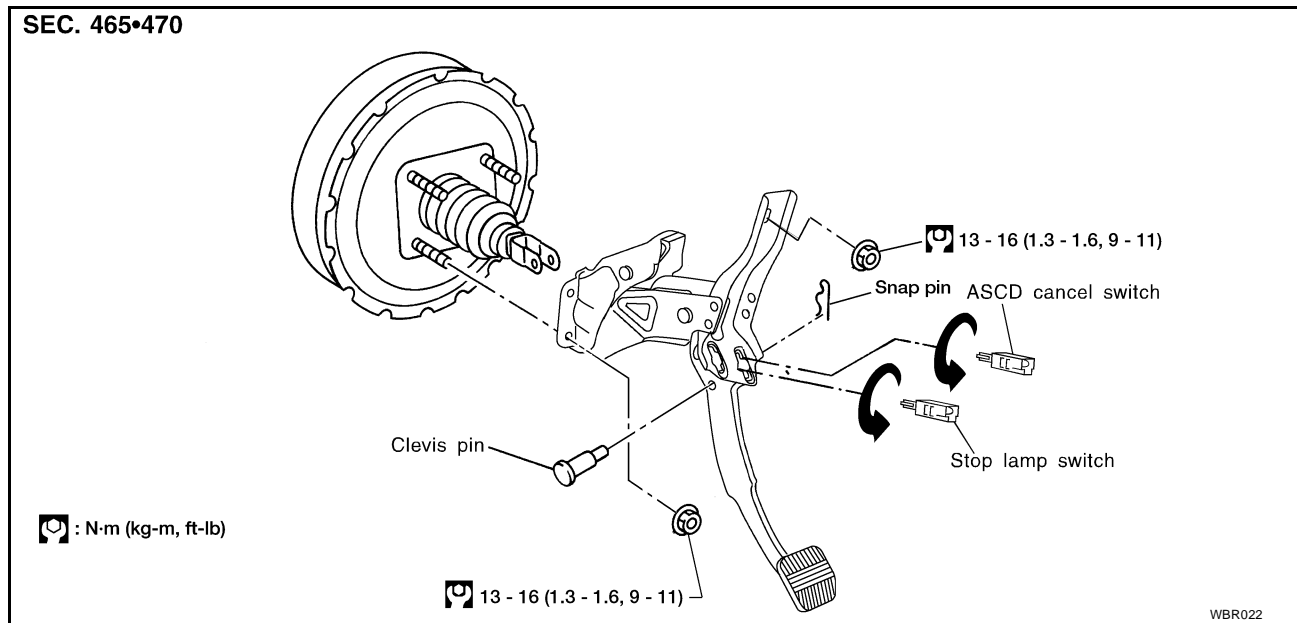

### Inspection

EFS001DJ

Check brake pedal for following items.

- Brake pedal bend
- Clevis pin deformation
- Crack of any welded portion
- Crack or deformation of clevis pin stopper

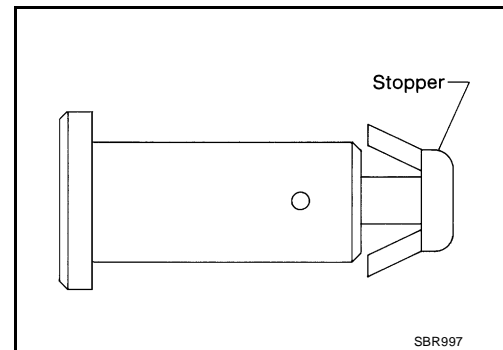

A  
B  
C  
D  
E  
BR  
G  
H  
I  
J  
K  
L  
M

# BRAKE PEDAL AND BRACKET

EFS001DK

## Adjustment BRAKE PEDAL HEIGHT

Check brake pedal free height from metal panel. Adjust if necessary.

- H : Free height**  
Refer to [BR-36, "Brake Pedal"](#) .
- D : Depressed height**  
90 mm (3.54 in)  
Under force of 490 N (50 kg, 110 lb)  
with engine running
- A : Pedal free play at pedal pad**  
1.0 - 3.0 mm (0.039 - 0.118 in)

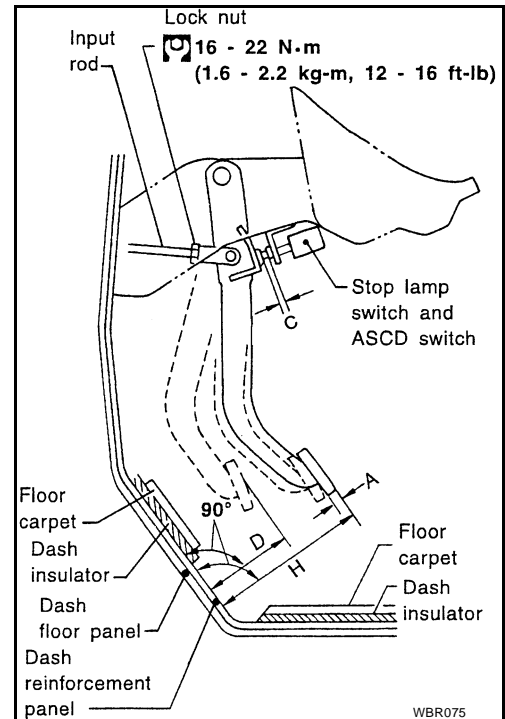

1. Loosen lock nut and adjust pedal free height by turning brake booster input rod. Then tighten lock nut.
2. Check pedal free play.  
**Make sure that stop lamps go off when pedal is released.**
3. Check brake pedal's depressed height while engine is running. If lower than specification, check brake system for leaks, accumulation of air or any damage to components (master cylinder, wheel cylinder, etc.); then make necessary repairs.

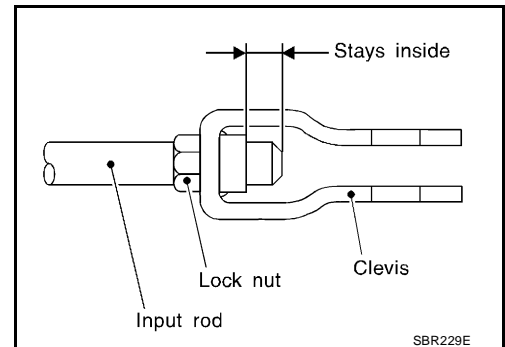

## STOP LAMP SWITCH AND ASCD CANCEL SWITCH CLEARANCE

1. Twist and pull to remove switch.
2. Pull up on brake pedal pad and hold.
3. Insert switch into retainer until switch plunger is completely depressed.
4. Turn the switch until it locks into place in the brake pedal bracket.
5. Release the brake pedal pad.

### NOTE:

When turning the switch to lock into place, the switch backs off the stopper to the correct clearance automatically.

# MASTER CYLINDER

PF0:46010

## MASTER CYLINDER

### Removal

EFS001DL

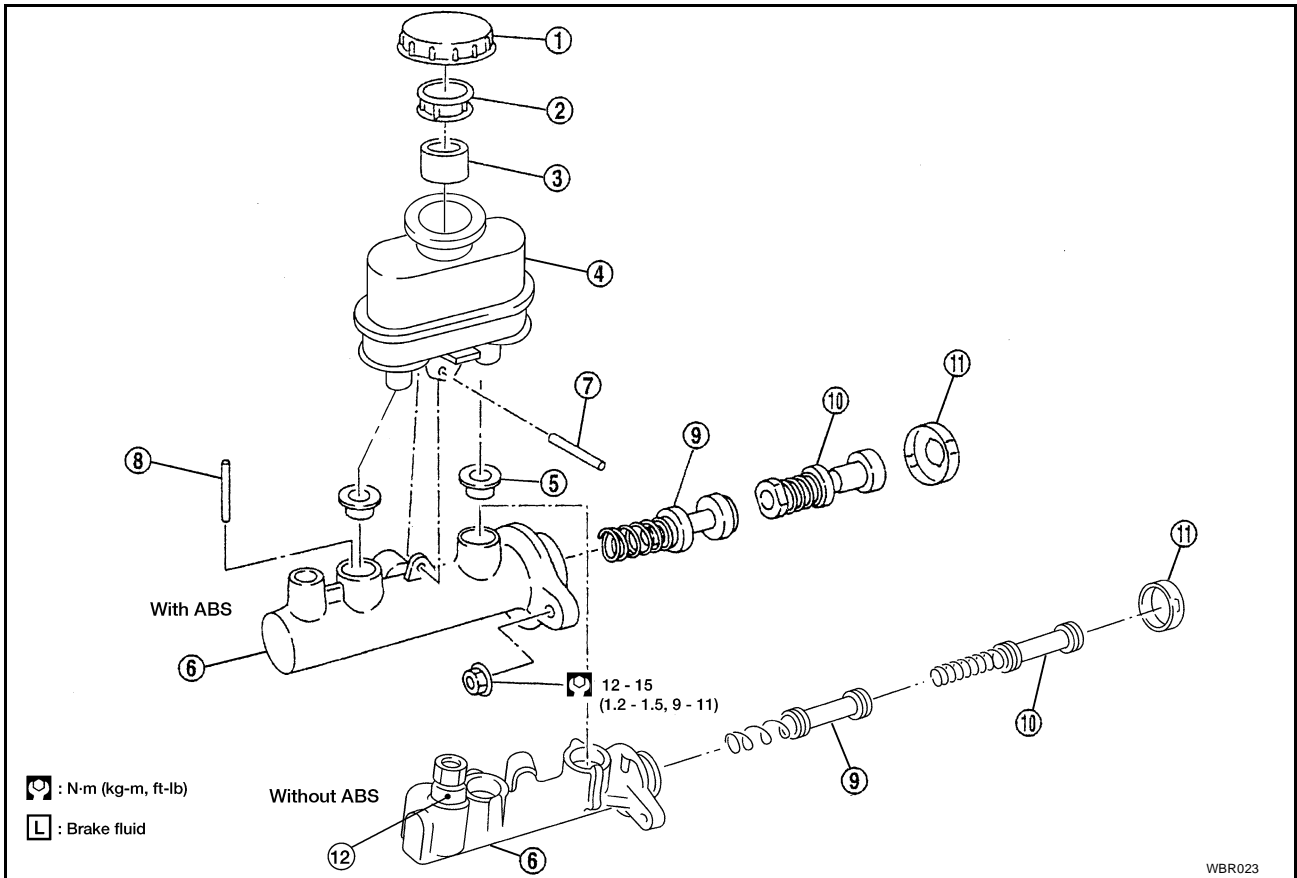

- |                             |                                  |                                       |
|-----------------------------|----------------------------------|---------------------------------------|
| 1. Reservoir cap            | 2. Oil filter                    | 3. Float                              |
| 4. Reservoir tank           | 5. Seal                          | 6. Cylinder body                      |
| 7. Spring pin (with ABS)    | 8. Piston stopper pin (with ABS) | 9. Secondary piston assembly          |
| 10. Primary piston assembly | 11. Stopper cap                  | 12. Proportioning valve (without ABS) |

### CAUTION:

Be careful not to splash brake fluid on painted areas; it may cause paint damage. If brake fluid is splashed on painted areas, wash it away with water immediately.

1. Connect a vinyl tube to air bleeder valve.
2. Drain brake fluid from each air bleeder valve, depressing brake pedal to empty fluid from master cylinder.
3. Remove brake line flare nuts from master cylinder.
4. Remove master cylinder mounting nuts.

### Disassembly

1. Bend claws of stopper cap outward and remove stopper cap.

EFS001DM

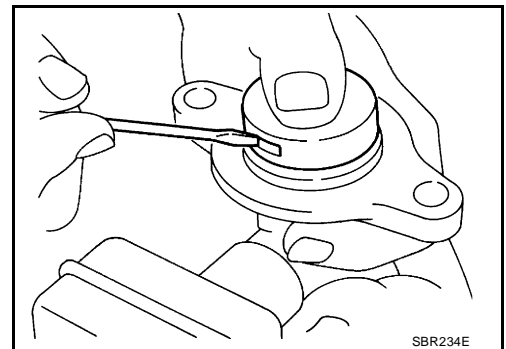

# MASTER CYLINDER

2. Drive out spring pin from cylinder body (with ABS).
3. Draw out reservoir tank and seals.

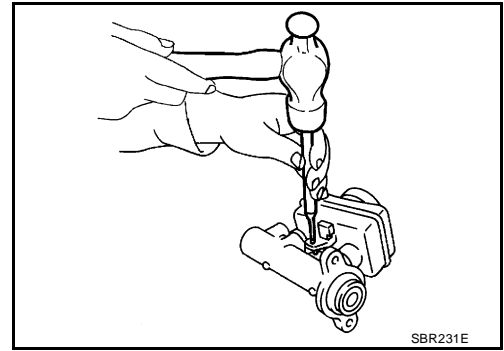

4. Remove piston stopper pin while piston is pushed into cylinder (with ABS).
5. Remove piston assemblies.  
**If it is difficult to remove secondary piston assembly, gradually apply compressed air through fluid outlet.**

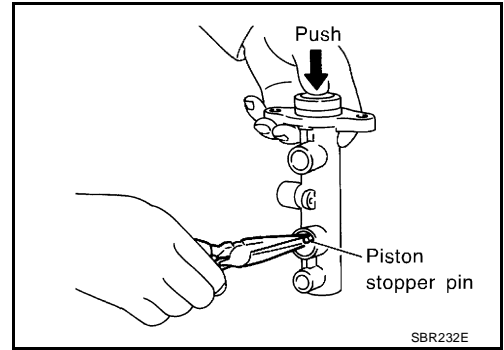

## Inspection

Check for the following items.

**Replace any part if damaged.**

**Master cylinder:**

- Pin holes or scratches on inner wall.

**Piston:**

- Deformation of or scratches on piston cups.

## Assembly

1. Insert secondary piston assembly. Then insert primary piston assembly.
  - **Pay attention to alignment of secondary piston slit with valve stopper mounting hole of cylinder body (with ABS).**

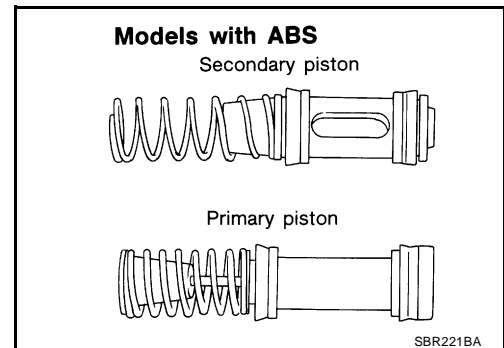
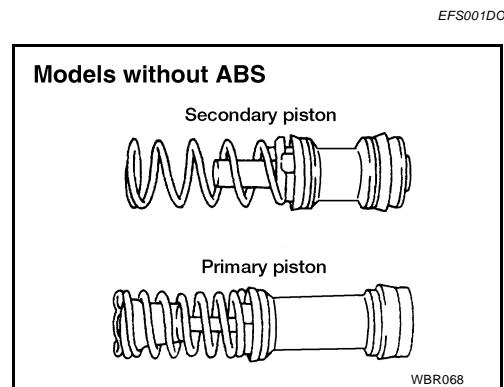

# MASTER CYLINDER

2. Install piston stopper pin while piston is pushed into cylinder (with ABS).
3. Push reservoir tank seals and reservoir tank into cylinder body.
4. Install spring pin (with ABS).

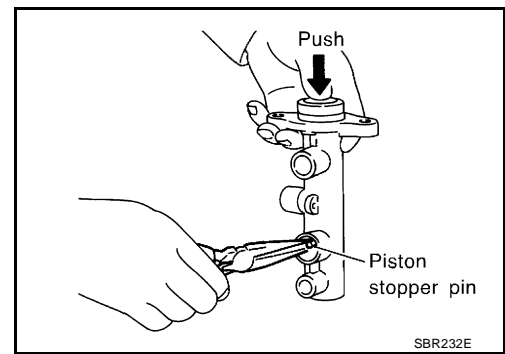

5. Install stopper cap.  
**Before installing stopper cap, ensure that claws are bent inward.**

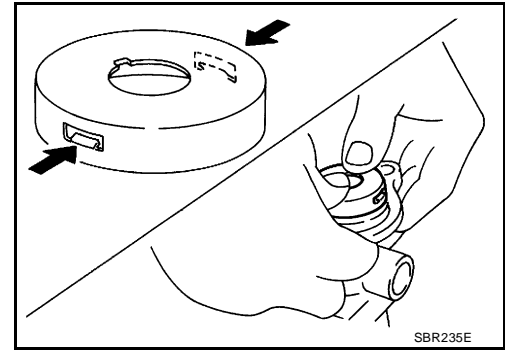

## Installation

### CAUTION:

- Refill with new brake fluid "DOT 3".
  - Never reuse drained brake fluid.
1. Place master cylinder onto brake booster and secure mounting nuts lightly.
  2. Torque mounting nuts.

 : 12 - 15 N·m (1.2 - 1.5 kg·m, 9 - 11 ft·lb)

3. Fill reservoir tank with new brake fluid "DOT 3".
4. Plug all ports on master cylinder with fingers to prevent air suction while releasing brake pedal.
5. Have driver depress brake pedal slowly several times until no air comes out of master cylinder.
6. Fit brake lines to master cylinder.
7. Tighten flare nuts.

 : 15 - 18 N·m (1.5 - 1.8 kg·m, 11 - 13 ft·lb)

8. Bleed air from brake system. Refer to [BR-7, "Bleeding Brake System"](#).

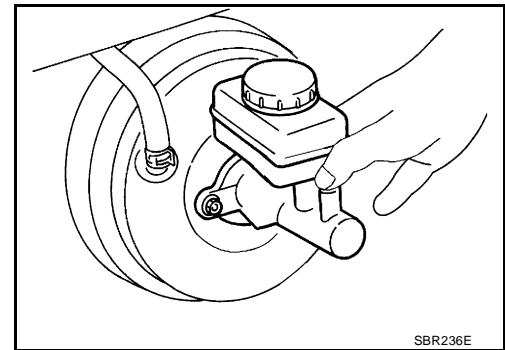

# BRAKE BOOSTER

PFP:47200

## BRAKE BOOSTER

### On-vehicle Service OPERATING CHECK

EFS001DQ

1. Stop engine and depress brake pedal several times. Check that pedal stroke does not change.
2. Depress brake pedal, then start engine. If pedal goes down slightly, operation is normal.

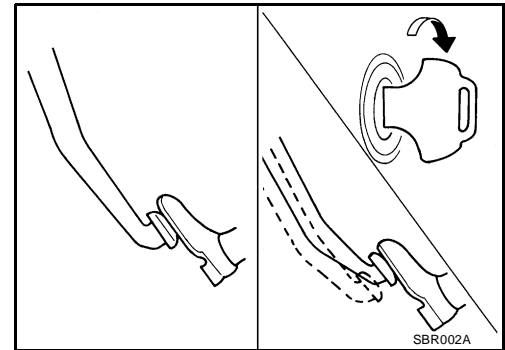

### AIRTIGHT CHECK

1. Start engine, and stop it after one or two minutes. Depress brake pedal several times slowly. The pedal should go further down the first time, and then it should gradually rise thereafter.
2. Depress brake pedal while engine is running, and stop engine with pedal depressed. The pedal stroke should not change after holding pedal down for **30 seconds**.

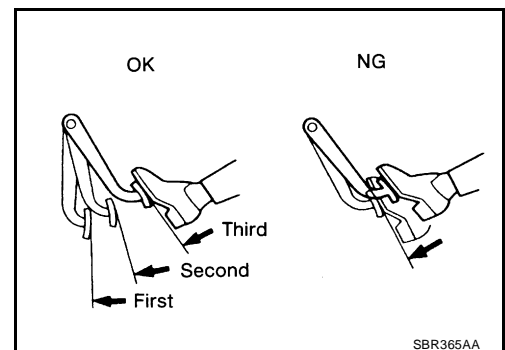

### Removal

EFS001DR

#### CAUTION:

- Be careful not to splash brake fluid on painted areas; it may cause paint damage. If brake fluid is splashed on painted areas, wash it away with water immediately.
- Be careful not to deform or bend brake lines, during removal of booster.

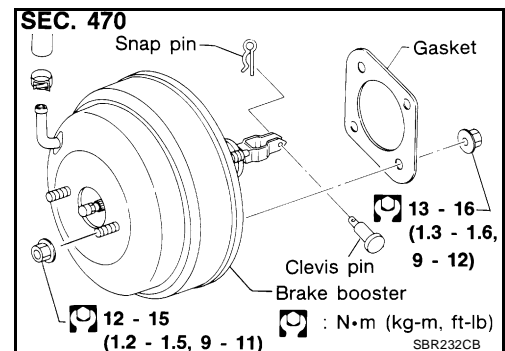

### Inspection

#### OUTPUT ROD LENGTH CHECK

EFS001DS

1. Apply vacuum of  $-66.7$  kPa ( $-500$  mmHg,  $-19.69$  inHg) to brake booster with a hand vacuum pump.
2. Add preload of  $19.6$  N ( $2$  kg,  $4.4$  lb) to output rod.
3. Check output rod length.

**Specified length : 10.275 - 10.525 mm  
(0.4045 - 0.4144 in)**

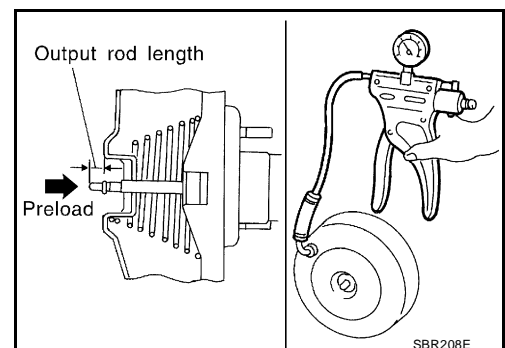



# BRAKE BOOSTER

EFS001DT

## Installation

### CAUTION:

- Be careful not to deform or bend brake lines, during installation of booster.
- Replace clevis pin if damaged.
- Refill with new brake fluid "DOT 3".
- Never reuse drained brake fluid.
- Take care not to damage brake booster mounting bolt thread when installing. Due to the acute angle of installation, the threads can be damaged with the dash panel.

1. Before fitting booster, temporarily adjust clevis to dimension shown.
2. Fit booster, then secure mounting nuts (brake pedal bracket to master cylinder) lightly.
3. Connect brake pedal and booster input rod with clevis pin.
4. Secure mounting nuts.

### Specification



: 13 - 16 N·m (1.3 - 1.6 kg·m, 9 - 12 ft-lb)

5. Install master cylinder. Refer to [BR-15, "Installation"](#).
6. Adjust brake pedal height. Refer to [BR-12, "BRAKE PEDAL HEIGHT"](#).
7. Bleed air. Refer to [BR-7, "Bleeding Brake System"](#).

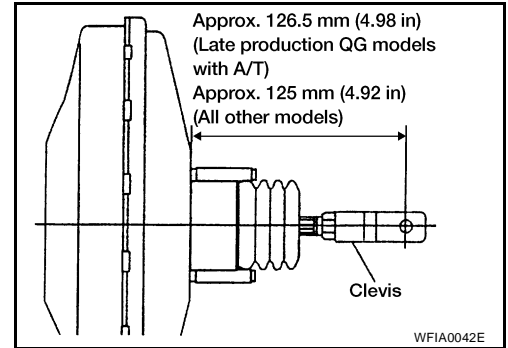

A  
B  
C  
D  
E  
BR  
G  
H  
I  
J  
K  
L  
M

# VACUUM HOSE

PFP:41920

## VACUUM HOSE

### Removal and Installation

EFS001DU

#### CAUTION:

When installing vacuum hoses, pay attention to the following points.

- Do not apply any oil or lubricants to vacuum hose with check valve.
- Insert vacuum tube into vacuum hose as shown.
- Install vacuum hose with internal check valve, paying attention to its direction.

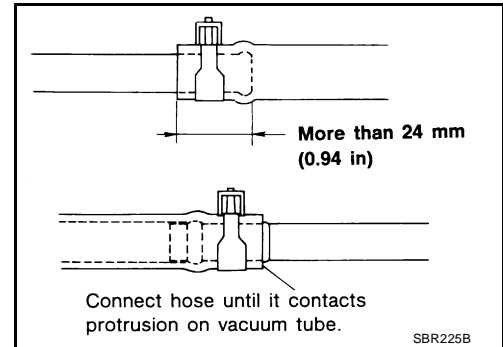

### Inspection

#### HOSES AND CONNECTORS

EFS001DV

Check vacuum lines and connections for airtightness, improper attachment, chafing and deterioration.

#### CHECK VALVE

Check vacuum with a vacuum pump.

Connect to booster side	Vacuum should exist.
Connect to engine side	Vacuum should not exist.

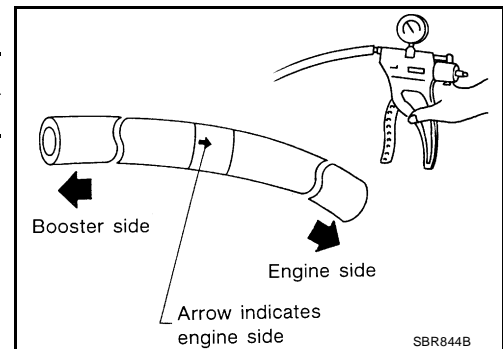

# FRONT DISC BRAKE

## FRONT DISC BRAKE

PFP:41000

### Component

EFS001DW

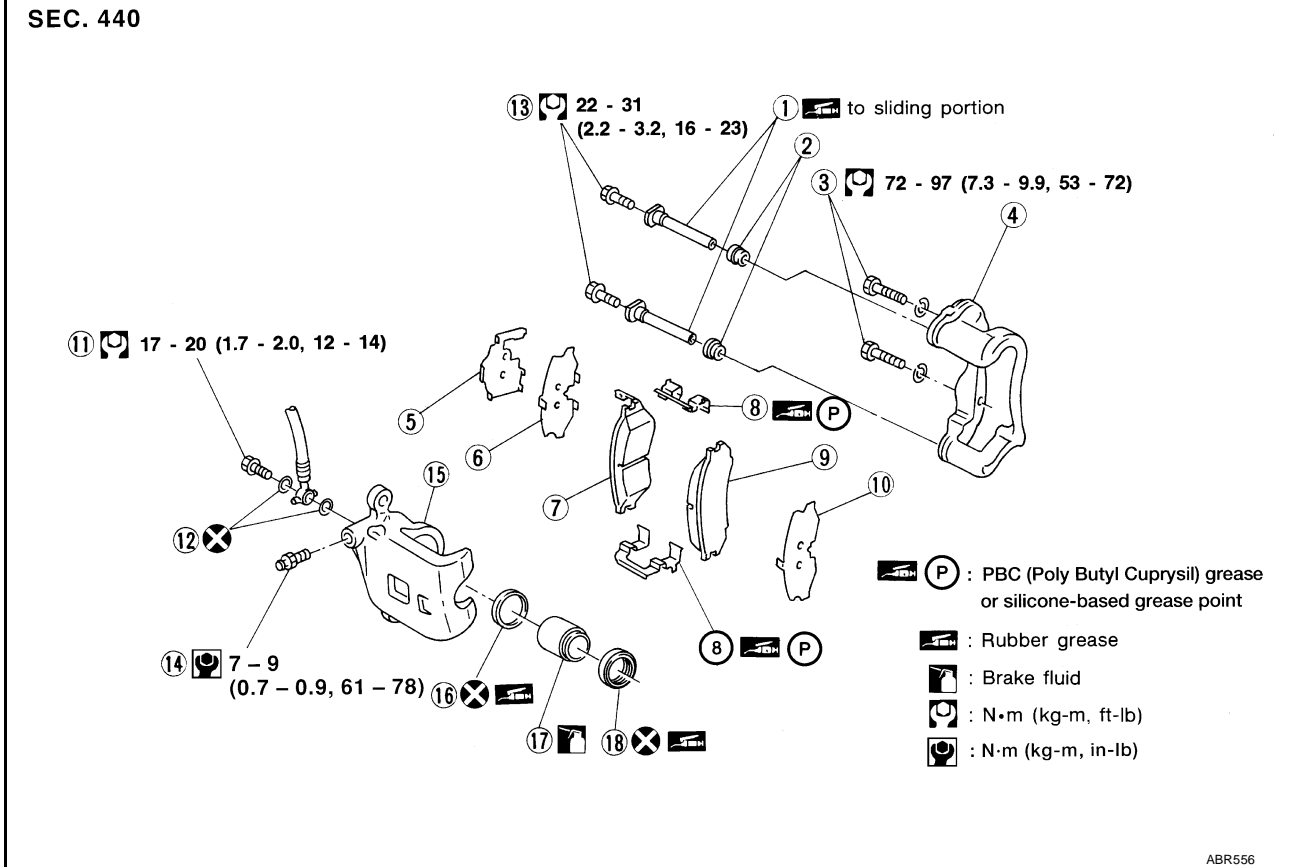

- |                   |                       |                              |
|-------------------|-----------------------|------------------------------|
| 1. Main pin       | 2. Pin boot           | 3. Torque member fixing bolt |
| 4. Torque member  | 5. Shim cover         | 6. Inner shim                |
| 7. Inner pad      | 8. Pad retainer       | 9. Outer pad                 |
| 10. Outer shim    | 11. Connecting bolt   | 12. Copper washer            |
| .                 | .                     | .                            |
| 13. Main pin bolt | 14. Air bleeder valve | 15. Cylinder body            |
| .                 | .                     | .                            |
| 16. Piston seal   | 17. Piston            | 18. Piston boot              |
| .                 | .                     | .                            |

## Pad Replacement

EFS001DX

### WARNING:

Clean brake pads with a vacuum dust collector to minimize the hazard of airborne particles or other materials.

### CAUTION:

- When cylinder body is open, do not depress brake pedal because piston will pop out.
- Be careful not to damage piston boot or get oil on rotor. Always replace shims when replacing pads.
- If shims are rusted or show peeling of the rubber coat, replace them with new shims.
- It is not necessary to remove connecting bolt except for disassembly or replacement of caliper assembly. In this case, suspend cylinder body with wire so as not to stretch brake hose.
- Burnish the brake contact surfaces after refinishing or replacing drums or rotors, after replacing pads or linings, or if a soft pedal occurs at very low mileage.  
Refer to [BR-6. "Brake Burnishing Procedure"](#).

1. Remove master cylinder reservoir cap.

# FRONT DISC BRAKE

2. Remove pin bolt.

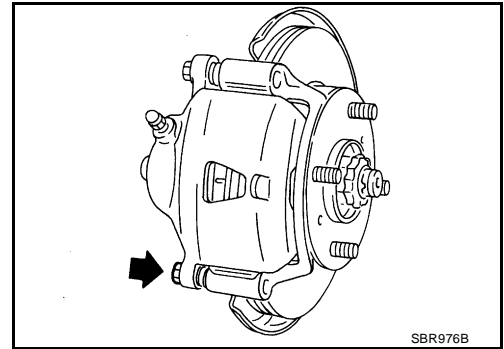

3. Open cylinder body upward. Then remove pad with retainers, inner and outer shims.

**Standard pad thickness** : 11 mm (0.43 in)  
(CL25VA, CL25VB)

**Pad wear limit** : 2.0 mm (0.079 in)  
(CL25VA, CL25VB)

Carefully monitor brake fluid level because brake fluid will return to reservoir when pushing back piston.

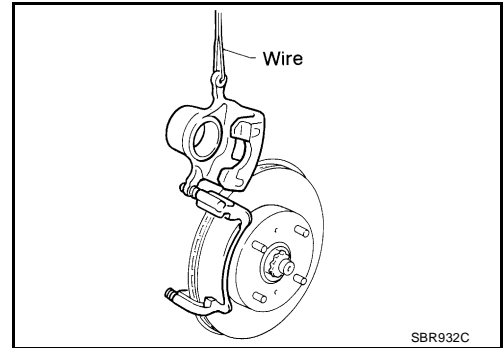

## Caliper Removal

### **WARNING:**

Clean brake pads with a vacuum dust collector to minimize the hazard of airborne particles or other materials.

1. Remove torque member fixing bolts and brake hose connecting bolt.

It is not necessary to remove brake hose connecting bolt except for disassembly or replacement of caliper assembly. In this case, suspend caliper assembly with wire so as not to stretch brake hose.

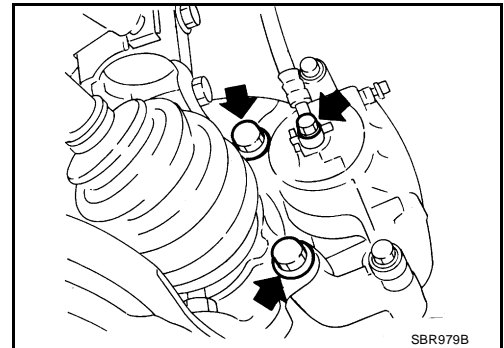

EFS001DY

## Caliper Disassembly

### **WARNING:**

Do not place your fingers in front of piston.

### **CAUTION:**

Do not scratch or score cylinder wall.

1. Push out piston with piston boot with compressed air.
2. Remove piston seal with a suitable tool.

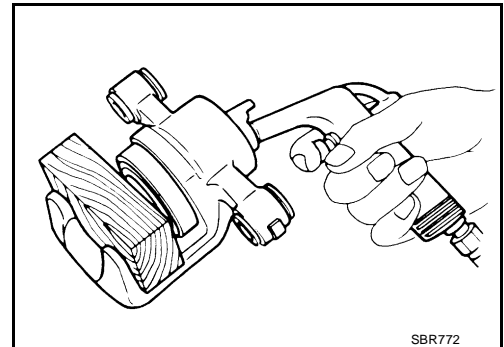

EFS001DZ

# FRONT DISC BRAKE

## CAUTION:

When removing the pad retainer from the torque member, lift it up and out in the direction of the arrows in the figure.

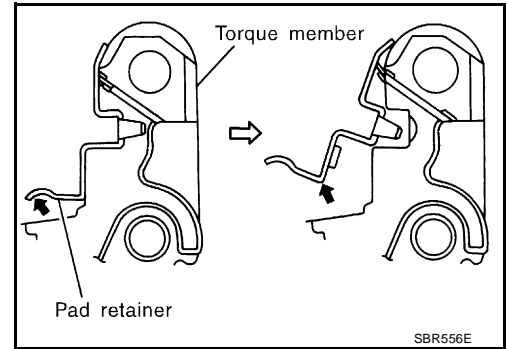

EFS001E0

## Inspection

### CALIPER

#### Cylinder Body

- Check inside surface of cylinder for score, rust, wear, damage or presence of foreign materials. If any of the above conditions are observed, replace cylinder body.
- Minor damage from rust or foreign materials may be eliminated by polishing surface with a fine emery paper. Replace cylinder body if necessary.

## CAUTION:

Use brake fluid to clean. Never use mineral oil.

#### Piston

## CAUTION:

Piston sliding surface is plated. Do not polish with emery paper even if rust or foreign materials are stuck to sliding surface.

Check piston for score, rust, wear, damage or presence of foreign materials. Replace if any of the above conditions are observed.

#### Slide Pin, Pin Bolt and Pin Boot

Check for wear, cracks or other damage. Replace if any of the above conditions are observed.

### ROTOR

#### Rubbing Surface

Check rotor for roughness, cracks or chips.

#### Runout

1. Secure rotor to wheel hub with at least two nuts (M12 x 1.25).
2. Check runout using a dial indicator.

**Make sure that wheel bearing axial end play is within the specifications before measuring. Refer to [FAX-5, "Front Wheel Bearing"](#).**

**Maximum runout : 0.07 mm (0.0028 in)**

3. If the runout is out of specification, find minimum runout position as follows:
  - a. Remove nuts and rotor from wheel hub.
  - b. Shift the rotor one hole and secure rotor to wheel hub with nuts.
  - c. Measure runout.
  - d. Repeat steps a. to c. so that minimum runout position can be found.
4. If the runout is still out of specification, turn rotor with on-car brake lathe ("MAD, DL-8700", "AMMCO 700 and 705" or equivalent).

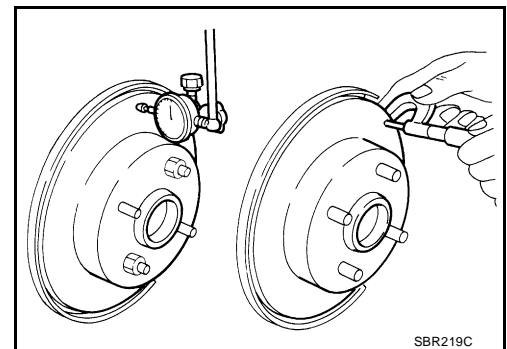

#### Thickness

**Thickness variation :Maximum 0.01 mm  
(At least 8 positions) (0.0004 in)**

If thickness variation exceeds the specification, turn rotor with on-car brake lathe.

# FRONT DISC BRAKE

**Rotor repair limit : 20.0 mm (0.787 in)**

## Caliper Assembly

1. Insert piston seal into groove on cylinder body.
2. With piston boot fitted to piston, insert piston boot into groove on cylinder body and install piston.
3. Properly secure piston boot.

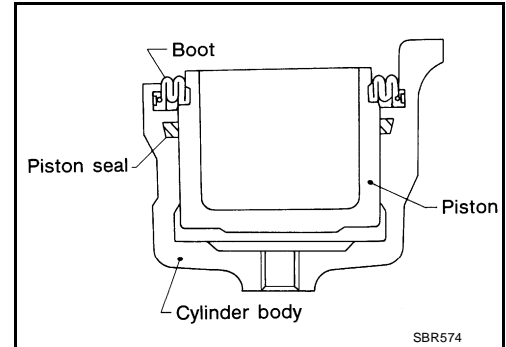

## Caliper Installation

### CAUTION:

- Refill with new brake fluid "DOT 3".
  - Never reuse drained brake fluid.
1. Install brake hose to caliper securely.
  2. Install all parts and secure all bolts.
  3. Bleed air. Refer to [BR-7, "Bleeding Brake System"](#) .

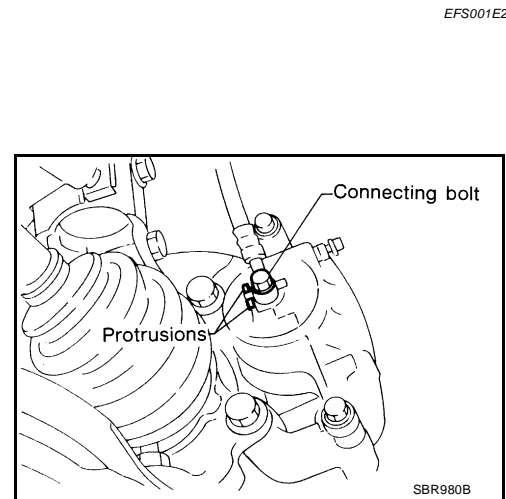

# REAR DISC BRAKE

PF0:44000

EF001E3

## REAR DISC BRAKE

### Component

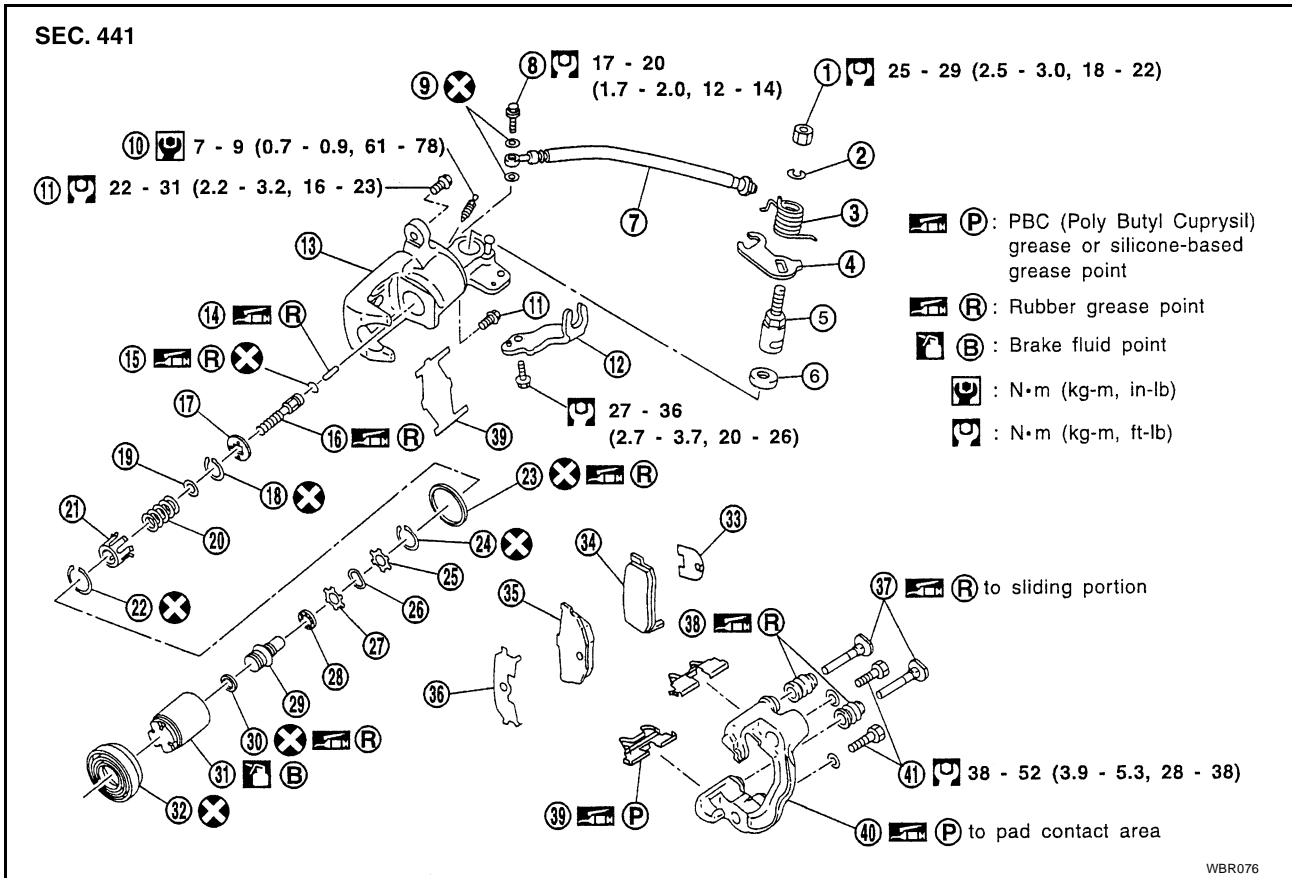

- |                        |                               |                            |
|------------------------|-------------------------------|----------------------------|
| 1. Nut                 | 2. Washer                     | 3. Return spring           |
| 4. Parking brake lever | 5. Cam                        | 6. Cam boot                |
| 7. Brake hose          | 8. Connecting bolt            | 9. Copper washer           |
| 10. Air bleeder valve  | 11. Pin bolt                  | 12. Cable mounting bracket |
| .                      | .                             | .                          |
| 13. Cylinder           | 14. Strut                     | 15. O-ring                 |
| .                      | .                             | .                          |
| 16. Push rod           | 17. Key plate                 | 18. Ring C                 |
| .                      | .                             | .                          |
| 19. Seat               | 20. Spring                    | 21. Spring cover           |
| .                      | .                             | .                          |
| 22. Ring B             | 23. Piston seal               | 24. Ring A                 |
| .                      | .                             | .                          |
| 25. Spacer             | 26. Wave washer               | 27. Spacer                 |
| .                      | .                             | .                          |
| 28. Ball bearing       | 29. Adjust nut                | 30. Cup                    |
| .                      | .                             | .                          |
| 31. Piston             | 32. Dust seal                 | 33. Inner shim             |
| .                      | .                             | .                          |
| 34. Inner pad          | 35. Outer pad                 | 36. Outer shim             |
| .                      | .                             | .                          |
| 37. Pin                | 38. Pin boot                  | 39. Pad retainer           |
| .                      | .                             | .                          |
| 40. Torque member      | 41. Torque member fixing bolt | .                          |
| .                      | .                             | .                          |

# REAR DISC BRAKE

EFS001E4

## Pad Replacement

### WARNING:

Clean brake pads with a vacuum dust collector to minimize the hazard of airborne particles or other materials.

### CAUTION:

- When cylinder body is open, do not depress brake pedal because piston will pop out.
- Be careful not to damage piston boot or get oil on rotor. Always replace shims in replacing pads.
- If shims are rusted or show peeling of rubber coat, replace them with new shims.
- It is not necessary to remove connecting bolt except for disassembly or replacement of caliper assembly. In this case, suspend cylinder body with wire so as not to stretch brake hose.
- Burnish the brake contact surfaces after refinishing or replacing drums or rotors, after replacing pads or linings, or if a soft pedal occurs at very low mileage. Refer to [BR-6, "Brake Burnishing Procedure"](#).

1. Remove master cylinder reservoir cap.

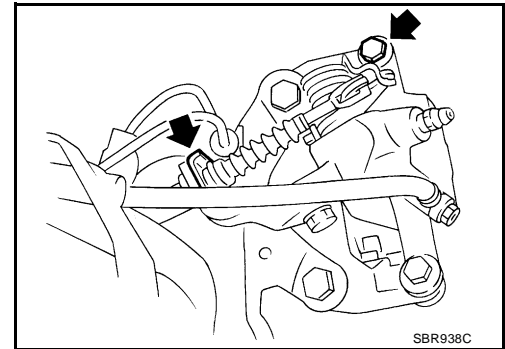

2. Remove brake cable mounting bolt and lock spring.
3. Release parking brake control lever, then disconnect cable from the caliper.
4. Remove upper pin bolt.
5. Open cylinder body downward. Then remove pad retainers, and inner and outer shims.

**Standard pad thickness : 10 mm (0.39 in)**  
**Pad wear limit : 2.0 mm (0.079 in)**

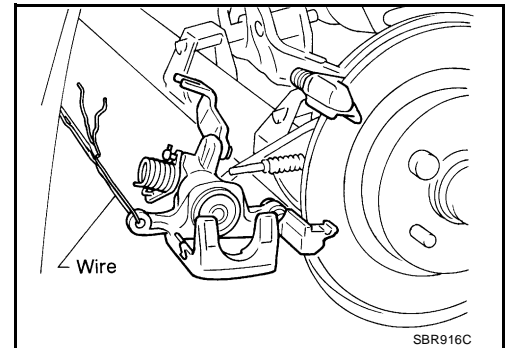

6. When installing new pads, push piston into cylinder body by gently turning piston clockwise, as shown. **Carefully monitor brake fluid level because brake fluid will return to reservoir when pushing back piston.**

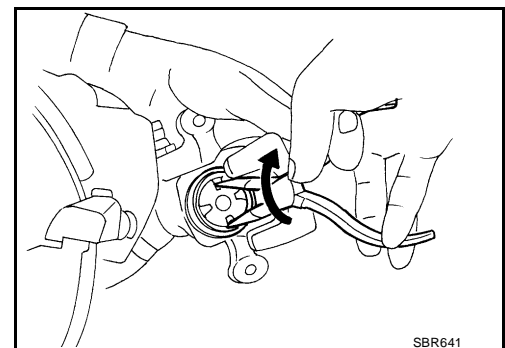



# REAR DISC BRAKE

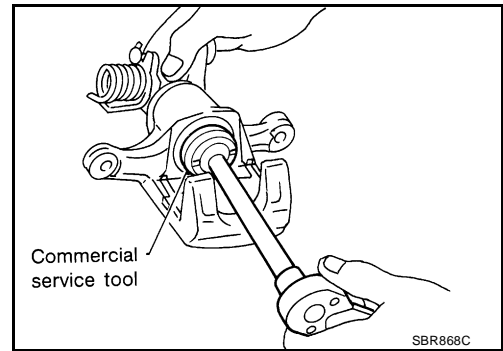

7. Adjust the piston to the right angle as shown in the figure.

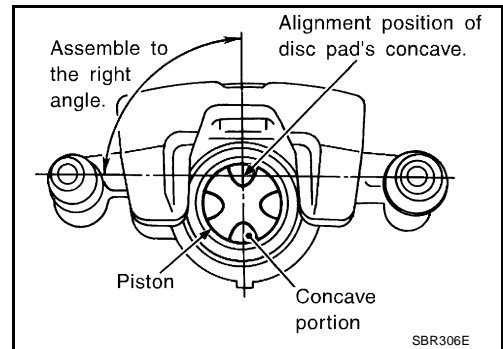

8. As shown in the figure, align the piston's concave to the pad's convex, then install the cylinder body to the torque member.

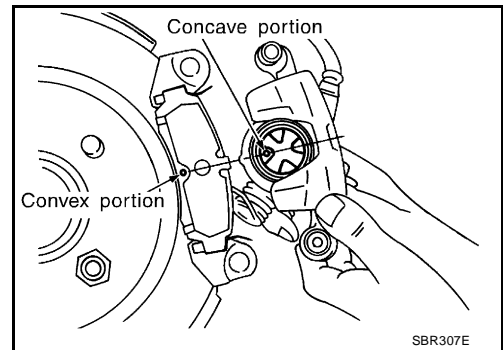

## Caliper Removal

### **WARNING:**

**Clean brake pads with a vacuum dust collector to minimize the hazard of airborne particles or other materials.**

1. Remove brake cable mounting bolt and lock spring.
2. Release parking brake control lever, then disconnect cable from the caliper.
3. Remove torque member fixing bolts and brake hose connecting bolt.

**It is not necessary to remove brake hose connecting bolt except for disassembly or replacement of caliper assembly. In this case, suspend caliper assembly with wire so as not to stretch brake hose.**

4. Remove caliper assembly.

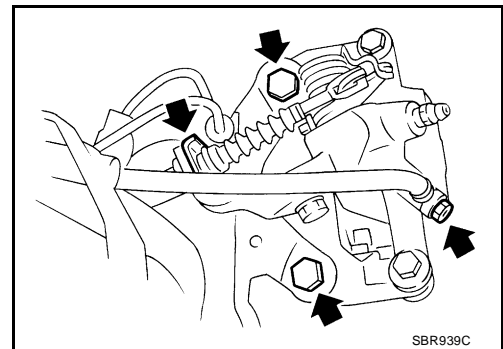

A  
B  
C  
D  
E  
BR  
G  
H  
I  
J  
K  
L  
M

# REAR DISC BRAKE

EFS001E6

## Caliper Disassembly

1. Remove piston by turning it counterclockwise with suitable commercial service tool or long nose pliers.

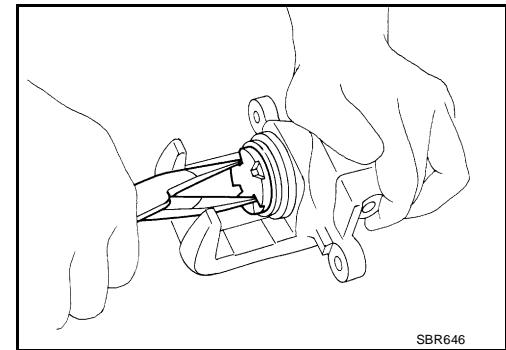
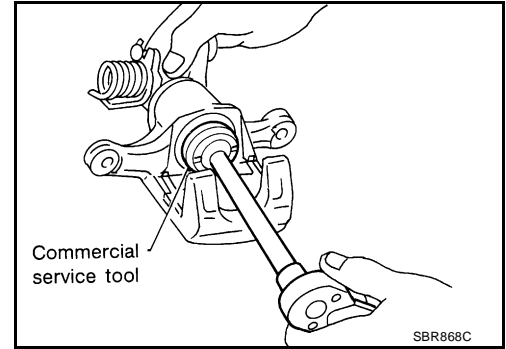

2. Pry off ring A from piston with suitable pliers and remove cup, adjuster, bearing, spacers, and washer.

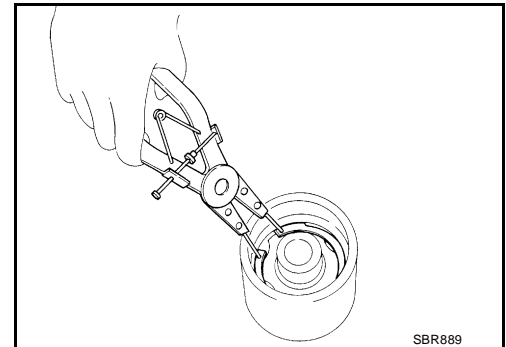

3. Disassemble cylinder body.
  - a. Pry off ring B with suitable pliers, then remove spring cover, spring and seat.
  - b. Pry off ring C, then remove key plate, push rod and rod.

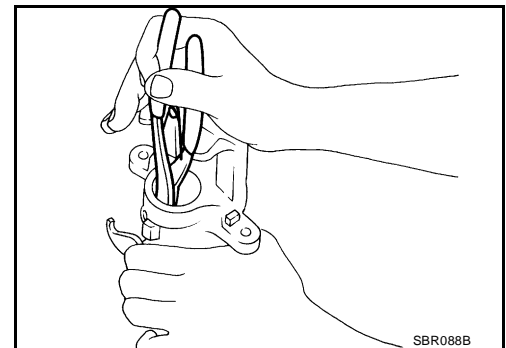

# REAR DISC BRAKE

- c. Remove piston seal with a suitable tool.  
**Be careful not to damage cylinder body.**

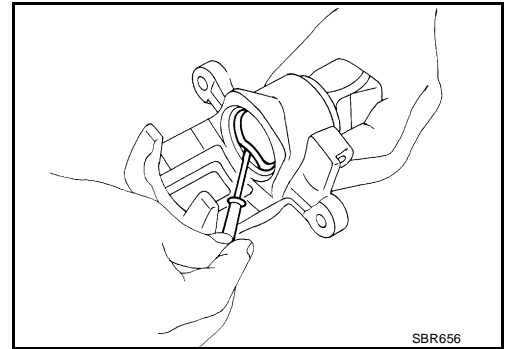

4. Remove return spring, toggle lever and cable guide.

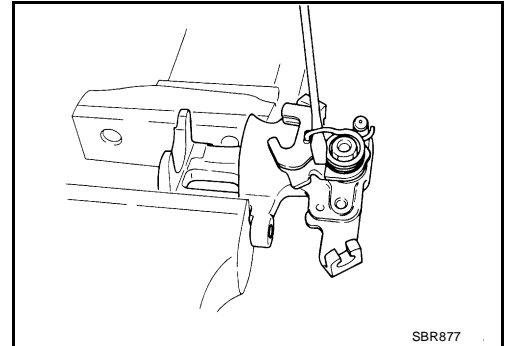

## Inspection CALIPER

### **CAUTION:**

**Use brake fluid to clean cylinder. Never use mineral oil.**

### Cylinder Body

- Check inside surface of cylinder for score, rust, wear, damage or presence of foreign materials. If any of the above conditions are observed, replace cylinder body.
- Minor damage from rust or foreign materials may be eliminated by polishing surface with a fine emery paper. Replace cylinder body if necessary.

### Torque Member

Check for wear, cracks or other damage. Replace if necessary.

### Piston

#### **CAUTION:**

**Piston sliding surface is plated. Do not polish with emery paper even if rust or foreign matter is stuck to sliding surface.**

Check piston for score, rust, wear, damage or presence of foreign materials.

Replace if any of the above conditions are observed.

### Pin and Pin Boot

Check for wear, cracks or other damage.

Replace if any of the above conditions are observed.

### ROTOR

#### Rubbing Surface

Check rotor for roughness, cracks or chips.

A  
B  
C  
D  
E  
G

BR

H  
I  
J  
K  
L  
M

EFS001E7

# REAR DISC BRAKE

## Runout

1. Secure rotor to wheel hub with two nuts (M12 x 1.25).
2. Check runout using a dial indicator.

**Make sure that axial end play is within the specifications before measuring. Refer to [RAX-5, "Rear Wheel Bearing"](#).**

3. Change relative positions of rotor and wheel hub so that runout is minimized.

**Maximum runout : 0.07 mm (0.0028 in)**

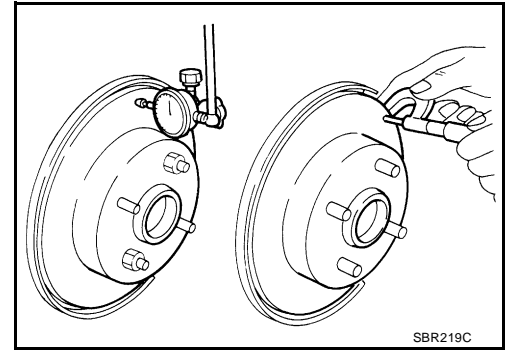

## Thickness

**Rotor repair limit**

**Standard thickness : 9 mm (0.35 in)**

**Minimum thickness : 8 mm (0.31 in)**

**Thickness variation : Maximum 0.02 mm (0.0008 in)  
(At least 8 portions)**

## Caliper Assembly

1. Insert cam with depression facing toward open end of cylinder.

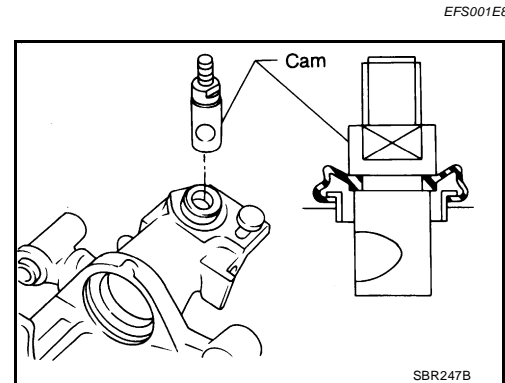

2. Generously apply rubber grease to strut and push rod to make insertion easy.

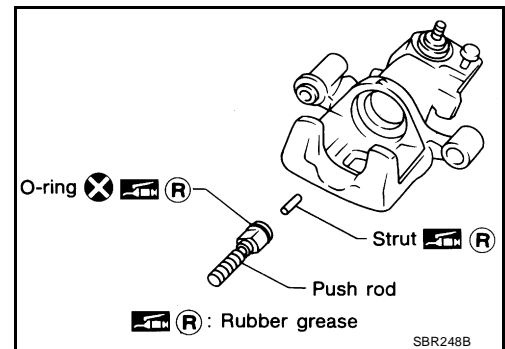

3. Fit push rod into square hole in key plate. Also match convex portion of key plate with concave portion of cylinder.

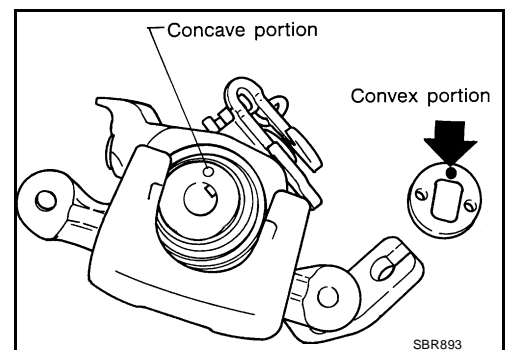

# REAR DISC BRAKE

4. Install ring C with a suitable tool.

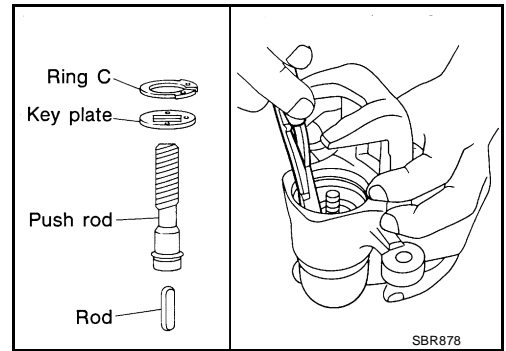

5. Install seat, spring, spring cover and ring B with suitable press and drift.

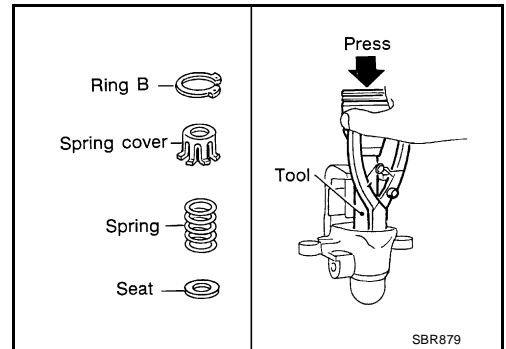
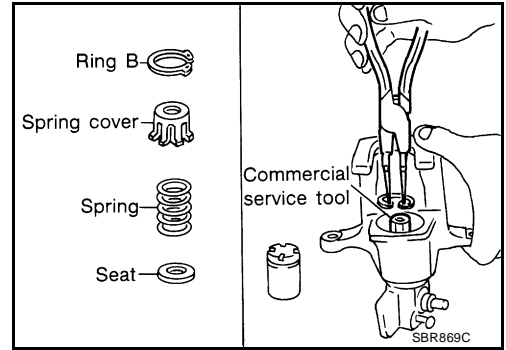

6. Install cup in the specified direction.

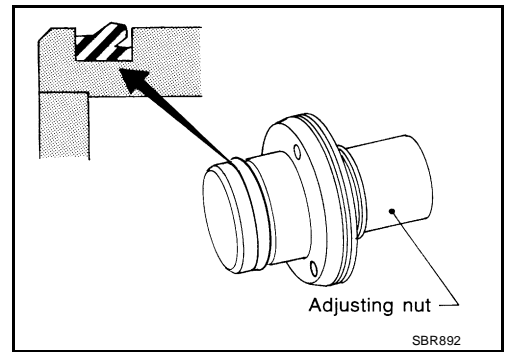

A  
B  
C  
D  
E  
BR  
G  
H  
I  
J  
K  
L  
M

# REAR DISC BRAKE

- 7. Install cup, adjuster, bearing, spacers, washer and ring A with a suitable tool.
- 8. Insert piston seal into groove on cylinder body.

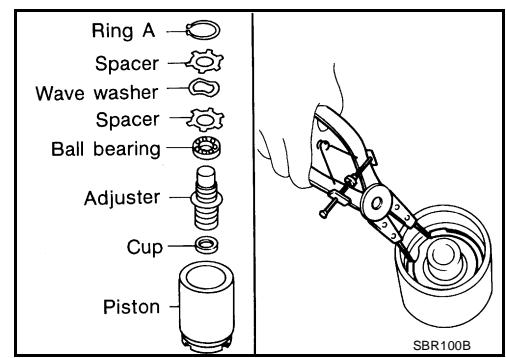

- 9. With piston boot fitted to piston, insert piston boot into groove on cylinder body and fit piston by turning it clockwise with long nose pliers, or suitable tool.

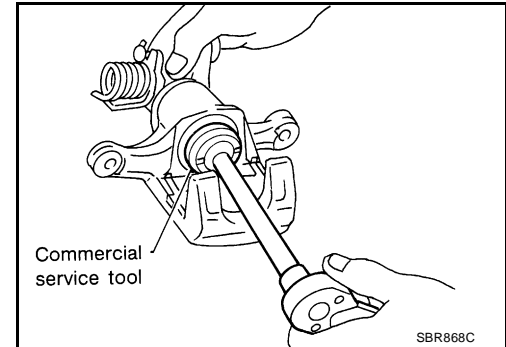
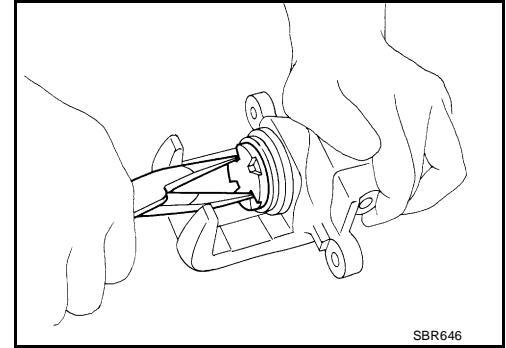

- 10. Fit toggle lever, return spring and cable guide.

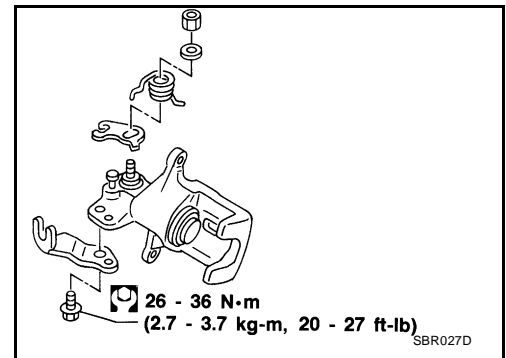

# REAR DISC BRAKE

11. Adjust the piston to the right angle as shown in the figure.

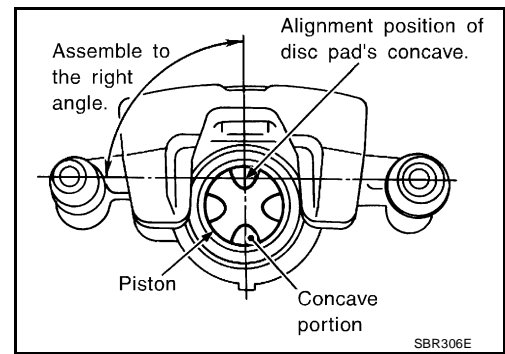

## Caliper Installation

### CAUTION:

- Refill with new brake fluid "DOT 3".
  - Never reuse drained brake fluid.
1. Install caliper assembly.
    - As shown in the figure, align the piston's concave to the pad's convex, then install the cylinder body to the torque member.
  2. Install brake hose to caliper securely.
  3. Install all parts and secure all bolts.
  4. Bleed air. Refer to [BR-7, "Bleeding Brake System"](#) .

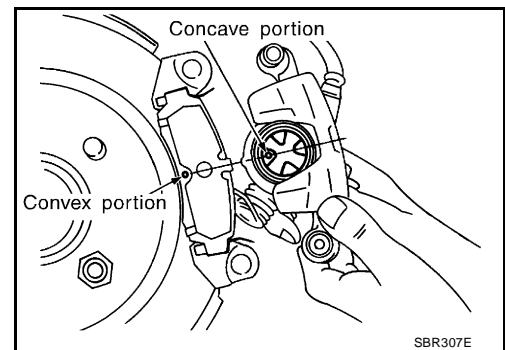

A  
B  
C  
D  
E  
BR  
G  
H  
I  
J  
K  
L  
M

# REAR DRUM BRAKE

## REAR DRUM BRAKE

PFP:43206

### Components

EFS001EA

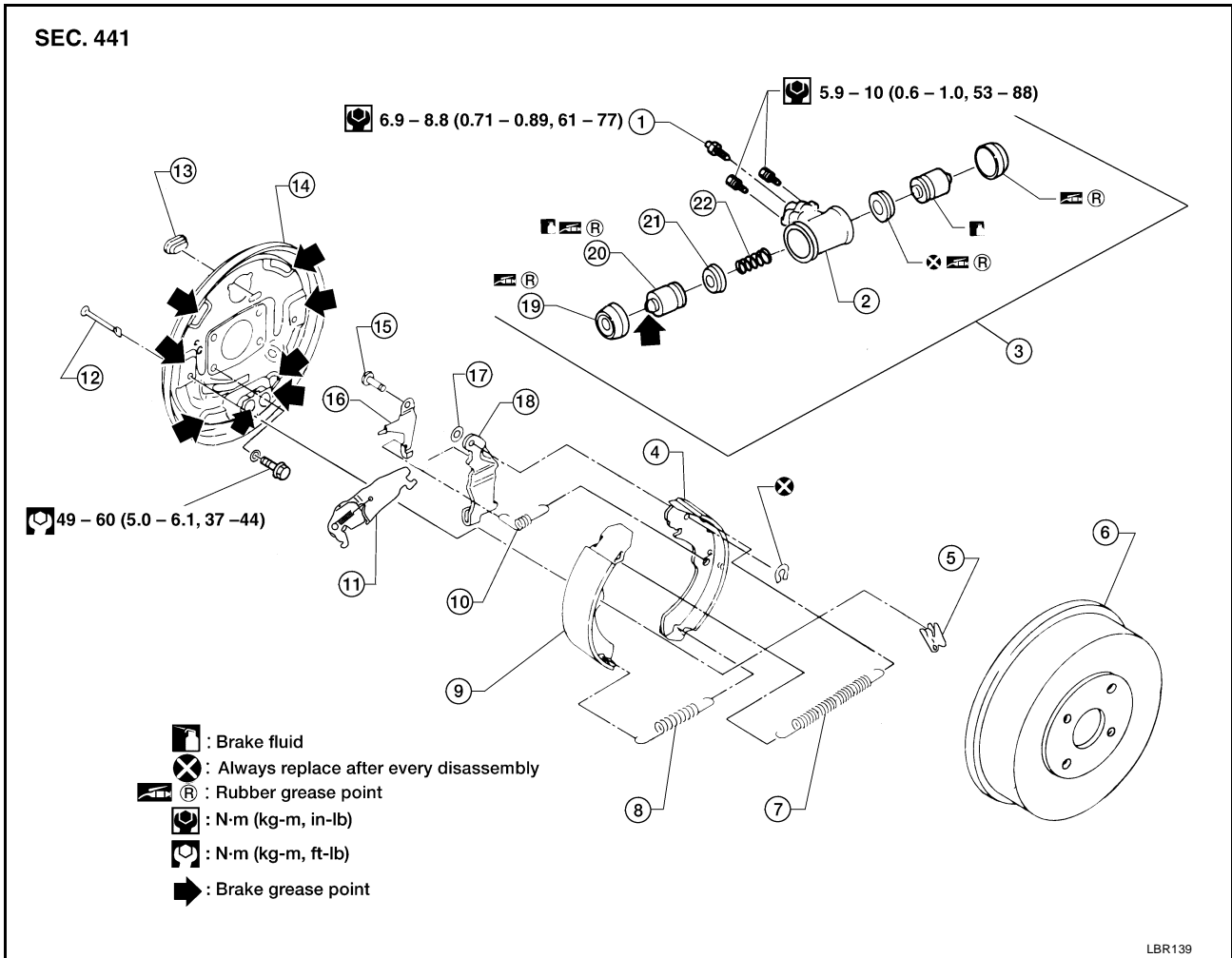

- |                      |                          |                        |
|----------------------|--------------------------|------------------------|
| 1. Air bleeder valve | 2. Cylinder body         | 3. Wheel cylinder      |
| 4. Shoe              | 5. Shoe hold-down spring | 6. Brake drum          |
| 7. Return spring     | 8. Return spring         | 9. Shoe                |
| 10. Adjuster spring  | 11. Adjuster             | 12. Shoe hold-down pin |
| .                    | .                        | .                      |
| 13. Adjuster plug    | 14. Back plate           | 15. Retainer           |
| .                    | .                        | .                      |
| 16. Adjusting lever  | 17. Washer               | 18. Toggle lever       |
| .                    | .                        | .                      |
| 19. Dust cover       | 20. Piston               | 21. Piston cap         |
| .                    | .                        | .                      |
| 22. Spring           | .                        | .                      |

### Removal

EFS001EB

#### **WARNING:**

Clean brake lining with a vacuum dust collector to minimize the hazard of airborne materials or other materials.

#### **CAUTION:**

Make sure parking brake lever is completely released.



## REAR DRUM BRAKE

1. Release parking brake lever fully, then remove drum.  
**If drum is hard to remove, the following procedures should be carried out.**
  - a. Remove adjuster plug. Shorten adjuster as shown to make clearance between brake shoe and drum.

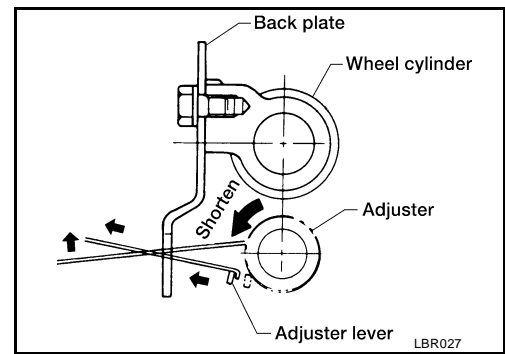

- b. Install two bolts as shown. Tighten the two bolts gradually.

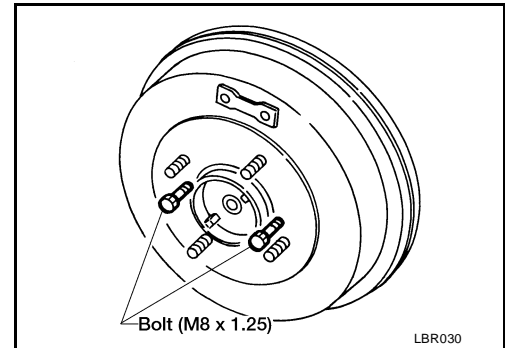

2. After removing retainer, remove spring by rotating shoes.  
**Be careful not to damage parking brake cable when separating it.**
  3. Remove adjuster.
  4. Disconnect parking brake cable from toggle lever.

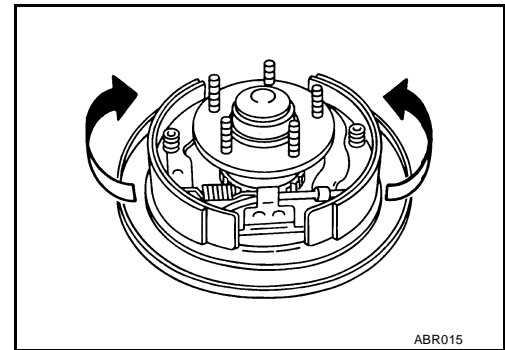

5. Remove retainer ring with a suitable tool. Then separate toggle lever and brake shoe.

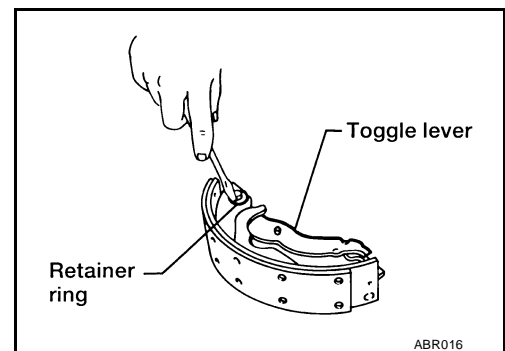

A  
B  
C  
D  
E  
BR  
G  
H  
I  
J  
K  
L  
M

# REAR DRUM BRAKE

EFS001EC

## Inspection WHEEL CYLINDER

- Check wheel cylinder for leakage.
- Check for wear, damage and loose conditions. Replace if any such condition exists.

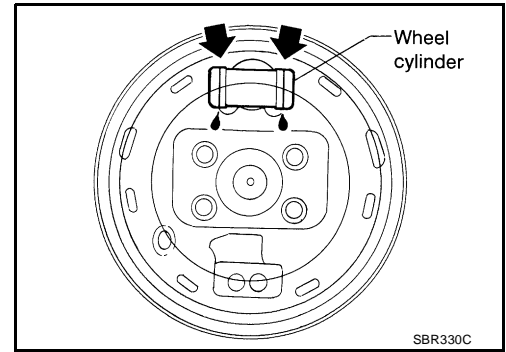

## WHEEL CYLINDER OVERHAUL

- Check all internal parts for wear, rust and damage. Replace if necessary.
- Be careful not to scratch cylinder when installing pistons.

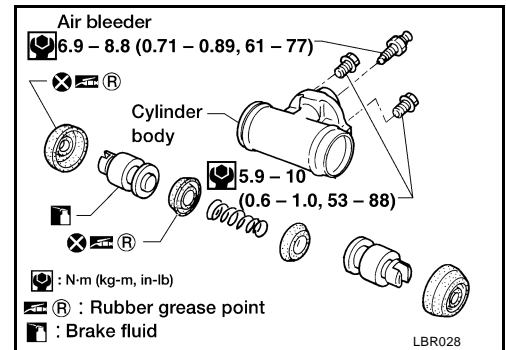

## DRUM

**Maximum inner diameter** : 204.5 mm (8.05 in)

**Out-of-roundness** : 0.03 mm (0.0012 in) or less

- Contact surface should be fine finished with No. 120 to 150 emery paper.
- Using a drum lathe, resurface brake drum if it shows score, partial wear or stepped wear.
- After brake drum has been completely reconditioned or replaced, check drum and shoes for proper contact pattern.

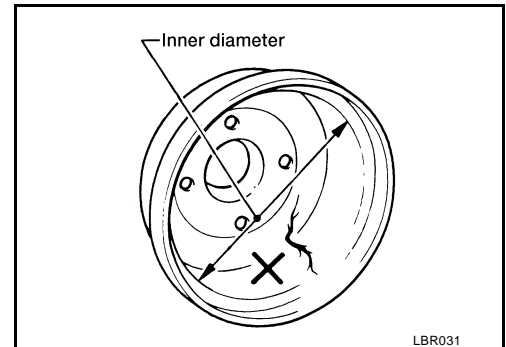

## LINING

Check lining thickness.

**Standard lining thickness** : 4.5 mm (0.177 in)

**Lining wear limit** : 1.5 mm (0.059 in)

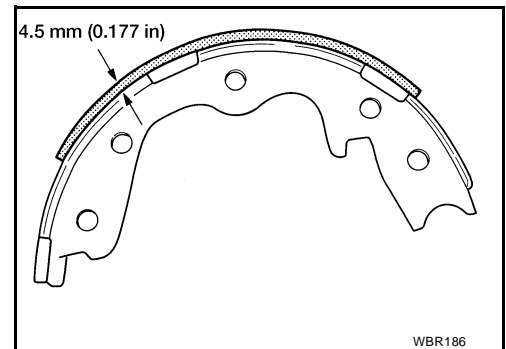

# REAR DRUM BRAKE

EFS001ED

## Installation

- Always perform shoe clearance adjustment. Refer to [PB-3, "Adjustment"](#) .
- Burnish the brake contact surfaces after refinishing or replacing drums, after replacing linings, or if a soft pedal occurs at very low mileage. Refer to [BR-6, "Brake Burnishing Procedure"](#) .

1. Fit toggle lever to brake shoe with retainer ring.
2. Apply brake grease to the contact areas shown.

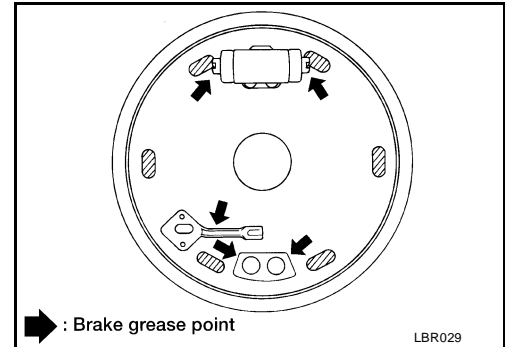

3. Shorten adjuster by rotating it.
  - Pay attention to direction of adjuster.

Wheel	Screw
Left	Left-hand thread
Right	Right-hand thread

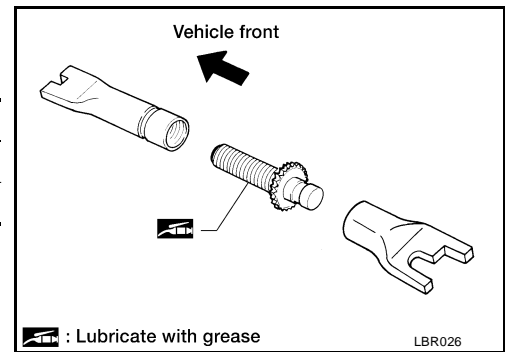

4. Connect parking brake cable to toggle lever.
  5. Install all parts.
- Be careful not to damage wheel cylinder piston boots.**
6. Check that all parts are installed properly.
- Pay attention to direction of adjuster assembly.**
7. Install brake drum.
  8. When installing new wheel cylinder or overhauling wheel cylinder, bleed air. Refer to [BR-7, "Bleeding Brake System"](#) .
  9. Adjust parking brake. Refer to [PB-3, "Adjustment"](#) .

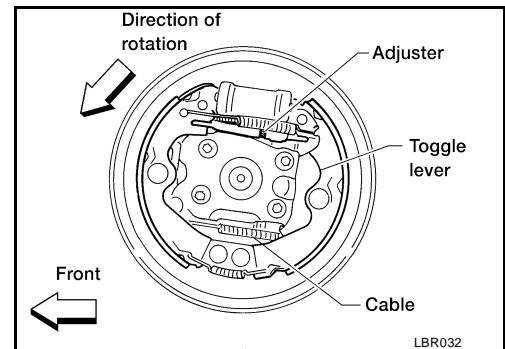

A  
B  
C  
D  
E  
BR  
G  
H  
I  
J  
K  
L  
M

# SERVICE DATA AND SPECIFICATIONS (SDS)

## SERVICE DATA AND SPECIFICATIONS (SDS)

PF0:00030

### General Specifications

EFS001EE

Unit: mm (in)

Applied Model		QG18DE	QR25DE
Front brake	Brake model	CL25VA	CL25VB
	Cylinder bore diameter	57.2 (2.252)	
	Pad length × width × thickness	125.6 × 46.0 × 11.0 (4.94 × 1.811 × 0.433)	
	Rotor outer diameter × thickness	257 × 22 (10.12 × 0.87)	280 × 22 (11.02 × 0.87)
Rear brake	Brake model	LT20G	CL9HC
	Cylinder bore diameter/caliper bore diameter	15.87 (5/8) type a 17.45 (11/16) type b	33.96 (1 11/32)
	Lining length × width × thickness	219.4 × 35 × 4.5 (8.64 × 1.38 × 0.177)	89.1 × 39.5 × 10 (3.508 × 1.555 × 0.39)
	Drum inner diameter/Disc diameter × thickness	203.2 (8)	258 × 9 (10.16 × 0.35)
Master cylinder	Cylinder bore diameter	23.81 (15/16)	
Control valve	Valve model	Dual proportioning valve	
	Split point [kPa (kg/cm <sup>2</sup> , psi)] × reducing ratio	1,961 (20,284) × 0.2	2,942 (30,427) × 0.2
Brake booster	Booster model	M215T	
	Diaphragm diameter	Primary: 230 (9.06) Secondary: 205 (8.07)	
Brake fluid	Recommended brake fluid	DOT 3	

### Disc Brake

EFS001EF

Unit: mm (in)

Brake model	CL25VA/CL25VB (Front)	CL9HC (Rear)
Pad wear limit Minimum thickness	2.0 (0.079)	2.0 (0.079)
Rotor repair limit Minimum thickness	20 (0.79)	8 (0.31)

### Drum Brake

EFS001EG

Unit: mm (in)

Brake model		LT20G
Lining wear limit	Minimum thickness	1.5 (0.059)
	Maximum inner diameter	204.5 (8.05)
Drum repair limit	Maximum out-of round	0.03 (0.0012)

### Brake Pedal

EFS001EH

Unit: mm (in)

Free height "H"*	M/T	156 - 166 (6.14 - 6.54)
	A/T	164.9 - 174.9 (6.49 - 6.89)
Depressed height "D" [under force of 490 N (50 kg, 110 lb) with engine running]		90 (3.54)
Pedal free play "A"		1.0 - 3.0 (0.039 - 0.118)

\*: Measured from surface of dash reinforcement panel.