

STARTING & CHARGING SYSTEM

SECTION SC

CONTENTS

PRECAUTIONS	2	MINIMUM SPECIFICATION OF CRANKING VOLTAGE REFERENCING COOLANT TEMPERATURE	20
Supplemental Restraint System (SRS) "AIR BAG" and "SEAT BELT PRE-TENSIONER"	2	Construction	20
Wiring Diagrams and Trouble Diagnosis	2	Removal and Installation	21
PREPARATION	3	QG18DE	21
Special Service Tool	3	SR20DE	22
BATTERY	4	Pinion/Clutch Check	22
How to Handle Battery	4	CHARGING SYSTEM	24
METHODS OF PREVENTING OVER-DISCHARGE	4	System Description	24
CHECKING ELECTROLYTE LEVEL	4	Wiring Diagram - CHARGE -	25
SPECIFIC GRAVITY CHECK	5	Trouble Diagnoses with Battery/Starting/Charging	
CHARGING THE BATTERY	6	System Tester	26
Trouble Diagnoses with Battery/Starting/Charging		DIAGNOSTIC RESULT ITEM CHART	28
System Tester	7	WORK FLOW	29
DIAGNOSTIC RESULT ITEM CHART	9	DIAGNOSTIC PROCEDURE 1	30
STARTING SYSTEM	10	DIAGNOSTIC PROCEDURE 2	31
System Description	10	DIAGNOSTIC PROCEDURE 3	32
M/T MODEL	10	MALFUNCTION INDICATOR	33
A/T MODEL	10	Construction	33
Wiring Diagram - START -	11	Removal and Installation	33
M/T MODEL	11	QG18DE	33
A/T MODEL	12	SR20DE	34
Trouble Diagnoses with Battery/Starting/Charging		SERVICE DATA AND SPECIFICATIONS (SDS)	35
System Tester	14	Battery	35
DIAGNOSTIC RESULT ITEM CHART	15	Starter	35
WORK FLOW	16	Generator	35
DIAGNOSTIC PROCEDURE 1	17		
DIAGNOSTIC PROCEDURE 2	19		

GI
MA
EM
LC
EC
FE
CL
MT
AT
AX
SU
BR
ST
RS
BT
HA
SC
EL
IDX

PRECAUTIONS

Supplemental Restraint System (SRS) "AIR BAG" and "SEAT BELT PRE-TENSIONER"

Supplemental Restraint System (SRS) "AIR BAG" and "SEAT BELT PRE-TENSIONER"

NISC0001

The Supplemental Restraint System such as "AIR BAG" and "SEAT BELT PRE-TENSIONER" used along with a seat belt, helps to reduce the risk or severity of injury to the driver and front passenger for certain types of collision. The SRS system composition which is available to NISSAN MODEL B15 is as follows:

- For a frontal collision
The Supplemental Restraint System consists of driver air bag module (located in the center of the steering wheel), front passenger air bag module (located on the instrument panel on passenger side), front seat belt pre-tensioners, a diagnosis sensor unit, warning lamp, wiring harness and spiral cable.
- For a side collision
The Supplemental Restraint System consists of front side air bag module (located in the outer side of front seat), side air bag (satellite) sensor, diagnosis sensor unit (one of components of air bags for a frontal collision), wiring harness, warning lamp (one of components of air bags for a frontal collision).

Information necessary to service the system safely is included in the **RS section** of this Service Manual.

WARNING:

- **To avoid rendering the SRS inoperative, which could increase the risk of personal injury or death in the event of a collision which would result in air bag inflation, all maintenance should be performed by an authorized NISSAN dealer.**
- **Improper maintenance, including incorrect removal and installation of the SRS, can lead to personal injury caused by unintentional activation of the system. For removal of Spiral Cable and Air Bag Module, see the RS section.**
- **Do not use electrical test equipment on any circuit related to the SRS unless instructed to in this Service Manual. Spiral cable and wiring harnesses (except "SEAT BELT PRE-TENSIONER") covered with yellow insulation either just before the harness connectors or for the complete harness are related to the SRS.**

Wiring Diagrams and Trouble Diagnosis

NISC0002

When you read wiring diagrams, refer to the following:

- **GI-11**, "HOW TO READ WIRING DIAGRAMS".
- **EL-9**, "POWER SUPPLY ROUTING" for power distribution circuit.

When you perform trouble diagnosis, refer to the following:

- **GI-35**, "How To Follow Test Groups In Trouble Diagnoses".
- **GI-24**, "HOW TO PERFORM EFFICIENT DIAGNOSIS FOR AN ELECTRICAL INCIDENT".

PREPARATION

Special Service Tool

Special Service Tool

NISC0020

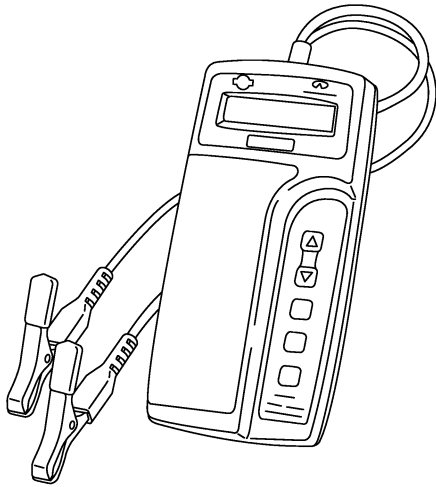
Tool number Tool name	Description
J-44373 Model 620 Battery/Starting/Charging system tester	 <p data-bbox="435 856 516 886">SEL403X</p>

- GI
- MA
- EM
- LC
- EC
- FE
- CL
- MT
- AT
- AX
- SU
- BR
- ST
- RS
- BT
- HA
- SC**
- EL
- IDX

BATTERY

How to Handle Battery

NISC0003

CAUTION:

- If it becomes necessary to start the engine with a booster battery and jumper cables, use a 12-volt booster battery.
- After connecting battery cables, ensure that they are tightly clamped to battery terminals for good contact.
- Never add distilled water through the hole used to check specific gravity.

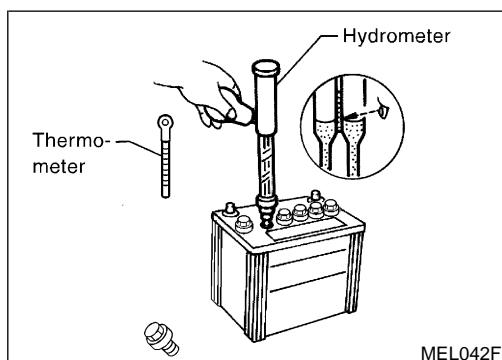
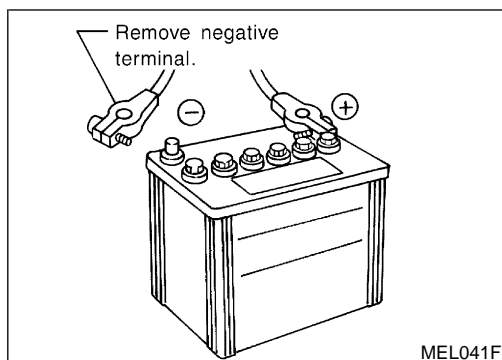
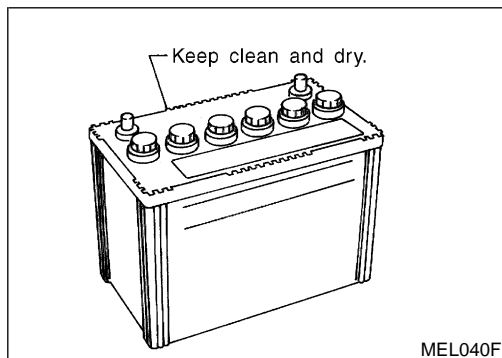

METHODS OF PREVENTING OVER-DISCHARGE

NISC0003S01

The following precautions must be taken to prevent over-discharging a battery.

- The battery surface (particularly its top) should always be kept clean and dry.
- The terminal connections should be clean and tight.
- At every routine maintenance, check the electrolyte level. This also applies to batteries designated as "low maintenance" and "maintenance-free".
- When the vehicle is not going to be used over a long period of time, disconnect the negative battery terminal.
- Check the charge condition of the battery. Periodically check the specific gravity of the electrolyte. Keep a close check on charge condition to prevent over-discharge.

CHECKING ELECTROLYTE LEVEL

NISC0003S02

WARNING:

Do not allow battery fluid to come in contact with skin, eyes, fabrics, or painted surfaces. After touching a battery, do not touch or rub your eyes until you have thoroughly washed your hands. If acid contacts eyes, skin or clothing, immediately flush with water for 15 minutes and seek medical attention.

BATTERY

How to Handle Battery (Cont'd)

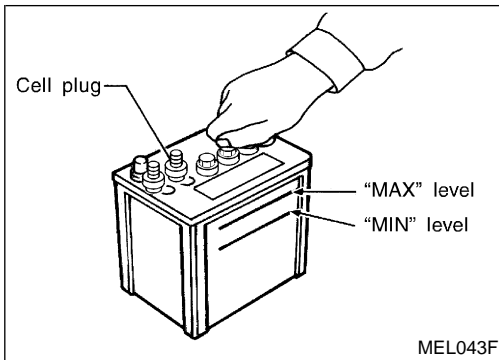

- Remove the cell plug using a suitable tool.
- Add distilled water up to the MAX level.

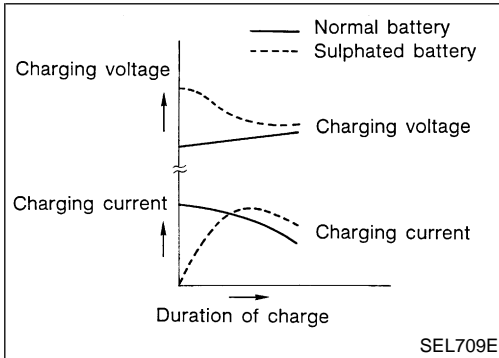

Sulphation

NISC0003S0201

A battery will be completely discharged if it is left unattended for a long time and the specific gravity will become less than 1.100. This may result in sulphation on the cell plates.

To determine if a battery has been "sulphated", note its voltage and current when charging it. As shown in the figure, less current and higher voltage are observed in the initial stage of charging sulphated batteries.

A sulphated battery may sometimes be brought back into service by means of a long, slow charge, 12 hours or more, followed by a battery capacity test.

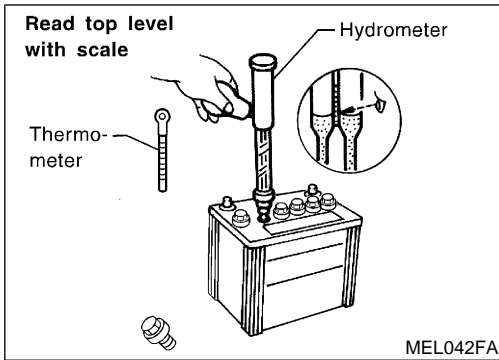

SPECIFIC GRAVITY CHECK

NISC0003S03

1. Read hydrometer and thermometer indications at eye level.

2. Use the chart below to correct your hydrometer reading according to electrolyte temperature.

Hydrometer Temperature Correction

NISC0003S0301

Battery electrolyte temperature °C (°F)	Add to specific gravity reading
71 (160)	0.032
66 (150)	0.028
60 (140)	0.024
54 (130)	0.020
49 (120)	0.016
43 (110)	0.012
38 (100)	0.008
32 (90)	0.004
27 (80)	0
21 (70)	-0.004
16 (60)	-0.008
10 (50)	-0.012

GI
MA
EM
LC
EC
FE
CL
MT
AT
AX
SU
BR
ST
RS
BT
HA
SC
EL
IDX

BATTERY

How to Handle Battery (Cont'd)

Battery electrolyte temperature °C (°F)	Add to specific gravity reading
4 (40)	-0.016
-1 (30)	-0.020
-7 (20)	-0.024
-12 (10)	-0.028
-18 (0)	-0.032

Corrected specific gravity	Approximate charge condition
1.260 - 1.280	Fully charged
1.230 - 1.250	3/4 charged
1.200 - 1.220	1/2 charged
1.170 - 1.190	1/4 charged
1.140 - 1.160	Almost discharged
1.110 - 1.130	Completely discharged

CHARGING THE BATTERY

NISC0003S04

CAUTION:

- Do not “quick charge” a fully discharged battery.
- Keep the battery away from open flame while it is being charged.
- When connecting the charger, connect the leads first, then turn on the charger. Do not turn on the charger first, as this may cause a spark.
- If battery electrolyte temperature rises above 60°C (140°F), stop charging. Always charge battery at a temperature below 60°C (140°F).

Charging Rates

NISC0003S0401

Amps	Time
50	1 hour
25	2 hours
10	5 hours
5	10 hours

Do not charge at more than 50 ampere rate.

NOTE:

The ammeter reading on your battery charger will automatically decrease as the battery charges. This indicates that the voltage of the battery is increasing normally as the state of charge improves. The charging amps indicated above refer to initial charge rate.

- If, after charging, the specific gravity of any two cells varies more than .050, the battery should be replaced.

BATTERY

Trouble Diagnoses with Battery/Starting/Charging System Tester

Trouble Diagnoses with Battery/Starting/Charging System Tester

NISC0017

CAUTION:

When working with batteries, always wear appropriate eye protection.

NOTE:

- To ensure a complete and thorough diagnosis, the battery, starter and generator test segments must be done as a set from start to finish.
- If battery surface charge is detected while testing, the tester will prompt you to turn on the headlights to remove the surface charge.
- If necessary, the tester will prompt you to determine if the battery temperature is above or below 0°C (32°F). Choose the appropriate selection by pressing the up or down arrow button, then press “ENTER” to make the selection.

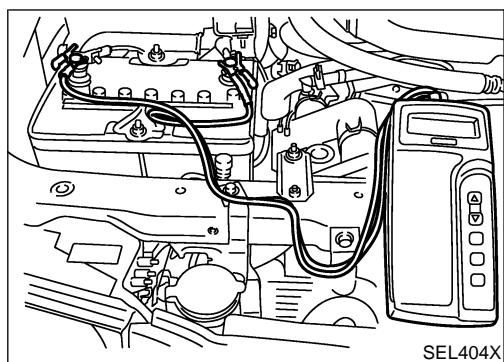

1. Turn off all loads on the vehicle electrical system. Clean or repair as necessary.
2. Visually inspect the battery, battery terminals and cable ends with ignition switch in “OFF” position.

NOTE:

The contact surface between the battery terminals, cable ends and tester leads must be clean for a valid test. A poor connection will prevent testing and a “CHECK CONNECTION” message will appear during the test procedures. If this occurs, clean the battery post and terminals, reconnect them and restart the test.

3. Connect the red tester lead clamp to the positive battery terminal, and the black to the negative terminal.

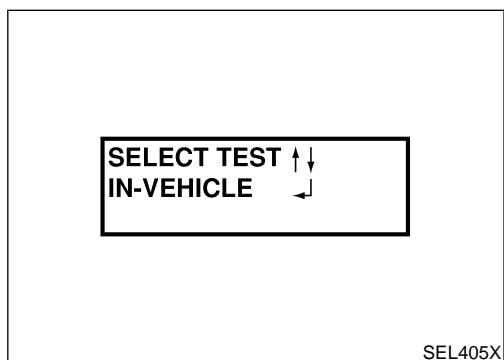

4. The tester will turn on automatically. Using the arrow keys, select “IN-VEHICLE” on the tester and then press the “ENTER” key.

GI

MA

EM

LC

EC

FE

CL

MT

AT

AX

SU

BR

ST

RS

BT

HA

SC

EL

IDX

BATTERY

Trouble Diagnoses with Battery/Starting/Charging System Tester (Cont'd)

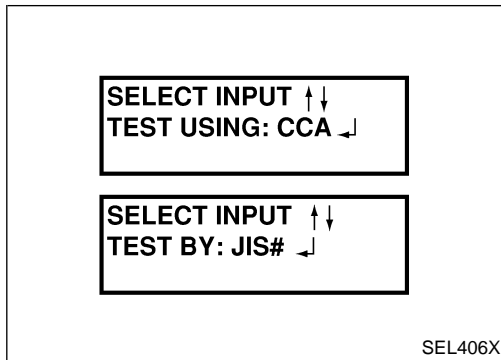

5. Locate the battery type and rating stamped or written on the top case of the battery to be tested.

NOTE:

The battery type and rating will have either of the following.

CCA: Cold Cranking Amps (490 CCA, 550 CCA, etc.)

JIS: Japanese Industrial Standard.

Battery is stamped with a number such as:

80D26L: 80 (rank of output), D (physical size-depth), 26 (width in cm). The last character L (post configuration) is not input into the tester.

The tester requires the rating for the battery be entered exactly as it is written or stamped on the battery. Do not attempt a CCA conversion for JIS stamped batteries. JIS must be input directly.

6. Using the arrow and "ENTER" keys alternately, select the battery type and rating.

NOTE:

The tester lists five choices; CCA, JIS, IEC, DIN, and EN. Only use CCA or JIS.

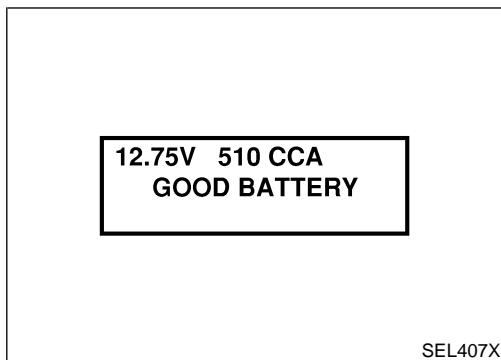

7. Press "ENTER" to begin the test. Diagnosis results are displayed on the tester. Refer to "DIAGNOSTIC RESULT ITEM CHART", SC-9.



8. Press "ENTER", then test output code is displayed. Record the test output code on the repair order.
9. Toggle back to the "DIAGNOSTIC SCREEN" for test results.

NOTE:

- If necessary, the tester will ask the user to determine if the battery has just been charged. Choose the appropriate selection by pressing the up or down arrow button and then press the "ENTER" button to make the selection.
- When testing a battery installed in a vehicle that has recently been driven, select "BEFORE CHARGE".
- If the battery has just been slow charged due to a "CHARGE & RETEST" decision by the tester, and the tester asks the user "BEFORE CHARGE/AFTER CHARGE", select "AFTER CHARGE".

BATTERY

Trouble Diagnoses with Battery/Starting/Charging System Tester (Cont'd)

DIAGNOSTIC RESULT ITEM CHART

NISC0017S01

Diagnostic item	Service procedure	
GOOD BATTERY	Battery is OK. Refer to "Trouble Diagnoses with Battery/Starting/Charging System Tester", SC-14.	GI
REPLACE BATTERY	Replace battery. Before replacing battery, clean the battery cable clamps and battery posts. Perform battery test again with Battery/Starting/Charging system tester. If second test result is "Replace Battery", then do so. Perform battery test again to confirm repair.	MA EM
BAD CELL-REPLACE	Replace the battery. Perform battery test again with Battery/Starting/Charging system tester to confirm repair.	LC
GOOD-RECHARGE	Perform the slow battery charging procedure. (Initial rate of charge is 10A for 12 hours.) Perform battery test again with Battery/Starting/Charging system tester.	EC
CHARGE & RETEST	Perform the slow battery charging. (Initial rate of charge is 10A for 12 hours.) Perform battery test again with Battery/Starting/Charging system tester to confirm repair. NOTE: If the tester asks the user "BEFORE CHARGE/AFTER CHARGE", select "AFTER CHARGE".	FE
		CL
		MT
		AT
		AX
		SU
		BR
		ST
		RS
		BT
		HA
		SC
		EL
		IDX

STARTING SYSTEM

System Description

System Description

NISC0004

NISC0004S01

M/T MODEL

Power is supplied at all times:

- through 40A fusible link (letter **c**, located in the fuse and fusible link box)
- to ignition switch terminal B.

With the ignition switch in the START position, power is supplied:

- from ignition switch terminal St
- to clutch interlock relay terminal 5.

With the ignition switch in the ON or START position, power is supplied:

- through 10A fuse [No. 20, located in the fuse block (J/B)]
- to clutch interlock relay terminal 1.

When the clutch pedal is depressed, ground is supplied to clutch interlock relay terminal 2 through the clutch interlock switch and body grounds E7 and E37.

The clutch interlock relay is energized and power is supplied:

- from terminal 3 of the clutch interlock relay
- to terminal S of the starter motor windings.

The starter motor plunger closes and provides a closed circuit between the battery and the starter motor. The starter motor is grounded to the cylinder block. With power and ground supplied, the starter motor operates.

A/T MODEL

NISC0004S02

Power is supplied at all times:

- through 40A fusible link (letter **c**, located in the fuse and fusible link box)
- to ignition switch terminal B.

With the ignition switch in the START position, power is supplied:

- from ignition switch terminal St
- to park/neutral position relay terminal 5 (without ASCD) or terminal 6 (with ASCD)

With the ignition switch in the ON or START position, power is supplied:

- through 10A fuse [No. 20, located in the fuse block (J/B)]
- to park/neutral position relay terminal 1.

Ground is supplied, with the selector lever in the P or N position:

- to park/neutral position relay terminal 2
- through park/neutral position switch.

The park/neutral position relay is energized and power is supplied:

- from ignition switch terminal St
- through park/neutral position relay terminals 5 and 3 (without ASCD) or terminals 6 and 7 (with ASCD)
- to terminal S of the starter motor windings.

The starter motor plunger closes and provides a closed circuit between the battery and the starter motor. The starter motor is grounded to the cylinder block. With power and ground supplied, the starter motor operates.

STARTING SYSTEM

Wiring Diagram — START —

Wiring Diagram — START —

M/T MODEL

NISC0005

NISC0005S01

SC-START-01

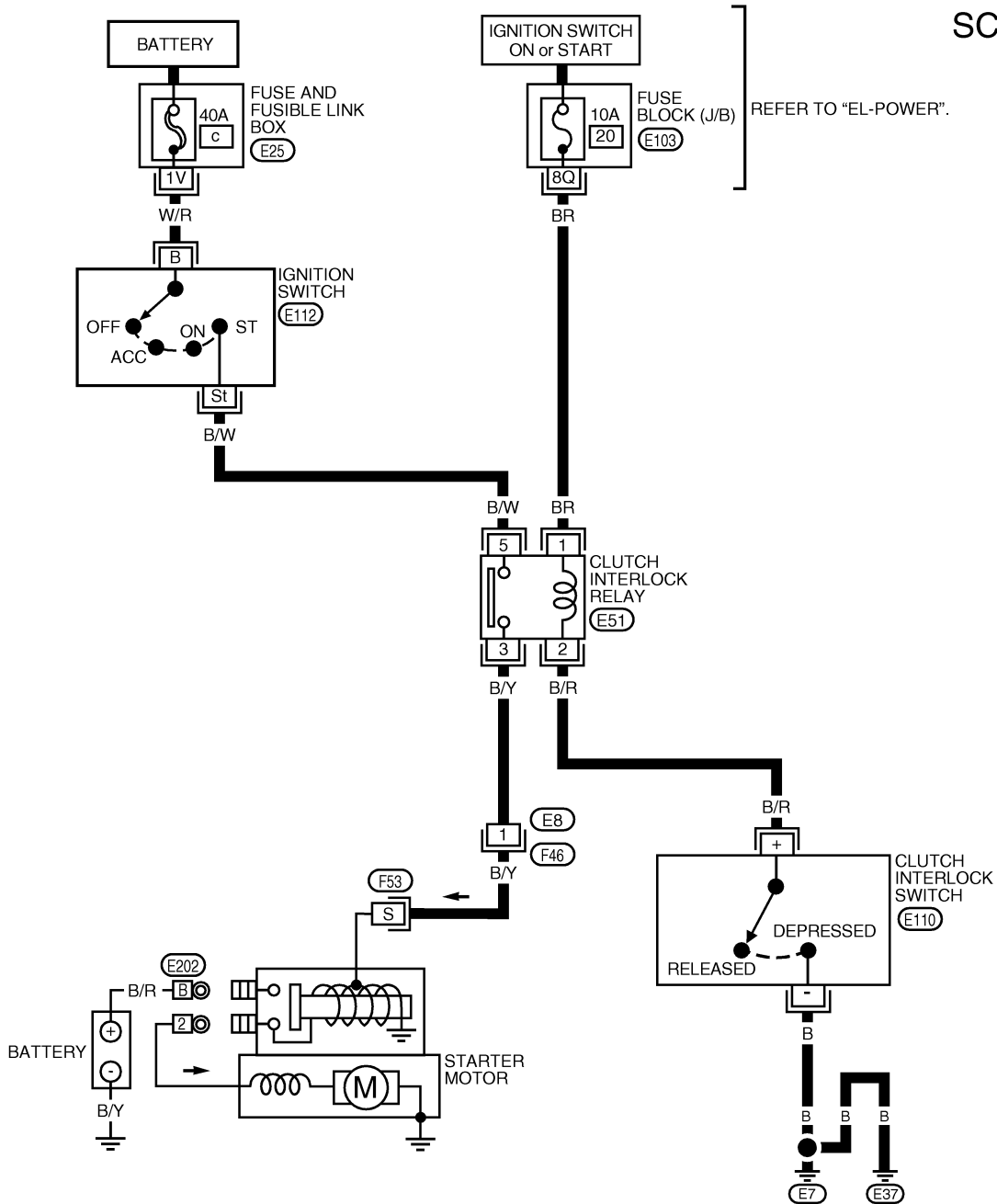

GI

MA

EM

LC

EC

FE

CL

MT

AT

AX

SU

BR

ST

RS

BT

HA

SC

EL

IDX

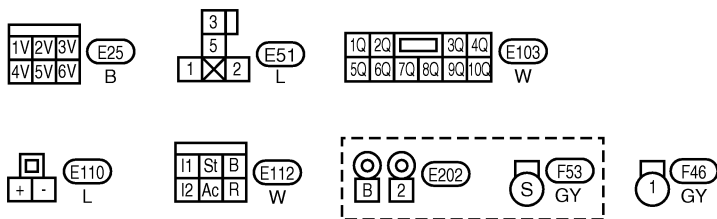

LSC049

STARTING SYSTEM

Wiring Diagram — START — (Cont'd)

A/T MODEL

NISC0005S02

SC-START-02

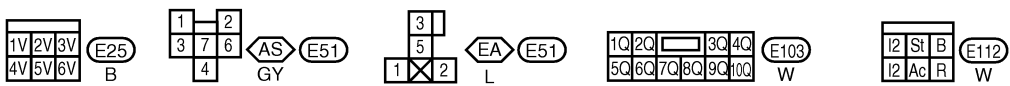
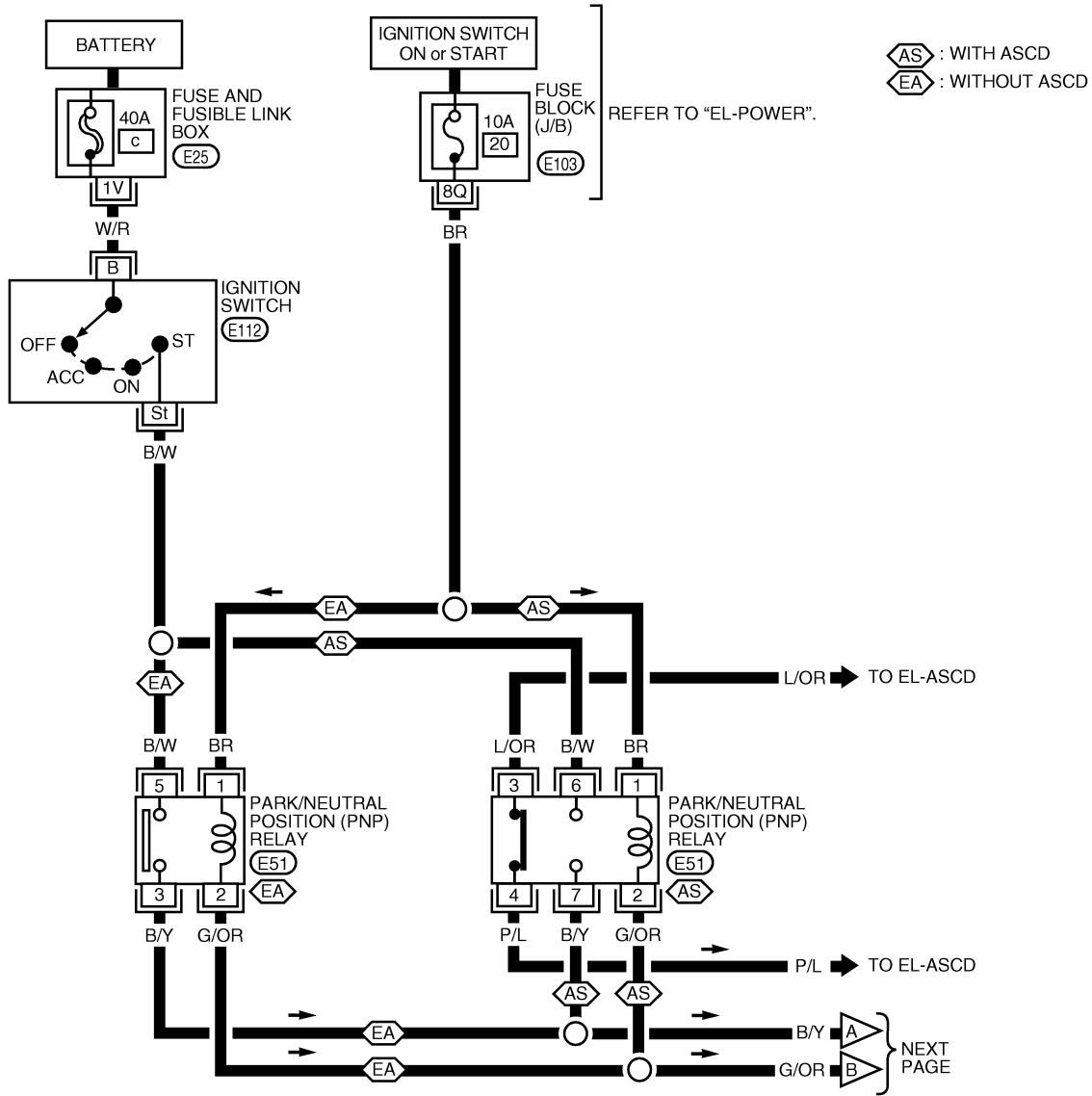

WSC004

STARTING SYSTEM

Wiring Diagram — START — (Cont'd)

SC-START-03

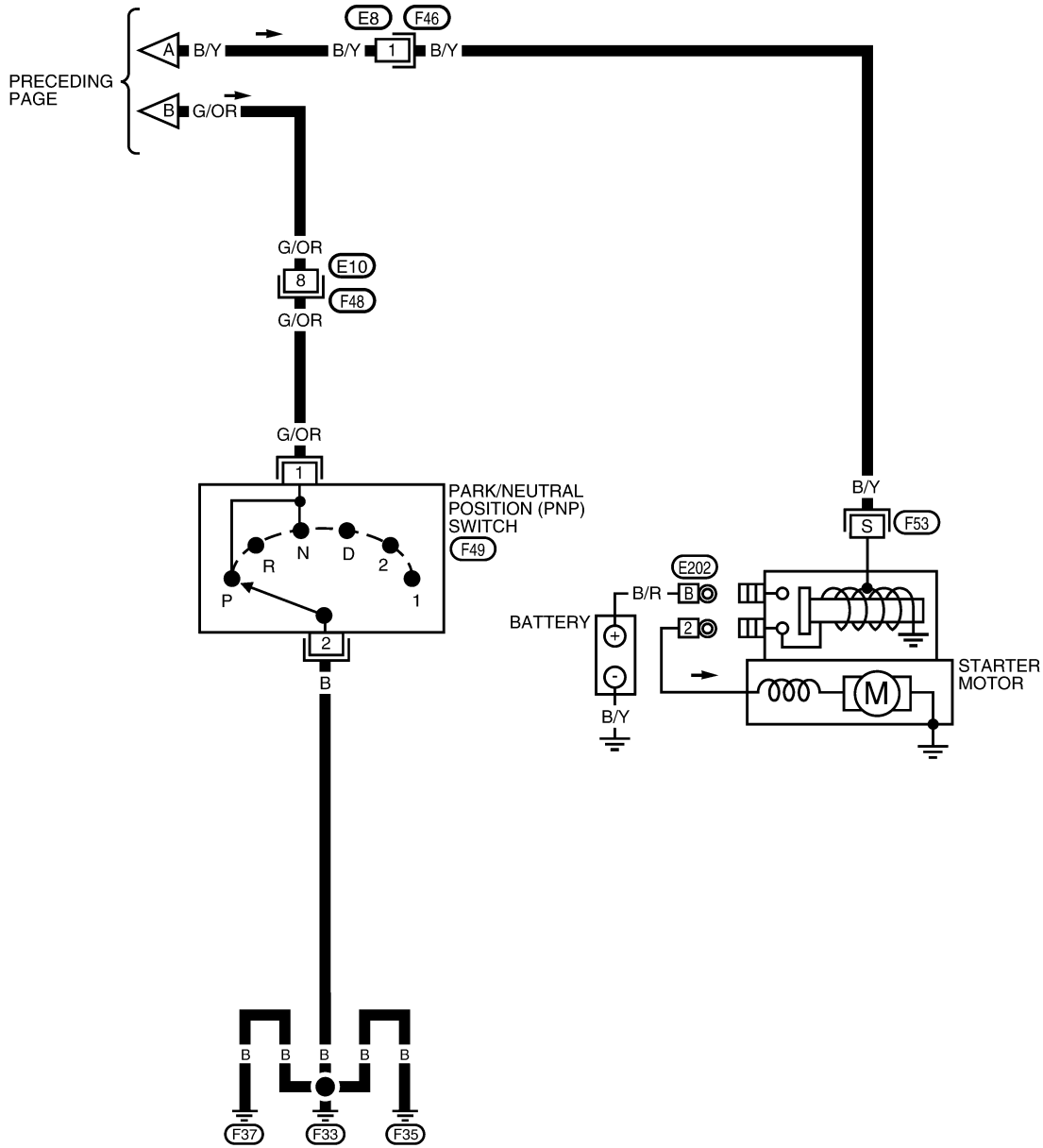

GI

MA

EM

LC

EC

FE

CL

MT

AT

AX

SU

BR

ST

RS

BT

HA

SC

EL

IDX

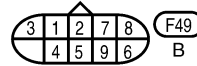
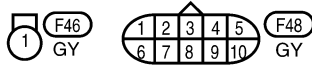
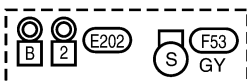

LSC050

STARTING SYSTEM

Trouble Diagnoses with Battery/Starting/Charging System Tester

Trouble Diagnoses with Battery/Starting/Charging System Tester

NISC0018

NOTE:

To ensure a complete and thorough diagnosis, the battery, starter and generator test segments must be done as a set from start to finish.

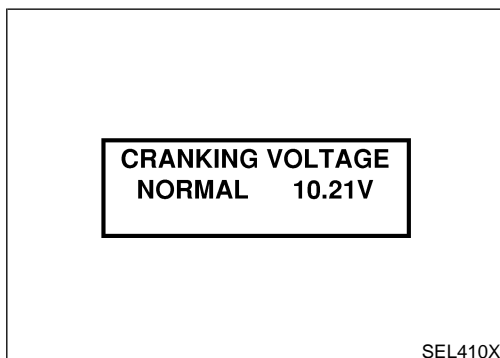
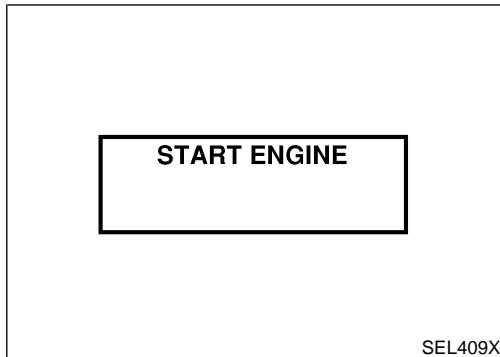

1. Turn off all loads on the vehicle electrical system.
2. Perform battery test with Battery/Starting/Charging system tester. Refer to "Trouble Diagnoses with Battery/Starting/Charging System Tester", SC-7.
3. Press "ENTER" to begin the starting system test.

4. Start the engine.

5. Diagnosis result is displayed on the tester. Refer to "DIAGNOSTIC RESULT ITEM CHART", SC-15.

NOTE:

- If the starter performs normally but the engine does not start, perform engine diagnosis.
- For intermittent "NO CRANK" or "NO STARTER OPERATION" incidents, refer to "DIAGNOSTIC PROCEDURE 2", SC-19.

STARTING SYSTEM

Trouble Diagnoses with Battery/Starting/Charging System Tester (Cont'd)

DIAGNOSTIC RESULT ITEM CHART

NISC0018S01

Diagnostic item	Service procedure	
CRANKING VOLTAGE NORMAL	Go to "WORK FLOW", SC-16.	GI
CRANKING VOLTAGE LOW	Go to "WORK FLOW", SC-16.	MA
CHARGE BATTERY	Perform the slow battery charging procedure. (Initial rate of charge is 10A for 12 hours.) Perform battery test again with Battery/Starting/Charging system tester. Refer to "Trouble Diagnoses with Battery/Starting/Charging System Tester", SC-7.	EM
REPLACE BATTERY	Before replacing battery, clean the battery cable clamps and battery posts. Perform battery test again with Battery/Starting/Charging system tester. Refer to "Trouble Diagnoses with Battery/Starting/Charging System Tester", SC-7. If second test result is "REPLACE BATTERY", then do so. Perform battery test again to confirm repair.	LC

EC

FE

CL

MT

AT

AX

SU

BR

ST

RS

BT

HA

SC

EL

IDX

STARTING SYSTEM

Trouble Diagnoses with Battery/Starting/Charging System Tester (Cont'd)

WORK FLOW

NISC0018S02

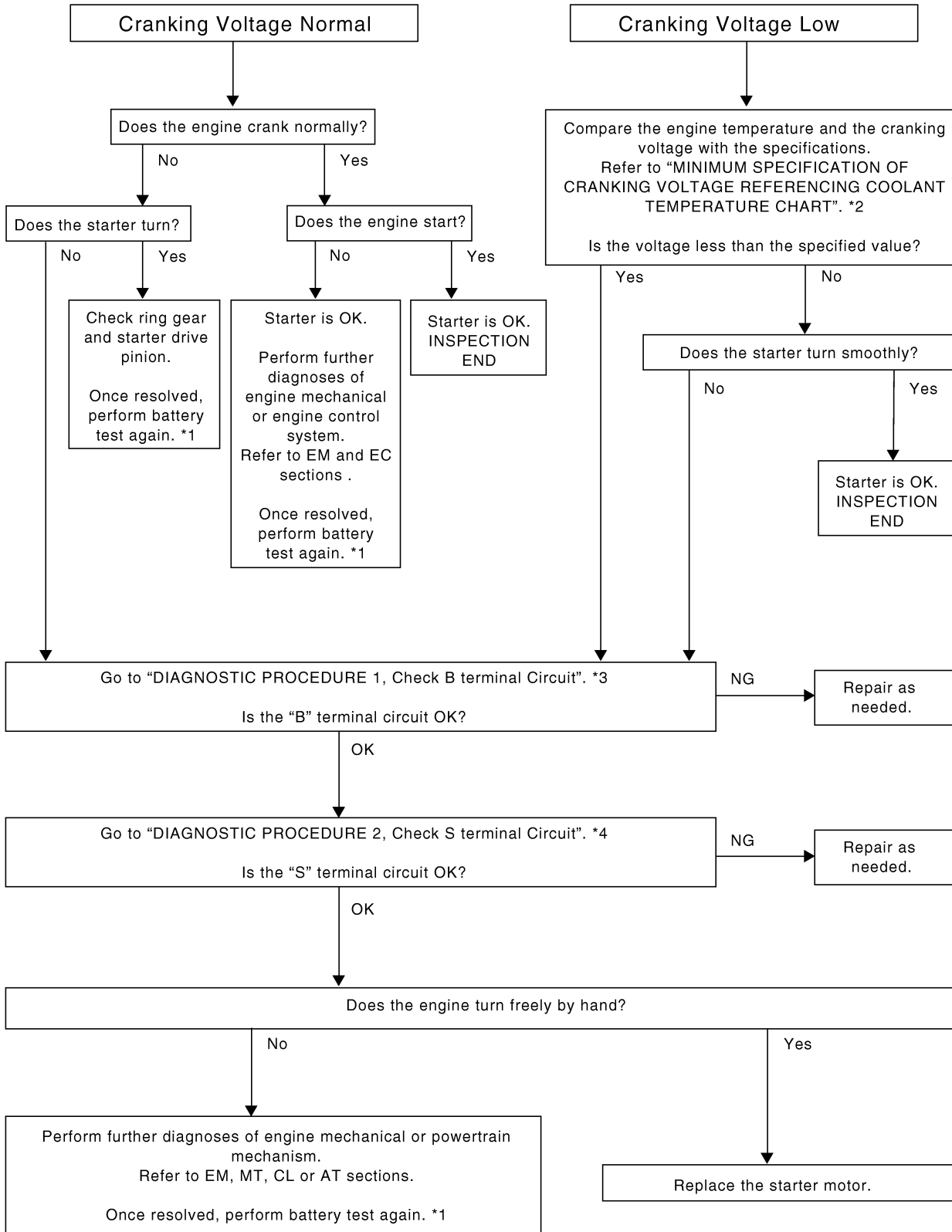

SEL411X

*1 SC-7
*2 SC-20

*3 SC-17

*4 SC-19

STARTING SYSTEM

Trouble Diagnoses with Battery/Starting/Charging System Tester (Cont'd)

DIAGNOSTIC PROCEDURE 1

Check "B" Terminal Circuit

NISC0018S03

NISC0018S0301

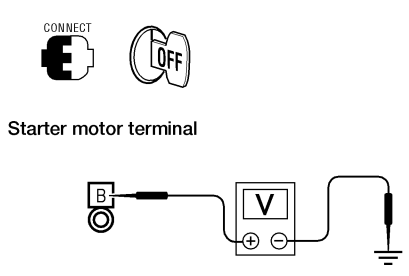
1	CHECK POWER SUPPLY FOR STARTER MOTOR "B" TERMINAL	
<ol style="list-style-type: none"> 1. Remove the fuel pump fuse. 2. Crank or start the engine (where possible) until the fuel pressure is released. 3. Turn the ignition switch OFF. 4. Check that the starter motor connector E202 terminal B (B/R) connection is clean and tight. 5. Check voltage between starter motor connector E202 terminal B (B/R) and ground using a digital circuit tester. 		
 <p style="text-align: center;">Battery voltage should exist.</p>		
LSC037		
OK or NG		
OK	▶	GO TO 2.
NG	▶	Check harness between the battery and the starter motor for open circuit.

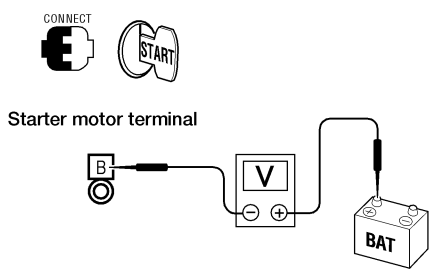
2	CHECK BATTERY CABLE CONNECTION QUALITY (VOLTAGE DROP TEST)	
<ol style="list-style-type: none"> 1. Check voltage between starter motor connector E202 terminal B (B/R) and battery positive terminal using a digital circuit tester. 		
 <p style="text-align: center;">When the ignition switch is in START position, Voltage: Less than 0.5V</p>		
LSC038		
OK or NG		
OK	▶	GO TO 3.
NG	▶	Check harness between the battery and the starter motor for poor continuity.

GI
MA
EM
LC
EC
FE
CL
MT
AT
AX
SU
BR
ST
RS
BT
HA
SC
EL
IDX

STARTING SYSTEM

Trouble Diagnoses with Battery/Starting/Charging System Tester (Cont'd)

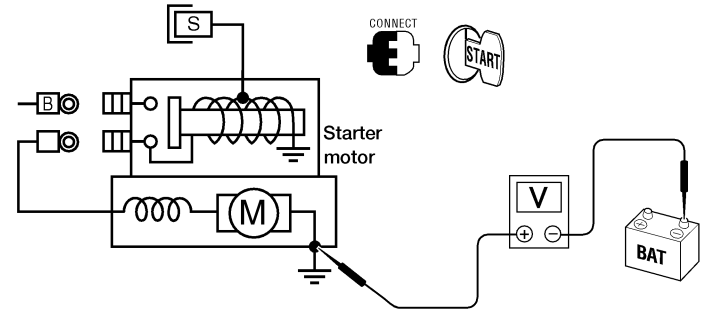
3	CHECK STARTER MOTOR GROUND CIRCUIT (VOLTAGE DROP TEST)	
1. Check voltage between starter motor case and battery negative terminal using a digital circuit tester.		
 <p data-bbox="893 378 1396 441">When the ignition switch is in START position, Voltage: Less than 0.2V</p> <p data-bbox="747 588 876 630">OK or NG</p> <p data-bbox="1396 546 1477 588">LSC039</p>		
OK	▶	Starter motor "B" terminal circuit is OK. Further inspection necessary. Refer to "WORK FLOW", SC-16.
NG	▶	Check the starter motor case and ground for poor continuity.

STARTING SYSTEM

Trouble Diagnoses with Battery/Starting/Charging System Tester (Cont'd)

DIAGNOSTIC PROCEDURE 2

Check "S" Terminal Circuit

-NISC0018S04

NISC0018S0401

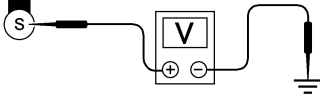
1	CHECK POWER SUPPLY FOR STARTER MOTOR "S" TERMINAL	
<ol style="list-style-type: none"> 1. Remove the fuel pump fuse. 2. Crank or start the engine (where possible) until the fuel pressure is released. 3. Turn the ignition switch OFF. 4. Disconnect starter motor connector F53 terminal S (B/Y) connector. 5. Check voltage between starter motor connector F53 terminal S (B/Y) and ground using a digital circuit tester. 		
<div style="display: flex; justify-content: space-between; align-items: flex-start;"> <div style="text-align: center;">  <p>Starter motor connector</p>  </div> <div style="text-align: right;"> <p>When the ignition switch is in START position, Battery voltage should exist.</p> </div> </div>		
LSC040		
OK or NG		
OK	▶	GO TO 2.
NG	▶	<p>Check the following.</p> <ul style="list-style-type: none"> ● 40A fusible link (letter c, located in fuse and fusible link box) ● Clutch interlock relay ● Park/neutral position relay ● Harness for open or short

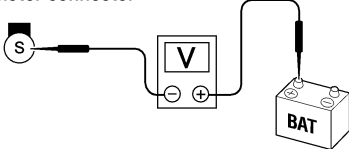
2	CHECK "S" TERMINAL CONNECTION QUALITY (VOLTAGE DROP TEST)	
<ol style="list-style-type: none"> 1. Connect starter motor connector F53 terminal S (B/Y) connector. 2. Check voltage between starter motor connector F53 terminal S (B/Y) and battery positive terminal using a digital tester. 		
<div style="display: flex; justify-content: space-between; align-items: flex-start;"> <div style="text-align: center;">  <p>Starter motor connector</p>  </div> <div style="text-align: right;"> <p>When the ignition switch is in START position, Voltage: Less than 1V</p> </div> </div>		
LSC041		
OK or NG		
OK	▶	Starter motor "S" terminal circuit is OK. Further inspection necessary. Refer to "WORK FLOW", SC-16.
NG	▶	Check harness between the battery and the starter motor "S" terminal for poor continuity.

GI
MA
EM
LC
EC
FE
CL
MT
AT
AX
SU
BR
ST
RS
BT
HA
SC
EL
IDX

STARTING SYSTEM

Trouble Diagnoses with Battery/Starting/Charging System Tester (Cont'd)

MINIMUM SPECIFICATION OF CRANKING VOLTAGE REFERENCING COOLANT TEMPERATURE

=NISC0018S05

Engine coolant temperature	Voltage V	
	QG18DE	SR20DE
-30°C to -20°C (-22°F to -4°F)	7.4	7.9
-19°C to -10°C (-2°F to 14°F)	8.2	8.7
-9°C to 0°C (16°F to 32°F)	9.3	9.6
More than 1°C (More than 34°F)	9.5	10.7

Construction

NISC0006

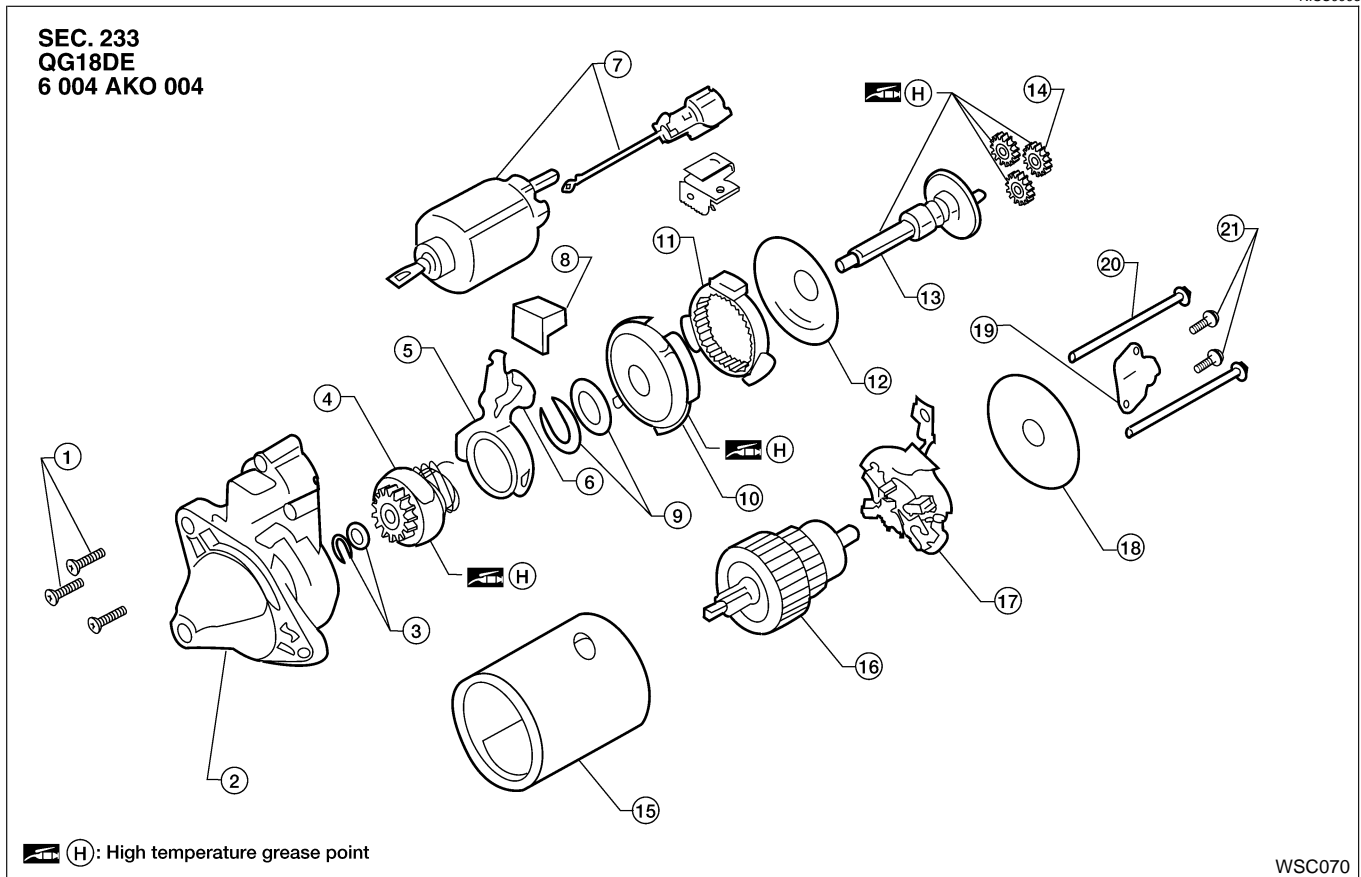

1. Solenoid through bolts
2. Drive end shield
3. Retainers
4. Pinion assembly
5. Fork lever
6. Bearing pedestal
7. Solenoid switch assembly

8. Seal
9. Locking washers
10. Intermediate bearing
11. Internal gear
12. Cover disc
13. Drive shaft
14. Planetary gears

15. Yoke assembly
16. Armature assembly
17. Brush holder
18. Commutator end shield
19. Closure cap
20. Starter through bolts
21. Closure cap screws

STARTING SYSTEM

Construction (Cont'd)

SEC. 233
SR20DE
S114 - 831

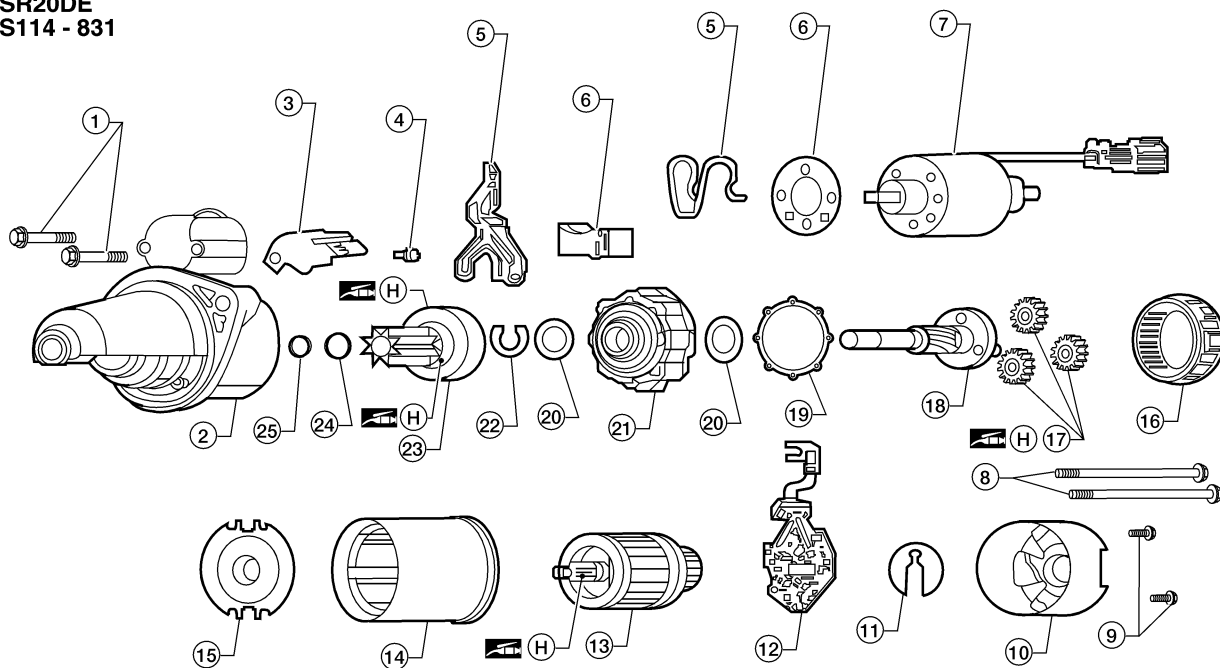

(H): High temperature grease point

LSC022

- | | | |
|-------------------------------|-----------------------------|----------------------------|
| 1. Solenoid through bolts | 10. Rear cover assembly | 18. Pinion shaft |
| 2. Gear case assembly | 11. Thrust washer | 19. Packing |
| 3. Connector stay | 12. Brush holder assembly | 20. Armature thrust washer |
| 4. Connector stay screw | 13. Armature assembly | 21. Pinion center bracket |
| 5. Shift lever set | 14. Yoke assembly | 22. E-ring |
| 6. Dust cover kit | 15. Armature center bracket | 23. Pinion assembly |
| 7. Magnetic switch assembly | 16. Internal gear | 24. Pinion stopper |
| 8. Through bolts | 17. Planet gears | 25. Pinion stopper clip |
| 9. Rear cover assembly screws | | |

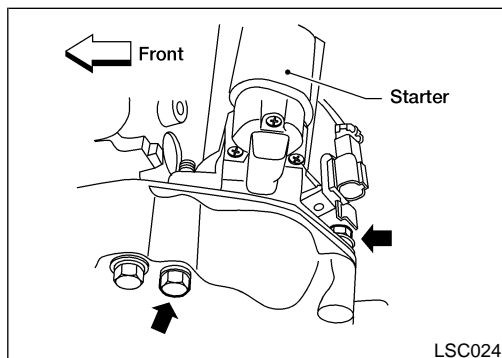

Removal and Installation

QG18DE

Removal

1. Disconnect the negative battery terminal.
2. Remove the upper starter mounting bolt.
3. Remove the harness protector from the starter engine room harness.
4. Disconnect the starter harness connectors.
5. Remove the lower starter mounting bolt.
6. Remove the starter.

NISC0007

NISC0007S01

NISC0007S0101

SC

EL

IDX

STARTING SYSTEM

Removal and Installation (Cont'd)

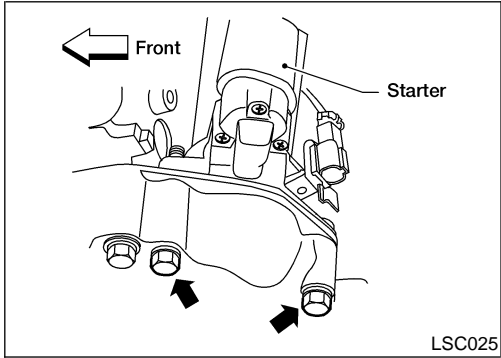
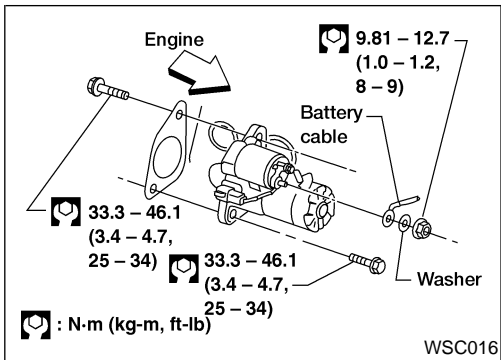

Installation

To install, reverse the removal procedure.

NISC0007S0102

SR20DE

NISC0007S02

Removal

NISC0007S0201

1. Disconnect the negative battery terminal.
2. Remove the air cleaner cover and the air cleaner to intake manifold collector duct.
3. Remove the intake manifold support.
4. Remove the harness protector from the starter engine room harness.
5. Disconnect the starter harness connectors.
6. Remove the two starter mounting bolts.
7. Remove the starter.

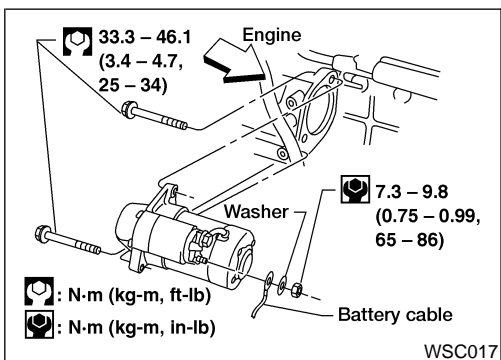

Installation

To install, reverse the removal procedure.

NISC0007S0202

Pinion/Clutch Check

NISC0008

1. Inspect pinion assembly teeth.
 - Replace pinion assembly if teeth are worn or damaged. (Also check condition of ring gear teeth.)
2. Inspect planetary gears/planet gears' teeth.
 - Replace planetary gears/planet gears if teeth are worn or damaged. (Also check condition of pinion shaft/drive shaft gear teeth.)
3. Check to see if pinion assembly locks in one direction and rotates smoothly in the opposite direction.

STARTING SYSTEM

Pinion/Clutch Check (Cont'd)

- If it locks or rotates in both directions, or unusual resistance is evident, replace.

GI

MA

EM

LC

EC

FE

CL

MT

AT

AX

SU

BR

ST

RS

BT

HA

SC

EL

IDX

CHARGING SYSTEM

System Description

System Description

NISC0009

The generator provides DC voltage to operate the vehicle's electrical system and to keep the battery charged. The voltage output is controlled by the IC regulator.

Power is supplied at all times to generator terminal B through:

- 100A fusible link (letter **a**, located in the fuse and fusible link box).

Power is supplied at all times to generator terminal S through:

- 10A fuse (No. 33, located in the fuse and fusible link box).

Terminal B supplies power to charge the battery and operate the vehicle's electrical system. Output voltage is controlled by the IC regulator at terminal S detecting the input voltage. The charging circuit is protected by the 100A fusible link.

The generator is grounded to the engine block.

With the ignition switch in the ON or START position, power is supplied:

- through 10A fuse [No. 30, located in the fuse block (J/B)]
- to combination meter terminal 26 (without tachometer) or 41 (with tachometer) for the charge warning lamp.

Ground is supplied to terminal 13 (without tachometer) or 19 (with tachometer) of the combination meter through terminal L of the generator. With power and ground supplied, the charge warning lamp will illuminate. When the generator is providing sufficient voltage with the engine running, the ground is opened and the charge warning lamp will go off.

If the charge warning lamp illuminates with the engine running, a fault is indicated.

CHARGING SYSTEM

Wiring Diagram — CHARGE —

Wiring Diagram — CHARGE —

NISC0010

SC-CHARGE-01

GI

MA

EM

LC

EC

FE

CL

MT

AT

AX

SU

BR

ST

RS

BT

HA

SC

EL

IDX

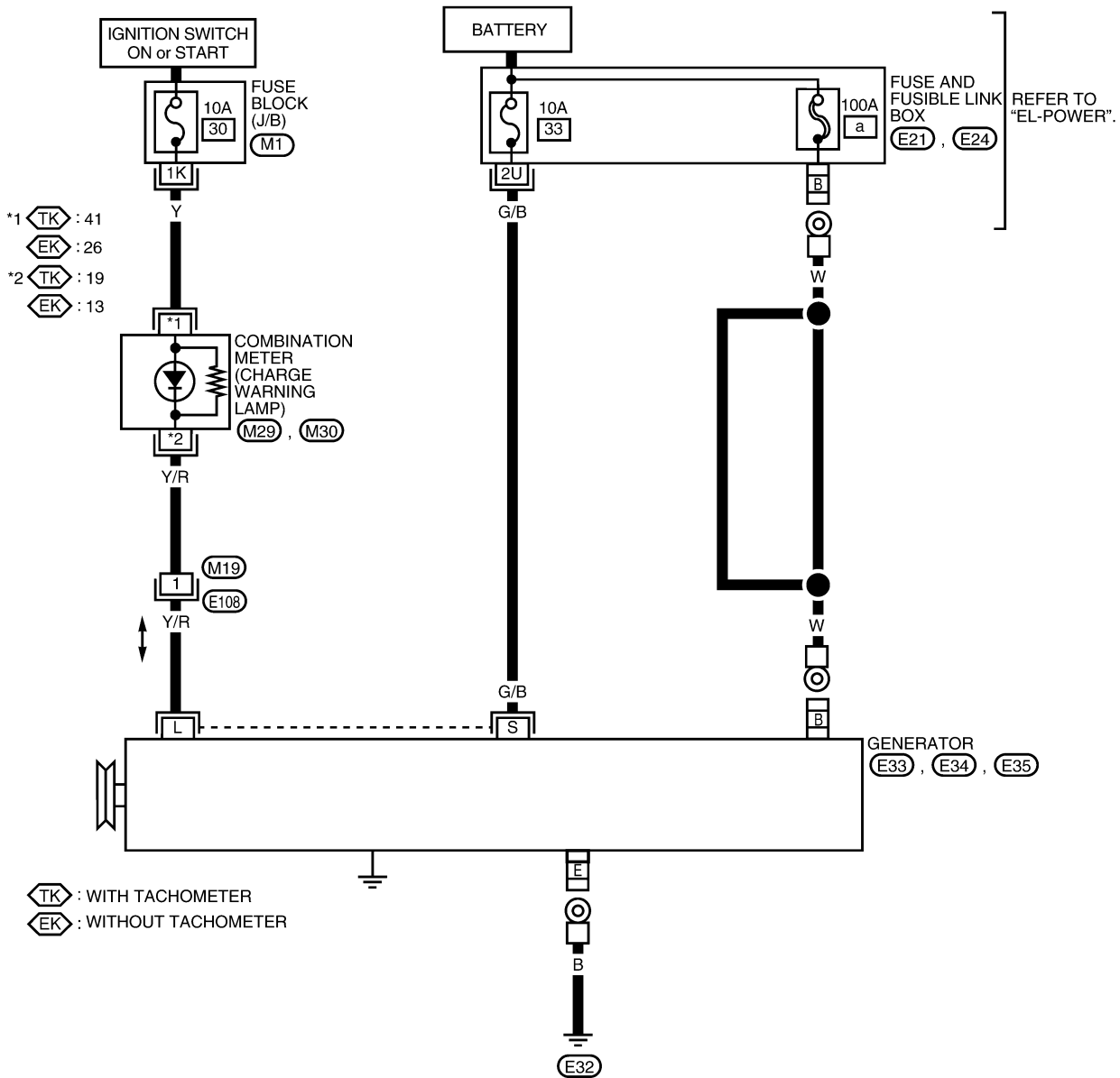

TK : WITH TACHOMETER
EK : WITHOUT TACHOMETER

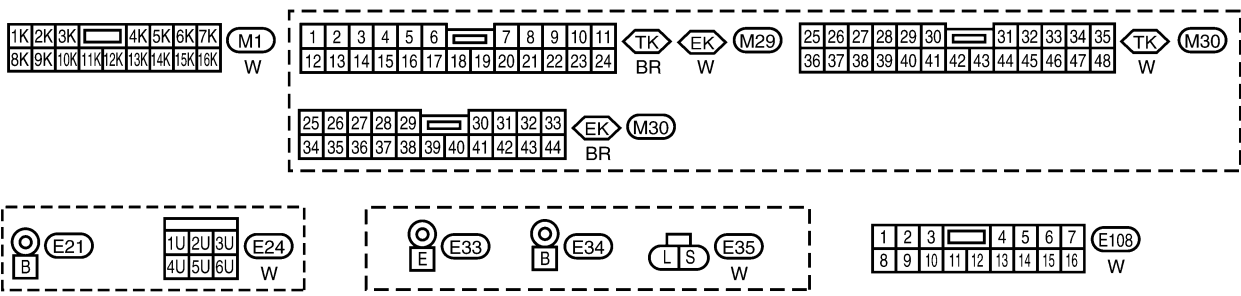

WSC071

CHARGING SYSTEM

Trouble Diagnoses with Battery/Starting/Charging System Tester

Trouble Diagnoses with Battery/Starting/Charging System Tester

NISC0019

NOTE:

To ensure a complete and thorough diagnosis, the battery, starter and generator test segments must be done as a set from start to finish.



PRESS ENTER FOR
CHARGING TEST

SEL417X



LOADS OFF
REV ENGINE 5 SEC

SEL418X

1. Turn off all loads on the vehicle electrical system.
2. Perform battery and starting system test with Battery/Starting/Charging system tester.
3. Press "ENTER" to begin the charging system test.
4. Start engine.

5. Press "ENTER" until "LOADS OFF REV ENGINE 5 SEC" is displayed.
6. Raise and hold the engine speed at 1,500 to 2,000 rpm for about 5 seconds, then return the engine to idle. Once the increase in engine rpm is detected, press "ENTER" to continue.

NOTE:

- If after 30 seconds an increase in engine idle speed is not detected, "RPM NOT DETECTED" will display.
- Some engines may have a higher idle initially after starting, particularly when the engine is cold. The tester may detect this without any other action being taken. If this occurs, continue on with the testing process. The final results will not be affected.



*** TESTING ***
ENGINE AT IDLE

*** TESTING ***
DIODE/RIPPLE

SEL419X

7. The tester now checks the engine at idle and performs the DIODE/RIPPLE check.
8. When complete, the tester will prompt you to turn on the following electrical loads.
 - Heater fan set to highest speed. Do not run the A/C or windshield defroster.
 - Headlamp high beam
 - Rear window defogger

NOTE:

Do not run the windshield wipers or any other cyclical loads.

CHARGING SYSTEM

Trouble Diagnoses with Battery/Starting/Charging System Tester (Cont'd)

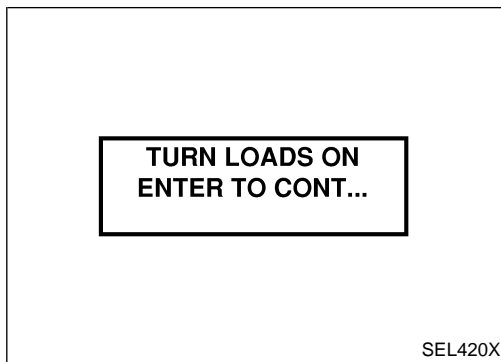

9. Press "ENTER" to continue.

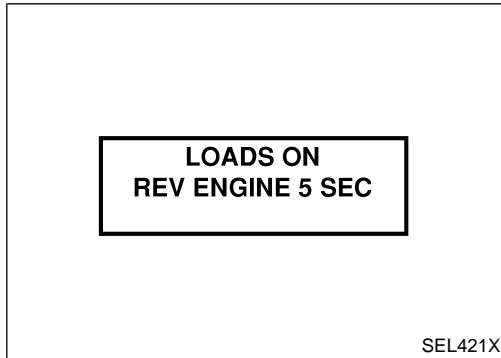

10. Raise and hold the engine speed at 1,500 to 2,000 rpm for about 5 seconds, then return the engine to idle. Once the increase in engine rpm is detected, press "ENTER" to continue.

NOTE:

If after 30 seconds an increase in engine idle speed is not detected, "RPM NOT DETECTED" will be displayed. Press "ENTER" to restart the test.

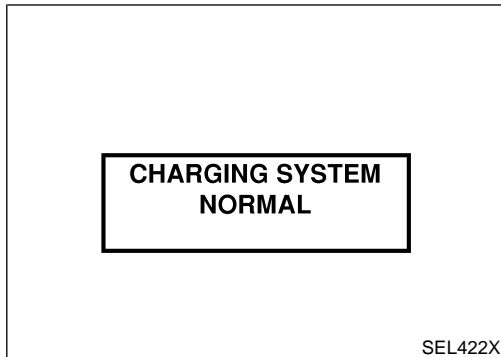

11. Diagnostic result is displayed on the tester. Refer to "DIAGNOSTIC RESULT ITEM CHART", SC-28.

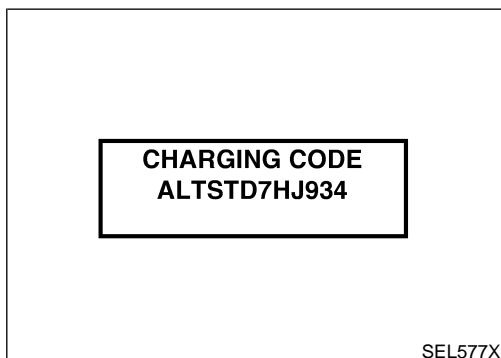

12. Press "ENTER" then test output code is displayed. Record the test output code on the repair order.

13. Toggle back to the "DIAGNOSTIC SCREEN" for test results.

GI
MA
EM
LC
EC
FE
CL
MT
AT
AX
SU
BR
ST
RS
BT
HA
SC
EL
IDX

CHARGING SYSTEM

Trouble Diagnoses with Battery/Starting/Charging System Tester (Cont'd)

DIAGNOSTIC RESULT ITEM CHART

NISC0019S01

Diagnostic item	Service procedure
CHARGING SYSTEM NORMAL	Charging system is normal and will also show DIODE RIPPLE test result.
NO CHARGING VOLTAGE	Go to "WORK FLOW", SC-29.
LOW CHARGING VOLTAGE	Go to "WORK FLOW", SC-29.
HIGH CHARGING VOLTAGE	Go to "WORK FLOW", SC-29.
DIODE RIPPLE NORMAL	Diode ripple is OK and will also show CHARGING VOLTAGE test result.
EXCESS RIPPLE DETECTED	Replace the generator. Perform "DIODE RIPPLE" test again using Battery/Starting/Charging system tester to confirm repair.
DIODE RIPPLE NOT DETECTED	Go to "WORK FLOW", SC-29.

CHARGING SYSTEM

Trouble Diagnoses with Battery/Starting/Charging System Tester (Cont'd)

WORK FLOW

NISC0019S02

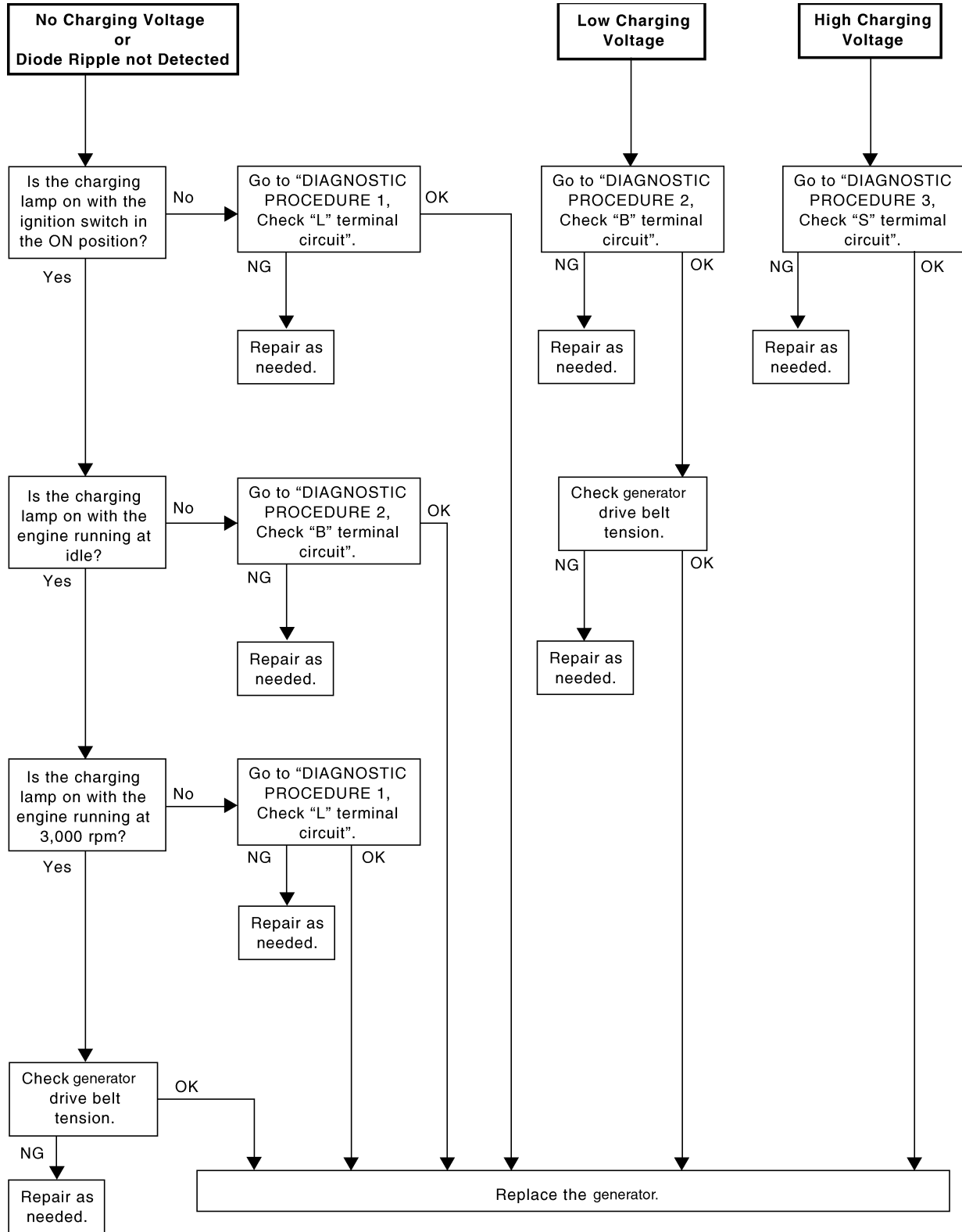

GI

MA

EM

LC

EC

FE

CL

MT

AT

AX

SU

BR

ST

RS

BT

HA

SC

EL

IDX

LSC047

CHARGING SYSTEM

Trouble Diagnoses with Battery/Starting/Charging System Tester (Cont'd)

DIAGNOSTIC PROCEDURE 1 Check "L" Terminal Circuit

NISC0019S03

NISC0019S0301

1	CHECK "L" TERMINAL CONNECTION	
Check to see if "L" terminal is clean and tight.		
OK or NG		
OK	▶	GO TO 2.
NG	▶	Repair "L" terminal connection. Confirm repair by performing complete Battery/Starting/Charging system test.

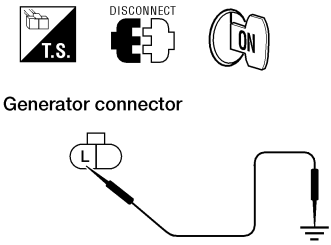
2	CHECK "L" TERMINAL CIRCUIT	
<p>1. Disconnect E35 connector from generator. 2. Apply ground to connector E35 terminal L (Y/R) with the ignition switch in the ON position.</p>		
 <p style="text-align: center;">CHARGE lamp should light up.</p>		
LSC042		
OK or NG		
OK	▶	Replace the generator. Confirm repair by performing complete Battery/Starting/Charging system test.
NG	▶	<p>Check the following.</p> <ul style="list-style-type: none"> ● 10A fuse [No. 20, located in fuse block (J/B)] ● CHARGE lamp ● Harness for open or short between combination meter and fuse ● Harness for open or short between combination meter and generator

CHARGING SYSTEM

Trouble Diagnoses with Battery/Starting/Charging System Tester (Cont'd)

DIAGNOSTIC PROCEDURE 2

Check "B" Terminal Circuit

-NISC0019S04

NISC0019S0401

1	CHECK "B" TERMINAL CONNECTION	
Check to see if "B" terminal is clean and tight.		
OK or NG		
OK	▶	GO TO 2. Confirm repair by performing complete Battery/Starting/Charging system test.
NG	▶	Repair "B" terminal connection.

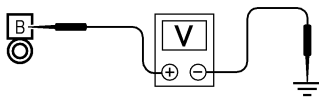
2	CHECK GENERATOR "B" TERMINAL CIRCUIT	
Check voltage between generator connector E34 terminal B (W) and ground using a digital circuit tester.		
<div style="display: flex; justify-content: space-between; align-items: center;"> <div style="text-align: center;">  Generator connector </div> <div style="text-align: center;">  </div> <div style="text-align: center;"> <p>Battery voltage should exist.</p> </div> </div>		
LSC043		
OK or NG		
OK	▶	GO TO 3.
NG	▶	Check the following. <ul style="list-style-type: none"> ● 100A fusible link (letter a, located in fuse and fusible link box) ● Harness for open or short between generator and fusible link

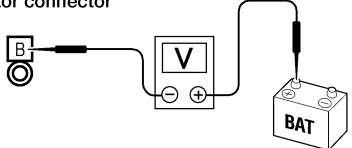
3	CHECK "B" TERMINAL CONNECTION QUALITY (VOLTAGE DROP TEST)	
Check voltage between generator connector E34 terminal B (W) and battery positive terminal using a digital tester.		
<div style="display: flex; justify-content: space-between; align-items: center;"> <div style="text-align: center;">  Generator connector </div> <div style="text-align: center;">  </div> <div style="text-align: center;"> <p>With the engine running at idle and warm, Voltage: Less than 0.2V</p> </div> </div>		
LSC044		
OK or NG		
OK	▶	Replace the generator. Confirm repair by performing complete Battery/Starting/Charging system test.
NG	▶	Check harness between the battery and the generator for poor continuity.

GI
MA
EM
LC
EC
FE
CL
MT
AT
AX
SU
BR
ST
RS
BT
HA
SC
EL
IDX

CHARGING SYSTEM

Trouble Diagnoses with Battery/Starting/Charging System Tester (Cont'd)

DIAGNOSTIC PROCEDURE 3 Check "S" Terminal Circuit

=NISC0019S05

NISC0019S0501

1	CHECK "S" TERMINAL CONNECTION
Check to see if "S" terminal is clean and tight.	
OK or NG	
OK	▶ GO TO 2.
NG	▶ Repair "S" terminal connection. Confirm repair by performing complete Battery/Starting/Charging system test.

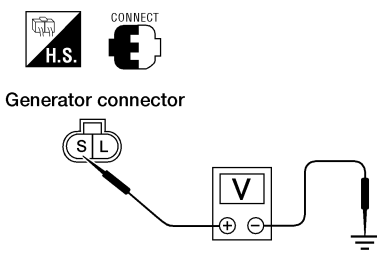
2	CHECK GENERATOR "S" TERMINAL CIRCUIT
Check voltage between generator connector E35 terminal S (G/B) and ground using a digital circuit tester.	
 <p style="text-align: center;">Battery voltage should exist.</p> <p style="text-align: right;">LSC045</p>	
OK or NG	
OK	▶ GO TO 3.
NG	▶ Check the following. <ul style="list-style-type: none"> ● 10A fuse (No. 33, located in fuse and fusible link box) ● Harness for open or short between generator and fuse

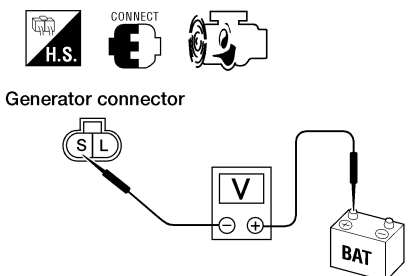
3	CHECK "S" TERMINAL CONNECTION QUALITY (VOLTAGE DROP TEST)
Check voltage between generator connector E35 terminal S (G/B) and battery positive terminal using a digital tester.	
 <p style="text-align: center;">With the engine running at idle and warm, Voltage: Less than 0.2V</p> <p style="text-align: right;">LSC046</p>	
OK or NG	
OK	▶ Replace the generator. Confirm repair by performing complete Battery/Starting/Charging system test.
NG	▶ Check harness between the battery and the generator for poor continuity.

CHARGING SYSTEM

Trouble Diagnoses with Battery/Starting/Charging System Tester (Cont'd)

MALFUNCTION INDICATOR

-NISC0019S06

The IC regulator warning function activates to illuminate "CHARGE" warning lamp, if any of the following symptoms occur while generator is operating:

- Excessive voltage is produced.
- No voltage is produced.

Construction

NISC0012

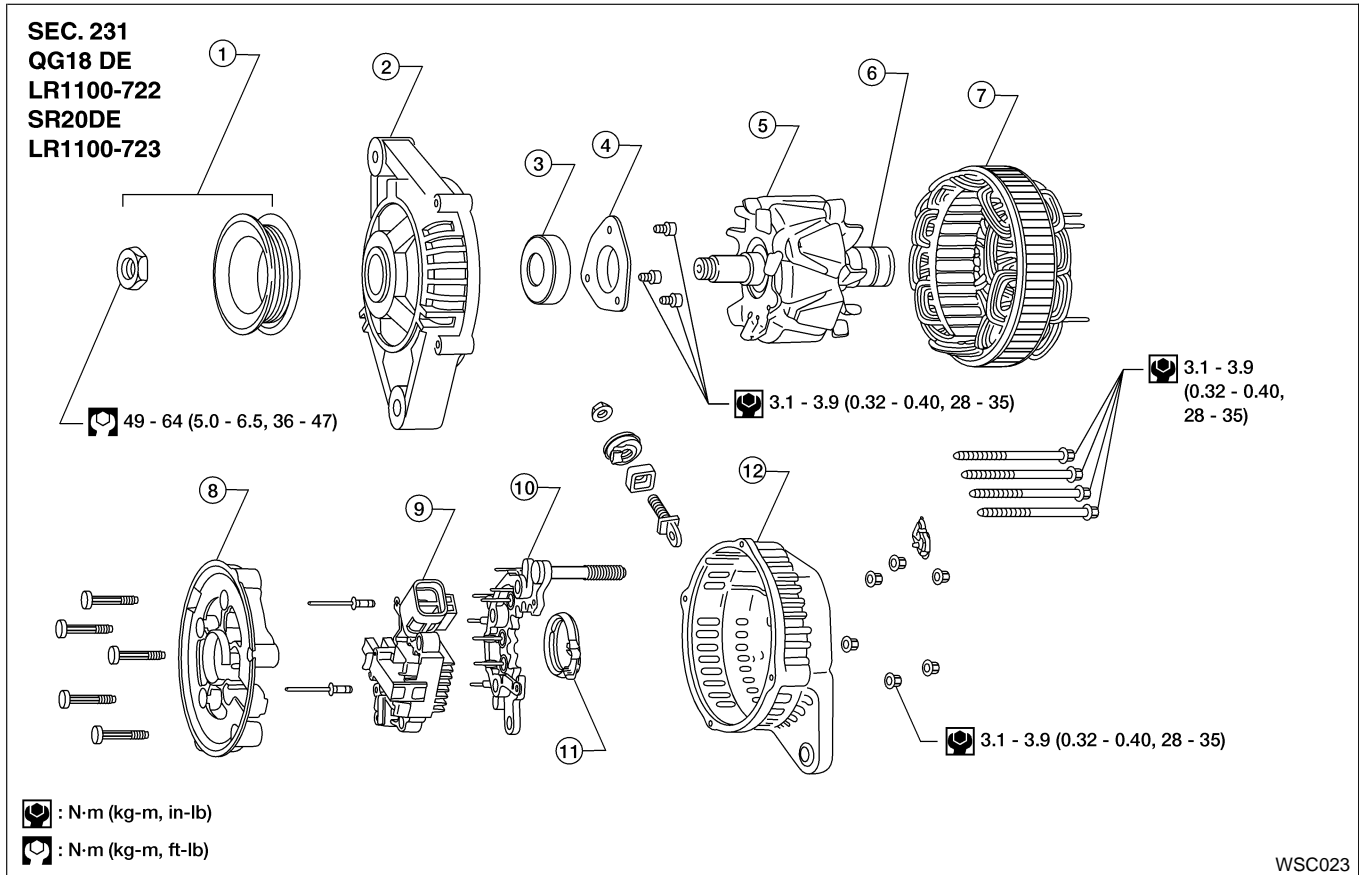

- | | | |
|--------------------|--------------|--------------------------|
| 1. Pulley assembly | 5. Rotor | 9. IC regulator assembly |
| 2. Front cover | 6. Slip ring | 10. Diode assembly |
| 3. Front bearing | 7. Stator | 11. Packing |
| 4. Retainer | 8. Fan guide | 12. Rear cover |

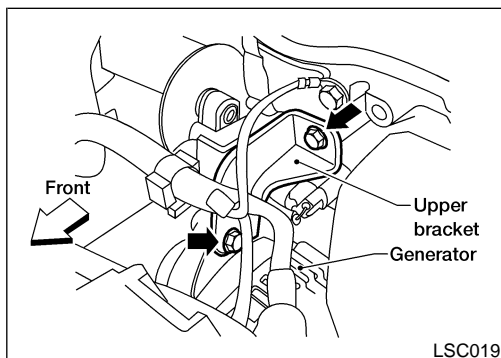

Removal and Installation

QG18DE

Removal

1. Disconnect the negative battery terminal.
2. Remove the front/right-side splash undercover.
3. Remove the drive belt.
4. Disconnect the A/C compressor harness connector.
5. Remove the four A/C compressor mounting bolts.
6. Slide the A/C compressor forward and support it.
7. Remove the two generator lower mounting bolts.

NISC0013

NISC0013S01

NISC0013S0101

SC

EL

IDX

CHARGING SYSTEM

Removal and Installation (Cont'd)

8. Disconnect the generator harness connectors.
9. Remove the generator upper bracket.
10. Remove the generator.

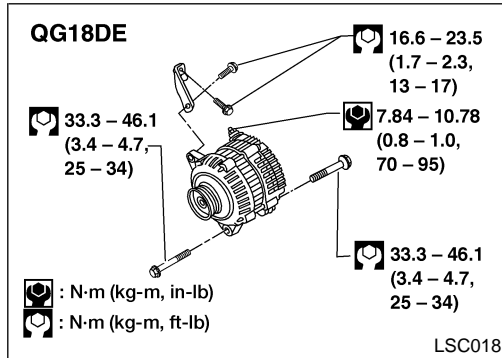

Installation

To install, reverse the removal procedure.

NISC0013S0102

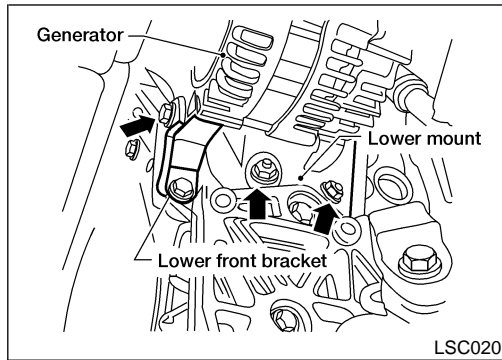

SR20DE

Removal

1. Disconnect the negative battery terminal.
2. Remove the generator adjustable top mount.
3. Disconnect the generator harness connectors.
4. Remove the front/right-side splash undercover.
5. Remove the drive belt.
6. Disconnect the A/C compressor harness connector.
7. Remove the four A/C compressor mounting bolts.
8. Slide the A/C compressor forward and support it.
9. Remove the generator lower mount bolt and nuts.
10. Remove the generator lower front bracket bolt.
11. Slide the generator out and remove.

NISC0013S02

NISC0013S0201

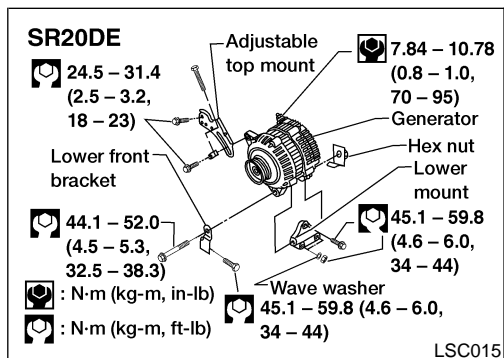

Installation

To install, reverse the removal procedure.

NISC0013S0202

SERVICE DATA AND SPECIFICATIONS (SDS)

Battery

Battery

NISC0014

Type	GR.21R (BCI)
Capacity (20 HR) minimum V-AH	12-49
Cold cranking current A (For reference value)	356 @ -18°C (0°F)

Starter

NISC0015

Application		QG18DE	SR20DE
Manufacturer		Bosch 6 004 AK0 004	Hitachi S114-831
Type		Reduction gear type	Reduction gear type
System voltage		12V	12V
No-load	Terminal voltage	11V	11V
	Current	90A Max.	90A Max.
	Revolution	3,500 rpm Min.	2,700 rpm Min.
Minimum diameter of commutator		32.1 mm	28 mm
Minimum length of brush		10.7 mm	10.5 mm
Brush spring tension		11.5 N (1.17 kg, 2.58 lb)	16.2 N (1.65 kg, 3.64 lb)
Clearance between pinion front edge and pinion stopper		1.8 mm	0.3 - 2.5 mm

Generator

NISC0016

Application		QG18DE	SR20DE
Type		LR1100-722	LR1100-723
		HITACHI	
Nominal rating		12V-100A	
Ground polarity		Negative	
Minimum revolution under no-load (When 13.5 volts is applied)		Less than 1000 rpm	
Hot output current (When 13.5 volts is applied)		More than 24A/1,300 rpm More than 71A/2,500 rpm More than 98A/5,000 rpm	
Regulated output voltage		14.1 - 14.7V	
Minimum length of brush		6 mm (0.236 in)	
Brush spring pressure		1.000 - 3.432 N (0.102 - 0.350 kg, 0.225 - 0.772 lbs)	
Slip ring minimum outer diameter		26.0 mm (1.024 in)	
Rotor (Field coil) resistance		1.9 - 2.2 ohms	

GI

MA

EM

LC

EC

FE

CL

MT

AT

AX

SU

BR

ST

RS

BT

HA

SC

EL

IDX

NOTES