

MAINTENANCE

SECTION MA

GI

MA

EM

LC

EC

FE

CL

MT

AT

AX

SU

BR

ST

RS

BT

HA

SC

EL

IDX

CONTENTS

PRECAUTIONS	3
Supplemental Restraint System (SRS) "AIR BAG" and "SEAT BELT PRE-TENSIONER"	3
PREPARATION	4
Special Service Tool	4
Commercial Service Tool	4
GENERAL MAINTENANCE	5
PERIODIC MAINTENANCE	8
Schedule 1	9
EMISSION CONTROL SYSTEM MAINTENANCE	9
CHASSIS AND BODY MAINTENANCE	10
Schedule 2	11
EMISSION CONTROL SYSTEM MAINTENANCE	11
CHASSIS AND BODY MAINTENANCE	12
RECOMMENDED FLUIDS AND LUBRICANTS	13
Fluids and Lubricants	13
SAE Viscosity Number	14
GASOLINE ENGINE OIL	14
Anti-freeze Coolant Mixture Ratio	15

QG18DE

ENGINE MAINTENANCE	16
Checking Drive Belts	16
Changing Engine Coolant	17
-DRAINING ENGINE COOLANT-	17
-REFILLING ENGINE COOLANT-	18
-FLUSHING COOLING SYSTEM-	19
Checking Fuel Lines	19
Changing Air Cleaner Filter	20
VISCIOUS PAPER TYPE	20
Changing Engine Oil	20
Changing Oil Filter	21
Changing Spark Plugs (Platinum-tipped type)	22
Checking EVAP Vapor Lines	23
SERVICE DATA AND SPECIFICATIONS (SDS)	24
Engine Maintenance	24
BELT DEFLECTION AND TENSION	24
SPARK PLUG	24

SR20DE

ENGINE MAINTENANCE	25
Checking Drive Belts	25
Changing Engine Coolant	26
-DRAINING ENGINE COOLANT-	26
-REFILLING ENGINE COOLANT-	27
-FLUSHING COOLING SYSTEM-	28
Checking Fuel Lines	29
Changing Air Cleaner Filter	29
VISCIOUS PAPER TYPE	29
Changing Engine Oil	29
Changing Oil Filter	30
Changing Spark Plugs (Platinum-tipped type)	31
Changing Spark Plugs (Conventional type)	32
Checking EVAP Vapor Lines	33
SERVICE DATA AND SPECIFICATIONS (SDS)	34
Engine Maintenance	34
BELT DEFLECTION AND TENSION	34
SPARK PLUG	34

CHASSIS AND BODY MAINTENANCE	35
Checking Exhaust System	35
Checking Clutch Fluid Level and Leaks	35
Checking M/T Oil	35
Changing M/T Oil	35
Checking A/T Fluid	36
Changing A/T Fluid	36
Balancing Wheels	37
Tire Rotation	37
Checking Brake Fluid Level and Leaks	37
Checking Brake Lines and Cables	37
Checking Disc Brake	37
ROTOR	37
CALIPER	38
PAD	38
Checking Drum Brake	38
WHEEL CYLINDER	38
DRUM	38
LINING	38

CONTENTS (Cont'd)

TEMPORARY METHOD FOR CHECKING LINING WEAR.....	39	Lubricating Locks, Hinges and Hood Latches.....	40
Checking Steering Gear and Linkage	39	Checking Seat Belts, Buckles, Retractors, Anchors and Adjusters.....	40
STEERING GEAR.....	39	SERVICE DATA AND SPECIFICATIONS (SDS)	41
STEERING LINKAGE.....	39	Chassis and Body Maintenance.....	41
Checking Power Steering Fluid and Lines	39	WHEEL BALANCE	41
CHECKING FLUID LEVEL	39		
CHECKING LINES	39		

PRECAUTIONS

Supplemental Restraint System (SRS) "AIR BAG" and "SEAT BELT PRE-TENSIONER"

Supplemental Restraint System (SRS) "AIR BAG" and "SEAT BELT PRE-TENSIONER"

NIMAG0011

The Supplemental Restraint System such as "AIR BAG" and "SEAT BELT PRE-TENSIONER" used along with a seat belt, helps to reduce the risk or severity of injury to the driver and front passenger for certain types of collision. The SRS system composition which is available to NISSAN MODEL B15 is as follows:

- For a frontal collision
The Supplemental Restraint System consists of driver air bag module (located in the center of the steering wheel), front passenger air bag module (located on the instrument panel on passenger side), front seat belt pre-tensioners, a diagnosis sensor unit, warning lamp, wiring harness and spiral cable.
- For a side collision
The Supplemental Restraint System consists of front side air bag module (located in the outer side of front seat), side air bag (satellite) sensor, diagnosis sensor unit (one of components of air bags for a frontal collision), wiring harness, warning lamp (one of components of air bags for a frontal collision).

Information necessary to service the system safely is included in the **RS section** of this Service Manual.

WARNING:

- To avoid rendering the SRS inoperative, which could increase the risk of personal injury or death in the event of a collision which would result in air bag inflation, all maintenance should be performed by an authorized NISSAN dealer.
- Improper maintenance, including incorrect removal and installation of the SRS, can lead to personal injury caused by unintentional activation of the system. For removal of Spiral Cable and Air Bag Module, see the RS section.
- Do not use electrical test equipment on any circuit related to the SRS unless instructed to in this Service Manual. Spiral cable and wiring harnesses (except "SEAT BELT PRE-TENSIONER") covered with yellow insulation either just before the harness connectors or for the complete harness are related to the SRS.

GI

MA

EM

LC

EC

FE

CL

MT

AT

AX

SU

BR

ST

RS

BT

HA

SC

EL

IDX

PREPARATION

Special Service Tool

Special Service Tool

NIMA0002

The actual shapes of Kent-Moore tools may differ from those of special service tools illustrated here.

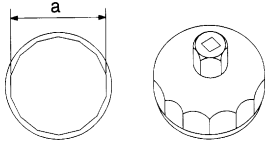
Tool number (Kent-Moore No.) Tool name	Description
KV10115801 (J-37140-A) Oil filter cap wrench	 <p data-bbox="948 348 1175 405">Removing oil filter a: 64.3 mm (2.531 in)</p> <p data-bbox="410 522 472 541">NT375</p>

Commercial Service Tool

NIMA0010

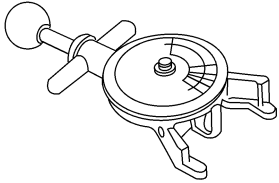
Tool name (Kent-Moore No.)	Description
Belt tension gauge (BT3373-F)	 <p data-bbox="948 709 1224 730">Checking drive belt tension</p> <p data-bbox="410 926 485 945">AMA126</p>

GENERAL MAINTENANCE

General maintenance includes those items which should be checked during the normal day-to-day operation of the vehicle. They are essential if the vehicle is to continue operating properly. The owners can perform checks and inspections themselves or they can have their NISSAN dealers do them.

OUTSIDE THE VEHICLE

The maintenance items listed here should be performed from time to time, unless otherwise specified.

Item		Reference page	
Tires	Check the pressure with a gauge periodically when at a service station, including the spare, and adjust to the specified pressure if necessary. Check carefully for damage, cuts or excessive wear.	—	GI MA EM
Wheel nuts	When checking the tires, make sure no nuts are missing, and check for any loose nuts. Tighten if necessary.	—	LC
Tire rotation	Tires should be rotated every 12,000 km (7,500 miles).	MA-37	EC
Wheel alignment and balance	If the vehicle pulls to either side while driving on a straight and level road, or if you detect uneven or abnormal tire wear, there may be a need for wheel alignment. If the steering wheel or seat vibrates at normal highway speeds, wheel balancing may be needed.	MA-37, SU-6 , "Front Wheel Alignment"	FE
Windshield wiper blades	Check for cracks or wear if they do not wipe properly.	—	CL
Doors and engine hood	Check that all doors and the engine hood operate smoothly as well as the trunk lid and back hatch. Also make sure that all latches lock securely. Lubricate if necessary. Make sure that the secondary latch keeps the hood from opening when the primary latch is released. When driving in areas using road salt or other corrosive materials, check lubrication frequently.	MA-40	MT AT
Lamps	Make sure that the headlamps, stop lamps, tail lamps, turn signal lamps, and other lamps are all operating properly and installed securely. Also check headlamp aim.	—	AX

INSIDE THE VEHICLE

The maintenance items listed here should be checked on a regular basis, such as when performing periodic maintenance, cleaning the vehicle, etc.

Item		Reference page	
Warning lamps and buzzers/chimes	Make sure that all warning lamps and buzzers/chimes are operating properly.	—	SU BR ST
Windshield wiper and washer	Check that the wipers and washer operate properly and that the wipers do not streak.	—	RS
Windshield defroster	Check that the air comes out of the defroster outlets properly and in sufficient quantity when operating the heater or air conditioning.	—	BT
Steering wheel	Check that it has the specified play. Be sure to check for changes in the steering condition, such as excessive play, hard steering or strange noises. Free play: Less than 35 mm (1.38 in)	—	HA
Seats	Check seat position controls such as seat adjusters, seat back recliner, etc. to make sure they operate smoothly and that all latches lock securely in every position. Check that the head restraints move up and down smoothly and that the locks (if equipped) hold securely in all latched positions. Check that the latches lock securely for folding-down rear seat backs.	—	SC
Seat belts	Check that all parts of the seat belt system (e.g. buckles, anchors, adjusters and retractors) operate properly and smoothly and are installed securely. Check the belt webbing for cuts, fraying, wear or damage.	MA-40 RS-8 , "Seat Belt Inspection"	EL IDX
Accelerator pedal	Check the pedal for smooth operation and make sure the pedal does not catch or require uneven effort. Keep the floor mats away from the pedal.	—	

GENERAL MAINTENANCE

Item		Reference page
Clutch pedal	Make sure the pedal operates smoothly and check that it has the proper free play.	CL-6 , "Adjusting Clutch Pedal"
Brakes	Check that the brake does not pull the vehicle to one side when applied.	—
Brake pedal and booster	Check the pedal for smooth operation and make sure it has the proper distance under it when depressed fully. Check the brake booster function. Be sure to keep floor mats away from the pedal.	BR-12 , "BRAKE PEDAL AND BRACKET" and BR-17 , "BRAKE BOOSTER"
Parking brake	Check that the lever has the proper travel and make sure that the vehicle is held securely on a fairly steep hill when only the parking brake is applied.	BR-37 , "PARKING BRAKE CONTROL"
Automatic transaxle "Park" mechanism	Check that the lock release button on the selector lever operates properly and smoothly. On a fairly steep hill check that the vehicle is held securely with the selector lever in the "P" position without applying any brakes.	—

UNDER THE HOOD AND VEHICLE

The maintenance items listed here should be checked periodically (e.g. each time you check the engine oil or refuel).

Item		Reference page	
		QG18DE	SR20DE
Windshield washer fluid	Check that there is adequate fluid in the tank.	—	
Engine coolant level	Check the coolant level when the engine is cold.	MA-18	MA-27
A/C condenser, radiator and hoses	Check the front of the condenser and radiator and clean off any dirt, insects, leaves, etc., that may have accumulated. Make sure the radiator hoses have no cracks, deformation, deterioration or loose connections.	—	
Brake and clutch fluid levels	Make sure that the brake and clutch fluid levels are between the "MAX" and "MIN" lines on the reservoirs.	MA-35, 37	
Battery	Check the fluid level in each cell. It should be between the "MAX" and "MIN" lines.	—	
Engine drive belts	Make sure that no belt is frayed, worn, cracked or oily.	MA-16	MA-25
Engine oil level	Check the level on the dipstick after parking the vehicle on a level spot and turning off the engine.	MA-20	MA-29
Power steering fluid level and lines	Check the level is between the "MAX" and "MIN" lines on the reservoir with the engine off. Check the lines for improper attachment, leaks, cracks, etc.	MA-39	
Automatic transaxle fluid level	Check the level on the dipstick after putting the selector lever in "P" with the engine idling.	MA-36	
Exhaust system	Make sure there are no loose supports, cracks or holes. If the sound of the exhaust seems unusual or there is a smell of exhaust fumes, immediately locate the trouble and correct it.	MA-35	
Underbody	The underbody is frequently exposed to corrosive substances such as those used on icy roads or to control dust. It is very important to remove these substances, otherwise rust will form on the floor pan, frame, fuel lines and around the exhaust system. At the end of winter, the underbody should be thoroughly flushed with plain water, being careful to clean those areas where mud and dirt can easily accumulate.	—	

GENERAL MAINTENANCE

Item		Reference page		
		QG18DE	SR20DE	
Fluid leaks	Check under the vehicle for fuel, oil, water or other fluid leaks after the vehicle has been parked for a while. Water dripping from the air conditioner after use is normal. If you should notice any leaks or gasoline fumes are evident, check for the cause and correct it immediately.	—		GI MA EM LC EC FE CL MT AT AX SU BR ST RS BT HA SC EL IDX

PERIODIC MAINTENANCE

Two different maintenance schedules are provided, and should be used, depending upon the conditions in which the vehicle is mainly operated. **After 60,000 miles (96,000 km) or 48 months, continue the periodic maintenance at the same mileage/time intervals.**

Schedule 1	Follow Periodic Maintenance Schedule 1 if your driving habits frequently includes one or more of the following driving conditions: <ul style="list-style-type: none"> ● Repeated short trips of less than 5 miles (8 km). ● Repeated short trips of less than 10 miles (16 km) with outside temperatures remaining below freezing. ● Operating in hot weather in stop-and-go “rush hour” traffic. ● Extensive idling and/or low speed driving for long distances, such as police, taxi or door-to-door delivery use. ● Driving in dusty conditions. ● Driving on rough, muddy, or salt spread roads. ● Towing a trailer, using a camper or a car-top carrier. 	Emission Control System Maintenance	MA-9
		Chassis and Body Maintenance	MA-10
Schedule 2	Follow Periodic Maintenance Schedule 2 if none of the driving conditions shown in Schedule 1 apply to your driving habits.	Emission Control System Maintenance	MA-11
		Chassis and Body Maintenance	MA-12

PERIODIC MAINTENANCE

Schedule 1

Schedule 1

NIMA0004S01

NIMA0004S0101

EMISSION CONTROL SYSTEM MAINTENANCE

Abbreviations: R = Replace. I = Inspect. Correct or replace if necessary. []: At the mileage intervals only

MAINTENANCE OPERATION	MAINTENANCE INTERVAL												Reference Section - Page or - Content Title				
	3.75 (6)	7.5 (12)	11.25 (18)	15 (24)	18.75 (30)	22.5 (36)	26.25 (42)	30 (48)	33.75 (54)	37.5 (60)	41.25 (66)	45 (72)		48.75 (78)	52.5 (84)	56.25 (90)	60 (96)
Perform at number of miles, kilometers or months, whichever comes first.	3.75 (6)	7.5 (12)	11.25 (18)	15 (24)	18.75 (30)	22.5 (36)	26.25 (42)	30 (48)	33.75 (54)	37.5 (60)	41.25 (66)	45 (72)	48.75 (78)	52.5 (84)	56.25 (90)	60 (96)	QG18DE SR20DE
Drive belts																I*	MA-16 MA-25
Air cleaner filter								[R]								[R]	MA-20 MA-29
EVAP vapor lines								I*								I*	MA-23 MA-33
Fuel lines								I*								I*	MA-19 MA-29
Fuel filter																	FE-8
Engine coolant																R*	MA-17 MA-26
Engine oil	R	R	R	R	R	R	R	R	R	R	R	R	R	R	R	R	MA-20 MA-29
Engine oil filter (Use part No. 15208-65F01, 15208-9E000 or equiv.)	R	R	R	R	R	R	R	R	R	R	R	R	R	R	R	R	MA-21 MA-30
Spark plugs (PLATI- NUM-TIPPED type)																	MA-22 MA-31
Intake and exhaust valve clearance (QG18DE)																	EM-67 —

NOTE:

- (1) After 60,000 miles (96,000 km) or 48 months, inspect every 15,000 miles (24,000 km) or 12 months.
- (2) If operating mainly in dusty conditions, more frequent maintenance may be required.
- (3) Maintenance-free item.
- (4) After 60,000 miles (96,000 km) or 48 months, replace every 30,000 miles (48,000 km) or 24 months.
- (5) Original equipment platinum-tipped plug should be replaced at 105,000 miles (169,000 km). For SR20DE engine, conventional spark plugs can be used but should be replaced at 30,000 miles (48,000 km) intervals.
- (6) If valve noise increases, inspect valve clearance.

★ Maintenance items and intervals with "*" are recommended by NISSAN for reliable vehicle operation. The owner need not perform such maintenance in order to maintain the emission warranty or manufacturer recall liability. Other maintenance items and intervals are required.

MA
 EM
 LC
 EC
 FE
 CL
 MT
 AT
 AX
 SU
 BR
 ST
 RS
 BT
 HA
 SC
 EL
 IDX

PERIODIC MAINTENANCE

Schedule 2

NIMA0004S02

NIMA0004S0201

GI

MA

EM

LC

EC

FE

CL

MT

AT

AX

SU

BR

ST

RS

BT

HA

SC

EL

IDX

Abbreviations: R = Replace. I = Inspect. Correct or replace if necessary. []: At the mileage intervals only

Schedule 2

EMISSION CONTROL SYSTEM MAINTENANCE

MAINTENANCE OPERATION	MAINTENANCE INTERVAL										Reference Section - Page or Content Title		
	Miles x 1,000 (km x 1,000) Months	7.5 (12) 6	15 (24) 12	22.5 (36) 18	30 (48) 24	37.5 (60) 30	45 (72) 36	52.5 (84) 42	60 (96) 48	QG18DE	SR20DE		
Perform at number of miles, kilometers or months, whichever comes first.													
Drive belts	NOTE (1)								I*	MA-16	MA-25		
Air cleaner filter					[R]				[R]	MA-20	MA-29		
EVAP vapor lines					I*				I*	MA-23	MA-33		
Fuel lines					I*				I*	MA-19	MA-29		
Fuel filter	NOTE (2)									FE-8			
Engine coolant	NOTE (3)								R*	MA-17	MA-26		
Engine oil		R	R	R	R	R	R	R	R	MA-20	MA-29		
Engine oil filter (Use part No. 15208-65F01, 15208-9E000 or equivalent.)		R	R	R	R	R	R	R	R	MA-21	MA-30		
Spark plugs (PLATINUM-TIPPED type)	NOTE (4)	Replace every 105,000 miles (169,000 km)										MA-22	MA-31
Intake and exhaust valve clearance (QG18DE)	NOTE (5)*										EM-67	—	

NOTE:

- (1) After 60,000 miles (96,000 km) or 48 months, inspect every 15,000 miles (24,000 km) or 12 months.
- (2) Maintenance-free item.
- (3) After 60,000 miles (96,000 km) or 48 months, replace every 30,000 miles (48,000 km) or 24 months.
- (4) Original equipment platinum-tipped plug should be replaced at 105,000 miles (169,000 km). For SR20DE, conventional spark plugs can be used but should be replaced at 30,000 miles (48,000 km) intervals.
- (5) If valve noise increases, inspect valve clearance.

★ Maintenance items and intervals with "*" are recommended by NISSAN for reliable vehicle operation. The owner need not perform such maintenance in order to maintain the emission warranty or manufacturer recall liability. Other maintenance items and intervals are required.

PERIODIC MAINTENANCE

Schedule 2 (Cont'd)

CHASSIS AND BODY MAINTENANCE

NIMA0004S0202

Abbreviations: R = Replace. I = Inspect. Correct or replace if necessary. L = Lubricate.

MAINTENANCE OPERATION	Miles x 1,000 (km x 1,000) Months	MAINTENANCE INTERVAL								Reference Section - Page or - Content Title	
		7.5 (12) 6	15 (24) 12	22.5 (36) 18	30 (48) 24	37.5 (60) 30	45 (72) 36	52.5 (84) 42	60 (96) 48		
Perform at number of miles, kilometers or months, whichever comes first.											
Brake lines & cables			I		I						MA-37
Brake pads, rotors, drums & linings (QG18DE)			I		I						MA-37, 38
Brake pads & rotors (SR20DE)			I		I						MA-37, 38
Manual transaxle oil or automatic transaxle fluid			I								MA-35, 36
Steering gear & linkage, axle & suspension parts							I				MA-39 NOTE (3)
Tire rotation	NOTE (1)										MA-5, 37
Front drive shaft boots			I								AX-15
Exhaust system											MA-35
Supplemental air bag and supplemental side air bags (if so equipped) system	NOTE (2)										RS-18

NOTE:

- (1) Refer to "Tire rotation" under the "GENERAL MAINTENANCE" heading earlier in this section.
- (2) Inspect the supplemental air bag system 10 years after the date of manufacture noted on the F.M.V.S.S. certification label.
- (3) Refer to **SU-6**, "FRONT SUSPENSION PARTS" and **SU-18**, "REAR SUSPENSION PARTS", **AX-3**, "FRONT AXLE PARTS" and **AX-22**, "REAR AXLE PARTS".

RECOMMENDED FLUIDS AND LUBRICANTS

Fluids and Lubricants

Fluids and Lubricants

NIMA0005S01

QG18DE		Capacity (Approximate)			Recommended Fluids/Lubricants
		US measure	Imp measure	Liter	
Engine oil Drain and refill	With oil filter change	2-7/8 qt	2-3/8 qt	2.7	<ul style="list-style-type: none"> ● API Certification Mark*1 ● API grade SG/SH, Energy Conserving I & II or API grade SJ, Energy Conserving*1 ● ILSAC grade GF-I & GF-II*1
	Without oil filter change	2-5/8 qt	2-1/4 qt	2.5	
Dry engine (engine overhaul)		3-1/4 qt	2-3/4 qt	3.1	
Cooling system (With reservoir)	MT	7-1/8 qt	5-7/8 qt	6.7	Genuine NISSAN Anti-freeze coolant or equivalent
	AT	7 qt	5-7/8 qt	6.6	
Manual transaxle gear oil	RS5F70A	6-3/8 pt	5-1/4 pt	3.0	API GL-4, Viscosity SAE 75W-85
Automatic transaxle fluid	RE4F03B	7-3/8 qt	6-1/8 qt	7.0	NISSAN Matic "D" (Continental U.S. and Alaska) or Canada NISSAN Automatic Transmission Fluid*2
Power steering fluid		—	—	—	Genuine NISSAN PSF II or equivalent*4
Brake and clutch fluid		—	—	—	Genuine NISSAN Brake Fluid*3 or equivalent DOT 3 (US FMVSS No. 116)
Multi-purpose grease		—	—	—	NLGI No. 2 (Lithium soap base)

*1: For further details, see "SAE Viscosity Number".

*2: DEXRON™ III/MERCON™, or equivalent may also be used. Outside the continental United States and Alaska contact a NISSAN dealership for more information regarding suitable fluids, including recommended brand(s) of DEXRON™ III/MERCON™ Automatic Transmission Fluid.

*3: Available in mainland U.S.A. through your NISSAN dealer.

*4: Genuine NISSAN PSF, Canada NISSAN Automatic Transmission Fluid, DEXRON™ III/MERCON™ or equivalent ATF may also be used.

GI

MA

EM

LC

EC

FE

CL

MT

AT

AX

SU

BR

ST

RS

BT

HA

SC

EL

IDX

RECOMMENDED FLUIDS AND LUBRICANTS

Fluids and Lubricants (Cont'd)

SR20DE		Capacity (Approximate)			Recommended Fluids/Lubricants
		US measure	Imp measure	Liter	
Engine oil Drain and refill	With oil filter change	3-1/2 qt	2-7/8 qt	3.3	<ul style="list-style-type: none"> • API Certification Mark*1 • API grade SG/SH, Energy Conserving I & II or API grade SJ, Energy Conserving*1 • ILSAC grade GF-I & GF-II*1
	Without oil filter change	3-1/4 qt	2-3/4 qt	3.1	
Dry engine (engine overhaul)		4-1/4 qt	3-1/2 qt	4.0	
Cooling system (With reservoir)	MT	7-3/16 qt	6 qt	6.8	Genuine NISSAN Anti-freeze coolant or equivalent
	AT	7-1/8 qt	5-7/8 qt	6.7	
Manual transaxle gear oil	RS5F70A RS5F70V	6-3/8 qt	5-1/4 qt	3.0	API GL-4, Viscosity SAE 75W-85
Automatic transaxle fluid	RE4F03B	7-3/8 qt	6-1/8 qt	7.0	NISSAN Matic "D" (Continental U.S. and Alaska) or Canada NISSAN Automatic Transmission Fluid*2
Power steering fluid		—	—	—	Genuine NISSAN PSF II or equivalent*4
Brake and clutch fluid		—	—	—	Genuine NISSAN Brake Fluid*3 or equivalent DOT 3 (US FMVSS No. 116)
Multi-purpose grease		—	—	—	NLGI No. 2 (Lithium soap base)

*1: For further details, see "SAE Viscosity Number".

*2: DEXRON™ III/MERCON™, or equivalent may also be used. Outside the continental United States and Alaska contact an authorized NISSAN dealership for more information regarding suitable fluids, including recommended brand(s) of DEXRON™ III/MERCON™ Automatic Transmission Fluid.

*3: Available in mainland U.S.A. through your authorized NISSAN dealer.

*4: Genuine NISSAN PSF, Canada NISSAN Automatic Transmission Fluid, DEXRON™ III/MERCON™ or equivalent ATF may also be used.

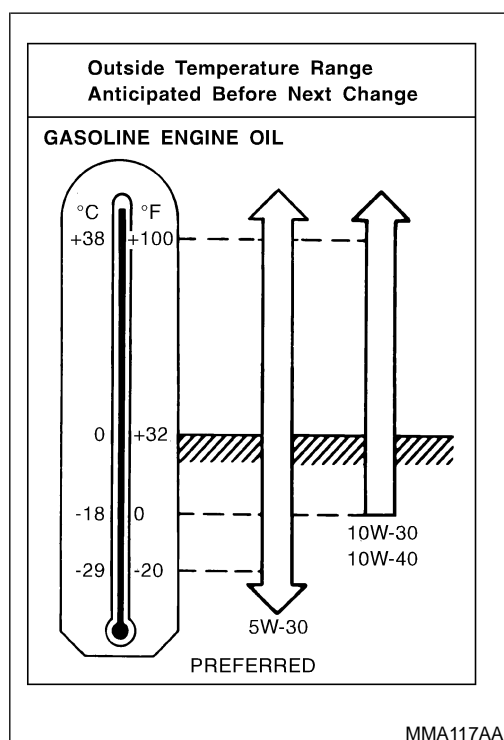

SAE Viscosity Number GASOLINE ENGINE OIL

NIMA0005S02

NIMA0005S0201

SAE 5W-30 viscosity oil is preferred for all temperatures. SAE 10W-30 and 10W-40 viscosity oil may be used if the ambient temperature is above -18°C (0°F).

RECOMMENDED FLUIDS AND LUBRICANTS

Anti-freeze Coolant Mixture Ratio

Anti-freeze Coolant Mixture Ratio

The engine cooling system is filled at the factory with a high-quality, year-round, anti-freeze coolant solution. The anti-freeze solution contains rust and corrosion inhibitors. Therefore, additional cooling system additives are not necessary.

CAUTION:

When adding or replacing coolant, be sure to use only a Genuine NISSAN anti-freeze coolant or equivalent with the proper mixture ratio.

Outside temperature down to:		Genuine NISSAN Anti-freeze Cool- ant or equivalent	Demineralized water or distilled water
°C	°F		
-35	-30	50%	50%

The use of other types of coolant solutions may damage the engine cooling system.

GI

MA

EM

LC

EC

FE

CL

MT

AT

AX

SU

BR

ST

RS

BT

HA

SC

EL

IDX

Checking Drive Belts

NIMA0006S01

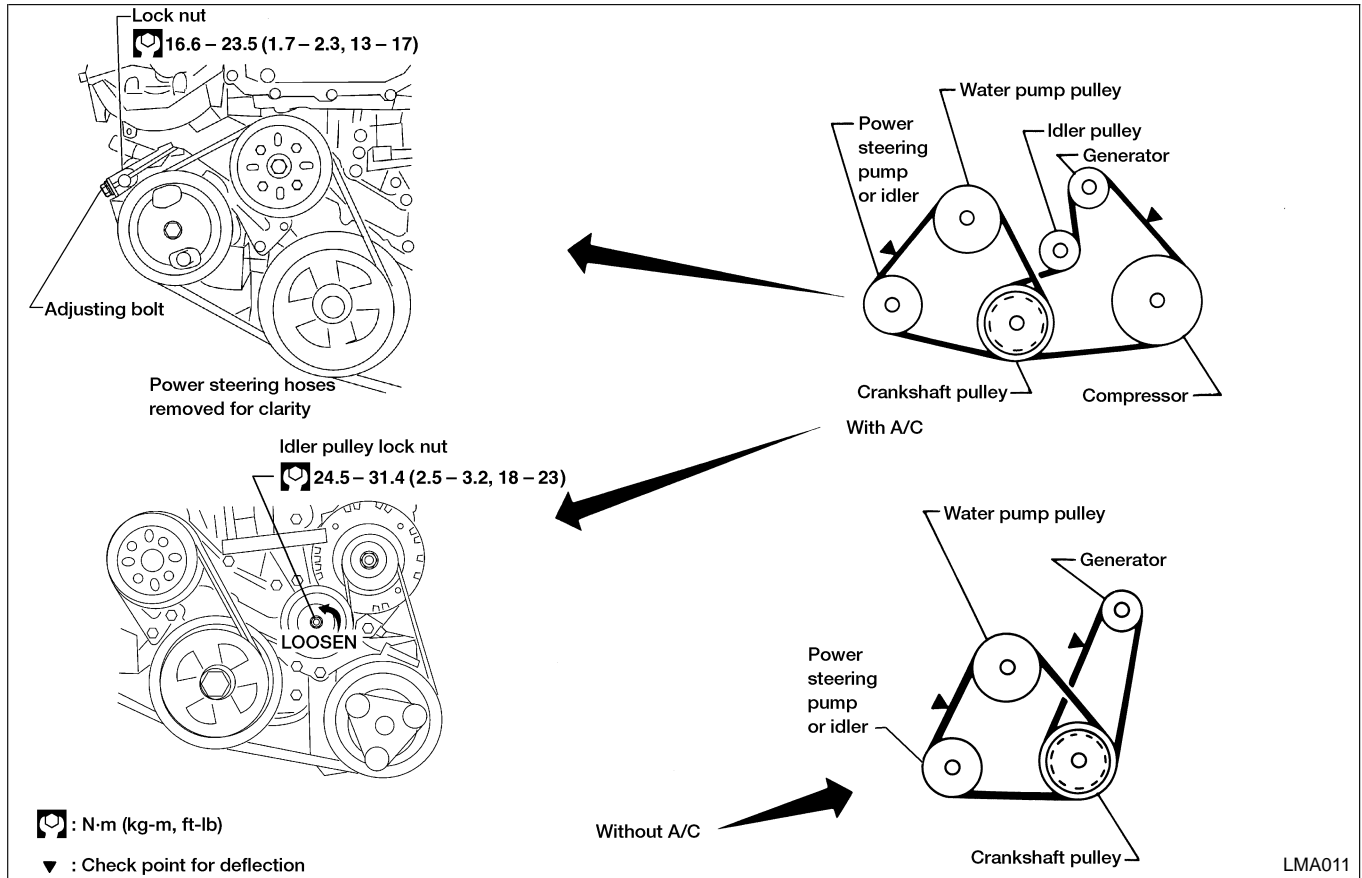

1. Inspect belt for cracks, fraying, wear and oil. If necessary, replace.
2. Inspect drive belt deflection or tension at a point on the belt midway between pulleys.
 - Check belt tension using Belt Tension Gauge BT3373-F or equivalent.
 - Inspect drive belt deflection or tension when engine is cold.

Adjust if belt deflection exceeds the limit or if belt tension is not within specifications.

- Drive belt tension can also be checked at other points on the belts.

BELT DEFLECTION AND TENSION

		Deflection adjustment Unit: mm (in)			Tension adjustment *1 Unit: N (kg, lb)		
		Used belt		New belt	Used belt		New belt
		Limit	After adjustment		Limit	After adjustment	
Generator	With air conditioner compressor	8.1 (0.319)	5.3 - 5.7 (0.209 - 0.224)	4.5 - 5.0 (0.177 - 0.197)	292 (30, 66)	652 - 740 (66.5 - 75.5, 146.6 - 166.4)	789 - 877 (80.5 - 89.5, 177.4 - 197.1)
	Without air conditioner compressor	10.2 (0.402)	6.5 - 7.0 (0.256 - 0.276)	5.5 - 6.1 (0.217 - 0.240)	292 (30, 66)	652 - 740 (66.5 - 75.5, 146.6 - 166.4)	789 - 877 (80.5 - 89.5, 177.4 - 197.1)
Power steering oil pump		7.1 (0.280)	4.4 - 4.9 (0.173 - 0.193)	3.9 - 4.4 (0.154 - 0.173)	196 (20, 44)	495 - 583 (50.5 - 59.5, 111.4 - 131.2)	603 - 691 (61.5 - 70.5, 135.6 - 155.5)
Applied pushing force		98 N (10 kg, 22 lb)			—		

*1: If the belt tension gauge cannot be installed at check points shown, check belt tension at a different location on the belt.

Changing Engine Coolant

WARNING:

To avoid the danger of being scalded, never change the coolant when the engine is hot.

—DRAINING ENGINE COOLANT—

1. Set climate control system as follows to prevent coolant from remaining in the system.
 - a. Turn ignition switch "ON" and set temperature controller to maximum hot position.
 - b. Wait 10 seconds before turning ignition switch "OFF".
2. Open radiator drain plug at the bottom of radiator (or remove lower radiator hose) and remove radiator cap.
3. Remove reservoir tank, drain coolant, then clean reservoir tank. Install it temporarily.
 - **Be careful not to allow coolant to contact drive belts.**
4. Cover the exhaust tube heat shield to prevent from splashing coolant.

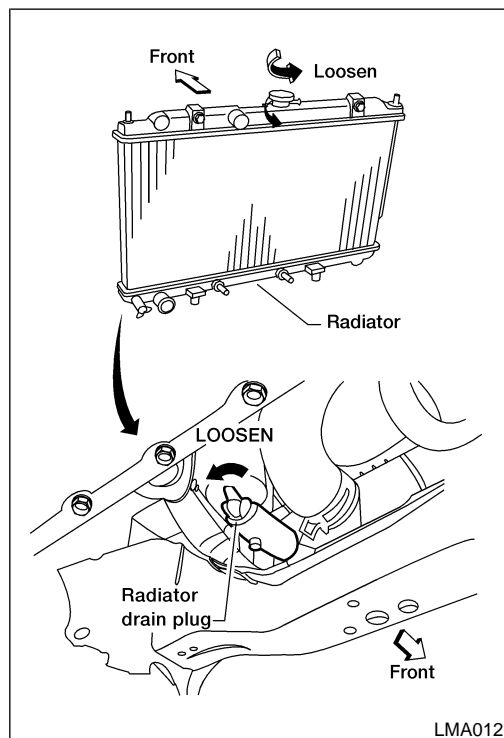

Changing Engine Coolant (Cont'd)

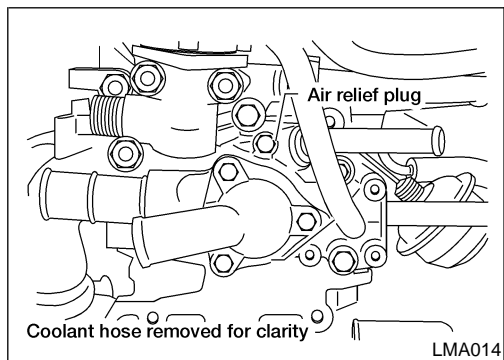
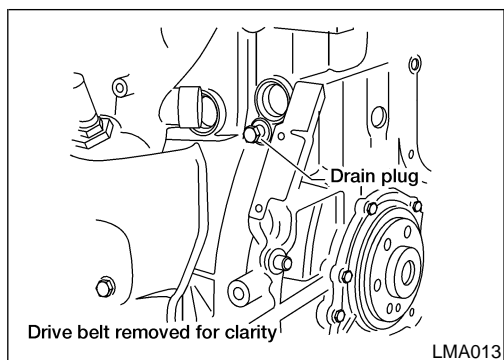

5. Remove cylinder block drain plug and air relief plug.
6. Check drained coolant for contaminants such as rust, corrosion or discoloration. If contaminated, flush engine cooling system. Refer to “—FLUSHING COOLING SYSTEM—”, MA-19.
7. Using compressed air, remove any coolant around the exhaust tube heat shield.

—REFILLING ENGINE COOLANT—

NIMA0006S0202

1. Install reservoir tank, radiator drain plug, and cylinder block drain plug.
 - Apply sealant to the thread of cylinder block drain plug.
 - ⚙️ : 34.3 - 44.1 N·m (3.5 - 4.5 kg-m, 26 - 32 ft-lb)

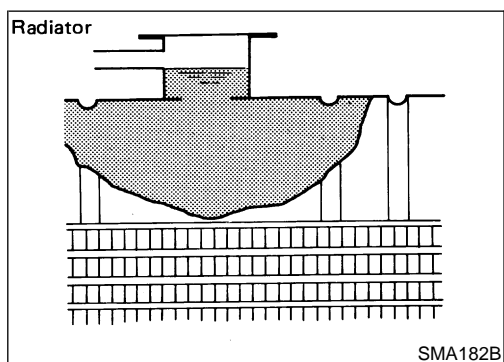

2. Fill radiator slowly with coolant until coolant spills from the air relief plug, then install air relief plug.
3. Fill radiator and reservoir tank to specified level as soon as coolant spills out without bubbles.

Air relief plug:

⚙️ : 6.68 - 7.85 N·m (0.68 - 0.80 kg-m, 59.0 - 69.4 in-lb)

- Use Genuine NISSAN anti-freeze coolant or equivalent mixed with water (demineralized water or distilled water).
- Pour coolant through coolant filler neck slowly to allow air in system to escape.

Refer to “RECOMMENDED FLUIDS AND LUBRICANTS”, MA-13.

Coolant capacity (Without reservoir tank):

M/T 6.0 ℓ (6-3/8 US qt, 5-1/4 Imp qt)

A/T 5.9 ℓ (6-1/4 US qt, 5-1/4 Imp qt)

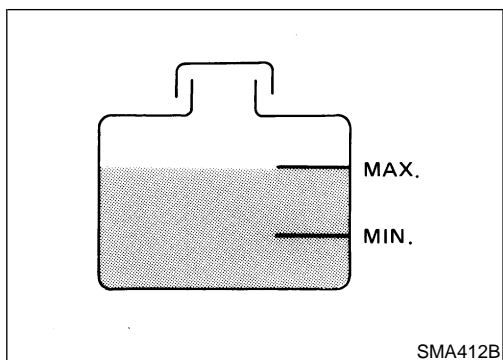

Reservoir tank capacity (for MAX level): 0.7 l (3/4 US qt, 5/8 Imp qt)

4. Warm up engine to normal operating temperature without radiator cap installed.
 - **If coolant overflows radiator filler neck, install filler cap.**
5. Run engine at 2,500 rpm for 10 seconds and return to idle speed with radiator cap installed. Repeat two or three times.
 - **Watch coolant temperature gauge so as not to overheat the engine.**
6. Stop engine and cool it down.
 - Cool down using a fan to reduce the time.
 - If necessary, refill radiator up to filler neck with coolant.
7. Refill reservoir tank to Max line with coolant.
8. Repeat step 4 through step 7 two or more times with radiator cap installed until coolant level no longer drops.
9. Check cooling system for leaks with engine running.
10. Warm up engine, and check for sound of coolant flow while running engine from idle up to 3,000 rpm with heater temperature control set at several positions between Cool and Hot.
11. If sound is heard, bleed air from cooling system by repeating steps 4 through 7 until coolant level no longer drops.
 - **Clean excess coolant from engine.**

—FLUSHING COOLING SYSTEM—

NIMA0006S0203

1. Open air relief plug.
2. Fill radiator with water until water spills from the air relief hole, then close air relief plug. Fill radiator and reservoir tank with water and reinstall radiator cap.
3. Run engine and warm it up to normal operating temperature.
4. Rev engine two or three times under no-load.
5. Stop engine and wait until it cools down.
6. Drain water.
7. Repeat steps 1 through 6 until clear water begins to drain from radiator.

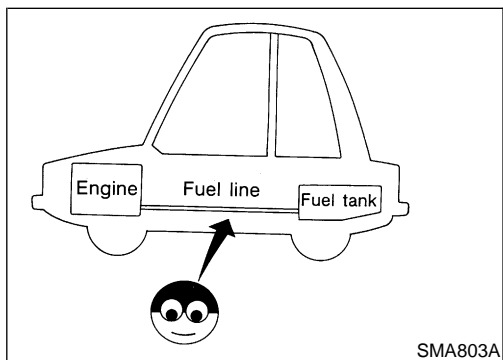

Checking Fuel Lines

NIMA0006S03

Inspect fuel lines and tank for improper attachment, leaks, cracks, damage, loose connections, chafing or deterioration. If necessary, repair or replace faulty parts.

Checking Fuel Lines (Cont'd)

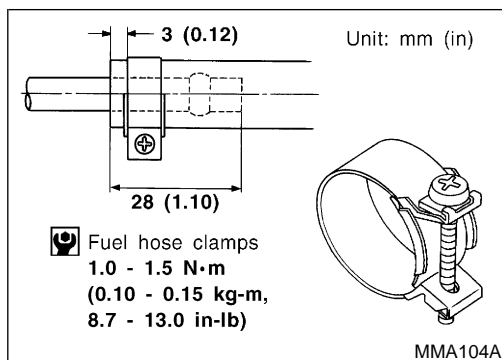

CAUTION:

Tighten high-pressure rubber hose clamp so that clamp end is 3 mm (0.12 in) from hose end.

Tightening torque specifications are the same for all rubber hose clamps.

Ensure that screw does not contact adjacent parts.

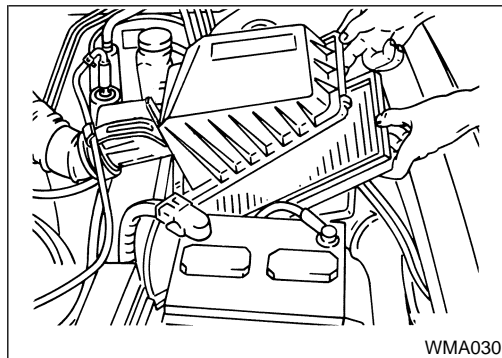

Changing Air Cleaner Filter

VISCOUS PAPER TYPE

NIMA0006S05

NIMA0006S0501

Unfasten clamps to change air cleaner filter.

- The viscous paper type filter does not need cleaning.

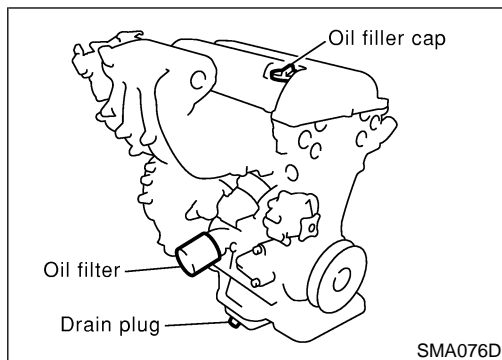

Changing Engine Oil

NIMA0006S06

WARNING:

- Be careful not to burn yourself, as the engine oil is hot.
- Prolonged and repeated contact with used engine oil may cause skin cancer; try to avoid direct skin contact with used oil. If skin contact is made, wash thoroughly with soap or hand cleaner as soon as possible.

1. Warm up engine, and check for oil leakage from engine components.
2. Stop engine.
3. Remove drain plug and oil filler cap.
4. Drain oil and refill with new engine oil.

Oil specification and viscosity

- API Certification Mark
- API grade SG/SH, Energy Conserving I & II or API grade SJ, Energy Conserving
- ILSAC grade GF-I & GF-II
- Refer to "RECOMMENDED FLUIDS AND LUBRICANTS", MA-13.

Oil capacity (Approximate):

Unit: ℓ (US qt, Imp qt)

Drain and refill	With oil filter change	2.7 (2-7/8, 2-3/8)
	Without oil filter change	2.5 (2-5/8, 2-1/4)
Dry engine (engine overhaul)		3.1 (3-1/4, 2-3/4)

CAUTION:

- Be sure to clean drain plug and install with new washer.

Oil pan drain plug:

 : 29 - 39 N·m (3.0 - 4.0 kg-m, 22 - 29 ft-lb)

- The refill capacity depends on the oil temperature and drain time. Use these specifications for reference only. Always use the dipstick to determine when the proper

amount of oil is in the engine.

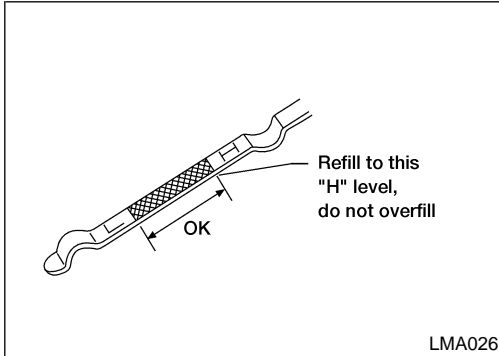

5. Warm up engine and check area around drain plug and oil filter for oil leakage.
6. Stop engine.
7. Check oil level.

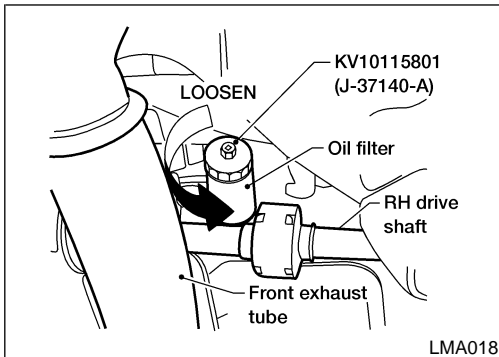

Changing Oil Filter

NIMA0006S07

1. Remove oil filter with Tool.

WARNING:

Be careful not to burn yourself, as the engine and engine oil are hot.

The filter is a full-flow cartridge type and is provided with a relief valve.

Refer to **LC-8**, "Oil Filter".

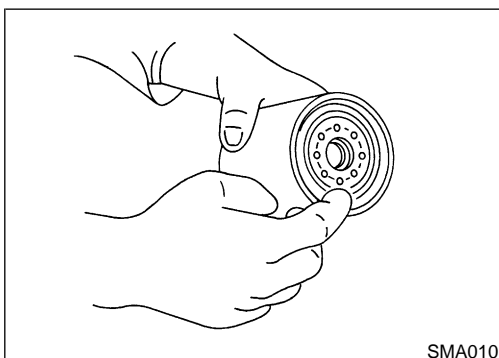

2. Clean oil filter mounting surface on cylinder block. Coat rubber seal of new oil filter with engine oil.

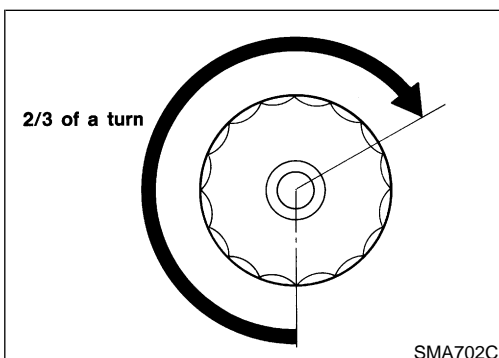

3. Screw in the oil filter until a slight resistance is felt, then tighten an additional 2/3 turn.

4. Add engine oil.

Refer to "Changing Engine Oil", MA-20.

- Clean excess oil from engine.

GI

MA

EM

LC

EC

FE

CL

MT

AT

AX

SU

BR

ST

RS

BT

HA

SC

EL

IDX

Changing Spark Plugs (Platinum-tipped type)

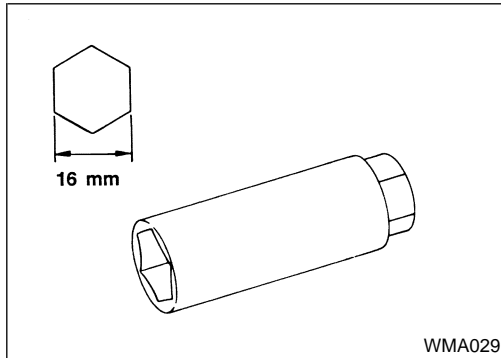
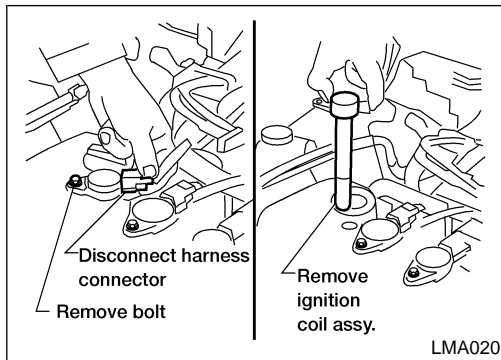

Changing Spark Plugs (Platinum-tipped type)

NIMA0006S08

1. Disconnect ignition coil harness connectors.
2. Remove ignition coils.

3. Remove spark plugs with spark plug socket.

Spark plug:

Standard type	PLFR5A-11
Hot type	PLFR4A-11
Cold type	PLFR6A-11

Gap (Nominal): 1.1 mm (0.043 in)

Use standard type spark plug for normal condition.

The hot type spark plug is suitable when fouling occurs with the standard type spark plug under conditions such as:

- frequent engine starts
- low ambient temperatures

The cold type spark plug is suitable when spark knock occurs with the standard type spark plug under conditions such as:

- extended highway driving
- frequent high engine revolution

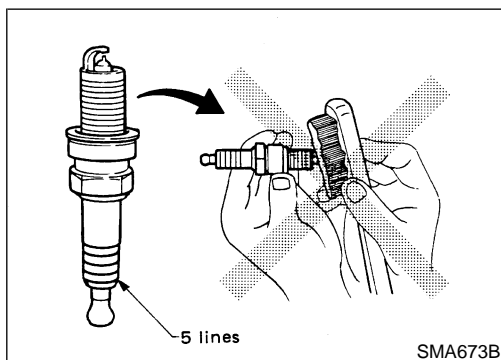

- Do not use a wire brush for cleaning.
- If plug tip is covered with carbon, spark plug cleaner may be used.

Cleaner air pressure:

Less than 588 kPa (6 kg/cm², 85 psi)

Cleaning time:

Less than 20 seconds

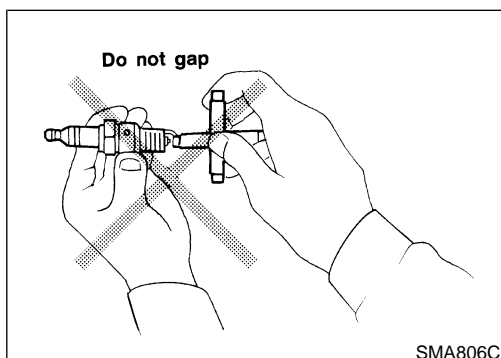

- Checking and adjusting plug gap is not required between change intervals.

4. Install spark plugs.

Spark plug:

 : 20 - 29 N·m (2.0 - 3.0 kg·m, 14 - 22 ft·lb)

5. Install ignition coils.
6. Connect ignition coil harness connectors.

GI

MA

EM

LC

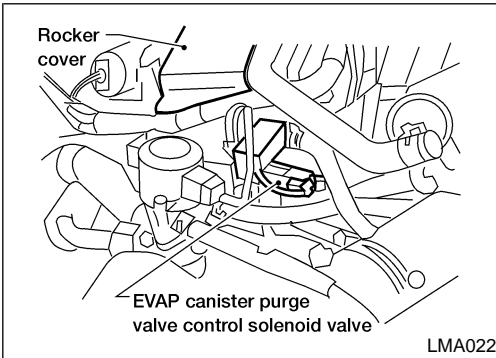

Checking EVAP Vapor Lines

NIMA0006S09

1. Visually inspect EVAP vapor lines for improper attachment, cracks, damage, loose connections, chafing or deterioration.
2. Inspect vacuum relief valve of fuel tank filler cap for clogging, sticking, etc.

EC

FE

Refer to **EC-48** [QG18DE (except Calif. CA Model)], **EC-725** [QG18DE (Calif. CA Model)], "Evaporative Emission System".

CL

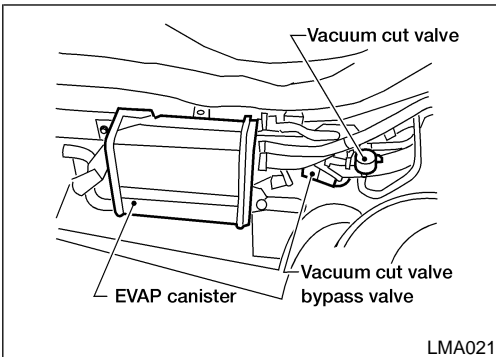

MT

AT

AX

SU

BR

ST

RS

BT

HA

SC

EL

IDX

Engine Maintenance

BELT DEFLECTION AND TENSION

N1MA0008

		Deflection adjustment Unit: mm (in)			Tension adjustment *1 Unit: N (kg, lb)		
		Used belt		New belt	Used belt		New belt
		Limit	After adjustment		Limit	After adjustment	
Generator	With air conditioner compressor	8.1 (0.319)	5.3 - 5.7 (0.209 - 0.224)	4.5 - 5.0 (0.177 - 0.197)	292 (30, 66)	652 - 740 (66.5 - 75.5, 146.6 - 166.4)	789 - 877 (80.5 - 89.5, 177.4 - 197.1)
	Without air conditioner compressor	10.2 (0.402)	6.5 - 7.0 (0.256 - 0.276)	5.5 - 6.1 (0.217 - 0.240)	292 (30, 66)	652 - 740 (66.5 - 75.5, 146.6 - 166.4)	789 - 877 (80.5 - 89.5, 177.4 - 197.1)
Power steering oil pump		7.1 (0.280)	4.4 - 4.9 (0.173 - 0.193)	3.9 - 4.4 (0.154 - 0.173)	196 (20, 44)	495 - 583 (50.5 - 59.5, 111.4 - 131.2)	603 - 691 (61.5 - 70.5, 135.6 - 155.5)
Applied pushing force		98 N (10 kg, 22 lb)			—		

*1: If the belt tension gauge cannot be installed at check points shown, check belt tension at a different location on the belt.

SPARK PLUG

N1MA0014

Type	Standard	PLFR5A-11
	Hot	PLFR4A-11
	Cold	PLFR6A-11
Plug gap		Nominal: 1.1 mm (0.043 in)

Checking Drive Belts

NIMA0012S01

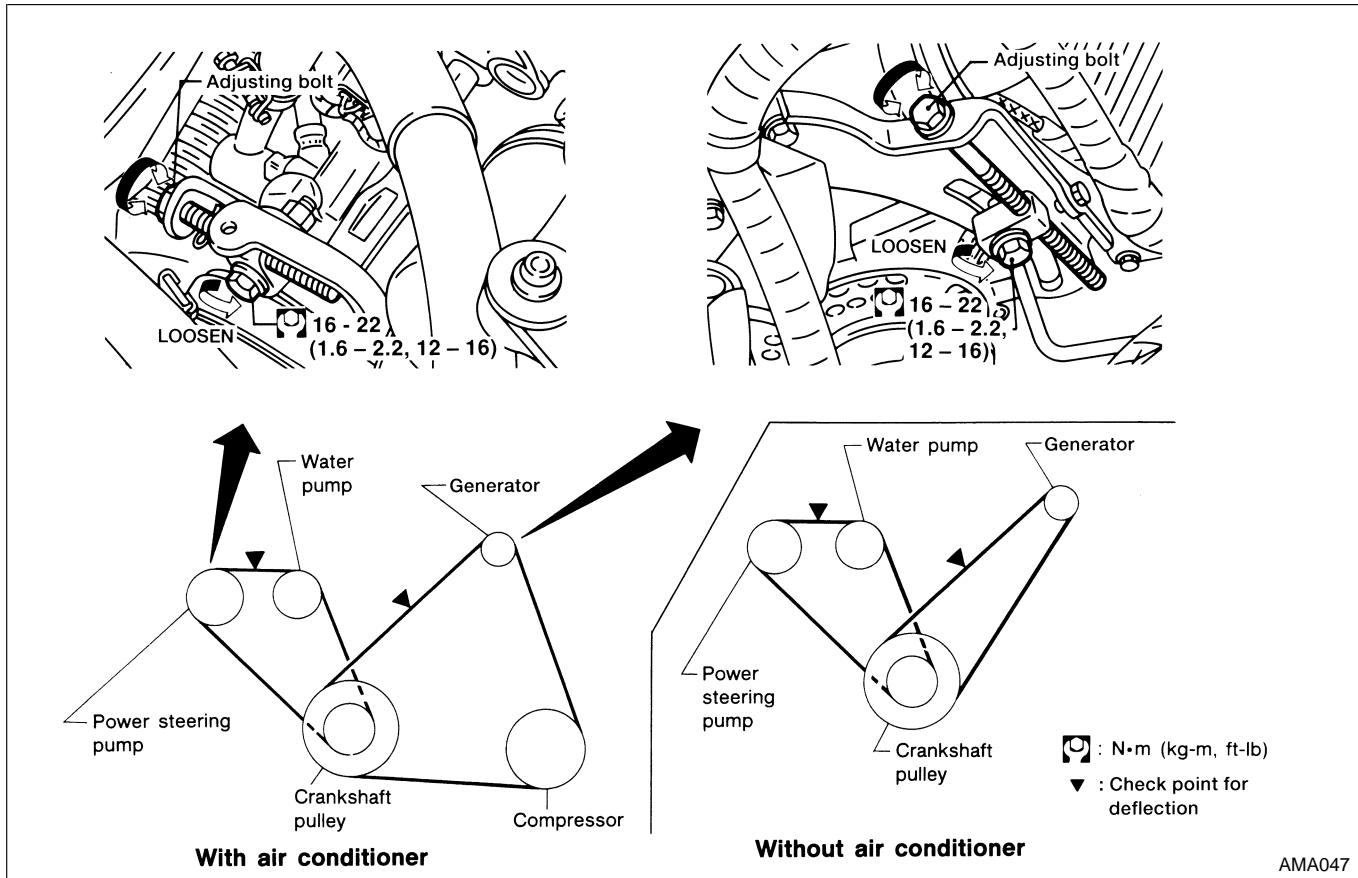

GI

MA

EM

LC

EC

FE

CL

MT

AT

AX

AMA047

1. Inspect belt for cracks, fraying, wear and oil. If necessary, replace.
2. Inspect drive belt deflection or tension at a point on the belt midway between pulleys.
 - **Check belt tension using Belt Tension Gauge BT3373-F or equivalent.**
 - **Inspect drive belt deflection or tension when engine is cold.**

Adjust if belt deflection exceeds the limit or if belt tension is not within specifications.

- **Drive belt tension can also be checked at other points on the belts.**

SU

BR

ST

RS

BT

HA

SC

EL

IDX

BELT DEFLECTION AND TENSION

		Deflection adjustment Unit: mm (in)			Tension adjustment *1 Unit: N (kg, lb)		
		Used belt		New belt	Used belt		New belt
		Limit	After adjustment		Limit	After adjustment	
Compressor	With air conditioner compressor	9 (0.35)	5.5 - 6.5 (0.217 - 0.256)	4.5 - 5.5 (0.177 - 0.217)	304 (31, 68)	534 - 623 (54.5 - 63.4, 120.2 - 139.8)	652 - 740 (66.5 - 75.5, 146.6 - 166.5)
Generator	Without air conditioner compressor	12 - 13 (0.47 - 0.51)	8 - 9 (0.31 - 0.35)	7 - 8 (0.28 - 0.31)	264 (26.9, 59.3)	495 - 583 (50.5 - 59.5, 111.3 - 131.2)	603 - 691 (61.5 - 70.5, 135.6 - 155.5)
Power steering oil pump	With air conditioner compressor	12 (0.47)	8 - 9 (0.31 - 0.35)	7 - 8 (0.28 - 0.31)	264 (26.9, 59.3)	495 - 583 (50.5 - 59.5, 111.3 - 131.2)	603 - 691 (61.5 - 70.5, 135.6 - 155.5)
	Without air conditioner compressor	12 (0.47)	8 - 9 (0.31 - 0.35)	7 - 8 (0.28 - 0.31)	264 (26.9, 59.3)	495 - 583 (50.5 - 59.5, 111.3 - 131.2)	495 - 691 (50.5 - 70.5, 111.3 - 155.5)
Applied pushing force		98 N (10 kg, 22 lb)			—		

*1: If the belt tension gauge cannot be installed at check points shown, check belt tension at a different location on the belt.

Changing Engine Coolant

NIMA0012S02

WARNING:

To avoid the danger of being scalded, never change the coolant when the engine is hot.

—DRAINING ENGINE COOLANT—

NIMA0012S0201

1. Set air conditioning system as follows to prevent coolant from remaining in the system.
 - a. Turn ignition switch "ON" and set temperature controller to maximum hot position.
 - b. Wait 10 seconds before turning ignition switch "OFF".

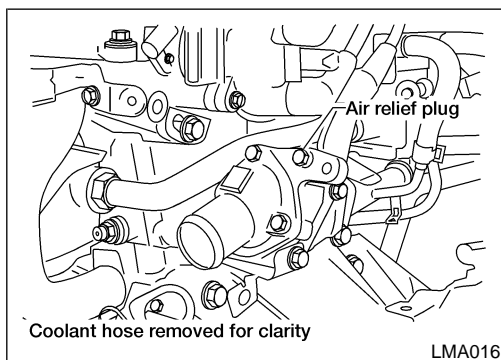
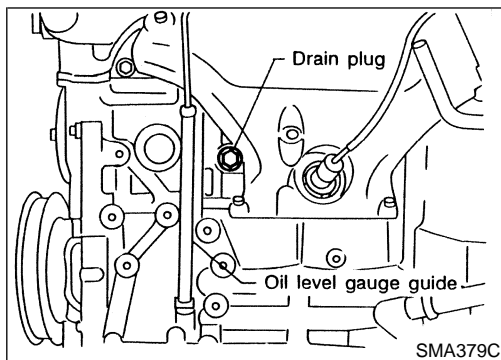
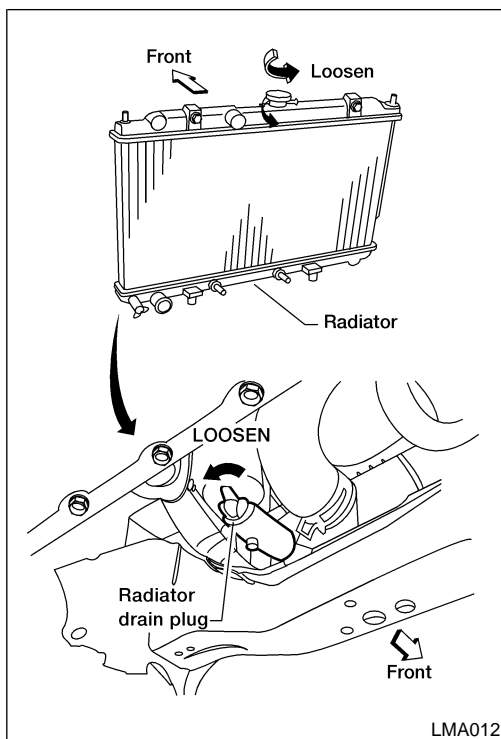

2. Open radiator drain plug at the bottom of radiator (or remove lower radiator hose) and remove radiator cap.
3. Remove reservoir tank, drain coolant, then clean reservoir tank. Install it temporarily.

- **Be careful not to allow coolant to contact drive belts.**

4. Cover the exhaust tube heat shield to prevent from splashing coolant.

5. Remove cylinder block drain plug and air relief plug.
6. Check drained coolant for contaminants such as rust, corrosion or discoloration. If contaminated, flush engine cooling system. Refer to “—FLUSHING COOLING SYSTEM—”, MA-28.
7. Using compressed air, remove any coolant around the exhaust tube heat shield.

—REFILLING ENGINE COOLANT—

NIMAA0012S0202

1. Install reservoir tank, radiator drain plug, and cylinder block drain plug.

- **Apply sealant to the thread of cylinder block drain plug.**

 : 8 - 12 N·m (0.8 - 1.2 kg·m, 69 - 104 ft·lb)

GI

MA

EM

LC

EC

FE

CL

MT

AT

AX

SU

BR

ST

RS

BT

HA

SC

EL

IDX

Changing Engine Coolant (Cont'd)

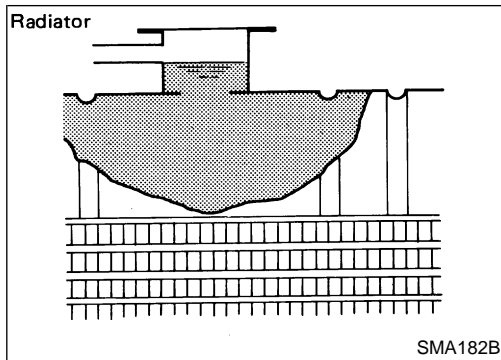

2. Fill radiator slowly with coolant until coolant spills from the air relief plug, then install air relief plug.
3. Fill radiator and reservoir tank to specified level as soon as coolant spills out without bubbles.

Air relief plug:

 : 7.2 - 9.8 N·m (0.73 - 1.0 kg-m, 63.4 - 86.8 in-lb)

- Use Genuine NISSAN anti-freeze coolant or equivalent mixed with water (demineralized water or distilled water).
- Pour coolant through coolant filler neck slowly to allow air in system to escape.

Refer to "RECOMMENDED FLUIDS AND LUBRICANTS", MA-13.

Coolant capacity (Without reservoir tank):

M/T 6.1 ℓ (6-1/2 US qt, 5-3/8 Imp qt)

A/T 6.0 ℓ (6-3/8 US qt, 5-1/4 Imp qt)

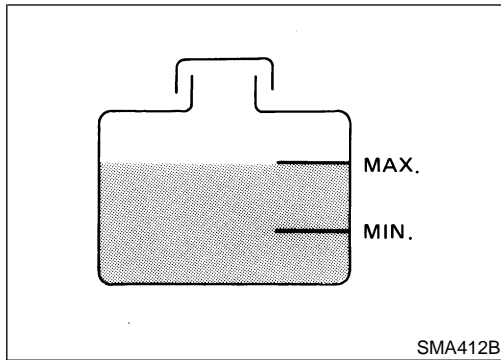

Reservoir tank capacity (for MAX level):

0.7 ℓ (3/4 US qt, 5/8 Imp qt)

4. Warm up engine to normal operating temperature without radiator cap installed.
 - If coolant overflows radiator filler neck, install filler cap.
5. Run engine at 2,500 rpm for 10 seconds and return to idle speed with radiator cap installed. Repeat two or three times.
 - Watch coolant temperature gauge so as not to overheat the engine.
6. Stop engine and cool it down.
 - Cool down using a fan to reduce the time.
 - If necessary, refill radiator up to filler neck with coolant.
7. Refill reservoir tank to Max line with coolant.
8. Repeat step 4 through step 7 two or more times with radiator cap installed until coolant level no longer drops.
9. Check cooling system for leaks with engine running.
10. Warm up engine, and check for sound of coolant flow while running engine from idle up to 3,000 rpm with heater temperature control set at several positions between Cool and Hot.
11. If sound is heard, bleed air from cooling system by repeating steps 4 through 7 until coolant level no longer drops.
 - Clean excess coolant from engine.

—FLUSHING COOLING SYSTEM—

NIMA0012S0203

1. Open air relief plug.
2. Fill radiator with water until water spills from the air relief hole, then close air relief plug. Fill radiator and reservoir tank with water and reinstall radiator cap.
3. Run engine and warm it up to normal operating temperature.
4. Rev engine two or three times under no-load.
5. Stop engine and wait until it cools down.
6. Drain water.

- Repeat steps 1 through 6 until clear water begins to drain from radiator.

GI

MA

EM

LC

EC

FE

CL

MT

AT

AX

SU

BR

ST

RS

BT

HA

SC

EL

IDX

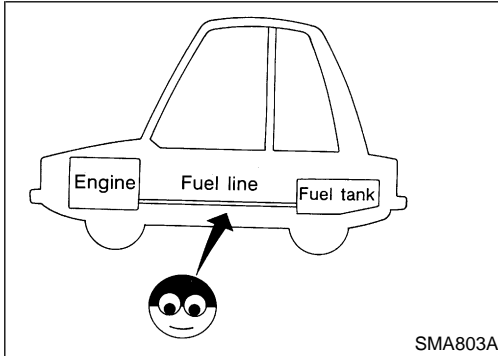

Checking Fuel Lines

Inspect fuel lines and tank for improper attachment, leaks, cracks, damage, loose connections, chafing or deterioration. If necessary, repair or replace faulty parts.

NIMA0012S03

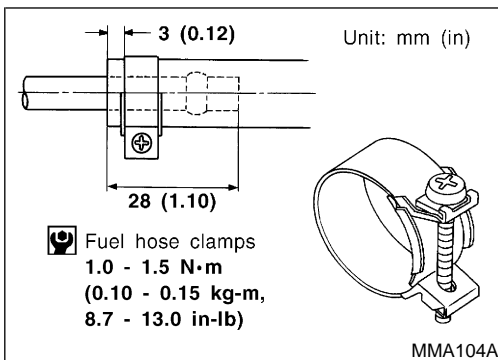

CAUTION:

Tighten high-pressure rubber hose clamp so that clamp end is 3 mm (0.12 in) from hose end.

Tightening torque specifications are the same for all rubber hose clamps.

Ensure that screw does not contact adjacent parts.

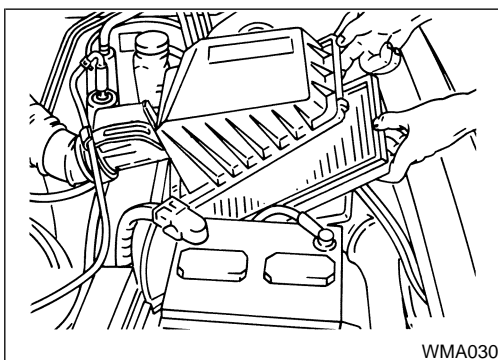

Changing Air Cleaner Filter

VISCOUS PAPER TYPE

Unfasten clamps to change air cleaner filter.

NIMA0012S05

NIMA0012S0501

- The viscous paper type filter does not need cleaning.

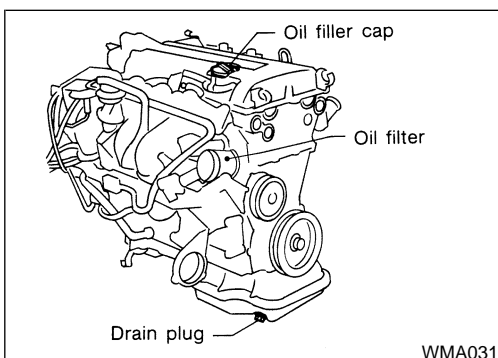

Changing Engine Oil

WARNING:

- Be careful not to burn yourself, as the engine oil is hot.
- Prolonged and repeated contact with used engine oil may cause skin cancer; try to avoid direct skin contact with used oil. If skin contact is made, wash thoroughly with soap or hand cleaner as soon as possible.

NIMA0012S06

- Warm up engine, and check for oil leakage from engine components.
- Stop engine.
- Remove drain plug and oil filler cap.

4. Drain oil and refill with new engine oil.

Oil specification and viscosity

- API Certification Mark
- API grade SG/SH, Energy Conserving I & II or API grade SJ, Energy Conserving
- ILSAC grade GF-I & GF-II
- Refer to "RECOMMENDED FLUIDS AND LUBRICANTS", MA-13.

Oil capacity (Approximate):

Unit: ℓ (US qt, Imp qt)

Drain and refill	With oil filter change	3.3 (3-1/2, 2-7/8)
	Without oil filter change	3.1 (3-1/4, 2-3/4)
Dry engine (engine overhaul)		4.0 (4-1/4, 3-1/2)

CAUTION:

- Be sure to clean drain plug and install with new washer.

Oil pan drain plug:

 : 29 - 39 N·m (3.0 - 4.0 kg-m, 22 - 29 ft-lb)

- The refill capacity depends on the oil temperature and drain time. Use these specifications for reference only. Always use the dipstick to determine when the proper amount of oil is in the engine.

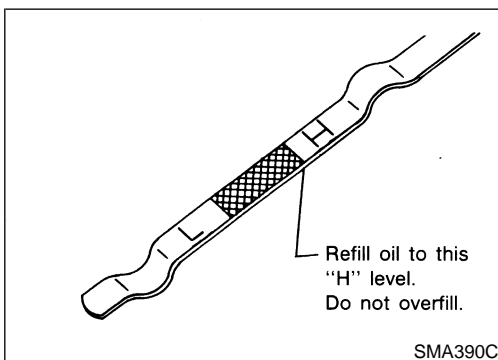

5. Warm up engine and check area around drain plug and oil filter for oil leakage.
6. Stop engine.
7. Check oil level.

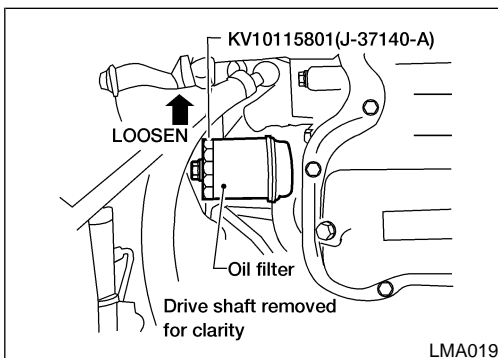

Changing Oil Filter

NIMA0012S07

1. Remove oil filter with Tool.

WARNING:

Be careful not to burn yourself, as the engine and engine oil are hot.

The filter is a full-flow cartridge type and is provided with a relief valve.

Refer to LC-25, "Oil Filter".

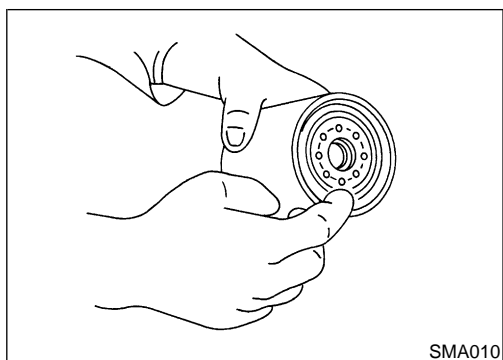

- Clean oil filter mounting surface on cylinder block. Coat rubber seal of new oil filter with engine oil.

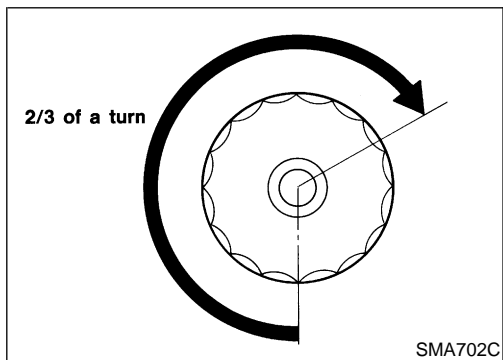

- Screw in the oil filter until a slight resistance is felt, then tighten an additional 2/3 turn.
- Add engine oil.

Refer to “Changing Engine Oil”, MA-20.

- Clean excess oil from engine.

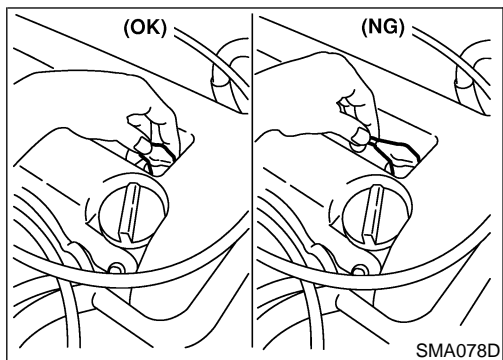

Changing Spark Plugs (Platinum-tipped type)

- Disconnect ignition wires from spark plugs at boot. Do not pull on the wire.

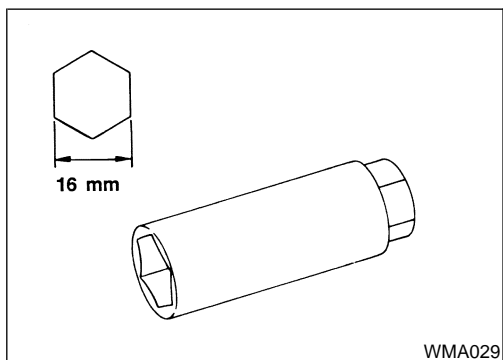

- Remove spark plugs with spark plug socket.

Spark plug:

Standard type	PFR5G-11
Hot type	—
Cold type	PFR6G-11, PFR7G-11

Gap (Nominal): 1.1 mm (0.043 in)

Use standard type spark plug for normal condition.

The hot type spark plug is suitable when fouling occurs with the standard type spark plug under conditions such as:

- frequent engine starts
- low ambient temperatures

The cold type spark plug is suitable when spark knock occurs with the standard type spark plug under conditions such as:

- extended highway driving
- frequent high engine revolution

GI

MA

EM

LC

EC

FE

CL

MT

AT

AX

SU

BR

ST

RS

BT

HA

SC

EL

IDX

Changing Spark Plugs (Platinum-tipped type) (Cont'd)

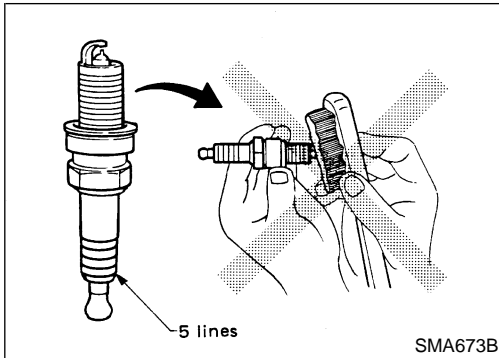

- Do not use a wire brush for cleaning.
- If plug tip is covered with carbon, spark plug cleaner may be used.

Cleaner air pressure:

Less than 588 kPa (6 kg/cm², 85 psi)

Cleaning time:

Less than 20 seconds

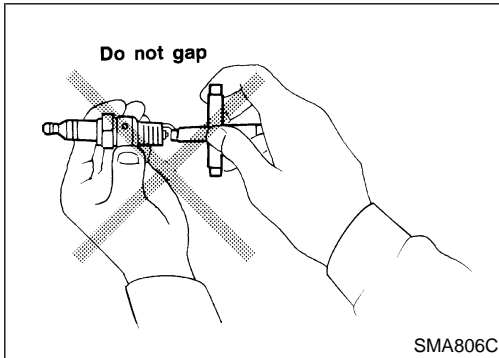

- Checking and adjusting plug gap is not required between change intervals.

3. Install spark plugs. Reconnect ignition wires according to numbers indicated on them.

Spark plug:

: 20 - 29 N·m (2.0 - 3.0 kg·m, 14 - 22 ft·lb)

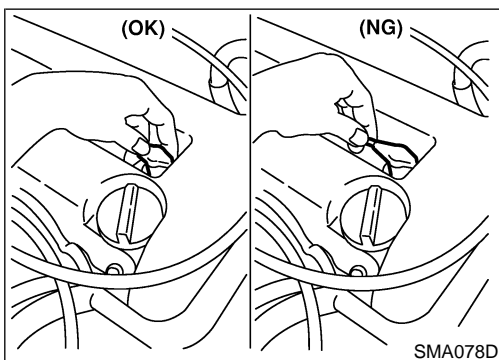

Changing Spark Plugs (Conventional type) NIMA0012S09

1. Disconnect ignition wires from spark plugs at boot. Do not pull on the wire.

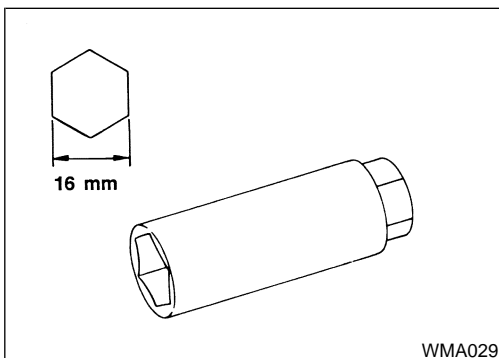

2. Remove spark plugs with spark plug socket.

Spark plug:

Standard type	BKR5E
Hot type	—
Cold type	BKR6E, BKR7E

Use standard type spark plug for normal condition.

The hot type spark plug is suitable when fouling occurs with the standard type spark plug under conditions such as:

- frequent engine starts

- low ambient temperatures

The cold type spark plug is suitable when spark knock occurs with the standard type spark plug under conditions such as:

- extended highway driving
- frequent high engine revolution

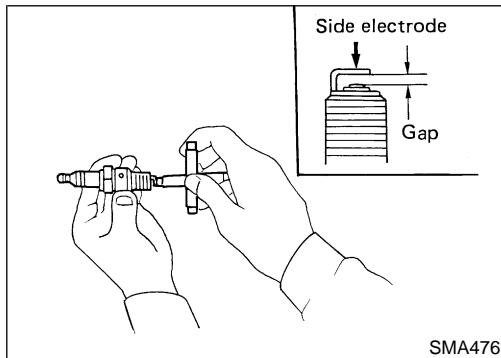

3. Check plug gap of each new spark plug.

Gap: 0.9 mm (0.035 in)

- **Use a wire brush for cleaning, if necessary.**
4. Install spark plugs. Reconnect ignition wires according to numbers indicated on them.

Spark plug:

⚙️ : 20 - 29 N·m (2.0 - 3.0 kg·m, 14 - 22 ft·lb)

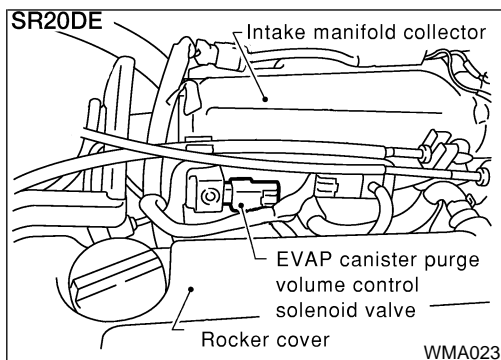

Checking EVAP Vapor Lines

1. Visually inspect EVAP vapor lines for improper attachment, cracks, damage, loose connections, chafing or deterioration.
2. Inspect vacuum relief valve of fuel tank filler cap for clogging, sticking, etc.

Refer to **EC-1385 (SR20DE)**, "Evaporative Emission System".

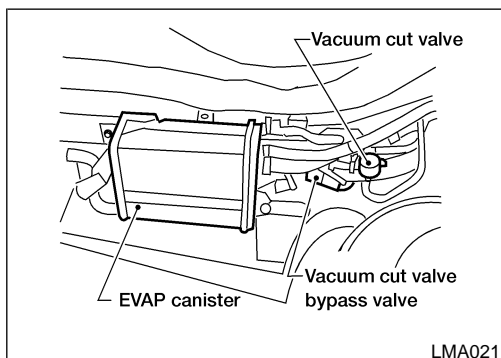

Engine Maintenance

BELT DEFLECTION AND TENSION

NIMA0013

		Deflection adjustment Unit: mm (in)			Tension adjustment *1 Unit: N (kg, lb)		
		Used belt		New belt	Used belt		New belt
		Limit	After adjustment		Limit	After adjustment	
Compressor	With air conditioner compressor	9 (0.35)	5.5 - 6.5 (0.217 - 0.256)	4.5 - 5.5 (0.177 - 0.217)	304 (31, 68)	534 - 623 (54.5 - 63.4, 120.2 - 139.8)	652 - 740 (66.5 - 75.5, 146.6 - 166.5)
Generator	Without air conditioner compressor	12 - 13 (0.47 - 0.51)	8 - 9 (0.31 - 0.35)	7 - 8 (0.28 - 0.31)	264 (26.9, 59.3)	495 - 583 (50.5 - 59.5, 111.3 - 131.2)	603 - 691 (61.5 - 70.5, 135.6 - 155.5)
Power steering oil pump	With air conditioner compressor	12 (0.47)	8 - 9 (0.31 - 0.35)	7 - 8 (0.28 - 0.31)	264 (26.9, 59.3)	495 - 583 (50.5 - 59.5, 111.3 - 131.2)	603 - 691 (61.5 - 70.5, 135.6 - 155.5)
	Without air conditioner compressor	12 (0.47)	8 - 9 (0.31 - 0.35)	7 - 8 (0.28 - 0.31)	264 (26.9, 59.3)	495 - 583 (50.5 - 59.5, 111.3 - 131.2)	495 - 691 (50.5 - 70.5, 111.3 - 155.5)
Applied pushing force		98 N (10 kg, 22 lb)			—		

*1: If the belt tension gauge cannot be installed at check points shown, check belt tension at a different location on the belt.

SPARK PLUG

NIMA0015

		Platinum-tipped type	Conventional type
Type	Standard	PFR5G-11	BKR5E
	Hot	—	—
	Cold	PFR6G-11, PFR7G-11	BKR6E, BKR7E
Plug gap		Nominal: 1.1 mm (0.043 in)	0.9 mm (0.035 in)

CHASSIS AND BODY MAINTENANCE

Checking Exhaust System

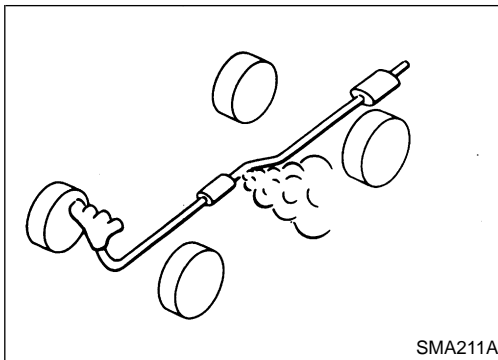

Checking Exhaust System

Check exhaust pipes, muffler and mounting for improper attachment, leaks, cracks, damage, loose connections, chafing or deterioration.

NIMA0007S01

GI

MA

EM

LC

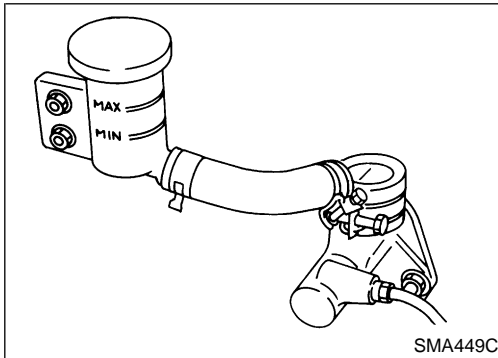

Checking Clutch Fluid Level and Leaks

If fluid level is extremely low, check clutch system for leaks.

NIMA0007S02

EC

FE

CL

MT

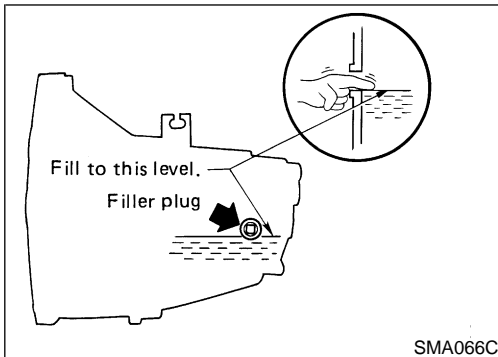

Checking M/T Oil

1. Check that oil is not leaking from transaxle or around it.
2. Check oil level.

NIMA0007S03

AT

Never start engine while checking oil level.

AX

Filler plug:

: 10 - 19 N·m (1.0 - 2.0 kg·m, 87 - 173 in·lb)

SU

BR

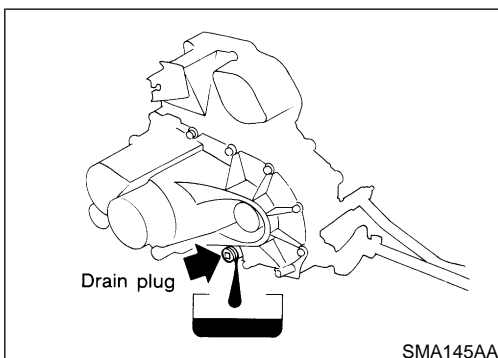

Changing M/T Oil

1. Drain oil from drain plug and refill with new gear oil.
2. Check oil level.

NIMA0007S04

ST

Oil grade:

API GL-4

RS

Viscosity:

Refer to "RECOMMENDED FLUIDS AND LUBRICANTS", MA-13.

BT

Capacity:

RS5F70A/V 3.0 l (6-3/8 US pt, 5-1/4 Imp pt)

HA

Oil level (Reference data):

QG18DE

RS5F70A 75.5 - 80.5 mm (2.972 - 3.169 in)

SC

SR20DE

RS5F70A 56.5 - 61.0 mm (2.224 - 2.402 in)

EL

RS5F70V 56.5 - 62.0 mm (2.224 - 2.441 in)

IDX

Drain plug:

: 25 - 34 N·m (2.5 - 3.5 kg·m, 18 - 25 ft·lb)

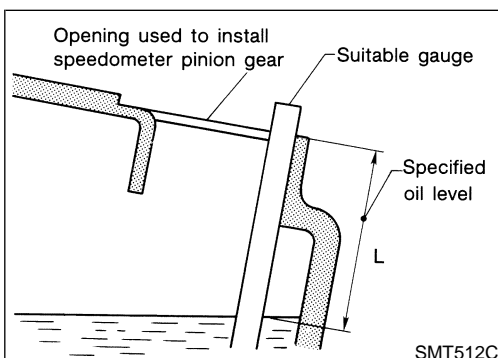

CHASSIS AND BODY MAINTENANCE

Checking A/T Fluid

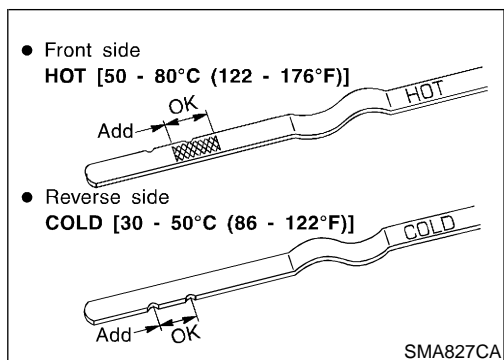

Checking A/T Fluid

NIMA0007S06

1. Warm up engine.
2. Check for fluid leakage.
3. Before driving, fluid level can be checked at fluid temperatures of 30 to 50°C (86 to 122°F) using "COLD" range on dipstick.
 - a. Park vehicle on level surface and set parking brake.
 - b. Start engine and move selector lever through each gear position. Leave selector lever in "P" position.
 - c. Check fluid level with engine idling.
 - d. Remove dipstick and note reading. If level is at low side of either range, add fluid to the charging pipe.
 - e. Re-insert dipstick into charging pipe as far as it will go.
 - f. Remove dipstick and note reading. If reading is at low side of range, add fluid to the charging pipe.

Do not overfill.

4. Drive vehicle for approximately 5 minutes in urban areas.
5. Re-check fluid level at fluid temperatures of 50 to 80°C (122 to 176°F) using "HOT" range on dipstick.



6. Check fluid condition.
 - If fluid is very dark or smells burned, refer to **AT-62**, "FLUID CONDITION CHECK". Flush cooling system after repair of A/T.
 - If A/T fluid contains frictional material (clutches, bands, etc.), replace radiator and flush cooler line using cleaning solvent and compressed air after repair of A/T. Refer to **LC-15**, "Radiator".

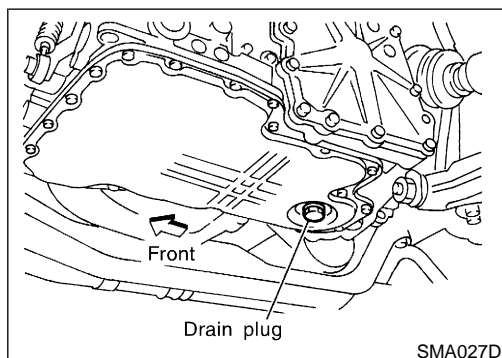

Changing A/T Fluid

NIMA0007S07

1. Warm up A/T fluid.
2. Stop engine.
3. Drain A/T fluid from drain plug and refill with new A/T fluid. Always refill same volume with drained fluid.

Fluid grade:

NISSAN Matic "D" (Continental U.S. and Alaska) or Canada NISSAN Automatic Transmission Fluid. Refer to "RECOMMENDED FLUIDS AND LUBRICANTS", MA-13.

Fluid capacity (With torque converter):

7.0 l (7-3/8 US qt, 6-1/8 Imp qt)

Drain plug:

🔧 : 29 - 39 N-m (3.0 - 4.0 kg-m, 22 - 29 ft-lb)

4. Run engine at idle speed for five minutes.
5. Check fluid level and condition. Refer to "Checking A/T Fluid", MA-36. If fluid is still dirty, repeat steps 2 through 5.

Balancing Wheels

NIMA0007S14

Adjust wheel balance using the road wheel center.

Wheel balance (Maximum allowable unbalance):
Refer to "WHEEL BALANCE", MA-41.

GI

MA

EM

LC

Tire Rotation

NIMA0007S15

- After rotating the tires, adjust the tire pressure.
- Retighten the wheel nuts when the vehicle has been driven for the first 1,000 km (600 miles) (also in cases of a flat tire, etc.).

Wheel nuts:

 : 98 - 127 N·m (10.0 - 12.9 kg·m, 73 - 93 ft·lb)

EC

FE

CL

MT

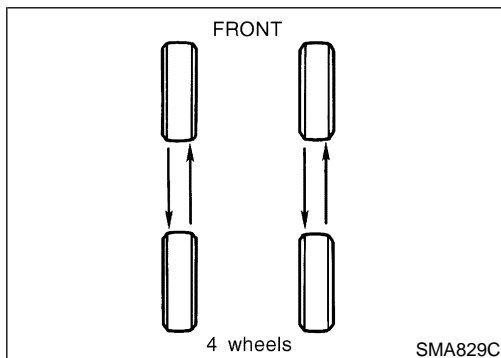

Checking Brake Fluid Level and Leaks

NIMA0007S16

If fluid level is extremely low, check brake system for leaks.

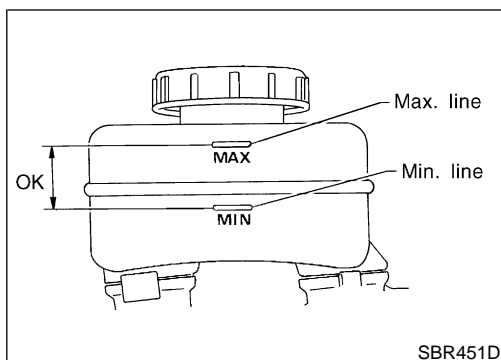

AT

AX

SU

BR

Checking Brake Lines and Cables

NIMA0007S17

Check brake fluid lines and parking brake cables for improper attachment, leaks, chafing, abrasions and deterioration.

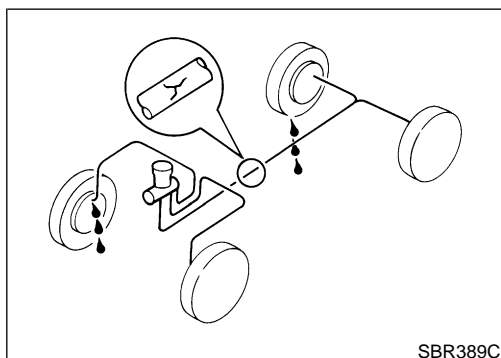

ST

RS

BT

HA

Checking Disc Brake ROTOR

NIMA0007S18

NIMA0007S1801

Check condition and thickness.

Standard thickness:

Front 22 mm (0.87 in)

Rear 9 mm (0.35 in)

Minimum thickness:

Front 20 mm (0.79 in)

Rear 8 mm (0.31 in)

SC

EL

IDX

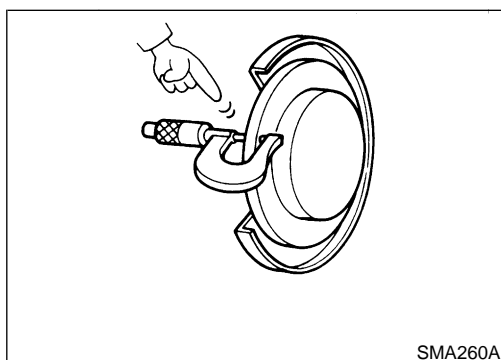

CHASSIS AND BODY MAINTENANCE

Checking Disc Brake (Cont'd)

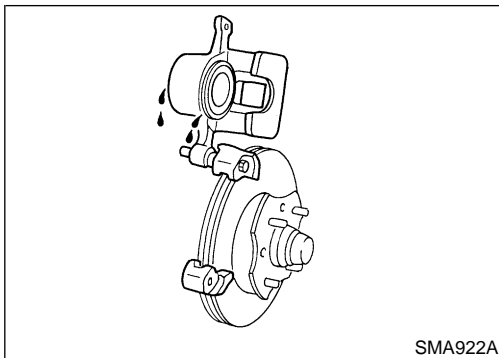

CALIPER

Check for leakage.

NIMA0007S1802

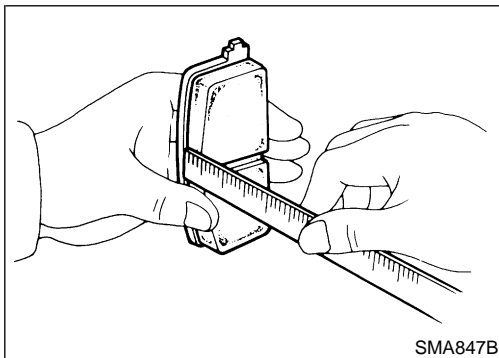

PAD

Check wear or damage.

NIMA0007S1803

Standard thickness:
Front 11 mm (0.43 in)
Rear 10 mm (0.39 in)
Minimum thickness:
Front 2 mm (0.08 in)
Rear 2 mm (0.08 in)

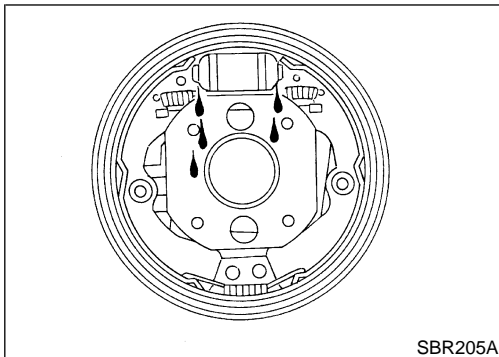

Checking Drum Brake WHEEL CYLINDER

Check operation and for leakage.

NIMA0007S24

NIMA0007S2401

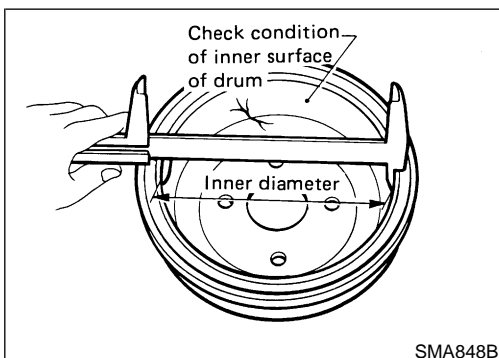

DRUM

Check condition of inner surface.

NIMA0007S2402

Standard diameter:
203.2 mm (8.000 in)
Maximum inner diameter:
204.5 mm (8.051 in)

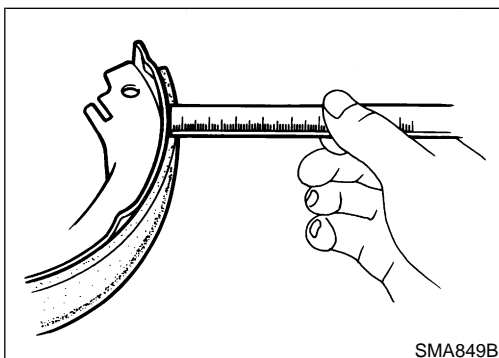

LINING

Measure wear and check for damage.

NIMA0007S2403

Standard thickness:
4.5 mm (0.177 in)
Minimum thickness:
1.5 mm (0.059 in)

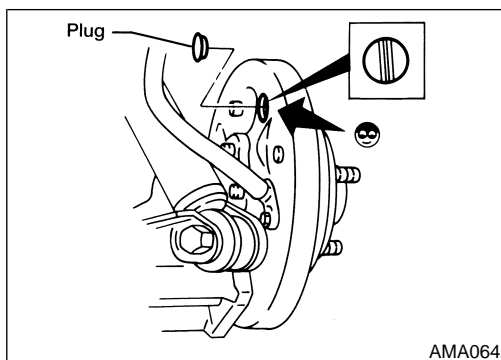

TEMPORARY METHOD FOR CHECKING LINING WEAR

NIMA0007S2404

Remove inspection hole plug and check lining wear.

GI

MA

EM

LC

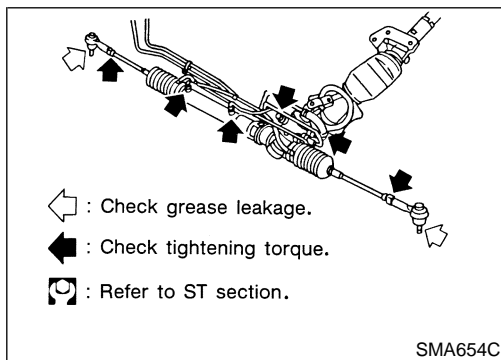

Checking Steering Gear and Linkage

NIMA0007S20

STEERING GEAR

NIMA0007S2001

- Check gear housing and boots for looseness, damage and grease leakage.
- Check connection with steering column for looseness.

EC

FE

STEERING LINKAGE

NIMA0007S2002

- Check ball joint, dust cover and other component parts for looseness, wear, damage and grease leakage.

CL

MT

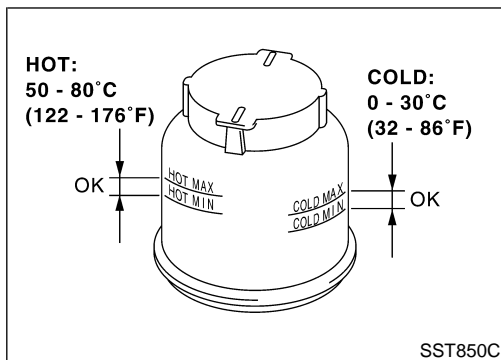

Checking Power Steering Fluid and Lines

NIMA0007S21

CHECKING FLUID LEVEL

NIMA0007S2101

- Check fluid level with engine off.
- Use the correct range of the tank depending on the fluid temperature. Use "HOT" range at fluid temperatures of 50 to 80°C (122 to 176°F). Use "COLD" range at fluid temperatures of 0 to 30°C (32 to 86°F).

AT

AX

SU

CAUTION:

- Do not overfill.
- Recommended fluid is Genuine NISSAN PSF II or equivalent.

BR

CHECKING LINES

NIMA0007S2102

- Check lines for improper attachment, leaks, cracks, damage, loose connections, chafing and deterioration.
- Check rack boots for accumulation of power steering fluid.

ST

RS

BT

HA

SC

EL

IDX

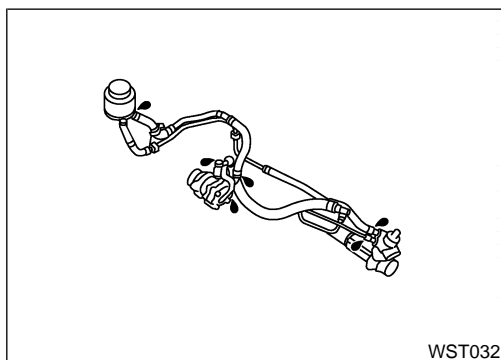

CHASSIS AND BODY MAINTENANCE

Lubricating Locks, Hinges and Hood Latches

Lubricating Locks, Hinges and Hood Latches

NIMA0007S22

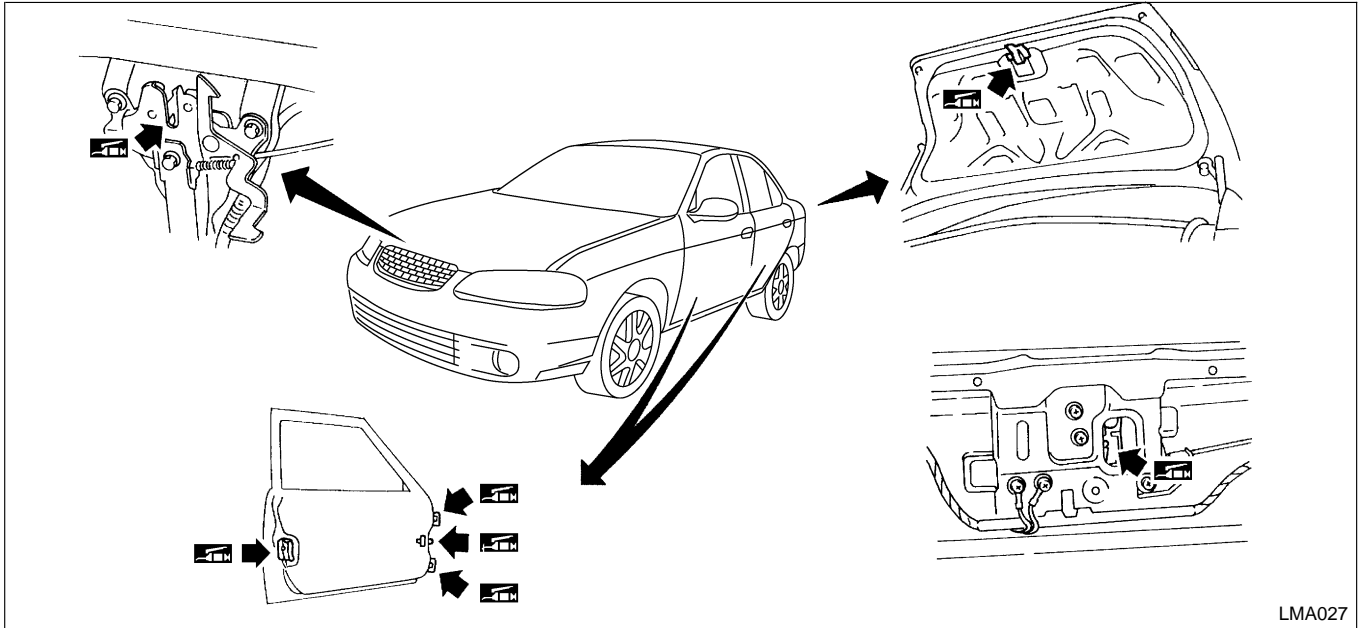

LMA027

Checking Seat Belts, Buckles, Retractors, Anchors and Adjusters

NIMA0007S23

CAUTION:

- After any collision, inspect all seat belt assemblies, including retractors and other attached hardware (i.e. anchor bolt, guide rail set). Nissan recommends to replace all seat belt assemblies in use during a collision, unless not damaged and properly operating after minor collision. Also inspect seat belt assemblies not in use during a collision, and replace if damaged or improperly operating. Seat belt pre-tensioner should be replaced even if the seat belts are not in use during a frontal collision where the driver and passenger air bags are deployed.
- If any component of seat belt assembly is questionable, do not repair. Replace as seat belt assembly.
- If webbing is cut, frayed, or damaged, replace belt assembly.
- Never oil tongue and buckle.
- Use a Genuine NISSAN seat belt assembly.

For details, refer to "Seat Belt Inspection," "SEAT BELTS" in RS section.

Anchor bolt

43.1 – 54.9 (4.4 – 5.6, 32 – 40)

: N·m (kg·m, ft·lb)

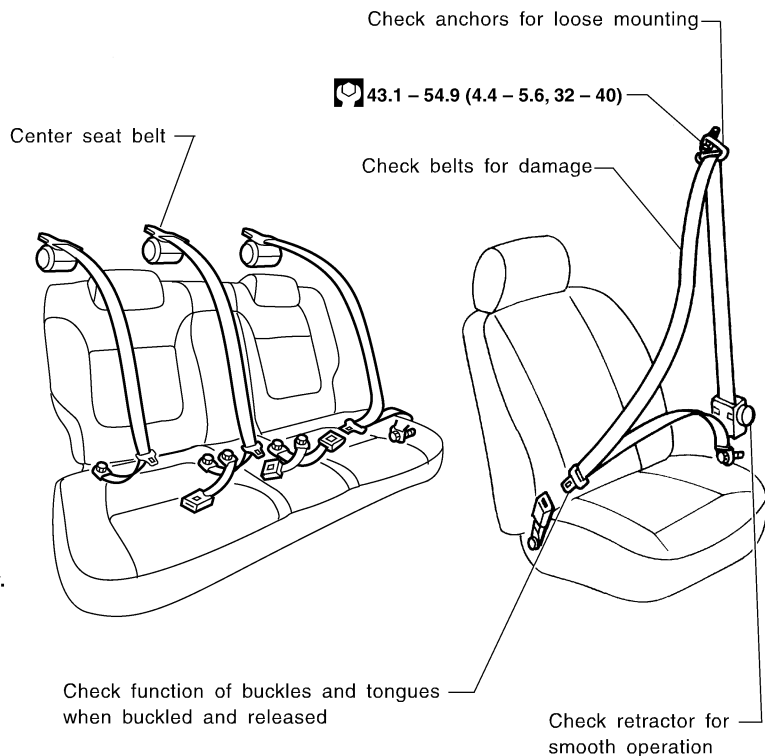

LMA028

SERVICE DATA AND SPECIFICATIONS (SDS)

Chassis and Body Maintenance

Chassis and Body Maintenance

NIMA0009

WHEEL BALANCE

NIMA0009S01

Maximum allowable unbalance	Dynamic (At rim flange) g (oz)	10 (0.35) (one side)
	Static g (oz)	20 (0.71)

GI

MA

EM

LC

EC

FE

CL

MT

AT

AX

SU

BR

ST

RS

BT

HA

SC

EL

IDX

NOTES