

SECTION BT

GI
MA
EM
LC
EC
FE
CL
MT
AT
AX
SU
BR
ST
RS
BT
HA
SC
EL
IDX

CONTENTS

PRECAUTIONS	2	Removal and Installation	27
Supplemental Restraint System (SRS) "AIR BAG" and "SEAT BELT PRE-TENSIONER"	2	ROOF TRIM	29
PREPARATION	3	Removal and Installation	29
Special Service Tools	3	TRUNK ROOM TRIM	30
Commercial Service Tools	3	Removal and Installation	30
SQUEAK AND RATTLE TROUBLE DIAGNOSES	4	EXTERIOR	31
Work Flow	4	Removal and Installation	31
CUSTOMER INTERVIEW	4	FRONT SEAT	37
DUPLICATE THE NOISE AND TEST DRIVE	5	Removal and Installation	37
CHECK RELATED SERVICE BULLETINS	5	REAR SEAT	39
LOCATE THE NOISE AND IDENTIFY THE ROOT CAUSE	5	Removal and Installation	39
REPAIR THE CAUSE	5	SUNROOF	40
CONFIRM THE REPAIR	6	Memory Reset Adjustment	40
Generic Squeak and Rattle Troubleshooting	6	Removal	41
INSTRUMENT PANEL	6	SUNROOF LID ASSEMBLY	42
CENTER CONSOLE	6	SHADE ASSEMBLY	42
DOORS	6	SUNROOF ASSEMBLY	42
TRUNK	7	Trouble Diagnoses	43
SUNROOF/HEADLINER	7	DIAGNOSTIC TABLE	43
SEATS	7	WIND DEFLECTOR (IF EQUIPPED)	43
UNDERHOOD	7	ADJUSTMENT	44
Diagnostic Worksheet	8	DRAIN HOSES	45
CLIP AND FASTENER	10	WEATHERSTRIP	45
Description	10	LINK AND WIRE ASSEMBLY	45
BODY FRONT END	13	WINDSHIELD AND WINDOWS	46
Removal and Installation	13	Removal and Installation	46
FRONT BUMPER ASSEMBLY	13	REMOVAL	46
BODY REAR END AND OPENER	16	INSTALLATION	46
Removal and Installation	16	WINDSHIELD AND REAR WINDOW	47
REAR BUMPER ASSEMBLY	16	QUARTER WINDOW	48
DOOR	19	DOOR MIRROR	49
Front Door	19	Removal and Installation	49
Rear Door	20	REAR VIEW MIRROR	50
INSTRUMENT PANEL ASSEMBLY	21	Removal and Installation	50
Removal and Installation	21	REMOVAL	50
SIDE AND FLOOR TRIM	25	INSTALLATION	50
Removal and Installation	25	BODY (ALIGNMENT)	51
DOOR TRIM	27	Alignment	51
		ENGINE COMPARTMENT	52
		UNDERBODY	55

PRECAUTIONS

Supplemental Restraint System (SRS) "AIR BAG" and "SEAT BELT PRE-TENSIONER"

Supplemental Restraint System (SRS) "AIR BAG" and "SEAT BELT PRE-TENSIONER"

NIBT0002

The Supplemental Restraint System such as "AIR BAG" and "SEAT BELT PRE-TENSIONER" used along with a seat belt, helps to reduce the risk or severity of injury to the driver and front passenger for certain types of collision. The SRS system composition which is available to NISSAN MODEL B15 is as follows:

- For a frontal collision
The Supplemental Restraint System consists of driver air bag module (located in the center of the steering wheel), front passenger air bag module (located on the instrument panel on passenger side), front seat belt pre-tensioners, a diagnosis sensor unit, warning lamp, wiring harness and spiral cable.
- For a side collision
The Supplemental Restraint System consists of front side air bag module (located in the outer side of front seat), side air bag (satellite) sensor, diagnosis sensor unit (one of components of air bags for a frontal collision), wiring harness, warning lamp (one of components of air bags for a frontal collision).

Information necessary to service the system safely is included in the **RS section** of this Service Manual.

WARNING:

- To avoid rendering the SRS inoperative, which could increase the risk of personal injury or death in the event of a collision which would result in air bag inflation, all maintenance should be performed by an authorized NISSAN dealer.
- Improper maintenance, including incorrect removal and installation of the SRS, can lead to personal injury caused by unintentional activation of the system. For removal of Spiral Cable and Air Bag Module, see the RS section.
- Do not use electrical test equipment on any circuit related to the SRS unless instructed to in this Service Manual. Spiral cable and wiring harnesses (except "SEAT BELT PRE-TENSIONER") covered with yellow insulation either just before the harness connectors or for the complete harness are related to the SRS.

PREPARATION

Special Service Tools

Special Service Tools

NIBT0027

The actual shapes of Kent-Moore tools may differ from those of special service tools illustrated here.

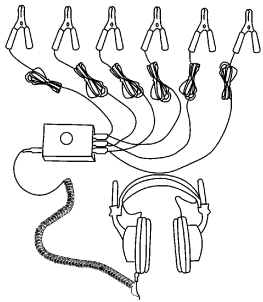
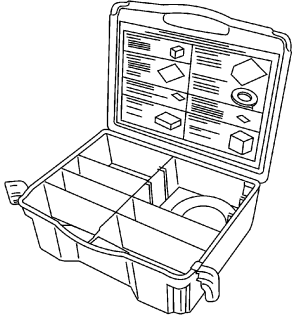
Tool number (Kent-Moore No.) Tool name	Description	
— (J-39570) Chassis ear	Locating the noise  SBT839	GI MA EM LC EC FE
— (J-43980) Nissan Squeak and Rattle kit	Repairing the cause of noise  SBT840	CL MT AT AX SU

Commercial Service Tools

NIBT0028

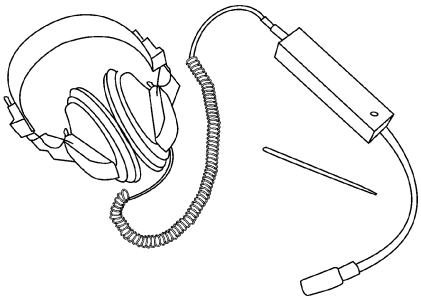
Tool name	Description	
Engine ear (J-39565)	Locating the noise  SBT841	BR ST RS BT HA SC

SQUEAK AND RATTLE TROUBLE DIAGNOSES

Work Flow

Work Flow

NIBT0029

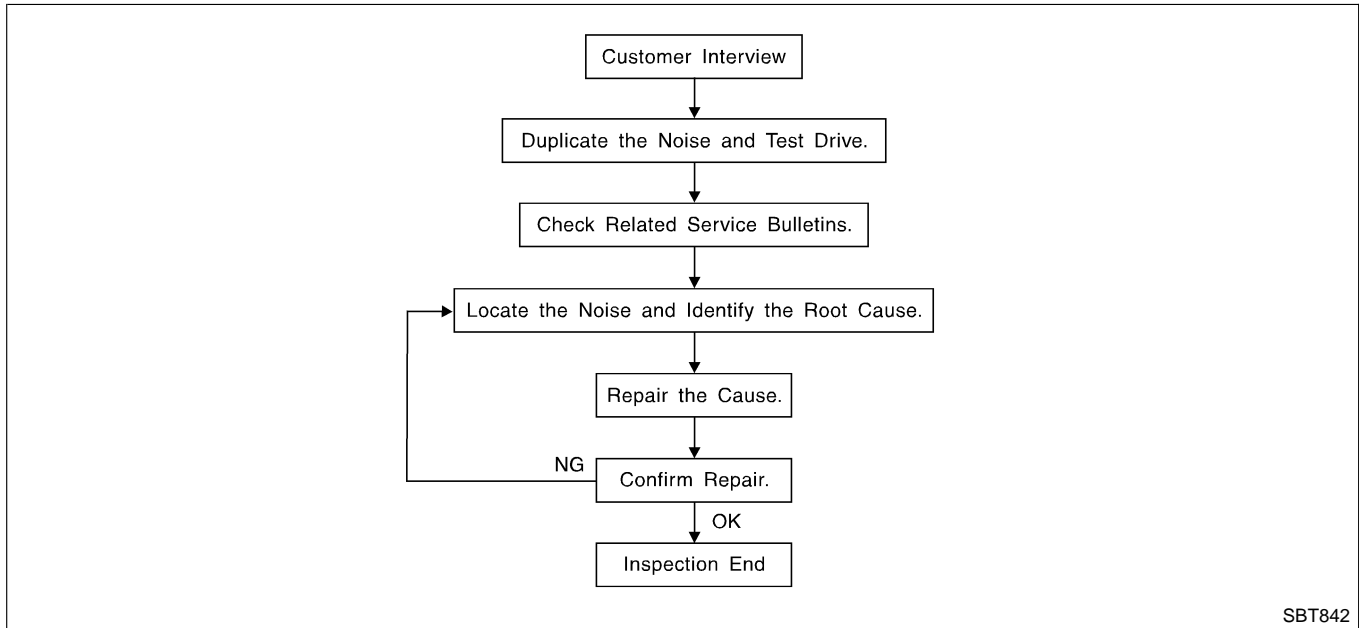

SBT842

CUSTOMER INTERVIEW

NIBT0029S01

Interview the customer, if possible, to determine the conditions that exist when the noise occurs. Use the Diagnostic Worksheet during the interview to document the facts and conditions when the noise occurs and any customer's comments; refer to "Diagnostic Worksheet", BT-8. This information is necessary to duplicate the conditions that exist when the noise occurs.

- The customer may not be able to provide a detailed description or the location of the noise. Attempt to obtain all the facts and conditions that exist when the noise occurs (or does not occur).
- If there is more than one noise in the vehicle, be sure to diagnose and repair the noise that the customer is concerned about. This can be accomplished by test driving the vehicle with the customer.
- After identifying the type of noise, isolate the noise in terms of its characteristics. The noise characteristics are provided so the customer, service adviser and technician are all speaking the same language when defining the noise.
- Squeak — (Like tennis shoes on a clean floor)
Squeak characteristics include the light contact/fast movement/brought on by road conditions/hard surfaces = higher pitch noise/softer surfaces = lower pitch noises/edge to surface = chirping
- Creak — (Like walking on an old wooden floor)
Creak characteristics include firm contact/slow movement/twisting with a rotational movement/pitch dependent on materials/often brought on by activity.
- Rattle — (Like shaking a baby rattle)
Rattle characteristics include the fast repeated contact/vibration or similar movement/loose parts/missing clip or fastener/incorrect clearance.
- Knock — (Like a knock on a door)
Knock characteristics include hollow sounding/sometimes repeating/often brought on by driver action.
- Tick — (Like a clock second hand)
Tick characteristics include gentle contacting of light materials/loose components/can be caused by driver action or road conditions.
- Thump — (Heavy, muffled knock noise)
Thump characteristics include softer knock/dead sound often brought on by activity.
- Buzz — (Like a bumblebee)
Buzz characteristics include high frequency rattle/firm contact.
- Often the degree of acceptable noise level will vary depending upon the person. A noise that you may judge as acceptable may be very irritating to the customer.
- Weather conditions, especially humidity and temperature, may have a great effect on noise level.

SQUEAK AND RATTLE TROUBLE DIAGNOSES

Work Flow (Cont'd)

DUPLICATE THE NOISE AND TEST DRIVE

NIBT0029S02

If possible, drive the vehicle with the customer until the noise is duplicated. Note any additional information on the Diagnostic Worksheet regarding the conditions or location of the noise. This information can be used to duplicate the same conditions when you confirm the repair.

If the noise can be duplicated easily during the test drive, to help identify the source of the noise, try to duplicate the noise with the vehicle stopped by doing one or all of the following:

- 1) Close a door.
 - 2) Tap or push/pull around the area where the noise appears to be coming from.
 - 3) Rev the engine.
 - 4) Use a floor jack to recreate vehicle "twist".
 - 5) At idle, apply engine load (electrical load, half-clutch on M/T model, drive position on A/T model).
 - 6) Raise the vehicle on a hoist and hit a tire with a rubber hammer.
- Drive the vehicle and attempt to duplicate the conditions the customer states exist when the noise occurs.
 - If it is difficult to duplicate the noise, drive the vehicle slowly on an undulating or rough road to stress the vehicle body.

CHECK RELATED SERVICE BULLETINS

NIBT0029S03

After verifying the customer concern or symptom, check ASIST for Technical Service Bulletins (TSBs) related to that concern or symptom.

If a TSB relates to the symptom, follow the procedure to repair the noise.

LOCATE THE NOISE AND IDENTIFY THE ROOT CAUSE

NIBT0029S04

1. Narrow down the noise to a general area. To help pinpoint the source of the noise, use a listening tool (Chassis Ear: J-39570, Engine Ear: J-39565 and mechanics stethoscope).
2. Narrow down the noise to a more specific area and identify the cause of the noise by:
 - Removing the components in the area that you suspect the noise is coming from.
Do not use too much force when removing clips and fasteners, otherwise clips and fasteners can be broken or lost during the repair, resulting in the creation of new noise.
 - Tapping or pushing/pulling the component that you suspect is causing the noise.
Do not tap or push/pull the component with excessive force, otherwise the noise will be eliminated only temporarily.
 - Feeling for a vibration with your hand by touching the component(s) that you suspect is (are) causing the noise.
 - Placing a piece of paper between components that you suspect are causing the noise.
 - Looking for loose components and contact marks.

Refer to "Generic Squeak and Rattle Troubleshooting", BT-6.

REPAIR THE CAUSE

NIBT0029S05

- If the cause is a loose component, tighten the component securely.
- If the cause is insufficient clearance between components:
 - Separate components by repositioning or loosening and retightening the component, if possible.
 - Insulate components with a suitable insulator such as urethane pads, foam blocks, felt cloth tape or urethane tape. A Nissan Squeak and Rattle Kit (J-43980) is available through your authorized Nissan Parts Department.

CAUTION:

Do not use excessive force as many components are constructed of plastic and may be damaged.

Always check with the Parts Department for the latest parts information.

The following materials are contained in the Nissan Squeak and Rattle Kit (J-43980). Each item can be ordered separately as needed.

URETHANE PADS [1.5 mm (0.059 in) thick]

Insulates connectors, harness, etc.

76268-9E005: 100 x 135 mm (3.94 x 5.31 in)/76884-71L01: 60 x 85 mm (2.36 x 3.35 in)/76884-71L02: 15 x 25 mm (0.59 x 0.98 in)

INSULATOR (Foam blocks)

Insulates components from contact. Can be used to fill space behind a panel.

73982-9E000: 45 mm (1.77 in) thick, 50 x 50 mm (1.97 x 1.97 in)/73982-50Y00: 10 mm (0.39 in) thick, 50 x 50 mm (1.97 x 1.97 in)

INSULATOR (Light foam block)

SQUEAK AND RATTLE TROUBLE DIAGNOSES

Work Flow (Cont'd)

80845-71L00: 30 mm (1.18 in) thick, 30 x 50 mm (1.18 x 1.97 in)

FELT CLOTH TAPE

Used to insulate where movement does not occur. Ideal for instrument panel applications.

68370-4B000: 15 x 25 mm (0.59 x 0.98 in) pad/68239-13E00: 5 mm (0.20 in) wide tape roll

The following materials, not found in the kit, can also be used to repair squeaks and rattles.

UHMW (TEFLON) TAPE

Insulates where slight movement is present. Ideal for instrument panel applications.

SILICONE GREASE

Used in place of UHMW tape that will be visible or not fit.

Note: Will only last a few months.

SILICONE SPRAY

Use when grease cannot be applied.

DUCT TAPE

Use to eliminate movement.

CONFIRM THE REPAIR

Confirm that the cause of a noise is repaired by test driving the vehicle. Operate the vehicle under the same conditions as when the noise originally occurred. Refer to the notes on the Diagnostic Worksheet.

NIBT0029S06

Generic Squeak and Rattle Troubleshooting

NIBT0030

Refer to Table of Contents for specific component removal and installation information.

INSTRUMENT PANEL

NIBT0030S01

Most incidents are caused by contact and movement between:

1. The cluster lid A and instrument panel
2. Acrylic lens and combination meter housing
3. Instrument panel to front pillar garnish
4. Instrument panel to windshield
5. Instrument panel mounting pins
6. Wiring harnesses behind the combination meter
7. A/C defroster duct and duct joint

These incidents can usually be located by tapping or moving the components to duplicate the noise or by pressing on the components while driving to stop the noise. Most of these incidents can be repaired by applying felt cloth tape or silicone spray (in hard to reach areas). Urethane pads can be used to insulate wiring harness.

CAUTION:

Do not use silicone spray to isolate a squeak or rattle. If you saturate the area with silicone, you will not be able to recheck the repair.

CENTER CONSOLE

NIBT0030S02

Components to pay attention to include:

1. Shifter assembly cover to finisher
2. A/C control unit and upper/lower cluster lid C
3. Wiring harnesses behind audio and A/C control unit

The instrument panel repair and isolation procedures also apply to the center console.

DOORS

NIBT0030S03

Pay attention to the:

1. Finisher and inner panel making a slapping noise
2. Inside handle escutcheon to door finisher
3. Wiring harnesses tapping
4. Door striker out of alignment causing a popping noise on starts and stops

Tapping or moving the components or pressing on them while driving to duplicate the conditions can isolate many of these incidents. You can usually insulate the areas with felt cloth tape or insulator foam blocks from the Nissan Squeak and Rattle Kit (J-43980) to repair the noise.

SQUEAK AND RATTLE TROUBLE DIAGNOSES

Generic Squeak and Rattle Troubleshooting (Cont'd)

TRUNK

=NIBT0030S04

Trunk noises are often caused by a loose jack or loose items put into the trunk by the owner. In addition look for:

1. Trunk lid bumpers out of adjustment
2. Trunk lid striker out of adjustment
3. The trunk lid torsion bars knocking together
4. A loose license plate or bracket

Most of these incidents can be repaired by adjusting, securing or insulating the item(s) or component(s) causing the noise.

SUNROOF/HEADLINER

NIBT0030S05

Noises in the sunroof/headliner area can often be traced to one of the following:

1. Sunroof lid, rail, linkage or seals making a rattle or light knocking noise
2. Sunvisor shaft shaking in the holder
3. Front or rear windshield touching headliner and squeaking

Again, pressing on the components to stop the noise while duplicating the conditions can isolate most of these incidents. Repairs usually consist of insulating with felt cloth tape.

SEATS

NIBT0030S06

When isolating seat noises it is important to note the position the seat is in and the load placed on the seat when the noise is present. These conditions should be duplicated when verifying and isolating the cause of the noise.

Cause of seat noise include:

1. Headrest rods and holders
2. A squeak between the seat pad cushion and frame
3. The rear seat back lock and bracket

These noises can be isolated by moving or pressing on the suspected components while duplicating the conditions under which the noise occurs. Most of these incidents can be repaired by repositioning the component or applying urethane tape to the contact area.

UNDERHOOD

NIBT0030S07

Some interior noises may be caused by components under the hood or on the engine wall. The noise is then transmitted into the passenger compartment.

Causes of transmitted underhood noises include:

1. Any component mounted to the engine wall
2. Components that pass through the engine wall
3. Engine wall mounts and connectors
4. Loose radiator mounting pins
5. Hood bumpers out of adjustment
6. Hood striker out of adjustment

These noises can be difficult to isolate since they cannot be reached from the interior of the vehicle. The best method is to secure, move or insulate one component at a time and test drive the vehicle. Also, engine RPM or load can be changed to isolate the noise. Repairs can usually be made by moving, adjusting, securing, or insulating the component causing the noise.

GI

MA

EM

LC

EC

FE

CL

MT

AT

AX

SU

BR

ST

RS

BT

HA

SC

EL

IDX

SQUEAK AND RATTLE TROUBLE DIAGNOSES

Diagnostic Worksheet



SQUEAK & RATTLE DIAGNOSTIC WORKSHEET

Dear Nissan Customer:

We are concerned about your satisfaction with your Nissan vehicle. Repairing a squeak or rattle sometimes can be very difficult. To help us fix your Nissan right the first time, please take a moment to note the area of the vehicle where the squeak or rattle occurs and under what conditions. You may be asked to take a test drive with a service advisor or technician to ensure we confirm the noise you are hearing.

I. WHERE DOES THE NOISE COME FROM? (circle the area of the vehicle)

The illustrations are for reference only, and may not reflect the actual configuration of your vehicle.

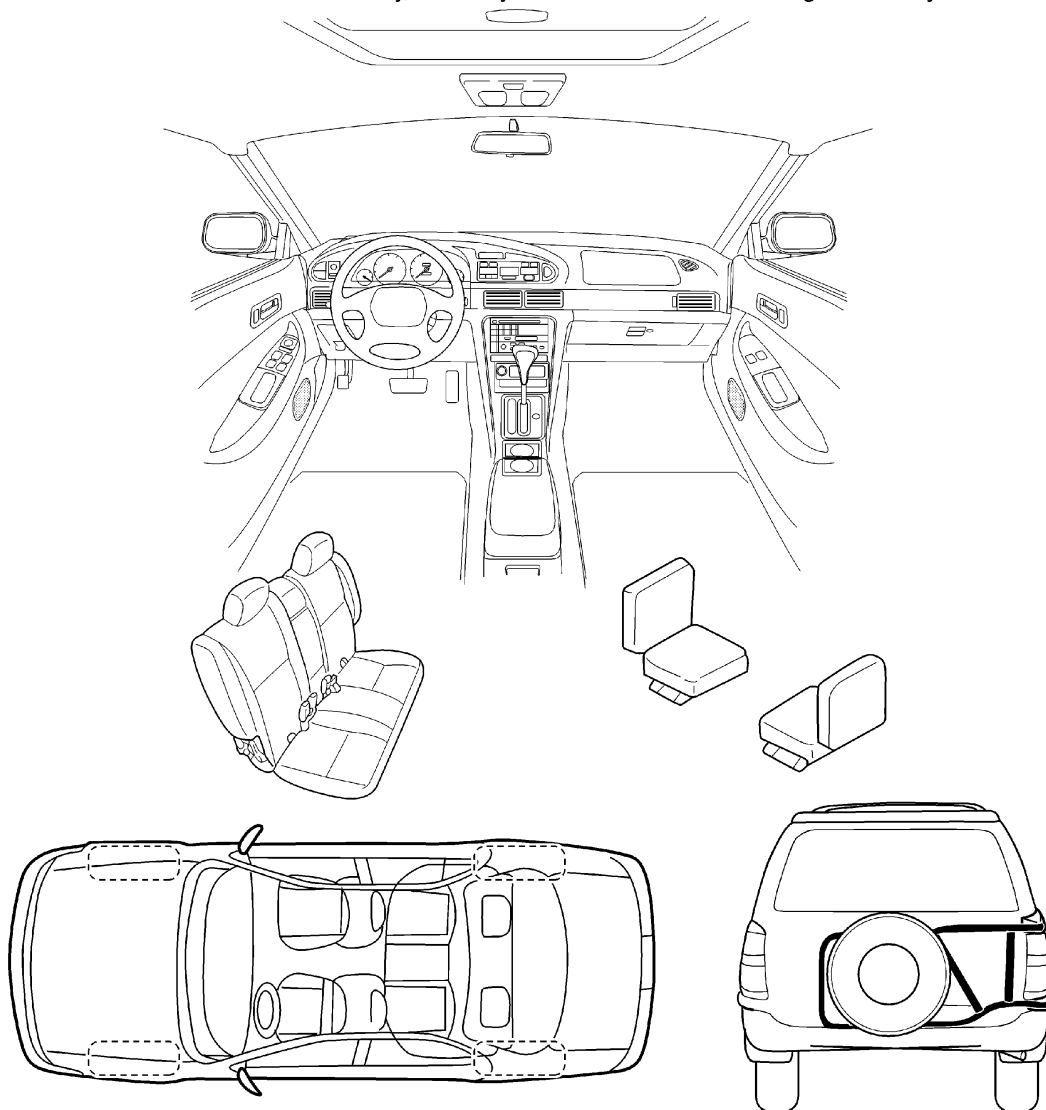

Continue to the back of the worksheet and briefly describe the location of the noise or rattle. In addition, please indicate the conditions which are present when the noise occurs.

SQUEAK AND RATTLE TROUBLE DIAGNOSES

Diagnostic Worksheet (Cont'd)

SQUEAK & RATTLE DIAGNOSTIC WORKSHEET- page 2

Briefly describe the location where the noise occurs:

II. WHEN DOES IT OCCUR? (check the boxes that apply)

- | | |
|--|---|
| <input type="checkbox"/> anytime | <input type="checkbox"/> after sitting out in the sun |
| <input type="checkbox"/> 1 st time in the morning | <input type="checkbox"/> when it is raining or wet |
| <input type="checkbox"/> only when it is cold outside | <input type="checkbox"/> dry or dusty conditions |
| <input type="checkbox"/> only when it is hot outside | <input type="checkbox"/> other: _____ |

III. WHEN DRIVING:

- through driveways
- over rough roads
- over speed bumps
- only at about ____ mph
- on acceleration
- coming to a stop
- on turns : left, right or either (circle)
- with passengers or cargo
- other: _____
- after driving ____ miles or ____ minutes

IV. WHAT TYPE OF NOISE?

- squeak (like tennis shoes on a clean floor)
- creak (like walking on an old wooden floor)
- rattle (like shaking a baby rattle)
- knock (like a knock on a door)
- tick (like a clock second hand)
- thump (heavy, muffled knock noise)
- buzz (like a bumble bee)

TO BE COMPLETED BY DEALERSHIP PERSONNEL

Test Drive Notes:

	<u>YES</u>	<u>NO</u>	<u>Initials of person performing</u>
Vehicle test driven with customer	<input type="checkbox"/>	<input type="checkbox"/>	_____
- Noise verified on test drive	<input type="checkbox"/>	<input type="checkbox"/>	_____
- Noise source located and repaired	<input type="checkbox"/>	<input type="checkbox"/>	_____
- Follow up test drive performed to confirm repair	<input type="checkbox"/>	<input type="checkbox"/>	_____

VIN: _____ Customer Name: _____

W.O. #: _____ Date: _____

This form must be attached to Work Order

SBT844

GI

MA

EM

LC

EC

FE

CL

MT

AT

AX

SU

BR

ST

RS

BT

HA

SC

EL

IDX







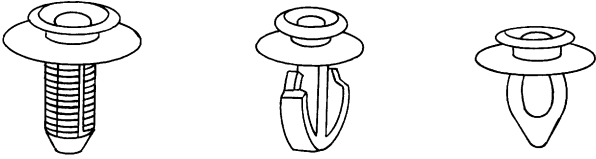
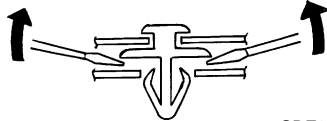

CLIP AND FASTENER

Description

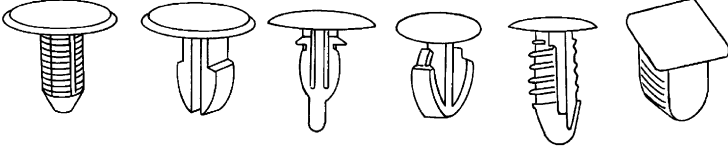
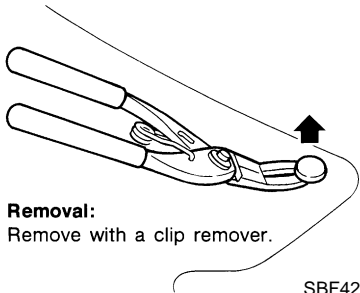
Description

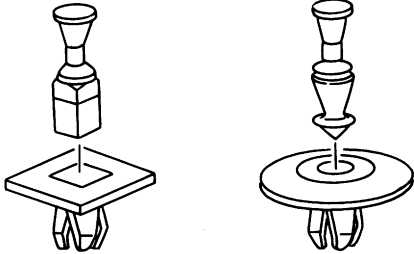
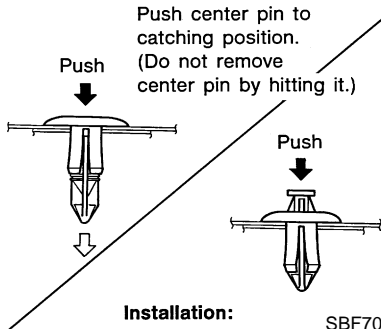

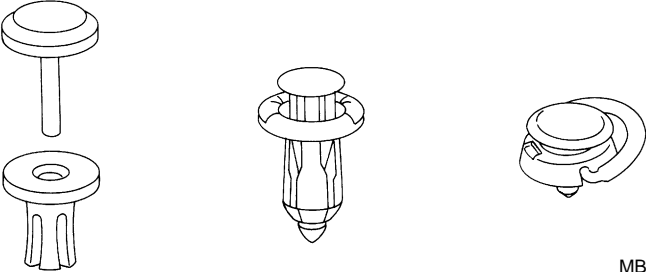
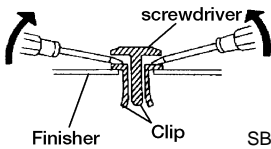

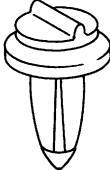
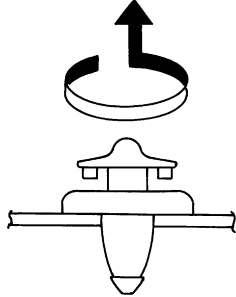

NIBT0003

- Clips and fasteners in BT section correspond to the following numbers and symbols.
- Replace any clips and/or fasteners which are damaged during removal or installation.

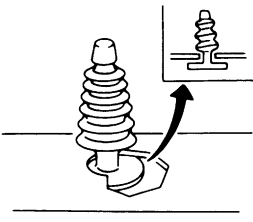
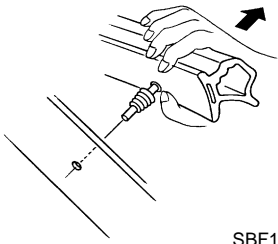
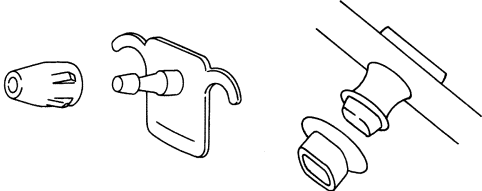
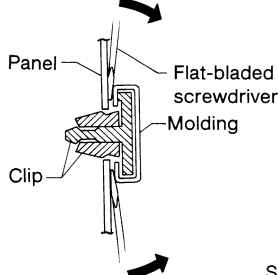
Symbol No.	Shapes	Removal & Installation
<p>C101</p> 	 <p>SBF302H</p>	<p>Removal: Remove by bending up with flat-bladed screwdrivers or clip remover.</p>  <p>SBF367BA</p>
<p>C103</p> 	 <p>SBT095</p>	 <p>Removal: Remove with a clip remover.</p> <p>SBF423H</p>
<p>C203</p> 	 <p>SBF258G</p>	<p>Push center pin to catching position. (Do not remove center pin by hitting it.)</p>  <p>Installation:</p> <p>SBF708E</p>
<p>C205</p> 	 <p>MBT080A</p>	<p>Removal:</p>  <p>Flat-bladed screwdriver</p> <p>Finisher</p> <p>Clip</p> <p>SBF638CA</p>
<p>C206</p> 	 <p>MBF519B</p>	 <p>MBF520B</p>

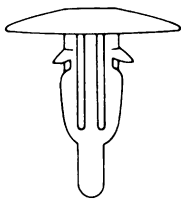
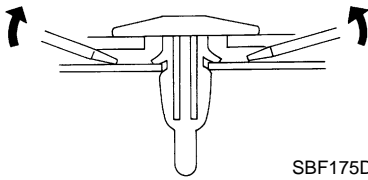

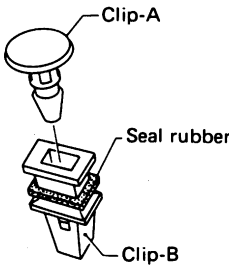
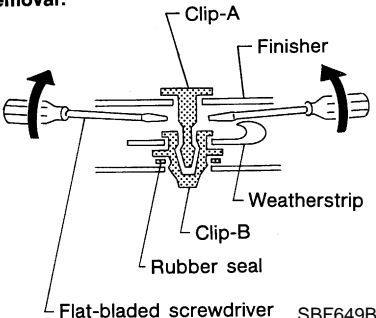

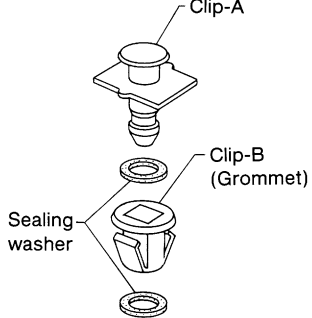
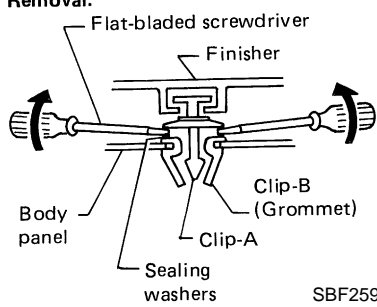
CLIP AND FASTENER

Description (Cont'd)

Symbol No.	Shapes	Removal & Installation	
<p>CE103</p> 	 <p>SBF104B</p>	<p>Removal:</p>  <p>SBF147B</p>	<p>GI MA EM LC</p>
<p>CE107</p>	 <p>SBF411H</p>	 <p>Panel Flat-bladed screwdriver Molding Clip</p> <p>SBF767B</p>	<p>EC FE CL MT</p>
<p>CE117</p> 	 <p>SBF174D</p>	<p>Removal: Remove by bending up with a flat-bladed screwdriver or pliers.</p>  <p>SBF175DA</p>	<p>AT AX SU</p>
<p>CF110</p> 	 <p>Clip-A Seal rubber Clip-B</p> <p>SBF648B</p>	<p>Removal:</p>  <p>Clip-A Finisher Weatherstrip Clip-B Rubber seal Flat-bladed screwdriver</p> <p>SBF649B</p>	<p>BR ST RS BT</p>
<p>CF118</p> 	 <p>Clip-A Clip-B (Grommet) Sealing washer</p> <p>SBF151D</p>	<p>Removal:</p>  <p>Flat-bladed screwdriver Finisher Body panel Clip-B (Grommet) Clip-A Sealing washers</p> <p>SBF259G</p>	<p>HA SC EL IDX</p>

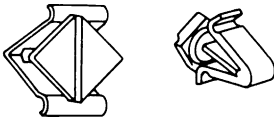
CLIP AND FASTENER

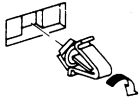
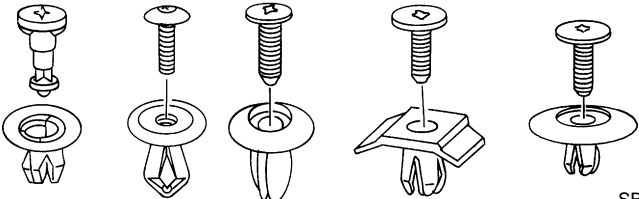
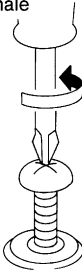
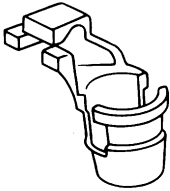
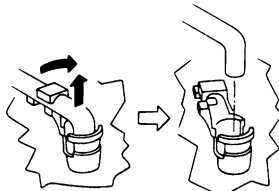
Description (Cont'd)

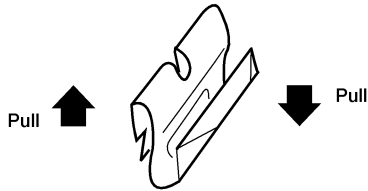
Symbol No.	Shapes	Removal & Installation
CG101	 <p style="text-align: right;">SBF145B</p>	<p>Removal:</p>  <p>Rotate 45° to remove.</p> <hr/> <p>Installation:</p>  <p style="text-align: right;">SBF085B</p>
CS101	 <p style="text-align: right;">SBF078B</p>	<p>Removal:</p> <ol style="list-style-type: none"> 1. Screw out with a Phillips screwdriver. 2. Remove female portion with flat-bladed screwdriver.  <p style="text-align: right;">SBF992G</p>
CR103	 <p style="text-align: right;">SBF768B</p>	<p>Removal:</p> <p>Holder portion of clip must be spread out to remove rod.</p>  <p style="text-align: right;">SBF770B</p>
Metal Clip	 <p style="text-align: right;">WBT072</p>	<p>Removal:</p>  <p style="text-align: right;">WBT073</p>

BODY FRONT END

Removal and Installation

Removal and Installation

NIBT0004

- When removing or installing hood, place a cloth or other padding on front fender panels and cowl top. This prevents vehicle body from being scratched. GI
- Bumper fascia is made of plastic. Do not use excessive force and be sure to keep oil away from it.
- Hood adjustment: Adjust at hinge portion. **B** MA
- Hood lock adjustment: After adjusting, check hood lock control operation. Apply a coat of grease to hood lock engaging mechanism. EM
- Hood opener: Do not attempt to bend cable forcibly. Doing so increases effort required to unlock hood.

FRONT BUMPER ASSEMBLY

NIBT0004S01

1. Remove screws securing left and right front fog lamps, and remove the lamps (if equipped); or remove filler trim panel. LC
2. Remove four clips C205 from the top of the front grille, pull up to unclip bottom and remove. **A** EC
3. Remove clips C205 and screws located on front side of fender protector at wheel opening.
4. Remove three bolts from the air deflector.
5. Remove two bolts securing lower side of front bumper fascia. FE
6. Pull off front bumper fascia and energy absorber.
7. Remove four nuts securing bumper reinforcement, then remove bumper reinforcement. CL
8. Remove four bolts securing front bumper side stays.
9. Remove front bumper side stays.
10. Remove the air dam if necessary. MT

AT

AX

SU

BR

ST

RS

BT

HA

SC

EL

IDX

BODY FRONT END

Removal and Installation (Cont'd)

SEC. 620 • 623 • 630

Hood lock adjustment

Adjust hood so that hood primary lock meshes at a position 1 to 1.5mm (0.039 to 0.059 in) lower than fender.

After hood lock adjustment, adjust bumper rubber.

When securing hood lock, ensure that it does not tilt. Striker must be positioned at the center of hood primary lock.

After adjustment, ensure that hood primary and secondary lock operate properly.

Hood lock secondary latch hooking length.

More than 5.0 mm (0.197 in)

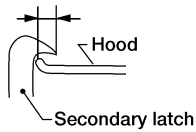

Bumper rubber adjustment

Adjust so that hood is aligned with fender, At that time deflection is approximately 2 mm (0.08 in).

[Bumper rubber free height is approximately 13 mm (0.51 in)]

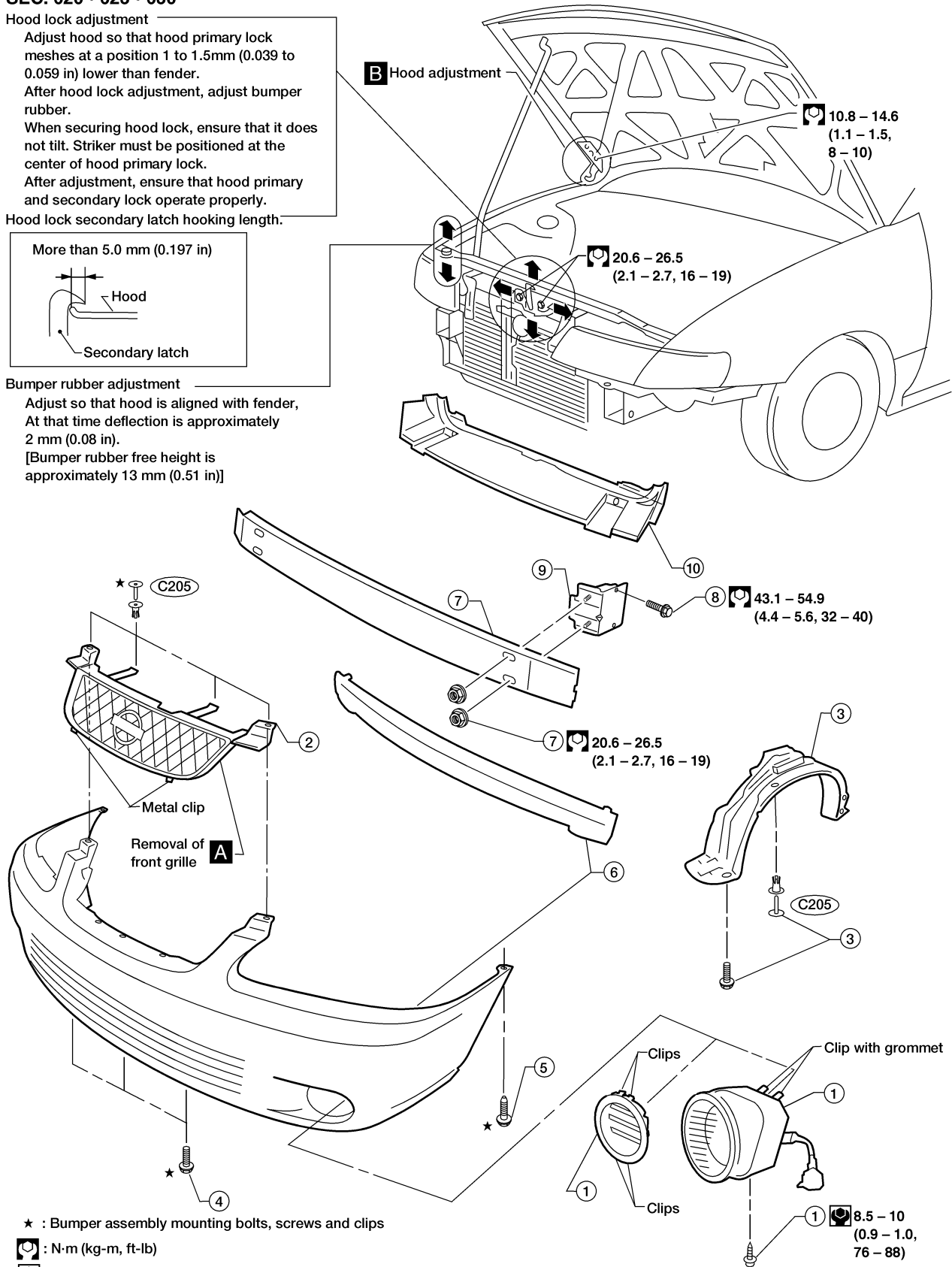

★ : Bumper assembly mounting bolts, screws and clips

☐ : N·m (kg·m, ft·lb)

⊙ : N·m (kg·m, in·lb)

WBT038

BODY FRONT END

Removal and Installation (Cont'd)

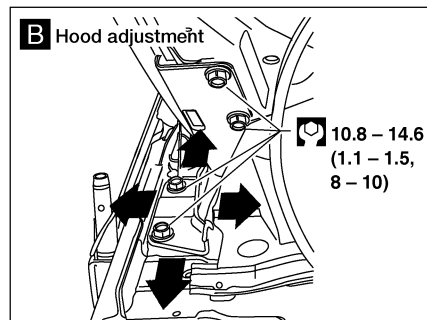
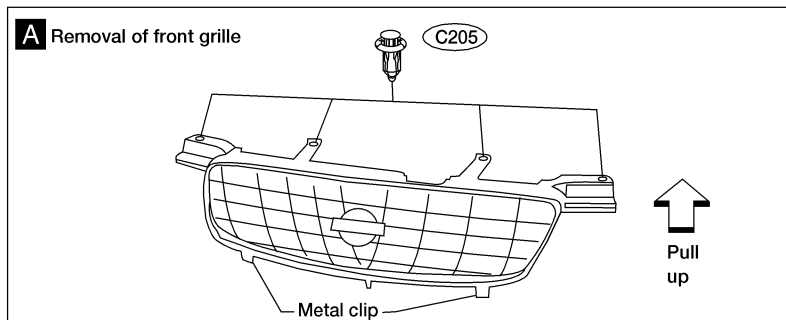

BT039

GI

MA

EM

LC

EC

FE

CL

MT

AT

AX

SU

BR

ST

RS

BT

HA

SC

EL

IDX

BODY REAR END AND OPENER

Removal and Installation

Removal and Installation

NIBT0005

- When removing or installing trunk lid, place a cloth or other padding on rear fender panels. This prevents vehicle body from being scratched.
- Bumper fascia is made of plastic. Do not use excessive force and be sure to keep oil away from it.
- Trunk lid adjustment: Adjust at hinge-trunk lid portion for proper trunk lid fit.
- Trunk lid lock system adjustment: Adjust striker so that it is in the center of the lock. After adjustment, check trunk lid lock operation.
- Opener cable: Do not attempt to bend cable using excessive force.
- After installation, make sure that trunk lid and fuel filler lid open smoothly.

REAR BUMPER ASSEMBLY

NIBT0005S01

1. Remove four bolts and one clip C205 from lower side of rear bumper fascia.
2. Remove two screws from each fender side.
3. Remove four clips C205 from upper side of rear bumper fascia.
4. Pull out rear bumper fascia.
5. Remove four nuts securing bumper reinforcement, then remove bumper reinforcement.
6. Remove four bolts securing bumper side stays, then remove bumper side stays.

BODY REAR END AND OPENER

Removal and Installation (Cont'd)

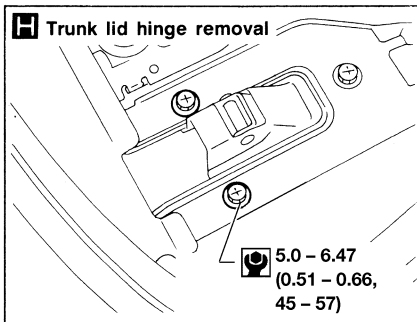
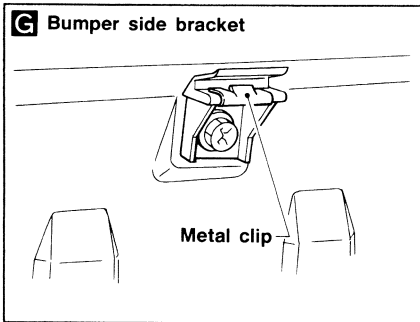
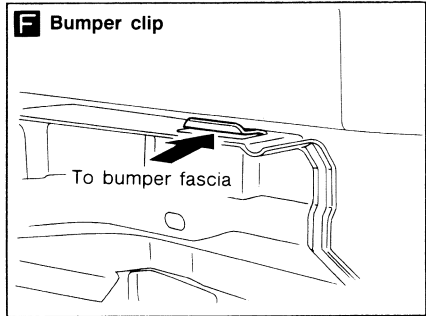
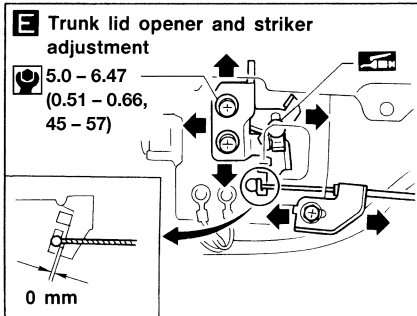
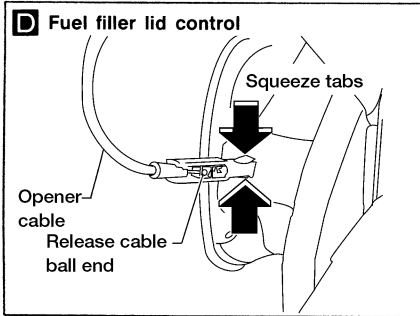
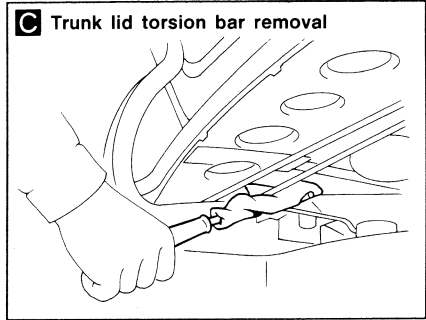
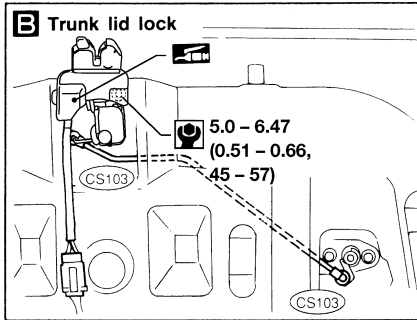
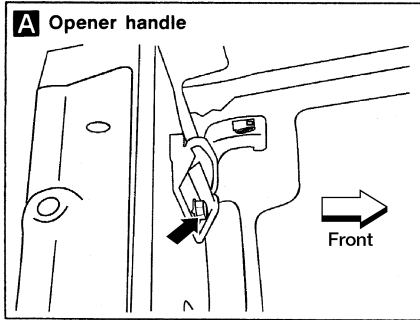

: N·m (kg-m, in-lb)

WBT086

DOOR

Front Door

Front Door

=NIBT0007

- For removal of door trim, refer to "Removal and Installation", BT-27.
- After adjusting the door or door lock, check the door lock operation.

GI
MA
EM
LC
EC
FE
CL
MT
AT
AX
SU
BR
ST
RS
BT
HA
SC
EL
IDX

SEC. 800-803-805

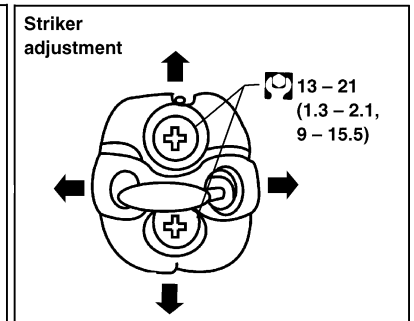
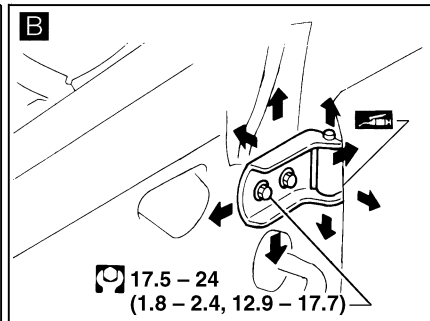
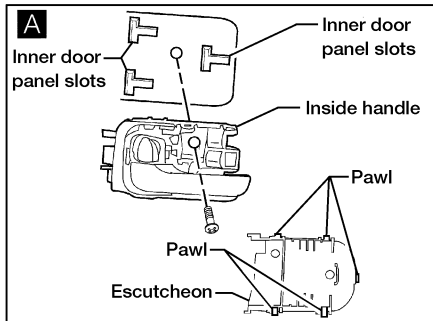
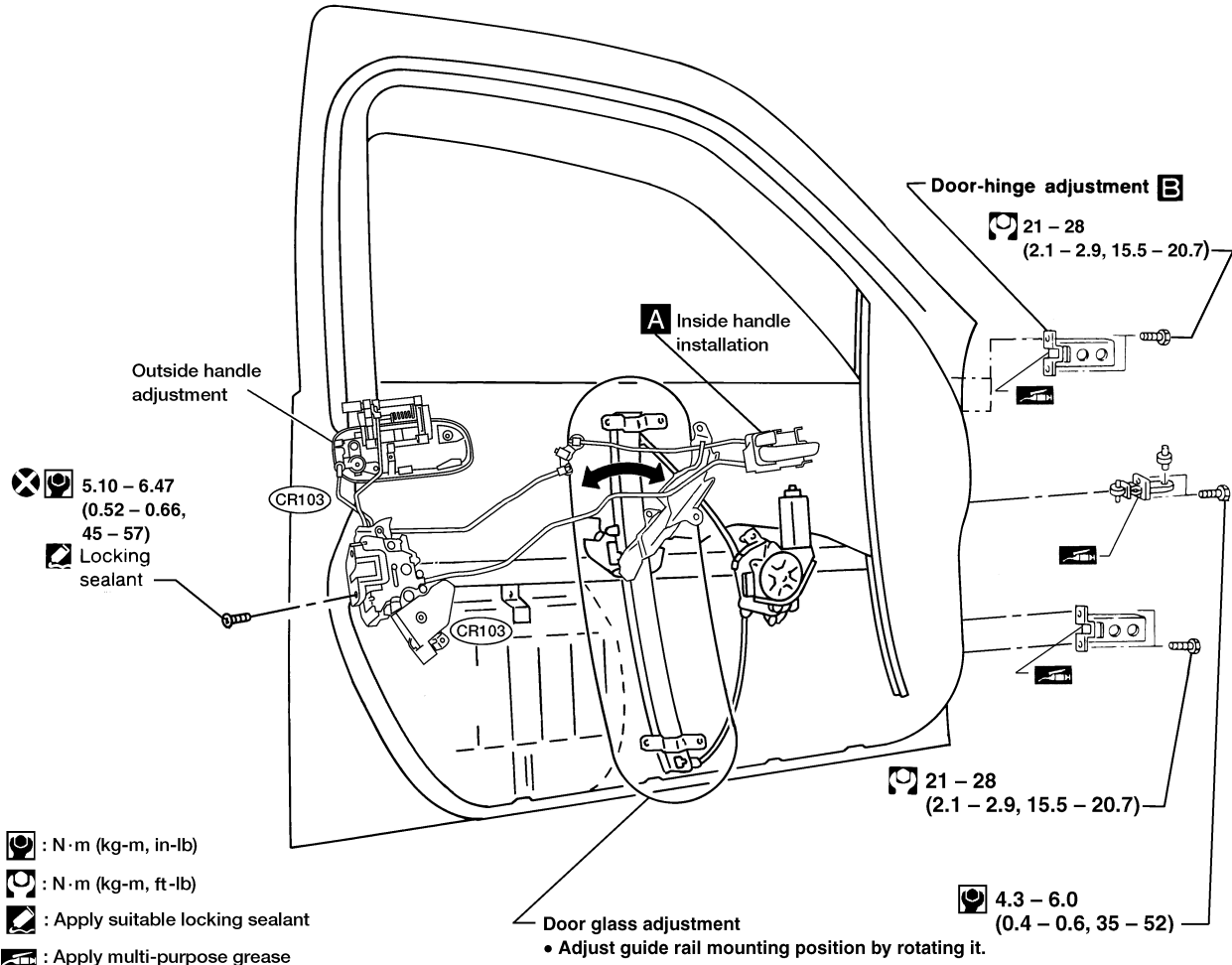

DOOR

Rear Door

NIBT0009

Rear Door

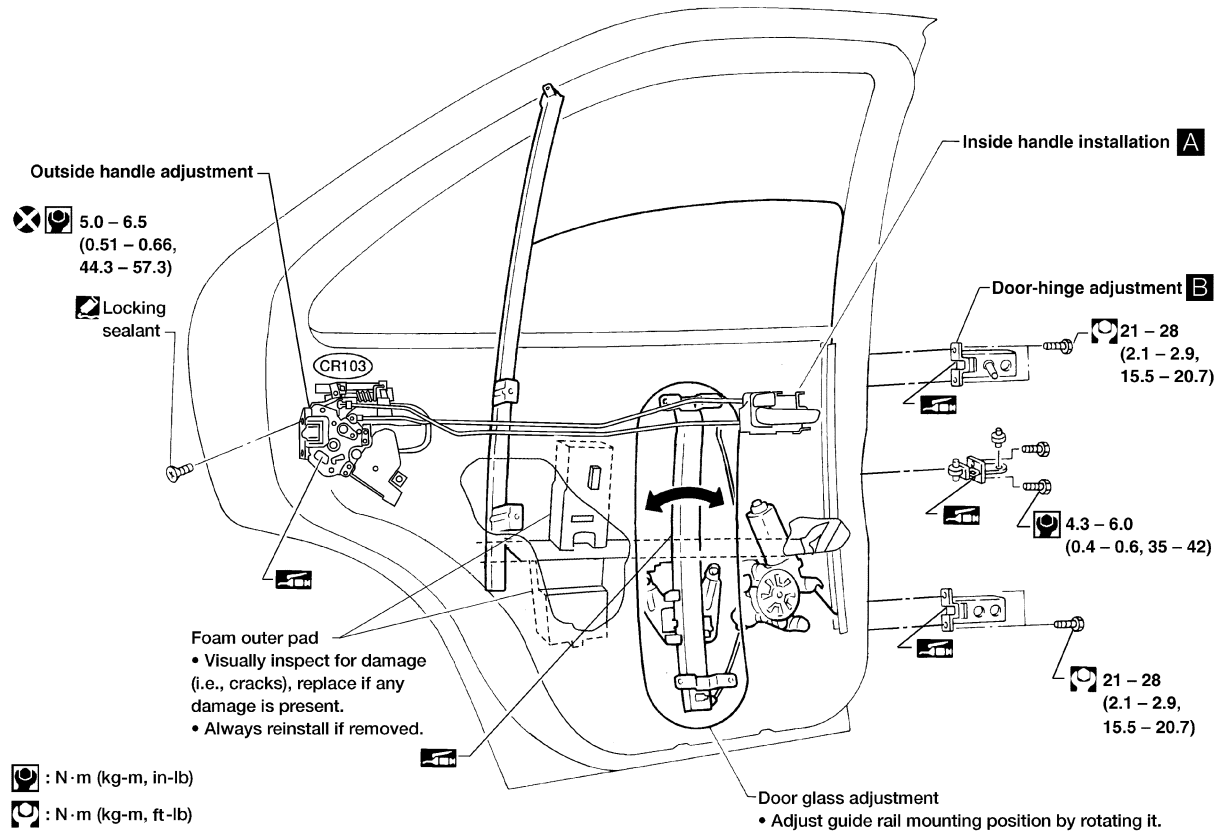

: N · m (kg · m, in · lb)

: N · m (kg · m, ft · lb)

: Apply suitable locking sealant

: Apply multi-purpose grease

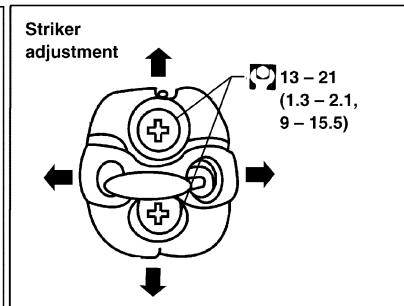
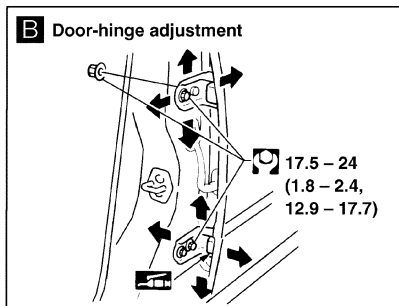
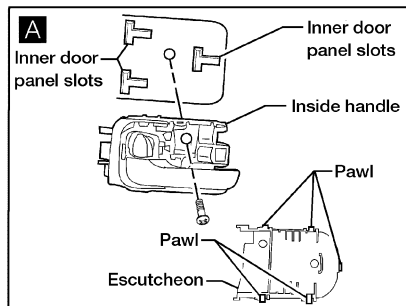

WBT103

INSTRUMENT PANEL ASSEMBLY

Removal and Installation

NIBT0012

Removal and Installation

CAUTION:

- Lock the CD changer unit mechanism (models with CD changer). Refer to *EL-163*, "LOCKING CD CHANGER UNIT MECHANISM".
- Lock the CD changer unit mechanism (models with CD changer). Refer to Owner's Manual for CD changer operating instructions.
- Disconnect both terminals from battery in advance.
- Disconnect air bag module connectors in advance.
- Be careful not to scratch pad and other parts.
- Never tamper with or force air bag lid open, as this may adversely affect air bag performance.

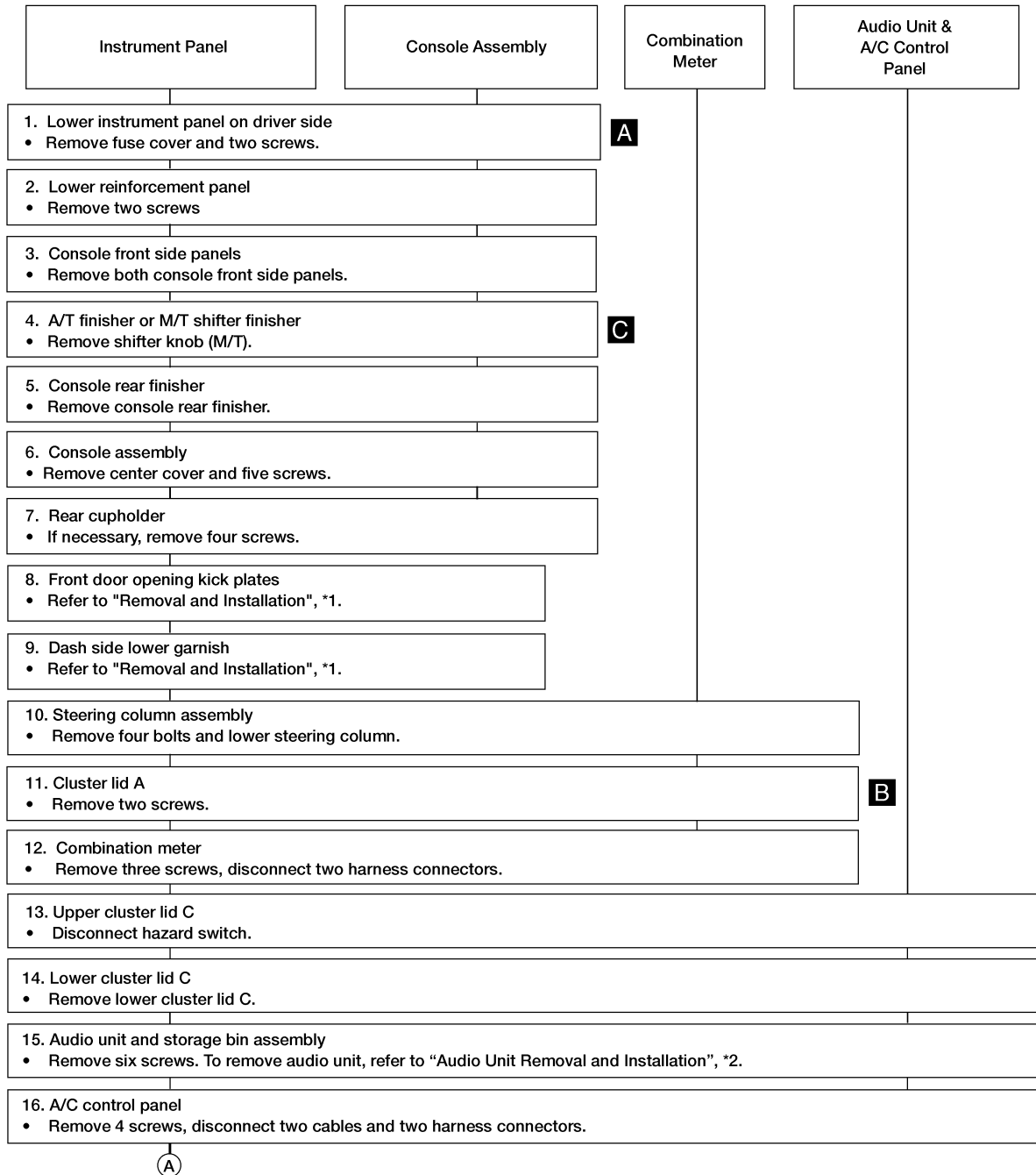

*1 BT-25

*2 EL-163

LBT041

GI
MA
EM
LC
EC
FE
CL
MT
AT
AX
SU
BR
ST
RS
BT
HA
SC
EL
IDX

INSTRUMENT PANEL ASSEMBLY

Removal and Installation (Cont'd)

(A)

17. Glove box assembly

- Remove two screws, two dampers, and six screws.

D

18. Passenger side air bag

- Remove front passenger air bag module, refer to *1, "REMOVAL".

19. Front pillar garnish

- Refer to "Removal and Installation", *2.

20. Instrument panel assembly

- Remove two bolts, three screws, and two nuts.

E

21. Instrument stay assemblies, if necessary

- Remove two bolts and two nuts.

22. Steering member assembly, if necessary

- Remove four nuts and two bolts.

LBT060

*1 **RS-24**

*2 **BT-25**

INSTRUMENT PANEL ASSEMBLY

Removal and Installation (Cont'd)

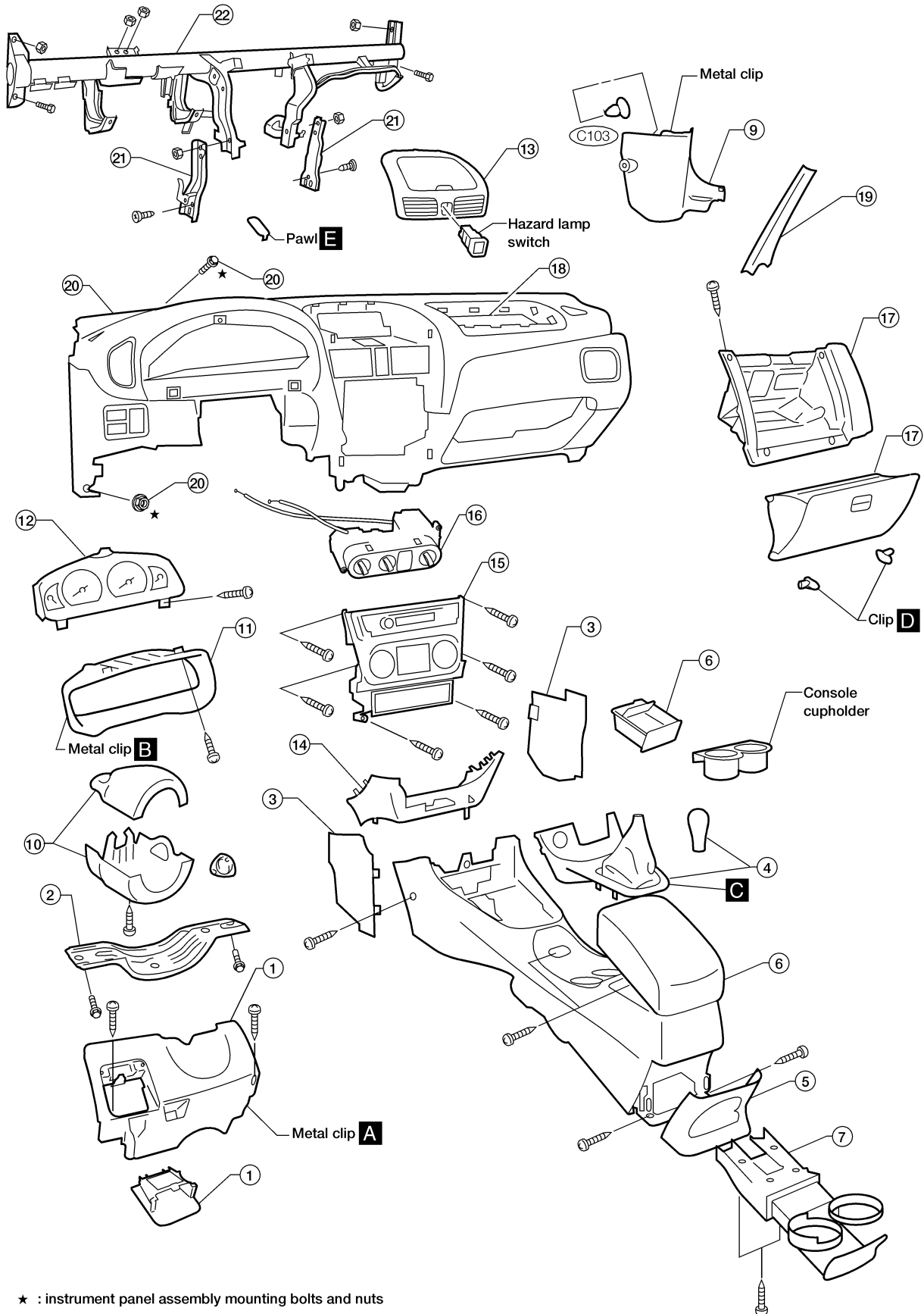

★ : instrument panel assembly mounting bolts and nuts

GI
MA
EM
LC
EC
FE
CL
MT
AT
AX
SU
BR
ST
RS
BT
HA
SC
EL
IDX

LBT042

INSTRUMENT PANEL ASSEMBLY

Removal and Installation (Cont'd)

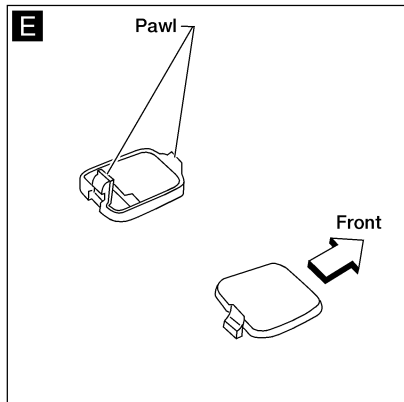
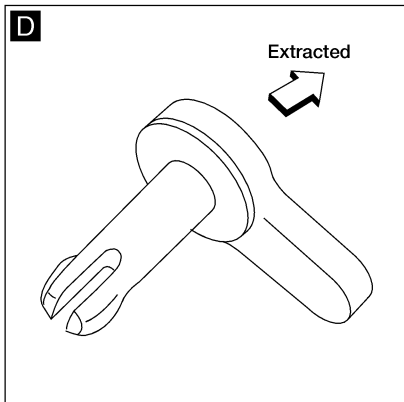
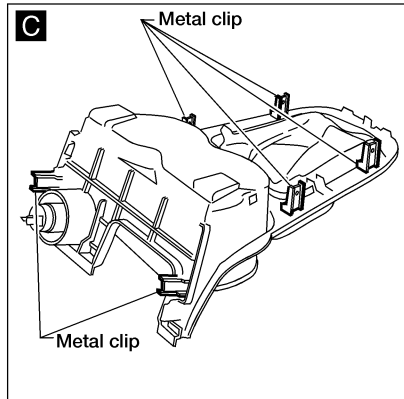
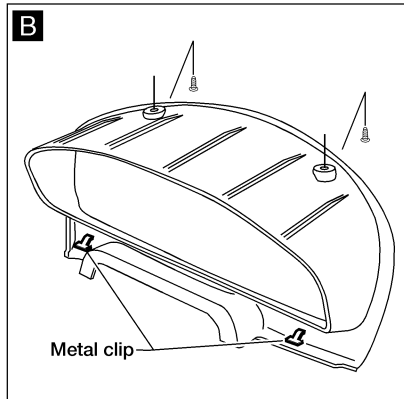
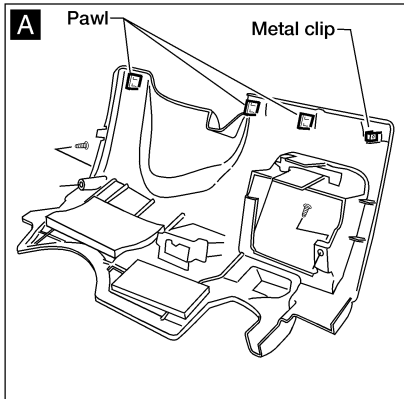

WBT043

Removal and Installation

NIBT0013

CAUTION:

- Wrap the tip of flat-bladed screwdriver with a cloth when removing metal clips from garnishes.

1. Remove A/T finisher or M/T shift lever boot. Refer to "Removal and Installation", BT-21.
2. Remove the console. Refer to "Removal and Installation", BT-21.
3. Remove front and rear seats. Refer to "Removal and Installation", BT-37 (front), or BT-39 (rear).
4. Remove kick plates.
5. Remove dash side lower garnish. **A**
6. Remove body side welts.
7. Remove front seat belt floor anchor bolt. Refer to **RS-4**, "REMOVAL AND INSTALLATION".
8. Remove rear seat belt floor anchor bolt. Refer to **RS-6**, "REMOVAL AND INSTALLATION".
9. Remove center pillar lower garnish.
10. Remove adjuster cover and pillar anchor bolt. Refer to **RS-4**, "REMOVAL AND INSTALLATION".
11. Remove floor carpet.
12. Remove center pillar upper garnish. **C**
13. Remove front pillar garnish. **B**
14. Remove rear pillar garnish. **D**
15. Remove parcel shelf.
16. Remove center rear seat back finisher.
17. Remove side rear seat back finishers. **E**

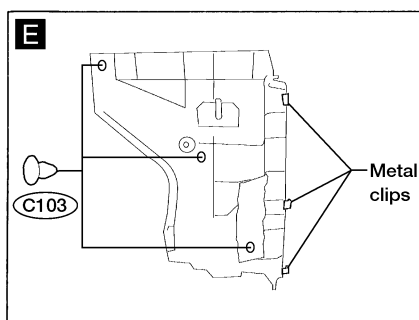
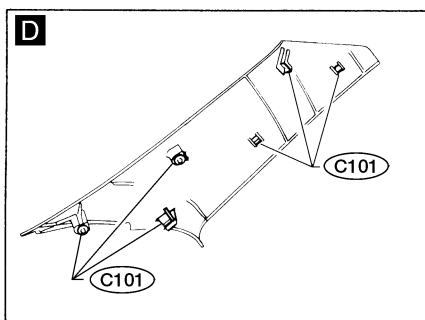
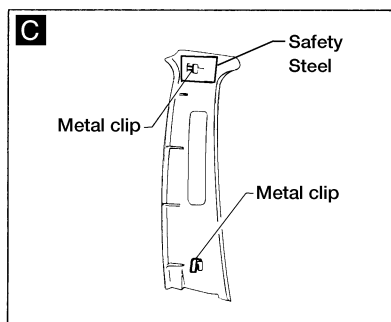
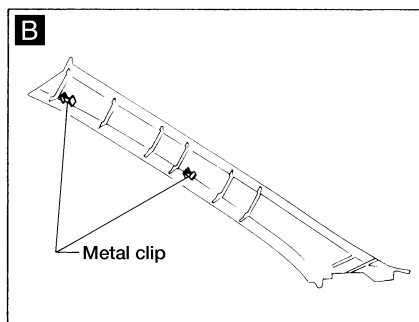
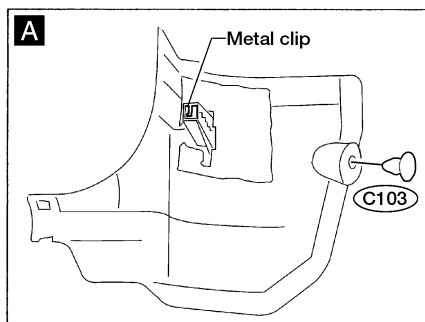

GI
MA
EM
LC
EC
FE
CL
MT
AT
AX
SU
BR
ST
RS
BT
HA
SC
EL
IDX

WBT044

SIDE AND FLOOR TRIM

Removal and Installation (Cont'd)

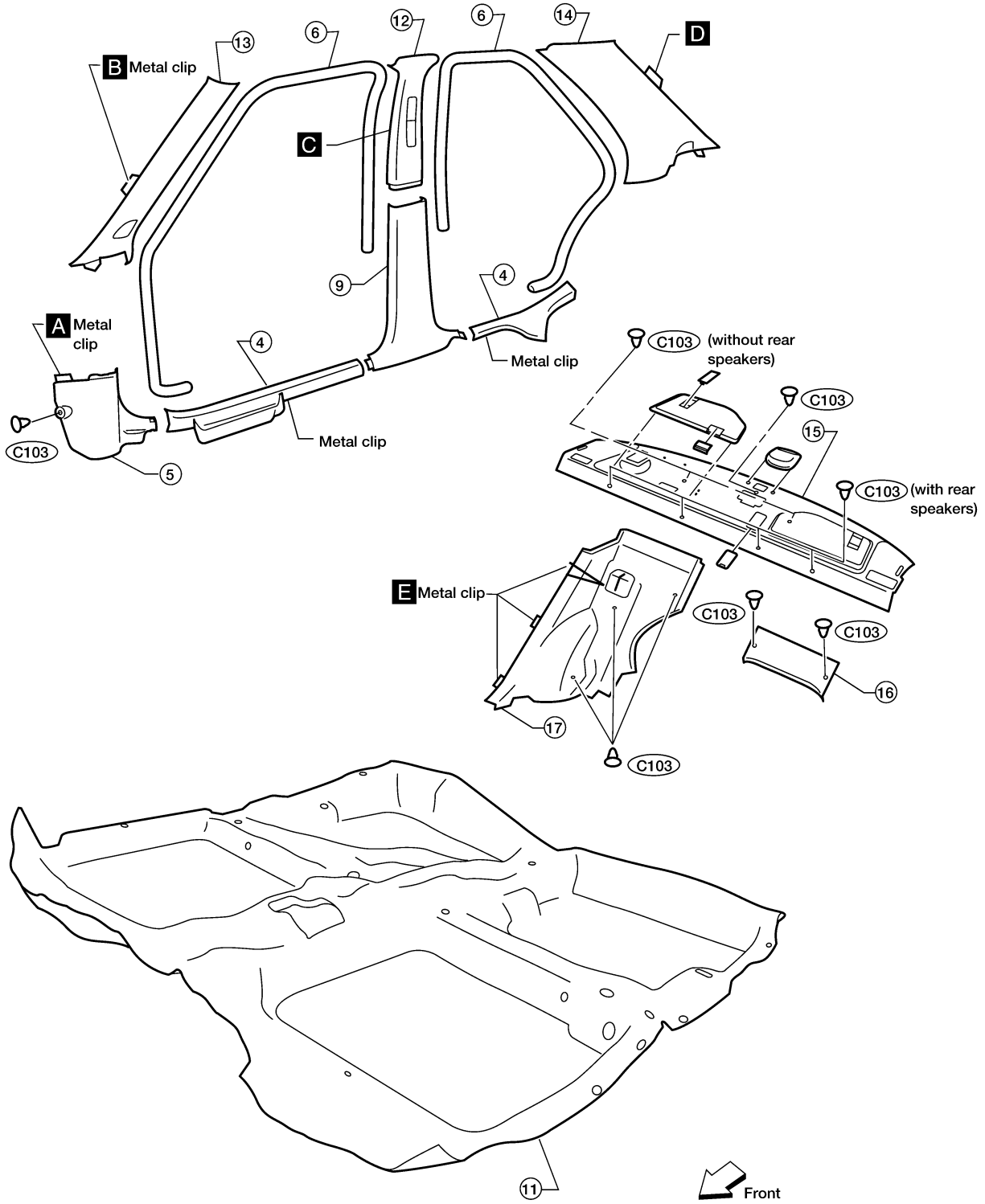

WBT128

DOOR TRIM

Removal and Installation

Removal and Installation

NIBT0014

CAUTION:

Wrap the tip of a flat-bladed screwdriver with a cloth when prying pawls from door trim.

1. Remove the door pull finisher(s). **A**
2. Remove power window switch(es) finisher(s), then disconnect the connector(s) (model equipped with power window). **B**
- **Do not lift the front of the power window switch assembly.**
3. Remove window regulator handle (models without power window). **C**
4. Remove screws and disconnect clips C101 and clips C103 from door.
5. Reach behind and carefully pull door trim panel from inside handle until finisher pops off.
6. Lift out door trim.

GI
MA
EM
LC
EC
FE
CL
MT
AT
AX
SU
BR
ST
RS
BT
HA
SC
EL
IDX

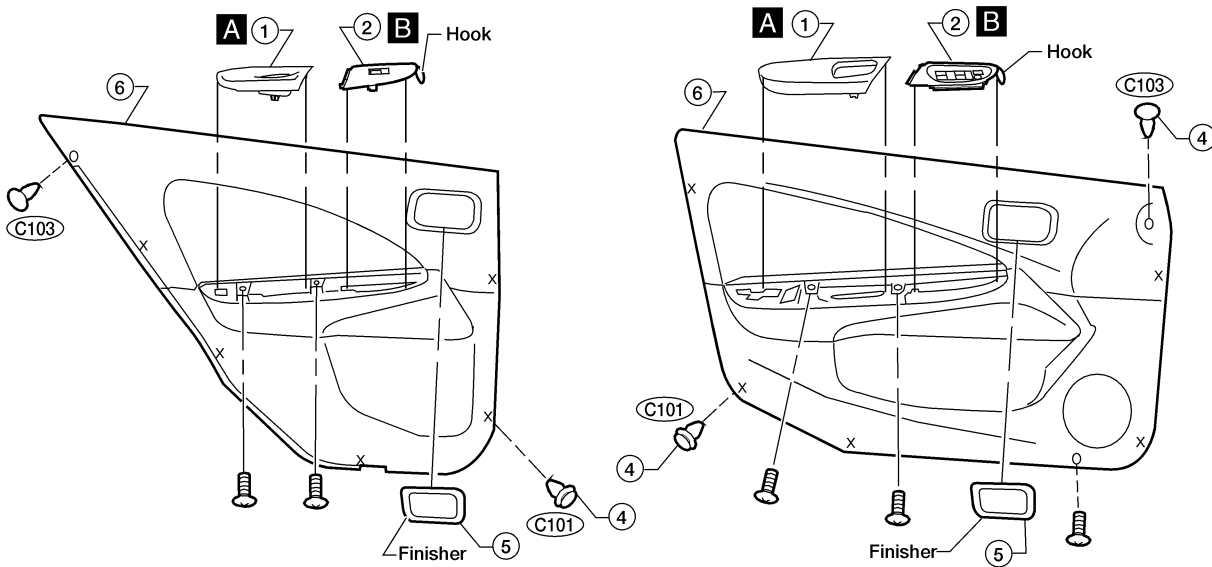

WBT046

DOOR TRIM

Removal and Installation (Cont'd)

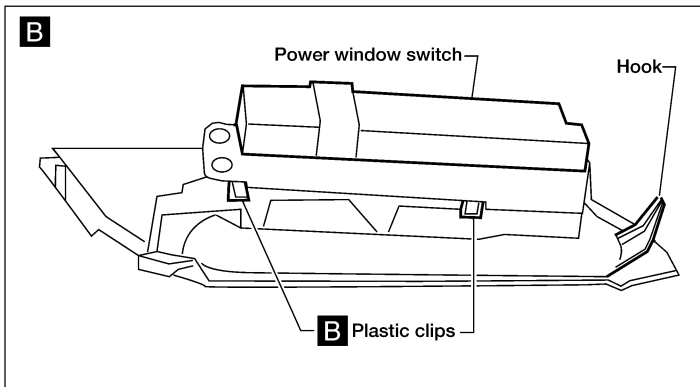
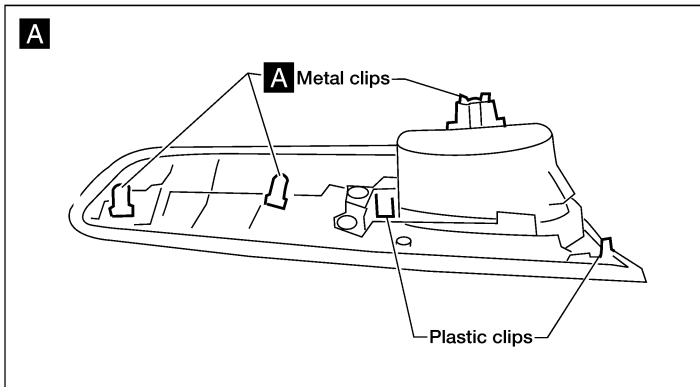
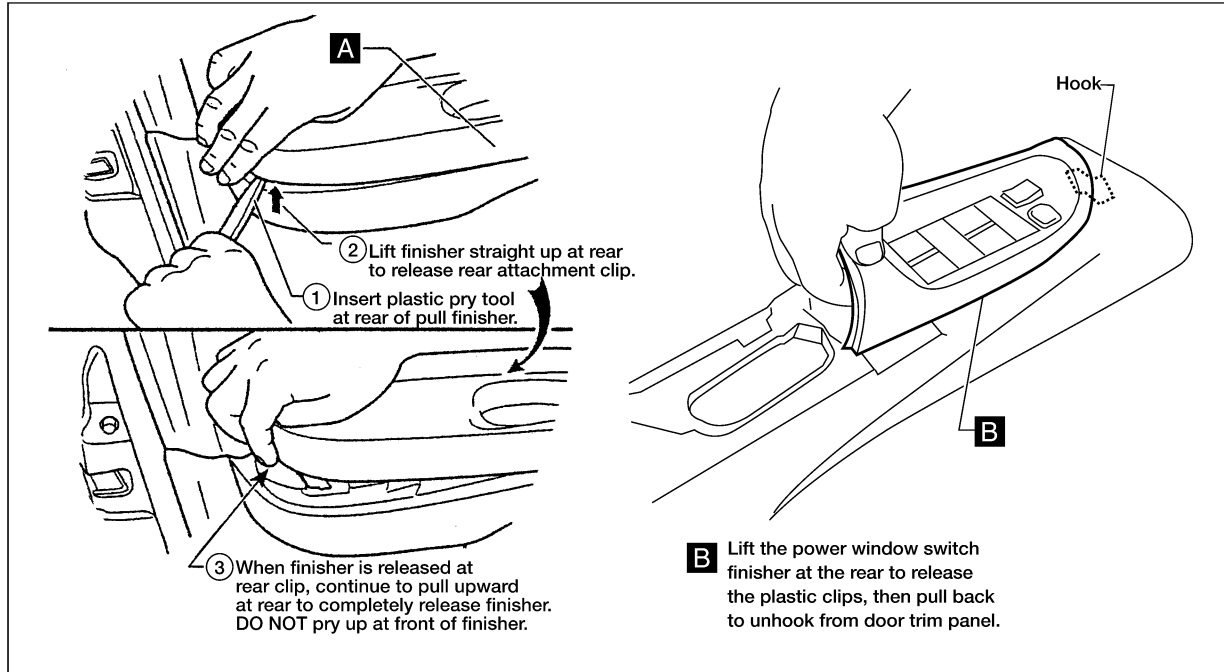

C Manual window regulator handle

Removal

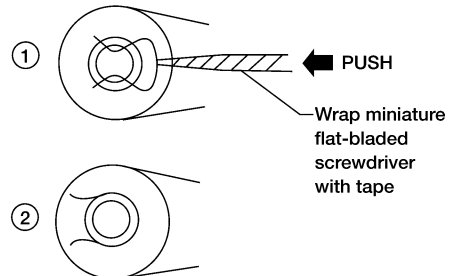

Push the regulator handle clip with a screwdriver, being careful not to scratch handle or door trim. Then remove the regulator handle from the regulator shaft.

Installation

Before installing, position the regulator handle clip as shown in figure ①.

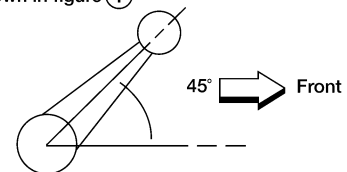

Push the regulator handle onto the regulator shaft. Install the regulator handle in place as shown in the figure with the window completely closed.

WBT149

Removal and Installation

NIBT0015

CAUTION:

Disconnect both terminals from battery in advance.

1. Remove driver air bag module and steering wheel. Refer to **RS-21**, "REMOVAL AND INSTALLATION" and **ST-10**, "Removal and Installation".
2. Fully tilt front right and left seat backs backward.
3. Remove front pillar garnish, front and rear kick plates. Refer to "Removal and Installation", BT-25.
4. Remove center pillar lower and upper garnish, and rear pillar garnish. Refer to "Removal and Installation", BT-25.
5. Remove sun visors.
6. Remove interior lamp.
7. Remove assist grips (if equipped). **A**
8. Remove sunroof welt (if equipped) and door welts.
9. Remove sunroof switch (if equipped) and map lamp assembly.
10. Remove clips attached to roof.
11. Take out headlining from the front passenger door.

SEC. 738-963-964

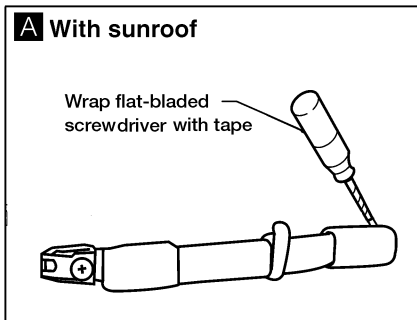
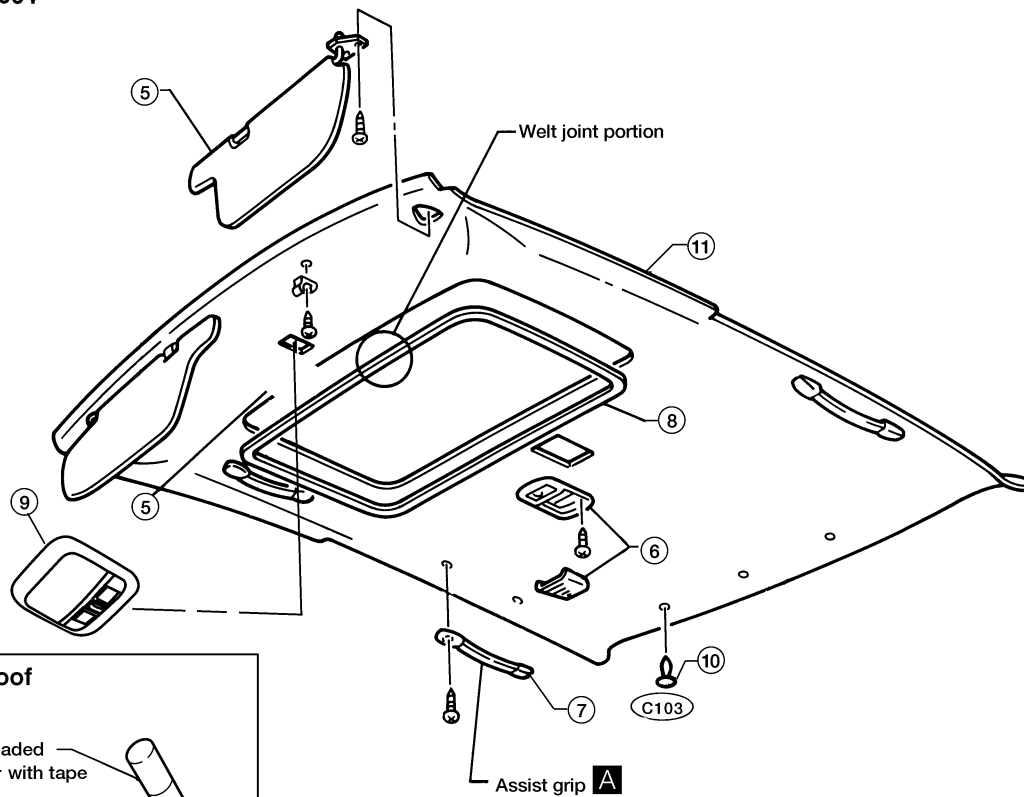

GI
MA
EM
LC
EC
FE
CL
MT
AT
AX
SU
BR
ST
RS
BT
HA
SC
EL
IDX

WBT048

TRUNK ROOM TRIM

Removal and Installation

Removal and Installation

NIBT0016

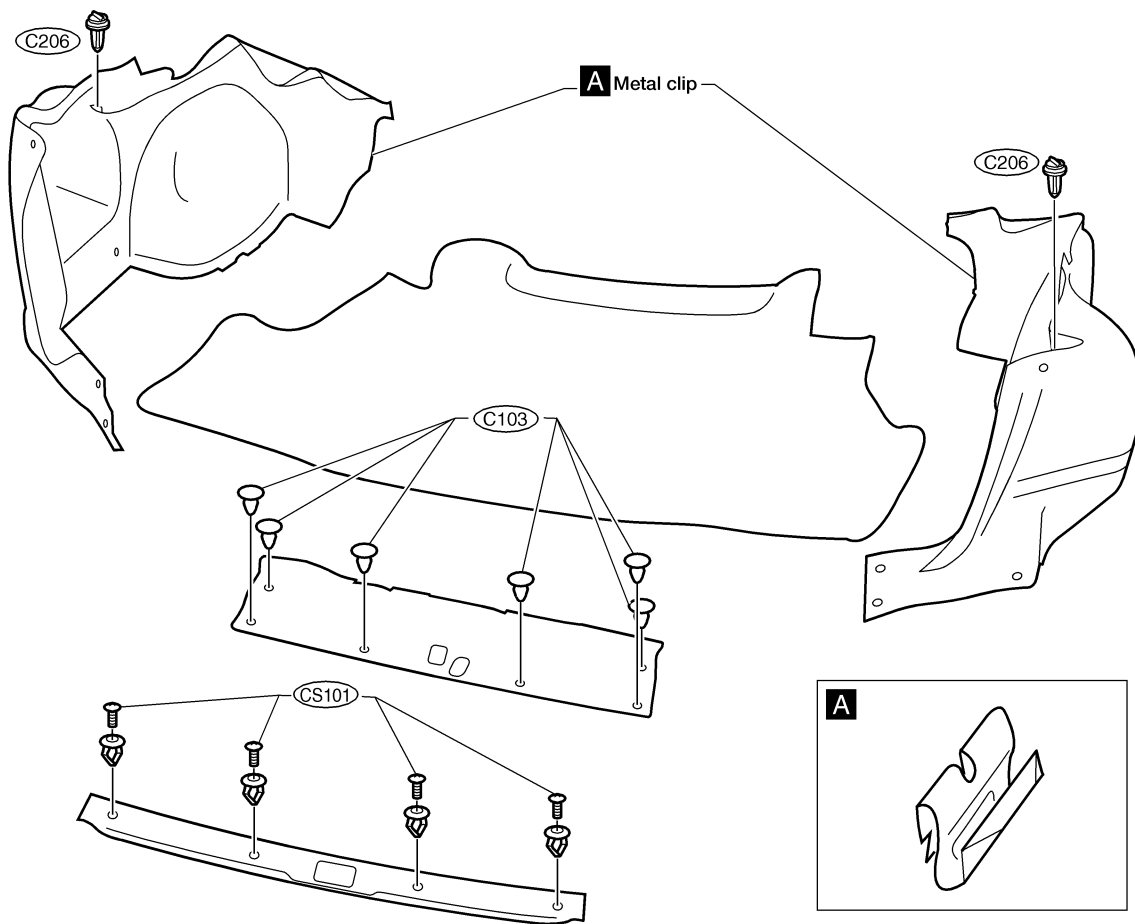

LBT049

Removal and Installation

NIBT0017

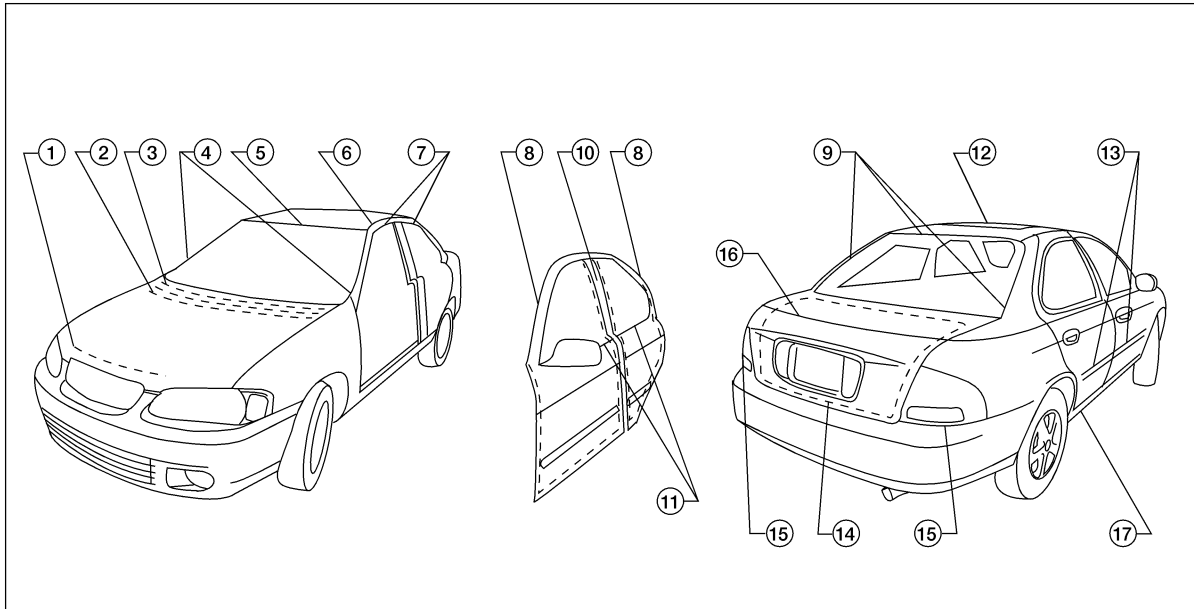

① Hood front seal

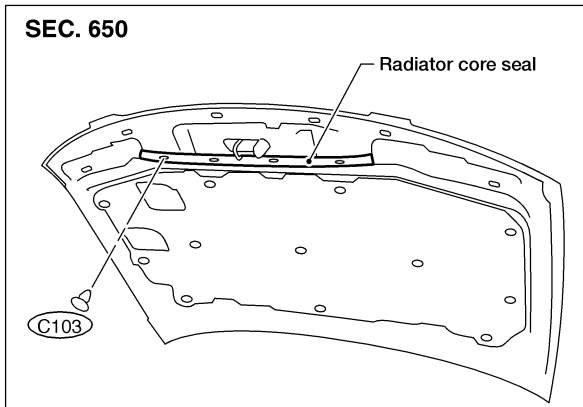

② ③ Cowl top seal and cowl top grille

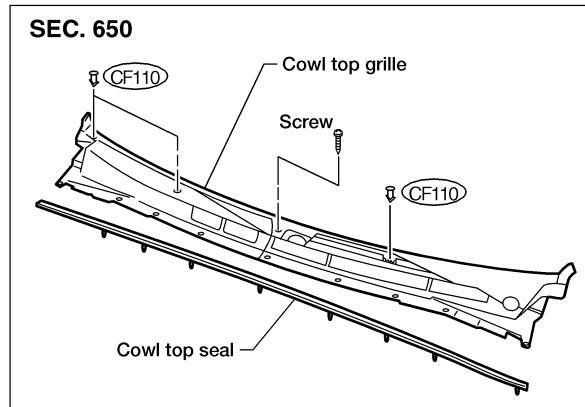

WBT054

GI

MA

EM

LC

EC

FE

CL

MT

AT

AX

SU

BR

ST

RS

BT

HA

SC

EL

IDX

EXTERIOR

Removal and Installation (Cont'd)

④ Windshield side molding

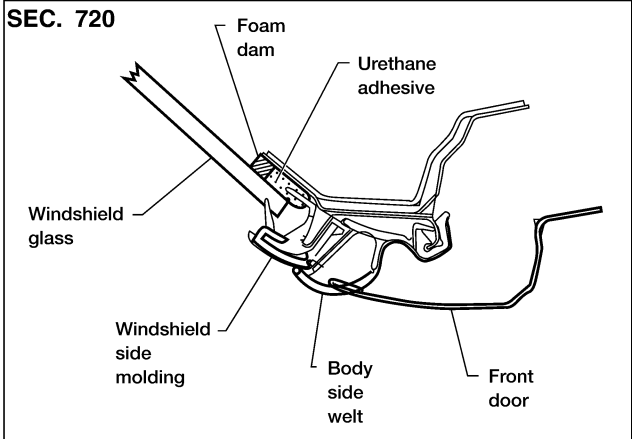

⑤ Windshield upper molding

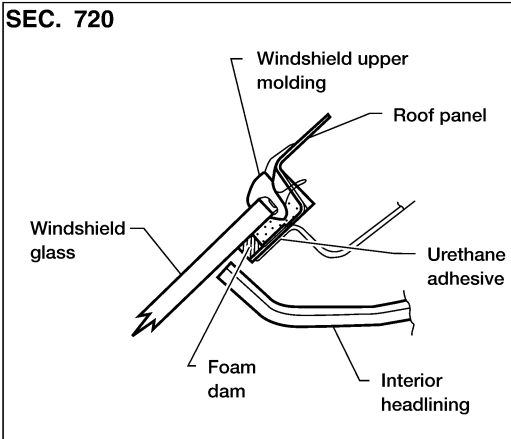

⑨ Rear window molding

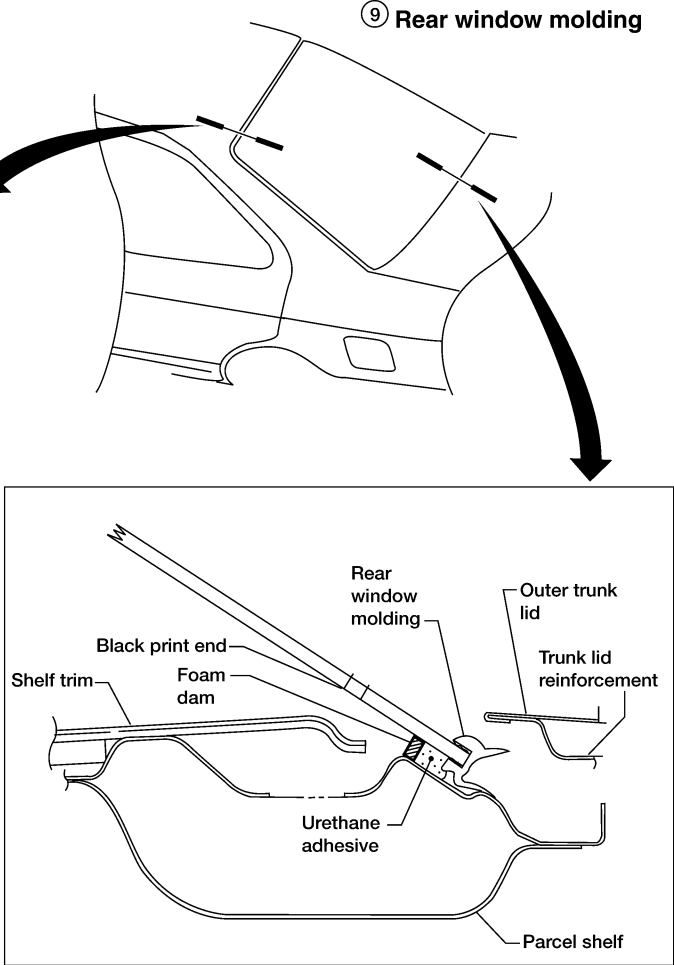
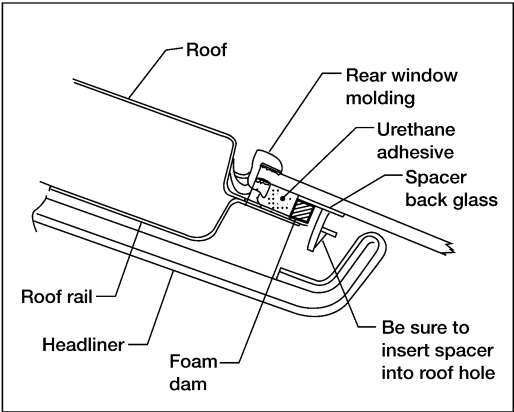

WBT113

⑥ Drip weatherstrip

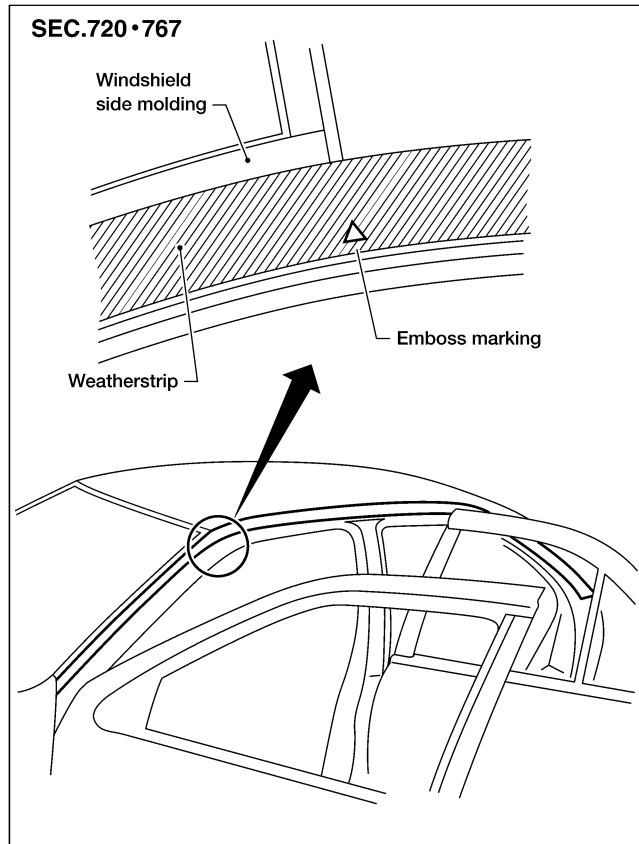

⑦ Body side welt

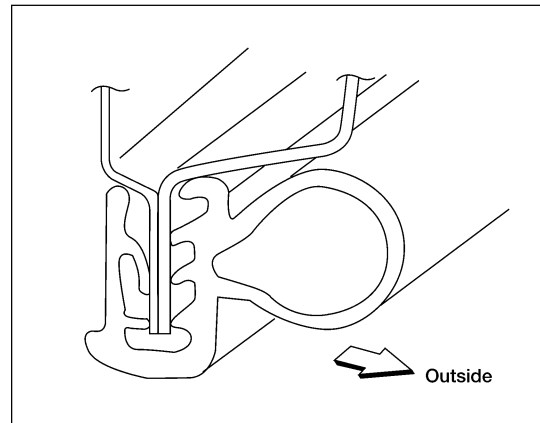

⑧ Door weatherstrip

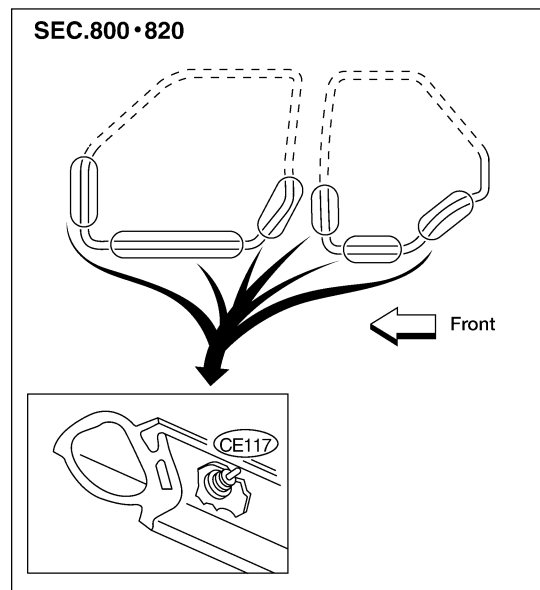

GI

MA

EM

LC

EC

FE

CL

MT

AT

AX

SU

BR

ST

RS

BT

WBT155

HA

SC

EL

IDX

EXTERIOR

Removal and Installation (Cont'd)

10 Rear door parting seal

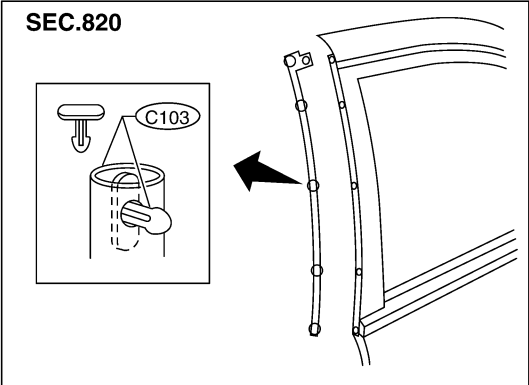

11 Door outside molding

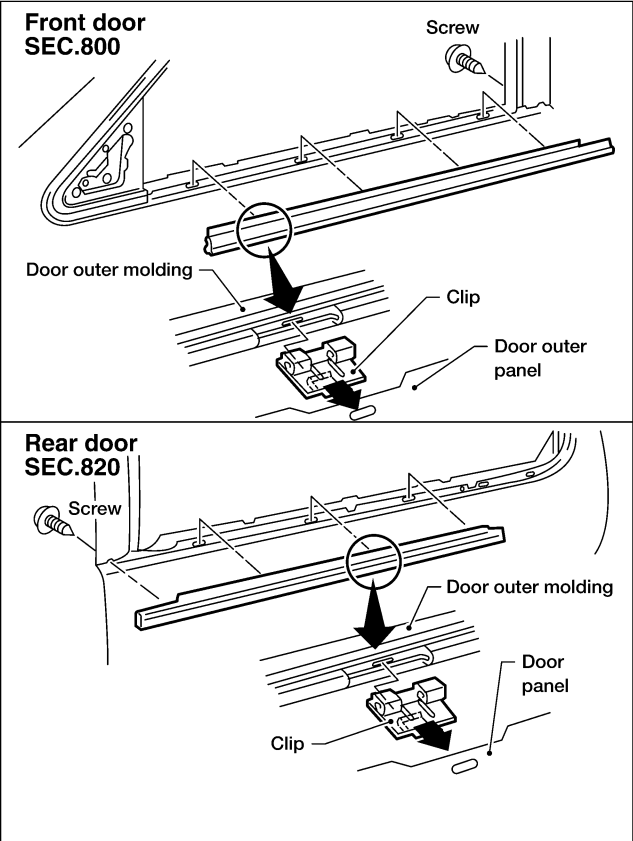

12 Sunroof lid weatherstrip

Sunroof weatherstrip is part of the glass lid and must be replaced as an assembly.

13 Side guard molding

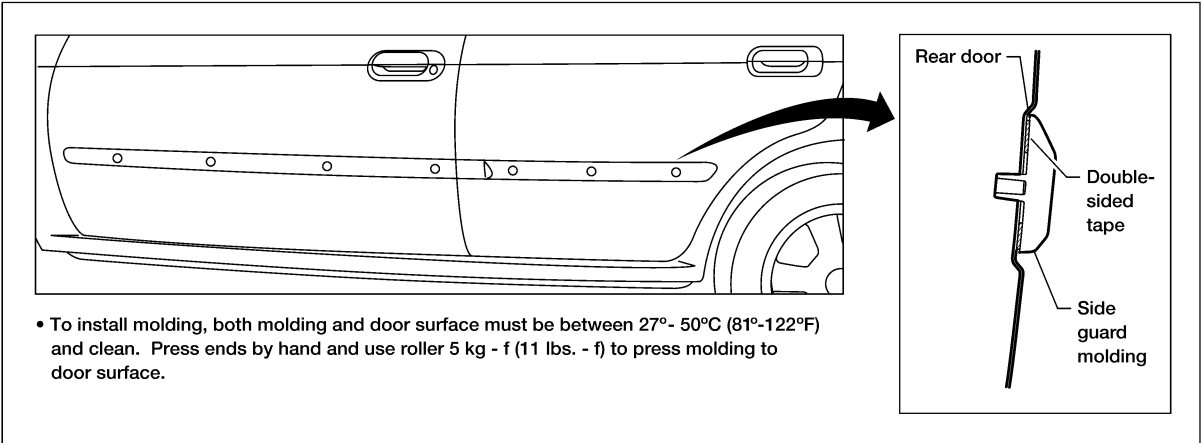

⑭ Trunk lid weatherstrip

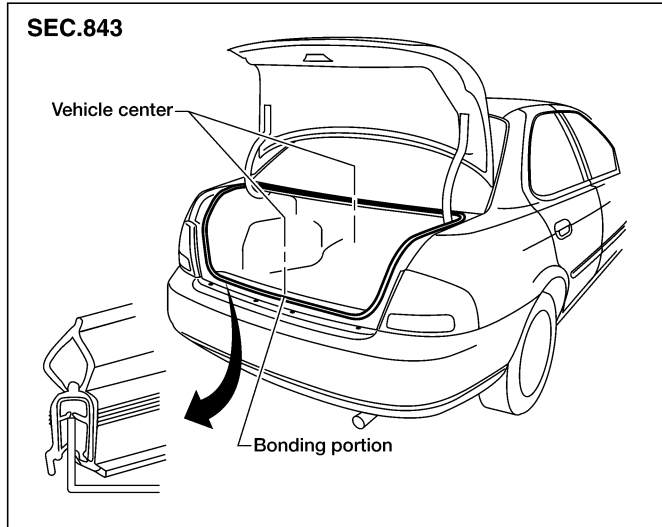

⑮ Rear combination lamp

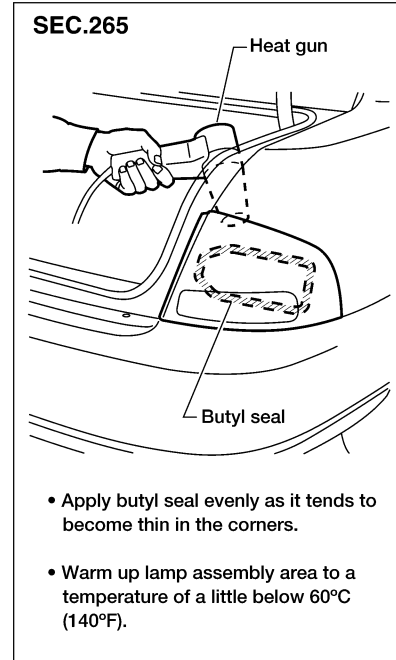

GI

MA

EM

LC

EC

FE

CL

MT

AT

AX

SU

WBT150

BR

ST

RS

BT

HA

SC

EL

IDX

EXTERIOR

Removal and Installation (Cont'd)

SEC. 960

16 Rear air spoiler and high-mounted stop lamp

- When installing, make sure that there are no gaps or waves at ends of air spoiler.
- Before installing spoiler, clean and remove oil from surface where spoiler will be mounted.

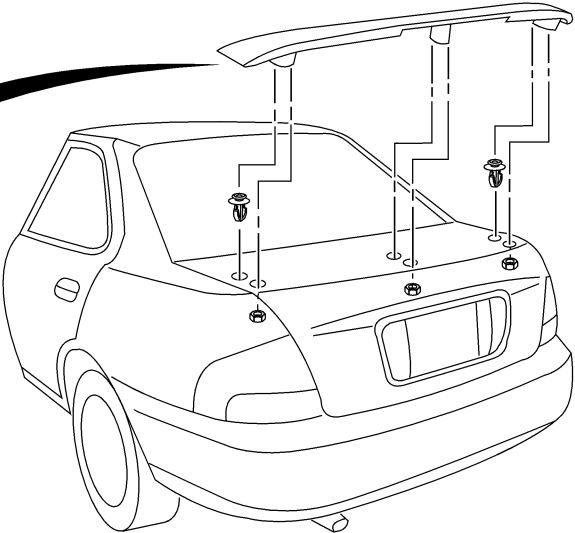
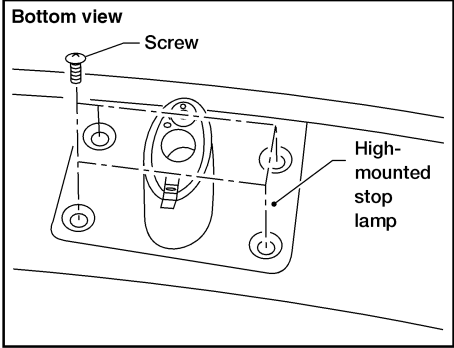

LBT065

17 Fender and center mudguard

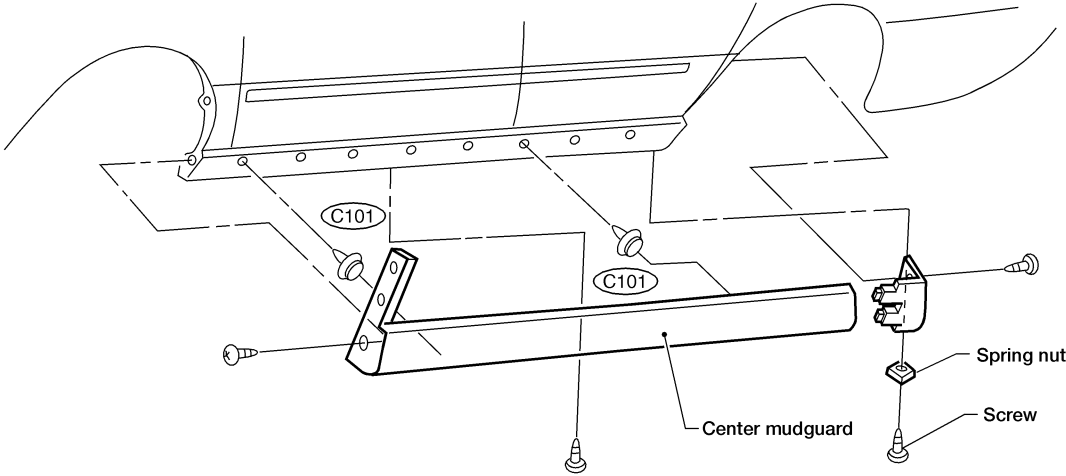

LBT059

Removal and Installation

For Wiring Diagrams, refer to **EL-4**, "Supplemental Restraint Systems (SRS) 'AIR BAG' and 'SEAT BELT PRE-TENSIONER'". ^{NIBT0018}

WARNING:

Removal of front side air bag module should only be done to allow deployment of front side air bag module prior to disposal of seatback assembly.

CAUTION:

- Before removing the front seat, turn the ignition switch off, disconnect the negative and positive battery cables and wait a minimum of 3 minutes.
- When checking the power seat circuitry for continuity using a circuit tester, do not confuse the seat connector with the side air bag connector. Doing so could cause the side air bag to deploy.
- Do not drop, tilt, or bump the side air bag module installed in the seat. Always handle it with care.
- Disconnect the side air bag harness connector and the power seat switch harness connector from under the seat before removing the seat. Refer to **RS-25**, "REMOVAL".
- After front side air bag module inflates, front seatback assembly must be replaced.

GI

MA

EM

LC

EC

FE

CL

MT

AT

AX

SU

BR

ST

RS

BT

HA

SC

EL

IDX

FRONT SEAT

Removal and Installation (Cont'd)

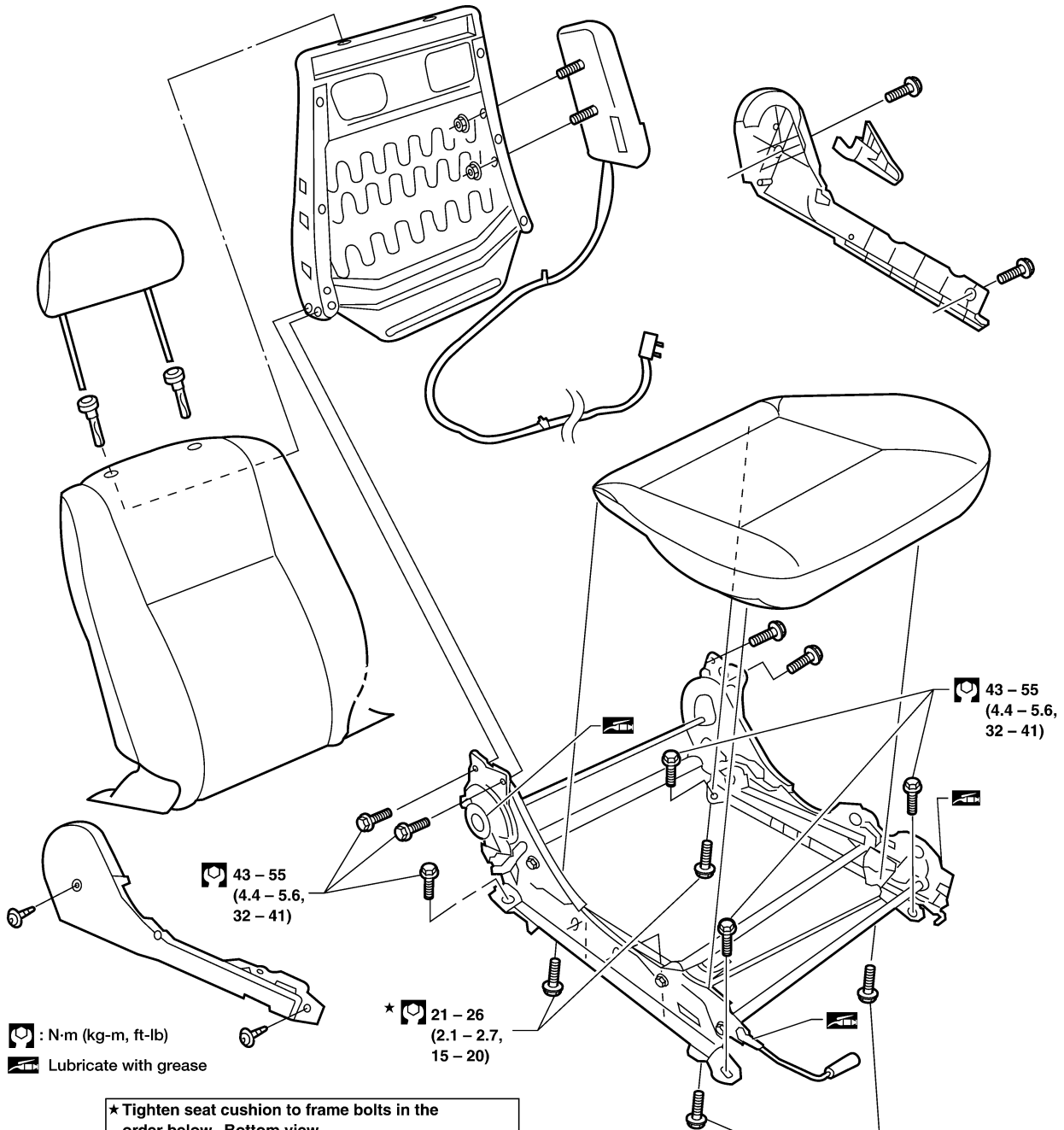

: N·m (kg-m, ft-lb)

Lubricate with grease

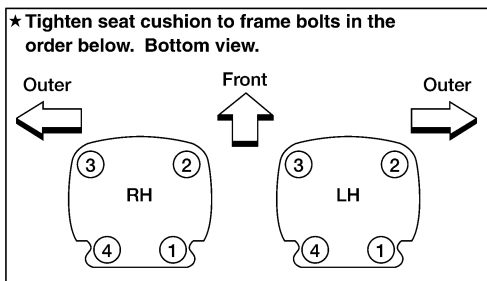

WBT194

REAR SEAT

Removal and Installation

Removal and Installation

NIBT0019

Type 1 (Fixed type)

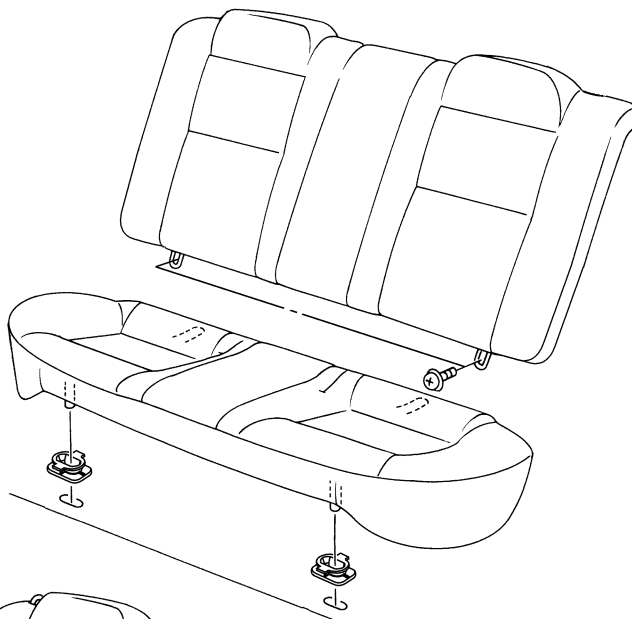

Type 2 (Folding type)

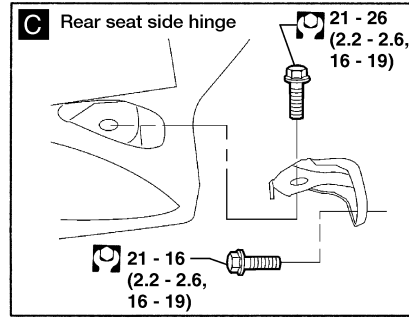
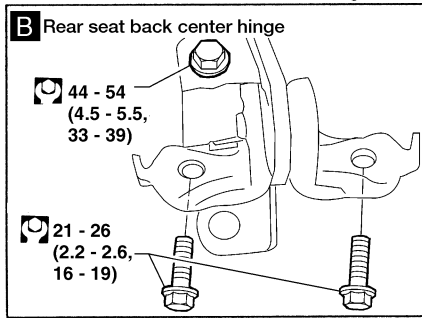
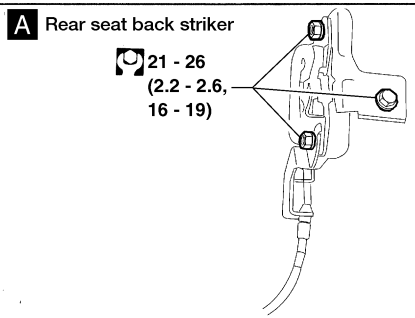
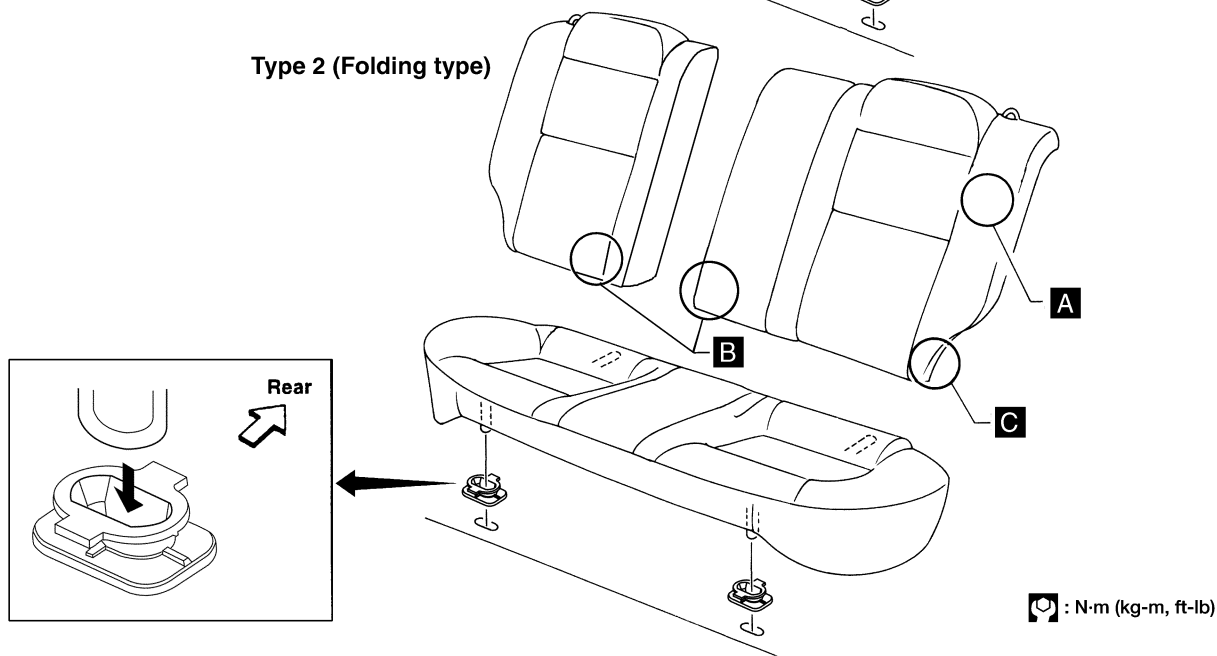

WBT152

GI
MA
EM
LC
EC
FE
CL
MT
AT
AX
SU
BR
ST
RS
BT
HA
SC
EL
IDX

SUNROOF

Memory Reset Adjustment

Memory Reset Adjustment

NIBT0020

If the battery is disconnected or the sunroof motor harness connector is disconnected, the sunroof motor memory must be reset. To reset the sunroof motor memory from any sunroof position (full open, partially open, closed, partially vented, and vented), push and hold the sunroof button in the forward position until the sunroof vents in the full-up position. This resets the sunroof motor memory and now the sunroof will operate correctly.

Install motor & limit SW assembly and sunroof rail assembly in the following sequence:

1. Arrange equal lengths of link and wire assemblies on both sides of sunroof opening.
2. Connect sunroof connector to sunroof switch and positive (+) power supply.
3. Set lid assembly to fully closed position **A** by operating CLOSE switch and TILT switch.
4. Fit outer side of lid assembly to the surface of roof on body outer panel.
5. Remove motor, and keep CLOSE switch pressed until motor pinion gear reaches the end of its rotating range.
6. Install motor.
7. Check that motor drive gear fits properly in wires.
8. Press TILT-UP switch to check lid assembly for normal tilting.
9. Check sunroof lid assembly for normal operations (tilt-up, tilt-down, open, and close).

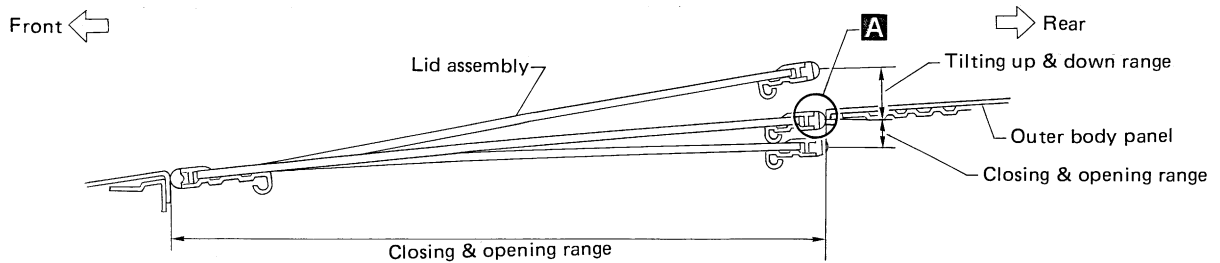

SBF920F

SUNROOF

Removal

Removal

NIBT0021

SEC. 736

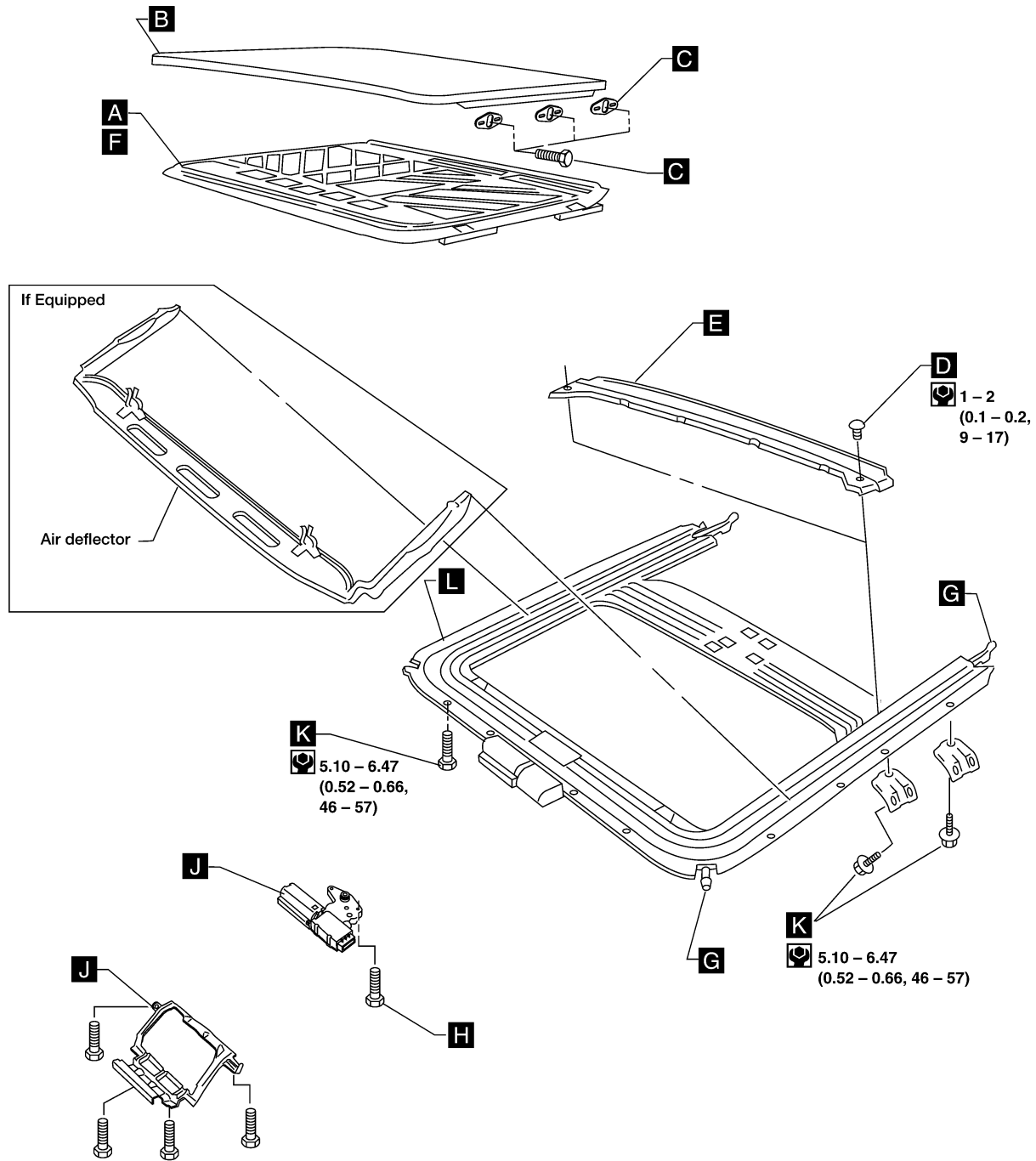

: N-m (kg-m, in-lb)

WBT193

- After any repair, check sunroof operation and glass lid alignment.
- Handle finisher plate and glass lid with care so as not to cause damage.
- To ease installation, mark each point before removal.

BT-41

GI
MA
EM
LC
EC
FE
CL
MT
AT
AX
SU
BR
ST
RS
BT
HA
SC
EL
IDX

SUNROOF

Removal (Cont'd)

CAUTION:

- Always work with a helper.
- Before removal, fully close the glass lid assembly, then after removal, do not move the motor assembly.

SUNROOF LID ASSEMBLY

NIBT0021S01

1. Open sunroof shade. **A**
2. Close glass lid. **B**
3. Remove the six bolts securing glass lid assembly to sunroof assembly. **C**

SHADE ASSEMBLY

NIBT0021S02

1. After removing glass lid assembly, remove two screws securing drain channel. **D**
2. Remove drain channel. **E**
3. Remove shade assembly. **F**

SUNROOF ASSEMBLY

NIBT0021S03

1. Remove headlining. Refer to "Removal and Installation", BT-29.
2. Disconnect front and rear drain hoses. **G**
3. Remove the two screws securing sunroof motor to sunroof assembly. **H**
4. Remove sunroof motor and bracket. **J**
5. Remove bolts securing sunroof assembly to roof. **K**
6. Remove sunroof assembly. **L**

SUNROOF

Trouble Diagnoses

Trouble Diagnoses DIAGNOSTIC TABLE

=NIBT0022

NIBT0022S01

NOTE:

For Wiring Diagram, refer to **EL-166**, "Wiring Diagram – SROOF –".

		Check items (Components)				
		Wind deflector (If Equipped)	Adjustment	Drain hoses	Weatherstrip	Link and wire assembly
Reference page		BT-43	BT-44	BT-45	BT-45	BT-45
Symptom	Excessive wind noise	1	2		3	
	Water leaks		1	2	3	
	Sunroof rattles		1	4	2	3
	Excessive operation noise		1		2	3

The numbers in this table mean checking order.

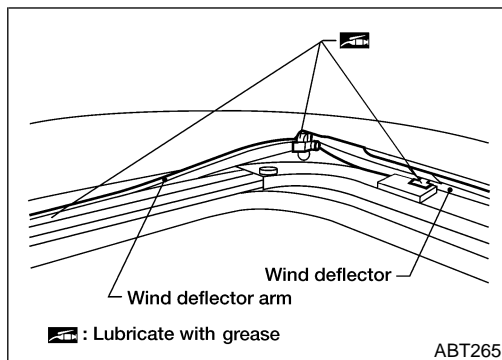

WIND DEFLECTOR (IF EQUIPPED)

NIBT0022S02

1. Open lid.
2. Check visually for proper installation.
3. Check to ensure a proper amount of grease has been applied to wind deflector connection points; apply if necessary.
4. Check that wind deflector will properly retract by hand. If not, remove and visually check condition. If wind deflector is damaged, replace with new one. If wind deflector is not damaged, re-install properly and lubricate connection points with grease. See step 3 above.

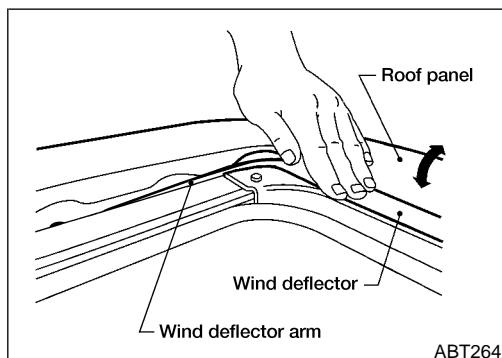

GI

MA

EM

LC

EC

FE

CL

MT

AT

AX

SU

BR

ST

RS

BT

HA

SC

EL

IDX

SUNROOF

Trouble Diagnoses (Cont'd)

ADJUSTMENT

NIBT0022S03

SEC. 736

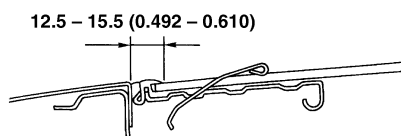
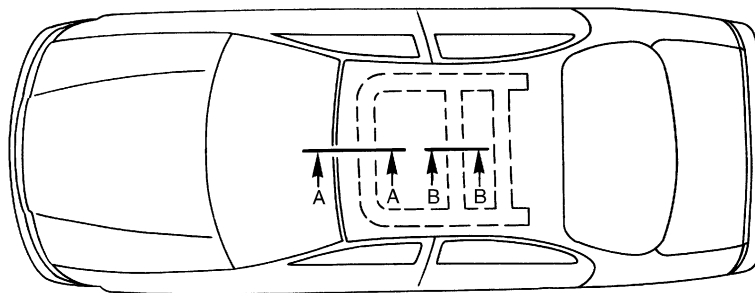

A - A

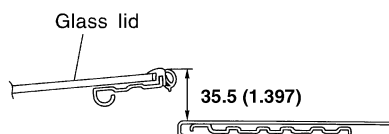

B - B (When sunroof is tilted up)

Unit: mm (in)

WBT061

If any gap or height difference between glass lid and roof is found, check glass lid fit and adjust as follows:

Gap Adjustment

NIBT0022S0301

1. Open shade assembly.
2. Tilt glass lid up then remove side trim.
3. Loosen glass lid securing bolts (3 each on left and right sides), then tilt glass lid down.
4. Adjust glass lid from outside of vehicle so it resembles "A-A" as shown in the figure above.
5. Tilt glass lid up and down until it is adjusted to "B-B" as shown in the figure above.
6. After adjusting glass lid, tilt glass lid up and tighten bolts.
7. Tilt glass lid up and down several times to check that it moves smoothly.

Height Difference Adjustment

NIBT0022S0302

1. Tilt glass lid up and down.
2. Check height difference between roof panel and glass lid to see if it is as "A-A" as shown in the figure above.
3. If necessary, adjust it by using one of following procedures.
 - Adjust by adding or removing adjustment shim(s) between glass lid and link assembly.
 - If glass lid protrudes above roof panel, add shim(s) or plain washer(s) at sunroof mounting bracket or stud bolt locations to adjust sunroof installation as required.

SUNROOF

Trouble Diagnoses (Cont'd)

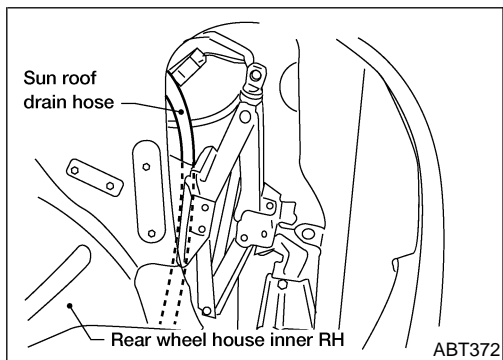
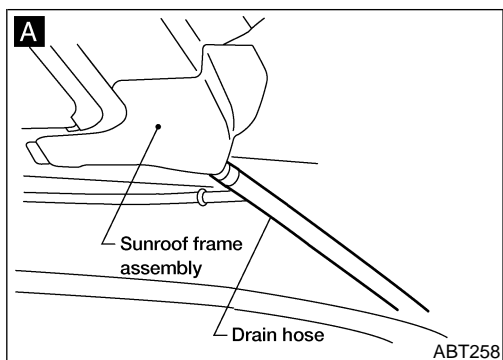

DRAIN HOSES

NIBT0022S04

1. Remove headlining to access drain hose connections. (Refer to "ROOF TRIM", BT-29, for details.)
2. Check visually for proper connections, damage or deterioration. **A** (The figure shows only the front side.)
3. If leakage occurs around trunk room, remove trunk room side trim and check connecting area. Check for proper connection or damage.
4. Remove drain hoses and check visually for any damage, cracks, or deterioration.
5. Pour water into drain hoses and find damaged portion.
 - If any damaged portion is found at each step, replace the damaged hose.

GI
MA
EM
LC
EC
FE
CL
MT

WEATHERSTRIP

NIBT0022S05

- In case of leakage around lid, close lid and pour water over lid to find damaged or gap portion.
- If gap is between weatherstrip and roof panel, perform gap adjustment. Refer to "Gap Adjustment", BT-44.
- If gap is between weatherstrip and lid, or if weatherstrip is flattened, damaged or deteriorated, replace lid assembly. (Weatherstrip is not serviceable.)

AT
AX
SU

LINK AND WIRE ASSEMBLY

NIBT0022S06

NOTE:

Before replacing a suspect part, carefully ensure it is the source of noise being experienced.

1. Check link to determine if coating film has peeled off to such an extent that substrate is visible. Check also to determine if link is the source of noise. If it is, replace it.
2. Visually check to determine if a sufficient amount of petroleum jelly has been applied to wire or rail groove. If not, add petroleum jelly as required.
3. Check wire for any damage or deterioration. If damaged, replace wire.

BR
ST
RS
BT
HA
SC
EL
IDX

WINDSHIELD AND WINDOWS

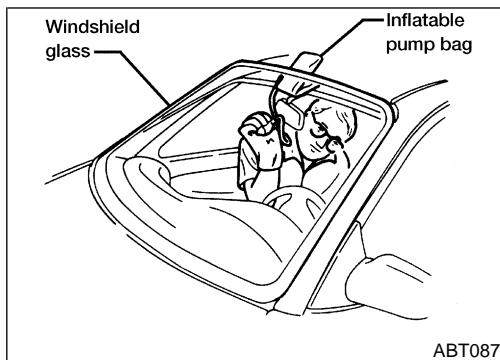
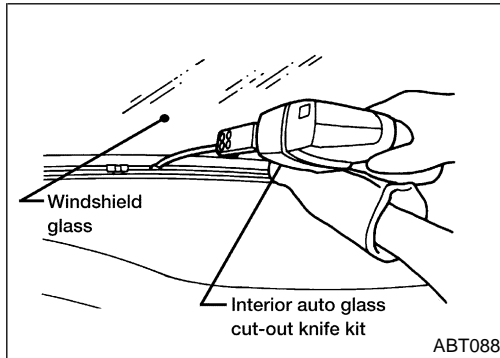
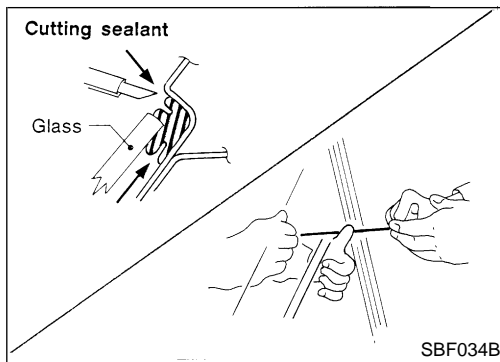

Removal and Installation

REMOVAL

After removing interior moldings and trim to access edge of glass, remove glass using piano wire or power cutting tool and an inflatable pump bag.

WARNING:

When removing the glass from the vehicle, always wear safety glasses and heavy gloves to help prevent glass splinters from entering your eyes or cutting your hands.

CAUTION:

- Be careful not to scratch the glass when removing.
- Do not set or stand the glass on its edge. Small chips may develop into cracks.

INSTALLATION

- Use genuine Nissan Urethane Adhesive Kit or equivalent and follow the instructions furnished with it.
- While the urethane adhesive is curing, open a door window. This will prevent the glass from being forced out by passenger compartment air pressure when a door is closed.
- The molding must be installed securely so that it is in position and leaves no gap.
- Inform the customer that the vehicle should remain stationary until the urethane adhesive has completely cured (preferably 24 hours). Curing time varies with temperature and humidity.

WARNING:

- Keep heat and open flames away as primers and adhesive are flammable.
- The materials contained in the kit are harmful if swallowed, and may irritate skin and eyes. Avoid contact with the skin and eyes.
- Use in an open, well ventilated location. Avoid breathing the vapors. They can be harmful if inhaled. If affected by vapor inhalation, immediately move to an area with fresh air.
- Driving the vehicle before the urethane adhesive has completely cured may affect the performance of the windshield in case of an accident.

CAUTION:

- Do not use an adhesive which is past its usable term. Shelf life of this product is limited to six months after the date of manufacture. Carefully adhere to the expiration or manufacture date printed on the box.
- Keep primers and adhesive in a cool, dry place. Ideally, they should be stored in a refrigerator.
- Do not leave primers or adhesive cartridge unattended with their caps open or off.
- The vehicle should not be driven for at least 24 hours or until the urethane adhesive has completely cured. Curing time varies depending on temperature and humidities. The curing time will increase under higher temperatures and lower humidities.

WINDSHIELD AND WINDOWS

Removal and Installation (Cont'd)

WINDSHIELD AND REAR WINDOW

NIBT0023S03

Windshield side molding

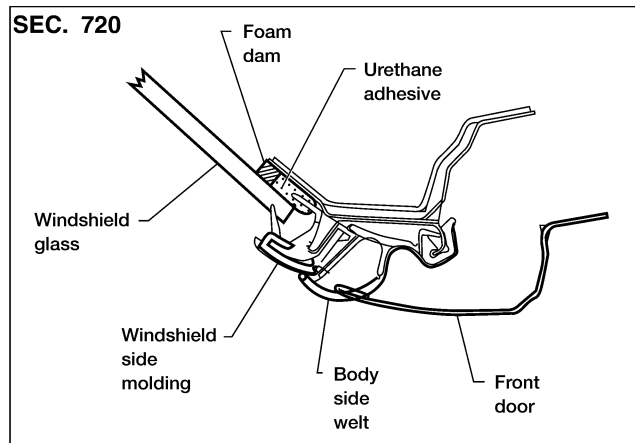

Windshield upper molding

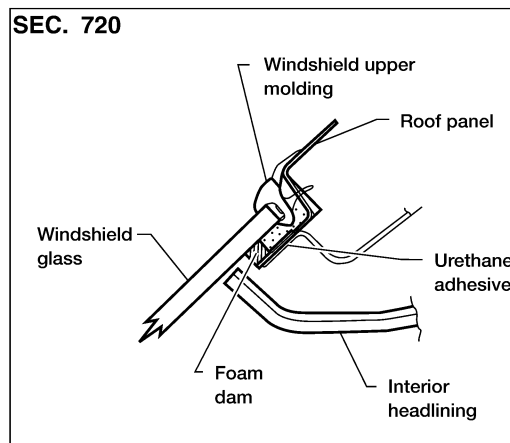

Rear window molding

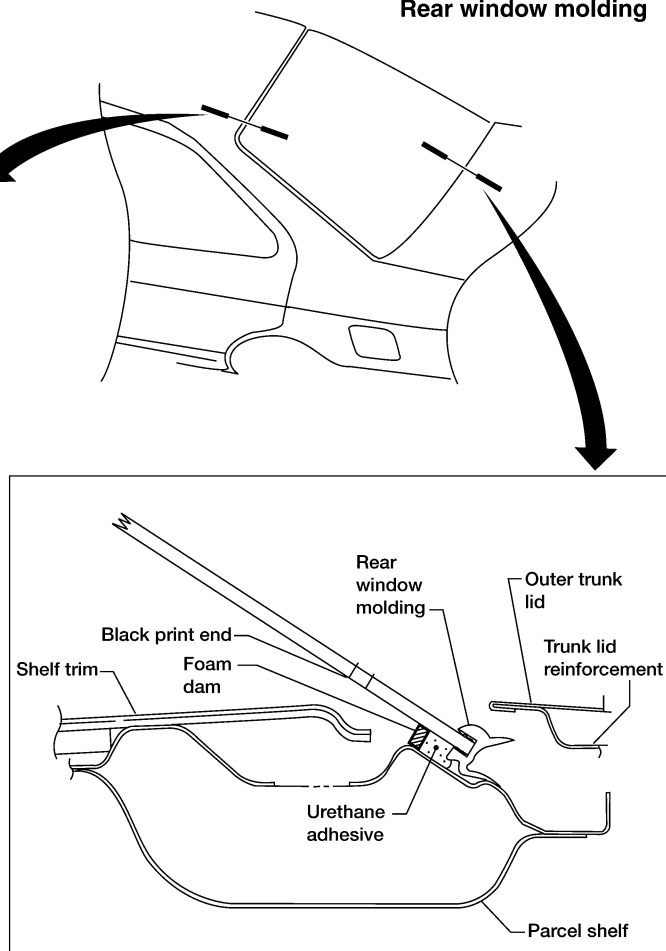
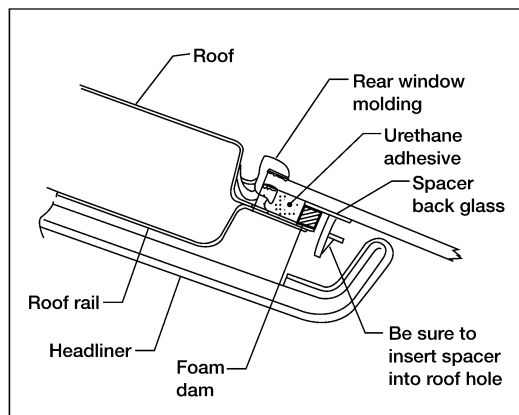

WBT114

Repairing Water Leaks for Windshield

NIBT0023S0301

Leaks can be repaired without removing and reinstalling glass. **If water is leaking between caulking material and body or glass, determine the extent of leakage. This can be determined by applying water while pushing glass outward.**

To stop the leak, apply primer and then sealant to the leak point.

GI
MA
EM
LC
EC
FE
CL
MT
AT
AX
SU
BR
ST
RS
BT
HA
SC
EL
IDX

WINDSHIELD AND WINDOWS

Removal and Installation (Cont'd)

QUARTER WINDOW

NIBT0023S04

SEC. 820-823-825

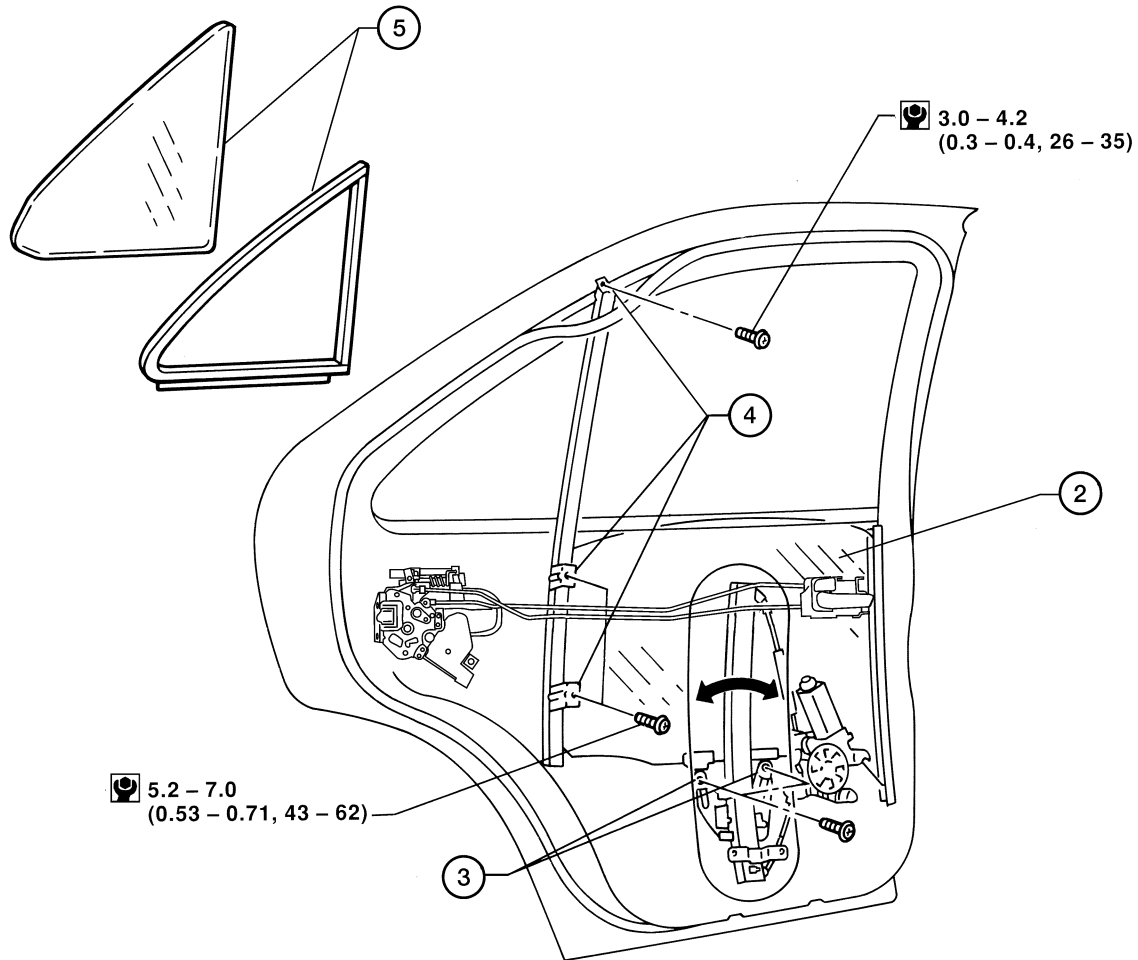

 : N·m (kg-m, in-lb)

WBT074

1. Remove the rear door trim. For details, refer to "Removal and Installation", BT-27.
2. Roll the rear window down.
3. Remove two screws securing rear glass, then remove rear glass.
4. Remove two bolts and one top screw securing rear door center sash, then remove rear door center sash.
5. Remove quarter glass and rubber seal.

DOOR MIRROR

Removal and Installation

Removal and Installation

NIBT0024

CAUTION:

Be careful not to scratch door mirror body.

★ For Wiring Diagram, refer to *EL-167* "Wiring Diagram — MIRROR —".

1. Remove door trim. Refer to "Removal and Installation", BT-27.
2. Remove inner cover from front corner of door.
3. Disconnect door mirror harness connector.
4. Remove three nuts securing door mirror assembly.

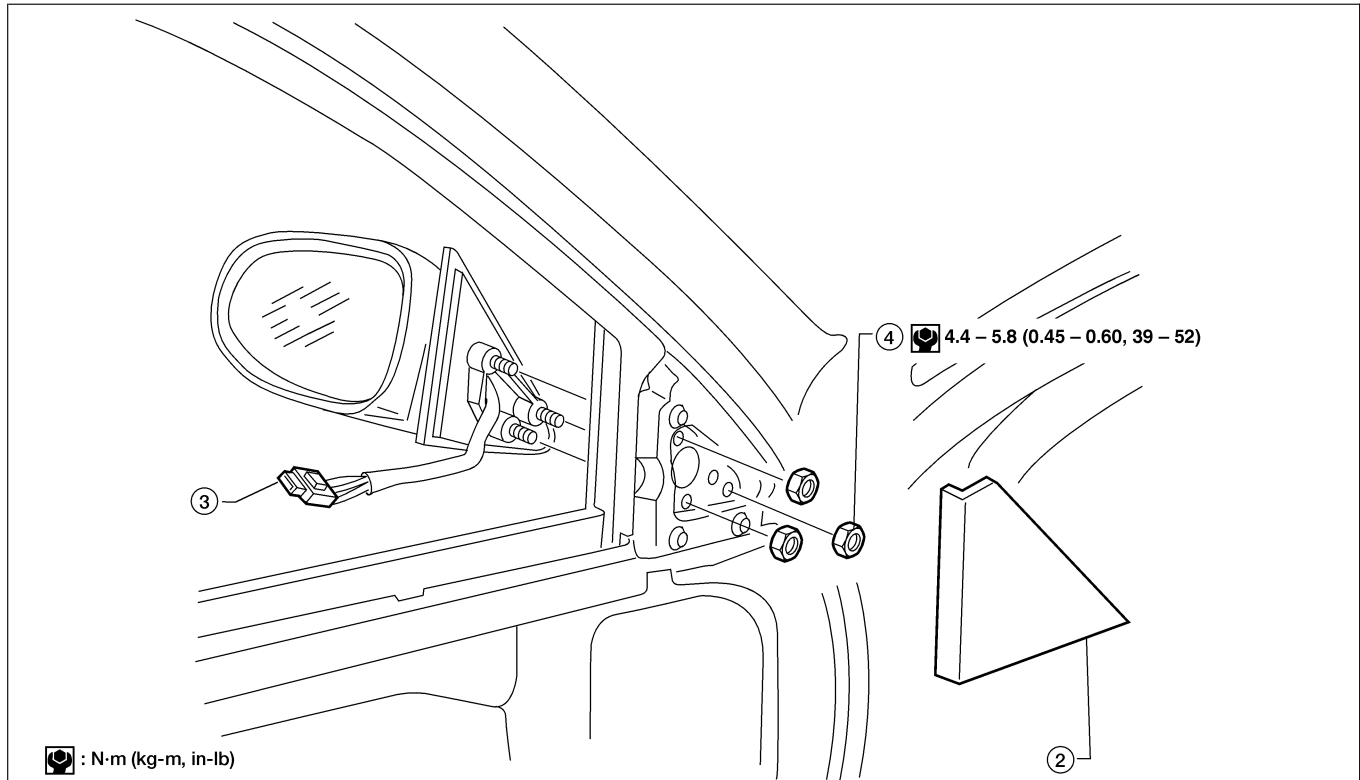

: N·m (kg·m, in·lb)

Mirror glass replacement

CAUTION:

Do not exceed specified temperature or time limit. Excess heat or duration may cause damage to the mirror housing.

• Removal

1. Use a heat lamp (at least 500 watts) to thoroughly warm the frame edge of the door mirror glass to approximately 70°C (159°F) for three minutes.

2. Insert a stiff blade scraper between the mirror glass and the frame. Pry the glass loose.
3. Remove any remaining adhesive (butyl tape) from the mounting surface on the frame.

• Installation

1. Install butyl/adhesive tape (2 pieces) on the frame.
2. Warm the mirror glass frame edge thoroughly with a heat lamp.
3. Position mirror glass on frame. Carefully press on the mirror glass to seat it in place.

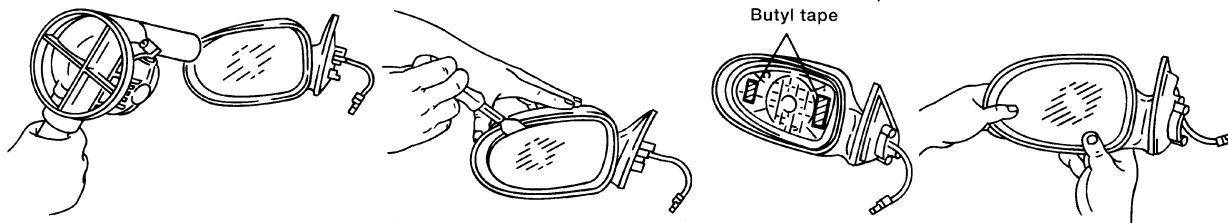

WBT052

GI
MA
EM
LC
EC
FE
CL
MT
AT
AX
SU
BR
ST
RS
BT
HA
SC
EL
IDX

REAR VIEW MIRROR

Removal and Installation

Removal and Installation

NIBT0025

REMOVAL

NIBT0025S01

Remove rear view mirror by pushing deflect spring with screwdriver as shown in the figure.

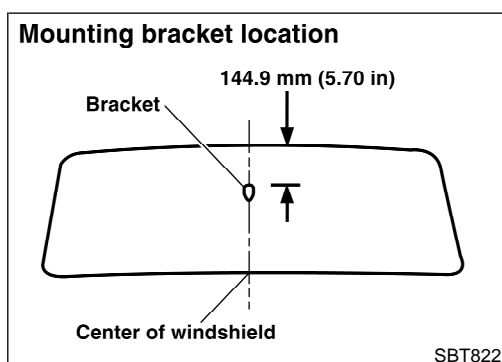
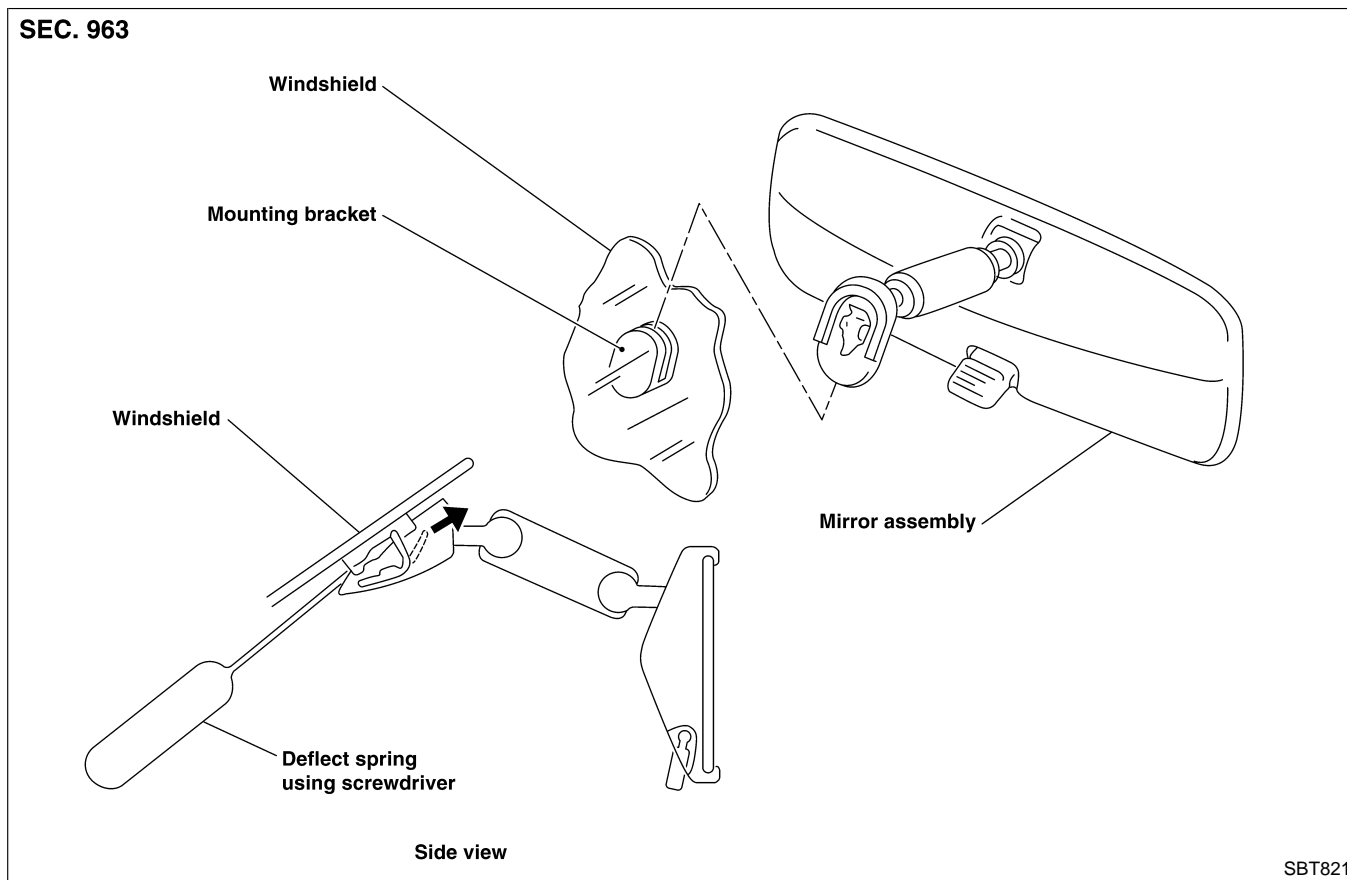

INSTALLATION

NIBT0025S02

1. Install mounting bracket as follows:
 - a. Determine mounting bracket position on windshield by measuring from top of windshield to top of mounting bracket as shown in the figure.
 - b. Mark location on outside of windshield with wax pencil or equivalent.
 - c. Clean attaching point on inside of windshield with an alcohol-saturated paper towel.
 - d. Sand bonding surface of mounting bracket with sandpaper (No. 320 or No. 360).
 - e. Clean bonding surface of mounting bracket with an alcohol-saturated paper towel.
 - f. Apply Loctite Adhesive 11067-2 or equivalent to bonding surface of mounting bracket.
 - g. Install mounting bracket at premarked position and press mounting bracket against glass for 30 to 60 seconds.
 - h. After five minutes, wipe off excess adhesive with an alcohol-moistened paper towel.
2. Install rear view mirror.

BODY ALIGNMENT

Alignment

Alignment

NIBT0026

- All dimensions indicated in figures are actual ones.
- When using a tracking gauge, adjust both pointers to equal length. Then check the pointers and gauge itself to make sure there is no free play.
- When a measuring tape is used, check to be sure there is no elongation, twisting or bending.
- Measurements should be taken at the center of the mounting holes.
- An asterisk (*) indicates the measuring point value is the same on both sides.
- The coordinates of the measurement points are the distances measured from the standard line of "X", "Y" and "Z".

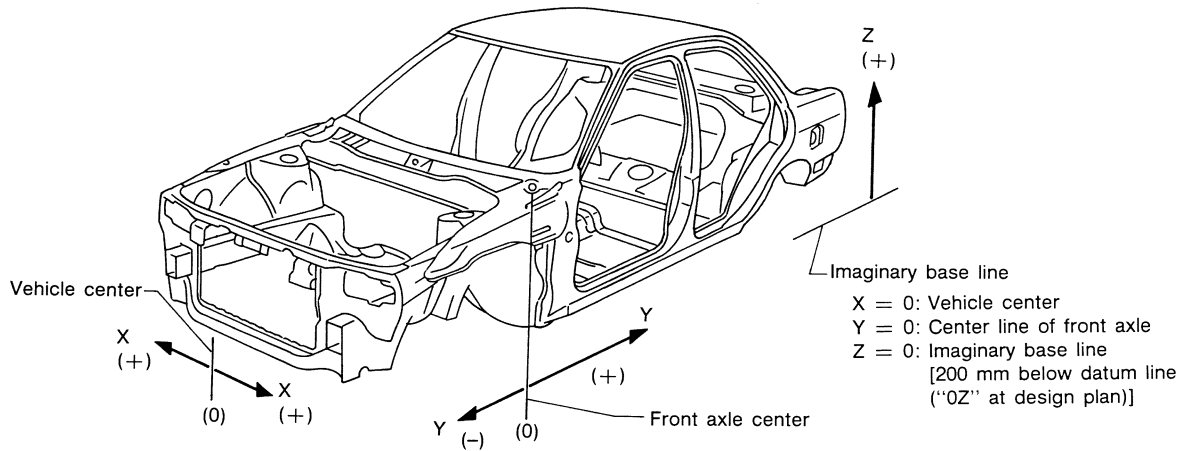

SBF874GC

GI

MA

EM

LC

EC

FE

CL

MT

AT

AX

SU

BR

ST

RS

BT

HA

SC

EL

IDX

BODY (ALIGNMENT)

Alignment (Cont'd)

ENGINE COMPARTMENT Measurement

NIBT0026S01

NIBT0026S0101

Unit: mm

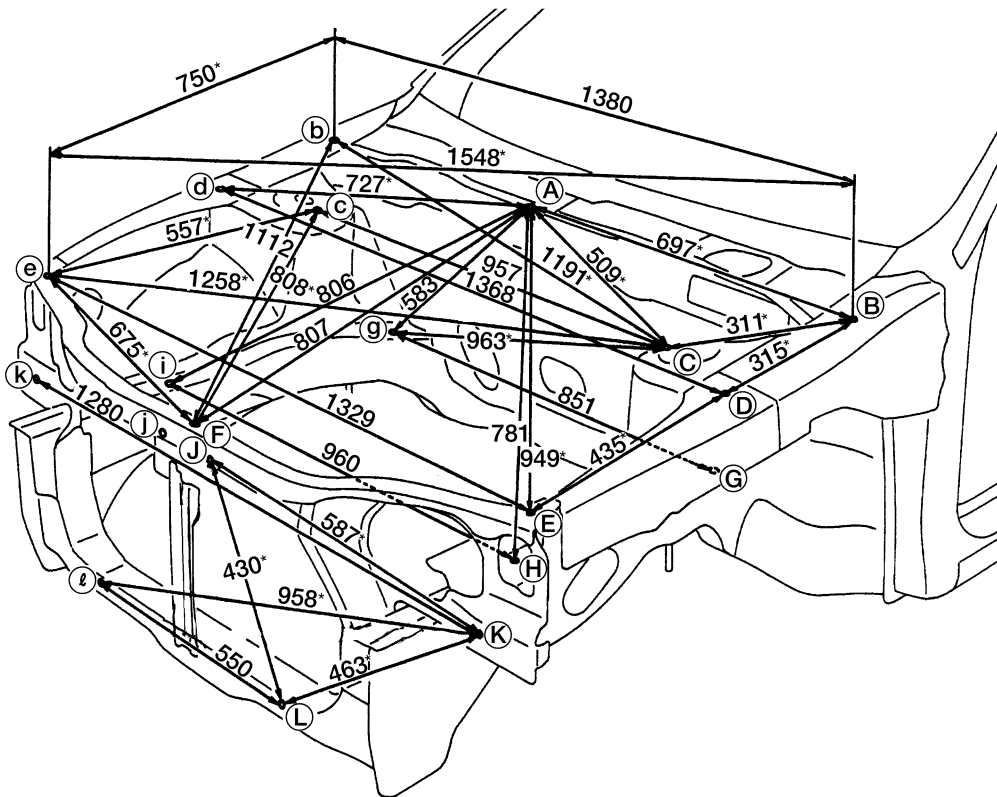

WBT062

BODY (ALIGNMENT)

Alignment (Cont'd)

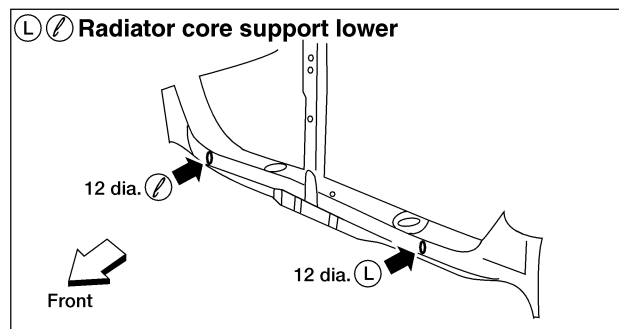
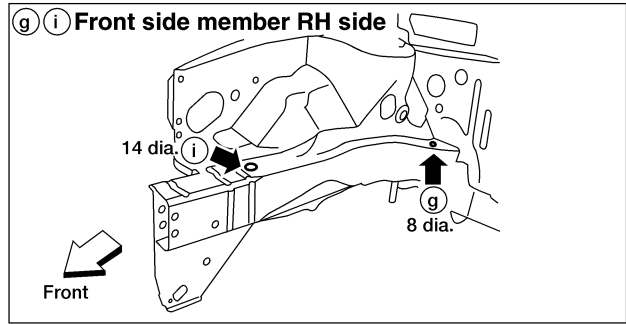
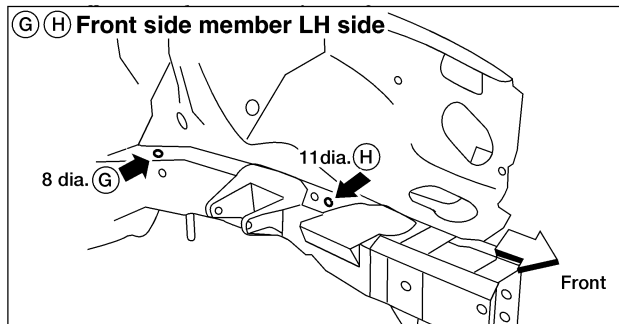
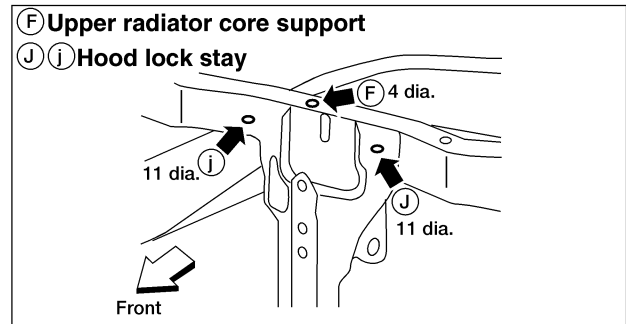
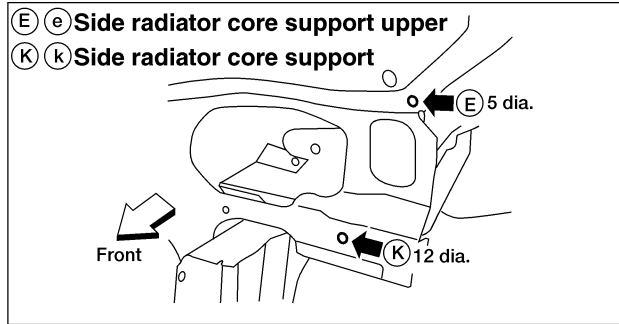
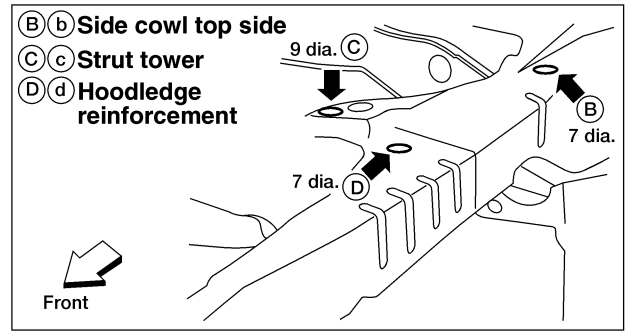
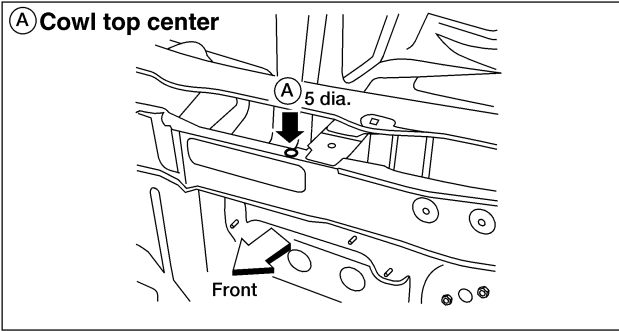

GI
 MA
 EM
 LC
 EC
 FE
 CL
 MT
 AT
 AX
 SU
 BR
 ST
 RS
 BT
 HA
 SC
 EL
 IDX

WBT071

Unit: mm

BODY (ALIGNMENT)

Alignment (Cont'd)

Measurement Points

NIBT0026S0102

As viewed from underside.

* Figures marked with an * indicates symmetrically identical dimensions on both right- and left-hand sides of the vehicle.

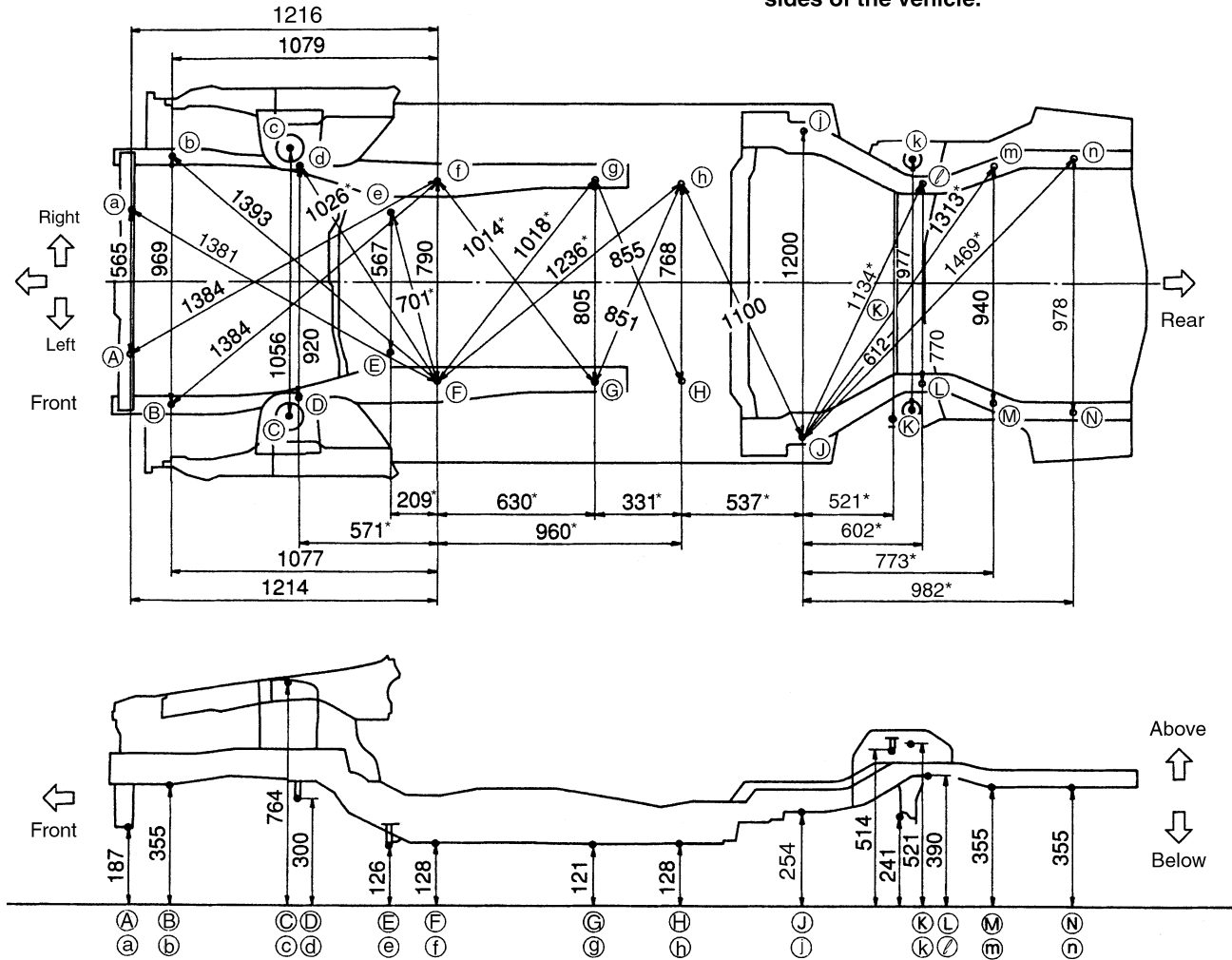

WBT063

BODY (ALIGNMENT)

Alignment (Cont'd)

UNDERBODY Measurement

NIBT0026S02

NIBT0026S0201

GI

MA

EM

LC

EC

FE

CL

MT

AT

AX

SU

BR

ST

RS

BT

HA

SC

EL

IDX

Unit: mm

As viewed from underside.

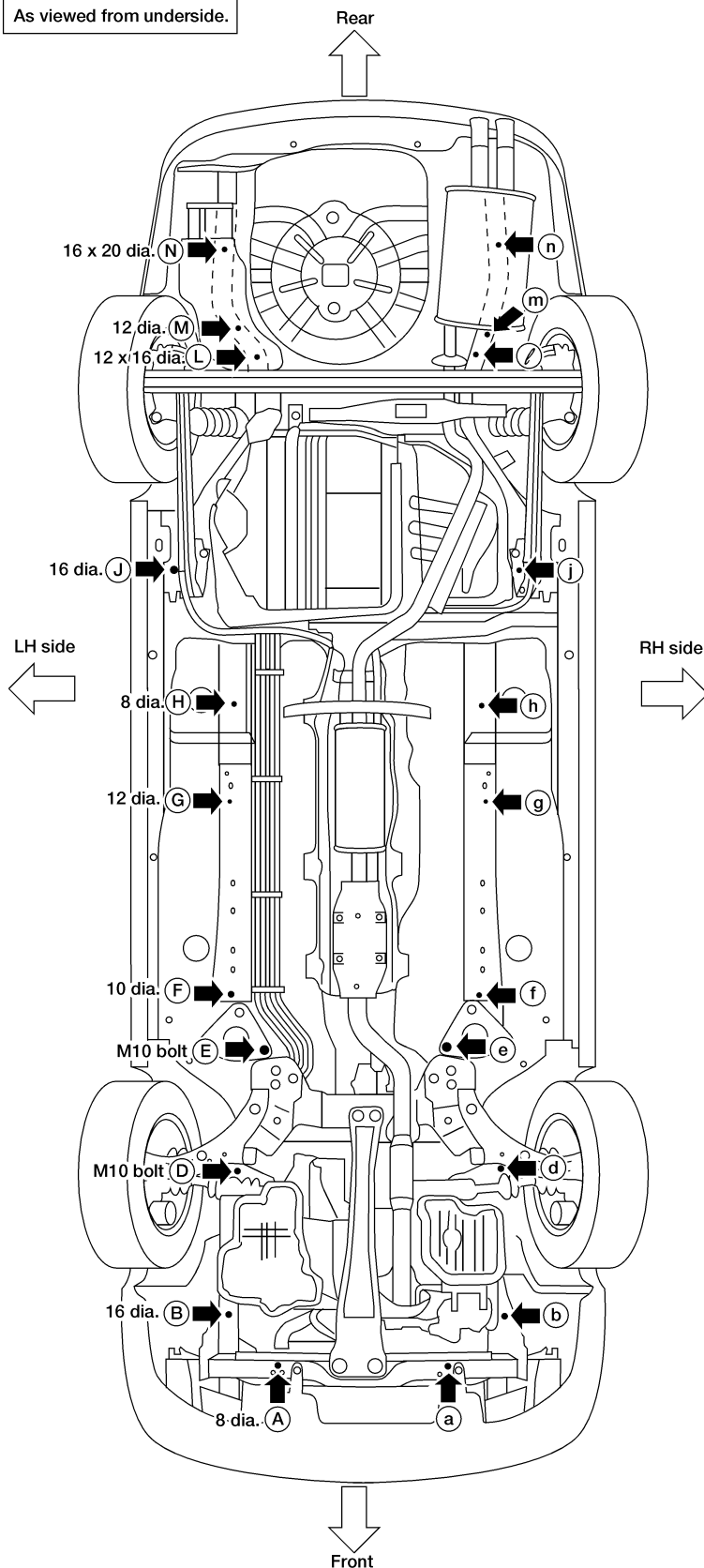

Coordinates:

(A), (a)
X: 280, -285
Y: 607, -609
Z: 186.8

(B), (b)
X: 477, -492
Y: -450
Z: 355

(C), (c)
X: 528
Y: 18
Z: 764

(D), (d)
X: 460
Y: 60
Z: 300.3

(E), (e)
X: 283.5
Y: 423
Z: 126.5

(F), (f)
X: 395
Y: 600
Z: 127.8

(G), (g)
X: 400, -405
Y: 1230
Z: 120.6

(H), (h)
X: 384
Y: 1560
Z: 128

(J), (j)
X: 600
Y: 2035
Z: 254

(K), (k)
X: 488.3
Y: 2467.8
Z: 520.6

(L), (l)
X: 385
Y: 2580
Z: 390

(M), (m)
X: 470
Y: 2790
Z: 355

(N), (n)
X: 489
Y: 3016
Z: 355

Front and rear strut tower centers

(C), (c) (K), (k)

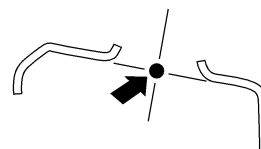

Front: 30 dia.
Rear: 68 dia.

WBT064

NOTES