

FRONT & REAR SUSPENSION

SECTION **SU**

CONTENTS

FRONT SUSPENSION	2	REAR SUSPENSION	15
Precautions	2	Precautions	15
PRECAUTIONS	2	PRECAUTIONS	15
Preparation	2	Preparation	15
SPECIAL SERVICE TOOLS	2	COMMERCIAL SERVICE TOOLS.....	15
COMMERCIAL SERVICE TOOLS.....	2	Noise, Vibration and Harshness (NVH)	
Noise, Vibration and Harshness (NVH)		Troubleshooting	15
Troubleshooting	4	Components.....	16
NVH TROUBLESHOOTING CHART	4	On-vehicle Service.....	17
Components.....	5	REAR SUSPENSION PARTS	17
On-vehicle Service.....	6	REAR WHEEL ALIGNMENT	17
FRONT SUSPENSION PARTS	6	Removal and Installation	20
FRONT WHEEL ALIGNMENT	6	REMOVAL.....	20
Coil Spring and Shock Absorber	9	INSTALLATION.....	20
REMOVAL AND INSTALLATION.....	9	Coil Spring and Shock Absorber	21
DISASSEMBLY.....	9	REMOVAL AND INSTALLATION.....	21
INSPECTION.....	9	DISASSEMBLY.....	21
ASSEMBLY	10	INSPECTION.....	21
Stabilizer Bar	10	ASSEMBLY	22
REMOVAL AND INSTALLATION.....	10	Torsion Beam, Lateral Link and Control Rod.....	22
Transverse Link and Lower Ball Joint	11	DISASSEMBLY.....	22
REMOVAL AND INSTALLATION.....	11	INSPECTION.....	22
INSPECTION.....	12	RUBBER BUSHING REPLACEMENT	22
Service Data and Specifications (SDS).....	13	ASSEMBLY	23
GENERAL SPECIFICATIONS (FRONT).....	13	Service Data and Specifications (SDS).....	25
FRONT WHEEL ALIGNMENT (UNLADEN*1)	13	GENERAL SPECIFICATIONS (REAR).....	25
LOWER BALL JOINT	13	REAR WHEEL ALIGNMENT (UNLADEN*)	25
WHEELARCH HEIGHT (UNLADEN*).....	14	WHEELARCH HEIGHT (UNLADEN*).....	25
WHEEL RUNOUT	14	WHEEL RUNOUT	25

GI
MA
EM
LC
EC
FE
CL
MT
AT
AX
SU
BR
ST
RS
BT
HA
SC
EL
IDX

FRONT SUSPENSION

Precautions

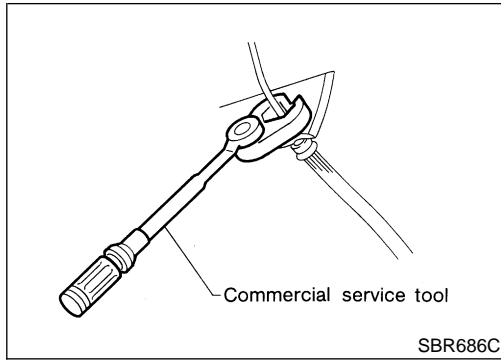

Precautions PRECAUTIONS

- When installing rubber parts, final tightening must be carried out under unladen condition* with tires on ground. Oil will shorten the life of rubber bushings. Be sure to wipe off any spilled oil.
*: Fuel, radiator coolant and engine oil full. Spare tire, jack, hand tools and mats in designated positions.
- After installing removed suspension parts, check wheel alignment and adjust if necessary.
- Use flare nut wrench when removing or installing brake tubes.
- Always torque brake lines when installing.
- Lock nuts are un reusable parts; always use new ones. When replacing, do not wipe the oil off the new lock nut before tightening.

NISU0001

Preparation

SPECIAL SERVICE TOOLS

The actual shapes of Kent-Moore tools may differ from those of special service tools illustrated here.

NISU0002

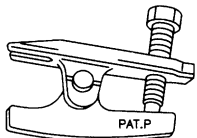
Tool number (Kent-Moore No.) Tool name	Description
HT72520000 (J25730-B) Ball joint remover	 Removing tie-rod outer end and lower ball joint NT146

COMMERCIAL SERVICE TOOLS

NISU0003

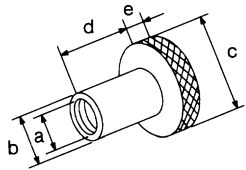
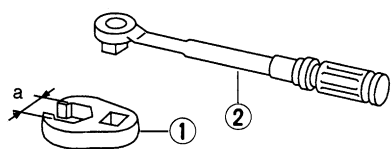
Tool name	Description
Attachment wheel alignment	 Measure wheel alignment a: Screw M24 x 1.5 pitch b: 35 mm (1.38 in) dia. c: 65 mm (2.56 in) dia. d: 56 mm (2.20 in) e: 12 mm (0.47 in) NT148
1 Flare nut crowfoot 2 Torque wrench	 Removing and installing each brake piping a: 10 mm (0.39 in) NT360

FRONT SUSPENSION

Preparation (Cont'd)

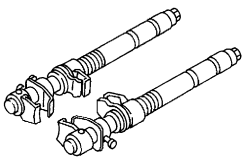
Tool name	Description
Spring compressor	 <p data-bbox="950 220 1307 247">Removing and installing coil spring</p> <p data-bbox="414 415 479 443">NT717</p>

GI

MA

EM

LC

EC

FE

CL

MT

AT

AX

SU

BR

ST

RS

BT

HA

SC

EL

IDX

FRONT SUSPENSION

Noise, Vibration and Harshness (NVH) Troubleshooting

Noise, Vibration and Harshness (NVH) Troubleshooting

=NISU0004

NVH TROUBLESHOOTING CHART

NISU0004S01

Use the chart below to help you find the cause of the symptom. If necessary, repair or replace these parts.

		Possible Cause and SUSPECTED PARTS														Reference page								
		Improper installation, looseness	Shock absorber deformation, damage or deflection	Bushing or mounting deterioration	Parts interference	Spring fatigue	Suspension looseness	Incorrect wheel alignment	Stabilizer bar fatigue	Out-of-round	Imbalance	Incorrect air pressure	Uneven tire wear	Deformation or damage	Non-uniformity	Incorrect tire size	DRIVE SHAFT	AXLE	SUSPENSION	TIRES	ROAD WHEEL	BRAKES	STEERING	
Symptom	SUSPENSION	Noise	x	x	x	x	x	x									x	x		x	x	x	x	
		Shake	x	x	x	x		x									x	x		x	x	x	x	
		Vibration	x	x	x	x	x										x	x		x				x
		Shimmy	x	x	x	x			x									x		x	x	x	x	x
		Judder	x	x	x													x		x	x	x	x	x
		Poor quality ride or handling	x	x	x	x	x		x	x									x		x	x		
	TIRES	Noise	x							x	x	x	x	x	x		x	x	x		x	x	x	x
		Shake	x							x	x	x	x	x		x	x	x	x		x	x	x	x
		Vibration										x				x	x	x	x					x
		Shimmy	x							x	x	x	x	x	x	x		x	x		x	x	x	x
		Judder	x							x	x	x	x	x		x		x	x		x	x	x	x
		Poor quality ride or handling	x							x	x	x	x	x		x		x	x		x			
ROAD WHEEL	Noise	x							x	x			x			x	x	x	x		x	x	x	
	Shake	x							x	x			x			x	x	x	x		x	x	x	
	Shimmy, Judder	x							x	x			x				x	x	x	x		x	x	
	Poor quality ride or handling	x							x	x			x				x	x	x	x				

x: Applicable

FRONT SUSPENSION

Components

SEC.400•401•406

NISU0005

Components

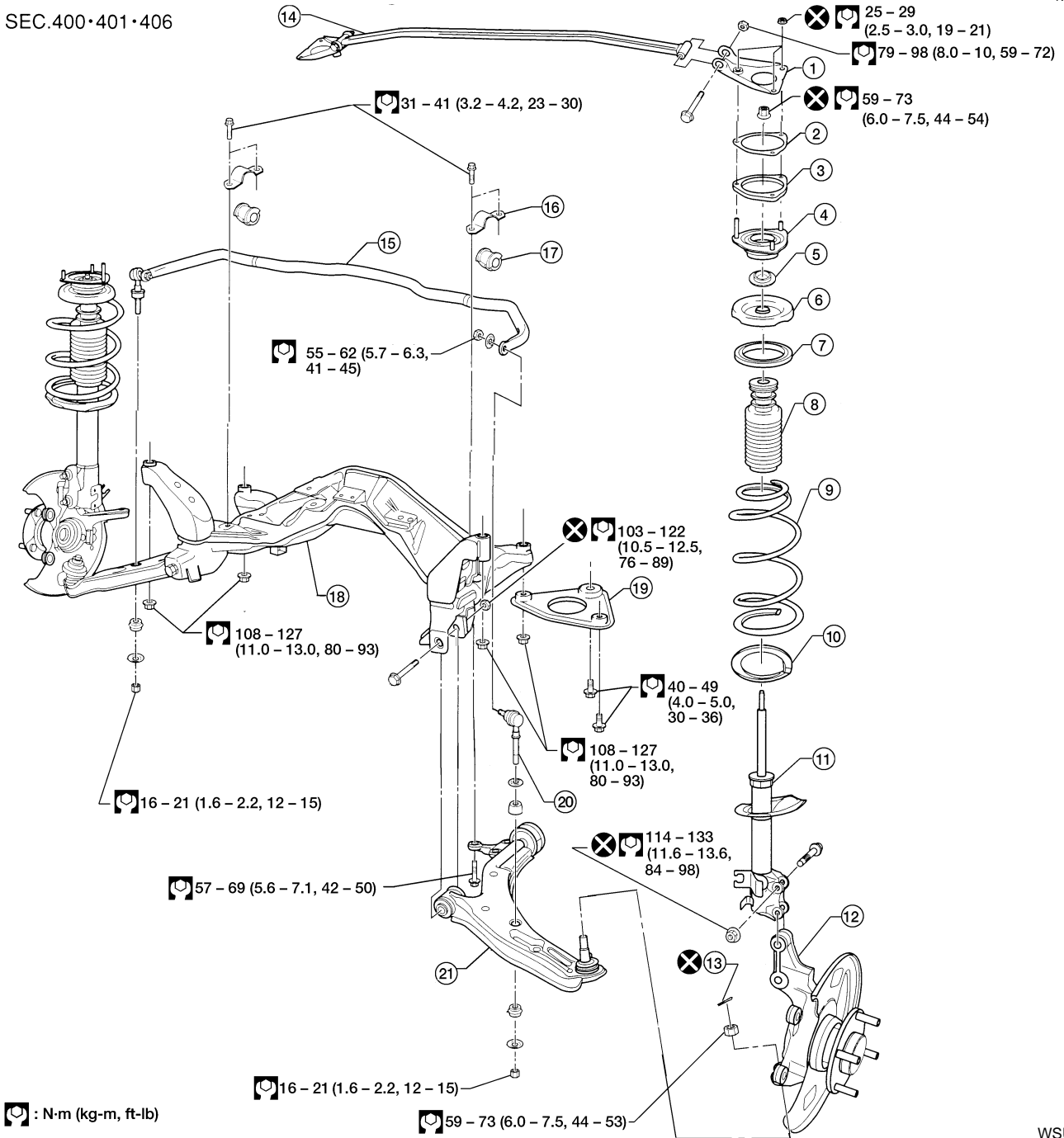

: N·m (kg·m, ft·lb)

WSU011

- | | | |
|-----------------------------|------------------------------------|-----------------------|
| 1. Strut tower bar bracket | 8. Bound bumper rubber | 15. Stabilizer |
| 2. Strut mount upper plate | 9. Coil spring | 16. Stabilizer clamp |
| 3. Strut spacer | 10. Lower spring rubber seat | 17. Bushing |
| 4. Strut mount bracket | 11. Shock absorber | 18. Suspension member |
| 5. Strut mount bearing | 12. Wheel hub and steering knuckle | 19. Rebound stopper |
| 6. Spring upper seat | 13. Cotter pin | 20. Connecting rod |
| 7. Upper spring rubber seat | 14. Strut tower bar | 21. Transverse link |

GI

MA

EM

LC

EC

FE

CL

MT

AT

AX

SU

BR

ST

RS

BT

HA

SC

EL

IDX

FRONT SUSPENSION

On-vehicle Service

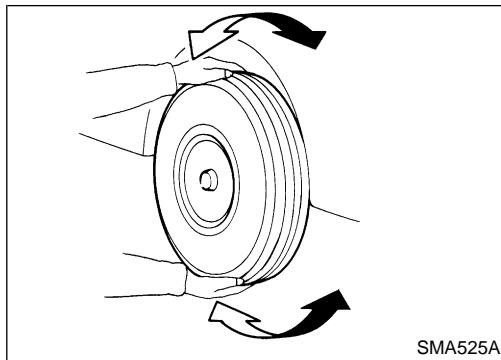

On-vehicle Service FRONT SUSPENSION PARTS

NISU0006

Check front axle and front suspension parts for excessive play, cracks, wear or other damage.

- Shake each front wheel to check for excessive play.
- Make sure that cotter pin is inserted.
- Retighten all axle and suspension nuts and bolts to the specified torque.

Tightening torque:

Refer to “FRONT SUSPENSION”, SU-5.

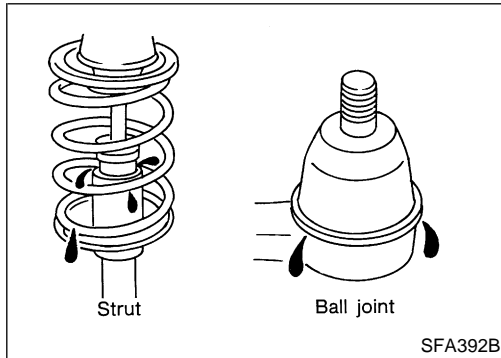

- Check strut (shock absorber) for oil leakage or other damage.
- Check suspension ball joint for grease leakage and ball joint dust cover for cracks or other damage. If ball joint dust cover is cracked or damaged, replace transverse link.

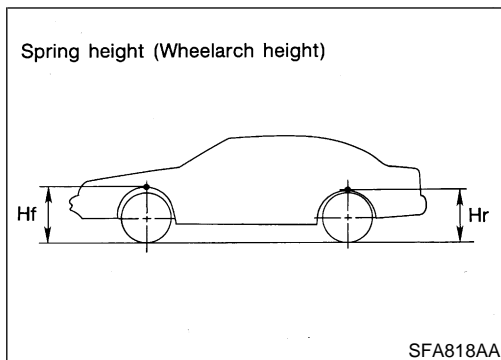

- Check spring height from top of wheelarch to the ground.
 - a) Vehicle must be unladen*, parked on a level surface, and tires checked for proper inflation and wear (tread wear indicator must not be showing).

*: Fuel, radiator coolant and engine oil full. Spare tire, jack, hand tools and mats in designated positions.
 - b) Bounce vehicle up and down several times before measuring. **Standard height: Refer to “WHEELARCH HEIGHT (UNLADEN*)”, SU-14.**
 - c) Spring height is not adjustable. If out of specification, check for worn springs or suspension parts.

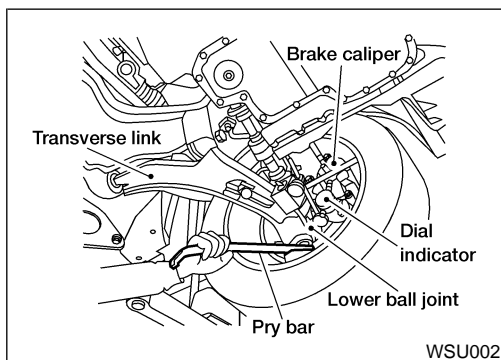

- Check suspension ball joint end play.
 - a) Jack up front of vehicle and set the stands.
 - b) Clamp dial indicator onto transverse link and place indicator tip on lower edge of brake caliper.
 - c) Make sure front wheels are straight and brake pedal is depressed.
 - d) Place a pry bar between transverse link and inner rim of road wheel.
 - e) While raising and releasing pry bar, observe maximum dial indicator value.

Vertical end play: 0 mm (0 in)

- f) If ball joint movement is beyond specifications, remove and replace it.

FRONT WHEEL ALIGNMENT

NISU0007

Before checking front wheel alignment, be sure to make a preliminary inspection (unladen*).

*: Fuel, radiator coolant and engine oil full. Spare tire, jack, hand tools and mats in designated positions.

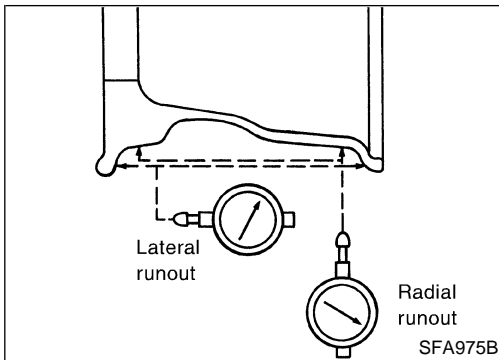

Preliminary Inspection

NISU0007S01

NISU0007S0103

Aluminum wheel

1. Check tires for wear and improper inflation.
2. Check wheels for deformation, cracks and other damage. If deformed, remove wheel and check wheel runout.
 - a. Remove tire from aluminum wheel and mount on a tire balance machine.
 - b. Set dial indicator as shown in the illustration.
 - Wheel runout (Dial indicator value):**
 - Refer to "WHEEL RUNOUT", SU-14.**
3. Check front wheel bearings for looseness.
4. Check front suspension for looseness.
5. Check steering linkage for looseness.
6. Check that front shock absorbers work properly.
7. Check vehicle wheelarch height (unladen*).

*: Fuel, radiator coolant and engine oil full. Spare tire, jack, hand tools and mats in designated positions.

GI

MA

EM

LC

EC

FE

CL

MT

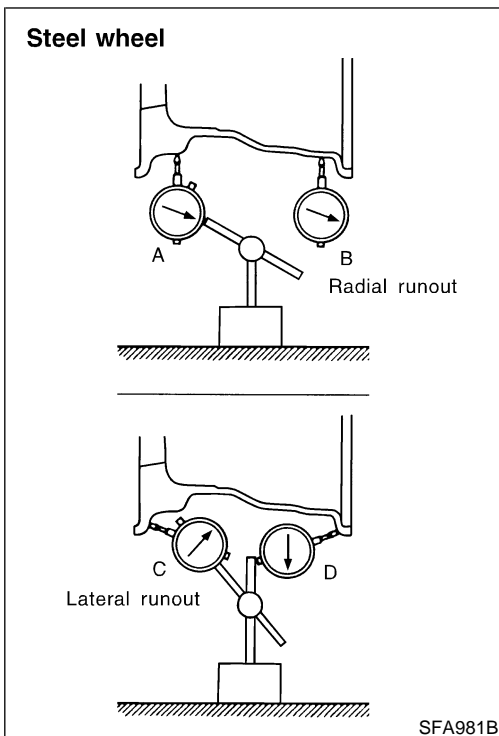

Steel wheel

NISU0007S0104

1. Check tires for wear and improper inflation.
2. Check wheels for deformation, cracks and other damage. If deformed, remove wheel and check wheel runout.
 - a. Remove tire from steel wheel and mount wheel on a tire balance machine.
 - b. Set two dial indicators as shown in the illustration.
 - c. Set each dial indicator to 0.
 - d. Rotate wheel and check dial indicators at several points around the circumference of the wheel.
 - e. Calculate runout at each point as shown below.

$$\text{Radial runout} = (A + B)/2$$

$$\text{Lateral runout} = (C + D)/2$$
 - f. Select maximum positive runout value and the maximum negative value. Add the two values to determine total runout. In case a positive or negative value is not available, use the maximum value (negative or positive) for total runout. If the total runout value exceeds the limit, replace steel wheel.

Wheel runout:

Refer to "WHEEL RUNOUT", SU-14.

3. Check front wheel bearings for looseness.
4. Check front suspension for looseness.
5. Check steering linkage for looseness.
6. Check that front shock absorbers work properly.
7. Check vehicle wheelarch height (unladen*).

*: Fuel, radiator coolant and engine oil full. Spare tire, jack, hand tools and mats in designated positions.

AT

AX

SU

BR

ST

RS

BT

HA

SC

EL

IDX

FRONT SUSPENSION

On-vehicle Service (Cont'd)

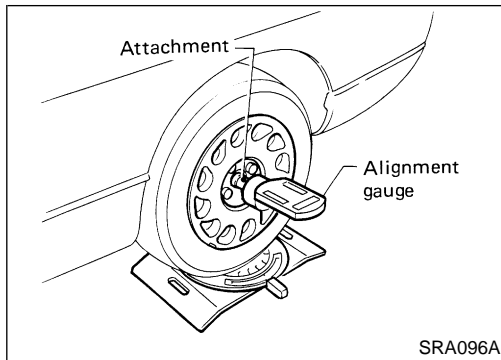

Camber, Caster and Kingpin Inclination

NISU0007S02

Camber, caster and kingpin inclination are preset at factory and cannot be adjusted.

1. Measure camber, caster and kingpin inclination of both right and left wheels with a suitable alignment gauge.

Camber, caster and kingpin inclination:

Refer to "FRONT WHEEL ALIGNMENT (UNLADEN*)", SU-13.

2. If camber, caster or kingpin inclination is not within specification, inspect front suspension parts. Replace damaged or worn out parts.

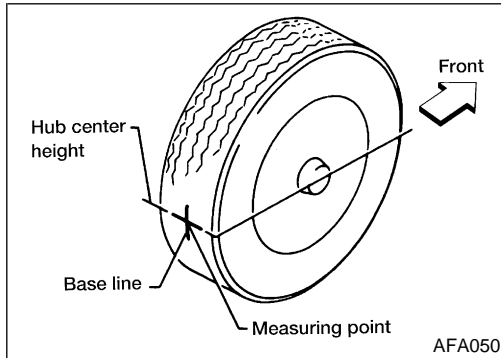

Toe-in

NISU0007S03

Measure toe-in using the following procedure.

WARNING:

- Always perform the following procedure on a flat surface.
- Make sure that no person is in front of the vehicle before pushing it.

1. Bounce front of vehicle up and down to stabilize the posture.
2. Push the vehicle straight ahead about 5 m (16 ft).
3. Put a mark on base line of tread (rear side) of both tires at the same height as hub center. These are measuring points.

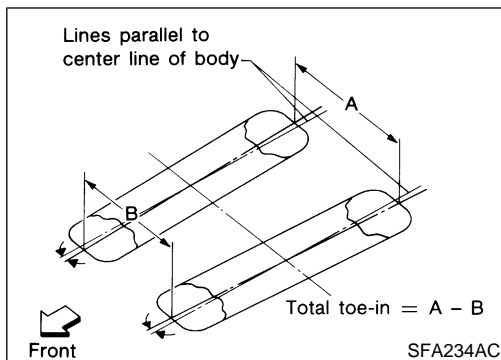

4. Measure distance "A" (rear side).

5. Push the vehicle slowly ahead to rotate the wheels 180 degrees (1/2 turn).

If the wheels have rotated more than 180 degrees (1/2 turn), try the above procedure again from the beginning. Never push vehicle backward.

6. Measure distance "B" (front side).

Total toe-in:

Refer to "FRONT WHEEL ALIGNMENT (UNLADEN*)", SU-13.

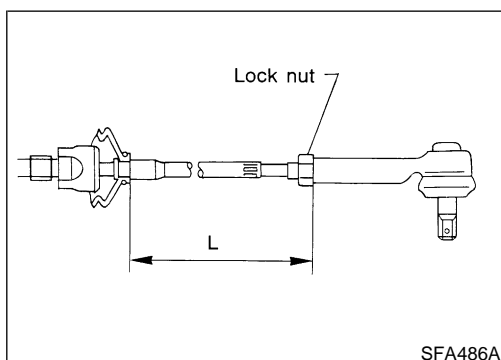

7. Adjust toe-in by varying the length of steering tie-rods.

- a. Loosen lock nuts.

- b. Adjust toe-in by screwing tie-rods in and out.

Standard length "L":

Refer to ST-29, "Steering Gear and Linkage".

- c. Tighten lock nuts to specified torque.

Lock nut tightening torque:

Refer to ST-15, "POWER STEERING GEAR AND LINKAGE".

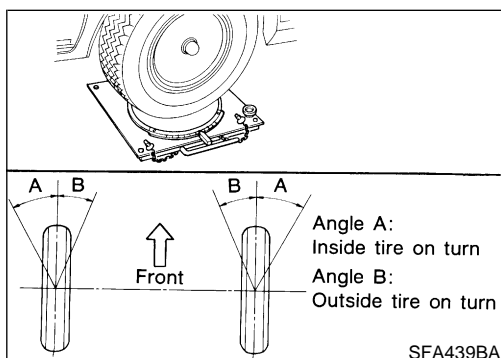

Front Wheel Turning Angle

NISU0007S04

1. Set wheels in straight-ahead position. Then move vehicle forward until front wheels rest on turning radius gauge properly.
2. Rotate steering wheel all the way right and left; measure turning angle.

Do not hold the steering wheel on full lock for more than 15 seconds.

Wheel turning angle (Full turn):

Refer to "FRONT WHEEL ALIGNMENT (UNLADEN*)", SU-13.

FRONT SUSPENSION

Coil Spring and Shock Absorber

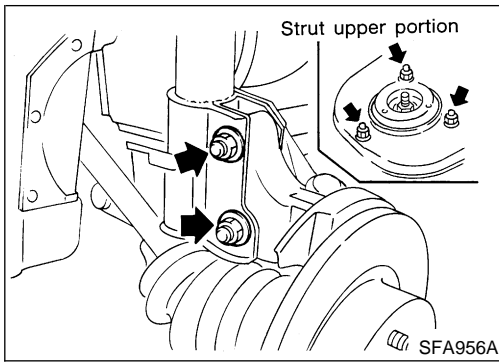

Coil Spring and Shock Absorber REMOVAL AND INSTALLATION

- Remove shock absorber fixing bolt and nut (to hoodledge). =NISU0009
- Do not remove piston rod lock nut on vehicle.

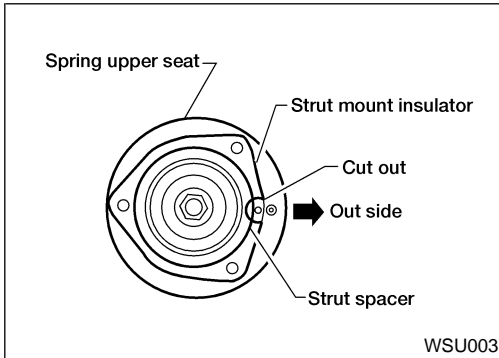

- When installing strut spacer, it must be positioned as shown left.

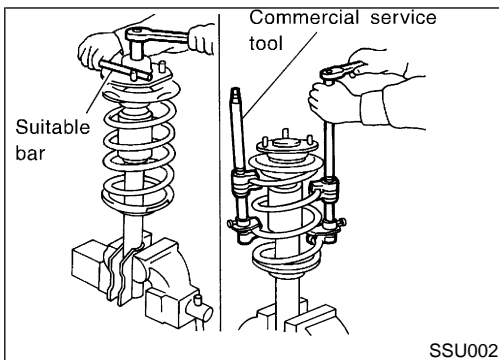

DISASSEMBLY

1. Set shock absorber on vise, then **loosen** piston rod lock nut. NISU0010
- Do not remove piston rod lock nut at this time.
2. Compress spring with Tool so that shock absorber mounting insulator can be turned by hand. AX

WARNING:

Make sure that the pawls of the two spring compressors are firmly hooked on the spring. The spring compressors must be tightened alternately so as not to tilt the spring. SU

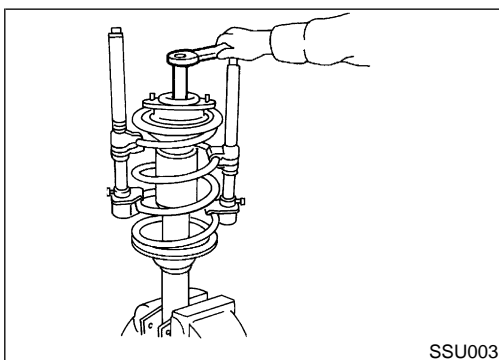

3. Remove piston rod lock nut.

INSPECTION

Shock Absorber Assembly

- Check for smooth operation through a full stroke, both compression and extension. NISU0011
- Check for oil leakage on welded or gland packing portions. NISU0011S01
- Check piston rod for cracks, deformation or other damage. Replace if necessary. EL

Mounting Insulator and Rubber Parts

- Check cemented rubber-to-metal portion for separation or IDX

FRONT SUSPENSION

Coil Spring and Shock Absorber (Cont'd)

cracks. Check rubber parts for deterioration. Replace if necessary.

Thrust Bearing

NISU0011S06

- Check thrust bearing parts for abnormal noise or excessive rattle in axial direction.
- Replace if necessary.

Coil Spring

NISU0011S03

- Check for cracks, deformation or other damage. Replace if necessary.

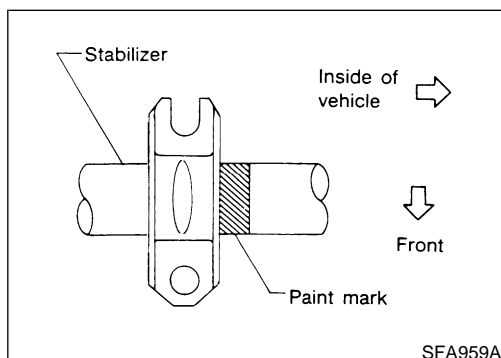
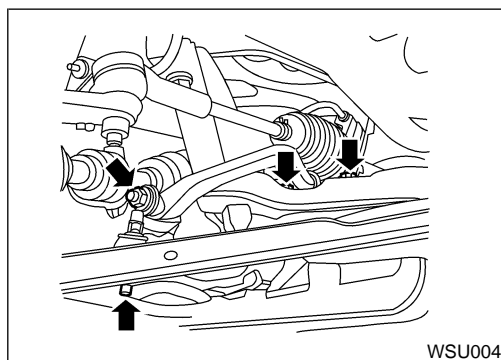
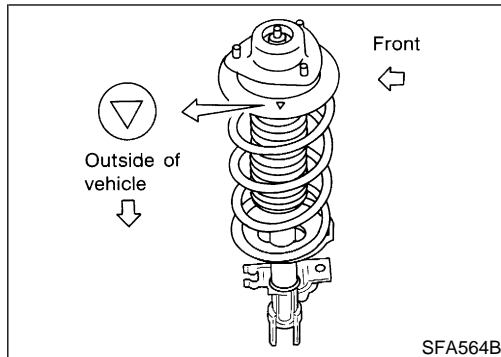
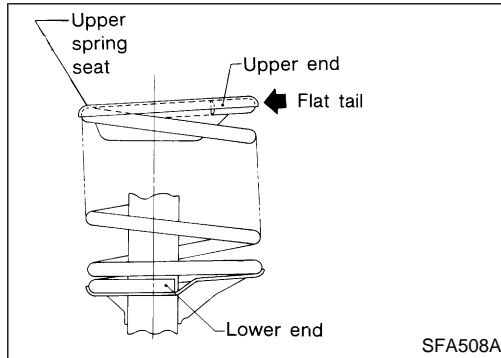

ASSEMBLY

NISU0012

- When installing coil spring on strut, it must be positioned as shown in the figure at left.

- Install upper spring seat with alignment mark facing the outer side of vehicle, in line with strut-to-knuckle attachment points.
- **Replace strut lower mounting nuts.**
- **When installing strut to knuckle, be sure to hold bolts and tighten nuts.**

 : 114 - 133 N·m (11.6 - 13.6 k·gm, 84 - 98 ft·lb).

Stabilizer Bar

REMOVAL AND INSTALLATION

NISU0017

- Remove four stabilizer bar mounting nuts from each side.

- When installing stabilizer, make sure the paint mark and clamp face in their correct directions.

FRONT SUSPENSION

Stabilizer Bar (Cont'd)

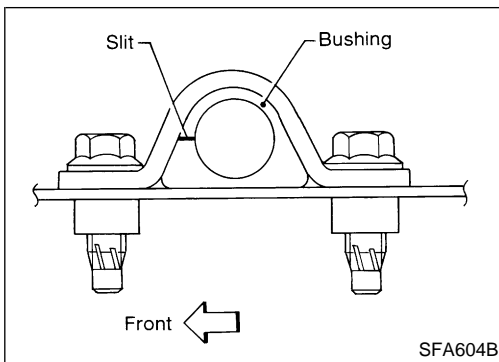

- Make sure that slit in bushing is in the position shown in the figure.

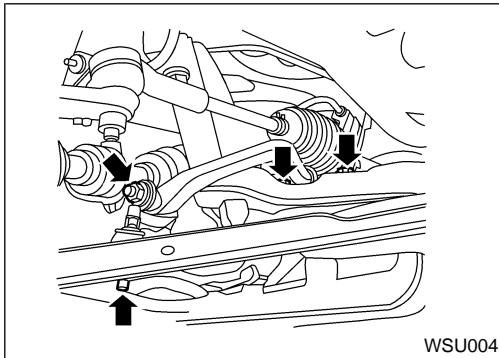

- Install four stabilizer bar mounting nuts at each side.

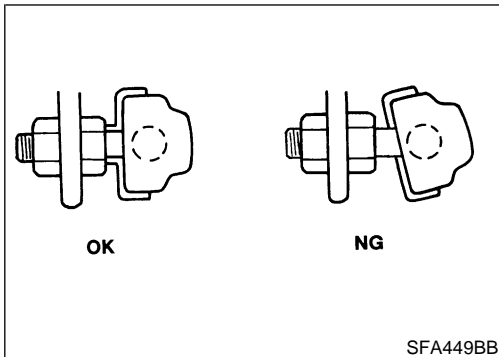

- Install stabilizer bar with ball joint socket properly placed.

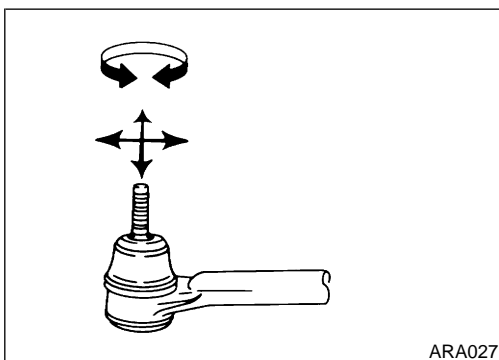

- Check stabilizer for deformation or cracks. Replace if necessary.
- Check rubber bushings for deterioration or cracks. Replace if necessary.
- Check ball joint can rotate in all directions. If movement is not smooth and free, replace stabilizer bar connecting rod.

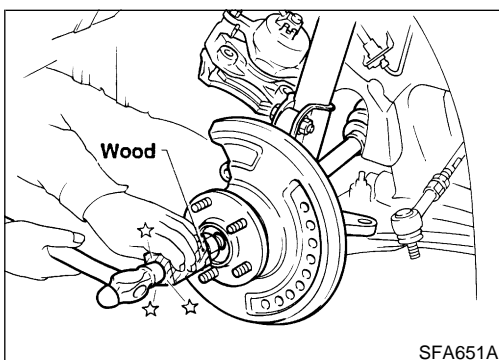

Transverse Link and Lower Ball Joint REMOVAL AND INSTALLATION

NISU0018

1. Remove wheel bearing lock nut.
2. Remove tie-rod ball joint.
3. Remove strut lower bracket fixing bolts and nuts.
4. Separate drive shaft from knuckle by slightly tapping drive shaft end.

Cover boots with shop towel so as not to damage them when removing drive shaft.

GI

MA

EM

LC

EC

FE

CL

MT

AT

AX

SU

BR

ST

RS

BT

HA

SC

EL

IDX

FRONT SUSPENSION

Transverse Link and Lower Ball Joint (Cont'd)

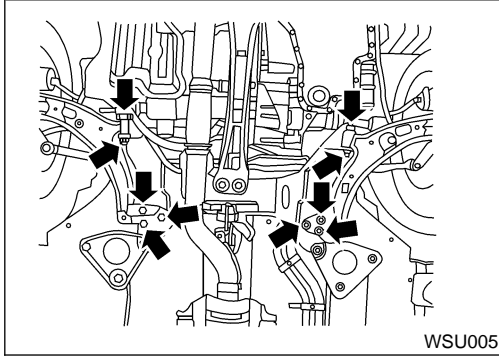
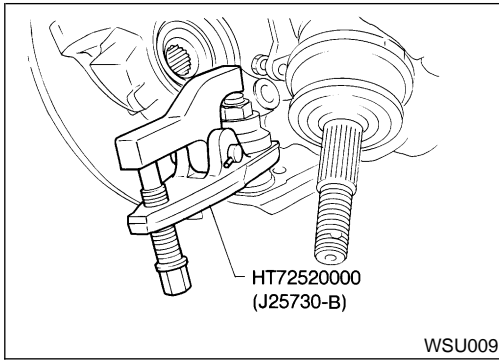

5. Separate lower ball joint stud from knuckle with suitable tool. Refer to **AX-5**, "Wheel Hub and Knuckle".

6. Remove fixing bolts.
7. Remove transverse link and lower ball joint.
8. During installation, final tightening must be carried out at curb weight with tires on the ground.

Tightening torque:

Refer to "**FRONT SUSPENSION**", **SU-5**.

9. After installation, check wheel alignment. Refer to "Front Wheel Alignment", **SU-6**.

INSPECTION

Transverse Link

NISU0019

NISU0019S01

- Check transverse link for damage, cracks or deformation. Replace it if necessary.
- Check rubber bushing for damage, cracks and deformation. Replace transverse link if necessary.

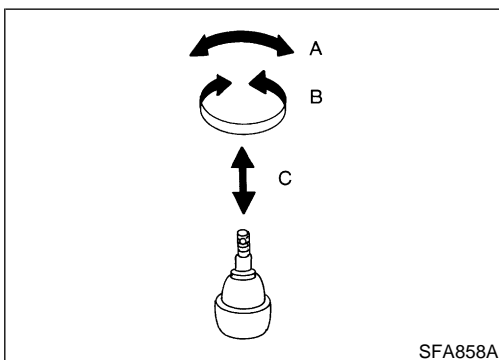

Lower Ball Joint

NISU0019S02

- Check ball joint for play. Replace transverse link assembly if any of the following cases occur. Ball stud is worn, play in axial direction is excessive or joint is hard to swing. Before checking, turn ball joint at least 10 revolutions so that ball joint is properly broken in.

Swinging force "A":

(measuring point: cotter pin hole of ball stud):

7.8 - 77.5 N (0.8 - 7.9 kg, 1.8 - 17.4 lb)

Turning torque "B":

0.50 - 4.90 N·m (5.1 - 50 kg-cm, 4.4 - 43.4 in-lb)

Vertical end play "C":

0 mm (0 in)

- Check dust cover for damage. Replace it and cover clamp if necessary.

FRONT SUSPENSION

Service Data and Specifications (SDS)

Service Data and Specifications (SDS)

GENERAL SPECIFICATIONS (FRONT)

=NISU0020

Suspension type	Independent MacPherson strut
Shock absorber type	Double-acting hydraulic
Stabilizer bar	Standard equipment

FRONT WHEEL ALIGNMENT (UNLADEN*1)

NISU0021

Camber Degree minute (Decimal degree)	Minimum	-1°10' (-1.17°)	
	Nominal	-0°25' (-0.42°)	
	Maximum	0°20' (0.33°)	
	Left and right difference	45' (0.75°) or less	
Caster Degree minute (Decimal degree)	Minimum	0°51' (0.85°)	
	Nominal	1°36' (1.60°)	
	Maximum	2°21' (2.35°)	
	Left and right difference	45' (0.75°) or less	
Kingpin inclination Degree minute (Decimal degree)	Minimum	13°58' (13.97°)	
	Nominal	14°43' (14.72°)	
	Maximum	15°28' (15.47°)	
Total toe-in	Distance (A - B) mm (in)	Minimum	1 (0.039")
		Nominal	2 (0.079")
		Maximum	3 (0.118")
	Angle (left plus right) Degree minute (Decimal degree)	Minimum	5.5' (0.08°)
		Nominal	11' (0.18°)
		Maximum	16' (0.27°)
Wheel turning angle Full turn*2	Inside Degree minute (Decimal degree)	Minimum	34° (34.0°)
		Nominal	37° (37.0°)
		Maximum	38° (38.0°)
	Outside Degree minute (Decimal degree)	Nominal	31° (31.0°)

*1: Fuel, radiator coolant and engine oil full. Spare tire, jack, hand tools and mats in designated positions.

*2: On power steering models, wheel turning force (at circumference of steering wheel) of 98 to 147 N (10 to 15 kg, 22 to 33 lb) with engine idle.

LOWER BALL JOINT

NISU0022

Swinging force "A" (Measuring point: cotter pin hole of ball stud) N (kg, lb)	7.8 - 77.5 (0.8 - 7.9, 1.8 - 17.4)
Turning torque "B" N·m (kg·cm, in·lb)	0.50 - 4.90 (5.1 - 50.0, 4.4 - 43.4)
Vertical end play "C" mm (in)	0 (0)

FRONT SUSPENSION

Service Data and Specifications (SDS) (Cont'd)

WHEELARCH HEIGHT (UNLADEN*)

NISU0041

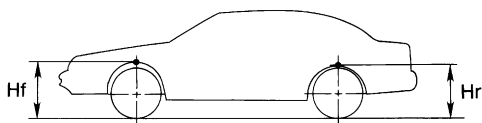

SFA818A

Engine	SR20DE		QG18DE		QG18DE Calif. CA Model
Tire Size	195/60R15	195/55R16	185/65R14	195/60R15	195/60R15
Front (HF) mm (in)	658 (25.91)	660 (25.98)	649 (25.55)	659 (25.94)	664 (26.14)
Rear (Hr) mm (in)	653 (25.71)	652 (25.67)	643 (25.31)	653 (25.71)	658 (25.91)

*: Fuel, radiator coolant and engine oil full. Spare tire, jack, hand tools and mats in designated positions.

WHEEL RUNOUT

NISU0023

Wheel type	Aluminum	Steel wheel
Radial runout limit mm (in)	0.3 (0.012)	0.5 (0.020)
Lateral runout limit mm (in)	0.3 (0.012)	0.8 (0.031)

REAR SUSPENSION

Precautions

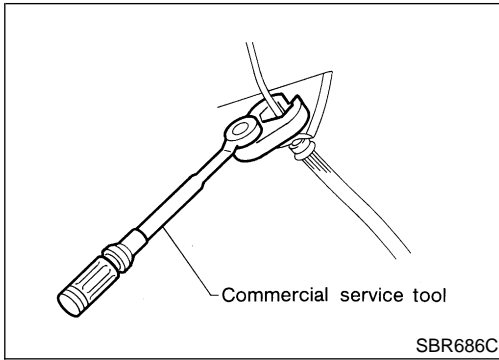

Precautions PRECAUTIONS

- When installing each rubber part, final tightening must be carried out under unladen condition* with tires on ground. Oil will shorten the life of rubber bushings. Be sure to wipe off any spilled oil.
*: Fuel, radiator coolant and engine oil full. Spare tire, jack, hand tools and mats in designated positions.
- Use flare nut wrench when removing or installing brake tubes.
- After installing removed suspension parts, check wheel alignment.
- Do not jack up at the trailing arm and lateral link.
- Always torque brake lines when installing.
- Lock nuts are un reusable parts; always use new ones. When replacing, do not wipe the oil off of the new lock nut before tightening.

NISU0024

GI

MA

EM

LC

EC

FE

CL

MT

Preparation

COMMERCIAL SERVICE TOOLS

NISU0026

Tool name	Description
Equivalent to GG94310000 1 Flare nut crowfoot 2 Torque wrench	<p>Removing and installing brake piping a: 10 mm (0.39 in)</p> <p>NT360</p>
Spring compressor	<p>Removing and installing coil spring</p> <p>NT717</p>

AT

AX

SU

BR

ST

RS

BT

HA

Noise, Vibration and Harshness (NVH) Troubleshooting

Refer to "Noise, Vibration and Harshness (NVH) Troubleshooting", SU-4.

NISU0027

EL

IDX

REAR SUSPENSION

Components

Components

NISU0028

SEC.431

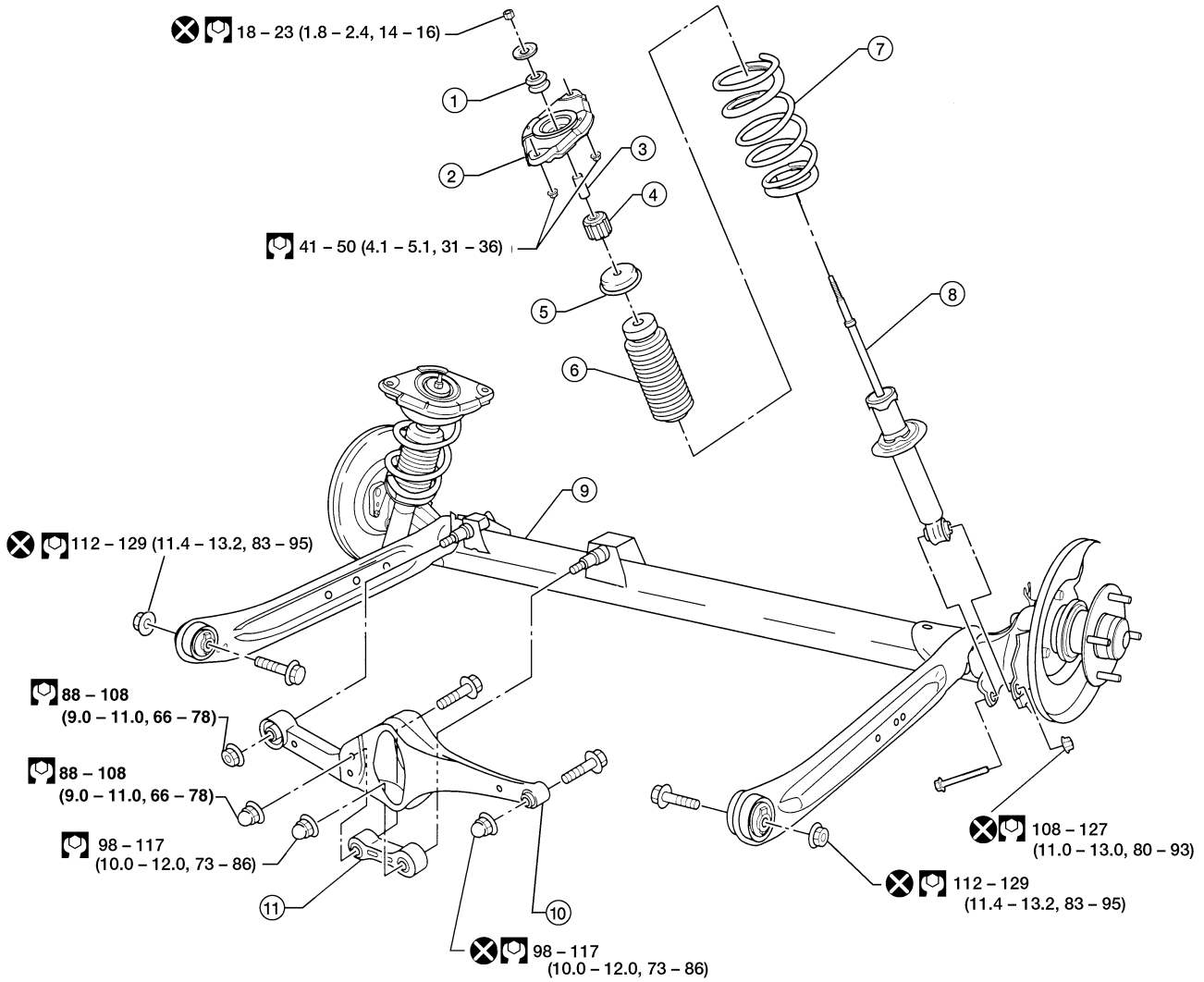

: N·m (kg·m, ft·lb)

WSU006

- | | | |
|------------------------------------|-----------------------|------------------|
| 1. Bushing | 5. Bound bumper cover | 9. Torsion beam |
| 2. Shock absorber mounting bracket | 6. Bound bumper | 10. Lateral link |
| 3. Distance tube | 7. Coil spring | 11. Control rod |
| 4. Distance tube bushing | 8. Shock absorber | |

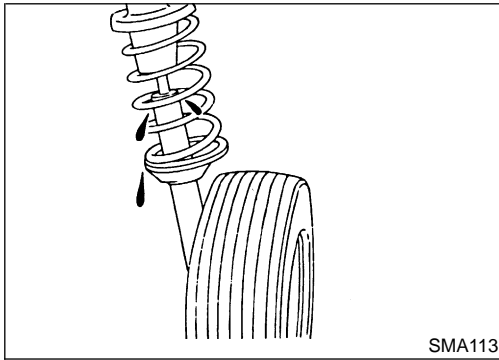
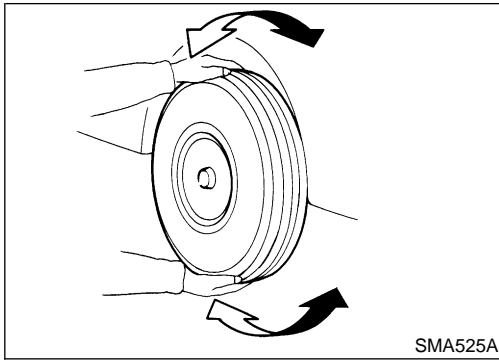

On-vehicle Service

REAR SUSPENSION PARTS

NISU0029

Check axle and suspension parts for excessive play, wear or damage.

- Shake each rear wheel to check for excessive play.
- Retighten all nuts and bolts to the specified torque.

Tightening torque:

Refer to "REAR SUSPENSION", SU-16.

- Check shock absorber for oil leakage or other damage.
- Check wheelarch height. Refer to "On-vehicle Service", SU-6.

REAR WHEEL ALIGNMENT

NISU0030

Before checking rear wheel alignment, be sure to make a preliminary inspection (Unladen*).

*: Fuel, radiator coolant and engine oil full. Spare tire, jack, hand tools and mats in designated positions.

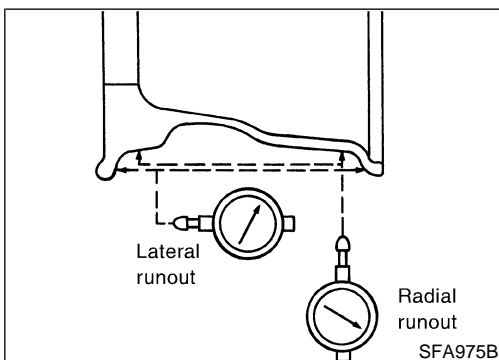

Preliminary Inspection

Aluminum wheel

NISU0030S01

NISU0030S0101

1. Check tires for wear and improper inflation.
2. Check wheels for deformation, cracks and other damage. If deformed, remove wheel and check wheel runout.
 - a. Remove tire from aluminum wheel and mount on a tire balance machine.
 - b. Set dial indicator as shown in the illustration.
 - Wheel runout (Dial indicator value):
 - Refer to "WHEEL RUNOUT", SU-25.
3. Check front wheel bearings for looseness.
4. Check front suspension for looseness.
5. Check steering linkage for looseness.
6. Check that front shock absorbers work properly.
7. Check vehicle wheelarch height (unladen*).

*: Fuel, radiator coolant and engine oil full. Spare tire, jack, hand tools and mats in designated positions.

REAR SUSPENSION

On-vehicle Service (Cont'd)

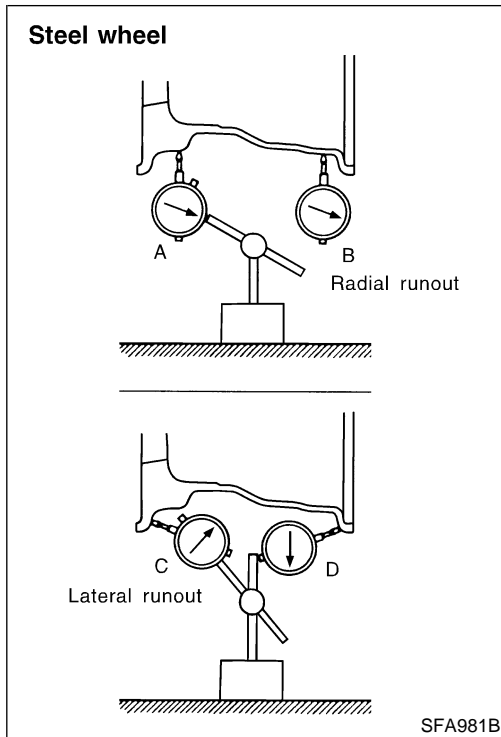

Steel wheel

NISU0030S0102

1. Check tires for wear and improper inflation.
2. Check wheels for deformation, cracks and other damage. If deformed, remove wheel and check wheel runout.
 - a. Remove tire from steel wheel and mount wheel on a tire balance machine.
 - b. Set two dial indicators as shown in the illustration.
 - c. Set each dial indicator to 0.
 - d. Rotate wheel and check dial indicators at several points around the circumference of the wheel.
 - e. Calculate runout at each point as shown below.
Radial runout = $(A + B)/2$
Lateral runout = $(C + D)/2$
 - f. Select maximum positive runout value and the maximum negative value. Add the two values to determine total runout. In case a positive or negative value is not available, use the maximum value (negative or positive) for total runout. If the total runout value exceeds the limit, replace steel wheel.

Wheel runout:

Refer to "WHEEL RUNOUT", SU-14.

3. Check front wheel bearings for looseness.
4. Check front suspension for looseness.
5. Check steering linkage for looseness.
6. Check that front shock absorbers work properly.
7. Check vehicle wheelarch height (unladen*).

*: Fuel, radiator coolant and engine oil full. Spare tire, jack, hand tools and mats in designated positions.

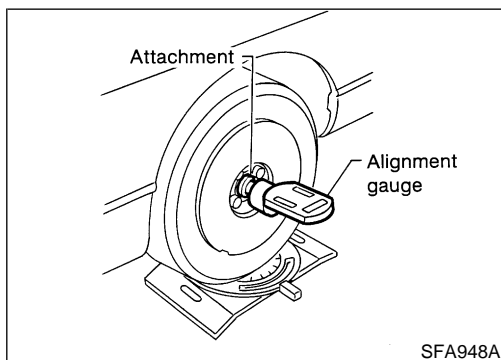

Camber

Camber is preset at factory and cannot be adjusted.

NISU0030S02

Camber:

Refer to "REAR WHEEL ALIGNMENT (UNLADEN*)", SU-25.

- If the camber is not within specification, inspect and replace any damaged or worn rear suspension parts.

REAR SUSPENSION

On-vehicle Service (Cont'd)

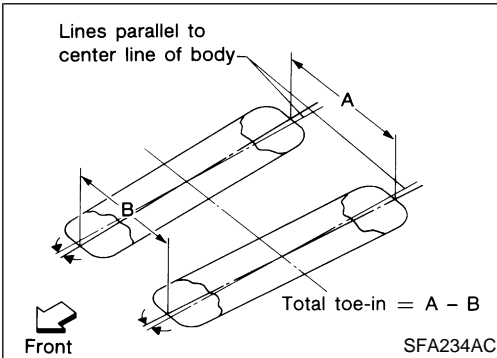
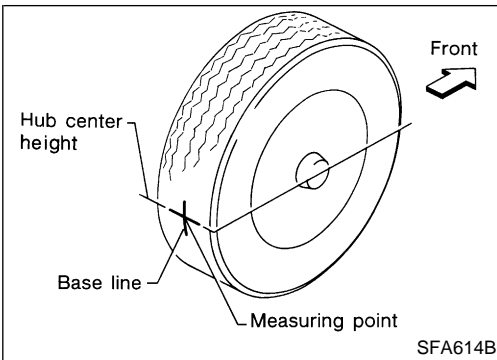

Toe-in

NISU0030S03

Toe-in is preset at factory and cannot be adjusted. Measure toe-in using following procedure. If out of specification, inspect and replace any damaged or worn rear suspension parts.

WARNING:

- Perform following procedure always on a flat surface.
 - Make sure that no person is in front of the vehicle before pushing it.
1. Bounce rear of vehicle up and down to stabilize the posture.
 2. Push the vehicle straight ahead about 5 m (16 ft).
 3. Put a mark on base line of the tread (rear side) of both tires at the same height of hub center. This mark is a measuring point.
 4. Measure distance "A" (rear side).
 5. Push the vehicle slowly ahead to rotate the wheels 180 degrees (1/2 turn).

If the wheels have rotated more than 180 degrees (1/2 turn), try the above procedure again from the beginning. Never push vehicle backward.

6. Measure distance "B" (front side).

Total toe-in: A - B

Refer to "REAR WHEEL ALIGNMENT (UNLADEN*)", SU-25.

GI
MA
EM
LC
EC
FE
CL
MT
AT
AX
SU
BR
ST
RS
BT
HA
SC
EL
IDX

REAR SUSPENSION

Removal and Installation

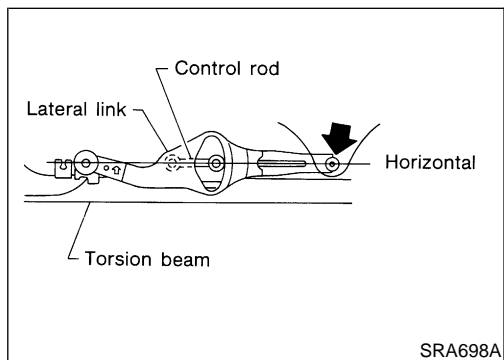
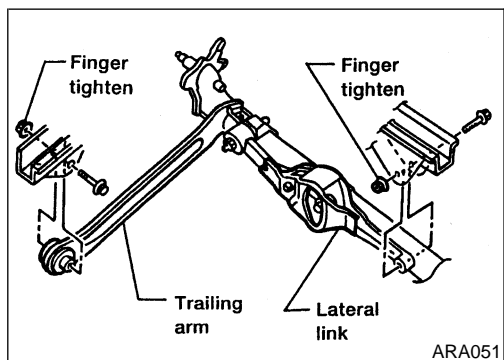
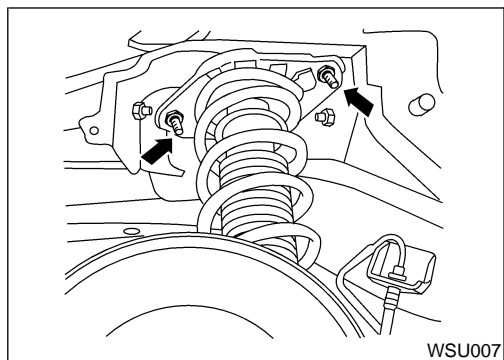
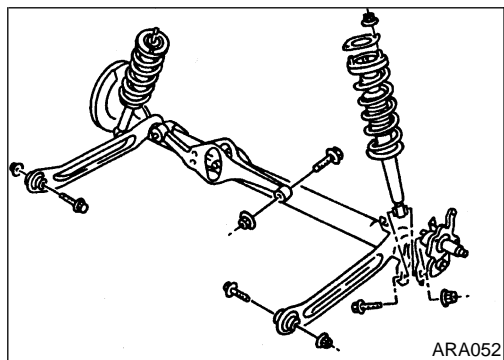
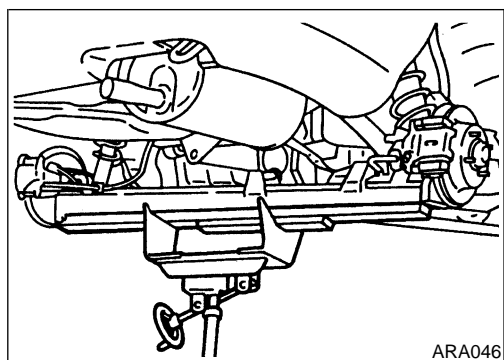

Removal and Installation

REMOVAL

NISU0031

NISU0031S01

CAUTION:

- Before removing the rear suspension assembly, disconnect the ABS wheel sensor from the assembly. Failure to do so may result in damaged sensor wires and sensor becoming inoperative.
 - Drain brake fluid before disconnecting brake lines.
1. Disconnect brake hydraulic lines and parking brake cables at toggle levers. (Models with drum brakes.)
 2. Disconnect brake hydraulic lines and parking brake cables from calipers and remove brake calipers and rotors. (Models with disc brakes.)
 3. Using a transmission jack, raise torsion beam a little, and remove nuts and bolts from the trailing arms, shock absorber assemblies (lower side) and lateral link.
 4. Lower transmission jack and remove suspension.
 5. Remove luggage compartment trim. Refer to **BT-30**, "TRUNK ROOM TRIM".
 6. Remove shock absorber fixing nuts (upper side). Then pull out shock absorber assemblies.

INSTALLATION

NISU0031S02

CAUTION:

- Refill with new brake fluid DOT 3.
- Never reuse drained brake fluid.

1. Attach torsion beam at trailing arm and lateral link to vehicle. Do not tighten bolts at this time.
2. Using a transmission jack, place lateral link and control rod horizontally against torsion beam. Tighten lateral link on vehicle.
3. Attach shock absorber assembly to vehicle. Then tighten the lower side of shock absorber assembly.
4. Lower torsion beam to fully extended position. Remove transmission jack and tighten torsion beam, at trailing arm, to specified torque. Refer to "Components", SU-16.

REAR SUSPENSION

Removal and Installation (Cont'd)

5. Install brake hydraulic lines and tighten flare nuts.
🔧 : 15 - 18 N·m (1.5 - 1.8 kg·m, 11 - 13 ft·lb)
6. Bleed air. Refer to **BR-8**, "Bleeding Brake System".
7. Install ABS wheel sensor.

GI

MA

EM

LC

Coil Spring and Shock Absorber

REMOVAL AND INSTALLATION

Remove shock absorber upper and lower fixing nuts.

Do not remove piston rod lock nut on vehicle.

NISU0032

EC

FE

CL

MT

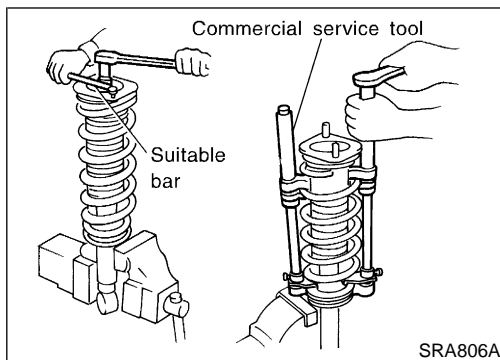

DISASSEMBLY

1. Set shock absorber in vise, then **loosen** piston rod lock nut. **Do not remove piston rod lock nut at this time.**
2. Compress spring with Tool so that the shock absorber upper spring seat can be turned by hand.

NISU0033

AT

AX

WARNING:

Make sure that the pawls of the two spring compressors are firmly hooked on the spring. The spring compressors must be tightened alternately so as not to tilt the spring.

SU

3. Remove piston rod lock nut.

BR

INSPECTION

Shock Absorber Assembly

- Check for smooth operation through a full stroke, both compression and extension.
- Check for oil leakage on welded or gland packing portions.
- Check piston rod for cracks, deformation or other damage. Replace if necessary.

NISU0034

ST

NISU0034S01

RS

BT

Upper Rubber Seat and Bushing

Check rubber parts for deterioration or cracks.
Replace if necessary.

NISU0034S02

HA

Coil Spring

Check for cracks, deformation or other damage. Replace if necessary.

NISU0034S03

SC

EL

IDX

REAR SUSPENSION

Coil Spring and Shock Absorber (Cont'd)

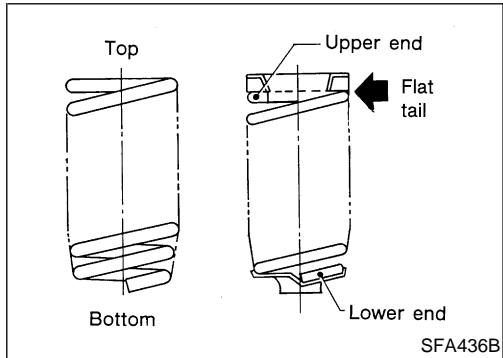
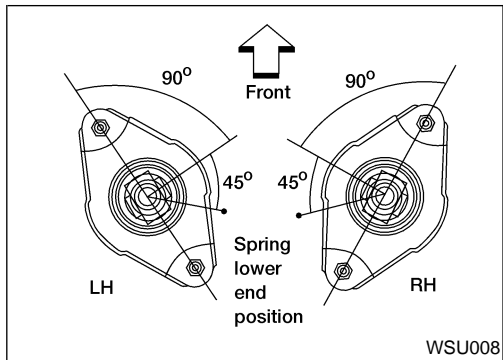

ASSEMBLY

NISU0035

- Locate upper spring seat as shown.

- When installing coil spring, be careful not to reverse top and bottom direction. (Top end is flat.)
- When installing coil spring on shock absorber, it must be positioned as shown in figure at left.

CAUTION:

Do not reuse piston rod lock nut.

Torsion Beam, Lateral Link and Control Rod DISASSEMBLY

NISU0036

- Remove torsion beam assembly. Refer to "Removal and Installation", SU-20.
- Remove lateral link and control rod from torsion beam.

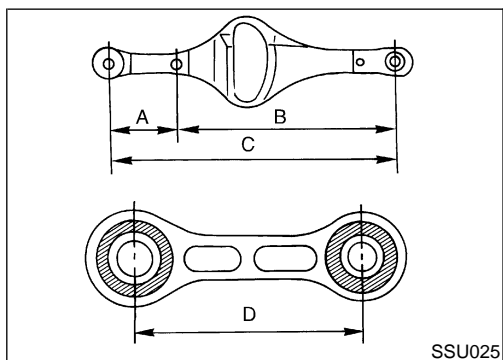

INSPECTION

NISU0037

- Check for cracks, distortion or other damage. Replace if necessary.

Standard length:

A 207 - 208 mm (8.15 - 8.19 in)

B 394 - 395 mm (15.51 - 15.55 in)

C 601 - 603 mm (23.66 - 23.74 in)

D 106 - 108 mm (4.17 - 4.25 in)

- Check all rubber parts for wear, cracks or deformation. Replace if necessary.

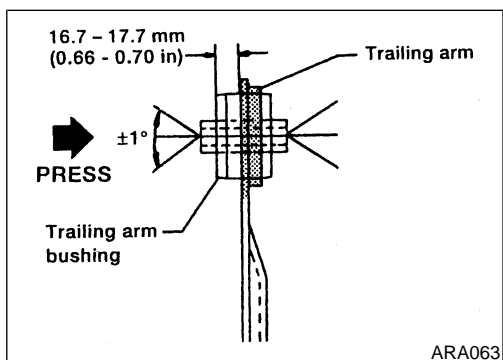

RUBBER BUSHING REPLACEMENT

NISU0042

Trailing Arm

NISU0042S01

Trailing arm bushings are press fit and must be centered properly in trailing arm collars.

1. Press out old bushing from trailing arm collar.
 2. Press in new bushing until inside edge of bushing is 16.7 to 17.7 mm (0.66 to 0.70 in) from inside edge of trailing arm.
- Do not allow bushing to incline more than 1 degree.
 - During installation, do not allow trailing arm to bend or twist.

REAR SUSPENSION

Torsion Beam, Lateral Link and Control Rod (Cont'd)

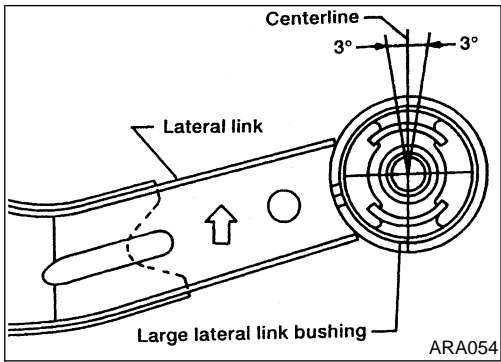

Lateral Link

NISU0042S02

Lateral link bushings are press fit. The large lateral link bushing is directional and must be installed in a specific position.

1. Remove lateral link.
2. Press out bushings. Note installation position of large bushing before removing.
3. Press in small bushing until bushing is centered in lateral link collar.
4. Press in large bushing until bushing is centered in lateral link collar.
 - a. Position bushing on lateral link collar.
 - b. Angle between bushing centerline and collar centerline must be within 3 degrees as shown in illustration.

Control Rod

NISU0042S03

Control rod bushings are not replaceable. If bushings are worn or damaged, replace control rod.

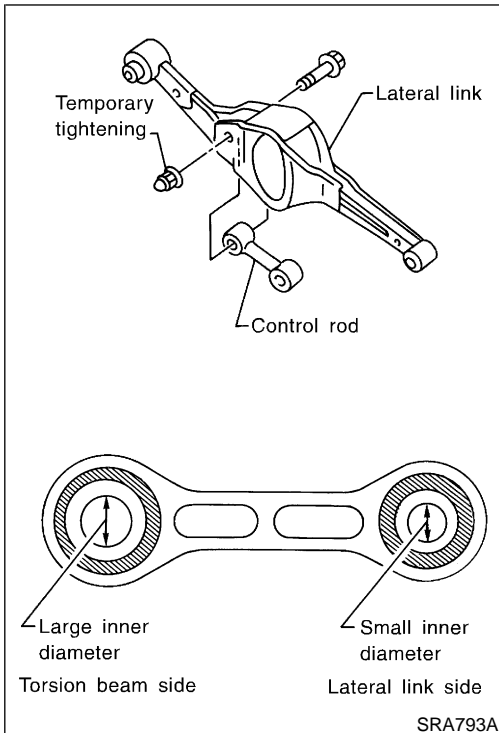

ASSEMBLY

NISU0038

1. Temporarily assemble lateral link and control rod.
 - When installing the control rod, connect the bushing with the smaller inner diameter to the lateral link.

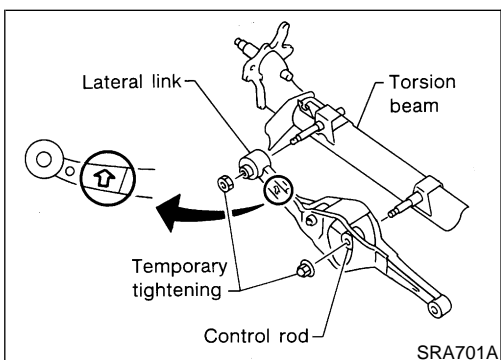

2. Temporarily install lateral link and control rod on torsion beam.
 - When installing, place lateral link with the arrow topside.

GI

MA

EM

LC

EC

FE

CL

MT

AT

AX

SU

BR

ST

RS

BT

HA

SC

EL

IDX

REAR SUSPENSION

Torsion Beam, Lateral Link and Control Rod (Cont'd)

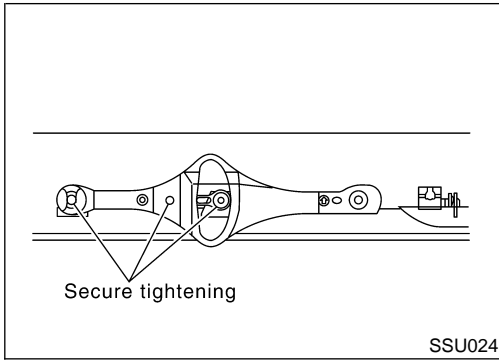

3. Place lateral link and control rod horizontally against torsion beam, and tighten to the specified torque.
4. Install torsion beam assembly. Refer to "Removal and Installation", SU-20.

REAR SUSPENSION

Service Data and Specifications (SDS)

Service Data and Specifications (SDS)

GENERAL SPECIFICATIONS (REAR)

=NISU0039

Suspension type	Multi-link beam suspension
Shock absorber type	Double-acting hydraulic

REAR WHEEL ALIGNMENT (UNLADEN*)

NISU0040

Camber Degree minute (Decimal degree)		Minimum	-1°45' (-1.75°)
		Nominal	-1°00' (-1.00°)
		Maximum	-0°15' (-0.25°)
Total toe-in	Distance (A - B) mm (in)	Minimum	-3 (-0.12)
		Nominal	1 (0.04)
		Maximum	5 (0.20)
	Angle (left plus right) Degree minute (Decimal degree)	Minimum	-16' (-0.27°)
		Nominal	5'30" (0.09°)
		Maximum	26' (0.43°)

*: Fuel, radiator coolant and engine oil full. Spare tire, jack, hand tools and mats in designated positions.

WHEELARCH HEIGHT (UNLADEN*)

NISU0044

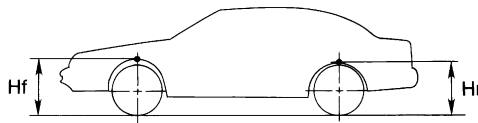

SFA818A

Engine	SR20DE		QG18DE		QG18DE Calif. CA Model
Tire Size	195/60R15	195/55R16	185/65R14	195/60R15	195/60R15
Front (HF) mm (in)	658 (25.91)	660 (25.98)	649 (25.55)	659 (25.94)	664 (26.14)
Rear (Hr) mm (in)	653 (25.71)	652 (25.67)	643 (25.31)	653 (25.71)	658 (25.91)

*: Fuel, radiator coolant and engine oil full. Spare tire, jack, hand tools and mats in designated positions.

WHEEL RUNOUT

NISU0043

Wheel type	Aluminum	Steel wheel
Radial runout limit mm (in)	0.3 (0.012)	0.5 (0.020)
Lateral runout limit mm (in)	0.3 (0.012)	0.8 (0.031)

NOTES