

# RESTRAINT SYSTEM

## SECTION RS

### CONTENTS

<b>PRECAUTIONS AND PREPARATION</b> ..... 2	Front Passenger Air Bag Module ..... 17
Supplemental Restraint System (SRS)	Removal..... 17
“AIR BAG” ..... 2	Installation..... 18
<b>SEAT BELTS</b> ..... 3	Disposal of Air Bag Module ..... 19
Front Seat Belt..... 4	Checking Deployment Tool..... 19
Removal..... 5	Deployment Procedures For Air Bag
Rear Seat Belt ..... 6	Module (Outside of vehicle) ..... 20
Removal..... 7	Deployment of Air Bag Module While
Seat Belt Inspection..... 8	Mounted In Vehicle..... 22
<b>SUPPLEMENTAL RESTRAINT SYSTEM (SRS)</b> ..... 11	Disposing of Air Bag Module..... 22
Precautions for SRS “AIR BAG” Service..... 11	<b>TROUBLE DIAGNOSES — Supplemental</b>
Special Service Tools..... 11	<b>Restraint System (SRS)</b> ..... 23
Description ..... 12	Trouble Diagnosis Introduction ..... 23
SRS Component Parts Location..... 12	How to Perform Trouble Diagnoses for Quick
Maintenance Items..... 13	and Accurate Repair ..... 26
Diagnosis Sensor Unit ..... 14	Schematic ..... 27
Removal And Installation..... 14	Wiring Diagram –SRS– ..... 28
Driver Air Bag Module and Spiral Cable ..... 15	Self-diagnosis..... 30
Removal..... 15	Trouble Diagnoses for Air Bag Warning Lamp..... 43
Installation..... 16	<b>COLLISION DIAGNOSIS</b> ..... 45

**When you read wiring diagrams:**

- Read GI section, “HOW TO READ WIRING DIAGRAMS”.
- See EL section, “POWER SUPPLY ROUTING” for power distribution circuit.

**When you perform trouble diagnoses, read GI section, “HOW TO FOLLOW FLOW CHART IN TROUBLE DIAGNOSES” and “HOW TO PERFORM EFFICIENT DIAGNOSIS FOR AN ELECTRICAL INCIDENT”.**

GI

MA

EM

LC

EC

FE

CL

MT

AT

FA

RA

BR

ST

**RS**

BT

HA

EL

IDX

## PRECAUTIONS AND PREPARATION

---

### Supplemental Restraint System (SRS) “AIR BAG”

The Supplemental Restraint System “AIR BAG”, used along with a seat belt, helps to reduce the risk or severity of injury to the driver and front passenger in a frontal collision. The Supplemental Restraint System consists of air bag modules (located in the center of the steering wheel and in the instrument panel on the passenger side), a diagnosis sensor unit, warning lamp, wiring harness and spiral cable.

**WARNING:**

- To avoid rendering the SRS inoperative, which could increase the risk of personal injury or death in the event of a collision which would result in air bag inflation, all maintenance should be performed by an authorized NISSAN dealer.
- Improper maintenance, including incorrect removal and installation of the SRS, can lead to personal injury caused by unintentional activation of the system.
- Do not use electrical test equipment on any circuit related to the SRS unless instructed to in this Service Manual. SRS wiring harnesses are covered with yellow insulation either just before the harness connectors or on the complete harness, for easy identification.

# SEAT BELTS

---

## CAUTION:

- Do not disassemble buckle or seat belt assembly.
- Replace anchor bolts if they are deformed or worn out.
- Never oil tongue and buckle.
- If any component of seat belt assembly is questionable, do not repair. Replace the seat belt assembly.
- If webbing is cut, frayed, or damaged, replace seat belt assembly.
- When replacing seat belt assembly, use a genuine NISSAN seat belt assembly.
- After any collision, inspect all seat belt assemblies, including retractors and other attached hardware.

GI

MA

EM

LC

EC

FE

CL

MT

AT

FA

RA

BR

ST

**RS**

BT

HA

EL

IDX

# SEAT BELTS

## Front Seat Belt

SEC. 868

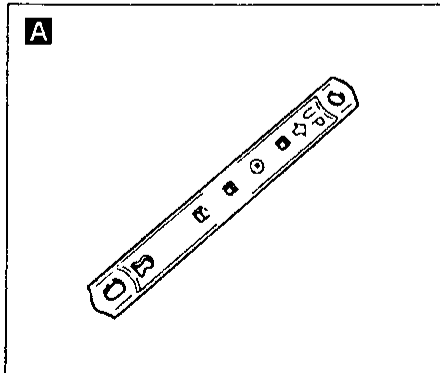
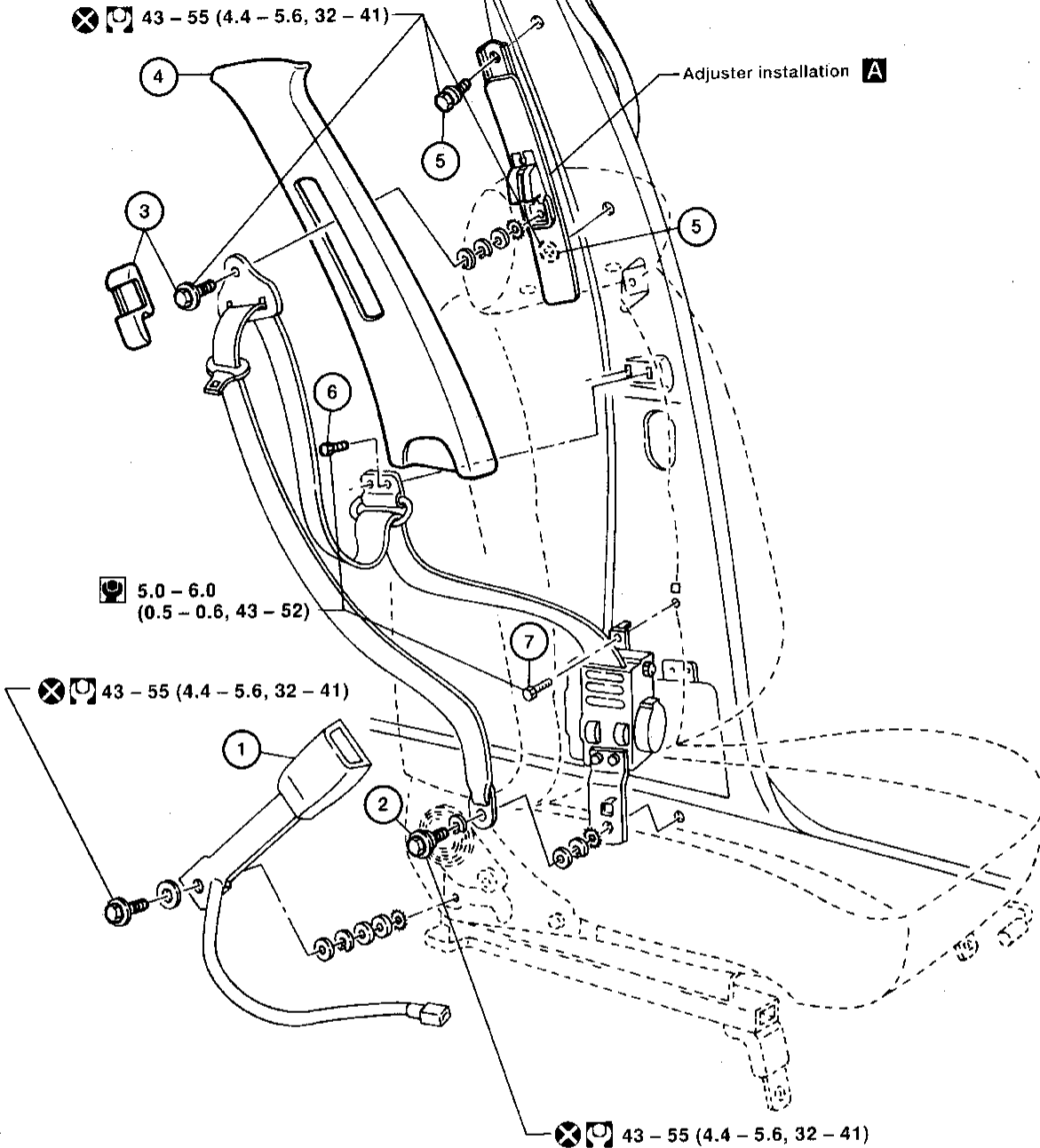

□ : N-m (kg-m, in-lb)

⊗ : N-m (kg-m, ft-lb)

# SEAT BELTS

## Front Seat Belt (Cont'd)

### REMOVAL

Remove front seat. Refer to BT section ("Front Seat", "SEAT").

- ① Remove buckle.  
Remove front and rear kick plates.
- ② Remove floor anchor bolt.  
Remove center pillar lower garnish.
- ③ Remove adjuster cover and pillar anchor bolt.
- ④ Remove center pillar upper garnish.
- ⑤ Remove two adjuster bolts and adjuster assembly. **A**
- ⑥ Remove two guide plate bolts.
- ⑦ Remove retractor bolt.  
Remove retractor.

GI

MA

EM

LC

EC

FE

CL

MT

AT

FA

RA

BR

ST

**RS**

BT

HA

EL

IDX



# SEAT BELTS

## Rear Seat Belt (Cont'd)

### REMOVAL

Remove rear seat cushion. Refer to BT section ("Rear Seat", "SEAT").

- ① Remove floor anchor bolt.
- ② Remove seat belt guide cover.  
Remove rear pillar garnish.
- ③ Remove pillar anchor bolt.  
Remove trunk side finisher.
- ④ Remove retractor bolt.
- ⑤ Remove retractor.

GI

MA

EM

LC

EC

FE

CL

MT

AT

FA

RA

BR

ST

**RS**

BT

HA

EL

IDX

# SEAT BELTS

## Seat Belt Inspection

### AFTER A COLLISION

#### WARNING:

Inspect all seat belt assemblies including retractors and attaching hardware after any collision. NISSAN recommends that all seat belt assemblies in use during a collision be replaced unless the collision was minor and the belts show no damage and continue to operate properly. Failure to do so could result in serious personal injury in an accident. Seat belt assemblies not in use during a collision should also be replaced if either damage or improper operation is noted.

Replace any seat belt assembly if:

- The seat belt was in use at the time of a collision (except for minor collisions when the belts, retractors and buckles show no damage and continue to operate properly.)
- The seat belt was damaged in an accident (i.e. torn webbing, bent retractor or guide, etc.).
- The seat belt attaching point was damaged in an accident. Inspect the seat belt attaching area for damage or distortion and repair as necessary before installing a new seat belt assembly.

### PRELIMINARY CHECKS

1. Check the seat belt warning lamp/chime for proper operation as follows:
  - a. Turn ignition switch ON. The seat belt warning lamp should illuminate. Also, the seat belt warning chime should sound for about seven seconds.
  - b. Fasten driver's seat belt. The seat belt warning lamp should go out and the chime (if sounding) should stop.
2. Check that the seat belt retractor, seat belt anchor and buckle bolts are securely attached.
3. Check the shoulder seat belt guide and shoulder belt height adjuster for front seats. Ensure guide swivels freely and that belt lays flat and does not bind in guide. Ensure height adjuster operates properly and holds securely.
4. Check retractor operation including:
  - a. Fully extend the seat belt webbing and check for twists, tears or other damage.

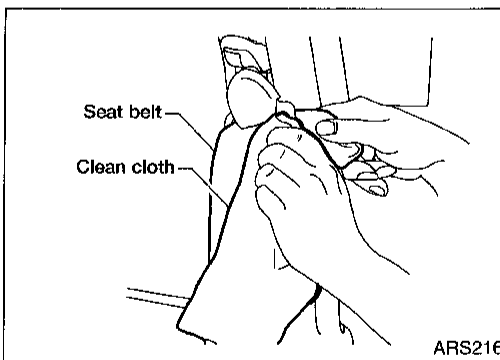

- b. Allow the seat belt to retract. Ensure that belt returns smoothly and completely into the retractor. If the seat belt does not return smoothly, wipe the inside of the loops with a clean paper cloth, etc. because dirt built up in the loops of the upper anchors can cause the seat belts to retract slowly.

- c. Fasten the seat belt. Pull firmly on belt and buckle to ensure belt remains latched. Unfasten seat belt. Ensure belt releases freely and buckle button returns to original position.
5. For center (non-retractable) seat belts, check that the seat belts are accessible. Check seat belt webbing for twists, tears or other damage. Fasten the seat belt. Pull firmly on belt and buckle to ensure belt remains latched. Unfasten seat belts. Ensure belt releases freely and buckle button returns to original position.
  6. Repeat steps above as necessary to check the other seat belts.



# SEAT BELTS

## Seat Belt Inspection (Cont'd)

### SEAT BELT RETRACTOR ON-VEHICLE CHECK

#### Emergency locking retractors (ELR) and Automatic locking retractors (ALR)

##### NOTE:

All seat belt retractors are of the Emergency Locking (ELR) type. In an emergency (sudden stop) the retractor will lock and prevent the belt from extending any further. All outboard 3-point type seat belt retractors except the driver's seat belt also have an Automatic Locking (ALR) mode. The ALR mode (also called child restraint mode) is used when installing child seats in outboard seating positions. The ALR mode is activated when the seat belt is fully extended. When the belt is then retracted partially, the ALR mode automatically locks the seat belt in a specific position so the belt cannot be extended any further. To cancel the ALR mode, allow the seat belt to fully wind back into the retractor.

Check the seat belt retractors using the following test(s) to determine if a retractor assembly is operating properly.

#### ELR function stationary check

Grasp the shoulder belt and pull forward quickly. The retractor should lock and prevent the belt from extending further.

#### ALR function stationary check

1. Pull out entire length of seat belt from retractor until a click is heard.
2. Retract the belt partially; a clicking noise should be heard as the belt retracts indicating retractor is in the automatic locking (ALR) mode.
3. Grasp the seat belt and try to pull out of retractor. Belt must lock and not extend further. If N.G., replace the retractor assembly.
4. Allow the entire length of belt to retract to cancel the automatic locking mode.

#### ELR function moving check (all outboard seating positions)

##### WARNING:

Perform the following test in a safe, open area clear of other vehicles and obstructions (for example, a large, empty parking lot). Road surface must be paved and dry. DO NOT perform the following test on wet or gravel roads or on public streets and highways. This could result in an accident and serious personal injury. The driver and passenger must be prepared to brace themselves in the event the retractor does not lock.

1. Fasten driver's seat belt. Buckle a passenger into the seat for the belt that is to be tested.
2. Proceed to the designated safe area.
3. Drive the vehicle at approximately 16 km/h (10 mph). Notify any passengers of a pending sudden stop. The driver and passenger must be prepared to brace themselves in the event the retractor does not lock. Apply brakes firmly and make a very hard stop.

During stop, seat belts should lock and not extend. If the seat belt retractor assembly does not lock, perform the retractor off-vehicle check.

GI

MA

EM

LC

EC

FE

CL

MT

AT

FA

RA

BR

ST

RS

BT

HA

EL

IDX

# SEAT BELTS

## Seat Belt Inspection (Cont'd)

### SEAT BELT RETRACTOR OFF-VEHICLE CHECK

1. Remove the seat belt retractor assembly.
2. Slowly pull out belt while tilting the retractor assembly forward from the mounted position as shown in the illustration.

**15 degrees or less tilt: Belt can be pulled out.**

**35 degrees or more tilt: Belt locks and cannot be pulled out.**

EX. (The mounted position and angle differ among models.)

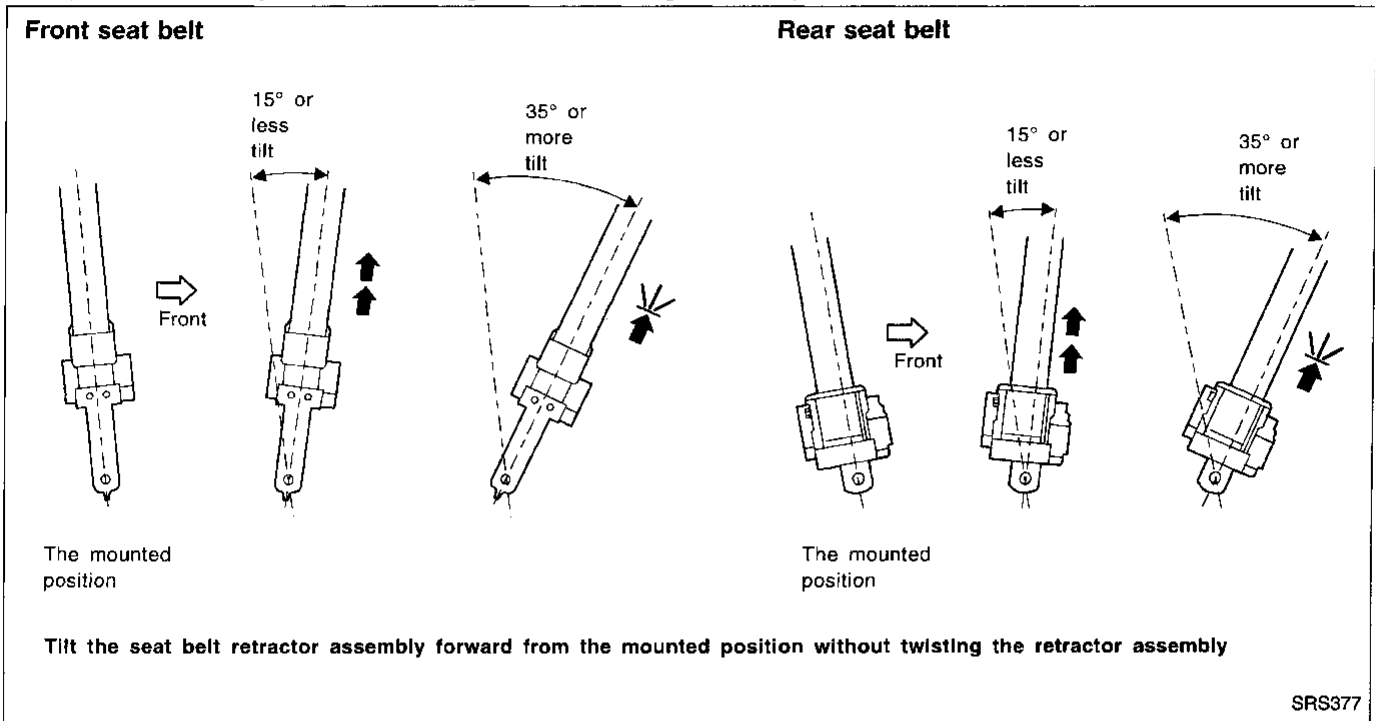

If NG replace the retractor assembly.

# SUPPLEMENTAL RESTRAINT SYSTEM (SRS)

## Precautions for SRS "AIR BAG" Service

- Do not use electrical test equipment on any circuit related to the SRS unless instructed to in this Service Manual. SRS wiring harnesses are covered with yellow insulation either just before the harness connectors or on the complete harness, for easy identification.
- Before servicing the SRS, turn ignition switch OFF, disconnect both battery cables and wait at least 3 minutes.  
For approximately 3 minutes after the cables are removed, it is still possible for the air bag to deploy. Therefore, do not work on any air bag system connectors or wires until at least 3 minutes have passed.
- Diagnosis sensor unit must always be installed with forward mark "⤴" pointing towards the front of the vehicle for proper operation. Also check diagnosis sensor unit for cracks, deformities or rust before installation and replace as required.
- The spiral cable must be aligned with the neutral position since its rotations are limited. Do not attempt to turn steering wheel or column after removal of steering gear.
- Handle air bag modules carefully. Always place them with the pad side facing upward.
- Do not use old bolts after removing any SRS parts; replace with new bolts. Conduct self-diagnosis to check entire SRS for proper function.
- After air bag inflates, the instrument panel assembly should be replaced if damaged.

## Special Service Tools

The actual shapes of Kent-Moore tools may differ from those of special service tools illustrated here.

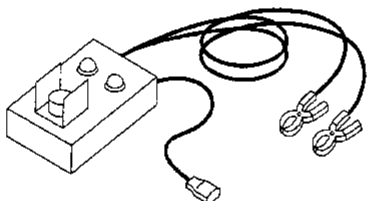
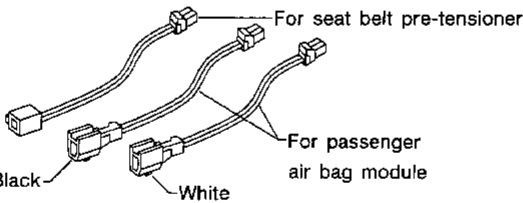
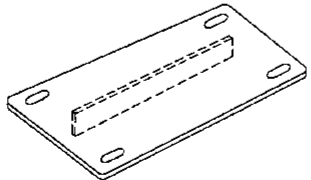
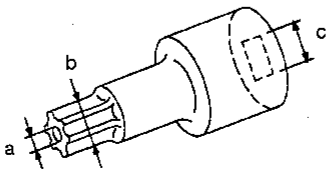
Tool number (Kent-Moore No.) Tool name	Description
KV991072S0 (J38381-KIT) Air bag deployment kit	Disposing of air bag module 
KV99106400 (J38381) Deployment tool	NT357
KV991065S0 (J38381-30) Deployment tool adapters	For seat belt pre-tensioner For passenger air bag module Black White 
KV99105300 (J41246) Air bag module bracket	Anchoring air bag module 
HT61961000 and HT62152000 combined (J38219) *Special torx bit	Use for special bolts [TAMPER RESISTANT TORX (Size T50)] a: 3.5 (0.138) dia. b: 8.5 - 8.6 (0.335 - 0.339) dia. c: approx. 10 (0.39) sq. 
NT361	Unit: mm (in)

\*: Special tool or commercial equivalent

# SUPPLEMENTAL RESTRAINT SYSTEM (SRS)

## Description

The air bags deploy if the diagnosis sensor unit activates while the ignition switch is in the ON or START position.

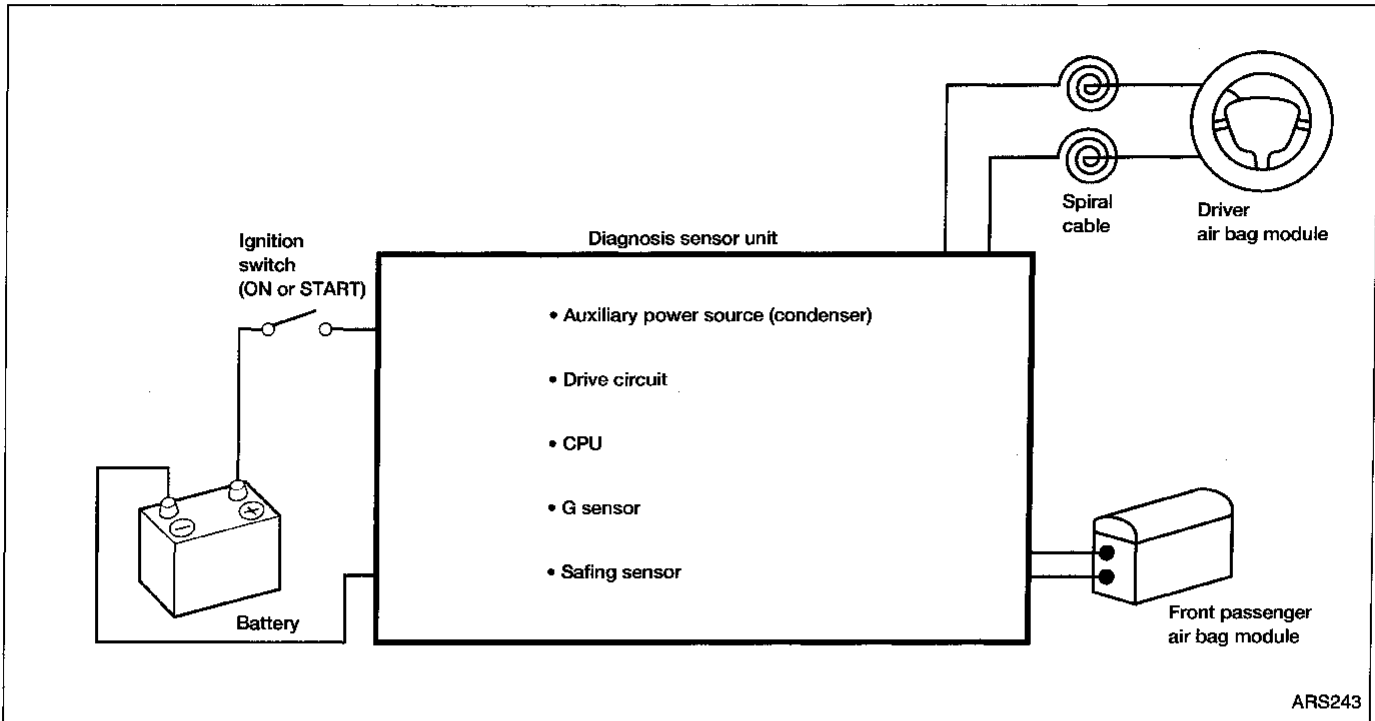

## SRS Component Parts Location

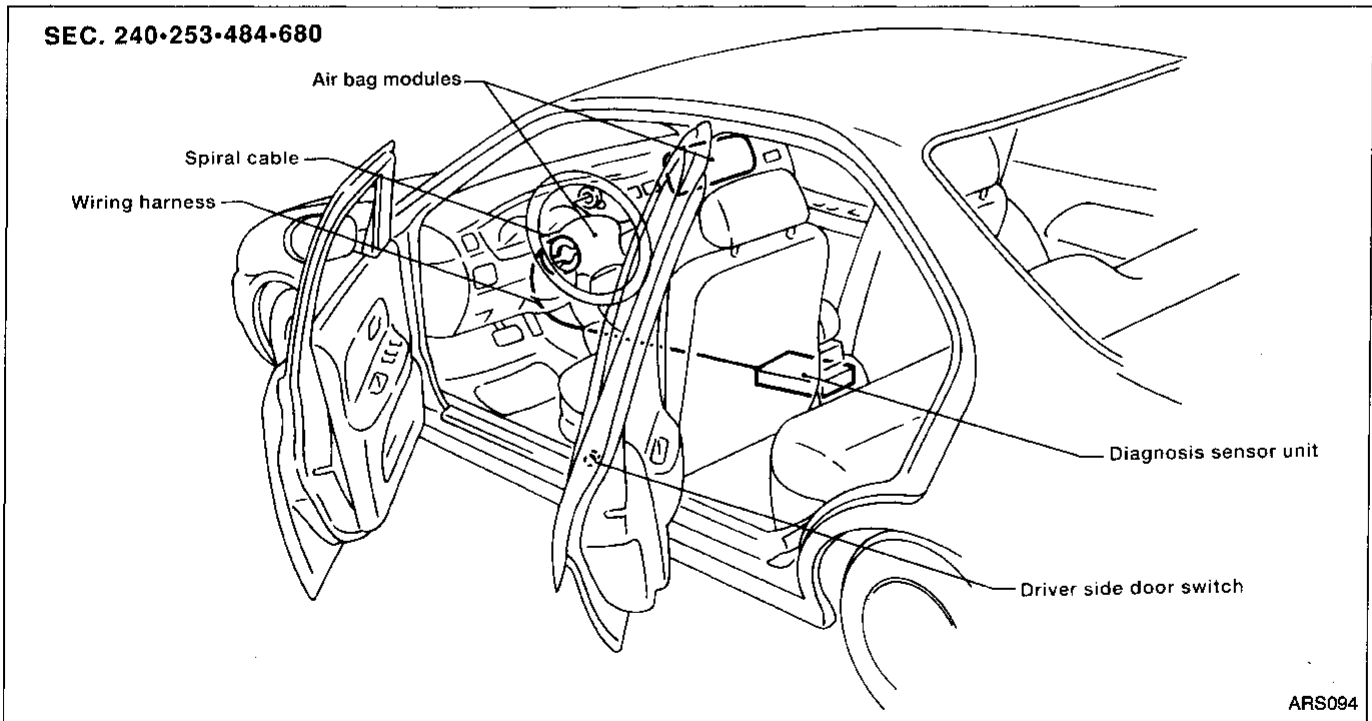

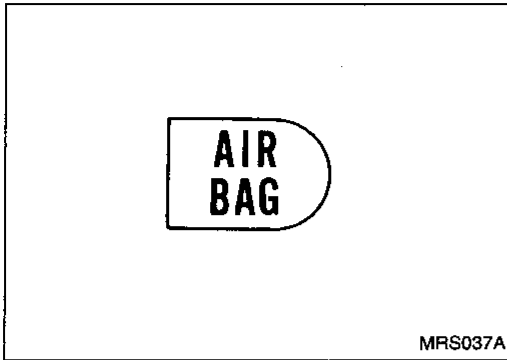

## Maintenance Items

1. Check "AIR BAG" warning lamp operation.
  - After turning the ignition switch ON, the "AIR BAG" warning lamp illuminates. The "AIR BAG" warning lamp will turn off after about 7 seconds if no malfunction is detected.
  - If any of the following "AIR BAG" warning lamp conditions occur, immediately check the air bag system. Refer to RS-30.
  - The warning lamp does not illuminate when the ignition switch is turned ON. GI
  - The warning lamp does not turn off about 7 seconds after the ignition switch is turned ON. MA
  - The warning lamp turns on or blinks about 7 seconds after the ignition switch is turned ON. EM
2. Visually check SRS components.
  - (1) Diagnosis sensor unit
    - Check diagnosis sensor unit and bracket for dents, cracks and deformities. LC
    - Check connectors for damage, and terminals for deformities. EC
  - (2) Air bag modules and steering wheel
    - Remove air bag module from steering wheel or instrument panel. Check harness cover and connectors for damage, terminals for deformities, and harness for binding. FE
    - Install driver air bag module in the steering wheel and check fit and alignment. CL
    - Check steering wheel for excessive free play. MT
    - Install front passenger air bag module in the instrument panel and check fit and alignment. AT
    - Check steering wheel for excessive free play. FA
    - Install front passenger air bag module in the instrument panel and check fit and alignment. RA
  - (3) Spiral cable
    - Check spiral cable and combination switch for damage. BR
    - Check connectors and protective tape for damage. ST
    - Check steering wheel for noise, binding and heavy operation. ST
  - (4) Main harness and air bag harness
    - Check connectors for poor connections, damage, and terminals for deformities. RS
    - Check harnesses for binding, chafing and cuts. BT

### CAUTION:

**Replace previously used special bolts and ground bolt with new ones.** HA

EL

IDX

# SUPPLEMENTAL RESTRAINT SYSTEM (SRS)

## Diagnosis Sensor Unit

### CAUTION:

- Before servicing SRS, turn the ignition switch OFF, disconnect both battery cables and wait at least 3 minutes.
- The special bolts are coated with a bonding agent while the other bolt is for ground. Do not use old bolts after removal; replace with new coated bolts.
- Check diagnosis sensor unit for proper installation.
- Check diagnosis sensor unit to ensure that there are no deformities, dents, cracks or rust. If there are any visible signs of damage, replace with a new one.
- Check diagnosis sensor unit brackets to ensure that they are free of deformities and rust.
- Replace diagnosis sensor unit if it has been dropped or sustained an impact.

### REMOVAL AND INSTALLATION

1. Disconnect driver and front passenger air bag module connectors.
2. Remove rear console. Refer to BT section, ("INSTRUMENT PANEL").
3. Disconnect diagnosis sensor unit connector.
4. Remove bolts from diagnosis sensor unit. Use TAMPER RESISTANT TORX (Size T50) to remove special bolts.
5. Remove the diagnosis sensor unit.

### NOTE:

- To install, reverse the removal procedure.
- After replacement, perform self-diagnosis for SRS. Refer to "TROUBLE DIAGNOSIS — Supplemental Restraint System (SRS)", "Self-diagnosis", RS-30.

### CAUTION:

Diagnosis sensor unit must always be installed with forward mark "⬅" pointing towards the front of the vehicle for proper operation. Also check diagnosis sensor unit for cracks, deformities and rust before installation and replace as required.

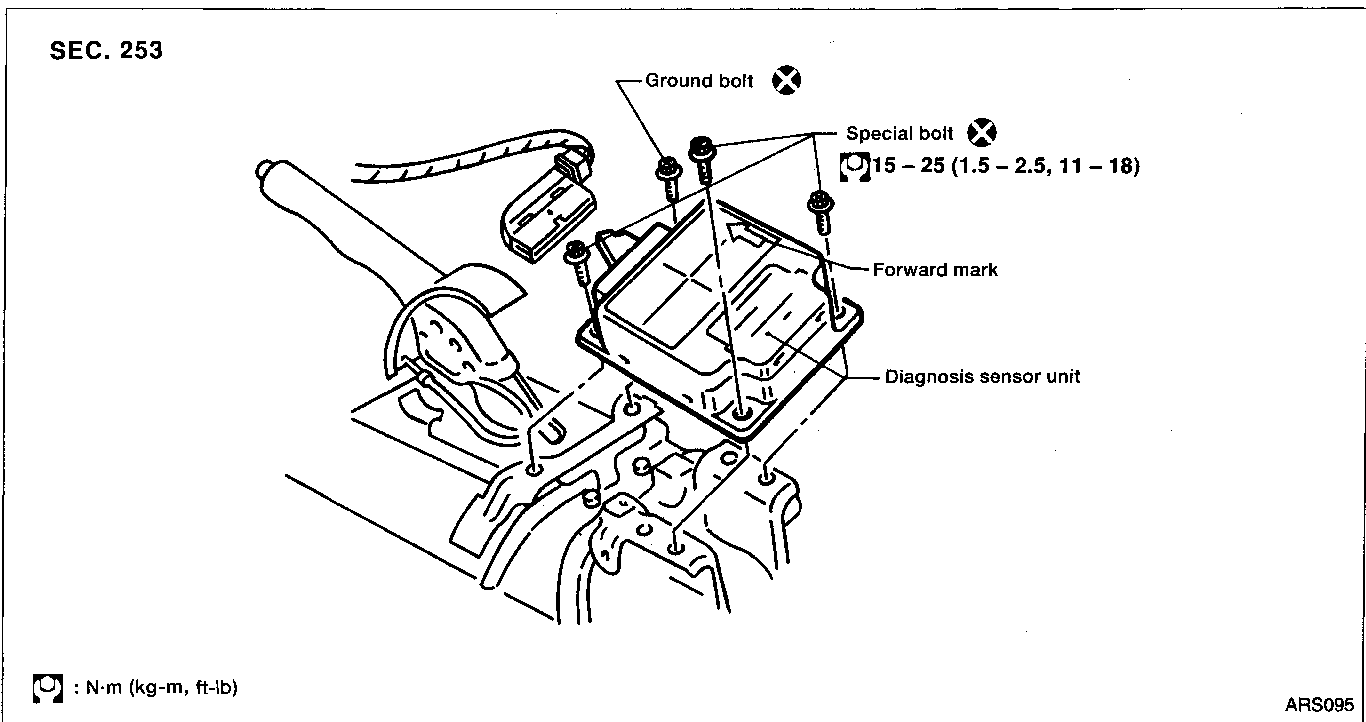

# SUPPLEMENTAL RESTRAINT SYSTEM (SRS)

## Driver Air Bag Module and Spiral Cable

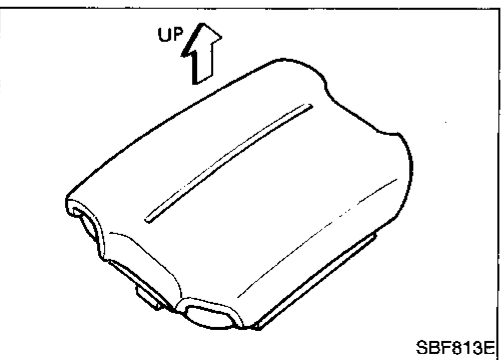
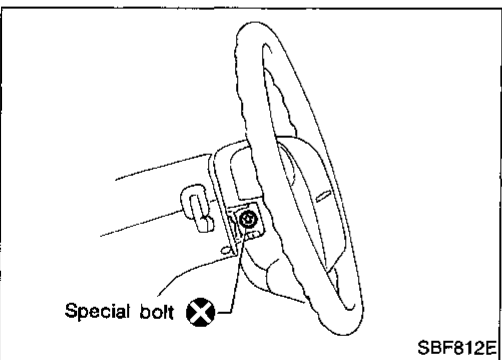
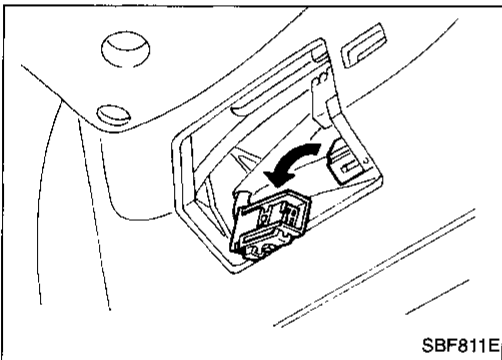
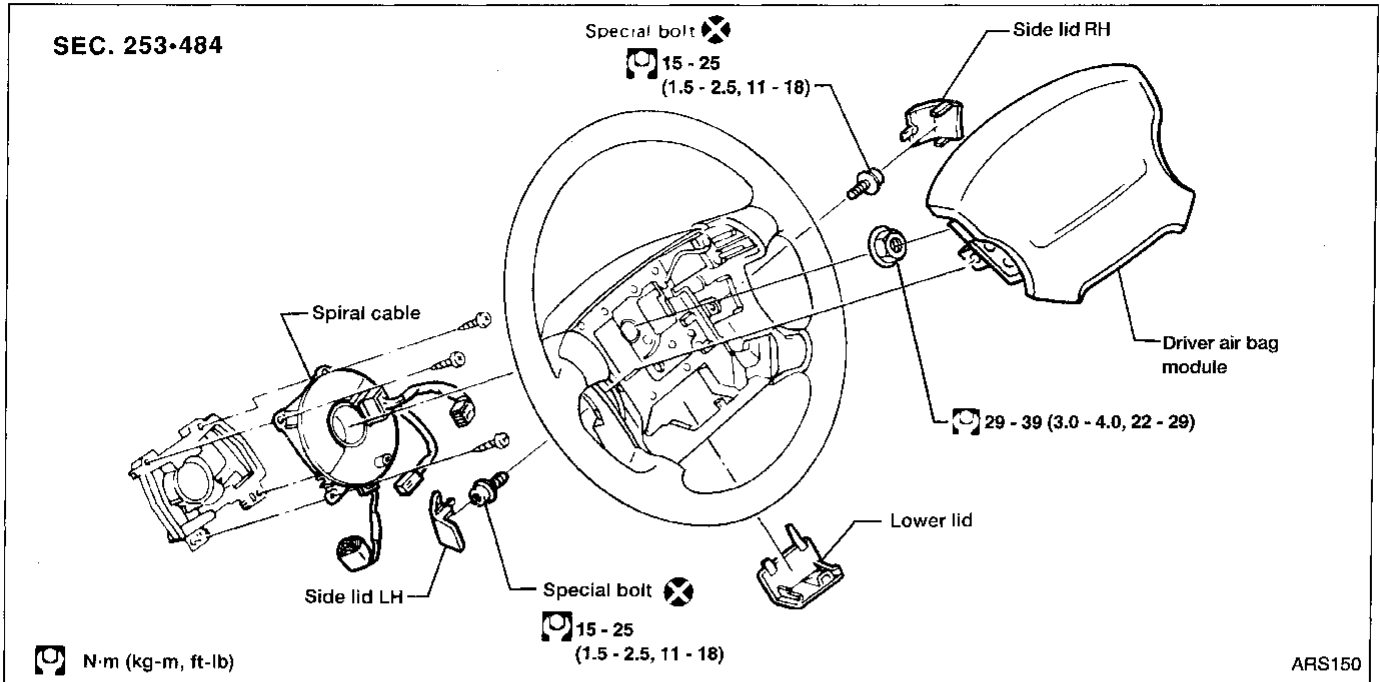

### REMOVAL

#### CAUTION:

- Before servicing SRS, turn the ignition switch OFF, disconnect both battery cables and wait for at least 3 minutes.
  - Always work from the side of air bag module.
1. Remove lower lid from steering wheel, and disconnect driver air bag module connector.
  2. Remove left and right side lids. Using the TAMPER RESISTANT TORX (Size T50), remove left and right special bolts. Driver air bag module can then be removed.

#### CAUTION:

- Always place air bag module with pad side facing upward.
- Do not attempt to disassemble air bag module.
- The special bolts are coated with a bonding agent. Do not use old bolts after removal; replace with new coated bolts.
- Do not insert any foreign objects (screwdriver, etc.) into air bag module connector.

GI  
MA  
EM  
LC  
EC  
FE  
CL  
MT  
AT  
FA  
RA  
BR  
ST  
RS  
BT  
HA  
EL  
IDX

## SUPPLEMENTAL RESTRAINT SYSTEM (SRS)

### Driver Air Bag Module and Spiral Cable (Cont'd)

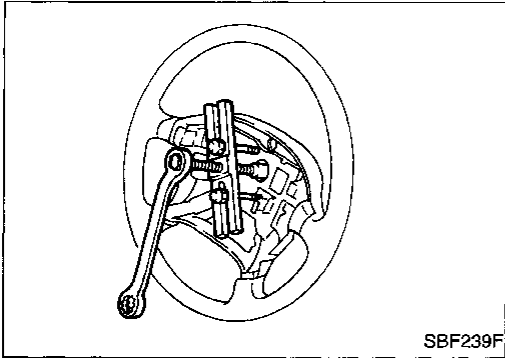
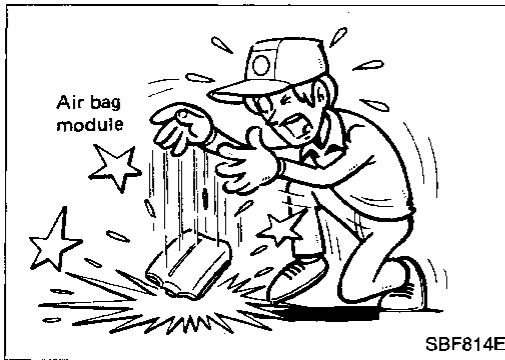

- Replace air bag module if it has been dropped or sustained an impact.
- Do not expose the air bag module to temperatures exceeding 90°C (194°F).
- Do not allow oil, grease or water to come in contact with the air bag module.

3. Set steering wheel in the neutral position.
4. Disconnect horn connector and remove steering wheel nut.
5. Using steering wheel puller, remove steering wheel. Be careful not to over-tighten puller bolt on steering wheel.

#### CAUTION:

**Do not tap or bump the steering wheel.**

6. Remove steering column covers.
7. Disconnect spiral cable connector.
8. Remove four spiral cable retaining screws. The spiral cable can then be removed.

#### CAUTION:

- Do not attempt to disassemble spiral cable.
- Do not apply lubricant to the spiral cable.

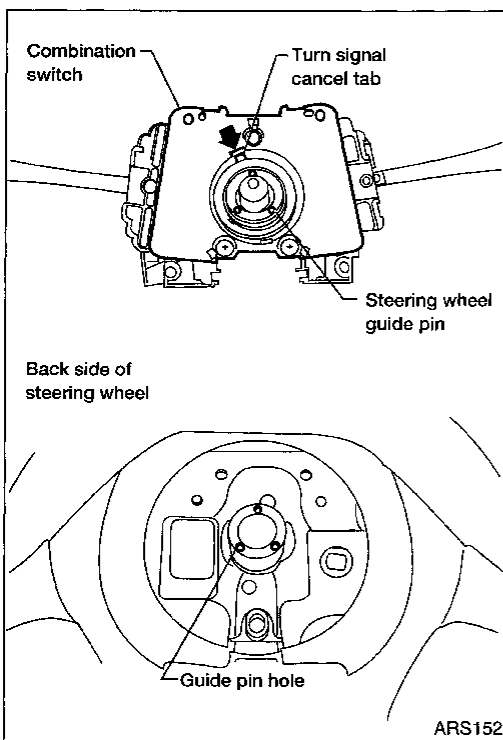

### INSTALLATION

1. Set the front wheels in the straight-ahead position.
2. Align the turn signal cancel tab with the notch of combination switch as shown.



# SUPPLEMENTAL RESTRAINT SYSTEM (SRS)

## Driver Air Bag Module and Spiral Cable (Cont'd)

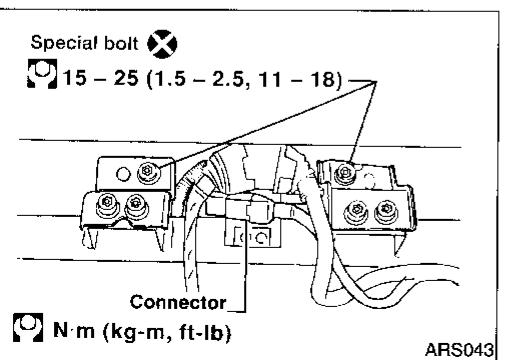
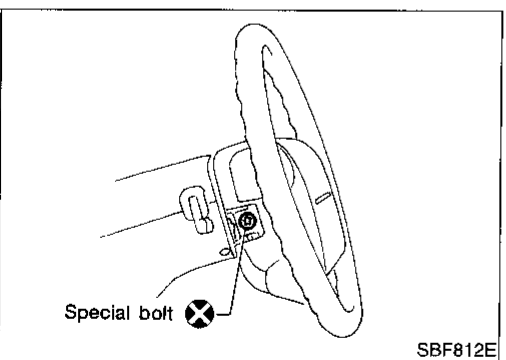
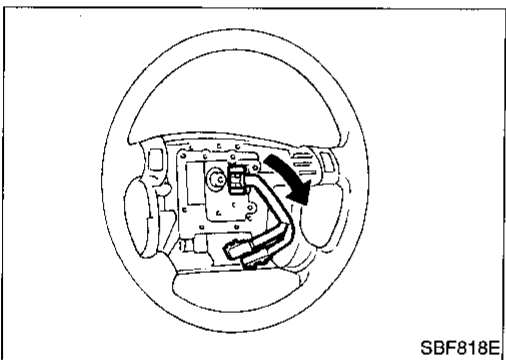
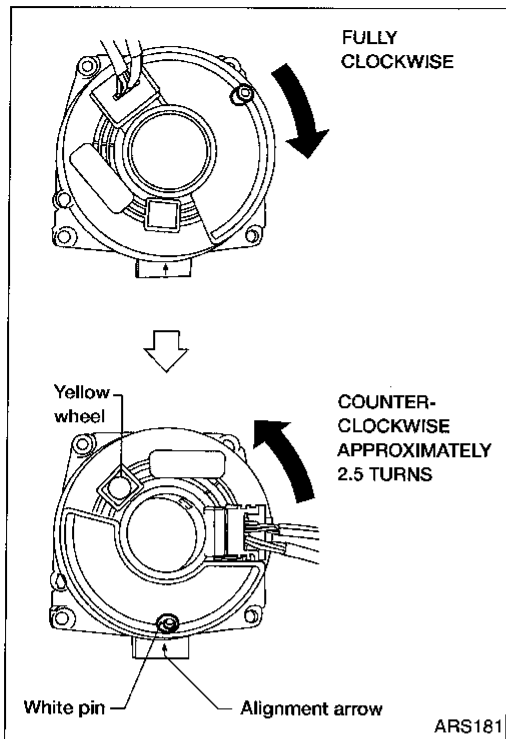

3. Rotate the spiral cable fully clockwise until tight.
  4. Rotate the spiral cable counterclockwise approximately 2.5 turns and align white pin with arrow on housing.
- When spiral cable is centered, white pin is aligned with arrow on housing and yellow wheel shows in window.

### CAUTION:

The spiral cable may snap during steering operation if the cable is installed improperly. Also, with the steering linkage disconnected, the cable may snap by turning the steering wheel more than 2.5 turns to the left or right of the neutral position.

5. Connect spiral cable and driver air bag harness connectors and tighten screws. Install steering column covers and driver side instrument lower panel.
6. Install steering wheel, setting spiral cable pin guide, and pull spiral cable through.
7. Connect horn connector and engage horn connector with pawls in steering wheel. Move driver air bag module connector away from steering wheel lower lid opening.
8. Tighten nut.  
Ⓜ: 29 - 39 N·m (3.0 - 4.0 kg-m, 22 - 29 ft-lb)
9. Position driver air bag module and tighten with new special bolts.  
Ⓜ: 15 - 25 N·m (1.5 - 2.5 kg-m, 11 - 18 ft-lb)
10. Connect driver air bag module connector.
11. Install ASCD switch and tighten screws.
12. Install all lids.
13. Connect both battery cables.
14. Conduct Self-diagnosis to ensure entire SRS operates properly. (Use CONSULT or warning lamp check.)
15. Turn steering wheel to the left end and then to the right end fully to make sure that spiral cable is set in the neutral position. If "AIR BAG" warning lamp blinks or stays on (in User mode), it shows the spiral cable may be snapped due to its improper position. Perform self-diagnosis again (Use CONSULT or warning lamp check). If a malfunction is detected, replace the spiral cable with a new one.

## Front Passenger Air Bag Module

### REMOVAL

#### CAUTION:

- Before servicing SRS, turn the ignition switch OFF, disconnect both battery cables and wait for at least 3 minutes.
  - Always work from the side of an air bag module.
1. Remove glove box lid and glove box.
  2. Disconnect front passenger air bag module connector.
  3. Using the TAMPER RESISTANT TORX (Size T50), remove two special bolts.

## SUPPLEMENTAL RESTRAINT SYSTEM (SRS)

### Front Passenger Air Bag Module (Cont'd)

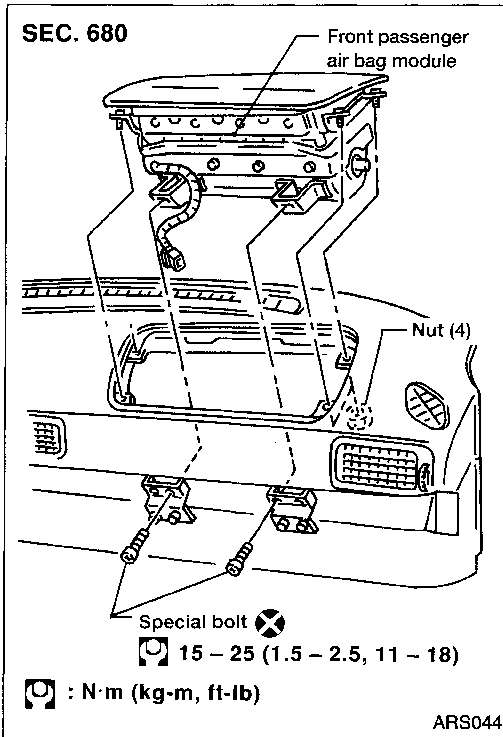

4. Remove four nuts.
  5. Remove front passenger air bag module.
- Air bag module is heavy and should be supported using both hands during removal.

#### CAUTION:

- Always place air bag module with pad side facing upward.
- Do not attempt to disassemble air bag module.
- The special bolts are coated with a bonding agent. Do not use old bolts after removal; replace with new coated bolts.
- Do not insert any foreign objects (screwdriver, etc.) into air bag module connector.



- Replace air bag module if it has been dropped or sustained an impact.
- Do not expose the air bag module to temperatures exceeding 90°C (194°F).
- Do not allow oil, grease or water to come in contact with the air bag module.

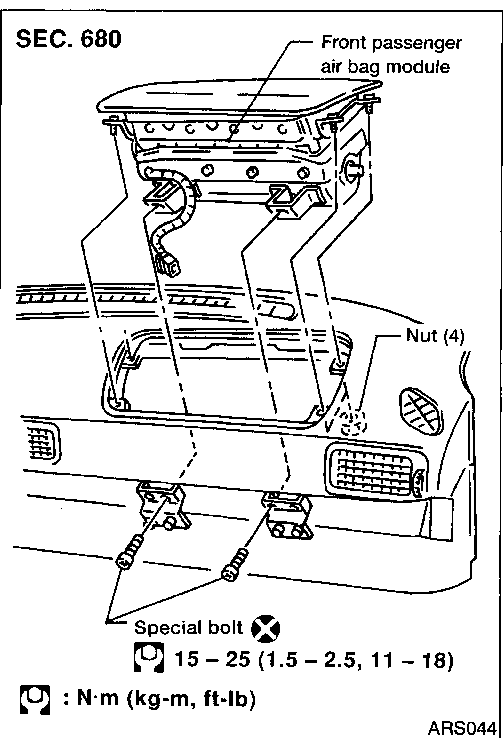

#### INSTALLATION

1. Install front passenger air bag module in instrument panel.
- Ensure that the harness is not caught between air bag module and support bracket.
  - Tighten four nuts.
  - Install two new special bolts using TAMPER RESISTANT TORX (Size T50).

## SUPPLEMENTAL RESTRAINT SYSTEM (SRS)

### Front Passenger Air Bag Module (Cont'd)

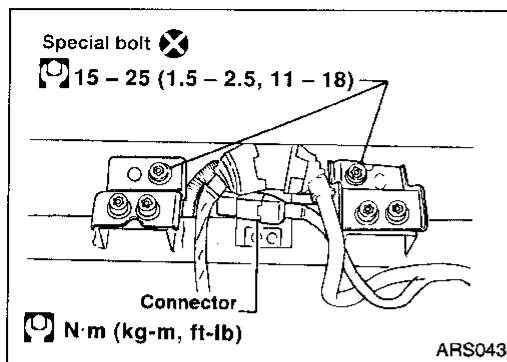

2. Connect front passenger air bag module connector to air bag harness.
3. Install glove box and glove box lid.

GI

MA

EM

LC

### Disposal of Air Bag Module

- Make sure to deploy air bag modules before disposing of them. Also, before disposing of a vehicle equipped with an air bag system, deploy air bag modules. If such a system has already been deployed due to an accident, dispose of as indicated in "DISPOSING OF AIR BAG MODULE", RS-22.
- Do not dispose of the air bag module undeployed.
- When deploying the air bag module, always use the Special Service Tool; Deployment tool [SST: KV99106400 (J38381)].
- When deploying the air bag module, stand at least 5 m (16 ft) away from the air bag module.
- Due to heat, do not touch air bag module for at least 30 minutes after deployment.
- Be sure to wear gloves when handling a deployed air bag module.
- Never apply water to a deployed air bag module.
- Wash your hands clean after finishing work.

EC

FE

CL

MT

AT

FA

RA

BR

### CHECKING DEPLOYMENT TOOL

#### Connecting to battery

- Place vehicle outdoors with at least 6 m (20 ft) of open space on all sides.
- Use a voltmeter to make sure the vehicle battery is fully charged.

#### CAUTION:

**The battery must show voltage of 9.6V or more.**

Remove the battery from the vehicle and place it on dry wood blocks approximately 5 m (16 ft) away from the vehicle.

- Wait 3 minutes after the vehicle battery is disconnected before proceeding.
- Connect red clip of deployment tool to battery positive terminal and black clip to negative terminal.

#### CAUTION:

**Make sure the polarity is correct. The right side lamp in the tool, marked "deployment tool power", should glow with a green light. If the right side lamp glows red, reverse the connections to the battery.**

ST

RS

BT

HA

EL

IDX

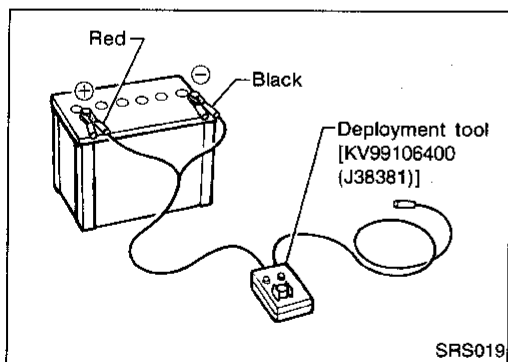

# SUPPLEMENTAL RESTRAINT SYSTEM (SRS)

## Disposal of Air Bag Module (Cont'd)

### Deployment tool check

Press the deployment tool switch to the ON position. The left side lamp in the tool, marked "air bag connector voltage" should illuminate. If it does not illuminate, replace the tool.

### Air bag deployment tool lamp illumination chart (Battery connected)

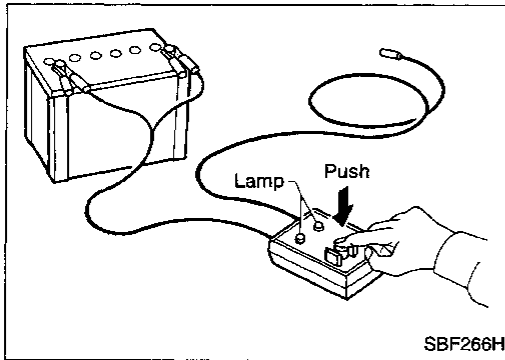

Switch operation	Left side lamp, green* "AIR BAG CONNECTOR VOLTAGE"	Right side lamp, green* "DEPLOYMENT TOOL POWER"
OFF	OFF	ON
ON	ON	ON

\*: If this lamp glows red, the tool is connected to the battery incorrectly. Reverse the connections and make sure the lamp glows green.

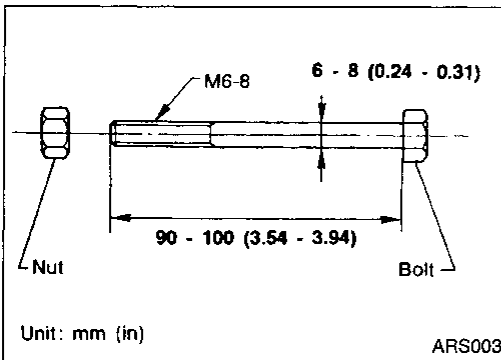

## DEPLOYMENT PROCEDURES FOR AIR BAG MODULE (Outside of vehicle)

Unless the vehicle is being scrapped, deploying the air bag module in the vehicle is not recommended. This may cause damage to the vehicle interior.

Anchor air bag module bracket [KV99105300 (J41246)] in a vise secured to a firm foundation during deployment.

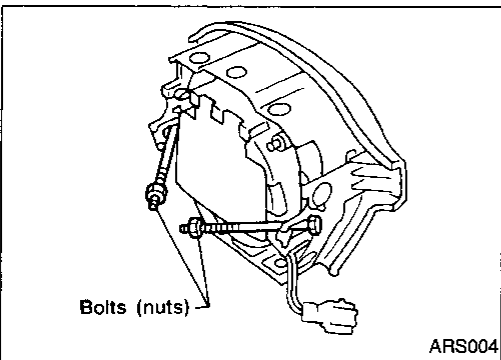

### Deployment of driver air bag module (outside of vehicle)

1. Prepare two sets of nuts and bolts (see figure at left). These bolts are required to secure driver air bag module to the vise.
2. Install one set of nuts and bolts to each side of driver air bag module.

#### CAUTION:

**Make sure to install a bolt and nut on each side.**

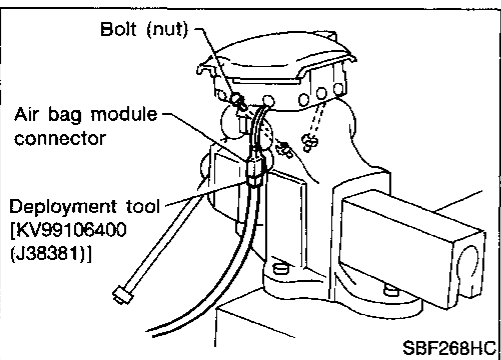

3. Firmly place two nuts (secured to driver air bag module) in the vise.

#### CAUTION:

**Ensure that these two nuts are equally placed in the vise. Never finish the installation with just one nut.**

4. Connect deployment tool [SST: KV99106400 (J38381)] to driver air bag module connector.

# SUPPLEMENTAL RESTRAINT SYSTEM (SRS)

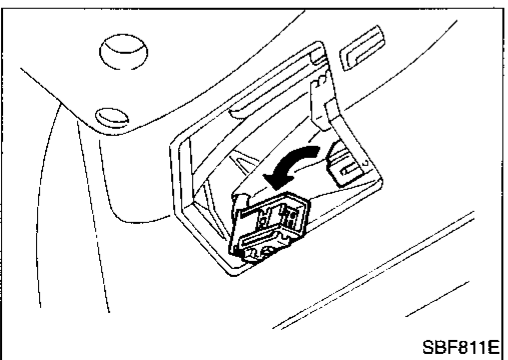
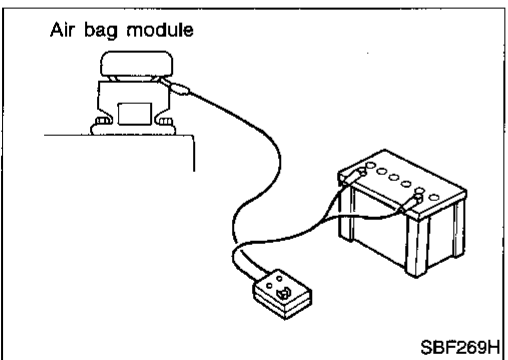
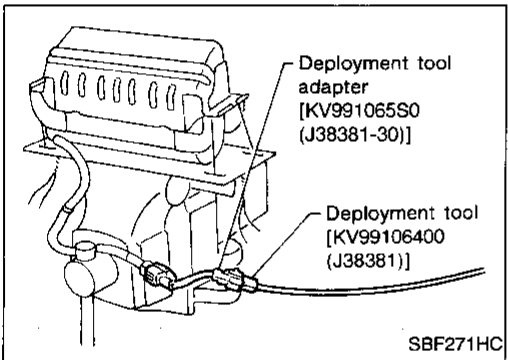
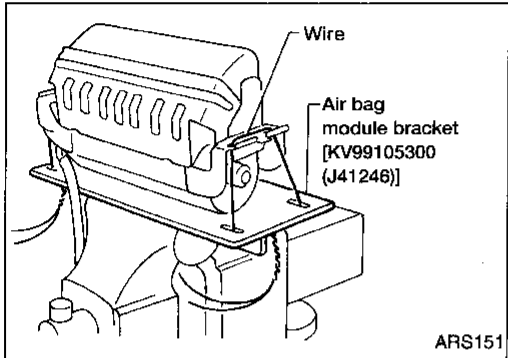
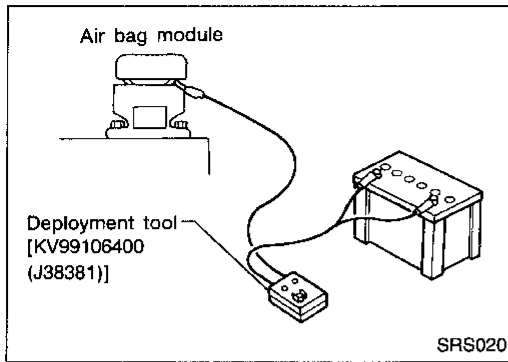

## Disposal of Air Bag Module (Cont'd)

5. Connect red clip of deployment tool to battery positive terminal and black clip to negative terminal.
6. The lamp on the right side of the tool, marked "deployment tool power", should glow green, not red.
7. Press the button on the deployment tool. The left side lamp on the tool, marked "air bag connector voltage", will illuminate and the air bag module will deploy.

### CAUTION:

When deploying the air bag module, stand at least 5 m (16 ft) away from the air bag module.

## Deployment of front passenger air bag module (outside of vehicle)

1. Using wire, secure front passenger air bag module to air bag module bracket [SST: KV99105300 (J41246)] at two places.

### CAUTION:

Use wire of at least 1 mm (0.04 in) in diameter.

2. Firmly anchor air bag module bracket in a vise.

### CAUTION:

Make sure that the vise is firmly secured and will not pivot.

- When positioning the air bag module, face pad side of air bag module to open area. Provide at least 2 m (7 ft) of clearance between pad side of module and any object.

3. Connect deployment tool adapter [SST: KV991065S0 (J38381-30)] to deployment tool [SST: KV99106400 (J38381)] connector and front passenger air bag module connector.

4. Connect red clip of deployment tool to battery positive terminal and black clip to negative terminal.

5. The lamp on the right side of the tool, marked "deployment tool power", should glow green, not red.

6. Press the button on the deployment tool. The left side lamp on the tool, marked "air bag connector voltage", will illuminate and the air bag module will deploy.

### CAUTION:

When deploying the air bag module, stand at least 5 m (16 ft) away from the air bag module.

GI

MA

EM

LC

EC

FE

CL

MT

AT

FA

RA

BR

ST

RS

BT

HA

EL

IDX

## SUPPLEMENTAL RESTRAINT SYSTEM (SRS)

### Disposal of Air Bag Module (Cont'd) DEPLOYMENT OF AIR BAG MODULE WHILE MOUNTED IN VEHICLE

When disposing of vehicles, deploy air bag module while it is mounted in vehicle.

#### CAUTION:

**When deploying air bag module, ensure that the vehicle is empty.**

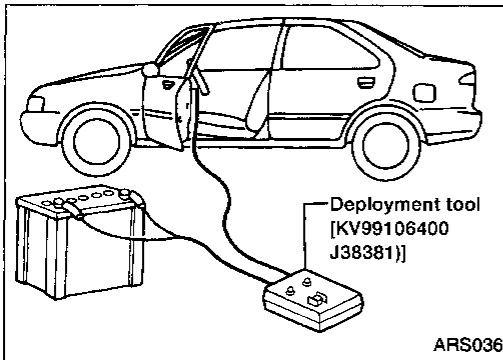

1. Turn ignition switch OFF, disconnect both battery cables and wait at least 3 minutes.
2. Disconnect air bag module connector.
3. Connect deployment tool [SST: KV99106400 (J38381)] connector to air bag module.

For front passenger air bag module, use adapters [SST: KV991065S0 (J38381-30)] to attach module to deployment tool connector.

4. Connect red clip of deployment tool to battery positive terminal and black clip to negative terminal.
5. The lamp on the right side of the tool, marked "deployment tool power", should glow green, not red.
6. Press the button on the deployment tool. The left side lamp on the tool, marked "air bag connector voltage", will illuminate and the air bag module will deploy.

### DISPOSING OF AIR BAG MODULE

Deployed air bag module is very hot. Before disposing of air bag module, wait at least 30 minutes. Seal in a plastic bag before disposal.

#### CAUTION:

- Never apply water to a deployed air bag module.
- Be sure to wear gloves when handling a deployed air bag module.
- No poisonous gas is produced upon air bag module deployment. However, be careful not to inhale gas since it irritates the throat and can cause choking.
- Do not attempt to disassemble air bag module.
- Air bag module cannot be reused.
- Wash your hands clean after finishing work.

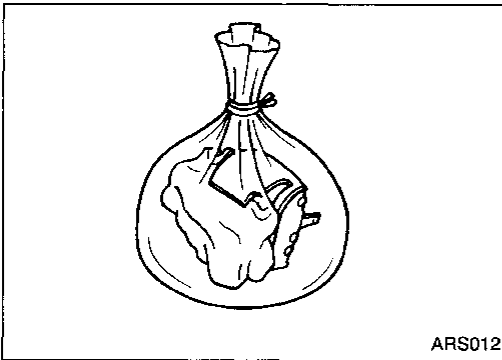

## Trouble Diagnosis Introduction

### CAUTION:

- Do not use electrical test equipment on any circuit related to the SRS unless instructed to in this Service Manual. SRS wiring harnesses are covered with yellow insulation either just before the harness connectors or on the complete harness, for easy identification.
- Do not attempt to repair, splice or modify the SRS wiring harness. If the harness is damaged, replace it with a new one.
- Keep ground portion clean.

### DIAGNOSIS FUNCTION

The SRS self-diagnosis results can be read by using the “AIR BAG” warning lamp and/or CONSULT. The reading of these results is accomplished using one of two modes — “User mode” and “Diagnosis mode”. The User mode is exclusively prepared for the customer (driver). This mode warns the driver of a system malfunction through the operation of the “AIR BAG” warning lamp.

The Diagnosis mode allows the technician to locate and inspect the malfunctioning part.

The mode applications for the “AIR BAG” warning lamp and CONSULT are as follows:

	User mode	Diagnosis mode	Display type
“AIR BAG” warning lamp	X	X	ON-OFF operation
CONSULT	—	X	Monitoring

### DIAGNOSIS MODE FOR CONSULT

- “SELF-DIAG [CURRENT]”

A current Self-diagnosis result (also indicated by the number of warning lamp flashes in the Diagnosis mode) is displayed on the CONSULT screen in real time. This refers to a malfunctioning part requiring repairs.

- “SELF-DIAG [PAST]”

Diagnosis results previously stored in the memory are displayed on the CONSULT screen. The stored results are not cleared until memory erasing is executed.

- “TROUBLE DIAG RECORD”

With “TROUBLE DIAG RECORD”, diagnosis results previously erased by a reset operation can be displayed on the CONSULT screen.

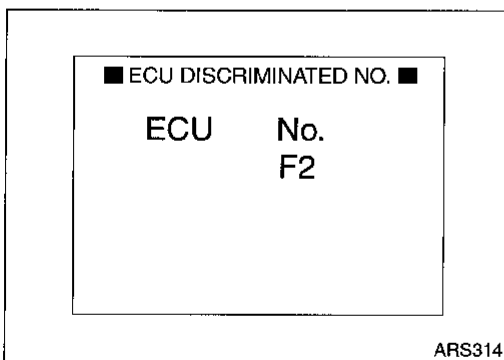

- “ECU DISCRIMINATED NO.”

The diagnosis sensor unit for each vehicle model is assigned with its own, individual classification number. This number will be displayed on the CONSULT screen, as shown at left. When replacing the diagnosis sensor unit, refer to the part number for the compatibility. After installation, replacement with a correct unit can be checked by confirming this classification number on the CONSULT screen.

**For NISSAN model B14, the diagnosis sensor unit classification number assigned is F2.**

# TROUBLE DIAGNOSES — Supplemental Restraint System (SRS)

## Trouble Diagnosis Introduction (Cont'd)

### HOW TO CHANGE SELF DIAGNOSIS MODE

#### With CONSULT

##### From User mode to Diagnosis mode

Touch "AIRBAG" on the "SELECT SYSTEM" screen. User mode automatically changes to Diagnosis mode.

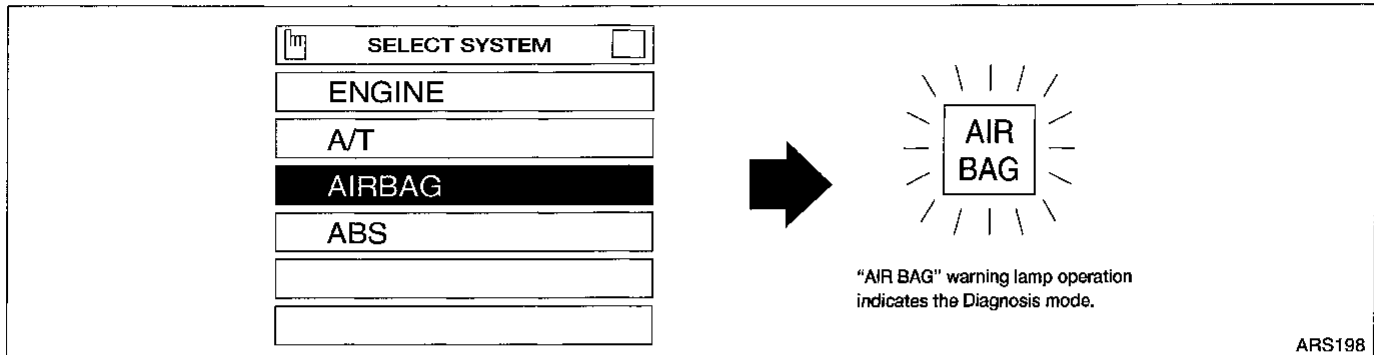

##### From Diagnosis mode to User mode

Touch "BACK" key of CONSULT until "SELECT SYSTEM" appears, Diagnosis mode automatically changes to User mode.

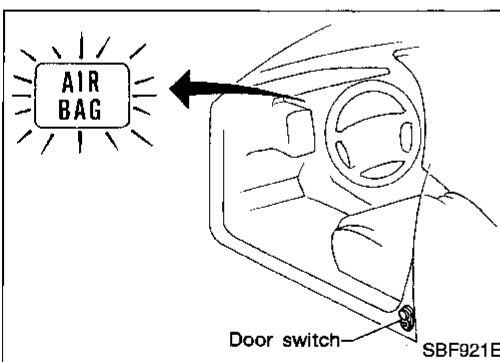
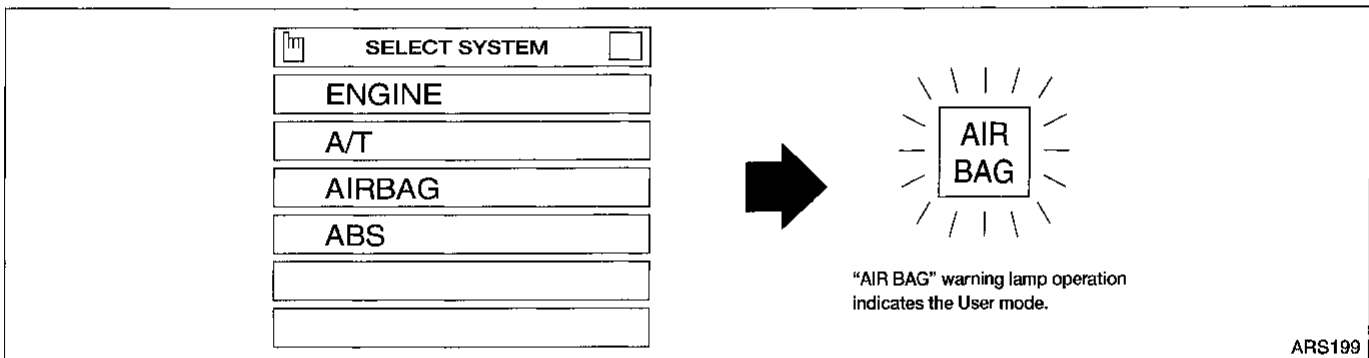

#### Without CONSULT

##### From User mode to Diagnosis mode

Diagnosis mode can be activated only when a malfunction is detected, by pressing the driver's door switch at least 5 times within 7 seconds after turning the ignition switch ON. SRS will not enter Diagnosis mode if no malfunction is detected.

##### From Diagnosis mode to User mode

- To return to User mode while a malfunction is being detected, turn the ignition switch OFF, then back ON and press the driver's door switch at least 5 times within 7 seconds.
- After a malfunction is repaired, turn the ignition switch OFF for at least 1 second, then back ON. Diagnosis mode returns to User mode.



### HOW TO ERASE SELF DIAGNOSIS RESULTS

#### With CONSULT

##### “SELF-DIAG [CURRENT]”

A current Self-diagnosis result is displayed on the CONSULT screen in real time. After the malfunction is repaired completely, no malfunction is detected on “SELF-DIAG [CURRENT]”.

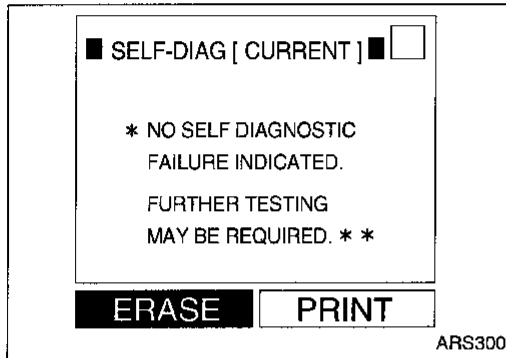

##### “SELF-DIAG [PAST]”

Return to the “SELF-DIAG [CURRENT]” CONSULT screen by pushing “BACK” key of CONSULT and select “SELF-DIAG [CURRENT]” in “SELECT DIAG MODE”. Touch “ERASE” in “SELF-DIAG [CURRENT]” mode.

#### NOTE:

If the memory of the malfunction in “SELF-DIAG [PAST]” is not erased, the User mode shows the system malfunction by the operation of the warning lamp even if the malfunction is repaired completely.

##### “TROUBLE DIAG RECORD”

The memory of “TROUBLE DIAG RECORD” cannot be erased.

#### Without CONSULT

After a malfunction is repaired, turn the ignition switch OFF for at least 1 second, then back ON. Diagnosis mode returns to User mode. At that time, the self-diagnostic result is cleared.

GI

MA

EM

LC

EC

FE

CL

MT

AT

FA

RA

BR

ST

RS

BT

HA

EL

IDX

## How to Perform Trouble Diagnoses for Quick and Accurate Repair

A good understanding of the malfunction conditions can make troubleshooting faster and more accurate. In general, each customer feels differently about a malfunction. It is important to fully understand the symptoms or conditions of a customer complaint.

### INFORMATION FROM CUSTOMER

- WHAT ..... Vehicle model
- WHEN ..... Date, Frequencies
- WHERE ..... Road conditions
- HOW ..... Operating conditions, Symptoms

### PRELIMINARY CHECK

Check that the following parts are in good order.

- Battery [Refer to EL section (“BATTERY”).]
- Fuse [Refer to EL section (“Fuse”, “POWER SUPPLY ROUTING”).]
- System component-to-harness connections

### WORK FLOW

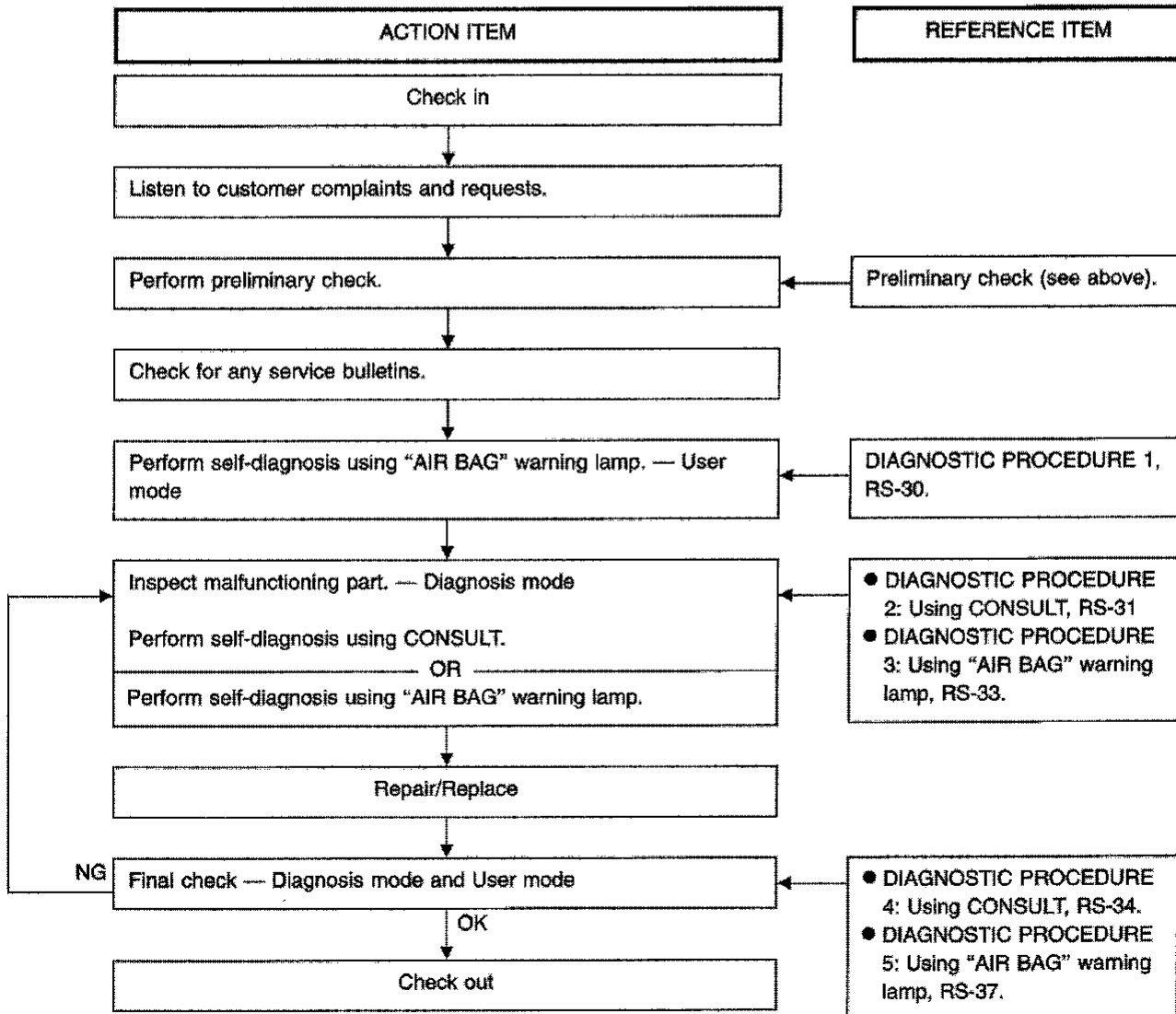

# TROUBLE DIAGNOSES — Supplemental Restraint System (SRS)

## Schematic

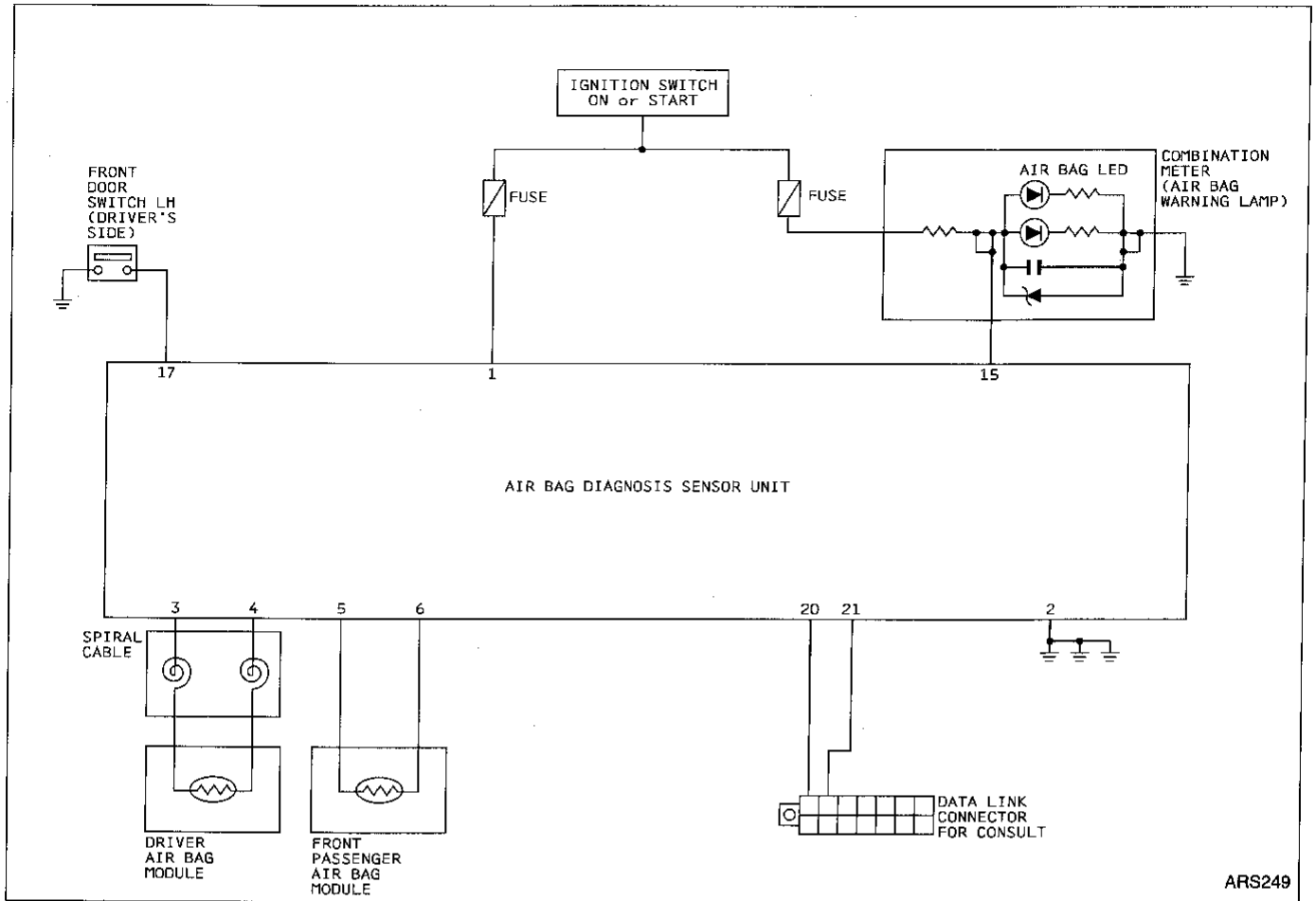

GI  
MA  
EM  
LC  
EC  
FE  
CL  
MT  
AT  
FA  
RA  
BR  
ST  
RS  
BT  
HA  
EL  
IDX

## Wiring Diagram -SRS-

RS-SRS-01

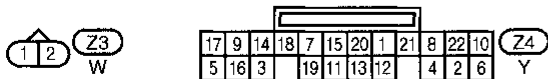
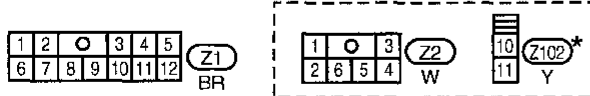
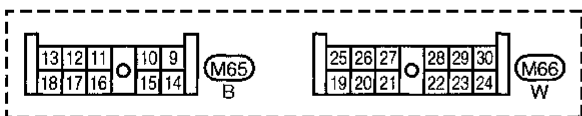
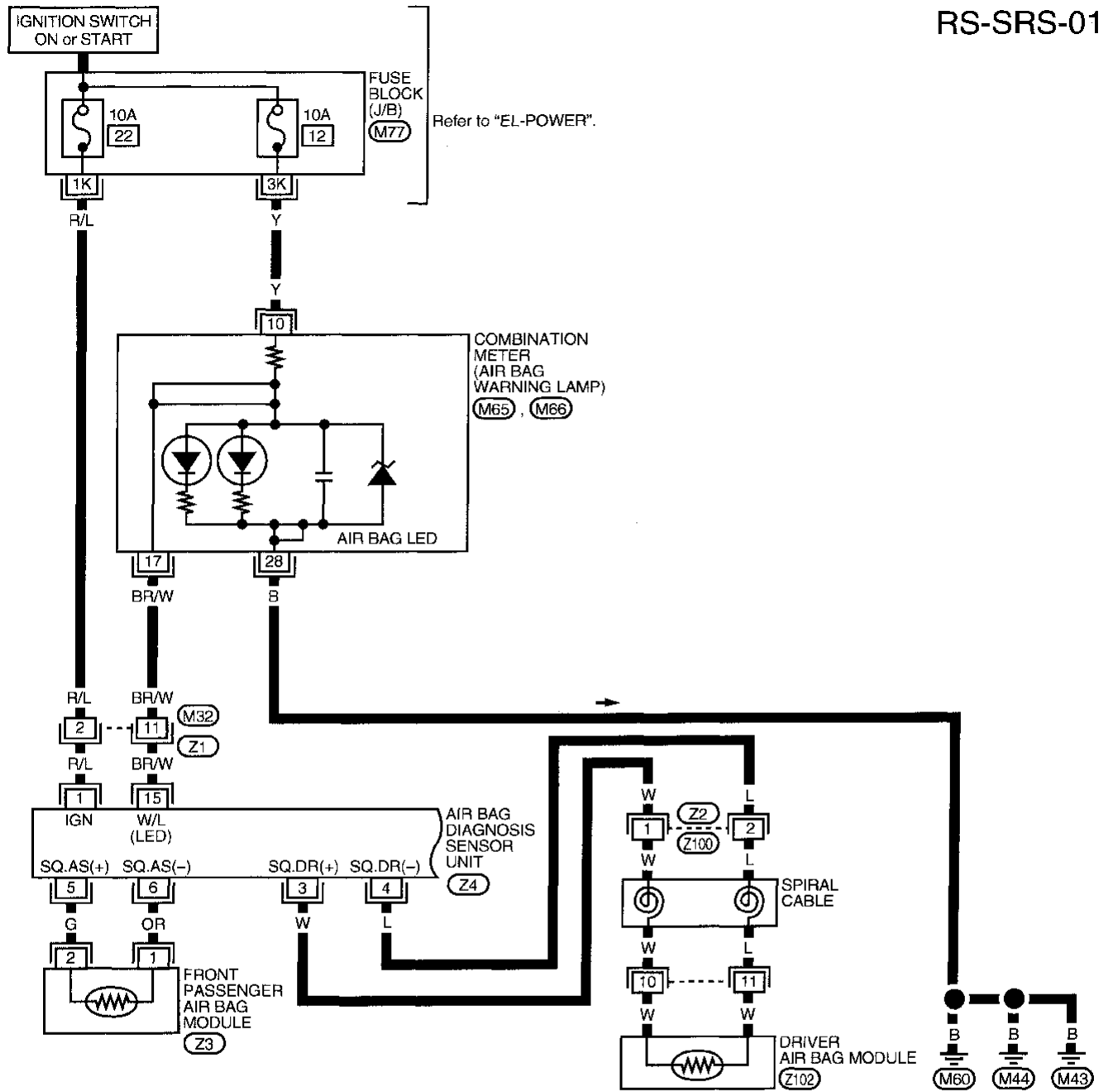

\*:This connector is not shown in "HARNESS LAYOUT" of EL section.

# TROUBLE DIAGNOSES — Supplemental Restraint System (SRS)

## Wiring Diagram —SRS— (Cont'd)

RS-SRS-02    GI

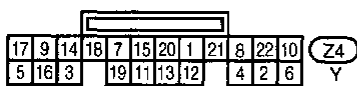
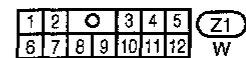
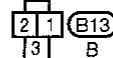
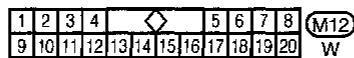
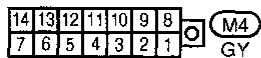
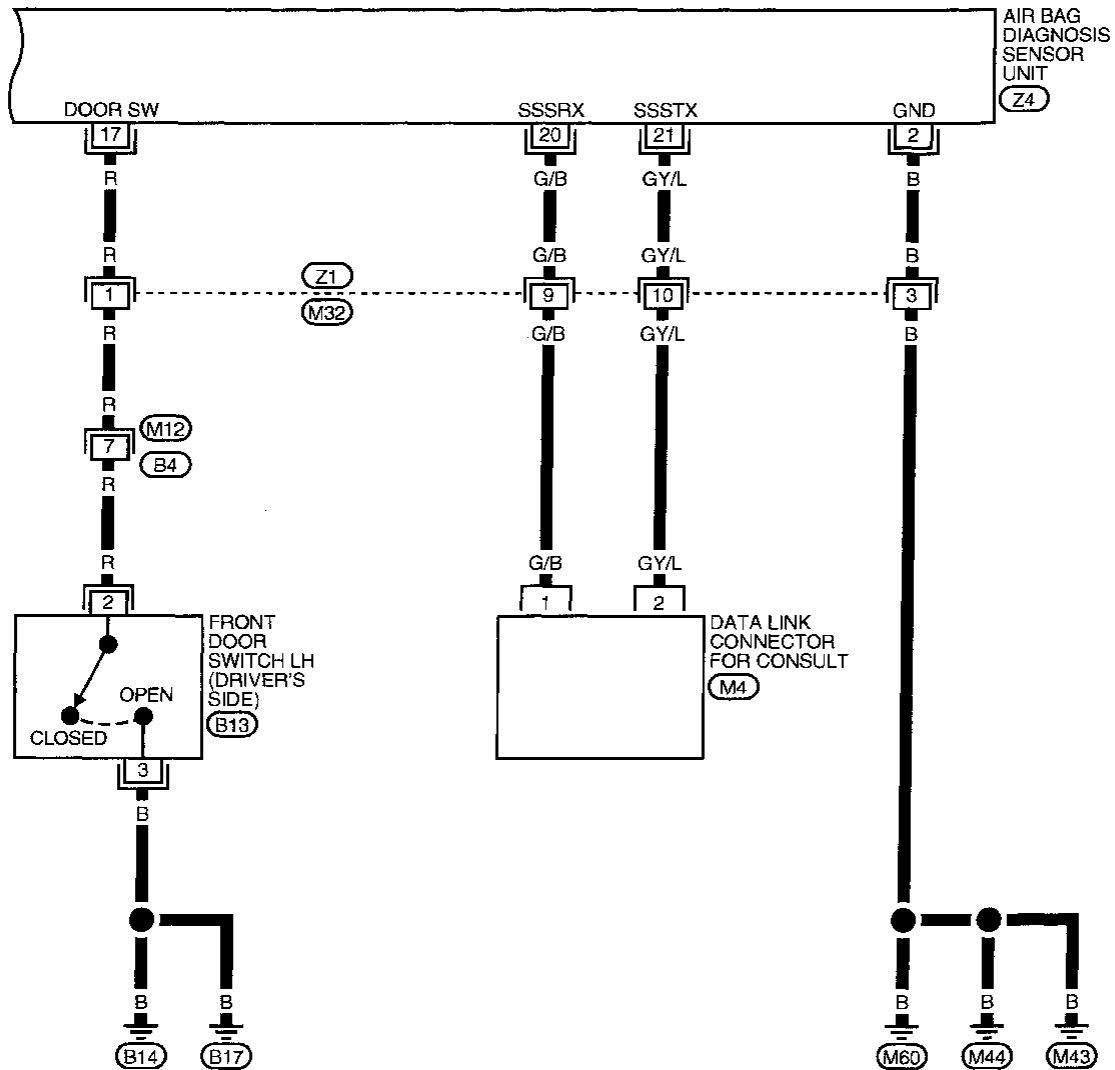

MA  
 EM  
 LC  
 EC  
 FE  
 CL  
 MT  
 AT  
 FA  
 RA  
 BR  
 ST  
**RS**

BT  
 HA  
 EL  
 IDX

# TROUBLE DIAGNOSES — Supplemental Restraint System (SRS)

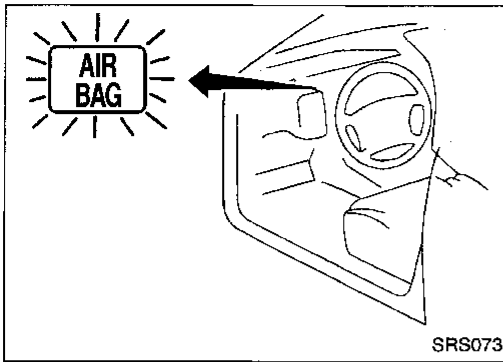

## Self-diagnosis

### DIAGNOSTIC PROCEDURE 1

#### Checking SRS operation by using "AIR BAG" warning lamp — User mode

1. After turning ignition switch from OFF to ON, "AIR BAG" warning lamp operates.
2. Compare "AIR BAG" warning lamp operation to the chart below.

"AIR BAG" warning lamp operation — User mode —	SRS condition	Reference item
<p>MRS095A</p>	No malfunction is detected. No further action is necessary.	—
<p>MRS096A</p>	The system is malfunctioning and needs to be repaired as indicated.	Go to DIAGNOSTIC PROCEDURE 2, or 3, RS-31 or 33.
<p>MRS097A</p>	Air bag is deployed.	Go to COLLISION DIAGNOSIS, RS-45.
<p>MRS098A</p>	Air bag fuse for diagnosis sensor unit or harness is malfunctioning and needs to be repaired.	Go to DIAGNOSTIC PROCEDURE 9, RS-43.
<p>MRS098A</p>	One of the following has occurred and needs to be repaired. <ul style="list-style-type: none"> <li>● Meter fuse is open.</li> <li>● "AIR BAG" warning lamp circuit is shorted or open.</li> <li>● Diagnosis sensor unit is malfunctioning.</li> </ul>	Go to DIAGNOSTIC PROCEDURE 10, RS-43.

#### NOTE:

If "AIR BAG" warning lamp operates differently from the operations shown above, refer to "AIR BAG" warning lamp operation — Diagnosis mode —, DIAGNOSTIC PROCEDURE 3 (step 4), RS-33. Then repair as necessary.

# TROUBLE DIAGNOSES — Supplemental Restraint System (SRS)

## Self-diagnosis (Cont'd)

### DIAGNOSTIC PROCEDURE 2 (CONSULT with CONSULT)

#### Inspecting SRS malfunctioning parts by using CONSULT — Diagnosis mode

1. Turn ignition switch OFF.
2. Connect CONSULT to Data link connector.

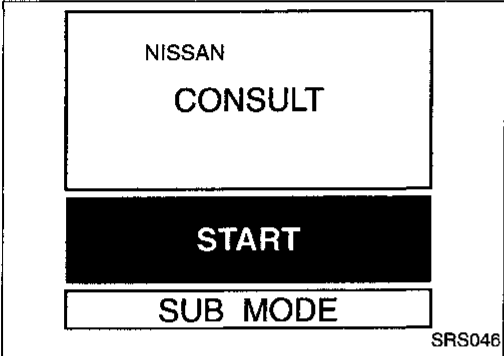
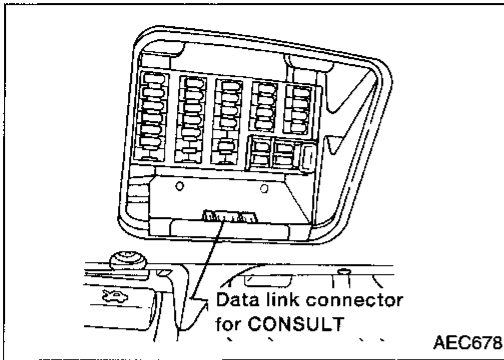

3. Turn ignition switch ON.
4. Touch "START".

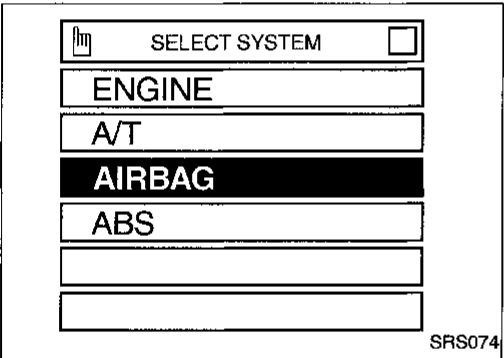

5. Touch "AIRBAG".

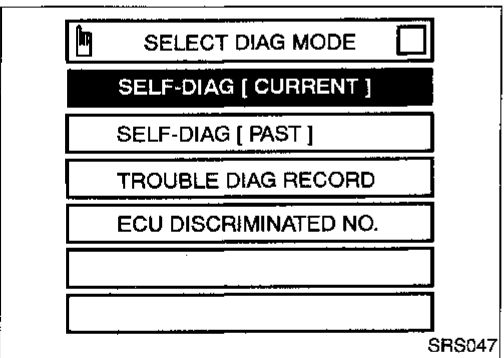

6. Touch "SELF-DIAG [CURRENT]".

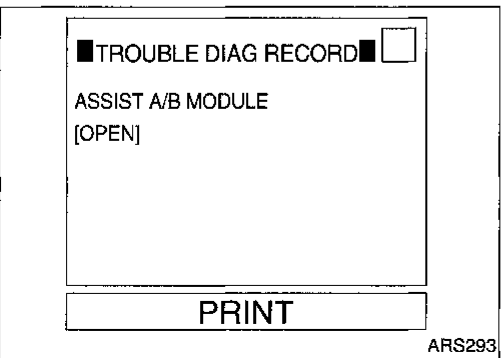

7. Diagnostic codes are displayed on "SELF-DIAG [CURRENT]".

GI

MA

EM

LC

EC

FE

CL

MT

AT

FA

RA

BR

ST

**RS**

BT

HA

EL

IDX

# TROUBLE DIAGNOSES — Supplemental Restraint System (SRS)

## Self-diagnosis (Cont'd)

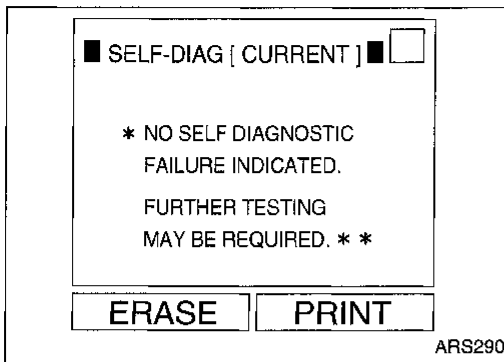

- If no malfunction is detected on “SELF-DIAG [CURRENT]” but malfunction is indicated by the “AIR BAG” warning lamp, check the battery voltage. If the battery voltage is less than 9V, charge the battery. Then go to **DIAGNOSTIC PROCEDURE 4**, page RS-34. If the battery voltage is OK, go to **DIAGNOSTIC PROCEDURE 6**, RS-39, to diagnose the following cases:
    - “SELF-DIAG [PAST]” (which was previously entered) might not have been erased after repair.
    - The SRS malfunctions intermittently.
8. Touch “PRINT”.
  9. Compare diagnostic codes to the CONSULT DIAGNOSTIC CODE CHART below.
  10. Touch “BACK” key of CONSULT until “SELECT SYSTEM” appears, then turn off CONSULT.
  11. Turn ignition switch OFF, then disconnect CONSULT and both battery cables.
  12. Repair the system as outlined by the Repair order in CONSULT DIAGNOSTIC CODE CHART, that corresponds to the self-diagnostic result. For replacement procedure of component parts, refer to RS-14.
  13. After repairing the system, connect battery cables and go to **DIAGNOSTIC PROCEDURE 4**, RS-34 for final checking.

## CONSULT DIAGNOSTIC CODE CHART (“SELF-DIAG [CURRENT]”)

Diagnostic item	Explanation	Repair order <b>*Recheck SRS at each replacement.</b>
NO SELF DIAGNOSTIC FAILURE INDICATED.	• Low battery voltage (less than 9V)	Charge the battery. Then go to <b>DIAGNOSTIC PROCEDURE 4</b> (RS-34).
	• No malfunction is detected	Go to <b>DIAGNOSTIC PROCEDURE 6</b> (RS-39).
AIRBAG MODULE [OPEN]	• Driver air bag module circuit is open. (including the spiral cable)	1. Visually check wiring harness connection. 2. Replace harness if it has visible damage. 3. Replace spiral cable. 4. Replace driver air bag module. (Before disposing of it, it must be deployed.) 5. Replace diagnosis sensor unit. 6. Replace air bag harness.
AIRBAG MODULE [VB-SHORT]	• Driver air bag module circuit is shorted to some power supply circuit. (including the spiral cable)	
AIRBAG MODULE [GND-SHORT]	• Driver air bag module circuit is shorted to ground. (including the spiral cable)	
AIRBAG MODULE [SHORT]	• Driver air bag module circuits are shorted to each other.	
ASSIST A/B MODULE [VB-SHORT]	• Front passenger air bag module circuit is shorted to some power supply circuit.	1. Visually check wiring harness connection. 2. Replace harness if it has visible damage. 3. Replace front passenger air bag module. (Before disposal of it, it must be deployed.) 4. Replace diagnosis sensor unit. 5. Replace air bag harness.
ASSIST A/B MODULE [OPEN]	• Front passenger air bag module circuit is open.	
ASSIST A/B MODULE [GND-SHORT]	• Front passenger air bag module circuit is shorted to ground.	
ASSIST A/B MODULE [SHORT]	• Front passenger air bag module circuits are shorted to each other.	
CONTROL UNIT	• Diagnosis sensor unit is malfunctioning.	1. Replace diagnosis sensor unit. 2. Replace air bag harness.

\*Follow the procedures in numerical order when repairing malfunctioning parts. Confirm whether malfunction is eliminated using the “AIR BAG” warning lamp (in User mode) or CONSULT each time repair is finished. If malfunction is still observed, proceed to the next step. When malfunction is eliminated, further repair work is not required.



# TROUBLE DIAGNOSES — Supplemental Restraint System (SRS)

## Self-diagnosis (Cont'd)

### DIAGNOSTIC PROCEDURE 3 ( without CONSULT)

Inspecting SRS malfunctioning parts by using "AIR BAG" warning lamp — Diagnosis mode

**NOTE:**

SRS will not enter Diagnosis mode if no malfunction is detected in User mode.

1. Open driver's door.
2. Turn ignition switch from OFF to ON.
3. Press driver's door switch at least 5 times within 7 seconds after turning ignition switch ON. SRS is now in Diagnosis mode.
4. "AIR BAG" warning lamp operates in Diagnosis mode as follows:

**NOTE:**

If SRS does not enter Diagnosis mode even though malfunction is detected in User mode, go to DIAGNOSTIC PROCEDURE 11, RS-44.

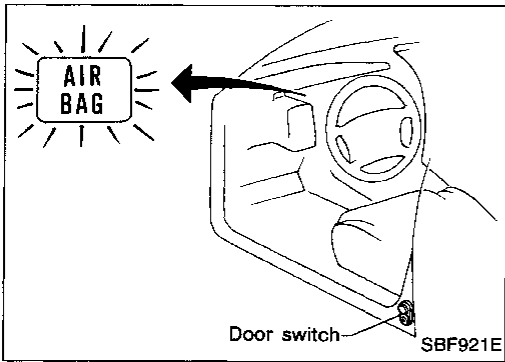

No.	"AIR BAG" warning lamp operation — Diagnosis mode —	SRS condition
1	<p style="text-align: right;">(a) through (b) are repeated.</p>	<ul style="list-style-type: none"> <li>●Diagnosis results (previously stored in the memory) might not have been erased after repair.</li> <li>●Intermittent malfunction has been detected in the past. Go to DIAGNOSTIC PROCEDURE 7, RS-39.</li> </ul>
2	<p style="text-align: right;">(a) through (d) are repeated. NOTE: (a) — Interval I (b) — Start signal (Start signal identifies display modes) (c) — Interval II (d) — Indicates malfunctioning part (0.5 sec. ON and 0.5 sec. OFF is counted as one flash.)</p>	<p>The system is malfunctioning and needs to be repaired.</p>

5. Malfunctioning part is indicated by the number of flashes (part (d)). Compare the number of flashes to AIR BAG WARNING LAMP FLASH CODE CHART and locate malfunctioning part.
6. Turn ignition switch OFF, and disconnect both battery cables.

# TROUBLE DIAGNOSES — Supplemental Restraint System (SRS)

## Self-diagnosis (Cont'd)

7. Repair the system as outlined by the Repair order in AIR BAG WARNING LAMP FLASH CODE CHART that corresponds to the flash code. For replacement procedure of component parts, refer to RS-14.
8. After repairing the system, go to DIAGNOSTIC PROCEDURE 5, RS-37.

## AIR BAG WARNING LAMP FLASH CODE CHART

Warning lamp	Flash code (d) (# of flashes)	Explanation	Repair order *Recheck SRS at each replacement
"AIR BAG" warning lamp	0	<ul style="list-style-type: none"> <li>● Diagnosis results (previously stored in the memory) might not be erased after repair.</li> <li>● Intermittent malfunction has been detected in the past.</li> </ul>	Go to DIAGNOSTIC PROCEDURE 7 (RS-39).
	2	<ul style="list-style-type: none"> <li>● The driver air bag module circuit is malfunctioning.</li> </ul>	<ol style="list-style-type: none"> <li>1. Visually check wiring harness connections.</li> <li>2. Replace spiral cable.</li> <li>3. Replace driver air bag module. (Before disposing of it, it must be deployed.)</li> <li>4. Replace diagnosis sensor unit.</li> <li>5. Replace air bag harness.</li> </ol>
	7	<ul style="list-style-type: none"> <li>● The diagnosis sensor unit is malfunctioning.</li> </ul>	<ol style="list-style-type: none"> <li>1. Visually check wiring harness connections.</li> <li>2. Replace diagnosis sensor unit.</li> </ol>
	8	<ul style="list-style-type: none"> <li>● The front passenger air bag module circuit is malfunctioning.</li> </ul>	<ol style="list-style-type: none"> <li>1. Visually check wiring harness connections.</li> <li>2. Replace front passenger air bag module. (Before disposing of it, it must be deployed.)</li> <li>3. Replace diagnosis sensor unit.</li> <li>4. Replace air bag harness.</li> </ol>

\*Follow the procedures in numerical order when repairing malfunctioning parts. Confirm whether malfunction is eliminated using the "AIR BAG" warning lamp (in Diagnosis mode) or CONSULT each time repair is finished. If malfunction is still observed, proceed to the next step. When malfunction is eliminated, further repair work is not required.

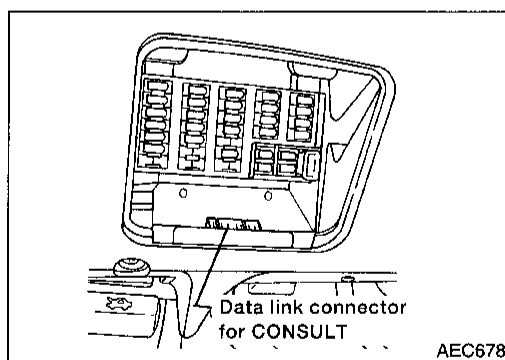

## DIAGNOSTIC PROCEDURE 4 (CONSULT with CONSULT)

### Final checking after repairing SRS by using CONSULT — Diagnosis mode

1. After repairing SRS, connect both battery cables.
2. Connect CONSULT to Data link connector.
3. Turn ignition switch from OFF to ON.

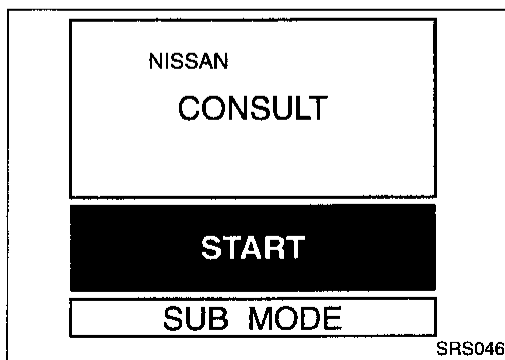

4. Touch "START".

# TROUBLE DIAGNOSES — Supplemental Restraint System (SRS)

## Self-diagnosis (Cont'd)

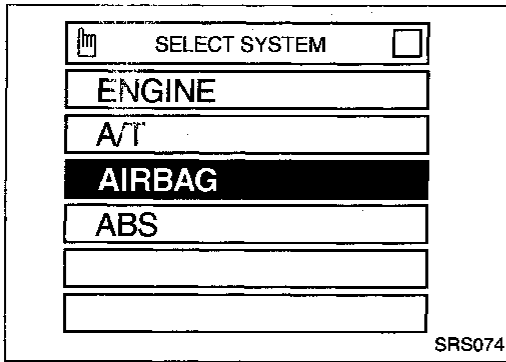

5. Touch "AIRBAG".

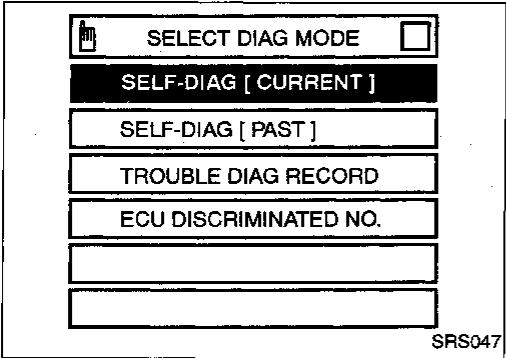

6. Touch "SELF-DIAG [CURRENT]".

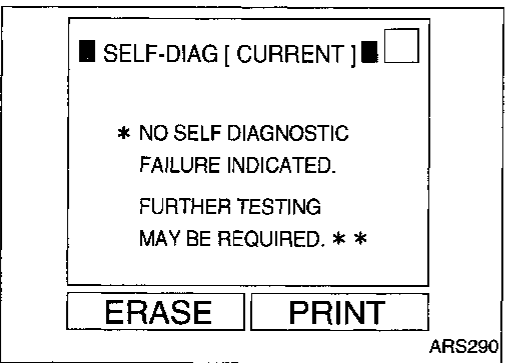

7. If no malfunction is detected on "SELF-DIAG [CURRENT]", repair of SRS is completed. Touch "ERASE".  
If any malfunction was detected on "SELF-DIAG [CURRENT]", the malfunctioning part is not repaired completely or another malfunctioning part is detected. Go to DIAGNOSTIC PROCEDURE 2, RS-31, and repair malfunctioning part completely.

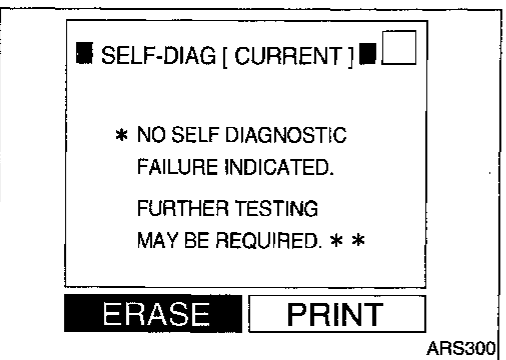

8. Touch "ERASE".

### NOTE:

Touch "ERASE" to clear the memory of the malfunction ("SELF-DIAG [PAST]").

If the memory of the malfunction in "SELF-DIAG [PAST]" is not erased, the User mode shows the system malfunction by the operation of the warning lamp even if the malfunction is repaired completely.

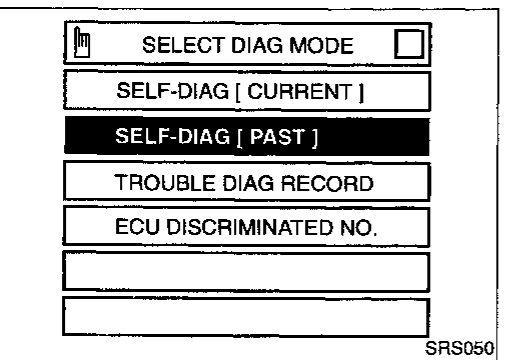

9. Touch "BACK" key of CONSULT to select "SELF-DIAG [PAST]" in the "SELECT DIAG MODE" screen. Touch "SELF-DIAG [PAST]".

GI  
MA  
EM  
LC  
EC  
FE  
CL  
MT  
AT  
FA  
RA  
BR  
ST  
RS  
BT  
HA  
EL  
IDX

## TROUBLE DIAGNOSES — Supplemental Restraint System (SRS)

### Self-diagnosis (Cont'd)

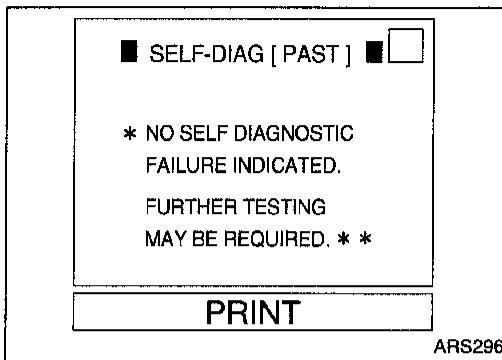

10. Check that no malfunction is detected on "SELF-DIAG [PAST]".

11. Touch "BACK" key of CONSULT until "SELECT SYSTEM" appears in order to return to User mode from Diagnosis mode, turn off CONSULT, then disconnect CONSULT.
12. Turn ignition switch OFF.
13. Go to DIAGNOSTIC PROCEDURE 1, RS-30 to check SRS operation by using "AIR BAG" warning lamp with User mode.

# TROUBLE DIAGNOSES — Supplemental Restraint System (SRS)

## Self-diagnosis (Cont'd)

### DIAGNOSTIC PROCEDURE 5 (⌚ without CONSULT)

#### Final checking after repairing SRS by using "AIR BAG" warning lamp — Diagnosis mode and User mode

1. After repairing SRS connect both battery cables.
2. Open driver's door.
3. Turn ignition switch from OFF to ON.
4. "AIR BAG" warning lamp operates in Diagnosis mode as follows:

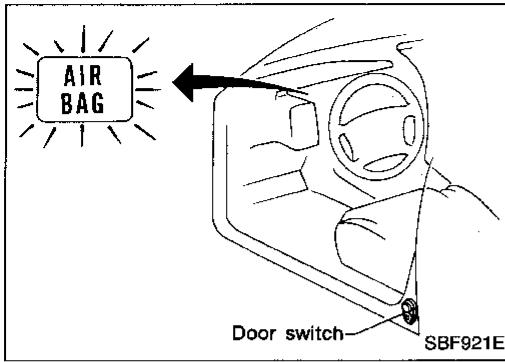

No.	"AIR BAG" warning lamp operation — Diagnosis mode —	SRS condition
1	<p style="text-align: right;">(a) through (b) are repeated.</p>	No malfunction is detected or repair is completed. No further action is necessary.
2	<p style="text-align: right;">(a) through (d) are repeated. NOTE: (a) — Interval I (b) — Start signal (Start signal identifies display modes) (c) — Interval II (d) — Indicates malfunctioning part (0.5 sec. ON and 0.5 sec. OFF is counted as one flash)</p>	The system is malfunctioning and needs to be repaired.

#### NOTE:

When diagnosis sensor unit is replaced with new one, "AIR BAG" warning lamp will operate in User mode. Checking "AIR BAG" warning lamp operation in Diagnosis mode is not required. Go to step 6.

5. If "AIR BAG" warning lamp operates as shown in No. 1 in the chart above, turn ignition switch OFF to reset from Diagnosis mode to User mode and to erase the memory of the malfunction. Then go to step 6.

If "AIR BAG" warning lamp operates as in No. 2 in chart above, the malfunctioning part is not repaired completely, or another malfunctioning part is detected. Go to DIAGNOSTIC PROCEDURE 3, RS-33, and repair malfunctioning part completely.

# TROUBLE DIAGNOSES — Supplemental Restraint System (SRS)

## Self-diagnosis (Cont'd)

6. Turn ignition switch ON. "AIR BAG" warning lamp operates in User mode. Compare "AIR BAG" warning lamp operation to the chart below.

### NOTE:

If switching from Diagnosis mode to User mode is required while malfunction is being detected, turn ignition switch from OFF to ON. Then press driver's door switch at least 5 times within 7 seconds after turning ignition switch ON. SRS is now in User mode.

"AIR BAG" warning lamp operation — User mode —	SRS condition	Reference item
<p>MRS095A</p>	<p>No malfunction is detected. No further action is necessary.</p>	<p>—</p>
<p>MRS096A</p>	<p>The system is malfunctioning and needs to be repaired as indicated.</p>	<p>Go to DIAGNOSTIC PROCEDURE 2 or 3, RS-31 or 33.</p>
<p>MRS097A</p>	<p>Air bag is deployed.</p> <p>Air bag fuse for diagnosis sensor unit or harness is malfunctioning and needs to be repaired.</p>	<p>Go to COLLISION DIAGNOSIS, RS-45.</p> <p>Go to DIAGNOSTIC PROCEDURE 9, RS-43.</p>
<p>MRS098A</p>	<p>One of the following has occurred and needs to be repaired.</p> <ul style="list-style-type: none"> <li>● Meter fuse is open.</li> <li>● "AIR BAG" warning lamp circuit is shorted or open.</li> <li>● Diagnosis sensor unit is malfunctioning.</li> </ul>	<p>Go to DIAGNOSTIC PROCEDURE 10, RS-43.</p>

# TROUBLE DIAGNOSES — Supplemental Restraint System (SRS)

## Self-diagnosis (Cont'd)

### DIAGNOSTIC PROCEDURE 6 (Continued from DIAGNOSTIC PROCEDURE 2) (📱 with CONSULT)

#### Inspecting SRS malfunctioning record

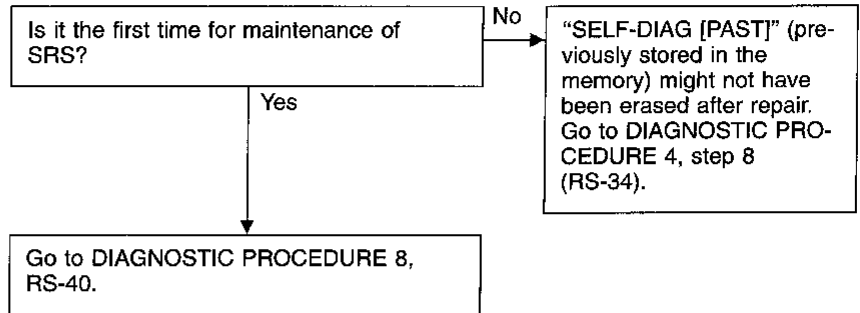

### DIAGNOSTIC PROCEDURE 7 (Continued from DIAGNOSTIC PROCEDURE 3) (🕒 without CONSULT)

#### Inspecting SRS malfunctioning record

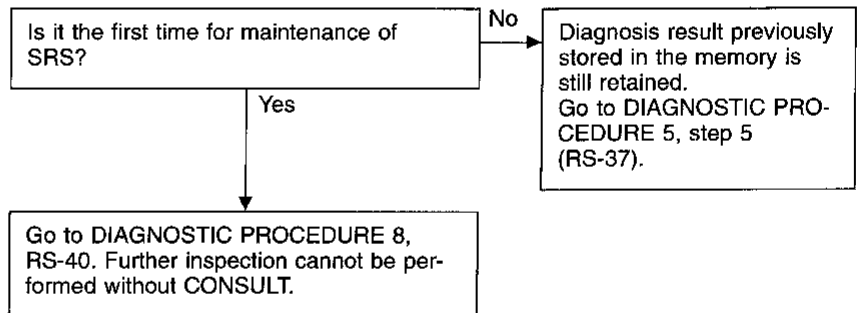

GI

MA

EM

LC

EC

FE

CL

MT

AT

FA

RA

BR

ST

**RS**

BT

HA

EL

IDX

# TROUBLE DIAGNOSES — Supplemental Restraint System (SRS)

## Self-diagnosis (Cont'd)

### DIAGNOSTIC PROCEDURE 8 (CONSULT with CONSULT)

#### Inspecting SRS intermittent malfunction by using CONSULT — Diagnosis mode

1. Turn ignition switch OFF.
2. Connect CONSULT to Data link connector.

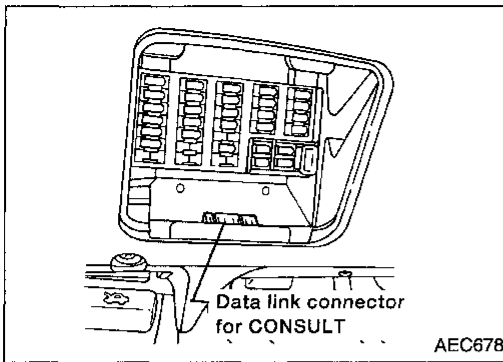

3. Turn ignition switch ON.
4. Touch "START".

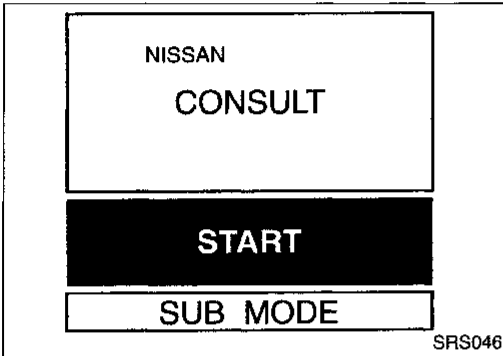

5. Touch "AIRBAG".

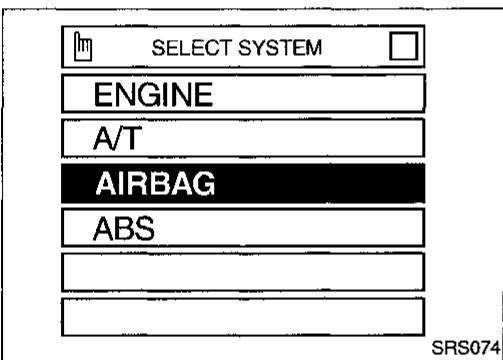

6. Touch "SELF-DIAG [PAST]".

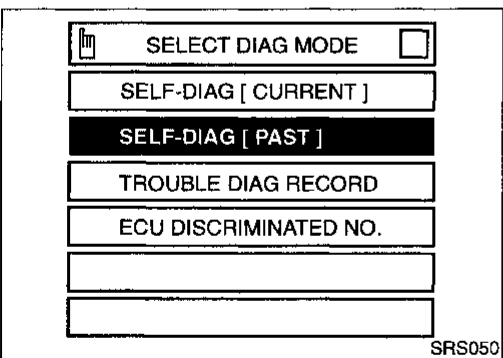

7. If diagnostic codes are displayed on "SELF-DIAG [PAST]", go to step 10.

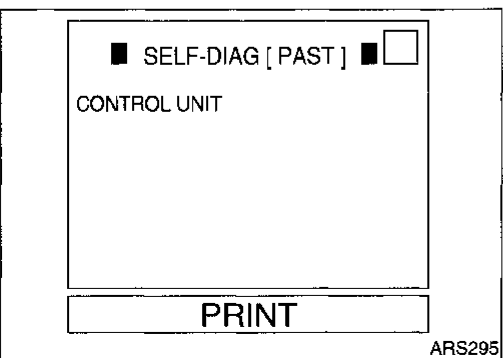



# TROUBLE DIAGNOSES — Supplemental Restraint System (SRS)

## Self-diagnosis (Cont'd)

If no malfunction is detected on "SELF-DIAG [PAST]", touch "BACK" and go back to "SELECT DIAG MODE".

■ SELF-DIAG [ PAST ] ■

\* NO SELF DIAGNOSTIC FAILURE INDICATED.  
FURTHER TESTING MAY BE REQUIRED. \* \*

PRINT

ARS296

SELECT DIAG MODE

SELF-DIAG [ CURRENT ]

SELF-DIAG [ PAST ]

TROUBLE DIAG RECORD

ECU DISCRIMINATED NO.

SRS055

■ TROUBLE DIAG RECORD ■

ASSIST A/B MODULE  
[ OPEN ]

PRINT

ARS297

8. Touch "TROUBLE DIAG RECORD".

### NOTE:

With "TROUBLE DIAG RECORD", diagnosis results previously erased by a reset operation can be displayed.

9. Diagnostic code is displayed on "TROUBLE DIAG RECORD".

10. Touch "PRINT".

11. Compare diagnostic codes to the INTERMITTENT MALFUNCTION DIAGNOSTIC CODE CHART, RS-42.

12. Touch BACK key of CONSULT until "SELECT SYSTEM" appears, then turn off CONSULT.

13. Turn ignition switch OFF, then disconnect CONSULT and both battery cables.

14. Repair the system as outlined by the Repair order in INTERMITTENT MALFUNCTION DIAGNOSTIC CODE CHART, that corresponds to the self-diagnostic result. For replacement procedure of component parts, refer to RS-14.

15. Go to DIAGNOSTIC PROCEDURE 4, RS-34, for final checking.

GI

MA

EM

LC

EC

FE

CL

MT

AT

FA

RA

BR

ST

RS

BT

HA

EL

IDX

# TROUBLE DIAGNOSES — Supplemental Restraint System (SRS)

## Self-diagnosis (Cont'd)

### INTERMITTENT MALFUNCTION DIAGNOSTIC CODE CHART (“SELF-DIAG [PAST]” or “TROUBLE DIAG RECORD”)

Diagnostic item	Explanation	*Repair order
NO SELF DIAGNOSTIC FAILURE INDICATED.	<ul style="list-style-type: none"> <li>● No malfunction is detected.</li> </ul>	Go to DIAGNOSTIC PROCEDURE 4, RS-34 after charging battery.
AIRBAG MODULE [OPEN]	<ul style="list-style-type: none"> <li>● Driver air bag module circuit is open. (including the spiral cable)</li> </ul>	<ul style="list-style-type: none"> <li>● Replace driver air bag module. (Before disposal of it, it must be deployed.)</li> <li>● Replace spiral cable.</li> <li>● Replace diagnosis sensor unit.</li> </ul>
AIRBAG MODULE [VB-SHORT]	<ul style="list-style-type: none"> <li>● Driver air bag module circuit is shorted to some power supply circuit. (including the spiral cable)</li> </ul>	<ul style="list-style-type: none"> <li>● Replace driver air bag module. (Before disposing of it, it must be deployed.)</li> <li>● Replace spiral cable.</li> </ul>
AIRBAG MODULE [GND-SHORT]	<ul style="list-style-type: none"> <li>● Driver air bag module circuit is shorted to ground. (including the spiral cable)</li> </ul>	<ul style="list-style-type: none"> <li>● Replace diagnosis sensor unit.</li> <li>● Replace harness if it has visible damage.</li> </ul>
AIRBAG MODULE [SHORT]	<ul style="list-style-type: none"> <li>● Driver air bag module circuits are shorted to each other.</li> </ul>	
ASSIST A/B MODULE [VB-SHORT]	<ul style="list-style-type: none"> <li>● Front passenger air bag module circuit is shorted to some power supply circuit.</li> </ul>	<ul style="list-style-type: none"> <li>● Replace front passenger air bag module. (Before disposal of it, it must be deployed.)</li> </ul>
ASSIST A/B MODULE [OPEN]	<ul style="list-style-type: none"> <li>● Front passenger air bag module circuit is open.</li> </ul>	<ul style="list-style-type: none"> <li>● Replace diagnosis sensor unit.</li> <li>● Replace harness if it has visible damage.</li> </ul>
ASSIST A/B MODULE [GND-SHORT]	<ul style="list-style-type: none"> <li>● Front passenger air bag module circuit is shorted to ground.</li> </ul>	
ASSIST A/B MODULE [SHORT]	<ul style="list-style-type: none"> <li>● Front passenger air bag module circuits are shorted to each other.</li> </ul>	
CONTROL UNIT	<ul style="list-style-type: none"> <li>● Diagnosis sensor unit is malfunctioning.</li> </ul>	<ul style="list-style-type: none"> <li>● Replace diagnosis sensor unit.</li> </ul>

\*Intermittent malfunction areas cannot be easily located. For this reason, perform the procedures outlined under the repair order, then make the final system check.

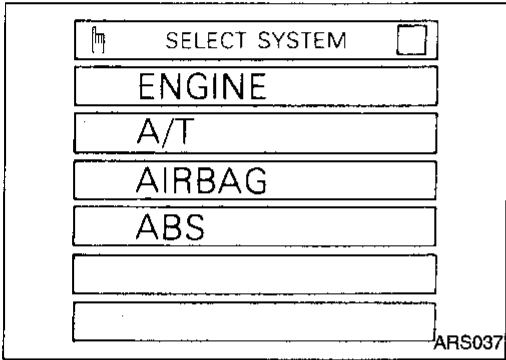
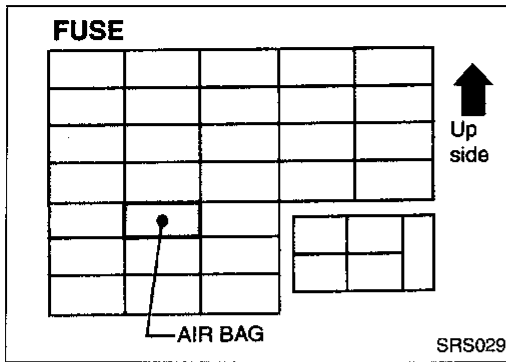

**Trouble Diagnoses for Air Bag Warning Lamp  
DIAGNOSTIC PROCEDURE 9**

**SYMPTOM: "AIR BAG" warning lamp does not turn off.**

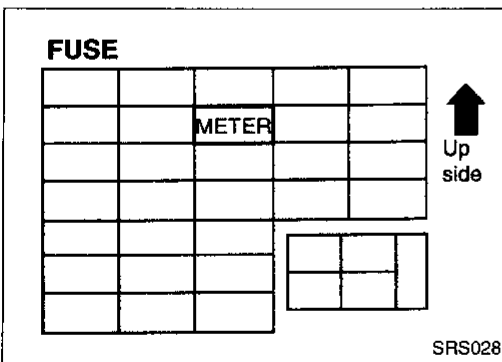
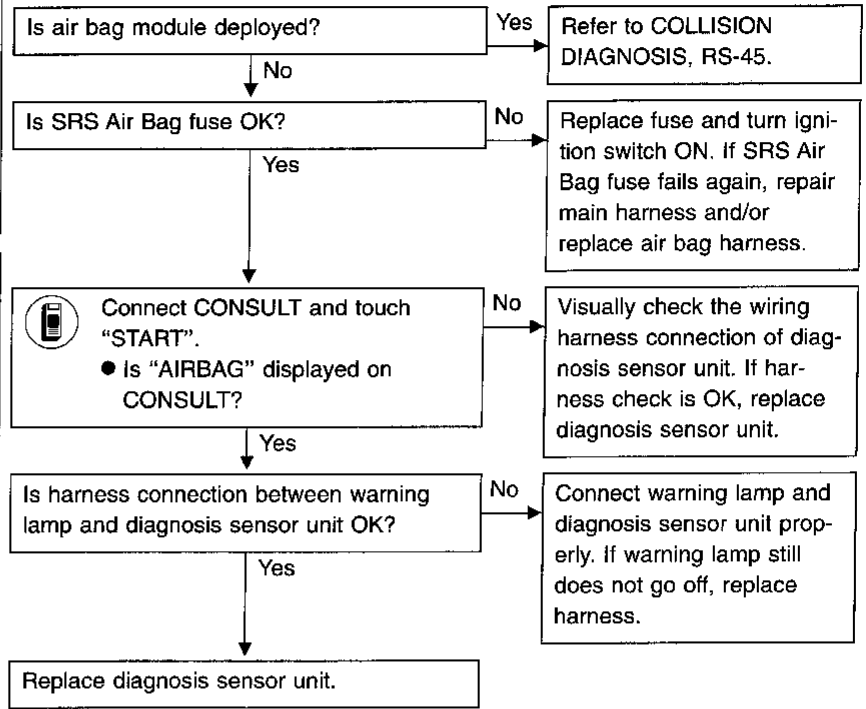

**DIAGNOSTIC PROCEDURE 10**

**SYMPTOM: "AIR BAG" warning lamp does not turn on.**

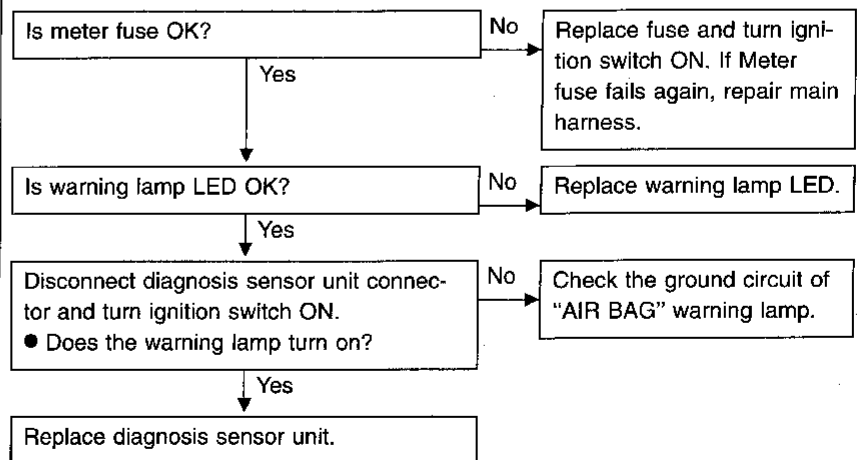

GI  
MA  
EM  
LC  
EC  
FE  
CL  
MT  
AT  
FA  
RA  
BR  
ST  
RS  
BT  
HA  
EL  
IDX

# TROUBLE DIAGNOSES — Supplemental Restraint System (SRS)

## Trouble Diagnoses for Air Bag Warning Lamp (Cont'd)

### DIAGNOSTIC PROCEDURE 11

**SYMPTOM: SRS does not enter Diagnosis mode.**

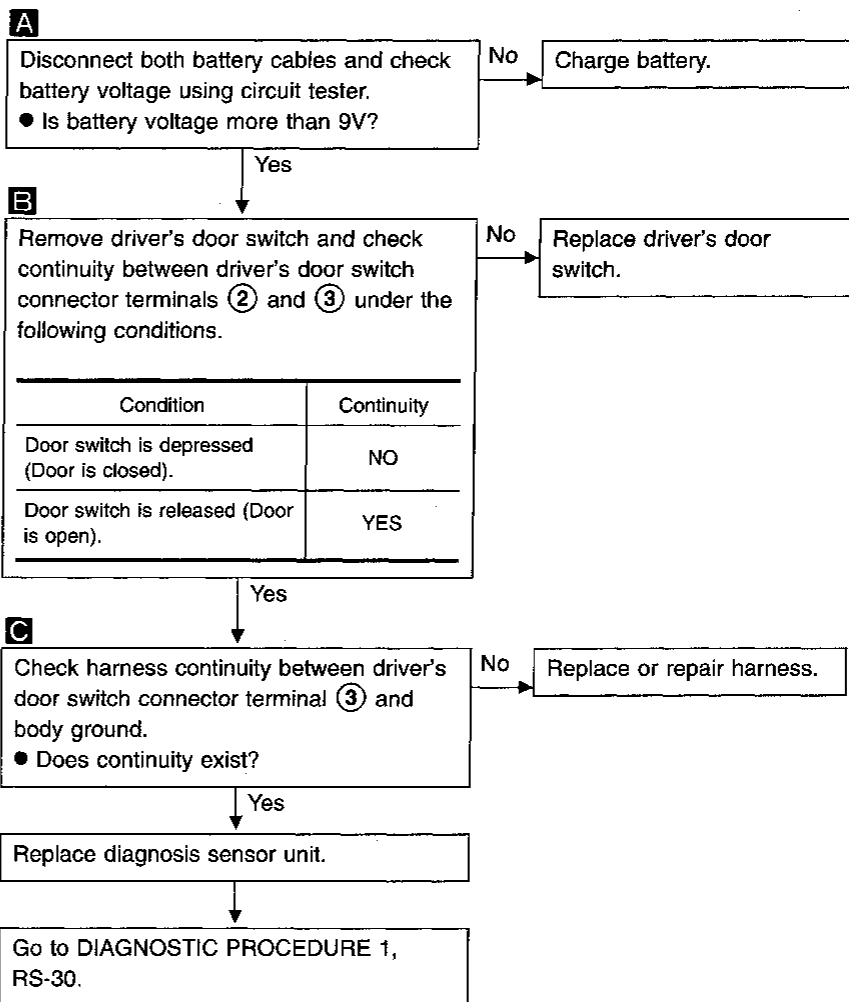
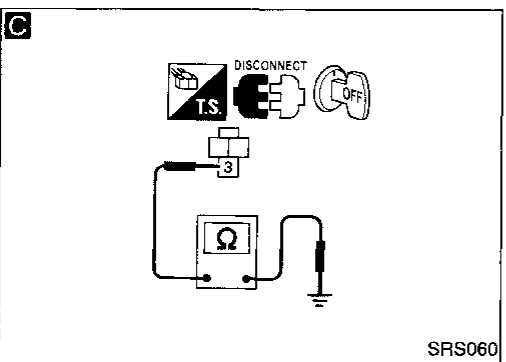
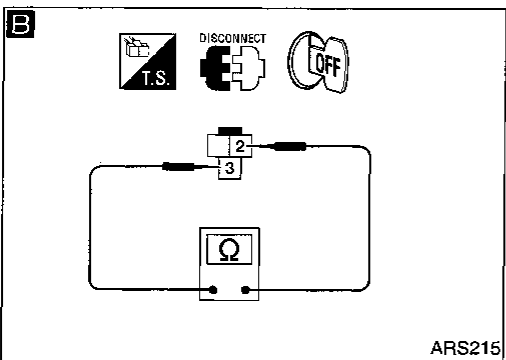
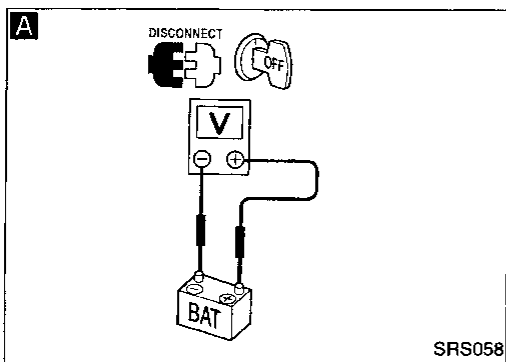

# COLLISION DIAGNOSIS

---

To repair the SRS, perform the following steps.

**When SRS is activated in a collision:**

- ① Replace the diagnosis sensor unit. GI
- ② Remove the air bag modules.
- ③ Check the SRS components using the table shown in the following pages.
  - Replace any SRS components showing visible signs of damage (dents, cracks, deformation). MA
- ④ Install new air bag modules.
- ⑤ Conduct self-diagnosis. Refer to "Self-diagnosis", RS-30. Ensure the remainder of the SRS is operating properly. EM

**When SRS is not activated in a collision:**

- ① Check the SRS components. Refer to "SRS inspection", RS-46.
  - Replace any SRS components showing visible signs of damage (dents, cracks, deformation). LC
- ② Conduct self-diagnosis using CONSULT and "AIR BAG" warning lamp. Refer to "Self-diagnosis", RS-30. Ensure entire SRS operates properly. EC

GI

MA

EM

LC

EC

FE

CL

MT

AT

FA

RA

BR

ST

**RS**

BT

HA

EL

IDX

# COLLISION DIAGNOSIS

## SRS inspection

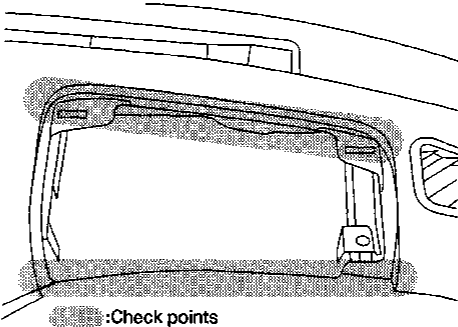
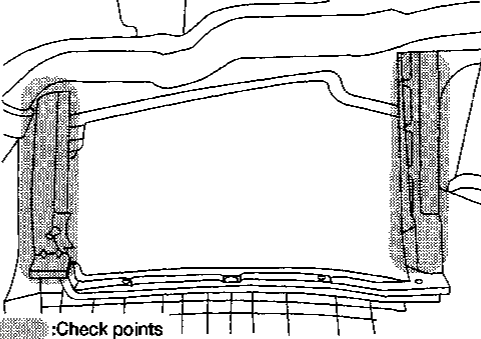
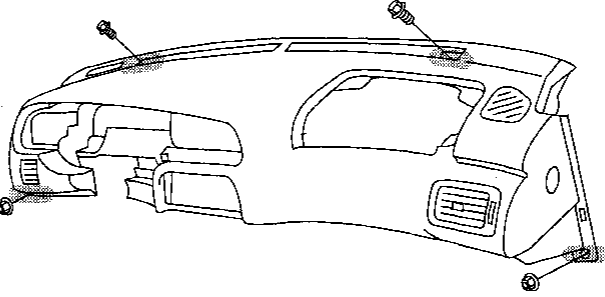
Part	SRS is activated	SRS is NOT activated
Air bag module (driver and passenger side)	<b>REPLACE</b> Install with new bolts.	<ol style="list-style-type: none"> <li>1. Remove air bag module. Check harness cover and connectors for damage, terminals for deformities, and harness for binding.</li> <li>2-1. Install driver air bag module into the steering wheel and check fit and alignment.</li> <li>2-2. Install front passenger air bag module into the instrument panel and check fit and alignment.</li> <li>3. No damage found, reinstall with new bolts.</li> <li>4. If damaged—REPLACE with new bolts. Air bag must be deployed before discarding.</li> </ol>
Diagnosis sensor unit	<b>REPLACE</b> Install with new bolts.	<ol style="list-style-type: none"> <li>1. Check case and bracket for dents, cracks and deformities.</li> <li>2. Check connectors for damage, and terminals for deformities.</li> <li>3. If no damage is found, reinstall with new bolts.</li> <li>4. If damaged—REPLACE with new bolts.</li> </ol>
Instrument panel	<ol style="list-style-type: none"> <li>1. When passenger air bag inflates, check the following points for bending, deformities and cracks:                             <ul style="list-style-type: none"> <li>● Opening portion for passenger air bag ex. (Details differ among models.)</li> </ul> <div style="text-align: center; margin: 10px 0;">  </div> <ul style="list-style-type: none"> <li>● Passenger air bag module brackets ex. (Details differ among models.)</li> </ul> <div style="text-align: center; margin: 10px 0;">  </div> <ul style="list-style-type: none"> <li>● The portions securing the instrument panel ex. (Details differ among models.)</li> </ul> <div style="text-align: center; margin: 10px 0;">  </div> </li> <li>2. If no damage is found, reinstall the instrument panel.</li> <li>3. If damaged - REPLACE the instrument panel with new bolts.</li> </ol>	

# COLLISION DIAGNOSIS

Part	SRS is activated	SRS is NOT activated	
Steering wheel	<ol style="list-style-type: none"> <li>1. Visually check steering wheel for deformities.</li> <li>2. Check harness (built into steering wheel) and connectors for damage, and terminals for deformities.</li> <li>3. Install driver air bag module and check fit and alignment.</li> <li>4. Check steering wheel for excessive free play.</li> <li>5. If no damage is found, reinstall the steering wheel.</li> <li>6. If damaged—REPLACE.</li> </ol>		GI
			MA
Spiral cable	<ol style="list-style-type: none"> <li>1. Visually check spiral cable and combination switch for damage.</li> <li>2. Check connectors, flat cable and protective tape for damage.</li> <li>3. Check steering wheel for noise, binding or heavy operation.</li> <li>4. If no damage is found, reinstall the spiral cable.</li> <li>5. If damaged—REPLACE.</li> </ol>		EM
			LC
Harness and Connectors	<ol style="list-style-type: none"> <li>1. Check connectors for poor connection, damage, and terminals for deformities.</li> <li>2. Check harness for binding, chafing, cuts, or deformities.</li> <li>3. If no damage is found, reinstall.</li> <li>4. Damaged—REPLACE damaged section of harness. Do not attempt to repair, splice or modify any SRS harness.</li> </ol>		EC
			FE
			CL
			MT
			AT
			FA
			RA
			BR
			ST
			<b>RS</b>
			BT
			HA
			EL
			IDX