

SECTION **EC**

GI
MA

EM

LC

EC

FE

CL

MT

AT

FA

RA

BR

ST

RS

BT

HA

EL

IDX

CONTENTS

DIAGNOSTIC TROUBLE CODE INDEX2	Idle Speed/Ignition Timing/Idle Mixture Ratio Adjustment 35
Alphabetical & P No. Index for DTC.....2	
PRECAUTIONS AND PREPARATION4	ON BOARD DIAGNOSTIC SYSTEM
Special Service Tools.....4	DESCRIPTION 42
Commercial Service Tools4	Introduction 42
Supplemental Restraint System (SRS)	Two Trip Detection Logic 42
“AIR BAG” 5	Emission-related Diagnostic Information 43
Precautions for On Board Diagnostic (OBD)	Malfunction Indicator Lamp (MIL) 54
System of Engine and A/T 5	OBD System Operation Chart 57
Engine Fuel & Emission Control System 6	CONSULT 62
Precautions 7	Generic Scan Tool (GST) 76
ENGINE AND EMISSION CONTROL OVERALL SYSTEM9	TROUBLE DIAGNOSIS — Introduction 78
Circuit Diagram 9	Introduction 78
System Diagram 10	Diagnostic Worksheet 78
Engine Control Component Parts Location 11	TROUBLE DIAGNOSIS — Work Flow 80
Vacuum Hose Drawing 15	Work Flow 80
System Chart 16	Description for Work Flow 81
ENGINE AND EMISSION BASIC CONTROL SYSTEM DESCRIPTION 17	TROUBLE DIAGNOSIS — Basic Inspection 82
Multiport Fuel Injection (MFI) System..... 17	Basic Inspection..... 82
Distributor Ignition (DI) System..... 19	TROUBLE DIAGNOSIS — General Description ... 87
Air Conditioning Cut Control..... 20	Diagnostic Trouble Code (DTC) Inspection
Fuel Cut Control..... 21	Priority Chart 87
EVAPORATIVE EMISSION SYSTEM 22	Fail-Safe Chart 88
Description 22	Symptom Matrix Chart 89
Inspection..... 22	CONSULT Reference Value in Data Monitor
Evaporative Emission Line Drawing 25	Mode 92
On Board Refueling Vapor Recovery (ORVR) 27	Major Sensor Reference Graph in Data
POSITIVE CRANKCASE VENTILATION 32	Monitor Mode 95
Description 32	ECM Terminals and Reference Value..... 97
Inspection..... 32	TROUBLE DIAGNOSIS FOR INTERMITTENT INCIDENT 106
BASIC SERVICE PROCEDURE 33	Description 106
Fuel Pressure Release 33	Common I/I Report Situations 106
Fuel Pressure Check 33	Diagnostic Procedure..... 106
Fuel Pressure Regulator Check 34	TROUBLE DIAGNOSIS FOR POWER SUPPLY ... 107
Injector Removal and Installation 34	Main Power Supply and Ground Circuit..... 107
	TROUBLE DIAGNOSIS FOR DTC P0100 112
	Mass Air Flow Sensor (MAFS) 112

CONTENTS (Cont'd.)

TROUBLE DIAGNOSIS FOR DTC P0105	122	No. 4 - 1 Cylinder Misfire, Multiple Cylinder	
Absolute Pressure Sensor.....	122	Misfire.....	245
TROUBLE DIAGNOSIS FOR DTC P0110	131	TROUBLE DIAGNOSIS FOR DTC P0325	250
Intake Air Temperature Sensor.....	131	Knock Sensor (KS).....	250
TROUBLE DIAGNOSIS FOR DTC P0115	137	TROUBLE DIAGNOSIS FOR DTC P0335	255
Engine Coolant Temperature Sensor (ECTS)		Crankshaft Position Sensor (CKPS) (OBD).....	255
(Circuit).....	137	TROUBLE DIAGNOSIS FOR DTC P0340	260
TROUBLE DIAGNOSIS FOR DTC P0120	142	Camshaft Position Sensor (CMPS).....	260
Throttle Position Sensor.....	142	TROUBLE DIAGNOSIS FOR DTC P0400	267
TROUBLE DIAGNOSIS FOR DTC P0125	157	EGR Function (Close).....	267
Engine Coolant Temperature (ECT) Sensor.....	157	TROUBLE DIAGNOSIS FOR DTC P0402	276
TROUBLE DIAGNOSIS FOR DTC P0130	163	EGRC-BPT Valve Function.....	276
Front Heated Oxygen Sensor (Circuit) (Front		TROUBLE DIAGNOSIS FOR DTC P0420	281
HO2S).....	163	Three Way Catalyst Function.....	281
TROUBLE DIAGNOSIS FOR DTC P0131	169	TROUBLE DIAGNOSIS FOR DTC P0440	285
Front Heated Oxygen Sensor (Lean Shift		Evaporative Emission (EVAP) Control System	
Monitoring) (Front HO2S).....	169	(Small Leak) (Negative Pressure).....	285
TROUBLE DIAGNOSIS FOR DTC P0132	175	TROUBLE DIAGNOSIS FOR DTC P0443	296
Front Heated Oxygen Sensor (Rich Shift		Evaporative Emission (EVAP) Canister Purge	
Monitoring) (Front HO2S).....	175	Volume Control Valve (Circuit).....	296
TROUBLE DIAGNOSIS FOR DTC P0133	181	TROUBLE DIAGNOSIS FOR DTC P0446	302
Front Heated Oxygen Sensor (Response		Evaporative Emission (EVAP) Canister Vent	
Monitoring) (Front HO2S).....	181	Control Valve (Circuit).....	302
TROUBLE DIAGNOSIS FOR DTC P0134	189	TROUBLE DIAGNOSIS FOR DTC P0450	307
Front Heated Oxygen Sensor (High Voltage)		Evaporative Emission (EVAP) Control System	
(Front HO2S).....	189	Pressure Sensor.....	307
TROUBLE DIAGNOSIS FOR DTC P0135	195	TROUBLE DIAGNOSIS FOR DTC P0500	314
Front Heated Oxygen Sensor Heater.....	195	Vehicle Speed Sensor (VSS).....	314
TROUBLE DIAGNOSIS FOR DTC P0137	199	TROUBLE DIAGNOSIS FOR DTC P0505	319
Rear Heated Oxygen Sensor (Min. Voltage		Idle Air Control Valve (IACV) — Auxiliary Air	
Monitoring) (Rear HO2S).....	199	Control (AAC) Valve.....	319
TROUBLE DIAGNOSIS FOR DTC P0138	206	TROUBLE DIAGNOSIS FOR DTC P0510	325
Rear Heated Oxygen Sensor (Max. Voltage		Closed Throttle Position Switch.....	325
Monitoring) (Rear HO2S).....	206	TROUBLE DIAGNOSIS FOR DTC P0605	331
TROUBLE DIAGNOSIS FOR DTC P0139	213	Engine Control Module (ECM).....	331
Rear Heated Oxygen Sensor (Response		TROUBLE DIAGNOSIS FOR DTC P1105	333
Monitoring) (Rear HO2S).....	213	Manifold Absolute Pressure (MAP)/	
TROUBLE DIAGNOSIS FOR DTC P0140	220	Barometric Pressure (BARO) Switch Solenoid	
Rear Heated Oxygen Sensor (High Voltage)		Valve.....	333
(Rear HO2S).....	220	TROUBLE DIAGNOSIS FOR DTC P1148	342
TROUBLE DIAGNOSIS FOR DTC P0141	226	Closed Loop Control.....	342
Rear Heated Oxygen Sensor Heater.....	226	TROUBLE DIAGNOSIS FOR DTC P1220	344
TROUBLE DIAGNOSIS FOR DTC P0171	230	Fuel Pump Control Module (FPCM).....	344
Fuel Injection System Function (Lean side).....	230	TROUBLE DIAGNOSIS FOR DTC P1320	351
TROUBLE DIAGNOSIS FOR DTC P0172	236	Ignition Signal.....	351
Fuel Injection System Function (Rich side).....	236	TROUBLE DIAGNOSIS FOR DTC P1336	358
TROUBLE DIAGNOSIS FOR DTC P0180	241	Crankshaft Position Sensor (CKPS) (OBD)	
Tank Fuel Temperature Sensor.....	241	(COG).....	358
TROUBLE DIAGNOSIS FOR DTC P0300 -		TROUBLE DIAGNOSIS FOR DTC P1400	363
P0304	245	EGRC-Solenoid Valve.....	363

CONTENTS (Cont'd.)

TROUBLE DIAGNOSIS FOR DTC P1401 368	Evaporative Emission (EVAP) Canister Purge Control Valve/Solenoid Valve (Circuit)..... 432	GI
EGR Temperature Sensor 368	TROUBLE DIAGNOSIS FOR DTC P1493 438	
TROUBLE DIAGNOSIS FOR DTC P1402 374	Evaporative Emission (EVAP) Canister Purge Control Valve/Solenoid Valve..... 438	MA
EGR Function (Open) 374	TROUBLE DIAGNOSIS FOR DTC P1605 447	
TROUBLE DIAGNOSIS FOR DTC P1440 381	A/T Diagnosis Communication Line 447	EM
Evaporative Emission (EVAP) Control System (Small Leak) (Positive Pressure) 381	TROUBLE DIAGNOSIS FOR DTC P1706 450	
TROUBLE DIAGNOSIS FOR DTC P1444 393	Park/Neutral Position (PNP) Switch 450	LC
Evaporative Emission (EVAP) Canister Purge Volume Control Valve 393	TROUBLE DIAGNOSIS FOR OVERHEAT 455	
TROUBLE DIAGNOSIS FOR DTC P1446 401	Overheat 455	
Evaporative Emission (EVAP) Canister Vent Control Valve (Close) 401	TROUBLE DIAGNOSIS FOR NON-DETECTABLE ITEMS 469	EC
TROUBLE DIAGNOSIS FOR DTC P1447 406	Injector 469	
Evaporative Emission (EVAP) Control System Purge Flow Monitoring..... 406	Start Signal 472	FE
TROUBLE DIAGNOSIS FOR DTC P1448 415	Fuel Pump..... 475	
Evaporative Emission (EVAP) Canister Vent Control Valve (Open) 415	Power Steering Oil Pressure Switch 479	CL
TROUBLE DIAGNOSIS FOR DTC P1490 421	IACV-Air Regulator..... 483	
Vacuum Cut Valve Bypass Valve (Circuit)..... 421	IACV-FICD Solenoid Valve 487	
TROUBLE DIAGNOSIS FOR DTC P1491 426	MIL & Data Link Connectors..... 491	MT
Vacuum Cut Valve Bypass Valve..... 426	SERVICE DATA AND SPECIFICATIONS (SDS) ... 492	
TROUBLE DIAGNOSIS FOR DTC P1492 432	General Specifications 492	
	Inspection and Adjustment..... 492	AT

When you read wiring diagrams:

- Read GI section, "HOW TO READ WIRING DIAGRAMS".
- Read EL section, "POWER SUPPLY ROUTING" for power distribution circuit.

When you perform trouble diagnoses, read GI section, "HOW TO FOLLOW FLOW CHART IN TROUBLE DIAGNOSES" and "HOW TO PERFORM EFFICIENT DIAGNOSIS FOR AN ELECTRICAL INCIDENT".

FA

RA

BR

ST

RS

BT

HA

EL

IDX

DIAGNOSTIC TROUBLE CODE INDEX

Alphabetical & P No. Index for DTC

ALPHABETICAL INDEX FOR DTC

Items (CONSULT screen terms)	DTC*6		Reference page
	CONSULT GST*2	ECM*1	
Unable to access ECM	—	—	EC-88
*COOLAN T SEN/CIRC	P0125	0908	EC-157
A/T 1ST GR FNCTN	P0731	1103	AT-96
A/T 2ND GR FNCTN	P0732	1104	AT-102
A/T 3RD GR FNCTN	P0733	1105	AT-107
A/T 4TH GR FNCTN	P0734	1106	AT-112
A/T DIAG COMM LINE	P1605	0804	EC-447
A/T TCC S/V FNCTN	P0744	1107	AT-124
ABSL PRES SEN/CIRC	P0105	0803	EC-122
AIR TEMP SEN/CIRC	P0110	0401	EC-131
ATF TEMP SEN/CIRC	P0710	1208	AT-85
CAM POS SEN/CIRC	P0340	0101	EC-260
CLOSED LOOP	P1148	0307	EC-342
CLOSED TP SW/CIRC	P0510	0203	EC-325
COOLANT T SEN/CIRC	P0115	0103	EC-137
CPS/CIRC (OBD) COG	P1336	0905	EC-358
CPS/CIRCUIT (OBD)	P0335	0802	EC-255
CYL 1 MISFIRE	P0301	0608	EC-245
CYL 2 MISFIRE	P0302	0607	EC-245
CYL 3 MISFIRE	P0303	0606	EC-245
CYL 4 MISFIRE	P0304	0605	EC-245
ECM	P0605	0301	EC-331
EGR SYSTEM	P0400	0302	EC-267
EGR SYSTEM	P1402	0514	EC-374
EGR TEMP SEN/CIRC	P1401	0305	EC-368
EGRC SOLENOID/V	P1400	1005	EC-363
EGRC-BPT VALVE	P0402	0306	EC-276
ENGINE SPEED SIG	P0725	1207	AT-93
EVAP PURG FLOW/MON	P1447	0111	EC-406
EVAP SMALL LEAK	P1440	0213	EC-381
EVAP SMALL LEAK	P0440	0705	EC-285
EVAPO SYS PRES SEN	P0450	0704	EC-307
FPCM/CIRCUIT	P1220	1305	EC-344
FR O2 SEN HEATER	P0135	0901	EC-195
FRONT O2 SENSOR	P0130	0303	EC-163
FRONT O2 SENSOR	P0131	0411	EC-169
FRONT O2 SENSOR	P0132	0410	EC-175
FRONT O2 SENSOR	P0133	0409	EC-181
FRONT O2 SENSOR	P0134	0412	EC-189
FUEL SYS DIAG-LEAN	P0171	0115	EC-230
FUEL SYS DIAG-RICH	P0172	0114	EC-236
FUEL TEMP SEN/CIRC	P0180	0402	EC-241
IACV/AAC VLV/CIRC	P0505	0205	EC-319
IGN SIGNAL-PRIMARY	P1320	0201	EC-351

Items (CONSULT screen terms)	DTC*6		Reference page
	CONSULT GST*2	ECM*1	
KNOCK SEN/CIRCUIT	P0325	0304	EC-250
L/PRESS SOL/CIRC	P0745	1205	AT-131
MAF SEN/CIRCUIT*3	P0100	0102	EC-112
MAP/BAR SW SOL/CIR	P1105	1302	EC-333
MULTI CYL MISFIRE	P0300	0701	EC-245
NO SELF DIAGNOSTIC FAILURE INDICATED	P0000	0505	—
NO SELF DIAGNOSTIC FAILURE INDICATED	No DTC	Flash- ing*5	EC-54
O/R CLTCH SOL/CIRC	P1760	1203	AT-150
OVER HEAT	—	0208	EC-455
P-N POS SW/CIRCUIT	P1706	1003	EC-450
PNP SW/CIRC	P0705	1101	AT-81
PURG CONT/V & S/V	P1493	0312	EC-438
PURG CONT/V S/V	P1492	0807	EC-432
PURG VOLUME CONT/V	P0443	1008	EC-296
PURG VOLUME CONT/V	P1444	0214	EC-393
REAR O2 SENSOR	P0137	0511	EC-199
REAR O2 SENSOR	P0138	0510	EC-206
REAR O2 SENSOR	P0139	0707	EC-213
REAR O2 SENSOR	P0140	0512	EC-220
RR O2 SEN HEATER	P0141	0902	EC-226
SFT SOL A/CIRC*3	P0750	1108	AT-135
SFT SOL B/CIRC*3	P0755	1201	AT-139
TCC SOLENOID/CIRC	P0740	1204	AT-120
THRTL POS SEN/CIRC*3	P0120	0403	EC-142
TP SEN/CIRC A/T*3	P1705	1206	AT-143
TW CATALYST SYSTEM	P0420	0702	EC-281
VC CUT/V BYPASS/V	P1491	0311	EC-426
VC/V BYPASS/V	P1490	0801	EC-421
VEH SPD SEN/CIR AT*4	P0720	1102	AT-89
VEH SPEED SEN/CIRC*4	P0500	0104	EC-314
VENT CONTROL VALVE	P0446	0903	EC-302
VENT CONTROL VALVE	P1446	0215	EC-401
VENT CONTROL VALVE	P1448	0309	EC-415

*1: In Diagnostic Test Mode II (Self-diagnostic results).
These numbers are controlled by NISSAN.

*2: These numbers are prescribed by SAE J2012.

*3: When the fail-safe operation occurs, the MIL illuminates.

*4: The MIL illuminates when both the "Revolution sensor signal" and the "Vehicle speed sensor signal" meet the fail-safe condition at the same time.

*5: While engine is running.

*6: 1st trip DTC No. is the same as DTC No.

DIAGNOSTIC TROUBLE CODE INDEX

Alphabetical & P No. Index for DTC (Cont'd)

P NO. INDEX FOR DTC

DTC*6		Items (CONSULT screen terms)	Reference page
CONSULT GST*2	ECM*1		
—	—	Unable to access ECM	EC-88
No DTC	Flash- ing*5	NO SELF DIAGNOSTIC FAILURE INDICATED	EC-54
P0000	0505	NO SELF DIAGNOSTIC FAILURE INDICATED	—
P0100	0102	MAF SEN/CIRCUIT*3	EC-112
P0105	0803	ABSL PRES SEN/CIRC	EC-122
P0110	0401	AIR TEMP SEN/CIRC	EC-131
P0115	0103	COOLANT T SEN/CIRC	EC-137
P0120	0403	THRTL POS SEN/CIRC*3	EC-142
P0125	0908	*COOLAN T SEN/CIRC	EC-157
P0130	0303	FRONT O2 SENSOR	EC-163
P0131	0411	FRONT O2 SENSOR	EC-169
P0132	0410	FRONT O2 SENSOR	EC-175
P0133	0409	FRONT O2 SENSOR	EC-181
P0134	0412	FRONT O2 SENSOR	EC-189
P0135	0901	FR O2 SEN HEATER	EC-195
P0137	0511	REAR O2 SENSOR	EC-199
P0138	0510	REAR O2 SENSOR	EC-206
P0139	0707	REAR O2 SENSOR	EC-213
P0140	0512	REAR O2 SENSOR	EC-220
P0141	0902	RR O2 SEN HEATER	EC-226
P0171	0115	FUEL SYS DIAG-LEAN	EC-230
P0172	0114	FUEL SYS DIAG-RICH	EC-236
P0180	0402	FUEL TEMP SEN/CIRC	EC-241
P0300	0701	MULTI CYL MISFIRE	EC-245
P0301	0608	CYL 1 MISFIRE	EC-245
P0302	0607	CYL 2 MISFIRE	EC-245
P0303	0606	CYL 3 MISFIRE	EC-245
P0304	0605	CYL 4 MISFIRE	EC-245
P0325	0304	KNOCK SEN/CIRCUIT	EC-250
P0335	0802	CPS/CIRCUIT (OBD)	EC-255
P0340	0101	CAM POS SEN/CIRC	EC-260
P0400	0302	EGR SYSTEM	EC-267
P0402	0306	EGRC-BPT VALVE	EC-276
P0420	0702	TW CATALYST SYSTEM	EC-281
P0440	0705	EVAP SMALL LEAK	EC-285
P0443	1008	PURG VOLUME CONT/V	EC-296
P0446	0903	VENT CONTROL VALVE	EC-302
P0450	0704	EVAP SYS PRES SEN	EC-307
P0500	0104	VEH SPEED SEN/CIRC*4	EC-314
P0505	0205	IACV/AAC VLV/CIRC	EC-319
P0510	0203	CLOSED TP SW/CIRC	EC-325
P0605	0301	ECM	EC-331
P0705	1101	PNP SW/CIRC	AT-81
P0710	1208	ATF TEMP SEN/CIRC	AT-85

DTC*6		Items (CONSULT screen terms)	Reference page
CONSULT GST*2	ECM*1		
P0720	1102	VEH SPD SEN/CIR AT*4	AT-89
P0725	1207	ENGINE SPEED SIG	AT-93
P0731	1103	A/T 1ST GR FNCTN	AT-96
P0732	1104	A/T 2ND GR FNCTN	AT-102
P0733	1105	A/T 3RD GR FNCTN	AT-107
P0734	1106	A/T 4TH GR FNCTN	AT-112
P0740	1204	TCC SOLENOID/CIRC	AT-120
P0744	1107	A/T TCC S/V FNCTN	AT-124
P0745	1205	L/PRESS SOL/CIRC	AT-131
P0750	1108	SFT SOL A/CIRC*3	AT-135
P0755	1201	SFT SOL B/CIRC*3	AT-139
P1105	1302	MAP/BAR SW SOL/CIR	EC-333
P1148	0307	CLOSED LOOP	EC-342
P1220	1305	FPCM/CIRCUIT	EC-344
P1320	0201	IGN SIGNAL-PRIMARY	EC-351
P1336	0905	CPS/CIRC (OBD) COG	EC-358
P1400	1005	EGRC SOLENOID/V	EC-363
P1401	0305	EGR TEMP SEN/CIRC	EC-368
P1402	0514	EGR SYSTEM	EC-374
P1440	0213	EVAP SMALL LEAK	EC-381
P1444	0214	PURG VOLUME CONT/V	EC-393
P1446	0215	VENT CONTROL VALVE	EC-401
P1447	0111	EVAP PURG FLOW/MON	EC-406
P1448	0309	VENT CONTROL VALVE	EC-415
P1490	0801	VC/V BYPASS/V	EC-421
P1491	0311	VC CUT/V BYPASS/V	EC-426
P1492	0807	PURG CONT/V S/V	EC-432
P1493	0312	PURG CONT/V & S/V	EC-438
P1605	0804	A/T DIAG COMM LINE	EC-447
P1705	1206	TP SEN/CIRC A/T*3	AT-143
P1706	1003	P-N POS SW/CIRCUIT	EC-450
P1760	1203	O/R CLTCH SOL/CIRC	AT-150
—	0208	OVERHEAT	EC-455

*1: In Diagnostic Test Mode II (Self-diagnostic results).

These numbers are controlled by NISSAN.

*2: These numbers are prescribed by SAE J2012.

*3: When the fail-safe operation occurs, the MIL illuminates.

*4: The MIL illuminates when both the "Revolution sensor signal" and the "Vehicle speed sensor signal" meet the fail-safe condition at the same time.

*5: While engine is running.

*6: 1st trip DTC No. is the same as DTC No.

GI

MA

EM

LC

EC

FE

CL

MT

AT

FA

RA

BR

ST

RS

BT

HA

EL

IDX

PRECAUTIONS AND PREPARATION

Special Service Tools

The actual shapes of Kent-Moore tools may differ from those of special service tools illustrated here.

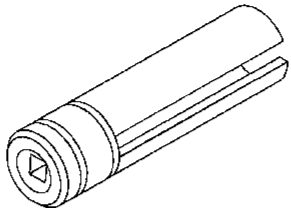
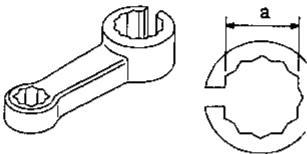
Tool number (Kent-Moore No.) Tool name	Description
KV10117100 (J36471-A) Heated oxygen sensor wrench	 <p style="text-align: right;">Loosening or tightening front heated oxygen sensor with 22 mm (0.87 in) hexagon nut</p> <p>NT379</p>
KV10114400 (J-38365) Heated oxygen sensor wrench	 <p style="text-align: right;">Loosening or tightening rear heated oxygen sensor</p> <p style="text-align: right;">a: 22 mm (0.87 in)</p> <p>NT636</p>

Commercial Service Tools

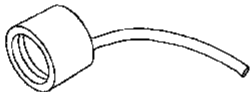
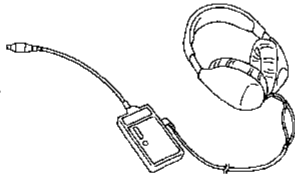
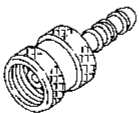
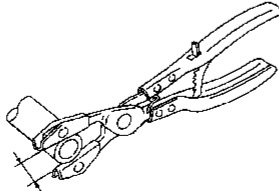
Tool name	Description
Fuel filler cap adapter	 <p style="text-align: right;">Checking fuel tank vacuum relief valve opening pressure</p> <p>NT653</p>
Leak detector (J41416)	 <p style="text-align: right;">Locating the EVAP leak</p> <p>NT703</p>
EVAP service port adapter (J41413-OBD)	 <p style="text-align: right;">Applying positive pressure through EVAP service port</p> <p>NT704</p>
Hose clipper (—)	 <p style="text-align: right;">Clamping the EVAP purge hose between the fuel tank and EVAP canister applied to DTC P1440 [EVAP control system (Small leak — Positive pressure)]</p> <p>NT720 Approx. 20 mm (0.79 in)</p>

PRECAUTIONS AND PREPARATION

Supplemental Restraint System (SRS) “AIR BAG”

The Supplemental Restraint System “AIR BAG”, used along with a seat belt, helps to reduce the risk or severity of injury to the driver and front passenger in a frontal collision. The Supplemental Restraint System consists of air bag modules (located in the center of the steering wheel and in the instrument panel on the passenger side), a diagnosis sensor unit, warning lamp, wiring harness and spiral cable. Information necessary to service the system safely is included in the **RS section** of this Service Manual.

WARNING:

- To avoid rendering the SRS inoperative, which could increase the risk of personal injury or death in the event of a collision which would result in air bag inflation, all maintenance should be performed by an authorized NISSAN dealer.
- Improper maintenance, including incorrect removal and installation of the SRS, can lead to personal injury caused by unintentional activation of the system.
- Do not use electrical test equipment on any circuit related to the SRS unless instructed to in this Service Manual. SRS wiring harnesses are covered with yellow insulation either just before the harness connectors or on the complete harness, for easy identification.

Precautions for On Board Diagnostic (OBD) System of Engine and A/T

The ECM has an on board diagnostic system. It will light up the malfunction indicator lamp (MIL) to warn the driver of a malfunction causing emission deterioration.

CAUTION:

- Be sure to turn the ignition switch “OFF” and disconnect the negative battery terminal before any repair or inspection work. The open/short circuit of related switches, sensors, solenoid valves, etc. will cause the MIL to light up.
- Be sure to connect and lock the connectors securely after work. A loose (unlocked) connector will cause the MIL to light up due to the open circuit. (Be sure the connector is free from water, grease, dirt, bent terminals, etc.)
- Certain systems and components, especially those related to OBD, may use a new style slide-locking type harness connector. For description and how to disconnect, refer to EL section, “Description”, “HARNESS CONNECTOR”.
- Be sure to route and secure the harnesses properly after work. The interference of the harness with a bracket, etc. may cause the MIL to light up due to the short circuit.
- Be sure to connect rubber tubes properly after work. A misconnected or disconnected rubber tube may cause the MIL to light up due to the malfunction of the EGR system or fuel injection system, etc.
- Be sure to erase the unnecessary malfunction information (repairs completed) from the ECM and TCM (Transmission Control Module) before returning the vehicle to the customer.

PRECAUTIONS AND PREPARATION

Engine Fuel & Emission Control System

BATTERY

- Always use a 12 volt battery as power source.
- Do not attempt to disconnect battery cables while engine is running.

ECM

- Do not disassemble ECM (ECCS control module).
- Do not turn on-board diagnostic test mode selector forcibly.
- If a battery terminal is disconnected, the memory will return to the ECM value. The ECM will now start to self-control at its initial value. Engine operation can vary slightly when the terminal is disconnected. However, this is not an indication of a problem. Do not replace parts because of a slight variation.

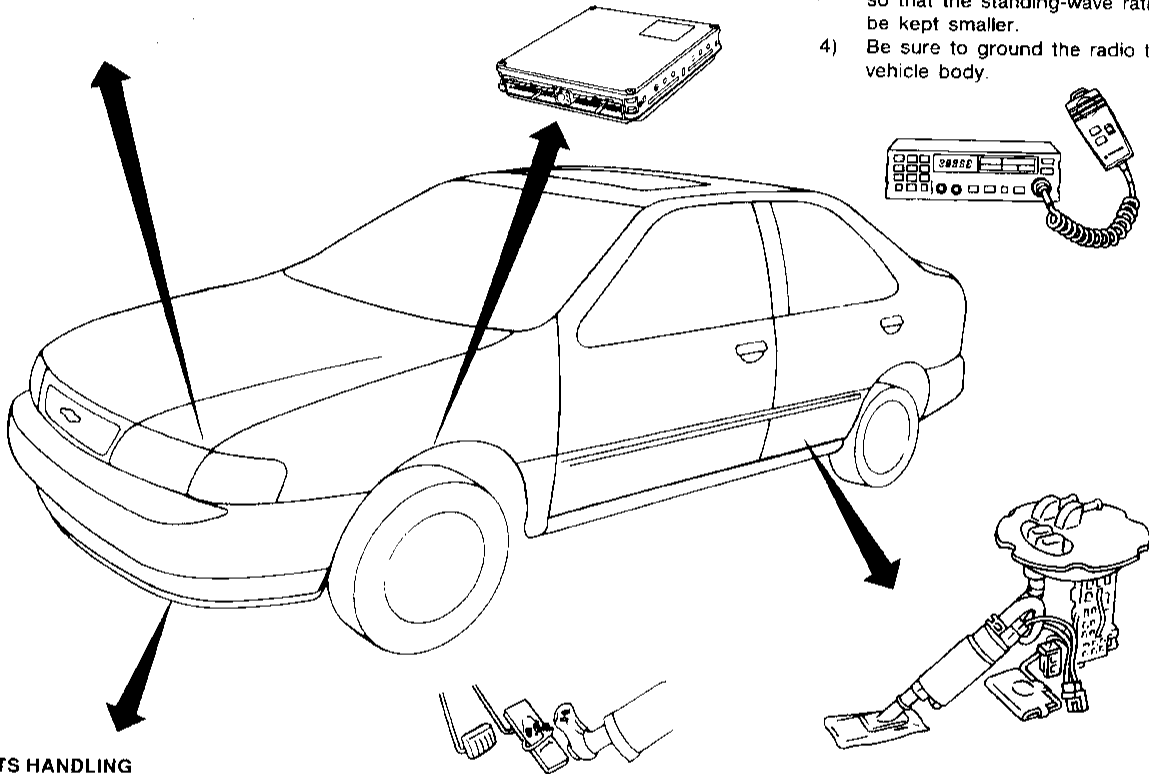

ECCS PARTS HANDLING

- Handle mass air flow sensor carefully to avoid damage.
- Do not disassemble mass air flow sensor.
- Do not clean mass air flow sensor with any type of detergent.
- Do not disassemble IAC valve-AAC valve.
- Even a slight leak in the air intake system can cause serious problems.
- Do not shock or jar the camshaft position sensor.

WHEN STARTING

- Do not depress accelerator pedal when starting.
- Immediately after starting, do not rev up engine unnecessarily.
- Do not rev up engine just prior to shutdown.

WIRELESS EQUIPMENT

- When installing C.B. ham radio or a mobile phone, be sure to observe the following as it may adversely affect electronic control systems depending on its installation location.
 - 1) Keep the antenna as far as possible away from the electronic control units.
 - 2) Keep the antenna feeder line more than 20 cm (8 in) away from the harness of electronic controls. Do not let them run parallel for a long distance.
 - 3) Adjust the antenna and feeder line so that the standing-wave ratio can be kept smaller.
 - 4) Be sure to ground the radio to vehicle body.

FUEL PUMP

- Do not operate fuel pump when there is no fuel in lines.
- Tighten fuel hose clamps to the specified torque.

ECM HARNESS HANDLING

- Securely connect ECM harness connectors. A poor connection can cause an extremely high (surge) voltage to develop in coil and condenser, thus resulting in damage to ICs.
- Keep ECM harness at least 10 cm (4 in) away from adjacent harnesses, to prevent an ECM system malfunction due to receiving external noise, degraded operation of ICs, etc.
- Keep ECM parts and harnesses dry.
- Before removing parts, turn off ignition switch and then disconnect battery ground cable.

PRECAUTIONS AND PREPARATION

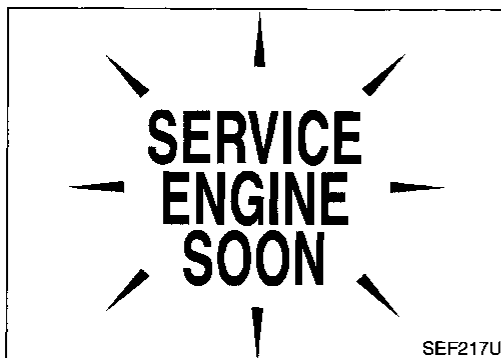
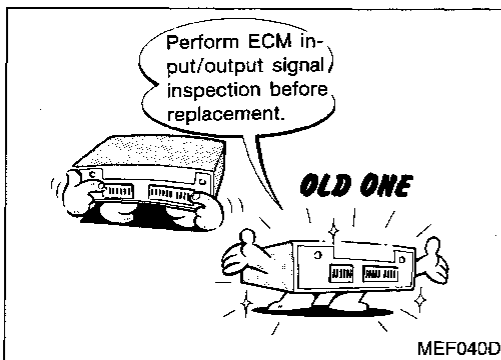
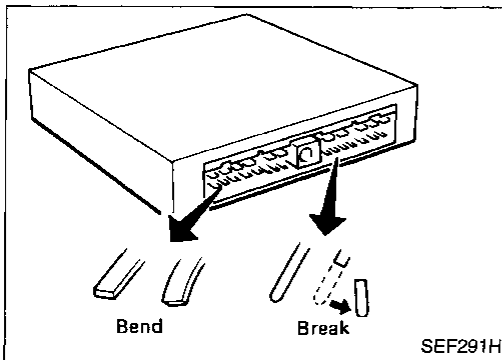
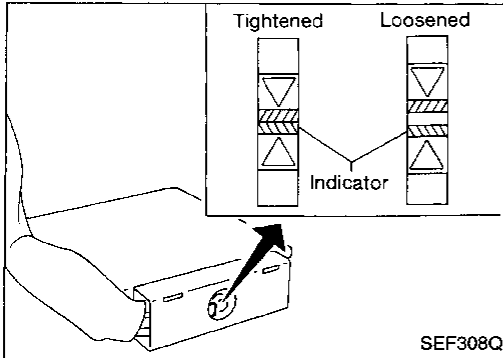
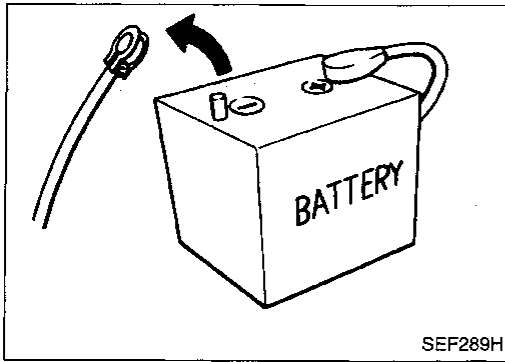

Precautions

- Before connecting or disconnecting the ECM harness connector, turn ignition switch OFF and disconnect negative battery terminal. Failure to do so may damage the ECM because battery voltage is applied to ECM even if ignition switch is turned off.

- When connecting ECM harness connector, tighten securing bolt until the gap between orange indicators disappears.

: 3.0 - 5.0 N·m (0.3 - 0.5 kg-m, 26 - 43 in-lb)

- When connecting or disconnecting pin connectors into or from ECM, take care not to damage pin terminals (bend or break). Make sure that there are not any bends or breaks on ECM pin terminals when connecting pin connectors.

- Before replacing ECM, perform Terminals and Reference Value inspection and make sure ECM functions properly. Refer to EC-97.

- After performing each TROUBLE DIAGNOSIS, perform "OVERALL FUNCTION CHECK" or "DTC (Diagnostic Trouble Code) CONFIRMATION PROCEDURE". The DTC should not be displayed in the "DIAGNOSTIC TROUBLE CODE CONFIRMATION PROCEDURE" if the repair is completed. The "OVERALL FUNCTION CHECK" should be a good result if the repair is completed.

GI

MA

EM

LC

EC

FE

CL

MT

AT

FA

RA

BR

ST

RS

BT

HA

EL

IDX

PRECAUTIONS AND PREPARATION

Precautions (Cont'd)

- When measuring ECM signals with a circuit tester, never allow the two tester probes to contact. Accidental contact of probes will cause a short circuit and damage the ECM power transistor.

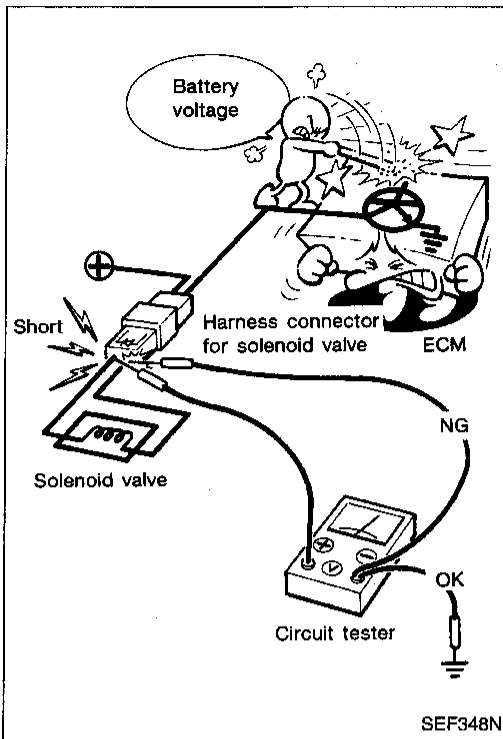

ENGINE AND EMISSION CONTROL OVERALL SYSTEM

Circuit Diagram

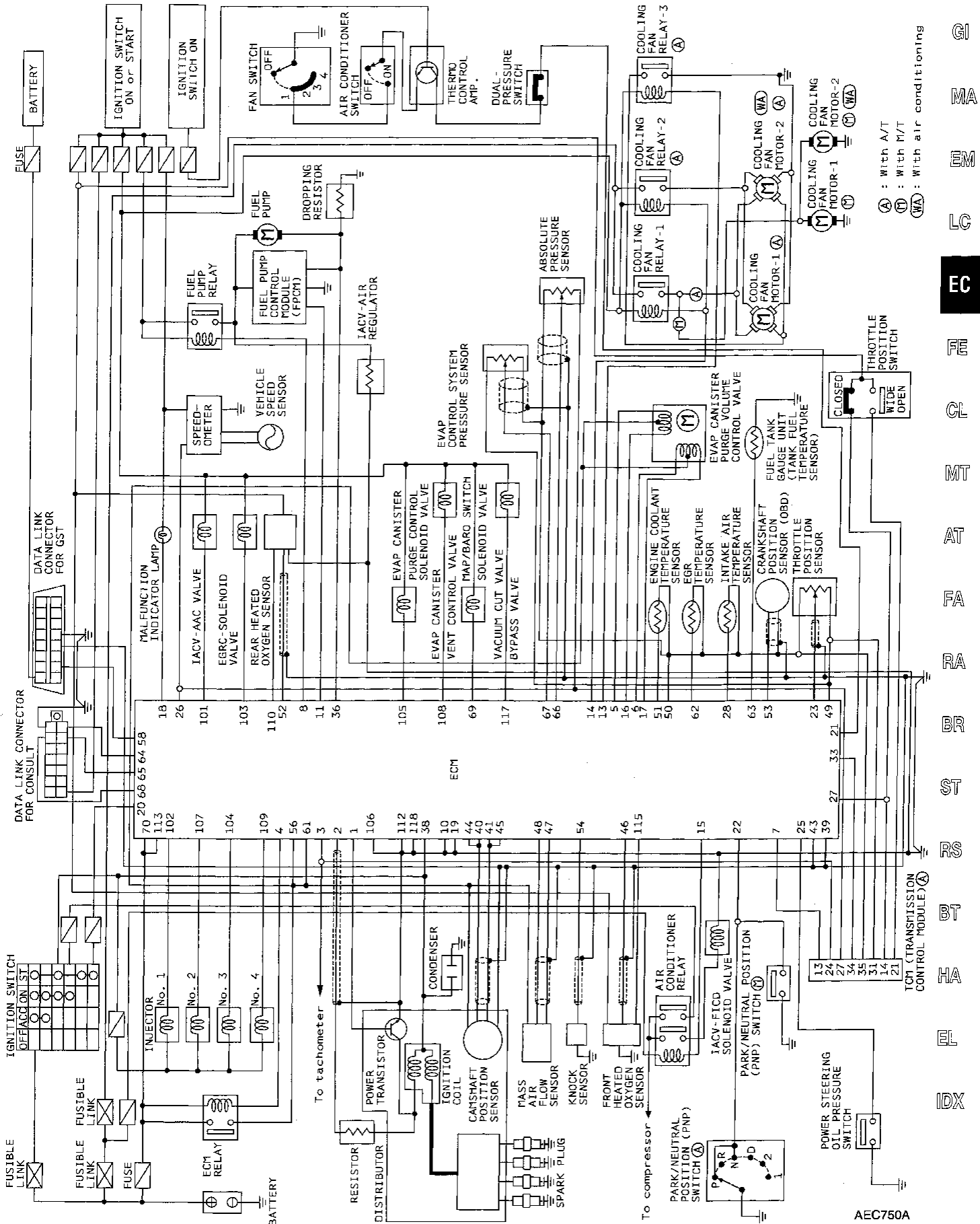

Ⓐ : With A/T
 Ⓜ : With M/T
 ⓂⒶ : With air conditioning

GI
 MA
 EM
 LG
EC
 FE
 CL
 MT
 AT
 FA
 RA
 BR
 ST
 RS
 BT
 HA
 EL
 IX

AEC750A

ENGINE AND EMISSION CONTROL OVERALL SYSTEM

System Diagram

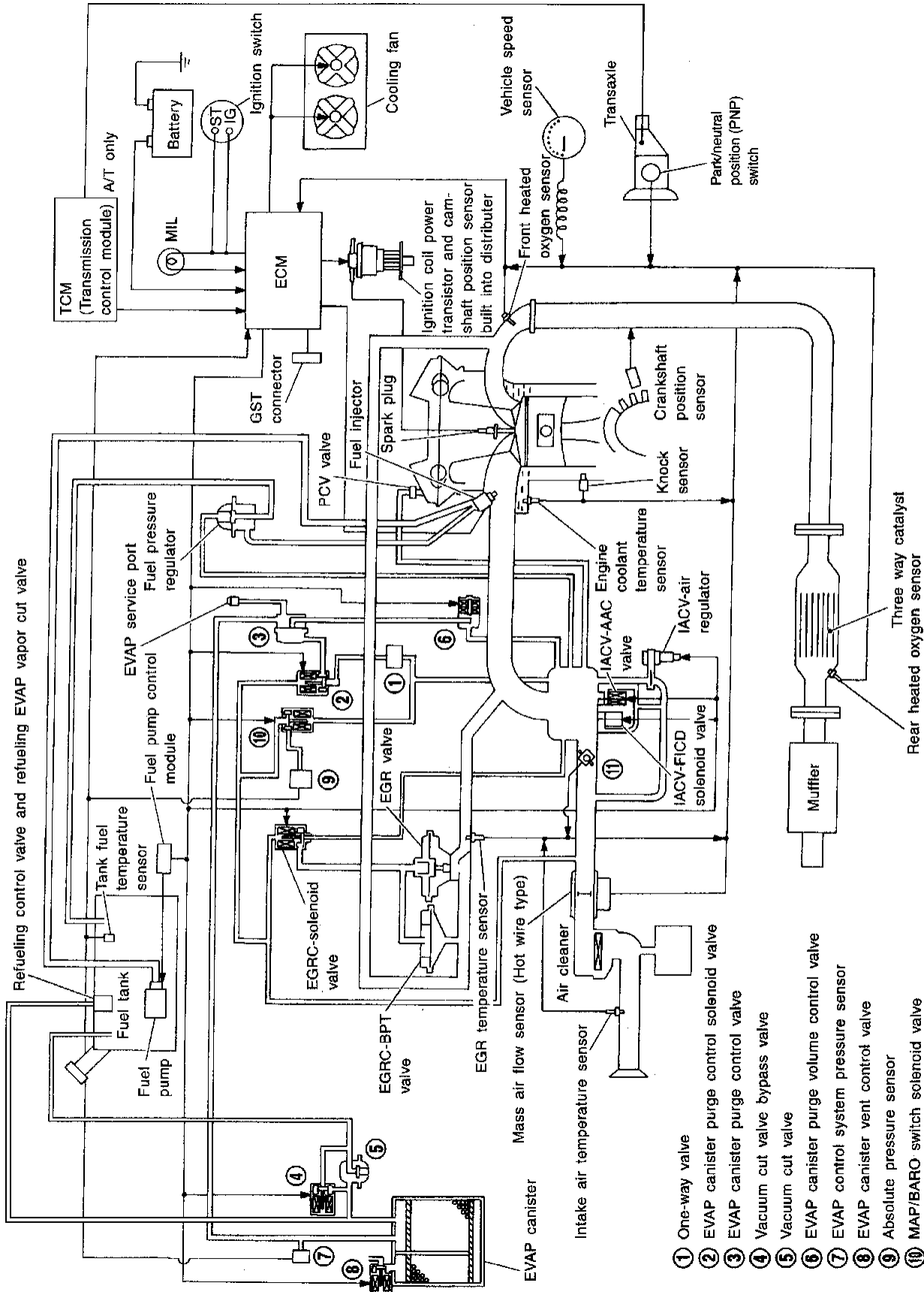

- ① One-way valve
- ② EVAP canister purge control solenoid valve
- ③ EVAP canister purge control valve
- ④ Vacuum cut valve bypass valve
- ⑤ Vacuum cut valve
- ⑥ EVAP canister purge volume control valve
- ⑦ EVAP control system pressure sensor
- ⑧ EVAP canister vent control valve
- ⑨ Absolute pressure sensor
- ⑩ MAP/BARO switch solenoid valve
- ⑪ Throttle position sensor with throttle position switch

ENGINE AND EMISSION CONTROL OVERALL SYSTEM

Engine Control Component Parts Location

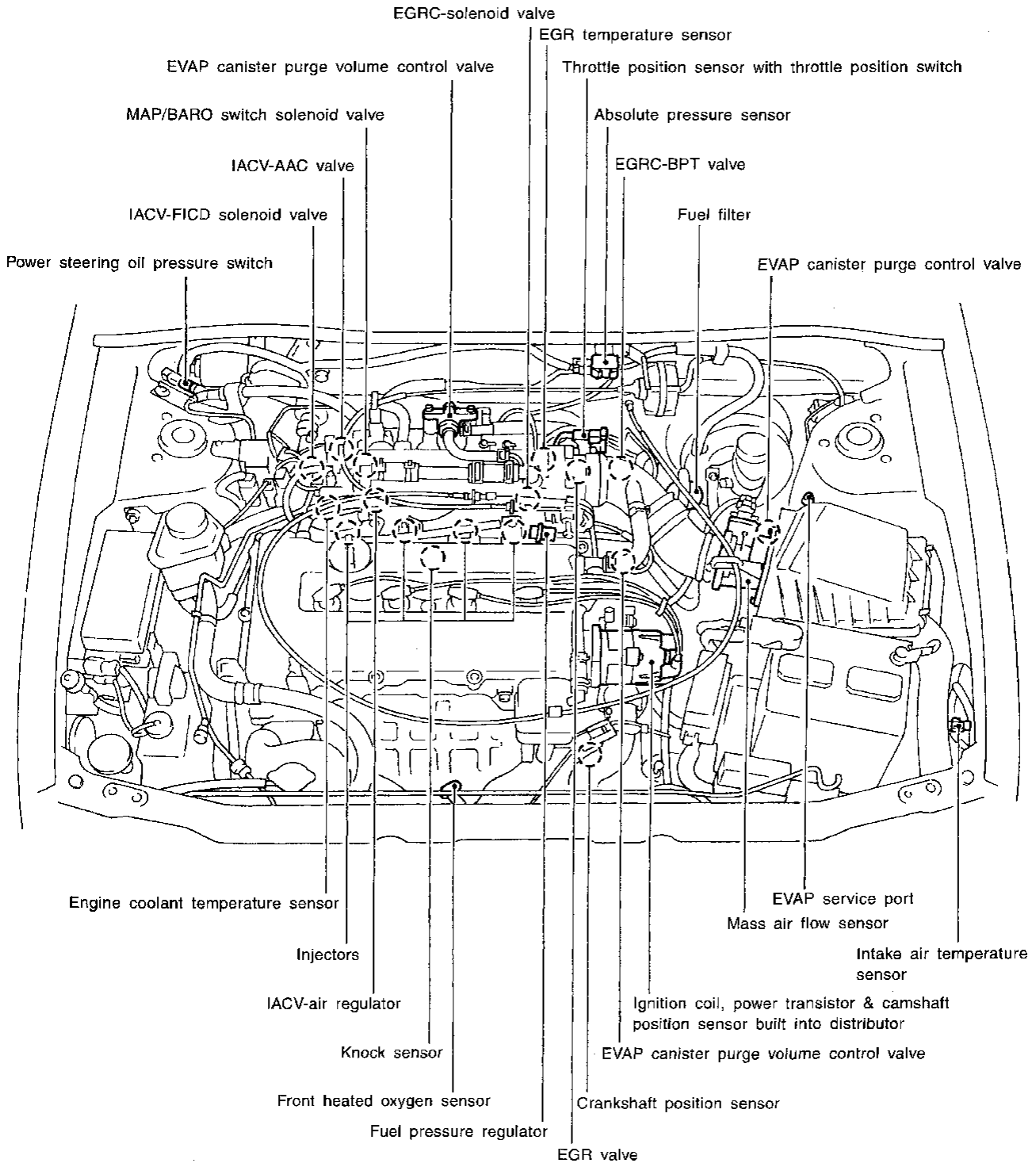

GI

MA

EM

LC

EC

FE

CL

MT

AT

FA

RA

BR

ST

RS

BT

HA

EL

IDX

ENGINE AND EMISSION CONTROL OVERALL SYSTEM

Engine Control Component Parts Location (Cont'd)

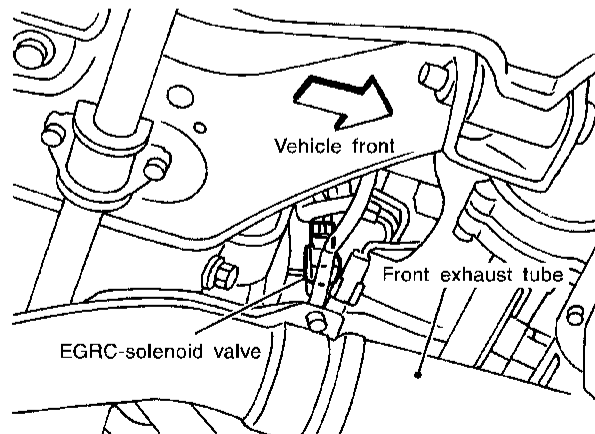
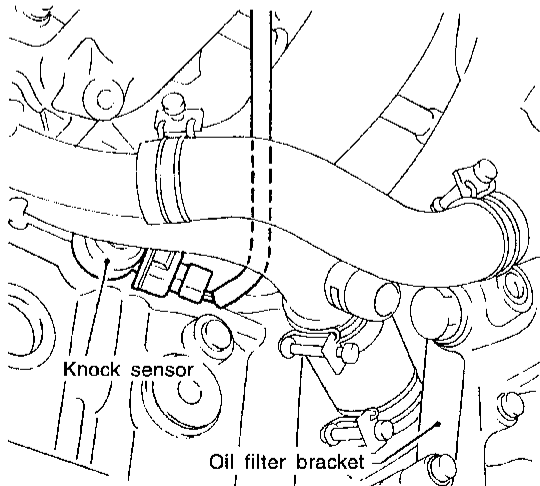
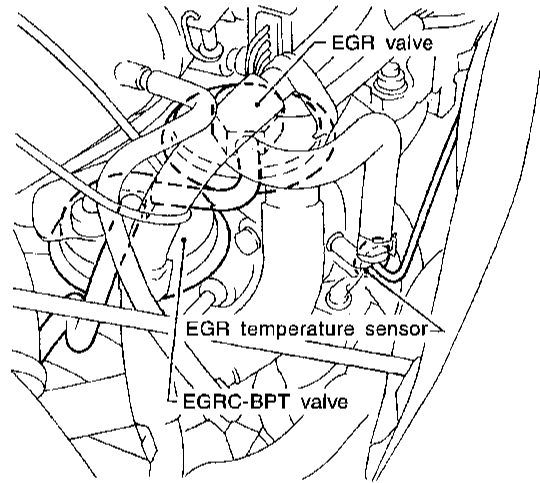
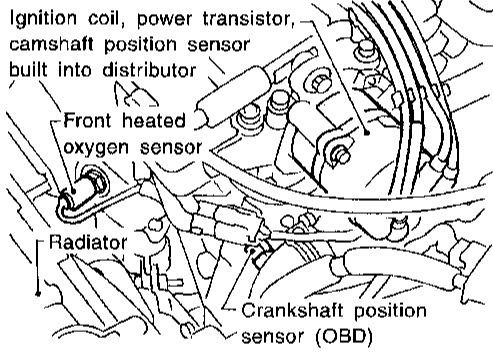
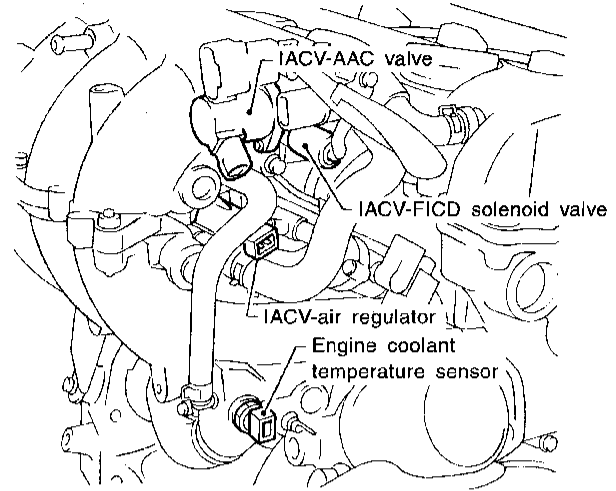
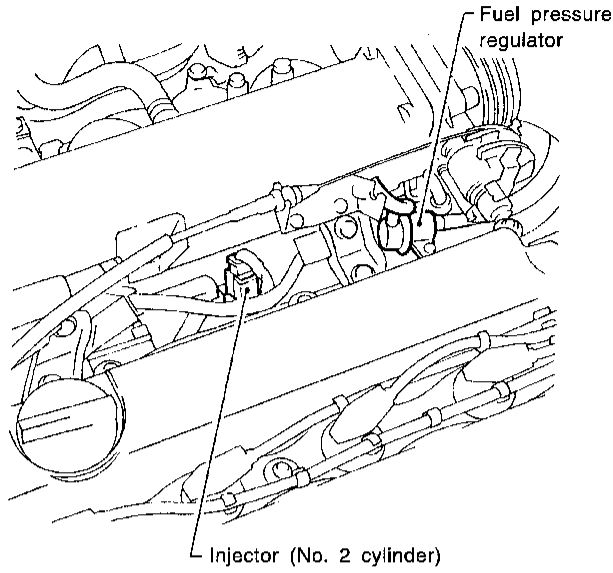

ENGINE AND EMISSION CONTROL OVERALL SYSTEM

Engine Control Component Parts Location (Cont'd)

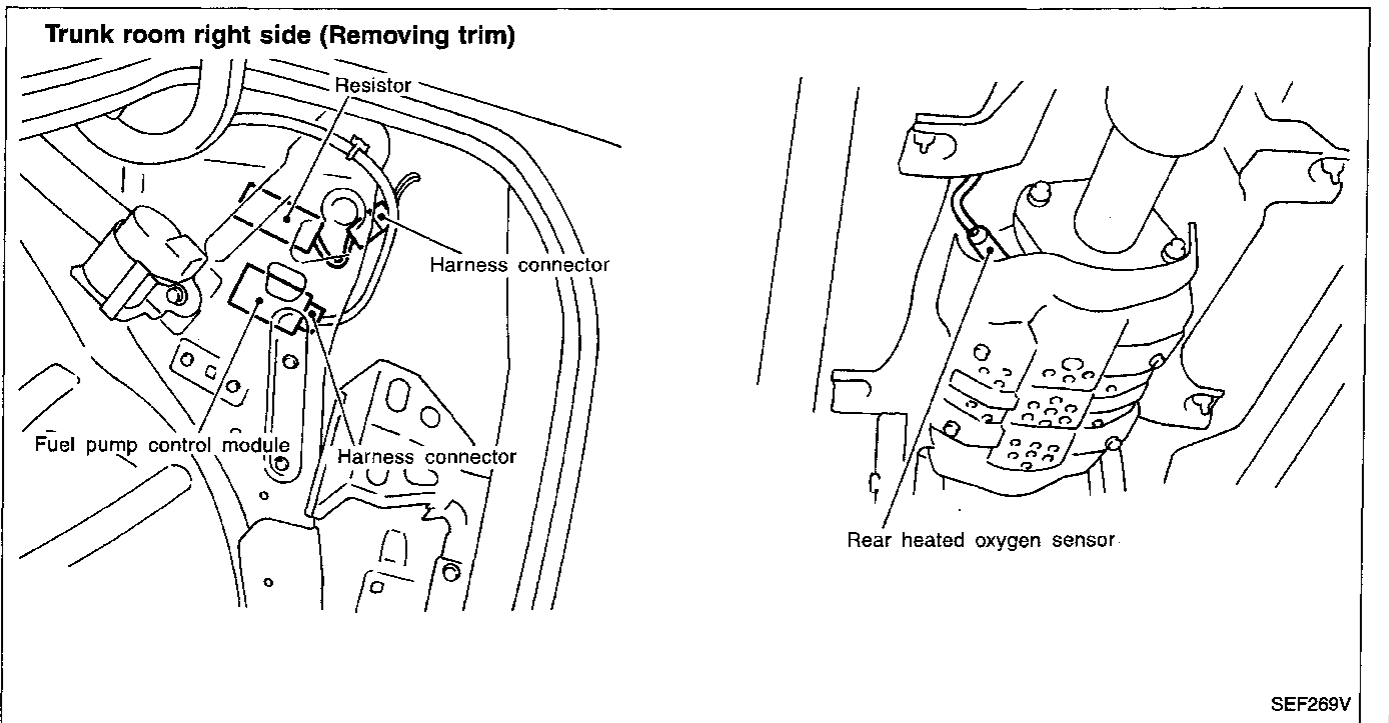
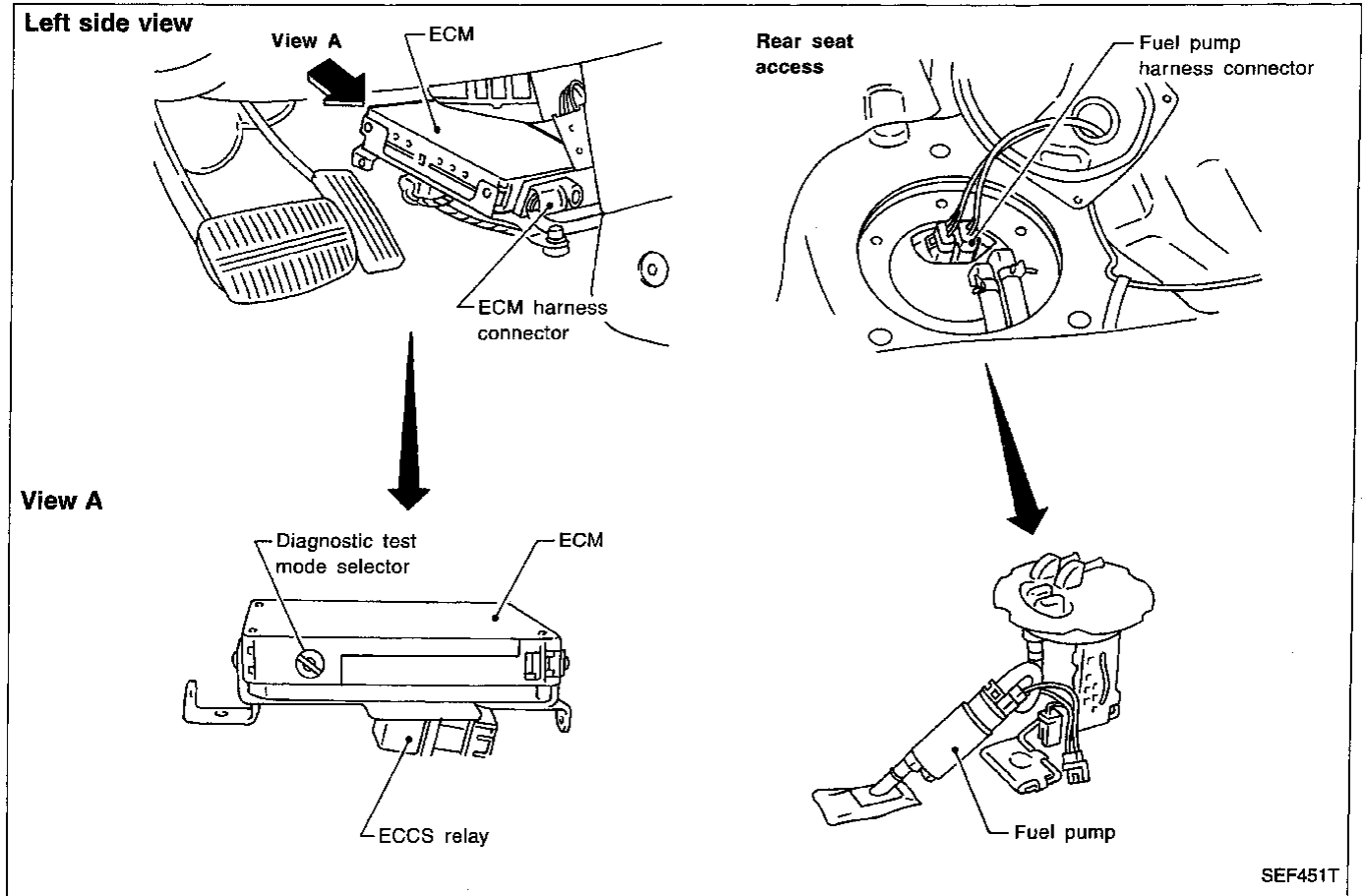

GI
MA
EM
LC
EC
FE
CL
MT
AT
FA
RA
BR
ST
RS
BT
HA
EL
IDX

ENGINE AND EMISSION CONTROL OVERALL SYSTEM

Engine Control Component Parts Location (Cont'd)

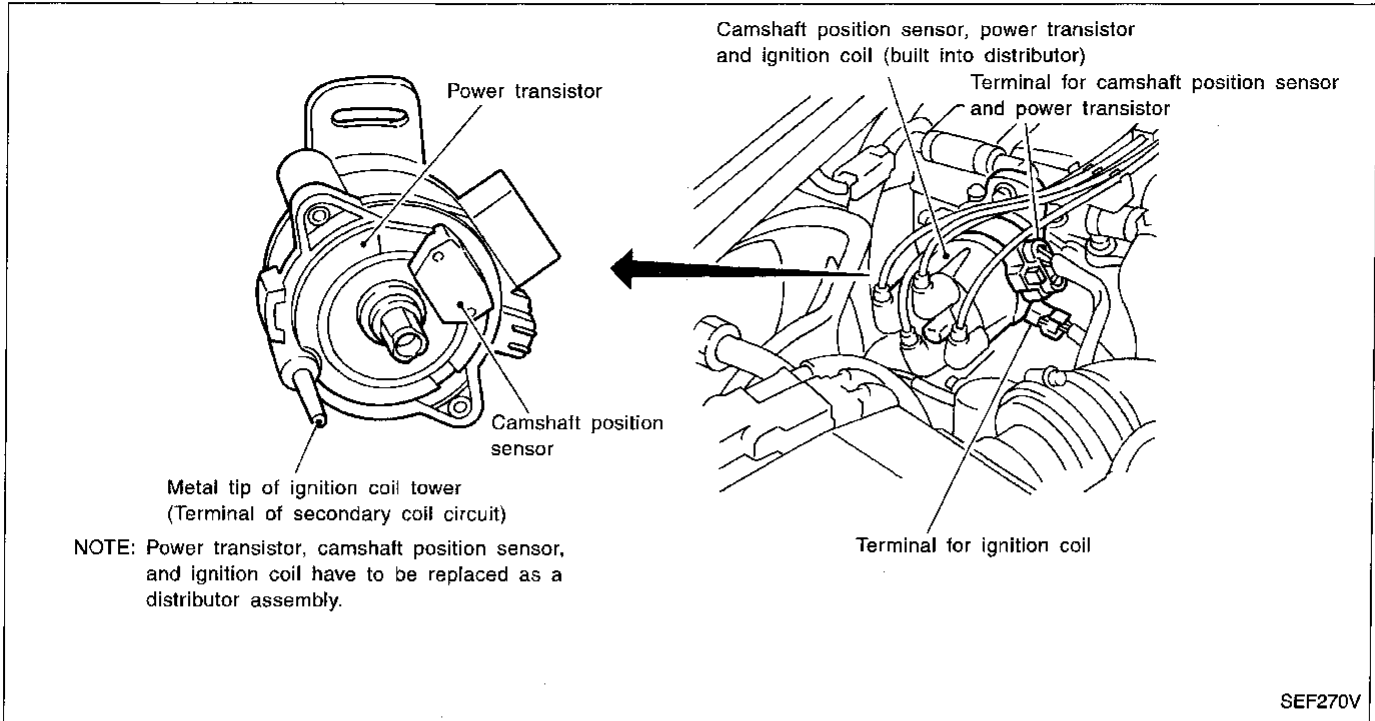

ENGINE AND EMISSION CONTROL OVERALL SYSTEM

Vacuum Hose Drawing

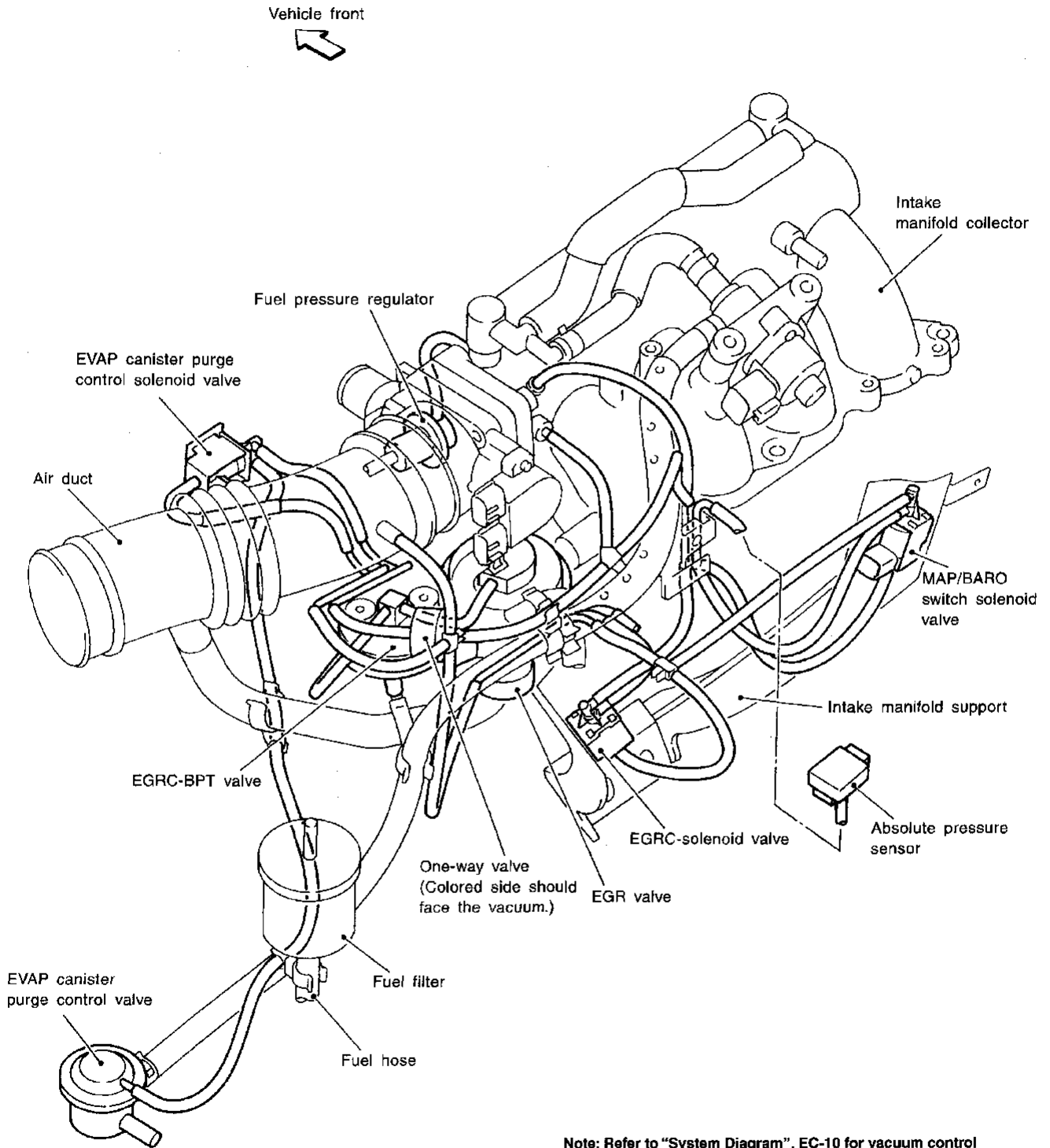

Note: Refer to "System Diagram", EC-10 for vacuum control system. Do not use soapy water or any type of solvent while installing vacuum hoses or purge hoses.

GI

MA

EM

LC

EC

FE

CL

MT

AT

FA

RA

BR

ST

RS

BT

HA

EL

IDX

ENGINE AND EMISSION CONTROL OVERALL SYSTEM

System Chart

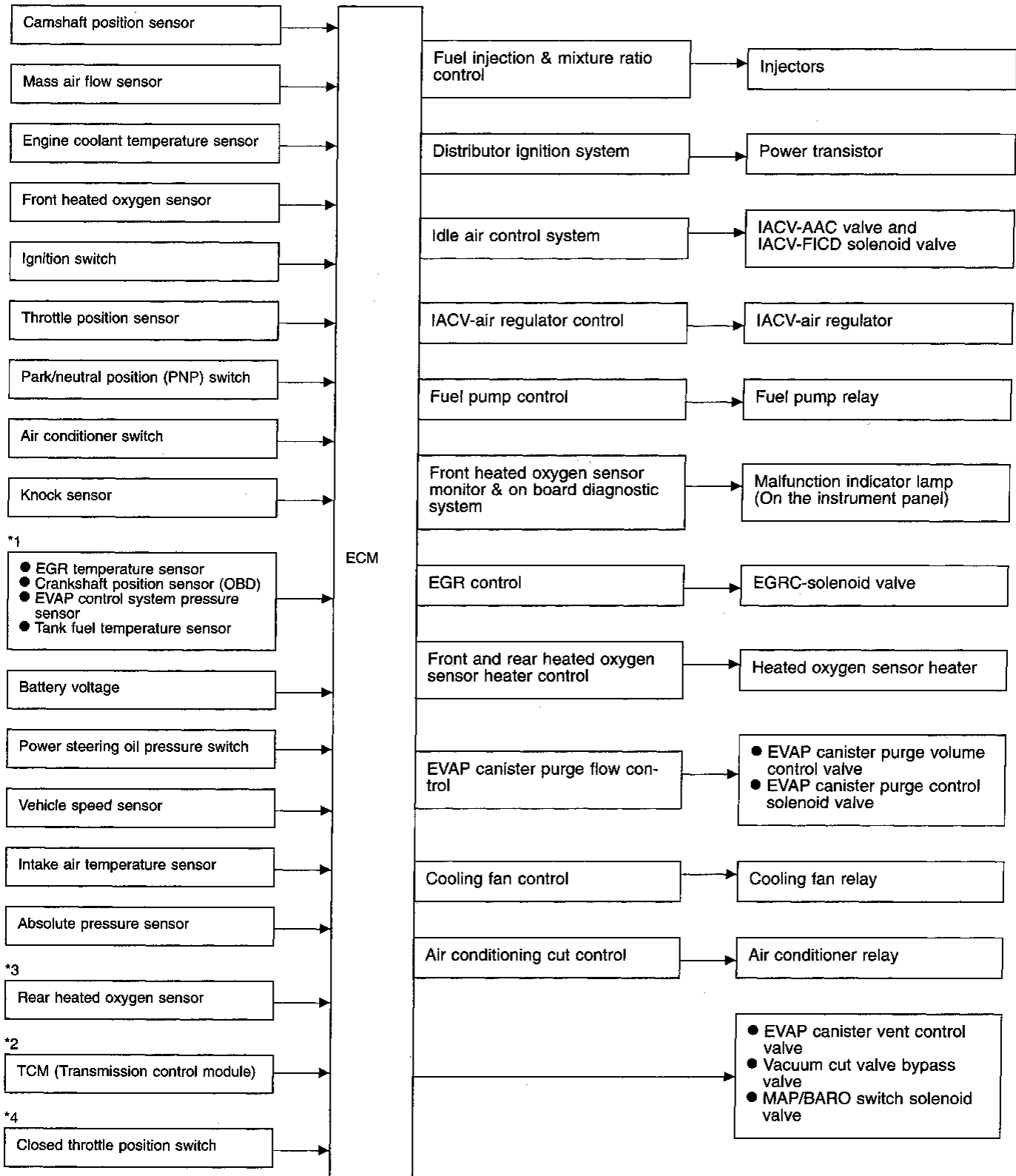

*1: These sensors are not used to control the engine system. They are used only for the on board diagnosis.

*2: The DTC related to A/T will be sent to ECM.

*3: Under normal conditions, this sensor is not for engine control operation.

*4: This switch will operate in place of the throttle position sensor to control EVAP parts if the sensor malfunctions.

ENGINE AND EMISSION BASIC CONTROL SYSTEM DESCRIPTION

Multiport Fuel Injection (MFI) System

INPUT/OUTPUT SIGNAL LINE

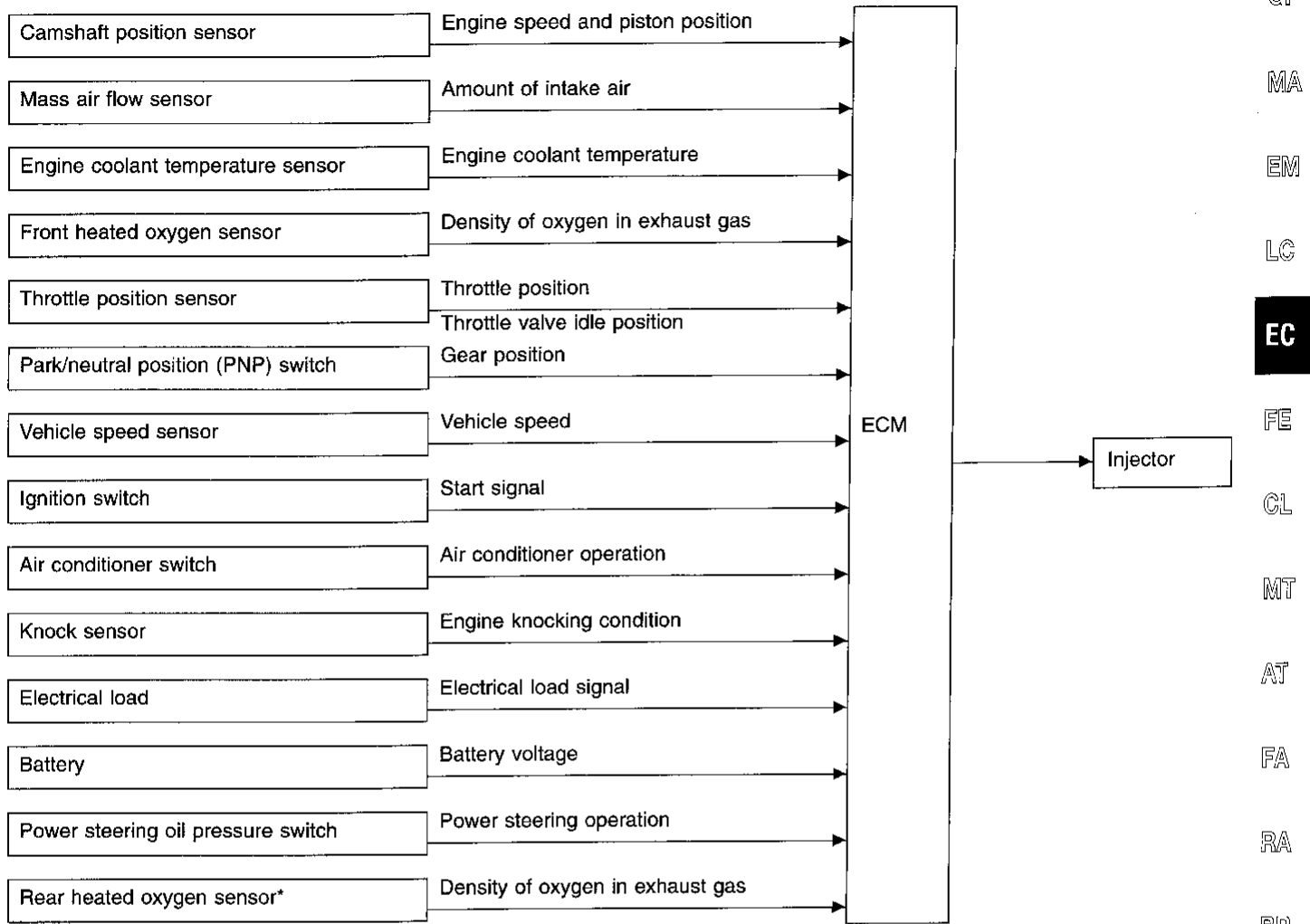

* Under normal conditions, this sensor is not for engine control operation.

BASIC MULTIPOINT FUEL INJECTION SYSTEM

The amount of fuel injected from the fuel injector is determined by the ECM. The ECM controls the length of time the valve remains open (injection pulse duration). The amount of fuel injected is a program value in the ECM memory. The program value is preset by engine operating conditions. These conditions are determined by input signals (for engine speed and intake air) from both the camshaft position sensor and the mass air flow sensor.

VARIOUS FUEL INJECTION INCREASE/DECREASE COMPENSATION

In addition, the amount of fuel injected is compensated to improve engine performance under various operating conditions as listed below.

<Fuel increase>

- During warm-up
- When starting the engine
- During acceleration
- Hot-engine operation
- When selector lever is changed from "N" to "D" (A/T models only)
- High-load, high-speed operation

<Fuel decrease>

- During deceleration
- During high engine speed operation
- During high vehicle speed operation (M/T models)
- Extremely high engine coolant temperature

ENGINE AND EMISSION BASIC CONTROL SYSTEM DESCRIPTION

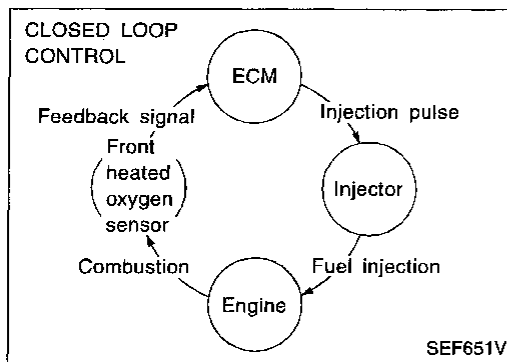

Multiport Fuel Injection (MFI) System (Cont'd) MIXTURE RATIO FEEDBACK CONTROL (CLOSED LOOP CONTROL)

The mixture ratio feedback system provides the best air-fuel mixture ratio for driveability and emission control. The three way catalyst can then better reduce CO, HC and NOx emissions. This system uses a front heated oxygen sensor in the exhaust manifold to monitor if the engine operation is rich or lean. The ECM adjusts the injection pulse width according to the sensor voltage signal. For more information about the front heated oxygen sensor, refer to EC-163. This maintains the mixture ratio within the range of stoichiometric (ideal air-fuel mixture).

This stage is referred to as the closed loop control condition. Rear heated oxygen sensor is located downstream of the three way catalyst. Even if the switching characteristics of the front heated oxygen sensor shift, the air-fuel ratio is controlled to stoichiometric by the signal from the rear heated oxygen sensor.

OPEN LOOP CONTROL

The open loop system condition refers to when the ECM detects any of the following conditions. Feedback control stops in order to maintain stabilized fuel combustion.

- Deceleration and acceleration
- High-load, high-speed operation
- Malfunction of front heated oxygen sensor or its circuit
- Insufficient activation of front heated oxygen sensor at low engine coolant temperature
- High engine coolant temperature
- During warm-up
- When starting the engine

MIXTURE RATIO SELF-LEARNING CONTROL

The mixture ratio feedback control system monitors the mixture ratio signal transmitted from the front heated oxygen sensor. This feedback signal is then sent to the ECM. The ECM controls the basic mixture ratio as close to the theoretical mixture ratio as possible. However, the basic mixture ratio is not necessarily controlled as originally designed. Both manufacturing differences (i.e., mass air flow sensor hot film) and characteristic changes during operation (i.e., injector clogging) directly affect mixture ratio. Accordingly, the difference between the basic and theoretical mixture ratios is monitored in this system. This is then computed in terms of "injection pulse duration" to automatically compensate for the difference between the two ratios.

"Fuel trim" refers to the feedback compensation value compared against the basic injection duration. Fuel trim includes short term fuel trim and long term fuel trim.

"Short term fuel trim" is the short-term fuel compensation used to maintain the mixture ratio at its theoretical value. The signal from the front heated oxygen sensor indicates whether the mixture ratio is RICH or LEAN compared to the theoretical value. The signal then triggers a reduction in fuel volume if the mixture ratio is rich, and an increase in fuel volume if it is lean.

"Long term fuel trim" is overall fuel compensation carried out long-term to compensate for continual deviation of the short term fuel trim from the central value. Such deviation will occur due to individual engine differences, wear over time and changes in the usage environment.

ENGINE AND EMISSION BASIC CONTROL SYSTEM DESCRIPTION

Multiport Fuel Injection (MFI) System (Cont'd)

FUEL INJECTION TIMING

Two types of systems are used.

Sequential multiport fuel injection system

Fuel is injected into each cylinder during each engine cycle according to the firing order. This system is used when the engine is running.

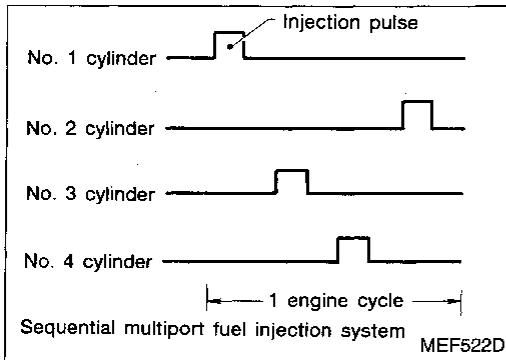

Simultaneous multiport fuel injection system

Fuel is injected simultaneously into all four cylinders twice each engine cycle. In other words, pulse signals of the same width are simultaneously transmitted from the ECM.

The four injectors will then receive the signals two times for each engine cycle.

This system is used when the engine is being started and/or if the fail-safe system (CPU) is operating.

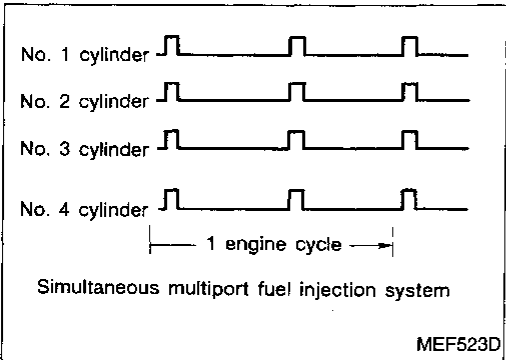

FUEL SHUT-OFF

Fuel to each cylinder is cut off during deceleration or operation of the engine at excessively high speeds.

Distributor Ignition (DI) System

INPUT/OUTPUT SIGNAL LINE

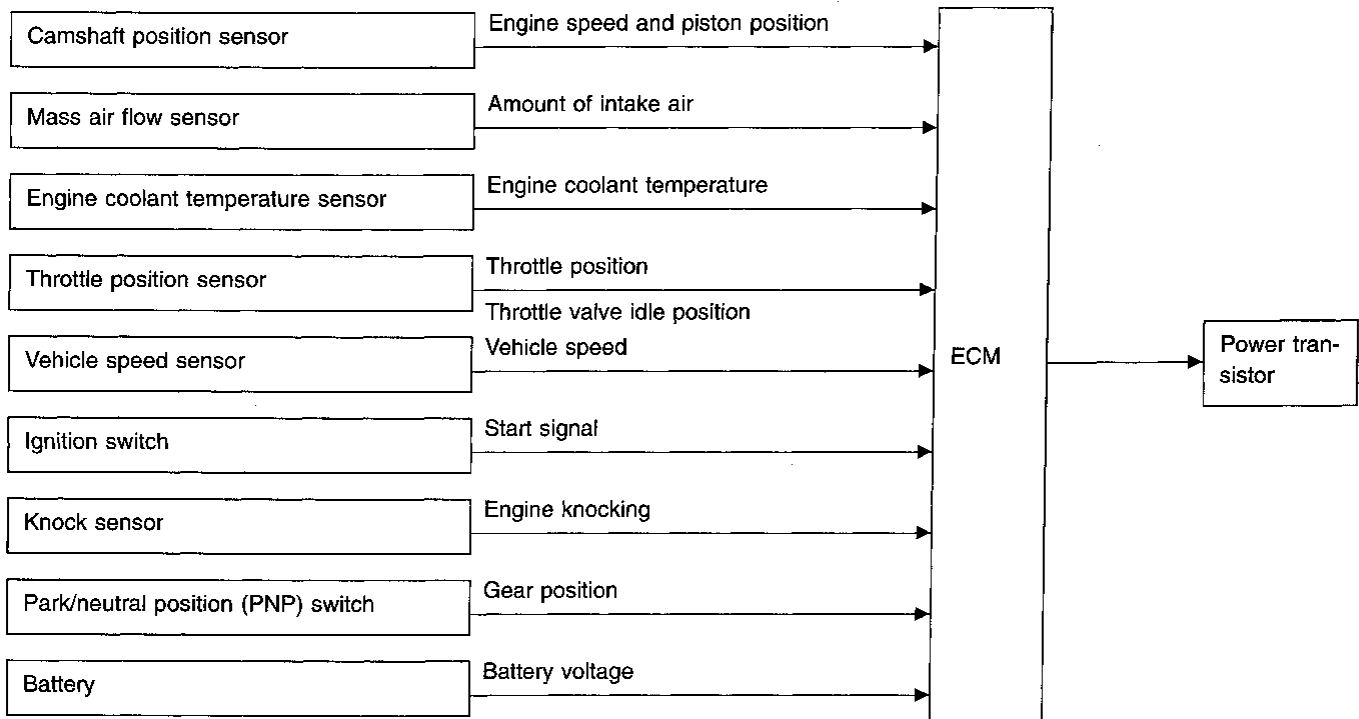

ENGINE AND EMISSION BASIC CONTROL SYSTEM DESCRIPTION

Distributor Ignition (DI) System (Cont'd)

SYSTEM DESCRIPTION

The ignition timing is controlled by the ECM to maintain the best air-fuel ratio for every running condition of the engine.

The ignition timing data is stored in the ECM. This data forms the map shown.

The ECM receives information such as the injection pulse width and camshaft position sensor signal. Computing this information, ignition signals are transmitted to the power transistor.

e.g., N: 1,800 rpm, Tp: 1.50 msec
A°BTDC

During the following conditions, the ignition timing is revised by the ECM according to the other data stored in the ECM.

- At starting
- During warm-up
- At idle
- At low battery voltage
- During acceleration

The knock sensor retard system is designed only for emergencies. The basic ignition timing is programmed within the anti-knocking zone, if recommended fuel is used under dry conditions. The retard system does not operate under normal driving conditions.

If engine knocking occurs, the knock sensor monitors the condition. The signal is transmitted to the ECM. The ECM retards the ignition timing to eliminate the knocking condition.

Air Conditioning Cut Control

INPUT/OUTPUT SIGNAL LINE

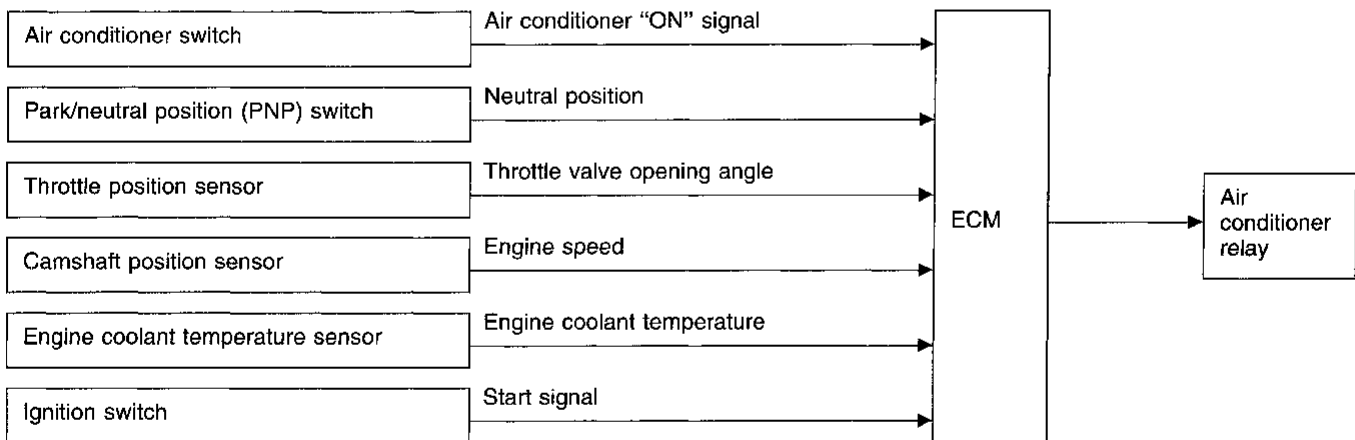

SYSTEM DESCRIPTION

This system improves engine operation when the air conditioner is used.

Under the following conditions, the air conditioner is turned off.

- When the accelerator pedal is fully depressed.
- When cranking the engine.
- At high engine speeds.
- When the engine coolant temperature becomes excessively high.

- When operating power steering during low engine speed or low vehicle speed.
- When engine speed is excessively low.

ENGINE AND EMISSION BASIC CONTROL SYSTEM DESCRIPTION

Fuel Cut Control (at no load & high engine speed)

INPUT/OUTPUT SIGNAL LINE

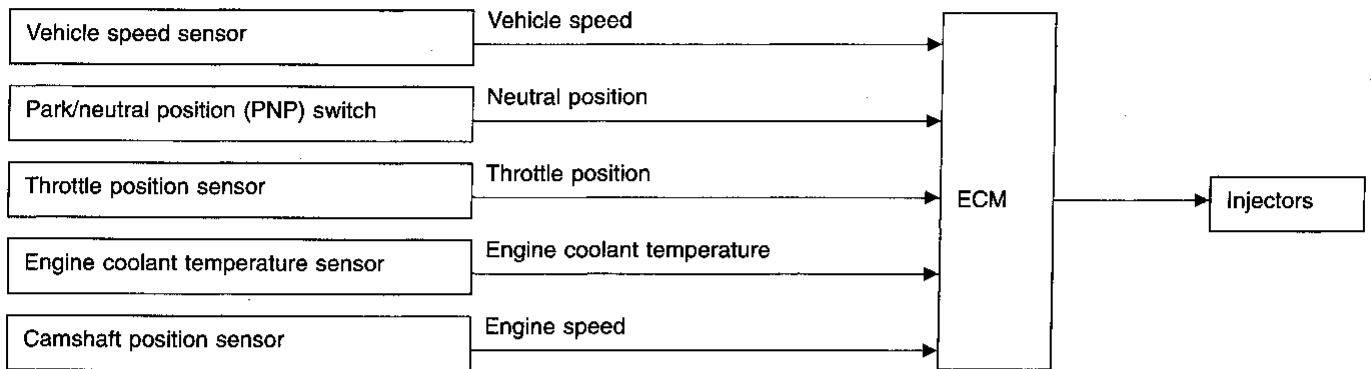

If the engine speed is above 3,950 rpm with no load, (for example, in Neutral and engine speed over 4,000 rpm) fuel will be cut off after some time. The exact time when the fuel is cut off varies based on engine speed. Fuel cut will operate until the engine speed reaches 1,150 rpm, then fuel cut is cancelled.

NOTE:

This function is different from deceleration control listed under "Multiport Fuel Injection (MFI) System", EC-17.

GI

MA

EM

LC

EC

FE

CL

MT

AT

FA

RA

BR

ST

RS

BT

HA

EL

IDX

EVAPORATIVE EMISSION SYSTEM

Description

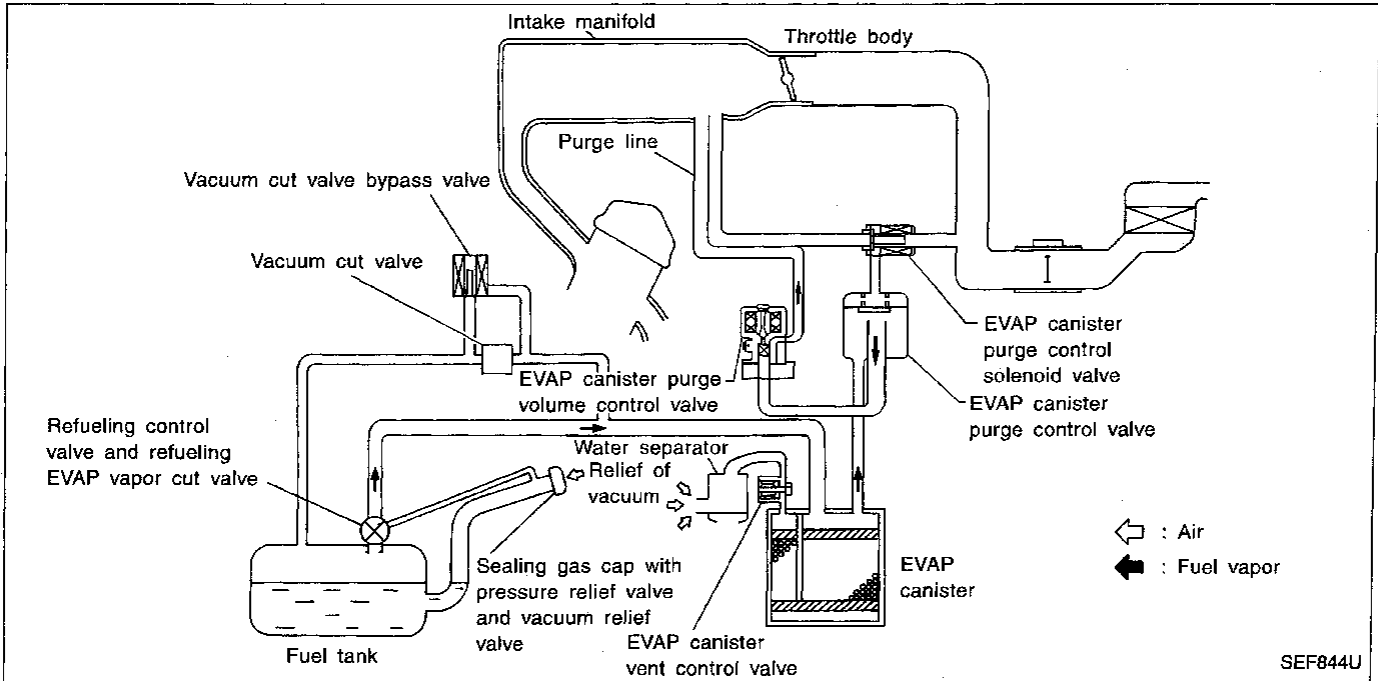

The evaporative emission system is used to reduce hydrocarbons emitted into the atmosphere from the fuel system. This reduction of hydrocarbons is accomplished by activated charcoals in the EVAP canister.

The fuel vapor in the sealed fuel tank is led into the EVAP canister which contains activated carbon and the vapor is stored there when the engine is not operating or when refueling to the fuel tank.

The vapor in the EVAP canister is purged by the air through the purge line to the intake manifold when the engine is operating. EVAP canister purge volume control valve is controlled by ECM. When the engine operates, the flow rate of vapor controlled by EVAP canister purge volume control valve is proportionally regulated as the air flow increases.

EVAP canister purge control valve also shuts off the vapor purge line during decelerating and idling.

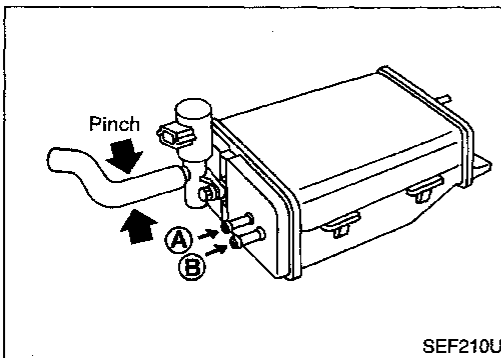

Inspection

EVAP CANISTER

Check EVAP canister as follows:

1. Pinch the fresh air hose.
2. Blow air into port (A) and check that air flows freely through port (B).

EVAPORATIVE EMISSION SYSTEM

Inspection (Cont'd)

TIGHTENING TORQUE

Tighten EVAP canister as shown in the figure.

Make sure new O-ring is installed properly between EVAP canister and EVAP canister vent control valve.

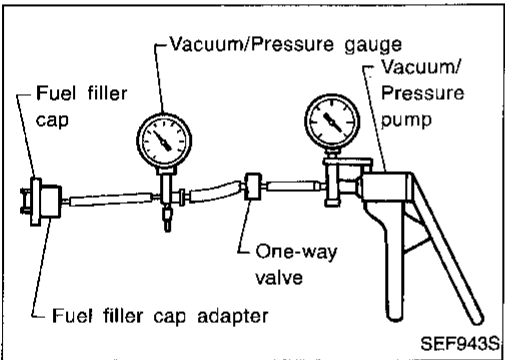
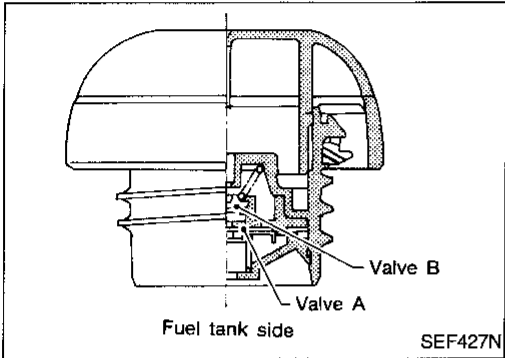
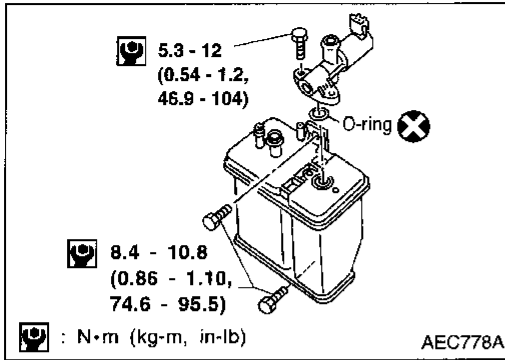

FUEL TANK VACUUM RELIEF VALVE (Built into fuel filler cap)

1. Wipe clean valve housing.
2. Check valve opening pressure and vacuum.

Pressure:

16.0 - 20.0 kPa (0.163 - 0.204 kg/cm², 2.32 - 2.90 psi)

Vacuum:

-6.0 to -3.5 kPa (-0.061 to -0.036 kg/cm², -0.87 to -0.51 psi)

3. If out of specification, replace fuel filler cap as an assembly.

CAUTION:

Use only a genuine NISSAN fuel filler cap as a replacement. If an incorrect fuel filler cap is used, the MIL may come on.

EVAPORATIVE EMISSION (EVAP) CANISTER PURGE CONTROL VALVE

Refer to EC-438.

VACUUM CUT VALVE AND VACUUM CUT VALVE BYPASS VALVE

Refer to EC-426.

EVAPORATIVE EMISSION (EVAP) CANISTER PURGE VOLUME CONTROL VALVE

Refer to EC-393.

EVAPORATIVE EMISSION (EVAP) CANISTER PURGE CONTROL SOLENOID VALVE

Refer to EC-438.

TANK FUEL TEMPERATURE SENSOR

Refer to EC-241.

EVAPORATIVE EMISSION SYSTEM

Inspection (Cont'd)

EVAP SERVICE PORT

Positive pressure is delivered to the EVAP system through the EVAP service port. If fuel vapor leakage in the EVAP system occurs, use a leak detector to locate the leak.

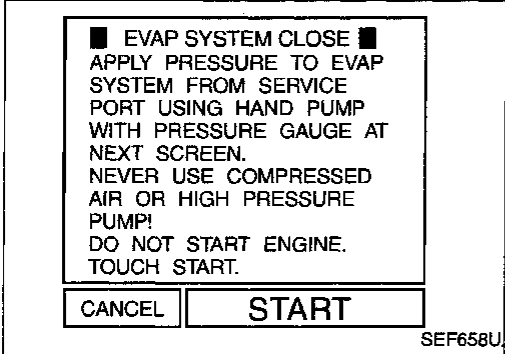
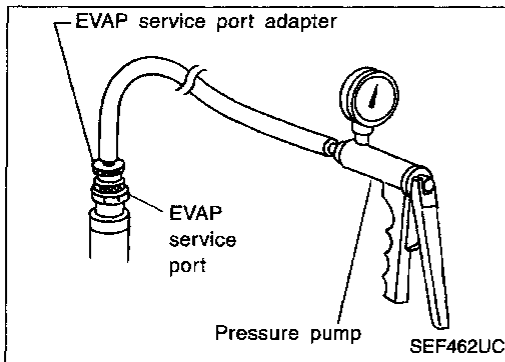

How to detect fuel vapor leakage

CAUTION:

- Never use compressed air or a high pressure pump.
- Do not start engine.
- Do not exceed 4.12 kPa (0.042 kg/cm², 0.6 psi) of pressure in EVAP system.

NOTE:

Improper installation of adapter to the service port may cause a leak.

1. Attach the EVAP service port adapter securely to the EVAP service port.
2. Also attach the pressure pump and hose.
3. Turn ignition switch "ON".
4. Select the "EVAP SYSTEM CLOSE" of "WORK SUPPORT MODE" with CONSULT.
5. Touch "START". A bar graph (Pressure indicating display) will appear on the screen.
6. Apply positive pressure to the EVAP system until the pressure indicator reaches the middle of the bar graph.
7. Remove EVAP service port adapter and hose with pressure pump.
8. Locate the leak using a leak detector. Refer to "Evaporative Emission Line Drawing", EC-25.

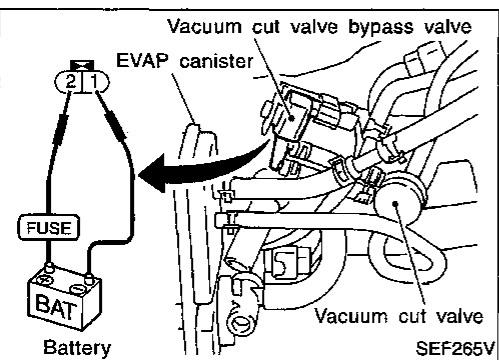
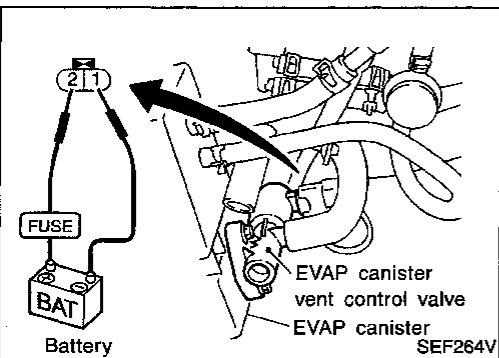
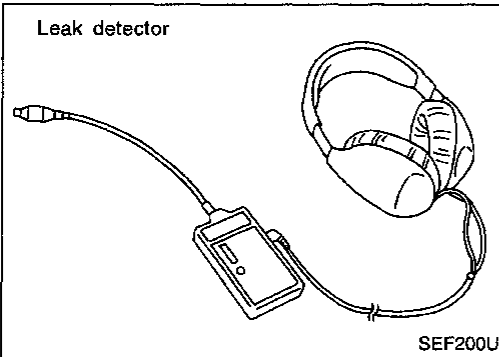

OR

1. Attach the EVAP service port adapter securely to the EVAP service port and pressure pump with pressure gauge to the EVAP service port.
2. Apply battery voltage to between the terminals of both EVAP canister vent control valve and vacuum cut valve bypass valve to make a closed EVAP system.
3. To locate the leak, deliver positive pressure to the EVAP system until pressure gauge points reach 1.38 to 2.76 kPa (0.014 to 0.028 kg/cm², 0.2 to 0.4 psi).
4. Remove EVAP service port adapter and hose with pressure pump.
5. Locate the leak using a leak detector. Refer to "Evaporative Emission Line Drawing", EC-25.

EVAPORATIVE EMISSION SYSTEM

Evaporative Emission Line Drawing

GI
MA
EM
LC
EC
FE
CL
MT
AT
FA
RA
BR
ST
RS
BT
HA
EL
IDX

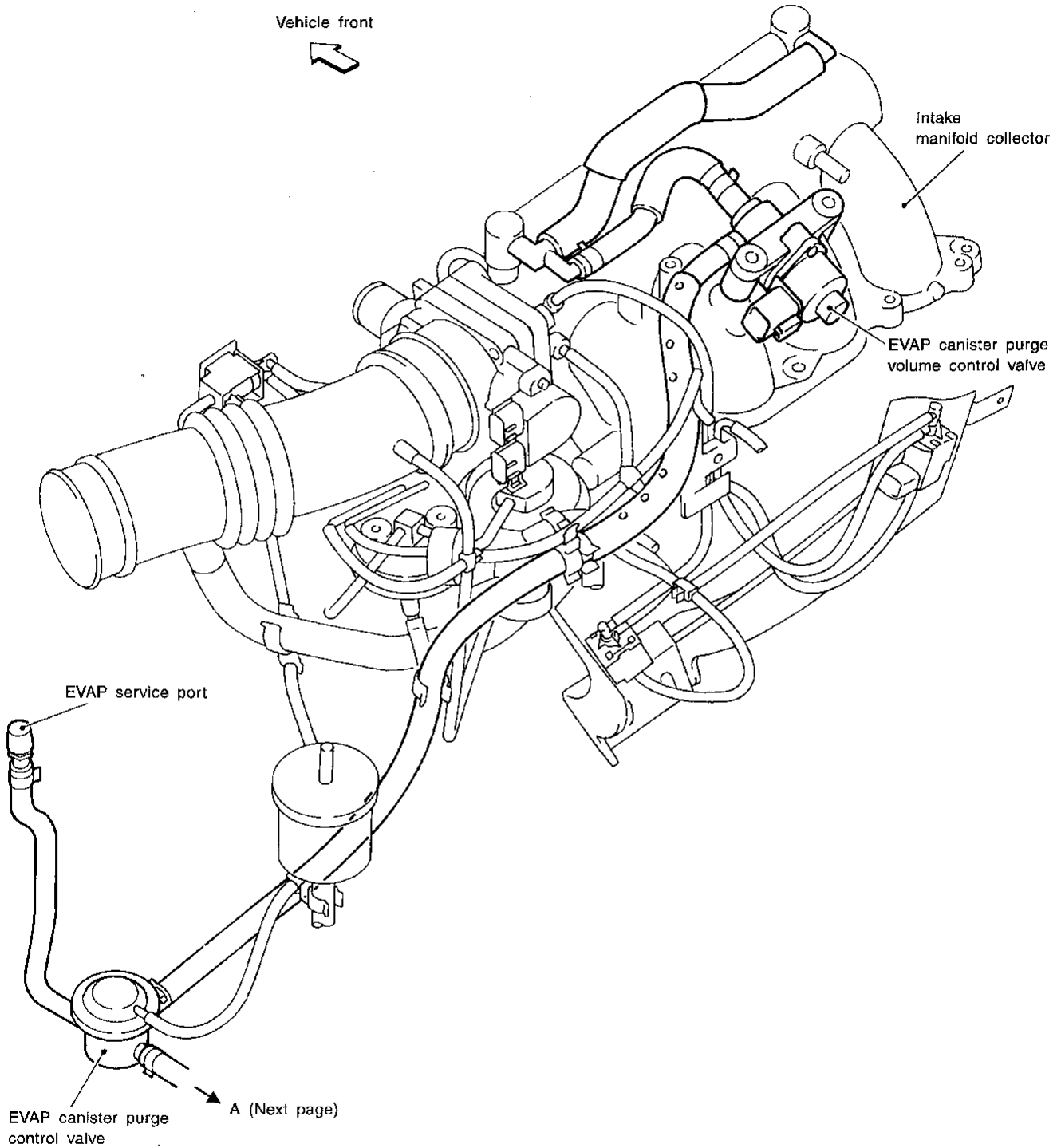

Note: Do not use soapy water or any type of solvent while installing vacuum hoses or purge hoses.

SEF272V

EVAPORATIVE EMISSION SYSTEM

Evaporative Emission Line Drawing (Cont'd)

Refer to
previous
page

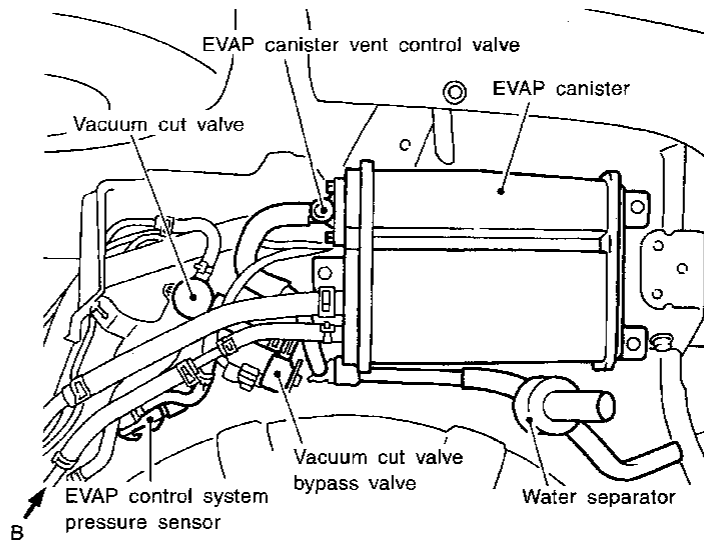
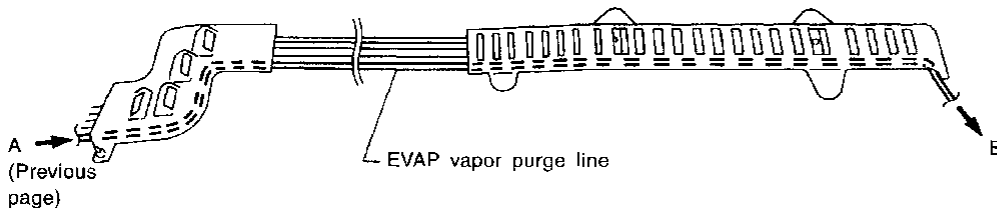
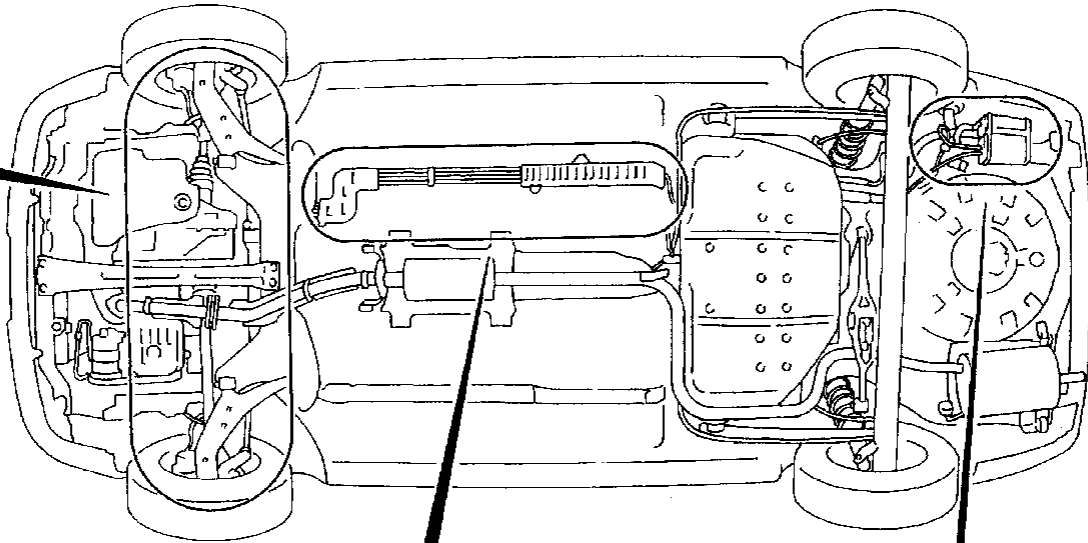

EVAPORATIVE EMISSION SYSTEM

On Board Refueling Vapor Recovery (ORVR)

SYSTEM DESCRIPTION

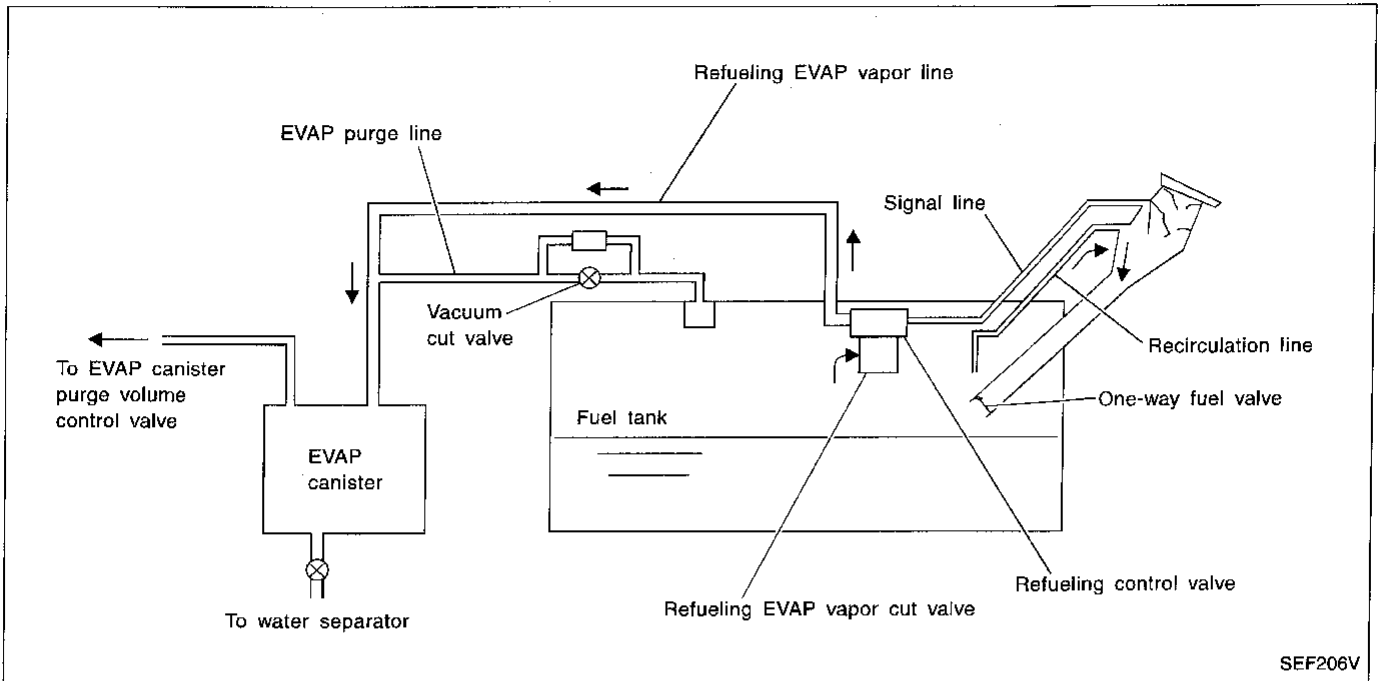

From the beginning of refueling, the fuel tank pressure goes up. When the pressure reaches the setting value of the refueling control valve (RCV) opening pressure, the RCV is opened. After RCV opens, the air and vapor inside the fuel tank go through refueling EVAP vapor cut valve, RCV and refueling vapor line to the EVAP canister. The vapor is absorbed by the EVAP canister and the air is released to the atmosphere.

When the refueling has reached the full level of the fuel tank, the refueling EVAP vapor cut valve is closed and refueling is stopped because of auto shut-off. The vapor which was absorbed by the EVAP canister is purged during driving.

The RCV is always closed during driving and the evaporative emission control system is operated the same as the conventional system.

WARNING:

When conducting inspections below, be sure to observe the following:

- Put a "CAUTION: INFLAMMABLE" sign in workshop.
- Do not smoke while servicing fuel system. Keep open flames and sparks away from work area.
- Be sure to furnish the workshop with a CO₂ fire extinguisher.

CAUTION:

- Before removing fuel line parts, carry out the following procedures:
 - a. Put drained fuel in an explosion-proof container and put lid on securely.
 - b. Release fuel pressure from fuel line. Refer to "Fuel Pressure Release", EC-33.
 - c. Disconnect battery ground cable.
- Always replace O-ring when the fuel gauge retainer is removed.
- Do not kink or twist hose and tube when they are installed.
- Do not tighten hose and clamps excessively to avoid damaging hoses.
- After installation, run engine and check for fuel leaks at connection.
- Do not attempt to top off the fuel tank after the fuel pump nozzle shuts off automatically.
- Continued refueling may cause fuel overflow, resulting in fuel spray and possibly a fire.

EVAPORATIVE EMISSION SYSTEM

On Board Refueling Vapor Recovery (ORVR) (Cont'd)

DIAGNOSTIC PROCEDURE

SYMPTOM: Fuel odor from EVAP canister is strong.

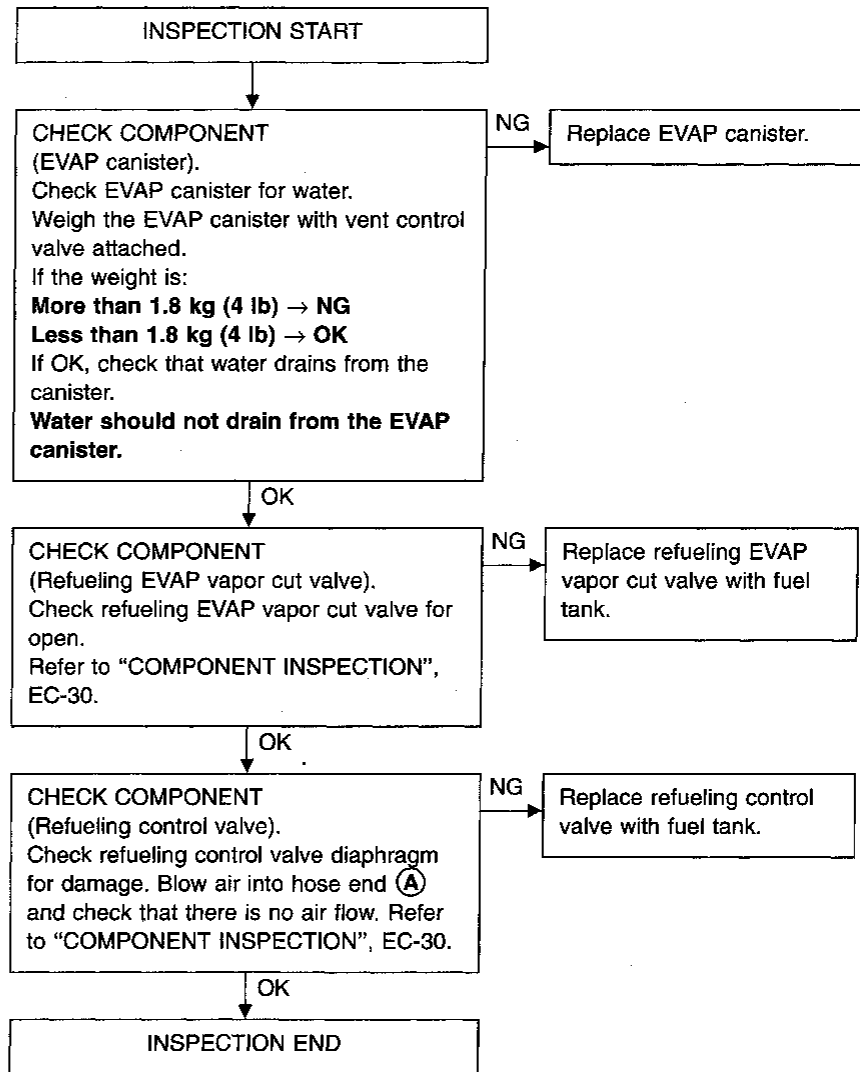

EVAPORATIVE EMISSION SYSTEM

On Board Refueling Vapor Recovery (ORVR) (Cont'd)

SYMPTOM: Cannot refuel/Fuel odor from the fuel filler opening is strong while refueling.

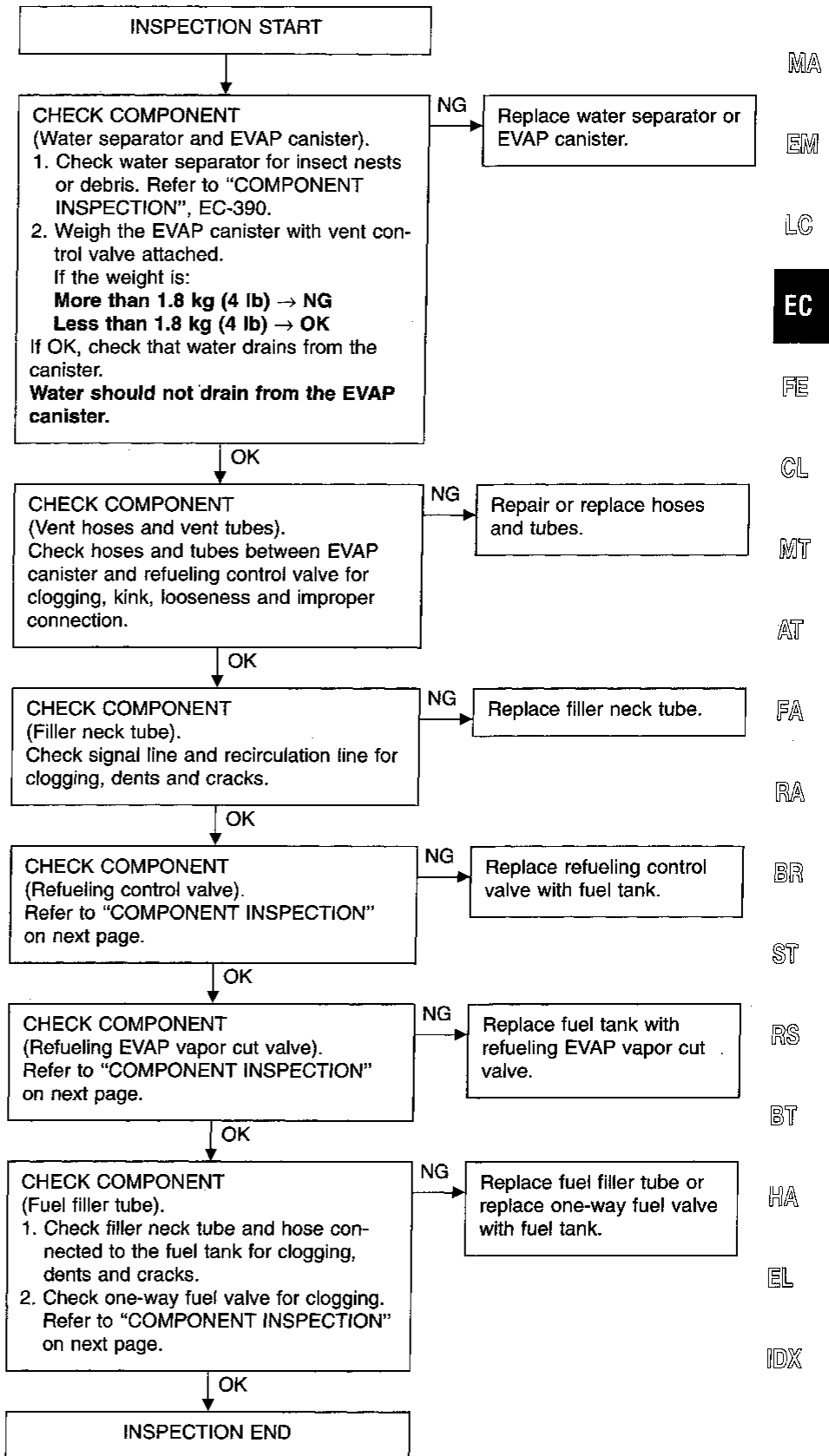

EVAPORATIVE EMISSION SYSTEM

On Board Refueling Vapor Recovery (ORVR) (Cont'd)

COMPONENT INSPECTION

Refueling control valve

Check refueling control valve as follows:

1. Remove fuel filler cap.
2. Check air continuity between hose ends (A) and (B).
Blow air into the hose end (B). Air should flow freely into the fuel tank.
3. Blow air into hose end (A) and check there is no leakage.
4. Apply pressure to both hose ends (A) and (B) [20 kPa (150 mmHg, 5.91 inHg)] using a pressure pump and a suitable 3-way connector. Check that there is no leakage.

If NG, replace refueling control valve with fuel tank.

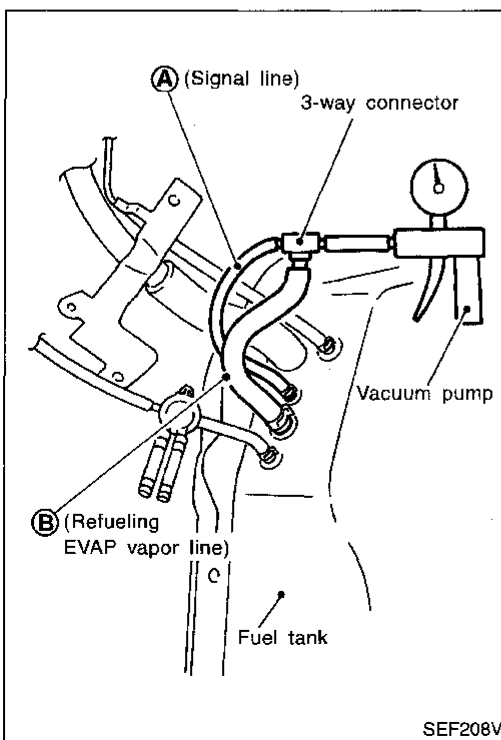
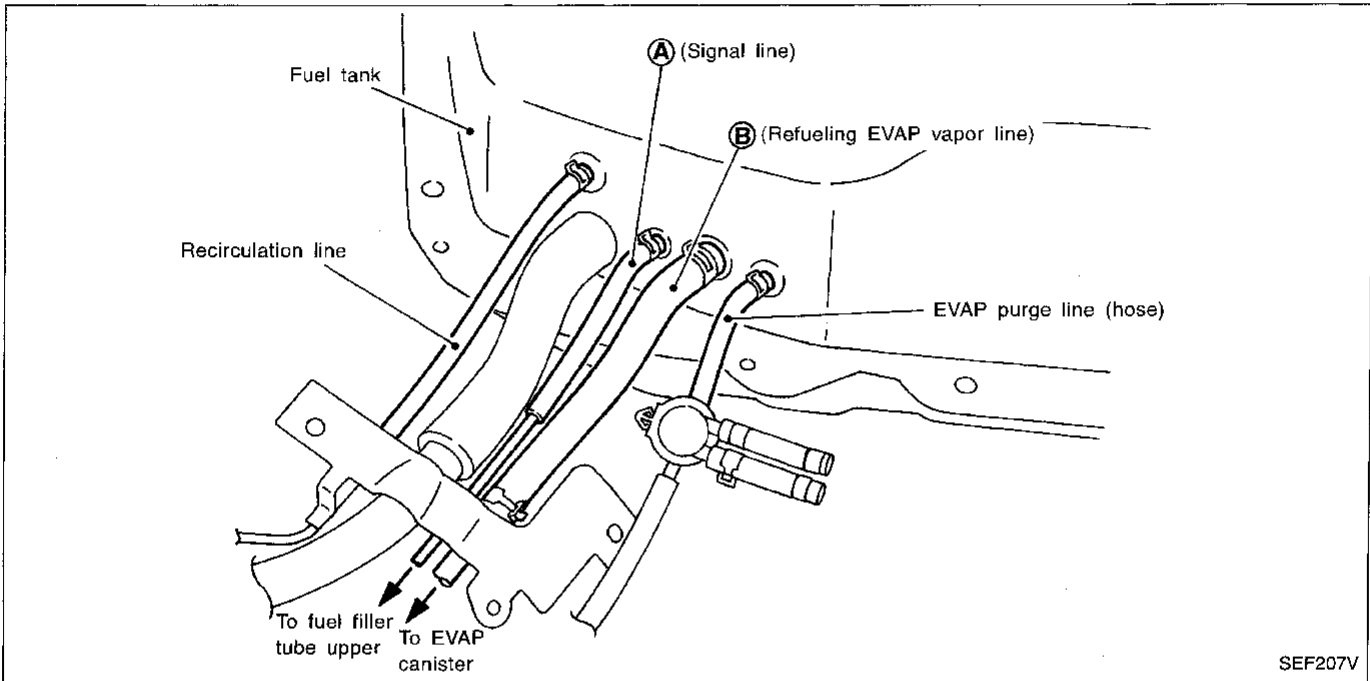

Refueling EVAP vapor cut valve

1. Remove fuel tank. Refer to "FUEL SYSTEM" in FE section.
Drain fuel from the tank as follows:

- a. Remove fuel feed hose located on the fuel gauge retainer.
- b. Connect a spare fuel hose, one side to fuel gauge retainer where the hose was removed and the other side to a fuel container.
- c. Drain fuel using "FUEL PUMP RELAY" in "ACTIVE TEST" mode with CONSULT.

OR

- a. Remove fuel gauge retainer.
 - b. Drain fuel from the tank using a hand pump into a fuel container.
2. Check refueling EVAP vapor cut valve for being stuck to close as follows.
Blow air into the refueling EVAP vapor cut valve (from hose end (B)), and check that the air flows freely into the tank.
 3. Check EVAP vapor cut valve for being stuck to open as follows.
 - a. Connect vacuum pump to hose ends (A) and (B) using a suitable 3-way connector.
 - b. Remove fuel gauge retainer with fuel gauge unit.

EVAPORATIVE EMISSION SYSTEM

On Board Refueling Vapor Recovery (ORVR) (Cont'd)

Always replace O-ring with new one.

- c. Put fuel tank upside down.
- d. Apply vacuum pressure to both hose ends ① and ② [-13.3 kPa (-100 mmHg, -3.94 inHg)] with fuel gauge retainer remaining open and check that the pressure is applicable. If NG, replace refueling EVAP vapor cut valve with fuel tank.

GI

MA

EM

LC

EC

FE

CL

MT

AT

FA

RA

BR

ST

RS

BT

HA

EL

IDX

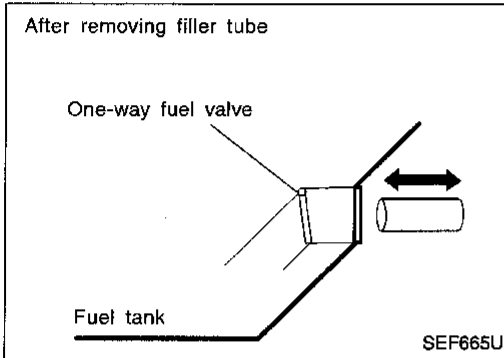

One-way fuel valve

1. Drain fuel from the tank. Refer to "COMPONENT INSPECTION" of refueling EVAP vapor cut valve on previous page.
2. Remove fuel filler tube and hose.
3. Check one-way fuel valve for operation as follows. When a stick is inserted, the valve should open, when removing stick, it should close.

Do not drop any material into the tank.

If NG, replace one-way fuel valve with fuel tank.

POSITIVE CRANKCASE VENTILATION

Description

This system returns blow-by gas to the intake collector.

The positive crankcase ventilation (PCV) valve is provided to conduct crankcase blow-by gas to the intake manifold.

During partial throttle operation of the engine, the intake manifold sucks the blow-by gas through the PCV valve.

Normally, the capacity of the valve is sufficient to handle any blow-by and a small amount of ventilating air.

The ventilating air is then drawn from the air duct

into the crankcase. In this process, the air passes through the hose connecting air inlet tubes to rocker cover.

Under full-throttle condition, the manifold vacuum is insufficient to draw the blow-by flow through the valve. The flow goes through the hose connection in the reverse direction.

On vehicles with an excessively high blow-by, the valve does not meet the requirement. This is because some of the flow will go through the hose connection to the intake collector under all conditions.

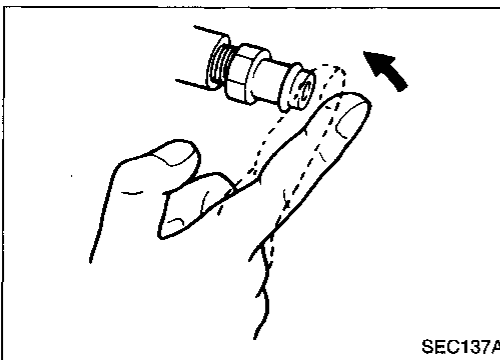
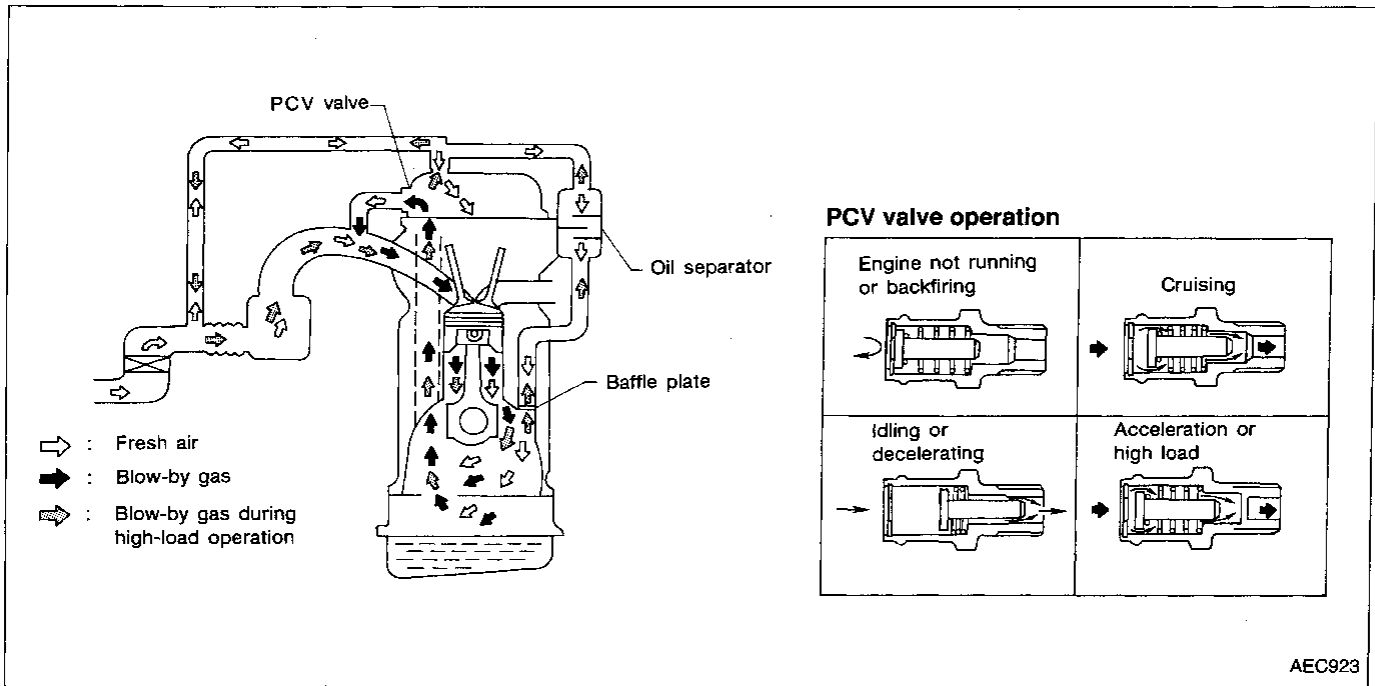

Inspection

PCV (Positive Crankcase Ventilation) VALVE

With engine running at idle, remove PCV valve from breather separator. A properly working valve makes a hissing noise as air passes through it. A strong vacuum should be felt immediately when a finger is placed over the valve inlet.

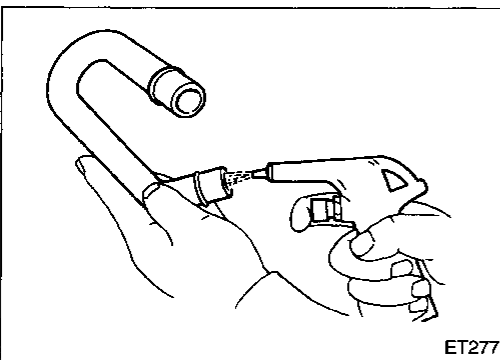

VENTILATION HOSE

1. Check hoses and hose connections for leaks.
2. Disconnect all hoses and clean with compressed air. If any hose cannot be freed of obstructions, replace.

BASIC SERVICE PROCEDURE

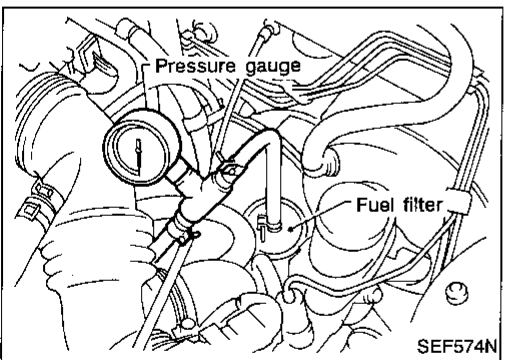
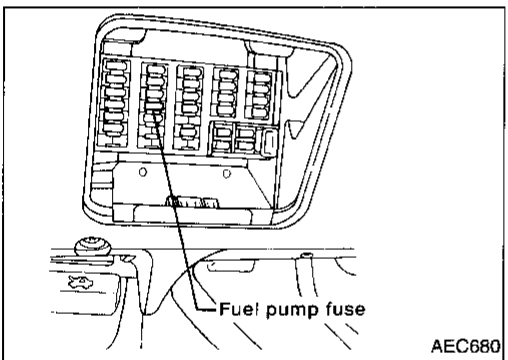
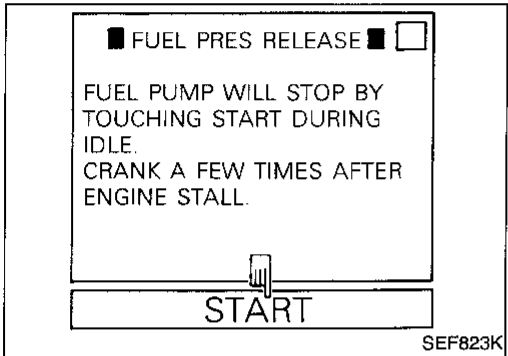
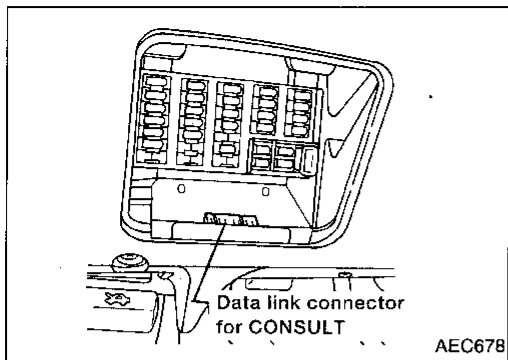

Fuel Pressure Release

Before disconnecting fuel line, release fuel pressure from fuel line to eliminate danger.

1. Start engine.
2. Perform "FUEL PRESSURE RELEASE" in "WORK SUPPORT" mode with CONSULT.
3. After engine stalls, crank it two or three times to release all fuel pressure.
4. Turn ignition switch OFF.

- OR
1. Remove fuse for fuel pump.
 2. Start engine.
 3. After engine stalls, crank it two or three times to release all fuel pressure.
 4. Turn ignition switch off and reconnect fuel pump fuse.

Fuel Pressure Check

- When reconnecting fuel line, always use new clamps.
- Make sure that clamp screw does not contact adjacent parts.
- Use a torque driver to tighten clamps.
- Use Pressure Gauge to check fuel pressure.
- Do not perform fuel pressure check with system operating. Fuel pressure gauge may indicate false readings.

1. Release fuel pressure to zero.
2. Disconnect fuel hose between fuel filter and fuel tube (engine side).
3. Install pressure gauge between fuel filter and fuel tube.
4. Start engine and check for fuel leakage.
5. Read the indication of fuel pressure gauge.

At idle speed:

With vacuum hose connected

Approximately 235 kPa (2.4 kg/cm², 34 psi)

With vacuum hose disconnected

Approximately 294 kPa (3.0 kg/cm², 43 psi)

If results are unsatisfactory, perform Fuel Pressure Regulator Check, EC-34.

BASIC SERVICE PROCEDURE

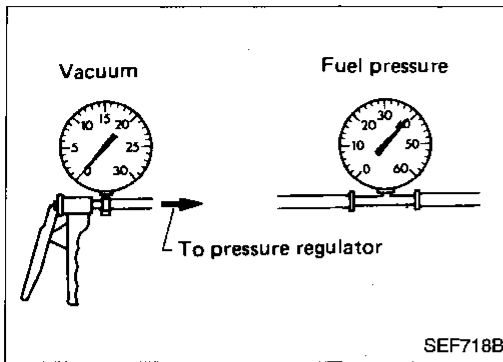

Fuel Pressure Regulator Check

1. Stop engine and disconnect fuel pressure regulator vacuum hose from intake manifold.
2. Plug intake manifold with a rubber cap.
3. Connect variable vacuum source to fuel pressure regulator.
4. Start engine and read indication of fuel pressure gauge as vacuum is changed.

Fuel pressure should decrease as vacuum increases. If results are unsatisfactory, replace fuel pressure regulator.

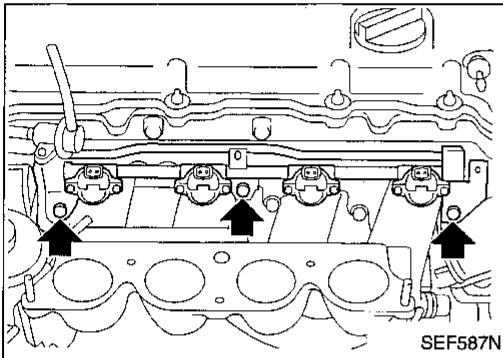

Injector Removal and Installation

1. Release fuel pressure to zero.
2. Remove intake manifold collector. Refer to EM section ("CYLINDER HEAD").
3. Disconnect vacuum hose from pressure regulator.
4. Disconnect fuel hoses from fuel tube assembly.
5. Disconnect injector harness connectors.
6. Remove injectors with fuel tube assembly.

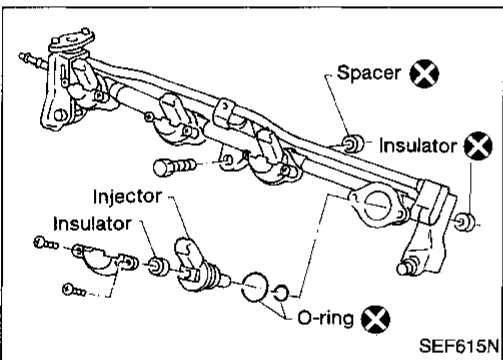

- Push injector tail piece.
- Do not pull on the connector.

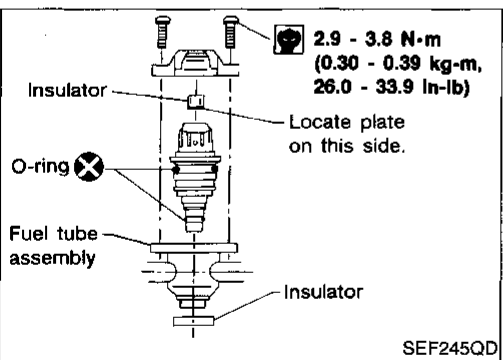

7. Install injectors.
- Clean exterior of injector tail piece.
 - Use new O-rings.

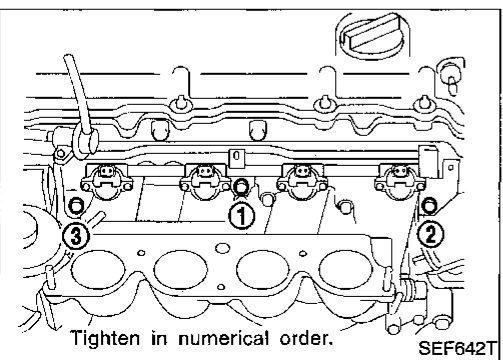

8. Install injectors with fuel tube assembly to intake manifold.
9. Install fuel hoses to fuel tube assembly.
10. Tighten fuel tube bolts to 9.32 to 10.8 N·m (0.95 to 1.10 kg-m, 6.9 to 8.0 ft-lb) as shown in the figure. Then tighten the bolts to 20.6 to 26.5 N·m (2.10 to 2.70 kg-m, 15 to 20 ft-lb).

Lubricate fuel hoses with a smear of silicone oil.

11. Reinstall any parts removed in reverse order of removal.

CAUTION:

After properly connecting fuel hose to injector and fuel tube assembly, check connection for fuel leakage.

Idle Speed/Ignition Timing/Idle Mixture Ratio Adjustment

PREPARATION

- Make sure that the following parts are in good order.
- (1) Battery
- (2) Ignition system
- (3) Engine oil and coolant levels
- (4) Fuses
- (5) ECM harness connector
- (6) Vacuum hoses
- (7) Air intake system
(Oil filler cap, oil level gauge, etc.)
- (8) Fuel pressure
- (9) Engine compression
- (10) EGR valve operation
- (11) Throttle valve
- (12) EVAP system

- On models equipped with air conditioner, checks should be carried out while the air conditioner is "OFF".
- On models equipped with automatic transaxle, when checking idle speed, ignition timing and mixture ratio, checks should be carried out while shift lever is in "P" or "N" position.
- When measuring "CO" percentage, insert probe more than 40 cm (15.7 in) into tail pipe.
- Turn off headlamps, heater blower, rear window defogger.
- Keep front wheels pointed straight ahead.
- Make the check after the cooling fan has stopped.

Overall inspection sequence

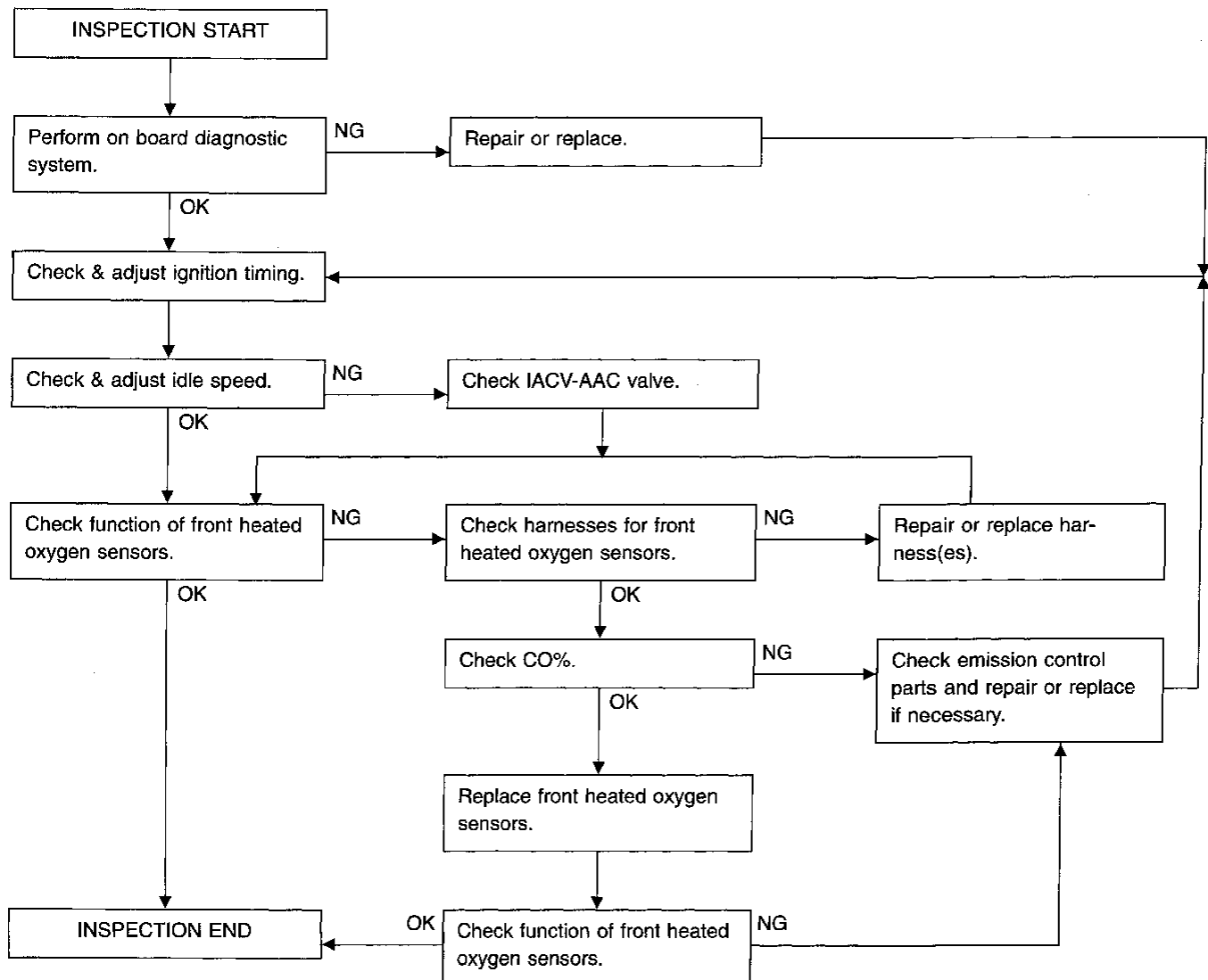

BASIC SERVICE PROCEDURE

Idle Speed/Ignition Timing/Idle Mixture Ratio Adjustment (Cont'd)

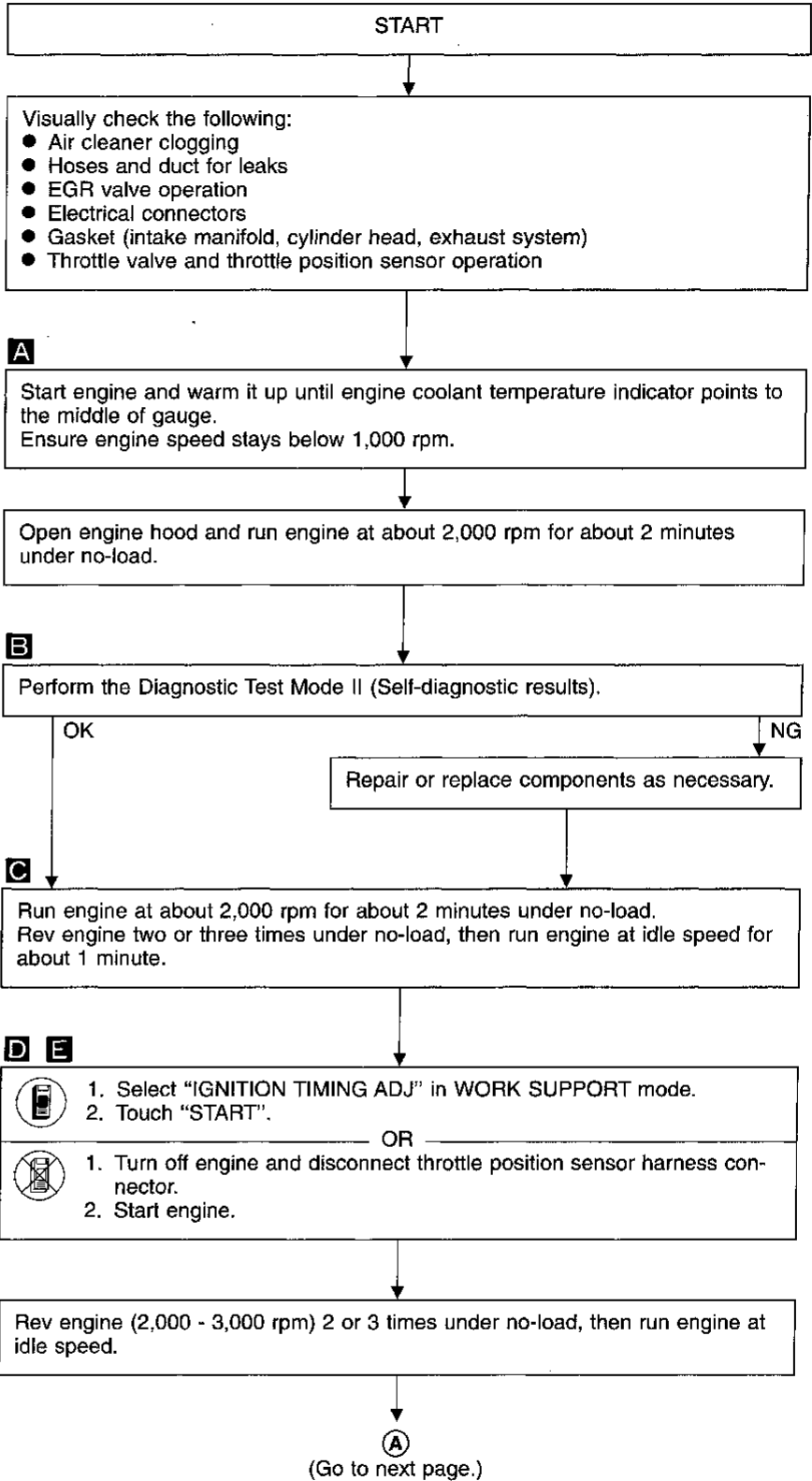
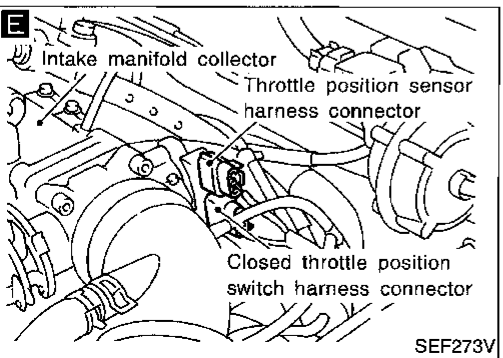
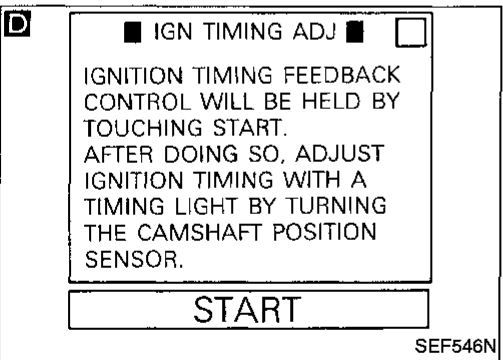
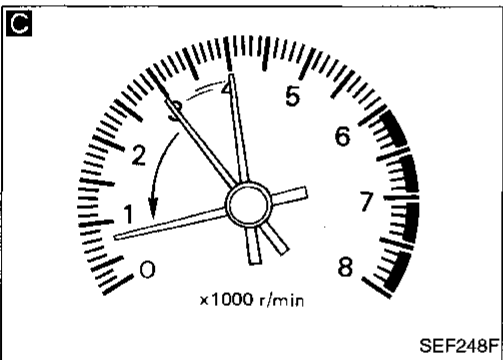
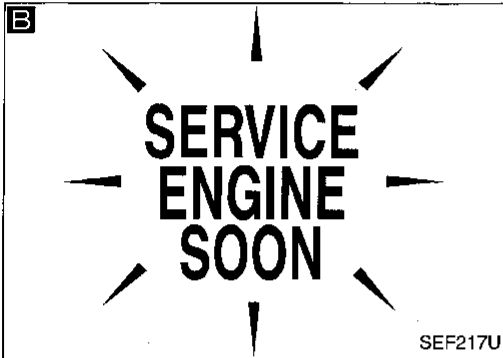
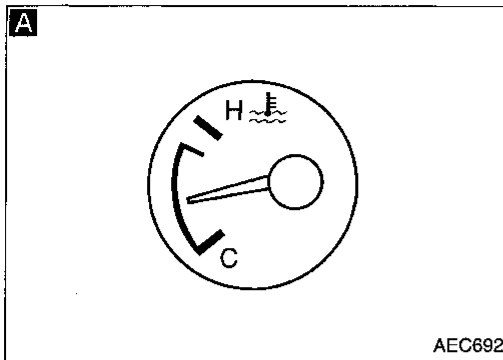

BASIC SERVICE PROCEDURE

Idle Speed/Ignition Timing/Idle Mixture Ratio Adjustment (Cont'd)

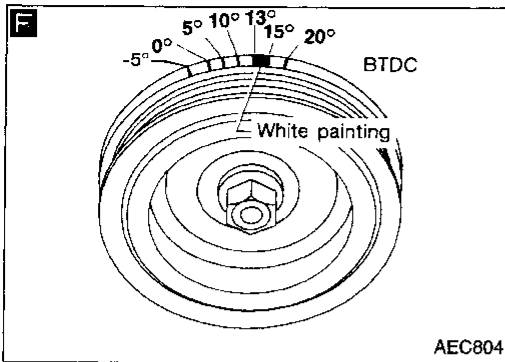

G ■ IGN TIMING ADJ ■ □

IGNITION TIMING FEEDBACK CONTROL WILL BE HELD BY TOUCHING START. AFTER DOING SO, ADJUST IGNITION TIMING WITH A TIMING LIGHT BY TURNING THE CAMSHAFT POSITION SENSOR.

START

SEF546N

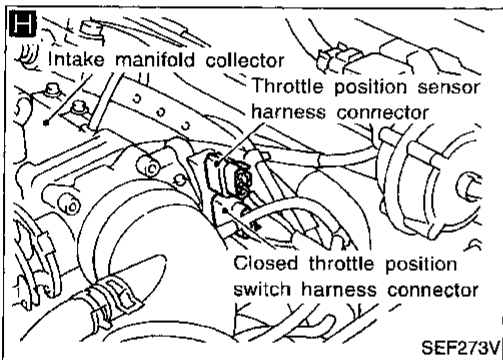

I ■ IGN TIMING ADJ ■ □

— — — CONDITION SETTING — — —

IGN/T FEEDBACK HOLD

=== MONITOR ===

CMPS•RPM (REF)	762rpm
IGN TIMING	15BTDC
CLOSED TH/POS	ON

SEF548N

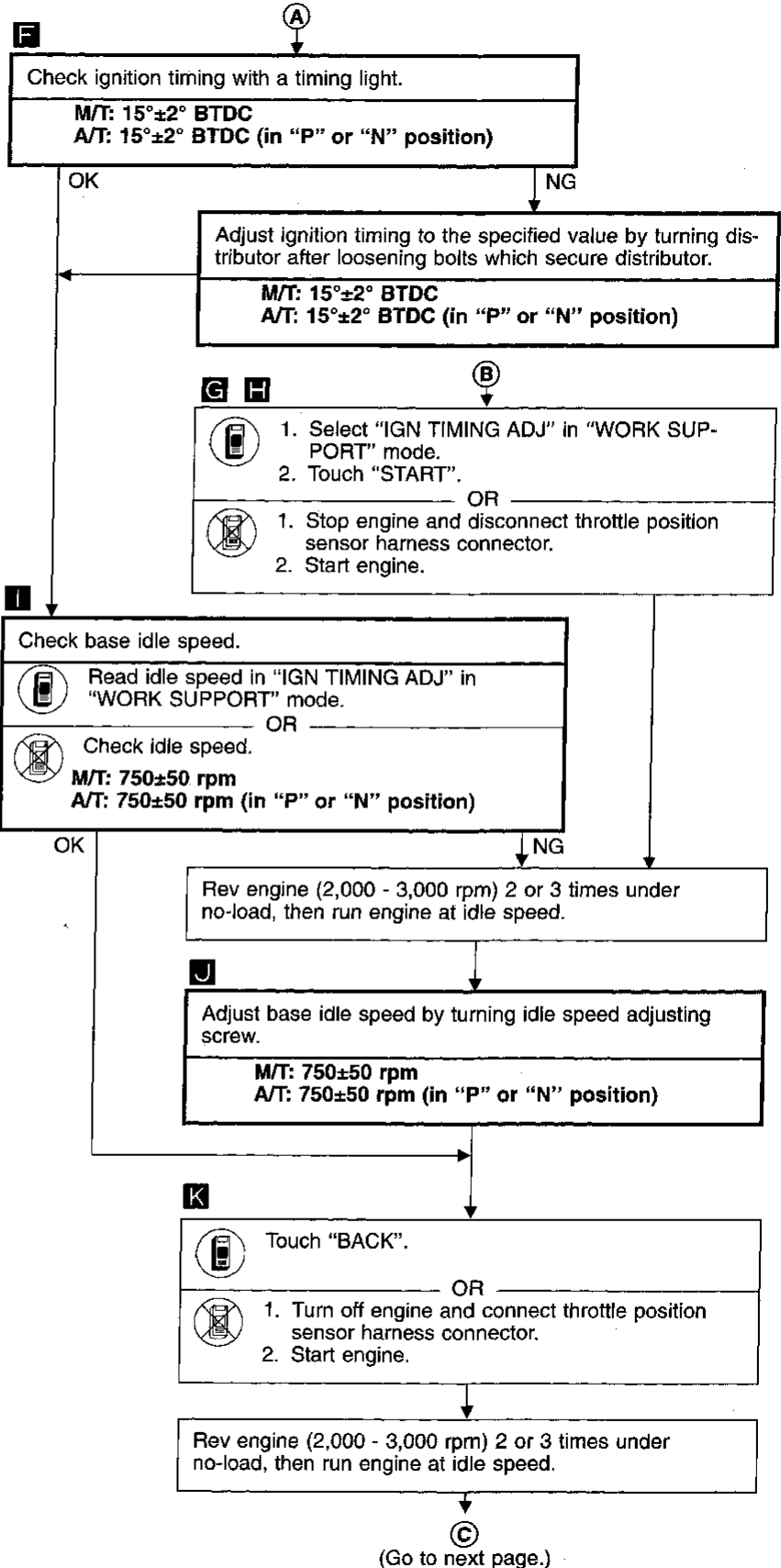
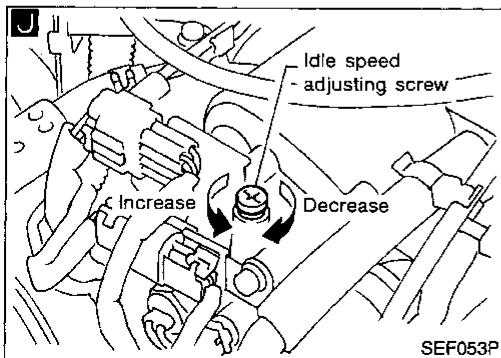

GI
MA
EM
LC
EC
FE
CL
MT
AT
FA
RA
BR
ST
RS
BT
HA
EL
IDX

BASIC SERVICE PROCEDURE

Idle Speed/Ignition Timing/Idle Mixture Ratio Adjustment (Cont'd)

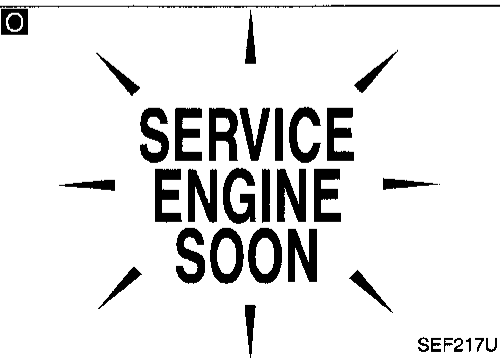
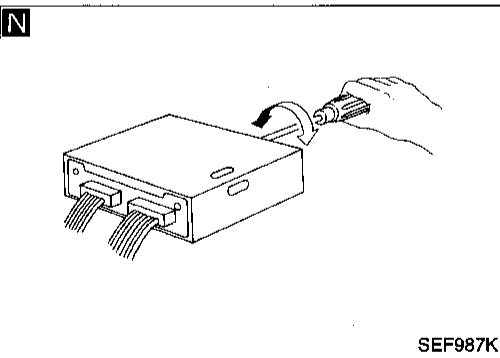
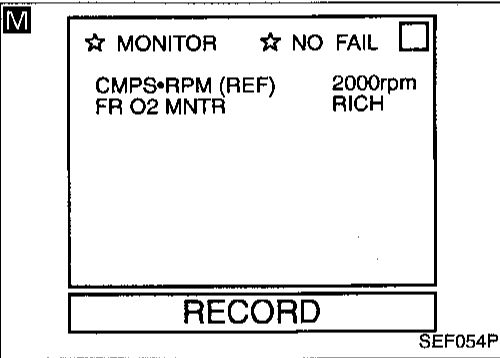
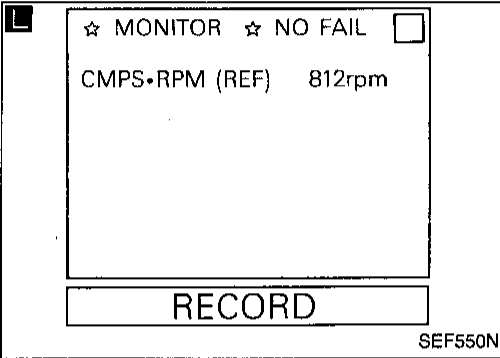
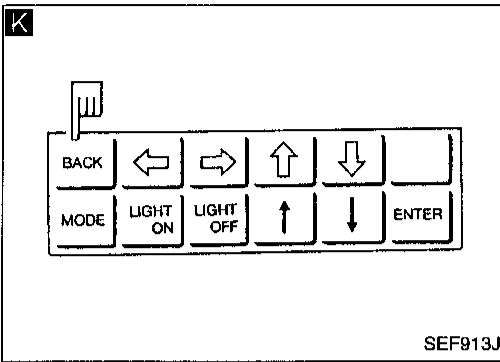

C

Check target idle speed.

L

Read idle speed in "DATA MONITOR" mode with CONSULT. OR Check idle speed.

M/T: 800±50 rpm
A/T: 800±50 rpm (in "P" or "N" position)

OK

NG

Check IACV-AAC valve and replace if necessary.

Check IACV-AAC valve harness and repair if necessary.

Check ECM function*1 by substituting another known good ECM.

*1: ECM may be the cause of a problem, but this is rarely the case.

M N O

1. See "FR O2 MNTR" in "DATA MONITOR" mode.
2. Run engine at about 2,000 rpm for about 2 minutes under no-load.
3. Maintain engine at 2,000 rpm under no-load (engine is warmed up to normal operating temperature). Check that the monitor fluctuates between "LEAN" and "RICH" more than 5 times during 10 seconds.
1 cycle: RICH → LEAN → RICH
2 cycles: RICH → LEAN → RICH → LEAN → RICH

OR

1. Set "Front heated oxygen sensor monitor" in the Diagnostic Test Mode II. (See page EC-54.)
2. Run engine at about 2,000 rpm for about 2 minutes under no-load.
3. Maintain engine at 2,000 rpm under no-load. Check that the malfunction indicator lamp goes on and off more than 5 times during 10 seconds.

NG → **D** (Go to next page.)

OK

END

BASIC SERVICE PROCEDURE

Idle Speed/Ignition Timing/Idle Mixture Ratio Adjustment (Cont'd)

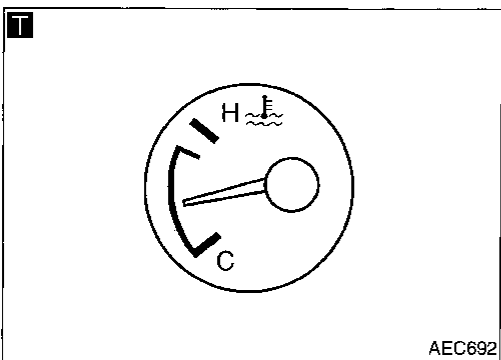
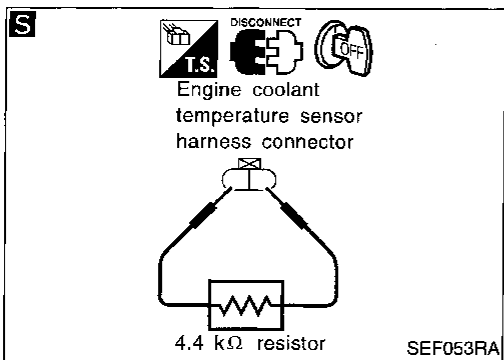
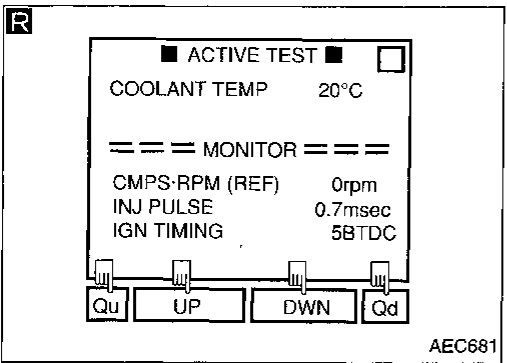
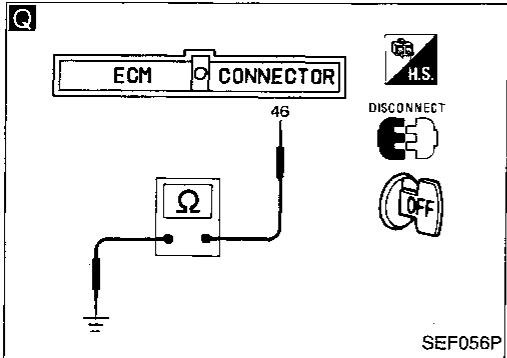
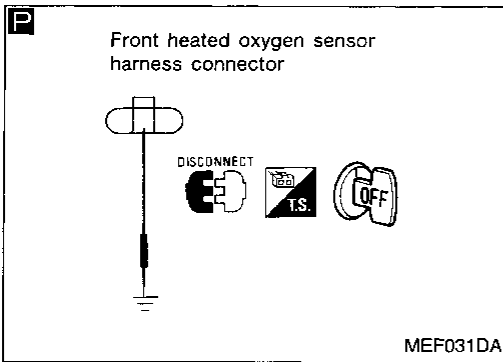

D

P Q

Check front heated oxygen sensor harness:

1. Turn off engine and disconnect battery ground cable.
2. Disconnect ECM harness connector from ECM.
3. Disconnect front heated oxygen sensor harness connector. Then connect harness side terminal for front heated oxygen sensor to ground with a jumper wire.
4. Check for continuity between terminal (46) of ECM harness connector and body ground.

Continuity existsOK
 Continuity does not exist.....NG

OK → Connect ECM harness connector to ECM.
 NG → Repair or replace harness. → **B** (Go to EC-37.)

R S

1. Connect battery ground cable.
2. Select "ENG COOLANT TEMP" in "ACTIVE TEST" mode.
3. Set "COOLANT TEMP" to 5°C (41°F) by touching "Qu" and "Qd" and "UP", "DWN".

OR

1. Disconnect engine coolant temperature sensor harness connector.
2. Connect a resistor (4.4 kΩ) between terminals of engine coolant temperature sensor harness connector.
3. Connect battery ground cable.

T

Start engine and warm it up until engine coolant temperature indicator points to middle of gauge. (Be sure to start engine after setting "COOLANT TEMP" or installing a 4.4 kΩ resistor.)

E
 (Go to next page.)

GI

MA

EM

LC

EC

FE

CL

MT

AT

FA

RA

BR

ST

RS

BT

HA

EL

IDX

BASIC SERVICE PROCEDURE

Idle Speed/Ignition Timing/Idle Mixture Ratio Adjustment (Cont'd)

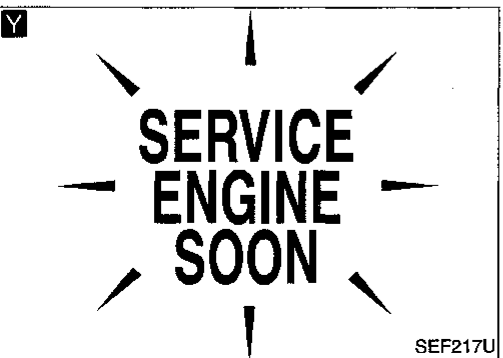
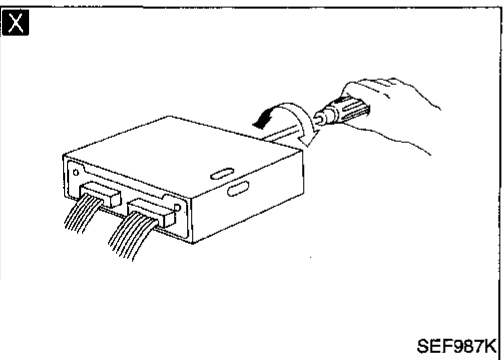
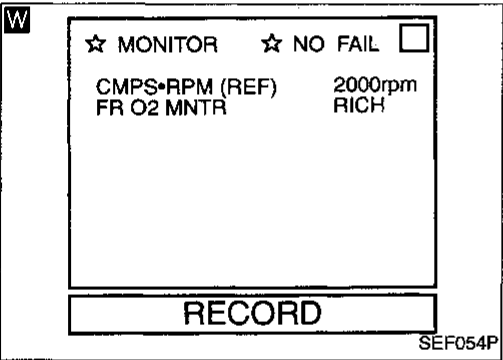
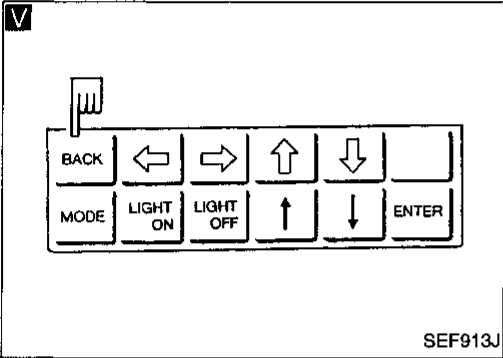
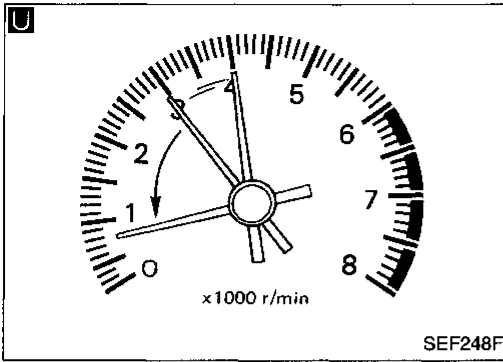

U
Rev engine two or three times under no-load, then run engine at idle speed.

V
Check "CO"%.
Idle CO: Less than 11% and engine runs smoothly.
After checking CO%,
1. Touch "BACK".
OR
1. Disconnect the resistor from terminals of engine coolant temperature sensor harness connector.
2. Connect engine coolant temperature sensor harness connector to engine coolant temperature sensor.

NG → Replace front heated oxygen sensor.
OK →

W X Y
1. See "FR O2 MNTR" in "Data monitor" mode.
2. Maintain engine at 2,000 rpm under no-load (engine is warmed up to normal operating temperature.). Check that the monitor fluctuates between "LEAN" and "RICH" more than 5 times during 10 seconds.
1 cycle: RICH → LEAN → RICH
2 cycles: RICH → LEAN → RICH → LEAN → RICH
OR
1. Set "Front heated oxygen sensor monitor" in the Diagnostic Test Mode II. (Refer to EC-54.)
2. Maintain engine at 2,000 rpm under no-load. Check that the malfunction indicator lamp goes ON and OFF more than 5 times during 10 seconds.

NG → **F** (Go to next page.)
OK → **B** (Go to EC-37.)

BASIC SERVICE PROCEDURE

Idle Speed/Ignition Timing/Idle Mixture Ratio Adjustment (Cont'd)

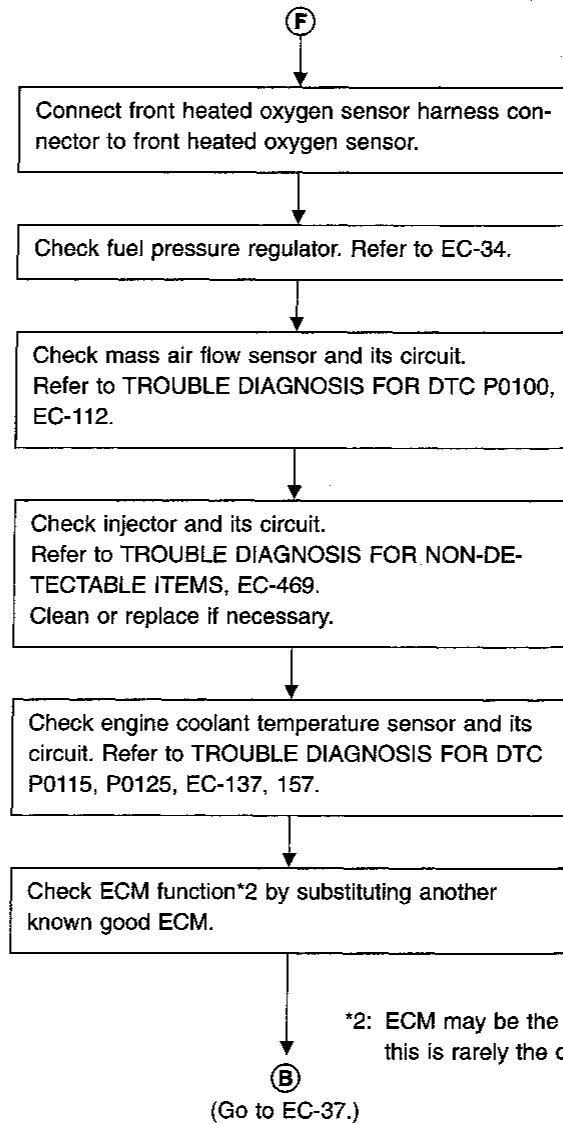

*2: ECM may be the cause of a problem, but this is rarely the case.

- If a vehicle contains a part which is operating outside of design specifications with no MIL illumination, the part shall not be replaced prior to emission testing unless it is determined that the part has been tampered with or abused in such a way that the diagnostic system cannot reasonably be expected to detect the resulting malfunction.

GI

MA

EM

LC

EC

FE

CL

MT

AT

FA

RA

BR

ST

RS

BT

HA

EL

IDX

ON BOARD DIAGNOSTIC SYSTEM DESCRIPTION

Introduction

The ECM has an on board diagnostic system which detects malfunctions related to engine sensors or actuators. The ECM also records various emission-related diagnostic information including:

- Diagnostic Trouble Code (DTC).....Mode 3 of SAE J1979
- Freeze Frame dataMode 2 of SAE J1979
- System Readiness Test (SRT) code.....Mode 1 of SAE J1979
- 1st Trip Diagnostic Trouble Code (1st Trip DTC)Mode 7 of SAE J1979
- 1st Trip Freeze Frame data
- Test values and Test limits.....Mode 6 of SAE J1979

The above information can be checked using procedures listed in the table below.

X: Applicable
—: Not applicable

	DTC	1st trip DTC	Freeze Frame data	1st trip Freeze Frame data	SRT code	Test value
Diagnostic test mode II (Self-diagnostic results)	X	X*1	—	—	—	—
CONSULT	X	X	X	X	X	—
GST	X	X*2	X	—	X	X

*1: When DTC and 1st trip DTC simultaneously appear on the display, they cannot be clearly distinguished from each other.

*2: 1st trip DTCs for self-diagnoses concerning SRT items cannot be shown on the GST display.

The malfunction indicator lamp (MIL) on the instrument panel lights up when the same malfunction is detected in two consecutive trips (Two trip detection logic), or when the ECM enters fail-safe mode. (Refer to EC-88.)

Two Trip Detection Logic

When a malfunction is detected for the first time, 1st trip DTC and 1st trip Freeze Frame data are stored in the ECM memory. The MIL will not light up at this stage. <1st trip>

If the same malfunction is detected again during the next drive, the DTC and Freeze Frame data are stored in the ECM memory, and the MIL lights up. The MIL lights up at the same time when the DTC is stored. <2nd trip> The "trip" in the "Two Trip Detection Logic" means a driving mode in which self-diagnosis is performed during vehicle operation. Specific on board diagnostic items will cause the ECM to light up or blink the MIL, and store DTC and Freeze Frame data, even in the 1st trip, as shown below.

X: Applicable
—: Not applicable

Items	MIL			DTC		1st trip DTC	
	1st trip		2nd trip lighting up	1st trip displaying	2nd trip displaying	1st trip displaying	2nd trip displaying
	Blinking	Lighting up					
Misfire (Possible three way catalyst damage) — DTC: P0300 - P0304 (0701, 0605 - 0608) is being detected	X	—	—	X	—	X	—
Misfire (Possible three way catalyst damage) — DTC: P0300 - P0304 (0701, 0605 - 0608) has been detected—	—	X	—	X	—	X	—
Closed loop control — DTC: P1148 (0307)	—	X	—	X	—	X	—
Fail-safe items (Refer to EC-88.)	—	X	—	X*1	—	X*1	—
Except above	—	—	X	—	X	X	X

*1: Except "ECM".

Emission-related Diagnostic Information

DTC AND 1ST TRIP DTC

The 1st trip DTC (whose number is the same as the DTC number) is displayed for the latest self-diagnostic result obtained. If the ECM memory was cleared previously, and the 1st trip DTC did not reoccur, the 1st trip DTC will not be displayed. If a malfunction is detected during the 1st trip, the 1st trip DTC is stored in the ECM memory. The MIL will not light up (two trip detection logic). If the same malfunction is not detected in the 2nd trip (meeting the required driving pattern), the 1st trip DTC is cleared from the ECM memory. If the same malfunction is detected in the 2nd trip, both the 1st trip DTC and DTC are stored in the ECM memory and the MIL lights up. In other words, the DTC is stored in the ECM memory and the MIL lights up when the same malfunction occurs in two consecutive trips. If a 1st trip DTC is stored and a non-diagnostic operation is performed between the 1st and 2nd trips, only the 1st trip DTC will continue to be stored. For malfunctions that blink or light up the MIL during the 1st trip, the DTC and 1st trip DTC are stored in the ECM memory.

Procedures for clearing the DTC and the 1st trip DTC from the ECM memory are described in "HOW TO ERASE EMISSION-RELATED DIAGNOSTIC INFORMATION". Refer to EC-52.

For malfunctions in which 1st trip DTCs are displayed, refer to EC-50. These items are required by legal regulations to continuously monitor the system/component. In addition, the items monitored non-continuously are also displayed on CONSULT.

1st trip DTC is specified in Mode 7 of SAE J1979. 1st trip DTC detection occurs without lighting up the MIL and therefore does not warn the driver of a problem. However, 1st trip DTC detection will not prevent the vehicle from being tested, for example during Inspection/Maintenance (I/M) tests.

When a 1st trip DTC is detected, check, print out or write down and erase (1st trip) DTC and Freeze Frame data as specified in "Work Flow" procedure Step II, refer to page EC-80. Then perform "Diagnostic trouble code confirmation procedure" or "Overall function check" to try to duplicate the problem. If the malfunction is duplicated, the item requires repair.

How to read DTC and 1st trip DTC

DTC and 1st trip DTC can be read by the following methods.

- NO TOOLS 1. The number of blinks of the malfunction indicator lamp in the Diagnostic Test Mode II (Self-Diagnostic Results) Examples: 0101, 0201, 1003, 1104, etc.
 These DTCs are controlled by NISSAN.
 - CONSULT 2. CONSULT or GST (Generic Scan Tool) Examples: P0340, P1320, P0705, P0750, etc.
 These DTCs are prescribed by SAE J2012.
 - GST (CONSULT also displays the malfunctioning component or system.)
- 1st trip DTC No. is the same as DTC No.
 - Output of a DTC indicates a malfunction. However, Mode II and GST do not indicate whether the malfunction is still occurring or has occurred in the past and has returned to normal. CONSULT can identify malfunction status as shown below. Therefore, using CONSULT (if available) is recommended.

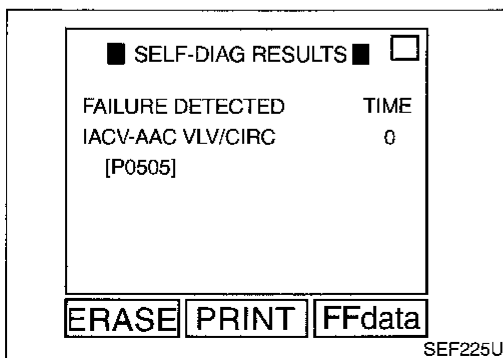

A sample of CONSULT display for DTC is shown at left. DTC or 1st trip DTC of a malfunction is displayed in SELF-DIAGNOSTIC RESULTS mode of CONSULT. Time data indicates how many times the vehicle was driven after the last detection of a DTC.

If the DTC is being detected currently, the time data will be "0".

GI
 MA
 EM
 LC
EC
 FE
 CL
 MT
 AT
 FA
 RA
 BR
 ST
 RS
 BT
 HA
 EL
 IDX

ON BOARD DIAGNOSTIC SYSTEM DESCRIPTION

Emission-related Diagnostic Information (Cont'd)

If a 1st trip DTC is stored in the ECM, the time data will be "[1t]".

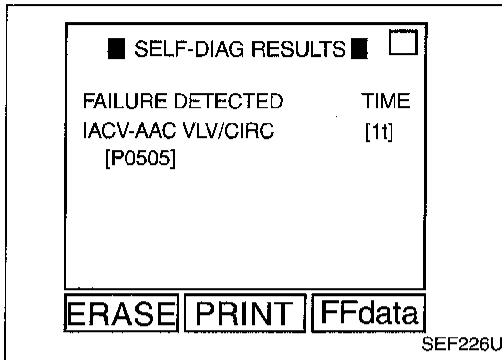

FREEZE FRAME DATA AND 1ST TRIP FREEZE FRAME DATA

The ECM records the driving conditions such as fuel system status, calculated load value, engine coolant temperature, short term fuel trim, long term fuel trim, engine speed, vehicle speed and absolute pressure sensor at the moment a malfunction is detected.

Data which are stored in the ECM memory, along with the 1st trip DTC, are called 1st trip freeze frame data. The data, stored together with the DTC data, are called freeze frame data and displayed on CONSULT or GST. The 1st trip freeze frame data can only be displayed on the CONSULT screen, not on the GST. For details, see EC-65.

Only one set of freeze frame data (either 1st trip freeze frame data or freeze frame data) can be stored in the ECM. 1st trip freeze frame data is stored in the ECM memory along with the 1st trip DTC. There is no priority for 1st trip freeze frame data and it is updated each time a different 1st trip DTC is detected. However, once freeze frame data (2nd trip detection/MIL on) is stored in the ECM memory, 1st trip freeze frame data is no longer stored. Remember, only one set of freeze frame data can be stored in the ECM. The ECM has the following priorities to update the data.

Priority	Items	
1	Freeze frame data	Misfire — DTC: P0300 - P0304 (0701, 0605 - 0608) Fuel Injection System Function — DTC: P0171 (0115), P0172 (0114)
2		Except the above items (Includes A/T related items)
3	1st trip freeze frame data	

For example, the EGR malfunction (Priority: 2) was detected and the freeze frame data was stored in the 2nd trip. After that when the misfire (Priority: 1) is detected in another trip, the freeze frame data will be updated from the EGR malfunction to the misfire. The 1st trip freeze frame data is updated each time a different malfunction is detected. There is no priority for 1st trip freeze frame data. However, once freeze frame data is stored in the ECM memory, 1st trip freeze data is no longer stored (because only one freeze frame data or 1st trip freeze frame data can be stored in the ECM). If freeze frame data is stored in the ECM memory and freeze frame data with the same priority occurs later, the first (original) freeze frame data remains unchanged in the ECM memory.

Both 1st trip freeze frame data and freeze frame data (along with the DTCs) are cleared when the ECM memory is erased. Procedures for clearing the ECM memory are described in "HOW TO ERASE EMISSION-RELATED DIAGNOSTIC INFORMATION". Refer to EC-52.

SYSTEM READINESS TEST (SRT) CODE

System Readiness Test (SRT) code is specified in Mode 1 of SAE J1979. It indicates whether the self-diagnostic tests for non-continuously monitored items have been completed or not.

Inspection/Maintenance (I/M) tests of the on board diagnostic (OBD) II system may become the legal requirements in some states/areas. All SRT codes must be set in this case. Unless all SRT codes are set, conducting the I/M test may not be allowed.

SRT codes are set after self-diagnosis has been performed one or more times. This occurs regardless of whether the diagnosis is in "OK" or "NG", and whether or not the diagnosis is performed in consecutive trips. The following table lists the five SRT items (18 test items) for the ECM used in B14 models.

ON BOARD DIAGNOSTIC SYSTEM DESCRIPTION

Emission-related Diagnostic Information (Cont'd)

SRT items	Self-diagnostic test items	
Catalyst monitoring	<ul style="list-style-type: none"> ● Three way catalyst function P0420 (0702) 	GI
EVAP system monitoring	<ul style="list-style-type: none"> ● EVAP control system (Small leak — Negative pressure) P0440 (0705) ● EVAP control system (Small leak — Positive pressure) P1440 (0213) ● EVAP control system purge flow monitoring P1447 (0111) 	MA
Oxygen sensor monitoring	<ul style="list-style-type: none"> ● Front heated oxygen sensor (Circuit) P0130 (0303) ● Front heated oxygen sensor (Lean shift monitoring) P0131 (0411) ● Front heated oxygen sensor (Rich shift monitoring) P0132 (0410) ● Front heated oxygen sensor (Response monitoring) P0133 (0409) ● Front heated oxygen sensor (High voltage) P0134 (0412) ● Rear heated oxygen sensor (Min. voltage monitoring) P0137 (0511) ● Rear heated oxygen sensor (Max. voltage monitoring) P0138 (0510) ● Rear heated oxygen sensor (Response monitoring) P0139 (0707) ● Rear heated oxygen sensor (High voltage) P0140 (0512) 	EM LC
Oxygen sensor heater monitoring	<ul style="list-style-type: none"> ● Front heated oxygen sensor heater P0135 (0901) ● Rear heated oxygen sensor heater P0141 (0902) 	FE
EGR system monitoring	<ul style="list-style-type: none"> ● EGR function (Close) P0400 (0302) ● EGRC-BPT valve function P0402 (0306) ● EGR function (Open) P1402 (0514) 	CL

Together with the DTC, the SRT code is cleared from the ECM memory using the method described later (Refer to EC-52). In addition, after Engine Control components/system are repaired or if the battery terminals remain disconnected for more than 24 hours, all SRT codes may be cleared from the ECM memory.

How to display SRT code

1. Selecting "SRT STATUS" in "DTC CONFIRMATION" mode with CONSULT.
For items whose SRT codes are set, a "CMPLT" is displayed on the CONSULT screen; for items whose SRT codes are not set, "INCMP" is displayed.
2. Selecting Mode 1 with GST (Generic Scan Tool)

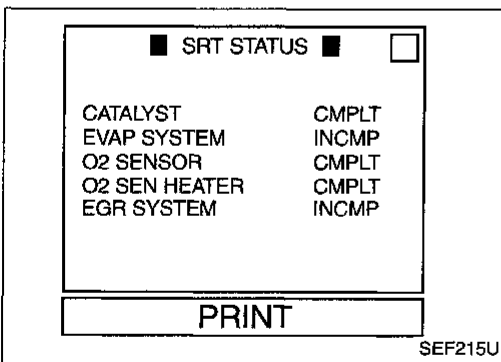

A sample of CONSULT display for SRT code is shown at left. "INCMP" means the self-diagnosis is incomplete and SRT is not set. "CMPLT" means the self-diagnosis is complete and SRT is set.

How to set SRT code

To set all SRT codes, self-diagnosis for the items indicated above must be performed one or more times. Each diagnosis may require a long period of actual driving under various conditions. The most efficient driving pattern in which SRT codes can be properly set is explained on the next page. The driving pattern should be performed one or more times to set all SRT codes.

ON BOARD DIAGNOSTIC SYSTEM DESCRIPTION

Emission-related Diagnostic Information (Cont'd)

Driving pattern

Note: Always drive vehicle in safe manner according to traffic conditions and obey all traffic laws. Refer to next page for more information and explanation of chart.

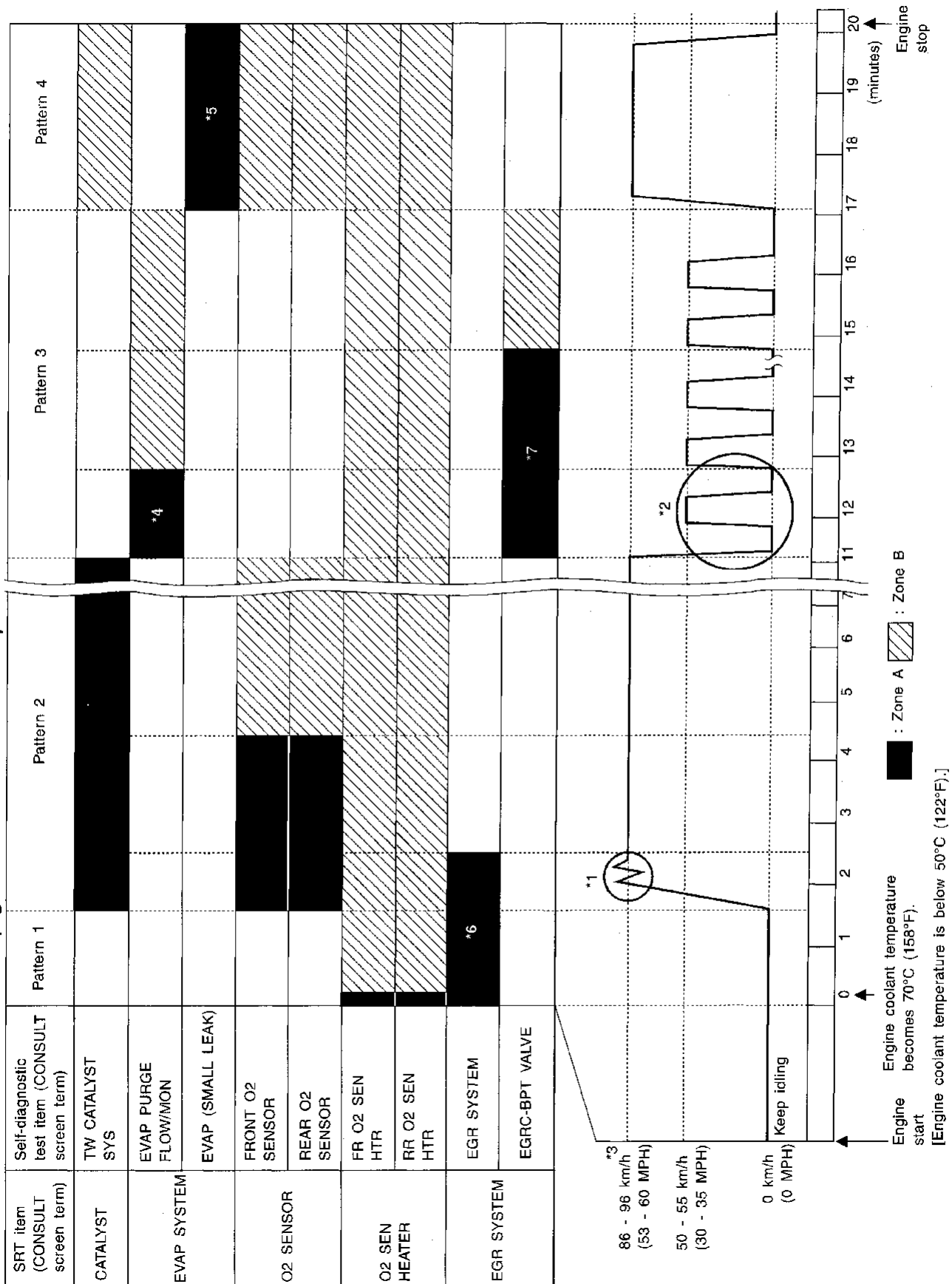

ON BOARD DIAGNOSTIC SYSTEM DESCRIPTION

Emission-related Diagnostic Information (Cont'd)

- The time required for each diagnosis varies with road surface conditions, weather, altitude, individual driving habits, etc.
Zone A refers to the range where the time required, for the diagnosis under normal conditions*, is the shortest.
Zone B refers to the range where the diagnosis can still be performed if the diagnosis is not completed within zone A.

*: Normal conditions refer to the following:

- Sea level
- Flat road
- Ambient air temperature: 20 - 30°C (68 - 86°F)
- Diagnosis is performed as quickly as possible under normal conditions.

Under different conditions [For example: ambient air temperature other than 20 - 30°C (68 - 86°F)], diagnosis may also be performed.

- Pattern 1: ● **The engine is started at the engine coolant temperature of -10 to 35°C (14 to 95°F) (where the voltage between the ECM terminals (51) and (50) is 3.0 - 4.3V).**
- **The engine must be operated at idle speed until the engine coolant temperature is greater than 70°C (158°F) (where the voltage between the ECM terminals (51) and (50) is lower than 1.4V).**
 - **The engine is started at the tank fuel temperature of warmer than 0°C (32°F) (where the voltage between the ECM terminal (63) and ground is less than 4.1V).**

Pattern 2: ● When steady-state driving is performed again even after it is interrupted, each diagnosis can be conducted. In this case, the time required for diagnosis may be extended.

Pattern 3: ● The driving pattern outlined in *2 must be repeated at least 3 times.
On M/T models, shift gears following "suggested upshift speeds" schedule on next page.

Pattern 4: ● Tests are performed after the engine has been operated for at least 17 minutes.

- The accelerator pedal must be held very steady during steady-state driving.
- If the accelerator pedal is moved, the test must be conducted all over again.

*1: Depress the accelerator pedal until vehicle speed is 90 km/h (56 MPH), then release the accelerator pedal and keep it released for more than 10 seconds. Depress the accelerator pedal until vehicle speed is 90 km/h (56 MPH) again.

*2: Operate the vehicle in the following driving pattern.

- 1) Decelerate vehicle to 0 km/h and let engine idle.
- 2) Repeat driving pattern shown below at least 10 times.
 - **During acceleration, hold the accelerator pedal as steady as possible. (The THROTL POS SEN value of CONSULT should be between 0.8 to 1.2V.)**
- 3) Repeat steps 1 and 2 until the EGR system SRT is set.

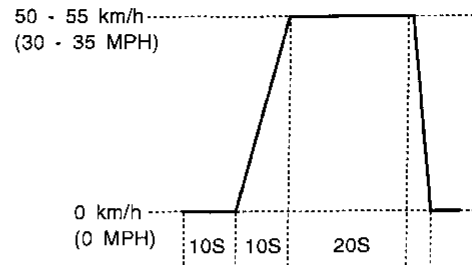

*3: Checking the vehicle speed with CONSULT or GST is advised.

*4: The driving pattern may be omitted when "PURG FLOW P1447" is performed using the "DTC WORK SUPPORT" mode with CONSULT.

*5: The driving pattern may be omitted when "EVAP SML LEAK P0440" is performed using the "DTC WORK SUPPORT" mode with CONSULT.

*6: The driving pattern may be omitted when all the following are performed using the "DTC WORK SUPPORT" mode with CONSULT.

- "EGR SYSTEM P0400"
- "EGR SYSTEM P1402"

*7: The driving pattern may be omitted when "EGRC-BPT/ VLV P0402" is performed using the "DTC WORK SUPPORT" mode with CONSULT.

GI

MA

EM

LC

EC

FE

CL

MT

AT

FA

RA

BR

ST

RS

BT

HA

EL

IDX

ON BOARD DIAGNOSTIC SYSTEM DESCRIPTION

Emission-related Diagnostic Information (Cont'd)

Suggested transmission gear position for A/T models

Set the selector lever in the "D" position with "O/D" ON.

Suggested upshift speeds for M/T models

Shown below are suggested vehicle speeds for shifting into a higher gear. These suggestions relate to fuel economy and vehicle performance. Actual upshift speeds will vary according to road conditions, the weather and individual driving habits.

For normal acceleration in low altitude areas [less than 1,219 m (4,000 ft)]:

Gear change	ACCEL shift point km/h (MPH)
1st to 2nd	24 (15)
2nd to 3rd	40 (25)
3rd to 4th	65 (40)
4th to 5th	75 (45)

For quick acceleration in low altitude areas and high altitude areas [over 1,219 m (4,000 ft)]:

Gear change	km/h (MPH)
1st to 2nd	25 (15)
2nd to 3rd	40 (25)
3rd to 4th	65 (40)
4th to 5th	75 (45)

Suggested maximum speed in each gear

Downshift to a lower gear if the engine is not running smoothly, or if you need to accelerate.

Do not exceed the maximum suggested speed (shown below) in any gear. For level road driving, use the highest gear suggested for that speed. Always observe posted speed limits and drive according to the road conditions to ensure safe operation. Do not over-rev the engine when shifting to a lower gear as it may cause engine damage or loss of vehicle control.

Gear	km/h (MPH)
1st	55 (35)
2nd	95 (60)
3rd	135 (85)

ON BOARD DIAGNOSTIC SYSTEM DESCRIPTION

Emission-related Diagnostic Information (Cont'd)

TEST VALUE AND TEST LIMIT (GST only — not applicable to CONSULT)

The following is the information specified in Mode 6 of SAE J1979.

The test value is a parameter used to determine whether a system/circuit diagnostic test is "OK" or "NG" while being monitored by the ECM during self-diagnosis. The test limit is a reference value which is specified as the maximum or minimum value and is compared with the test value being monitored.

Items for which these data (test value and test limit) are displayed are the same as SRT code items (9 test items).

These data (test value and test limit) are specified by Test ID (TID) and Component ID (CID) and can be displayed on the GST screen.

X: Applicable
—: Not applicable

SRT item	Self-diagnostic test item	Test value (GST display)		Test limit	Application
		TID	CID		
CATALYST	Three way catalyst function	01H	01H	Max.	X
		02H	81H	Min.	X
EVAP SYSTEM	EVAP control system (Small leak)	05H	03H	Max.	X
	EVAP control system purge flow monitoring	06H	83H	Min.	X
O2 SENSOR	Front heated oxygen sensor	09H	04H	Max.	X
		0AH	84H	Min.	X
		0BH	04H	Max.	X
		0CH	04H	Max.	X
	Rear heated oxygen sensor	0DH	04H	Max.	X
		19H	86H	Min.	X
		1AH	86H	Min.	X
		1BH	06H	Max.	X
1CH	06H	Max.	X		
O2 SENSOR HEATER	Front heated oxygen sensor heater	29H	08H	Max.	X
		2AH	88H	Min.	X
	Rear heated oxygen sensor heater	2DH	0AH	Max.	X
		2EH	8AH	Min.	X
EGR SYSTEM	EGR function	31H	8CH	Min.	X
		32H	8CH	Min.	X
		33H	8CH	Min.	X
		34H	8CH	Min.	X
		35H	0CH	Max.	X
	EGRC-BPT valve function	36H	0CH	Max.	X
		37H	8CH	Min.	X

ON BOARD DIAGNOSTIC SYSTEM DESCRIPTION

Emission-related Diagnostic Information (Cont'd)

EMISSION-RELATED DIAGNOSTIC INFORMATION ITEMS

X: Applicable
—: Not applicable

Items (CONSULT screen terms)	DTC*4		SRT code	Test value/ Test limit (GST only)	1st trip DTC*4	Reference page
	CONSULT GST*2	ECM*1				
NO SELF DIAGNOSTIC FAILURE INDICATED	P0000	0505	—	—	—	—
MAF SEN/CIRCUIT	P0100	0102	—	—	X	EC-112
ABSL PRES SEN/CIRC	P0105	0803	—	—	X	EC-122
AIR TEMP SEN/CIRC	P0110	0401	—	—	X	EC-131
COOLANT T SEN/CIRC	P0115	0103	—	—	X	EC-137
THRTL POS SEN/CIRC	P0120	0403	—	—	X	EC-142
*COOLAN T SEN/CIRC	P0125	0908	—	—	X	EC-157
FRONT O2 SENSOR	P0130	0303	X	X	X*3	EC-163
FRONT O2 SENSOR	P0131	0411	X	X	X*3	EC-169
FRONT O2 SENSOR	P0132	0410	X	X	X*3	EC-175
FRONT O2 SENSOR	P0133	0409	X	X	X*3	EC-181
FRONT O2 SENSOR	P0134	0412	X	X	X*3	EC-189
FR O2 SEN HEATER	P0135	0901	X	X	X*3	EC-195
REAR O2 SENSOR	P0137	0511	X	X	X*3	EC-199
REAR O2 SENSOR	P0138	0510	X	X	X*3	EC-206
REAR O2 SENSOR	P0139	0707	X	X	X*3	EC-213
REAR O2 SENSOR	P0140	0512	X	X	X*3	EC-220
RR O2 SEN HEATER	P0141	0902	X	X	X*3	EC-226
FUEL SYS DIAG-LEAN	P0171	0115	—	—	X	EC-230
FUEL SYS DIAG-RICH	P0172	0114	—	—	X	EC-236
FUEL TEMP SEN/CIRC	P0180	0402	—	—	X	EC-241
MULTI CYL MISFIRE	P0300	0701	—	—	X	EC-245
CYL 1 MISFIRE	P0301	0608	—	—	X	EC-245
CYL 2 MISFIRE	P0302	0607	—	—	X	EC-245
CYL 3 MISFIRE	P0303	0606	—	—	X	EC-245
CYL 4 MISFIRE	P0304	0605	—	—	X	EC-245
KNOCK SEN/CIRCUIT	P0325	0304	—	—	X	EC-250
CPS/CIRCUIT (OBD)	P0335	0802	—	—	X	EC-255
CAM POS SEN/CIRC	P0340	0101	—	—	X	EC-260
EGR SYSTEM	P0400	0302	X	X	X*3	EC-267
EGRC-BPT VALVE	P0402	0306	X	X	X*3	EC-276
TW CATALYST SYSTEM	P0420	0702	X	X	X*3	EC-281
EVAP SMALL LEAK	P0440	0705	X	X	X*3	EC-285
PURG VOLUME CONT/V	P0443	1008	—	—	X	EC-296
VENT CONTROL VALVE	P0446	0903	—	—	X	EC-302
EVAPO SYS PRES SEN	P0450	0704	—	—	X	EC-307

*1: In Diagnostic Test Mode II (Self-diagnostic results). These numbers are controlled by NISSAN.

*2: These numbers are prescribed by SAE J2012.

*3: These are not displayed with GST.

*4: 1st trip DTC No. is the same as DTC No.

ON BOARD DIAGNOSTIC SYSTEM DESCRIPTION

Emission-related Diagnostic Information (Cont'd)

X: Applicable
—: Not applicable

Items (CONSULT screen terms)	DTC*4		SRT code	Test value/ Test limit (GST only)	1st trip DTC*4	Reference page
	CONSULT GST*2	ECM*1				
VEH SPEED SEN/CIRC	P0500	0104	—	—	X	EC-314
IACV/AAC VLV/CIRC	P0505	0205	—	—	X	EC-319
CLOSED TP SW/CIRC	P0510	0203	—	—	X	EC-325
ECM	P0605	0301	—	—	X	EC-331
PNP SW/CIRC	P0705	1101	—	—	X	AT-81
ATF TEMP SEN/CIRC	P0710	1208	—	—	X	AT-85
VEH SPD SEN/CIR AT	P0720	1102	—	—	X	AT-89
ENGINE SPEED SIG	P0725	1207	—	—	X	AT-93
A/T 1ST GR FNCTN	P0731	1103	—	—	X	AT-96
A/T 2ND GR FNCTN	P0732	1104	—	—	X	AT-102
A/T 3RD GR FNCTN	P0733	1105	—	—	X	AT-107
A/T 4TH GR FNCTN	P0734	1106	—	—	X	AT-112
TCC SOLENOID/CIRC	P0740	1204	—	—	X	AT-120
A/T TCC S/V FNCTN	P0744	1107	—	—	X	AT-124
L/PRESS SOL/CIRC	P0745	1205	—	—	X	AT-131
SFT SOL A/CIRC	P0750	1108	—	—	X	AT-135
SFT SOL B/CIRC	P0755	1201	—	—	X	AT-139
MAP/BAR SW SOL/CIR	P1105	1302	—	—	X	EC-333
CLOSED LOOP	P1148	0307	—	—	X	EC-342
FPCM/CIRCUIT	P1220	1305	—	—	X	EC-344
IGN SIGNAL-PRIMARY	P1320	0201	—	—	X	EC-351
CPS/CIRC (OBD) COG	P1336	0905	—	—	X	EC-358
EGRC SOLENOID/V	P1400	1005	—	—	X	EC-363
EGR TEMP SEN/CIRC	P1401	0305	—	—	X	EC-368
EGR SYSTEM	P1402	0514	X	X	X*3	EC-374
EVAP SMALL LEAK	P1440	0213	X	X	X*3	EC-381
PURG VOLUME CONT/V	P1444	0214	—	—	X	EC-393
VENT CONTROL VALVE	P1446	0215	—	—	X	EC-401
EVAP PURG FLOW/MON	P1447	0111	X	X	X*3	EC-406
VENT CONTROL VALVE	P1448	0309	—	—	X	EC-415
VC/V BYPASS/V	P1490	0801	—	—	X	EC-421
VC CUT/V BYPASS/V	P1491	0311	—	—	X	EC-426
PURG CONT/V S/V	P1492	0807	—	—	X	EC-432
PURG CONT/V & S/V	P1493	0312	—	—	X	EC-438
A/T DIAG COMM LINE	P1605	0804	—	—	X	EC-447
TP SEN/CIRC A/T	P1705	1206	—	—	X	AT-143
P-N POS SW/CIRCUIT	P1706	1003	—	—	X	EC-450
O/R CLTCH SOL/CIRC	P1760	1203	—	—	X	AT-150

*1: In Diagnostic Test Mode II (Self-diagnostic results). These numbers are controlled by NISSAN.

*2: These numbers are prescribed by SAE J2012.

*3: These are not displayed with GST.

*4: 1st trip DTC No. is the same as DTC No.

ON BOARD DIAGNOSTIC SYSTEM DESCRIPTION

Emission-related Diagnostic Information (Cont'd)

HOW TO ERASE EMISSION-RELATED DIAGNOSTIC INFORMATION

How to erase DTC (With CONSULT)

Note: If the diagnostic trouble code is not for A/T related items (see EC-2), skip steps 2 through 4.

1. If the ignition switch stays "ON" after repair work, be sure to turn ignition switch "OFF" once. Wait at least 5 seconds and then turn it "ON" (engine stopped) again.
 2. Turn CONSULT "ON" and touch "A/T".
 3. Touch "SELF-DIAG RESULTS".
 4. Touch "ERASE". [The DTC in the TCM (Transmission control module) will be erased.] Then touch "BACK" twice.
 5. Touch "ENGINE".
 6. Touch "SELF-DIAG RESULTS".
 7. Touch "ERASE". (The DTC in the ECM will be erased.)
- If DTCs are displayed for both ECM and TCM (Transmission control module), they need to be erased individually from the ECM and TCM (Transmission control module).

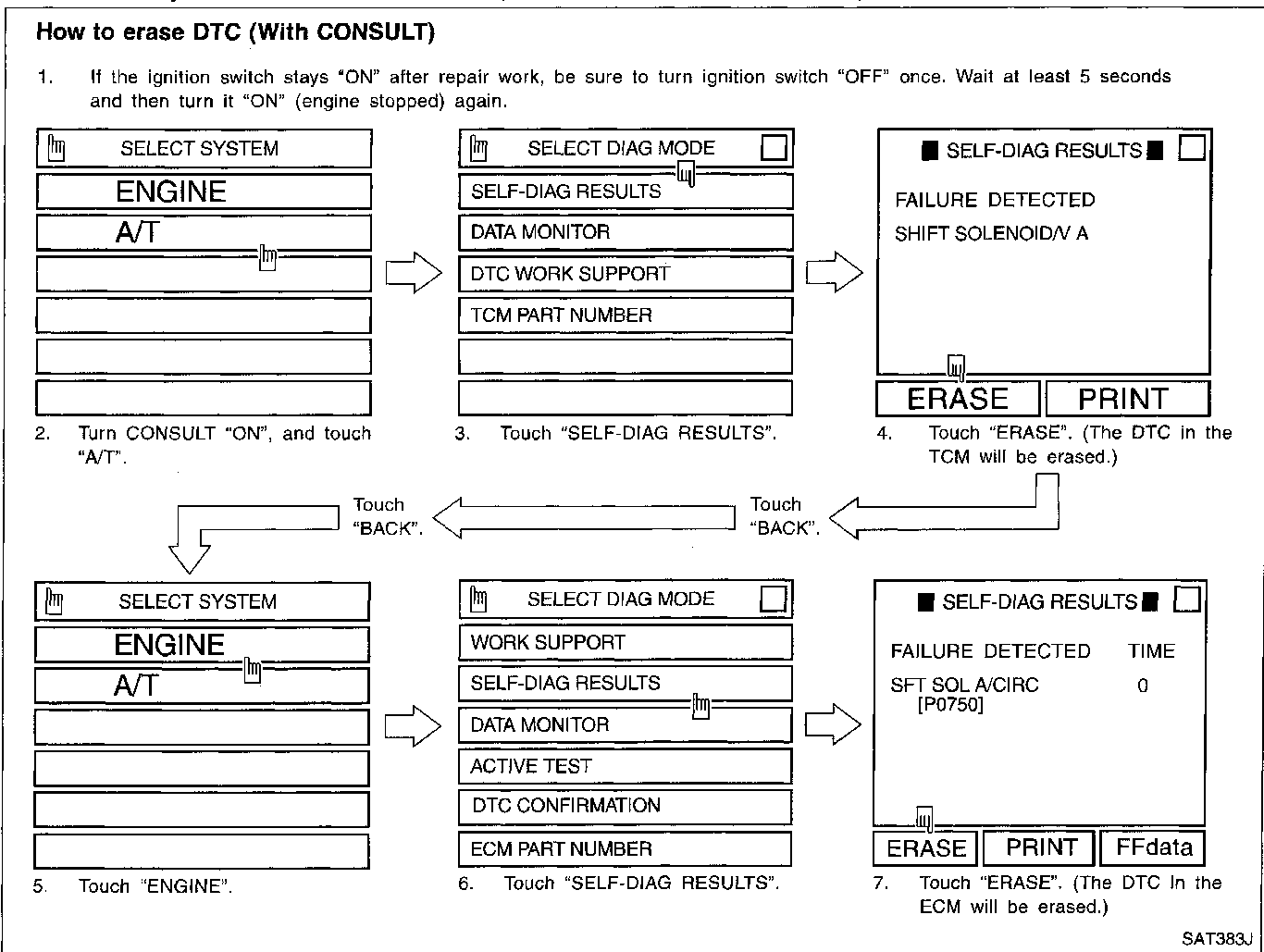

The emission-related diagnostic information can be erased by selecting "ERASE" in the "SELF-DIAG RESULTS" mode with CONSULT.

ON BOARD DIAGNOSTIC SYSTEM DESCRIPTION

Emission-related Diagnostic Information (Cont'd)

How to erase DTC (With GST)

Note: If the diagnostic trouble code is not for A/T related items (see EC-2), skip step 2.

1. If the ignition switch stays "ON" after repair work, be sure to turn ignition switch "OFF" once. Wait at least 5 seconds and then turn it "ON" (engine stopped) again.
2. Perform "SELF-DIAGNOSTIC PROCEDURE (Without CONSULT)" in AT section titled "TROUBLE DIAGNOSIS", "Self-diagnosis". (The engine warm-up step can be skipped when performing the diagnosis only to erase the DTC.)
3. Select Mode 4 with GST (Generic Scan Tool).

The emission-related diagnostic information can be erased by selecting Mode 4 with GST (Generic Scan Tool).

How to erase DTC (No Tools)

Note: If the diagnostic trouble code is not for A/T related items (see EC-2), skip step 2.

1. If the ignition switch stays "ON" after repair work, be sure to turn ignition switch "OFF" once. Wait at least 5 seconds and then turn it "ON" again.
2. Perform "SELF-DIAGNOSTIC PROCEDURE (Without CONSULT)" in AT section titled "TROUBLE DIAGNOSIS", "Self-diagnosis". (The engine warm-up step can be skipped when performing the diagnosis only to erase the DTC.)
3. Change the diagnostic test mode from Mode II to Mode I by turning the mode selector on the ECM.

(See EC-55.)
The emission-related diagnostic information can be erased by changing the diagnostic test mode from Diagnostic Test Mode II to Mode I by turning the mode selector on the ECM. (Refer to EC-55.)

NOTE:

- If the battery is disconnected, the emission-related diagnostic information will be lost after approx. 24 hours.
- Erasing the emission-related diagnostic information using CONSULT or GST is easier and quicker than switching the mode selector on the ECM.
- The following data are cleared when the ECM memory is erased.
 1. Diagnostic trouble codes
 2. 1st trip diagnostic trouble codes
 3. Freeze frame data
 4. 1st trip freeze frame data
 5. System readiness test (SRT) codes
 6. Test values
 7. Others

Actual work procedures are explained using a DTC as an example. Be careful so that not only the DTC, but all of the data listed above, are cleared from the ECM memory during work procedures.

GI

MA

EM

LC

EC

FE

CL

MT

AT

FA

RA

BR

ST

RS

BT

HA

EL

IDX

ON BOARD DIAGNOSTIC SYSTEM DESCRIPTION

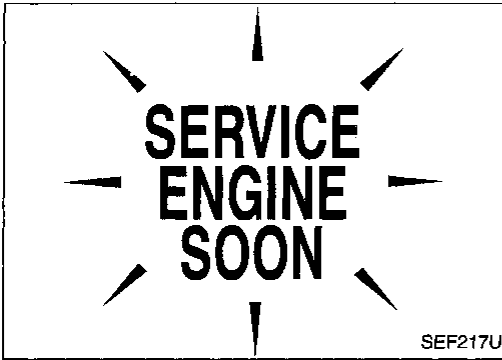

Malfunction Indicator Lamp (MIL)

The MIL is located on the instrument panel.

1. The malfunction indicator lamp will light up when the ignition switch is turned ON without the engine running. This is a bulb check.
 - If the malfunction indicator lamp does not light up, refer to EL section ("WARNING LAMPS") or see EC-491.
2. When the engine is started, the malfunction indicator lamp should go off.
 - If the lamp remains on, the on board diagnostic system has detected an engine system malfunction.

ON BOARD DIAGNOSTIC SYSTEM FUNCTION

The on board diagnostic system has the following four functions.

Diagnostic Test Mode I

1. BULB CHECK : This function checks the MIL bulb for damage (blown, open circuit, etc.).
If the MIL does not come on, check MIL circuit and ECM test mode selector. (See next page.)
2. MALFUNCTION WARNING : This is a usual driving condition. When a malfunction is detected twice in two consecutive driving cycles (two trip detection logic), the MIL will light up to inform the driver that a malfunction has been detected. The following malfunctions will light up or blink the MIL in the 1st trip.
 - "Misfire (Possible three way catalyst damage)"
 - "Closed loop control"
 - Fail-safe mode



Diagnostic Test Mode II

3. SELF-DIAGNOSTIC RESULTS : This function allows DTCs and 1st trip DTCs to be read.
4. FRONT HEATED OXYGEN SENSOR MONITOR : This function allows the fuel mixture condition (lean or rich), monitored by front heated oxygen sensor, to be read.

MIL flashing without DTC

If the ECM is in Diagnostic Test Mode II, MIL may flash when engine is running. In this case, check ECM test mode selector following "HOW TO SWITCH DIAGNOSTIC TEST MODES" on next page.

How to switch the diagnostic test (function) modes, and details of the above functions are described later. (Refer to EC-55.)

Condition		Diagnostic Test Mode I	Diagnostic Test Mode II
Ignition switch in "ON" position 	Engine stopped 	BULB CHECK	SELF-DIAGNOSTIC RESULTS
	Engine running 	MALFUNCTION WARNING	FRONT HEATED OXYGEN SENSOR MONITOR

ON BOARD DIAGNOSTIC SYSTEM DESCRIPTION

Malfunction Indicator Lamp (MIL) (Cont'd)

HOW TO SWITCH DIAGNOSTIC TEST MODES

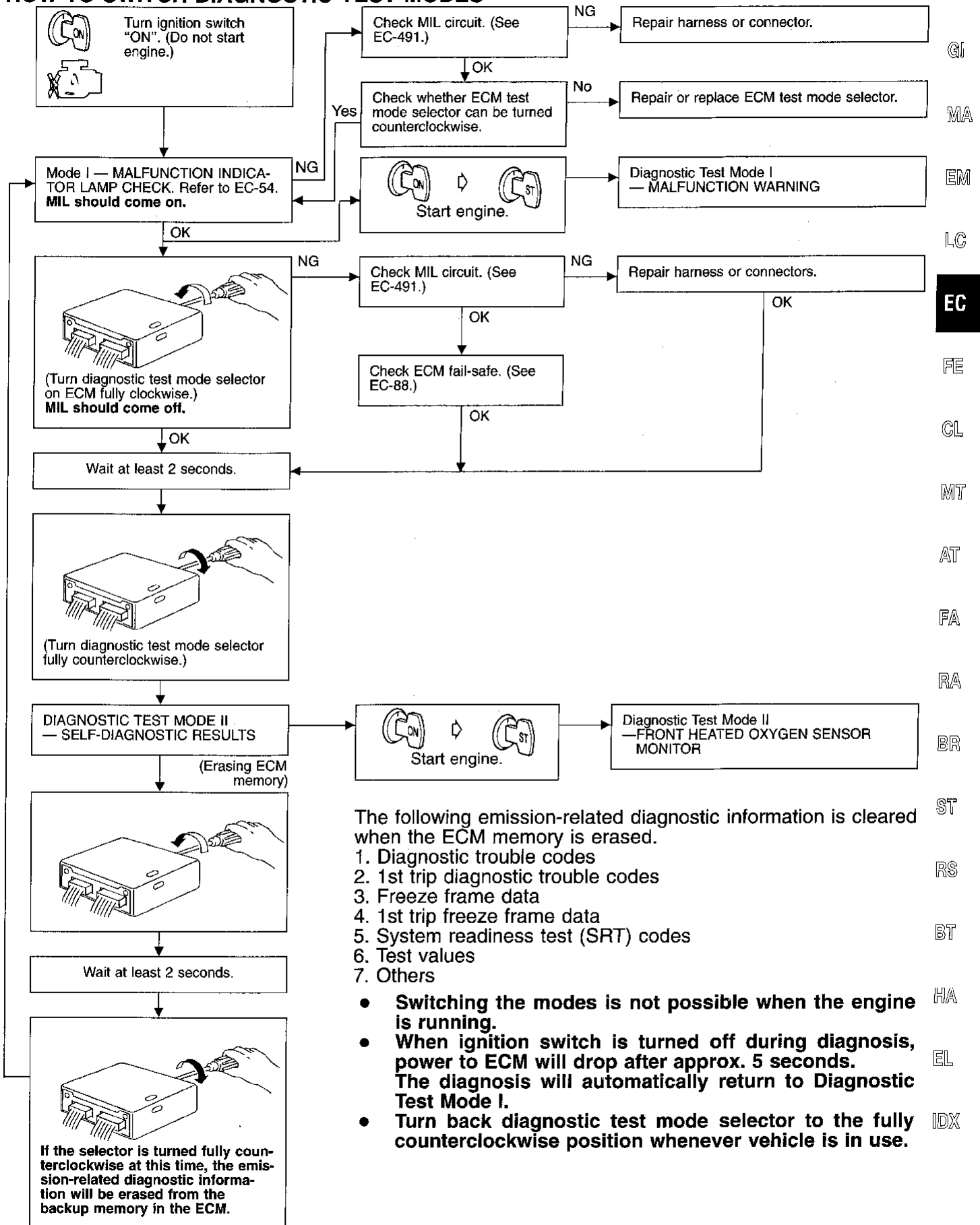

The following emission-related diagnostic information is cleared when the ECM memory is erased.

1. Diagnostic trouble codes
2. 1st trip diagnostic trouble codes
3. Freeze frame data
4. 1st trip freeze frame data
5. System readiness test (SRT) codes
6. Test values
7. Others

- Switching the modes is not possible when the engine is running.
- When ignition switch is turned off during diagnosis, power to ECM will drop after approx. 5 seconds. The diagnosis will automatically return to Diagnostic Test Mode I.
- Turn back diagnostic test mode selector to the fully counterclockwise position whenever vehicle is in use.

ON BOARD DIAGNOSTIC SYSTEM DESCRIPTION

Malfunction Indicator Lamp (MIL) (Cont'd)

DIAGNOSTIC TEST MODE I — BULB CHECK

In this mode, the MALFUNCTION INDICATOR LAMP on the instrument panel should stay ON. If it remains OFF, check the bulb. Refer to EL section ("WARNING LAMPS") or see EC-491.

DIAGNOSTIC TEST MODE I — MALFUNCTION WARNING

MALFUNCTION INDICATOR LAMP	Condition
ON	When the malfunction is detected or the ECM's CPU is malfunctioning.
OFF	No malfunction.

- These Diagnostic Trouble Code Numbers are clarified in Diagnostic Test Mode II (SELF-DIAGNOSTIC RESULTS).

DIAGNOSTIC TEST MODE II — SELF-DIAGNOSTIC RESULTS

In this mode, the DTC and 1st trip DTC are indicated by the number of blinks of the MALFUNCTION INDICATOR LAMP.

The DTC and 1st trip DTC are displayed at the same time. If the MIL does not illuminate in diagnostic test mode I (Malfunction warning), all displayed items are 1st trip DTCs. If only one code is displayed when the MIL illuminates in diagnostic test mode II (SELF-DIAGNOSTIC RESULTS), it is a DTC; if two or more codes are displayed, they may be either DTCs or 1st trip DTCs. DTC No. is same as that of 1st trip DTC. These unidentified codes can be identified by using the CONSULT or GST. A DTC will be used as an example for how to read a code.

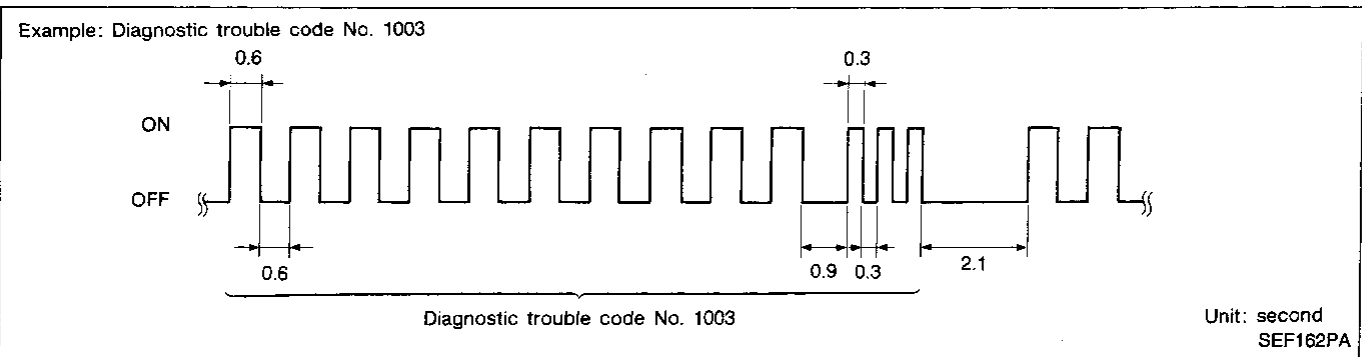
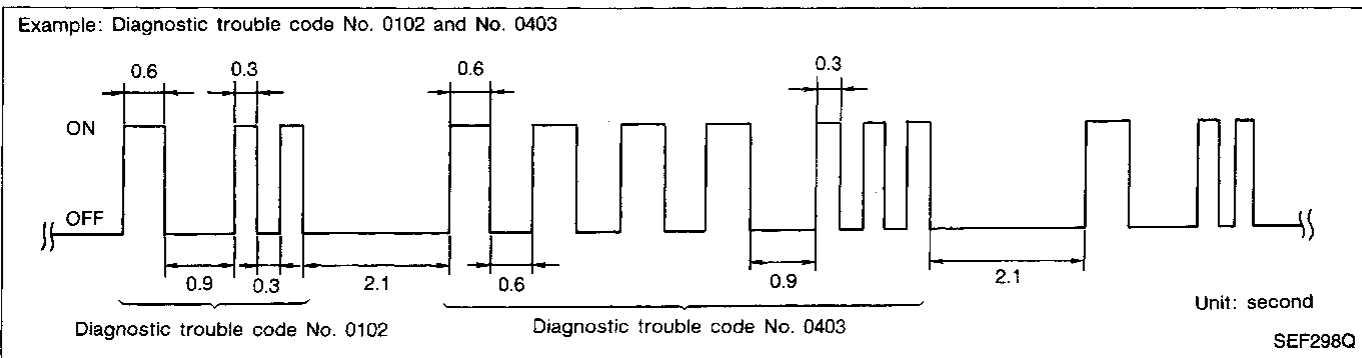

Long (0.6 second) blinking indicates the two LH digits of number and short (0.3 second) blinking indicates the two RH digits of number. For example, the malfunction indicator lamp blinks 10 times for 6 seconds (0.6 sec x 10 times) and then it blinks three times for about 1 second (0.3 sec x 3 times). This indicates the DTC "1003" and refers to the malfunction of the park/neutral position (PNP) switch.

In this way, all the detected malfunctions are classified by their diagnostic trouble code numbers. The DTC "0505" refers to no malfunction. (See DIAGNOSTIC TROUBLE CODE (DTC) INDEX, EC-2.)

ON BOARD DIAGNOSTIC SYSTEM DESCRIPTION

Malfunction Indicator Lamp (MIL) (Cont'd)

How to erase diagnostic test mode II (Self-diagnostic results)

The diagnostic trouble code can be erased from the backup memory in the ECM when the diagnostic test mode is changed from Diagnostic Test Mode II to Diagnostic Test Mode I. (Refer to "HOW TO SWITCH DIAGNOSTIC TEST MODES".)

- If the battery is disconnected, the diagnostic trouble code will be lost from the backup memory after approx. 24 hours.
- Be careful not to erase the stored memory before starting trouble diagnoses.

DIAGNOSTIC TEST MODE II — FRONT HEATED OXYGEN SENSOR MONITOR

In this mode, the MALFUNCTION INDICATOR LAMP displays the condition of the fuel mixture (lean or rich) which is monitored by the front heated oxygen sensor.

MALFUNCTION INDICATOR LAMP	Fuel mixture condition in the exhaust gas	Air fuel ratio feedback control condition
ON	Lean	Closed loop system
OFF	Rich	
*Remains ON or OFF	Any condition	Open loop system

*: Maintains conditions just before switching to open loop.

To check the front heated oxygen sensor function, start engine in the Diagnostic Test Mode II and warm it up until engine coolant temperature indicator points to the middle of the gauge.

Next run engine at about 2,000 rpm for about 2 minutes under no-load conditions. Then make sure that the MALFUNCTION INDICATOR LAMP comes ON more than 5 times within 10 seconds with engine running at 2,000 rpm under no-load.

OBD System Operation Chart

RELATIONSHIP BETWEEN MIL, 1ST TRIP DTC, DTC, AND DETECTABLE ITEMS

- When a malfunction is detected for the first time, the 1st trip DTC and the 1st trip freeze frame data are stored in the ECM memory.
- When the same malfunction is detected in two consecutive trips, the DTC and the freeze frame data are stored in the ECM memory, and the MIL will come on. For details, refer to "Two Trip Detection Logic" on EC-42.
- The MIL will go off after the vehicle is driven 3 times with no malfunction. The drive is counted only when the recorded driving pattern is met (as stored in the ECM). If another malfunction occurs while counting, the counter will reset.
- The DTC and the freeze frame data will be stored until the vehicle is driven 40 times (driving pattern A) without the same malfunction recurring (except for Misfire and Fuel Injection System). For Misfire and Fuel Injection System, the DTC and freeze frame data will be stored until the vehicle is driven 80 times (driving pattern C) without the same malfunction recurring. The "TIME" in "SELF-DIAGNOSTIC RESULTS" mode of CONSULT will count the number of times the vehicle is driven.
- The 1st trip DTC is not displayed when the self-diagnosis results in "OK" for the 2nd trip.

SUMMARY CHART

Items	Fuel Injection System	Misfire	Other
MIL (goes off)	3 (pattern B)	3 (pattern B)	3 (pattern B)
DTC, Freeze Frame Data (no display)	80 (pattern C)	80 (pattern C)	40 (pattern A)
1st Trip DTC (clear)	1 (pattern C), *1	1 (pattern C), *1	1 (pattern B)
1st Trip Freeze Frame Data (clear)	*1, *2	*1, *2	1 (pattern B)

For details about patterns "B" and "C" under "Fuel Injection System" and "Misfire", see EC-59.

For details about patterns "A" and "B" under "Other", see EC-61.

*1: Clear timing is at the moment OK is detected.

*2: Clear timing is when the same malfunction is detected in the 2nd trip.

ON BOARD DIAGNOSTIC SYSTEM DESCRIPTION

OBD System Operation Chart (Cont'd)

RELATIONSHIP BETWEEN MIL, DTC, 1ST TRIP DTC AND DRIVING PATTERNS FOR "MISFIRE" <EXHAUST QUALITY DETERIORATION>, "FUEL INJECTION SYSTEM"

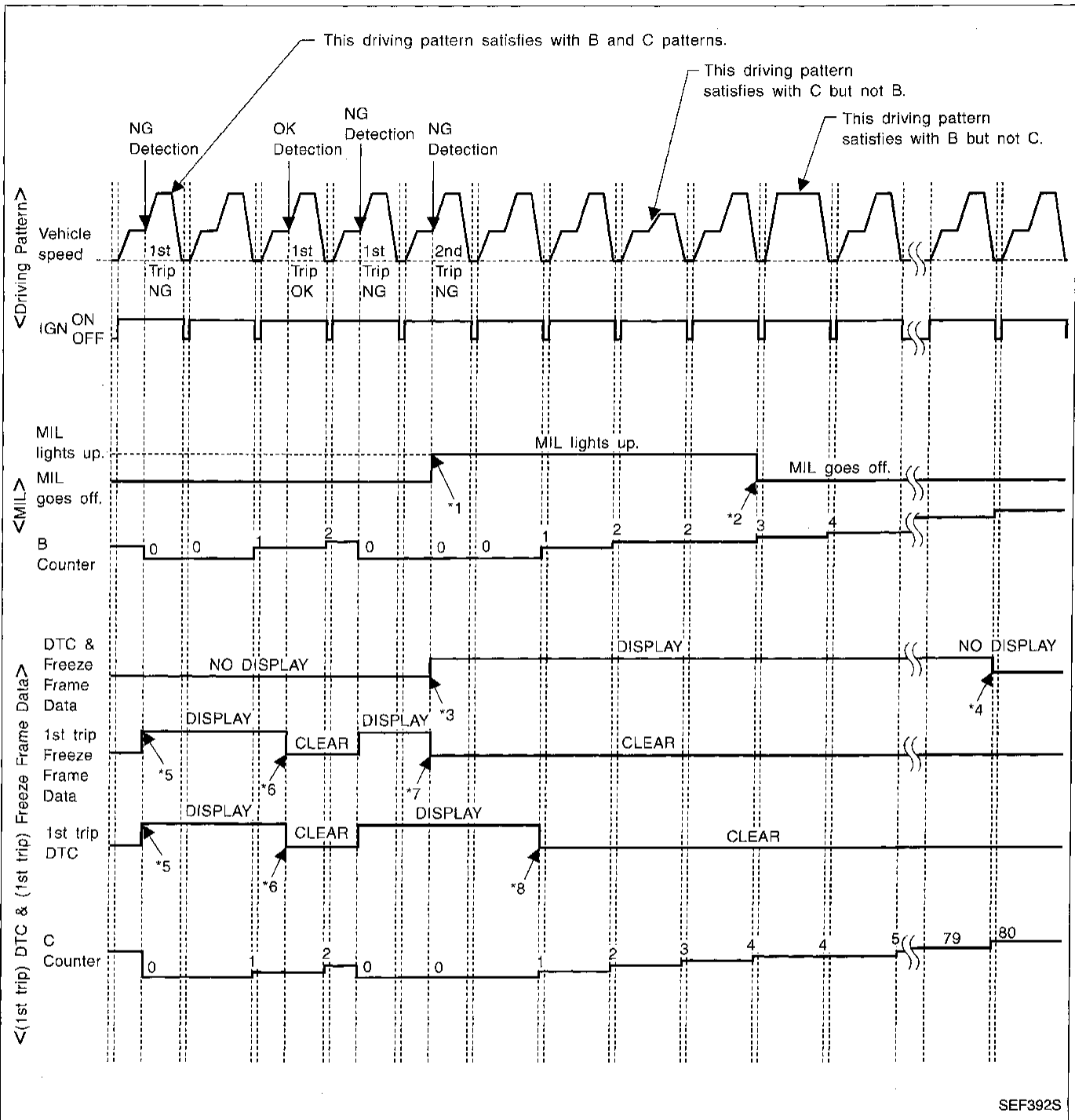

- *1: When the same malfunction is detected in two consecutive trips, MIL will light up.
- *2: MIL will go off after vehicle is driven 3 times (pattern B) without any malfunctions.
- *3: When the same malfunction is detected in two consecutive trips, the DTC and the freeze frame data will be stored in ECM.
- *4: The DTC and the freeze frame data will not be displayed any longer after vehicle is driven 80 times (pattern C) without the same malfunction. (The DTC and the freeze frame data still remain in ECM.)

- *5: When a malfunction is detected for the first time, the 1st trip DTC and the 1st trip freeze frame data will be stored in ECM.
- *6: The 1st trip DTC and the 1st trip freeze frame data will be cleared at the moment OK is detected.
- *7: When the same malfunction is detected in the 2nd trip, the 1st trip freeze frame data will be cleared.
- *8: 1st trip DTC will be cleared when vehicle is driven once (pattern C) without the same malfunction after DTC is stored in ECM.

ON BOARD DIAGNOSTIC SYSTEM DESCRIPTION

OBD System Operation Chart (Cont'd)

EXPLANATION FOR DRIVING PATTERNS FOR "MISFIRE <EXHAUST QUALITY DETERIORATION>", "FUEL INJECTION SYSTEM"

<Driving pattern B>

Driving pattern B means the vehicle operation as follows:

All components and systems should be monitored at least once by the OBD system.

- The B counter will be cleared when the malfunction is detected once regardless of the driving pattern.
- The B counter will be counted up when driving pattern B is satisfied without any malfunction.
- The MIL will go off when the B counter reaches 3. (*2 in "OBD SYSTEM OPERATION CHART")

<Driving pattern C>

Driving pattern C means the vehicle operation as follows:

(1) The following conditions should be satisfied at the same time:

Engine speed: (Engine speed in the freeze frame data) ± 375 rpm

Calculated load value: (Calculated load value in the freeze frame data) $\times (1 \pm 0.1)$ [%]

Engine coolant temperature (T) condition:

- When the freeze frame data shows lower than 70°C (158°F), "T" should be lower than 70°C (158°F).
- When the freeze frame data shows higher than or equal to 70°C (158°F), "T" should be higher than or equal to 70°C (158°F).

Example:

If the stored freeze frame data is as follows:

Engine speed: 850 rpm, Calculated load value: 30%, Engine coolant temperature: 80°C (176°F)

To be satisfied with driving pattern C, the vehicle should run under the following conditions:

Engine speed: 475 - 1,225 rpm, Calculated load value: 27 - 33%, Engine coolant temperature: more than 70°C (158°F)

- The C counter will be cleared when the malfunction is detected regardless of (1).
- The C counter will be counted up when (1) is satisfied without the same malfunction.
- The DTC will not be displayed after C counter reaches 80.
- The 1st trip DTC will be cleared when C counter is counted once without the same malfunction after DTC is stored in ECM.

GI

MA

EM

LC

EC

FE

CL

MT

AT

FA

RA

BR

ST

RS

BT

HA

EL

IDX

ON BOARD DIAGNOSTIC SYSTEM DESCRIPTION

OBD System Operation Chart (Cont'd)

RELATIONSHIP BETWEEN MIL, DTC, 1ST TRIP DTC AND DRIVING PATTERNS EXCEPT FOR "MISFIRE <EXHAUST QUALITY DETERIORATION>", "FUEL INJECTION SYSTEM"

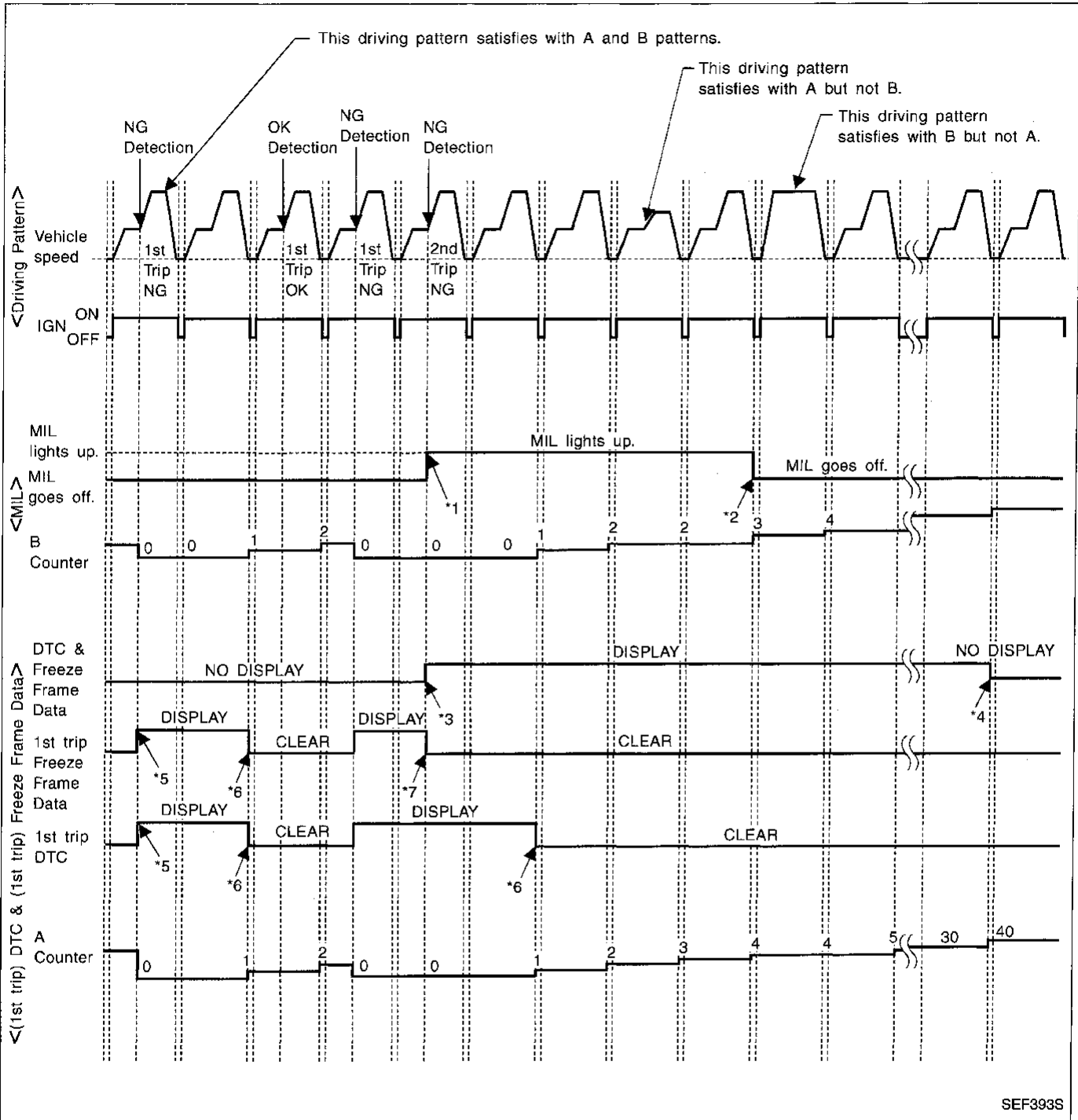

SEF393S

- *1: When the same malfunction is detected in two consecutive trips, MIL will light up.
- *2: MIL will go off after vehicle is driven 3 times (pattern B) without any malfunctions.
- *3: When the same malfunction is detected in two consecutive trips, the DTC and the freeze frame data will be stored in ECM.
- *4: The DTC and the freeze frame data will not be displayed any longer after vehicle is driven 40 times (pattern A) without the same malfunction. (The DTC and the freeze frame data still remain in ECM.)

- *5: When a malfunction is detected for the first time, the 1st trip DTC and the 1st trip freeze frame data will be stored in ECM.
- *6: 1st trip DTC will be cleared after vehicle is driven once (pattern B) without the same malfunction.
- *7: When the same malfunction is detected in the 2nd trip, the 1st trip freeze frame data will be cleared.

ON BOARD DIAGNOSTIC SYSTEM DESCRIPTION

OBD System Operation Chart (Cont'd)

EXPLANATION FOR DRIVING PATTERNS EXCEPT FOR "MISFIRE <EXHAUST QUALITY DETERIORATION>", "FUEL INJECTION SYSTEM"

<Driving pattern A>

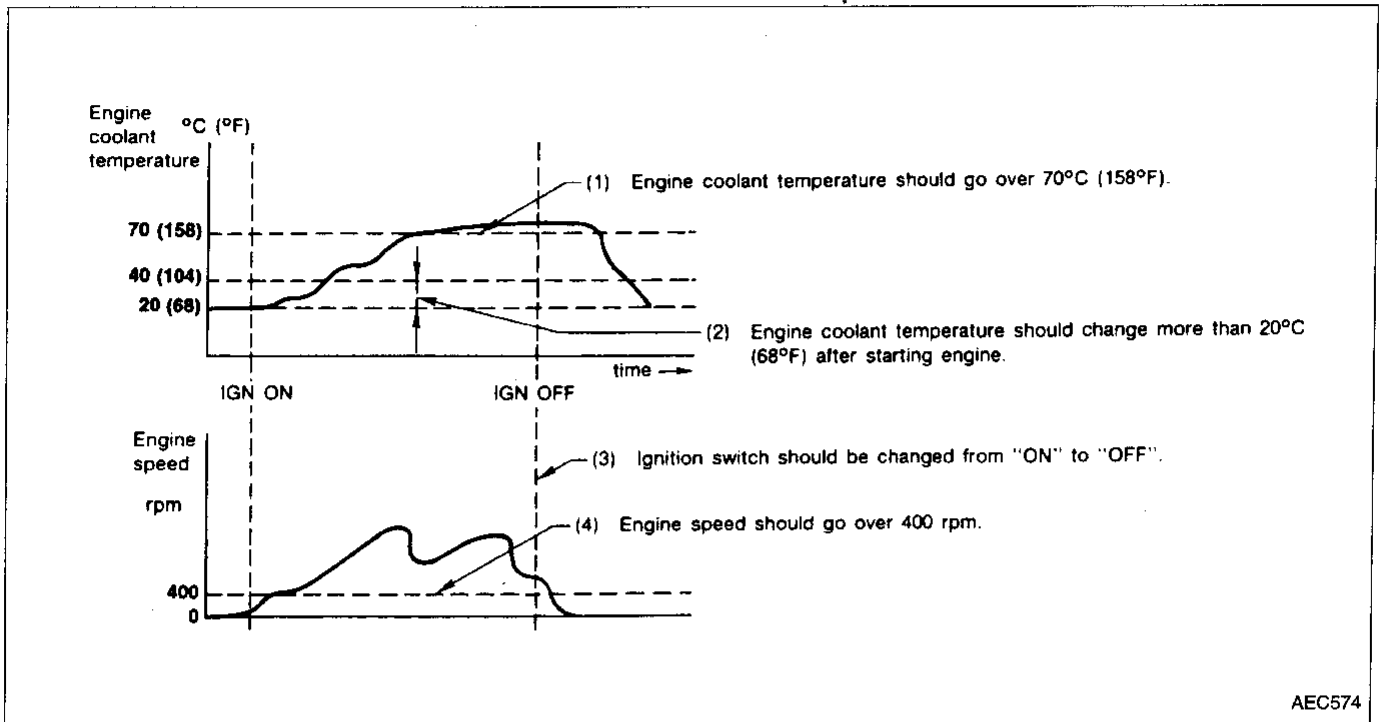

- The A counter will be cleared when the malfunction is detected regardless of (1) - (4).
- The A counter will be counted up when (1) - (4) are satisfied without the same malfunction.
- The DTC will not be displayed after the A counter reaches 40.

<Driving pattern B>

Driving pattern B means the vehicle operation as follows:

All components and systems should be monitored at least once by the OBD system.

- The B counter will be cleared when the malfunction is detected once regardless of the driving pattern.
- The B counter will be counted up when driving pattern B is satisfied without any malfunctions.
- The MIL will go off when the B counter reaches 3 (*2 in "OBD SYSTEM OPERATION CHART").

GI
MA
EM
LC
EC
FE
CL
MT
AT
FA
RA
BR
ST
RS
BT
HA
EL
IDX

ON BOARD DIAGNOSTIC SYSTEM DESCRIPTION

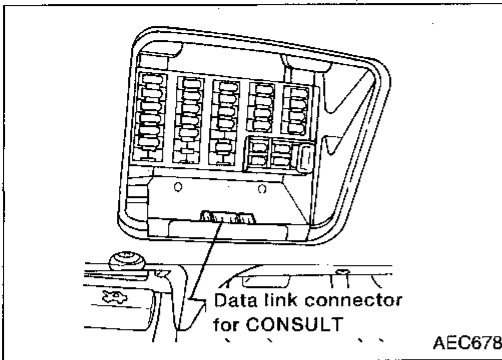

CONSULT

CONSULT INSPECTION PROCEDURE

1. Turn ignition switch OFF.
2. Connect "CONSULT" to data link connector for CONSULT. (Data link connector for CONSULT is located behind the fuse box cover.)

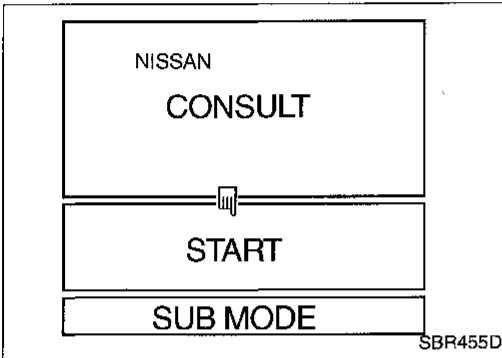

3. Turn ignition switch ON.
4. Touch "START".

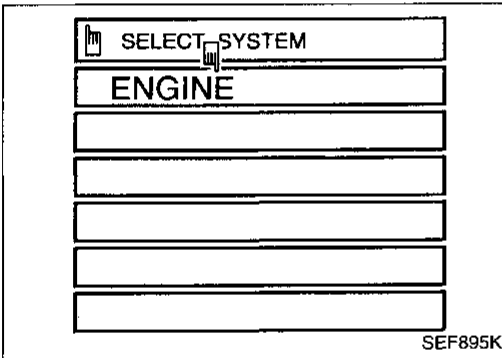

5. Touch "ENGINE".

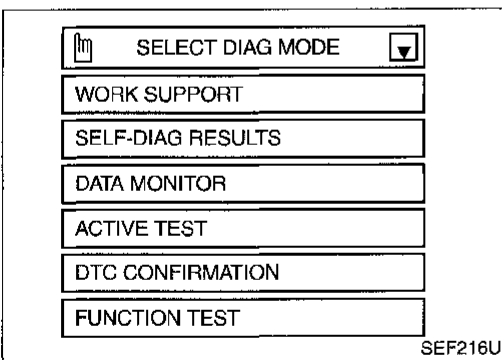

6. Perform each diagnostic test mode according to each service procedure.

For further information, see the CONSULT Operation Manual.

This sample shows the display when using the UE990 program card. Screen differs in accordance with the program card used.

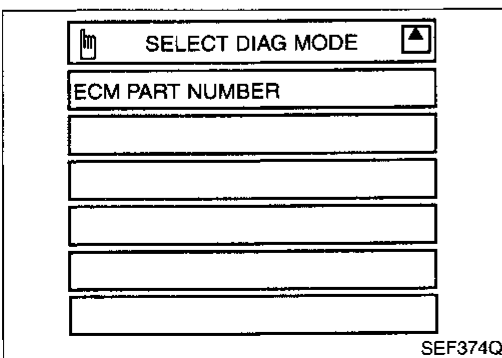

ON BOARD DIAGNOSTIC SYSTEM DESCRIPTION

CONSULT (Cont'd)

ENGINE CONTROL COMPONENT PARTS/CONTROL SYSTEMS APPLICATION

Item		DIAGNOSTIC TEST MODE							
		WORK SUP-PORT	SELF-DIAGNOSTIC RESULTS*1		DATA MONITOR	ACTIVE TEST	FUNCTION TEST	DTC CONFIRMATION	
				FREEZE FRAME DATA*2				SRT STATUS	DTC WORK SUP-PORT
ENGINE CONTROL COMPONENT PARTS	INPUT	Camshaft position sensor		X	X	X			
		Mass air flow sensor		X		X			
		Engine coolant temperature sensor		X	X	X	X		
		Front heated oxygen sensor		X		X		X	X
		Rear heated oxygen sensor		X		X		X	X
		Vehicle speed sensor		X	X	X		X	
		Throttle position sensor	X	X		X		X	
		Tank fuel temperature sensor		X		X	X		
		EVAP control system pressure sensor		X		X			
		Absolute pressure sensor		X	X	X			
		EGR temperature sensor		X		X			
		Intake air temperature sensor		X		X			
		Crankshaft position sensor (OBD)		X					
		Knock sensor		X					
		Ignition switch (start signal)				X		X	
		Closed throttle position switch		X		X			
		Closed throttle position switch (throttle position sensor signal)				X		X	
		Air conditioner switch				X			
	Park/neutral position (PNP) switch		X		X		X		
	Power steering oil pressure switch				X		X		
	Battery voltage				X				
	OUTPUT	Injectors				X	X	X	
		Power transistor (Ignition timing)	X	X (Ignition signal)		X	X	X	
		IACV-AAC valve	X	X		X	X	X	
		EVAP canister purge control solenoid valve		X		X	X		X
		EVAP canister purge volume control valve		X		X	X		X
		Air conditioner relay				X			
		Fuel pump relay	X			X	X	X	
		EGRC-solenoid valve		X		X	X	X*3	
		Front heated oxygen sensor heater		X		X			X
		Rear heated oxygen sensor heater		X		X			X
		Cooling fan		X		X	X	X	
EVAP canister vent control valve			X		X	X			
Vacuum cut valve bypass valve			X		X	X		X	
MAP/BARO switch solenoid valve			X		X	X			
Calculated load value			X	X					
Fuel pump control module		X		X	X				

X: Applicable

*1: This item includes 1st trip DTCs.

*2: This mode includes 1st trip freeze frame data or freeze frame data. The items appear on CONSULT screen in freeze frame data mode only if a 1st trip DTC or DTC is detected. For details, refer to EC-44.

*3: If this function test mode is not available, use the "ACTIVE TEST" mode.

ON BOARD DIAGNOSTIC SYSTEM DESCRIPTION

CONSULT (Cont'd)

FUNCTION

Diagnostic test mode	Function
Work support	This mode enables a technician to adjust some devices faster and more accurately by following the indications on the CONSULT unit.
Self-diagnostic results	Self-diagnostic results such as 1st trip DTC, DTCs and 1st trip freeze frame data or freeze frame data can be read and erased quickly.*1
Data monitor	Input/Output data in the ECM can be read.
Active test	Diagnostic Test Mode in which CONSULT drives some actuators apart from the ECMs and also shifts some parameters in a specified range.
DTC confirmation	The status of system monitoring tests and the self-diagnosis status/result can be confirmed.
Function test	Conducted by CONSULT instead of a technician to determine whether each system is "OK" or "NG".
ECM part numbers	ECM part numbers can be read.

- *1 The following emission-related diagnostic information is cleared when the ECM memory is erased.
1. Diagnostic trouble codes
 2. 1st trip diagnostic trouble codes
 3. Freeze frame data
 4. 1st trip freeze frame data
 5. System readiness test (SRT) codes
 6. Test values
 7. Others

WORK SUPPORT MODE

WORK ITEM	CONDITION	USAGE
THRTL POS SEN ADJ	CHECK THE THROTTLE POSITION SENSOR SIGNAL. ADJUST IT TO THE SPECIFIED VALUE BY ROTATING THE SENSOR BODY UNDER THE FOLLOWING CONDITIONS. <ul style="list-style-type: none"> ● IGN SW "ON" ● ENG NOT RUNNING ● ACC PEDAL NOT PRESSED 	When adjusting throttle position sensor initial position
IGNITION TIMING ADJ	<ul style="list-style-type: none"> ● IGNITION TIMING FEEDBACK CONTROL WILL BE HELD BY TOUCHING "START". AFTER DOING SO, ADJUST IGNITION TIMING WITH A TIMING LIGHT BY TURNING THE CRANK-SHAFT POSITION SENSOR. 	When adjusting initial ignition timing
IACV-AAC VALVE ADJ	SET ENGINE SPEED AT THE SPECIFIED VALUE UNDER THE FOLLOWING CONDITIONS. <ul style="list-style-type: none"> ● ENGINE WARMED UP ● NO-LOAD 	When adjusting idle speed
FUEL PRESSURE RELEASE	<ul style="list-style-type: none"> ● FUEL PUMP WILL STOP BY TOUCHING "START" DURING IDLING. CRANK A FEW TIMES AFTER ENGINE STALLS. 	When releasing fuel pressure from fuel line
EVAP SYSTEM CLOSE	<p>OPEN THE VACUUM CUT VALVE BYPASS VALVE AND CLOSE THE EVAP CANISTER VENT CONTROL VALVE IN ORDER TO MAKE EVAP SYSTEM CLOSE UNDER THE FOLLOWING CONDITIONS.</p> <ul style="list-style-type: none"> ● BATTERY VOLTAGE IS SUFFICIENT. ● IGN SW "ON" ● ENGINE NOT RUNNING ● AMBIENT TEMPERATURE IS ABOVE 0°C (32°F). ● NO VACUUM AND NO HIGH PRESSURE IN EVAP SYSTEM ● TANK FUEL TEMP. IS MORE THAN 0°C (32°F). ● WITHIN 10 MINUTES AFTER STARTING "EVAP SYSTEM CLOSE" <p>WHEN TRYING TO EXECUTE "EVAP SYSTEM CLOSE" UNDER THE CONDITIONS ABOVE, CONSULT WILL DISCONTINUE AND DISPLAY INSTRUCTIONS.</p> <p>NOTE: WHEN STARTING ENGINE, CONSULT MAY DISPLAY "BATTERY VOLTAGE IS LOW. CHARGE BATTERY", EVEN WHEN USING A CHARGED BATTERY.</p>	When detecting EVAP vapor leak point of EVAP system

ON BOARD DIAGNOSTIC SYSTEM DESCRIPTION

CONSULT (Cont'd)

SELF-DIAGNOSTIC MODE

DTC and 1st trip DTC

Regarding items of "DTC and 1st trip DTC", refer to "DIAGNOSTIC TROUBLE CODE INDEX" (See EC-2.).

Freeze frame data and 1st trip freeze frame data

Freeze frame data item*	Description
DIAG TROUBLE CODE [PXXXX]	<ul style="list-style-type: none"> When engine control component part/control system has a trouble code, it is displayed as "PXXXX". [Refer to "Alphabetical & P No. Index for DTC" (EC-2).]
FUEL SYS DATA	<ul style="list-style-type: none"> "Fuel injection system status" is displayed at the moment a malfunction is detected. One of the following modes is displayed. <ul style="list-style-type: none"> "MODE 2": Open loop due to detected system malfunction "MODE 3": Open loop due to driving conditions (power enrichment, deceleration enrichment) "MODE 4": Closed loop - using oxygen sensor(s) as feedback for fuel control "MODE 5": Open loop - has not yet satisfied condition to go to closed loop
CAL/LD VALUE [%]	<ul style="list-style-type: none"> "Calculated load value" is displayed at the moment a malfunction is detected.
COOLANT TEMP [°C] or [°F]	<ul style="list-style-type: none"> "Engine coolant temperature" is displayed at the moment a malfunction is detected.
S-FUEL TRIM [%]	<ul style="list-style-type: none"> "Short-term fuel trim" is displayed at the moment a malfunction is detected. The short-term fuel trim indicates dynamic or instantaneous feedback compensation to the base fuel schedule.
L-FUEL TRIM [%]	<ul style="list-style-type: none"> "Long-term fuel trim" is displayed at the moment a malfunction is detected. The long-term fuel trim indicates much more gradual feedback compensation to the base fuel schedule than short-term fuel trim.
ENGINE SPEED [rpm]	<ul style="list-style-type: none"> "Engine speed" is displayed at the moment a malfunction is detected.
VHCL SPEED [km/h] or [mph]	<ul style="list-style-type: none"> "Vehicle speed" is displayed at the moment a malfunction is detected.
ABSOL PRESS [kPa] or [kg/cm ²] or [psi]	<ul style="list-style-type: none"> "Absolute pressure" is displayed at the moment a malfunction is detected.

*: The items are the same as those of 1st trip freeze frame data.

ON BOARD DIAGNOSTIC SYSTEM DESCRIPTION

CONSULT (Cont'd)

DATA MONITOR MODE

Monitored item [Unit]	ECM input signals	Main signals	Description	Remarks
CMPS-RPM (REF) [rpm]	<input type="radio"/>	<input type="radio"/>	<ul style="list-style-type: none"> Indicates the engine speed computed from the REF signal (180° signal) of the camshaft position sensor. 	<ul style="list-style-type: none"> Accuracy becomes poor if engine speed drops below the idle rpm. If the signal is interrupted while the engine is running, an abnormal value may be indicated.
MAS AIR/FL SE [V]	<input type="radio"/>	<input type="radio"/>	<ul style="list-style-type: none"> The signal voltage of the mass air flow sensor is displayed. 	<ul style="list-style-type: none"> When the engine is stopped, a certain value is indicated.
COOLAN TEMP/S [°C] or [°F]	<input type="radio"/>	<input type="radio"/>	<ul style="list-style-type: none"> The engine coolant temperature (determined by the signal voltage of the engine coolant temperature sensor) is displayed. 	<ul style="list-style-type: none"> When the engine coolant temperature sensor is open or short-circuited, ECM enters fail-safe mode. The engine coolant temperature determined by the ECM is displayed.
FR O2 SENSOR [V]	<input type="radio"/>	<input type="radio"/>	<ul style="list-style-type: none"> The signal voltage of the front heated oxygen sensor is displayed. 	
RR O2 SENSOR [V]	<input type="radio"/>	<input type="radio"/>	<ul style="list-style-type: none"> The signal voltage of the rear heated oxygen sensor is displayed. 	
FR O2 MNTR [RICH/LEAN]	<input type="radio"/>	<input type="radio"/>	<ul style="list-style-type: none"> Display of front heated oxygen sensor signal during air-fuel ratio feedback control: RICH ... means the mixture became "rich", and control is being affected toward a leaner mixture. LEAN ... means the mixture became "lean", and control is being affected toward a rich mixture. 	<ul style="list-style-type: none"> After turning ON the ignition switch, "RICH" is displayed until air-fuel mixture ratio feedback control begins. When the air-fuel ratio feedback is clamped, the value just before the clamping is displayed continuously.
RR O2 MNTR [RICH/LEAN]	<input type="radio"/>		<ul style="list-style-type: none"> Display of rear heated oxygen sensor signal: RICH ... means the amount of oxygen after three way catalyst is relatively small. LEAN ... means the amount of oxygen after three way catalyst is relatively large. 	<ul style="list-style-type: none"> When the engine is stopped, a certain value is indicated.
VHCL SPEED SE [km/h] or [mph]	<input type="radio"/>	<input type="radio"/>	<ul style="list-style-type: none"> The vehicle speed computed from the vehicle speed sensor signal is displayed. 	
BATTERY VOLT [V]	<input type="radio"/>	<input type="radio"/>	<ul style="list-style-type: none"> The power supply voltage of ECM is displayed. 	
THRTL POS SEN [V]	<input type="radio"/>	<input type="radio"/>	<ul style="list-style-type: none"> The throttle position sensor signal voltage is displayed. 	
TANK F/TMP SE [°C] or [°F]	<input type="radio"/>		<ul style="list-style-type: none"> The fuel temperature judged from the tank fuel temperature sensor signal voltage is displayed. 	
EGR TEMP SEN [V]	<input type="radio"/>		<ul style="list-style-type: none"> The signal voltage of the EGR temperature sensor is displayed. 	
INT/A TEMP SE [°C] or [°F]	<input type="radio"/>		<ul style="list-style-type: none"> The intake air temperature determined by the signal voltage of the intake air temperature sensor is indicated. 	
START SIGNAL [ON/OFF]	<input type="radio"/>	<input type="radio"/>	<ul style="list-style-type: none"> Indicates [ON/OFF] condition from the starter signal. 	<ul style="list-style-type: none"> After starting the engine, [OFF] is displayed regardless of the starter signal.

NOTE:

Any monitored item that does not match the vehicle being diagnosed is deleted from the display automatically.

ON BOARD DIAGNOSTIC SYSTEM DESCRIPTION

CONSULT (Cont'd)

Monitored item [Unit]	ECM input signals	Main signals	Description	Remarks	
CLSD THL/P SW [ON/OFF]			<ul style="list-style-type: none"> Indicates mechanical contact [ON/OFF] condition of the closed throttle position sensor. 		GI
CLSD THL POS [ON/OFF]	○	○	<ul style="list-style-type: none"> Indicates idle position [ON/OFF] computed by ECM according to the throttle position sensor signal. 		MA EM
AIR COND SIG [ON/OFF]	○	○	<ul style="list-style-type: none"> Indicates [ON/OFF] condition of the air conditioner switch as determined by the air conditioning signal. 		LC
PNP SW/CIRC [ON/OFF]	○	○	<ul style="list-style-type: none"> Indicates [ON/OFF] condition from the park/neutral position (PNP) switch signal. 		EC
PW/ST SIGNAL [ON/OFF]	○	○	<ul style="list-style-type: none"> Indicates [ON/OFF] condition of the power steering oil pressure switch determined by the power steering oil pressure switch signal. 		FE
IGNITION SW [ON/OFF]	○		<ul style="list-style-type: none"> Indicates [ON/OFF] condition from ignition switch. 		CL
INJ PULSE [msec]		○	<ul style="list-style-type: none"> Indicates the actual fuel injection pulse width compensated by ECM according to the input signals. 	<ul style="list-style-type: none"> When the engine is stopped, a certain computed value is indicated. 	MT
B/FUEL SCHDL [msec]		○	<ul style="list-style-type: none"> "Base fuel schedule" indicates the fuel injection pulse width programmed into ECM, prior to any learned on board correction. 		AT
IGN TIMING [BTDC]		○	<ul style="list-style-type: none"> Indicates the ignition timing computed by ECM according to the input signals. 		FA
IACV-AAC/V [%]		○	<ul style="list-style-type: none"> Indicates the IACV-AAC valve control value computed by ECM according to the input signals. 		RA
PURG VOL C/V [step]			<ul style="list-style-type: none"> Indicates the EVAP canister purge volume control valve control value computed by the ECM according to the input signals. The opening becomes larger as the value increases. 		BR ST
A/F ALPHA [%]		○	<ul style="list-style-type: none"> Indicates the mean value of the air-fuel ratio feedback correction factor per cycle. 	<ul style="list-style-type: none"> When the engine is stopped, a certain value is indicated. This data also includes the data for the air-fuel ratio learning control. 	RS BT
EVAP SYS PRES [V]			<ul style="list-style-type: none"> The signal voltage of EVAP control system pressure sensor is displayed. 		HA
AIR COND RLY [ON/OFF]			<ul style="list-style-type: none"> Indicates the air conditioner relay control condition (determined by ECM according to the input signal). 		EL
FUEL PUMP RLY [ON/OFF]			<ul style="list-style-type: none"> Indicates the fuel pump relay control condition determined by ECM according to the input signals. 		IDX

ON BOARD DIAGNOSTIC SYSTEM DESCRIPTION

CONSULT (Cont'd)

Monitored item [Unit]	ECM input signals	Main signals	Description	Remarks
COOLING FAN [HI/LOW/OFF]			<ul style="list-style-type: none"> Indicates the control condition of the cooling fan (determined by ECM according to the input signal). HI ... High speed operation LOW ... Low speed operation OFF ... Stop 	
EGRC SOL/V [ON/OFF] (FLOW/CUT)			<ul style="list-style-type: none"> Indicates the control condition of the EGRC-solenoid valve (determined by ECM according to the input signal). ON ... EGR valve is operational OFF ... EGR valve operation is cut off 	
VENT CONT/V [ON/OFF]			<ul style="list-style-type: none"> The control condition of the EVAP canister vent control valve (determined by ECM according to the input signal) is indicated. ON ... Closed OFF ... Open 	
FR O2 HEATER [ON/OFF]			<ul style="list-style-type: none"> Indicates [ON/OFF] condition of front heated oxygen sensor heater determined by ECM according to the input signals. 	
RR O2 HEATER [ON/OFF]			<ul style="list-style-type: none"> Indicates [ON/OFF] condition of rear heated oxygen sensor heater determined by ECM according to the input signals. 	
VC/V BYPASS/V [ON/OFF]			<ul style="list-style-type: none"> The control condition of the vacuum cut valve bypass valve (determined by ECM according to the input signal) is indicated. ON ... Open OFF ... Closed 	
PURG CONT S/V [ON/OFF]			<ul style="list-style-type: none"> The control condition of the EVAP canister purge control solenoid valve (computed by the ECM according to the input signals) is indicated. ON ... Canister purge is operational OFF ... Canister purge operation is cut off 	
CAL/LD VALUE [%]			<ul style="list-style-type: none"> "Calculated load value" indicates the value of the current airflow divided by peak airflow. 	
ABSOL TH-P/S [%]			<ul style="list-style-type: none"> "Absolute throttle position sensor" indicates the throttle opening computed by ECM according to the signal voltage of the throttle position sensor. 	
MASS AIRFLOW [gm/s]			<ul style="list-style-type: none"> Indicates the mass airflow computed by ECM according to the signal voltage of the mass air flow sensor. 	
MAP/BARO SW/V [MAP/BARO]			<ul style="list-style-type: none"> The control condition of the MAP/BARO switch solenoid valve (determined by ECM according to the input signal) is indicated. MAP ... Intake manifold absolute pressure BARO ... Ambient barometric pressure 	

ON BOARD DIAGNOSTIC SYSTEM DESCRIPTION

CONSULT (Cont'd)

Monitored item [Unit]	ECM input signals	Main signals	Description	Remarks
ABSOL PRES/SE [V]			<ul style="list-style-type: none"> The signal voltage of the absolute pressure sensor is displayed. 	
FPCM [LOW/HI]			<ul style="list-style-type: none"> The control condition of the fuel pump control module (FPCM) (determined by ECM according to the input signal) is indicated. LOW ... Low amount of fuel flow HI ... High amount of fuel flow 	
FPCM DR VOLT [V]			<ul style="list-style-type: none"> The voltage between fuel pump and FPCM is displayed. 	
VOLTAGE [V]			<ul style="list-style-type: none"> Voltage measured by the voltage probe. 	
PULSE [msec] or [Hz] or [%]			<ul style="list-style-type: none"> Pulse width, frequency or duty cycle measured by the pulse probe. 	<ul style="list-style-type: none"> Only “#” is displayed if item is unable to be measured. Figures with “#”s are temporary ones. They are the same figures as an actual piece of data which was just previously measured.

GI

MA

EM

LC

EC

FE

CL

MT

AT

FA

RA

BR

ST

RS

BT

HA

EL

IDX

ON BOARD DIAGNOSTIC SYSTEM DESCRIPTION

CONSULT (Cont'd)

ACTIVE TEST MODE

TEST ITEM	CONDITION	JUDGEMENT	CHECK ITEM (REMEDY)
FUEL INJECTION	<ul style="list-style-type: none"> ● Engine: Return to the original trouble condition ● Change the amount of fuel injection using CONSULT. 	If trouble symptom disappears, see CHECK ITEM.	<ul style="list-style-type: none"> ● Harness and connector ● Fuel injectors ● Front heated oxygen sensor
IACV-AAC/V OPENING	<ul style="list-style-type: none"> ● Engine: After warming up, idle the engine. ● Change the IACV-AAC valve opening percent using CONSULT. 	Engine speed changes according to the opening percent.	<ul style="list-style-type: none"> ● Harness and connector ● IACV-AAC valve
ENG COOLANT TEMP	<ul style="list-style-type: none"> ● Engine: Return to the original trouble condition ● Change the engine coolant temperature indication using CONSULT. 	If trouble symptom disappears, see CHECK ITEM.	<ul style="list-style-type: none"> ● Harness and connector ● Engine coolant temperature sensor ● Fuel injectors
IGNITION TIMING	<ul style="list-style-type: none"> ● Engine: Return to the original trouble condition ● Timing light: Set ● Retard the ignition timing using CONSULT. 	If trouble symptom disappears, see CHECK ITEM.	<ul style="list-style-type: none"> ● Adjust initial ignition timing
POWER BALANCE	<ul style="list-style-type: none"> ● Engine: After warming up, idle the engine. ● Air conditioner switch "OFF" ● Shift lever "N" ● Cut off each injector signal one at a time using CONSULT. 	Engine runs rough or dies.	<ul style="list-style-type: none"> ● Harness and connector ● Compression ● Injectors ● Power transistor ● Spark plugs ● Ignition coils
COOLING FAN	<ul style="list-style-type: none"> ● Ignition switch: ON ● Turn the cooling fan "ON" and "OFF" using CONSULT. 	Cooling fan moves and stops.	<ul style="list-style-type: none"> ● Harness and connector ● Cooling fan motor
FUEL PUMP RELAY	<ul style="list-style-type: none"> ● Ignition switch: ON (Engine stopped) ● Turn the fuel pump relay "ON" and "OFF" using CONSULT and listen to operating sound. 	Fuel pump relay makes the operating sound.	<ul style="list-style-type: none"> ● Harness and connector ● Fuel pump relay
EGRC SOLENOID VALVE	<ul style="list-style-type: none"> ● Ignition switch: ON ● Turn EGRC-solenoid valve "ON" and "OFF" using CONSULT and listen to operating sound. 	EGRC-solenoid valve makes an operating sound.	<ul style="list-style-type: none"> ● Harness and connector ● EGRC-solenoid valve
SELF-LEARNING CONT	<ul style="list-style-type: none"> ● In this test, the coefficient of self-learning control mixture ratio returns to the original coefficient by touching "CLEAR" on the screen. 		
FPCM	<ul style="list-style-type: none"> ● Ignition switch: ON ● Select "LOW" and "HI" with CONSULT and check that "FPCM DR VOLT" of CONSULT changes. 	"FPCM DR VOLT" of CONSULT changes as follows; LOW ... Approx. 5.0 V HI ... Approx. 0.4 V	<ul style="list-style-type: none"> ● Harness and connector ● FPCM
PURG VOL CONT/V	<ul style="list-style-type: none"> ● Engine: After warming up, run engine at 1,500 rpm. ● Change the EVAP canister purge volume control valve opening step using CONSULT. 	Engine speed changes according to the opening step.	<ul style="list-style-type: none"> ● Harness and connector ● EVAP canister purge volume control valve

ON BOARD DIAGNOSTIC SYSTEM DESCRIPTION

CONSULT (Cont'd)

TEST ITEM	CONDITION	JUDGEMENT	CHECK ITEM (REMEDY)
VENT CONTROL/V	<ul style="list-style-type: none"> ● Ignition switch: ON (Engine stopped) ● Turn solenoid valve "ON" and "OFF" using CONSULT and listen to operating sound. 	Solenoid valve makes an operating sound.	<ul style="list-style-type: none"> ● Harness and connector ● Solenoid valve
VC/V BYPASS/V	<ul style="list-style-type: none"> ● Ignition switch: ON (Engine stopped) ● Turn solenoid valve "ON" and "OFF" using CONSULT and listen to operating sound. 	Solenoid valve makes an operating sound.	<ul style="list-style-type: none"> ● Harness and connector ● Solenoid valve
PURG CONT S/V	<ul style="list-style-type: none"> ● Start engine. ● Turn the EVAP canister purge control solenoid valve "ON" and "OFF" using CONSULT and listen for operating sound. 	EVAP canister purge control solenoid valve makes an operating sound. Check vacuum signal for EVAP canister purge control valve. VC ON ... Vacuum exists. VC OFF ... Vacuum does not exist.	<ul style="list-style-type: none"> ● Harness and connector ● EVAP canister purge control solenoid valve ● Vacuum hose
MAP/BARO SW/V	<ul style="list-style-type: none"> ● Ignition switch: ON (Engine stopped) ● Turn the MAP/BARO switch solenoid valve between "MAP" and "BARO" using CONSULT and listen for operating sound. 	MAP/BARO switch solenoid valve makes an operating sound.	<ul style="list-style-type: none"> ● Harness and connector ● MAP/BARO switch solenoid valve
TANK F/TEMP SEN	<ul style="list-style-type: none"> ● Change the tank fuel temperature using CONSULT. 		

DTC CONFIRMATION MODE

SRT STATUS mode

For details, refer to "SYSTEM READINESS TEST (SRT) CODE", EC-44.

DTC WORK SUPPORT MODE

TEST MODE	TEST ITEM	CONDITION	REFERENCE PAGE
EVAPORATIVE SYSTEM	PURGE FLOW P1447	Refer to corresponding trouble diagnosis for DTC.	EC-406
	VC CUT/V BP/V P1491		EC-426
	PURG CN/V & S/V P1493		EC-438
	PURG VOL CN/V P1444		EC-393
	EVAP SML LEAK P0440		EC-285
	EVAP SML LEAK P1440		EC-381
FR O2 SENSOR	FR O2 SENSOR P0130		EC-163
	FR O2 SENSOR P0131		EC-169
	FR O2 SENSOR P0132		EC-175
	FR O2 SENSOR P0133		EC-181
RR O2 SENSOR	RR O2 SENSOR P0137		EC-199
	RR O2 SENSOR P0138		EC-206
	RR O2 SENSOR P0139		EC-213
EGR SYSTEM	EGR SYSTEM P0400	EC-267	
	EGRC-BPT/VLV P0402	EC-276	
	EGR SYSTEM P1402	EC-374	

ON BOARD DIAGNOSTIC SYSTEM DESCRIPTION

CONSULT (Cont'd)

FUNCTION TEST MODE

FUNCTION TEST ITEM	CONDITION	JUDGEMENT		CHECK ITEM (REMEDY)
SELF-DIAG RESULTS	<ul style="list-style-type: none"> ● Ignition switch: ON (Engine stopped) ● Displays the results of on board diagnostic system. 	—		Objective system
CLOSED THROTTLE POSI	<ul style="list-style-type: none"> ● Ignition switch: ON (Engine stopped) ● Closed throttle position sensor circuit is tested when throttle is opened and closed fully. ("IDLE POSITION" is the test item name for the vehicles in which idle is selected by throttle position sensor.) 	Throttle valve: opened	OFF	<ul style="list-style-type: none"> ● Harness and connector ● Throttle position sensor (Closed throttle position) ● Throttle position sensor (Closed throttle position) adjustment ● Throttle linkage ● Verify operation in DATA MONITOR mode.
		Throttle valve: closed	ON	
THROTTLE POSI SEN CKT	<ul style="list-style-type: none"> ● Ignition switch: ON (Engine stopped) ● Throttle position sensor circuit is tested when throttle is opened and closed fully. 	Range (Throttle valve fully opened — Throttle valve fully closed)	More than 3.0V	<ul style="list-style-type: none"> ● Harness and connector ● Throttle position sensor ● Throttle position sensor adjustment ● Throttle linkage ● Verify operation in DATA MONITOR mode.
PNP SW/CIRC	<ul style="list-style-type: none"> ● Ignition switch: ON (Engine stopped) ● Park/neutral position (PNP) switch circuit is tested when shift lever is manipulated. 	Out of "N" or "P" positions	OFF	<ul style="list-style-type: none"> ● Harness and connector ● Park/neutral position (PNP) switch ● Linkage or park/neutral position (PNP) switch adjustment
		In "N" or "P" positions	ON	
FUEL PUMP CIRCUIT	<ul style="list-style-type: none"> ● Ignition switch: ON (Engine stopped) ● Fuel pump circuit is tested by checking the pulsation in fuel pressure when fuel tube is pinched. 	There is pressure pulsation on the fuel feed hose.		<ul style="list-style-type: none"> ● Harness and connector ● Fuel pump ● Fuel pump relay ● Fuel filter clogging ● Fuel level
EGRC SOL/V CIRCUIT*	<ul style="list-style-type: none"> ● Ignition switch: ON (Engine stopped) ● EGRC-solenoid valve circuit is tested by checking solenoid valve operating noise. 	The EGRC-solenoid valve makes an operating sound every 3 seconds.		<ul style="list-style-type: none"> ● Harness and connector ● EGRC-solenoid valve
COOLING FAN CIRCUIT	<ul style="list-style-type: none"> ● Ignition switch: ON (Engine stopped) ● Cooling fan circuit is tested when cooling fan is rotated. 	The cooling fan rotates and stops every 3 seconds.		<ul style="list-style-type: none"> ● Harness and connector ● Cooling fan motor ● Cooling fan relay

*: If this function test mode is not available, use the "ACTIVE TEST" mode.

ON BOARD DIAGNOSTIC SYSTEM DESCRIPTION

CONSULT (Cont'd)

FUNCTION TEST ITEM	CONDITION	JUDGEMENT		CHECK ITEM (REMEDY)	
START SIGNAL CIRCUIT	<ul style="list-style-type: none"> ● Ignition switch: ON → START ● Start signal circuit is tested when engine is started by operating the starter. Before cranking, battery voltage and engine coolant temperature are displayed. During cranking, average battery voltage, mass air flow sensor output voltage and cranking speed are displayed. 	Start signal: OFF → ON		<ul style="list-style-type: none"> ● Harness and connector ● Ignition switch 	GI
		Locked position	ON		<ul style="list-style-type: none"> ● Harness and connector ● Power steering oil pressure switch ● Power steering oil pump
PW/ST SIGNAL CIRCUIT	<ul style="list-style-type: none"> ● Ignition switch: ON (Engine running) ● Power steering circuit is tested when steering wheel is rotated fully and then set to a straight line running position. 	Neutral position	OFF	<ul style="list-style-type: none"> ● Harness and connector ● Power steering oil pressure switch ● Power steering oil pump 	
VEHICLE SPEED SEN CKT		Vehicle speed sensor input signal is greater than 4 km/h (2 MPH).			<ul style="list-style-type: none"> ● Harness and connector ● Vehicle speed sensor ● Electric speedometer
IGN TIMING ADJ	<ul style="list-style-type: none"> ● After warming up, idle the engine. ● Ignition timing adjustment is checked by reading ignition timing with a timing light and checking whether it agrees with specifications. 	The timing light indicates the same value on the screen.		<ul style="list-style-type: none"> ● Adjust ignition timing (by moving camshaft position sensor or distributor) ● Camshaft position sensor drive mechanism 	
MIXTURE RATIO TEST		<ul style="list-style-type: none"> ● Air-fuel ratio feedback circuit (injection system, ignition system, vacuum system, etc.) is tested by examining the front heated oxygen sensor output at 2,000 rpm under non-loaded state. 	Front heated oxygen sensor COUNT: More than 5 times during 10 seconds		<ul style="list-style-type: none"> ● INJECTION SYS (Injector, fuel pressure regulator, harness or connector) ● IGNITION SYS (Spark plug, power transistor, ignition coil, harness or connector) ● VACUUM SYS (Intake air leaks) ● Front heated oxygen sensor circuit ● Front heated oxygen sensor operation ● Fuel pressure high or low ● Mass air flow sensor
					MT
					AT
					FA
					RA
					BR
					ST
					RS
					BT
					HA

GI
MA
EM
LC
EC
FE
CL
MT
AT
FA
RA
BR
ST
RS
BT
HA
EL
IDX

ON BOARD DIAGNOSTIC SYSTEM DESCRIPTION

CONSULT (Cont'd)

FUNCTION TEST ITEM	CONDITION	JUDGEMENT	CHECK ITEM (REMEDY)
POWER BALANCE	<ul style="list-style-type: none"> ● After warming up, idle the engine. ● Injector operation of each cylinder is stopped one after another, and resultant change in engine rotation is examined to evaluate combustion of each cylinder. (This is only displayed for models where a sequential multiport fuel injection system is used.) 	Difference in engine speed is greater than 25 rpm before and after cutting off the injector of each cylinder.	<ul style="list-style-type: none"> ● Injector circuit (Injector, harness or connector) ● Ignition circuit (Spark plug, power transistor, ignition coil, harness or connector) ● Compression ● Valve timing
IACV-AAC/V SYSTEM	<ul style="list-style-type: none"> ● After warming up, idle the engine. ● IACV-AAC valve system is tested by detecting change in engine speed when IACV-AAC valve opening is changed to 0%, 20% and 80%. 	Difference in engine speed is greater than 150 rpm between when valve opening is at 80% and at 20%.	<ul style="list-style-type: none"> ● Harness and connector ● IACV-AAC valve ● Air passage restriction between air inlet and IACV-AAC valve ● IAS (Idle adjusting screw) adjustment

ON BOARD DIAGNOSTIC SYSTEM DESCRIPTION

CONSULT (Cont'd)

REAL TIME DIAGNOSIS IN DATA MONITOR MODE (Recording vehicle data)

CONSULT has two kinds of triggers and they can be selected by touching "SETTING" in "DATA MONITOR" mode.

1. "AUTO TRIG" (Automatic trigger):
 - The malfunction will be identified on the CONSULT screen in real time. In other words, DTC/1st trip DTC and malfunction item will be displayed at the moment the malfunction is detected by ECM.
 - DATA MONITOR can be performed continuously until a malfunction is detected. However, DATA MONITOR cannot continue any longer after the malfunction detection.
2. "MANU TRIG" (Manual trigger):
 - DTC/1st trip DTC and malfunction item will not be displayed automatically on CONSULT screen even though a malfunction is detected by ECM.
 - DATA MONITOR can be performed continuously even though a malfunction is detected.

Use these triggers as follows:

1. "AUTO TRIG"
 - While trying to detect the DTC/1st trip DTC by performing the "DIAGNOSTIC TROUBLE CODE CONFIRMATION PROCEDURE", be sure to select to "DATA MONITOR (AUTO TRIG)" mode. You can confirm the malfunction at the moment it is detected.
 - While narrowing down the possible causes, CONSULT should be set in "DATA MONITOR (AUTO TRIG)" mode, especially in case the incident is intermittent.

When you are inspecting the circuit by gently shaking (or twisting) the suspicious connectors, components and harness in the "DIAGNOSTIC TROUBLE CODE CONFIRMATION PROCEDURE", the moment a malfunction is found the DTC/1st trip DTC will be displayed. (Refer to GI section, "Incident Simulation Tests" in "HOW TO PERFORM EFFICIENT DIAGNOSIS FOR AN ELECTRICAL INCIDENT".)
2. "MANU TRIG"
 - If the malfunction is displayed as soon as "DATA MONITOR" is selected, reset CONSULT to "MANU TRIG". By selecting "MANU TRIG" you can monitor and store the data. The data can be utilized for further diagnosis, such as a comparison with the value for the normal operating condition.

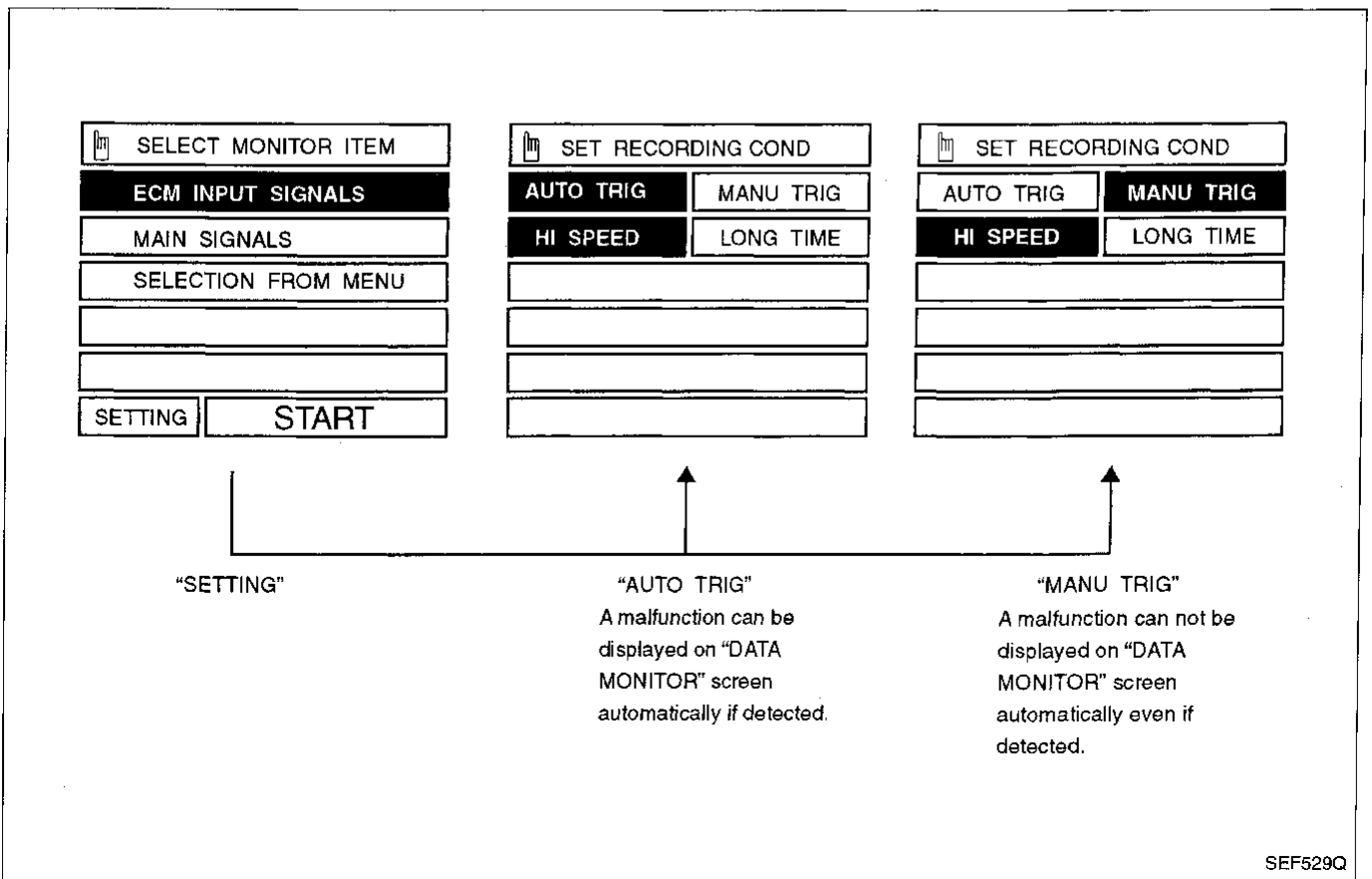

SEF529Q

ON BOARD DIAGNOSTIC SYSTEM DESCRIPTION

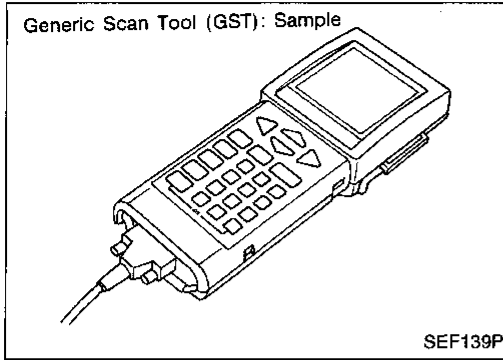

Generic Scan Tool (GST)

DESCRIPTION

Generic Scan Tool (OBDII scan tool) complying with SAE J1978 has 7 different functions explained on the next page. ISO9141 is used as the protocol. The name "GST" or "Generic Scan Tool" is used in this service manual.

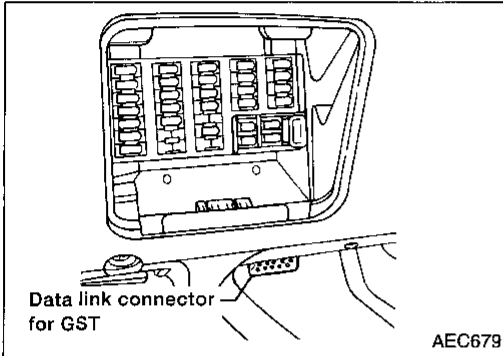

GST INSPECTION PROCEDURE

1. Turn ignition switch OFF.
2. Connect "GST" to data link connector for GST. (Data link connector for GST is located under LH dash panel near the fuse box cover.)

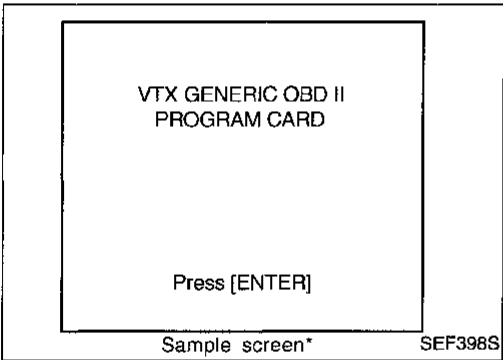

3. Turn ignition switch ON.
4. Enter the program according to instruction on the screen or in the operation manual.

(*: Regarding GST screens in this section, sample screens are shown.)

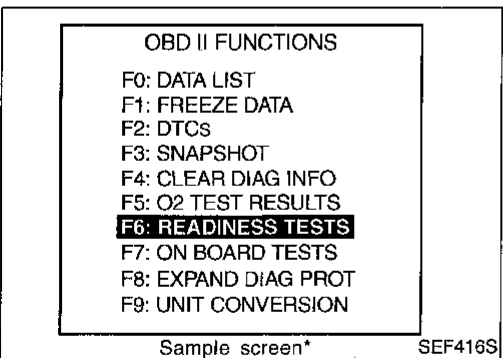

5. Perform each diagnostic mode according to each service procedure.

For further information, see the GST Operation Manual of the tool maker.

ON BOARD DIAGNOSTIC SYSTEM DESCRIPTION

Generic Scan Tool (GST) (Cont'd)

FUNCTION

Diagnostic test mode		Function	
MODE 1	READINESS TESTS	This mode gains access to current emission-related data values, including analog inputs and outputs, digital inputs and outputs, and system status information.	GI
MODE 2	(FREEZE DATA)	This mode gains access to emission-related data value which were stored by ECM during the freeze frame. [For details, refer to "Freeze Frame Data" (EC-65).]	MA
MODE 3	DTCs	This mode gains access to emission-related power train trouble codes which were stored by ECM.	EM
MODE 4	CLEAR DIAG INFO	This mode can clear all emission-related diagnostic information. This includes: <ul style="list-style-type: none"> ● Clear number of diagnostic trouble codes (MODE 1) ● Clear diagnostic trouble codes (MODE 3) ● Clear trouble code for freeze frame data (MODE 1) ● Clear freeze frame data (MODE 2) ● Reset status of system monitoring test (MODE 1) ● Clear on board monitoring test results (MODE 6 and 7) 	LC EC
MODE 6	(ON BOARD TESTS)	This mode accesses the results of on board diagnostic monitoring tests of specific components/systems that are not continuously monitored.	FE
MODE 7	(ON BOARD TESTS)	This mode enables the off board test drive to obtain test results for emission-related powertrain components/systems that are continuously monitored during normal driving conditions.	CL
MODE 8	—	This mode can close EVAP system in ignition switch "ON" position (Engine stopped). When this mode is performed, following parts can be opened or closed. <ul style="list-style-type: none"> ● EVAP canister vent control valve open ● Vacuum cut valve bypass valve closed In the following conditions, this mode cannot function. <ul style="list-style-type: none"> ● Low ambient temperature ● Low battery voltage ● Engine running ● Ignition switch "OFF" ● Low fuel temperature ● Too much pressure applied to EVAP system 	MT AT FA RA

BR

ST

RS

BT

HA

EL

IDX

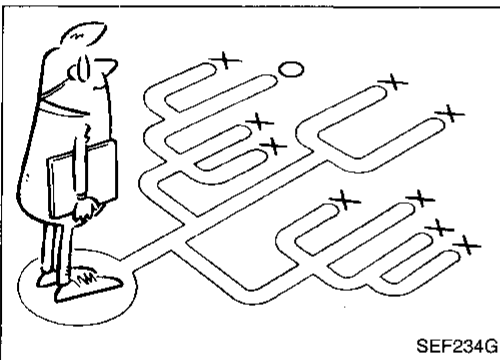
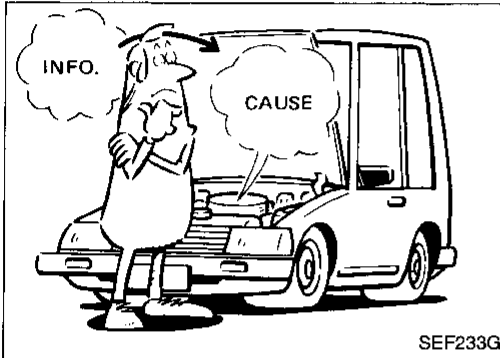
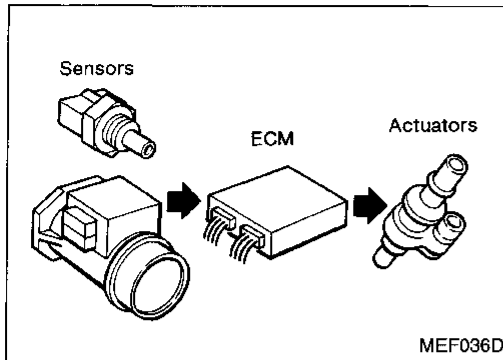

KEY POINTS	
WHAT	Vehicle & engine model
WHEN	Date, Frequencies
WHERE	Road conditions
HOW	Operating conditions, Weather conditions, Symptoms

SEF907L

Introduction

The engine has an ECM to control major systems such as fuel control, ignition control, idle air control system, etc. The ECM accepts input signals from sensors and instantly drives actuators. It is essential that both input and output signals are proper and stable. At the same time, it is important that there are no problems such as vacuum leaks, fouled spark plugs, or other problems with the engine.

It is much more difficult to diagnose a problem that occurs intermittently rather than continuously. Most intermittent problems are caused by poor electric connections or improper wiring. In this case, careful checking of suspected circuits may help prevent the replacement of good parts.

A visual check only may not find the cause of the problems. A road test with CONSULT (or GST) or a circuit tester connected should be performed. Follow the "Work Flow" on EC-80.

Before undertaking actual checks, take a few minutes to talk with a customer who approaches with a driveability complaint. The customer can supply good information about such problems, especially intermittent ones. Find out what symptoms are present and under what conditions they occur. A "Diagnostic Worksheet" like the example on the next page should be used.

Start your diagnosis by looking for "conventional" problems first. This will help troubleshoot driveability problems on an electronically controlled engine vehicle.

Diagnostic Worksheet

There are many operating conditions that lead to the malfunction of engine components. A good grasp of such conditions can make trouble-shooting faster and more accurate.

In general, each customer feels differently about a problem. It is important to fully understand the symptoms or conditions for a customer complaint.

Utilize a diagnostic worksheet like the one on the next page in order to organize all the information for troubleshooting.

Some conditions may cause the malfunction indicator lamp to come on steady or blink and DTC to be detected. Examples:

- Vehicle ran out of fuel, which caused the engine to misfire.
- Fuel filler cap was left off or incorrectly screwed on, allowing fuel to evaporate into the atmosphere [for the models with EVAP (SMALL LEAK) diagnosis].

TROUBLE DIAGNOSIS — Work Flow

Work Flow

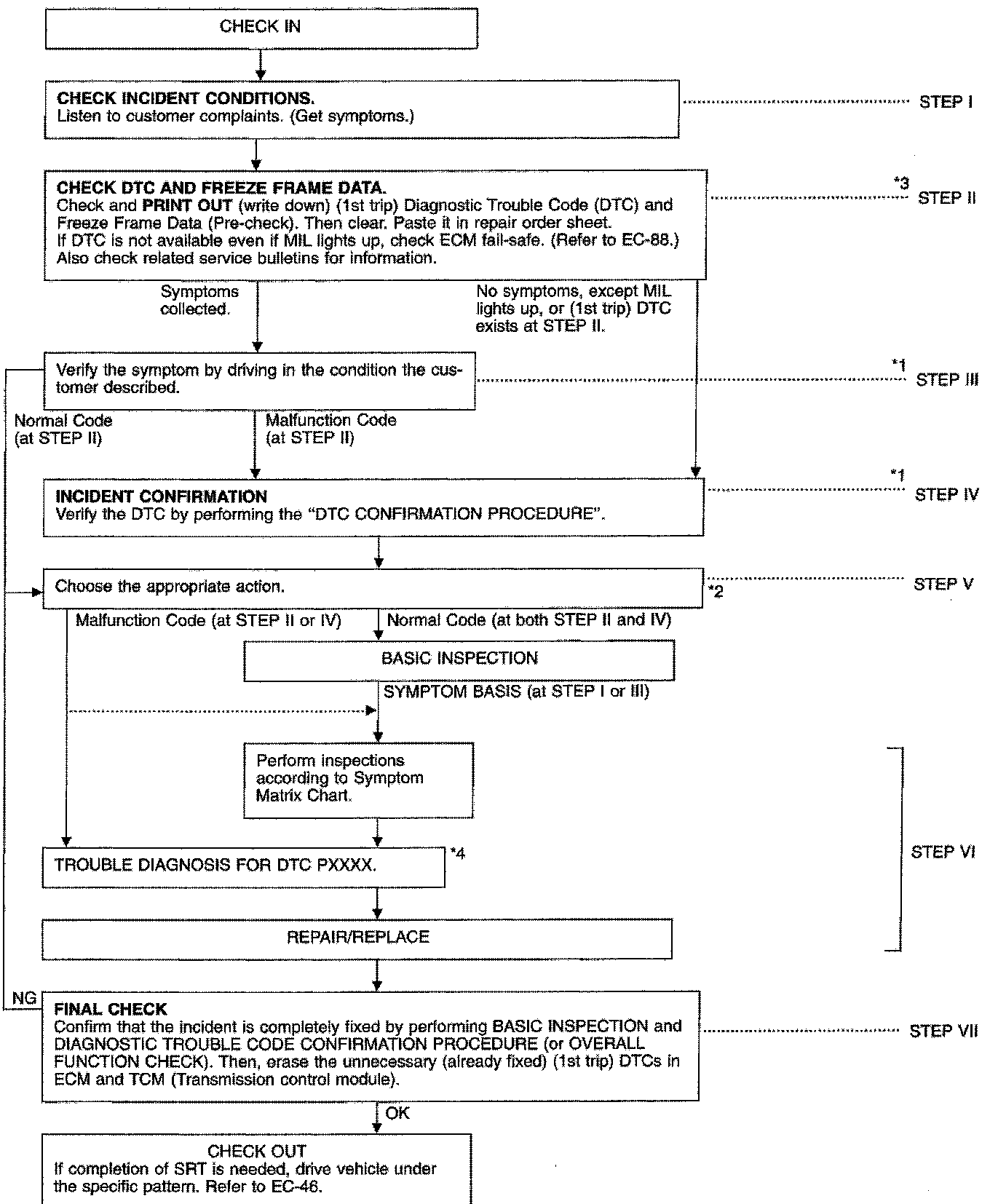

*1: If the incident cannot be duplicated, refer to "TROUBLE DIAGNOSIS FOR INTERMITTENT INCIDENT", EC-106.

*2: If the on board diagnostic system cannot be performed, check main power supply and ground circuit. Refer to "TROUBLE DIAGNOSIS FOR POWER SUPPLY", EC-107.

*3: If time data of "SELF-DIAG RESULTS" is other than "0" or "1t" refer to "TROUBLE DIAGNOSIS FOR INTERMITTENT", EC-106.

*4: If the malfunctioning part cannot be found, refer to "TROUBLE DIAGNOSIS FOR INTERMITTENT INCIDENT", EC-106.

TROUBLE DIAGNOSIS — Work Flow

Description for Work Flow

STEP	DESCRIPTION
STEP I	Get detailed information about the conditions and the environment when the incident/symptom occurred using the "DIAGNOSTIC WORK SHEET", EC-79.
STEP II	Before confirming the concern, check and write down (print out using CONSULT or Generic Scan Tool) the (1st trip) Diagnostic Trouble Code (DTC) and the (1st trip) freeze frame data, then erase the code and the data. (Refer to EC-52.) The (1st trip) DTC and the (1st trip) freeze frame data can be used when duplicating the incident at STEP III & IV. Study the relationship between the cause, specified by (1st trip) DTC, and the symptom described by the customer. (The "Symptom Matrix Chart" will be useful. See EC-89.) Also check related service bulletins for information.
STEP III	Try to confirm the symptom and under what conditions the incident occurs. The "DIAGNOSTIC WORK SHEET" and the freeze frame data are useful to verify the incident. Connect CONSULT to the vehicle in DATA MONITOR (AUTO TRIG) mode and check real time diagnosis results. If the incident cannot be verified, perform INCIDENT SIMULATION TESTS. (Refer to GI section.) If the malfunction code is detected, skip STEP IV and perform STEP V.
STEP IV	Try to detect the (1st trip) Diagnostic Trouble Code by driving in (or performing) the "DIAGNOSTIC TROUBLE CODE CONFIRMATION PROCEDURE". Check and read the (1st trip) DTC and (1st trip) freeze frame data by using CONSULT or Generic Scan Tool. During the (1st trip) DTC verification, be sure to connect CONSULT to the vehicle in DATA MONITOR (AUTO TRIG) mode and check real time diagnosis results. If the incident cannot be verified, perform INCIDENT SIMULATION TESTS. (Refer to GI section.) In case the "DIAGNOSTIC TROUBLE CODE CONFIRMATION PROCEDURE" is not available, perform the "OVERALL FUNCTION CHECK" instead. The (1st trip) DTC cannot be displayed by this check, however, this simplified "check" is an effective alternative. The "NG" result of the "OVERALL FUNCTION CHECK" is the same as the (1st trip) DTC detection.
STEP V	Take the appropriate action based on the results of STEP I through IV. If the malfunction code is indicated, proceed to TROUBLE DIAGNOSIS FOR DTC PXXXX. If the normal code is indicated, proceed to the BASIC INSPECTION. (Refer to EC-82.) Then perform inspections according to the Symptom Matrix Chart. (Refer to EC-89.)
STEP VI	Identify where to begin diagnosis based on the relationship study between symptom and possible causes. Inspect the system for mechanical binding, loose connectors or wiring damage using (tracing) "Harness Layouts". Gently shake the related connectors, components or wiring harness with CONSULT set in "DATA MONITOR (AUTO TRIG)" mode. Check the voltage of the related ECM terminals or monitor the output data from the related sensors with CONSULT. Refer to EC-97. The "DIAGNOSTIC PROCEDURE" in EC section contains a description based on open circuit inspection. A short circuit inspection is also required for the circuit check in the DIAGNOSTIC PROCEDURE. For details, refer to GI section ("HOW TO PERFORM EFFICIENT DIAGNOSIS FOR AN ELECTRICAL INCIDENT", "Circuit Inspection"). Repair or replace the malfunction parts.
STEP VII	Once you have repaired the circuit or replaced a component, you need to run the engine in the same conditions and circumstances which resulted in the customer's initial complaint. Perform the "DIAGNOSTIC TROUBLE CODE CONFIRMATION PROCEDURE" and confirm the normal code [Diagnostic trouble code No. P0000 or 0505] is detected. If the incident is still detected in the final check, perform STEP VI by using a different method from the previous one. Before returning the vehicle to the customer, be sure to erase the unnecessary (already fixed) (1st trip) DTC in ECM. (Refer to EC-52.)

GI

MA

EM

LC

EC

FE

CL

MT

AT

FA

RA

BR

ST

RS

BT

HA

EL

IDX

TROUBLE DIAGNOSIS — Basic Inspection

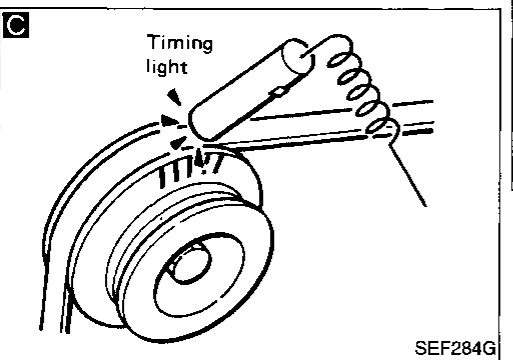
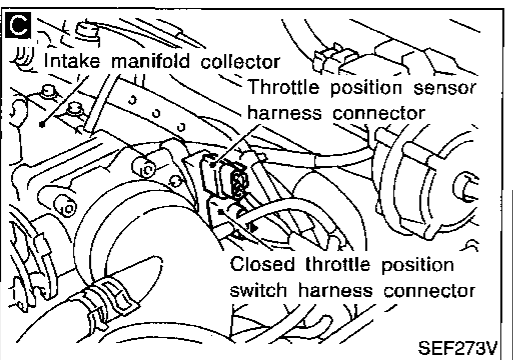
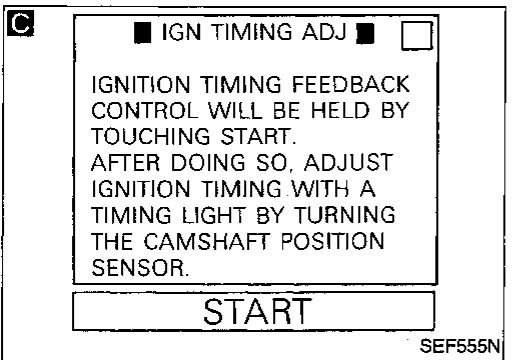
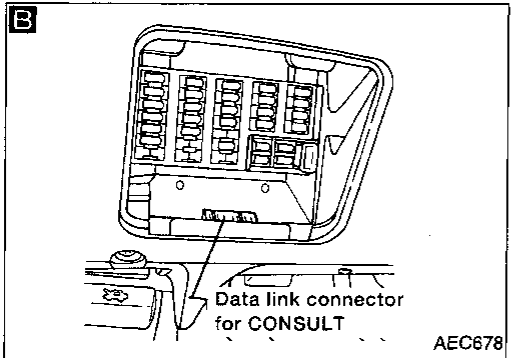
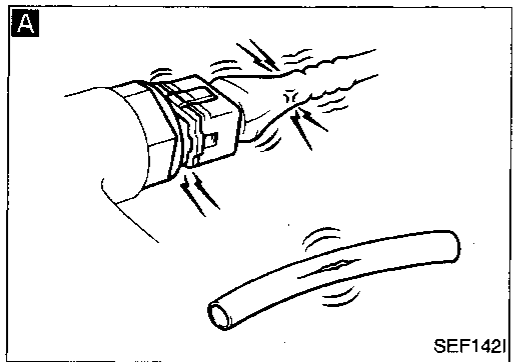

Basic Inspection

Precaution:

Perform Basic Inspection without electrical or mechanical loads applied;

- Headlamp switch is OFF,
- Air conditioner switch is OFF,
- Rear window defogger switch is OFF,
- Steering wheel is in the straight-ahead position, etc.

A

BEFORE STARTING

1. Check service records for any recent repairs that may indicate a related problem, or the current need for scheduled maintenance.
2. Open engine hood and check the following:
 - Harness connectors for improper connections
 - Vacuum hoses for splits, kinks, or improper connections
 - Wiring for improper connections, pinches, or cuts

B

CONNECT CONSULT TO THE VEHICLE.
Connect "CONSULT" to the data link connector for CONSULT and select "ENGINE" from the menu. Refer to EC-62.

C

CHECK IGNITION TIMING.

1. Warm up engine to normal operating temperature.

2. Select "IGN TIMING ADJ" in "WORK SUPPORT" mode.

3. Touch "START".

4. Check ignition timing at idle using timing light.
Ignition timing:
 $15^{\circ} \pm 2^{\circ}$ BTDC

OR

1. Warm up engine to normal operating temperature.

2. Stop engine and disconnect throttle position sensor harness connector.

3. Start engine.

4. Rev engine (2,000 to 3,000 rpm) 2 or 3 times under no-load and then run engine at idle speed.

5. Check ignition timing at idle using timing light.
Ignition timing:
 $15^{\circ} \pm 2^{\circ}$ BTDC

Adjust ignition timing by turning camshaft position sensor.

OK

(Go to next page.)

TROUBLE DIAGNOSIS — Basic Inspection

Basic Inspection (Cont'd)

D IGN TIMING ADJ

IGNITION TIMING FEEDBACK CONTROL WILL BE HELD BY TOUCHING START.
AFTER DOING SO, ADJUST IGNITION TIMING WITH A TIMING LIGHT BY TURNING THE CAMSHAFT POSITION SENSOR.

START

SEF546N

E ☆ MONITOR ☆ NO FAIL
CLSD THL/P SW ON

RECORD

SEF577W

E ☆ MONITOR ☆ NO FAIL
CLSD THL/P SW OFF

RECORD

SEF122W

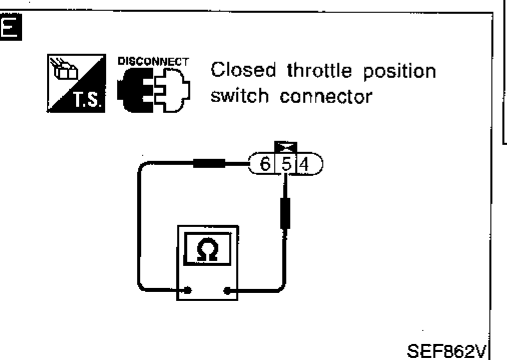
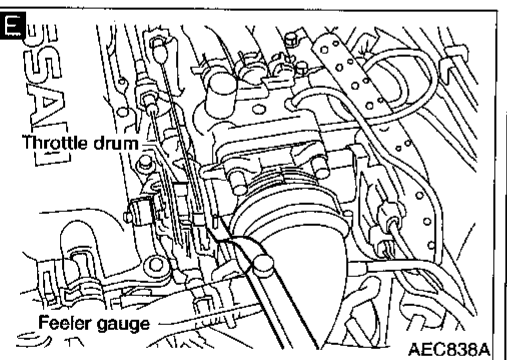

(A)

D

CHECK BASE IDLE SPEED.

1. Select "IGN TIMING ADJ" in "WORK SUPPORT" mode.
2. When touching "START", does engine speed fall to 750±50 rpm (A/T in "P" or "N" position)?

OR

Does engine run at 750±50 rpm (A/T in "P" or "N" position)?

NG → Adjust base idle speed by turning idle speed adjusting screw. Refer to "Idle Speed/ Ignition Timing/Idle Mixture Ratio Adjustment", EC-35.

OK

E

CHECK CLOSED THROTTLE POSITION SWITCH IDLE POSITION. (Check throttle position sensor idle position.)

- Always check ignition timing and base idle speed before performing the following.

1. Warm up engine to normal operating temperature.
2. Stop engine.

3. Turn ignition switch "ON".

4. Select "DATA MONITOR" mode with CONSULT.

5. Select "CLSD THL/P SW" from the menu.

6. Read "CLSD THL/P SW" signal under the following conditions.

- Insert a 0.15 mm (0.006 in) and 0.3 mm (0.012 in) feeler gauge alternately between the throttle adjust screw (TAS) and throttle drum as shown in the figure and check the signal.

"CLSD THL/P SW" signal should remain "ON" while inserting 0.15 mm (0.006 in) feeler gauge.

"CLSD THL/P SW" signal should remain "OFF" while inserting 0.3 mm (0.012 in) feeler gauge.

OR

3. Disconnect closed throttle position switch harness connector.

4. Connect the tester probe to closed throttle position switch terminals ⑤ and ⑥.

5. Check harness continuity under the following conditions.

- Insert the 0.15 mm (0.006 in) and 0.3 mm (0.012 in) feeler gauge alternately between the throttle adjust screw (TAS) and throttle drum as shown in the figure and check continuity.

"Continuity should exist" while inserting 0.15 mm (0.006 in) feeler gauge.

"Continuity should not exist" while inserting 0.3 mm (0.012 in) feeler gauge.

NG → **F**

F

ADJUSTMENT

Refer to "THROTTLE POSITION SENSOR IDLE POSITION ADJUSTMENT".

Go to EC-85.

OK

(Go to next page.)

(B)

GI
MA
EM
LC
EC
FE
CL
MT
AT
FA
RA
BR
ST
RS
BT
HA
EL
IDX

TROUBLE DIAGNOSIS — Basic Inspection

Basic Inspection (Cont'd)

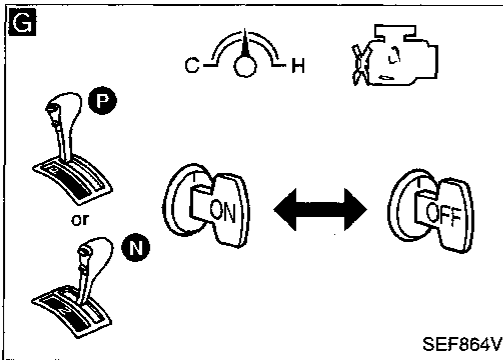

(B)

- Reconnect throttle position sensor harness connector and closed throttle position switch harness connector.
- Rev engine (2,000 to 3,000 rpm) 2 or 3 times under no-load and then run engine at idle speed.

(C)

RESET THROTTLE POSITION SENSOR IDLE POSITION MEMORY.
Note: Always warm up engine to normal operating temperature. If engine is cool, the throttle position sensor idle position memory will not be reset correctly.

1. Start engine.
2. Warm up engine to normal operating temperature.
3. Select "CLSD THL POS" in "DATA MONITOR" mode (Manual trigger) with CONSULT.
4. Stop engine. (Turn ignition switch "OFF".)
5. Turn ignition switch "ON" and wait at least 5 seconds.
6. Turn ignition switch "OFF" and wait at least 5 seconds.
7. Repeat steps 5 and 6 until "CLSD THL POS" in "DATA MONITOR" mode with CONSULT changes to "ON".

OR

7. Repeat steps 5 and 6, 20 times.

OK

CHECK TARGET IDLE SPEED.

Read the engine idle speed in "DATA MONITOR" mode with CONSULT.

M/T = 800±50 rpm
A/T = 800±50 rpm
 (in "P" or "N" position)

OR

Check idle speed.

M/T = 800±50 rpm
A/T = 800±50 rpm
 (in "P" or "N" position)

NG → Adjust idle speed. Refer to EC-35.

OK

After this inspection, unnecessary diagnostic trouble code No. might be displayed.
 Erase the stored memory in ECM.
 Refer to "ON BOARD DIAGNOSTIC SYSTEM DESCRIPTION" (EC-42) and "HOW TO ERASE DTC" in AT section.

OK

INSPECTION END

TROUBLE DIAGNOSIS — Basic Inspection

Basic Inspection (Cont'd)

THROTTLE POSITION SENSOR IDLE POSITION ADJUSTMENT

Note:

- Never adjust throttle adjust screw (TAS).
- Do not touch throttle drum when checking "CLSD THL/P SW" signal or "continuity"; doing so may cause an incorrect adjustment.

1. Warm engine up to normal operating temperature.
2. Stop engine.
3. Loosen throttle position sensor fixing bolts.



4. Turn ignition switch "ON".
5. Select "DATA MONITOR" mode with CONSULT.
6. Select "CLSD THL/P SW" from the menu.
7. Read "CLSD THL/P SW" signal under the following conditions.

- Insert 0.15 mm (0.006 in) feeler gauge between throttle adjust screw and throttle drum as shown in the figure and check the following.

- Open throttle valve and then close.
- "CLSD THL/P SW" signal should remain "OFF" when the throttle valve is closed. (If signal is "ON", turn throttle position sensor body counterclockwise until the signal switches to "OFF".)

8. Temporarily tighten sensor body fixing bolts as follows.

- Gradually move the sensor body clockwise and stop it when "CLSD THL/P SW" signal switches from "OFF" to "ON", then tighten sensor body fixing bolts.

9. Make sure the signal is "ON" when the throttle valve is closed and "OFF" when it is opened. Repeat it 2 or 3 times.

10. Remove 0.15 mm (0.006 in) feeler gauge then insert 0.3 mm (0.012 in) feeler gauge and check the following. Make sure the signal remains "OFF" when the throttle valve is closed. Repeat it 2 or 3 times.

11. Tighten throttle position sensor. Check that the "CLSD THL/P SW" signal remains "OFF" while closing throttle valve. If NG, repeat from the step 3.

After this adjustment, go to procedure G RESET THROTTLE POSITION SENSOR IDLE POSITION MEMORY.

OR



4. Disconnect closed throttle position sensor harness connector.
5. Connect tester probe to the closed throttle position switch terminals ⑤ and ⑥ and check continuity under the following conditions.

- Insert the 0.15 mm (0.006 in) feeler gauge between the throttle adjust screw and throttle drum as shown in the figure and check the following.

- Open throttle valve then close.
- The continuity should not exist while closing the throttle valve. If the continuity exists, turn throttle position sensor body counterclockwise until the continuity does not exist.

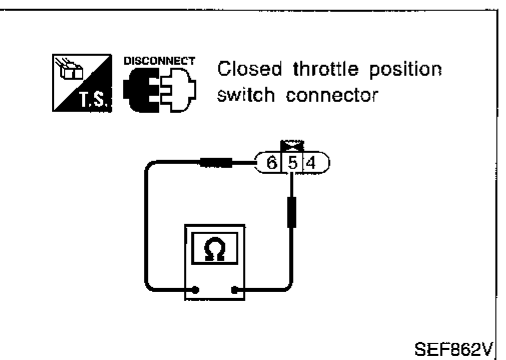
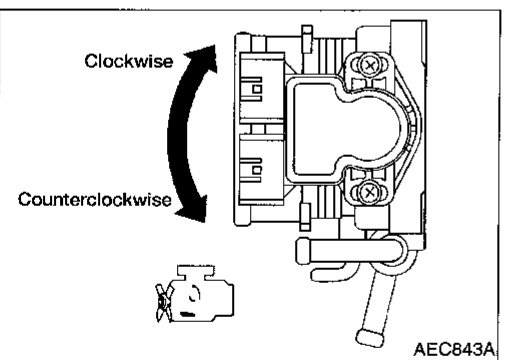
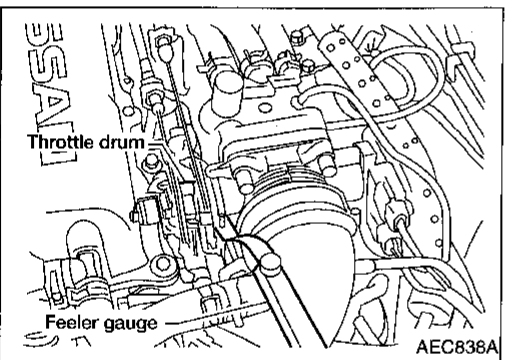
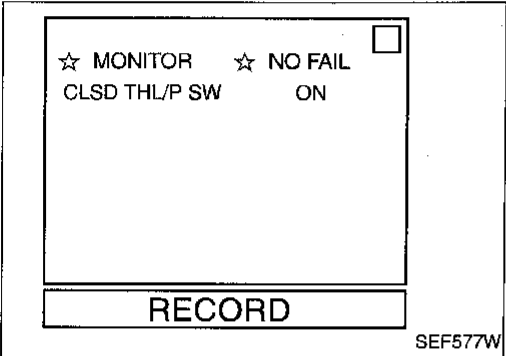
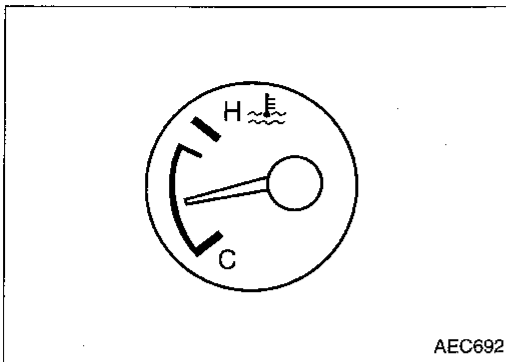

GI

MA

EM

LC

EC

FE

CL

MT

AT

FA

RA

BR

ST

RS

BT

HA

EL

IDX

TROUBLE DIAGNOSIS — Basic Inspection

Basic Inspection (Cont'd)

6. Temporarily tighten sensor body fixing bolts as follows.
 - **Gradually move the sensor body clockwise and stop it when the continuity comes to exist, then tighten sensor body fixing bolts.**
7. Make sure the continuity exists when the throttle valve is closed and continuity does not exist when it is opened. Repeat it 2 or 3 times.
8. Remove 0.15 mm (0.006 in) feeler gauge, then insert 0.3 mm (0.012 in) feeler gauge and check the following.

Make sure the continuity does not exist when the throttle valve is closed. Repeat it 2 or 3 times.
9. Tighten throttle position sensor.

Check that the continuity does not exist while closing the throttle valve. If NG, repeat from the step 4.

After this adjustment, go to procedure  RESET THROTTLE POSITION SENSOR IDLE POSITION MEMORY.

TROUBLE DIAGNOSIS — General Description

Diagnostic Trouble Code (DTC) Inspection Priority Chart

If some DTCs are displayed at the same time, perform inspections one by one based on the following priority chart.

Priority	Detected items (DTC)	
1	<ul style="list-style-type: none"> ● P0100 Mass air flow sensor (0102) ● P0110 Intake air temperature sensor (0401) ● P0115 P0125 Engine coolant temperature sensor (0103) (0908) ● P0120 Throttle position sensor (0403) ● P0180 Tank fuel temperature sensor (0402) ● P0325 Knock sensor (0304) ● P0340 Camshaft position sensor (0101) ● P0605 ECM (0301) ● P1320 Ignition signal (0201) ● P1400 EGRC-solenoid valve (1005) ● P1605 A/T diagnosis communication line (0804) ● P1706 Park/Neutral position switch (1003) 	GI MA EM LC EC FE
2	<ul style="list-style-type: none"> ● P0105 Absolute pressure sensor (0803) ● P0130-P0134 Front heated oxygen sensor (0303-0412) ● P0135 Front heated oxygen sensor heater (0901) ● P0137-P0140 Rear heated oxygen sensor (0510-0707) ● P0141 Rear heated oxygen sensor heater (0902) ● P0335 P1336 Crankshaft position sensor (OBD) (0802) (0905) ● P0443 P1444 EVAP canister purge volume control valve (1008) (0214) ● P0446 P1446 P1448 EVAP canister vent control valve (0903) (0215) (0309) ● P0450 EVAP control system pressure sensor (0704) ● P0510 Closed throttle position switch (0203) ● P0705-P0725 P0740-P1760 A/T related sensors, solenoid valves and switches (1101-1208) (1108-1206) ● P1105 MAP/BARO switch solenoid valve (1302) ● P1401 EGR temperature sensor (0305) ● P1447 EVAP control system purge flow monitoring (0111) ● P1490 P1491 Vacuum cut valve bypass valve (0801) (0311) ● P1492 P1493 EVAP canister purge control valve/solenoid valve (0807) (0312) 	CL MT AT FA RA
3	<ul style="list-style-type: none"> ● P0172 P0171 Fuel injection system function (0114) (0115) ● P0304 - P0300 Misfire (0605 - 0701) ● P0400 P1402 EGR function (0302) (0514) ● P0402 EGRC-BPT valve function (0306) ● P0420 Three way catalyst function (0702) ● P0440 P1440 EVAP control system (SMALL LEAK) (0705) (0213) ● P0505 IACV-AAC valve (0205) ● P0731-P0734 P0744 A/T function (1103 - 1106) (1107) ● P1148 Closed loop control (0307) ● P1220 Fuel pump control module (FPCM) (1305) 	BR ST RS BT

HA

EL

IDX

TROUBLE DIAGNOSIS — General Description

Fail-Safe Chart

The ECM enters fail-safe mode if any of the following malfunctions is detected due to the open or short circuit. When the ECM enters the fail-safe mode, the MIL illuminates.

DTC No.		Detected items	Engine operating condition in fail-safe mode												
CONSULT GST	ECM*														
P0100	0102	Mass air flow sensor circuit	Engine speed will not rise more than 2,400 rpm due to the fuel cut.												
P0110	0401	Intake air temperature sensor	The ECM functions on the assumption that the intake air temperature is 25°C (77°F).												
P0115	0103	Engine coolant temperature sensor circuit	<p>Engine coolant temperature will be determined by ECM based on the time after turning ignition switch "ON" or "START". CONSULT displays the engine coolant temperature decided by ECM.</p> <table border="1" style="width: 100%; border-collapse: collapse;"> <thead> <tr> <th style="text-align: center;">Condition</th> <th style="text-align: center;">Engine coolant temperature decided (CONSULT display)</th> </tr> </thead> <tbody> <tr> <td>Just as ignition switch is turned ON or Start</td> <td style="text-align: center;">40°C (104°F)</td> </tr> <tr> <td>More than approx. 4 minutes after ignition ON or Start</td> <td style="text-align: center;">80°C (176°F)</td> </tr> <tr> <td>Except as shown above</td> <td style="text-align: center;">40 - 80°C (104 - 176°F) (Depends on the time)</td> </tr> </tbody> </table>	Condition	Engine coolant temperature decided (CONSULT display)	Just as ignition switch is turned ON or Start	40°C (104°F)	More than approx. 4 minutes after ignition ON or Start	80°C (176°F)	Except as shown above	40 - 80°C (104 - 176°F) (Depends on the time)				
Condition	Engine coolant temperature decided (CONSULT display)														
Just as ignition switch is turned ON or Start	40°C (104°F)														
More than approx. 4 minutes after ignition ON or Start	80°C (176°F)														
Except as shown above	40 - 80°C (104 - 176°F) (Depends on the time)														
P0120	0403	Throttle position sensor circuit	<p>Throttle position will be determined based on the injected fuel amount and the engine speed. Therefore, acceleration will be poor.</p> <table border="1" style="width: 100%; border-collapse: collapse;"> <thead> <tr> <th style="text-align: center;">Condition</th> <th style="text-align: center;">Driving condition</th> </tr> </thead> <tbody> <tr> <td>When engine is idling</td> <td style="text-align: center;">Normal</td> </tr> <tr> <td>When accelerating</td> <td style="text-align: center;">Poor acceleration</td> </tr> </tbody> </table>	Condition	Driving condition	When engine is idling	Normal	When accelerating	Poor acceleration						
Condition	Driving condition														
When engine is idling	Normal														
When accelerating	Poor acceleration														
Unable to access ECM	Unable to access Diagnostic Test Mode II	ECM	<p>ECM fail-safe activating condition The computing function of the ECM was judged to be malfunctioning. When the fail-safe system activates (i.e., if the ECM detects a malfunction condition in the CPU of ECM), the MALFUNCTION INDICATOR LAMP on the instrument panel lights to warn the driver. However it is not possible to access ECM and DTC cannot be confirmed.</p> <p>Engine control with fail-safe When ECM fail-safe is operating, fuel injection, ignition timing, fuel pump operation, and IACV-AAC valve operation are controlled under certain limitations.</p> <table border="1" style="width: 100%; border-collapse: collapse;"> <thead> <tr> <th colspan="2" style="text-align: center;">ECM fail-safe operation</th> </tr> </thead> <tbody> <tr> <td style="text-align: center;">Engine speed</td> <td style="text-align: center;">Engine speed will not rise more than 3,000 rpm</td> </tr> <tr> <td style="text-align: center;">Fuel injection</td> <td style="text-align: center;">Simultaneous multipoint fuel injection system</td> </tr> <tr> <td style="text-align: center;">Ignition timing</td> <td style="text-align: center;">Ignition timing is fixed at the preset value</td> </tr> <tr> <td style="text-align: center;">Fuel pump</td> <td style="text-align: center;">Fuel pump relay is "ON" when engine is running and "OFF" when engine stalls</td> </tr> <tr> <td style="text-align: center;">IACV-AAC valve</td> <td style="text-align: center;">Full open</td> </tr> </tbody> </table> <p>Replace ECM, if ECM fail-safe condition is confirmed.</p>	ECM fail-safe operation		Engine speed	Engine speed will not rise more than 3,000 rpm	Fuel injection	Simultaneous multipoint fuel injection system	Ignition timing	Ignition timing is fixed at the preset value	Fuel pump	Fuel pump relay is "ON" when engine is running and "OFF" when engine stalls	IACV-AAC valve	Full open
ECM fail-safe operation															
Engine speed	Engine speed will not rise more than 3,000 rpm														
Fuel injection	Simultaneous multipoint fuel injection system														
Ignition timing	Ignition timing is fixed at the preset value														
Fuel pump	Fuel pump relay is "ON" when engine is running and "OFF" when engine stalls														
IACV-AAC valve	Full open														

*: In Diagnostic Test Mode II (Self-diagnostic results)

TROUBLE DIAGNOSIS — General Description

Symptom Matrix Chart

SYSTEM — Basic engine control system		SYMPTOM													Reference page
		HARD/NO START/RESTART (EXCP. HA)	ENGINE STALL	HESITATION/SURGING/FLAT SPOT	SPARK KNOCK/DETONATION	LACK OF POWER/POOR ACCELERATION	HIGH IDLE/LOW IDLE	ROUGH IDLE/HUNTING	IDLING VIBRATION	SLOW/NO RETURN TO IDLE	OVERHEATS/WATER TEMPERATURE HIGH	EXCESSIVE FUEL CONSUMPTION	EXCESSIVE OIL CONSUMPTION	BATTERY DEAD (UNDER CHARGE)	
Warranty symptom code		AA	AB	AC	AD	AE	AF	AG	AH	AJ	AK	AL	AM	HA	
Fuel	Fuel pump circuit	1	1	2	3	2		2	2			3		2	EC-475
	Fuel pressure regulator system	3	3	4	4	4	4	4	4	4		4			EC-34
	Injector circuit	1	1	2	3	2		2	2			2			EC-469
	Evaporative emission system	3	3	4	4	4	4	4	4	4		4			EC-22
Air	Positive crankcase ventilation system	3	3	4	4	4	4	4	4	4		4	1		EC-32
	Incorrect idle speed adjustment	3	3				1	1	1	1		1			EC-35
	IACV-AAC valve circuit	1	1	2	3	3	2	2	2	2		2		2	EC-319
	IACV-FICD solenoid valve circuit	2	2	3	3	3	3	3	3	3		3			EC-487
Ignition	Incorrect ignition timing adjustment	3	3	1	1	1		1	1			1			EC-35
	Ignition circuit	1	1	2	2	2		2	2			2			EC-351
EGR	EGRC-solenoid valve circuit		2	2	3	3						3			EC-363
	EGR system	2	1	2	3	3	3	2	2	3		3			EC-267, 276, 374
Main power supply and ground circuit		2	2	3	3	3		3	3		2	3		2	EC-107
Air conditioner circuit		2	2	3	3	3	3	3	3	3		3		2	HA section

1 - 6: The numbers refer to the order of inspection.

(continued on next page)

GI
 MA
 EM
 LC
EC
 FE
 CL
 MT
 AT
 FA
 RA
 BR
 ST
 RS
 BT
 HA
 EL
 IDX

TROUBLE DIAGNOSIS — General Description

Symptom Matrix Chart (Cont'd)

SYSTEM — Engine Control system		SYMPTOM													Reference page
		HARD/NO START/RESTART (EXCP. HA)	ENGINE STALL	HESITATION/SURGING/FLAT SPOT	SPARK KNOCK/DETONATION	LACK OF POWER/POOR ACCELERATION	HIGH IDLE/LOW IDLE	ROUGH IDLE/HUNTING	IDLING VIBRATION	SLOW/NO RETURN TO IDLE	OVERHEATS/WATER TEMPERATURE HIGH	EXCESSIVE FUEL CONSUMPTION	EXCESSIVE OIL CONSUMPTION	BATTERY DEAD (UNDER CHARGE)	
Warranty symptom code		AA	AB	AC	AD	AE	AF	AG	AH	AJ	AK	AL	AM	HA	
Engine Control	Camshaft position sensor circuit	2	2	3	3	3		3	3			3			EC-260
	Mass air flow sensor circuit	1	1	2	2	2		2	2			2			EC-112
	Front heated oxygen sensor circuit		1	2	3	2		2	2			2			EC-163, 169
	Engine coolant temperature sensor circuit	1	1	2	3	2	3	2	2	3		2			EC-137, 157
	Throttle position sensor circuit		1	2		2	2	2	2	2		2			EC-142
	Incorrect throttle position sensor adjustment		3	1		1	1	1	1	1		1			EC-82
	Vehicle speed sensor circuit		2	3		3						3			EC-314
	Knock sensor circuit			2								3			EC-250
	ECM	2	2	3	3	3	3	3	3	3	3	3			EC-331, 88
	Start signal circuit	2													EC-472
Park/neutral position (PNP) switch circuit			3		3		3	3			3			EC-450	
Power steering oil pressure switch circuit		2						3	3					EC-479	

1 - 6: The numbers refer to the order of inspection.

(continued on next page)

TROUBLE DIAGNOSIS — General Description

Symptom Matrix Chart (Cont'd)

SYSTEM		SYMPTOM													Reference page
		HARD/NO START/RESTART (EXCP. HA)	ENGINE STALL	HESITATION/SURGING/FLAT SPOT	SPARK KNOCK/DETONATION	LACK OF POWER/POOR ACCELERATION	HIGH IDLE/LOW IDLE	ROUGH IDLE/HUNTING	IDLING VIBRATION	SLOW/NO RETURN TO IDLE	OVERHEATS/WATER TEMPERATURE HIGH	EXCESSIVE FUEL CONSUMPTION	EXCESSIVE OIL CONSUMPTION	BATTERY DEAD (UNDER CHARGE)	
Warranty symptom code		AA	AB	AC	AD	AE	AF	AG	AH	AJ	AK	AL	AM	HA	
Fuel	Fuel tank	5													FE section
	Fuel piping			5	5	5		5	5			5			
	Vapor lock		5												
	Valve deposit														
	Poor fuel (Heavy weight gasoline, Low octane)	5		5	5	5		5	5			5			
Air	Air duct														FE section
	Air cleaner														
	Air leakage from air duct (Mass air flow sensor — throttle body)		5	5		5		5	5			5			
	Throttle body, Throttle wire	5			5		5		5	5					
	Air leakage from intake manifold/Collector/Gasket														
Cranking	Battery	1	1	1		1		1	1					1	EL section
	Alternator circuit														
	Starter circuit	3										1			
	Flywheel/Drive plate	6													
	Park/neutral position (PNP) switch	4													
Engine	Cylinder head	5	5	5	5	5		5	5			4	5	3	EM section
	Cylinder head gasket														
	Cylinder block														
	Piston													4	
	Piston ring														
	Connecting rod	6	6	6	6	6		6	6			6			
	Bearing														
	Crankshaft														
Valve mechanism	Timing chain														FE section
	Camshaft	5	5	5	5	5		5	5			5			
	Intake valve												3		
	Exhaust valve														
Exhaust	Exhaust manifold/Tube/Muffler/Gasket	5	5	5	5	5		5	5			5		FE section	
	Three way catalyst														
Lubrication	Oil pan/Oil strainer/Oil pump/Oil filter/Oil gallery	5	5	5	5	5		5	5			5		MA, EM and LC sections	
	Oil level (Low)/Filthy oil														
Cooling	Radiator/Hose/Radiator filler cap													LC section	
	Thermostat														
	Water pump	5	5	5	5	5		5	5		5				
	Water gallery														
	Cooling fan														
	Coolant level (low)/Contaminated coolant														

1 - 6: The numbers refer to the order of inspection.

GI

MA

EM

LC

EC

FE

CL

MT

AT

FA

RA

BR

ST

RS

BT

HA

EL

IDX

TROUBLE DIAGNOSIS — General Description

CONSULT Reference Value in Data Monitor Mode

Remarks:

- Specification data are reference values.
- Specification data are output/input values which are detected or supplied by the ECM at the connector.
- * Specification data may not be directly related to their components signals/values/operations.
(i.e., Adjust ignition timing with a timing light before monitoring IGN TIMING. Specification data might be displayed even when ignition timing is not adjusted to specification. This IGN TIMING monitors the data calculated by the ECM according to the input signals from the camshaft position sensor and other ignition timing related sensors.)
- If the real-time diagnosis results are NG, and the on board diagnostic system results are OK, when diagnosing the mass air flow sensor, first check to see if the fuel pump control circuit is normal.

MONITOR ITEM	CONDITION		SPECIFICATION
CMPS-RPM (REF)	<ul style="list-style-type: none"> ● Tachometer: Connect ● Run engine and compare tachometer indication with the CONSULT value. 		Almost the same speed as the CONSULT value.
MAS AIR/FL SE	<ul style="list-style-type: none"> ● Engine: After warming up ● Air conditioner switch: OFF ● Shift lever: "N" ● No-load 	Idle	1.3 - 1.7V
		2,500 rpm	1.8 - 2.4V
COOLAN TEMP/S	<ul style="list-style-type: none"> ● Engine: After warming up 		More than 70°C (158°F)
FR O2 SENSOR	<ul style="list-style-type: none"> ● Engine: After warming up 	Maintaining engine speed at 2,000 rpm	0 - 0.3V ↔ 0.6 - 1.0V
FR O2 MNTR			LEAN ↔ RICH Changes more than 5 times during 10 seconds.
RR O2 SENSOR	<ul style="list-style-type: none"> ● Engine: After warming up 	Revving engine from idle to 3,000 rpm quickly	0 - 0.3V ↔ 0.6 - 1.0V
RR O2 MNTR			LEAN ↔ RICH
VHCL SPEED SE	<ul style="list-style-type: none"> ● Turn drive wheels and compare speedometer indication with the CONSULT value 		Almost the same speed as the CONSULT value
BATTERY VOLT	<ul style="list-style-type: none"> ● Ignition switch: ON (Engine stopped) 		11 - 14V
THRTL POS SEN	<ul style="list-style-type: none"> ● Ignition switch: ON (Engine stopped) ● Engine: After warming up 	Throttle valve fully closed	0.35 - 0.65V
		Throttle valve fully opened	Approx. 4.0V
EGR TEMP SEN	<ul style="list-style-type: none"> ● Engine: After warming up 		Less than 4.5V
START SIGNAL	<ul style="list-style-type: none"> ● Ignition switch: ON → START → ON 		OFF → ON → OFF
CLSD THL/P SW	<ul style="list-style-type: none"> ● Engine: After warming up ● Ignition switch: ON (Engine stopped) 	Throttle valve: Idle position	ON
		Throttle valve: Slightly open	OFF
CLSD THL POS	<ul style="list-style-type: none"> ● Engine: After warming up ● Ignition switch: ON (engine stopped) 	Throttle valve: Idle position	ON
		Throttle valve: Slightly open	OFF
AIR COND SIG	<ul style="list-style-type: none"> ● Engine: After warming up, idle the engine 	A/C switch "OFF"	OFF
		A/C switch "ON" (Compressor operates)	ON
PNP SW/CIRC	<ul style="list-style-type: none"> ● Ignition switch: ON 	Shift lever "P" or "N"	ON
		Except above	OFF

TROUBLE DIAGNOSIS — General Description

CONSULT Reference Value in Data Monitor Mode (Cont'd)

MONITOR ITEM	CONDITION		SPECIFICATION	
PW/ST SIGNAL	<ul style="list-style-type: none"> ● Engine: After warming up, idle the engine 	Steering wheel in neutral position (forward direction)	OFF	GI
		The steering wheel is turned	ON	MA
IGNITION SW	<ul style="list-style-type: none"> ● Ignition switch: ON → OFF 		ON → OFF	
INJ PULSE	<ul style="list-style-type: none"> ● Engine: After warming up ● Air conditioner switch: OFF ● Shift lever: "N" ● No-load 	Idle	2.4 - 3.2 msec	EM
		2,000 rpm	1.9 - 2.8 msec	LC
B/FUEL SCHDL	<ul style="list-style-type: none"> ● Engine: After warming up ● Air conditioner switch: OFF ● Shift lever: "N" ● No-load 	Idle	1.0 - 1.6 msec	
		2,000 rpm	0.7 - 1.3 msec	EC
IGN TIMING	<ul style="list-style-type: none"> ● Engine: After warming up ● Air conditioner switch: OFF ● Shift lever: "N" ● No-load 	Idle	13 - 15° BTDC	
		2,000 rpm	More than 25° BTDC	FE
IACV-AAC/V	<ul style="list-style-type: none"> ● Engine: After warming up ● Air conditioner switch: OFF ● Shift lever: "N" ● No-load 	Idle	20 - 40%	CL
		2,000 rpm	—	
PURG VOL C/V	<ul style="list-style-type: none"> ● Engine: After warming up ● No-load ● M/T models: Lift up drive wheels and shift to 1st gear position. 	Idle	0 step	MT
		More than 60 seconds after starting engine A/T models: Rev engine up from 2,000 to 4,000 rpm. M/T models: Rev engine up from 2,000 to 4,000 rpm.	More than 1 step	AT
A/F ALPHA	<ul style="list-style-type: none"> ● Engine: After warming up 	Maintaining engine speed at 2,000 rpm	53 - 155%	FA
EVAP SYS PRES	<ul style="list-style-type: none"> ● Ignition switch: ON 		Approx. 3.4V	
AIR COND RLY	<ul style="list-style-type: none"> ● Air conditioner switch: OFF → ON 		OFF → ON	RA
FUEL PUMP RLY	<ul style="list-style-type: none"> ● Ignition switch is turned to ON (Operates for 5 seconds) ● Engine running and cranking ● When engine is stopped (stops in 1.0 seconds) 		ON	BR
		<ul style="list-style-type: none"> ● Except as shown above 		OFF
COOLING FAN	<ul style="list-style-type: none"> ● After warming up engine, idle the engine. ● Air conditioner switch: OFF 	Engine coolant temperature is 94°C (201°F) or less for A/T models, and 99°C (210°F) or less for M/T models.	OFF	ST
		Engine coolant temperature is between 95°C (203°F) and 104°C (219°F) for A/T models only.	LOW	RS
		Engine coolant temperature is 105°C (221°F) or more for A/T models, and 100°C (212°F) or more for M/T models.	HIGH	BT
VENT CONT/V	<ul style="list-style-type: none"> ● Ignition switch: ON 		OFF	
EGRC SOL/V	<ul style="list-style-type: none"> ● Engine: After warming up ● Air conditioner switch: OFF ● Shift lever: N ● No-load ● M/T models: Lift up drive wheels and shift to 1st gear position. 	Idle	OFF (CUT)	HA
		A/T models: Rev engine up from 2,000 to 4,000 rpm. M/T models: Rev engine up from 2,000 to 4,000 rpm.	ON (FLOW)	EL

*: 1st position for USA models, 2nd position for Canada models

IDX

TROUBLE DIAGNOSIS — General Description

CONSULT Reference Value in Data Monitor Mode (Cont'd)

MONITOR ITEM	CONDITION	SPECIFICATION	
FR O2 HEATER	● Engine speed: Idle	ON	
	● Engine speed: Above 3,200 rpm	OFF	
RR O2 HEATER	● Engine speed: Idle [after driving 2 minutes at 70 km/h (43 MPH) or more]	ON	
	● Ignition switch ON (Engine stopped)	OFF	
VC/V BYPASS/V	● Ignition switch: ON	OFF	
PURG CONT S/V	Idle	OFF	
	<ul style="list-style-type: none"> ● Engine: After warming up ● No-load ● M/T models: Lift up drive wheels and shift to 1st gear position. 	More than 60 seconds after starting engine A/T models: 2,000 rpm M/T models: 2,000 rpm and more than 16 km/h (10 MPH)	
CAL/LD VALUE	<ul style="list-style-type: none"> ● Engine: After warming up ● Air conditioner switch: OFF ● Shift lever: "N" ● No-load 	Idle	20.0 - 35.5%
		2,500 rpm	17.0 - 30.0%
ABSOL TH·P/S	<ul style="list-style-type: none"> ● Ignition switch: ON (Engine stopped) ● After warming up 	Throttle valve fully closed	0.0%
		Throttle valve fully opened	Approx. 88%
MASS AIRFLOW	<ul style="list-style-type: none"> ● Engine: After warming up ● Air conditioner switch: OFF ● Shift lever: N ● No-load 	Idle	2.5 - 5.0 g/m/s
		2,500 rpm	7.1 - 12.5 g/m/s
FPCM DR VOLT	● When cranking engine		Approx. 0.4V
	● Idle at coolant temperatures above 10°C (50°F)		Approx. 5.0V
FPCM	● When cranking engine		HI
	● Idle at coolant temperatures above 10°C (50°F)		LOW
MAP/BARO SW/V	● Ignition switch: ON (Engine stopped)		MAP
	● Engine speed: idle	For 5 seconds after starting engine	BARO
		More than 5 seconds after starting engine	MAP
ABSOL PRES/SE	● Ignition switch: ON (Engine stopped)		Approx. 4.4V
	● Engine speed: idle	For 5 seconds after starting engine	Approx. 4.4V
		More than 5 seconds after starting engine	Approx. 1.2V

TROUBLE DIAGNOSIS — General Description

Major Sensor Reference Graph in Data Monitor Mode

The following are the major sensor reference graphs in "DATA MONITOR" mode.
(Select "HI SPEED" in "DATA MONITOR" with CONSULT.)

THRTL POS SEN, ABSOL TH·P/S, CLSD THL POS

Below is the data for "THRTL POS SEN", "ABSOL TH·P/S" and "CLSD THL POS" when depressing the accelerator pedal with the ignition switch "ON".

The signal of "THRTL POS SEN" and "ABSOL TH·P/S" should rise gradually without any intermittent drop or rise after "CLSD THL POS" is changed from "ON" to "OFF".

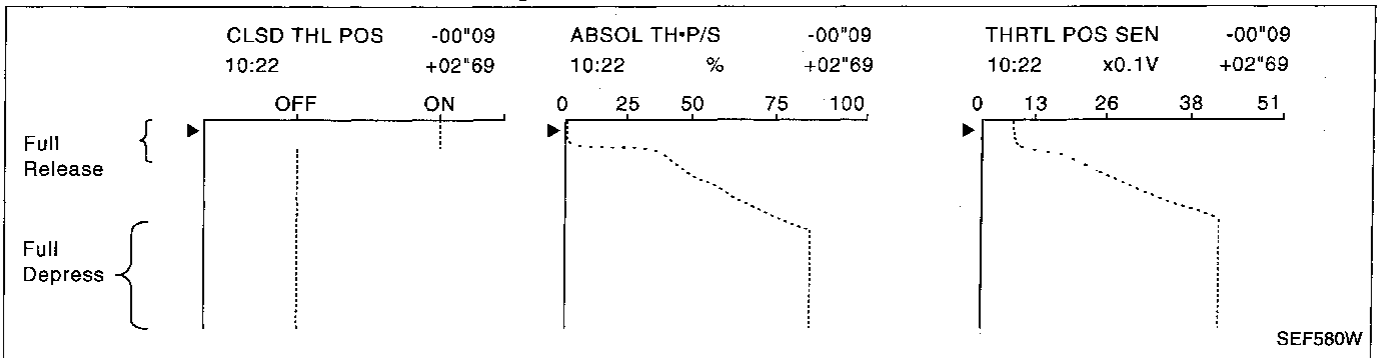

CMPS-RPM (REF), MAS AIR/FL SE, THRTL POS SEN, RR O2 SEN, FR O2 SEN, INJ PULSE

Below is the data for "CMPS-RPM (REF)", "MAS AIR/FL SE", "THRTL POS SEN", "RR O2 SEN", "FR O2 SEN" and "INJ PULSE" when revving engine quickly up to 4,800 rpm under no load after warming up engine to normal operating temperature.

Each value is for reference, the exact value may vary.

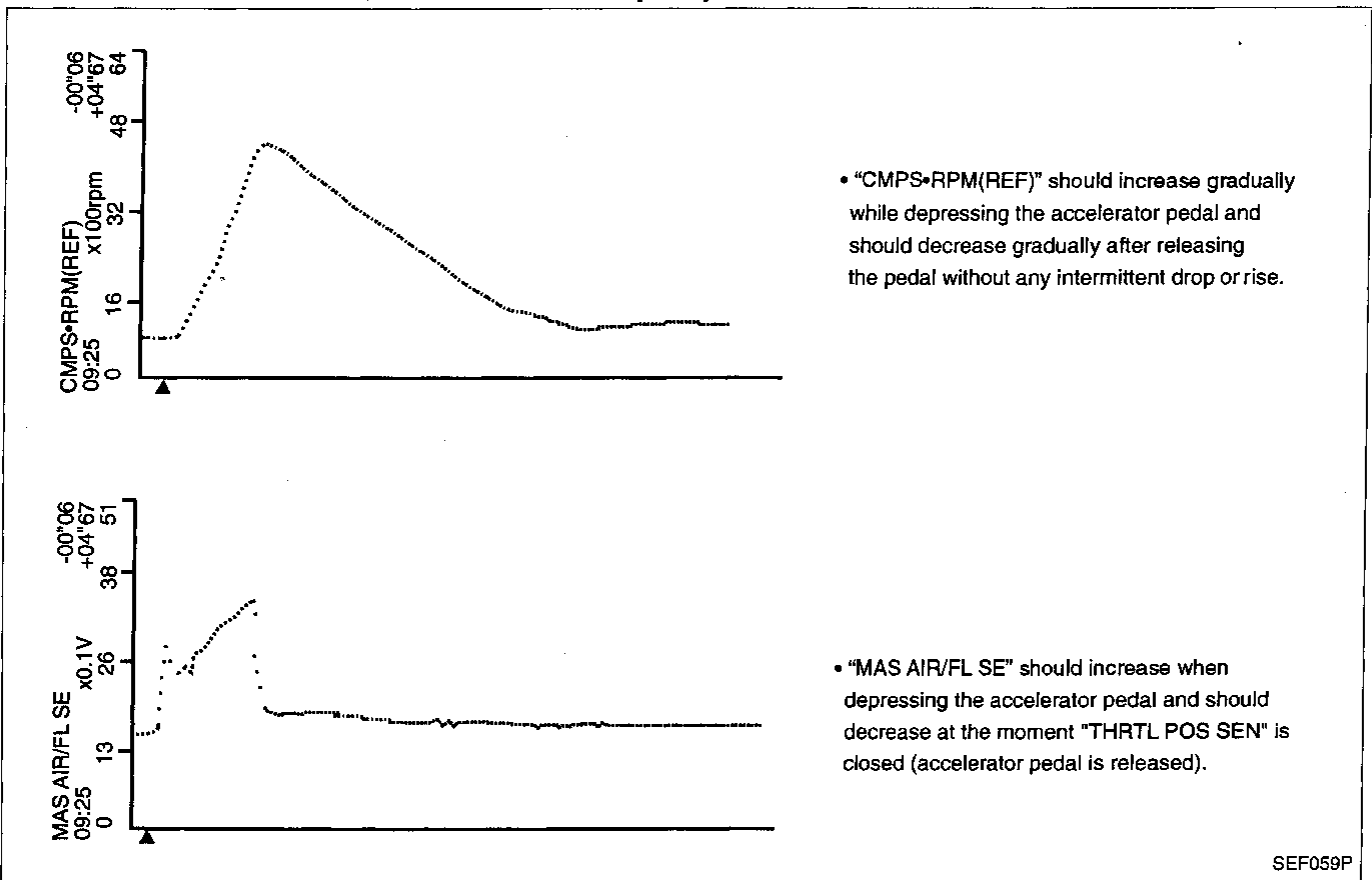

TROUBLE DIAGNOSIS — General Description

Major Sensor Reference Graph in Data Monitor Mode (Cont'd)

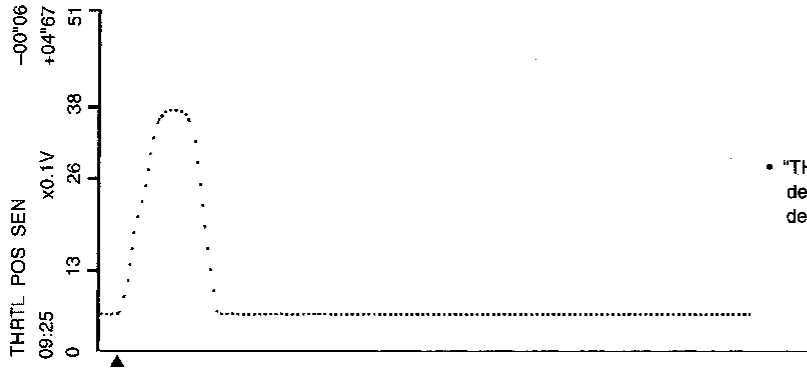

- "THRTL POS SEN" should increase while depressing the accelerator pedal and should decrease while releasing it.

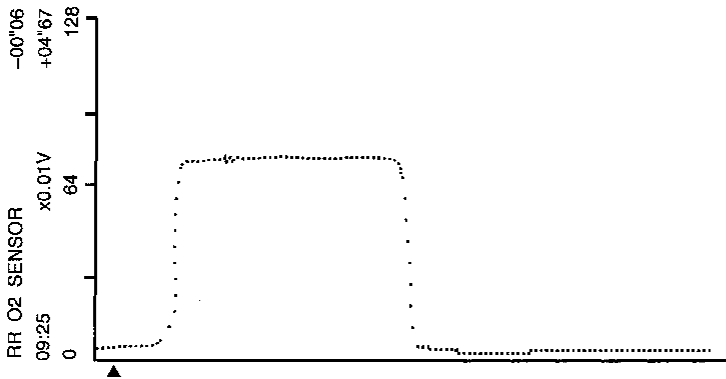

- "RR O2 SENSOR" may increase immediately after depressing the accelerator pedal and may decrease after releasing the pedal.

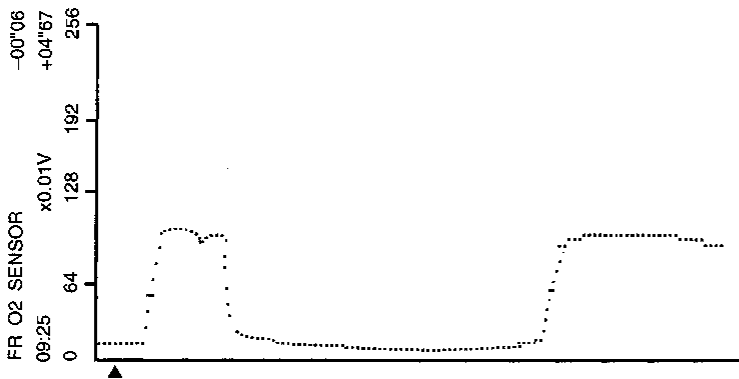

- "FR O2 SENSOR" may increase immediately after depressing the accelerator pedal and may decrease after releasing the pedal.

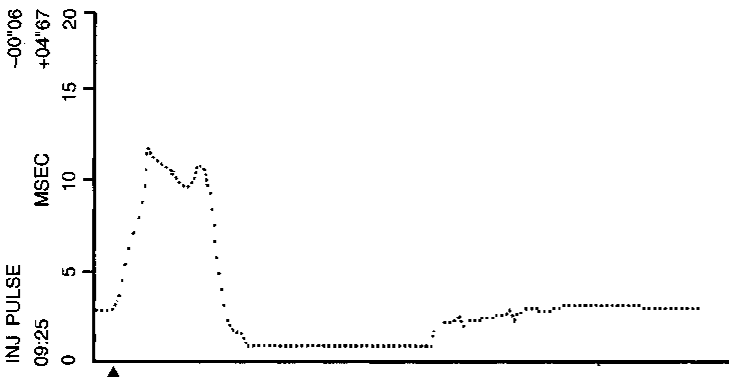

- "INJ PULSE" should increase when depressing the accelerator pedal and should decrease when the pedal is released.

TROUBLE DIAGNOSIS — General Description

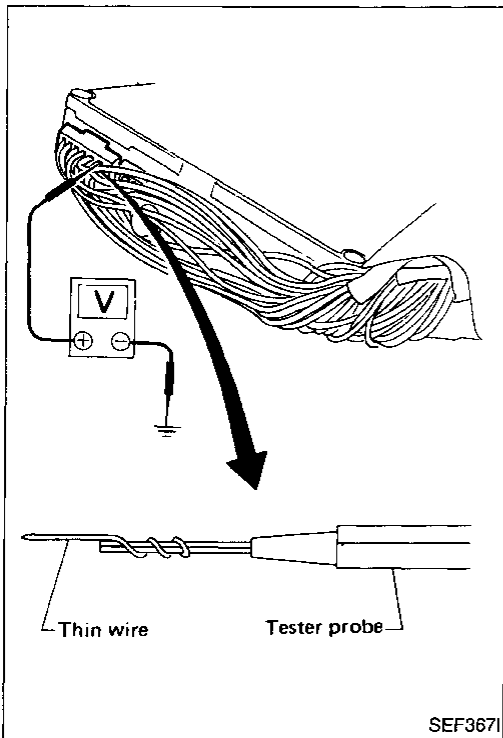
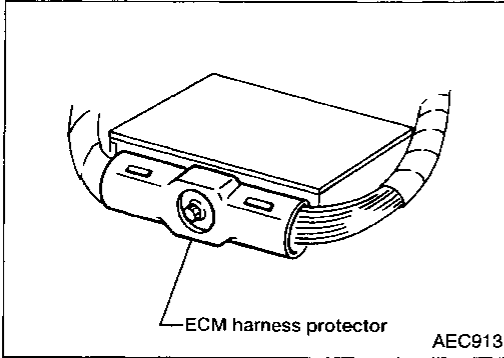
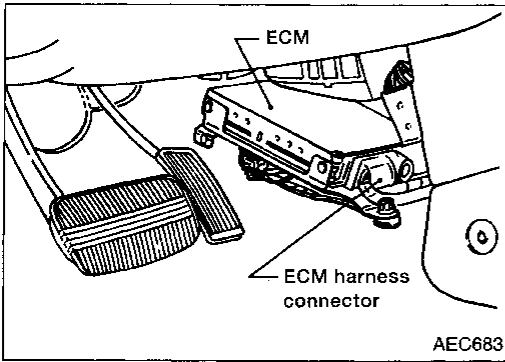

ECM Terminals and Reference Value

PREPARATION

- ECM is located behind the center console. For this inspection:
 - Remove the front passenger center console panel.
- Remove ECM harness protector.
- Perform all voltage measurements with the connector connected. Extend tester probe as shown to perform tests easily.
 - Open harness securing clip to make testing easier.
 - Use extreme care not to touch 2 pins at one time.
 - Data is for comparison and may not be exact.

ECM HARNESS CONNECTOR TERMINAL LAYOUT

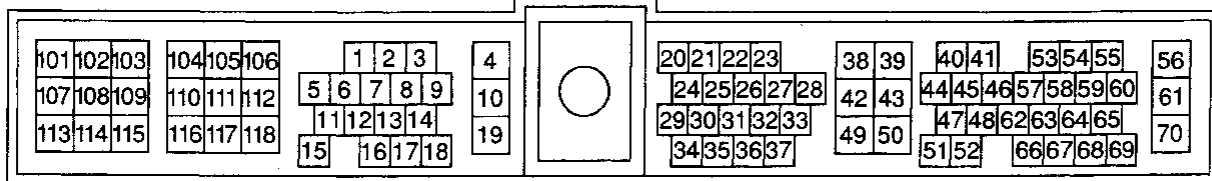

SEF064P

GI
MA
EM
LC
EC
FE
CL
MT
AT
FA
RA
BR
ST
RS
BT
HA
EL
IDX

TROUBLE DIAGNOSIS — General Description

ECM Terminals and Reference Value (Cont'd)

ECM INSPECTION TABLE

Specification data are reference values and are measured between each terminal and ground.

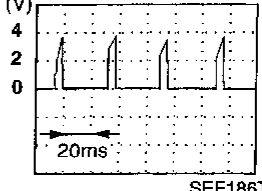
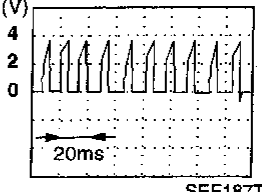
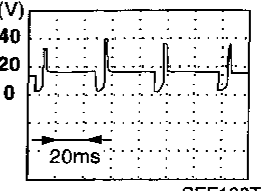
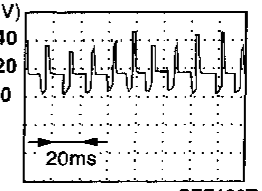
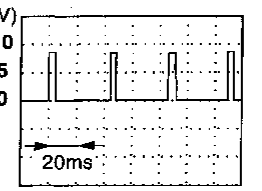
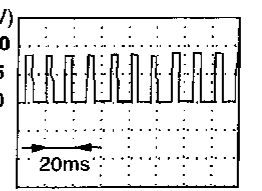
TER-MINAL NO.	WIRE COLOR	ITEM	CONDITION	DATA (DC voltage)
1	W/B	Ignition signal	<p>Engine is running. (Warm-up condition)</p> <p>└ Idle speed</p>	<p>0.2 - 0.3V</p>  <p style="text-align: right;">SEF186T</p>
			<p>Engine is running.</p> <p>└ Engine speed is 2,000 rpm.</p>	<p>Approximately 0.5V</p>  <p style="text-align: right;">SEF187T</p>
2	W	Ignition check	<p>Engine is running. (Warm-up condition)</p> <p>└ Idle speed</p>	<p>Approximately 13V</p>  <p style="text-align: right;">SEF188T</p>
			<p>Engine is running.</p> <p>└ Engine speed is 2,000 rpm.</p>	<p>Approximately 13V</p>  <p style="text-align: right;">SEF189T</p>
3	L/OR	Tachometer	<p>Engine is running. (Warm-up condition)</p> <p>└ Idle speed</p>	<p>0.6 - 1.6V</p>  <p style="text-align: right;">SEF190T</p>
			<p>Engine is running.</p> <p>└ Engine speed is 2,000 rpm.</p>	<p>2 - 3V</p>  <p style="text-align: right;">SEF191T</p>

TROUBLE DIAGNOSIS — General Description

ECM Terminals and Reference Value (Cont'd)

TER-MINAL NO.	WIRE COLOR	ITEM	CONDITION	DATA (DC voltage)	
4	W/G	ECCS relay (Self-shutoff)	Engine is running.	0 - 1V	GI
			Ignition switch "OFF" └ For 5 seconds after turning ignition switch "OFF"		MA
			Ignition switch "OFF" └ 5 seconds passed after turning ignition switch "OFF"	BATTERY VOLTAGE (11 - 14V)	EM LC
5	L	EVAP canister purge volume control valve	Engine is running. (Warm-up condition)	0 - 0.6V	EC
6	G		└ Idle speed		
7	PU (A/T models)	A/T check signal	Ignition switch "ON" Engine is running.	0 - 4V	FE
8	B/P	Fuel pump relay	Ignition switch "ON" └ For 5 seconds after turning ignition switch "ON"	0 - 1V	CL
			Engine is running.	MT	
			Ignition switch "ON" └ More than 5 seconds after turning ignition switch "ON"	BATTERY VOLTAGE (11 - 14V)	AT
10	B	ECM ground	Engine is running. └ Idle speed	Engine ground	FA
11	B/P	Fuel pump control module	When cranking the engine	Approximately 0.4V	RA
			Engine is running. (Warm-up condition) └ Idle speed	Approximately 10V	BR
13	LG (A/T models)	Cooling fan relay (High)	Engine is running. └ Cooling fan is not operating.	BATTERY VOLTAGE (11 - 14V)	ST
			Engine is running. └ Cooling fan (High) is operating.	0 - 0.6V	RS
14	LG/R	Cooling fan relay	Engine is running. └ Cooling fan is not operating.	BATTERY VOLTAGE (11 - 14V)	BT
			Engine is running. └ Cooling fan is operating.	0 - 0.6V	HA
15	G/Y	Air conditioner relay	Engine is running. └ Both A/C switch and blower switch are "ON".	0 - 0.6V	EL
			Engine is running. └ A/C switch is "OFF".	BATTERY VOLTAGE (11 - 14V)	IDX
16	Y	EVAP canister purge volume control valve	Engine is running.	BATTERY VOLTAGE (11 - 14V)	
17	OR		└ Idle speed		

TROUBLE DIAGNOSIS — General Description

ECM Terminals and Reference Value (Cont'd)

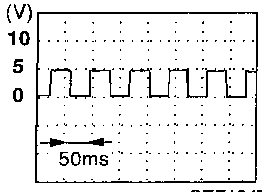
TER-MINAL NO.	WIRE COLOR	ITEM	CONDITION	DATA (DC voltage)
18	OR/L	Malfunction indicator lamp	Ignition switch "ON"	Approximately 0.1V
			Engine is running. └ Idle speed	BATTERY VOLTAGE (11 - 14V)
19	B	ECM ground	Engine is running. └ Idle speed	Engine ground
20	B/Y	Start signal	Ignition switch "ON"	Approximately 0V
			Ignition switch "START"	BATTERY VOLTAGE (11 - 14V)
21	L/W	Air conditioner switch	Engine is running. └ Both air conditioner switch and blower switch are "ON" (Compressor operates).	Approximately 0V
			Engine is running. └ Air conditioner switch is "OFF".	BATTERY VOLTAGE (11 - 14V)
22	G/OR	Park/neutral position (PNP) switch	Ignition switch "ON" └ Gear position is "Neutral position" (M/T models). └ Gear position is "N" or "P" (A/T models).	Approximately 0V
			Ignition switch "ON" └ Except the above gear position	BATTERY VOLTAGE (11 - 14V)
23	Y	Throttle position sensor	Ignition switch "ON" └ Accelerator pedal released	0.35 - 0.65V
			Ignition switch "ON" └ Accelerator pedal fully depressed	Approximately 4V
25	SB	Power steering oil pressure switch	Engine is running. └ Steering wheel is fully turned.	Approximately 0V
			Engine is running. └ Steering wheel is not turned.	Approximately 5V
26	PU/R	Vehicle speed sensor	Engine is running. └ Lift up the vehicle. └ In 2nd gear position └ Vehicle speed is 40 km/h (25 MPH).	0 - Approximately 4.2V  <small>SEF194T</small>
27	Y	Throttle position switch (Closed position)	Ignition switch "ON" (Warm-up condition) └ Accelerator pedal released	BATTERY VOLTAGE (11 - 14V)
			Ignition switch "ON" └ Accelerator pedal depressed	Approximately 0V
28	R/Y	Intake air temperature sensor	Engine is running.	Approximately 0 - 4.8V Output voltage varies with intake air temperature.

TROUBLE DIAGNOSIS — General Description

ECM Terminals and Reference Value (Cont'd)

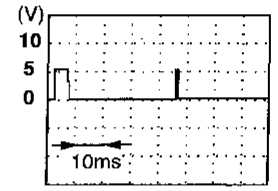
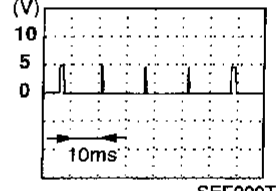
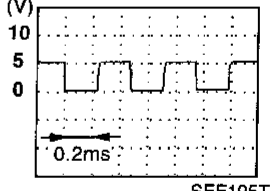
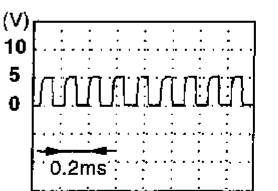
TER-MINAL NO.	WIRE COLOR	ITEM	CONDITION	DATA (DC voltage)
36	G/R	Fuel pump control module (FPCM) check	When cranking the engine	Approximately 0V
			Engine is running. (Warm-up condition) └ Idle speed	Approximately 5V
38	B/R	Ignition switch	Ignition switch "OFF"	0V
			Ignition switch "ON"	BATTERY VOLTAGE (11 - 14V)
39	B	ECM ground	Engine is running. └ Idle speed	Engine ground
40 44	L L	Camshaft position signal (Reference signal)	Engine is running. (Warm-up condition) └ Idle speed	0.1 - 0.4V 
			Engine is running. └ Engine speed is 2,000 rpm.	0.1 - 0.4V 
43	B	ECM ground	Engine is running. └ Idle speed	Engine ground (Probe this terminal with ⊖ tester probe when measuring.)
41 45	B/W B/W	Camshaft position sensor (Position signal)	Engine is running. (Warm-up condition) └ Idle speed	Approximately 2.5V 
			Engine is running. └ Engine speed is 2,000 rpm.	Approximately 2.4V 

GI
MA
EM
LC
EC
FE
CL
MT
AT
FA
RA
BR
ST
RS
BT
HA
EL
IDX

TROUBLE DIAGNOSIS — General Description

ECM Terminals and Reference Value (Cont'd)

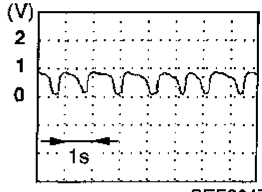
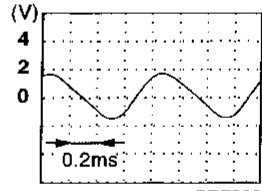
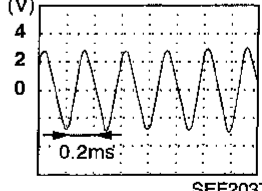
TER-MINAL NO.	WIRE COLOR	ITEM	CONDITION	DATA (DC voltage)
46	W	Front heated oxygen sensor	<p>Engine is running.</p> <p>After warming up to normal operating temperature and engine speed is 2,000 rpm</p>	<p>0 - Approximately 0.7V</p>  <p style="text-align: right;">SEF201T</p>
47	OR	Mass air flow sensor	<p>Engine is running. (Warm-up condition)</p> <p>Idle speed</p>	1.3 - 1.7V
			<p>Engine is running. (Warm-up condition)</p> <p>Engine speed is 2,500 rpm.</p>	1.8 - 2.4V
48	W	Mass air flow sensor ground	<p>Engine is running. (Warm-up condition)</p> <p>Idle speed</p>	Approximately 0V
49	P/L	Sensors' power supply	Ignition switch "ON"	Approximately 5V
50	B	Sensors' ground	<p>Engine is running. (Warm-up condition)</p> <p>Idle speed</p>	Approximately 0V
51	BR/Y	Engine coolant temperature sensor	Engine is running.	Approximately 0 - 4.8V Output voltage varies with engine coolant temperature.
52	W	Rear heated oxygen sensor	<p>Engine is running.</p> <p>After warming up to normal operating temperature and engine speed is 2,000 rpm</p>	0 - Approximately 1.0V
53	W	Crankshaft position sensor (OBD)	<p>Engine is running. (Warm-up condition)</p> <p>Idle speed</p>	<p>Approximately 0V</p>  <p style="text-align: right;">SEF202T</p>
			<p>Engine is running.</p> <p>Engine speed is 2,000 rpm.</p>	<p>Approximately 0V</p>  <p style="text-align: right;">SEF203T</p>
54	W	Knock sensor	<p>Engine is running.</p> <p>Idle speed</p>	2.0 - 3.0V
56 61	W/R W/R	Power supply for ECM	Ignition switch "ON"	BATTERY VOLTAGE (11 - 14V)
58	L/B	Data link connector for GST	<p>Engine is running.</p> <p>Idle speed (GST is disconnected.)</p>	6 - 10V

TROUBLE DIAGNOSIS — General Description

ECM Terminals and Reference Value (Cont'd)

TER-MINAL NO.	WIRE COLOR	ITEM	CONDITION	DATA (DC voltage)	
62	R/B	EGR temperature sensor	Engine is running. (Warm-up condition) └ Idle speed	Less than 4.5V	GI
			Engine is running. (Warm-up condition) └ EGR system is operating.	0 - 1.5V	MA
63	LG/R	Tank fuel temperature sensor	Engine is running.	Approximately 0 - 4.8V Output voltage varies with fuel temperature.	EM
64	G/B	Data link connector for CONSULT	Engine is running.	Approximately 0V	LC
65	GY/L		└ Idle speed (CONSULT is connected and turned on.)	Approximately 4 - 9V	EC
68	G/W			Approximately 3.5V	
66	W	Absolute pressure sensor	Ignition switch "ON" └ For 5 seconds after turning ignition switch "ON"	Approximately 4.4V	FE
			Engine is running. └ For 5 seconds after starting engine		CL
			Engine is running. (Warm-up condition) └ More than 5 seconds after starting engine	Approximately 1.4V	MT
67	W	EVAP control system pressure sensor	Ignition switch "ON"	Approximately 3.4V	AT
69	GY/R	MAP/BARO switch solenoid valve	Ignition switch "ON" └ For 5 seconds after turning ignition switch "ON"	0 - 1V	FA
			Engine is running. └ For 5 seconds after starting engine		RA
			Ignition switch "ON" └ More than 5 seconds after turning ignition switch "ON"	BATTERY VOLTAGE (11 - 14V)	BR
Engine is running. └ More than 5 seconds after starting engine	ST				
70	W/L	Power supply for ECM (Back-up)	Ignition switch "OFF"	BATTERY VOLTAGE (11 - 14V)	
101	SB	IACV-AAC valve	Engine is running. (Warm-up condition) └ Idle speed	Approximately 10V	RS
			Engine is running. (Warm-up condition) └ Engine speed is 2,000 rpm.	Approximately 10V	BT

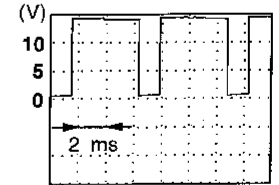

SEF645U

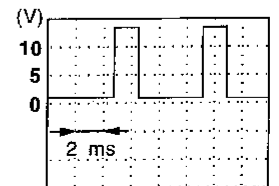

SEF646U

TROUBLE DIAGNOSIS — General Description

ECM Terminals and Reference Value (Cont'd)

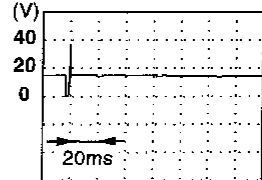
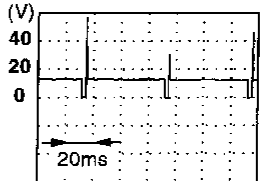
TER-MINAL NO.	WIRE COLOR	ITEM	CONDITION	DATA (DC voltage)
102 104 107 109	R/B G/B Y/B L/B	Injector No. 1 Injector No. 3 Injector No. 2 Injector No. 4	Engine is running. (Warm-up condition) └ Idle speed	BATTERY VOLTAGE (11 - 14V)  SEF204T
			Engine is running. (Warm-up condition) └ Engine speed is 2,000 rpm.	BATTERY VOLTAGE (11 - 14V)  SEF205T
103	P	EGRC-solenoid valve	Engine is running. (Warm-up condition) └ M/T models: Lift up drive wheels and shift to 1st gear position. └ Rev engine up from 2,000 to 4,000 rpm.	0 - 0.7V
			Engine is running. (Warm-up condition) └ Idle speed	BATTERY VOLTAGE (11 - 14V)
105	PU	EVAP canister purge control solenoid valve	Engine is running. (Warm-up condition) └ More than 60 seconds after starting engine └ M/T models: Lift up drive wheels and drive at 16 km/h (10 MPH). └ Engine speed is 2,000 rpm.	Approximately 0V
			Engine is running. (Warm-up condition) └ Idle speed	BATTERY VOLTAGE (11 - 14V)
106	B	ECM ground	Engine is running. └ Idle speed	Engine ground
108	PU/W	EVAP canister vent control valve	Ignition switch "ON"	BATTERY VOLTAGE (11 - 14V)
110	R/Y	Rear heated oxygen sensor heater	Engine is running. └ Idle speed {after driving 2 minutes at 70 km/h (43 MPH) or more.}	Approximately 0.7V
			Ignition switch "ON" └ Engine stopped.	BATTERY VOLTAGE (11 - 14V)
112	B	ECM ground	Engine is running. └ Idle speed	Engine ground
113	W/L	Current return	Engine is running. └ Idle speed	BATTERY VOLTAGE (11 - 14V)

TROUBLE DIAGNOSIS — General Description

ECM Terminals and Reference Value (Cont'd)

TER-MINAL NO.	WIRE COLOR	ITEM	CONDITION	DATA (DC voltage)
115	OR	Front heated oxygen sensor heater	Engine is running.	Approximately 0V
			└ Engine speed is below 3,200 rpm	
117	PU/R	Vacuum cut valve bypass valve	Engine is running.	BATTERY VOLTAGE (11 - 14V)
			└ Engine speed is above 3,200 rpm	
118	B	ECM ground	Ignition switch "ON"	BATTERY VOLTAGE (11 - 14V)
118	B	ECM ground	Engine is running.	Engine ground
			└ Idle speed	

GI

MA

EM

LC

EC

FE

CL

MT

AT

FA

RA

BR

ST

RS

BT

HA

EL

IDX

TROUBLE DIAGNOSIS FOR INTERMITTENT INCIDENT

Description

Intermittent incidents (I/I) may occur. In many cases, the problem resolves itself (the part or circuit function returns to normal without intervention). It is important to realize that the symptoms described in the customer's complaint often do not recur on DTC (1st trip) visits. Realize also that the most frequent cause of I/I occurrences is poor electrical connections. Because of this, the conditions under which the incident occurred may not be clear. Therefore, circuit checks made as part of the standard diagnostic procedure may not indicate the specific problem area.

Common I/I Report Situations

STEP in Work Flow	Situation
II	The CONSULT is used. The SELF-DIAG RESULTS screen shows time data other than "0" or "1".
III	The symptom described by the customer does not recur.
IV	(1st trip) DTC data does not appear during the DTC CONFIRMATION PROCEDURE.
VI	The TROUBLE DIAGNOSIS for PXXXX does not indicate the problem area.

Diagnostic Procedure

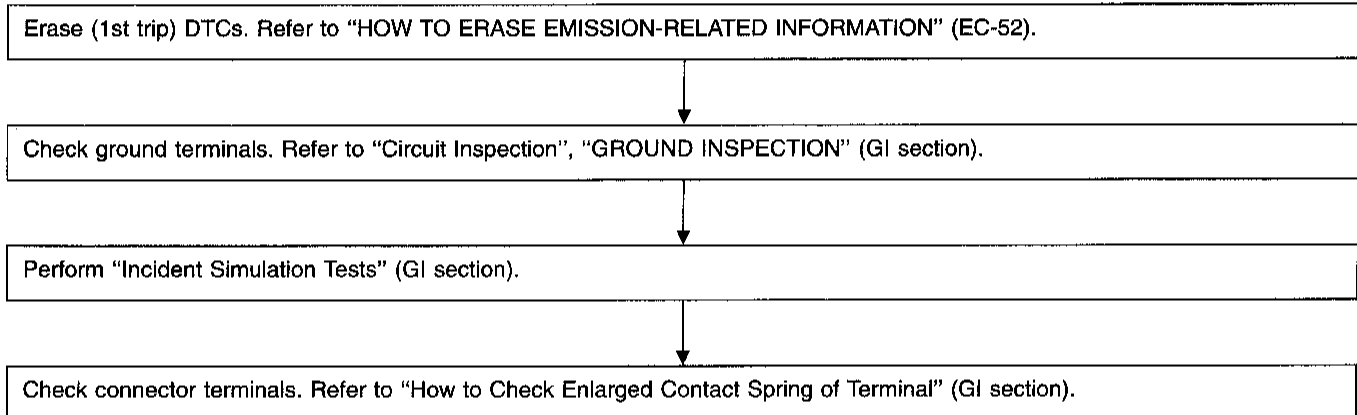

TROUBLE DIAGNOSIS FOR POWER SUPPLY

Main Power Supply and Ground Circuit

EC-MAIN-01

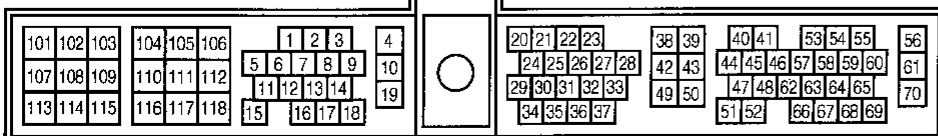
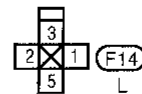
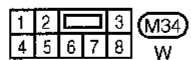
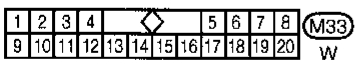
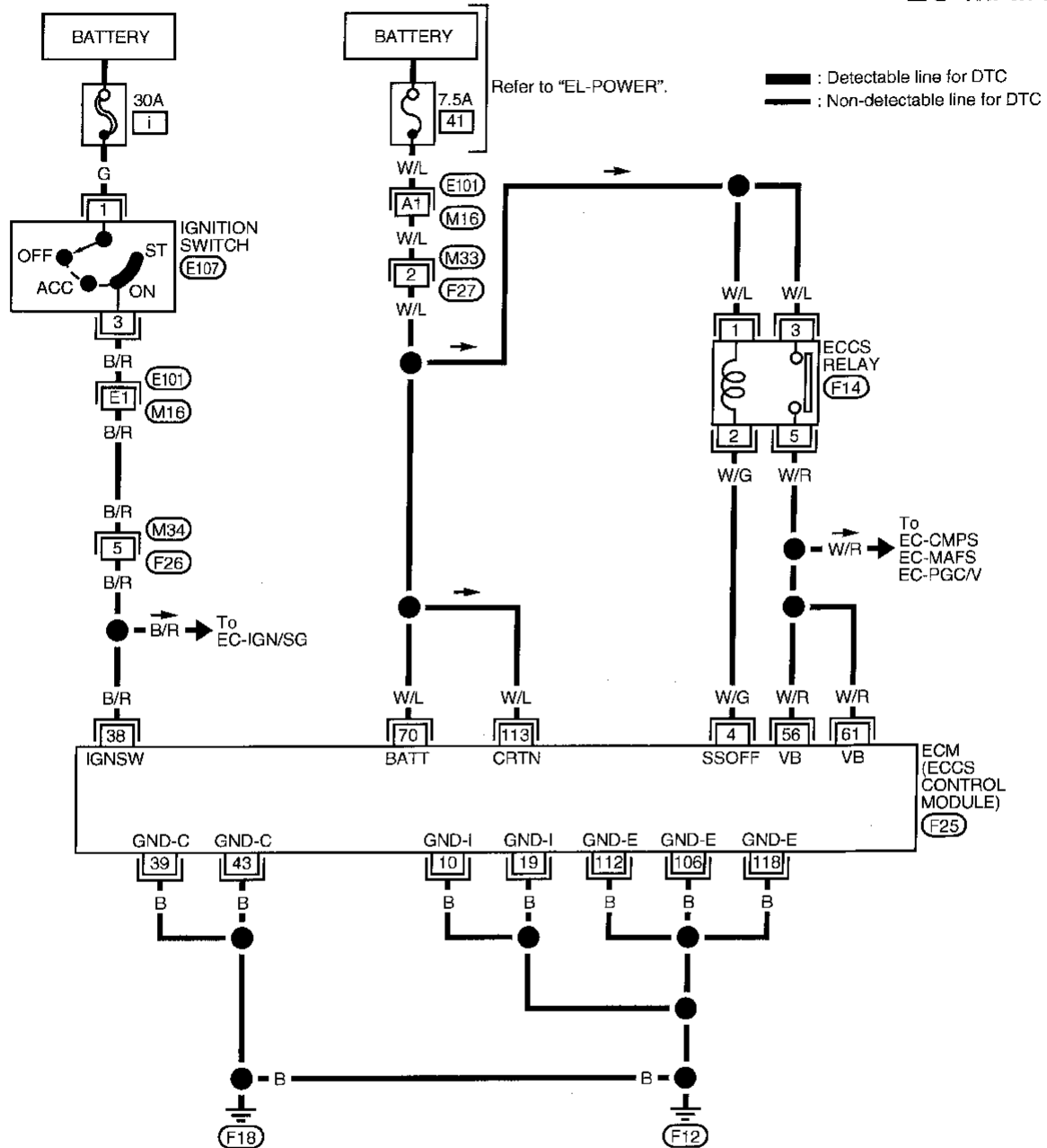

Refer to last page (Foldout page).

(M16), (E101)

TROUBLE DIAGNOSIS FOR POWER SUPPLY

Main Power Supply and Ground Circuit (Cont'd)

ECM TERMINALS AND REFERENCE VALUE

Specification data are reference values and are measured between each terminal and engine ground.

TER-MINAL NO.	WIRE COLOR	ITEM	CONDITION	DATA (DC voltage)
4	W/G	ECCS relay (Self-shutoff)	Engine is running. Ignition switch "OFF" └ For 5 seconds after turning ignition switch "OFF"	0 - 1V
			Ignition switch "OFF" └ 5 seconds passed after turning ignition switch "OFF"	BATTERY VOLTAGE (11 - 14V)
10	B	ECM ground	Engine is running. └ Idle speed	Engine ground
19	B	ECM ground	Engine is running. └ Idle speed	Engine ground
38	B/R	Ignition switch	Ignition switch "OFF"	0V
			Ignition switch "ON"	BATTERY VOLTAGE (11 - 14V)
39	B	ECM ground	Engine is running. └ Idle speed	Engine ground
43	B	ECM ground	Engine is running. └ Idle speed	Engine ground (Probe this terminal with ⊖ tester probe when measuring.)
56 61	W/R W/R	Power supply for ECM	Ignition switch "ON"	BATTERY VOLTAGE (11 - 14V)
70	W/L	Power supply for ECM (Back-up)	Ignition switch "OFF"	BATTERY VOLTAGE (11 - 14V)
106	B	ECM ground	Engine is running. └ Idle speed	Engine ground
112	B	ECM ground	Engine is running. └ Idle speed	Engine ground
113	W/L	Current return	Engine is running. └ Idle speed	BATTERY VOLTAGE (11 - 14V)
118	B	ECM ground	Engine is running. └ Idle speed	Engine ground

TROUBLE DIAGNOSIS FOR POWER SUPPLY

Main Power Supply and Ground Circuit (Cont'd)

DIAGNOSTIC PROCEDURE

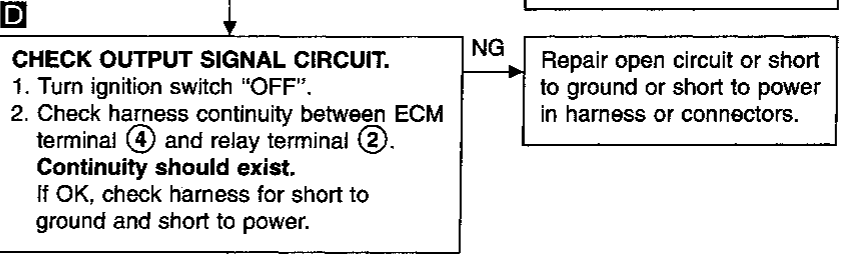
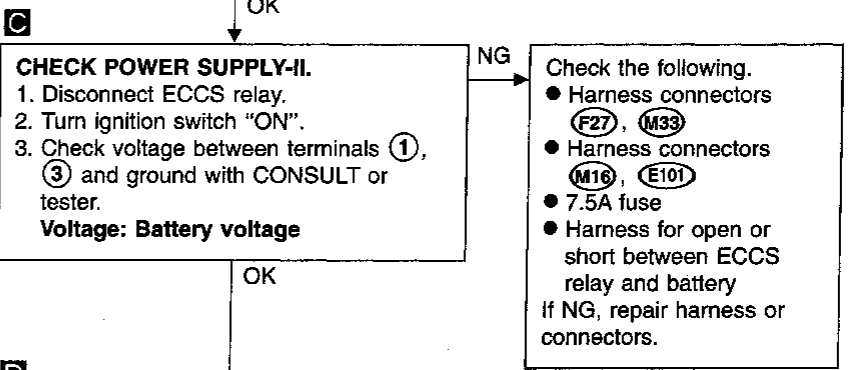
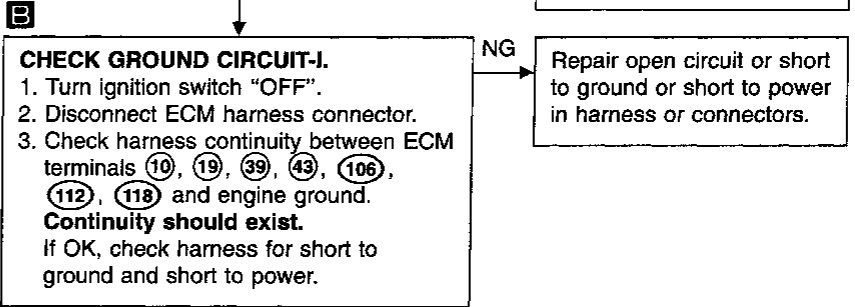
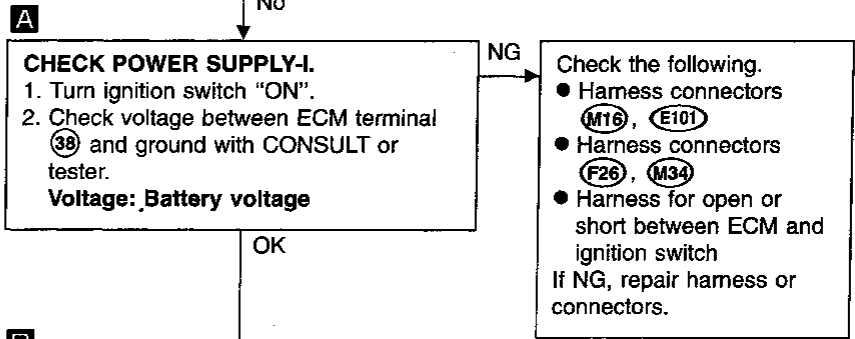
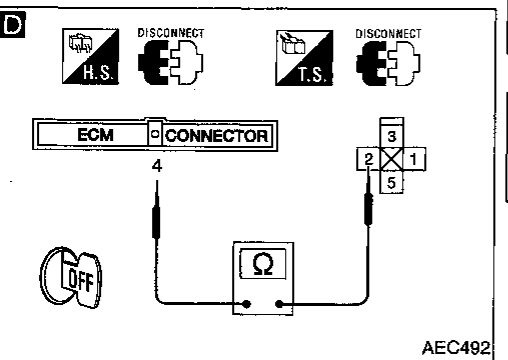
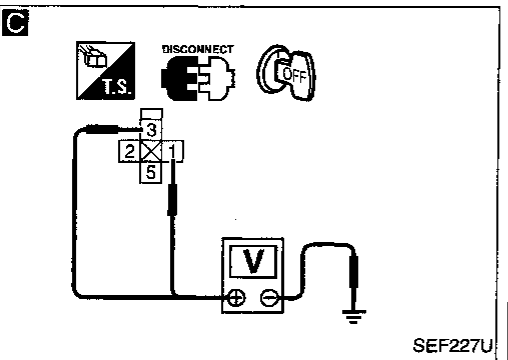
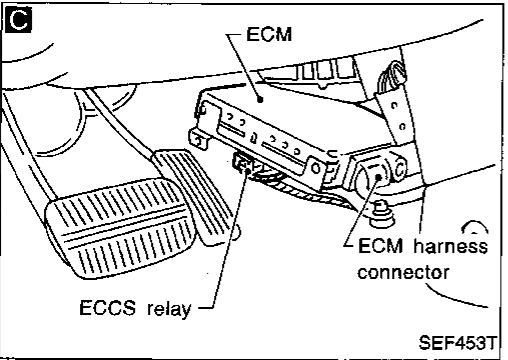
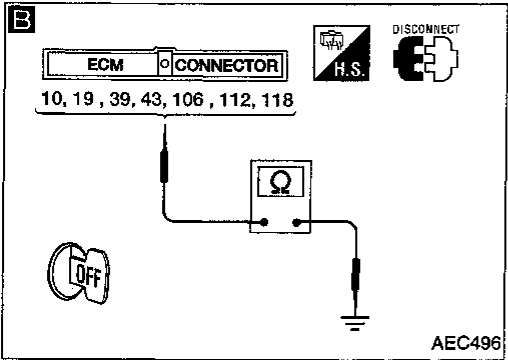
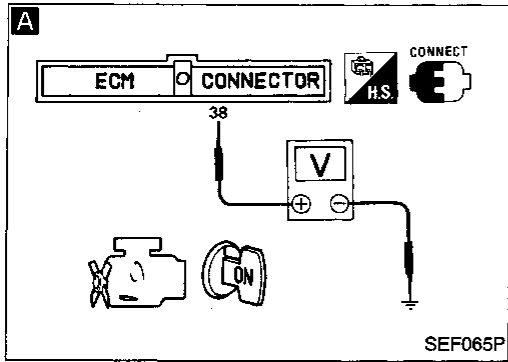
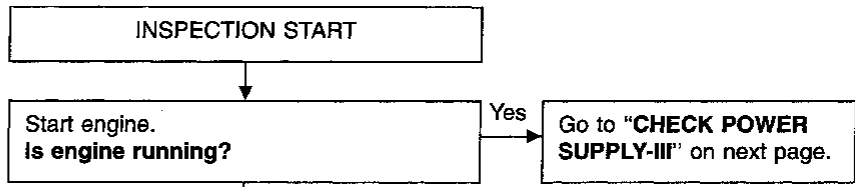

Go to "TROUBLE DIAGNOSIS FOR NON-DETECTABLE ITEM (Injector)", EC-469.

↓ OK
 (A)
 (Go to next page.)

GI
 MA
 EM
 LC
EC
 FE
 CL
 MT
 AT
 FA
 RA
 BR
 ST
 RS
 BT
 HA
 EL
 IDX

TROUBLE DIAGNOSIS FOR POWER SUPPLY

Main Power Supply and Ground Circuit (Cont'd)

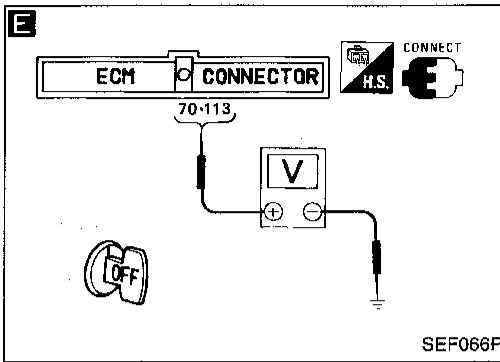

E

CHECK POWER SUPPLY-III.
Check voltage between ECM terminals (70), (113) and ground with CONSULT or tester.
Voltage: Battery voltage

NG

Check the following.

- Harness connectors (M16), (E101)
- Harness connectors (F27), (M33)
- Harness for open or short between ECM and fuse

If NG, repair harness or connectors.

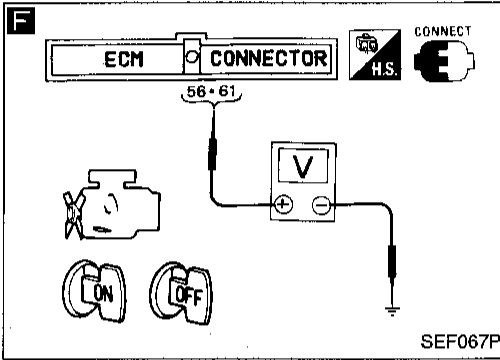

F

CHECK POWER SUPPLY-IV.
1. Turn ignition switch "ON" and then "OFF".
2. Check voltage between ECM terminals (56), (61) and ground with CONSULT or tester.
Voltage: After turning ignition switch "OFF", battery voltage will exist for a few seconds, then drop to approximately 0V.

OK

Go to **K** "CHECK GROUND CIRCUIT-II" on next page.

Case-1: Battery voltage does not exist.
Case-2: Battery voltage exists for more than a few seconds.

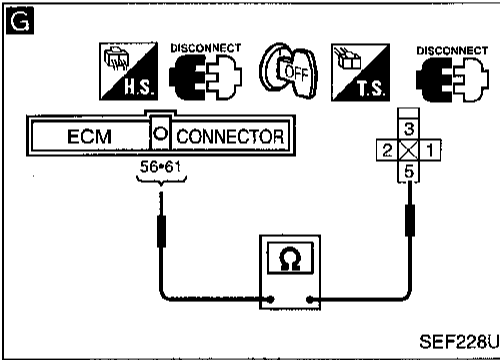

G

CHECK HARNESS CONTINUITY BETWEEN ECCS RELAY AND ECM.
1. Disconnect ECM harness connector.
2. Disconnect ECCS relay.
3. Check harness continuity between ECM terminals (56), (61) and relay terminal (5).
Continuity should exist.
If OK, check harness for short to ground and short to power.

NG

Repair open circuit or short to ground or short to power in harness or connectors.

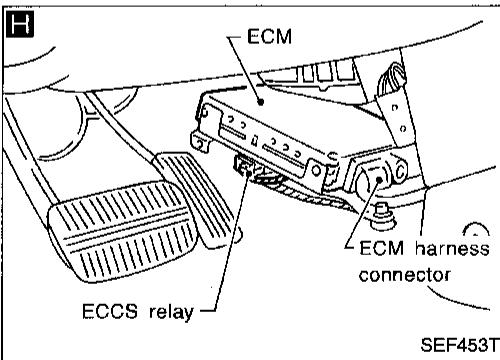

H

CHECK VOLTAGE BETWEEN ECCS RELAY AND GROUND.
Check voltage between relay terminals (1), (3) and ground with CONSULT or tester.
Voltage: Battery voltage

NG

Check the following.

- Harness for open or short between ECCS relay and 7.5A fuse

If NG, repair harness or connectors.

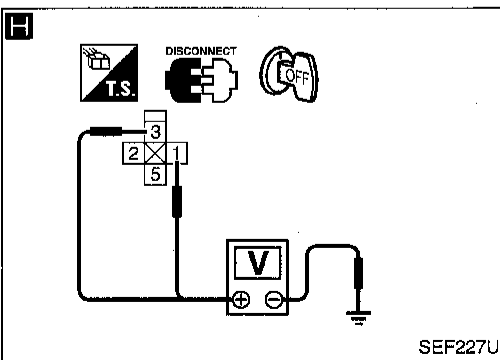

OK

(Go to next page.)

TROUBLE DIAGNOSIS FOR POWER SUPPLY

Main Power Supply and Ground Circuit (Cont'd)

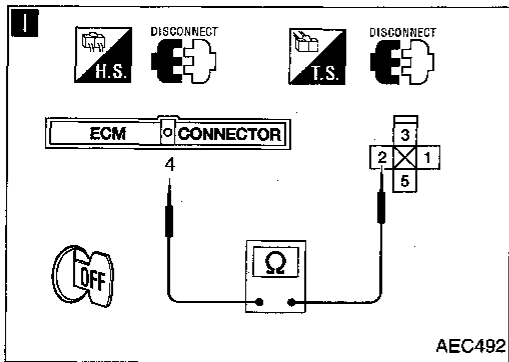

I

CHECK OUTPUT SIGNAL CIRCUIT.
Check harness continuity between ECM terminal (4) and relay terminal (2).
Continuity should exist.
If OK, check harness for short to ground and short to power.

NG → Repair open circuit or short to ground or short to power in harness or connectors.

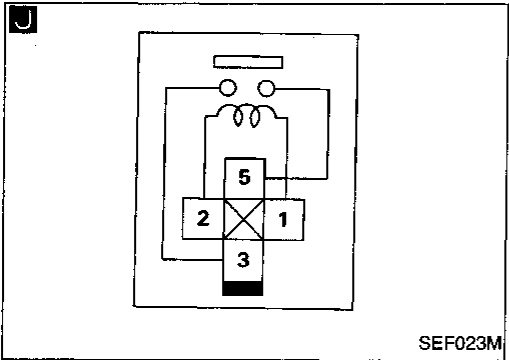

J

CHECK ECCS RELAY.
1. Apply 12V direct current between relay terminals (1) and (2).
2. Check continuity between relay terminals (3) and (5).
12V (1 - 2) applied:
Continuity exists.
No voltage applied:
No continuity

NG → Replace ECCS relay.

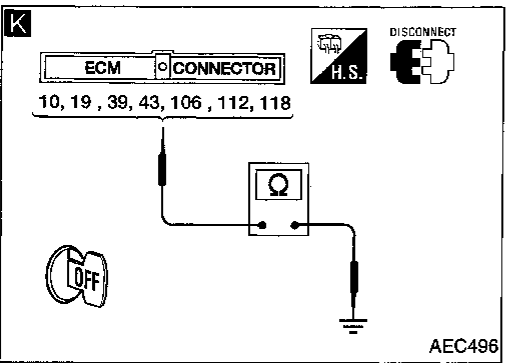

K

CHECK GROUND CIRCUIT-II.
1. Turn ignition switch "OFF".
2. Disconnect ECM harness connector.
3. Check harness continuity between ECM terminals (10), (19), (39), (43), (106), (112), (118) and engine ground.
Continuity should exist.
If OK, check harness for short to ground and short to power.

NG → Repair open circuit or short to ground or short to power in harness or connectors.

OK → Perform "TROUBLE DIAGNOSIS FOR INTERMITTENT INCIDENT", EC-106.

INSPECTION END

GI

MA

EM

LC

EC

FE

CL

MT

AT

FA

RA

BR

ST

RS

BT

HA

EL

IDX

TROUBLE DIAGNOSIS FOR DTC P0100

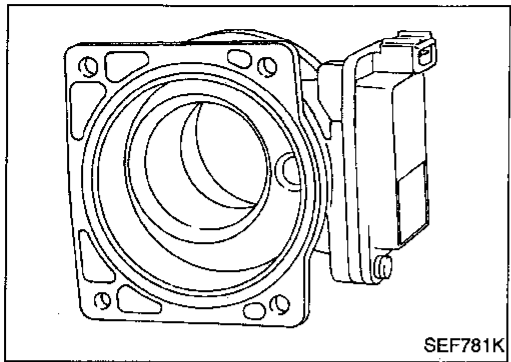

Mass Air Flow Sensor (MAFS)

COMPONENT DESCRIPTION

The mass air flow sensor is placed in the stream of intake air. It measures the intake flow rate by measuring a part of the entire intake flow. It consists of a hot wire that is supplied with electric current from the ECM. The temperature of the hot wire is controlled by the ECM a certain amount. The heat generated by the hot wire is reduced as the intake air flows around it. The more air, the greater the heat loss.

Therefore, the ECM must supply more electric current to maintain the temperature of the hot wire as air flow increases. The ECM detects the air flow by means of this current change.

CONSULT REFERENCE VALUE IN DATA MONITOR MODE

Specification data are reference values.

MONITOR ITEM	CONDITION	SPECIFICATION
MAS AIR/FL SE	<ul style="list-style-type: none"> ● Engine: After warming up ● Air conditioner switch: "OFF" ● Shift lever: "N" ● No-load Idle	1.3 - 1.7V
	2,500 rpm	1.8 - 2.4V
CAL/LD VALUE	<ul style="list-style-type: none"> ● Engine: After warming up ● Air conditioner switch: "OFF" ● Shift lever: "N" ● No-load Idle	20.0 - 35.5%
	2,500 rpm	17.0 - 30.0%
MASS AIRFLOW	<ul style="list-style-type: none"> ● Engine: After warming up ● Air conditioner switch: "OFF" ● Shift lever: "N" ● No-load Idle	2.5 - 5.0 g/m/s
	2,500 rpm	7.1 - 12.5 g/m/s

ECM TERMINALS AND REFERENCE VALUE

Specification data are reference values and are measured between each terminal and engine ground.

TER-MINAL NO.	WIRE COLOR	ITEM	CONDITION	DATA (DC voltage)
47	OR	Mass air flow sensor	Engine is running. (Warm-up condition) └ Idle speed	1.3 - 1.7V
			Engine is running. (Warm-up condition) └ Engine speed is 2,500 rpm.	1.8 - 2.4V
48	W	Mass air flow sensor ground	Engine is running. (Warm-up condition) └ Idle speed	Approximately 0V

TROUBLE DIAGNOSIS FOR DTC P0100

Mass Air Flow Sensor (MAFS) (Cont'd)

ON BOARD DIAGNOSIS LOGIC

Diagnostic Trouble Code No.	Malfunction is detected when ...	Check Items (Possible Cause)	
P0100 0102	A) An excessively high voltage from the sensor is sent to ECM when engine is not running.	<ul style="list-style-type: none"> ● Harness or connectors (The sensor circuit is open or shorted.) ● Mass air flow sensor 	GI
	C) A high voltage from the sensor is sent to ECM under light load driving condition.		MA
	B) An excessively low voltage from the sensor is sent to ECM* when engine is running.	<ul style="list-style-type: none"> ● Harness or connectors (The sensor circuit is open or shorted.) ● Intake air leaks ● Mass air flow sensor 	EM
	D) A low voltage from the sensor is sent to ECM under heavy load driving condition.		LC

*: When this malfunction is detected, the ECM enters fail-safe mode and the MIL lights up.

Detected items	Engine operating condition in fail-safe mode	
Mass air flow sensor circuit	Engine speed will not rise more than 2,400 rpm due to the fuel cut.	FE
		CL

DIAGNOSTIC TROUBLE CODE CONFIRMATION PROCEDURE

Perform "Procedure for malfunction A" first. If the 1st trip DTC cannot be confirmed, perform "Procedure for malfunction B". If there is no problem on "Procedure for malfunction B", perform "Procedure for malfunction C". If there is no problem on "Procedure for malfunction C", perform "Procedure for malfunction D".

CAUTION:

Always drive vehicle at a safe speed.

NOTE:

If "DIAGNOSTIC TROUBLE CODE CONFIRMATION PROCEDURE" has been previously conducted, always turn ignition switch "OFF" and wait at least 5 seconds before conducting the next test.

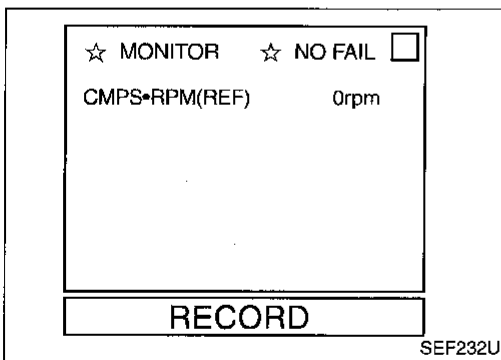

Procedure for malfunction A

- 1) Turn ignition switch "ON".
- 2) Select "DATA MONITOR" mode with CONSULT.
- 3) Wait at least 6 seconds.
- 4) If 1st trip DTC is detected, go to "DIAGNOSTIC PROCEDURE", EC-118.

OR

- 1) Turn ignition switch "ON", and wait at least 6 seconds.
- 2) Select "MODE 7" with GST.
- 3) If 1st trip DTC is detected, go to "DIAGNOSTIC PROCEDURE", EC-118.

OR

- 1) Turn ignition switch "ON", and wait at least 6 seconds.
- 2) Turn ignition switch "OFF", wait at least 5 seconds and then turn "ON".
- 3) Perform "Diagnostic Test Mode II (Self-diagnostic results)" with ECM.
- 4) If 1st trip DTC is detected, go to "DIAGNOSTIC PROCEDURE", EC-118.

TROUBLE DIAGNOSIS FOR DTC P0100

Mass Air Flow Sensor (MAFS) (Cont'd)

Procedure for malfunction B

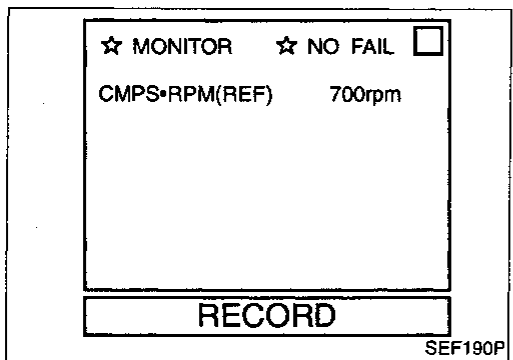

- 1) Turn ignition switch "ON".
- 2) Select "DATA MONITOR" mode with CONSULT.
- 3) Start engine and wait 5 seconds at most.
- 4) If 1st trip DTC is detected, go to "DIAGNOSTIC PROCEDURE", EC-118.

OR

- 1) Turn ignition switch "ON".
- 2) Start engine and wait 5 seconds at most.
- 3) Select "MODE 7" with GST.
- 4) If 1st trip DTC is detected, go to "DIAGNOSTIC PROCEDURE", EC-118.

OR

- 1) Turn ignition switch "ON".
- 2) Start engine and wait 5 seconds at most.
- 3) Turn ignition switch "OFF", wait at least 5 seconds and then turn "ON".
- 4) Perform "Diagnostic Test Mode II (Self-diagnostic results)" with ECM.
- 5) If 1st trip DTC is detected, go to "DIAGNOSTIC PROCEDURE", EC-118.

NOTE:

If 1st trip DTC confirmed after more than 5 seconds, there may be malfunction C.

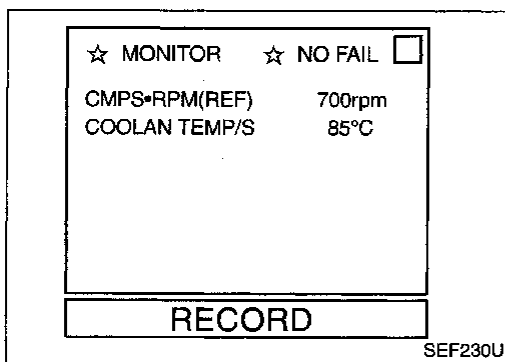

Procedure for malfunction C

NOTE:

If engine will not start or stops soon, wait at least 10 seconds with engine stopped (ignition switch "ON") instead of running engine at idle speed.

- 1) Turn ignition switch "ON".
- 2) Select "DATA MONITOR" mode with CONSULT.
- 3) Start engine and warm it up to normal operating temperature.
- 4) Run engine for at least 10 seconds at idle speed.
- 5) If 1st trip DTC is detected, go to "DIAGNOSTIC PROCEDURE", EC-118.

OR

- 1) Start engine and warm it up to normal operating temperature.
- 2) Run engine for at least 10 seconds at idle speed.
- 3) Select "MODE 7" with GST.
- 4) If 1st trip DTC is detected, go to "DIAGNOSTIC PROCEDURE", EC-118.

OR

- 1) Start engine and warm it up to normal operating temperature.

TROUBLE DIAGNOSIS FOR DTC P0100

Mass Air Flow Sensor (MAFS) (Cont'd)

- 2) Run engine for at least 10 seconds at idle speed.
- 3) Turn ignition switch "OFF", wait at least 5 seconds and then turn "ON".
- 4) Perform "Diagnostic Test Mode II (Self-diagnostic results)" with ECM.
- 5) If 1st trip DTC is detected, go to "DIAGNOSTIC PROCEDURE", EC-118.

GI

MA

EM

LC

EC

FE

CL

MT

AT

FA

RA

BR

ST

RS

BT

HA

EL

IDX

TROUBLE DIAGNOSIS FOR DTC P0100

Mass Air Flow Sensor (MAFS) (Cont'd)

Procedure for malfunction D

- 1) Turn ignition switch "ON".
- 2) Start engine and warm it up to normal operating temperature.
If engine cannot be started, go to "DIAGNOSTIC PROCEDURE", EC-118.
- 3) Select "DATA MONITOR" mode with CONSULT.
- 4) Check the voltage of MAS AIR/FL SE with "DATA MONITOR".
- 5) Increases engine speed to about 4,000 rpm.
- 6) Monitor the linear voltage rise in response to engine speed increases.
If NG, go to "DIAGNOSTIC PROCEDURE", EC-118.
If OK, go to following step.
- 7) Maintain the following conditions for at least 10 consecutive seconds.
CMPS-RPM (REF): More than 2,000 rpm
THRTL POS SEN: More than 3V
Selector lever: Suitable position
Driving location: Driving vehicle uphill (Increased engine load) will help maintain the driving conditions required for this test.
- 8) If 1st trip DTC is detected, go to "DIAGNOSTIC PROCEDURE", EC-118.

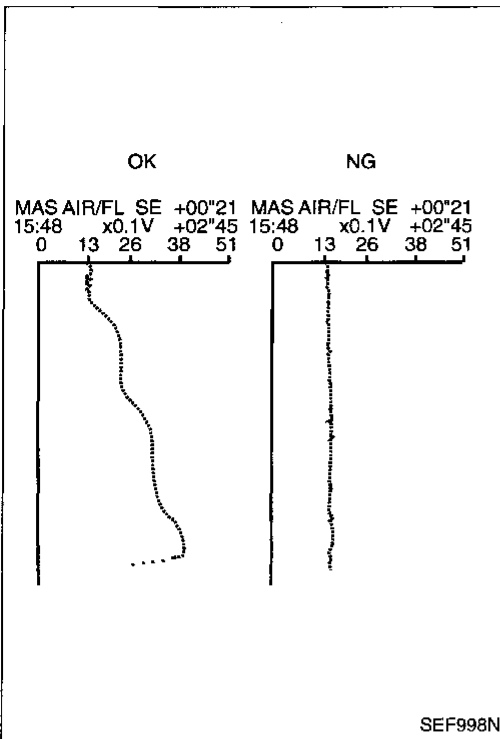

☆ MONITOR	☆ NO FAIL	<input type="checkbox"/>
CMPS-RPM(REF)	3000rpm	
VHCL SPEED SE	70km/h	
THRTL POS SEN	3.2V	
RECORD		

SEF231U

CALC LOAD	20%
COOLANT TEMP	95°C
SHORT FT #1	2%
LONG FT #1	0%
SHORT FT #2	4%
LONG FT #2	0%
ENGINE SPD	2637RPM
VEHICLE SPD	0MPH
IGN ADVANCE	41.0°
INTAKE AIR	41°C
MAF	14.1gm/sec
THROTTLE POS	3%

SEF534P

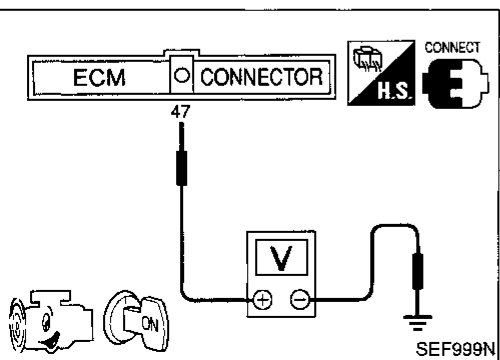

OVERALL FUNCTION CHECK

Use this procedure to check the overall function of the mass air flow sensor circuit. During this check, a 1st trip DTC might not be confirmed.

Procedure for malfunction D

- 1) Turn ignition switch "ON".
 - 2) Start engine and warm it up to normal operating temperature.
 - 3) Select "MODE 1" with GST. *
 - 4) Check the mass air flow sensor signal with "MODE 1".
 - 5) Check for linear mass air flow rise in response to increases to about 4,000 rpm in engine speed.
 - 6) If NG, go to "DIAGNOSTIC PROCEDURE", EC-118.
- OR
- 1) Turn ignition switch "ON".
 - 2) Start engine and warm it up to normal operating temperature.
 - 3) Check the voltage between ECM terminal ④7 and engine ground.
 - 4) Check for linear voltage rise in response to increases to about 4,000 rpm in engine speed.
 - 5) If NG, go to "DIAGNOSTIC PROCEDURE", EC-118.

TROUBLE DIAGNOSIS FOR DTC P0100

Mass Air Flow Sensor (MAFS) (Cont'd)

EC-MAFS-01

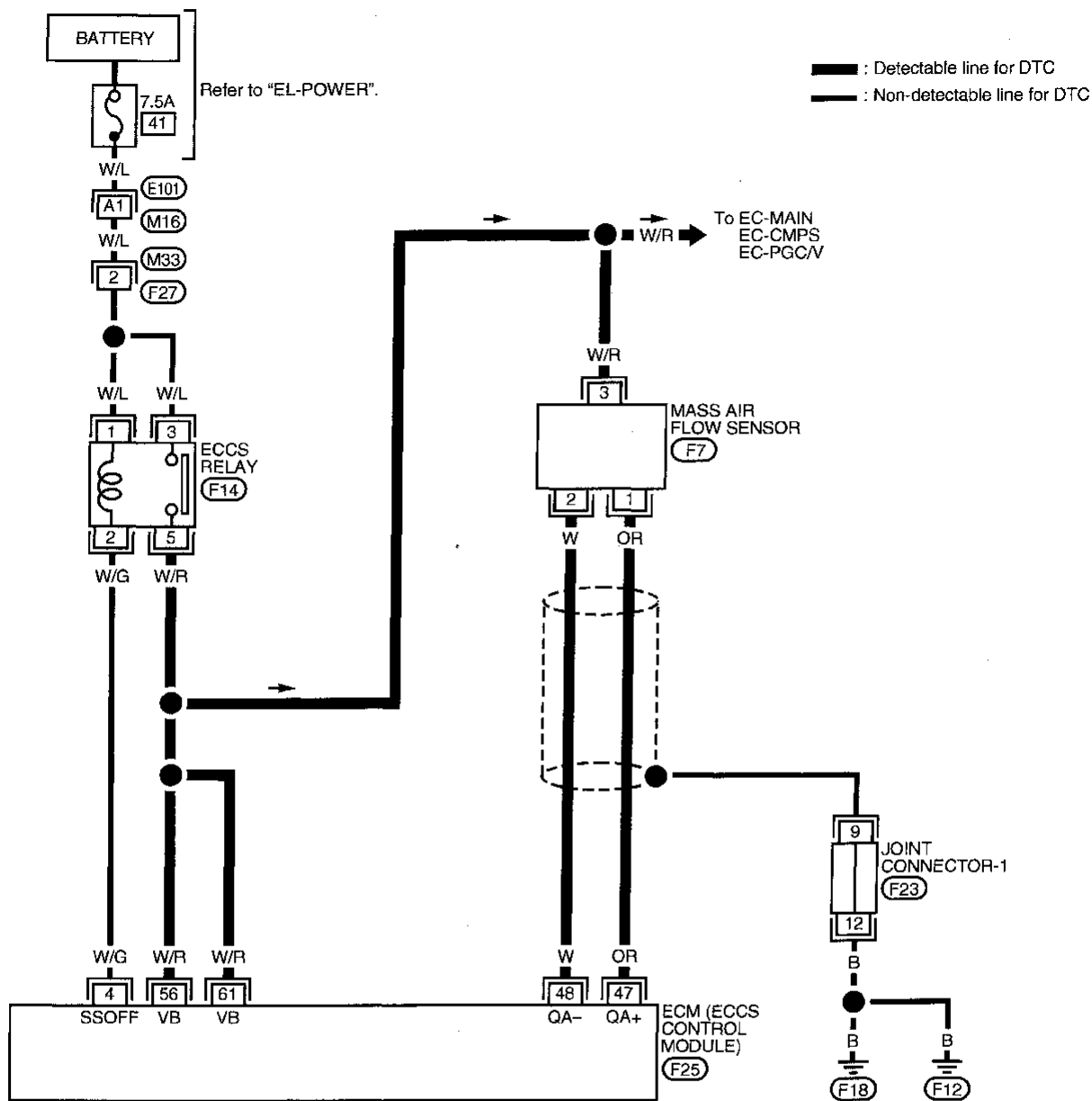

GI
MA
EM
LC
EC
FE
CL
MT
AT
FA
RA
BR
ST
RS
BT
HA
EL
IDX

Refer to last page (Foldout page).

(M16) (E101)
(F23)

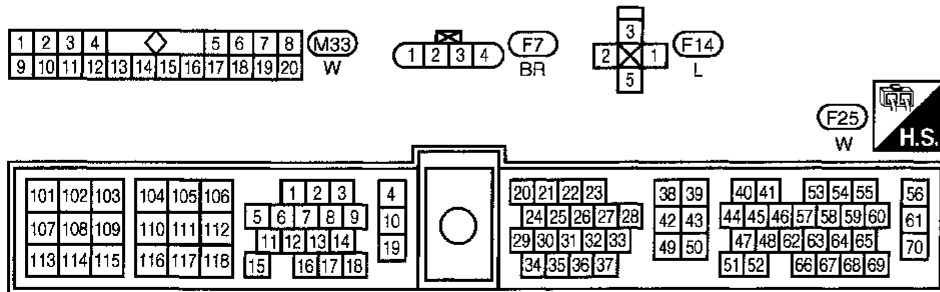

TROUBLE DIAGNOSIS FOR DTC P0100

Mass Air Flow Sensor (MAFS) (Cont'd)

DIAGNOSTIC PROCEDURE

If the trouble is duplicated after "Procedure for malfunction A or C", perform "Procedure A" below. If the trouble is duplicated after "Procedure for malfunction B or D", perform "Procedure B" on next page.

Procedure A

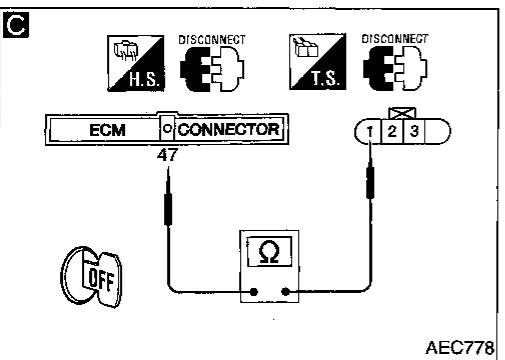
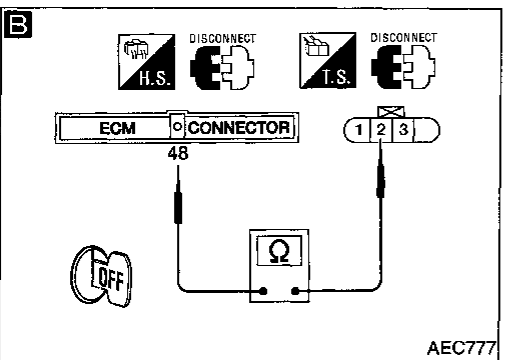
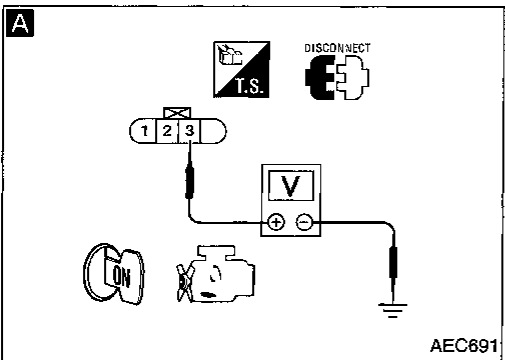
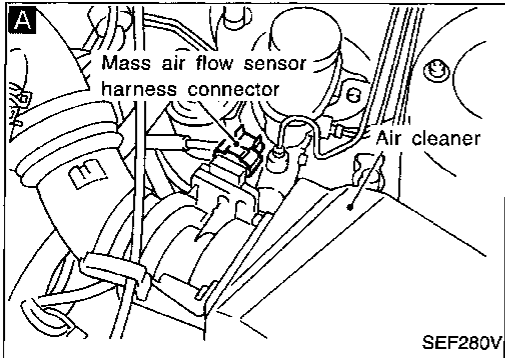
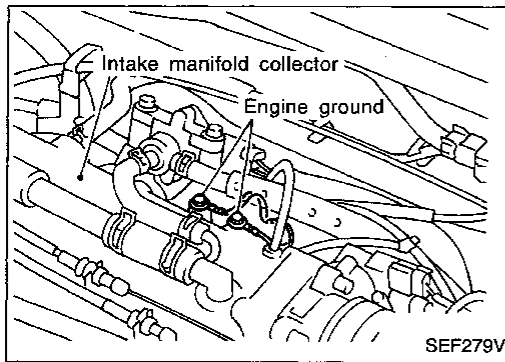

INSPECTION START

1. Turn ignition switch "OFF".
2. Loosen and retighten engine ground screws.

A

CHECK POWER SUPPLY.

1. Disconnect mass air flow sensor harness connector.
2. Turn ignition switch "ON".
3. Check voltage between terminal ③ and ground with CONSULT or tester.

Voltage: Battery voltage

NG

Check the following.

- Harness for open or short between ECCS relay and mass air flow sensor
- Harness for open or short between mass air flow sensor and ECM

If NG, repair harness or connectors.

B

CHECK GROUND CIRCUIT.

1. Turn ignition switch "OFF".
2. Disconnect ECM harness connector.
3. Check harness continuity between terminal ② and ECM terminal ④⑧.

Continuity should exist.

If OK, check harness for short to ground and short to power.

NG

Repair open circuit or short to ground or short to power in harness or connectors.

C

CHECK INPUT SIGNAL CIRCUIT.

Check harness continuity between terminal ① and ECM terminal ④⑦.

Continuity should exist.

If OK, check harness for short to ground and short to power.

NG

Repair open circuit or short to ground or short to power in harness or connectors.

OK

Ⓐ

(Go to next page.)

TROUBLE DIAGNOSIS FOR DTC P0100

Mass Air Flow Sensor (MAFS) (Cont'd)

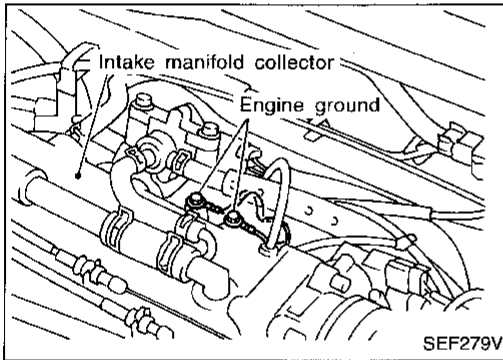
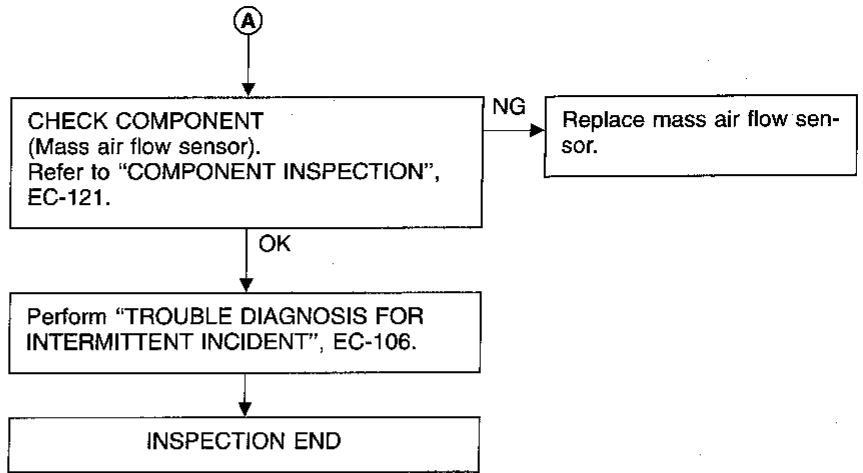

Procedure B

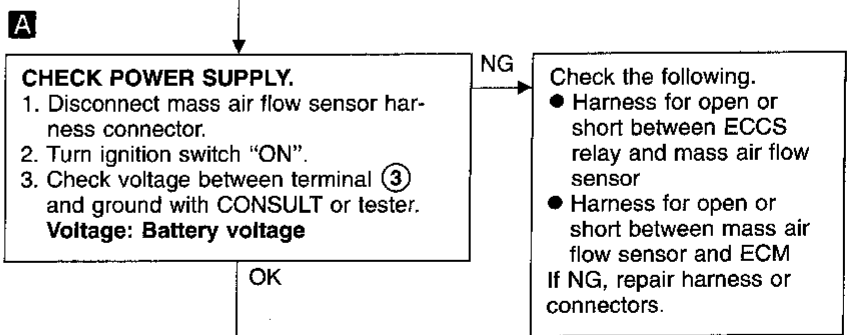
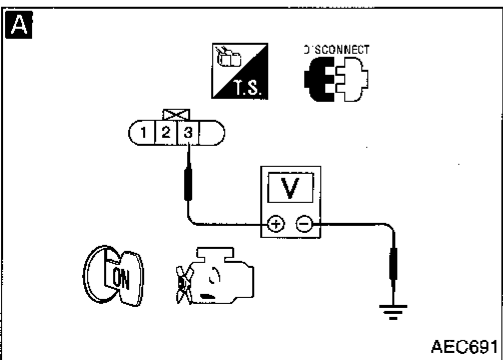
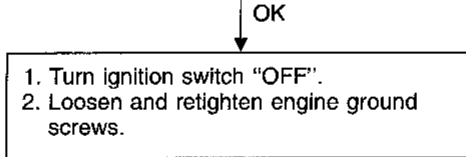
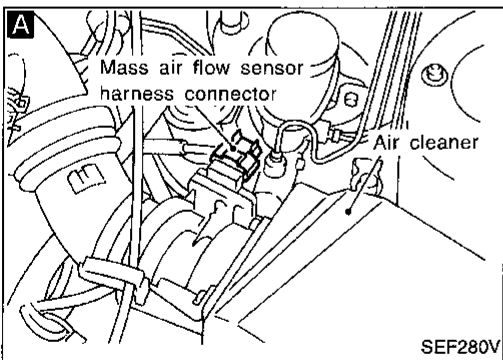
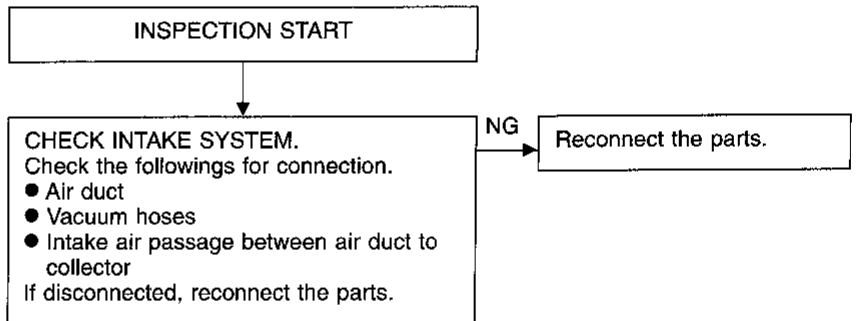

TROUBLE DIAGNOSIS FOR DTC P0100

Mass Air Flow Sensor (MAFS) (Cont'd)

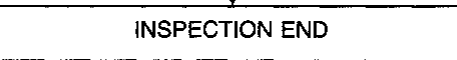
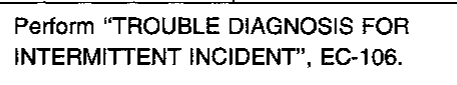
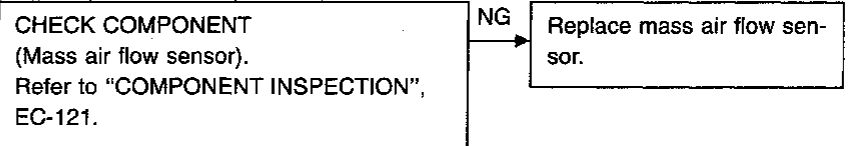
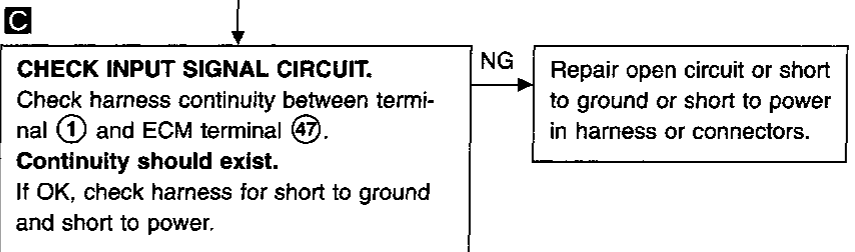
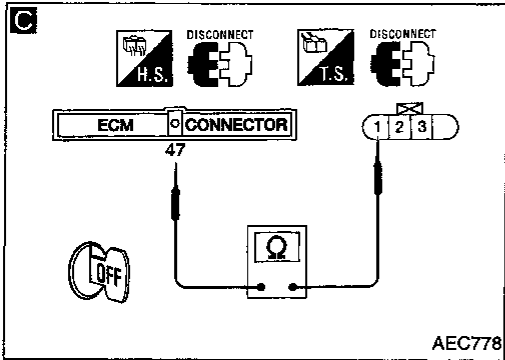
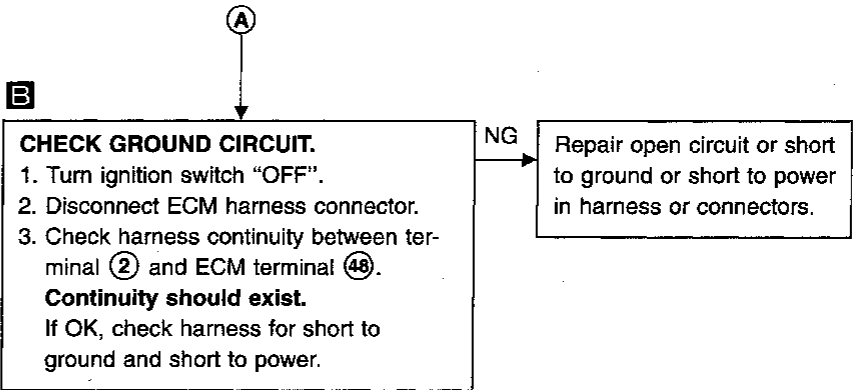
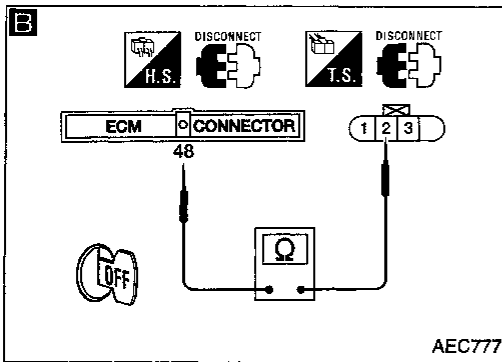

TROUBLE DIAGNOSIS FOR DTC P0100

Mass Air Flow Sensor (MAFS) (Cont'd)

COMPONENT INSPECTION

Mass air flow sensor

1. Turn ignition switch "ON".
2. Start engine and warm it up to normal operating temperature.
3. Check voltage between ECM terminal ④7 and engine ground.

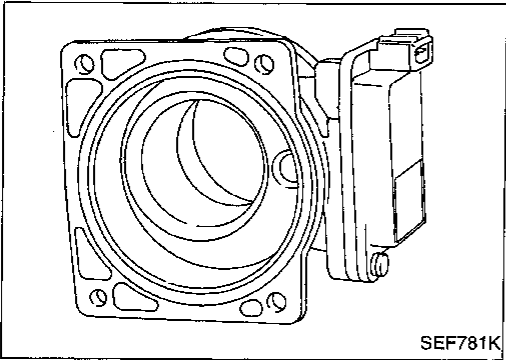
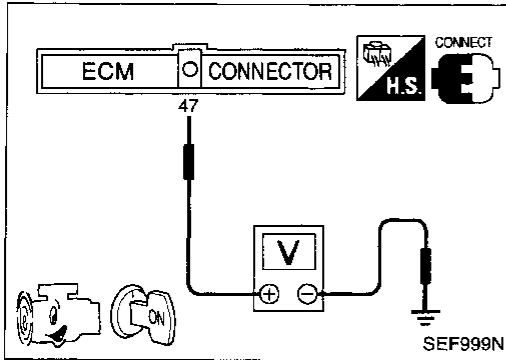

Conditions	Voltage V
Ignition switch "ON" (Engine stopped.)	Less than 1.0
Idle (Engine is warmed-up to normal operating temperature.)	1.3 - 1.7
2,500 rpm (Engine is warmed-up to normal operating temperature.)	1.8 - 2.4
Idle to about 4,000 rpm*	1.3 - 1.7 to Approx. 4.0

*: Check for linear voltage rise in response to increases to about 4,000 rpm in engine speed.

4. If the voltage is out of specification, disconnect mass air flow sensor harness connector and connect it again. Repeat above check.
5. If NG, remove mass air flow sensor from air duct. Check hot film for damage or dust.

GI

MA

EM

LC

EC

FE

CL

MT

AT

FA

RA

BR

ST

RS

BT

HA

EL

IDX

TROUBLE DIAGNOSIS FOR DTC P0105

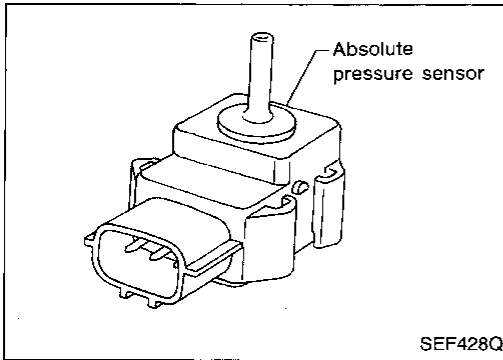

Absolute Pressure Sensor

COMPONENT DESCRIPTION

The absolute pressure sensor is connected to the MAP/BARO switch solenoid valve by a hose. The sensor detects ambient barometric pressure and intake manifold pressure and sends the voltage signal to the ECM. As the pressure increases, the voltage rises.

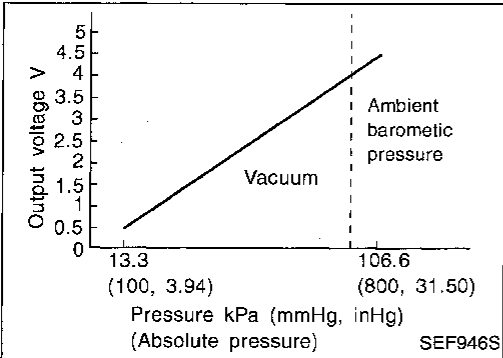

ON BOARD DIAGNOSIS LOGIC

Diagnostic Trouble Code No.	Malfunction is detected when	Check Items (Possible Cause)
P0105 0803	A) An excessively low or high voltage from the sensor is sent to ECM.	<ul style="list-style-type: none"> ● Harness or connectors (Absolute pressure sensor circuit is open or shorted.) ● Absolute pressure sensor
	B) A high voltage from the sensor is sent to ECM under light load driving conditions.	<ul style="list-style-type: none"> ● Hoses (Hoses between the intake manifold and absolute pressure sensor are disconnected or clogged.) ● Intake air leaks ● MAP/BARO switch solenoid valve ● Absolute pressure sensor
	C) A low voltage from the sensor is sent to ECM under heavy load driving conditions.	<ul style="list-style-type: none"> ● Absolute pressure sensor

DIAGNOSTIC TROUBLE CODE CONFIRMATION PROCEDURE

Perform "Procedure for malfunction A" first. If the 1st trip DTC cannot be confirmed, perform "Procedure for malfunction B". If the 1st trip DTC is not confirmed on "Procedure for malfunction B", perform "Procedure for malfunction C".

TROUBLE DIAGNOSIS FOR DTC P0105

Absolute Pressure Sensor (Cont'd)

Procedure for malfunction A

NOTE:

If "DIAGNOSTIC TROUBLE CODE CONFIRMATION PROCEDURE" has been previously conducted, always turn ignition switch "OFF" and wait at least 5 seconds before conducting the next test.

- 1) Turn ignition switch "ON".
- 2) Select "DATA MONITOR" mode with CONSULT.
- 3) Wait at least 6 seconds.
- 4) If 1st trip DTC is detected, go to "DIAGNOSTIC PROCEDURE", EC-127.

OR

- 1) Turn ignition switch "ON" and wait at least 6 seconds.
- 2) Select "MODE 7" with GST.
- 3) If 1st trip DTC is detected, go to "DIAGNOSTIC PROCEDURE", EC-127.

OR

- 1) Turn ignition switch "ON" and wait at least 6 seconds.
- 2) Turn ignition switch "OFF", wait at least 5 seconds and then turn "ON".
- 3) Perform "Diagnostic Test Mode II (Self-diagnostic results)" with ECM.
- 4) If 1st trip DTC is detected, go to "DIAGNOSTIC PROCEDURE", EC-127.

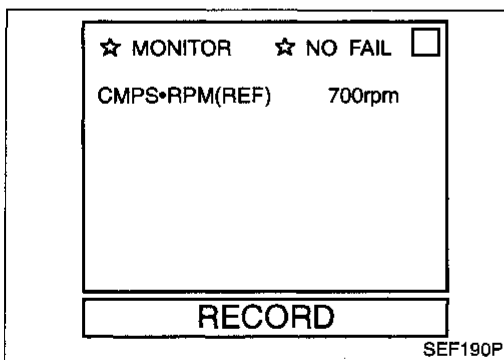
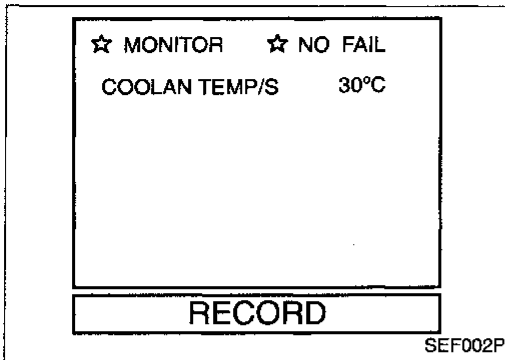

Procedure for malfunction B

NOTE:

If "DIAGNOSTIC TROUBLE CODE CONFIRMATION PROCEDURE" has been previously conducted, always turn ignition switch "OFF" and wait at least 5 seconds before conducting the next test.

- 1) Start engine and warm it up to normal operating temperature.
- 2) Turn ignition switch "OFF" and wait at least 5 seconds.
- 3) Turn ignition switch "ON" and select "DATA MONITOR" mode with CONSULT.
- 4) Start engine and let it idle.
- 5) Wait at least 15 seconds.
- 6) If 1st trip DTC is detected, go to "DIAGNOSTIC PROCEDURE", EC-127.

OR

- 1) Start engine and warm it up to normal operating temperature.
- 2) Turn ignition switch "OFF" and wait at least 5 seconds.
- 3) Start engine.

TROUBLE DIAGNOSIS FOR DTC P0105

Absolute Pressure Sensor (Cont'd)

- 4) Let engine idle and wait at least 15 seconds.
- 5) Select "MODE 7" with GST.
- 6) If 1st trip DTC is detected, go to "DIAGNOSTIC PROCEDURE", EC-127.

OR



- 1) Start engine and warm it up to normal operating temperature.
- 2) Turn ignition switch "OFF" and wait at least 5 seconds.
- 3) Start engine.
- 4) Let engine idle and wait at least 15 seconds.
- 5) Turn ignition switch "OFF", wait at least 5 seconds and then turn "ON".
- 6) Perform "Diagnostic Test Mode II (Self-diagnostic results)" with ECM.
- 7) If 1st trip DTC is detected, go to "DIAGNOSTIC PROCEDURE", EC-127.

☆ MONITOR	☆ NO FAIL	<input type="checkbox"/>
CMPS•RPM(REF)	4000rpm	
VHCL SPEED SE	70km/h	
B/FUEL SCHDL	4.8msec	
ABSOL PRES/SE	4.4V	
RECORD		

SEF127V

Procedure for malfunction C

CAUTION:

Always drive vehicle at a safe speed.

NOTE:

If "DIAGNOSTIC TROUBLE CODE CONFIRMATION PROCEDURE" has been previously conducted, always turn ignition switch "OFF" and wait at least 5 seconds before conducting the next test.



- 1) Turn ignition switch "ON".
- 2) Select "DATA MONITOR" mode with CONSULT.
The voltage of "ABSOL PRES/SE" should be more than 1.74 [V].
If the check result is NG, go to "DIAGNOSTIC PROCEDURE", EC-127.
If the check result is OK, go to following step.
- 3) Start engine and warm it up to normal operating temperature.
- 4) Turn ignition switch "OFF" and wait at least 5 seconds.
- 5) Start engine and let it idle for at least 13 seconds.
- 6) Select "DATA MONITOR" mode with CONSULT.
- 7) Drive the vehicle at least 3 consecutive seconds under the following conditions,
B/FUEL SCHDL: More than 3.7 msec
CMPS-RPM (REF): 3,000 - 4,800 rpm
Selector lever: Suitable position
Driving location: Driving vehicle uphill (Increased engine load) will help maintain the driving conditions required for this test.
- 8) If 1st trip DTC is detected, go to "DIAGNOSTIC PROCEDURE", EC-127.

TROUBLE DIAGNOSIS FOR DTC P0105

Absolute Pressure Sensor (Cont'd)

ENGINE SPD	0RPM
COOLANT TEMP	69°C
VEHICLE SPD	0MPH
IGN ADVANCE	3.0°
CALC LOAD	0.0%
MAP	101 kPaA
MAF	0.25gm/s
THROTTLE POS	0.0%
INTAKE AIR	27°C
FUEL SYS #1	OL
FUEL SYS #2	UNUSED
SHORT FT #1	0.0%
LONG FT #1	0.0%
O2S B1 S1	0.000V
O2FT B1 S1	0.0%
O2S B1 S2	0.000V

SEF518R

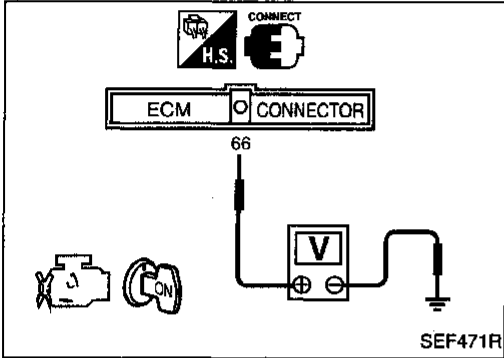

SEF471R

OR

OVERALL FUNCTION CHECK

Use this procedure to check the overall function of the front heated oxygen sensor circuit. During this check, a 1st trip DTC might not be confirmed.

Procedure for malfunction C

- 1) Turn ignition switch "ON".
- 2) Select absolute pressure sensor signal in "MODE 1" with GST.
- 3) Make sure that the pressure of absolute pressure sensor signal is more than 46 kPa (0.47 kg/cm², 6.7 psi).
- 4) If NG, go to "DIAGNOSTIC PROCEDURE", EC-127.

OR

- 1) Turn ignition switch "ON".
- 2) Make sure that the voltage between ECM terminal 66 and engine ground is more than 1.74 [V].
- 3) If NG, go to "DIAGNOSTIC PROCEDURE", EC-127.

GI

MA

EM

LC

EC

FE

CL

MT

AT

FA

RA

BR

ST

RS

BT

HA

EL

IDX

TROUBLE DIAGNOSIS FOR DTC P0105

Absolute Pressure Sensor (Cont'd)

EC-AP/SEN-01

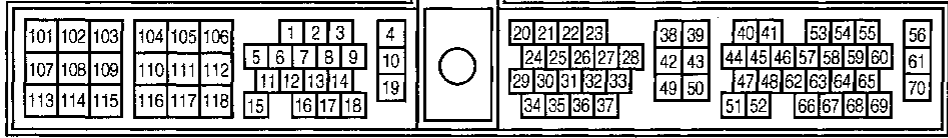
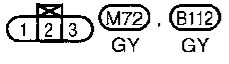
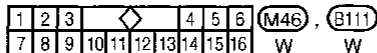
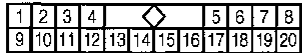
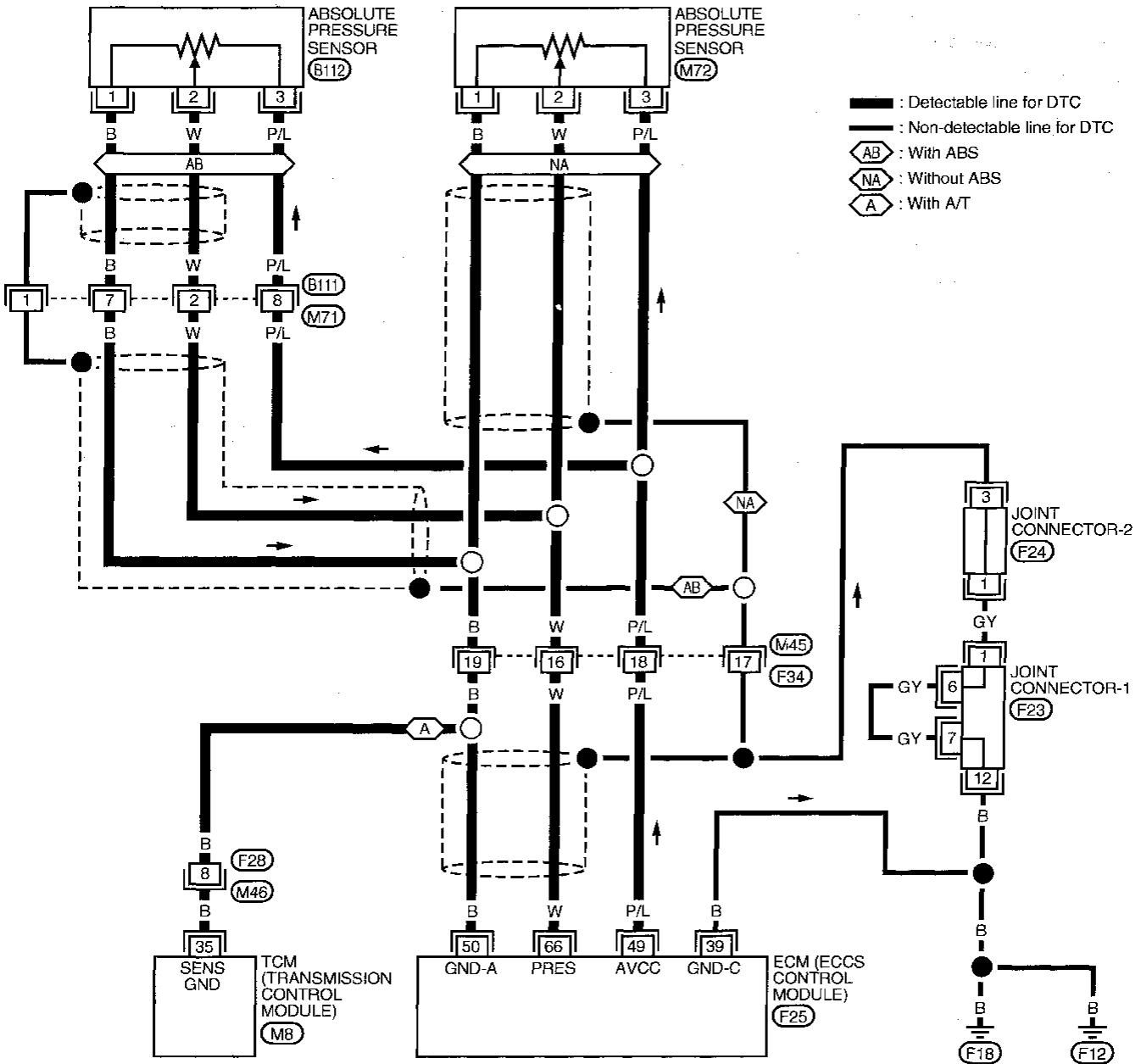

Refer to last page (Foldout page).

- (M8)
- (F23)
- (F24)

TROUBLE DIAGNOSIS FOR DTC P0105

Absolute Pressure Sensor (Cont'd)

DIAGNOSTIC PROCEDURE

If the trouble is duplicated after "Procedure for malfunction A or C", perform "Procedure A" below. If the trouble is duplicated after "Procedure for malfunction B", perform "Procedure B" on next page.

Procedure A

INSPECTION START

1. Turn ignition switch "OFF".
2. Loosen and retighten engine ground screws.

NG → Repair harness or connectors.

A

CHECK POWER SUPPLY.

1. Turn ignition switch "OFF".
2. Disconnect absolute pressure sensor harness connector.
3. Check sensor connector for water. **Water should not exist.**
4. Turn ignition switch "ON".
5. Check voltage between terminal ③ and engine ground with CONSULT or tester. **Voltage: Approximately 5V**

NG → Check the following.

- Harness connectors
With ABS: (B111), (M71), (M45), (F34)
Without ABS: (M45), (F34)
- Harness for open or short between ECM and absolute pressure sensor

If NG, repair harness or connectors.

B

CHECK GROUND CIRCUIT.

1. Turn ignition switch "OFF".
 2. Check harness continuity between terminal ① and engine ground. **Continuity should exist.**
- If OK, check harness for short to ground and short to power.

NG → Check the following.

- Harness connectors
With ABS: (B111), (M71), (M45), (F34)
Without ABS: (M45), (F34)
- Harness for open or short between ECM and absolute pressure sensor
- Harness for open or short between absolute pressure sensor and TCM (With A/T)

If NG, repair open circuit or short to ground or short to power in harness or connectors.

C

CHECK INPUT SIGNAL CIRCUIT.

1. Disconnect ECM harness connector.
 2. Check harness continuity between ECM terminal ⑥⑥ and terminal ②. **Continuity should exist.**
- If OK, check harness for short to ground and short to power.

NG → Check the following.

- Harness connectors
With ABS: (B111), (M71), (M45), (F34)
Without ABS: (M45), (F34)
- Harness for open or short between ECM and absolute pressure sensor

If NG, repair open circuit or short to ground or short to power in harness or connectors.

(Go to next page.)

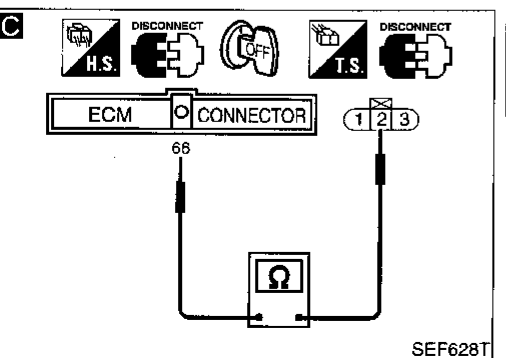
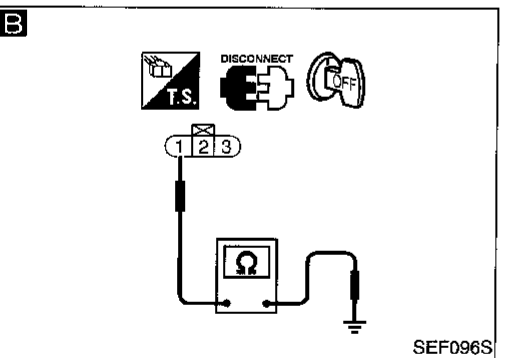
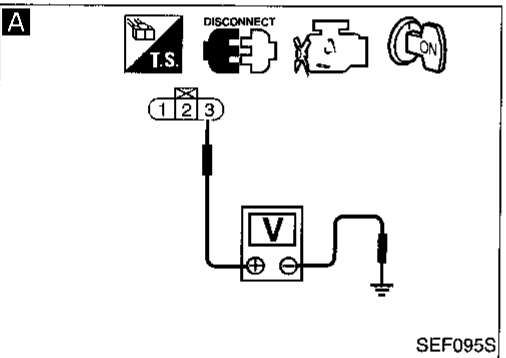
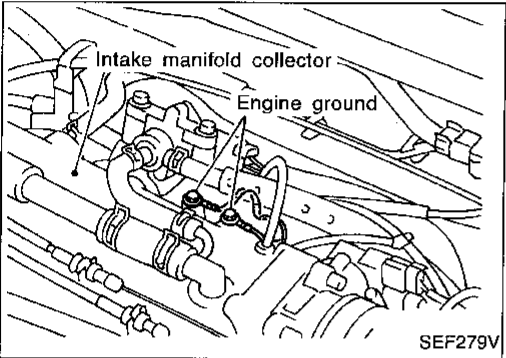
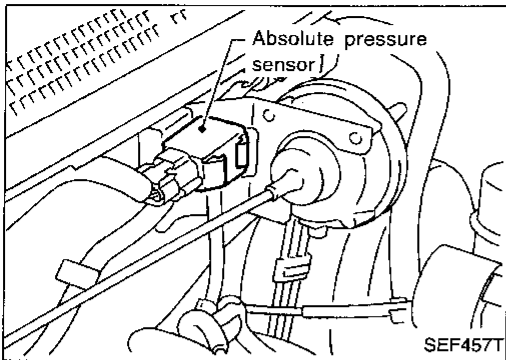

TROUBLE DIAGNOSIS FOR DTC P0105

Absolute Pressure Sensor (Cont'd)

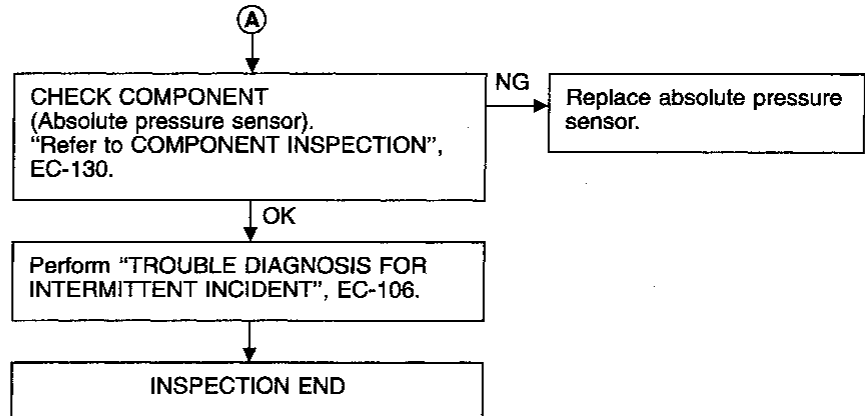

TROUBLE DIAGNOSIS FOR DTC P0105

Absolute Pressure Sensor (Cont'd)

Procedure B

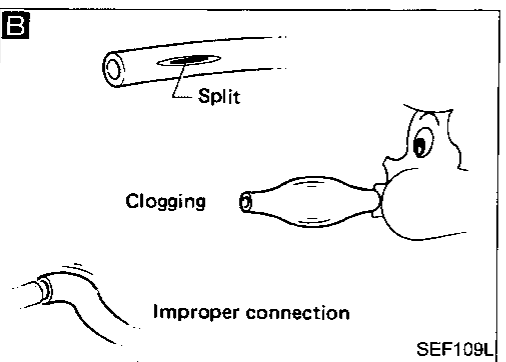
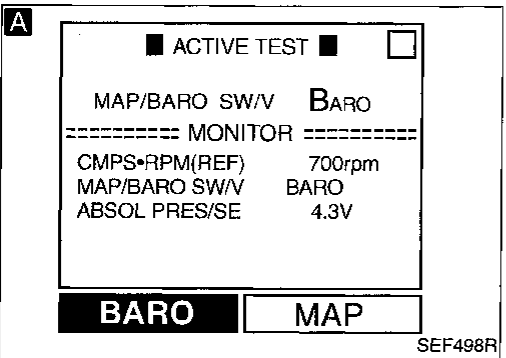
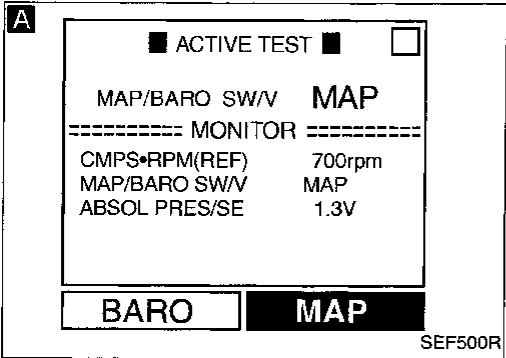
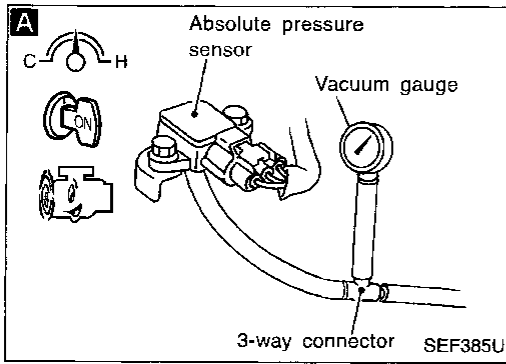

INSPECTION START

A
CHECK VACUUM SOURCE TO ABSOLUTE PRESSURE SENSOR.
 1. Start engine and warm it up to normal operating temperature.
 2. Turn ignition switch "OFF".
 3. Connect MAP/BARO switch solenoid valve and absolute pressure sensor with a rubber tube that has vacuum gauge.
 4. Turn ignition switch "ON".
 5. Select "MAP/BARO SW/V" in "ACTIVE TEST" mode with CONSULT.
 6. Start engine and let it idle.
 7. Touch "MAP" and "BARO" alternately and check for vacuum.

MAP/BARO SW/V	Vacuum
BARO	Should not exist
MAP	Should exist

OR

4. Turn ignition switch "ON".
 5. Start engine and let it idle.
 6. Check for vacuum.
 For 5 seconds after starting engine:
Vacuum should not exist.
 More than 5 seconds after starting engine:
Vacuum should exist.

B
CHECK HOSE BETWEEN ABSOLUTE PRESSURE SENSOR AND MAP/BARO SWITCH SOLENOID VALVE.
 1. Turn ignition switch "OFF".
 2. Check hose for clogging, cracks or improper connection.

CHECK COMPONENT (Absolute pressure sensor).
 Refer to "COMPONENT INSPECTION", on next page.

Perform "TROUBLE DIAGNOSIS FOR INTERMITTENT INCIDENT", EC-106.

INSPECTION END

NG → **CHECK VACUUM HOSE.**
 Check vacuum hose for clogging, cracks, disconnection or improper connection.
 If NG, repair or replace the hose.

OK → Check vacuum port for clogging.
 If NG, clean it.

OK → **CHECK COMPONENT (MAP/BARO switch solenoid valve).**
 Refer to "COMPONENT INSPECTION", EC-341.

NG → **Replace MAP/BARO switch solenoid valve.**

OK → **CHECK INTAKE SYSTEM.**
 Check intake system for air leaks.

NG → **Repair or reconnect hose.**

NG → **Replace absolute pressure sensor.**

GI
 MA
 EM
 LC
EC
 FE
 CL
 MT
 AT
 FA
 RA
 BR
 ST
 RS
 BT
 HA
 EL
 IDX

TROUBLE DIAGNOSIS FOR DTC P0105

Absolute Pressure Sensor (Cont'd)

COMPONENT INSPECTION

Absolute pressure sensor

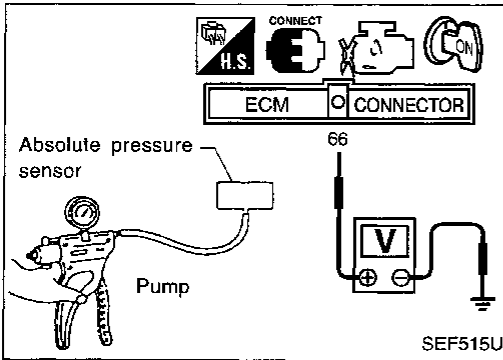

1. Remove absolute pressure sensor with its harness connector connected.
2. Remove hose from absolute pressure sensor.
3. Turn ignition switch "ON" and check output voltage between terminal ⑥ and engine ground.
The voltage should be 3.2 to 4.8 V.
4. Use pump to apply vacuum of -26.7 kPa (-200 mmHg, -7.87 inHg) to absolute pressure sensor as shown in figure and check the output voltage.
The voltage should be 1.0 to 1.4 V lower than the value measured in step 3.

CAUTION:

- Always calibrate the vacuum pump gauge when using it.
 - Do not apply below -93.3 kPa (-700 mmHg, -27.56 inHg) or over 101.3 kPa (760 mmHg, 29.92 inHg) of pressure.
5. If NG, replace absolute pressure sensor.

TROUBLE DIAGNOSIS FOR DTC P0110

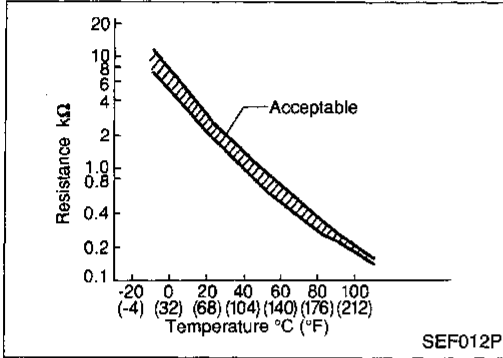
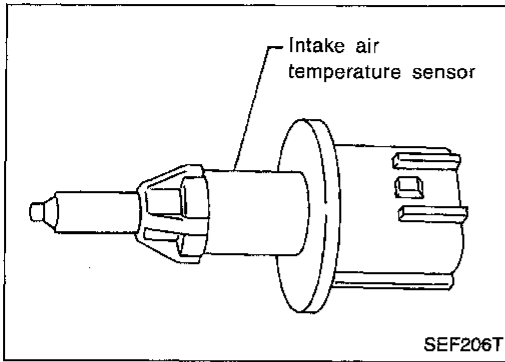

Intake Air Temperature Sensor

COMPONENT DESCRIPTION

The intake air temperature sensor is mounted to the air duct housing. The sensor detects intake air temperature and transmits a signal to the ECM.

The temperature sensing unit uses a thermistor which is sensitive to the change in temperature. Electrical resistance of the thermistor decreases in response to the temperature rise.

<Reference data>

Intake air temperature °C (°F)	Voltage* V	Resistance kΩ
20 (68)	3.5	2.1 - 2.9
80 (176)	1.23	0.27 - 0.38

*: These data are reference values and are measured between ECM terminal (28) (Intake air temperature sensor) and engine ground.

ON BOARD DIAGNOSIS LOGIC

Diagnostic Trouble Code No.	Malfunction is detected when ...	Check Items (Possible Cause)
P0110 0401	A) An excessively low or high voltage from the sensor is sent to ECM. B) Rationally incorrect voltage from the sensor is sent to ECM, compared with the voltage signal from engine coolant temperature sensor.	<ul style="list-style-type: none"> ● Harness or connectors (The sensor circuit is open or shorted.) ● Intake air temperature sensor

Engine operating condition in fail-safe mode

The ECM functions on the assumption that the intake air temperature is 25°C (77°F).

DIAGNOSTIC TROUBLE CODE CONFIRMATION PROCEDURE

Perform "Procedure for malfunction A" first. If DTC cannot be confirmed, perform "Procedure for malfunction B".

NOTE:

If "DIAGNOSTIC TROUBLE CODE CONFIRMATION PROCEDURE" has been previously conducted, always turn ignition switch "OFF" and wait at least 5 seconds before conducting the next test.

Procedure for malfunction A

- 1) Turn ignition switch "ON".
- 2) Select "DATA MONITOR" mode with CONSULT.
- 3) Wait at least 5 seconds.
- 4) If 1st trip DTC is detected, go to "DIAGNOSTIC PROCEDURE", EC-135.

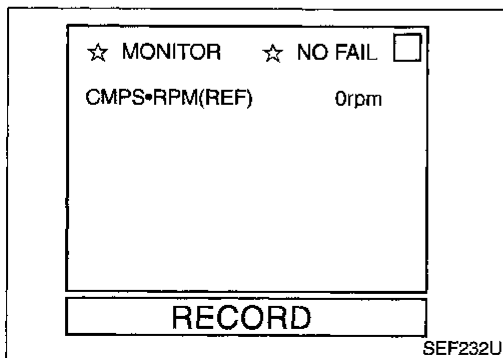

TROUBLE DIAGNOSIS FOR DTC P0110

Intake Air Temperature Sensor (Cont'd)

OR



- 1) Turn ignition switch "ON" and wait at least 5 seconds.
- 2) Select MODE 7 with GST.
- 3) If 1st trip DTC is detected, go to "DIAGNOSTIC PROCEDURE", EC-135.

OR



- 1) Turn ignition switch "ON" and wait at least 5 seconds.
- 2) Turn ignition switch "OFF", wait at least 5 seconds and then turn "ON".
- 3) Perform "Diagnostic Test Mode II (Self-diagnostic results)" with ECM.
- 4) If 1st trip DTC is detected, go to "DIAGNOSTIC PROCEDURE", EC-135.

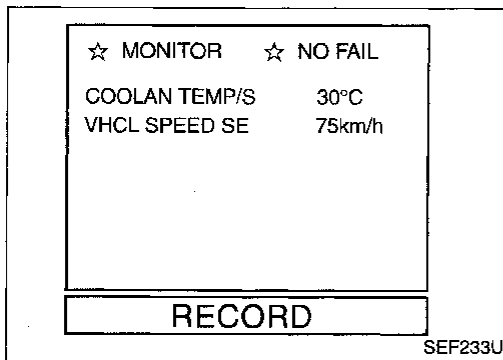

Procedure for malfunction B

CAUTION:

Always drive vehicle at a safe speed.

TESTING CONDITION:

This test may be conducted with the drive wheels lifted in the shop or by driving the vehicle. If a road test is expected to be easier, it is unnecessary to lift the vehicle.



- 1) Wait until engine coolant temperature is less than 90°C (194°F).
 - (a) Turn ignition switch "ON".
 - (b) Select "DATA MONITOR" mode with CONSULT.
 - (c) Check the engine coolant temperature.
 - (d) If the engine coolant temperature is not less than 90°C (194°F), turn ignition switch "OFF" and cool down engine.

- Perform the following steps before engine coolant temperature is above 90°C (194°F).

- 2) Turn ignition switch "ON".
- 3) Select "DATA MONITOR" mode with CONSULT.
- 4) Start engine.
- 5) Hold vehicle speed more than 70 km/h (44 MPH) for 105 consecutive seconds.
- 6) If 1st trip DTC is detected, go to "DIAGNOSTIC PROCEDURE", EC-135.

OR



- 1) Wait until engine coolant temperature is less than 90°C (194°F).
 - (a) Turn ignition switch "ON".
 - (b) Select MODE 1 with GST.
 - (c) Check the engine coolant temperature.
 - (d) If the engine coolant temperature is above 90°C (194°F), turn ignition switch "OFF" and cool down engine.

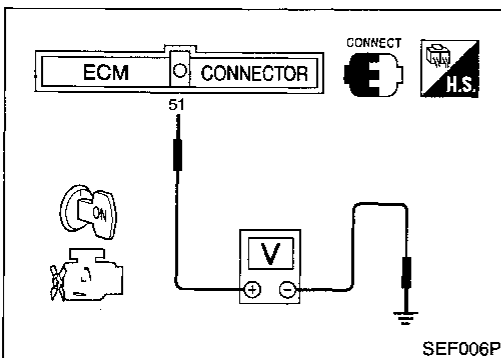
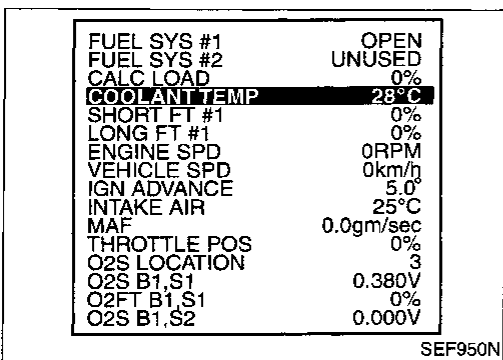

TROUBLE DIAGNOSIS FOR DTC P0110

Intake Air Temperature Sensor (Cont'd)

- Perform the following steps before engine coolant temperature is above 90°C (194°F).
- 2) Start engine.
- 3) Hold vehicle speed more than 70 km/h (44 MPH) for 105 consecutive seconds.
- 4) Select MODE 7 with GST.
- 5) If 1st trip DTC is detected, go to "DIAGNOSTIC PROCEDURE", EC-135.

OR



- 1) Wait until engine coolant temperature is less than 90°C (194°F).
 - (a) Turn ignition switch "ON".
 - (b) Check voltage between ECM terminal ⑥1 and engine ground.

Voltage: More than 1.0 (V)

- (c) If the voltage is less than 1.0 (V), turn ignition switch "OFF" and cool down engine.
- Perform the following steps before the voltage is below 1.0V.
 - 2) Start engine.
 - 3) Hold vehicle speed more than 70 km/h (44 MPH) for 105 consecutive seconds.
 - 4) Turn ignition switch "OFF", wait at least 5 seconds and then turn "ON".
 - 5) Perform "Diagnostic Test Mode II (Self-diagnostic results)" with ECM.
 - 6) If 1st trip DTC is detected, go to "DIAGNOSTIC PROCEDURE", EC-135.

GI

MA

EM

LC

EC

FE

CL

MT

AT

FA

RA

BR

ST

RS

BT

HA

EL

IDX

TROUBLE DIAGNOSIS FOR DTC P0110

Intake Air Temperature Sensor (Cont'd)

EC-IATS-01

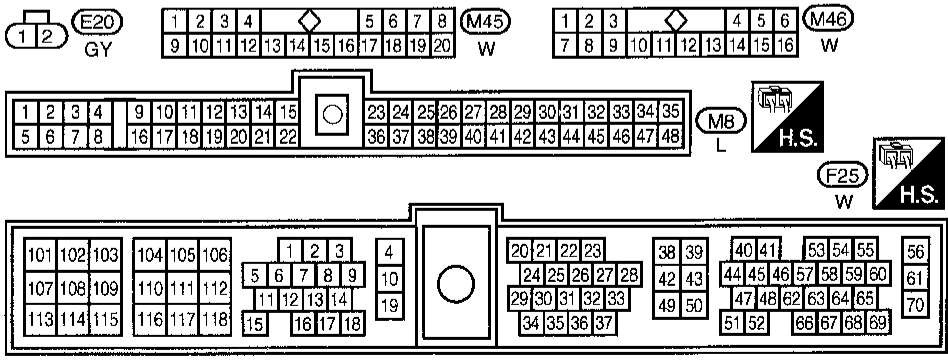
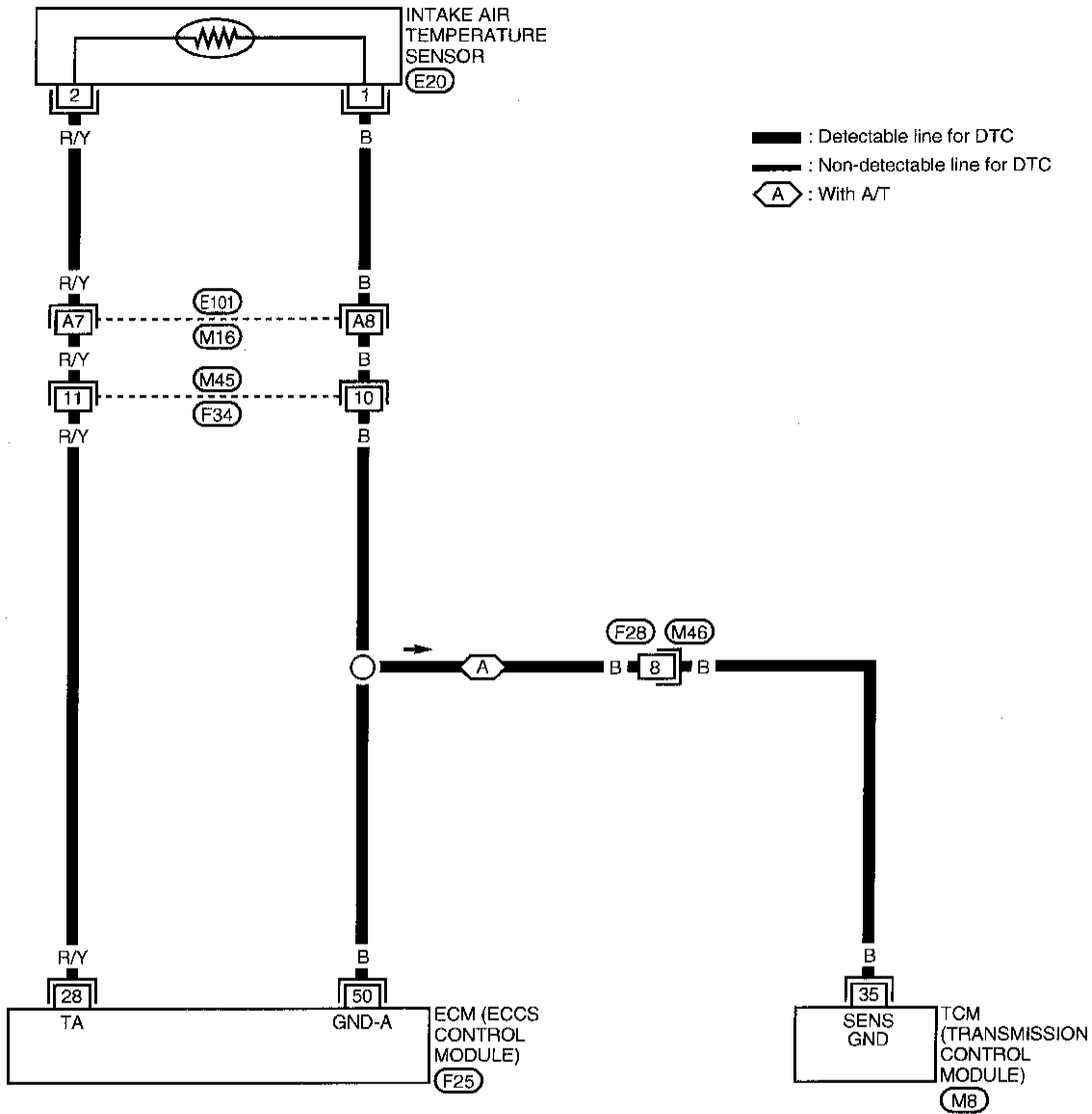

Refer to last page (Foldout page).
 M16, E101

TROUBLE DIAGNOSIS FOR DTC P0110

Intake Air Temperature Sensor (Cont'd)

DIAGNOSTIC PROCEDURE

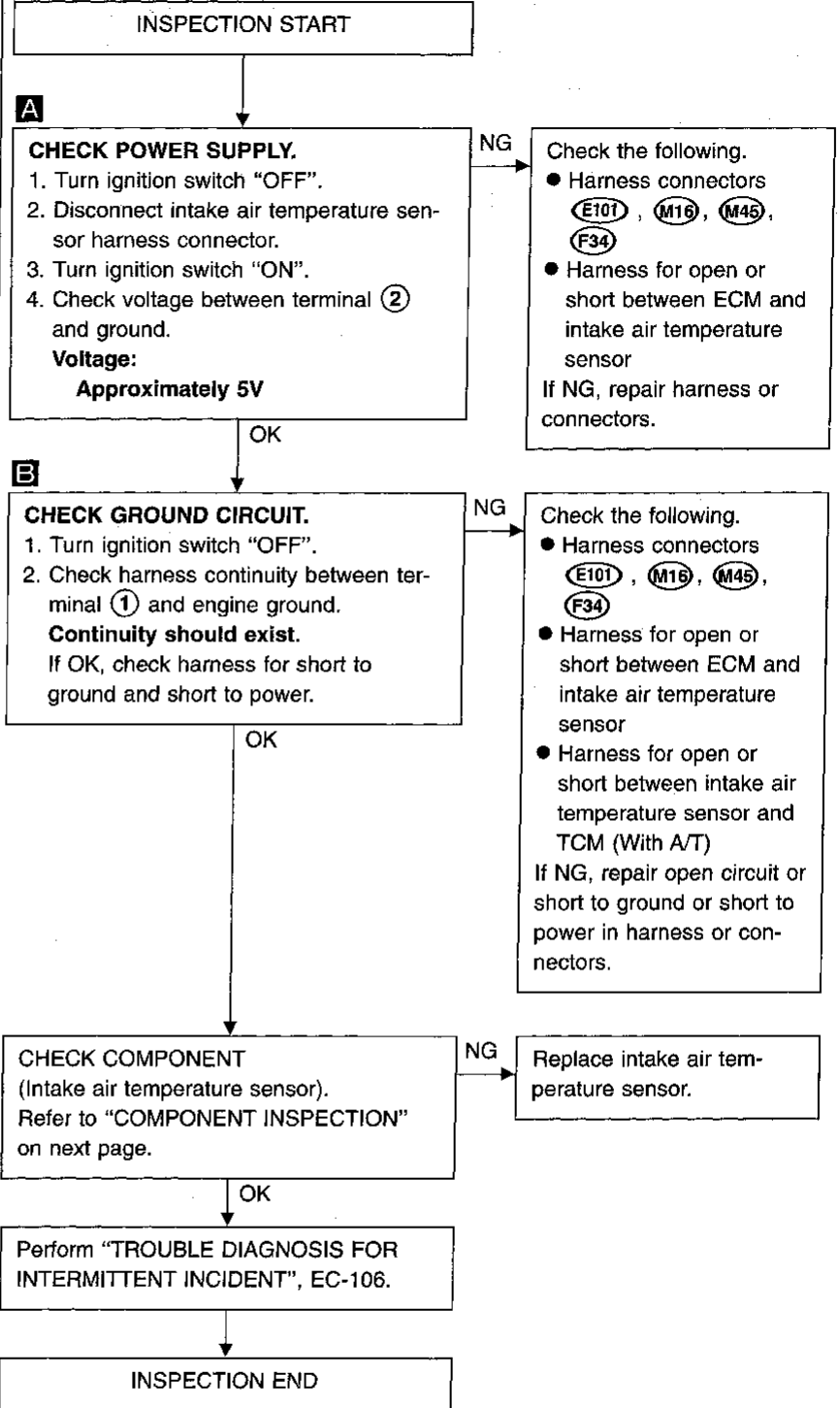
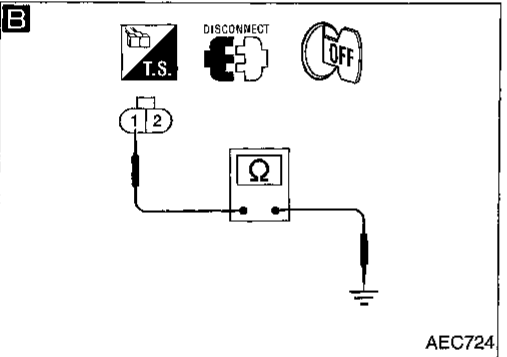
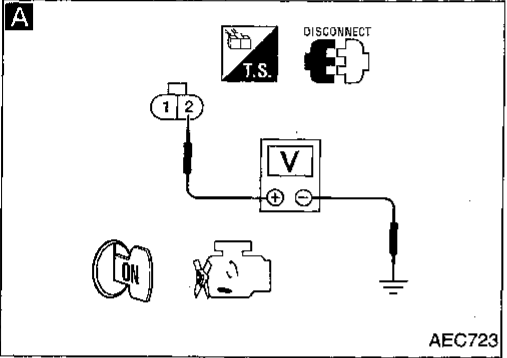
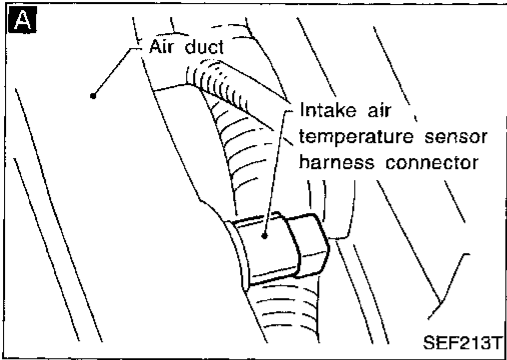

GI
MA
EM
LC
EC
FE
CL
MT
AT
FA
RA
BR
ST
RS
BT
HA
EL
IDX

TROUBLE DIAGNOSIS FOR DTC P0110

Intake Air Temperature Sensor (Cont'd)

COMPONENT INSPECTION

Intake air temperature sensor

Check resistance as shown in the figure.

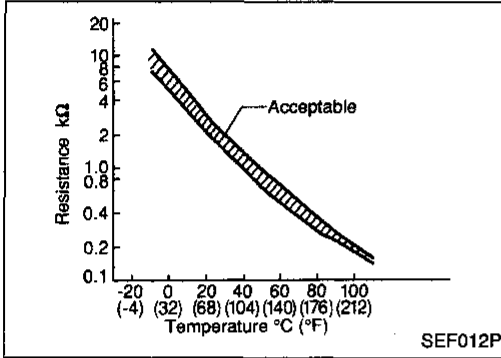
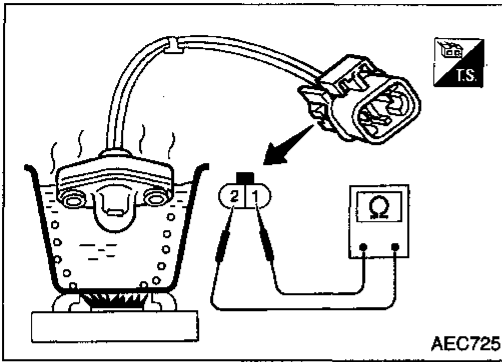

<Reference data>

Intake air temperature °C (°F)	Resistance kΩ
20 (68)	2.1 - 2.9
80 (176)	0.27 - 0.38

If NG, replace intake air temperature sensor.

TROUBLE DIAGNOSIS FOR DTC P0115

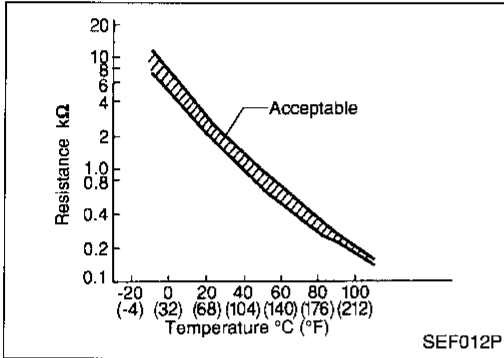
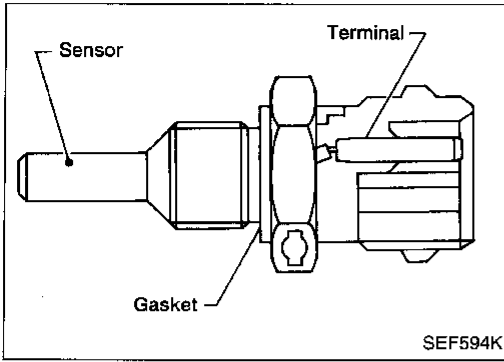

Engine Coolant Temperature Sensor (ECTS) (Circuit)

COMPONENT DESCRIPTION

The engine coolant temperature sensor is used to detect the engine coolant temperature. The sensor modifies a voltage signal from the ECM. The modified signal returns to the ECM as the engine coolant temperature input. The sensor uses a thermistor which is sensitive to the change in temperature. The electrical resistance of the thermistor decreases as temperature increases.

<Reference data>

Engine coolant temperature °C (°F)	Voltage* V	Resistance kΩ
-10 (14)	4.4	7.0 - 11.4
20 (68)	3.5	2.1 - 2.9
50 (122)	2.2	0.68 - 1.00
90 (194)	0.9	0.236 - 0.260

*: These data are reference values and are measured between ECM terminal ⑤1 (Engine coolant temperature sensor) and engine ground.

CONSULT REFERENCE VALUE IN DATA MONITOR MODE

MONITOR ITEM	CONDITION	SPECIFICATION
COOLAN TEMP/S	● Engine: After warming up	More than 70°C (158°F)

ON BOARD DIAGNOSIS LOGIC

Diagnostic Trouble Code No.	Malfunction is detected when ...	Check Items (Possible Cause)
P0115 0103	● An excessively high or low voltage from the sensor is sent to ECM.*	<ul style="list-style-type: none"> ● Harness or connectors (The sensor circuit is open or shorted.) ● Engine coolant temperature sensor

*: When this malfunction is detected, the ECM enters fail-safe mode and the MIL lights up.

Detected items	Engine operating condition in fail-safe mode								
Engine coolant temperature sensor circuit	Engine coolant temperature will be determined by ECM based on the time after turning ignition switch "ON" or "START". CONSULT displays the engine coolant temperature decided by ECM.								
	<table border="1"> <thead> <tr> <th>Condition</th> <th>Engine coolant temperature decided (CONSULT display)</th> </tr> </thead> <tbody> <tr> <td>Just as ignition switch is turned to ON or START</td> <td>40°C (104°F)</td> </tr> <tr> <td>More than approx. 4 minutes after ignition is turned to ON or START</td> <td>80°C (176°F)</td> </tr> <tr> <td>Except as shown above</td> <td>40 - 80°C (104 - 176°F) (Depends on the time)</td> </tr> </tbody> </table>	Condition	Engine coolant temperature decided (CONSULT display)	Just as ignition switch is turned to ON or START	40°C (104°F)	More than approx. 4 minutes after ignition is turned to ON or START	80°C (176°F)	Except as shown above	40 - 80°C (104 - 176°F) (Depends on the time)
	Condition	Engine coolant temperature decided (CONSULT display)							
	Just as ignition switch is turned to ON or START	40°C (104°F)							
More than approx. 4 minutes after ignition is turned to ON or START	80°C (176°F)								
Except as shown above	40 - 80°C (104 - 176°F) (Depends on the time)								
When the fail-safe system for engine coolant temperature sensor is activated, the cooling fan operates while the engine is running.									

TROUBLE DIAGNOSIS FOR DTC P0115

Engine Coolant Temperature Sensor (ECTS) (Circuit) (Cont'd)

DIAGNOSTIC TROUBLE CODE CONFIRMATION PROCEDURE

NOTE:

If "DIAGNOSTIC TROUBLE CODE CONFIRMATION PROCEDURE" has been previously conducted, always turn ignition switch "OFF" and wait at least 5 seconds before conducting the next test.

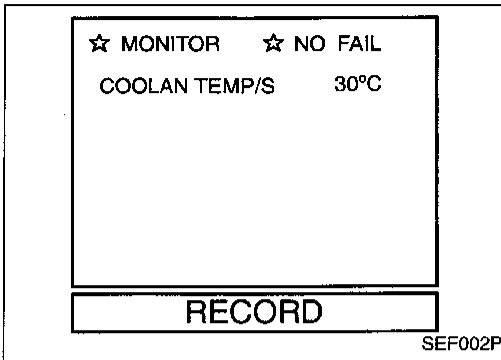

- 1) Turn ignition switch "ON".
- 2) Select "DATA MONITOR" mode with CONSULT.
- 3) Wait at least 5 seconds.
- 4) If 1st trip DTC is detected, go to "DIAGNOSTIC PROCEDURE", EC-140.

OR



- 1) Turn ignition switch "ON" and wait at least 5 seconds.
- 2) Select "MODE 7" with GST.
- 3) If 1st trip DTC is detected, go to "DIAGNOSTIC PROCEDURE", EC-140.

OR



- 1) Turn ignition switch "ON" and wait at least 5 seconds.
- 2) Turn ignition switch "OFF", wait at least 5 seconds and then turn "ON".
- 3) Perform "Diagnostic Test Mode II (Self-diagnostic results)" with ECM.
- 4) If 1st trip DTC is detected, go to "DIAGNOSTIC PROCEDURE", EC-140.

TROUBLE DIAGNOSIS FOR DTC P0115

Engine Coolant Temperature Sensor (ECTS) (Circuit) (Cont'd)

EC-ECTS-01 GI

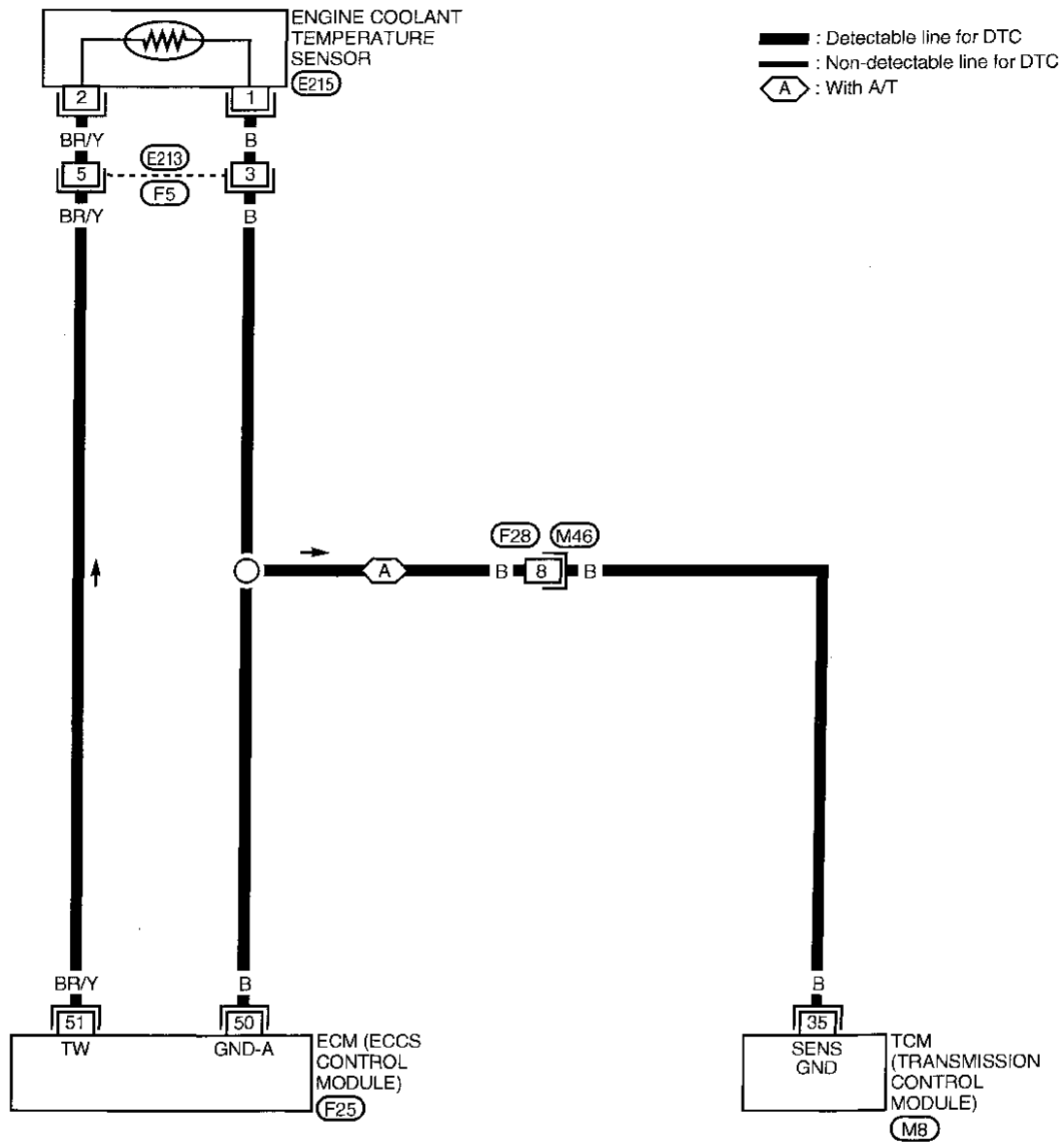

MA
EM
LC
EC
FE
CL
MT
AT
FA
RA
BR
ST
RS
BT

HA
EL
IDX

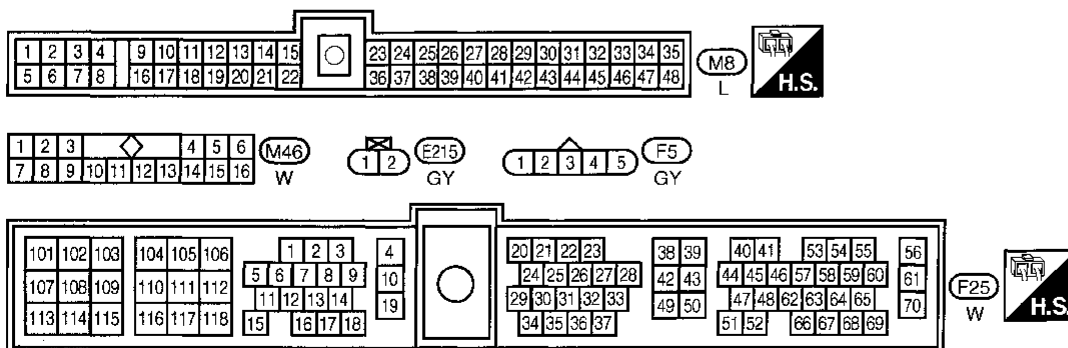

TROUBLE DIAGNOSIS FOR DTC P0115

Engine Coolant Temperature Sensor (ECTS) (Circuit) (Cont'd) DIAGNOSTIC PROCEDURE

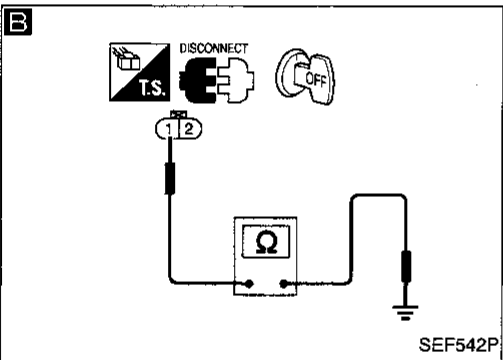
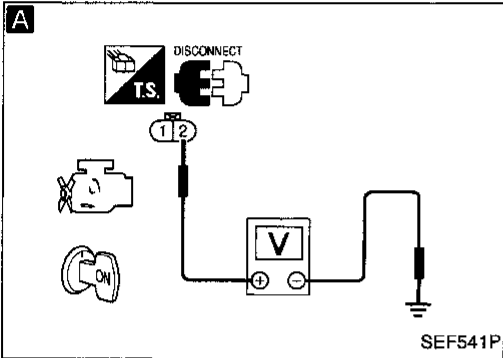
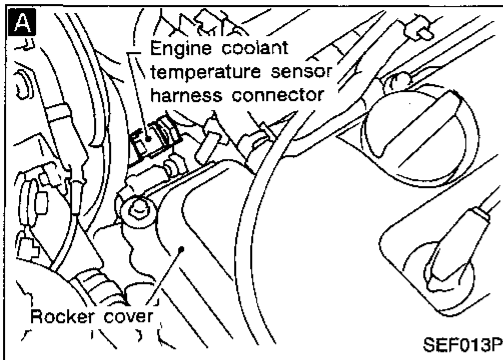

INSPECTION START

A
CHECK POWER SUPPLY.
1. Turn ignition switch "OFF".
2. Disconnect engine coolant temperature sensor harness connector.
3. Turn ignition switch "ON".
4. Check voltage between terminal ② and ground with CONSULT or tester.
Voltage:
Approximately 5V

NG → Check the following.
● Harness connectors
● E213, F5
If NG, repair harness or connectors.

B
CHECK GROUND CIRCUIT.
1. Turn ignition switch "OFF".
2. Check harness continuity between terminal ① and engine ground.
Continuity should exist.
If OK, check harness for short to ground and short to power.

NG → Check the following.
● Harness connectors
● E213, F5
● Harness connectors
● F28, M46
● Harness for open or short between ECM and engine coolant temperature sensor
● Harness for open or short between intake air temperature sensor and TCM (With A/T)
If NG, repair open circuit or short to ground or short to power in harness or connectors.

CHECK COMPONENT
(Engine coolant temperature sensor).
Refer to "COMPONENT INSPECTION" on next page.

NG → Replace engine coolant temperature sensor.

Perform "TROUBLE DIAGNOSIS FOR INTERMITTENT INCIDENT", EC-106.

INSPECTION END

TROUBLE DIAGNOSIS FOR DTC P0115

Engine Coolant Temperature Sensor (ECTS) (Circuit) (Cont'd)

COMPONENT INSPECTION

Engine coolant temperature sensor

Check resistance as shown in the figure.

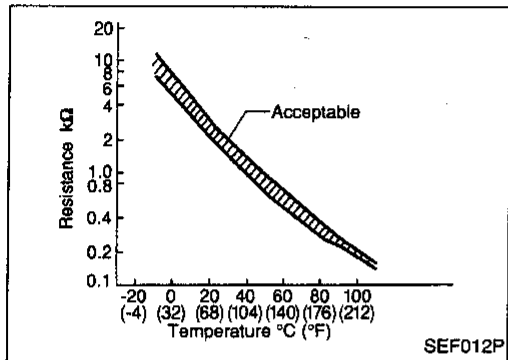
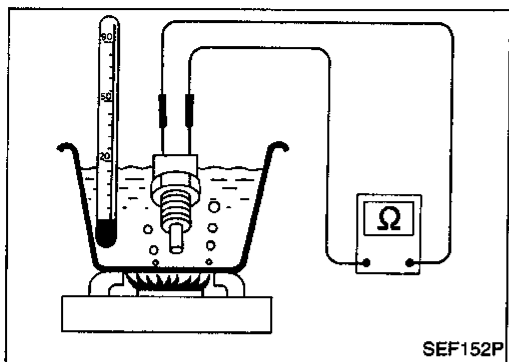

<Reference data>

Temperature °C (°F)	Resistance kΩ
20 (68)	2.1 - 2.9
50 (122)	0.68 - 1.00
90 (194)	0.236 - 0.260

If NG, replace engine coolant temperature sensor.

GI

MA

EM

LC

EC

FE

CL

MT

AT

FA

RA

BR

ST

RS

BT

HA

EL

IDX

TROUBLE DIAGNOSIS FOR DTC P0120

Throttle Position Sensor

Note: If DTC P0120 (0403) is displayed with DTC P0510 (0203), perform TROUBLE DIAGNOSIS FOR DTC P0510 first. (See EC-325.)

COMPONENT DESCRIPTION

The throttle position sensor responds to the accelerator pedal movement. This sensor is a kind of potentiometer which transforms the throttle position into output voltage, and emits the voltage signal to the ECM. In addition, the sensor detects the opening and closing speed of the throttle valve and feeds the voltage signal to the ECM.

Idle position of the throttle valve is determined by the ECM receiving the signal from the throttle position sensor. This sensor controls engine operation such as fuel cut. On the other hand, the "Wide open and closed throttle position switch", which is built into the throttle position sensor unit, is not used for engine control.

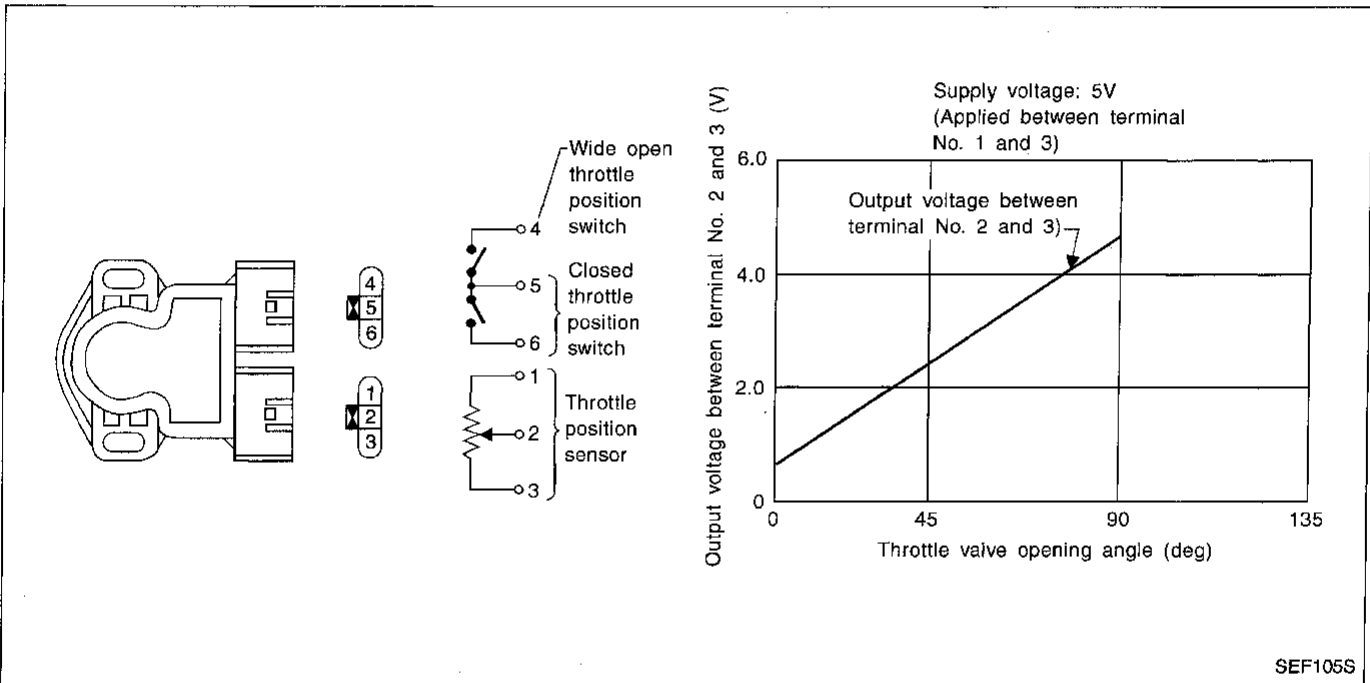

CONSULT REFERENCE VALUE IN DATA MONITOR MODE

Specification data are reference values.

MONITOR ITEM	CONDITION		SPECIFICATION
THRTL POS SEN	<ul style="list-style-type: none"> ● Ignition switch: ON (Engine stopped) ● Engine: After warming up 	Throttle valve: fully closed	0.35 - 0.65V
		Throttle valve: fully opened	Approx. 4.0V
ABSOL TH-P/S	<ul style="list-style-type: none"> ● Ignition switch: ON (Engine stopped) ● Engine: After warming up 	Throttle valve: fully closed	0.0%
		Throttle valve: fully opened	Approx. 88%

TROUBLE DIAGNOSIS FOR DTC P0120

Throttle Position Sensor (Cont'd)

ECM TERMINALS AND REFERENCE VALUE

Specification data are reference values and are measured between each terminal and engine ground.

TER-MINAL NO.	WIRE COLOR	ITEM	CONDITION	DATA (DC voltage)
23	Y	Throttle position sensor	Ignition switch "ON" (Warm-up condition) └ Accelerator pedal fully released	0.35 - 0.65V
			Ignition switch "ON" └ Accelerator pedal fully depressed	Approximately 4V
49	P/L	Sensors' power supply	Ignition switch "ON"	Approximately 5V
50	B	Sensors' ground	Engine is running. └ Idle speed	Approximately 0V

ON BOARD DIAGNOSIS LOGIC

Diagnostic Trouble Code No.	Malfunction is detected when ...	Check Items (Possible Cause)
P0120 0403	A) An excessively low or high voltage from the sensor is sent to ECM.*	<ul style="list-style-type: none"> ● Harness or connectors (The throttle position sensor circuit is open or shorted.) ● Throttle position sensor
	B) A high voltage from the sensor is sent to ECM under light load driving condition.	<ul style="list-style-type: none"> ● Harness or connectors (The throttle position sensor circuit is open or shorted.) ● Throttle position sensor ● Fuel injector ● Camshaft position sensor ● Mass air flow sensor
	C) A low voltage from the sensor is sent to ECM under heavy load driving condition.	<ul style="list-style-type: none"> ● Harness or connectors (The throttle position sensor circuit is open or shorted.) ● Intake air leaks ● Throttle position sensor

*: When this malfunction is detected, the ECM enters fail-safe mode and the MIL lights up.

Detected items	Engine operating condition in fail-safe mode						
Throttle position sensor circuit	Throttle position will be determined based on the injected fuel amount and the engine speed. Therefore, acceleration will be poor.						
	<table border="1" style="margin-left: auto; margin-right: auto;"> <thead> <tr> <th>Condition</th> <th>Driving condition</th> </tr> </thead> <tbody> <tr> <td>When engine is idling</td> <td>Normal</td> </tr> <tr> <td>When accelerating</td> <td>Poor acceleration</td> </tr> </tbody> </table>	Condition	Driving condition	When engine is idling	Normal	When accelerating	Poor acceleration
	Condition	Driving condition					
When engine is idling	Normal						
When accelerating	Poor acceleration						

TROUBLE DIAGNOSIS FOR DTC P0120

Throttle Position Sensor (Cont'd)

DIAGNOSTIC TROUBLE CODE CONFIRMATION PROCEDURE

Perform "Procedure for malfunction A" first. If the DTC cannot be confirmed, perform "Procedure for malfunction B". If there is no problem on "Procedure for malfunction B", perform "Procedure for malfunction C".

Procedure for malfunction A

NOTE:

If "DIAGNOSTIC TROUBLE CODE CONFIRMATION PROCEDURE" has been previously conducted, always turn ignition switch "OFF" and wait at least 5 seconds before conducting the next test.

CAUTION:

Always drive vehicle at a safe speed.

TESTING CONDITION:

- Before performing the following procedure, confirm that battery voltage is more than 10V at idle.
- This test may be conducted with the drive wheels lifted in the shop or by driving the vehicle. If a road test is expected to be easier, it is unnecessary to lift the vehicle.

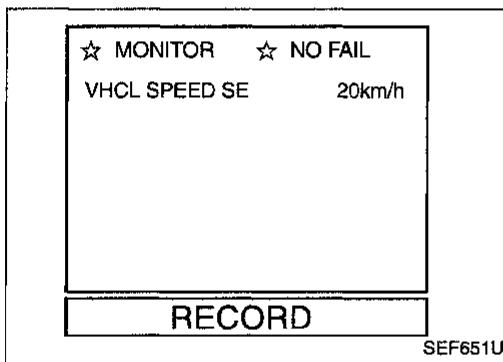

- 1) Turn ignition switch "ON" and select "DATA MONITOR" mode with CONSULT.
- 2) Start engine and maintain the following conditions for at least 5 consecutive seconds.
VHCL SPEED SE: More than 4 km/h (2 MPH)
Selector lever: Suitable position except "P" or "N" position
- 3) If 1st trip DTC is detected, go to "DIAGNOSTIC PROCEDURE", EC-150.

OR



- 1) Start engine and maintain the following conditions for at least 5 consecutive seconds.
Vehicle speed: More than 4 km/h (2 MPH)
Selector lever: Suitable position except "P" or "N" position
- 2) Select "MODE 7" with GST.
- 3) If 1st trip DTC is detected, go to "DIAGNOSTIC PROCEDURE", EC-150.

OR



- 1) Start engine and maintain the following conditions for at least 5 consecutive seconds.
Vehicle speed: More than 4 km/h (2 MPH)
Selector lever: Suitable position except "P" or "N" position
- 2) Turn ignition switch "OFF" and wait at least 5 seconds.
- 3) Turn ignition switch "ON" and perform "Diagnostic Test Mode II (Self-diagnostic results)" with ECM.
- 4) If 1st trip DTC is detected, go to "DIAGNOSTIC PROCEDURE", EC-150.

TROUBLE DIAGNOSIS FOR DTC P0120

Throttle Position Sensor (Cont'd)

Procedure for malfunction B

NOTE:

If "DIAGNOSTIC TROUBLE CODE CONFIRMATION PROCEDURE" has been previously conducted, always turn ignition switch "OFF" and wait at least 5 seconds before conducting the next test.



- 1) Turn ignition switch "ON".
- 2) Select "DATA MONITOR" mode with CONSULT.
- 3) Start engine and let it idle for at least 10 seconds. If idle speed is over 1,000 rpm, maintain the following conditions for at least 10 seconds to keep engine speed below 1,000 rpm.

A/T model

Selector lever: Suitable position except "P" or "N"

Brake pedal: Depressed

Vehicle speed: 0 km/h (0 MPH)

M/T model

Selector lever: Suitable position except "N" (Higher gear position such as 3rd or 4th is better to keep low engine rpm.)

Accelerator pedal: Released

Vehicle speed: As slow as possible

- 4) If 1st trip DTC is detected, go to "DIAGNOSTIC PROCEDURE", EC-150.

OR



- 1) Start engine and let it idle for at least 10 seconds. If idle speed is over 1,000 rpm, maintain the following conditions for at least 10 seconds to keep engine speed below 1,000 rpm.

A/T model

Selector lever: Suitable position except "P" or "N"

Brake pedal: Depressed

Vehicle speed: 0 km/h (0 MPH)

M/T model

Selector lever: Suitable position except "N" (Higher gear position such as 3rd or 4th is better to keep low engine rpm.)

Accelerator pedal: Released

Vehicle speed: As slow as possible

- 2) Select "MODE 7" with GST.
- 3) If 1st trip DTC is detected, go to "DIAGNOSTIC PROCEDURE", EC-150.

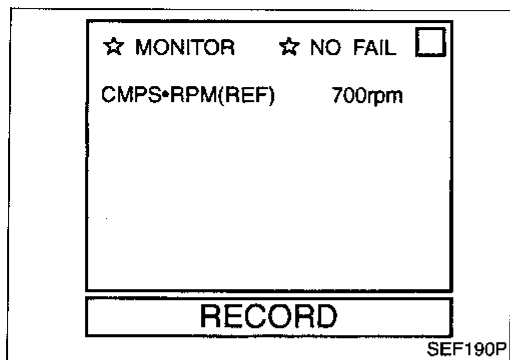

GI

MA

EM

LC

EC

FE

CL

MT

AT

FA

RA

BR

ST

RS

BT

HA

EL

IDX

TROUBLE DIAGNOSIS FOR DTC P0120

Throttle Position Sensor (Cont'd)

OR



- 1) Start engine and let it idle for at least 10 seconds. If idle speed is over 1,000 rpm, maintain the following conditions for at least 10 seconds to keep engine speed below 1,000 rpm.

A/T model

Selector lever: Suitable position except "P" or "N"

Brake pedal: Depressed

Vehicle speed: 0 km/h (0 MPH)M/T model

Selector lever: Suitable position except "N"
(Higher gear position such as 3rd or 4th is better to keep low engine rpm.)

Accelerator pedal: Released

Vehicle speed: As slow as possible

- 2) Turn ignition switch "OFF" and wait at least 5 seconds.
- 3) Turn ignition switch "ON" and perform "Diagnostic Test Mode II (Self-diagnostic results)" with ECM.
- 4) If 1st trip DTC is detected, go to "DIAGNOSTIC PROCEDURE", EC-150.

TROUBLE DIAGNOSIS FOR DTC P0120

Throttle Position Sensor (Cont'd)

Procedure for malfunction C

CAUTION:

Always drive vehicle at a safe speed.

NOTE:

If "DIAGNOSTIC TROUBLE CODE CONFIRMATION PROCEDURE" has been previously conducted, always turn ignition switch "OFF" and wait at least 5 seconds before conducting the next test.

☆ MONITOR ☆ NO FAIL

THRTL POS SEN 0.48V
ABSOL TH•P/S 0.0%

RECORD

SEF024P

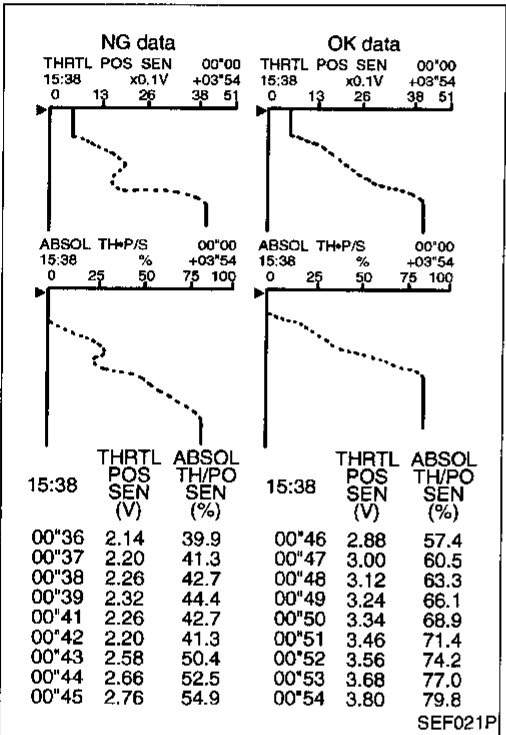

☆ MONITOR ☆ NO FAIL

CMPS•RPM(REF) 2137rpm
MAS AIR/FL SE 3.07V
COOLAN TEMP/S 84°C

RECORD

SEF235U



- 1) Start engine and warm it up to normal operating temperature.
- 2) Turn ignition switch "OFF" and wait at least 5 seconds.
- 3) Turn ignition switch "ON".
- 4) Select "MANU TRIG" and "HI SPEED" in "DATA MONITOR" mode with CONSULT.
- 5) Select "THRTL POS SEN" and "ABSOL TH•P/S" in "DATA MONITOR" mode with CONSULT.
- 6) Press RECORD on CONSULT SCREEN at the same time accelerator pedal is depressed.
- 7) Print out the recorded graph and check the following:
 - The voltage rise is linear in response to accelerator pedal depression.
 - The voltage when accelerator pedal is fully depressed is approximately 4V.
 If NG, go to "DIAGNOSTIC PROCEDURE", EC-150. If OK, go to following step.
- 8) Select "AUTO TRIG" in "DATA MONITOR" mode with CONSULT.
- 9) Maintain the following conditions for at least 10 consecutive seconds.
 - CMPS-RPM (REF):** More than 2,000 rpm
 - MAS AIR/FL SE:** More than 3V
 - COOLAN TEMP/S:** More than 70°C (158°F)
 - Selector lever:** Suitable position
 - Driving location:** Driving vehicle uphill (Increased engine load) will help maintain the driving conditions required for this test.
- 10) If 1st trip DTC is detected, go to "DIAGNOSTIC PROCEDURE", EC-150.

GI
MA
EM
LC
EC
FE
CL
MT
AT
FA
RA
BR
ST
RS
BT
HA
EL
IDX

TROUBLE DIAGNOSIS FOR DTC P0120

Throttle Position Sensor (Cont'd)

OR

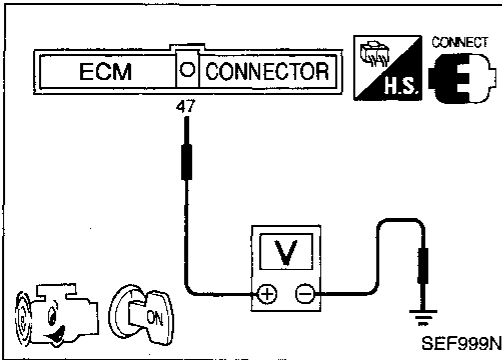

- 1) Maintain the following conditions for at least 10 consecutive seconds.

Gear position: Suitable position

Engine speed: More than 2,000 rpm

Engine coolant temperature: More than 70°C (158°F)

Voltage between ECM terminal ④⑦ and engine ground:

More than 3V

- 2) If 1st trip DTC is detected, go to "DIAGNOSTIC PROCEDURE", EC-150.

OR

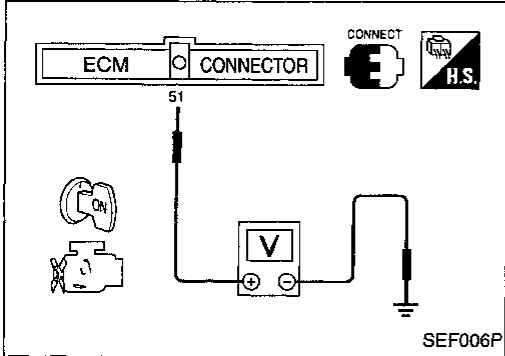

- 1) Maintain the following conditions for at least 10 consecutive seconds.

Gear position: Suitable position

Engine speed: More than 2,000 rpm

Voltage between ECM terminal ④⑦ and engine ground:

More than 3V

Voltage between ECM terminal ⑤① and engine ground:

Less than 1.5V

- 2) Stop the vehicle, turn ignition switch "OFF", wait at least 5 seconds and then turn "ON".
- 3) Perform "Diagnostic Test Mode II (Self-diagnostic results)" with ECM.
- 4) If 1st trip DTC is detected, go to "DIAGNOSTIC PROCEDURE", EC-150.

TROUBLE DIAGNOSIS FOR DTC P0120

Throttle Position Sensor (Cont'd)

EC-TPS-01

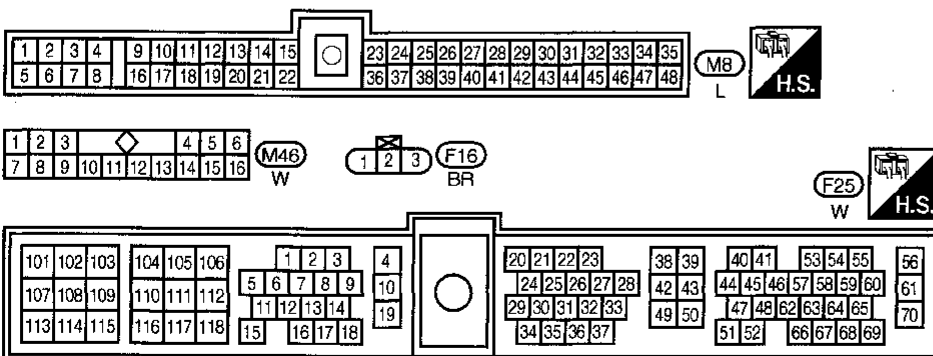
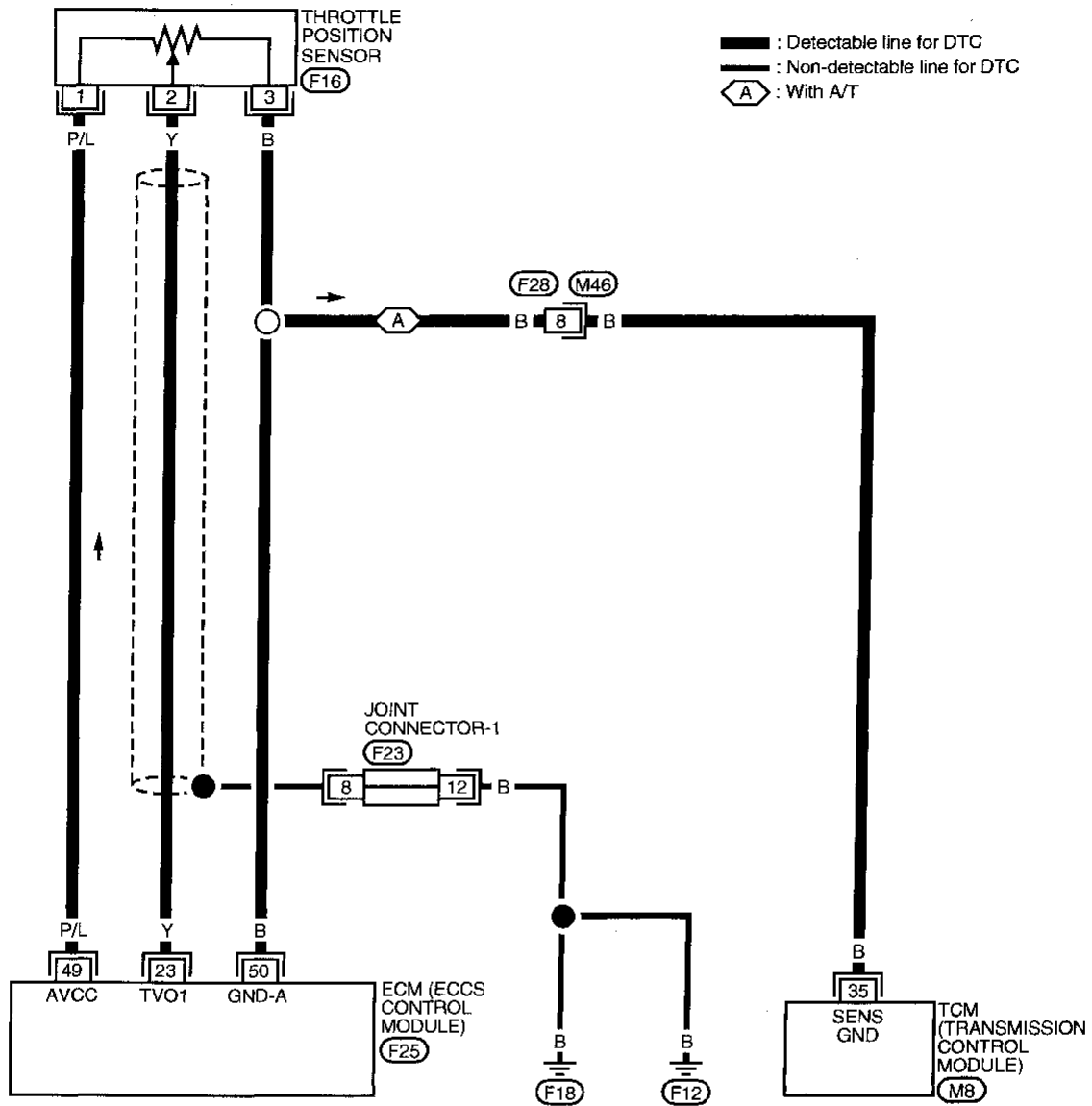

Refer to last page (Foldout page).

F23

TROUBLE DIAGNOSIS FOR DTC P0120

Throttle Position Sensor (Cont'd)

DIAGNOSTIC PROCEDURE

If the trouble is duplicated after "Procedure for malfunction A", perform "Procedure A" below. If the trouble is duplicated after "Procedure for malfunction B", perform "Procedure B" on next page. If the trouble is duplicated after "Procedure for malfunction C", perform "Procedure C" on EC-154.

Procedure A

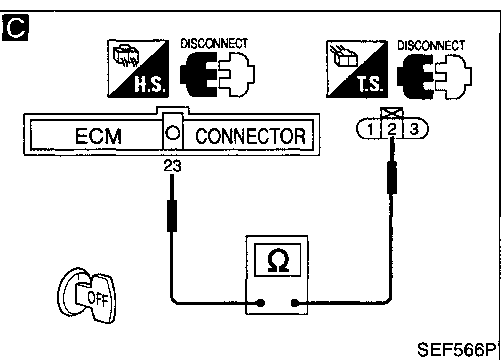
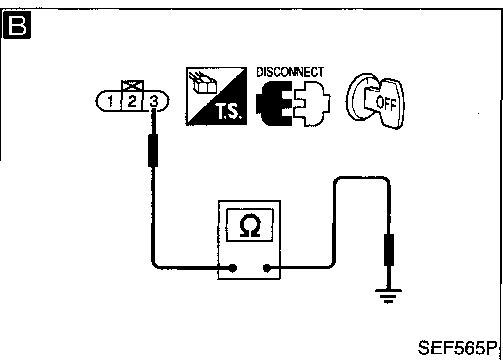
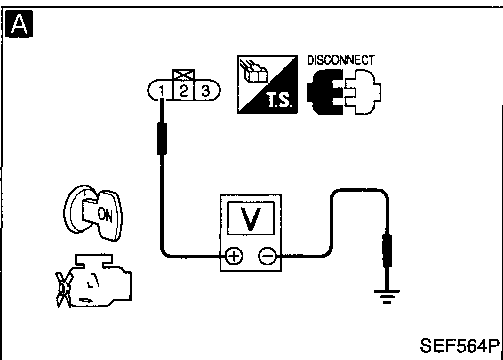
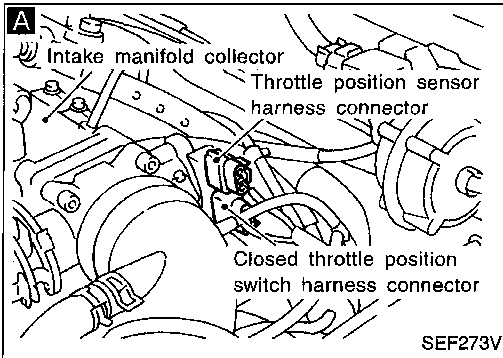
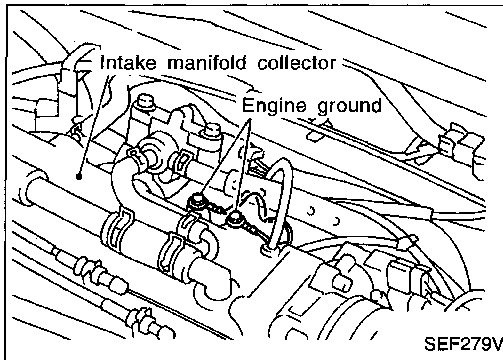

INSPECTION START

1. Turn ignition switch "OFF".
2. Loosen and retighten engine ground screws.

A
CHECK POWER SUPPLY.
1. Disconnect throttle position sensor harness connector.
2. Turn ignition switch "ON".
3. Check voltage between terminal ① and ground with CONSULT or tester.
Voltage: Approximately 5V

NG → Repair harness or connectors.

B
CHECK GROUND CIRCUIT.
1. Turn ignition switch "OFF".
2. Check harness continuity between terminal ③ and engine ground.
Continuity should exist.
If OK, check harness for short to ground and short to power.

NG → Check the following.

- Harness connectors
- Harness for open or short between ECM and throttle position sensor
- Harness for open or short between throttle position sensor and TCM (With A/T)

 If NG, repair open circuit or short to ground or short to power in harness or connectors.

C
CHECK INPUT SIGNAL CIRCUIT.
1. Disconnect ECM harness connector.
2. Check harness continuity between ECM terminal ②③ and terminal ②.
Continuity should exist.
If OK, check harness for short to ground and short to power.

NG → Repair open circuit or short to ground or short to power in harness or connectors.

OK
A
(Go to next page.)

TROUBLE DIAGNOSIS FOR DTC P0120

Throttle Position Sensor (Cont'd)

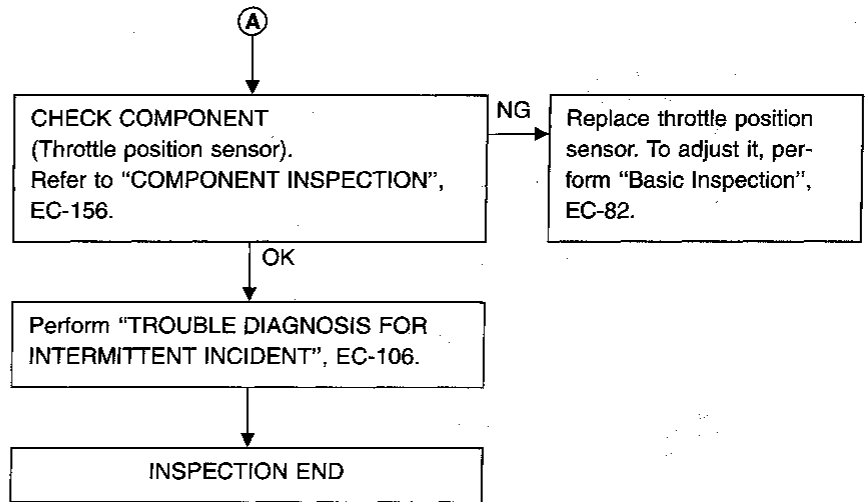

GI
MA
EM
LC
EC
FE
CL
MT
AT
FA
RA
BR
ST
RS
BT
HA
EL
IDX

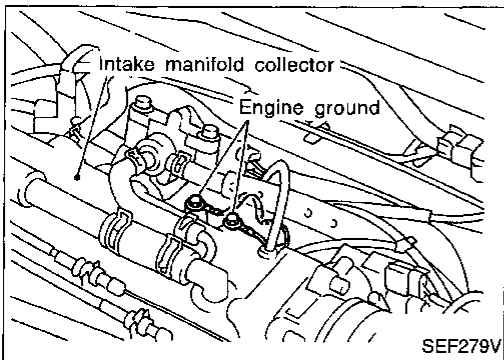

Procedure B

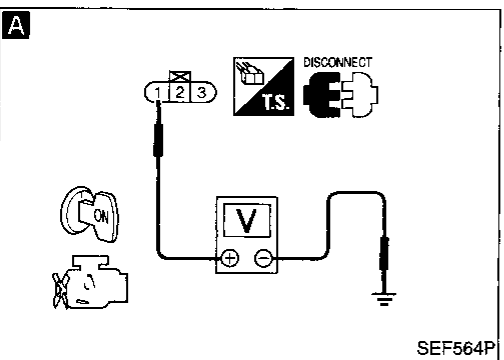
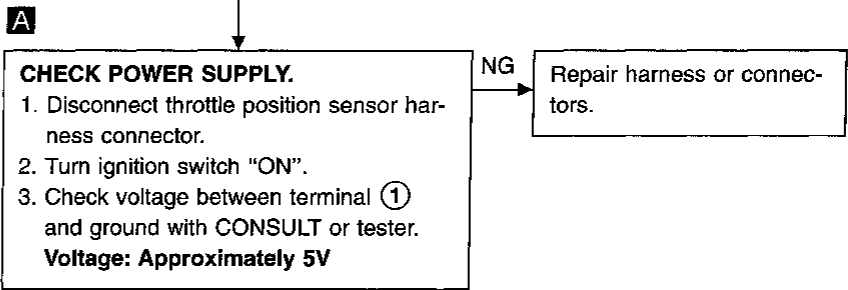
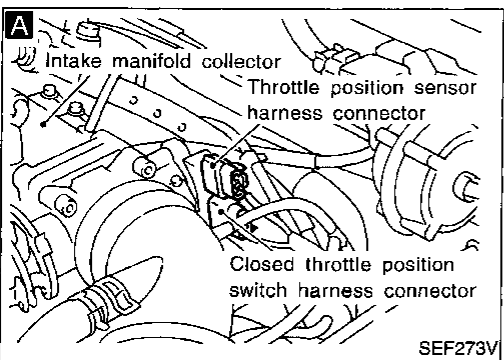
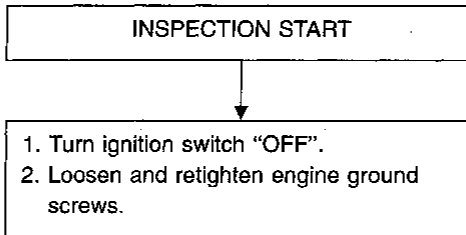

TROUBLE DIAGNOSIS FOR DTC P0120

Throttle Position Sensor (Cont'd)

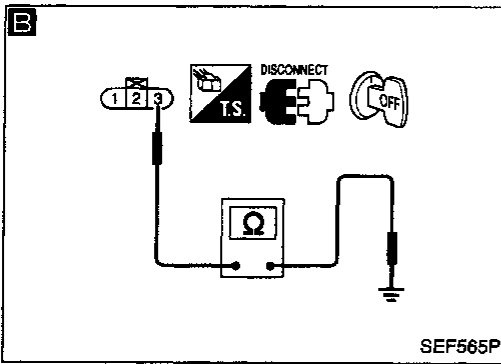

B

CHECK GROUND CIRCUIT.
 1. Turn ignition switch "OFF".
 2. Check harness continuity between terminal ③ and engine ground.
Continuity should exist.
 If OK, check harness for short to ground and short to power.

NG → Check the following.

- Harness connectors (F28), (M48) (With A/T)
- Harness for open or short between ECM and throttle position sensor
- Harness for open or short between throttle position sensor and TCM (With A/T)

If NG, repair open circuit or short to ground or short to power in harness or connectors.

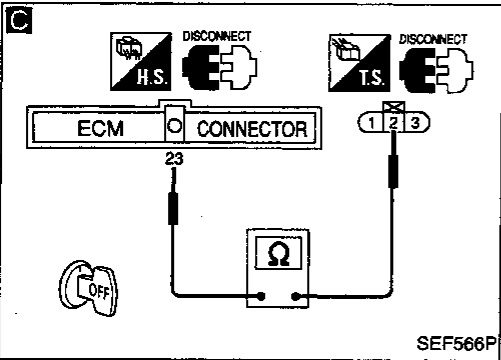

C

CHECK INPUT SIGNAL CIRCUIT.
 1. Disconnect ECM harness connector.
 2. Check harness continuity between ECM terminal ②③ and terminal ②.
Continuity should exist.
 If OK, check harness for short to ground and short to power.

NG → Repair open circuit or short to ground or short to power in harness or connectors.

CHECK COMPONENT
 (Throttle position sensor).
 Refer to "COMPONENT INSPECTION", EC-156.

NG → Replace throttle position sensor. To adjust it, perform "Basic Inspection", EC-82.

CHECK COMPONENT
 (Mass air flow sensor).
 Refer to "COMPONENT INSPECTION", EC-121.

NG → Replace mass air flow sensor.

CHECK COMPONENT
 (Camshaft position sensor).
 Refer to "COMPONENT INSPECTION", EC-266.

NG → Replace camshaft position sensor.

CHECK COMPONENT
 (Fuel injector).
 Refer to "COMPONENT INSPECTION", EC-471.

NG → Replace fuel injector.

B
 (Go to next page.)

TROUBLE DIAGNOSIS FOR DTC P0120

Throttle Position Sensor (Cont'd)

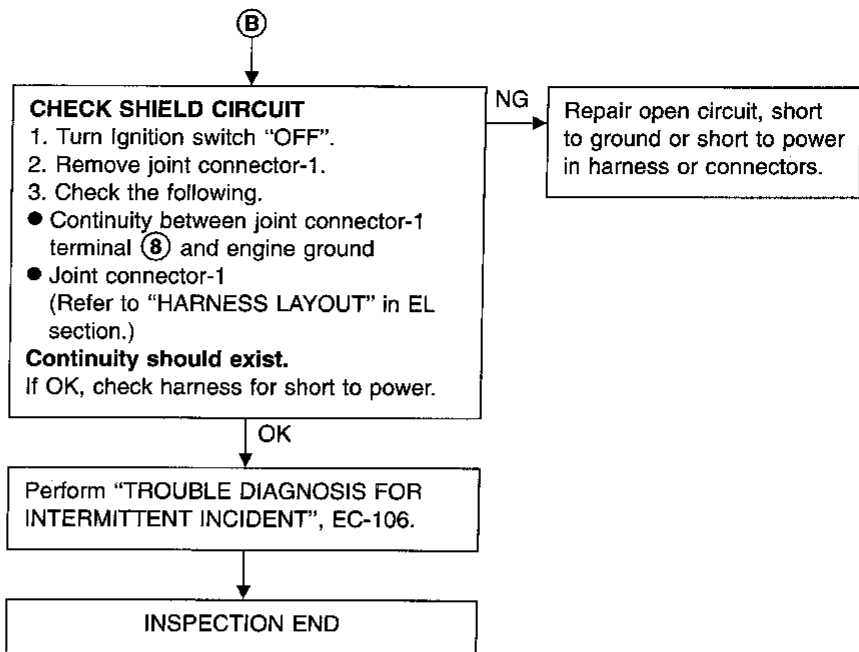

GI
MA
EM
LC
EC
FE
CL
MT
AT
FA
RA
BR
ST
RS
BT
HA
EL
IDX

TROUBLE DIAGNOSIS FOR DTC P0120

Throttle Position Sensor (Cont'd)

Procedure C

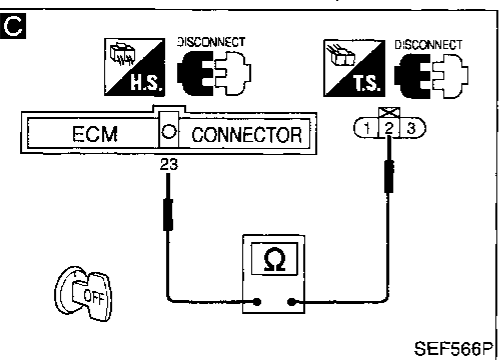
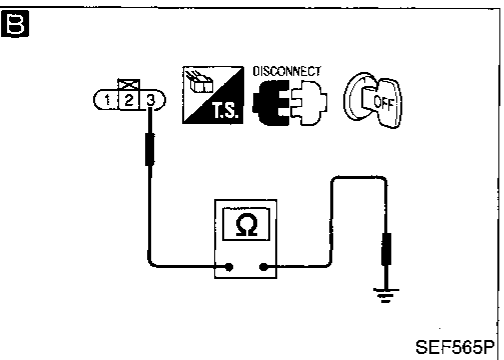
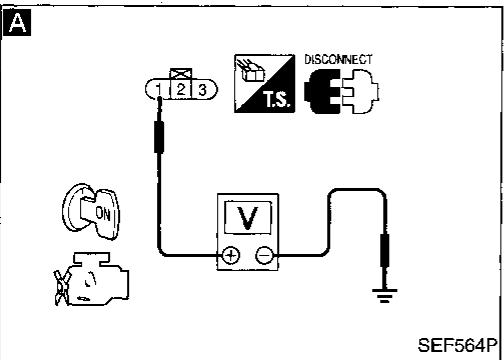
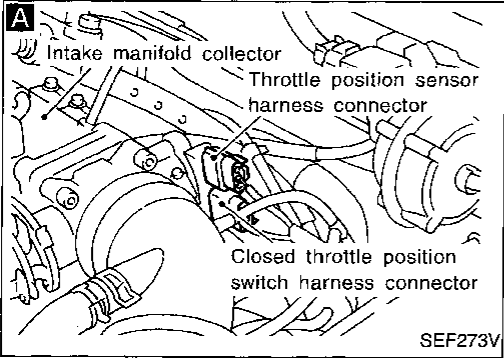
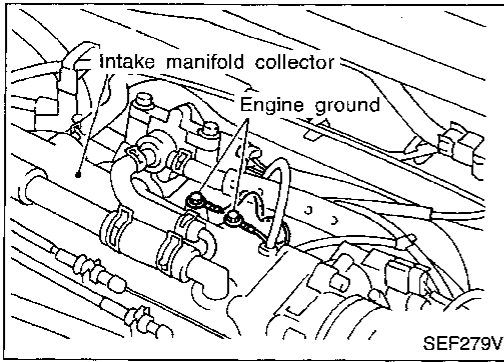

INSPECTION START

ADJUST THROTTLE POSITION SENSOR.
Perform "Basic Inspection", EC-82.

OK

CHECK INTAKE SYSTEM.
Check the following for connection.
● Air duct
● Vacuum hoses
● Intake air passage between air duct to collector
If disconnected, reconnect the parts.

NG → Reconnect the parts.

OK

1. Turn ignition switch "OFF".
2. Loosen and retighten engine ground screws.

A
CHECK POWER SUPPLY.
1. Disconnect throttle position sensor harness connector.
2. Turn ignition switch "ON".
3. Check voltage between terminal ① and ground with CONSULT or tester.
Voltage: Approximately 5V

NG → Repair harness or connectors.

OK

B
CHECK GROUND CIRCUIT.
1. Turn ignition switch "OFF".
2. Check harness continuity between terminal ③ and engine ground.
Continuity should exist.
If OK, check harness for short to ground and short to power.

NG → Check the following.
● Harness connectors (F28), (M46) (With A/T)
● Harness for open or short between ECM and throttle position sensor
● Harness for open or short between throttle position sensor and TCM (With A/T)
If NG, repair open circuit or short to ground or short to power in harness or connectors.

OK

C
CHECK INPUT SIGNAL CIRCUIT.
1. Disconnect ECM harness connector.
2. Check harness continuity between ECM terminal ②③ and terminal ②.
Continuity should exist.
If OK, check harness for short to ground and short to power.

NG → Repair open circuit or short to ground or short to power in harness or connectors.

OK

Ⓐ
(Go to next page.)

TROUBLE DIAGNOSIS FOR DTC P0120

Throttle Position Sensor (Cont'd)

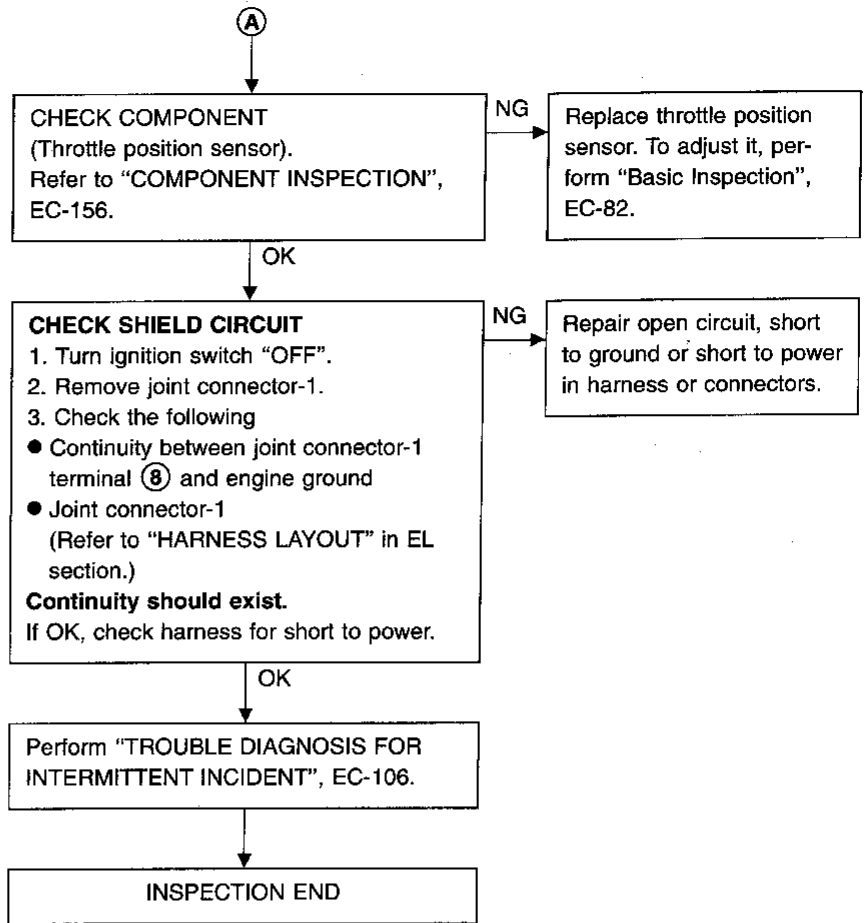

GI

MA

EM

LC

EC

FE

CL

MT

AT

FA

RA

BR

ST

RS

BT

HA

EL

IDX

TROUBLE DIAGNOSIS FOR DTC P0120

Throttle Position Sensor (Cont'd)

COMPONENT INSPECTION

Throttle position sensor



1. Start engine and warm it up to normal operating temperature.
2. Stop engine and turn ignition switch "ON".
3. Select "DATA MONITOR" mode with CONSULT.
4. Check voltage of "THRTL POS SEN".

Voltage measurement must be made with throttle position sensor installed in vehicle.

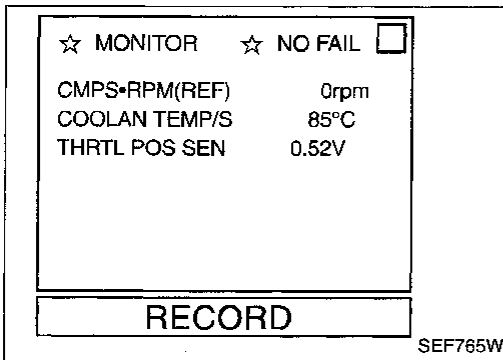

SEF765W

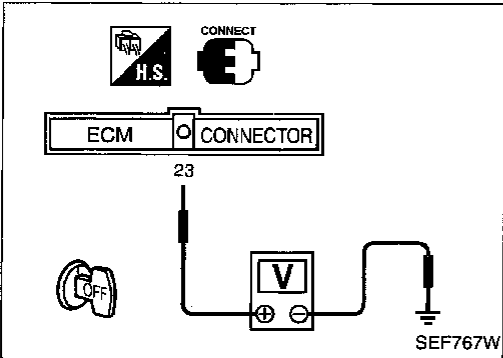

SEF767W

Throttle valve conditions	THRTL POS SEN
Completely closed (a)	0.15 - 0.85
Partially open	Between (a) and (b)
Completely open (b)	3.5 - 4.7

If NG, adjust closed throttle position switch. Refer to "Basic Inspection", EC-82.

5. If it is impossible to adjust closed throttle position switch in "Basic Inspection", replace throttle position sensor.

OR



1. Start engine and warm it up to normal operating temperature.
2. Stop engine and turn ignition switch "ON".
3. Check voltage between ECM terminal ② (Throttle position sensor signal) and ground.

Voltage measurement must be made with throttle position sensor installed in vehicle.

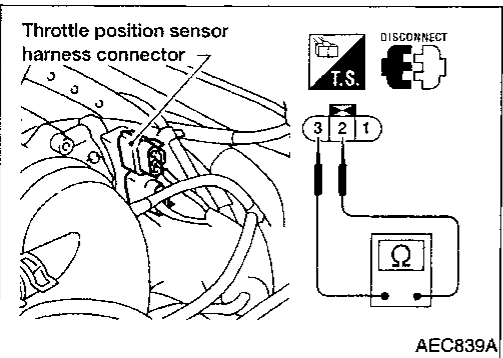

AEC839A

Throttle valve conditions	Voltage(V)
Completely closed	0.15 - 0.85
Partially open	Between (a) and (b)
Completely open	3.5 - 4.7

If NG, adjust closed throttle position switch. Refer to "Basic Inspection", EC-82.

4. If it is impossible to adjust closed throttle position switch in "Basic Inspection", replace throttle position sensor.

TROUBLE DIAGNOSIS FOR DTC P0125

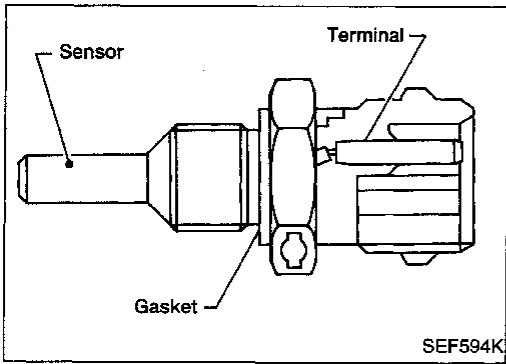

Engine Coolant Temperature (ECT) Sensor COMPONENT DESCRIPTION

The engine coolant temperature sensor is used to detect the engine coolant temperature. The sensor modifies a voltage signal from the ECM. The modified signal returns to the ECM as the engine coolant temperature input. The sensor uses a thermistor which is sensitive to the change in temperature. The electrical resistance of the thermistor decreases as temperature increases.

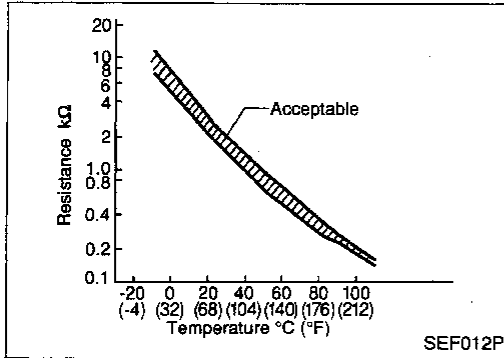

<Reference data>

Engine coolant temperature °C (°F)	Voltage* V	Resistance kΩ
-10 (14)	4.4	9.2
20 (68)	3.5	2.1 - 2.9
50 (122)	2.2	0.68 - 1.00
90 (194)	0.9	0.236 - 0.260

*: These data are reference values and are measured between ECM terminal ⑤1 (Engine coolant temperature sensor) and engine ground.

CONSULT REFERENCE VALUE IN DATA MONITOR MODE

MONITOR ITEM	CONDITION	SPECIFICATION
COOLAN TEMP/S	● Engine: After warming up	More than 70°C (158°F)

ON BOARD DIAGNOSIS LOGIC

Diagnostic Trouble Code No.	Malfunction is detected when ...	Check Items (Possible Cause)
P0125 0908	<ul style="list-style-type: none"> ● Voltage sent to ECM from the sensor is not practical, even when some time has passed after starting the engine. ● Engine coolant temperature is insufficient for closed loop fuel control. 	<ul style="list-style-type: none"> ● Harness or connectors (High resistance in the circuit) ● Engine coolant temperature sensor ● Thermostat

TROUBLE DIAGNOSIS FOR DTC P0125

Engine Coolant Temperature (ECT) Sensor (Cont'd)

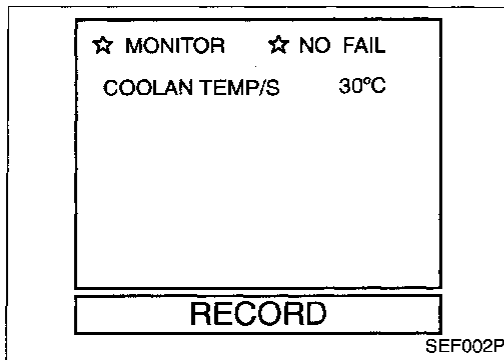

DIAGNOSTIC TROUBLE CODE CONFIRMATION PROCEDURE

CAUTION:

Be careful not to overheat engine.

NOTE:

- If DTC P0125 (0908) is displayed with P0115 (0103), perform "TROUBLE DIAGNOSIS FOR DTC P0115". Refer to EC-137 first.
- If "DIAGNOSTIC TROUBLE CODE CONFIRMATION PROCEDURE" has been previously conducted, always turn ignition switch "OFF" and wait at least 5 seconds before conducting the next test.



- 1) Turn ignition switch "ON".
- 2) Select "DATA MONITOR" mode with CONSULT.
- 3) Check that "COOLAN TEMP/S" is above 15°C (59°F).
**If it is above 15°C (59°F), the test result will be OK.
If it is below 15°C (59°F), go to following step.**
- 4) Start engine and run it for 65 minutes at idle speed.
If "COOLAN TEMP/S" increases to more than 15°C (59°F) within 65 minutes, stop engine because the test result will be OK.
- 5) If 1st trip DTC is detected, go to "DIAGNOSTIC PROCEDURE", EC-161.

OR



- 1) Turn ignition switch "ON".
- 2) Select "MODE 1" with GST.
- 3) Check that engine coolant temperature is above 15°C (59°F).
**If it is above 15°C (59°F), the test result will be OK.
If it is below 15°C (59°F), go to following step.**
- 4) Start engine and run it for 65 minutes at idle speed.
If engine coolant temperature increases to more than 15°C (59°F) within 65 minutes, stop engine because the test result will be OK.
- 5) Select "MODE 7" with GST.
- 6) If 1st trip DTC is detected, go to "DIAGNOSTIC PROCEDURE", EC-161.

OR



- 1) Turn ignition switch "ON".
- 2) Check that voltage between ECM terminal ⑤1 and engine ground is less than 3.72V.
**If it is less than 3.72V, the test result will be OK.
If it is over 3.72V, go to following step.**
- 3) Start engine and run it for 65 minutes at idle speed.
Then measure voltage between ECM terminal ⑤1 and engine ground.
If the voltage decreases to less than 3.72V within 65 minutes, stop engine because the test result will be OK.
- 4) Turn ignition switch "OFF", wait at least 5 seconds and then turn "ON".
- 5) Perform "Diagnostic Test Mode II (Self-diagnostic results)" with ECM.

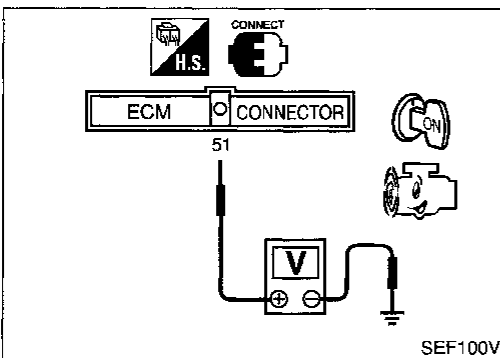
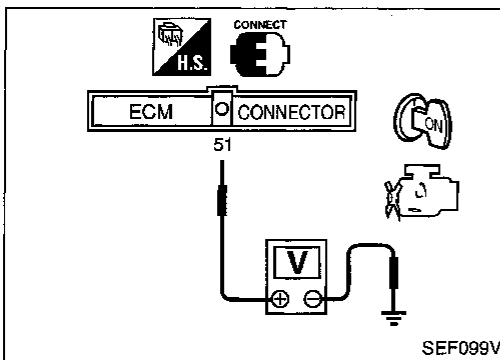

TROUBLE DIAGNOSIS FOR DTC P0125

Engine Coolant Temperature (ECT) Sensor (Cont'd)

- 6) If 1st trip DTC is detected, go to "DIAGNOSTIC PROCEDURE", EC-161.

GI

MA

EM

LC

EC

FE

CL

MT

AT

FA

RA

BR

ST

RS

BT

HA

EL

IDX

TROUBLE DIAGNOSIS FOR DTC P0125

Engine Coolant Temperature (ECT) Sensor (Cont'd)

EC-ECTS-01

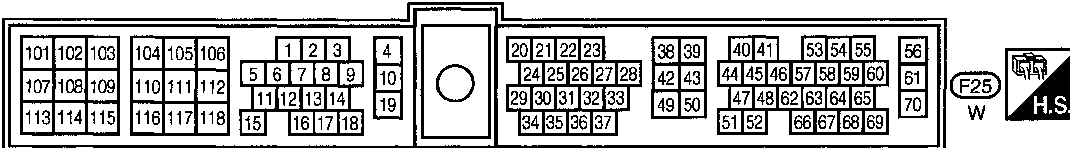
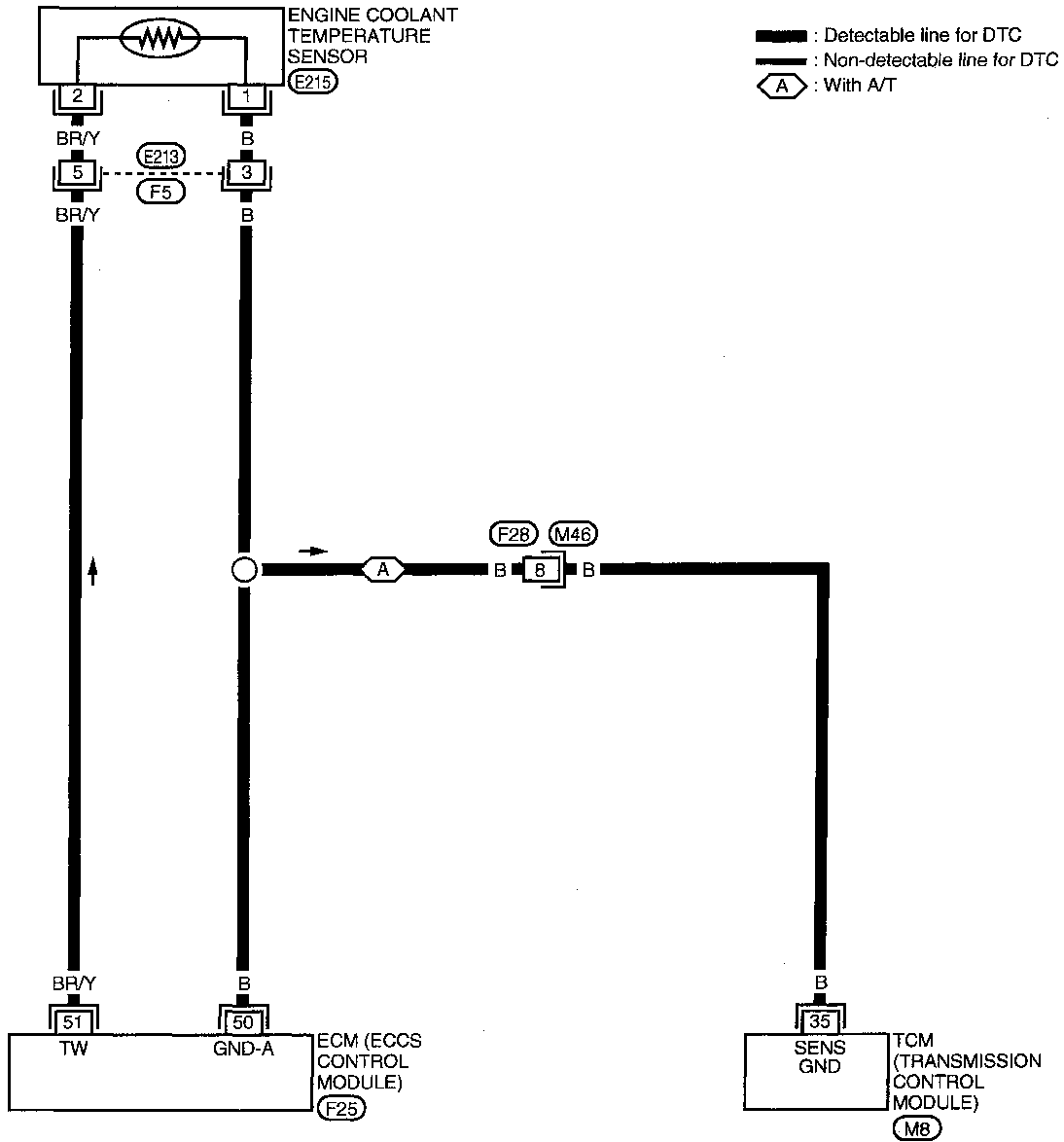

TROUBLE DIAGNOSIS FOR DTC P0125

Engine Coolant Temperature (ECT) Sensor (Cont'd)

DIAGNOSTIC PROCEDURE

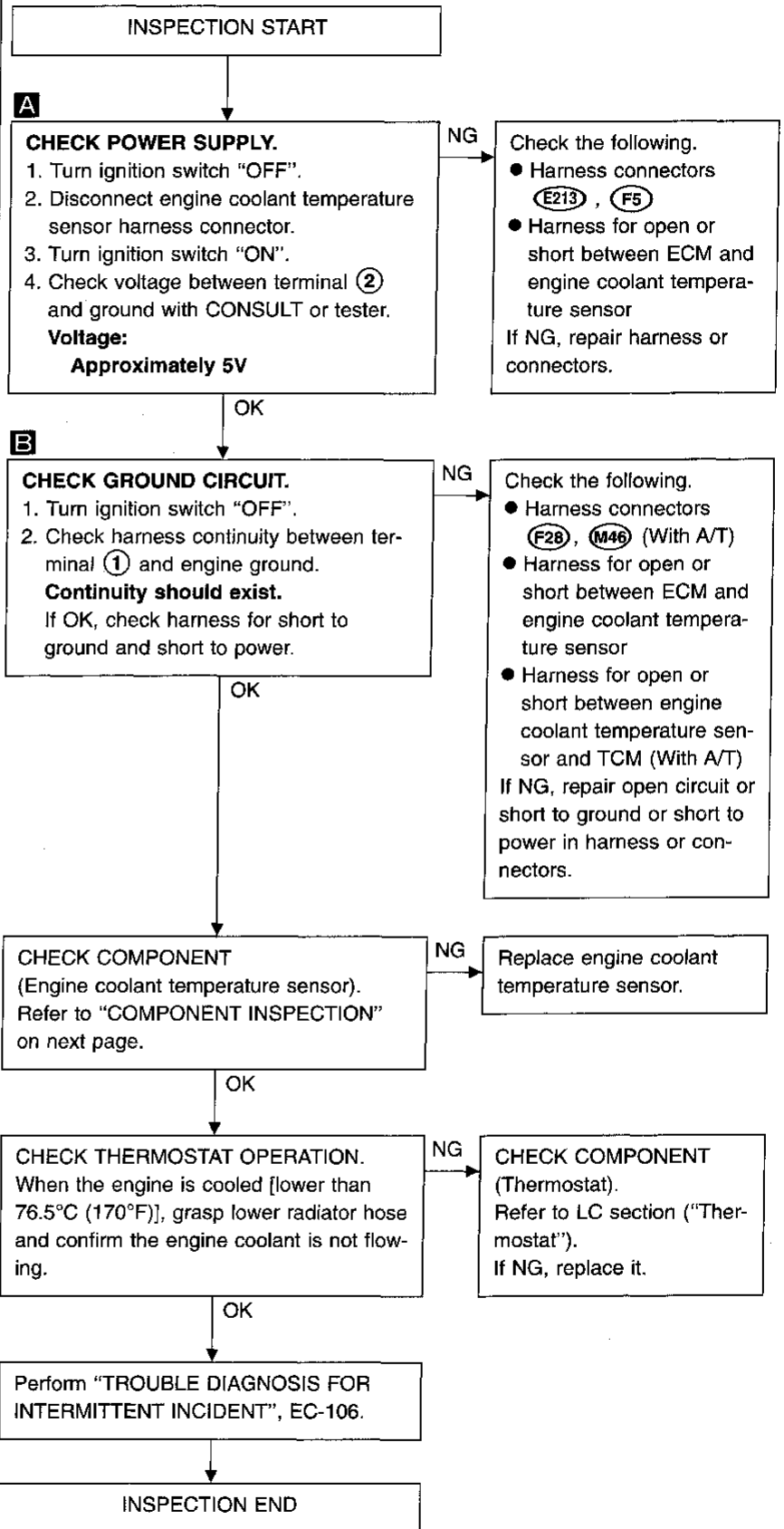
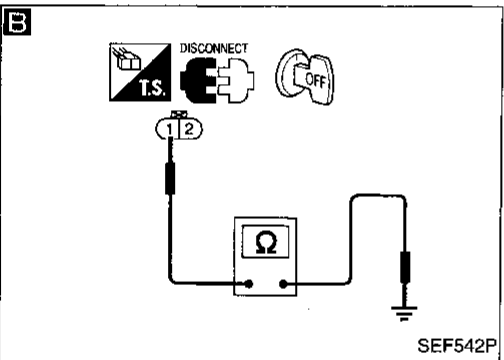
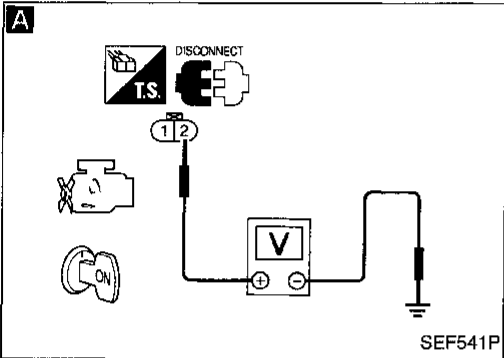
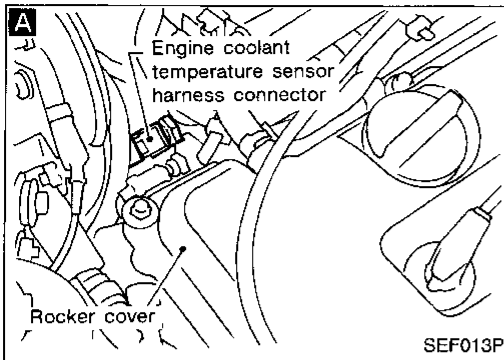

GI
MA
EM
LC
EC
FE
CL
MT
AT
FA
RA
BR
ST
RS
BT
HA
EL
IDX

TROUBLE DIAGNOSIS FOR DTC P0125

Engine Coolant Temperature (ECT) Sensor (Cont'd)

COMPONENT INSPECTION

Engine coolant temperature sensor

Check resistance as shown in the figure.

<Reference data>

Temperature °C (°F)	Resistance k Ω
20 (68)	2.1 - 2.9
50 (122)	0.68 - 1.0
90 (194)	0.236 - 0.260

If NG, replace engine coolant temperature sensor.

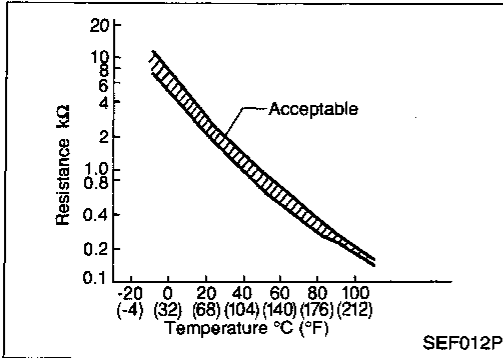
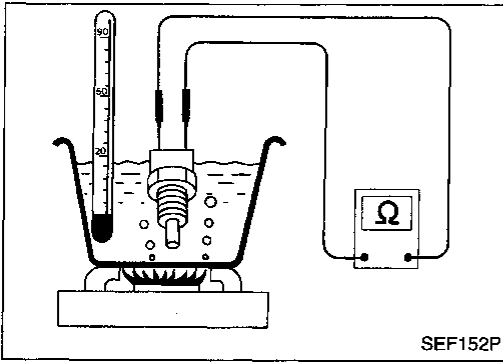

TROUBLE DIAGNOSIS FOR DTC P0130

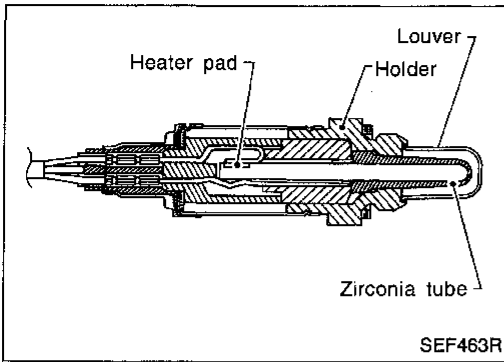

Front Heated Oxygen Sensor (Circuit) (Front HO2S)

COMPONENT DESCRIPTION

The front heated oxygen sensor is placed into the exhaust manifold. It detects the amount of oxygen in the exhaust gas compared to the outside air. The front heated oxygen sensor has a closed-end tube made of ceramic zirconia. The zirconia generates voltage from approximately 1V in richer conditions to 0V in leaner conditions. The front heated oxygen sensor signal is sent to the ECM. The ECM adjusts the injection pulse duration to achieve the ideal air-fuel ratio. The ideal air-fuel ratio occurs near the radical change from 1V to 0V.

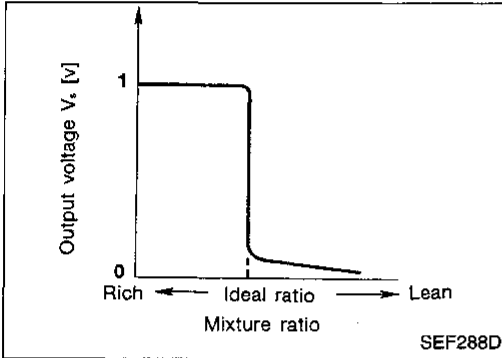

CONSULT REFERENCE VALUE IN DATA MONITOR MODE

Specification data are reference values.

MONITOR ITEM	CONDITION	SPECIFICATION
FR O2 SENSOR FR O2 MNTR	<ul style="list-style-type: none"> ● Engine: After warming up Maintaining engine speed at 2,000 rpm	0 - 0.3V ↔ Approx. 0.6 - 1.0V LEAN ↔ RICH Changes more than 5 times during 10 seconds.

ECM TERMINALS AND REFERENCE VALUE

Specification data are reference values and are measured between each terminal and engine ground.

TER-MINAL NO.	WIRE COLOR	ITEM	CONDITION	DATA (DC voltage)
46	W	Front heated oxygen sensor	Engine is running. After warming up to normal operating temperature and engine speed is 2,000 rpm	0 - Approximately 1.0V

GI

MA

EM

LC

EC

FE

CL

MT

AT

FA

RA

BR

ST

RS

BT

HA

EL

IDX

TROUBLE DIAGNOSIS FOR DTC P0130

Front Heated Oxygen Sensor (Circuit) (Front HO2S) (Cont'd)

ON BOARD DIAGNOSIS LOGIC

Under the condition in which the front heated oxygen sensor signal is not input, the ECM circuits will read a continuous approximately 0.3V. Therefore, for this diagnosis, the time that output voltage is within 200 to 400 mV range is monitored, and the diagnosis checks that this time is not inordinately long.

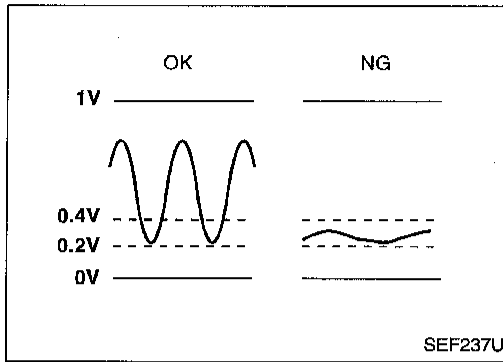

Diagnostic Trouble Code No.	Malfunction is detected when ...	Check Items (Possible Cause)
P0130 0303	<ul style="list-style-type: none"> ● The voltage from the sensor is constantly approx. 0.3V. 	<ul style="list-style-type: none"> ● Harness or connectors (The sensor circuit is open or shorted.) ● Front heated oxygen sensor

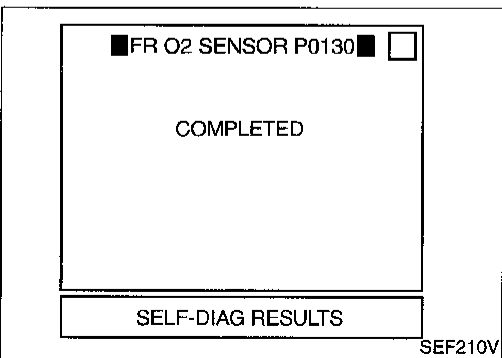
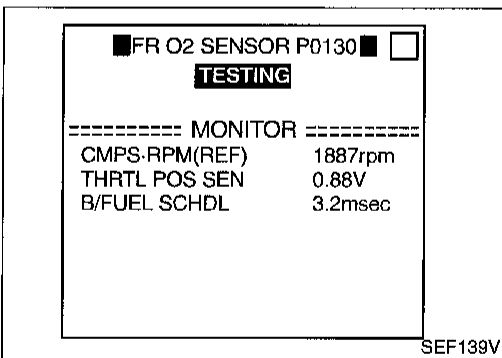
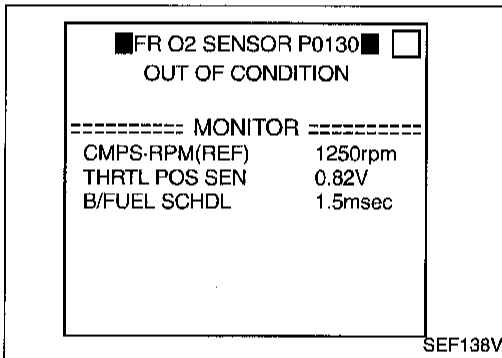

DIAGNOSTIC TROUBLE CODE CONFIRMATION PROCEDURE

CAUTION:

Always drive vehicle at a safe speed.

NOTE:

If "DIAGNOSTIC TROUBLE CODE CONFIRMATION PROCEDURE" has been previously conducted, always turn ignition switch "OFF" and wait at least 5 seconds before conducting the next test.

TESTING CONDITION:

Before performing the following procedure, confirm that battery voltage is more than 11V at idle.



- 1) Start engine and warm it up to normal operating temperature.
- 2) Select "FR O2 SENSOR P0130" of "FRONT O2 SENSOR" in "DTC WORK SUPPORT" mode with CONSULT.
- 3) Touch "START".
- 4) Let it idle for at least 3.5 minutes.

NOTE:

Never raise engine speed above 3,200 rpm after this step. If the engine speed limit is exceeded, return to step 4).

- 5) When the following conditions are met, "TESTING" will be displayed on the CONSULT screen. Maintain the conditions continuously until "TESTING" changes to "COMPLETED". (It will take approximately 10 to 60 seconds.)

**CMPS-RPM (REF): 1,400 - 2,800 rpm (A/T)
2,200 - 2,800 rpm (M/T)**

Vehicle speed: 70 - 100 km/h (43 - 62 MPH)

**B/FUEL SCHDL: 1.0 - 4.5 msec (A/T)
1.0 - 3.7 msec (M/T)**

TROUBLE DIAGNOSIS FOR DTC P0130

Front Heated Oxygen Sensor (Circuit) (Front HO2S) (Cont'd)

Selector lever: Suitable position

If "TESTING" is not displayed after 5 minutes, retry from step 2).

6) Make sure that "OK" is displayed after touching "SELF-DIAG RESULTS". If "NG" is displayed, refer to "DIAGNOSTIC PROCEDURE", EC-167.

During this test, P1148 may be displayed on CONSULT screen.

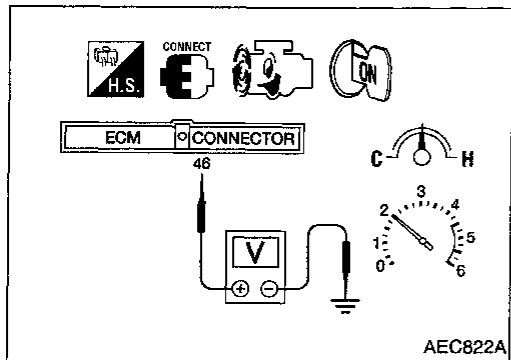

OR OVERALL FUNCTION CHECK

Use this procedure to check the overall function of the front heated oxygen sensor circuit. During this check, a 1st trip DTC might not be confirmed.

- 1) Start engine and warm it up to normal operating temperature.
- 2) Set voltmeter probes between ECM terminal ④⑥ (sensor signal) and engine ground.
- 3) Check the following with engine speed held at 2,000 rpm constant under no load.
 - The voltage does not remain in the range of 0.2 - 0.4V.
- 4) If NG, go to "DIAGNOSTIC PROCEDURE", EC-167.

TROUBLE DIAGNOSIS FOR DTC P0130

Front Heated Oxygen Sensor (Circuit) (Front HO2S) (Cont'd)

EC-FRO2-01

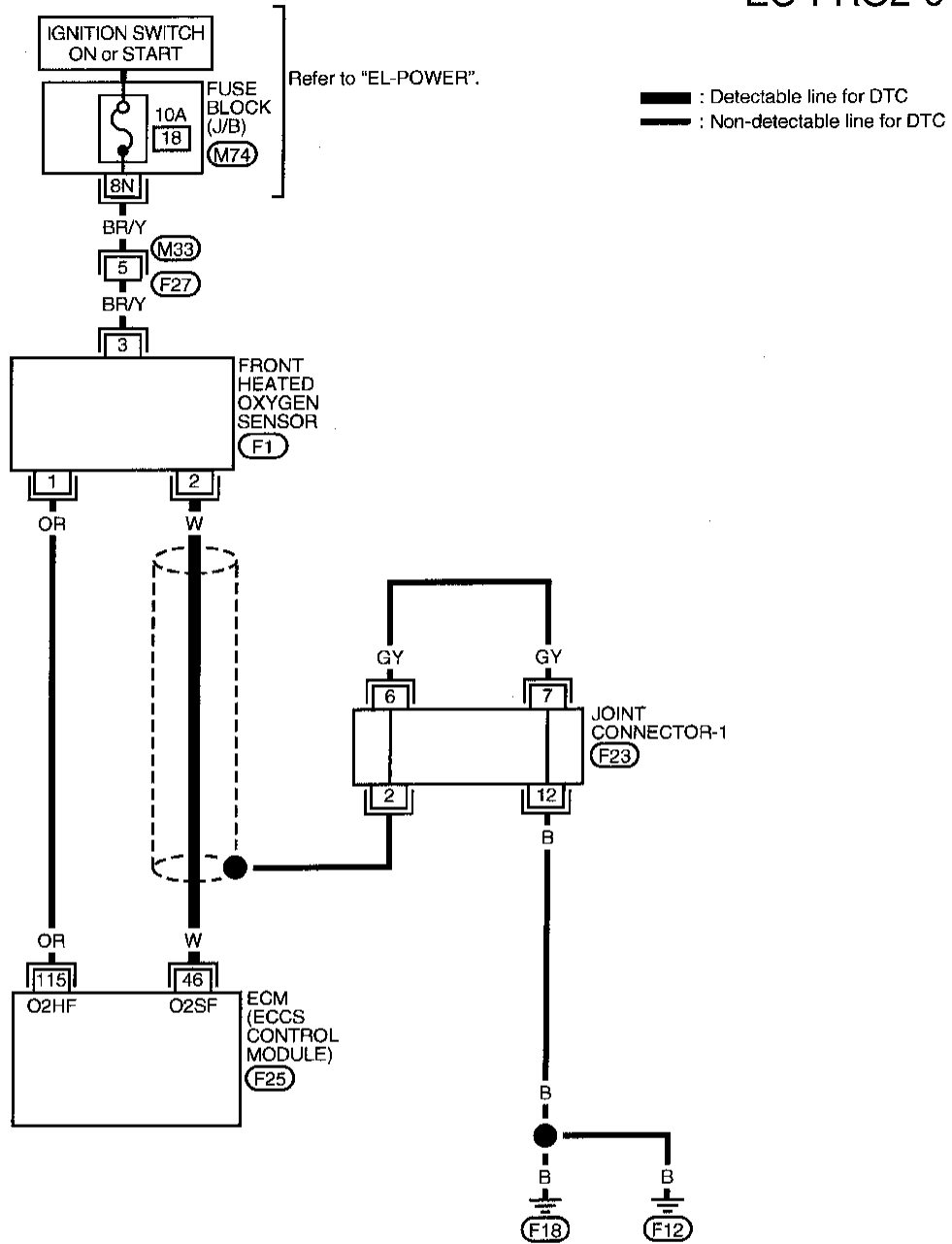

Refer to last page (Foldout page).

(F23)

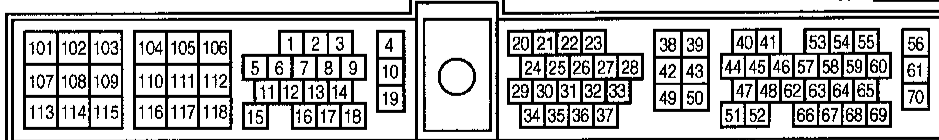
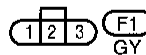
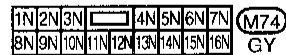

TROUBLE DIAGNOSIS FOR DTC P0130

Front Heated Oxygen Sensor (Circuit) (Front HO2S) (Cont'd)

DIAGNOSTIC PROCEDURE

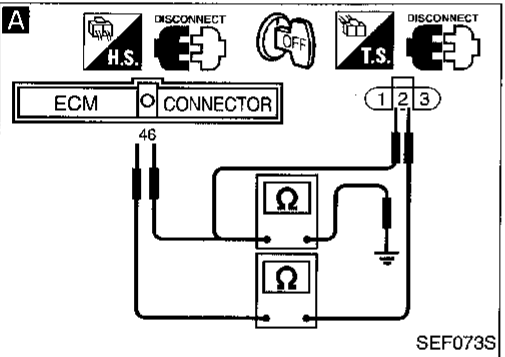
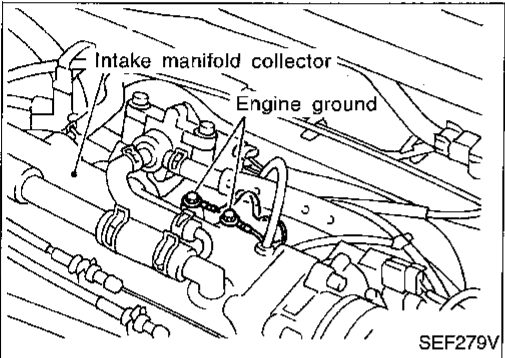
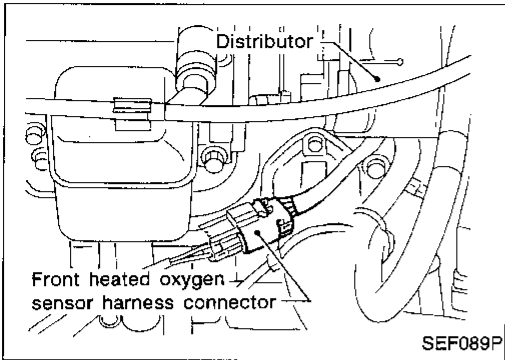

INSPECTION START

1. Turn ignition switch "OFF".
2. Loosen and retighten engine ground screws.

A

CHECK INPUT SIGNAL CIRCUIT.

1. Disconnect front heated oxygen sensor harness connector and ECM harness connector.
2. Check harness continuity between ECM terminal (46) and terminal (2).
Continuity should exist.
3. Check harness continuity between ECM terminal (46) (or terminal (2)) and ground.
Continuity should not exist.

If OK, check harness for short to ground and short to power.

NG → Repair open circuit or short to ground or short to power in harness or connectors.

OK →

CHECK COMPONENT
(Front heated oxygen sensor).
Refer to "COMPONENT INSPECTION" on next page.

NG → Replace front heated oxygen sensor.

OK →

CHECK SHIELD CIRCUIT

1. Turn ignition switch "OFF".
2. Remove joint connector-1.
3. Check the following.
 - Continuity between joint connector-1 terminal (2) and engine ground
 - Joint connector-1 (Refer to "HARNESS LAYOUT" in EL section.)

Continuity should exist.
If OK, check harness for short to power.

NG → Repair open circuit, short to ground or short to power in harness or connectors.

OK →

Perform "TROUBLE DIAGNOSIS FOR INTERMITTENT INCIDENT", EC-106.

INSPECTION END

GI

MA

EM

LC

EC

FE

CL

MT

AT

FA

RA

BR

ST

RS

BT

HA

EL

IDX

TROUBLE DIAGNOSIS FOR DTC P0130

Front Heated Oxygen Sensor (Circuit) (Front HO2S) (Cont'd)

COMPONENT INSPECTION

Front heated oxygen sensor

CAUTION:

Discard any heated oxygen sensor which has been dropped from a height of more than 0.5 m (19.7 in) onto a hard surface such as a concrete floor; use a new one.

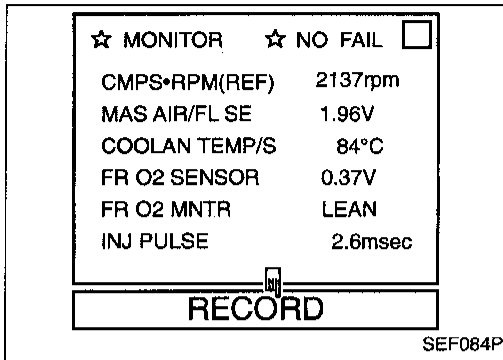

- 1) Start engine and warm it up to normal operating temperature.
- 2) Select "MANU TRIG" and "HI SPEED" in "DATA MONITOR" mode with CONSULT, and select "FR O2 SENSOR" and "FR O2 MNTR".
- 3) Hold engine speed at 2,000 rpm under no load during the following steps.
- 4) Touch "RECORD" on CONSULT screen.
- 5) Check the following.

- "FR O2 MNTR" in "DATA MONITOR" mode changes from "RICH" to "LEAN" to "RICH" 5 times in 10 seconds.

5 times (cycles) are counted as shown below:

cycle | 1 | 2 | 3 | 4 | 5 |
FR O2 MNTR R-L-R-L-R-L-R-L-R-L-R

R = "FR O2 MNTR", "RICH"
L = "FR O2 MNTR", "LEAN"

- "FR O2 SENSOR" voltage goes above 0.6V at least once.
- "FR O2 SENSOR" voltage goes below 0.3V at least once.
- "FR O2 SENSOR" voltage never exceeds 1.0V.

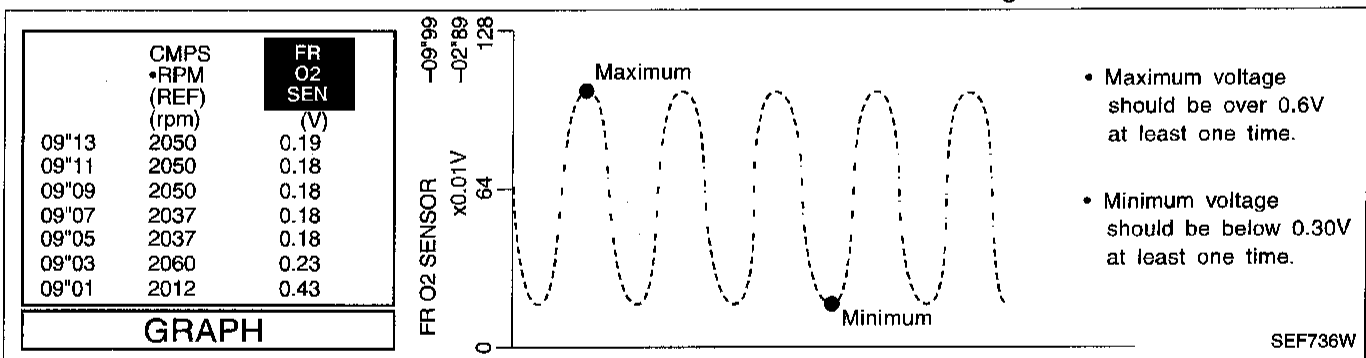

OR

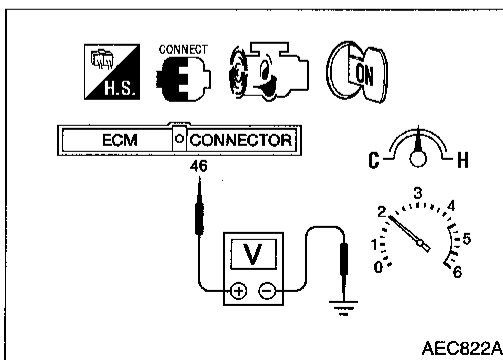

- 1) Start engine and warm it up to normal operating temperature.
- 2) Set voltmeter probes between ECM terminal ④⑥ (sensor signal) and engine ground.
- 3) Check the following with engine speed held at 2,000 rpm constant under no load.
 - Malfunction indicator lamp goes on more than 5 times within 10 seconds in Diagnostic Test Mode II (FRONT HEATED OXYGEN SENSOR MONITOR).
 - The maximum voltage is over 0.6V at least one time.
 - The minimum voltage is below 0.3V at least one time.
 - The voltage never exceeds 1.0V.

TROUBLE DIAGNOSIS FOR DTC P0131

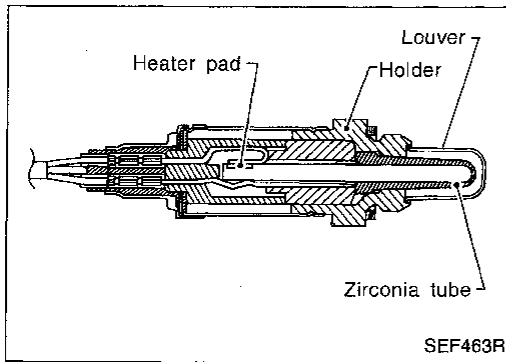

SEF463R

Front Heated Oxygen Sensor (Lean Shift Monitoring) (Front HO2S)

COMPONENT DESCRIPTION

The front heated oxygen sensor is placed into the exhaust manifold. It detects the amount of oxygen in the exhaust gas compared to the outside air. The front heated oxygen sensor has a closed-end tube made of ceramic zirconia. The zirconia generates voltage from approximately 1V in richer conditions to 0V in leaner conditions. The front heated oxygen sensor signal is sent to the ECM. The ECM adjusts the injection pulse duration to achieve the ideal air-fuel ratio. The ideal air-fuel ratio occurs near the radical change from 1V to 0V.

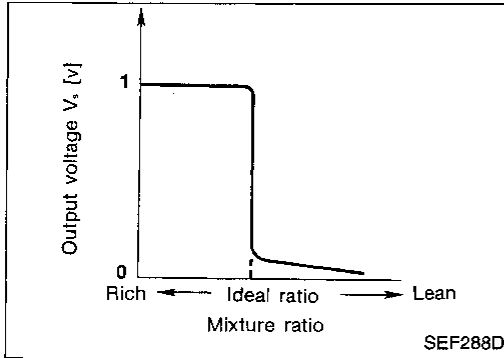

SEF288D

CONSULT REFERENCE VALUE IN DATA MONITOR MODE

Specification data are reference values.

MONITOR ITEM	CONDITION	SPECIFICATION
FR O2 SENSOR	● Engine: After warming up Maintaining engine speed at 2,000 rpm	0 - 0.3V ↔ Approx. 0.6 - 1.0V
FR O2 MNTR		LEAN ↔ RICH Changes more than 5 times during 10 seconds.

ECM TERMINALS AND REFERENCE VALUE

Specification data are reference values and are measured between each terminal and engine ground.

TER-MINAL NO.	WIRE COLOR	ITEM	CONDITION	DATA (DC voltage)
46	W	Front heated oxygen sensor	<p>Engine is running.</p> <p>After warming up to normal operating temperature and engine speed is 2,000 rpm</p>	<p>0 - Approximately 1.0V</p> <p>SEF201T</p>

TROUBLE DIAGNOSIS FOR DTC P0131

Front Heated Oxygen Sensor (Lean Shift Monitoring) (Front HO2S) (Cont'd)

ON BOARD DIAGNOSIS LOGIC

To judge the malfunction, the output from the front heated oxygen sensor is monitored to determine whether the "rich" output is sufficiently high and whether the "lean" output is sufficiently low. When both the outputs are shifting to the lean side, the malfunction will be detected.

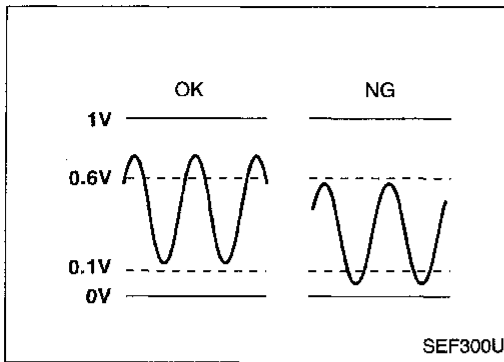

Diagnostic Trouble Code No.	Malfunction is detected when ...	Check Items (Possible Cause)
P0131 0411	<ul style="list-style-type: none"> ● The maximum and minimum voltages from the sensor are not reached to the specified voltages. 	<ul style="list-style-type: none"> ● Front heated oxygen sensor ● Front heated oxygen sensor heater ● Fuel pressure ● Injectors ● Intake air leaks

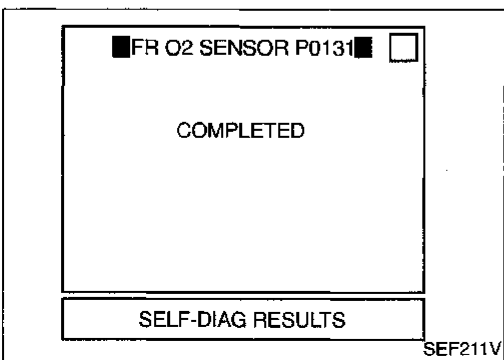
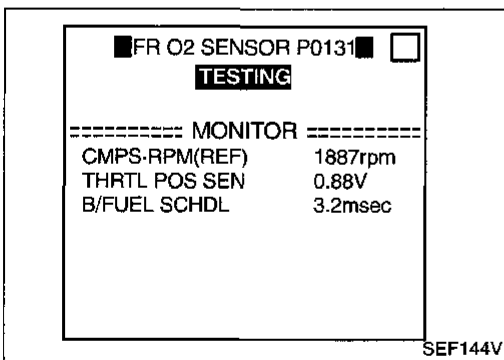
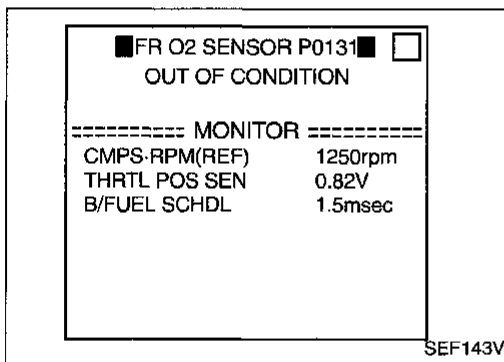

DIAGNOSTIC TROUBLE CODE CONFIRMATION PROCEDURE

CAUTION:

Always drive vehicle at a safe speed.

NOTE:

If "DIAGNOSTIC TROUBLE CODE CONFIRMATION PROCEDURE" has been previously conducted, always turn ignition switch "OFF" and wait at least 5 seconds before conducting the next test.

TESTING CONDITION:

- Always perform at a temperature above -10°C (14°F).
- Before performing the following procedure, confirm that battery voltage is more than 11V at idle.



- 1) Start engine and warm it up to normal operating temperature.
- 2) Stop engine and wait at least 5 seconds.
- 3) Turn ignition switch "ON" and select "FR O2 SENSOR P0131" of "FRONT O2 SENSOR" in "DTC WORK SUPPORT" mode with CONSULT.
- 4) Touch "START".
- 5) Start engine and let it idle for at least 3.5 minutes.

NOTE:

Never raise engine speed above 3,200 rpm after this step. If the engine speed limit is exceeded, return to step 5).

- 6) When the following conditions are met, "TESTING" will be displayed on the CONSULT screen. Maintain the conditions continuously until "TESTING" changes to "COMPLETED". (It will take approximately 50 seconds or more.)

CMPS-RPM (REF): 1,400 - 2,800 rpm (A/T)
2,000 - 3,000 rpm (M/T)

Vehicle speed: 80 - 100 km/h (50 - 62 MPH)

TROUBLE DIAGNOSIS FOR DTC P0131

Front Heated Oxygen Sensor (Lean Shift Monitoring) (Front HO2S) (Cont'd)

B/FUEL SCHDL: 1.3 - 4.5 msec (A/T)
1.0 - 4.5 msec (M/T)

Selector lever: Suitable position

If "TESTING" is not displayed after 5 minutes, retry from step 2).

7) Make sure that "OK" is displayed after touching "SELF-DIAG RESULTS". If "NG" is displayed, refer to "DIAGNOSTIC PROCEDURE", EC-172.

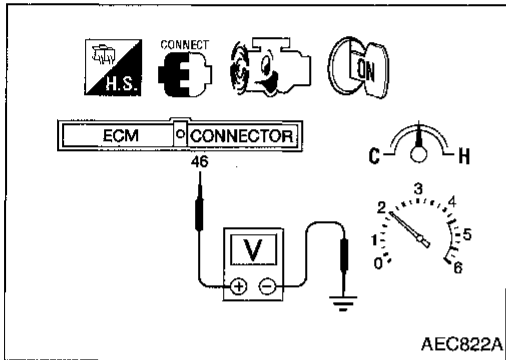

OR

OVERALL FUNCTION CHECK

Use this procedure to check the overall function of the front heated oxygen sensor circuit. During this check, a 1st trip DTC might not be confirmed.

- 1) Start engine and warm it up to normal operating temperature.
 - 2) Set voltmeter probes between ECM terminal ④⑥ (sensor signal) and engine ground.
 - 3) Check the following with engine speed held at 2,000 rpm constant under no load.
 - The maximum voltage is over 0.6V at least one time.
- OR
- The minimum voltage is over 0.1V at least one time.
 - 4) If NG, go to "DIAGNOSTIC PROCEDURE", EC-172.

TROUBLE DIAGNOSIS FOR DTC P0131

Front Heated Oxygen Sensor (Lean Shift Monitoring) (Front HO2S) (Cont'd)

DIAGNOSTIC PROCEDURE

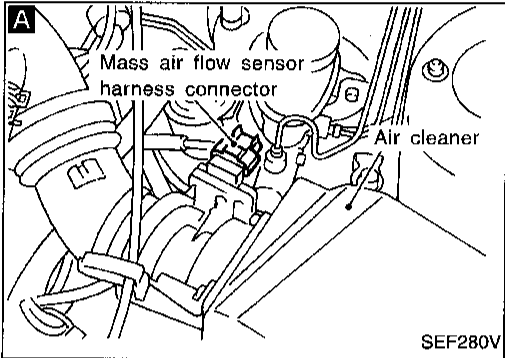
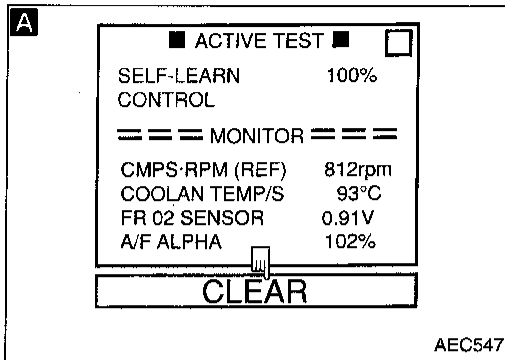

INSPECTION START

1. Turn ignition switch "OFF".
2. Loosen and retighten front heated oxygen sensor.
Tightening torque:
40 - 60 N·m
(4.1 - 6.1 kg·m, 30 - 44 ft·lb)

A

- CLEAR THE SELF-LEARNING DATA.**
1. Start engine and warm it up to normal operating temperature.
 2. Select "SELF-LEARNING CONT" in "ACTIVE TEST" mode with CONSULT.
 3. Clear the self-learning control coefficient by touching "CLEAR".
 4. Run engine for at least 10 minutes at idle speed.
Is the 1st trip DTC P0171 detected? Is it difficult to start engine?

Yes → Go to "TROUBLE DIAGNOSIS FOR DTC P0171", EC-230.

- OR
2. Turn ignition switch "OFF".
 3. Disconnect mass air flow sensor harness connector, and restart and run engine for at least 3 seconds at idle speed.
 4. Stop engine and reconnect mass air flow sensor harness connector.
 5. Make sure diagnostic trouble code No. 0102 is displayed in Diagnostic Test Mode II.
 6. Erase the diagnostic test mode II (Self-diagnostic results) memory. Make sure diagnostic trouble code No. 0505 is displayed in Diagnostic Test Mode II.
 7. Run engine for at least 10 minutes at idle speed.
Is the 1st trip DTC 0115 detected? Is it difficult to start engine?

No

CHECK COMPONENT
(Front heated oxygen sensor heater). Refer to "COMPONENT INSPECTION" on next page.

NG → Replace front heated oxygen sensor.

OK

A
(Go to next page.)

TROUBLE DIAGNOSIS FOR DTC P0131

Front Heated Oxygen Sensor (Lean Shift Monitoring) (Front HO2S) (Cont'd)

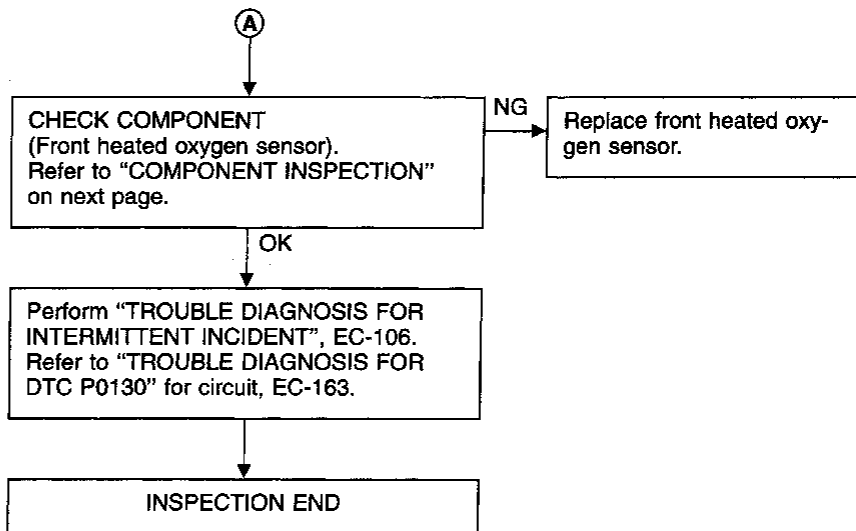

GI

MA

EM

LC

EC

FE

CL

MT

AT

FA

RA

BR

ST

RS

BT

HA

EL

IDX

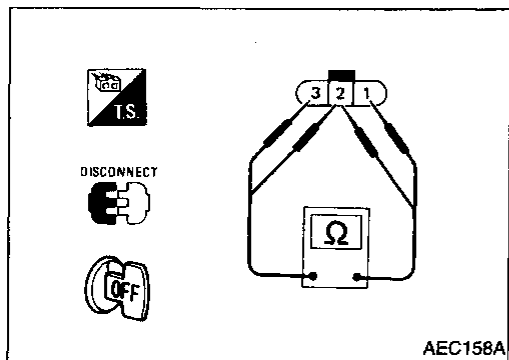

COMPONENT INSPECTION

Front heated oxygen sensor heater

Check resistance between terminals ③ and ①.

Resistance: 2.3 - 4.3Ω at 25°C (77°F)

Check continuity between terminals ② and ①, ③ and ②.

Continuity should not exist.

If NG, replace the front heated oxygen sensor.

CAUTION:

Discard any heated oxygen sensor which has been dropped from a height of more than 0.5 m (19.7 in) onto a hard surface such as a concrete floor; use a new one.

TROUBLE DIAGNOSIS FOR DTC P0131

Front Heated Oxygen Sensor (Lean Shift Monitoring) (Front HO2S) (Cont'd)

Front heated oxygen sensor

CAUTION:

Discard any heated oxygen sensor which has been dropped from a height of more than 0.5 m (19.7 in) onto a hard surface such as a concrete floor; use a new one.

☆ MONITOR ☆ NO FAIL

CMPS•RPM(REF)	2137rpm
MAS AIR/FL SE	1.96V
COOLAN TEMP/S	84°C
FR O2 SENSOR	0.37V
FR O2 MNTR	LEAN
INJ PULSE	2.6msec

RECORD

SEF084P



- 1) Start engine and warm it up to normal operating temperature.
 - 2) Select "MANU TRIG" and "HI SPEED" in "DATA MONITOR" mode with CONSULT, and select "FR O2 SENSOR" and "FR O2 MNTR".
 - 3) Hold engine speed at 2,000 rpm under no load during the following steps.
 - 4) Touch "RECORD" on CONSULT screen.
 - 5) Check the following.
 - "FR O2 MNTR" in "DATA MONITOR" mode changes from "RICH" to "LEAN" to "RICH" 5 times in 10 seconds.
- 5 times (cycles) are counted as shown below:

cycle | 1 | 2 | 3 | 4 | 5 |
FR O2 MNTR R-L-R-L-R-L-R-L-R-L-R

R = "FR O2 MNTR", "RICH"
L = "FR O2 MNTR", "LEAN"

- "FR O2 SENSOR" voltage goes above 0.6V at least once.
- "FR O2 SENSOR" voltage goes below 0.3V at least once.
- "FR O2 SENSOR" voltage never exceeds 1.0V.

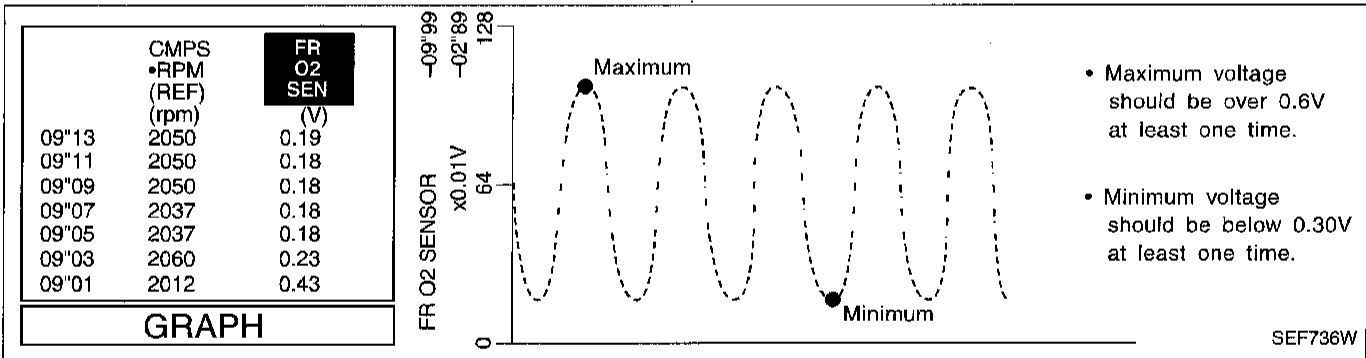

OR

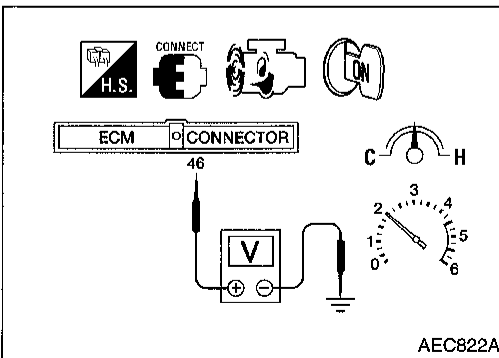

- 1) Start engine and warm it up to normal operating temperature.
- 2) Set voltmeter probes between ECM terminal 46 (sensor signal) and engine ground.
- 3) Check the following with engine speed held at 2,000 rpm constant under no load.
 - Malfunction indicator lamp goes on more than 5 times within 10 seconds in Diagnostic Test Mode II (FRONT HEATED OXYGEN SENSOR MONITOR).
 - The maximum voltage is over 0.6V at least one time.
 - The minimum voltage is below 0.3V at least one time.
 - The voltage never exceeds 1.0V.

TROUBLE DIAGNOSIS FOR DTC P0132

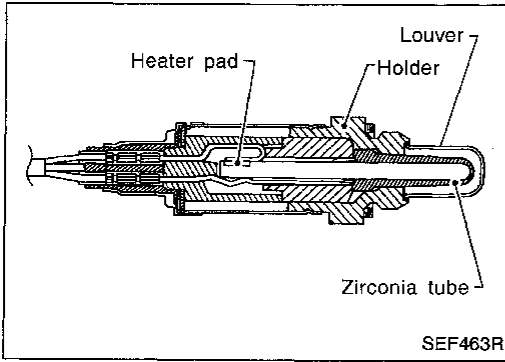

SEF463R

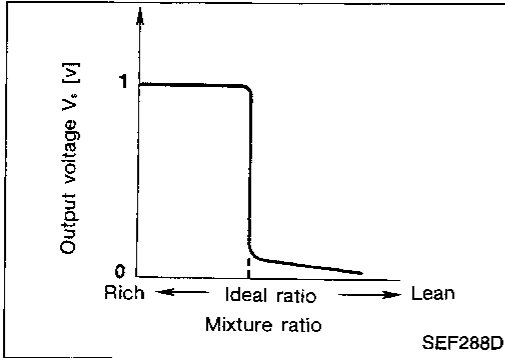

SEF288D

Front Heated Oxygen Sensor (Rich Shift Monitoring) (Front HO2S)

COMPONENT DESCRIPTION

The front heated oxygen sensor is placed into the exhaust manifold. It detects the amount of oxygen in the exhaust gas compared to the outside air. The front heated oxygen sensor has a closed-end tube made of ceramic zirconia. The zirconia generates voltage from approximately 1V in richer conditions to 0V in leaner conditions. The front heated oxygen sensor signal is sent to the ECM. The ECM adjusts the injection pulse duration to achieve the ideal air-fuel ratio. The ideal air-fuel ratio occurs near the radical change from 1V to 0V.

CONSULT REFERENCE VALUE IN DATA MONITOR MODE

Specification data are reference values.

MONITOR ITEM	CONDITION	SPECIFICATION
FR O2 SENSOR FR O2 MNTR	<ul style="list-style-type: none"> Engine: After warming up Maintaining engine speed at 2,000 rpm	0 - 0.3V ↔ Approx. 0.6 - 1.0V LEAN ↔ RICH Changes more than 5 times during 10 seconds.

ECM TERMINALS AND REFERENCE VALUE

Specification data are reference values and are measured between each terminal and engine ground.

TER-MINAL NO.	WIRE COLOR	ITEM	CONDITION	DATA (DC voltage)
46	W	Front heated oxygen sensor	Engine is running. After warming up to normal operating temperature and engine speed is 2,000 rpm	0 - Approximately 1.0V

SEF201T

TROUBLE DIAGNOSIS FOR DTC P0132

Front Heated Oxygen Sensor (Rich Shift Monitoring) (Front HO2S) (Cont'd)

ON BOARD DIAGNOSIS LOGIC

To judge the malfunction, the output from the front heated oxygen sensor is monitored to determine whether the "rich" output is sufficiently high and whether the "lean" output is sufficiently low. When both the outputs are shifting to the rich side, the malfunction will be detected.

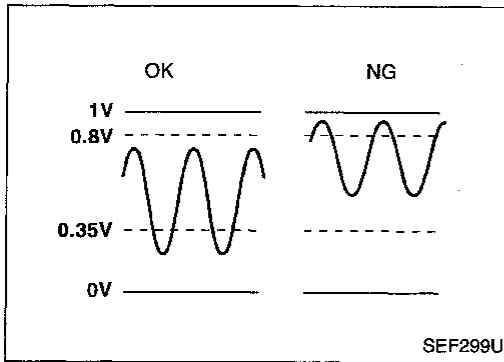

Diagnostic Trouble Code No.	Malfunction is detected when ...	Check Items (Possible Cause)
P0132 0410	<ul style="list-style-type: none"> ● The maximum and minimum voltages from the sensor are beyond the specified voltages. 	<ul style="list-style-type: none"> ● Front heated oxygen sensor ● Front heated oxygen sensor heater ● Fuel pressure ● Injectors

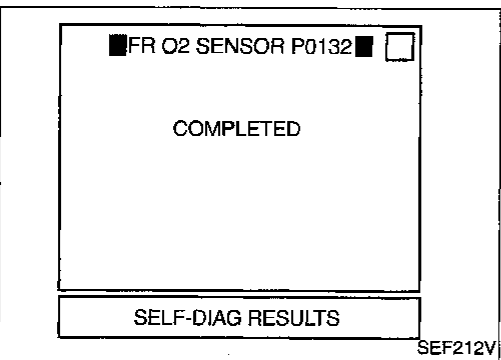
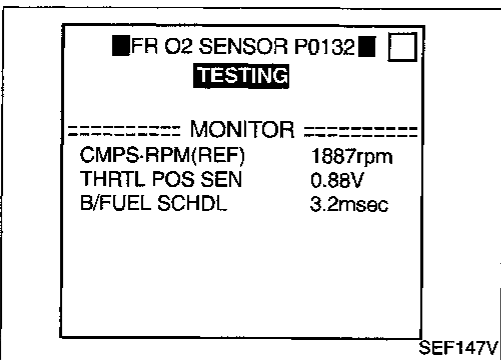
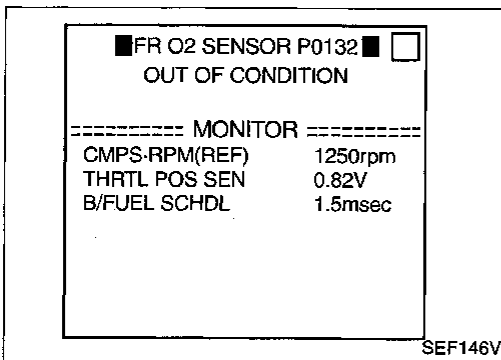

DIAGNOSTIC TROUBLE CODE CONFIRMATION PROCEDURE

CAUTION:

Always drive vehicle at a safe speed.

NOTE:

If "DIAGNOSTIC TROUBLE CODE CONFIRMATION PROCEDURE" has been previously conducted, always turn ignition switch "OFF" and wait at least 5 seconds before conducting the next test.

TESTING CONDITION:

- Always perform at a temperature above -10°C (14°F).
- Before performing the following procedure, confirm that battery voltage is more than 11V at idle.



- 1) Start engine and warm it up to normal operating temperature.
- 2) Stop engine and wait at least 5 seconds.
- 3) Turn ignition switch "ON" and select "FR O2 SENSOR P0132" of "FRONT O2 SENSOR" in "DTC WORK SUPPORT" mode with CONSULT.
- 4) Touch "START".
- 5) Start engine and let it idle for at least 3.5 minutes.

NOTE:

Never raise engine speed above 3,200 rpm after this step. If the engine speed limit is exceeded, return to step 4).

- 6) When the following conditions are met, "TESTING" will be displayed on the CONSULT screen. Maintain the conditions continuously until "TESTING" changes to "COMPLETED". (It will take approximately 50 seconds or more.)

**CMPS-RPM (REF): 1,400 - 2,800 rpm (A/T)
2,000 - 3,000 rpm (M/T)**

Vehicle speed: 80 - 100 km/h (50 - 62 MPH)

TROUBLE DIAGNOSIS FOR DTC P0132

Front Heated Oxygen Sensor (Rich Shift Monitoring) (Front HO2S) (Cont'd)

B/FUEL SCHDL: 1.3 - 4.5 msec (A/T)
1.0 - 4.5 msec (M/T)

Selector lever: Suitable position

If "TESTING" is not displayed after 5 minutes, retry from step 2).

7) Make sure that "OK" is displayed after touching "SELF-DIAG RESULTS". If "NG" is displayed, refer to "DIAGNOSTIC PROCEDURE", EC-178.

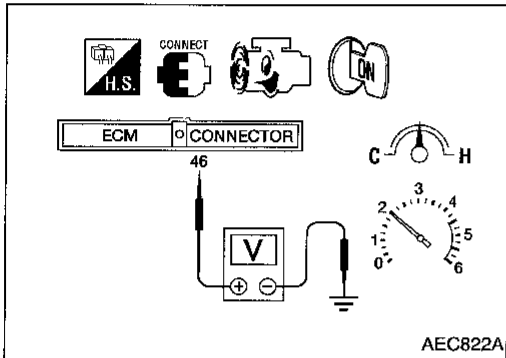

OR

OVERALL FUNCTION CHECK

Use this procedure to check the overall function of the front heated oxygen sensor circuit. During this check, a 1st trip DTC might not be confirmed.

- 1) Start engine and warm it up to normal operating temperature.
- 2) Set voltmeter probes between ECM terminal ④⑥ (sensor signal) and engine ground.
- 3) Check the following with engine speed held at 2,000 rpm constant under no load.
 - The maximum voltage is below 0.8V at least one time.

- OR
- The minimum voltage is below 0.35V at least one time.
 - 4) If NG, go to "DIAGNOSTIC PROCEDURE", EC-178.

TROUBLE DIAGNOSIS FOR DTC P0132

Front Heated Oxygen Sensor (Rich Shift Monitoring) (Front HO2S) (Cont'd)

DIAGNOSTIC PROCEDURE

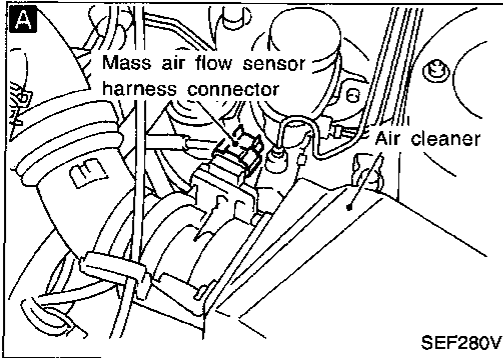
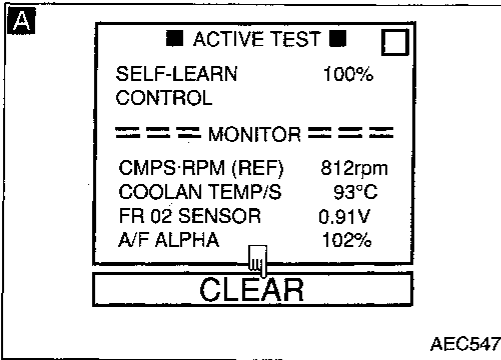

INSPECTION START

1. Turn ignition switch "OFF".
2. Loosen and retighten front heated oxygen sensor.
Tightening torque:
40 - 60 N·m
(4.1 - 6.1 kg·m, 30 - 44 ft·lb)

- CLEAR THE SELF-LEARNING DATA**
1. Start engine and warm it up to normal operating temperature.
 2. Select "SELF-LEARNING CONT" in "ACTIVE TEST" mode with CONSULT.
 3. Clear the self-learning control coefficient by touching "CLEAR".
 4. Run engine for at least 10 minutes at idle speed.
Is the 1st trip DTC P0172 detected? Is it difficult to start engine?

Yes → Go to "TROUBLE DIAGNOSIS FOR DTC P0172", EC-236.

- OR
2. Turn ignition switch "OFF".
 3. Disconnect mass air flow sensor harness connector, and restart and run engine for at least 3 seconds at idle speed.
 4. Stop engine and reconnect mass air flow sensor harness connector.
 5. Make sure diagnostic trouble code No. 0102 is displayed in Diagnostic Test Mode II.
 6. Erase the diagnostic test mode II (Self-diagnostic results) memory. Make sure diagnostic trouble code No. 0505 is displayed in Diagnostic Test Mode II.
 7. Run engine for at least 10 minutes at idle speed.
Is the 1st trip DTC 0114 detected? Is it difficult to start engine?

No



(Go to next page.)

TROUBLE DIAGNOSIS FOR DTC P0132

Front Heated Oxygen Sensor (Rich Shift Monitoring) (Front HO2S) (Cont'd)

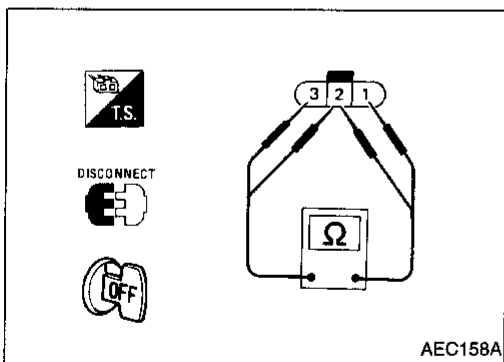
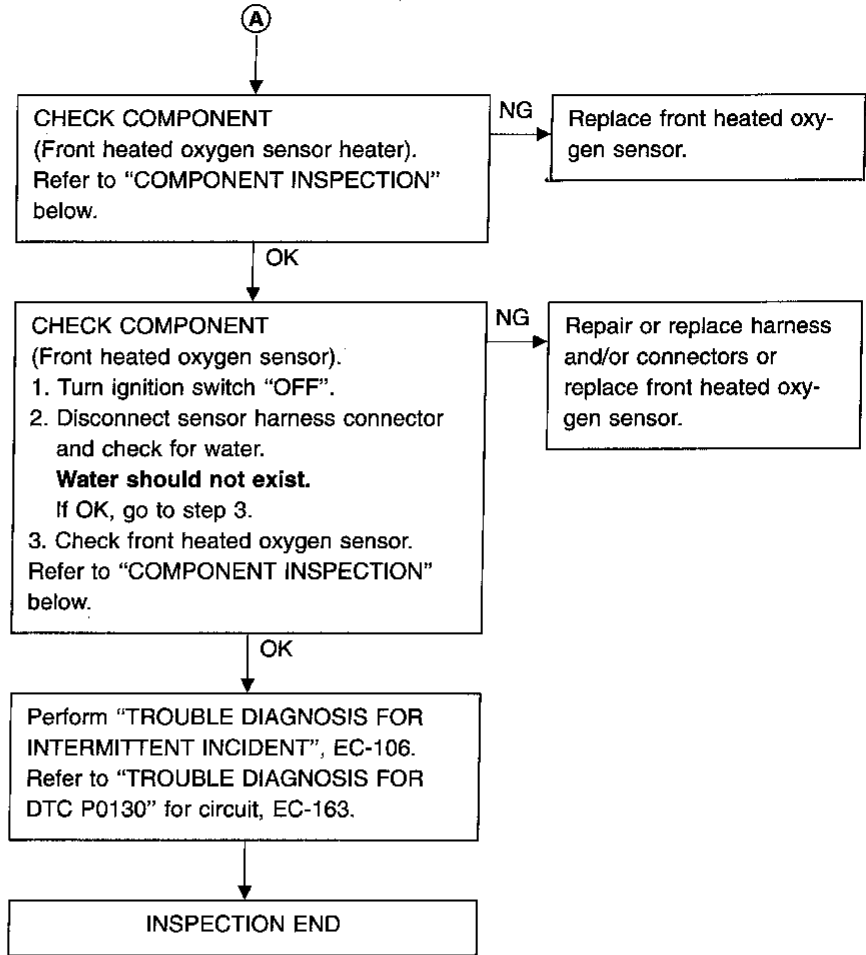

COMPONENT INSPECTION

Front heated oxygen sensor heater

Check resistance between terminals ③ and ①.

Resistance: 2.3 - 4.3Ω at 25°C (77°F)

Check continuity between terminals ② and ①, ③ and ②.

Continuity should not exist.

If NG, replace the front heated oxygen sensor.

CAUTION:

Discard any heated oxygen sensor which has been dropped from a height of more than 0.5 m (19.7 in) onto a hard surface such as a concrete floor; use a new one.

GI
MA
EM
LC
EC
FE
CL
MT
AT
FA
RA
BR
ST
RS
BT
HA
EL
IDX

TROUBLE DIAGNOSIS FOR DTC P0132

Front Heated Oxygen Sensor (Rich Shift Monitoring) (Front HO2S) (Cont'd)

Front heated oxygen sensor

CAUTION:

Discard any heated oxygen sensor which has been dropped from a height of more than 0.5 m (19.7 in) onto a hard surface such as a concrete floor; use a new one.

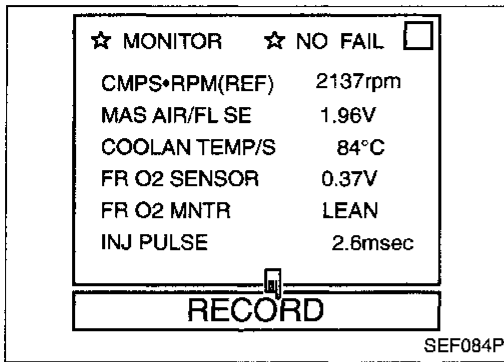

- 1) Start engine and warm it up to normal operating temperature.
 - 2) Select "MANU TRIG" and "HI SPEED" in "DATA MONITOR" mode with CONSULT, and select "FR O2 SENSOR" and "FR O2 MNTR".
 - 3) Hold engine speed at 2,000 rpm under no load during the following steps.
 - 4) Touch "RECORD" on CONSULT screen.
 - 5) Check the following.
 - "FR O2 MNTR" in "DATA MONITOR" mode changes from "RICH" to "LEAN" to "RICH" 5 times in 10 seconds.
- 5 times (cycles) are counted as shown below:

cycle | 1 | 2 | 3 | 4 | 5 |
FR O2 MNTR R-L-R-L-R-L-R-L-R-L-R

R = "FR O2 MNTR", "RICH"
L = "FR O2 MNTR", "LEAN"

- "FR O2 SENSOR" voltage goes above 0.6V at least once.
- "FR O2 SENSOR" voltage goes below 0.3V at least once.
- "FR O2 SENSOR" voltage never exceeds 1.0V.

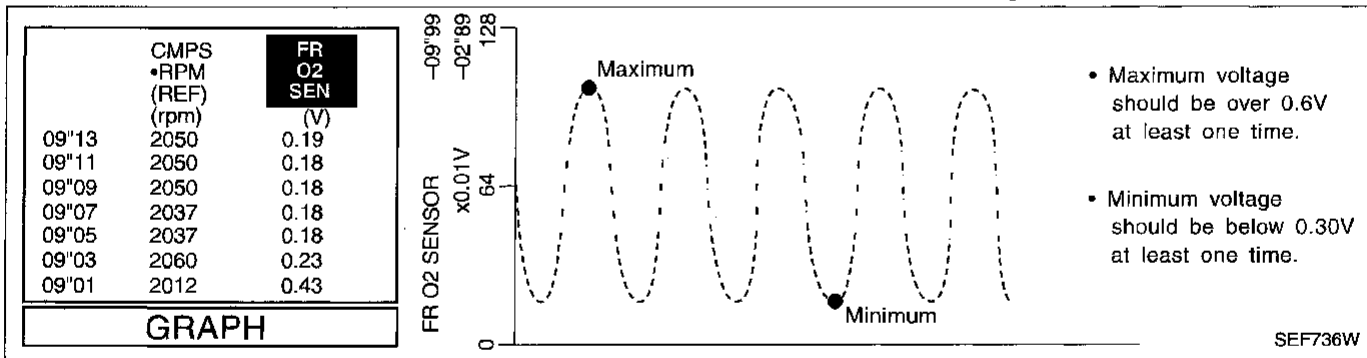

OR

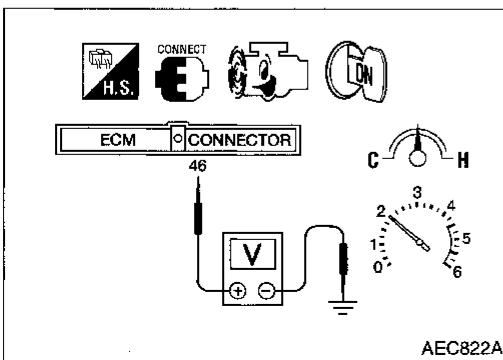

- 1) Start engine and warm it up to normal operating temperature.
- 2) Set voltmeter probes between ECM terminal ④⑥ (sensor signal) and engine ground.
- 3) Check the following with engine speed held at 2,000 rpm constant under no load.
 - Malfunction indicator lamp goes on more than 5 times within 10 seconds in Diagnostic Test Mode II (FRONT HEATED OXYGEN SENSOR MONITOR).
 - The maximum voltage is over 0.6V at least one time.
 - The minimum voltage is below 0.3V at least one time.
 - The voltage never exceeds 1.0V.

TROUBLE DIAGNOSIS FOR DTC P0133

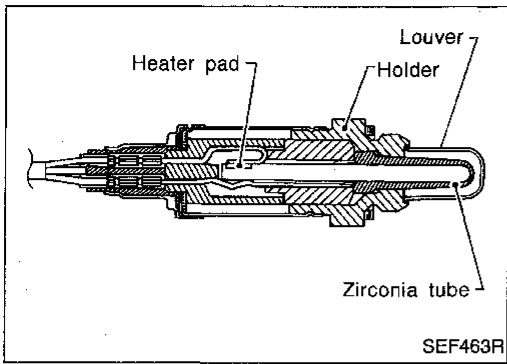

SEF463R

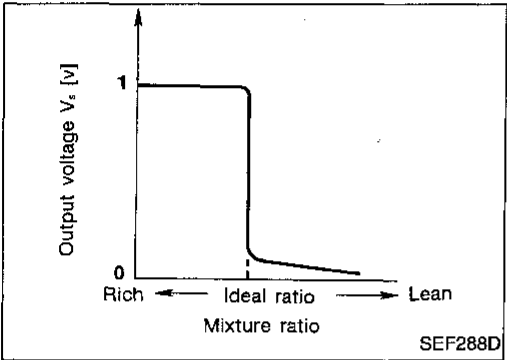

SEF288D

Front Heated Oxygen Sensor (Response Monitoring) (Front HO2S)

COMPONENT DESCRIPTION

The front heated oxygen sensor is placed into the exhaust manifold. It detects the amount of oxygen in the exhaust gas compared to the outside air. The front heated oxygen sensor has a closed-end tube made of ceramic zirconia. The zirconia generates voltage from approximately 1V in richer conditions to 0V in leaner conditions. The front heated oxygen sensor signal is sent to the ECM. The ECM adjusts the injection pulse duration to achieve the ideal air-fuel ratio. The ideal air-fuel ratio occurs near the radical change from 1V to 0V.

CONSULT REFERENCE VALUE IN DATA MONITOR MODE

Specification data are reference values.

MONITOR ITEM	CONDITION		SPECIFICATION
FR O2 SENSOR	● Engine: After warming up	Maintaining engine speed at 2,000 rpm	0 - 0.3V ↔ Approx. 0.6 - 1.0V
FR O2 MNTR			LEAN ↔ RICH Changes more than 5 times during 10 seconds.

ECM TERMINALS AND REFERENCE VALUE

Specification data are reference values and are measured between each terminal and engine ground.

TER-MINAL NO.	WIRE COLOR	ITEM	CONDITION	DATA (DC voltage)
46	W	Front heated oxygen sensor	<p>Engine is running.</p> <p>After warming up to normal operating temperature and engine speed is 2,000 rpm</p>	<p>0 - Approximately 1.0V</p>

SEF201T

GI
MA
EM
LC
EC
FE
CL
MT
AT
FA
RA
BR
ST
RS
BT
HA
EL
IDX

TROUBLE DIAGNOSIS FOR DTC P0133

Front Heated Oxygen Sensor (Response Monitoring) (Front HO2S) (Cont'd)

ON BOARD DIAGNOSIS LOGIC

To judge the malfunction of front heated oxygen sensor, this diagnosis measures response time of front heated oxygen sensor signal. The time is compensated by engine operating (speed and load), fuel feedback control constant, and front heated oxygen sensor temperature index. Judgment is based on whether the compensated time (front heated oxygen sensor cycling time index) is inordinately long or not.

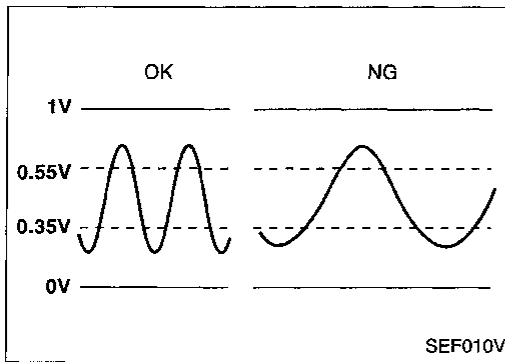

Diagnostic Trouble Code No.	Malfunction is detected when ...	Check Items (Possible Cause)
P0133 0409	<ul style="list-style-type: none"> ● The response of the voltage signal from the sensor takes more than the specified time. 	<ul style="list-style-type: none"> ● Harness or connectors (The sensor circuit is open or shorted.) ● Front heated oxygen sensor ● Front heated oxygen sensor heater ● Fuel pressure ● Injectors ● Intake air leaks ● Exhaust gas leaks ● PCV ● Mass air flow sensor

■ FR O2 SENSOR P0133 ■

OUT OF CONDITION

===== MONITOR =====

CMPS-RPM(REF)	1250rpm
THRTL POS SEN	0.82V
B/FUEL SCHDL	1.5msec

SEF148V

■ FR O2 SENSOR P0133 ■

TESTING

===== MONITOR =====

CMPS-RPM(REF)	1887rpm
THRTL POS SEN	0.88V
B/FUEL SCHDL	3.2msec

SEF149V

■ FR O2 SENSOR P0133 ■

COMPLETED

SELF-DIAG RESULTS

SEF213V

DIAGNOSTIC TROUBLE CODE CONFIRMATION PROCEDURE

CAUTION:

Always drive vehicle at a safe speed.

NOTE:

If "DIAGNOSTIC TROUBLE CODE CONFIRMATION PROCEDURE" has been previously conducted, always turn ignition switch "OFF" and wait at least 5 seconds before conducting the next test.

TESTING CONDITION:

- Always perform at a temperature above -10°C (14°F).
- Before performing the following procedure, confirm that battery voltage is more than 11V at idle.



- 1) Start engine and warm it up to normal operating temperature.
- 2) Stop engine and wait at least 5 seconds.
- 3) Turn ignition switch "ON" and select "FR O2 SENSOR P0133" of "FRONT O2 SENSOR" in "DTC WORK SUPPORT" mode with CONSULT.
- 4) Touch "START".
- 5) Start engine and let it idle for at least 3.5 minutes.

NOTE:

Never raise engine speed above 3,200 rpm after this step. If the engine speed limit is exceeded, return to step 5).

- 6) When the following conditions are met, "TESTING" will be displayed on the CONSULT screen. Maintain the conditions continuously until "TESTING" changes to "COMPLETED". (It will take approximately 50 seconds or more.)

CMPS-RPM (REF): 1,900 - 3,200 rpm (A/T)
2,200 - 3,200 rpm (M/T)

Vehicle speed: 78 - 120 km/h (49 - 75 MPH)

TROUBLE DIAGNOSIS FOR DTC P0133

Front Heated Oxygen Sensor (Response Monitoring) (Front HO2S) (Cont'd)

B/FUEL SCHDL: 2.0 - 4.5 msec (A/T)

1.7 - 4.5 msec (M/T)

Selector lever: Suitable position

If "TESTING" is not displayed after 5 minutes, retry from step 2).

7) Make sure that "OK" is displayed after touching "SELF-DIAG RESULTS". If "NG" is displayed, refer to "DIAGNOSTIC PROCEDURE", EC-185.

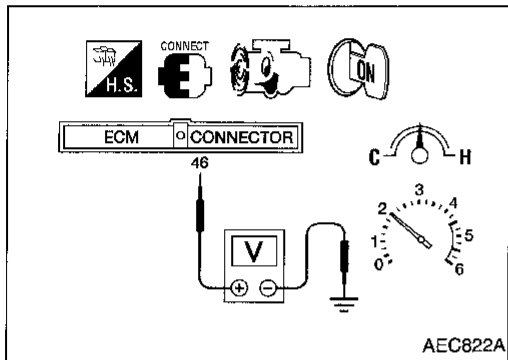

OR OVERALL FUNCTION CHECK

Use this procedure to check the overall function of the front heated oxygen sensor circuit. During this check, a 1st trip DTC might not be confirmed.

- 1) Start engine and warm it up to normal operating temperature.
- 2) Set voltmeter probes between ECM terminal ④⑥ (sensor signal) and engine ground.
- 3) Check the following with engine speed held at 2,000 rpm constant under no load.
 - Malfunction indicator lamp goes on more than 5 times within 10 seconds in Diagnostic Test Mode II (FRONT HEATED OXYGEN SENSOR MONITOR).
- 4) If NG, go to "DIAGNOSTIC PROCEDURE", EC-185.

TROUBLE DIAGNOSIS FOR DTC P0133

Front Heated Oxygen Sensor (Response Monitoring) (Front HO2S) (Cont'd)

EC-FRO2-01

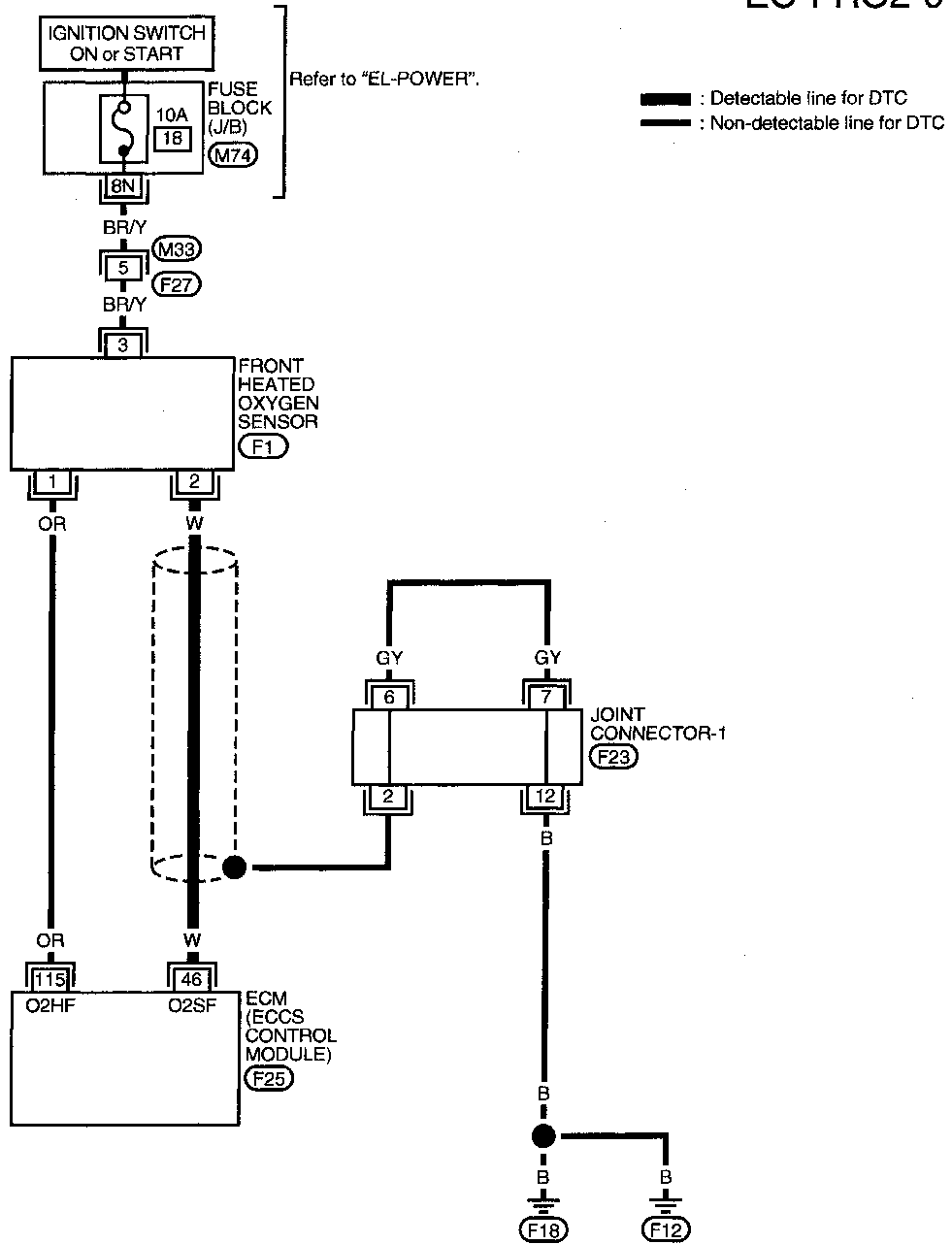

Refer to last page (Foldout page).

(F23)

1	2	3	4	5	6	7	8	(M33)				
9	10	11	12	13	14	15	16	17	18	19	20	W

1N	2N	3N	4N	5N	6N	7N	(M74)		
8N	9N	10N	11N	12N	13N	14N	15N	16N	GY

1	2	3	(F1)
			GY

(F25)	H.S.
W	

101	102	103	104	105	106	1	2	3	4		20	21	22	23	38	39	40	41	53	54	55	56				
107	108	109	110	111	112	5	6	7	8	9	10	24	25	26	27	28	42	43	44	45	46	57	58	59	60	61
113	114	115	116	117	118	11	12	13	14	19	29	30	31	32	33	49	50	47	48	62	63	64	65	70		
						15	16	17	18		34	35	36	37			51	52	66	67	68	69				

TROUBLE DIAGNOSIS FOR DTC P0133

Front Heated Oxygen Sensor (Response Monitoring) (Front HO2S) (Cont'd)

DIAGNOSTIC PROCEDURE

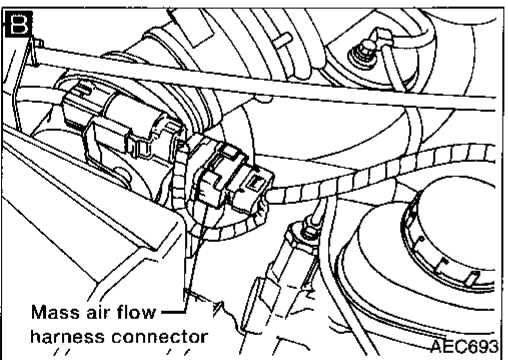
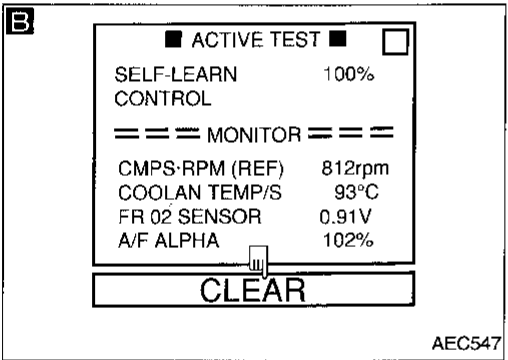
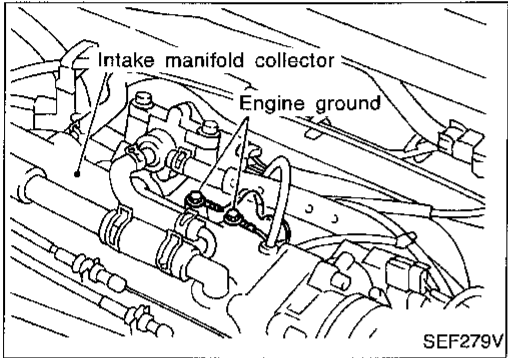
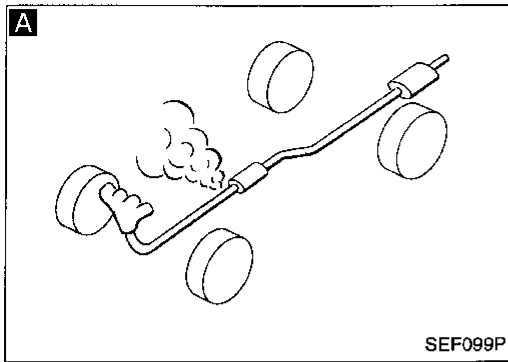

INSPECTION START

1. Turn ignition switch "OFF".
2. Loosen and retighten engine ground screws.

Loosen and retighten front heated oxygen sensor.

Tightening torque:
40 - 60 N·m
(4.1 - 6.1 kg-m, 30 - 44 ft-lb)

A
CHECK EXHAUST AIR LEAK.
Start engine and run it at idle. Listen for an exhaust air leak before three way catalyst.

NG → Repair or replace.

OK
CHECK FOR INTAKE AIR LEAK.
Start engine and run it at idle. Listen for an intake air leak between the mass air flow sensor and the intake manifold.

NG → Repair or replace.

B
CLEAR THE SELF-LEARNING DATA
1. Start engine and warm it up to normal operating temperature.

Yes → Go to "TROUBLE DIAGNOSIS FOR DTC P0171, P0172", EC-230, 236.

2. Select "SELF-LEARNING CONTROL" in "ACTIVE TEST" mode with CONSULT.
3. Clear the self-learning control coefficient by touching "CLEAR".
4. Run engine for at least 10 minutes at idle speed.
Is the 1st trip DTC P0171 or P0172 detected? Is it difficult to start engine?

OR

2. Turn ignition switch "OFF".
3. Disconnect mass air flow sensor harness connector, and restart and run engine for at least 3 seconds at idle speed.
4. Stop engine and reconnect mass air flow sensor harness connector.
5. Make sure diagnostic trouble code No. 0102 is displayed in Diagnostic Test Mode II.
6. Erase the diagnostic test mode II (Self-diagnostic results) memory. Make sure diagnostic trouble code No. 0505 is displayed in Diagnostic Test Mode II.
7. Run engine for at least 10 minutes at idle speed.
Is the 1st trip DTC 0114 or 0115 detected? Is it difficult to start engine?

↓ No

A

(Go to next page.)

GI

MA

EM

LC

EC

FE

CL

MT

AT

FA

RA

BR

ST

RS

BT

HA

EL

IDX

TROUBLE DIAGNOSIS FOR DTC P0133

Front Heated Oxygen Sensor (Response Monitoring) (Front HO2S) (Cont'd)

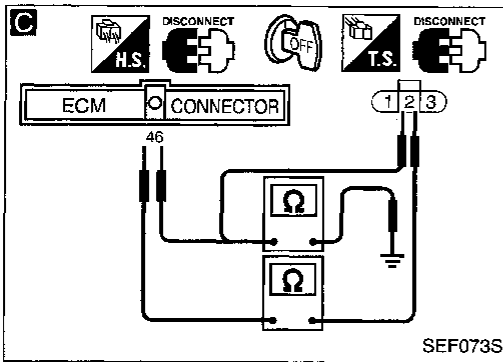

A

C

CHECK INPUT SIGNAL CIRCUIT.

1. Disconnect front heated oxygen sensor harness connector and ECM harness connector.
2. Check harness continuity between ECM terminal 46 and terminal 2.
Continuity should exist.
3. Check harness continuity between ECM terminal 46 (or terminal 2) and ground.
Continuity should not exist.

If OK, check harness for short to ground and short to power.

NG → Repair open circuit or short to ground or short to power in harness or connectors.

OK ↓

CHECK COMPONENT
(Front heated oxygen sensor heater).
Refer to "COMPONENT INSPECTION" on next page.

NG → Replace front heated oxygen sensor.

OK ↓

CHECK COMPONENT
(Front heated oxygen sensor).
Refer to "COMPONENT INSPECTION" on next page.

NG → Replace front heated oxygen sensor.

OK ↓

CHECK COMPONENT
(Mass air flow sensor).
Refer to "COMPONENT INSPECTION", EC-121.

NG → Replace mass air flow sensor.

OK ↓

CHECK COMPONENT
(PCV valve).
Refer to "COMPONENT INSPECTION", EC-32.

NG → Repair or replace PCV valve.

OK ↓

CHECK SHIELD CIRCUIT

1. Turn ignition switch "OFF".
2. Remove joint connector-1.
3. Check the following.
 - Continuity between joint connector-1 terminal 2 and engine ground
 - Joint connector-1 (Refer to "HARNES LAYOUT" in EL section.)

Continuity should exist.
If OK, check harness for short to power.

NG → Repair open circuit, short to ground or short to power in harness or connectors.

OK ↓

Perform "TROUBLE DIAGNOSIS FOR INTERMITTENT INCIDENT", EC-106.

↓

INSPECTION END

TROUBLE DIAGNOSIS FOR DTC P0133

Front Heated Oxygen Sensor (Response Monitoring) (Front HO2S) (Cont'd)

COMPONENT INSPECTION

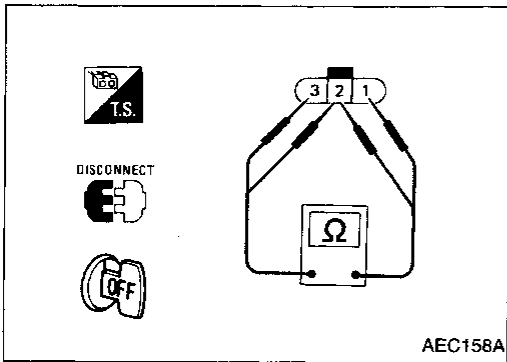

Front heated oxygen sensor heater

Check resistance between terminals ③ and ①.

Resistance: 2.3 - 4.3Ω at 25°C (77°F)

Check continuity between terminals ② and ①, ③ and ②.

Continuity should not exist.

If NG, replace the front heated oxygen sensor.

CAUTION:

Discard any heated oxygen sensor which has been dropped from a height of more than 0.5 m (19.7 in) onto a hard surface such as a concrete floor; use a new one.

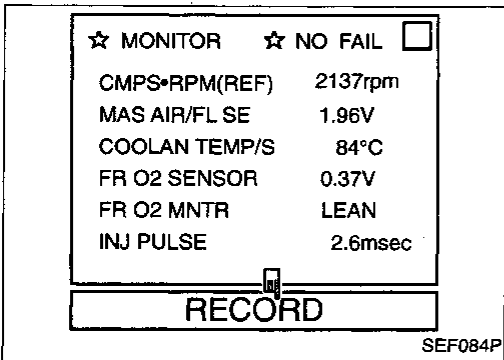

Front heated oxygen sensor

CAUTION:

Discard any heated oxygen sensor which has been dropped from a height of more than 0.5 m (19.7 in) onto a hard surface such as a concrete floor; use a new one.



- 1) Start engine and warm it up to normal operating temperature.
- 2) Select "MANU TRIG" and "HI SPEED" in "DATA MONITOR" mode with CONSULT, and select "FR O2 SENSOR" and "FR O2 MNTR".
- 3) Hold engine speed at 2,000 rpm under no load during the following steps.
- 4) Touch "RECORD" on CONSULT screen.
- 5) Check the following.
 - "FR O2 MNTR" in "DATA MONITOR" mode changes from "RICH" to "LEAN" to "RICH" 5 times in 10 seconds.

5 times (cycles) are counted as shown below:

cycle | 1 | 2 | 3 | 4 | 5 |
FR O2 MNTR R-L-R-L-R-L-R-L-R-L-R

R = "FR O2 MNTR", "RICH"

L = "FR O2 MNTR", "LEAN"

- "FR O2 SENSOR" voltage goes above 0.6V at least once.
- "FR O2 SENSOR" voltage goes below 0.3V at least once.
- "FR O2 SENSOR" voltage never exceeds 1.0V.

TROUBLE DIAGNOSIS FOR DTC P0133

Front Heated Oxygen Sensor (Response Monitoring) (Front HO2S) (Cont'd)

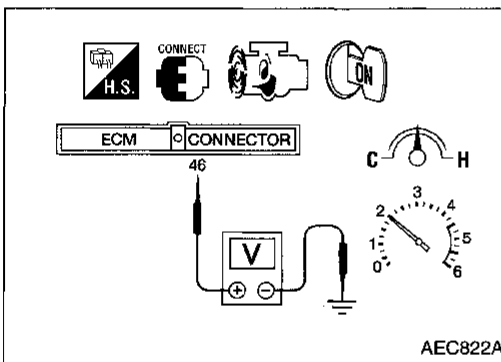
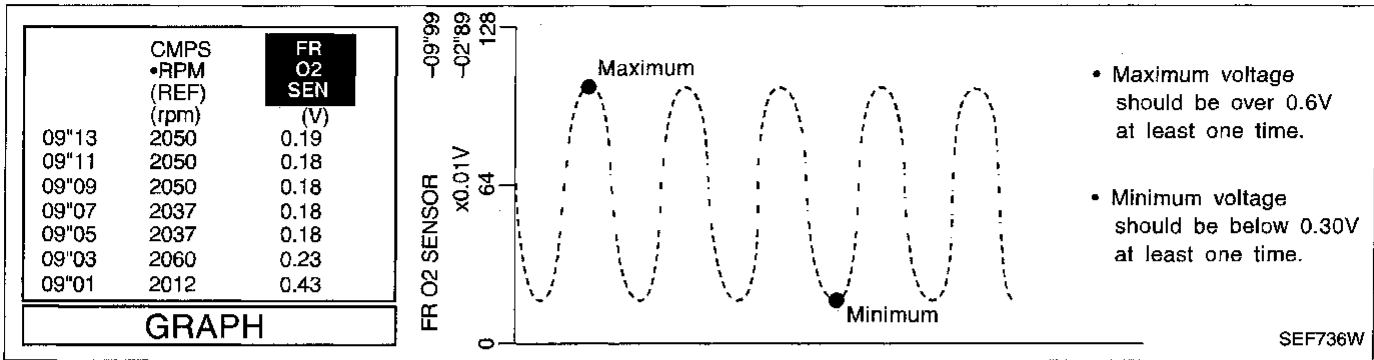

OR



- 1) Start engine and warm it up to normal operating temperature.
- 2) Set voltmeter probes between ECM terminal ④⑥ (sensor signal) and engine ground.
- 3) Check the following with engine speed held at 2,000 rpm constant under no load.
 - Malfunction indicator lamp goes on more than 5 times within 10 seconds in Diagnostic Test Mode II (FRONT HEATED OXYGEN SENSOR MONITOR).
 - The maximum voltage is over 0.6V at least one time.
 - The minimum voltage is below 0.3V at least one time.
 - The voltage never exceeds 1.0V.

TROUBLE DIAGNOSIS FOR DTC P0134

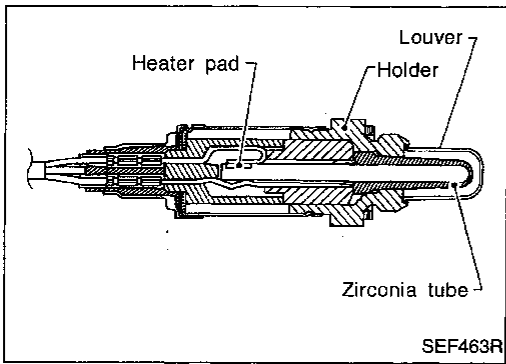

Front Heated Oxygen Sensor (High Voltage) (Front HO2S)

COMPONENT DESCRIPTION

The front heated oxygen sensor is placed into the exhaust manifold. It detects the amount of oxygen in the exhaust gas compared to the outside air. The front heated oxygen sensor has a closed-end tube made of ceramic zirconia. The zirconia generates voltage from approximately 1V in richer conditions to 0V in leaner conditions. The front heated oxygen sensor signal is sent to the ECM. The ECM adjusts the injection pulse duration to achieve the ideal air-fuel ratio. The ideal air-fuel ratio occurs near the radical change from 1V to 0V.

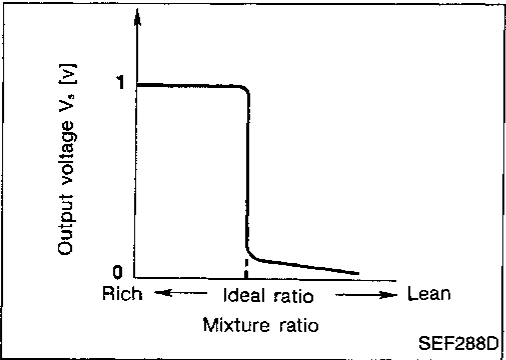

CONSULT REFERENCE VALUE IN DATA MONITOR MODE

Specification data are reference values.

MONITOR ITEM	CONDITION	SPECIFICATION
FR O2 SENSOR FR O2 MNTR	● Engine: After warming up Maintaining engine speed at 2,000 rpm	0 - 0.3V ↔ Approx. 0.6 - 1.0V LEAN ↔ RICH Changes more than 5 times during 10 seconds.

ECM TERMINALS AND REFERENCE VALUE

Specification data are reference values and are measured between each terminal and engine ground.

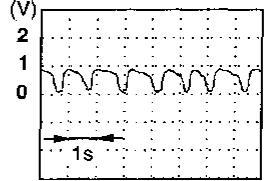
TER-MINAL NO.	WIRE COLOR	ITEM	CONDITION	DATA (DC voltage)
46	W	Front heated oxygen sensor	Engine is running. After warming up to normal operating temperature and engine speed is 2,000 rpm	0 - Approximately 1.0V 

TROUBLE DIAGNOSIS FOR DTC P0134

Front Heated Oxygen Sensor (High Voltage) (Front HO2S) (Cont'd)

ON BOARD DIAGNOSIS LOGIC

To judge the malfunction, the diagnosis checks that the front heated oxygen sensor output is not inordinately high.

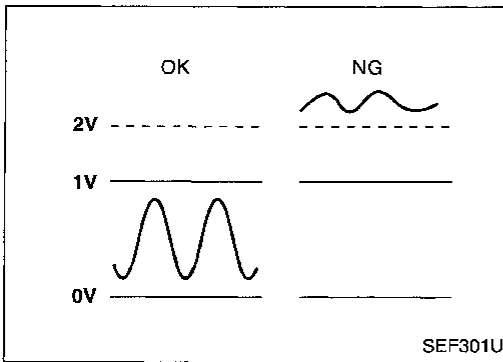

Diagnostic Trouble Code No.	Malfunction is detected when ...	Check Items (Possible Cause)
P0134 0412	<ul style="list-style-type: none"> ● An excessively high voltage from the sensor is sent to ECM. 	<ul style="list-style-type: none"> ● Harness or connectors (The sensor circuit is open or shorted.) ● Front heated oxygen sensor

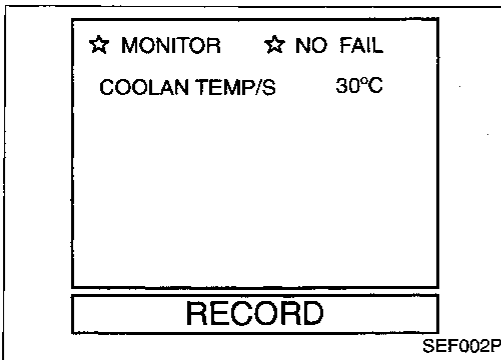

DIAGNOSTIC TROUBLE CODE CONFIRMATION PROCEDURE

NOTE:

If "DIAGNOSTIC TROUBLE CODE CONFIRMATION PROCEDURE" has been previously conducted, always turn ignition switch "OFF" and wait at least 5 seconds before conducting the next test.



- 1) Start engine and warm it up to normal operating temperature.
- 2) Turn ignition switch "OFF" and wait at least 5 seconds.
- 3) Turn ignition switch "ON".
- 4) Select "DATA MONITOR" mode with CONSULT.
- 5) Restart engine and let it idle for 2 minutes.
- 6) If 1st trip DTC is detected, go to "Diagnostic Procedure", EC-193.

OR



- 1) Start engine and warm it up to normal operating temperature.
- 2) Turn ignition switch "OFF" and wait at least 5 seconds.
- 3) Restart engine and let it idle for 2 minutes.
- 4) Turn ignition switch "OFF" and wait at least 5 seconds.
- 5) Restart engine and let it idle for 2 minutes.
- 6) Select "MODE 3" with GST.
- 7) If DTC is detected, go to "Diagnostic Procedure", EC-193.

OR



- 1) Start engine and warm it up to normal operating temperature.
- 2) Turn ignition switch "OFF" and wait at least 5 seconds.
- 3) Restart engine and let it idle for 2 minutes.

TROUBLE DIAGNOSIS FOR DTC P0134

Front Heated Oxygen Sensor (High Voltage) (Front HO2S) (Cont'd)

- 4) Turn ignition switch "OFF", wait at least 5 seconds and then turn "ON".
 - 5) Perform "Diagnostic Test Mode II (Self-diagnostic results)" with ECM.
 - 6) If 1st trip DTC is detected, go to "Diagnostic Procedure", EC-193.
- When using GST, "DTC Confirmation Procedure" should be performed twice as much as when using CONSULT or ECM (Diagnostic Test Mode II) because GST cannot display MODE 7 (1st trip DTC) concerning this diagnosis.
Therefore, using CONSULT or ECM (Diagnostic Test Mode II) is recommended.

GI

MA

EM

LC

EC

FE

CL

MT

AT

FA

RA

BR

ST

RS

BT

HA

EL

IDX

TROUBLE DIAGNOSIS FOR DTC P0134

Front Heated Oxygen Sensor (High Voltage) (Front HO2S) (Cont'd)

EC-FRO2-01

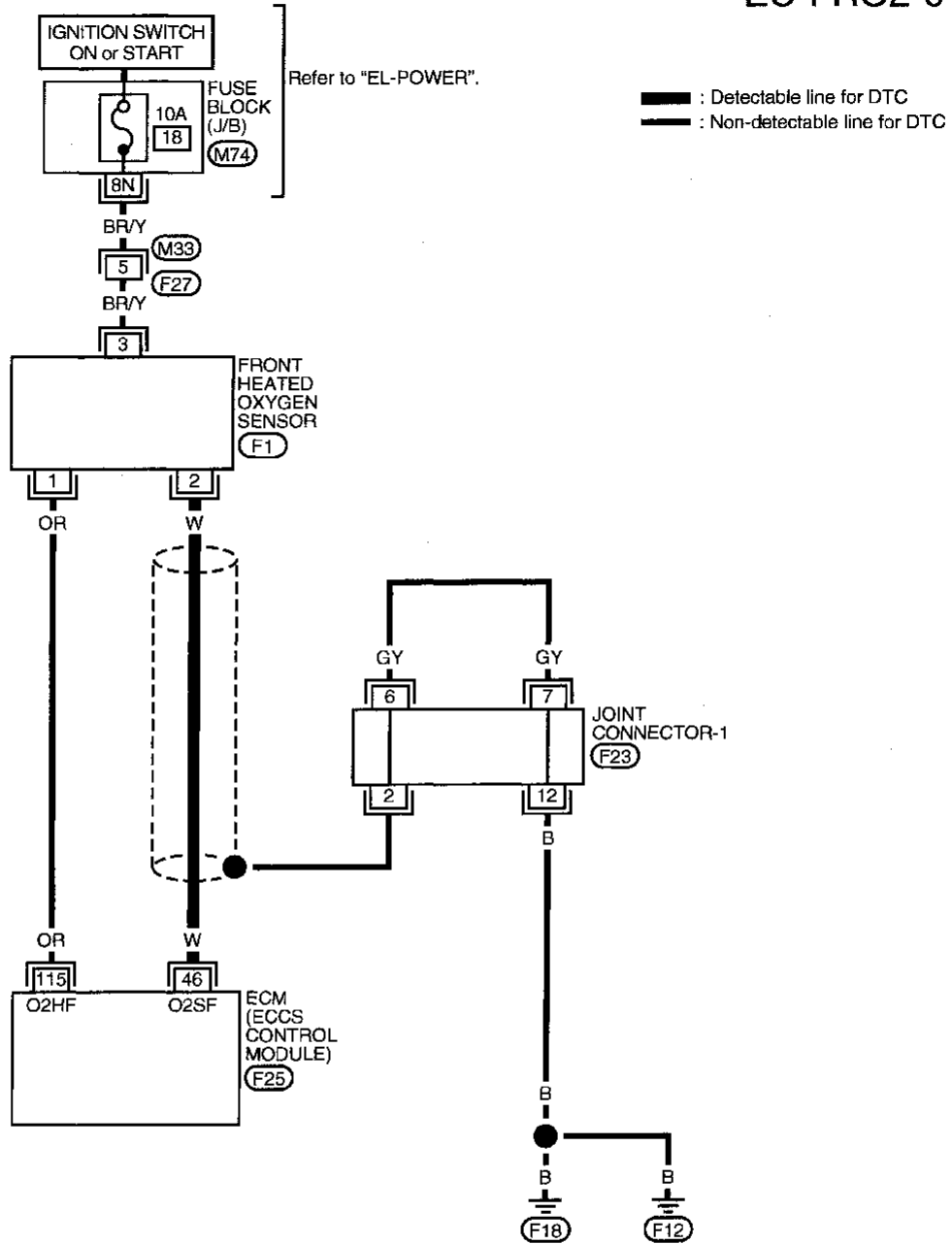

Refer to last page (Foldout page).

(F23)

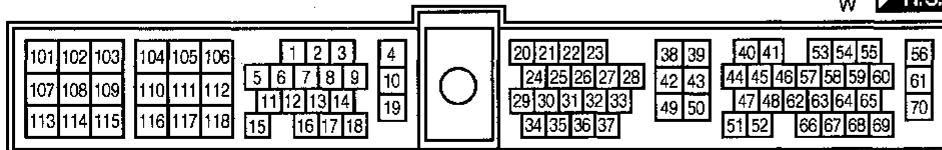
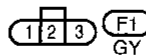

TROUBLE DIAGNOSIS FOR DTC P0134

Front Heated Oxygen Sensor (High Voltage) (Front HO2S) (Cont'd)

DIAGNOSTIC PROCEDURE

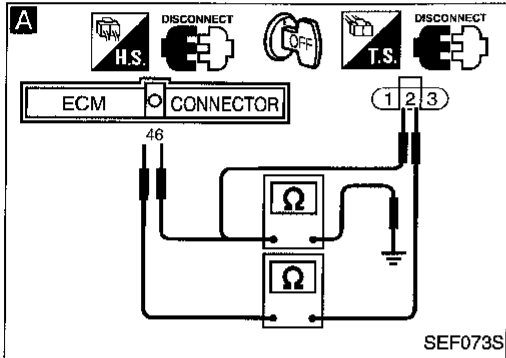
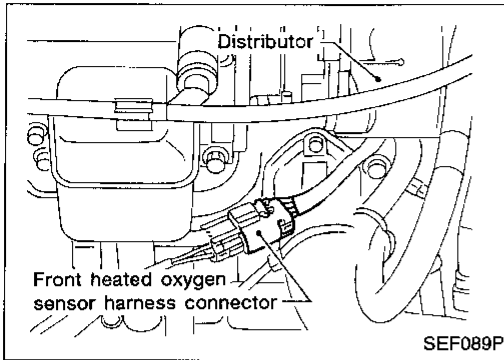

INSPECTION START

Loosen and retighten front heated oxygen sensor.

Tightening torque:
40 - 60 N·m
(4.1 - 6.1 kg-m, 30 - 44 ft-lb)

CHECK INPUT SIGNAL CIRCUIT.

1. Disconnect front heated oxygen sensor harness connector and ECM harness connector.
 2. Check harness continuity between ECM terminal (46) and terminal (2).
Continuity should exist.
 3. Check harness continuity between ECM terminal (46) (or terminal (2)) and ground.
Continuity should not exist.
- If OK, check harness for short to ground and short to power.

NG → Repair open circuit or short to ground or short to power in harness or connectors.

CHECK COMPONENT

- (Front heated oxygen sensor).
1. Turn ignition switch "OFF".
 2. Disconnect sensor harness connector and check for water.
Water should not exist.
- If OK, go to step 3.
3. Check front heated oxygen sensor. Refer to "COMPONENT INSPECTION" on next page.

NG → Repair or replace harness and/or connectors or replace front heated oxygen sensor.

CHECK SHIELD CIRCUIT

1. Turn ignition switch "OFF".
 2. Remove joint connector-1.
 3. Check the following.
 - Continuity between joint connector-1 terminal (2) and engine ground
 - Joint connector-1 (Refer to "HARNES LAYOUT" in EL section.)**Continuity should exist.**
- If OK, check harness for short to power.

NG → Repair open circuit, short to ground or short to power in harness or connectors.

Perform "TROUBLE DIAGNOSIS FOR INTERMITTENT INCIDENT", EC-106.

INSPECTION END

GI

MA

EM

LC

EC

FE

CL

WT

AT

FA

RA

BR

ST

RS

BT

HA

EL

IDX

TROUBLE DIAGNOSIS FOR DTC P0134

Front Heated Oxygen Sensor (High Voltage) (Front HO2S) (Cont'd)

COMPONENT INSPECTION

Front heated oxygen sensor

CAUTION:

Discard any heated oxygen sensor which has been dropped from a height of more than 0.5 m (19.7 in) onto a hard surface such as a concrete floor; use a new one.

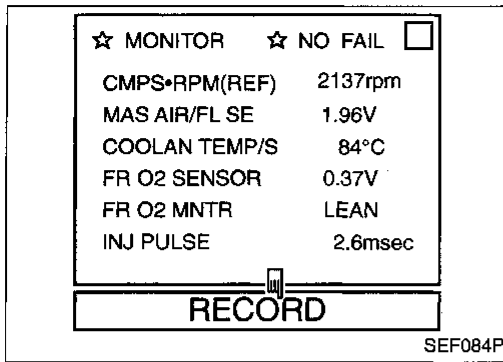

- 1) Start engine and warm it up to normal operating temperature.
- 2) Select "MANU TRIG" and "HI SPEED" in "DATA MONITOR" mode with CONSULT, and select "FR O2 SENSOR" and "FR O2 MNTR".
- 3) Hold engine speed at 2,000 rpm under no load during the following steps.
- 4) Touch "RECORD" on CONSULT screen.
- 5) Check the following.

- "FR O2 MNTR" in "DATA MONITOR" mode changes from "RICH" to "LEAN" to "RICH" 5 times in 10 seconds.

5 times (cycles) are counted as shown below:

cycle | 1 | 2 | 3 | 4 | 5 |
FR O2 MNTR R-L-R-L-R-L-R-L-R-L-R

R = "FR O2 MNTR", "RICH"
L = "FR O2 MNTR", "LEAN"

- "FR O2 SENSOR" voltage goes above 0.6V at least once.
- "FR O2 SENSOR" voltage goes below 0.3V at least once.
- "FR O2 SENSOR" voltage never exceeds 1.0V.

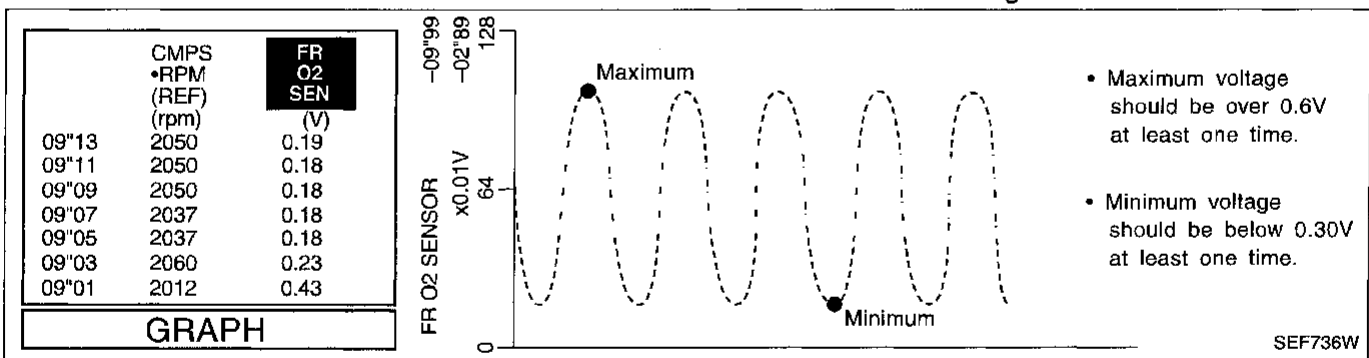

OR

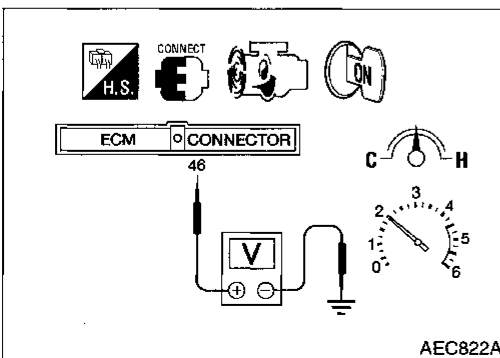

- 1) Start engine and warm it up to normal operating temperature.
- 2) Set voltmeter probes between ECM terminal ④⑥ (sensor signal) and engine ground.
- 3) Check the following with engine speed held at 2,000 rpm constant under no load.
 - Malfunction indicator lamp goes on more than 5 times within 10 seconds in Diagnostic Test Mode II (FRONT HEATED OXYGEN SENSOR MONITOR).
 - The maximum voltage is over 0.6V at least one time.
 - The minimum voltage is below 0.3V at least one time.
 - The voltage never exceeds 1.0V.

TROUBLE DIAGNOSIS FOR DTC P0135

Front Heated Oxygen Sensor Heater

SYSTEM DESCRIPTION

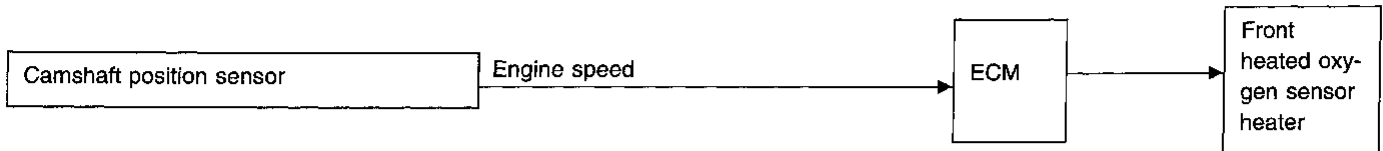

The ECM performs ON/OFF control of the front heated oxygen sensor heater corresponding to the engine operating condition.

OPERATION

Engine speed	Front heated oxygen sensor heater
Above 3,200 rpm	OFF
Below 3,200 rpm	ON

CONSULT REFERENCE VALUE IN DATA MONITOR MODE

Specification data are reference values.

MONITOR ITEM	CONDITION	SPECIFICATION
FR O2 HEATER	● Engine speed: Idle	ON
	● Engine speed: Above 3,200 rpm	OFF

ECM TERMINALS AND REFERENCE VALUE

Specification data are reference values and are measured between each terminal and engine ground.

TER-MINAL NO.	WIRE COLOR	ITEM	CONDITION	DATA (DC voltage)
115	OR	Front heated oxygen sensor heater	Engine is running. └ Engine speed is below 3,200 rpm	Approximately 0V
			Engine is running. └ Engine speed is above 3,200 rpm	BATTERY VOLTAGE (11 - 14V)

ON BOARD DIAGNOSIS LOGIC

Diagnostic Trouble Code No.	Malfunction is detected when	Check Items (Possible Cause)
P0135 0901	<ul style="list-style-type: none"> The current amperage in the front heated oxygen sensor heater circuit is out of the normal range. (An improper voltage drop signal is sent to ECM through the front heated oxygen sensor heater.) 	<ul style="list-style-type: none"> Harness or connectors (The front heated oxygen sensor heater circuit is open or shorted.) Front heated oxygen sensor heater

TROUBLE DIAGNOSIS FOR DTC P0135

Front Heated Oxygen Sensor Heater (Cont'd) DIAGNOSTIC TROUBLE CODE CONFIRMATION PROCEDURE

☆ MONITOR	☆ NO FAIL	<input type="checkbox"/>
CMPS•RPM(REF)	700rpm	
RECORD		

SEF190P

NOTE:

If "DIAGNOSTIC TROUBLE CODE CONFIRMATION PROCEDURE" has been previously conducted, always turn ignition switch "OFF" and wait at least 5 seconds before conducting the next test.

TESTING CONDITION:

Before performing the following procedure, confirm that battery voltage is between 10.5V and 16V at idle.



- 1) Turn ignition switch "ON" and select "DATA MONITOR" mode with CONSULT.
- 2) Start engine and run it for at least 5 seconds at idle speed.
- 3) If 1st trip DTC is detected, go to "DIAGNOSTIC PROCEDURE", EC-198.

OR



- 1) Start engine and run it for at least 5 seconds at idle speed.
- 2) Turn ignition switch "OFF" and wait at least 5 seconds.
- 3) Start engine and run it for at least 5 seconds at idle speed.
- 4) Select "MODE 3" with GST.
- 5) If DTC is detected, go to "DIAGNOSTIC PROCEDURE", EC-198.

OR



- 1) Start engine and run it for at least 5 seconds at idle speed.
- 2) Turn ignition switch "OFF", wait at least 5 seconds and then turn "ON".
- 3) Perform "Diagnostic Test Mode II (Self-diagnostic results)" with ECM.
- 4) If 1st trip DTC is detected, go to "DIAGNOSTIC PROCEDURE", EC-198.

- When using GST, "DIAGNOSTIC TROUBLE CODE CONFIRMATION PROCEDURE" should be performed twice as much as when using CONSULT or ECM (Diagnostic Test Mode II) because GST cannot display MODE 7 (1st trip DTC) concerning this diagnosis. Therefore, using CONSULT or ECM (Diagnostic Test Mode II) is recommended.

TROUBLE DIAGNOSIS FOR DTC P0135

Front Heated Oxygen Sensor Heater (Cont'd)

EC-FRO2/H-01

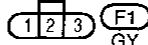
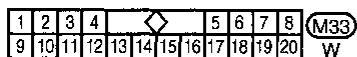
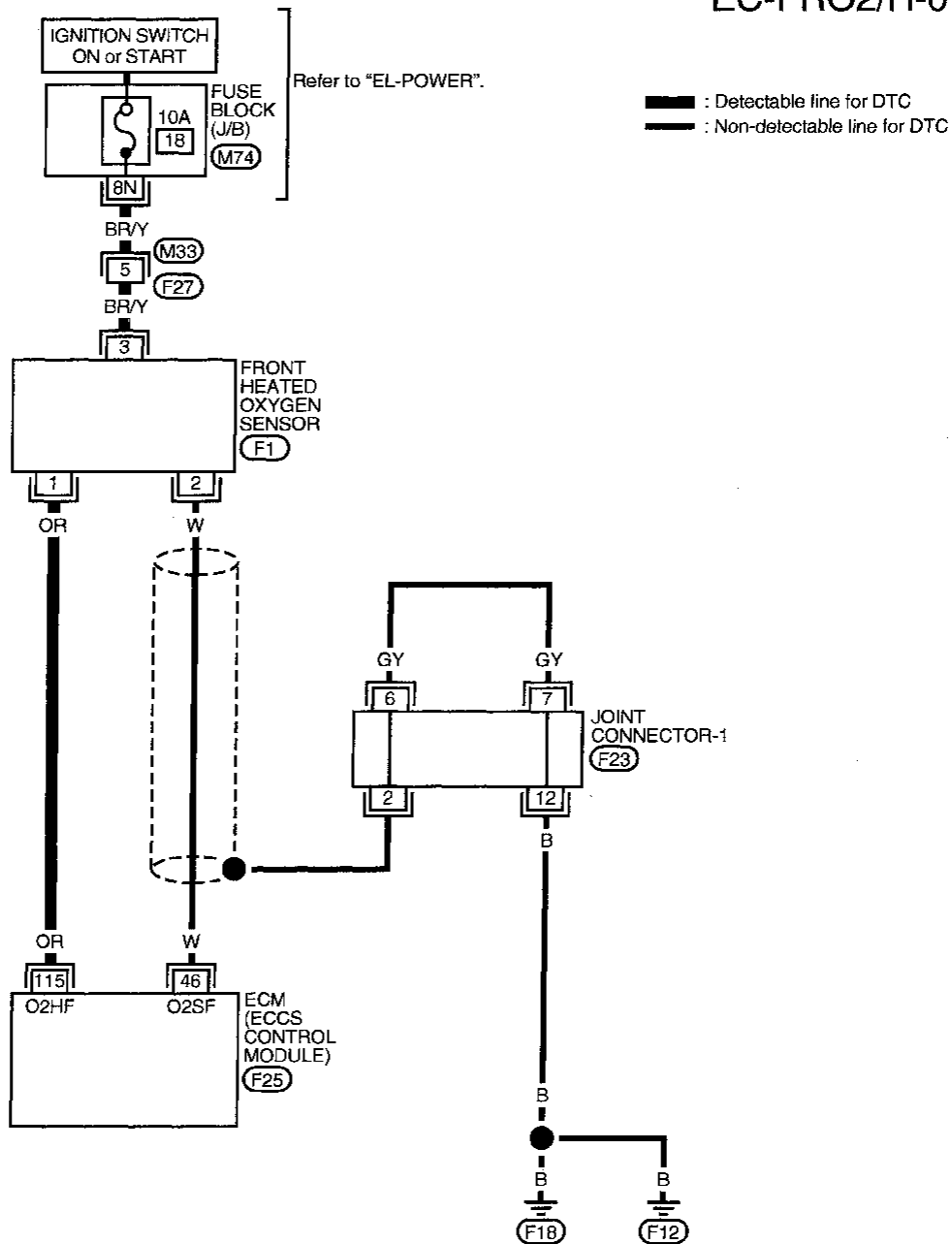

Refer to last page (Foldout page).

(F23)

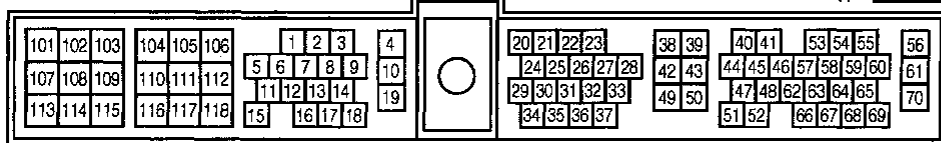

TROUBLE DIAGNOSIS FOR DTC P0135

Front Heated Oxygen Sensor Heater (Cont'd)

DIAGNOSTIC PROCEDURE

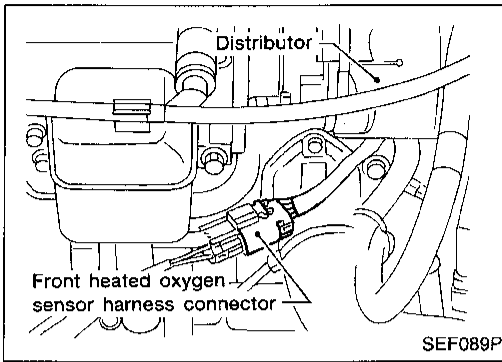

INSPECTION START

A

CHECK POWER SUPPLY.

1. Turn ignition switch "OFF".
2. Disconnect front heated oxygen sensor harness connector.
3. Turn ignition switch "ON".
4. Check voltage between terminal ③ and ground with CONSULT or tester.

Voltage: Battery voltage

NG

Check the following.

- Harness connectors (F27, M33)
- 10A fuse
- Harness for open or short between front heated oxygen sensor and fuse

If NG, repair harness or connectors.

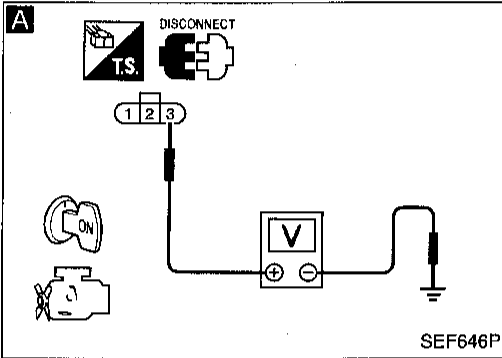

OK

B

CHECK GROUND CIRCUIT.

1. Turn ignition switch "OFF".
2. Disconnect ECM harness connector.
3. Check harness continuity between terminal ① and ECM terminal ①15.

Continuity should exist.

If OK, check harness for short to ground and short to power.

NG

Repair open circuit or short to ground or short to power in harness or connectors.

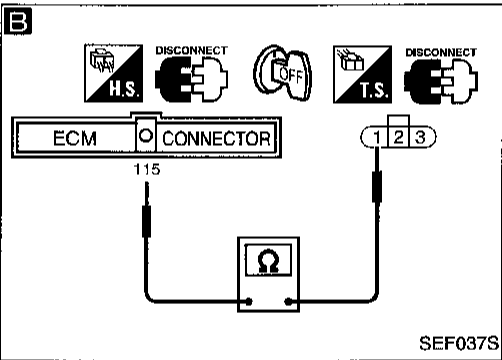

OK

CHECK COMPONENT
(Front heated oxygen sensor heater).
Refer to "COMPONENT INSPECTION" below.

NG

Replace front heated oxygen sensor.

OK

Perform "TROUBLE DIAGNOSIS FOR INTERMITTENT INCIDENT", EC-106.

INSPECTION END

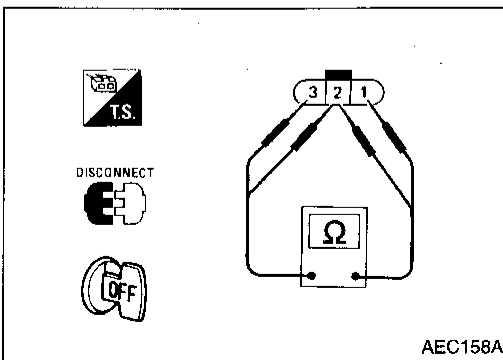

COMPONENT INSPECTION

Front heated oxygen sensor heater

Check resistance between terminals ③ and ①.

Resistance: 2.3 - 4.3Ω at 25°C (77°F)

Check continuity between terminals ② and ①, ③ and ②.

Continuity should not exist.

If NG, replace the front heated oxygen sensor.

CAUTION:

Discard any heated oxygen sensor which has been dropped from a height of more than 0.5 m (19.7 in) onto a hard surface such as a concrete floor; use a new one.

TROUBLE DIAGNOSIS FOR DTC P0137

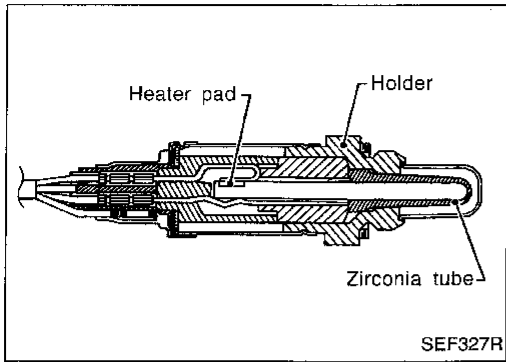

Rear Heated Oxygen Sensor (Min. Voltage Monitoring) (Rear HO2S)

COMPONENT DESCRIPTION

The rear heated oxygen sensor (Rear HO2S), after three way catalyst, monitors the oxygen level in the exhaust gas. Even if switching characteristics of the front heated oxygen sensor are shifted, the air fuel ratio is controlled to stoichiometric, by the signal from the rear heated oxygen sensor. This sensor is made of ceramic zirconia. The zirconia generates voltage from approximately 1V in richer conditions to 0V in leaner conditions. Under normal conditions the rear heated oxygen sensor is not used for engine control operation.

CONSULT REFERENCE VALUE IN DATA MONITOR MODE

Specification data are reference values.

MONITOR ITEM	CONDITION	SPECIFICATION
RR O2 SENSOR	● Engine: After warming up Revsing engine from idle to 3,000 rpm	0 - 0.3V ↔ Approx. 0.6 - 1.0V
RR O2 MNTR		LEAN ↔ RICH

ECM TERMINALS AND REFERENCE VALUE

Specification data are reference values and are measured between each terminal and engine ground.

TER-MINAL NO.	WIRE COLOR	ITEM	CONDITION	DATA (DC voltage)
52	W	Rear heated oxygen sensor	Engine is running. After warming up to normal operating temperature and revving engine from idle to 2,000 rpm	0 - Approximately 1.0V

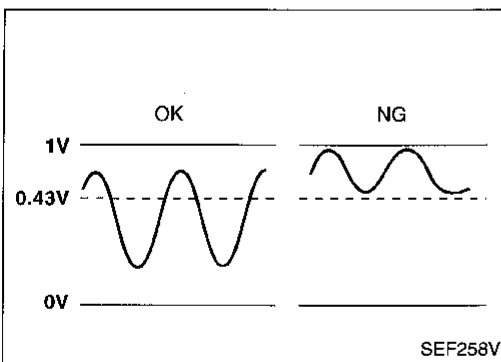

ON BOARD DIAGNOSIS LOGIC

The rear heated oxygen sensor has a much longer switching time between rich and lean than the front heated oxygen sensor. The oxygen storage capacity before the three way catalyst causes the longer switching time. To judge the malfunctions of the rear heated oxygen sensor, ECM monitors whether the minimum voltage of the sensor is sufficiently low during various driving conditions such as fuel-cut.

Diagnostic Trouble Code No.	Malfunction is detected when ...	Check Items (Possible Cause)
P0137 0511	● The minimum voltage from the sensor does not reach the specified voltage.	<ul style="list-style-type: none"> ● Harness or connectors (The sensor circuit is open or shorted.) ● Rear heated oxygen sensor ● Fuel pressure ● Injectors

TROUBLE DIAGNOSIS FOR DTC P0137

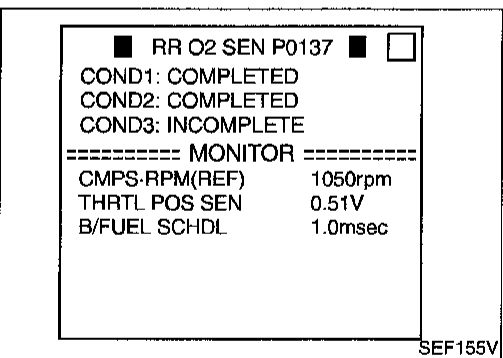
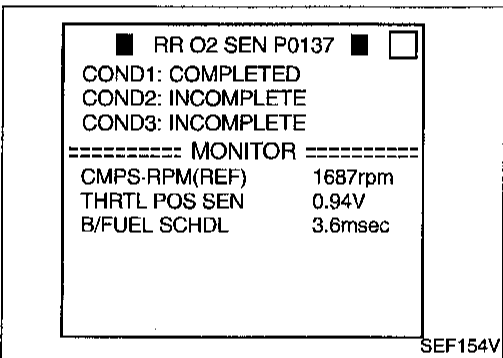
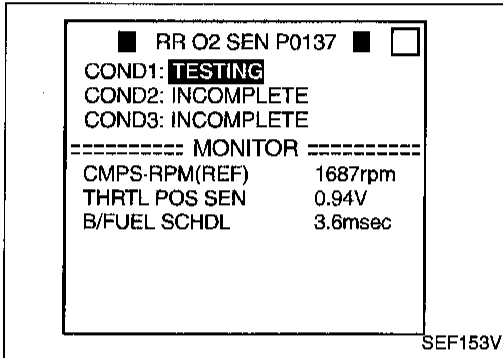
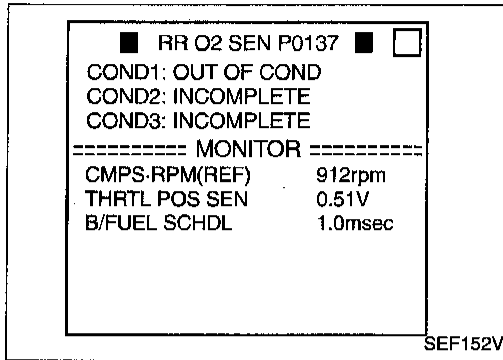

Rear Heated Oxygen Sensor (Min. Voltage Monitoring) (Rear HO2S) (Cont'd)

DIAGNOSTIC TROUBLE CODE CONFIRMATION PROCEDURE

CAUTION:

Always drive vehicle at a safe speed.

NOTE:

- "COMPLETED" will appear on CONSULT screen when all tests "COND1", "COND2" and "COND3" are completed.
- If "DIAGNOSTIC TROUBLE CODE CONFIRMATION PROCEDURE" has been previously conducted, always turn ignition switch "OFF" and wait at least 5 seconds before conducting the next test.

TESTING CONDITION:

Never stop engine during this procedure. If the engine is stopped, retry this procedure from step 2).



Procedure for COND1

- 1) Start engine and warm it up to normal operating temperature.
- 2) Turn ignition switch "OFF" and wait at least 5 seconds.
- 3) Turn ignition switch "ON" and select "RR O2 SENSOR P0137" of "REAR O2 SENSOR" in "DTC WORK SUPPORT" mode with CONSULT.
- 4) Touch "START".
- 5) Start engine and let it idle for at least 30 seconds.
- 6) Rev engine up to 2,000 rpm 2 or 3 times quickly under no load.

If "COMPLETED" appears on CONSULT screen, go to step 11).

If "COMPLETED" does not appear on CONSULT screen, go to the following step.

- 7) Drive vehicle at a speed of more than 70 km/h (43 MPH) for 2 consecutive minutes.
- 8) When the following conditions are met, "TESTING" will be displayed at "COND1" on the CONSULT screen. Maintain the conditions continuously until "TESTING" changes to "COMPLETED". (It will take approximately 30 seconds.)

**CMPS-RPM (REF): 1,400 - 3,400 rpm (A/T)
1,400 - 3,500 rpm (M/T)**

Vehicle speed: 64 - 120 km/h (40 - 75 MPH)

B/FUEL SCHDL: 0.5 - 3.9 msec

Selector lever: Suitable position

NOTE:

- If "TESTING" is not displayed after 5 minutes, retry from step 2).
- If "COMPLETED" already appears at "COND2" on CONSULT screen before "Procedure for COND2" is conducted, it is unnecessary to conduct step 9).

Procedure for COND2

- 9) While driving, release accelerator pedal completely with "O/D" OFF (A/T models only) from the above condition [step 8] until "INCOMPLETE" at "COND2" on CONSULT screen has turned to "COMPLETED". (It will take approximately 4 seconds.)

TROUBLE DIAGNOSIS FOR DTC P0137

Rear Heated Oxygen Sensor (Min. Voltage Monitoring) (Rear HO2S) (Cont'd)

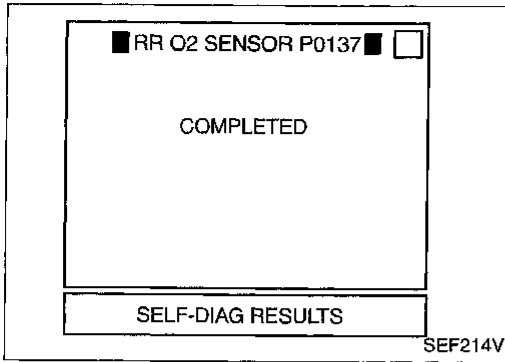

NOTE:

If "COMPLETED" already appears at "COND3" on CONSULT screen before "Procedure for COND3" is conducted, it is unnecessary to conduct step 10).

Procedure for COND3

- 10) Stop vehicle and let it idle until "INCOMPLETE" of "COND3" on CONSULT screen has turned to "COMPLETED". (It will take a maximum of approximately 6 minutes.)
- 11) Make sure that "OK" is displayed after touching "SELF-DIAG RESULTS". If "NG" is displayed, refer to "DIAGNOSTIC PROCEDURE", EC-203.

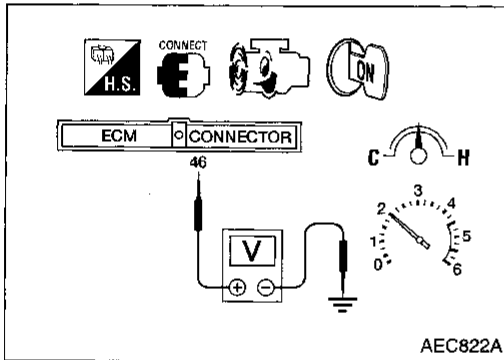

OR

OVERALL FUNCTION CHECK

Use this procedure to check the overall function of the rear heated oxygen sensor circuit. During this check, a 1st trip DTC might not be confirmed.

- 1) Start engine and drive vehicle at a speed of more than 70 km/h (43 MPH) for 2 consecutive minutes.
- 2) Stop vehicle with engine running.
- 3) Set voltmeter probes between ECM terminal ⑤2 (sensor signal) and engine ground.
- 4) Check the voltage when revving engine up to 4,000 rpm under no load at least 10 times. (Depress and release accelerator pedal as soon as possible.)
The voltage should be below 0.43V at least once during this procedure.
If the voltage can be confirmed in step 4, step 5 is not necessary.
- 5) Keep vehicle idling for 10 minutes, then check the voltage. Or check the voltage when coasting from 80 km/h (50 MPH) in 3rd gear position (M/T), D position with "O/D" OFF (A/T).
The voltage should be below 0.43V at least once during this procedure.
- 6) If NG, go to "DIAGNOSTIC PROCEDURE", EC-203.

TROUBLE DIAGNOSIS FOR DTC P0137

Rear Heated Oxygen Sensor (Min. Voltage Monitoring) (Rear HO2S) (Cont'd)

EC-RRO2-01

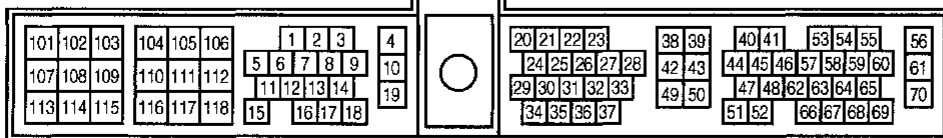
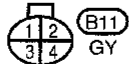
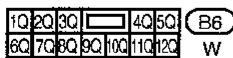
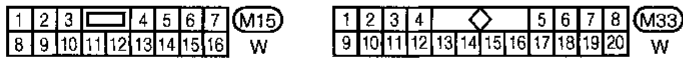
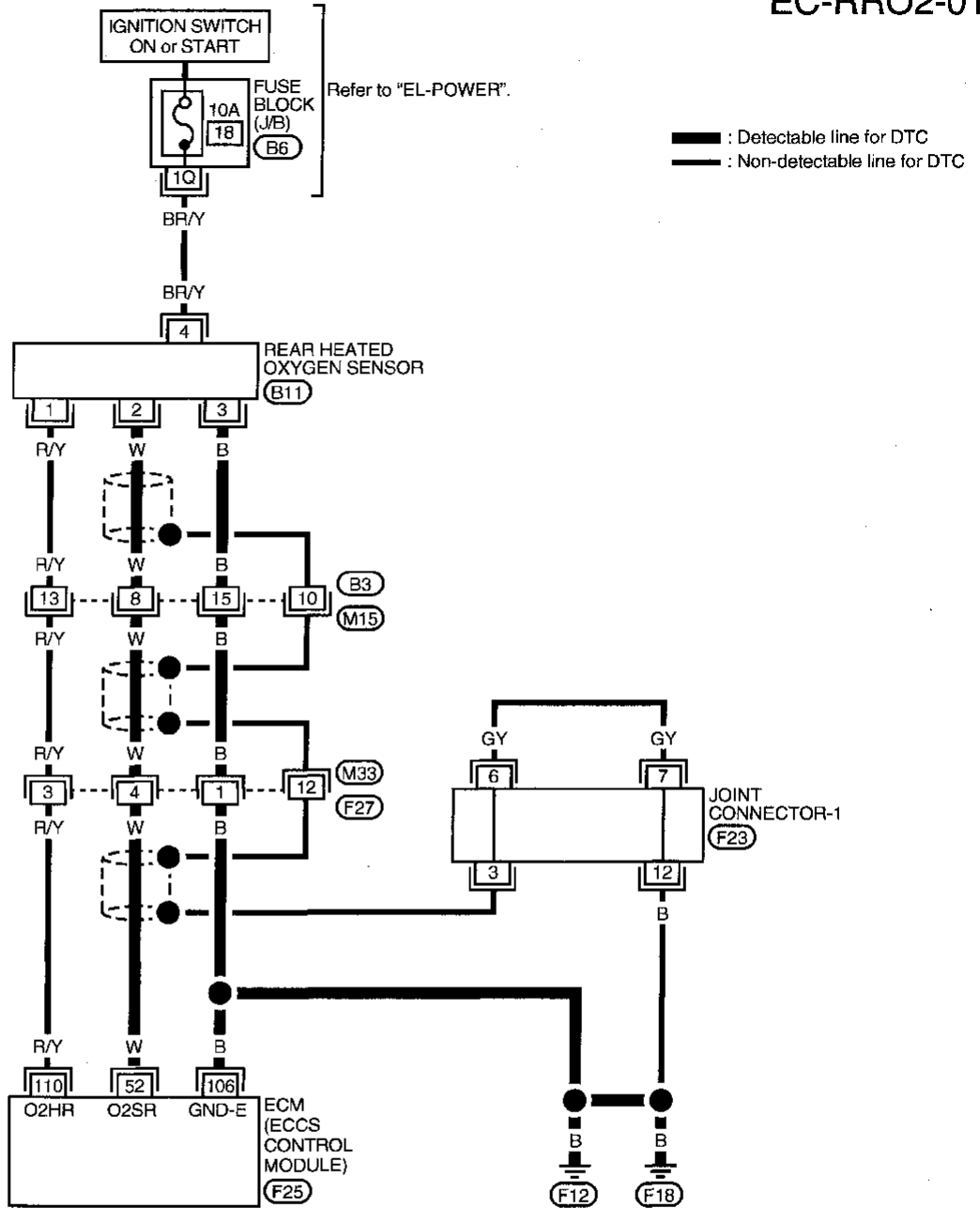

Refer to fast page (Foldout page).
 (F23)

TROUBLE DIAGNOSIS FOR DTC P0137

Rear Heated Oxygen Sensor (Min. Voltage Monitoring) (Rear HO2S) (Cont'd) DIAGNOSTIC PROCEDURE

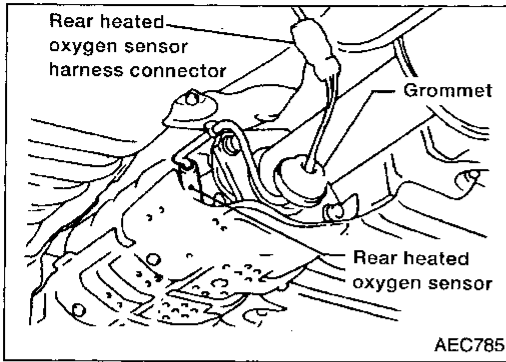

INSPECTION START

1. Turn ignition switch "OFF".
2. Loosen and retighten engine ground screws.

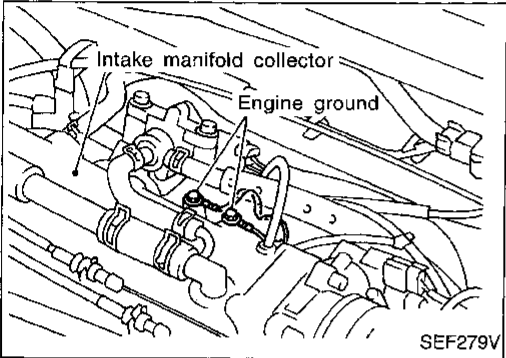

- A**
- CLEAR THE SELF-LEARNING DATA**
1. Start engine and warm it up to normal operating temperature.
 2. Select "SELF-LEARNING CONT" in "ACTIVE TEST" mode with CONSULT.
 3. Clear the self-learning control coefficient by touching "CLEAR".
 4. Run engine for at least 10 minutes at idle speed.
- Is the 1st trip DTC P0172 detected? Is it difficult to start engine?**

Yes → Go to "TROUBLE DIAGNOSIS FOR DTC P0172", EC-236.

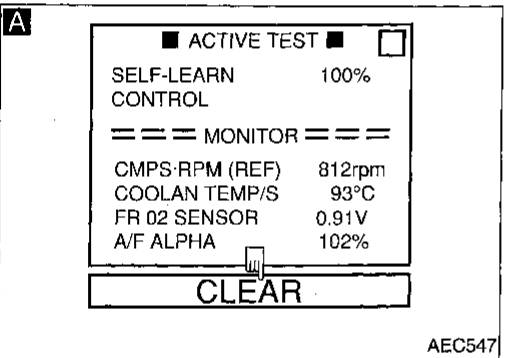

- OR
2. Turn ignition switch "OFF".
 3. Disconnect mass air flow sensor harness connector, and restart and run engine for at least 3 seconds at idle speed.
 4. Stop engine and reconnect mass air flow sensor harness connector.
 5. Make sure diagnostic trouble code No. 0102 is displayed in Diagnostic Test Mode II.
 6. Erase the diagnostic test mode II (Self-diagnostic results) memory. Make sure diagnostic trouble code No. 0505 is displayed in Diagnostic Test Mode II.
 7. Run engine for at least 10 minutes at idle speed.
- Is the 1st trip DTC 0114 detected? Is it difficult to start engine?**

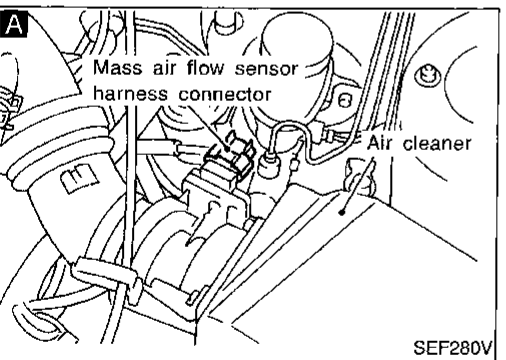

No ↓

A

(Go to next page.)

GI
MA
EM
LC
EC
FE
CL
MT
AT
FA
RA
BR
ST
RS
BT
HA
EL
IDX

TROUBLE DIAGNOSIS FOR DTC P0137

Rear Heated Oxygen Sensor (Min. Voltage Monitoring) (Rear HO2S) (Cont'd)

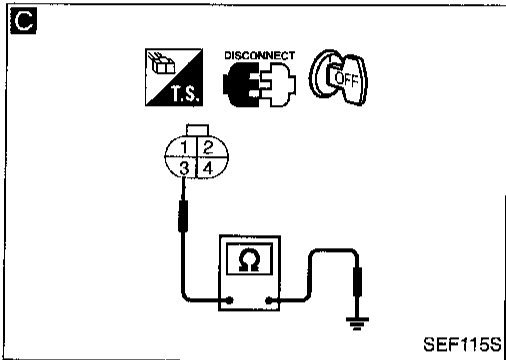
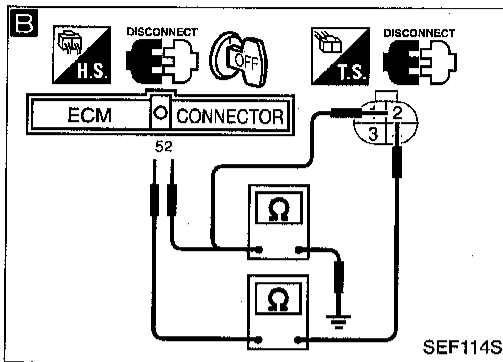

CHECK INPUT SIGNAL CIRCUIT.

1. Disconnect rear heated oxygen sensor harness connector and ECM harness connector.
2. Check harness continuity between ECM terminal (52) and terminal (2).
Continuity should exist.
3. Check harness continuity between ECM terminal (52) (or terminal (2)) and ground.
Continuity should not exist.
If OK, check harness for short to ground and short to power.

NG

Check the following.

- Harness connectors (B3), (M15)
- Harness connectors (M33), (F27)
- Harness for open or short between rear heated oxygen sensor and ECM

If NG, repair open circuit or short to ground or short to power in harness or connectors.

OK

CHECK GROUND CIRCUIT.

Check harness continuity between terminal (3) and engine ground.
Continuity should exist.
If OK, check harness for short to ground and short to power.

NG

Check the following.

- Harness connectors (B3), (M15)
- Harness connectors (M33), (F27)
- Harness for open or short between rear heated oxygen sensor and engine ground

If NG, repair open circuit or short to ground or short to power in harness or connectors.

OK

CHECK COMPONENT
(Rear heated oxygen sensor).
Refer to "COMPONENT INSPECTION" on next page.

NG

Replace rear heated oxygen sensor.

OK

CHECK SHIELD CIRCUIT

1. Reconnect harness connectors disconnected.
2. Disconnect harness connectors (B3), (M15).
3. Check harness continuity between terminal (10) and engine ground.
Continuity should exist.
If OK, check harness for short to ground and short to power.
Then reconnect harness connectors.

NG

DETECT MALFUNCTIONING PART.

Check the following.

- Harness connectors (F27), (M33)
- Harness connectors (B3), (M15)
- Joint connector-1 (Refer to "HARNESS LAYOUT" in EL section.)
- Harness for open or short between harness connector (M15) and engine ground

If NG, repair open circuit, short to ground or short to power in harness or connectors.

OK

Perform "TROUBLE DIAGNOSIS FOR INTERMITTENT INCIDENT", EC-106.

INSPECTION END

TROUBLE DIAGNOSIS FOR DTC P0137

Rear Heated Oxygen Sensor (Min. Voltage Monitoring) (Rear HO2S) (Cont'd)

COMPONENT INSPECTION

Rear heated oxygen sensor

- 1) Start engine and drive vehicle at a speed of more than 70 km/h (43 MPH) for 2 consecutive minutes.
- 2) Stop vehicle with engine running.
- 3) Select "FUEL INJECTION" in "ACTIVE TEST" mode, and select "RR O2 SENSOR" as the monitor item with CONSULT.
- 4) Check "RR O2 SENSOR" at idle speed when adjusting "FUEL INJECTION" to $\pm 25\%$.
 "RR O2 SENSOR" should be above 0.48V at least once when the "FUEL INJECTION" is +25%.
 "RR O2 SENSOR" should be below 0.43V at least once when the "FUEL INJECTION" is -25%.

CAUTION:

Discard any heated oxygen sensor which has been dropped from a height of more than 0.5 m (19.7 in) onto a hard surface such as a concrete floor; use a new one.

OR

- 1) Start engine and drive vehicle at a speed of more than 70 km/h (43 MPH) for 2 consecutive minutes.
- 2) Stop vehicle with engine running.
- 3) Set voltmeter probes between ECM terminal ⑤₂ (sensor signal) and engine ground.
- 4) Check the voltage when revving up to 4,000 rpm under no load at least 10 times.
(Depress and release accelerator pedal as soon as possible.)
 The voltage should be above 0.48V at least once. If the voltage is above 0.48V at step 4, step 5 is not necessary.
- 5) Check the voltage when revving up to 6,000 rpm under no load. Or keep vehicle idling for 10 minutes, then check the voltage. Or check the voltage when coasting from 80 km/h (50 MPH) in 3rd gear position (M/T), D position with "O/D" OFF (A/T).
 The voltage should be below 0.43V at least once.

CAUTION:

Discard any heated oxygen sensor which has been dropped from a height of more than 0.5 m (19.7 in) onto a hard surface such as a concrete floor; use a new one.

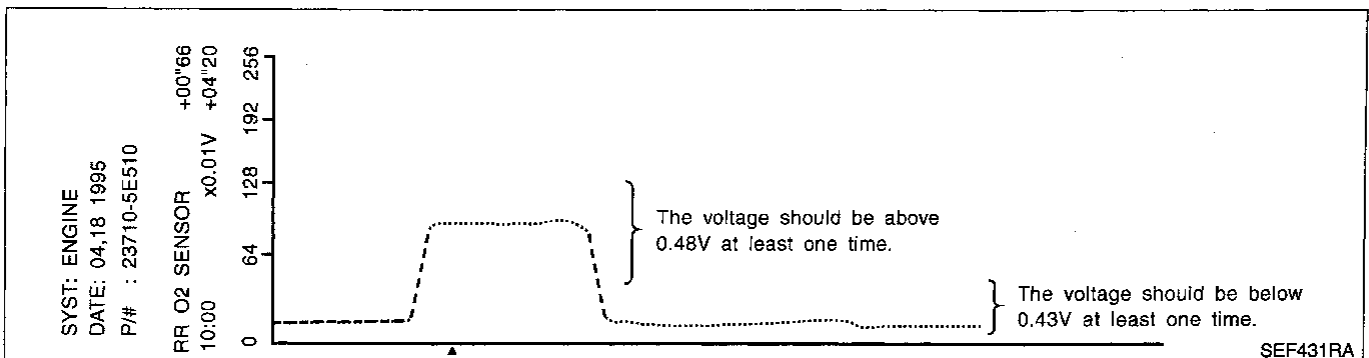
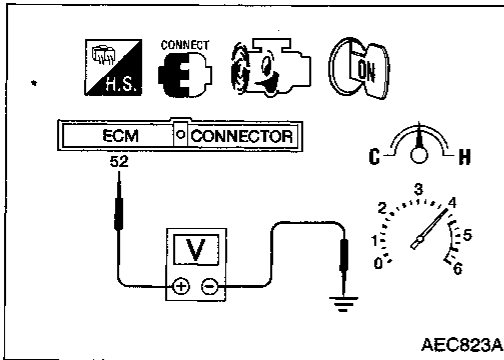
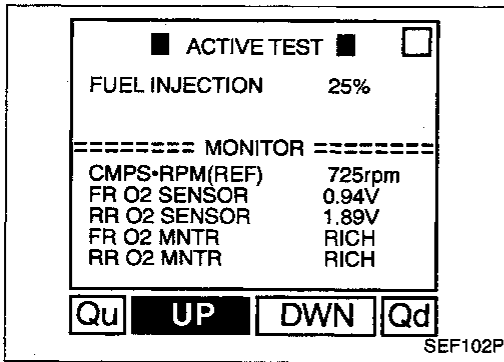

TROUBLE DIAGNOSIS FOR DTC P0138

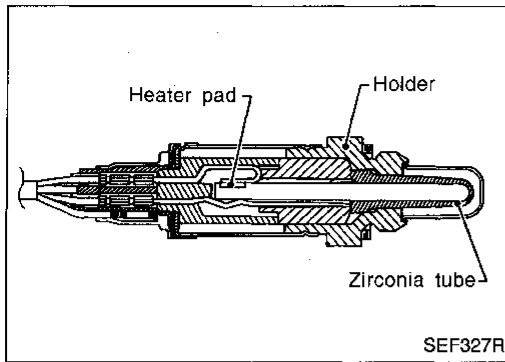

Rear Heated Oxygen Sensor (Max. Voltage Monitoring) (Rear HO2S)

COMPONENT DESCRIPTION

The rear heated oxygen sensor (Rear HO2S), after three way catalyst, monitors the oxygen level in the exhaust gas.

Even if switching characteristics of the front heated oxygen sensor are shifted, the air fuel ratio is controlled to stoichiometric, by the signal from the rear heated oxygen sensor.

This sensor is made of ceramic zirconia. The zirconia generates voltage from approximately 1V in richer conditions to 0V in leaner conditions.

Under normal conditions the rear heated oxygen sensor is not used for engine control operation.

CONSULT REFERENCE VALUE IN DATA MONITOR MODE

Specification data are reference values.

MONITOR ITEM	CONDITION		SPECIFICATION
RR O2 SENSOR	● Engine: After warming up	Revsing engine from idle to 3,000 rpm	0 - 0.3V ↔ Approx. 0.6 - 1.0V
RR O2 MNTR			LEAN ↔ RICH

ECM TERMINALS AND REFERENCE VALUE

Specification data are reference values and are measured between each terminal and engine ground.

TER-MINAL NO.	WIRE COLOR	ITEM	CONDITION	DATA (DC voltage)
52	W	Rear heated oxygen sensor	Engine is running. After warming up to normal operating temperature and revving engine from idle to 2,000 rpm	0 - Approximately 1.0V

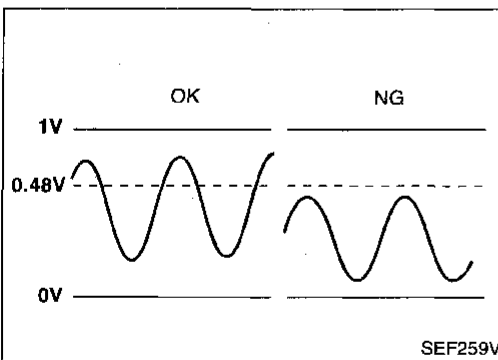

ON BOARD DIAGNOSIS LOGIC

The rear heated oxygen sensor has a much longer switching time between rich and lean than the front heated oxygen sensor. The oxygen storage capacity before the three way catalyst causes the longer switching time. To judge the malfunctions of the rear heated oxygen sensor, ECM monitors whether the maximum voltage of the sensor is sufficiently high during various driving conditions such as fuel-cut.

Diagnostic Trouble Code No.	Malfunction is detected when ...	Check Items (Possible Cause)
P0138 0510	● The maximum voltage from the sensor does not reach the specified voltage.	<ul style="list-style-type: none"> ● Harness or connectors (The sensor circuit is open or shorted.) ● Rear heated oxygen sensor ● Fuel pressure ● Injectors ● Intake air leaks

TROUBLE DIAGNOSIS FOR DTC P0138

Rear Heated Oxygen Sensor (Max. Voltage Monitoring) (Rear HO2S) (Cont'd)

DIAGNOSTIC TROUBLE CODE CONFIRMATION PROCEDURE

CAUTION:

Always drive vehicle at a safe speed.

NOTE:

- "COMPLETED" will appear on CONSULT screen when all tests "COND1", "COND2" and "COND3" are completed.
- If "DIAGNOSTIC TROUBLE CODE CONFIRMATION PROCEDURE" has been previously conducted, always turn ignition switch "OFF" and wait at least 5 seconds before conducting the next test.

TESTING CONDITION:

Never stop engine during this procedure. If the engine is stopped, retry this procedure from step 2).



Procedure for COND1

- 1) Start engine and warm it up to normal operating temperature.
- 2) Turn ignition switch "OFF" and wait at least 5 seconds.
- 3) Turn ignition switch "ON" and select "RR O2 SENSOR P0138" of "REAR O2 SENSOR" in "DTC WORK SUPPORT" mode with CONSULT.
- 4) Touch "START".
- 5) Start engine and let it idle for at least 30 seconds.
- 6) Rev engine up to 2,000 rpm 2 or 3 times quickly under no load.

If "COMPLETED" appears on CONSULT screen, go to step 11).

If "COMPLETED" does not appear on CONSULT screen, go to the following step.

- 7) Drive vehicle at a speed of more than 70 km/h (43 MPH) for 2 consecutive minutes.
- 8) When the following conditions are met, "TESTING" will be displayed at "COND1" on the CONSULT screen. Maintain the conditions continuously until "TESTING" changes to "COMPLETED". (It will take approximately 30 seconds.)

CMPS-RPM (REF): 1,400 - 3,400 rpm (A/T)

1,400 - 3,500 rpm (M/T)

Vehicle speed: 64 - 120 km/h (40 - 75 MPH)

B/FUEL SCHDL: 0.5 - 3.9 msec

Selector lever: Suitable position

NOTE:

- If "TESTING" is not displayed after 5 minutes, retry from step 2).
- If "COMPLETED" already appears at "COND2" on CONSULT screen before "Procedure for COND2" is conducted, it is unnecessary to conduct step 9).

Procedure for COND2

- 9) While driving, release accelerator pedal completely with "O/D" OFF (A/T models only) from the above condition [step 8] until "INCOMPLETE" at "COND2" on CONSULT screen is turned to "COMPLETED". (It will take approximately 4 seconds.)

■ RR O2 SENSOR P0138 ■ <input type="checkbox"/>	
COND1:	OUT OF COND
COND2:	INCOMPLETE
COND3:	INCOMPLETE
----- MONITOR -----	
CMPS-RPM(REF)	912rpm
THRTL POS SEN	0.51V
B/FUEL SCHDL	1.0msec

SEF160V

■ RR O2 SENSOR P0138 ■ <input type="checkbox"/>	
COND1:	TESTING
COND2:	INCOMPLETE
COND3:	INCOMPLETE
----- MONITOR -----	
CMPS-RPM(REF)	1687rpm
THRTL POS SEN	0.94V
B/FUEL SCHDL	3.6msec

SEF161V

■ RR O2 SENSOR P0138 ■ <input type="checkbox"/>	
COND1:	COMPLETED
COND2:	INCOMPLETE
COND3:	INCOMPLETE
----- MONITOR -----	
CMPS-RPM(REF)	1687rpm
THRTL POS SEN	0.94V
B/FUEL SCHDL	3.6msec

SEF162V

■ RR O2 SENSOR P0138 ■ <input type="checkbox"/>	
COND1:	COMPLETED
COND2:	COMPLETED
COND3:	INCOMPLETE
----- MONITOR -----	
CMPS-RPM(REF)	1050rpm
THRTL POS SEN	0.51V
B/FUEL SCHDL	1.0msec

SEF163V

GI

MA

EM

LC

EC

FE

CL

MT

AT

FA

RA

BR

ST

RS

BT

HA

EL

IDX

TROUBLE DIAGNOSIS FOR DTC P0138

Rear Heated Oxygen Sensor (Max. Voltage Monitoring) (Rear HO2S) (Cont'd)

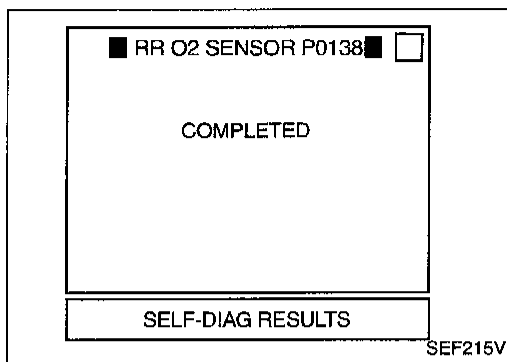

NOTE:

If "COMPLETED" already appears at "COND3" on CONSULT screen before "Procedure for COND3" is conducted, it is unnecessary to conduct step 10).

Procedure for COND3

- 10) Stop vehicle and let it idle until "INCOMPLETE" of "COND3" on CONSULT screen has turned to "COMPLETED". (It will take a maximum of approximately 6 minutes.)
- 11) Make sure that "OK" is displayed after touching "SELF-DIAG RESULTS".
If "NG" is displayed, refer to "DIAGNOSTIC PROCEDURE", EC-210.

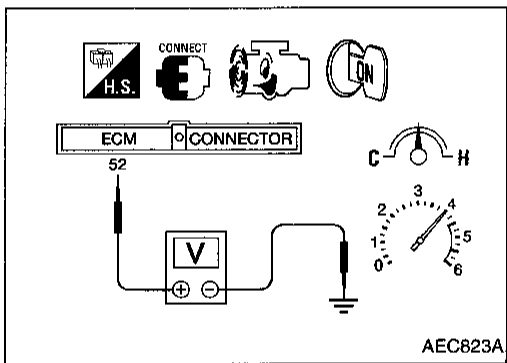

OR

OVERALL FUNCTION CHECK

Use this procedure to check the overall function of the rear heated oxygen sensor circuit. During this check, a 1st trip DTC might not be confirmed.



- 1) Start engine and drive vehicle at a speed of more than 70 km/h (43 MPH) for 2 consecutive minutes
- 2) Stop vehicle with engine running.
- 3) Set voltmeter probes between ECM terminal 52 (sensor signal) and engine ground.
- 4) Check the voltage when revving engine up to 4,000 rpm under no load at least 10 times.
(Depress and release accelerator pedal as soon as possible.)
The voltage should be above 0.48V at least once during this procedure.
If the voltage can be confirmed in step 4, step 5 is not necessary.
- 5) Keep vehicle idling for 10 minutes, then check the voltage. Or check the voltage when coasting from 80 km/h (50 MPH) in 3rd gear position (M/T), D position with "O/D" OFF (A/T).
The voltage should be above 0.48V at least once during this procedure.
- 6) If NG, go to "DIAGNOSTIC PROCEDURE", EC-210.

TROUBLE DIAGNOSIS FOR DTC P0138

Rear Heated Oxygen Sensor (Max. Voltage Monitoring) (Rear HO2S) (Cont'd)

EC-RRO2-01

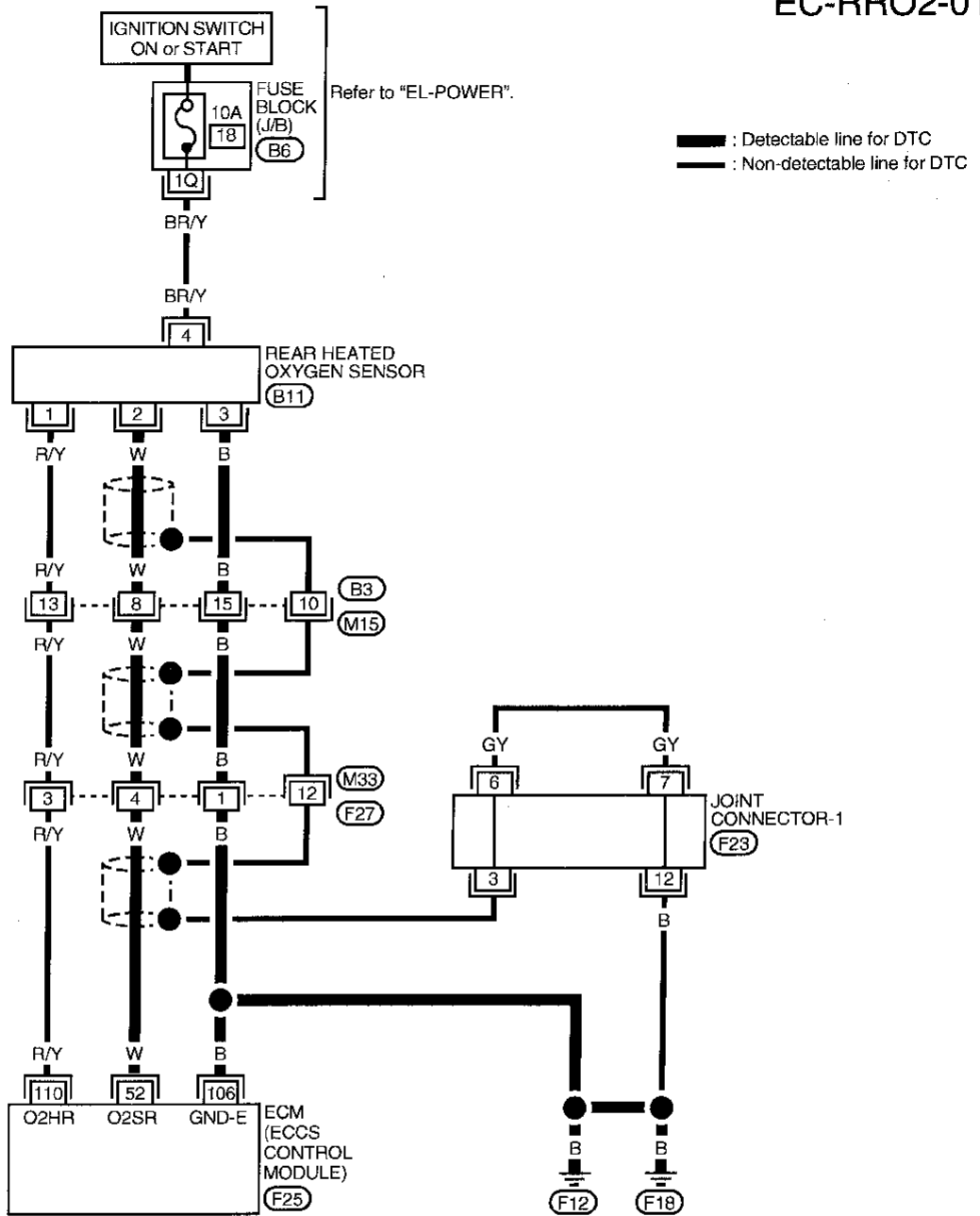

Refer to last page (Foldout page).

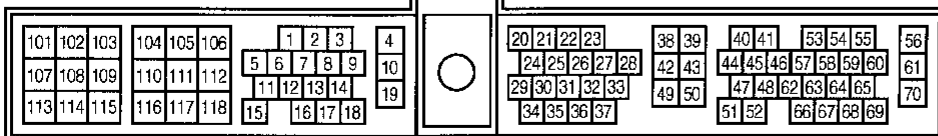
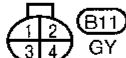
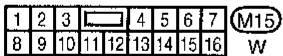

- CI
- MA
- EM
- LC
- EC**
- FE
- CL
- MT
- AT
- FA
- RA
- BR
- ST
- RS
- BT
- HA
- EL
- IDX

TROUBLE DIAGNOSIS FOR DTC P0138

Rear Heated Oxygen Sensor (Max. Voltage Monitoring) (Rear HO2S) (Cont'd)

DIAGNOSTIC PROCEDURE

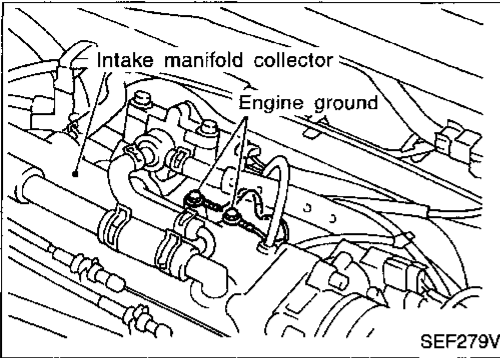

INSPECTION START

1. Turn ignition switch "OFF".
2. Loosen and retighten engine ground screws.

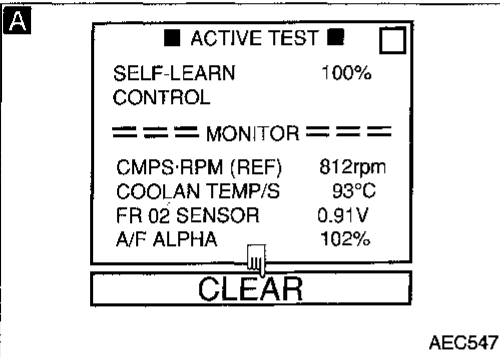

A

- #### CLEAR THE SELF-LEARNING DATA
1. Start engine and warm it up to normal operating temperature.
 2. Select "SELF-LEARNING CONT" in "ACTIVE TEST" mode with CONSULT.
 3. Clear the self-learning control coefficient by touching "CLEAR".
 4. Run engine for at least 10 minutes at idle speed.
- Is the 1st trip DTC P0171 detected? Is it difficult to start engine?**

Yes → Go to "TROUBLE DIAGNOSIS FOR DTC P0171", EC-230.

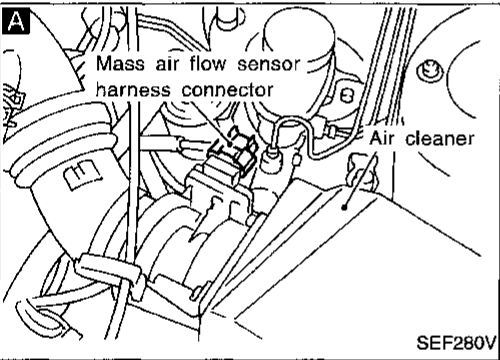

- OR
2. Turn ignition switch "OFF".
 3. Disconnect mass air flow sensor harness connector, and restart and run engine for at least 3 seconds at idle speed.
 4. Stop engine and reconnect mass air flow sensor harness connector.
 5. Make sure diagnostic trouble code No. 0102 is displayed in Diagnostic Test Mode II.
 6. Erase the diagnostic test mode II (Self-diagnostic results) memory. Make sure diagnostic trouble code No. 0505 is displayed in Diagnostic Test Mode II.
 7. Run engine for at least 10 minutes at idle speed.
- Is the 1st trip DTC 0115 detected? Is it difficult to start engine?**

No

A

(Go to next page.)

TROUBLE DIAGNOSIS FOR DTC P0138

Rear Heated Oxygen Sensor (Max. Voltage Monitoring) (Rear HO2S) (Cont'd)

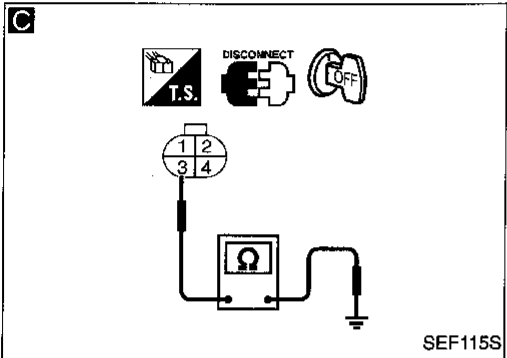
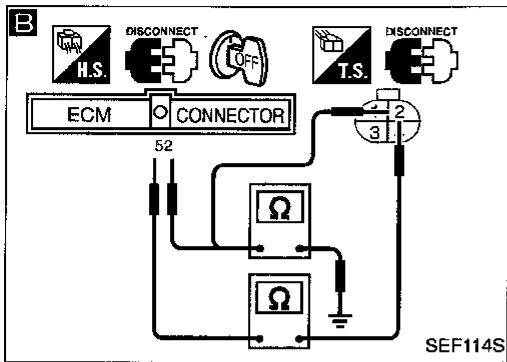

B

CHECK INPUT SIGNAL CIRCUIT.

1. Disconnect rear heated oxygen sensor harness connector and ECM harness connector.
2. Check harness continuity between ECM terminal (52) and terminal (2).
Continuity should exist.
3. Check harness continuity between ECM terminal (52) (or terminal (2)) and ground.
Continuity should not exist.
If OK, check harness for short to ground and short to power.

NG

Check the following.

- Harness connectors (B3), (M15)
- Harness connectors (M33), (F27)

If NG, repair open circuit or short to ground or short to power in harness or connectors.

OK

C

CHECK GROUND CIRCUIT.

Check harness continuity between terminal (3) and engine ground.
Continuity should exist.
If OK, check harness for short to ground and short to power.

NG

Check the following.

- Harness connectors (B3), (M15)
- Harness connectors (M33), (F27)
- Harness for open or short between rear heated oxygen sensor and engine ground

If NG, repair open circuit or short to ground or short to power in harness or connectors.

OK

CHECK COMPONENT
(Rear heated oxygen sensor).
Refer to "COMPONENT INSPECTION" on next page.

NG

Replace rear heated oxygen sensor.

OK

CHECK SHIELD CIRCUIT

1. Reconnect harness connectors disconnected.
2. Disconnect harness connectors (B3), (M15).
3. Check harness continuity between terminal (10) and engine ground.
Continuity should exist.
If OK, check harness for short to ground and short to power. Then reconnect harness connectors.

NG

DETECT MALFUNCTIONING PART.

Check the following.

- Harness connectors (F27), (M33)
- Harness connectors (B3), (M15)
- Joint connector-1 (Refer to "HARNES LAYOUT" in EL section.)
- Harness for open or short between harness connector (M15) and engine ground

If NG, repair open circuit, short to ground or short to power in harness or connectors.

OK

Perform "TROUBLE DIAGNOSIS FOR INTERMITTENT INCIDENT", EC-106.

INSPECTION END

GI
MA
EM
LC
EC
FE
CL
MT
AT
FA
RA
BR
ST
RS
BT
HA
EL
IDX

TROUBLE DIAGNOSIS FOR DTC P0138

Rear Heated Oxygen Sensor (Max. Voltage Monitoring) (Rear HO2S) (Cont'd)

COMPONENT INSPECTION

Rear heated oxygen sensor

- 1) Start engine and drive vehicle at a speed of more than 70 km/h (43 MPH) for 2 consecutive minutes.
- 2) Stop vehicle with engine running.
- 3) Select "FUEL INJECTION" in "ACTIVE TEST" mode, and select "RR O2 SENSOR" as the monitor item with CONSULT.
- 4) Check "RR O2 SENSOR" at idle speed when adjusting "FUEL INJECTION" to $\pm 25\%$.
 "RR O2 SENSOR" should be above 0.48V at least once when the "FUEL INJECTION" is +25%.
 "RR O2 SENSOR" should be below 0.43V at least once when the "FUEL INJECTION" is -25%.

CAUTION:

Discard any heated oxygen sensor which has been dropped from a height of more than 0.5 m (19.7 in) onto a hard surface such as a concrete floor; use a new one.

OR

- 1) Start engine and drive vehicle at a speed of more than 70 km/h (43 MPH) for 2 consecutive minutes.
- 2) Stop vehicle with engine running.
- 3) Set voltmeter probes between ECM terminal ⑤2 (sensor signal) and engine ground.
- 4) Check the voltage when revving up to 4,000 rpm under no load at least 10 times.
 (Depress and release accelerator pedal as soon as possible.)
The voltage should be above 0.48V at least once. If the voltage is above 0.48V at step 4, step 5 is not necessary.
- 5) Check the voltage when revving up to 6,000 rpm under no load. Or keep vehicle idling for 10 minutes, then check the voltage. Or check the voltage when coasting from 80 km/h (50 MPH) in 3rd gear position (M/T), D position with "O/D" OFF (A/T).
The voltage should be below 0.43V at least once.

CAUTION:

Discard any heated oxygen sensor which has been dropped from a height of more than 0.5 m (19.7 in) onto a hard surface such as a concrete floor; use a new one.

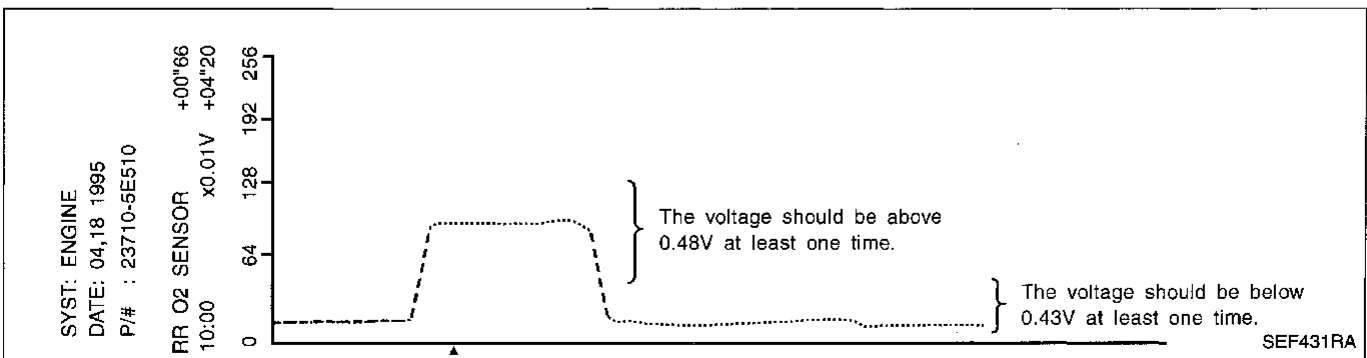
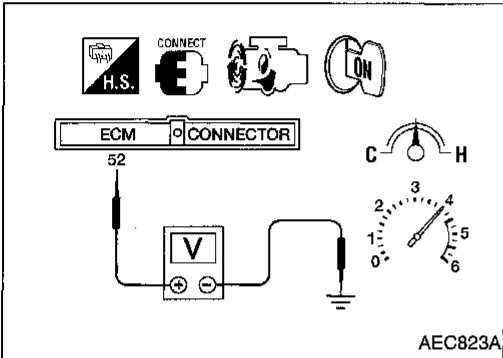
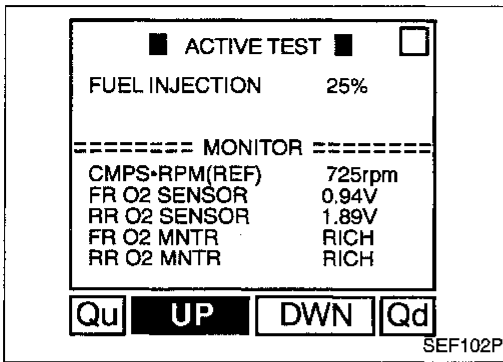

TROUBLE DIAGNOSIS FOR DTC P0139

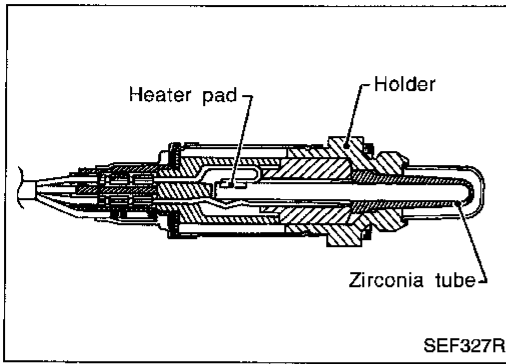

Rear Heated Oxygen Sensor (Response Monitoring) (Rear HO2S)

COMPONENT DESCRIPTION

The rear heated oxygen sensor (Rear HO2S), after three way catalyst, monitors the oxygen level in the exhaust gas.

Even if switching characteristics of the front heated oxygen sensor are shifted, the air fuel ratio is controlled to stoichiometric, by the signal from the rear heated oxygen sensor.

This sensor is made of ceramic zirconia. The zirconia generates voltage from approximately 1V in richer conditions to 0V in leaner conditions.

Under normal conditions the rear heated oxygen sensor is not used for engine control operation.

CONSULT REFERENCE VALUE IN DATA MONITOR MODE

Specification data are reference values.

MONITOR ITEM	CONDITION	SPECIFICATION
RR O2 SENSOR	● Engine: After warming up Revsing engine from idle to 3,000 rpm	0 - 0.3V ↔ Approx. 0.6 - 1.0V
RR O2 MNTR		LEAN ↔ RICH

ECM TERMINALS AND REFERENCE VALUE

Specification data are reference values and are measured between each terminal and engine ground.

TER-MINAL NO.	WIRE COLOR	ITEM	CONDITION	DATA (DC voltage)
52	W	Rear heated oxygen sensor	Engine is running. After warming up to normal operating temperature and revving engine from idle to 2,000 rpm	0 - Approximately 1.0V

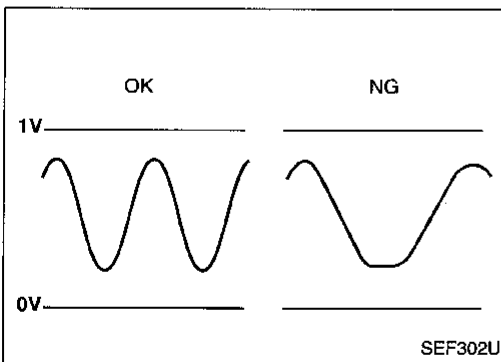

ON BOARD DIAGNOSIS LOGIC

The rear heated oxygen sensor has a much longer switching time between rich and lean than the front heated oxygen sensor. The oxygen storage capacity before the three way catalyst causes the longer switching time. To judge the malfunctions of the rear heated oxygen sensor, ECM monitors whether the switching response of the sensor's voltage is faster than specified during various driving conditions such as fuel-cut.

Diagnostic Trouble Code No.	Malfunction is detected when ...	Check Items (Possible Cause)
P0139 0707	● It takes more than the specified time for the sensor to respond between rich and lean.	<ul style="list-style-type: none"> ● Harness or connectors (The sensor circuit is open or shorted.) ● Rear heated oxygen sensor ● Fuel pressure ● Injectors ● Intake air leaks

TROUBLE DIAGNOSIS FOR DTC P0139

Rear Heated Oxygen Sensor (Response Monitoring) (Rear HO2S) (Cont'd)

DIAGNOSTIC TROUBLE CODE CONFIRMATION PROCEDURE

CAUTION:

Always drive vehicle at a safe speed.

NOTE:

- "COMPLETED" will appear on CONSULT screen when all tests "COND1", "COND2" and "COND3" are completed.
- If "DIAGNOSTIC TROUBLE CODE CONFIRMATION PROCEDURE" has been previously conducted, always turn ignition switch "OFF" and wait at least 5 seconds before conducting the next test.

TESTING CONDITION:

Never stop engine during this procedure. If the engine is stopped, retry this procedure from step 2).



Procedure for COND1

- 1) Start engine and warm it up to normal operating temperature.
- 2) Turn ignition switch "OFF" and wait at least 5 seconds.
- 3) Turn ignition switch "ON" and select "RR O2 SENSOR P0139" of "REAR O2 SENSOR" in "DTC WORK SUPPORT" mode with CONSULT.
- 4) Touch "START".
- 5) Start engine and let it idle for at least 30 seconds.
- 6) Rev engine up to 2,000 rpm 2 or 3 times quickly under no load.

If "COMPLETED" appears on CONSULT screen, go to step 11).

If "COMPLETED" does not appear on CONSULT screen, go to the following step.

- 7) Drive vehicle at a speed of more than 70 km/h (43 MPH) for 2 consecutive minutes.
- 8) When the following conditions are met, "TESTING" will be displayed at "COND1" on the CONSULT screen. Maintain the conditions continuously until "TESTING" changes to "COMPLETED". (It will take approximately 30 seconds.)

CMPS-RPM (REF): 1,400 - 3,400 rpm (A/T)

1,400 - 3,500 rpm (M/T)

Vehicle speed: 64 - 120 km/h (40 - 75 MPH)

B/FUEL SCHDL: 0.5 - 3.9 msec

Selector lever: Suitable position

NOTE:

- If "TESTING" is not displayed after 5 minutes, retry from step 2).
- If "COMPLETED" already appears at "COND2" on CONSULT screen before "Procedure for COND2" is conducted, it is unnecessary to conduct step 9).

Procedure for COND2

- 9) While driving, release accelerator pedal completely with "O/D" OFF (A/T models only) from the above condition [step 8] until "INCOMPLETE" at "COND2" on CONSULT screen has turned to "COMPLETED". (It will take approximately 4 seconds.)

■ RR O2 SENSOR P0139 ■ <input type="checkbox"/>	
COND1: OUT OF COND	
COND2: INCOMPLETE	
COND3: INCOMPLETE	
----- MONITOR -----	
CMPS-RPM(REF)	912rpm
THRTL POS SEN	0.51V
B/FUEL SCHDL	1.0msec

SEF164V

■ RR O2 SENSOR P0139 ■ <input type="checkbox"/>	
COND1: TESTING	
COND2: INCOMPLETE	
COND3: INCOMPLETE	
----- MONITOR -----	
CMPS-RPM(REF)	1687rpm
THRTL POS SEN	0.94V
B/FUEL SCHDL	3.6msec

SEF165V

■ RR O2 SENSOR P0139 ■ <input type="checkbox"/>	
COND1: COMPLETED	
COND2: INCOMPLETE	
COND3: INCOMPLETE	
----- MONITOR -----	
CMPS-RPM(REF)	1687rpm
THRTL POS SEN	0.94V
B/FUEL SCHDL	3.6msec

SEF166V

■ RR O2 SENSOR P0139 ■ <input type="checkbox"/>	
COND1: COMPLETED	
COND2: COMPLETED	
COND3: INCOMPLETE	
----- MONITOR -----	
CMPS-RPM(REF)	1050rpm
THRTL POS SEN	0.51V
B/FUEL SCHDL	1.0msec

SEF167V

TROUBLE DIAGNOSIS FOR DTC P0139

Rear Heated Oxygen Sensor (Response Monitoring) (Rear HO2S) (Cont'd)

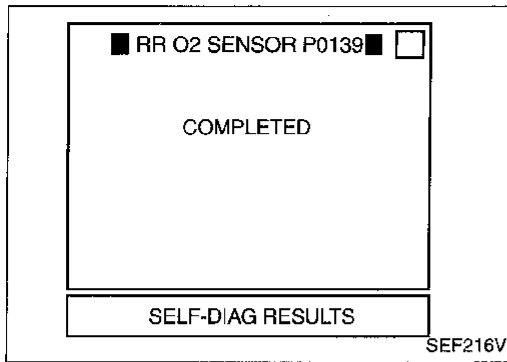

NOTE:

If "COMPLETED" already appears at "COND3" on CONSULT screen before "Procedure for COND3" is conducted, it is unnecessary to conduct step 10).

Procedure for COND3

- 10) Stop vehicle and let it idle until "INCOMPLETE" of "COND3" on CONSULT screen has turned to "COMPLETED". (It will take a maximum of approximately 6 minutes.)
- 11) Make sure that "OK" is displayed after touching "SELF-DIAG RESULTS".
If "NG" is displayed, refer to "DIAGNOSTIC PROCEDURE", EC-217.

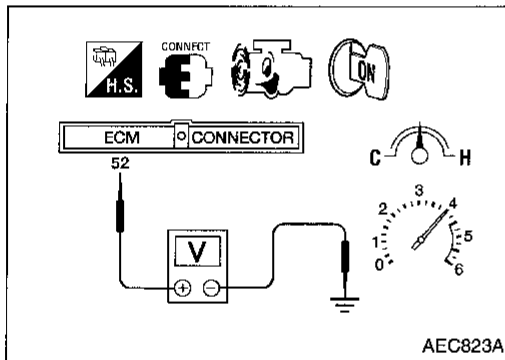

OR OVERALL FUNCTION CHECK

Use this procedure to check the overall function of the rear heated oxygen sensor circuit. During this check, a 1st trip DTC might not be confirmed.

- 1) Start engine and drive vehicle at a speed of more than 70 km/h (43 MPH) for 2 consecutive minutes.
- 2) Stop vehicle with engine running.
- 3) Set voltmeter probes between ECM terminal ⑤2 (sensor signal) and engine ground.
- 4) Check the voltage when revving up to 4,000 rpm under no load at least 10 times.
(Depress and release accelerator pedal as soon as possible.)

The voltage should change at more than 0.06V for 1 second during this procedure.

If the voltage can be confirmed in step 4, step 5 is not necessary.

- 5) Keep vehicle idling for 10 minutes, then check the voltage. Or check the voltage when coasting from 80 km/h (50 MPH) in 3rd gear position (M/T), D position with "O/D" OFF (A/T).
The voltage should change at more than 0.06V for 1 second during this procedure.
- 6) If NG, go to "DIAGNOSTIC PROCEDURE", EC-217.

TROUBLE DIAGNOSIS FOR DTC P0139

Rear Heated Oxygen Sensor (Response Monitoring) (Rear HO2S) (Cont'd)

EC-RRO2-01

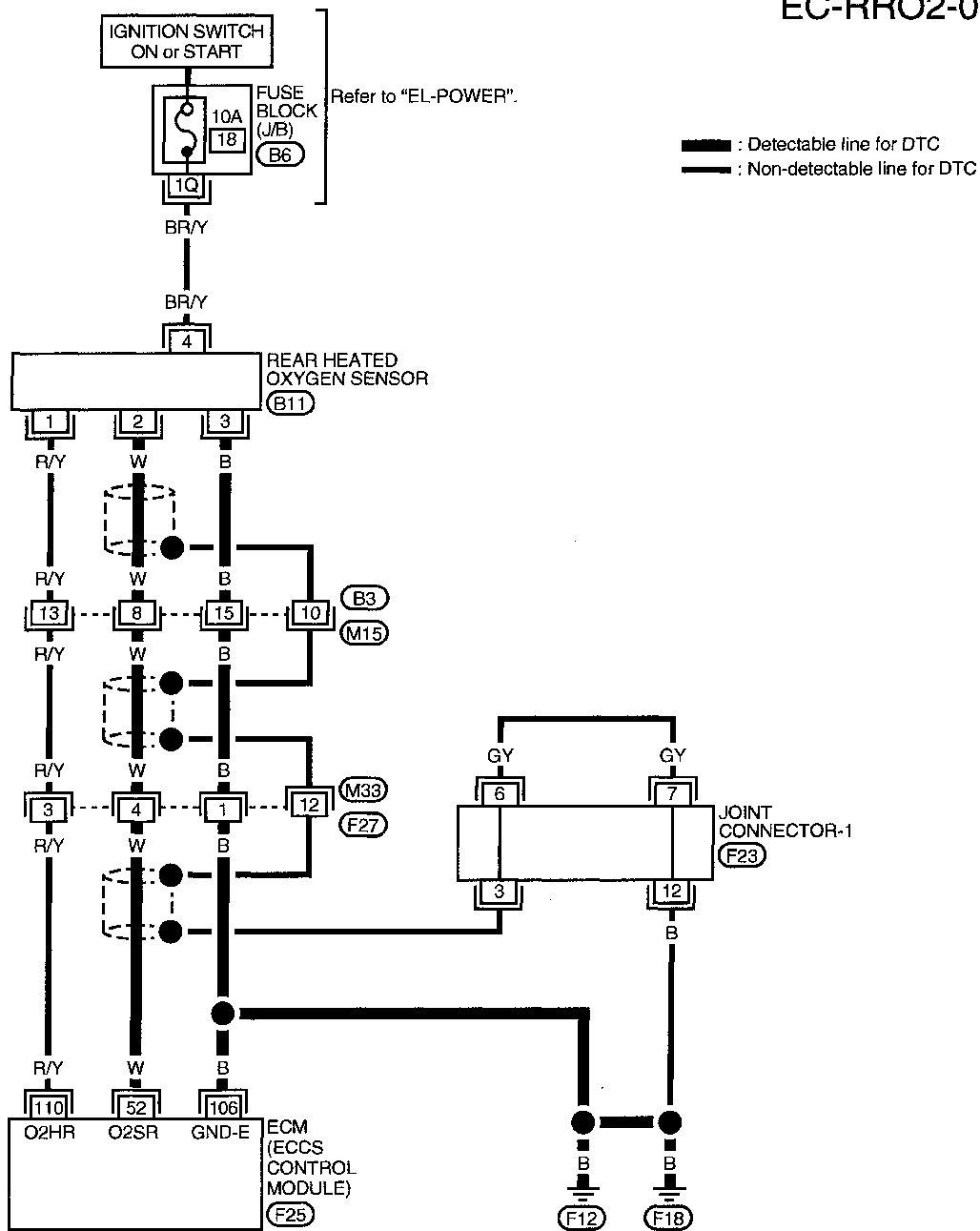

1	2	3	4	5	6	7	(M15)		
8	9	10	11	12	13	14	15	16	W

1	2	3	4	5	6	7	8	(M33)				
9	10	11	12	13	14	15	16	17	18	19	20	W

1Q	2Q	3Q	4Q	6Q	(B6)		
6Q	7Q	8Q	9Q	10Q	11Q	12Q	W

1	2	(B11)
3	4	GY

(F25)	H.S.
W	

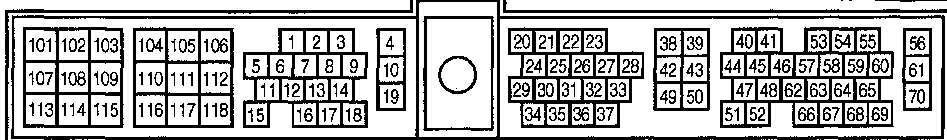

Refer to last page (Foldout page).

(F23)

TROUBLE DIAGNOSIS FOR DTC P0139

Rear Heated Oxygen Sensor (Response Monitoring) (Rear HO2S) (Cont'd) DIAGNOSTIC PROCEDURE

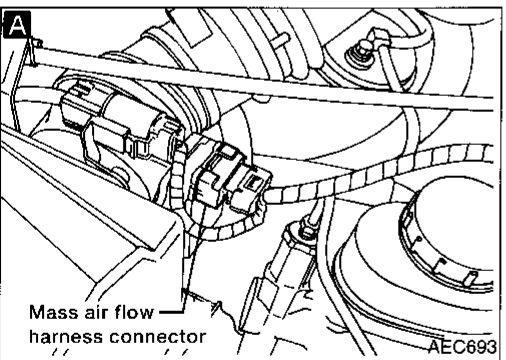
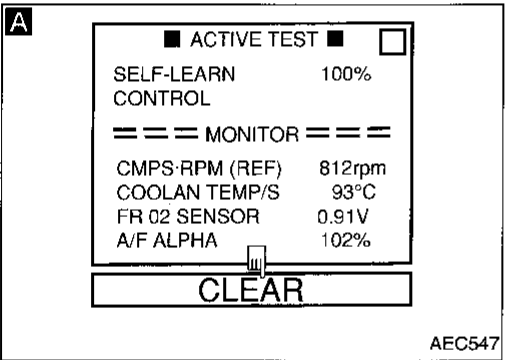
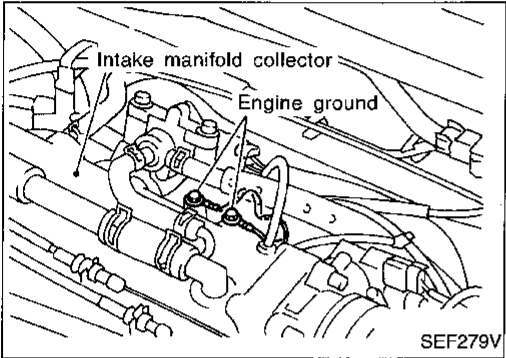
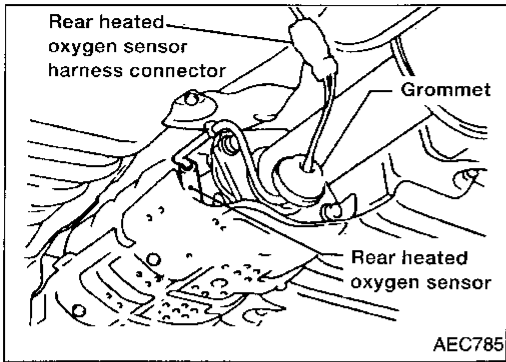

INSPECTION START

1. Turn ignition switch "OFF".
2. Loosen and retighten engine ground screws.

A

CLEAR THE SELF-LEARNING DATA

1. Start engine and warm it up to normal operating temperature.
2. Select "SELF-LEARNING CONT" in "ACTIVE TEST" mode with CONSULT.
3. Clear the self-learning control coefficient by touching "CLEAR".
4. Run engine for at least 10 minutes at idle speed.

Is the 1st trip DTC P0171 or P0172 detected? Is it difficult to start engine?

Yes → Go to "TROUBLE DIAGNOSIS FOR DTC P0171, P0172", EC-230, 236.

OR

2. Turn ignition switch "OFF".
 3. Disconnect mass air flow sensor harness connector, and restart and run engine for at least 3 seconds at idle speed.
 4. Stop engine and reconnect mass air flow sensor harness connector.
 5. Make sure diagnostic trouble code No. 0102 is displayed in Diagnostic Test Mode II.
 6. Erase the diagnostic test mode II (Self-diagnostic results) memory. Make sure diagnostic trouble code No. 0505 is displayed in Diagnostic Test Mode II.
 7. Run engine for at least 10 minutes at idle speed.
- Is the 1st trip DTC 0114 or 0115 detected? Is it difficult to start engine?**

No
A
 (Got to next page.)

GI
 MA
 EM
 LC
EC
 FE
 CL
 MT
 AT
 FA
 RA
 BR
 ST
 RS
 BT
 HA
 EL
 IDX

TROUBLE DIAGNOSIS FOR DTC P0139

Rear Heated Oxygen Sensor (Response Monitoring) (Rear HO2S) (Cont'd)

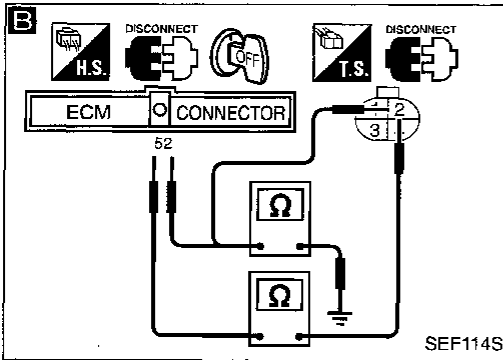

SEF114S

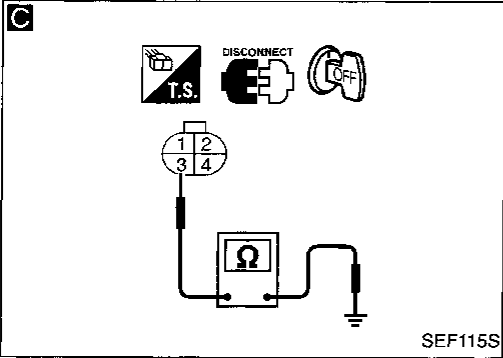

SEF115S

B

CHECK INPUT SIGNAL CIRCUIT.

1. Disconnect rear heated oxygen sensor RH harness connector and ECM harness connector.
2. Check harness continuity between ECM terminal (52) and terminal (2).
Continuity should exist.
3. Check harness continuity between ECM terminal (52) (or terminal (2)) and ground.
Continuity should not exist.
If OK, check harness for short to ground and short to power.

NG

Check the following.

- Harness connectors (B3), (M15)
- Harness connectors (M33), (F27)
- Harness for open or short between rear heated oxygen sensor and ECM

If NG, repair open circuit or short to ground or short to power in harness or connectors.

C

CHECK GROUND CIRCUIT.

Check harness continuity between terminal (3) and engine ground.
Continuity should exist.
If OK, check harness for short to ground and short to power.

NG

Check the following.

- Harness connectors (B3), (M15)
- Harness connectors (M33), (F27)
- Harness for open or short between rear heated oxygen sensor and engine ground

If NG, repair open circuit or short to ground or short to power in harness or connectors.

CHECK COMPONENT
(Rear heated oxygen sensor).
Refer to "COMPONENT INSPECTION" on next page.

NG

Replace rear heated oxygen sensor.

CHECK SHIELD CIRCUIT

1. Reconnect harness connectors disconnected.
2. Disconnect harness connectors (B3), (M15).
3. Check harness continuity between terminal (10) and engine ground.
Continuity should exist.
If OK, check harness for short to ground and short to power. Then reconnect harness connectors.

NG

DETECT MALFUNCTIONING PART.

Check the following.

- Harness connectors (F27), (M33)
- Harness connectors (B3), (M15)
- Joint connector-1 (Refer to "HARNES LAYOUT" in EL section.)
- Harness for open or short between harness connector (M15) and engine ground

If NG, repair open circuit, short to ground or short to power in harness or connectors.

Perform "TROUBLE DIAGNOSIS FOR INTERMITTENT INCIDENT", EC-106.

INSPECTION END

TROUBLE DIAGNOSIS FOR DTC P0139

Rear Heated Oxygen Sensor (Response Monitoring) (Rear HO2S) (Cont'd)

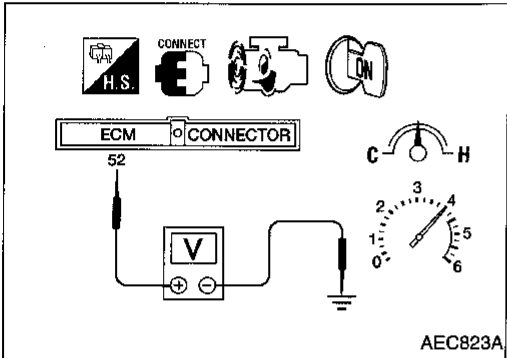
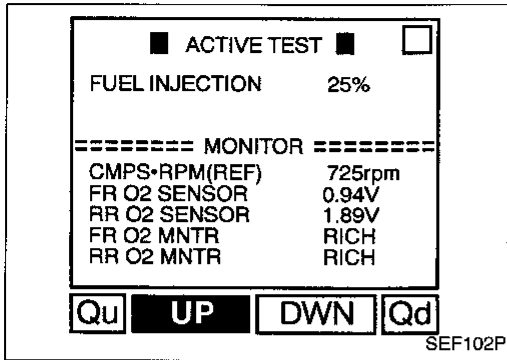

COMPONENT INSPECTION

Rear heated oxygen sensor

- 1) Start engine and drive vehicle at a speed of more than 70 km/h (43 MPH) for 2 consecutive minutes.
- 2) Stop vehicle with engine running.
- 3) Select "FUEL INJECTION" in "ACTIVE TEST" mode, and select "RR O2 SENSOR" as the monitor item with CONSULT.
- 4) Check "RR O2 SENSOR" at idle speed when adjusting "FUEL INJECTION" to $\pm 25\%$.
 "RR O2 SENSOR" should be above 0.48V at least once when the "FUEL INJECTION" is +25%.
 "RR O2 SENSOR" should be below 0.43V at least once when the "FUEL INJECTION" is -25%.

CAUTION:

Discard any heated oxygen sensor which has been dropped from a height of more than 0.5 m (19.7 in) onto a hard surface such as a concrete floor; use a new one.



- 1) Start engine and drive vehicle at a speed of more than 70 km/h (43 MPH) for 2 consecutive minutes.
- 2) Stop vehicle with engine running.
- 3) Set voltmeter probes between ECM terminal ⑤2 (sensor signal) and engine ground.
- 4) Check the voltage when revving up to 4,000 rpm under no load at least 10 times.
(Depress and release accelerator pedal as soon as possible.)
 The voltage should be above 0.48V at least once. If the voltage is above 0.48V at step 4, step 5 is not necessary.
- 5) Check the voltage when revving up to 6,000 rpm under no load. Or keep vehicle idling for 10 minutes, then check the voltage. Or check the voltage when coasting from 80 km/h (50 MPH) in 3rd gear position (M/T), D position with "O/D" OFF (A/T).
 The voltage should be below 0.43V at least once.

CAUTION:

Discard any heated oxygen sensor which has been dropped from a height of more than 0.5 m (19.7 in) onto a hard surface such as a concrete floor; use a new one.

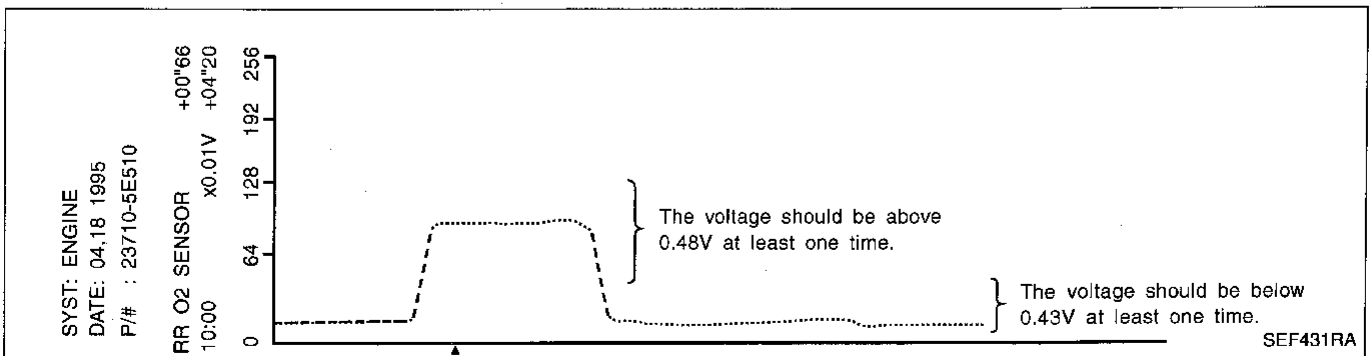

TROUBLE DIAGNOSIS FOR DTC P0140

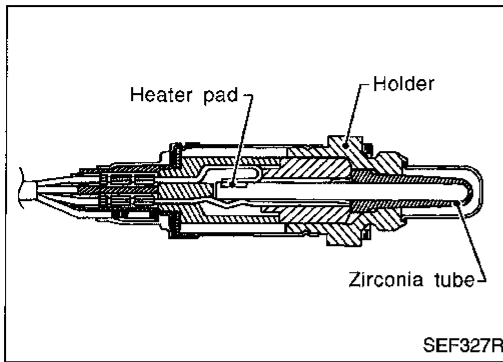

Rear Heated Oxygen Sensor (High Voltage) (Rear HO2S)

COMPONENT DESCRIPTION

The rear heated oxygen sensor (Rear HO2S), after three way catalyst, monitors the oxygen level in the exhaust gas.

Even if switching characteristics of the front heated oxygen sensor are shifted, the air fuel ratio is controlled to stoichiometric, by the signal from the rear heated oxygen sensor.

This sensor is made of ceramic zirconia. The zirconia generates voltage from approximately 1V in richer conditions to 0V in leaner conditions.

Under normal conditions the rear heated oxygen sensor is not used for engine control operation.

CONSULT REFERENCE VALUE IN DATA MONITOR MODE

Specification data are reference values.

MONITOR ITEM	CONDITION		SPECIFICATION
RR O2 SENSOR	● Engine: After warming up	Revving engine from idle to 3,000 rpm	0 - 0.3V ↔ Approx. 0.6 - 1.0V
RR O2 MNTR			LEAN ↔ RICH

ECM TERMINALS AND REFERENCE VALUE

Specification data are reference values and are measured between each terminal and engine ground.

TER-MINAL NO.	WIRE COLOR	ITEM	CONDITION	DATA (DC voltage)
52	W	Rear heated oxygen sensor	Engine is running. After warming up to normal operating temperature and revving engine from idle to 2,000 rpm	0 - Approximately 1.0V

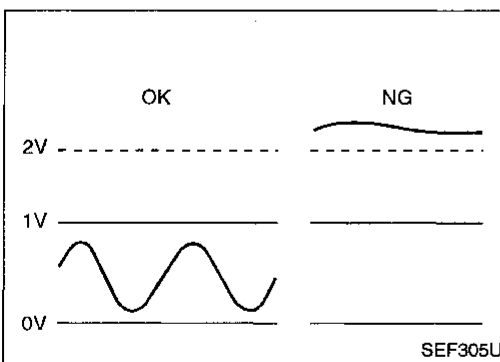

ON BOARD DIAGNOSIS LOGIC

The rear heated oxygen sensor has a much longer switching time between rich and lean than the front heated oxygen sensor. The oxygen storage capacity before the three way catalyst causes the longer switching time. To judge the malfunctions of the rear heated oxygen sensor, ECM monitors whether or not the voltage is too high during various driving conditions such as fuel-cut.

Diagnostic Trouble Code No.	Malfunction is detected when ...	Check Items (Possible Cause)
P0140 0512	● An excessively high voltage from the sensor is sent to ECM.	● Harness or connectors (The sensor circuit is open or shorted.) ● Rear heated oxygen sensor

TROUBLE DIAGNOSIS FOR DTC P0140

Rear Heated Oxygen Sensor (High Voltage) (Rear HO2S) (Cont'd)

☆ MONITOR	☆ NO FAIL	<input type="checkbox"/>
CMPS-RPM(REF)	2040rpm	
COOLAN TEMP/S	82°C	
VHCL SPEED SE	76km/h	
B/FUEL SCHDL	2.5msec	
RECORD		

SEF168V

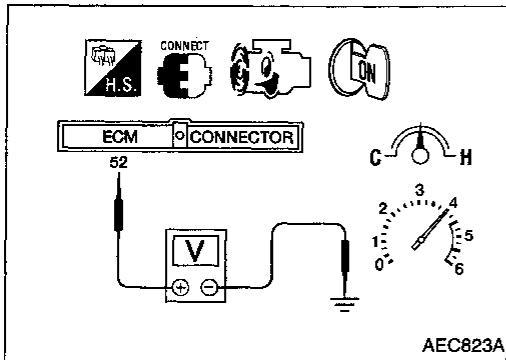

DIAGNOSTIC TROUBLE CODE CONFIRMATION PROCEDURE

NOTE:

If "DIAGNOSTIC TROUBLE CODE CONFIRMATION PROCEDURE" has been previously conducted, always turn ignition switch "OFF" and wait at least 5 seconds before conducting the next test.

- 1) Turn ignition switch "ON" and select "DATA MONITOR" mode with CONSULT.
- 2) Start engine and drive vehicle at a speed of more than 70 km/h (43 MPH) for 2 consecutive minutes.
- 3) Maintain the following conditions for at least 5 consecutive seconds.
 - CMPS-RPM (REF):** 1,400 - 3,400 rpm (A/T)
1,400 - 3,500 rpm (M/T)
 - VHCL SPEED SE:** 64 - 120 km/h (40 - 75 MPH)
 - B/FUEL SCHDL:** 0.5 - 3.9 msec
 - COOLAN TEMP/S:** 70 - 100°C (158 - 212°F)
 - Selector lever:** Suitable position
- 4) If 1st trip DTC is detected, go to "DIAGNOSTIC PROCEDURE", EC-223.

OR

OVERALL FUNCTION CHECK

Use this procedure to check the overall function of the rear heated oxygen sensor circuit. During this check, a 1st trip DTC might not be confirmed.

- 1) Start engine and warm it up to normal operating temperature.
- 2) Set voltmeter probes between ECM terminal 82 (sensor signal) and engine ground.
- 3) Check the voltage after revving up to 4,000 rpm under no load at least 10 times.
(Depress and release accelerator pedal as soon as possible.)
The voltage should be below 2V during this procedure.
- 4) If NG, go to "DIAGNOSTIC PROCEDURE", EC-223.

GI
 MA
 EM
 LC
 EC
 FE
 CL
 MT
 AT
 FA
 RA
 BR
 ST
 RS
 BT
 HA
 EL
 IDX

TROUBLE DIAGNOSIS FOR DTC P0140

Rear Heated Oxygen Sensor (High Voltage) (Rear HO2S) (Cont'd)

EC-RRO2-01

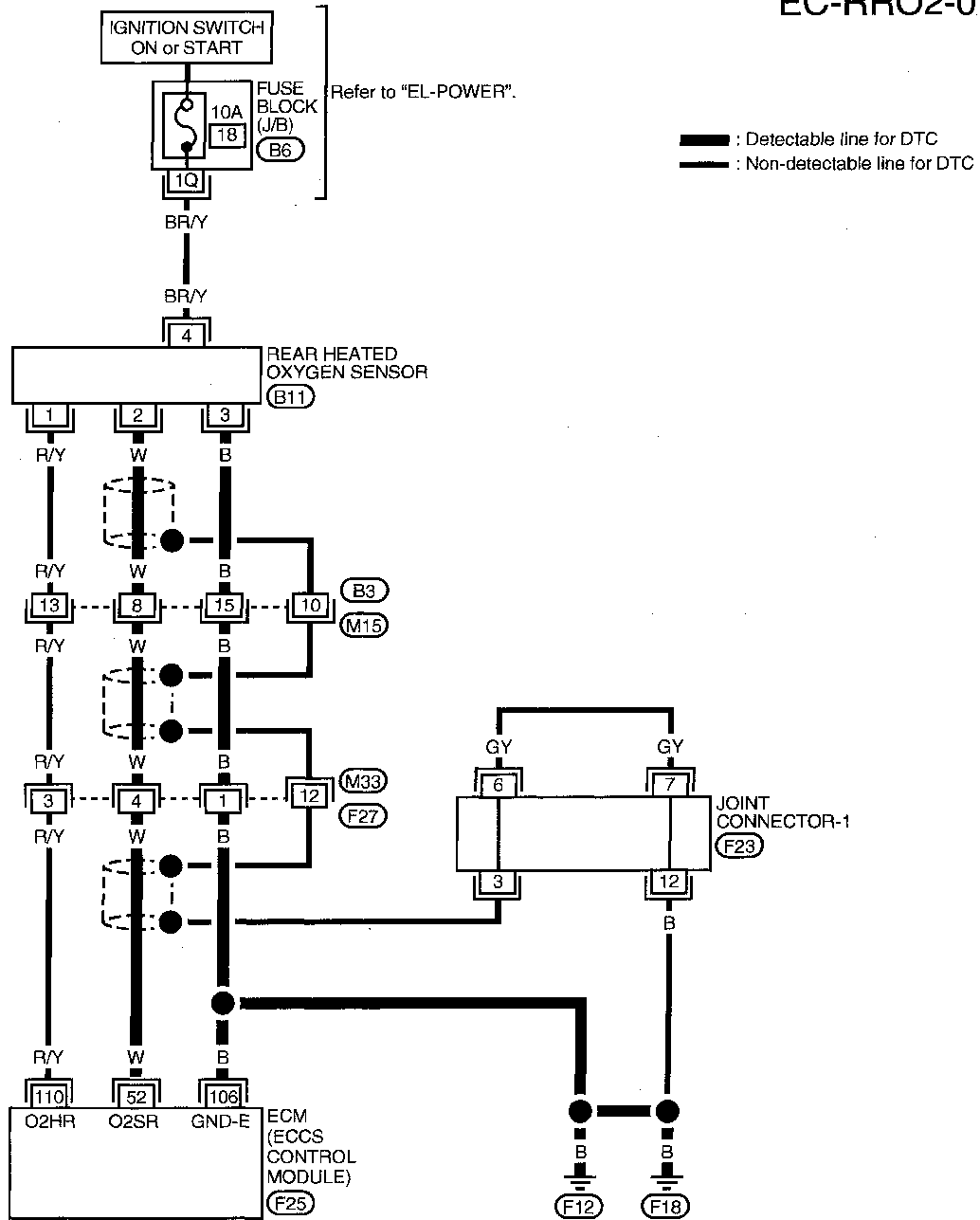

1	2	3	4	5	6	7	(M15)		
8	9	10	11	12	13	14	15	16	W

1	2	3	4	5	6	7	8	(M33)				
9	10	11	12	13	14	15	16	17	18	19	20	W

1Q	2Q	3Q	4Q	5Q	(B6)		
6Q	7Q	8Q	9Q	10Q	11Q	12Q	W

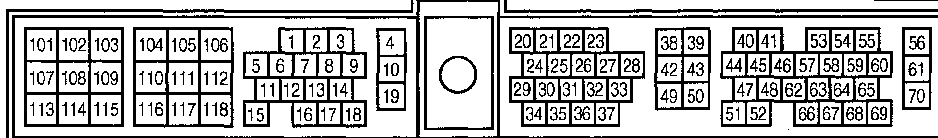

Refer to last page (Foldout page).
(F23)

TROUBLE DIAGNOSIS FOR DTC P0140

Rear Heated Oxygen Sensor (High Voltage) (Rear HO2S) (Cont'd) DIAGNOSTIC PROCEDURE

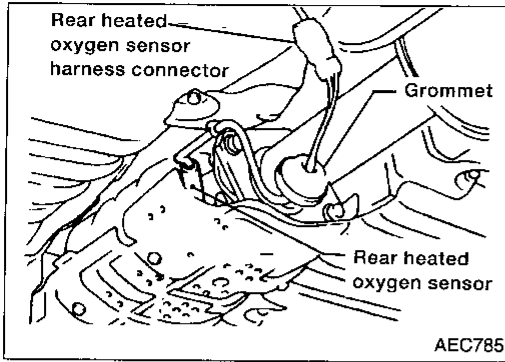

INSPECTION START

1. Turn ignition switch "OFF".
2. Loosen and retighten engine ground screws.

A

CHECK INPUT SIGNAL CIRCUIT.

1. Disconnect rear heated oxygen sensor RH harness connector and ECM harness connector.
2. Check harness continuity between ECM terminal 52 and terminal 2.
Continuity should exist.
3. Check harness continuity between ECM terminal 52 (or terminal 2) and ground.
Continuity should not exist.

If OK, check harness for short to ground and short to power.

- NG
- Check the following.
- Harness connectors B3, M15
 - Harness connectors M33, F27
- If NG, repair open circuit or short to ground or short to power in harness or connectors.

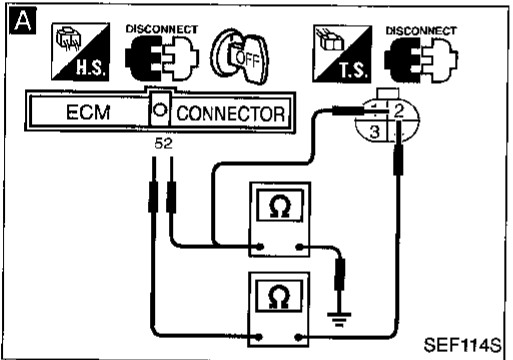
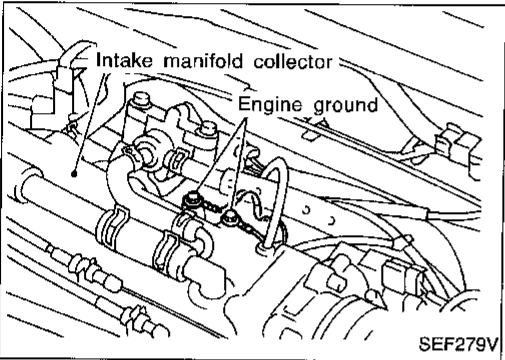

B

CHECK GROUND CIRCUIT.

Check harness continuity between terminal 3 and engine ground.
Continuity should exist.

If OK, check harness for short to ground and short to power.

- NG
- Check the following.
- Harness connectors B3, M15
 - Harness connectors M33, F27
 - Harness for open or short between rear heated oxygen sensor and engine ground
- If NG, repair open circuit or short to ground or short to power in harness or connectors.

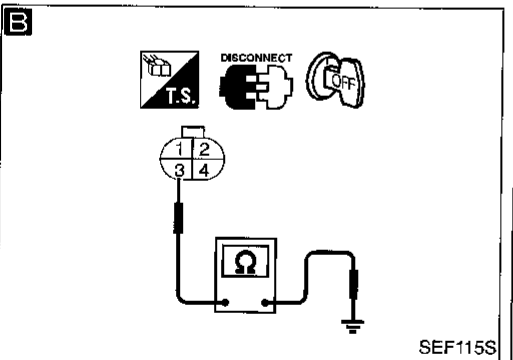

CHECK COMPONENT
(Rear heated oxygen sensor).

1. Turn ignition switch "OFF".
2. Disconnect sensor harness connector and check for water.
Water should not exist.

If OK, go to step 3.

3. Check rear heated oxygen sensor. Refer to "COMPONENT INSPECTION", EC-225.

- NG
- Repair or replace harness and/or connectors or replace rear heated oxygen sensor.

OK

A

(Go to next page.)

GI
MA
EM
LC
EC
FE
CL
MT
AT
FA
RA
BR
ST
RS
BT
HA
EL
IDX

TROUBLE DIAGNOSIS FOR DTC P0140

Rear Heated Oxygen Sensor (High Voltage) (Rear HO2S) (Cont'd)

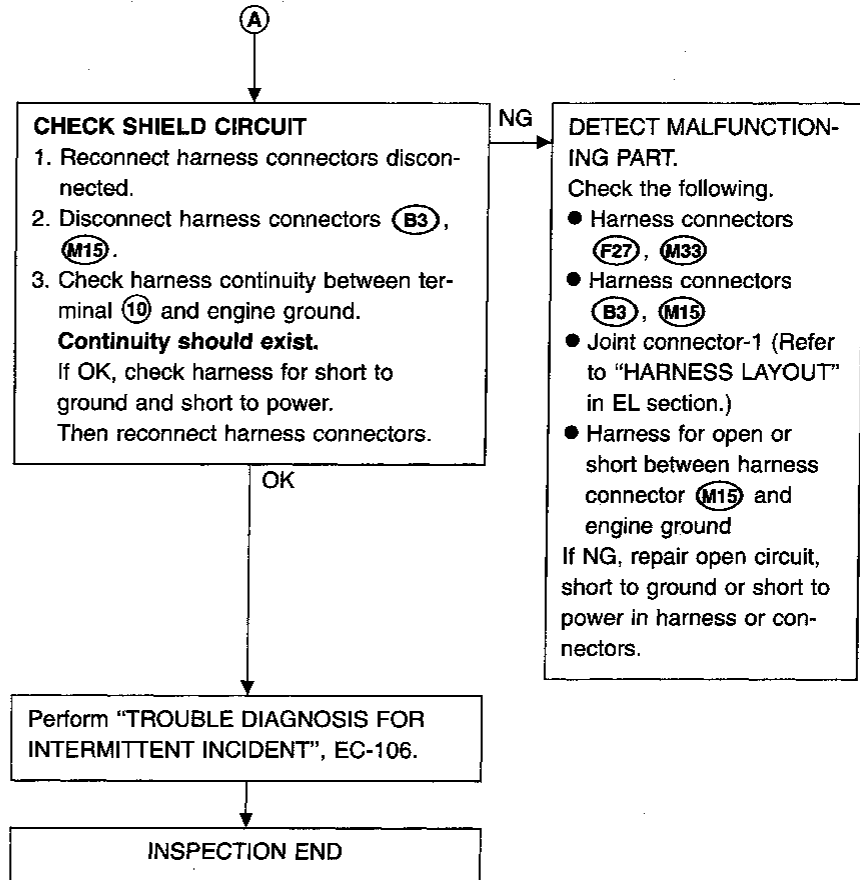

TROUBLE DIAGNOSIS FOR DTC P0140

Rear Heated Oxygen Sensor (High Voltage) (Rear HO2S) (Cont'd)

■ ACTIVE TEST ■	
FUEL INJECTION	25%
----- MONITOR -----	
CMPS•RPM(REF)	725rpm
FR O2 SENSOR	0.94V
RR O2 SENSOR	1.89V
FR O2 MNTR	RICH
RR O2 MNTR	RICH
Qu	UP
DWN	Qd

SEF102P

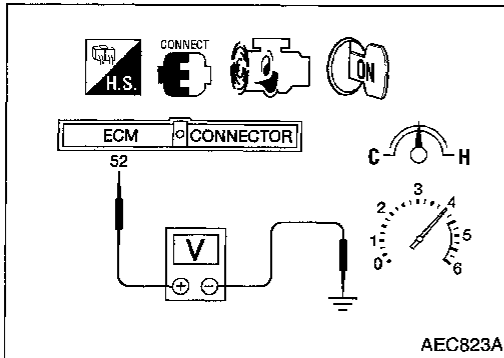

COMPONENT INSPECTION

Rear heated oxygen sensor

- 1) Start engine and drive vehicle at a speed of more than 70 km/h (43 MPH) for 2 consecutive minutes.
- 2) Stop vehicle with engine running.
- 3) Select "FUEL INJECTION" in "ACTIVE TEST" mode, and select "RR O2 SENSOR" as the monitor item with CONSULT.
- 4) Check "RR O2 SENSOR" at idle speed when adjusting "FUEL INJECTION" to $\pm 25\%$.
 "RR O2 SENSOR" should be above 0.48V at least once when the "FUEL INJECTION" is +25%.
 "RR O2 SENSOR" should be below 0.43V at least once when the "FUEL INJECTION" is -25%.

CAUTION:

Discard any heated oxygen sensor which has been dropped from a height of more than 0.5 m (19.7 in) onto a hard surface such as a concrete floor; use a new one.

OR

- 1) Start engine and drive vehicle at a speed of more than 70 km/h (43 MPH) for 2 consecutive minutes.
- 2) Stop vehicle with engine running.
- 3) Set voltmeter probes between ECM terminal 52 (sensor signal) and engine ground.
- 4) Check the voltage when revving up to 4,000 rpm under no load at least 10 times.
(Depress and release accelerator pedal as soon as possible.)
 The voltage should be above 0.48V at least once. If the voltage is above 0.48V at step 4, step 5 is not necessary.
- 5) Check the voltage when revving up to 6,000 rpm under no load. Or keep vehicle idling for 10 minutes, then check the voltage. Or check the voltage when coasting from 80 km/h (50 MPH) in 3rd gear position (M/T), D position with "O/D" OFF (A/T).
 The voltage should be below 0.43V at least once.

CAUTION:

Discard any heated oxygen sensor which has been dropped from a height of more than 0.5 m (19.7 in) onto a hard surface such as a concrete floor; use a new one.

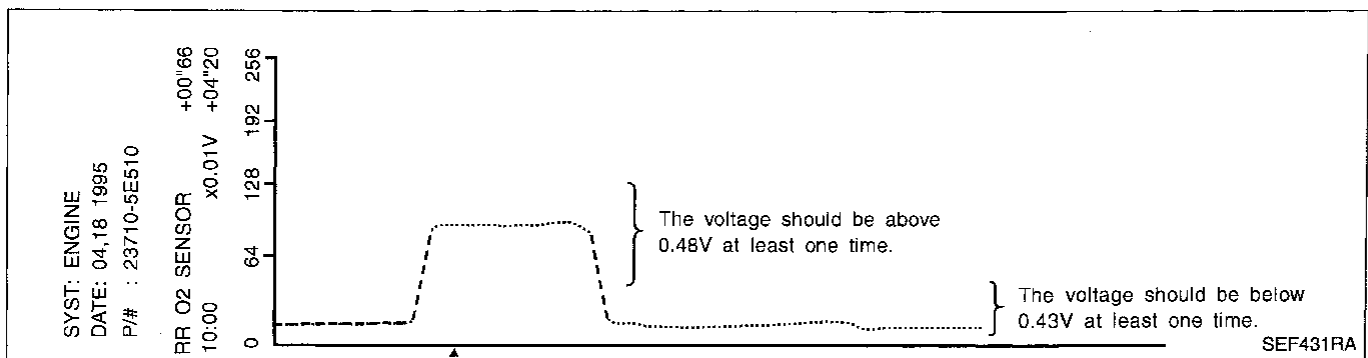

TROUBLE DIAGNOSIS FOR DTC P0141

Rear Heated Oxygen Sensor Heater

SYSTEM DESCRIPTION



The ECM performs ON/OFF control of the rear heated oxygen sensor heater corresponding to the engine speed.

OPERATION

Engine condition	Rear heated oxygen sensor heater
Engine stopped	OFF
Engine is running.	ON

CONSULT REFERENCE VALUE IN DATA MONITOR MODE

Specification data are reference values.

MONITOR ITEM	CONDITION	SPECIFICATION
RR O2 HEATER	● Engine speed: Idle [after driving 2 mins at 70 km/h (43 MPH) or more]	ON
	● Ignition switch ON (Engine stopped)	OFF

ECM TERMINALS AND REFERENCE VALUE

Specification data are reference values and are measured between each terminal and engine ground.

TER-MINAL NO.	WIRE COLOR	ITEM	CONDITION	DATA (DC voltage)
110	R/Y	Rear heated oxygen sensor heater	Engine is running. └ Idle speed {after driving 2 minutes at 70 km/h (43 MPH) or more.}	Approximately 0.7V
			Ignition switch "ON" └ Engine stopped.	BATTERY VOLTAGE (11 - 14V)

ON BOARD DIAGNOSIS LOGIC

Diagnostic Trouble Code No.	Malfunction is detected when	Check Items (Possible Cause)
P0141 0902	● The current amperage in the rear heated oxygen sensor heater circuit is out of the normal range. (An improper voltage drop signal is sent to ECM through the rear heated oxygen sensor heater.)	● Harness or connectors (The rear heated oxygen sensor heater circuit is open or shorted.) ● Rear heated oxygen sensor heater

TROUBLE DIAGNOSIS FOR DTC P0141

Rear Heated Oxygen Sensor Heater (Cont'd)

DIAGNOSTIC TROUBLE CODE CONFIRMATION PROCEDURE

NOTE:

If "DIAGNOSTIC TROUBLE CODE CONFIRMATION PROCEDURE" has been previously conducted, always turn ignition switch "OFF" and wait at least 5 seconds before conducting the next test.

TESTING CONDITION:

Before performing the following procedure, confirm that battery voltage is in between 10.5V and 16V at idle.

-  1) Turn ignition switch "ON" and select "DATA MONITOR" mode with CONSULT.
- 2) Start engine and drive vehicle at a speed of more than 70 km/h (43 MPH) for 2 consecutive minutes.
- 3) If 1st trip DTC is detected, go to "DIAGNOSTIC PROCEDURE", EC-229.

OR

-  1) Start engine and drive vehicle at a speed of more than 70 km/h (43 MPH) for 2 consecutive minutes.
- 2) Turn ignition switch "OFF" and wait at least 5 seconds.
- 3) Start engine and run it for at least 5 seconds at idle
- 4) Select "MODE 3" with GST.
- 5) If DTC is detected, go to "DIAGNOSTIC PROCEDURE", EC-229.

OR

-  1) Start engine and drive vehicle at a speed of more than 70 km/h (43 MPH) for 2 consecutive minutes.
- 2) Turn ignition switch "OFF", wait at least 5 seconds and then turn "ON".
- 3) Perform "Diagnostic Test Mode II (Self-diagnostic results)" with ECM.
- 4) If 1st trip DTC is detected, go to "DIAGNOSTIC PROCEDURE", EC-229.

When using GST, "DIAGNOSTIC TROUBLE CODE CONFIRMATION PROCEDURE" should be performed twice as much as when using CONSULT or ECM (Diagnostic Test Mode II) because GST cannot display MODE 7 (1st trip DTC) concerning this diagnosis. Therefore, using CONSULT or ECM (Diagnostic Test Mode II) is recommended.

☆ MONITOR	☆ NO FAIL	<input type="checkbox"/>
CMPS•RPM(REF)	2040rpm	
COOLAN TEMP/S	82°C	
VHCL SPEED SE	76km/h	
B/FUEL SCHDL	2.5ms	
RECORD		

SEF346U

GI

MA

EM

LC

EC

FE

CL

MT

AT

FA

RA

BR

ST

RS

BT

HA

EL

IDX

TROUBLE DIAGNOSIS FOR DTC P0141

Rear Heated Oxygen Sensor Heater (Cont'd)

EC-RRO2/H-01

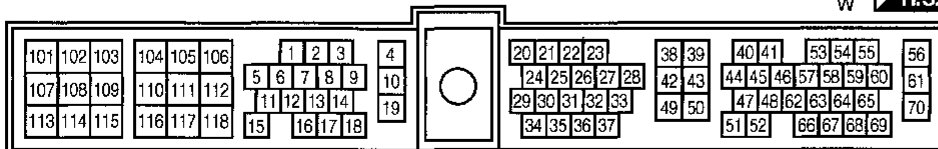
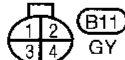
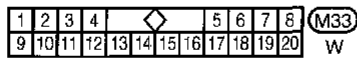
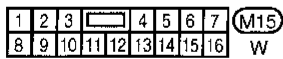
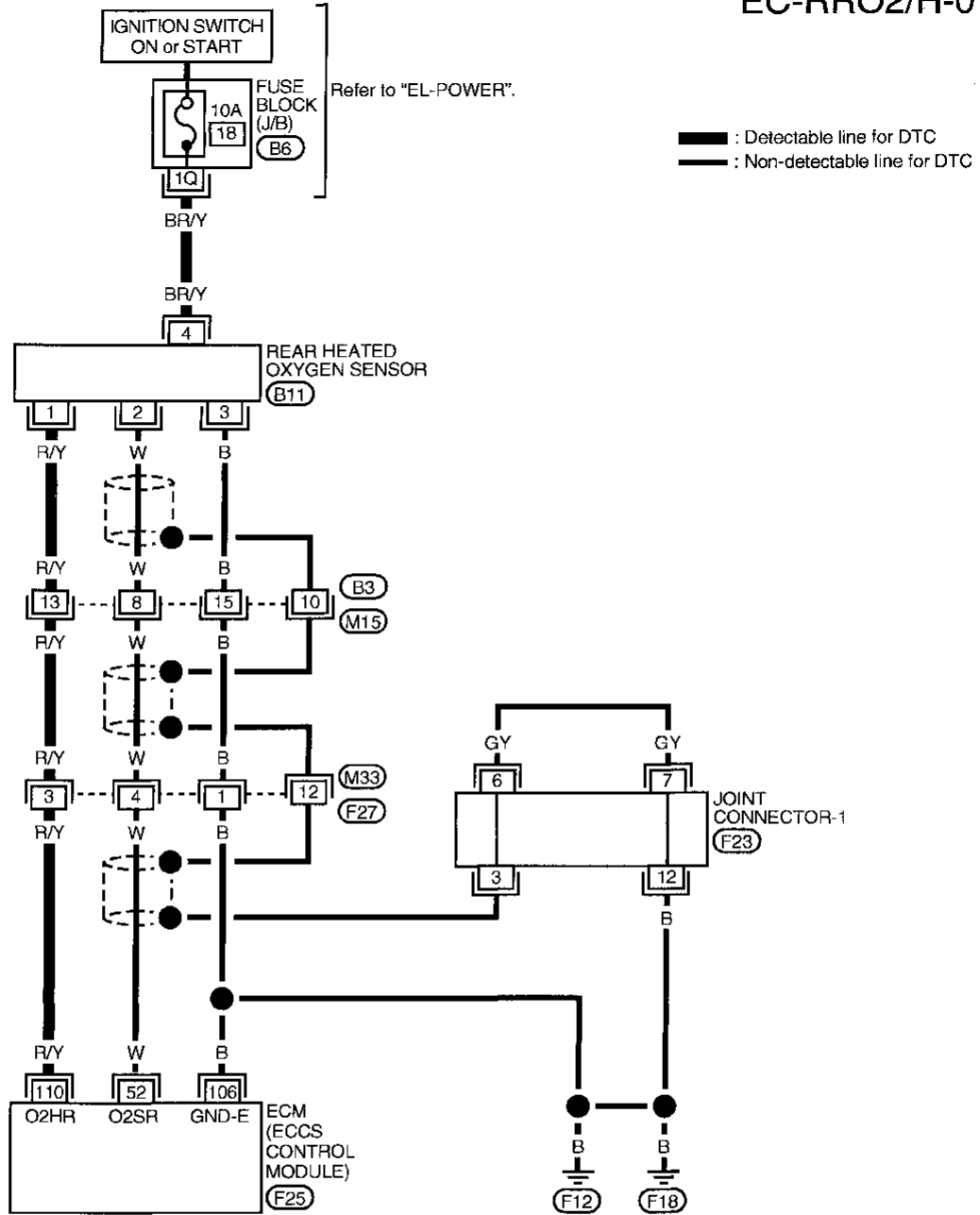

Refer to last page (Foldout page).

F23

TROUBLE DIAGNOSIS FOR DTC P0141

Rear Heated Oxygen Sensor Heater (Cont'd)

DIAGNOSTIC PROCEDURE

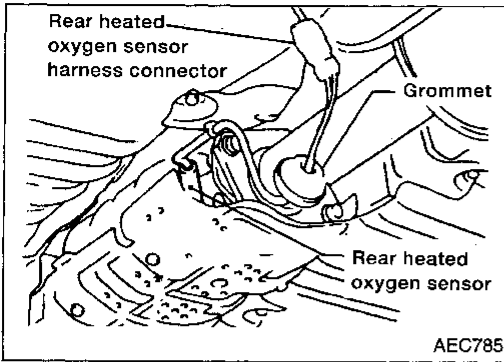

INSPECTION START

A

CHECK POWER SUPPLY.

1. Turn ignition switch "OFF".
2. Disconnect rear heated oxygen sensor harness connector.
3. Turn ignition switch "ON".
4. Check voltage between terminal ④ and ground.

Voltage: Battery voltage

NG

Check the following.

- Harness connectors (F27, M33)
- Harness connectors (B3, M15)
- Harness for open or short between rear heated oxygen sensor and fuse

If NG, repair harness or connectors.

OK

B

CHECK GROUND CIRCUIT.

1. Turn ignition switch "OFF".
2. Disconnect ECM harness connector.
3. Check harness continuity between terminal ① and ECM terminal ①10. **Continuity should exist.**

If OK, check harness for short to ground and short to power.

NG

Check the following.

- Harness connectors (B3, M15)
- Harness connectors (M33, F27)
- Harness for open or short between rear heated oxygen sensor heater and ground

If NG, repair open circuit or short to ground or short to power in harness or connectors.

OK

CHECK COMPONENT
(Rear heated oxygen sensor heater).
Refer to "COMPONENT INSPECTION" below.

NG

Replace rear heated oxygen sensor.

OK

Perform "TROUBLE DIAGNOSIS FOR INTERMITTENT INCIDENT", EC-106.

INSPECTION END

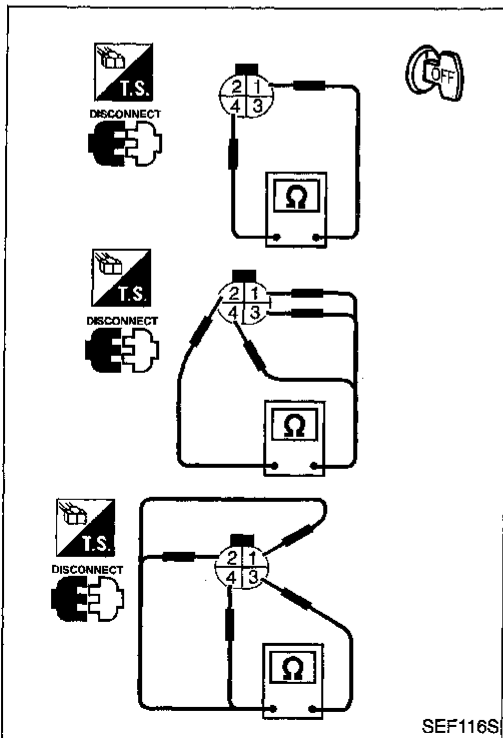
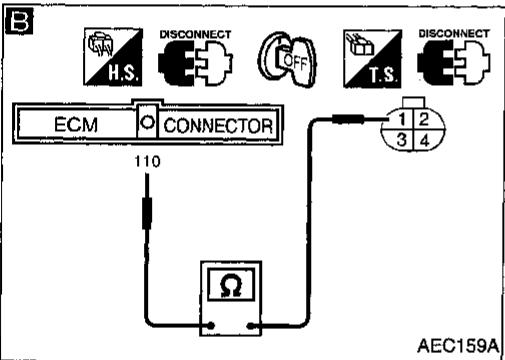
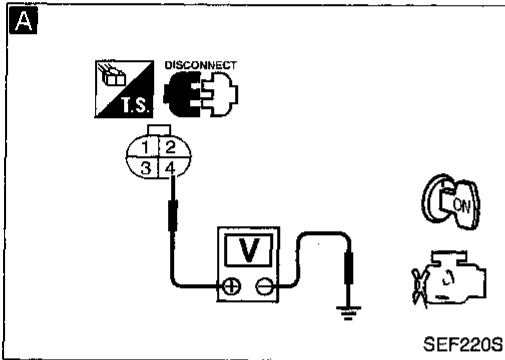

COMPONENT INSPECTION

Rear heated oxygen sensor heater

Check the following.

1. Check resistance between terminals ① and ④.
Resistance: 2.3 - 4.3Ω at 25°C (77°F)
2. Check continuity.

Terminal No.	Continuity
② and ①, ③, ④	No
③ and ①, ②, ④	

If NG, replace the rear heated oxygen sensor.

CAUTION:

Discard any heated oxygen sensor which has been dropped from a height of more than 0.5 m (19.7 in) onto a hard surface such as a concrete floor; use a new one.

Fuel Injection System Function (Lean side)

ON BOARD DIAGNOSIS LOGIC

With the Air/Fuel Mixture Ratio Self-Learning Control, the actual mixture ratio can be brought closely to the theoretical mixture ratio based on the mixture ratio feedback signal from the front heated oxygen sensor. The ECM calculates the necessary compensation to correct the offset between the actual and the theoretical ratios.

In case the amount of the compensation value is extremely large (The actual mixture ratio is too lean.), the ECM judges the condition as the fuel injection system malfunction and lights up the MIL (2 trip detection logic).

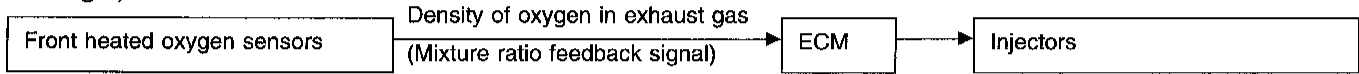

Diagnostic Trouble Code No.	Malfunction is detected when ...	Check Items (Possible Cause)
P0171 0115	<ul style="list-style-type: none"> ● Fuel injection system does not operate properly. ● The amount of mixture ratio compensation is too large. (The mixture ratio is too lean.) 	<ul style="list-style-type: none"> ● Intake air leaks ● Front heated oxygen sensor ● Injectors ● Exhaust gas leaks ● Incorrect fuel pressure ● Lack of fuel ● Mass air flow sensor

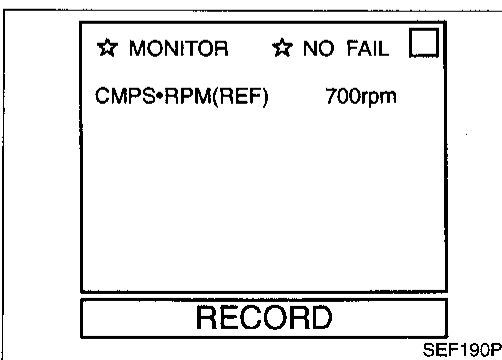
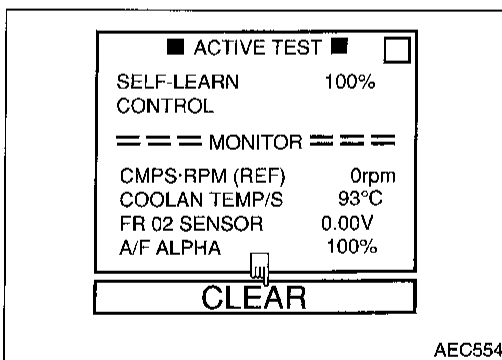

DIAGNOSTIC TROUBLE CODE CONFIRMATION PROCEDURE

NOTE:

If "DIAGNOSTIC TROUBLE CODE CONFIRMATION PROCEDURE" has been previously conducted, always turn ignition switch "OFF" and wait at least 5 seconds before conducting the next test.



- 1) Start engine and warm it up to normal operating temperature.
- 2) Turn ignition switch "OFF" and wait at least 5 seconds.
- 3) Turn ignition switch "ON" and select "SELF-LEARN CONTROL" in "ACTIVE TEST" mode with CONSULT.
- 4) Clear the self-learning control coefficient by touching "CLEAR".
- 5) Select "DATA MONITOR" mode with CONSULT.
- 6) Start engine again and let it idle for at least 10 minutes.

The 1st trip DTC P0171 should be detected at this stage, if a malfunction exists.

TROUBLE DIAGNOSIS FOR DTC P0171

Fuel Injection System Function (Lean side) (Cont'd)

- 7) If it is difficult to start engine at step 6, the fuel injection system has a malfunction.
- 8) Crank engine while depressing accelerator pedal. If 1st trip DTC is detected and engine starts, go to "DIAGNOSTIC PROCEDURE", EC-234. If engine does not start, visually check for exhaust and intake air leak.

OR

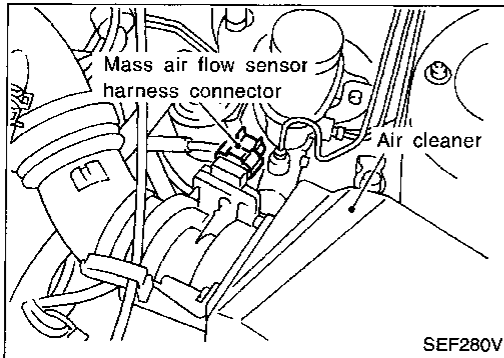

- 1) Start engine and warm it up to normal operating temperature.
- 2) Turn ignition switch "OFF" and wait at least 5 seconds.
- 3) Disconnect mass air flow sensor harness connector. Then restart and run engine for at least 3 seconds at idle speed.
- 4) Stop engine and reconnect mass air flow sensor harness connector.
- 5) Select "MODE 7" with GST. Make sure 1st trip DTC P0100 is detected.
- 6) Select "MODE 4" with GST and erase the 1st trip DTC P0100.
- 7) Start engine again and run it for at least 10 minutes at idle speed.
- 8) Select "MODE 7" with GST. The 1st trip DTC P0171 should be detected at this stage, if a malfunction exists.
- 9) If it is difficult to start engine at step 8, the fuel injection system has a malfunction.
- 10) Crank engine while depressing accelerator pedal. If 1st trip DTC is detected and engine starts, go to "DIAGNOSTIC PROCEDURE", EC-234. If engine does not start, visually check for exhaust and intake air leak.

OR



- 1) Start engine and warm it up to normal operating temperature.
- 2) Turn ignition switch "OFF" and wait at least 5 seconds.
- 3) Disconnect mass air flow sensor harness connector. Then restart and run engine for at least 3 seconds at idle speed.
- 4) Stop engine and reconnect mass air flow sensor harness connector.
- 5) Turn ignition switch "ON".
- 6) Perform Diagnostic Test Mode II (Self-diagnostic results) with ECM. Make sure 1st trip DTC 0102 is detected.
- 7) Erase the 1st trip DTC 0102 by changing from Diagnostic Test Mode II to Diagnostic Test Mode I.
- 8) Perform Diagnostic Test Mode II (Self-diagnostic results) with ECM. Make sure DTC 0505 is detected.

TROUBLE DIAGNOSIS FOR DTC P0171

Fuel Injection System Function (Lean side) (Cont'd)

- 9) Start engine again and run it for at least 10 minutes at idle speed.
The 1st trip DTC 0115 should be detected at this stage, if a malfunction exists.
- 10) If it is difficult to start engine at step 9, the fuel injection system also has a malfunction.
- 11) Crank engine while depressing accelerator pedal. If 1st trip DTC is detected and engine starts, go to "DIAGNOSTIC PROCEDURE", EC-234. If engine does not start, visually check for exhaust and intake air leak.

TROUBLE DIAGNOSIS FOR DTC P0171

Fuel Injection System Function (Lean side) (Cont'd)

EC-FUEL-01

GI

MA

EM

LC

EC

FE

CL

MT

AT

FA

RA

BR

ST

RS

BT

HA

EL

IDX

— : Detectable line for DTC
 - - - : Non-detectable line for DTC

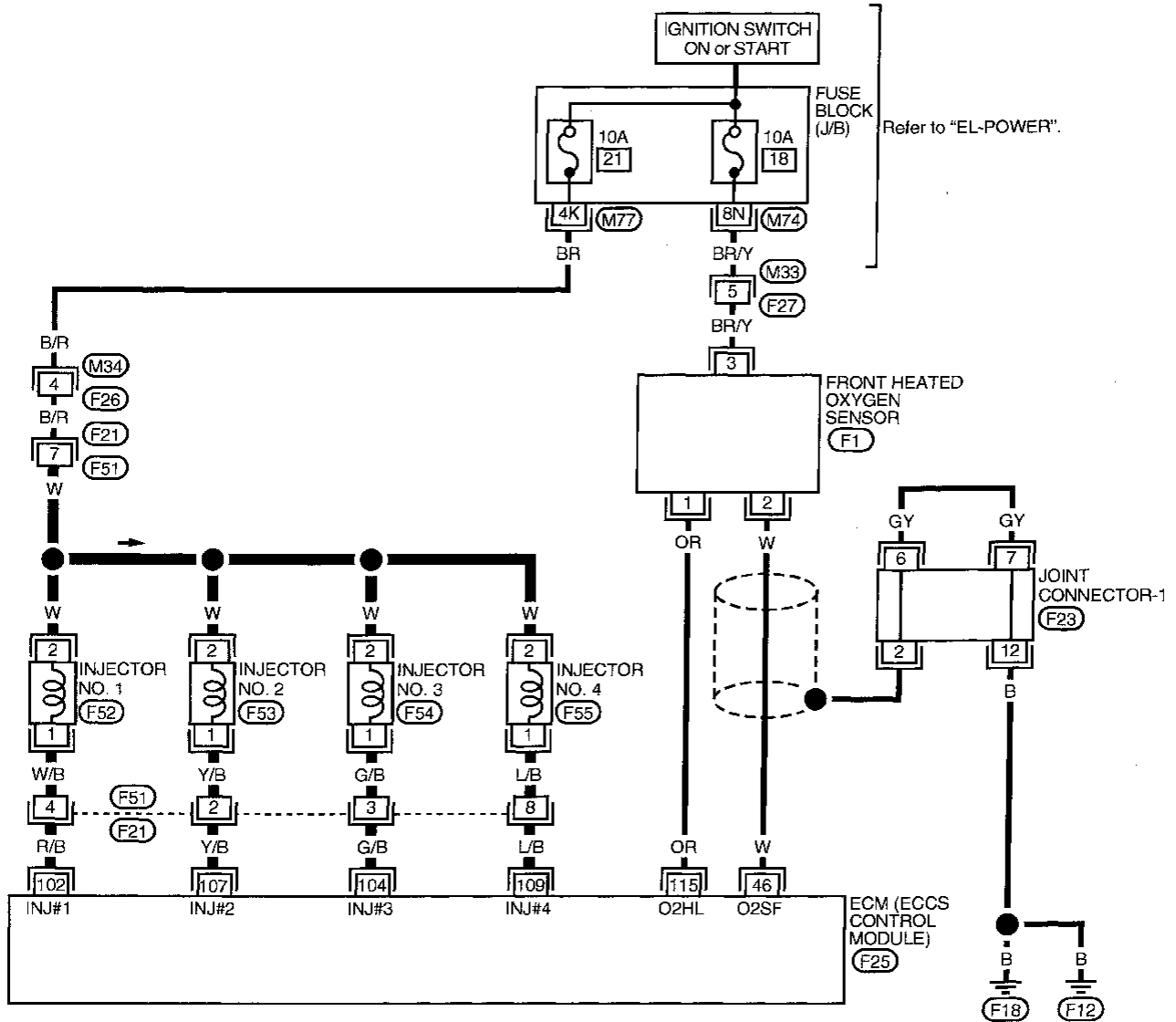

Refer to last page (Foldout page).

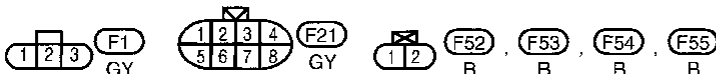
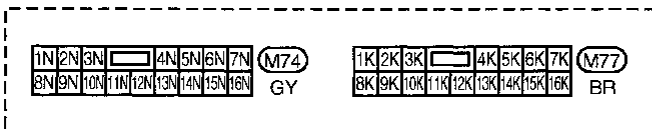
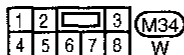

TROUBLE DIAGNOSIS FOR DTC P0171

Fuel Injection System Function (Lean side) (Cont'd)

DIAGNOSTIC PROCEDURE

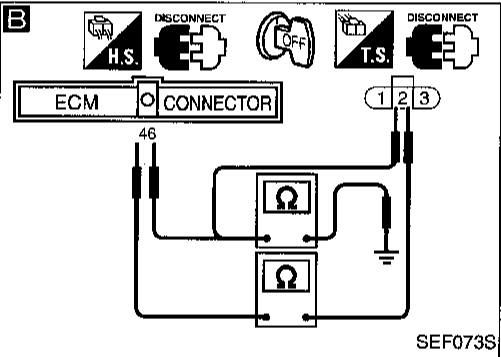
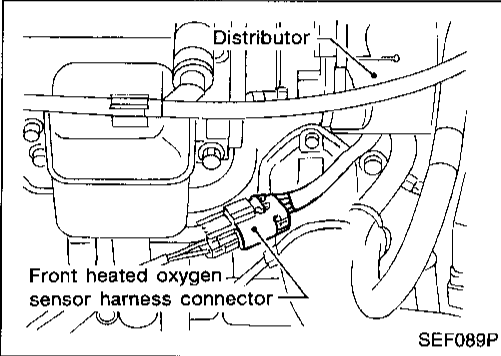
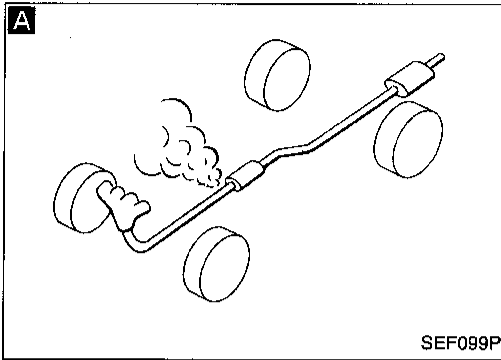

INSPECTION START

A
CHECK EXHAUST AIR LEAK.
Start engine and run it at idle. Listen for an exhaust air leak before three way catalyst.

NG → Repair or replace.

OK
CHECK FOR INTAKE AIR LEAK.
Start engine and run it at idle. Listen for an intake air leak between the mass air flow sensor and the intake manifold.

NG → Repair or replace.

B
CHECK FRONT HEATED OXYGEN SENSOR.
1. Turn ignition switch "OFF".
2. Disconnect front heated oxygen sensor harness connector and ECM harness connector.
3. Check harness continuity between ECM terminal (46) and terminal (2).
Continuity should exist.
4. Check harness continuity between ECM terminal (46) (or terminal (2)) and ground.
Continuity should not exist.
If OK, check harness for short to ground and short to power.

NG → Repair open circuit or short to ground or short to power in harness or connectors.

OK
CHECK FUEL PRESSURE.
1. Release fuel pressure to zero. Refer to EC-34.
2. Install fuel pressure gauge and check fuel pressure.
At idling:
When fuel pressure regulator valve vacuum hose is connected.
235 kPa
(2.4 kg/cm², 34 psi)
When fuel pressure regulator valve vacuum hose is disconnected.
294 kPa
(3.0 kg/cm², 43 psi)

NG → Check the following.
● Fuel pump and circuit Refer to EC-475.
● Fuel pressure regulator Refer to EC-34.
● Fuel lines Refer to "ENGINE MAINTENANCE" in MA section.
● Fuel filter for clogging If NG, repair or replace.

OK
CHECK MASS AIR FLOW SENSOR.
 Check "MASS AIR FLOW" in "DATA MONITOR" mode with CONSULT.
2.5 - 5.0 g-m/sec: at idling
7.1 - 12.5 g-m/sec: at 2,500 rpm
OR
 Check "MASS AIR FLOW" in MODE 1 with GST.
2.5 - 5.0 g-m/sec: at idling
7.1 - 12.5 g-m/sec: at 2,500 rpm
OR
 Check voltage between ECM terminal (47) and ground.
1.3 - 1.7V: at idling
1.8 - 2.4V: at 2,500 rpm

NG → Check connectors for rusted terminals or loose connections in the mass air flow sensor circuit or engine grounds. Refer to EC-118.

OK
A
(Go to next page.)

TROUBLE DIAGNOSIS FOR DTC P0171

Fuel Injection System Function (Lean side) (Cont'd)

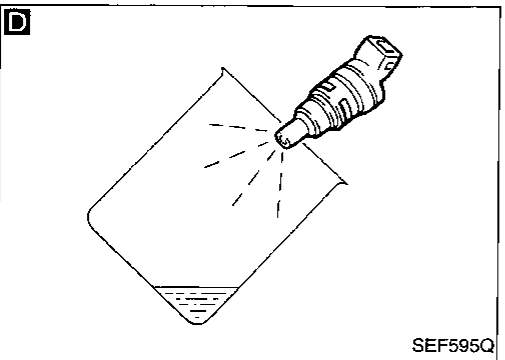
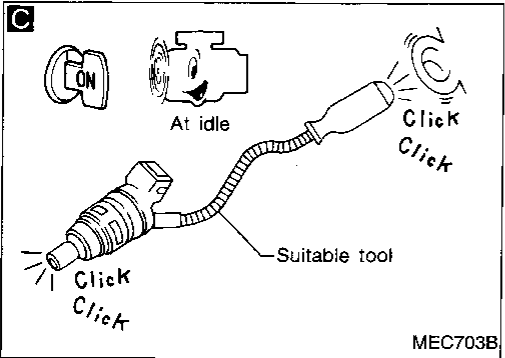
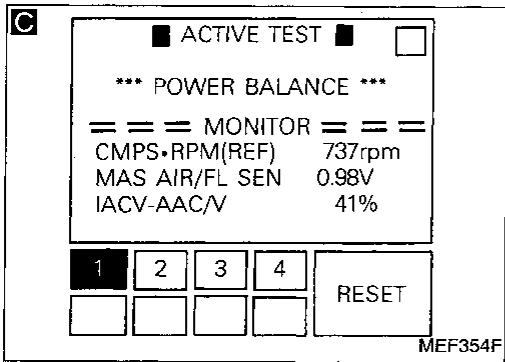

C

CHECK FUNCTION OF INJECTORS.

1. Install all parts removed.
2. Start engine.
3. Perform "POWER BALANCE" in "ACTIVE TEST" mode with CONSULT.
4. Make sure that each circuit produces a momentary engine speed drop.

OR

3. Listen to each injector operating sound.
Clicking noise should be heard.

NG → Perform TROUBLE DIAGNOSIS FOR NON-DETECTABLE ITEMS, "Injectors", EC-469. Repair harness or connectors.

OK → Confirm that the engine is cooled down and there are no fire hazards near the vehicle.

1. Turn ignition switch "OFF".
2. Remove injector with fuel tube assembly. Refer to EC-34. Keep fuel hose and all injectors connected to injector gallery.
The injector harness connectors should remain connected.

D

1. Disconnect all ignition coil harness connectors.
2. Place pans or saucers under each injector.
3. Crank engine for about 3 seconds. Make sure that fuel sprays out from injectors.
Fuel should be sprayed evenly for each cylinder.

NG → Replace injectors from which fuel does not spray out. Always replace O-ring with new one.

OK → Perform "TROUBLE DIAGNOSIS FOR INTERMITTENT INCIDENT", EC-106.

INSPECTION END

GI
MA
EM
LC
EC
FE
CL
MT
AT
FA
RA
BR
ST
RS
BT
HA
EL
IDX

Fuel Injection System Function (Rich side)

ON BOARD DIAGNOSIS LOGIC

With the Air/Fuel Mixture Ratio Self-Learning Control, the actual mixture ratio can be brought closely to the theoretical mixture ratio based on the mixture ratio feedback signal from the front heated oxygen sensor. The ECM calculates the necessary compensation to correct the offset between the actual and the theoretical ratios.

In case the amount of the compensation value is extremely large (The actual mixture ratio is too rich.), the ECM judges the condition as a fuel injection system malfunction and lights up the MIL (2 trip detection logic).

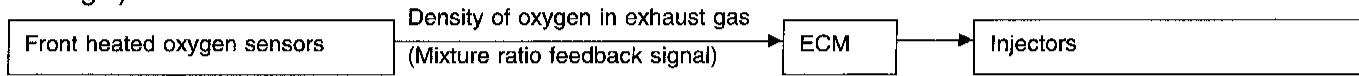

Diagnostic Trouble Code No.	Malfunction is detected when ...	Check Items (Possible Cause)
P0172 0114	<ul style="list-style-type: none"> ● Fuel injection system does not operate properly. ● The amount of mixture ratio compensation is too large. (The mixture ratio is too rich.) 	<ul style="list-style-type: none"> ● Front heated oxygen sensor ● Injectors ● Exhaust gas leaks ● Incorrect fuel pressure ● Mass air flow sensor

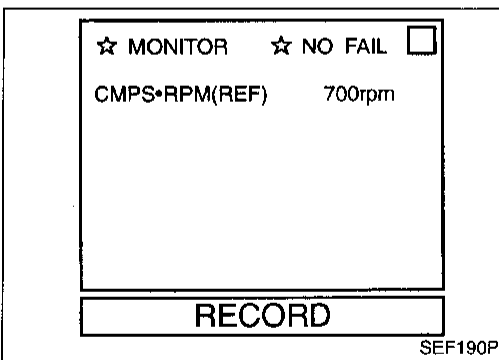
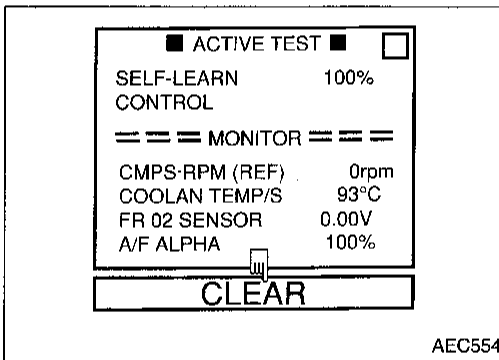

DIAGNOSTIC TROUBLE CODE CONFIRMATION PROCEDURE

NOTE:

If "DIAGNOSTIC TROUBLE CODE CONFIRMATION PROCEDURE" has been previously conducted, always turn ignition switch "OFF" and wait at least 5 seconds before conducting the next test.



- 1) Start engine and warm it up to normal operating temperature.
- 2) Turn ignition switch "OFF" and wait at least 5 seconds.
- 3) Turn ignition switch "ON" and select "SELF-LEARN CONTROL" in "ACTIVE TEST" mode with CONSULT.
- 4) Clear the self-learning control coefficient by touching "CLEAR".
- 5) Select "DATA MONITOR" mode with CONSULT.
- 6) Start engine again and let it idle for at least 10 minutes.
The 1st trip DTC P0172 should be detected at this stage, if a malfunction exists.
- 7) If it is difficult to start engine at step 6, the fuel injection system has a malfunction.
- 8) Crank engine while depressing accelerator pedal. If 1st trip DTC is detected and engine starts, go to "DIAGNOSTIC PROCEDURE", EC-239. If engine does not start, remove ignition plugs and check for fouling, etc.

OR

TROUBLE DIAGNOSIS FOR DTC P0172

Fuel Injection System Function (Rich side) (Cont'd)

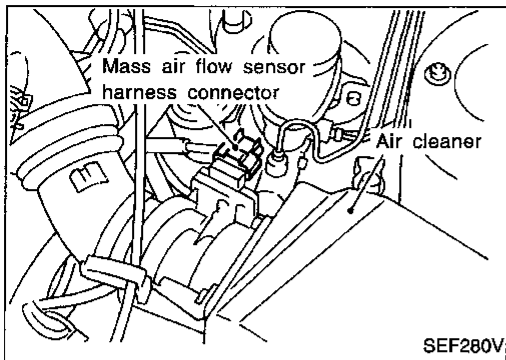

- 1) Start engine and warm it up to normal operating temperature.
- 2) Turn ignition switch "OFF" and wait at least 5 seconds.
- 3) Disconnect mass air flow sensor harness connector. Then restart and run engine for at least 3 seconds at idle speed.
- 4) Stop engine and reconnect mass air flow sensor harness connector.
- 5) Select "MODE 7" with GST. Make sure 1st trip DTC P0100 is detected.
- 6) Select "MODE 4" with GST and erase the 1st trip DTC P0100.
- 7) Start engine again and run it for at least 10 minutes at idle speed.
- 8) Select "MODE 7" with GST. The 1st trip DTC P0172 should be detected at this stage, if a malfunction exists.
- 9) If it is difficult to start engine at step 8, the fuel injection system has a malfunction.
- 10) Crank engine while depressing accelerator pedal. If 1st trip DTC is detected and engine starts, go to "DIAGNOSTIC PROCEDURE", EC-239. If engine does not start, remove ignition plugs and check for fouling, etc.

GI

MA

EM

LC

EC

FE

CL

MT

AT

OR



- 1) Start engine and warm it up to normal operating temperature.
- 2) Turn ignition switch "OFF" and wait at least 5 seconds.
- 3) Disconnect mass air flow sensor harness connector. Then restart engine and run it for at least 3 seconds at idle speed.
- 4) Stop engine and reconnect mass air flow sensor harness connector.
- 5) Turn ignition switch "ON".
- 6) Perform Diagnostic Test Mode II (Self-diagnostic results) with ECM. Make sure 1st trip DTC 0102 is detected.
- 7) Erase the 1st trip DTC 0102 by changing from Diagnostic Test Mode II to Diagnostic Test Mode I.
- 8) Perform Diagnostic Test Mode II (Self-diagnostic results) with ECM. Make sure DTC 0505 is detected.
- 9) Start engine again and run it for at least 10 minutes at idle speed. The 1st trip DTC 0114 should be detected at this stage, if a malfunction exists.
- 10) If it is difficult to start engine at step 9, the fuel injection system also has a malfunction.
- 11) Crank engine while depressing accelerator pedal. If 1st trip DTC is detected and engine starts, go to "DIAGNOSTIC PROCEDURE", EC-239. If engine does not start, remove ignition plugs and check for fouling, etc.

FA

RA

BR

ST

RS

BT

HA

EL

IDX

TROUBLE DIAGNOSIS FOR DTC P0172

Fuel Injection System Function (Rich side) (Cont'd)

EC-FUEL-01

— : Detectable line for DTC
— : Non-detectable line for DTC

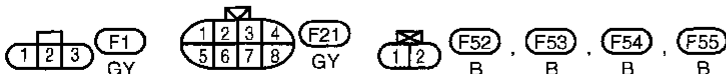
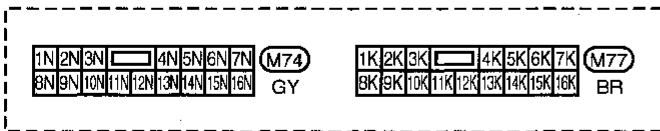
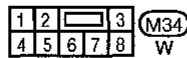
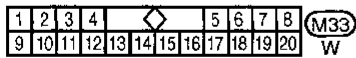
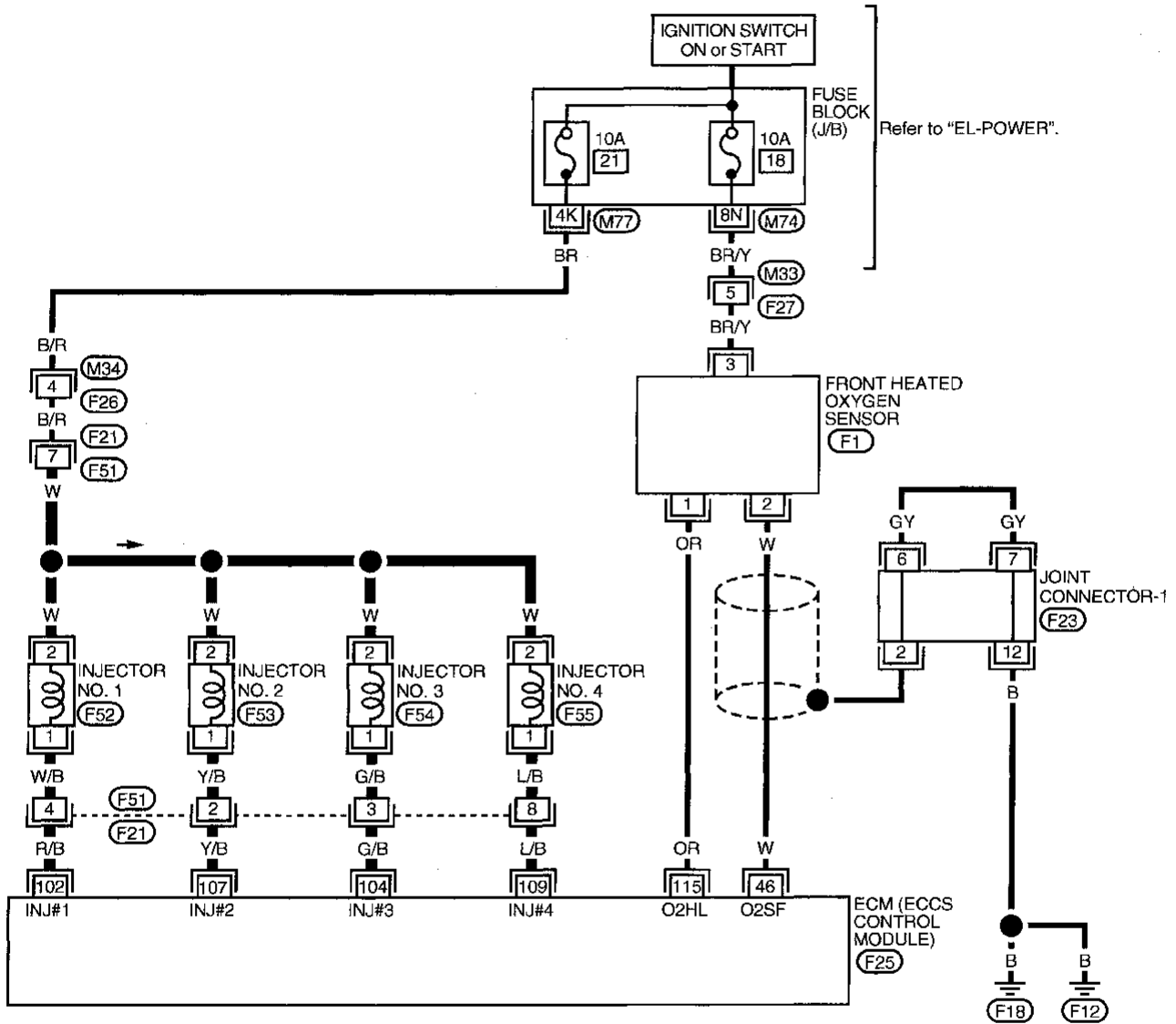

Refer to last page (Foldout page).

(F23)
(F25)

TROUBLE DIAGNOSIS FOR DTC P0172

Fuel Injection System Function (Rich side) (Cont'd)

DIAGNOSTIC PROCEDURE

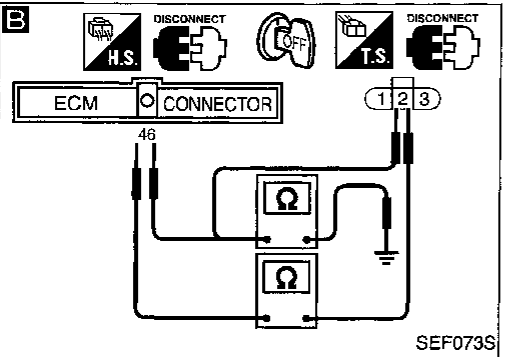
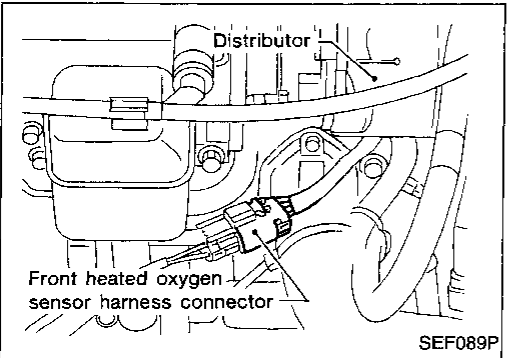
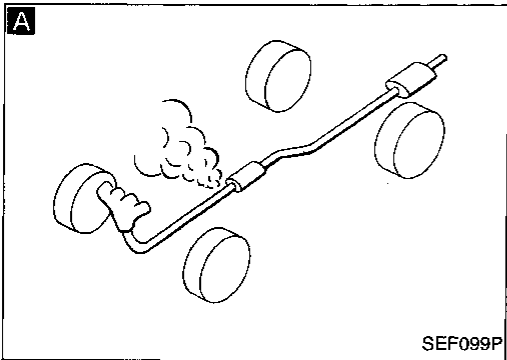

INSPECTION START

A
CHECK FOR EXHAUST AIR LEAK.
Start engine and run it at idle. Listen for an exhaust air leak before the three way catalyst.

NG → Repair or replace.

B
CHECK FRONT HEATED OXYGEN SENSOR.
1. Turn ignition switch "OFF".
2. Disconnect front heated oxygen sensor RH harness connector and ECM harness connector.
3. Check harness continuity between ECM terminal (46) and terminal (2).
Continuity should exist.
4. Check harness continuity between ECM terminal (46) (or terminal (2)) and ground.
Continuity should not exist.
If OK, check harness for short to ground and short to power.

NG → Repair open circuit or short to ground or short to power in harness or connectors.

CHECK FUEL PRESSURE.
1. Release fuel pressure to zero. Refer to EC-34.
2. Install fuel pressure gauge and check fuel pressure.
At idling:
When fuel pressure regulator valve vacuum hose is connected.
Approximately 235 kPa (2.4 kg/cm², 34 psi)
When fuel pressure regulator valve vacuum hose is disconnected.
Approximately 294 kPa (3.0 kg/cm², 43 psi)

NG → Check the following.
● Fuel pump and circuit Refer to EC-475.
● Fuel pressure regulator Refer to EC-34.
If NG, repair or replace.

CHECK MASS AIR FLOW SENSOR.
Check "MASS AIR FLOW" in "DATA MONITOR" mode with CONSULT.
2.5 - 5.0 g-m/sec: at idling
7.1 - 12.5 g-m/sec: at 2,500 rpm
OR
Check "MASS AIR FLOW" in MODE 1 with GST.
2.5 - 5.0 g-m/sec: at idling
7.1 - 12.5 g-m/sec: at 2,500 rpm
OR
NO TOOLS Check voltage between ECM terminal (47) and ground.
1.3 - 1.7V: at idling
1.8 - 2.4V: at 2,500 rpm

NG → Check connectors for rusted terminals or loose connections in the mass air flow sensor circuit or engine grounds. Refer to EC-118.

OK
A
(Go to next page.)

GI
MA
EM
LC
EC
FE
CL
MT
AT
FA
RA
BR
ST
RS
BT
HA
EL
IDX

TROUBLE DIAGNOSIS FOR DTC P0172

Fuel Injection System Function (Rich side) (Cont'd)

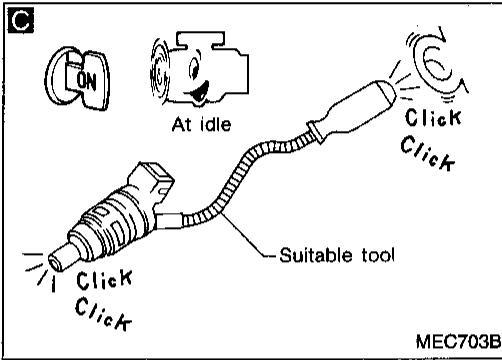
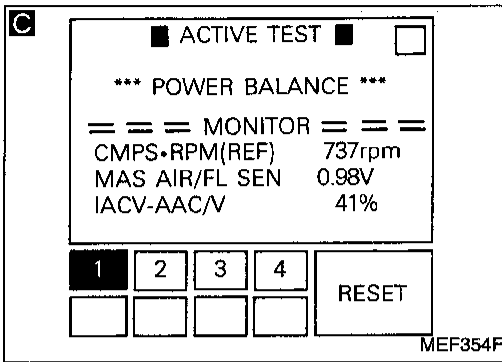

CHECK FUNCTION OF INJECTORS.

1. Install all parts removed.
2. Start engine.
3. Perform "POWER BALANCE" in "ACTIVE TEST" mode with CONSULT.
4. Make sure that each circuit produces a momentary engine speed drop.

OR

3. Listen to each injector operating sound. **Clicking noise should be heard.**

NG

Perform TROUBLE DIAGNOSIS FOR NON-DETECTABLE ITEMS, "Injectors", EC-469. Repair harness or connectors.

OK

Remove injector assembly. Refer to EC-34. Keep fuel hose and all injectors connected to injector gallery.

Confirm that the engine is cooled down and there are no fire hazards near the vehicle.

1. Disconnect all injector harness connectors.
2. Disconnect all ignition coil harness connectors.
3. Crank engine for about 3 seconds. Make sure fuel does not drip from injector.

Drips

Replace the injectors from which fuel is dripping. Always replace O-ring with new one.

Does not drip.

Perform "TROUBLE DIAGNOSIS FOR INTERMITTENT INCIDENT", EC-106.

INSPECTION END

TROUBLE DIAGNOSIS FOR DTC P0180

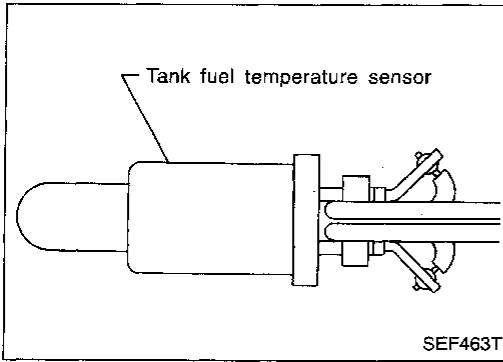

Tank Fuel Temperature Sensor

COMPONENT DESCRIPTION

The tank fuel temperature sensor is used to detect the fuel temperature inside the fuel tank. The sensor modifies a voltage signal from the ECM. The modified signal returns to the ECM as the fuel temperature input. The sensor uses a thermistor which is sensitive to the change in temperature. The electrical resistance of the thermistor decreases as temperature increases.

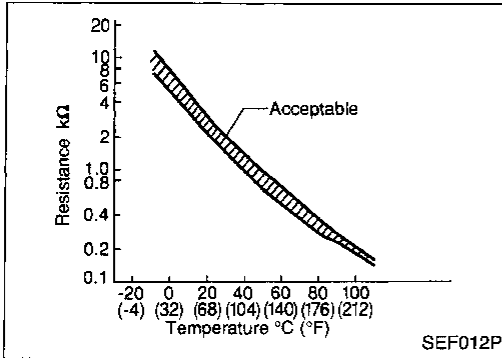

<Reference data>

Fluid temperature °C (°F)	Voltage* V	Resistance kΩ
20 (68)	3.5	2.3 - 2.7
50 (122)	2.2	0.79 - 0.90

*: These data are reference values and are measured between ECM terminal 63 (Tank fuel temperature sensor) and engine ground.

ON BOARD DIAGNOSIS LOGIC

Diagnostic Trouble Code No.	Malfunction is detected when ...	Check Items (Possible Causes)
P0180 0402	<ul style="list-style-type: none"> An excessively high or low voltage is sent to ECM. Rationally incorrect voltage is sent to ECM, compared with the voltage signals from engine coolant temperature sensor and intake air temperature sensor. 	<ul style="list-style-type: none"> Harness or connectors (The sensor circuit is open or shorted.) Tank fuel temperature sensor

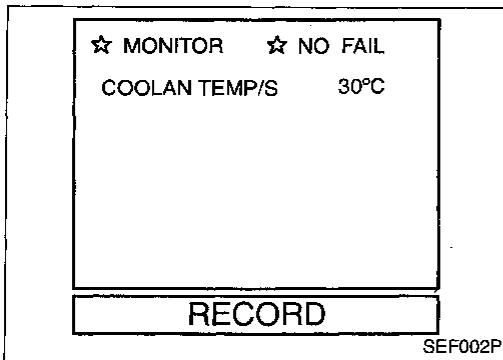

DIAGNOSTIC TROUBLE CODE CONFIRMATION PROCEDURE

NOTE:

If "DIAGNOSTIC TROUBLE CODE CONFIRMATION PROCEDURE" has been previously conducted, always turn ignition switch "OFF" and wait at least 5 seconds before conducting the next test.



- 1) Turn ignition switch "ON".
- 2) Select "DATA MONITOR" mode with CONSULT.
- 3) Wait at least 10 seconds.
If 1st trip DTC is detected, go to "DIAGNOSTIC PROCEDURE", EC-244.
If the result is OK, go to following step.

NOTE: If "COOLAN TEMP/S" is already less than 60°C (140°F) before step 4), the result will be OK.

If "COOLAN TEMP/S" is above 60°C (140°F), go to the following step.

- 4) Cool engine down until "COOLAN TEMP/S" is less than 60°C (140°F).
- 5) Wait at least 10 seconds.
- 6) If 1st trip DTC is detected, go to "DIAGNOSTIC PROCEDURE", EC-244.

TROUBLE DIAGNOSIS FOR DTC P0180

Tank Fuel Temperature Sensor (Cont'd)

OR



- 1) Turn ignition switch "ON" and wait at least 10 seconds.
- 2) Select "MODE 7" with GST.
If the result is NG, go to "DIAGNOSTIC PROCEDURE", EC-244.
If the result is OK, go to following step.
- 3) Select "MODE 1" with GST and check for the engine coolant temperature.
If the temperature is less than 60°C (140°F), the result will be OK.
If the temperature is above 90°C (194°F), go to the following step.
- 4) Cool engine down until the engine coolant temperature is less than 60°C (140°F).
- 5) Wait at least 10 seconds.
- 6) Select "MODE 7" with GST.
- 7) If 1st trip DTC is detected, go to "DIAGNOSTIC PROCEDURE", EC-244.

OR



- 1) Turn ignition switch "ON" and wait at least 10 seconds.
- 2) Turn ignition switch "OFF", wait at least 5 seconds and then turn "ON".
- 3) Perform "Diagnostic Test Mode II (Self-diagnostic results)" with ECM.
If the result is NG, go to "DIAGNOSTIC PROCEDURE", EC-244.
If the result is OK, go to following step.
- 4) Check voltage between ECM terminal ⑥ (Engine coolant temperature sensor) and engine ground.
If the voltage is more than 1.88V, the result will be OK.
If the voltage is less than 1.88V, go to the following step.
- 5) Cool engine down until the voltage becomes more than 1.88V.
- 6) Wait at least 10 seconds.
- 7) Turn ignition switch "OFF", wait at least 5 seconds and then turn "ON".
- 8) Perform "Diagnostic Test Mode II (Self-diagnostic results)" with ECM.
- 9) If 1st trip DTC is detected, go to "DIAGNOSTIC PROCEDURE", EC-244.

TROUBLE DIAGNOSIS FOR DTC P0180

Tank Fuel Temperature Sensor (Cont'd)

EC-TFTS-01

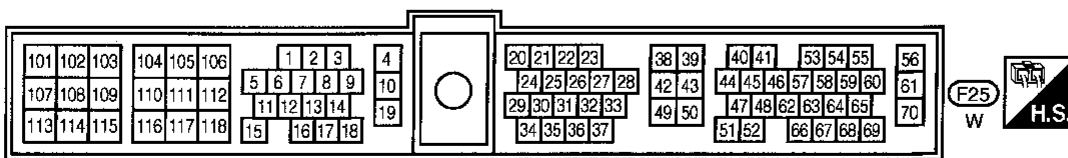
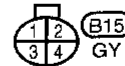
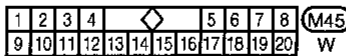
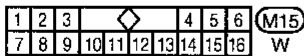
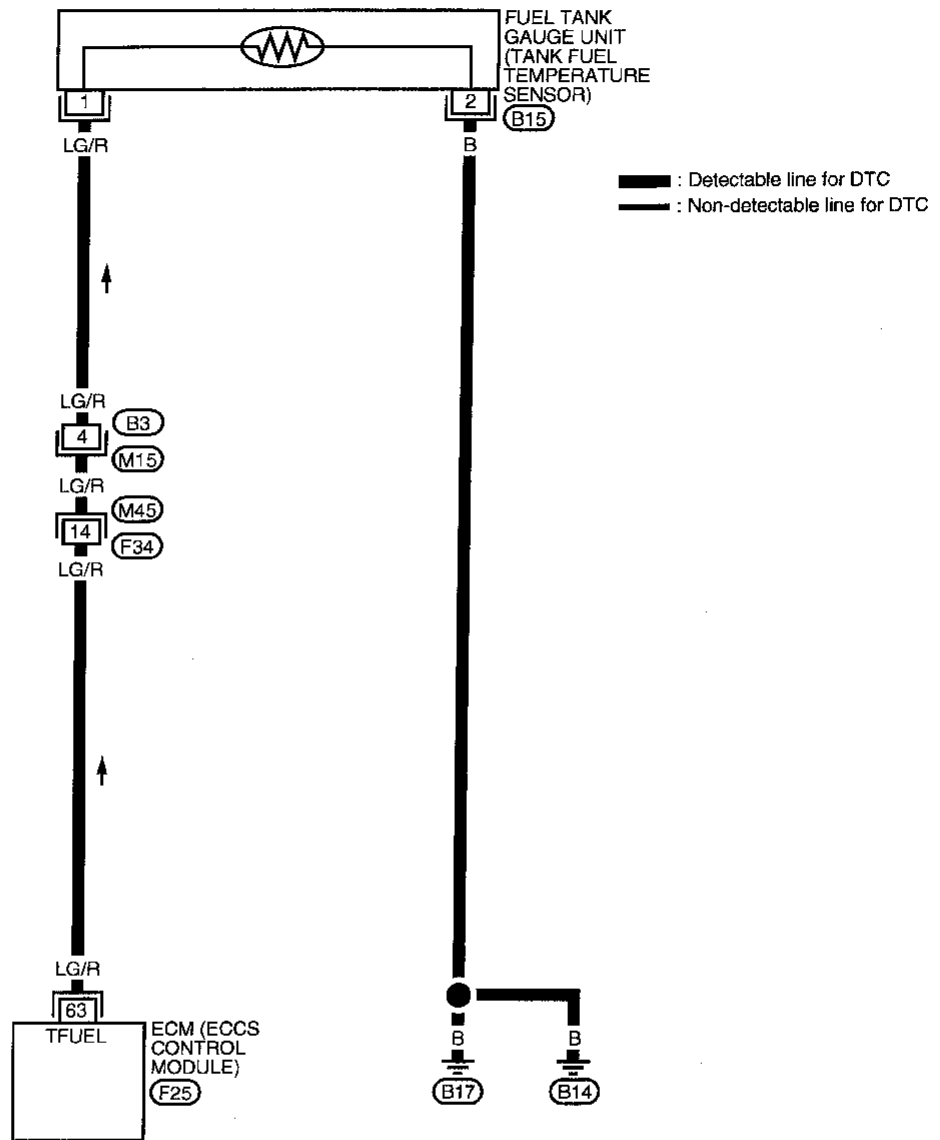

TROUBLE DIAGNOSIS FOR DTC P0180

Tank Fuel Temperature Sensor (Cont'd)

DIAGNOSTIC PROCEDURE

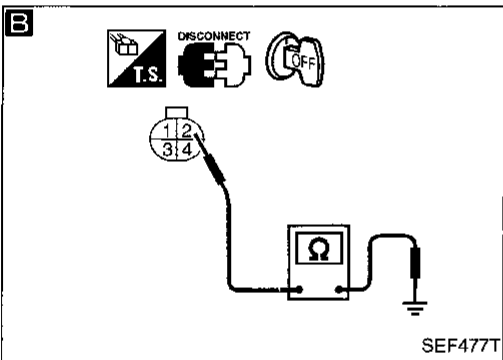
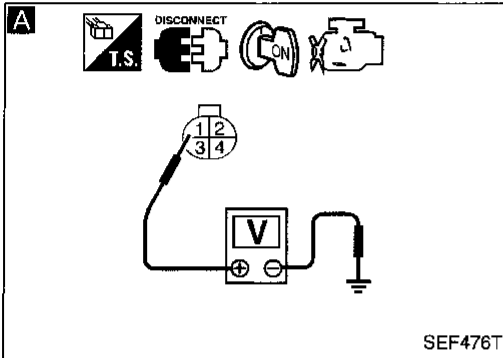
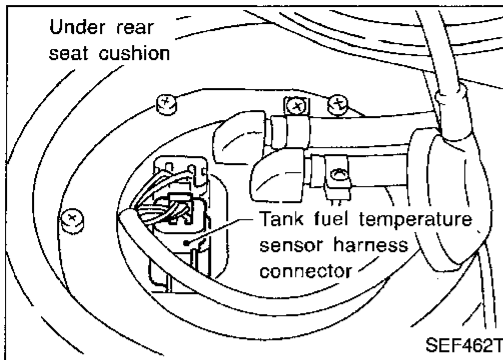

INSPECTION START

A
CHECK POWER SUPPLY.
 1. Turn ignition switch "OFF".
 2. Disconnect tank fuel temperature sensor harness connector.
 3. Turn ignition switch "ON".
 4. Check voltage between terminal ① and ground with CONSULT or tester.
Voltage: Approximately 5V

NG
 Check the following.
 ● Harness connectors
 ● (B3), (M15), (F34), (M45)
 ● Harness for open or short between ECM and tank fuel temperature sensor
 If NG, repair harness or connector.

OK
B
CHECK GROUND CIRCUIT.
 1. Turn ignition switch "OFF".
 2. Check harness continuity between terminal ② and body ground.
Continuity should exist.
 If OK, check harness for short to ground and short to power.

NG
 Repair open circuit or short to ground or short to power in harness or connectors.

OK
CHECK COMPONENT
 (Tank fuel temperature sensor).
 Refer to "COMPONENT INSPECTION" below.

NG
 Replace tank fuel temperature sensor.

OK
 Perform "TROUBLE DIAGNOSIS FOR INTERMITTENT INCIDENT", EC-106.

INSPECTION END

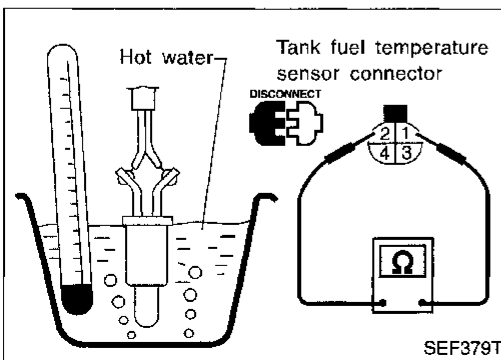

COMPONENT INSPECTION

Tank fuel temperature sensor

Check resistance by heating with hot water or heat gun as shown in the figure.

Temperature °C (°F)	Resistance kΩ
20 (68)	2.3 - 2.7
50 (122)	0.79 - 0.90

If NG, replace tank fuel temperature sensor.

No. 4 - 1 Cylinder Misfire, Multiple Cylinder Misfire

ON BOARD DIAGNOSIS LOGIC

If a misfire occurs, the engine speed will fluctuate. If the fluctuation is detected by the crankshaft position sensor (OBD), the misfire is diagnosed.

The misfire detection logic consists of the following two conditions.

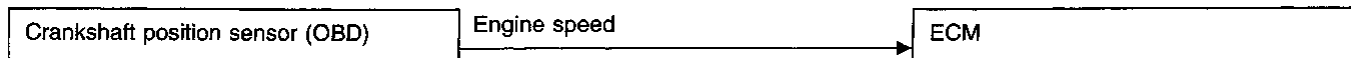

1. One Trip Detection Logic (Three Way Catalyst Damage)

When a misfire is detected which will overheat and damage the three way catalyst, the malfunction indicator lamp (MIL) will start blinking, even during the first trip. In this condition, ECM monitors the misfire every 200 revolutions.

If the misfire frequency decreases to a level that will not damage the three way catalyst, the MIL will change from blinking to lighting up.

(After the first trip detection, the MIL will light up from engine starting. If a misfire is detected that will cause three way catalyst damage, the MIL will start blinking.)

2. Two Trip Detection Logic (Exhaust quality deterioration)

When a misfire that will not damage the three way catalyst (but will affect exhaust emission) occurs, the malfunction indicator lamp will light up based on two trip detection logic. In this condition, ECM monitors the misfire for every 1,000 revolutions of the engine.

Diagnostic Trouble Code No.	Malfunction is detected when ...	Check Items (Possible Cause)
P0300 (0701)	● Multiple cylinders misfire.	● Improper spark plug ● Insufficient compression
P0301 (0608)	● No. 1 cylinder misfires.	● Incorrect fuel pressure ● EGR valve
P0302 (0607)	● No. 2 cylinder misfires.	● The injector circuit is open or shorted ● Injectors
P0303 (0606)	● No. 3 cylinder misfires.	● Intake air leak ● The ignition secondary circuit is open or shorted
P0304 (0605)	● No. 4 cylinder misfires.	● Lack of fuel ● Drive plate/Flywheel ● Front heated oxygen sensor ● Incorrect distributor rotor

TROUBLE DIAGNOSIS FOR DTC P0300 - P0304

No. 4 - 1 Cylinder Misfire, Multiple Cylinder Misfire (Cont'd)

DIAGNOSTIC TROUBLE CODE CONFIRMATION PROCEDURE (Overall)

CAUTION:

Always drive vehicle at a safe speed.

NOTE:

If "DIAGNOSTIC TROUBLE CODE CONFIRMATION PROCEDURE" has been previously conducted, always turn ignition switch "OFF" and wait at least 5 seconds before conducting the next test.

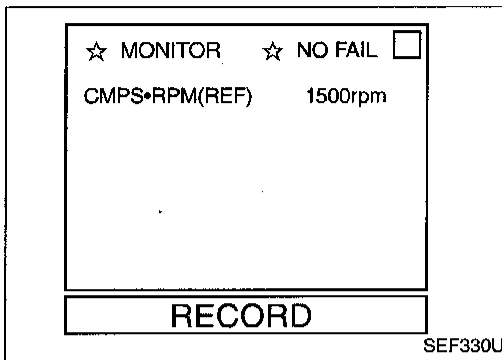

- 1) Turn ignition switch "ON", and select "DATA MONITOR" mode with CONSULT.
- 2) Start engine and warm it up to normal operating temperature.
- 3) Turn ignition switch "OFF" and wait at least 5 seconds.
- 4) Start engine again and drive at 1,500 - 3,000 rpm for at least 3 minutes.
Hold the accelerator pedal as steady as possible.
Note: Refer to the freeze frame data for the test driving conditions.
- 5) If 1st trip DTC is detected, go to "DIAGNOSTIC PROCEDURE", EC-247.

OR



- 1) Start engine and warm it up to normal operating temperature.
- 2) Turn ignition switch "OFF" and wait at least 5 seconds.
- 3) Start engine again and drive at 1,500 - 3,000 rpm for at least 3 minutes.
Hold the accelerator pedal as steady as possible.
Note: Refer to the freeze frame data for the test driving conditions.
- 4) Select "MODE 7" with GST.
- 5) If 1st trip DTC is detected, go to "DIAGNOSTIC PROCEDURE", EC-247.

OR



- 1) Start engine and warm it up to normal operating temperature.
- 2) Turn ignition switch "OFF" and wait at least 5 seconds.
- 3) Start engine again and drive at 1,500 - 3,000 rpm for at least 3 minutes.
Hold the accelerator pedal as steady as possible.
- 4) Turn ignition switch "OFF", wait at least 5 seconds, and then turn "ON".
- 5) Perform "Diagnostic Test Mode II (Self-diagnostic results)" with ECM.
- 6) If 1st trip DTC is detected, go to "DIAGNOSTIC PROCEDURE", EC-247.

TROUBLE DIAGNOSIS FOR DTC P0300 - P0304

No. 4 - 1 Cylinder Misfire, Multiple Cylinder Misfire (Cont'd)

DIAGNOSTIC PROCEDURE

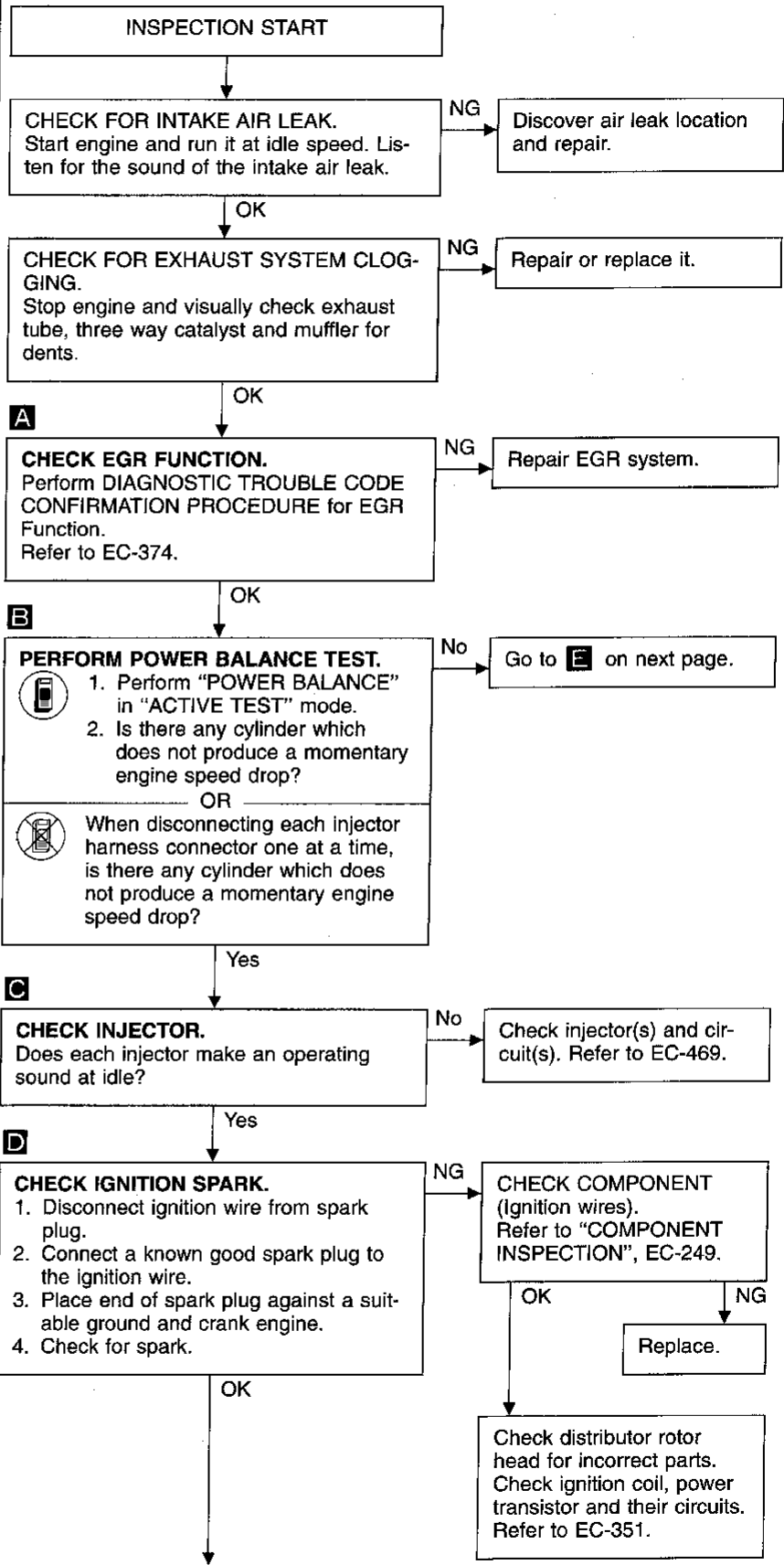
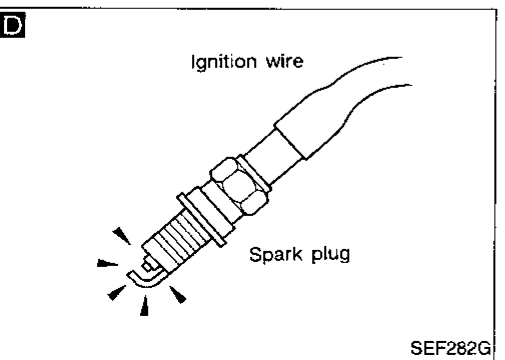
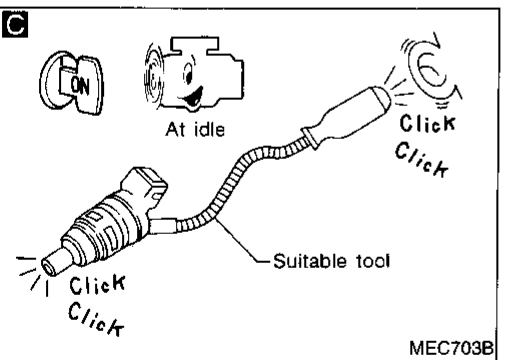
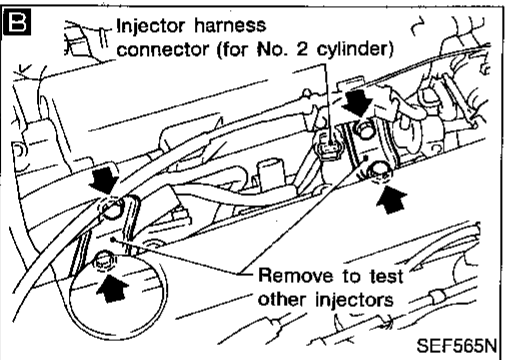
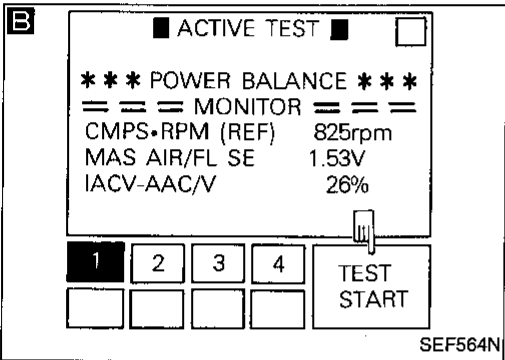
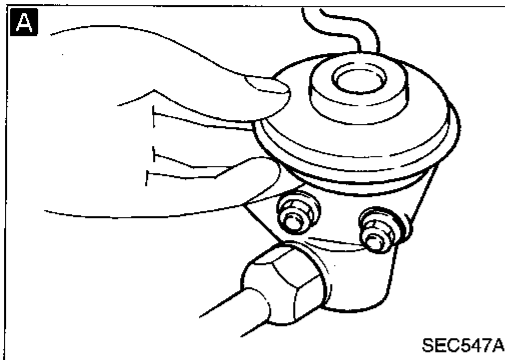

(Go to next page.)

GI
MA
EM
LC
EC
FE
CL
MT
AT
FA
RA
BR
ST
RS
BT
HA
EL
IDX

TROUBLE DIAGNOSIS FOR DTC P0300 - P0304

No. 4 - 1 Cylinder Misfire, Multiple Cylinder Misfire (Cont'd)

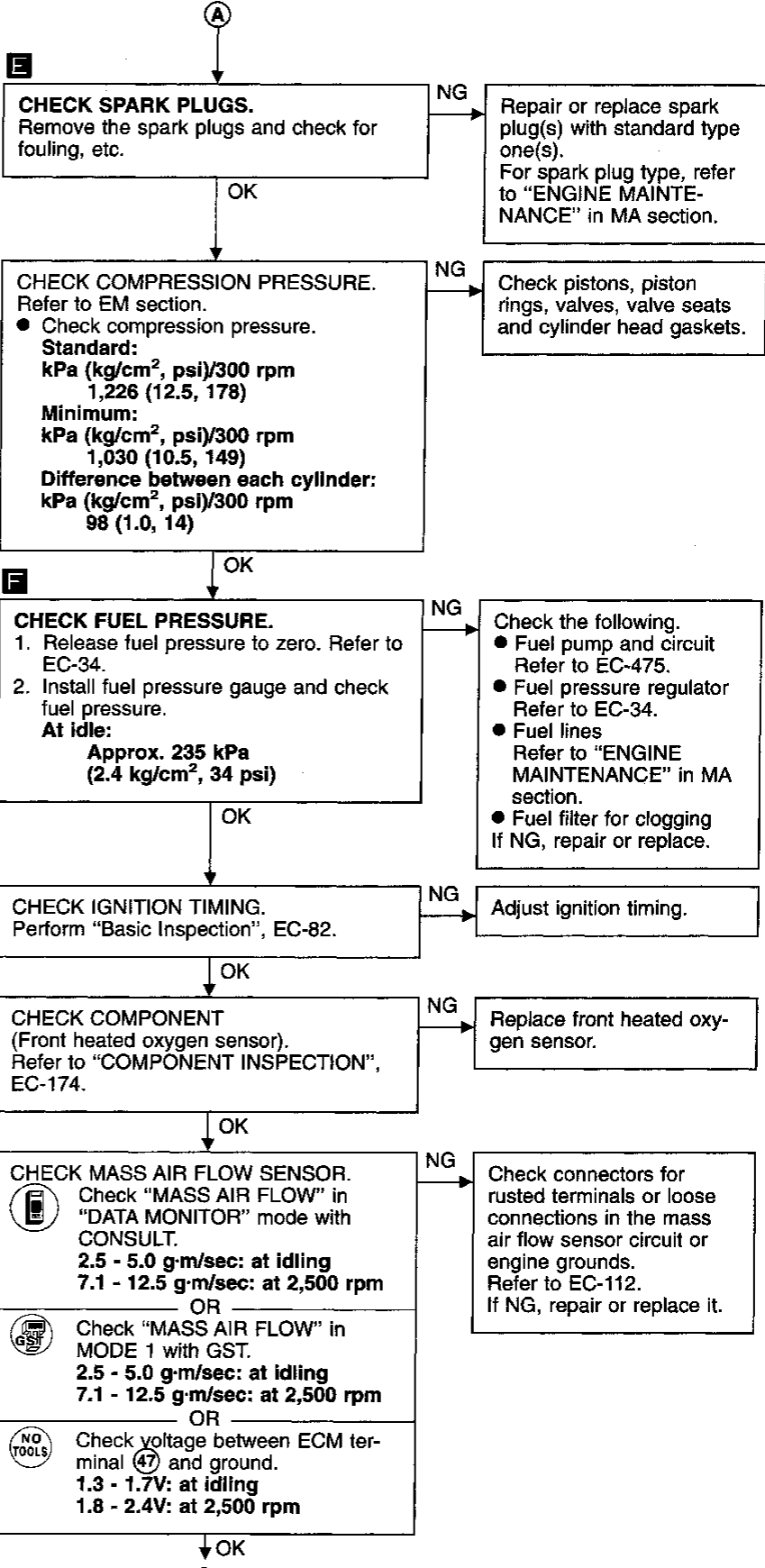
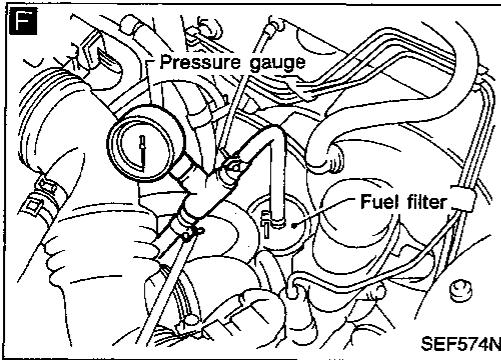
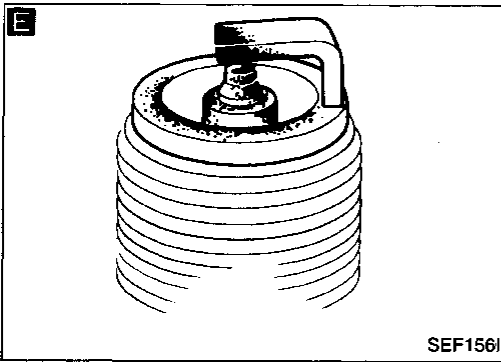

TROUBLE DIAGNOSIS FOR DTC P0300 - P0304

No. 4 - 1 Cylinder Misfire, Multiple Cylinder Misfire (Cont'd)

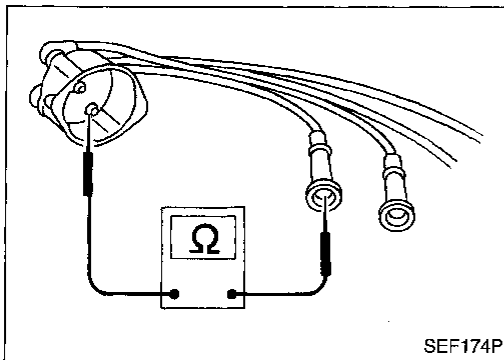
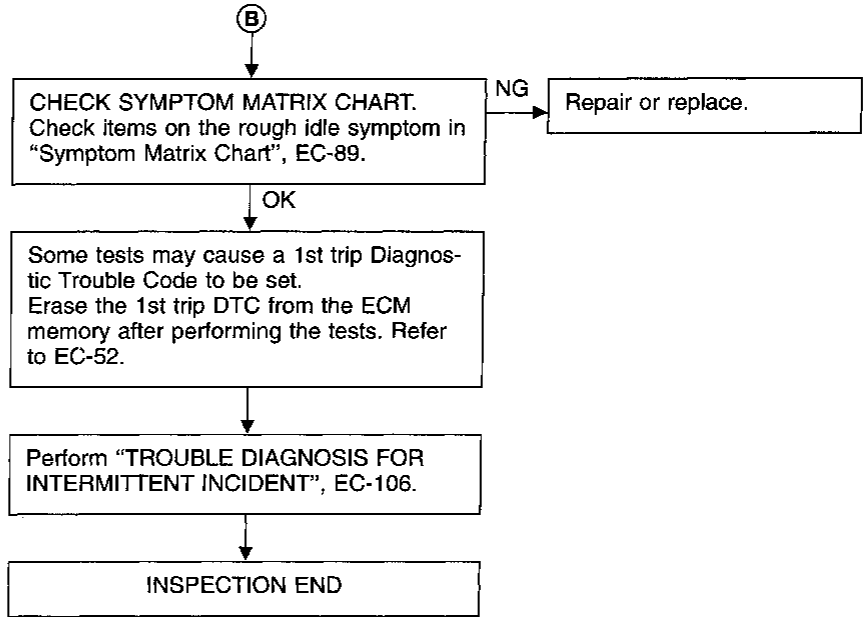

COMPONENT INSPECTION

Ignition wires

1. Inspect wires for cracks, damage, burned terminals and for improper fit.
2. Measure the resistance of wires to their distributor cap terminal. Move each wire while testing to check for intermittent breaks.

Resistance:

13.6 - 18.4 k Ω /m (4.15 - 5.61 k Ω /ft) at 25°C (77°F)

If the resistance exceeds the above specification, inspect ignition wire to distributor cap connection. Clean connection or replace the ignition wire with a new one.

TROUBLE DIAGNOSIS FOR DTC P0325

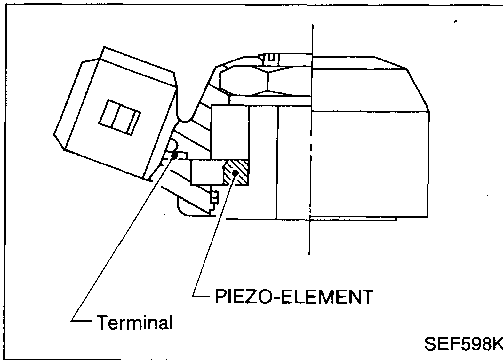

Knock Sensor (KS)

COMPONENT DESCRIPTION

The knock sensor is attached to the cylinder block. It senses engine knocking using a piezoelectric element. A knocking vibration from the cylinder block is sensed as vibrational pressure. This pressure is converted into a voltage signal and sent to the ECM.

* Freeze frame data will not be stored in the ECM for the knock sensor. The MIL will not light for knock sensor malfunction. The knock sensor has one trip detection logic.

ECM TERMINALS AND REFERENCE VALUE

Specification data are reference values and are measured between each terminal and engine ground.

TER-MINAL NO.	WIRE COLOR	ITEM	CONDITION	DATA (DC voltage)
54	W	Knock sensor	Engine is running. Idle speed	2.0 - 3.0V

ON BOARD DIAGNOSIS LOGIC

Diagnostic Trouble Code No.	Malfunction is detected when	Check Items (Possible Cause)
P0325 0304	<ul style="list-style-type: none"> An excessively low or high voltage from the knock sensor is sent to ECM. 	<ul style="list-style-type: none"> Harness or connectors (The knock sensor circuit is open or shorted.) Knock sensor

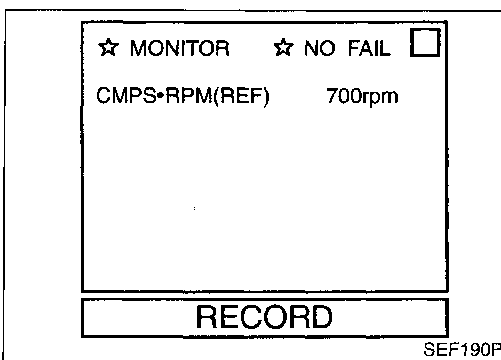

DIAGNOSTIC TROUBLE CODE CONFIRMATION PROCEDURE

NOTE:

If "DIAGNOSTIC TROUBLE CODE CONFIRMATION PROCEDURE" has been previously conducted, always turn ignition switch "OFF" and wait at least 5 seconds before conducting the next test.

TESTING CONDITION:

Before performing the following procedure, confirm that battery voltage is more than 10V at idle.

- 1) Turn ignition switch "ON" and select "DATA MONITOR" mode with CONSULT.
- 2) Start engine and run it for at least 5 seconds at idle speed.
- 3) If DTC is detected, go to "DIAGNOSTIC PROCEDURE", EC-253.

OR

- 1) Start engine and run it for at least 5 seconds at idle speed.
- 2) Select "MODE 3" with GST.
- 3) If DTC is detected, go to "DIAGNOSTIC PROCEDURE", EC-253.

TROUBLE DIAGNOSIS FOR DTC P0325

Knock Sensor (KS) (Cont'd)

OR



- 1) Start engine and run it for at least 5 seconds at idle speed.
- 2) Turn ignition switch "OFF", wait at least 5 seconds and then turn "ON".
- 3) Perform "Diagnostic Test Mode II" (Self-diagnostic results) with ECM.
- 4) If DTC is detected, go to "DIAGNOSTIC PROCEDURE", EC-253.

GI

MA

EM

LC

EC

FE

CL

MT

AT

FA

RA

BR

ST

RS

BT

HA

EL

IDX

TROUBLE DIAGNOSIS FOR DTC P0325

Knock Sensor (KS) (Cont'd)

EC-KS-01

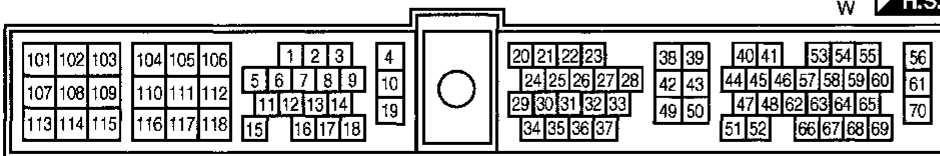
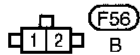
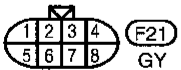
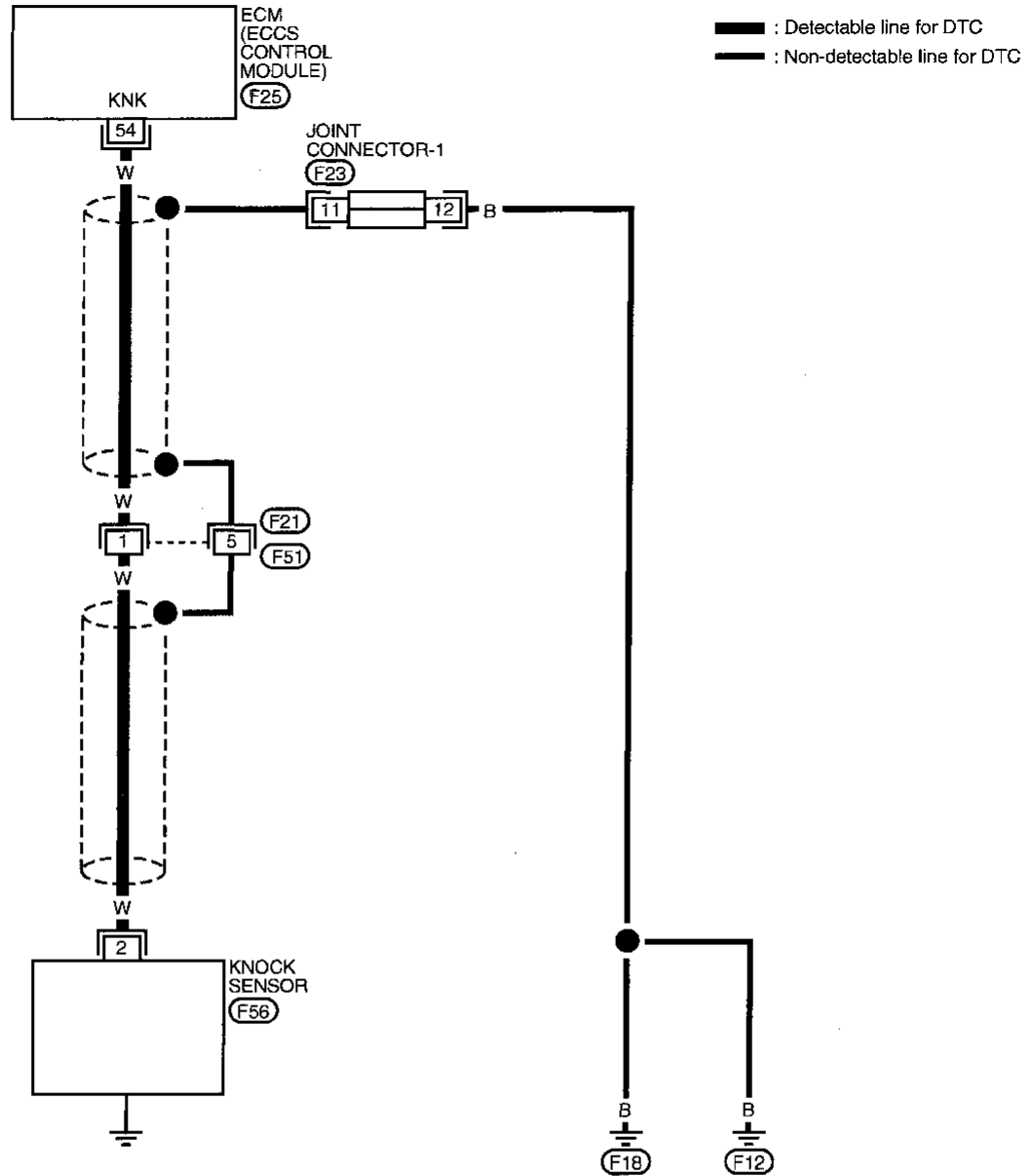

Refer to last page (Foldout page).

F23

TROUBLE DIAGNOSIS FOR DTC P0325

Knock Sensor (KS) (Cont'd)

DIAGNOSTIC PROCEDURE

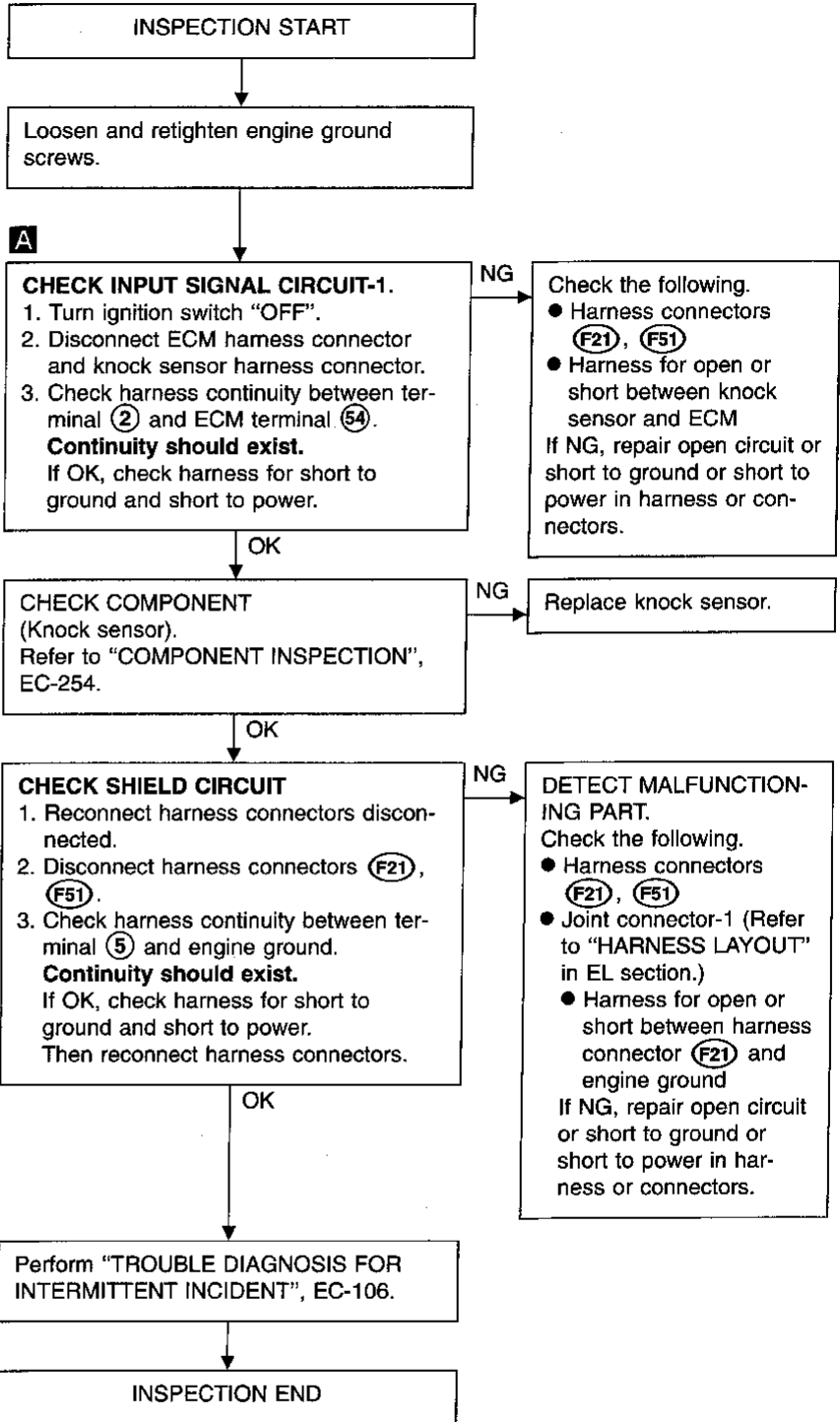
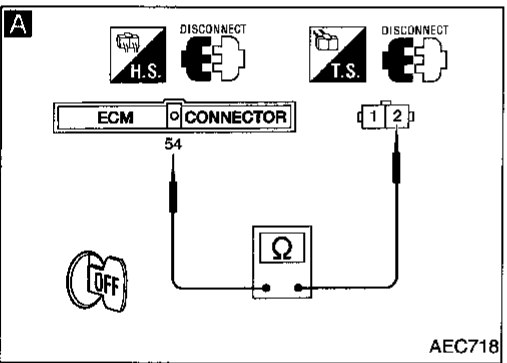
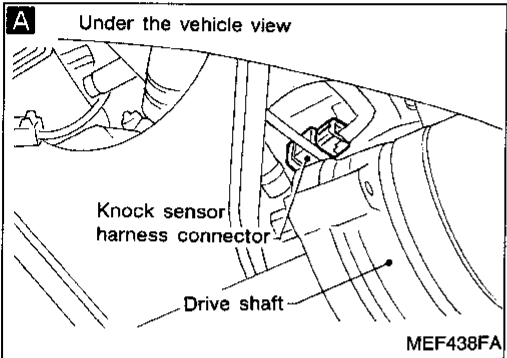
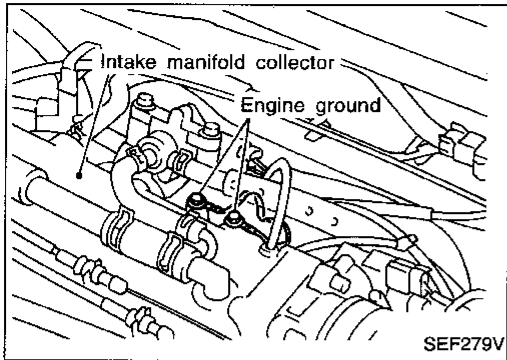

GI
MA
EM
LC
EC
FE
CL
MT
AT
FA
RA
BR
ST
RS
BT
HA
EL
IDX

TROUBLE DIAGNOSIS FOR DTC P0325

Knock Sensor (KS) (Cont'd)

COMPONENT INSPECTION

Knock sensor

- Use an ohmmeter which can measure more than 10 M Ω .
- 1. Disconnect knock sensor harness connector.
- 2. Check resistance between terminal ② and ground.

Resistance: 500 - 620 k Ω [at 25°C (77°F)]

CAUTION:

Discard any knock sensors that have been dropped or physically damaged. Use only new ones.

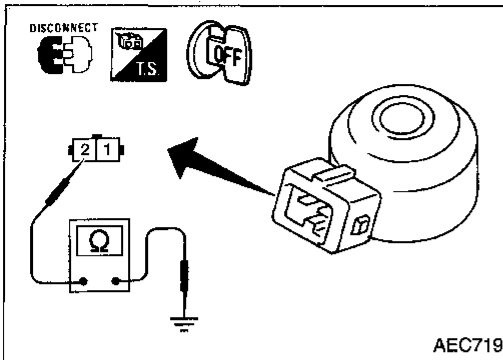

AEC719

TROUBLE DIAGNOSIS FOR DTC P0335

Crankshaft Position Sensor (CKPS) (OBD)

COMPONENT DESCRIPTION

The crankshaft position sensor (OBD) is located on the transaxle housing facing the gear teeth (cogs) of the flywheel or drive plate. It detects the fluctuation of the engine revolution. The sensor consists of a permanent magnet, core and coil. When the engine is running, the high and low parts of the teeth cause the gap with the sensor to change. The changing gap causes the magnetic field near the sensor to change.

Due to the changing magnetic field, the voltage from the sensor changes.

The ECM receives the voltage signal and detects the fluctuation of the engine revolution.

This sensor is not directly used to control the engine system. It is used only for the on board diagnosis.

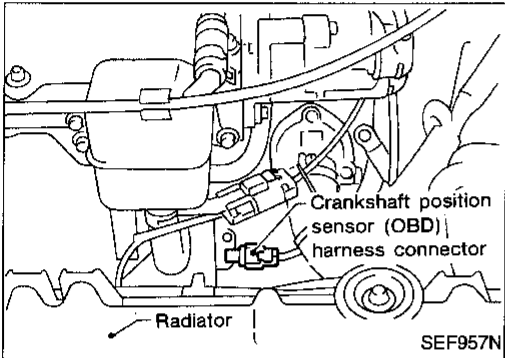
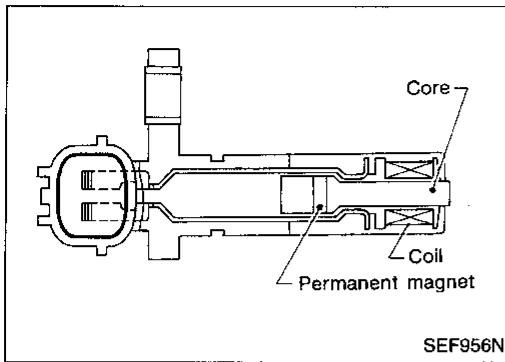

ECM TERMINALS AND REFERENCE VALUE

Specification data are reference values and are measured between each terminal and engine ground.

TER-MINAL NO.	WIRE COLOR	ITEM	CONDITION	DATA (DC voltage)
53	W	Crankshaft position sensor (OBD)	Engine is running. (Warm-up condition) Idle speed	Approximately 0.03V
			Engine is running. Engine speed is 2,000 rpm.	Approximately 0.03V

ON BOARD DIAGNOSIS LOGIC

Diagnostic Trouble Code No.	Malfunction is detected when	Check Items (Possible Cause)
P0335 0802	<ul style="list-style-type: none"> The proper pulse signal from the crankshaft position sensor (OBD) is not sent to ECM while the engine is running at the specified engine speed. 	<ul style="list-style-type: none"> Harness or connectors (The crankshaft position sensor (OBD) circuit is open.) Crankshaft position sensor (OBD)

TROUBLE DIAGNOSIS FOR DTC P0335

Crankshaft Position Sensor (CKPS) (OBD) (Cont'd)

DIAGNOSTIC TROUBLE CODE CONFIRMATION PROCEDURE

NOTE:

If "DIAGNOSTIC TROUBLE CODE CONFIRMATION PROCEDURE" has been previously conducted, always turn ignition switch "OFF" and wait at least 5 seconds before conducting the next test.

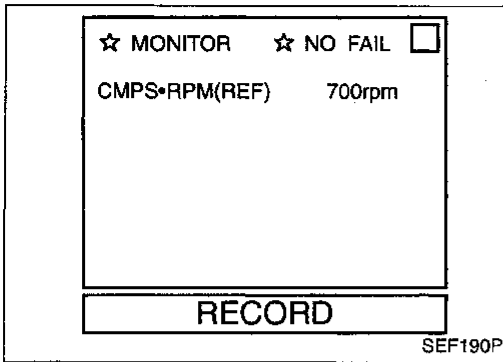

- 1) Turn ignition switch "ON" and select "DATA MONITOR" mode with CONSULT.
- 2) Start engine and run it for at least 10 seconds at idle speed.
- 3) If 1st trip DTC is detected, go to "DIAGNOSTIC PROCEDURE", EC-258.

OR



- 1) Start engine and run it for at least 10 seconds at idle speed.
- 2) Select "MODE 7" with GST.
- 3) If 1st trip DTC is detected, go to "DIAGNOSTIC PROCEDURE", EC-258.

OR



- 1) Start engine and run it for at least 10 seconds at idle speed.
- 2) Turn ignition switch "OFF", wait at least 5 seconds and then turn "ON".
- 3) Perform "Diagnostic Test Mode II" (Self-diagnostic results) with ECM.
- 4) If 1st trip DTC is detected, go to "DIAGNOSTIC PROCEDURE", EC-258.

TROUBLE DIAGNOSIS FOR DTC P0335

Crankshaft Position Sensor (CKPS) (OBD) (Cont'd)

EC-CKPS-01

GI

MA

EM

LC

EC

FE

CL

MT

AT

FA

RA

BR

ST

RS

BT

HA

EL

IDX

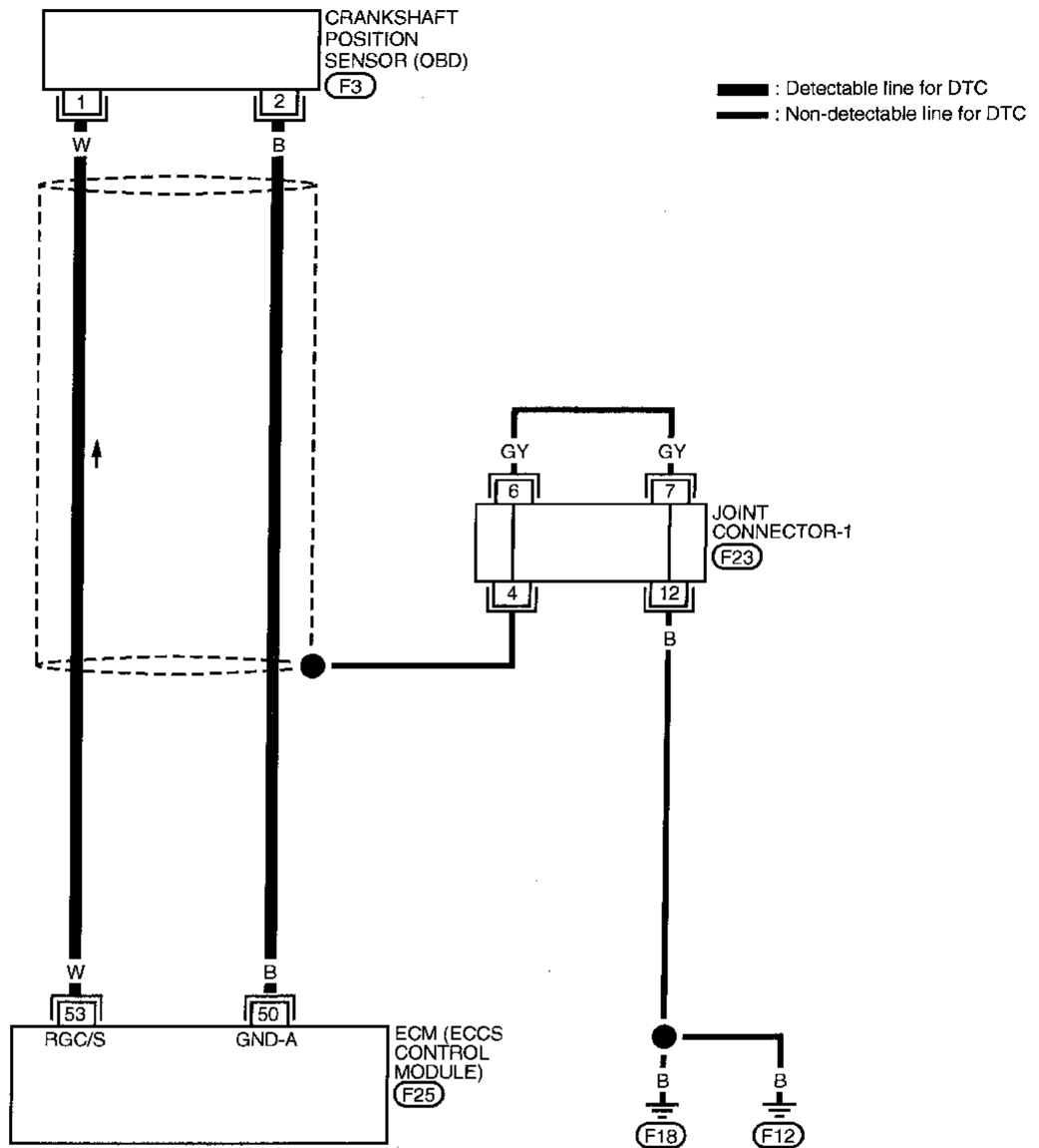

Refer to last page (Foldout page).

F23

1 2 F3
GY

F25
W H.S.

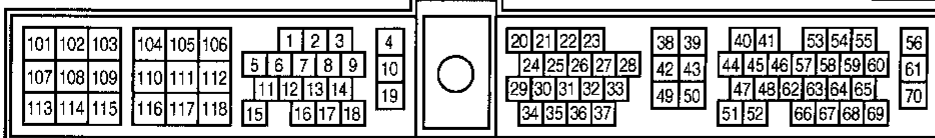

TROUBLE DIAGNOSIS FOR DTC P0335

Crankshaft Position Sensor (CKPS) (OBD) (Cont'd)

DIAGNOSTIC PROCEDURE

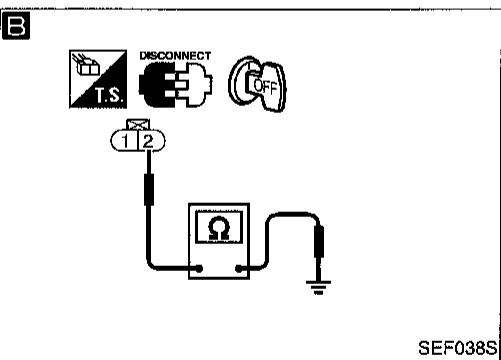
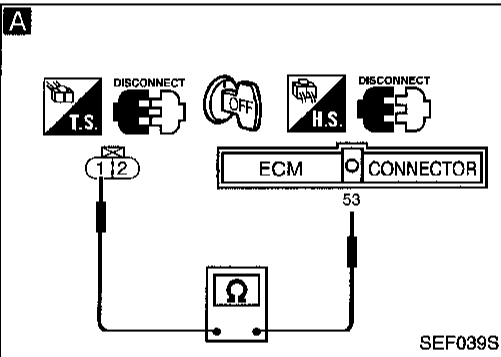
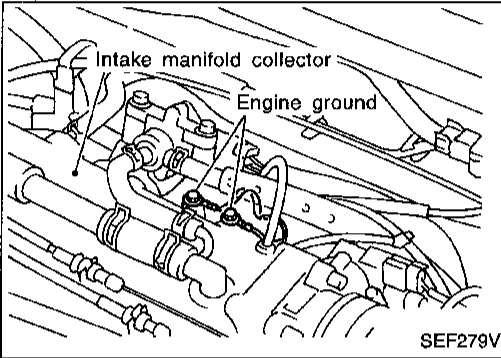
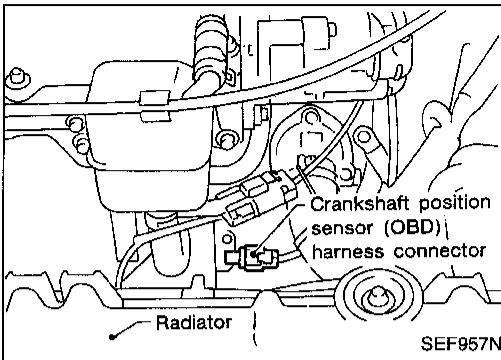

INSPECTION START

1. Turn ignition switch "OFF".
2. Loosen and retighten engine ground screws.

A

CHECK INPUT SIGNAL CIRCUIT.

1. Disconnect crankshaft position sensor (OBD) and ECM harness connectors.
 2. Check continuity between ECM terminal ⑤③ and terminal ①.
- Continuity should exist.**
If OK, check harness for short to ground and short to power.

NG

Repair open circuit or short to ground or short to power in harness or connectors.

OK

B

CHECK GROUND CIRCUIT.

1. Reconnect ECM harness connector.
 2. Check harness continuity between terminal ② and engine ground.
- Continuity should exist.**
If OK, check harness for short to ground and short to power.

NG

Repair open circuit or short to ground or short to power in harness or connectors.

OK

CHECK COMPONENT

[Crankshaft position sensor (OBD)].
Refer to "COMPONENT INSPECTION" on next page.

NG

Replace crankshaft position sensor (OBD).

OK

CHECK SHIELD CIRCUIT

1. Turn ignition switch "OFF".
 2. Remove joint connector-1.
 3. Check the following.
 - Continuity between joint connector-1 terminal ④ and engine ground
 - Joint connector-1 (Refer to "HARNESS LAYOUT" in EL section.)
- Continuity should exist.**
If OK, check harness for short to power.

NG

Repair open circuit, short to ground or short to power in harness or connectors.

OK

Perform "TROUBLE DIAGNOSIS FOR INTERMITTENT INCIDENT", EC-106.

INSPECTION END

TROUBLE DIAGNOSIS FOR DTC P0335

Crankshaft Position Sensor (CKPS) (OBD) (Cont'd)

COMPONENT INSPECTION

Crankshaft position sensor (OBD)

1. Disconnect crankshaft position sensor (OBD) harness connector.
2. Loosen the fixing bolt of the sensor.
3. Remove the sensor.
4. Visually check the sensor for chipping.

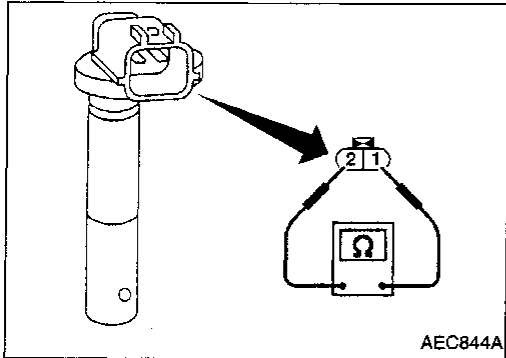
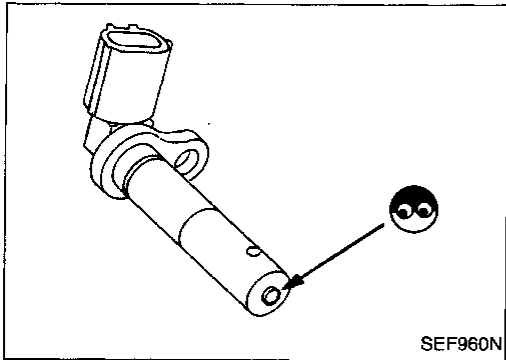

5. Check resistance as shown in the figure.

Resistance:

166 - 204 Ω [at 25°C (77°F)]

If NG, replace crankshaft position sensor (OBD).

GI

MA

EM

LC

EC

FE

CL

MT

AT

FA

RA

BR

ST

RS

BT

HA

EL

IDX

TROUBLE DIAGNOSIS FOR DTC P0340

Camshaft Position Sensor (CMPS)

COMPONENT DESCRIPTION

The camshaft position sensor is a basic component of the engine control system. It monitors engine speed and piston position. These input signals to the ECM are used to control fuel injection, ignition timing and other functions.

The camshaft position sensor has a rotor plate and a wave-forming circuit. The rotor plate has 360 slits for a 1° (POS) signal and 4 slits for a 180° (REF) signal. The wave-forming circuit consists of Light Emitting Diodes (LED) and photo diodes.

The rotor plate is positioned between the LED and the photo diode. The LED transmits light to the photo diode. As the rotor plate turns, the slits cut the light to generate rough-shaped pulses. These pulses are converted into on-off signals by the wave-forming circuit and sent to the ECM.

The distributor is not repairable and must be replaced as an assembly except distributor cap and rotor head.

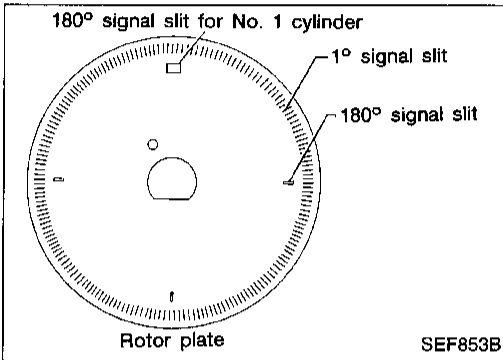
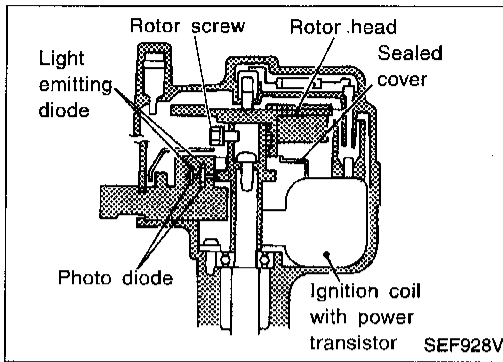

ECM TERMINALS AND REFERENCE VALUE

Specification data are reference values and are measured between each terminal and engine ground.

TER-MINAL NO.	WIRE COLOR	ITEM	CONDITION	DATA (DC voltage)
40	L	Camshaft position sensor (Reference signal)	<div style="border: 1px solid black; padding: 2px;">Engine is running.</div> (Warm-up condition) └ Idle speed	0.1 - 0.4V SEF199T
44	L		<div style="border: 1px solid black; padding: 2px;">Engine is running.</div> └ Engine speed is 2,000 rpm.	0.1 - 0.4V SEF200T

TROUBLE DIAGNOSIS FOR DTC P0340

Camshaft Position Sensor (CMPS) (Cont'd)

TER-MINAL NO.	WIRE COLOR	ITEM	CONDITION	DATA (DC voltage)
41 45	B/W B/W	Camshaft position sensor (Position signal)	<div style="border: 1px solid black; padding: 2px; display: inline-block;">Engine is running.</div> (Warm-up condition) Idle speed	Approximately 2.5V
			<div style="border: 1px solid black; padding: 2px; display: inline-block;">Engine is running.</div> Engine speed is 2,000 rpm.	Approximately 2.3 - 2.5V
56 61	W/R W/R	Power supply for ECM	<div style="border: 1px solid black; padding: 2px; display: inline-block;">Ignition switch "ON"</div>	BATTERY VOLTAGE (11 - 14V)

ON BOARD DIAGNOSIS LOGIC

Diagnostic Trouble Code No.	Malfunction is detected when	Check Items (Possible Cause)
P0340 0101	A) Either 1° or 180° signal is not sent to ECM for the first few seconds during engine cranking. ----- B) Either 1° or 180° signal is not sent to ECM often enough while the engine speed is higher than the specified engine speed. ----- C) The relation between 1° and 180° signal is not in the normal range during the specified engine speed.	<ul style="list-style-type: none"> ● Harness or connectors (The camshaft position sensor circuit is open or shorted.) ● Camshaft position sensor ● Starter motor (Refer to EL section.) ● Starting system circuit (Refer to EL section.) ● Dead (Weak) battery

DIAGNOSTIC TROUBLE CODE CONFIRMATION PROCEDURE

Perform "Procedure for malfunction A" first. If DTC cannot be confirmed, perform "Procedure for malfunction B and C".

NOTE:

If "DIAGNOSTIC TROUBLE CODE CONFIRMATION PROCEDURE" has been previously conducted, always turn ignition switch "OFF" and wait at least 5 seconds before conducting the next test.

TESTING CONDITION:

Before performing the following procedure, confirm that battery voltage is more than 10.5V at idle.

TROUBLE DIAGNOSIS FOR DTC P0340

Camshaft Position Sensor (CMPS) (Cont'd)

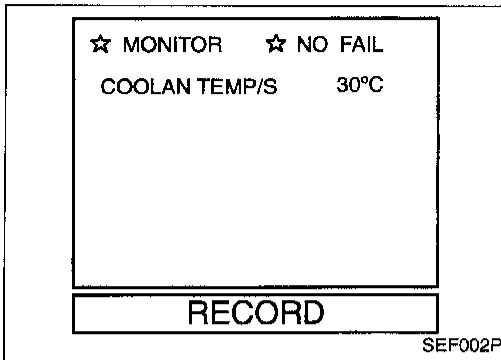

Procedure for malfunction A

- 1) Turn ignition switch "ON".
- 2) Select "DATA MONITOR" mode with CONSULT.
- 3) Crank engine for at least 2 seconds.
- 4) If 1st trip DTC is detected, go to "DIAGNOSTIC PROCEDURE", EC-264.

OR

- 1) Crank engine for at least 2 seconds.
- 2) Select "MODE 7" with GST.
- 3) If 1st trip DTC is detected, go to "DIAGNOSTIC PROCEDURE", EC-264.

OR

- 1) Crank engine for at least 2 seconds.
- 2) Turn ignition switch "OFF", wait at least 5 seconds and then turn "ON".
- 3) Perform "Diagnostic Test Mode II" (Self-diagnostic results) with ECM.
- 4) If 1st trip DTC is detected, go to "DIAGNOSTIC PROCEDURE", EC-264.

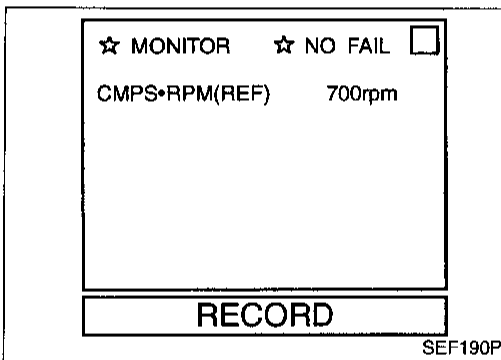

Procedure for malfunction B and C

- 1) Turn ignition switch "ON".
- 2) Select "DATA MONITOR" mode with CONSULT.
- 3) Start engine and run it for at least 2 seconds at idle speed.
- 4) If 1st trip DTC is detected, go to "DIAGNOSTIC PROCEDURE", EC-264.

OR

- 1) Start engine and run it for at least 2 seconds at idle speed.
- 2) Select "MODE 7" with GST.
- 3) If 1st trip DTC is detected, go to "DIAGNOSTIC PROCEDURE", EC-264.

OR

- 1) Start engine and run it for at least 2 seconds at idle speed.
- 2) Turn ignition switch "OFF", wait at least 5 seconds and then turn "ON".
- 3) Perform "Diagnostic Test Mode II" (Self-diagnostic results) with ECM.
- 4) If 1st trip DTC is detected, go to "DIAGNOSTIC PROCEDURE", EC-264.

TROUBLE DIAGNOSIS FOR DTC P0340

Camshaft Position Sensor (CMPS) (Cont'd) DIAGNOSTIC PROCEDURE (DETECTABLE CIRCUIT)

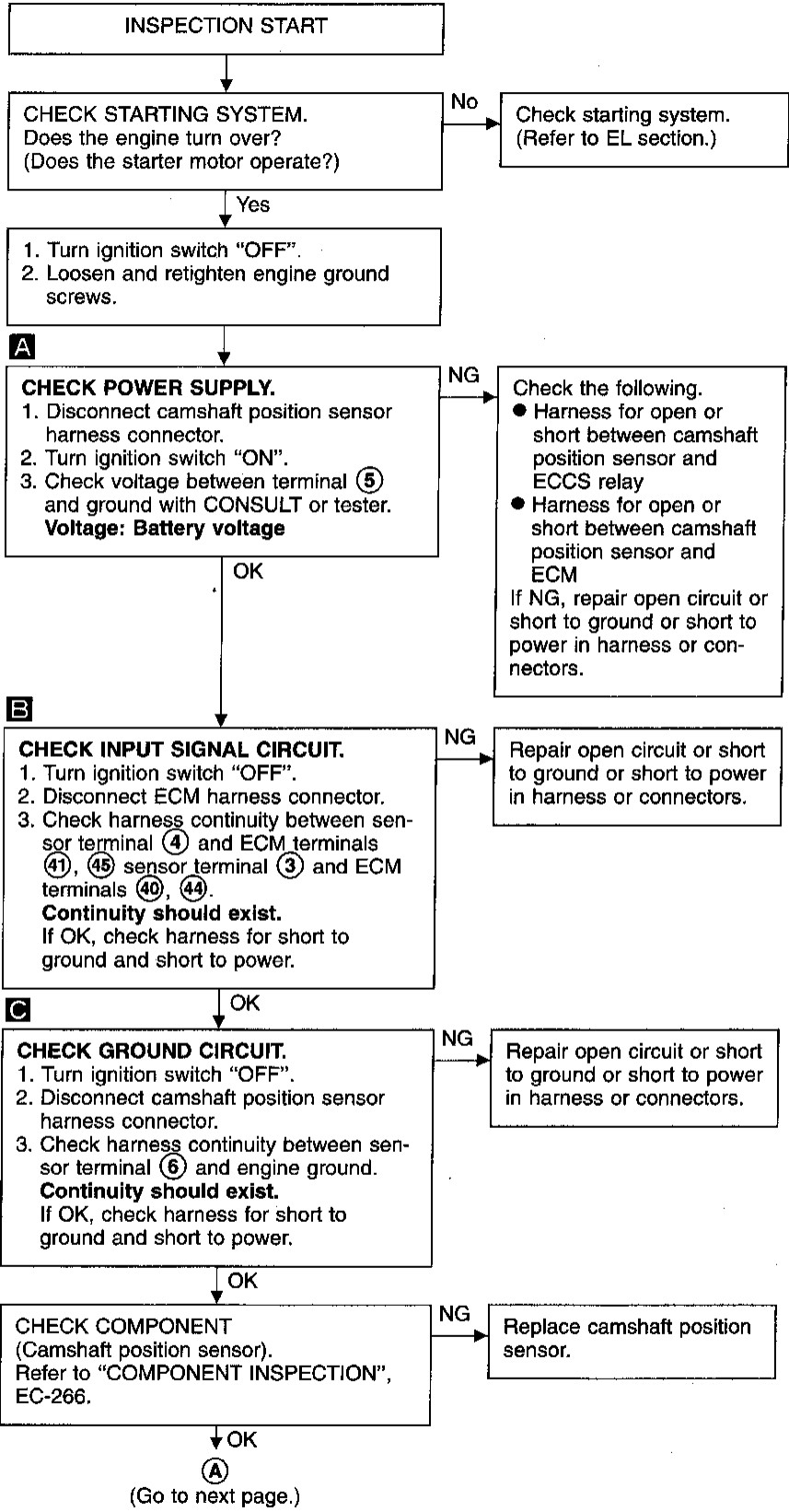
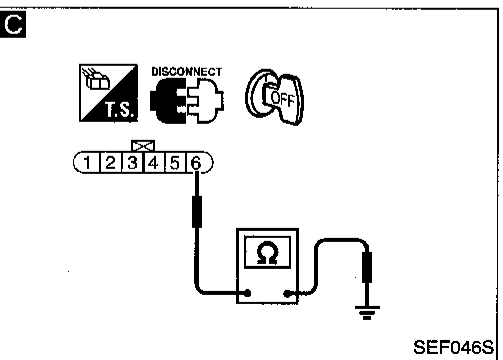
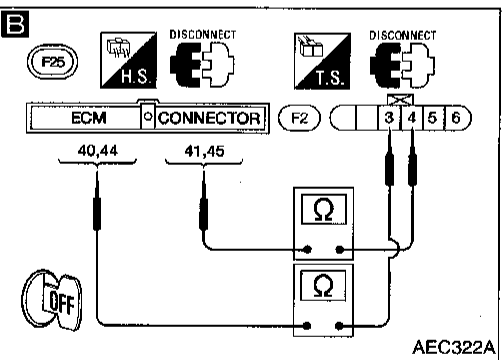
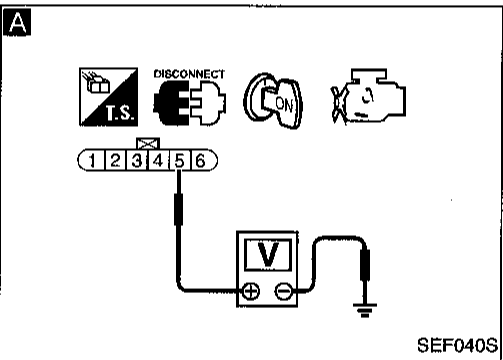
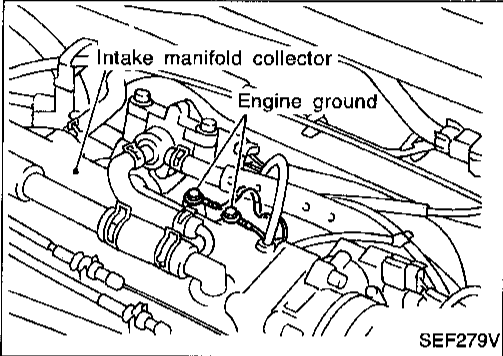
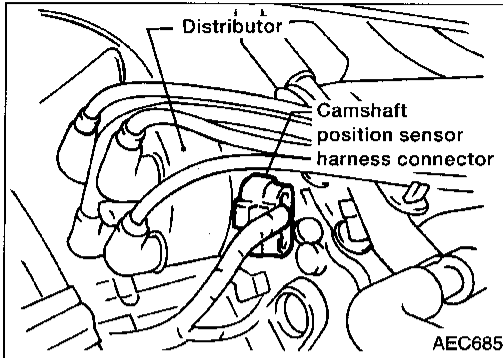

TROUBLE DIAGNOSIS FOR DTC P0340

Camshaft Position Sensor (CMPS) (Cont'd)

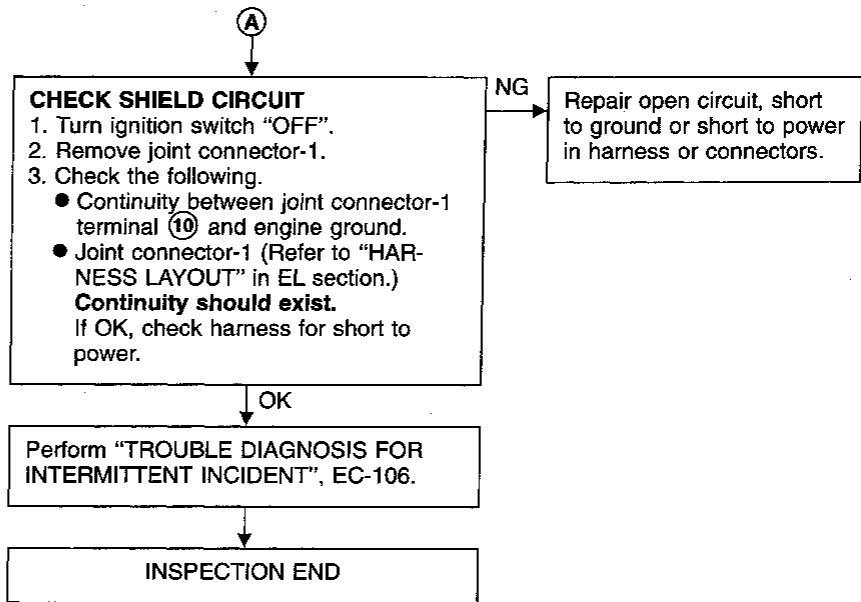

GI
MA
EM
LC
EC
FE
CL
MT
AT
FA
RA
BR
ST
RS
BT
HA
EL
IDX

TROUBLE DIAGNOSIS FOR DTC P0340

Camshaft Position Sensor (CMPS) (Cont'd) COMPONENT INSPECTION

Camshaft position sensor

1. Start engine and warm it up to normal operating temperature.
2. Check voltage between ECM terminals ④①, ④① and engine ground.

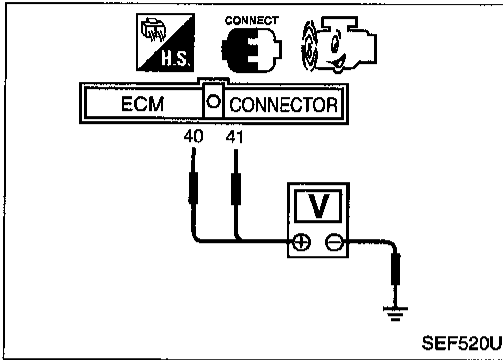

Terminal ④① (or ④④) and engine ground

Condition	Idle	2,000 rpm
Voltage	0.1 - 0.4V	0.1 - 0.4V
Pulse signal	<p style="text-align: right;">SEF199T</p>	<p style="text-align: right;">SEF200T</p>

Terminal ④② (or ④⑤) and engine ground

Condition	Idle	2,000 rpm
Voltage	Approximately 2.5V	Approximately 2.4V
Pulse signal	<p style="text-align: right;">SEF195T</p>	<p style="text-align: right;">SEF196T</p>

If NG, replace distributor assembly with camshaft position sensor.

EGR Function (Close)

SYSTEM DESCRIPTION

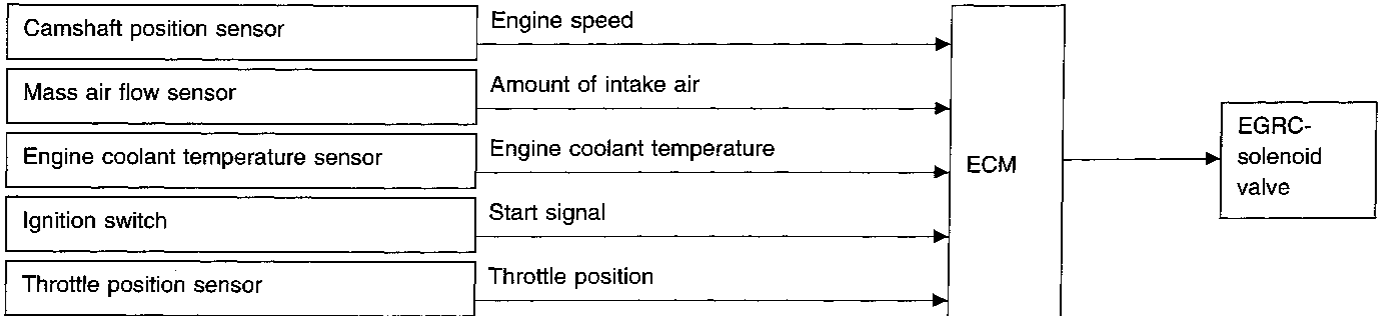

This system cuts and controls vacuum applied to the EGR valve to suit engine operating conditions. This cut-and-control operation is accomplished through the ECM and the EGRC-solenoid valve. When the ECM detects any of the following conditions, current through the solenoid valve is cut. This causes the vacuum to be discharged into the atmosphere. The EGR valve remains closed.

- Low engine coolant temperature
- Engine starting
- High-speed engine operation
- Engine idling
- Excessively high engine coolant temperature.
- Mass air flow sensor malfunction

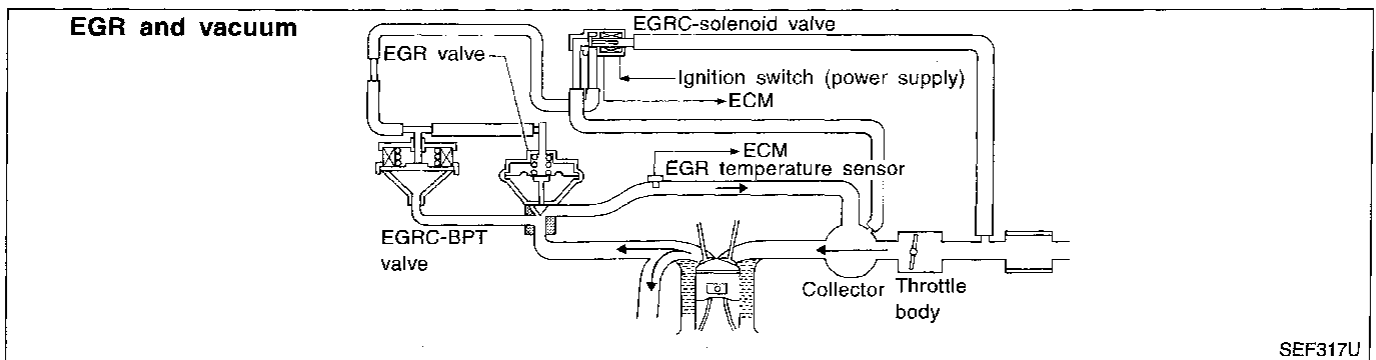

SEF317U

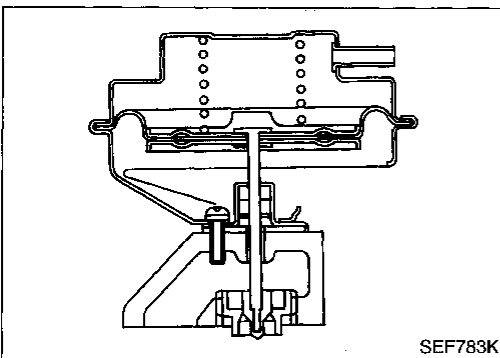

SEF783K

COMPONENT DESCRIPTION

Exhaust gas recirculation (EGR) valve

The EGR valve controls the amount of exhaust gas routed to the intake manifold. Vacuum is applied to the EGR valve in response to throttle valve opening. The vacuum controls the movement of a taper valve connected to the vacuum diaphragm in the EGR valve.

TROUBLE DIAGNOSIS FOR DTC P0400

EGR Function (Close) (Cont'd)

EGRC-solenoid valve

The EGRC-solenoid valve responds to signals from the ECM. When the ECM sends an ON (ground) signal, the coil in the solenoid valve is energized. The vacuum signal passes through the solenoid valve. The signal then reaches the EGR valve.

When the ECM sends an OFF signal, a plunger will then move to cut the vacuum signal from the intake manifold collector to the EGR valve.

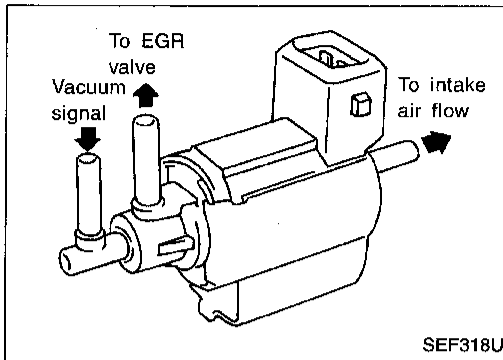

ON BOARD DIAGNOSIS LOGIC

If the absence of EGR flow is detected by EGR temperature sensor under the condition that calls for EGR, a low-flow malfunction is diagnosed.

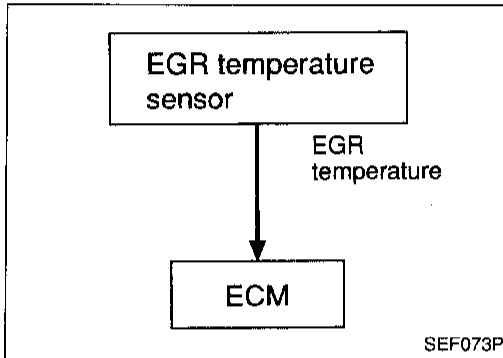

Diagnostic Trouble Code No.	Malfunction is detected when ...	Check Items (Possible Cause)
P0400 0302	<ul style="list-style-type: none"> ● No EGR flow is detected under condition that calls for EGR. 	<ul style="list-style-type: none"> ● EGR valve stuck closed ● EGRC-BPT valve ● Vacuum hose ● EGRC-solenoid valve ● EGR passage ● EGR temperature sensor ● Exhaust gas leaks

TROUBLE DIAGNOSIS FOR DTC P0400

EGR Function (Close) (Cont'd)

DIAGNOSTIC TROUBLE CODE CONFIRMATION PROCEDURE

CAUTION:

Always drive vehicle at a safe speed.

NOTE:

- If "DIAGNOSTIC TROUBLE CODE CONFIRMATION PROCEDURE" has been previously conducted, always turn ignition switch "OFF" and wait at least 5 seconds before conducting the next test.
- P0400 will not be displayed at "SELF-DIAG RESULTS" mode with CONSULT even though DTC work support test result is "NG".

TESTING CONDITION:

For best results, perform test at a temperature above 5°C (41°F).



- 1) Turn ignition switch "ON".
- 2) Check "COOLAN TEMP/S" in "DATA MONITOR" mode with CONSULT.

Confirm COOLAN TEMP/S value is within the range listed below.

COOLAN TEMP/S: Less than 40°C (104°F)

If the value is out of range, park the vehicle in a cool place and allow the engine temperature to stabilize. Do not attempt to lower the coolant temperature with a fan or means other than ambient air. Doing so may produce an inaccurate diagnostic result.

- 3) Start engine and let it idle monitoring "COOLAN TEMP/S" value. When the "COOLAN TEMP/S" value reaches 70°C (158°F), immediately go to the next step.
- 4) Select "EGR SYSTEM P0400" of "EGR SYSTEM" in "DTC WORK SUPPORT" mode with CONSULT.
- 5) Touch "START".
- 6) Accelerate vehicle to a speed of 40 km/h (25 MPH) once and then stop vehicle with engine running. If "COMPLETED" appears on CONSULT screen, go to step 9). If "COMPLETED" does not appear on CONSULT screen, go to the following step.
- 7) Check the output voltage of "THRTL POS SEN" (at closed throttle position) and note it.
- 8) When the following conditions are met, "TESTING" will be displayed on the CONSULT screen. Maintain the conditions until "TESTING" changes to "COMPLETED". (It will take approximately 40 seconds or more.)

**CMPS-RPM (REF): 1,800 - 2,800 rpm (A/T)
1,600 - 2,800 rpm (M/T)**

Vehicle speed: 10 km/h (6 MPH) or more

**B/FUEL SCHDL: 2.0 - 3.5 msec (A/T)
1.8 - 3.0 msec (M/T)**

**THRTL POS SEN: X - (X + 0.87) V
X = Voltage value measured at step 7)**

Selector lever: Suitable position

If "TESTING" is not displayed after 5 minutes, retry from step 2).

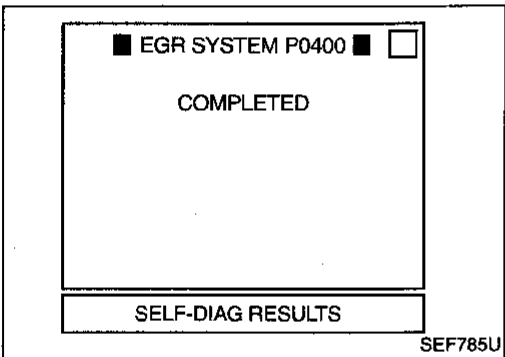
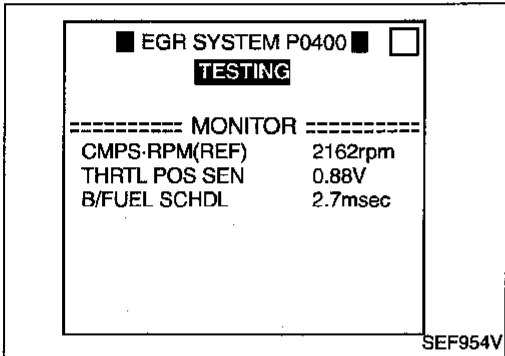
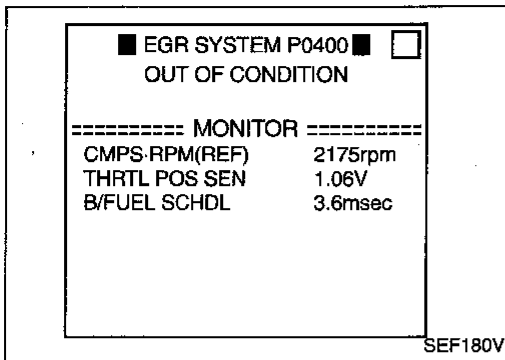

GI

MA

EM

LC

EC

FE

CL

MT

AT

FA

RA

BR

ST

RS

BT

HA

EL

IDX

TROUBLE DIAGNOSIS FOR DTC P0400

EGR Function (Close) (Cont'd)

- 9) Make sure that "OK" is displayed after touching "SELF-DIAG RESULTS". If "NG" is displayed, refer to "DIAGNOSTIC PROCEDURE", EC-272.

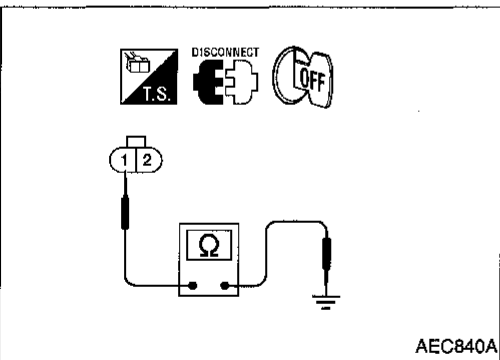
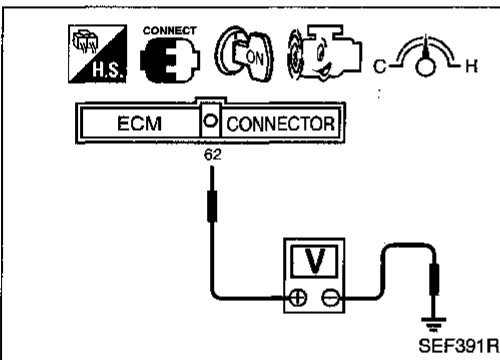
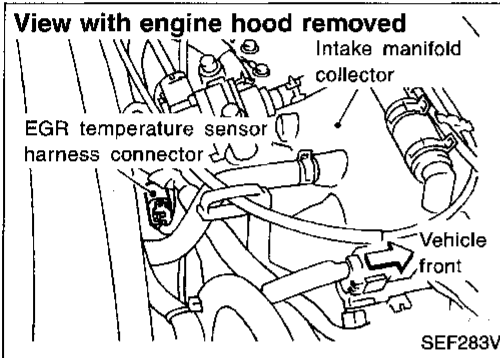

Overall function check

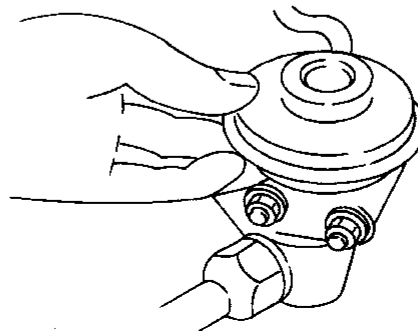
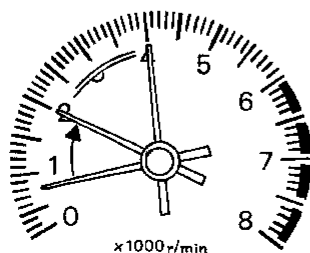

SEF642Q

OR

OVERALL FUNCTION CHECK

Use this procedure to check the overall EGR function. During this check, a 1st trip DTC might not be confirmed.

- 1) Start engine and warm it up to normal operating temperature.
- 2) Check the EGR valve lifting when revving engine from idle to 3,000 rpm under no load.
EGR valve should lift up and down without sticking.
If NG, go to "DIAGNOSTIC PROCEDURE", EC-272.
- 3) Check voltage between ECM terminal ⑥2 and engine ground at idle speed.
Less than 4.5V should exist.
- 4) Turn ignition switch "OFF".
- 5) Disconnect EGR temperature sensor harness connector.
- 6) Check harness continuity between EGR temperature sensor harness connector terminal ① and engine ground.
Continuity should exist.
- 7) Perform "COMPONENT INSPECTION", "EGR temperature sensor". Refer to EC-275.

TROUBLE DIAGNOSIS FOR DTC P0400

EGR Function (Close) (Cont'd)

DIAGNOSTIC PROCEDURE

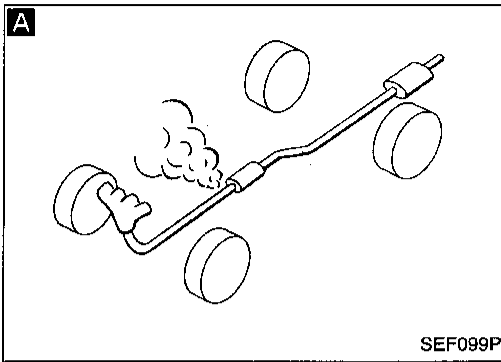

INSPECTION START

A
CHECK EXHAUST SYSTEM.
Check exhaust pipes and muffler for leaks.

NG → Repair or replace exhaust system.

OK

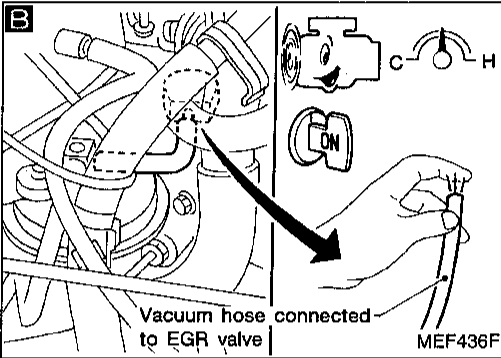

B
CHECK VACUUM SOURCE TO EGR VALVE.

1. Start engine and warm it up to normal operating temperature.
2. Disconnect vacuum hose to EGR valve.
3. Check for vacuum existence.

Vacuum should not exist at idle.

4. Check for vacuum existence when revving from 2,000 to 3,000 rpm with the following method.

- Select "EGRC SOLENOID VALVE" in "ACTIVE TEST" mode with CONSULT and turn the solenoid valve "ON".

Vacuum should exist when revving engine.

OR

4. Stop engine.
5. Start engine and check for vacuum existence when revving from 2,000 to 3,000 rpm.

Vacuum should exist when revving engine.

OK → CHECK COMPONENT (EGR valve).
Refer to "COMPONENT INSPECTION", EC-379.

NG

Replace EGR valve.

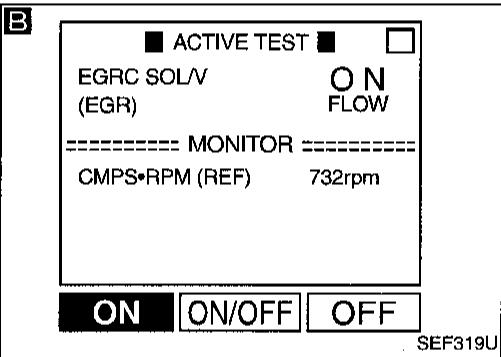

NG

C
CHECK VACUUM HOSE.
Check vacuum hose for clogging, cracks or improper connection.

NG → Repair or replace vacuum hose.

OK

A

(Go to next page.)

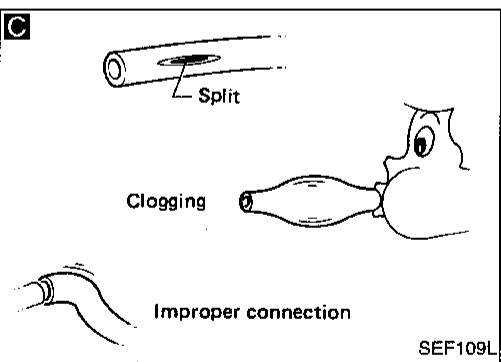

TROUBLE DIAGNOSIS FOR DTC P0400

EGR Function (Close) (Cont'd)

D

■ EGRC SOL/V CIRCUIT ■

DOES THE SOLENOID VALVE MAKE AN OPERATING SOUND EVERY 3 SECONDS?

NEXT NO YES

MEF957D

D

■ ACTIVE TEST ■

EGRC SOL/V (EGR) ON FLOW

MONITOR

CMPS•RPM (REF) 732rpm

ON ON/OFF OFF

SEF319U

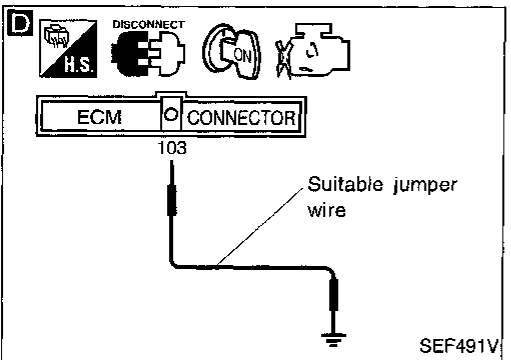

D

CHECK COMPONENT
(EGRC-solenoid valve).

1. Turn ignition switch "ON".
2. Perform "EGRC SOL/V CIRCUIT" in "FUNCTION TEST" mode with CONSULT.

Note: If this function test mode is not available, use "ACTIVE TEST" mode.

NG → Repair or replace EGRC-solenoid valve or repair circuit.

OR

1. Turn ignition switch "ON".
2. Turn EGRC-solenoid valve "ON" and "OFF" in "ACTIVE TEST" mode with CONSULT and check operating sound.

OR

1. Turn ignition switch "OFF".
2. Disconnect ECM harness connector.
3. Turn ignition switch "ON".
4. Connect a suitable jumper wire between ECM terminal 103 and engine ground.
5. Check operating sound of the solenoid valve when disconnecting and reconnecting the jumper wire.

OK

CHECK COMPONENT
(EGRC-solenoid valve).
Refer to "COMPONENT INSPECTION" on the next page.

NG → Replace EGRC-solenoid valve.

OK

CHECK COMPONENT
(EGRC-BPT valve).
Refer to "COMPONENT INSPECTION", EC-275.

NG → Replace EGRC-BPT valve.

OK

CHECK COMPONENT
(EGR temperature sensor).
Refer to "COMPONENT INSPECTION", EC-275.

NG → Replace EGR temperature sensor.

OK

Perform "TROUBLE DIAGNOSIS FOR INTERMITTENT INCIDENT", EC-106.

INSPECTION END

GI
MA
EM
LC
EC
FE
CL
MT
AT
FA
RA
BR
ST
RS
BT
HA
EL
IDX

TROUBLE DIAGNOSIS FOR DTC P0400

EGR Function (Close) (Cont'd)

COMPONENT INSPECTION

EGR valve

- Apply vacuum to EGR vacuum port with a hand vacuum pump.

EGR valve spring should lift.

- Check for sticking.
If NG, repair or replace EGR valve.

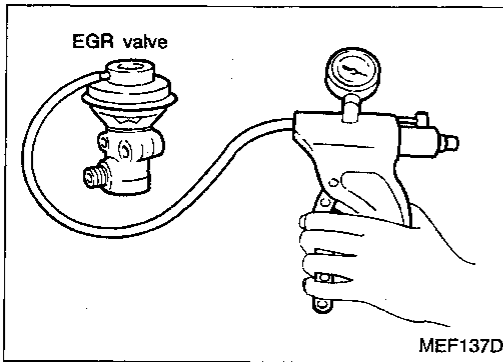

EGRC-solenoid valve

Check air passage continuity.

- Perform "EGRC SOLENOID VALVE" in "ACTIVE TEST" mode.

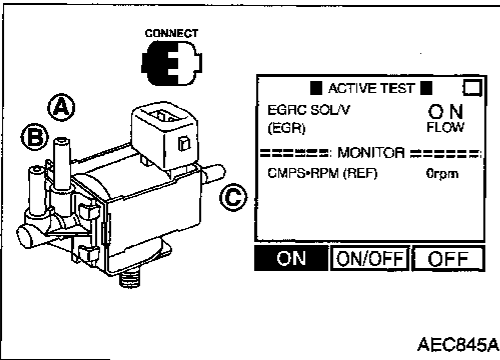

Condition EGRC SOLENOID VALVE	Air passage continuity between (A) and (B)	Air passage continuity between (A) and (C)
ON	Yes	No
OFF	No	Yes

OR

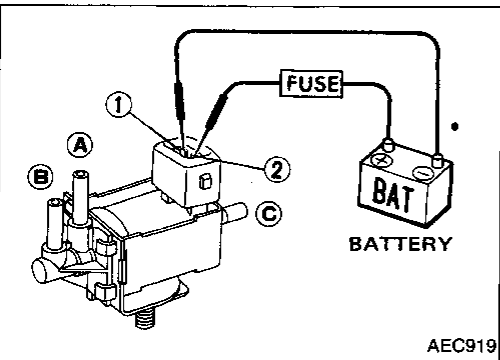

Conditions	Air passage continuity between (A) and (B)	Air passage continuity between (A) and (C)
12V direct current supply between terminals (1) and (2)	Yes	No
No supply	No	Yes

If NG or operation takes more than 1 second, replace EGRC-solenoid valve.

TROUBLE DIAGNOSIS FOR DTC P0400

EGR Function (Close) (Cont'd)

EGR temperature sensor

Check resistance change and resistance value.

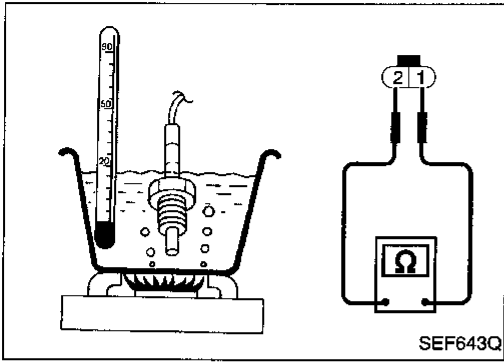

EGR temperature °C (°F)	Voltage (V)	Resistance (MΩ)
0 (32)	4.81	7.9 - 9.7
50 (122)	2.82	0.57 - 0.70
100 (212)	0.8	0.08 - 0.10

If NG, replace EGR temperature sensor.

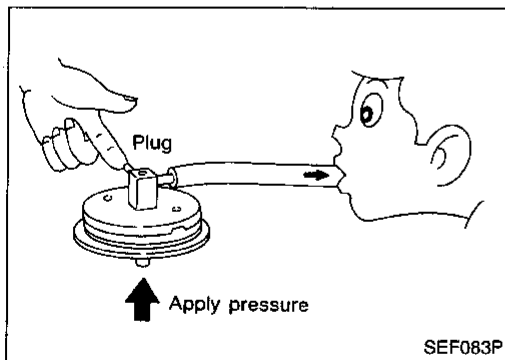
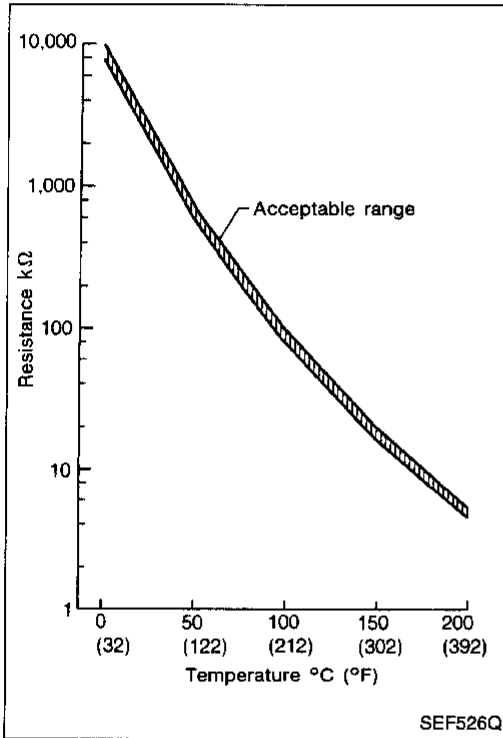

EGRC-BPT valve

1. Plug one of two ports of EGRC-BPT valve.
2. Vacuum from the other port and check for leakage while applying a pressure above 0.981 kPa (100 mmH₂O, 3.94 inH₂O) from under EGRC-BPT valve.
3. If a leakage is noted, replace the valve.

GI

MA

EM

LC

EC

FE

CL

MT

AT

FA

RA

BR

ST

RS

BT

HA

EL

IDX

EGRC-BPT Valve Function

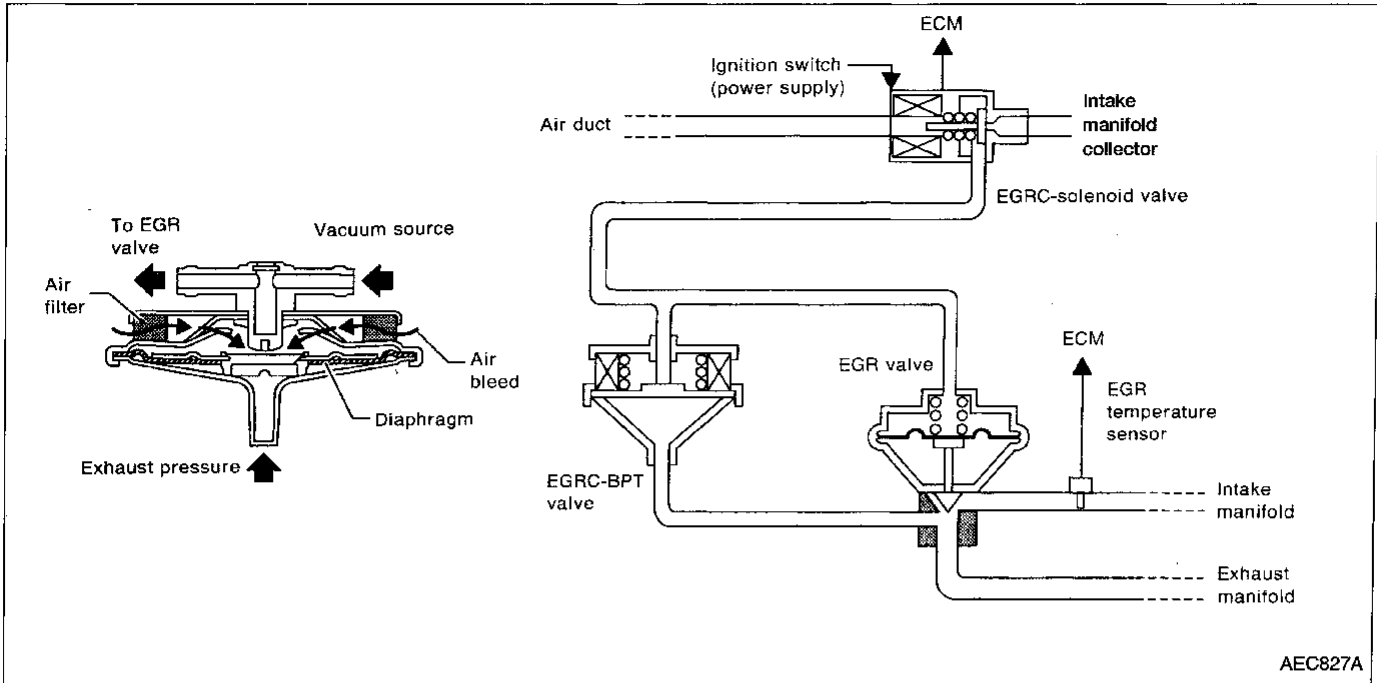

SYSTEM DESCRIPTION

The EGRC-BPT valve monitors exhaust pressure to activate the diaphragm, controlling throttle body vacuum applied to the EGR valve. In other words, recirculated exhaust gas is controlled in response to positioning of the EGR valve or to engine operation.

ON BOARD DIAGNOSIS LOGIC

If too much EGR flow exists due to an EGRC-BPT valve malfunction, off idle engine roughness will increase. If the roughness is large, then the vacuum to the EGR valve is interrupted through the EGRC-solenoid valve. If the engine roughness is reduced at that time, the EGRC-BPT valve malfunction is indicated.

Diagnostic Trouble Code No.	Malfunction is detected when ...	Check Items (Possible Cause)
P0402 0306	<ul style="list-style-type: none"> ● The EGRC-BPT valve does not operate properly. 	<ul style="list-style-type: none"> ● EGRC-BPT valve ● EGR valve ● Loose or disconnected rubber tube ● Blocked rubber tube ● Camshaft position sensor ● Blocked exhaust system ● Orifice ● Mass air flow sensor ● EGRC-solenoid valve

TROUBLE DIAGNOSIS FOR DTC P0402

EGRC-BPT Valve Function (Cont'd)

DIAGNOSTIC TROUBLE CODE CONFIRMATION PROCEDURE

CAUTION:

Always drive vehicle at a safe speed.

NOTE:

If "DIAGNOSTIC TROUBLE CODE CONFIRMATION PROCEDURE" has been previously conducted, always turn ignition switch "OFF" and wait at least 5 seconds before conducting the next test.

TESTING CONDITION:

For best results, perform test at a temperature above 5°C (41°F).

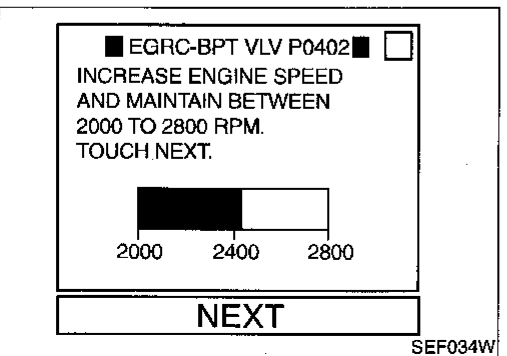
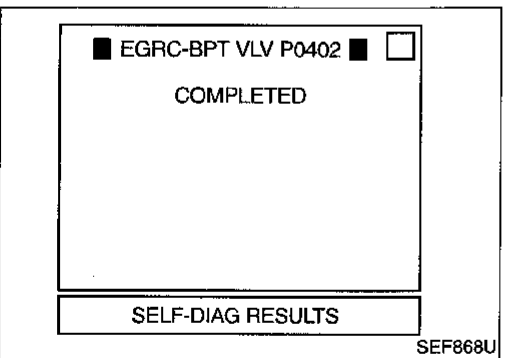
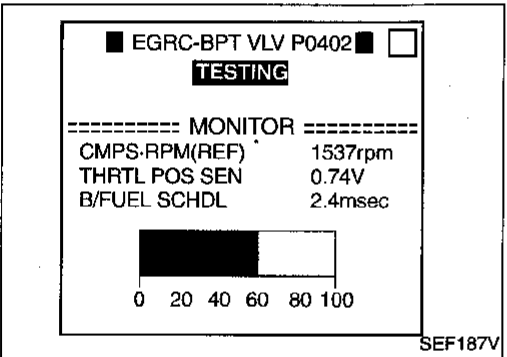
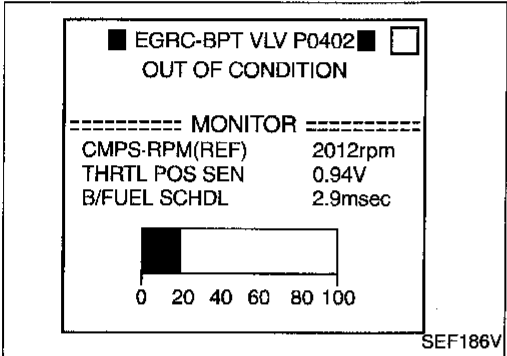
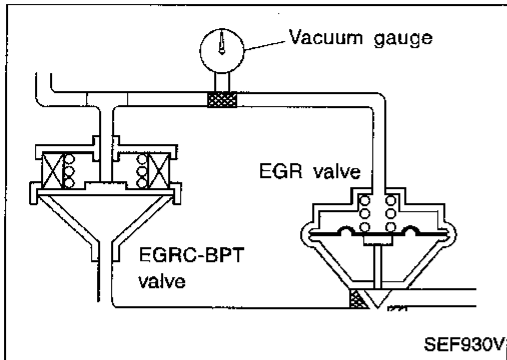

- 1) Install vacuum gauge between EGRC-BPT valve and EGR valve as shown in the illustration.
- 2) Start engine and warm it up to normal operating temperature.
- 3) Stop engine and wait at least 5 seconds.
- 4) Turn ignition switch "ON" and select "EGRC-BPT/V P0402" of "EGR SYSTEM" in "DTC WORK SUPPORT" mode with CONSULT.
- 5) Start engine and let it idle.
- 6) Touch "START".
- 7) Check the output voltage of "THRTL POS SEN" (at closed throttle position) and note it.
- 8) When the following conditions are met, "TESTING" will be displayed on the CONSULT screen and the bar chart may increase. Maintain the conditions many times until "COMPLETED" appears.

Selector lever: Suitable position
CMPS-RPM (REF): 1,400 - 2,200 rpm
Vehicle speed: 30 - 100 km/h (19 - 62 MPH)
B/FUEL SCHDL: 1.3 - 2.0 msec
THRTL POS SEN: $X - (X + 0.88) V$
X = Voltage value measured at step 6)

 - The bar chart on CONSULT screen indicates the status of this test. However, the test may be finished before the bar chart becomes full scale.
 - If the bar chart indication does not continue to progress, completely release accelerator pedal once and try to meet the conditions again.
 - If "TESTING" does not appear on CONSULT screen, retry from step 2).
- 9) If CONSULT instructs to carry out "OVERALL FUNCTION CHECK", go to next step. If "NG" is displayed, refer to "DIAGNOSTIC PROCEDURE", EC-279.
- 10) Open engine hood.
- 11) Raise engine speed to 2,400 ± 400 rpm under no-load and hold it. Then touch "NEXT" of CONSULT screen.

GI
MA
EM
LC
EC
FE
CL
MT
AT
FA
RA
BR
ST
RS
BT
HA
EL
IDX

TROUBLE DIAGNOSIS FOR DTC P0402

EGRC-BPT Valve Function (Cont'd)

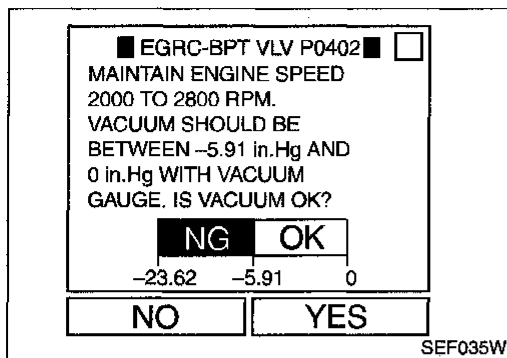

- 12) Check vacuum gauge while keeping engine speed at $2,400 \pm 400$ rpm.

Vacuum should be 0 to -150 mmHg (0 to -5.91 inHg).

If NG, go to "DIAGNOSTIC PROCEDURE", EC-279.
If OK, touch "YES" on the CONSULT screen.

- 13) Check the rubber tube between intake manifold collector, EGRC-solenoid valve, EGR valve and EGRC-BPT valve for cracks, blockages or twists.

If NG, repair or replace.

If OK, touch "YES" on the CONSULT screen.

OR

OVERALL FUNCTION CHECK

Use this procedure to check the overall function of the EGRC-BPT valve. During this check, a 1st trip DTC might not be confirmed.



- 1) Install vacuum gauge between EGRC-BPT valve and EGR valve as shown in the figure at left.

- 2) Lift up vehicle.

- 3) Start engine and shift to 1st gear or 1 position.

- 4) Check vacuum gauge while keeping engine speed at $2,400 \pm 400$ rpm.

Vacuum should be 0 to -150 mmHg (0 to -5.91 inHg).

If NG, go to "DIAGNOSTIC PROCEDURE", EC-279.
If OK, go to next step.

- 5) Check rubber tube between intake manifold collector, EGRC-solenoid valve, EGR valve and EGRC-BPT valve for misconnection, cracks or blockages. If NG, repair or replace.

- 6) If NG, go to "DIAGNOSTIC PROCEDURE", EC-279.

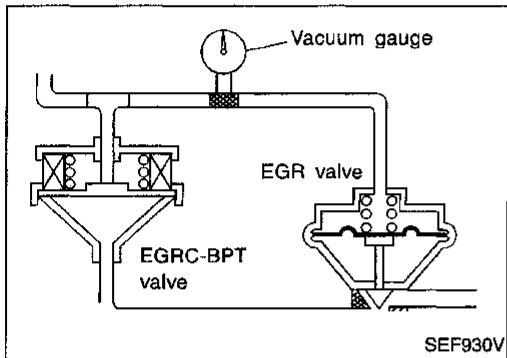

TROUBLE DIAGNOSIS FOR DTC P0402

EGRC-BPT Valve Function (Cont'd)

DIAGNOSTIC PROCEDURE

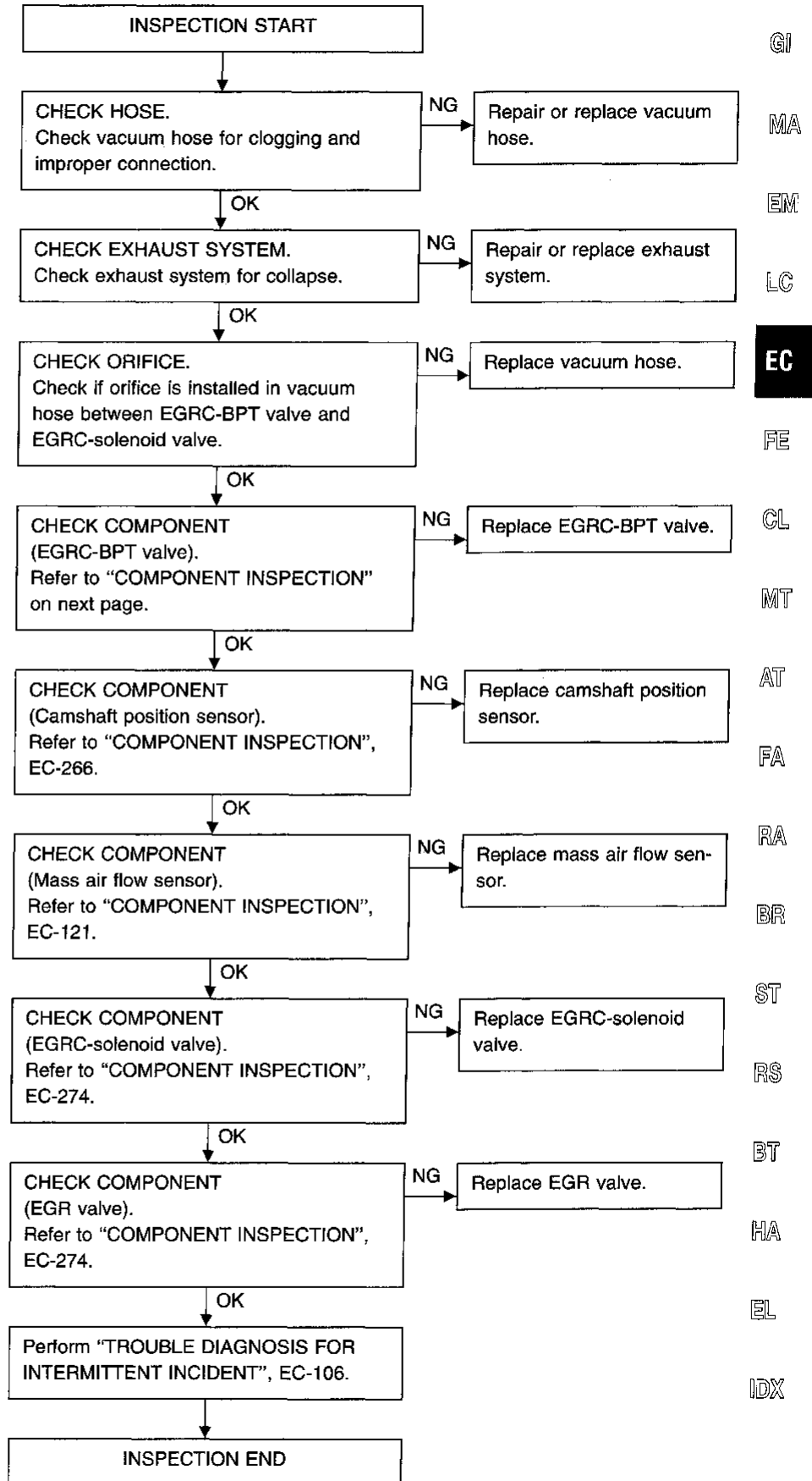

TROUBLE DIAGNOSIS FOR DTC P0402

EGRC-BPT Valve Function (Cont'd)

COMPONENT INSPECTION

EGRC-BPT valve

1. Plug one of two ports of EGRC-BPT valve.
2. Vacuum from the other port and check leakage without applying any pressure from under EGR-BPT valve.
Leakage should exist.

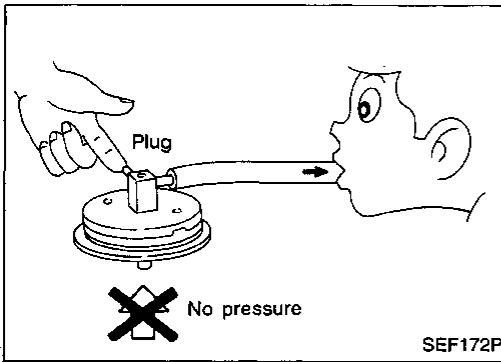

TROUBLE DIAGNOSIS FOR DTC P0420

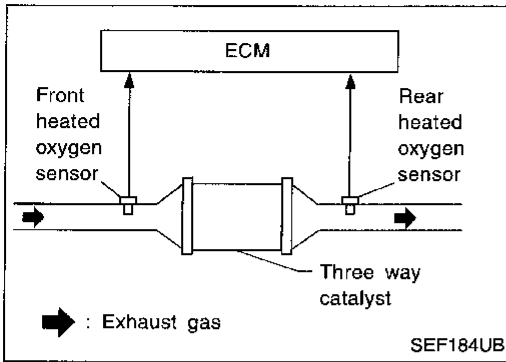

Three Way Catalyst Function

ON BOARD DIAGNOSIS LOGIC

The ECM monitors the switching frequency ratio of front and rear heated oxygen sensors.

A three way catalyst with high oxygen storage capacity will indicate a low switching frequency of rear heated oxygen sensor. As oxygen storage capacity decreases, the rear heated oxygen sensor switching frequency will increase.

When the frequency ratio of front and rear heated oxygen sensors approaches a specified limit value, the three way catalyst malfunction is diagnosed.

Diagnostic Trouble Code No.	Malfunction is detected when ...	Check Items (Possible Cause)
P0420 0702	<ul style="list-style-type: none"> ● Three way catalyst does not operate properly. ● Three way catalyst does not have enough oxygen storage capacity. 	<ul style="list-style-type: none"> ● Three way catalyst ● Exhaust tube ● Intake air leaks ● Injectors ● Injector leaks ● Spark plug ● Improper ignition timing

☆ MONITOR ☆ NO FAIL

CMPS•RPM (REF)	2037rpm
FR O2 SEN	0.68V
RR O2 SEN	0.04V
FR O2 MNTR	RICH
RR O2 MNTR	LEAN
VHCL SPEED SE	0km/h

RECORD

SEF321U

■ SRT STATUS

CATALYST	CMPLT
EVAP SYSTEM	INCMP
O2 SENSOR	CMPLT
O2 SEN HEATER	CMPLT
EGR SYSTEM	INCMP

PRINT

SEF215U

DIAGNOSTIC TROUBLE CODE CONFIRMATION PROCEDURE

CAUTION:

Always drive vehicle at a safe speed.

NOTE:

If "DIAGNOSTIC TROUBLE CODE CONFIRMATION PROCEDURE" has been previously conducted, always turn ignition switch "OFF" and wait at least 5 seconds before conducting the next test.



- 1) Start engine and drive vehicle at a speed of more than 70 km/h (43 MPH) for 2 consecutive minutes.
- 2) Stop vehicle with engine running.
- 3) Set "MANU TRIG" and "HI SPEED", then select "FR O2 SENSOR", "RR O2 SENSOR", "FR O2 MNTR", "RR O2 MNTR" in "DATA MONITOR" mode with CONSULT.
- 4) Touch "RECORD" on CONSULT screen with engine speed held at 2,000 rpm constantly under no load.
- 5) Make sure that the switching frequency between "RICH" and "LEAN" of "RR O2 MNTR" is much less than that of "FR O2 MNTR" as shown below.

Switching frequency ratio =

Rear heated oxygen sensor switching frequency

Front heated oxygen sensor switching frequency

This ratio should be less than 0.75.

If the ratio is greater than above, the three way catalyst is not operating properly.

If the "FR O2 MNTR" does not indicate "RICH" and "LEAN" periodically more than 5 times within 10 seconds at step 4), perform TROUBLE

TROUBLE DIAGNOSIS FOR DTC P0420

Three Way Catalyst Function (Cont'd)

DIAGNOSES FOR DTC P0133 first. (See EC-181.)

If the result is NG, go to "DIAGNOSTIC PROCEDURE", EC-283.

If the result is OK, go to following step.

- 6) Select "AUTO TRIG" in "DATA MONITOR" mode with CONSULT.
- 7) Drive vehicle at a speed of approximately 84 to 96 km/h (52 to 60 MPH) with the following for at least 10 consecutive minutes.

(Drive the vehicle in an area where vehicle speed and accelerator pressure can be held steady and constant.)

M/T: 5th position

A/T: D position ("O/D" ON)

If the result is NG, go to "DIAGNOSTIC PROCEDURE", EC-283.

- 8) Select "SRT STATUS" in "DTC CONFIRMATION" mode with CONSULT.
- 9) Verify that "CATALYST" is "CMPLT".
If not "CMPLT", repeat the test from step 6).

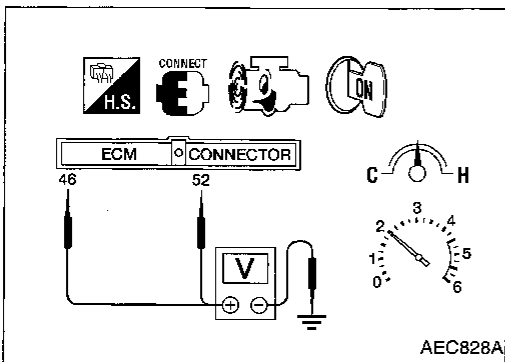

OR

OVERALL FUNCTION CHECK

Use this procedure to check the overall function of the three way catalyst.

During this check, a 1st trip DTC might not be confirmed.



- 1) Start engine and drive vehicle at a speed of more than 70 km/h (43 MPH) for 2 consecutive minutes.
- 2) Stop vehicle with engine running.
- 3) Set voltmeters probes between ECM terminals ④⑥ (front heated oxygen sensor signal), ⑤② (rear heated oxygen sensor signal) and engine ground.
- 4) Keep engine speed at 2,000 rpm constant under no load.
- 5) Make sure that the voltage switching frequency (high & low) between ECM terminal ⑤② and engine ground is much less than that of ECM terminal ④⑥ and engine ground.

Switching frequency ratio =

Rear heated oxygen sensor voltage switching frequency

Front heated oxygen sensor voltage switching frequency

This ratio should be less than 0.75.

If the ratio is greater than above, it means three way catalyst does not operate properly.

- 6) If NG, go to "DIAGNOSTIC PROCEDURE", EC-283.

Note: If the voltage at terminal ④⑥ does not switch periodically more than 5 times within 10 seconds at step 4, perform TROUBLE DIAGNOSIS FOR DTC P0133 first. (See EC-163.)

TROUBLE DIAGNOSIS FOR DTC P0420

Three Way Catalyst Function (Cont'd)

DIAGNOSTIC PROCEDURE

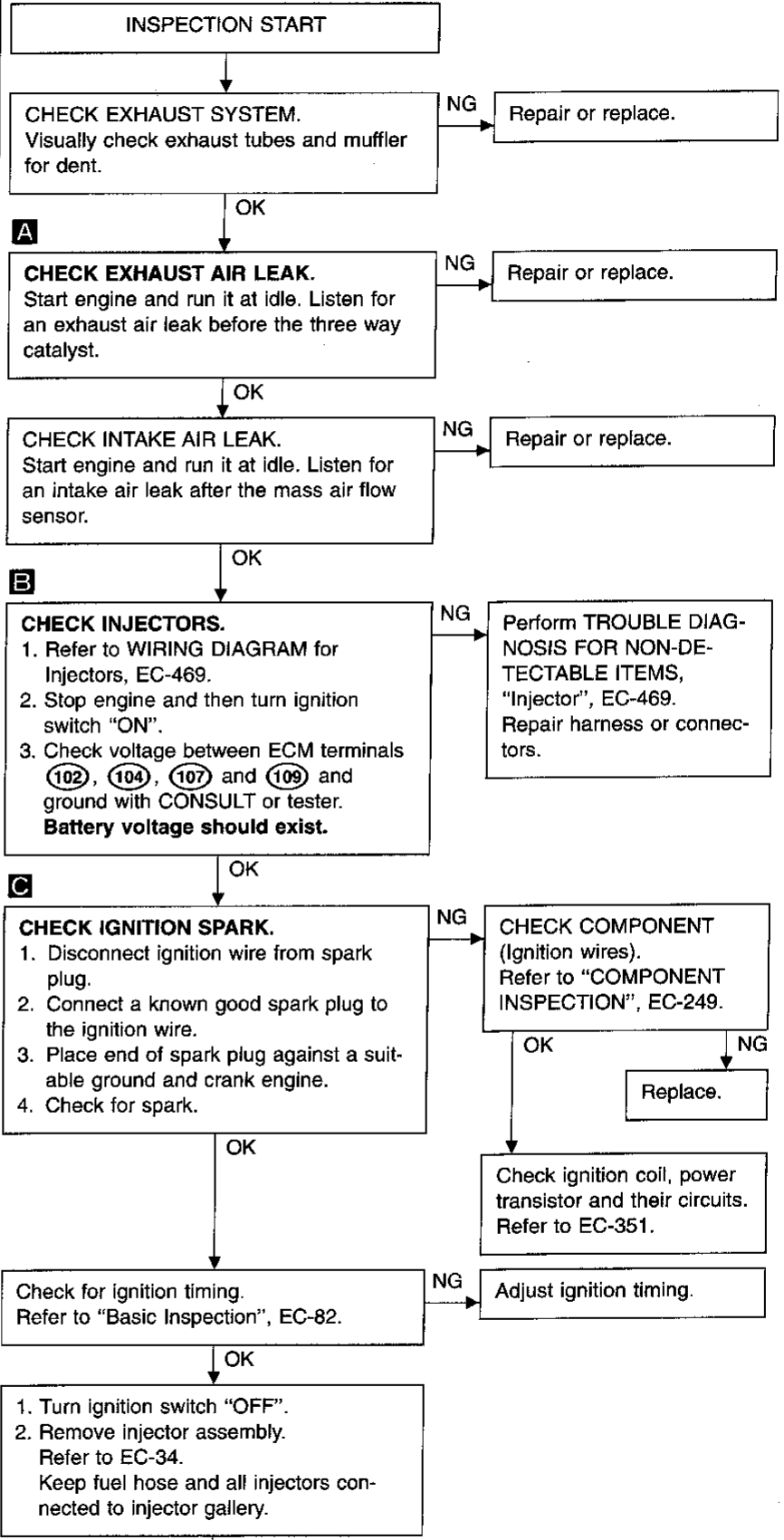
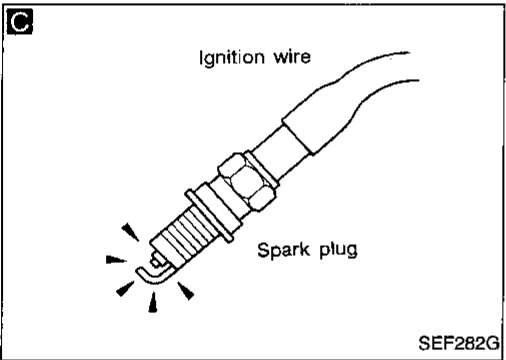
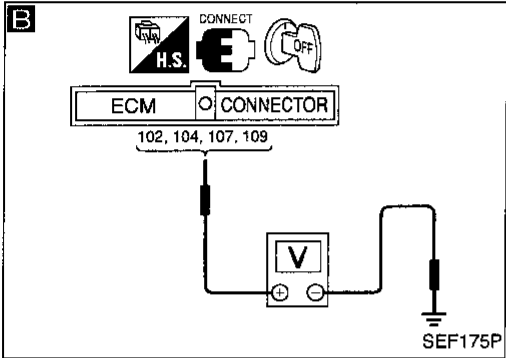
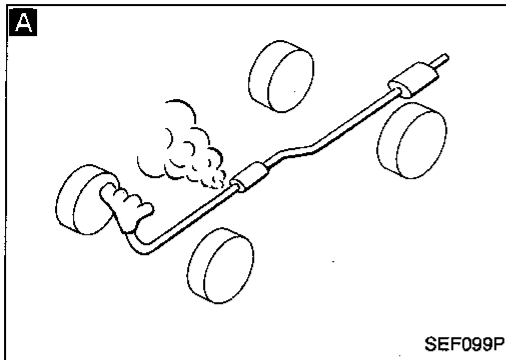

(Go to next page.)

GI
MA
EM
LC
EC
FE
CL
MT
AT
FA
RA
BR
ST
RS
BT
HA
EL
IDX

TROUBLE DIAGNOSIS FOR DTC P0420

Three Way Catalyst Function (Cont'd)

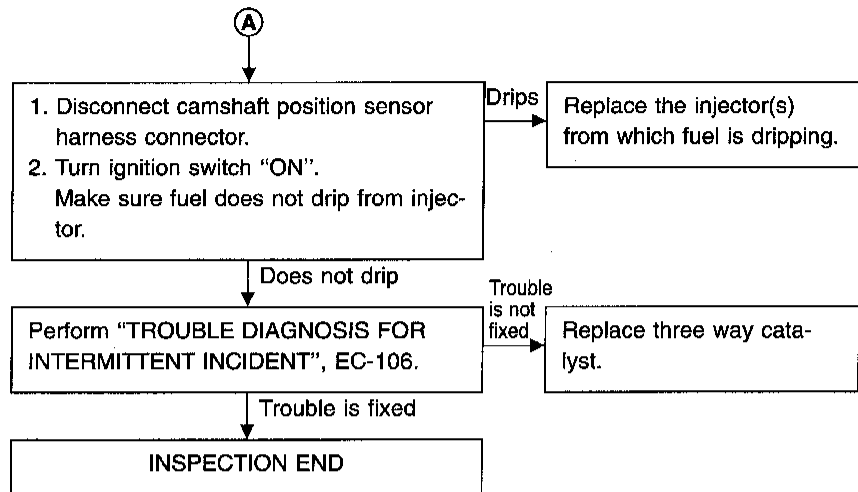

TROUBLE DIAGNOSIS FOR DTC P0440

Evaporative Emission (EVAP) Control System (Small Leak) (Negative Pressure)

Note: If both DTC P0440 and P1448 are displayed, perform TROUBLE DIAGNOSIS FOR DTC P1448 first. (See EC-415.)

ON BOARD DIAGNOSIS LOGIC

This diagnosis detects leaks in the EVAP purge line using engine intake manifold vacuum. If pressure does not increase, the ECM will check for leaks in the line between the fuel tank and EVAP canister purge control valve under the following "Vacuum test" conditions. The vacuum cut valve bypass valve is opened to clear the line between the fuel tank and the EVAP canister purge control valve. The EVAP canister vent control valve will then be closed to shut the EVAP purge line off. The EVAP canister purge volume control valve and EVAP canister purge control valve are opened to depressurize the EVAP purge line using intake manifold vacuum. After this occurs, the EVAP canister purge volume control valve and EVAP canister purge control valve will be closed.

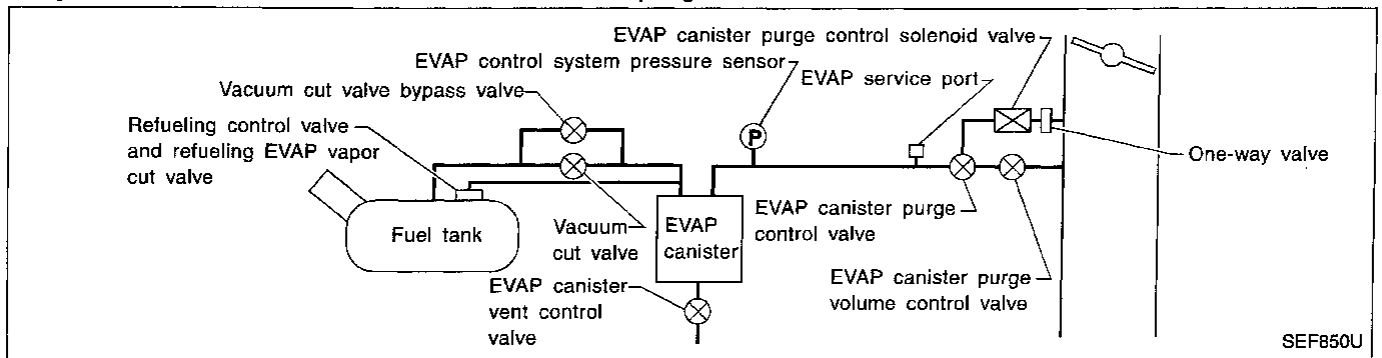

Diagnostic Trouble Code No.	Malfunction is detected when	Check Items (Possible Cause)
P0440 0705	<ul style="list-style-type: none"> ● EVAP control system has a leak. ● EVAP control system does not operate properly. 	<ul style="list-style-type: none"> ● Incorrect fuel tank vacuum relief valve ● Incorrect fuel filler cap used ● Fuel filler cap remains open or fails to close ● Foreign matter caught in fuel filler cap ● Leak is in line between intake manifold and EVAP canister purge control valve ● Foreign matter caught in EVAP canister vent control valve. ● EVAP canister or fuel tank leaks ● EVAP purge line (pipe and rubber tube) leaks ● EVAP purge line rubber tube bent ● Blocked or bent rubber tube to EVAP control system pressure sensor ● Loose or disconnected rubber tube ● EVAP canister vent control valve and the circuit ● EVAP canister purge control valve ● EVAP canister purge volume control valve ● EVAP canister purge control solenoid valve and the circuit ● Absolute pressure sensor ● Tank fuel temperature sensor ● MAP/BARO switch solenoid valve and the circuit ● Blocked or bent rubber tube to MAP/BARO switch solenoid valve ● O-ring of EVAP canister vent control valve is missing or damaged ● Water separator ● EVAP canister is saturated with water ● EVAP control system pressure sensor ● Refueling EVAP vapor cut valve ● ORVR system leaks

CAUTION:

- Use only a genuine NISSAN fuel filler cap as a replacement. If an incorrect fuel filler cap is used, the MIL may come on.
- If the fuel filler cap is not tightened properly, the MIL may come on.
- Use only a genuine NISSAN rubber tube as a replacement.

TROUBLE DIAGNOSIS FOR DTC P0440

Evaporative Emission (EVAP) Control System (Small Leak) (Negative Pressure) (Cont'd)

DIAGNOSTIC TROUBLE CODE CONFIRMATION PROCEDURE

NOTE:

- If DTC P0440 is displayed with P1448, perform **TROUBLE DIAGNOSIS FOR DTC P1448** first. Refer to EC-415.
- If "DIAGNOSTIC TROUBLE CODE CONFIRMATION PROCEDURE" has been previously conducted, always turn ignition switch "OFF" and wait at least 5 seconds before conducting the next test.

TESTING CONDITION:

- Perform "DTC WORK SUPPORT" when the fuel level is less than 3/4 full and vehicle is placed on flat level surface.
- Always perform test at a temperature of 0 to 30°C (32 to 86°F).
- It is better that the fuel level is low.



- 1) Turn ignition switch "ON".
- 2) Turn ignition switch "OFF" and wait at least 5 seconds.
- 3) Turn ignition switch "ON" and select "DATA MONITOR" mode with CONSULT.
- 4) Check that the following conditions are met.
COOLAN TEMP/S: 0 - 70°C (32 - 158°F)
INT/A TEMP SE: 0 - 60°C (32 - 140°F)
- 5) Select "EVAP SML LEAK P0440" of "EVAPORATIVE SYSTEM" in "DTC WORK SUPPORT" mode with CONSULT.
Follow the instruction displayed.

NOTE:

- If the CONSULT screen shown at left is displayed, stop the engine and stabilize the vehicle temperature at 25°C (77°F) or cooler. After "TANK F/TMP SE" becomes less than 30°C (86°F), retest. (Use a fan to reduce the stabilization time.)
- If the engine cannot be maintained within the range on CONSULT screen, go to "Basic Inspection", EC-82.
- 6) Make sure that "OK" is displayed.
If "NG" is displayed, refer to "DIAGNOSTIC PROCEDURE", EC-288.

OR

NOTE:

Be sure to read the explanation of "Driving pattern" on EC-46 before driving vehicle.



- 1) Start engine.
- 2) Drive vehicle according to "Driving pattern", EC-46.
- 3) Stop vehicle.
- 4) Select "MODE 1" with GST.
 - If SRT of EVAP system is not set yet, go to the following step.
 - If SRT of EVAP system is set, the result will be OK.
- 5) Turn ignition switch "OFF" and wait at least 5 seconds.
- 6) Start engine.

■ EVAP SML LEAK P0440 ■

1)PERFORM TEST AT A LOCATION OF 0-30C (32-86F)
2)OPEN ENGINE HOOD.
3)START ENGINE WITH VEHICLE STOPPED. IF ENG IS ON, STOP FOR 5 SEC. THEN RESTART.
4)TOUCH START.

EXIT START

SEF405W

■ EVAP SML LEAK P0440 ■

CAN NOT BE DIAGNOSED

FUEL TEMPERATURE IS TOO HIGH. RETEST AFTER FUEL HAS COOLED.

EXIT PRINT

SEF669U

■ EVAP SML LEAK P0440 ■

WAIT. . .

2 TO 10 MINUTES
KEEP ENGINE RUNNING
AT IDLE SPEED.

SEF929V

■ EVAP SML LEAK P0440 ■

***** OK *****

END PRINT

SEF297U

TROUBLE DIAGNOSIS FOR DTC P0440

Evaporative Emission (EVAP) Control System (Small Leak) (Negative Pressure) (Cont'd)

It is not necessary to cool engine down before driving.

- 7) Drive vehicle again according to the "Driving pattern". GI
- 8) Stop vehicle.
- 9) Select "MODE 3" with GST. MA
 - If P1447 is displayed on the screen, go to "TROUBLE DIAGNOSIS FOR DTC P1447", EC-406.
 - If P0440 is displayed on the screen, go to "DIAGNOSTIC PROCEDURE", EC-288. EM
 - If P1440 is displayed on the screen, go to "DIAGNOSTIC PROCEDURE" in "TROUBLE DIAGNOSIS FOR DTC P1440", EC-384. LC
 - If P0440, P1440 and P1447 are not displayed on the screen, go to the following step. EC
- 10) Select "MODE 1" with GST. FE
 - If SRT of EVAP system is set, the result will be OK.
 - If SRT of EVAP system is not set, go to step 5).

OR

NOTE:

- Be sure to read the explanation of "Driving pattern" on EC-46 before driving vehicle. CL
- It is better that the fuel level is low. MT



- 1) Start engine.
- 2) Drive vehicle according to "Driving pattern", EC-46.
- 3) Stop vehicle. AT
- 4) Turn ignition switch "OFF" and wait at least 5 seconds.
- 5) Turn ignition switch "ON" and perform "Diagnostic Test Mode II (Self-diagnostic results)" with ECM. FA
- 6) If 1st trip DTC is detected, go to "DIAGNOSTIC PROCEDURE", EC-288. RA

BR

ST

RS

BT

HA

EL

IDX

TROUBLE DIAGNOSIS FOR DTC P0440

Evaporative Emission (EVAP) Control System (Small Leak) (Negative Pressure) (Cont'd) DIAGNOSTIC PROCEDURE

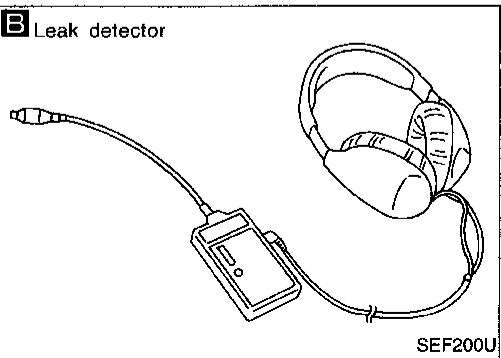
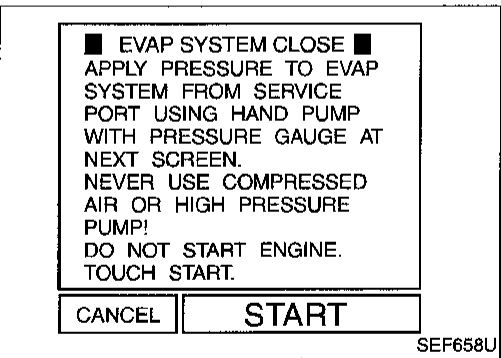
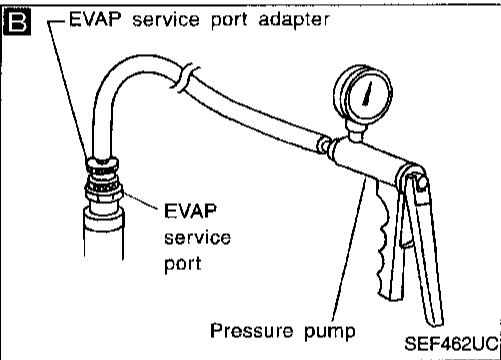
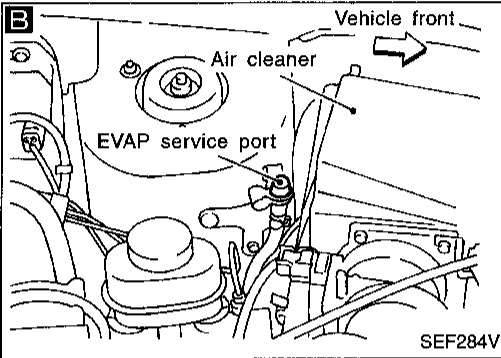
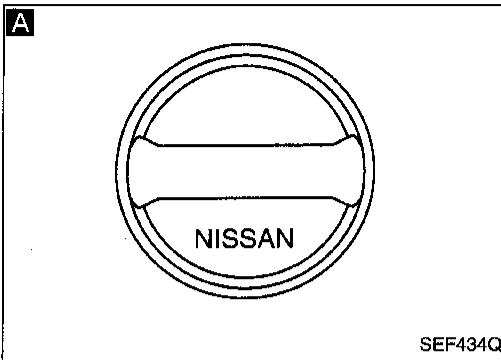

INSPECTION START

A

CHECK FUEL FILLER CAP.

1. Turn ignition switch "OFF".
2. Check for genuine NISSAN fuel filler cap design.
If NG, replace with genuine NISSAN fuel filler cap.
If OK, go to next step.
3. Check that the cap is tightened properly by rotating the cap clockwise.
 - Open fuel filler cap, then clean cap and fuel filler neck threads using air blower.
 - Retighten until ratcheting sound is heard.
 If OK, go to next step.
4. Check for air releasing sound while opening the fuel filler cap.

NG

Check fuel tank vacuum relief valve. (Refer to "EVAPORATIVE EMISSION SYSTEM", EC-22.)
If NG, replace with genuine NISSAN fuel filler cap.
If OK, go to **B** "CHECK FOR EVAP LEAK".

OK

B

CHECK FOR EVAP LEAK.

- Never use compressed air or high pressure pump.
- Improper installation of service port may cause leaking.
- Do not exceed 4.12 kPa (0.042 kg/cm², 0.6 psi) of pressure in the system.

To locate the EVAP leak, do the following.

1. Install the EVAP service port adapter and the pressure pump securely.
2. Turn ignition switch "ON". Select "EVAP SYSTEM CLOSE" of "WORK SUPPORT" mode with CONSULT.
3. Touch "START" and apply pressure into the EVAP line until the pressure indicator reaches the middle of bar graph.
4. Locate the leak using a leak detector. Refer to the instruction manual for more details about the leak detector. Refer to "Evaporative Emission Line Drawing", EC-25.

OR

2. Turn ignition switch "OFF".
3. Apply 12 volts DC to EVAP canister vent control valve. The valve will close. (Continue to apply 12 volts until the end of test.)
4. Apply 12 volts DC to vacuum cut valve bypass valve. The valve will open. (Continue to apply 12 volts until the end of test.)
5. Pressurize the EVAP line using pressure pump with 1.3 to 2.7 kPa (10 to 20 mmHg, 0.39 to 0.79 inHg).
6. Locate the leak using a leak detector. Refer to the instruction manual for more details about the leak detector. Refer to "Evaporative Emission Line Drawing", EC-25.

NG

Repair or replace.

OK

A

(Go to next page.)

TROUBLE DIAGNOSIS FOR DTC P0440

Evaporative Emission (EVAP) Control System (Small Leak) (Negative Pressure) (Cont'd)

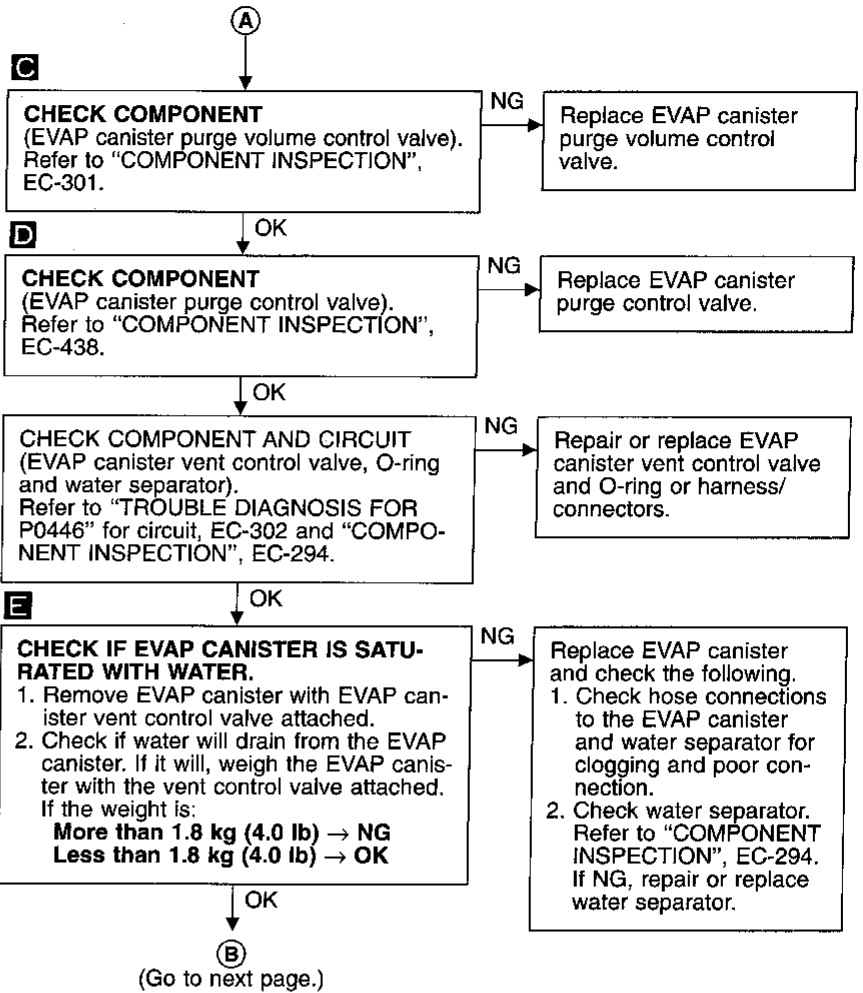
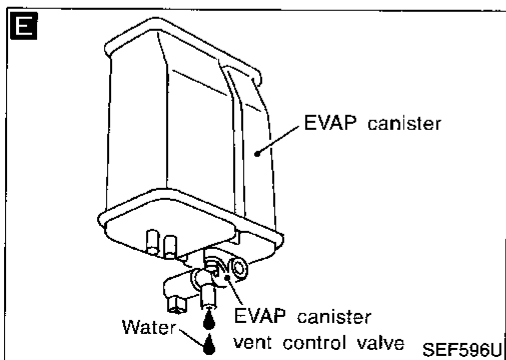
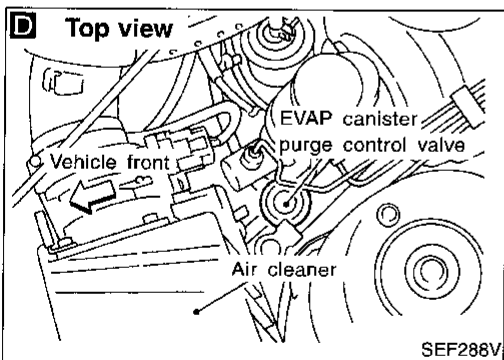
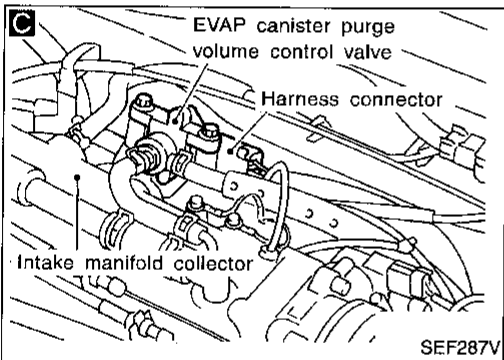
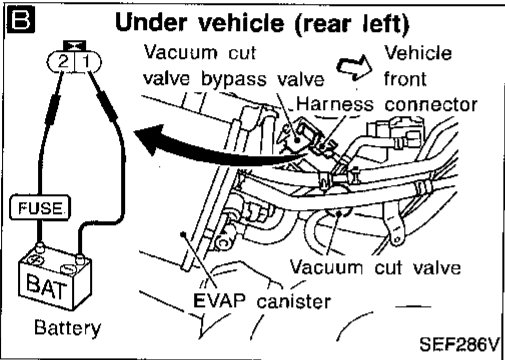
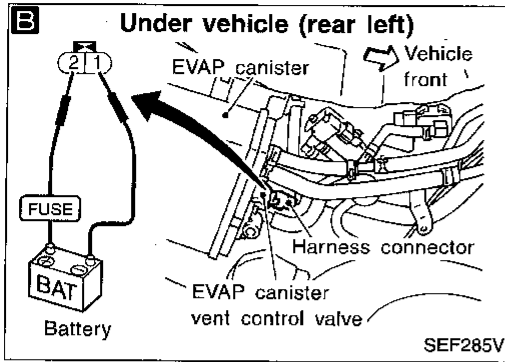

GI

MA

EM

LC

EC

FE

CL

MT

AT

FA

RA

BR

ST

RS

BT

HA

EL

IDX

TROUBLE DIAGNOSIS FOR DTC P0440

Evaporative Emission (EVAP) Control System (Small Leak) (Negative Pressure) (Cont'd)

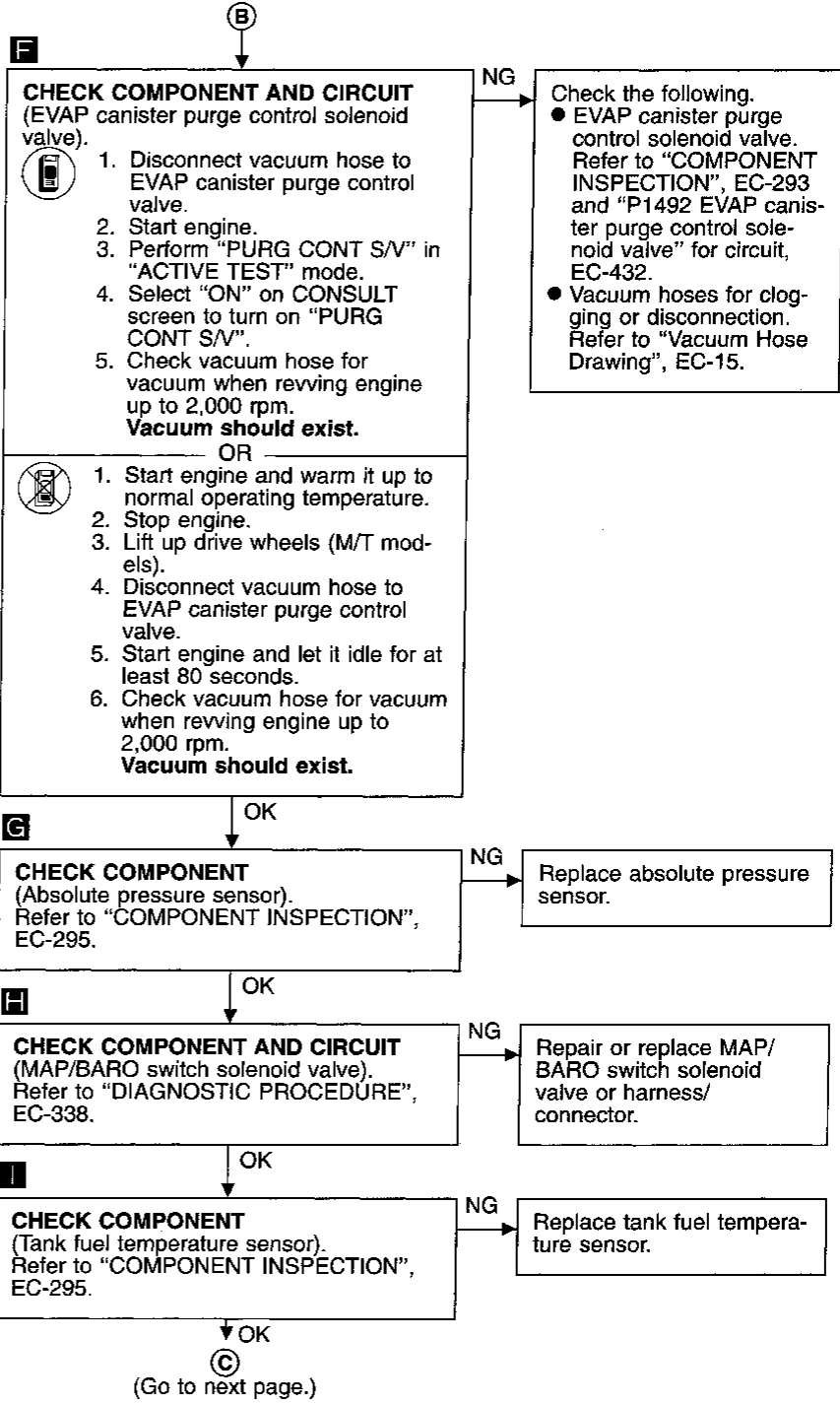
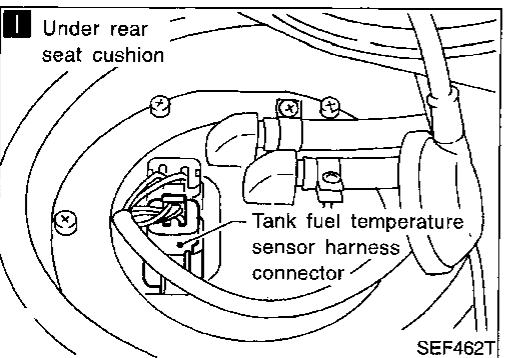
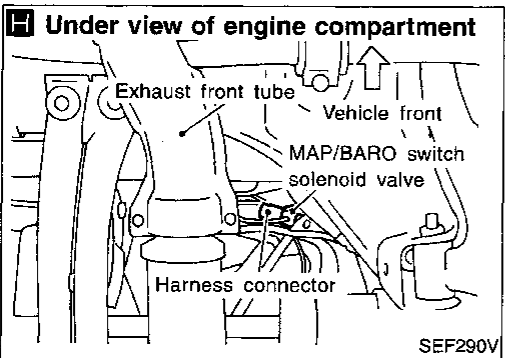
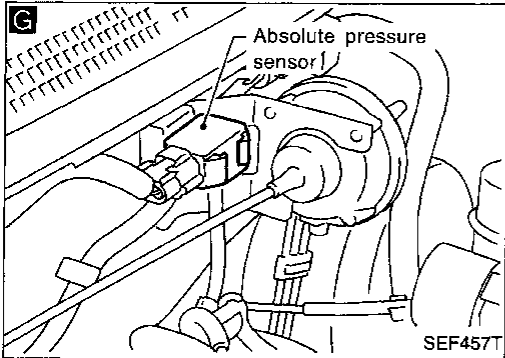
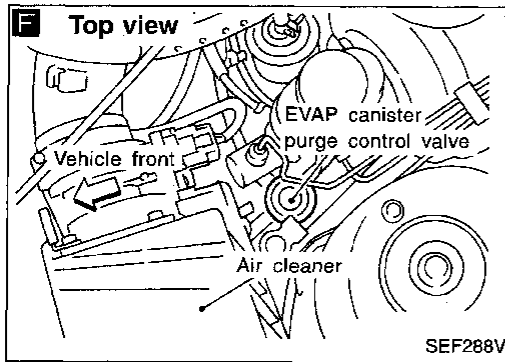

TROUBLE DIAGNOSIS FOR DTC P0440

Evaporative Emission (EVAP) Control System (Small Leak) (Negative Pressure) (Cont'd)

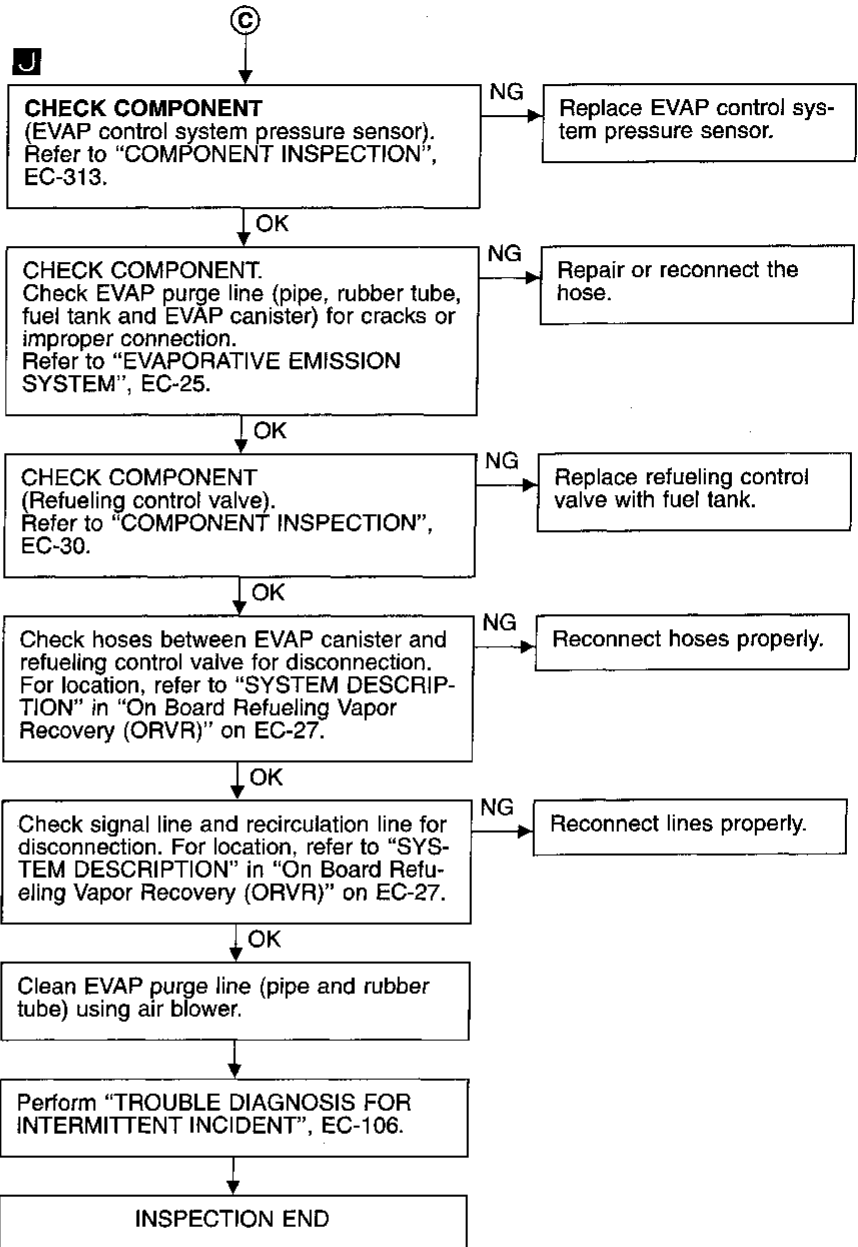
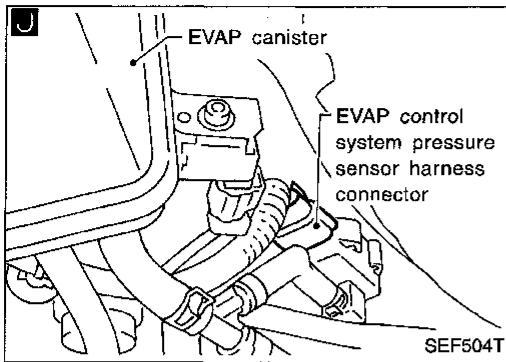

GI

MA

EM

LC

EC

FE

CL

MT

AT

FA

RA

BR

ST

RS

BT

HA

EL

IDX

TROUBLE DIAGNOSIS FOR DTC P0440

Evaporative Emission (EVAP) Control System (Small Leak) (Negative Pressure) (Cont'd)

COMPONENT INSPECTION

EVAP canister purge volume control valve

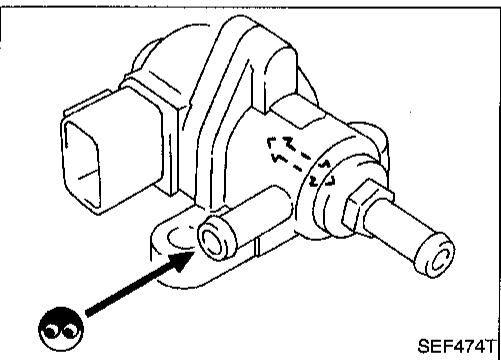
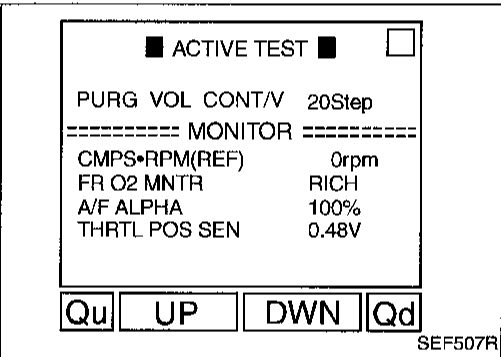
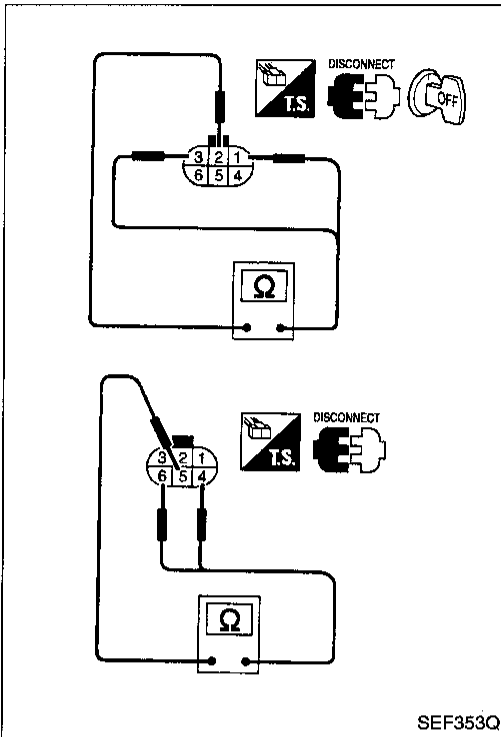

1. Disconnect EVAP canister purge volume control valve harness connector.
2. Check resistance between the following terminals.
terminal ② and terminals ①, ③
terminal ⑤ and terminals ④, ⑥

Resistance:

35 - 43Ω [At 20°C (68°F)]

3. Reconnect EVAP canister purge volume control valve harness connector.
4. Remove EVAP canister purge volume control valve from intake manifold collector and disconnect hoses from the valve.
(Plug the purge hoses. The EVAP canister purge volume control valve harness connector should remain connected.)
5. Turn ignition switch "ON".
6. Perform "PURG VOL CONT/V" in "ACTIVE TEST" mode with CONSULT. Check that EVAP canister purge volume control valve shaft moves smoothly forward and backward according to the valve opening.

If NG, replace the EVAP canister purge volume control valve.

OR

1. Disconnect EVAP canister purge volume control valve harness connector.
2. Check resistance between the following terminals.
terminal ② and terminals ①, ③
terminal ⑤ and terminals ④, ⑥

Resistance:

35 - 43Ω [At 20°C (68°F)]

3. Reconnect EVAP canister purge volume control valve harness connector.
4. Remove EVAP canister purge volume control valve from intake manifold collector and disconnect hoses from the valve.
(Plug the purge hoses. The EVAP canister purge volume control valve harness connector should remain connected.)
5. Turn ignition switch "ON" and "OFF". Check that EVAP canister purge volume control valve shaft moves smoothly forward and backward according to the ignition switch position.
If NG, replace the EVAP canister purge volume control valve.

TROUBLE DIAGNOSIS FOR DTC P0440

Evaporative Emission (EVAP) Control System (Small Leak) (Negative Pressure) (Cont'd)

EVAP canister purge control solenoid valve

1. Jack up driving wheels (M/T models only).
2. Turn ignition switch "ON".
3. Select "PURG CONT S/V" of "ACTIVE TEST" mode with CONSULT.
4. Start engine and warm it up to normal operating temperature.
5. Disconnect vacuum hose at EVAP canister purge control valve.
6. Touch "ON" and "OFF" and check for vacuum passing through the hose.

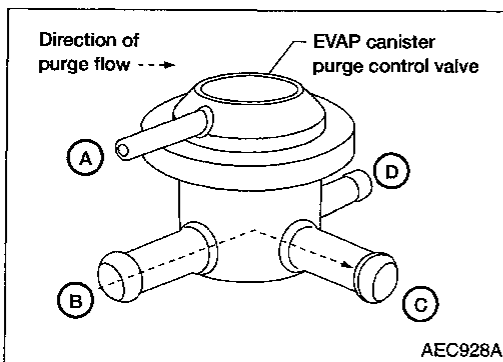
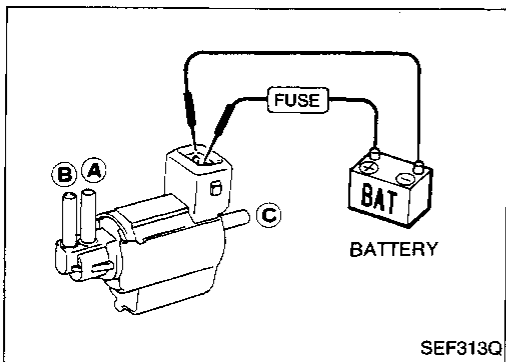
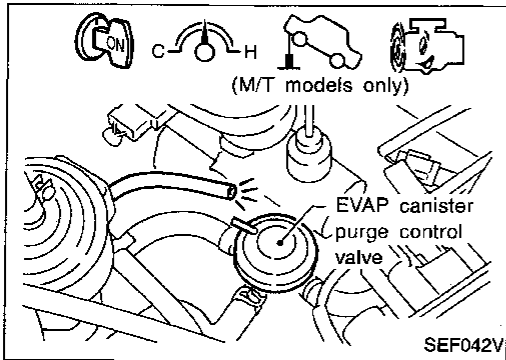
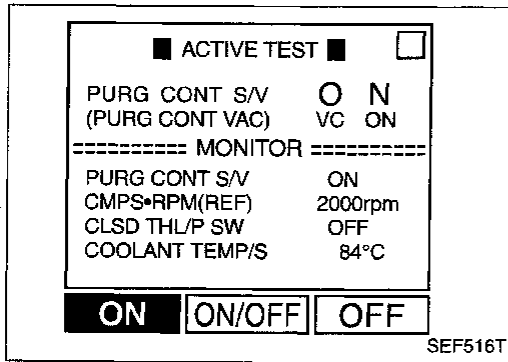

Condition	Vacuum
Idle	Not exist
Rev engine up from 2,000 to 4,000 rpm (A/T models). Rev engine up from 2,000 to 4,000 rpm with 1st gear position (M/T models).	Exist

OR

Check air passage continuity.

Condition	Air passage continuity between (A) and (B)	Air passage continuity between (A) and (C)
12V direct current supply between terminals	Yes	No
No supply	No	Yes

If NG or operation takes more than 1 second, replace solenoid valve.

EVAP canister purge control valve

Check EVAP canister purge control valve as follows:

1. Blow air in port (A) and (C) and ensure that there is no leakage.
2. Plug port (D) and blow air in port (B). Ensure that there is resistance to flow out of port (C).
3. Plug port (B) and blow air in port (D). Ensure that there is resistance to flow out of port (C).
4. Apply vacuum to port (A) [approximately -13.3 to -20.0 kPa (-100 to -150 mmHg, -3.94 to -5.91 inHg)]. Plug port (D) and blow air in port (C) and ensure free flow out of port (B). Plug port (B) and blow air in port (C) and ensure free flow out of port (D).

TROUBLE DIAGNOSIS FOR DTC P0440

Evaporative Emission (EVAP) Control System (Small Leak) (Negative Pressure) (Cont'd)

EVAP canister vent control valve

Check air passage continuity.

① Perform "VENT CONTROL/V" in "ACTIVE TEST" mode.

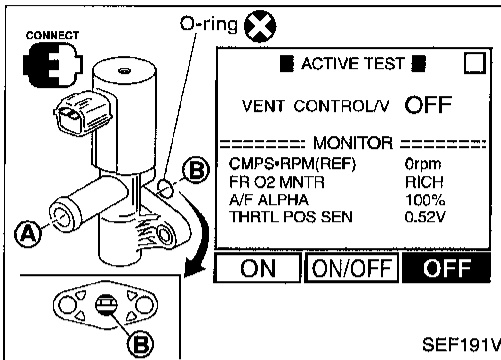

Condition VENT CONTROL/V	Air passage continuity between (A) and (B)
ON	No
OFF	Yes

OR

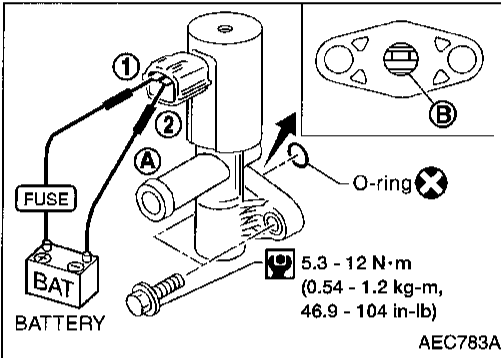

Condition	Air passage continuity between (A) and (B)
12V direct current supply between terminals ① and ②	No
No supply	Yes

If NG or operation takes more than 1 second, clean valve using air blower or replace as necessary.

If the portion (B) is rusted, replace EVAP canister vent control valve.

Make sure new O-ring is installed properly.

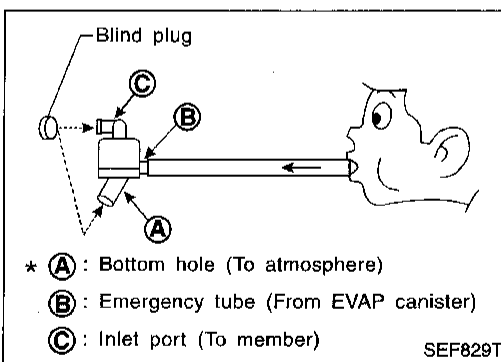

Water separator

1. Check visually for insect nests in the water separator air inlet.
 2. Check visually for cracks or flaws in the appearance.
 3. Check visually for cracks or flaws in the hose.
 4. Check that (A) and (C) are not clogged by blowing air into (B) with (A), and then (C) plugged.
 5. In case of NG in items 2 - 4, replace the parts.
- **Do not disassemble water separator.**

TROUBLE DIAGNOSIS FOR DTC P0440

Evaporative Emission (EVAP) Control System (Small Leak) (Negative Pressure) (Cont'd)

Absolute pressure sensor

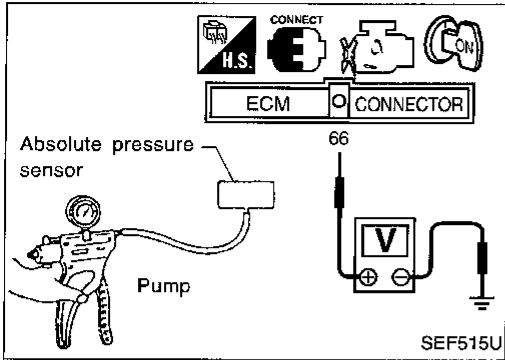

1. Remove absolute pressure sensor with its harness connector connected. GI
2. Remove hose from absolute pressure sensor. MA
3. Turn ignition switch "ON" and check output voltage between ECM terminal 66 and engine ground. EM
The voltage should be 3.2 to 4.8 V.
4. Use pump to apply vacuum pressure of -26.7 kPa (-200 mmHg , -7.87 inHg) to absolute pressure sensor as shown in figure and check the output voltage. LC
The voltage should be 1.0 to 1.4 V lower than the value measured in step 3.

CAUTION:

- Always calibrate the vacuum pump gauge when using it. EC
- Do not apply below -93.3 kPa (-700 mmHg , -27.56 inHg) or over 101.3 kPa (760 mmHg , 29.92 inHg) of pressure. FE
- 5. If NG, replace absolute pressure sensor. CL

Tank fuel temperature sensor

Check resistance by heating with hot water or heat gun as shown in the figure. MT

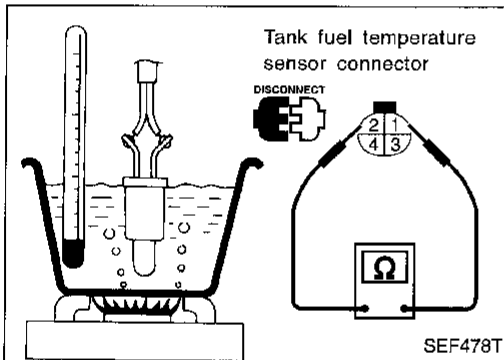

Temperature °C (°F)	Resistance kΩ
20 (68)	2.3 - 2.7
50 (122)	0.79 - 0.90

If NG, replace tank fuel temperature sensor. AT

FA

RA

BR

ST

RS

BT

HA

EL

IDX

Evaporative Emission (EVAP) Canister Purge Volume Control Valve (Circuit)

SYSTEM DESCRIPTION

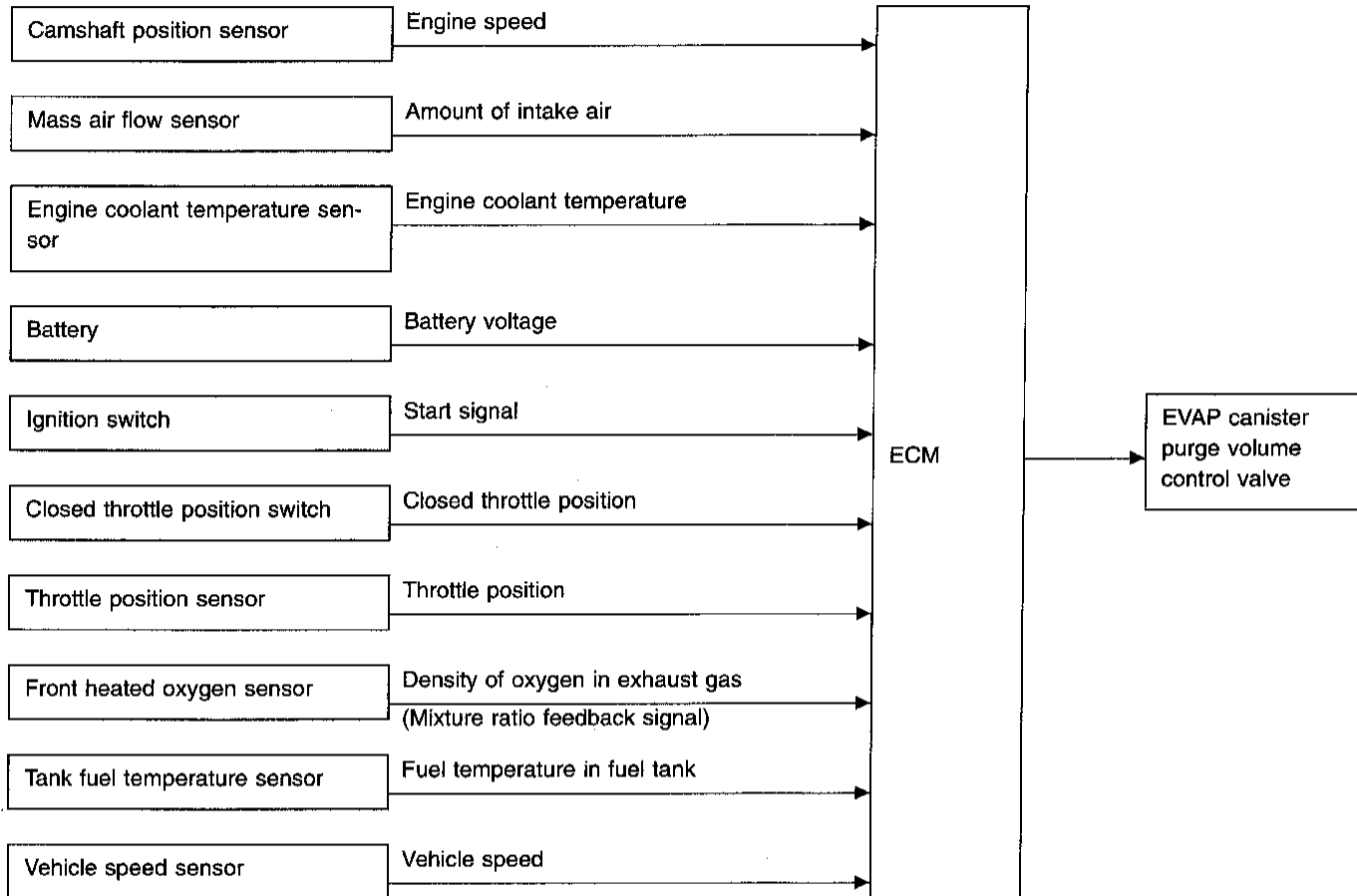

This system controls flow rate of fuel vapor from the EVAP canister. The opening of the vapor bypass passage in the EVAP canister purge volume control valve changes to control the flow rate. A built-in step motor moves the valve in steps corresponding to the ECM output pulses. The opening of the valve varies for optimum engine control. The optimum value stored in the ECM is determined by considering various engine conditions. When the engine is operating, the flow rate of fuel vapor from the EVAP canister is regulated as the air flow changes.

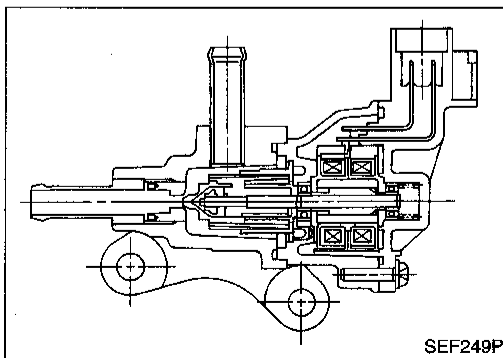

COMPONENT DESCRIPTION

The EVAP canister purge volume control valve uses a step motor to control the flow rate of fuel vapor from the EVAP canister. This motor has four winding phases. It operates according to the output pulse signal of the ECM. Two windings are turned ON and OFF in sequence. Each time an ON pulse is issued, the valve opens or closes, changing the flow rate. When no change in the flow rate is needed, the ECM does not issue the pulse signal. A certain voltage signal is issued so that the valve remains at that particular opening.

TROUBLE DIAGNOSIS FOR DTC P0443

Evaporative Emission (EVAP) Canister Purge Volume Control Valve (Circuit) (Cont'd)

CONSULT REFERENCE VALUE IN DATA MONITOR MODE

MONITOR ITEM	CONDITION	SPECIFICATION
PURG VOL CV	<ul style="list-style-type: none"> ● Engine: After warming up ● No-load ● Lift up drive wheels and shift to 1st gear position. 	Idle 0 step
	<ul style="list-style-type: none"> More than 60 seconds after starting engine More than 16 km/h (10 MPH) 	More than 1 step

ECM TERMINALS AND REFERENCE VALUE

Specification data are reference values and are measured between each terminal and engine ground.

TER-MINAL NO.	WIRE COLOR	ITEM	CONDITION	DATA (DC voltage)
5	L	EVAP canister purge volume control valve	Engine is running. (Warm-up condition)	0 - 0.6V
6	G		└ Idle speed	
16	Y	EVAP canister purge volume control valve	Engine is running.	BATTERY VOLTAGE (11 - 14V)
17	OR		└ Idle speed	
56 61	W/R W/R	Power supply for ECM	Ignition switch "ON"	BATTERY VOLTAGE (11 - 14V)

ON BOARD DIAGNOSIS LOGIC

Diagnostic Trouble Code No.	Malfunction is detected when	Check Items (Possible Cause)
P0443 1008	<ul style="list-style-type: none"> ● An improper voltage signal is sent to ECM through the valve. 	<ul style="list-style-type: none"> ● Harness or connectors (The valve circuit is open or shorted.) ● EVAP canister purge volume control valve

TROUBLE DIAGNOSIS FOR DTC P0443

Evaporative Emission (EVAP) Canister Purge Volume Control Valve (Circuit) (Cont'd)

DIAGNOSTIC TROUBLE CODE CONFIRMATION PROCEDURE

NOTE:

If "DIAGNOSTIC TROUBLE CODE CONFIRMATION PROCEDURE" has been previously conducted, always turn ignition switch "OFF" and wait at least 5 seconds before conducting the next test.

TESTING CONDITION:

Before performing the following procedure, confirm battery voltage is more than 11V with ignition switch "ON".



- 1) Turn ignition switch "ON".
- 2) Select "DATA MONITOR" mode with CONSULT.
- 3) Wait at least 5 seconds.
- 4) If 1st trip DTC is detected, go to "DIAGNOSTIC PROCEDURE", EC-300.

OR



- 1) Turn ignition switch "ON" and wait at least 5 seconds.
- 2) Select "MODE 7" with GST.
- 3) If 1st trip DTC is detected, go to "DIAGNOSTIC PROCEDURE", EC-300.

OR



- 1) Turn ignition switch "ON" and wait at least 5 seconds.
- 2) Turn ignition switch "OFF", wait at least 5 seconds and then turn "ON".
- 3) Perform "Diagnostic Test Mode II (Self-diagnostic results)" with ECM.
- 4) If 1st trip DTC is detected, go to "DIAGNOSTIC PROCEDURE", EC-300.

TROUBLE DIAGNOSIS FOR DTC P0443

Evaporative Emission (EVAP) Canister Purge Volume Control Valve (Circuit) (Cont'd)

EC-PGC/V-01

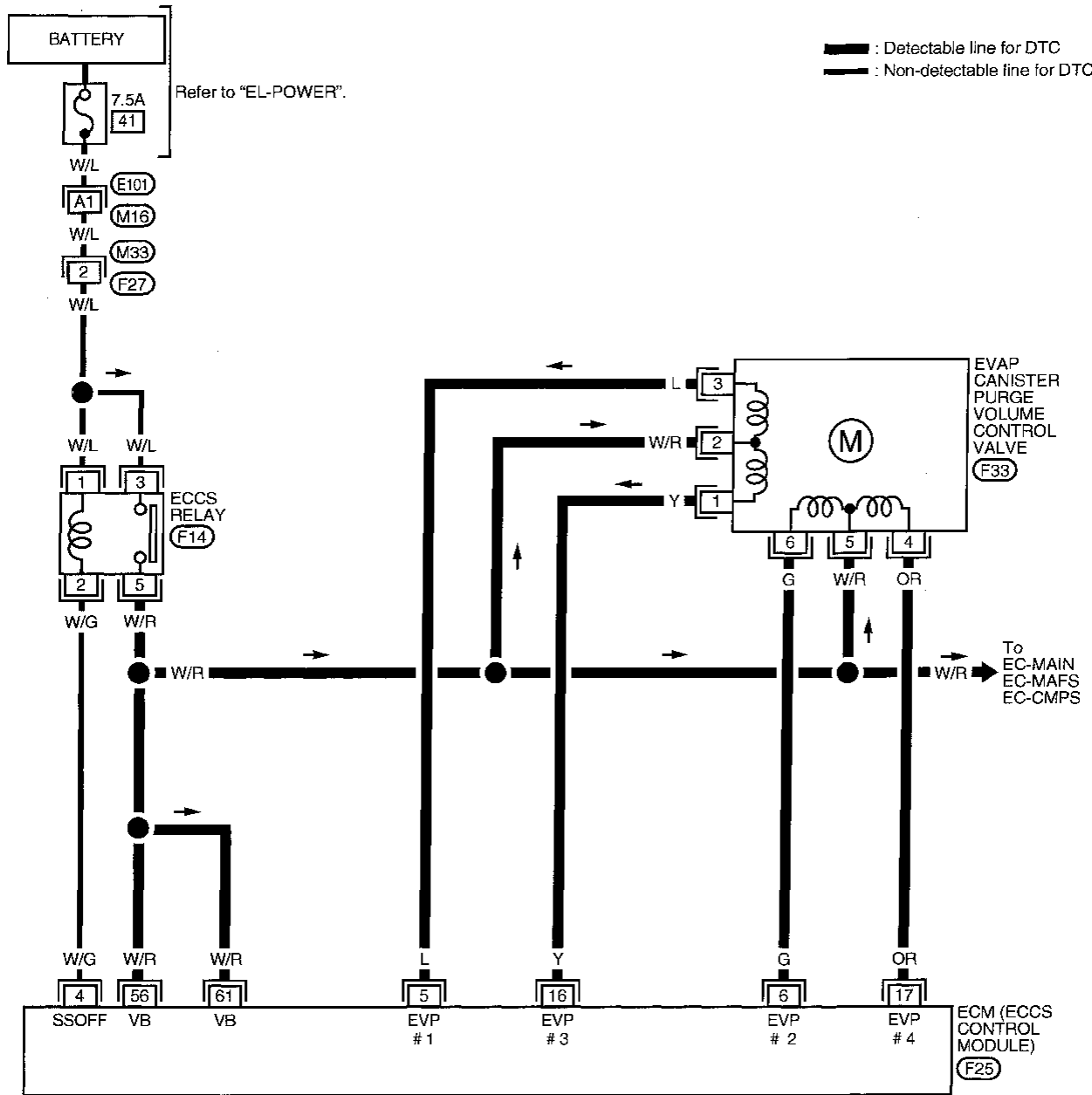

GI
 MA
 EM
 LC
EC
 FE
 CL
 MT
 AT
 FA
 RA
 BR
 ST
 RS
 BT

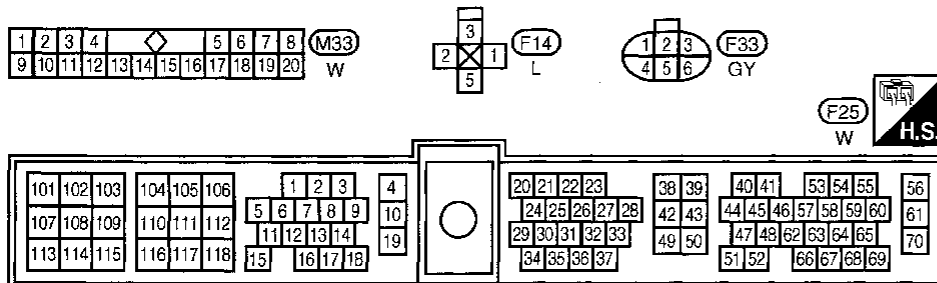

Refer to last page (Foldout page).
 (M16), (E101)

HA
 EL
 IDX

TROUBLE DIAGNOSIS FOR DTC P0443

Evaporative Emission (EVAP) Canister Purge Volume Control Valve (Circuit) (Cont'd) DIAGNOSTIC PROCEDURE

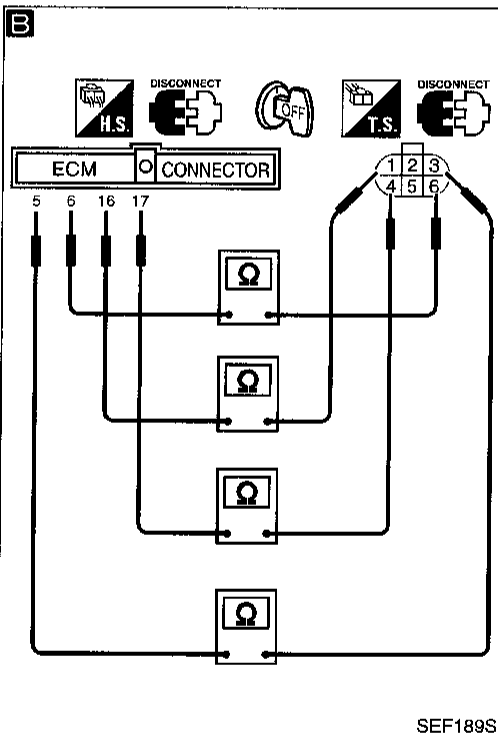
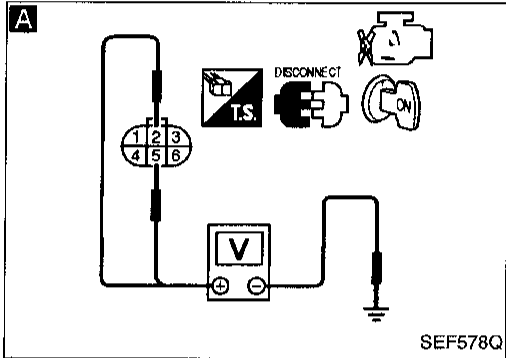
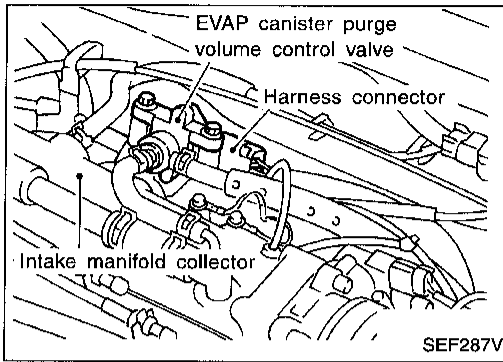

INSPECTION START

A
CHECK POWER SUPPLY.
1. Turn ignition switch "OFF".
2. Disconnect EVAP canister purge volume control valve harness connector.
3. Turn ignition switch "ON".
4. Check voltage between terminals ②, ⑤ and engine ground with CONSULT or tester.
Voltage: Battery voltage

NG → Check the following.
● ECCS relay
● 7.5A fuse
● Harness connectors (E101), (M16), (M33), (F27)
● Harness for open or short between EVAP canister purge volume control valve and fuse
● Harness for open or short between EVAP canister purge volume control valve and ECM
If NG, repair harness or connectors.

OK ↓

B
CHECK OUTPUT SIGNAL CIRCUIT.
1. Turn ignition switch "OFF".
2. Disconnect ECM harness connector.
3. Check harness continuity between ECM terminal ⑬ and terminal ①, ECM terminal ⑰ and terminal ④, ECM terminal ⑤ and terminal ③, ECM terminal ⑥ and terminal ⑥.
Continuity should exist.
If OK, check harness for short to ground and short to power.

NG → Repair open circuit or short to ground or short to power in harness or connectors.

OK ↓

CHECK COMPONENT
(EVAP canister purge volume control valve).
Refer to "COMPONENT INSPECTION" on next page.

NG → Replace EVAP canister purge volume control valve.

OK ↓

Perform "TROUBLE DIAGNOSIS FOR INTERMITTENT INCIDENT", EC-106.

INSPECTION END

TROUBLE DIAGNOSIS FOR DTC P0443

Evaporative Emission (EVAP) Canister Purge Volume Control Valve (Circuit) (Cont'd)

COMPONENT INSPECTION

EVAP canister purge volume control valve

1. Disconnect EVAP canister purge volume control valve harness connector.
2. Check resistance between the following terminals.
terminal ② and terminals ①, ③
terminal ⑤ and terminals ④, ⑥

Resistance:

35 - 43Ω [At 20°C (68°F)]

3. Reconnect EVAP canister purge volume control valve harness connector.
4. Remove EVAP canister purge volume control valve from intake manifold collector and disconnect hoses from the valve.
(Plug the purge hoses. The EVAP canister purge volume control valve harness connector should remain connected.)
5. Turn ignition switch "ON".
6. Perform "PURG VOL CONT/V" in "ACTIVE TEST" mode with CONSULT. Check that EVAP canister purge volume control valve shaft moves smoothly forward and backward according to the valve opening.

If NG, replace the EVAP canister purge volume control valve.

OR

1. Disconnect EVAP canister purge volume control valve harness connector.
2. Check resistance between the following terminals.
terminal ② and terminals ①, ③
terminal ⑤ and terminals ④, ⑥

Resistance:

35 - 43Ω [At 20°C (68°F)]

3. Reconnect EVAP canister purge volume control valve harness connector.
4. Remove EVAP canister purge volume control valve from intake manifold collector and disconnect hoses from the valve.
(Plug the purge hoses. The EVAP canister purge volume control valve harness connector should remain connected.)
5. Turn ignition switch "ON" and "OFF". Check that EVAP canister purge volume control valve shaft moves smoothly forward and backward according to the ignition switch position.
If NG, replace the EVAP canister purge volume control valve.

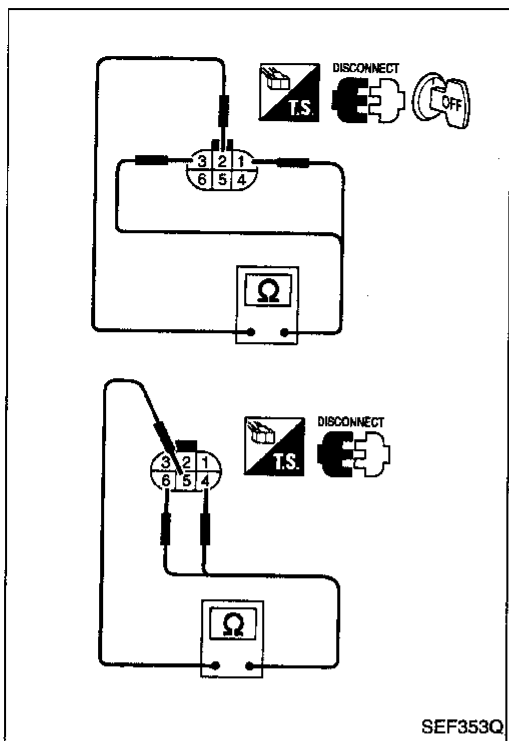

SEF353Q

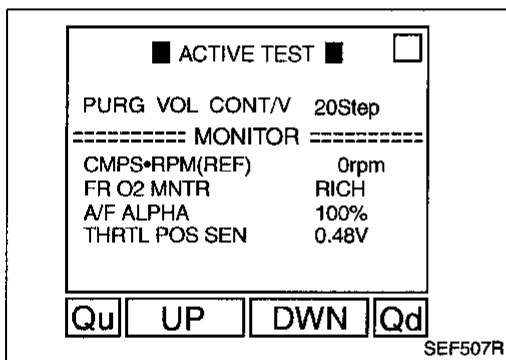

SEF507R

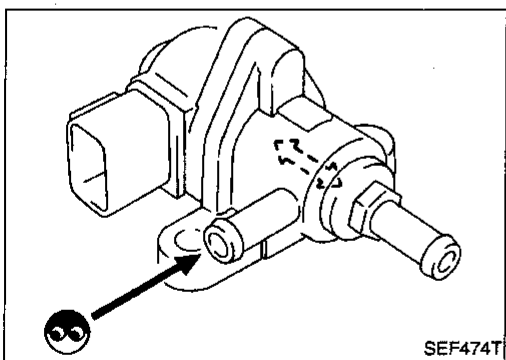

SEF474T

TROUBLE DIAGNOSIS FOR DTC P0446

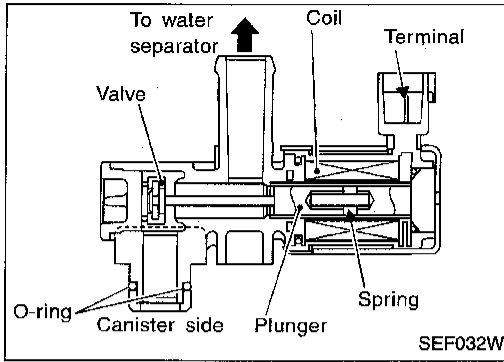

SEF032W

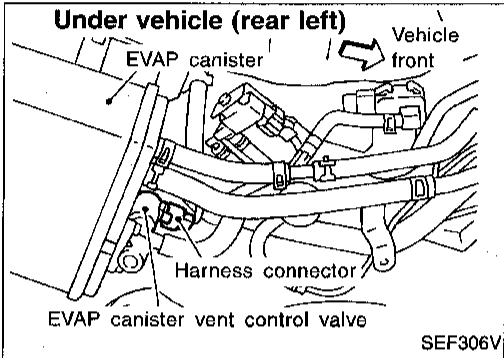

SEF306V

Evaporative Emission (EVAP) Canister Vent Control Valve (Circuit)

COMPONENT DESCRIPTION

The EVAP canister vent control valve is located on the EVAP canister and is used to seal the canister vent.

This solenoid (the EVAP canister vent control valve) responds to signals from the ECM.

When the ECM sends an ON signal, the coil in the solenoid valve is energized.

A plunger will then move to seal the canister vent. The ability to seal the vent is necessary for the on board diagnosis of other evaporative emission control system components.

This solenoid valve is used only for diagnosis, and usually remains opened.

When the vent is closed, under normal purge conditions, the evaporative emission control system is depressurized and allows "EVAP Control System (Small Leak)" diagnosis.

CONSULT REFERENCE VALUE IN DATA MONITOR MODE

Specification data are reference values.

MONITOR ITEM	CONDITION	SPECIFICATION
VENT CONT/V	● Ignition switch: ON	OFF

ECM TERMINALS AND REFERENCE VALUE

Specification data are reference values and are measured between each terminal and engine ground.

TER-MINAL NO.	WIRE COLOR	ITEM	CONDITION	DATA (DC voltage)
108	PU/W	EVAP canister vent control valve	Ignition switch "ON"	BATTERY VOLTAGE (11 - 14V)

ON BOARD DIAGNOSIS LOGIC

Diagnostic Trouble Code No.	Malfunction is detected when	Check Items (Possible Cause)
P0446 0903	● An improper voltage signal is sent to ECM through EVAP canister vent control valve.	<ul style="list-style-type: none"> ● Harness or connectors (EVAP canister vent control valve circuit is open or shorted.) ● EVAP canister vent control valve

TROUBLE DIAGNOSIS FOR DTC P0446

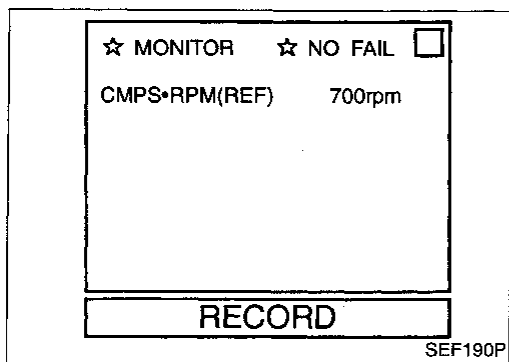

Evaporative Emission (EVAP) Canister Vent Control Valve (Circuit) (Cont'd)

DIAGNOSTIC TROUBLE CODE CONFIRMATION PROCEDURE

NOTE:

If "DIAGNOSTIC TROUBLE CODE CONFIRMATION PROCEDURE" has been previously conducted, always turn ignition switch "OFF" and wait at least 5 seconds before conducting the next test.

TESTING CONDITION:

Before performing the following procedure, confirm battery voltage is more than 11V at idle.

-  1) Turn ignition switch "ON".
2) Select "DATA MONITOR" mode with CONSULT.
3) Start engine and wait at least 5 seconds.
4) If 1st trip DTC is detected, go to "DIAGNOSTIC PROCEDURE", EC-305.

OR

-  1) Start engine and wait at least 5 seconds.
2) Select "MODE 7" with GST.
3) If 1st trip DTC is detected, go to "DIAGNOSTIC PROCEDURE", EC-305.

OR

-  1) Start engine and wait at least 5 seconds.
2) Turn ignition switch "OFF", wait at least 5 seconds and then turn "ON".
3) Perform "Diagnostic Test Mode II (Self-diagnostic results)" with ECM.
4) If 1st trip DTC is detected, go to "DIAGNOSTIC PROCEDURE", EC-305.

GI

MA

EM

LC

EC

FE

CL

MT

AT

FA

RA

BR

ST

RS

BT

HA

EL

IDX

TROUBLE DIAGNOSIS FOR DTC P0446

Evaporative Emission (EVAP) Canister Vent Control Valve (Circuit) (Cont'd)

EC-VENT/V-01

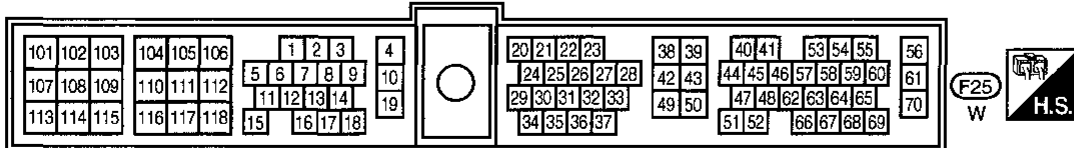
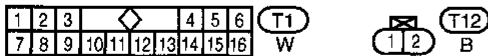
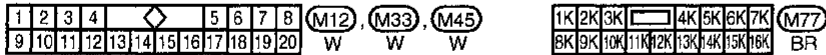
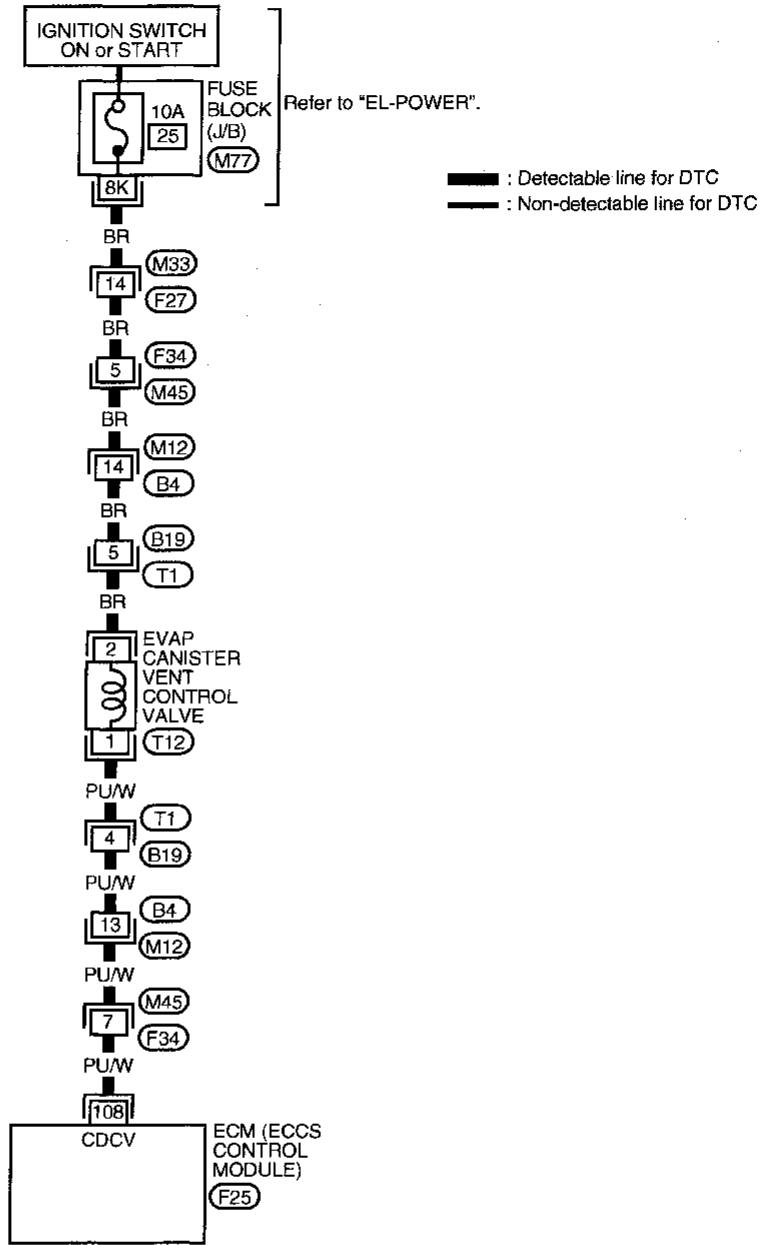

TROUBLE DIAGNOSIS FOR DTC P0446

Evaporative Emission (EVAP) Canister Vent Control Valve (Circuit) (Cont'd) DIAGNOSTIC PROCEDURE

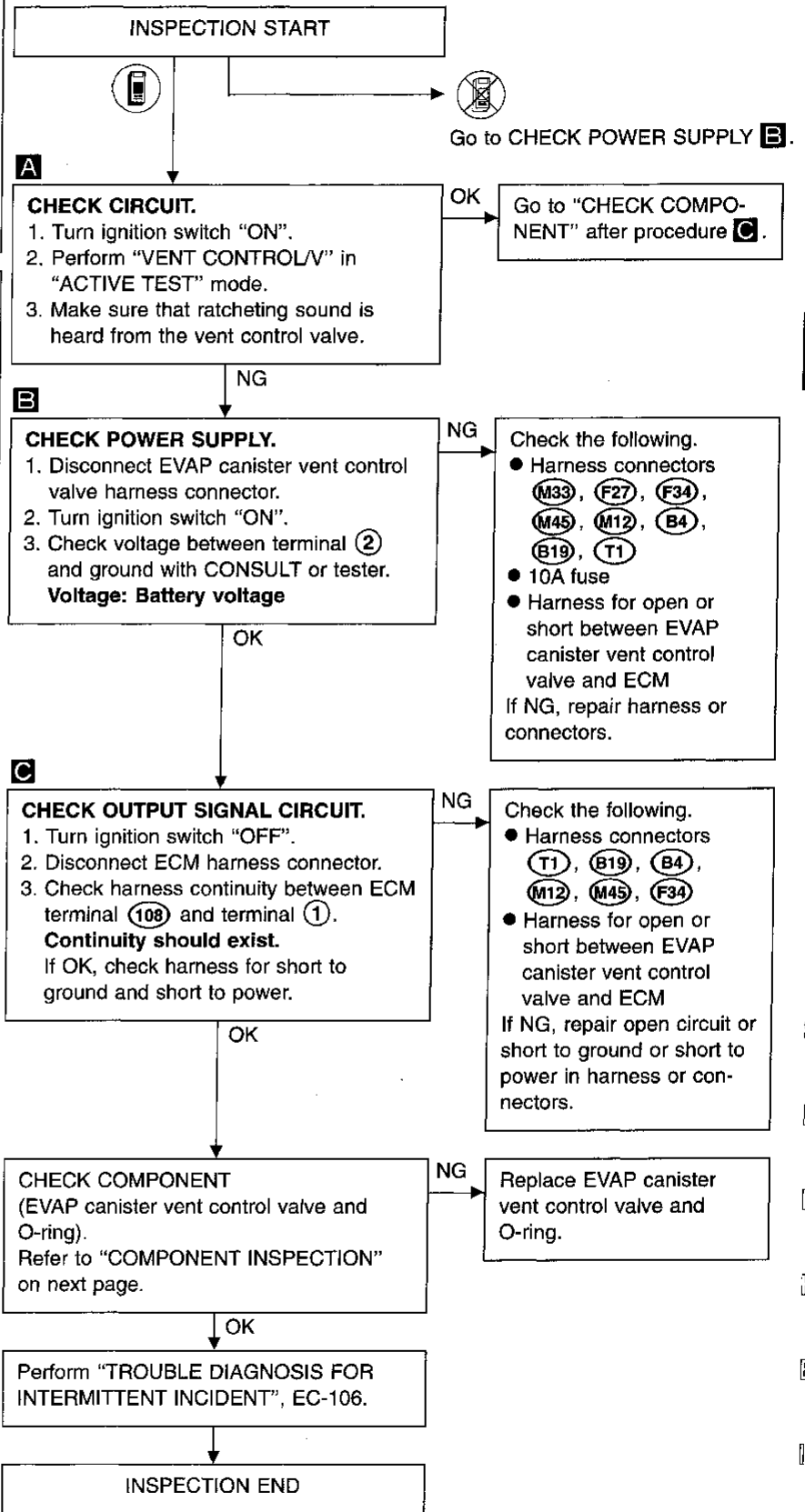
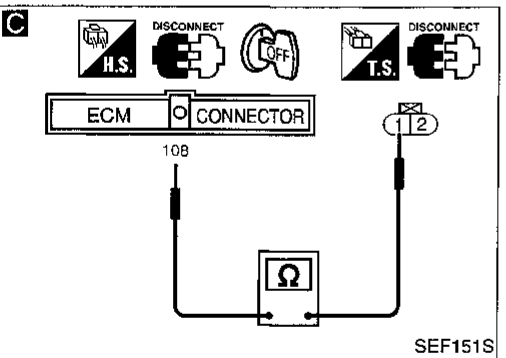
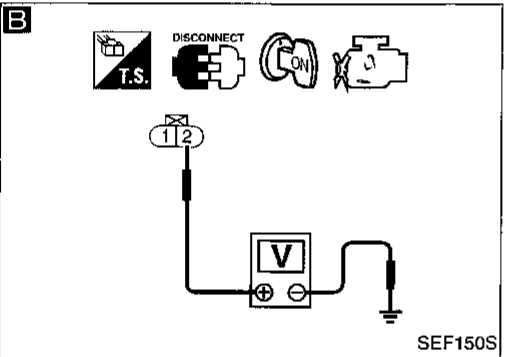
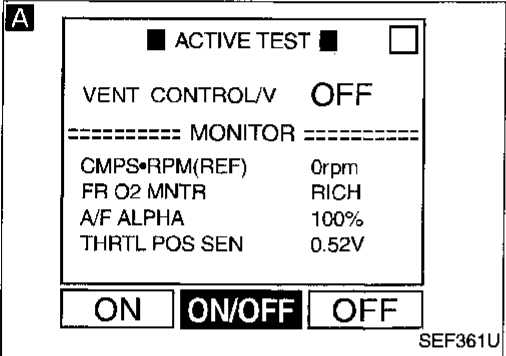
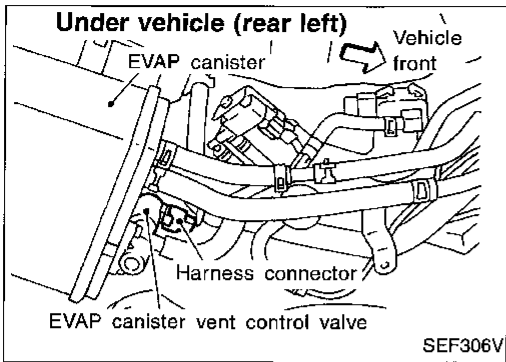

GI
MA
EM
LC
EC
FE
CL
MT
AT
FA
RA
BR
ST
RS
BT
HA
EL
IDX

TROUBLE DIAGNOSIS FOR DTC P0446

Evaporative Emission (EVAP) Canister Vent Control Valve (Circuit) (Cont'd)

COMPONENT INSPECTION

EVAP canister vent control valve

Check air passage continuity.

 Perform "VENT CONTROL/V" in "ACTIVE TEST" mode.

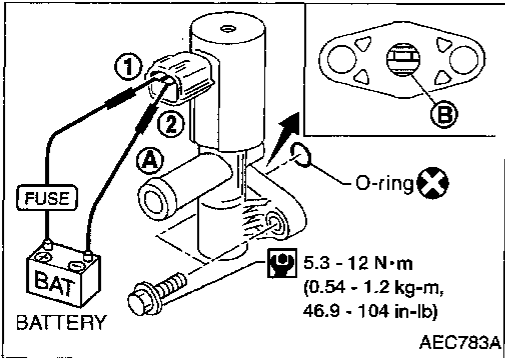
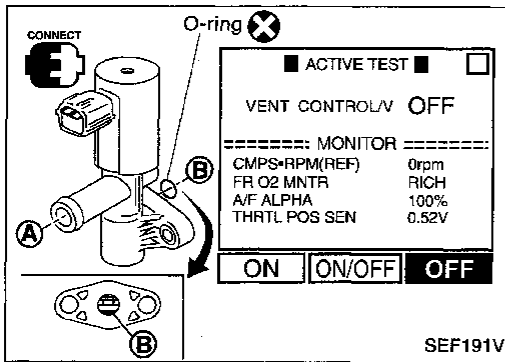

Condition VENT CONTROL/V	Air passage continuity between (A) and (B)
ON	No
OFF	Yes

OR



Condition	Air passage continuity between (A) and (B)
12V direct current supply between terminals (1) and (2)	No
No supply	Yes

If NG or operation takes more than 1 second, clean valve using air blower or replace as necessary.

If the portion (B) is rusted, replace EVAP canister vent control valve.

Make sure new O-ring is installed properly.

TROUBLE DIAGNOSIS FOR DTC P0450

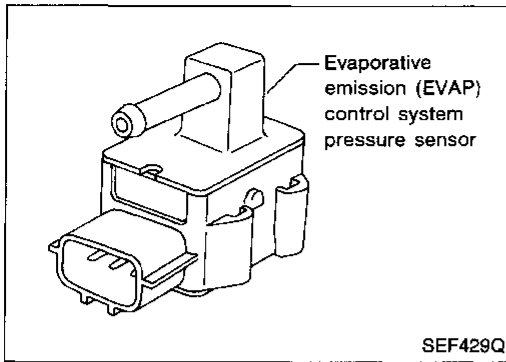

Evaporative Emission (EVAP) Control System Pressure Sensor

COMPONENT DESCRIPTION

The EVAP control system pressure sensor detects pressure in the purge line. The sensor output voltage to the ECM increases as pressure increases. The EVAP control system pressure sensor is not used to control the engine system. It is used only for on board diagnosis.

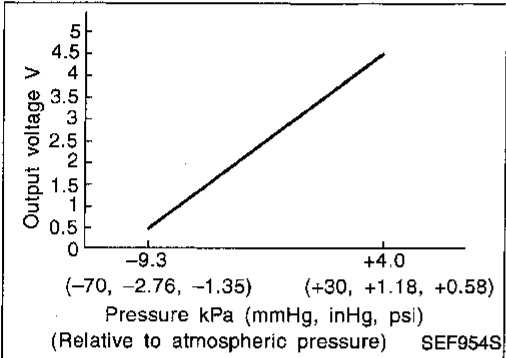

CONSULT REFERENCE VALUE IN DATA MONITOR MODE

Specification data are reference values.

MONITOR ITEM	CONDITION	SPECIFICATION
EVAP SYS PRES	● Ignition switch: ON	Approx. 3.4V

ECM TERMINALS AND REFERENCE VALUE

Specification data are reference values and are measured between each terminal and engine ground.

TERMINAL NO.	WIRE COLOR	ITEM	CONDITION	DATA (DC voltage)
49	P/L	Sensors' power supply	Ignition switch "ON"	Approximately 5V
50	B	Sensors' ground	Engine is running. (Warm-up condition) └ Idle speed	Approximately 0V
67	W	EVAP control system pressure sensor	Ignition switch "ON"	Approximately 3.4V

ON BOARD DIAGNOSIS LOGIC

Diagnostic Trouble Code No.	Malfunction is detected when	Check Items (Possible Cause)
P0450 0704	● An improper voltage signal from EVAP control system pressure sensor is sent to ECM.	<ul style="list-style-type: none"> ● Harness or connectors (The EVAP control system pressure sensor circuit is open or shorted.) ● Rubber hose to EVAP control system pressure is clogged, vented, kinked, disconnected or improperly connected. ● EVAP control system pressure sensor ● EVAP canister vent control valve ● EVAP canister purge volume control valve ● EVAP canister ● Rubber hose from EVAP canister vent control valve to water separator

TROUBLE DIAGNOSIS FOR DTC P0450

☆ MONITOR	☆ NO FAIL	<input type="checkbox"/>
CMPS-RPM(REF)	750rpm	
COOLAN TEMP/S	85°C	
TANK F/TMP SE	29°C	
RECORD		

SEF362U

Evaporative Emission (EVAP) Control System Pressure Sensor (Cont'd)

DIAGNOSTIC TROUBLE CODE CONFIRMATION PROCEDURE

NOTE:

If "DIAGNOSTIC TROUBLE CODE CONFIRMATION PROCEDURE" has been previously conducted, always turn ignition switch "OFF" and wait at least 5 seconds before conducting the next test.

TESTING CONDITION:

- Always perform test at a temperature above 5°C (41°F).
- Before performing the following procedure, confirm battery voltage is more than 10V at idle.



- 1) Start engine and warm it up to normal operating temperature.
- 2) Turn ignition switch "OFF" and wait at least 5 seconds.
- 3) Turn ignition switch "ON".
- 4) Select "DATA MONITOR" mode with CONSULT.
- 5) Make sure that "TANK F/TEMP SE" is more than 0°C (32°F).
- 6) Start engine and wait at least 20 seconds.
- 7) If 1st trip DTC is detected, go to "DIAGNOSTIC PROCEDURE", EC-310.

OR



- 1) Start engine and warm it up to normal operating temperature.
- 2) Check that voltage between ECM terminal ⑥3 and ground is less than 4.2V.
- 3) Turn ignition switch "OFF" and wait at least 5 seconds.
- 4) Start engine and wait at least 20 seconds.
- 5) Select "MODE 7" with GST.
- 6) If 1st trip DTC is detected, go to "DIAGNOSTIC PROCEDURE", EC-310.

OR



- 1) Start engine and warm it up to normal operating temperature.
- 2) Check that voltage between ECM terminal ⑥3 and ground is less than 4.2V.
- 3) Turn ignition switch "OFF" and wait at least 5 seconds.
- 4) Start engine and wait at least 20 seconds.
- 5) Turn ignition switch "OFF", wait at least 5 seconds and then turn "ON".
- 6) Perform "Diagnostic Test Mode II (Self-diagnostic results)" with ECM.
- 7) If 1st trip DTC is detected, go to "DIAGNOSTIC PROCEDURE", EC-310.

TROUBLE DIAGNOSIS FOR DTC P0450

Evaporative Emission (EVAP) Control System Pressure Sensor (Cont'd)

EC-PRE/SE-01

GI

MA

EM

LC

EC

FE

CL

MT

AT

FA

RA

BR

ST

RS

BT

HA

EL

IDX

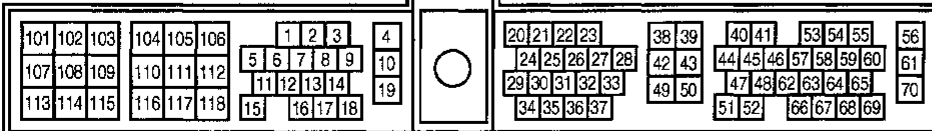
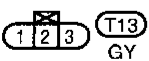
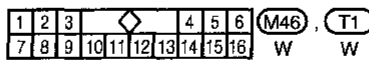
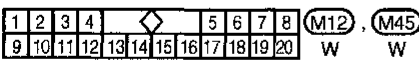
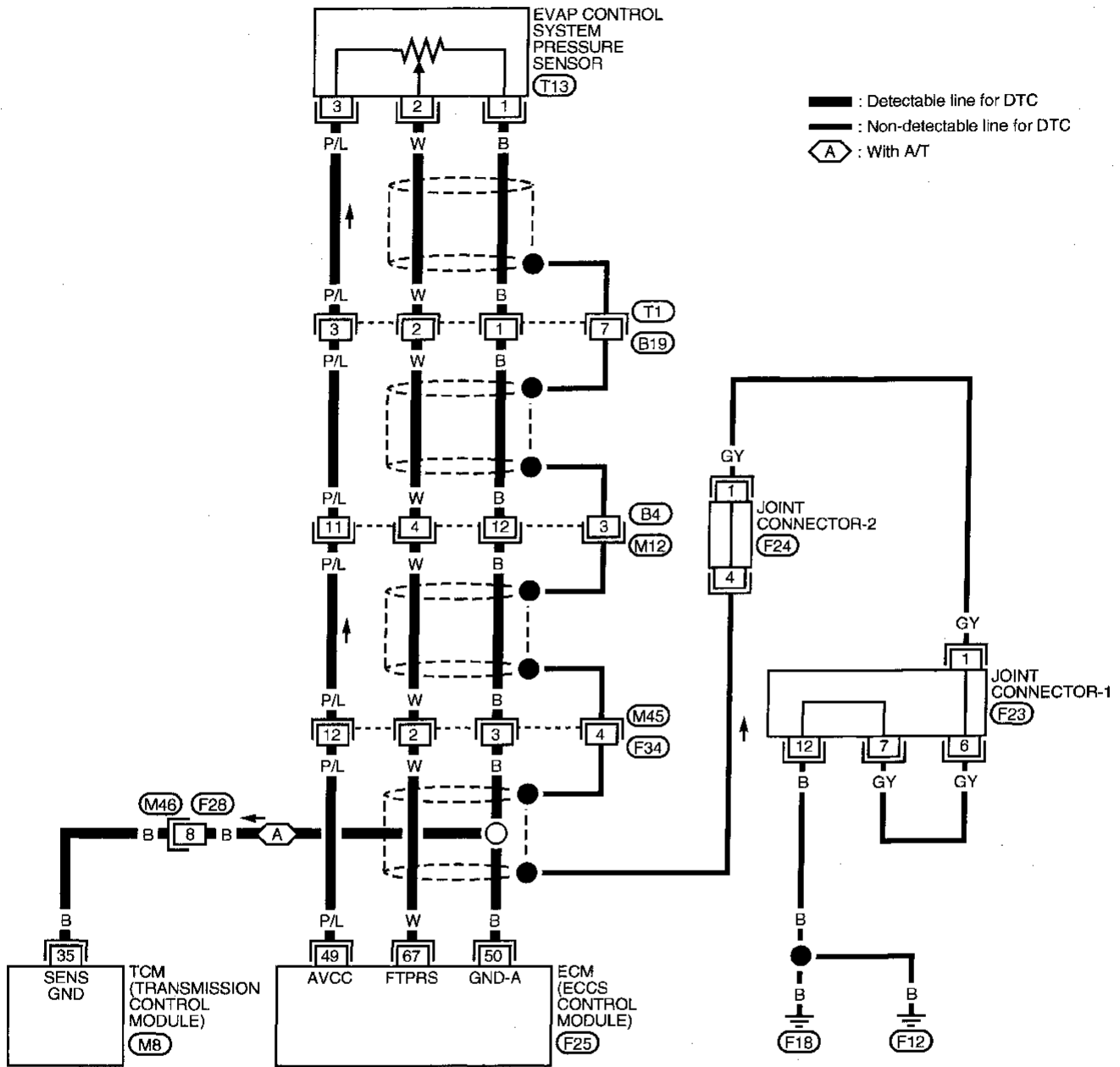

Refer to last page (Foldout page).



TROUBLE DIAGNOSIS FOR DTC P0450

Evaporative Emission (EVAP) Control System Pressure Sensor (Cont'd) DIAGNOSTIC PROCEDURE

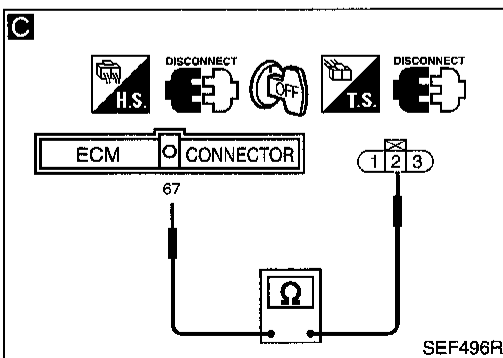
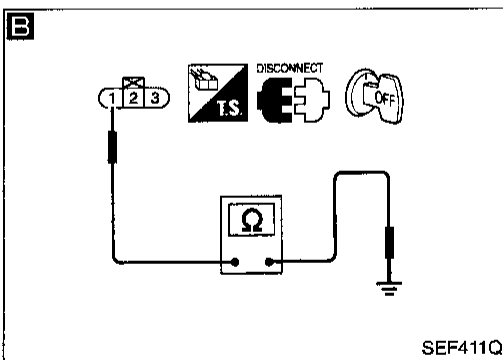
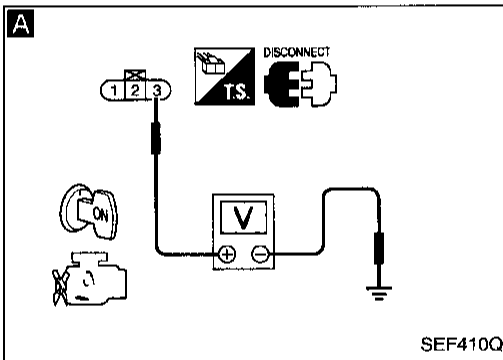
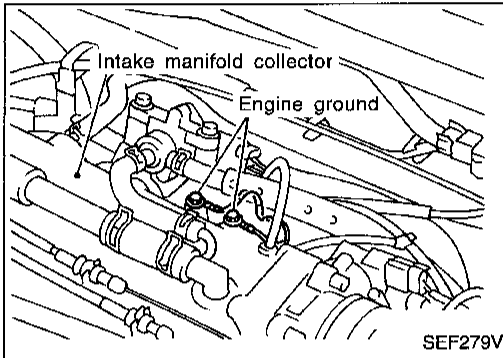
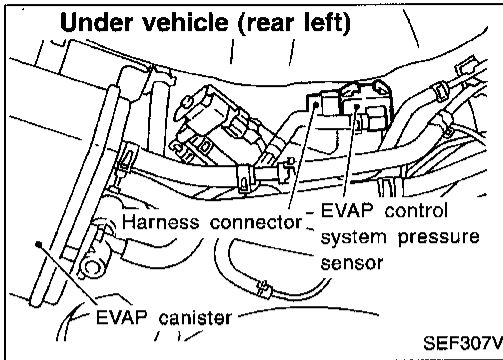

INSPECTION START

CHECK RUBBER TUBE CONNECTED TO THE SENSOR.
Check rubber tube connected to the sensor for clogging, vent, kink, disconnection or improper connection.

NG → Reconnect, repair or replace.

OK

1. Turn ignition switch "OFF".
2. Loosen and retighten engine ground screws.

A

CHECK POWER SUPPLY.
1. Disconnect EVAP control system pressure sensor harness connector.
2. Check sensor harness connector for water.
Water should not exist.
If OK, go to step 3. If NG, repair or replace harness connector.
3. Turn ignition switch "ON".
4. Check voltage between terminal ③ and engine ground with CONSULT or tester.
Voltage: Approximately 5V

NG → Check the following.

- Harness connectors T1, B19, B4, M12, M45, F34
- Harness for open or short between EVAP control system pressure sensor and ECM

If NG, repair harness or connectors.

OK

B

CHECK GROUND CIRCUIT.
1. Turn ignition switch "OFF".
2. Check harness continuity between terminal ① and engine ground.
Continuity should exist.
If OK, check harness for short to ground and short to power.

NG → Check the following.

- Harness connectors T1, B19, B4, M12, M45, F34
- Harness for open or short between EVAP control system pressure sensor and ECM
- Harness for open or short between EVAP control system pressure sensor and TCM (With A/T)

If NG, repair open circuit or short to ground or short to power in harness or connectors.

OK

C

CHECK INPUT SIGNAL CIRCUIT.
1. Disconnect ECM harness connector.
2. Check harness continuity between ECM terminal ⑥7 and terminal ②.
Continuity should exist.
If OK, check harness for short to ground and short to power.

NG → Check the following.

- Harness connectors T1, B19, B4, M12, M45, F34
- Harness for open or short between ECM and EVAP control system pressure sensor

If NG, repair open circuit or short to ground or short to power in harness or connectors.

OK

(Go to next page.)

TROUBLE DIAGNOSIS FOR DTC P0450

Evaporative Emission (EVAP) Control System Pressure Sensor (Cont'd)

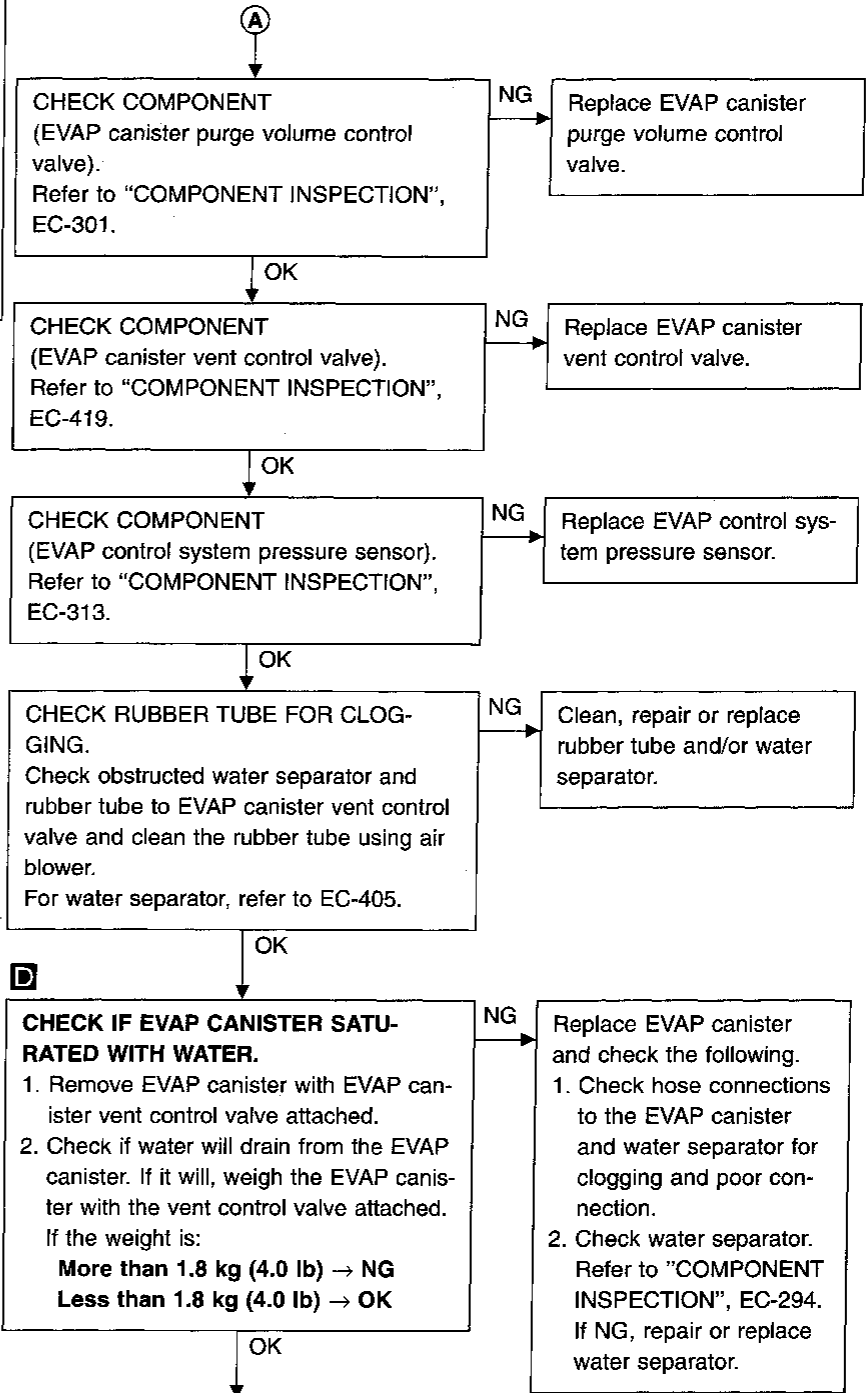
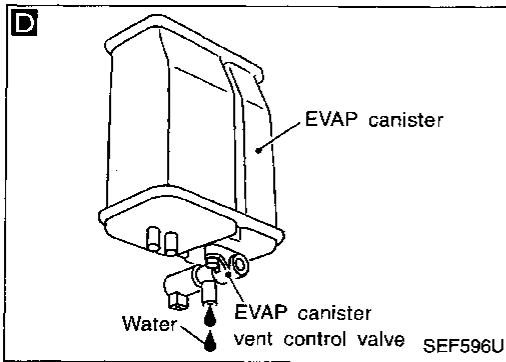

B
(Go to next page.)

GI

MA

EM

LG

EC

FE

CL

MT

AT

FA

RA

BR

ST

RS

BT

HA

EL

IDX

TROUBLE DIAGNOSIS FOR DTC P0450

Evaporative Emission (EVAP) Control System Pressure Sensor (Cont'd)

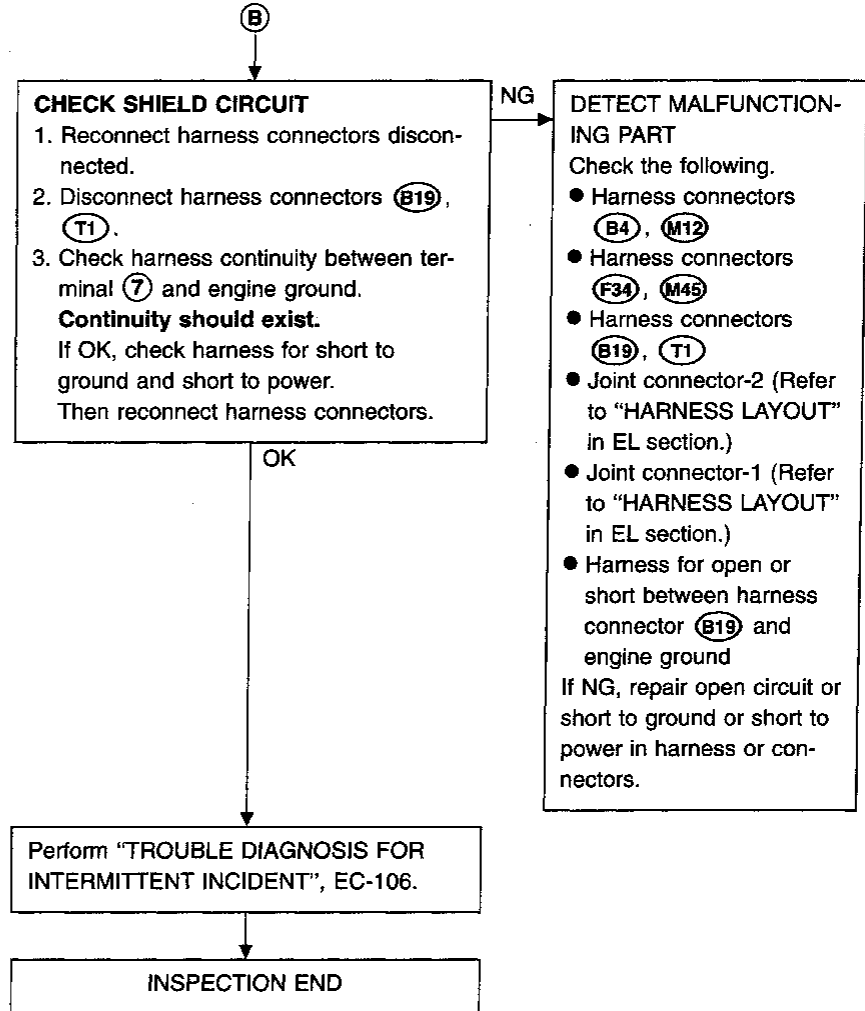

TROUBLE DIAGNOSIS FOR DTC P0450

Evaporative Emission (EVAP) Control System Pressure Sensor (Cont'd)

COMPONENT INSPECTION

EVAP control system pressure sensor

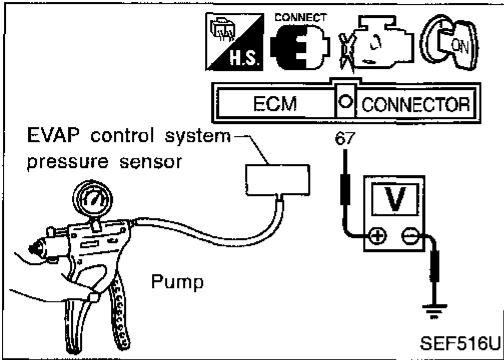

1. Remove EVAP control system pressure sensor with its harness connector connected.
2. Remove hose from EVAP control system pressure sensor.
3. Use pump to apply vacuum and pressure to EVAP control system pressure sensor as shown in figure.
4. Check output voltage between ECM terminal ⑥7 and engine ground.

Pressure (Relative to atmospheric pressure)	Voltage (V)
0 kPa (0 mmHg, 0 inHg)	3.0 - 3.6
-9.3 kPa (-70 mmHg, -2.76 inHg)	0.4 - 0.6

CAUTION:

- Always calibrate the vacuum pump gauge when using it.
 - Do not apply below -20 kPa (-150 mmHg, -5.91 inHg) or over 20 kPa (150 mmHg, 5.91 inHg) of pressure.
5. If NG, replace EVAP control system pressure sensor.

GI

MA

EM

LC

EC

FE

CL

MT

AT

FA

RA

BR

ST

RS

BT

HA

EL

IDX

TROUBLE DIAGNOSIS FOR DTC P0500

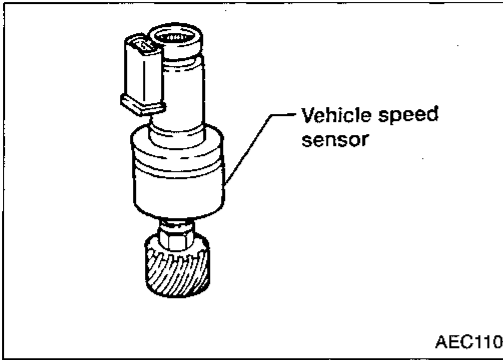

Vehicle Speed Sensor (VSS)

COMPONENT DESCRIPTION

The vehicle speed sensor is installed in the transaxle. It contains a pulse generator which provides a vehicle speed signal to the speedometer. The speedometer then sends a signal to the ECM.

ECM TERMINALS AND REFERENCE VALUE

Specification data are reference values and are measured between each terminal and engine ground.

TER-MINAL NO.	WIRE COLOR	ITEM	CONDITION	DATA (DC voltage)
26	PU/R	Vehicle speed sensor	<div style="border: 1px solid black; padding: 2px; display: inline-block;">Engine is running.</div> <ul style="list-style-type: none"> — Lift up the vehicle. — In 2nd gear position — Vehicle speed is 40 km/h (25 MPH). 	0 - Approximately 4.2V <p style="text-align: right;">SEF194T</p>

ON BOARD DIAGNOSIS LOGIC

Diagnostic Trouble Code No.	Malfunction is detected when	Check Items (Possible Cause)
P0500 0104	<ul style="list-style-type: none"> ● The almost 0 km/h (0 MPH) signal from vehicle speed sensor is sent to ECM even when vehicle is being driven. 	<ul style="list-style-type: none"> ● Harness or connector (The vehicle speed sensor circuit is open or shorted.) ● Vehicle speed sensor

TROUBLE DIAGNOSIS FOR DTC P0500

Vehicle Speed Sensor (VSS) (Cont'd)

DIAGNOSTIC TROUBLE CODE CONFIRMATION PROCEDURE

CAUTION:

Always drive vehicle at a safe speed.

NOTE:

If "DIAGNOSTIC TROUBLE CODE CONFIRMATION PROCEDURE" has been previously conducted, always turn ignition switch "OFF" and wait at least 5 seconds before conducting the next test.

TESTING CONDITION:

Steps 1 and 2 may be conducted with the drive wheels lifted in the shop or by driving the vehicle. If a road test is expected to be easier, it is unnecessary to lift the vehicle.

- 1) Start engine.
- 2) Perform "VEHICLE SPEED SEN CIRCUIT" in "FUNCTION TEST" mode with CONSULT.
- 3) If 1st trip DTC is detected, go to "DIAGNOSTIC PROCEDURE", EC-318.

OR

- 1) Start engine
- 2) Read vehicle speed sensor signal in "DATA MONITOR" mode with CONSULT. The vehicle speed on CONSULT should exceed 10 km/h (6 MPH) when rotating wheels with suitable gear position. If NG, go to "DIAGNOSTIC PROCEDURE", EC-318. If OK, go to following step.
- 3) Select "DATA MONITOR" mode with CONSULT.
- 4) Warm engine up to normal operating temperature.
- 5) Maintain the following conditions for at least 10 consecutive seconds.

**CMPS·RPM (REF): 2,000 - 3,200 rpm (A/T)
1,950 - 2,900 rpm (M/T)**

COOLAN TEMP/S: More than 70°C (158°F)

**B/FUEL SCHDL: 2.3 - 3.5 msec (A/T)
2.3 - 3.7 msec (M/T)**

Selector lever: Suitable position

PW/ST SIGNAL: OFF

- 6) If 1st trip DTC is detected, go to "DIAGNOSTIC PROCEDURE", EC-318.

OR

OVERALL FUNCTION CHECK

Use this procedure to check the overall function of the EVAP canister vent control valve circuit. During this check, a DTC might not be confirmed.

- 1) Lift up drive wheels.
- 2) Start engine.
- 3) Read vehicle speed sensor signal in "MODE 1" with GST.

The vehicle speed sensor on GST should be able to exceed 10 km/h (6 MPH) when rotating wheels with suitable gear position.

- 4) If NG, go to "DIAGNOSTIC PROCEDURE", EC-318.

OR

- 1) Lift up drive wheels.
- 2) Start engine.

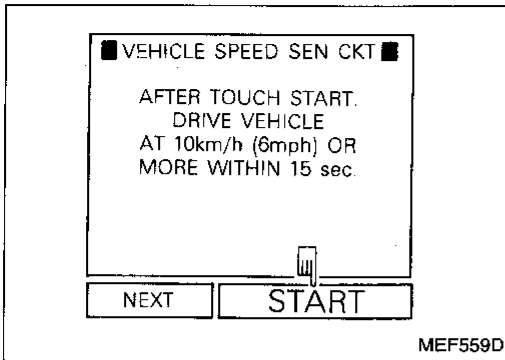

MEF559D

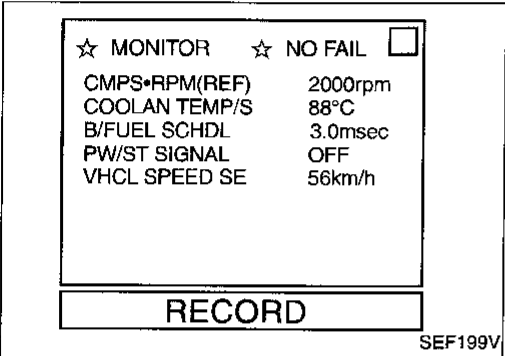

SEF199V

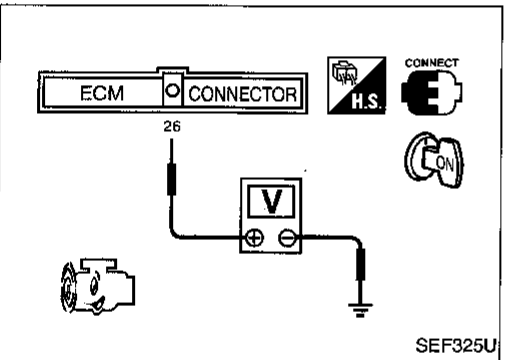

SEF325U

GI

MA

EM

LC

EC

FE

CL

MT

AT

FA

RA

BR

ST

RS

BT

HA

EL

IDX

TROUBLE DIAGNOSIS FOR DTC P0500

Vehicle Speed Sensor (VSS) (Cont'd)

- 3) Read the voltage signal between ECM terminal ②⑥ (Vehicle speed sensor signal) and ground with oscilloscope.
- 4) Verify that the oscilloscope screen shows the signal wave as shown at "ECM TERMINALS AND REFERENCE VALUE" on the previous page.
- 5) If NG, go to "DIAGNOSTIC PROCEDURE", EC-318.

TROUBLE DIAGNOSIS FOR DTC P0500

Vehicle Speed Sensor (VSS) (Cont'd)

EC-VSS-01

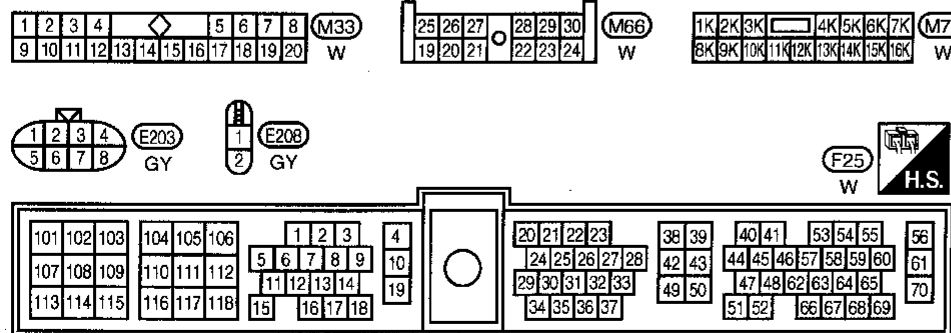
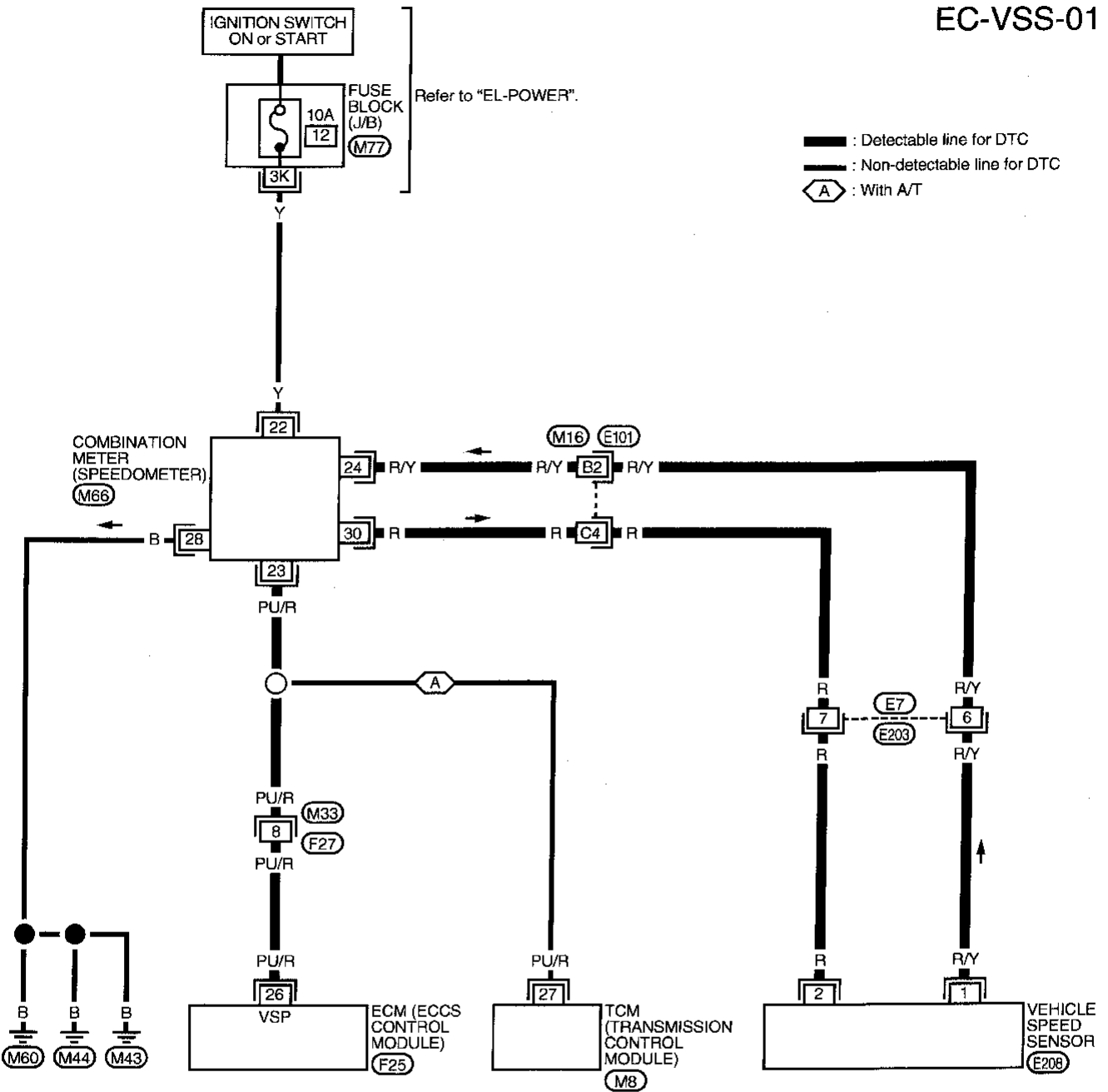

Refer to last page (Foldout page).

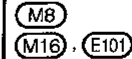

TROUBLE DIAGNOSIS FOR DTC P0500

Vehicle Speed Sensor (VSS) (Cont'd)

DIAGNOSTIC PROCEDURE

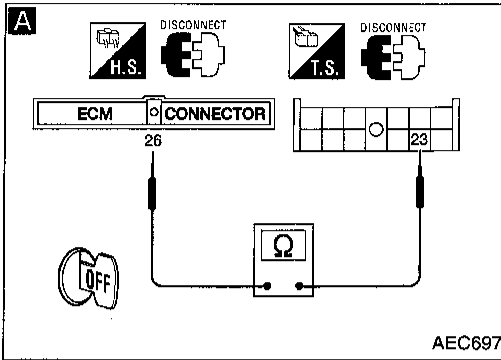

INSPECTION START

A

CHECK INPUT SIGNAL CIRCUIT.

1. Turn ignition switch "OFF".
2. Disconnect ECM harness connector and combination meter harness connector.
3. Check harness continuity.

Terminals	
ECM	Meter
26	23

Continuity should exist.
If OK, check harness for short to ground and short to power.

NG

Check the following.

- Harness connectors (M33, F27)
- Harness for open or short between ECM and combination meter
- Harness for open or short between combination meter and TCM (With A/T)

If NG, repair open circuit or short to ground or short to power in harness or connectors.

OK

CHECK SPEEDOMETER FUNCTION.
Make sure that speedometer functions properly.

NG

Check the following.

- Harness connectors (M15, E101)
- Harness connectors (E7, E203)
- Harness for open or short between combination meter and vehicle speed sensor

If NG, repair harness or connectors.
Check vehicle speed sensor and its circuit.
Refer to EL section.

OK

Perform "TROUBLE DIAGNOSIS FOR INTERMITTENT INCIDENT", EC-106.

INSPECTION END

Idle Air Control Valve (IACV) — Auxiliary Air Control (AAC) Valve

SYSTEM DESCRIPTION

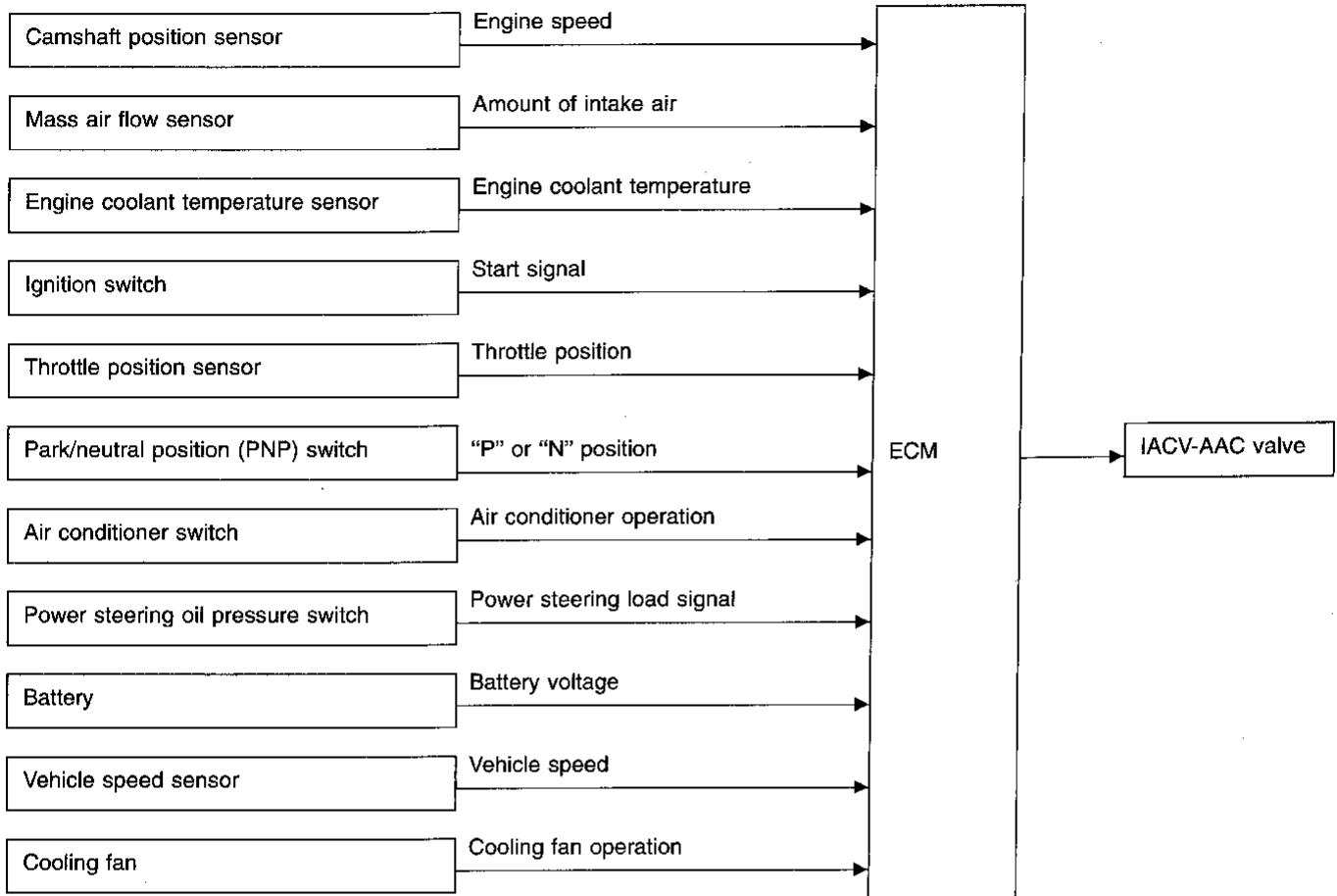

This system automatically controls engine idle speed to a specified level. Idle speed is controlled through fine adjustment of the amount of air which bypasses the throttle valve via IACV-AAC valve. The IACV-AAC valve repeats ON/OFF operation according to the signal sent from the ECM. The camshaft position sensor detects the actual engine speed and sends a signal to the ECM. The ECM then controls the ON/OFF time of the IACV-AAC valve so that engine speed coincides with the target value memorized in ECM. The target engine speed is the lowest speed at which the engine can operate steadily. The optimum value stored in the ECM is determined by taking into consideration various engine conditions, such as during warm up, deceleration, and engine load (air conditioner, power steering and cooling fan operation).

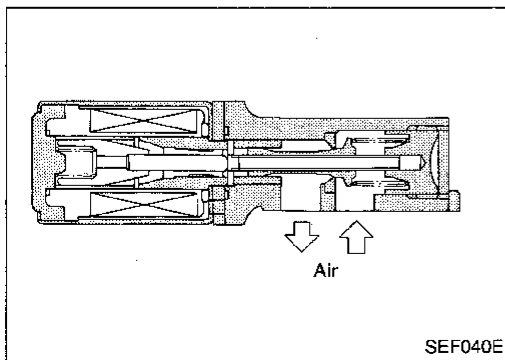

COMPONENT DESCRIPTION

IACV-AAC valve

The IAC valve-AAC valve is moved by ON/OFF pulses from the ECM. The longer the ON pulse, the greater the amount of air that will flow through the valve. The more air that flows through the valve, the higher the idle speed.

TROUBLE DIAGNOSIS FOR DTC P0505

Idle Air Control Valve (IACV) — Auxiliary Air Control (AAC) Valve (Cont'd)

CONSULT REFERENCE VALUE IN DATA MONITOR MODE

MONITOR ITEM	CONDITION	SPECIFICATION
IACV-AAC/V	● Engine: After warming up ● Air conditioner switch: OFF ● Shift lever: "N" ● No-load	Idle
		2,000 rpm
		20 - 40%
		—

ECM TERMINALS AND REFERENCE VALUE

Specification data are reference values and are measured between each terminal and engine ground.

TER-MINAL NO.	WIRE COLOR	ITEM	CONDITION	DATA (DC voltage)
101	SB	IACV-AAC valve	<div style="border: 1px solid black; padding: 2px;">Engine is running.</div> (Warm-up condition) └ Idle speed	Approximately 10V
			<div style="border: 1px solid black; padding: 2px;">Engine is running.</div> (Warm-up condition) └ Engine speed is 2,000 rpm.	Approximately 10V

ON BOARD DIAGNOSIS LOGIC

Diagnostic Trouble Code No.	Malfunction is detected when	Check Items (Possible Cause)
P0505 0205	A) The IACV-AAC valve does not operate properly.	<ul style="list-style-type: none"> ● Harness or connectors (The IACV-AAC valve circuit is open.) ● IACV-AAC valve
	B) The IACV-AAC valve does not operate properly.	<ul style="list-style-type: none"> ● Harness or connectors (The IACV-AAC valve circuit is shorted.) ● IACV-AAC valve

DIAGNOSTIC TROUBLE CODE CONFIRMATION PROCEDURE

NOTE:

- If "DIAGNOSTIC TROUBLE CODE CONFIRMATION PROCEDURE" has been previously conducted, always turn ignition switch "OFF" and wait at least 5 seconds before conducting the next test.
- Perform "Procedure for malfunction A" first. If DTC cannot be confirmed, perform "Procedure for malfunction B".

TROUBLE DIAGNOSIS FOR DTC P0505

Idle Air Control Valve (IACV) — Auxiliary Air Control (AAC) Valve (Cont'd)

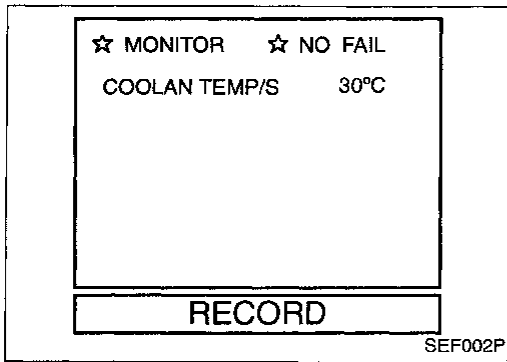

Procedure for malfunction A

-  1) Turn ignition switch "ON".
- 2) Select "DATA MONITOR" mode with CONSULT.
- 3) Start engine and run it at idle at least 2 seconds.
- 4) If 1st trip DTC is detected, go to "DIAGNOSTIC PROCEDURE", EC-324.

OR

-  1) Start engine and run it at idle at least 2 seconds.
- 2) Select "MODE 7" with GST.
- 3) If 1st trip DTC is detected, go to "DIAGNOSTIC PROCEDURE", EC-324.

OR

-  1) Start engine and run it at idle at least 2 seconds.
- 2) Turn ignition switch "OFF", wait at least 5 seconds and then turn "ON".
- 3) Perform "Diagnostic Test Mode II (Self-diagnostic results)" with ECM.
- 4) If 1st trip DTC is detected, go to "DIAGNOSTIC PROCEDURE", EC-324.

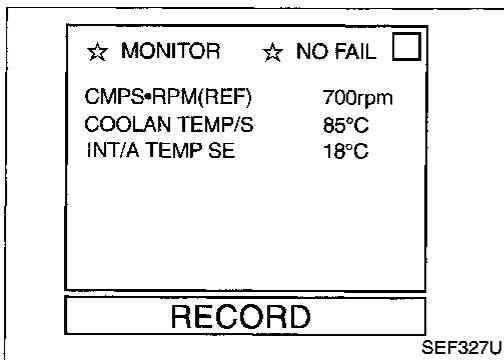

Procedure for malfunction B

TESTING CONDITION:

Before performing the following procedure, confirm battery voltage is more than 11V at idle.

-  1) Start engine and warm it up to normal operating temperature.
- 2) Turn ignition switch "OFF" and wait at least 5 seconds.
- 3) Turn ignition switch "ON" again and select "DATA MONITOR" mode with CONSULT.
- 4) Start engine and run it for at least 1 minute at idle speed.
- 5) If 1st trip DTC is detected, go to "DIAGNOSTIC PROCEDURE", EC-324.

OR

-  1) Start engine and warm it up to normal operating temperature.
- 2) Turn ignition switch "OFF" and wait at least 5 seconds.
- 3) Start engine again and run it for at least 1 minute at idle speed.
- 4) Select "MODE 7" with GST.
- 5) If 1st trip DTC is detected, go to "DIAGNOSTIC PROCEDURE", EC-324.

OR

-  1) Start engine and warm it up to normal operating temperature.
- 2) Turn ignition switch "OFF" and wait at least 5 seconds.
- 3) Start engine again and run it for at least 1 minute at idle speed.
- 4) Turn ignition switch "OFF", wait at least 5 seconds and then turn "ON".

TROUBLE DIAGNOSIS FOR DTC P0505

Idle Air Control Valve (IACV) — Auxiliary Air Control (AAC) Valve (Cont'd)

- 5) Perform “Diagnostic Test Mode II (Self-diagnostic results)” with ECM.
- 6) If 1st trip DTC is detected, go to “DIAGNOSTIC PROCEDURE”, EC-324.

TROUBLE DIAGNOSIS FOR DTC P0505

Idle Air Control Valve (IACV) — Auxiliary Air Control (AAC) Valve (Cont'd)

EC-AAC/V-01

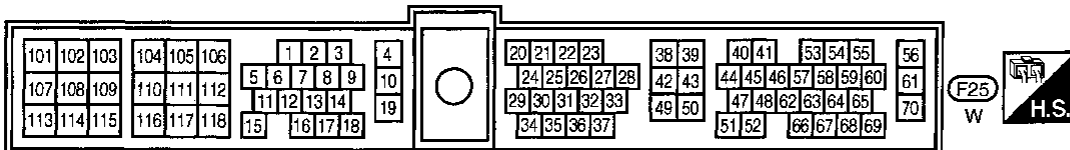
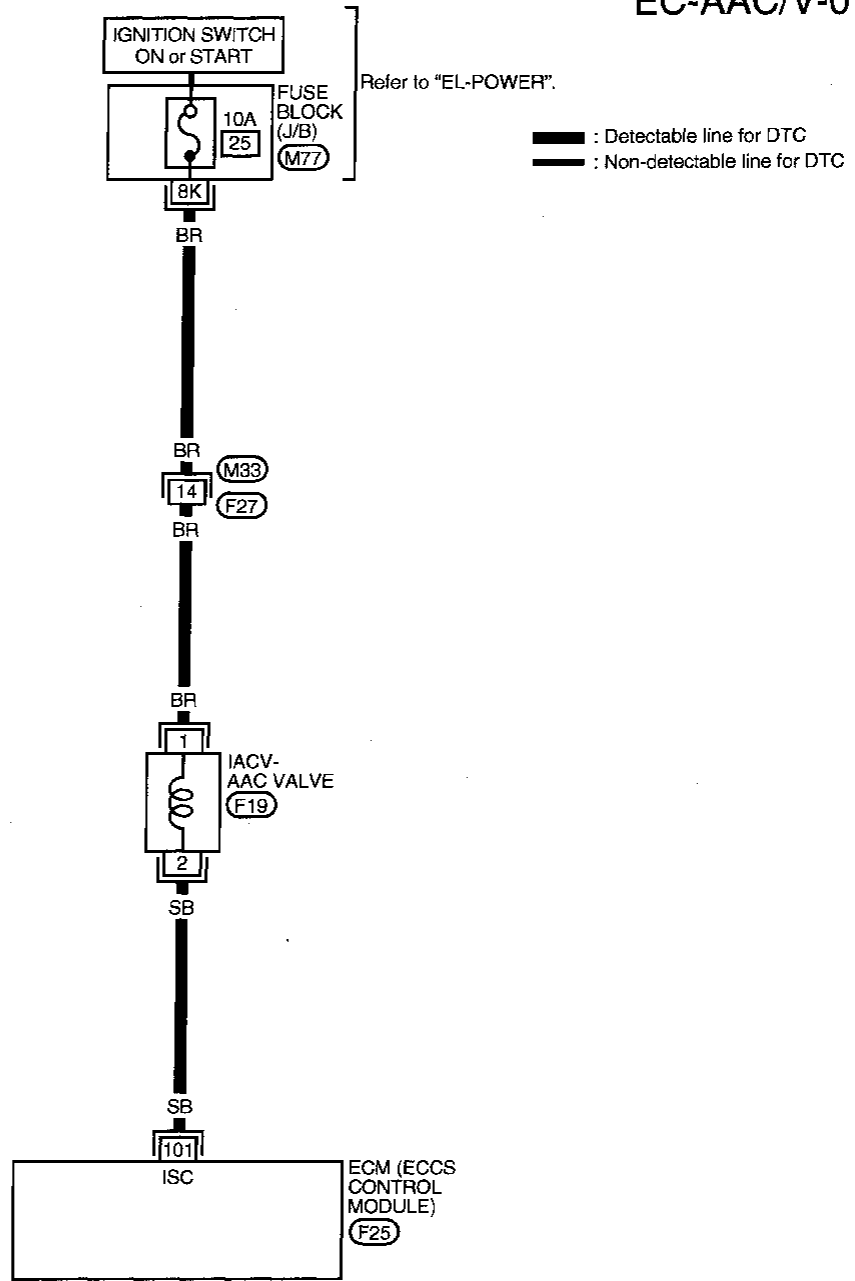

GI
MA
EM
LC
EC
FE
CL
MT
AT
FA
RA
BR
ST
RS
BT
HA
EL

IDX

TROUBLE DIAGNOSIS FOR DTC P0505

Idle Air Control Valve (IACV) — Auxiliary Air Control (AAC) Valve (Cont'd) DIAGNOSTIC PROCEDURE

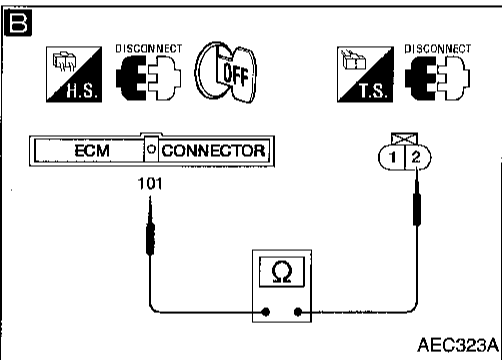
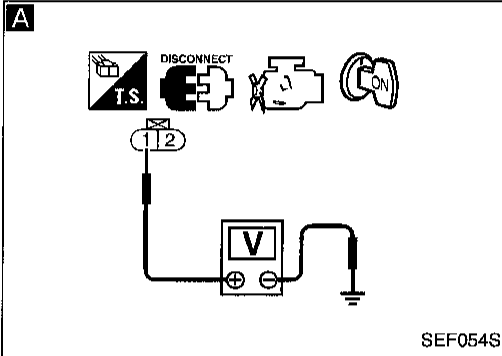
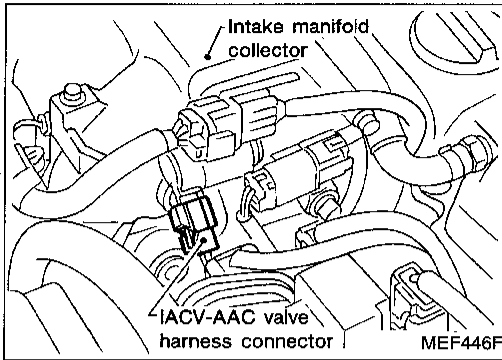

INSPECTION START

A
CHECK POWER SUPPLY.
1. Stop engine.
2. Disconnect IACV-AAC valve harness connector.
3. Turn ignition switch "ON".
4. Check voltage between terminal ① and ground with CONSULT or tester.
Voltage: Battery voltage

NG → Check the following.
● Harness connectors
● M33, F27
● 10A fuse
● Harness for open or short between IACV-AAC valve harness connector and fuse
If NG, repair harness or connectors.

B
CHECK OUTPUT SIGNAL CIRCUIT.
1. Disconnect ECM harness connector.
2. Check harness continuity between ECM terminal ①01 and terminal ②.
Continuity should exist.
If OK, check harness for short to ground and short to power.

NG → Repair open circuit or short to ground or short to power in harness or connectors.

CHECK COMPONENT
(IACV-AAC valve).
Refer to "COMPONENT INSPECTION" below.

NG → Replace IACV-AAC valve.

Perform "TROUBLE DIAGNOSIS FOR INTERMITTENT INCIDENT", EC-106.

INSPECTION END

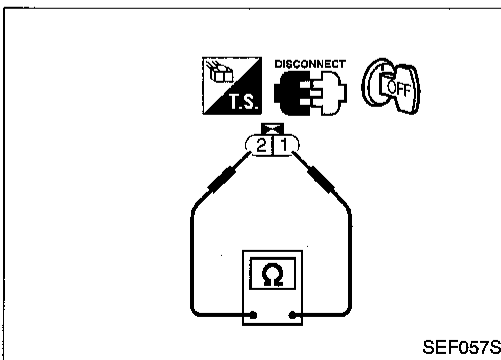

COMPONENT INSPECTION

IACV-AAC valve

Disconnect IACV-AAC valve harness connector.

- Check IACV-AAC valve resistance.

Resistance:

Approximately 10Ω [at 25°C (77°F)]

- Check plunger for seizing or sticking.
- Check for broken spring.

TROUBLE DIAGNOSIS FOR DTC P0510

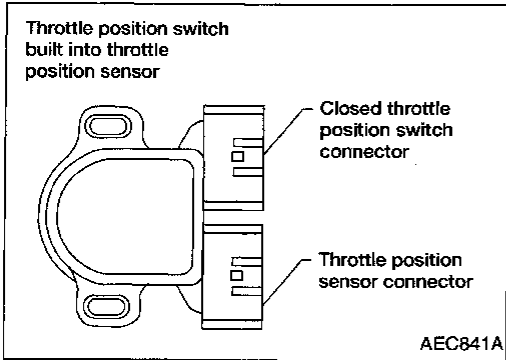

Closed Throttle Position Switch

COMPONENT DESCRIPTION

A closed throttle position switch and wide open throttle position switch are built into the throttle position sensor unit. The wide open throttle position switch is used only for A/T control. When the throttle valve is in the closed position, the closed throttle position switch sends a voltage signal to the ECM. The ECM only uses this signal to open or close the EVAP canister purge control valve when the throttle position sensor is malfunctioning.

ECM TERMINALS AND REFERENCE VALUE

Specification data are reference values and are measured between each terminal and engine ground.

TER-MINAL NO.	WIRE COLOR	ITEM	CONDITION	DATA (DC voltage)
27	Y	Throttle position switch (Closed position)	Ignition switch "ON" (Warm-up condition) └ Accelerator pedal fully released	BATTERY VOLTAGE (11 - 14V)
			Ignition switch "ON" └ Accelerator pedal depressed	Approximately 0V

ON BOARD DIAGNOSIS LOGIC

Diagnostic Trouble Code No.	Malfunction is detected when	Check Items (Possible Cause)
P0510 0203	<ul style="list-style-type: none"> Battery voltage from the closed throttle position switch is sent to ECM with the throttle valve opened. 	<ul style="list-style-type: none"> Harness or connectors (The closed throttle position switch circuit is shorted.) Closed throttle position switch Throttle position sensor

GI
 MA
 EM
 LG
EC
 FE
 CL
 MT
 AT
 FA
 RA
 BR
 ST
 RS
 BT
 HA
 EL
 IDX

TROUBLE DIAGNOSIS FOR DTC P0510

Closed Throttle Position Switch (Cont'd) DIAGNOSTIC TROUBLE CODE CONFIRMATION PROCEDURE

CAUTION:

Always drive vehicle at a safe speed.

NOTE:

If "DIAGNOSTIC TROUBLE CODE CONFIRMATION PROCEDURE" has been previously conducted, always turn ignition switch "OFF" and wait at least 5 seconds before conducting the next test.

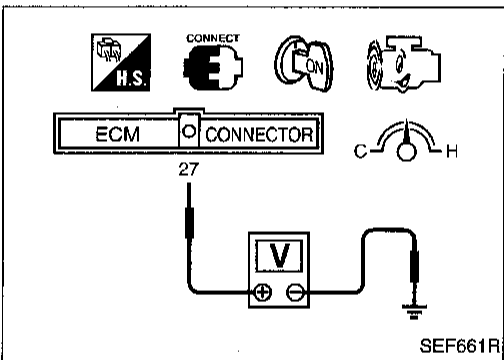
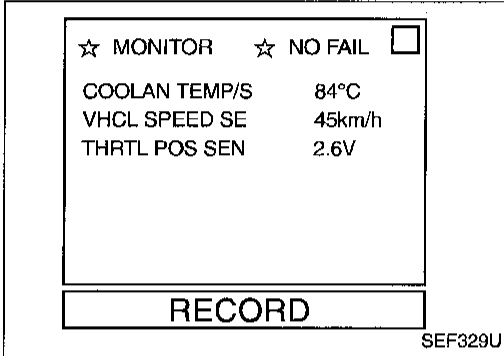
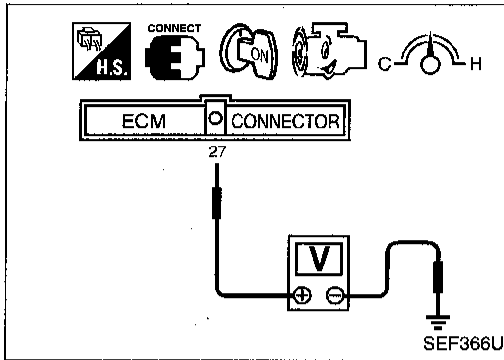

1) Start engine and warm it up to normal operating temperature.

2) Check voltage between ECM terminal ②⑦ and ground under the following conditions.

At idle: Battery voltage

At 2,000 rpm: Approximately 0V

If the check result is NG, go to "DIAGNOSTIC PROCEDURE", EC-328.

If OK, go to following step.

3) Select "DATA MONITOR" mode with CONSULT.

4) Drive the vehicle for at least 5 consecutive seconds under the following condition.

THRTL POS SEN: More than 2.5V

VHCL SPEED SE: More than 4 km/h (2 MPH)

Selector lever: Suitable position

Driving pattern: Driving vehicle uphill (Increased engine load) will help maintain the driving conditions required for this test.

5) If 1st trip DTC is detected, go to "DIAGNOSTIC PROCEDURE", EC-328.

OR

OVERALL FUNCTION CHECK

Use this procedure to check the overall function of the closed throttle position switch circuit. During this check, a 1st trip DTC might not be confirmed.



1) Start engine and warm it up to normal operating temperature.

2) Check the voltage between ECM terminal ②⑦ and ground under the following conditions.

At idle: Battery voltage

At 2,000 rpm: Approximately 0V

3) If NG, go to "DIAGNOSTIC PROCEDURE", EC-328.

TROUBLE DIAGNOSIS FOR DTC P0510

Closed Throttle Position Switch (Cont'd)

EC-TP/SW-01

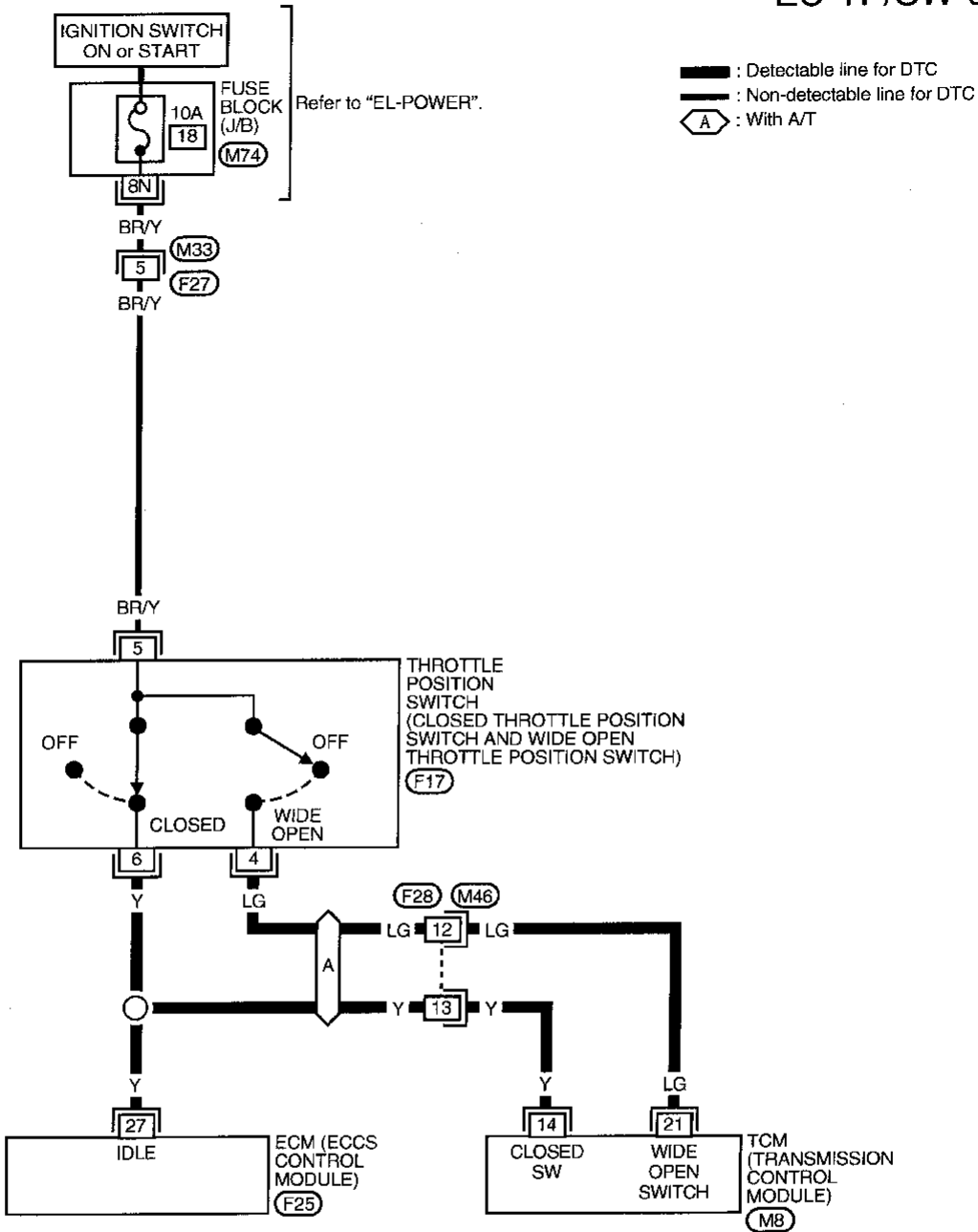

1	2	3	4	◇	5	6	7	8	(M33)			
9	10	11	12	13	14	15	16	17	18	19	20	W

1	2	3	◇	4	5	6	(M46)			
7	8	9	10	11	12	13	14	15	16	W

1N	2N	3N	◇	4N	5N	6N	7N	(M74)	
8N	9N	10N	11N	12N	13N	14N	15N	16N	GY

4	5	6	(F17)
GY			

(F25)	H.S.
W	

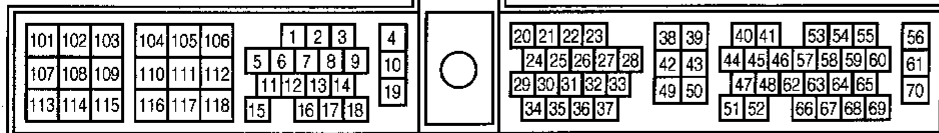

Refer to last page (Foldout page).
(M8)

GI
MA
EM
LC
EC
FE
CL
MT
AT
FA
RA
BR
ST
RS
BT
HA
EL
IDX

TROUBLE DIAGNOSIS FOR DTC P0510

Closed Throttle Position Switch (Cont'd)

DIAGNOSTIC PROCEDURE

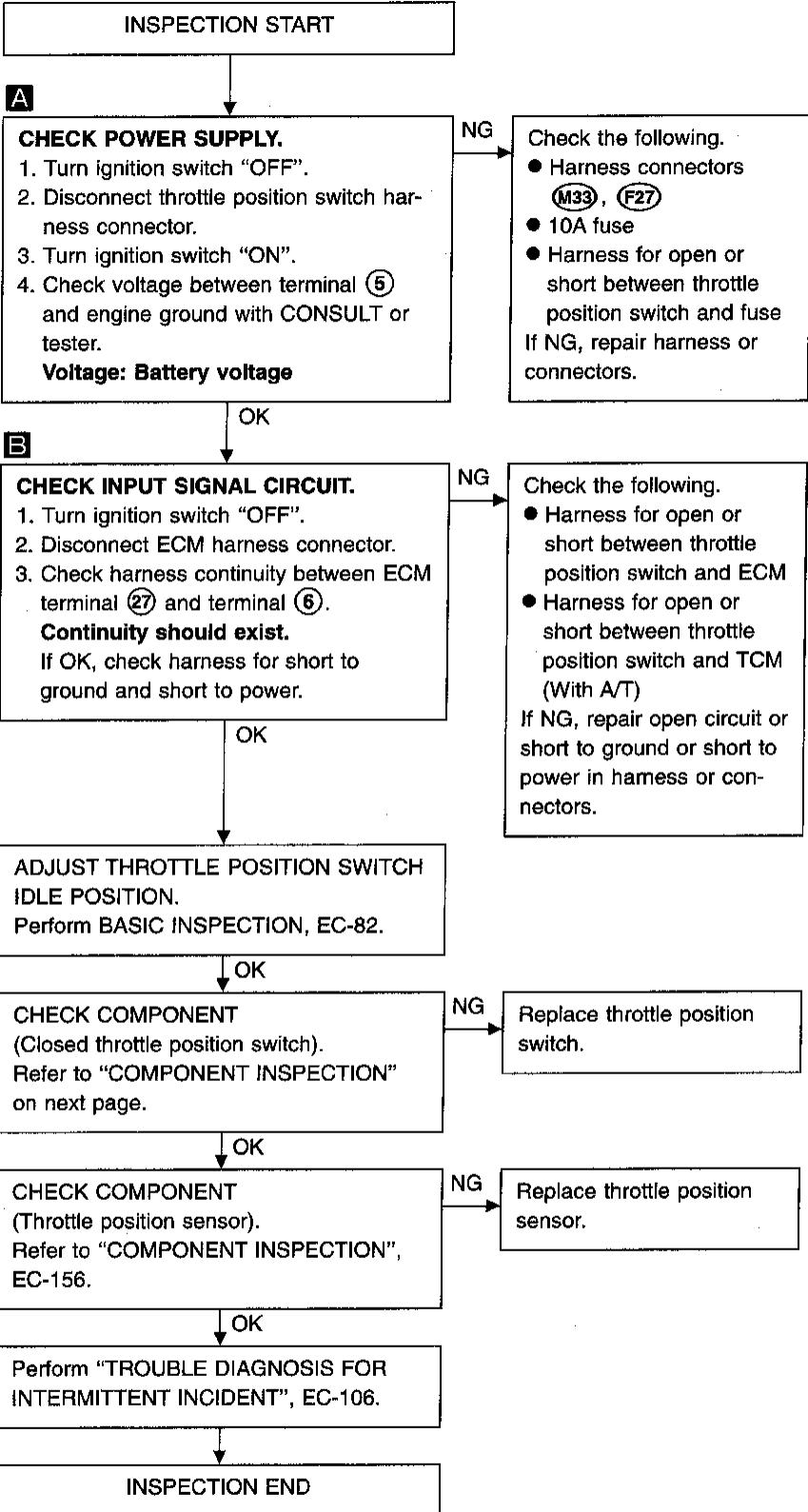
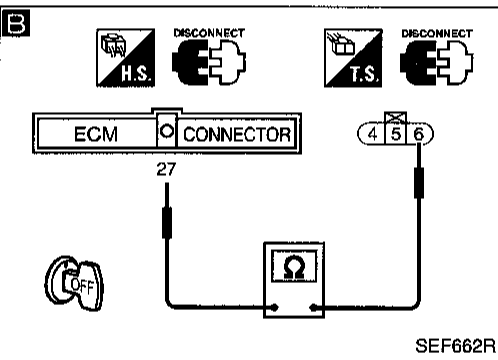
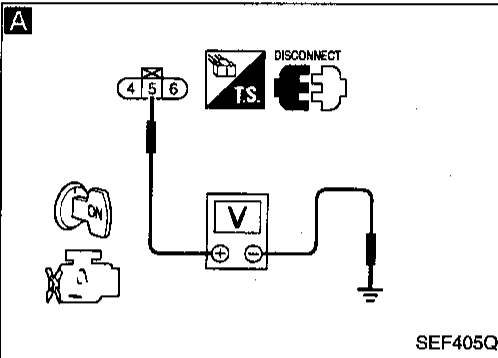
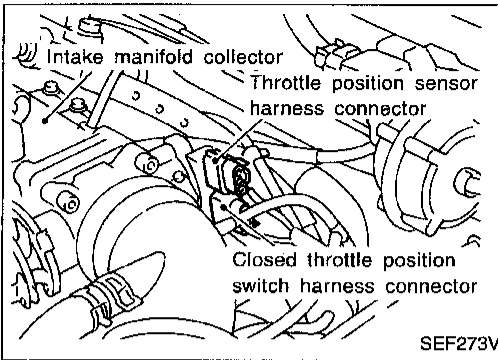

TROUBLE DIAGNOSIS FOR DTC P0510

Closed Throttle Position Switch (Cont'd)

COMPONENT INSPECTION

Closed throttle position switch



1. Start engine and warm it up to normal operating temperature.
2. Stop engine and turn ignition switch "ON".
3. Select "DATA MONITOR" mode with CONSULT.
4. Check indication of "CLSD THL/P SW".

Measurement must be made with closed throttle position switch installed in vehicle.

Throttle valve conditions	CLSD THL/P SW
Completely closed	ON
Partially open or completely open	OFF

If NG, adjust closed throttle position switch. Refer to "Basic Inspection", EC-82.

5. If it is impossible to adjust closed throttle position switch in "Basic Inspection", replace closed throttle position switch.

OR

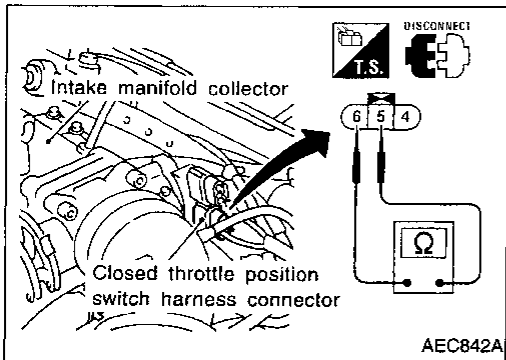
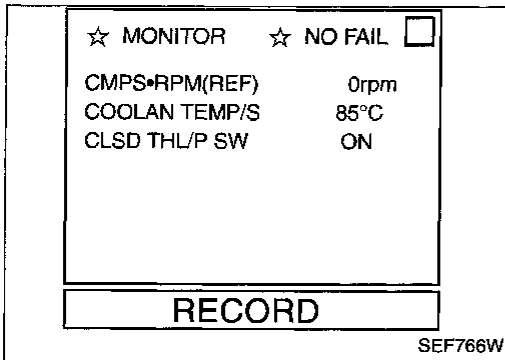

1. Start engine and warm it up to normal operating temperature.
2. Turn ignition switch "OFF".
3. Disconnect closed throttle position switch harness connector.
4. Check continuity between terminals ⑤ and ⑥.

Resistance measurement must be made with closed throttle position switch installed in vehicle.

Throttle valve conditions	Continuity
Completely closed	Yes
Partially open or completely open	No

If NG, adjust closed throttle position switch. Refer to "Basic Inspection", EC-82.

5. If it is impossible to adjust closed throttle position switch in "Basic Inspection", replace closed throttle position switch.

GI
MA
EM
LC
EC
FE
CL
MT
AT
FA
RA
BR
ST
RS
BT
HA
EL
IDX

TROUBLE DIAGNOSIS FOR DTC P0510

Closed Throttle Position Switch (Cont'd)

Throttle position sensor

☆ MONITOR ☆ NO FAIL

CMPS•RPM(REF) 0rpm
 COOLAN TEMP/S 85°C
 THRTL POS SEN 0.52V

RECORD

SEF765W



1. Start engine and warm it up to normal operating temperature.
2. Stop engine and turn ignition switch "ON".
3. Select "DATA MONITOR" mode with CONSULT.
4. Check voltage of "THRTL POS SEN".

Voltage measurement must be made with throttle position sensor installed in vehicle.

Throttle valve conditions	THRTL POS SEN
Completely closed (a)	0.15 - 0.85
Partially open	Between (a) and (b)
Completely open (b)	3.5 - 4.7

If NG, adjust closed throttle position switch. Refer to "Basic Inspection", EC-82.

5. If it is impossible to adjust closed throttle position switch in "Basic Inspection", replace throttle position sensor.

OR

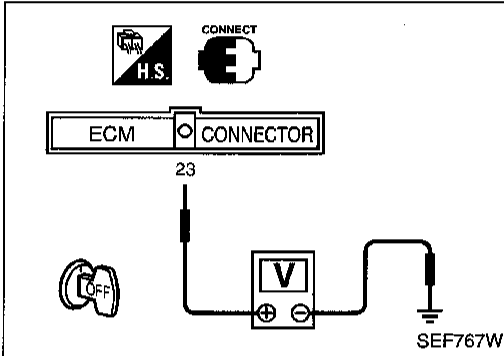

1. Start engine and warm it up to normal operating temperature.
2. Stop engine and turn ignition switch "ON".
3. Check voltage between ECM terminal ② (Throttle position sensor signal) and ground.

Voltage measurement must be made with throttle position sensor installed in vehicle.

Throttle valve conditions	Voltage(V)
Completely closed	0.15 - 0.85
Partially open	Between (a) and (b)
Completely open	3.5 - 4.7

If NG, adjust closed throttle position switch. Refer to "Basic Inspection", EC-82.

5. If it is impossible to adjust closed throttle position switch in "Basic Inspection", replace throttle position sensor.

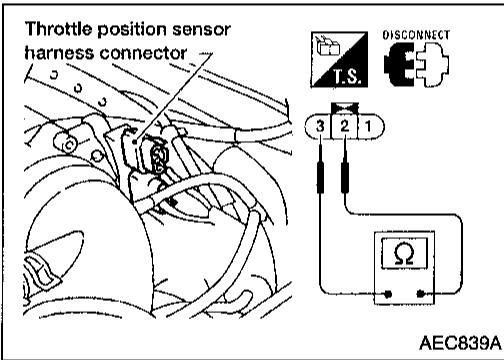

TROUBLE DIAGNOSIS FOR DTC P0605

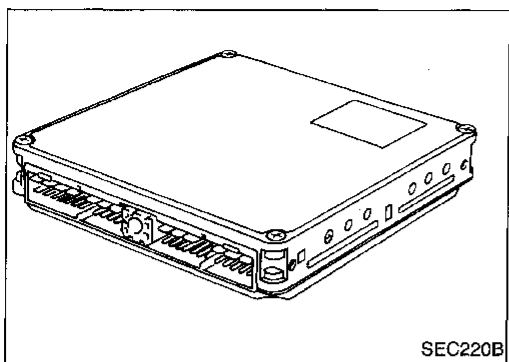

SEC220B

Engine Control Module (ECM)

COMPONENT DESCRIPTION

The ECM consists of a microcomputer, diagnostic test mode selector, and connectors for signal input and output and for power supply. The ECM controls the engine.

ON BOARD DIAGNOSIS LOGIC

Diagnostic Trouble Code No.	Malfunction is detected when	Check Item (Possible Cause)
P0605 0301	● ECM calculation function is malfunctioning.	● ECM

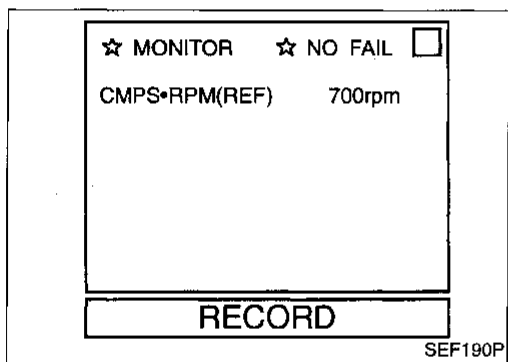

SEF190P

DIAGNOSTIC TROUBLE CODE CONFIRMATION PROCEDURE

NOTE:

If "DIAGNOSTIC TROUBLE CODE CONFIRMATION PROCEDURE" has been previously conducted, always turn ignition switch "OFF" and wait at least 5 seconds before conducting the next test.



- 1) Turn ignition switch "ON".
- 2) Select "DATA MONITOR" mode with CONSULT.
- 3) Start engine.
- 4) Run engine for at least 30 seconds at idle speed.
- 5) If 1st trip DTC is detected, go to "DIAGNOSTIC PROCEDURE", EC-332.

OR



- 1) Turn ignition switch "ON".
- 2) Start engine.
- 3) Run engine for at least 30 seconds at idle speed.
- 4) Select "Mode 7" with GST.
- 5) If 1st trip DTC is detected, go to "DIAGNOSTIC PROCEDURE", EC-332.

OR



- 1) Turn ignition switch "ON".
- 2) Start engine and wait at least 30 seconds.
- 3) Turn ignition switch "OFF", wait at least 5 seconds and then turn "ON".
- 4) Perform "Diagnostic Test Mode II" (Self-diagnostic results) with ECM.
- 5) If 1st trip DTC is detected, go to "DIAGNOSTIC PROCEDURE", EC-332.

TROUBLE DIAGNOSIS FOR DTC P0605

Engine Control Module (ECM) (Cont'd) DIAGNOSTIC PROCEDURE

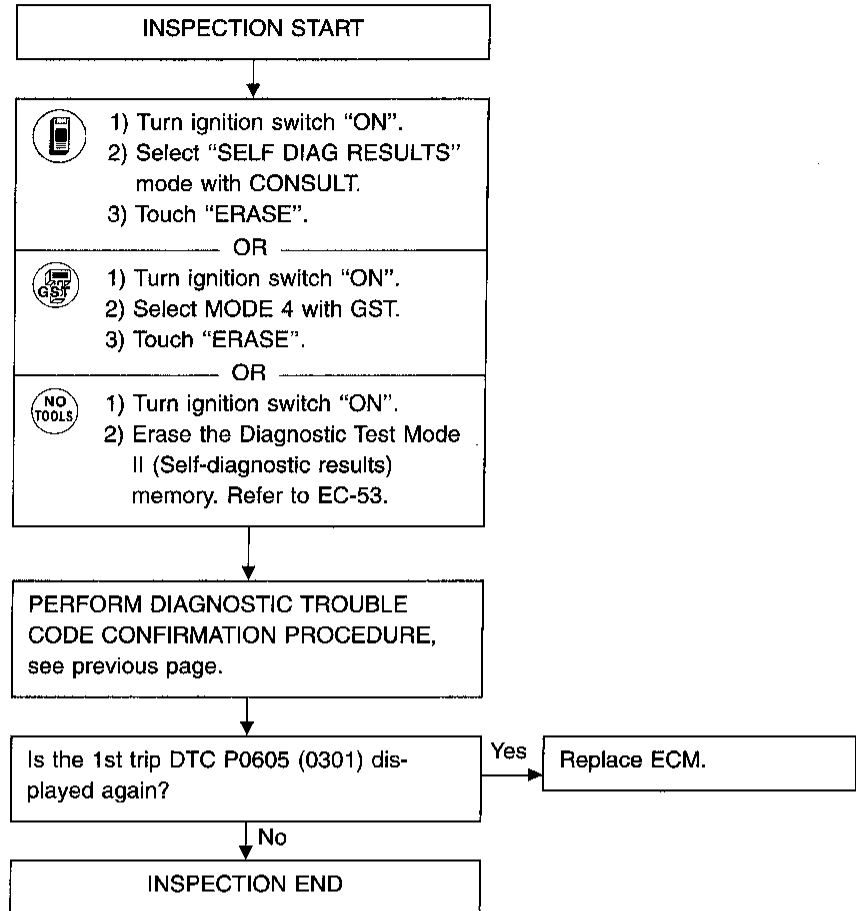

Manifold Absolute Pressure (MAP)/ Barometric Pressure (BARO) Switch Solenoid Valve

SYSTEM DESCRIPTION

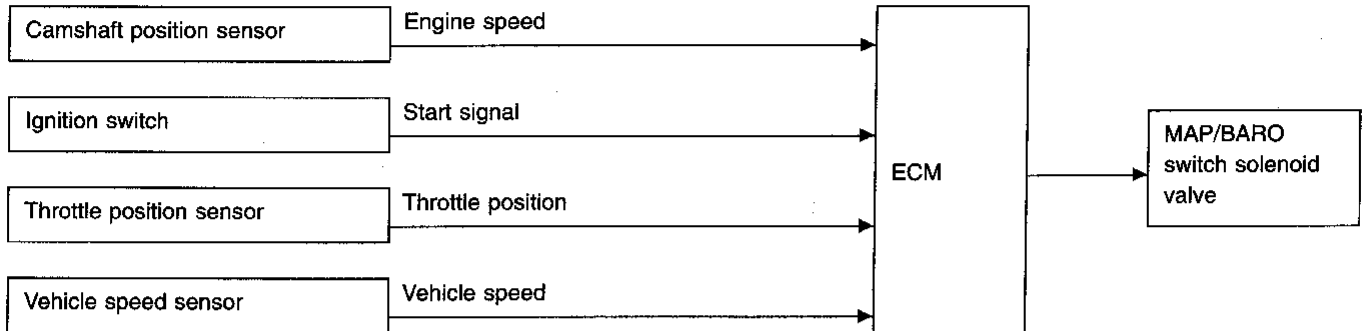

This system allows the absolute pressure sensor to monitor either ambient barometric pressure or intake manifold pressure. The MAP/BARO switch solenoid valve switches between two passages by ON-OFF pulse signals from the ECM. (One passage is from the intake air duct, the other is from the intake manifold.) Either ambient barometric pressure or intake manifold pressure is applied to the absolute pressure sensor.

Solenoid	Conditions
ON	<ul style="list-style-type: none"> For 5 seconds after turning ignition switch "ON" (Engine is not running)
	<ul style="list-style-type: none"> For 5 seconds after starting engine
	<ul style="list-style-type: none"> More than 5 minutes after the solenoid valve shuts OFF.
	<ul style="list-style-type: none"> and
	<ul style="list-style-type: none"> Throttle valve is shut or almost fully shut for more than 5 seconds
	<ul style="list-style-type: none"> and
	<ul style="list-style-type: none"> Vehicle speed is less than 100 km/h (62 MPH).

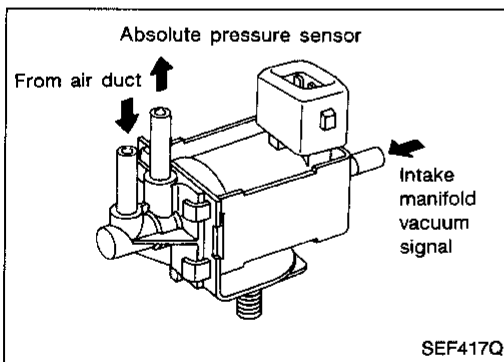

COMPONENT DESCRIPTION

The MAP/BARO switch solenoid valve switches its air flow passage according to the voltage signal sent from the ECM. When voltage is supplied from the ECM, the MAP/BARO switch solenoid turns "ON". Then, the absolute pressure sensor can monitor the ambient barometric pressure. When voltage is not supplied from the ECM, the MAP/BARO switch solenoid valve turns "OFF". Then, the sensor monitors intake manifold pressure.

CONSULT REFERENCE VALUE IN DATA MONITOR MODE

Specification data are reference values.

MONITOR ITEM	CONDITION	SPECIFICATION
MAP/BARO SW/V	<ul style="list-style-type: none"> For 5 seconds after starting engine 	BARO
	<ul style="list-style-type: none"> Ignition switch: More than 5 seconds after turning ignition switch "ON". 	MAP
	<ul style="list-style-type: none"> More than 5 seconds after starting engine 	

TROUBLE DIAGNOSIS FOR DTC P1105

Manifold Absolute Pressure (MAP)/ Barometric Pressure (BARO) Switch Solenoid Valve (Cont'd)

ECM TERMINALS AND REFERENCE VALUE

Specification data are reference values and are measured between each terminal and engine ground.

TER-MINAL NO.	WIRE COLOR	ITEM	CONDITION	DATA (DC voltage)
69	GY/R	MAP/BARO switch solenoid valve	Ignition switch "ON" └ For 5 seconds after turning ignition switch "ON" Engine is running. └ For 5 seconds after starting engine	0 - 1V
			Ignition switch "ON" └ More than 5 seconds after ignition switch "ON" Engine is running. └ More than 5 seconds after starting engine	BATTERY VOLTAGE (11 - 14V)

ON BOARD DIAGNOSIS LOGIC

Diagnostic Trouble Code No.	Malfunction is detected when	Check Items (Possible Cause)
P1105 1302	A) MAP/BARO switch solenoid valve receives the voltage supplied though ECM does not supply the voltage to the valve.	<ul style="list-style-type: none"> ● Harness or connectors (MAP/BARO switch solenoid valve circuit is open or shorted.) ● MAP/BARO switch solenoid valve
	B) There is little difference between MAP/BARO switch solenoid valve input voltage at ambient barometric pressure and voltage at intake manifold pressure.	<ul style="list-style-type: none"> ● Harness or connectors (MAP/BARO switch solenoid valve circuit is open or shorted.) ● Hoses (Hoses are clogged, vented, kinked, disconnected or improperly connected.) ● Absolute pressure sensor ● MAP/BARO switch solenoid valve

DIAGNOSTIC TROUBLE CODE CONFIRMATION PROCEDURE

Perform "Procedure for malfunction A" first. If the 1st trip DTC cannot be confirmed, perform "Procedure for malfunction B".

NOTE:

If "DIAGNOSTIC TROUBLE CODE CONFIRMATION PROCEDURE" has been previously conducted, always turn ignition switch "OFF" and wait at least 5 seconds before conducting the next test.

TROUBLE DIAGNOSIS FOR DTC P1105

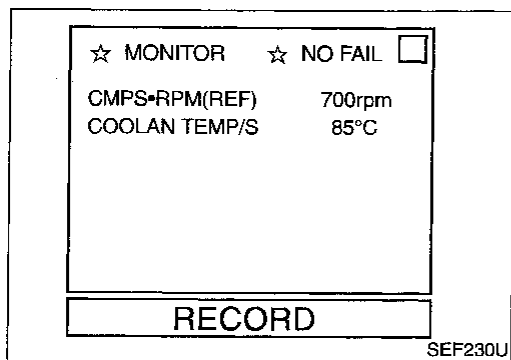

Manifold Absolute Pressure (MAP)/ Barometric Pressure (BARO) Switch Solenoid Valve (Cont'd)

Procedure for malfunction A

TESTING CONDITION:

Before performing the following procedure, confirm that battery voltage is more than 11V with ignition switch "ON".

- 1) Turn ignition switch "ON" and select "DATA MONITOR" mode with CONSULT.
- 2) Wait at least 10 seconds.
- 3) If 1st trip DTC is detected, go to "DIAGNOSTIC PROCEDURE", EC-338.

OR

- 1) Turn ignition switch "ON" and wait at least 10 seconds.
- 2) Select "MODE 7" with GST.
- 3) If 1st trip DTC is detected, go to "DIAGNOSTIC PROCEDURE", EC-338.

OR

- 1) Turn ignition switch "ON" and wait at least 10 seconds.
- 2) Turn ignition switch "OFF", wait at least 5 seconds and then turn "ON".
- 3) Perform "Diagnostic Test Mode II (Self-diagnostic results)" with ECM.
- 4) If 1st trip DTC is detected, go to "DIAGNOSTIC PROCEDURE", EC-338.

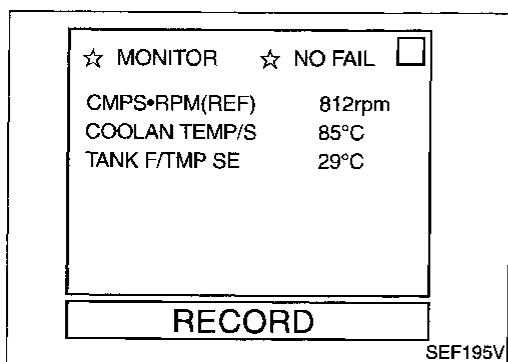

Procedure for malfunction B

TESTING CONDITION:

Always perform test at a temperature above 5°C (41°F).

- 1) Start engine and warm it up to normal operating temperature.
- 2) Turn ignition switch "OFF" and wait at least 5 seconds.
- 3) Turn ignition switch "ON" again and select "DATA MONITOR" mode with CONSULT.
- 4) Make sure that "TANK/F/TEMP SE" is more than 0°C (32°F).
- 5) Start engine and let it idle for at least 10 seconds.
- 6) If 1st trip DTC is detected, go to "DIAGNOSTIC PROCEDURE", EC-338.

OR

- 1) Start engine and warm it up to normal operating temperature.
- 2) Turn ignition switch "OFF" and wait at least 5 seconds.
- 3) Turn ignition switch "ON".
- 4) Check that voltage between ECM terminal ⑥ and ground is less than 4.2V.

TROUBLE DIAGNOSIS FOR DTC P1105

Manifold Absolute Pressure (MAP)/ Barometric Pressure (BARO) Switch Solenoid Valve (Cont'd)

- 5) Start engine and let it idle for at least 10 seconds.
- 6) Select "MODE 7" with GST.
- 7) If 1st trip DTC is detected, go to "DIAGNOSTIC PROCEDURE", EC-338.

OR



- 1) Start engine and warm it up to normal operating temperature.
- 2) Turn ignition switch "OFF" and wait at least 5 seconds.
- 3) Turn ignition switch "ON".
- 4) Check that voltage between ECM terminal ⑥3 and ground is less than 4.2V.
- 5) Start engine and let it idle for at least 10 seconds.
- 6) Turn ignition switch "OFF", wait at least 5 seconds and then turn "ON".
- 7) Perform "Diagnostic Test Mode II (Self-diagnostic results)" with ECM.
- 8) If 1st trip DTC is detected, go to "DIAGNOSTIC PROCEDURE", EC-338.

TROUBLE DIAGNOSIS FOR DTC P1105

Manifold Absolute Pressure (MAP)/ Barometric Pressure (BARO) Switch Solenoid Valve (Cont'd)

EC-SW/V-01

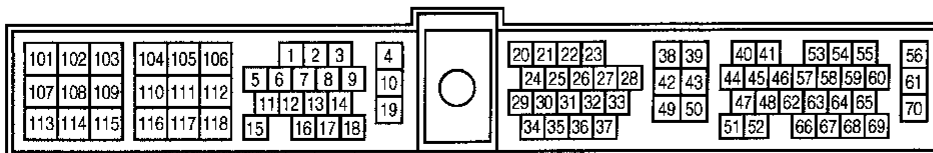
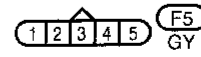
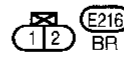
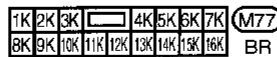
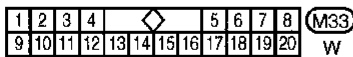
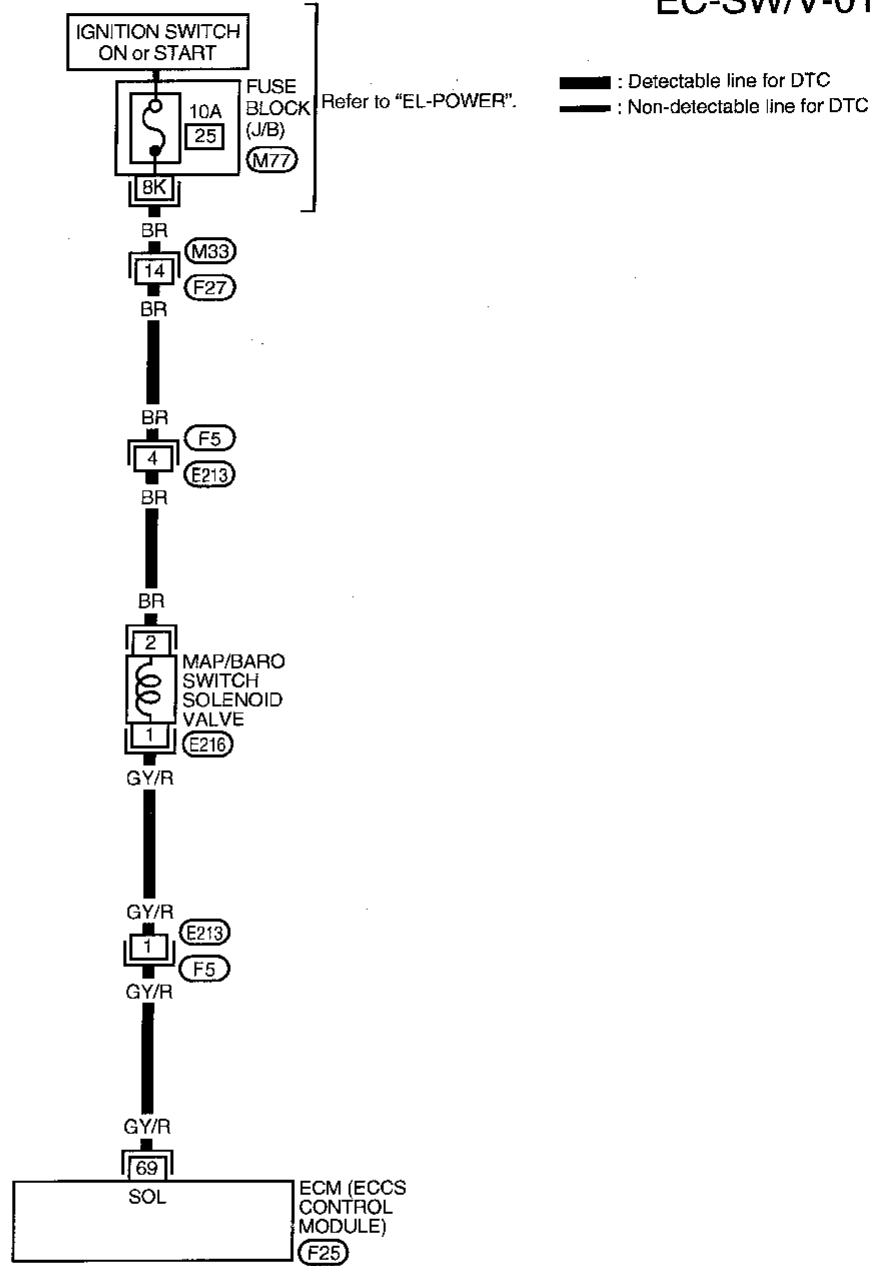

TROUBLE DIAGNOSIS FOR DTC P1105

Manifold Absolute Pressure (MAP)/ Barometric Pressure (BARO) Switch Solenoid Valve (Cont'd)

DIAGNOSTIC PROCEDURE

If the trouble is duplicated after "Procedure for malfunction A", perform "Procedure A" below. If the trouble is duplicated after "Procedure for malfunction B", perform "Procedure B" on next page.

Procedure A

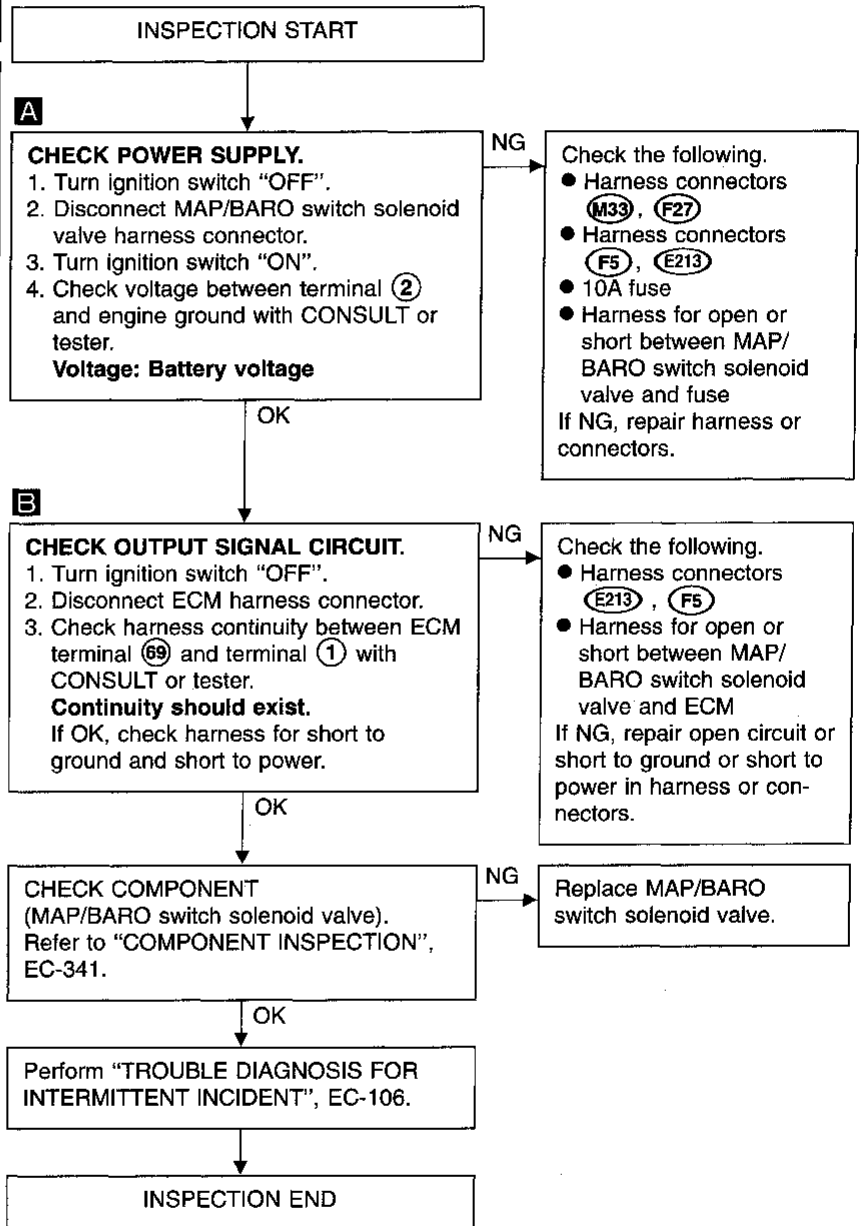
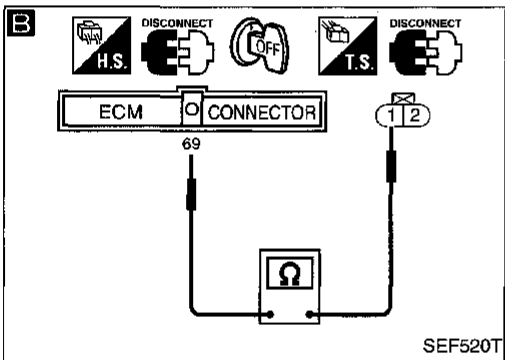
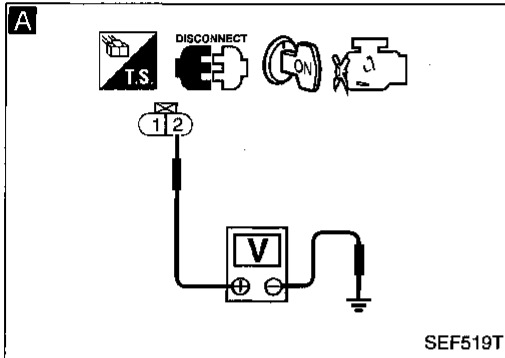
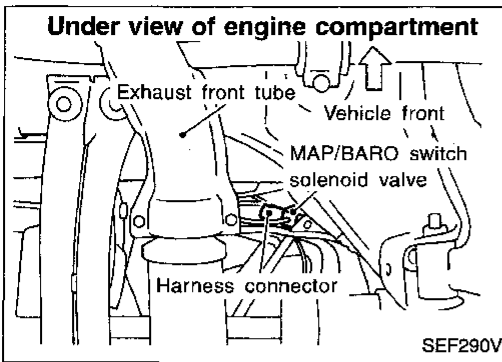

TROUBLE DIAGNOSIS FOR DTC P1105

Manifold Absolute Pressure (MAP)/ Barometric Pressure (BARO) Switch Solenoid Valve (Cont'd)

Procedure B

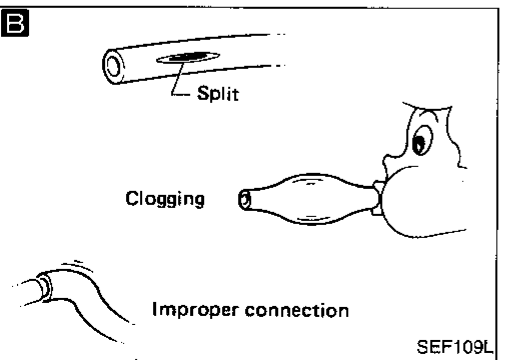
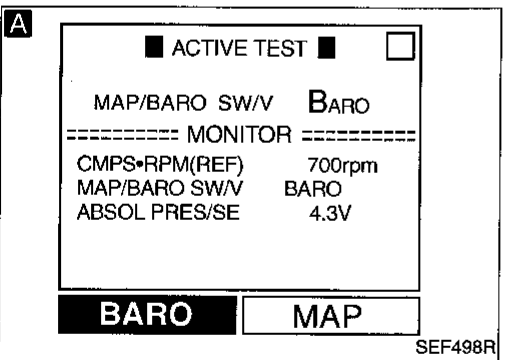
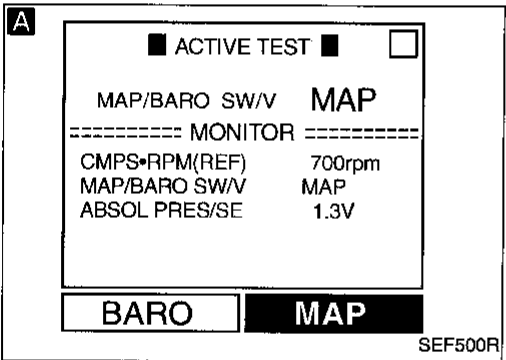
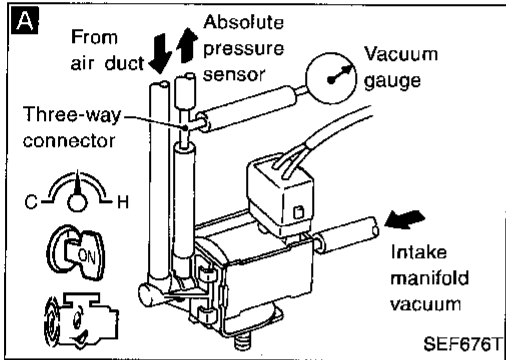
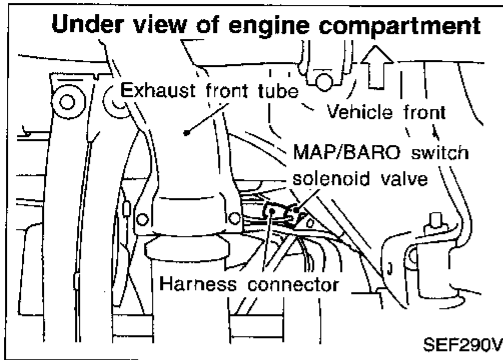

INSPECTION START

A

CHECK VACUUM SOURCE AND CIRCUIT TO MAP/BARO SWITCH SOLENOID VALVE.

1. Start engine and warm it up to normal operating temperature.
2. Turn ignition switch "OFF".
3. Connect MAP/BARO switch solenoid valve and absolute pressure sensor with a rubber tube that has vacuum gauge.
4. Turn ignition switch "ON".
5. Select "MAP/BARO SW/V" in "ACTIVE TEST" mode with CONSULT.
6. Start engine and let it idle.
7. Touch "MAP" and "BARO" alternately and check for vacuum.

MAP/BARO SW/V	Vacuum
BARO	Should not exist
MAP	Should exist

OR

4. Turn ignition switch "ON".
5. Start engine and let it idle.
6. Check for vacuum.

For 5 seconds after starting engine:
Vacuum should not exist.

For 5 seconds after starting engine:
Vacuum should exist.

B

CHECK HOSE.

1. Turn ignition switch "OFF".
2. Check hose for clogging, cracks, disconnection or improper connection.

CHECK COMPONENT
(Absolute pressure sensor).

1. Check for disconnection of vacuum hose connected to the sensor.
2. Disconnect sensor's connector and check sensor harness connectors for water.

Water should not exist.

Refer to "COMPONENT INSPECTION" of "TROUBLE DIAGNOSIS FOR DTC P0105", EC-306.

Repair (disconnection) or replace absolute pressure sensor or harness connectors.

Go to "TROUBLE DIAGNOSIS FOR INTERMITTENT INCIDENT", EC-106.

Clean, repair or reconnect the hose.
If NG, check vacuum port for clogging.

CHECK INTAKE SYSTEM.
Check the intake system for air leaks.

(Go to next page.)

GI
MA
EM
LC
EC
FE
CL
MT
AT
FA
RA
BR
ST
RS
BT
HA
EL
IDX

TROUBLE DIAGNOSIS FOR DTC P1105

Manifold Absolute Pressure (MAP)/ Barometric Pressure (BARO) Switch Solenoid Valve (Cont'd)

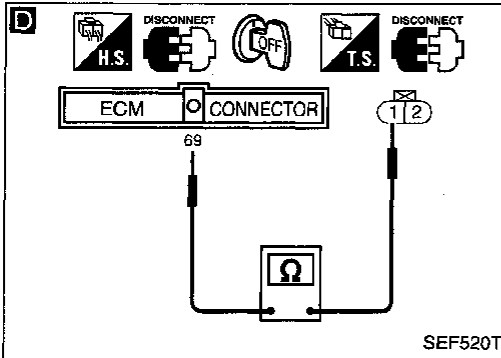
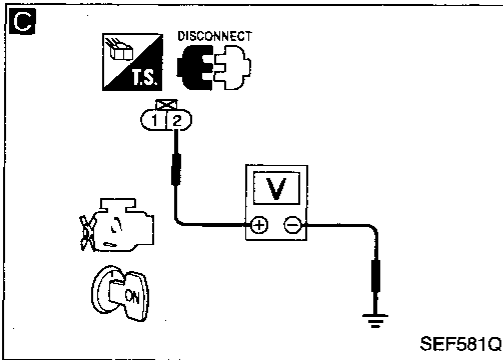

C

CHECK POWER SUPPLY.

1. Turn ignition switch "OFF".
2. Disconnect MAP/BARO switch solenoid valve harness connector.
3. Turn ignition switch "ON".
4. Check voltage between terminal ② and engine ground with CONSULT or tester.

Voltage: Battery voltage
If OK, check harness for short.

NG

Check the following.

- Harness connectors (F27, M33)
- Harness connectors (F5, E213)
- 10A fuse
- Harness for open or short between MAP/BARO switch solenoid valve and fuse

If NG, repair harness or connectors.

D

CHECK OUTPUT SIGNAL CIRCUIT.

1. Turn ignition switch "OFF".
2. Disconnect ECM harness connector.
3. Check harness continuity between ECM terminal ⑥⑨ and terminal ① with CONSULT or tester.

Continuity should exist.
If OK, check harness for short to ground and short to power.

NG

Check the following.

- Harness connectors (F5, E213)

If NG, repair open circuit, short to ground or short to power in harness connectors.

CHECK COMPONENT
(MAP/BARO switch solenoid valve).
Refer to "COMPONENT INSPECTION" on next page.

NG

Replace MAP/BARO switch solenoid valve.

OK

Perform "TROUBLE DIAGNOSIS FOR INTERMITTENT INCIDENT", EC-106.

INSPECTION END

TROUBLE DIAGNOSIS FOR DTC P1105

Manifold Absolute Pressure (MAP)/ Barometric Pressure (BARO) Switch Solenoid Valve (Cont'd)

COMPONENT INSPECTION

MAP/BARO switch solenoid valve

1. Start engine and warm it up to normal operating temperature.
2. Perform "MAP/BARO SW/V" in "ACTIVE TEST" mode with CONSULT.
3. Check the following.
 - Condition: At idle under no-load
 - CONSULT display

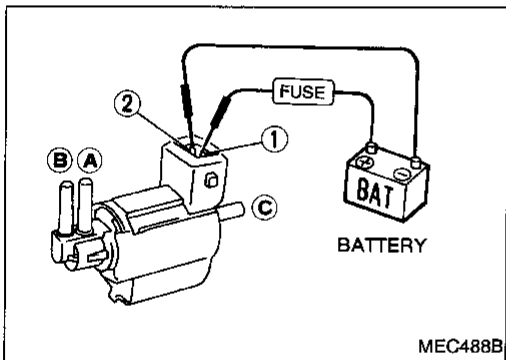
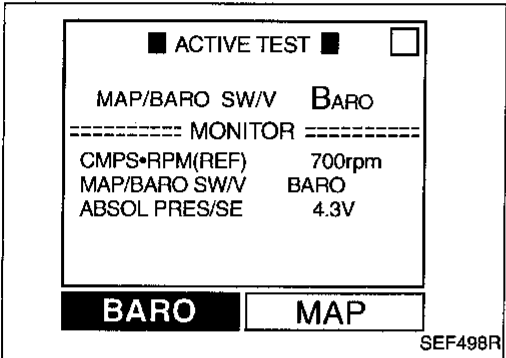
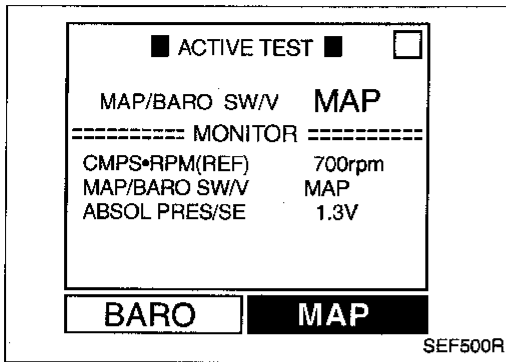

MAP/BARO	ABSOL PRES/SE (Voltage)
BARO	More than 2.6V
MAP	Less than the voltage at BARO

- Time for voltage to change

MAP/BARO SW/V	Required time to switch
BARO to MAP	Less than 1 second
MAP to BARO	

4. If NG, check solenoid valve as shown below.

OR

1. Turn ignition switch "OFF" and remove MAP/BARO switch solenoid valve.
2. Check air passage continuity.

Condition	Air passage continuity between (A) and (B)	Air passage continuity between (A) and (C)
12V direct current supply between terminals (1) and (2)	Yes	No
No supply	No	Yes

3. Check the time required for the solenoid valve to switch. It should be less than 1 second.
4. If NG, replace solenoid valve.

TROUBLE DIAGNOSIS FOR DTC P1148

Closed Loop Control

ON BOARD DIAGNOSIS LOGIC

★ The closed loop control has the one trip detection logic.

Diagnostic Trouble Code No.	Malfunction is detected when ...	Check Items (Possible Cause)
P1148 0307	<ul style="list-style-type: none"> The closed loop control function does not operate even when vehicle is driving in the specified condition. 	<ul style="list-style-type: none"> The front heated oxygen sensor circuit is open or shorted. Front heated oxygen sensor Front heated oxygen sensor heater

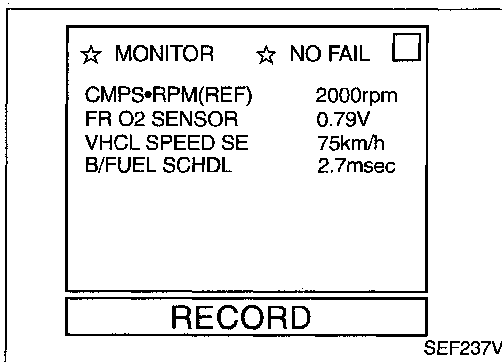

DIAGNOSTIC TROUBLE CODE CONFIRMATION PROCEDURE

CAUTION:

Always drive vehicle at a safe speed.

NOTE:

If "DIAGNOSTIC TROUBLE CODE CONFIRMATION PROCEDURE" has been previously conducted, always turn ignition switch "OFF" and wait at least 5 seconds before conducting the next test.

TESTING CONDITION:

- Never raise engine speed above 3,200 rpm during the "DIAGNOSTIC TROUBLE CODE CONFIRMATION PROCEDURE". If the engine speed limit is exceeded, retry the procedure from step 4).
- Before performing the following procedure, confirm that battery voltage is more than 11V at idle.



- Start engine and warm it up to normal operating temperature.
- Select "DATA MONITOR" mode with CONSULT.
- Hold engine speed at 2,000 rpm and check the following.
 - "FR O2 SENSOR" voltage should go above 0.70V at least once.

OR

- "FR O2 SENSOR" voltage should go below 0.23V at least once.
If the check result is NG, perform "DIAGNOSIS PROCEDURE", EC-185.
If the check result is OK, perform the following step.
- Let engine idle at least 4 minutes.
 - Maintain the following condition at least 50 consecutive seconds.

TROUBLE DIAGNOSIS FOR DTC P1148

Closed Loop Control (Cont'd)

B/FUEL SCHDL: 1.0 msec or more

CMPS-RPM (REF): 1,800 - 3,200 rpm (A/T)
1,900 - 3,200 rpm (M/T)

Selector lever: Suitable position

VHCL SPEED SE: More than 70 km/h (44 MPH)

During this test, DTC P0130 may be displayed on CONSULT screen.

6) If DTC is detected, go to "DIAGNOSTIC PROCEDURE" below.

OR

OVERALL FUNCTION CHECK

Use this procedure to check the overall function of the closed loop control. During this check, a DTC might not be confirmed.



1) Start engine and warm it up to normal operating temperature.

2) Set voltmeter probes between ECM terminal ④⑥ (sensor signal) and engine ground.

3) Check the following with engine speed held at 2,000 rpm constant under no load.

- The voltage should go above 0.70V at least once.

OR

- The voltage should go below 0.23V at least once.

4) If NG, go to "DIAGNOSTIC PROCEDURE" below.

DIAGNOSTIC PROCEDURE

Refer to TROUBLE DIAGNOSIS FOR DTC P0133, EC-185.

GI

MA

EM

LC

EC

FE

CL

MT

AT

FA

RA

BR

ST

RS

BT

HA

EL

IDX

TROUBLE DIAGNOSIS FOR DTC P1220

Fuel Pump Control Module (FPCM)

SYSTEM DESCRIPTION

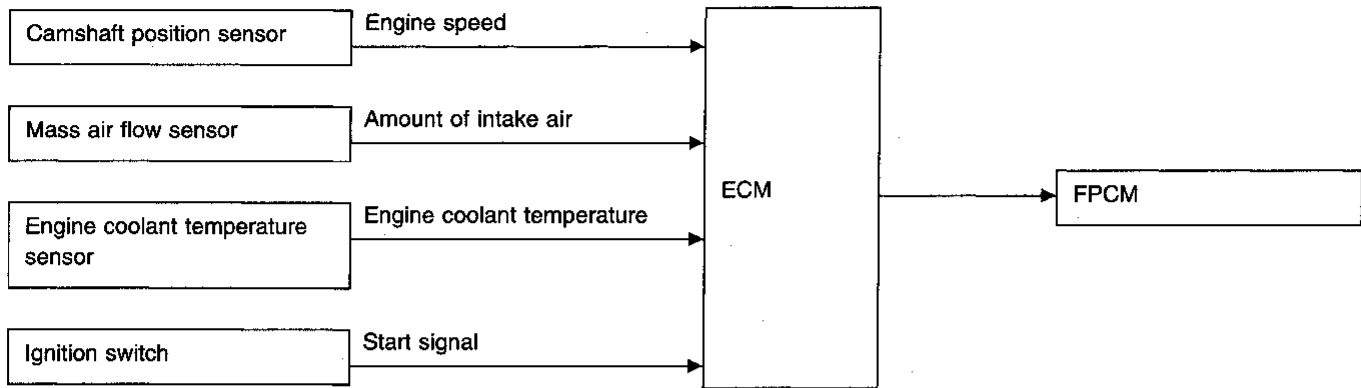

This system controls the fuel pump operation. The amount of fuel flow delivered from the fuel pump is altered between two flow rates by the FPCM operation. The FPCM determines the voltage supplied to the fuel pump (and therefore fuel flow) according to the following conditions.

Conditions	Amount of fuel flow	Supplied voltage
<ul style="list-style-type: none"> ● Engine cranking ● Engine coolant temperature is below 10°C (50°F). ● Engine is running under heavy load and high speed conditions 	high	Battery voltage (11 - 14V)
Except the above	low	Approximately 7V

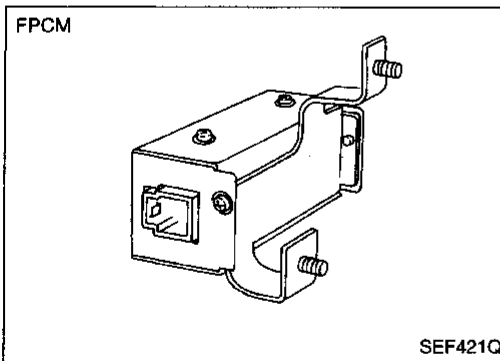

COMPONENT DESCRIPTION

The FPCM adjusts the voltage supplied to the fuel pump to control the amount of fuel flow. When the FPCM increases the voltage supplied to the fuel pump, the fuel flow is increased. When the FPCM decreases the voltage, the fuel flow is decreased.

CONSULT REFERENCE VALUE IN DATA MONITOR MODE

Specification data are reference values.

MONITOR ITEM	CONDITION	SPECIFICATION
FPCM	● When cranking engine	HI
	● Idle at coolant temperatures above 10°C (50°F)	LOW
FPCM DR VOLT	● When cranking engine	Approx. 0.4V
	● Idle at coolant temperatures above 10°C (50°F)	Approx. 5.0V

TROUBLE DIAGNOSIS FOR DTC P1220

Fuel Pump Control Module (FPCM) (Cont'd)

ECM TERMINALS AND REFERENCE VALUE

Specification data are reference values, and are measured between each terminal and engine ground.

TER-MINAL NO.	WIRE COLOR	ITEM	CONDITION	DATA (DC voltage)
11	B/P	Fuel pump control module	When cranking the engine	Approximately 0.4V
			Engine is running. (Warm-up condition) └ Idle speed	Approximately 10V
36	G/R	Fuel pump control module (FPCM) check	When cranking the engine	Approximately 0V
			Engine is running. (Warm-up condition) └ Idle speed	Approximately 5V

ON BOARD DIAGNOSIS LOGIC

Diagnostic Trouble Code No.	Malfunction is detected when	Check Items (Possible Cause)
P1220 1305	<ul style="list-style-type: none"> An improper voltage signal from the FPCM, which is supplied to a point between the fuel pump and the dropping resistor, is detected by ECM. 	<ul style="list-style-type: none"> Harness or connectors (FPCM circuit is open or shorted.) Dropping resistor FPCM

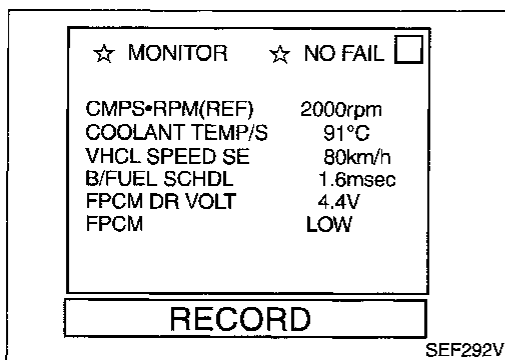

DIAGNOSTIC TROUBLE CODE CONFIRMATION PROCEDURE

CAUTION:

Always drive vehicle at a safe speed.

NOTE:

If "DIAGNOSTIC TROUBLE CODE CONFIRMATION PROCEDURE" has been previously conducted, always turn ignition switch "OFF" and wait at least 5 seconds before conducting the next test.

TESTING CONDITION:

- Always perform test with coolant temperature above 10°C (50°F).
- Confirm that battery voltage is more than 11V at idle.



- Turn ignition switch "ON" and select "DATA MONITOR" mode with CONSULT.
- Start engine.
- Hold vehicle at the following conditions for 12 seconds.

**CMPS-RPM (REF): 1,700 - 2,500 rpm (A/T)
2,000 - 3,000 rpm (M/T)**

TROUBLE DIAGNOSIS FOR DTC P1220

Fuel Pump Control Module (FPCM) (Cont'd)

Vehicle speed: 70 - 100 km/h (44 - 62 MPH)

B/FUEL SCHDL: 1 - 5 msec

Selector lever: Suitable position

- 4) If 1st trip DTC is detected, go to "DIAGNOSTIC PROCEDURE", EC-348.

OR



- 1) Start engine.
- 2) Hold vehicle at the following conditions for 12 seconds.

Engine speed: 1,700 - 2,500 rpm (A/T)

2,000 - 3,000 rpm (M/T)

Vehicle speed: 70 - 100 km/h (44 - 62 MPH)

Selector lever: Suitable position

- 3) Select "MODE 7" with GST.
- 4) If 1st trip DTC is detected, go to "DIAGNOSTIC PROCEDURE", EC-348.

OR



- 1) Start engine.
- 2) Hold vehicle at the following conditions for 12 seconds.

Engine speed: 1,700 - 2,500 rpm (A/T)

2,000 - 3,000 rpm (M/T)

Vehicle speed: 70 - 100 km/h (44 - 62 MPH)

Selector lever: Suitable position

- 3) Turn ignition switch "OFF", wait at least 5 seconds and then turn "ON".
- 4) Perform "Diagnostic Test Mode II (Self-diagnostic results)" with ECM.
- 5) If 1st trip DTC is detected, go to "DIAGNOSTIC PROCEDURE", EC-348.

TROUBLE DIAGNOSIS FOR DTC P1220

Fuel Pump Control Module (FPCM) (Cont'd)

EC-FPCM-01

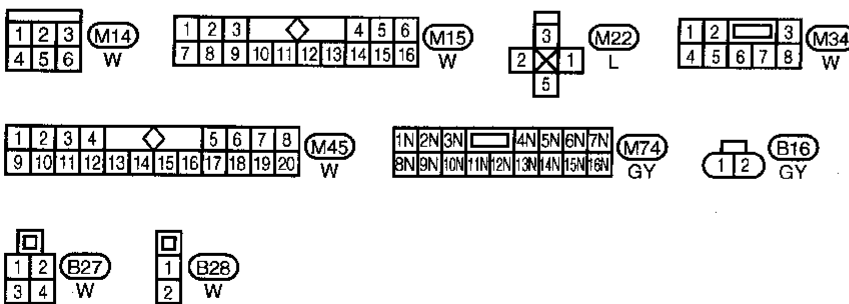
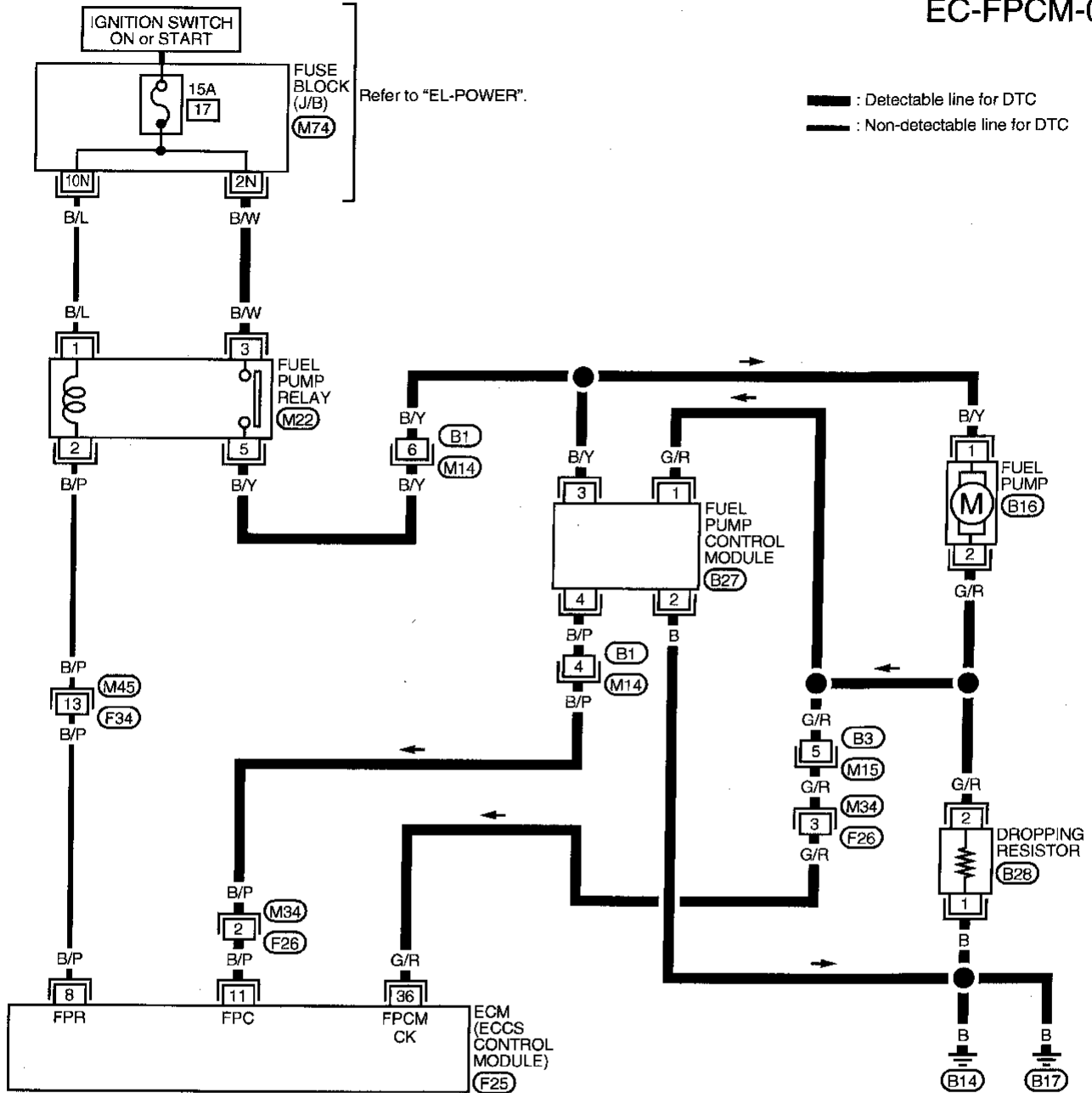

Refer to last page (Foldout page).
(F25)

TROUBLE DIAGNOSIS FOR DTC P1220

Fuel Pump Control Module (FPCM) (Cont'd)

DIAGNOSTIC PROCEDURE

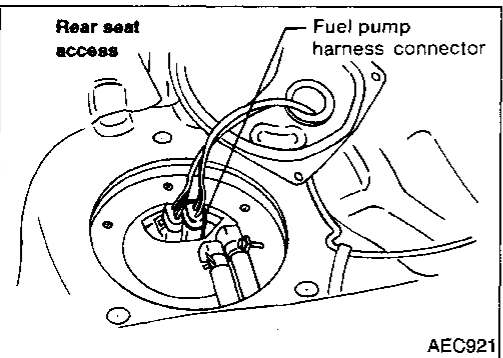
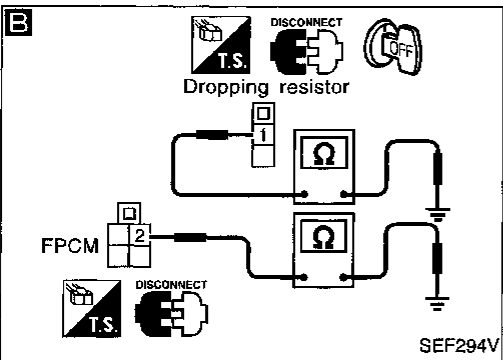
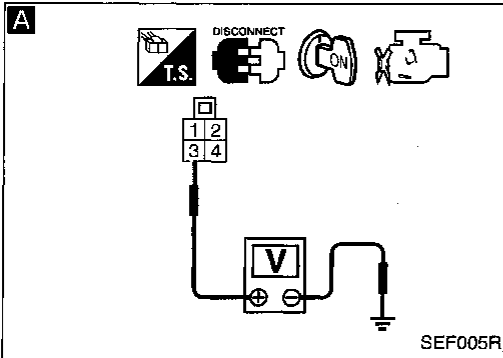
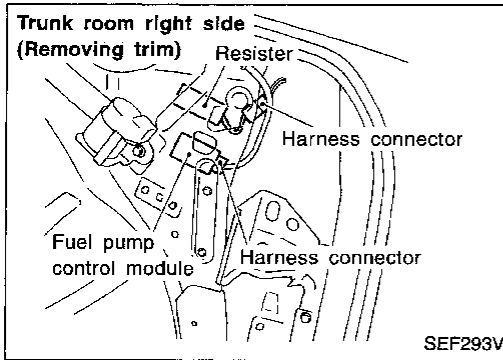

INSPECTION START

A

CHECK POWER SUPPLY.

1. Turn ignition switch "OFF".
2. Disconnect FPCM harness connector.
3. Turn ignition switch "ON".
4. Check voltage between terminal ③ and ground with CONSULT or tester.

Voltage: Battery voltage

NG

Check the following.

- Harness connectors (B1), (M14)
- Harness for open or short between FPCM and fuel pump relay

If NG, repair harness or connectors.

B

CHECK GROUND CIRCUIT-I.

1. Turn ignition switch "OFF".
2. Disconnect dropping resistor harness connector.
3. Check harness continuity between FPCM terminal ② and dropping resistor terminal ① and engine ground.

Continuity should exist.

If OK, check harness for short to ground and short to power.

NG

Repair open circuit or short to ground or short to power in harness or connectors.

C

CHECK GROUND CIRCUIT-II.

1. Disconnect fuel pump harness connector.
2. Check harness continuity between fuel pump terminal ② and dropping resistor terminal ②, resistor terminal ② and FPCM terminal ①.
3. Check harness continuity between FPCM terminal ① and engine ground, fuel pump terminal ② and engine ground.

Continuity should exist.

Continuity should not exist.

If OK, check harness for short to ground and short to power.

NG

Repair open circuit or short to ground or short to power in harness or connectors.

D

CHECK OUTPUT SIGNAL CIRCUIT.

1. Disconnect ECM harness connector.
2. Check harness continuity between ECM terminal ① and terminal ④.

Continuity should exist.

If OK, check harness for short to ground and short to power.

NG

Check the following.

- Harness connectors (F26), (M34)
- Harness connectors (M14), (B1)
- Harness for open between ECM and FPCM

If NG, repair open circuit or short to ground or short to power in harness or connectors.

OK

A

(Go to next page.)

TROUBLE DIAGNOSIS FOR DTC P1220

Fuel Pump Control Module (FPCM) (Cont'd)

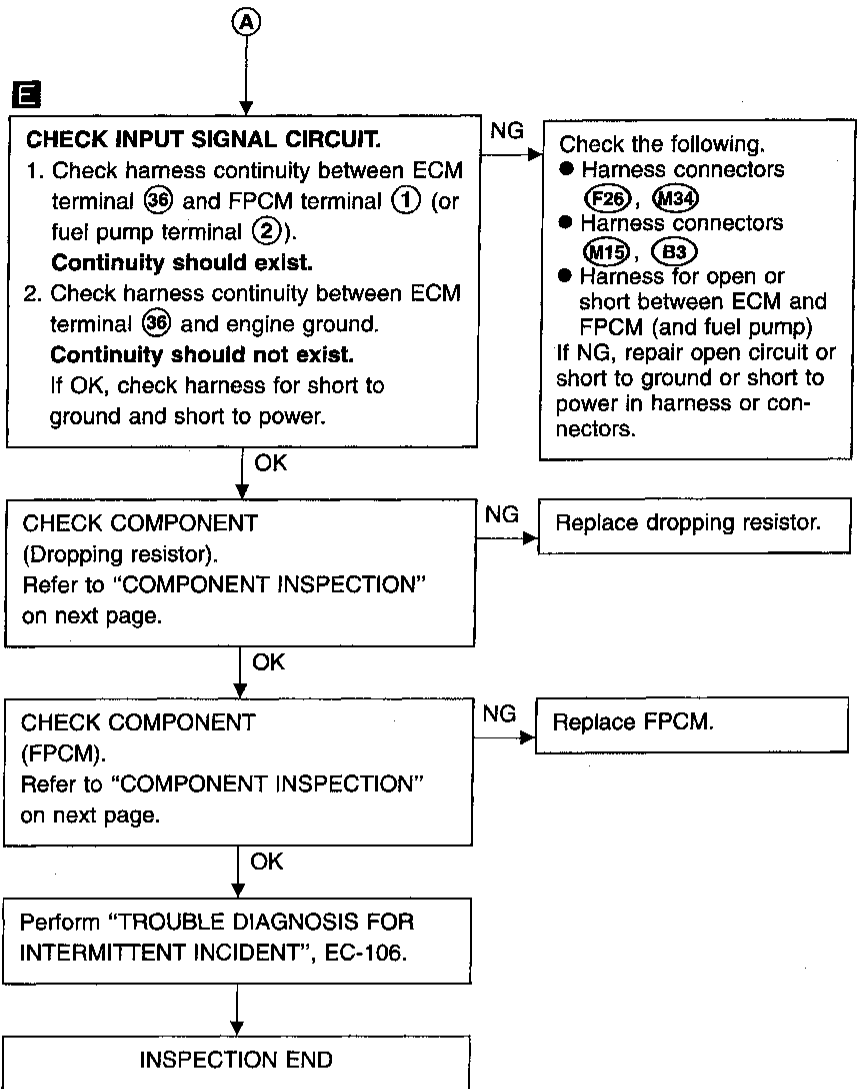
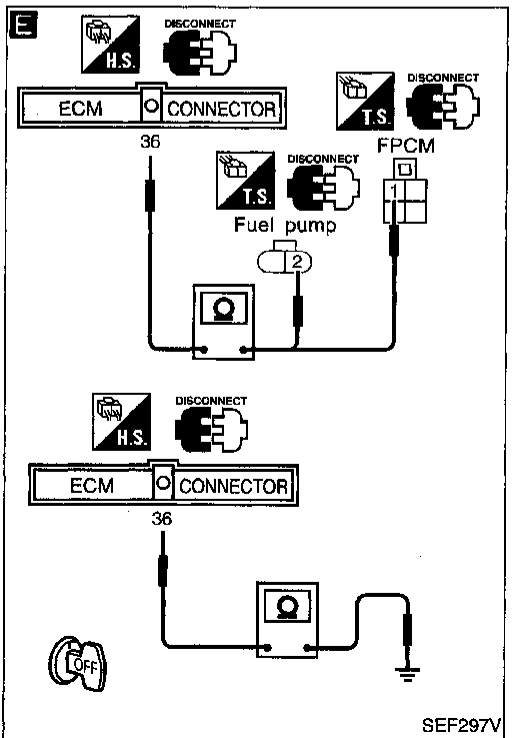
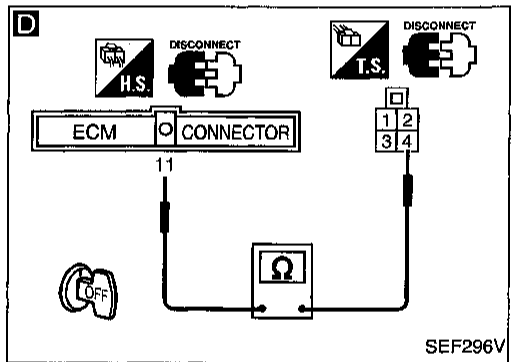
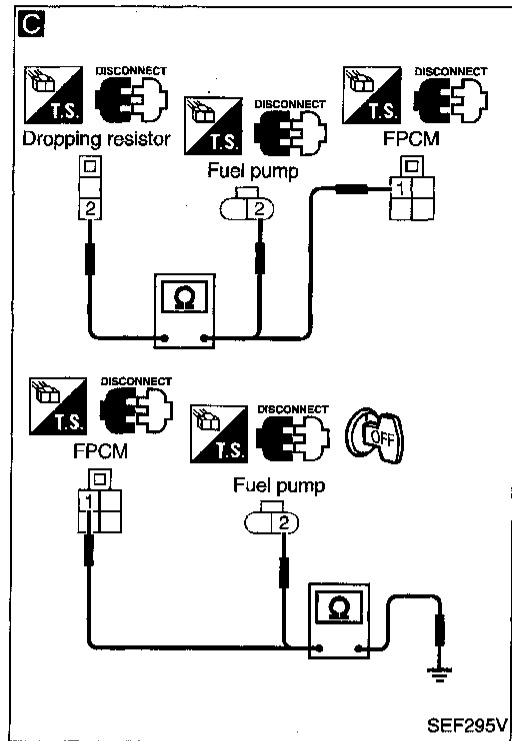

GI
MA
EM
LC
EC
FE
CL
MT
AT
FA
RA
BR
ST
RS
BT
HA
EL
IDX

TROUBLE DIAGNOSIS FOR DTC P1220

Fuel Pump Control Module (FPCM) (Cont'd) COMPONENT INSPECTION

FPCM

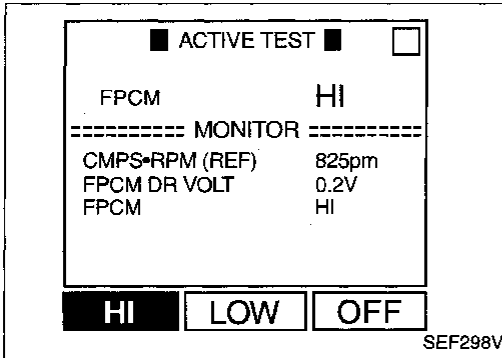

1. Start engine and let it idle.
2. Perform "FPCM" in "ACTIVE TEST" mode with CONSULT.
3. Check the following.
 - When selecting "HI", "FPCM DR VOLT" indicates approximately 0V.
 - When selecting "LOW", "FPCM DR VOLT" indicates approximately 4.4V.
4. If NG, replace FPCM.

OR

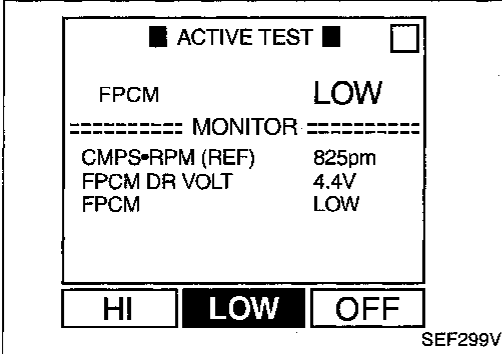

1. Start engine and warm it up to normal operating temperature.
2. Turn ignition switch "OFF" and wait at least 5 seconds.
3. Start engine and let it idle.
4. Check voltage between terminals ① and ②.

When starting engine:

Approximately 0V

After starting engine:

Approximately 5V

5. If NG, replace FPCM.

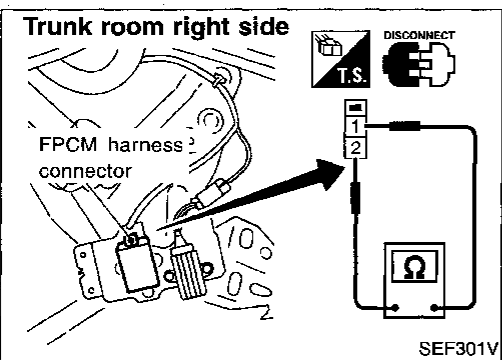
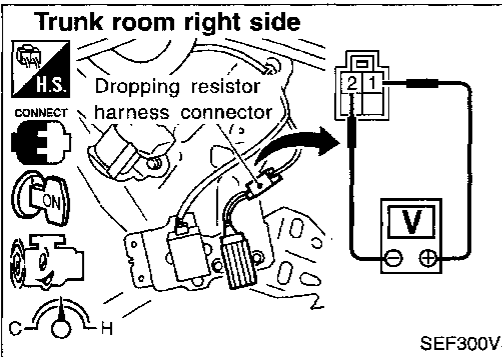

Dropping resistor

Check resistance between terminals ① and ②.

Resistance: Approximately 0.8Ω at 25°C (77°F)

TROUBLE DIAGNOSIS FOR DTC P1320

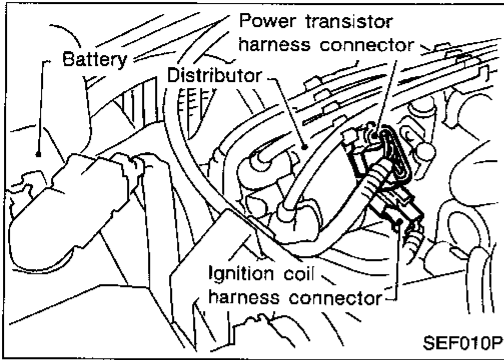

Ignition Signal

COMPONENT DESCRIPTION

Ignition coil & power transistor (Built into distributor)

The ignition coil is built into distributor. The ignition signal from the ECM is sent to the power transistor. The power transistor switches on and off the ignition coil primary circuit. As the primary circuit is turned on and off, the proper high voltage is induced in the coil secondary circuit.

The distributor is not repairable and must be replaced as an assembly except distributor cap and rotor head.

CONSULT REFERENCE VALUE IN DATA MONITOR MODE

MONITOR ITEM	CONDITION	SPECIFICATION
IGN TIMING	<ul style="list-style-type: none"> ● Engine: After warming up ● Air conditioner switch: OFF ● Shift lever: "N" ● No-load Idle	13 - 15° BTDC
	2,000 rpm	More than 25° BTDC

ECM TERMINALS AND REFERENCE VALUE

Specification data are reference values and are measured between each terminal and engine ground.

TER-MINAL NO.	WIRE COLOR	ITEM	CONDITION	DATA (DC voltage)
1	W/B	Ignition signal	Engine is running. (Warm-up condition) └ Idle speed	0.2 - 0.6V SEF186T
			Engine is running. └ Engine speed is 2,000 rpm.	Approximately 0.5V SEF187T

TROUBLE DIAGNOSIS FOR DTC P1320

Ignition Signal (Cont'd)

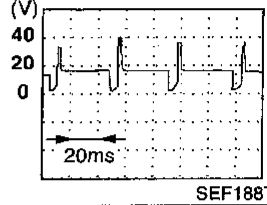
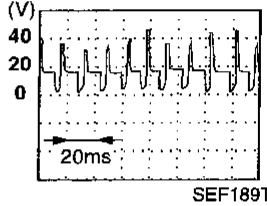
TER-MINAL NO.	WIRE COLOR	ITEM	CONDITION	DATA (DC voltage)
2	W	Ignition check	<div style="border: 1px solid black; padding: 2px; display: inline-block;">Engine is running.</div> (Warm-up condition) ↳ Idle speed	Approximately 13V 
			<div style="border: 1px solid black; padding: 2px; display: inline-block;">Engine is running.</div> ↳ Engine speed is 2,000 rpm.	Approximately 13V 

ON BOARD DIAGNOSIS LOGIC

Diagnostic Trouble Code No.	Malfunction is detected when ...	Check Items (Possible Cause)
P1320 0201	<ul style="list-style-type: none"> ● The ignition signal in the primary circuit is not sent to ECM during engine cranking or running. 	<ul style="list-style-type: none"> ● Harness or connectors (The ignition primary circuit is open or shorted.) ● Power transistor unit. ● Resistor ● Camshaft position sensor ● Camshaft position sensor circuit

DIAGNOSTIC TROUBLE CODE CONFIRMATION PROCEDURE

NOTE:

- If “DIAGNOSTIC TROUBLE CODE CONFIRMATION PROCEDURE” has been previously conducted, always turn ignition switch “OFF” and wait at least 5 seconds before conducting the next test.
- If DTC P1320 (0201) is displayed with P0340 (0101), perform TROUBLE DIAGNOSIS FOR DTC P0340 first. Refer to EC-260.



- 1) Turn ignition switch “ON”.
- 2) Select “DATA MONITOR” mode with CONSULT.
- 3) Start engine and wait at least 4 seconds. (If engine does not run, turn ignition switch to “START” at least 5 seconds.)
- 4) If 1st trip DTC is detected, go to “DIAGNOSTIC PROCEDURE”, EC-355.

OR



- 1) Turn ignition switch “ON”.
- 2) Start engine and wait at least 4 seconds. (If engine does not run, turn ignition switch to “START” at least 5 seconds.)
- 3) Select MODE 3 with GST.
- 4) If 1st trip DTC is detected, go to “DIAGNOSTIC PROCEDURE”, EC-355.

OR

TROUBLE DIAGNOSIS FOR DTC P1320

Ignition Signal (Cont'd)



- 1) Turn ignition switch "ON".
- 2) Start engine and wait at least 4 seconds. (If engine does not run, turn ignition switch to "START" at least 5 seconds.)
- 3) Turn ignition switch "OFF" and wait at least 5 seconds, and then turn "ON".
- 4) Perform "Diagnostic Test Mode II" (Self-diagnostic results) with ECM.
- 5) If 1st trip DTC is detected, go to "DIAGNOSTIC PROCEDURE", EC-355.

GI

MA

EM

LC

EC

FE

CL

MT

AT

FA

RA

BR

ST

RS

BT

HA

EL

IDX

TROUBLE DIAGNOSIS FOR DTC P1320

Ignition Signal (Cont'd)

EC-IGN/SG-01

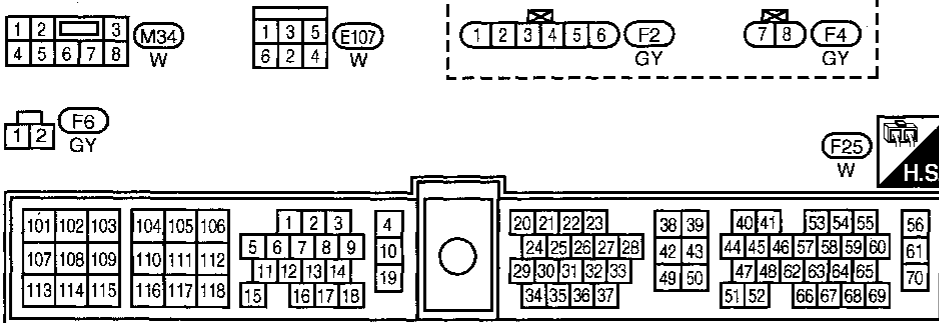
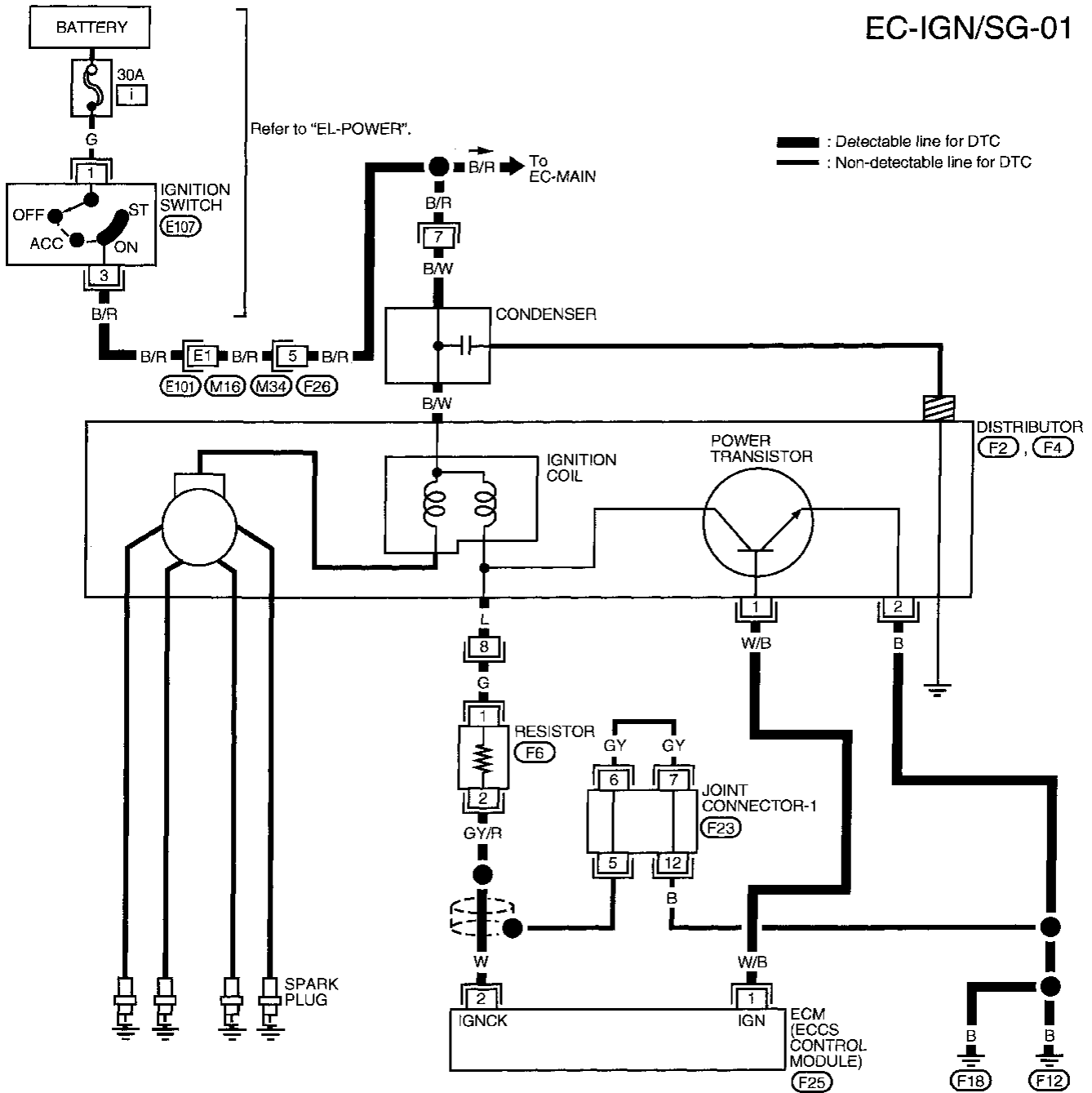

Refer to last page (Foldout page).

(M16), (E101)
(F23)

TROUBLE DIAGNOSIS FOR DTC P1320

Ignition Signal (Cont'd) DIAGNOSTIC PROCEDURE

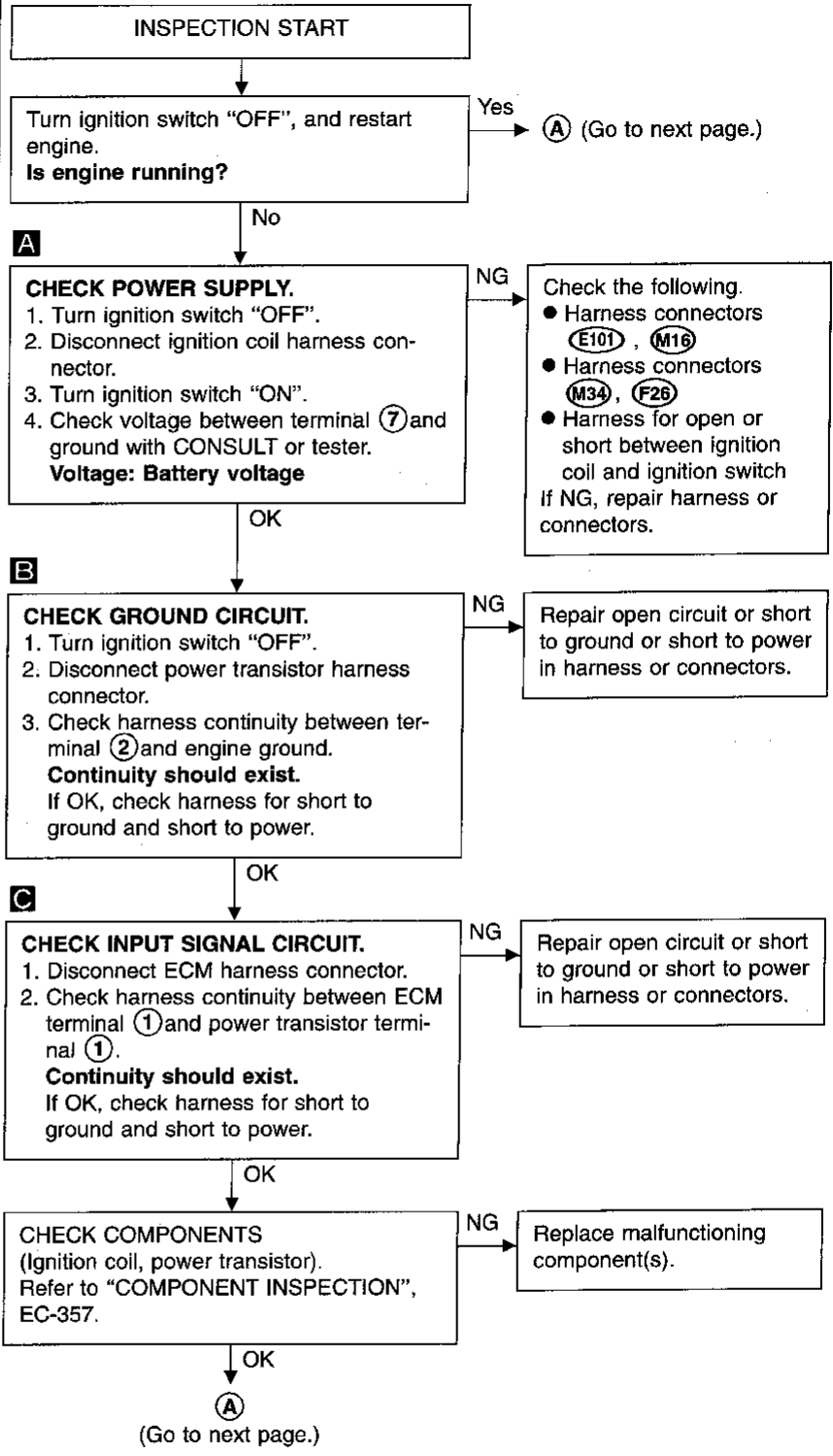
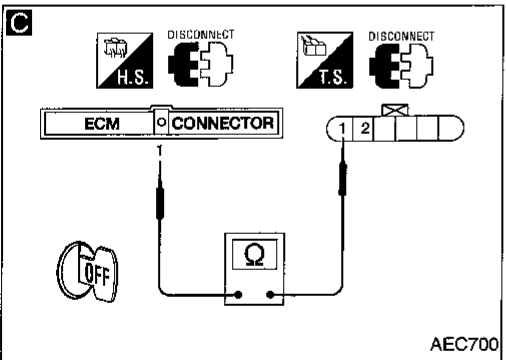
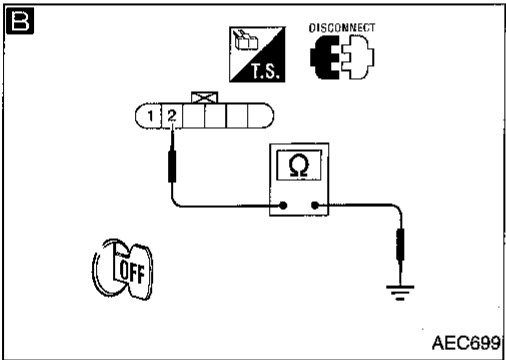
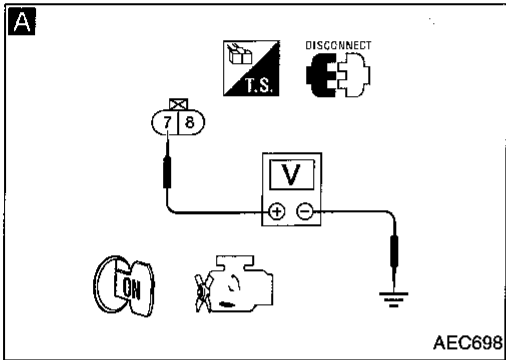
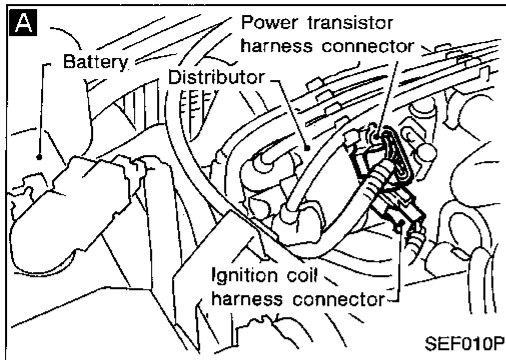

GI
MA
EM
LC
EC
FE
CL
MT
AT
FA
RA
BR
ST
RS
BT
HA
EL
IDX

TROUBLE DIAGNOSIS FOR DTC P1320

Ignition Signal (Cont'd)

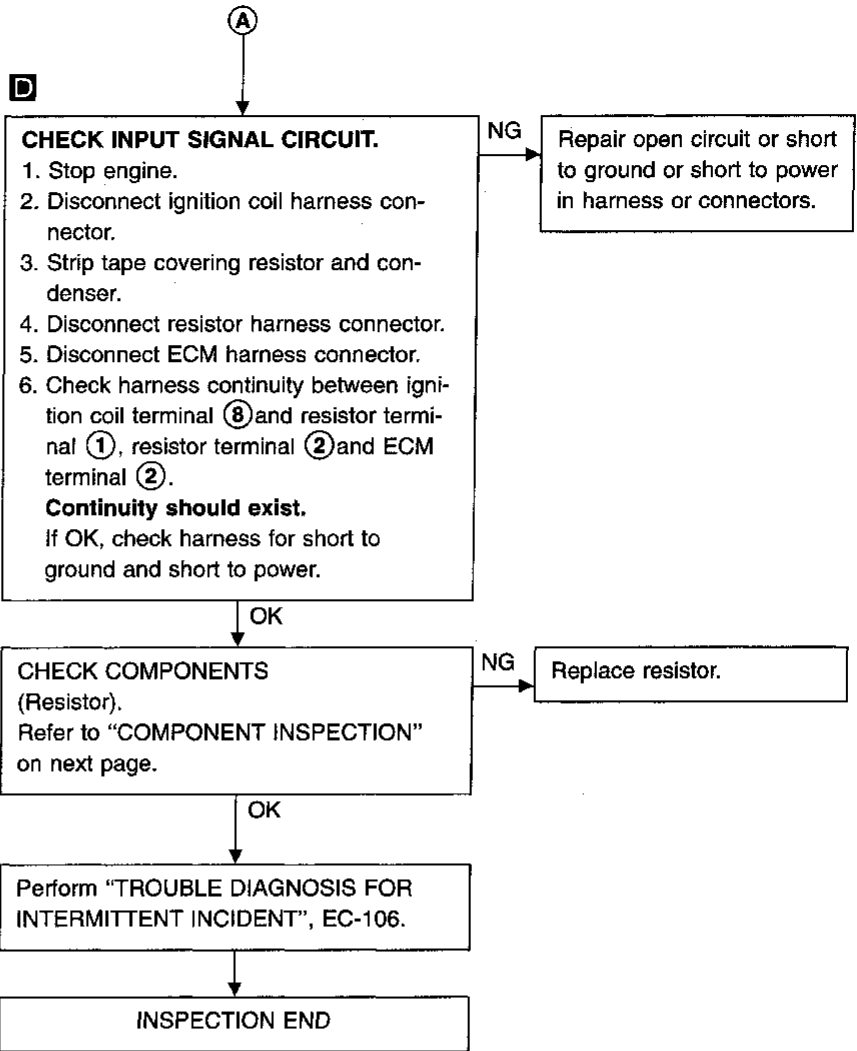
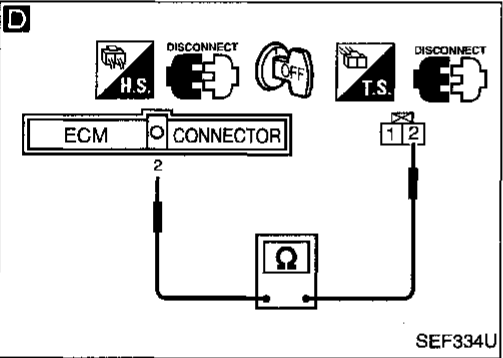
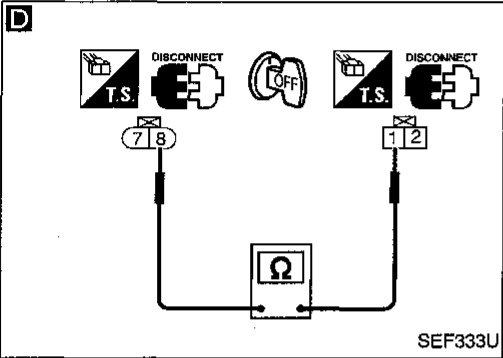
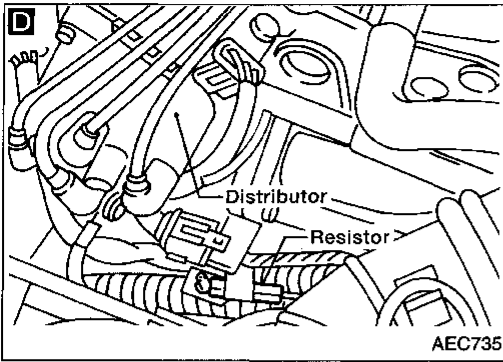

TROUBLE DIAGNOSIS FOR DTC P1320

Ignition Signal (Cont'd) COMPONENT INSPECTION

Ignition coil

1. Disconnect ignition coil harness connector.
2. Check resistance as shown in the figure.

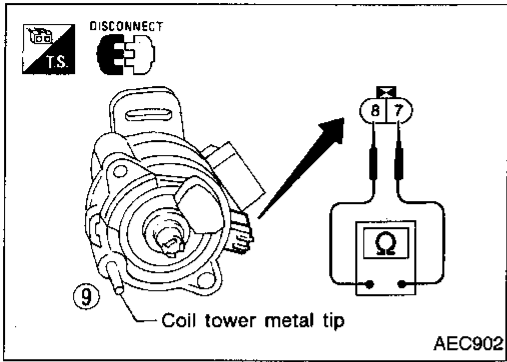

Terminal	Resistance [at 25°C (77°F)]
⑦ - ⑧ (Primary coil)	Approximately 0.5 - 1.0Ω
⑦ - secondary terminal on distributor head (Secondary coil)	Approximately 25 kΩ

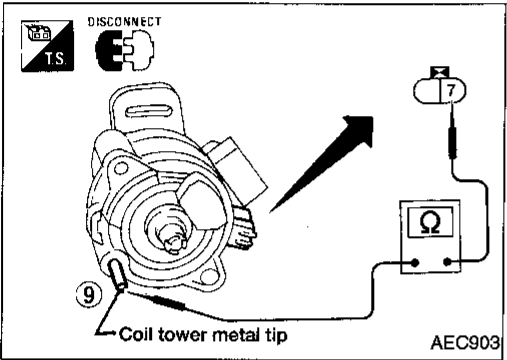

3. For checking secondary coil, remove distributor cap.
4. Check resistance between ignition coil harness connector terminal ⑦ and coil tower metal tip ⑨ (secondary terminal) on the distributor head.
If NG, replace distributor.

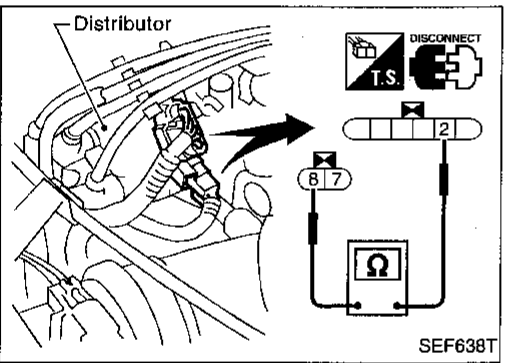

Power transistor

1. Disconnect power transistor harness connector.
2. Check power transistor resistance between terminals ② and ⑧.

Terminals	Resistance	Result
② and ⑧	Except 0Ω	OK
	0Ω	NG

If NG, replace distributor.

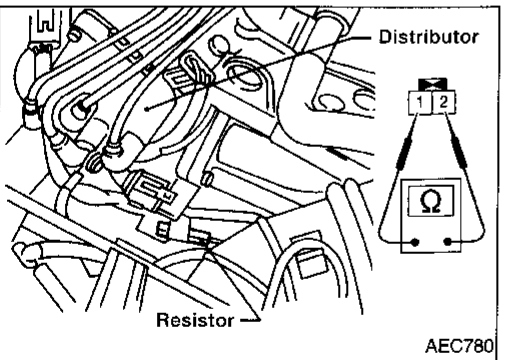

Resistor

1. Disconnect resistor harness connector.
2. Check resistance between terminals ① and ②.
Resistance: Approximately 2.2 kΩ [at 25°C (77°F)]
If NG, replace resistor.

GI

MA

EM

LC

EC

FE

CL

MT

AT

FA

RA

BR

ST

RS

BT

HA

EL

IDX

TROUBLE DIAGNOSIS FOR DTC P1336

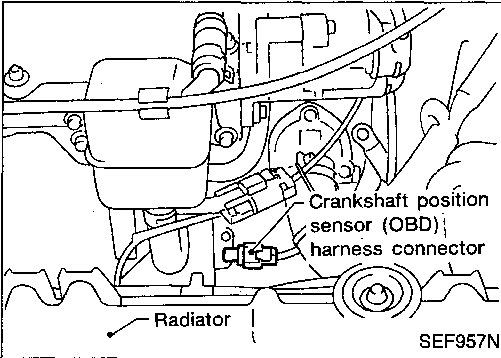
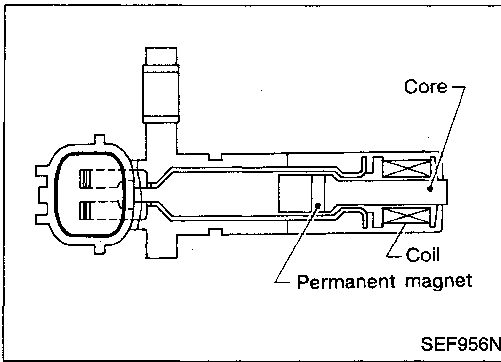

Crankshaft Position Sensor (CKPS) (OBD) (COG)

COMPONENT DESCRIPTION

The crankshaft position sensor (OBD) is located on the transmission housing facing the gear teeth (cogs) of the flywheel or drive plate. It detects the fluctuation of the engine revolution.

The sensor consists of a permanent magnet, core and coil.

When the engine is running, the high and low parts of the teeth cause the gap with the sensor to change.

The changing gap causes the magnetic field near the sensor to change.

Due to the changing magnetic field, the voltage from the sensor changes.

The ECM receives the voltage signal and detects the fluctuation of the engine revolution.

This sensor is not directly used to control the engine system.

It is used only for the on board diagnosis.

ECM TERMINALS AND REFERENCE VALUE

Specification data are reference values and are measured between each terminal and engine ground.

TER-MINAL NO.	WIRE COLOR	ITEM	CONDITION	DATA (DC voltage)
50	B	Sensors' ground	<div style="border: 1px solid black; padding: 2px;">Engine is running.</div> (Warm-up condition) Idle speed	Approximately 0V
53	W	Crankshaft position sensor (OBD)	<div style="border: 1px solid black; padding: 2px;">Engine is running.</div> (Warm-up condition) Idle speed	Approximately 0.03V <p style="text-align: right;">SEF643U</p>
			<div style="border: 1px solid black; padding: 2px;">Engine is running.</div> Engine speed is 2,000 rpm.	Approximately 0V <p style="text-align: right;">SEF644U</p>

TROUBLE DIAGNOSIS FOR DTC P1336

Crankshaft Position Sensor (CKPS) (OBD) (COG) (Cont'd)

ON BOARD DIAGNOSIS LOGIC

Diagnostic Trouble Code No.	Malfunction is detected when	Check Items (Possible Cause)
P1336 0905	<ul style="list-style-type: none"> ● A chipping of the flywheel or drive plate gear tooth (cog) is detected by the ECM. 	<ul style="list-style-type: none"> ● Harness or connectors ● Crankshaft position sensor (OBD) ● Drive plate/Flywheel

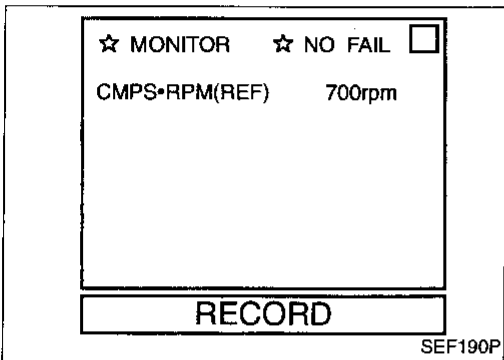

DIAGNOSTIC TROUBLE CODE CONFIRMATION PROCEDURE

NOTE:

If "DIAGNOSTIC TROUBLE CODE CONFIRMATION PROCEDURE" has been previously conducted, always turn ignition switch "OFF" and wait at least 5 seconds before conducting the next test.

- 1) Turn ignition switch "ON" and select "DATA MONITOR" mode with CONSULT.
- 2) Start engine and run it for at least 4 minutes at idle speed.
- 3) If 1st trip DTC is detected, go to "DIAGNOSTIC PROCEDURE", EC-361.

OR

- 1) Start engine and run it for at least 4 minutes at idle speed.
- 2) Select "MODE 7" with GST.
- 3) If 1st trip DTC is detected, go to "DIAGNOSTIC PROCEDURE", EC-361.

OR

- 1) Start engine and run it for at least 4 minutes at idle speed.
- 2) Turn ignition switch "OFF", wait at least 5 seconds and then turn "ON".
- 3) Perform "Diagnostic Test Mode II" (Self-diagnostic results) with ECM.
- 4) If 1st trip DTC is detected, go to "DIAGNOSTIC PROCEDURE", EC-361.

GI

MA

EM

LC

EC

FE

CL

MT

AT

FA

RA

BR

ST

RS

BT

HA

EL

IDX

TROUBLE DIAGNOSIS FOR DTC P1336

Crankshaft Position Sensor (CKPS) (OBD) (COG) (Cont'd)

EC-CKPS-01

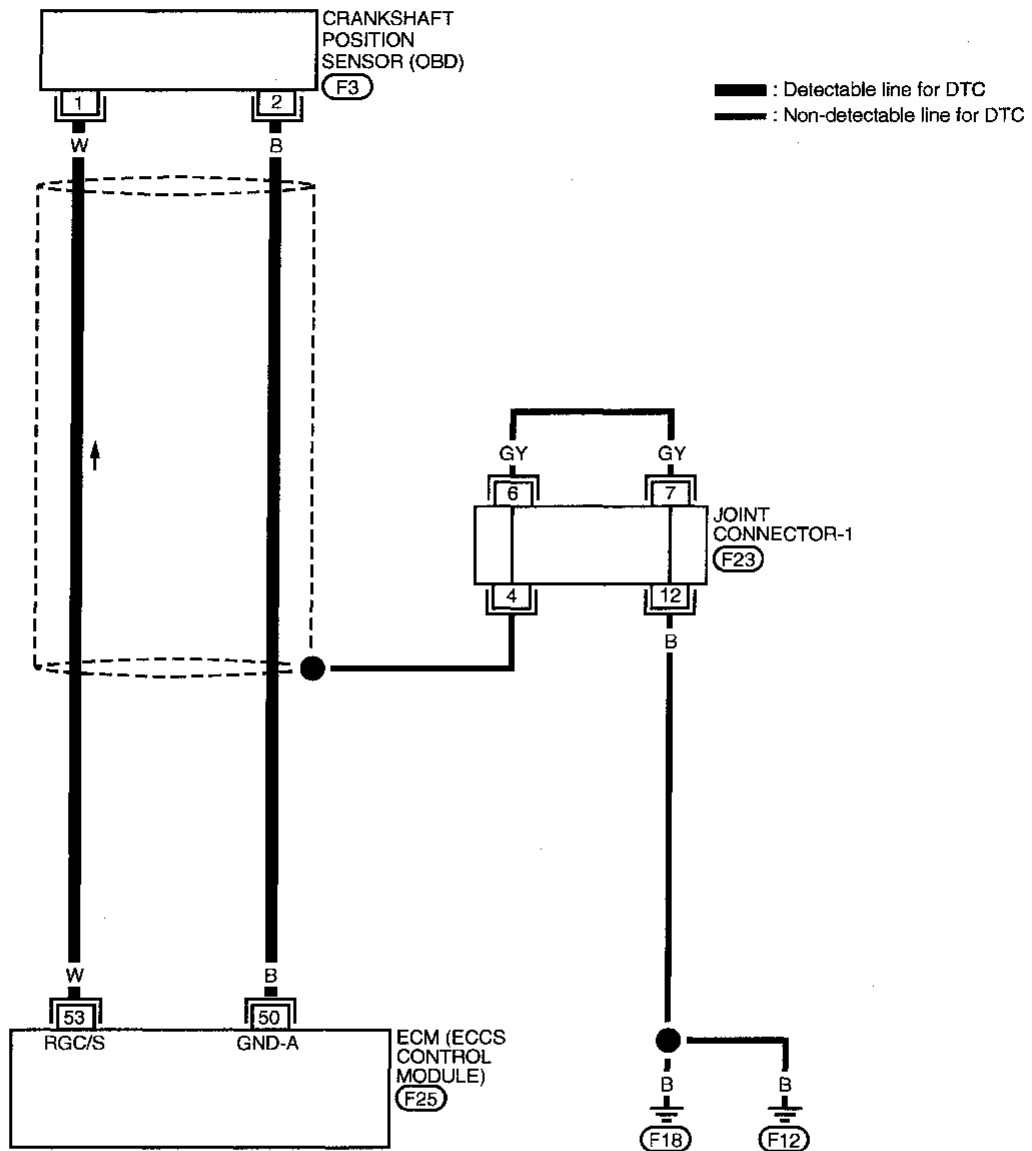

Refer to last page (Foldout page).

(F23)

(1 2) (F3) GY

(F25) W H.S.

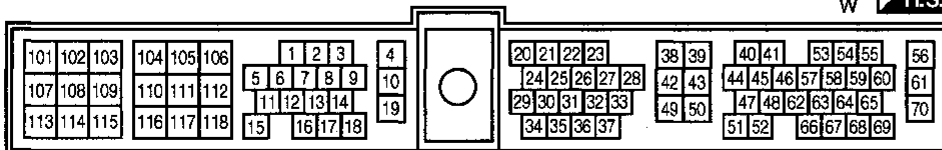

TROUBLE DIAGNOSIS FOR DTC P1336

Crankshaft Position Sensor (CKPS) (OBD) (COG) (Cont'd)

DIAGNOSTIC PROCEDURE

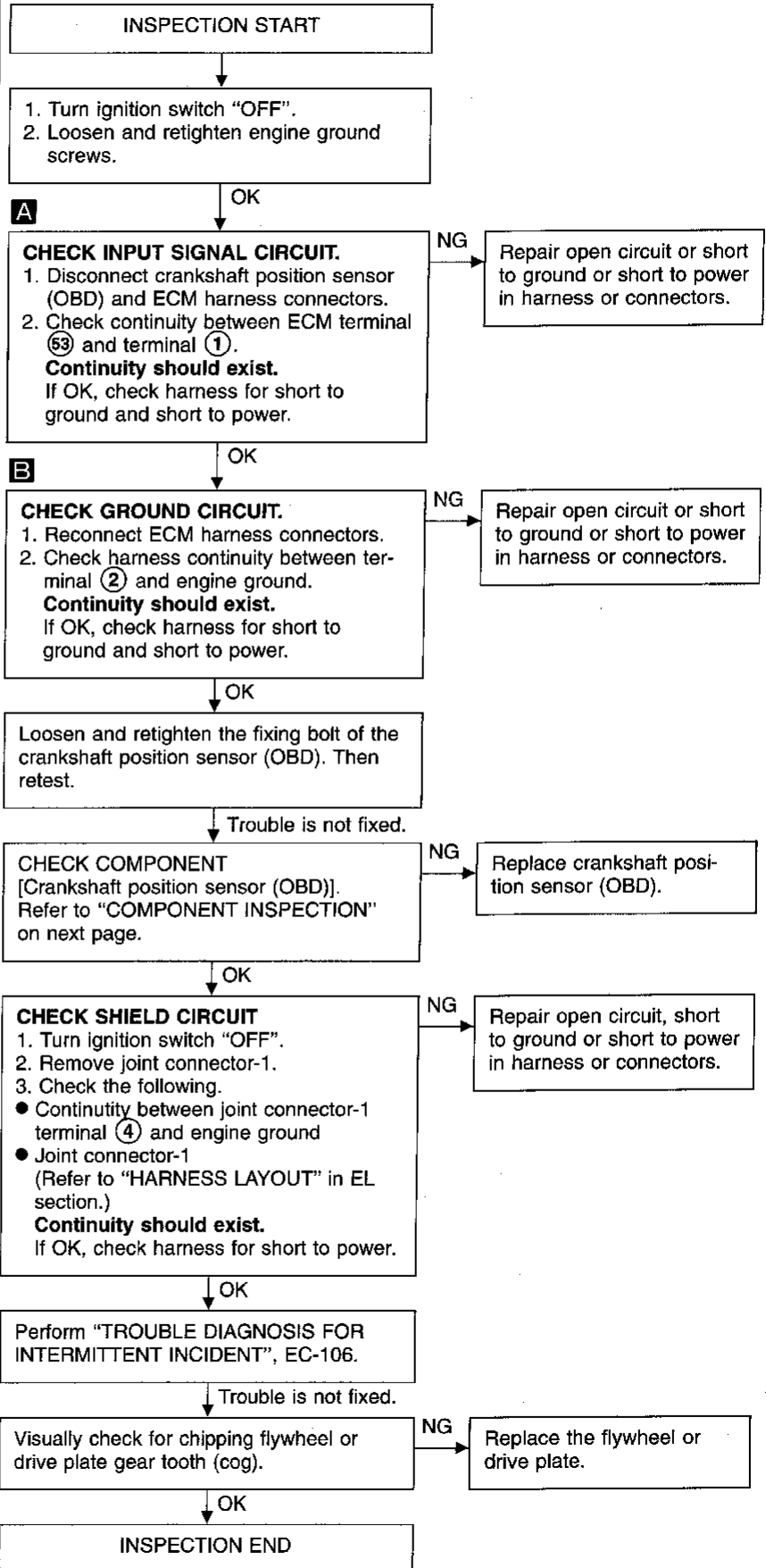
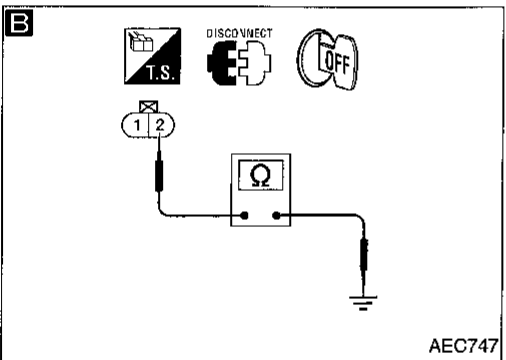
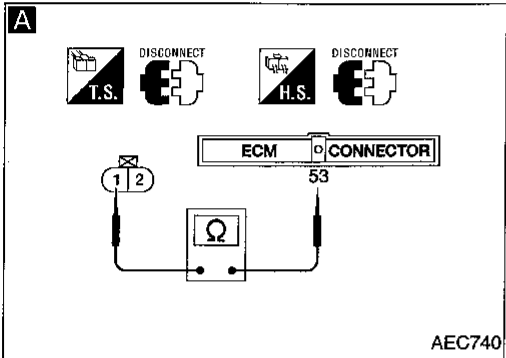
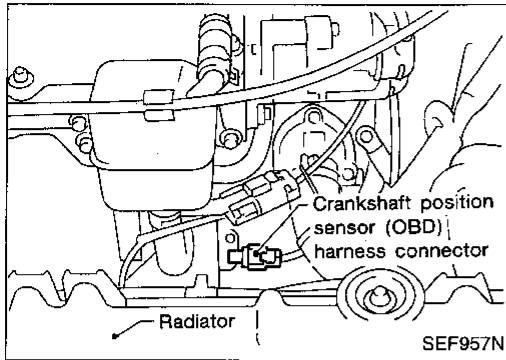

GI
MA
EM
LC
EC
FE
CL
MT
AT
FA
RA
BR
ST
RS
BT
HA
EL
IDX

TROUBLE DIAGNOSIS FOR DTC P1336

Crankshaft Position Sensor (CKPS) (OBD) (COG) (Cont'd)

COMPONENT INSPECTION

Crankshaft position sensor (OBD)

1. Disconnect crankshaft position sensor (OBD) harness connector.
2. Loosen the fixing bolt of the sensor.
3. Remove the sensor.
4. Visually check the sensor for chipping.

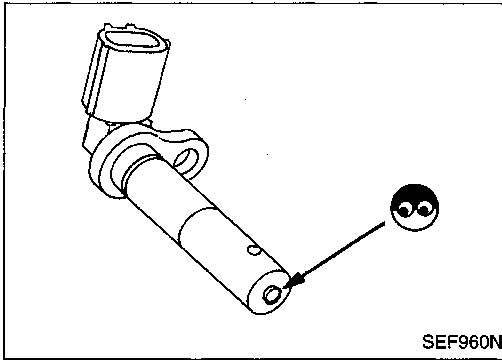

5. Check resistance as shown in the figure.

Resistance:

166 - 204 Ω [at 25°C (77°F)]

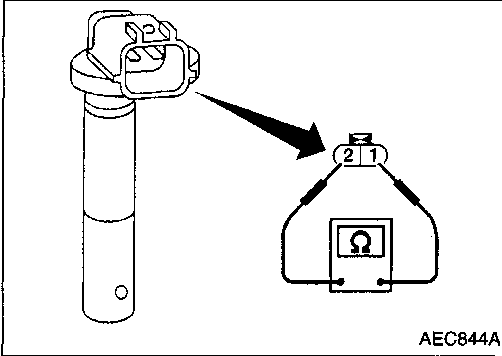

TROUBLE DIAGNOSIS FOR DTC P1400

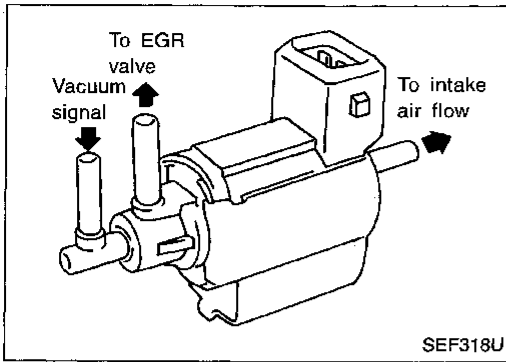

EGRC-Solenoid Valve

COMPONENT DESCRIPTION

The EGRC-solenoid valve responds to signals from the ECM. When the ECM sends an ON (ground) signal, the coil in the solenoid valve is energized. The vacuum signal passes through the solenoid valve. The signal then reaches the EGR valve. When the ECM sends an OFF signal, a plunger will then move to cut the vacuum signal from the intake manifold collector to the EGR valve.

CONSULT REFERENCE VALUE IN DATA MONITOR MODE

Specification data are reference values.

MONITOR ITEM	CONDITION	SPECIFICATION
EGRC SOL/V	<ul style="list-style-type: none"> ● Engine: After warming up ● Air conditioner switch: "OFF" ● Shift lever: "N" ● No-load 	Idle OFF
	Rev engine up from 2,000 to 4,000 rpm.	ON

ECM TERMINALS AND REFERENCE VALUE

Specification data are reference values and are measured between each terminal and engine ground.

TER-MINAL NO.	WIRE COLOR	ITEM	CONDITION	DATA (DC voltage)
103	P	EGRC-solenoid valve	Engine is running. (Warm-up condition) └ Idle speed	BATTERY VOLTAGE (11 - 14V)
			Engine is running. (Warm-up condition) └ Rev engine up from 2,000 to 4,000 rpm.	0 - 0.7V

ON BOARD DIAGNOSIS LOGIC

Diagnostic Trouble Code No.	Malfunction is detected when	Check Items (Possible Cause)
P1400 1005	<ul style="list-style-type: none"> ● The improper voltage signal is sent to ECM through EGRC-solenoid valve. 	<ul style="list-style-type: none"> ● Harness or connectors (The EGRC-solenoid valve circuit is open or shorted.) ● EGRC-solenoid valve

TROUBLE DIAGNOSIS FOR DTC P1400

EGRC-Solenoid Valve (Cont'd)

DIAGNOSTIC TROUBLE CODE CONFIRMATION PROCEDURE

NOTE:

If "DIAGNOSTIC TROUBLE CODE CONFIRMATION PROCEDURE" has been previously conducted, always turn ignition switch "OFF" and wait at least 5 seconds before conducting the next test.

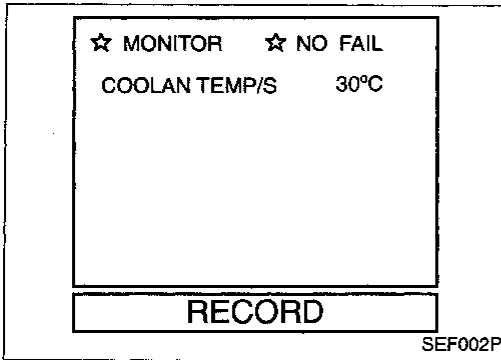

- 1) Turn ignition switch "ON".
- 2) Select "DATA MONITOR" mode with CONSULT and wait at least 5 seconds.
- 3) If 1st trip DTC is detected, go to "DIAGNOSTIC PROCEDURE", EC-366.

OR



- 1) Turn ignition switch "ON" and wait at least 5 seconds.
- 2) Select "MODE 7" with GST.
- 3) If 1st trip DTC is detected, go to "DIAGNOSTIC PROCEDURE", EC-366.

OR



- 1) Turn ignition switch "ON" and wait at least 5 seconds.
- 2) Turn ignition switch "OFF" and wait at least 5 seconds.
- 3) Turn ignition switch "ON" and perform "Diagnostic Test Mode II (Self-diagnostic results)" with ECM.
- 4) If 1st trip DTC is detected, go to "DIAGNOSTIC PROCEDURE", EC-366.

TROUBLE DIAGNOSIS FOR DTC P1400

EGRC-Solenoid Valve (Cont'd)

EC-EGRC/V-01

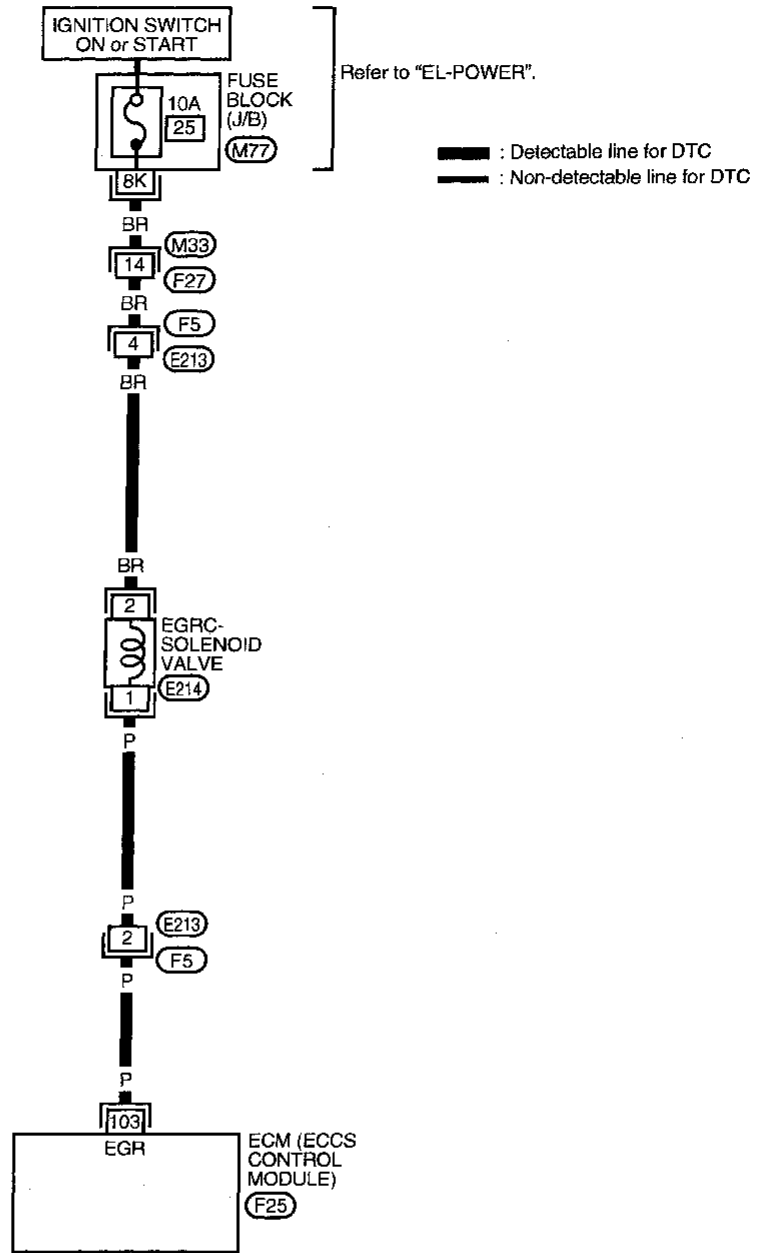

GI
MA
EM
LC
EC
FE
CL
MT
AT
FA
RA
BR
ST
RS
BT
HA
EL
IDX

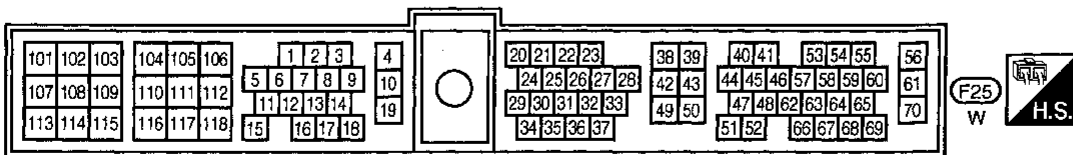

TROUBLE DIAGNOSIS FOR DTC P1400

EGRC-Solenoid Valve (Cont'd)

DIAGNOSTIC PROCEDURE

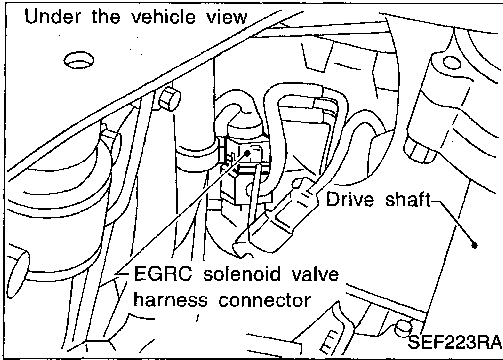

INSPECTION START

A

CHECK POWER SUPPLY.

1. Turn ignition switch "OFF".
2. Disconnect EGRC-solenoid valve harness connector.
3. Turn ignition switch "ON".
4. Check voltage between terminal ② and ground with CONSULT or tester.

Voltage: Battery voltage

NG

Check the following.

- Harness connectors (M33), (F27)
- Harness connectors (F5), (E213)
- 10A fuse
- Harness for open or short between EGRC-solenoid valve and fuse

If NG, repair harness or connectors.

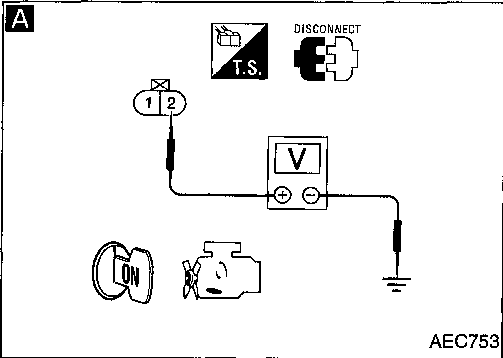

B

CHECK OUTPUT SIGNAL CIRCUIT.

1. Turn ignition switch "OFF".
2. Disconnect ECM harness connector.
3. Check harness continuity between ECM terminal ⑩③ and terminal ①.

Continuity should exist.

If OK, check harness for short to ground and short to power.

NG

Check the following.

- Harness connectors (F5), (E213)
- Harness for open or short between EGRC-solenoid valve and ECM

If NG, repair open circuit or short to ground or short to power in harness or connectors.

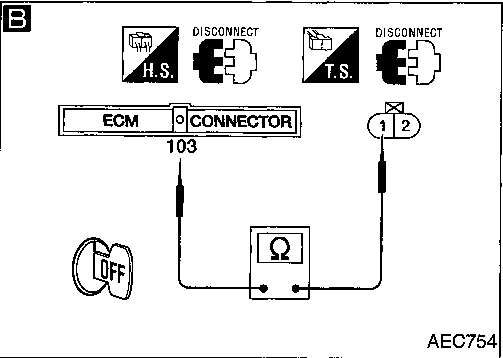

CHECK COMPONENT
(EGRC-solenoid valve).
Refer to "COMPONENT INSPECTION" on next page.

NG

Replace EGRC-solenoid valve.

OK

Perform "TROUBLE DIAGNOSIS FOR INTERMITTENT INCIDENT", EC-106.

INSPECTION END

TROUBLE DIAGNOSIS FOR DTC P1400

EGRC-Solenoid Valve (Cont'd)

COMPONENT INSPECTION

EGRC-solenoid valve

Check air passage continuity.

 Perform "EGRC SOLENOID VALVE" in "ACTIVE TEST" mode.

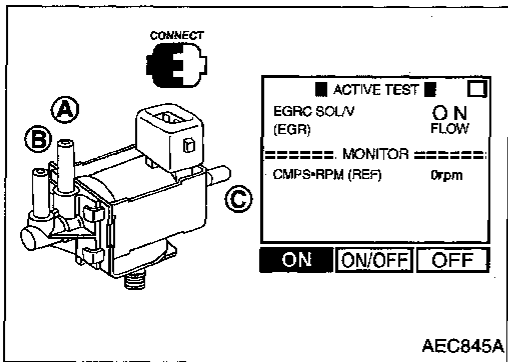

AEC845A

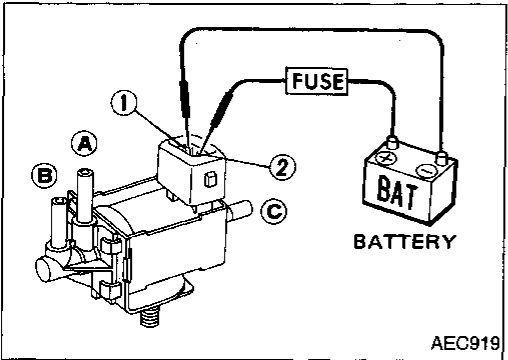

AEC919

Condition EGRC SOLENOID VALVE	Air passage continuity between (A) and (B)	Air passage continuity between (A) and (C)
ON	Yes	No
OFF	No	Yes

OR



Condition	Air passage continuity between (A) and (B)	Air passage continuity between (A) and (C)
12V direct current supply between terminals ① and ②	Yes	No
No supply	No	Yes

If NG or operation takes more than 1 second, replace solenoid valve.

GI
MA
EM
LC
EC
FE
CL
MT
AT
FA
RA
BR
ST
RS
BT
HA
EL
IDX

TROUBLE DIAGNOSIS FOR DTC P1401

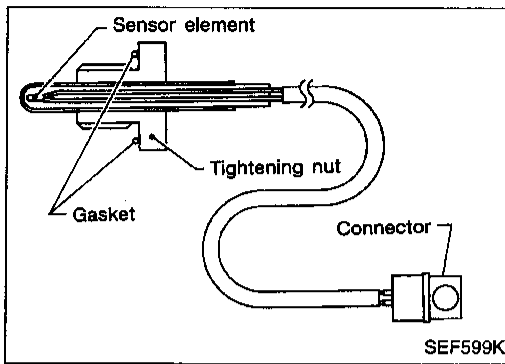

EGR Temperature Sensor

COMPONENT DESCRIPTION

The EGR temperature sensor detects temperature changes in the EGR passageway. When the EGR valve opens, hot exhaust gases flow, and the temperature in the passageway changes. The EGR temperature sensor is a thermistor that modifies a voltage signal sent from the ECM. This modified signal then returns to the ECM as an input signal. As the temperature increases, EGR temperature sensor resistance decreases. This sensor is not used to control the engine system. It is used only for the on board diagnosis.

<Reference data>

EGR temperature °C (°F)	Voltage* V	Resistance MΩ
0 (32)	4.81	7.9 - 9.7
50 (122)	2.82	0.57 - 0.70
100 (212)	0.8	0.08 - 0.10

*: These data are reference values and are measured between ECM terminal ⑥2 (EGR temperature sensor) and engine ground when EGR system is operating.

Voltage: 0 - 1.5V

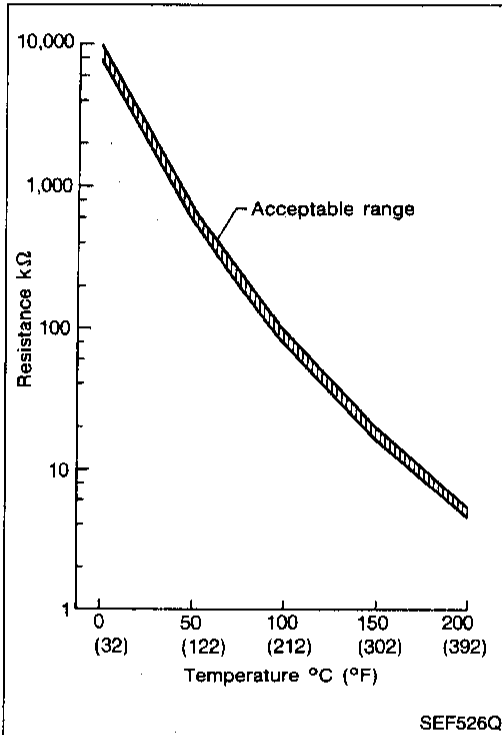

ON BOARD DIAGNOSIS LOGIC

Diagnostic Trouble Code No.	Malfunction is detected when	Check Items (Possible Cause)
P1401 0305	A) An excessively low voltage from the EGR temperature sensor is sent to ECM even when engine coolant temperature is low.	<ul style="list-style-type: none"> ● Harness or connectors (The EGR temperature sensor circuit is shorted.) ● EGR temperature sensor ● Malfunction of EGR function, EGRC-BPT valve or EGRC-solenoid valve
	B) An excessively high voltage from the EGR temperature sensor is sent to ECM even when engine coolant temperature is high.	<ul style="list-style-type: none"> ● Harness or connectors (The EGR temperature sensor circuit is open.) ● EGR temperature sensor ● Malfunction of EGR function, EGRC-BPT valve or EGRC-solenoid valve

TROUBLE DIAGNOSIS FOR DTC P1401

EGR Temperature Sensor (Cont'd)

DIAGNOSTIC TROUBLE CODE CONFIRMATION PROCEDURE

Perform "Procedure for malfunction A" first. If DTC cannot be confirmed, perform "Procedure for malfunction B".

Procedure for malfunction A

NOTE:

If "DIAGNOSTIC TROUBLE CODE CONFIRMATION PROCEDURE" has been previously conducted, always turn ignition switch "OFF" and wait at least 5 seconds before conducting the next test.



- 1) Turn ignition switch "ON".
- 2) Select "DATA MONITOR" mode with CONSULT.
- 3) Verify that engine coolant temperature is less than 40°C (104°F).

If the engine coolant temperature is above the range, cool the engine down.

- 4) Start engine and let it idle for at least 8 seconds.
- 5) If 1st trip DTC is detected, go to "DIAGNOSTIC PROCEDURE", EC-372.

OR



- 1) Turn ignition switch "ON".
- 2) Select "MODE 1" with GST.
- 3) Verify that engine coolant temperature is less than 40°C (104°F).

If the engine coolant temperature is above the range, cool the engine down.

- 4) Start engine and let it idle for at least 8 seconds.
- 5) Select "MODE 7" with GST.
- 6) If 1st trip DTC is detected, go to "DIAGNOSTIC PROCEDURE", EC-372.

OR



- 1) Turn ignition switch "ON".
- 2) Verify that voltage between ECM terminal ⑤1 (engine coolant temperature) and engine ground is more than 2.7V.

If the voltage is below the range, cool the engine down.

- 3) Start engine and let it idle for at least 8 seconds.
- 4) Turn ignition switch "OFF" and wait at least 5 seconds.
- 5) Turn ignition switch "ON" and perform "Diagnostic Test Mode II (Self-diagnostic results)" with ECM.
- 6) If 1st trip DTC is detected, go to "DIAGNOSTIC PROCEDURE", EC-372.

Procedure for malfunction B

CAUTION:

Always drive vehicle at a safe speed.

NOTE:

If "DIAGNOSTIC TROUBLE CODE CONFIRMATION PROCEDURE" has been previously conducted, always turn ignition switch "OFF" and wait at least 5 seconds before conducting the next test.

TESTING CONDITION:

Always perform test at a temperature above 5°C (41°F).

★ MONITOR	★ NO FAIL	<input type="checkbox"/>
CMPS•RPM(REF)	700rpm	
COOLAN TEMP/S	20°C	

SEF335U

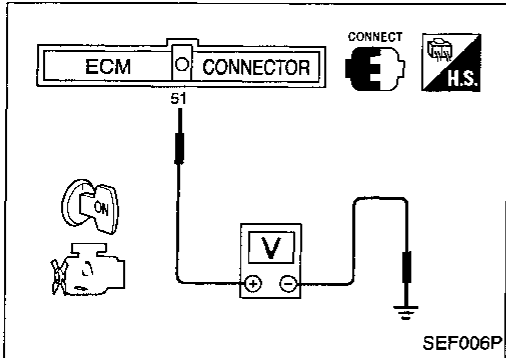

SEF006P

9	★ MONITOR	★ NO FAIL	<input type="checkbox"/>
	CMPS•RPM(REF)	1900rpm	
	COOLAN TEMP/S	85°C	
	VHCL SPEED SEN	20km/h	
	THRTL POS SEN	1.68V	
	B/FUEL SCHDL	1.0msec	

SEF724W

TROUBLE DIAGNOSIS FOR DTC P1401

EGR Temperature Sensor (Cont'd)



- 1) Start engine and warm it up to normal operating temperature.
- 2) Run engine at idle for at least 2 minutes.
- 3) Confirm that EGR valve is not lifting.
If the check result is NG, go to "TROUBLE DIAGNOSES FOR DTC P1402". (See page EC-374.)
- 4) Select "DATA MONITOR" mode with CONSULT.
- 5) Read "EGR TEMP SEN" at about 1,500 rpm while holding the EGR valve in full open position by hand.
Voltage should decrease to less than 1.0V.
If the check result is NG, go to "DIAGNOSTIC PROCEDURE", EC-372.
If the check result is OK, go to following step.
- 6) Turn ignition switch "OFF" and wait at least 5 seconds.
- 7) Turn ignition switch "ON".
- 8) Check the output voltage of "THRTL POS SEN" (at closed throttle position) and note it.
- 9) Start engine.
- 10) Maintain the following conditions for at least 5 consecutive seconds.
**CMPS-RPM (REF): 1,800 - 2,800 rpm (A/T)
1,600 - 2,800 rpm (M/T)**
VHCL SPEED SE: 10 km/h (6 MPH) or more
**B/FUEL SCHDL: 2.0 - 3.5 msec (A/T)
1.8 - 3.0 msec (M/T)**
THRTL POS SEN: $X - (X + 0.87) V$
X = Voltage value measured at step 8)
Selector lever: Suitable position
- 11) If 1st trip DTC is detected, go to "DIAGNOSTIC PROCEDURE", EC-372.

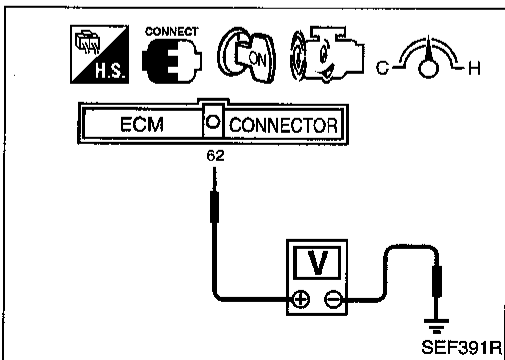
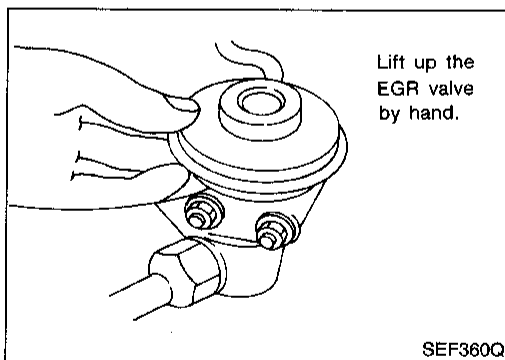

OR

OVERALL FUNCTION CHECK

Use this procedure to check the overall function of the EGR temperature sensor. During this check, a 1st trip DTC might not be confirmed.

Procedure for malfunction B



- 1) Start engine and warm it up to normal operating temperature.
- 2) Run engine at idle for at least 2 minutes.
- 3) Confirm that EGR valve is not lifting. If NG, go to "TROUBLE DIAGNOSES FOR DTC P1402" (See page EC-374).
- 4) Check voltage between ECM terminal 62 and ground at about 1,500 rpm with EGR valve lifted up to the full position by hand.
Voltage should decrease to less than 1.0V.
- 5) If step 4 is OK, perform "TROUBLE DIAGNOSES FOR DTC P0400 and P1400" (See pages EC-267, 363).
If step 4 is NG, go to "DIAGNOSTIC PROCEDURE", EC-372.

TROUBLE DIAGNOSIS FOR DTC P1401

EGR Temperature Sensor (Cont'd)

EC-EGR/TS-01

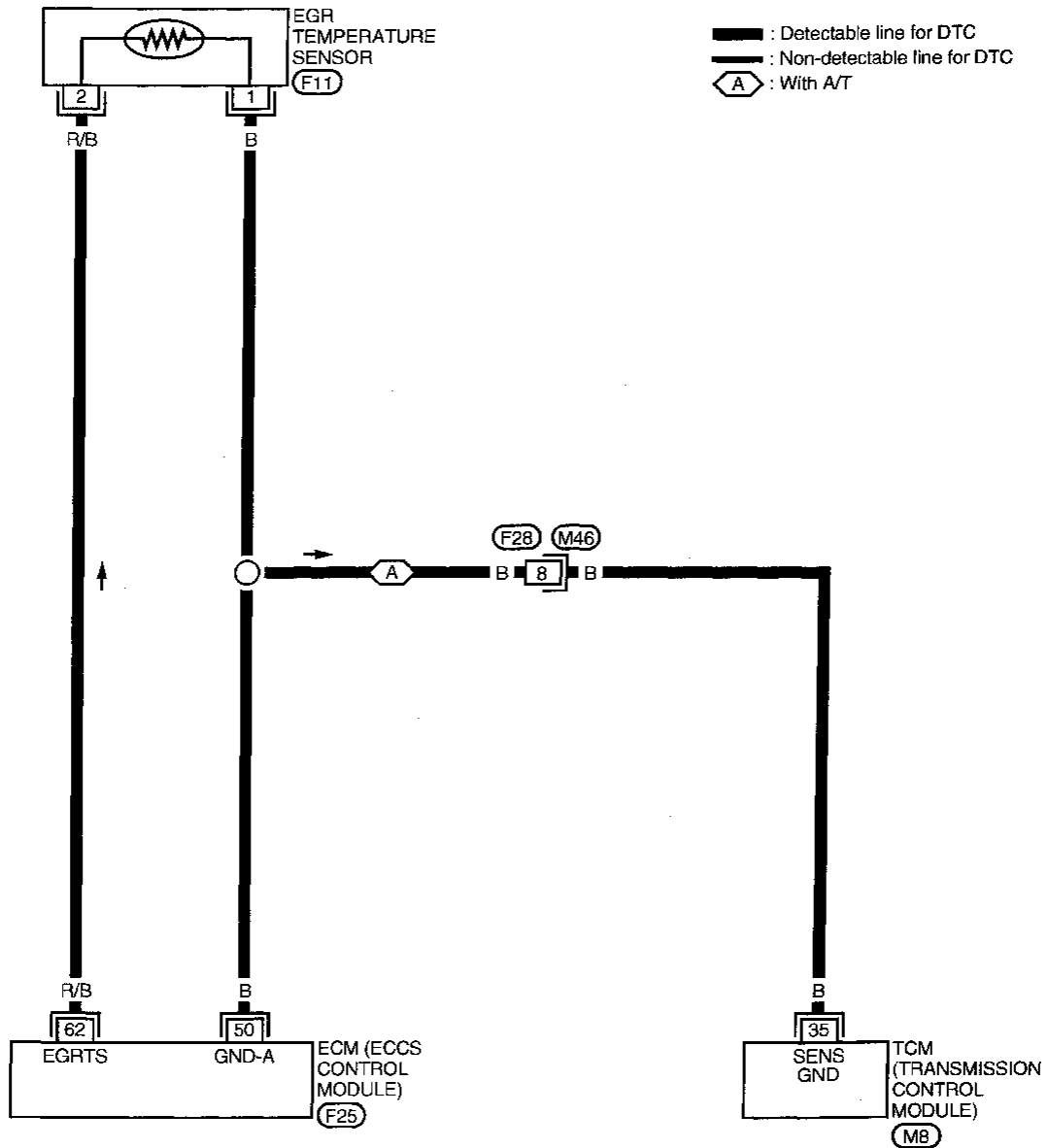

GI
 MA
 EM
 LC
EC
 FE
 CL
 MT
 AT
 FA
 RA
 BR
 ST
 RS
 BT
 HA
 EL

IDX

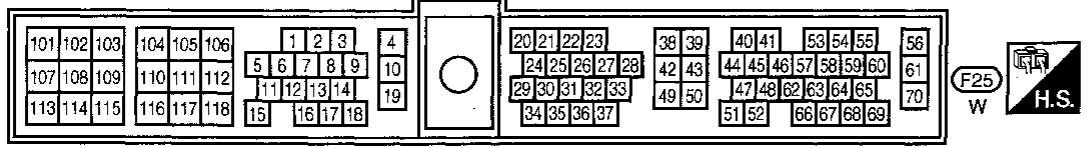
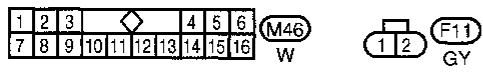
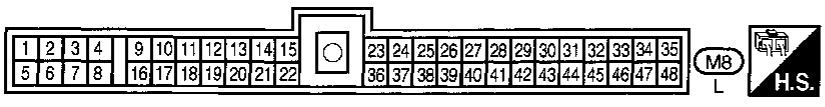

TROUBLE DIAGNOSIS FOR DTC P1401

EGR Temperature Sensor (Cont'd)

DIAGNOSTIC PROCEDURE

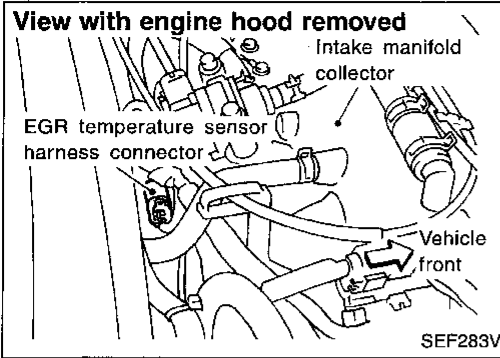

INSPECTION START

A

CHECK POWER SUPPLY.

1. Disconnect EGR temperature sensor harness connector.
2. Turn ignition switch "ON".
3. Check voltage between terminal ② and ground with CONSULT or tester.

Voltage: Approximately 5V

NG → Repair harness or connectors.

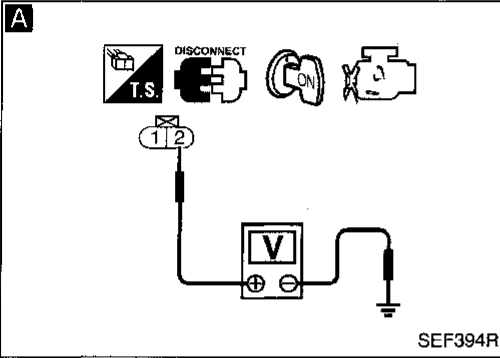

B

CHECK GROUND CIRCUIT.

1. Turn ignition switch "OFF".
2. Check harness continuity between terminal ① and engine ground.

Continuity should exist.
If OK, check harness for short to ground and short to power.

NG → Check the following.

- Harness connectors (F28, M46) (With A/T)
- Harness for open or short between EGR temperature sensor and ECM
- Harness for open or short between EGR temperature sensor and TCM (With A/T)

If NG, repair open circuit or short to ground or short to power in harness or connector.

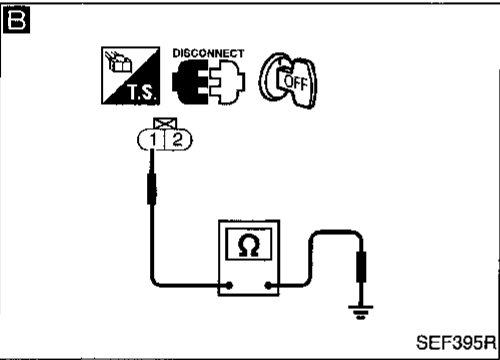

CHECK COMPONENT
(EGR temperature sensor).
Refer to "COMPONENT INSPECTION" on next page.

NG → Replace EGR temperature sensor.

OK → Perform "TROUBLE DIAGNOSIS FOR INTERMITTENT INCIDENT", EC-106.

INSPECTION END

TROUBLE DIAGNOSIS FOR DTC P1401

EGR Temperature Sensor (Cont'd)

COMPONENT INSPECTION

EGR temperature sensor

Check resistance change and resistance value.

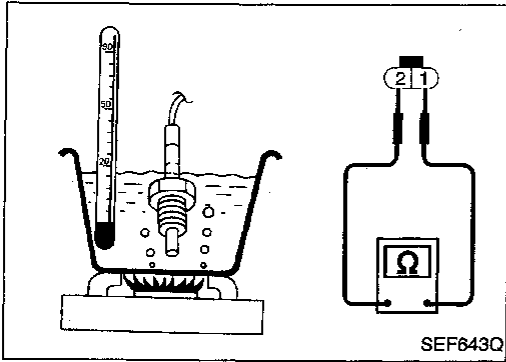

<Reference data>

EGR temperature °C (°F)	Voltage V	Resistance MΩ
0 (32)	4.81	7.9 - 9.7
50 (122)	2.82	0.57 - 0.70
100 (212)	0.8	0.08 - 0.10

If NG, replace EGR temperature sensor.

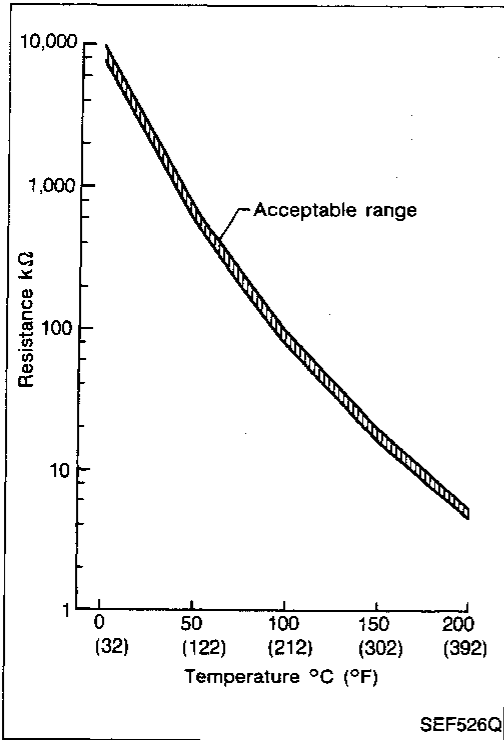

GI

MA

EM

LC

EC

FE

CL

MT

AT

FA

RA

BR

ST

RS

BT

HA

EL

IDX

EGR Function (Open)

SYSTEM DESCRIPTION

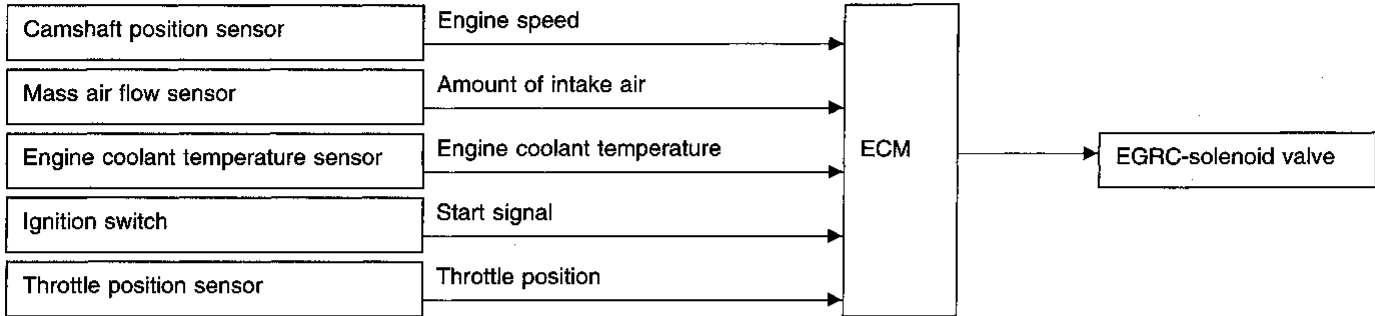

This system cuts and controls vacuum applied to the EGR valve to suit engine operating conditions. This cut-and-control operation is accomplished through the ECM and the EGRC-solenoid valve. When the ECM detects any of the following conditions, current through the solenoid valve is cut. This causes the vacuum to be cut. The EGR valve remains closed.

- Low engine coolant temperature
- Engine starting
- High-speed engine operation
- Engine idling
- Excessively high engine coolant temperature
- Mass air flow sensor malfunction

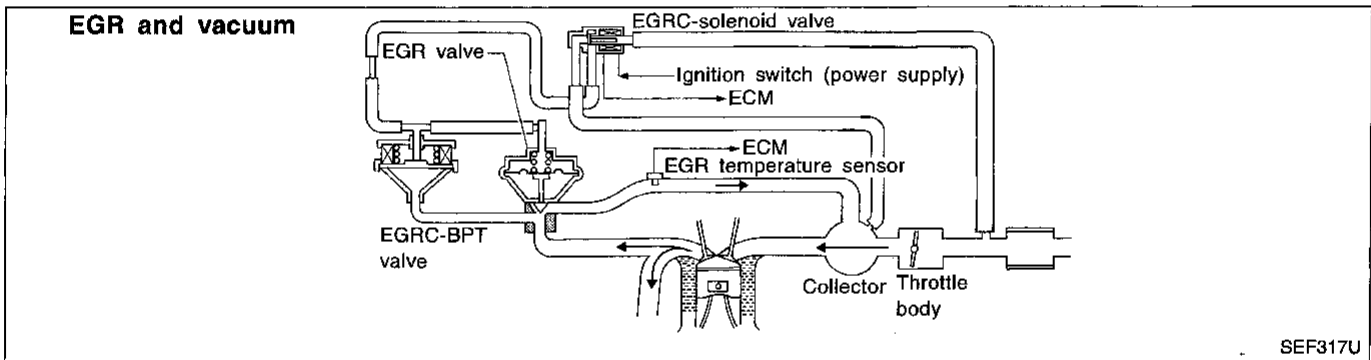

SEF317U

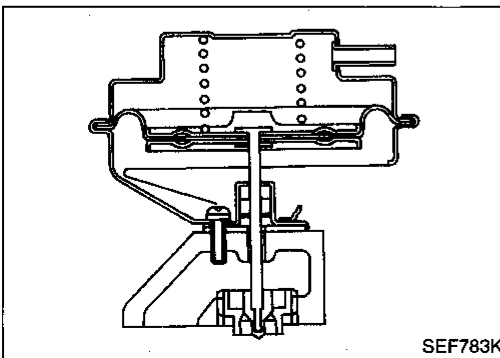

SEF783K

COMPONENT DESCRIPTION

Exhaust gas recirculation (EGR) valve

The EGR valve controls the amount of exhaust gas routed to the intake manifold. Vacuum is applied to the EGR valve in response to throttle valve opening. The vacuum controls the movement of a taper valve connected to the vacuum diaphragm in the EGR valve.

TROUBLE DIAGNOSIS FOR DTC P1402

EGR Function (Open) (Cont'd)

EGRC-solenoid valve

The EGRC-solenoid valve responds to signals from the ECM. When the ECM sends an ON (ground) signal, the coil in the solenoid valve is energized. The vacuum signal passes through the solenoid valve. The signal then reaches the EGR valve. When the ECM sends an OFF signal, a plunger will then move to cut the vacuum signal from the intake manifold collector to the EGR valve.

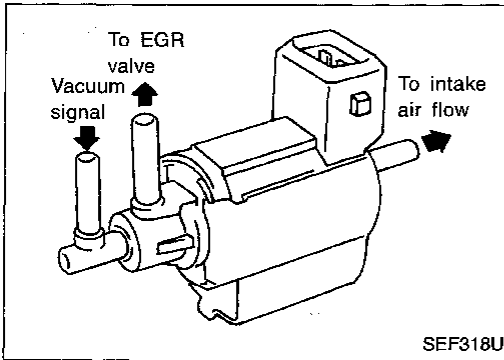

SEF318U

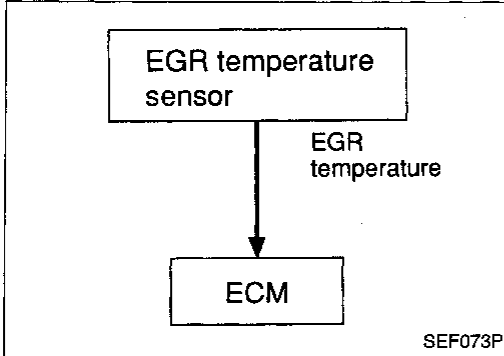

SEF073P

ON BOARD DIAGNOSIS LOGIC

If EGR temperature sensor detects EGR flow under the condition that does not call for EGR, a high-flow malfunction is diagnosed.

NOTE:

Diagnosis for this DTC will end when engine coolant temperature is approx. 50 - 60°C (122 - 140°F). Ignition switch must be turned "ON" (engine start) with engine coolant temperature below 40°C (104°F) when starting DTC confirmation procedure.

Diagnostic Trouble Code No.	Malfunction is detected when ...	Check Items (Possible Cause)
P1402 0514	<ul style="list-style-type: none"> EGR flow is detected under condition that does not call for EGR. 	<ul style="list-style-type: none"> EGRC-solenoid valve EGR valve leaking or stuck open EGR temperature sensor EGRC-BPT valve

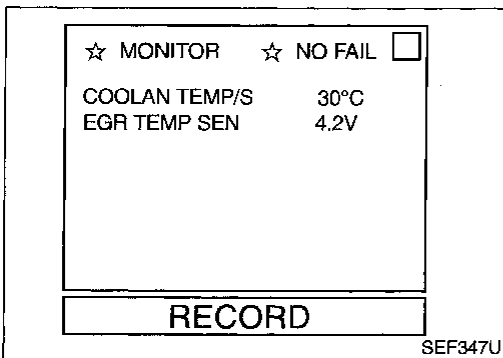

SEF347U

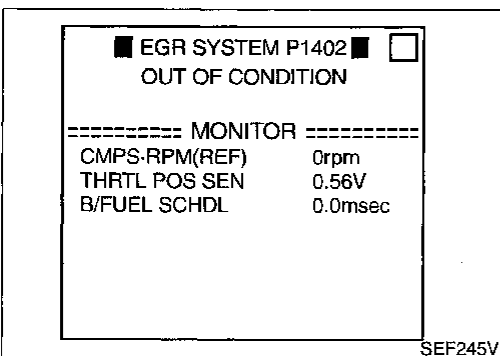

SEF245V

DIAGNOSTIC TROUBLE CODE CONFIRMATION PROCEDURE

NOTE:

If "DIAGNOSTIC TROUBLE CODE CONFIRMATION PROCEDURE" has been previously conducted, always turn ignition switch "OFF" and wait at least 5 seconds before conducting the next test.

TESTING CONDITION:

- Always perform test at a temperature above -10°C (14°F).
- Engine coolant temperature and EGR temperature must be verified in "DATA MONITOR" mode with CONSULT before starting DTC WORK SUPPORT test. If it is out of range below, the test cannot be conducted.
 - COOLAN TEMP/S: -10 to 30°C (14 to 86°F)*
 - EGR TEMP SEN: Less than 4.8V

If the values are out of the ranges indicated above, park the vehicle in a cool place and allow the engine temperature to stabilize. Do not attempt to reduce the engine coolant or EGR temperature with a fan or means other than ambient air. Doing so may produce an inaccurate diagnostic result.

*: Although CONSULT screen displays "-10 to 40°C (14 to 104°F)" as a range of engine coolant temperature, ignore it.

TROUBLE DIAGNOSIS FOR DTC P1402

EGR Function (Open) (Cont'd)

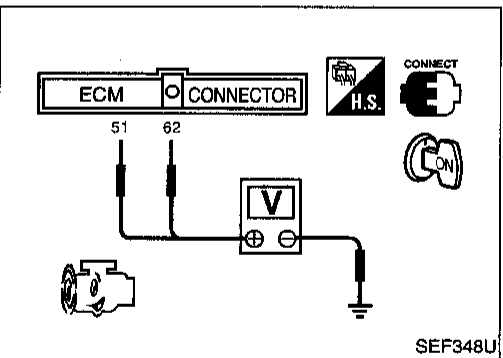
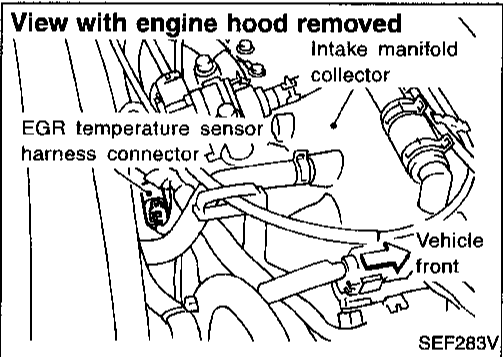
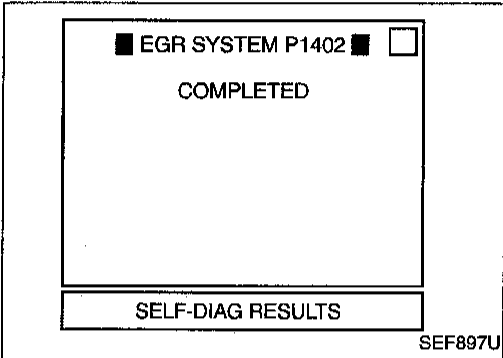
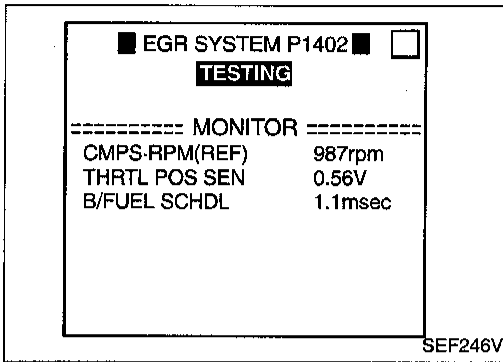

- 1) Turn ignition switch "OFF" and wait at least 5 seconds. Then turn ignition switch "ON".
- 2) Select "EGR SYSTEM P1402" of "EGR SYSTEM" in "DTC WORK SUPPORT" mode with CONSULT.
- 3) Follow the instruction of CONSULT.
- 4) Start engine and let it idle until "TESTING" on CONSULT screen is turned to "COMPLETED". (It will take 60 seconds or more.)

If "TESTING" is not displayed after 5 minutes, turn ignition "OFF" and cool the engine coolant temperature to the range of -10 to 30°C (14 to 86°F). Retry from step 1).

- 5) Make sure that "OK" is displayed after touching "SELF-DIAG RESULTS". If "NG" is displayed, refer to "DIAGNOSTIC PROCEDURE", EC-378.

OR



- 1) Turn ignition switch "ON" and select "MODE 1" with GST.
- 2) Check that engine coolant temperature is within the range of -10 to 30°C (14 to 86°F).
- 3) Check that voltage between ECM terminal ⑥② (EGR temperature) and ground is less than 4.8V.
- 4) Start engine and let it idle for at least 60 seconds.
- 5) Stop engine.
- 6) Perform from step 1) to 4).
- 7) Select "MODE 3" with GST.
- 8) If DTC is detected, go to "DIAGNOSTIC PROCEDURE", EC-378.

OR



- 1) Turn ignition switch "ON".
- 2) Check the following voltages.
ECM terminal ⑤① (engine coolant temperature) and ground:
3.2 - 4.4V
ECM terminal ⑥② (EGR temperature) and ground:
Less than 4.8V
- 3) Start engine and let it idle for at least 60 seconds.
- 4) Turn ignition switch "OFF", wait at least 5 seconds and then turn "ON".
- 5) Perform "Diagnostic Test Mode II (Self-diagnostic results)" with ECM.
- 6) If 1st trip DTC is detected, go to "DIAGNOSTIC PROCEDURE", EC-378.

When using GST, "DIAGNOSTIC TROUBLE CODE CONFIRMATION PROCEDURE" should be performed twice as much as when using CONSULT or ECM (Diagnostic Test Mode II) because GST cannot display MODE 7 (1st trip DTC) concerning this diagnosis. Therefore, using CONSULT or ECM (Diagnostic Test Mode II) is recommended.

TROUBLE DIAGNOSIS FOR DTC P1402

EGR Function (Open) (Cont'd)

EC-EGRC1-01

GI
MA
EM
LC
EC
FE
CL
MT
AT
FA
RA
BR
ST
RS
BT
HA
EL
IDX

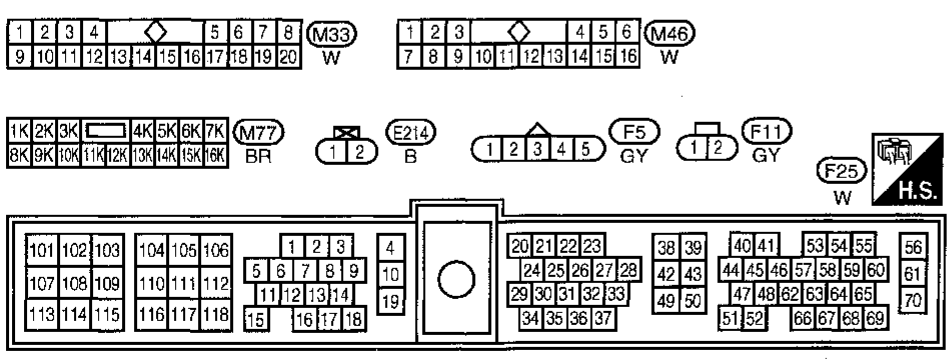
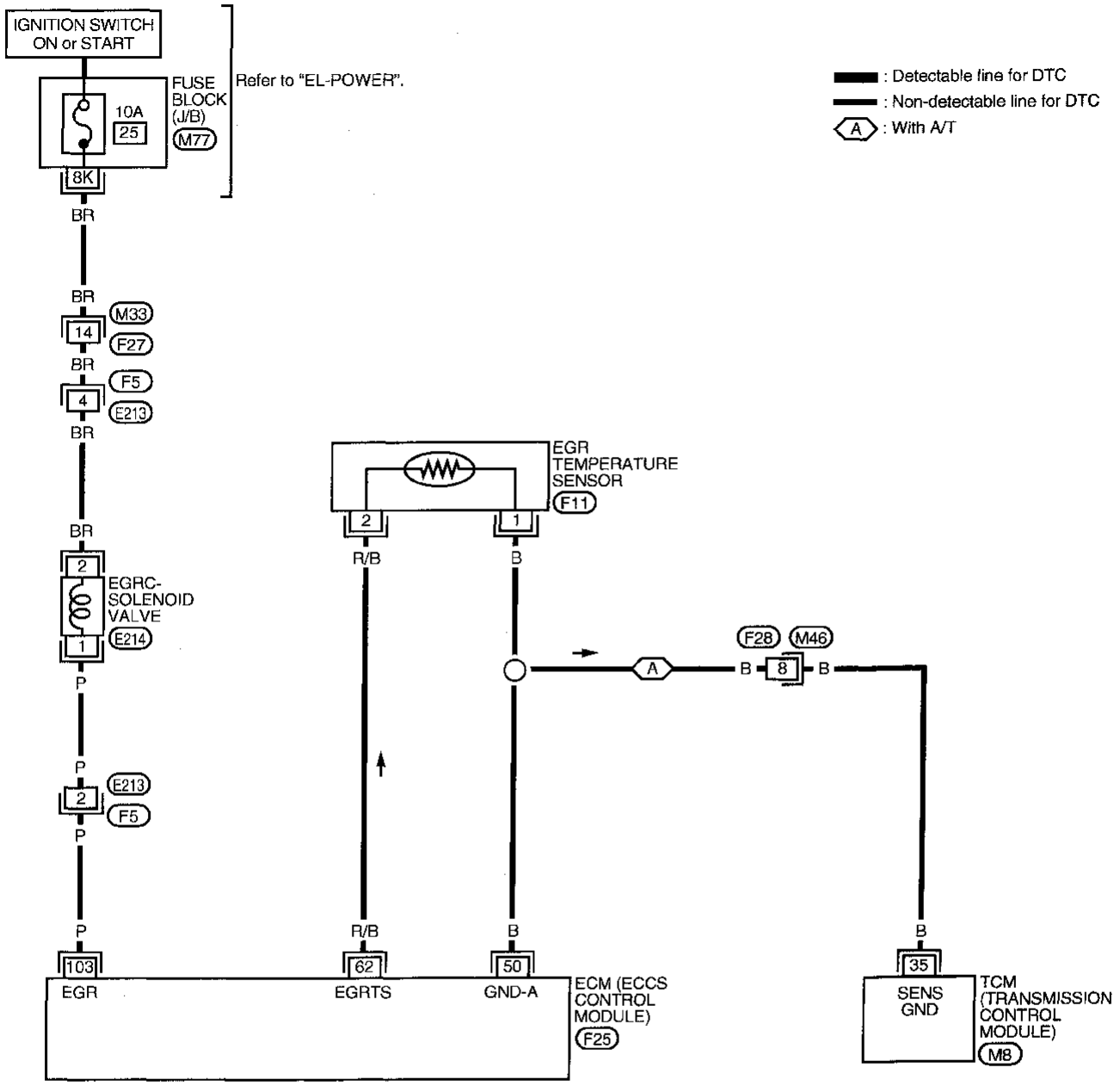

Refer to last page (Foldout page).

(M8)

TROUBLE DIAGNOSIS FOR DTC P1402

EGR Function (Open) (Cont'd)

DIAGNOSTIC PROCEDURE

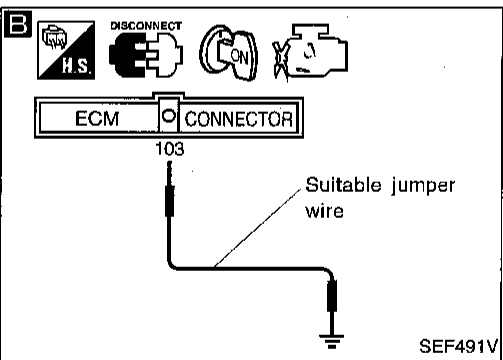
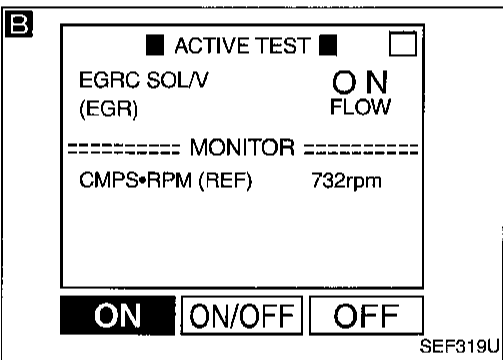
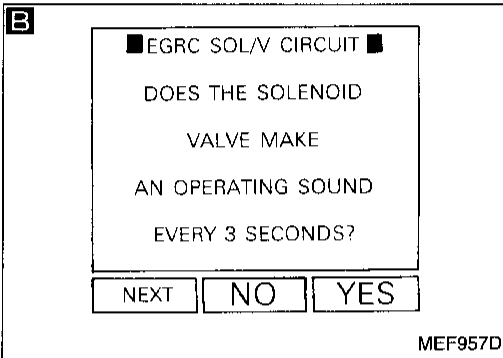
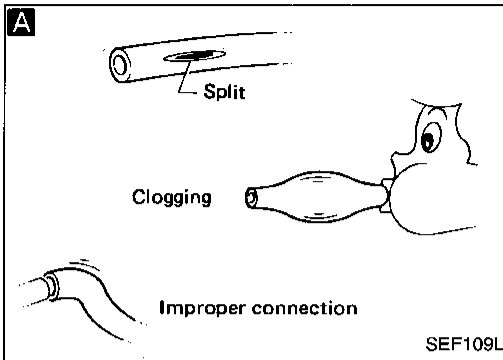

INSPECTION START

A
CHECK VACUUM HOSE.
Check vacuum hose for clogging, cracks or improper connection.
Refer to "Vacuum Hose Drawing", EC-15.

NG → Repair or replace vacuum hose.

OK ↓

B
CHECK COMPONENT (EGRC-solenoid valve).
1. Turn ignition switch "ON".
2. Perform "EGRC SOL/V CIRCUIT" in "FUNCTION TEST" mode with CONSULT.
Note: If this function test mode is not available, use "ACTIVE TEST" mode.

NG → Repair or replace EGRC-solenoid valve or repair circuit.

OR
1. Turn ignition switch "ON".
2. Turn EGRC-solenoid valve "ON" and "OFF" in "ACTIVE TEST" mode with CONSULT and check operating sound.

OR
1. Turn ignition switch "OFF".
2. Disconnect ECM harness connector.
3. Turn ignition switch "ON".
4. Connect a suitable jumper wire between ECM terminal (103) and engine ground.
5. Check operating sound of the solenoid valve when disconnecting and reconnecting the jumper wire.

OK ↓

CHECK COMPONENT (EGRC-solenoid valve).
Refer to "COMPONENT INSPECTION" on next page.

NG → Replace EGRC-solenoid valve.

OK ↓

CHECK COMPONENT (EGR valve).
Refer to "COMPONENT INSPECTION" on the next page.

NG → Replace EGR valve.

OK ↓

CHECK COMPONENT (EGRC-BPT valve).
Refer to "COMPONENT INSPECTION" on EC-380.

NG → Replace EGRC-BPT valve.

OK ↓

CHECK COMPONENT (EGR temperature sensor).
Refer to "COMPONENT INSPECTION" on EC-380.

NG → Replace EGR temperature sensor.

OK ↓

Perform "TROUBLE DIAGNOSIS FOR INTERMITTENT INCIDENT", EC-106.

INSPECTION END

TROUBLE DIAGNOSIS FOR DTC P1402

EGR Function (Open) (Cont'd)

COMPONENT INSPECTION

EGR valve

- Apply vacuum to EGR vacuum port with a hand vacuum pump.

EGR valve spring should lift.

- Check for sticking.
- If NG, repair or replace EGR valve.

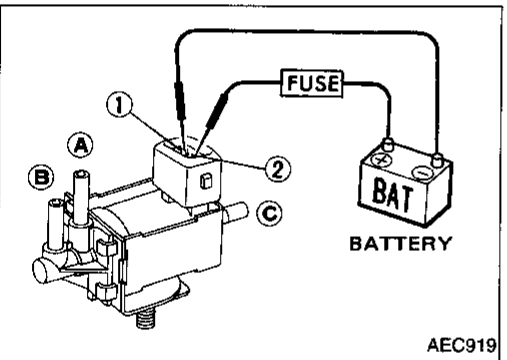
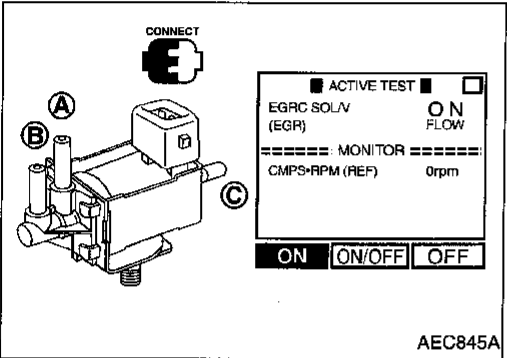
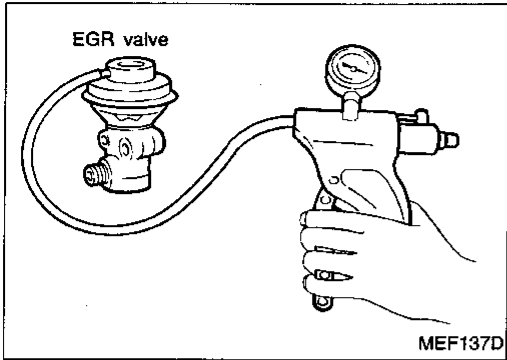

EGRC-solenoid valve

Check air passage continuity.

- Perform "EGRC SOLENOID VALVE" in "ACTIVE TEST" mode.

Condition EGRC SOLENOID VALVE	Air passage continuity between (A) and (B)	Air passage continuity between (A) and (C)
ON	Yes	No
OFF	No	Yes

OR



Conditions	Air passage continuity between (A) and (B)	Air passage continuity between (A) and (C)
12V direct current supply between terminals ① and ②	Yes	No
No supply	No	Yes

If NG or operation takes more than 1 second, replace EGRC-solenoid valve.

GI

MA

EM

LC

EC

FE

CL

MT

AT

FA

RA

BR

ST

RS

BT

HA

EL

IDX

TROUBLE DIAGNOSIS FOR DTC P1402

EGR Function (Open) (Cont'd)

EGR temperature sensor

Check resistance change and resistance value.

<Reference data>

EGR temperature °C (°F)	Voltage V	Resistance MΩ
0 (32)	4.81	7.9 - 9.7
50 (122)	2.82	0.57 - 0.70
100 (212)	0.8	0.08 - 0.10

If NG, replace EGR temperature sensor.

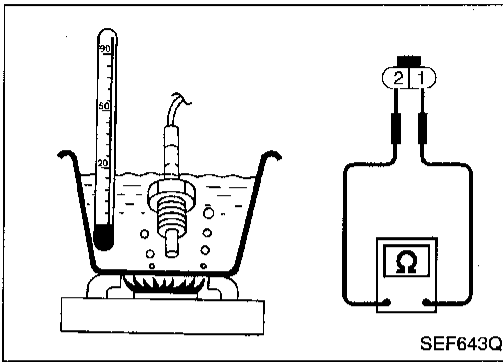

SEF643Q

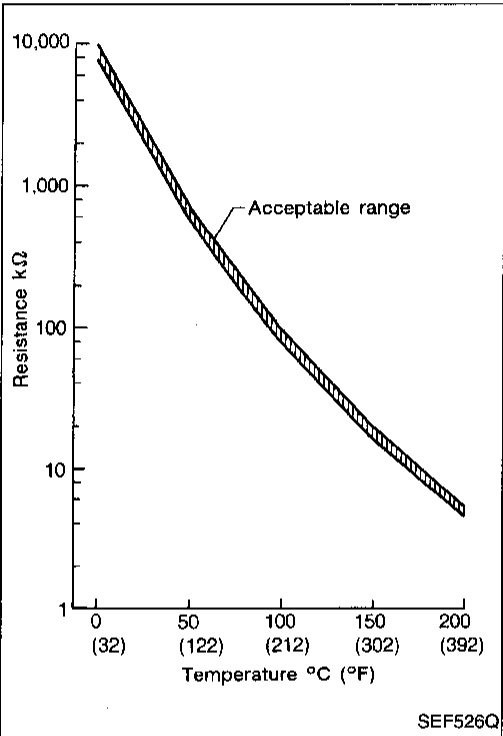

SEF526Q

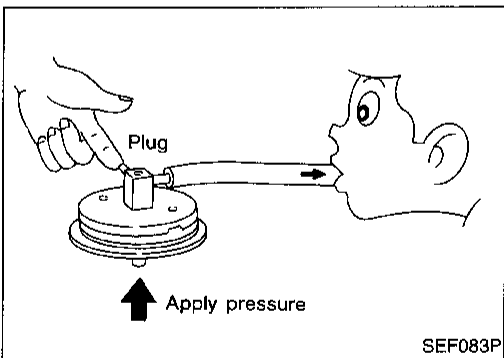

SEF083P

EGRC-BPT valve

1. Plug one of two ports of EGRC-BPT valve.
2. Vacuum from the other port and check for leakage while applying a pressure above 0.981 kPa (100 mmH₂O, 3.94 inH₂O) from under EGRC-BPT valve.
3. If a leakage is noted, replace the valve.

TROUBLE DIAGNOSIS FOR DTC P1440

Evaporative Emission (EVAP) Control System (Small Leak) (Positive Pressure)

Note: If DTC P1448 is displayed with P1440, perform TROUBLE DIAGNOSIS FOR DTC P1448 first.
(See EC-415.)

ON BOARD DIAGNOSIS LOGIC

This diagnosis detects leaks in the EVAP purge line using vapor pressure in the fuel tank. The EVAP canister vent control valve is closed to shut the EVAP purge line. The vacuum cut valve bypass valve will then be opened to clear the line between the fuel tank and the EVAP canister purge control valve. The EVAP control system pressure sensor can now monitor the pressure inside the fuel tank. If pressure increases, the ECM will check for leaks in the line between the vacuum cut valve and EVAP canister purge control valve.

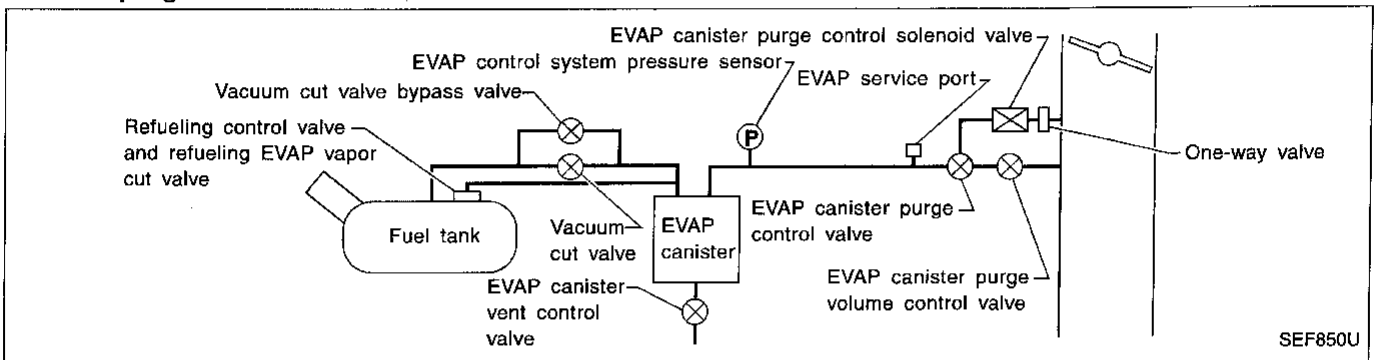

ON BOARD DIAGNOSIS LOGIC

Diagnostic Trouble Code No.	Malfunction is detected when	Check Items (Possible Cause)
P1440 0213	<ul style="list-style-type: none"> ● EVAP control system has a leak. ● EVAP control system does not operate properly. 	<ul style="list-style-type: none"> ● Incorrect fuel tank vacuum relief valve ● Incorrect fuel filler cap used ● Fuel filler cap remains open or fails to close. ● Foreign matter caught in fuel filler cap. ● Leak is in line between intake manifold and EVAP canister purge control valve. ● Foreign matter caught in EVAP canister vent control valve. ● EVAP canister or fuel tank leaks ● EVAP purge line (pipe and rubber tube) leaks ● EVAP purge line rubber tube bent. ● Blocked or bent rubber tube to EVAP control system pressure sensor ● Loose or disconnected rubber tube ● EVAP canister vent control valve and the circuit ● EVAP canister purge control valve ● EVAP canister purge volume control valve ● EVAP canister purge control solenoid valve ● Absolute pressure sensor ● Tank fuel temperature sensor ● MAP/BARO switch solenoid valve ● Blocked or bent rubber tube to MAP/BARO switch solenoid valve ● O-ring of EVAP canister vent control valve is missing or damaged. ● Water separator ● EVAP canister is saturated with water. ● Refueling EVAP vapor cut valve

CAUTION:

- Use only a genuine NISSAN fuel filler cap as a replacement. If an incorrect fuel filler cap is used, the MIL may come on.
- If the fuel filler cap is not tightened properly, the MIL may come on.
- Use only a genuine NISSAN rubber tube as a replacement.

TROUBLE DIAGNOSIS FOR DTC P1440

Evaporative Emission (EVAP) Control System (Small Leak) (Positive Pressure) (Cont'd)

DIAGNOSTIC TROUBLE CODE CONFIRMATION PROCEDURE

CAUTION:

- Never use compressed air or high pressure pump. Otherwise, EVAP system may be damaged.
- Do not exceed 4.12 kPa (0.042 kg/cm², 0.6 psi) of pressure in EVAP system.

NOTE:

- If "DIAGNOSTIC TROUBLE CODE CONFIRMATION PROCEDURE" has been previously conducted, always turn ignition switch "OFF" and wait at least 5 seconds before conducting the next test.
- Always remove service port adapter from service port after applying air up to 0.69 to 1.38 kPa (5.14 to 10.34 mmHg, 0.202 to 0.407 inHg).
- During the test, clamp the EVAP hose tightly as shown at left.
- If DTC P1448 is displayed with P1440, perform TROUBLE DIAGNOSIS FOR DTC P1448 first. (See EC-415.)



- 1) Turn ignition switch "OFF".
- 2) Clamp the EVAP hose as shown at left.
- 3) Turn ignition switch "ON".
- 4) Select "EVAP SML LEAK P1440" of "EVAPORATIVE SYSTEM" in "DTC WORK SUPPORT" mode with CONSULT. Follow the instruction displayed.
- 5) Make sure that "OK" is displayed. If "NG" is displayed, refer to "DIAGNOSTIC PROCEDURE", EC-384.

OR

NOTE:

Be sure to read the explanation of "Driving pattern" on EC-46 before driving vehicle.



- 1) Start engine.
- 2) Drive vehicle according to "Driving pattern", EC-46.
- 3) Stop vehicle.
- 4) Select "MODE 1" with GST.
 - If SRT of EVAP system is not set yet, go to the following step.
 - If SRT of EVAP system is set, the result will be OK.
- 5) Turn ignition switch "OFF" and wait at least 5 seconds.
- 6) Start engine.

It is not necessary to cool engine down before driving.

- 7) Drive vehicle again according to the "Driving pattern", EC-46.
- 8) Stop vehicle.
- 9) Select "MODE 3" with GST.
 - If P1447 is displayed on the screen, go to "TROUBLE DIAGNOSIS FOR DTC P1447", EC-406.
 - If P0440 is displayed on the screen, go to "DIAGNOSTIC PROCEDURE", EC-288.
 - If P1440 is displayed on the screen, go to "TROUBLE DIAGNOSIS FOR DTC P1440", EC-384.

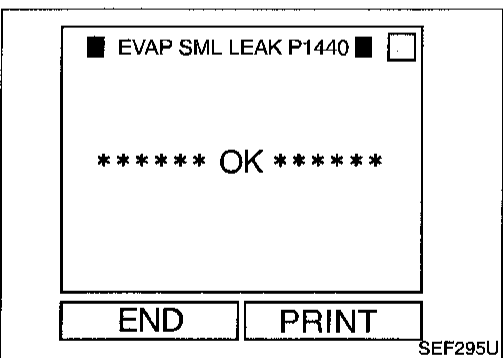
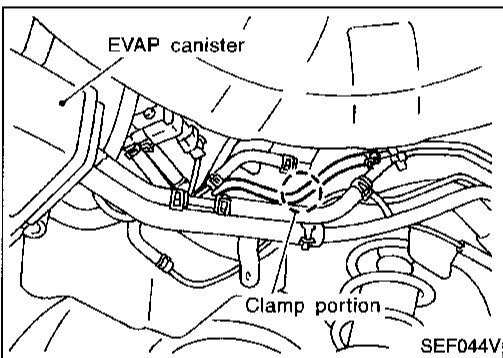
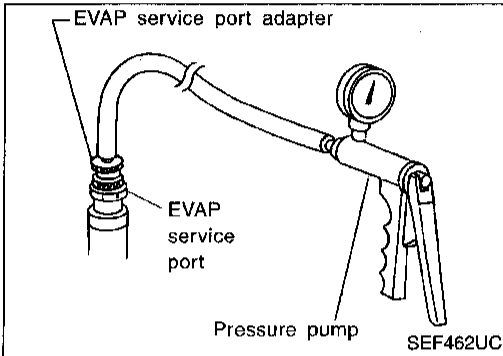
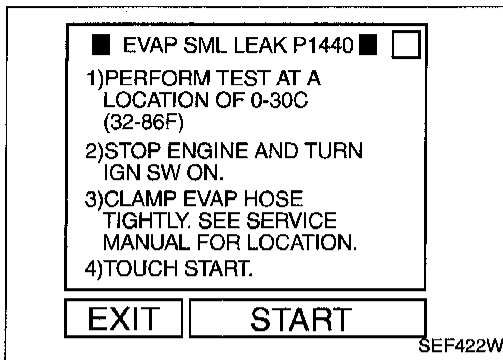

TROUBLE DIAGNOSIS FOR DTC P1440

Evaporative Emission (EVAP) Control System (Small Leak) (Positive Pressure) (Cont'd)

- If P0440, P1440 and P1447 are not displayed on the screen, go to the following step. GI
- 10) Select "MODE 1" with GST.
- If SRT of EVAP system is set, the result will be OK.
- If SRT of EVAP system is not set, go to step 5). MA

OR

NOTE:

- Be sure to read the explanation of "Driving pattern" on EC-46 before driving vehicle. EM
- It is better that the fuel level is low. LC



- 1) Start engine.
- 2) Drive vehicle according to "Driving pattern", EC-46.
- 3) Stop vehicle.
- 4) Turn ignition switch "OFF" and wait at least 5 seconds. EC
- 5) Turn ignition switch "ON" and perform "Diagnostic Test Mode II (Self-diagnostic results)" with ECM. FE
- 6) If 1st trip DTC is detected, go to "DIAGNOSTIC PROCEDURE", EC-384. CL

MT

AT

FA

RA

BR

ST

RS

BT

HA

EL

IDX

TROUBLE DIAGNOSIS FOR DTC P1440

Evaporative Emission (EVAP) Control System (Small Leak) (Positive Pressure) (Cont'd) DIAGNOSTIC PROCEDURE

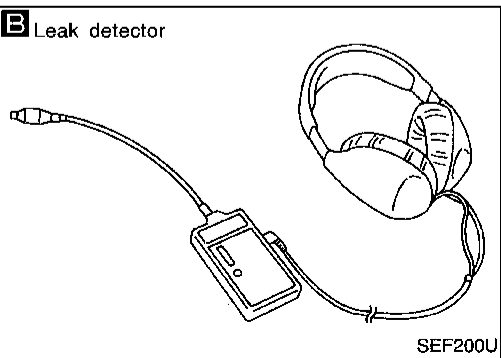
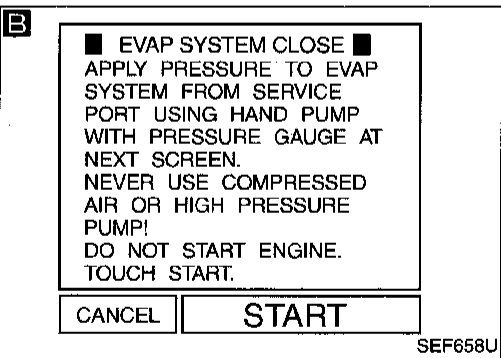
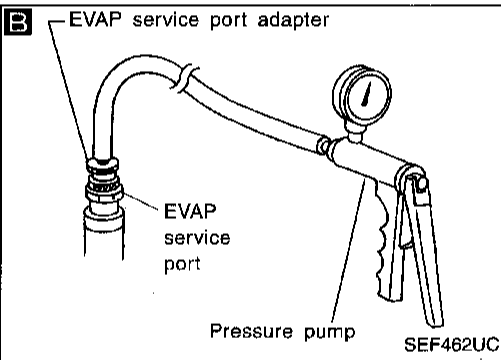
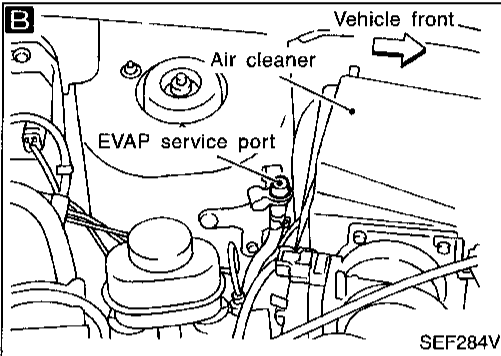
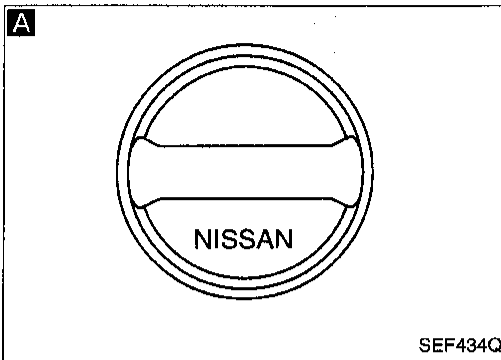

INSPECTION START

A

CHECK FUEL FILLER CAP.

1. Turn ignition switch "OFF".
2. Check for genuine NISSAN fuel filler cap design.
If NG, replace with genuine NISSAN fuel filler cap.
If OK, go to next step.
3. Check that the cap is tightened properly by rotating the cap clockwise.
 - Open fuel filler cap, then clean cap and fuel filler neck threads using air blower.
 - Retighten until ratcheting sound is heard.
 If OK, go to next step.
4. Check for air releasing sound while opening the fuel filler cap.

NG

Check fuel tank vacuum relief valve. (Refer to "EVAPORATIVE EMISSION SYSTEM", EC-22.)
If NG, replace with genuine NISSAN fuel filler cap.
If OK, go to **B** "CHECK FOR EVAP LEAK".

OK

B

CHECK FOR EVAP LEAK.

- Never use compressed air or high pressure pump.
- Improper installation of service port may cause leaking.
- Do not exceed 4.12 kPa (0.042 kg/cm², 0.6 psi) of pressure in the system.

To locate the EVAP leak, do the following.

1. Install the EVAP service port adapter and the pressure pump securely.
2. Turn ignition switch "ON". Select "EVAP SYSTEM CLOSE" of "WORK SUPPORT" mode with CONSULT.
3. Touch "START" and apply pressure into the EVAP line until the pressure indicator reaches the middle of bar graph.
4. Locate the leak using a leak detector. Refer to the instruction manual for more details about the leak detector. Refer to "Evaporative Emission Line Drawing", EC-25.

NG

Repair or replace.

OR

2. Turn ignition switch "OFF".
3. Apply 12 volts DC to EVAP canister vent control valve. The valve will close. (Continue to apply 12 volts until the end of test.)
4. Apply 12 volts DC to vacuum cut valve bypass valve. The valve will open. (Continue to apply 12 volts until the end of test.)
5. Pressurize the EVAP line using pressure pump with 1.3 to 2.7 kPa (10 to 20 mmHg, 0.39 to 0.79 inHg).
6. Locate the leak using a leak detector. Refer to the instruction manual for more details about the leak detector. Refer to "Evaporative Emission Line Drawing", EC-25.

OK

A

(Go to next page.)

TROUBLE DIAGNOSIS FOR DTC P1440

Evaporative Emission (EVAP) Control System (Small Leak) (Positive Pressure) (Cont'd)

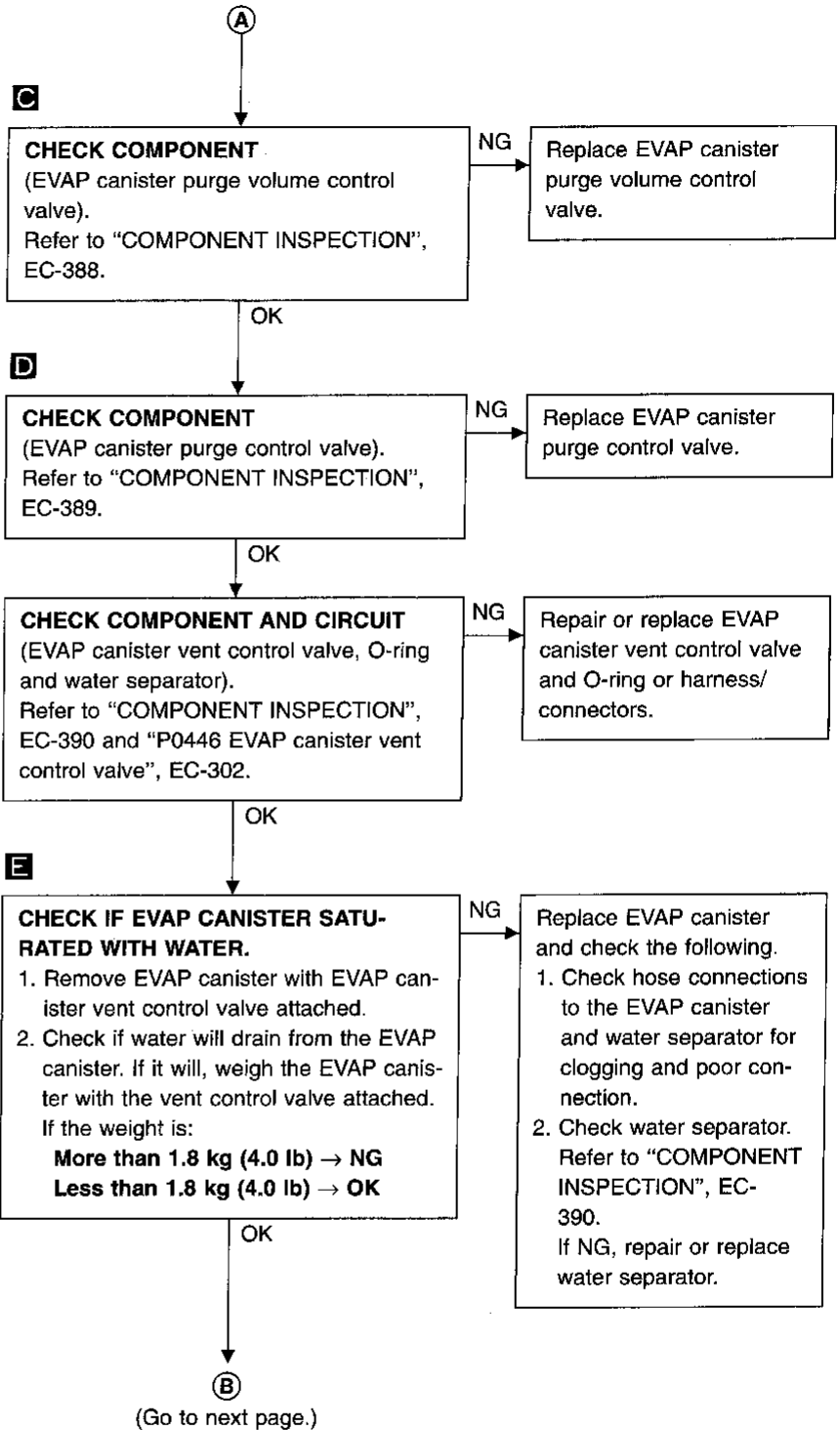
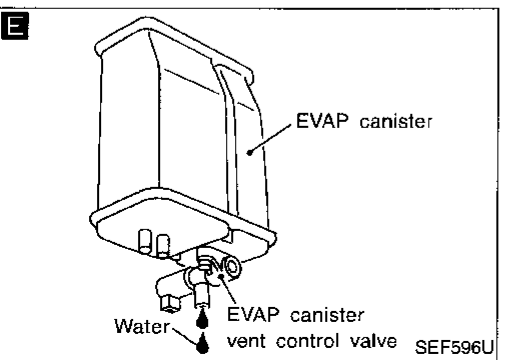
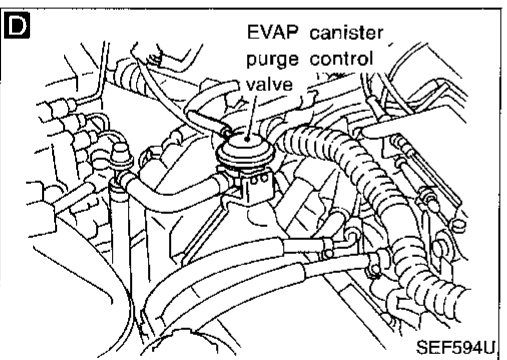
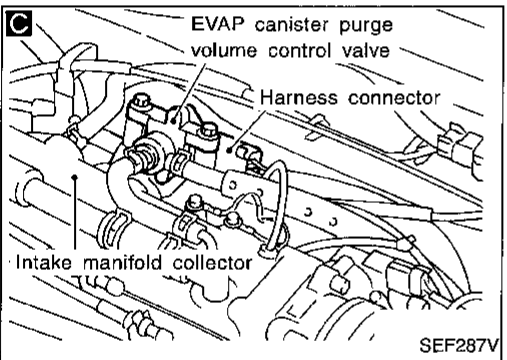
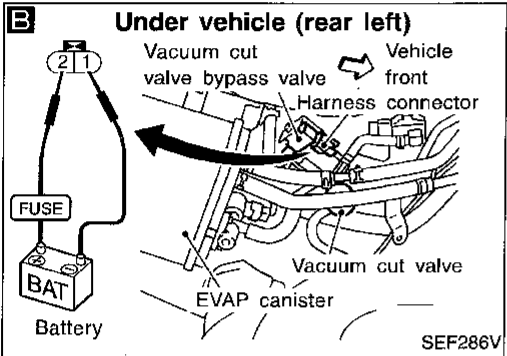
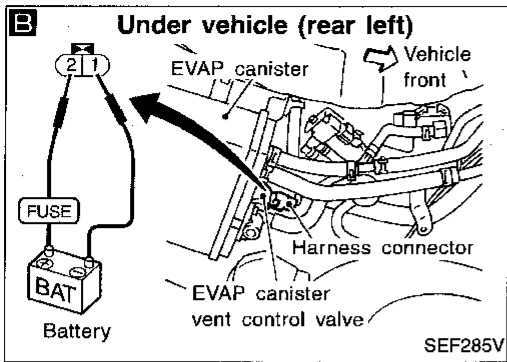

GI

MA

EM

LC

EC

FE

CL

MT

AT

FA

RA

BR

ST

RS

BT

HA

EL

IDX

TROUBLE DIAGNOSIS FOR DTC P1440

Evaporative Emission (EVAP) Control System (Small Leak) (Positive Pressure) (Cont'd)

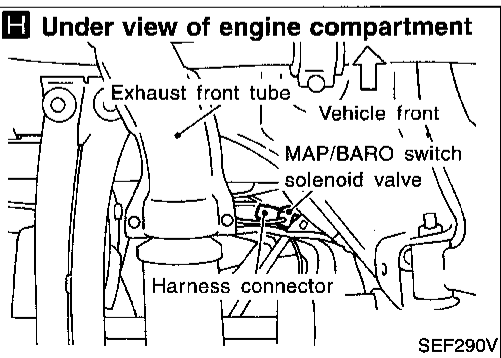
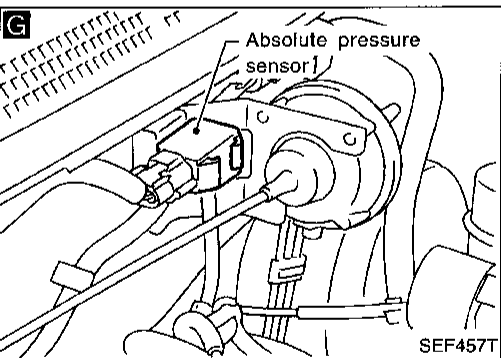
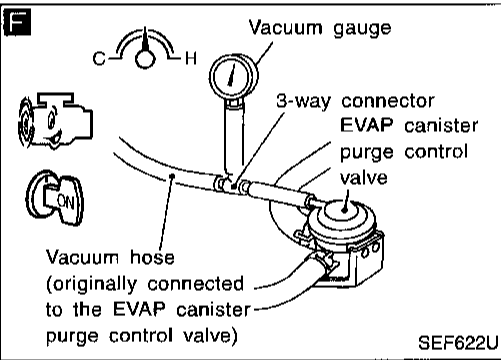
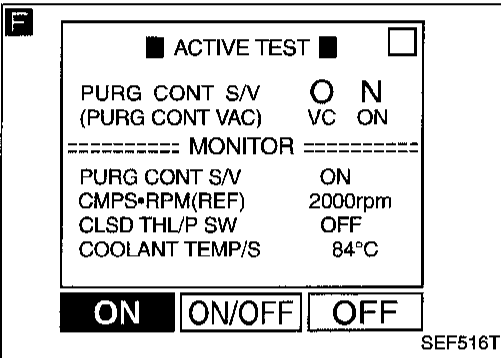
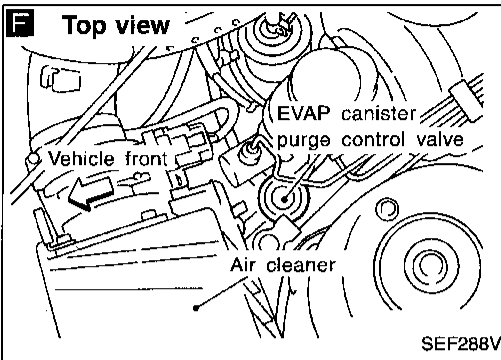

B

F

CHECK COMPONENT (EVAP canister purge control solenoid valve).

1. Disconnect vacuum hose from EVAP canister purge control valve and install vacuum gauge.
2. Start engine and let it idle.
3. Perform "PURG CONT S/V" in "ACTIVE TEST" mode.
4. Rev engine up to 2,000 rpm.
5. Select "ON" and "OFF" on CONSULT screen to turn on "PURG CONT/V S/V".

ON: Vacuum should exist.
OFF: Vacuum should not exist.

OR

1. Start engine and warm it up to normal operating temperature.
2. Stop engine.
3. Lift up drive wheels.
4. Disconnect vacuum hose from EVAP canister purge volume control valve and install vacuum gauge.
5. Start engine and let it idle for at least 60 seconds.
6. Check vacuum hose for vacuum when revving engine up to 2,000 rpm.
7. Release the accelerator pedal and let idle.

While operating solenoid valve, vacuum should exist.
Vacuum should not exist.

NG

Check the following.

- EVAP canister purge control solenoid valve Refer to "COMPONENT INSPECTION", EC-389.
- Vacuum hoses for clogging or disconnection. Refer to "Vacuum Hose Drawing", EC-15.

If NG, repair hoses or replace EVAP canister purge control solenoid valve.

OK

G

CHECK COMPONENT (Absolute pressure sensor). Refer to "COMPONENT INSPECTION", EC-391.

NG

Replace absolute pressure sensor.

OK

H

CHECK COMPONENT (MAP/BARO switch solenoid valve). Refer to "COMPONENT INSPECTION", EC-392.

NG

Replace MAP/BARO switch solenoid valve.

OK

C

(Go to next page.)

TROUBLE DIAGNOSIS FOR DTC P1440

Evaporative Emission (EVAP) Control System (Small Leak) (Positive Pressure) (Cont'd)

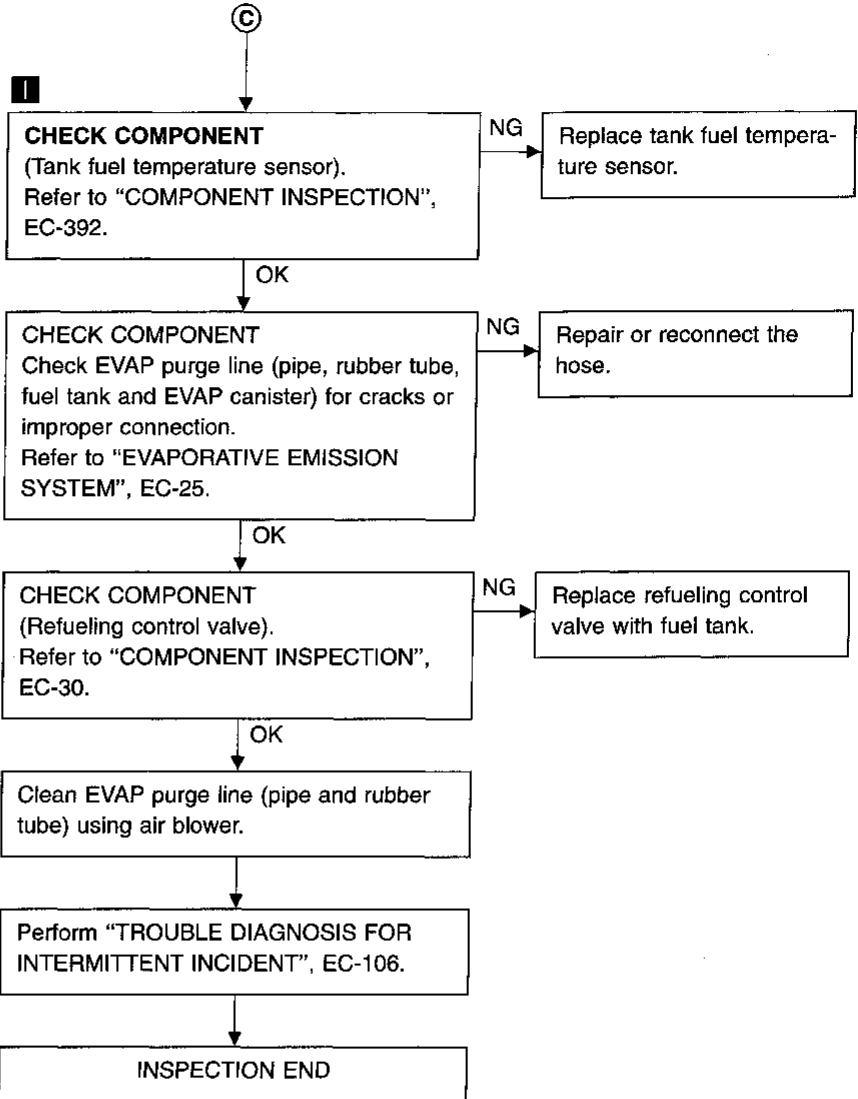
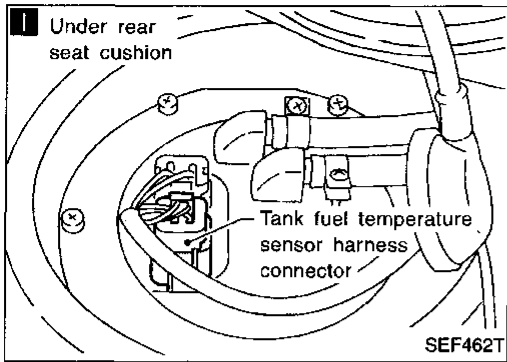

GI

MA

EM

LC

EC

FE

CL

MT

AT

FA

RA

BR

ST

RS

BT

HA

EL

IDX

TROUBLE DIAGNOSIS FOR DTC P1440

Evaporative Emission (EVAP) Control System (Small Leak) (Positive Pressure) (Cont'd)

COMPONENT INSPECTION

EVAP canister purge volume control valve

- ① 1. Disconnect EVAP canister purge volume control valve harness connector.
2. Check resistance between the following terminals.
terminal ② and terminals ①, ③
terminal ⑤ and terminals ④, ⑥

Resistance:

35 - 43Ω [At 20°C (68°F)]

3. Reconnect EVAP canister purge volume control valve harness connector.
4. Remove EVAP canister purge volume control valve from intake manifold collector and disconnect hoses from the valve.
(Plug the purge hoses. The EVAP canister purge volume control valve harness connector should remain connected.)
5. Turn ignition switch "ON".
6. Perform "PURG VOL CONT/V" in "ACTIVE TEST" mode with CONSULT. Check that EVAP canister purge volume control valve shaft moves smoothly forward and backward according to the valve opening.

If NG, replace the EVAP canister purge volume control valve.

OR

- ⊗ 1. Disconnect EVAP canister purge volume control valve harness connector.
2. Check resistance between the following terminals.
terminal ② and terminals ①, ③
terminal ⑤ and terminals ④, ⑥

Resistance:

35 - 43Ω [At 20°C (68°F)]

3. Reconnect EVAP canister purge volume control valve harness connector.
4. Remove EVAP canister purge volume control valve from intake manifold collector and disconnect hoses from the valve.
(Plug the purge hoses. The EVAP canister purge volume control valve harness connector should remain connected.)
5. Turn ignition switch "ON" and "OFF". Check that EVAP canister purge volume control valve shaft moves smoothly forward and backward according to the ignition switch position.

If NG, replace the EVAP canister purge volume control valve.

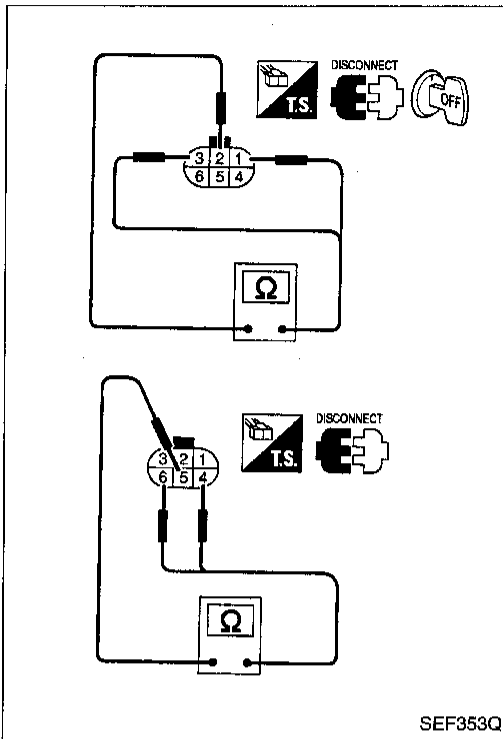

SEF353Q

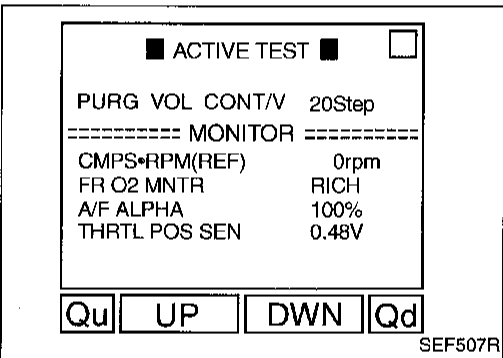

SEF507R

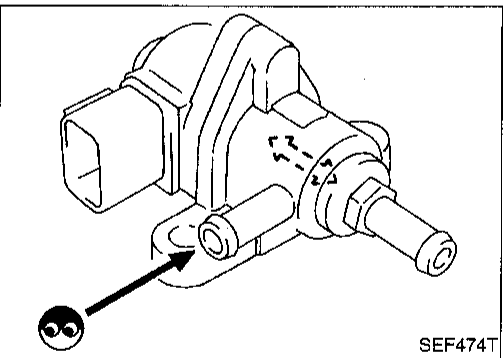

SEF474T

TROUBLE DIAGNOSIS FOR DTC P1440

Evaporative Emission (EVAP) Control System (Small Leak) (Positive Pressure) (Cont'd)

EVAP canister purge control solenoid valve

1. Lift up drive wheels (M/T models only).
2. Turn ignition switch "ON".
3. Select "PURG CONT S/V" of "ACTIVE TEST" mode with CONSULT.
4. Start engine and warm it up to normal operating temperature.
5. Disconnect vacuum hose at EVAP canister purge control valve.
6. Touch "ON" and "OFF" and check for vacuum passing through the hose.

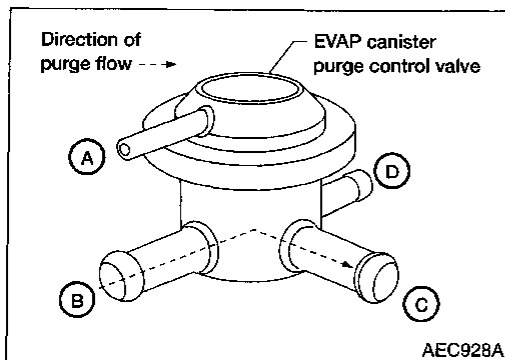
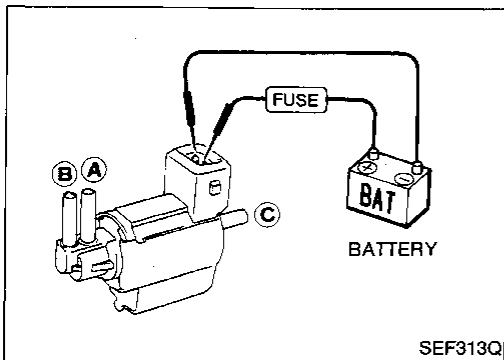
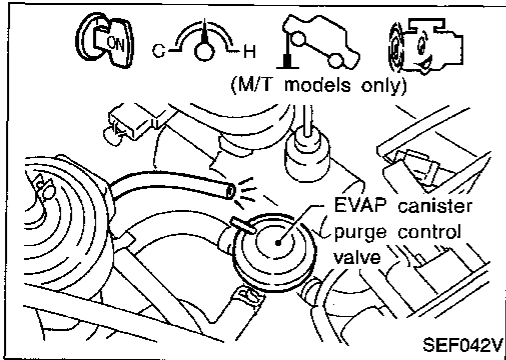
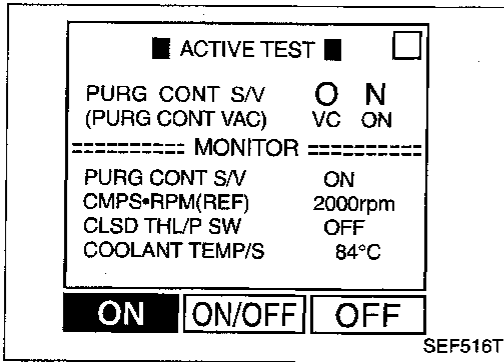

Condition	Vacuum
Idle	Not exist
Rev engine up from 2,000 to 3,000 rpm (A/T models).	Exist
Rev engine up from 2,000 to 3,000 rpm with 1st gear position (M/T models).	

OR

1. Check air passage continuity.

Condition	Air passage continuity between (A) and (B)	Air passage continuity between (A) and (C)
12V direct current supply between terminals	Yes	No
No supply	No	Yes

If NG or operation takes more than 1 second, replace solenoid valve.

EVAP canister purge control valve

Check EVAP canister purge control valve as follows:

1. Blow air in port (A) and (C) and ensure that there is no leakage.
2. Plug port (D) and blow air in port (B). Ensure that there is resistance to flow out of port (C).
3. Plug port (B) and blow air in port (D). Ensure that there is resistance to flow out of port (C).
4. Apply vacuum to port (A) [approximately -13.3 to -20.0 kPa (-100 to -150 mmHg, -3.94 to -5.91 inHg)]. Plug port (D) and blow air in port (C) and ensure free flow out of port (B). Plug port (B) and blow air in port (C) and ensure free flow out of port (D).

TROUBLE DIAGNOSIS FOR DTC P1440

Evaporative Emission (EVAP) Control System (Small Leak) (Positive Pressure) (Cont'd)

EVAP canister vent control valve

Check air passage continuity.

① Perform "VENT CONTROL/V" in "ACTIVE TEST" mode.

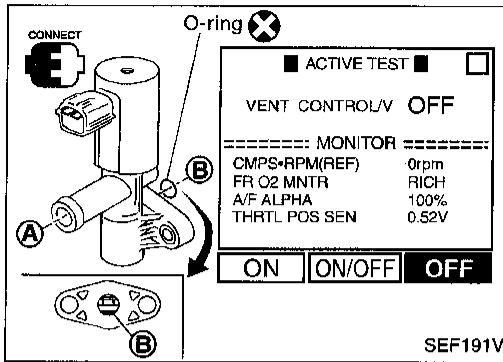

Condition	Air passage continuity between (A) and (B)
VENT CONTROL/V ON	No
VENT CONTROL/V OFF	Yes

OR

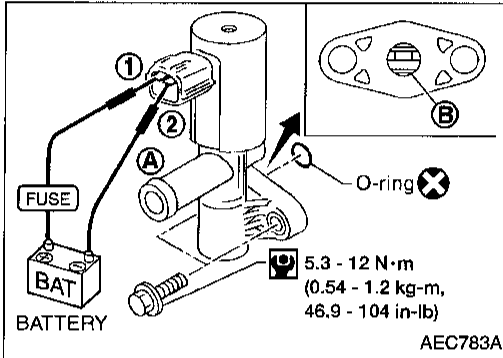

Condition	Air passage continuity between (A) and (B)
12V direct current supply between terminals ① and ②	No
No supply	Yes

If NG or operation takes more than 1 second, clean valve using air blower or replace as necessary.

If the portion (B) is rusted, replace EVAP canister vent control valve.

Make sure new O-ring is installed properly.

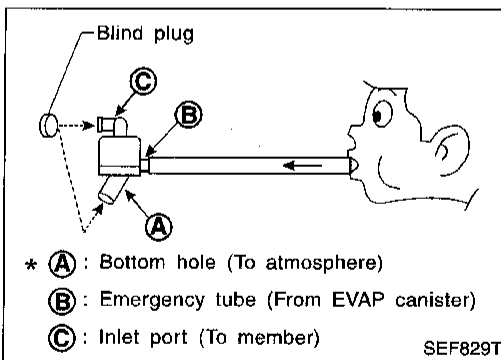

Water separator

1. Check visually for insect nests in the water separator air inlet.
 2. Check visually for cracks or flaws in the appearance.
 3. Check visually for cracks or flaws in the hose.
 4. Check that (A) and (C) are not clogged by blowing air into (B) with (A), and then (C) plugged.
 5. In case of NG in items 2 - 4, replace the parts.
- **Do not disassemble water separator.**

TROUBLE DIAGNOSIS FOR DTC P1440

Evaporative Emission (EVAP) Control System (Small Leak) (Positive Pressure) (Cont'd)

Absolute pressure sensor

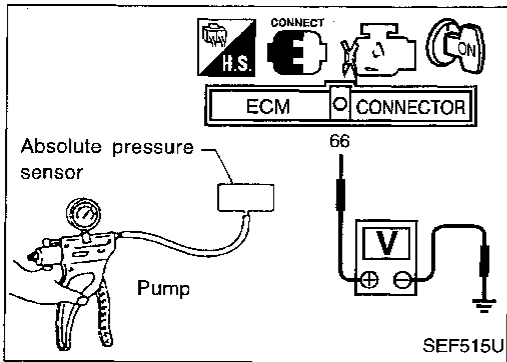

1. Remove absolute pressure sensor with its harness connector connected.
2. Remove hose from absolute pressure sensor.
3. Turn ignition switch "ON" and check output voltage between ECM terminal 66 and engine ground.
The voltage should be 3.2 to 4.8 V.
4. Use pump to apply vacuum pressure of -26.7 kPa (-200 mmHg, -7.87 inHg) to absolute pressure sensor as shown in figure and check the output voltage.
The voltage should be 1.0 to 1.4 V lower than the value measured in step 3.

CAUTION:

- Always calibrate the vacuum pump gauge when using it.
 - Do not apply below -93.3 kPa (-700 mmHg, -27.56 inHg) or over 101.3 kPa (760 mmHg, 29.92 inHg) of pressure.
5. If NG, replace absolute pressure sensor.

GI

MA

EM

LG

EC

FE

CL

MT

AT

FA

RA

BR

ST

RS

BT

HA

EL

IDX

TROUBLE DIAGNOSIS FOR DTC P1440

Evaporative Emission (EVAP) Control System (Small Leak) (Positive Pressure) (Cont'd)

MAP/BARO switch solenoid valve

1. Start engine and warm it up to normal operating temperature.
2. Perform "MAP/BARO SW/V" in "ACTIVE TEST" mode with CONSULT.
3. Check the following.
 - Condition: At idle under no-load
 - CONSULT display

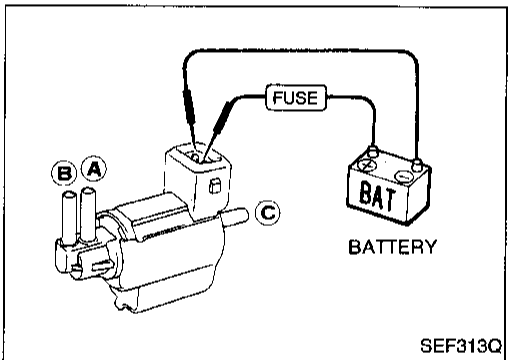
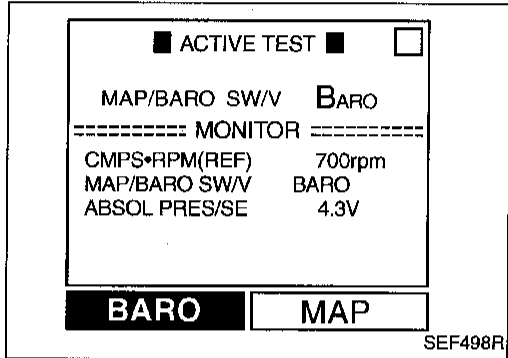
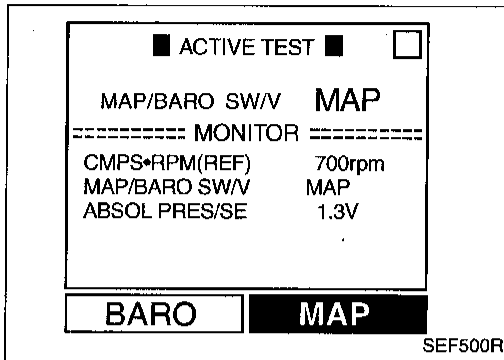

MAP/BARO	ABSOL PRES/SE (Voltage)
BARO	More than 2.6V
MAP	Less than the voltage at BARO

- Time for voltage to change

MAP/BARO SW/V	Required time to switch
BARO to MAP	Less than 1 second
MAP to BARO	

4. If NG, check solenoid valve as shown below.

OR

1. Remove MAP/BARO switch solenoid valve.
2. Check air passage continuity.

Condition	Air passage continuity between (A) and (B)	Air passage continuity between (A) and (C)
12V direct current supply between terminals (1) and (2)	Yes	No
No supply	No	Yes

3. If NG or operation takes more than 1 second, replace solenoid valve.

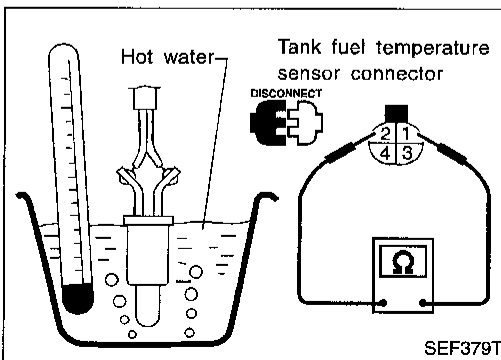

Tank fuel temperature sensor

Check resistance by heating with hot water or heat gun as shown in the figure.

Temperature °C (°F)	Resistance kΩ
20 (68)	2.3 - 2.7
50 (122)	0.79 - 0.90

If NG, replace tank fuel temperature sensor.

Evaporative Emission (EVAP) Canister Purge Volume Control Valve

SYSTEM DESCRIPTION

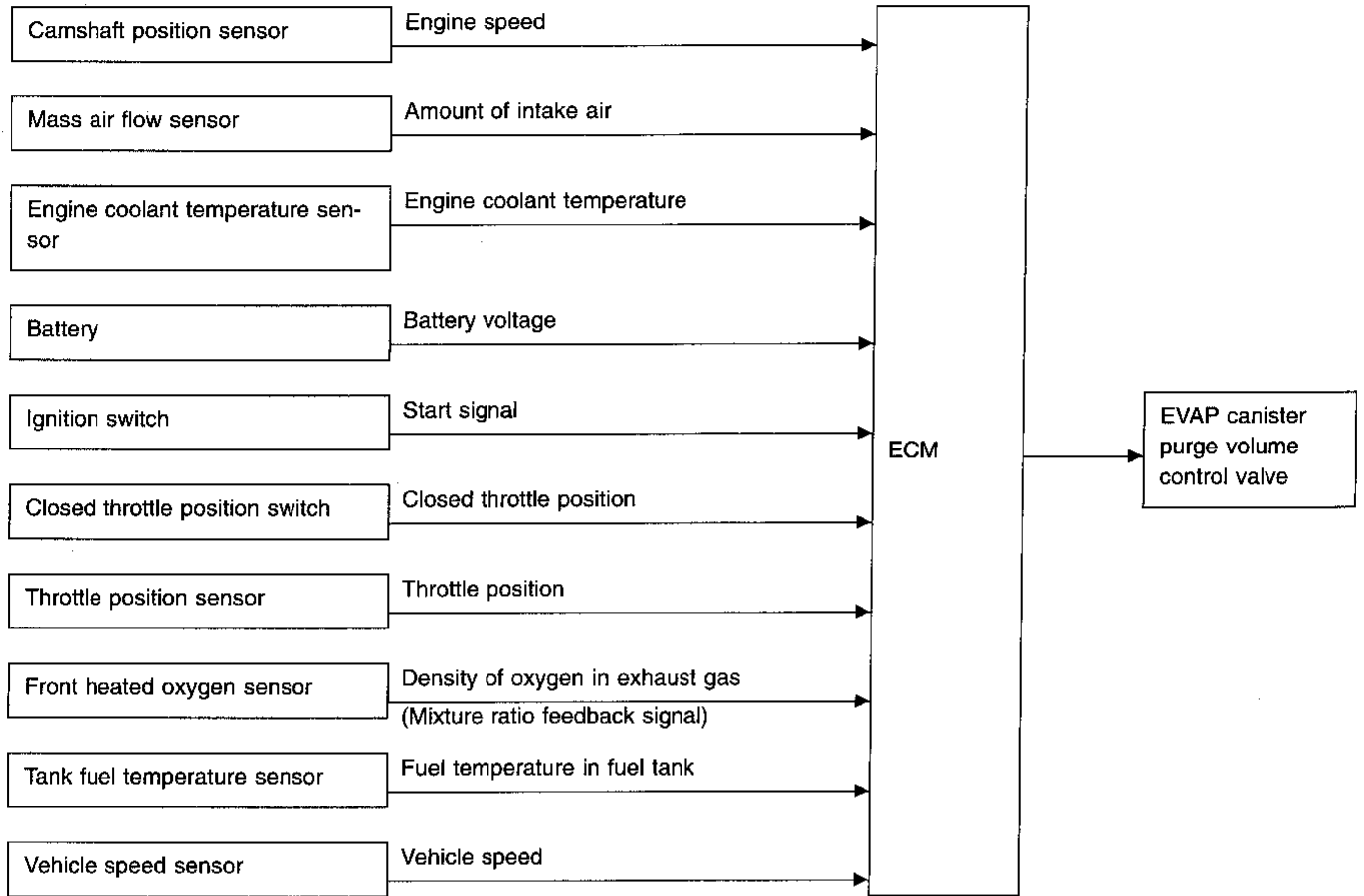

This system controls flow rate of fuel vapor from the EVAP canister. The opening of the vapor by-pass passage in the EVAP canister purge volume control valve changes to control the flow rate. A built-in step motor moves the valve in steps corresponding to the ECM output pulses. The opening of the valve varies for optimum engine control. The optimum value stored in the ECM is determined by considering various engine conditions. When the engine is operating, the flow rate of fuel vapor from the EVAP canister is regulated as the air flow changes.

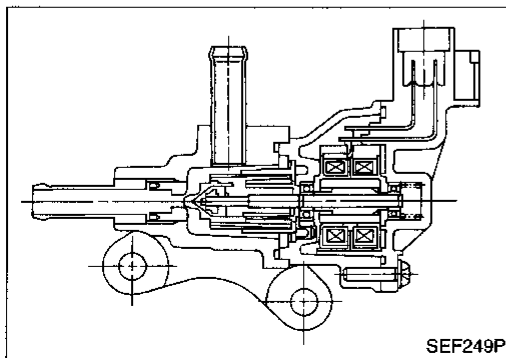

COMPONENT DESCRIPTION

The EVAP canister purge volume control valve uses a step motor to control the flow rate of fuel vapor from the EVAP canister. This motor has four winding phases. It operates according to the output pulse signal of the ECM. Two windings are turned ON and OFF in sequence. Each time an ON pulse is issued, the valve opens or closes, changing the flow rate. When no change in the flow rate is needed, the ECM does not issue the pulse signal. A certain voltage signal is issued so that the valve remains at that particular opening.

TROUBLE DIAGNOSIS FOR DTC P1444

Evaporative Emission (EVAP) Canister Purge Volume Control Valve (Cont'd)

CONSULT REFERENCE VALUE IN DATA MONITOR MODE

MONITOR ITEM	CONDITION	SPECIFICATION
PURG VOL C/V	<ul style="list-style-type: none"> ● Engine: After warming up ● No-load ● Lift up drive wheels and shift to 1st gear position. 	Idle
	More than 60 seconds after starting engine A/T models: 2,000 rpm M/T models: 2,000 rpm and more than 16 km/h (10 MPH)	0 step
		More than 1 step

ECM TERMINALS AND REFERENCE VALUE

Specification data are reference values and are measured between each terminal and engine ground.

TER-MINAL NO.	WIRE COLOR	ITEM	CONDITION	DATA (DC voltage)
5	L	EVAP canister purge volume control valve	Engine is running.	0 - 0.6V
6	G		└ Idle speed	
16	Y	EVAP canister purge volume control valve	Engine is running.	BATTERY VOLTAGE (11 - 14V)
17	OR		└ Idle speed	
56 61	W/R W/R	Power supply for ECM	Ignition switch "ON"	BATTERY VOLTAGE (11 - 14V)

ON BOARD DIAGNOSIS LOGIC

Diagnostic Trouble Code No.	Malfunction is detected when	Check Items (Possible Cause)
P1444 0214	<ul style="list-style-type: none"> ● The canister purge flow is detected during the specified driving conditions, even when EVAP canister purge volume control valve is completely closed. 	<ul style="list-style-type: none"> ● EVAP control system pressure sensor and circuit ● EVAP canister purge volume control valve (The valve is stuck open.) ● EVAP canister purge control valve ● EVAP canister ● Hoses (Hoses are connected incorrectly or clogged.) ● EVAP canister vent control valve

TROUBLE DIAGNOSIS FOR DTC P1444

Evaporative Emission (EVAP) Canister Purge Volume Control Valve (Cont'd)

■ PURG CN/V&S/V P1493 ■

THIS SUPPORT FUNCTION IS FOR DTC P1493. SEE THE SERVICE MANUAL ABOUT THE OPERATING CONDITION FOR THIS DIAGNOSIS.

EXIT START

SEF610U

■ PURG CN/V&S/V P1493 ■

***** OK *****

■ SELF-DIAG RESULTS ■

**** NO FAILURE ****

END PRINT

SEF611U

■ PURG VOL CN/V P1444 ■

THIS SUPPORT FUNCTION IS FOR DTC P1447. SEE THE SERVICE MANUAL ABOUT THE OPERATING CONDITION FOR THIS DIAGNOSIS.

EXIT START

SEF612U

■ PURG VOL CN/V P1444 ■

TESTING

===== MONITOR =====

CMPS•RPM(REF)	1687rpm
THRTL POS SEN	0.74V
B/FUEL SCHDL	2.5msec

SEF853U

■ PURG VOL CN/V P1444 ■

COMPLETED

SELF-DIAG RESULTS

SEF902U

DIAGNOSTIC TROUBLE CODE CONFIRMATION PROCEDURE

CAUTION:

Always drive vehicle at a safe speed.

NOTE:

If "DTC CONFIRMATION PROCEDURE" has been previously conducted, always turn ignition switch "OFF" and wait at least 5 seconds before conducting the next test.

TESTING CONDITION:

Always perform test at a temperature above 5°C (41°F).



- 1) Start engine and warm it up to normal operating temperature.
- 2) Turn ignition switch "OFF" and wait at least 5 seconds.
- 3) Turn ignition switch "ON".
- 4) Select "PURG CN/V & S/V P1493" of "EVAPORATIVE SYSTEM" in "DTC WORK SUPPORT" mode with CONSULT.
- 5) Touch "START".
- 6) Start engine and let it idle for at least 90 seconds.
- 7) When the following conditions are met, "TESTING" will be displayed on the CONSULT screen. Maintain the conditions continuously until "TESTING" changes to "COMPLETED". (It will take at least 30 seconds.)

Selector lever: Suitable position
Vehicle speed: 36 - 120 km/h (22 - 75 MPH)
CMPS•RPM (REF): 1,000 rpm or more
B/FUEL SCHDL: 1 - 4.5 msec

- 8) Stop vehicle with engine running.
 - 9) Select "PURG VOL CN/V P1444" of "EVAPORATIVE SYSTEM" in "DTC WORK SUPPORT" mode with CONSULT.
 - 10) Touch "START".
- If "COMPLETED" is displayed, go to step 12.
- 11) When the following conditions are met, "TESTING" will be displayed on the CONSULT screen. Maintain the conditions continuously until "TESTING" changes to "COMPLETED". (It will take at least 20 seconds.)

Selector lever: Suitable position
Vehicle speed: 36 - 120 km/h (22 - 75 MPH)
CMPS•RPM (REF): 1,000 rpm or more
B/FUEL SCHDL: 1 - 4.5 msec

NOTE:

If "TESTING" is not displayed after 5 minutes, retry from step 2).

- 12) Make sure that "OK" is displayed after touching "SELF-DIAG RESULTS". If "NG" is displayed, refer to "DIAGNOSTIC PROCEDURE", EC-398.

GI

MA

EM

LC

EC

FE

CL

MT

AT

FA

RA

BR

ST

RS

BT

HA

EL

IDX

TROUBLE DIAGNOSIS FOR DTC P1444

Evaporative Emission (EVAP) Canister Purge Volume Control Valve (Cont'd)

ENGINE SPD	825RPM
COOLANT TEMP	69°C
VEHICLE SPD	0MPH
IGN ADVANCE	8.0°
CALC LOAD	28.2%
MAP	36KPaA
MAF	5.20gm/s
THROTTLE POS	0.0%
INTAKE AIR	27°C
FUEL SYS #1	OLDRIVE
FUEL SYS #2	UNUSED
SHORT FT #1	0.8%
LONG FT #1	0.0%
O2S B1 S1	0.200V
O2FT B1 S1	0.8%
O2S B1 S2	0.010V

SEF519R

OR



- 1) Start engine and warm it up to normal operating temperature.
- 2) Select "MODE 1" with GST.
- 3) Check coolant temperature.
Coolant temperature: 40 - 100°C (104 - 212°F)
Be sure that water temperature does not exceed 100°C. If it becomes higher than 100°C, cool down the engine and perform the procedure again from the beginning.
- 4) Turn ignition switch "OFF" and wait at least 5 seconds.
- 5) Restart engine and let it idle for at least 100 seconds.
- 6) Maintain the following conditions for at least 80 seconds.
Gear position: Suitable gear position
Vehicle speed: 36 - 120 km/h (22 - 75 MPH)
Engine speed: 1,000 rpm or more
Coolant temperature: 40 - 100°C (104 - 212°F)
- 7) Select "MODE 7" with GST.
- 8) If 1st trip DTC is detected, go to "DIAGNOSTIC PROCEDURE", EC-398.

NOTE:

- Hold the accelerator pedal as steady as possible during driving in step 6.
- If the driving conditions are not satisfied in step 6, restart the procedure.
- It is better that the fuel level is low.

OR

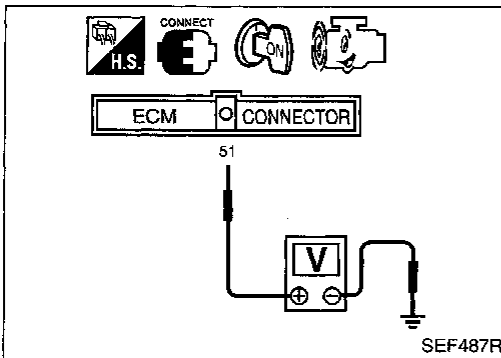

- 1) Start engine and warm it up to normal operating temperature.
- 2) Check voltage between ECM terminal ⑤ and ground
Voltage: 0.8 - 1.5V
Perform the following procedure before the voltage drops below 0.8V. If the voltage drops below 0.8V, cool down the engine and perform the procedure again from the beginning.
- 3) Turn ignition switch "OFF" and wait at least 5 seconds.
- 4) Restart engine and let it idle for at least 100 seconds.
- 5) Maintain the following conditions for at least 80 seconds.
Gear position: Suitable gear position
Vehicle speed: 36 - 120 km/h (22 - 75 MPH)
Engine speed: 1,000 rpm or more
Check voltage between ECM terminal ⑤ and ground: 0.8 - 1.5 V
- 6) Turn ignition switch "OFF", wait at least 5 seconds, and then turn "ON".
- 7) Perform "Diagnostic Test Mode II (Self-diagnostic results)" with ECM.

TROUBLE DIAGNOSIS FOR DTC P1444

Evaporative Emission (EVAP) Canister Purge Volume Control Valve (Cont'd)

8) If 1st trip DTC is detected, go to "DIAGNOSTIC PROCEDURE", EC-398.

NOTE:

- Hold the accelerator pedal as steady as possible during driving in step 5.
- If the driving conditions are not satisfied in step 5, restart the procedure.
- It is better that the fuel level is low.

GI

MA

EM

LC

EC

FE

CL

MT

AT

FA

RA

BR

ST

RS

BT

HA

EL

IDX

TROUBLE DIAGNOSIS FOR DTC P1444

Evaporative Emission (EVAP) Canister Purge Volume Control Valve (Cont'd)

DIAGNOSTIC PROCEDURE

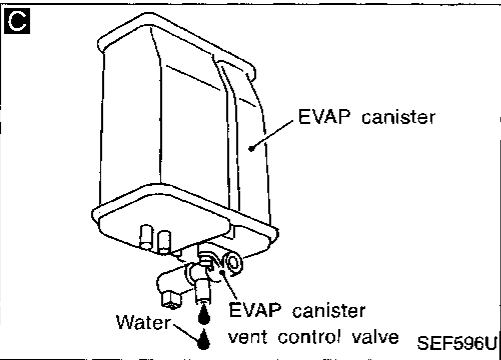
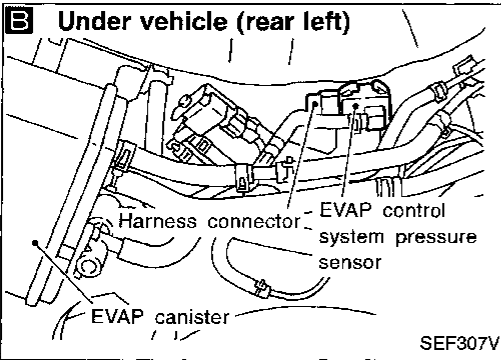
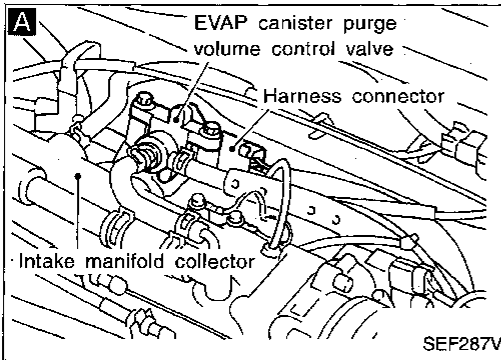

INSPECTION START

A
CHECK COMPONENT
(EVAP canister purge volume control valve).
Refer to "COMPONENT INSPECTION" on next page.

NG → Replace EVAP canister purge volume control valve.

B
CHECK COMPONENT AND CIRCUIT
(EVAP control system pressure sensor).
1. Check disconnection of hose connected to the sensor.
2. Check sensor harness connector for water.
Water should not exist.
If OK, go to step 3.
3. Check EVAP control system pressure sensor.
Refer to "COMPONENT INSPECTION", EC-400 and EC-310.

NG → Replace EVAP control system pressure sensor and repair or replace harness and connector.

C
CHECK COMPONENT
(EVAP canister vent control valve).
Refer to "COMPONENT INSPECTION", EC-400.

NG → Replace EVAP canister vent control valve.

C
CHECK RUBBER TUBE FOR CLOGGING.
Check obstructed water separator, improper connection of hose and rubber tube to EVAP canister vent control valve and clean the rubber tube using air blower.
For water separator, refer to "COMPONENT INSPECTION", EC-405.

NG → Clean, repair or replace rubber tube and/or water separator.

C
CHECK IF EVAP CANISTER IS SATURATED WITH WATER.
1. Remove EVAP canister with EVAP canister vent control valve attached.
2. Check if water will drain from the EVAP canister. If it will, weigh the EVAP canister with the vent control valve attached.
If the weight is:
More than 1.8 kg (4.0 lb) → NG
Less than 1.8 kg (4.0 lb) → OK

NG → Replace EVAP canister and check the following.
1. Check hose connections to the EVAP canister and water separator for clogging and poor connection.
2. Check water separator. Refer to "COMPONENT INSPECTION", EC-405. If NG, repair or replace water separator.

Perform "TROUBLE DIAGNOSIS FOR INTERMITTENT INCIDENT", EC-106.

INSPECTION END

TROUBLE DIAGNOSIS FOR DTC P1444

Evaporative Emission (EVAP) Canister Purge Volume Control Valve (Cont'd)

COMPONENT INSPECTION

EVAP canister purge volume control valve

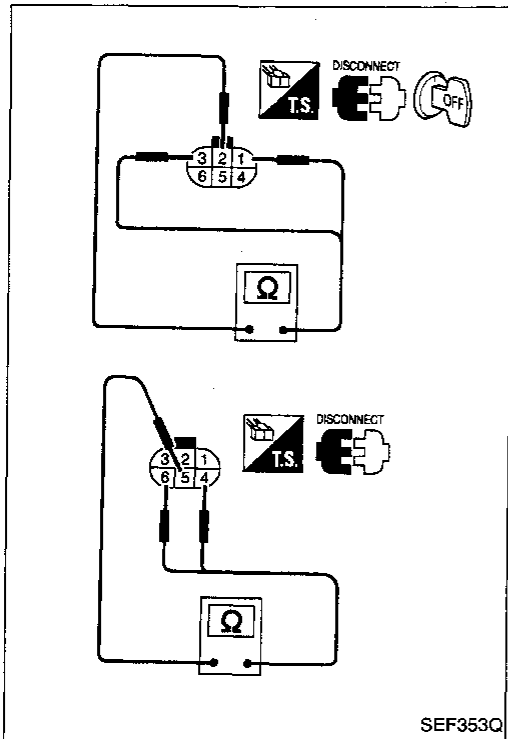

SEF353Q

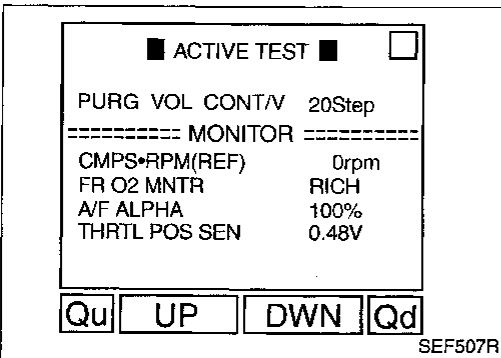

SEF507R

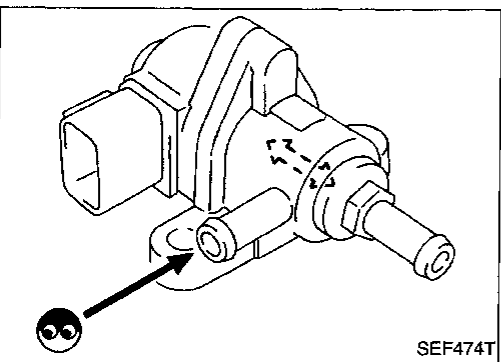

SEF474T

1. Disconnect EVAP canister purge volume control valve harness connector.
 2. Check resistance between the following terminals.
terminal ② and terminals ①, ③
terminal ⑤ and terminals ④, ⑥
Resistance:
35 - 43Ω [At 20°C (68°F)]
 3. Reconnect EVAP canister purge volume control valve harness connector.
 4. Remove EVAP canister purge volume control valve from intake manifold collector and disconnect hoses from the valve.
(Plug the purge hoses. The EVAP canister purge volume control valve harness connector should remain connected.)
 5. Turn ignition switch "ON".
 6. Perform "PURG VOL CONT/V" in "ACTIVE TEST" mode with CONSULT. Check that EVAP canister purge volume control valve shaft moves smoothly forward and backward according to the valve opening.
- If NG, replace the EVAP canister purge volume control valve.

OR

1. Disconnect EVAP canister purge volume control valve harness connector.
 2. Check resistance between the following terminals.
terminal ② and terminals ①, ③
terminal ⑤ and terminals ④, ⑥
Resistance:
35 - 43Ω [At 20°C (68°F)]
 3. Reconnect EVAP canister purge volume control valve harness connector.
 4. Remove EVAP canister purge volume control valve from intake manifold collector and disconnect hoses from the valve.
(Plug the purge hoses. The EVAP canister purge volume control valve harness connector should remain connected.)
 5. Turn ignition switch "ON" and "OFF". Check that EVAP canister purge volume control valve shaft moves smoothly forward and backward according to the ignition switch position.
- If NG, replace the EVAP canister purge volume control valve.

GI
MA
EM
LC
EC
FE
CL
MT
AT
FA
RA
BR
ST
RS
BT
HA
EL
IDX

TROUBLE DIAGNOSIS FOR DTC P1444

Evaporative Emission (EVAP) Canister Purge Volume Control Valve (Cont'd)

COMPONENT INSPECTION

EVAP control system pressure sensor

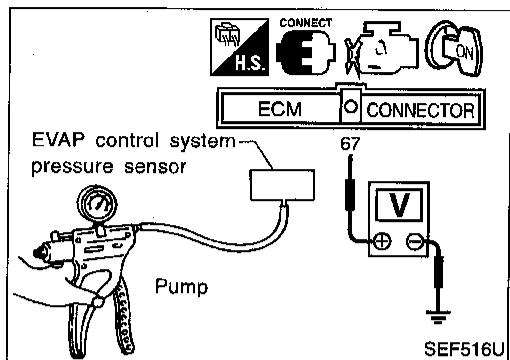

1. Remove EVAP control system pressure sensor with its harness connector connected.
2. Remove hose from EVAP control system pressure sensor.
3. Use pump to apply vacuum and pressure to EVAP control system pressure sensor as shown in figure.
4. Check output voltage between ECM terminal 67 and engine ground.

Pressure (Relative to atmospheric pressure)	Voltage (V)
0 kPa (0 mmHg, 0 inHg)	3.0 - 3.6
-9.3 kPa (-70 mmHg, -2.76 inHg)	0.4 - 0.6

CAUTION:

- Always calibrate the vacuum pump gauge when using it.
- Do not apply below -20 kPa (-150 mmHg, -5.91 inHg) or over 20 kPa (150 mmHg, 5.91 inHg) of pressure.
- 5. If NG, replace EVAP control system pressure sensor.

EVAP canister vent control valve

Check air passage continuity.

- Perform "VENT CONTROL/V" in "ACTIVE TEST" mode with CONSULT.

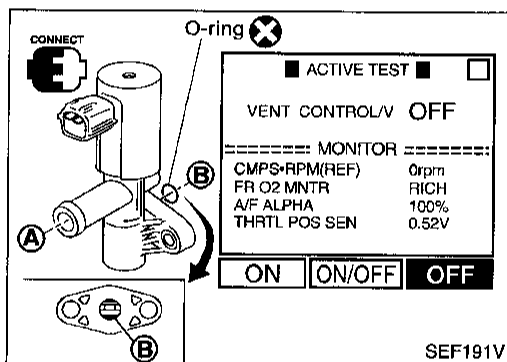

Condition	Air passage continuity between (A) and (B)
VENT CONTROL/V ON	No
VENT CONTROL/V OFF	Yes

OR

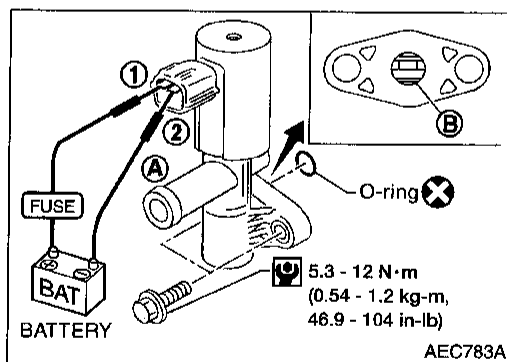

Condition	Air passage continuity between (A) and (B)
12V direct current supply between terminals 1 and 2	No
No supply	Yes

If NG or operation takes more than 1 second, clean valve using air blower or replace as necessary.

If the portion (B) is rusted, replace EVAP canister vent control valve.

Make sure new O-ring is installed properly.

TROUBLE DIAGNOSIS FOR DTC P1446

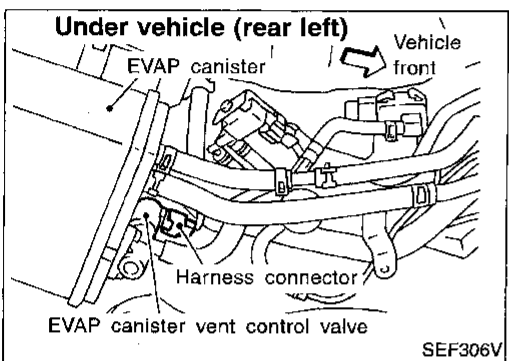
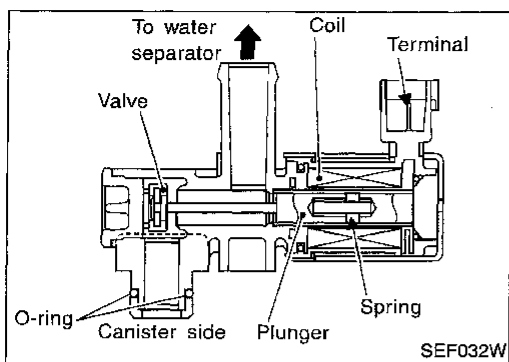

Evaporative Emission (EVAP) Canister Vent Control Valve (Close)

COMPONENT DESCRIPTION

The EVAP canister vent control valve is located on the EVAP canister and is used to seal the canister vent.

This solenoid (the EVAP canister vent control valve) responds to signals from the ECM.

When the ECM sends an ON signal, the coil in the solenoid valve is energized.

A plunger will then move to seal the canister vent. The ability to seal the vent is necessary for the on board diagnosis of other evaporative emission control system components.

This solenoid valve is used only for diagnosis, and usually remains opened.

When the vent is closed, under normal purge conditions, the evaporative emission control system is depressurized and allows "EVAP Control System (Small Leak)" diagnosis.

CONSULT REFERENCE VALUE IN DATA MONITOR MODE

Specification data are reference values.

MONITOR ITEM	CONDITION	SPECIFICATION
VENT CONT/V	● Ignition switch: ON	OFF

ECM TERMINALS AND REFERENCE VALUE

Specification data are reference values and are measured between each terminal and engine ground.

TER-MINAL NO.	WIRE COLOR	ITEM	CONDITION	DATA (DC voltage)
108	PU/W	EVAP canister vent control valve	Ignition switch "ON"	BATTERY VOLTAGE (11 - 14V)

ON BOARD DIAGNOSIS LOGIC

Diagnostic Trouble Code No.	Malfunction is detected when	Check Items (Possible Cause)
P1446 0215	● EVAP canister vent control valve remains closed under specified driving conditions.	<ul style="list-style-type: none"> ● EVAP canister vent control valve ● EVAP control system pressure sensor and the circuit ● Blocked rubber tube to EVAP canister vent control valve ● Water separator ● EVAP canister is saturated with water.

GI

MA

EM

LC

EC

FE

CL

MT

AT

FA

RA

BR

ST

RS

BT

HA

EL

IDX

TROUBLE DIAGNOSIS FOR DTC P1446

4	★ MONITOR	★ NO FAIL	<input type="checkbox"/>
	CMPS•RPM(REF)	2300rpm	
	COOLAN TEMP/S	85°C	
	VHCL SPEED SEN	80km/h	
	THRTL POS SEN	1.68V	
	B/FUEL SCHDL	1.8msec	

SEF725W

Evaporative Emission (EVAP) Canister Vent Control Valve (Close) (Cont'd)

DIAGNOSTIC TROUBLE CODE CONFIRMATION PROCEDURE

CAUTION:

Always drive vehicle at a safe speed.

NOTE:

If "DIAGNOSTIC TROUBLE CODE CONFIRMATION PROCEDURE" has been previously conducted, always turn ignition switch "OFF" and wait at least 5 seconds before conducting the next test.



- 1) Turn ignition switch "ON".
- 2) Select "DATA MONITOR" mode with CONSULT.
- 3) Start engine.
- 4) Drive vehicle at a speed of approximately 80 km/h (50 MPH) for a maximum of 15 minutes.
- 5) If 1st trip DTC is detected, go to "DIAGNOSTIC PROCEDURE", EC-403.

NOTE:

If a malfunction exists, NG result may be displayed quicker.

OR



- 1) Start engine.
- 2) Drive vehicle at a speed of approximately 80 km/h (50 MPH) for 15 minutes.
- 3) Select "MODE 7" with GST.
- 4) If 1st trip DTC is detected, go to "DIAGNOSTIC PROCEDURE", EC-403.

OR



- 1) Start engine.
- 2) Drive vehicle at a speed of approximately 80 km/h (50 MPH) for 15 minutes.
- 3) Turn ignition switch "OFF" and wait at least 5 seconds.
- 4) Turn ignition switch "ON" and perform "Diagnostic Test Mode II (Self-diagnostic results)" with ECM.
- 5) If 1st trip DTC is detected, go to "DIAGNOSTIC PROCEDURE", EC-403.

TROUBLE DIAGNOSIS FOR DTC P1446

Evaporative Emission (EVAP) Canister Vent Control Valve (Close) (Cont'd)

DIAGNOSTIC PROCEDURE

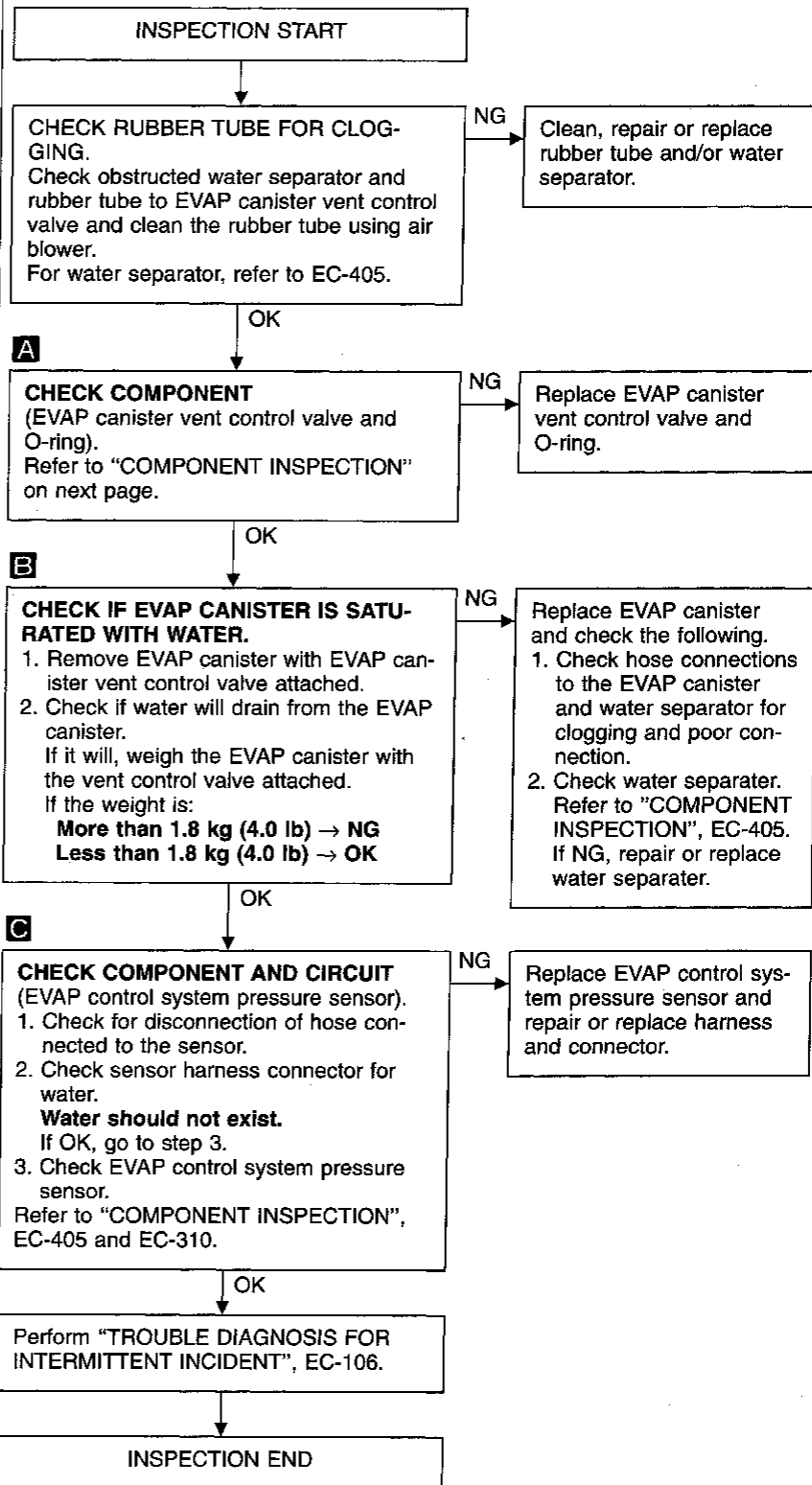
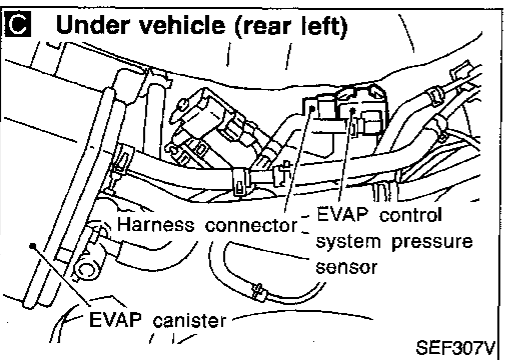
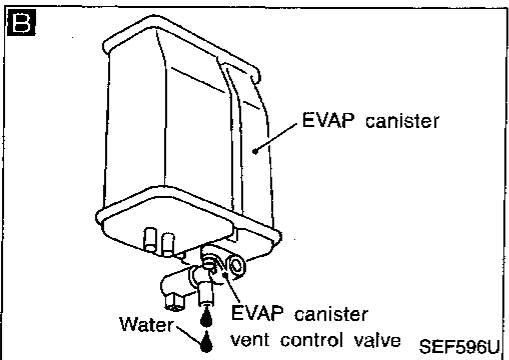
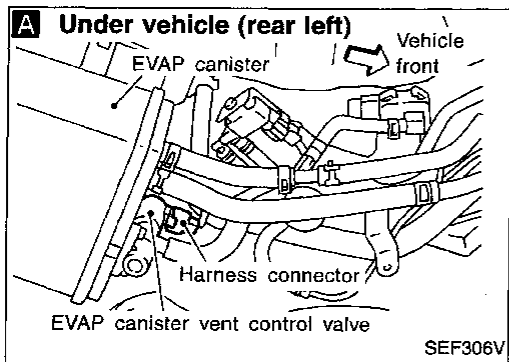

GI

MA

EM

LC

EC

FE

CL

MT

AT

FA

RA

BR

ST

RS

BT

HA

EL

IDX

TROUBLE DIAGNOSIS FOR DTC P1446

Evaporative Emission (EVAP) Canister Vent Control Valve (Close) (Cont'd)

COMPONENT INSPECTION

EVAP canister vent control valve

Check air passage continuity.

① Perform "VENT CONTROL/V" in "ACTIVE TEST" mode.

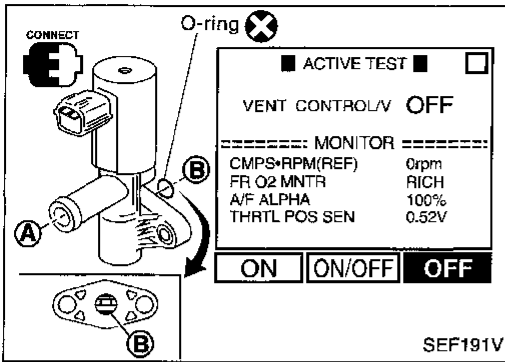

Condition VENT CONTROL/V	Air passage continuity between ① and ②
ON	No
OFF	Yes

OR

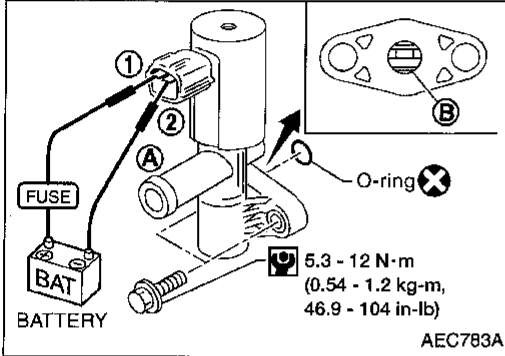

Condition	Air passage continuity between ① and ②
12V direct current supply between terminals ① and ②	No
No supply	Yes

If NG or operation takes more than 1 second, clean valve using air blower or replace as necessary.

If the portion ② is rusted, replace EVAP canister vent control valve.

Make sure new O-ring is installed properly.

TROUBLE DIAGNOSIS FOR DTC P1446

Evaporative Emission (EVAP) Canister Vent Control Valve (Close) (Cont'd)

EVAP control system pressure sensor

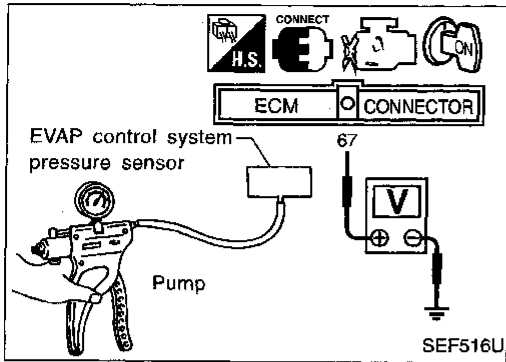

1. Remove EVAP control system pressure sensor with its harness connector connected.
2. Remove hose from EVAP control system pressure sensor.
3. Use pump to apply vacuum and pressure to EVAP control system pressure sensor as shown in figure.
4. Check output voltage between ECM terminal 67 and engine ground.

Pressure (Relative to atmospheric pressure)	Voltage (V)
0 kPa (0 mmHg, 0 inHg)	3.0 - 3.6
-9.3 kPa (-70 mmHg, -2.76 inHg)	0.4 - 0.6

CAUTION:

- Always calibrate the vacuum pump gauge when using it.
 - Do not apply below -20 kPa (-150 mmHg, -5.91 inHg) or over 20 kPa (150 mmHg, 5.91 inHg) of pressure.
5. If NG, replace EVAP control system pressure sensor.

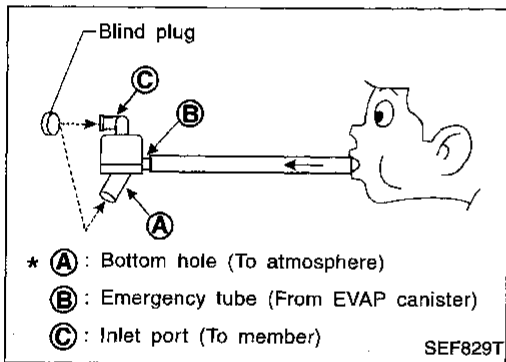

Water separator

1. Check visually for insect nests in the water separator air inlet.
 2. Check visually for cracks or flaws in the appearance.
 3. Check visually for cracks or flaws in the hose.
 4. Check that (A) and (C) are not clogged by blowing air into (B) with (A), and then (C) plugged.
 5. In case of NG in items 2 - 4, replace the parts.
- Do not disassemble water separator.

TROUBLE DIAGNOSIS FOR DTC P1447

Evaporative Emission (EVAP) Control System Purge Flow Monitoring

Note: If DTC P1447 is displayed with P0510, perform TROUBLE DIAGNOSIS FOR DTC P0510 first.
(See EC-325.)

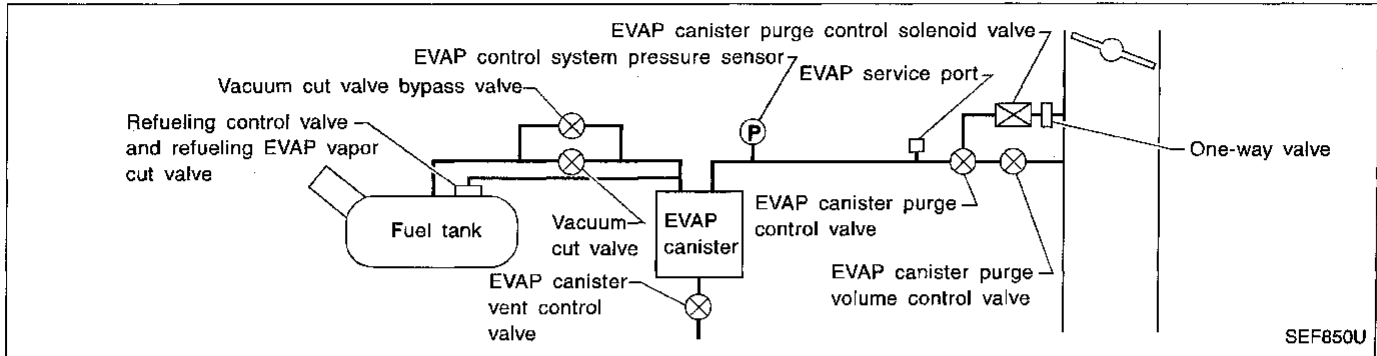

SYSTEM DESCRIPTION

In this evaporative emission (EVAP) control system, purge flow occurs during non-vehicle stopped conditions (M/T models) and non-closed throttle conditions. Purge volume is related to air intake volume. Under normal purge conditions (non-closed throttle), the EVAP canister purge volume control valve and EVAP canister purge control valve are open. Purge flow exposes the EVAP control system pressure sensor to intake manifold vacuum.

ON BOARD DIAGNOSIS LOGIC

Under normal conditions (non-closed throttle), sensor output voltage indicates if pressure drop and purge flow are adequate. If not, a fault is determined.

Diagnostic Trouble Code No.	Malfunction is detected when	Check Items (Possible Cause)
P1447 0111	<ul style="list-style-type: none"> ● EVAP control system does not operate properly. ● EVAP control system has a leak between intake manifold and EVAP control system pressure sensor. 	<ul style="list-style-type: none"> ● EVAP canister purge volume control valve stuck closed ● EVAP canister purge control valve stuck closed ● EVAP control system pressure sensor ● Loose, disconnected or improper connection of rubber tube ● Blocked rubber tube ● EVAP canister purge control solenoid valve ● Blocked or bent rubber tube to MAP/BARO switch solenoid valve ● Cracked EVAP canister ● Closed throttle position switch ● Improper connection of one-way valve ● Blocked purge port ● EVAP canister vent control valve

TROUBLE DIAGNOSIS FOR DTC P1447

Evaporative Emission (EVAP) Control System Purge Flow Monitoring (Cont'd)

DIAGNOSTIC TROUBLE CODE CONFIRMATION PROCEDURE

CAUTION:

Always drive vehicle at a safe speed.

NOTE:

If "DIAGNOSTIC TROUBLE CODE CONFIRMATION PROCEDURE" has been previously conducted, always turn ignition switch "OFF" and wait at least 5 seconds before conducting the next test.

TESTING CONDITION:

Always perform test at a temperature above 5°C (41°F).

- 1) Start engine and warm it up to normal operating temperature.
- 2) Turn ignition switch "OFF" and wait at least 5 seconds.
- 3) Start engine and let it idle for at least 1 minute.
- 4) Select "PURG CN/V & S/V P1493" of "EVAPORATIVE SYSTEM" in "DTC WORK SUPPORT" mode with CONSULT.
- 5) Touch "START".
- 6) When the following conditions are met, "TESTING" will be displayed on the CONSULT screen. Maintain the conditions continuously until "TESTING" changes to "COMPLETED". (It will take at least 30 seconds.)
CMPS-RPM (REF): 1,000 rpm or more
Selector lever: Suitable position
Vehicle speed: 36 - 120 km/h (22 - 75 MPH)
B/FUEL SCHDL: 1 - 4.5 msec
 If "TESTING" is not displayed after 5 minutes, retry from step 2).
- 7) Make sure that "OK" is displayed after touching "SELF-DIAG RESULTS" and go to the following step. If "NG" is displayed, refer to "DIAGNOSTIC PROCEDURE" of "TROUBLE DIAGNOSIS FOR DTC P1493", EC-438.
- 8) Select "PURG VOL CN/V P1444" of "EVAPORATIVE SYSTEM" in "DTC WORK SUPPORT" mode with CONSULT.
- 9) Touch "START".
 If "COMPLETED" is displayed, go to step 11.
- 10) When the following conditions are met, "TESTING" will be displayed on the CONSULT screen. Maintain the conditions continuously until "TESTING" changes to "COMPLETED". (It will take at least 20 seconds.)
CMPS-RPM (REF): 1,000 rpm or more
Selector lever: Suitable position
Vehicle speed: 36 - 120 km/h (22 - 75 MPH)
B/FUEL SCHDL: 1 - 4.5 msec
 If "TESTING" is not displayed after 5 minutes, retry from step 2).

■ PURG CN/V&S/V P1493 ■

THIS SUPPORT FUNCTION IS FOR DTC P1493. SEE THE SERVICE MANUAL ABOUT THE OPERATING CONDITION FOR THIS DIAGNOSIS.

EXIT START

SEF610U

■ PURG CN/V&S/V P1493 ■

***** OK *****

■ SELF-DIAG RESULTS ■

**** NO FAILURE ****

END PRINT

SEF611U

■ PURG VOL CN/V P1444 ■

THIS SUPPORT FUNCTION IS FOR DTC P1447. SEE THE SERVICE MANUAL ABOUT THE OPERATING CONDITION FOR THIS DIAGNOSIS.

EXIT START

SEF612U

■ PURG VOL CN/V P1444 ■

COMPLETED

SELF-DIAG RESULTS

SEF902U

GI

MA

EM

LC

EC

FE

CL

MT

AT

FA

RA

BR

ST

RS

BT

HA

EL

IDX

TROUBLE DIAGNOSIS FOR DTC P1447

Evaporative Emission (EVAP) Control System Purge Flow Monitoring (Cont'd)

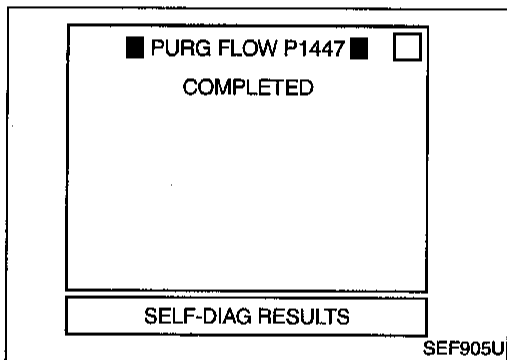
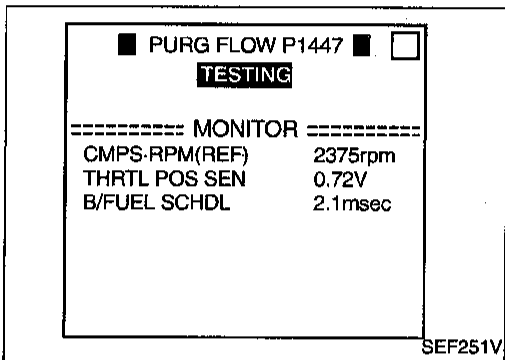
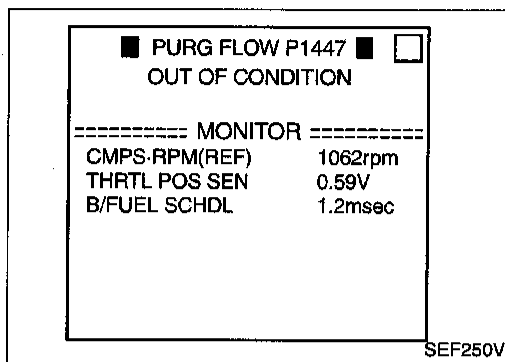

11) Make sure that "OK" is displayed after touching "SELF-DIAG RESULTS" and go to the following step. If "NG" is displayed, refer to "DIAGNOSTIC PROCEDURE" of "TROUBLE DIAGNOSIS FOR DTC P1444", EC-393.

12) Select "PURG FLOW P1447" of "EVAPORATIVE SYSTEM" in "DTC CONFIRMATION" mode with CONSULT.

13) Touch "START".

14) When the following conditions are met, "TESTING" will be displayed on the CONSULT screen. Maintain the conditions continuously until "TESTING" changes to "COMPLETED". (It will take at least 35 seconds.)

Selector lever: Suitable position

Vehicle speed: 36 - 120 km/h (22 - 75 MPH)

CMPS-RPM (REF): 1,000 rpm or more

Engine coolant temperature: 70 - 100°C

(158 - 212°F)

If "TESTING" is not displayed after 5 minutes, retry from step 2).

15) Make sure that "OK" is displayed after touching "SELF-DIAG RESULTS". If "NG" is displayed, refer to "DIAGNOSTIC PROCEDURE", EC-410.

TROUBLE DIAGNOSIS FOR DTC P1447

Evaporative Emission (EVAP) Control System Purge Flow Monitoring (Cont'd)

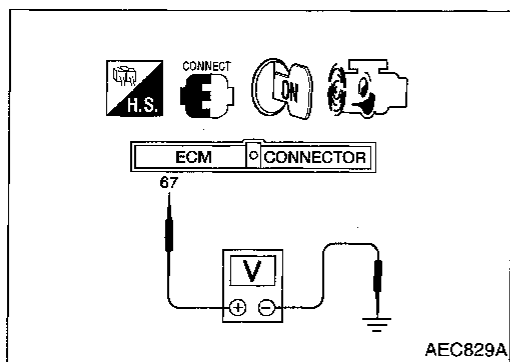

OR OVERALL FUNCTION CHECK

Use this procedure to check the overall monitoring function of the EVAP control system purge flow. During this check, a 1st trip DTC might not be confirmed.

- 1) Start engine and warm it up to normal operating temperature.
- 2) Turn ignition switch "OFF", wait at least 5 seconds.
- 3) Start engine and wait at least 70 seconds.
- 4) Set voltmeter probes to ECM terminal 67 (EVAP control system pressure sensor signal) and ground.
- 5) Check EVAP control system pressure sensor value at idle speed.
- 6) Establish and maintain the following conditions for at least 1 minute.

Air conditioner switch: ON

Steering wheel: Fully turned

Headlamp switch: ON

Rear window defogger switch: ON

Engine speed: Approx. 3,000 rpm

Gear position:

M/T models

Any position other than "Neutral" or "Reverse"

A/T models

Any position other than "P", "N" or "R"

Verify that EVAP control system pressure sensor value stays 0.1V less than the value at idle speed for at least 1 second.

- 7) If NG, go to "DIAGNOSTIC PROCEDURE", EC-410.

GI

MA

EM

LC

EC

FE

CL

MT

AT

FA

RA

BR

ST

RS

BT

HA

EL

IDX

TROUBLE DIAGNOSIS FOR DTC P1447

Evaporative Emission (EVAP) Control System Purge Flow Monitoring (Cont'd) DIAGNOSTIC PROCEDURE

A

■ ACTIVE TEST ■		<input type="checkbox"/>
PURG CONT S/V (PURG CONT VAC)	<input type="radio"/> N VC ON	
===== MONITOR =====		
PURG CONT S/V	ON	
CMPS•RPM(REF)	2000rpm	
CLSD THL/P SW	OFF	
COOLANT TEMP/S	84°C	
ON	ON/OFF	OFF

SEF516T

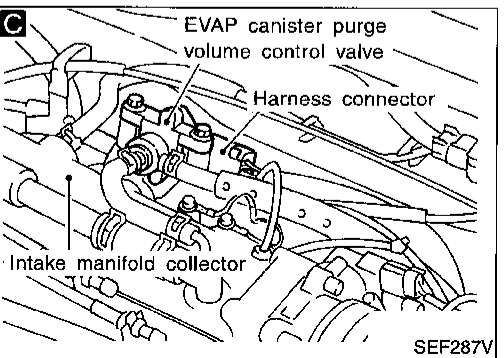
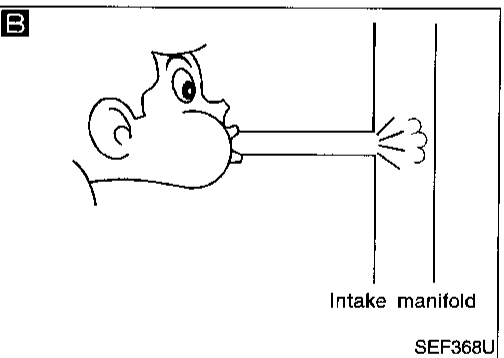
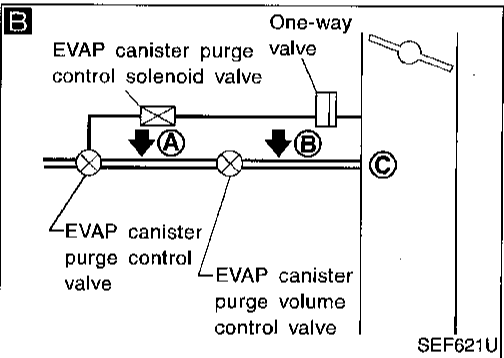
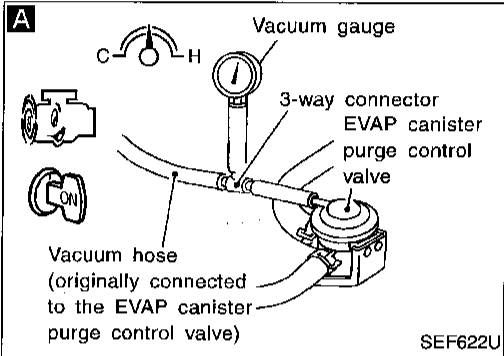

INSPECTION START

CHECK EVAP CANISTER.
Check EVAP canister for cracks.

NG → Replace EVAP canister.

OK ↓

A

CHECK PURGE FLOW.

1. Disconnect vacuum hose from EVAP canister purge control valve and install vacuum gauge.
2. Start engine and let it idle.
3. Perform "PURG CONT S/V" in "ACTIVE TEST" mode.
4. Rev engine up to 2,000 rpm.
5. Select "ON" and "OFF" on CONSULT screen to turn on "PURG CONT/V S/V".

ON: Vacuum should exist.
OFF: Vacuum should not exist.

OR

1. Start engine and warm it up to normal operating temperature.
2. Stop engine.
3. Lift up drive wheels.
4. Disconnect vacuum hose from EVAP canister purge volume control valve and install vacuum gauge.
5. Start engine and let it idle for at least 60 seconds.
6. Check vacuum hose for vacuum when revving engine up to 2,000 rpm.
7. Release the accelerator pedal and let idle.

While operating solenoid valve, vacuum should exist.
Vacuum should not exist.

B

CHECK EVAP PURGE LINE.
Check EVAP purge line for improper connection, disconnection and blocked purge port.

1. Turn ignition switch "OFF".
2. Disconnect purge hoses connected to EVAP canister purge control valve (A) and EVAP canister purge volume control valve (B).
3. Blow air into each hose and make sure air flows freely.
4. Check EVAP purge port (C).
5. Check improper connection of one-way valve. Refer to "COMPONENT INSPECTION", EC-414.

If NG, reconnect one-way valve properly or repair or clean hoses and/or purge port.

OK ↓

CHECK COMPONENT
(EVAP canister purge control solenoid valve).
Refer to "COMPONENT INSPECTION", EC-413.

C

CHECK COMPONENT
(EVAP canister purge volume control valve).
Refer to "COMPONENT INSPECTION", EC-412.

NG → Replace EVAP canister purge volume control valve.

OK ↓

(Go to next page.)

TROUBLE DIAGNOSIS FOR DTC P1447

Evaporative Emission (EVAP) Control System Purge Flow Monitoring (Cont'd)

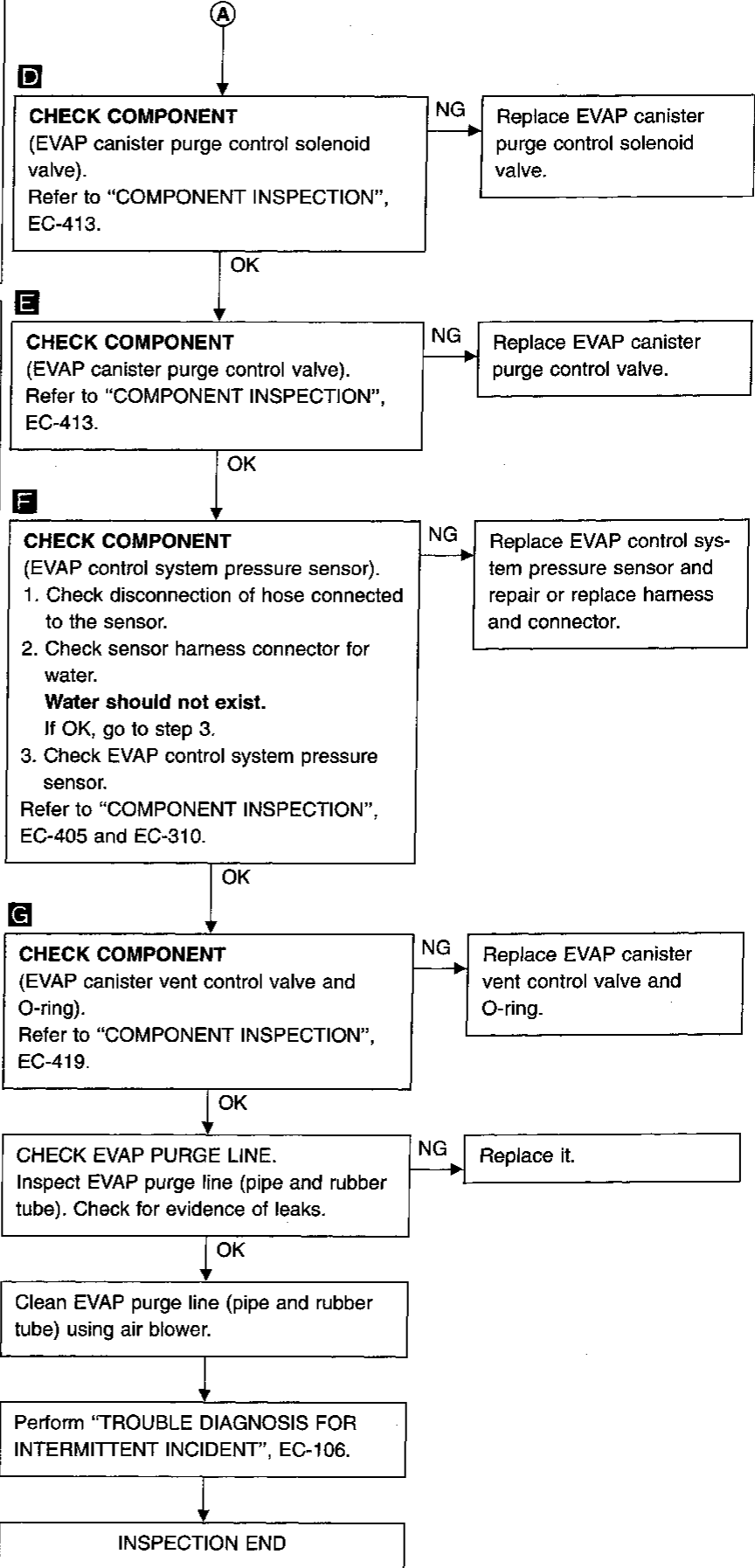
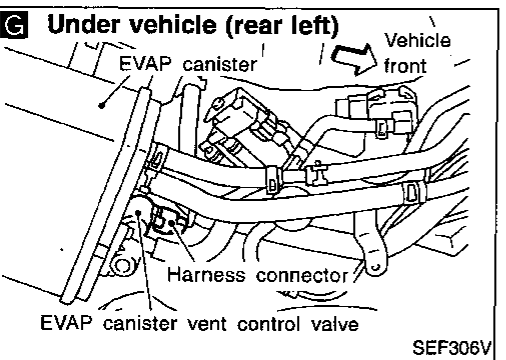
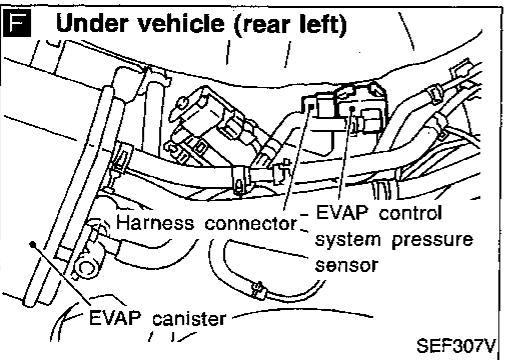
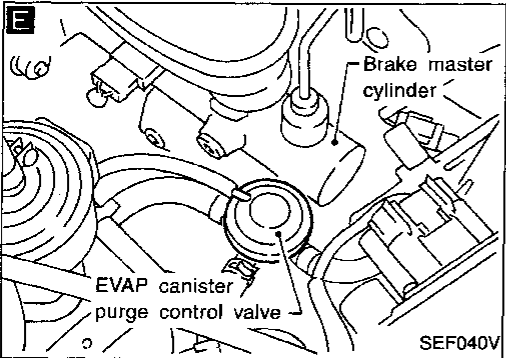
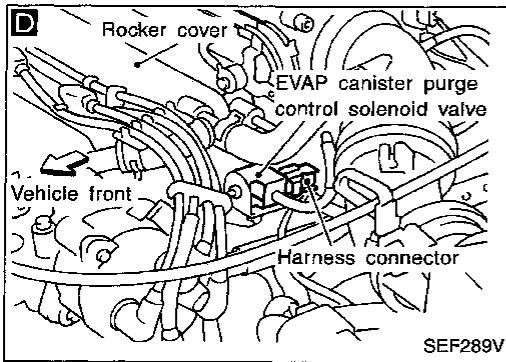

GI
MA
EM
LC
EC
FE
CL
MT
AT
FA
RA
BR
ST
RS
BT
HA
EL
IDX

TROUBLE DIAGNOSIS FOR DTC P1447

Evaporative Emission (EVAP) Control System Purge Flow Monitoring (Cont'd)

COMPONENT INSPECTION

EVAP canister purge volume control valve

- 1) Disconnect EVAP canister purge volume control valve harness connector.
- 2) Check resistance between the following terminals.
terminal ② and terminals ①, ③
terminal ⑤ and terminals ④, ⑥

Resistance:

35 - 43Ω [At 20°C (68°F)]

- 3) Reconnect EVAP canister purge volume control valve harness connector.
- 4) Remove EVAP canister purge volume control valve from intake manifold collector and disconnect hoses from the valve.
(Plug the purge hoses. The EVAP canister purge volume control valve harness connector should remain connected.)
- 5) Turn ignition switch "ON".
- 6) Perform "PURG VOL CONT/V" in "ACTIVE TEST" mode with CONSULT. Check that EVAP canister purge volume control valve shaft moves smoothly forward and backward according to the valve opening.
If NG, replace the EVAP canister purge volume control valve.

OR

- 1) Disconnect EVAP canister purge volume control valve harness connector.
- 2) Check resistance between the following terminals.
terminal ② and terminals ①, ③
terminal ⑤ and terminals ④, ⑥

Resistance:

35 - 43Ω [At 20°C (68°F)]

- 3) Reconnect EVAP canister purge volume control valve harness connector.
- 4) Remove EVAP canister purge volume control valve from intake manifold collector and disconnect hoses from the valve.
(Plug the purge hoses. The EVAP canister purge volume control valve harness connector should remain connected.)
- 5) Turn ignition switch "ON" and "OFF". Check that EVAP canister purge volume control valve shaft moves smoothly forward and backward according to the ignition switch position.
If NG, replace the EVAP canister purge volume control valve.

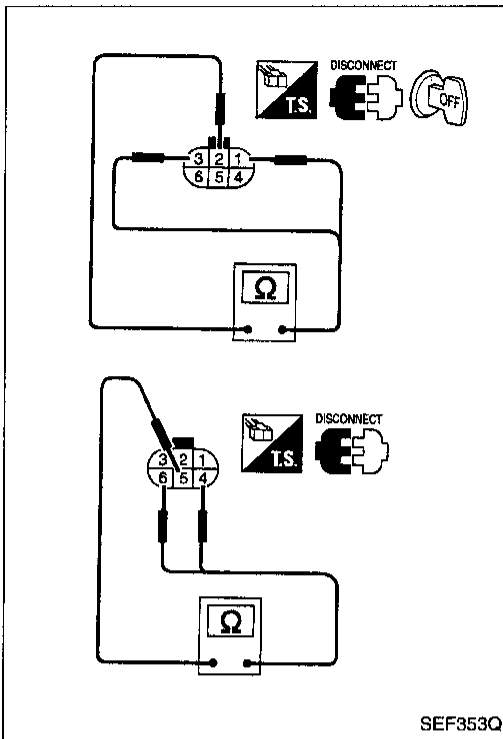

SEF353Q

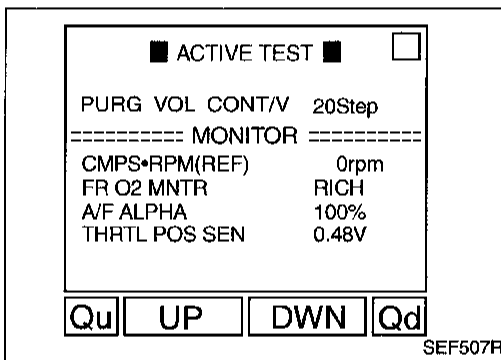

SEF507R

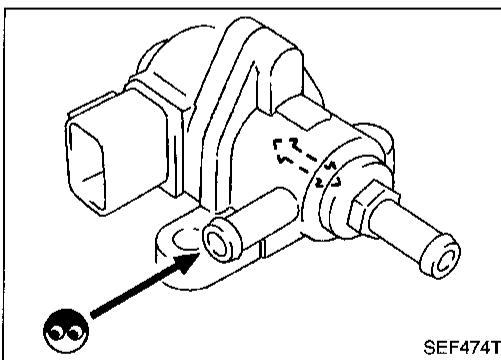

SEF474T

TROUBLE DIAGNOSIS FOR DTC P1447

Evaporative Emission (EVAP) Control System Purge Flow Monitoring (Cont'd)

EVAP canister purge control valve

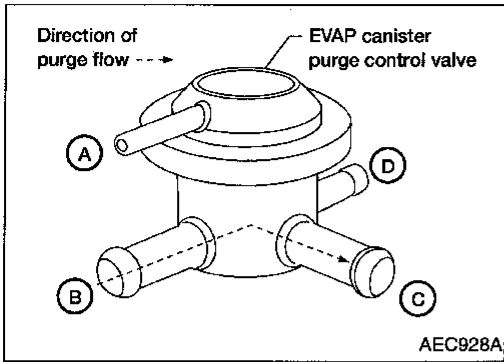

Check EVAP canister purge control valve as follows:

1. Blow air in port **(A)** and **(C)** and ensure that there is no leakage.
2. Plug port **(D)** and blow air in port **(B)**. Ensure that there is resistance to flow out of port **(C)**.
3. Plug port **(B)** and blow air in port **(D)**. Ensure that there is resistance to flow out of port **(C)**.
4. Apply vacuum to port **(A)** [approximately -13.3 to -20.0 kPa (-100 to -150 mmHg, -3.94 to -5.91 inHg)]. Plug port **(D)** and blow air in port **(C)** and ensure free flow out of port **(B)**. Plug port **(B)** and blow air in port **(C)** and ensure free flow out of port **(D)**.

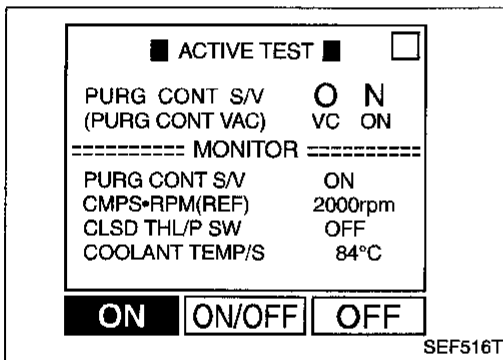

EVAP canister purge control solenoid valve

1. Lift up driving wheels (M/T models only).
2. Turn ignition switch "ON".
3. Select "PURG CONT S/V" of "ACTIVE TEST" mode with CONSULT.
4. Start engine and warm it up to normal operating temperature.
5. Disconnect vacuum hose at EVAP canister purge control valve.
6. Touch "ON" and "OFF" and check for vacuum passing through the hose.

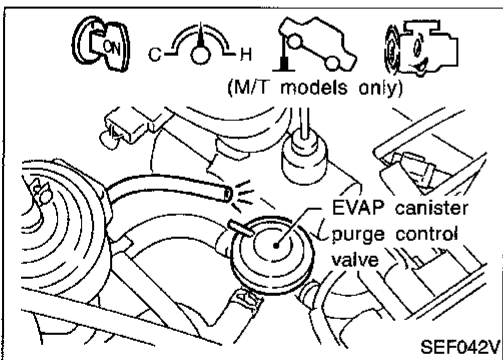

Condition	Vacuum
Idle	Not exist
2,000 rpm (A/T models) 2,000 rpm with 1st gear position (M/T models)	Exist

OR

- Check air passage continuity.

Condition	Air passage continuity between (A) and (B)	Air passage continuity between (A) and (C)
12V direct current supply between terminals	Yes	No
No supply	No	Yes

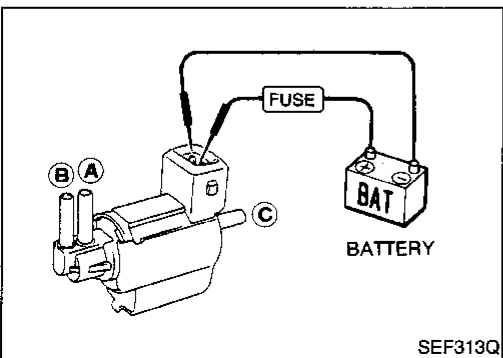

If NG or operation takes more than 1 second, replace solenoid valve.

TROUBLE DIAGNOSIS FOR DTC P1447

Evaporative Emission (EVAP) Control System Purge Flow Monitoring (Cont'd)

EVAP control system pressure sensor

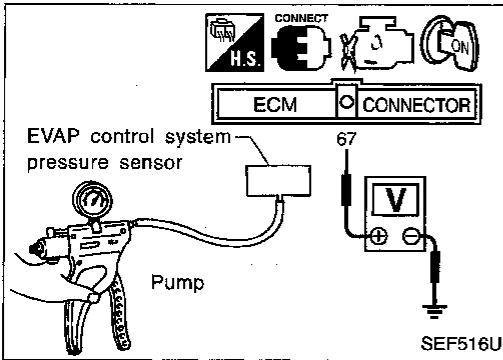

1. Remove EVAP control system pressure sensor with its harness connector connected.
2. Remove hose from EVAP control system pressure sensor.
3. Use pump to apply vacuum and pressure to EVAP control system pressure sensor as shown in figure.
4. Check output voltage between ECM terminal 67 and engine ground.

Pressure (Relative to atmospheric pressure)	Voltage (V)
0 kPa (0 mmHg, 0 inHg)	3.0 - 3.6
-9.3 kPa (-70 mmHg, -2.76 inHg)	0.4 - 0.6

CAUTION:

- Always calibrate the vacuum pump gauge when using it.
 - Do not apply below -20 kPa (-150 mmHg, -5.91 inHg) or over 20 kPa (150 mmHg, 5.91 inHg) of pressure.
5. If NG, replace EVAP control system pressure sensor.

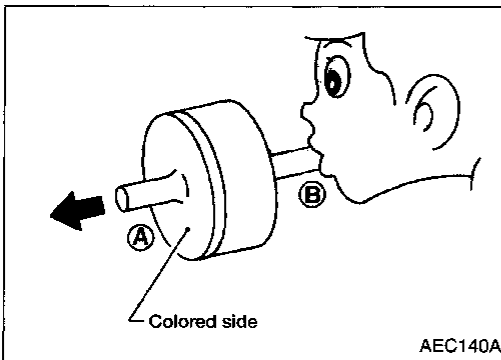

One-way valve

Check one-way valve air passage continuity.

Condition	Air passage continuity
Blow air into side B to A	Yes
Blow air into side A to B	No

If NG, replace one-way valve.

Make sure to install one-way valve with the colored side facing the vacuum.

TROUBLE DIAGNOSIS FOR DTC P1448

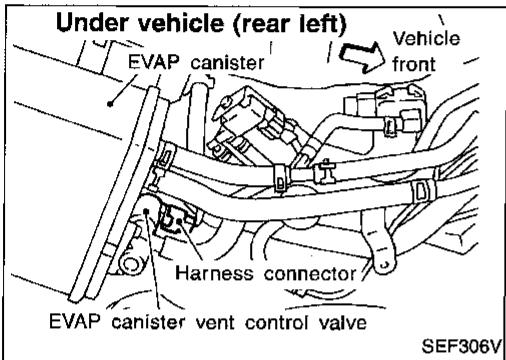
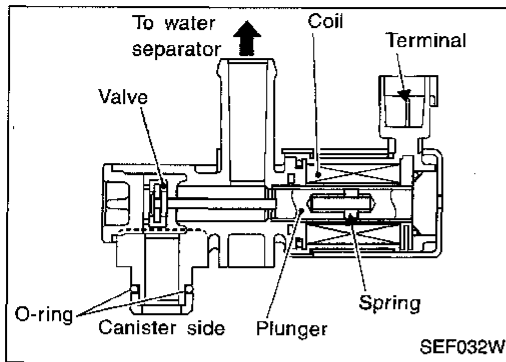

Evaporative Emission (EVAP) Canister Vent Control Valve (Open)

COMPONENT DESCRIPTION

NOTE:

If DTC P1448 is displayed with P0440 or P1440, perform TROUBLE DIAGNOSIS FOR DTC P1448 first.

The EVAP canister vent control valve is located on the EVAP canister and is used to seal the canister vent.

This solenoid (the EVAP canister vent control valve) responds to signals from the ECM.

When the ECM sends an ON signal, the coil in the solenoid valve is energized.

A plunger will then move to seal the canister vent. The ability to seal the vent is necessary for the on board diagnosis of other evaporative emission control system components.

This solenoid valve is used only for diagnosis, and usually remains opened.

When the vent is closed, under normal purge conditions, the evaporative emission control system is depressurized and allows "EVAP Control System (Small Leak)" diagnosis.

CONSULT REFERENCE VALUE IN DATA MONITOR MODE

Specification data are reference values.

MONITOR ITEM	CONDITION	SPECIFICATION
VENT CONT/V	● Ignition switch: ON	OFF

ECM TERMINALS AND REFERENCE VALUE

Specification data are reference values and are measured between each terminal and engine ground.

TERMINAL NO.	WIRE COLOR	ITEM	CONDITION	DATA (DC voltage)
108	PU/W	EVAP canister vent control valve	Ignition switch "ON"	BATTERY VOLTAGE (11 - 14V)

ON BOARD DIAGNOSIS LOGIC

Diagnostic Trouble Code No.	Malfunction is detected when	Check Items (Possible Cause)
P1448 0309	● EVAP canister vent control valve remains opened under specified driving conditions.	<ul style="list-style-type: none"> ● EVAP canister vent control valve ● EVAP control system pressure sensor ● Blocked rubber tube to EVAP canister vent control valve ● Water separator ● EVAP canister is saturated with water. ● Vacuum cut valve

TROUBLE DIAGNOSIS FOR DTC P1448

Evaporative Emission (EVAP) Canister Vent Control Valve (Open) (Cont'd)

DIAGNOSTIC TROUBLE CODE CONFIRMATION PROCEDURE

NOTE:

- If DTC P1448 is displayed with P0440 or P1440, perform **TROUBLE DIAGNOSIS FOR DTC P1448** first.
- If "DIAGNOSTIC TROUBLE CODE CONFIRMATION PROCEDURE" has been previously conducted, always turn ignition switch "OFF" and wait at least 5 seconds before conducting the next test.

TESTING CONDITION:

- Perform "DTC WORK SUPPORT" when the fuel level is less than 3/4 full and vehicle is placed on flat level surface.
- Always perform test at a temperature of 0 to 30°C (32 to 86°F).
- It is better that the fuel level is low.



- 1) Turn ignition switch "ON".
- 2) Turn ignition switch "OFF" and wait at least 5 seconds.
- 3) Turn ignition switch "ON" and select "DATA MONITOR" mode with CONSULT.
- 4) Make sure that the following conditions are met.
COOLAN TEMP/S: 0 - 70°C (32 - 158°F)
INT/A TEMP SE: 0 - 60°C (32 - 140°F)
- 5) Select "EVAP SML LEAK P0440" of "EVAPORATIVE SYSTEM" in "DTC WORK SUPPORT" mode with CONSULT.
Follow the instruction displayed.

NOTE:

- If the CONSULT screen shown at left is displayed, stop the engine and stabilize the vehicle temperature at 25°C (77°F) or cooler. After "TANK F/TMP SE" becomes less than 30°C (86°F), retest. (Use a fan to reduce the stabilization time.)
 - If the engine speed cannot be maintained within the range displayed on CONSULT screen, go to "Basic Inspection", EC-82.
 - The engine idle portion of this test (see illustration at left) will take approximately 5 minutes.
- 6) Make sure that "OK" is displayed.
If "NG" is displayed, go to the following step.

NOTE:

Make sure that EVAP hoses are connected to EVAP canister purge volume control solenoid valve properly.

- 7) Stop engine and wait at least 5 seconds, then turn "ON".
- 8) Disconnect hose from water separator.
- 9) Select "VENT CONTROL/V" of "ACTIVE TEST" mode with CONSULT.
- 10) Touch "ON" and "OFF" alternately.

■ EVAP SML LEAK P0440 ■

1)PERFORM TEST AT A LOCATION OF 0-30C (32-86F)
2)OPEN ENGINE HOOD.
3)START ENGINE WITH VEHICLE STOPPED. IF ENG IS ON, STOP FOR 5 SEC. THEN RESTART.
4)TOUCH START.

SEF405W

■ EVAP SML LEAK P0440 ■

CAN NOT BE DIAGNOSED

FUEL TEMPERATURE IS TOO HIGH. RETEST AFTER FUEL HAS COOLED.

SEF669U

■ EVAP SML LEAK P0440 ■

WAIT. . .

2 TO 10 MINUTES
KEEP ENGINE RUNNING
AT IDLE SPEED.

SEF929V

■ EVAP SML LEAK P0440 ■

***** OK *****

SEF297U

TROUBLE DIAGNOSIS FOR DTC P1448

Evaporative Emission (EVAP) Canister Vent Control Valve (Open) (Cont'd)

11) Make sure of the following.

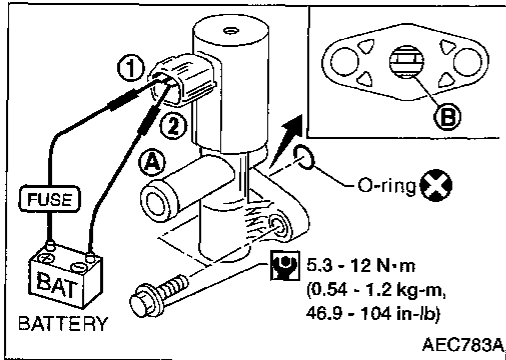
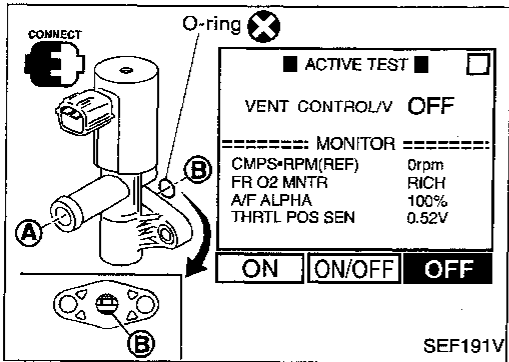

Condition	Air passage continuity between (A) and (B)
VENT CONTROL/V	
ON	No
OFF	Yes

If the result is NG, go to "DIAGNOSTIC PROCEDURE", EC-418.

If the result is OK, go to "DIAGNOSTIC PROCEDURE" for "TROUBLE DIAGNOSIS FOR DTC P0440", EC-285.

OR

OVERALL FUNCTION CHECK

Use this procedure to check the overall function of the EVAP canister vent control valve circuit. During this check, a DTC might not be confirmed.

- 1) Disconnect hose from water separator.
- 2) Disconnect EVAP canister vent control valve harness connector.
- 3) Verify the following.

Condition	Air passage continuity
12V direct current supply between terminals ① and ②	No
No supply	Yes

If the result is NG, go to "DIAGNOSTIC PROCEDURE", EC-418.

If the result is OK, go to "TROUBLE DIAGNOSIS FOR DTC P0440", EC-285.

TROUBLE DIAGNOSIS FOR DTC P1448

Evaporative Emission (EVAP) Canister Vent Control Valve (Open) (Cont'd)

DIAGNOSTIC PROCEDURE

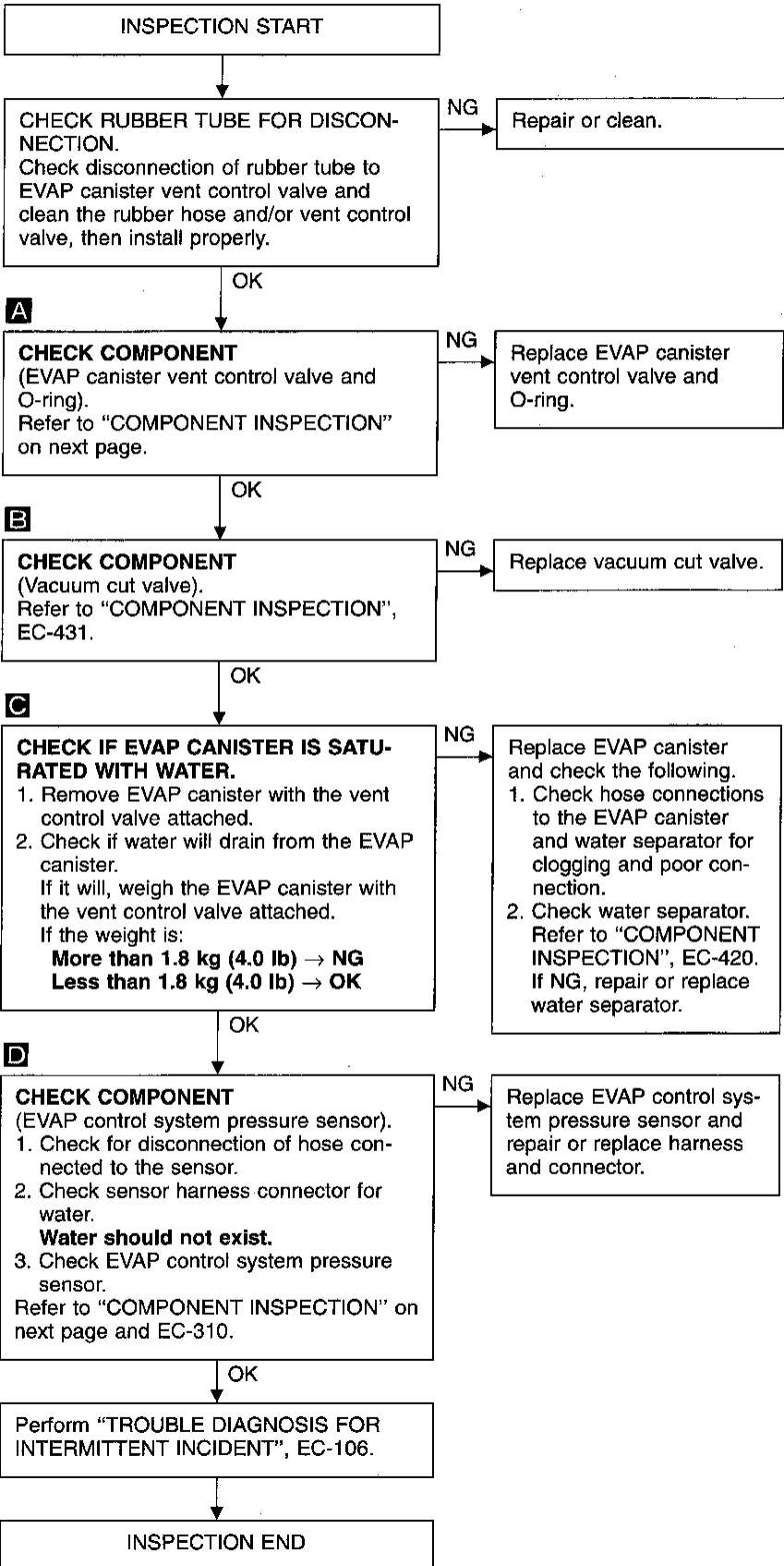
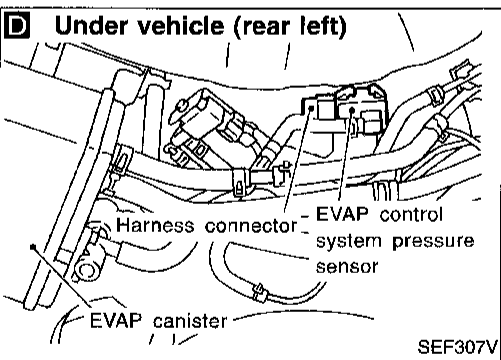
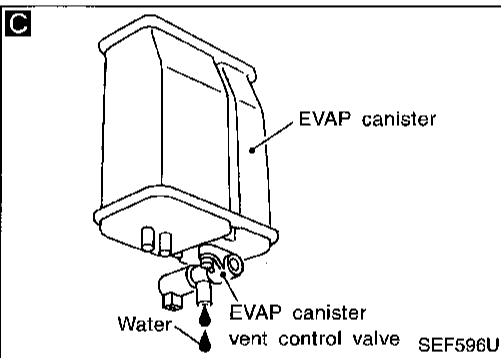
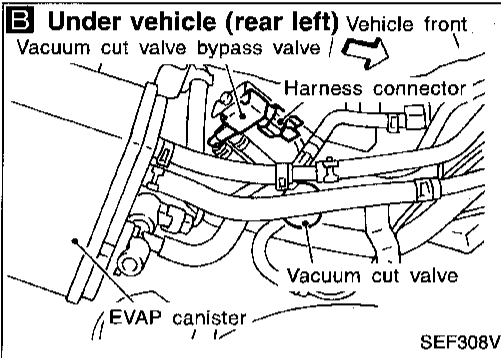
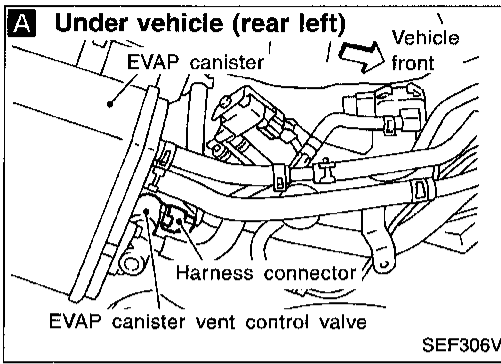

TROUBLE DIAGNOSIS FOR DTC P1448

Evaporative Emission (EVAP) Canister Vent Control Valve (Open) (Cont'd)

COMPONENT INSPECTION

EVAP canister vent control valve

Check air passage continuity.

Perform "VENT CONTROL/V" in "ACTIVE TEST" mode.

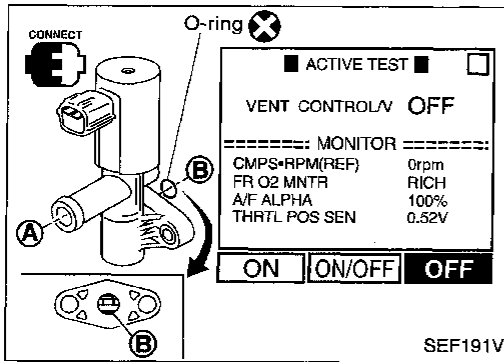

SEF191V

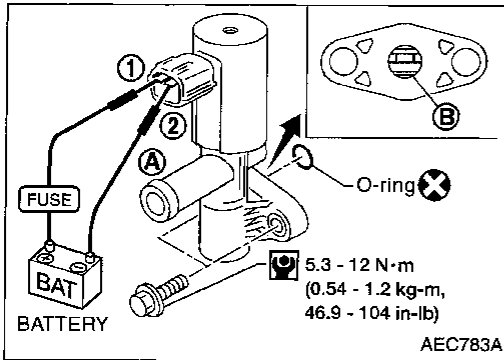

AEC783A

Condition	Air passage continuity between (A) and (B)
VENT CONTROL/V ON	No
VENT CONTROL/V OFF	Yes

OR

Condition	Air passage continuity between (A) and (B)
12V direct current supply between terminals (1) and (2)	No
No supply	Yes

If NG or operation takes more than 1 second, clean valve using air blower or replace as necessary.

If the portion (B) is rusted, replace EVAP canister vent control valve.

Make sure new O-ring is installed properly.

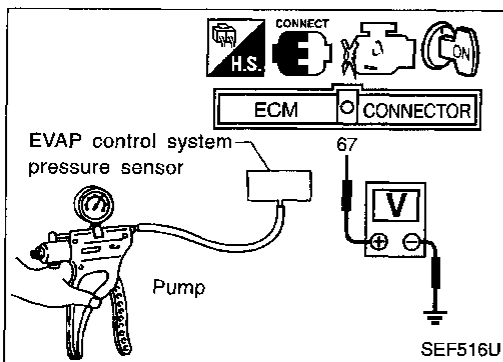

SEF516U

EVAP control system pressure sensor

1. Remove EVAP control system pressure sensor with its harness connector connected.
2. Remove hose from EVAP control system pressure sensor.
3. Use pump to apply vacuum and pressure to EVAP control system pressure sensor as shown in figure.
4. Check output voltage between ECM terminal (67) and engine ground.

Pressure (Relative to atmospheric pressure)	Voltage (V)
0 kPa (0 mmHg, 0 inHg)	3.0 - 3.6
-9.3 kPa (-70 mmHg, -2.76 inHg)	0.4 - 0.6

CAUTION:

- Always calibrate the vacuum pump gauge when using it.
- Do not apply below -20 kPa (-150 mmHg, -5.91 inHg) or over 20 kPa (150 mmHg, 5.91 inHg) of pressure.
- 5. If NG, replace EVAP control system pressure sensor.

TROUBLE DIAGNOSIS FOR DTC P1448

Evaporative Emission (EVAP) Canister Vent Control Valve (Open) (Cont'd)

Water separator

1. Check visually for insect nests in water separator air inlet.
 2. Check visually for cracks or flaws in the appearance.
 3. Check visually for cracks or flaws in the hose.
 4. Check that (A) and (C) are not clogged by blowing air into (B) with (A), and then (C) plugged.
 5. In case of NG in items 2 - 4, replace the parts.
- **Do not disassemble water separator.**

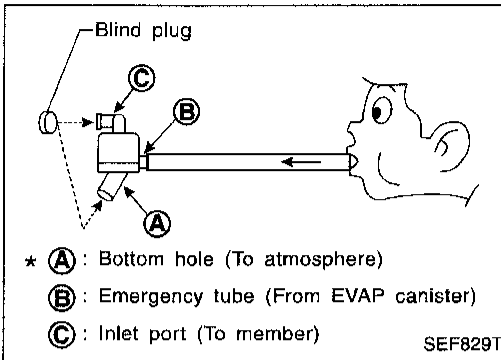

TROUBLE DIAGNOSIS FOR DTC P1490

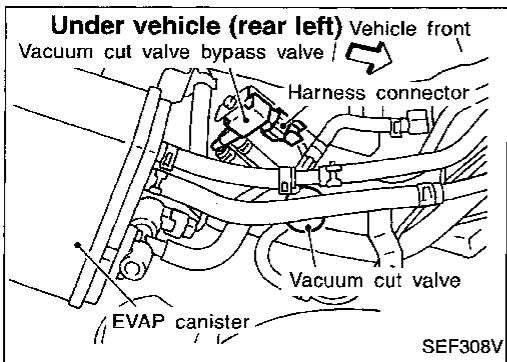

Vacuum Cut Valve Bypass Valve (Circuit)

COMPONENT DESCRIPTION

The vacuum cut valve and vacuum cut valve bypass valve are installed in parallel on the EVAP purge line between the fuel tank and the EVAP canister.

The vacuum cut valve prevents the intake manifold vacuum from being applied to the fuel tank.

The vacuum cut valve bypass valve is a solenoid type valve and generally remains closed. It opens only for on board diagnosis. The vacuum cut valve bypass valve responds to signals from the ECM. When the ECM sends an ON (ground) signal, the valve is opened. The vacuum cut valve is then bypassed to apply intake manifold vacuum to the fuel tank.

EVAPORATIVE EMISSION SYSTEM DIAGRAM

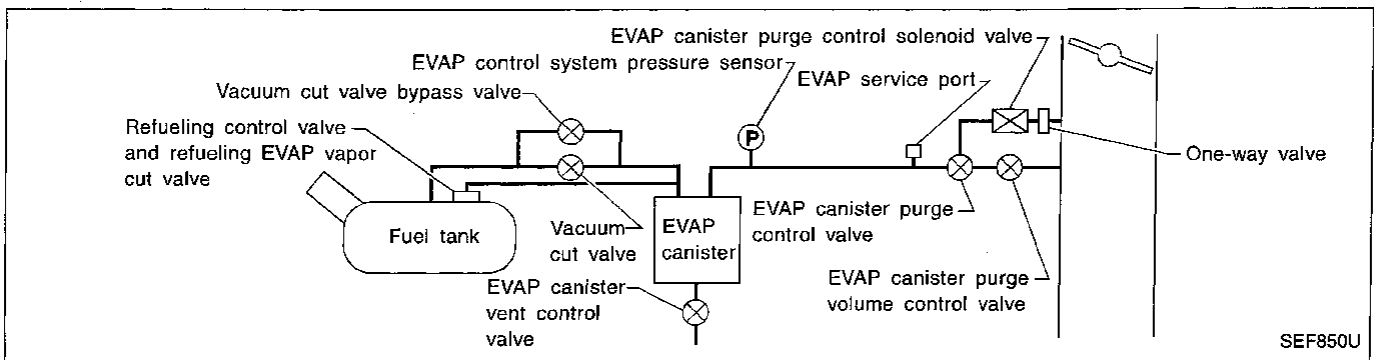

CONSULT REFERENCE VALUE IN DATA MONITOR MODE

Specification data are reference values.

MONITOR ITEM	CONDITION	SPECIFICATION
VCV/ BYPASS/V	● Ignition switch: ON	OFF

ECM TERMINALS AND REFERENCE VALUE

Specification data are reference values and are measured between each terminal and engine ground.

TER-MINAL NO.	WIRE COLOR	ITEM	CONDITION	DATA (DC voltage)
117	PU/R	Vacuum cut valve bypass valve	Ignition switch "ON"	BATTERY VOLTAGE (11 - 14V)

ON BOARD DIAGNOSIS LOGIC

Diagnostic Trouble Code No.	Malfunction is detected when	Check Items (Possible Cause)
P1490 0801	● An improper voltage signal is sent to ECM through vacuum cut valve bypass valve.	<ul style="list-style-type: none"> ● Harness or connectors (The vacuum cut valve bypass valve circuit is open or shorted.) ● Vacuum cut valve bypass valve

TROUBLE DIAGNOSIS FOR DTC P1490

Vacuum Cut Valve Bypass Valve (Circuit) (Cont'd)

DIAGNOSTIC TROUBLE CODE CONFIRMATION PROCEDURE

NOTE:

If "DIAGNOSTIC TROUBLE CODE CONFIRMATION PROCEDURE" has been previously conducted, always turn ignition switch "OFF" and wait at least 5 seconds before conducting the next test.

TESTING CONDITION:

Before performing the following procedure, confirm battery voltage is more than 11V at idle.

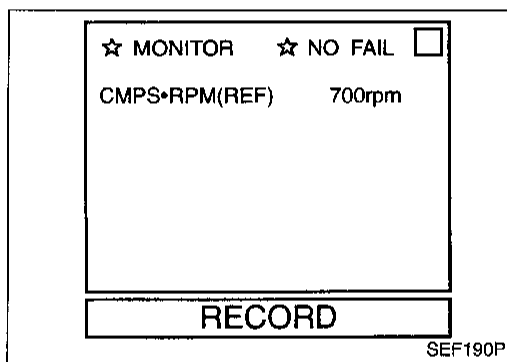

- 1) Turn ignition switch "ON".
- 2) Select "DATA MONITOR" mode with CONSULT.
- 3) Start engine and wait at least 5 seconds.
- 4) If 1st trip DTC is detected, go to "DIAGNOSTIC PROCEDURE", EC-424.

OR



- 1) Start engine and wait at least 5 seconds.
- 2) Select "MODE 7" with GST.
- 3) If 1st trip DTC is detected, go to "DIAGNOSTIC PROCEDURE", EC-424.

OR



- 1) Start engine and wait at least 5 seconds.
- 2) Turn ignition switch "OFF", wait at least 5 seconds and then turn "ON".
- 3) Perform "Diagnostic Test Mode II (Self-diagnostic results)" with ECM.
- 4) If 1st trip DTC is detected, go to "DIAGNOSTIC PROCEDURE", EC-424.

TROUBLE DIAGNOSIS FOR DTC P1490

Vacuum Cut Valve Bypass Valve (Circuit) (Cont'd)

EC-BYPS/V-01 GI

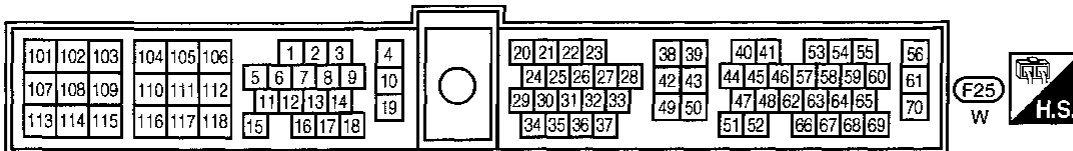
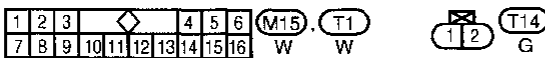
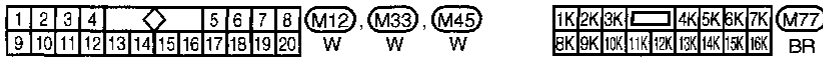
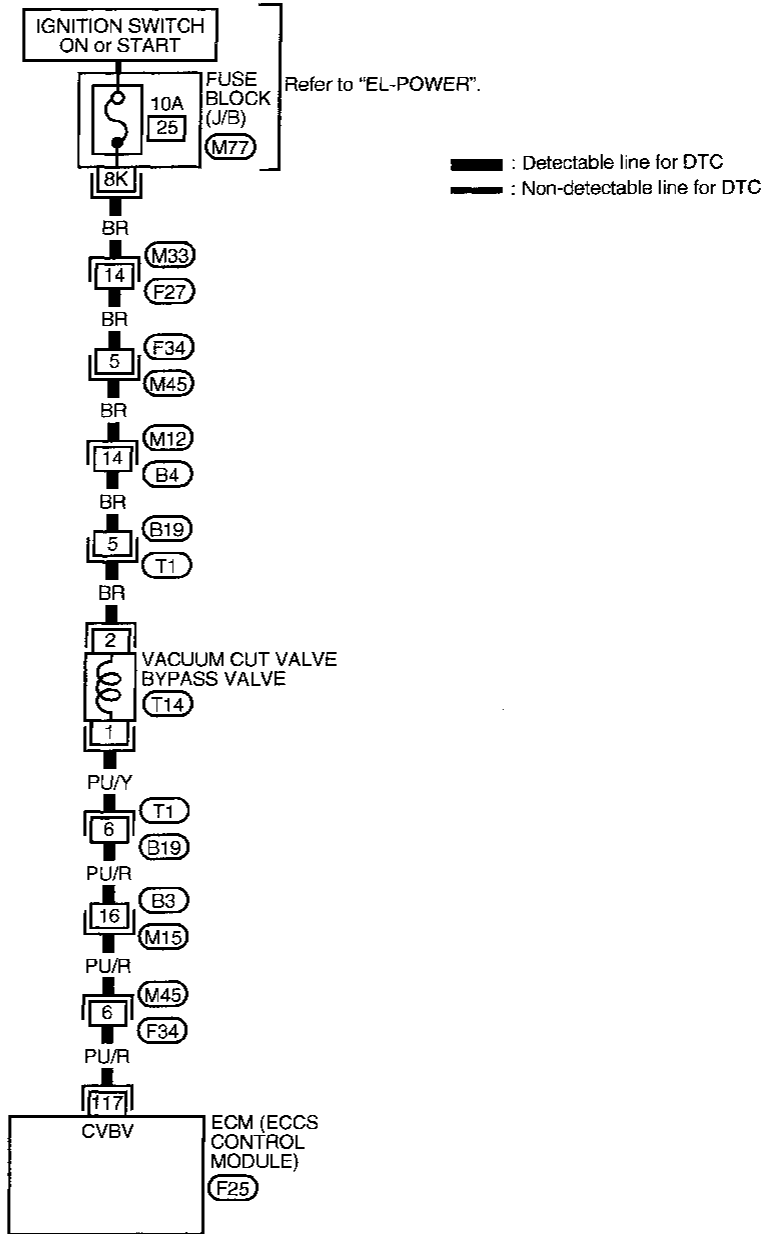

TROUBLE DIAGNOSIS FOR DTC P1490

Vacuum Cut Valve Bypass Valve (Circuit)

(Cont'd)

DIAGNOSTIC PROCEDURE

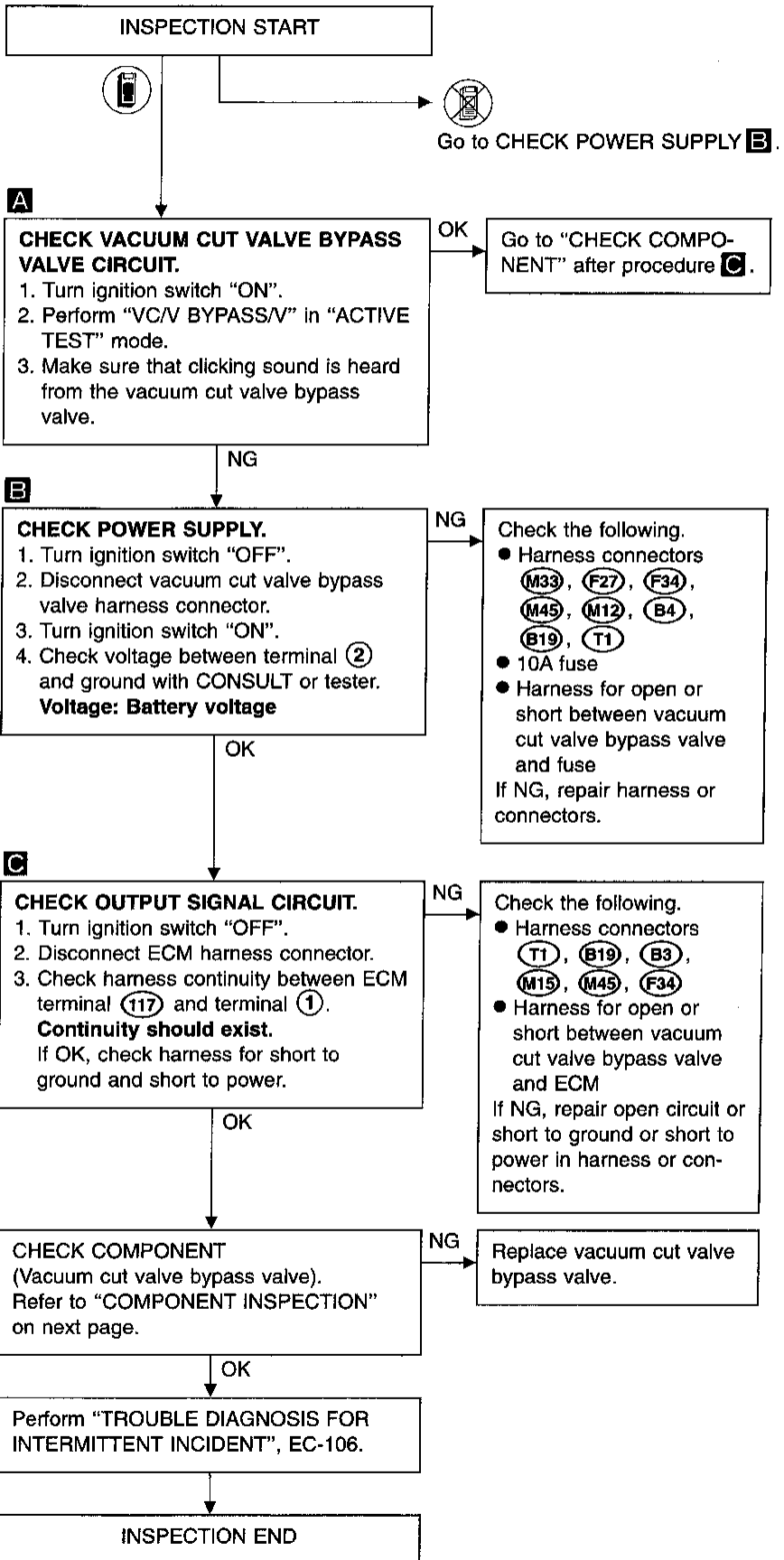
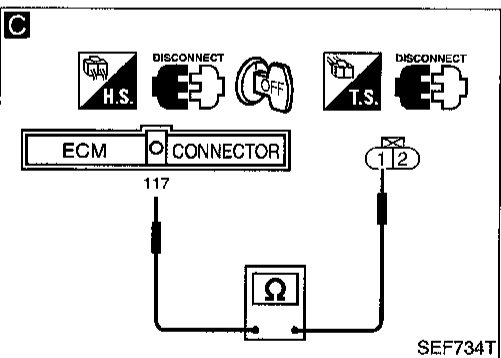
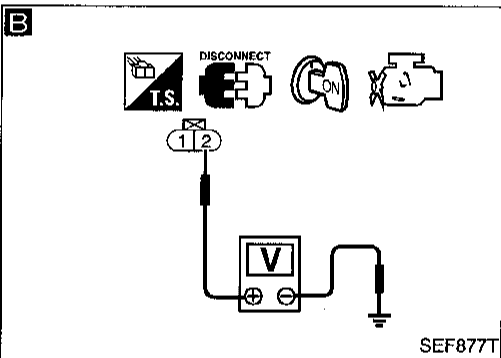
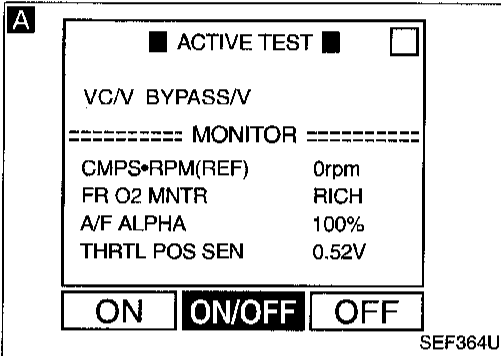
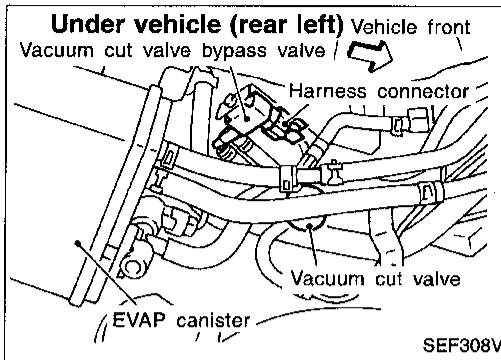

TROUBLE DIAGNOSIS FOR DTC P1490

Vacuum Cut Valve Bypass Valve (Circuit) (Cont'd)

COMPONENT INSPECTION

Vacuum cut valve bypass valve

Check air passage continuity.

 Perform "VC/V BYPASS/V" in "ACTIVE TEST" mode.

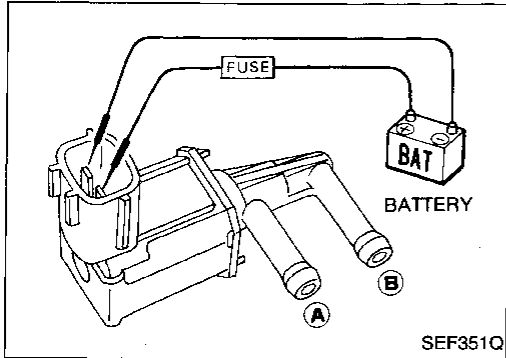
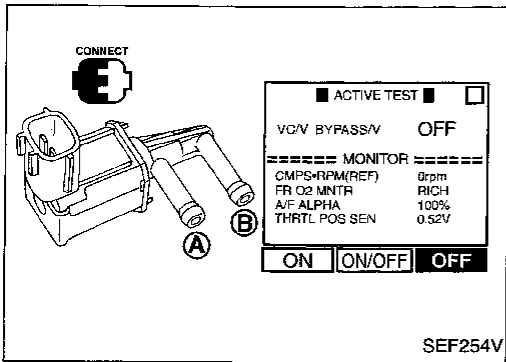

Condition VC/V BYPASS/V	Air passage continuity between (A) and (B)
ON	Yes
OFF	No

OR



Condition	Air passage continuity between (A) and (B)
12V direct current supply between terminals	Yes
No supply	No

If NG or operation takes more than 1 second, replace vacuum cut valve bypass valve.

GI

MA

EM

LC

EC

FE

CL

MT

AT

FA

RA

BR

ST

RS

BT

HA

EL

IDX

TROUBLE DIAGNOSIS FOR DTC P1491

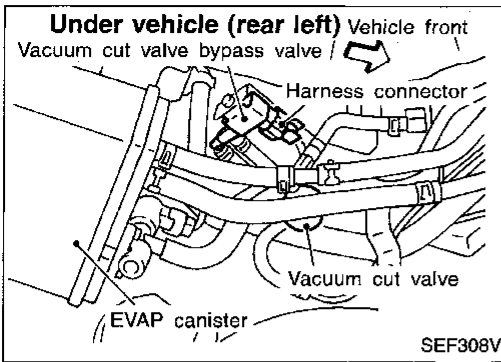

Vacuum Cut Valve Bypass Valve

COMPONENT DESCRIPTION

The vacuum cut valve and vacuum cut valve bypass valve are installed in parallel on the EVAP purge line between the fuel tank and the EVAP canister.

The vacuum cut valve prevents the intake manifold vacuum from being applied to the fuel tank.

The vacuum cut valve bypass valve is a solenoid type valve and generally remains closed. It opens only for on board diagnosis. The vacuum cut valve bypass valve responds to signals from the ECM. When the ECM sends an ON (ground) signal, the valve is opened. The vacuum cut valve is then bypassed to apply intake manifold vacuum to the fuel tank.

EVAPORATIVE EMISSION SYSTEM DIAGRAM

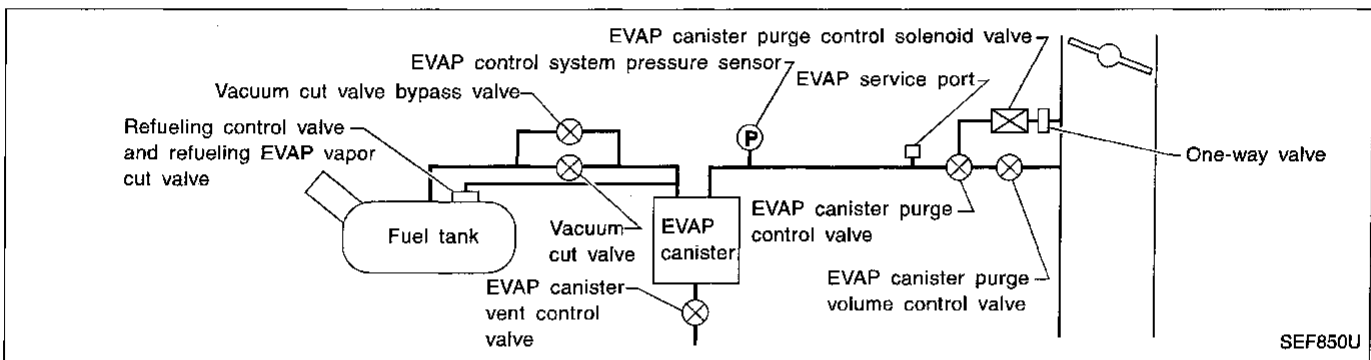

CONSULT REFERENCE VALUE IN DATA MONITOR MODE

Specification data are reference values.

MONITOR ITEM	CONDITION	SPECIFICATION
VC/V BYPASS/V	● Ignition switch: ON	OFF

ECM TERMINALS AND REFERENCE VALUE

Specification data are reference values and are measured between each terminal and engine ground.

TER-MINAL NO.	WIRE COLOR	ITEM	CONDITION	DATA (DC voltage)
117	PU/R	Vacuum cut valve bypass valve	Ignition switch "ON"	BATTERY VOLTAGE (11 - 14V)

TROUBLE DIAGNOSIS FOR DTC P1491

Vacuum Cut Valve Bypass Valve (Cont'd)

ON BOARD DIAGNOSIS LOGIC

Diagnostic Trouble Code No.	Malfunction is detected when	Check Items (Possible Cause)
P1491 0311	<ul style="list-style-type: none"> ● Vacuum cut valve bypass valve does not operate properly. 	<ul style="list-style-type: none"> ● Vacuum cut valve bypass valve ● Vacuum cut valve ● Bypass hoses for clogging ● EVAP control system pressure sensor ● EVAP canister vent control valve ● Hose between fuel tank and vacuum cut valve clogged ● Hose between vacuum cut valve and EVAP canister clogged ● EVAP canister ● EVAP purge port of fuel tank for clogging ● ORVR system leaks

GI

MA

EM

LC

EC

FE

CL

MT

AT

FA

RA

BR

ST

RS

BT

HA

EL

IDX

■ PURG CNV&S/V P1493 ■

THIS SUPPORT FUNCTION IS FOR DTC P1493. SEE THE SERVICE MANUAL ABOUT THE OPERATING CONDITION FOR THIS DIAGNOSIS.

EXIT
START

SEF610U

■ PURG CNV&S/V P1493 ■

***** OK *****

■ SELF-DIAG RESULTS ■

**** NO FAILURE ****

END
PRINT

SEF611U

■ PURG VOL CNV P1444 ■

THIS SUPPORT FUNCTION IS FOR DTC P1447. SEE THE SERVICE MANUAL ABOUT THE OPERATING CONDITION FOR THIS DIAGNOSIS.

EXIT
START

SEF612U

DIAGNOSTIC TROUBLE CODE CONFIRMATION PROCEDURE

CAUTION:

Always drive vehicle at a safe speed.

NOTE:

If "DTC CONFIRMATION PROCEDURE" has been previously conducted, always turn ignition switch "OFF" and wait at least 5 seconds before conducting the next test.

TESTING CONDITION:

Always perform test at a temperature of 5 to 30°C (41 to 86°F).



- 1) Turn ignition switch "ON".
- 2) Start engine and warm it up to normal operating temperature.
- 3) Turn ignition switch "OFF" and wait at least 5 seconds.
- 4) Start engine and let it idle for at least 1 minute.
- 5) Select "PURG CNV & S/V P1493" of "EVAPORATIVE SYSTEM" in "DTC WORK SUPPORT" mode with CONSULT.
- 6) Touch "START".
- 7) When the following conditions are met, "TESTING" will be displayed on the CONSULT screen. Maintain the conditions continuously until "TESTING" changes to "COMPLETED". (It will take at least 30 seconds.)
 - CMPS-RPM (REF): 1,000 rpm or more**
 - Selector lever: Suitable position**
 - Vehicle speed: 36 - 120 km/h (22 - 75 MPH)**
 - B/FUEL SCHDL: 1 - 4.5 msec**

If "TESTING" is not displayed after 5 minutes, retry from step 3).

TROUBLE DIAGNOSIS FOR DTC P1491

Vacuum Cut Valve Bypass Valve (Cont'd)

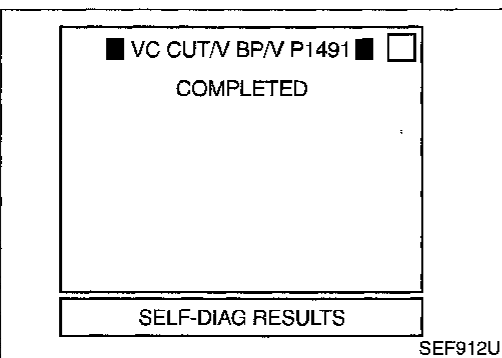
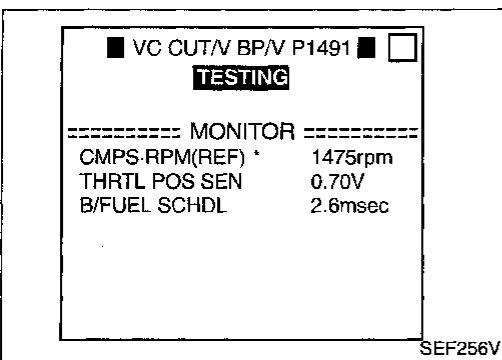
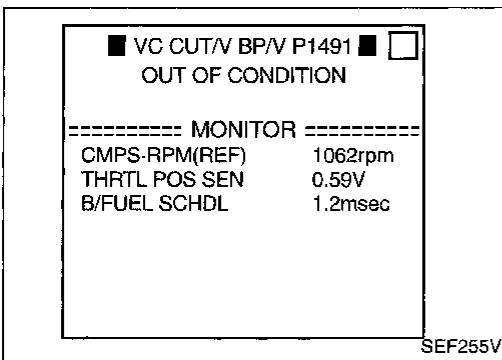
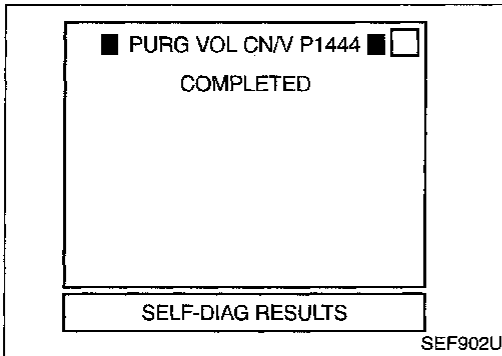
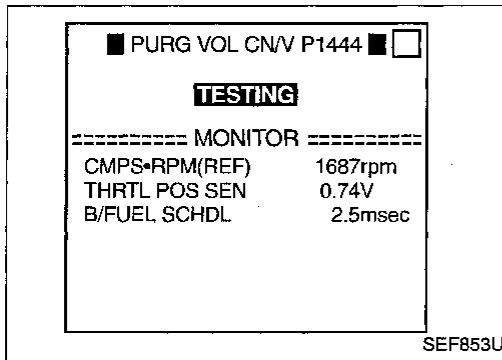

8) Make sure that "OK" is displayed after touching "SELF-DIAG RESULTS" and go to the following step.

If "NG" is displayed, refer to "DIAGNOSTIC PROCEDURE" of "TROUBLE DIAGNOSIS FOR DTC P1493", EC-438.

9) Select "PURG VOL CN/V P1444" of "EVAPORATIVE SYSTEM" in "DTC WORK SUPPORT" mode with CONSULT.

10) Touch "START".

If "COMPLETED" is displayed, go to step 12.

11) When the following conditions are met, "TESTING" will be displayed on the CONSULT screen. Maintain the conditions continuously until "TESTING" changes to "COMPLETED". (It will take at least 20 seconds.)

CMPS-RPM (REF): 1,000 rpm or more

Selector lever: Suitable position

Vehicle speed: 36 - 120 km/h (22 - 75 MPH)

B/FUEL SCHDL: 1 - 4.5 msec

If "TESTING" is not displayed after 5 minutes, retry from step 3).

12) Make sure that "OK" is displayed after touching "SELF-DIAG RESULTS" and go to the following step.

If "NG" is displayed, refer to "DIAGNOSTIC PROCEDURE" of "TROUBLE DIAGNOSIS FOR DTC P1444", EC-393.

13) Select "VC/V BYPASS/V P1491" of "EVAPORATIVE SYSTEM" in "DTC WORK SUPPORT" mode with CONSULT.

14) Touch "START".

15) When the following conditions are met, "TESTING" will be displayed on the CONSULT screen. Maintain the conditions continuously until "TESTING" changes to "COMPLETED". (It will take at least 30 seconds.)

CMPS-RPM (REF): 1,000 rpm or more

Selector lever: Suitable position

Vehicle speed: 36 - 120 km/h (22 - 75 MPH)

B/FUEL SCHDL: 0.5 - 4.5 msec

If "TESTING" is not displayed after 5 minutes, retry from step 3).

16) Make sure that "OK" is displayed after touching "SELF-DIAG RESULTS".

If "NG" is displayed, refer to "DIAGNOSTIC PROCEDURE", EC-430.

TROUBLE DIAGNOSIS FOR DTC P1491

Vacuum Cut Valve Bypass Valve (Cont'd)

OR

OVERALL FUNCTION CHECK



- 1) Remove vacuum cut valve and vacuum cut valve bypass valve as an assembly.
- 2) Apply vacuum to port (A) and check that there is no suction from port (B).
- 3) Apply vacuum to port (B) and check that there is suction from port (A).
- 4) Blow air in port (B) and check that there is a resistance to flow out of port (A).
- 5) Supply battery voltage to the terminal.
- 6) Blow air in port (A) and check that air flows freely out of port (B).
- 7) Blow air in port (B) and check that air flows freely out of port (A).
- 8) If NG, go to "DIAGNOSTIC PROCEDURE", EC-430.

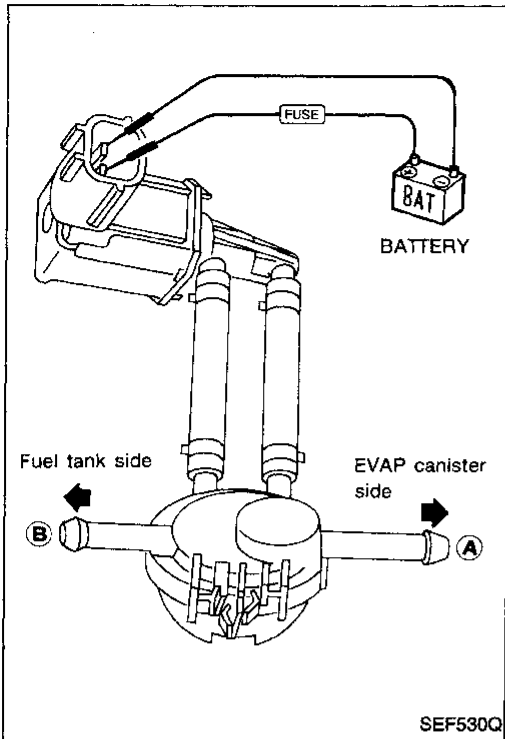

GI

MA

EM

LC

EC

FE

CL

MT

AT

FA

RA

BR

ST

RS

BT

HA

EL

IDX

TROUBLE DIAGNOSIS FOR DTC P1491

Vacuum Cut Valve Bypass Valve (Cont'd)

DIAGNOSTIC PROCEDURE

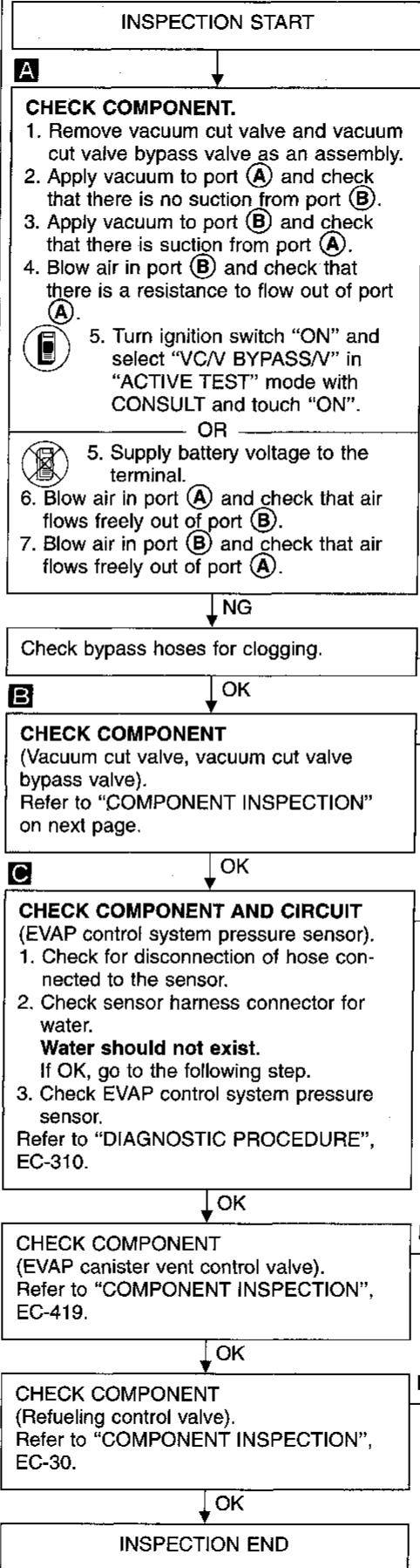
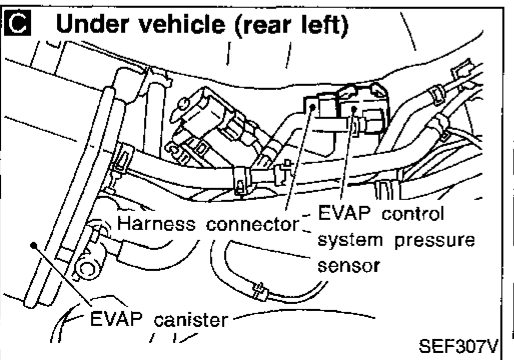
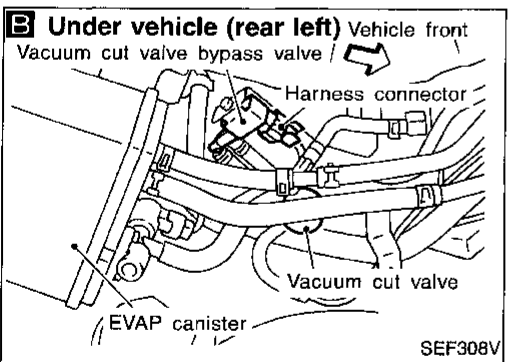
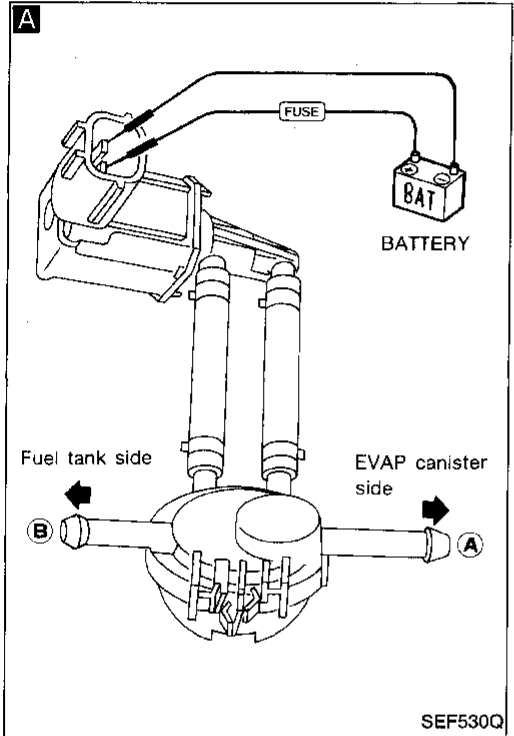
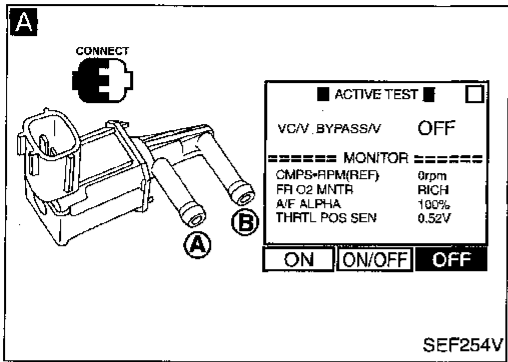

TROUBLE DIAGNOSIS FOR DTC P1491

Vacuum Cut Valve Bypass Valve (Cont'd)

COMPONENT INSPECTION

Vacuum cut valve bypass valve

Check air passage continuity.

① Perform "VC/V BYPASS/V" in "ACTIVE TEST" mode.

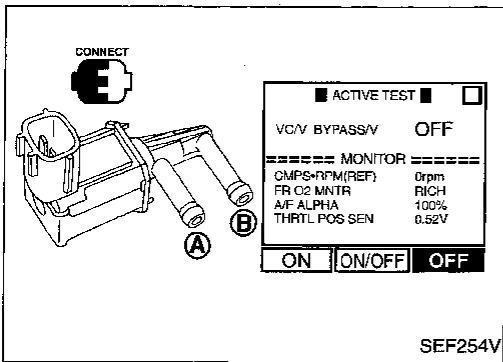

Condition VC/V BYPASS/V	Air passage continuity between (A) and (B)
ON	Yes
OFF	No

OR

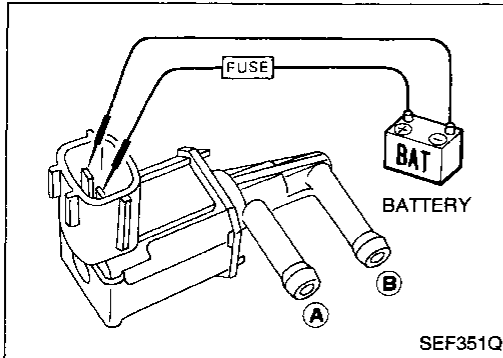

Condition	Air passage continuity between (A) and (B)
12V direct current supply between terminals	Yes
No supply	No

If NG or operation takes more than 1 second, replace vacuum cut valve bypass valve.

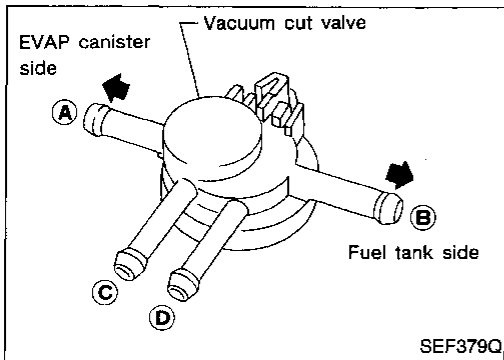

Vacuum cut valve

Check vacuum cut valve as follows:

1. Plug port (C) and (D) with fingers.
2. Apply vacuum to port (A) and check that there is no suction from port (B).
3. Apply vacuum to port (B) and check that there is suction from port (A).
4. Blow air in port (B) and check that there is a resistance to flow out of port (A).
5. Open port (C) and (D).
6. Blow air in port (A) and check that air flows freely out of port (C).
7. Blow air in port (B) and check that air flows freely out of port (D).

Evaporative Emission (EVAP) Canister Purge Control Valve/Solenoid Valve (Circuit)

SYSTEM DESCRIPTION

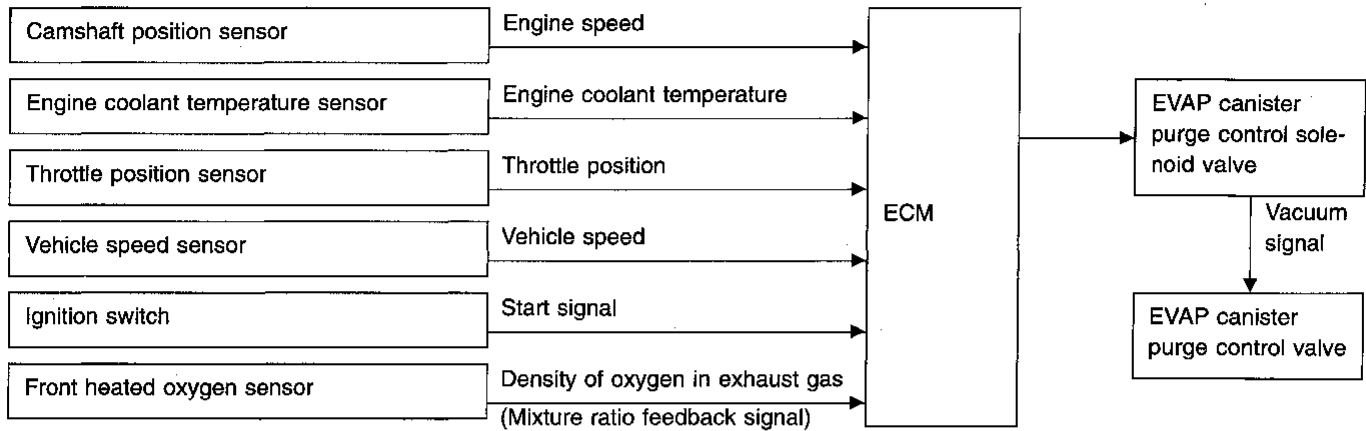

This system controls the vacuum signal applied to the EVAP canister purge control valve.

When the ECM detects any of the following conditions, current does not flow through the EVAP canister purge control solenoid valve.

The solenoid valve cuts the vacuum signal so that the EVAP canister purge control valve remains closed.

- Ignition switch "ON"
- Closed throttle position
- Low engine coolant temperature
- During deceleration
- Engine stopped
- Low vehicle speed (M/T models)
- For 60 seconds after starting engine (After warm-up to normal operating temperature)

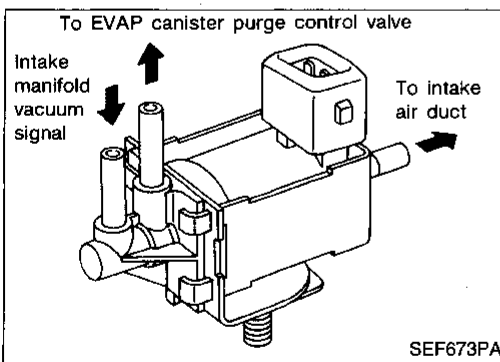

COMPONENT DESCRIPTION

EVAP canister purge control solenoid valve

The EVAP canister purge control solenoid valve responds to signals from the ECM. When the ECM sends an OFF signal, the vacuum signal (from the intake manifold to the EVAP canister purge control valve) is cut.

When the ECM sends an ON (ground) signal, the vacuum signal passes through the EVAP canister purge control solenoid valve. The signal then opens the EVAP canister purge control valve.

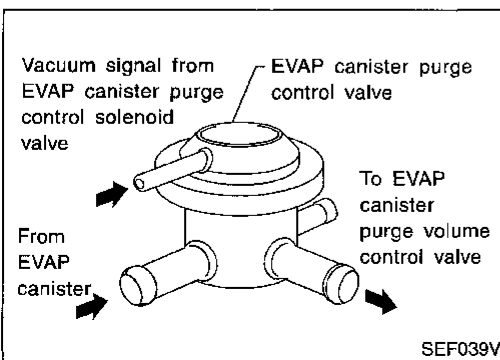

EVAP canister purge control valve

When the vacuum signal is cut by EVAP canister purge control solenoid valve, EVAP canister purge control valve closes.

TROUBLE DIAGNOSIS FOR DTC P1492

Evaporative Emission (EVAP) Canister Purge Control Valve/Solenoid Valve (Circuit) (Cont'd)

EVAPORATIVE EMISSION SYSTEM DIAGRAM

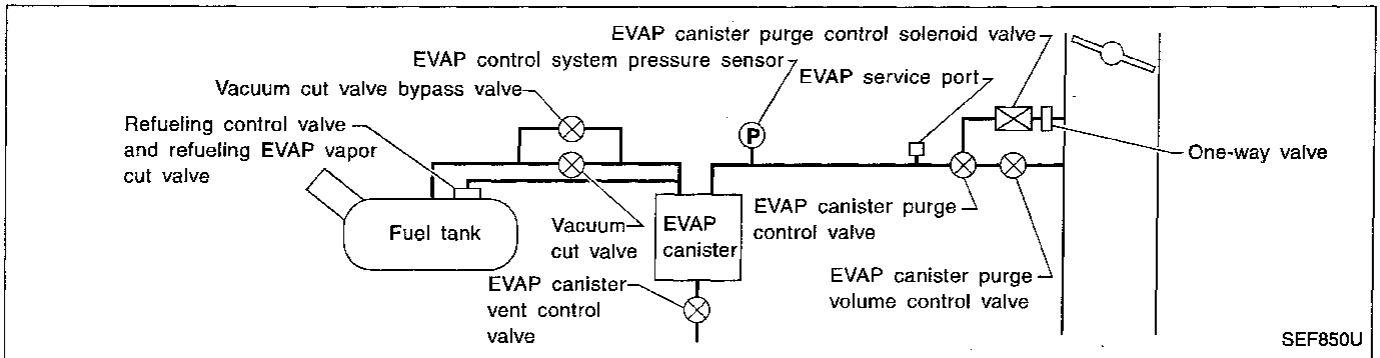

CONSULT REFERENCE VALUE IN DATA MONITOR MODE

MONITOR ITEM	CONDITION	SPECIFICATION
PURG CONT S/V	<ul style="list-style-type: none"> ● Engine: After warming up ● Shift lever: N ● No-load ● M/T models: Lift up drive wheels and shift to 1st gear position. 	OFF
	<ul style="list-style-type: none"> Idle More than 60 seconds after starting engine A/T models: 2,000 rpm M/T models: 2,000 rpm and more than 16 km/h (10 MPH) 	ON

ECM TERMINALS AND REFERENCE VALUE

Specification data are reference values and are measured between each terminal and engine ground.

TER-MINAL NO.	WIRE COLOR	ITEM	CONDITION	DATA (DC voltage)
105	PU	EVAP canister purge control solenoid valve	Engine is running. (Warm-up condition) <ul style="list-style-type: none"> — More than 60 seconds after starting engine — M/T models: Jack up front wheels and drive wheels at 16 km/h (10 MPH). — Engine speed is 2,000 rpm. 	Approximately 0V
			Engine is running. (Warm-up condition) <ul style="list-style-type: none"> — Idle speed 	BATTERY VOLTAGE (11 - 14V)

ON BOARD DIAGNOSIS LOGIC

Diagnostic Trouble Code No.	Malfunction is detected when	Check Items (Possible Cause)
P1492	<ul style="list-style-type: none"> ● An improper voltage signal is sent to ECM through EVAP canister purge control solenoid valve. 	<ul style="list-style-type: none"> ● Harness or connectors (The EVAP canister purge control solenoid valve circuit is open or shorted.) ● EVAP canister purge control solenoid valve

TROUBLE DIAGNOSIS FOR DTC P1492

Evaporative Emission (EVAP) Canister Purge Control Valve/Solenoid Valve (Circuit) (Cont'd)

DIAGNOSTIC TROUBLE CODE CONFIRMATION PROCEDURE

NOTE:

If "DIAGNOSTIC TROUBLE CODE CONFIRMATION PROCEDURE" has been previously conducted, always turn ignition switch "OFF" and wait at least 5 seconds before conducting the next test.



- 1) Turn ignition switch "ON".
- 2) Select "DATA MONITOR" mode with CONSULT.
- 3) Wait at least 5 seconds.
- 4) If 1st trip DTC is detected, go to "DIAGNOSTIC PROCEDURE", EC-436.

OR



- 1) Turn ignition switch "ON" and wait at least 5 seconds.
- 2) Select "MODE 3" with GST.
- 3) If 1st trip DTC is detected, go to "DIAGNOSTIC PROCEDURE", EC-436.

OR



- 1) Turn ignition switch "ON" and wait at least 5 seconds.
- 2) Turn ignition switch "OFF", wait at least 5 seconds and then turn "ON".
- 3) Perform "Diagnostic Test Mode II (Self-diagnostic results)" with ECM.
- 4) If 1st trip DTC is detected, go to "DIAGNOSTIC PROCEDURE", EC-436.

TROUBLE DIAGNOSIS FOR DTC P1492

Evaporative Emission (EVAP) Canister Purge Control Valve/Solenoid Valve (Circuit) (Cont'd)

EC-CANI/V-01

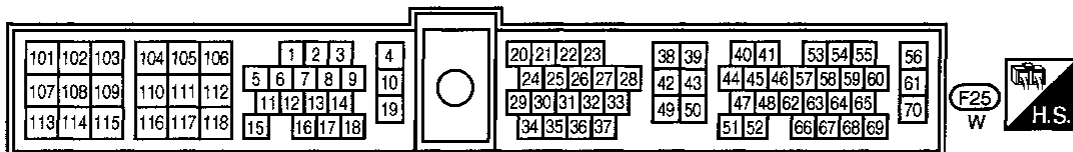
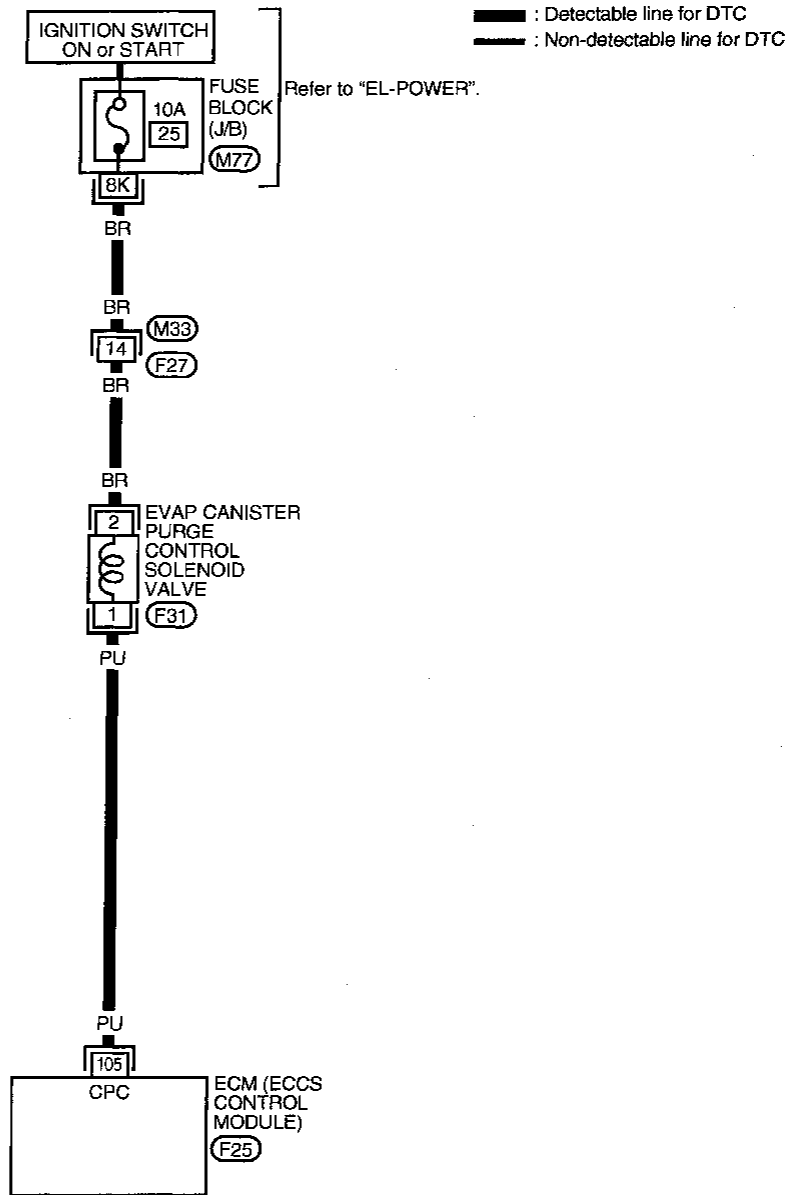

TROUBLE DIAGNOSIS FOR DTC P1492

Evaporative Emission (EVAP) Canister Purge Control Valve/Solenoid Valve (Circuit) (Cont'd)

DIAGNOSTIC PROCEDURE

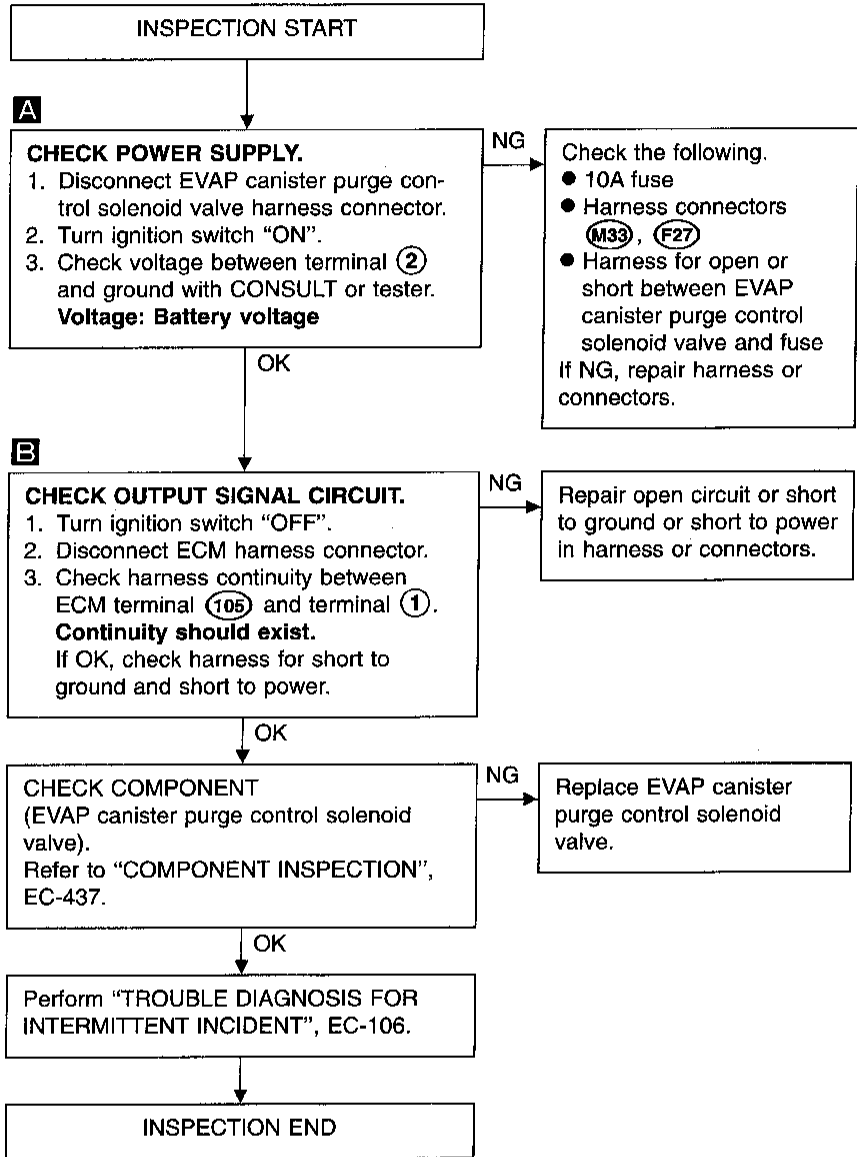
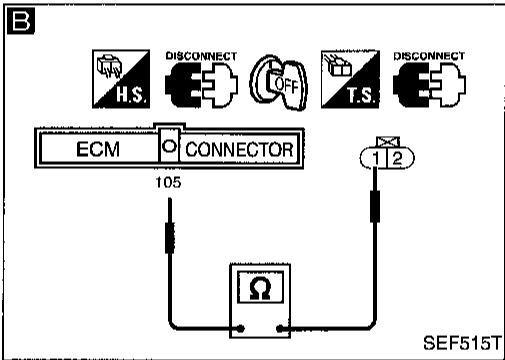
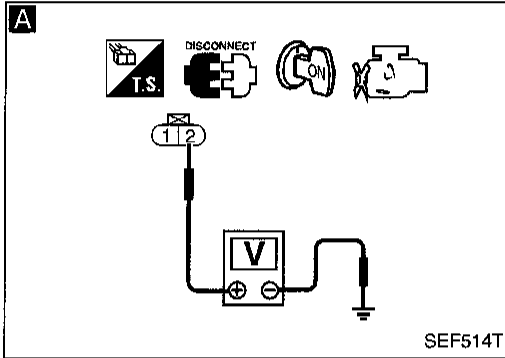
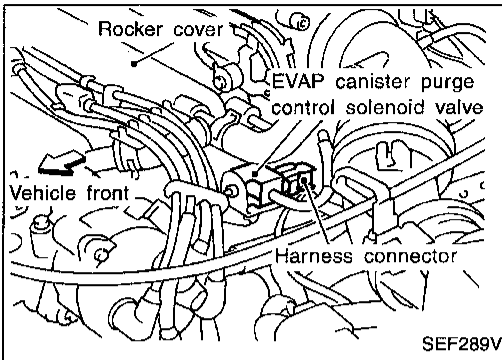

TROUBLE DIAGNOSIS FOR DTC P1492

Evaporative Emission (EVAP) Canister Purge Control Valve/Solenoid Valve (Circuit) (Cont'd)

COMPONENT INSPECTION

EVAP canister purge control solenoid valve

1. Jack up driving wheels (M/T models only).
2. Turn ignition switch "ON".
3. Select "PURG CONT S/V" of "ACTIVE TEST" mode with CONSULT.
4. Start engine and warm it up to normal operating temperature.
5. Disconnect vacuum hose at EVAP canister purge control valve.
6. Touch "ON" and "OFF" and check for vacuum passing through the hose.

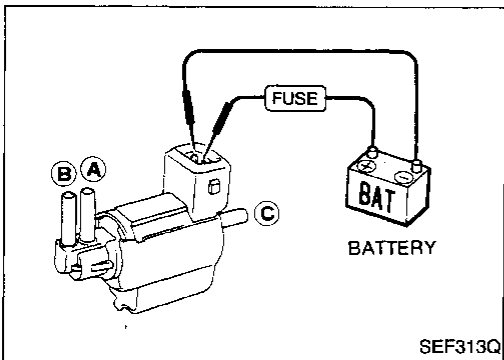
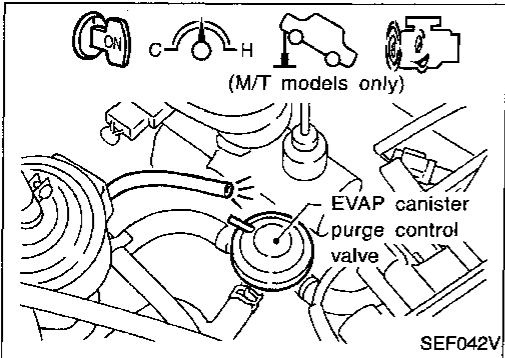
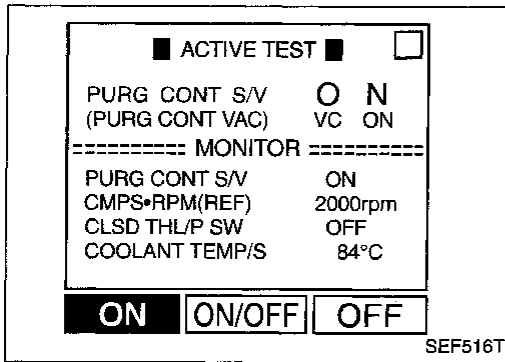

Condition	Vacuum
Idle	Not exist
2,000 rpm (A/T models) 2,000 rpm with 1st gear position (M/T models)	Exist

OR

- ⊗ Check air passage continuity.

Condition	Air passage continuity between (A) and (B)	Air passage continuity between (A) and (C)
12V direct current supply between terminals	Yes	No
No supply	No	Yes

If NG or operation takes more than 1 second, replace solenoid valve.

EVAP canister purge control valve

Check EVAP canister purge control valve as follows:

1. Blow air in port (A) and (C) and ensure that there is no leakage.
2. Plug port (D) and blow air in port (B). Ensure that there is resistance to flow out of port (C).
3. Plug port (B) and blow air in port (D). Ensure that there is resistance to flow out of port (C).
4. Apply vacuum to port (A) [approximately -13.3 to -20.0 kPa (-100 to -150 mmHg, -3.94 to -5.91 inHg)]. Plug port (D) and blow air in port (C) and ensure free flow out of port (B). Plug port (B) and blow air in port (C) and ensure free flow out of port (D).

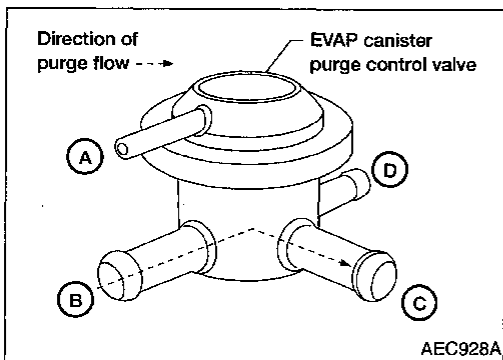

Evaporative Emission (EVAP) Canister Purge Control Valve/Solenoid Valve

SYSTEM DESCRIPTION

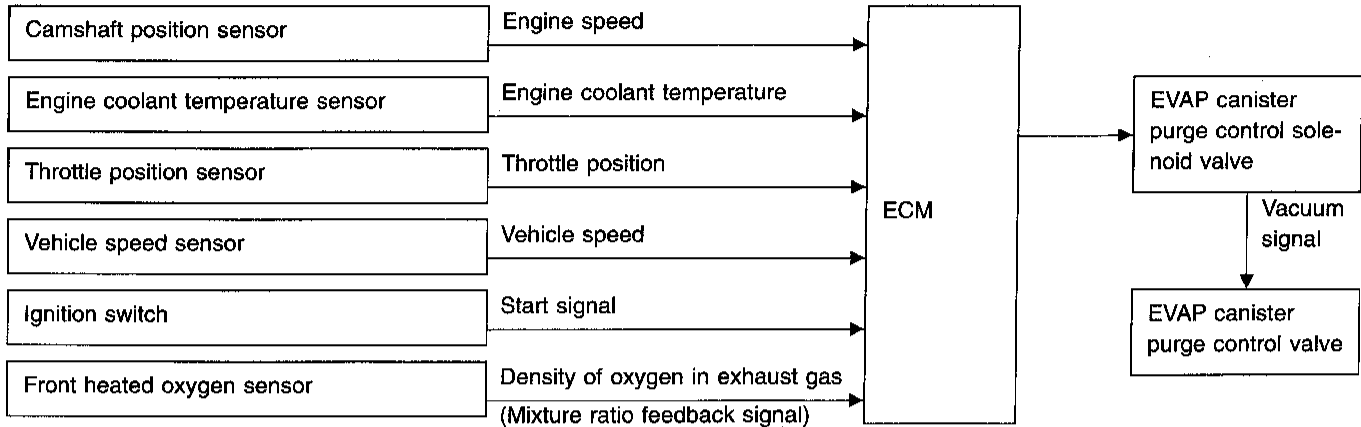

This system controls the vacuum signal applied to the EVAP canister purge control valve. When the ECM detects any of the following conditions, current does not flow through the EVAP canister purge control solenoid valve. The solenoid valve cuts the vacuum signal so that the EVAP canister purge control valve remains closed.

- Ignition switch "ON"
- Closed throttle position
- Low engine coolant temperature
- During deceleration
- Engine stopped
- Low vehicle speed (M/T models)
- For 60 seconds after starting engine (After warm-up to normal operating temperature)

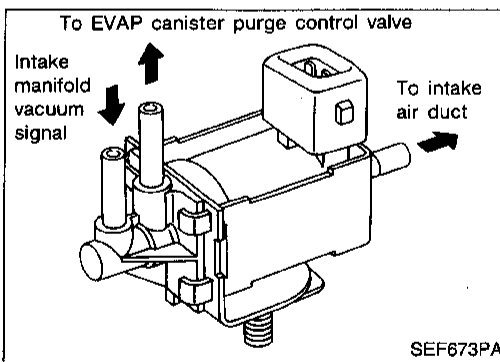

COMPONENT DESCRIPTION

EVAP canister purge control solenoid valve

The EVAP canister purge control solenoid valve responds to signals from the ECM. When the ECM sends an OFF signal, the vacuum signal (from the intake manifold to the EVAP canister purge control valve) is cut.

When the ECM sends an ON (ground) signal, the vacuum signal passes through the EVAP canister purge control solenoid valve. The signal then opens the EVAP canister purge control valve.

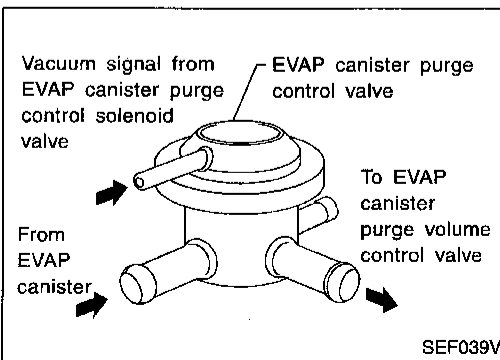

EVAP canister purge control valve

When the vacuum signal is cut by EVAP canister purge control solenoid valve, EVAP canister purge control valve closes.

TROUBLE DIAGNOSIS FOR DTC P1493

Evaporative Emission (EVAP) Canister Purge Control Valve/Solenoid Valve (Cont'd)

EVAPORATIVE EMISSION SYSTEM DIAGRAM

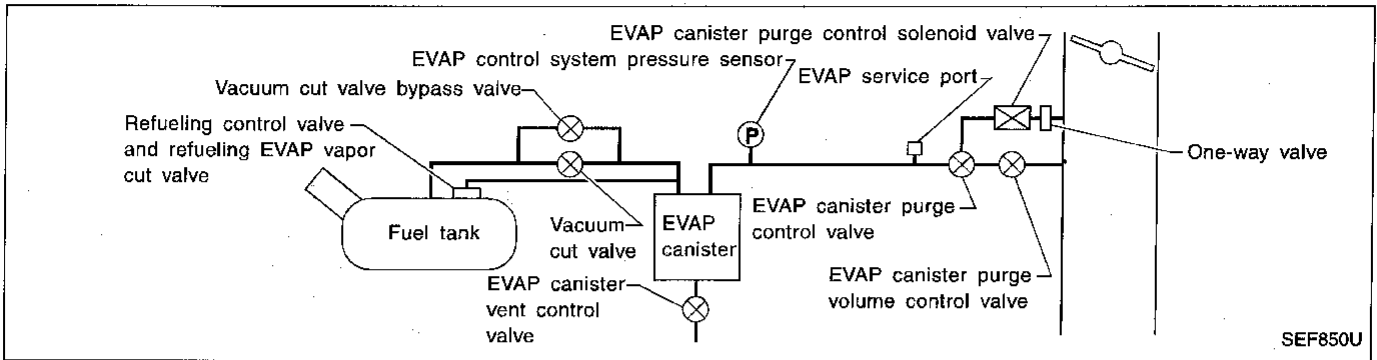

SEF850U

CONSULT REFERENCE VALUE IN DATA MONITOR MODE

MONITOR ITEM	CONDITION	SPECIFICATION
PURG CONT S/V	<ul style="list-style-type: none"> ● Engine: After warming up ● Shift lever: N ● No-load ● M/T models: Lift up drive wheels and shift to 1st gear position. 	OFF
	<ul style="list-style-type: none"> Idle More than 60 seconds after starting engine A/T models: 2,000 rpm M/T models: 2,000 rpm and more than 16 km/h (10 MPH) 	ON

ECM TERMINALS AND REFERENCE VALUE

Specification data are reference values and are measured between each terminal and engine ground.

TER-MINAL NO.	WIRE COLOR	ITEM	CONDITION	DATA (DC voltage)
105	PU	EVAP canister purge control solenoid valve	Engine is running. (Warm-up condition) <ul style="list-style-type: none"> More than 60 seconds after starting engine M/T models: Jack up front wheels and drive wheels at 16 km/h (10 MPH). Engine speed is 2,000 rpm. 	Approximately 0V
			Engine is running. (Warm-up condition) <ul style="list-style-type: none"> Idle speed 	BATTERY VOLTAGE (11 - 14V)

ON BOARD DIAGNOSIS LOGIC

Diagnostic Trouble Code No.	Malfunction is detected when	Check Items (Possible Cause)
P1493	<ul style="list-style-type: none"> ● EVAP canister purge control valve does not operate properly (stuck open). 	<ul style="list-style-type: none"> ● EVAP canister purge control valve ● EVAP canister purge control solenoid valve ● Vacuum hoses for clogging or disconnection ● EVAP control system pressure sensor ● EVAP canister vent control valve ● Water separator ● EVAP canister saturated with water

TROUBLE DIAGNOSIS FOR DTC P1493

Evaporative Emission (EVAP) Canister Purge Control Valve/Solenoid Valve (Cont'd)

DIAGNOSTIC TROUBLE CODE CONFIRMATION PROCEDURE

CAUTION:

Always drive vehicle at a safe speed.

NOTE:

- If DTC P1493 is displayed with P1492, perform TROUBLE DIAGNOSIS FOR DTC P1492 first. (See EC-433.)
- If "DTC CONFIRMATION PROCEDURE" has been previously conducted, always turn ignition switch "OFF" and wait at least 5 seconds before conducting the next test.



- 1) Start engine and warm it up to normal operating temperature.
- 2) Turn ignition switch "OFF" and wait at least 5 seconds.
- 3) Turn ignition switch "ON".
- 4) Select "PURG CN/V & S/V P1493" of "EVAPORATIVE SYSTEM" in "DTC WORK SUPPORT" mode with CONSULT.
- 5) Touch "START".
- 6) Start engine and let it idle for at least 90 seconds.
- 7) When the following conditions are met, "TESTING" will be displayed on the CONSULT screen. Maintain the conditions continuously until "TESTING" changes to "COMPLETED". (It will take approximately 30 seconds.)

Selector lever: Suitable position

Vehicle speed: 36 - 120 km/h (22 - 75 MPH)

CMPS-RPM (REF): 1,000 rpm or more

B/FUEL SCHDL: 1 - 4.5 msec

If "TESTING" is not displayed after 5 minutes, retry from step 2).

- 8) Make sure that "OK" is displayed after touching "SELF-DIAG RESULTS".

If "NG" is displayed, refer to "DIAGNOSTIC PROCEDURE", EC-443.

■ PURG CN/V&S/V P1493 ■

THIS SUPPORT FUNCTION IS FOR DTC P1493. SEE THE SERVICE MANUAL ABOUT THE OPERATING CONDITION FOR THIS DIAGNOSIS.

EXITSTART

SEF610U

■ PURG CN/V&S/V P1493 ■

***** OK *****

■ SELF-DIAG RESULTS ■

**** NO FAILURE ****

ENDPRINT

SEF611U

TROUBLE DIAGNOSIS FOR DTC P1493

Evaporative Emission (EVAP) Canister Purge Control Valve/Solenoid Valve (Cont'd)

ENGINE SPD	825RPM
COOLANT TEMP	69°C
VEHICLE SPD	0MPH
IGN ADVANCE	8.0°
CALC LOAD	28.2%
MAP	36KPaA
MAF	5.20gm/s
THROTTLE POS	0.0%
INTAKE AIR	27°C
FUEL SYS #1	OLDRIVE
FUEL SYS #2	UNUSED
SHORT FT #1	0.8%
LONG FT #1	0.0%
O2S B1 S1	0.200V
O2FT B1 S1	0.8%
O2S B1 S2	0.010V

SEF519R

OR



- 1) Start engine and warm it up to normal operating temperature.
- 2) Select "MODE 1" with GST.
- 3) Check coolant temperature.

GI

MA

EM

LC

EC

FE

CL

MT

AT

FA

Coolant temperature: 40 - 100°C (104 - 212°F)
Be sure that water temperature does not exceed 100°C. If it becomes higher than 100°C, cool down the engine and perform the procedure again from the beginning.

- 4) Turn ignition switch "OFF" and wait at least 5 seconds.
- 5) Restart engine and let it idle for at least 100 seconds.
- 6) Maintain the following conditions for at least 30 seconds.

Gear position: Suitable gear position

Vehicle speed: 36 - 120 km/h (22 - 75 MPH)

Engine speed: 1,000 rpm or more

Coolant temperature: 40 - 100°C (104 - 212°F)

- 7) Select "MODE 7" with GST.
- 8) If 1st trip DTC is detected, go to "DIAGNOSTIC PROCEDURE", EC-443.

NOTE:

- Hold the accelerator pedal as steady as possible during driving in step 6.
- If the driving conditions are not satisfied in step 6, restart the procedure.
- It is better that the fuel level is low.

OR



- 1) Start engine and warm it up to normal operating temperature.
- 2) Check voltage between ECM terminal (51) and ground
Voltage: 0.8 - 1.5V

RA

BR

ST

RS

BT

HA

EL

IDX

Perform the following procedure before the voltage drops below 0.8V. If the voltage drops below 0.8V, cool down the engine and perform the entire procedure all over again.

- 3) Turn ignition switch "OFF" and wait at least 5 seconds.
- 4) Restart engine and let it idle for at least 100 seconds.
- 5) Maintain the following conditions for at least 30 seconds.

Gear position: Suitable gear position

Vehicle speed: 36 - 120 km/h (22 - 75 MPH)

Engine speed: 1,000 rpm or more

Check voltage between ECM terminal (51) and ground: 0.8 - 1.5 V

- 6) Stop the vehicle, turn ignition switch "OFF", wait at least 5 seconds, and then turn "ON".
- 7) Perform "Diagnostic Test Mode II (Self-diagnostic results)" with ECM.
- 8) If 1st trip DTC is detected, go to "DIAGNOSTIC PROCEDURE", EC-443.

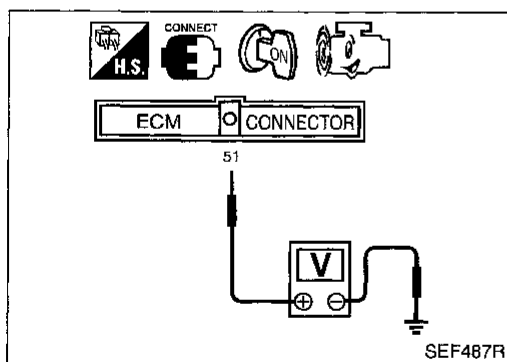

SEF487R

TROUBLE DIAGNOSIS FOR DTC P1493

Evaporative Emission (EVAP) Canister Purge Control Valve/Solenoid Valve (Cont'd)

NOTE:

- Hold the accelerator pedal as steady as possible during driving in step 5.
- If the driving conditions are not satisfied in step 5, restart the procedure.
- It is better that the fuel level is low.

TROUBLE DIAGNOSIS FOR DTC P1493

Evaporative Emission (EVAP) Canister Purge Control Valve/Solenoid Valve (Cont'd)

DIAGNOSTIC PROCEDURE

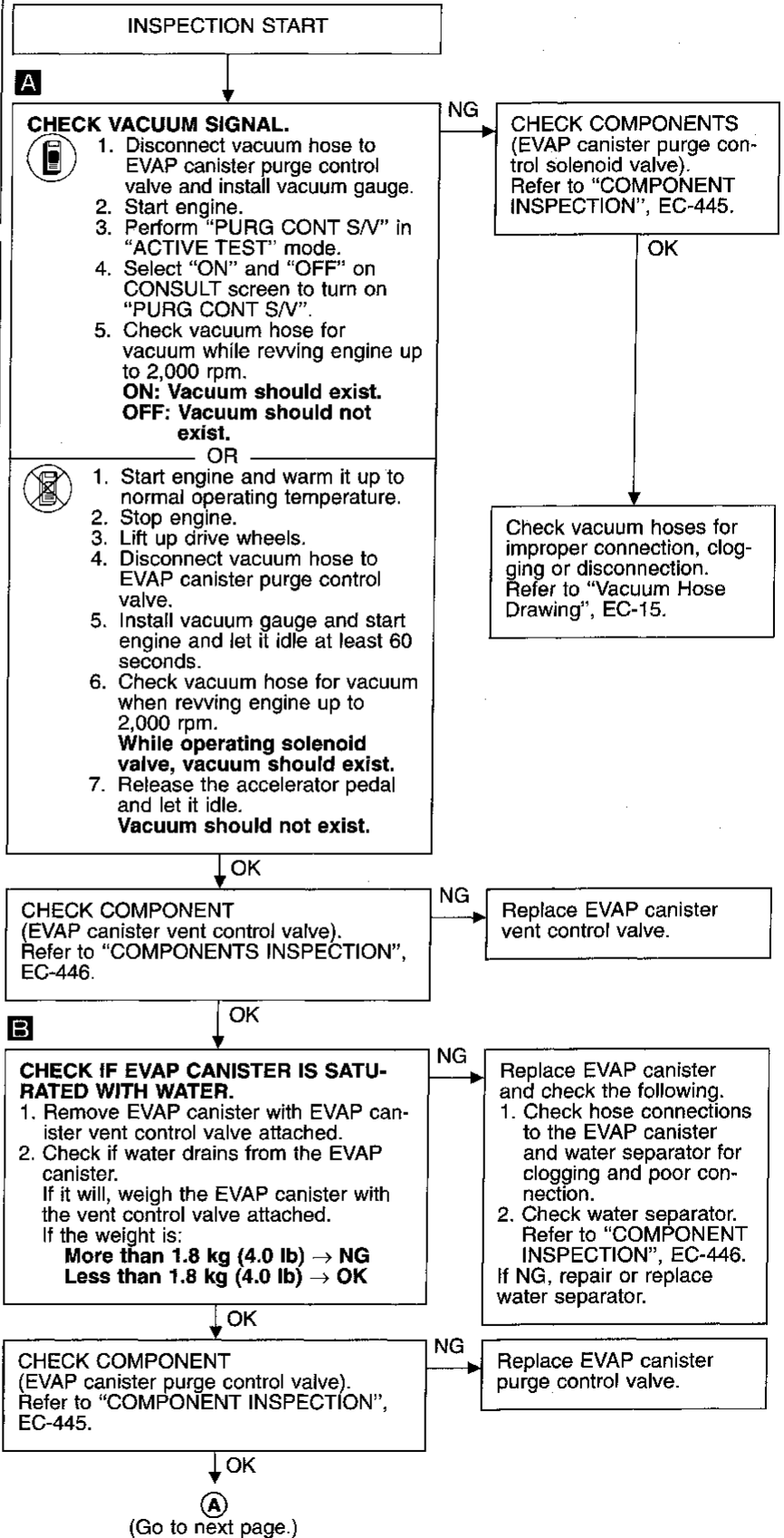
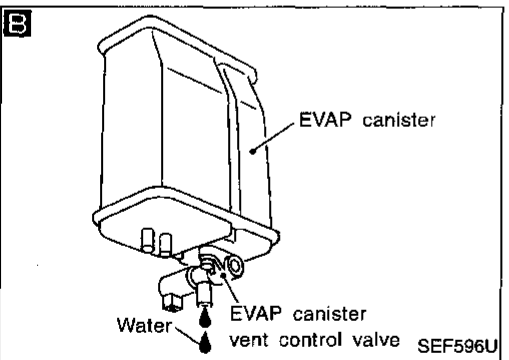
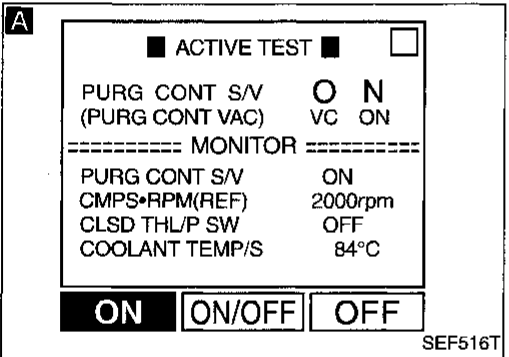
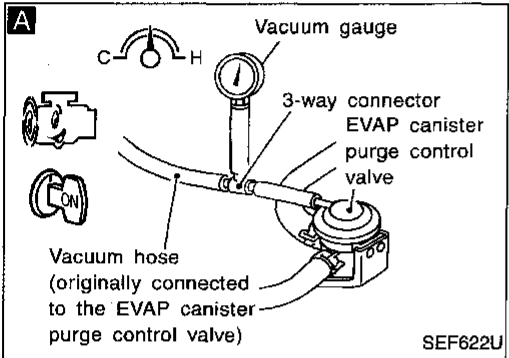
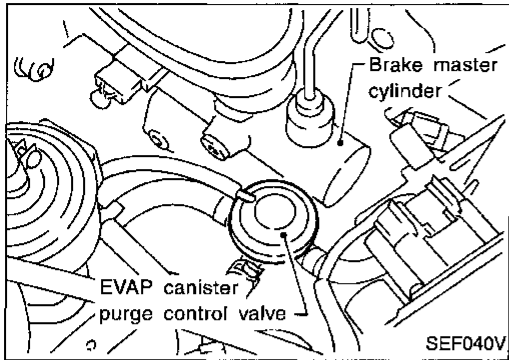

TROUBLE DIAGNOSIS FOR DTC P1493

Evaporative Emission (EVAP) Canister Purge Control Valve/Solenoid Valve (Cont'd)

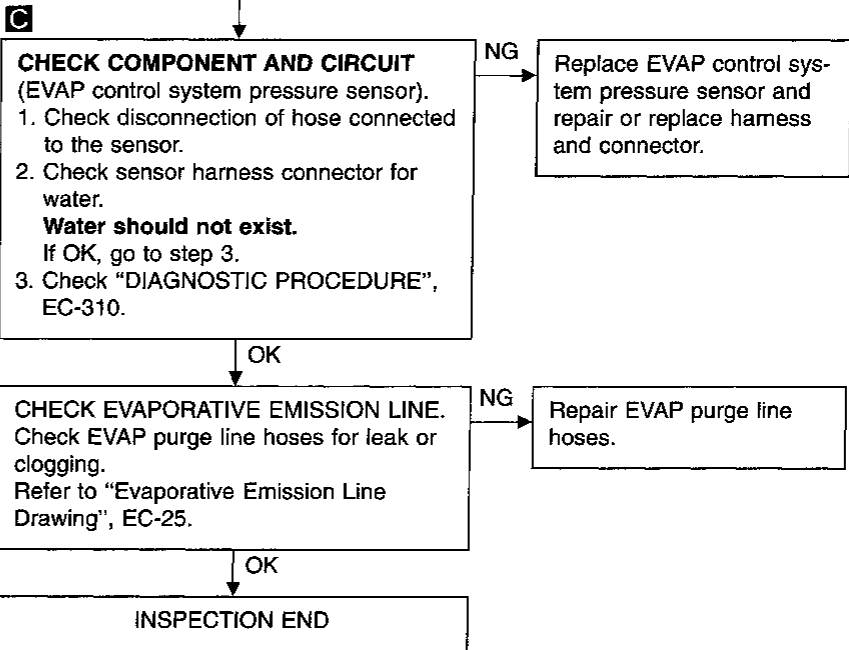
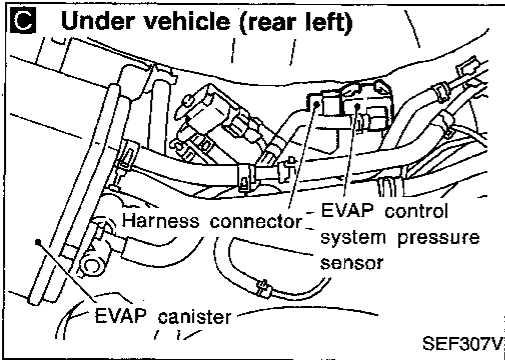

TROUBLE DIAGNOSIS FOR DTC P1493

Evaporative Emission (EVAP) Canister Purge Control Valve/Solenoid Valve (Cont'd)

COMPONENT INSPECTION

EVAP canister purge control solenoid valve

1. Lift up driving wheels (M/T models only).
2. Turn ignition switch "ON".
3. Select "PURG CONT S/V" of "ACTIVE TEST" mode with CONSULT.
4. Start engine and warm it up to normal operating temperature.
5. Disconnect vacuum hose at EVAP canister purge control valve.
6. Touch "ON" and "OFF" and check for vacuum passing through the hose.

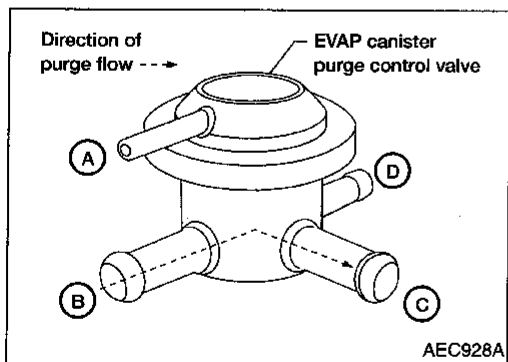
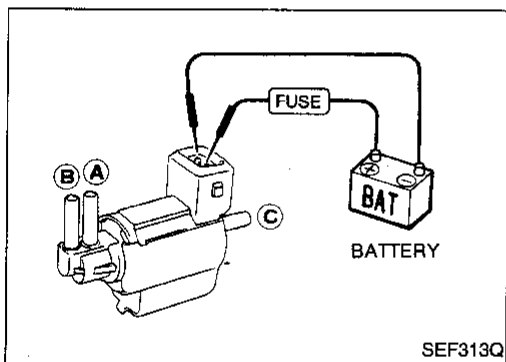
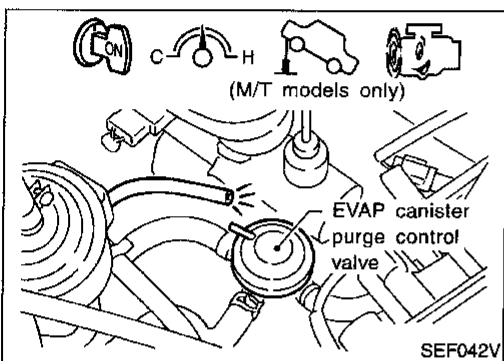
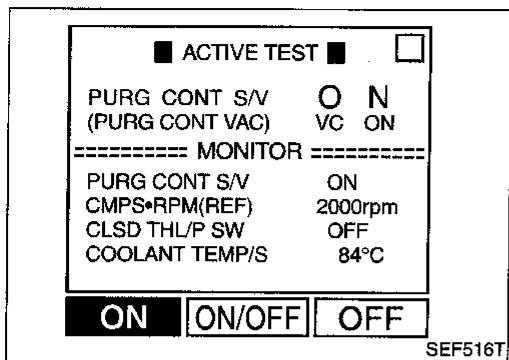

Condition	Vacuum
Idle	Not exist
2,200 rpm (A/T models) 2,000 rpm with 1st gear position (M/T models)	Exist

OR

- ⊗ Check air passage continuity.

Condition	Air passage continuity between (A) and (B)	Air passage continuity between (A) and (C)
12V direct current supply between terminals	Yes	No
No supply	No	Yes

If NG or operation takes more than 1 second, replace solenoid valve.

EVAP canister purge control valve

Check EVAP canister purge control valve as follows:

1. Blow air in port (A) and (C) and ensure that there is no leakage.
2. Plug port (D) and blow air in port (B). Ensure that there is resistance to flow out of port (C).
3. Plug port (B) and blow air in port (D). Ensure that there is resistance to flow out of port (C).
4. Apply vacuum to port (A) [approximately -13.3 to -20.0 kPa (-100 to -150 mmHg, -3.94 to -5.91 inHg)]. Plug port (D) and blow air in port (C) and ensure free flow out of port (B). Plug port (B) and blow air in port (C) and ensure free flow out of port (D).

TROUBLE DIAGNOSIS FOR DTC P1493

Evaporative Emission (EVAP) Canister Purge Control Valve/Solenoid Valve (Cont'd)

EVAP canister vent control valve

Check air passage continuity.

- ① Perform "VENT CONTROL/V" in "ACTIVE TEST" mode with CONSULT.

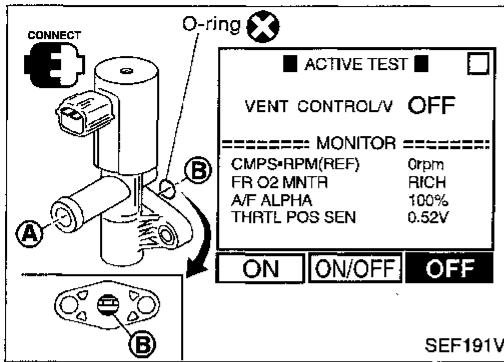

Condition	Air passage continuity between (A) and (B)
VENT CONTROL/V ON	No
VENT CONTROL/V OFF	Yes

OR

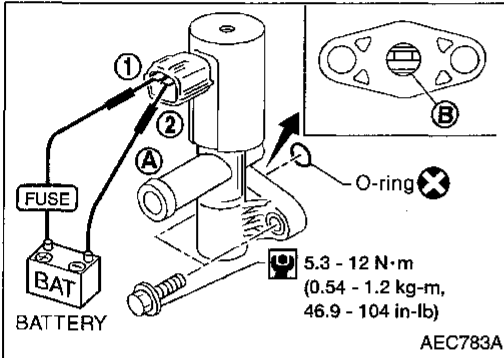

Condition	Air passage continuity between (A) and (B)
12V direct current supply between terminals ① and ②	No
No supply	Yes

If NG or operation takes more than 1 second, clean valve using air blower or replace as necessary.

If the portion (B) is rusted, replace EVAP canister vent control valve.

Make sure new O-ring is installed properly.

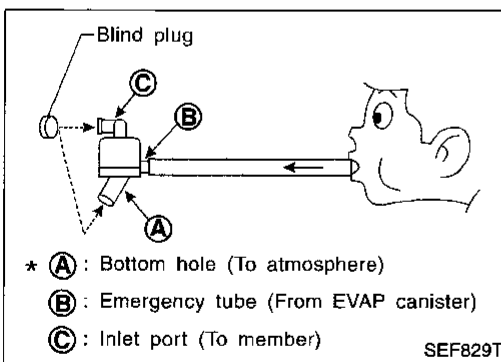

Water separator

1. Check visually for insect nests in the water separator air inlet.
2. Check visually for cracks or flaws in the appearance.
3. Check visually for cracks or flaws in the hose.
4. Check that (A) and (C) are not clogged by blowing air into (B) with (A), and then (C) plugged.
5. In case of NG in items 2 - 4, replace the parts.

NOTE:

- Do not disassemble water separator.

TROUBLE DIAGNOSIS FOR DTC P1605

A/T Diagnosis Communication Line

The malfunction information related to A/T (Automatic Transaxle) is transferred through the line (circuit) from TCM (Transmission Control Module) to ECM. Therefore, be sure to erase the malfunction information such as DTC not only in TCM (Transmission Control Module) but also ECM after the A/T related repair.

ECM TERMINALS AND REFERENCE VALUE

Specification data are reference values and are measured between each terminal and ground.

TER-MINAL NO.	WIRE COLOR	ITEM	CONDITION	DATA (DC voltage)
7	PU (A/T models)	A/T check signal	Ignition switch "ON" Engine is running.	0 - 4V

ON BOARD DIAGNOSIS LOGIC

Diagnostic Trouble Code No.	Malfunction is detected when ...	Check Items (Possible Cause)
P1605 0804	<ul style="list-style-type: none"> An incorrect signal from TCM (Transmission Control Module) is sent to ECM. 	<ul style="list-style-type: none"> Harness or connectors [The communication line circuit between ECM and TCM (Transmission Control Module) is open or shorted.] Dead (Weak) battery TCM (Transmission Control Module)

DIAGNOSTIC TROUBLE CODE CONFIRMATION PROCEDURE

NOTE:

If "DTC CONFIRMATION PROCEDURE" has been previously conducted, always turn ignition switch "OFF" and wait at least 5 seconds before conducting the next test.



- 1) Turn ignition switch "ON".
- 2) Select "DATA MONITOR" mode with CONSULT.
- 3) Start engine and let it idle for at least 40 seconds.
- 4) If 1st trip DTC is detected, go to "DIAGNOSTIC PROCEDURE", EC-449.

OR



- 1) Start engine and let it idle for at least 40 seconds.
- 2) Select "MODE 3" with GST.
- 3) If 1st trip DTC is detected, go to "DIAGNOSTIC PROCEDURE", EC-449.

OR



- 1) Start engine and let it idle for at least 40 seconds.
- 2) Turn ignition switch "OFF", wait at least 5 seconds and then turn "ON".
- 3) Perform "Diagnostic Test Mode II" (Self-diagnostic results) with ECM.
- 4) If 1st trip DTC is detected, go to "DIAGNOSTIC PROCEDURE", EC-449.

TROUBLE DIAGNOSIS FOR DTC P1605

A/T Diagnosis Communication Line (Cont'd)

EC-ATDIAG-01

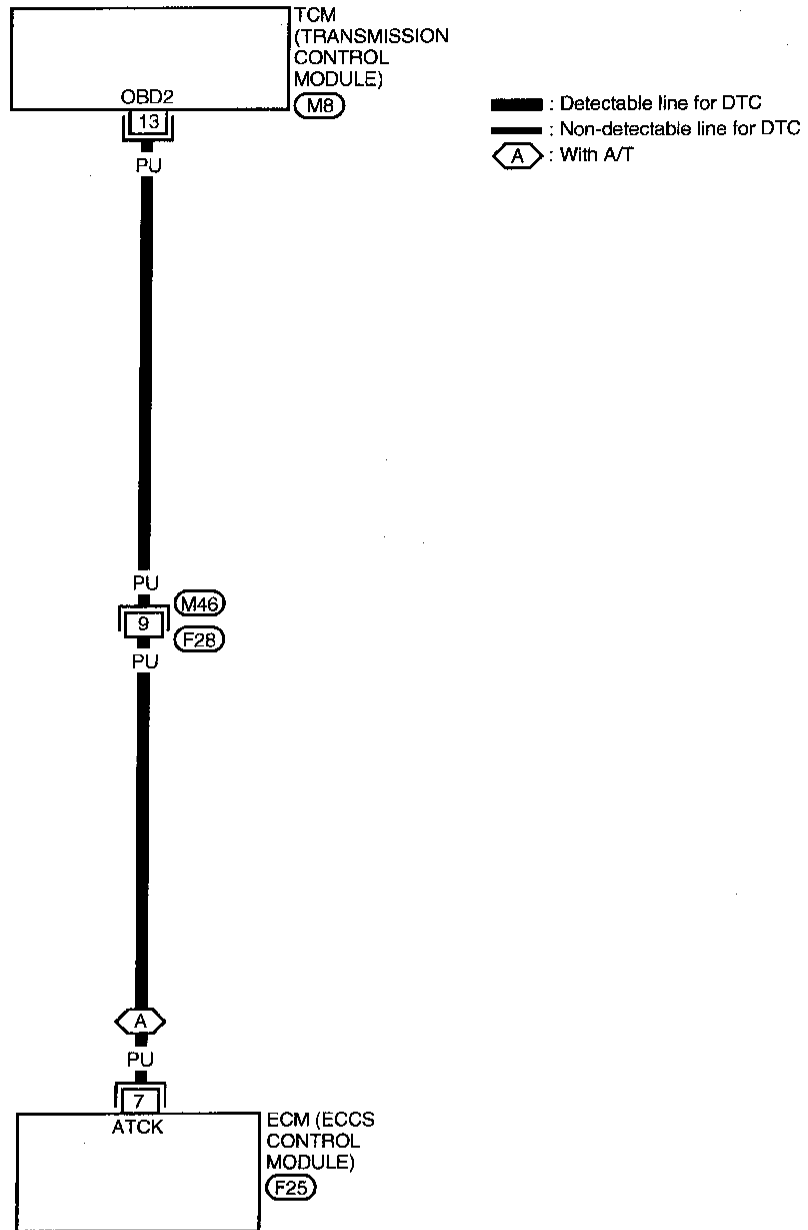

1	2	3	◊	4	5	6	(M46)			
7	8	9	10	11	12	13	14	15	16	W

1	2	3	4	9	10	11	12	13	14	15	23	24	25	26	27	28	29	30	31	32	33	34	35	(M8)	H.S.
5	6	7	8	16	17	18	19	20	21	22	36	37	38	39	40	41	42	43	44	45	46	47	48	L	

101	102	103	104	105	106	1	2	3	4	20	21	22	23	38	39	40	41	53	54	55	56	(F25)	H.S.										
107	108	109	110	111	112	5	6	7	8	9	10	24	25	26	27	28	42	43	44	45	46	57	58	59	60	61	66	67	68	69	70	W	
113	114	115	116	117	118	11	12	13	14	19	29	30	31	32	33	47	48	62	63	64	65												
						15	16	17	18		34	35	36	37	49	50	51	52	66	67	68	69											

TROUBLE DIAGNOSIS FOR DTC P1605

A/T Diagnosis Communication Line (Cont'd)

DIAGNOSTIC PROCEDURE

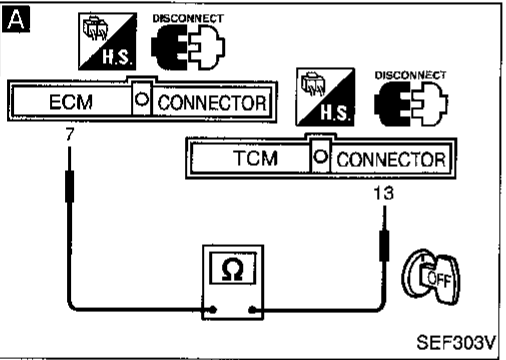
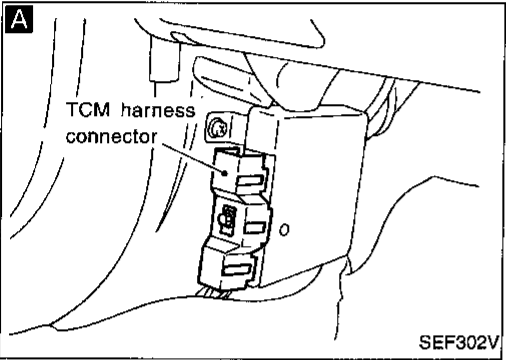
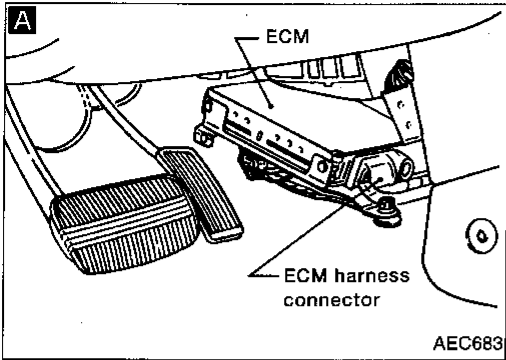

INSPECTION START

A
CHECK INPUT SIGNAL CIRCUIT.
 1. Turn ignition switch "OFF".
 2. Disconnect ECM harness connector and TCM harness connector.
 3. Check harness continuity between ECM terminal ⑦ and TCM terminal ⑬.
Continuity should exist.
 If OK, check harness for short.

NG → Check the following.
 ● Harness connectors
 ● (F28), (M46)
 ● Harness for open or short between ECM and TCM
 If NG, repair open circuit or short to ground or short to power in harness or connectors.

OK ↓

Perform "TROUBLE DIAGNOSIS FOR INTERMITTENT INCIDENT", EC-106.

INSPECTION END

GI
 MA
 EM
 LC
EC
 FE
 CL
 MT
 AT
 FA
 RA
 BR
 ST
 RS
 BT
 HA
 EL
 IDX

TROUBLE DIAGNOSIS FOR DTC P1706

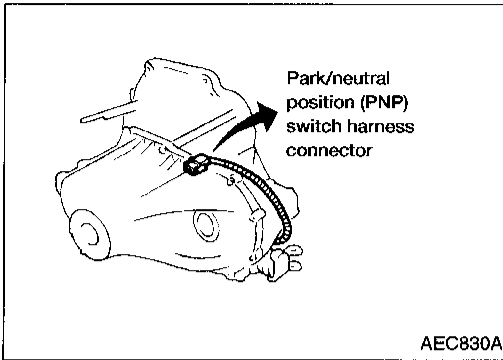

Park/Neutral Position (PNP) Switch

COMPONENT DESCRIPTION

When the gear position is "P" (A/T models only) or "N", park/neutral position (PNP) switch is "ON".

ECM detects the park/neutral position when continuity with ground exists.

For A/T models, the park/neutral position (PNP) switch assembly also includes a transmission range switch to detect selector lever position.

CONSULT REFERENCE VALUE IN DATA MONITOR MODE

Specification data are reference values.

MONITOR ITEM	CONDITION	SPECIFICATION
P/N POSI SW	● Ignition switch: ON	Shift lever: "P" or "N" ON
		Except above OFF

ECM TERMINALS AND REFERENCE VALUE

Specification data are reference values and are measured between each terminal and engine ground.

TER-MINAL NO.	WIRE COLOR	ITEM	CONDITION	DATA (DC voltage)
22	G/OR	Park/neutral position (PNP) switch	Ignition switch "ON" └ Gear position is "Neutral position" (M/T models). └ Gear position is "N" or "P" (A/T models).	Approximately 0V
			Ignition switch "ON" └ Except the above gear position	BATTERY VOLTAGE (11 - 14V)

ON BOARD DIAGNOSIS LOGIC

Diagnostic Trouble Code No.	Malfunction is detected when	Check Items (Possible Cause)
P1706 1003	● The signal of the park/neutral position (PNP) switch is not changed in the process of engine starting and driving.	● Harness or connectors (The park/neutral position (PNP) switch circuit is open or shorted.) ● Park/neutral position (PNP) switch

TROUBLE DIAGNOSIS FOR DTC P1706

Park/Neutral Position (PNP) Switch (Cont'd) DIAGNOSTIC TROUBLE CODE CONFIRMATION PROCEDURE

CAUTION:

Always drive vehicle at a safe speed.

NOTE:

If "DIAGNOSTIC TROUBLE CODE CONFIRMATION PROCEDURE" has been previously conducted, always turn ignition switch "OFF" and wait at least 5 seconds before conducting the next test.



- 1) Turn ignition switch "ON".
 - 2) Perform "PARK/NEUT POSI SW CKT" in "FUNCTION TEST" mode with CONSULT.
If NG, go to "DIAGNOSTIC PROCEDURE", EC-453.
If OK, go to following step.
- OR
- 2) Select "P/N POSI SW" in "DATA MONITOR" mode with CONSULT. Then check the "P/N POSI SW" signal under the following conditions.

Position (Selector lever)	Known good signal
"N" and "P" (A/T only) position	ON
Except the above position	OFF

If NG, go to "DIAGNOSTIC PROCEDURE", EC-453.
If OK, go to following step.

- 3) Select "DATA MONITOR" mode with CONSULT.
- 4) Start engine and warm it up to normal operating temperature.
- 5) Maintain the following conditions for at least 60 consecutive seconds (A/T), 40 consecutive seconds (M/T).
CMPS·RPM (REF): 2,100 - 3,000 rpm (M/T)
1,800 - 2,600 rpm (A/T)
COOLAN TEMP/S: More than 70°C (158°F)
B/FUEL SCHDL: 1 - 4 msec (A/T)
0.9 - 3.7 msec (M/T)
VHCL SPEED SE: 70 - 100 km/h (43 - 62 MPH)
Selector lever: Suitable position
- 6) If 1st trip DTC is detected, go to "DIAGNOSTIC PROCEDURE", EC-453.

OR

OVERALL FUNCTION CHECK

Use this procedure to check the overall function of the park/neutral position (PNP) switch circuit. During this check, a 1st trip DTC might not be confirmed.



- 1) Turn ignition switch "ON".
- 2) Check voltage between ECM terminal ② and body ground under the following conditions.

Condition (Gear position)	Voltage (V) (Known good data)
"P" (A/T only) and "N" position	Approx. 0
Except the above position	BATTERY VOLTAGE (11 - 14V)

- 3) If NG, go to "DIAGNOSTIC PROCEDURE", EC-453.

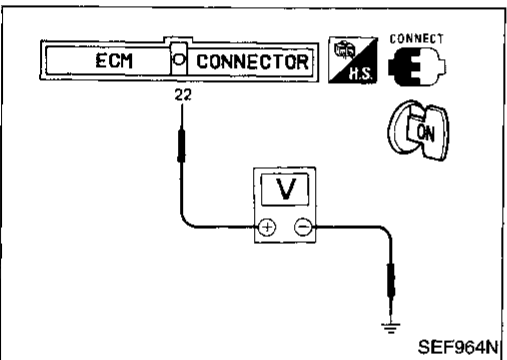
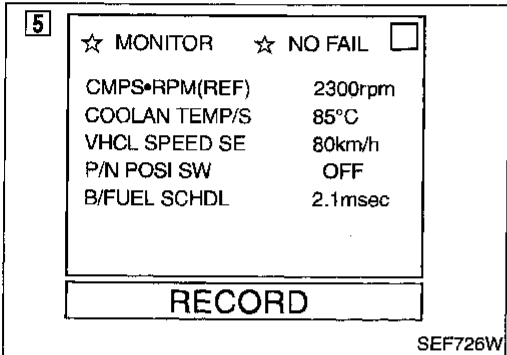
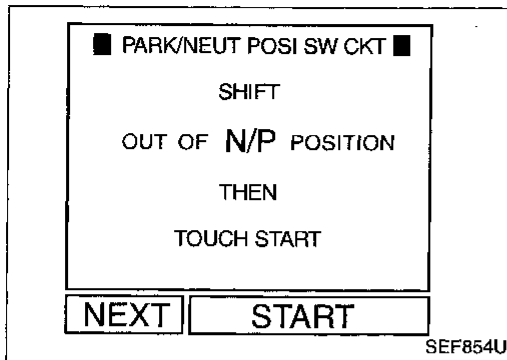

TROUBLE DIAGNOSIS FOR DTC P1706

Park/Neutral Position (PNP) Switch (Cont'd)

EC-PNP/SW-01

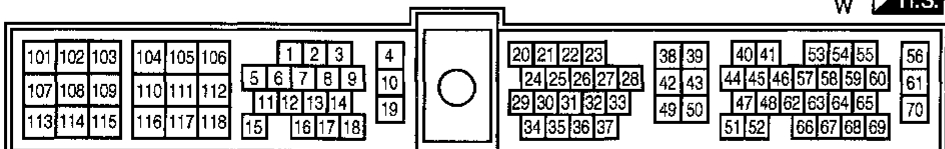
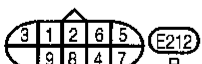
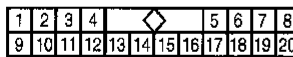
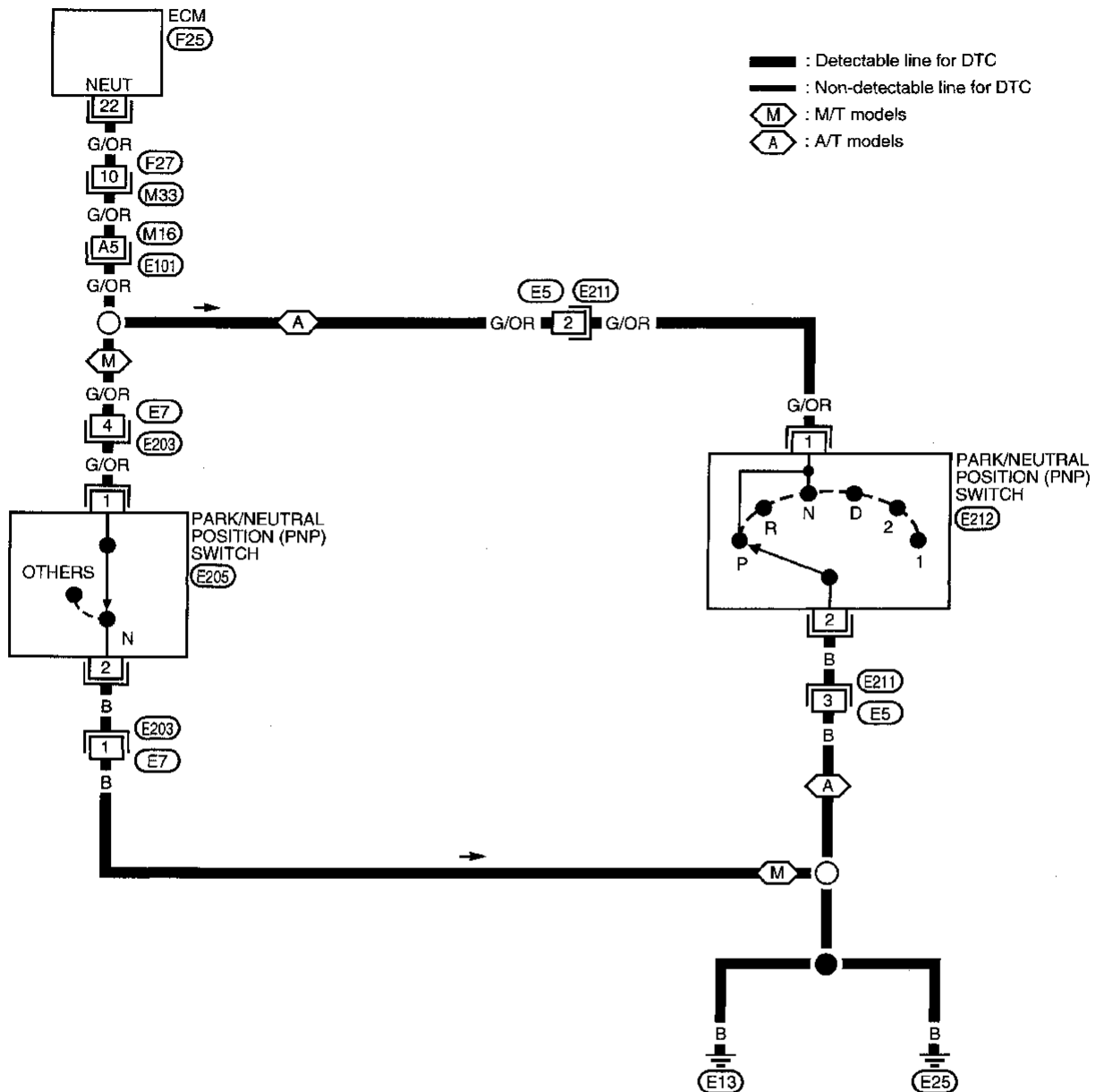

Refer to last page (Foldout page).
M16, E101

TROUBLE DIAGNOSIS FOR DTC P1706

Park/Neutral Position (PNP) Switch (Cont'd)

DIAGNOSTIC PROCEDURE

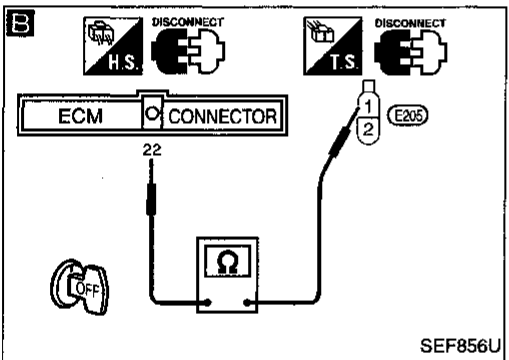
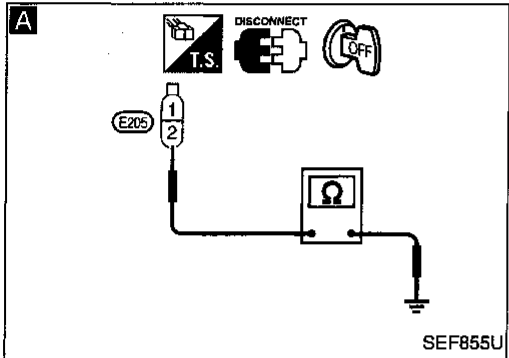
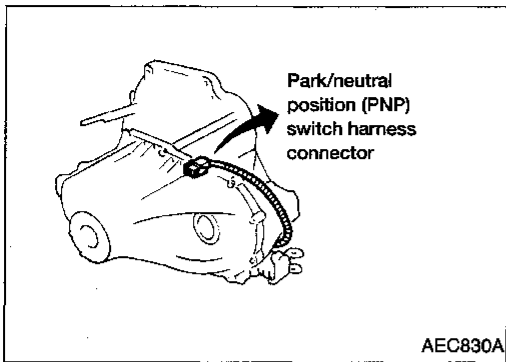

Neutral position switch (M/T models)

INSPECTION START

A

CHECK GROUND CIRCUIT.

1. Disconnect park/neutral position (PNP) switch harness connector.
2. Check harness continuity between terminal ② and body ground.
Continuity should exist.
If OK, check harness for short to ground and short to power.

NG

Check the following.

- Harness connectors **E203**, **E7**
- Harness for open or short between park/neutral position (PNP) switch and body ground

If NG, repair open circuit or short to ground or short to power in harness or connectors.

B

CHECK INPUT SIGNAL CIRCUIT.

1. Disconnect ECM harness connector.
2. Check harness continuity between ECM terminal ② and terminal ①.
Continuity should exist.
If OK, check harness for short to ground and short to power.

NG

Check the following.

- Harness connectors **F27**, **M33**, **M16**, **E101**
- Harness connectors **E7**, **E203**
- Harness for open or short between ECM and park/neutral position (PNP) switch

If NG, repair open circuit or short to ground or short to power in harness or connectors.

CHECK COMPONENT
(Park/neutral position (PNP) switch).
Refer to MT section.

NG

Replace park/neutral position (PNP) switch.

OK

Perform "TROUBLE DIAGNOSIS FOR INTERMITTENT INCIDENT", EC-106.

INSPECTION END

GI
MA
EM
LC
EC
FE
CL
MT
AT
FA
RA
BR
ST
RS
BT
HA
EL
IDX

TROUBLE DIAGNOSIS FOR DTC P1706

Park/Neutral Position (PNP) Switch (Cont'd)

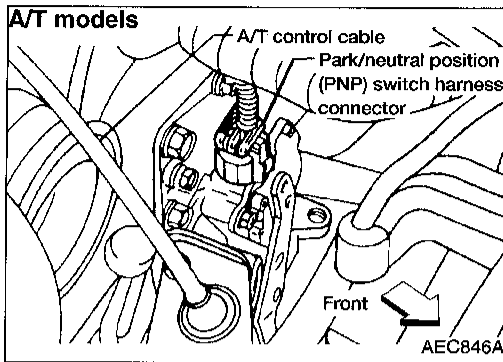

Park/neutral position (PNP) switch (A/T models)

INSPECTION START

A
CHECK GROUND CIRCUIT.
 1. Disconnect park/neutral position (PNP) switch harness connector.
 2. Check continuity between terminal ② and ground with CONSULT or tester.
Continuity should exist.
 If OK, check harness for short to ground and short to power.

NG
 Check the following.
 ● Harness connectors (E211, E5)
 ● Harness for open or short between park/neutral position (PNP) switch and ground
 If NG, repair open circuit or short to ground or short to power in harness or connectors.

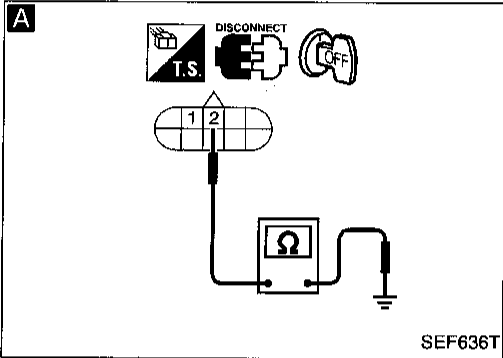

B
CHECK INPUT SIGNAL CIRCUIT.
 1. Disconnect ECM harness connector.
 2. Check harness continuity between ECM terminal ②② and terminals ①.
Continuity should exist.
 If OK, check harness for short to ground and short to power.

NG
 Check the following.
 ● Harness connectors (F27, M33, M16, E101)
 ● Harness connectors (E5, E211)
 ● Harness for open or short between park/neutral position (PNP) switch and ECM
 If NG, repair open circuit or short to ground or short to power in harness or connectors.

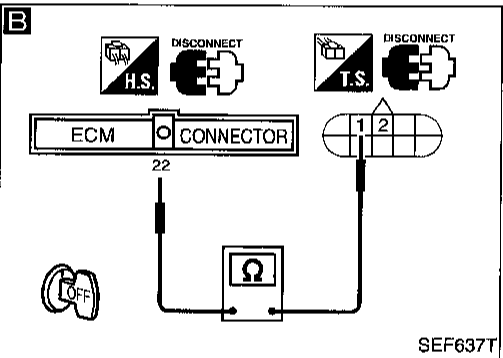

CHECK COMPONENT
 (Park/neutral position (PNP) switch).
 Refer to AT section.

NG
 Replace park/neutral position (PNP) switch.

OK
 Perform "TROUBLE DIAGNOSIS FOR INTERMITTENT INCIDENT", EC-106.

INSPECTION END

TROUBLE DIAGNOSIS FOR OVERHEAT

Overheat

SYSTEM DESCRIPTION

Cooling fan control

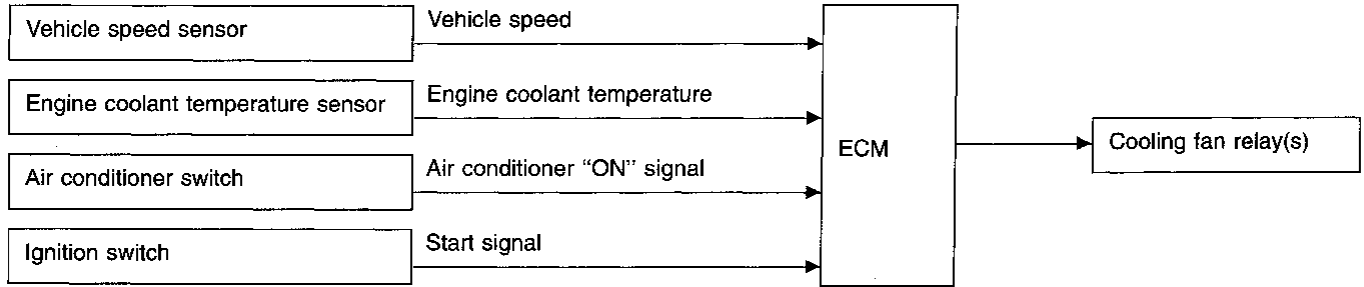

The ECM controls the cooling fan corresponding to the vehicle speed, engine coolant temperature, and air conditioner ON signal. The control system has 3-step control [HIGH/LOW/OFF] on A/T models and 2-step control [HIGH/OFF] on M/T models.

Operation

For A/T models

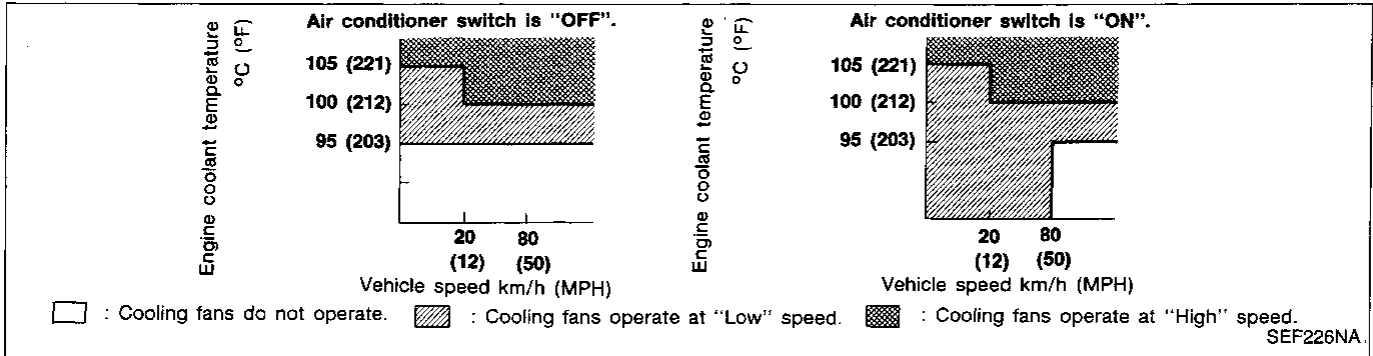

For M/T models

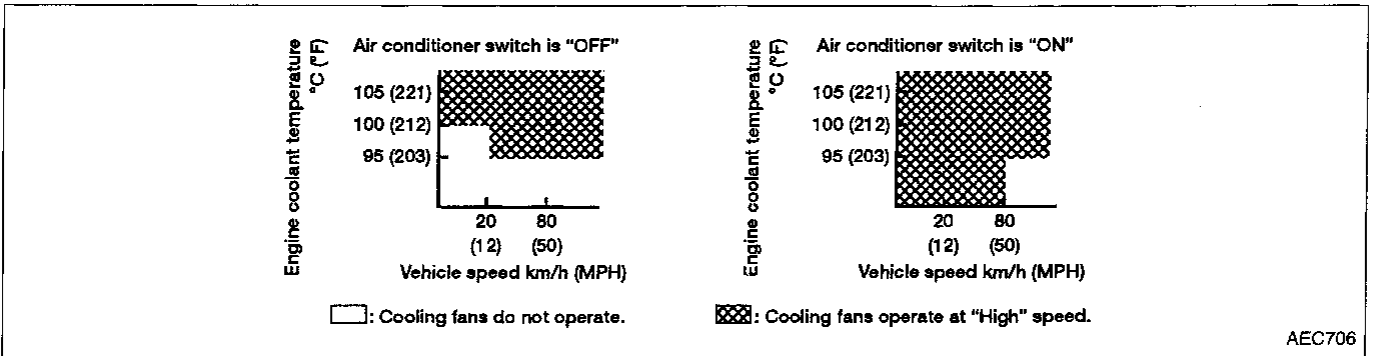

TROUBLE DIAGNOSIS FOR OVERHEAT

Overheat (Cont'd)

CONSULT REFERENCE VALUE IN DATA MONITOR MODE

Specification data are reference values.

MONITOR ITEM	CONDITION	SPECIFICATION
AIR COND SIG	● Engine: After warming up, idle the engine	Air conditioner switch: OFF OFF
		Air conditioner switch: ON (Compressor operates) ON
COOLING FAN	<ul style="list-style-type: none"> ● After warming up engine, idle the engine. ● Air conditioner switch: OFF 	Engine coolant temperature is 94°C (201°F) or less for A/T models, and 99°C (210°F) or less for M/T models. OFF
		Engine coolant temperature is between 95°C (203°F) and 104°C (219°F) for A/T models only. LOW
		Engine coolant temperature is 105°C (221°F) or more for A/T models, and 100°C (212°F) or more for M/T models. HIGH

ECM TERMINALS AND REFERENCE VALUE

Specification data are reference values and are measured between each terminal and engine ground.

TER-MINAL NO.	WIRE COLOR	ITEM	CONDITION	DATA (DC voltage)
13	LG (A/T models)	Cooling fan relay (High)	Engine is running. └ Cooling fan is not operating.	BATTERY VOLTAGE (11 - 14V)
			Engine is running. └ Cooling fan (High) is operating.	0 - 0.6V
14	LG/R	Cooling fan relay (Low)	Engine is running. └ Cooling fan is not operating.	BATTERY VOLTAGE (11 - 14V)
			Engine is running. └ Cooling fan (Low) is operating.	0.06V
21	L/W	Air conditioner switch	Engine is running. └ Both air conditioner switch and blower switch are "ON" (Compressor operates).	Approximately 0V
			Engine is running. └ Air conditioner switch is "OFF".	BATTERY VOLTAGE (11 - 14V)

TROUBLE DIAGNOSIS FOR OVERHEAT

Overheat (Cont'd)

ON BOARD DIAGNOSIS LOGIC

If the cooling fan or another component in the cooling system malfunctions, engine coolant temperature will rise.

When the engine coolant temperature reaches an abnormally high temperature condition, a malfunction is indicated.

Diagnostic Trouble Code No.	Malfunction is detected when ...	Check Items (Possible Cause)
0208	<ul style="list-style-type: none">● Cooling fan does not operate properly (Overheat).● Cooling fan system does not operate properly (Overheat).● Engine coolant was not added to the system using the proper filling method.	<ul style="list-style-type: none">● Harness or connectors (The cooling fan circuit is open or shorted.)● Cooling fan● Radiator hose● Radiator● Radiator cap● Water pump● Thermostat <p>For more information, refer to "MAIN 12 CAUSES OF OVERHEATING", EC-467.</p>

CAUTION:

When a malfunction is indicated, be sure to replace the coolant following the procedure in the MA section ("Changing Engine Coolant", "ENGINE MAINTENANCE"). Also, replace the engine oil.

- Fill radiator with coolant up to specified level with a filling speed of 2 liters per minute. Be sure to use coolant with the proper mixture ratio. Refer to MA section ("Anti-freeze Coolant Mixture Ratio", "RECOMMENDED FLUIDS AND LUBRICANTS").
- After refilling coolant, run engine to ensure that no water-flow noise is emitted.

TROUBLE DIAGNOSIS FOR OVERHEAT

Overheat (Cont'd)

OVERALL FUNCTION CHECK

Use this procedure to check the overall function of the cooling fan. During this check, a DTC might not be confirmed.

WARNING:

Never remove the radiator cap when the engine is hot. Serious burns could be caused by high pressure fluid escaping from the radiator.

Wrap a thick cloth around cap. Carefully remove the cap by turning it a quarter turn to allow built-up pressure to escape. Then turn the cap all the way off.

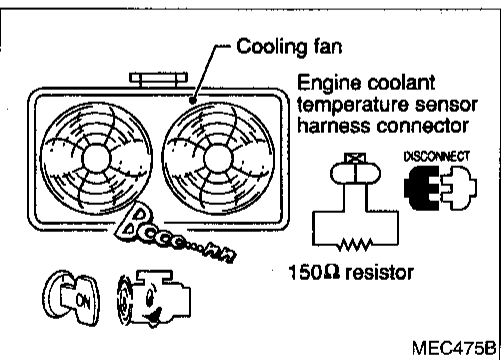
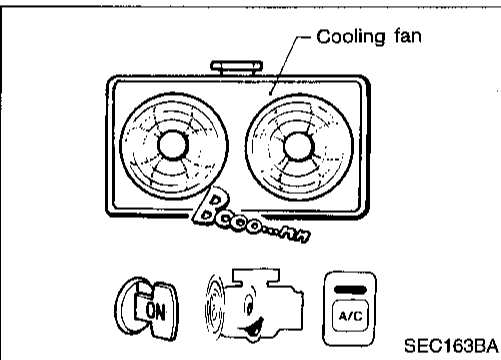
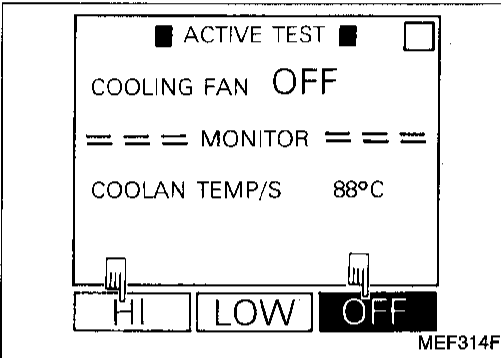
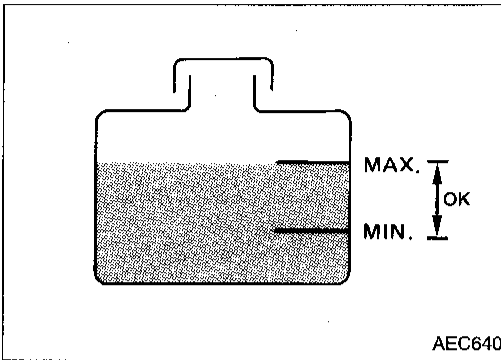

- 1) Check the coolant level in the reservoir tank and radiator. **Allow engine to cool before checking coolant level.** If the coolant level in the reservoir tank and/or radiator is below the proper range, skip the following steps and go to "DIAGNOSTIC PROCEDURE" (EC-461).
- 2) Confirm whether customer filled the coolant or not. If customer filled the coolant, skip the following steps and go to "DIAGNOSTIC PROCEDURE" (EC-461).



- 3) Turn ignition switch "ON".
- 4) Perform "COOLING FAN" in "ACTIVE TEST" mode with CONSULT.
- 5) If NG, go to "DIAGNOSTIC PROCEDURE", EC-461.

OR



- 3) Start engine. **Be careful not to overheat engine.**
- 4) Set temperature control lever to full cold position.
- 5) Turn air conditioner switch "ON".
- 6) Turn blower fan switch "ON".
- 7) Run engine at idle for a few minutes with air conditioner operating. **Be careful not to overheat engine.**
- 8) Make sure that cooling fan operates at low speed for A/T models and high speed for M/T models.
- 9) Turn ignition switch "OFF".
- 10) Turn air conditioner switch and blower fan switch "OFF".

—A/T models only—

- 11) Disconnect engine coolant temperature sensor harness connector.
- 12) Connect 150Ω resistor to engine coolant temperature sensor harness connector.
- 13) Restart engine and make sure that cooling fan operates at higher speed than low speed. **Be careful not to overheat engine.**
- 14) If NG, go to "DIAGNOSTIC PROCEDURE", EC-461.

TROUBLE DIAGNOSIS FOR OVERHEAT

Overheat (Cont'd)

FOR AT MODELS

EC-COOL/F-01

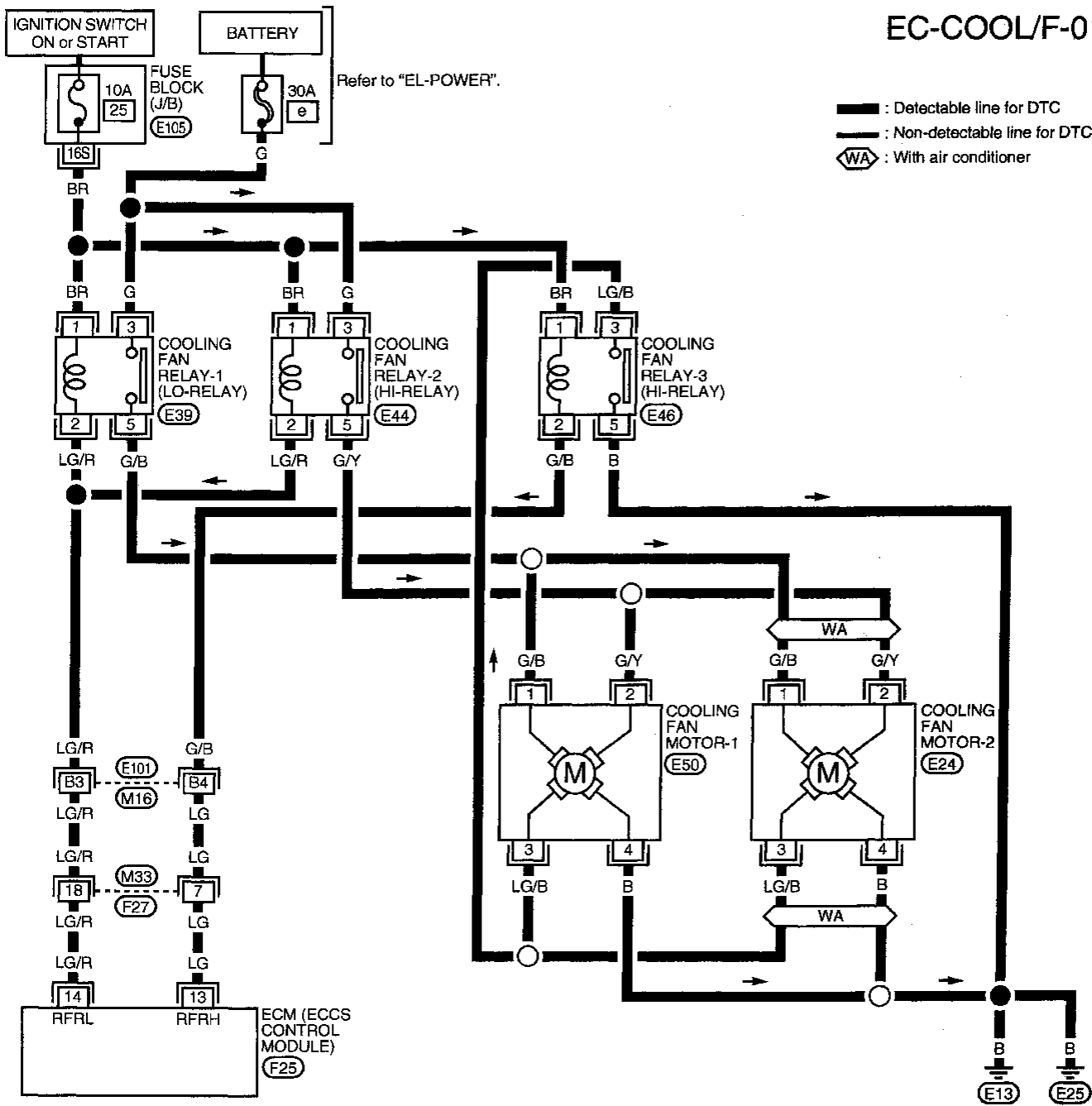

GI
MA
EM
LC
EC
FE
CL
MT
AT
FA
RA
BR
ST
RS
BT

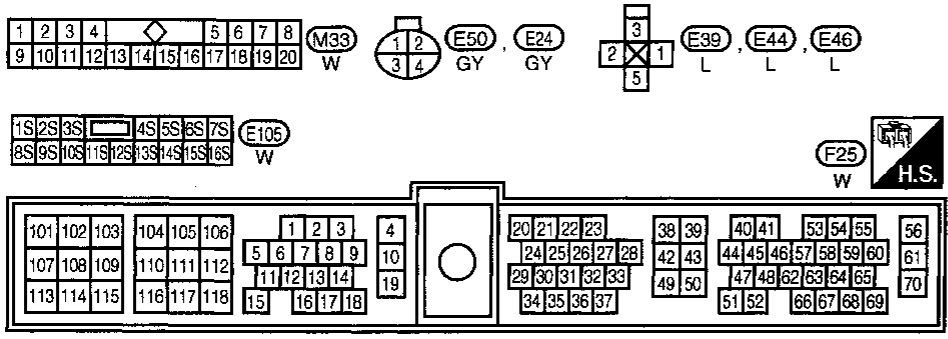

Refer to last page (Foldout page).
M16 E101

HA
EL
IDX

TROUBLE DIAGNOSIS FOR OVERHEAT

Overheat (Cont'd)

FOR M/T MODELS

EC-COOL/F-02

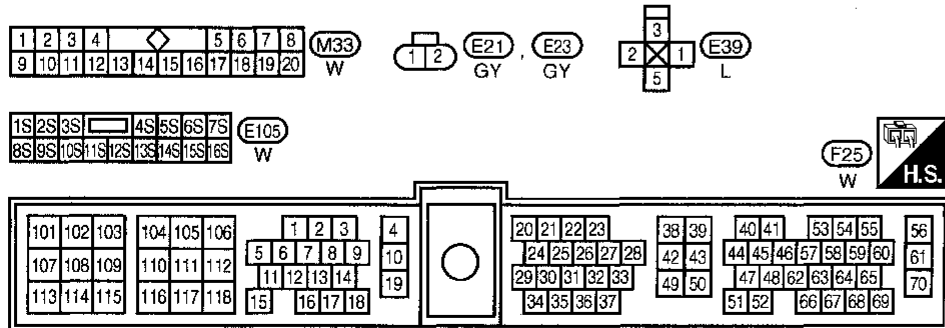
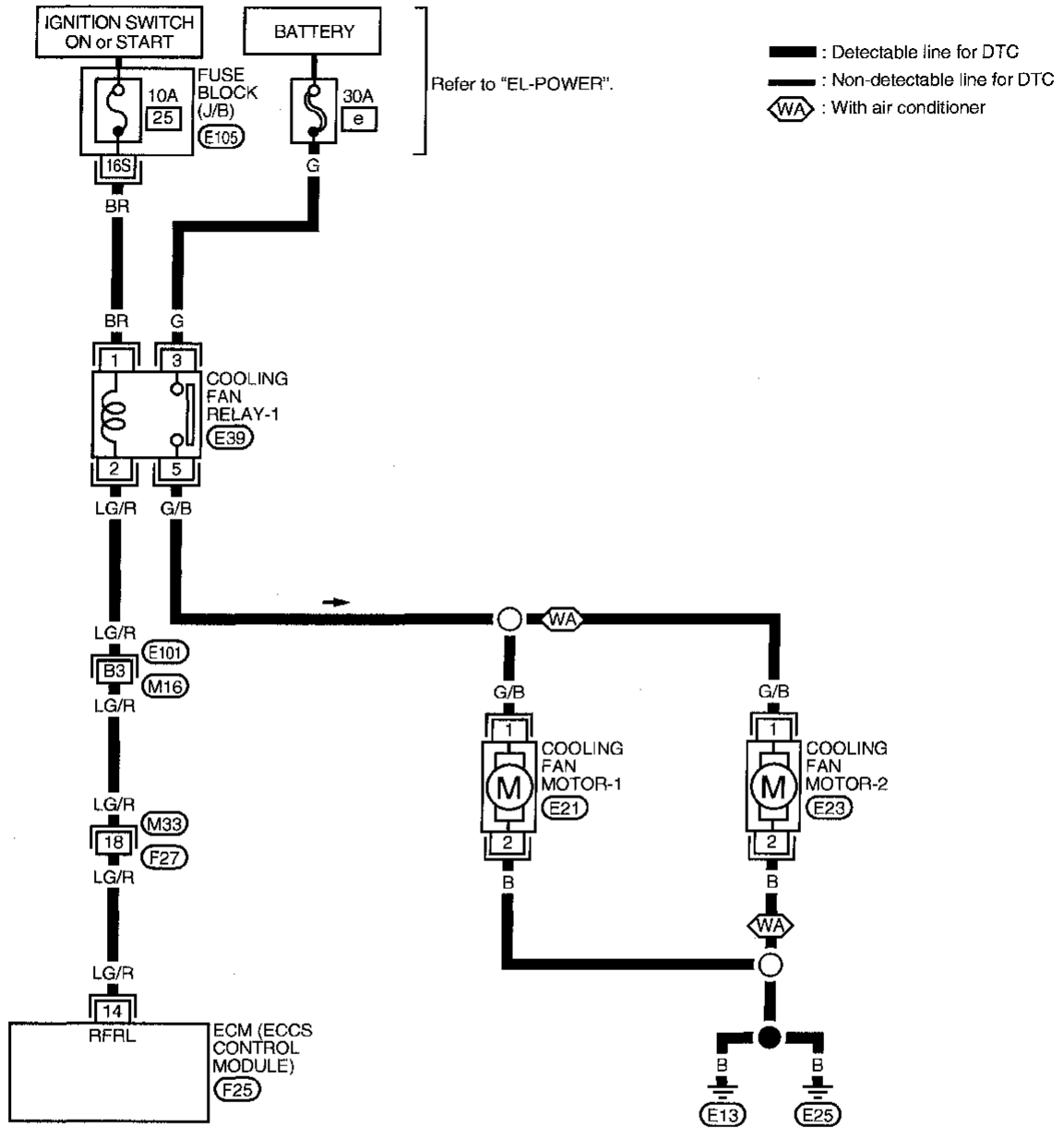

Refer to last page (Foldout page).

M16, E101

TROUBLE DIAGNOSIS FOR OVERHEAT

Overheat (Cont'd)

DIAGNOSTIC PROCEDURE

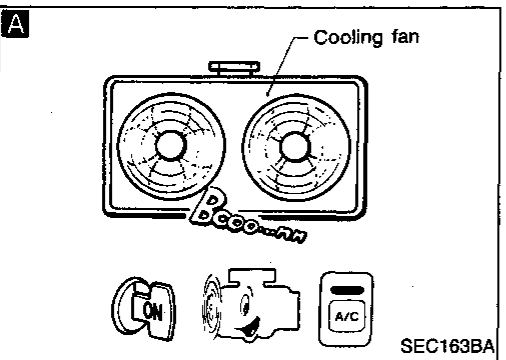
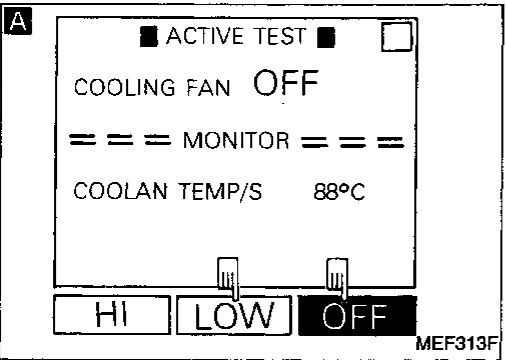
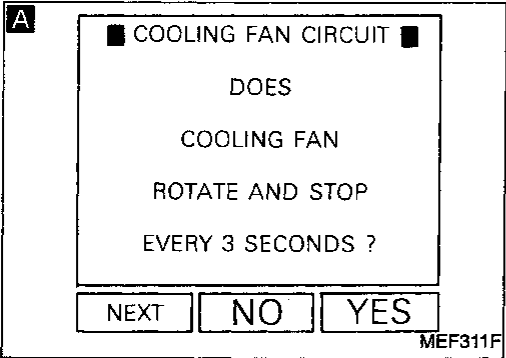
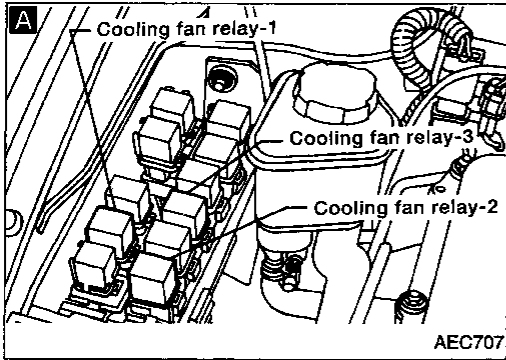

INSPECTION START

A **CHECK COOLING FAN LOW SPEED OPERATION (A/T MODELS) AND HIGH SPEED OPERATION (M/T MODELS).**

1. Disconnect cooling fan relays-2 and -3 for A/T models.
2. Turn ignition switch "ON".
3. Perform "COOLING FAN CIRCUIT" in "FUNCTION TEST" mode with CONSULT.

OR

2. Turn ignition switch "ON".
3. Perform "COOLING FAN" in "ACTIVE TEST" mode with CONSULT.

OR

2. Start engine.
3. Set temperature lever at full cold position.
4. Turn air conditioner switch "ON".
5. Turn blower fan switch "ON".
6. Run engine at idle for a few minutes with air conditioner operating.
7. Make sure that cooling fan operates at low speed for A/T models and at high speed for M/T models.

NG → Check cooling fan low speed control circuit (A/T models) and high speed control circuit (M/T models). (Go to PROCEDURE A, EC-463.)

OK
A
 (Go to next page.)

GI
 MA
 EM
 LC
EC
 FE
 CL
 MT
 AT
 FA
 RA
 BR
 ST
 RS
 BT
 HA
 EL
 IDX

TROUBLE DIAGNOSIS FOR OVERHEAT

Overheat (Cont'd)

B

■ COOLING FAN CIRCUIT ■

DOES
COOLING FAN
ROTATE AND STOP
EVERY 3 SECONDS ?

NEXT NO YES

MEF311F

B

■ ACTIVE TEST ■

COOLING FAN OFF

== MONITOR ==

COOLANT TEMP/S 88°C

HI LOW OFF

MEF314F

B

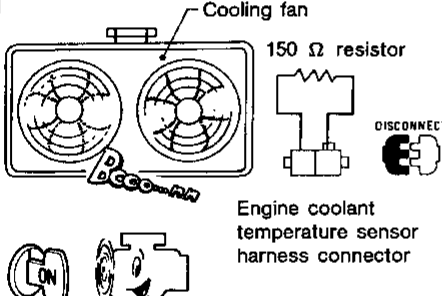

Cooling fan

150 Ω resistor

DISCONNECT

Engine coolant temperature sensor harness connector

MEF613EA

A

B

CHECK COOLING FAN HIGH SPEED OPERATION (A/T MODELS).

1. Turn ignition switch "OFF".
2. Reconnect cooling fan relays-2 and -3.
3. Disconnect cooling fan relay-1.

 4. Turn ignition switch "ON".

5. Perform "COOLING FAN CIRCUIT" in "FUNCTION TEST" mode with CONSULT.

OR

 4. Turn ignition switch "ON".

5. Perform "COOLING FAN" in "ACTIVE TEST" mode with CONSULT.

OR

 4. Turn air conditioner switch and blower fan switch "OFF".

5. Disconnect engine coolant temperature sensor harness connector.

6. Connect 150Ω resistor to engine coolant temperature sensor harness connector.

7. Restart engine and make sure that cooling fan operates at higher speed than low speed.

NG → Check cooling fan high speed control circuit. (Go to PROCEDURE B, EC-464.)

OK

B

(Go to EC-466.)

TROUBLE DIAGNOSIS FOR OVERHEAT

Overheat (Cont'd)

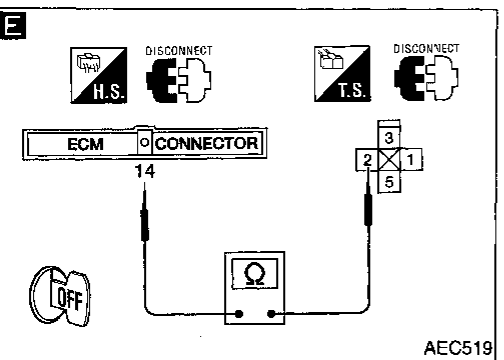
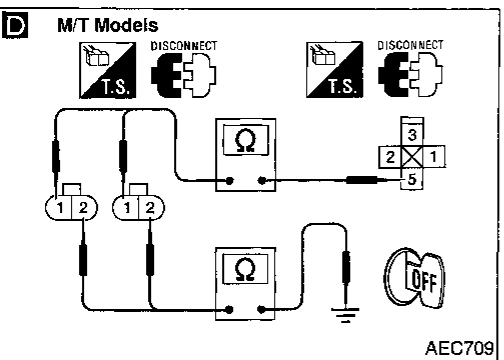
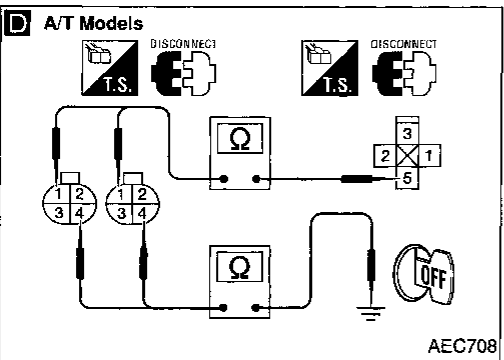
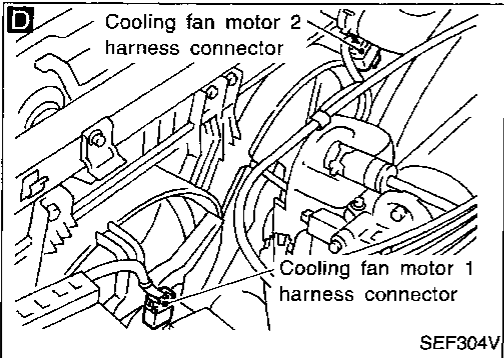
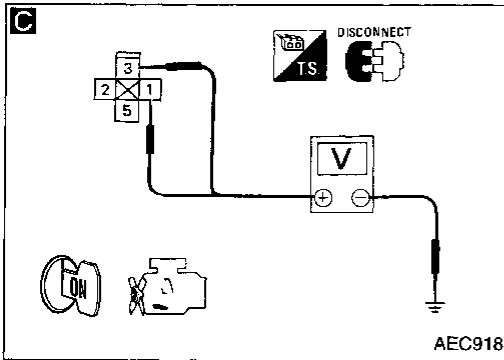

PROCEDURE A

INSPECTION START

C

CHECK POWER SUPPLY.

1. Turn ignition switch "OFF".
2. Disconnect cooling fan relay-1.
3. Turn ignition switch "ON".
4. Check voltage between terminals ①, ③ and ground with CONSULT or tester.

Voltage: Battery voltage

NG

Check the following.

- 10A fuse
- 30A fusible link
- Harness for open or short between cooling fan relay-1 and fuse
- Harness for open or short between cooling fan relay-1 and battery

If NG, repair open circuit or short to ground or short to power in harness or connectors.

OK

D

CHECK GROUND CIRCUIT.

1. Turn ignition switch "OFF".
2. Disconnect cooling fan motor-1 harness connector and cooling fan motor-2 harness connector.
3. Check harness continuity between terminal ① and terminal ⑤. **Continuity should exist.** If OK, check harness for short.
4. Check harness continuity between terminal ④ (A/T models), ② (M/T models) and body ground. **Continuity should exist.** If OK, check harness for short to ground and short to power.

NG

Repair open circuit or short to ground or short to power in harness or connectors.

OK

E

CHECK OUTPUT SIGNAL CIRCUIT.

1. Disconnect ECM harness connector.
2. Check harness continuity between ECM terminal ⑭ and relay-1 terminal ②. **Continuity should exist.** If OK, check harness for short to ground and short to power.

NG

Check the following.

- Harness connectors (M16, E101)
- Harness connectors (F27, M33)
- Harness for open or short between cooling fan relay-1 and ECM

If NG, repair open circuit or short to ground or short to power in harness or connectors.

OK

CHECK COMPONENT
(Cooling fan relay-1).
Refer to "COMPONENT INSPECTION", EC-468.

NG

Replace cooling fan relay.

OK

Ⓒ
(Go to next page.)

GI
MA
EM
LC
EC
FE
CL
MT
AT
FA
RA
BR
ST
RS
BT
HA
EL
IDX

TROUBLE DIAGNOSIS FOR OVERHEAT

Overheat (Cont'd)

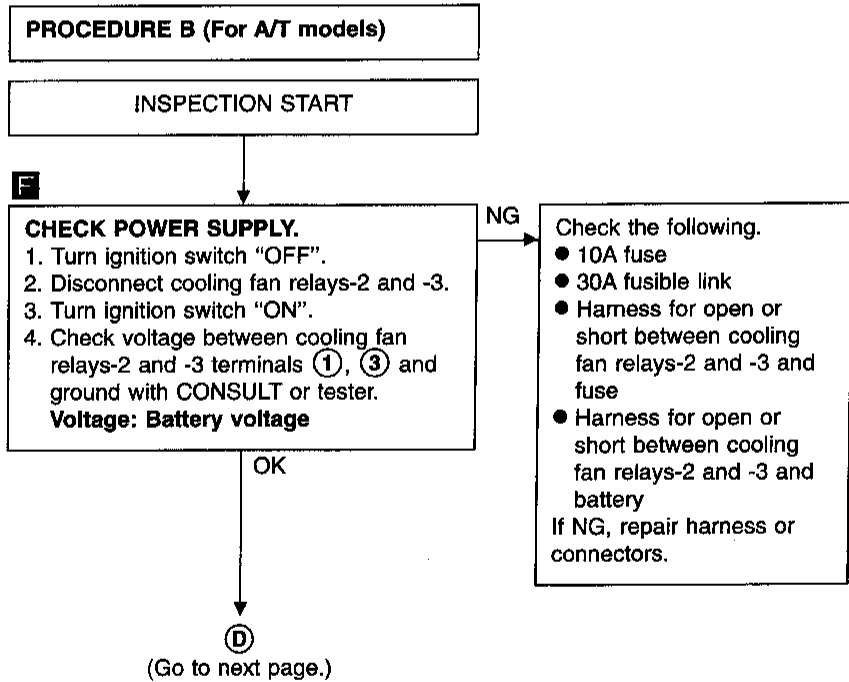
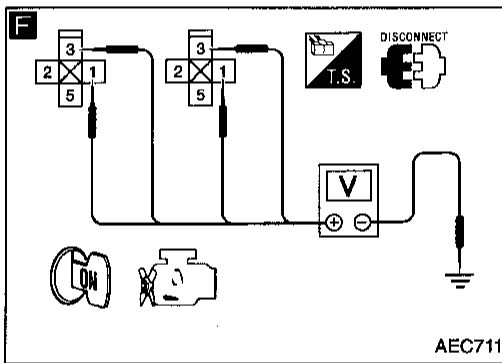
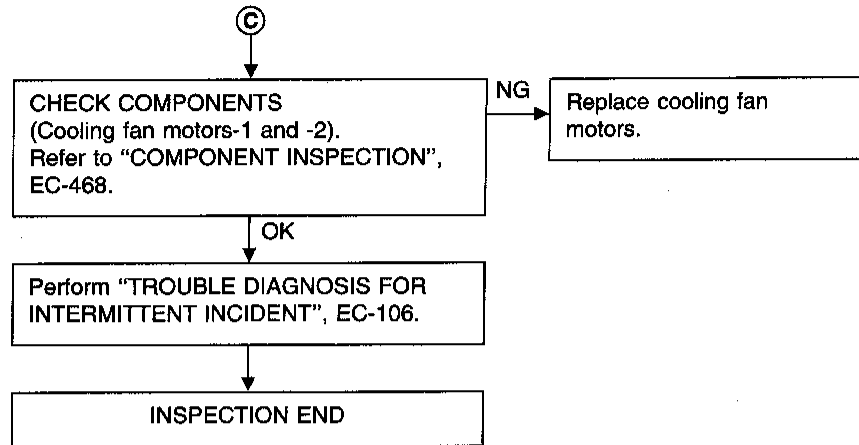

TROUBLE DIAGNOSIS FOR OVERHEAT

Overheat (Cont'd)

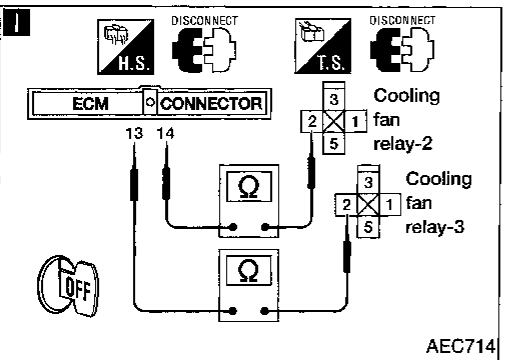
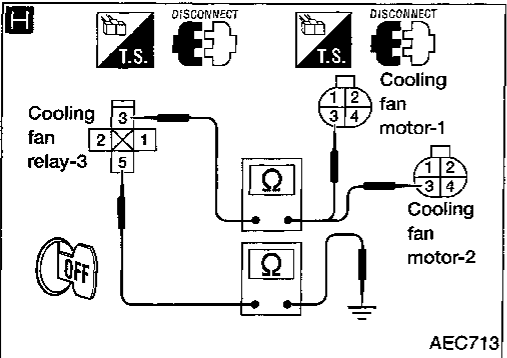
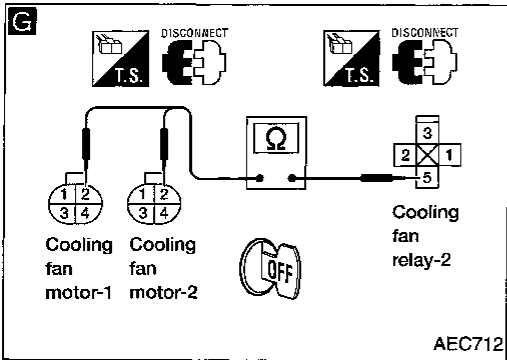

D

CHECK POWER AND GROUND CIRCUIT.

1. Turn ignition switch "OFF".
2. Disconnect cooling fan motors-1 and -2 harness connectors.

G 3. Check harness continuity between cooling fan relay-2 terminal (5) and cooling fan motors-1 and -2 terminal (2).
Continuity should exist.
 If OK, check harness for short.

H 4. Check harness continuity between cooling fan relay-3 terminal (3) and cooling fan motors-1 and -2 terminal (3), cooling fan relay-3 terminal (5) and body ground.
Continuity should exist.
 If OK, check harness for short to ground and short to power.

NG → Repair open circuit or short to ground or short to power in harness or connectors.

OK

I

CHECK OUTPUT SIGNAL CIRCUIT.

1. Disconnect ECM harness connector.
2. Check harness continuity between ECM terminal (13) and cooling fan relay-3 terminal (2), ECM terminal (14) and cooling fan relay-2 terminal (2).
Continuity should exist.
 If OK, check harness for short to ground and short to power.

NG → Check the following.
 ● Harness connectors (M16, E101)
 ● Harness connectors (F27, M33)
 ● Harness for open or short between cooling fan relays-2 and -3 and ECM
 If NG, repair open circuit or short to ground or short to power in harness or connectors.

OK

CHECK COMPONENTS
 (Cooling fan relays-2 and -3).
 Refer to "COMPONENT INSPECTION", EC-468.

NG → Replace cooling fan relays.

OK

CHECK COMPONENTS
 (Cooling fan motors -1 and -2).
 Refer to "COMPONENT INSPECTION", EC-468.

NG → Replace cooling fan motors.

OK

Perform "TROUBLE DIAGNOSIS FOR INTERMITTENT INCIDENT", EC-106.

INSPECTION END

GI
MA
EM
LC
EC
FE
CL
MT
AT
FA
RA
BR
ST
RS
BT
HA
EL
IDX

TROUBLE DIAGNOSIS FOR OVERHEAT

Overheat (Cont'd)

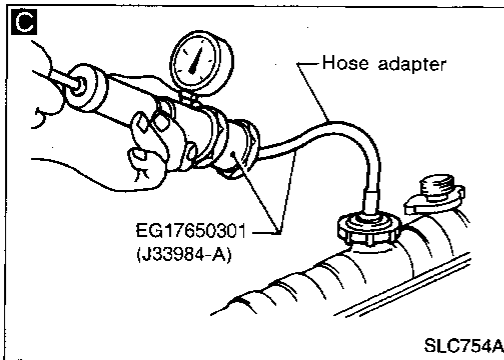

C

CHECK COOLING SYSTEM FOR LEAK.
Apply pressure to the cooling system with a tester, and check if the pressure drops.
Testing pressure:
157 kPa (1.6 kg/cm², 23 psi)
Pressure should not drop.
CAUTION:
Higher than the specified pressure may cause radiator damage.

NG → Check the following for leak.

- Hose
- Radiator
- Water pump

Refer to LC section ("Water Pump").

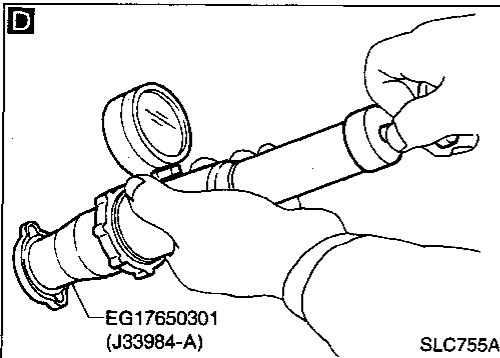

D

CHECK RADIATOR CAP.
Apply pressure to cap with a tester.
Radiator cap relief pressure:
59 - 98 kPa (0.6 - 1.0 kg/cm², 9 - 14 psi)

NG → Replace radiator cap.

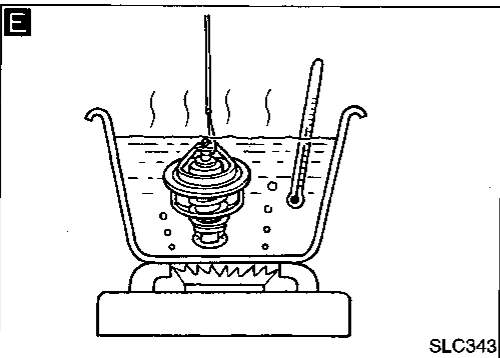

E

CHECK THERMOSTAT.

1. Check valve seating condition at normal room temperatures. It should seat tightly.
2. Check valve opening temperature and valve lift.
Valve opening temperature:
76.5°C (170°F) [standard]
Valve lift:
More than 8 mm/90°C (0.31 in/194°F)
3. Check if valve is closed at 5°C (9°F) below valve opening temperature. For details, refer to LC section ("Thermostat").

NG → Replace thermostat

OK

Check engine coolant temperature sensor. Refer to "COMPONENT INSPECTION", EC-141.

NG → Replace engine coolant temperature sensor.

If the cause cannot be isolated, go to "MAIN 12 CAUSES OF OVERHEATING" on next page.

INSPECTION END

TROUBLE DIAGNOSIS FOR OVERHEAT

Overheat (Cont'd)

MAIN 12 CAUSES OF OVERHEATING

Engine	Step	Inspection item	Equipment	Standard	Reference page
OFF	1	<ul style="list-style-type: none"> ● Blocked radiator ● Blocked condenser ● Blocked radiator grille ● Blocked bumper 	● Visual	No blocking	—
	2	● Coolant mixture	● Coolant tester	50 - 50% coolant mixture	See "RECOMMENDED FLUIDS AND LUBRICANTS" in MA section.
	3	● Coolant level	● Visual	Coolant up to MAX level in reservoir tank and radiator filler neck	See "Changing Engine Coolant", "ENGINE MAINTENANCE" in MA section.
	4	● Radiator cap	● Pressure tester	59 - 98 kPa (0.6 - 1.0 kg/cm ² , 9 - 14 psi) (Limit)	See "System Check", "ENGINE COOLING SYSTEM" in LC section.
ON*2	5	● Coolant leaks	● Visual	No leaks	See "System Check", "ENGINE COOLING SYSTEM" in LC section.
ON*2	6	● Thermostat	● Touch the upper and lower radiator hoses	Both hoses should be hot	See "Thermostat" and "Radiator", "ENGINE COOLING SYSTEM" in LC section.
ON*1	7	● Cooling fan	● CONSULT	Operating	See "TROUBLE DIAGNOSIS FOR OVERHEAT" (EC-455).
OFF	8	● Combustion gas leak	● Color checker chemical tester 4 Gas analyzer	Negative	—
ON*3	9	● Coolant temperature gauge	● Visual	Gauge less than 3/4 when driving	—
		● Coolant overflow to reservoir tank	● Visual	No overflow during driving and idling	See "Changing Engine Coolant", "ENGINE MAINTENANCE" in MA section.
OFF*4	10	● Coolant return from reservoir tank to radiator	● Visual	Should be initial level in reservoir tank	See "ENGINE MAINTENANCE" in MA section.
OFF	11	● Cylinder head	● Straight gauge feeler gauge	0.1 mm (0.004 in) Maximum distortion (warping)	See "Inspection", "CYLINDER HEAD" in EM section.
	12	● Cylinder block and pistons	● Visual	No scuffing on cylinder walls or piston	See "Inspection", "CYLINDER BLOCK" in EM section.

*1: Turn the ignition switch ON.

*2: Engine running at 3,000 rpm for 10 minutes.

*3: Drive at 90 km/h (55 MPH) for 30 minutes and then let idle for 10 minutes.

*4: After 60 minutes of cool down time.

For more information, refer to "OVERHEATING CAUSE ANALYSIS" in LC section.

TROUBLE DIAGNOSIS FOR OVERHEAT

Overheat (Cont'd)

COMPONENT INSPECTION

Cooling fan relays-1, -2 and -3

Check continuity between terminals ③ and ⑤.

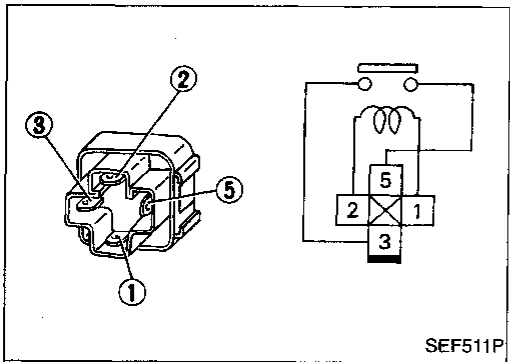

Conditions	Continuity
12V direct current supply between terminals ① and ②	Yes
No current supply	No

If NG, replace relay.

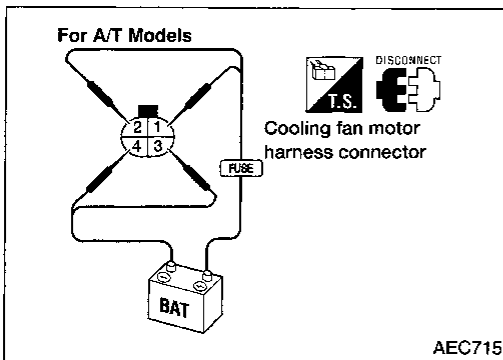

Cooling fan motors-1 and -2

1. Disconnect cooling fan motor harness connectors.
2. Supply cooling fan motor terminals with battery voltage and check operation.

	Speed	Terminals	
		(⊕)	(⊖)
Cooling fan motor	Low (A/T models)	①	④
	High (A/T models)	②	③
	High (M/T models)	①	②

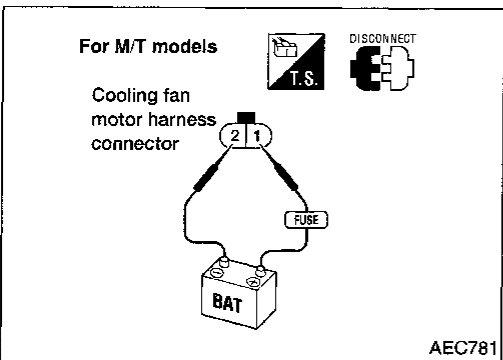

Cooling fan motor should operate.

If NG, replace cooling fan motor.

TROUBLE DIAGNOSIS FOR NON-DETECTABLE ITEMS

Injector

EC-INJECT-01

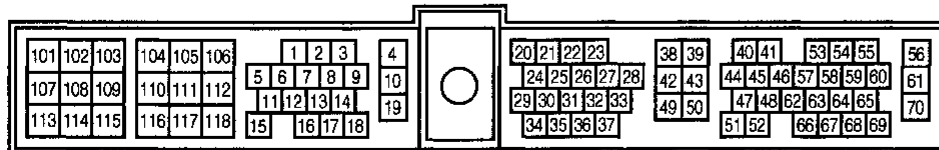
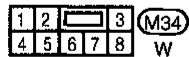
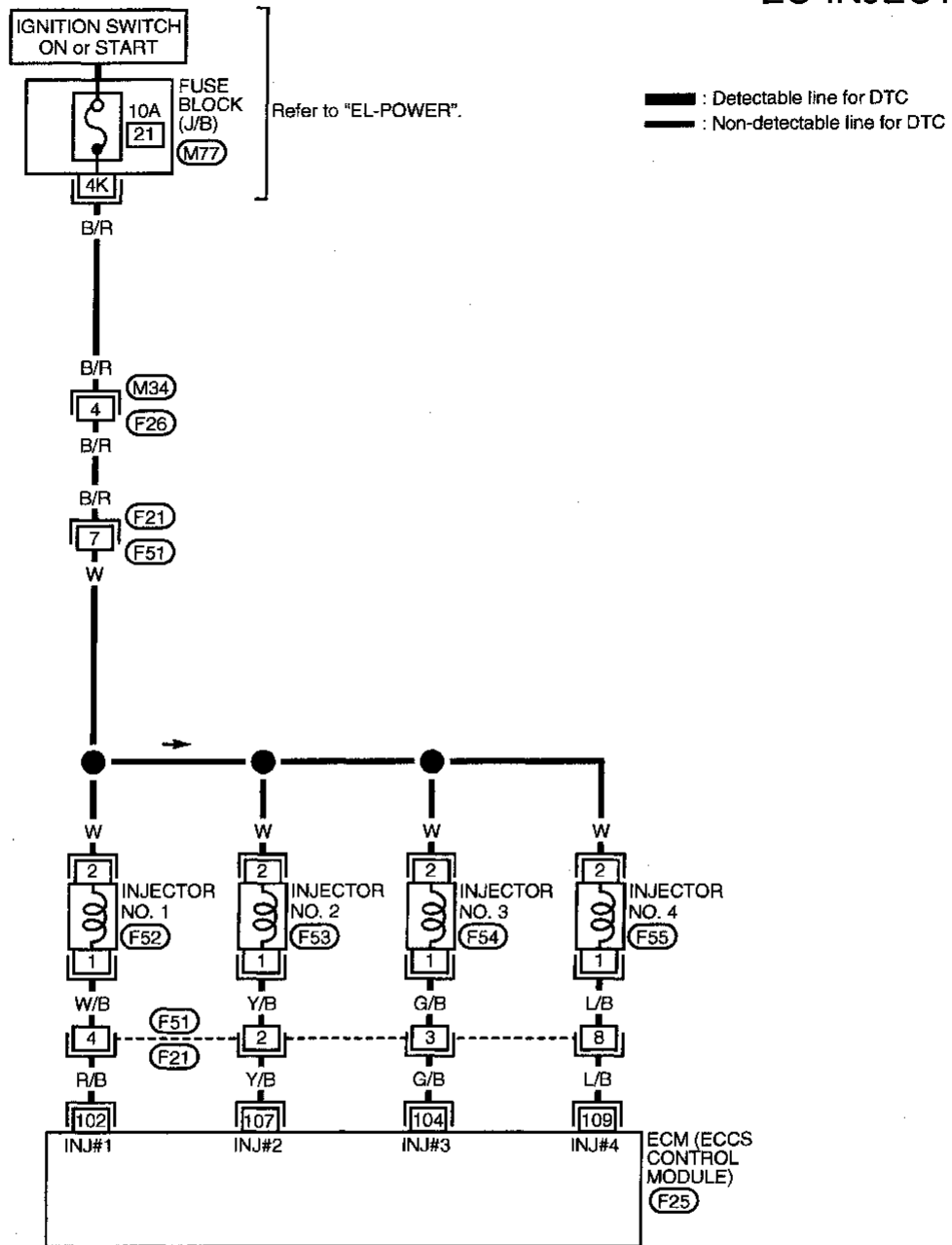

TROUBLE DIAGNOSIS FOR NON-DETECTABLE ITEMS

Injector (Cont'd)

COMPONENT DESCRIPTION

The fuel injector is a small, precise solenoid valve. When the ECM supplies a ground to the injector circuit, the coil in the injector is energized. The energized coil pulls the needle valve back and allows fuel to flow through the injector into the intake manifold. The amount of fuel injected depends upon the injection pulse duration. Pulse duration is the length of time the injector remains open. The ECM controls the injection pulse duration based on engine fuel needs.

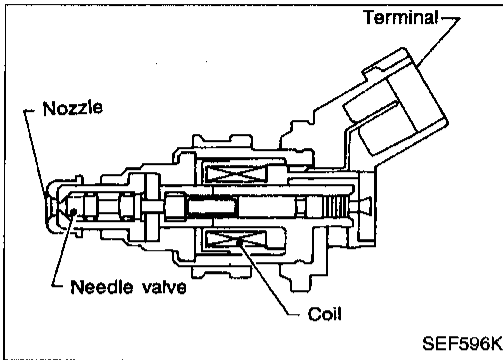

CONSULT REFERENCE VALUE IN DATA MONITOR MODE

MONITOR ITEM	CONDITION	SPECIFICATION
INJ PULSE	● Engine: After warming up ● Air conditioner switch: OFF ● Shift lever: "N" ● No-load Idle	2.4 - 3.2 msec
	2,000 rpm	1.9 - 2.8 msec
B/FUEL SCHDL	● Engine: After warming up ● Air conditioner switch: OFF ● Shift lever: "N" ● No-load Idle	1.0 - 1.6 msec
	2,000 rpm	0.7 - 1.3 msec

ECM TERMINALS AND REFERENCE VALUE

Specification data are reference values and are measured between each terminal and engine ground.

TER-MINAL NO.	WIRE COLOR	ITEM	CONDITION	DATA (DC voltage)
102 104 107 109	R/B G/B Y/B L/B	Injector No. 1 Injector No. 3 Injector No. 2 Injector No. 4	<p>Engine is running. (Warm-up condition)</p> <p>└ Idle speed</p>	<p>BATTERY VOLTAGE (11 - 14V)</p>
			<p>Engine is running. (Warm-up condition)</p> <p>└ Engine speed is 2,000 rpm.</p>	<p>BATTERY VOLTAGE (11 - 14V)</p>

TROUBLE DIAGNOSIS FOR NON-DETECTABLE ITEMS

Injector (Cont'd)

DIAGNOSTIC PROCEDURE

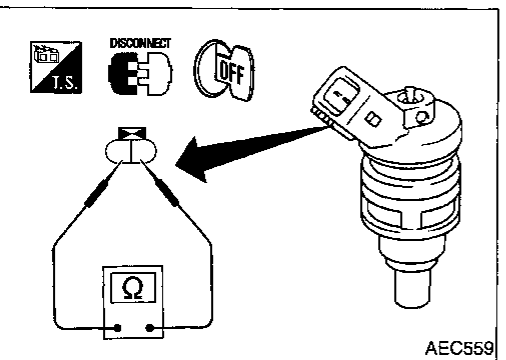
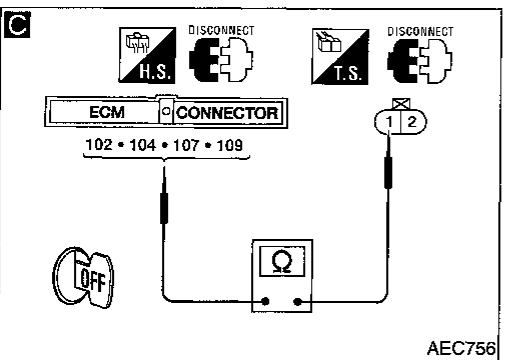
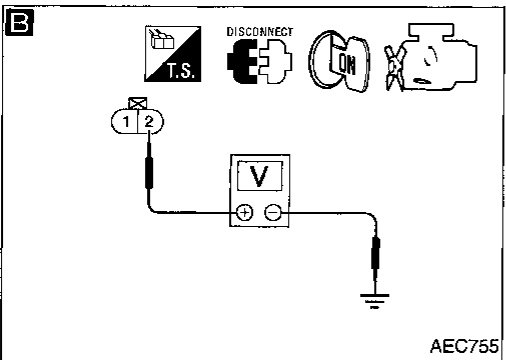
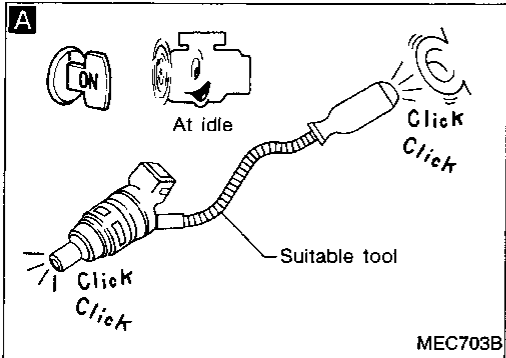
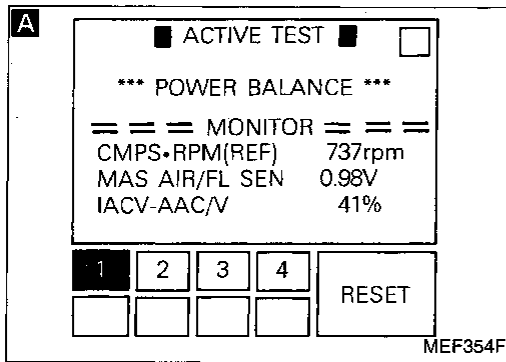

INSPECTION START

A

CHECK OVERALL FUNCTION.

1. Start engine.
2. Perform "POWER BALANCE" in "ACTIVE TEST" mode with CONSULT.
3. Make sure that each circuit produces a momentary engine speed drop.

OR

1. Start engine.
2. Listen to each injector operating sound.

Clicking noise should be heard.

B

CHECK POWER SUPPLY.

1. Stop engine.
2. Disconnect injector harness connector.
3. Turn ignition switch "ON".
4. Check voltage between terminal ② and ground with CONSULT or tester.

Voltage: Battery voltage

C

CHECK OUTPUT SIGNAL CIRCUIT.

1. Turn ignition switch "OFF".
2. Disconnect ECM harness connector.
3. Check harness continuity between injector harness connector terminal ① and ECM terminals ⑩②, ⑩④, ⑩⑦, ⑩⑨.

Continuity should exist.

If OK, check harness for short to ground and short to power.

CHECK COMPONENT (Injector).

Refer to "COMPONENT INSPECTION" below.

Perform "TROUBLE DIAGNOSIS FOR INTERMITTENT INCIDENT", EC-106.

INSPECTION END

INSPECTION END

Check the following.

- 10A fuse
- Harness connectors
- (M34), (F26)
- Harness connectors (F21), (F51)
- Harness for open or short between injector and battery

If NG, repair harness or connectors.

Check the following.

- Harness connectors (F51), (F21)
- Harness for open or short between ECM and injector

If NG, repair open circuit or short to ground or short to power in harness or connectors.

Replace injector.

COMPONENT INSPECTION

Injector

1. Disconnect injector harness connector.
 2. Check resistance between terminals as shown in the figure.
- Resistance: 10 - 14Ω [at 25°C (77°F)]**
- If NG, replace injector.

GI
MA
EM
LC
EC
FE
CL
MT
AT
FA
RA
BR
ST
RS
BT
HA
EL
IDX

TROUBLE DIAGNOSIS FOR NON-DETECTABLE ITEMS

Start Signal (Cont'd)

CONSULT REFERENCE VALUE IN DATA MONITOR MODE

Specification data are reference values.

MONITOR ITEM	CONDITION	SPECIFICATION
START SIGNAL	● Ignition switch: ON → START → ON	OFF → ON → OFF

ECM TERMINALS AND REFERENCE VALUE

Specification data are reference values and are measured between each terminal and engine ground.

TER-MINAL NO.	WIRE COLOR	ITEM	CONDITION	DATA (DC voltage)
20	B/Y	Start signal	Ignition switch "ON"	Approximately 0V
			Ignition switch "START"	BATTERY VOLTAGE (11 - 14V)

A

■ START SIGNAL CKT ■

1. CLOSE THROTTLE, SHIFT TO P OR N RANGE
2. TOUCH START AND START ENGINE IMMEDIATELY.

SEF191L

A

☆ MONITOR	☆ NO FAIL	<input type="checkbox"/>
START SIGNAL	OFF	
CLSD TH/P SW	ON	
AIR COND SIG	OFF	
P/N POSI SW	ON	

RECORD

SEF111P

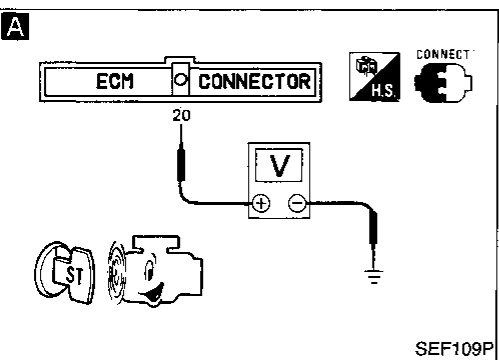

DIAGNOSTIC PROCEDURE

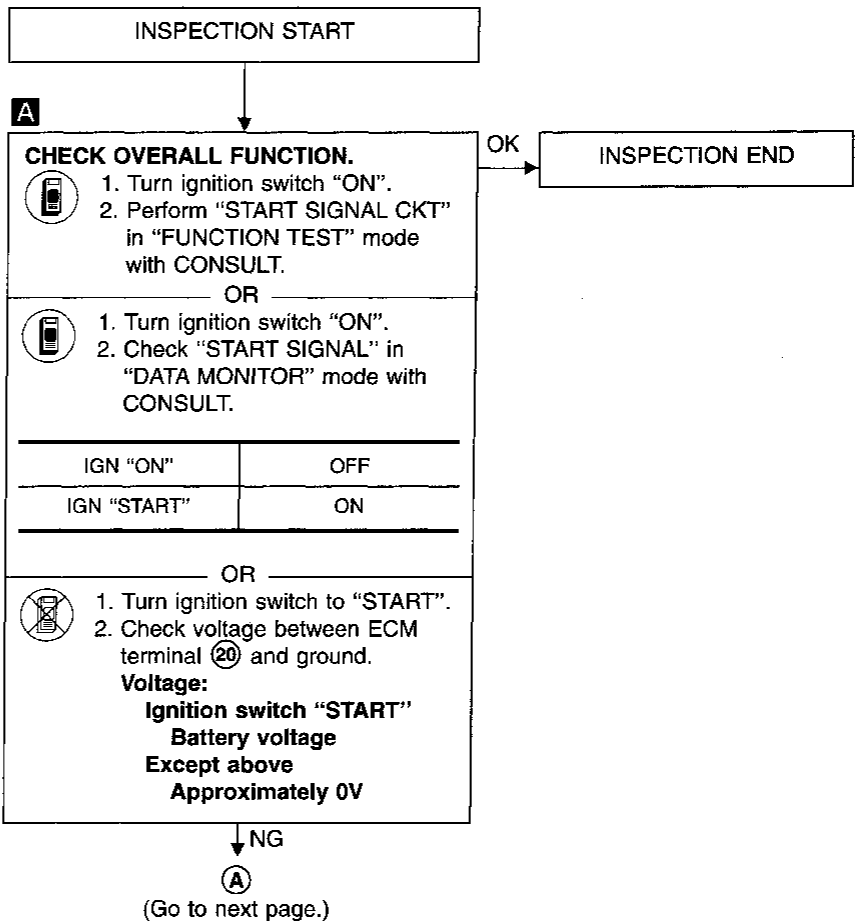

TROUBLE DIAGNOSIS FOR NON-DETECTABLE ITEMS

Start Signal (Cont'd)

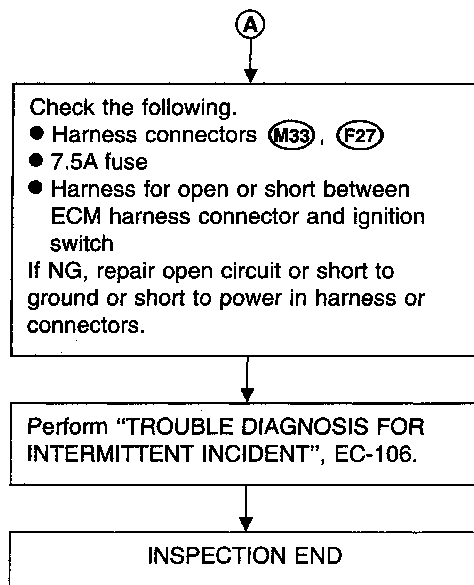

TROUBLE DIAGNOSIS FOR NON-DETECTABLE ITEMS

Fuel Pump

SYSTEM DESCRIPTION

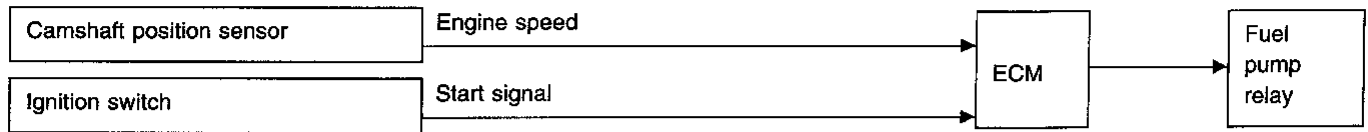

The ECM activates the fuel pump for several seconds after the ignition switch is turned on to improve engine startability. If the ECM receives a 180° signal from the camshaft position sensor, it knows that the engine is rotating, and causes the pump to perform. If the 180° signal is not received when the ignition switch is on, the engine stalls. The ECM stops pump operation and prevents battery discharging, thereby improving safety. The ECM does not directly drive the fuel pump. It controls the ON/OFF fuel pump relay, which in turn controls the fuel pump.

Condition	Fuel pump operation
Ignition switch is turned to ON.	Operates for 5 seconds
Engine running and cranking	Operates
When engine is stopped	Stops in 1 second
Except as shown above	Stops

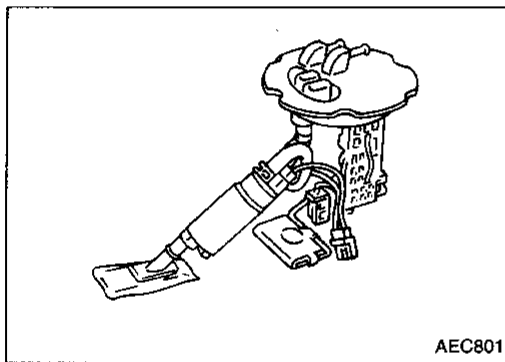

COMPONENT DESCRIPTION

A turbine type design fuel pump is used in the fuel tank.

CONSULT REFERENCE VALUE IN DATA MONITOR MODE

MONITOR ITEM	CONDITION	SPECIFICATION
FUEL PUMP RLY	<ul style="list-style-type: none"> ● Ignition switch is turned to ON (Operates for 5 seconds) ● Engine running and cranking ● When engine is stopped (stops in 1.0 seconds) 	ON
	<ul style="list-style-type: none"> ● Except as shown above 	OFF

ECM TERMINALS AND REFERENCE VALUE

Specification data are reference values and are measured between each terminal and engine ground.

TER-MINAL NO.	WIRE COLOR	ITEM	CONDITION	DATA (DC voltage)
8	B/P	Fuel pump relay	Ignition switch "ON" └ For 5 seconds after turning ignition switch "ON"	0 - 1V
			Engine is running.	
			Ignition switch "ON" └ More than 5 seconds after turning ignition switch "ON"	BATTERY VOLTAGE (11 - 14V)

TROUBLE DIAGNOSIS FOR NON-DETECTABLE ITEMS

Fuel Pump (Cont'd)

EC-F/PUMP-01

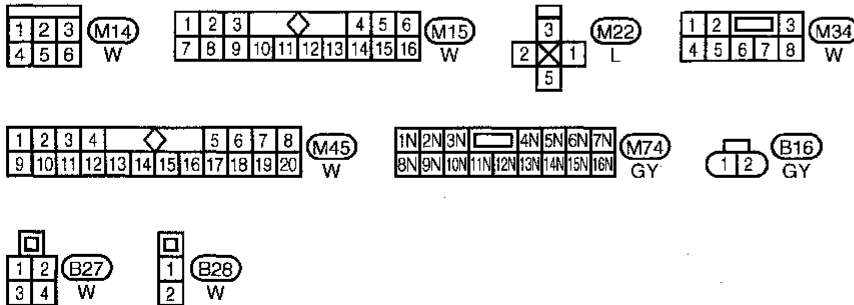
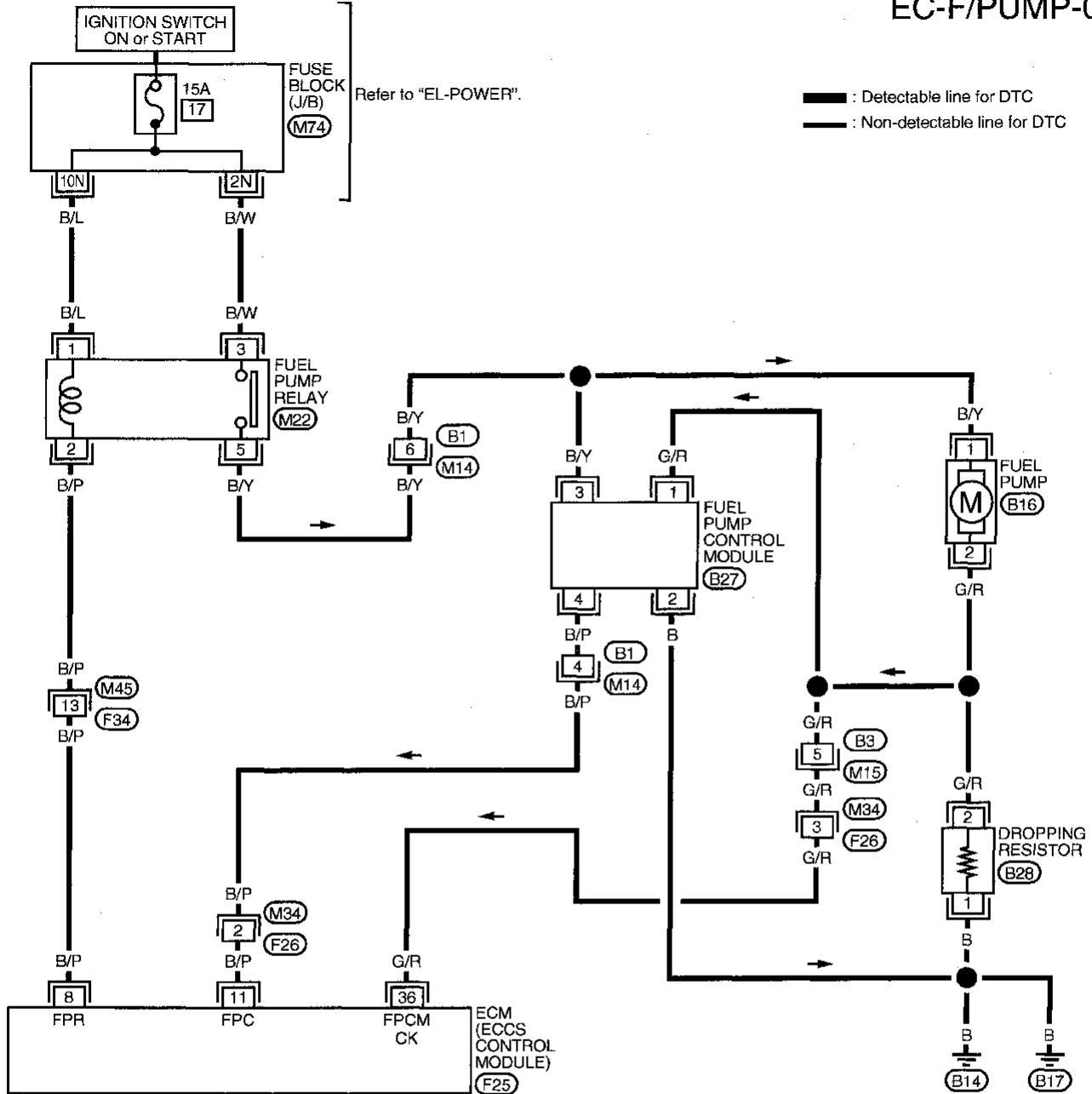

Refer to last page (Foldout page).

F25

TROUBLE DIAGNOSIS FOR NON-DETECTABLE ITEMS

Fuel Pump (Cont'd) DIAGNOSTIC PROCEDURE

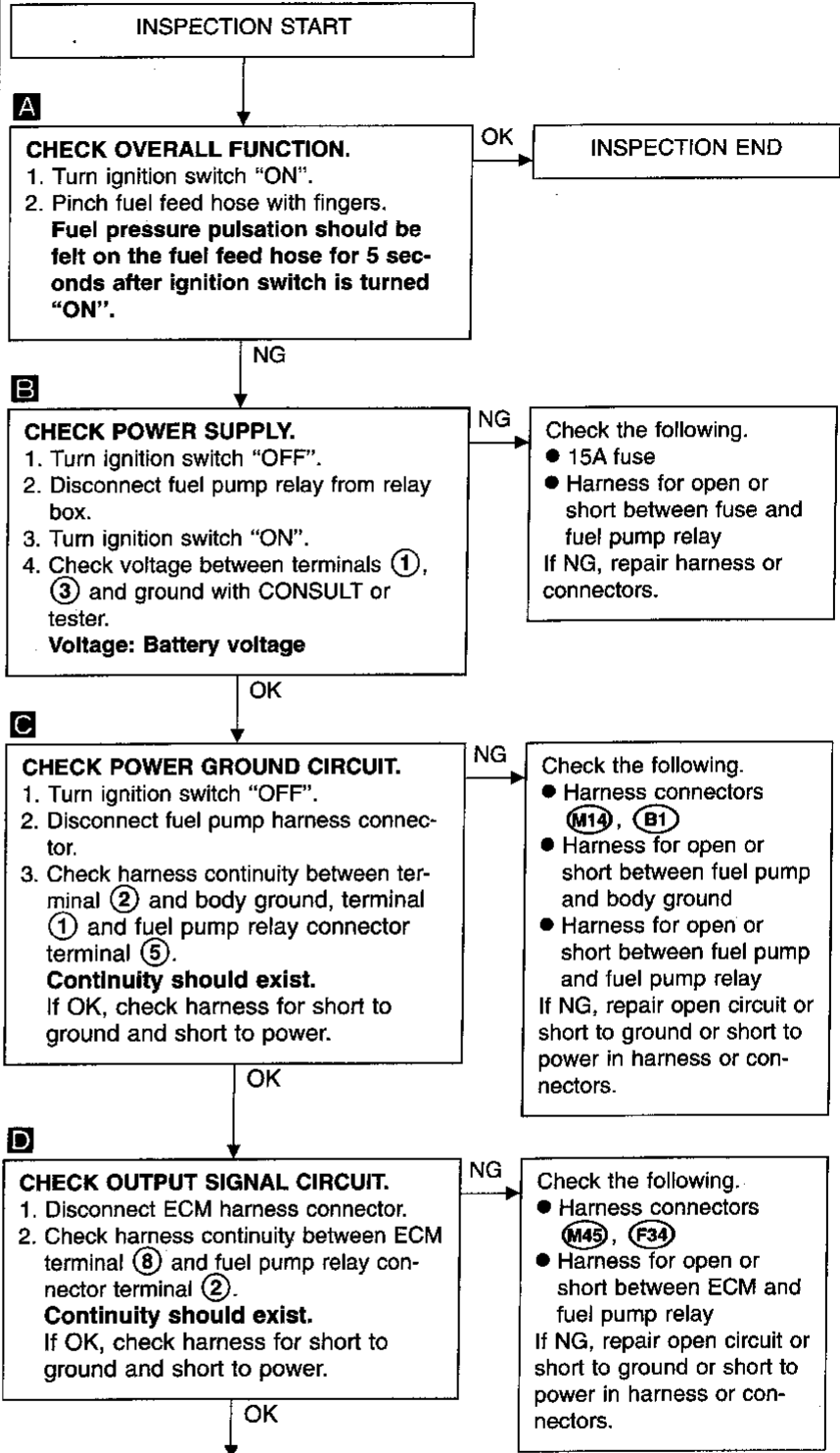
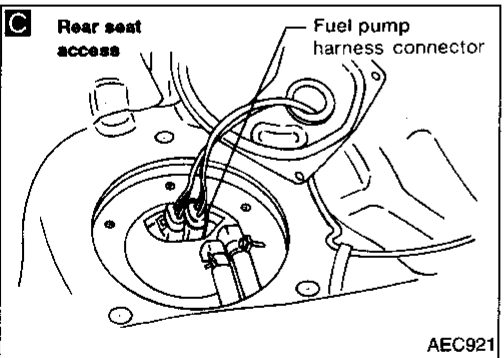
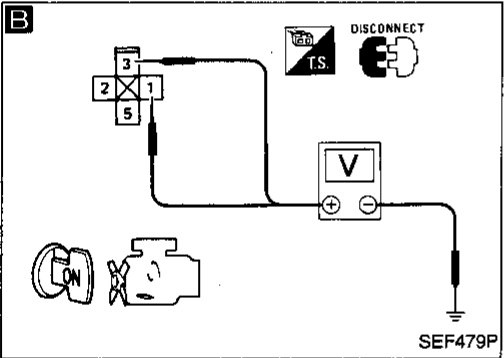
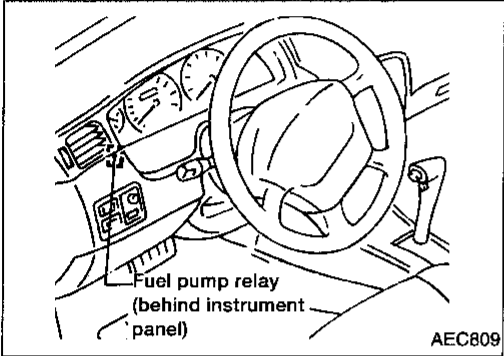
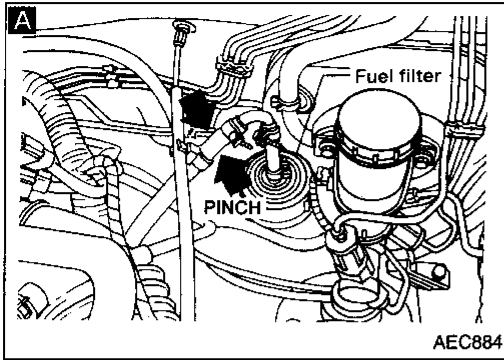

(Go to next page.)

GI

MA

EM

LC

EC

FE

CL

MT

AT

FA

RA

BR

ST

RS

BT

HA

EL

IDX

TROUBLE DIAGNOSIS FOR NON-DETECTABLE ITEMS

Fuel Pump (Cont'd)

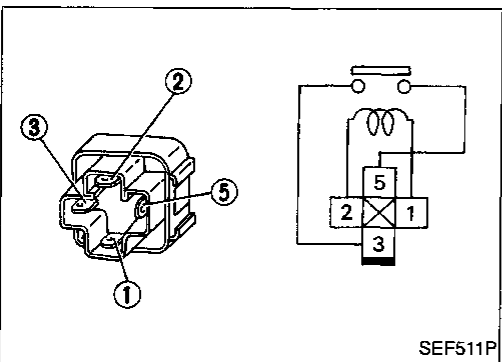
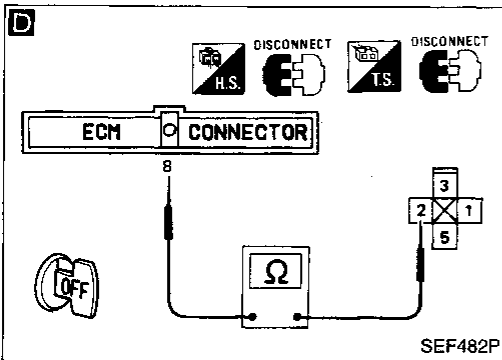
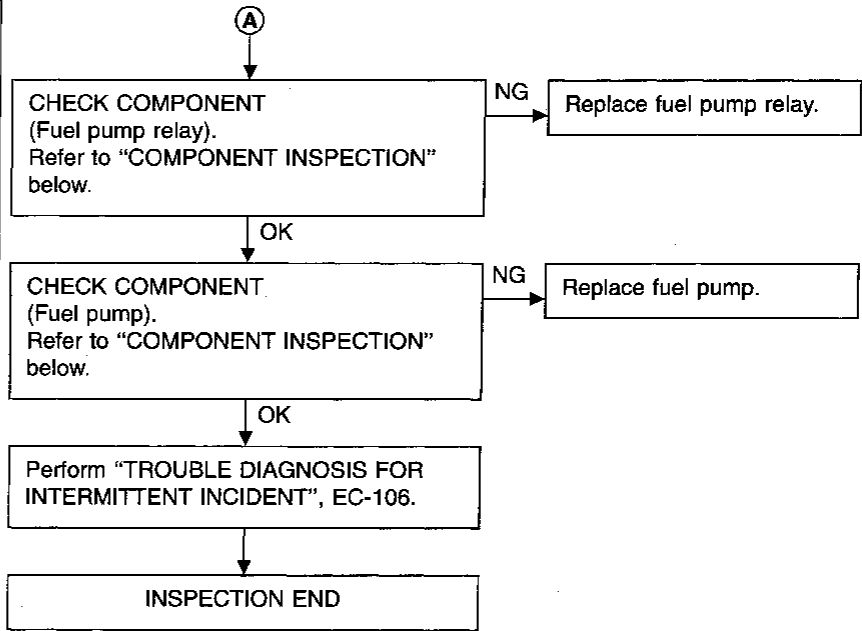
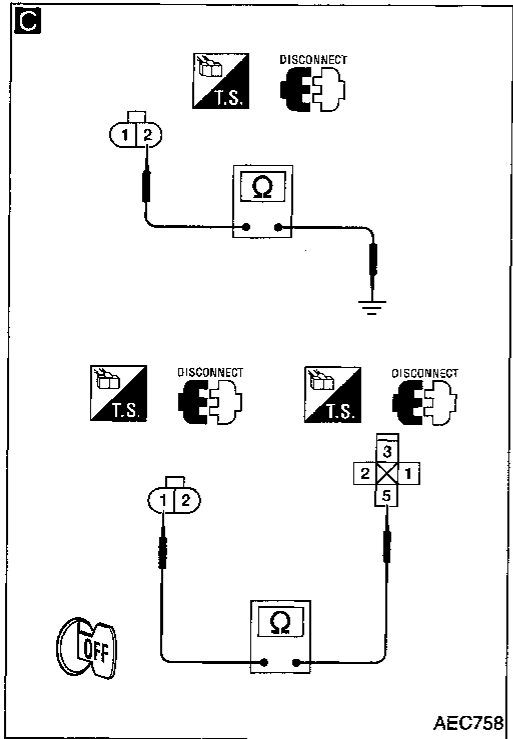

COMPONENT INSPECTION

Fuel pump relay

Check continuity between terminals ③ and ⑤.

Conditions	Continuity
12V direct current supply between terminals ① and ②	Yes
No current supply	No

If NG, replace relay.

Fuel pump

1. Disconnect fuel pump harness connector.
2. Check resistance between terminals ① and ②.
Resistance: 0.2 - 5.0Ω [at 25°C (77°F)]
If NG, replace fuel pump.

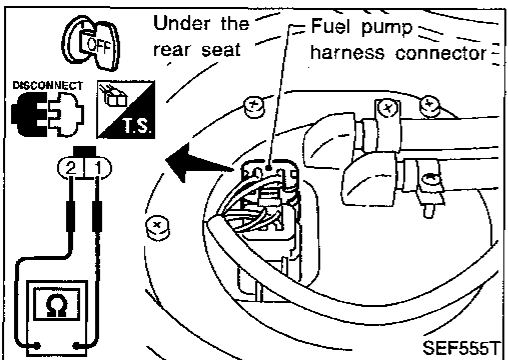

TROUBLE DIAGNOSIS FOR NON-DETECTABLE ITEMS

Power Steering Oil Pressure Switch

EC-PST/SW-01

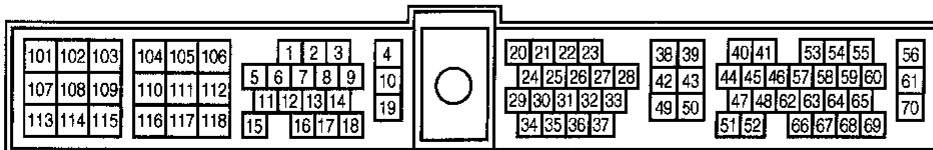
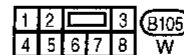
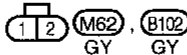
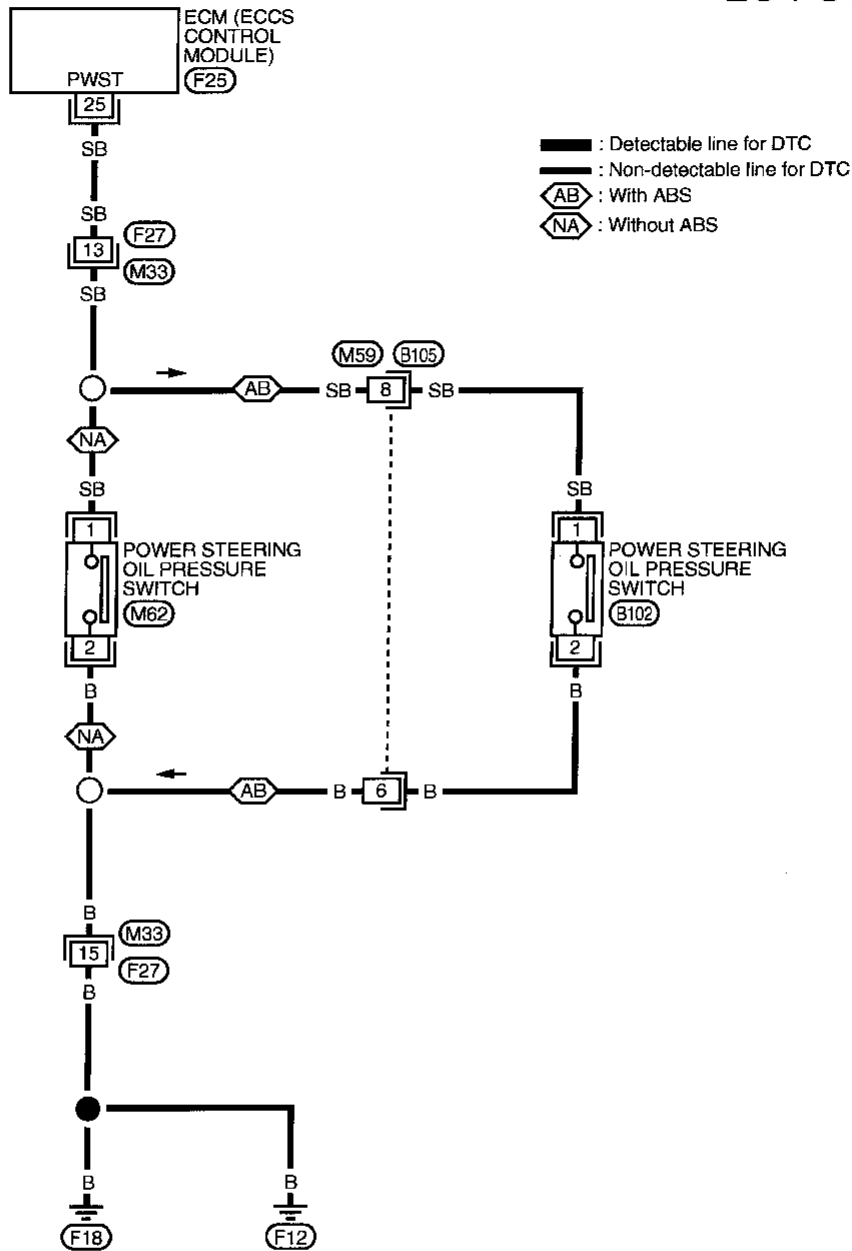

TROUBLE DIAGNOSIS FOR NON-DETECTABLE ITEMS

Power Steering Oil Pressure Switch (Cont'd)

COMPONENT DESCRIPTION

The power steering oil pressure switch is attached to the power steering high-pressure tube and detects a power steering load. When a power steering load is detected, it signals the ECM. The ECM adjusts the IACV-AAC valve to increase the idle speed and adjust for the increased load.

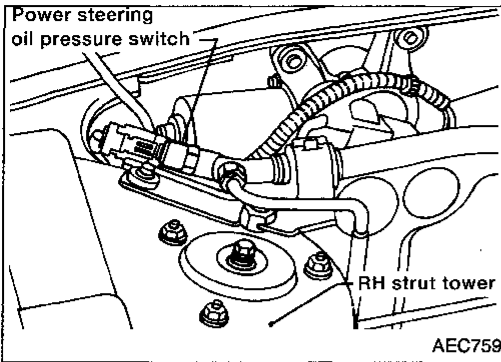

CONSULT REFERENCE VALUE IN DATA MONITOR MODE

Specification data are reference values.

MONITOR ITEM	CONDITION	SPECIFICATION
PW/ST SIGNAL	● Engine: After warming up, idle the engine	Steering wheel in neutral position (forward direction)
		The steering wheel is fully turned
		OFF
		ON

ECM TERMINALS AND REFERENCE VALUE

Specification data are reference values and are measured between each terminal and engine ground.

TER-MINAL NO.	WIRE COLOR	ITEM	CONDITION	DATA (DC voltage)
25	SB	Power steering oil pressure switch	Engine is running. └ Steering wheel is fully turned.	Approximately 0V
			Engine is running. └ Steering wheel is not turned.	Approximately 5V

TROUBLE DIAGNOSIS FOR NON-DETECTABLE ITEMS

Power Steering Oil Pressure Switch (Cont'd)

DIAGNOSTIC PROCEDURE

A

■ PW/ST SIGNAL CIRCUIT ■

HOLD STEERING WHEEL
IN A FULL
LOCKED POSITION
THEN
TOUCH START

NEXT START

MEF023E

A

☆ MONITOR ☆ NO FAIL

PW/ST SIGNAL OFF

RECORD

SEF5911

A

ECM CONNECTOR H.S. CONNECT

25

V

ON

SEF126P

B

T.S. DISCONNECT

1 2

Ω

OFF

AEC760

C

H.S. DISCONNECT T.S. DISCONNECT

ECM CONNECTOR

25

1 2

Ω

OFF

AEC761

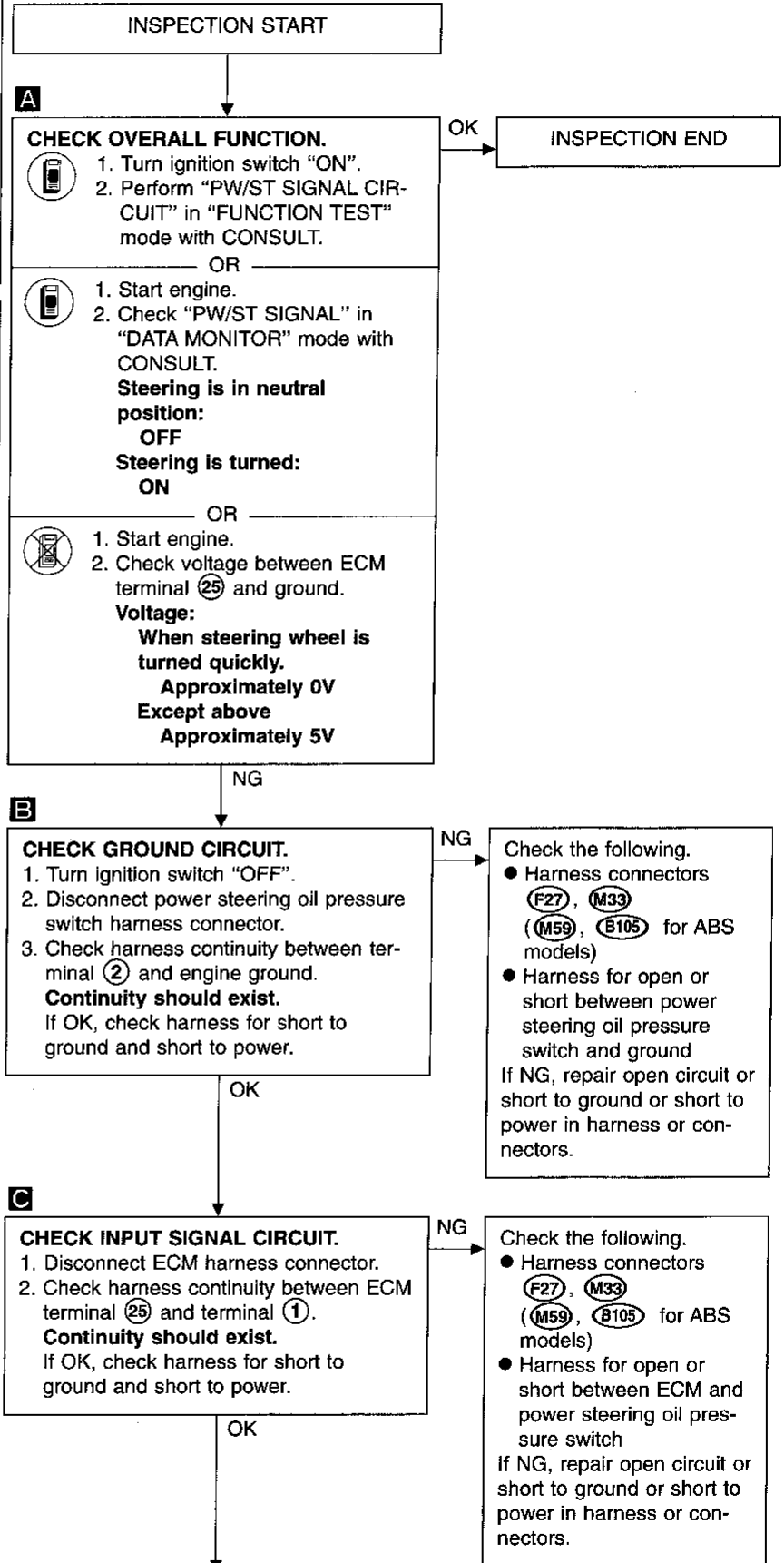

GI

MA

EM

LC

EC

FE

CL

MT

AT

FA

RA

BR

ST

RS

BT

HA

EL

IDX

TROUBLE DIAGNOSIS FOR NON-DETECTABLE ITEMS

Power Steering Oil Pressure Switch (Cont'd)

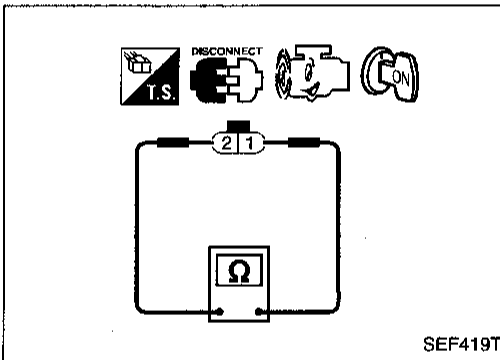
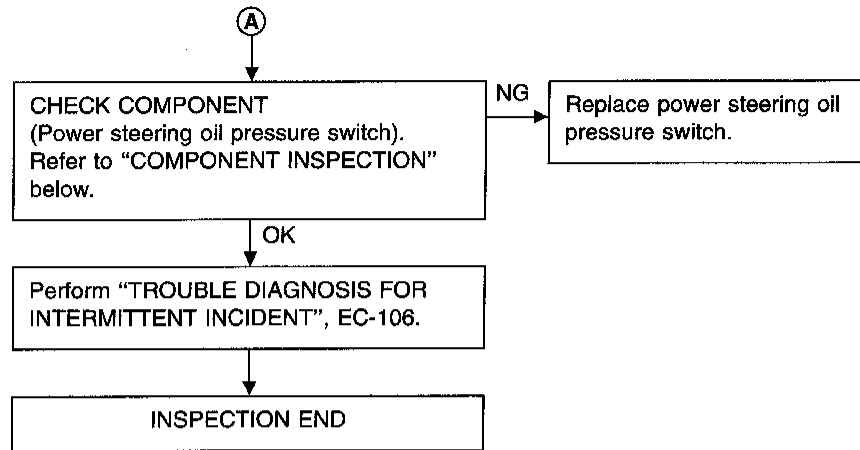

COMPONENT INSPECTION

Power steering oil pressure switch

1. Disconnect power steering oil pressure switch harness connector then start engine.
2. Check continuity between terminals ① and ②.

Conditions	Continuity
Steering wheel is being turned	Yes
Steering wheel is not being turned	No

If NG, replace power steering oil pressure switch.

TROUBLE DIAGNOSIS FOR NON-DETECTABLE ITEMS

IACV-Air Regulator

EC-AIRREG-01

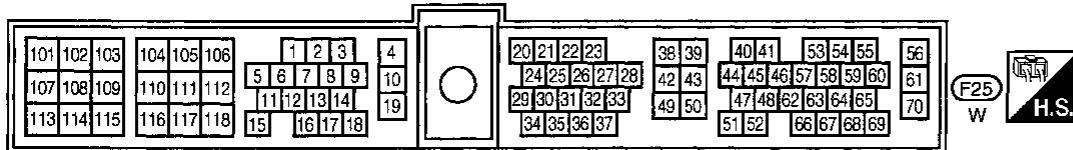
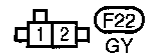
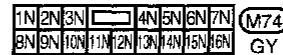
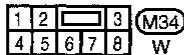
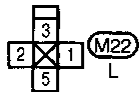
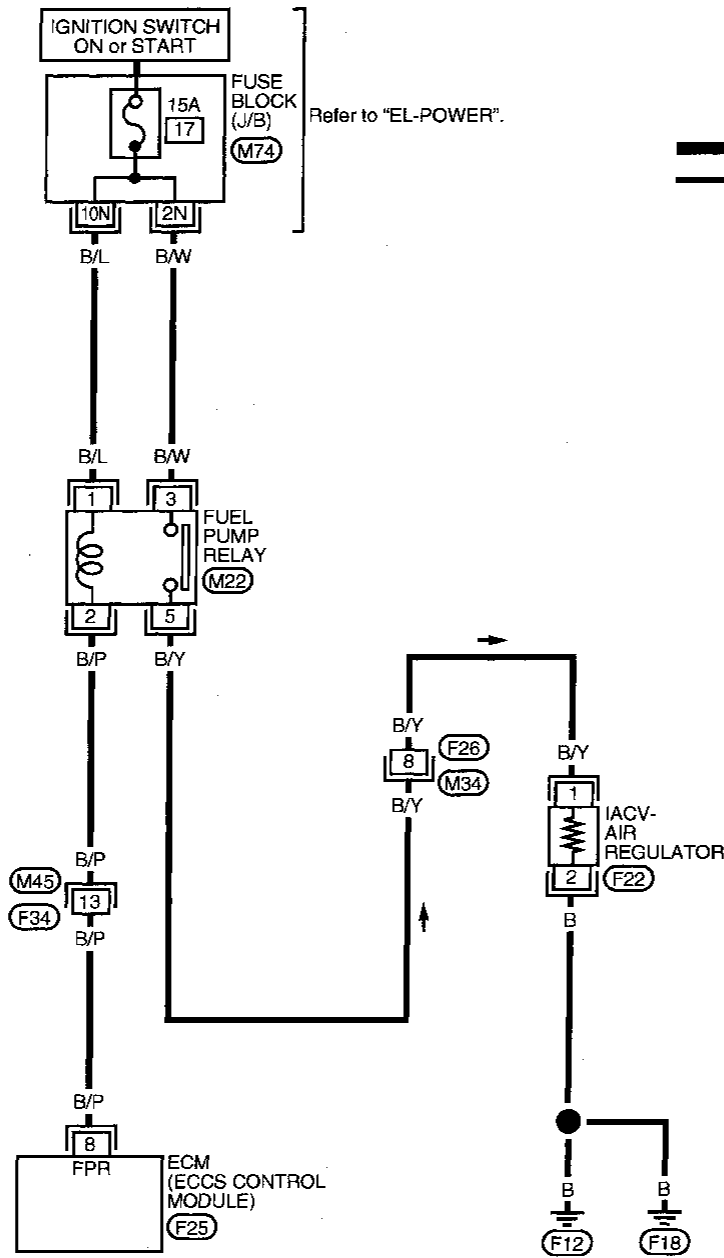

TROUBLE DIAGNOSIS FOR NON-DETECTABLE ITEMS

IACV-Air Regulator (Cont'd)

DESCRIPTION

The idle air control valve (IACV)-air regulator provides an air bypass when the engine is cold for a fast idle during warm-up. A bimetal, heater and rotary shutter are built into the IACV-air regulator. When the bimetal temperature is low, the air bypass port opens. As the engine starts and electric current flows through a heater, the bimetal begins to turn the shutter to close the bypass port. The air passage remains closed until the engine stops and the bimetal temperature drops.

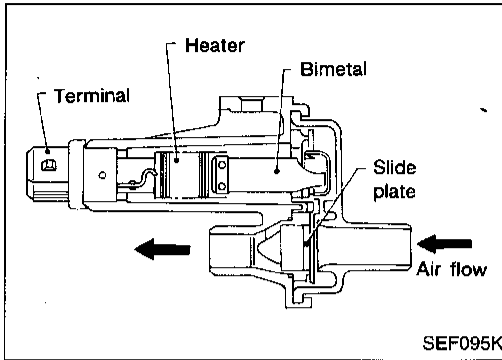

ECM TERMINALS AND REFERENCE VALUE

Specification data are reference values and are measured between each terminal and engine ground.

TER-MINAL NO.	WIRE COLOR	ITEM	CONDITION	DATA (DC voltage)
8	B/P	Fuel pump relay	Ignition switch "ON" └ For 5 seconds after turning ignition switch "ON"	0 - 1V
			Engine is running.	
			Ignition switch "ON" └ More than 5 seconds after turning ignition switch "ON"	BATTERY VOLTAGE (11 - 14V)

TROUBLE DIAGNOSIS FOR NON-DETECTABLE ITEMS

IACV-Air Regulator (Cont'd)

DIAGNOSTIC PROCEDURE

A

■ FUEL PUMP CIRCUIT ■
 PINCH FUEL FEED HOSE WITH FINGERS IS THERE ANY PRESSURE PULSATION ON THE FUEL FEED HOSE?
 OR
 DOES THE FUEL PUMP RELAY MAKE AN OPERATING SOUND EVERY 3 SECONDS?

NEXT NO YES

MEF591B

A

■ ACTIVE TEST ■

FUEL PUMP RELAY ON

== == MONITOR == ==
 CMPS•RPM(REF) 0rpm

ON ON/OFF OFF

MEF309F

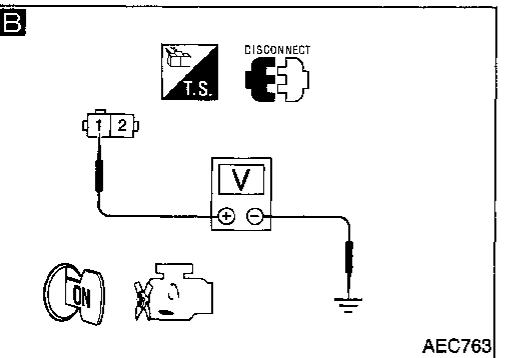
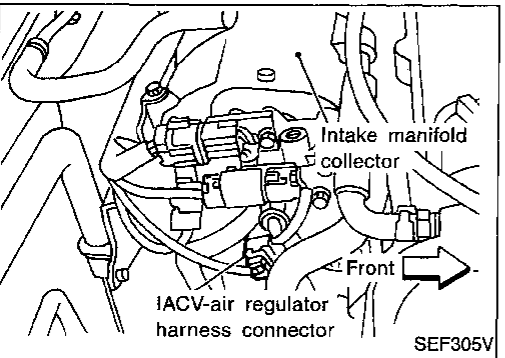
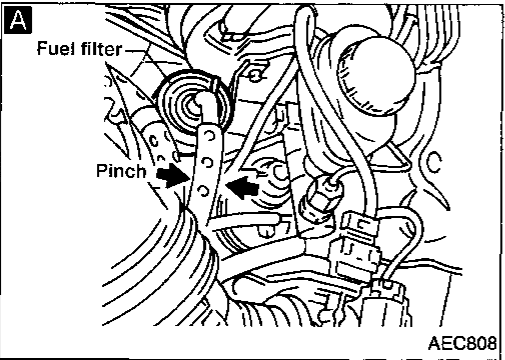

INSPECTION START

A

CHECK CONTROL FUNCTION.

1. Turn ignition switch "ON".

2. Perform "FUEL PUMP CIRCUIT" in "FUNCTION TEST" mode with CONSULT.

OR

2. Turn fuel pump relay "ON" and "OFF" in "ACTIVE TEST" mode with CONSULT and check operating sound.

OR

2. Pinch fuel feed hose with fingers.
Fuel pressure pulsation should be felt on the fuel feed hose for 5 seconds after ignition switch is turned "ON".

NG

Check fuel pump control circuit.
 Refer to EC-475.

B

CHECK POWER SUPPLY.

1. Turn ignition switch "OFF".

2. Disconnect IACV-air regulator harness connector.

3. Turn ignition switch "ON".

4. Check voltage between terminal ① and ground with CONSULT or tester.
Battery voltage should exist for 5 seconds after ignition switch is turned "ON".

NG

Check the following.

- Harness connectors (F26, M34)
- Harness for open or short between IACV-air regulator and fuel pump relay

If NG, repair harness or connectors.

OK

A

(Go to next page.)

GI
 MA
 EM
 LC
EC
 FE
 CL
 MT
 AT
 FA
 RA
 BR
 ST
 RS
 BT
 HA
 EL
 IDX

TROUBLE DIAGNOSIS FOR NON-DETECTABLE ITEMS

IACV-Air Regulator (Cont'd)

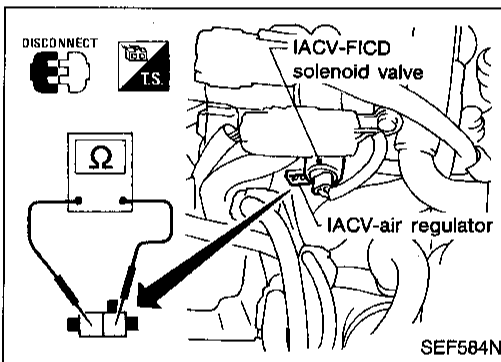
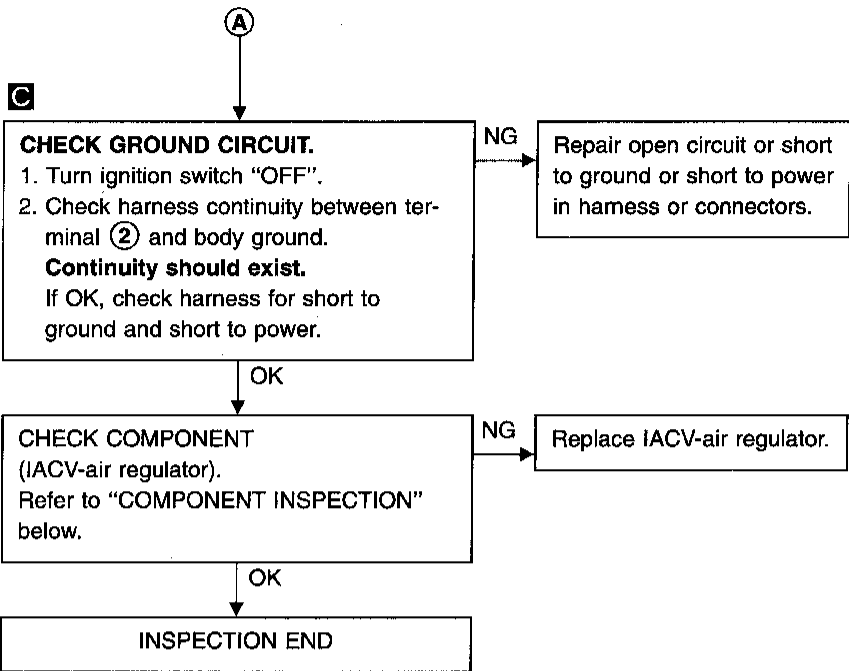
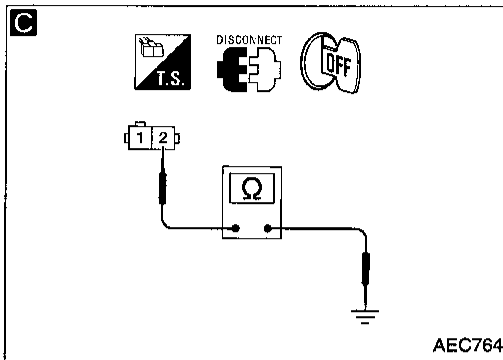

COMPONENT INSPECTION

IACV-air regulator

Disconnect IACV-air regulator harness connector.

- Check IACV-air regulator resistance.
Resistance:
Approximately 70 - 80Ω [at 25°C (77°F)]
- Check IACV-air regulator for clogging.

TROUBLE DIAGNOSIS FOR NON-DETECTABLE ITEMS

IACV-FICD Solenoid Valve

EC-FICD-01

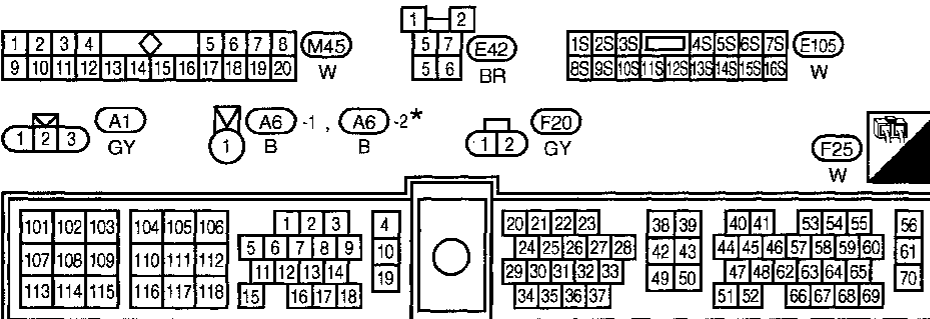
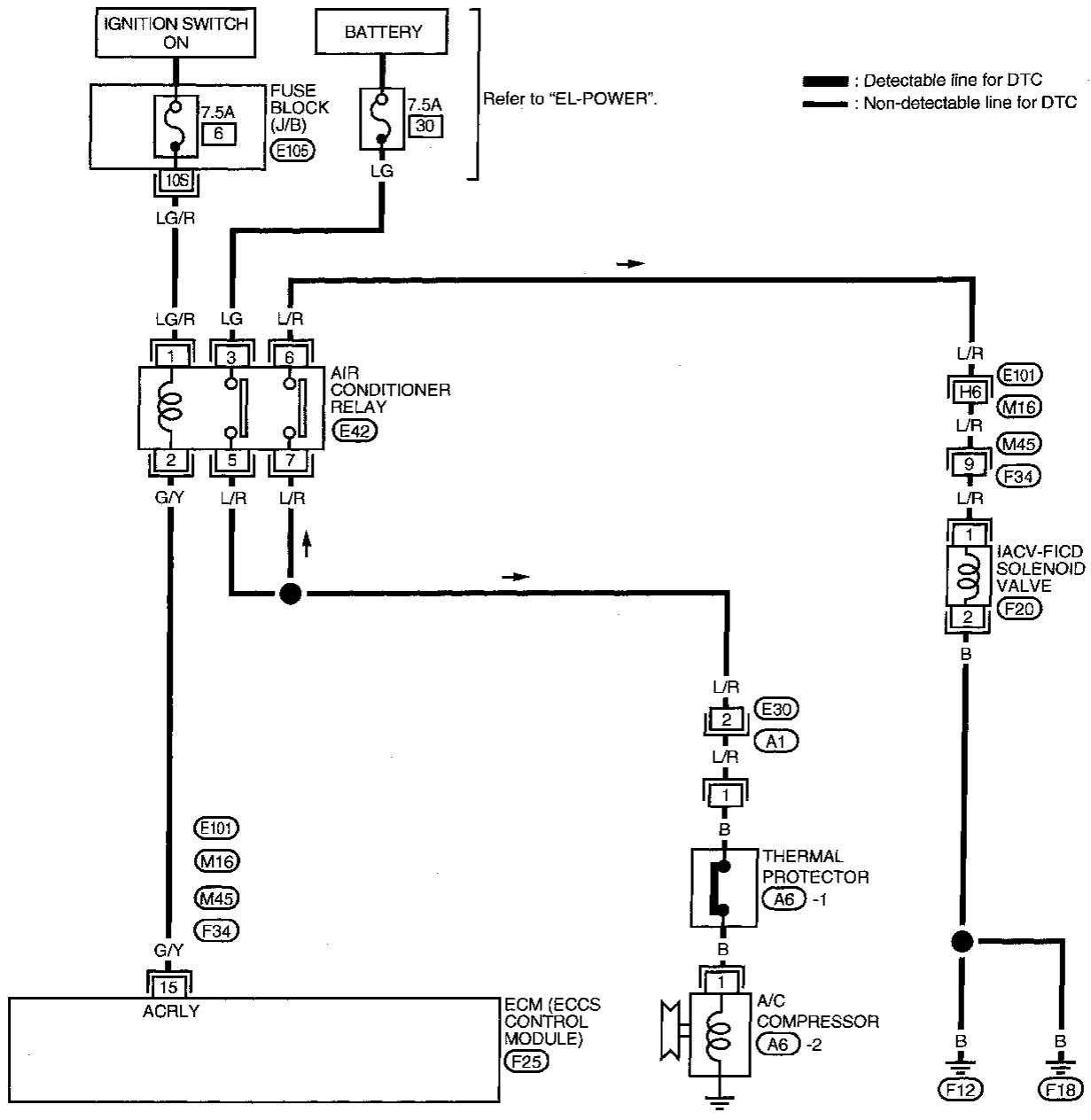

Refer to last page (Foldout page).

(M16), (E101)

*: This connector is not shown in "HARNES LAYOUT" of EL section.

TROUBLE DIAGNOSIS FOR NON-DETECTABLE ITEMS

IACV-FICD Solenoid Valve (Cont'd)

COMPONENT DESCRIPTION

When the air conditioner is on, the IAC valve-FICD solenoid valve supplies additional air to adjust to the increased load.

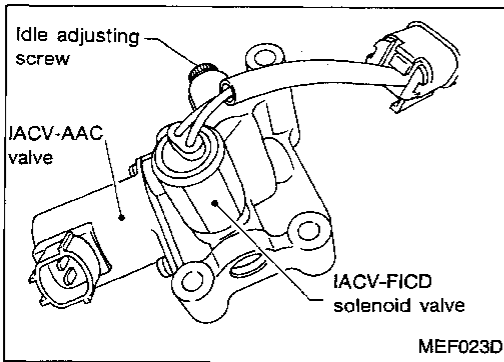

ECM TERMINALS AND REFERENCE VALUE

Specification data are reference values and are measured between each terminal and engine ground.

TER-MINAL NO.	WIRE COLOR	ITEM	CONDITION	DATA (DC voltage)
15	G/Y	Air conditioner relay	Engine is running. └ Both A/C switch and blower switch are "ON".	0 - 0.6V
			Engine is running. └ A/C switch is "OFF".	BATTERY VOLTAGE (11 - 14V)
21	L/W	Air conditioner switch	Engine is running. └ Both air conditioner switch and blower switch are "ON" (Compressor operates).	Approximately 0V
			Engine is running. └ Air conditioner switch is "OFF".	BATTERY VOLTAGE (11 - 14V)

TROUBLE DIAGNOSIS FOR NON-DETECTABLE ITEMS

IACV-FICD Solenoid Valve (Cont'd)

DIAGNOSTIC PROCEDURE

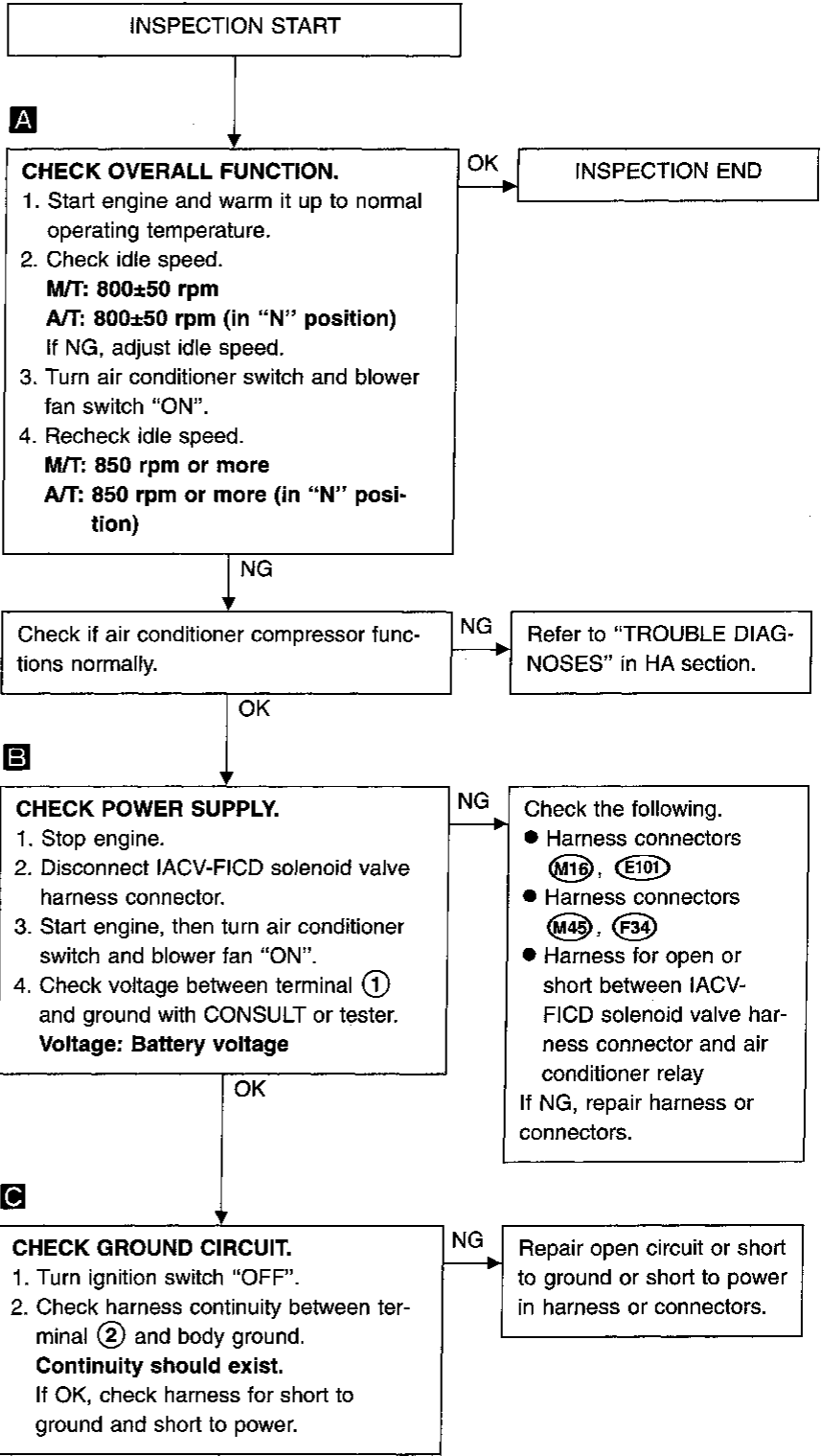
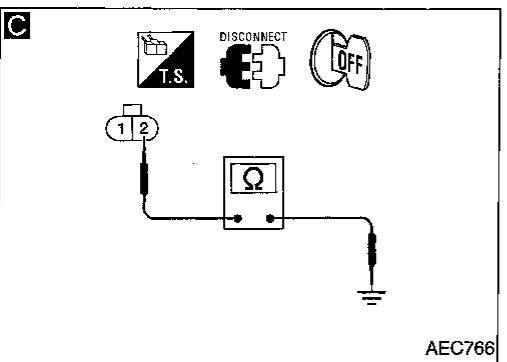
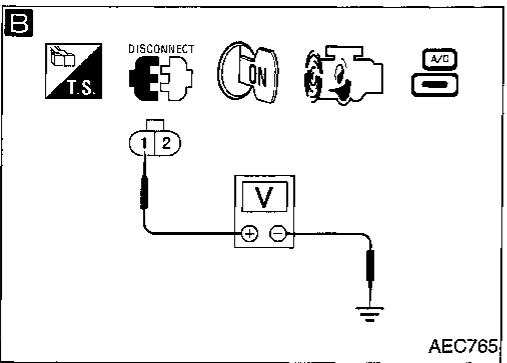
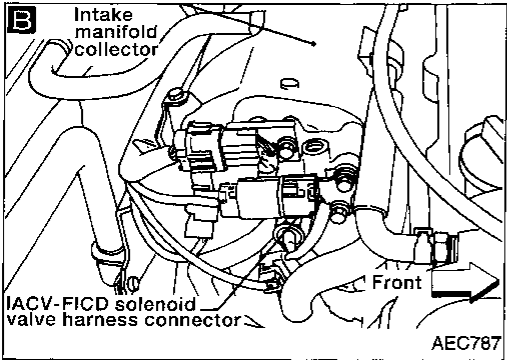
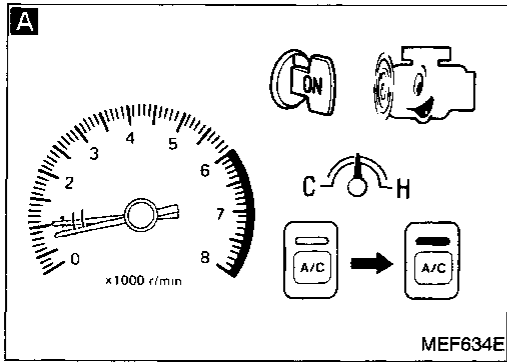

(Go to next page.)

GI
MA
EM
LC
EC
FE
CL
MT
AT
FA
RA
BR
ST
RS
BT
HA
EL
IDX

TROUBLE DIAGNOSIS FOR NON-DETECTABLE ITEMS

IACV-FICD Solenoid Valve (Cont'd)

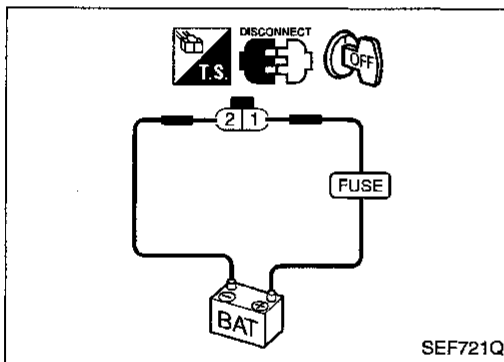
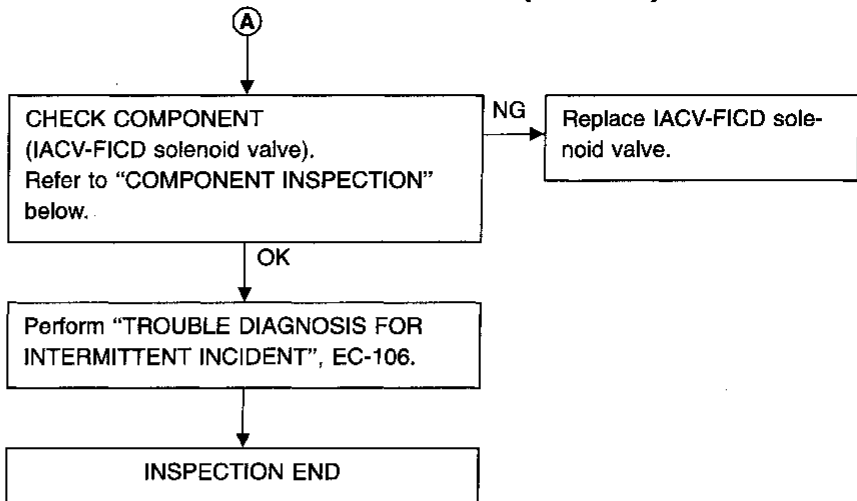

COMPONENT INSPECTION

IACV-FICD solenoid valve

Disconnect IACV-FICD solenoid valve harness connector.

- Check for clicking sound when applying 12V direct current to terminals.

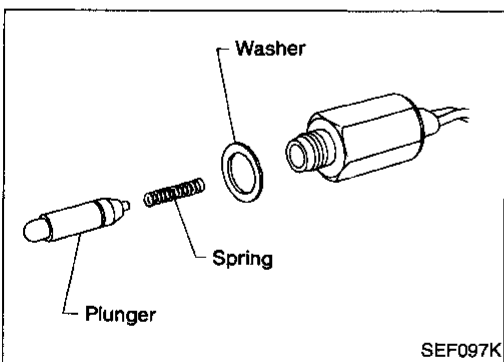

- Check plunger for seizing or sticking.
- Check for broken spring.

TROUBLE DIAGNOSIS FOR NON-DETECTABLE ITEMS

MIL & Data Link Connectors

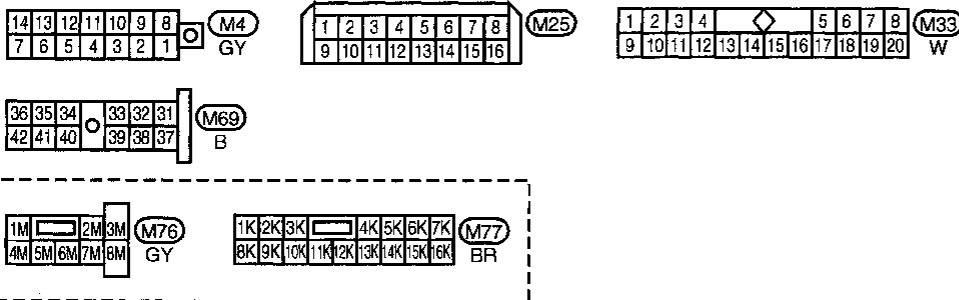
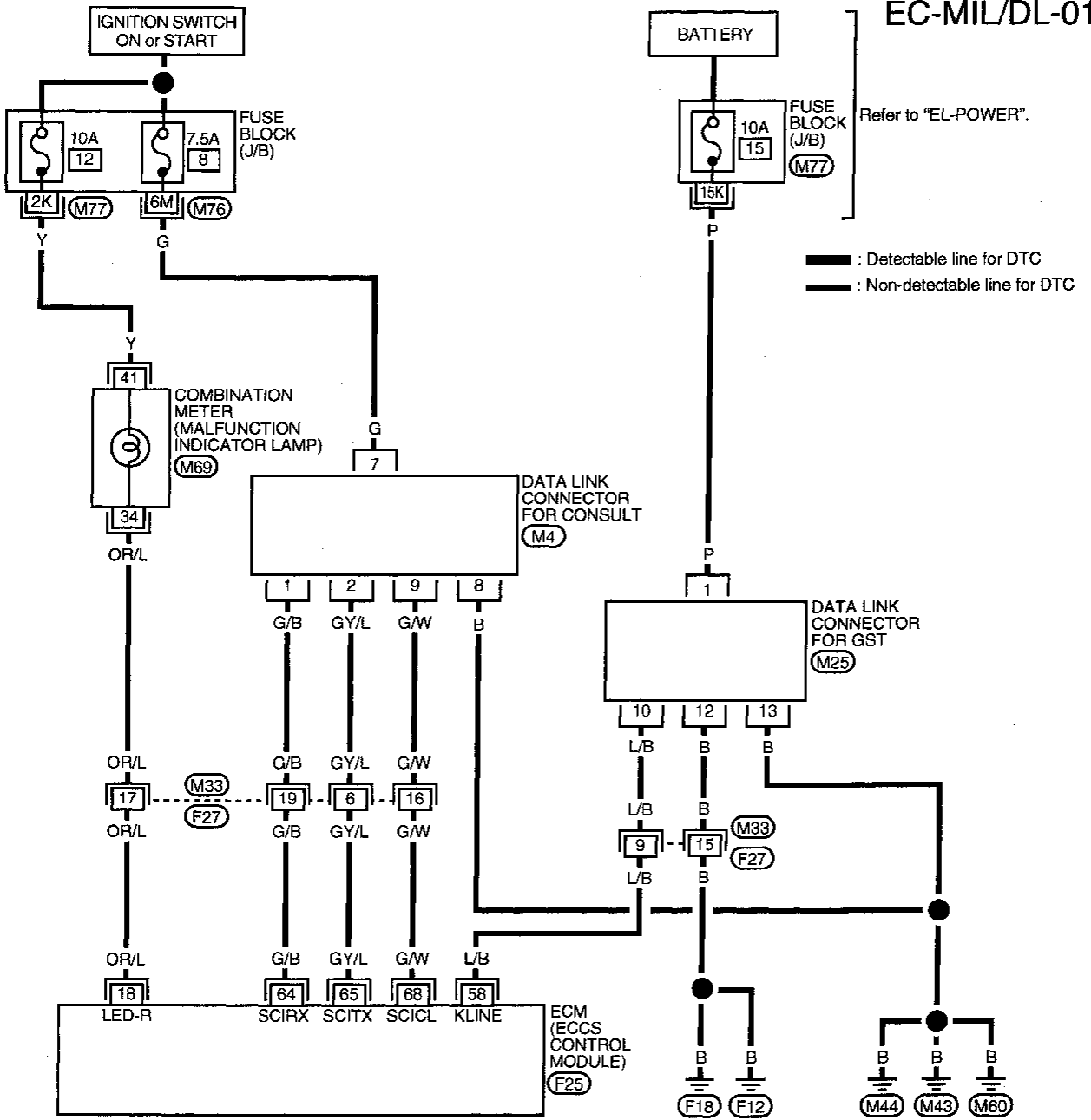

GI
MA
EM
LC
EC
FE
CL
MT
AT
FA
RA
BR
ST
RS
BT
HA
EL
IDX

SERVICE DATA AND SPECIFICATIONS (SDS)

General Specifications

FUEL PRESSURE REGULATOR

Fuel pressure at idling kPa (kg/cm ² , psi)	
Vacuum hose is connected	Approximately 235 (2.4, 34)
Vacuum hose is disconnected	Approximately 294 (3.0, 43)

Inspection and Adjustment

Target idle speed *1 No-load *3 (In "N" position)	rpm	800±50 rpm (In "N" position)
Base idle speed *2 No-load *3 (In "N" position)	rpm	750±50 rpm (In "N" position)
Air conditioner: ON (In "N" position)	rpm	850 or more
Ignition timing		15° ± 2° BTDC
Throttle position sensor idle position	V	0.35 - 0.65

*1: Throttle position sensor harness connector connected

*2: Throttle position sensor harness connector disconnected or using CONSULT "WORK SUPPORT"

*3: Under the following conditions:

- Air conditioner switch: OFF
- Electric load: OFF (Lights, heater fan & rear window defogger)

IGNITION COIL

Primary voltage	V	Battery voltage (11 - 14)
Primary resistance [at 25°C (77°F)]	Ω	0.5 - 1.0
Secondary resistance [at 25°C (77°F)]	kΩ	Approximately 25

MASS AIR FLOW SENSOR

Supply voltage	V	Battery voltage (11 - 14)
Output voltage	V	1.3 - 1.7*
Mass air flow (Using CONSULT or GST) g-m/sec		2.5 - 5.0 at idle* 7.1 - 12.5 at 2,500 rpm*

*: Engine is warmed up to normal operating temperature and idling under no-load.

ENGINE COOLANT TEMPERATURE SENSOR

Temperature °C (°F)	Resistance kΩ
20 (68)	2.1 - 2.9
50 (122)	0.68 - 1.00
90 (194)	0.236 - 0.260

EGR TEMPERATURE SENSOR

EGR temperature °C (°F)	Voltage (V)	Resistance (MΩ)
0 (32)	4.81	7.9 - 9.7
50 (122)	2.82	0.57 - 0.70
100 (212)	0.8	0.08 - 0.10

FUEL PUMP

Resistance [at 25°C (77°F)]	Ω	0.2 - 5.0
-----------------------------	---	-----------

IACV-AAC VALVE

Resistance [at 25°C (77°F)]	Ω	Approximately 10.0
-----------------------------	---	--------------------

INJECTOR

Resistance [at 25°C (77°F)]	Ω	10 - 14
-----------------------------	---	---------

RESISTOR

Resistance [at 25°C (77°F)]	kΩ	Approximately 2.2
-----------------------------	----	-------------------

THROTTLE POSITION SENSOR

Throttle valve conditions	Voltage (at normal operating temp., engine off, ignition switch on)
Completely closed (a)	0.15 - 0.85V
Partially open	Between (a) and (b)
Completely open (b)	3.5 - 4.7V

FRONT HEATED OXYGEN SENSOR HEATER

Resistance [at 25°C (77°F)]	Ω	2.3 - 4.3
-----------------------------	---	-----------

SERVICE DATA AND SPECIFICATIONS (SDS)

Inspection and Adjustment (Cont'd)

CALCULATED LOAD VALUE

	Calculated load value % (Using CONSULT or GST)
At idle	20.0 - 35.5
At 2,500 rpm	17.0 - 30.0

INTAKE AIR TEMPERATURE SENSOR

Temperature °C (°F)	Resistance kΩ
20 (68)	2.1 - 2.9
80 (176)	0.27 - 0.38

EVAP CANISTER PURGE VOLUME CONTROL VALVE

Resistance [at 20°C (68°F)] Ω	
	35 - 43

DROPPING RESISTOR FOR FPCM

Resistance [at 25°C (77°F)] Ω	
	Approximately 0.8

REAR HEATED OXYGEN SENSOR HEATER

Resistance [at 25°C (77°F)] Ω	
	2.3 - 4.3

CRANKSHAFT POSITION SENSOR (OBD)

Resistance [at 25°C (77°F)] Ω	
	166 - 204

TANK FUEL TEMPERATURE SENSOR

Temperature °C (°F)	Resistance kΩ
20 (68)	2.3 - 2.7
50 (122)	0.79 - 0.90

GI

MA

EM

LC

EC

FE

CL

MT

AT

FA

RA

BR

ST

RS

BT

HA

EL

IDX