

# REAR AXLE & REAR SUSPENSION

## SECTION RA

GI  
MA  
EM  
LC  
EC  
FE  
CL  
MT  
AT  
FA  
**RA**  
BR  
ST  
RS  
BT  
HA  
EL  
IDX

### CONTENTS

<b>PRECAUTIONS AND PREPARATION</b> .....	2	Removal.....	10
Precautions.....	2	Installation.....	10
Commercial Service Tools.....	2	<b>Coil Spring and Shock Absorber</b> .....	11
<b>NOISE, VIBRATION AND HARSHNESS (NVH)</b>		Removal.....	11
<b>TROUBLESHOOTING</b> .....	3	Disassembly.....	11
NVH Troubleshooting Chart.....	3	Inspection.....	11
<b>REAR SUSPENSION SYSTEM</b> .....	4	Assembly.....	12
Components.....	4	<b>Torsion Beam, Lateral Link and Control Rod</b> .....	13
<b>ON-VEHICLE SERVICE</b> .....	5	Disassembly.....	13
Rear Axle and Rear Suspension Parts.....	5	Inspection.....	13
Rear Wheel Bearing.....	5	Rubber Bushing Replacement.....	13
Rear Wheel Alignment.....	6	Assembly.....	14
<b>REAR AXLE</b> .....	7	<b>SERVICE DATA AND SPECIFICATIONS (SDS)</b> .....	15
Wheel Hub.....	7	General Specifications.....	15
<b>REAR SUSPENSION</b> .....	9	Inspection and Adjustment.....	15
Components.....	9		

# PRECAUTIONS AND PREPARATION

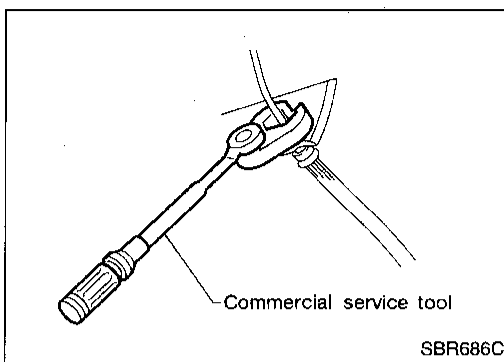

## Precautions

- When installing rubber parts, final tightening must be carried out under unladen condition\* with tires on ground.
- \*: Fuel, radiator coolant and engine oil full. Spare tire, jack, hand tools and mats in designated positions.
- Use flare nut wrench when removing or installing brake tubes.
- After installing removed suspension components, check wheel alignment and adjust if necessary.
- Do not jack up at the trailing arm and lateral link.
- Always torque brake lines when installing.

## Commercial Service Tools

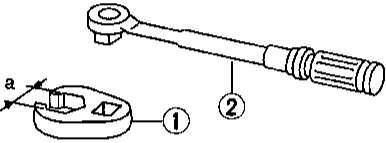
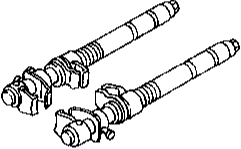
Tool name	Description
① Flare nut crowfoot ② Torque wrench	 <p>NT360</p> <p>a: 10 mm (0.39 in)</p>
Spring compressor	 <p>NT717</p>

# NOISE, VIBRATION AND HARSHNESS (NVH) TROUBLESHOOTING

## NVH Troubleshooting Chart

Use the chart below to help you find the cause of the symptom. If necessary, repair or replace these parts.

Symptom		Possible cause and SUSPECTED PARTS	Reference page													
			RA-4, 9	RA-11	RA-11	—	—	RA-5	RA-6	RA-5	NVH in FA section	NVH in FA section	NVH in FA section	NVH in FA section	NVH in BR section	NVH in ST section
REAR AXLE AND REAR SUSPENSION	Noise	Improper installation, looseness	X	X	X	X	X	X			X	X	X	X	X	X
	Shake	Shock absorber deformation, damage or deflection	X	X	X	X		X			X	X	X	X	X	X
	Vibration	Bushing or mounting deterioration	X	X	X	X	X				X	X	X			X
	Shimmy	Parts interference	X	X	X	X			X			X	X	X	X	X
	Judder	Spring fatigue	X	X	X							X	X	X	X	X
	Poor quality ride or handling	Suspension looseness	X	X	X	X		X	X			X	X	X		
		Incorrect wheel alignment														
		Wheel bearing damage														
		DRIVESHAFT														
		FRONT AXLE AND FRONT SUSPENSION														
		TIRES														
		ROAD WHEEL														
		BRAKES														
		STEERING														

X: Applicable

GI  
MA  
EM  
LC  
EC  
FE  
CL  
MT  
AT  
FA  
**RA**  
BR  
ST  
RS  
BT  
HA  
EL  
IDX

# REAR SUSPENSION SYSTEM

## Components

### SEC. 431

When installing each rubber part, final tightening must be carried out under unladen condition\* with tires on ground.

\* Fuel, radiator coolant and engine oil full.  
Spare tire, jack, hand tools and mats in designated positions.

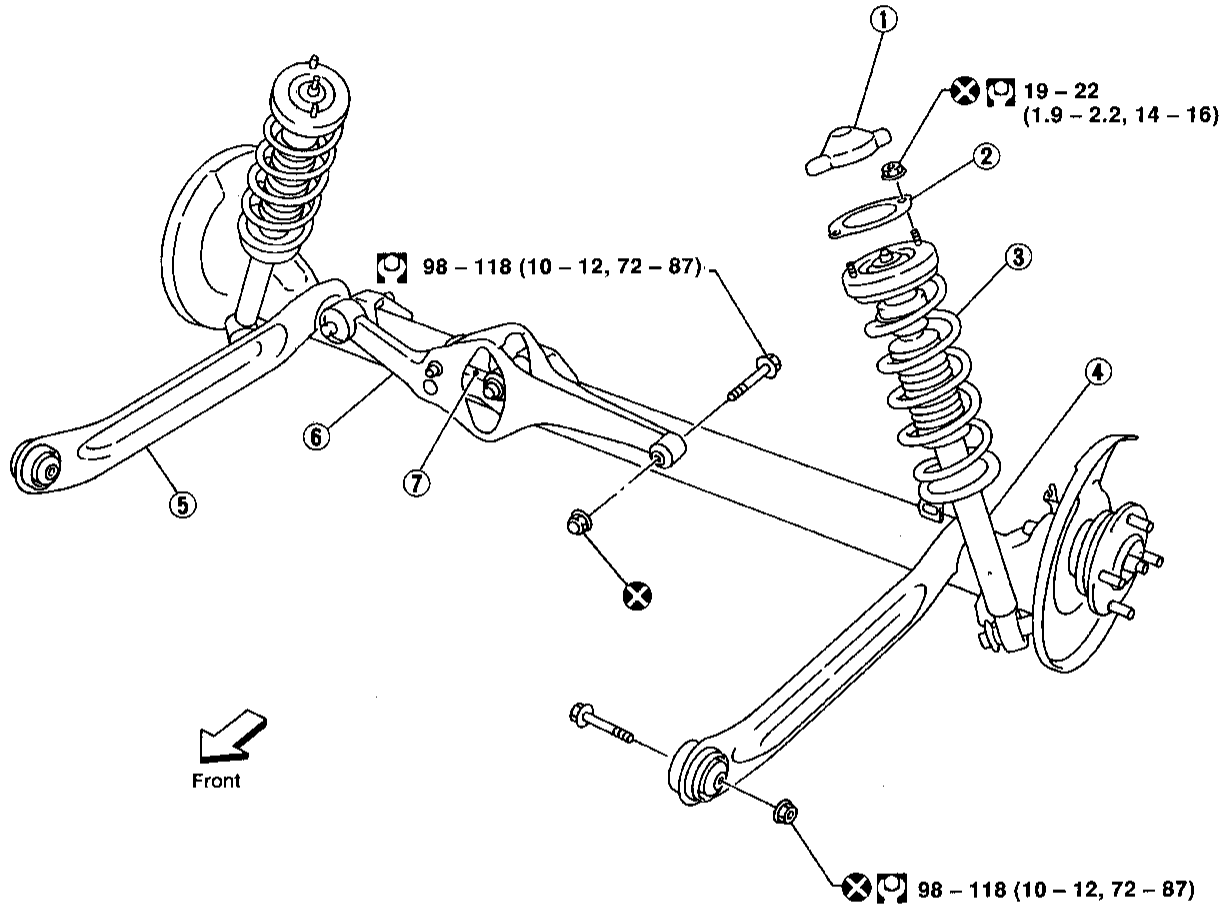

: N·m (kg-m, ft-lb)

ARA060

- ① Shock absorber cap
- ② Shock absorber mounting seal
- ③ Coil spring

- ④ Shock absorber
- ⑤ Torsion beam

- ⑥ Lateral link
- ⑦ Control rod

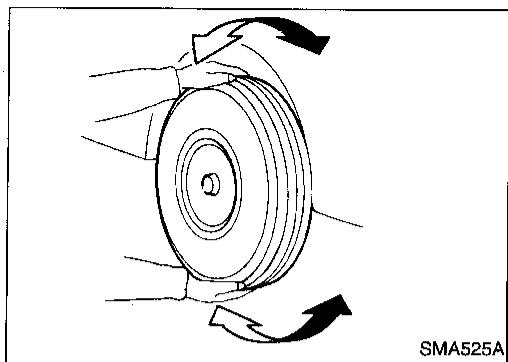

## Rear Axle and Rear Suspension Parts

Check axle and suspension parts for excessive play, wear or damage.

- Shake each rear wheel to check for excessive play.

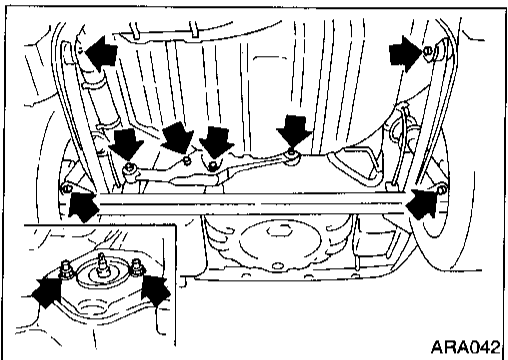

- Retighten all nuts and bolts to the specified torque.

**Tightening torque:**

**Refer to RA-9.**

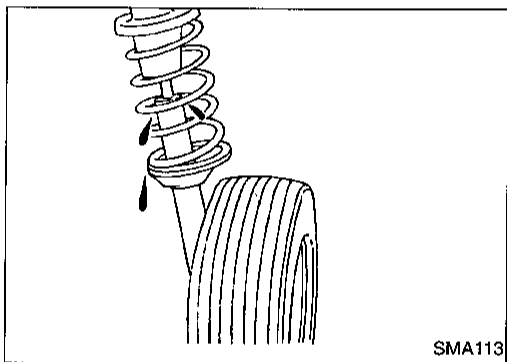

- Check shock absorber for oil leakage and damage.
- Check wheelarch height. Refer to FA section ("Front Axle and Front Suspension Parts", "ON-VEHICLE SERVICE").

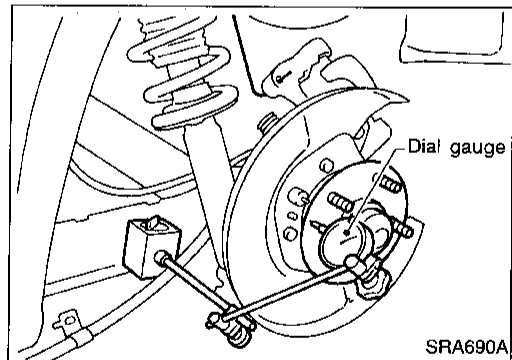

## Rear Wheel Bearing

- Check axial end play.  
**Axial end play:**  
**0.05 mm (0.0020 in) or less**
- Check that wheel hub bearing operates smoothly.
- Check tightening torque of wheel bearing lock nut.  
**□: 187 - 255 N·m (19 - 26 kg·m, 137 - 188 ft·lb)**
- If axial end play is not within specification, or wheel bearing does not turn smoothly, replace wheel hub bearing assembly. Refer to RA-7.

GI

MA

EM

LC

EC

FE

CL

MT

AT

FA

RA

BR

ST

RS

BT

HA

EL

IDX

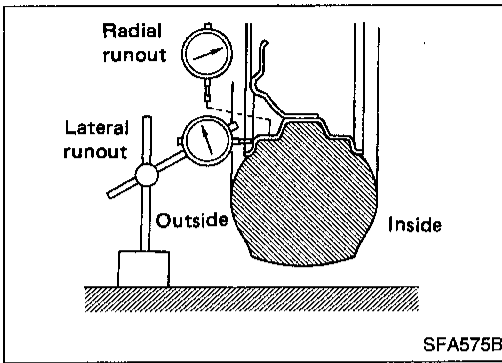

## Rear Wheel Alignment

### PRELIMINARY INSPECTION

Make following checks. Adjust, repair or replace if necessary.

- Check tires for wear and for proper inflation.
- Check rear wheel bearings for excessive play.
- Check wheel runout.

#### Wheel runout:

Refer to FA section ("Inspection and Adjustment", "SDS").

- Check that rear shock absorber works properly.
- Check rear axle and rear suspension parts for excessive play.
- Check vehicle posture (Unladen\*).

\*: Fuel, radiator coolant and engine oil full. Spare tire, jack, hand tools and mats in designated positions.

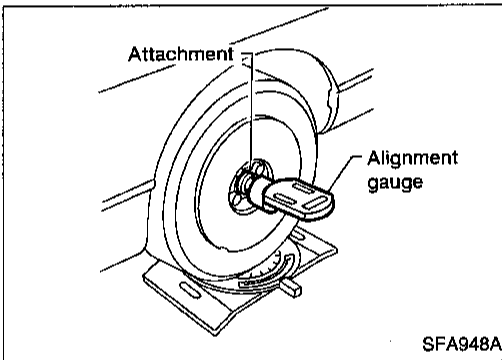

### CAMBER

- **Camber is preset at factory and cannot be adjusted.**

#### Camber:

Refer to SDS, RA-15.

- If the camber is not within specification, inspect and replace any damaged or worn rear suspension parts.

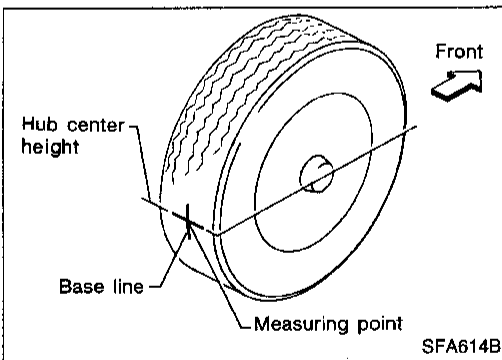

### TOE-IN

Toe-in is preset at factory and cannot be adjusted.

Measure toe-in using following procedure. If out of specification, inspect and replace any damaged or worn rear suspension parts.

#### WARNING:

- Always perform following procedure on a flat surface.
- Make sure that no one is in front of the vehicle before pushing it.

1. Bounce rear of vehicle up and down to stabilize the posture.
2. Push the vehicle straight ahead about 5 m (16 ft).
3. Put a mark on base line of the tread (rear side) of both rear tires at the same height as hub center. This mark is a measuring point.
4. Measure distance "A" (rear side).
5. Push the vehicle slowly ahead to rotate the wheels 180 degrees (1/2 turn).

- If the wheels have rotated more than 180 degrees (1/2 turn), try the above procedure again from the beginning. Never push vehicle backward.

6. Measure distance "B" (front side).

#### Total toe-in:

Refer to SDS, RA-15.

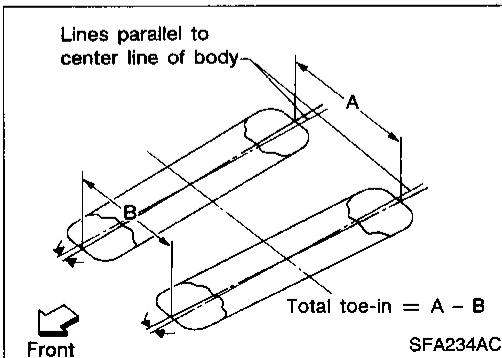

## Wheel Hub

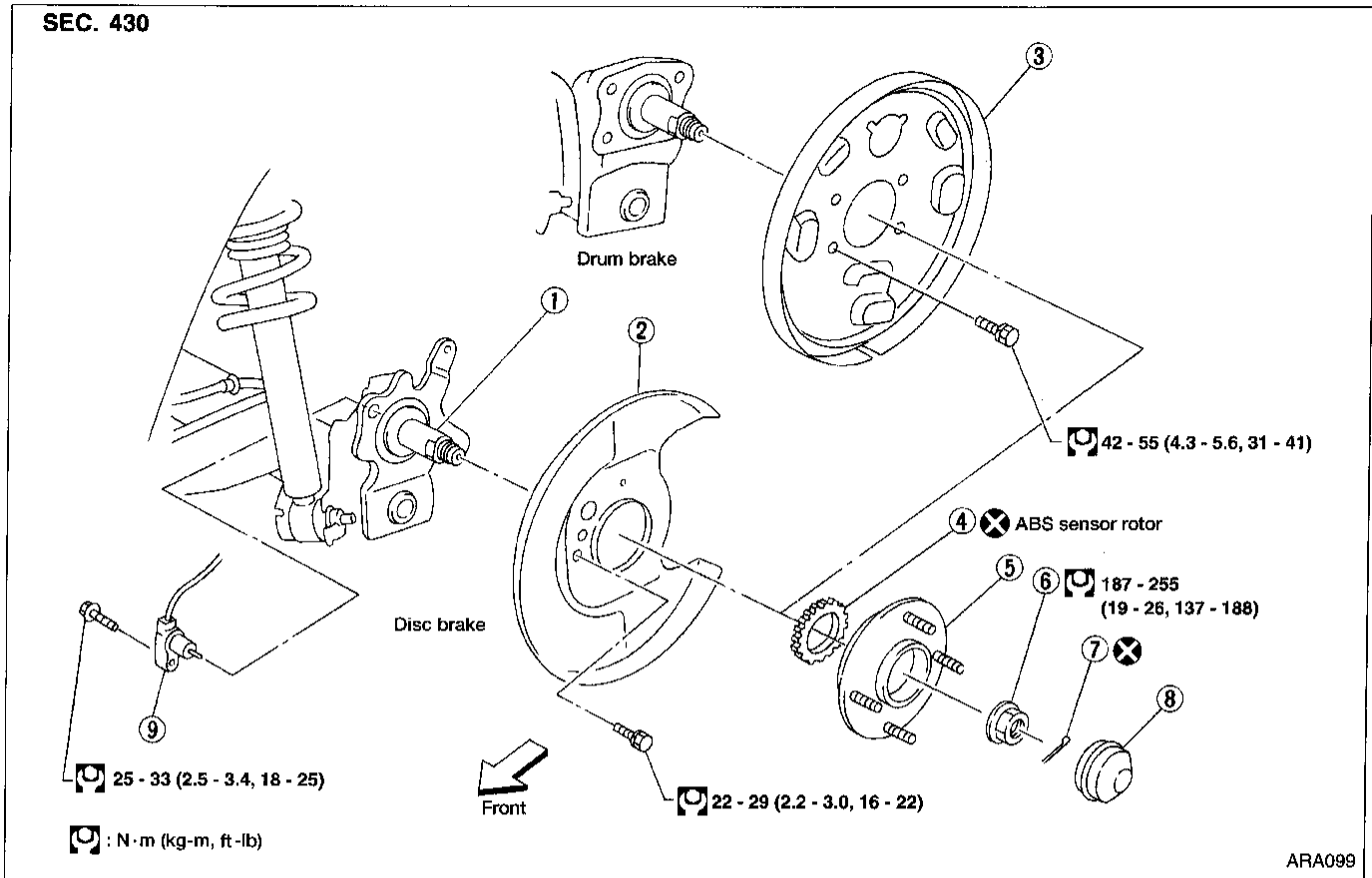

- ① Spindle
- ② Baffle plate
- ③ Back plate

- ④ ABS sensor rotor
- ⑤ Wheel hub bearing
- ⑥ Wheel bearing lock nut

- ⑦ Cotter pin
- ⑧ Hub cap

### REMOVAL

#### CAUTION:

- Before removing the wheel hub bearing assembly, disconnect the ABS wheel sensor from the assembly. Move it away from the hub assembly. Failure to do so may result in damage to the sensor wires and the sensor becoming inoperative.
- Wheel hub bearing does not require maintenance. If any of the following occurs, replace wheel hub bearing assembly.
  - (1) Growling noise is emitted from wheel hub bearing during operation.
  - (2) Wheel hub bearing drags or turns roughly. This occurs when turning wheel hub by hand after wheel bearing lock nut is tightened to specified torque.

## REAR AXLE

### Wheel Hub (Cont'd)

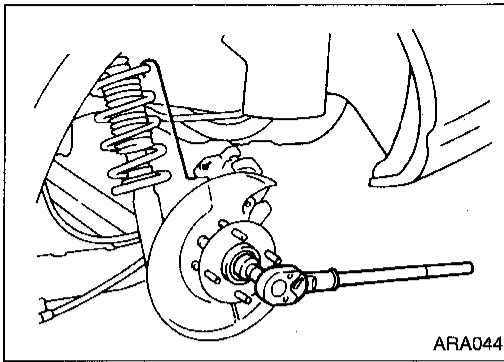

1. Remove brake caliper assembly.
2. Remove wheel bearing lock nut.
3. Remove brake rotor (models with disc brakes) or brake drum (models with drum brakes).
4. Remove wheel hub bearing from spindle.
  - Brake hose does not need to be disconnected from brake caliper.
  - Suspend caliper assembly with wire so as not to stretch brake hose.
  - Be careful not to depress brake pedal, or caliper piston will pop out.
  - Make sure brake hose is not twisted.
5. Remove the sensor rotor using suitable puller, drift and bearing replacer.

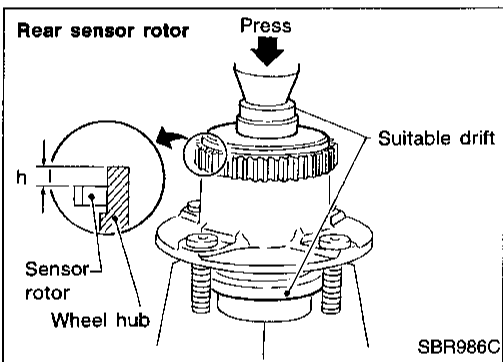
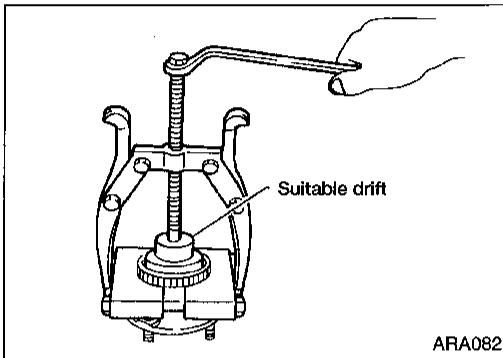

### INSTALLATION

1. Install the sensor rotor. Use suitable drift and press.
  - Always replace sensor rotor with a new one.
2. Pay attention to the dimension of rear sensor rotor as shown in figure  
**h: 4.5 - 5.5 mm (0.177 - 0.217 in)**

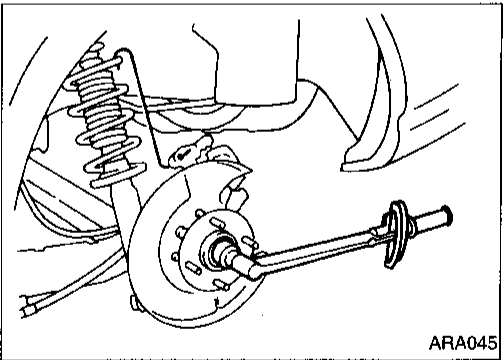

3. Install wheel hub bearing assembly.
4. Tighten wheel bearing lock nut.  
Before tightening, apply oil to threaded portion of rear spindle  
**⌚: 187 - 255 N·m (19 - 26 kg·m, 137 - 188 ft·lb)**
5. Check that wheel hub bearing operates smoothly.

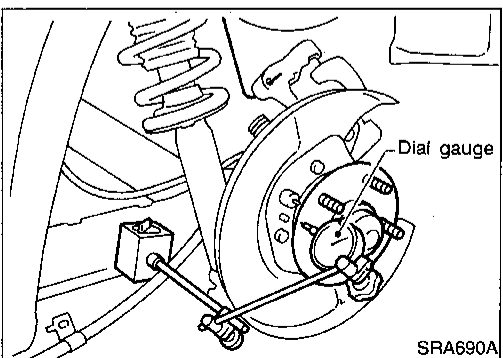

6. Check wheel hub bearing axial end play.  
**Axial end play:**  
**0.05 mm (0.0020 in) or less**



# REAR SUSPENSION

## Components

### SEC. 431

When installing each rubber part, final tightening must be carried out under unladen condition\* with tires on ground.

\* Fuel, radiator coolant and engine oil full.

Spare tire, jack, hand tools and mats in designated positions.

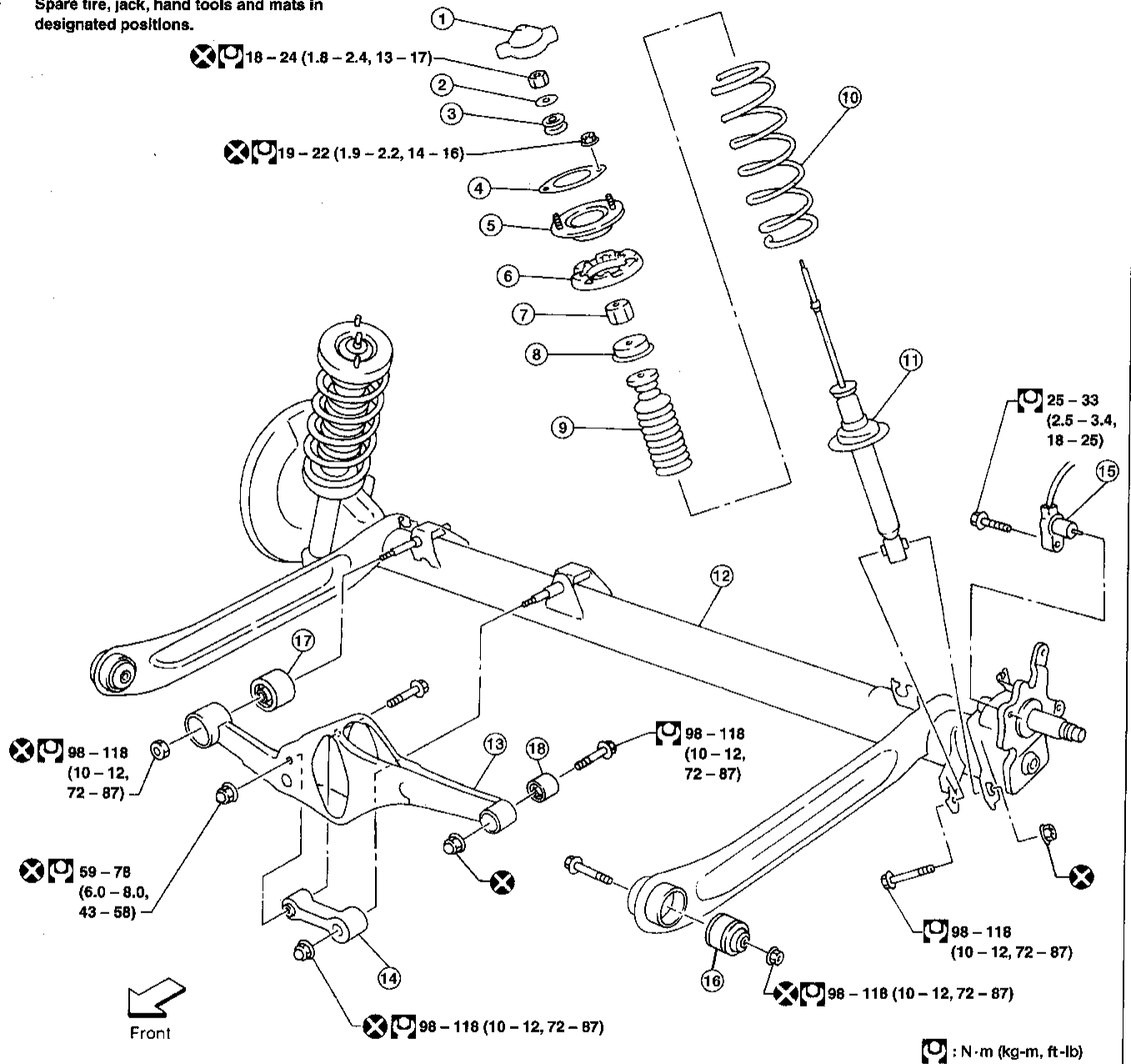

① Shock absorber cap

② Washer

③ Bushing

④ Shock absorber mounting seal

⑤ Shock absorber mounting bracket

⑥ Upper spring seat rubber

⑦ Bushing

⑧ Bound bumper cover

⑨ Bound bumper

⑩ Coil spring

⑪ Shock absorber

⑫ Torsion beam

⑬ Lateral link

⑭ Control rod

⑮ ABS sensor

⑯ Trailing arm bushing

⑰ Large lateral link bushing

⑱ Small lateral link bushing

# REAR SUSPENSION

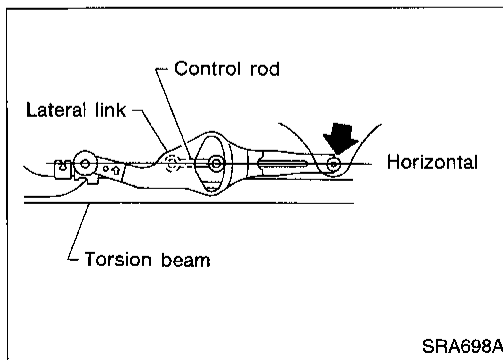
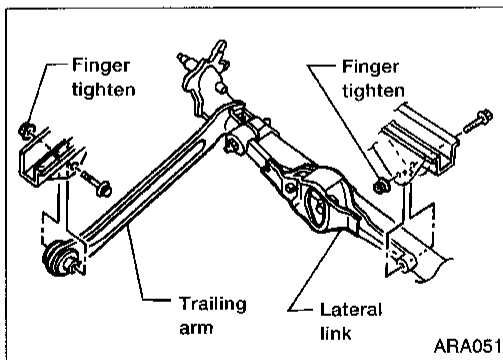
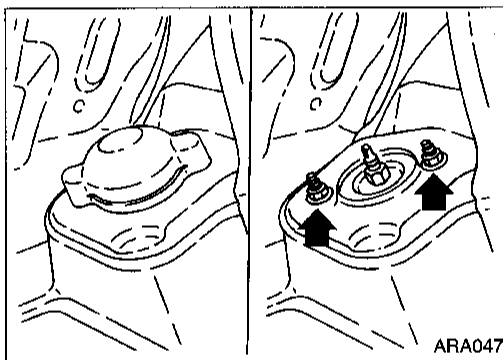
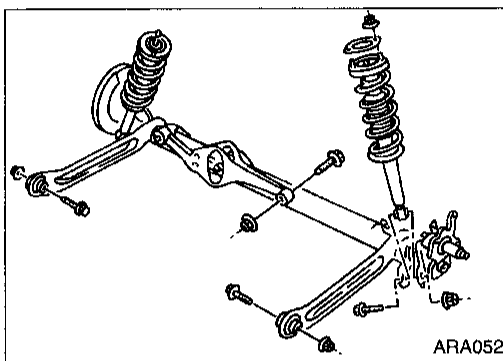
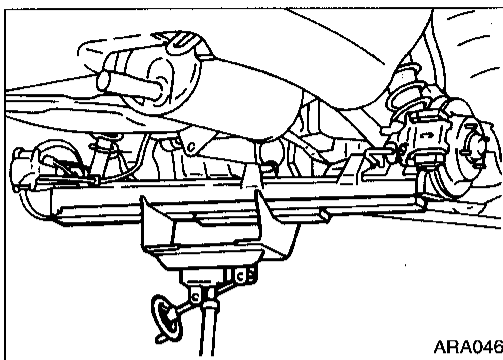

## Removal

### CAUTION:

- Before removing the rear suspension assembly, disconnect the ABS wheel sensor from the assembly. Failure to do so may result in damaged sensor wires and the sensor becoming inoperative.
  - Drain brake fluid before disconnecting brake lines.
1. Disconnect brake hydraulic lines and parking brake cables at toggle levers. (Models with drum brakes.)
  2. Disconnect brake hydraulic lines and parking brake cables from calipers and remove brake calipers and rotors. (Models with disc brakes.)
  3. Using a transmission jack, raise torsion beam a little, and remove nuts and bolts from the trailing arms, shock absorber assemblies (lower side) and lateral link.
  4. Lower transmission jack and remove suspension.
  5. Remove luggage compartment trim. Refer to BT section ("Trunk Trim", "INTERIOR TRIM").
  6. Remove shock absorber fixing nuts (upper side). Then pull out shock absorber assemblies.

## Installation

### CAUTION:

- Refill with new brake fluid DOT 3.
  - Never reuse drained brake fluid.
1. Attach torsion beam at trailing arm and lateral link to vehicle. Do not tighten bolts at this time.
  2. Using a transmission jack, place lateral link and control rod horizontally against torsion beam. Tighten lateral link on vehicle.
  3. Attach shock absorber assembly to vehicle. Then tighten the lower side of shock absorber assembly.
  4. Lower torsion beam to fully extended position. Remove transmission jack and tighten torsion beam, at trailing arm, to specified torque. Refer to RA-9.
  5. Install brake hydraulic lines and tighten flare nuts.  
☞: 15 - 18 N·m (1.5 - 1.8 kg·m, 11 - 13 ft·lb)

## REAR SUSPENSION

### Installation (Cont'd)

6. Bleed air. Refer to BR section ("Bleeding Procedure", "AIR BLEEDING").
7. Install ABS wheel sensor.

GI

MA

EM

LC

### Coil Spring and Shock Absorber

#### REMOVAL

Remove shock absorber upper and lower fixing nuts.

#### WARNING:

**Do not remove piston rod lock nut on vehicle.**

EC

FE

CL

MT

AT

FA

RA

BR

ST

RS

BT

HA

EL

IDX

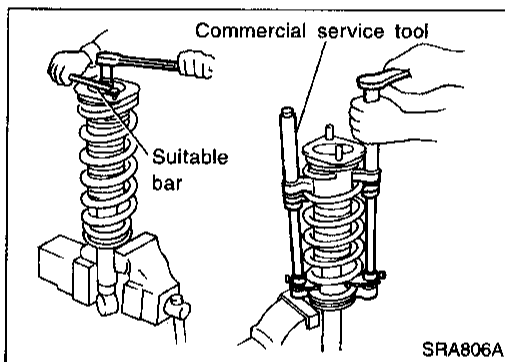

#### DISASSEMBLY

1. Set shock absorber in vise, then **loosen** piston rod lock nut.

#### WARNING:

**Do not remove piston rod lock nut at this time.**

2. Compress spring with tool so that the shock absorber upper spring seat can be turned by hand.

#### WARNING:

**Make sure that the pawls of the two spring compressors are firmly hooked on the spring. The spring compressors must be tightened alternately so as not to tilt the spring.**

3. Remove piston rod lock nut.

#### INSPECTION

##### Shock absorber assembly

- Check both compression and extension for smooth operation through a full stroke.
- Check for oil leakage on welded or gland packing portions.
- Check piston rod for cracks, deformation or other damage. Replace if necessary.

##### Upper rubber seat and bushing

Check rubber parts for deterioration or cracks.

Replace if necessary.

##### Coil spring

Check for cracks, deformation or other damage. Replace if necessary.

## REAR SUSPENSION

### Coil Spring and Shock Absorber (Cont'd)

#### ASSEMBLY

- When installing coil spring, be careful not to reverse top and bottom direction. (Top end is flat.)
- When installing coil spring on shock absorber, it must be positioned as shown in figure.

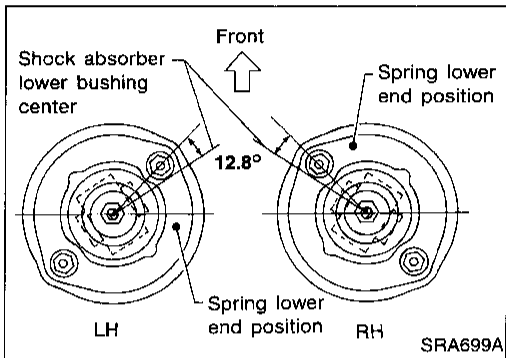
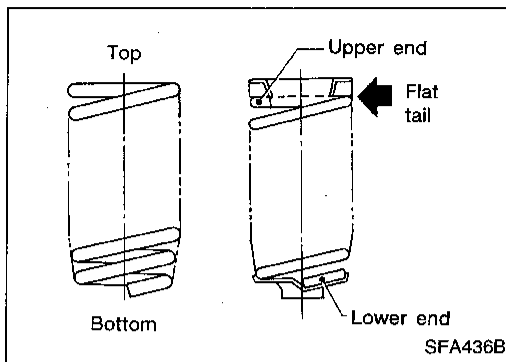

- Locate upper spring seat as shown.

# REAR SUSPENSION

## Torsion Beam, Lateral Link and Control Rod

### DISASSEMBLY

- Remove torsion beam assembly. Refer to RA-10.
- Remove lateral link and control rod from torsion beam.

GI

MA

EM

LC

EC

FE

CL

MT

AT

FA

RA

BR

ST

RS

BT

HA

EL

IDX

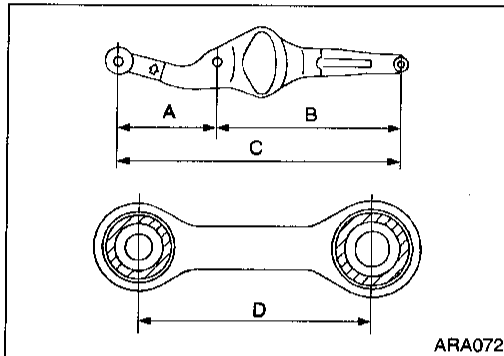

### INSPECTION

- Check for cracks, distortion or other damage. Replace if necessary.

#### Standard length:

- A 207 - 208 mm (8.15 - 8.19 in)
- B 394 - 395 mm (15.51 - 15.55 in)
- C 601 - 603 mm (23.66 - 23.74 in)
- D 106 - 108 mm (4.17 - 4.25 in)

- Check all rubber parts for wear, cracks or deformation. Replace if necessary.

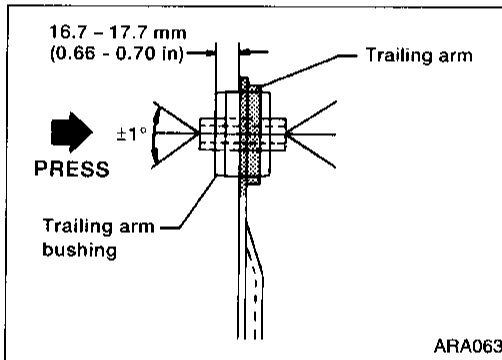

### RUBBER BUSHING REPLACEMENT

#### Trailing arm

Trailing arm bushings are press fit and must be centered properly in trailing arm collars.

1. Press out old bushing from trailing arm collar.
  2. Press in new bushing until inside edge of bushing is 16.7 to 17.7 mm (0.66 to 0.70 in) from inside edge of trailing arm.
- Do not allow bushing to incline more than 1 degree.
  - During installation, do not allow trailing arm to bend or twist.

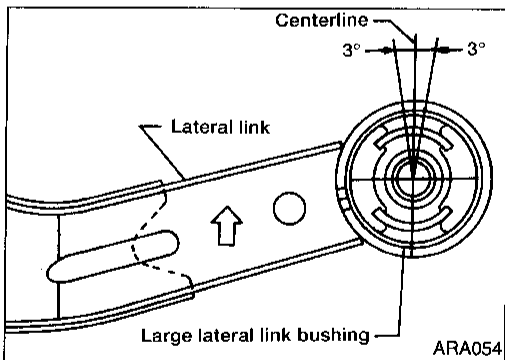

#### Lateral link

Lateral link bushings are press fit. The large lateral link bushing is directional and must be installed in a specific position.

1. Remove lateral link.
2. Press out bushings. Note installation position of large bushing before removing.
3. Press in small bushing until bushing is centered in lateral link collar.
4. Press in large bushing until bushing is centered in lateral link collar.
  - a. Position bushing on lateral link collar.
  - b. Angle between bushing centerline and collar centerline must be within 3 degrees as shown in illustration.

#### Control rod

Control rod bushings are not replaceable. If bushings are worn or damaged, replace control rod.

## REAR SUSPENSION

### Torsion Beam, Lateral Link and Control Rod (Cont'd)

#### ASSEMBLY

1. Temporarily assemble lateral link and control rod.
  - When installing the control rod, connect the end with the smaller inner diameter to the lateral link.

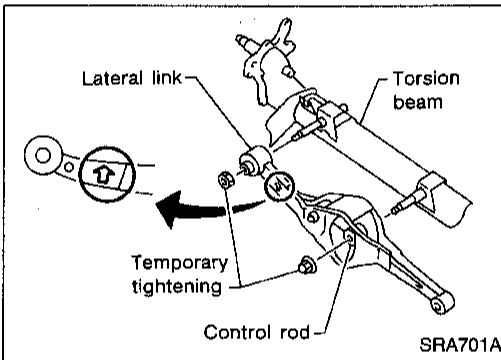
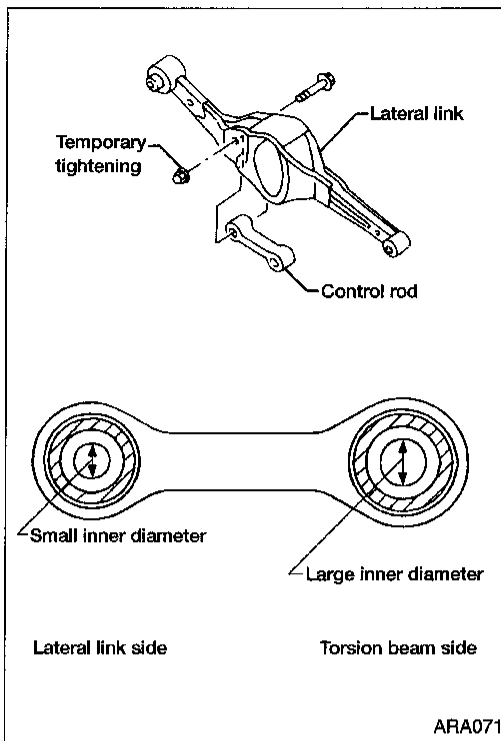

2. Temporarily install lateral link and control rod on torsion beam.
  - Install lateral link with the arrow upward.

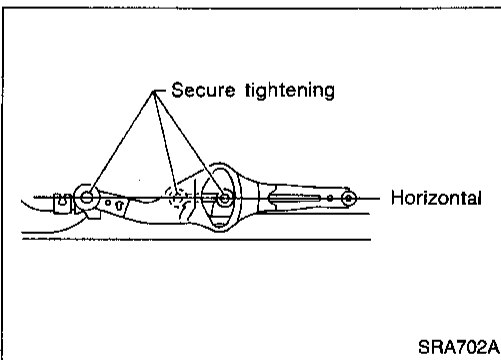

3. Ensure lateral link and control rod are horizontal against torsion beam, and tighten to the specified torque. Refer to RA-9.
4. Install torsion beam assembly. Refer to RA-10.

# SERVICE DATA AND SPECIFICATIONS (SDS)

## General Specifications

Suspension type	Multi link beam suspension
Shock absorber	Double-acting hydraulic

## Inspection and Adjustment

### WHEEL ALIGNMENT (Unladen\*)

Camber Degree minute (Decimal degree)	Minimum	-1°45' (-1.75°)
	Nominal	-1°00' (-1.00°)
	Maximum	-0°15' (-0.25°)
Total toe-in Distance (A - B) mm (in)	Minimum	-3 (-0.12)
	Nominal	1 (0.04)
	Maximum	5 (0.20)
Angle (left plus right) Degree minute (Decimal degree)	Minimum	-18' (-0.30°)
	Nominal	6' (0.10°)
	Maximum	30' (0.50°)

\*: Fuel, radiator coolant and engine oil full. Spare tire, jack, hand tools and mats in designated positions.

### WHEEL BEARING

Wheel bearing axial end play mm (in)	0.05 (0.0020) or less
Wheel bearing lock nut tightening torque N·m (kg-m, ft-lb)	187 - 255 (19 - 26, 137 - 188)

GI

MA

EM

LG

EC

FE

CL

MT

AT

FA

RA

BR

ST

RS

BT

HA

EL

IDX