

## SECTION MA

GI

MA

EM

LC

### CONTENTS

EC

FE

CL

MT

AT

FA

RA

BR

ST

RS

BT

HA

EL

IDX

<b>PRECAUTIONS AND PREPARATION</b> .....	2	Checking EVAP Vapor Lines .....	17
Supplemental Restraint System (SRS)		<b>CHASSIS AND BODY MAINTENANCE</b> .....	19
“AIR BAG” .....	2	Checking Exhaust System.....	19
Special Service Tool .....	2	Checking Clutch System.....	19
Commercial Service Tool .....	2	Checking M/T Oil .....	19
<b>GENERAL MAINTENANCE</b> .....	3	Changing M/T Oil.....	19
<b>PERIODIC MAINTENANCE</b> .....	5	Checking A/T Fluid.....	20
Schedule 1 .....	6	Changing A/T Fluid .....	21
Schedule 2 .....	7	Checking Brake Fluid Level and Leaks.....	21
<b>RECOMMENDED FLUIDS AND LUBRICANTS</b> .....	8	Checking Brake Lines and Cables .....	21
Fluids and Lubricants.....	8	Checking Disc Brake .....	21
SAE Viscosity Number.....	8	Checking Drum Brake.....	22
Antifreeze Coolant Mixture Ratio.....	9	Balancing Wheels .....	23
<b>ENGINE MAINTENANCE</b> .....	10	Tire Rotation.....	23
Checking Drive Belts .....	10	Checking Steering Gear and Linkage .....	23
Changing Engine Coolant.....	12	Checking Power Steering Fluid and Lines .....	23
Checking Fuel Lines .....	14	Lubricating Locks, Hinges and Hood Latches .....	24
Changing Fuel Filter .....	14	Checking Seat Belts, Buckles, Retractors,	
Changing Air Cleaner Filter .....	15	Anchors and Adjusters.....	24
Changing Engine Oil.....	15	<b>SERVICE DATA AND SPECIFICATIONS (SDS)</b> .....	25
Changing Oil Filter.....	16	Engine Maintenance .....	25
Changing Spark Plugs .....	16	Chassis and Body Maintenance .....	25

## PRECAUTIONS AND PREPARATION

### Supplemental Restraint System (SRS) “AIR BAG”

The Supplemental Restraint System “AIR BAG” used along with a seat belt, helps to reduce the risk or severity of injury to the driver and front passenger in a frontal collision. The Supplemental Restraint System consists of air bag modules (located in the center of the steering wheel and on the instrument panel on the passenger side), a diagnosis sensor unit, warning lamp, wiring harness and spiral cable. Information necessary to service the system safely is included in the **RS section** of this Service Manual.

**WARNING:**

- To avoid rendering the SRS inoperative, which could increase the risk of personal injury or death in the event of a collision which would result in air bag inflation, all maintenance should be performed by an authorized NISSAN dealer.
- Improper maintenance, including incorrect removal and installation of the SRS, can lead to personal injury caused by unintentional activation of the system.
- Do not use electrical test equipment on any circuit related to the SRS unless instructed to in this Service Manual. SRS wiring harnesses are covered with yellow insulation either just before the harness connectors or on the complete harness, for easy identification.

### Special Service Tool

The actual shapes of Kent-Moore tools may differ from those of special service tools illustrated here.

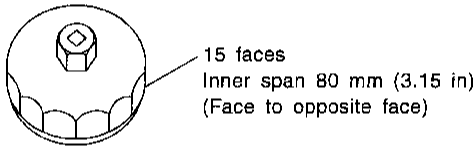
Tool number (Kent-Moore No.) Tool name	Description	
KV10105900 (J34274) Oil filter wrench	 <p>15 faces Inner span 80 mm (3.15 in) (Face to opposite face)</p>	Removing oil filter     80 mm (3.15 In) dia.
	NT646	

### Commercial Service Tool

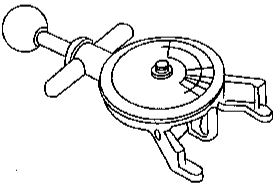
Tool number (Kent-Moore No.) Tool name	Description	
(BT3373-F) Belt tension gauge		Checking drive belt tension
	AMA126	

# GENERAL MAINTENANCE

General maintenance includes those items which should be checked during the normal day-to-day operation of the vehicle. They are essential if the vehicle is to continue operating properly. The owners can perform checks and inspections themselves or have their NISSAN dealers do them.

Item	Reference page	GI
<b>OUTSIDE THE VEHICLE</b>		
The maintenance items listed here should be performed from time to time, unless otherwise specified.		
<b>Tires</b> Check the pressure, including the spare, with a gauge periodically when at a service station and adjust to the specified pressure if necessary. Check carefully for damage, cuts and excessive wear.	—	EM
<b>Wheel nuts</b> When checking the tires, make sure no nuts are missing, and check for any loose nuts. Tighten if necessary.	MA-23	LC
<b>Tire rotation</b> Tires should be rotated every 12,000 km (7,500 miles).	MA-23	EC
<b>Wheel alignment and balance</b> If the vehicle pulls to either side while driving on a straight and level road, or if you detect uneven or abnormal tire wear, there may be a need for wheel alignment. If the steering wheel or seat vibrates at normal highway speeds, wheel balancing may be needed.	MA-23, FA-7	FE
<b>Windshield wiper blades</b> Check for cracks and wear if they do not wipe properly.	—	CL
<b>Doors and engine hood</b> Check that all doors, engine hood and trunk lid operate smoothly. Also make sure that all latches lock securely. Lubricate hinges, latches, rollers and links if necessary. Make sure that the secondary latch keeps the hood from opening when the primary latch is released. When driving in areas using road salt or other corrosive materials, check lubrication frequently.	MA-24	MT
<b>Lamps</b> Make sure that the headlamps, stop lamps, tail lamps, turn signal lamps, and other lamps are all operating properly and installed securely. Also check headlamp aim.	—	AT
<b>INSIDE THE VEHICLE</b>		
The maintenance items listed here should be checked on a regular basis, such as when performing periodic maintenance, cleaning the vehicle, etc.		
<b>Warning lamps and buzzers/chimes</b> Make sure that all warning lamps and buzzers/chimes are operating properly.	—	RA
<b>Windshield wiper and washer</b> Check that the wipers and washer operate properly and that the wipers do not streak.	—	BR
<b>Windshield defroster</b> Check that the air comes out of the defroster outlets properly and in sufficient quantity when operating the heater or air conditioner.	—	ST
<b>Steering wheel</b> Check that it has the specified play. Be sure to check for changes in the steering condition, such as excessive play, hard steering or strange noises. <b>Free play: Less than 35 mm (1.38 in)</b>	ST-8	RS
<b>Seats</b> Check seat position controls such as seat adjusters, seatback recliner, etc. to make sure they operate smoothly and that all latches lock securely in every position. Check that the head restraints move up and down smoothly and that the locks (if equipped) hold securely in all latched positions. Check that the latches lock securely for folding-down rear seatbacks.	—	BT
<b>Seat belts</b> Check that all parts of the seat belt system (e.g., buckles, anchors, adjusters and retractors) operate properly and smoothly and are installed securely. Check the belt webbing for cuts, fraying, wear and damage.	MA-24 RS-3	HA
<b>Accelerator pedal</b> Check the pedal for smooth operation and make sure the pedal does not catch or require uneven effort. Keep the floor mats away from the pedal.	FE-2	EL
<b>Clutch pedal</b> Make sure the pedal operates smoothly and check that it has the proper free play.	CL-5	IDX
<b>Brakes</b> Check that the brake does not pull the vehicle to one side when applied.	—	IDX
<b>Brake pedal and booster</b> Check the pedal for smooth operation and make sure it has the proper distance under it when depressed fully. Check the brake booster function. Be sure to keep the floor mats away from the pedal.	BR-10, 16	

## GENERAL MAINTENANCE

Item	Reference page
<b>Parking brake</b> Check that the lever has the proper travel and make sure that the vehicle is held securely on a fairly steep hill when only the parking brake is applied.	BR-35
<b>Automatic transmission "Park position" mechanism</b> Check that the lock release button on the selector lever operates properly and smoothly. On a fairly steep hill, check that the vehicle is held securely with the selector lever in the "P" position without applying any brakes.	—
<b>UNDER THE HOOD AND VEHICLE</b>	
The maintenance items listed here should be checked periodically (e.g., each time you check the engine oil or refuel).	
<b>Windshield washer fluid</b> Check that there is adequate fluid in the tank.	—
<b>Engine coolant level</b> Check the coolant level when the engine is cold.	MA-12
<b>Radiator and hoses</b> Check the front of the radiator and clean off any dirt, insects, leaves, etc., that may have accumulated. Make sure the hoses have no cracks, deformation, deterioration or loose connections.	—
<b>Brake fluid level</b> Make sure that the brake fluid level is between the "MAX" and "MIN" lines on the reservoir.	MA-21
<b>Battery</b> Check the fluid level in each cell. It should be between the "MAX" and "MIN" lines.	—
<b>Engine drive belts</b> Make sure that no belt is frayed, worn, cracked or oily.	MA-10
<b>Engine oil level</b> Check the level on the dipstick after parking the vehicle on a level surface and turning off the engine.	MA-15
<b>Power steering fluid level and lines</b> Check the level in the reservoir tank with the engine off. Check the lines for improper attachment, leaks, cracks, etc.	MA-23
<b>Automatic transmission fluid level</b> Check the level on the dipstick after putting the selector lever in "P" with the engine idling.	MA-20
<b>Exhaust system</b> Make sure there are no loose supports, cracks or holes. If the sound of the exhaust seems unusual or there is a smell of exhaust fumes, immediately locate the trouble and correct it.	MA-19
<b>Underbody</b> The underbody is frequently exposed to corrosive substances such as those used on icy roads or to control dust. It is very important to remove these substances, otherwise rust will form on the floor pan, frame, fuel lines and around the exhaust system. At the end of winter, the underbody should be thoroughly flushed with plain water, being careful to clean those areas where mud and dirt can easily accumulate.	—
<b>Fluid leaks</b> Check under the vehicle for fuel, oil, water and other fluid leaks after the vehicle has been parked for a while. Water dripping from the air conditioner after use is normal. If any leaks or gasoline fumes are evident, check for the cause and correct it immediately.	—

# PERIODIC MAINTENANCE

---

Two different maintenance schedules are provided, and should be used, depending upon the conditions in which the vehicle is usually operated. **After 60,000 miles (96,000 km) or 48 months, continue the periodic maintenance at the same mileage/time intervals.**

GI

## SCHEDULE 1

Follow Periodic Maintenance Schedule 1 if your driving habits frequently include one or more of the following driving conditions:

**MA**

- Repeated short trips of less than 5 miles (8 km).
- Repeated short trips of less than 10 miles (16 km) with outside temperatures remaining below freezing.
- Operating in hot weather in stop-and-go “rush hour” traffic.
- Extensive idling and/or low speed driving for long distances, such as police, taxi or door-to-door delivery use.
- Driving in dusty conditions.
- Driving on rough, muddy, or salted roads.
- Towing a trailer, using a camper or a car-top carrier.

EM

LC

EC

## SCHEDULE 2

Follow Periodic Maintenance Schedule 2 if none of the driving conditions shown in Schedule 1 apply to your driving habits.

FE

CL

MT

AT

FA

RA

BR

ST

RS

BT

HA

EL

IDX

# PERIODIC MAINTENANCE

## Schedule 1

Abbreviations: R = Replace. I = Inspect. Correct or replace if necessary. [ ]: At the mileage intervals only

		MAINTENANCE INTERVAL												Reference page			
		3.75	7.5	11.25	15	18.75	22.5	26.25	30	33.75	37.5	41.25	45	48.75	52.5	56.25	60
		(6)	(12)	(18)	(24)	(30)	(36)	(42)	(48)	(54)	(60)	(66)	(72)	(78)	(84)	(90)	(96)
		Months	Months	Months	Months	Months	Months	Months	Months	Months	Months	Months	Months	Months	Months	Months	Months

### Emission control system maintenance

Drive belts	See NOTE (1)																I*	MA-10
Air cleaner filter	See NOTE (2)							[R]									[R]	MA-15
EVAP vapor lines								I*									I*	MA-17
Fuel lines								I*									I*	MA-14
Fuel filter*	See NOTE (3)																	MA-14
Engine coolant	See NOTE (4)																	MA-12
Engine oil		R	R	R	R	R	R	R	R	R	R	R	R	R	R	R	R	MA-15
Engine oil filter (Use part No. 15208-H8903)		R	R	R	R	R	R	R	R	R	R	R	R	R	R	R	R	MA-16
Spark plugs								[R]									[R]	MA-16
Idle rpm								I*									I*	EC-36
Intake & exhaust valve clearance*	See NOTE (5)																	EM-37

### Chassis and body maintenance

Brake lines & cables																		MA-21
Brake pads, rotors, drums & linings																		MA-21, 22
Manual transmission oil & automatic transmission fluid	See NOTE (6)																	MA-19, 20, 21
Steering gear & linkage, axle & suspension parts																		MA-28, FA-6, RA-5, ST-14, 19
Exhaust system																		MA-19
Drive shaft boots																		FA-8
Air bag system	See NOTE (7)																	RS-13

**NOTE:** (1) After 60,000 miles (96,000 km) or 48 months, inspect every 15,000 miles (24,000 km) or 12 months.  
 (2) If vehicle is usually operated in dusty conditions, more frequent maintenance may be required.  
 (3) If vehicle is operated under extremely adverse weather conditions or in areas where ambient temperatures are either extremely low or extremely high, the filters might become clogged. In such an event, replace them immediately.  
 (4) After 60,000 miles (96,000 km) or 48 months, replace every 30,000 miles (48,000 km) or 24 months.  
 (5) If valve noise increases, inspect valve clearance.  
 (6) If towing a trailer, using a camper or a car-top carrier, or driving on rough or muddy roads, change (not just inspect) oil at every 30,000 miles (48,000 km) or 24 months.  
 (7) Inspect the air bag system 10 years after the date of manufacture noted on the FMVSS certification label.

\* Maintenance items and intervals with "\*" are recommended by NISSAN for reliable vehicle operation. The owner need not perform such maintenance in order to maintain the emission warranty or manufacturer recall liability. Other maintenance items and intervals are required.

Schedule 2

Abbreviations: R = Replace. I = Inspect. Correct or replace if necessary. [ ]: At the mileage intervals only

MAINTENANCE OPERATION	MAINTENANCE INTERVAL								Reference page		
	Miles x 1,000 (km x 1,000)	7.5 (12)	15 (24)	22.5 (36)	30 (48)	37.5 (60)	45 (72)	52.5 (84)		60 (96)	
Perform at number of miles, kilometers or months, whichever comes first.	Months	6	12	18	24	30	36	42	48		
<b>Emission control system maintenance</b>											
Drive belts	See NOTE (1)									I*	MA-10
Air cleaner filter					[R]					[R]	MA-15
EVAP vapor lines					I*					I*	MA-17
Fuel lines					I*					I*	MA-14
Fuel filter*	See NOTE (2)										MA-14
Engine coolant	See NOTE (3)										MA-12
Engine oil		R	R	R	R	R	R	R	R	R	MA-15
Engine oil filter (Use Part No. 15208-H8903)		R	R	R	R	R	R	R	R	R	MA-16
Spark plugs					[R]					[R]	MA-16
Idle rpm					I*					I*	EC-36
Intake & exhaust valve clearance*	See NOTE (4)										EM-37
<b>Chassis and body maintenance</b>											
Brake lines & cables		I	I	I	I	I	I	I	I	I	MA-21
Brake pads, rotors, drums & linings		I	I	I	I	I	I	I	I	I	MA-21, 22
Manual transmission oil & automatic transmission fluid		I	I	I	I	I	I	I	I	I	MA-19, 20, 21
Steering gear linkage, axle & suspension parts											MA-23, FA-6, RA-5, ST-14, 19
Exhaust system											MA-19
Drive shaft boots											FA-8
Air bag system	See NOTE (5)										RS-13

**NOTE: (1)** After 60,000 miles (96,000 km) or 48 months, inspect every 15,000 miles (24,000 km) or 12 months.  
**(2)** If vehicle is operated under extremely adverse weather conditions or in areas where ambient temperatures are either extremely low or extremely high, the filters might become clogged. In such an event, replace them immediately.  
**(3)** After 60,000 miles (96,000 km) or 48 months, replace every 30,000 miles (48,000 km) or 24 months.  
**(4)** If valve noise increases, inspect valve clearance.  
**(5)** Inspect the air bag system 10 years after the date of manufacture noted on the FMVSS certification label.  
 \* Maintenance items and intervals with "\*" are recommended by NISSAN for reliable vehicle operation. The owner need not perform such maintenance in order to maintain the emission warranty or manufacturer recall liability. Other maintenance items and intervals are required.

# RECOMMENDED FLUIDS AND LUBRICANTS

## Fluids and Lubricants

		Capacity (Approximate)			Recommended fluids and lubricants
		US measure	Imp measure	Liter	
Engine oil *4 Drain and refill					<ul style="list-style-type: none"> <li>● API Certification Mark*2</li> <li>● API grade SG/SH, Energy Conserving II or API grade SJ, Energy Conserving*2</li> <li>● ILSAC grade GF-II*2</li> </ul>
	With oil filter change	3-1/8 qt	2-5/8 qt	3.0	
	Without oil filter change	2-7/8 qt	2-3/8 qt	2.7	
Dry engine (engine overhaul)		3-5/8 qt	3 qt	3.4	
Cooling system (With reservoir tank)	M/T	5-1/2 qt	4-5/8 qt	5.2	50% Genuine NISSAN Anti-freeze coolant or equivalent 50% Demineralized or Distilled water
	A/T	6 qt	5 qt	5.7	
Manual transmission gear oil		6-1/8 - 6-3/4 pt	5-1/8 - 5-5/8 pt	2.9 - 3.2	API GL-4, Viscosity SAE 80W-90 only
Automatic transmission fluid		7-3/8 qt	6-1/8 qt	7.0	Nissan Matic 'D' (Continental U.S. and Alaska) or Genuine Nissan Automatic Transmission Fluid (Canada). *1
Power steering fluid		—	—	—	Type DEXRON™ III or equivalent
Brake fluid		—	—	—	Genuine Nissan Brake Fluid*3 or equivalent DOT 3 (US FMVSS No. 116)
Multi-purpose grease		—	—	—	NLGI No. 2 (Lithium soap base)

\*1: Dexron™ III/Mercon™ or equivalent may also be used. Outside the continental United States and Alaska contact a Nissan dealership for more information regarding suitable fluids, including recommended brand(s) of Dexron™ III/Mercon™ Automatic Transmission Fluid.

\*2: For further details, see "SAE Viscosity Number".

\*3: Available in mainland USA through your NISSAN dealer

\*4: For further details, see "Changing Engine Oil".

## SAE Viscosity Number

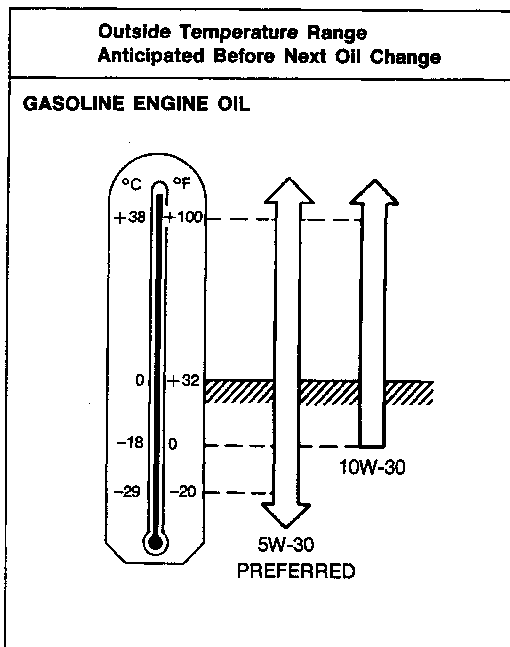

AMA079

**SAE 5W-30 viscosity oil is preferred for all temperatures. SAE 10W-30 viscosity oil may be used if the ambient temperature is above -18°C (0°F).**



## Antifreeze Coolant Mixture Ratio

The engine cooling system is filled at the factory with a high-quality, year-round, antifreeze coolant solution. The antifreeze solution contains rust and corrosion inhibitors. Additional cooling system additives are not necessary.

**CAUTION:**

**When adding or replacing coolant, be sure to use only an ethylene glycol antifreeze with a mixture ratio of 50% genuine NISSAN Anti-freeze coolant or equivalent, 50% demineralized water or distilled water.**

Outside temperature down to		Genuine NISSAN Anti-freeze coolant or equivalent	Demineralized water or distilled water
°C	°F		
-35	-30	50%	50%

**Other types of coolant solutions may damage the cooling system.**

GI

MA

EM

LC

EC

FE

CL

MT

AT

FA

RA

BR

ST

RS

BT

HA

EL

IDX

## Checking Drive Belts

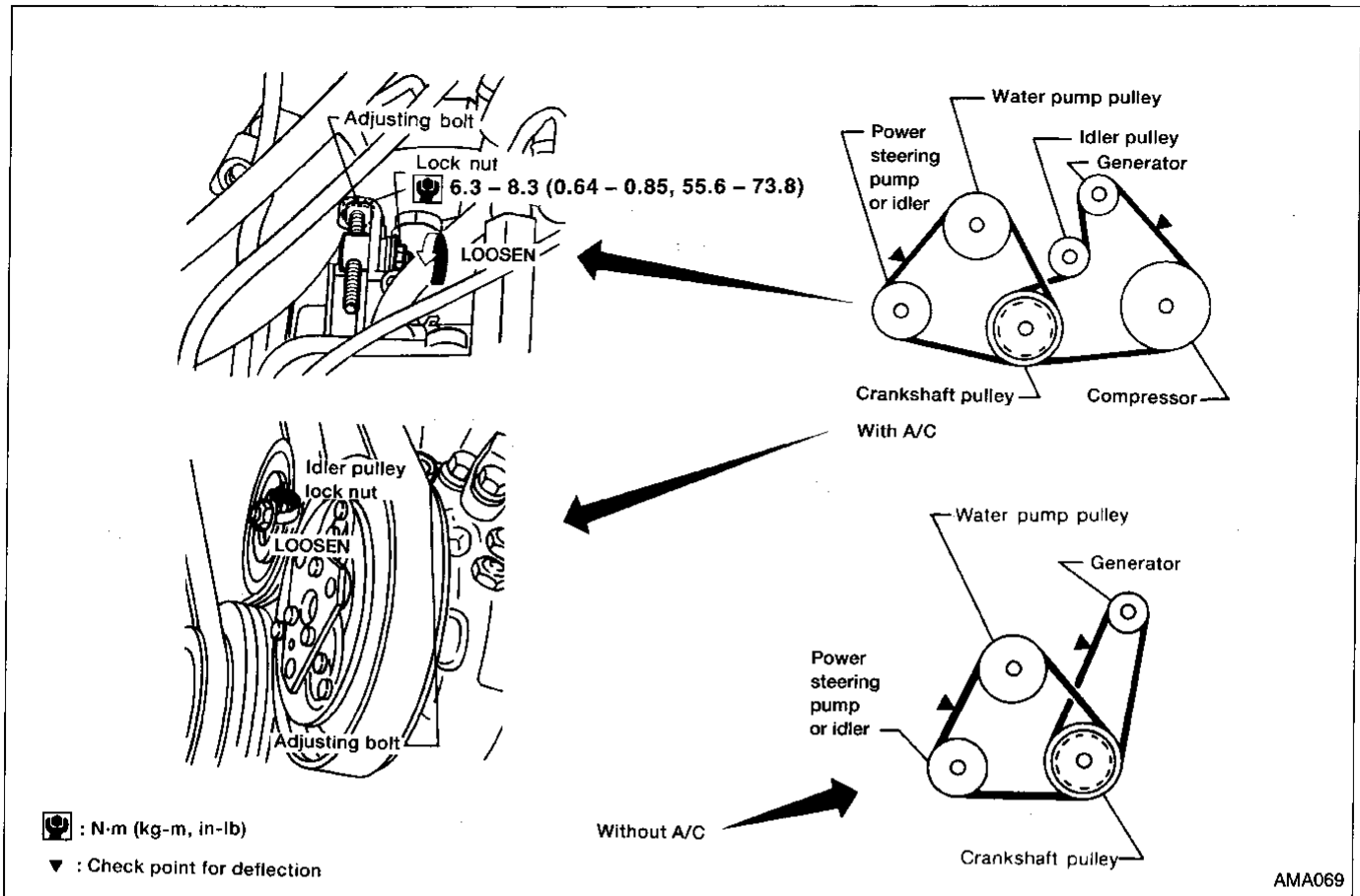

1. Inspect belt for cracks, fraying, wear and oil. If necessary, replace.
2. Inspect drive belt deflection or tension at a point on the belt midway between pulleys.
  - Check belt tension using belt tension gauge (BT3373-F or equivalent).
  - Inspect drive belt deflection or tension when engine is cold.
  - Adjust if belt deflection exceeds the limit or if belt tension is not within specifications.
  - Drive belt tension can also be checked at other points on the belt.

# ENGINE MAINTENANCE

## Checking Drive Belts (Cont'd)

### Belt deflection and tension

	Deflection adjustment		Unit: mm (in)	Tension adjustment *1		Unit: N (kg, lb)
	Used belt		New belt	Used belt		New belt
	Limit	After adjustment		Limit	After adjustment	
Generator						
With A/C compressor	9.5 (0.374)	6 - 6.5 (0.24 - 0.256)	5 - 6 (0.20 - 0.24)	196 (20, 44)	535 - 623 (55 - 63, 120 - 140)	652 - 740 (67 - 75, 147 - 166)
Without A/C compressor	11.5 (0.453)	7.5 - 8 (0.295 - 0.315)	6.5 - 7 (0.256 - 0.28)	196 (20, 44)	535 - 623 (55 - 63, 120 - 140)	652 - 740 (67 - 75, 147 - 166)
Water pump						
With power steering pump	7.5 (0.295)	4 - 6 (0.16 - 0.24)	3 - 5 (0.12 - 0.20)	196 (20, 44)	495 - 583 (51 - 59, 112 - 131)	603 - 691 (62 - 70, 136 - 155)
Without power steering pump	6 (0.24)	3 - 4.5 (0.12 - 0.177)	3 - 4 (0.12 - 0.16)	196 (20, 44)	495 - 583 (51 - 59, 112 - 131)	603 - 691 (62 - 70, 136 - 155)
Applied pushing force	98 N (10 kg, 22 lb)		—			

\*1: If belt tension gauge cannot be installed at check points shown, check drive belt tension at a different location on the belt.

GI

MA

EM

LC

EC

FE

CL

MT

AT

FA

RA

BR

ST

RS

BT

HA

EL

IDX

# ENGINE MAINTENANCE

## Changing Engine Coolant

### WARNING:

To avoid being scalded, never change the coolant when the engine is hot.

### -DRAINING ENGINE COOLANT-

1. Move heater temperature control lever all the way to WARM.
  - Make sure air conditioner switch is OFF.
2. Open radiator drain plug at the bottom of radiator and remove radiator filler cap.
3. Remove reservoir tank, drain coolant, then clean reservoir tank. Install it temporarily.
  - Be careful not to allow coolant to contact drive belts.

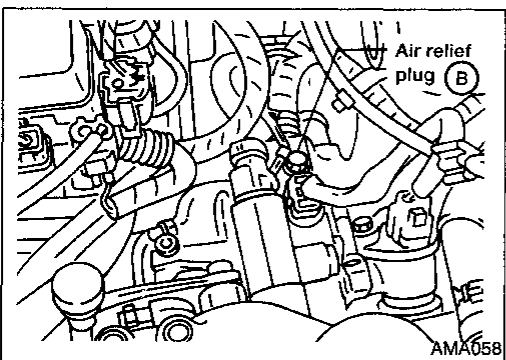
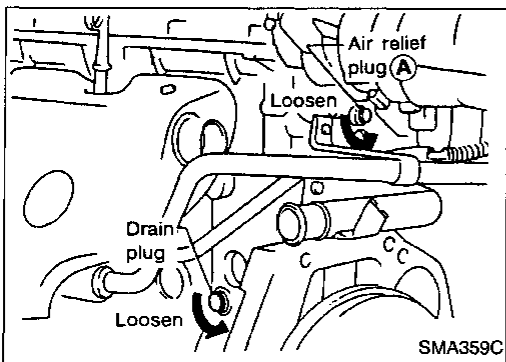
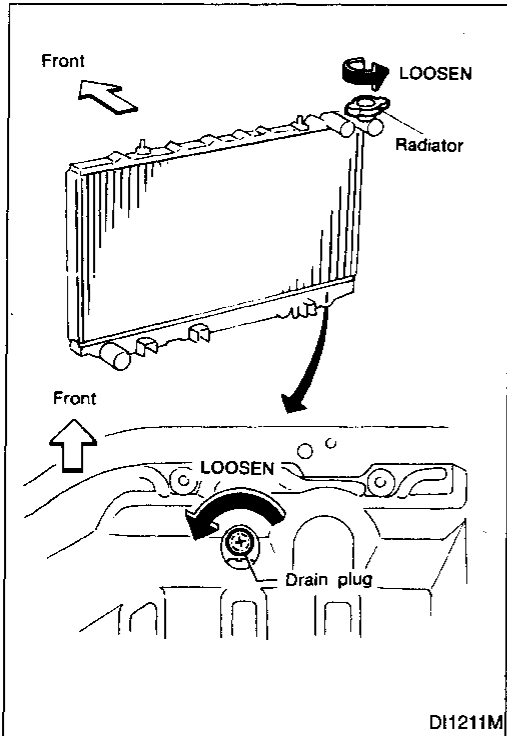
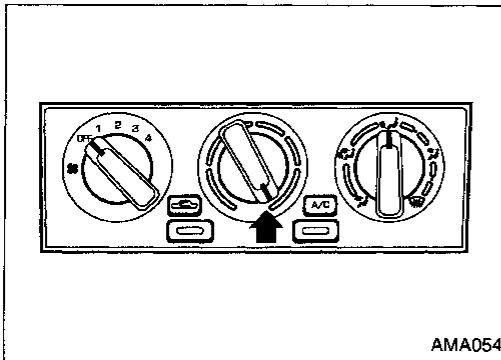

4. Remove cylinder block drain plug and air relief plugs (A) and (B).
5. Check drained coolant for contaminants such as rust, corrosion or discoloration. If contaminated, flush engine cooling system. Refer to "FLUSHING COOLING SYSTEM" MA-13.

### -REFILLING ENGINE COOLANT-

6. Install reservoir tank, radiator drain plug and cylinder block drain plug.
  - Apply sealant to the thread of drain plug on cylinder block.
7. Fill radiator with coolant until coolant spills from either of air relief holes, install each air relief plug as soon as coolant spills out without bubbles.

⊗: 34.3 - 44.1 N·m  
(3.50 - 4.50 kg-m, 25.30 - 32.53 ft-lb)

⊗: 7 - 8 N·m (0.7 - 0.8 kg-m, 61 - 69 in-lb)

# ENGINE MAINTENANCE

## Changing Engine Coolant (Cont'd)

- Pour coolant through coolant filler neck slowly (less than 2 l {2-1/8 US qt, 1-3/4 Imp qt}/min) to allow air in system to escape.
- Use Genuine NISSAN antifreeze coolant or equivalent mixed with demineralized water or distilled water.
- Refer to "RECOMMENDED FLUIDS AND LUBRICANTS", MA-9.

### Engine coolant capacity (With reservoir tank):

M/T 5.2 l (5-1/2 US qt, 4-5/8 Imp qt)

A/T 5.7 l (6 US qt, 5 Imp qt)

### Reservoir tank capacity:

0.7 l (3/4 US qt, 5/8 Imp qt)

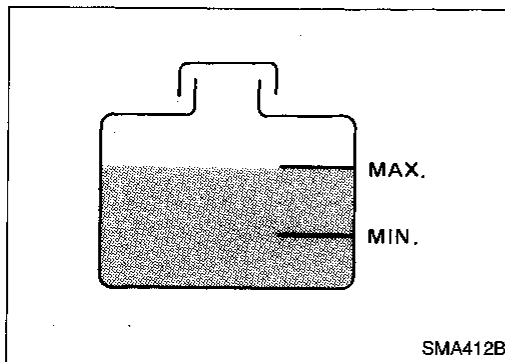
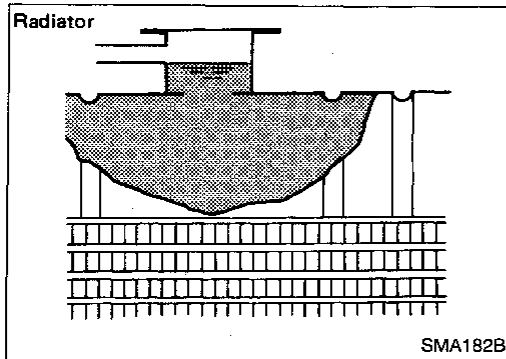

8. Fill radiator and reservoir tank to specified level.
  9. Warm up engine to normal operating temperature without radiator cap installed.
  10. Install radiator cap and run engine at 2,500 rpm for 10 seconds and return to idle speed.
- Repeat two or three times.

### Watch coolant temperature gauge so as not to overheat the engine.

11. Stop engine and cool it down.
- Cool down using a fan to reduce the time.
- If necessary, refill radiator up to filler neck.
12. Refill reservoir tank to MAX level line.
13. Repeat steps 10 through 12 two or more times until coolant level no longer drops.
14. Check cooling system for leaks with engine running.
15. Warm up engine, and check for sound of coolant flow while running engine from idle up to 3,000 rpm with heater temperature control lever set at several positions between COOL and WARM.
- Sound may be noticeable at heater water cock.
16. If sound is heard, bleed air from cooling system by repeating steps 9 through 12 until coolant level no longer drops.
- Clean excess coolant from engine.

### -FLUSHING COOLING SYSTEM-

1. Open air relief plugs.
2. Fill radiator with water until water spills from air relief hole, close each air relief plug. Fill radiator and reservoir tank with water and install radiator cap.
3. Run engine and warm it up to normal operating temperature.
4. Rev engine two or three times under no-load.
5. Stop engine and wait until it cools down.
6. Drain water.
7. Repeat steps 1 through 6 until clear water begins to drain from radiator.

# ENGINE MAINTENANCE

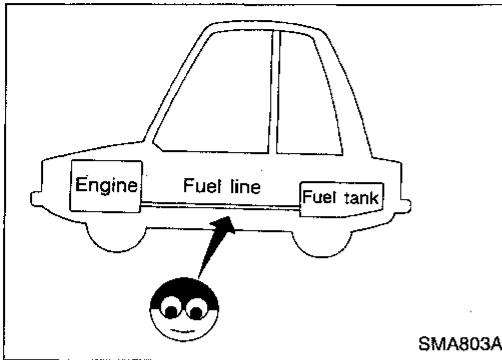

## Checking Fuel Lines

Inspect fuel lines and tank for improper attachment, leaks, cracks, damage, chafing and deterioration. If necessary, repair or replace.

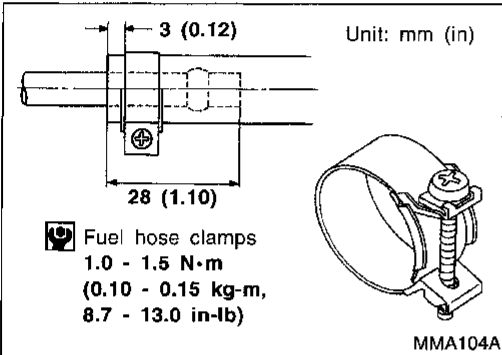

### CAUTION:

Tighten high-pressure rubber hose clamp so that clamp end is 3 mm (0.12 in) from hose end.

Tightening torque specifications are the same for all rubber hose clamps.

Ensure that screw does not contact adjacent parts.

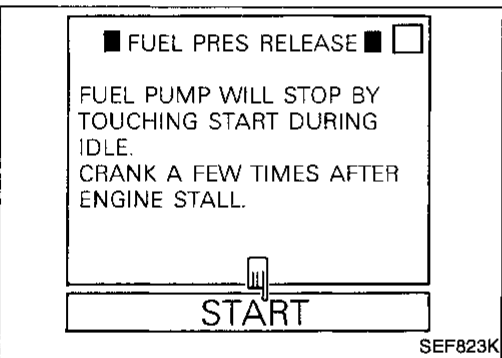

## Changing Fuel Filter

### WARNING:

Before removing fuel filter, release fuel pressure from fuel line.

1. Release fuel pressure using the following procedure.

- Start engine.
- Perform "FUEL PRESSURE RELEASE" in "WORK SUPPORT" mode and release fuel pressure to zero.
- After engine stalls, crank engine two or three times to make sure that fuel pressure is released.
- Turn ignition switch OFF.

OR

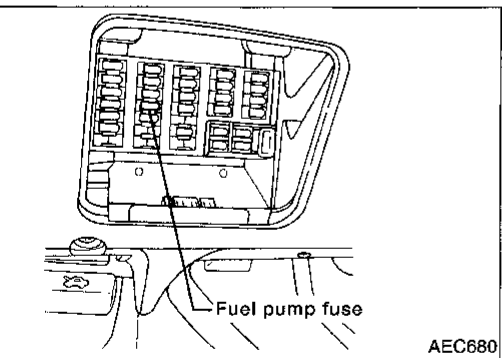

- Remove fuse for fuel pump.
- Start engine.
- After engine stalls, crank engine two or three times to make sure that fuel pressure is released.
- Turn ignition switch OFF and install fuse for fuel pump.

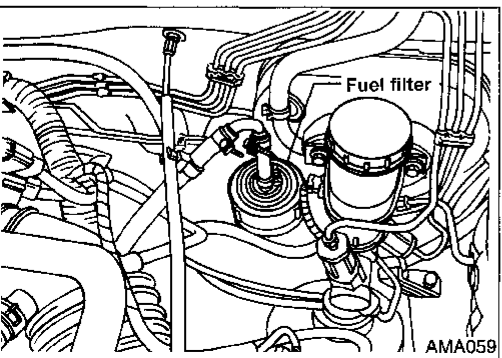

### WARNING:

Use rubber gloves to prevent fuel from contacting skin when removing fuel hoses and filter.

- Loosen fuel hose clamps.
  - Replace fuel filter.
- Be careful not to spill fuel over engine compartment. Place a shop towel to absorb fuel.
  - Use a high-pressure type fuel filter. Do not use a synthetic resinous fuel filter.
  - When tightening fuel hose clamps, refer to "Checking Fuel Lines", MA-14.

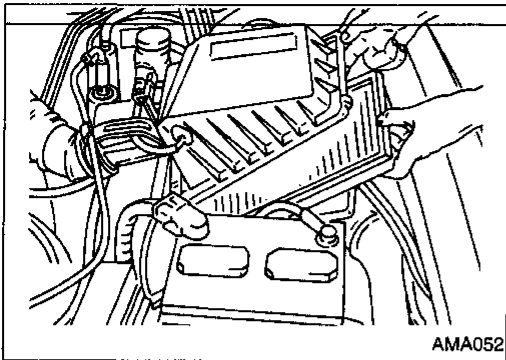

## Changing Air Cleaner Filter

Unfasten clamps to change air cleaner filter.  
The viscous paper type filter does not need cleaning.

GI

MA

EM

LC

EC

FE

CL

MT

AT

FA

RA

BR

ST

RS

BT

HA

EL

IDX

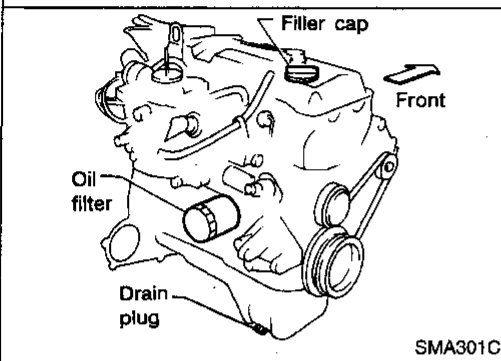

## Changing Engine Oil

### WARNING:

- Be careful not to burn yourself, as the engine oil is hot.
- Prolonged and repeated contact with used engine oil may cause skin cancer; try to avoid direct skin contact with used oil. If skin contact is made, wash thoroughly with soap or hand cleaner as soon as possible.

1. Warm up engine, and check for oil leakage from engine components.
2. Stop engine.
3. Remove drain plug and oil filler cap.
4. Drain oil and refill with new engine oil.

### Oil specification and viscosity:

- API Certification Mark
- API grade SG/SH, Energy Conserving II or API grade SJ, Energy Conserving
- ILSAC grade GF II
- See "RECOMMENDED FLUIDS AND LUBRICANTS", MA-8.

### Refill oil capacity (Approximately):

Unit: ℓ (US qt, Imp qt)

Drain and refill	
without oil filter change	2.7 (2-7/8, 2-3/8)
with oil filter change	3.0 (3-1/8, 2-5/8)
Dry engine (engine overhaul)	3.4 (3-5/8, 3)

### CAUTION:

- Be sure to clean drain plug and install with new washer.  
**Drain plug:**  
 □: 29 - 39 N·m  
 (3.0 - 4.0 kg-m, 22 - 29 ft-lb)
- The refill capacity depends on the oil temperature and drain time. Use these specifications for reference only. Always use the dipstick to determine when the proper amount of oil is in the engine.

## ENGINE MAINTENANCE

### Changing Engine Oil (Cont'd)

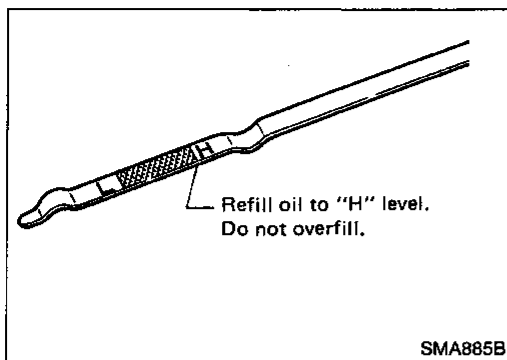

5. Warm up engine and check area around drain plug and oil filter for oil leakage.
6. Stop engine.
7. Check oil level.

### Changing Oil Filter

1. Remove oil filter with Tool.

#### **WARNING:**

**Be careful not to burn yourself. Engine and engine oil are hot.**

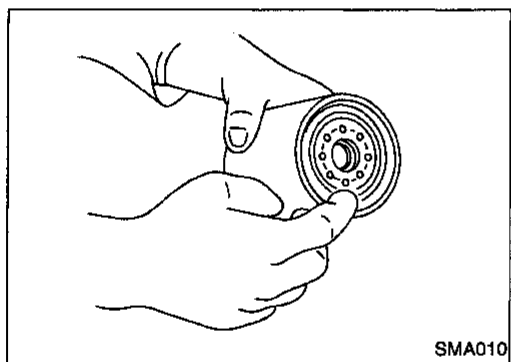

2. Clean oil filter mounting surface on cylinder block. Coat the rubber seal of new oil filter with engine oil.

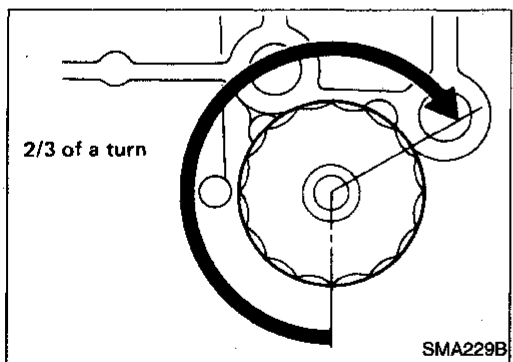

3. Screw in the oil filter until a slight resistance is felt, then tighten additionally more than 2/3 of a turn.
4. Add engine oil.

**Refer to "Changing Engine Oil", MA-15.**

- Clean excess oil from engine.

### Changing Spark Plugs

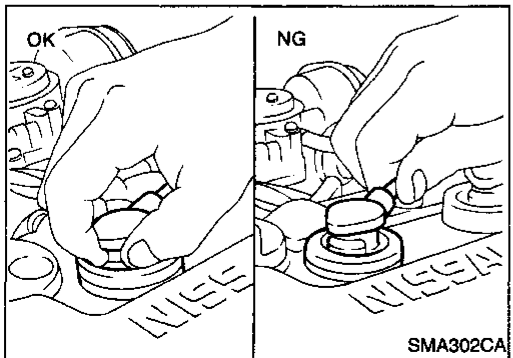

1. Disconnect ignition wires from spark plugs at boot. Do not pull on the wire.



# ENGINE MAINTENANCE

## Changing Spark Plugs (Cont'd)

2. Remove spark plugs with spark plug socket.

### Spark plug:

Standard type	BKR5E-11
Hot type	BKR4E-11
Cold type	BKR6E-11
	BKR7E-11

**Use standard type spark plug for normal condition.**

The hot type spark plug is suitable when fouling occurs with the standard type spark plug under conditions such as:

- frequent engine starts
- low ambient temperatures

The cold type spark plug is suitable when spark knock occurs with the standard type spark plug under conditions such as:

- extended highway driving
- frequent high engine revolution

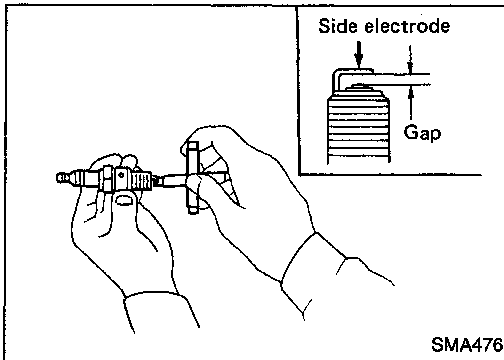
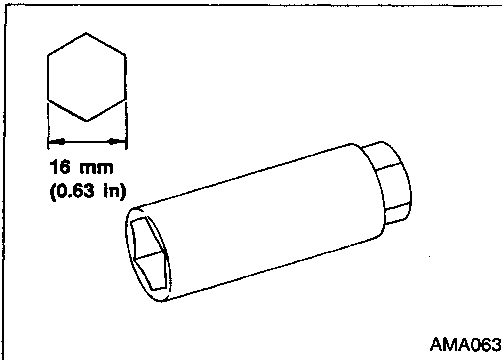

3. Check gap of each new spark plug.

**Gap: 1.0 - 1.1 mm (0.039 - 0.043 in)**

- Use a wire brush for cleaning, if necessary.

4. Install spark plugs. Reconnect ignition wires according to numbers indicated on them.

### Spark plug:

**⊗: 20 - 29 N·m**

**(2.0 - 3.0 kg-m, 14 - 22 ft-lb)**

## Checking EVAP Vapor Lines

1. Visually inspect EVAP vapor lines for improper attachment, cracks, damage, chafing and deterioration.
2. Inspect vacuum relief valve of fuel tank filler cap for clogging, sticking, etc.

Refer to EC section ("Inspection", EVAPORATIVE EMISSION SYSTEM").

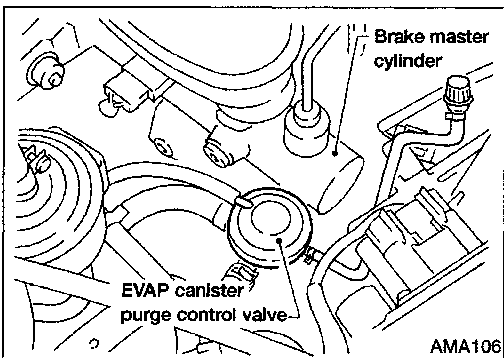
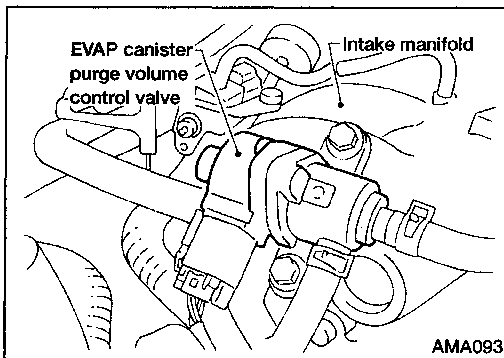

# ENGINE MAINTENANCE

## Checking EVAP Vapor Lines (Cont'd)

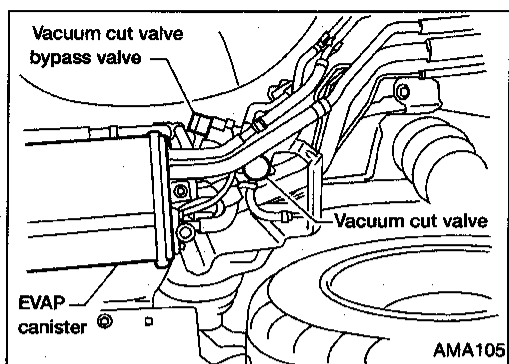

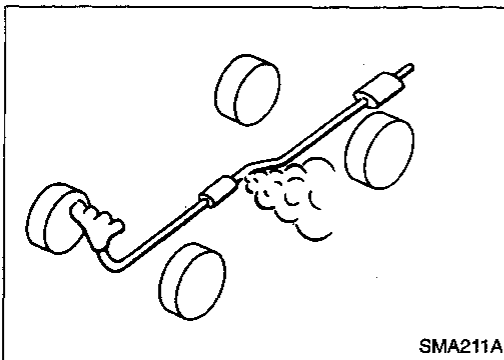

## Checking Exhaust System

Check exhaust pipes, muffler and mounting for improper attachment, leaks, cracks, damage, chafing and deterioration.

GI

MA

EM

LC

EC

FE

CL

MT

AT

FA

RA

BR

ST

RS

BT

HA

EL

IDX

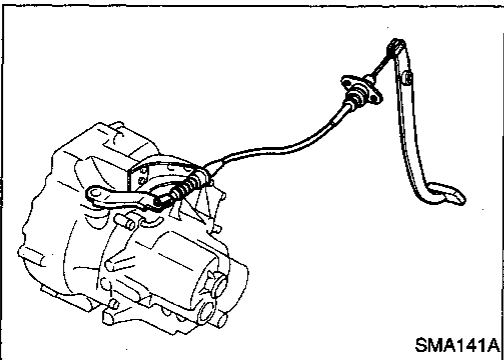

## Checking Clutch System

Check cable and lever for improper attachment, chafing, wear and deterioration.

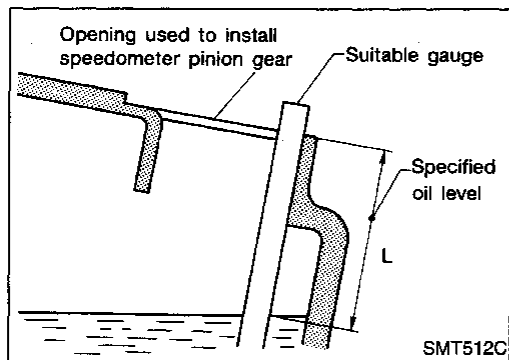

## Checking M/T Oil

- Check that oil is not leaking from transaxle or around it.
- Remove speedometer pinion and check that the oil level L at vehicle rear side is within specification.

**Oil level "L":**

**57 - 66 mm (2.24 - 2.60 in)**

- Always replace o-ring for speedometer pinion.

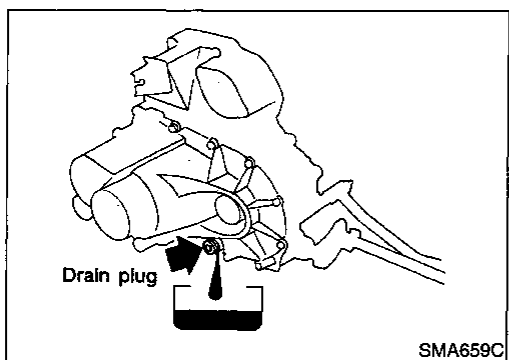

## Changing M/T Oil

1. Drain oil from drain plug and refill with new gear oil.
2. Check oil level. Refer to "Checking M/T Oil".

**Oil grade: API GL-4**

**Viscosity: Refer to MA-8.**

**Capacity:**

**2.9 - 3.2 liters (6-1/8 - 6-3/4 US pt, 5-1/8 - 5-5/8 Imp pt)**

3. Apply genuine anaerobic liquid, Three Bond TB1215 or equivalent to threads of drain plug.

**Drain plug:**

**☐: 25 - 34 N·m (2.5 - 3.5 kg·m, 18 - 25 ft·lb)**

## CHASSIS AND BODY MAINTENANCE

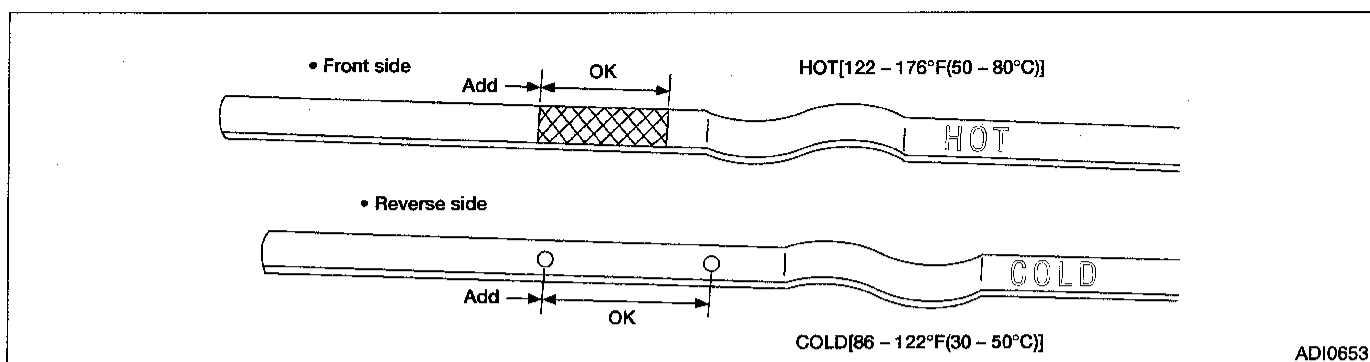

### Checking A/T Fluid

1. Warm up engine.
2. Check for fluid leakage.
3. Before driving, fluid level can be checked at fluid temperatures of 30 to 50°C (86 to 122°F) using COLD range on dipstick.
  - a. Park vehicle on level surface and set parking brake.
  - b. Start engine and move selector lever through each gear position. Leave selector lever in "P" position.
  - c. Check fluid level with engine idling.
  - d. Remove dipstick and wipe clean with lint-free paper.
  - e. Reinsert dipstick as far as it will go into charging pipe.
  - f. Remove dipstick and note reading. If reading is at low side of range, add fluid to the charging pipe.
4. Drive vehicle for approximately 5 minutes in urban area.
5. Recheck fluid level at fluid temperatures of 50 to 80°C (122 to 176°F) using HOT range on dipstick.

#### Do not overfill.

6. Check fluid condition.
  - If fluid is very dark or smells burned, refer to A/T section for checking operation of A/T. Flush engine cooling system after repair of A/T.
  - If A/T fluid contains frictional material (clutches, bands, etc.), replace radiator and flush cooler line using cleaning solvent and compressed air after repair of A/T. Refer to LC section ("Radiator", "ENGINE COOLING SYSTEM").

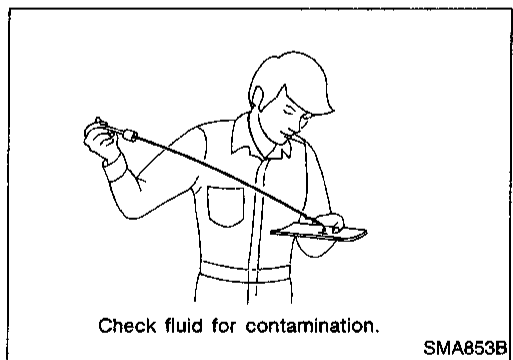

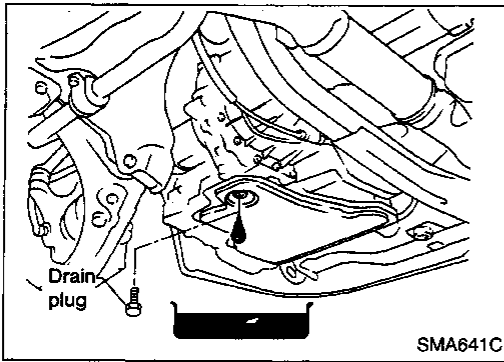

## Changing A/T Fluid

1. Warm up A/T fluid.
2. Stop engine.
3. Drain A/T fluid from drain plug and refill with new A/T fluid. Measure amount of fluid drained and refill with equal amount of new fluid.

### Fluid grade:

**Nissan Matic "D" (Continental U.S. and Alaska) or Genuine Nissan Automatic Transmission Fluid (Canada)**

Refer to "RECOMMENDED FLUIDS AND LUBRICANTS", MA-8.

**Fluid capacity (With torque converter):**  
7.0 liters (7-3/8 US qt, 6-1/8 Imp qt)

### Drain plug:

: 29 - 39 N·m (3.0 - 4.0 kg-m, 22 - 29 ft-lb)

4. Run engine at idle speed for 5 minutes.
5. Check fluid level and condition. Refer to "Checking A/T Fluid", MA-20. If fluid is still dirty, repeat steps 2 through 5.

GI

MA

EM

LC

EC

FE

CL

MT

AT

FA

RA

BR

ST

RS

BT

HA

EL

IDX

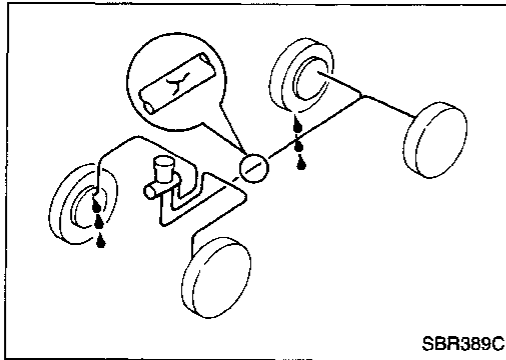

## Checking Brake Fluid Level and Leaks

If fluid level is extremely low, check brake system for leaks.

## Checking Brake Lines and Cables

Check brake fluid lines and parking brake cables for improper attachment, leaks, chafing, abrasions and deterioration.

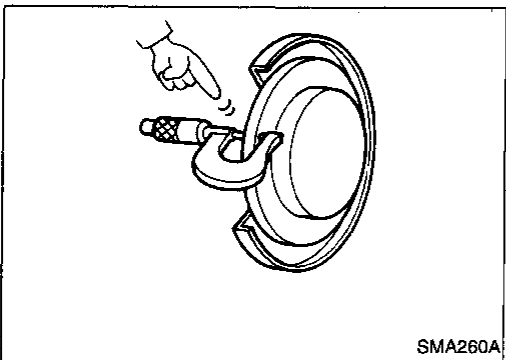

## Checking Disc Brake

### ROTOR

Check condition and thickness.

### Thickness:

	Unit: mm (in)	
	CL22VD, CL22VE	CL7HB
Standard	18 (0.71)	7 (0.28)
Minimum	16.0 (0.630)	6.0 (0.236)

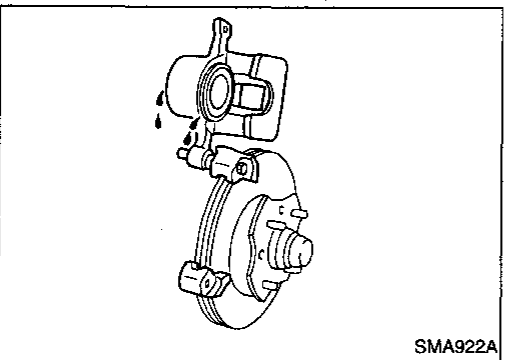

### CALIPER

Check operation and for leakage.

# CHASSIS AND BODY MAINTENANCE

## Checking Disc Brake (Cont'd)

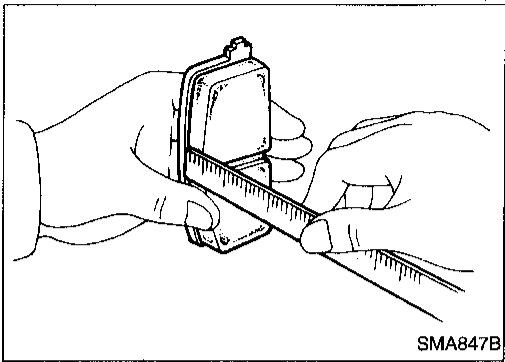

### PAD

Measure wear and check for damage.

**Thickness:**

Unit: mm (in)

	CL22VD, CL22VE	CL7HB
Standard	11 (0.43)	10 (0.39)
Minimum	2.0 (0.079)	1.5 (0.059)

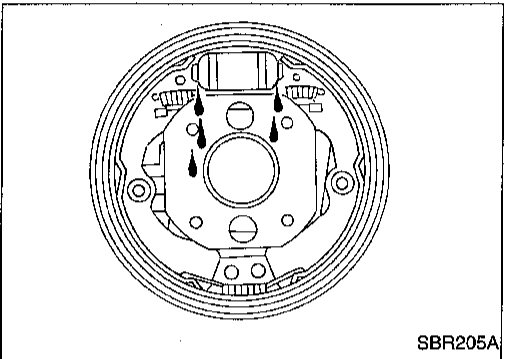

## Checking Drum Brake

### WHEEL CYLINDER

Check operation and for leakage.

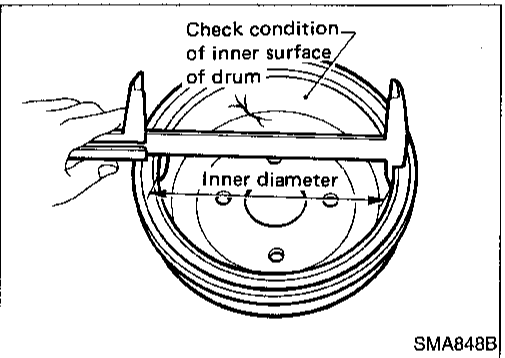

### DRUM

Check condition of inner surface.

**Standard diameter:**

180 mm (7.09 in)

**Maximum inner diameter:**

181 mm (7.13 in)

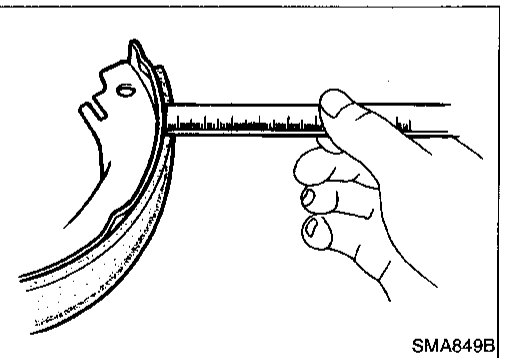

### LINING

Measure wear and check for damage.

**Standard thickness:**

4 mm (0.16 in)

**Minimum thickness:**

1.5 mm (0.059 in)

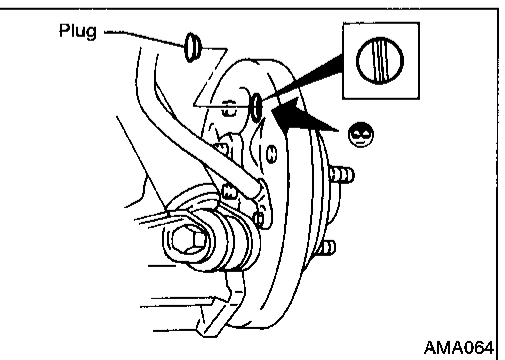

## TEMPORARY METHOD FOR CHECKING LINING WEAR

Remove inspection hole plug and check lining wear.

## Balancing Wheels

- Adjust wheel balance using road wheel center.
- Wheel balance (Maximum allowable unbalance):**  
Refer to SDS, MA-25.

GI

MA

EM

LC

EC

FE

CL

MT

AT

FA

RA

BR

ST

RS

BT

HA

EL

IDX

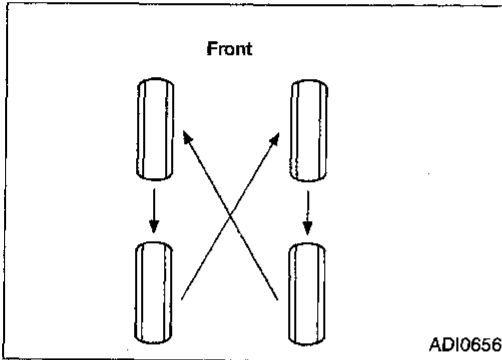

## Tire Rotation

- After rotating the tires, adjust the tire pressure.
- Retighten the wheel nuts after aluminum wheels have been run for the first 1,000 km (600 miles) or if a flat tire occurs.

**Do not include the T-type spare tire when rotating the tires.**

**Wheel nuts:**

: 98 - 118 N·m (10.0 - 12.0 kg-m, 72 - 87 ft-lb)

CL

MT

## Checking Steering Gear and Linkage

### STEERING GEAR

- Check gear housing and boots for looseness, damage and grease leakage.
- Check connection with steering column for looseness.

RA

### STEERING LINKAGE

Check ball joint, dust cover and other component parts for looseness, wear, damage and grease leakage.

BR

## Checking Power Steering Fluid and Lines

Check fluid level with engine off. Check fluid level in reservoir. Use HOT range at fluid temperatures of 50 to 80°C (122 to 176°F). Use COLD range at fluid temperatures of 0 to 30°C (32 to 86°F).

### CAUTION:

- Do not overfill.
- Recommended fluid is Automatic Transmission Fluid type DEXRON™ III or equivalent.

ST

RS

BT

HA

EL

IDX

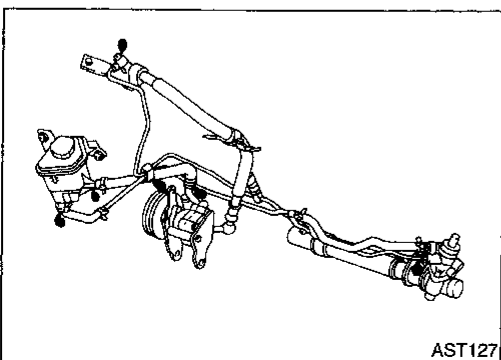
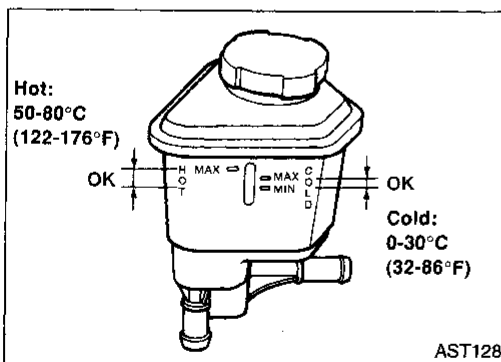
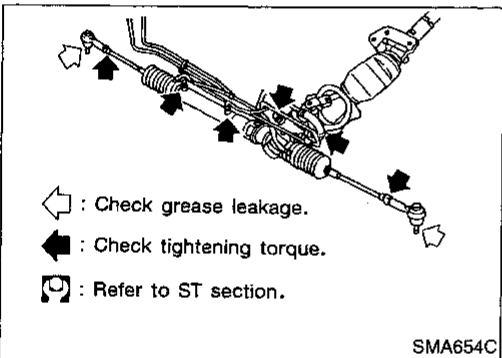

- Check lines for improper attachment, leaks, cracks, damage, loose connections, chafing and deterioration.
- Check rack boots for accumulation of power steering fluid.

## Lubricating Locks, Hinges and Hood Latches

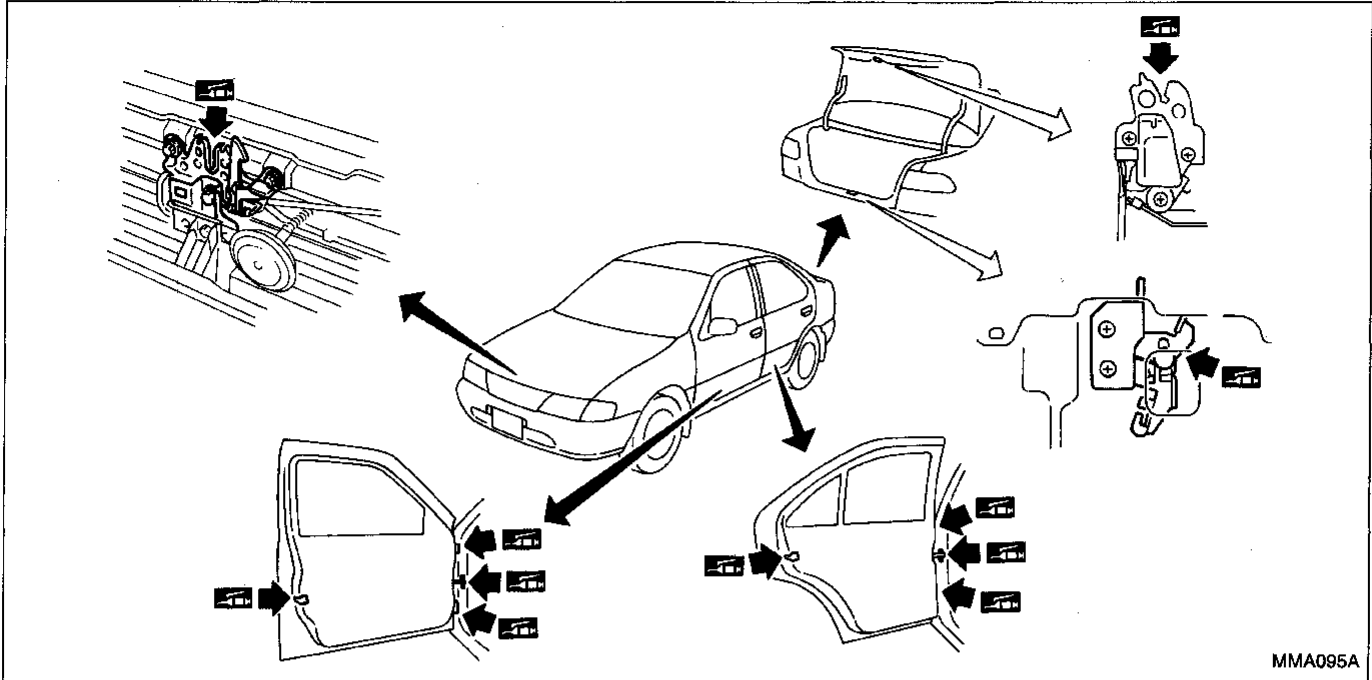

MMA095A

## Checking Seat Belts, Buckles, Retractors, Anchors and Adjusters

### CAUTION:

- After any collision, inspect all seat belt assemblies, including retractors and other attached hardware (i.e. guide rail set). Nissan recommends to replace all seat belt assemblies in use during a collision, unless not damaged and properly operating after minor collision. Also inspect seat belt assemblies not in use during a collision, and replace if damaged or improperly operating.
- If any component of seat belt assembly is questionable, do not repair. Replace as seat belt assembly.
- If webbing is cut, frayed, or damaged, replace belt assembly.
- Do not spill drinks, oil etc. on inner lap belt buckle. Never oil tongue and buckle.
- Use a NISSAN genuine seat belt assembly.

- For details, refer to "Seat Belt inspection", "SEAT BELTS" in RS section.

 Anchor bolt  
43 - 55 N·m  
(4.4 - 5.6 kg-m,  
32 - 41 ft-lb)

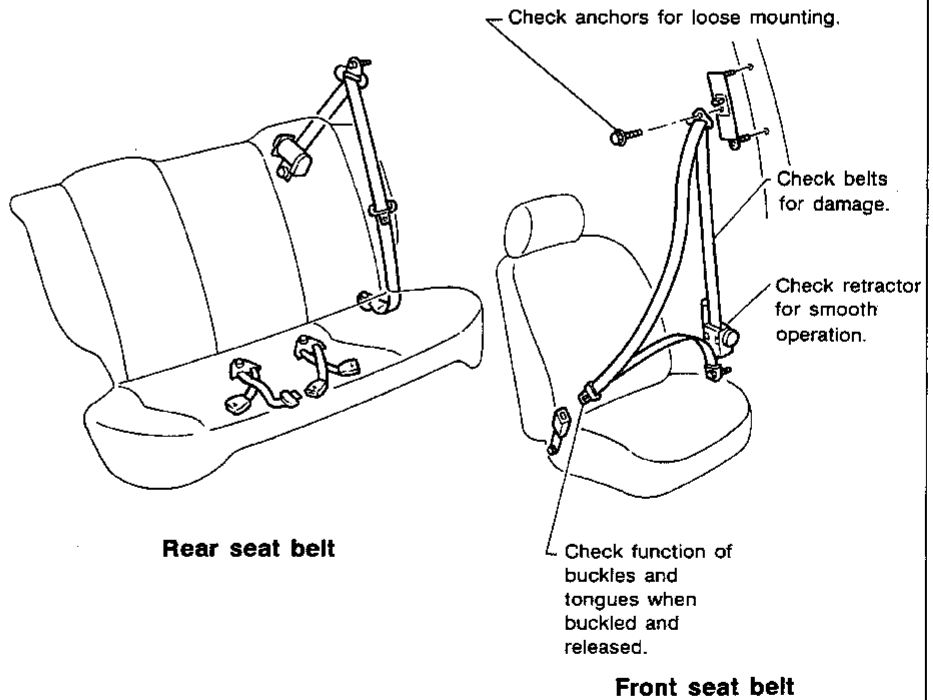

AMA108



# SERVICE DATA AND SPECIFICATIONS (SDS)

## Engine Maintenance

### INSPECTION AND ADJUSTMENT

#### Drive belt deflection and tension

	Deflection adjustment Unit: mm (in)			Tension adjustment *1 Unit: N (kg, lb)		
	Used belt		New belt	Used belt		
	Limit	After adjustment		Limit	After adjustment	New belt
Generator With A/C compressor	9.5 (0.374)	6 - 6.5 (0.24 - 0.256)	5 - 6 (0.20 - 0.24)	196 (20, 44)	535 - 623 (55 - 63, 120 - 140)	652 - 740 (67 - 75, 147 - 166)
	11.5 (0.453)	7.5 - 8 (0.295 - 0.315)	6.5 - 7 (0.256 - 0.28)	196 (20, 44)	535 - 623 (55 - 63, 120 - 140)	652 - 740 (67 - 75, 147 - 166)
Water pump With power steering pump	7.5 (0.295)	4 - 6 (0.16 - 0.24)	3 - 5 (0.12 - 0.20)	196 (20, 44)	495 - 583 (51 - 59, 112 - 131)	603 - 691 (62 - 70, 136 - 155)
	6 (0.24)	3 - 4.5 (0.12 - 0.177)	3 - 4 (0.12 - 0.16)	196 (20, 44)	495 - 583 (51 - 59, 112 - 131)	603 - 691 (62 - 70, 136 - 155)
Applied pushing force	98 N (10 kg, 22 lb)			—		

\*1: If belt tension gauge cannot be installed at check points, check drive belt tension at a different location on the belt.

#### Spark plug

Type	
Standard	BKR5E-11
Hot	BKR4E-11
Cold	BKR6E-11 BKR7E-11
Plug gap	mm (in) 1.0 - 1.1 (0.039 - 0.043)

## Chassis and Body Maintenance

### INSPECTION AND ADJUSTMENT

#### Wheel balance

Maximum allowable unbalance	Dynamic (at rim flange) g (oz)	10 (0.35) (One side)
	Static g (oz)	20 (0.71)

GI

MA

EM

LC

EC

FE

CL

MT

AT

FA

RA

BR

ST

RS

BT

HA

EL

IDX