

STEERING SYSTEM

SECTION **ST**

GI

MA

EM

LC

EC

PE

CL

MT

AT

FA

RA

BR

ST

RS

BT

HA

EL

IDX

CONTENTS

PRECAUTIONS AND PREPARATION	2	Checking Gear Housing Movement.....	7
Supplemental Restraint System (SRS)		Checking Hydraulic System.....	8
“Air Bag”.....	2	STEERING WHEEL AND STEERING COLUMN	9
Precautions for Steering System.....	2	Steering Wheel.....	9
Special Service Tools.....	2	Steering Column.....	10
Commercial Service Tool.....	3	POWER STEERING GEAR AND LINKAGE	13
NOISE, VIBRATION AND HARSHNESS (NVH)		Removal and Installation.....	13
TROUBLESHOOTING	4	Disassembly.....	16
NVH Troubleshooting Chart.....	4	Inspection.....	16
ON-VEHICLE SERVICE	5	Assembly.....	16
Checking and Adjusting Drive Belts.....	5	POWER STEERING PUMP	18
Checking Fluid Level.....	5	Pre-disassembly Inspection.....	18
Checking Fluid Leakage.....	5	Disassembly.....	19
Bleeding Hydraulic System.....	6	Inspection.....	19
Checking Steering Wheel Turning Force.....	6	Assembly.....	20
Checking Steering Wheel Play.....	7	SERVICE DATA AND SPECIFICATIONS (SDS)	21
Checking Neutral Position on Steering Wheel.....	7	General Specifications.....	21
Front Wheel Turning Angle.....	7	Inspection and Adjustment.....	21

PRECAUTIONS AND PREPARATION

Supplemental Restraint System (SRS) “Air Bag”

The Supplemental Restraint System “AIR BAG”, used along with a seat belt, helps to reduce the risk or severity of injury to the driver and front passenger in a frontal collision. The Supplemental Restraint System consists of air bag modules (located in the center of the steering wheel and in the instrument panel on the passenger side), a diagnosis sensor unit, warning lamp, wiring harness and spiral cable. Information necessary to service the system safely is included in the **RS section** of this Service Manual.

WARNING:

- To avoid rendering the SRS inoperative, which could increase the risk of personal injury or death in the event of a collision, which would result in air bag inflation, all maintenance should be performed by an authorized NISSAN dealer.
- Improper maintenance, including incorrect removal and installation of the SRS, can lead to personal injury caused by unintentional activation of the system.
- Do not use electrical test equipment on any circuit related to the SRS unless instructed to in this Service Manual. SRS wiring harnesses are covered with yellow insulation either just before the harness connectors or on the complete harness, for easy identification.

Precautions for Steering System

- Before disassembly, thoroughly clean the outside of the unit.
- Disassembly should be done in a clean work area. It is important to prevent the internal parts from becoming contaminated by dirt or other foreign matter.
- For easier and proper assembly, place disassembled parts in order on a parts rack.
- Use nylon cloths or paper towels to clean the parts; common shop rags can leave lint that might interfere with their operation.
- Before inspection or reassembly, carefully clean all parts with a general purpose, non-flammable solvent.
- Before assembly, apply a coat of recommended ATF* to hydraulic parts. Petroleum jelly may be applied to O-rings and seals. Do not use any grease.
- Replace all gaskets, seals and O-rings. Avoid damaging O-rings, seals and gaskets during installation. Perform functional tests whenever designated.

*: Automatic Transmission Fluid type DEXRON™III or equivalent.

Special Service Tools

The actual shapes of Kent-Moore tools may differ from those of special service tools illustrated here.

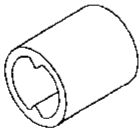
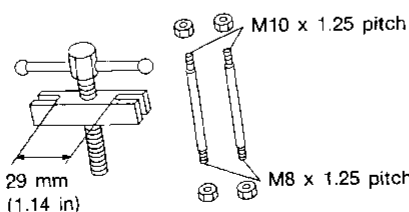
Tool number (Kent-Moore No.) Tool name	Description
KV48100700 (J26364) Torque adapter	 Measuring pinion rotating torque NT169
ST27180001 (J25726-A) Steering wheel puller	 Removing and installing steering wheel NT544

PRECAUTIONS AND PREPARATION

Special Service Tools (Cont'd)

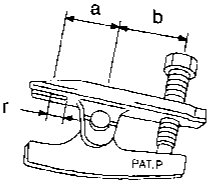
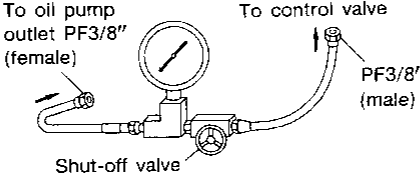
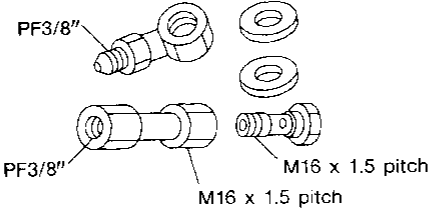
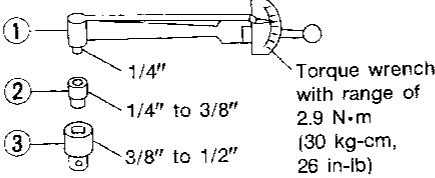
Tool number (Kent-Moore No.) Tool name	Description	
HT72520000 (J25730-B) Ball joint remover	 <p style="text-align: right;"> a: 33 mm (1.30 in) b: 50 mm (1.97 in) r: R11.5 mm (0.453 in) </p>	GI MA EM LC
ST27091000 (J26357 and J26357-10) Pressure gauge	 <p style="text-align: center;">Shut-off valve</p>	EC FE CL
KV48102500 (J33914) Pressure gauge adapter		AT FA RA BR
ST3127S000 ① GG91030000 (See J25765-A) Torque wrench ② HT62940000 (—) Socket adapter ③ HT62900000 (—) Socket adapter	 <p style="text-align: right;"> Torque wrench with range of 2.9 N·m (30 kg·cm, 26 in·lb) </p>	ST

Commercial Service Tool

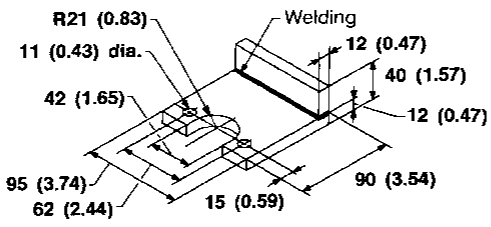
Tool name	Description	
Power steering pump attachment	 <p style="text-align: right;">Unit: mm (in)</p>	BT HA EL IDX

NOISE, VIBRATION AND HARSHNESS (NVH) TROUBLESHOOTING

NVH Troubleshooting Chart

Use the chart below to help you find the cause of the problem. If necessary, repair or replace these parts.

Symptom		STEERING	Possible Cause AND SUSPECTED PARTS													Reference page								
			Fluid level	Air in hydraulic system	Tie-rod ball joint swinging force	Tie-rod ball joint rotating torque	Tie-rod ball joint end play	Steering gear fluid leakage	Steering wheel play	Steering gear rack sliding force	Drive belt looseness	Improper steering wheel	Improper installation or looseness of tilt lock lever	Mounting rubber deterioration	Steering column deformation or damage		Improper installation or looseness of steering column	Steering linkage looseness	AXLE AND SUSPENSION	TIRES	ROAD WHEEL	DRIVESHAFT	BRAKES	
Noise	STEERING	Noise	X	X	X	X	X	X	X	X	X							X	X	X	X	X		ST-5 ST-6 ST-21 ST-21 ST-16, 21 ST-5 ST-7 ST-6 ST-5
		Shake										X	X	X				X	X	X	X	X		
		Vibration										X	X	X	X	X		X	X		X			
		Shimmy										X	X	X			X	X	X	X			X	
		Judder												X			X	X	X	X			X	

X: Applicable

Checking and Adjusting Drive Belts

Refer to MA section ("Checking Drive Belts", "ENGINE MAINTENANCE").

GI

MA

EM

LC

EC

FE

CL

MT

AT

FA

RA

BR

ST

RS

BT

HA

EL

IDX

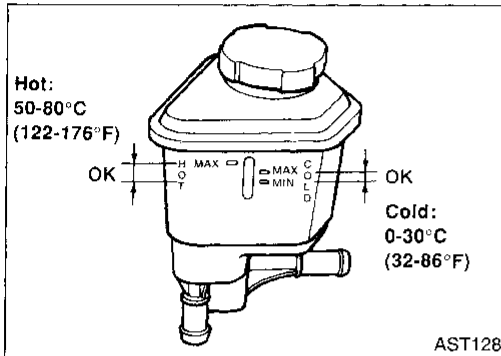

Checking Fluid Level

Check fluid level with engine OFF.

Check fluid level referring to the scale on reservoir tank.

Use HOT range for fluid temperatures of 50 to 80°C (122 to 176°F).

Use COLD range for fluid temperatures of 0 to 30°C (32 to 86°F).

CAUTION:

- Do not overfill.
- Recommended fluid is Automatic Transmission Fluid type DEXRON™III or equivalent.

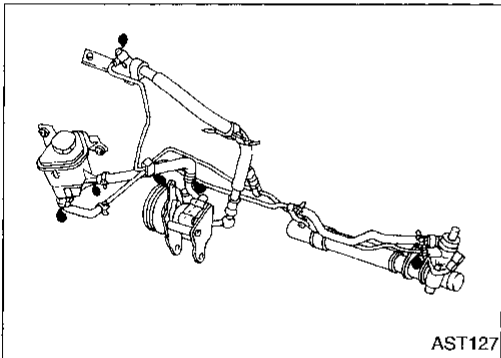

Checking Fluid Leakage

Check the lines for improper attachment, leaks, cracks, damage, chafing or deterioration.

1. Run engine between idle speed and 1,000 rpm.
- Make sure fluid temperature in reservoir tank rises to 60 to 80°C (140 to 176°F).
2. Turn steering wheel right-to-left several times.
3. Hold steering wheel at each lock position for five seconds and carefully check for fluid leakage.

CAUTION:

Do not hold the steering wheel in a locked position for more than 15 seconds.

4. If fluid leakage at any line is noticed, loosen flare nut and then retighten or tighten hose clamps.
- Do not overtighten flare nut as this can damage O-ring, washer and threads.
5. Check rack boots for accumulation of power steering fluid.

Bleeding Hydraulic System

1. Raise front end of vehicle until wheels are clear of the ground.
2. Add fluid into reservoir tank to specified level. Then quickly turn steering wheel fully to the right and left, lightly touch steering stoppers.
Repeat steering wheel operation until fluid level no longer decreases.
3. Start engine.
Repeat step 2.

- Incomplete air bleeding will cause the following to occur:
 - a. Air bubbles in reservoir tank
 - b. Clicking noise in power steering pump
 - c. Excessive buzzing in power steering pump

Fluid noise may occur in the valve or power steering pump. This is common when the vehicle is stationary or while turning the steering wheel slowly. This does not affect the performance or durability of the system.

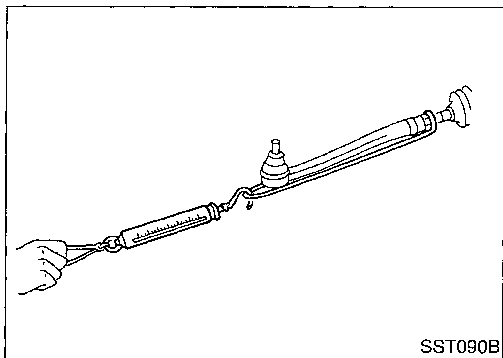
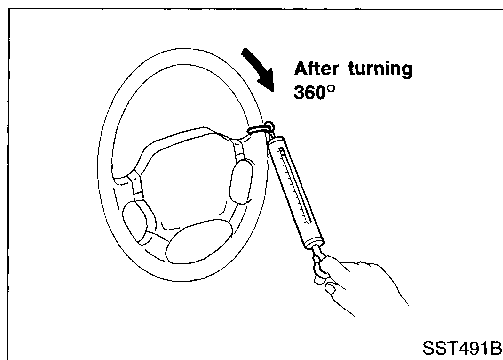

Checking Steering Wheel Turning Force

1. Park vehicle on a level, dry surface and set parking brake.
2. Run engine at idle speed or 1,000 RPM.
3. Bring power steering fluid up to adequate operating temperature.
 - **Make sure fluid temperature in reservoir tank reaches 60° to 80°C (140° to 176°F).**
 - **Tires need to be inflated to normal pressure.**
4. Check steering wheel turning force when steering wheel has been turned 360° from the neutral position.

Steering wheel turning force:

39 N (4 kg, 9 lb) or less

5. If steering wheel turning force is out of specification, check rack sliding force.
 - a. Disconnect steering column lower joint and knuckle arms from the gear.
 - b. Start and run engine at idle to make sure steering fluid has reached normal operating temperature.
 - c. Pull tie-rod slowly to move it from neutral position to ± 11.5 mm (± 0.453 in) at speed of 3.5 mm (0.138 in)/s. Check that rack sliding force is within specification.

Average rack sliding force:

108 - 245 N (11 - 25 kg, 24 - 55 lb)

Maximum rack sliding force:

294 N (30 kg, 66 lb)

6. If rack sliding force is not within specification, refer to "Checking Hydraulic System", ST-8.
7. If rack sliding force is OK, inspect steering column. Refer to ST-12.

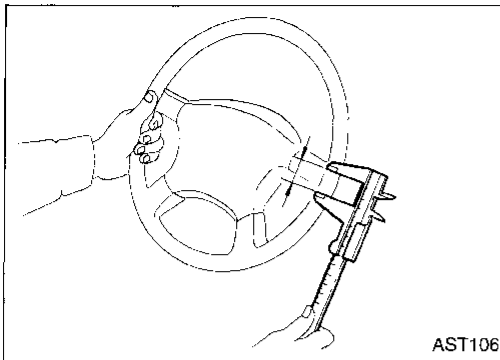

Checking Steering Wheel Play

- With wheels in a straight-ahead position, check steering wheel play.

Steering wheel play:

35 mm (1.38 in) or less

- If it is not within specification, check the following for loose or worn components.
 - a. Steering gear assembly
 - b. Steering column
 - c. Front suspension and axle

GI

MA

EM

LC

EC

FE

CL

MT

AT

FA

RA

BR

ST

RS

BT

HA

EL

IDX

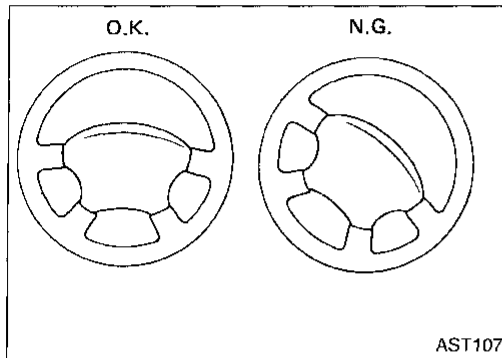

Checking Neutral Position on Steering Wheel

Pre-checking

- Make sure that wheel alignment is correct.

Wheel alignment:

Refer to FA section ("Inspection and Adjustment", "SERVICE DATA AND SPECIFICATIONS").

- Verify that the steering gear is centered before removing the steering wheel.

Checking

1. Check that the steering wheel is in the neutral position when driving straight ahead.
2. If it is not in the neutral position, remove the steering wheel and reinstall it correctly.
3. If the neutral position is still not correct:
 - a. Loosen tie-rod lock nuts.
 - b. Move tie-rods in the opposite direction by the same amount on both left and right sides.
This will compensate for error in the neutral position.

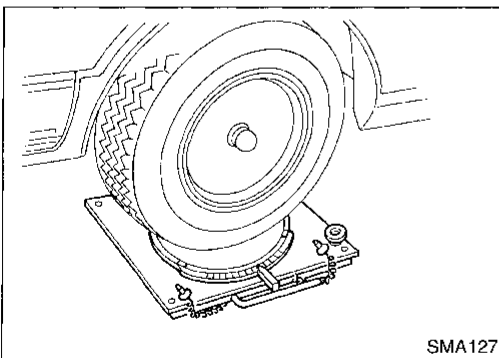

Front Wheel Turning Angle

1. Rotate steering wheel all the way right and left; measure turning angle.

Turning angle of full turns:

Refer to FA section ("Inspection and Adjustment", "SERVICE DATA AND SPECIFICATIONS").

2. If it is not within specification, check rack stroke.

Rack stroke "S":

Refer to SDS, ST-22.

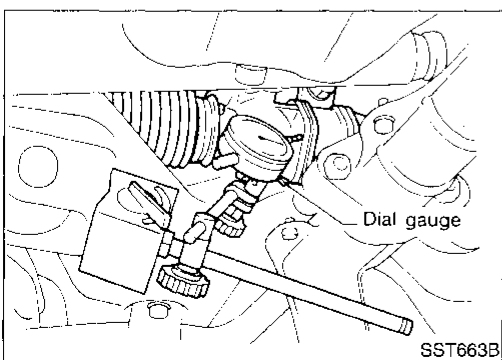

Checking Gear Housing Movement

1. Check the movement of steering gear housing during stationary steering on a dry paved surface.

- Apply a force of 49 N (5 kg, 11 lb) to steering wheel to check the gear housing movement.

Turn ignition key OFF while checking.

Movement of gear housing:

±2 mm (±0.08 in) or less

2. If movement exceeds the limit, replace mounting insulator after confirming proper installation of gear housing mounting brackets.

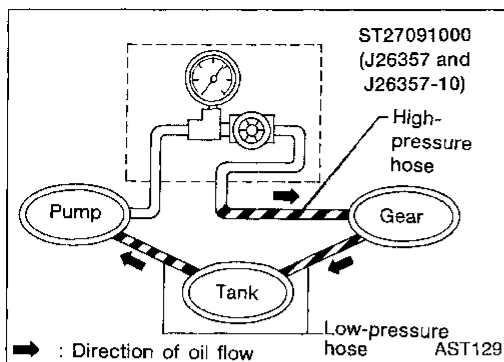

Checking Hydraulic System

Before starting, check belt tension, drive pulley and tire pressure.

1. Set Tool. Open shut-off valve. Then bleed air. Refer to "Bleeding Hydraulic System", ST-6.
2. Run engine at idle speed or 1,000 RPM.

Make sure fluid temperature in reservoir tank reaches 60 to 80°C (140 to 176°F).

WARNING:

Warm up engine with shut-off valve fully opened. If engine is started with shut-off valve closed, fluid pressure in the power steering pump will increase to maximum. This will raise the fluid temperature abnormally.

3. Check pressure with steering wheel fully turned to left and right positions with engine idling at 1,000 rpm.

CAUTION:

Do not hold the steering wheel in a locked position for more than 15 seconds.

Power steering pump maximum operating pressure:

7,159 - 7,748 kPa

(73 - 79 kg/cm², 1,038 - 1,123 psi)

- If pressure reaches maximum operating pressure, system is OK.
- If pressure increases above maximum operating pressure, check power steering pump flow control valve. Refer to ST-19.
- If power steering pressure is below maximum operating pressure, slowly close shut-off valve and check pressure.

CAUTION:

Do not close shut-off valve for more than 15 seconds.

- If pressure increases to maximum operating pressure, gear is damaged. Refer to "Removal and Installation", ST-13.
 - If pressure remains below maximum operating pressure, pump is damaged. Refer to "Disassembly", ST-19.
4. After checking hydraulic system, remove Tool and add fluid as necessary. Then completely bleed air out of system. Refer to "Bleeding Hydraulic System", ST-6.

STEERING WHEEL AND STEERING COLUMN

Steering Wheel

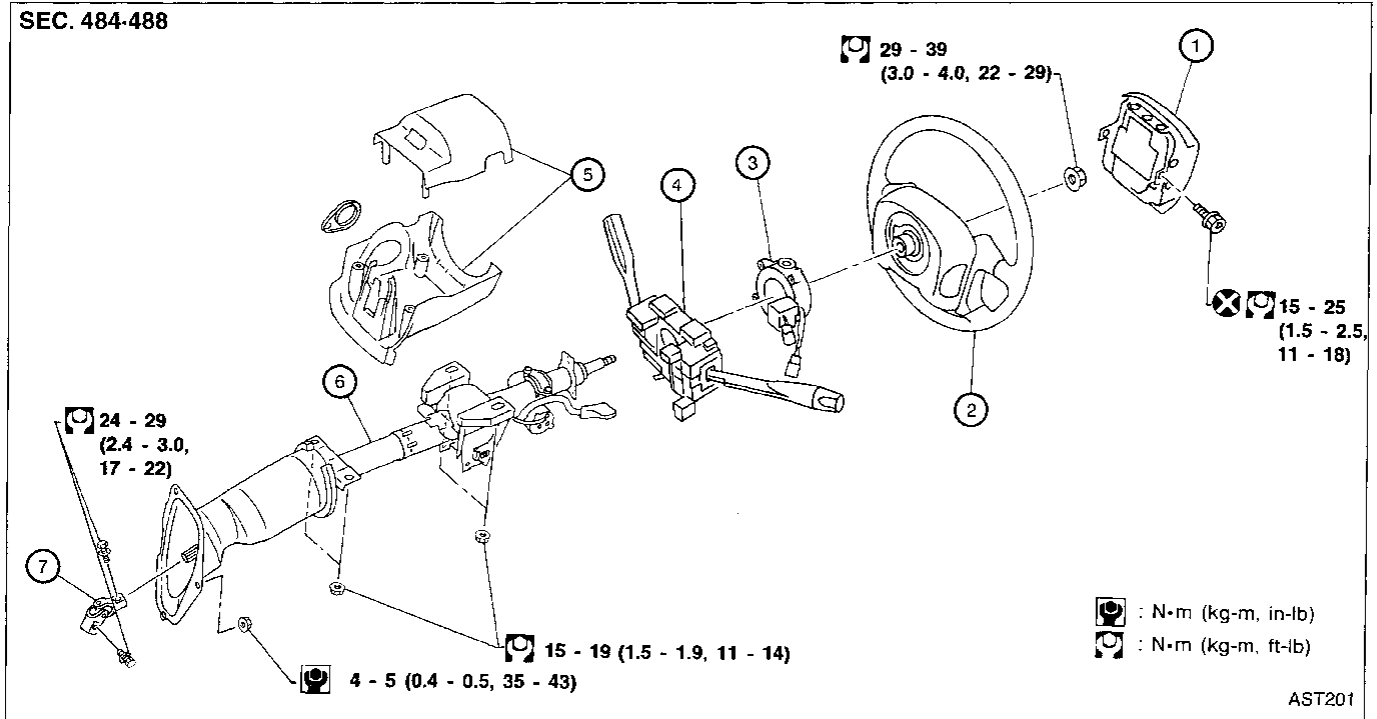

- ① Air bag module
- ② Steering wheel
- ③ Spiral cable

- ④ Combination switch
- ⑤ Column covers

- ⑥ Steering column assembly
- ⑦ Lower joint

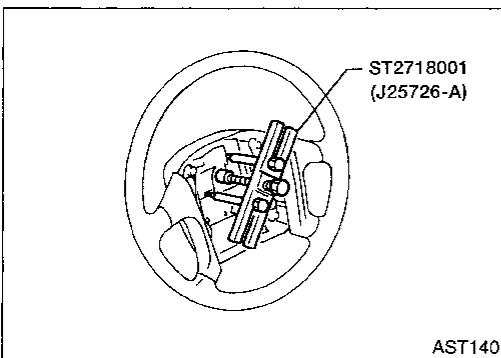
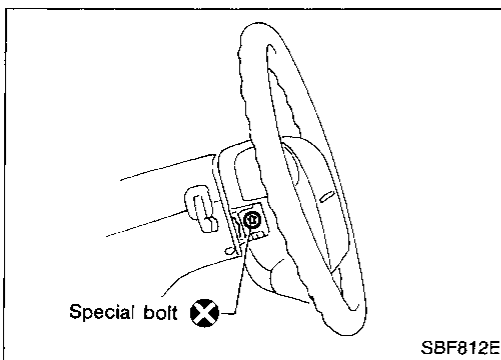

REMOVAL AND INSTALLATION

1. Remove driver air bag module.
Refer to RS section ["Driver Air Bag Module and Spiral Cable", "SUPPLEMENTAL RESTRAINT SYSTEM (SRS)"].
2. Disconnect horn connector and remove steering wheel nut.

3. Remove steering wheel with Tool.
 - For installation, refer to RS section ["Driver Air Bag Module and Spiral Cable", "SUPPLEMENTAL RESTRAINT SYSTEM (SRS)"].

STEERING WHEEL AND STEERING COLUMN

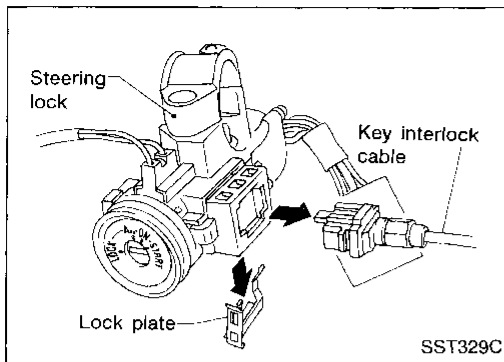

Steering Column

REMOVAL

CAUTION:

- The rotation of the spiral cable (SRS "Air bag" component part) is limited. If the steering gear must be removed, set the front wheels in the straight-ahead direction. Do not rotate the steering column while the steering gear is removed.
- Remove the steering wheel before removing the steering lower joint to avoid damaging the SRS spiral cable. Refer to ST-9.

1. Remove steering wheel, refer to ST-9.
2. Remove instrument lower panel and dash lower reinforcement panel.
3. Remove steering column covers.
4. Disconnect electrical connectors from the ignition switch and combination switch.
5. Remove three screws securing combination switch and remove combination switch.
6. Remove key interlock cable (A/T models).
7. Remove the hole cover then remove bolt from lower joint.
8. Remove the steering column lower cover.
9. Remove four nuts securing steering column and remove steering column.

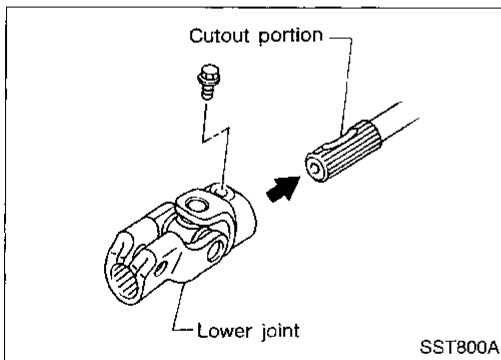

INSTALLATION

- When installing steering column, fingertighten all lower bracket and clamp retaining bolts; then tighten them securely. Do not apply undue stress to steering column.
- When attaching coupling joint, be sure tightening bolt faces cutout portion.

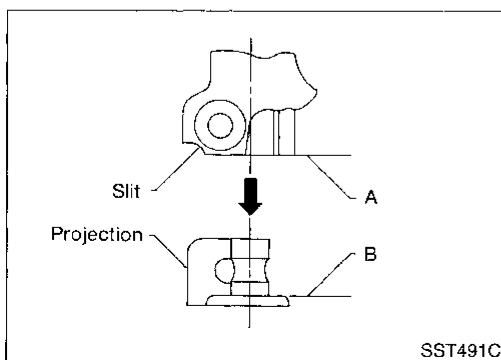

- Align slit of lower joint with projection on dust cover. Insert joint until surface A contacts surface B.

CAUTION:

After installation, turn steering wheel to make sure it moves smoothly. Ensure that the number of turns from the straight forward position to left and right locks are the same. Be sure that the steering wheel is in a neutral position when driving straight ahead.

STEERING WHEEL AND STEERING COLUMN

Steering Column (Cont'd)

SEC. 487-488

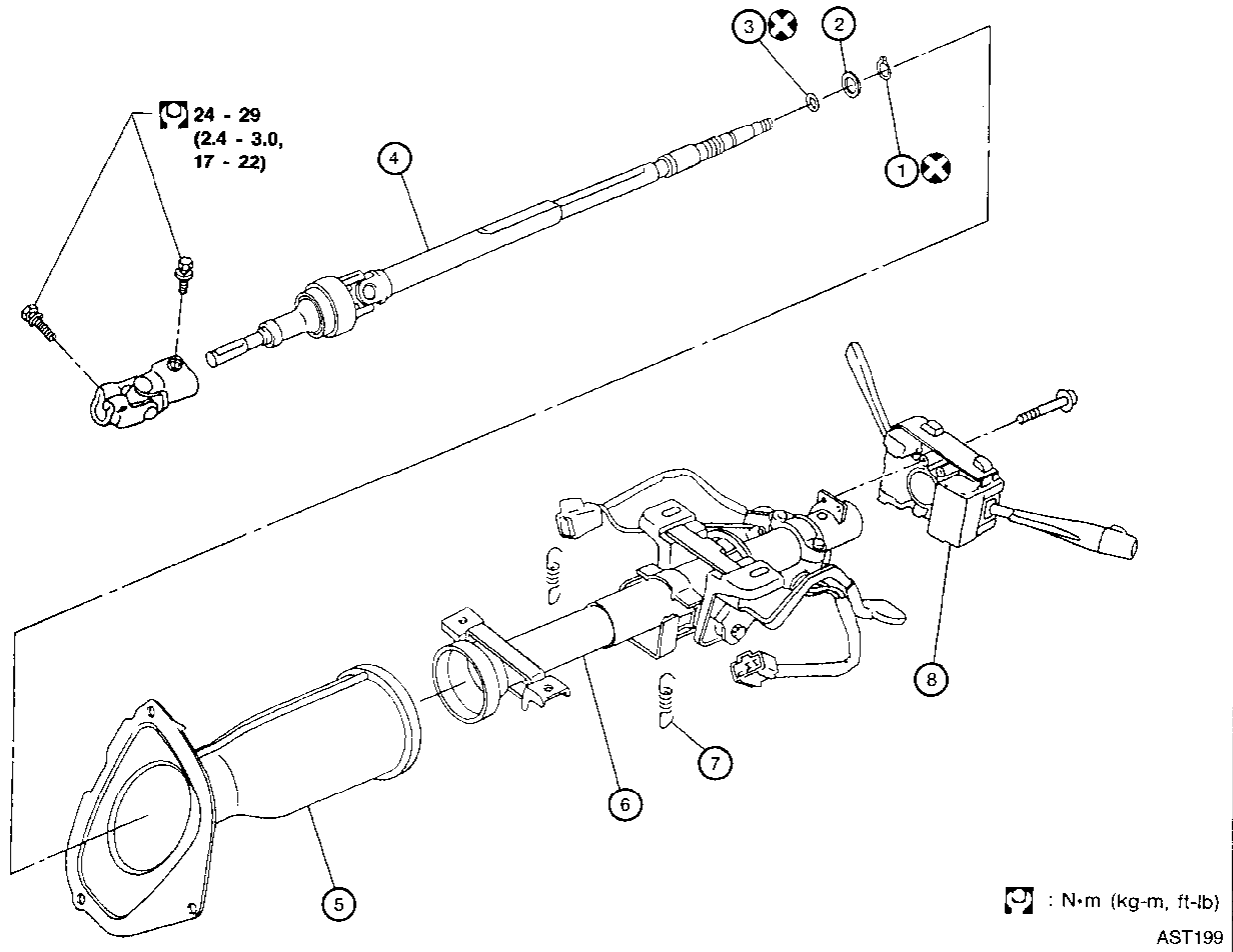

- | | | |
|-------------|-------------------------------|----------------------|
| ① Snap ring | ④ Steering column shaft | ⑦ Spring |
| ② Washer | ⑤ Steering column lower cover | ⑧ Combination switch |
| ③ O-ring | ⑥ Jacket tube assembly | |

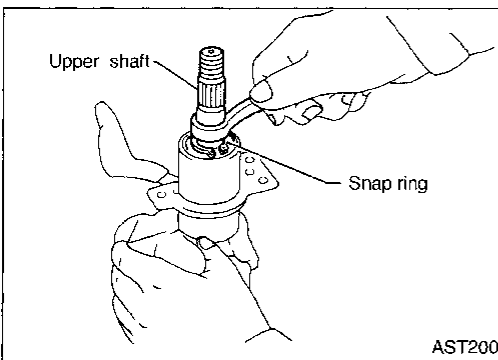

DISASSEMBLY AND ASSEMBLY

- When disassembling and assembling, unlock steering lock with key.
- Remove combination switch.
- Ensure that rounded surface of snap ring faces toward bearing when snap ring is installed.
- Install snap ring on upper shaft with a suitable tool.

GI
MA
EM
LC
EC
FE
CL
MT
AT
FA
RA
BR
ST
RS
BT
HA
EL
IDX

STEERING WHEEL AND STEERING COLUMN

Steering Column (Cont'd)

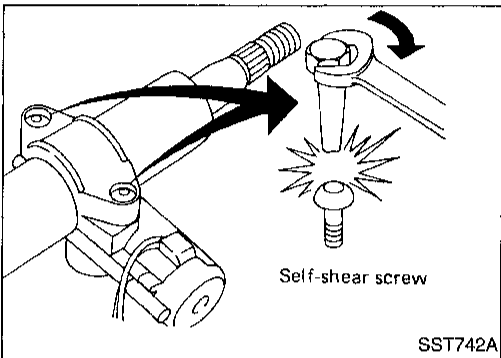
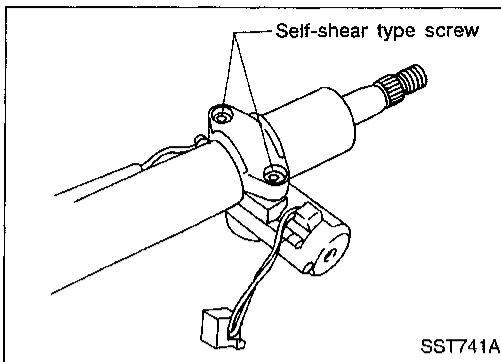

- Steering lock
 - a. Break self-shear type screws with a drill or other appropriate tool.
 - b. Install self-shear type screws, then tighten until screw heads break off.

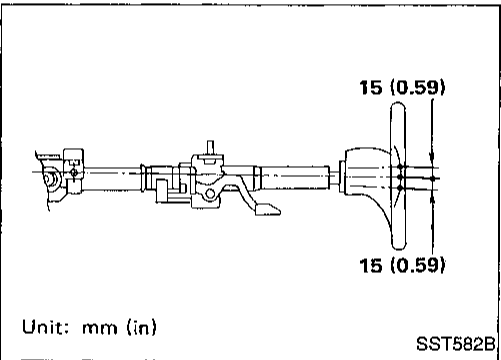

Tilt mechanism

- After installing steering column, check tilt mechanism operation.

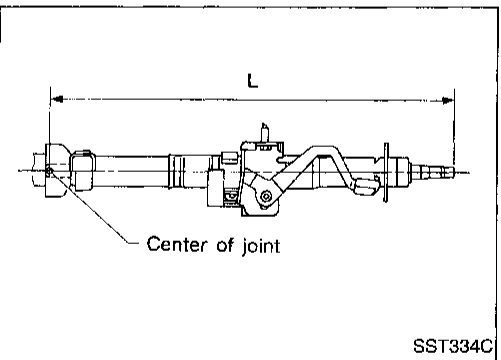

INSPECTION

- When steering wheel does not turn smoothly, check the steering column as follows and replace damaged parts.
 - a. Check column bearings for damage or unevenness. Lubricate with recommended multi-purpose grease or replace steering column as an assembly, if necessary.
 - b. Check jacket tube for deformation or breakage.
- When the vehicle is involved in a light collision, check column length "L". If it is not within specifications, replace steering column as an assembly.

Column length "L":

535.9 - 538.1 mm (21.10 - 21.18 in)

POWER STEERING GEAR AND LINKAGE

Removal and Installation

SEC. 492

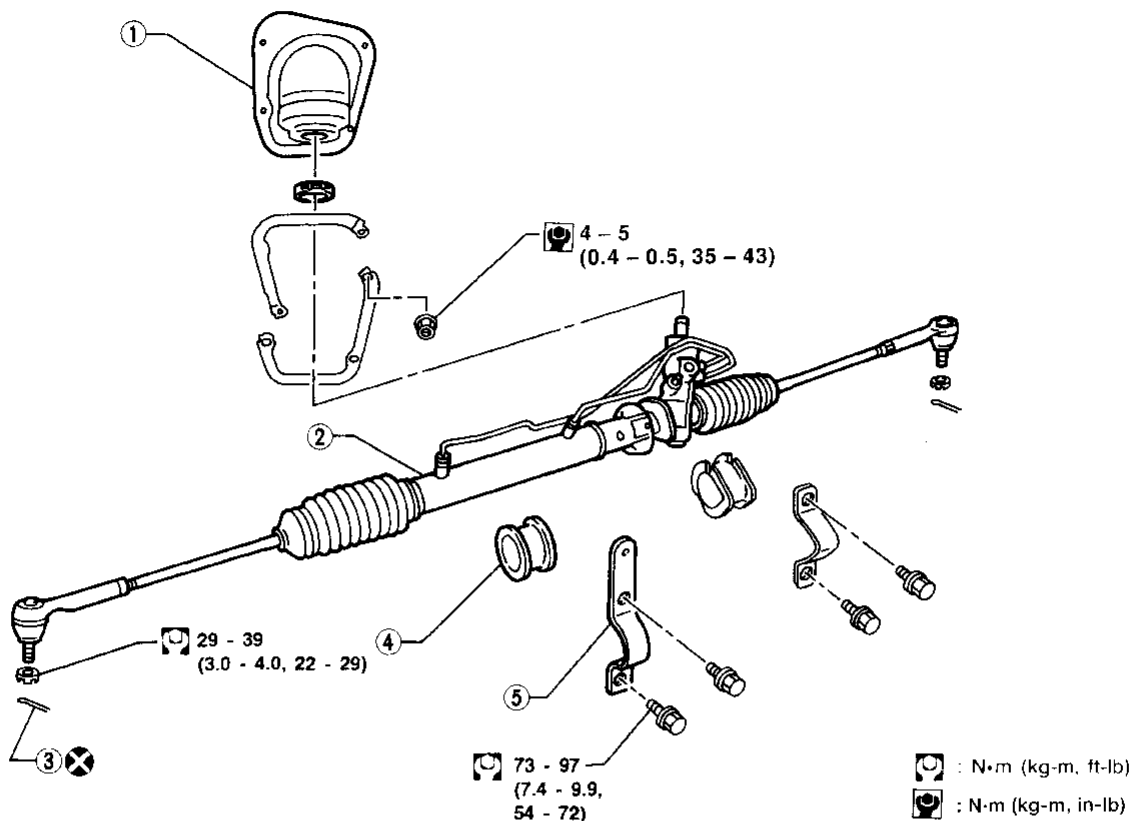

- ① Hole cover
- ② Gear and linkage assembly
- ③ Cotter pin
- ④ Rack mounting insulator
- ⑤ Gear housing mounting bracket

CAUTION:

The rotation of the spiral cable (SRS "Air bag" component part) is limited. If the steering gear must be removed, set the front wheels in the straight-ahead position. Do not rotate the steering column while the steering gear is removed.

- Loosen upper clamp on dust boot in engine compartment.
- Remove lower bolt from coupling joint.
- Detach tie-rod outer sockets from knuckle arms with Tool.

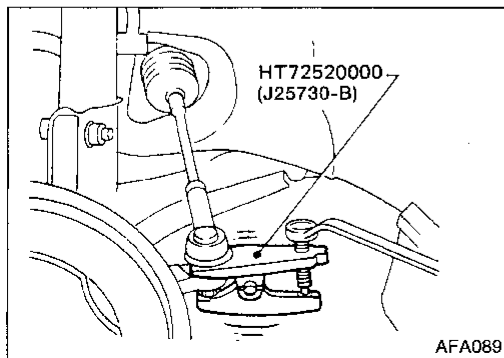

AFA089

CI
MA
EM
LC
EC
FE
CL
MT
AT
FA
RA
BR
ST
RS
BT
HA
EL
IDX

POWER STEERING GEAR AND LINKAGE

Removal and Installation (Cont'd)

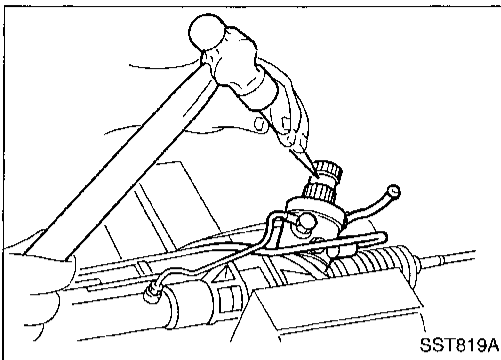

- After removing steering gear from vehicle, mark pinion shaft and pinion housing to record neutral position.
- To install, set left and right dust boots to equal deflection. Align matching marks on pinion shaft and pinion housing.

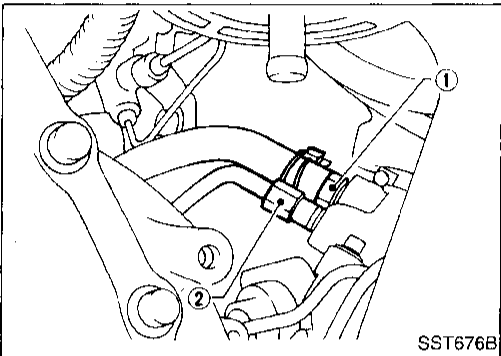

- The O-ring in the low-pressure line ① is larger than that in the high-pressure line ②. Take care to install the proper O-ring.
- Observe specified tightening torque when tightening high-pressure and low-pressure line flare nuts. Excessive tightening can damage threads or O-ring.

Flare nut tightening torque:

Low-pressure side ①

27 - 39 N·m (2.8 - 4.0 kg-m, 20 - 29 ft-lb)

High-pressure side ②

15 - 25 N·m (1.5 - 2.5 kg-m, 11 - 18 ft-lb)

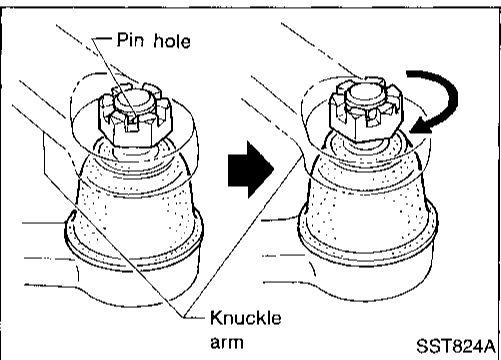

- Initially, tighten nut on tie-rod outer socket and knuckle arm to 29 to 39 N·m (3 to 4 kg-m, 22 to 29 ft-lb). Then tighten further to align nut groove with first pin hole so that cotter pin can be installed.

CAUTION:

Tightening torque must not exceed 49 N·m (5 kg-m, 36 ft-lb).

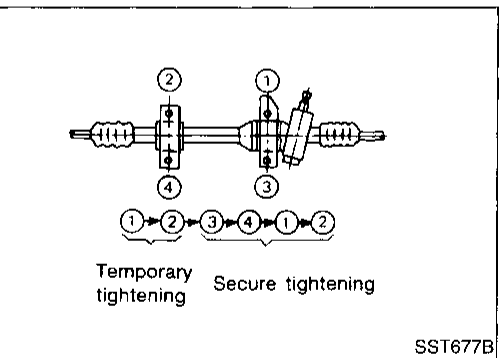

- Tighten gear housing mounting bracket bolts in the order shown.

POWER STEERING GEAR AND LINKAGE

SEC. 492

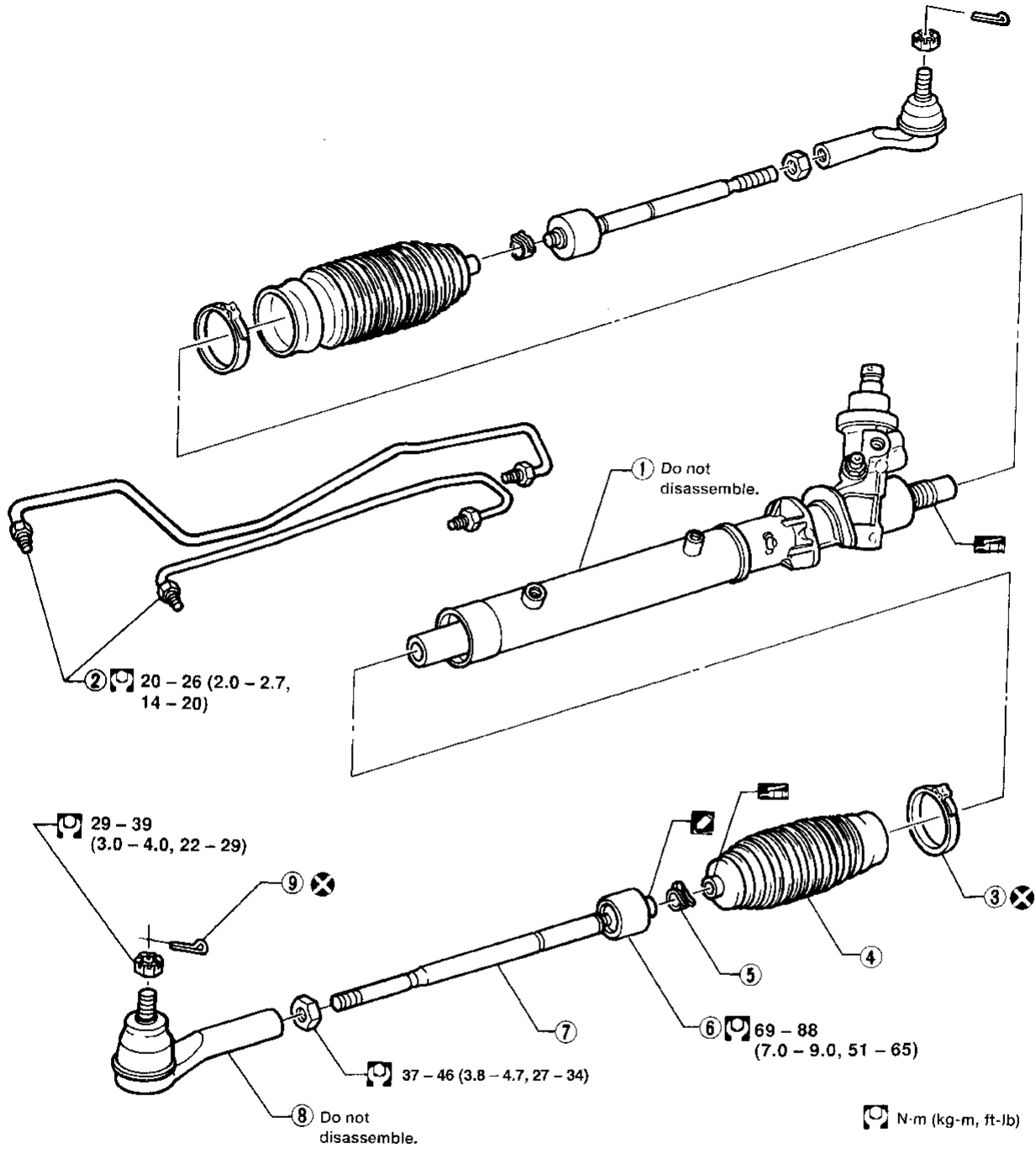

- ① Steering gear
- ② Gear housing tube
- ③ Boot clamp

- ④ Dust boot
- ⑤ Boot band
- ⑥ Tie-rod inner socket

- ⑦ Tie-rod
- ⑧ Tie-rod outer socket
- ⑨ Cotter pin

AST192

GI
MA
EM
LC
EC
FE
CL
MT
AT
FA
RA
BR
ST
RS
BT
HA
EL
IDX

POWER STEERING GEAR AND LINKAGE

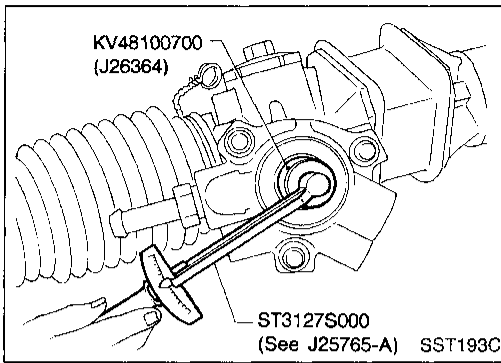

Disassembly

1. Prior to disassembling, measure pinion rotating torque.
Within $\pm 100^\circ$ from the neutral position:
Average rotating torque
0.3 - 1.3 N·m (3 - 13 kg-cm, 2.6 - 11.3 in-lb)
Maximum torque deviation
0.6 N·m (6 kg-cm, 5.2 in-lb)
Except for above measuring range:
Maximum rotating torque
1.9 N·m (19 kg-cm, 16 in-lb)
Maximum force deviation
0.6 N·m (6 kg-cm, 5.2 in-lb)
 - If pinion rotating torque is not within the specifications, replace steering gear assembly.
 - Before measuring, disconnect gear housing tube and drain fluid.
 - Use soft jaws when holding steering gear housing. Handle gear housing carefully, as it is made of aluminum. Do not grip cylinder in a vise.
2. Remove tie-rod outer sockets and boots.
3. Remove tie-rod inner sockets.

Inspection

Thoroughly clean all parts in cleaning solvent or automatic transmission fluid type DEXRONTMIII or equivalent. Blow dry with compressed air, if available.

BOOT

- Check condition of boot. If cracked excessively, replace it.
- Check boots for accumulation of power steering fluid.

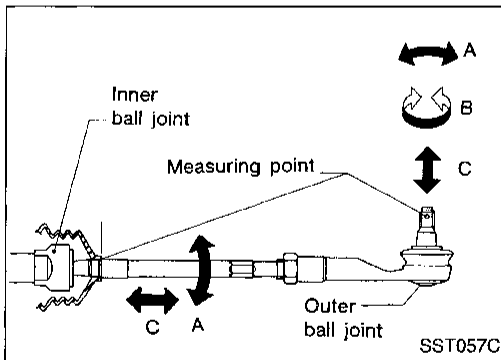

TIE-ROD OUTER AND INNER SOCKETS

- Check outer and inner ball joints for swinging force "A" and axial end play "C".
Refer to SDS, ST-21.
- Check outer ball joint for rotating torque "B".
Refer to SDS, ST-21.
- Check condition of dust cover. If excessively cracked, replace outer tie-rod.

Assembly

1. Install tie-rod inner sockets, dust boots and outer sockets.
Apply locking sealant to inner socket threads.

POWER STEERING GEAR AND LINKAGE

Assembly (Cont'd)

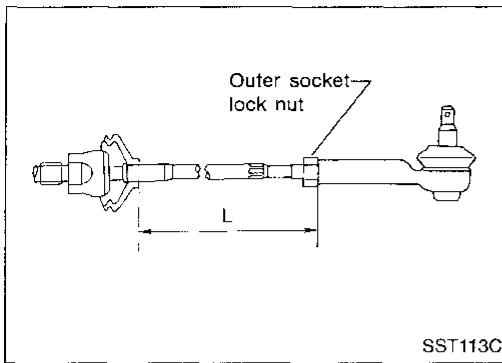

2. Tighten outer socket lock nut.
Tie-rod length "L":
Refer to SDS, ST-21.

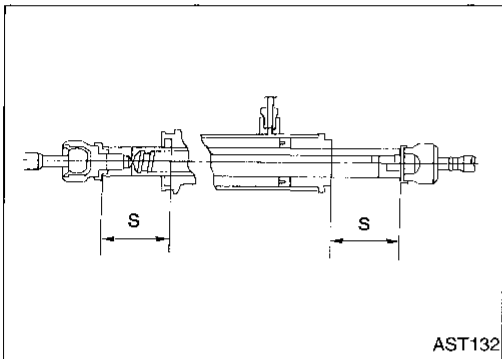

3. Measure rack stroke.
Rack stroke "S":
Refer to SDS, ST-22.

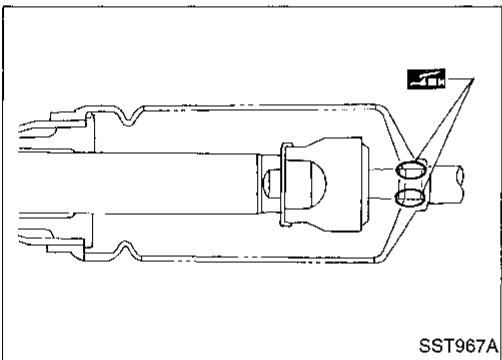

4. Before installing boot, coat the contact surfaces between boot and tie-rod with grease.

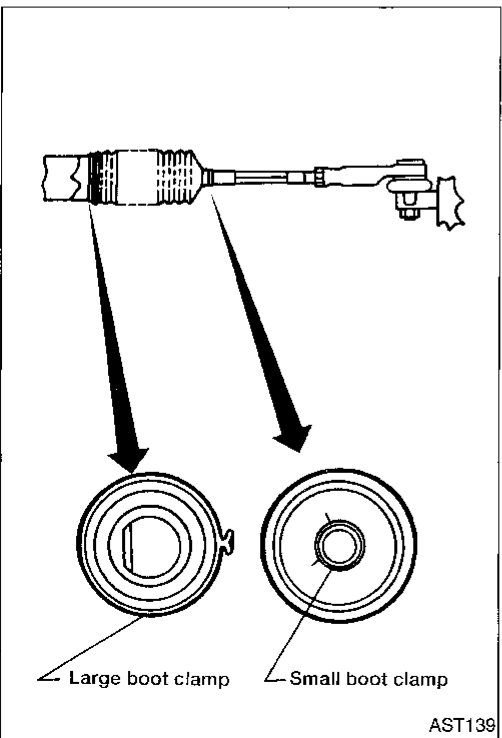

5. Install boot clamps.
 - Install large boot clamp using suitable tool and crimp securely.
 - Install small boot clamp as shown.

GI

MA

EM

LC

EC

FE

CL

MT

AT

FA

RA

BR

ST

RS

BT

HA

EL

IDX

POWER STEERING PUMP

Disassembly

CAUTION:

- Parts which can be disassembled are strictly limited. Never disassemble parts other than those specified.
- Disassemble in as clean a place as possible.
- Clean your hands before disassembly.
- Do not use rags; use nylon cloths or paper towels.
- When disassembling and reassembling, do not let foreign matter enter or contact the parts.

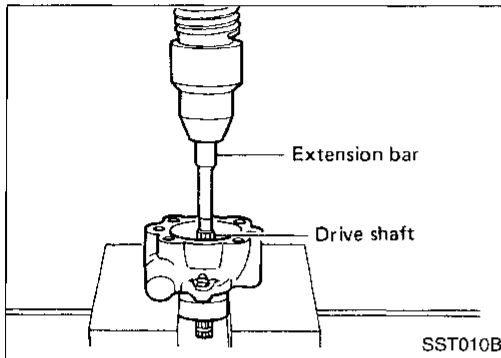

- Remove snap ring, then remove drive shaft.
- Be careful not to drop drive shaft.

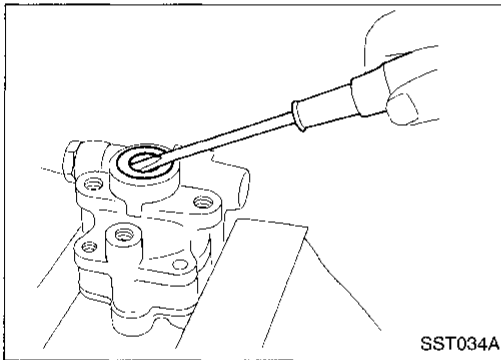

- Remove oil seal.
- Be careful not to damage front housing.

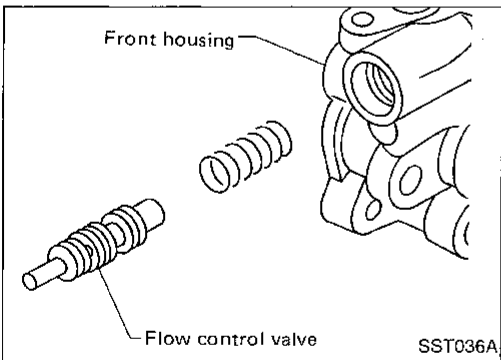

- Remove connector and flow control valve with spring.
- Be careful not to drop flow control valve.

Inspection

- If pulley is cracked or deformed, replace it.
- If an oil leak is found around pulley shaft oil seal, replace the seal.
- If serration on pulley or pulley shaft is deformed or worn, replace it.

POWER STEERING PUMP

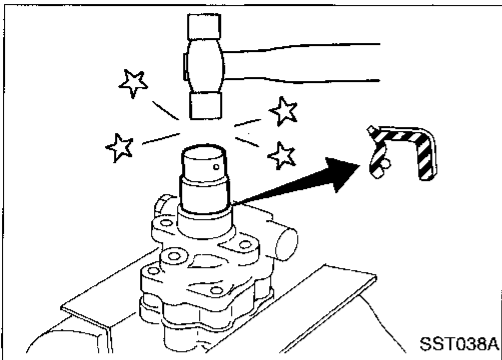

Assembly

Assemble power steering pump, noting the following instructions:

- Make sure O-rings and oil seal are properly installed.
- Always install new O-rings and oil seal.
- Be careful of oil seal direction.
- Cam ring, rotor and vanes must be replaced as a set if necessary.
- Coat each part with ATF when assembling.

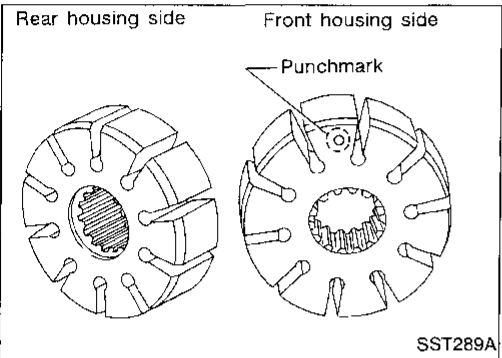

- Pay attention to the direction of rotor.

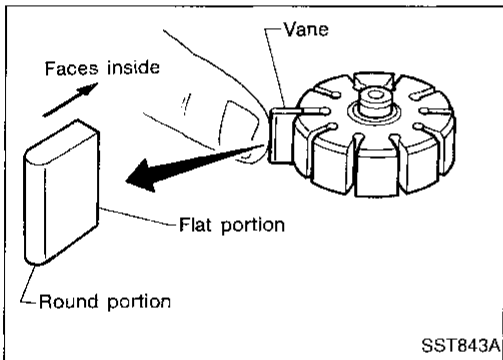

- When assembling vanes to rotor, rounded surfaces of vanes must face cam ring side.

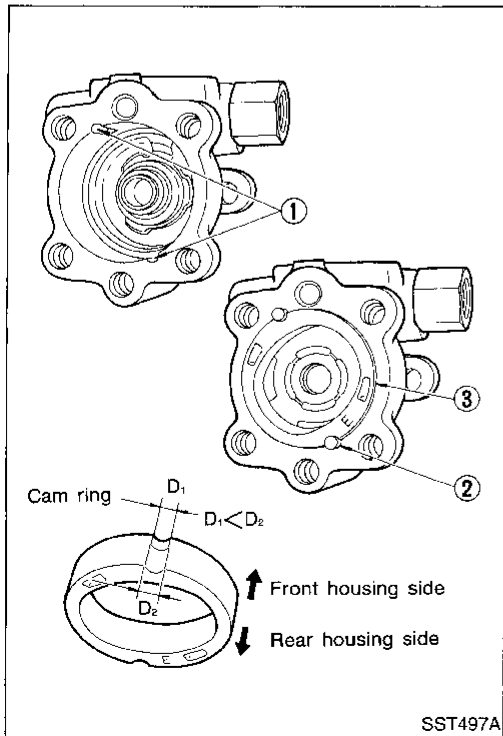

- Insert pin ② into pin groove ① of front housing and front side plate. Then install cam ring ③ as shown at left.

Cam ring:

D_1 is less than D_2

SERVICE DATA AND SPECIFICATIONS (SDS)

General Specifications

Steering model	Power steering
Steering overall gear ratio	17.5
Turns of steering wheel (Lock to lock)	3.02
Steering column type	Collapsible, tilt

GI

MA

EM

Inspection and Adjustment

GENERAL

Steering wheel axial play mm (in)	0 (0)
Steering wheel play limit mm (in)	35 (1.38)
Maximum movement of gear housing mm (in)	±2 (±0.08)

LC

EC

FE

CL

STEERING COLUMN

Steering column length "L" mm (in)	535.9 - 538.1 (21.10 - 21.18)
---------------------------------------	----------------------------------

MT

AT

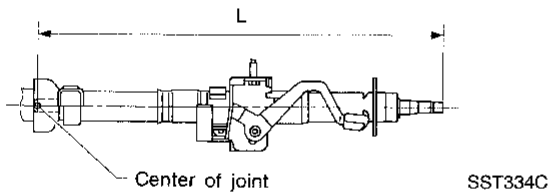

STEERING GEAR AND LINKAGE

Tie-rod outer ball joint	
Swinging force "A" at cotter pin hole N (kg, lb)	6.9 - 64.7 (0.7 - 6.6, 1.5 - 14.6)
Rotating torque "B" N·m (kg-cm, in-lb)	0.3 - 2.9 (3 - 30, 2.6 - 26.0)
Axial end play limit "C" mm (in)	Less than 0.5 (0.020)
Tie-rod inner ball joint	
Swinging force*1 "A" N (kg, lb)	0.2 - 215.8 (0.02 - 22, 0.04 - 48.5)
Axial end play limit "C" mm (in)	0.4 (0.016)
Tie-rod standard length "L" mm (in)	140.6 (5.54)

FA

RA

BR

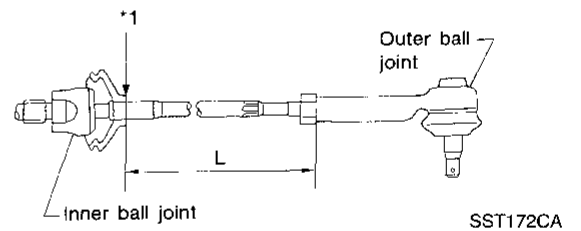

ST

*1: Measuring point of swing force

RS

BT

HA

EL

IDX

SERVICE DATA AND SPECIFICATIONS (SDS)

Inspection and Adjustment (Cont'd)

STEERING GEAR AND LINKAGE (Cont'd)

Rack stroke "S"	mm (in)	65 (2.56)
-----------------	---------	-----------

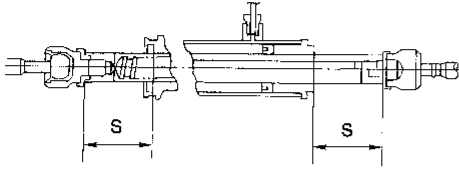

AST132

Pinion gear preload without gear oil	N-m (kg-cm, in-lb)
Within $\pm 100^\circ$ from the neutral position	
Average rotating torque	0.3 - 1.3 (3 - 13, 2.6 - 11.3)
Maximum torque deviation	0.6 (6, 5.2)
Except above range	
Maximum rotating torque	1.9 (19, 16)
Maximum torque deviation	0.6 (6, 5.2)

POWER STEERING

Rack sliding force	N (kg, lb)	
Under normal operating oil pressure		
Range within ± 11.5 mm (± 0.453 in) from the neutral position		108 - 245 (11 - 25, 24 - 55)
Except above range		Not more than 294 (30, 66)
Steering wheel turning force (Measured at one full turn from the neutral position)	N (kg, lb)	39 (4, 9) or less
Fluid capacity (Approximate)	ℓ (US qt, Imp qt)	1 (1-1/8, 7/8)
Power steering pump maximum pressure	kPa (kg/cm ² , psi)	7,649 - 8,238 (78 - 84, 1,109 - 1,194)