

SECTION **AT**

CONTENTS

DIAGNOSTIC TROUBLE CODE INDEX	2	TCM Terminals and Reference Value.....	76
Alphabetical & P No. Index for DTC.....	2	TROUBLE DIAGNOSIS FOR POWER SUPPLY	80
PRECAUTIONS AND PREPARATION	3	Main Power Supply and Ground Circuit.....	80
Precautions For Supplemental Restraint		TROUBLE DIAGNOSIS FOR P0705	81
System (SRS) "AIR BAG"	3	Inhibitor Switch.....	81
Precautions	4	TROUBLE DIAGNOSIS FOR DTC P0710	85
Service Notice or Precautions	5	A/T Fluid Temperature Sensor.....	85
Special Service Tools.....	7	TROUBLE DIAGNOSIS FOR DTC P0720	89
Commercial Service Tools	10	Vehicle Speed Sensor-A/T (Revolution sensor) ...	89
OVERALL SYSTEM	11	TROUBLE DIAGNOSIS FOR DTC P0725	93
Circuit Diagram for Quick Pinpoint Check.....	12	Engine Speed Signal	93
Wiring Diagram –A/T–	13	TROUBLE DIAGNOSIS FOR DTC P0731	96
Cross-sectional View	19	A/T 1st Gear Function	96
Hydraulic Control Circuit.....	20	TROUBLE DIAGNOSIS FOR DTC P0732	102
Shift Mechanism	21	A/T 2nd Gear Function	102
Control System	30	TROUBLE DIAGNOSIS FOR DTC P0733	107
Control Mechanism.....	32	A/T 3rd Gear Function.....	107
Control Valve.....	37	TROUBLE DIAGNOSIS FOR DTC P0734	112
ON BOARD DIAGNOSTIC SYSTEM		A/T 4th Gear Function	112
DESCRIPTION	38	TROUBLE DIAGNOSIS FOR DTC P0740	120
Introduction	38	Torque Converter Clutch Solenoid Valve.....	120
OBD-II Function for A/T System.....	38	TROUBLE DIAGNOSIS FOR DTC P0744	124
One or Two Trip Detection Logic of OBD-II	38	A/T TCC S/V Function (Lock-up).....	124
OBD-II Diagnostic Trouble Code (DTC)	38	TROUBLE DIAGNOSIS FOR DTC P0745	131
Malfunction Indicator Lamp (MIL)	42	Line Pressure Solenoid Valve.....	131
CONSULT	42	TROUBLE DIAGNOSIS FOR DTC P0750	135
Diagnostic Procedure without CONSULT.....	49	Shift Solenoid Valve A.....	135
TROUBLE DIAGNOSIS — Introduction	53	TROUBLE DIAGNOSIS FOR DTC P0755	139
Introduction	53	Shift Solenoid Valve B	139
Diagnostic Worksheet.....	54	TROUBLE DIAGNOSIS FOR DTC P1705	143
Work Flow	57	Throttle Position Sensor	143
TROUBLE DIAGNOSIS — Basic Inspection	58	TROUBLE DIAGNOSIS FOR DTC P1760	150
A/T Fluid Check	58	Overrun Clutch Solenoid Valve.....	150
Stall Test	58	TROUBLE DIAGNOSIS FOR BATT/FLUID	
Line Pressure Test.....	61	TEMP SEN	154
Road Test.....	62	A/T Fluid Temperature Sensor Circuit and	
TROUBLE DIAGNOSIS — General Description ...	73	TCM Power Source	154
Symptom Chart.....	73		

CONTENTS (Cont'd.)

TROUBLE DIAGNOSIS FOR VHCL SPEED

SEN-MTR..... 158

Vehicle Speed Sensor-MTR..... 158

TROUBLE DIAGNOSIS FOR SYMPTOMS 161

1. O/D OFF Indicator Lamp Does Not Come On 161

2. Engine Cannot Be Started In "P" and "N" Position 162

3. In "P" Position, Vehicle Moves Forward or Backward When Pushed 162

4. In "N" Position, Vehicle Moves 163

5. Large Shock. "N" → "R" Position 164

6. Vehicle Does Not Creep Backward In "R" Position 165

7. Vehicle Does Not Creep Forward In "D", "2" or "1" Position 166

8. Vehicle Cannot Be Started From D₁ 167

9. A/T Does Not Shift: D₁ → D₂ or Does Not Kickdown: D₄ → D₂ 168

10. A/T Does Not Shift: D₂ → D₃..... 169

11. A/T Does Not Shift: D₃ → D₄..... 170

12. A/T Does Not Perform Lock-up 171

13. A/T Does Not Hold Lock-up Condition 172

14. Lock-up Is Not Released 172

15. Engine Speed Does Not Return To Idle (Light Braking D₄ → D₃) 173

16. Vehicle Does Not Start From D₁ 174

17. A/T Does Not Shift: D₄ → D₃, When Overdrive Control Switch "ON" → "OFF" 174

18. A/T Does Not Shift: D₃ → 2₂, When Selector Lever "D" → "2" Position..... 175

19. A/T Does Not Shift: 2₂ → 1₁, When Selector Lever "2" → "1" Position 175

20. Vehicle Does Not Decelerate By Engine Brake..... 176

21. TCM Self-diagnosis Does Not Activate (Inhibitor, Overdrive Control and Throttle Position Switch Circuit Checks)..... 176

TROUBLE DIAGNOSES — A/T Shift Lock

System..... 182

Shift Lock System Electrical Parts Location..... 182

Wiring Diagram -SHIFT-..... 183

Diagnostic Procedure..... 184

Key Interlock Cable..... 186

Component Check 188

ON-VEHICLE SERVICE 189

Control Valve Assembly and Accumulator..... 189

Control Cable Adjustment 190

Inhibitor Switch Adjustment..... 190

Differential Side Oil Seal Replacement 191

Revolution Sensor Replacement 191

REMOVAL AND INSTALLATION 192

MAJOR OVERHAUL 195

Locations of Adjusting Shims, Needle Bearings, Thrust Washers and Snap Rings 195

Oil Channel 196

DISASSEMBLY 200

REPAIR FOR COMPONENT PARTS 214

Manual Shaft..... 214

Oil Pump 217

Control Valve Assembly 221

Control Valve Upper Body 230

Control Valve Lower Body 234

Reverse Clutch 236

High Clutch 240

Forward Clutch and Overrun Clutch..... 245

Low & Reverse Brake..... 251

Rear Internal Gear, Forward Clutch Hub and Overrun Clutch Hub 255

Output Shaft, Idler Gear, Reduction Pinion Gear and Bearing Retainer..... 259

Band Servo Piston Assembly 264

Final Drive..... 269

ASSEMBLY 273

Assembly 1 273

Adjustment 1 274

Assembly 2 279

Adjustment 2 283

Assembly 3 287

Assembly 4 289

SERVICE DATA AND SPECIFICATIONS (SDS) ... 294

General Specifications 294

Specifications and Adjustments 294

When you read wiring diagrams:

• Read GI section, "HOW TO READ WIRING DIAGRAMS".

• See EL section, "POWER SUPPLY ROUTING" for power distribution circuit.

When you perform trouble diagnoses, read GI section, "HOW TO FOLLOW FLOW CHART IN TROUBLE DIAGNOSES" and "HOW TO PERFORM EFFICIENT DIAGNOSIS FOR AN ELECTRICAL INCIDENT".

GI

MA

EM

LC

EC

FE

CL

MT

AT

FA

RA

BR

ST

RS

BT

HA

EL

IDX

DIAGNOSTIC TROUBLE CODE INDEX

Alphabetical & P No. Index for DTC

ALPHABETICAL INDEX FOR DTC

Items (CONSULT screen terms)	DTC		Reference page
	ECM*1	CONSULT GST*2	
A/T 1ST GR FNCTN	1103	P0731	AT-96
A/T 2ND GR FNCTN	1104	P0732	AT-102
A/T 3RD GR FNCTN	1105	P0733	AT-107
A/T 4TH GR FNCTN	1106	P0734	AT-112
A/T TCC S/V FNCTN	1107	P0744	AT-124
ENGINE SPEED SIG*4	1207	P0725	AT-93
ATF TEMP SEN/CIRC	1208	P0710	AT-85
INHIBITOR SW/CIRC	1101	P0705	AT-81
L/PRESS SOL/CIRC	1205	P0745	AT-131
O/R CLTCH SOL/CIRC	1203	P1760	AT-150
SFT SOL A/CIRC*3	1108	P0750	AT-135
SFT SOL B/CIRC*3	1201	P0755	AT-139
TP SEN/CIRC A/T*3	1206	P1705	AT-143
TCC SOLENOID/CIRC	1204	P0740	AT-120
VEH SPD SEN/CIR AT*4	1102	P0720	AT-89

P NO. INDEX FOR DTC

DTC		Items (CONSULT screen terms)	Reference page
CONSULT GST*2	ECM*1		
P0705	1101	INHIBITOR SW/CIRC	AT-81
P0710	1208	ATF TEMP SEN/CIRC	AT-85
P0720	1102	VEH SPD SEN/CIR AT*4	AT-89
P0725	1207	ENGINE SPEED SIG*4	AT-93
P0731	1103	A/T 1ST GR FNCTN	AT-96
P0732	1104	A/T 2ND GR FNCTN	AT-102
P0733	1105	A/T 3RD GR FNCTN	AT-107
P0734	1106	A/T 4TH GR FNCTN	AT-112
P0740	1204	TCC SOLENOID/CIRC	AT-120
P0744	1107	A/T TCC S/V FNCTN	AT-124
P0745	1205	L/PRESS SOL/CIRC	AT-131
P0750	1108	SFT SOL A/CIRC*3	AT-135
P0755	1201	SFT SOL B/CIRC*3	AT-139
P1705	1206	TP SEN/CIRC A/T*3	AT-143
P1760	1203	O/R CLTCH SOL/CIRC	AT-150

*1: In Diagnostic Test Mode II (Self-diagnostic results), these numbers are controlled by NISSAN.

*2: These numbers are prescribed by SAE J2012.

*3: When the fail-safe operation occurs, the MIL illuminates.

*4: The MIL illuminates after TCM enters the fail-safe mode in two consecutive trips, if both the "Revolution sensor" and the "Engine speed signal" meet the fail-safe condition at the same time.

Precautions For Supplemental Restraint System (SRS) "AIR BAG"

The Supplemental Restraint System "Air Bag", used along with a seat belt, helps to reduce the risk or severity of injury to the driver and front passenger in a frontal collision. The Supplemental Restraint System consists of air bag modules (located in the center of the steering wheel and in the instrument panel on the passenger side), a diagnosis sensor unit, warning lamp, wiring harness and spiral cable. Information necessary to service the system safely is included in the **RS section** of this Service Manual.

WARNING:

- To avoid rendering the SRS inoperative, which could increase the risk of personal injury or death in the event of a collision which would result in air bag inflation, all maintenance should be performed by an authorized NISSAN dealer.
- Improper maintenance, including incorrect removal and installation of the SRS, can lead to personal injury caused by unintentional activation of the system.
- Do not use electrical test equipment on any circuit related to the SRS unless instructed to in this Service Manual. SRS wiring harnesses are covered with yellow insulation either just before the harness connectors or on the complete harness, for easy identification.

GI
MA
EM
LC
EC
FE
CL
MT
AT
FA
RA
BR
ST
RS
BT
HA
EL
IDX

PRECAUTIONS AND PREPARATION

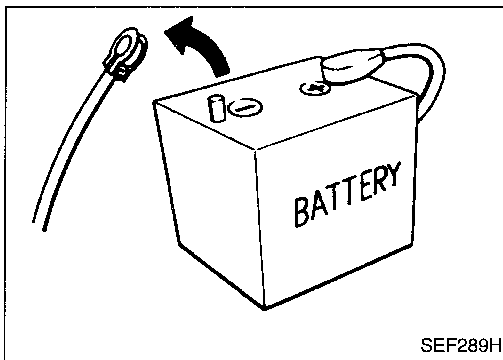

Precautions

- Before connecting or disconnecting the TCM harness connector, turn ignition switch OFF and disconnect negative battery terminal. Failure to do so may damage the TCM. Because battery voltage is applied to TCM even if ignition switch is turned off.

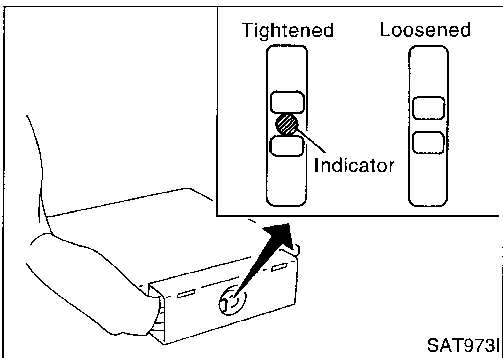

- When connecting TCM harness connector, tighten securing bolt until the orange indicator appears.
☞: 3.0 - 5.0 N-m (0.3 - 0.5 kg-m, 26 - 43 in-lb)

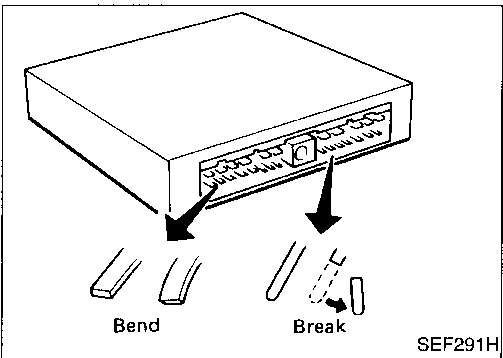

- When connecting or disconnecting pin connectors into or from TCM, take care not to damage pin terminals (bend or break).
Make sure that there are not any bends or breaks on TCM pin terminal, when connecting pin connectors.

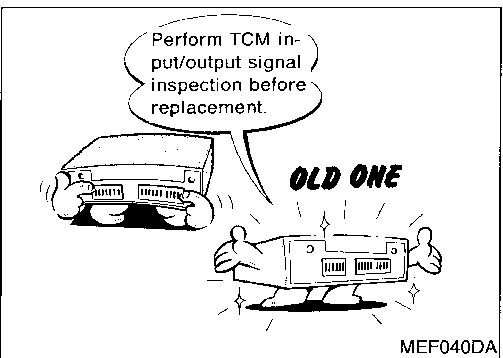

- Before replacing TCM, perform TCM input/output signal inspection and make sure whether TCM functions properly or not. (See page AT-76.)

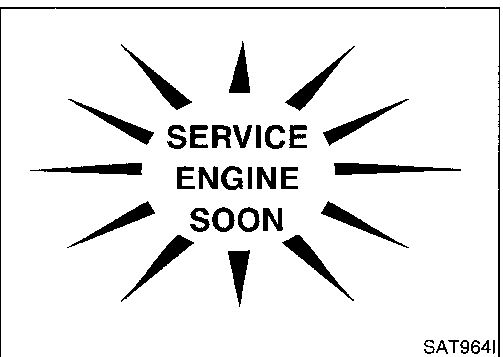

- After performing each TROUBLE DIAGNOSIS, perform "DTC (Diagnostic Trouble Code) CONFIRMATION PROCEDURE".
The DTC should not be displayed in the "DTC CONFIRMATION PROCEDURE" if the repair is completed.

PRECAUTIONS AND PREPARATION

Precautions (Cont'd)

- Before proceeding with disassembly, thoroughly clean the outside of the transaxle. It is important to prevent the internal parts from becoming contaminated by dirt or other foreign matter.
 - Disassembly should be done in a clean work area.
 - Use lint-free cloth or towels for wiping parts clean. Common shop rags can leave fibers that could interfere with the operation of the transaxle.
 - Place disassembled parts in order for easier and proper assembly.
 - All parts should be carefully cleaned with a general purpose, non-flammable solvent before inspection or reassembly.
 - Gaskets, seals and O-rings should be replaced any time the transaxle is disassembled.
 - It is very important to perform functional tests whenever they are indicated.
 - The valve body contains precision parts and requires extreme care when parts are removed and serviced. Place disassembled valve body parts in order for easier and proper assembly. Care will also prevent springs and small parts from becoming scattered or lost.
 - Properly installed valves, sleeves, plugs, etc. will slide along bores in valve body under their own weight.
 - Before assembly, apply a coat of recommended ATF to all parts. Apply petroleum jelly to protect O-rings and seals, or hold bearings and washers in place during assembly. Do not use grease.
 - Extreme care should be taken to avoid damage to O-rings, seals and gaskets when assembling.
 - Replace ATF cooler if excessive foreign material is found in oil pan or clogging strainer. Refer to "ATF COOLER SERVICE" (Refer to AT-6).
 - After overhaul, refill the transmission with new ATF.
 - When the A/T drain plug is removed, only some of the fluid is drained. Old A/T fluid will remain in torque converter and ATF cooling system.
- Always follow the procedures under "Changing A/T Fluid" in the MA section when changing A/T fluid.

GI

MA

EM

LC

EC

FE

CL

MT

Service Notice or Precautions

FAIL-SAFE

The TCM has an electronic Fail-Safe (limp home mode). This allows the vehicle to be driven even if a major electrical input/output device circuit is damaged.

Under Fail-Safe, the vehicle always runs in third gear, even with a shift lever position of "1", "2" or "D". The customer may complain of sluggish or poor acceleration.

When the ignition key is turned "ON" following Fail-Safe operation, O/D OFF indicator lamp blinks for about 8 seconds. (For "TCM SELF-DIAGNOSTIC PROCEDURE (No Tools)", refer to AT-49.)

Fail-Safe may occur without electrical circuit damage if the vehicle is driven under extreme conditions (such as excessive wheel spin followed by sudden braking). To recover normal shift pattern, turn the ignition key "OFF" for 5 seconds, then "ON".

The blinking of the O/D OFF indicator lamp for about 8 seconds will appear only once and be cleared. The customer may resume normal driving conditions.

Always follow the "WORK FLOW" (Refer to AT-57).

The SELF-DIAGNOSIS results will be as follows:

The first SELF-DIAGNOSIS will indicate damage to the vehicle speed sensor or the revolution sensor.

During the next SELF-DIAGNOSIS, performed after checking the sensor, no damages will be indicated.

TORQUE CONVERTER SERVICE

The torque converter should be replaced under any of the following conditions:

- External leaks in the hub weld area.
- Converter hub is scored or damaged.
- Converter pilot is broken, damaged or fits poorly into crankshaft.
- Steel particles are found after flushing the cooler and cooler lines.
- Pump is damaged or steel particles are found in the converter.
- Vehicle has TCC shudder and/or no TCC apply. Replace only after all hydraulic and electrical diagnoses have been made. (Converter clutch material may be glazed.)
- Converter is contaminated with engine coolant containing antifreeze.
- Internal failure of stator roller clutch.
- Heavy clutch debris due to overheating (blue converter).

AT

FA

RA

BR

ST

RS

BT

HA

EL

IDX

PRECAUTIONS AND PREPARATION

Service Notice or Precautions (Cont'd)

- Steel particles or clutch lining material found in fluid filter or on magnet when no internal parts in unit are worn or damaged — indicates that lining material came from converter.

The torque converter should not be replaced if:

- The oil has an odor, is discolored, and there is no evidence of metal or clutch facing particles.
- The threads in one or more of the converter bolt holes are damaged.
- Transaxle failure did not display evidence of damaged or worn internal parts, steel particles or clutch plate lining material in unit and inside the fluid filter.
- Vehicle has been exposed to high mileage (only). The exception may be where the torque converter clutch dampener plate lining has seen excess wear by vehicles operated in heavy and/or constant traffic, such as taxi, delivery or police use.

ATF COOLER SERVICE

Replace ATF cooler if excessive foreign material is found in oil pan or clogging strainer.

Replace radiator lower tank (which includes ATF cooler) with a new one and flush cooler line using cleaning solvent and compressed air.

OBD-II SELF-DIAGNOSIS

- A/T self-diagnosis is performed by the TCM in combination with the ECM. The results can be read through the blinking pattern of the O/D OFF indicator or the malfunction indicator lamp (MIL). Refer to the table on AT-43 for the indicator used to display each self-diagnostic result.
- The self-diagnostic results indicated by the MIL are automatically stored in both the ECM and TCM memories.

Always perform the procedure “HOW TO ERASE DTC” on AT-40 to complete the repair and avoid unnecessary blinking of the MIL.

- The following self-diagnostic items can be detected using ECM self-diagnostic results mode* only when the O/D OFF indicator lamp does not indicate any malfunctions.
 - Inhibitor switch
 - A/T 1st, 2nd, 3rd, or 4th gear function
 - A/T TCC S/V function (lock-up).

*: For details of OBD-II, refer to EC section (“ON BOARD DIAGNOSTIC SYSTEM DESCRIPTION”).

PRECAUTIONS AND PREPARATION

Special Service Tools

The actual shapes of Kent-Moore tools may differ from those of special service tools illustrated here.

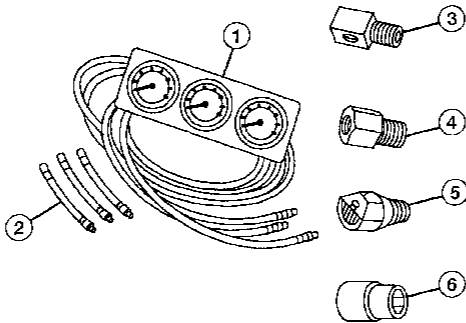
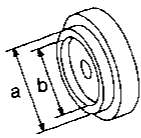
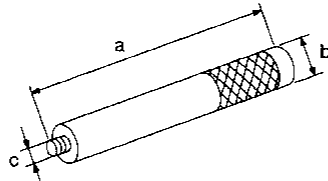
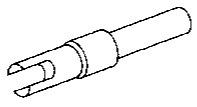
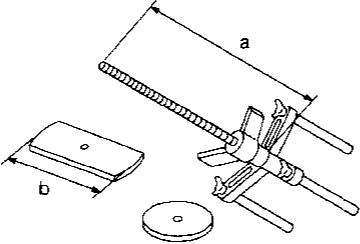
Tool number (Kent-Moore No.) Tool name	Description
(J34301-C) Oil pressure gauge set ① (J34301-1) Oil pressure gauge ② (J34301-2) Hoses ③ (J34298) Adapter ④ (J34282-2) Adapter ⑤ (790-301-1230-A) 60° Adapter ⑥ (J34301-15) Square socket	 <p style="text-align: center;">AAT896</p> <p style="text-align: right;">Measuring line pressure and governor pressure</p>
KV31103000 (J38982) Drift	 <p style="text-align: center;">NT105</p> <p style="text-align: right;">Installing differential oil seal (Use with ST35325000.)</p> <p style="text-align: right;">a: 59 mm (2.32 in) dia. b: 49 mm (1.93 in) dia.</p>
ST35325000 (—) Drift	 <p style="text-align: center;">NT417</p> <p style="text-align: right;">Installing differential oil seal (Use with KV31103000.)</p> <p style="text-align: right;">a: 215 mm (8.46 in) b: 25 mm (0.98 in) dia. c: M12 x 1.5P</p>
KV38107700 (J39027) Preload adapter	 <p style="text-align: center;">NT087</p> <ul style="list-style-type: none"> ● Measuring turning torque of final drive assembly ● Measuring clearance between side gear and differential case with washer ● Selecting differential side bearing adjusting shim
KV31103200 (J34285-A and J34285-87) Clutch spring compressor	 <p style="text-align: center;">NT423</p> <p style="text-align: right;">Removing and installing clutch return spring</p> <p style="text-align: right;">a: 320 mm (12.60 in) b: 174 mm (6.85 in)</p>

GI

MA

EM

LC

EC

FE

CL

MT

AT

FA

RA

BR

ST

RS

BT



HA

EL

IDX

PRECAUTIONS AND PREPARATION

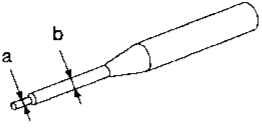
Special Service Tools (Cont'd)

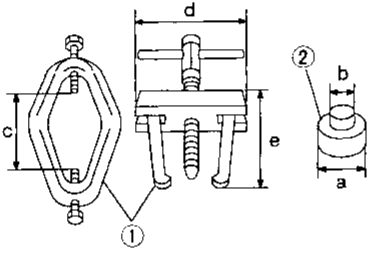
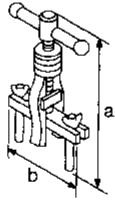
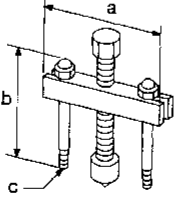
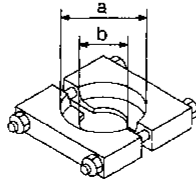
Tool number (Kent-Moore No.) Tool name	Description	
ST23540000 (J25689-A) Pin punch		Removing and installing parking rod plate, manual plate and differential pinion mate shaft retaining pins a: 2.3 mm (0.091 in) dia. b: 4 mm (0.16 in) dia.
KV32101000 (J25689-A) Pin punch		Installing throttle lever and manual shaft retaining pins a: 4 mm (0.16 in) dia.
ST25710000 (—) Pin punch		Aligning groove of manual shaft and hole of transmission case a: 2 mm (0.08 in) dia.
ST3306S001 (J22888-D) Differential side bearing puller set ① ST33051001 (J22888-D) Puller ② ST33061000 (J8107-2) Adapter		Removing differential side bearing inner race a: 39 mm (1.54 in) dia. b: 29.5 mm (1.161 in) dia. c: 130 mm (5.12 in) d: 135 mm (5.31 in) e: 120 mm (4.72 in)
KV381054S0 (J34286) Puller		<ul style="list-style-type: none"> ● Removing idler gear bearing outer race ● Removing differential side oil seals ● Removing differential side bearing outer race ● Removing needle bearing from bearing retainer a: 250 mm (9.84 in) b: 160 mm (6.30 in)
ST27180001 (J25726-A) Puller		<ul style="list-style-type: none"> ● Removing idler gear a: 100 mm (3.94 in) b: 110 mm (4.33 in) c: M8 x 1.25P
ST30031000 (J22912-1) Puller		Removing reduction gear bearing inner race a: 90 mm (3.54 in) dia. b: 50 mm (1.97 in) dia.

PRECAUTIONS AND PREPARATION

Special Service Tools (Cont'd)

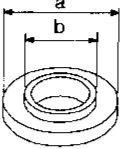
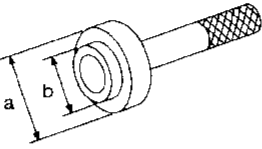
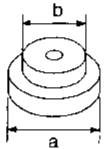
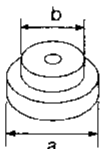
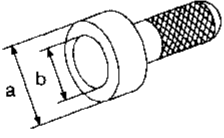
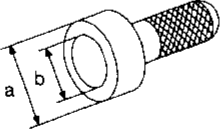
Tool number (Kent-Moore No.) Tool name	Description	
ST35272000 (J26092) Drift		<ul style="list-style-type: none"> ● Installing reduction gear bearing inner race ● Installing idler gear bearing inner race <p>a: 72 mm (2.83 in) dia. b: 35.5 mm (1.398 in) dia.</p>
ST37830000 (—) Drift		<p>Installing idler gear bearing outer race</p> <p>a: 62 mm (2.44 in) dia. b: 39 mm (1.54 in) dia.</p>
ST35321000 (—) Drift		<p>Installing output shaft bearing</p> <p>a: 49 mm (1.93 in) dia. b: 41 mm (1.61 in) dia.</p>
ST30633000 (—) Drift		<p>Installing differential side bearing outer race</p> <p>a: 67 mm (2.64 in) dia. b: 49 mm (1.93 in) dia.</p>
ST35271000 (J26091) Drift		<ul style="list-style-type: none"> ● Installing idler gear <p>a: 72 mm (2.83 in) dia. b: 63 mm (2.48 in) dia.</p>
ST33400001 (J26082) Drift		<ul style="list-style-type: none"> ● Installing oil pump housing oil seal <p>a: 60 mm (2.36 in) dia. b: 47 mm (1.85 in) dia.</p>

GI

MA

EM

LC

EC

FE

CL

MT

AT

FA

RA

BR

ST

RS

BT

HA

EL

IDX

PRECAUTIONS AND PREPARATION

Commercial Service Tools

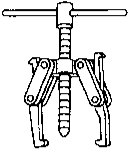
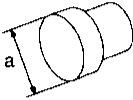
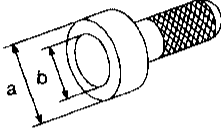
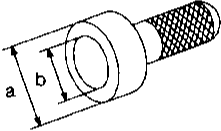
Tool name	Description
Puller	<div style="display: flex; align-items: center; justify-content: center;">  <ul style="list-style-type: none"> ● Removing idler gear bearing inner race ● Removing and installing band servo piston snap ring </div> <p>NT077</p>
Drift	<div style="display: flex; align-items: center; justify-content: center;">  <p>Removing idler gear bearing inner race</p> </div> <p>NT109</p> <p>a: 34 mm (1.34 in) dia.</p>
Drift	<div style="display: flex; align-items: center; justify-content: center;">  <p>Installing differential left side bearing</p> </div> <p>NT115</p> <p>a: 86 mm (3.39 in) dia. b: 80 mm (3.15 in) dia.</p>
Drift	<div style="display: flex; align-items: center; justify-content: center;">  <p>Installing differential right side bearing</p> </div> <p>NT115</p> <p>a: 46 mm (1.81 in) dia. b: 40 mm (1.57 in) dia.</p>

OVERALL SYSTEM

A/T Electrical Parts Location

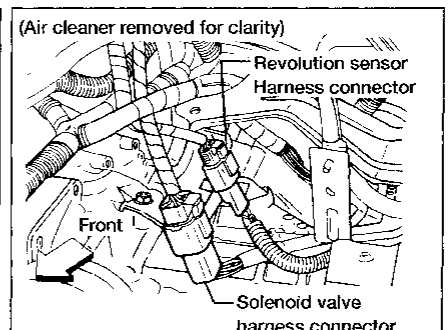
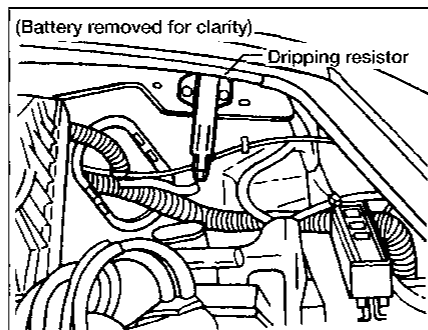
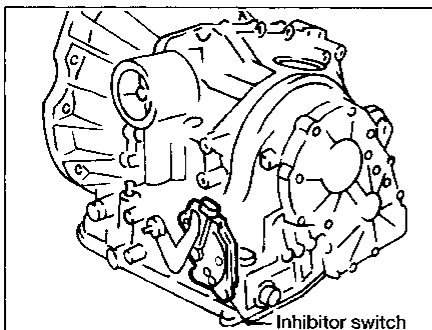
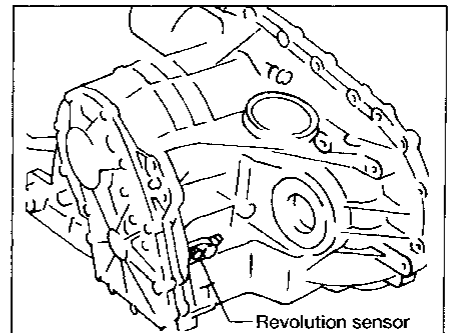
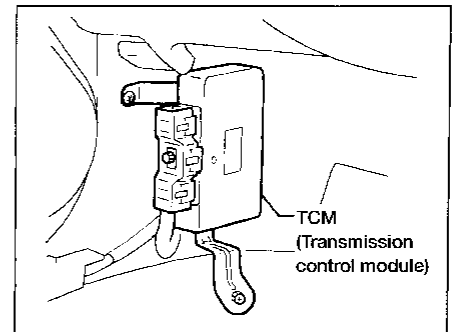
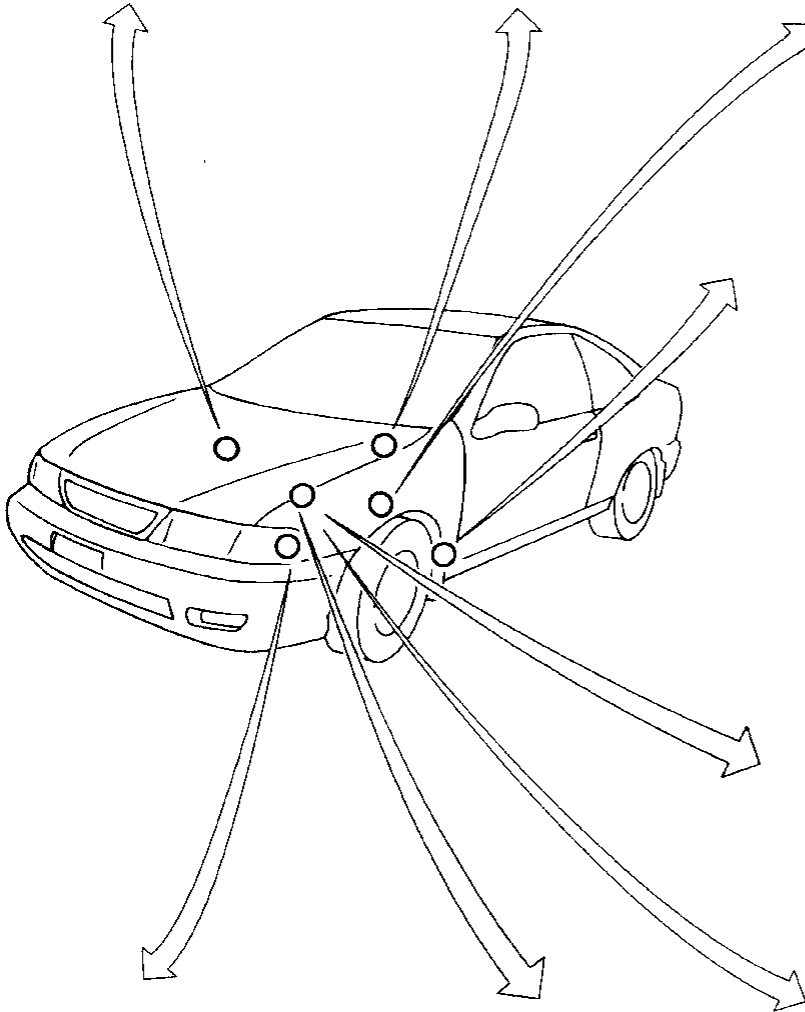
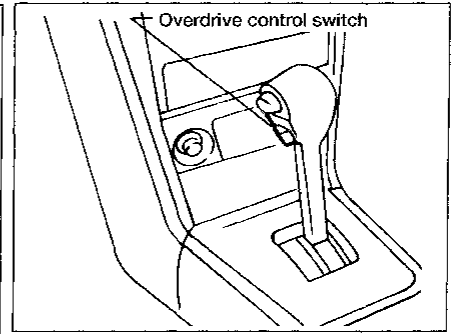
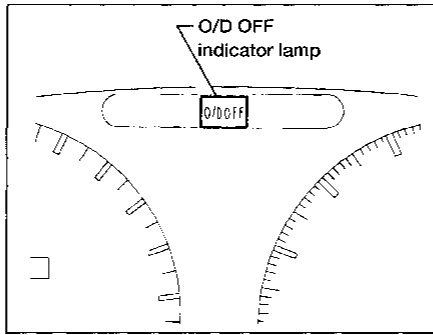
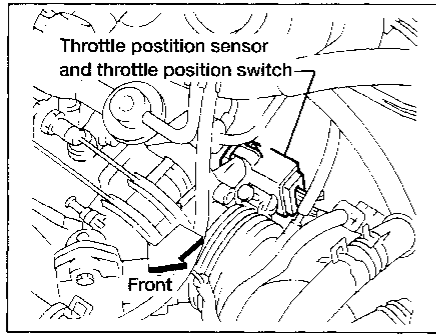

GI

MA

EM

LC

EC

FE

CL

MT

AT

FA

RA

BR

ST

RS

BT

HA

EL

IDX

OVERALL SYSTEM

Circuit Diagram for Quick Pinpoint Check

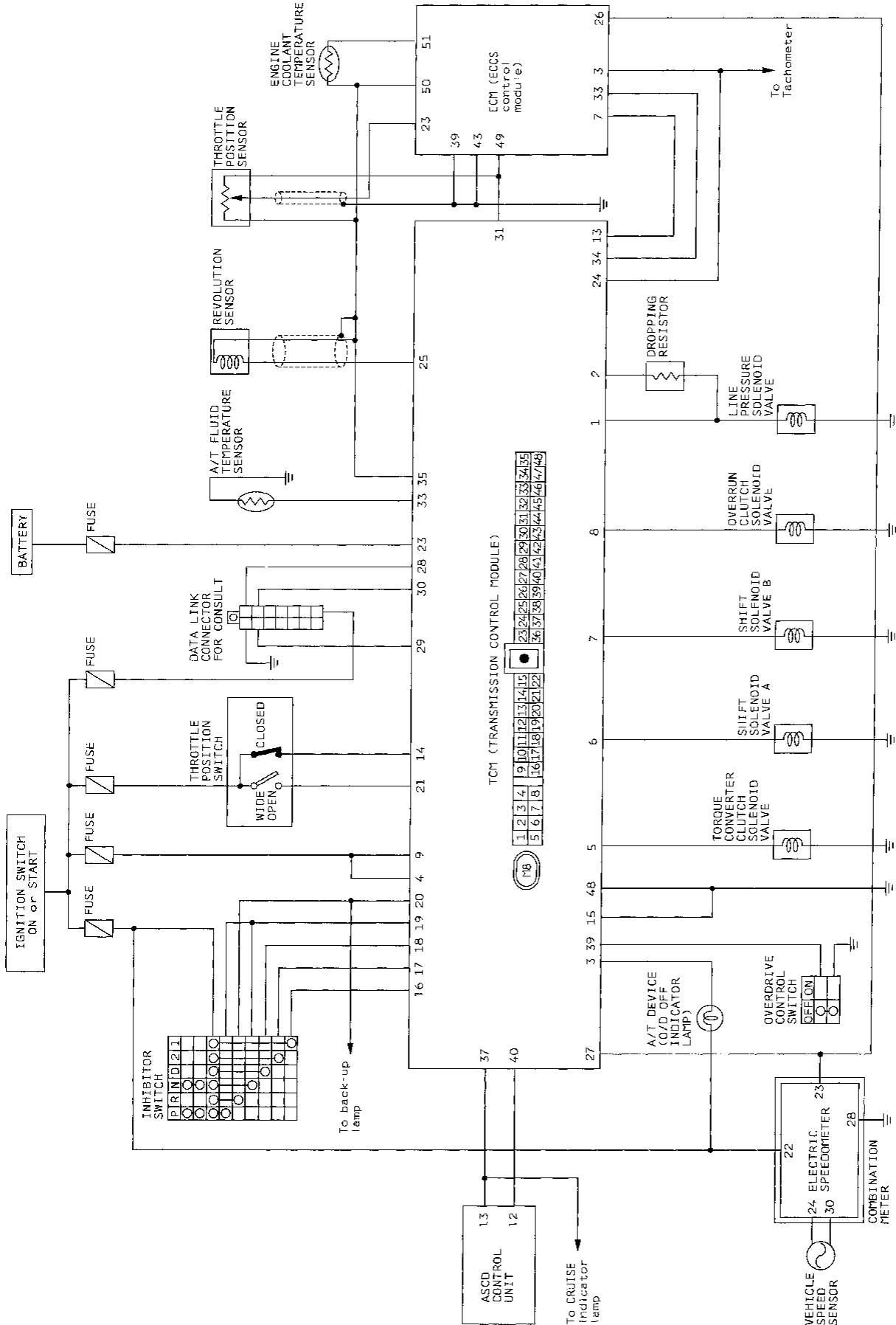

OVERALL SYSTEM

Wiring Diagram -A/T-

AT-A/T-01 CI

MA

EM

LC

EC

FE

CL

MT

AT

FA

RA

BR

ST

RS

BT

HA

EL

IDX

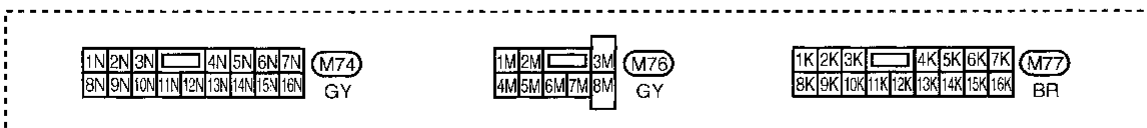
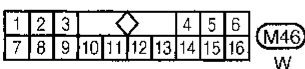
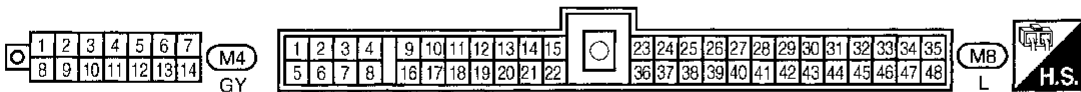
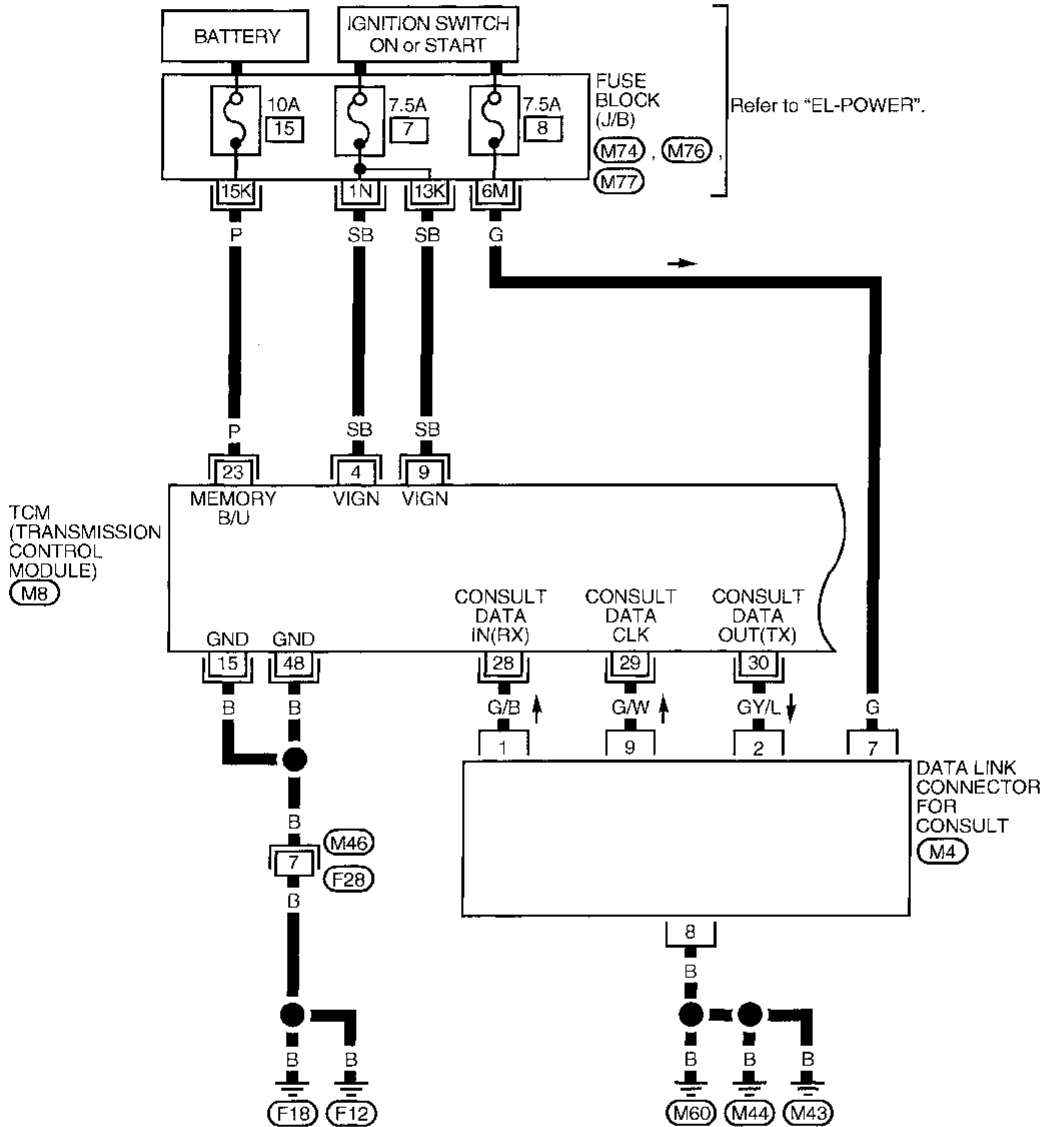

AAT167A

OVERALL SYSTEM

Wiring Diagram -A/T- (Cont'd)

AT-A/T-02

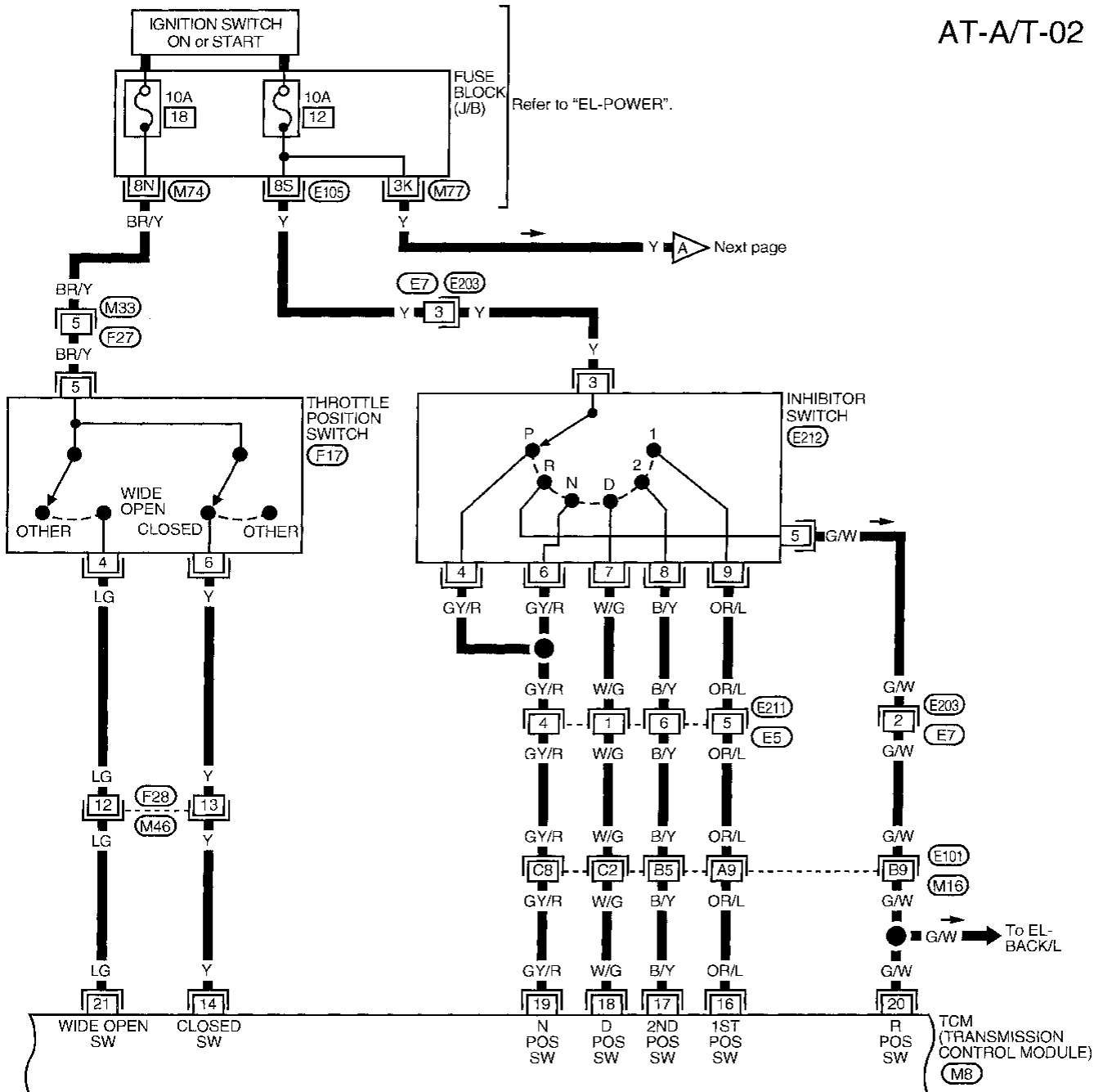

Refer to last page (Foldout page).

(M16) (E101)

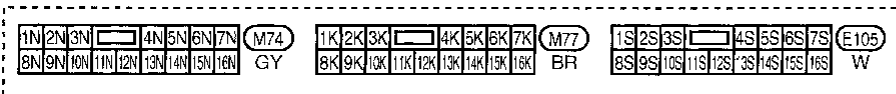
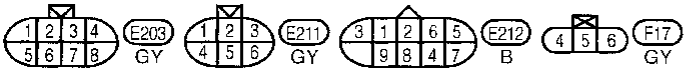
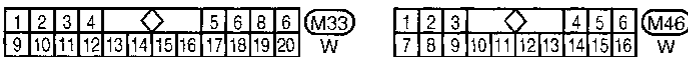
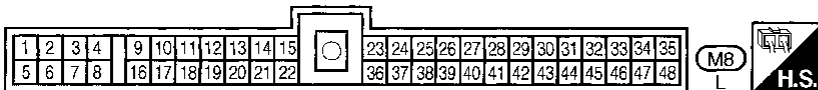

OVERALL SYSTEM

Wiring Diagram -A/T- (Cont'd)

AT-A/T-03

GI

MA

EM

LC

EC

FE

CL

MT

AT

FA

RA

BR

ST

RS

BT

HA

EL

IDX

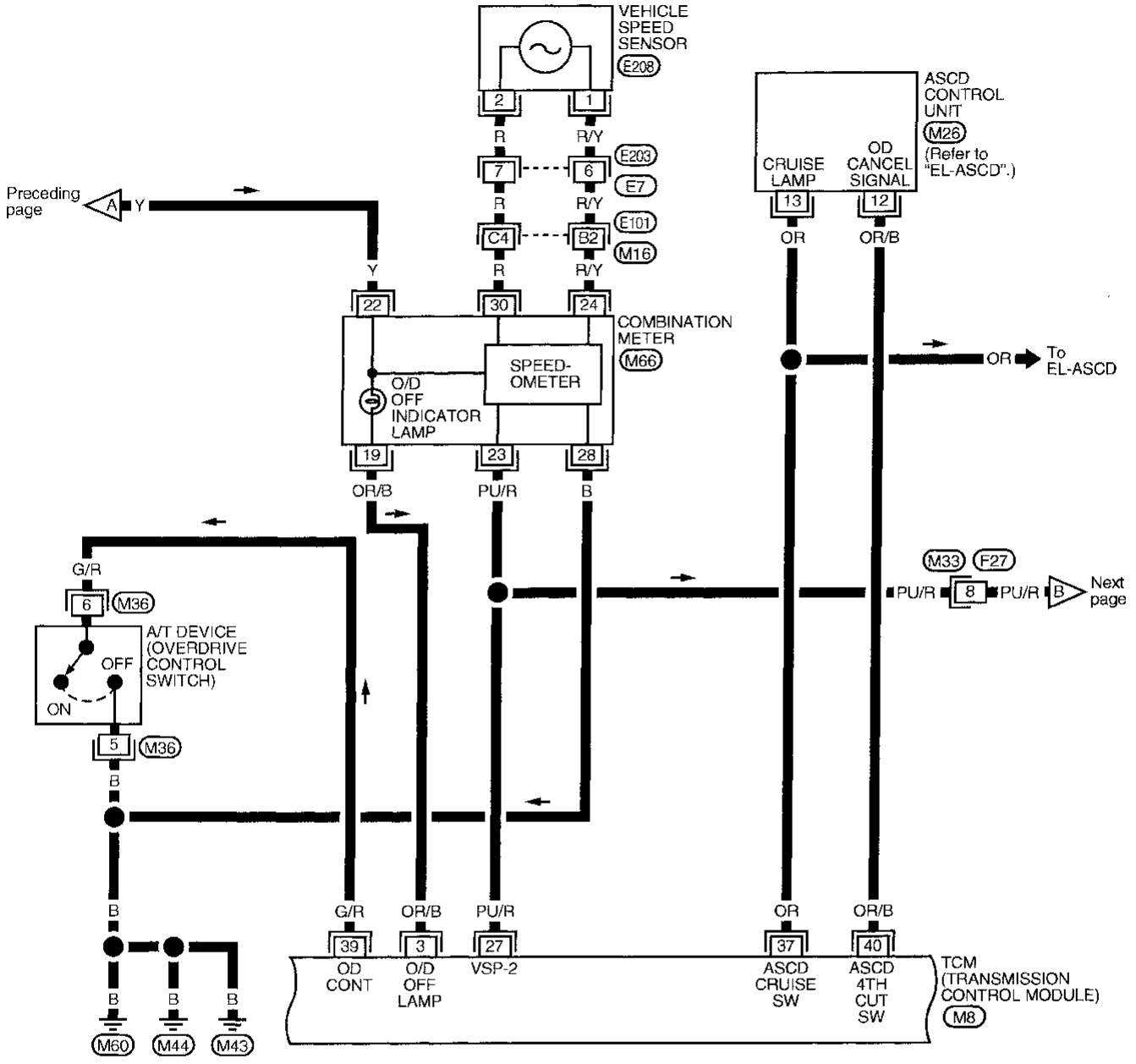

Refer to last page (Foldout page).
 (M16), (E101)

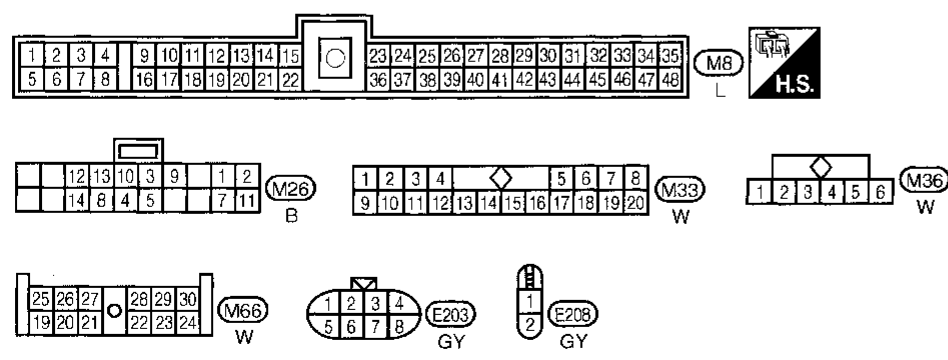

OVERALL SYSTEM

Wiring Diagram -A/T- (Cont'd)

AT-A/T-04

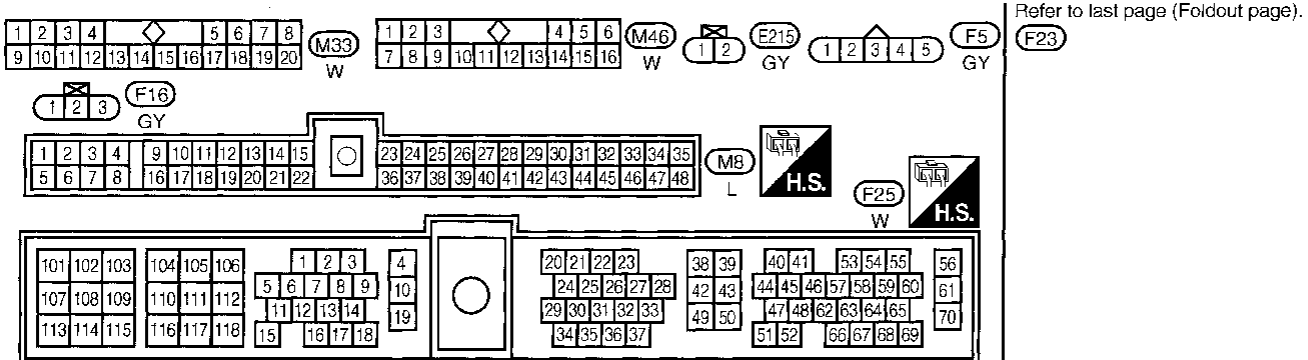
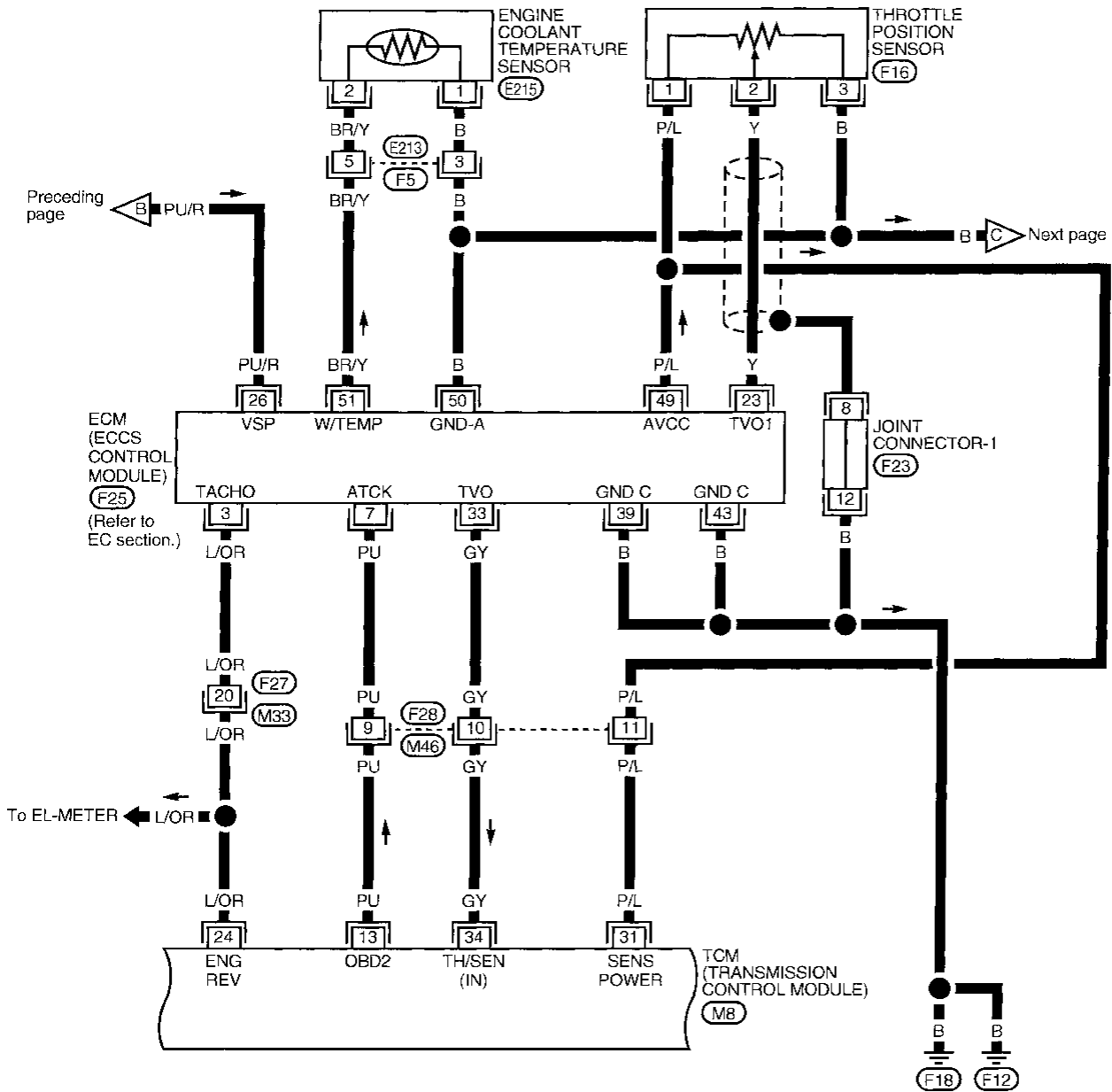

Refer to last page (Foldout page).

OVERALL SYSTEM

Wiring Diagram -A/T- (Cont'd)

AT-A/T-05

GI

MA

EM

LC

EC

FE

CL

MT

AT

FA

RA

BR

ST

RS

BT

HA

EL

IDX

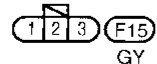
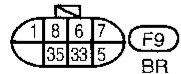
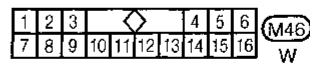
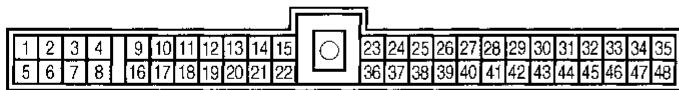
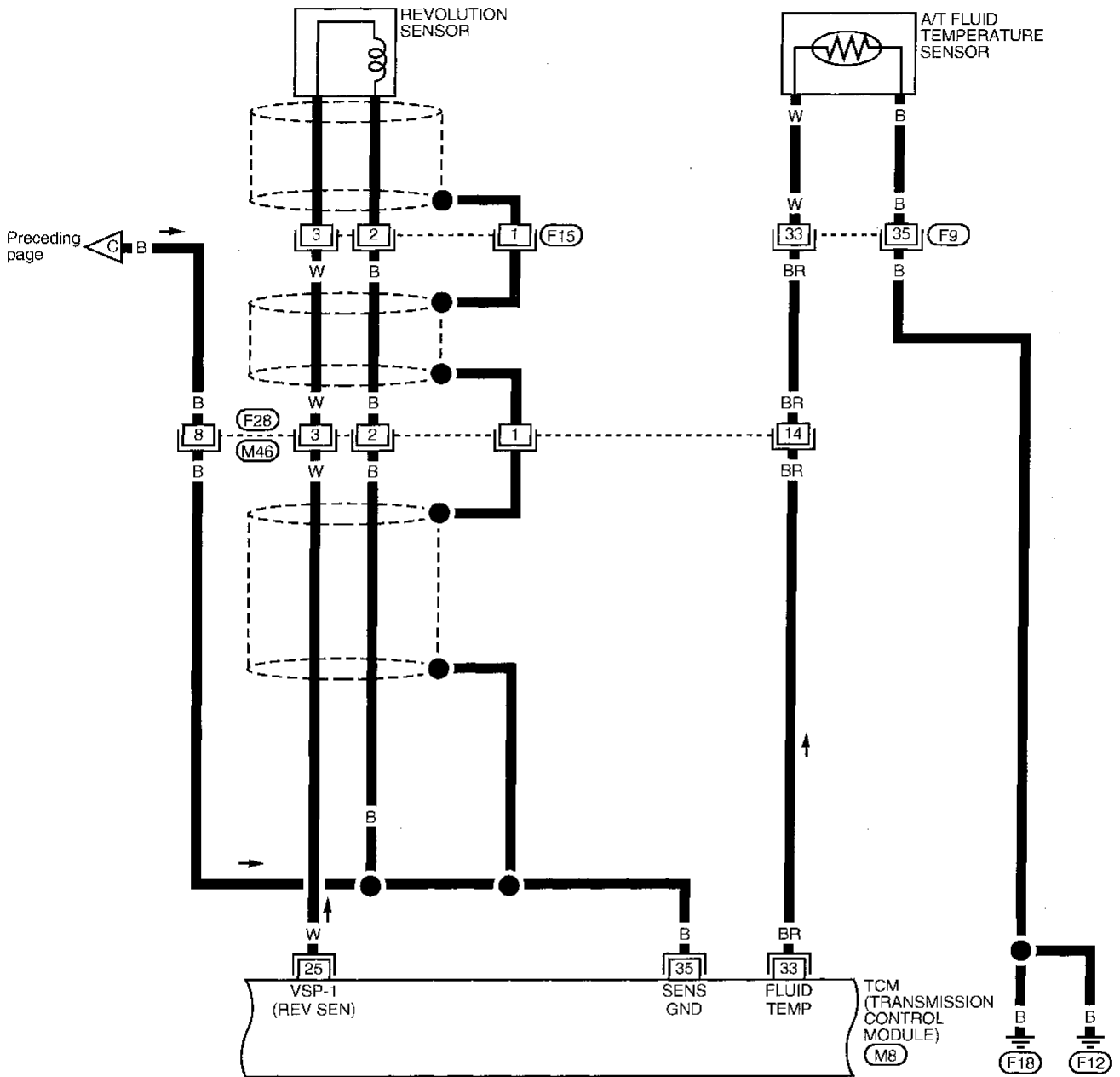

OVERALL SYSTEM

Wiring Diagram -A/T- (Cont'd)

AT-A/T-06

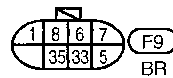
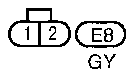
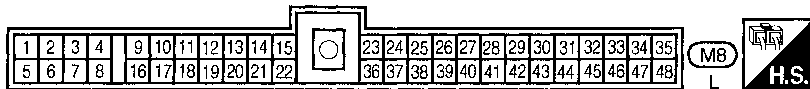
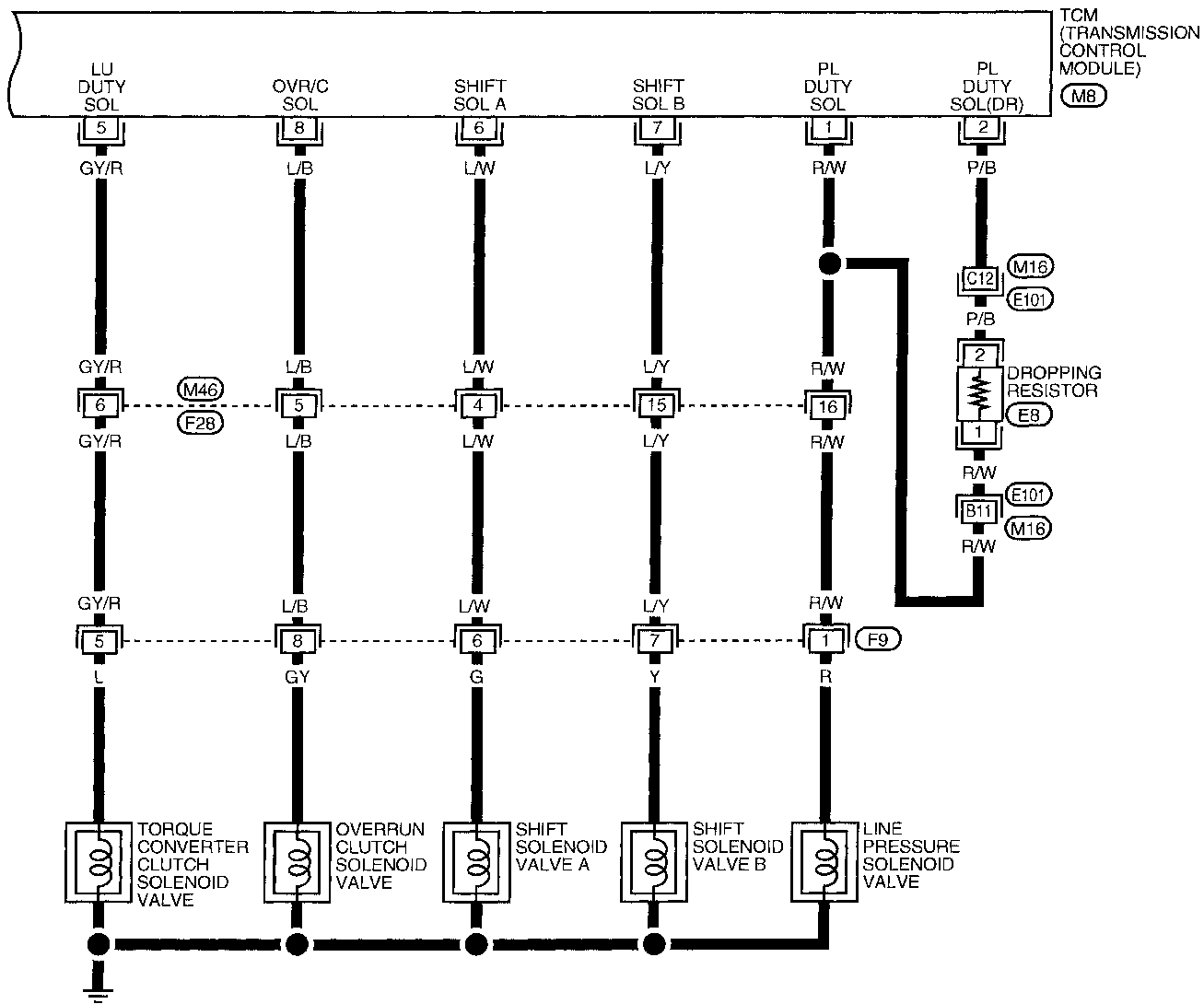

Refer to last page (Foldout page).

(M16), (E101)

OVERALL SYSTEM

Cross-sectional View

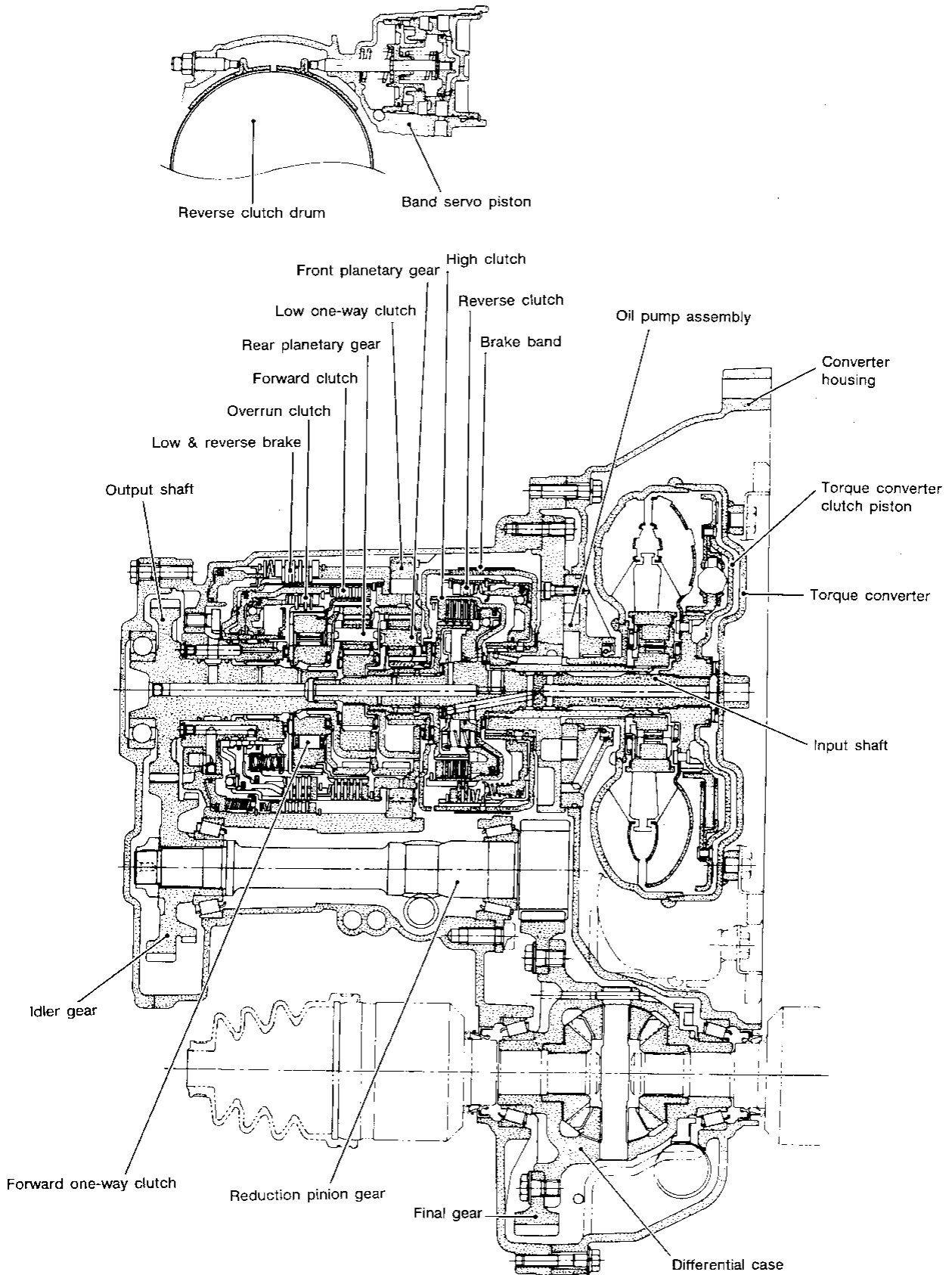

- GI
- MA
- EM
- LC
- EC
- FE
- CL
- MT
- AT**
- FA
- RA
- BR
- ST
- RS
- BT
- HA
- EL
- IDX

OVERALL SYSTEM

Hydraulic Control Circuit

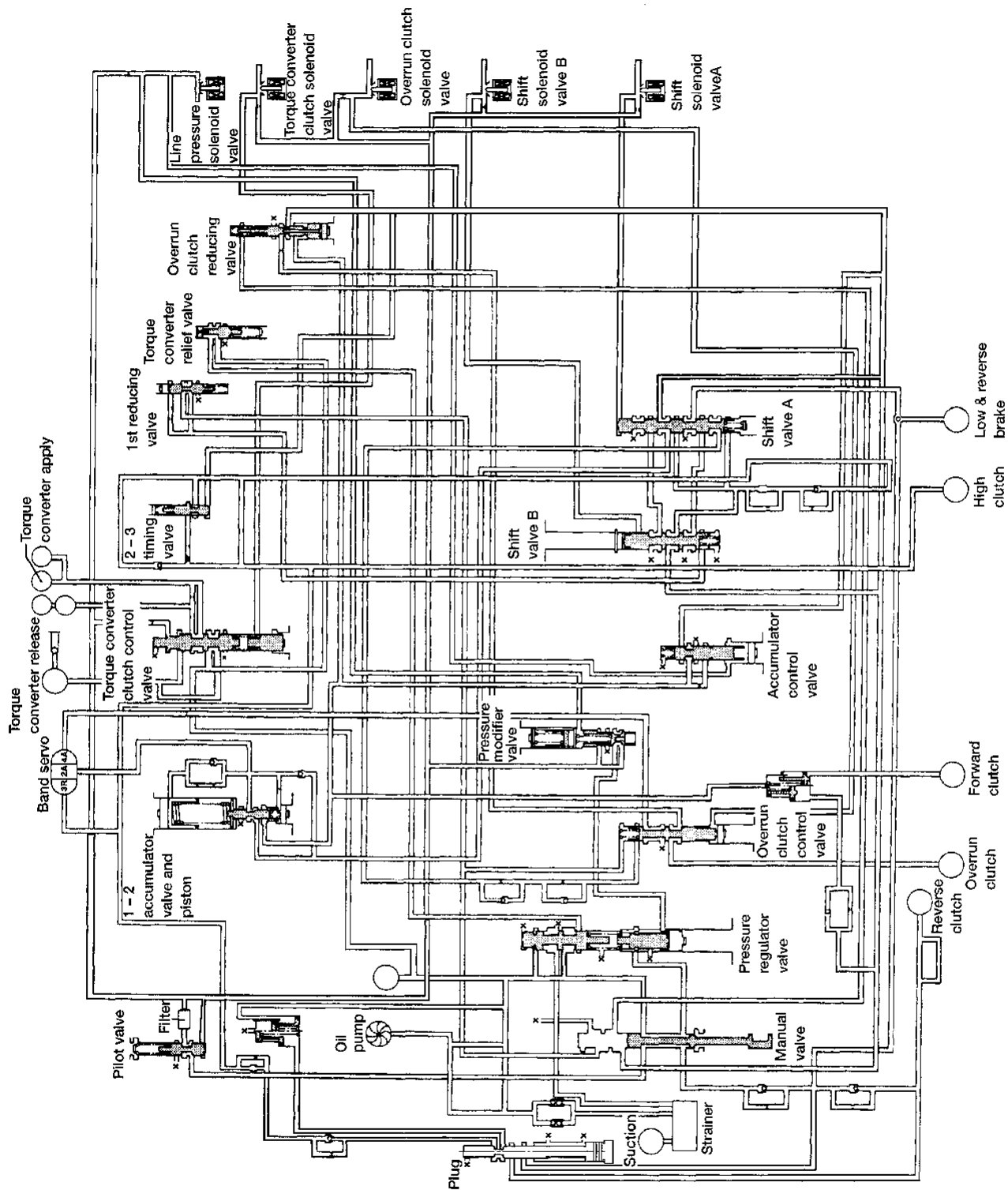

OVERALL SYSTEM

Shift Mechanism CONSTRUCTION

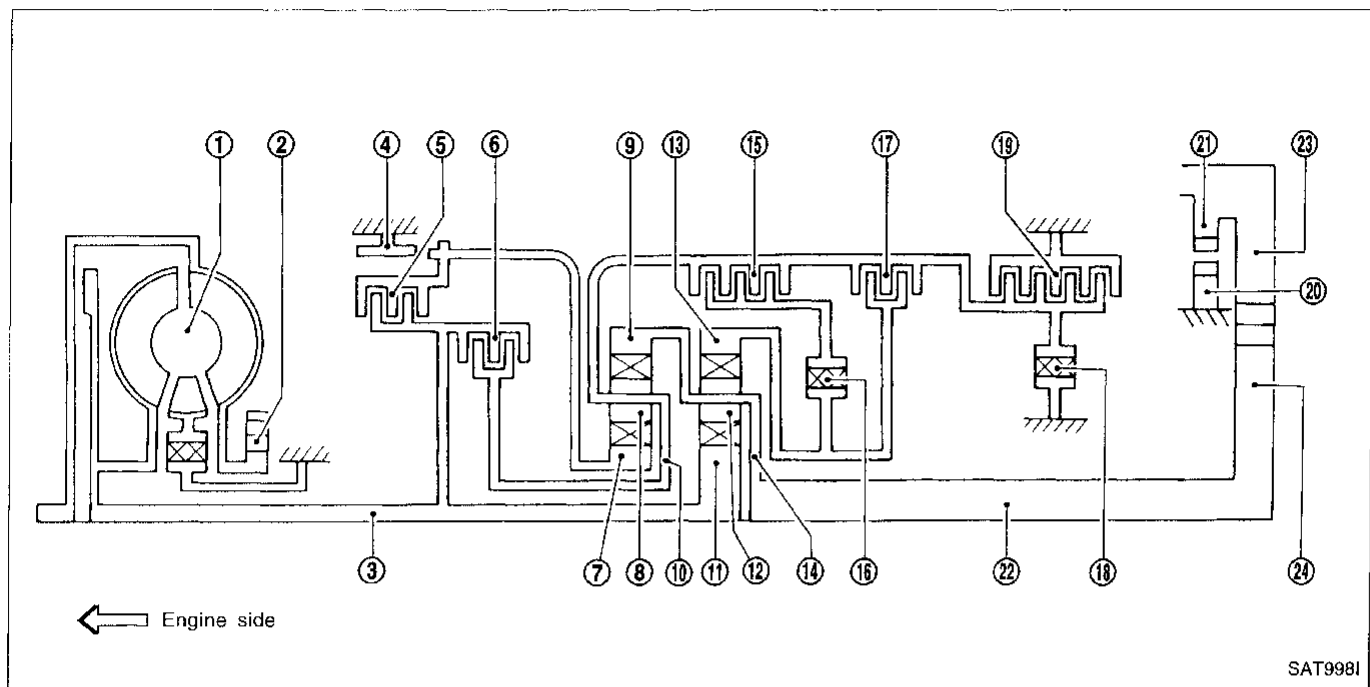

- ① Torque converter
- ② Oil pump
- ③ Input shaft
- ④ Brake band
- ⑤ Reverse clutch
- ⑥ High clutch
- ⑦ Front sun gear
- ⑧ Front pinion gear

- ⑨ Front internal gear
- ⑩ Front planetary carrier
- ⑪ Rear sun gear
- ⑫ Rear pinion gear
- ⑬ Rear internal gear
- ⑭ Rear planetary carrier
- ⑮ Forward clutch
- ⑯ Forward one-way clutch

- ⑰ Overrun clutch
- ⑱ Low one-way clutch
- ⑲ Low & reverse brake
- ⑳ Parking pawl
- ㉑ Parking gear
- ㉒ Output shaft
- ㉓ Idle gear
- ㉔ Output gear

GI
MA
EM
LC
EC
FE
CL
MT
AT
FA
RA
BR
ST
RS
BT
HA
EL
IDX

OVERALL SYSTEM

Shift Mechanism (Cont'd)

FUNCTION OF CLUTCH AND BRAKE

Clutch and brake components	Abbr.	Function
⑤ Reverse clutch	R/C	To transmit input power to front sun gear ⑦.
⑥ High clutch	H/C	To transmit input power to front planetary carrier ⑩.
⑮ Forward clutch	F/C	To connect front planetary carrier ⑩ with forward one-way clutch ⑯.
⑰ Overrun clutch	O/C	To connect front planetary carrier ⑩ with rear internal gear ⑬.
④ Brake band	B/B	To lock front sun gear ⑦.
⑯ Forward one-way clutch	F/O.C	When forward clutch ⑮ is engaged, to stop rear internal gear ⑬ from rotating in opposite direction against engine revolution.
⑱ Low one-way clutch	L/O.C	To stop front planetary carrier ⑩ from rotating in opposite direction against engine revolution.
⑲ Low & reverse brake	L & R/B	To lock front planetary carrier ⑩.

CLUTCH AND BAND CHART

Shift position	Reverse clutch ⑤	High clutch ⑥	Forward clutch ⑮	Overrun clutch ⑰	Band servo			Forward one-way clutch ⑯	Low one-way clutch ⑱	Low & reverse brake ⑲	Lock-up	Remarks
					2nd apply	3rd release	4th apply					
P												PARK POSITION
R	○									○		REVERSE POSITION
N												NEUTRAL POSITION
D*4	1st		○	*1⊗				●	●			Automatic shift 1 ↔ 2 ↔ 3 ↔ 4
	2nd		○	*1⊙	○			●				
	3rd		○	*1⊙	*2⊗	⊗		●			*5○	
	4th		○	⊗		*3⊗	⊗	○			○	
2	1st		○	⊗				●	●			Automatic shift 1 ↔ 2 ← 3
	2nd		○	⊙	○			●				
1	1st		○	○				●		○		Locks (held stationary) in 1st speed 1 ← 2 ← 3
	2nd		○	○	○			●				

*1: Operates when overdrive control switch is set in "OFF" position.

*2: Oil pressure is applied to both 2nd "apply" side and 3rd "release" side of band servo piston. However, brake band does not contract because oil pressure area on the "release" side is greater than that on the "apply" side.

*3: Oil pressure is applied to 4th "apply" side in condition *2 above, and brake band contracts.

*4: A/T will not shift to 4th when overdrive control switch is set in "OFF" position.

*5: Operates when overdrive control switch is "OFF".

○ : Operates

⊙ : Operates when throttle opening is less than 3/16, activating engine brake.

● : Operates during "progressive" acceleration.

⊗ : Operates but does not affect power transmission.

⊗ : Operates when throttle opening is less than 3/16, but does not affect engine brake.

OVERALL SYSTEM

Shift Mechanism (Cont'd)

POWER TRANSMISSION

"N" and "P" positions

- "N" position
Power from the input shaft is not transmitted to the output shaft because the clutches do not operate.
- "P" position
Similar to the "N" position, the clutches do not operate. The parking pawl engages with the parking gear to mechanically hold the output shaft so that the power train is locked.

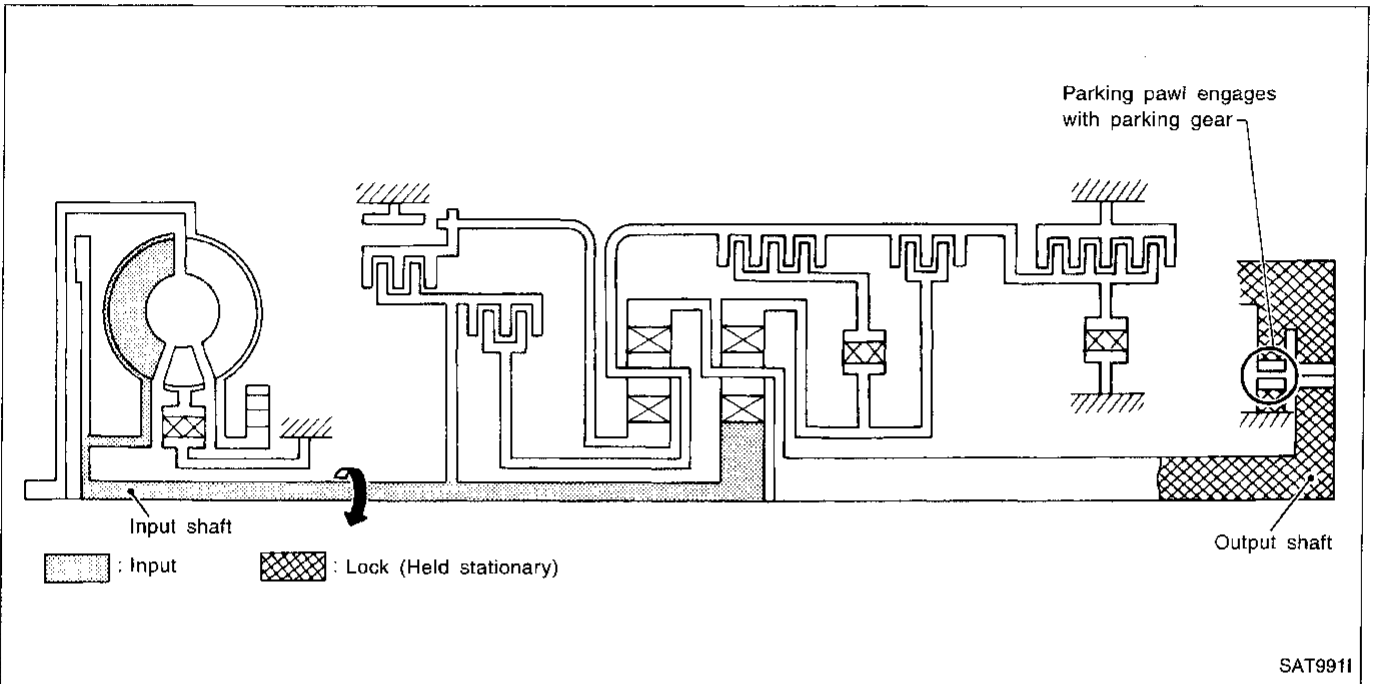

GI
MA
EM
LC
EC
FE
CL
MT
AT
FA
RA
BR
ST
RS
BT
HA
EL
IDX

OVERALL SYSTEM

Shift Mechanism (Cont'd)

"1_r" position

<ul style="list-style-type: none"> ● Forward clutch ● Forward one-way clutch ● Overrun clutch ● Low and reverse brake 	<p>As overrun clutch engages, rear internal gear is locked by the operation of low and reverse brake.</p> <p>This is different from that of D₁ and 2₁.</p>
<p>Engine brake</p>	<p>Overrun clutch always engages, therefore engine brake can be obtained when decelerating.</p>
<p>Power flow</p>	<pre> graph TD A[Input shaft] --> B[Rear sun gear] B --> C[Rear pinion gear] C --> D[Rear planetary carrier] D --> E[Output shaft] </pre>

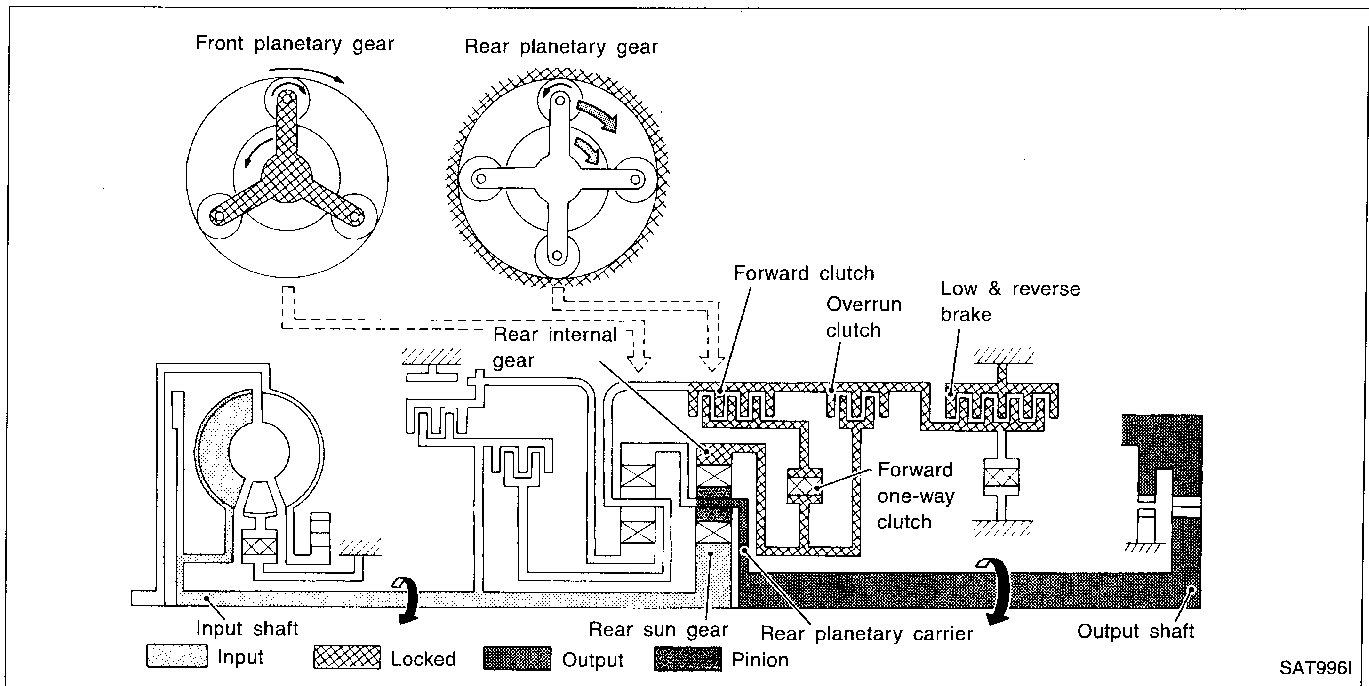

OVERALL SYSTEM

Shift Mechanism (Cont'd)

"D₁" and "2₁" positions

<ul style="list-style-type: none"> ● Forward one-way clutch ● Forward clutch ● Low one-way clutch 	<p>Rear internal gear is locked to rotate counterclockwise because of the functioning of these three clutches.</p>
<p>Overrun clutch engagement conditions (Engine brake)</p>	<p>D₁: Overdrive control switch "OFF" and throttle opening is less than 3/16 2₁: Always engaged At D₁ and 2₁ positions, engine brake is not activated due to free turning of low one-way clutch.</p>
<p>Power flow</p>	<pre> Input shaft ↓ Rear sun gear ↓ Rear planetary carrier ↓ Output shaft </pre>

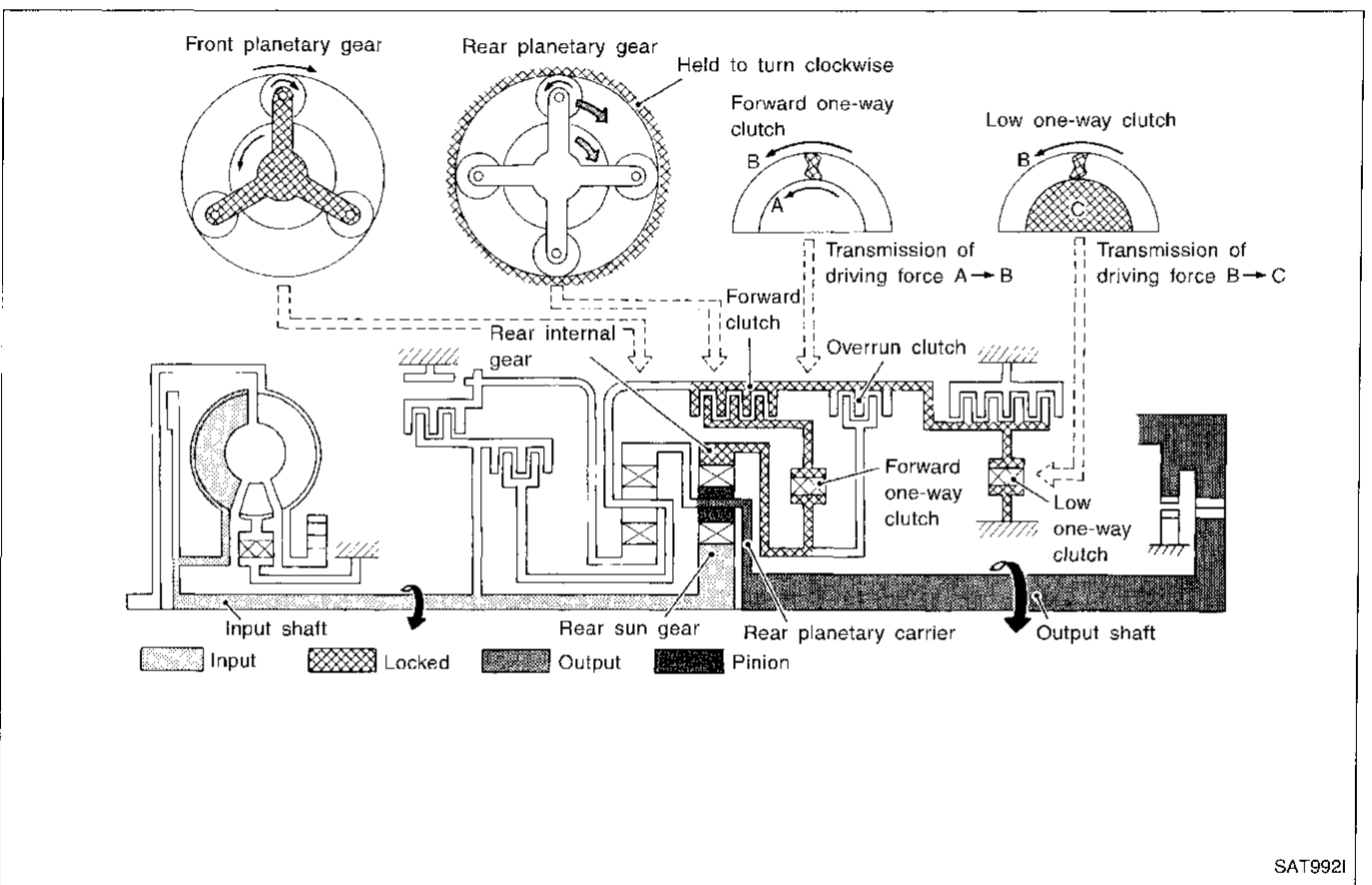

SAT992I

OVERALL SYSTEM

Shift Mechanism (Cont'd)

"D₂", "2₂" and "1₂" positions

<ul style="list-style-type: none"> • Forward clutch • Forward one-way clutch • Brake band 	<p>Rear sun gear drives rear planetary carrier and combined front internal gear. Front internal gear now rotates around front sun gear accompanying front planetary carrier.</p> <p>As front planetary carrier transfers the power to rear internal gear through forward clutch and forward one-way clutch, this rotation of rear internal gear increases the speed of rear planetary carrier compared with that of the 1st speed.</p>
<p>Overrun clutch engagement conditions</p>	<p>D₂: Overdrive control switch "OFF" and throttle opening is less than 3/16 2₂ and 1₂: Always engaged</p>
<p>Power flow</p>	<pre> graph TD IS[Input shaft] --> RS[Rear sun gear] RS --> RP[Rear pinion gear] RP --> RPL[Rear planetary carrier] RPL --> OS[Output shaft] RPL --> FI[Front internal gear] FI --> FP[Front pinion gear] FP --> FPC[Front planetary carrier] FPC --> FC[Forward clutch] FC --> FOC[Forward one-way clutch] FOC --> RI[Rear internal gear] RI --> RP </pre>

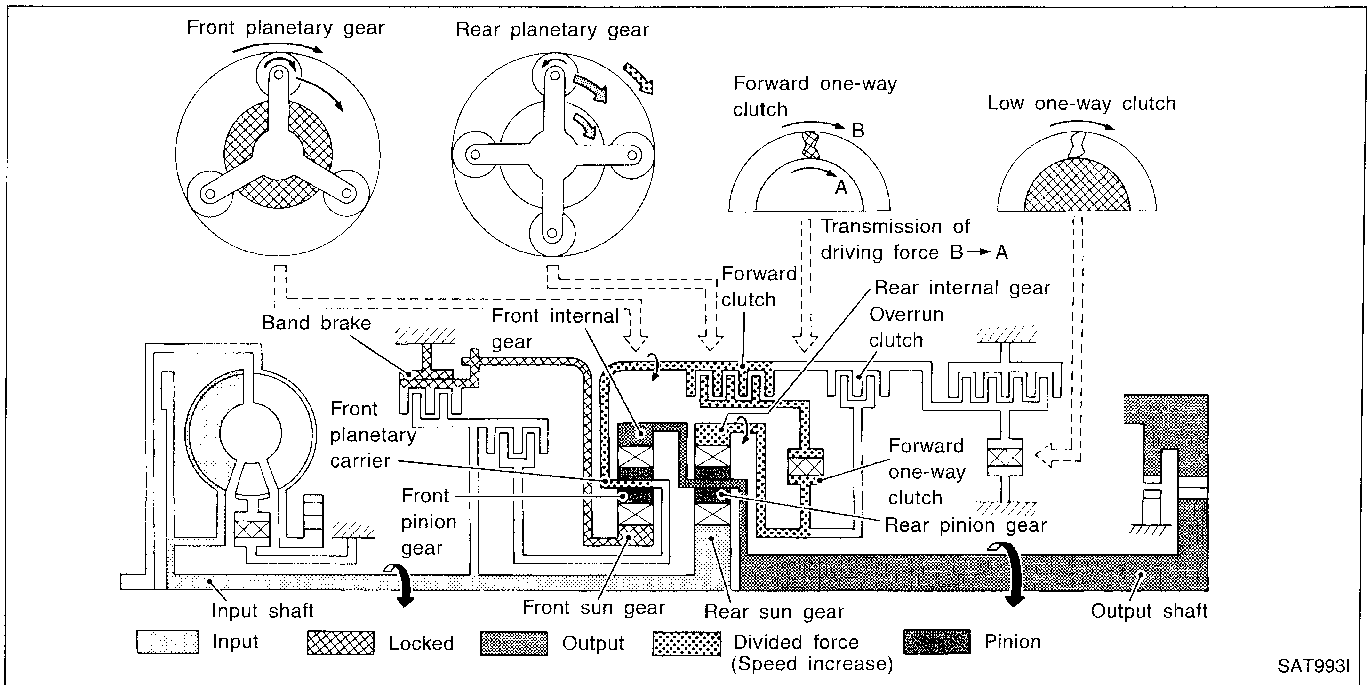

OVERALL SYSTEM

Shift Mechanism (Cont'd)

"D₃" position

<ul style="list-style-type: none"> ● High clutch ● Forward clutch ● Forward one-way clutch 	<p>Input power is transmitted to front planetary carrier through high clutch. And front planetary carrier is connected to rear internal gear by operation of forward clutch and forward one-way clutch. This rear internal gear rotation and another input (the rear sun gear) accompany rear planetary carrier to turn at the same speed.</p>
<p>Overrun clutch engagement conditions</p>	<p>D₃: Overdrive control switch "OFF" and throttle opening is less than 3/16</p>
<p>Power flow</p>	

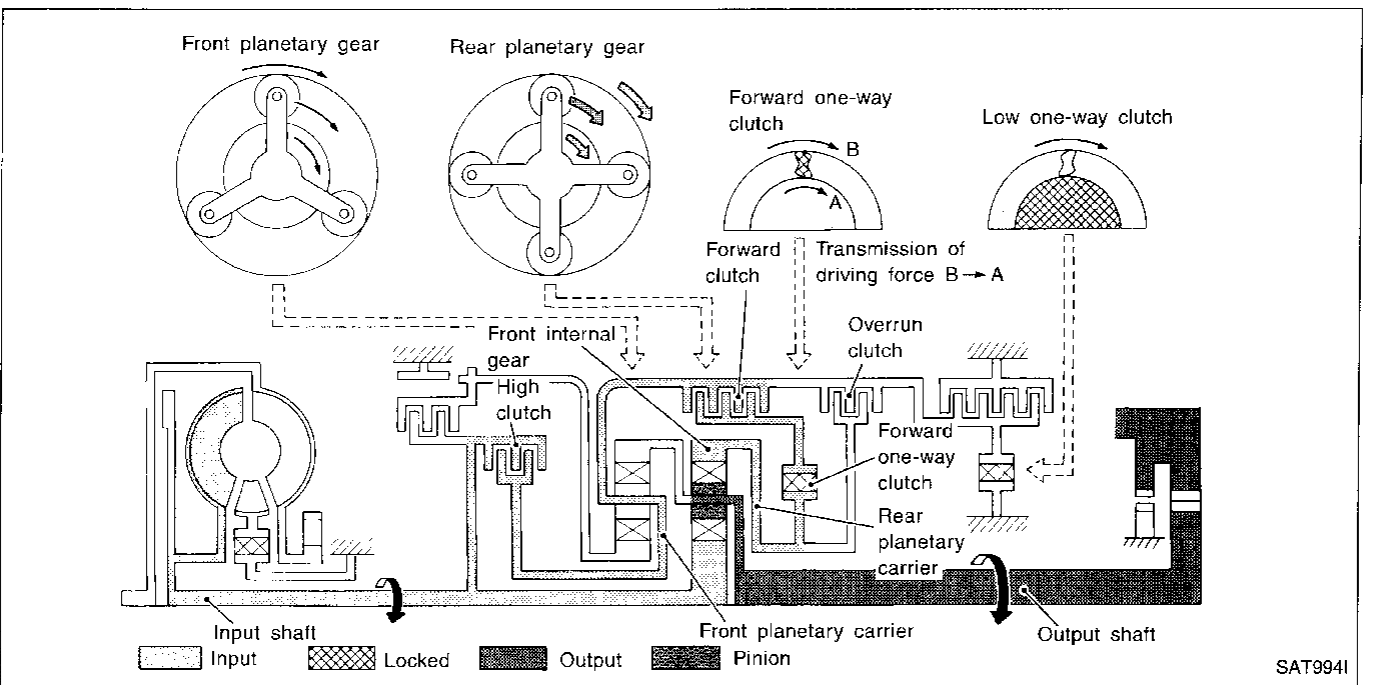

SAT994I

GI
MA
EM
LC
EC
FE
CL
MT
AT
FA
RA
BR
ST
RS
BT
HA
EL
IDX

OVERALL SYSTEM

Shift Mechanism (Cont'd)

"D₄" (OD) position

<ul style="list-style-type: none"> ● High clutch ● Brake band ● Forward clutch (Does not affect power transmission) 	<p>Input power is transmitted to front carrier through high clutch. This front carrier turns around the sun gear which is fixed by brake band and makes front internal gear (output) turn faster.</p>
<p>Engine brake</p>	<p>At D₄ position, there is no one-way clutch in the power transmission line and engine brake can be obtained when decelerating.</p>
<p>Power flow</p>	<pre style="text-align: center;"> Input shaft ↓ High clutch ↓ Front planetary carrier ↓ Front pinion gear ↓ Front internal gear ↓ Rear planetary carrier ↓ Output shaft </pre>

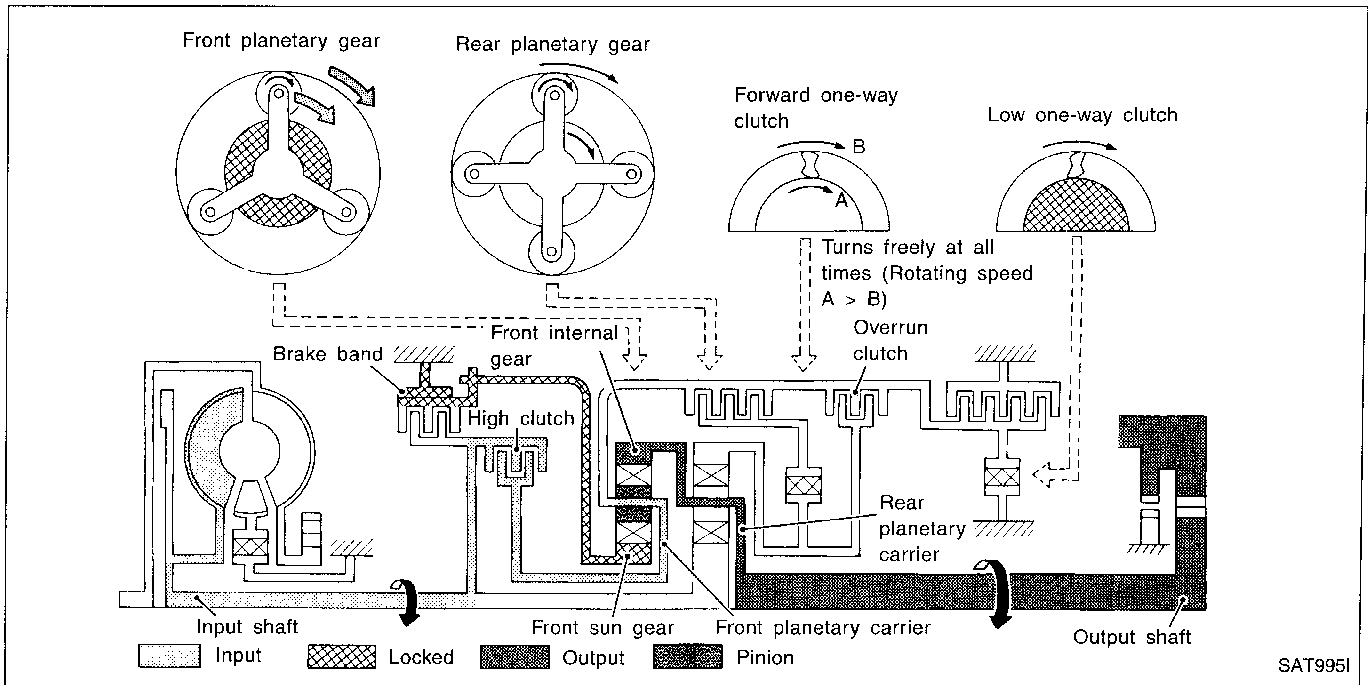

OVERALL SYSTEM

Control System

OUTLINE

The automatic transaxle senses vehicle operating conditions through various sensors. It always controls the optimum shaft position and reduces shifting and lock-up shocks.

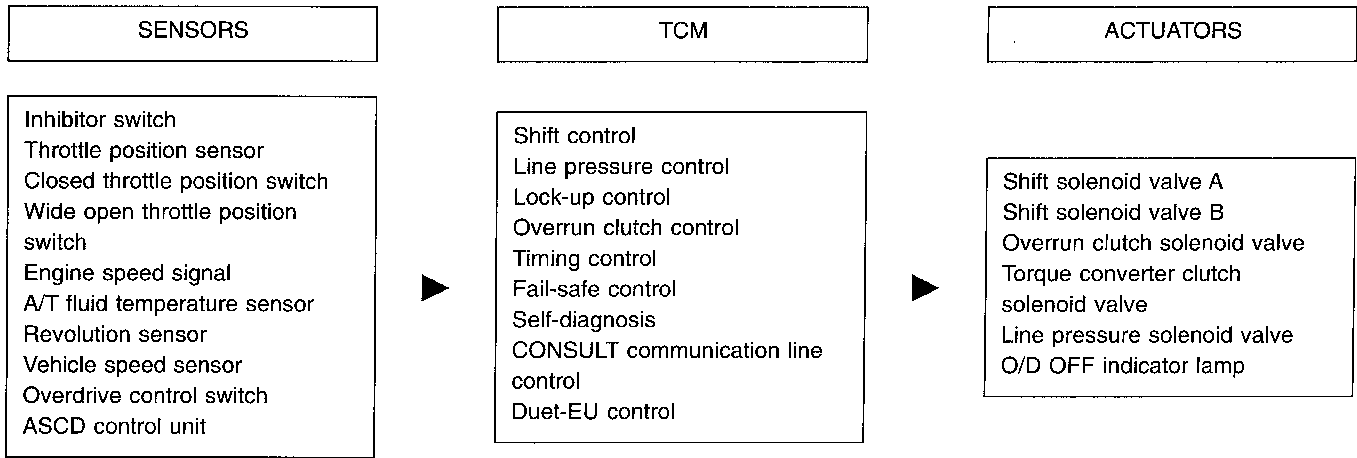

CONTROL SYSTEM

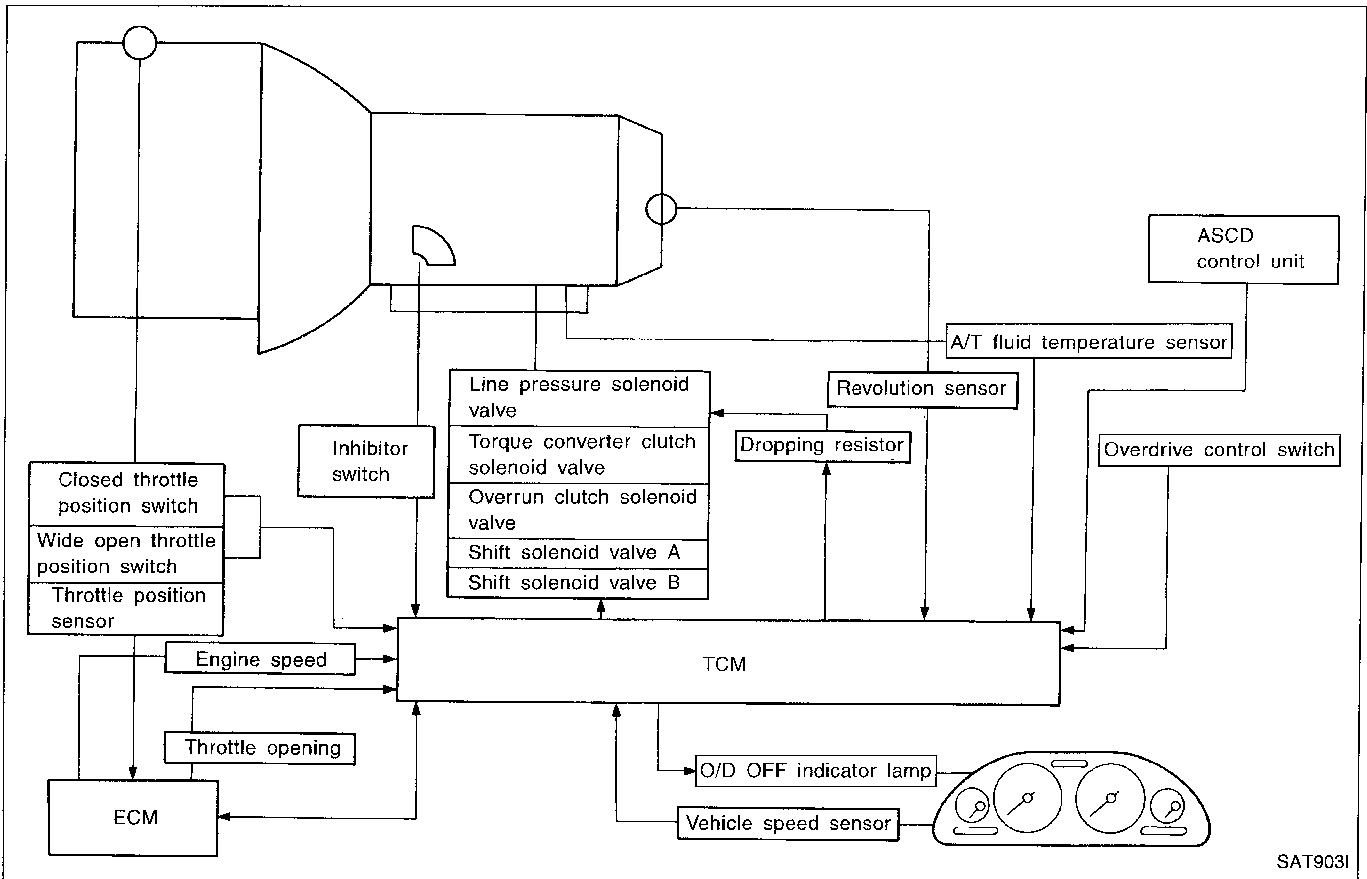

SAT9031

OVERALL SYSTEM

Control System (Cont'd)

TCM FUNCTION

The function of the TCM is to:

- Receive input signals sent from various switches and sensors.
- Determine required line pressure, shifting point, lock-up operation, and engine brake operation.
- Send required output signals to the respective solenoids.

INPUT/OUTPUT SIGNAL OF TCM

	Sensors and solenoid valves	Function	
Input	Inhibitor switch	Detects select lever position and sends a signal to TCM.	GI
	Throttle position sensor	Detects throttle valve position and sends a signal to TCM.	MA
	Closed throttle position switch	Detects throttle valve's fully-closed position and sends a signal to TCM.	EM
	Wide open throttle position switch	Detects a throttle valve position of greater than 1/2 of full throttle and sends a signal to TCM.	LC
	Engine speed signal	From ECM.	EC
	A/T fluid temperature sensor	Detects transmission fluid temperature and sends a signal to TCM.	FE
	Revolution sensor	Detects output shaft rpm and sends a signal to TCM.	
	Vehicle speed sensor	Used as an auxiliary vehicle speed sensor. Sends a signal when revolution sensor (installed on transmission) malfunctions.	CL
	Overdrive control switch	Sends a signal, which prohibits a shift to "D ₄ " (overdrive) position, to the TCM.	
	ASCD control unit	Sends the cruise signal and D ₄ (overdrive) cancellation signal from ASCD control unit to TCM.	MT
Output	Shift solenoid valve A/B	Selects shifting point suited to driving conditions in relation to a signal sent from TCM.	AT
	Line pressure solenoid valve	Regulates (or decreases) line pressure suited to driving conditions in relation to a signal sent from TCM.	FA
	Torque converter clutch solenoid valve	Regulates (or decreases) lock-up pressure suited to driving conditions in relation to a signal sent from TCM.	RA
	Overrun clutch solenoid valve	Controls an "engine brake" effect suited to driving conditions in relation to a signal sent from TCM.	
	O/D OFF indicator lamp	Shows TCM faults, when A/T control components malfunction.	BR

Control Mechanism

LINE PRESSURE CONTROL

TCM has various line pressure control characteristics to match the driving conditions.

An ON-OFF duty signal is sent to the line pressure solenoid valve based on TCM characteristics.

Hydraulic pressure on the clutch and brake is electronically controlled through the line pressure solenoid valve to accommodate engine torque. This results in smooth shift operation.

Normal control

The line pressure to throttle opening characteristics is set for suitable clutch operation.

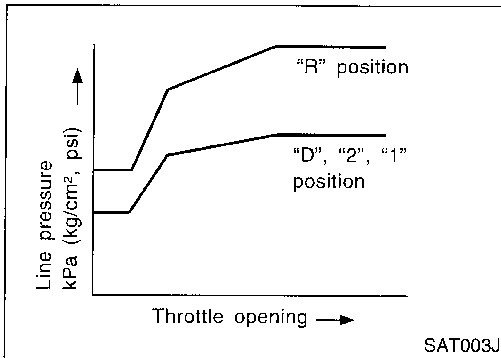

Back-up control (Engine brake)

If the selector lever is shifted to "2" position while driving in D_4 (OD) or D_3 , great driving force is applied to the clutch inside the transmission. Clutch operating pressure (line pressure) must be increased to deal with this driving force.

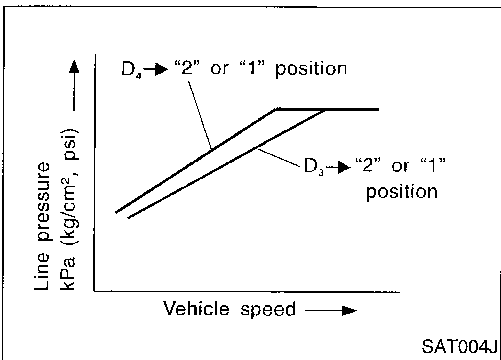

During shift change

The line pressure is temporarily reduced corresponding to a change in engine torque when shifting gears (that is, when the shift solenoid valve is switched for clutch operation) to reduce shifting shock.

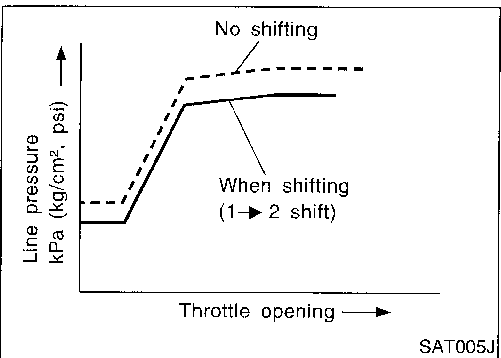

At low fluid temperature

- Fluid viscosity and frictional characteristics of the clutch facing change with fluid temperature. Clutch engaging or band-contacting pressure is compensated for, according to fluid temperature, to stabilize shifting quality.

OVERALL SYSTEM

Control Mechanism (Cont'd)

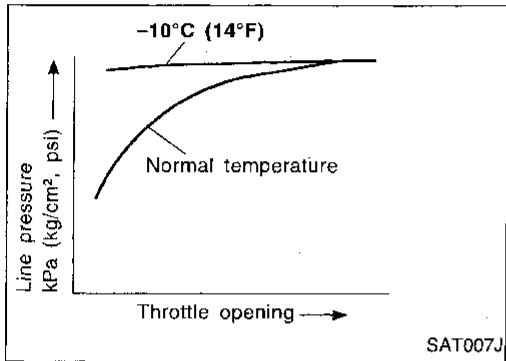
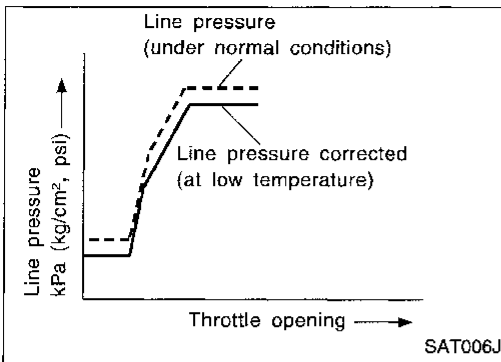

- The line pressure is reduced below 60°C (140°F) to prevent shifting shock due to low viscosity of automatic transmission fluid when temperature is low.

- Line pressure is increased to a maximum irrespective of the throttle opening when fluid temperature drops to -10°C (14°F). This pressure rise is adopted to prevent a delay in clutch and brake operation due to extreme drop of fluid viscosity at low temperature.

SHIFT CONTROL

The shift is regulated entirely by electronic control to accommodate vehicle speed and varying engine operations. This is accomplished by electrical signals transmitted by the revolution sensor and throttle position sensor. This results in improved acceleration performance and fuel economy.

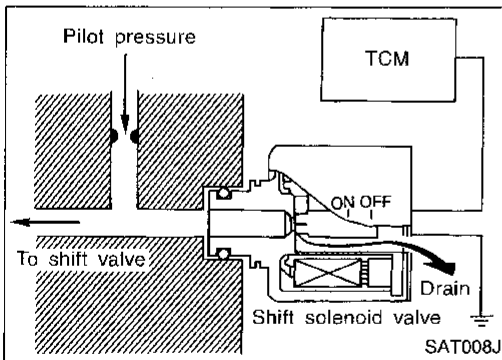

Control of shift solenoid valves A and B

The TCM activates shift solenoid valves A and B according to signals from the throttle position sensor and revolution sensor to select the optimum gear position on the basis of the shift schedule memorized in the TCM.

The shift solenoid valve performs simple ON-OFF operation. When set to ON, the drain circuit closes and pilot pressure is applied to the shift valve.

Relation between shift solenoid valves A and B and gear positions

Gear position	D ₁ , 2 ₁ , 1 ₁	D ₂ , 2 ₂ , 1 ₂	D ₃	D ₄ (OD)	N-P
Shift solenoid valve					
A	ON (Closed)	OFF (Open)	OFF (Open)	ON (Closed)	ON (Closed)
B	ON (Closed)	ON (Closed)	OFF (Open)	OFF (Open)	ON (Closed)

OVERALL SYSTEM

Control Mechanism (Cont'd)

Control of shift valves A and B

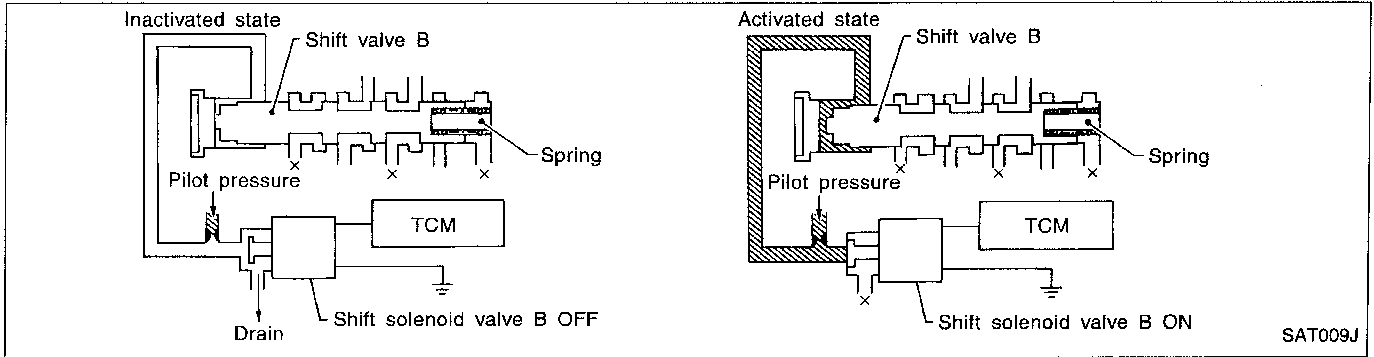

Pilot pressure generated by the operation of shift solenoid valves A and B is applied to the end face of shift valves A and B.

The drawing above shows the operation of shift valve B. When the shift solenoid valve is ON, pilot pressure applied to the end face of the shift valve overcomes spring force, moving the valve upward.

LOCK-UP CONTROL

The torque converter clutch piston in the torque converter is locked to eliminate torque converter slip to increase power transmission efficiency. The solenoid valve is controlled by an ON-OFF duty signal sent from the TCM. The signal is converted to an oil pressure signal which controls the torque converter clutch piston.

Conditions for lock-up operation

When vehicle is driven in 4th gear position, vehicle speed and throttle opening are detected. If the detected values fall within the lock-up zone memorized in the TCM, lock-up is performed.

Overdrive control switch	ON	OFF
Selector lever	"D" position	
Gear position	D ₄	D ₃
Vehicle speed sensor	More than set value	
Throttle position sensor	Less than set opening	
Closed throttle position switch	OFF	
A/T fluid temperature sensor	More than 40°C (104°F)	

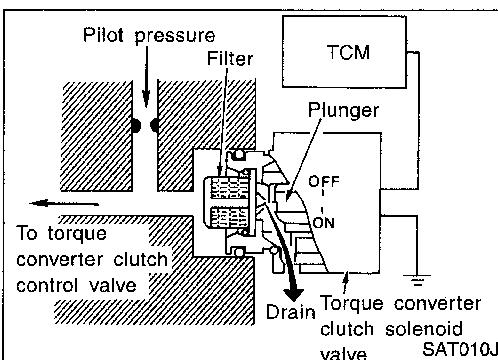

Torque converter clutch solenoid valve control

The torque converter clutch solenoid valve is controlled by the TCM. The plunger closes the drain circuit during the OFF period, and opens the circuit during the ON period. If the percentage of OFF-time increases in one cycle, the pilot pressure drain time is reduced and pilot pressure remains high.

The torque converter clutch piston is designed to slip to adjust the ratio of ON-OFF, thereby reducing lock-up shock.

OVERALL SYSTEM

Control Mechanism (Cont'd)

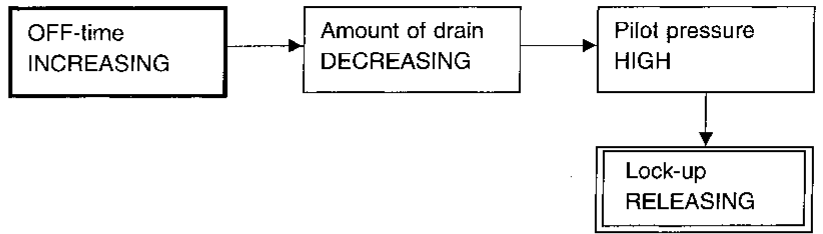
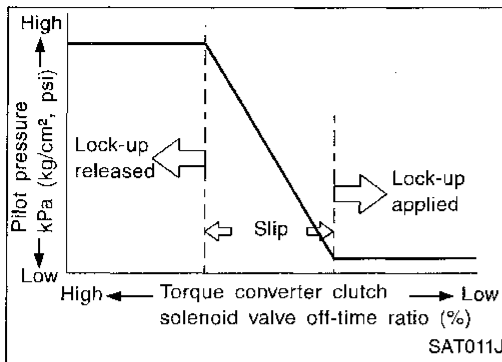

Torque converter clutch control valve operation

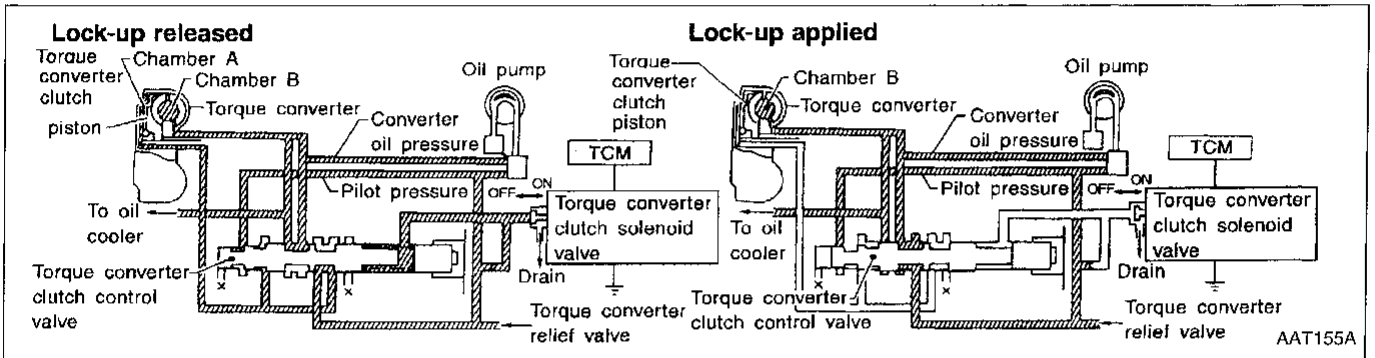

Lock-up released

The OFF-duration of the torque converter clutch solenoid valve is long, and pilot pressure is high. The pilot pressure pushes the end face of the torque converter clutch control valve in combination with spring force to move the valve to the left. As a result, converter pressure is applied to chamber A (torque converter clutch release side). Accordingly, the torque converter clutch piston remains unlocked.

Lock-up applied

When the OFF-duration of the torque converter clutch solenoid valve is short, pilot pressure drains and becomes low. Accordingly, the control valve moves to the right by the pilot pressure of the other circuit and converter pressure. As a result, converter pressure is applied to chamber B, keeping the torque converter clutch piston applied.

Also smooth lock-up is provided by transient application and release of the lock-up.

OVERRUN CLUTCH CONTROL (ENGINE BRAKE CONTROL)

Forward one-way clutch is used to reduce shifting shocks in downshifting operations. This clutch transmits engine torque to the wheels. However, drive force from the wheels is not transmitted to the engine because the one-way clutch rotates idle. This means the engine brake is not effective.

The overrun clutch operates when the engine brake is needed.

Overrun clutch operating conditions

	Gear position	Throttle opening
"D" position	D ₁ , D ₂ , D ₃ gear position	Less than 3/16
"2" position	2 ₁ , 2 ₂ gear position	
"1" position	1 ₁ , 1 ₂ gear position	At any position

OVERALL SYSTEM

Control Mechanism (Cont'd)

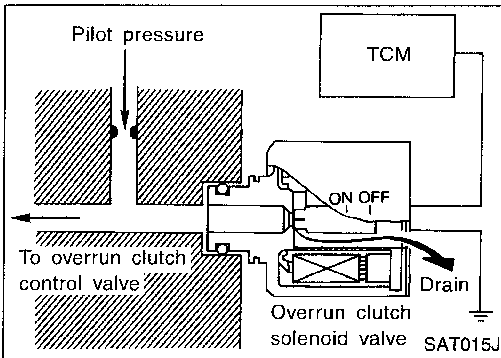
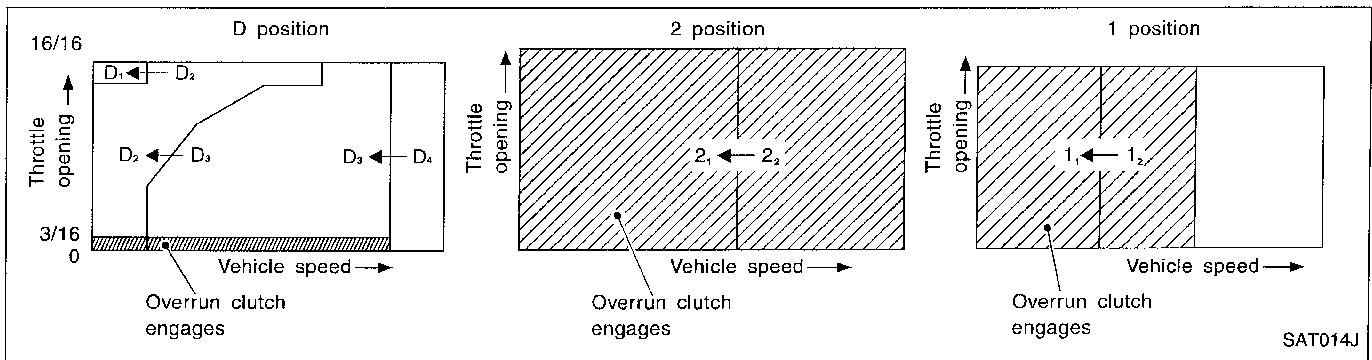

Overrun clutch solenoid valve control

The overrun clutch solenoid valve is operated by an ON-OFF signal transmitted by the TCM to provide overrun clutch control (engine brake control).

When this solenoid valve is ON, the pilot pressure drain port closes. When it is OFF, the drain port opens.

During the solenoid valve ON pilot pressure is applied to the end face of the overrun clutch control valve.

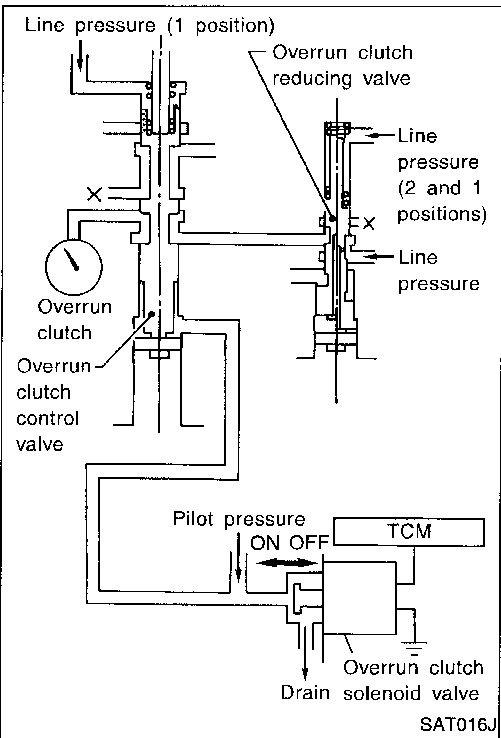

Overrun clutch control valve operation

When the solenoid valve is ON, pilot pressure is applied to the overrun clutch control valve. This pushes up the overrun clutch control valve. The line pressure is then shut off so that the clutch does not engage.

When the solenoid valve is OFF, pilot pressure is not generated. At this point, the overrun clutch control valve moves downward by spring force. As a result, overrun clutch operation pressure is provided by the overrun clutch reducing valve. This causes the overrun clutch to engage.

In the 1 position, the overrun clutch control valve remains pushed down so that the overrun clutch is engaged at all times.

OVERALL SYSTEM

Control Valve

FUNCTION OF CONTROL VALVES

Valve name	Function
Pressure regulator valve, plug and sleeve	Regulates oil discharged from the oil pump to provide optimum line pressure for all driving conditions.
Pressure modifier valve and sleeve	Used as a signal supplementary valve to the pressure regulator valve. Regulates pressure-modifier pressure (signal pressure) which controls optimum line pressure for all driving conditions.
Pilot valve	Regulates line pressure to maintain a constant pilot pressure level which controls lock-up mechanism, overrun clutch, shift timing.
Accumulator control valve	Regulates accumulator backpressure to pressure suited to driving conditions.
Manual valve	Directs line pressure to oil circuits corresponding to select positions. Hydraulic pressure drains when the shift lever is in Neutral.
Shift valve A	Simultaneously switches four oil circuits using output pressure of shift solenoid valve A to meet driving conditions (vehicle speed, throttle opening, etc.). Provides automatic downshifting and up-shifting (1st→2nd→3rd→4th gears/4th→3rd→2nd→1st gears) in combination with shift valve B.
Shift valve B	Simultaneously switches three oil circuits using output pressure of shift solenoid valve B in relation to driving conditions (vehicle speed, throttle opening, etc.). Provides automatic downshifting and up-shifting (1st→2nd→3rd→4th gears/4th→3rd→2nd→1st gears) in combination with shift valve A.
Overrun clutch control valve	Switches hydraulic circuits to prevent engagement of the overrun clutch simultaneously with application of the brake band in D ₄ . (Interlocking occurs if the overrun clutch engages during D ₄ .)
"1" reducing valve	Reduces low & reverse brake pressure to dampen engine-brake shock when down-shifting from the "1" position 1 ₂ to 1 ₁ .
Overrun clutch reducing valve	Reduces oil pressure directed to the overrun clutch and prevents engine-brake shock. In "1" and "2" positions, line pressure acts on the overrun clutch reducing valve to increase the pressure-regulating point, with resultant engine brake capability.
Torque converter relief valve	Prevents an excessive rise in torque converter pressure.
Torque converter clutch control valve, plug and sleeve	Activates or inactivates the lock-up function. Also provides smooth lock-up through transient application and release of the lock-up system.
1-2 accumulator valve and piston	Dampens the shock encountered when 2nd gear band servo contracts, and provides smooth shifting.

GI

MA

EM

LC

EC

FE

CL

MT

AT

FA

RA

BR

ST

RS

BT

HA

EL

IDX

ON BOARD DIAGNOSTIC SYSTEM DESCRIPTION

Introduction

The A/T system has two self-diagnostic systems.

The first is the emission-related on board diagnostic system (OBD-II) performed by the TCM (transmission control module) in combination with the ECM. The malfunction is indicated by the MIL (malfunction indicator lamp) and is stored as a DTC in the ECM memory but not the TCM memory.

The second is the TCM original self-diagnosis indicated by the O/D OFF indicator lamp. The malfunction is stored in the TCM memory. The detected items are overlapped with OBD-II self-diagnostic items. For detail, refer to AT-51.

OBD-II Function for A/T System

The ECM provides emission-related on board diagnostic (OBD-II) functions for the A/T system. One function is to receive a signal from the TCM used with OBD-related parts of the A/T system. The signal is sent to the ECM when a malfunction occurs in the corresponding OBD-related part. The other function is to indicate a diagnostic result by means of the MIL (malfunction indicator lamp) on the instrument panel. Sensors, switches and solenoid valves are used as sensing elements.

The MIL automatically illuminates in One or Two Trip Detection Logic when a malfunction is sensed in relation to A/T system parts.

One or Two Trip Detection Logic of OBD-II

ONE TRIP DETECTION LOGIC

If a malfunction is sensed during the first test drive, the MIL will illuminate and the malfunction will be stored in the ECM memory as a DTC. The TCM is not provided with such a memory function.

TWO TRIP DETECTION LOGIC

When a malfunction is sensed during the first test drive, it is stored in the ECM memory as a 1st trip DTC (diagnostic trouble code) or 1st trip freeze frame data. At this point, the MIL will not illuminate. — First Trip

If the same malfunction as that experienced during the first test drive is sensed during the second test drive, the MIL will illuminate. — Second Trip

A/T-related parts for which the MIL illuminates during the first or second test drive are listed below.



Items	MIL	
	One trip detection	Two trip detection
Shift solenoid valve A — DTC: P0750 (1108)	X	
Shift solenoid valve B — DTC: P0755 (1201)	X	
Throttle position sensor or switch — DTC: P1705 (1206)	X	
Except above		X

The “trip” in the “One or Two Trip Detection Logic” means a driving mode in which self-diagnosis is performed during vehicle operation.

OBD-II Diagnostic Trouble Code (DTC)

How to read DTC and 1st trip DTC

DTC and 1st trip DTC can be read by the following methods.

-  1. The number of blinks of the malfunction indicator lamp in the Diagnostic Test Mode II (Self-Diagnostic Results) Examples: 1101, 1102, 1103, 1104, etc. For details, refer to EC section [“Malfunction Indicator Lamp (MIL)”, “ON BOARD DIAGNOSTIC SYSTEM DESCRIPTION”]. These DTCs are controlled by NISSAN.
-  2. CONSULT or GST (Generic Scan Tool) Examples: P0705, P0710, P0720, P0725, etc. These DTCs are prescribed by SAE J2012.
-  (CONSULT also displays the malfunctioning component or system.)

ON BOARD DIAGNOSTIC SYSTEM DESCRIPTION

OBD-II Diagnostic Trouble Code (DTC) (Cont'd)

- 1st trip DTC No. is the same as DTC No.
- Output of the diagnostic trouble code indicates that the indicated circuit has a malfunction. However, in case of the Mode II and GST they do not indicate whether the malfunction is still occurring or occurred in the past and returned to normal. CONSULT can identify them as shown below. Therefore, using CONSULT (if available) is recommended.

CI

MA

EM

LC

EC

FE

CL

MT

AT

FA

RA

BR

ST

RS

BT

HA

EL

IDX

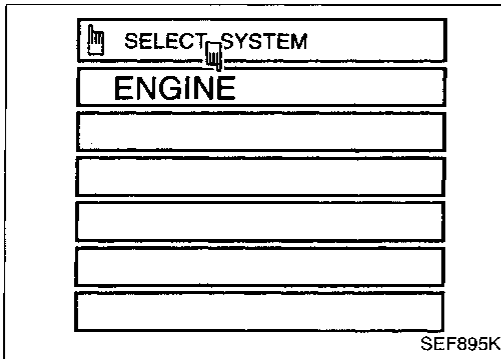

A sample of CONSULT display for DTC is shown at left. DTC or 1st trip DTC of a malfunction is displayed in SELF-DIAGNOSTIC RESULTS mode for "ENGINE" with CONSULT. Time data indicates how many times the vehicle was driven after the last detection of a DTC.

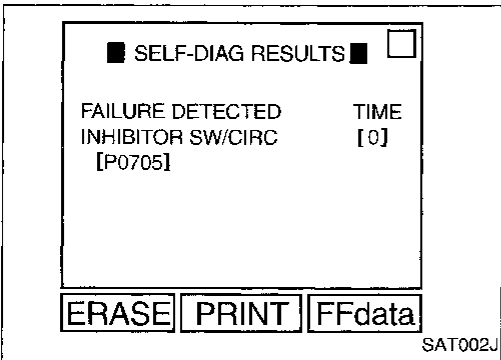

If the DTC is being detected currently, the time data will be "0".

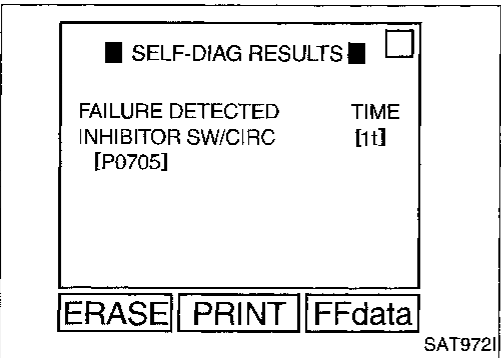

If a 1st trip DTC is stored in the ECM, the time data will be "[1t]".

ON BOARD DIAGNOSTIC SYSTEM DESCRIPTION

OBD-II Diagnostic Trouble Code (DTC) (Cont'd)

FREEZE FRAME DATA AND 1ST TRIP FREEZE FRAME DATA

The ECM has a memory function, which stores the driving condition such as fuel system status, calculated load value, engine coolant temperature, short term fuel trim, long term fuel trim, engine speed and vehicle speed at the moment the ECM detects a malfunction.

Data which are stored in the ECM memory, along with the 1st trip DTC, are called 1st trip freeze frame data, and the data, stored together with the DTC data, are called freeze frame data and displayed on CONSULT or GST. The 1st trip freeze frame data can only be displayed on the CONSULT screen, not on the GST. For detail, refer to EC section (“CONSULT”, “ON BOARD DIAGNOSTIC SYSTEM DESCRIPTION”).

Only one set of freeze frame data (either 1st trip freeze frame data or freeze frame data) can be stored in the ECM. 1st trip freeze frame data is stored in the ECM memory along with the 1st trip DTC. There is no priority for 1st trip freeze frame data and it is updated each time a different 1st trip DTC is detected. However, once freeze frame data (2nd trip detection/MIL on) is stored in the ECM memory, 1st trip freeze frame data is no longer stored. Remember, only one set of freeze frame data can be stored in the ECM. The ECM has the following priorities to update the data.

Priority	Items	
1	Freeze frame data	Misfire — DTC: P0300 - P0306 (0701, 0603 - 0608) Fuel Injection System Function — DTC: P0171 (0115), P0172 (0114), P0174 (0209), P0175 (0210)
2		Except the above items (Includes A/T related items)
3	1st trip freeze frame data	

Both 1st trip freeze frame data and freeze frame data (along with the DTCs) are cleared when the ECM memory is erased.

HOW TO ERASE DTC

The diagnostic trouble code can be erased by CONSULT, GST or ECM DIAGNOSTIC TEST MODE as described following.

- **If the battery terminal is disconnected, the diagnostic trouble code will be lost within 24 hours.**
- **When you erase the DTC, using CONSULT or GST is easier and quicker than switching the mode selector on the ECM.**

The following emission-related diagnostic information is cleared from the ECM memory when erasing DTC related to OBD-II. For details, refer to EC section (“Emission-related Diagnostic Information”, “ON BOARD DIAGNOSTIC SYSTEM DESCRIPTION”).

- **Diagnostic trouble codes (DTC)**
- **1st trip diagnostic trouble codes (1st trip DTC)**
- **Freeze frame data**
- **1st trip freeze frame data**
- **System readiness test (SRT) codes**
- **Test values**

HOW TO ERASE DTC (With CONSULT)

- **If a DTC is displayed for both ECM and TCM, it needs to be erased for both ECM and TCM.**
1. If the ignition switch stays “ON” after repair work, be sure to turn ignition switch “OFF” once. Wait at least 5 seconds and then turn it “ON” (engine stopped) again.
 2. Turn CONSULT “ON” and touch “A/T”.
 3. Touch “SELF-DIAG RESULTS”.
 4. Touch “ERASE”. (The DTC in the TCM will be erased.) Then touch “BACK” twice.
 5. Touch “ENGINE”.
 6. Touch “SELF-DIAG RESULTS”.
 7. Touch “ERASE”. (The DTC in the ECM will be erased.)

ON BOARD DIAGNOSTIC SYSTEM DESCRIPTION

OBD-II Diagnostic Trouble Code (DTC) (Cont'd)

How to erase DTC (With CONSULT)

1. If the ignition switch stays "ON" after repair work, be sure to turn ignition switch "OFF" once. Wait at least 5 seconds and then turn it "ON" (engine stopped) again.

SELECT SYSTEM
ENGINE
A/T

2. Turn CONSULT "ON", and touch "A/T".

SELECT DIAG MODE
SELF-DIAG RESULTS
DATA MONITOR
DTC WORK SUPPORT
ECU PART NUMBER

3. Touch "SELF-DIAG RESULTS".

SELF-DIAG RESULTS
FAILURE DETECTED
SHIFT SOLENOID/V A
ERASE
PRINT

4. Touch "ERASE". (The DTC in the TCM will be erased.)



SELECT SYSTEM
ENGINE
A/T

5. Touch "ENGINE".

SELECT DIAG MODE
WORK SUPPORT
SELF-DIAG RESULTS
DATA MONITOR
ACTIVE TEST
DTC CONFIRMATION
ECM PART NUMBER

6. Touch "SELF-DIAG RESULTS".

SELF-DIAG RESULTS
FAILURE DETECTED
SFT SOL A/CIRC
[P0750]
TIME
0
ERASE
PRINT
FFdata

7. Touch "ERASE". (The DTC in the ECM will be erased.)

SAT9041



HOW TO ERASE DTC (With GST)

1. If the ignition switch stays "ON" after repair work, be sure to turn ignition switch "OFF" once. Wait at least 5 seconds and then turn it "ON" (engine stopped) again.
2. Perform "OBD-II SELF-DIAGNOSTIC PROCEDURE (No Tools)". Refer to AT-49. (The engine warm-up step can be skipped when performing the diagnosis only to erase the DTC.)
3. Select Mode 4 with Generic Scan Tool (GST). For details, refer to EC section ["Generic Scan Tool (GST)", "ON BOARD DIAGNOSTIC SYSTEM DESCRIPTION"].



HOW TO ERASE DTC (No Tools)

1. If the ignition switch stays "ON" after repair work, be sure to turn ignition switch "OFF" once. Wait at least 5 seconds and then turn it "ON" (engine stopped) again.
2. Perform "TCM SELF-DIAGNOSTIC PROCEDURE (No Tools)". Refer to AT-49. (The engine warm-up step can be skipped when performing the diagnosis only to erase the DTC.)
3. Change the diagnostic test mode from Mode II to Mode I by turning the mode selector on the ECM. Refer to EC section ["HOW TO SWITCH DIAGNOSTIC TEST MODES", "Malfunction Indicator Lamp (MIL)", "ON BOARD DIAGNOSTIC SYSTEM DESCRIPTION"].

ON BOARD DIAGNOSTIC SYSTEM DESCRIPTION

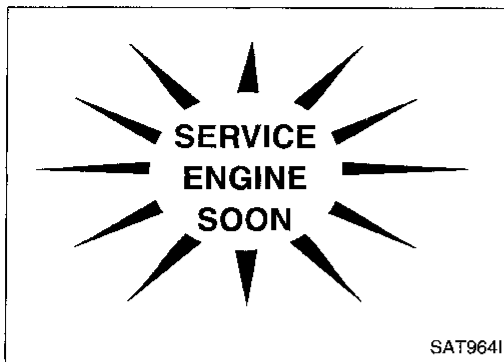

Malfunction Indicator Lamp (MIL)

1. The malfunction indicator lamp will light up when the ignition switch is turned ON without the engine running. This is for checking the lamp.
 - If the malfunction indicator lamp does not light up, refer to EL section ("Warning Lamps/System Description", "WARNING LAMPS AND CHIME"). (Or see MIL & Data Link Connectors in EC section.)
2. When the engine is started, the malfunction indicator lamp should go off. If the lamp remains on, the on board diagnostic system has detected an emission-related (OBD-II) malfunction. For detail, refer to EC section ("ON BOARD DIAGNOSTIC SYSTEM DESCRIPTION").

CONSULT

NOTICE

1. The CONSULT electrically displays shift timing and lock-up timing (that is, operation timing of each solenoid).
Check for time difference between actual shift timing and the CONSULT display. If the difference is noticeable, mechanical parts (except solenoids, sensors, etc.) may be malfunctioning. Check mechanical parts using applicable diagnostic procedures.
2. Shift schedule (which implies gear position) displayed on CONSULT and that indicated in Service Manual may differ slightly. This occurs because of the following reasons:
 - Actual shift schedule has more or less tolerance or allowance,
 - Shift schedule indicated in Service Manual refers to the point where shifts start, and
 - Gear position displayed on CONSULT indicates the point where shifts are completed.
3. Shift solenoid valve "A" or "B" is displayed on CONSULT at the start of shifting. Gear position is displayed upon completion of shifting (which is computed by TCM).
4. Additional CONSULT information can be found in the Operation Manual supplied with the CONSULT unit.

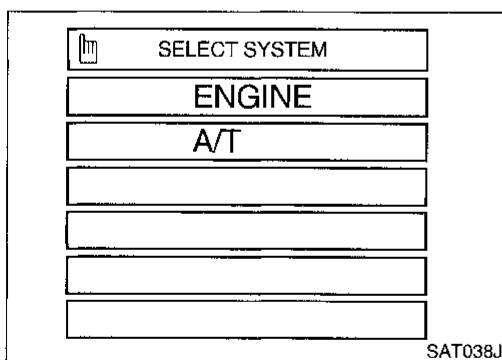

SELF-DIAGNOSIS

After performing this procedure, place check marks for results on the "DIAGNOSTIC WORKSHEET", AT-55. Reference pages are provided following the items.

SELF-DIAGNOSTIC PROCEDURE (With CONSULT)

1. Turn on CONSULT and touch "ENGINE" for OBD-II detected items or touch "A/T" for TCM self-diagnosis. If A/T is not displayed, check TCM power supply and ground circuit. Refer to AT-76. If result is NG, refer to EL section ("POWER SUPPLY ROUTING").

ON BOARD DIAGNOSTIC SYSTEM DESCRIPTION

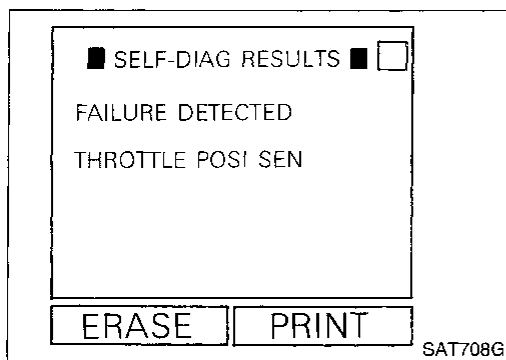

CONSULT (Cont'd)



- Touch "SELF-DIAG RESULTS".
Display shows malfunction experienced since the last erasing operation.
CONSULT performs REAL-TIME SELF-DIAGNOSIS.
Also, any malfunction detected while in this mode will be displayed at real time.

CI
MA
EM
LC
EC
FE
CL
MT
AT
FA
RA
BR
ST
RS
BT
HA
EL
IDX

SELF-DIAGNOSTIC RESULT TEST MODE

Detected items (Screen terms for CONSULT, "SELF-DIAG RESULTS" test mode)		Malfunction is detected when ...	TCM self-diagnosis	OBD-II (DTC)
"A/T"	"ENGINE"		 Available by O/D OFF indicator lamp or "A/T" on CONSULT	 Available by malfunction indicator lamp*2, "ENGINE" on CONSULT or GST
Inhibitor switch circuit		● TCM does not receive the correct voltage signal (based on the gear position) from the switch.	—	P0705
—	INHIBITOR SW/CIRC			
Revolution sensor		● TCM does not receive the proper voltage signal from the sensor.	X	P0720
VHCL SPEED SEN-A/T	VEH SPD SEN/CIR AT			
Vehicle speed sensor (Meter)		● TCM does not receive the proper voltage signal from the sensor.	X	—
VHCL SPEED SEN-MTR	—			
A/T 1st gear function		● A/T cannot be shifted to the 1st gear position even if electrical circuit is good.	—	P0731*1
—	A/T 1ST GR FNCTN			
A/T 2nd gear function		● A/T cannot be shifted to the 2nd gear position even if electrical circuit is good.	—	P0732*1
—	A/T 2ND GR FNCTN			
A/T 3rd gear function		● A/T cannot be shifted to the 3rd gear position even if electrical circuit is good.	—	P0733*1
—	A/T 3RD GR FNCTN			
A/T 4th gear function		● A/T cannot be shifted to the 4th gear position even if electrical circuit is good.	—	P0734*1
—	A/T 4TH GR FNCTN			
A/T TCC S/V function (lock-up)		● A/T cannot perform lock-up even if electrical circuit is good.	—	P0744*1
—	A/T TCC S/V FNCTN			
Shift solenoid valve A		● TCM detects an improper voltage drop when it tries to operate the solenoid valve.	X	P0750
SHIFT SOLENOID/V A	SFT SOL A/CIRC			
Shift solenoid valve B		● TCM detects an improper voltage drop when it tries to operate the solenoid valve.	X	P0755
SHIFT SOLENOID/V B	SFT SOL B/CIRC			
Overrun clutch solenoid valve		● TCM detects an improper voltage drop when it tries to operate the solenoid valve.	X	P1760
VERRUN CLUTCH S/V	O/R CLUCH SOL/CIRC			
T/C clutch solenoid valve		● TCM detects an improper voltage drop when it tries to operate the solenoid valve.	X	P0740
T/C CLUTCH SOL/V	TCC SOLENOID/CIRC			
Line pressure solenoid valve		● TCM detects an improper voltage drop when it tries to operate the solenoid valve.	X	P0745
LINE PRESSURE S/V	L/PRESS SOL/GRC			
Throttle position sensor, throttle position switch		● TCM receives an excessively low or high voltage from the sensor.	X	P1705
THROTTLE POSI SEN	TP SEN/CIRC A/T			
Engine speed signal		● TCM does not receive the proper voltage signal from the ECM.	X	P0725
ENGINE SPEED SIG	—			
A/T fluid temperature sensor		● TCM receives an excessively low or high voltage from the sensor.	X	P0710
BATT/FLUID TEMP SEN	ATF TEMP SEN/CIRC			
Initial start		● This is not a malfunction message (Whenever shutting off a power supply to the TCM, this message appears on the screen.)	X	—
INITIAL START	—			
No failure (NO SELF DIAGNOSTIC FAILURE INDICATED FURTHER TESTING MAY BE REQUIRED**)		● No failure has been detected.	X	X

X : Applicable

— : Not applicable

*1 : These malfunctions cannot be displayed by MIL  if another malfunction is assigned to MIL.

*2 : Refer to EC section ["Malfunction Indicator Lamp (MIL)", "ON BOARD DIAGNOSTIC SYSTEM DESCRIPTION"].

ON BOARD DIAGNOSTIC SYSTEM DESCRIPTION

CONSULT (Cont'd)

DATA MONITOR MODE (A/T)

Item	Display	Monitor item		Description	Remarks
		TCM input signals	Main signals		
Vehicle speed sensor 1 (A/T) (Revolution sensor)	VHCL/S SE-A/T [km/h] or [mph]	X	—	● Vehicle speed computed from signal of revolution sensor is displayed.	When racing engine in "N" or "P" position with vehicle stationary, CONSULT data may not indicate 0 km/h (0 mph).
Vehicle speed sensor 2 (Meter)	VHCL/S SE-MTR [km/h] or [mph]	X	—	● Vehicle speed computed from signal of vehicle speed sensor is displayed.	Vehicle speed display may not be accurate under approx. 10 km/h (6 mph). It may not indicate 0 km/h (0 mph) when vehicle is stationary.
Throttle position sensor	THRTL POS SEN [V]	X	—	● Throttle position sensor signal voltage is displayed.	
A/T fluid temperature sensor	FLUID TEMP SE [V]	X	—	● A/T fluid temperature sensor signal voltage is displayed. ● Signal voltage lowers as fluid temperature rises.	
Battery voltage	BATTERY VOLT [V]	X	—	● Source voltage of TCM is displayed.	
Engine speed	ENGINE SPEED [rpm]	X	X	● Engine speed, computed from engine speed signal, is displayed.	Engine speed display may not be accurate under approx. 800 rpm. It may not indicate 0 rpm even when engine is not running.
Overdrive control switch	OVERDRIVE SW [ON/OFF]	X	—	● ON/OFF state computed from signal of overdrive control SW is displayed.	
P/N position switch	P/N POSI SW [ON/OFF]	X	—	● ON/OFF state computed from signal of P/N position SW is displayed.	
R position switch	R POSITION SW [ON/OFF]	X	—	● ON/OFF state computed from signal of R position SW is displayed.	
D position switch	D POSITION SW [ON/OFF]	X	—	● ON/OFF state computed from signal of D position SW is displayed.	
2 position switch	2 POSITION SW [ON/OFF]	X	—	● ON/OFF status, computed from signal of 2 position SW, is displayed.	
1 position switch	1 POSITION SW [ON/OFF]	X	—	● ON/OFF status, computed from signal of 1 position SW, is displayed.	
ASCD cruise signal	ASCD-CRUISE [ON/OFF]	X	—	● Status of ASCD cruise signal is displayed. ON ... Cruising state OFF ... Normal running state	● This is displayed even when no ASCD is mounted.
ASCD OD cut signal	ASCD-OD CUT [ON/OFF]	X	—	● Status of ASCD OD release signal is displayed. ON ... OD released OFF ... OD not released	● This is displayed even when no ASCD is mounted.
Kickdown switch	KICKDOWN SW [ON/OFF]	X	—	● ON/OFF status, computed from signal of kickdown SW, is displayed.	● This is displayed even when no kickdown switch is equipped.
Closed throttle position switch	CLOSED THL/SW [ON/OFF]	X	—	● ON/OFF status, computed from signal of closed throttle position SW, is displayed.	
Wide open throttle position switch	W/O THRL/P-SW [ON/OFF]	X	—	● ON/OFF status, computed from signal of wide open throttle position SW, is displayed.	
Gear position	GEAR	—	X	● Gear position data used for computation by TCM, is displayed.	

ON BOARD DIAGNOSTIC SYSTEM DESCRIPTION

CONSULT (Cont'd)

Item	Display	Monitor item		Description	Remarks
		TCM input signals	Main signals		
Selector lever position	SLCT LVR POSI	—	X	● Selector lever position data, used for computation by TCM, is displayed.	● A specific value used for control is displayed if fail-safe is activated due to error.
Vehicle speed	VEHICLE SPEED [km/h] or [mph]	—	X	● Vehicle speed data, used for computation by TCM, is displayed.	
Throttle position	THROTTLE POSI [7/8]	—	X	● Throttle position data, used for computation by TCM, is displayed.	● A specific value used for control is displayed if fail-safe is activated due to error.
Line pressure duty	LINE PRES DTY [%]	—	X	● Control value of line pressure solenoid valve, computed by TCM from each input signal, is displayed.	
Torque converter clutch solenoid valve duty	TCC S/V DUTY [%]	—	X	● Control value of torque converter clutch solenoid valve, computed by TCM from each input signal, is displayed.	
Shift solenoid valve A	SHIFT S/V A [ON/OFF]	—	X	● Control value of shift solenoid valve A, computed by TCM from each input signal, is displayed.	Control value of solenoid is displayed even if solenoid circuit is disconnected. The "OFF" signal is displayed if solenoid circuit is shorted.
Shift solenoid valve B	SHIFT S/V B [ON/OFF]	—	X	● Control value of shift solenoid valve B, computed by TCM from each input signal, is displayed.	
Overrun clutch solenoid valve	OVERRUN/C S/V [ON/OFF]	—	X	● Control value of overrun clutch solenoid valve computed by TCM from each input signal is displayed.	
Self-diagnosis display lamp (O/D OFF indicator lamp)	SELF-D DP LMP [ON/OFF]	—	X	● Control status of O/D OFF indicator lamp is displayed.	

X: Applicable

—: Not applicable

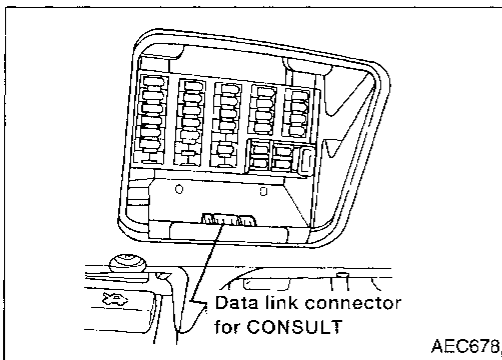

DTC WORK SUPPORT MODE WITH CONSULT

CONSULT setting procedure

1. Turn ignition switch "OFF".
2. Connect CONSULT to Data link connector for CONSULT. Data link connector for CONSULT is located in left side dash panel.
3. Turn ignition switch "ON".
4. Touch "START".

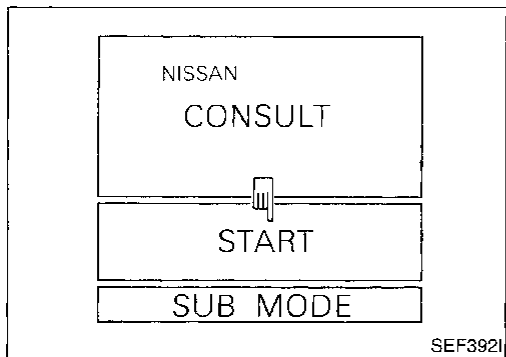

ON BOARD DIAGNOSTIC SYSTEM DESCRIPTION

CONSULT (Cont'd)

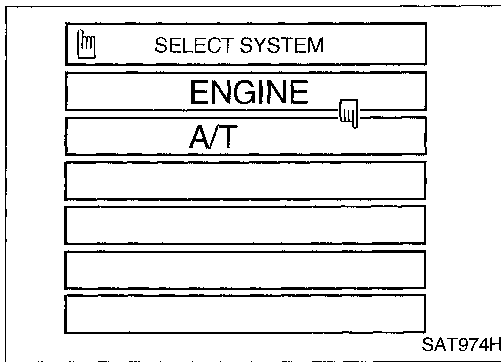

5. Touch "A/T".

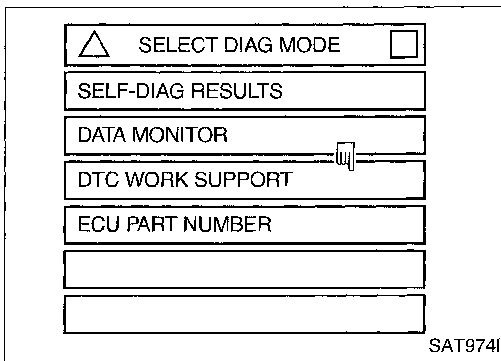

6. Touch "DTC WORK SUPPORT".

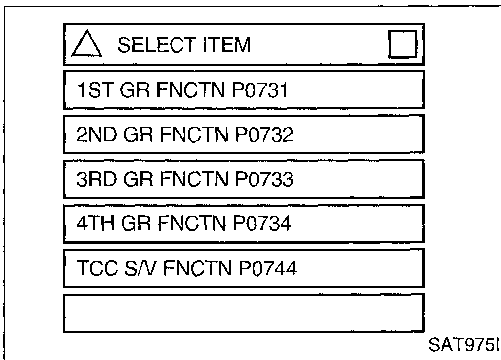

7. Touch select item menu (1ST, 2ND, etc.).

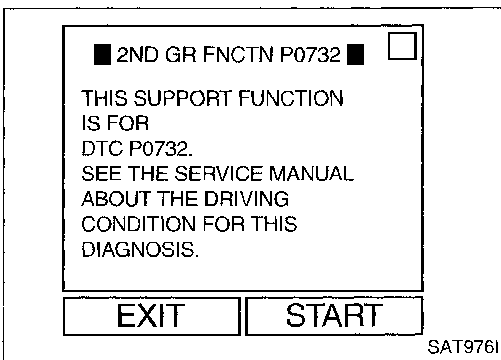

8. Touch "START".

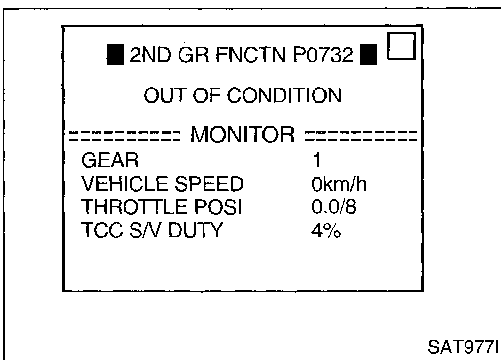

9. Perform driving test according to "DTC CONFIRMATION PROCEDURE" in "TROUBLE DIAGNOSIS FOR DTC".

ON BOARD DIAGNOSTIC SYSTEM DESCRIPTION

CONSULT (Cont'd)

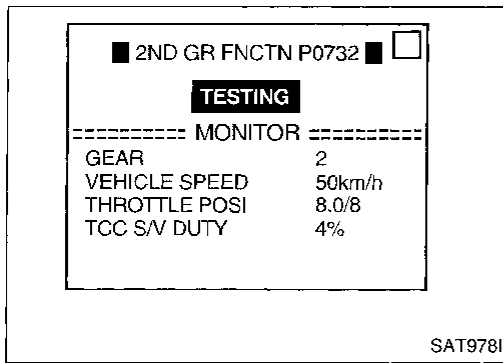

- When testing conditions are satisfied, CONSULT screen changes from "OUT OF CONDITION" to "TESTING".

GI

MA

EM

LC

EC

FE

CL

MT

AT

FA

RA

BR

ST

RS

BT

HA

EL

IDX

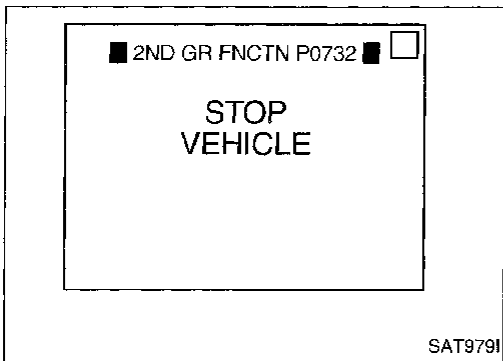

- Stop vehicle. If "NG" appears on the screen, malfunction may exist. Go to "DIAGNOSTIC PROCEDURE".

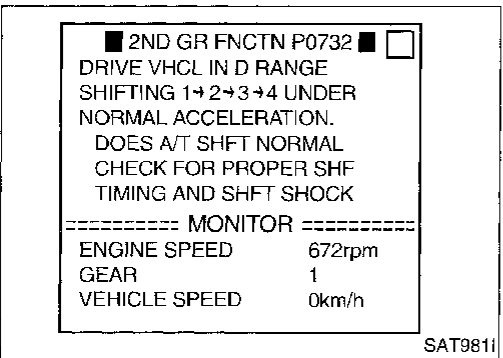
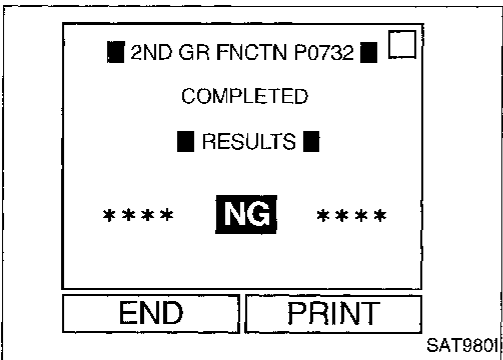

- Perform test drive to check gear shift feeling in accordance with instructions displayed.

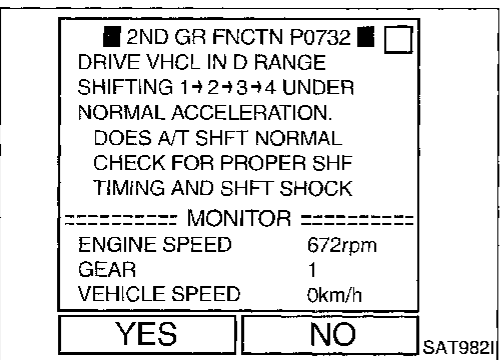

- Touch "YES" or "NO".

ON BOARD DIAGNOSTIC SYSTEM DESCRIPTION

CONSULT (Cont'd)

13. CONSULT procedure ended.

If "NG" appears on the screen, a malfunction may exist. Go to "DIAGNOSTIC PROCEDURE".

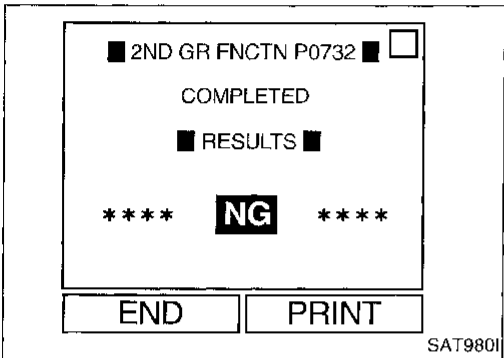
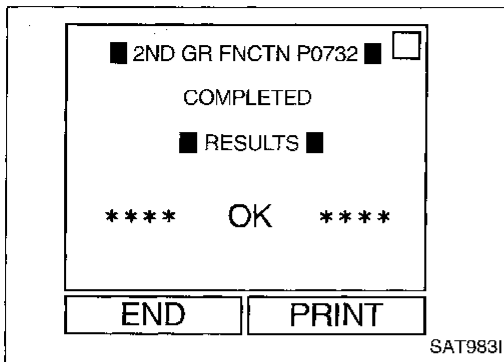

DTC WORK SUPPORT MODE

DTC work support item	Description	Check item
1ST GR FNCTN P0731	<p>Following items for "A/T 1st gear function (P0731)" can be confirmed.</p> <ul style="list-style-type: none"> ● Self-diagnosis status (whether the diagnosis is being conducted or not) ● Self-diagnosis result (OK or NG) 	<ul style="list-style-type: none"> ● Shift solenoid valve A ● Shift solenoid valve B ● Each clutch ● Hydraulic control circuit
2ND GR FNCTN P0732	<p>Following items for "A/T 2nd gear function (P0732)" can be confirmed.</p> <ul style="list-style-type: none"> ● Self-diagnosis status (whether the diagnosis is being conducted or not) ● Self-diagnosis result (OK or NG) 	<ul style="list-style-type: none"> ● Shift solenoid valve B ● Each clutch ● Hydraulic control circuit
3RD GR FNCTN P0733	<p>Following items for "A/T 3rd gear function (P0733)" can be confirmed.</p> <ul style="list-style-type: none"> ● Self-diagnosis status (whether the diagnosis is being conducted or not) ● Self-diagnosis result (OK or NG) 	<ul style="list-style-type: none"> ● Shift solenoid valve A ● Each clutch ● Hydraulic control circuit
4TH GR FNCTN P0734	<p>Following items for "A/T 4th gear function (P0734)" can be confirmed.</p> <ul style="list-style-type: none"> ● Self-diagnosis status (whether the diagnosis is being conducted or not) ● Self-diagnosis result (OK or NG) 	<ul style="list-style-type: none"> ● Shift solenoid valve A ● Shift solenoid valve B ● Overrun clutch solenoid valve ● Line pressure solenoid valve ● Each clutch ● Hydraulic control circuit
TCC S/V FNCTN P0744	<p>Following items for "A/T TCC S/V function (lock-up)" can be confirmed.</p> <ul style="list-style-type: none"> ● Self-diagnosis status (whether the diagnosis is being conducted or not) ● Self-diagnosis result (OK or NG) 	<ul style="list-style-type: none"> ● Torque converter clutch solenoid valve ● Each clutch ● Hydraulic control circuit

ON BOARD DIAGNOSTIC SYSTEM DESCRIPTION

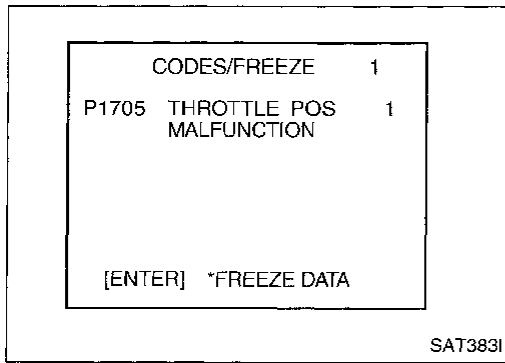

Diagnostic Procedure without CONSULT



OBD-II SELF-DIAGNOSTIC PROCEDURE (With GST)

Refer to EC section ["Generic Scan Tool (GST)", "ON BOARD DIAGNOSTIC SYSTEM DESCRIPTION"].



OBD-II SELF-DIAGNOSTIC PROCEDURE (No Tools)

Refer to EC section ["Malfunction Indicator Lamp (MIL)", "ON BOARD DIAGNOSTIC SYSTEM DESCRIPTION"].

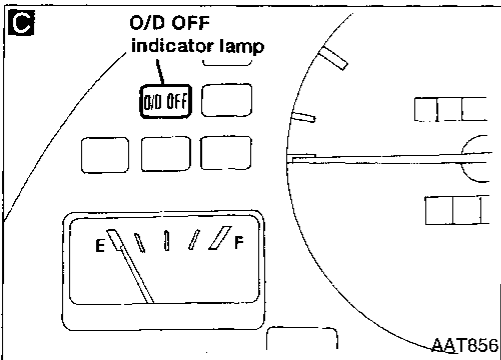
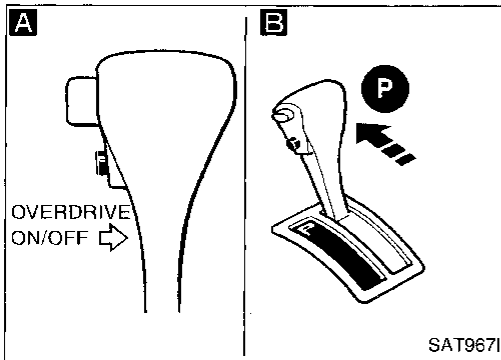

TCM SELF-DIAGNOSTIC PROCEDURE (No Tools)

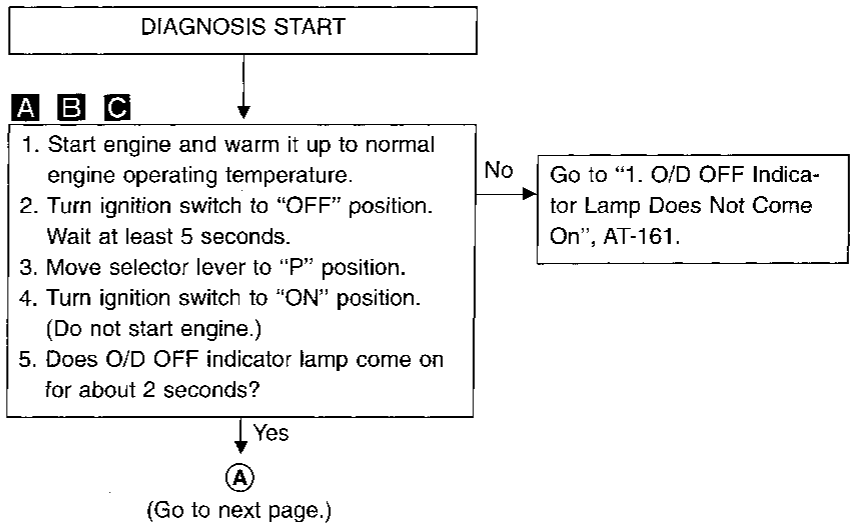

ON BOARD DIAGNOSTIC SYSTEM DESCRIPTION

Diagnostic Procedure without CONSULT (Cont'd)

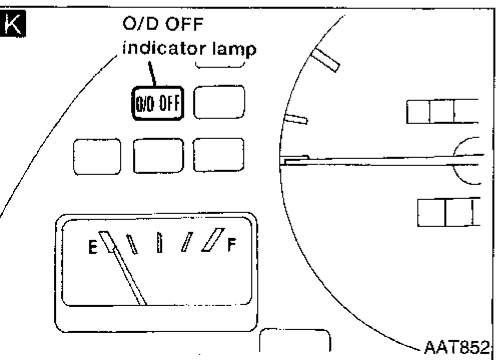
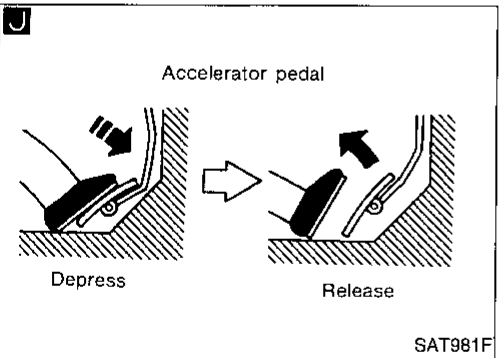
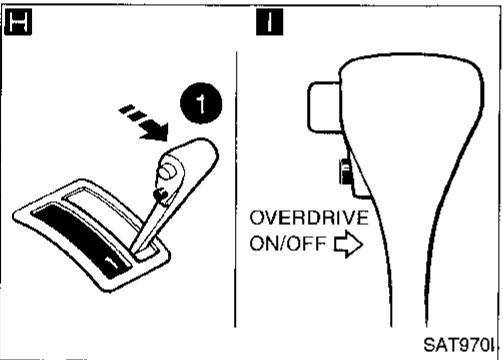
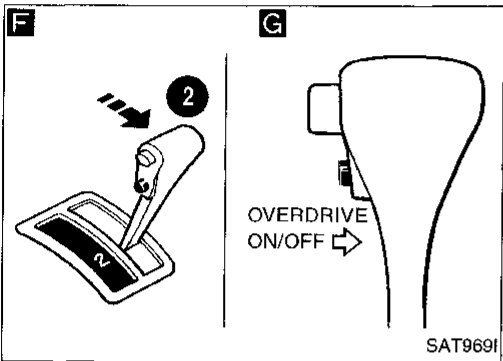
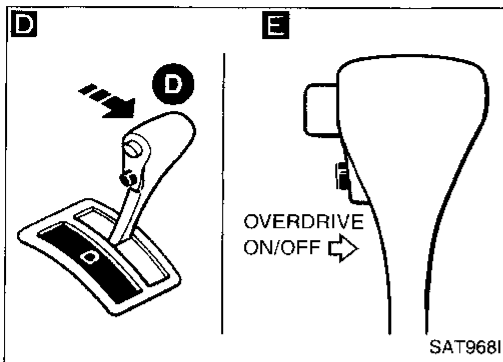

A

D E

1. Turn ignition switch to "OFF" position.
2. Turn ignition switch to "ACC" position.
3. Move selector lever to "D" position.
4. Turn ignition switch to "ON" position.
(Do not start engine.)
5. Depress and hold overdrive control switch in "OFF" position until next step is completed.
6. Turn ignition switch to "OFF" position.
7. Turn ignition switch to "ON" position
(Do not start engine.)

- Wait more than 2 seconds after ignition switch "ON".

F G

1. Move selector lever to "2" position.
2. Depress and hold overdrive control switch in "ON" position until next step is completed.

H I

1. Move selector lever to "1" position.
2. Cycle overdrive control switch from "OFF" to "ON" position, depress and hold in "OFF" position until next step is completed.

J

Depress accelerator pedal fully and release it.

K

Check O/D OFF indicator lamp.
Refer to JUDGEMENT OF SELF-DIAGNOSIS CODE, AT-51.

DIAGNOSIS END

ON BOARD DIAGNOSTIC SYSTEM DESCRIPTION

Diagnostic Procedure without CONSULT (Cont'd)

JUDGEMENT OF SELF-DIAGNOSIS CODE

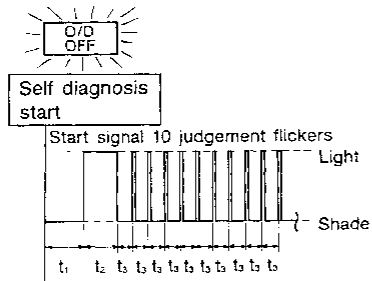
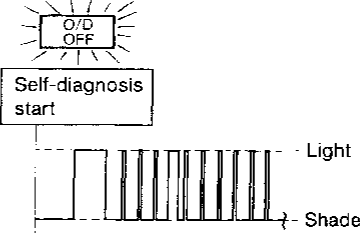
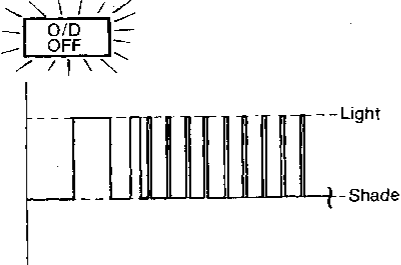
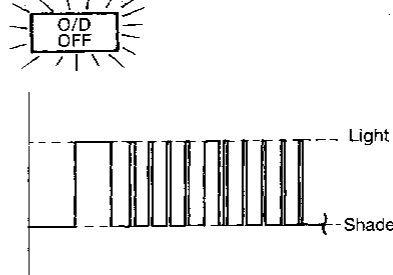
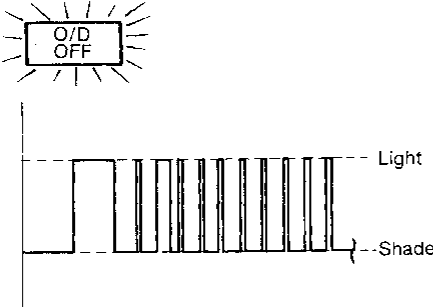
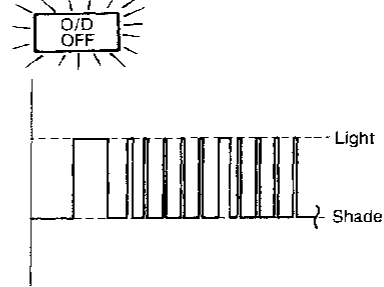
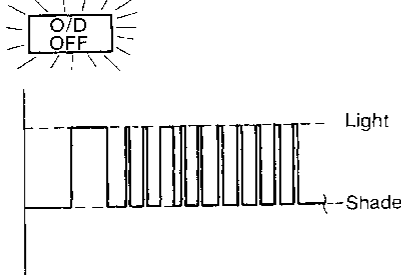
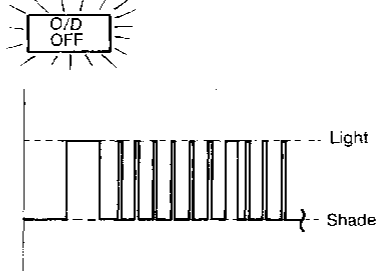
O/D OFF indicator lamp:	
<p>All judgement flickers are the same.</p>  <p style="text-align: right;">SAT436F</p>	<p>4th judgement flicker is longer than others.</p>  <p style="text-align: right;">SAT443F</p> <p>Shift solenoid valve A circuit is short-circuited or disconnected. Go to SHIFT SOLENOID VALVE A (DTC: 1108), AT-135.</p>
<p>All circuits that can be confirmed by self-diagnosis are OK.</p> <p>1st judgement flicker is longer than others.</p>  <p style="text-align: right;">SAT437F</p> <p>Revolution sensor circuit is short-circuited or disconnected. Go to VEHICLE SPEED SENSOR-A/T (REVOLUTION SENSOR) (DTC: 1102), AT-89.</p>	<p>5th judgement flicker is longer than others.</p>  <p style="text-align: right;">SAT445F</p> <p>Shift solenoid valve B circuit is short-circuited or disconnected. Go to SHIFT SOLENOID VALVE B (DTC: 1201), AT-139.</p>
<p>2nd judgement flicker is longer than others.</p>  <p style="text-align: right;">SAT439F</p> <p>Vehicle speed sensor circuit is short-circuited or disconnected. Go to VEHICLE SPEED SENSOR-MTR, AT-158.</p>	<p>6th judgement flicker is longer than others.</p>  <p style="text-align: right;">SAT447F</p> <p>Overrun clutch solenoid valve circuit is short-circuited or disconnected. Go to OVERRUN CLUTCH SOLENOID VALVE (DTC: 1203), AT-150.</p>
<p>3rd judgement flicker is longer than others.</p>  <p style="text-align: right;">SAT441F</p> <p>Throttle position sensor circuit is short-circuited or disconnected. Go to THROTTLE POSITION SENSOR (DTC: 1206), AT-143.</p>	<p>7th judgement flicker is longer than others.</p>  <p style="text-align: right;">SAT449F</p> <p>Torque converter clutch solenoid valve circuit is short-circuited or disconnected. Go to TORQUE CONVERTER CLUTCH SOLENOID VALVE (DTC: 1204), AT-120.</p>

$t_1 = 2.5$ seconds $t_2 = 2.0$ seconds $t_3 = 1.0$ second

GI
MA
EM
LC
EC
FE
CL
MT
AT
FA
RA
BR
ST
RS
BT
HA
EL
IDX

ON BOARD DIAGNOSTIC SYSTEM DESCRIPTION

Diagnostic Procedure without CONSULT (Cont'd)

O/D OFF indicator lamp:

8th judgement flicker is longer than others.

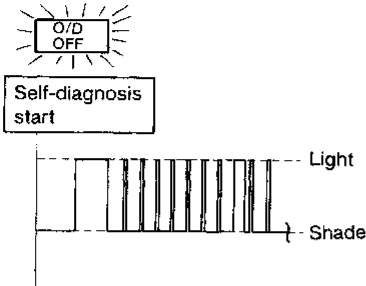

SAT451F

A/T fluid temperature sensor is disconnected or TCM power source circuit is damaged.
 ➤ Go to **A/T FLUID TEMPERATURE SENSOR AND TCM POWER SOURCE, AT-154.**

Flickers as shown below.

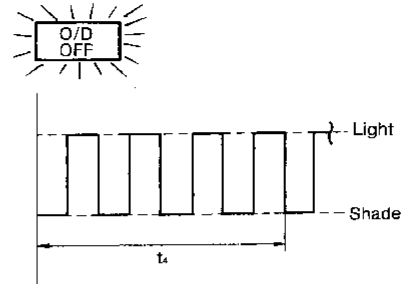

SAT457F

Battery power is low.
 Battery has been disconnected for a long time.
 Battery is connected conversely.
 (When reconnecting TCM connectors. — This is not a problem.)

9th judgement flicker is longer than others.

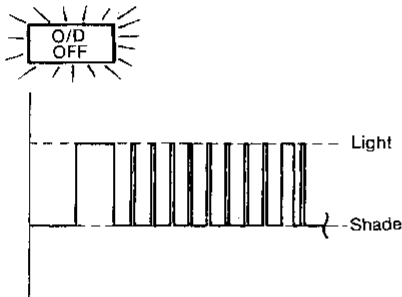

SAT453F

Engine speed signal circuit is short-circuited or disconnected.
 ➤ Go to **ENGINE SPEED SIGNAL (DTC: 1207), AT-93.**

Does not come on.

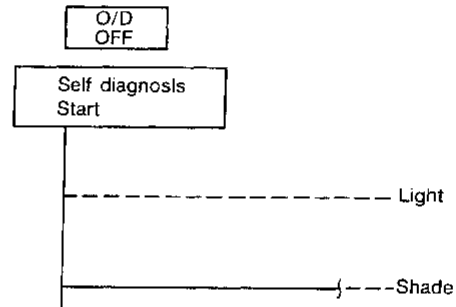

SAT414G

Inhibitor switch, overdrive control switch or throttle position switch circuit is disconnected or TCM is damaged.
 ➤ Go to **INHIBITOR, OVERDRIVE CONTROL AND THROTTLE POSITION SWITCHES, AT-176.**

10th judgement flicker is longer than others.

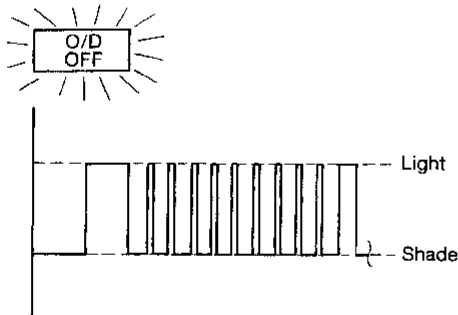

SAT455F

Line pressure solenoid valve circuit is short-circuited or disconnected.
 ➤ Go to **LINE PRESSURE SOLENOID VALVE (DTC: 1205), AT-131.**

$t_4 = 1.0$ second

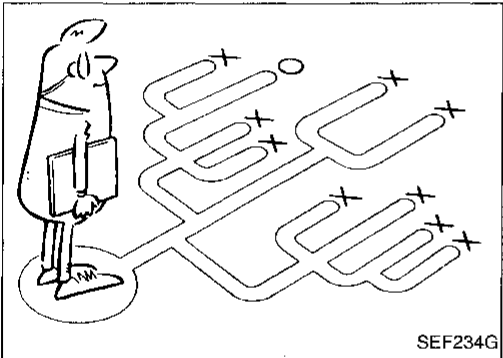
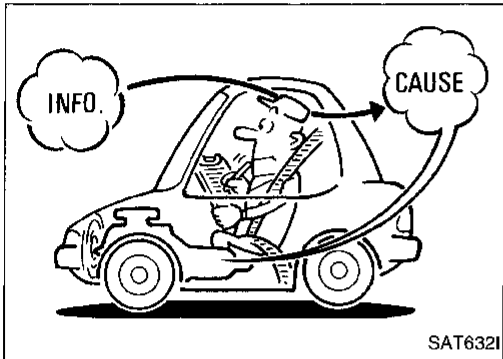
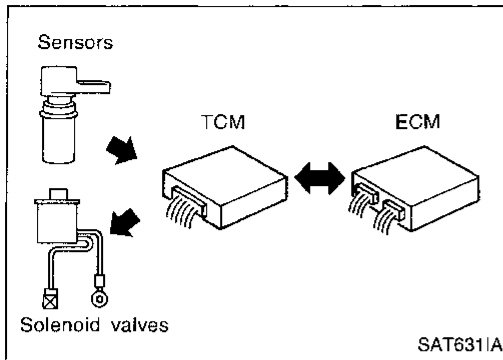

Introduction

The TCM receives a signal from the vehicle speed sensor, throttle position sensor or inhibitor switch and provides shift control or lock-up control via A/T solenoid valves.

The TCM also communicates with the ECM by means of a signal sent from sensing elements used with the OBD-related parts of the A/T system for malfunction-diagnostic purposes. The TCM is capable of diagnosing malfunctioning parts while the ECM can store malfunctions in its memory.

Input and output signals must always be correct and stable in the operation of the A/T system. The A/T system must be in good operating condition and be free of valve seizure, solenoid valve malfunction, etc.

It is much more difficult to diagnose a problem that occurs intermittently rather than continuously. Most intermittent problems are caused by poor electric connections or improper wiring. In this case, careful checking of suspected circuits may help prevent the replacement of good parts.

A visual check only, may not find the cause of the problems. A road test with CONSULT (or GST) or a circuit tester connected should be performed. Follow the "Work Flow". Refer to AT-57. Before undertaking actual checks, take a few minutes to talk with a customer who approaches with a driveability complaint. The customer can supply good information about such problems, especially intermittent ones. Find out what symptoms are present and under what conditions they occur. A "Diagnostic Worksheet" like the example (AT-54) should be used.

Start your diagnosis by looking for "conventional" problems first. This will help troubleshoot driveability problems on an electronically controlled engine vehicle.

Also check related Service bulletins for information.

GI
MA
EM
LC
EC
FE
CL
MT
AT
FA
RA
BR
ST
RS
BT
HA
EL
IDX

TROUBLE DIAGNOSIS — Introduction

Diagnostic Worksheet (Cont'd)

DIAGNOSTIC WORKSHEET

1.	<input type="checkbox"/> Read the Fail-safe and listen to customer complaints.	AT-5	GI
2.	<input type="checkbox"/> CHECK A/T FLUID <input type="checkbox"/> Leakage (Follow specified procedure) <input type="checkbox"/> Fluid condition <input type="checkbox"/> Fluid level	AT-58	MA
3.	<input type="checkbox"/> Perform STALL TEST and LINE PRESSURE TEST. <input type="checkbox"/> Stall test — Mark possible damaged components/others. <div style="display: flex; justify-content: space-between;"> <div style="width: 48%;"> <input type="checkbox"/> Torque converter one-way clutch <input type="checkbox"/> Reverse clutch <input type="checkbox"/> Forward clutch <input type="checkbox"/> Overrun clutch <input type="checkbox"/> Forward one-way clutch </div> <div style="width: 48%;"> <input type="checkbox"/> Low & reverse brake <input type="checkbox"/> Low one-way clutch <input type="checkbox"/> Engine <input type="checkbox"/> Line pressure is low <input type="checkbox"/> Clutches and brakes except high clutch and brake band are OK </div> </div> <input type="checkbox"/> Line pressure test — Suspected parts:	AT-58, 61	EM LC EC FE
4.	<input type="checkbox"/> Perform all ROAD TEST and mark required procedures. 4-1. Check before engine is started <input type="checkbox"/> SELF-DIAGNOSTIC PROCEDURE — Mark detected items. <input type="checkbox"/> Inhibitor switch, AT-81. <input type="checkbox"/> A/T fluid temperature sensor, AT-85. <input type="checkbox"/> Vehicle speed sensor-A/T (Revolution sensor), AT-89. <input type="checkbox"/> Engine speed signal, AT-93. <input type="checkbox"/> Torque converter clutch solenoid valve, AT-120. <input type="checkbox"/> Line pressure solenoid valve, AT-131. <input type="checkbox"/> Shift solenoid valve A, AT-135. <input type="checkbox"/> Shift solenoid valve B, AT-139. <input type="checkbox"/> Throttle position sensor, AT-143. <input type="checkbox"/> Overrun clutch solenoid valve, AT-150. <input type="checkbox"/> Inhibitor, overdrive control and throttle position switches, AT-176. <input type="checkbox"/> A/T fluid temperature sensor and TCM power source, AT-154. <input type="checkbox"/> Vehicle speed sensor-MTR, AT-158. <input type="checkbox"/> Battery <input type="checkbox"/> Others	AT-62 AT-63	CL MT
	4-2. Check at idle <input type="checkbox"/> 1. O/D OFF Indicator Lamp Does Not Come On, AT-161. <input type="checkbox"/> 2. Engine Cannot Be Started In "P" And "N" Position, AT-162. <input type="checkbox"/> 3. In "P" Position, Vehicle Moves Forward Or Backward When Pushed, AT-162. <input type="checkbox"/> 4. In "N" Position, Vehicle Moves, AT-163. <input type="checkbox"/> 5. Large Shock. "N" → "R" Position, AT-164. <input type="checkbox"/> 6. Vehicle Does Not Creep Backward In "R" Position, AT-165. <input type="checkbox"/> 7. Vehicle Does Not Creep Forward In "D", "2" Or "1" Position, AT-166.	AT-64	ST RS
	4-3. Cruise test Part-1 <input type="checkbox"/> 8. Vehicle Cannot Be Started From D ₁ , AT-167. <input type="checkbox"/> 9. A/T Does Not Shift: D ₁ → D ₂ Or Does Not Kickdown: D ₄ → D ₂ , AT-168. <input type="checkbox"/> 10. A/T Does Not Shift: D ₂ → D ₃ , AT-169. <input type="checkbox"/> 11. A/T Does Not Shift: D ₃ → D ₄ , AT-170. <input type="checkbox"/> 12. A/T Does Not Perform Lock-up, AT-171. <input type="checkbox"/> 13. A/T Does Not Hold Lock-up Condition, AT-172. <input type="checkbox"/> 14. Lock-up Is Not Released, AT-172. <input type="checkbox"/> 15. Engine Speed Does Not Return To Idle (Light Braking D ₄ → D ₃), AT-173.	AT-66, AT-69	HA EL IDX

GI

MA

EM

LC

EC

FE

CL

MT

AT

FA

RA

BR

ST

RS

BT

HA

EL

IDX

TROUBLE DIAGNOSIS — Introduction

Diagnostic Worksheet (Cont'd)

4.	<p>Part-2</p> <ul style="list-style-type: none"> <input type="checkbox"/> 16. Vehicle Does Not Start From D₁, AT-174. <input type="checkbox"/> 9. A/T Does Not Shift: D₁ → D₂ Or Does Not Kickdown: D₄ → D₂, AT-168. <input type="checkbox"/> 10. A/T Does Not Shift: D₂ → D₃, AT-169. <input type="checkbox"/> 11. A/T Does Not Shift: D₃ → D₄, AT-170. <p>Part-3</p> <ul style="list-style-type: none"> <input type="checkbox"/> 17. A/T Does Not Shift: D₄ → D₃ When Overdrive Control Switch "ON" → "OFF", AT-174 <input type="checkbox"/> 15. Engine Speed Does Not Return To Idle (Engine Brake In D₃), AT-173. <input type="checkbox"/> 18. A/T Does Not Shift: D₃ → 2₂, When Selector Lever "D" → "2" Position, AT-175. <input type="checkbox"/> 15. Engine Speed Does Not Return To Idle (Engine Brake In 2₂), AT-173. <input type="checkbox"/> 19. A/T Does Not Shift: 2₂ → 1₁, When Selector Lever "2" → "1" Position, AT-175. <input type="checkbox"/> 20. Vehicle Does Not Decelerate By Engine Brake, AT-176. <input type="checkbox"/> SELF-DIAGNOSTIC PROCEDURE — Mark detected items. <ul style="list-style-type: none"> <input type="checkbox"/> Inhibitor switch, AT-81. <input type="checkbox"/> A/T fluid temperature sensor, AT-85. <input type="checkbox"/> Vehicle speed sensor-A/T (Revolution sensor), AT-89. <input type="checkbox"/> Engine speed signal, AT-93. <input type="checkbox"/> Torque converter clutch solenoid valve, AT-120. <input type="checkbox"/> Line pressure solenoid valve, AT-131. <input type="checkbox"/> Shift solenoid valve A, AT-135. <input type="checkbox"/> Shift solenoid valve B, AT-139. <input type="checkbox"/> Throttle position sensor, AT-143. <input type="checkbox"/> Overrun clutch solenoid valve, AT-150. <input type="checkbox"/> Inhibitor, overdrive control and throttle position switches, AT-176. <input type="checkbox"/> A/T fluid temperature sensor and TCM power source, AT-154. <input type="checkbox"/> Vehicle speed sensor-MTR, AT-158. <input type="checkbox"/> Battery <input type="checkbox"/> Others 	AT-71
5.	<input type="checkbox"/> For self-diagnosis NG items, inspect each component. Repair or replace the damaged parts.	AT-43
6.	<input type="checkbox"/> Perform all ROAD TEST and re-mark required procedures.	AT-62
7.	<input type="checkbox"/> Perform DTC CONFIRMATION PROCEDURE for following MIL indicating items and check out NG items. Refer to EC section ["Emission-related Diagnostic Information", "ON BOARD DIAGNOSTIC SYSTEM DESCRIPTION"]. <ul style="list-style-type: none"> <input type="checkbox"/> DTC (P0731, 1103) A/T 1st gear function, AT-96. <input type="checkbox"/> DTC (P0732, 1104) A/T 2nd gear function, AT-102. <input type="checkbox"/> DTC (P0733, 1105) A/T 3rd gear function, AT-107. <input type="checkbox"/> DTC (P0734, 1106) A/T 4th gear function, AT-112. <input type="checkbox"/> DTC (P0744, 1107) A/T TCC S/V function (lock-up), AT-124. 	EC section
8.	<input type="checkbox"/> Perform the Diagnostic Procedures for all remaining items marked NG. Repair or replace the damaged parts. Refer to the Symptom Chart when you perform the procedures. (The chart also shows some other possible symptoms and the component inspection orders.)	AT-76, AT-73
9.	<input type="checkbox"/> Erase DTC from TCM and ECM memories.	AT-40

TROUBLE DIAGNOSIS — Introduction

Work Flow

HOW TO PERFORM TROUBLE DIAGNOSES FOR QUICK AND ACCURATE REPAIR

A good understanding of the malfunction conditions can make troubleshooting faster and more accurate. In general, each customer feels differently about a problem. It is important to fully understand the symptoms or conditions for a customer complaint.

Make good use of the two sheets provided, "INFORMATION FROM CUSTOMER" (AT-54) and "DIAGNOSTIC WORKSHEET" (AT-55), to perform the best troubleshooting possible.

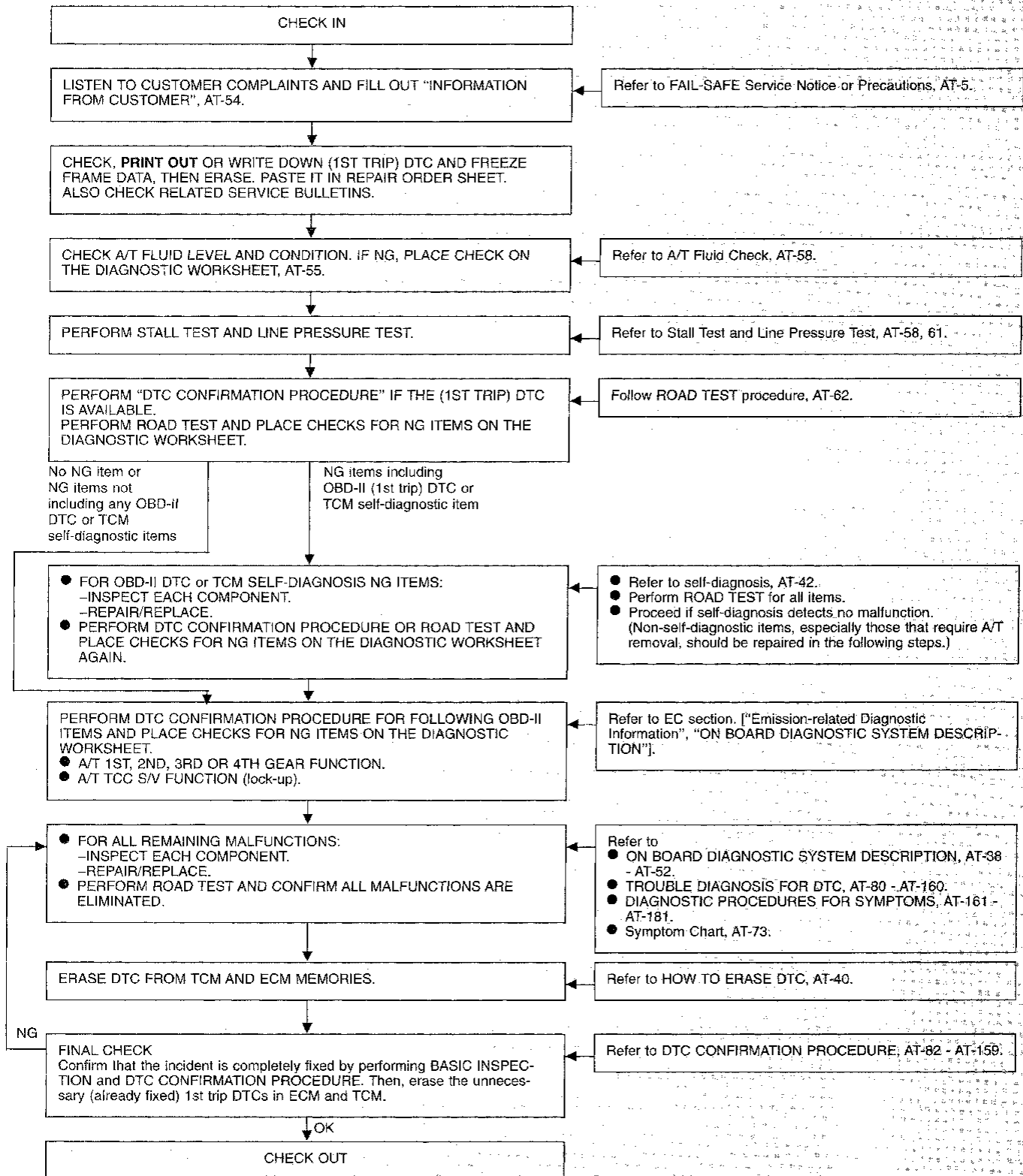

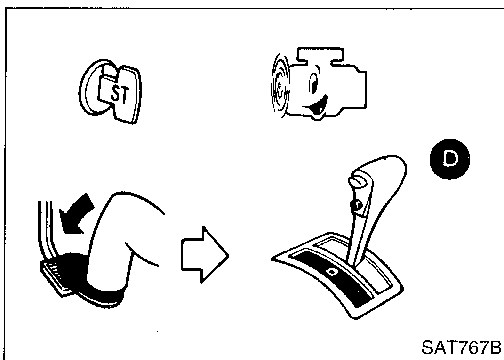

A/T Fluid Check

FLUID LEAKAGE CHECK

1. Clean area suspected of leaking. — for example, mating surface of converter housing and transmission case.
2. Start engine, apply foot brake, place selector lever in “D” position and wait a few minutes.
3. Stop engine.

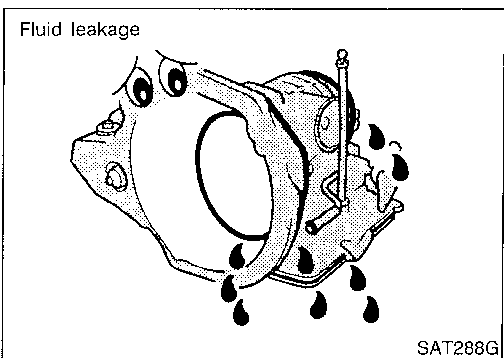

4. Check for fresh leakage.

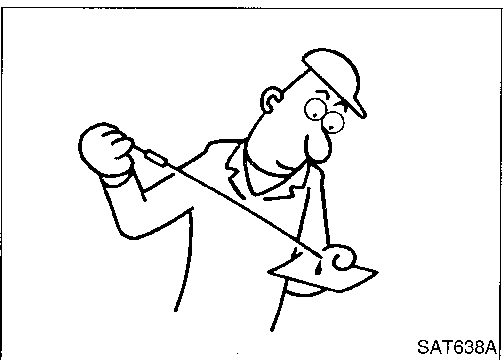

FLUID CONDITION CHECK

Fluid color	Suspected problem
Dark or black with burned odor	Wear of frictional material
Milky pink	Water contamination — Road water entering through filler tube or breather
Varnished fluid, light to dark brown and tacky	Oxidation — Over or under filling, — Overheating

FLUID LEVEL CHECK

Refer to MA section (“Checking A/T Fluid”, “CHASSIS AND BODY MAINTENANCE”).

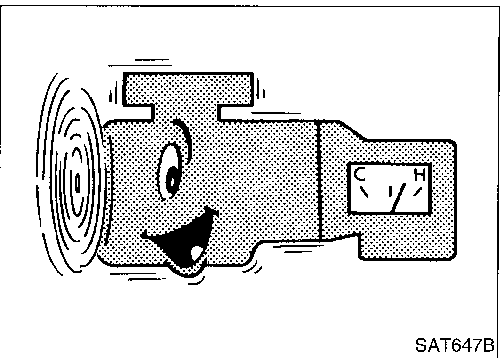

Stall Test

STALL TEST PROCEDURE

1. Check A/T and engine fluid levels. If necessary, add.
2. Drive vehicle for approx. 10 minutes or until engine oil and ATF reach operating temperature.

ATF operating temperature:
50 - 80°C (122 - 176°F)

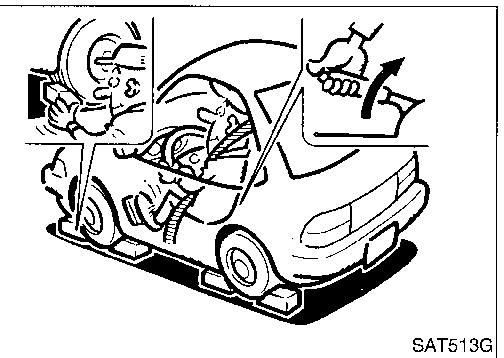

3. Set parking brake and block wheels.
 4. Install a tachometer where it can be seen by driver during test.
- It is good practice to mark the point of specified engine rpm on indicator.

TROUBLE DIAGNOSIS — Basic Inspection

Stall Test (Cont'd)

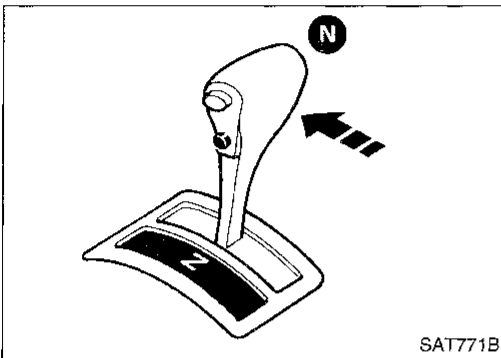
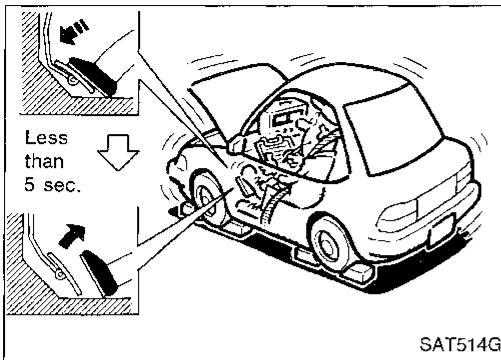

5. Start engine, apply foot brake, and place selector lever in D position.
6. Accelerate to wide-open throttle gradually while applying foot brake.
7. Quickly note the engine stall revolution and immediately release throttle.

- **During test, never hold throttle wide-open for more than 5 seconds.**

Stall revolution:
1,850 - 2,150 rpm

8. Move selector lever to "N" position.
9. Cool off ATF.
- **Run engine at idle for at least one minute.**
10. Repeat steps 5 through 9 with selector lever in "2", "1" and "R" positions.

JUDGEMENT OF STALL TEST

The test result and possible damaged components relating to each result are shown in the illustrations on next page.

In order to pinpoint the possible damaged components, follow the WORK FLOW shown in AT-57.

Note

Stall revolution is too high in "D", "2" or "1" position:

- Slippage occurs in 1st gear but not in 2nd and 3rd gears. Low one-way clutch slippage
- Slippage occurs in the following gears:
1st through 3rd gears in "D" position and engine brake functions with overdrive control switch set to "OFF".
1st and 2nd gears in "2" position and engine brake functions with accelerator pedal released (fully closed throttle). Forward clutch or forward one-way clutch slippage

Stall revolution is too high in R position:

- Engine brake does not function in "1" position. Low & reverse brake slippage
- Engine brake functions in "1" position. Reverse clutch slippage

Stall revolution within specifications:

- Vehicle does not achieve speed of more than 80 km/h (50 MPH). One-way clutch seizure in torque converter housing

CAUTION:

Be careful since automatic fluid temperature increases abnormally.

- Slippage occurs in 3rd and 4th gears in "D" position. High clutch slippage
- Slippage occurs in 2nd and 4th gear in "D" position. Brake band slippage
- Engine brake does not function in 2nd and 3rd gears in "D" position, 2nd gear in "2" position, and 1st gear in "1" position with overdrive control switch set to "OFF".

Stall revolution less than specifications:

- Poor acceleration during starts. One-way clutch seizure in torque converter

TROUBLE DIAGNOSIS — Basic Inspection

Stall Test (Cont'd)

JUDGEMENT OF STALL TEST

Selector lever position	Judgement		
	H	O	L
D	H	O	L
2	H	O	L
1	H	O	L
R	O	H	L

O : Stall revolution is normal.
 H : Stall revolution is higher than specified.
 L : Stall revolution is lower than specified.

Damaged components

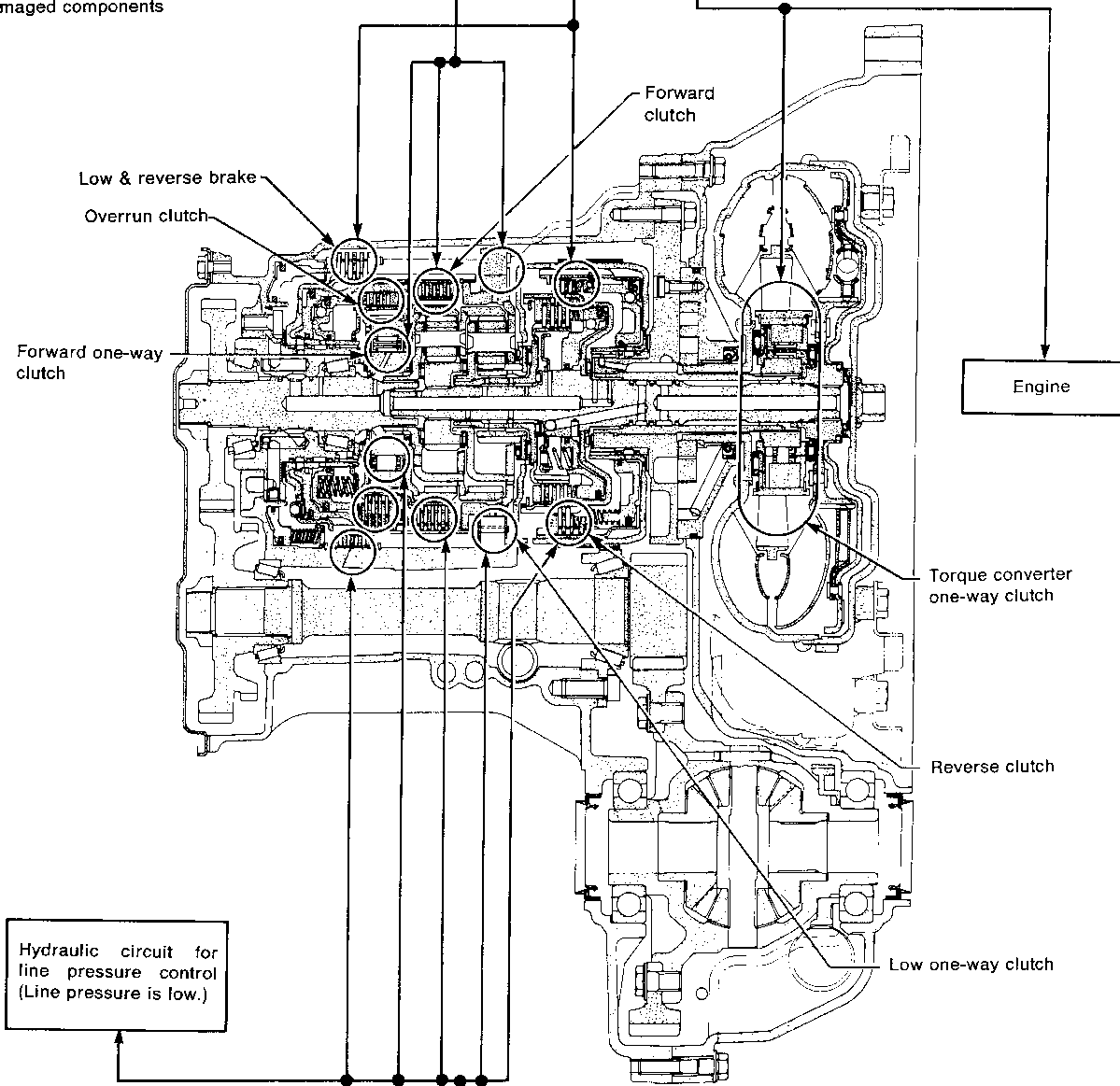

D	H	O
2	H	O
1	H	O
R	H	O
Selector lever position	Judgement	

Clutches and brakes except high clutch and brake band are OK. (Condition of high clutch and brake band cannot be confirmed by stall test.)

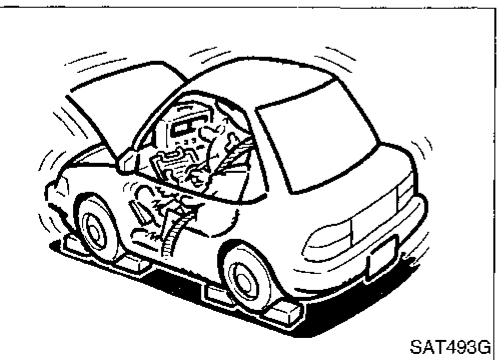
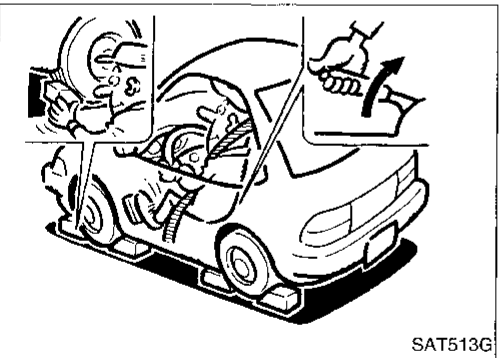
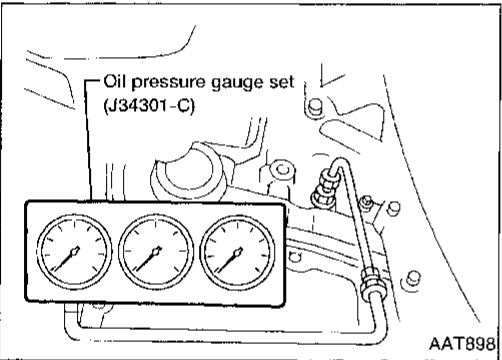
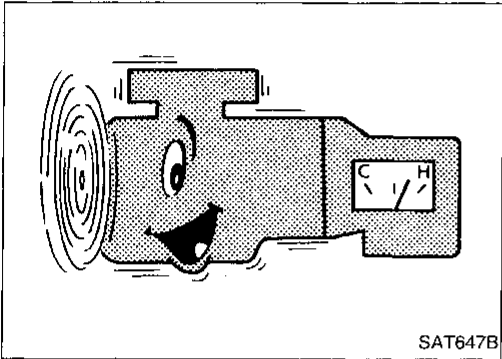
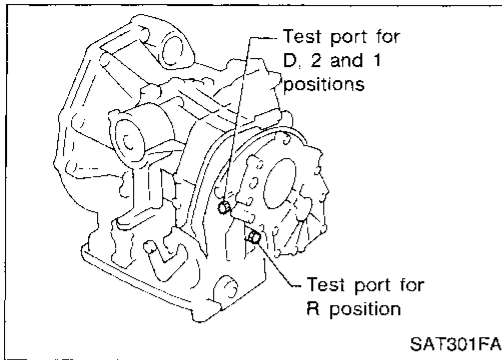

Line Pressure Test

PRESSURE TEST PORTS

Location of pressure test ports are shown in the illustration.

- Always replace pressure plugs as they are self-sealing bolts.

LINE PRESSURE TEST PROCEDURE

1. Check A/T and engine fluid levels. If necessary, add fluid.
2. Drive vehicle for approx. 10 minutes or until engine oil and ATF reach operating temperature.

ATF operating temperature:
50 - 80°C (122 - 176°F)

3. Install pressure gauge to corresponding line pressure port.

4. Set parking brake and block wheels.
 - Continue to depress brake pedal fully while line pressure test is being performed at stall speed.

5. Start engine and measure line pressure at idle and stall speed.

- When measuring line pressure at stall speed, follow the stall test procedure.

Line pressure: Refer to SDS, AT-294.

GI
MA
EM
LC
EC
FE
CL
MT
AT
FA
RA
BR
ST
RS
BT
HA
EL
IDX

TROUBLE DIAGNOSIS — Basic Inspection

Line Pressure Test (Cont'd)

JUDGEMENT OF LINE PRESSURE TEST

Judgement		Suspected parts
At idle	Line pressure is low in all positions.	<ul style="list-style-type: none"> ● Oil pump wear ● Control piston damage ● Pressure regulator valve or plug sticking ● Spring for pressure regulator valve damaged ● Fluid pressure leakage between oil strainer and pressure regulator valve ● Clogged strainer
	Line pressure is low in particular position.	<ul style="list-style-type: none"> ● Fluid pressure leakage between manual valve and particular clutch ● For example, line pressure is: <ul style="list-style-type: none"> - Low in "R" and "1" positions, but - Normal in "D" and "2" positions. Therefore, fluid leakage exists at or around low and reverse brake circuit. Refer to "CLUTCH AND BAND CHART", AT-22.
	Line pressure is high.	<ul style="list-style-type: none"> ● Maladjustment of throttle position sensor ● A/T fluid temperature sensor damaged ● Line pressure solenoid valve sticking ● Short circuit of line pressure solenoid valve circuit ● Pressure modifier valve sticking ● Pressure regulator valve or plug sticking ● Open in dropping resistor circuit
At stall speed	Line pressure is low.	<ul style="list-style-type: none"> ● Maladjustment of throttle position sensor ● Line pressure solenoid valve sticking ● Short circuit of line pressure solenoid valve circuit ● Pressure regulator valve or plug sticking ● Pressure modifier valve sticking ● Pilot valve sticking

ROAD TEST PROCEDURE

1. Check before engine is started.



2. Check at idle.



3. Cruise test.

SAT786A

Road Test

DESCRIPTION

- The purpose of the test is to determine overall performance of A/T and analyze causes of problems.
- The road test consists of the following three parts:
 1. Check before engine is started
 2. Check at idle
 3. Cruise test
- Before road test, familiarize yourself with all test procedures and items to check.
- Conduct tests on all items until specified symptom is found. Troubleshoot items which check out No Good after road test. Refer to "ON BOARD DIAGNOSTIC SYSTEM DESCRIPTION" and "DIAGNOSTIC PROCEDURES FOR SYMPTOMS", AT-38 - AT-52 and AT-161 - AT-181.

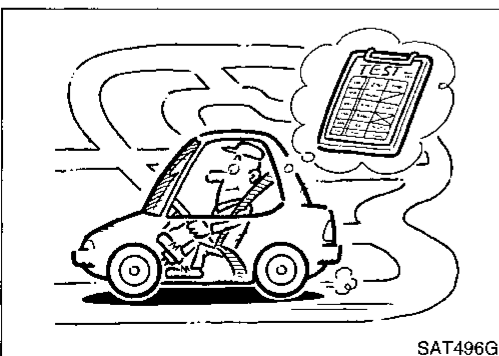

SAT496G

TROUBLE DIAGNOSIS — Basic Inspection

Road Test (Cont'd)

1. CHECK BEFORE ENGINE IS STARTED

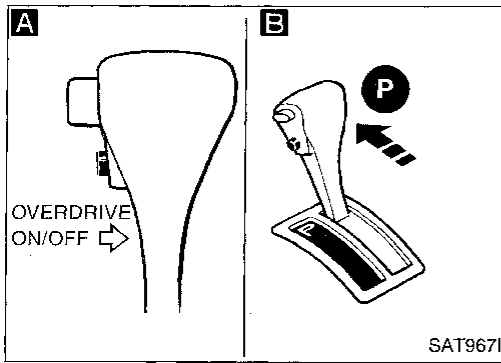

A B C

1. Park vehicle on flat surface.
2. Move selector lever to "P" position.
3. Turn ignition switch to "OFF" position. Wait at least 5 seconds.
4. Turn ignition switch to "ON" position. (Do not start engine.)
5. Does O/D OFF indicator lamp come on for about 2 seconds?

No

Stop ROAD TEST.
Go to "1. O/D OFF Indicator Lamp Does Not Come On", AT-161.

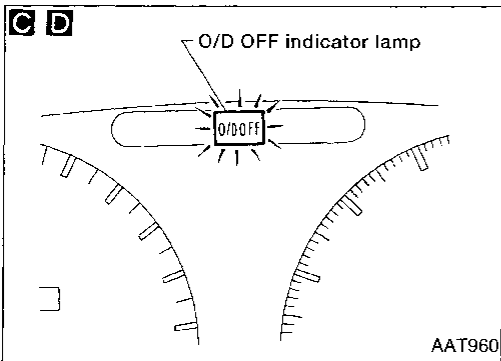

D

Does O/D OFF indicator lamp flicker for about 8 seconds?

Yes

Perform self-diagnosis and check NG items on the DIAGNOSTIC WORKSHEET, AT-55. Refer to SELF-DIAGNOSIS PROCEDURE, AT-42.

No

1. Turn ignition switch to "OFF" position.
2. Perform self-diagnosis and note NG items. Refer to SELF-DIAGNOSIS PROCEDURE, AT-42.
3. Go to "2. CHECK AT IDLE", AT-64.

GI

MA

EM

LC

EC

FE

CL

MT

AT

FA

RA

BR

ST

RS

BT

HA

EL

IDX

TROUBLE DIAGNOSIS — Basic Inspection

Road Test (Cont'd)

2. CHECK AT IDLE

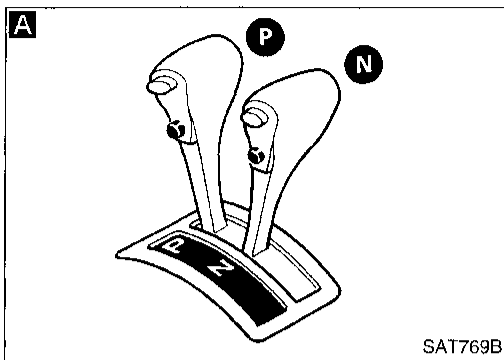

- A**
1. Park vehicle on flat surface.
 2. Move selector lever to "P" position.
 3. Turn ignition switch to "OFF" position.
 4. Turn ignition switch to "START" position.
 5. Is engine started?

No → Mark the box on the DIAGNOSTIC WORKSHEET. Go to "2. Engine Cannot Be Started In "P" and "N" Position", AT-162. Continue ROAD TEST.

Yes

Turn ignition switch to "ACC" position.

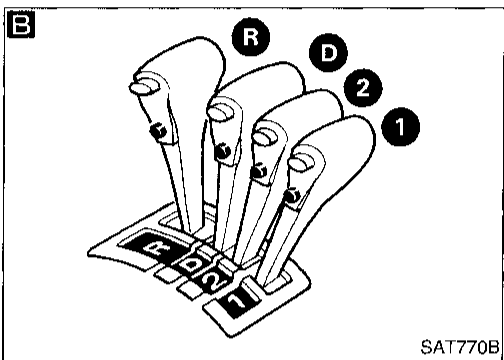

- B**
1. Move selector lever to "D", "1", "2" or "R" position.
 2. Turn ignition switch to "START" position.
 3. Is engine started?

Yes → Mark the box on the DIAGNOSTIC WORKSHEET. Go to "2. Engine Cannot Be Started In "P" and "N" Position", AT-162. Continue ROAD TEST.

No

- C**
1. Move selector lever to "P" position.
 2. Turn ignition switch to "OFF" position.
 3. Release parking brake.

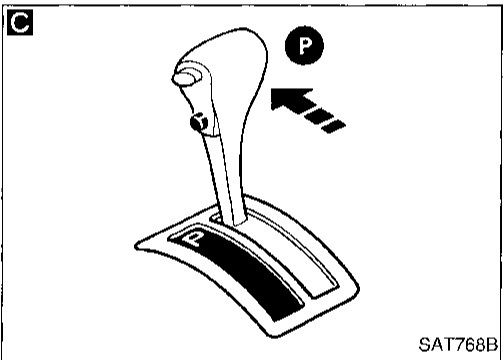

- D**
1. Push vehicle forward or backward.
 2. Does vehicle move when it is pushed forward or backward?
 3. Apply parking brake.

Yes → Mark the box on the DIAGNOSTIC WORKSHEET. Go to "3. In "P" Position, Vehicle Moves Forward Or Backward When Pushed", AT-162. Continue ROAD TEST.

No

- E**
1. Start engine.
 2. Move selector lever to "N" position.
 3. Release parking brake.
 4. Does vehicle move forward or backward?

Yes → Mark the box on the DIAGNOSTIC WORKSHEET. Go to "4. In "N" Position, Vehicle Moves", AT-163. Continue ROAD TEST.

No

A

(Go to next page.)

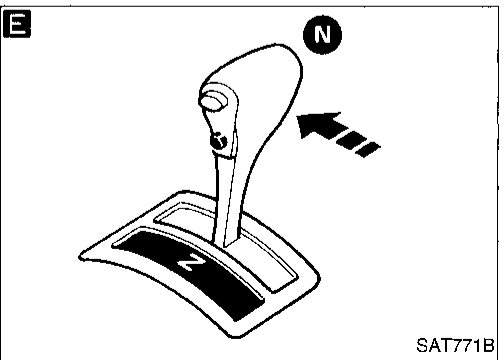
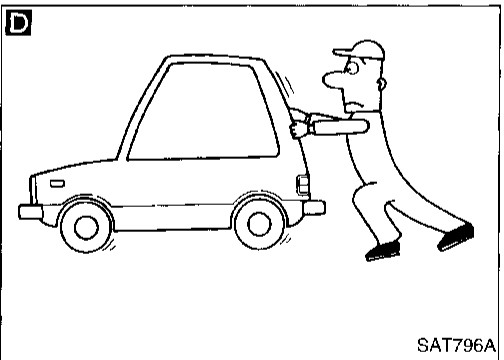

TROUBLE DIAGNOSIS — Basic Inspection

Road Test (Cont'd)

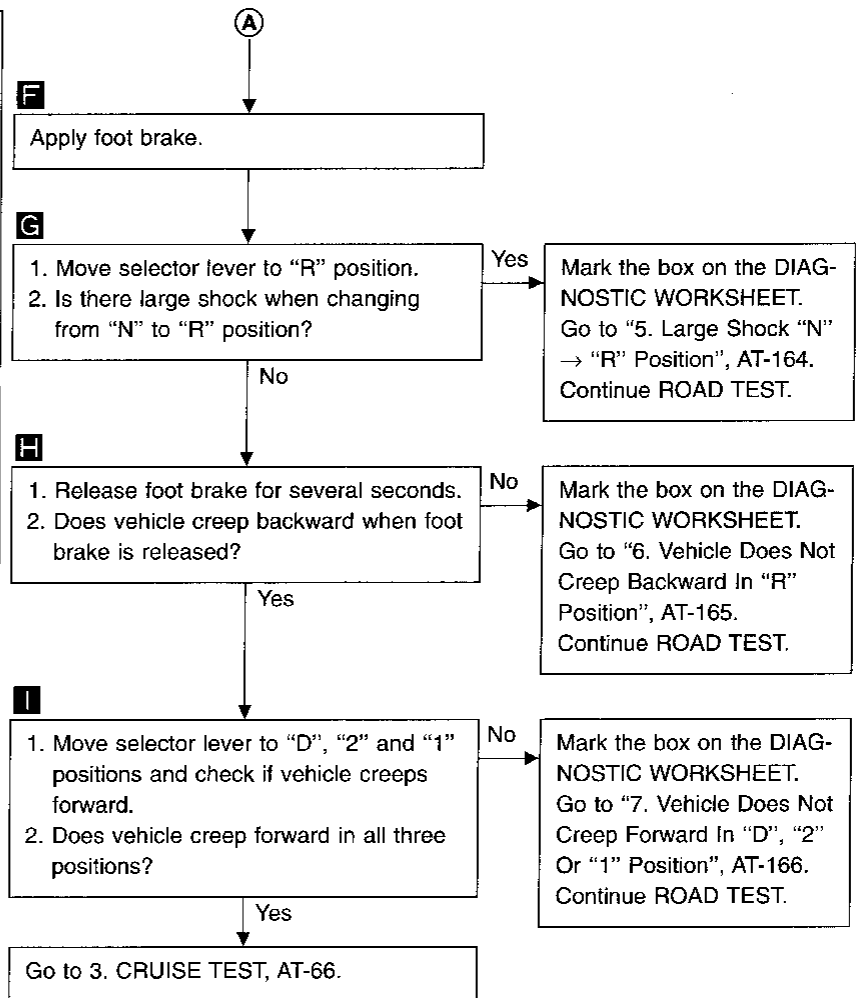
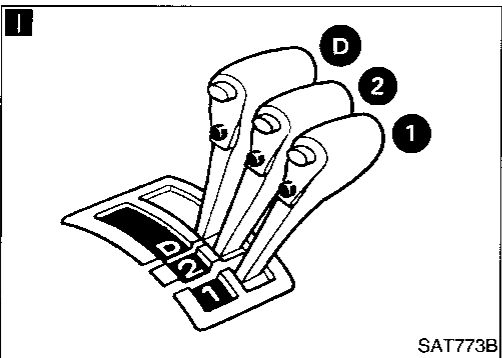
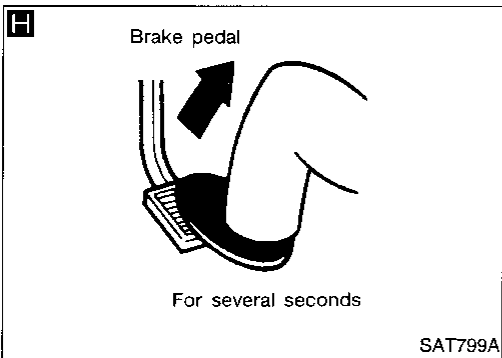
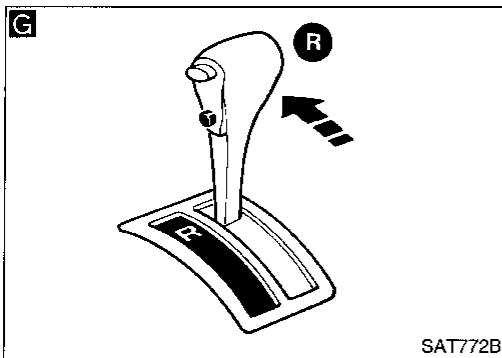
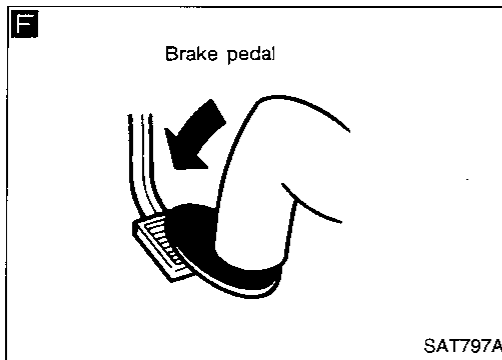

GI
MA
EM
LC
EC
FE
CL
MT
AT
FA
RA
BR
ST
RS
BT
HA
EL
IDX

TROUBLE DIAGNOSIS — Basic Inspection

Road Test (Cont'd)

3. CRUISE TEST

- Check all items listed in Parts 1 through 3.

With CONSULT

- Using CONSULT, conduct a cruise test and record the result.
- Print the result and ensure that shifts and lock-ups take place as per Shift Schedule.

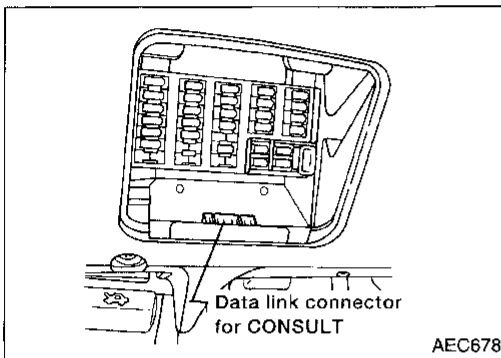
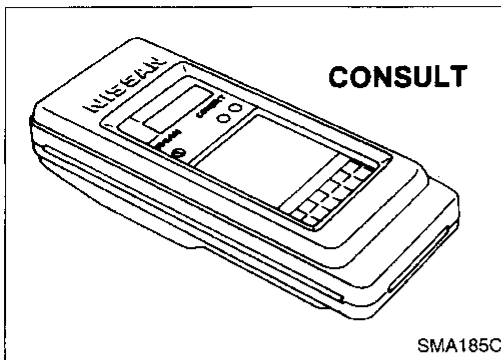

CONSULT setting procedure

1. Turn ignition switch "OFF".
2. Connect CONSULT to Data link connector for CONSULT. Data link connector for CONSULT is located in left side dash panel.

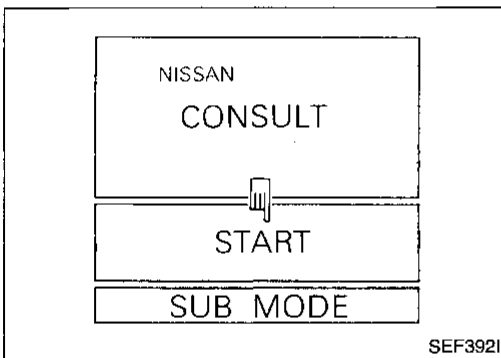

3. Turn ignition switch "ON".
4. Touch "START".

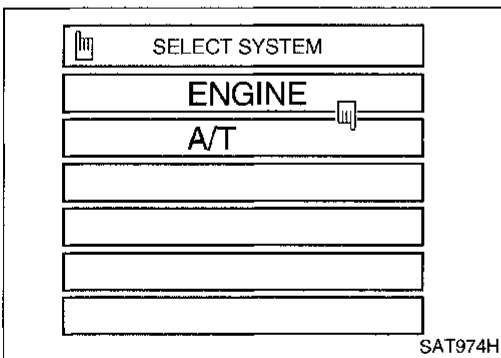

5. Touch "A/T".

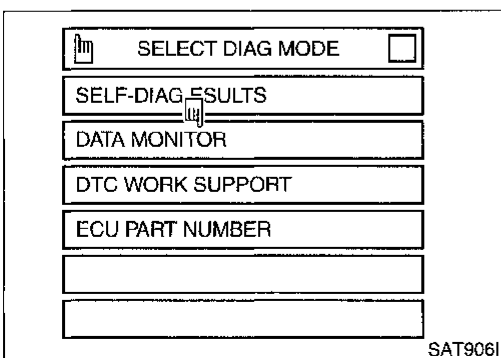

6. Touch "DATA MONITOR".

TROUBLE DIAGNOSIS — Basic Inspection

Road Test (Cont'd)

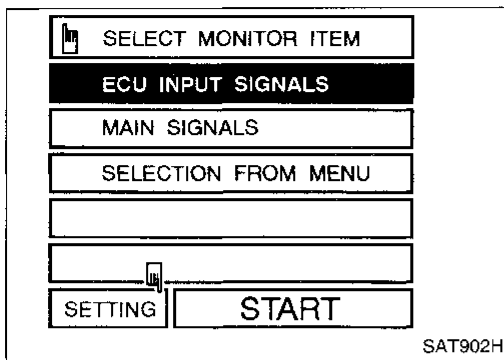

7. Touch "SETTING" to set recording condition.

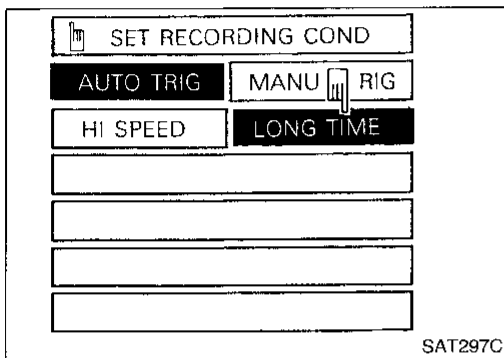

8. Touch "LONG TIME" and "ENTER" key.

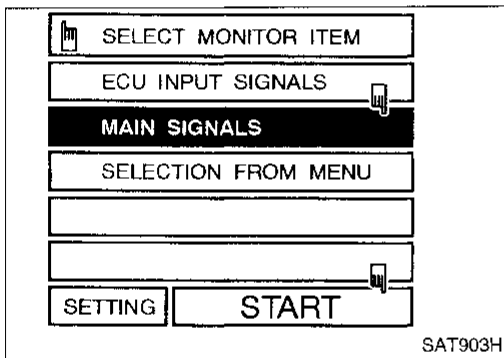

9. Go back to SELECT MONITOR ITEM and touch "MAIN SIGNALS".

10. Touch "START".

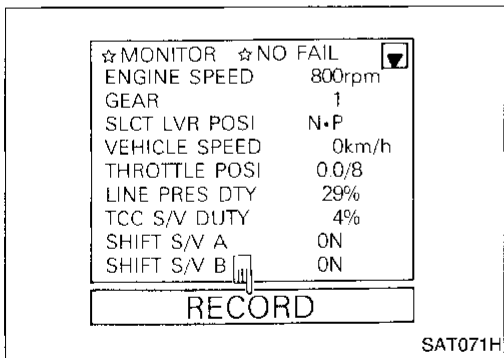

11. When performing cruise test, touch "RECORD".

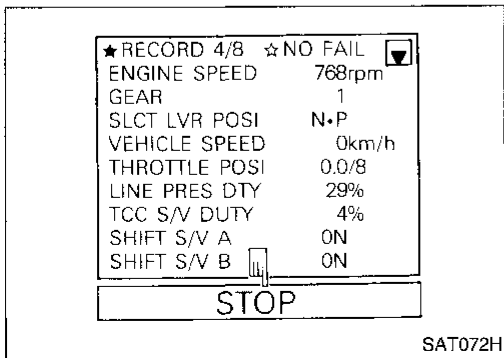

12. After finishing cruise test part 1, touch "STOP".

GI
MA
EM
LG
EC
FE
CL
MT
AT
FA
RA
BR
ST
RS
BT
HA
EL
DX

TROUBLE DIAGNOSIS — Basic Inspection

Road Test (Cont'd)

13. Touch "DISPLAY".

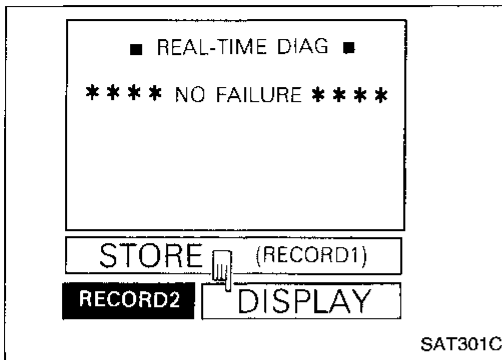

14. Touch "PRINT".

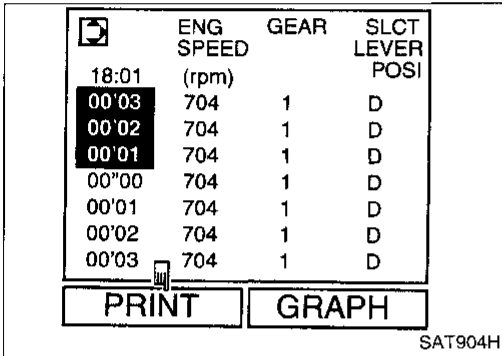

15. Touch "PRINT" again.

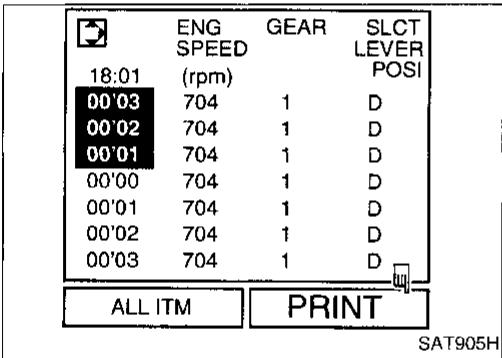

16. Check the monitor data printed out.
17. Continue cruise test part 2 and 3.

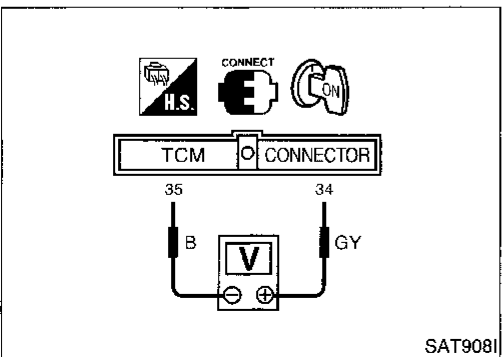
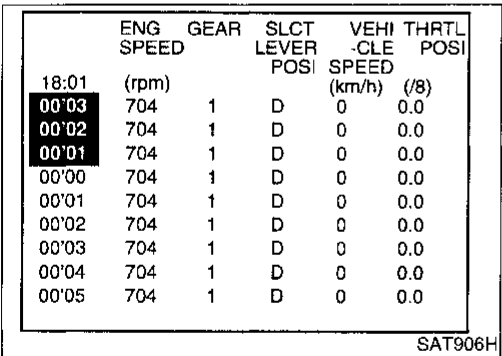

Without CONSULT

- Throttle position can be checked by voltage across terminals ③④ and ③⑤ of TCM.

TROUBLE DIAGNOSIS — Basic Inspection

Road Test (Cont'd)

CRUISE TEST — Part 1

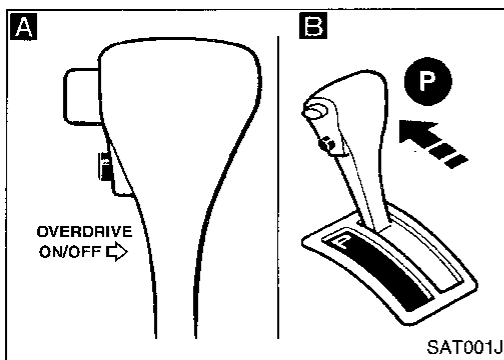

1. Drive vehicle for approx. 10 minutes to warm engine oil and ATF up to operating temperature.
ATF operating temperature:
50 - 80°C (122 - 176°F)

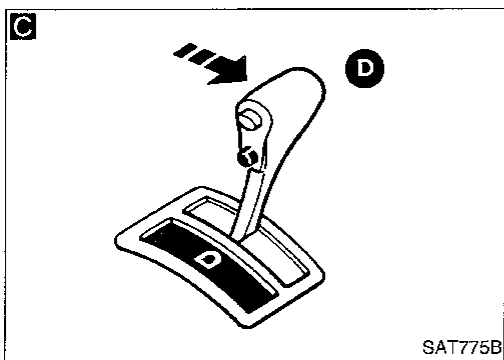

- A B**
1. Park vehicle on flat surface.
 2. Set overdrive control switch to "ON" position.
 3. Move selector lever to "P" position.
 4. Start engine.

C
Move selector lever to "D" position.

D
Accelerate vehicle by constantly depressing accelerator pedal half-way.

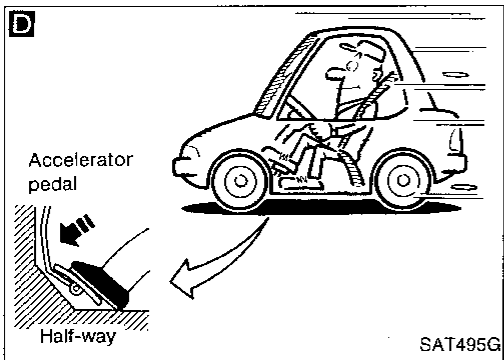

Does vehicle start from "D₁"?
Read gear position.

No
Go to "8. Vehicle Cannot Be Started From D₁", AT-167.
Continue ROAD TEST.

E
Does A/T shift from "D₁" to "D₂" at the specified speed?
Read gear position, throttle opening and vehicle speed.
Specified speed when shifting from "D₁" to "D₂":
Refer to Shift schedule, AT-294.

No
Go to "9. A/T Does Not Shift: D₁ → D₂ Or Does Not Kickdown: D₄ → D₂", AT-168.
Continue ROAD TEST.

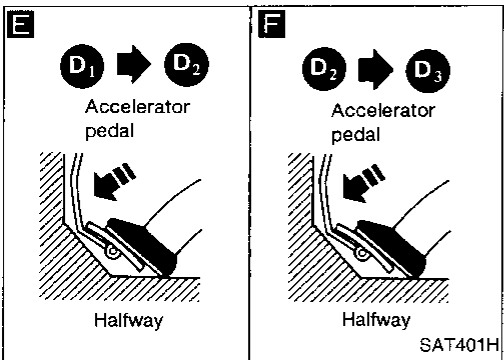

F
Does A/T shift from "D₂" to "D₃" at the specified speed?
Read gear position, throttle position and vehicle speed.
Specified speed when shifting from "D₂" to "D₃":
Refer to Shift schedule, AT-294.

No
Go to "10. A/T Does Not Shift: D₂ → D₃", AT-169.
Continue ROAD TEST.

Yes

A

(Go to next page.)

GI

MA

EM

LC

EC

FE

CL

MT

AT

FA

RA

BR

ST

RS

BT

HA

EL

IDX

TROUBLE DIAGNOSIS — Basic Inspection

Road Test (Cont'd)

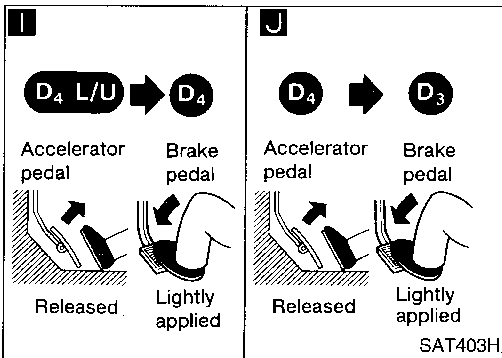
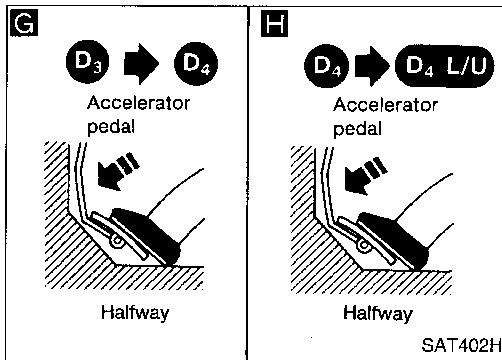

A

G

Does A/T shift from "D₃" to "D₄" at the specified speed?

Read gear position, throttle position and vehicle speed.

Specified speed when shifting from D₃ to D₄:
Refer to Shift schedule, AT-294.

No → Go to "11. A/T Does Not Shift: D₃ → D₄", AT-170. Continue ROAD TEST.

Yes

H

Does A/T perform lock-up at the specified speed?

Read vehicle speed, throttle position when lock-up duty becomes 94%.

Specified speed when lock-up occurs:
Refer to Shift schedule, AT-294.

No → Go to "12. A/T Does Not Perform Lock-up", AT-171. Continue ROAD TEST.

Yes

Does A/T hold lock-up condition for more than 30 seconds?

No → Go to "13. A/T Does Not Hold Lock-up Condition", AT-172.

i

1. Release accelerator pedal.
 2. Is lock-up released when accelerator pedal is released?

No → Go to "14. Lock-up Is Not Released", AT-172. Continue ROAD TEST.

Yes

J

1. Decelerate vehicle by applying foot brake lightly.
 2. Does engine speed return to idle smoothly when A/T is shifted from "D₄" to "D₃"?

Read gear position and engine speed.

No → Go to "15. Engine Speed Does Not Return To Idle (Light Braking D₄ → D₃)", AT-173. Continue ROAD TEST.

Yes

1. Stop vehicle.
 2. Go to "CRUISE TEST — Part 2", AT-71.

TROUBLE DIAGNOSIS — Basic Inspection

Road Test (Cont'd)

CRUISE TEST — Part 2

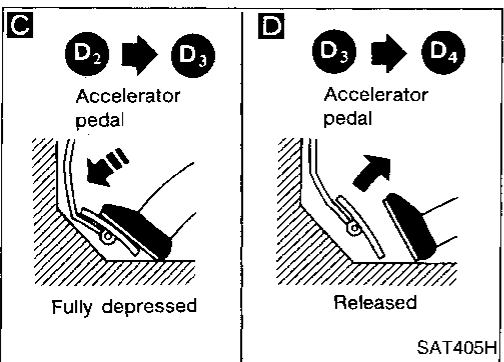
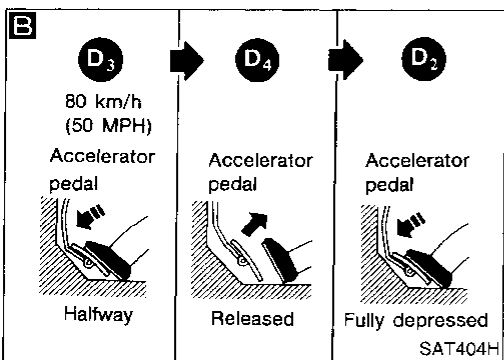
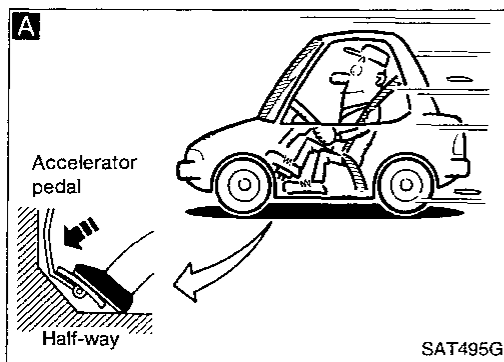

1. Confirm overdrive control switch is in "ON" position.
2. Confirm selector lever is in "D" position.

A

1. Accelerate vehicle by half throttle again.
2. Does vehicle start from "D₁"?

Read gear position.

Yes: Proceeds to step B.

No: Go to "16. Vehicle Does Not Start From D₁", AT-174. Continue ROAD TEST.

B

1. Accelerate vehicle to 80 km/h (50 MPH) as shown in illustration.
2. Release accelerator pedal and then quickly depress it fully.
3. Does A/T shift from "D₄" to "D₂" as soon as accelerator pedal is depressed fully?

Read gear position and throttle position.

Yes: Proceeds to step C.

No: Go to "9. A/T Does Not Shift: D₁ → D₂ Or Does Not Kickdown: D₄ → D₂", AT-168. Continue ROAD TEST.

C

Does A/T shift from "D₂" to "D₃" at the specified speed?

Read gear position, throttle position and vehicle speed.

Specified speed when shifting from "D₂" to "D₃":
Refer to Shift schedule, AT-294.

Yes: Proceeds to step D.

No: Go to "10. A/T Does Not Shift: D₂ → D₃", AT-169. Continue ROAD TEST.

D

Release accelerator pedal after shifting from "D₂" to "D₃".

Does A/T shift from "D₃" to "D₄" and does vehicle decelerate by engine brake?

Read gear position, throttle position and vehicle speed.

Yes: Proceeds to final step.

No: Go to "11. A/T Does Not Shift: D₃ → D₄", AT-170. Continue ROAD TEST.

1. Stop vehicle.
2. Go to "CRUISE TEST — Part 3", AT-72.

GI
MA
EM
LC
EC
FE
CL
MT
AT
FA
RA
BR
ST
RS
BT
HA
EL
IDX

Road Test (Cont'd)

CRUISE TEST — Part 3

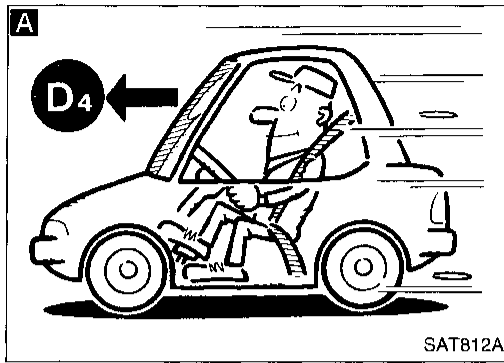

1. Confirm overdrive control switch is in "ON" position.
2. Confirm selector lever is in "D" position.

A
Accelerate vehicle using half-throttle to "D₄".

B
Release accelerator pedal.

C
Set overdrive control switch to "OFF" position while driving in "D₄".

D
Does A/T shift from "D₄" to "D₃" (O/D OFF)?
Read gear position and vehicle speed.

No
Go to "17. A/T Does Not Shift: D₄ → D₃, When Overdrive Control Switch "ON" → "OFF", AT-174. Continue ROAD TEST.

E
Does vehicle decelerate by engine brake?

No
Go to "15. Engine Speed Does Not Return To Idle (Light Braking D₄ → D₃)", AT-173. Continue ROAD TEST.

Yes

F
Move selector lever from "D" to "2" position while driving in "D₃" (O/D OFF).

G
Does A/T shift from "D₃" (O/D OFF) to "2₂"?
Read gear position.

No
Go to "18. A/T Does Not Shift: D₃ → D₂, When Selector Lever "D" → "2" Position", AT-175. Continue ROAD TEST.

Yes

H
Does vehicle decelerate by engine brake?

No
Go to "15. Engine Speed Does Not Return To Idle (Light Braking D₄ → D₃)", AT-173. Continue ROAD TEST.

Yes

I J
1. Move selector lever from "2" to "1" position while driving in "2₂".
2. Does A/T shift from "2₂" to "1₁" position?
Read gear position.

No
Go to "19. A/T Does Not Shift: 2₂ → 1₁, When Selector Lever "2" → "1" Position", AT-175. Continue ROAD TEST.

Yes

K
Does vehicle decelerate by engine brake?

No
Go to "20. Vehicle Does Not Decelerate By Engine Brake", AT-176. Continue ROAD TEST.

Yes

1. Stop vehicle.
2. Perform self-diagnosis. Refer to SELF-DIAGNOSTIC PROCEDURE, AT-42.

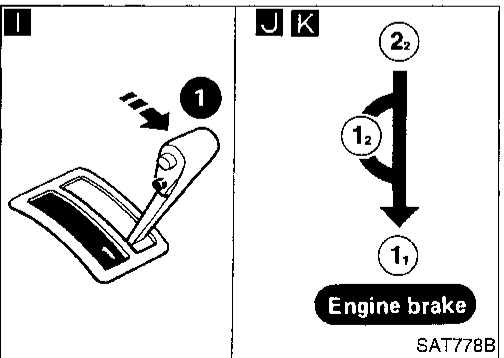
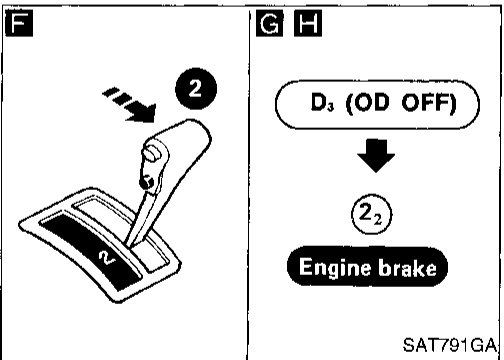
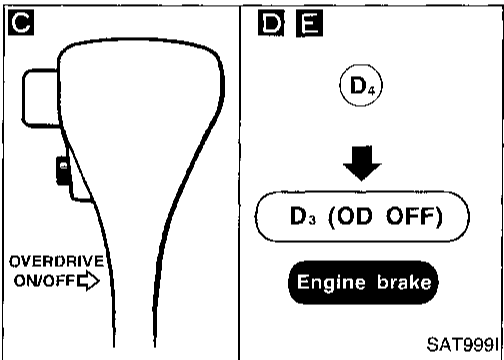
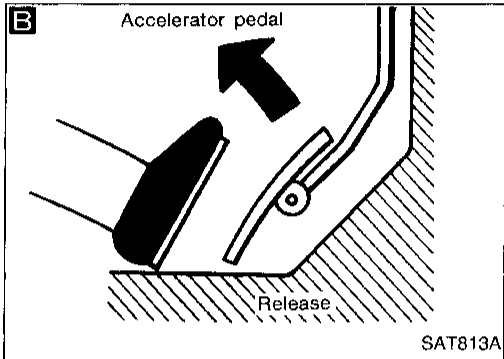

TROUBLE DIAGNOSIS — General Description

Symptom Chart

Reference page (AT-)		ON vehicle									OFF vehicle																									
		58, 190	190	89, 93, 158	61	189, 135	139, 131	120, 150	85, 189	189	200, 217	236, 240	245, 255	245	251, 264	—																				
Reference page (AT-)		Fluid level	Control cable adjustment	Inhibitor switch adjustment	Throttle position sensor (Adjustment)	Revolution sensor and vehicle speed sensor	Engine speed signal	Engine idling rpm	Line pressure	Control valve assembly	Shift solenoid valve A	Shift solenoid valve B	Line pressure solenoid valve	Torque converter clutch solenoid valve	Overrun clutch solenoid valve	A/T fluid temperature sensor	Accumulator N-D	Accumulator servo release	Ignition switch and starter	Torque converter	Oil pump	Reverse clutch	High clutch	Forward clutch	Forward one-way clutch	Overrun clutch	Low one-way clutch	Low & reverse brake	Brake band	Parking components						
162	Engine does not start in "N", "P" positions.	2	3															1																		
162	Engine starts in positions other than "N" and "P".	1	2																																	
—	Transaxle noise in "P" and "N" positions.	1		3	4	5		2												7	6															
162	Vehicle moves when changing into "P" position or parking gear does not disengage when shifted out of "P" position.	1																													2					
163	Vehicle runs in "N" position.	1																																		
165	Vehicle will not run in "R" position (but runs in "D", "2" and "1" positions). Clutch slips. Very poor acceleration.	1					2	4				3											5	6	7		8		9							
—	Vehicle braked when shifting into "R" position.	1	2				3	5			4												6	8		9				7						
—	Sharp shock in shifting from "N" to "D" position.			2		5	1	3	7			6			4	8									9											
—	Vehicle will not run in "D" and "2" positions (but runs in "1" and "R" positions).	1																										2								
166	Vehicle will not run in "D", "1", "2" positions (but runs in "R" position). Clutch slips. Very poor acceleration.	1					2	4			3					5							6	7	8	9		10								
—	Clutches or brakes slip somewhat in starting.	1	2		3		4	6		5						7					12	11	9		8				10							
—	Excessive creep.						1																													
165, 166	No creep at all.	1					2	3													6	5			4											
—	Failure to change gear from "D ₁ " to "D ₂ ".	2	1		5			4	3																							6				
—	Failure to change gear from "D ₂ " to "D ₃ ".	2	1		5			4	3														6									7				
—	Failure to change gear from "D ₃ " to "D ₄ ".	2	1		4				3						5																	6				
168, 169, 170	Too high a gear change point from "D ₁ " to "D ₂ ", from "D ₂ " to "D ₃ ", from "D ₃ " to "D ₄ ".			1	2				3	4																										
—	Gear change directly from "D ₁ " to "D ₃ " occurs.	1																2														3				
—	Engine stops when shifting lever into "R", "D", "2" and "1".						1	3					2																							
—	Too sharp a shock in change from "D ₁ " to "D ₂ ".			1			2	4							5	3																	6			
—	Too sharp a shock in change from "D ₂ " to "D ₃ ".			1			2	3																										5		

CI
 MA
 EM
 LC
 EC
 FE
 CL
 MT
AT
 FA
 RA
 BR
 ST
 RS
 BT
 HA
 EL
 IDX

TROUBLE DIAGNOSIS — General Description

Symptom Chart (Cont'd)

Reference page (AT-)		ON vehicle									OFF vehicle																			
		58, 190	190	89, 93, 158	61	189, 135	139, 131	120, 150	85, 189	189	200, 217	236, 240	245, 255	245	251, 264	—														
Reference page (AT-)		Fluid level	Control cable adjustment	Inhibitor switch adjustment	Throttle position sensor (Adjustment)	Revolution sensor and vehicle speed sensor	Engine speed signal	Engine idling rpm	Line pressure	Control valve assembly	Shift solenoid valve A	Shift solenoid valve B	Line pressure solenoid valve	Torque converter clutch solenoid valve	Overrun clutch solenoid valve	AT fluid temperature sensor	Accumulator N-D	Accumulator servo release	Ignition switch and starter	Torque converter	Oil pump	Reverse clutch	High clutch	Forward clutch	Forward one-way clutch	Overrun clutch	Low one-way clutch	Low & reverse brake	Brake band	Parking components
—	Numbers are arranged in order of inspection. Perform inspections starting with number one and work up. Circled numbers indicate that the transaxle must be removed from the vehicle.																													
—	Too sharp a shock in change from "D ₃ " to "D ₄ ".		1			2	3																			5			4	
—	Almost no shock or clutches slipping in change from "D ₁ " to "D ₂ ".	1		2			3	5										4											6	
—	Almost no shock or slipping in change from "D ₂ " to "D ₃ ".	1		2			3	4															5						6	
—	Almost no shock or slipping in change from "D ₃ " to "D ₄ ".	1		2			3	4															5						6	
—	Vehicle braked by gear change from "D ₁ " to "D ₂ ".	1																				2	4				5	3		
—	Vehicle braked by gear change from "D ₂ " to "D ₃ ".	1																											2	
—	Vehicle braked by gear change from "D ₃ " to "D ₄ ".	1																				4			3	2				
—	Maximum speed not attained. Acceleration poor.	1	2					5	3	4										11	10	6	7					9	8	
—	Failure to change gear from "D ₄ " to "D ₃ ".	1		2				6	4		5		3														8		7	
—	Failure to change gear from "D ₃ " to "D ₂ " or from "D ₄ " to "D ₂ ".	1		2				5	3	4													6						7	
—	Failure to change gear from "D ₂ " to "D ₁ " or from "D ₃ " to "D ₁ ".	1		2				5	3	4													7				6		8	
—	Gear change shock felt during deceleration by releasing accelerator pedal.			1			2	4					3																	
—	Too high a change point from "D ₄ " to "D ₃ ", from "D ₃ " to "D ₂ ", from "D ₂ " to "D ₁ ".			1	2																									
—	Kickdown does not operate when depressing pedal in "D ₄ " within kickdown vehicle speed.			1	2					3	4																			
—	Kickdown operates or engine overruns when depressing pedal in "D ₄ " beyond kickdown vehicle speed limit.			2	1					3	4																			
—	Races extremely fast or slips in changing from "D ₄ " to "D ₃ " when depressing pedal.	1		2			3	5			4												6	7						
—	Races extremely fast or slips in changing from "D ₄ " to "D ₂ " when depressing pedal.	1		2			3	6	5		4													8					7	
—	Races extremely fast or slips in changing from "D ₃ " to "D ₂ " when depressing pedal.	1		2			3	5			4			6									9	8					7	
—	Races extremely fast or slips in changing from "D ₄ " or "D ₃ " to "D ₁ " when depressing pedal.	1		2			3	5			4													6	7		8			
—	Vehicle will not run in any position.	1	2				3				4									9	5		6					8	7	10
—	Transaxle noise in "D", "2", "1" and "R" positions.	1																		2										

TROUBLE DIAGNOSIS — General Description

Symptom Chart (Cont'd)

Reference page (AT-)		ON vehicle									OFF vehicle																			
		58, 190	190	89, 93, 158	61	189, 135	139, 131	120, 150	85, 189	189	200, 217	236, 240	245, 255	245	251, 264	—														
Reference page (AT-)	Numbers are arranged in order of inspection. Perform inspections starting with number one and work up. Circled numbers indicate that the transaxle must be removed from the vehicle.	Fluid level	Control cable adjustment	Inhibitor switch adjustment	Throttle position sensor (Adjustment)	Revolution sensor and vehicle speed sensor	Engine speed signal	Engine idling rpm	Line pressure	Control valve assembly	Shift solenoid valve A	Shift solenoid valve B	Line pressure solenoid valve	Torque converter clutch solenoid valve	Overrun clutch solenoid valve	A/T fluid temperature sensor	Accumulator N-D	Accumulator servo release	Ignition switch and starter	Torque converter	Oil pump	Reverse clutch	High clutch	Forward clutch	Forward one-way clutch	Overrun clutch	Low one-way clutch	Low & reverse brake	Brake band	Parking components
173	Failure to change from "D ₃ " to "2 ₂ " when changing lever into "2" position.	7	1 2	6 5	4	.	.	3	9	.	.	8	.	
—	Gear change from "2 ₂ " to "2 ₃ " in "2" position.	.	1
174	Engine brake does not operate in "1" position.	2	1 3	4	.	.	.	6 5	.	.	.	7	8	.	9	.	.	
—	Gear change from "1 ₁ " to "1 ₂ " in "1" position.	2	1
—	Does not change from "1 ₂ " to "1 ₁ " in "1" position.	.	1	.	2	.	.	4 3	.	.	.	5	6	.	7	.	.	
—	Large shock changing from "1 ₂ " to "1 ₁ " in "1" position.	1	2	.	.	
---	Transaxle overheats.	1	.	3	.	.	2 4	6	.	.	5	14 7	8 9	11	.	12	.	13 10	.	.	.	
—	ATF shoots out during operation. White smoke emitted from exhaust pipe during operation.	1	2 3	5	.	6	.	7 4	.	.	
—	Offensive smell at fluid charging pipe.	1	2 3	4 5	7	.	8	.	9 6	.	.	.	
—	Torque converter is not locked up.	.	3 1	2 4	.	6 8	.	.	.	7	5	9
—	Torque converter clutch piston slip.	1	.	2	.	.	3 6	.	5 4	7
171	Lock-up point is extremely high or low.	.	.	1 2	.	.	.	4	.	.	.	3	
—	A/T does not shift to "D ₄ " when driving with overdrive control switch "ON".	.	2 1	3	.	.	8 6 4	5 7	10	.	9	.	.	
—	Engine is stopped at "R", "D", "2" and "1" positions.	1	5 4 3	.	2

GI
 MA
 EM
 LC
 EC
 FE
 CL
 MT
AT
 FA
 RA
 BR
 ST
 RS
 BT
 HA
 EL
 IX

TROUBLE DIAGNOSIS — General Description

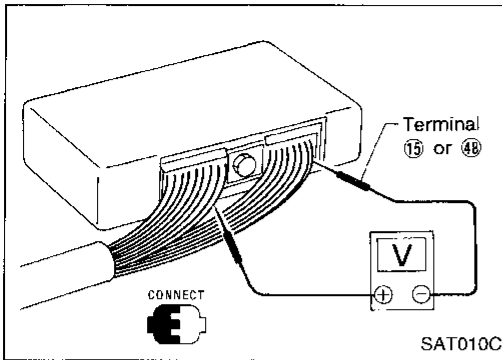

TCM Terminals and Reference Value

PREPARATION

- Measure voltage between each terminal and terminal ⑮ or ④⑧ by following "TCM INSPECTION TABLE".

TCM HARNESS CONNECTOR TERMINAL LAYOUT

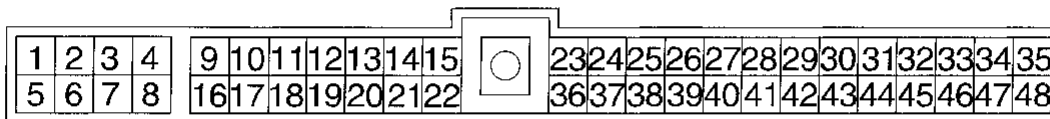

SAT2071

TCM INSPECTION TABLE

(Data are reference values.)

Terminal No.	Wire color	Item	Condition	Judgement standard
1	R/W	Line pressure solenoid valve	When releasing accelerator pedal after warming up engine.	1.5 - 2.5V
			When depressing accelerator pedal fully after warming up engine.	0.5V or less
2	P/B	Line pressure solenoid valve (with dropping resistor)	When releasing accelerator pedal after warming up engine.	5 - 14V
			When depressing accelerator pedal fully after warming up engine.	0.5V or less
3	OR/B	O/D OFF indicator lamp	When setting overdrive control switch in "OFF" position.	1V or less
			When setting overdrive control switch in "ON" position.	Battery voltage
4	SB	Power source	When turning ignition switch to "ON".	Battery voltage
			When turning ignition switch to "OFF".	1V or less

TROUBLE DIAGNOSIS — General Description









TCM Terminals and Reference Value (Cont'd)

Terminal No.	Wire color	Item	Condition	Judgement standard	
5	GY/R	Torque converter clutch solenoid valve	When A/T performs lock-up.	8 - 15V	GI
			When A/T does not perform lock-up.	1V or less	MA
6	L/W	Shift solenoid valve A	When shift solenoid valve A operates. (When driving in "D ₁ " or "D ₄ ".)	Battery voltage	EM
			When shift solenoid valve A does not operate. (When driving in "D ₂ " or "D ₃ ".)	1V or less	LC
7	L/Y	Shift solenoid valve B	When shift solenoid valve B operates. (When driving in "D ₁ " or "D ₂ ".)	Battery voltage	EC
			When shift solenoid valve B does not operate. (When driving in "D ₃ " or "D ₄ ".)	1V or less	FE
8	L/B	Overrun clutch solenoid valve	When overrun clutch solenoid valve operates.	Battery voltage	CL
			When overrun clutch solenoid valve does not operate.	1V or less	MT
9	SB	Power source	Same as No. 4		
10	—	—	—	—	AT
11	—	—	—	—	
12	—	—	—	—	FA
13*	PU	"N" position signal	When setting selector lever to "N" or "P" position.	1V or less	RA
			When setting selector lever to other positions.	Approximately 5V	RA
14	Y	Closed throttle position switch (in throttle position switch)	When releasing accelerator pedal after warming up engine.	Battery voltage	BR
			When depressing accelerator pedal after warming up engine.	1V or less	ST
15	B	Ground	—	—	
16	OR/L	Inhibitor "1" position switch	When setting selector lever to "1" position.	Battery voltage	RS
			When setting selector lever to other positions.	1V or less	BT
17	B/Y	Inhibitor "2" position switch	When setting selector lever to "2" position.	Battery voltage	HA
			When setting selector lever to other positions.	1V or less	HA
18	W/G	Inhibitor "D" position switch	When setting selector lever to "D" position.	Battery voltage	EL
			When setting selector lever to other positions.	1V or less	IDX

*: This terminal is connected to the ECM.

TROUBLE DIAGNOSIS — General Description

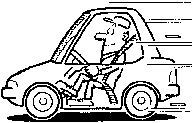
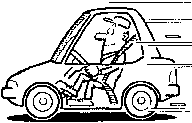





TCM Terminals and Reference Value (Cont'd)

Terminal No.	Wire color	Item	Condition		Judgement standard
19	GY/R	Inhibitor "N" or "P" position switch		When setting selector lever to "N" or "P" position.	Battery voltage
				When setting selector lever to other positions.	1V or less
20	G/W	Inhibitor "R" position switch		When setting selector lever to "R" position.	Battery voltage
				When setting selector lever to other positions.	1V or less
21	LG	Wide open throttle position switch (in throttle position switch)		When depressing accelerator pedal more than half-way after warming up engine.	Battery voltage
				When releasing accelerator pedal after warming up engine.	1V or less
22	—	—	—	—	—
23	P	Power source (Memory back-up)	 or 	When turning ignition switch to "OFF".	Battery voltage
				When turning ignition switch to "ON".	Battery voltage
24	L/OR	Engine speed signal	 	When engine runs at idle speed.	0.5 - 1.5V
25	W	Revolution sensor (Measure in AC range)		When vehicle cruises at 30 km/h (19 MPH).	1V or more Voltage rises gradually in response to vehicle speed.
				When vehicle parks.	0V
26	—	—	—	—	—
27	PU/R	Vehicle speed sensor		When moving vehicle at 2 to 3 km/h (1 to 2 MPH) for 1 m (3 ft) or more.	Voltage varies between less than 1V and more than 4.5V
28*	G/B	—		—	—
29*	G/W	—		—	—
30*	GY/L	—		—	—
31	P/L	Throttle position sensor (Power source)		—	4.5 - 5.5V
32	—	—	—	—	—

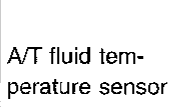
*: These terminals are connected to the Data link connector for CONSULT.

TROUBLE DIAGNOSIS — General Description

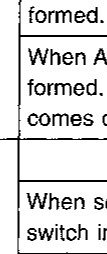
TCM Terminals and Reference Value (Cont'd)

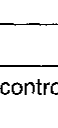





Terminal No.	Wire color	Item	Condition	Judgement standard		
33	BR	A/T fluid temperature sensor		When ATF temperature is 20°C (68°F).	Approximately 1.5V	GI
				When ATF temperature is 80°C (176°F).	Approximately 0.5V	MA
34	GY	Throttle position sensor		When depressing accelerator pedal slowly after warming up engine. (Voltage rises gradually in response to throttle position.)	Fully-closed throttle: Approximately 0.5V	EM
					Fully-open throttle: Approximately 4V	LC
35	B	Throttle position sensor (Ground)	—	—	EC	FE
36	—	—	—	—	—	CL
37	OR	ASCD cruise switch		When ASCD cruise is being performed. ("CRUISE" light comes on.)	Battery voltage	AT
				When ASCD cruise is not being performed. ("CRUISE" light does not come on.)	1V or less	MT
38	—	—	—	—	—	AT
39	G/R	Overdrive control switch		When setting overdrive control switch in "ON" position	Battery voltage	FA
				When setting overdrive control switch in "OFF" position	1V or less	RA
40	OR/B	ASCD OD cut signal		When "ACCEL" set switch on ASCD cruise is in "D ₄ " position.	5 - 8V	BR
				When "ACCEL" set switch on ASCD cruise is in "D ₃ " position.	1V or less	BR
41	—	—	—	—	—	ST
42	—	—	—	—	—	ST
43	—	—		—	—	RS
44	—	—	—	—	—	RS
45	—	—	—	—	—	RS
46	—	—		—	—	BT
47	—	—	—	—	—	BT
48	B	Ground	—	—	—	HA

TROUBLE DIAGNOSIS FOR POWER SUPPLY

Main Power Supply and Ground Circuit

TCM TERMINALS AND REFERENCE VALUE

Remarks: Specification data are reference values.

Terminal No.	Wire color	Item	Condition	Judgement standard
4	SB	Power source		Battery voltage
				1V or less
9	SB	Power source	Same as No. 4	—
15	B	Ground		
23	P	Power source (Memory back-up)	 or 	Battery voltage
				Battery voltage
48	B	Ground	 	—

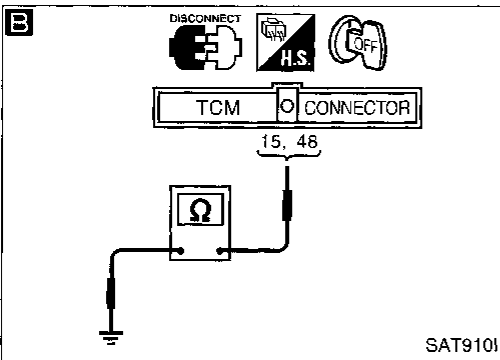
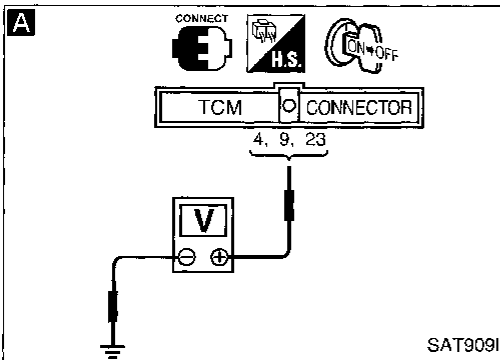

DIAGNOSTIC PROCEDURE

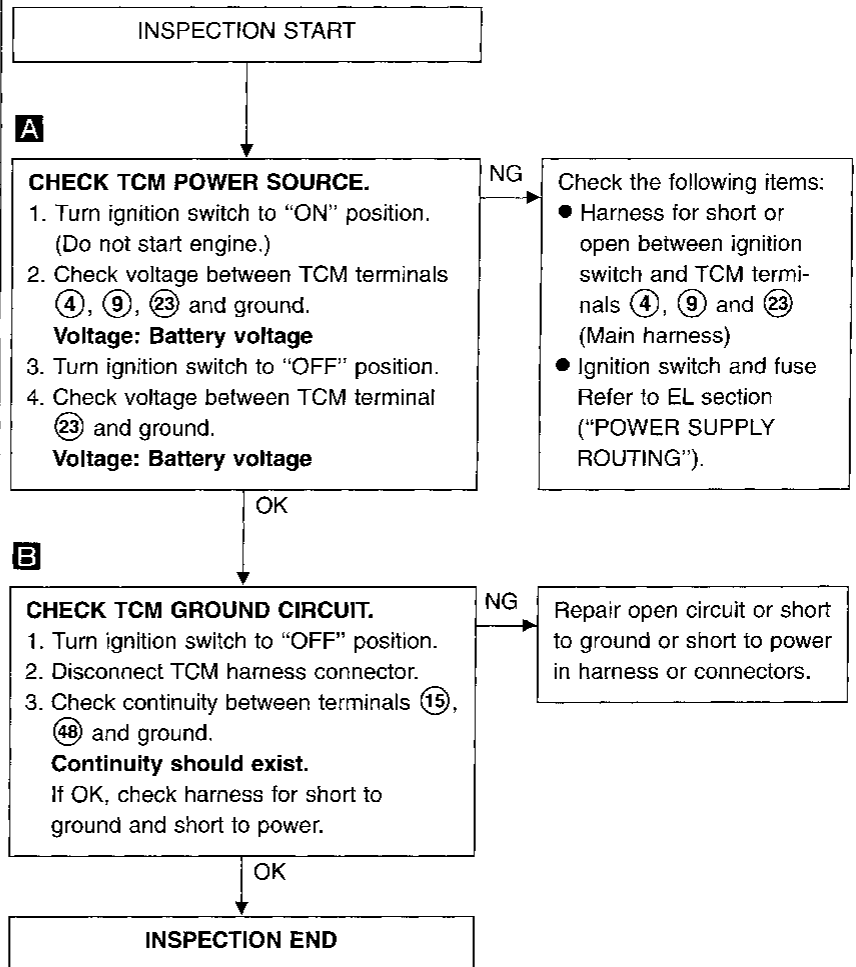

TROUBLE DIAGNOSIS FOR P0705

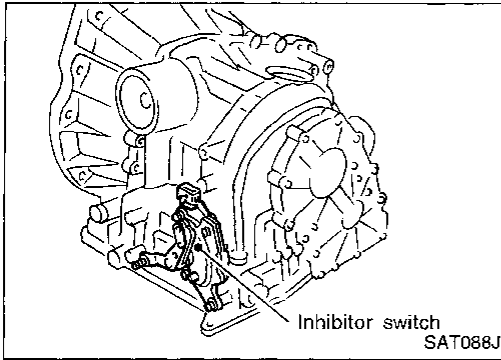

Inhibitor Switch

DESCRIPTION

Detects the selector lever position and sends a signal to the TCM.

TCM TERMINALS AND REFERENCE VALUE

Remarks: Specification data are reference values.

Terminal No.	Wire color	Item	Condition	Judgement standard
16	OR/L	Inhibitor "1" position switch	When setting selector lever to "1" position.	Battery voltage
			When setting selector lever to other positions.	1V or less
17	B/Y	Inhibitor "2" position switch	When setting selector lever to "2" position.	Battery voltage
			When setting selector lever to other positions.	1V or less
18	W/G	Inhibitor "D" position switch	When setting selector lever to "D" position.	Battery voltage
			When setting selector lever to other positions.	1V or less
19	GY/R	Inhibitor "N" or "P" position switch	When setting selector lever to "N" or "P" position.	Battery voltage
			When setting selector lever to other positions.	1V or less
20	G/W	Inhibitor "R" position switch	When setting selector lever to "R" position.	Battery voltage
			When setting selector lever to other positions.	1V or less



ON BOARD DIAGNOSIS LOGIC

Diagnostic trouble code	Malfunction is detected when ...	Check item (Possible cause)
: INHIBITOR SW/CIRC : P0705 : MIL Code No. 1101	TCM does not receive the correct voltage signal from the switch based on the gear position.	<ul style="list-style-type: none"> ● Harness or connectors (The inhibitor switch circuit is open or shorted.) ● Inhibitor switch

TROUBLE DIAGNOSIS FOR P0705

Inhibitor Switch (Cont'd)

DIAGNOSTIC TROUBLE CODE (DTC) CONFIRMATION PROCEDURE

CAUTION:

Always drive vehicle at a safe speed.

NOTE:

If "DIAGNOSTIC TROUBLE CODE CONFIRMATION PROCEDURE" has been previously conducted, always turn ignition switch "OFF" and wait at least 5 seconds before conducting the next test.

After the repair, perform the following procedure to confirm the malfunction is eliminated.

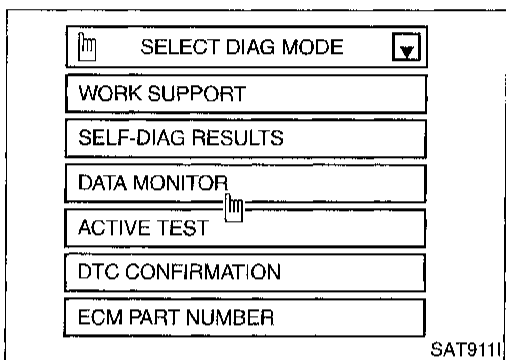
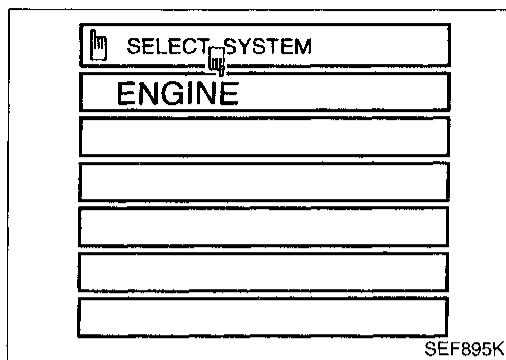

- 1) Turn ignition switch "ON".
- 2) Select "DATA MONITOR" mode for "ENGINE" with CONSULT.
- 3) Start engine and maintain the following conditions for at least 5 consecutive seconds.

VHCL SPEED SE: 10 km/h (6 MPH) or more

THRTL POS SEN: More than 1.3V

Selector lever: D position (OD "ON" or "OFF")

OR

- 1) Start engine.
- 2) Drive vehicle under the following conditions:
Selector lever in "D", overdrive control switch in "ON" or "OFF" position, vehicle speed higher than 10 km/h (6 MPH), throttle position sensor more than 1.3V and driving for more than 5 seconds.
- 3) Select "MODE 7" with GST.

OR

- 1) Start engine.
- 2) Drive vehicle under the following conditions:
Selector lever in "D", overdrive control switch in "ON" or "OFF" position, vehicle speed higher than 10 km/h (6 MPH), throttle opening greater than 1/2 of the full throttle position and driving for more than 5 seconds.
- 3) Perform self-diagnosis for ECM.
Refer to EC section ["Malfunction Indicator Lamp (MIL)", "ON BOARD DIAGNOSTIC SYSTEM DESCRIPTION"].

TROUBLE DIAGNOSIS FOR P0705

Inhibitor Switch (Cont'd) DIAGNOSTIC PROCEDURE

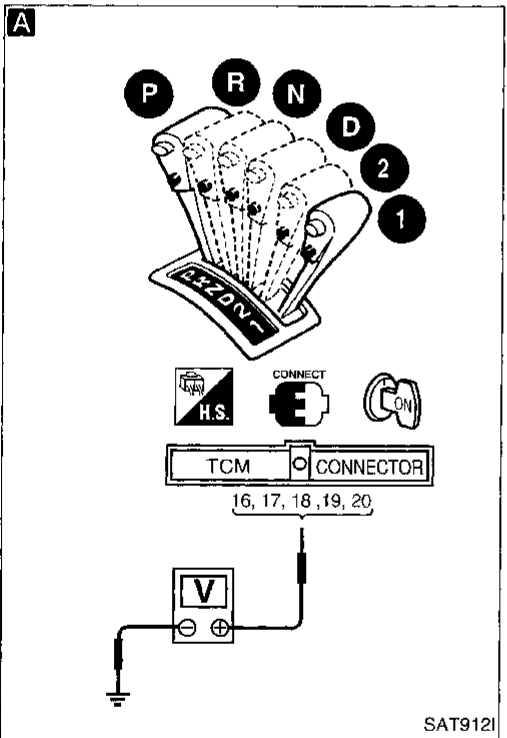
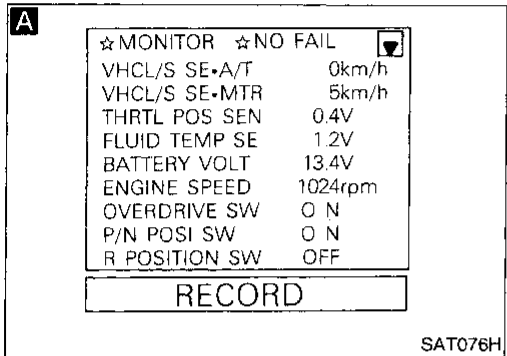
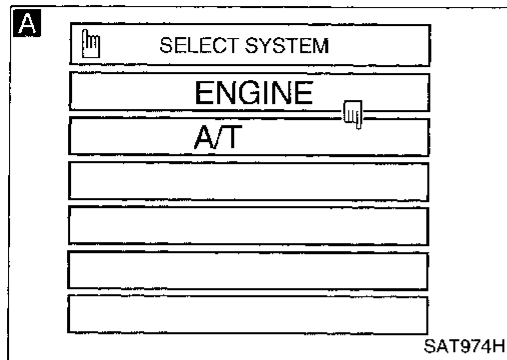

INSPECTION START

A

CHECK INHIBITOR SWITCH CIRCUIT.

- Turn ignition switch to "ON" position. (Do not start engine.)
- Select "ECU INPUT SIGNALS" in "DATA MONITOR" mode for "A/T" with CONSULT.
- Read out "P/N", "R", "D", "2" and "1" position switches moving selector lever to each position. Check the signal of the selector lever position is indicated properly.

NG

Check the following items:

- Inhibitor switch Refer to "Component Inspection", AT-84.
- Harness for short or open between ignition switch and inhibitor switch (Main harness)
- Harness for short or open between inhibitor switch and TCM (Main harness)
- Ignition switch and fuse Refer to EL section ("POWER SUPPLY ROUTING").

OR

- Turn ignition switch to "ON" position. (Do not start engine.)
- Check voltage between TCM terminals ⑱, ⑳, ⑲, ⑲, ⑳ and ground while moving selector lever through each position.

Voltage:
B: Battery voltage
0: 0V

Lever position	Terminal No.				
	⑲	⑳	⑱	⑰	⑰
P, N	B	0	0	0	0
R	0	B	0	0	0
D	0	0	B	0	0
2	0	0	0	B	0
1	0	0	0	0	B

OK

Perform Diagnostic Trouble Code (DTC) confirmation procedure, AT-82.

NG

- Perform TCM input/output signal inspection.
- If NG, recheck TCM pin terminals for damage or loose connection with harness connector.

OK

INSPECTION END

GI
MA
EM
LC
EC
FE
CL
MT
AT
FA
RA
BR
ST
RS
BT
HA
EL
IDX

TROUBLE DIAGNOSIS FOR P0705

Inhibitor Switch (Cont'd) COMPONENT INSPECTION

Inhibitor switch

1. Check continuity between terminals ① and ② and between terminals ③ and ④, ⑤, ⑥, ⑦, ⑧, ⑨ while moving manual shaft through each position.

Lever position	Terminal No.	
P	③ — ④	① — ②
R	③ — ⑤	
N	③ — ⑥	① — ②
D	③ — ⑦	
2	③ — ⑧	
1	③ — ⑨	

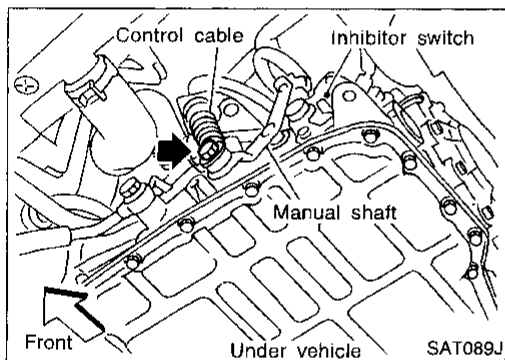
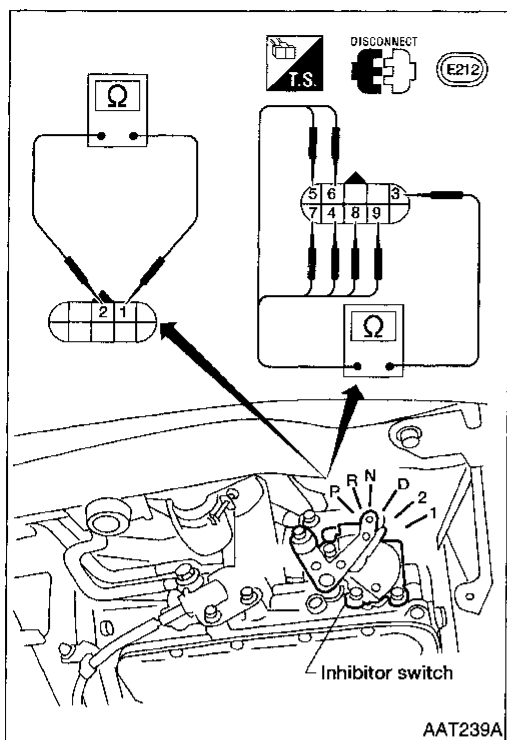

2. If NG, check again with manual control cable disconnected from manual shaft of A/T assembly. Refer to step 1.
3. If OK on step 2, adjust manual control cable. Refer to AT-190.
4. If NG on step 2, remove inhibitor switch from A/T and check continuity of inhibitor switch terminals. Refer to step 1.
5. If OK on step 4, adjust inhibitor switch. Refer to AT-190.
6. If NG on step 4, replace inhibitor switch.

TROUBLE DIAGNOSIS FOR DTC P0710

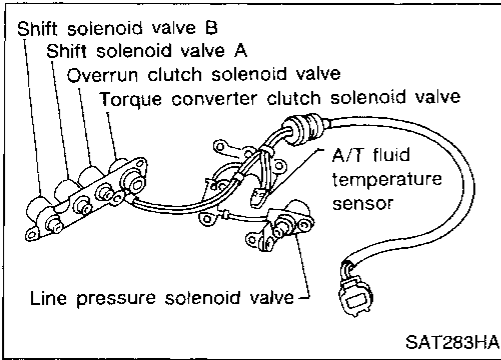

A/T Fluid Temperature Sensor

DESCRIPTION

The A/T fluid temperature sensor detects the A/T fluid temperature and sends a signal to the TCM.

GI
MA
EM
LC
EC
FE
CL
MT

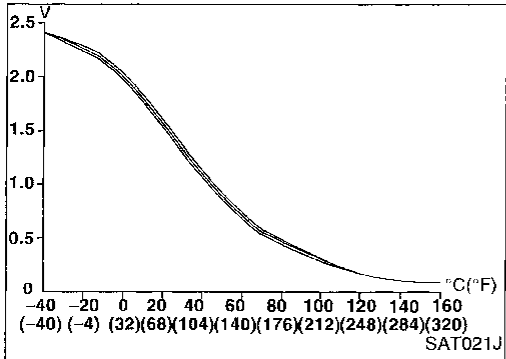

CONSULT REFERENCE VALUE IN DATA MONITOR MODE

Remarks: Specification data are reference values.

Monitor item	Condition	Specification
A/T fluid temperature sensor	Cold [20°C (68°F)]	Approximately 1.5V
	Hot [80°C (176°F)]	Approximately 0.5V

AT
FA

TCM TERMINALS AND REFERENCE VALUE

Remarks: Specification data are reference values.

Terminal No.	Wire color	Item	Condition	Judgement standard
33	BR	A/T fluid temperature sensor	When ATF temperature is 20°C (68°F).	Approximately 1.5V
			When ATF temperature is 80°C (176°F).	Approximately 0.5V
35	B	Throttle position sensor (Ground)	—	—

RA
BR
ST
RS
BT

ON BOARD DIAGNOSIS LOGIC

Diagnostic trouble code	Malfunction is detected when ...	Check item (Possible cause)
: ATF TEMP SEN/CIRC : P0710 : MIL Code No. 1208	TCM receives an excessively low or high voltage from the sensor.	<ul style="list-style-type: none"> ● Harness or connectors (The sensor circuit is open or shorted.) ● A/T fluid temperature sensor

HA
EL
IDX

TROUBLE DIAGNOSIS FOR DTC P0710

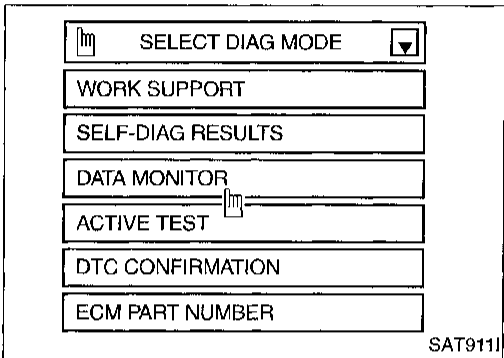
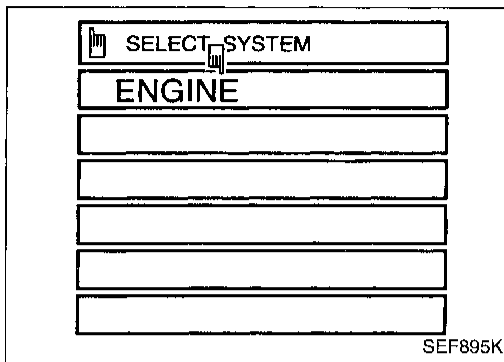

A/T Fluid Temperature Sensor (Cont'd) DIAGNOSTIC TROUBLE CODE (DTC) CONFIRMATION PROCEDURE

CAUTION:

Always drive vehicle at a safe speed.

NOTE:

If "DIAGNOSTIC TROUBLE CODE CONFIRMATION PROCEDURE" has been previously conducted, always turn ignition switch "OFF" and wait at least 5 seconds before conducting the next test.

After the repair, perform the following procedure to confirm the malfunction is eliminated.

-  1) Turn ignition switch "ON" and select "DATA MONITOR" mode for "ENGINE" with CONSULT.
- 2) Start engine and maintain the following conditions for at least 10 minutes (Total). (It is not necessary to maintain continuously.)
CMPS-RPM (REF): 450 rpm or more
VHCL SPEED SE: 10 km/h (6 MPH) or more
THRTL POS SEN: More than 1.2V
Selector lever: D position (OD "ON")

OR

-  1) Start engine.
- 2) Drive vehicle under the following conditions:
Selector lever in "D" (OD "ON"), vehicle speed higher than 10 km/h (6 MPH), throttle opening greater than 1/8 of the full open position, engine speed higher than 450 rpm and driving for more than 10 minutes (Total).
- 3) Select "MODE 7" with GST.

OR

-  1) Start engine.
- 2) Drive vehicle under the following conditions:
Selector lever in "D" (OD "ON"), vehicle speed higher than 10 km/h (6 MPH), throttle opening greater than 1/8 of the full open position, engine speed higher than 450 rpm and driving for more than 10 minutes (Total).
- 3) Perform self-diagnosis for ECM.
Refer to EC section ["Malfunction Indicator Lamp (MIL)", "ON BOARD DIAGNOSTIC SYSTEM DESCRIPTION"].

TROUBLE DIAGNOSIS FOR DTC P0710

A/T Fluid Temperature Sensor (Cont'd) DIAGNOSTIC PROCEDURE

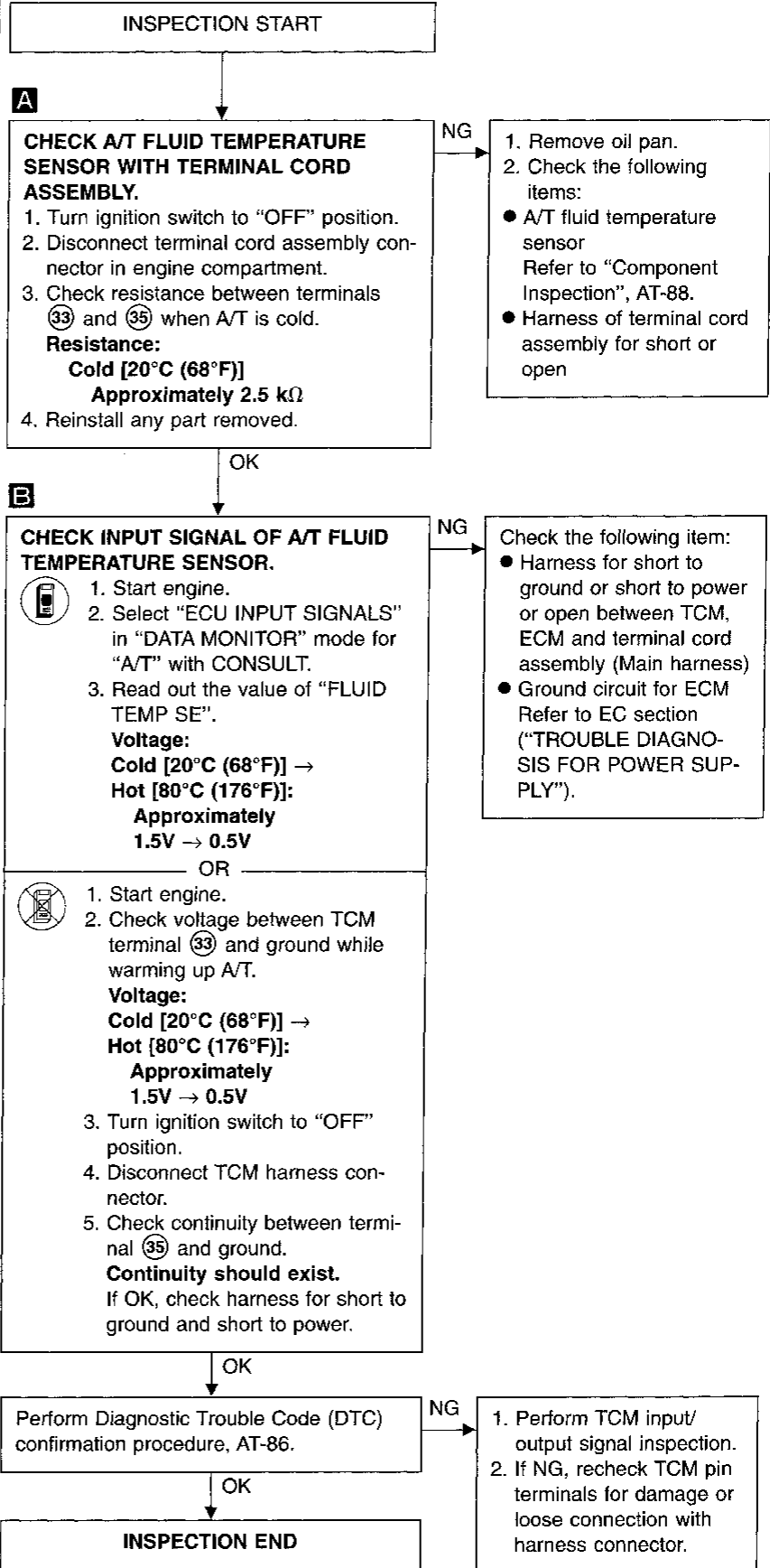
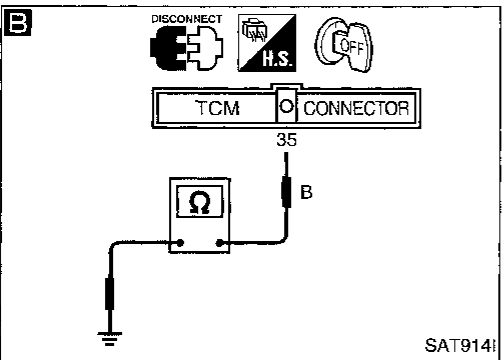
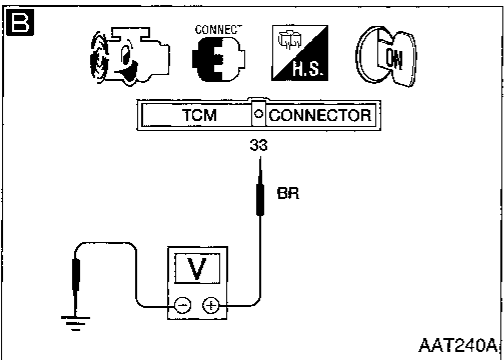
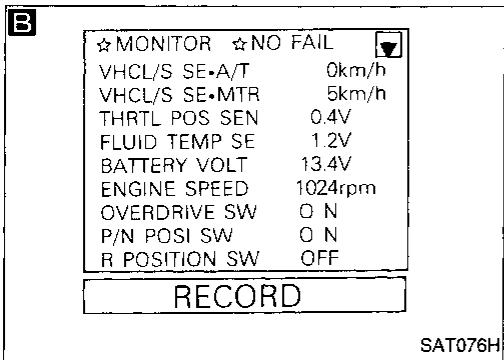
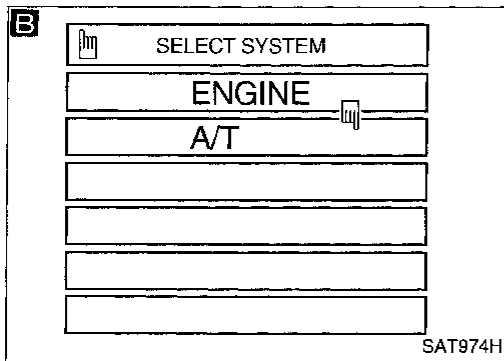
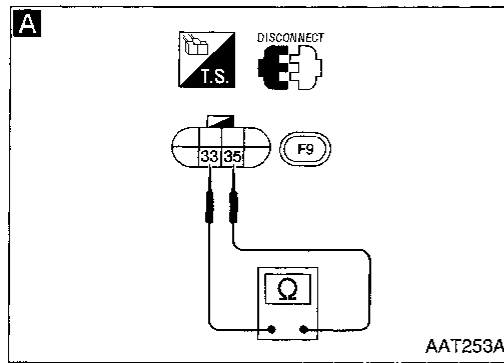

GI
MA
EM
LC
EC
FE
CL
MT
AT
FA
RA
BR
ST
RS
BT
HA
EL
IDX

TROUBLE DIAGNOSIS FOR DTC P0710

A/T Fluid Temperature Sensor (Cont'd) COMPONENT INSPECTION

A/T fluid temperature sensor

- For removal, refer to AT-189.
- Check resistance between two terminals while changing temperature as shown at left.

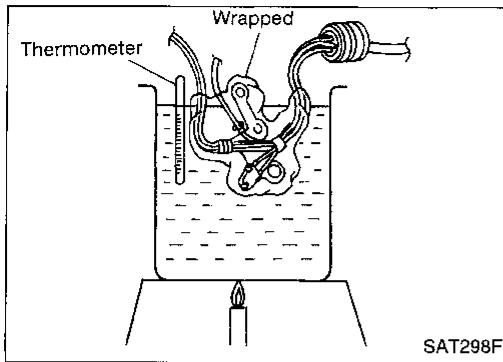

Temperature °C (°F)	Resistance
20 (68)	Approximately 2.5 k Ω
80 (176)	Approximately 0.3 k Ω

TROUBLE DIAGNOSIS FOR DTC P0720

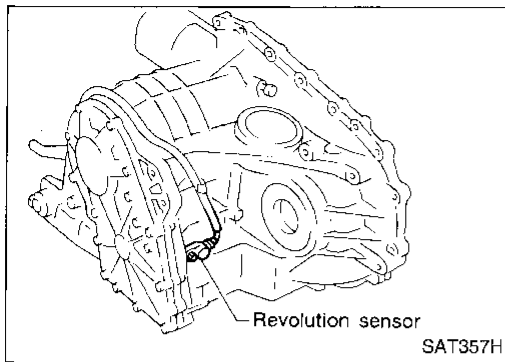

Vehicle Speed Sensor-AT (Revolution sensor)

DESCRIPTION

The revolution sensor detects the revolution of the idler gear parking pawl lock gear and emits a pulse signal. The pulse signal is sent to the TCM which converts it into vehicle speed.

TCM TERMINALS AND REFERENCE VALUE

Remarks: Specification data are reference values.

Terminal No.	Wire color	Item	Condition		Judgement standard
25	W	Revolution sensor (Measure in AC range)		When vehicle cruises at 30 km/h (19 MPH).	1V or more Voltage rises gradually in response to vehicle speed.
				When vehicle parks.	0V
35	B	Throttle position sensor (Ground)		—	—

ON BOARD DIAGNOSIS LOGIC

Diagnostic trouble code	Malfunction is detected when ...	Check item (Possible cause)
 : VEH SPD SEN/CIR AT : P0720 : MIL Code No. 1102	TCM does not receive the proper voltage signal from the sensor.	<ul style="list-style-type: none"> ● Harness or connectors (The sensor circuit is open or shorted.) ● Revolution sensor

TROUBLE DIAGNOSIS FOR DTC P0720

Vehicle Speed Sensor A/T (Revolution sensor) (Cont'd)

DIAGNOSTIC TROUBLE CODE (DTC) CONFIRMATION PROCEDURE

CAUTION:

- Always drive vehicle at a safe speed.
- Be careful not to rev engine into the red zone on the tachometer.

NOTE:

If "DIAGNOSTIC TROUBLE CODE CONFIRMATION PROCEDURE" has been previously conducted, always turn ignition switch "OFF" and wait at least 5 seconds before conducting the next test.

After the repair, perform the following procedure to confirm the malfunction is eliminated.

- 1) Turn ignition switch "ON" and select "DATA MONITOR" mode for "A/T" with CONSULT.

- 2) Drive vehicle and check for an increase of "VHCL/S SE·A/T" value in response to "VHCL/S SE·MTR" value increase.

If the check result is NG, go to "DIAGNOSTIC PROCEDURE", AT-159.

If the check result is OK, go to following step.

- 3) Select "DATA MONITOR" mode for "ENGINE" with CONSULT.

- 4) Start engine and maintain the following conditions for at least 5 consecutive seconds.

VHCL SPEED SE: 30 km/h (19 MPH) or more

THRTL POS SEN: More than 1.2V

Selector lever: D position (OD "ON")

Driving pattern: Driving the vehicle uphill (increased engine load) will help maintain the driving conditions required for this test.

If the check result is NG, go to "DIAGNOSTIC PROCEDURE", AT-92.

If the check result is OK, go to following step.

- 5) Maintain the following conditions for at least 5 consecutive seconds.

CMPS·RPM (REF): 3,500 rpm or more

THRTL POS SEN: More than 1.2V

Selector lever: D position (OD "ON")

Driving pattern: Driving the vehicle uphill (increased engine load) will help maintain the driving conditions required for this test.

OR



- 1) Start engine.
- 2) Drive vehicle under the following conditions:
Selector lever in "D" (OD "ON"), vehicle speed higher than 30 km/h (19 MPH), throttle opening greater than 1/8 of the full throttle position and driving for more than 5 seconds.

- 3) Select "MODE 7" with GST.

OR



- 1) Start engine.
- 2) Drive vehicle under the following conditions:
Selector lever in "D" (OD "ON"), vehicle speed higher than 30 km/h (19 MPH), throttle opening greater than 1/8 of the full throttle position and driving for more than 5 seconds.

SELECT SYSTEM
ENGINE
A/T

SAT974H

SELECT DIAG MODE
SELF-DIAG RESULTS
DATA MONITOR
DTC WORK SUPPORT
ECU PART NUMBER

SAT906I

SELECT SYSTEM
ENGINE

SEF895K

SELECT DIAG MODE
WORK SUPPORT
SELF-DIAG RESULTS
DATA MONITOR
ACTIVE TEST
DTC CONFIRMATION
ECM PART NUMBER

SAT911I

TROUBLE DIAGNOSIS FOR DTC P0720

Vehicle Speed Sensor-A/T (Revolution sensor) (Cont'd)

- 3) Perform self-diagnosis for ECM.
Refer to EC section ["Malfunction Indicator Lamp (MIL)", "ON BOARD DIAGNOSTIC SYSTEM DESCRIPTION"].

GI

MA

EM

LC

EC

FE

CL

MT

AT

FA

RA

BR

ST

RS

BT

HA

EL

IDX

TROUBLE DIAGNOSIS FOR DTC P0720

Vehicle Speed Sensor-A/T (Revolution sensor) (Cont'd)

DIAGNOSTIC PROCEDURE

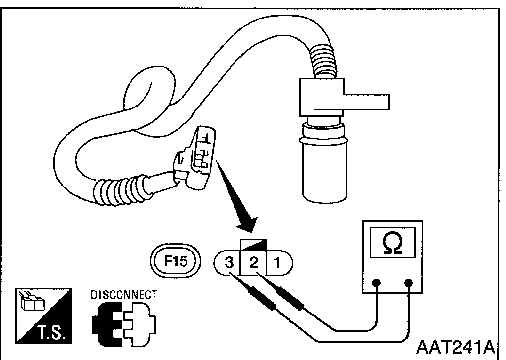
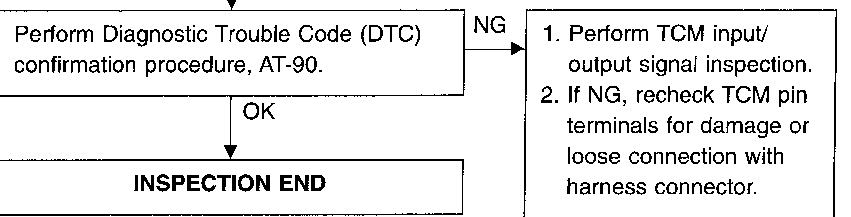
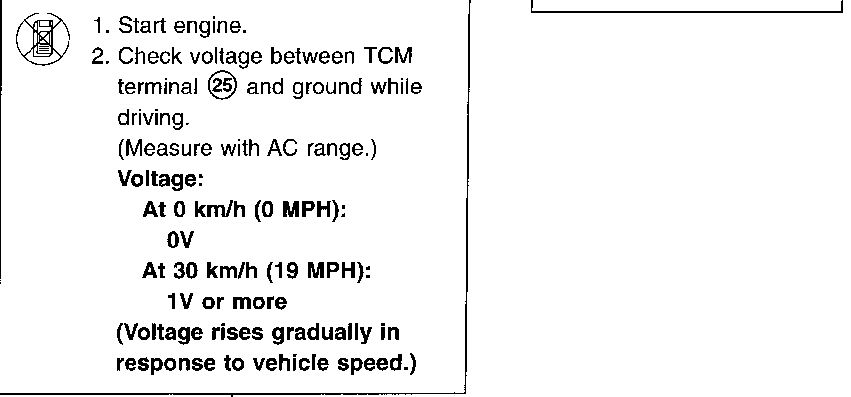
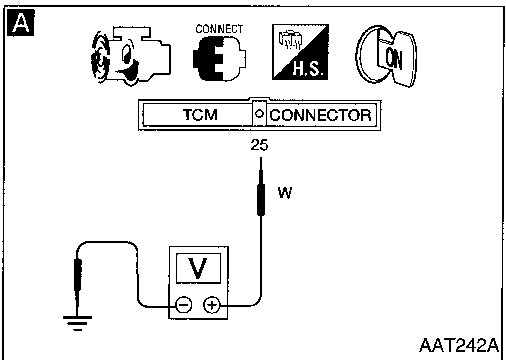
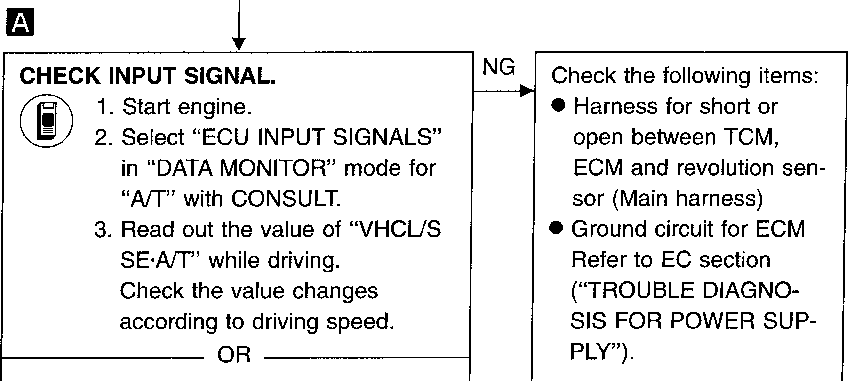
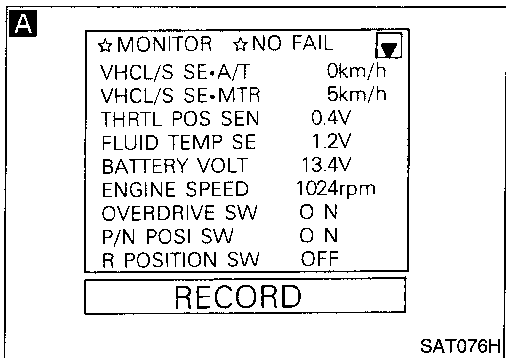
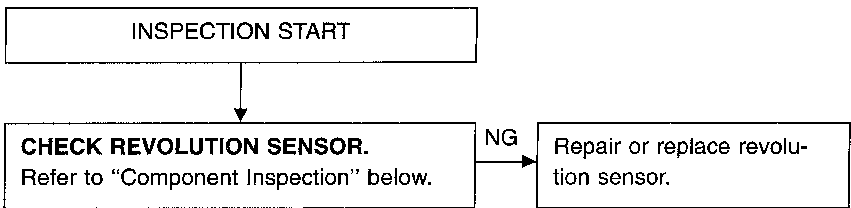
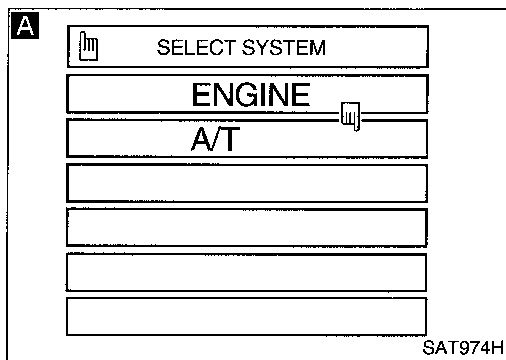

COMPONENT INSPECTION

Revolution sensor

- For removal, refer to AT-191.
- Check resistance between terminals (3) and (2).

Terminal No.		Resistance
(3)	(2)	500 - 650Ω

TROUBLE DIAGNOSIS FOR DTC P0725

Engine Speed Signal

DESCRIPTION



The engine speed signal is sent from the ECM to the TCM.

TCM TERMINALS AND REFERENCE VALUE

Remarks: Specification data are reference values.

Terminal No.	Wire color	Item	Condition	Judgement standard
24	L/OR	Engine speed signal		When engine runs at idle speed. 0.5 - 1.5V

ON BOARD DIAGNOSIS LOGIC

Diagnostic trouble code	Malfunction is detected when ...	Check item (Possible cause)
 : ENGINE SPEED SIG  : P0725  : MIL Code No. 1207	TCM does not receive the proper voltage signal from ECM.	<ul style="list-style-type: none"> ● Harness or connectors (The sensor circuit is open or shorted.)

GI

MA

EM

LC

EC

FE

CL

MT

AT

FA

RA

BR

ST

RS

BT

HA

EL

DX

TROUBLE DIAGNOSIS FOR DTC P0725

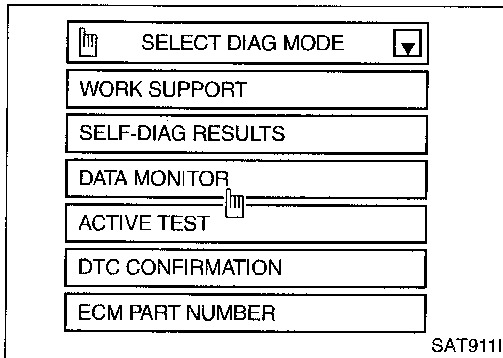
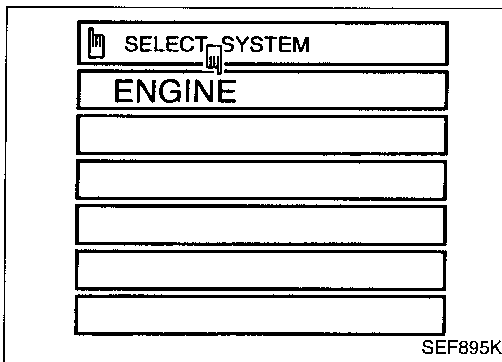

Engine Speed Signal (Cont'd)

DIAGNOSTIC TROUBLE CODE (DTC) CONFIRMATION PROCEDURE

CAUTION:

Always drive vehicle at a safe speed.

NOTE:

If "DIAGNOSTIC TROUBLE CODE CONFIRMATION PROCEDURE" has been previously conducted, always turn ignition switch "OFF" and wait at least 5 seconds before conducting the next test.

After the repair, perform the following procedure to confirm the malfunction is eliminated.



- 1) Turn ignition switch "ON" and select "DATA MONITOR" mode for "ENGINE" with CONSULT.
- 2) Start engine and maintain the following conditions for at least 10 consecutive seconds.

VHCL SPEED SE: 10 km/h (6 MPH) or more

THRTL POS SEN: More than 1.2V

Selector lever: D position (OD "ON")

OR



- 1) Start engine.
- 2) Drive vehicle under the following conditions:
Selector lever in "D" (OD "ON"), vehicle speed higher than 10 km/h (6 MPH), throttle opening greater than 1/8 of the full throttle position and driving for more than 10 consecutive seconds.
- 3) Select "MODE 7" with GST.

OR



- 1) Start engine.
- 2) Drive vehicle under the following conditions:
Selector lever in "D" (OD "ON"), vehicle speed higher than 10 km/h (6 MPH), throttle opening greater than 1/8 of the full throttle position and driving for more than 10 consecutive seconds.
- 3) Perform self-diagnosis for ECM.
Refer to EC section ["Malfunction Indicator Lamp (MIL)", "ON BOARD DIAGNOSTIC SYSTEM DESCRIPTION"].

TROUBLE DIAGNOSIS FOR DTC P0725

Engine Speed Signal (Cont'd) DIAGNOSTIC PROCEDURE

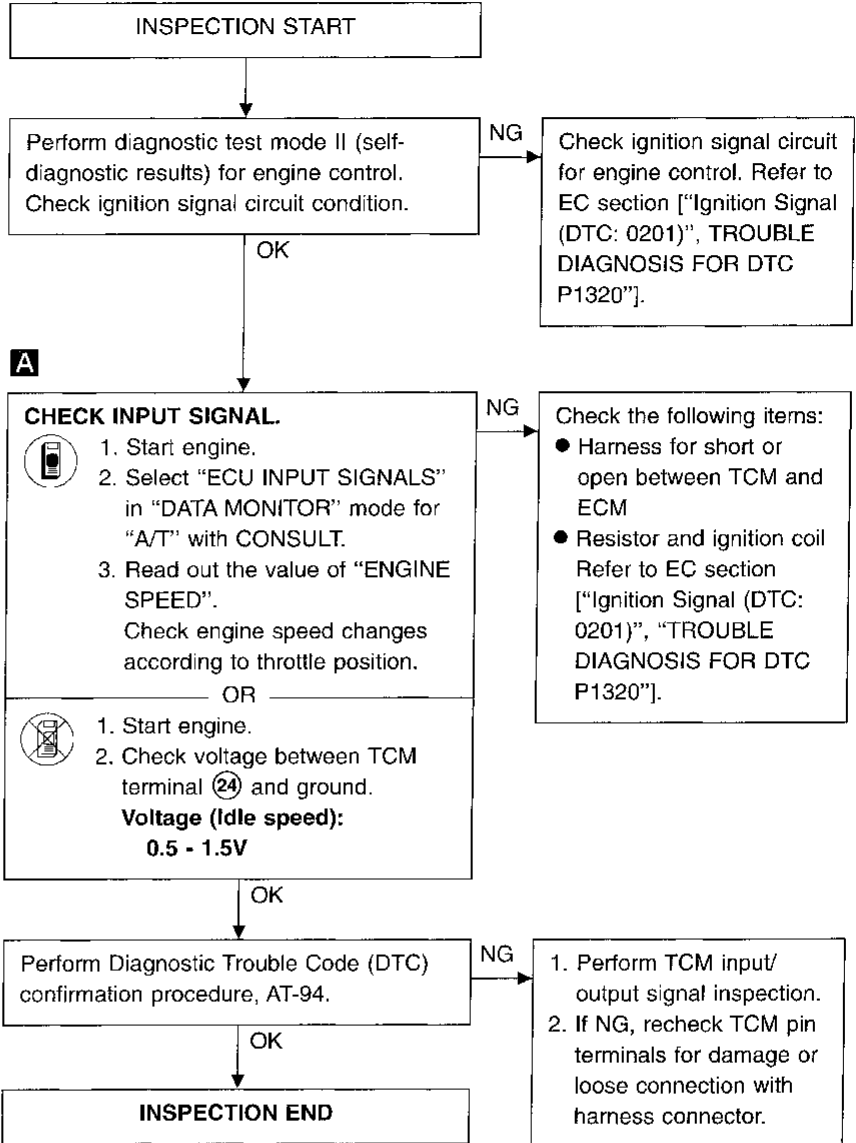
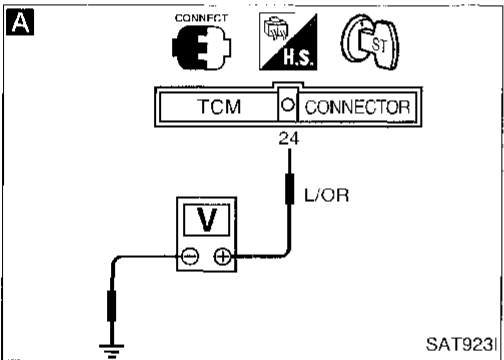
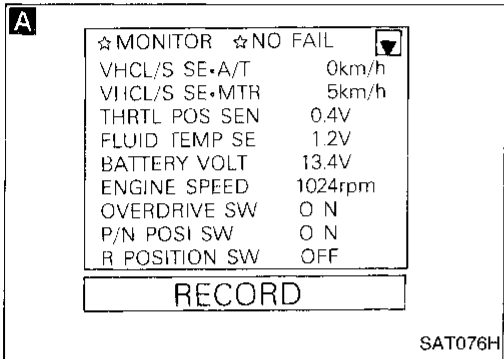
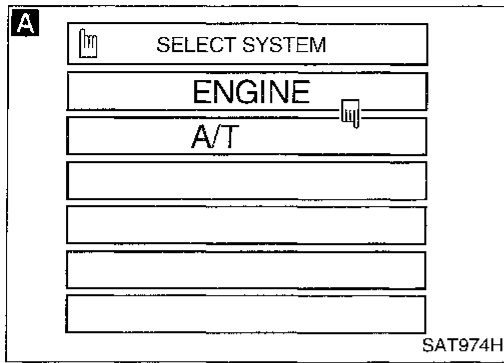

GI
MA
EM
LC
EC
FE
CL
MT
AT
FA
RA
BR
ST
RS
BT
HA
EL
DX

TROUBLE DIAGNOSIS FOR DTC P0731

A/T 1st Gear Function

DESCRIPTION

- This is an OBD-II self-diagnostic item and not available in TCM self-diagnosis.
- This malfunction will not be detected while the O/D OFF indicator lamp is indicating another self-diagnosis malfunction.
- This malfunction is detected when the A/T does not shift into first gear position as instructed by the TCM. This is not caused by electrical malfunction (circuits open or shorted) but by mechanical malfunction such as control valve sticking, improper solenoid valve operation, etc.

Gear position	1	2	3	4
Shift solenoid valve A	ON (Closed)	OFF (Open)	OFF (Open)	ON (Closed)
Shift solenoid valve B	ON (Closed)	ON (Closed)	OFF (Open)	OFF (Open)

TCM TERMINALS AND REFERENCE VALUE

Remarks: Specification data are reference values.

Terminal No.	Wire color	Item	Condition	Judgement standard
6	L/W	Shift solenoid valve A	When shift solenoid valve A operates. (When driving in "D ₁ " or "D ₄ ".)	Battery voltage
			When shift solenoid valve A does not operate. (When driving in "D ₂ " or "D ₃ ".)	1V or less
7	L/Y	Shift solenoid valve B	When shift solenoid valve B operates. (When driving in "D ₁ " or "D ₂ ".)	Battery voltage
			When shift solenoid valve B does not operate. (When driving in "D ₃ " or "D ₄ ".)	1V or less



ON BOARD DIAGNOSTIC LOGIC

This diagnosis monitors actual gear position by checking the torque converter slip ratio calculated by TCM as follows:

Torque converter slip ratio = A x C/B

A: Output shaft revolution signal from revolution sensor

B: Engine speed signal from ECM

C: Gear ratio determined as gear position which TCM supposes

If the actual gear position is higher than the position (1st) supposed by TCM, the slip ratio will be more than normal. In case the ratio exceeds the specified value, TCM judges this diagnosis malfunction.



This malfunction will be caused when either shift solenoid valve A is stuck open or shift solenoid valve B is stuck open.

TROUBLE DIAGNOSIS FOR DTC P0731

A/T 1st Gear Function (Cont'd)

Gear position supposed by TCM	1	2	3	4
In case of gear position with no malfunctions	1	2	3	4
In case of gear position with shift solenoid valve A stuck open	②	2	3	3
In case of gear position with shift solenoid valve B stuck open	④	3	3	4

○: P0731 is detected.

Diagnostic trouble code	Malfunction is detected when ...	Check item (Possible cause)
 : A/T 1ST GR FNCTN  : P0731  : MIL Code No. 1103	A/T cannot be shifted to the 1st gear position even if electrical circuit is good.	<ul style="list-style-type: none"> ● Shift solenoid valve A ● Shift solenoid valve B ● Each clutch ● Hydraulic control circuit

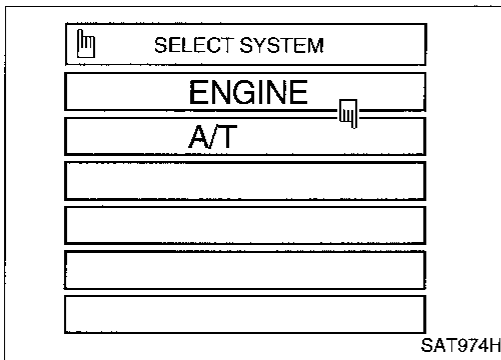

DIAGNOSTIC TROUBLE CODE (DTC) CONFIRMATION PROCEDURE

CAUTION:

- Always drive vehicle at a safe speed.
- Be careful not to rev engine into the red zone on the tachometer.

NOTE:

If "DIAGNOSTIC TROUBLE CODE CONFIRMATION PROCEDURE" has been previously conducted, always turn ignition switch "OFF" and wait at least 5 seconds before conducting the next test.

TESTING CONDITION:

Always drive vehicle on a level road to improve the accuracy of test.

After the repair, perform the following procedure to confirm the malfunction is eliminated.

- 1) Start engine and select "DATA MONITOR" mode for "A/T" with CONSULT.
- 2) Make sure that output voltage of A/T fluid temperature sensor is within the range below.
FLUID TEMP SEN: 0.4 - 1.5V
- 3) Select "1ST GR FNCTN P0731" of "DTC WORK SUPPORT" mode for "A/T" with CONSULT and touch "START".
- 4) Accelerate vehicle to 20 to 25 km/h (12 to 16 MPH) under the following condition and release the accelerator pedal completely.

THROTTLE POSI: Less than 1/8 (at all times during step 4)

Selector lever: D position (OD "ON")

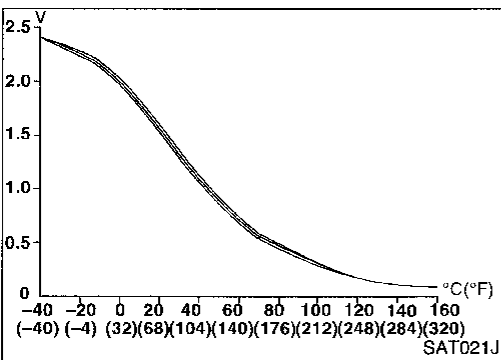
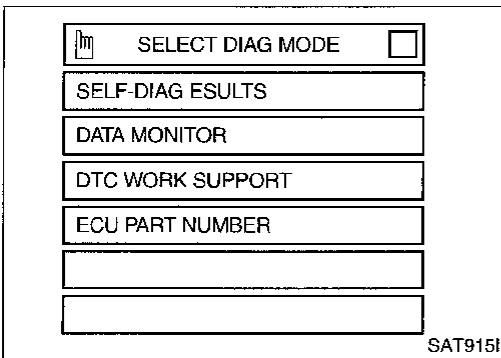

TROUBLE DIAGNOSIS FOR DTC P0731

A/T 1st Gear Function (Cont'd)

- Check that “GEAR” shows “2” after releasing pedal.
- 5) Depress accelerator pedal to WOT (more than 7/8 of “THROTTLE POSI”) quickly from a speed of 20 to 25 km/h (12 to 16 MPH) until “TESTING” changes to “STOP VEHICLE” or “COMPLETED”. (It will take approximately 3 seconds.)
If the check result NG appears on CONSULT screen, go to “DIAGNOSTIC PROCEDURE”, AT-100.
If “STOP VEHICLE” appears on CONSULT screen, go to the following step.
- Check that “GEAR” shows “1” when depressing accelerator pedal to WOT.
- If “TESTING” does not appear on CONSULT for a long time, select “SELF-DIAG RESULTS” for “ENGINE”. In case a 1st trip DTC other than P0731 is shown, refer to applicable “TROUBLE DIAGNOSIS FOR DTC”.
- 6) Stop vehicle.
- 7) Follow the instruction displayed. (Check for normal shifting referring to the table below.)

Vehicle condition	Gear on actual transmission shift pattern when screen is changed to 1 → 2 → 3 → 4
No malfunction exists	1 → 2 → 3 → 4
Malfunction for P0731 exists.	2 → 2 → 3 → 3
	4 → 3 → 3 → 4

- 8) Make sure that “OK” is displayed. (If “NG” is displayed, refer to “DIAGNOSTIC PROCEDURE”.)
Refer to “DIAGNOSTIC PROCEDURE”, AT-100.
Refer to shift schedule, AT-294.

OR



- 1) Start engine and warm up ATF.
- 2) Accelerate vehicle to 20 to 25 km/h (12 to 16 MPH) under the following condition and release the accelerator pedal completely.
THROTTLE POSI: Less than 1/8
Selector lever: D position (OD “ON”)
Refer to shift schedule, AT-294.
- 3) Depress accelerator pedal to WOT (more than 7/8 of “THROTTLE POSI”) quickly from a speed of 20 to 25 km/h (12 to 16 MPH). (It will take approximately 3 seconds.)
- 4) Select “MODE 7” with GST.

OR



- 1) Start engine and warm up ATF.
- 2) Accelerate vehicle to 20 to 25 km/h (12 to 16 MPH) under the following condition and release the accelerator pedal completely.
THROTTLE POSI: Less than 1/8
Selector lever: D position (OD “ON”)
Refer to shift schedule, AT-294.

TROUBLE DIAGNOSIS FOR DTC P0731

A/T 1st Gear Function (Cont'd)

- 3) Depress accelerator pedal to WOT (more than 7/8 of "THROTTLE POS1") quickly from a speed of 20 to 25 km/h (12 to 16 MPH). (It will take approximately 3 seconds.)
- 4) Perform self-diagnosis for ECM.
Refer to EC section ["Malfunction Indicator Lamp (MIL)", "ON BOARD DIAGNOSTIC SYSTEM DESCRIPTION"].

GI

MA

EM

LC

EC

FE

CL

MT

AT

FA

RA

BR

ST

RS

BT

HA

EL

IDX

TROUBLE DIAGNOSIS FOR DTC P0731

A/T 1st Gear Function (Cont'd)

DIAGNOSTIC PROCEDURE

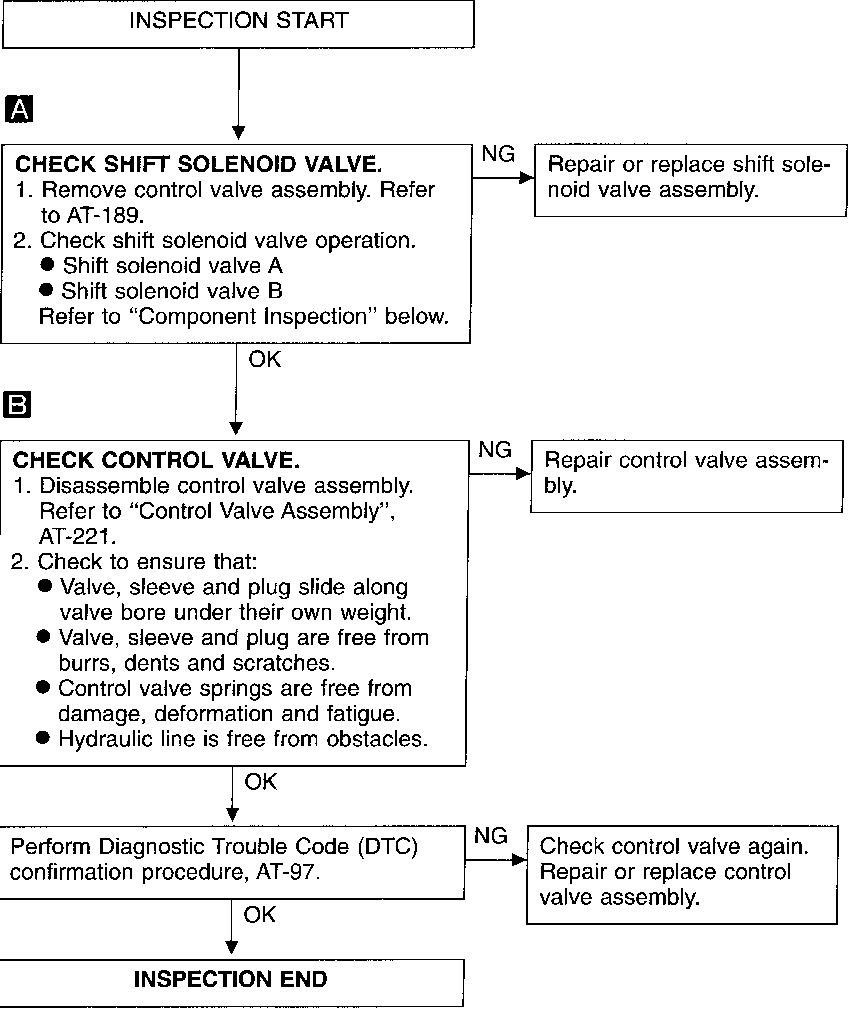
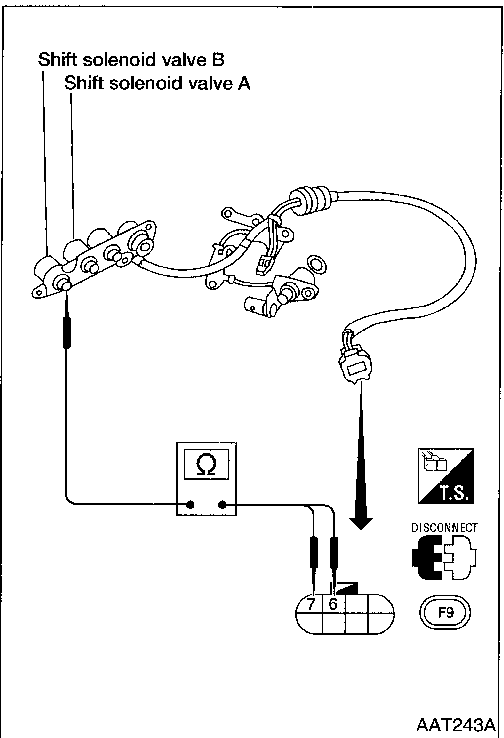
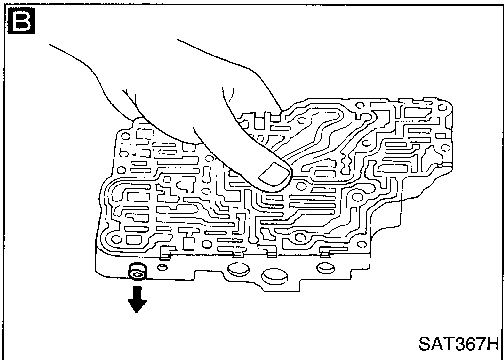
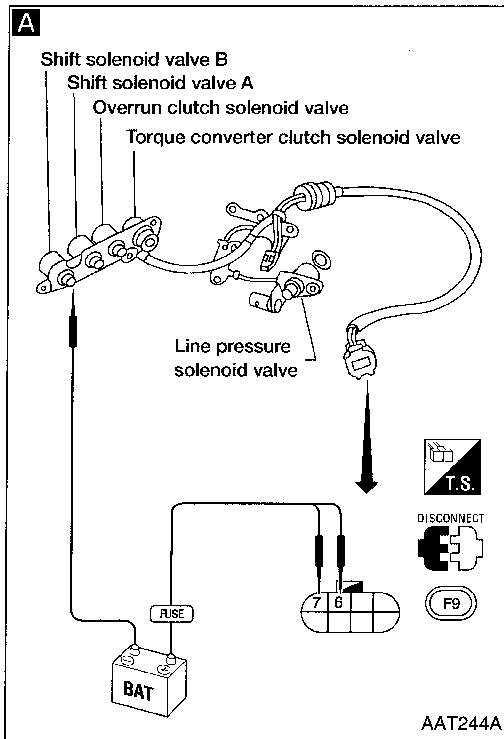

COMPONENT INSPECTION

Shift solenoid valve A and B

- For removal, refer to AT-189.

Resistance check

- Check resistance between two terminals.

Solenoid valve	Terminal No.		Resistance (Approx.)
Shift solenoid valve A	⑥	Ground	20 - 40Ω
Shift solenoid valve B	⑦		

TROUBLE DIAGNOSIS FOR DTC P0731

A/T 1st Gear Function (Cont'd)

Operation check

- Check solenoid valve by listening for its operating sound while applying battery voltage to the terminal and ground.

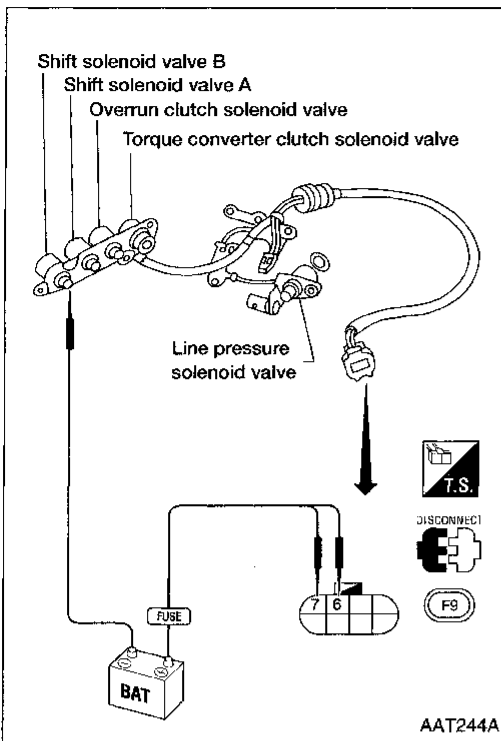

GI

MA

EM

LC

EC

FE

CL

MT

AT

FA

RA

BR

ST

RS

BT

HA

EL

IDX

TROUBLE DIAGNOSIS FOR DTC P0732

A/T 2nd Gear Function

DESCRIPTION

- This is an OBD-II self-diagnostic item and not available in TCM self-diagnosis.
- This malfunction will not be detected while the O/D OFF indicator lamp is indicating another self-diagnosis malfunction.
- This malfunction is detected when the A/T does not shift into second gear position as instructed by the TCM. This is not caused by electrical malfunction (circuits open or shorted) but by mechanical malfunction such as control valve sticking, improper solenoid valve operation, etc.

Gear position	1	2	3	4
Shift solenoid valve A	ON (Closed)	OFF (Open)	OFF (Open)	ON (Closed)
Shift solenoid valve B	ON (Closed)	ON (Closed)	OFF (Open)	OFF (Open)

TCM TERMINALS AND REFERENCE VALUE

Remarks: Specification data are reference values.

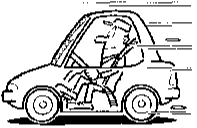
Terminal No.	Wire color	Item	Condition	Judgement standard
7	LY	Shift solenoid valve B	 When shift solenoid valve B operates. (When driving in "D ₁ " or "D ₂ ".)	Battery voltage
			When shift solenoid valve B does not operate. (When driving in "D ₃ " or "D ₄ ".)	1V or less

ON BOARD DIAGNOSTIC LOGIC

This diagnosis monitors actual gear position by checking the torque converter slip ratio calculated by TCM as follows:

$$\text{Torque converter slip ratio} = A \times C/B$$

A: Output shaft revolution signal from revolution sensor

B: Engine speed signal from ECM



C: Gear ratio determined as gear position which TCM supposes

If the actual gear position is higher than the position (2nd) supposed by TCM, the slip ratio will be more than normal. In case the ratio exceeds the specified value, TCM judges this diagnosis malfunction.

This malfunction will be caused when shift solenoid valve B is stuck open.

Gear position supposed by TCM	1	2	3	4
In case of gear position with no malfunctions	1	2	3	4
In case of gear position with shift solenoid valve B stuck open	4	③	3	4

○: P0732 is detected.

Diagnostic trouble code	Malfunction is detected when ...	Check item (Possible cause)
 : A/T 2ND GR FNCTN  : P0732  : MIL Code No. 1104	A/T cannot be shifted to the 2nd gear position even if electrical circuit is good.	<ul style="list-style-type: none"> ● Shift solenoid valve B ● Each clutch ● Hydraulic control circuit

TROUBLE DIAGNOSIS FOR DTC P0732

A/T 2nd Gear Function (Cont'd)

DIAGNOSTIC TROUBLE CODE (DTC) CONFIRMATION PROCEDURE

CAUTION:

- Always drive vehicle at a safe speed.
- Be careful not to rev engine into the red zone on the tachometer.

NOTE:

If "DIAGNOSTIC TROUBLE CODE CONFIRMATION PROCEDURE" has been previously conducted, always turn ignition switch "OFF" and wait at least 5 seconds before conducting the next test.

TESTING CONDITION:

Always drive vehicle on a level road to improve the accuracy of test.

After the repair, perform the following procedure to confirm the malfunction is eliminated.

- 1) Start engine and select "DATA MONITOR" mode for "A/T" with CONSULT.

- 2) Make sure that output voltage of A/T fluid temperature sensor is within the range below.

FLUID TEMP SEN: 0.4 - 1.5V

If out of range, drive the vehicle to decrease the voltage (warm up the fluid) or stop engine to increase the voltage (cool down the fluid).

- 3) Select "2ND GR FNCTN P0732" of "DTC WORK SUPPORT" mode for "A/T" with CONSULT and touch "START".

- 4) Accelerate vehicle to 59 to 64 km/h (37 to 40 MPH) under the following condition and release the accelerator pedal completely.

THROTTLE POSI: Less than 1/8 (at all times during step 4)

Selector lever: D position (OD "ON")

- Check that "GEAR" shows "3" or "4" after releasing pedal.

- 5) Depress accelerator pedal to WOT (more than 7/8 of "THROTTLE POSI") quickly from a speed of 59 to 64 km/h (37 to 40 MPH) until "TESTING" changes to "STOP VEHICLE" or "COMPLETED". (It will take approximately 3 seconds.)

If the check result NG appears on CONSULT screen, go to "DIAGNOSTIC PROCEDURE", AT-105.

If "STOP VEHICLE" appears on CONSULT screen, go to following step.

- Check that "GEAR" shows "2" when depressing accelerator pedal to WOT.

- If "TESTING" does not appear on CONSULT for a long time, select "SELF-DIAG RESULTS" for "ENGINE". In case a 1st trip DTC other than P0732 is shown, refer to applicable "TROUBLE DIAGNOSIS FOR DTC".

- 6) Stop vehicle.

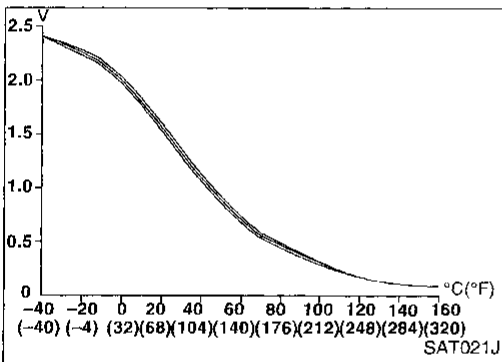
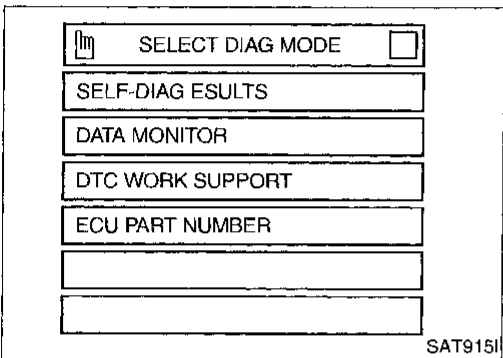
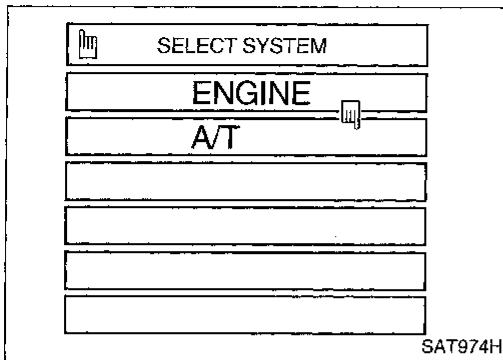

TROUBLE DIAGNOSIS FOR DTC P0732

A/T 2nd Gear Function (Cont'd)

- 7) Follow the instruction displayed. (Check for normal shifting referring to the table below.)

Vehicle condition	Gear on actual transmission shift pattern when screen is changed to 1 → 2 → 3 → 4
No malfunction exists	1 → 2 → 3 → 4
Malfunction for P0732 exists.	4 → 3 → 3 → 4

- 8) Make sure that "OK" is displayed. (If "NG" is displayed, refer to "DIAGNOSTIC PROCEDURE".) Refer to "DIAGNOSTIC PROCEDURE", AT-105. Refer to shift schedule, AT-294.

OR



- 1) Start engine and warm up ATF.
- 2) Accelerate vehicle to 59 to 64 km/h (37 to 40 MPH) under the following condition and release the accelerator pedal completely.
THROTTLE POSI: Less than 1/8
Selector lever: D position (OD "ON")
Refer to shift schedule, AT-294.
- 3) Depress accelerator pedal to WOT (more than 7/8 of "THROTTLE POSI") quickly from a speed of 59 to 64 km/h (37 to 40 MPH). (It will take approximately 3 seconds.)
- 4) Select "MODE 7" with GST.

OR



- 1) Start engine and warm up ATF.
- 2) Accelerate vehicle to 59 to 64 km/h (37 to 40 MPH) under the following condition and release the accelerator pedal completely.
THROTTLE POSI: Less than 1/8
Selector lever: D position (OD "ON")
Refer to shift schedule, AT-294.
- 3) Depress accelerator pedal to WOT (more than 7/8 of "THROTTLE POSI") quickly from a speed of 59 to 64 km/h (37 to 40 MPH). (It will take approximately 3 seconds.)
- 4) Perform self-diagnosis for ECM.
Refer to EC section ["Malfunction Indicator Lamp (MIL)", "ON BOARD DIAGNOSTIC SYSTEM DESCRIPTION"].

TROUBLE DIAGNOSIS FOR DTC P0732

A/T 2nd Gear Function (Cont'd)

DIAGNOSTIC PROCEDURE

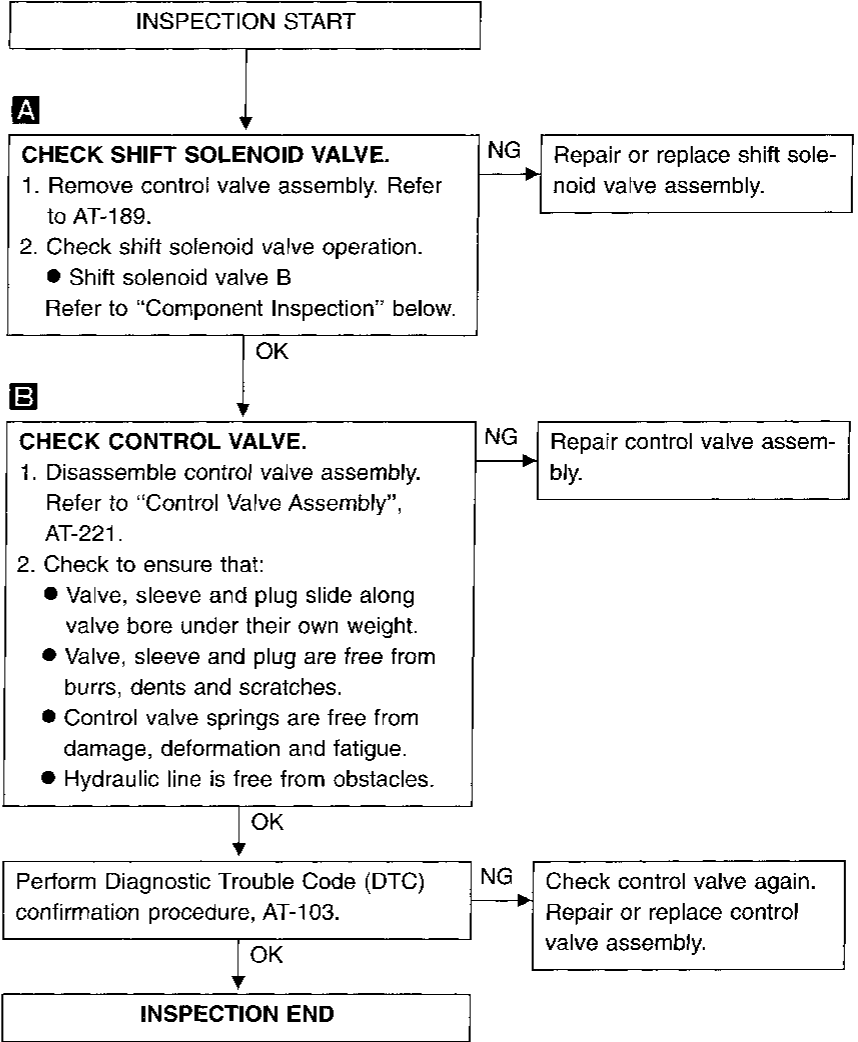
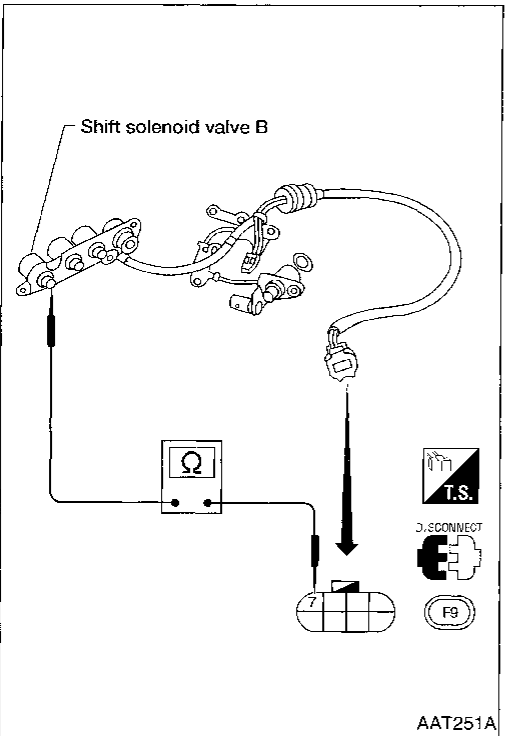
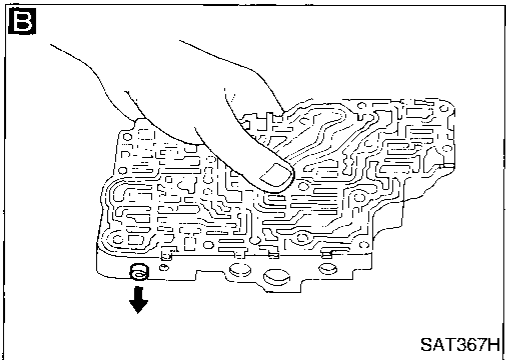
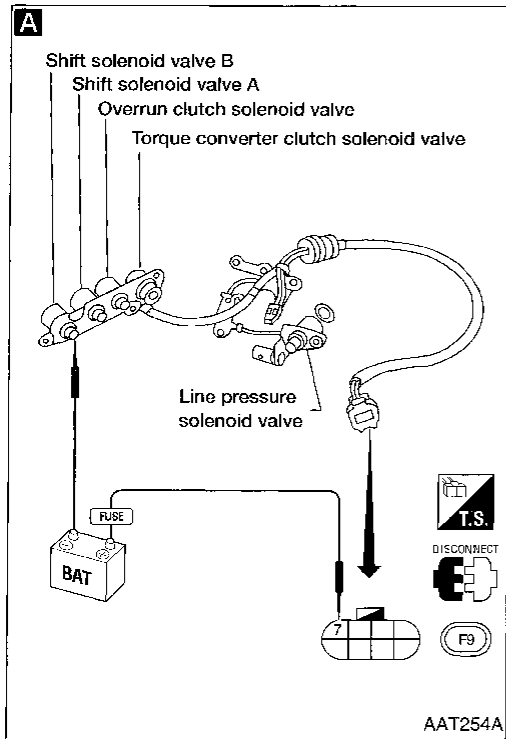

COMPONENT INSPECTION

Shift solenoid valve B

- For removal, refer to AT-189.

Resistance check

- Check resistance between two terminals.

Solenoid valve	Terminal No.		Resistance (Approx.)
Shift solenoid valve B	⑦	Ground	20 - 40Ω

GI
MA
EM
LC
FC
FE
CL
MT
AT
FA
RA
BR
ST
RS
BT
HA
EL
IDX

TROUBLE DIAGNOSIS FOR DTC P0732

A/T 2nd Gear Function (Cont'd)

Operation check

- Check solenoid valve by listening for its operating sound while applying battery voltage to the terminal and ground.

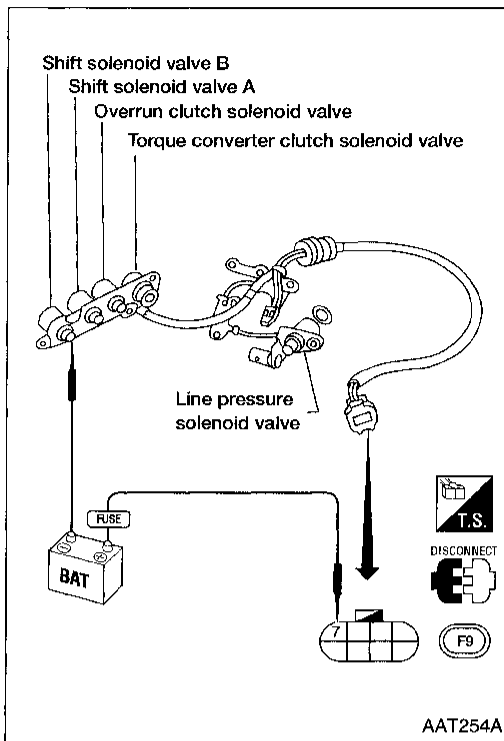

TROUBLE DIAGNOSIS FOR DTC P0733

A/T 3rd Gear Function

DESCRIPTION

- This is an OBD-II self-diagnostic item and not available in TCM self-diagnosis.
- This malfunction will not be detected while the O/D OFF indicator lamp is indicating another self-diagnosis malfunction.
- This malfunction is detected when the A/T does not shift into third gear position as instructed by the TCM. This is not caused by electrical malfunction (circuits open or shorted) but by mechanical malfunction such as control valve sticking, improper solenoid valve operation, malfunctioning servo piston or brake band, etc.

Gear position	1	2	3	4
Shift solenoid valve A	ON (Closed)	OFF (Open)	OFF (Open)	ON (Closed)
Shift solenoid valve B	ON (Closed)	ON (Closed)	OFF (Open)	OFF (Open)

TCM TERMINALS AND REFERENCE VALUE

Remarks: Specification data are reference values.

Terminal No.	Wire color	Item	Condition	Judgement standard
6	L/W	Shift solenoid valve A	 When shift solenoid valve A operates. (When driving in "D ₁ " or "D ₄ ".)	Battery voltage
			When shift solenoid valve A does not operate. (When driving in "D ₂ " or "D ₃ ".)	1V or less

ON BOARD DIAGNOSTIC LOGIC

This diagnosis monitors actual gear position by checking the torque converter slip ratio calculated by TCM as follows:

$$\text{Torque converter slip ratio} = A \times C/B$$

A: Output shaft revolution signal from revolution sensor

B: Engine speed signal from ECM



C: Gear ratio determined as gear position which TCM supposes

If the actual gear position is higher than the position (3rd) supposed by TCM, the slip ratio will be more than normal. In case the ratio exceeds the specified value, TCM judges this diagnosis malfunction.

This malfunction will be caused when shift solenoid valve A is stuck closed.

Gear position supposed by TCM	1	2	3	4
In case of gear position with no malfunctions	1	2	3	4
In case of gear position with shift solenoid valve A stuck closed	1	1	④	4

○: P0733 is detected.

Diagnostic trouble code	Malfunction is detected when ...	Check item (Possible cause)
 : A/T 3RD GR FNCTN	A/T cannot be shifted to the 3rd gear position even if electrical circuit is good.	<ul style="list-style-type: none"> ● Shift solenoid valve A ● Each clutch ● Hydraulic control circuit
 : P0733		
 : MIL Code No. 1105		

TROUBLE DIAGNOSIS FOR DTC P0733

A/T 3rd Gear Function (Cont'd)

DIAGNOSTIC TROUBLE CODE (DTC) CONFIRMATION PROCEDURE

CAUTION:

- Always drive vehicle at a safe speed.
- Be careful not to rev engine into the red zone on the tachometer.

NOTE:

If "DIAGNOSTIC TROUBLE CODE CONFIRMATION PROCEDURE" has been previously conducted, always turn ignition switch "OFF" and wait at least 5 seconds before conducting the next test.

TESTING CONDITION:

Always drive vehicle on a level road to improve the accuracy of test.

After the repair, perform the following procedure to confirm the malfunction is eliminated.

1) Start engine and select "DATA MONITOR" mode for "A/T" with CONSULT.

2) Make sure that output voltage of A/T fluid temperature sensor is within the range below.

FLUID TEMP SEN: 0.4 - 1.5V

If out of range, drive the vehicle to decrease the voltage (warm up the fluid) or stop engine to increase the voltage (cool down the fluid).

3) Select "3RD GR FNCTN P0733" of "DTC WORK SUPPORT" mode for "A/T" with CONSULT and touch "START".

4) Accelerate vehicle to 70 to 85 km/h (44 to 53 MPH) under the following condition and release the accelerator pedal completely.

THROTTLE POSI: Less than 1/8 (at all times during step 4)

Selector lever: D position (OD "ON")

• Check that "GEAR" shows "4" after releasing pedal.

5) Depress accelerator pedal steadily with 3.5/8 - 4.5/8 of "THROTTLE POSI" from a speed of 70 to 85 km/h (44 to 53 MPH) until "TESTING" changes to "STOP VEHICLE" or "COMPLETED". (It will take approximately 3 seconds.)

If the check result NG appears on CONSULT screen, go to "DIAGNOSTIC PROCEDURE", AT-110.

If "STOP VEHICLE" appears on CONSULT screen, go to following step.

• Check that "GEAR" shows "3" when depressing accelerator pedal with 3.5/8 - 4.5/8 of "THROTTLE POSI".

• If "TESTING" does not appear on CONSULT for a long time, select "SELF-DIAG RESULTS" for "ENGINE". In case a 1st trip DTC other than P0733 is shown, refer to applicable "TROUBLE DIAGNOSIS FOR DTC".

6) Stop vehicle.

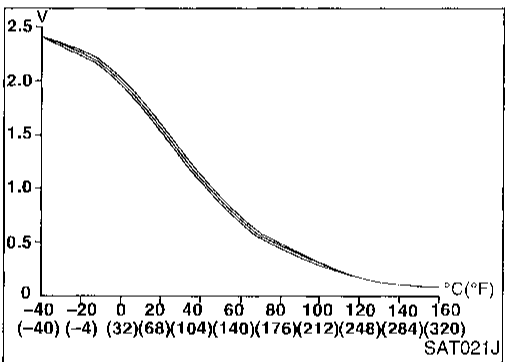
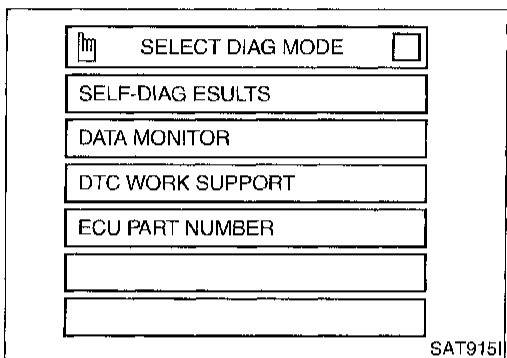
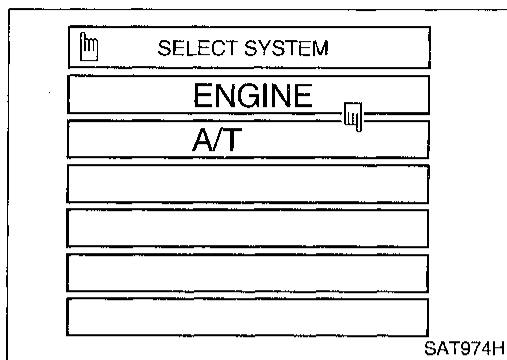

TROUBLE DIAGNOSIS FOR DTC P0733

A/T 3rd Gear Function (Cont'd)

- 7) Follow the instruction displayed. (Check for normal shifting referring to the table below.)

Vehicle condition	Gear on actual transmission shift pattern when screen is changed to 1 → 2 → 3 → 4
No malfunction exists.	1 → 2 → 3 → 4
Malfunction for P0733 exists.	1 → 1 → 4 → 4

- 8) Make sure that "OK" is displayed. (If "NG" is displayed, refer to "DIAGNOSTIC PROCEDURE".) Refer to "DIAGNOSTIC PROCEDURE", AT-110. Refer to shift schedule, AT-294.

OR



- 1) Start engine and warm up ATF.
- 2) Accelerate vehicle to 70 to 85 km/h (44 to 53 MPH) under the following condition and release the accelerator pedal completely.

THROTTLE POSI: Less than 1/8

Selector lever: D position (OD "ON")

Refer to shift schedule, AT-294.

- 3) Depress accelerator pedal with 3.5/8 - 4.5/8 of "THROTTLE POSI" from a speed of 70 to 85 km/h (44 to 53 MPH). (It will take approximately 3 seconds.)
- 4) Select "MODE 7" with GST.

OR



- 1) Start engine and warm up ATF.
- 2) Accelerate vehicle to 70 to 85 km/h (44 to 53 MPH) under the following condition and release the accelerator pedal completely.

THROTTLE POSI: Less than 1/8

Selector lever: D position (OD "ON")

Refer to shift schedule, AT-294.

- 3) Depress accelerator pedal with 3.5/8 - 4.5/8 of "THROTTLE POSI" from a speed of 70 to 85 km/h (44 to 53 MPH). (It will take approximately 3 seconds.)
- 4) Perform self-diagnosis for ECM. Refer to EC section ["Malfunction Indicator Lamp (MIL)", "ON BOARD DIAGNOSTIC SYSTEM DESCRIPTION"].

TROUBLE DIAGNOSIS FOR DTC P0733

A/T 3rd Gear Function (Cont'd)

DIAGNOSTIC PROCEDURE

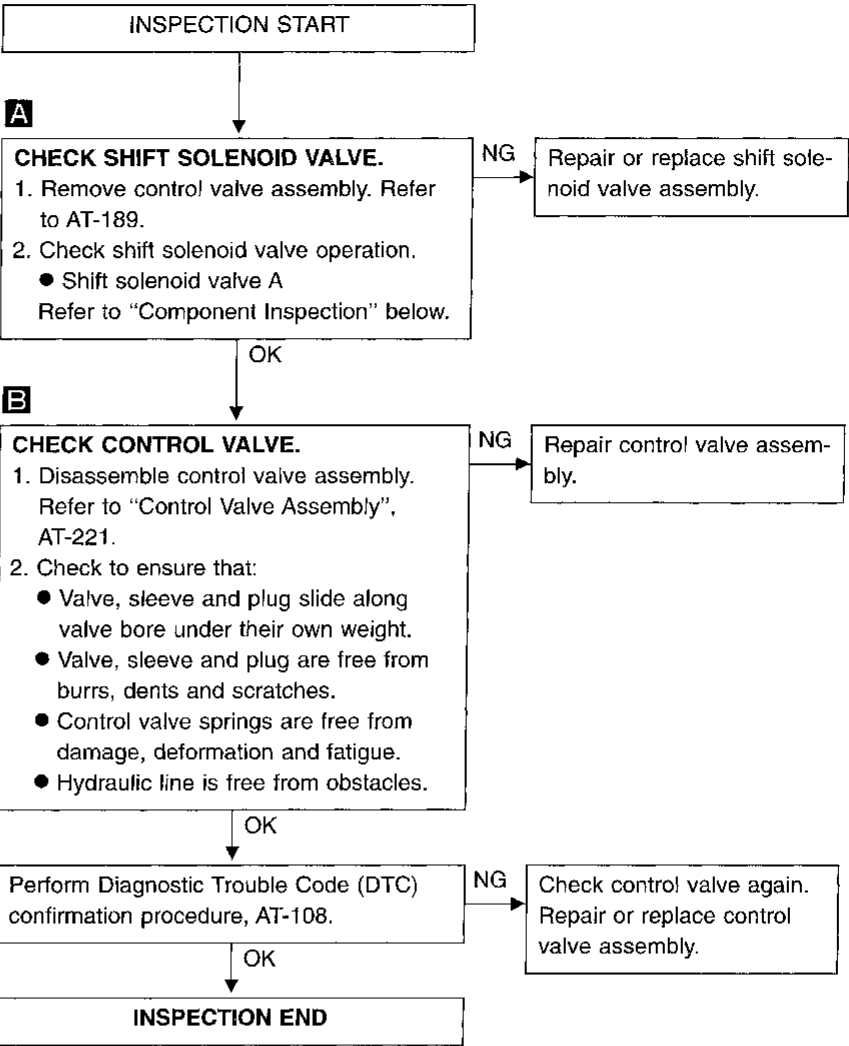
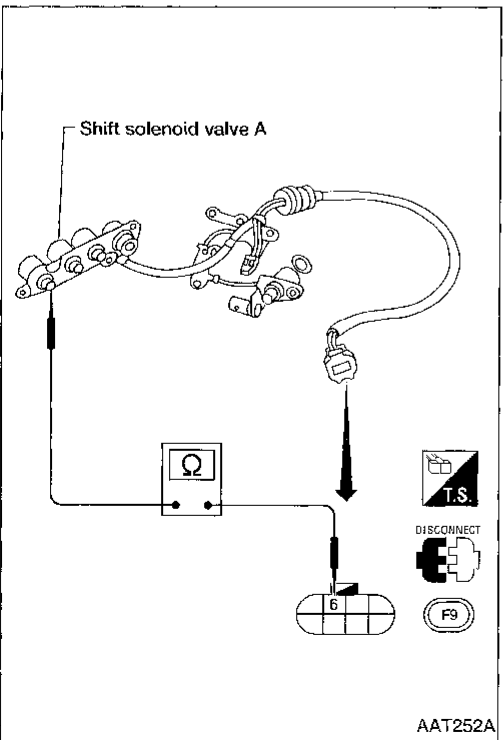
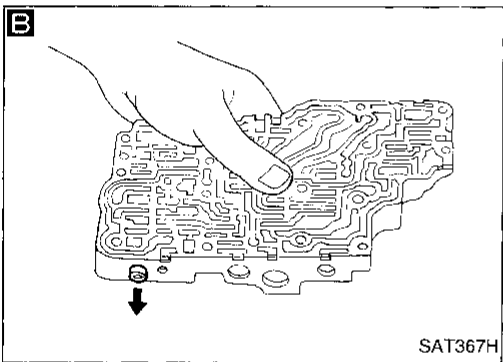
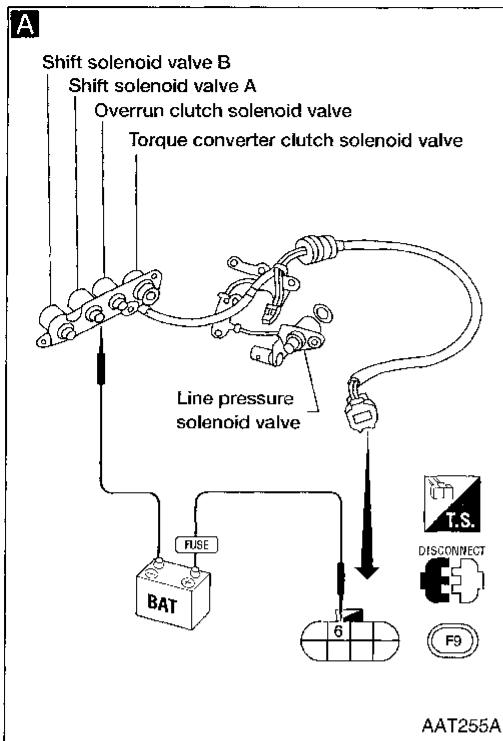

COMPONENT INSPECTION

Shift solenoid valve A

- For removal, refer to AT-189.

Resistance check

- Check resistance between two terminals.

Solenoid valve	Terminal No.		Resistance (Approx.)
Shift solenoid valve A	⑥	Ground	20 - 40Ω

TROUBLE DIAGNOSIS FOR DTC P0733

A/T 3rd Gear Function (Cont'd)

Operation check

- Check solenoid valve by listening for its operating sound while applying battery voltage to the terminal and ground.

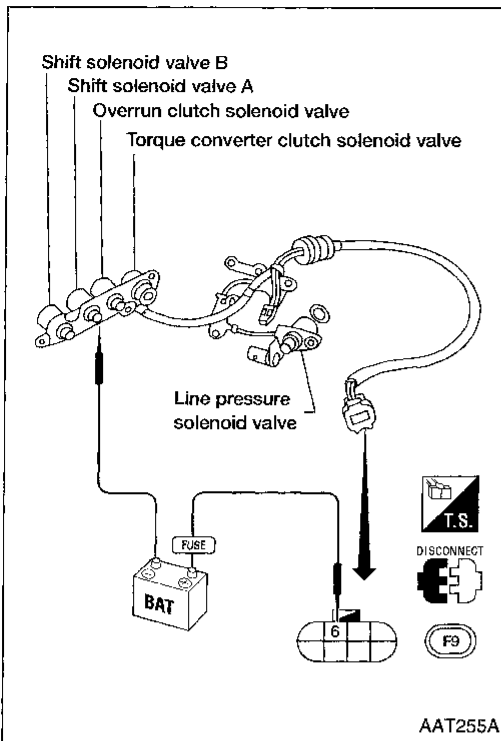

GI
MA
EM
LC
EC
FE
CL
MT
AT
FA
RA
BR
ST
RS
BT
HA
EL
IDX

TROUBLE DIAGNOSIS FOR DTC P0734

A/T 4th Gear Function

DESCRIPTION

- This is an OBD-II self-diagnostic item and not available in TCM self-diagnosis.
- This malfunction will not be detected while the O/D OFF indicator lamp is indicating another self-diagnosis malfunction.
- This malfunction is detected when the A/T does not shift into fourth gear position or the torque converter clutch does not lock up as instructed by the TCM. This is not caused by electrical malfunction (circuits open or shorted) but by mechanical malfunction such as control valve sticking, improper solenoid valve operation, malfunctioning oil pump or torque converter clutch, etc.

Gear position	1	2	3	4
Shift solenoid valve A	ON (Closed)	OFF (Open)	OFF (Open)	ON (Closed)
Shift solenoid valve B	ON (Closed)	ON (Closed)	OFF (Open)	OFF (Open)







CONSULT REFERENCE VALUE IN DATA MONITOR MODE

Remarks: Specification data are reference values.

Monitor item	Condition	Specification
Torque converter clutch solenoid valve duty	Lock-up "OFF"	Approximately 4%
	↓	
	Lock-up "ON"	Approximately 94%
Line pressure solenoid valve duty	Small throttle opening (Low line pressure)	Approximately 24%
	↓	
	Large throttle opening (High line pressure)	Approximately 95%

TCM TERMINALS AND REFERENCE VALUE

Remarks: Specification data are reference values.

Terminal No.	Wire color	Item	Condition	Judgement standard	
1	R/W	Line pressure solenoid valve		When releasing accelerator pedal after warming up engine.	1.5 - 2.5V
				When depressing accelerator pedal fully after warming up engine.	0.5V or less
2	P/B	Line pressure solenoid valve (with dropping resistor)		When releasing accelerator pedal after warming up engine.	5 - 14V
				When depressing accelerator pedal fully after warming up engine.	0.5V or less
5	GY/R	Torque converter clutch solenoid valve		When A/T performs lock-up.	8 - 15V
				When A/T does not perform lock-up.	1V or less
6	L/W	Shift solenoid valve A		When shift solenoid valve A operates. (When driving in "D ₁ " or "D ₄ ".)	Battery voltage
				When shift solenoid valve A does not operate. (When driving in "D ₂ " or "D ₃ ".)	1V or less
7	L/Y	Shift solenoid valve B		When shift solenoid valve B operates. (When driving in "D ₁ " or "D ₂ ".)	Battery voltage
				When shift solenoid valve B does not operate. (When driving in "D ₃ " or "D ₄ ".)	1V or less
8	L/B	Overrun clutch solenoid valve		When overrun clutch solenoid valve operates.	Battery voltage
				When overrun clutch solenoid valve does not operate.	1V or less

TROUBLE DIAGNOSIS FOR DTC P0734

A/T 4th Gear Function (Cont'd)

ON BOARD DIAGNOSTIC LOGIC

This diagnosis monitors actual gear position by checking the torque converter slip ratio calculated by TCM as follows:

Torque converter slip ratio = $A \times C/B$

A: Output shaft revolution signal from revolution sensor

B: Engine speed signal from ECM



C: Gear ratio determined as gear position which TCM supposes

If the actual gear position is much lower than the position (4th) supposed by TCM, the slip ratio will be much less than normal. In case the ratio does not reach the specified value, TCM judges this diagnosis malfunction.

This malfunction will be caused when shift solenoid valve B is stuck closed.

Gear position supposed by TCM	1	2	3	4
In case of gear position with no malfunctions	1	2	3	4
In case of gear position with shift solenoid valve B stuck closed	1	2	2	①

○: P0734 is detected.

Diagnostic trouble code	Malfunction is detected when ...	Check item (Possible cause)
 : A/T 4TH GR FNCTN  : P0734  : MIL Code No. 1106	A/T cannot be shifted to the 4th gear position even if electrical circuit is good.	<ul style="list-style-type: none"> ● Shift solenoid valve A ● Shift solenoid valve B ● Overrun clutch solenoid valve ● Line pressure solenoid valve ● Each clutch ● Hydraulic control circuit ● Torque converter clutch solenoid valve

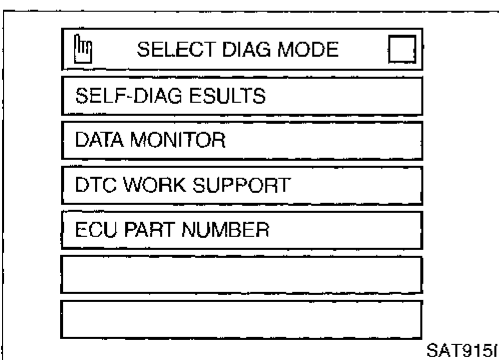
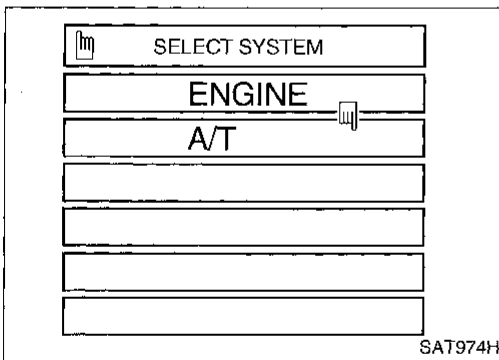

DIAGNOSTIC TROUBLE CODE (DTC) CONFIRMATION PROCEDURE

CAUTION:

- Always drive vehicle at a safe speed.
- If conducting this "DTC CONFIRMATION PROCEDURE" again, always turn ignition switch "OFF" and wait at least 5 seconds before continuing.
- Be careful not to rev engine into the red zone on the tachometer.

NOTE:

If "DIAGNOSTIC TROUBLE CODE CONFIRMATION PROCEDURE" has been previously conducted, always turn ignition switch "OFF" and wait at least 5 seconds before conducting the next test.

TESTING CONDITION:

Always drive vehicle on a level road to improve the accuracy of test.

After the repair, perform the following procedure to confirm the malfunction is eliminated.

- 1) Start engine and select "DATA MONITOR" mode for "A/T" with CONSULT.

TROUBLE DIAGNOSIS FOR DTC P0734

A/T 4th Gear Function (Cont'd)

- 2) Make sure that output voltage of A/T fluid temperature sensor is within the range below.

FLUID TEMP SEN: 0.4 - 1.5V

If out of range, drive the vehicle to decrease the voltage (warm up the fluid) or stop engine to increase the voltage (cool down the fluid).

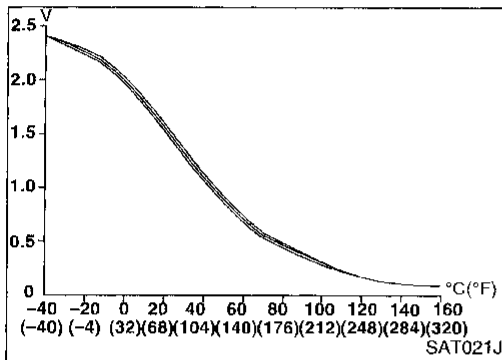

- 3) Select "4TH GR FNCTN P0734" of "DTC WORK SUPPORT" mode for "A/T" with CONSULT and touch "START".

- 4) Accelerate vehicle to 40 to 50 km/h (25 to 31 MPH) under the following condition and release the accelerator pedal completely.

THROTTLE POSI: Less than 5.5/8 (at all times during step 4)

Selector lever: D position (OD "ON")

- Check that "GEAR" shows "3" after releasing pedal.
- 5) Depress accelerator pedal steadily with 1/8 - 2/8 of "THROTTLE POSI" from a speed of 40 to 50 km/h (25 to 31 MPH) until "TESTING" has turned to "STOP VEHICLE" or "COMPLETED". (It will take approximately 3 seconds.)
If the check result NG appears on CONSULT screen, go to "DIAGNOSTIC PROCEDURE", AT-116.
If "STOP VEHICLE" appears on CONSULT screen, go to following step.
 - Check that "GEAR" shows "4" when depressing accelerator pedal with 1/8 - 2/8 of "THROTTLE POSI".
 - If "TESTING" does not appear on CONSULT for a long time, select "SELF-DIAG RESULTS" for "ENGINE". In case a 1st trip DTC other than P0734 is shown, refer to applicable "TROUBLE DIAGNOSIS FOR DTC".
 - 6) Stop vehicle.
 - 7) Follow the instruction displayed. (Check for normal shifting referring to the table below.)

Vehicle condition	Gear on actual transmission shift pattern when screen is changed to 1 → 2 → 3 → 4
No malfunction exists	1 → 2 → 3 → 4
Malfunction for P0734 exists.	1 → 2 → 2 → 1

- 8) Make sure that "OK" is displayed. (If "NG" is displayed, refer to "DIAGNOSTIC PROCEDURE".) Refer to "DIAGNOSTIC PROCEDURE", AT-116. Refer to shift schedule, AT-294.

OR



- 1) Start engine and warm up ATF.
- 2) Accelerate vehicle to 40 to 50 km/h (25 to 31 MPH) under the following condition and release the accelerator pedal completely.

TROUBLE DIAGNOSIS FOR DTC P0734

A/T 4th Gear Function (Cont'd)

THROTTLE POSI: Less than 5.5/8

Selector lever: D position (OD "ON")

Refer to shift schedule, AT-294.

- 3) Depress accelerator pedal with 1/8 - 2/8 of "THROTTLE POSI" from a speed of 40 to 50 km/h (25 to 31 MPH). (It will take approximately 3 seconds.)
- 4) Select "MODE 7" with GST.

OR



- 1) Start engine and warm up ATF.
- 2) Accelerate vehicle to 40 to 50 km/h (25 to 31 MPH) under the following condition and release the accelerator pedal completely.

THROTTLE POSI: Less than 5.5/8

Selector lever: D position (OD "ON")

Refer to shift schedule, AT-294.

- 3) Depress accelerator pedal with 1/8 - 2/8 of "THROTTLE POSI" from a speed of 40 to 50 km/h (25 to 31 MPH). (It will take approximately 3 seconds.)
- 4) Perform self-diagnosis for ECM.
Refer to EC section ["Malfunction Indicator Lamp (MIL)", "ON BOARD DIAGNOSTIC SYSTEM DESCRIPTION"].

GI
MA
EM
LC
EC
FE
CL
MT
AT
FA
RA
BR
ST
RS
BT
HA
EL
IDX

TROUBLE DIAGNOSIS FOR DTC P0734

A/T 4th Gear Function (Cont'd)

DIAGNOSTIC PROCEDURE

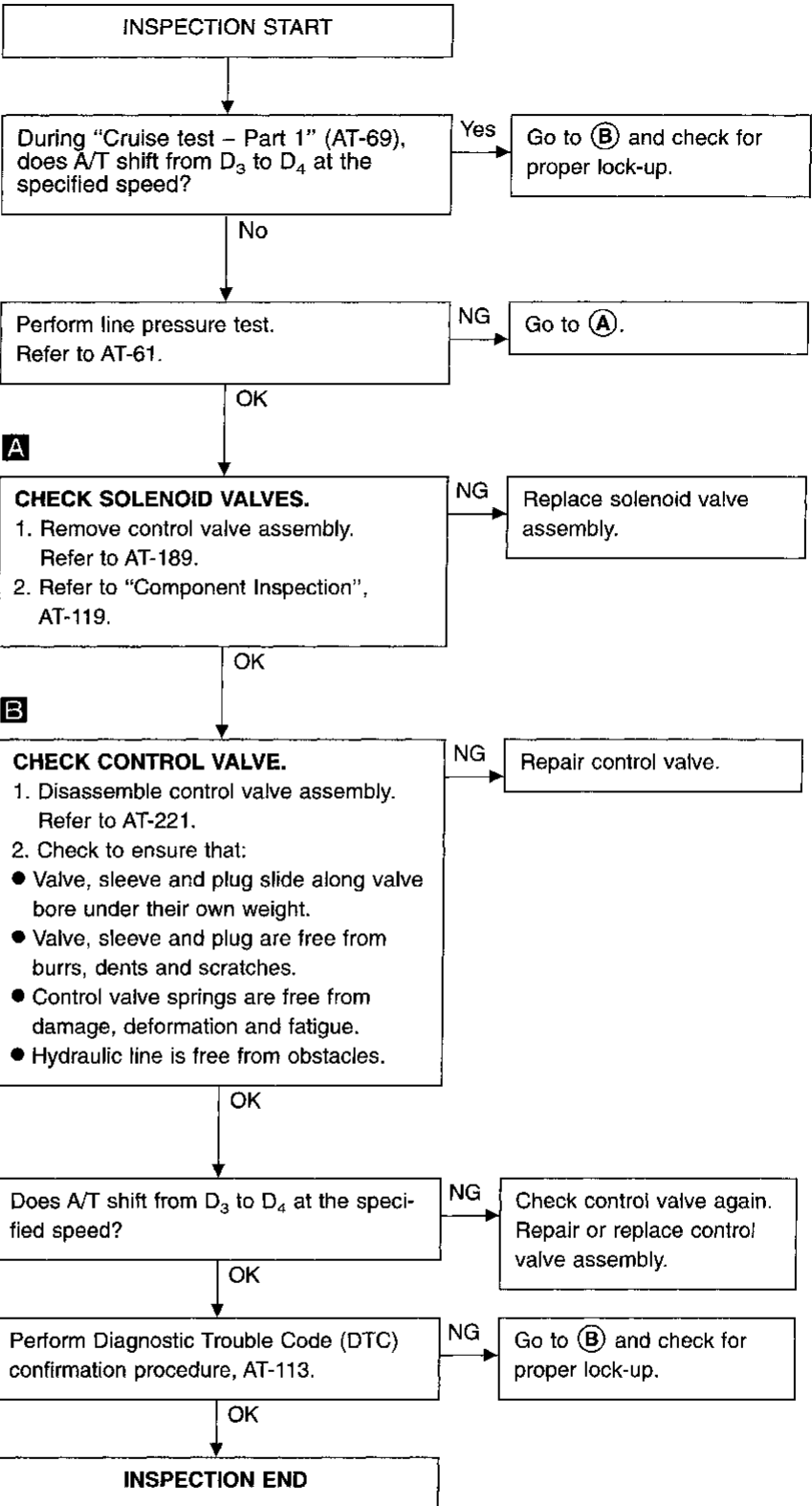
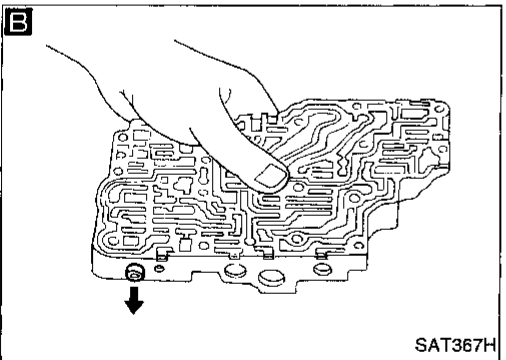
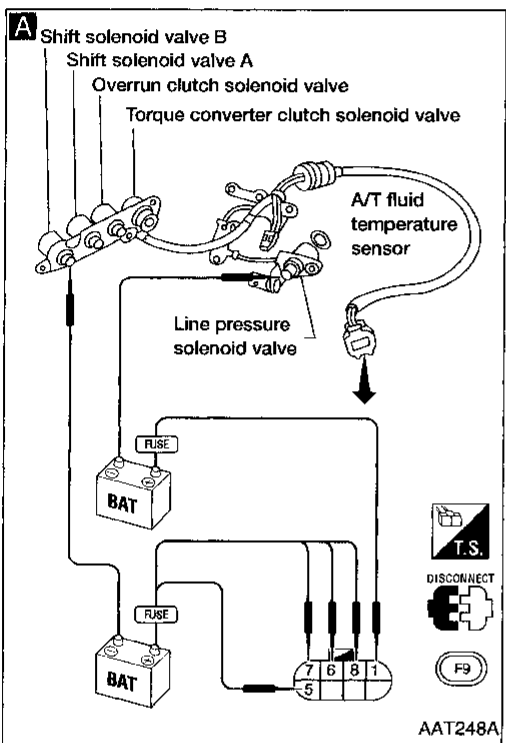
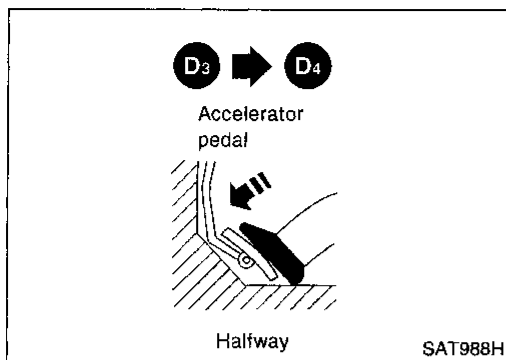

TROUBLE DIAGNOSIS FOR DTC P0734

A/T 4th Gear Function (Cont'd)

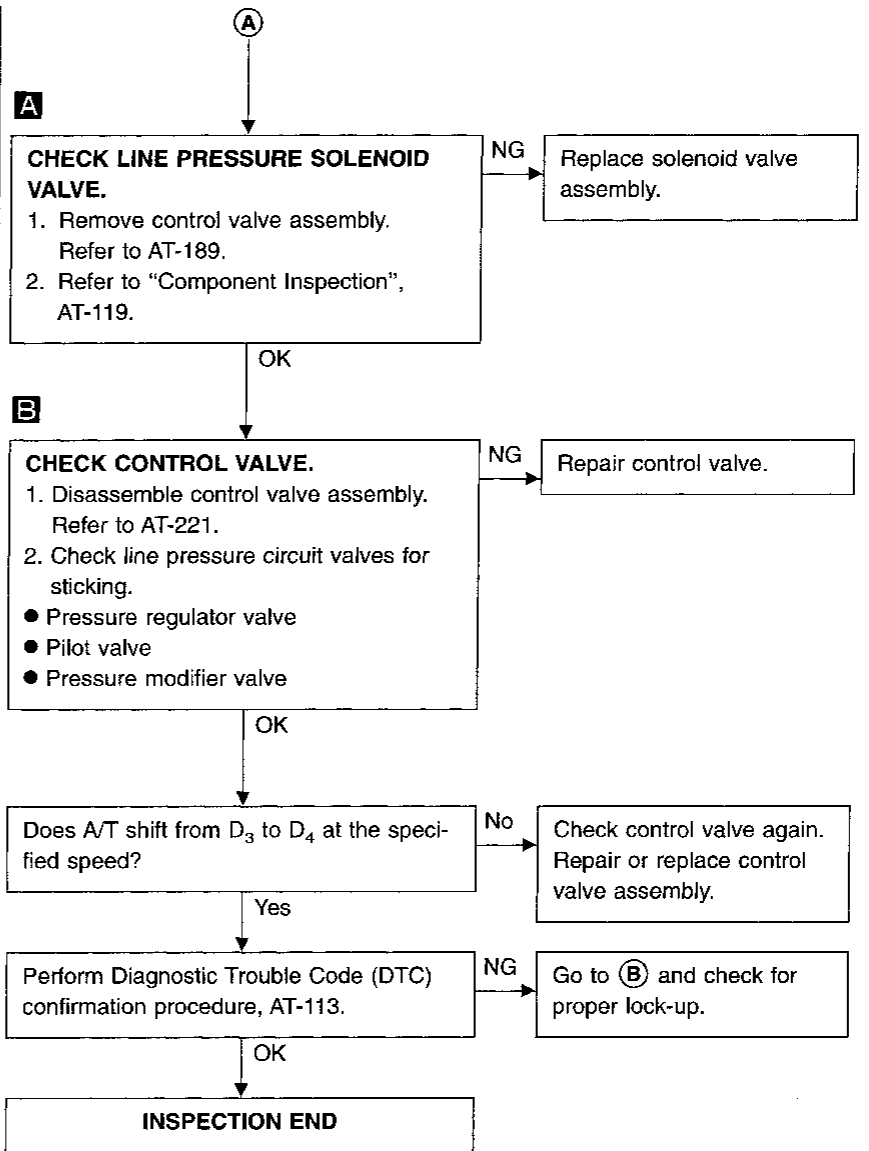
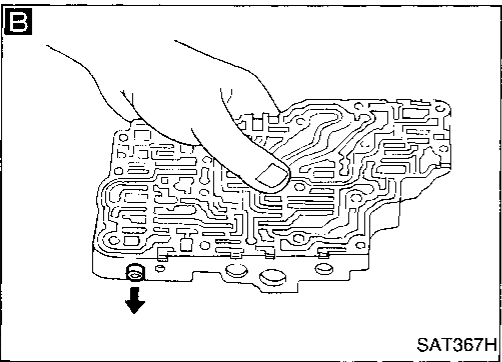
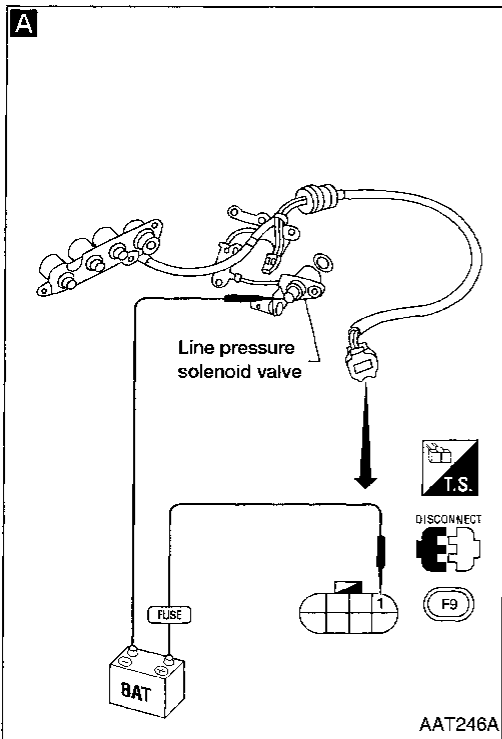

CI
MA
EM
LC
EC
FE
CL
MT
AT
FA
RA
BR
ST
RS
BT
HA
EL
IDX

TROUBLE DIAGNOSIS FOR DTC P0734

A/T 4th Gear Function (Cont'd)

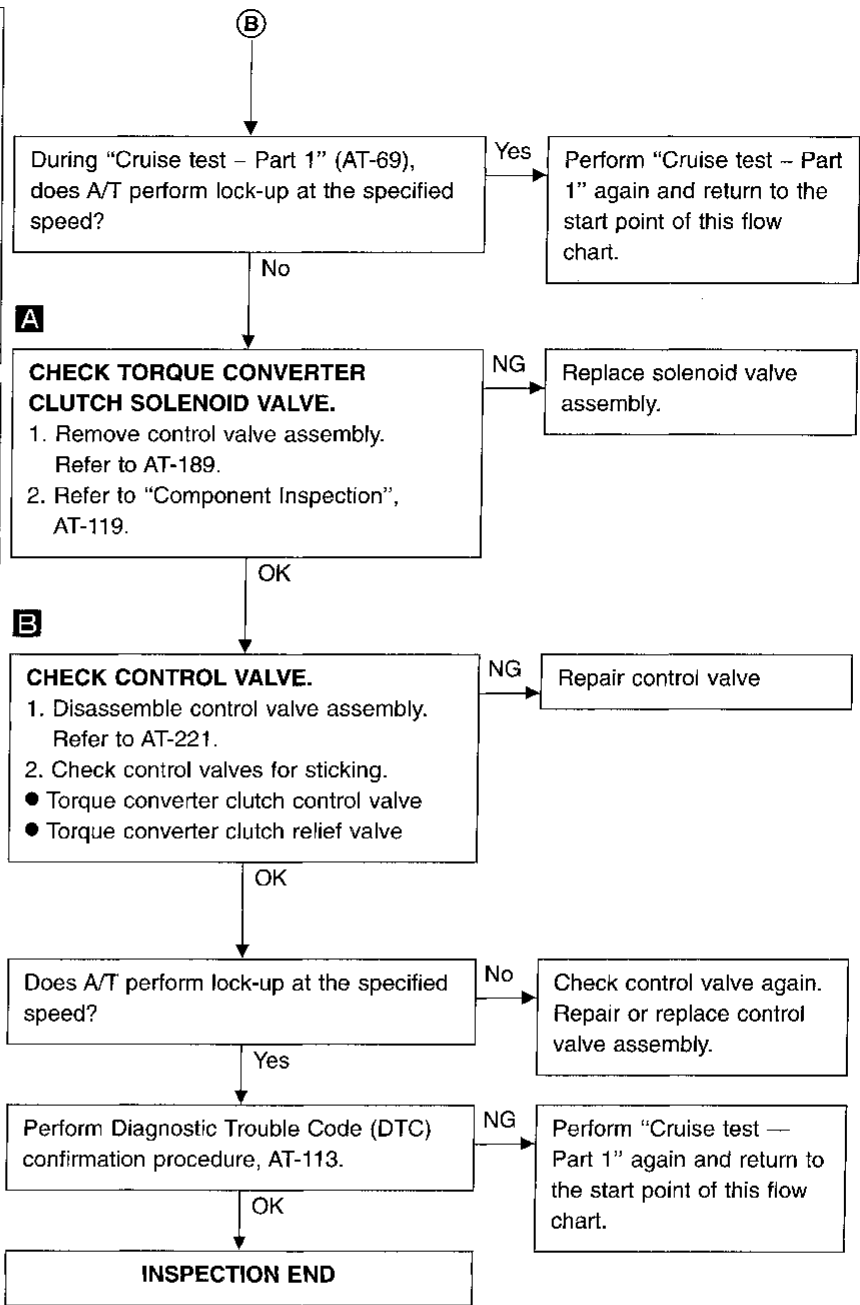
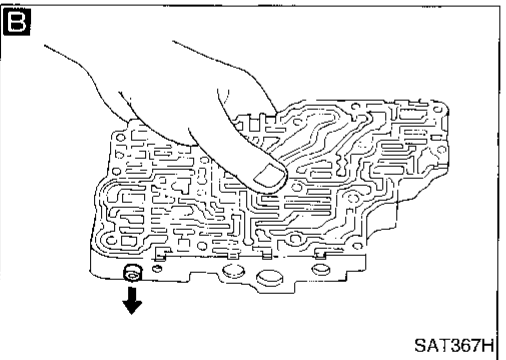
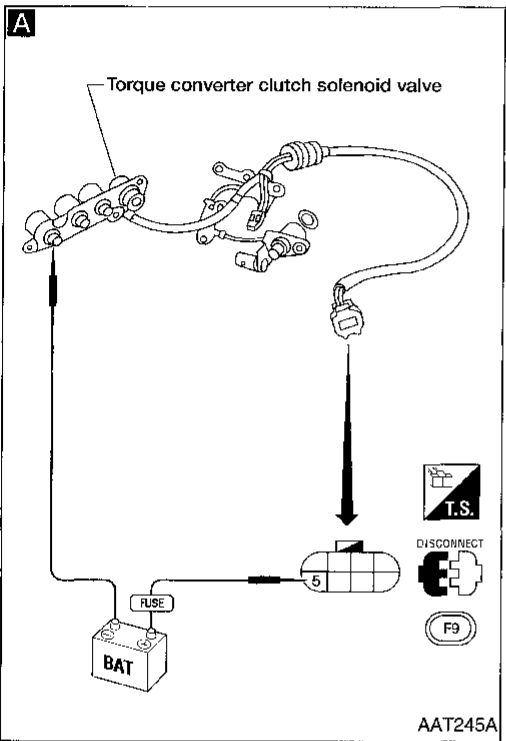
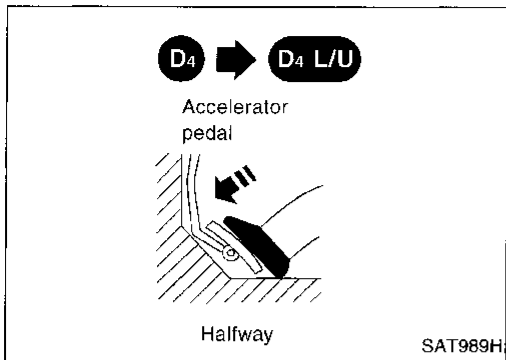

TROUBLE DIAGNOSIS FOR DTC P0734

A/T 4th Gear Function (Cont'd)

COMPONENT INSPECTION

Solenoid valves

- For removal, refer to AT-189.

Resistance check

- Check resistance between two terminals.

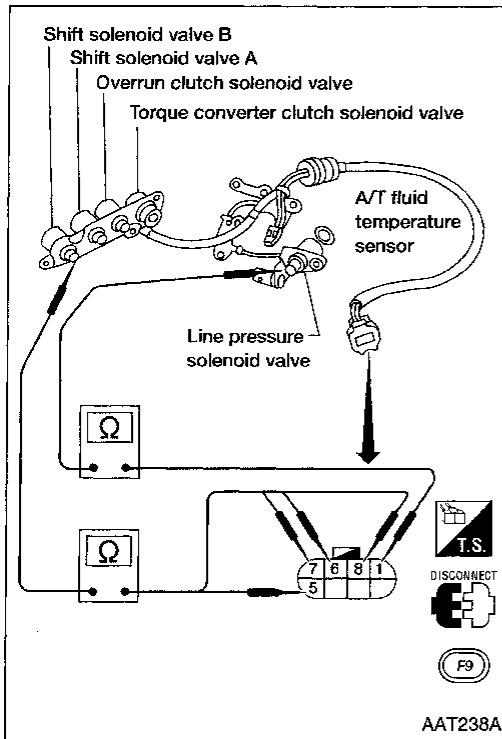

Solenoid valve	Terminal No.	Resistance (Approx.)
Shift solenoid valve A	⑥	20 - 40Ω
Shift solenoid valve B	⑦	
Overrun clutch solenoid valve	⑧	
Line pressure solenoid valve	①	2.5 - 5Ω
Torque converter clutch solenoid valve	⑤	10 - 20Ω

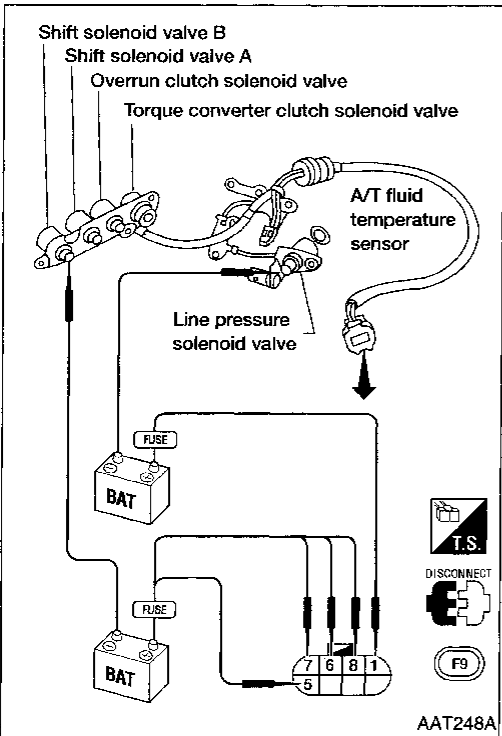

Operation check

- Check solenoid valve by listening for its operating sound while applying battery voltage to the terminal and ground.

GI
MA
EM
LC
EC
FE
CL
MT
AT
FA
RA
BR
ST
RS
BT
HA
EL
IDX

TROUBLE DIAGNOSIS FOR DTC P0740

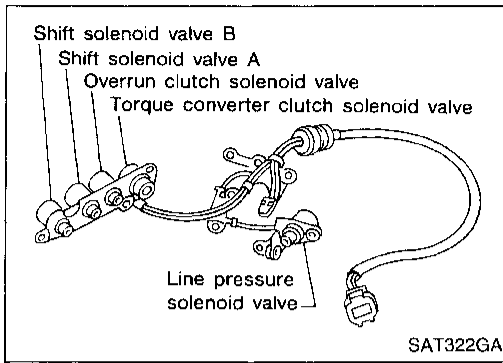

Torque Converter Clutch Solenoid Valve

DESCRIPTION

The torque converter clutch solenoid valve is activated, with the gear in "D₄", by the TCM in response to signals sent from the vehicle speed and throttle position sensors. Lock-up piston operation will then be controlled.

Lock-up operation, however, is prohibited when A/T fluid temperature is too low.

When the accelerator pedal is depressed (less than 2/8) in lock-up condition, the engine speed should not change abruptly. If there is a big jump in engine speed, there is no lock-up.

CONSULT REFERENCE VALUE IN DATA MONITOR MODE

Remarks: Specification data are reference values.



Monitor item	Condition	Specification
Torque converter clutch solenoid valve duty	Lock-up "OFF"	Approximately 4%
	↓ Lock-up "ON"	↓ Approximately 94%

TCM TERMINALS AND REFERENCE VALUE

Remarks: Specification data are reference values.

Terminal No.	Wire color	Item	Condition	Judgement standard	
5	GY/R	Torque converter clutch solenoid valve		When A/T performs lock-up.	8 - 15V
				When A/T does not perform lock-up.	1V or less

ON BOARD DIAGNOSIS LOGIC

Diagnostic trouble code	Malfunction is detected when ...	Check item (Possible cause)
 : TCC SOLENOID/CIRC  : P0740  : MIL Code No. 1204	TCM detects an improper voltage drop when it tries to operate the solenoid valve.	<ul style="list-style-type: none"> ● Harness or connectors (The solenoid circuit is open or shorted.) ● T/C clutch solenoid valve

TROUBLE DIAGNOSIS FOR DTC P0740

Torque Converter Clutch Solenoid Valve (Cont'd)

DIAGNOSTIC TROUBLE CODE (DTC) CONFIRMATION PROCEDURE

NOTE:

If "DIAGNOSTIC TROUBLE CODE CONFIRMATION PROCEDURE" has been previously conducted, always turn ignition switch "OFF" and wait at least 5 seconds before conducting the next test.

After the repair, perform the following procedure to confirm the malfunction is eliminated.

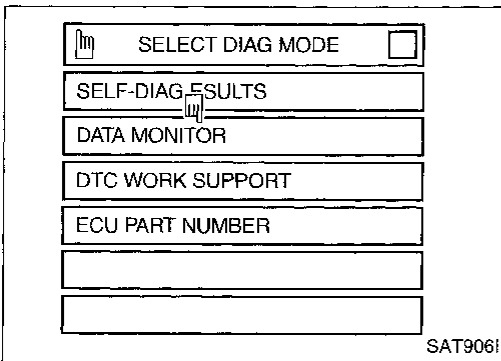
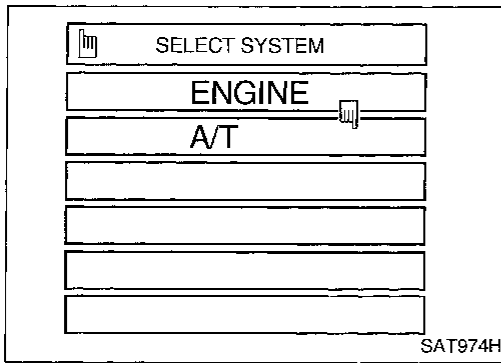

-  1) Turn ignition switch "ON".
 2) Select "DATA MONITOR" mode for "ENGINE" with CONSULT and wait at least 1 second.

OR

-  1) Turn ignition switch "ON".
 2) Select "MODE 7" with GST.

OR

-  1) Turn ignition switch "ON".
 2) Perform self-diagnosis for ECM. Refer to EC section ["Malfunction Indicator Lamp (MIL)", "ON BOARD DIAGNOSTIC SYSTEM DESCRIPTION"].

GI

MA

EM

LC

EC

FE

CL

MT

AT

FA

RA

BR

ST

RS

BT

HA

EL

DX

TROUBLE DIAGNOSIS FOR DTC P0740

Torque Converter Clutch Solenoid Valve (Cont'd)

DIAGNOSTIC PROCEDURE

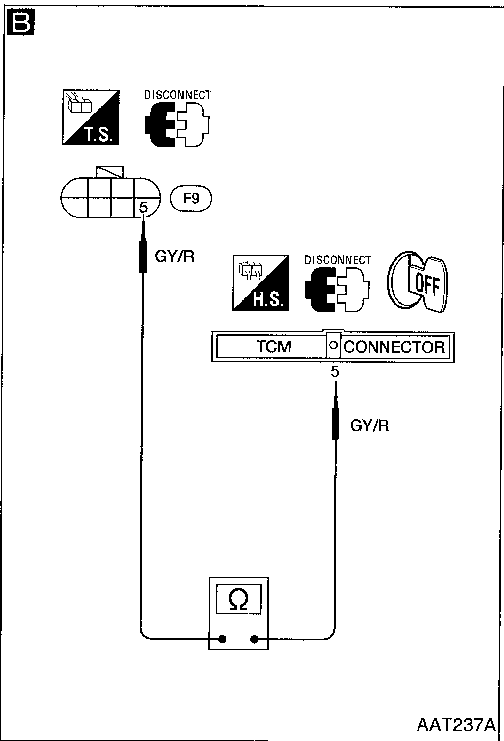
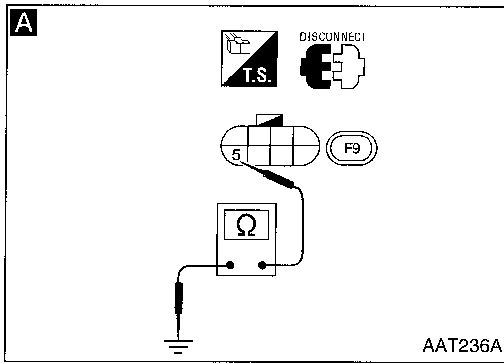

INSPECTION START

A

CHECK GROUND CIRCUIT.

1. Turn ignition switch to "OFF" position.
2. Disconnect terminal cord assembly connector in engine compartment.
3. Check resistance between terminal ⑤ and ground.

Resistance: 10 - 20Ω

NG

1. Remove oil pan. Refer to AT-189.
2. Check the following items:
 - Torque converter clutch solenoid valve
 - Refer to "Component Inspection", AT-123.
 - Harness of terminal cord assembly for short or open

OK

B

CHECK POWER SOURCE CIRCUIT.

1. Turn ignition switch to "OFF" position.
2. Disconnect TCM harness connector.
3. Check continuity between terminal ⑤ and TCM harness connector terminal ⑤.

Continuity should exist.

If OK, check harness for short to ground and short to power.

4. Reinstall any part removed.

NG

Repair open circuit or short to ground or short to power in harness or connectors.

OK

Perform Diagnostic Trouble Code (DTC) confirmation procedure, AT-121.

NG

1. Perform TCM input/output signal inspection.
2. If NG, recheck TCM pin terminals for damage or loose connection with harness connector.

OK

INSPECTION END

TROUBLE DIAGNOSIS FOR DTC P0740

Torque Converter Clutch Solenoid Valve (Cont'd)

COMPONENT INSPECTION

Torque converter clutch solenoid valve

- For removal, refer to AT-189.

Resistance check

- Check resistance between two terminals.

Solenoid valve	Terminal No.		Resistance (Approx.)
Torque converter clutch solenoid valve	⑤	Ground	10 - 20Ω

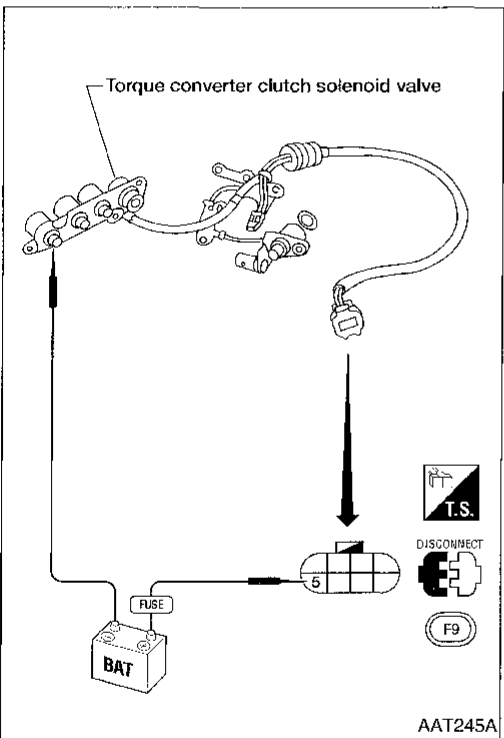
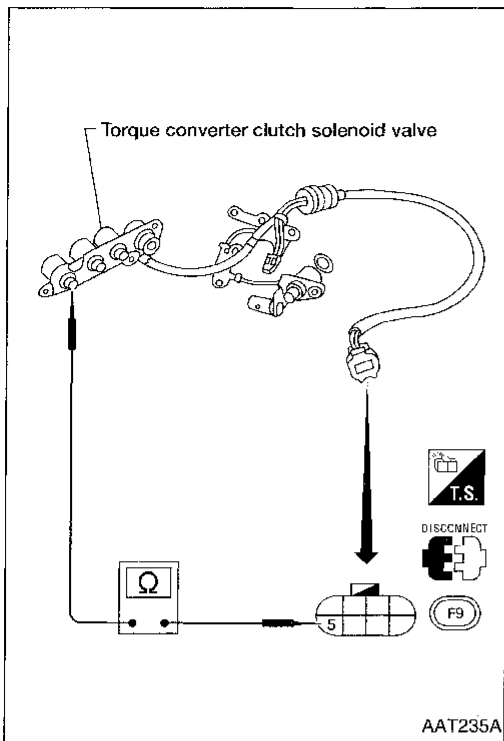

Operation check

- Check solenoid valve by listening for its operating sound while applying battery voltage to the terminal and ground.

GI

MA

EM

LC

EC

FE

CL

MT

AT

FA

RA

BR

ST

RS

BT

HA

EL

IDX

TROUBLE DIAGNOSIS FOR DTC P0744

A/T TCC S/V Function (Lock-up)

DESCRIPTION

- This is an OBD-II self-diagnostic item and not available in TCM self-diagnosis.
- This malfunction will not be detected while the O/D OFF indicator lamp is indicating another self-diagnosis malfunction.
- This malfunction is detected when the A/T does not shift into fourth gear position or the torque converter clutch does not lock up as instructed by the TCM. This is not caused by electrical malfunction (circuits open or shorted) but by mechanical malfunction such as control valve sticking, improper solenoid valve operation, malfunctioning oil pump or torque converter clutch, etc.







CONSULT REFERENCE VALUE IN DATA MONITOR MODE

Remarks: Specification data are reference values.

Monitor item	Condition	Specification
Torque converter clutch solenoid valve duty	Lock-up "OFF"	Approximately 4%
	↓	↓
	Lock-up "ON"	Approximately 94%

TCM TERMINALS AND REFERENCE VALUE

Remarks: Specification data are reference values.

Terminal No.	Wire color	Item	Condition	Judgement standard	
1	R/W	Line pressure solenoid valve		When releasing accelerator pedal after warming up engine.	1.5 - 2.5V
				When depressing accelerator pedal fully after warming up engine.	0.5V or less
2	P/B	Line pressure solenoid valve (with dropping resistor)		When releasing accelerator pedal after warming up engine.	5 - 14V
				When depressing accelerator pedal fully after warming up engine.	0.5V or less
5	GY/R	Torque converter clutch solenoid valve		When A/T performs lock-up.	8 - 15V
				When A/T does not perform lock-up.	1V or less
6	L/W	Shift solenoid valve A		When shift solenoid valve A operates. (When driving in "D ₁ " or "D ₄ ".)	Battery voltage
				When shift solenoid valve A does not operate. (When driving in "D ₂ " or "D ₃ ".)	1V or less
7	L/Y	Shift solenoid valve B		When shift solenoid valve B operates. (When driving in "D ₁ " or "D ₂ ".)	Battery voltage
				When shift solenoid valve B does not operate. (When driving in "D ₃ " or "D ₄ ".)	1V or less
8	L/B	Overrun clutch solenoid valve		When overrun clutch solenoid valve operates.	Battery voltage
				When overrun clutch solenoid valve does not operate.	1V or less

TROUBLE DIAGNOSIS FOR DTC P0744

A/T TCC S/V Function (Lock-up) (Cont'd)

ON BOARD DIAGNOSTIC LOGIC

This diagnosis monitors actual gear position by checking the torque converter slip ratio calculated by TCM as follows:

Torque converter slip ratio = $A \times C/B$

A: Output shaft revolution signal from revolution sensor

B: Engine speed signal from ECM



C: Gear ratio determined as gear position which TCM supposes

If the actual gear position is much lower than the position (4th) supposed by TCM, the slip ratio will be much less than normal. In case the ratio does not reach the specified value, TCM judges this diagnosis malfunction.

This malfunction will be caused when shift solenoid valve B is stuck closed.

Gear position supposed by TCM	1	2	3	4
In case of gear position with no malfunctions	1	2	3	4
In case of gear position with shift solenoid valve B stuck closed	1	2	2	①

①: P0744 is detected.

Diagnostic trouble code	Malfunction is detected when ...	Check item (Possible cause)
 : A/T TCC S/V FNCTN  : P0744  : MIL Code No. 1107	A/T cannot perform lock-up even if electrical circuit is good.	<ul style="list-style-type: none"> ● Torque converter clutch solenoid valve ● Each clutch ● Hydraulic control circuit

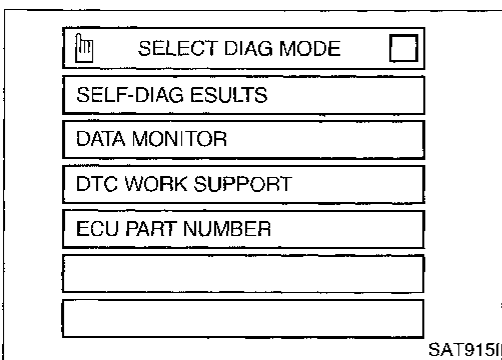
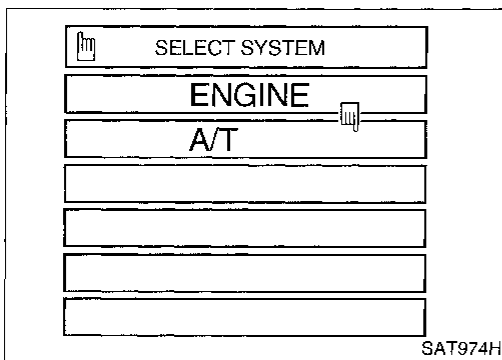

DIAGNOSTIC TROUBLE CODE (DTC) CONFIRMATION PROCEDURE

CAUTION:

Always drive vehicle at a safe speed.

NOTE:

If "DIAGNOSTIC TROUBLE CODE CONFIRMATION PROCEDURE" has been previously conducted, always turn ignition switch "OFF" and wait at least 5 seconds before conducting the next test.

After the repair, perform the following procedure to confirm the malfunction is eliminated.

- 1) Start engine and select "DATA MONITOR" mode for "A/T" with CONSULT.
- 2) Make sure that output voltage of A/T fluid temperature sensor is within the range below.
FLUID TEMP SEN: 0.4 - 1.5V
 If out of range, drive the vehicle to decrease the voltage (warm up the fluid) or stop engine to increase the voltage (cool down the fluid).
- 3) Select "TCC S/V FNCTN P0744" of "DTC WORK SUPPORT" mode for "A/T" with CONSULT and touch "START".

TROUBLE DIAGNOSIS FOR DTC P0744

A/T TCC S/V Function (Lock-up) (Cont'd)

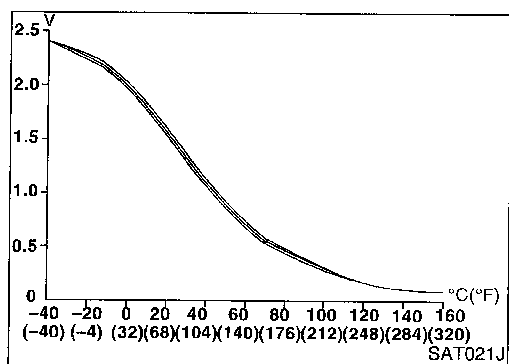

- 4) Accelerate vehicle to more than 70 km/h (44 MPH) and maintain the following condition continuously until "TESTING" has turned to "COMPLETE". (It will take approximately 30 seconds after "TESTING" shows.)

THROTTLE POSI: 1/8 - 2/8 (at all times during step 4)

Selector lever: D position (OD "ON")

TCC S/V DUTY: More than 94%

VHCL/S SE-AT: Constant speed of more than 70 km/h (44 MPH)

- Check that "GEAR" shows "4".
 - For shift schedule, refer to SDS, AT-294.
 - If "TESTING" does not appear on CONSULT for a long time, select "SELF-DIAG RESULTS". In case a 1st trip DTC other than P0744 is shown, refer to applicable "TROUBLE DIAGNOSIS FOR DTC".
- 5) Make sure that "OK" is displayed. (If "NG" is displayed, refer to "DIAGNOSTIC PROCEDURE".) Refer to "DIAGNOSTIC PROCEDURE", AT-127. Refer to shift schedule, AT-294.

OR



- 1) Start engine and warm up ATF.
- 2) Start vehicle with selector lever in "D" (OD "ON"), throttle opening halfway and D₄ lock-up position for approximately 30 seconds. Check that vehicle runs through gear shift of D₁ → D₂ → D₃ → D₄ → D₄ lock-up, in accordance with shift schedule. Refer to shift schedule, AT-294.
- 3) Select "MODE 7" with GST.

OR



- 1) Start engine and warm up ATF.
- 2) Start vehicle with selector lever in "D" (OD "ON"), throttle opening halfway and D₄ lock-up position for approximately 30 seconds. Check that vehicle runs through gear shift of D₁ → D₂ → D₃ → D₄ → D₄ lock-up, in accordance with shift schedule. Refer to shift schedule, AT-294.
- 3) Perform self-diagnosis for ECM. Refer to EC section ["Malfunction Indicator Lamp (MIL)", "ON BOARD DIAGNOSTIC SYSTEM DESCRIPTION"].

TROUBLE DIAGNOSIS FOR DTC P0744

A/T TCC S/V Function (Lock-up) (Cont'd) DIAGNOSTIC PROCEDURE

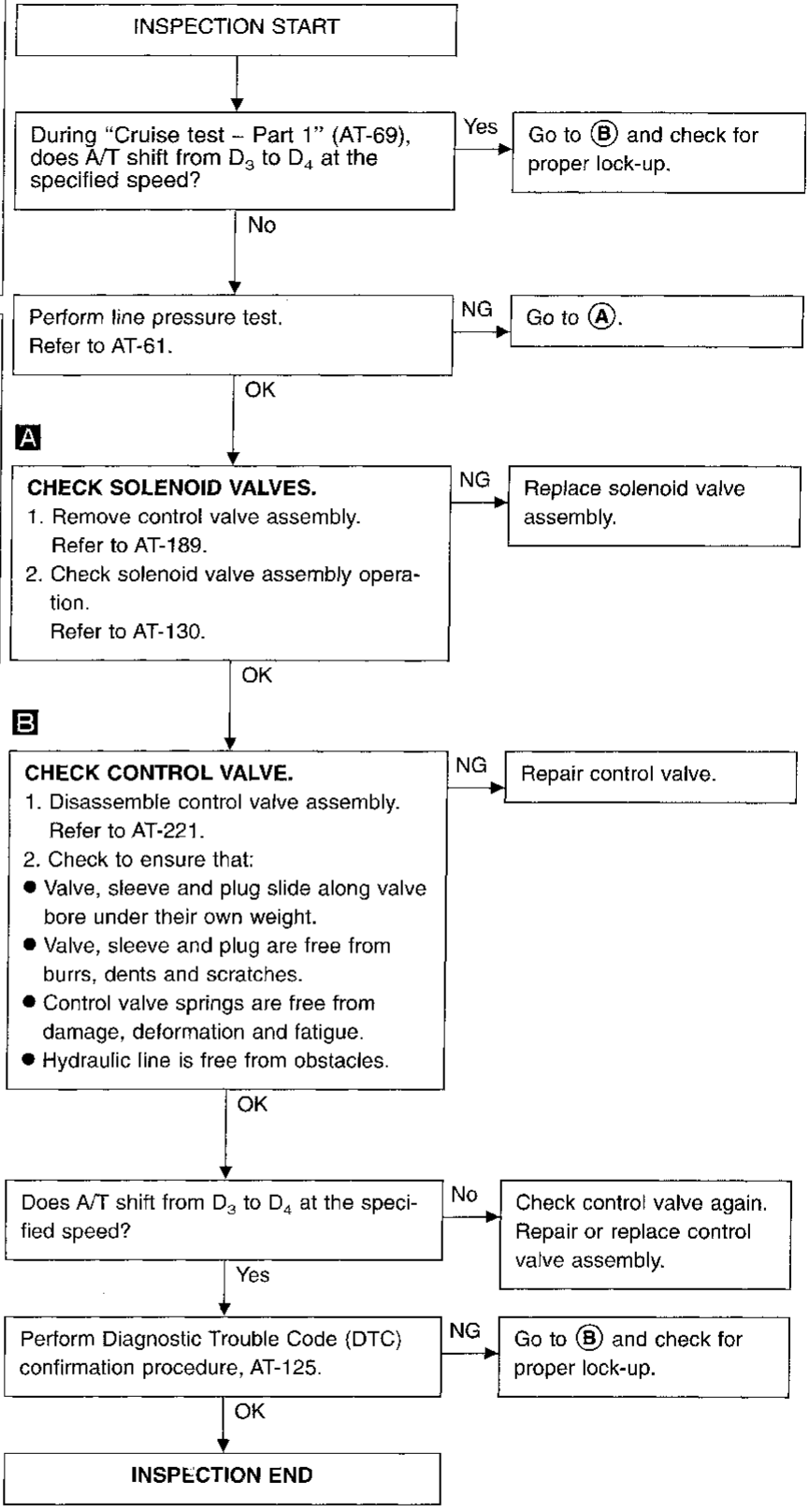
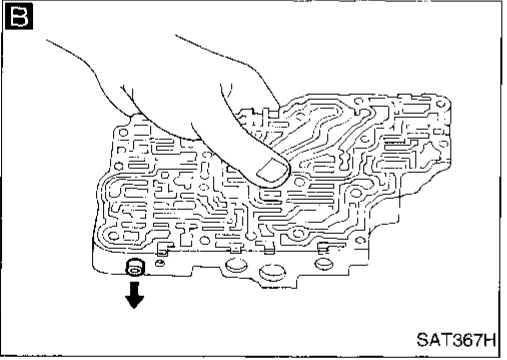
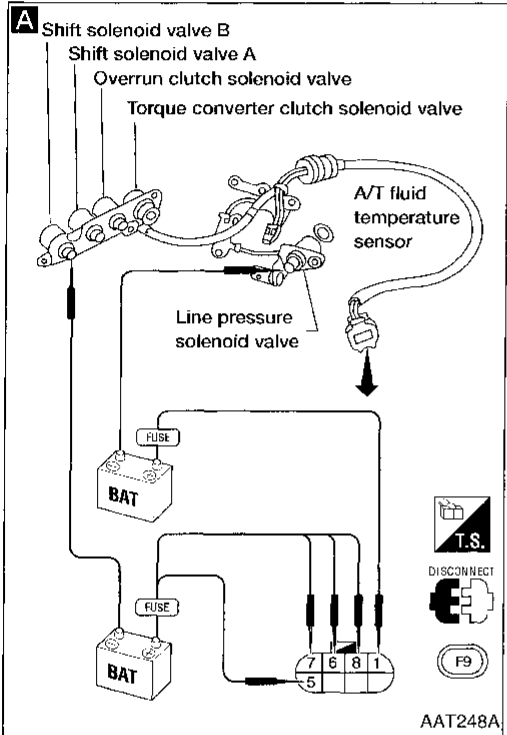
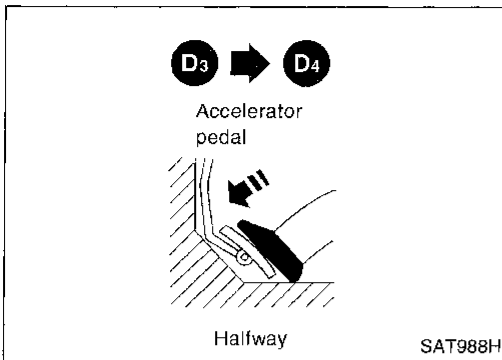

GI
MA
EM
LC
EC
FE
CL
MT
AT
FA
RA
BR
ST
RS
BT
HA
EL
IDX

TROUBLE DIAGNOSIS FOR DTC P0744

A/T TCC S/V Function (Lock-up) (Cont'd)

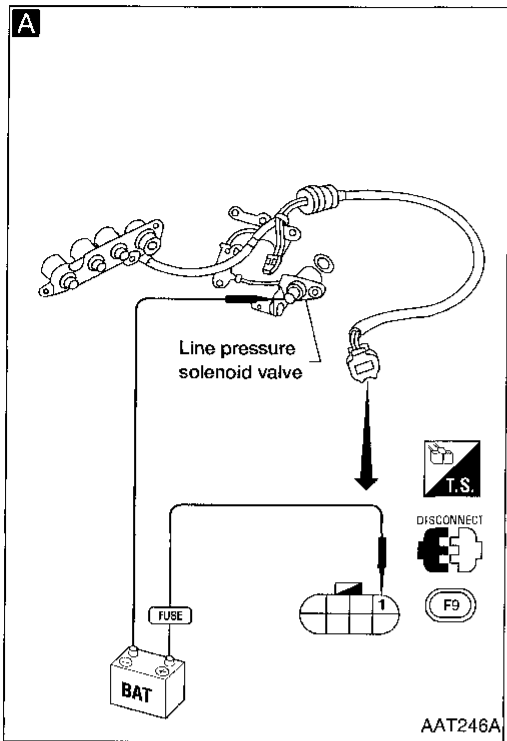

A

CHECK LINE PRESSURE SOLENOID VALVE.

1. Remove control valve assembly. Refer to AT-189.
2. Check line pressure solenoid valve operation. Refer to AT-130.

NG → Replace solenoid valve assembly.

B

CHECK CONTROL VALVE.

1. Disassemble control valve assembly. Refer to AT-221.
2. Check line pressure circuit valves for sticking.
 - Pressure regulator valve
 - Pilot valve
 - Pressure modifier valve

NG → Repair control valve.

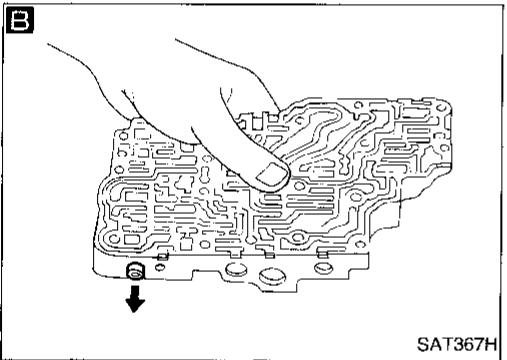

Does A/T shift from D₃ to D₄ at the specified speed?

No → Check control valve again. Repair or replace control valve assembly.

Perform Diagnostic Trouble Code (DTC) confirmation procedure, AT-125.

NG → Go to **(B)** and check for proper lock-up.

INSPECTION END

TROUBLE DIAGNOSIS FOR DTC P0744

A/T TCC S/V Function (Lock-up) (Cont'd)

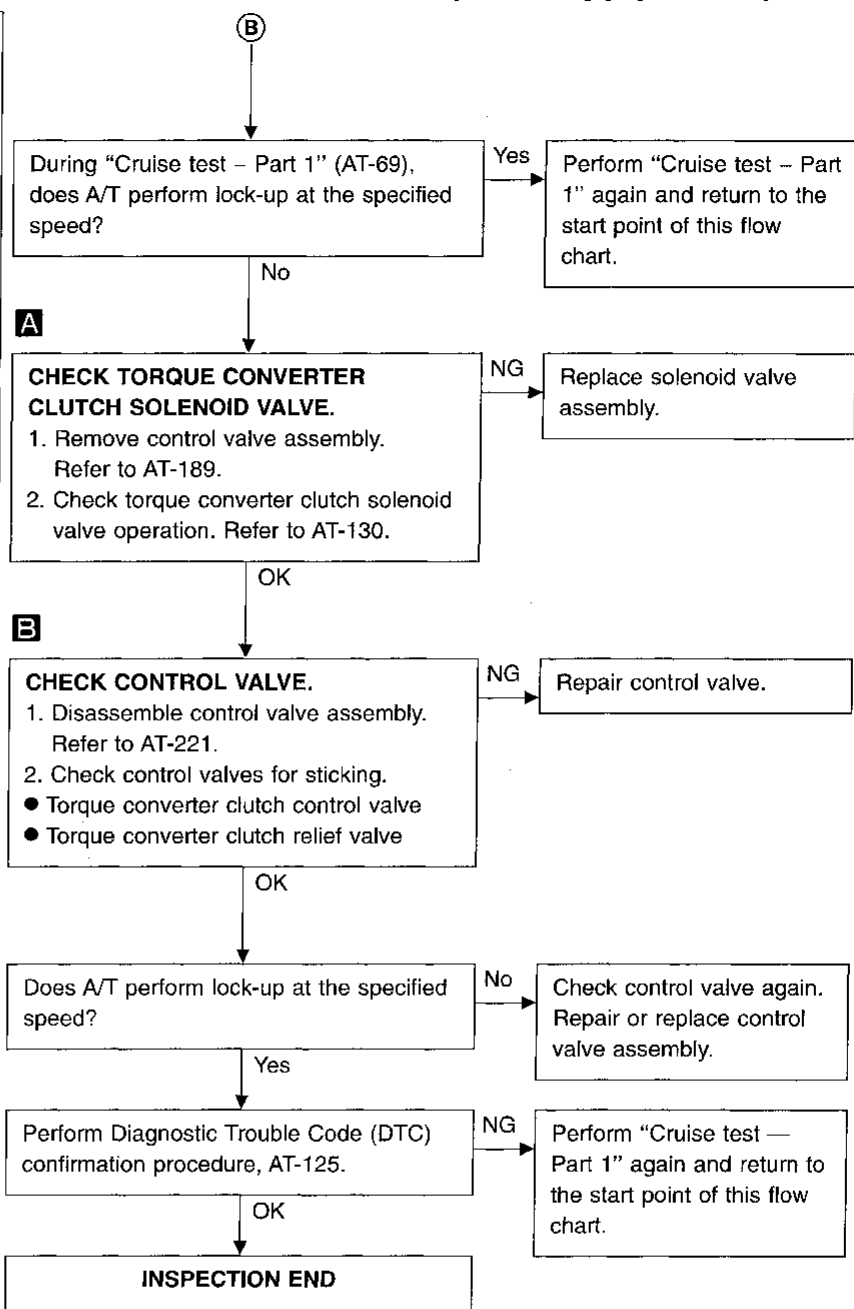
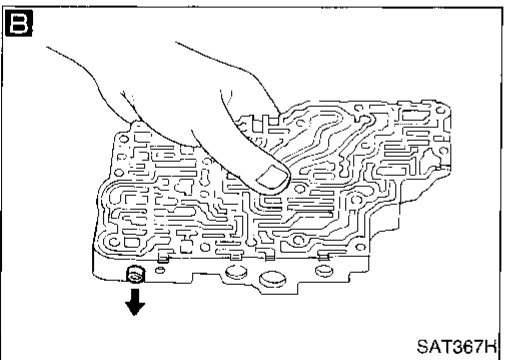
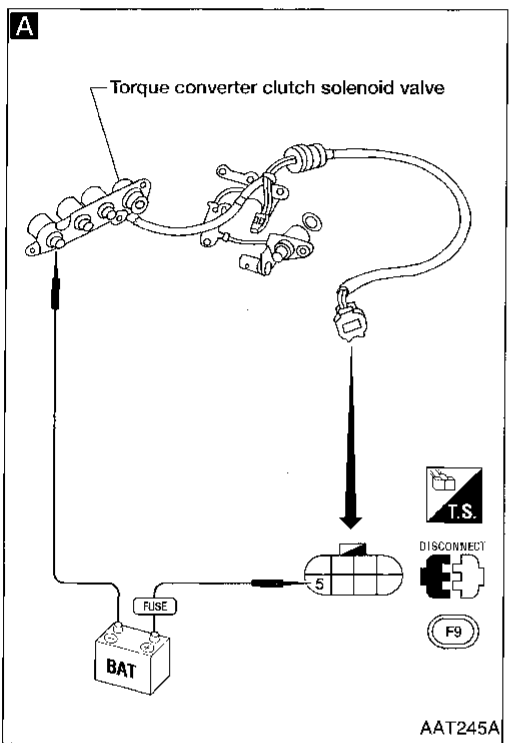
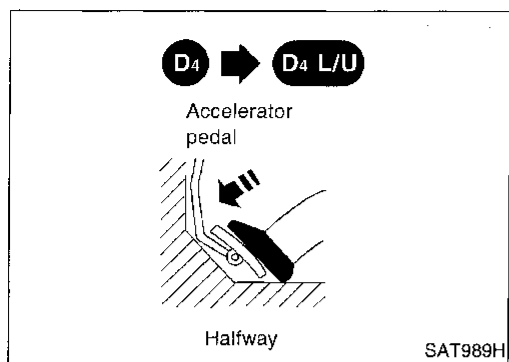

GI

MA

EM

LC

EC

FE

CL

MT

AT

FA

RA

BR

ST

RS

BT

HA

EL

IDX

TROUBLE DIAGNOSIS FOR DTC P0744

A/T TCC S/V Function (Lock-up) (Cont'd) COMPONENT INSPECTION

Solenoid valves

- For removal, refer to AT-189.

Resistance check

- Check resistance between two terminals.

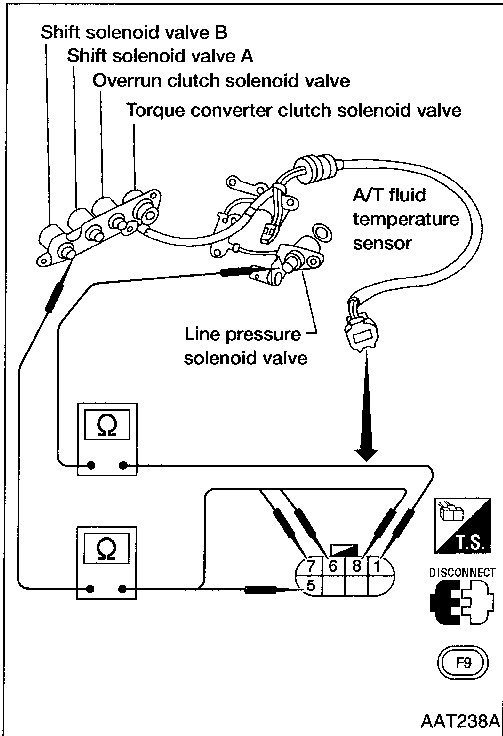

Solenoid valve	Terminal No.	Resistance (Approx.)
Shift solenoid valve A	⑥	20 - 40Ω
Shift solenoid valve B	⑦	
Overrun clutch solenoid valve	⑧	
Line pressure solenoid valve	①	2.5 - 5Ω
Torque converter clutch solenoid valve	⑤	10 - 20Ω

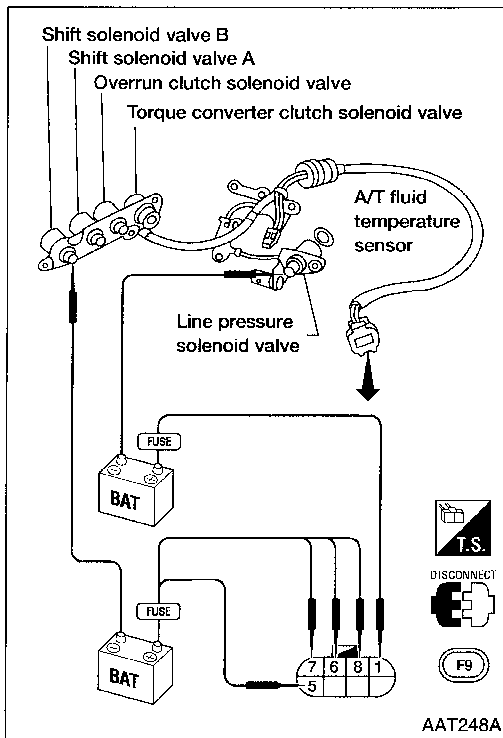

Operation check

- Check solenoid valve by listening for its operating sound while applying battery voltage to the terminal and ground.

TROUBLE DIAGNOSIS FOR DTC P0745

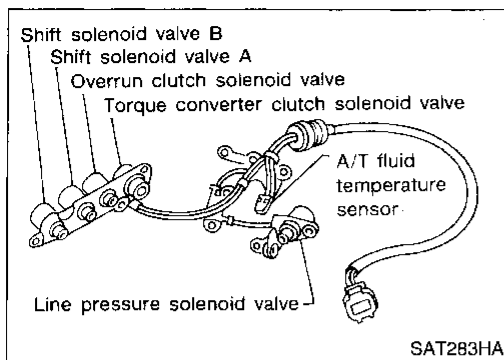

Line Pressure Solenoid Valve

DESCRIPTION

The line pressure solenoid valve regulates the oil pump discharge pressure to suit the driving condition in response to a signal sent from the TCM.

The line pressure duty cycle value is not consistent when the closed throttle position switch is "ON". To confirm the line pressure duty cycle at low pressure, the accelerator (throttle) should be open until the closed throttle position switch is "OFF".

CONSULT REFERENCE VALUE IN DATA MONITOR MODE

Remarks: Specification data are reference values.

Monitor item	Condition	Specification
Line pressure solenoid valve duty	Small throttle opening (Low line pressure)	Approximately 24%
	↓ Large throttle opening (High line pressure)	↓ Approximately 95%

Note: The line pressure duty cycle value is not consistent when the closed throttle position switch is "ON". To confirm the line pressure duty cycle at low pressure, the accelerator (throttle) should be open until the closed throttle position switch is "OFF".

TCM TERMINALS AND REFERENCE VALUE

Remarks: Specification data are reference values.

Terminal No.	Wire color	Item	Condition	Judgement standard
1	R/W	Line pressure solenoid valve	When releasing accelerator pedal after warming up engine.	1.5 - 2.5V
			When depressing accelerator pedal fully after warming up engine.	0.5V or less
2	P/B	Line pressure solenoid valve (with dropping resistor)	When releasing accelerator pedal after warming up engine.	5 - 14V
			When depressing accelerator pedal fully after warming up engine.	0.5V or less

ON BOARD DIAGNOSIS LOGIC

Diagnostic trouble code	Malfunction is detected when ...	Check item (Possible cause)
: L/PRESS SOL/CIRC : P0745 : MIL Code No. 1205	TCM detects an improper voltage drop when it tries to operate the solenoid valve.	<ul style="list-style-type: none"> • Harness or connectors (The solenoid circuit is open or shorted.) • Line pressure solenoid valve

TROUBLE DIAGNOSIS FOR DTC P0745

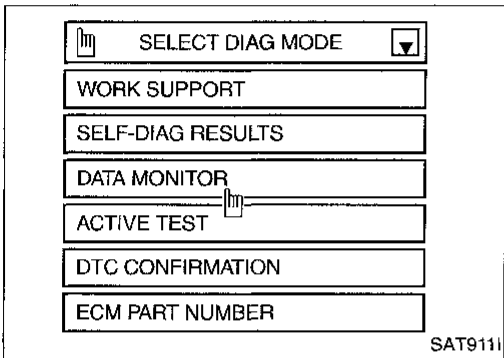
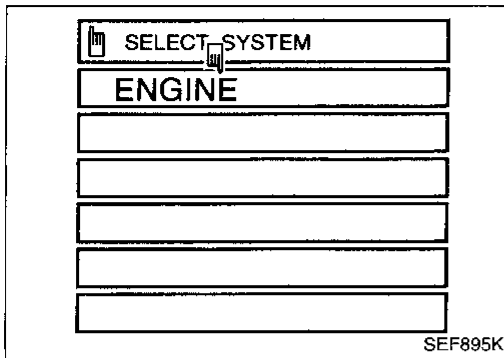

Line Pressure Solenoid Valve (Cont'd) DIAGNOSTIC TROUBLE CODE (DTC) CONFIRMATION PROCEDURE

NOTE:

If "DIAGNOSTIC TROUBLE CODE CONFIRMATION PROCEDURE" has been previously conducted, always turn ignition switch "OFF" and wait at least 5 seconds before conducting the next test.

After the repair, perform the following procedure to confirm the malfunction is eliminated.



- 1) Turn ignition switch "ON" and select "DATA MONITOR" mode for "ENGINE" with CONSULT.
- 2) Depress accelerator pedal completely and wait at least 1 second.

OR



- 1) Turn ignition switch "ON".
- 2) Depress accelerator pedal completely and wait at least 1 second.
- 3) Select "MODE 7" with GST.

OR



- 1) Turn ignition switch "ON".
- 2) Depress accelerator pedal completely and wait at least 1 second.
- 3) Perform self-diagnosis for ECM.

Refer to EC section ["Malfunction Indicator Lamp (MIL)", "ON BOARD DIAGNOSTIC SYSTEM DESCRIPTION"].

TROUBLE DIAGNOSIS FOR DTC P0745

Line Pressure Solenoid Valve (Cont'd) DIAGNOSTIC PROCEDURE

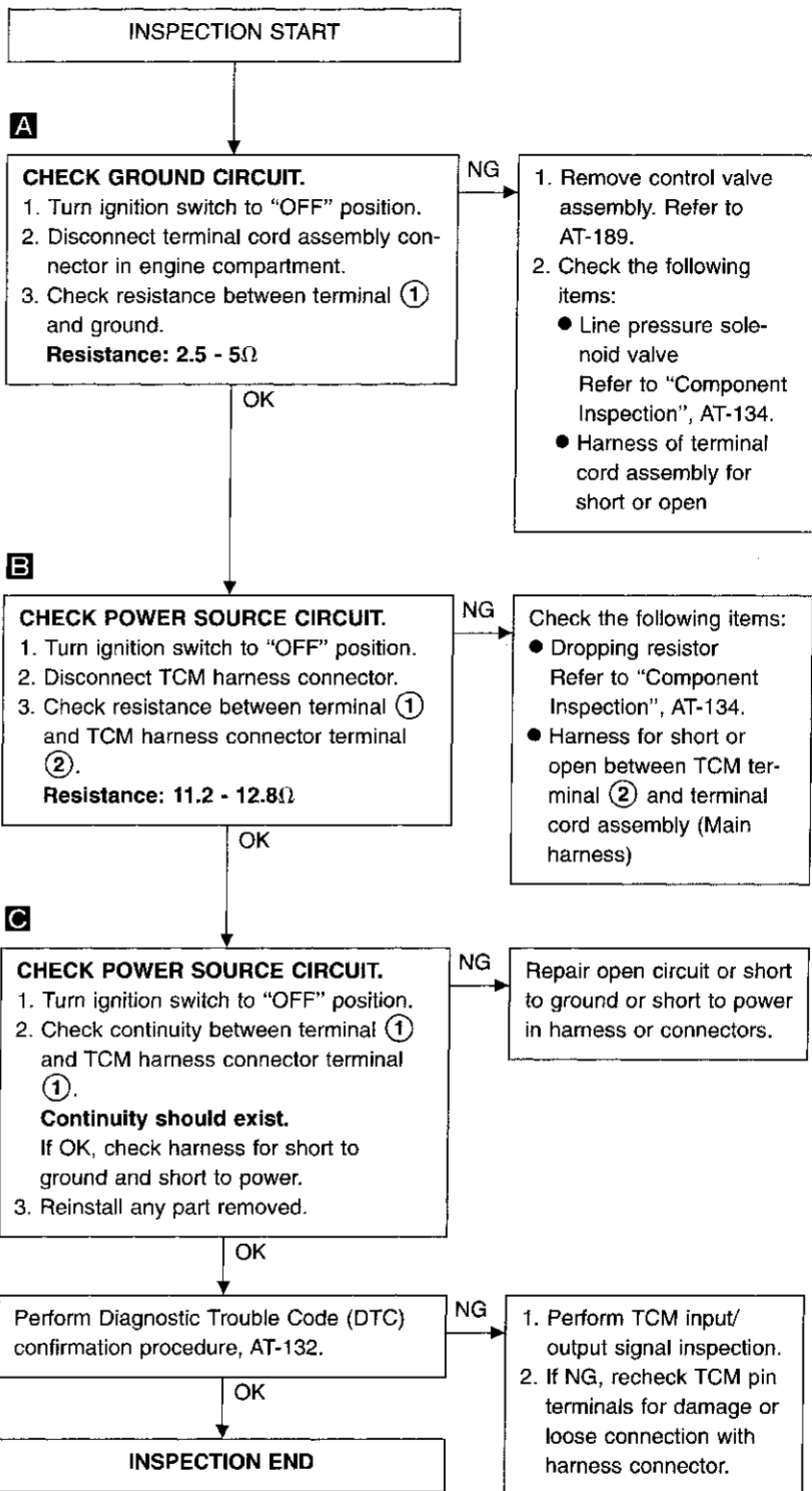
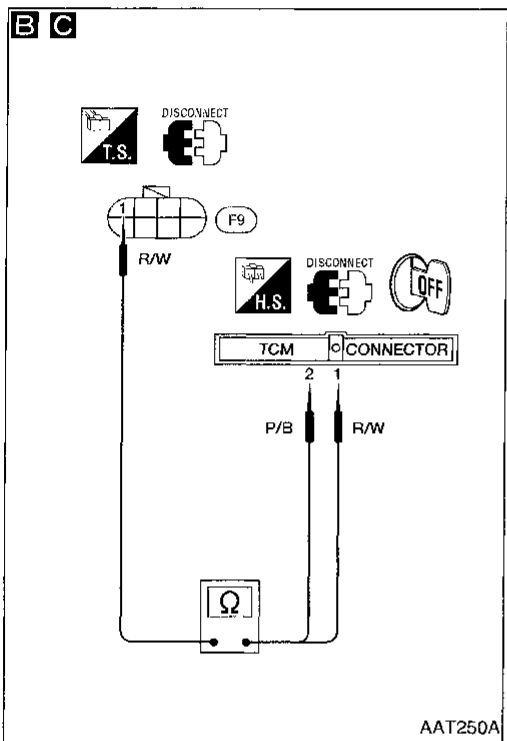
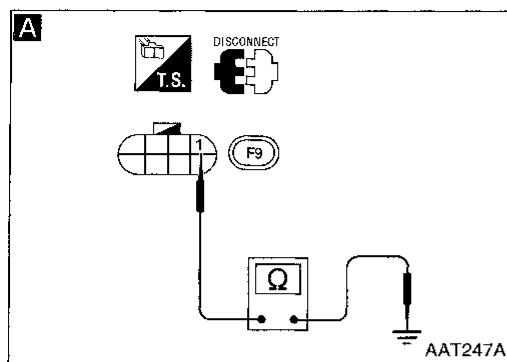

GI

MA

EM

LC

EC

FE

CL

MT

AT

FA

RA

BR

ST

RS

BT

HA

EL

IDX

TROUBLE DIAGNOSIS FOR DTC P0745

Line Pressure Solenoid Valve (Cont'd) COMPONENT INSPECTION

Line pressure solenoid valve

- For removal, refer to AT-189.

Resistance check

- Check resistance between two terminals.

Solenoid valve	Terminal No.		Resistance (Approx.)
Line pressure solenoid valve	①	Ground	2.5 - 5Ω

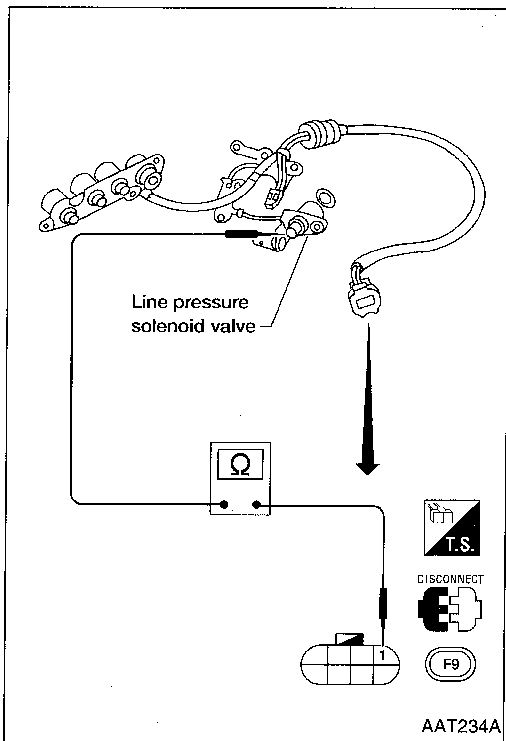

Operation check

- Check solenoid valve by listening for its operating sound while applying battery voltage to the terminal and ground.

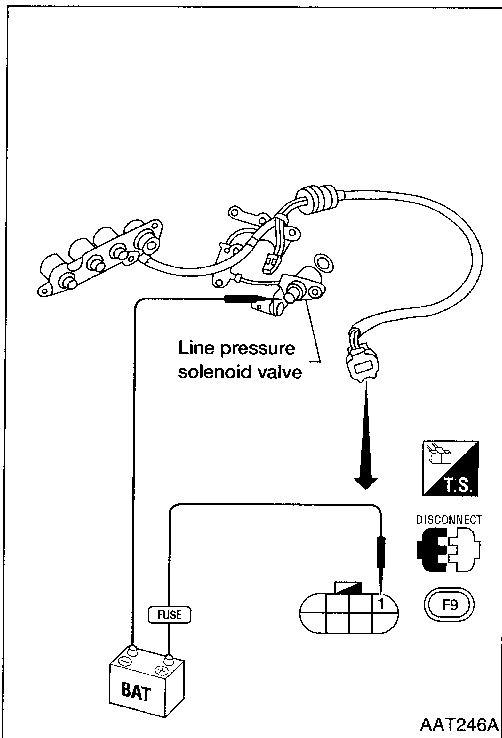

Dropping resistor

- Check resistance between two terminals.

Resistance: 11.2 - 12.8Ω

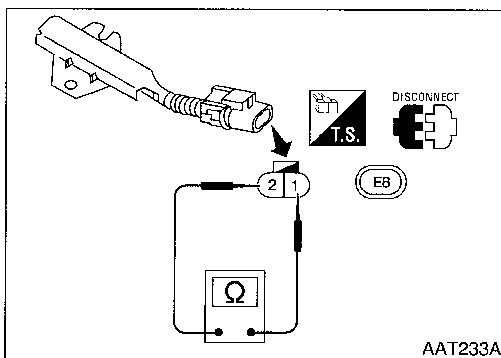

TROUBLE DIAGNOSIS FOR DTC P0750

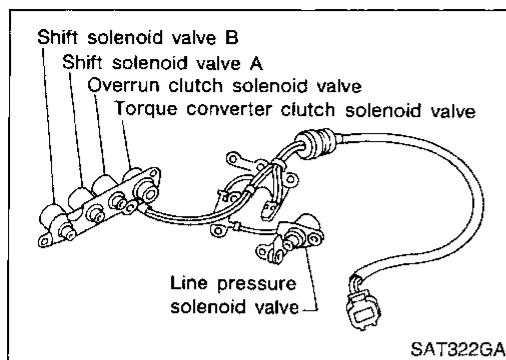

Shift Solenoid Valve A

DESCRIPTION

Shift solenoid valves A and B are turned "ON" or "OFF" by the TCM in response to signals sent from the inhibitor switch, vehicle speed and throttle position sensors. Gears will then be shifted to the optimum position.



Gear position	1	2	3	4
Shift solenoid valve A	ON (Closed)	OFF (Open)	OFF (Open)	ON (Closed)
Shift solenoid valve B	ON (Closed)	ON (Closed)	OFF (Open)	OFF (Open)

TCM TERMINALS AND REFERENCE VALUE

Remarks: Specification data are reference values.

Terminal No.	Wire color	Item	Condition	Judgement standard
6	L/W	Shift solenoid valve A	 When shift solenoid valve A operates. (When driving in "D ₁ " or "D ₄ ".)	Battery voltage
			When shift solenoid valve A does not operate. (When driving in "D ₂ " or "D ₃ ".)	1V or less

ON BOARD DIAGNOSIS LOGIC

Diagnostic trouble code	Malfunction is detected when ...	Check item (Possible cause)
 : SFT SOL A/CIRC  : P0750  : MIL Code No. 1108	TCM detects an improper voltage drop when it tries to operate the solenoid valve.	<ul style="list-style-type: none"> ● Harness or connectors (The solenoid circuit is open or shorted.) ● Shift solenoid valve A

TROUBLE DIAGNOSIS FOR DTC P0750

Shift Solenoid Valve A (Cont'd)

DIAGNOSTIC TROUBLE CODE (DTC) CONFIRMATION PROCEDURE

CAUTION:

Always drive vehicle at a safe speed.

NOTE:

If "DIAGNOSTIC TROUBLE CODE CONFIRMATION PROCEDURE" has been previously conducted, always turn ignition switch "OFF" and wait at least 5 seconds before conducting the next test.

After the repair, perform the following procedure to confirm the malfunction is eliminated.

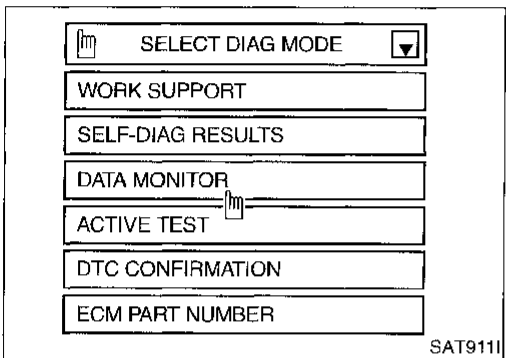
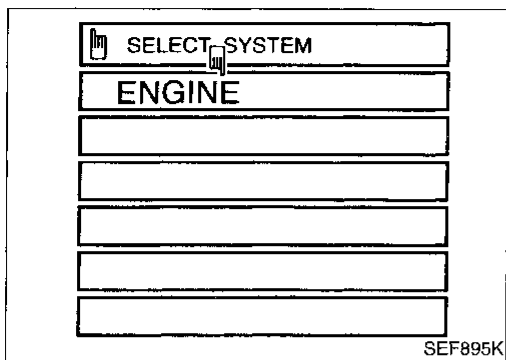

- 1) Turn ignition switch "ON" and select "DATA MONITOR" mode for "ENGINE" with CONSULT.
- 2) Start engine.
- 3) Drive vehicle in D position and allow the transmission to shift "1" → "2" ("GEAR").

OR



- 1) Start engine.
- 2) Drive vehicle in D₁ → D₂ position.
- 3) Select "MODE 7" with GST.

OR



- 1) Start engine.
- 2) Drive vehicle in D₁ → D₂ position.
- 3) Perform self-diagnosis for ECM.
Refer to EC section ["Malfunction Indicator Lamp (MIL)", "ON BOARD DIAGNOSTIC SYSTEM DESCRIPTION"].

TROUBLE DIAGNOSIS FOR DTC P0750

Shift Solenoid Valve A (Cont'd)

DIAGNOSTIC PROCEDURE

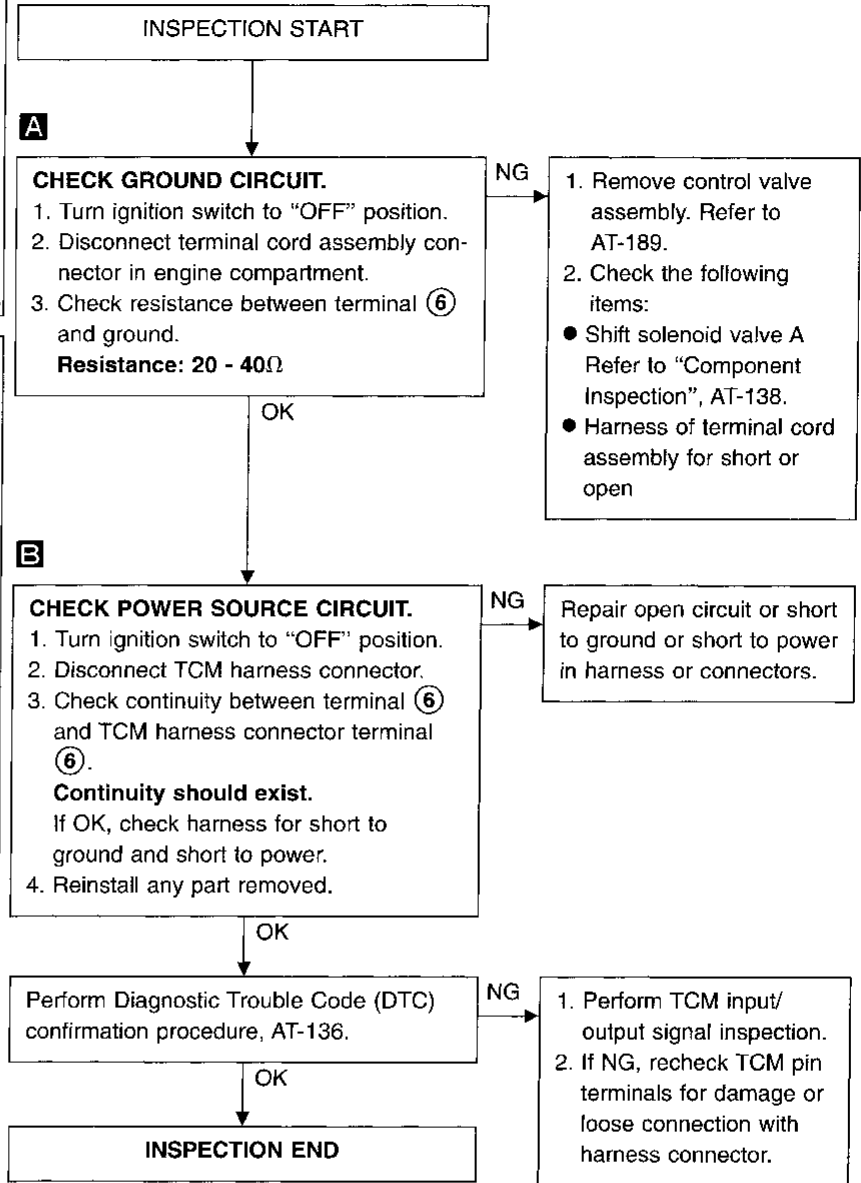
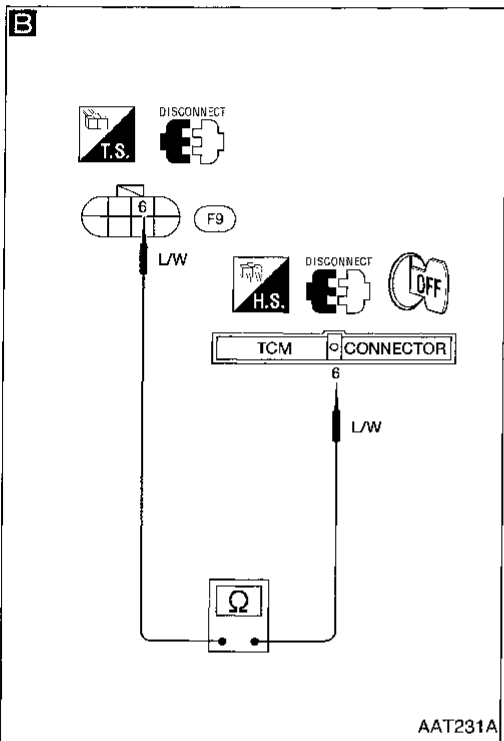
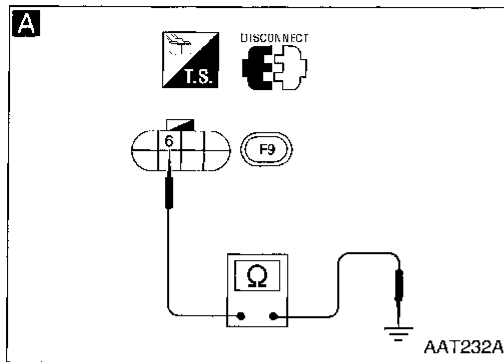

CI
MA
EM
LC
EC
FE
CL
MT
AT
FA
RA
BR
ST
RS
BT
HA
EL
IDX

TROUBLE DIAGNOSIS FOR DTC P0750

Shift Solenoid Valve A (Cont'd) COMPONENT INSPECTION

Shift solenoid valve A

- For removal, refer to AT-189.

Resistance check

- Check resistance between two terminals.

Solenoid valve	Terminal No.		Resistance (Approx.)
Shift solenoid valve A	⑥	Ground	20 - 40Ω

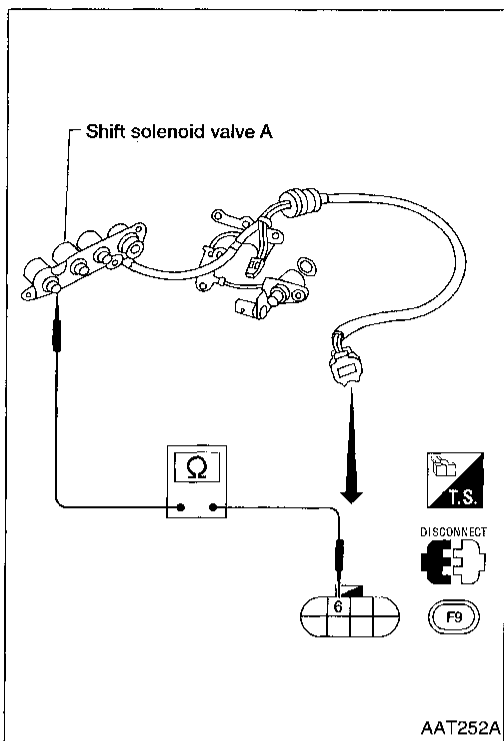

Operation check

- Check solenoid valve by listening for its operating sound while applying battery voltage to the terminal and ground.

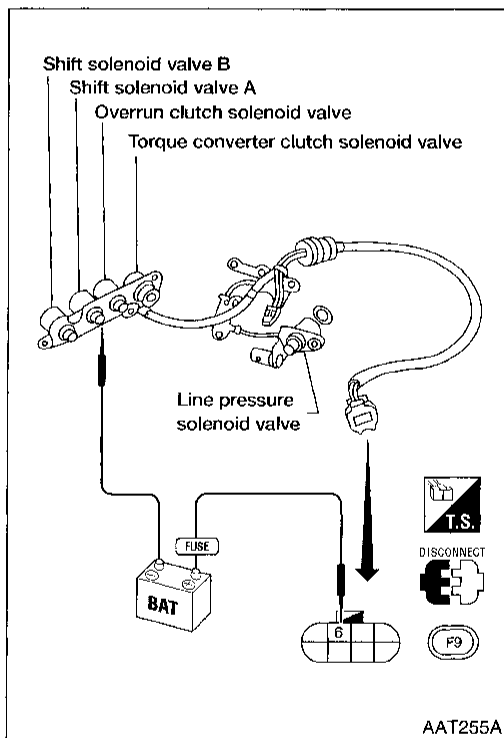

TROUBLE DIAGNOSIS FOR DTC P0755

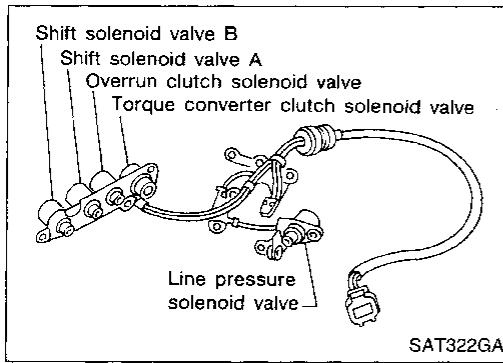

Shift Solenoid Valve B

DESCRIPTION

Shift solenoid valves A and B are turned "ON" or "OFF" by the TCM in response to signals sent from the inhibitor switch, vehicle speed and throttle position sensors. Gears will then be shifted to the optimum position.



Gear position	1	2	3	4
Shift solenoid valve A	ON (Closed)	OFF (Open)	OFF (Open)	ON (Closed)
Shift solenoid valve B	ON (Closed)	ON (Closed)	OFF (Open)	OFF (Open)

TCM TERMINALS AND REFERENCE VALUE

Remarks: Specification data are reference values.

Terminal No.	Wire color	Item	Condition	Judgement standard
7	L/Y	Shift solenoid valve B	 When shift solenoid valve B operates. (When driving in "D ₁ " or "D ₂ ".)	Battery voltage
			When shift solenoid valve B does not operate. (When driving in "D ₃ " or "D ₄ ".)	1V or less

ON BOARD DIAGNOSIS LOGIC

Diagnostic trouble code	Malfunction is detected when ...	Check item (Possible cause)
 : SFT SOL B/CIRC  : P0755  : MIL Code No. 1201	TCM detects an improper voltage drop when it tries to operate the solenoid valve.	<ul style="list-style-type: none"> ● Harness or connectors (The solenoid circuit is open or shorted.) ● Shift solenoid valve B

TROUBLE DIAGNOSIS FOR DTC P0755

Shift Solenoid Valve B (Cont'd)

DIAGNOSTIC TROUBLE CODE (DTC) CONFIRMATION PROCEDURE

CAUTION:

Always drive vehicle at a safe speed.

NOTE:

If "DIAGNOSTIC TROUBLE CODE CONFIRMATION PROCEDURE" has been previously conducted, always turn ignition switch "OFF" and wait at least 5 seconds before conducting the next test.

After the repair, perform the following procedure to confirm the malfunction is eliminated.

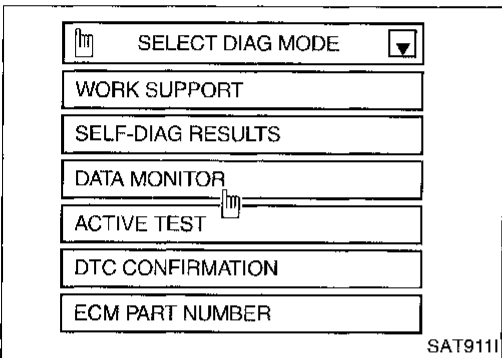
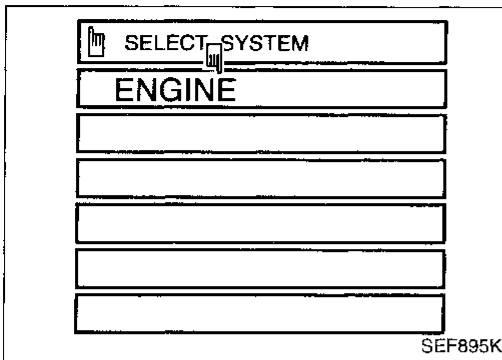

- 1) Turn ignition switch "ON" and select "DATA MONITOR" mode for "ENGINE" with CONSULT.
- 2) Start engine.
- 3) Drive vehicle in D position and allow the transmission to shift 1 → 2 → 3 ("GEAR").

OR



- 1) Start engine.
- 2) Drive vehicle in D₁ → D₂ → D₃ position.
- 3) Select "MODE 7" with GST.

OR



- 1) Start engine.
- 2) Drive vehicle in D₁ → D₂ → D₃ position.
- 3) Perform self-diagnosis for ECM.
Refer to EC section ["Malfunction Indicator Lamp (MIL)", "ON BOARD DIAGNOSTIC SYSTEM DESCRIPTION"].

TROUBLE DIAGNOSIS FOR DTC P0755

Shift Solenoid Valve B (Cont'd)

DIAGNOSTIC PROCEDURE

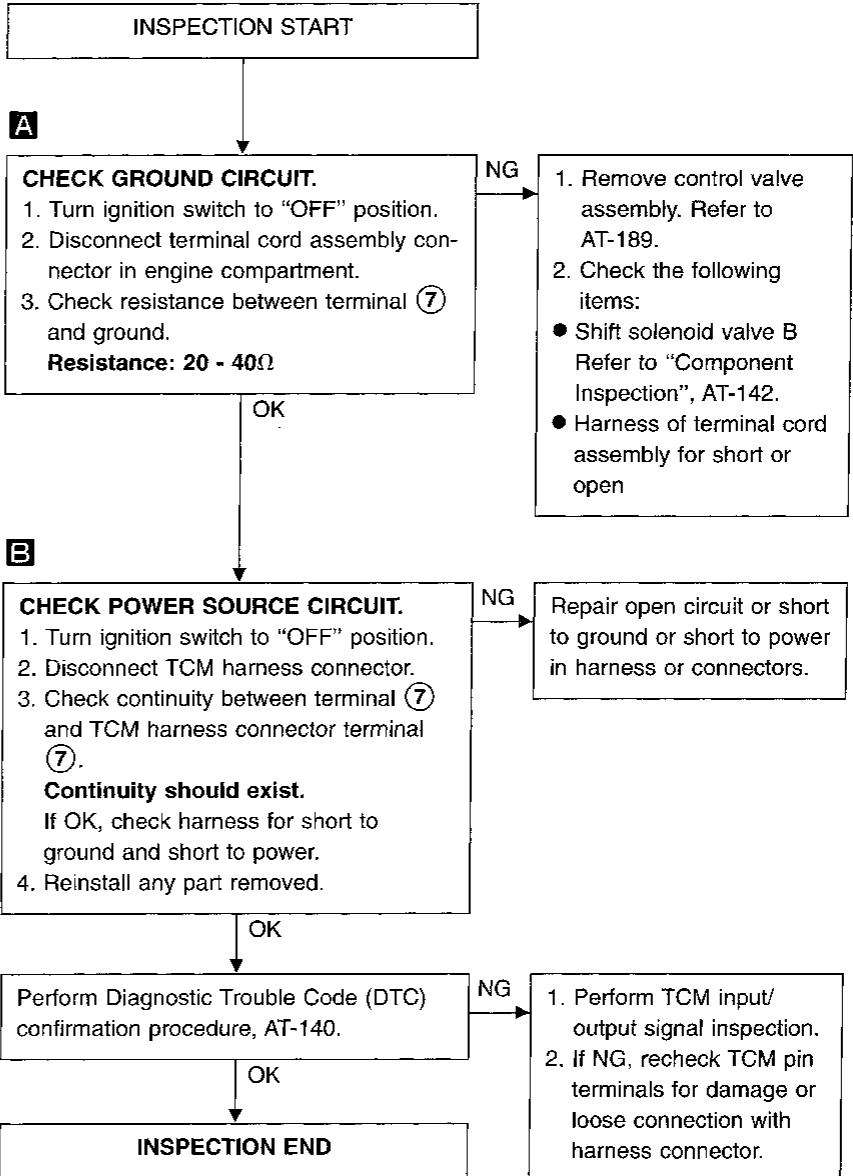
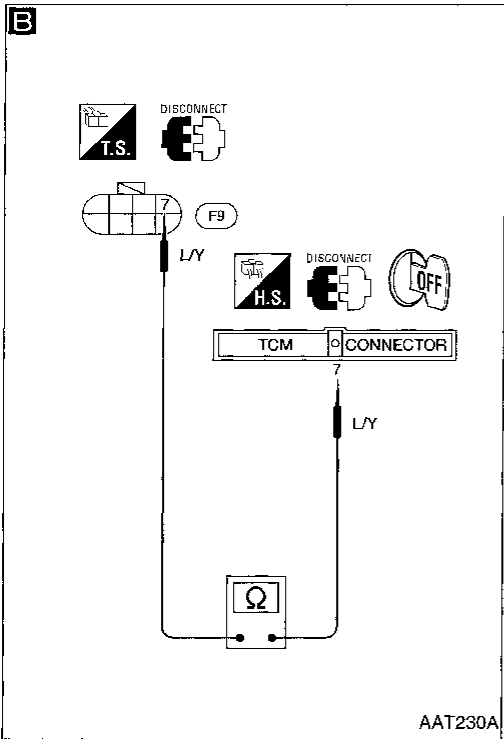
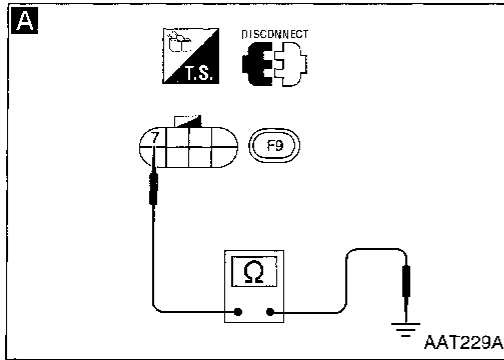

CI
MA
EM
LC
EC
FE
CL
MT
AT
FA
RA
BR
ST
RS
BT
HA
EL
IDX

TROUBLE DIAGNOSIS FOR DTC P0755

Shift Solenoid Valve B (Cont'd)

COMPONENT INSPECTION

Shift solenoid valve B

- For removal, refer to AT-189.

Resistance check

- Check resistance between two terminals.

Solenoid valve	Terminal No.		Resistance (Approx.)
Shift solenoid valve B	⑦	Ground	20 - 40Ω

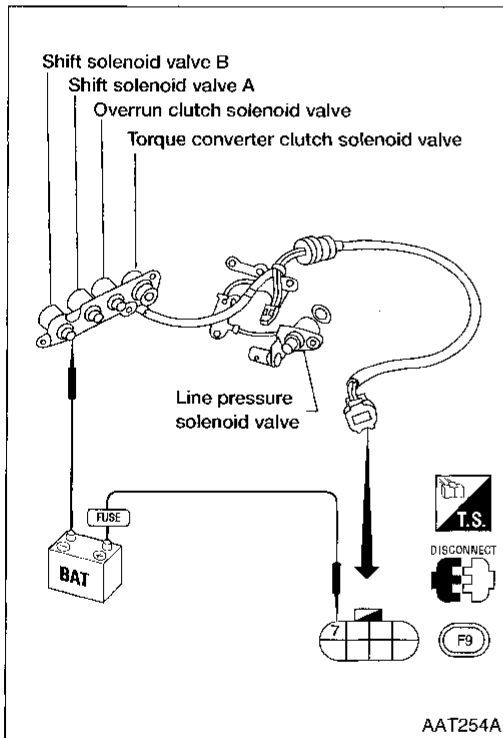
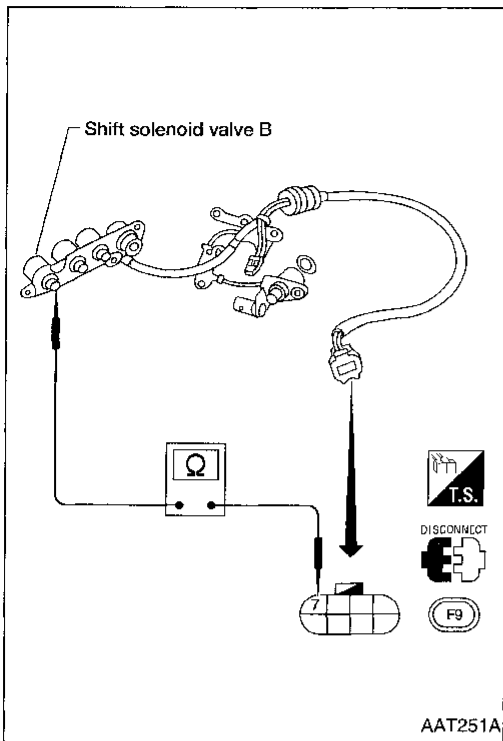

Operation check

- Check solenoid valve by listening for its operating sound while applying battery voltage to the terminal and ground.

TROUBLE DIAGNOSIS FOR DTC P1705

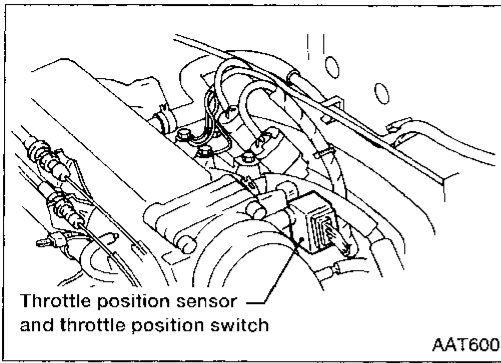

Throttle Position Sensor

DESCRIPTION

- Throttle position sensor
The throttle position sensor detects the throttle valve position and sends a signal to the TCM.
- Throttle position switch
Consists of a wide open throttle position switch and a closed throttle position switch.
The wide open throttle position switch sends a signal to the TCM when the throttle valve is open at least 1/2 of the full throttle position. The closed throttle position switch sends a signal to the TCM when the throttle valve is fully closed.

GI
MA
EM
LC
EC
FE
CL
MT
AT
FA
RA
BR
ST
RS
BT
HA
EL
IDX

CONSULT REFERENCE VALUE IN DATA MONITOR MODE

Remarks: Specification data are reference values.

Monitor item	Condition	Specification
Throttle position sensor	Fully-closed throttle	Approximately 0.5V
	Fully-open throttle	Approximately 4V

TCM TERMINALS AND REFERENCE VALUE



Remarks: Specification data are reference values.

Terminal No.	Wire color	Item	Condition	Judgement standard
14	Y	Closed throttle position switch (in throttle position switch)	When releasing accelerator pedal after warming up engine.	Battery voltage
			When depressing accelerator pedal after warming up engine.	1V or less
21	LG	Wide open throttle position switch (in throttle position switch)	When depressing accelerator pedal more than half-way after warming up engine.	Battery voltage
			When releasing accelerator pedal after warming up engine.	1V or less
31	P/L	Throttle position sensor (Power source)	—	4.5 - 5.5V
34	GY	Throttle position sensor	When depressing accelerator pedal slowly after warming up engine. (Voltage rises gradually in response to throttle position.)	Fully-closed throttle: Approximately 0.5V
				Fully-open throttle: Approximately 4V
35	B	Throttle position sensor (Ground)	—	—

TROUBLE DIAGNOSIS FOR DTC P1705

Throttle Position Sensor (Cont'd)

ON BOARD DIAGNOSIS LOGIC

Diagnostic trouble code	Malfunction is detected when ...	Check item (Possible cause)
 : TP SEN/CIRC A/T  : P1705  : MIL Code No. 1206	TCM receives an excessively low or high voltage from the sensor.	<ul style="list-style-type: none">● Harness or connectors (The sensor circuit is open or shorted.)● Throttle position sensor● Throttle position switch

TROUBLE DIAGNOSIS FOR DTC P1705

Throttle Position Sensor (Cont'd)

DIAGNOSTIC TROUBLE CODE (DTC) CONFIRMATION PROCEDURE

CAUTION:

Always drive vehicle at a safe speed.

NOTE:

If "DIAGNOSTIC TROUBLE CODE CONFIRMATION PROCEDURE" has been previously conducted, always turn ignition switch "OFF" and wait at least 5 seconds before conducting the next test.

After the repair, perform the following procedure to confirm the malfunction is eliminated.

- 1) Turn ignition switch "ON" and select "DATA MONITOR" mode for "A/T" with CONSULT.
- 2) Check the following.

Accelerator pedal condition	THRTL POS SEN	CLOSED THL/SW	W/O THRL/P-SW
Fully released	Less than 4.7V	ON	OFF
Partially depressed	0.1 - 4.6V	OFF	OFF
Fully depressed	1.9 - 4.6V	OFF	ON

If the check result is NG, go to "DIAGNOSTIC PROCEDURE", AT-147.

If the check result is OK, go to following step.

- 3) Turn ignition switch "ON" and select "DATA MONITOR" mode for "ENGINE" with CONSULT.
- 4) Start engine and maintain the following conditions for at least 3 consecutive seconds. Then release accelerator pedal completely.

VHCL SPEED SE: 10 km/h (6 MPH) or more
THRTL POS SEN: Approximately 3V or less
Selector lever: D position (OD "ON")

If the check result is NG, go to "DIAGNOSTIC PROCEDURE", AT-147.

If the check result is OK, go to following step.

- 5) Maintain the following conditions for at least 3 consecutive seconds. Then release accelerator pedal completely.

VHCL SPEED SE: 10 km/h (6 MPH) or more
Accelerator pedal: Wide open throttle
Selector lever: D position (OD "ON")

OR



- 1) Start engine.
- 2) Drive vehicle under the following conditions:
Selector lever in "D" (OD "ON"), vehicle speed higher than 10 km/h (6 MPH), throttle opening greater than 1/2 of the full throttle position and driving for more than 3 seconds.
- 3) Select "MODE 7" with GST.

OR



- 1) Start engine.
- 2) Drive vehicle under the following conditions:
Selector lever in "D" (OD "ON"), vehicle speed higher than 10 km/h (6 MPH), throttle opening greater than 1/2 of the full throttle position and driving for more than 3 seconds.

SELECT SYSTEM

ENGINE

A/T

SAT974H

SELECT DIAG MODE

SELF-DIAG RESULTS

DATA MONITOR

DTC WORK SUPPORT

ECU PART NUMBER

SAT906I

SELECT SYSTEM

ENGINE

SEF895K

SELECT DIAG MODE

WORK SUPPORT

SELF-DIAG RESULTS

DATA MONITOR

ACTIVE TEST

DTC CONFIRMATION

ECM PART NUMBER

SAT911I

TROUBLE DIAGNOSIS FOR DTC P1705

Throttle Position Sensor (Cont'd)

- 3) Perform self-diagnosis for ECM.
Refer to EC section ["Malfunction Indicator Lamp (MIL)", "ON BOARD DIAGNOSTIC SYSTEM DESCRIPTION"].

TROUBLE DIAGNOSIS FOR DTC P1705

Throttle Position Sensor (Cont'd)

DIAGNOSTIC PROCEDURE

A

SELECT SYSTEM

ENGINE

A/T

SAT974H

INSPECTION START

Perform diagnostic test mode II (self-diagnostic results) for engine control. Refer to EC section ["Malfunction Indicator Lamp (MIL)", "ON BOARD DIAGNOSTIC SYSTEM DESCRIPTION"].

NG → Check throttle position sensor circuit for engine control. Refer to EC section ["Throttle Position Sensor (DTC: 0403)", "TROUBLE DIAGNOSIS FOR DTC P0120"].

A

☆MONITOR ☆NO FAIL

VHCL/S SE·A/T	0km/h
VHCL/S SE·MTR	5km/h
THRTL POS SEN	0.4V
FLUID TEMP SE	1.2V
BATTERY VOLT	13.4V
ENGINE SPEED	1024rpm
OVERDRIVE SW	O N
P/N POSI SW	O N
R POSITION SW	OFF

RECORD

SAT076H

OK

A

CHECK INPUT SIGNAL.

- Turn ignition switch to "ON" position. (Do not start engine.)
- Select "ECU INPUT SIGNALS" in "DATA MONITOR" mode for "A/T" with CONSULT.
- Read out the value of "THRTL POS SEN".

Voltage:
Fully-closed throttle:
 Approximately 0.5V
Fully-open throttle:
 Approximately 4V

NG → Check harness for short or open between ECM and TCM regarding throttle position sensor circuit. (Main harness)

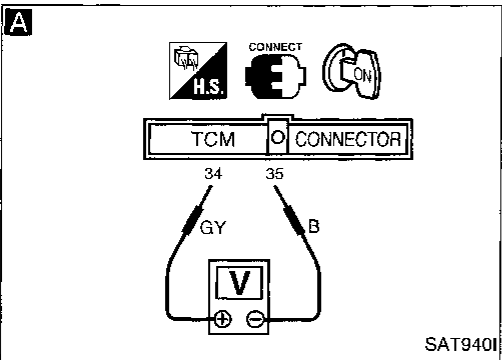

OR

- Turn ignition switch to "ON" position. (Do not start engine.)
- Check voltage between TCM terminals (34) and (35) while accelerator pedal is depressed slowly.

Voltage:
Fully-closed throttle valve:
 Approximately 0.5V
Fully-open throttle valve:
 Approximately 4V
 (Voltage rises gradually in response to throttle position)

OK

A
 (Go to next page.)

GI
 MA
 EM
 LC
 EC
 FE
 CL
 MT
AT
 FA
 RA
 BR
 ST
 PS
 BT
 HA
 EL
 IDX

TROUBLE DIAGNOSIS FOR DTC P1705

Throttle Position Sensor (Cont'd)

B

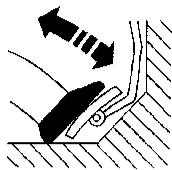

☆ MONITOR	☆ NO FAIL	
D POSITION SW	OFF	
2 POSITION SW	OFF	
1 POSITION SW	OFF	
ASCD • CRUISE	OFF	
ASCD • OD CUT	OFF	
KICKDOWN SW	OFF	
POWERSHIFT SW	OFF	
CLOSED THL/SW	ON	
W/O THRL/P-SW	OFF	

RECORD

SAT963H

B

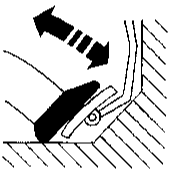
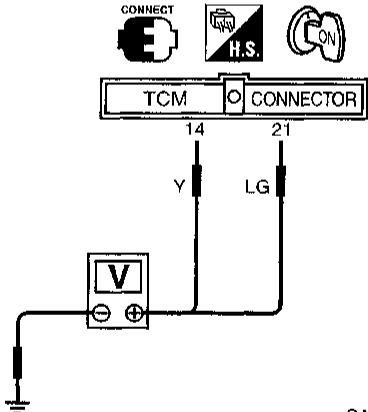
SAT945I

A

B

CHECK THROTTLE POSITION SWITCH CIRCUIT.

1. Turn ignition switch to "ON" position. (Do not start engine.)
2. Select "ECU INPUT SIGNALS" in "DATA MONITOR" mode for "A/T" with CONSULT.
3. Read out "CLOSED THL/SW" and "W/O THRL/P-SW" depressing and releasing accelerator pedal. Check the signal of throttle position switch is indicated properly.

Accelerator pedal condition	Data monitor	
	CLOSED THL/SW	W/O THRL/P-SW
Released	ON	OFF
Fully depressed	OFF	ON

OR

1. Turn ignition switch to "ON" position. (Do not start engine.)
2. Check voltage between TCM terminals (14), (21) and ground while depressing, and releasing accelerator pedal slowly. (After warming up engine)

Accelerator pedal condition	Voltage	
	Terminal No. (14)	Terminal No. (21)
Released	Battery voltage	1V or less
Fully depressed	1V or less	Battery voltage

OK

Perform Diagnostic Trouble Code (DTC) confirmation procedure, AT-145.

OK

INSPECTION END

NG

Check the following items:

- Throttle position switch — Refer to "Components Inspection", AT-149.
- Harness for short or open between ignition switch and throttle position switch (Main harness)
- Harness for short or open between throttle position switch and TCM (Main harness)

NG

1. Perform TCM input/output signal inspection.
2. If NG, recheck TCM pin terminals for damage or loose connection with harness connector.

TROUBLE DIAGNOSIS FOR DTC P1705

Throttle Position Sensor (Cont'd)

COMPONENT INSPECTION

Throttle position switch

Closed throttle position switch (idle position)

- Check continuity between terminals ⑤ and ⑥.

GI

MA

EM

LC

EC

FE

CL

MT

AT

FA

RA

BR

ST

RS

BT

HA

EL

IDX

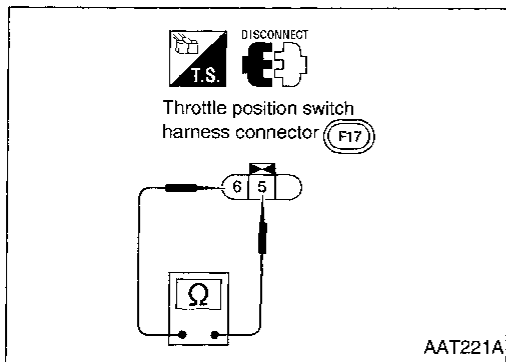

Accelerator pedal condition	Continuity
Released	Yes
Depressed	No

- To adjust closed throttle position switch, refer to EC section ("Basic Inspection", "TROUBLE DIAGNOSIS — Basic Inspection").

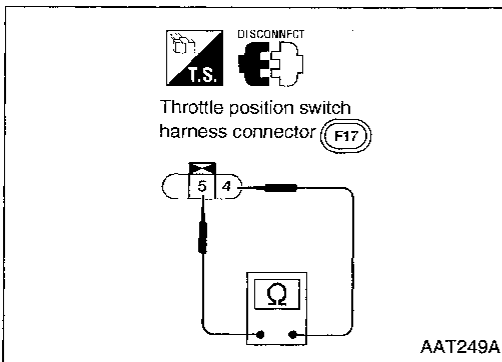

Wide open throttle position switch

- Check continuity between terminals ④ and ⑤.

Accelerator pedal condition	Continuity
Released	No
Depressed	Yes

TROUBLE DIAGNOSIS FOR DTC P1760

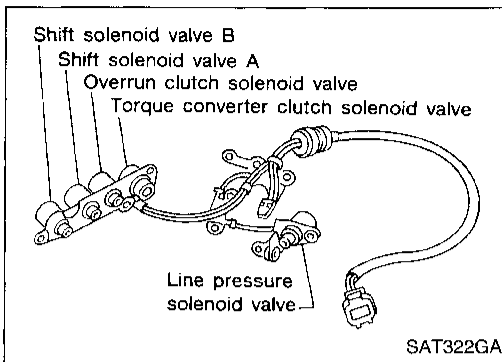

Overrun Clutch Solenoid Valve

DESCRIPTION



The overrun clutch solenoid valve is activated by the TCM in response to signals sent from the inhibitor switch, overdrive control switch, vehicle speed and throttle position sensors. The overrun clutch operation will then be controlled.

TCM TERMINALS AND REFERENCE VALUE

Remarks: Specification data are reference values.

Terminal No.	Wire color	Item	Condition	Judgement standard	
8	L/B	Overrun clutch solenoid valve		When overrun clutch solenoid valve operates.	Battery voltage
				When overrun clutch solenoid valve does not operate.	1V or less

ON BOARD DIAGNOSIS LOGIC

Diagnostic trouble code	Malfunction is detected when ...	Check item (Possible cause)
 : O/R CLTCH SOL/CIRC  : P1760  : MIL Code No. 1203	TCM detects an improper voltage drop when it tries to operate the solenoid valve.	<ul style="list-style-type: none"> ● Harness or connectors (The solenoid circuit is open or shorted.) ● Overrun clutch solenoid valve

TROUBLE DIAGNOSIS FOR DTC P1760

Overrun Clutch Solenoid Valve (Cont'd)

DIAGNOSTIC TROUBLE CODE (DTC) CONFIRMATION PROCEDURE

CAUTION:

Always drive vehicle at a safe speed.

NOTE:

If "DIAGNOSTIC TROUBLE CODE CONFIRMATION PROCEDURE" has been previously conducted, always turn ignition switch "OFF" and wait at least 5 seconds before conducting the next test.

TESTING CONDITION:

Always drive vehicle on a level road to improve accuracy of test.

After the repair, perform the following procedure to confirm the malfunction is eliminated.

SEF895K

SAT911J

- 1) Turn ignition switch "ON" and select "DATA MONITOR" mode for "ENGINE" with CONSULT.
- 2) Start engine.
- 3) Accelerate vehicle to a speed of more than 10 km/h (6 MPH) with "D" position (OD "ON").
- 4) Release accelerator pedal completely with "D" position (OD "OFF").

OR

- 1) Start engine.
- 2) Drive vehicle under the following conditions: Selector lever in "D", overdrive control switch in "ON" or "OFF" position and vehicle speed higher than 10 km/h (6 MPH).
- 3) Select "MODE 7" with GST.

OR

- 1) Start engine.
- 2) Drive vehicle under the following conditions: Selector lever in "D", overdrive control switch in "ON" or "OFF" position and vehicle speed higher than 10 km/h (6 MPH).
- 3) Perform self-diagnosis for ECM. Refer to EC section ["Malfunction Indicator Lamp (MIL)", "ON BOARD DIAGNOSTIC SYSTEM DESCRIPTION"].

GI

MA

EM

LC

EC

FE

CL

MT

AT

FA

RA

BR

ST

RS

BT

HA

EL

IDX

TROUBLE DIAGNOSIS FOR DTC P1760

Overrun Clutch Solenoid Valve (Cont'd)

DIAGNOSTIC PROCEDURE

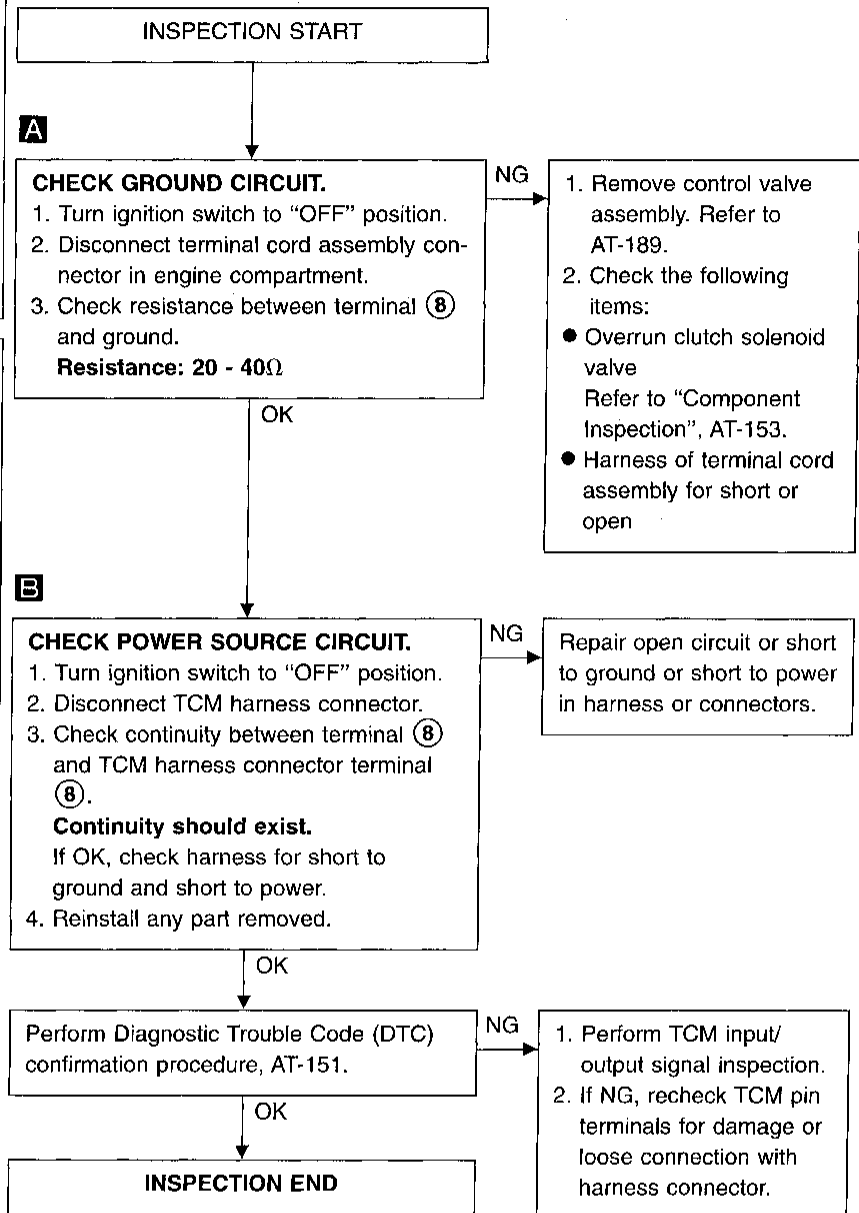
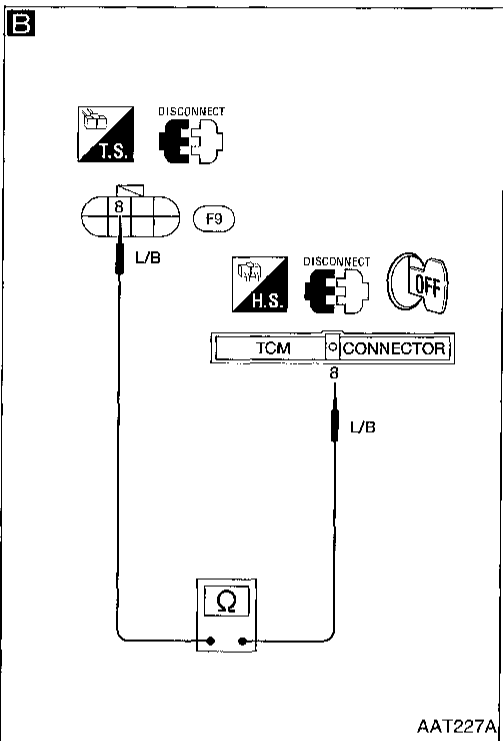
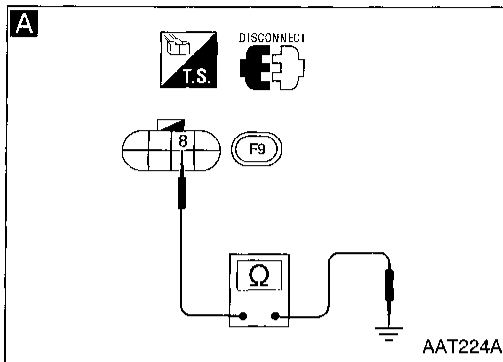

TROUBLE DIAGNOSIS FOR DTC P1760

Overrun Clutch Solenoid Valve (Cont'd)

COMPONENT INSPECTION

Overrun clutch solenoid valve

- For removal, refer to AT-189.

Resistance check

- Check resistance between two terminals.

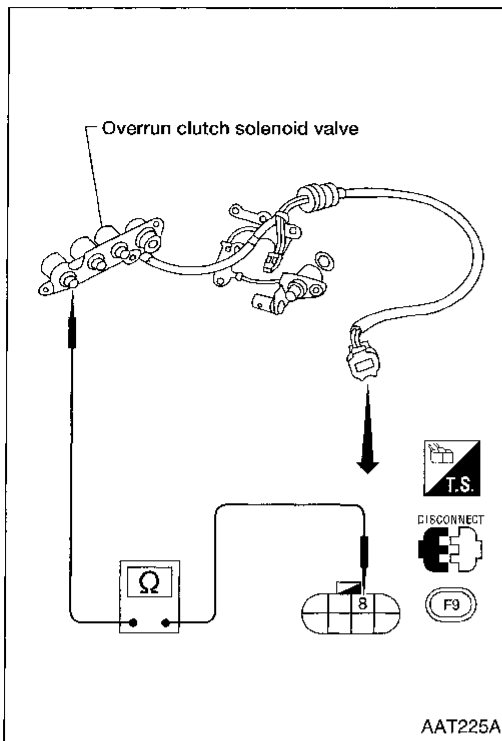

Solenoid valve	Terminal No.		Resistance (Approx.)
Overrun clutch solenoid valve	⑧	Ground	20 - 40Ω

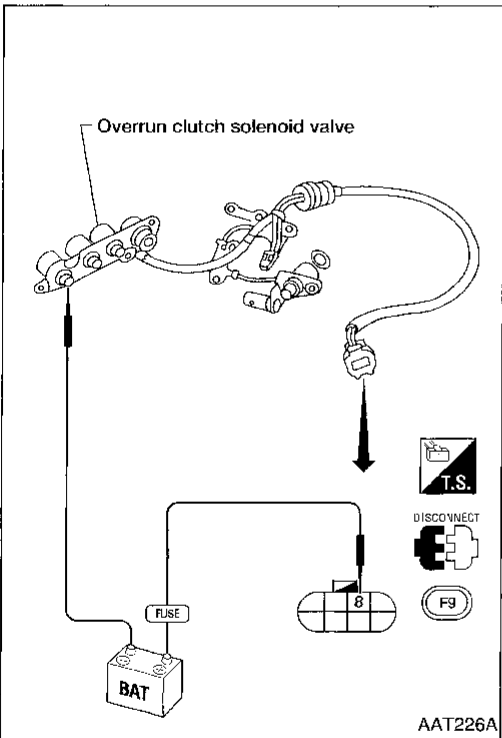

Operation check

- Check solenoid valve by listening for its operating sound while applying battery voltage to the terminal and ground.

GI

MA

EM

LG

EC

FE

CL

MT

AT

JA

RA

BR

ST

RS

BT

HA

EL

IDX

TROUBLE DIAGNOSIS FOR BATT/FLUID TEMP SEN

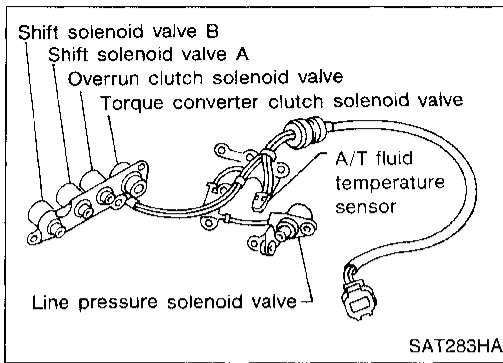

A/T Fluid Temperature Sensor Circuit and TCM Power Source

DESCRIPTION

The A/T fluid temperature sensor detects the A/T fluid temperature and sends a signal to the TCM.

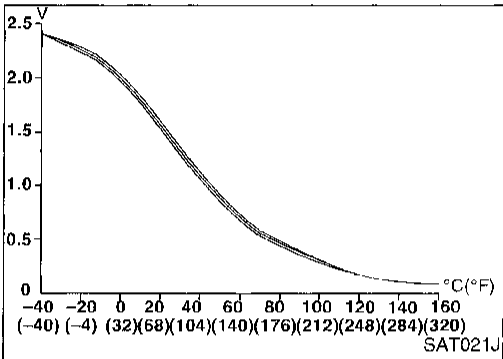

CONSULT REFERENCE VALUE IN DATA MONITOR MODE

Remarks: Specification data are reference values.

Monitor item	Condition	Specification
A/T fluid temperature sensor	Cold [20°C (68°F)]	Approximately 1.5V
	↓	↓
	Hot [80°C (176°F)]	Approximately 0.5V

TCM TERMINALS AND REFERENCE VALUE



Remarks: Specification data are reference values.

Terminal No.	Wire color	Item	Condition	Judgement standard	
4	SB	Power source		When turning ignition switch to "ON".	Battery voltage
				When turning ignition switch to "OFF".	1V or less
9	SB	Power source	Same as No. 4		
23	P	Power source (Memory back-up)		When turning ignition switch to "OFF".	Battery voltage
				When turning ignition switch to "ON".	Battery voltage
33	BR	A/T fluid temperature sensor		When ATF temperature is 20°C (68°F).	Approximately 1.5V
				When ATF temperature is 80°C (176°F).	Approximately 0.5V
35	B	Throttle position sensor (Ground)		—	—

TROUBLE DIAGNOSIS FOR BATT/FLUID TEMP SEN

A/T Fluid Temperature Sensor Circuit and TCM Power Source (Cont'd)

ON BOARD DIAGNOSIS LOGIC

Diagnostic trouble code	Malfunction is detected when ...	Check item (Possible cause)
 : BATT/FLUID TEMP SEN  : 8th judgement flicker	TCM receives an excessively low or high voltage from the sensor.	<ul style="list-style-type: none"> • Harness or connectors (The sensor circuit is open or shorted.) • A/T fluid temperature sensor

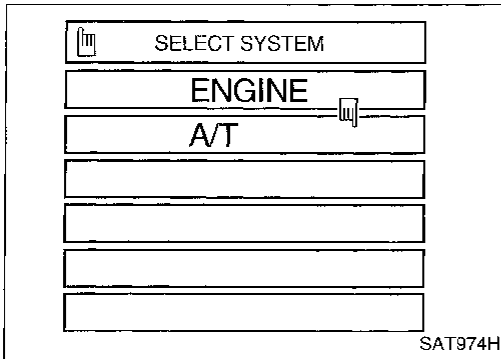

DIAGNOSTIC TROUBLE CODE (DTC) CONFIRMATION PROCEDURE

After the repair, perform the following procedure to confirm the malfunction is eliminated.

- 1) Start engine.
- 2) Select "DATA MONITOR" mode for "A/T" with CONSULT.
- 3) Drive vehicle under the following conditions:
Selector lever in "D", vehicle speed higher than 20 km/h (12 MPH).

OR

- 1) Start engine.
- 2) Drive vehicle under the following conditions:
Selector lever in "D", vehicle speed higher than 20 km/h (12 MPH).
- 3) Perform self-diagnosis.
Refer to TCM SELF-DIAGNOSTIC PROCEDURE (No Tools), AT-49.

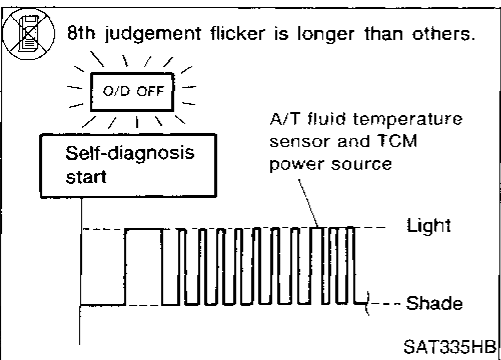
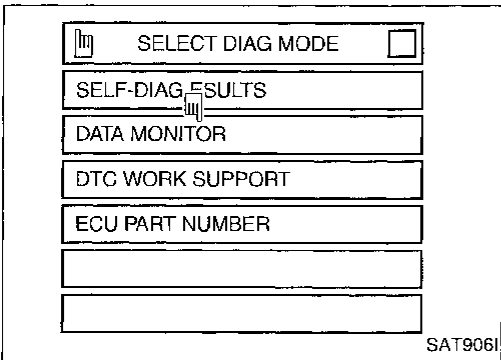

TROUBLE DIAGNOSIS FOR BATT/FLUID TEMP SEN

A/T Fluid Temperature Sensor Circuit and TCM Power Source (Cont'd)

DIAGNOSTIC PROCEDURE

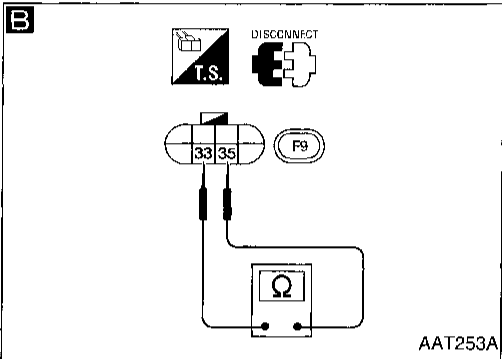
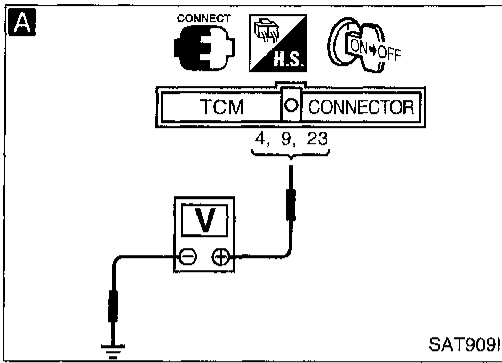

INSPECTION START

A

CHECK TCM POWER SOURCE.

1. Turn ignition switch to "ON" position. (Do not start engine.)
2. Check voltage between TCM terminals ④, ⑨, ⑳ and ground.
Voltage: Battery voltage
3. Turn ignition switch to "OFF" position.
4. Check voltage between TCM terminal ㉓ and ground.
Voltage: Battery voltage

NG

Check the following items:

- Harness for short or open between ignition switch and TCM (Main harness)
- Ignition switch and fuse
Refer to EL section ("POWER SUPPLY ROUTING").

OK

B

CHECK A/T FLUID TEMPERATURE SENSOR WITH TERMINAL CORD ASSEMBLY.

1. Turn ignition switch to "OFF" position.
2. Disconnect terminal cord assembly connector in engine compartment.
3. Check resistance between terminals ㉓ and ㉕ when A/T is cold.
Resistance:
Cold [20°C (68°F)]
Approximately 2.5 kΩ
4. Reinstall any part removed.

NG

1. Remove oil pan.
2. Check the following items:
 - A/T fluid temperature sensor
Refer to "Component Inspection", AT-157.
 - Harness of terminal cord assembly for short or open

OK

Ⓐ
(Go to next page.)

TROUBLE DIAGNOSIS FOR BATT/FLUID TEMP SEN

A/T Fluid Temperature Sensor Circuit and TCM Power Source (Cont'd)

☆ MONITOR ☆ NO FAIL

VHCL/S SE-A/T	0km/h
VHCL/S SE-MTR	5km/h
THRTL POS SEN	0.4V
FLUID TEMP SE	1.2V
BATTERY VOLT	13.4V
ENGINE SPEED	1024rpm
OVERDRIVE SW	○ N
P/N POSI SW	○ N
R POSITION SW	OFF

RECORD

SAT076H

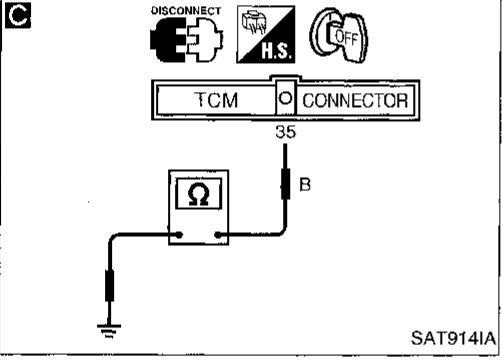
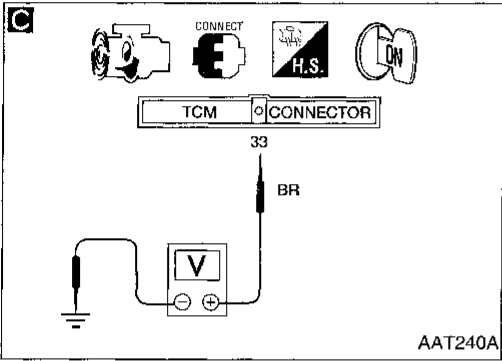

CHECK INPUT SIGNAL OF A/T FLUID TEMPERATURE SENSOR.

- Start engine.
- Select "ECU INPUT SIGNALS" in "DATA MONITOR" mode for "A/T" with CONSULT.
- Read out the value of "FLUID TEMP SE".

Voltage:
 Cold [20°C (68°F)] →
 Hot [80°C (176°F)]:
 Approximately
 1.5V → 0.5V

NG → Check the following item:
 ● Harness for short or open between TCM, ECM and terminal cord assembly (Main harness)
 ● Ground circuit for ECM Refer to EC section ("TROUBLE DIAGNOSIS FOR POWER SUPPLY").

OR

- Start engine.
- Check voltage between TCM terminal (33) and ground while warming up A/T.

Voltage:
 Cold [20°C (68°F)] →
 Hot [80°C (176°F)]:
 Approximately
 1.5V → 0.5V

- Turn ignition switch to "OFF" position.
- Disconnect TCM harness connector.
- Check resistance between terminal (35) and ground.

Continuity should exist.

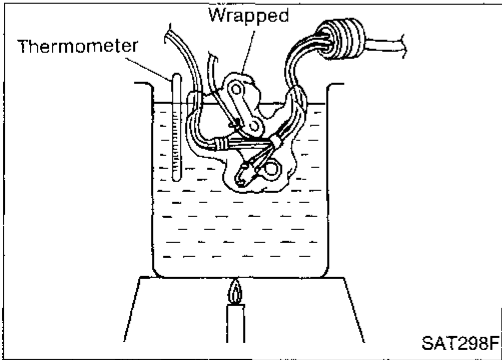
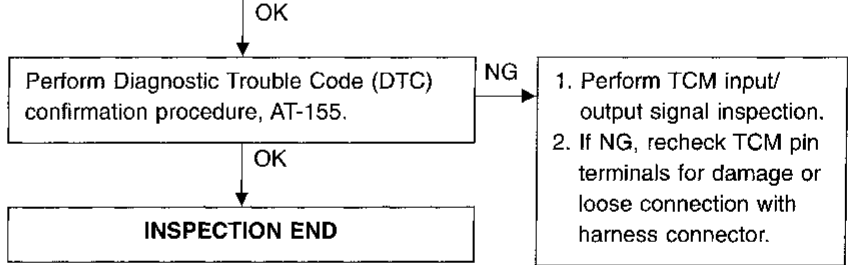

COMPONENT INSPECTION

A/T fluid temperature sensor

- For removal, refer to AT-189.
- Check resistance between two terminals while changing temperature as shown at left.

Temperature °C (°F)	Resistance
20 (68)	Approximately 2.5 kΩ
80 (176)	Approximately 0.3 kΩ

GI
MA
EM
LG
EC
FE
CL
MT
AT
FA
RA
BR
ST
RS
BT
HA
EL
IDX

TROUBLE DIAGNOSIS FOR VHCL SPEED SEN-MTR

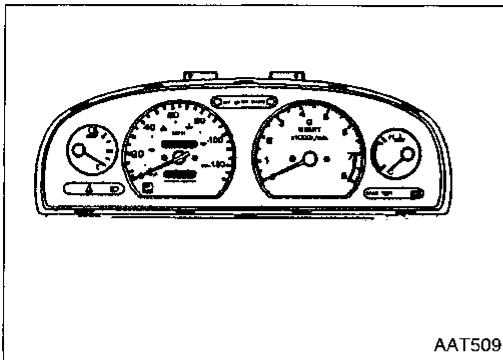

Vehicle Speed Sensor-MTR

DESCRIPTION



The vehicle speed sensor-MTR is built into the speedometer assembly. The sensor functions as an auxiliary device to the revolution sensor when it is malfunctioning. The TCM will then use a signal sent from the vehicle speed sensor-MTR.

TCM TERMINALS AND REFERENCE VALUE

Remarks: Specification data are reference values.

Terminal No.	Wire color	Item	Condition	Judgement standard
27	PU/R	Vehicle speed sensor	 When moving vehicle at 2 to 3 km/h (1 to 2 MPH) for 1 m (3 ft) or more.	Voltage varies between less than 1V and more than 4.5V

ON BOARD DIAGNOSIS LOGIC

Diagnostic trouble code	Malfunction is detected when ...	Check item (Possible cause)
 : VHCL SPEED SEN-MTR  : 2nd judgement flicker	TCM does not receive the proper voltage signal from the sensor.	<ul style="list-style-type: none"> ● Harness or connectors (The sensor circuit is open or shorted.) ● Vehicle speed sensor

TROUBLE DIAGNOSIS FOR VHCL SPEED SEN-MTR

Vehicle Speed Sensor-MTR (Cont'd)

DIAGNOSTIC TROUBLE CODE (DTC) CONFIRMATION PROCEDURE

CAUTION:

- Always drive vehicle at a safe speed.
- If conducting this "DTC CONFIRMATION PROCEDURE" again, always turn ignition switch "OFF" and wait at least 5 seconds before continuing.

After the repair, perform the following procedure to confirm the malfunction is eliminated.

- 1) Turn ignition switch "ON" and select "DATA MONITOR" mode for "A/T" with CONSULT.
- 2) Start engine and accelerate vehicle from 0 to 25 km/h (0 to 16 MPH).

OR

- 1) Start engine.
- 2) Drive vehicle under the following conditions:
Selector lever in "D" and vehicle speed higher than 25 km/h (16 MPH).
- 3) Perform self-diagnosis.
Refer to TCM SELF-DIAGNOSTIC PROCEDURE (No Tools), AT-49.

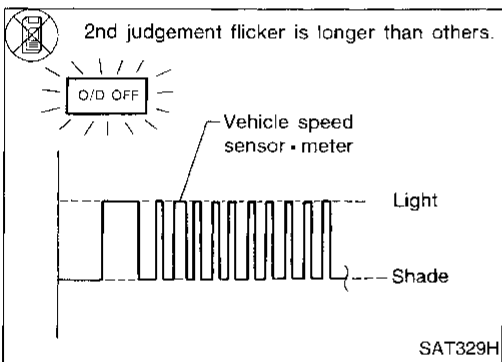
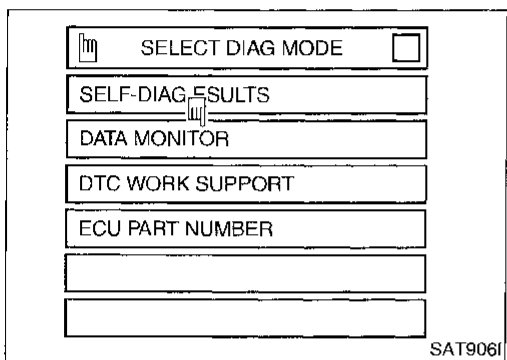
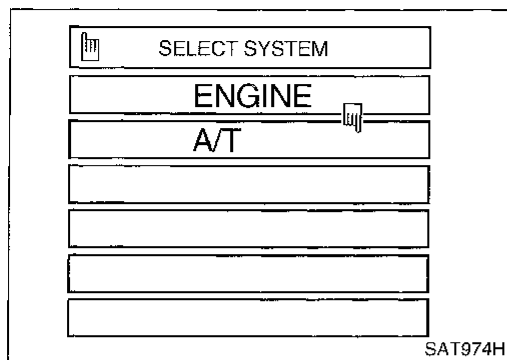

GI

MA

EM

LC

EC

FE

CL

MT

AT

FA

RA

BR

ST

RS

BT

HA

EL

IDX

TROUBLE DIAGNOSIS FOR VHCL SPEED SEN-MTR

Vehicle Speed Sensor-MTR (Cont'd) DIAGNOSTIC PROCEDURE

A

☆ MONITOR	☆ NO FAIL	
VHCL/S SE-A/T	0km/h	
VHCL/S SE-MTR	5km/h	
THRTL POS SEN	0.4V	
FLUID TEMP SE	1.2V	
BATTERY VOLT	13.4V	
ENGINE SPEED	1024rpm	
OVERDRIVE SW	O N	
P/N POSI SW	O N	
R POSITION SW	OFF	

RECORD

SAT076H

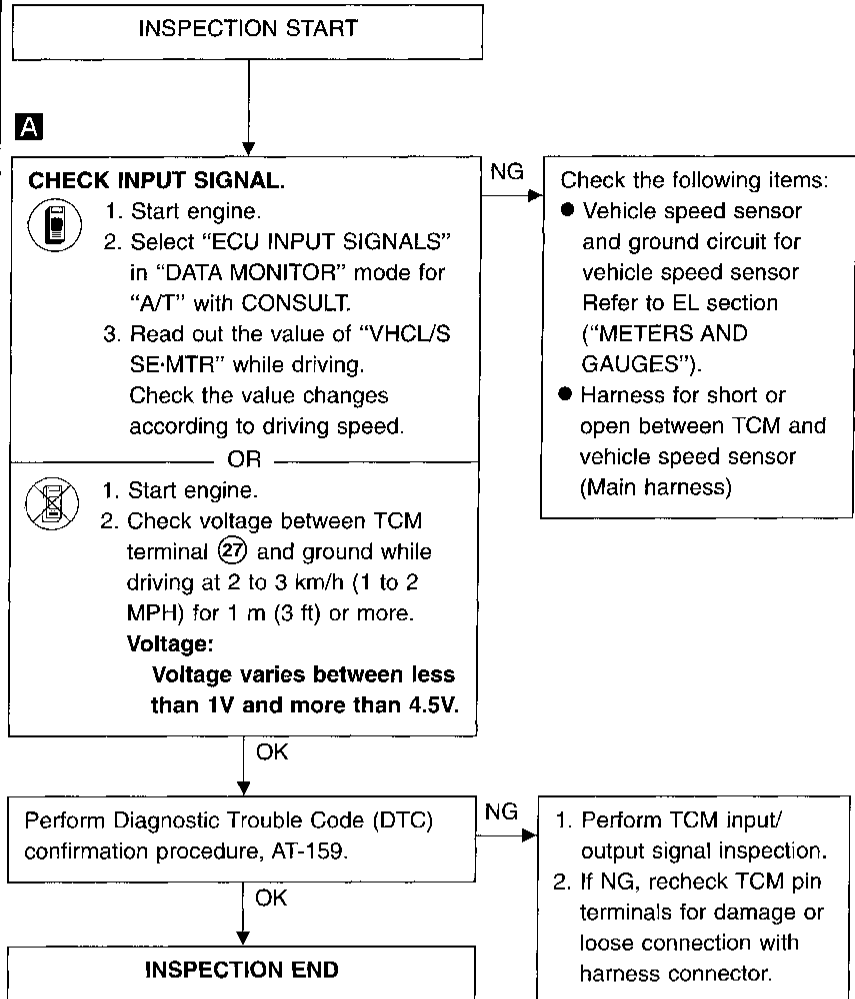
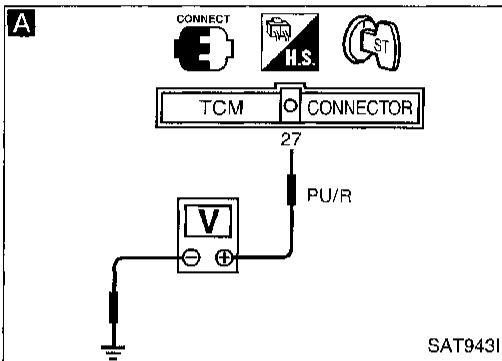

TROUBLE DIAGNOSIS FOR SYMPTOMS

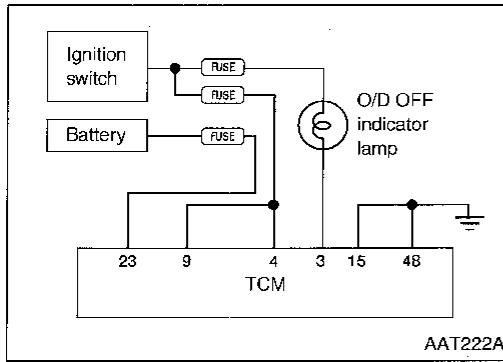

1. O/D OFF Indicator Lamp Does Not Come On

SYMPTOM:

O/D OFF indicator lamp does not come on for about 2 seconds when turning ignition switch to "ON".

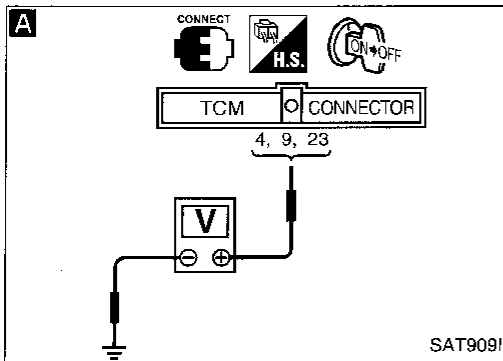

A

CHECK TCM POWER SOURCE.

1. Turn ignition switch to "ON" position. (Do not start engine.)
2. Check voltage between TCM terminals ④, ⑨, ⑳ and ground.
Voltage: Battery voltage
3. Turn ignition switch to "OFF" position.
4. Check voltage between TCM terminal ⑳ and ground.
Voltage: Battery voltage

NG

Check the following items:

- Harness for short or open between ignition switch and TCM (Main harness)
Refer to "Wiring Diagram — A/T" in AT-13.
- Ignition switch and fuse
Refer to EL section ("POWER SUPPLY ROUTING").

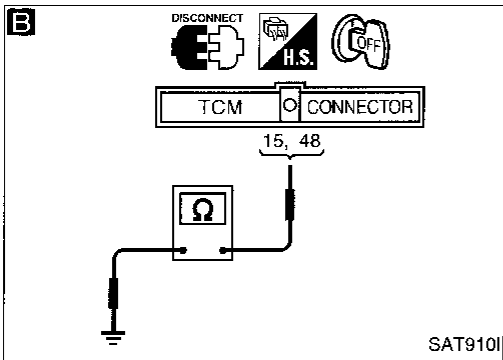

B

CHECK TCM GROUND CIRCUIT.

1. Turn ignition switch to "OFF" position.
2. Disconnect TCM harness connector.
3. Check continuity between TCM terminals ⑮, ④⑧ and ground.
Continuity should exist.
If OK, check harness for short to ground and short to power.

NG

Repair open circuit or short to ground or short to power in harness or connectors.
Refer to "Wiring Diagram — A/T" in AT-13.

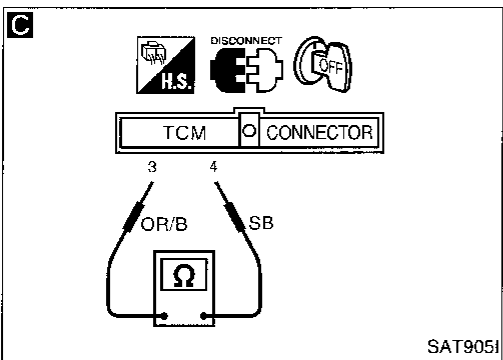

C

CHECK LAMP CIRCUIT.

1. Turn ignition switch to "OFF" position.
2. Check resistance between TCM terminals ③ and ④.
Resistance: 50 - 100Ω
3. Reinstall any part removed.

NG

Check the following items:

- O/D OFF indicator lamp
Refer to EL section.
- Harness and fuse for short or open between ignition switch and O/D OFF indicator lamp (Main harness)
Refer to EL section ("POWER SUPPLY ROUTING").
- Harness for short or open between O/D OFF indicator lamp and TCM

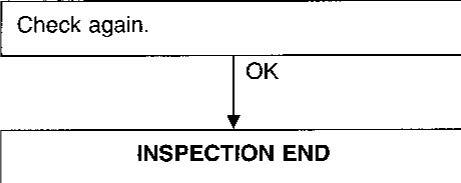

NG

1. Perform TCM input/output signal inspection.
2. If NG, recheck TCM pin terminals for damage or loose connection with harness connector.

TROUBLE DIAGNOSIS FOR SYMPTOMS

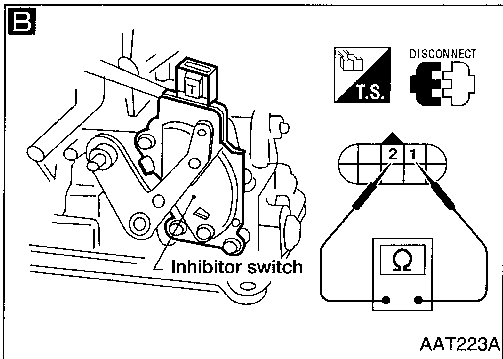
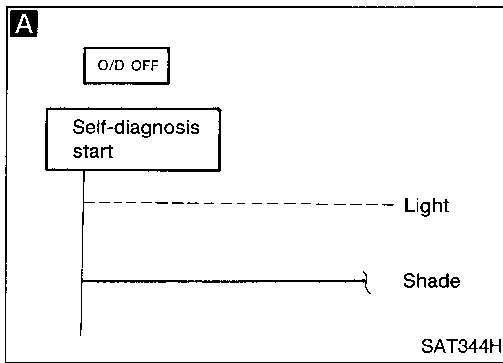

2. Engine Cannot Be Started In "P" and "N" Position

SYMPTOM:

- Engine cannot be started with selector lever in "P" or "N" position.
- Engine can be started with selector lever in "D", "2", "1" or "R" position.

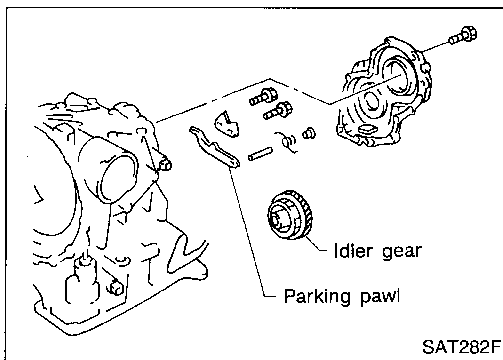
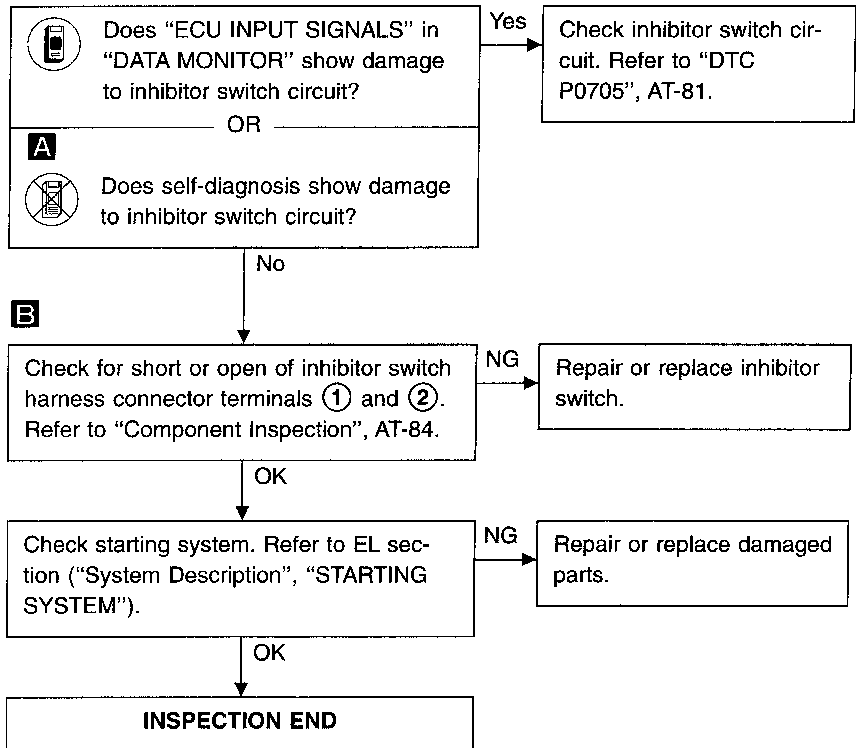

3. In "P" Position, Vehicle Moves Forward or Backward When Pushed

SYMPTOM:

Vehicle moves when it is pushed forward or backward with selector lever in "P" position.

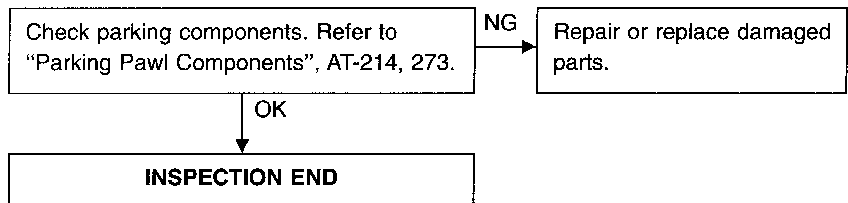

TROUBLE DIAGNOSIS FOR SYMPTOMS

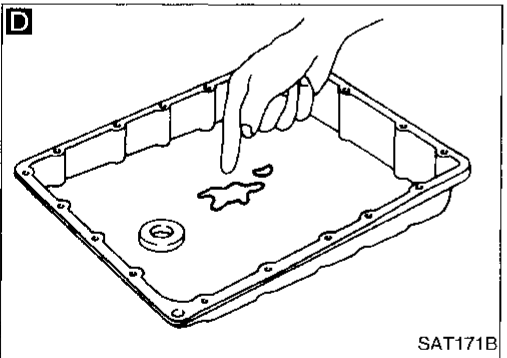
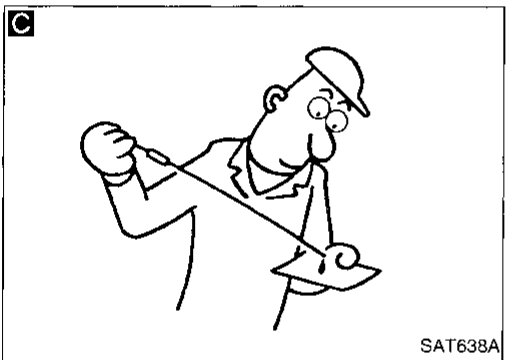
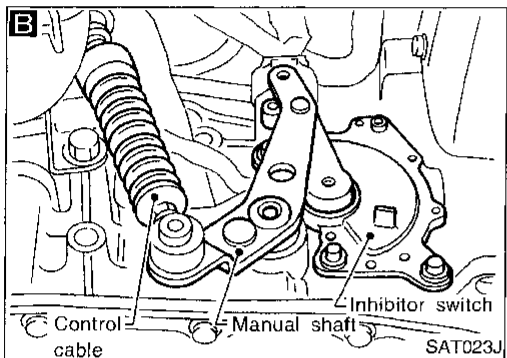
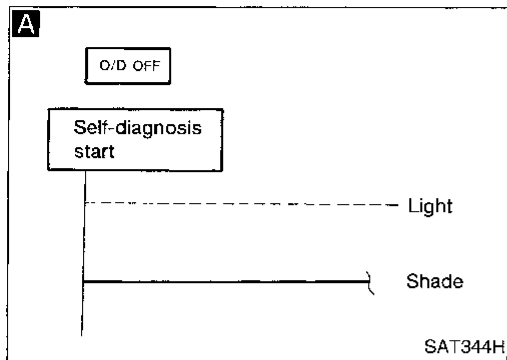

4. In "N" Position, Vehicle Moves

SYMPTOM:

Vehicle moves forward or backward when selecting "N" position.

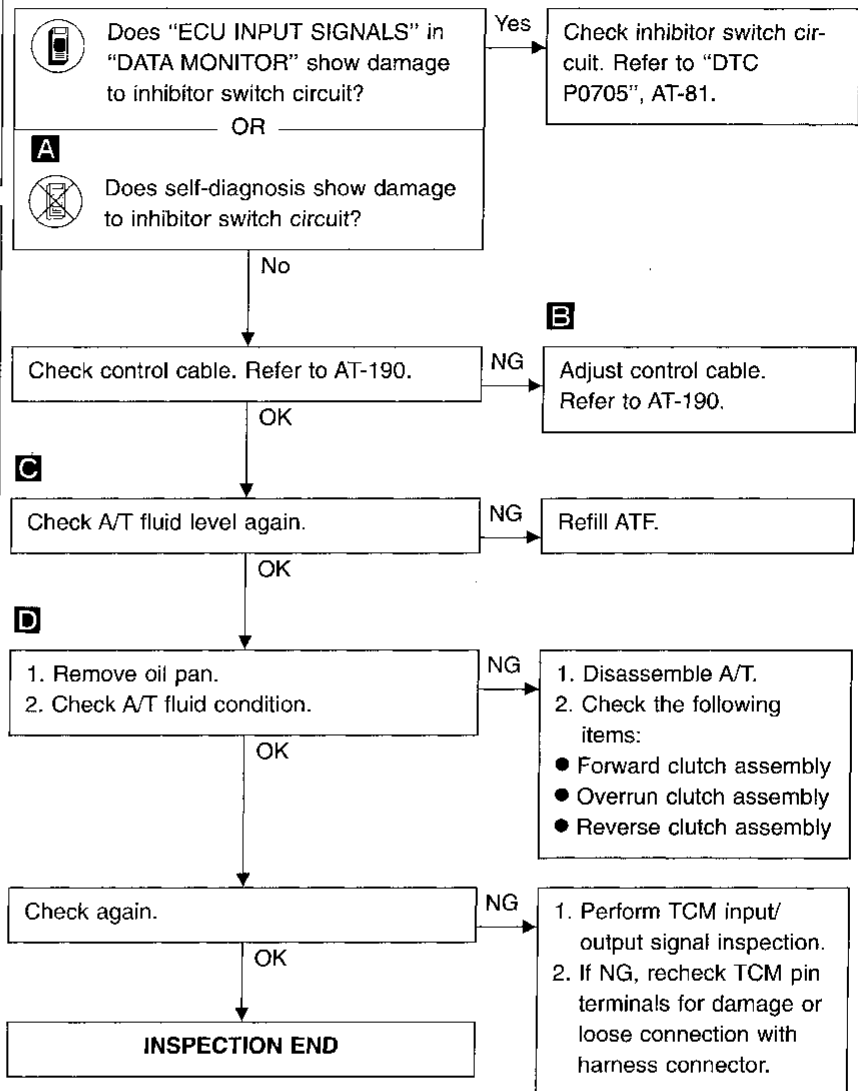

CI
MA
EM
LC
EC
FE
CL
MT
AT
FA
RA
BR
ST
RS
BT
HA
EL
IDX

TROUBLE DIAGNOSIS FOR SYMPTOMS

5. Large Shock. "N" → "R" Position

SYMPTOM:

There is large shock when changing from "N" to "R" position.

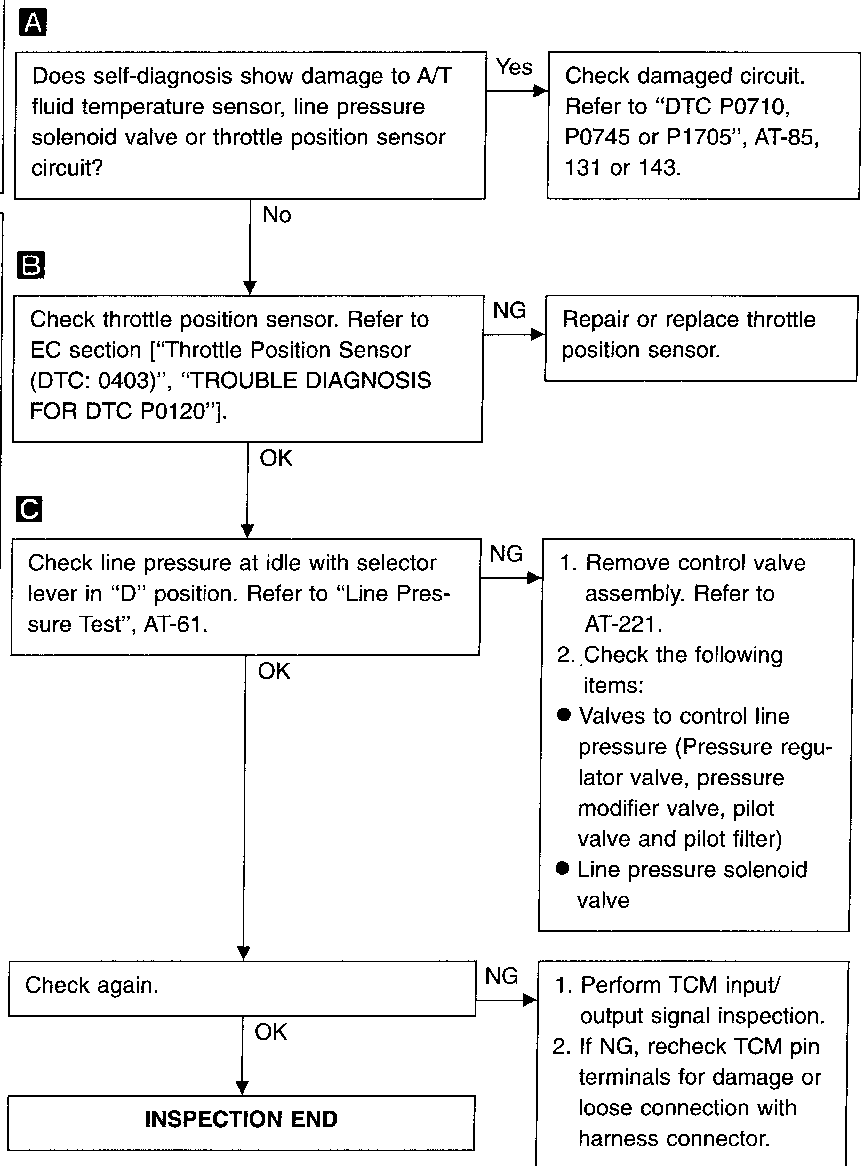
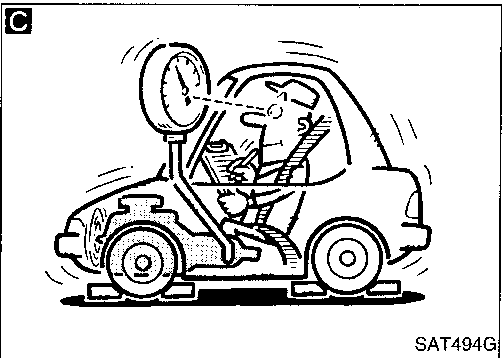
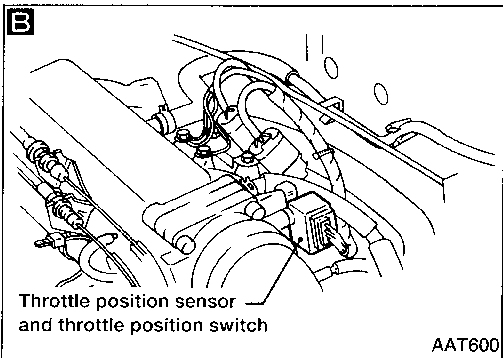
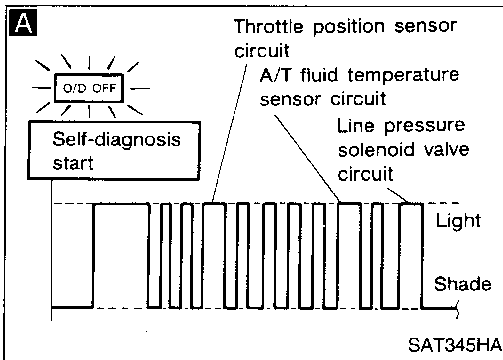

TROUBLE DIAGNOSIS FOR SYMPTOMS

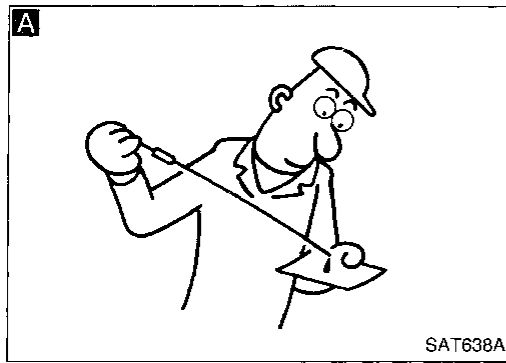

6. Vehicle Does Not Creep Backward In "R" Position

SYMPTOM:

Vehicle does not creep backward when selecting "R" position.

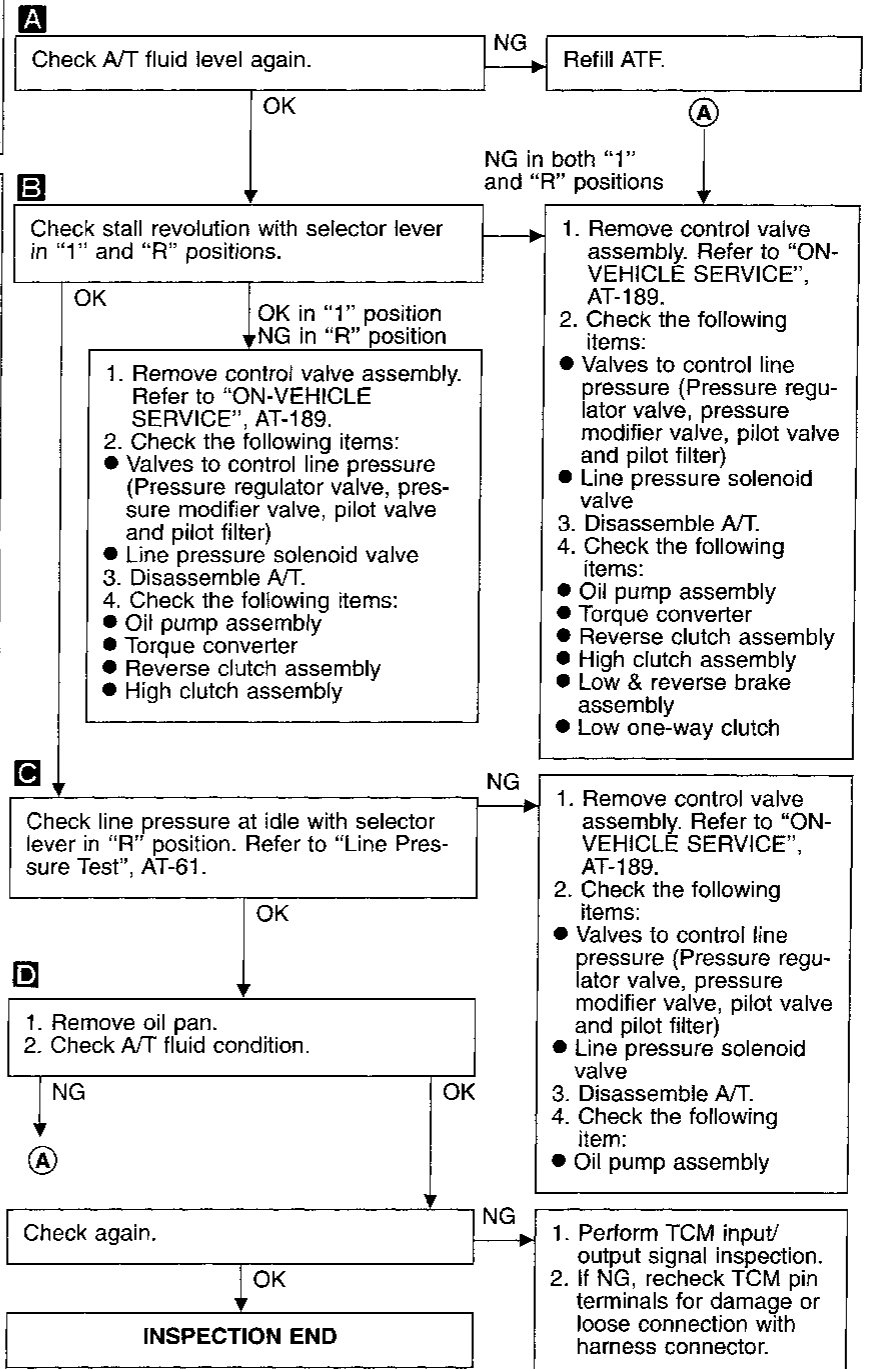
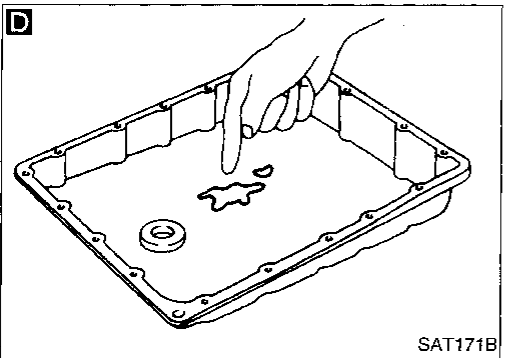
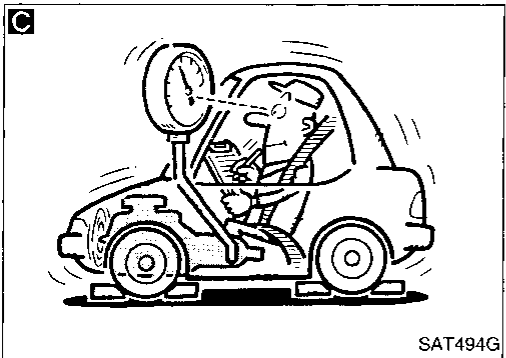
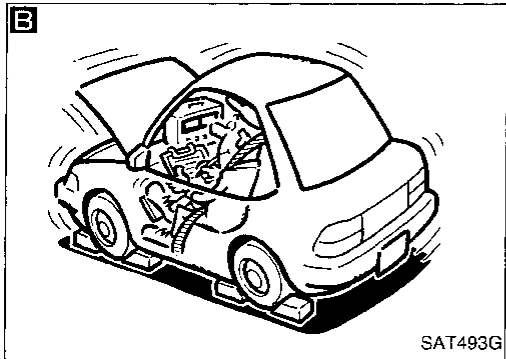

G1
MA
EM
LC
EC
FE
CL
MT
AT
FA
RA
BR
ST
RS
BT
HA
EL
IDX

TROUBLE DIAGNOSIS FOR SYMPTOMS

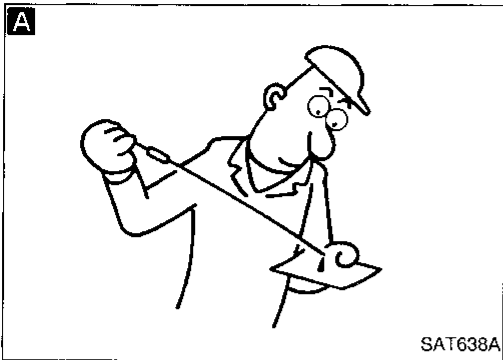

7. Vehicle Does Not Creep Forward In "D", "2" or "1" Position

SYMPTOM:

Vehicle does not creep forward when selecting "D", "2" or "1" position.

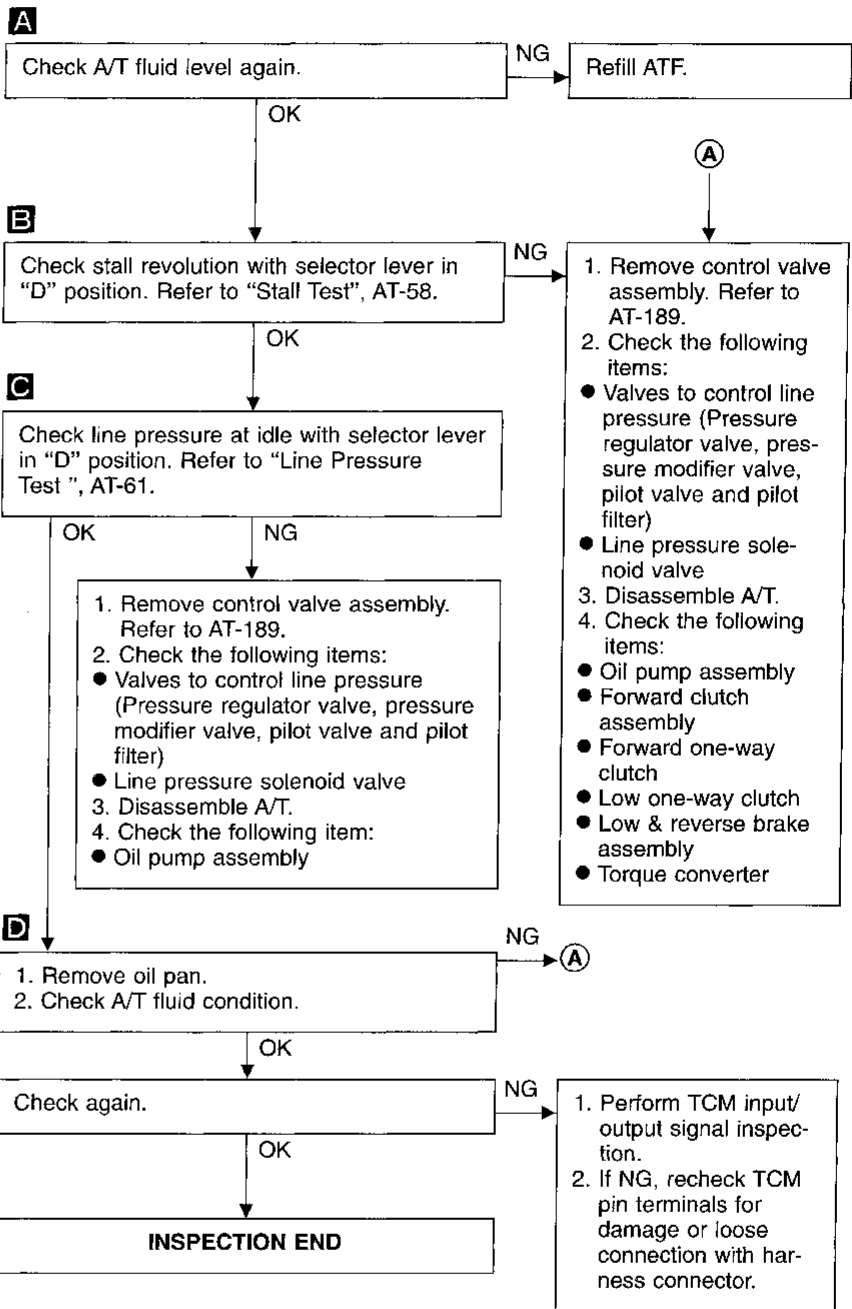
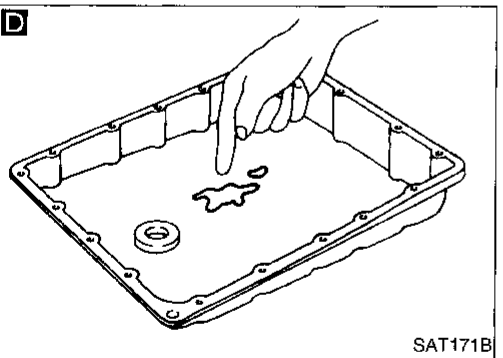
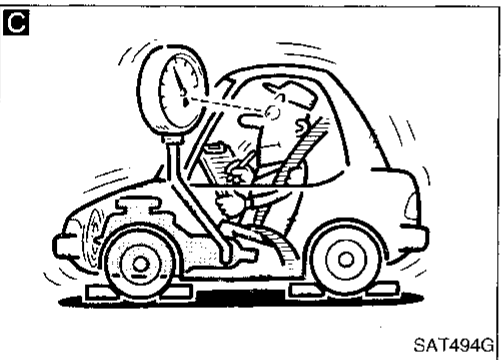
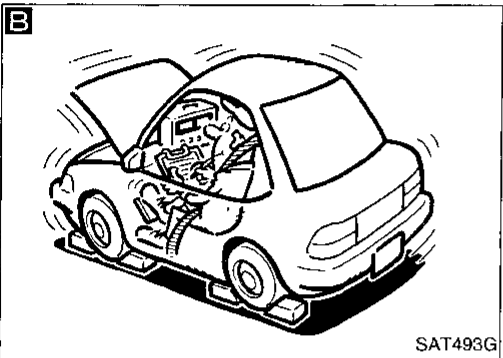

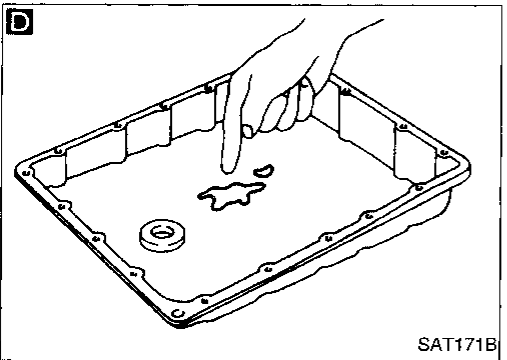
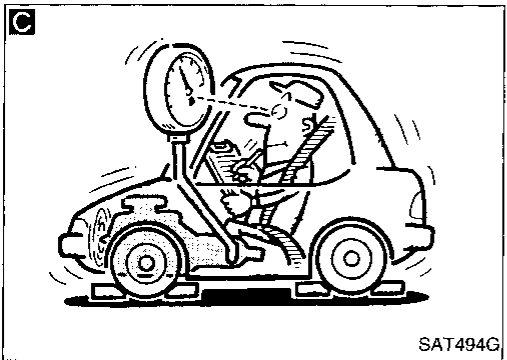
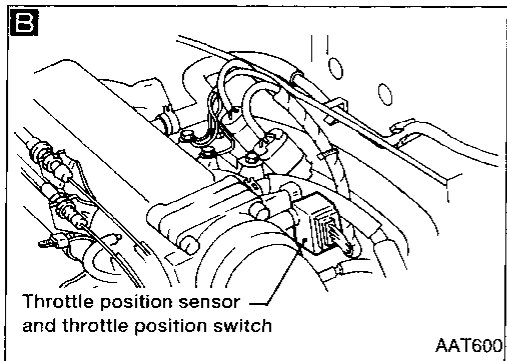
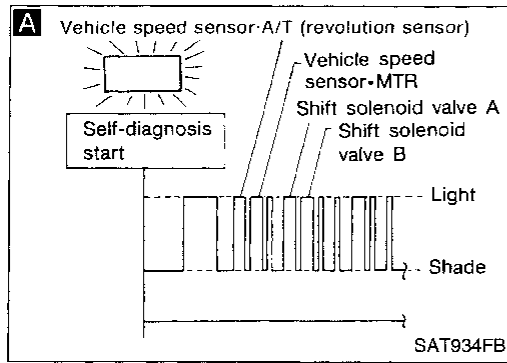

8. Vehicle Cannot Be Started From D₁

SYMPTOM:

Vehicle cannot be started from D₁ on Cruise test — Part 1.

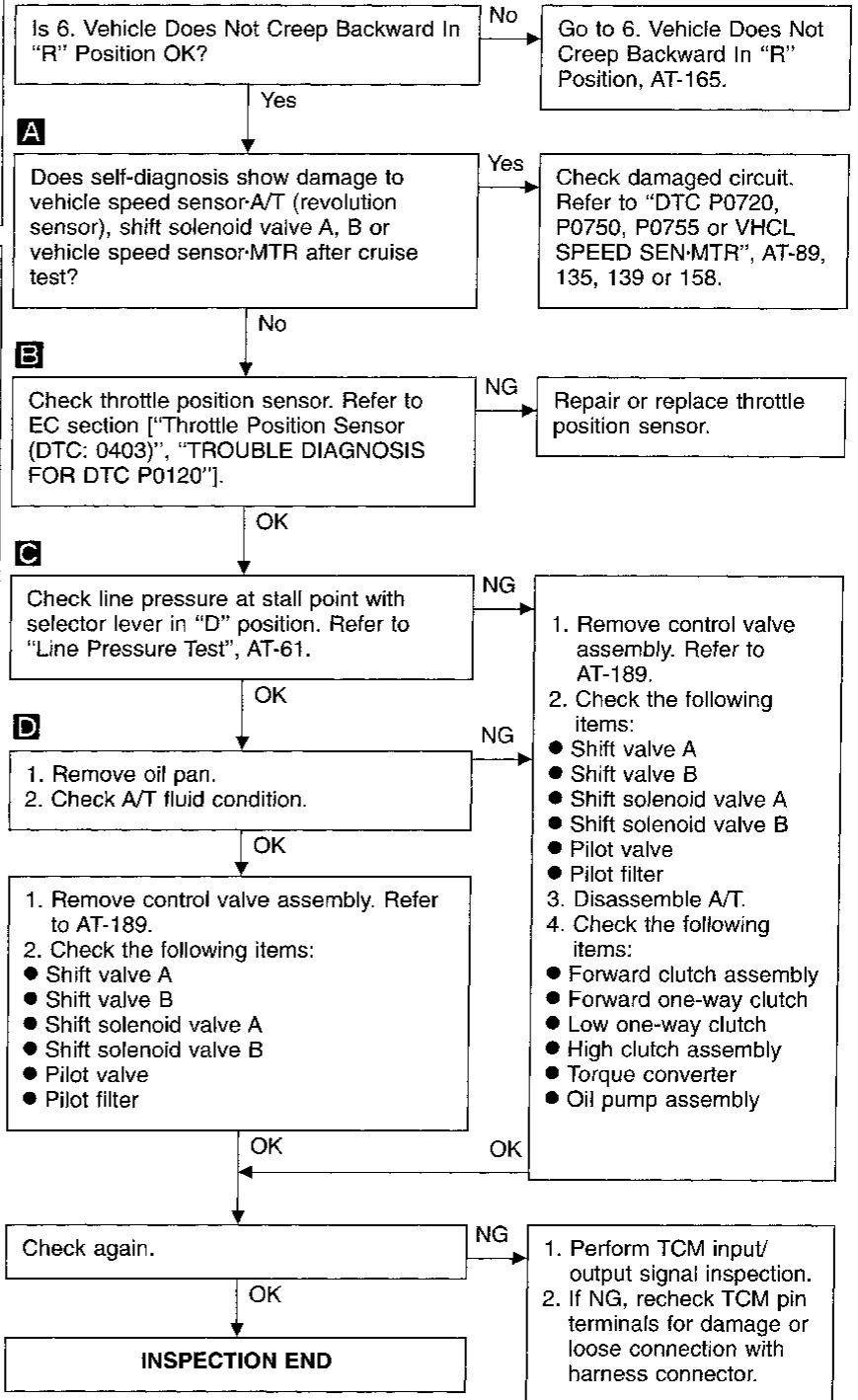

GI
MA
EM
LC
EC
FE
CL
MT
AT
FA
RA
BR
ST
RS
BT
HA
EL
IDX

TROUBLE DIAGNOSIS FOR SYMPTOMS

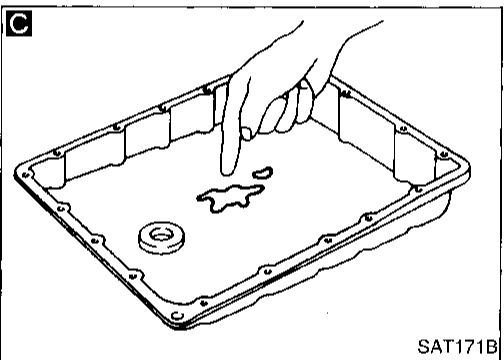
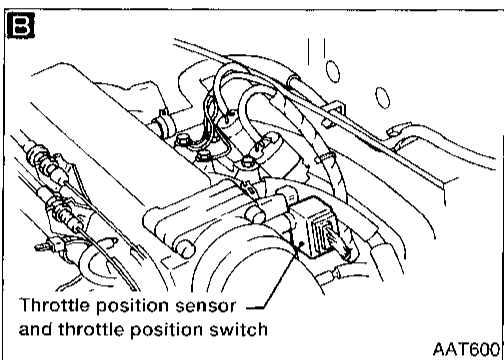
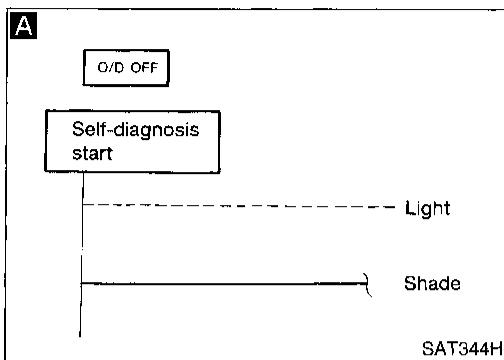

9. A/T Does Not Shift: D₁ → D₂ or Does Not Kickdown: D₄ → D₂

SYMPTOM:

A/T does not shift from D₁ to D₂ at the specified speed.
A/T does not shift from D₄ to D₂ when depressing accelerator pedal fully at the specified speed.

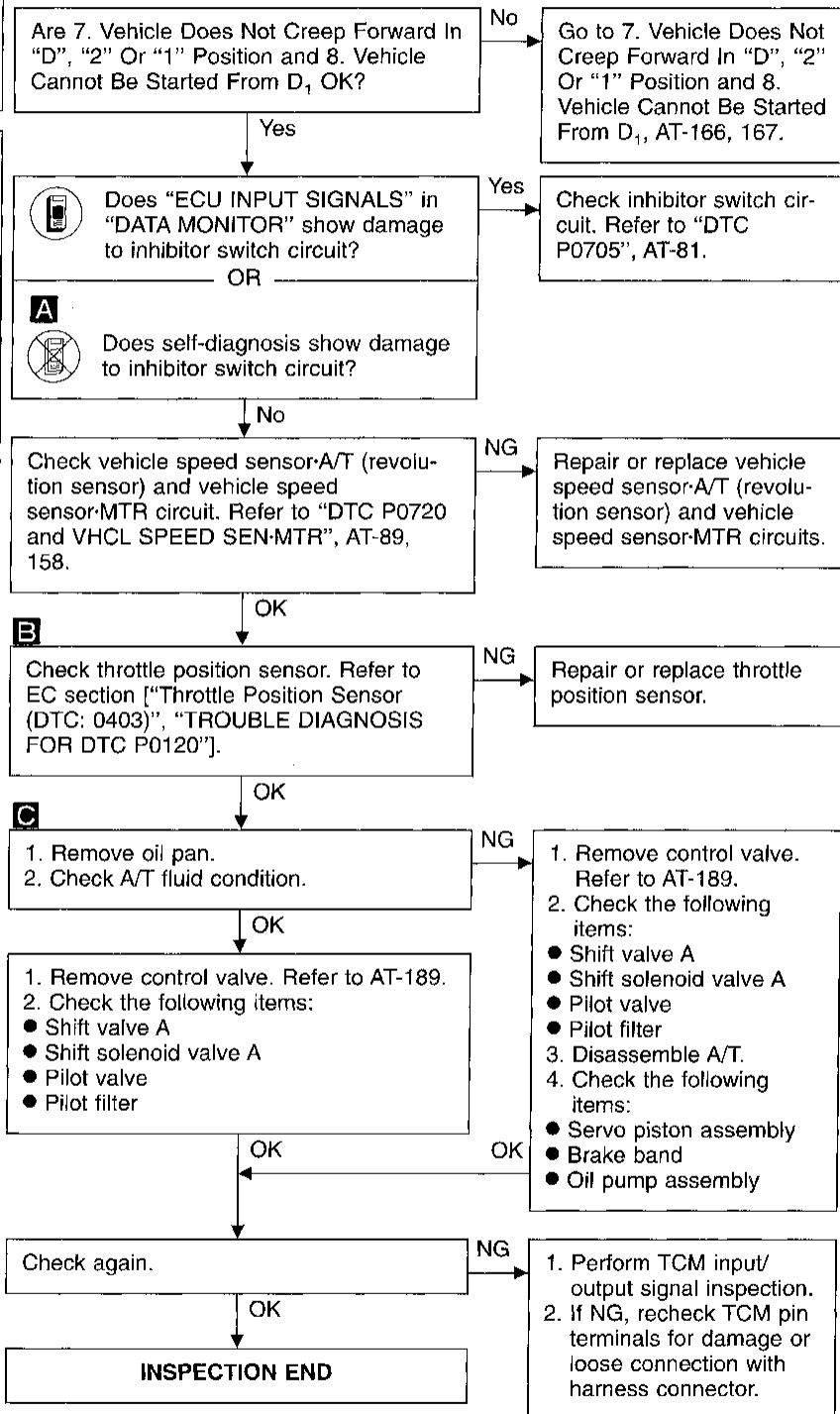

TROUBLE DIAGNOSIS FOR SYMPTOMS

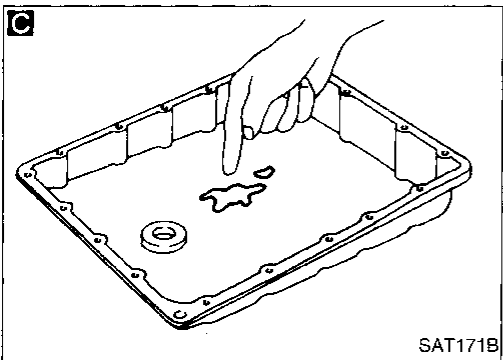
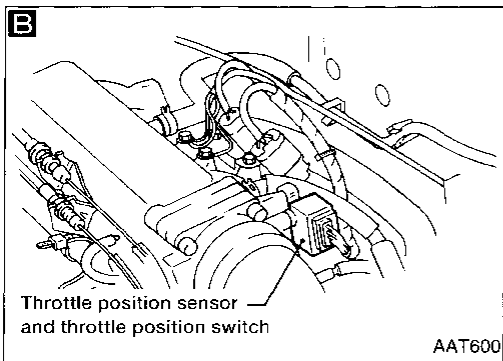
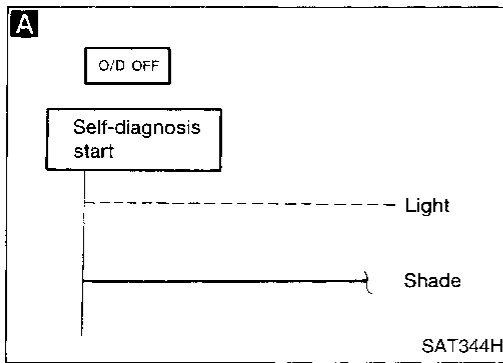

10. A/T Does Not Shift: $D_2 \rightarrow D_3$

SYMPTOM:

A/T does not shift from D_2 to D_3 at the specified speed.

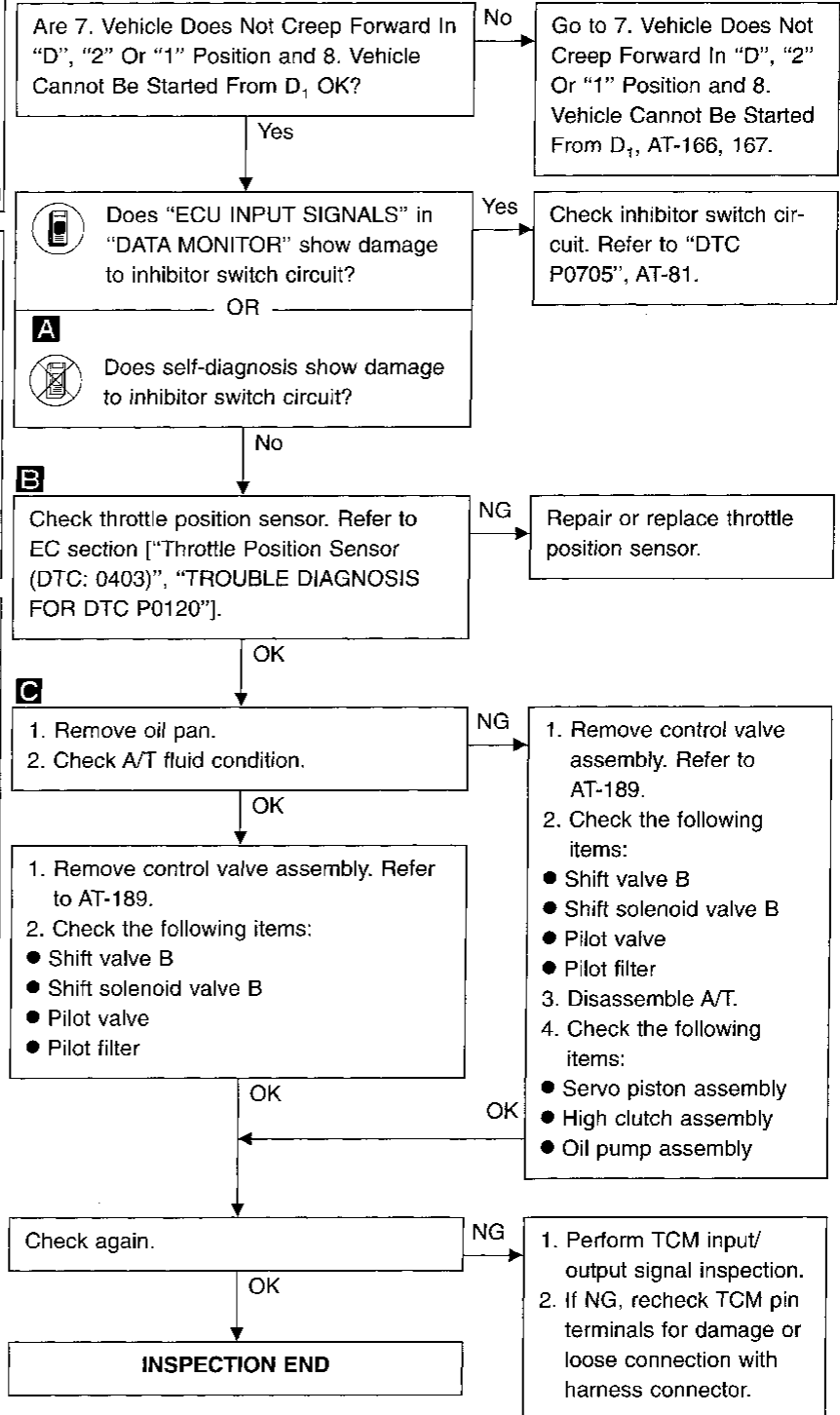

GI
MA
EM
LC
EC
FE
CL
MT
AT
FA
RA
BR
ST
RS
BT
HA
EL
IDX

TROUBLE DIAGNOSIS FOR SYMPTOMS

11. A/T Does Not Shift: D₃ → D₄

SYMPTOM:

- A/T does not shift from D₃ to D₄ at the specified speed.
- A/T must be warm before D₃ to D₄ shift will occur.

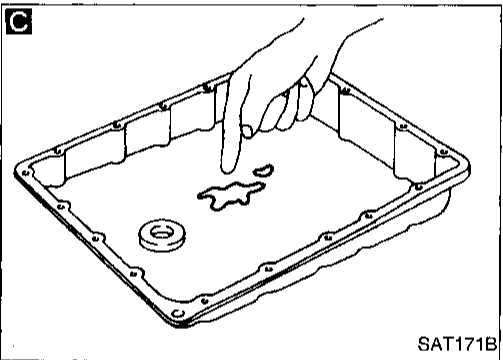
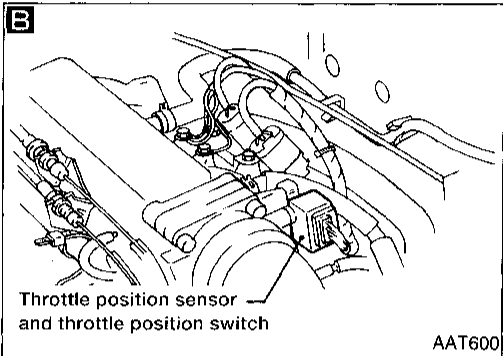
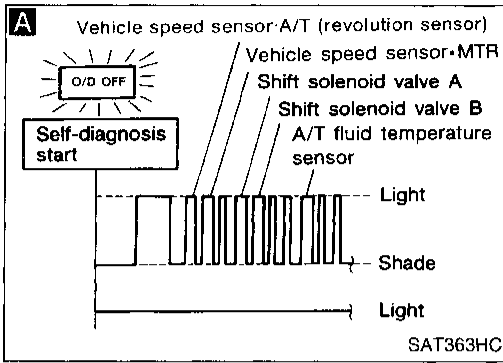

Are 7. Vehicle Does Not Creep Forward In "D", "2" Or "1" Position and 8. Vehicle Cannot Be Started From D₁ OK?

No → Go to 7. Vehicle Does Not Creep Forward In "D", "2" Or "1" Position and 8. Vehicle Cannot Be Started From D₁, AT-166, 167.

A Does self-diagnosis, after cruise test, show damage to any of the following circuits?

- Inhibitor switch
- Overdrive control switch
- A/T fluid temperature sensor
- Vehicle speed sensor-A/T (revolution sensor)
- Shift solenoid valve A or B
- Vehicle speed sensor-MTR

Yes → Check damaged circuit. Refer to "DTC P0705, P0710, P0720, P0750, P0755 or VHCL SPEED SEN-MTR", AT-81, 85, 89, 135, 139 or 158.

B Check throttle position sensor. Refer to EC section ["Throttle Position Sensor (DTC: 0403)", "TROUBLE DIAGNOSIS FOR DTC P0120"].

NG → Repair or replace throttle position sensor.

C 1. Remove oil pan.
2. Check A/T fluid condition.

NG → 1. Remove control valve assembly. Refer to AT-189.
2. Check the following items:
● Shift valve B
● Overrun clutch control valve
● Shift solenoid valve B
● Pilot valve
● Pilot filter
3. Disassemble A/T.
4. Check the following items:
● Servo piston assembly
● Brake band
● Torque converter
● Oil pump assembly

1. Remove control valve assembly. Refer to AT-189.
2. Check the following items:
● Shift valve B
● Overrun clutch control valve
● Shift solenoid valve B
● Pilot valve
● Pilot filter

Check again.

NG → 1. Perform TCM input/output signal inspection.
2. If NG, recheck TCM pin terminals for damage or loose connection with harness connector.

INSPECTION END

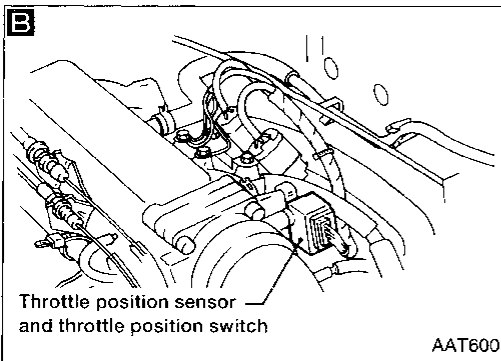
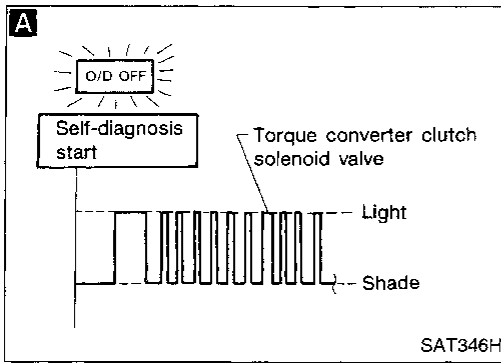

12. A/T Does Not Perform Lock-up

SYMPTOM:

A/T does not perform lock-up at the specified speed.

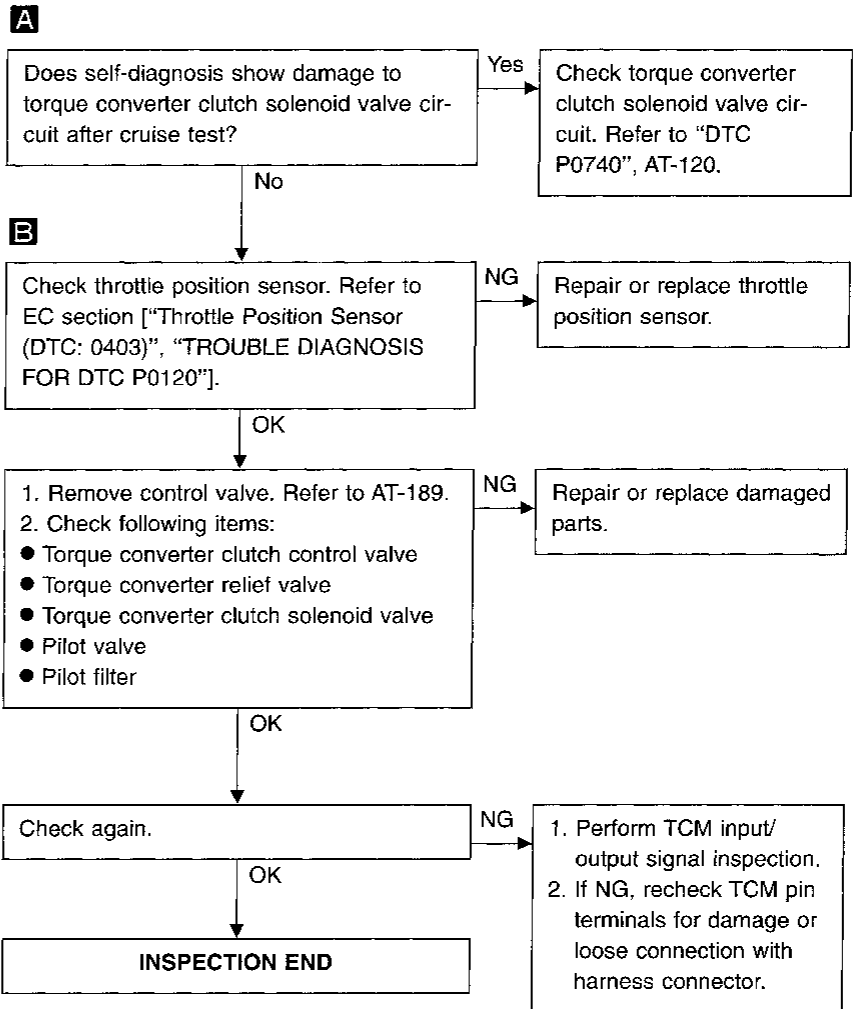

GI
MA
EM
LC
EC
FE
CL
MT
AT
FA
RA
BR
ST
RS
BT
HA
EL
IDX

TROUBLE DIAGNOSIS FOR SYMPTOMS

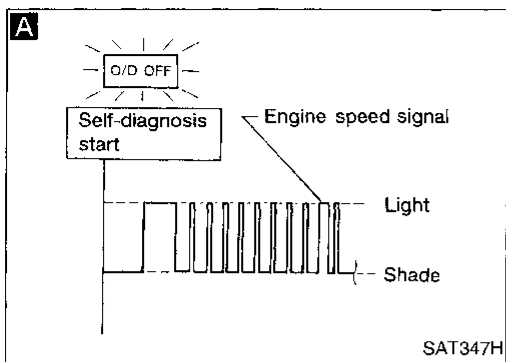

13. A/T Does Not Hold Lock-up Condition

SYMPTOM:

A/T does not hold lock-up condition for more than 30 seconds.

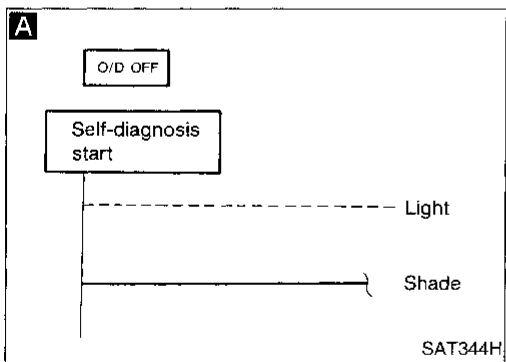
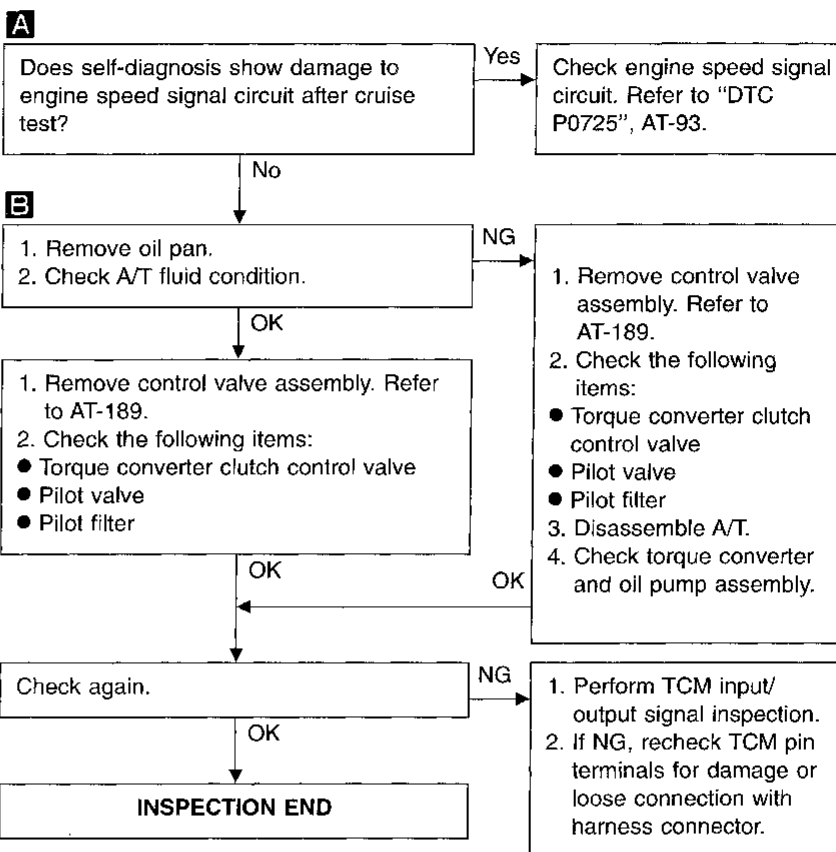
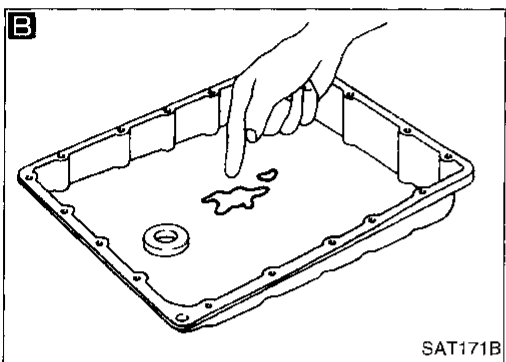

14. Lock-up Is Not Released

SYMPTOM:

Lock-up is not released when accelerator pedal is released.

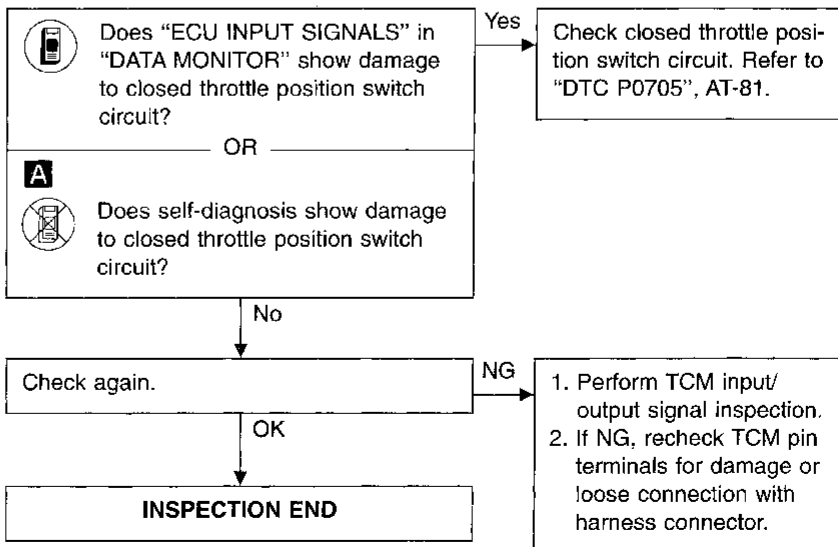

TROUBLE DIAGNOSIS FOR SYMPTOMS

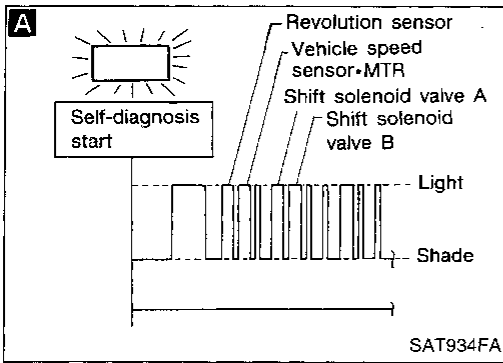

16. Vehicle Does Not Start From D₁

SYMPTOM:

Vehicle does not start from D₁ on Cruise test — Part 2.

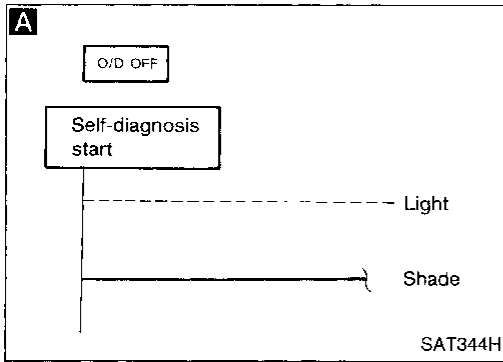
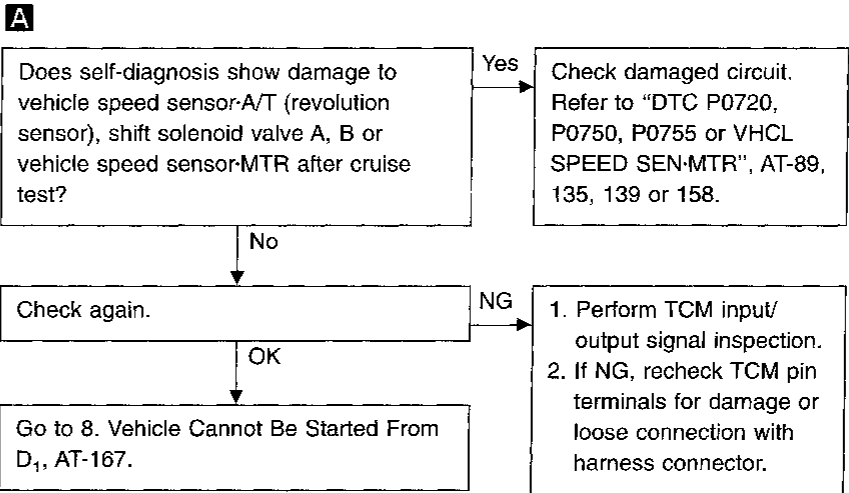

17. A/T Does Not Shift: D₄ → D₃, When Overdrive Control Switch "ON" → "OFF"

SYMPTOM:

A/T does not shift from D₄ to D₃ when changing overdrive control switch to "OFF" position.

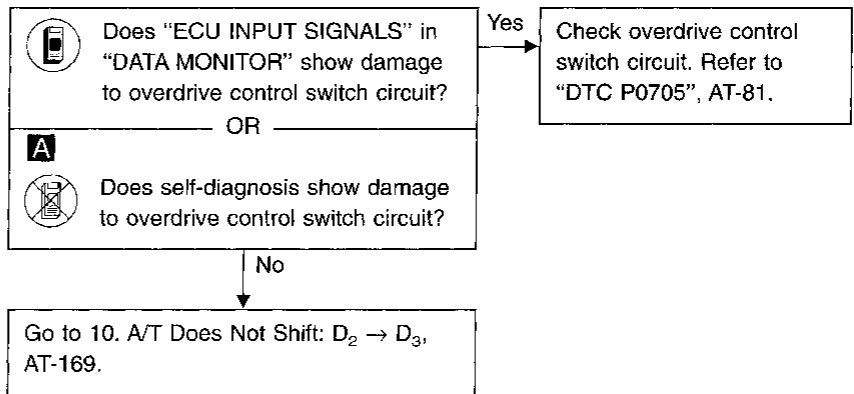

TROUBLE DIAGNOSIS FOR SYMPTOMS

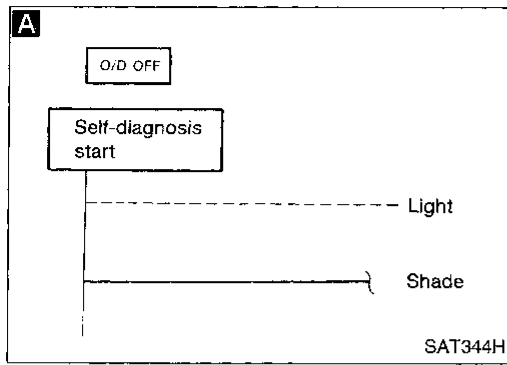

18. A/T Does Not Shift: D₃ → 2₂, When Selector Lever "D" → "2" Position

SYMPTOM:

A/T does not shift from D₃ to 2₂ when changing selector lever from "D" to "2" position.

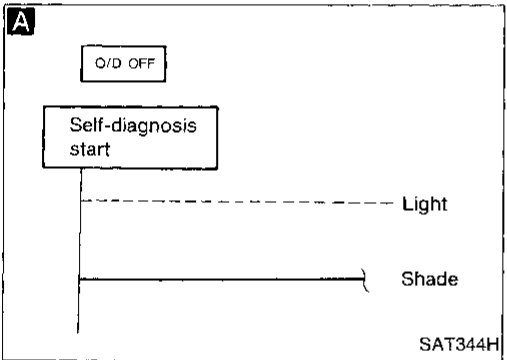
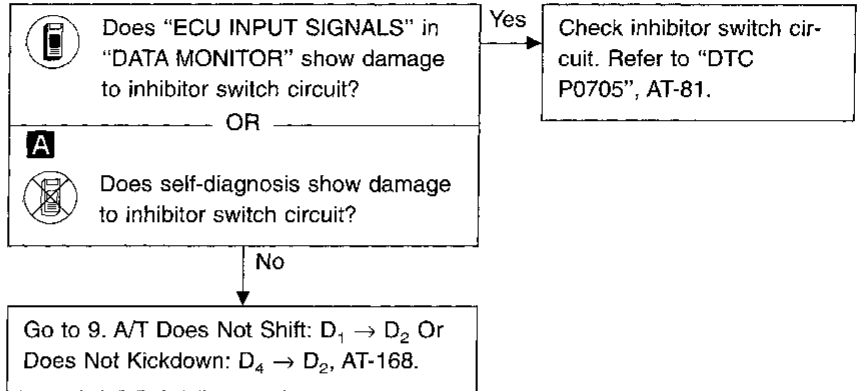

19. A/T Does Not Shift: 2₂ → 1₁, When Selector Lever "2" → "1" Position

SYMPTOM:

A/T does not shift from 2₂ to 1₁ when changing selector lever from "2" to "1" position.

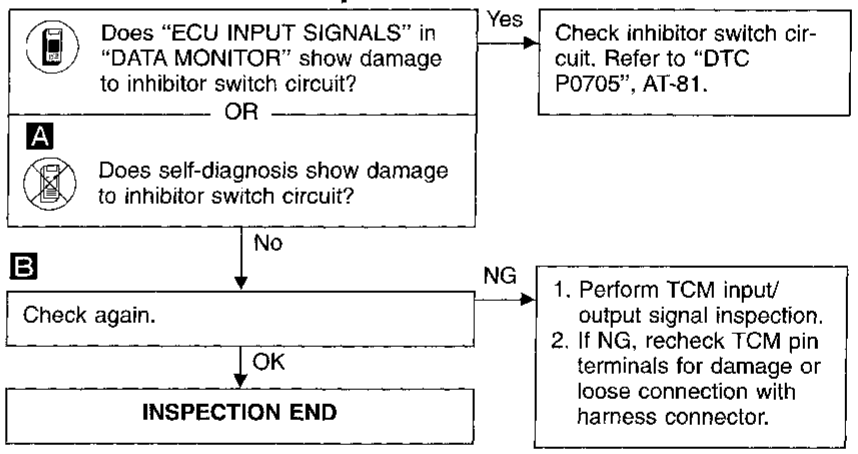
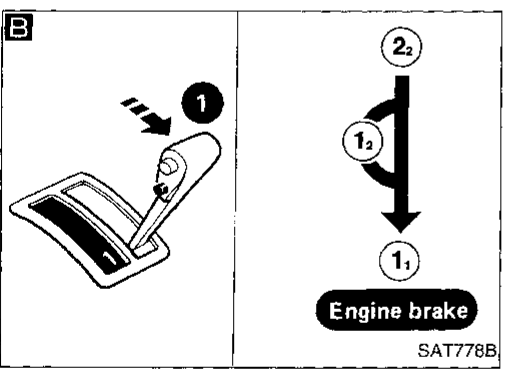

GI
MA
EM
LC
EC
FE
CL
MT
AT
FA
RA
BR
ST
RS
BT
HA
EL
IDX

TROUBLE DIAGNOSIS FOR SYMPTOMS

20. Vehicle Does Not Decelerate By Engine Brake

SYMPTOM:

Vehicle does not decelerate by engine brake when shifting from 2₂ (1₂) to 1₁.

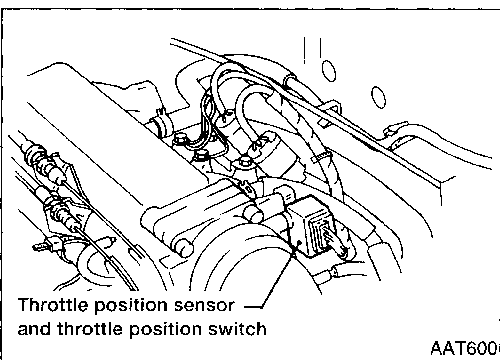
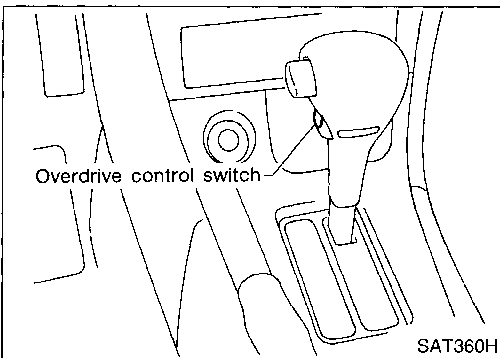
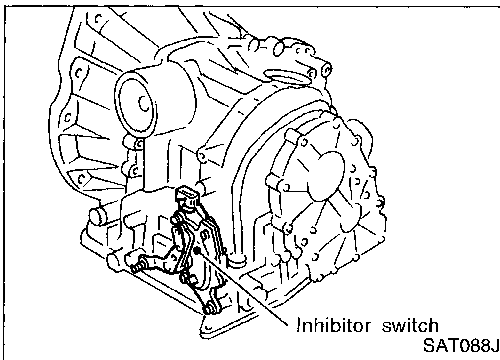
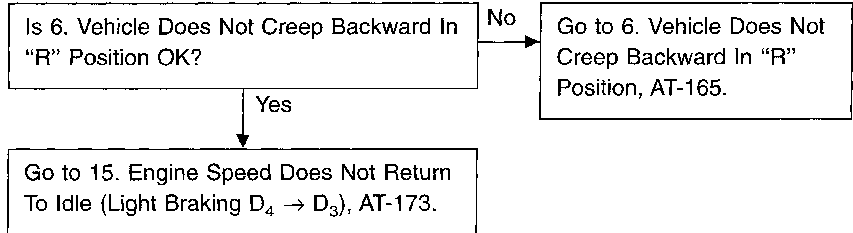

21. TCM Self-diagnosis Does Not Activate (Inhibitor, Overdrive Control and Throttle Position Switch Circuit Checks)

SYMPTOM:

O/D OFF indicator lamp does not come on in TCM self-diagnostic procedure even if the lamp circuit is good.

DESCRIPTION

- Inhibitor switch
Detects the selector lever position and sends a signal to the TCM.
- Overdrive control switch
Detects the overdrive control switch position (ON or OFF) and sends a signal to the TCM.
- Throttle position switch
Consists of a wide open throttle position switch and a closed throttle position switch.
The wide open throttle position switch sends a signal to the TCM when the throttle valve is open at least 1/2 of the full throttle position. The closed throttle position switch sends a signal to the TCM when the throttle valve is fully closed.

TROUBLE DIAGNOSIS FOR SYMPTOMS

21. TCM Self-diagnosis Does Not Activate (Inhibitor, Overdrive Control and Throttle Position Switch Circuit Checks) (Cont'd)

A

☆ MONITOR	☆ NO FAIL	<input checked="" type="checkbox"/>
VHCL/S SE-A/T	0km/h	
VHCL/S SE-MTR	5km/h	
THRTL POS SEN	0.4V	
FLUID TEMP SE	1.2V	
BATTERY VOLT	13.4V	
ENGINE SPEED	1024rpm	
OVERDRIVE SW	O N	
P/N POSI SW	O N	
R POSITION SW	OFF	

RECORD

SAT076H

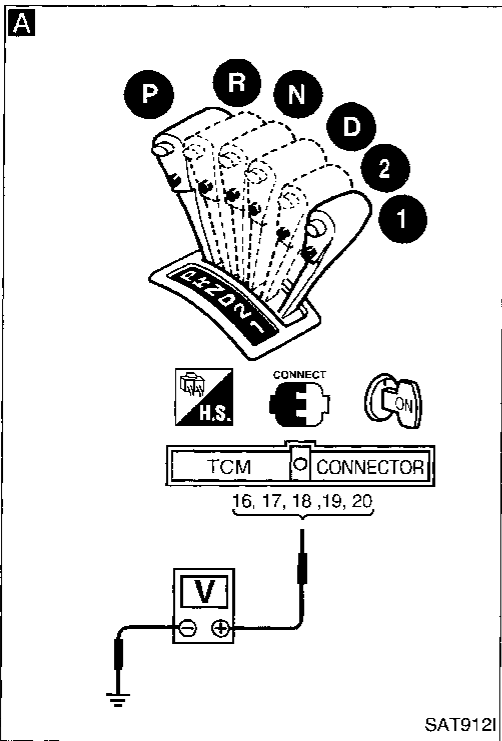

DIAGNOSTIC PROCEDURE

A

CHECK INHIBITOR SWITCH CIRCUIT.

1. Turn ignition switch to "ON" position. (Do not start engine.)
 2. Select "ECU INPUT SIGNALS" in "DATA MONITOR" mode for "A/T" with CONSULT.
 3. Read out "P/N", "R", "D", "2" and "1" position switches moving selector lever to each position.
- Check that the signal of the selector lever position is indicated properly.

- NG → Check the following items:
- Inhibitor switch (Refer to "Component Inspection", AT-180.)
 - Harness for short or open between ignition switch and inhibitor switch (Main harness)
 - Harness for short or open between inhibitor switch and TCM (Main harness)

OR

1. Turn ignition switch to "ON" position. (Do not start engine.)
2. Check voltage between TCM terminals 16, 17, 18, 19, 20 and ground while moving selector lever through each position.

Voltage:

B: Battery voltage
0: 0V

Lever position	Terminal No.				
	19	20	18	17	16
P, N	B	0	0	0	0
R	0	B	0	0	0
D	0	0	B	0	0
2	0	0	0	B	0
1	0	0	0	0	B

OK

A

(Go to next page.)

GI

MA

EM

LC

EC

FE

CL

MT

AT

FA

RA

BR

ST

RS

BT

HA

EL

IDX

TROUBLE DIAGNOSIS FOR SYMPTOMS

21. TCM Self-diagnosis Does Not Activate (Inhibitor, Overdrive Control and Throttle Position Switch Circuit Checks) (Cont'd)

B

☆ MONITOR	☆ NO FAIL	<input type="checkbox"/>
VHCL/S SE-A/T	0km/h	
VHCL/S SE-MTR	5km/h	
THRTL POS SEN	0.4V	
FLUID TEMP SE	1.2V	
BATTERY VOLT	13.4V	
ENGINE SPEED	1024rpm	
OVERDRIVE SW	O N	
P/N POSI SW	O N	
R POSITION SW	OFF	

RECORD

SAT076H

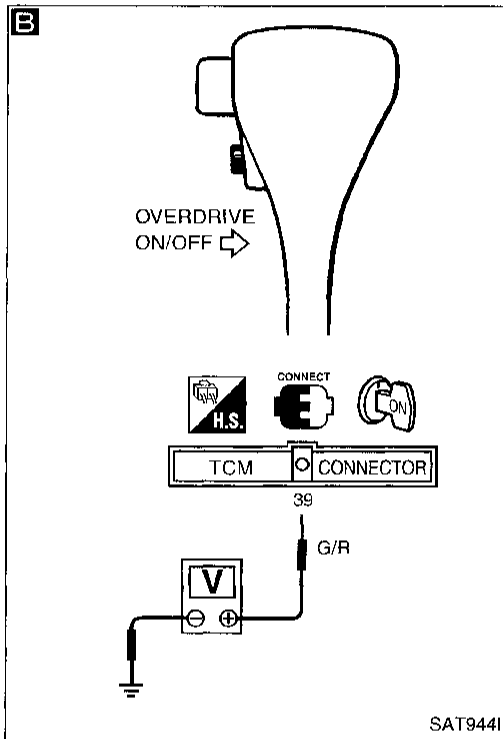

B

CHECK OVERDRIVE CONTROL SWITCH CIRCUIT.



1. Turn ignition switch to "ON" position.
(Do not start engine.)
2. Select "ECU INPUT SIGNALS" in "DATA MONITOR" mode for "A/T" with CONSULT.
3. Read out "OVERDRIVE SWITCH".
Check the signal of the overdrive control switch is indicated properly.
(Overdrive control switch "ON" displayed on CONSULT means overdrive "OFF".)

OR



1. Turn ignition switch to "ON" position.
(Do not start engine.)
2. Check voltage between TCM terminal (39) and ground when overdrive control switch is "ON" and "OFF".

Switch position	Voltage
ON	Battery voltage
OFF	1V or less

NG

- Check the following items:
- Overdrive control switch (Refer to "Component Inspection", AT-180.)
 - Harness for short or open between TCM and overdrive control switch (Main harness)
 - Harness of ground circuit for overdrive control switch (Main harness) for short or open

OK

B

(Go to next page.)

TROUBLE DIAGNOSIS FOR SYMPTOMS

21. TCM Self-diagnosis Does Not Activate (Inhibitor, Overdrive Control and Throttle Position Switch Circuit Checks) (Cont'd)

C

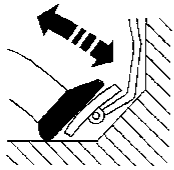

☆ MONITOR	☆ NO FAIL	↕
D POSITION SW	OFF	
2 POSITION SW	OFF	
1 POSITION SW	OFF	
ASCD • CRUISE	OFF	
ASCD • OD CUT	OFF	
KICKDOWN SW	OFF	
POWERSHIFT SW	OFF	
CLOSED THL/SW	ON	
W/O THRL/P-SW	OFF	

RECORD

SAT963H

C

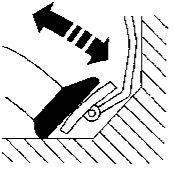
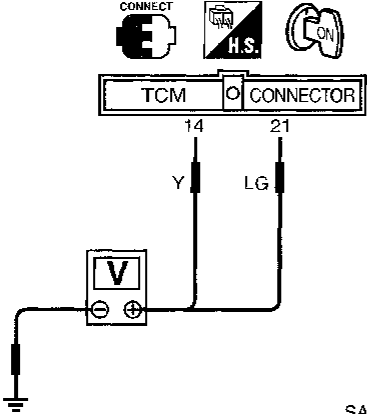
CONNECT H.S. ON

TCM CONNECTOR

14 21

Y LG

V

SAT945I

B

C

CHECK THROTTLE POSITION SWITCH CIRCUIT.

- Turn ignition switch to "ON" position. (Do not start engine.)
- Select "ECU INPUT SIGNALS" in "DATA MONITOR" mode for "A/T" with CONSULT.
- Read out "CLOSED THL/SW" and "W/O THRL/P-SW" depressing and releasing accelerator pedal. Check the signal of throttle position switch is indicated properly.

NG

Check the following items:

- Throttle position switch — Refer to "Component Inspection", AT-181.
- Harness for short or open between ignition switch and throttle position switch (Main harness)
- Harness for short or open between throttle position switch and TCM (Main harness)

Accelerator pedal condition	Data monitor	
	CLOSED THL/SW	W/O THRL/P-SW
Released	ON	OFF
Fully depressed	OFF	ON

OR

- Turn ignition switch to "ON" position. (Do not start engine.)
- Check voltage between TCM terminals (14), (21) and ground while depressing, and releasing accelerator pedal slowly. (After warming up engine)

Accelerator pedal condition	Voltage	
	Terminal No. (14)	Terminal No. (21)
Released	Battery voltage	1V or less
Fully depressed	1V or less	Battery voltage

OK

Perform self-diagnosis again after driving for a while.

OK

INSPECTION END

NG

- Perform TCM input/output signal inspection.
- If NG, recheck TCM pin terminals for damage or loose connection with harness connector.

GI

MA

EM

LC

EC

FE

CL

MT

AT

FA

RA

BR

ST

RS

BT

HA

EL

IDX

TROUBLE DIAGNOSIS FOR SYMPTOMS

21. TCM Self-diagnosis Does Not Activate (Inhibitor, Overdrive Control and Throttle Position Switch Circuit Checks) (Cont'd)

COMPONENT INSPECTION

Overdrive control switch

- Check continuity between two terminals.

Switch position	Continuity
ON	No
OFF	Yes

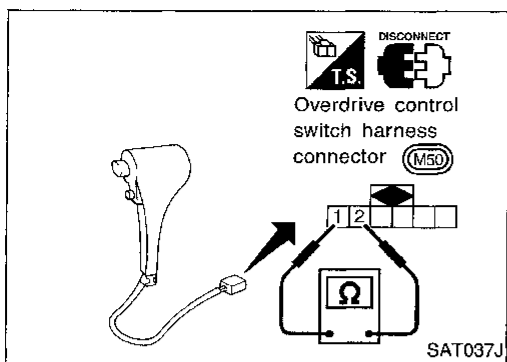

Inhibitor switch

1. Check continuity between terminals ① and ② and between terminals ③ and ④, ⑤, ⑥, ⑦, ⑧, ⑨ while moving manual shaft through each position.

Lever position	Terminal No.	
P	③ — ④	① — ②
R	③ — ⑤	
N	③ — ⑥	① — ②
D	③ — ⑦	
2	③ — ⑧	
1	③ — ⑨	

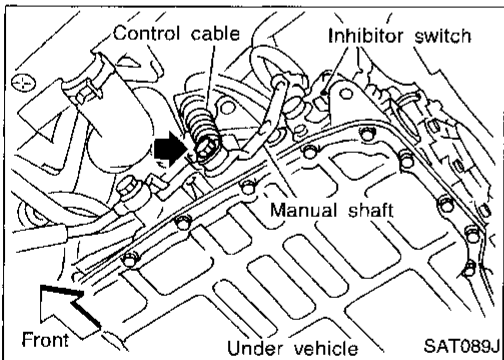
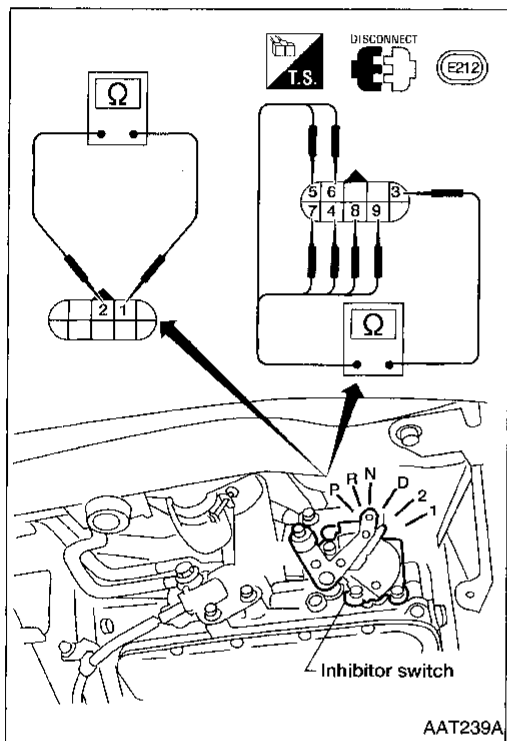

2. If NG, check again with manual control cable disconnected from manual shaft of A/T assembly. Refer to step 1.
3. If OK on step 2, adjust manual control cable. Refer to AT-190.
4. If NG on step 2, remove inhibitor switch from A/T and check continuity of inhibitor switch terminals. Refer to step 1.
5. If OK on step 4, adjust inhibitor switch. Refer to AT-190.
6. If NG on step 4, replace inhibitor switch.

TROUBLE DIAGNOSIS FOR SYMPTOMS

21. TCM Self-diagnosis Does Not Activate (Inhibitor, Overdrive Control and Throttle Position Switch Circuit Checks) (Cont'd)

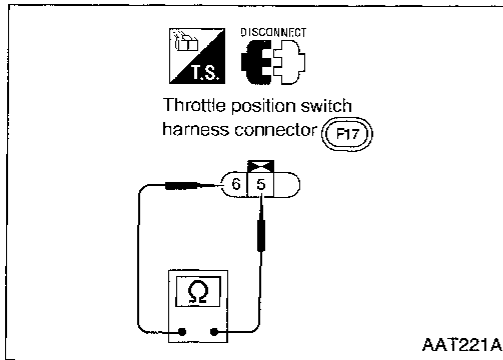

Throttle position switch

Closed throttle position switch (idle position)

- Check continuity between terminals ⑤ and ⑥.

Accelerator pedal condition	Continuity
Released	Yes
Depressed	No

- To adjust closed throttle position switch, refer to EC section ("Basic Inspection", "TROUBLE DIAGNOSIS — Basic Inspection").

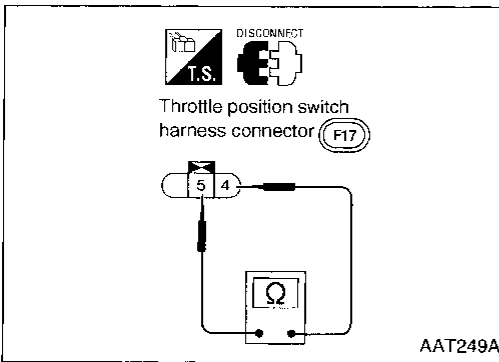

Wide open throttle position switch

- Check continuity between terminals ④ and ⑤.

Accelerator pedal condition	Continuity
Released	No
Depressed	Yes

GI

MA

EM

LC

EC

FE

CL

MT

AT

FA

RA

BR

ST

RS

BT

HA

EL

IDX

TROUBLE DIAGNOSES — A/T Shift Lock System

Description

- The mechanical key interlock mechanism also operates as a shift lock:
With the key switch turned to ON, the selector lever cannot be shifted from "P" (parking) to any other position unless the brake pedal is depressed.
With the key removed, the selector lever cannot be shifted from "P" to any other position.
The key cannot be removed unless the selector lever is placed in "P".
- The shift lock and key interlock mechanisms are controlled by the ON-OFF operation of the shift lock solenoid and by the operation of the rotator and slider located inside the key cylinder.

Shift Lock System Electrical Parts Location

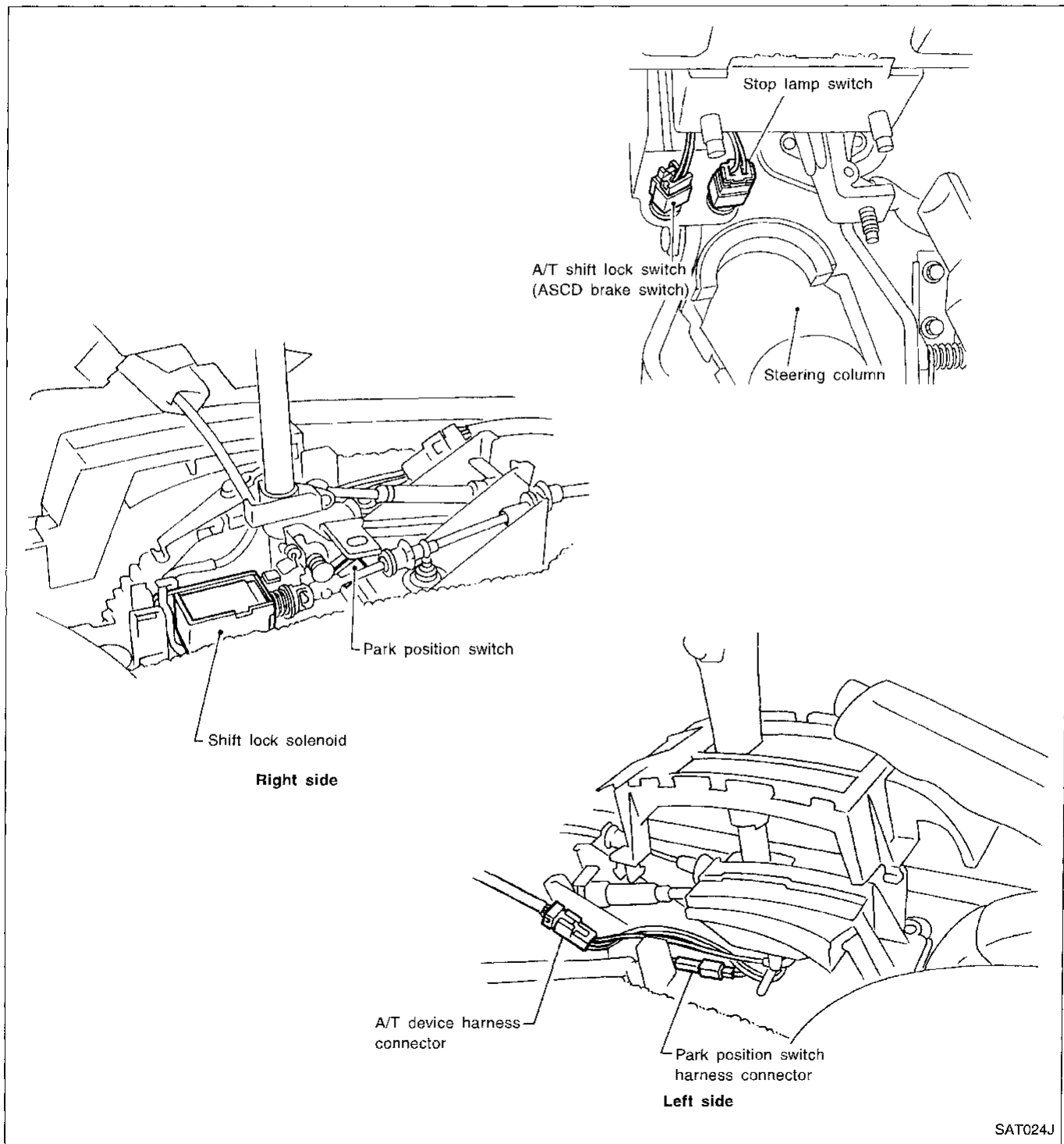

SAT024J

Wiring Diagram —SHIFT—

AT-SHIFT-01

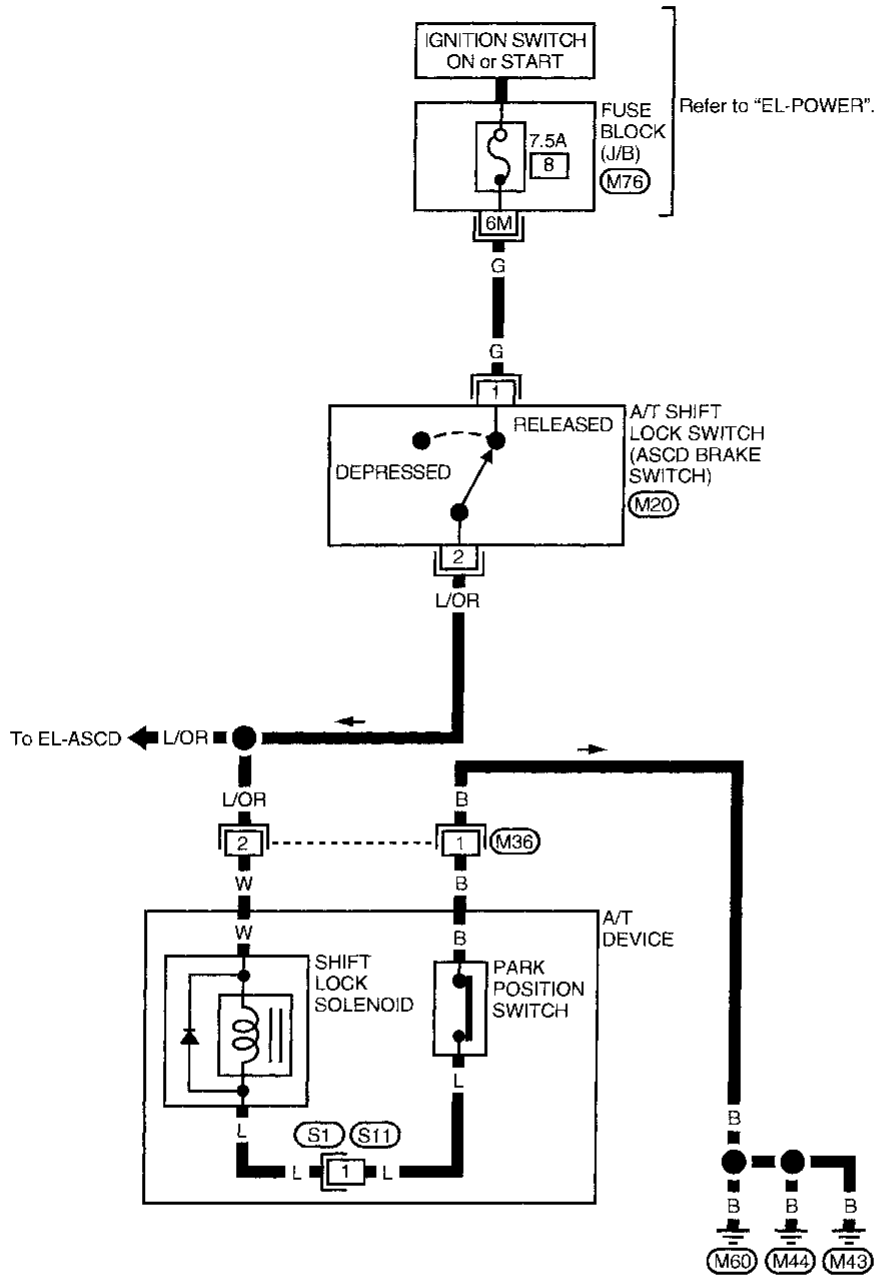

GI
MA
EM
LC
EC
FE
CL
MT
AT
FA
RA
BR
ST
RS
BT
HA
EL
IDX

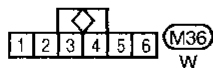

* This connector is not shown in "HARNESS LAYOUT" of EL section.

Diagnostic Procedure

SYMPTOM 1:

- Selector lever cannot be moved from “P” position with key in ON position and brake pedal applied.
- Selector lever can be moved from “P” position with key in ON position and brake pedal released.
- Selector lever can be moved from “P” position when key is removed from key cylinder.

SYMPTOM 2:

Ignition key cannot be removed when selector lever is set to “P” position. It can be removed when selector lever is set to any position except “P”.

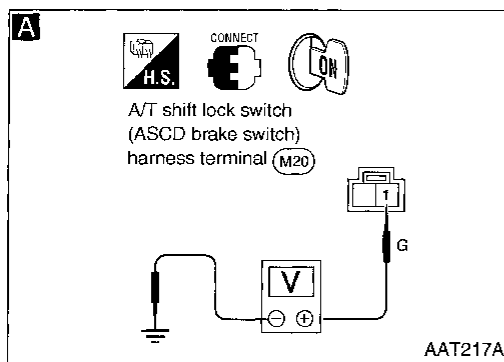
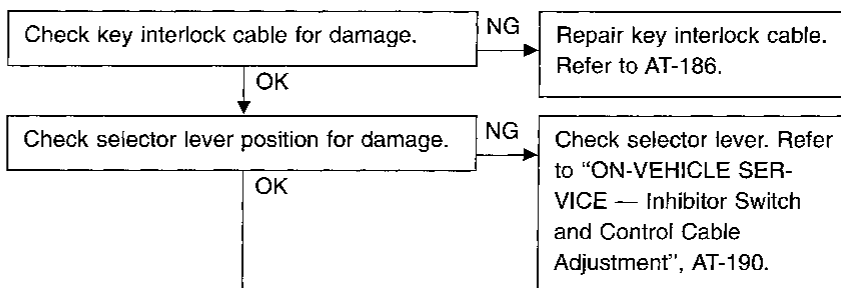

A

CHECK POWER SOURCE.

1. Turn ignition switch to “ON” position. (Do not start engine.)
2. Check voltage between A/T shift lock switch (ASC D brake switch) harness terminal ① and ground.

Voltage: Battery voltage.

NG

Check the following items:

- Harness for short or open between battery and A/T shift lock switch (ASC D brake switch) harness terminal ①

2. Fuse
3. Ignition switch (Refer to EL section.)

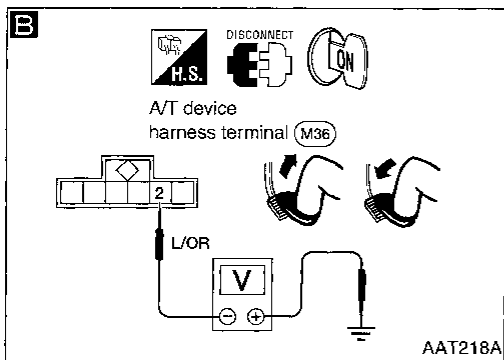

B

CHECK INPUT SIGNAL [A/T SHIFT LOCK SWITCH (ASC D brake switch)].

1. Turn ignition switch to “ON” position. (Do not start engine.)

- Check voltage between A/T device harness terminal ② and ground.

Brake pedal	Voltage
Depressed	0V
Released	Battery voltage

NG

Check the following items:

1. Harness for short or open between A/T device harness connector ② and A/T shift lock switch (ASC D brake switch) harness connector ②
2. A/T shift lock switch (ASC D brake switch) (Refer to “Component Check”, AT-188.)

OK

Ⓐ

(Go to next page.)

TROUBLE DIAGNOSES — A/T Shift Lock System

Diagnostic Procedure (Cont'd)

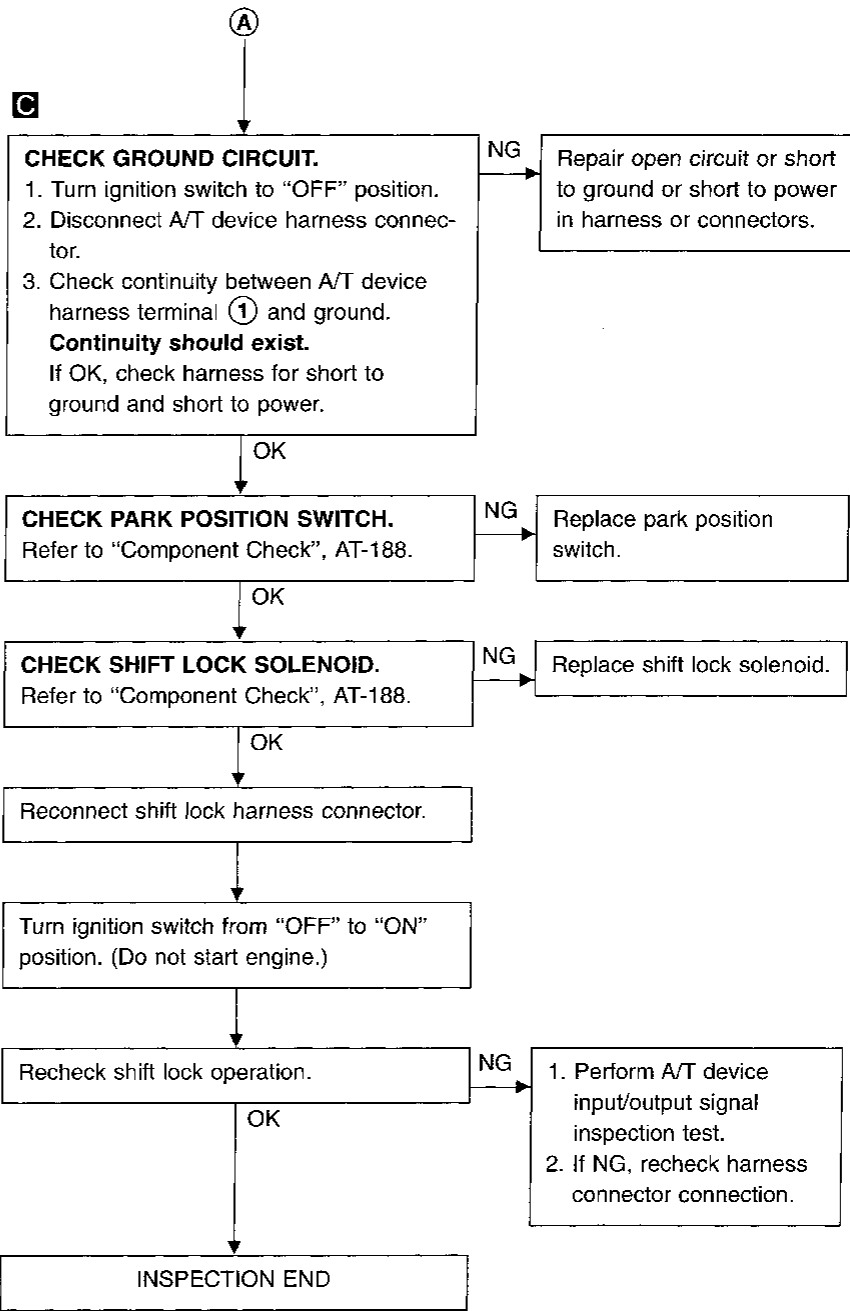
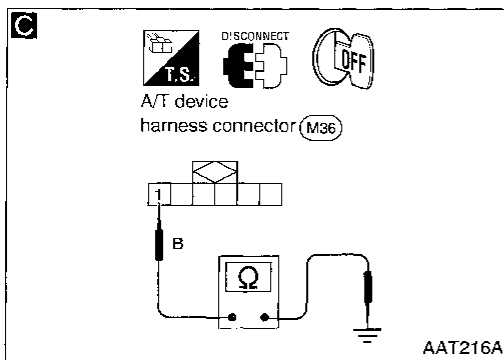

GI
MA
EM
LC
EC
FE
CL
MT
AT
FA
RA
BR
ST
RS
BT
HA
EL
DX

Key Interlock Cable

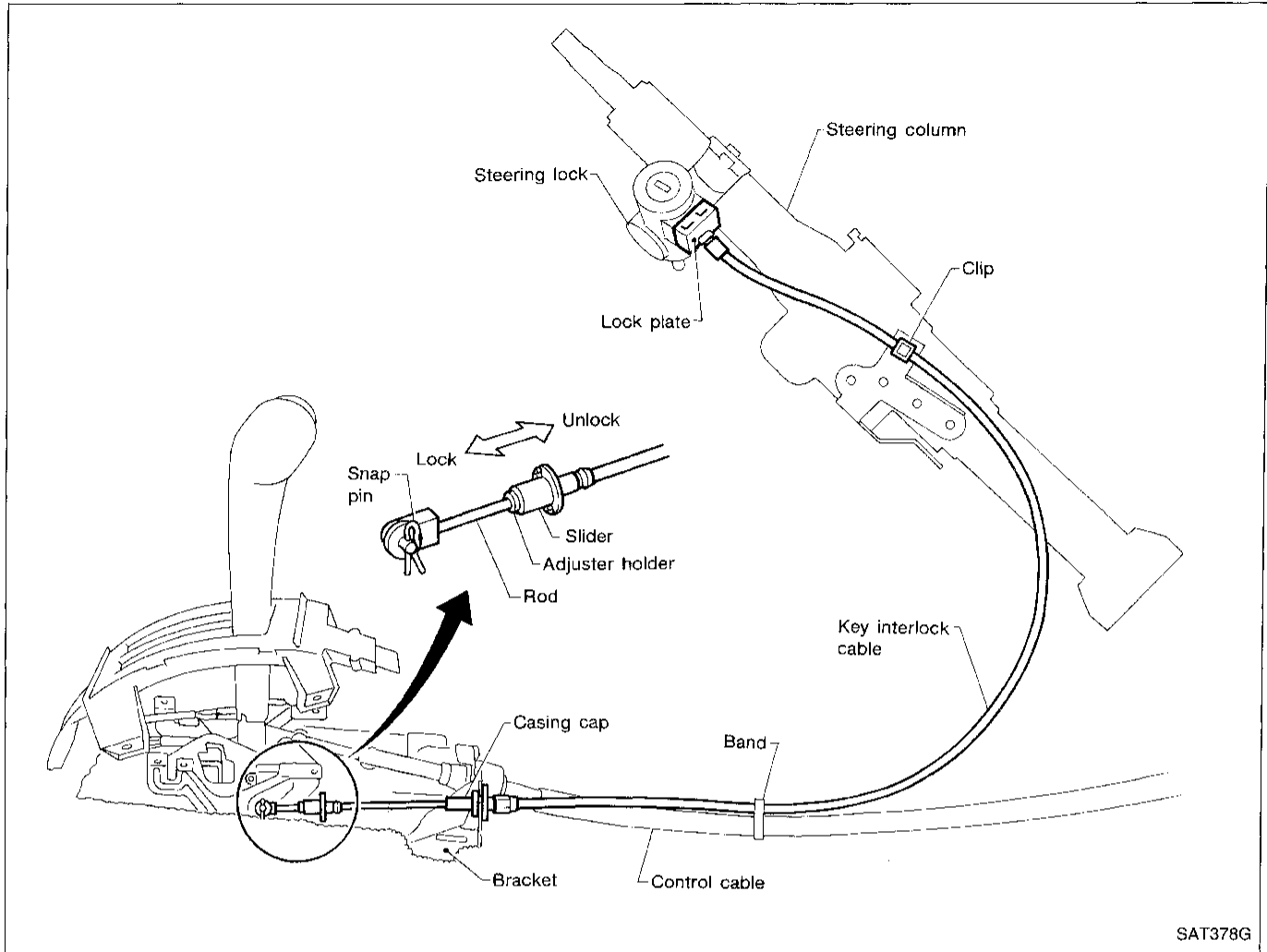

SAT378G

CAUTION:

- Install key interlock cable in such a way that it will not be damaged by sharp bends, twists or interference with adjacent parts.
- After installing key interlock cable to control device, make sure that casing cap and bracket are firmly secured in their positions. If casing cap can be removed with an external load of less than 39.2 N (4.0 kg, 8.8 lb), replace key interlock cable with new one.

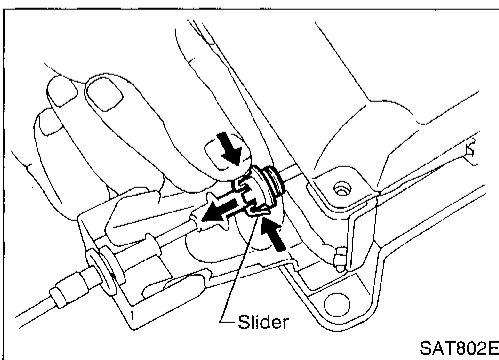

SAT802E

REMOVAL

Unlock slider from adjuster holder and remove rod from cable.

TROUBLE DIAGNOSES — A/T Shift Lock System

Key Interlock Cable (Cont'd)

INSTALLATION

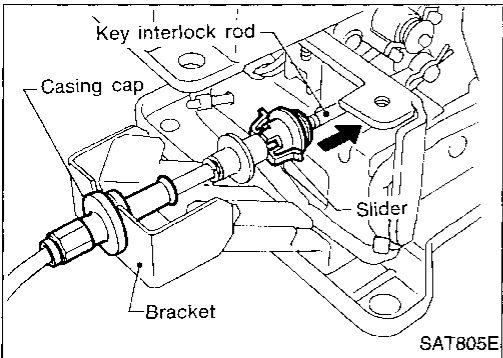
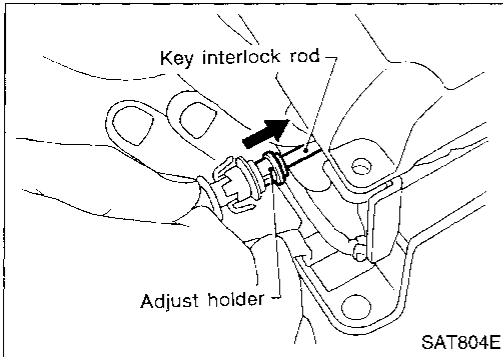
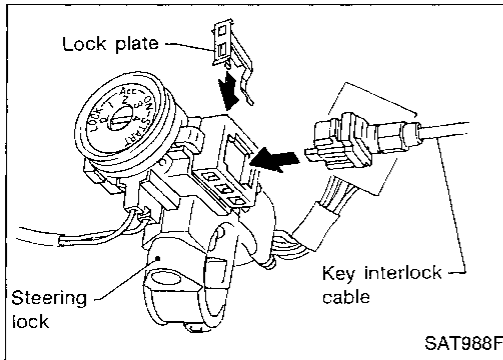

1. Set key interlock cable to steering lock assembly and install lock plate.
2. Clamp cable to steering column and fix to control cable with band.
3. Set control lever to P position.

4. Insert interlock rod into adjuster holder.

5. Install casing cap to bracket.
6. Move slider in order to fix adjuster holder to interlock rod.

GI

MA

EM

LC

EC

FE

CL

MT

AT

FA

RA

BR

ST

RS

BT

HA

EL

IDX

TROUBLE DIAGNOSES — A/T Shift Lock System

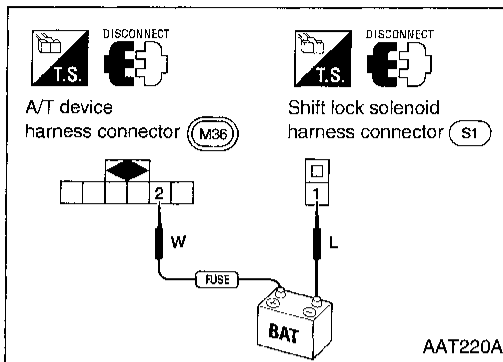

Component Check

SHIFT LOCK SOLENOID

- Check operation by applying battery voltage to A/T device harness terminal ② and shift lock solenoid harness terminal ①.

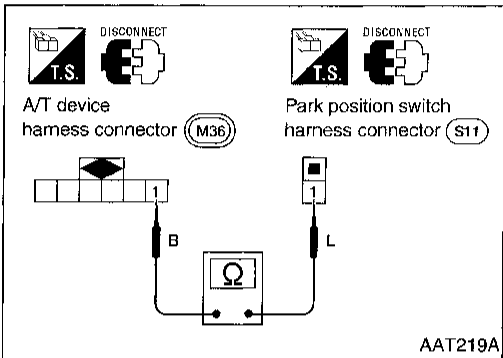

PARK POSITION SWITCH

- Check continuity between A/T device harness terminal ① and park position switch harness terminal ①.

Condition	Continuity
When selector lever is set in "P" position and selector lever button is released	Yes
Except above	No

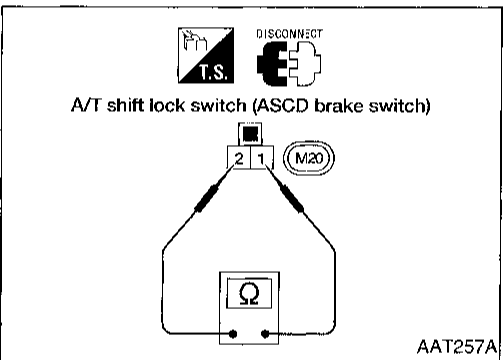

A/T SHIFT LOCK SWITCH (ASCD BRAKE SWITCH)

- Check continuity between terminals ① and ②.

Condition	Continuity
When brake pedal is depressed	No
When brake pedal is released	Yes

Check A/T shift lock switch (ASCD brake switch) after adjusting brake pedal — refer to BR section ("Adjustment", "BRAKE PEDAL AND BRACKET").

Control Valve Assembly and Accumulator

REMOVAL

1. Drain ATF from transaxle.
2. Remove oil pan and gasket.
3. Disconnect A/T solenoid harness connector.
4. Remove stopper ring from A/T solenoid harness terminal body.
5. Remove A/T solenoid harness by pushing terminal body into transmission case.

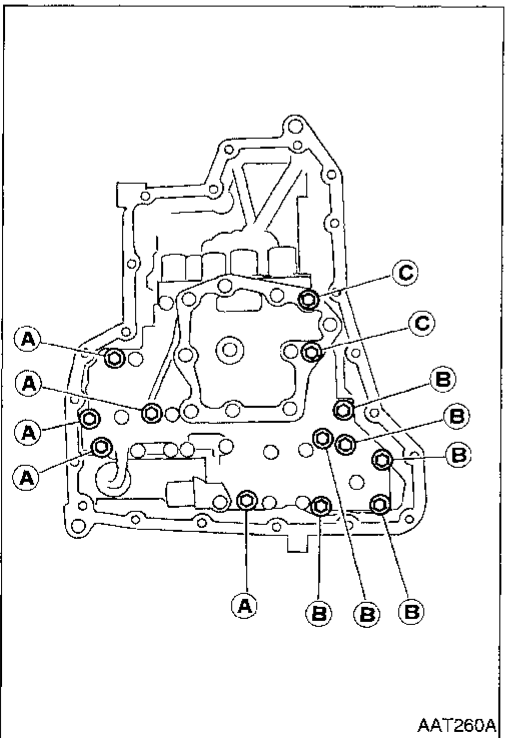
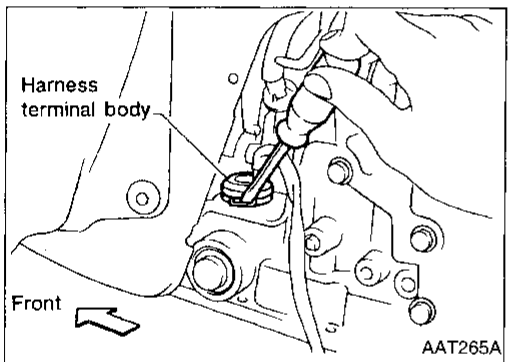
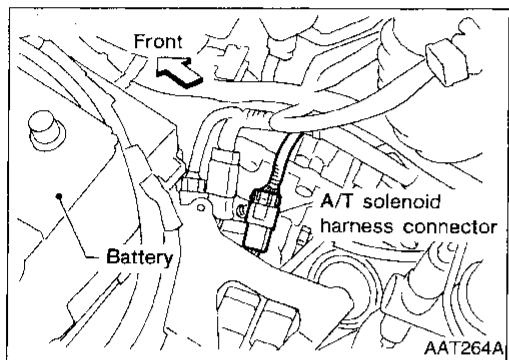
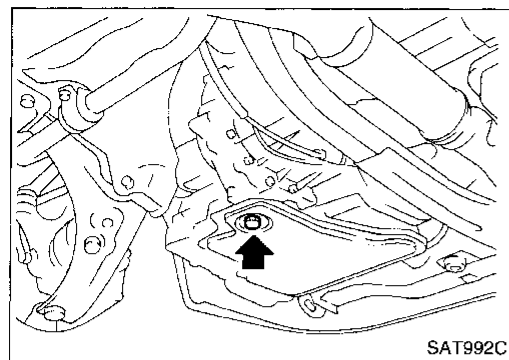

6. Remove control valve assembly by removing fixing bolts.
- Bolt length, number and location:**

Bolt symbol		A	B	C
Bolt length "ℓ"	mm (in)	40.0 (1.575)	33.0 (1.299)	43.5 (1.713)
Number of bolts		5	6	2

- Be careful not to drop manual valve and servo release accumulator return springs.
7. Disassemble and inspect control valve assembly if necessary. Refer to AT-221.

GI

MA

EM

LC

EC

FE

CL

MT

AT

FA

RA

BR

ST

RS

BT

HA

EL

IDX

ON-VEHICLE SERVICE

Control Valve Assembly and Accumulator (Cont'd)

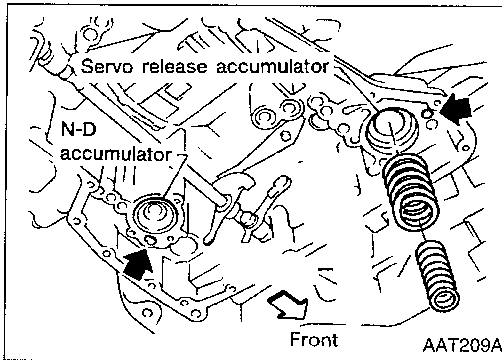

8. Remove servo release and N-D accumulators by applying compressed air if necessary.
 - Hold each piston with a rag.

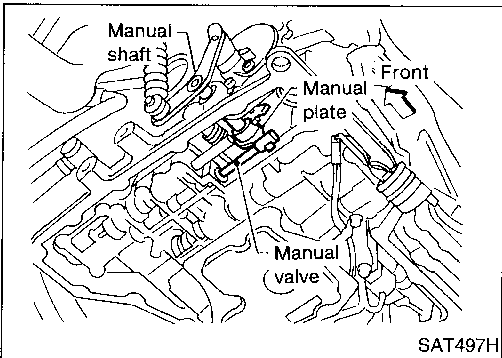

INSTALLATION

- Tighten fixing bolts to specification.
 - Torque : 7 - 9 N·m (0.7 - 0.9 kg·m, 61 - 78 in·lb)
- Set manual shaft in Neutral position, then align manual plate with groove in manual valve.
- After installing control valve assembly to transmission case, make sure that selector lever can be moved to all positions.

Control Cable Adjustment

Move selector lever from the "P" position to the "1" position. You should be able to feel the detents in each position. If the detents cannot be felt or if the pointer indicating the position is improperly aligned, the control cable needs adjustment.

1. Place selector lever in "P" position.
2. Loosen control cable lock nut and place manual shaft in "P" position.
3. Pull control cable, by specified force, in the direction of the arrow shown in the illustration.
 - Specified force: 6.9 N (0.7 kg, 1.5 lb)
4. Return control cable in the opposite direction of the arrow for 1.0 mm (0.039 in).
5. Tighten control cable lock nut.
6. Move selector lever from "P" to "1" position again. Make sure that selector lever moves smoothly.
7. Apply grease to contacting areas of selector lever and control cable. Install any part removed.

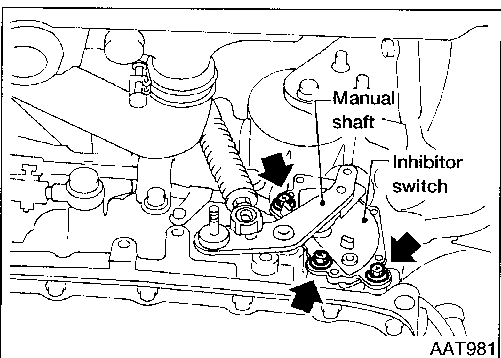
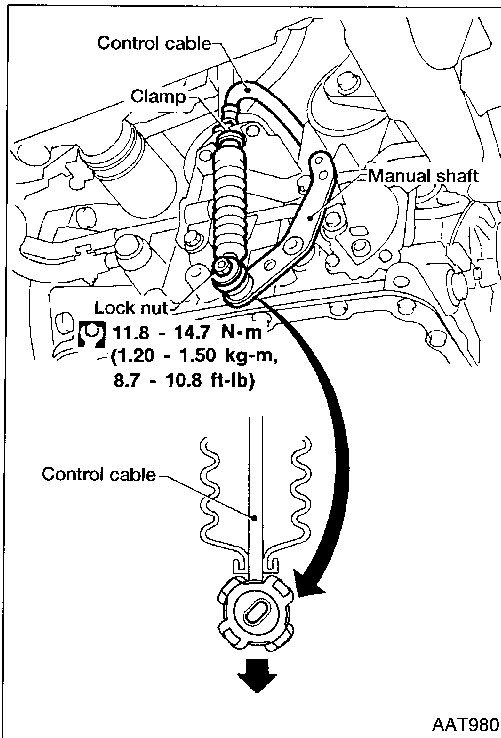

Inhibitor Switch Adjustment

1. Remove control cable end from manual shaft.
2. Set manual shaft in "N" position.
3. Loosen inhibitor switch fixing bolts.

ON-VEHICLE SERVICE

Inhibitor Switch Adjustment (Cont'd)

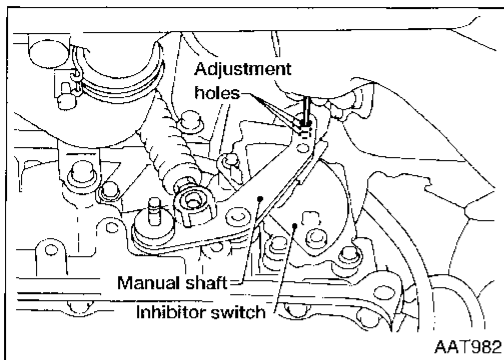

4. Use a 4mm (0.157 in) pin for this adjustment.
 - a) Insert the pin straight into the manual shaft adjustment hole.
 - b) Rotate inhibitor switch until the pin can also be inserted straight into hole in inhibitor switch.
5. Tighten inhibitor switch fixing bolts.
6. Remove pin from adjustment hole after adjusting inhibitor switch.
7. Reinstall any part removed.
8. Adjust control cable. Refer to "Control Cable Adjustment".
9. Check continuity of inhibitor switch. Refer to AT-84.

Differential Side Oil Seal Replacement

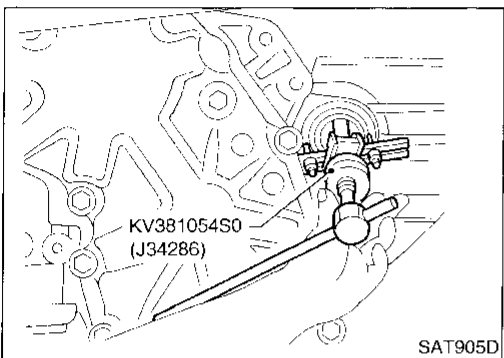

1. Remove drive shaft assemblies. Refer to FA section ("Drive Shaft", "FRONT AXLE").
2. Remove oil seals.

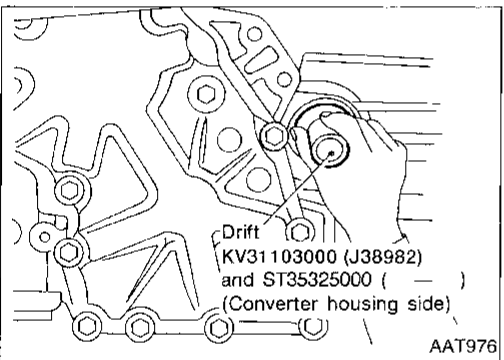

3. Install oil seals.
 - Apply ATF to oil seal surface before installing.

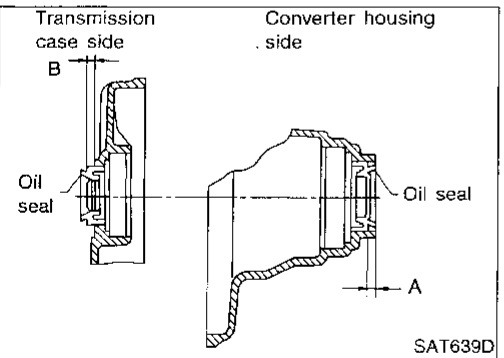

- Install oil seals so that dimensions "A" and "B" are within specifications.

Unit: mm (in)

A	B
5.5 - 6.5 (0.217 - 0.256)	0.5 (0.020) or less

4. Reinstall any part removed.

Revolution Sensor Replacement

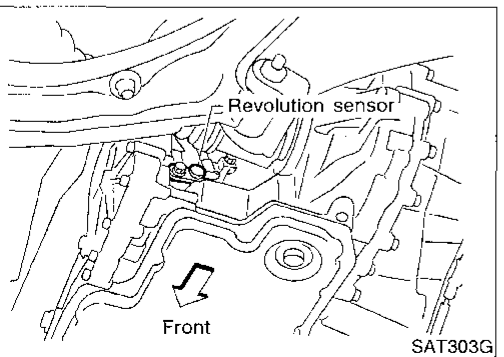

1. Disconnect revolution sensor harness connector.
2. Remove harness bracket from A/T.
3. Remove revolution sensor from A/T.
4. Reinstall any part removed.

Always use new sealing parts.

REMOVAL AND INSTALLATION

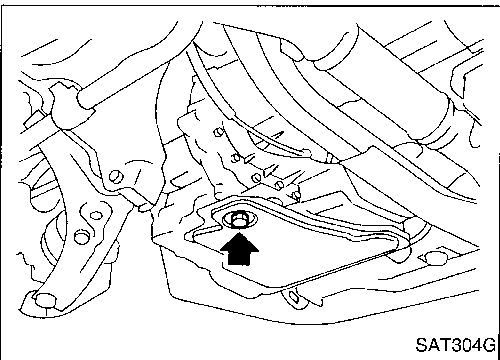
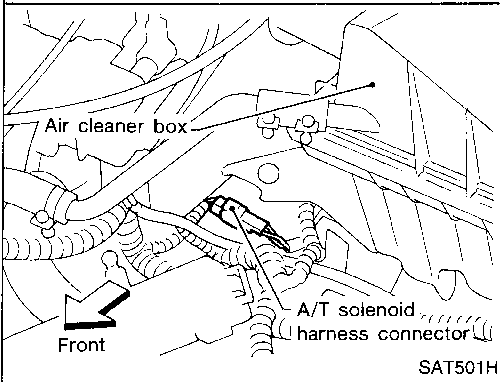
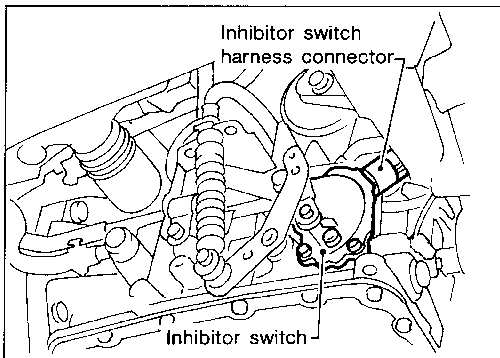

Removal

CAUTION:

Before separating transaxle from engine, remove the crankshaft position sensor (OBD) from transaxle. Be careful not to damage sensor.

1. Remove battery and bracket.
2. Remove air duct between throttle body and air cleaner.
3. Disconnect A/T solenoid harness connector, inhibitor switch harness connector and revolution sensor harness connector.
4. Remove crankshaft position sensor (OBD) from transaxle.

5. Drain ATF from transaxle.
6. Disconnect control cable from transaxle.
7. Disconnect oil cooler hoses.
8. Remove drive shafts. Refer to FA section ("Drive Shaft", "FRONT AXLE").
9. Remove the intake manifold support bracket. Refer to EM section ("SR or GA", "OUTER COMPONENT PARTS").
10. Remove starter motor from transaxle.

Tighten bolts to specified torque.

: 41 - 52 N·m (4.2 - 5.3 kg·m, 30 - 38 ft·lb)

11. Remove upper bolts fixing transaxle to engine.
12. Support transaxle with a jack.

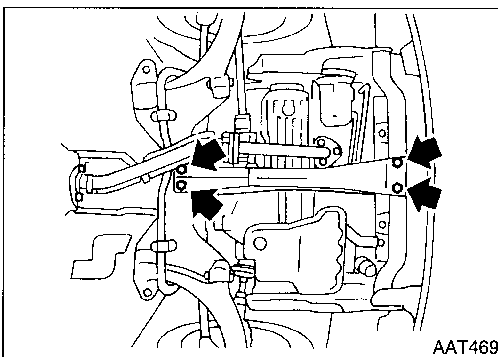

13. Remove center member.
 - Tighten center member fixing bolts to specified torque, Refer to EM section ("ENGINE REMOVAL").

REMOVAL AND INSTALLATION

Removal (Cont'd)

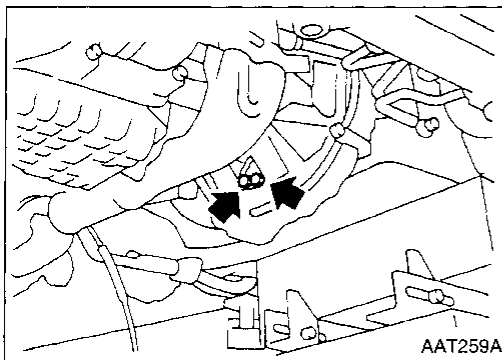

14. Remove rear plate cover.
15. Remove torque converter bolts.
Rotate crankshaft to gain access to securing bolts.
16. Remove rear transaxle to engine bracket. Refer to EM section ("ENGINE REMOVAL").
17. Support engine with a jack.
18. Remove rear transaxle mount. Refer to EM section ("ENGINE REMOVAL").
19. Remove lower bolts fixing transaxle to engine.
20. Lower transaxle with an A/T jack.

GI

MA

EM

LC

EC

FE

CL

MT

AT

FA

RA

BR

ST

RS

BT

HA

EL

IDX

Installation

1. Check drive plate runout.

CAUTION:

Do not allow any magnetic materials to contact the ring gear teeth.

Maximum allowable runout:

Refer to EM section ("Inspection", "CYLINDER BLOCK").

If this runout is out of allowance, replace drive plate with ring gear.

2. When connecting torque converter to transaxle, measure distance "A" to be certain that they are correctly assembled.

Distance "A":

15.9 mm (0.626 in) or more

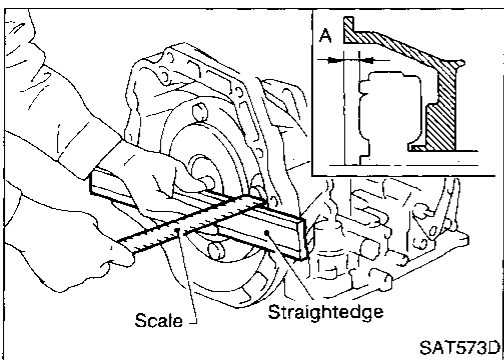
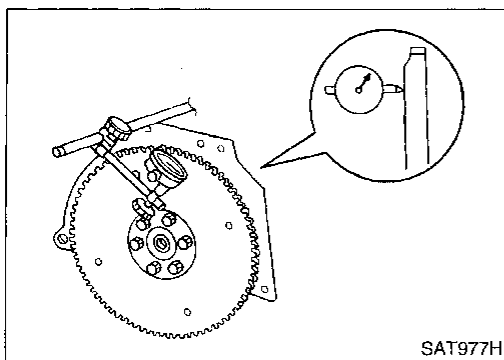

REMOVAL AND INSTALLATION

Installation (Cont'd)

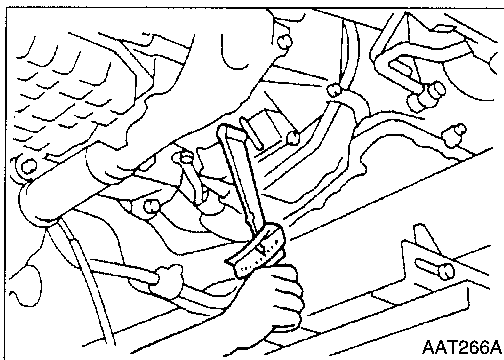

3. Install torque converter to drive plate.
 - **With converter installed, rotate crankshaft several turns to check that transaxle rotates freely without binding.**

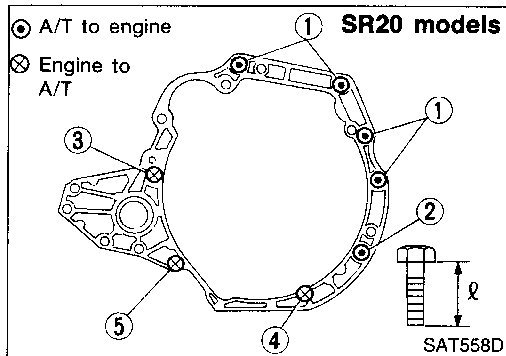

4. Tighten belts fixing transaxle.

Bolt No.	Tightening torque N-m (kg-m, ft-lb)	Bolt length "l" mm (in)
①	70 - 79 (7.1 - 8.1, 51 - 59)	55 (2.17)
②	70 - 79 (7.1 - 8.1, 51 - 59)	50 (1.97)
③	70 - 79 (7.1 - 8.1, 51 - 59)	65 (2.56)
④	16 - 21 (1.6 - 2.1, 12 - 15)	35 (1.38)
⑤	16 - 21 (1.6 - 2.1, 12 - 15)	45 (1.77)

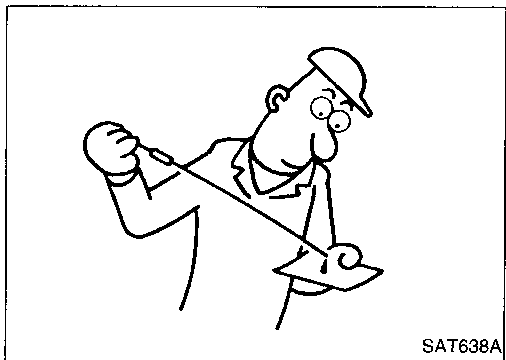

5. Reinstall any part removed.
6. Adjust control cable. Refer to AT-190.
7. Check continuity of inhibitor switch. Refer to AT-84.
8. Refill transaxle with ATF and check fluid level.
9. Move selector lever through all positions to be sure that transaxle operates correctly. With parking brake applied, idle engine. Move selector lever through "N" to "D", to "2", to "1" and "R" positions. A slight shock should be felt through the hand gripping the selector each time the transaxle is shifted.
10. Perform road test. Refer to AT-62.

MAJOR OVERHAUL

Locations of Adjusting Shims, Needle Bearings, Thrust Washers and Snap Rings

Outer diameter and color of thrust washers

Item number	Outer diameter mm (in)	Color
17	72.0 (2.835)	Black
18	78.5 (3.091)	

Outer & inner diameter of needle bearings

Item number	Outer diameter mm (in)	Inner diameter mm (in)
8	47.0 (1.850)	32.0 (1.260)
9	35.0 (1.378)	20.0 (0.787)
10	60.0 (2.362)	42.0 (1.654)
11	60.0 (2.362)	45.0 (1.772)
12	47.0 (1.850)	30.0 (1.181)
13	42.6 (1.677)	26.0 (1.024)
14	48.0 (1.890)	33.5 (1.319)
15	55.0 (2.165)	40.5 (1.594)
16	60.0 (2.362)	40.0 (1.575)

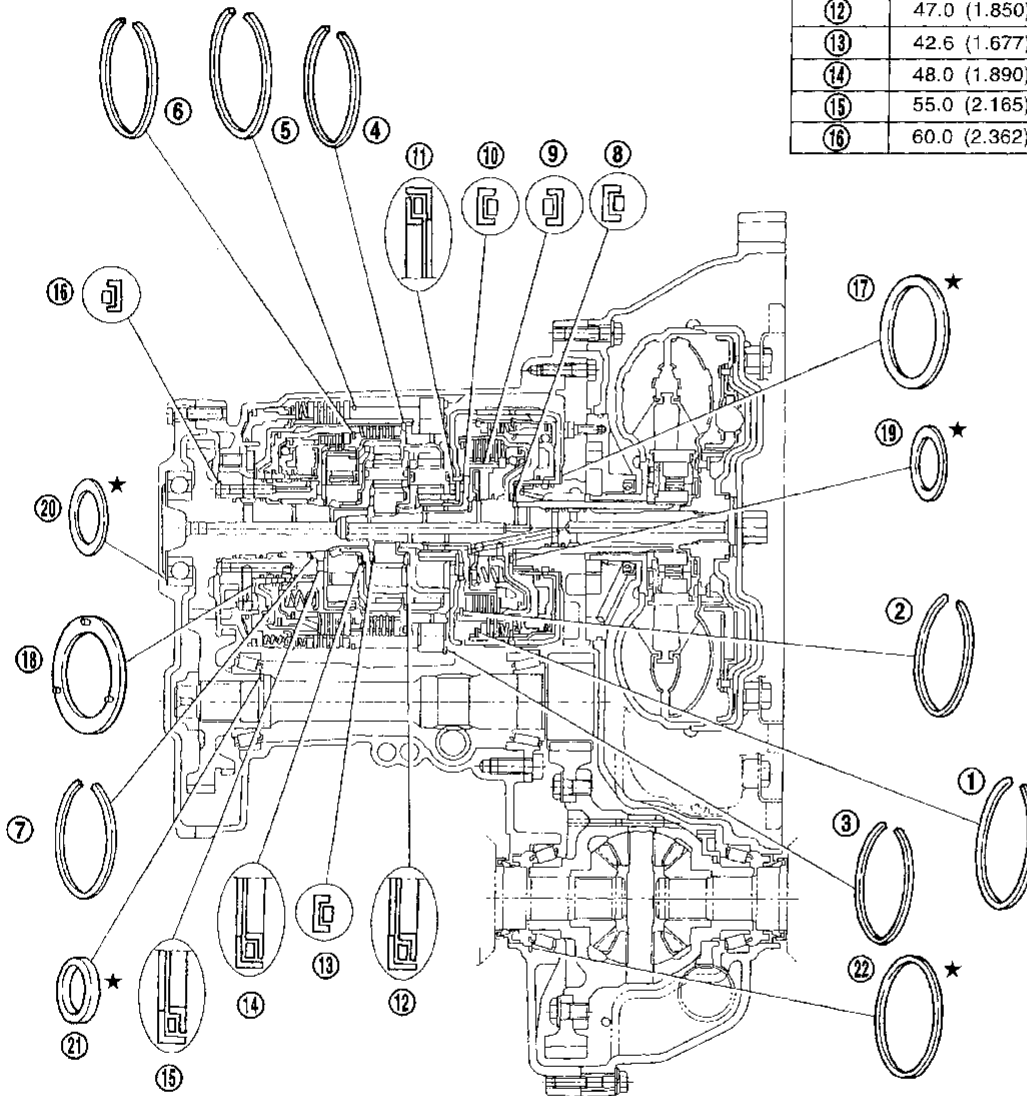

★ : Select proper thickness.

Outer & inner diameter of bearing race and adjusting shims

Item number	Outer diameter mm (in)	Inner diameter mm (in)
19	48.0 (1.890)	33.0 (1.299)
20	72.0 (2.835)	61.0 (2.402)
21	34.5 (1.358)	26.1 (1.028)
22	68.0 (2.677)	60.0 (2.362)

Outer diameter of snap rings

Item number	Outer diameter mm (in)
1	142.0 (5.59)
2	113.0 (4.45)
3	162.4 (6.39)
4	135.4 (5.33)
5	161.5 (6.36)
6	126.0 (4.96)
7	40.5 (1.594)

GI

MA

EM

LC

EC

FE

CL

MT

AT

FA

RA

BR

ST

RS

BT

HA

EL

IDX

MAJOR OVERHAUL

Oil Channel

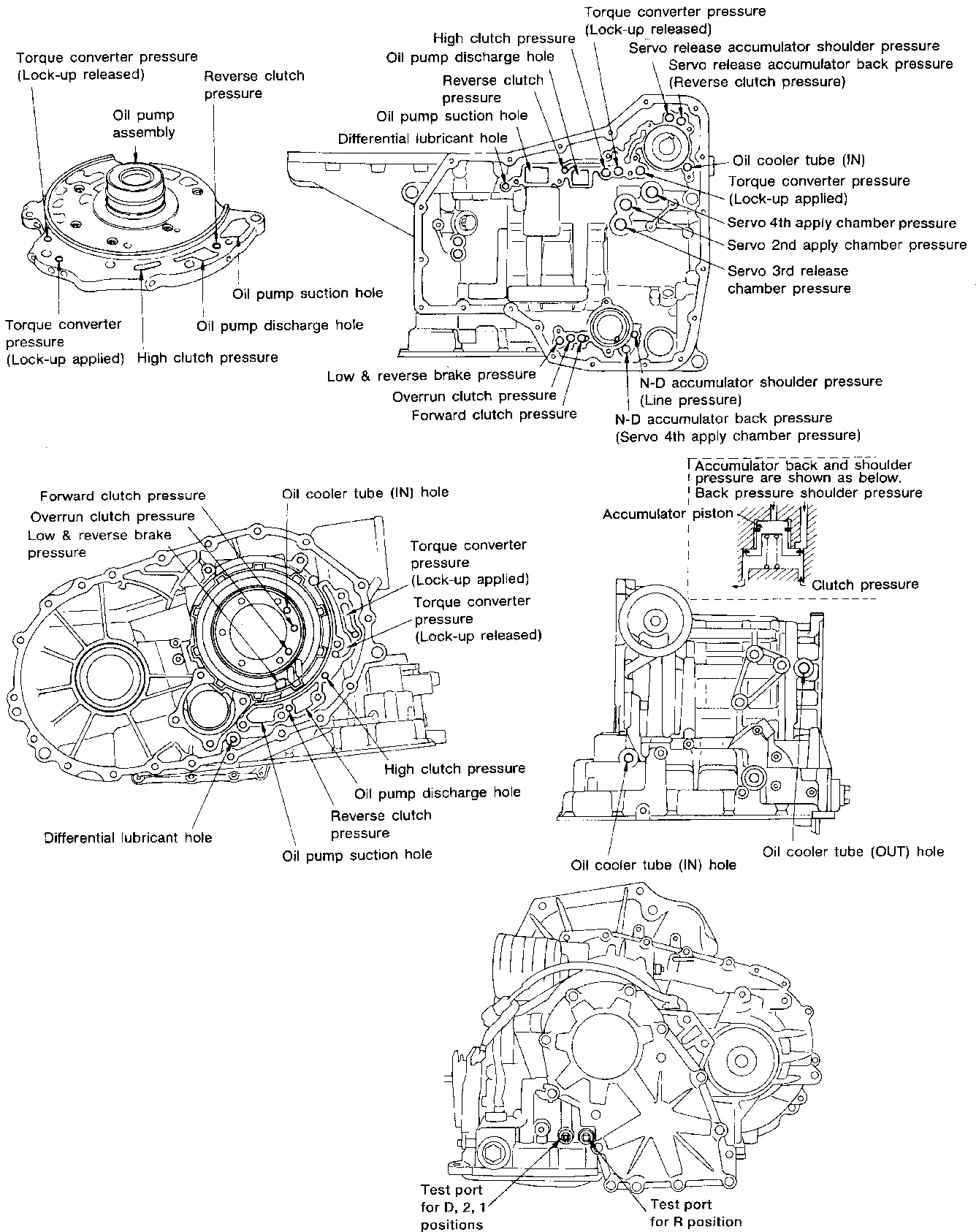

MAJOR OVERHAUL

SEC. 311-313-327-381

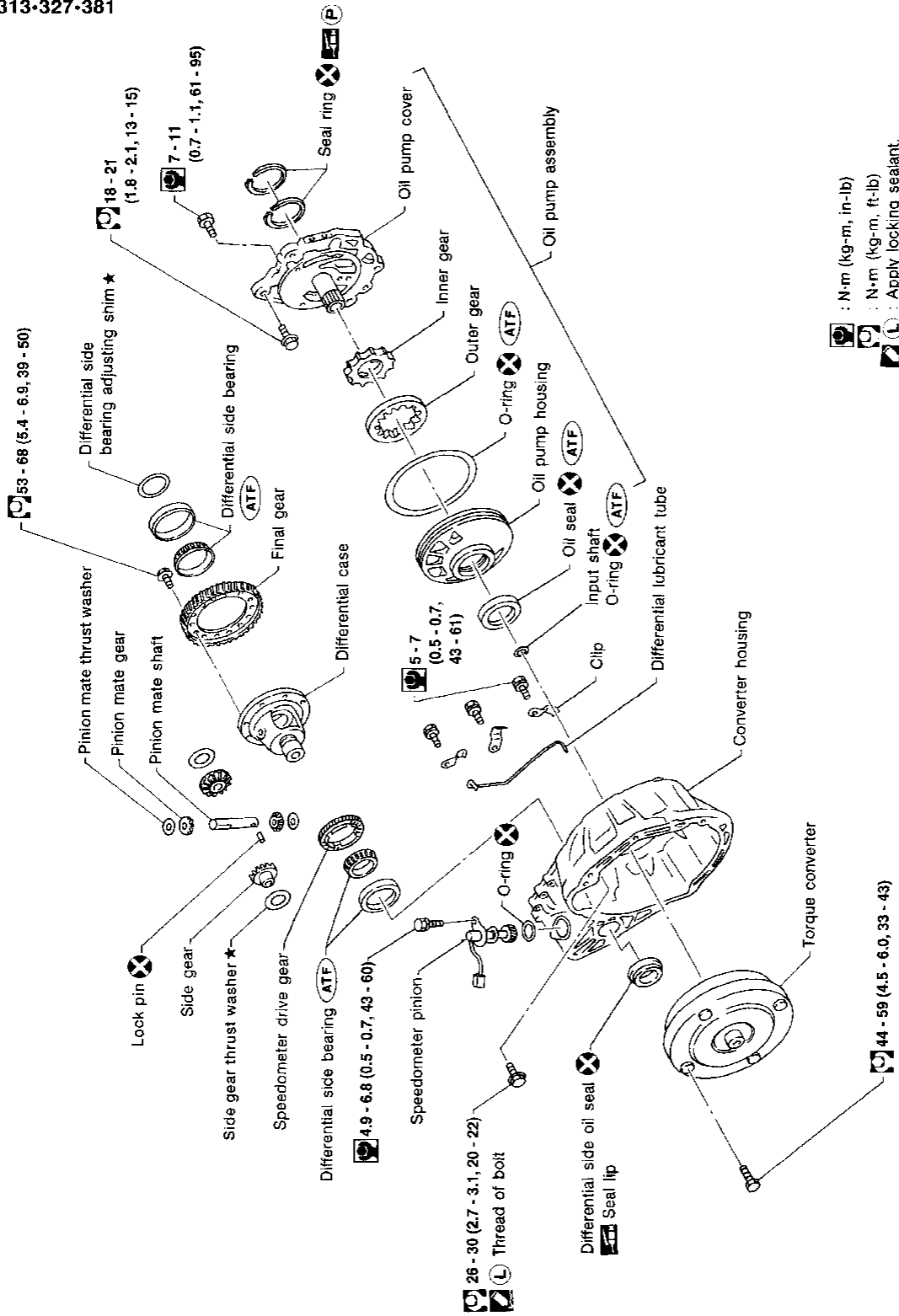

- : N-m (kg-m, in-lb)
- : N-m (kg-m, ft-lb)
- : Apply locking sealant.
- : Apply ATF.
- : Apply petroleum jelly.
- : Select proper thickness.

GI
MA
EM
LC
EC
FE
CL
MT
AT
FA
RA
BR
ST
RS
BT
HA
EL
IDX

DISASSEMBLY

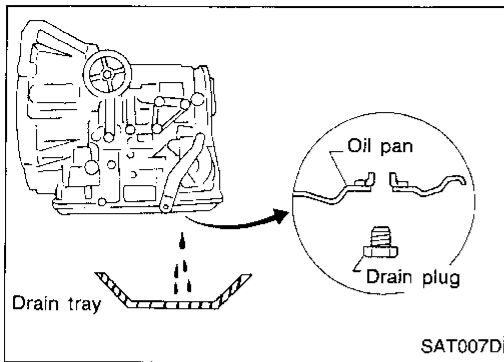

1. Drain ATF through drain plug.

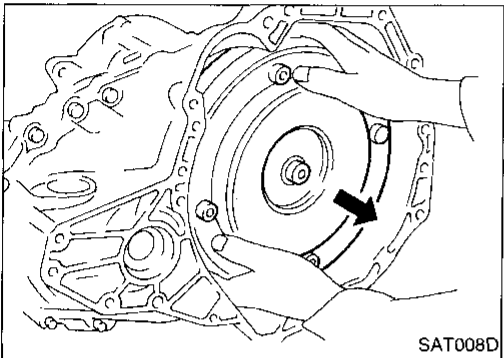

2. Remove torque converter.

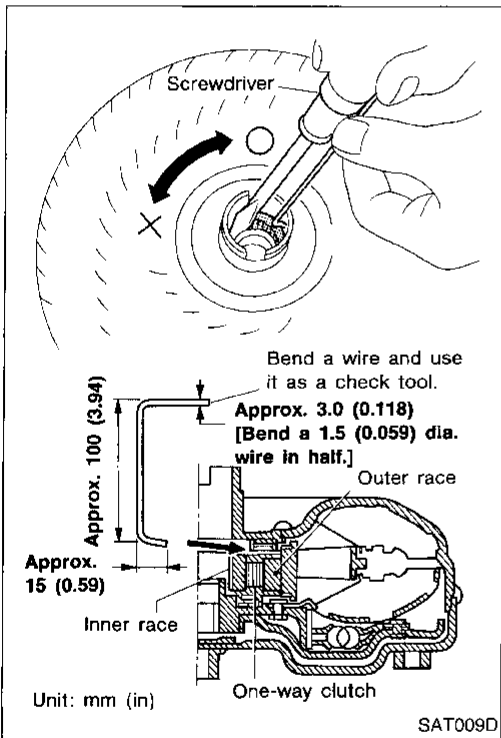

3. Check torque converter one-way clutch using check tool as shown at left.

a. Insert check tool into the groove of bearing support built into one-way clutch outer race.

b. While fixing bearing support with check tool, rotate one-way clutch spline using flat-bladed screwdriver.

c. Check inner race rotates clockwise only. If not, replace torque converter assembly.

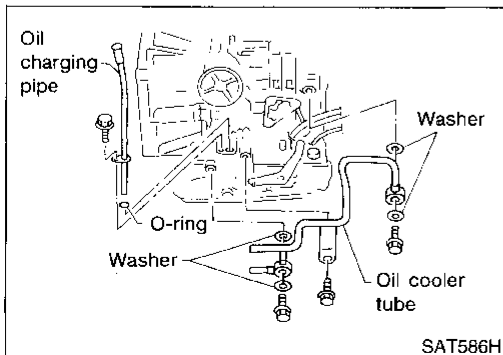

4. Remove oil charging pipe and oil cooler tube.

DISASSEMBLY

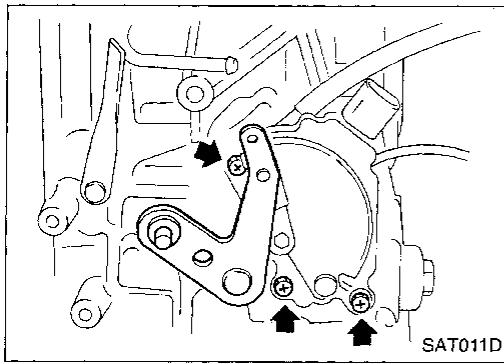

5. Set manual shaft to "P" position.
6. Remove inhibitor switch.

GI

MA

EM

LC

EC

FE

CL

WT

AT

FA

RA

BR

ST

RS

BT

HA

EL

IDX

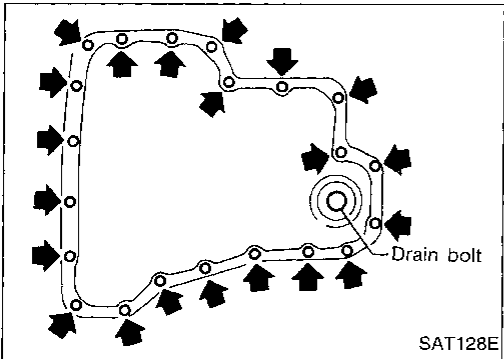

7. Remove oil pan and oil pan gasket.
 - **Do not reuse oil pan bolts.**
8. Check foreign materials in oil pan to help determine cause of malfunction. If the fluid is very dark, smells burned, or contains foreign particles, the frictional material (clutches, band) may need replacement. A tacky film that will not wipe clean indicates varnish build up. Varnish can cause valves, servo, and clutches to stick and may inhibit pump pressure.
 - **If frictional material is detected, replace radiator after repair of A/T. Refer to LC section ("Radiator", "ENGINE COOLING SYSTEM").**
9. Remove control valve assembly according to the following procedures.

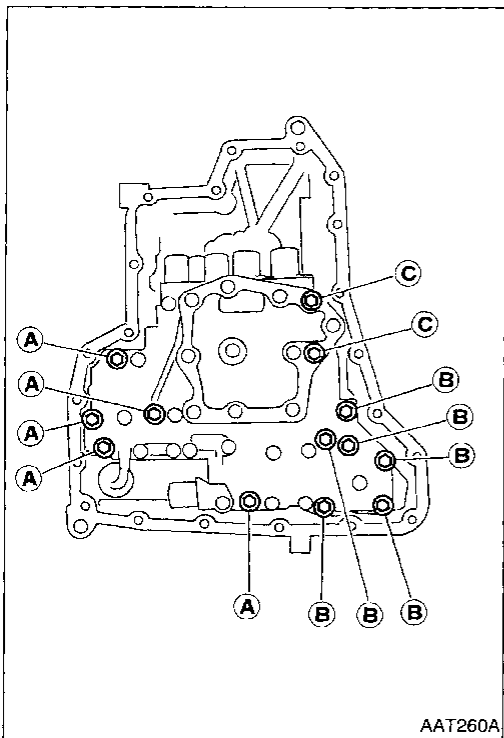

- a. Remove control valve assembly mounting bolts (A), (B) and (C).

DISASSEMBLY

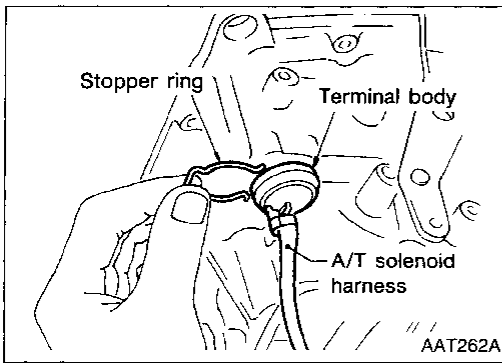

- b. Remove stopper ring from terminal body.
- c. Push terminal body into transmission case and draw out solenoid harness.

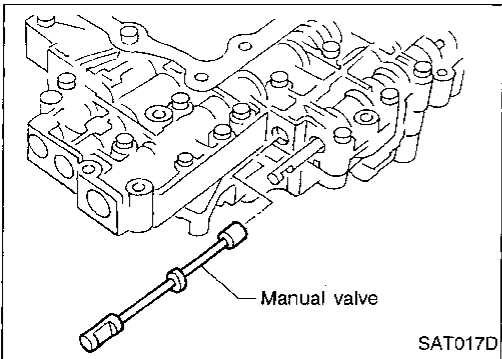

- 10. Remove manual valve from control valve assembly as a precaution.

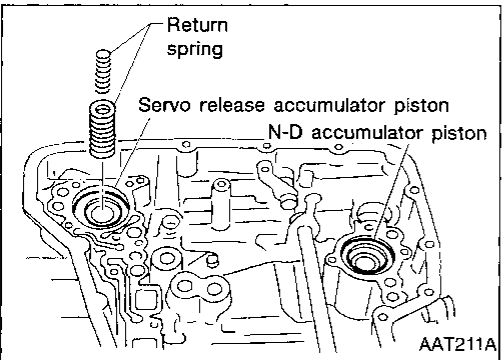

- 11. Remove return spring from servo release accumulator piston.

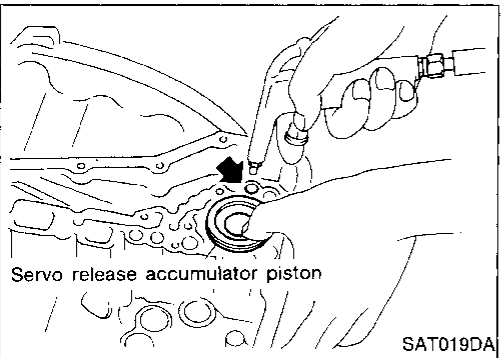

- 12. Remove servo release accumulator piston with compressed air.
- 13. Remove O-rings from servo release accumulator piston.

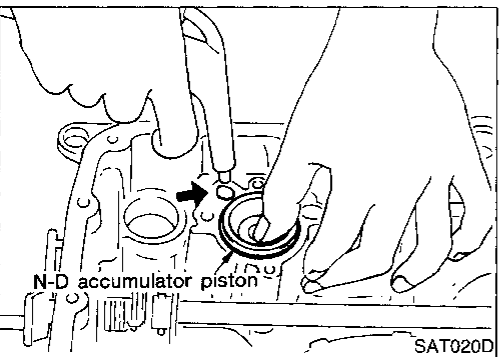

- 14. Remove N-D accumulator piston and return spring with compressed air.
- 15. Remove O-rings from N-D accumulator piston.

DISASSEMBLY

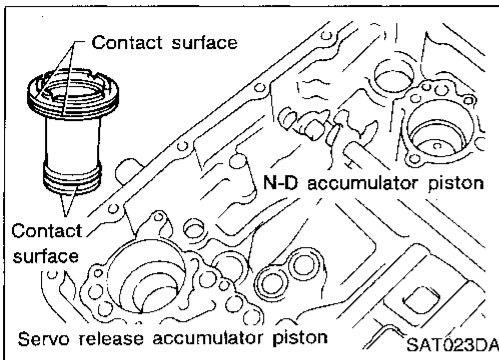

16. Check accumulator pistons and contact surface of transmission case for damage.
17. Check accumulator return springs for damage and free length.

Return springs:

Refer to SDS, AT-300.

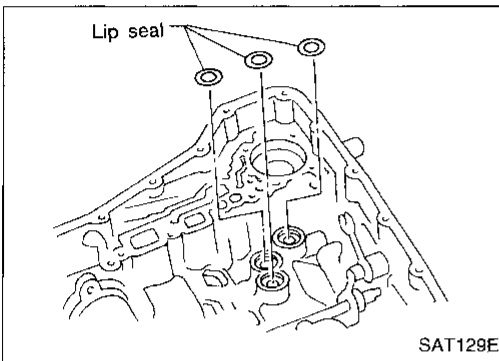

18. Remove lip seals from band servo oil port.

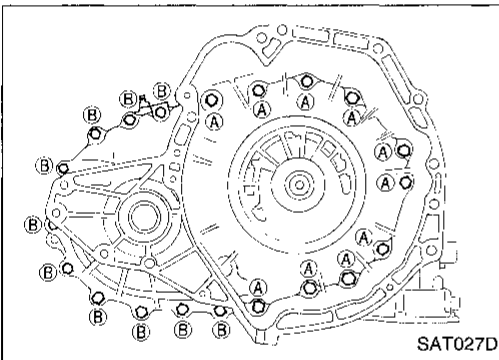

19. Remove converter housing according to the following procedures.

- a. Remove converter housing mounting bolts (A) and (B).

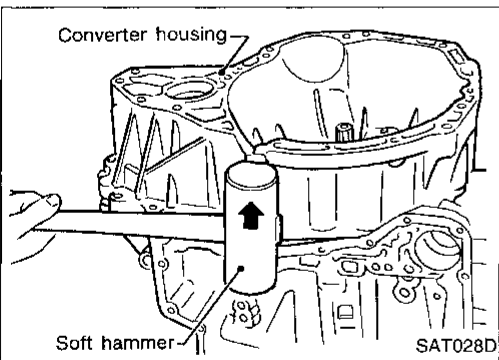

- b. Remove converter housing.

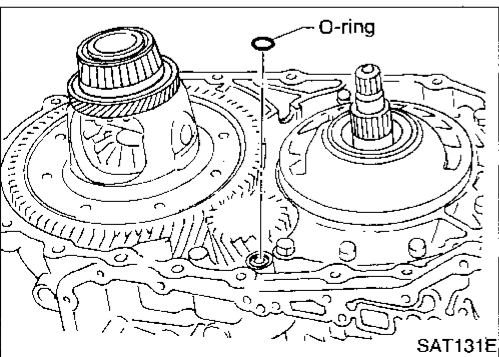

- c. Remove O-ring from differential oil port.

GI

MA

EM

LC

EC

FE

CL

MT

AT

FA

RA

BR

ST

RS

BT

HA

EL

IDX

DISASSEMBLY

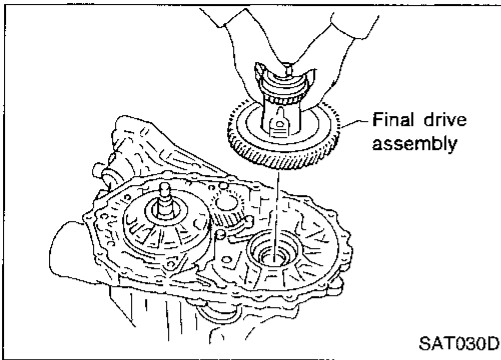

20. Remove final drive assembly from transmission case.

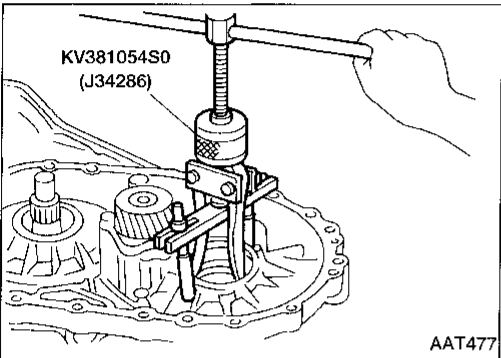

21. Remove differential side bearing outer race from transmission case.

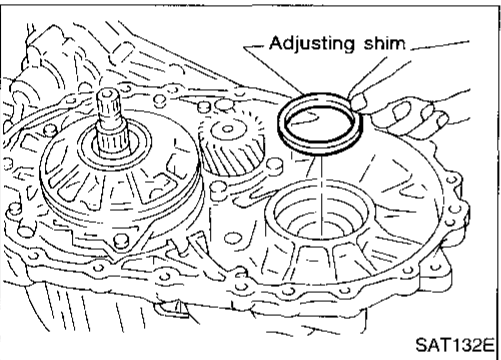

22. Remove differential side bearing adjusting shim from transmission case.

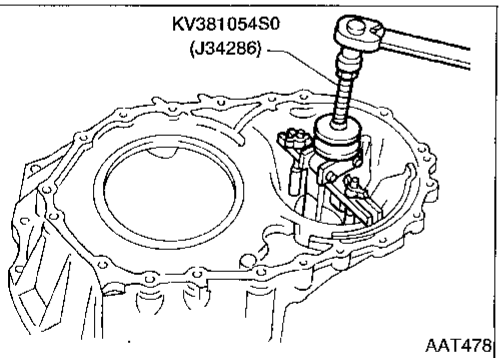

23. Remove differential side bearing outer race from converter housing.

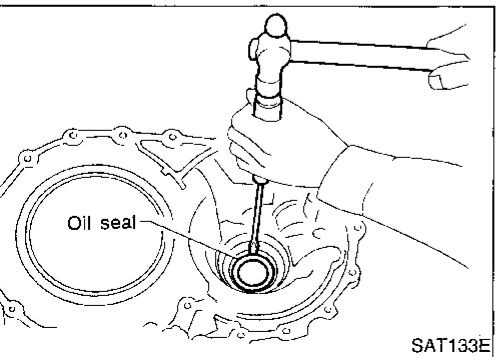

24. Remove oil seal from converter housing using a screwdriver.

- **Be careful not to damage case.**

DISASSEMBLY

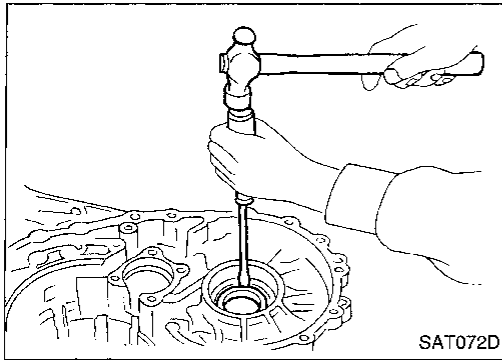

25. Remove side oil seal from transmission case using a screwdriver.

GI

MA

EM

LC

EC

FE

CL

MT

AT

FA

RA

BR

ST

RS

BT

HA

EL

IDX

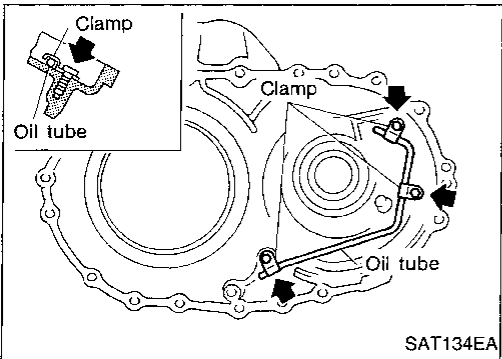

26. Remove oil tube from converter housing.

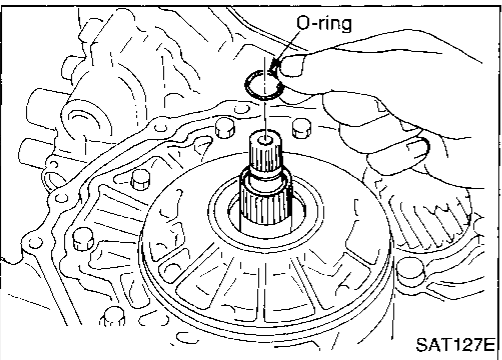

27. Remove oil pump according to the following procedures.
a. Remove O-ring from input shaft.

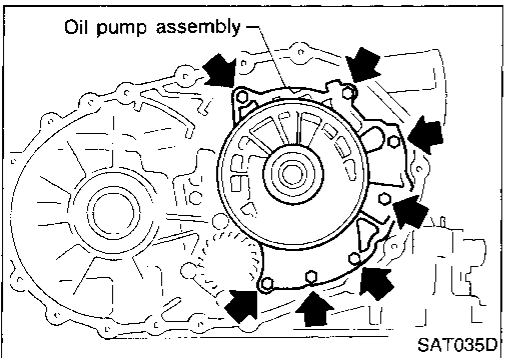

b. Remove oil pump assembly from transmission case.

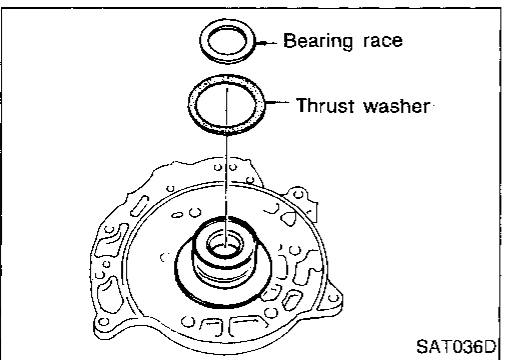

c. Remove thrust washer and bearing race from oil pump assembly.

DISASSEMBLY

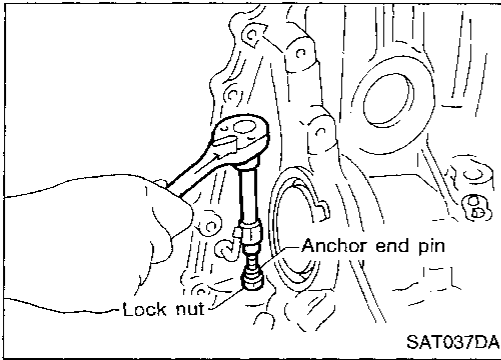

28. Remove brake band according to the following procedures.
- Loosen lock nut, then back off anchor end pin.
 - Do not reuse anchor end pin.**

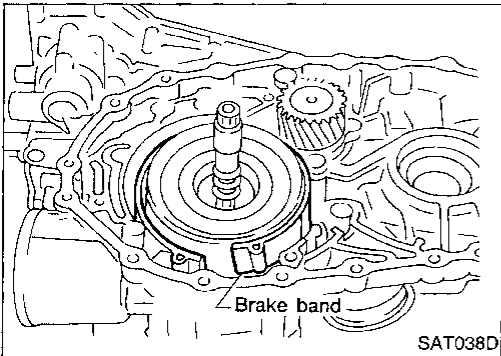

- Remove brake band from transmission case.

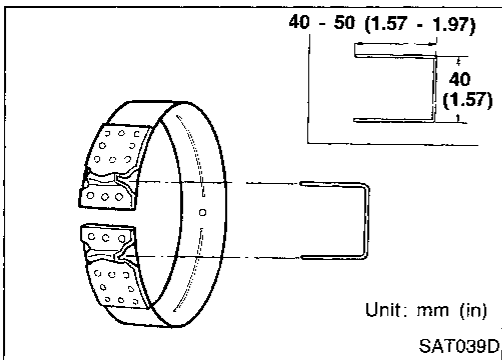

- To prevent brake linings from cracking or peeling, do not stretch the flexible band unnecessarily. When removing the brake band, always secure it with a clip as shown in the figure at left. Leave the clip in position after removing the brake band.**

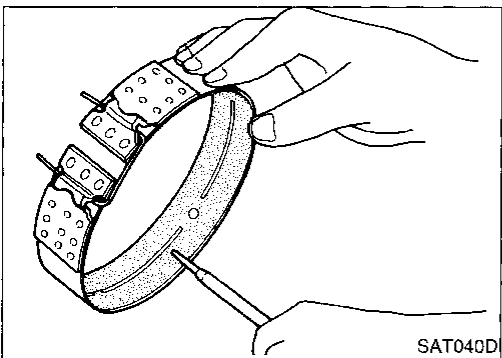

- Check brake band facing for damage, cracks, wear or burns.

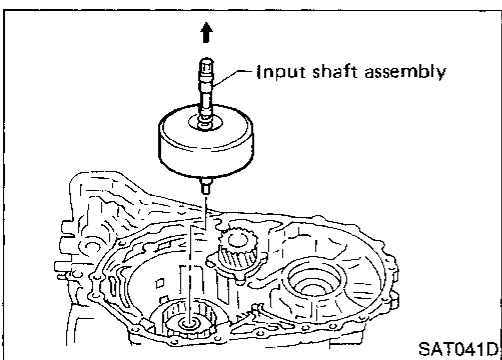

29. Remove input shaft assembly (high clutch) and reverse clutch according to the following procedures.
- Remove input shaft assembly (high clutch) with reverse clutch.

DISASSEMBLY

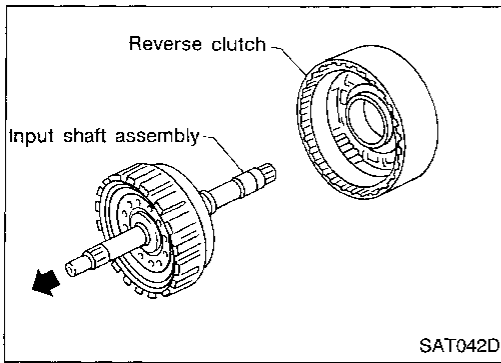

- b. Remove input shaft assembly (high clutch) from reverse clutch.

GI

MA

EM

LC

EC

FE

CL

MT

AT

FA

RA

BR

ST

RS

BT

HA

EL

IDX

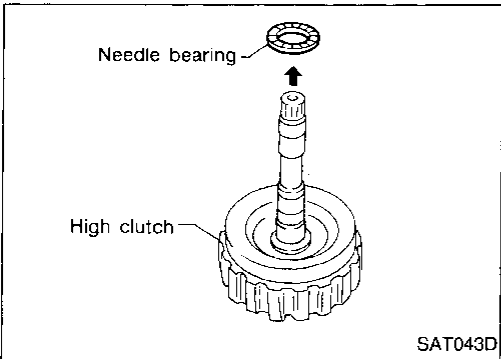

- c. Remove needle bearing from high clutch drum.
d. Check input shaft assembly and needle bearing for damage or wear.

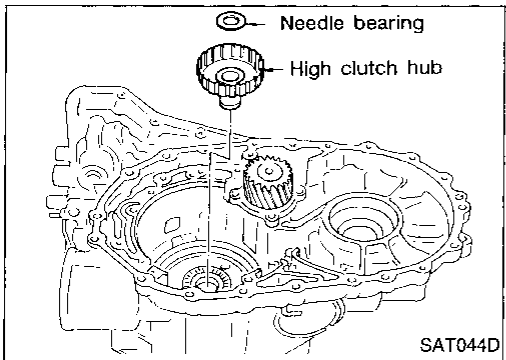

30. Remove high clutch hub and needle bearing from transmission case.
31. Check high clutch hub and needle bearing for damage or wear.

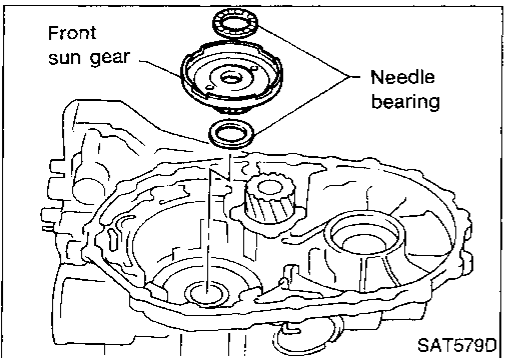

32. Remove front sun gear and needle bearings from transmission case.
33. Check front sun gear and needle bearings for damage or wear.

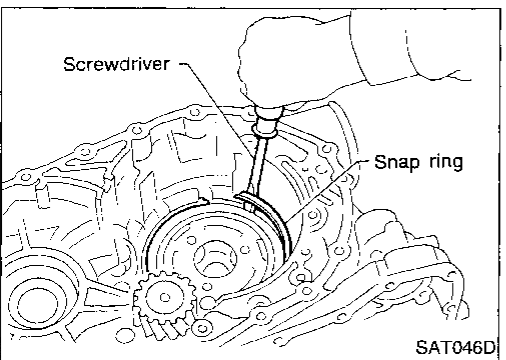

34. Remove front planetary carrier assembly and low one-way clutch according to the following procedures.
a. Remove snap ring using a screwdriver.

DISASSEMBLY

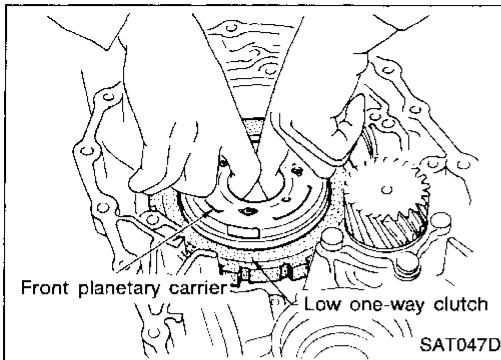

- b. Remove front planetary carrier with low one-way clutch.

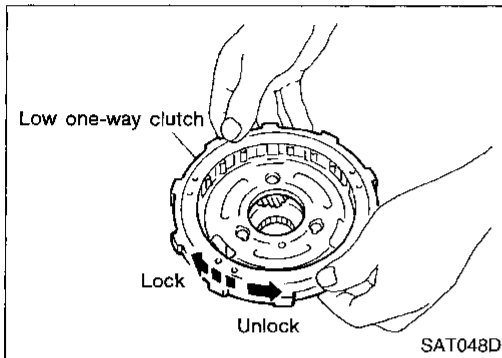

- c. Check that low one-way clutch rotates in the direction of the arrow and locks in the opposite direction.
- d. Remove low one-way clutch from front planetary carrier by rotating it in the direction of unlock.

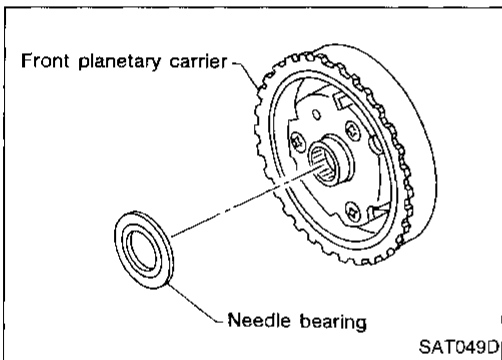

- e. Remove needle bearing from front planetary carrier.

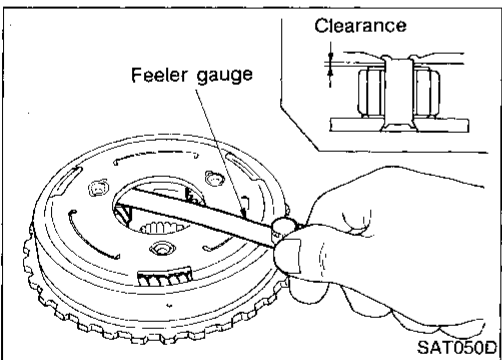

- f. Check front planetary carrier, low one-way clutch and needle bearing for damage or wear.
- g. Check clearance between pinion washer and planetary carrier using feeler gauge.

Standard clearance:

0.15 - 0.70 mm (0.0059 - 0.0276 in)

Allowable limit:

0.80 mm (0.0315 in)

Replace front planetary carrier if the clearance exceeds allowable limit.

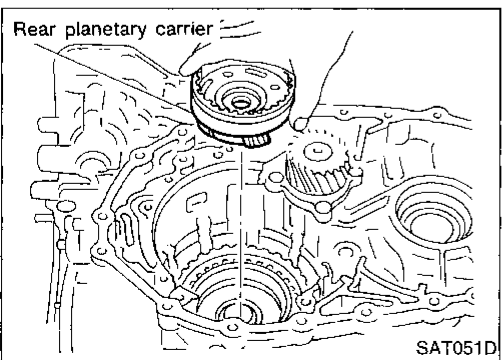

35. Remove rear planetary carrier assembly and rear sun gear according to the following procedures.
- a. Remove rear planetary carrier assembly from transmission case.

DISASSEMBLY

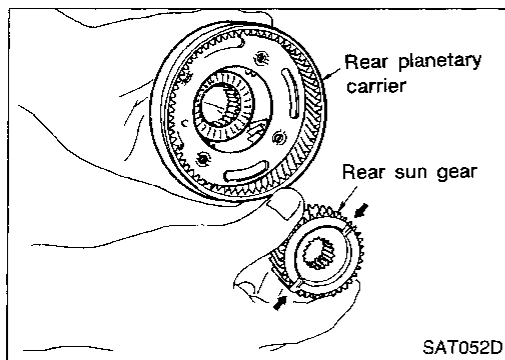

b. Remove rear sun gear from rear planetary carrier.

GI

MA

EM

LC

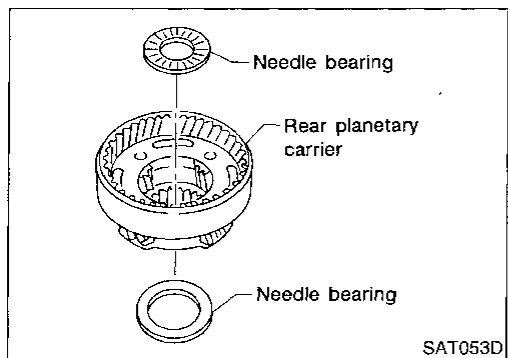

c. Remove needle bearings from rear planetary carrier assembly.

EC

FE

CL

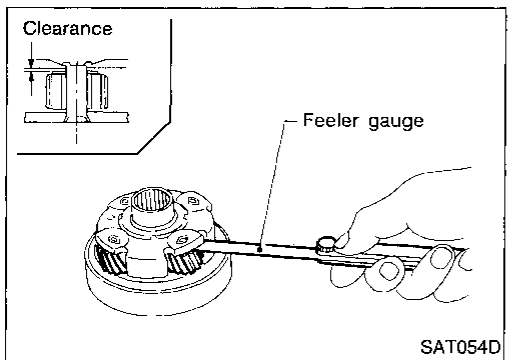

d. Check rear planetary carrier, rear sun gear and needle bearings for damage or wear.

e. Check clearance between pinion washer and rear planetary carrier using feeler gauge.

Standard clearance:

0.15 - 0.70 mm (0.0059 - 0.0276 in)

Allowable limit:

0.80 mm (0.0315 in)

Replace rear planetary carrier if the clearance exceeds allowable limit.

MT

AT

FA

RA

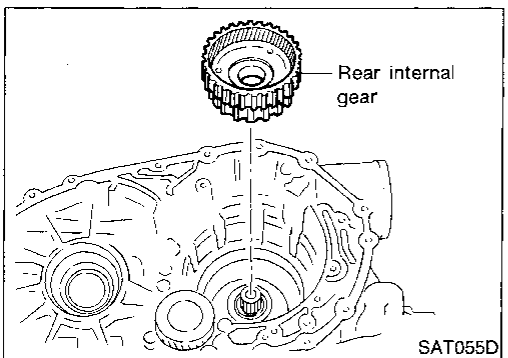

36. Remove rear internal gear from transmission case.

BR

ST

RS

BT

HA

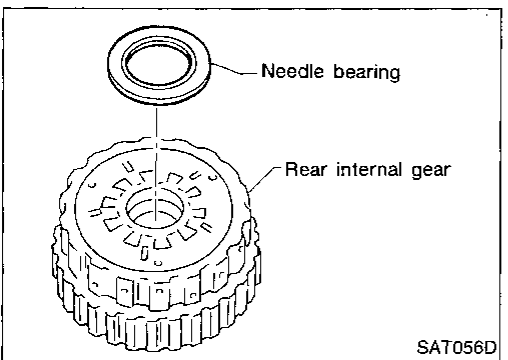

37. Remove needle bearing from rear internal gear.

- Check needle bearing for damage or wear.

EL

IDX

DISASSEMBLY

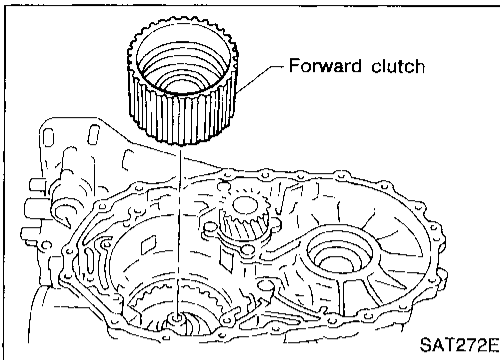

38. Remove forward clutch assembly from transmission case.

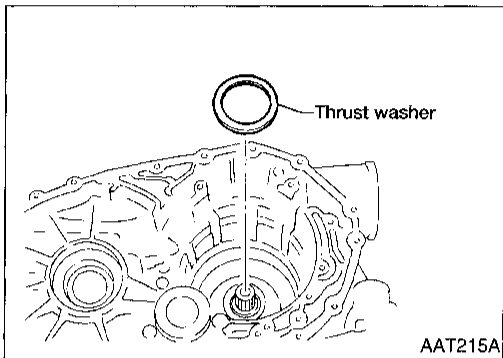

39. Remove thrust washer from transmission case.

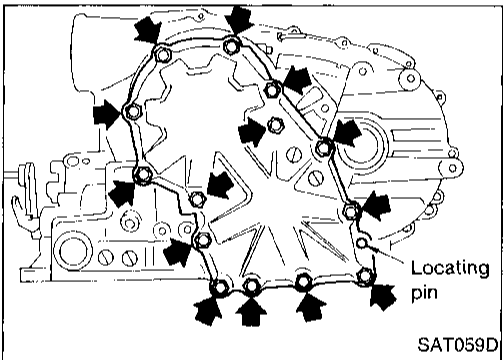

40. Remove output shaft assembly according to the following procedures.

a. Remove side cover bolts.

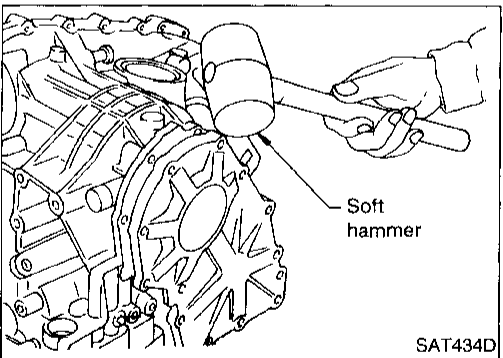

b. Remove side cover by lightly tapping it with a soft hammer.

- **Be careful not to drop output shaft assembly. It might come out when removing side cover.**

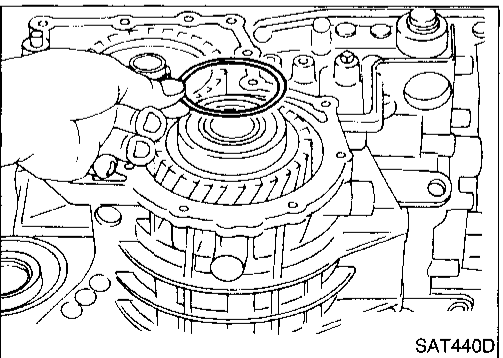

c. Remove adjusting shim.

DISASSEMBLY

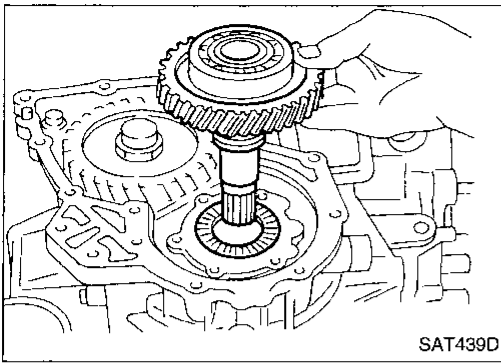

d. Remove output shaft assembly.

GI

MA

EM

LC

EC

FE

CL

MT

AT

FA

RA

BR

ST

RS

BT

HA

EL

IDX

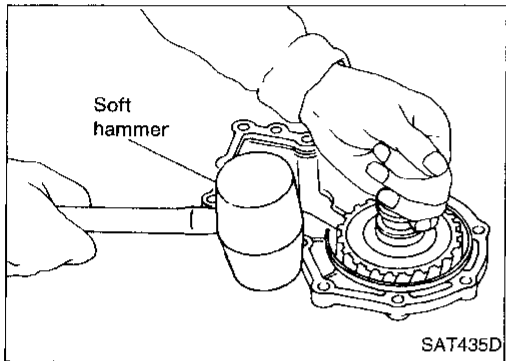

- If output shaft assembly came off with side cover, tap cover with a soft hammer to separate.

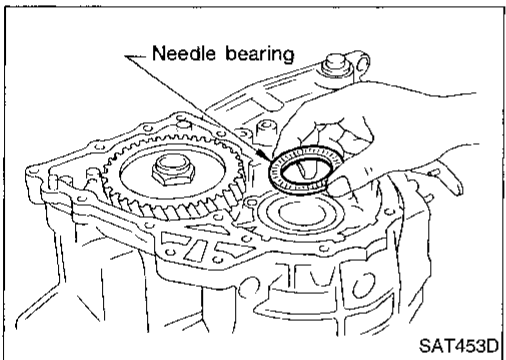

e. Remove needle bearing.

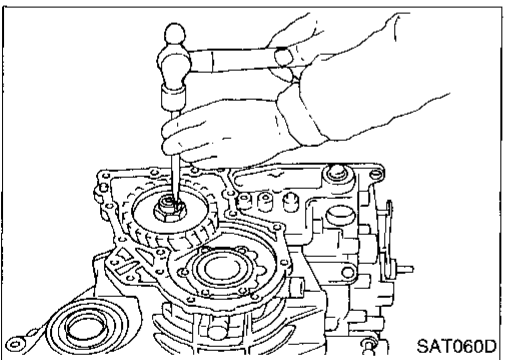

41. Disassemble reduction pinion gear according to the following procedures.

- Set manual shaft to position "P" to fix idler gear.
- Unlock idler gear lock nut using a pin punch.

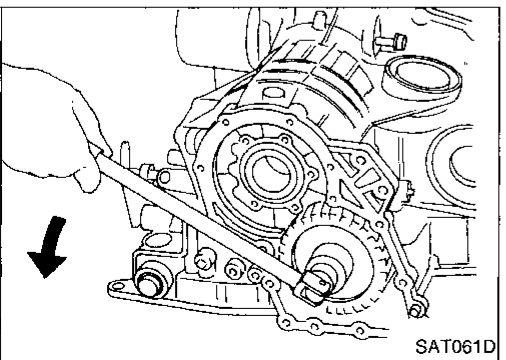

- Remove idler gear lock nut.
- Do not reuse idler gear lock nut.

DISASSEMBLY

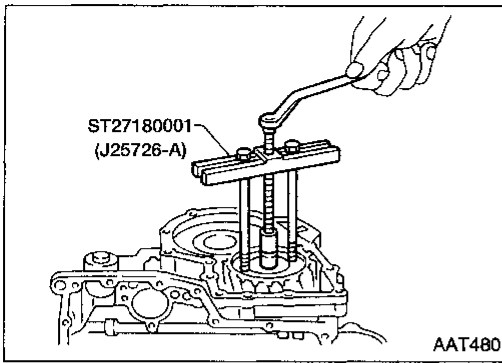

d. Remove idler gear with puller.

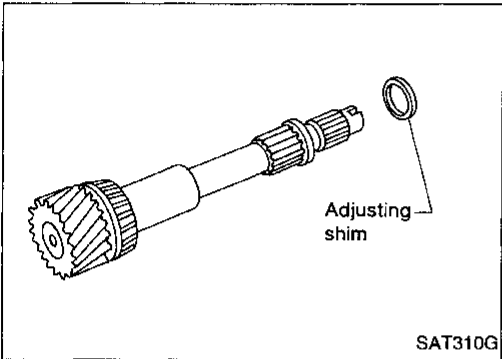

e. Remove reduction pinion gear.

f. Remove adjusting shim from reduction pinion gear.

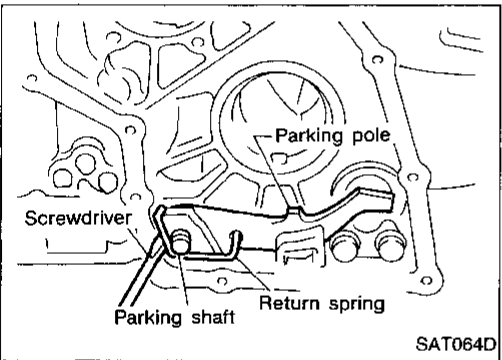

42. Remove return spring from parking shaft using a screwdriver.

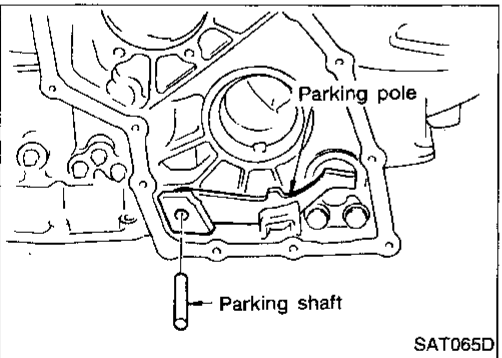

43. Draw out parking shaft and remove parking pole from transmission case.

44. Check parking pole and shaft for damage or wear.

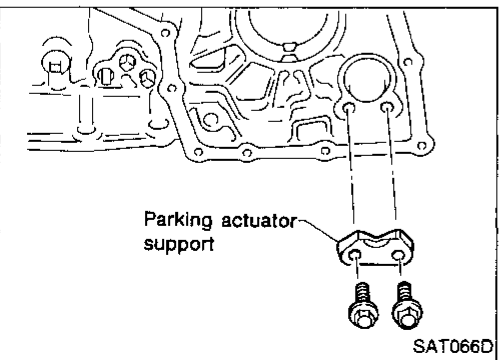

45. Remove parking actuator support from transmission case.

- Check parking actuator support for damage or wear.

DISASSEMBLY

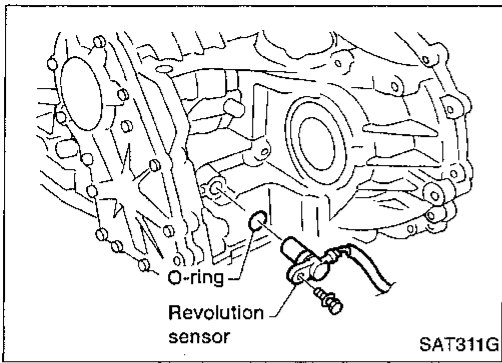

46. Remove revolution sensor from transmission case.

GI

MA

EM

LC

EC

FE

CL

MT

AT

FA

RA

BR

ST

RS

BT

HA

EL

IDX

Manual Shaft

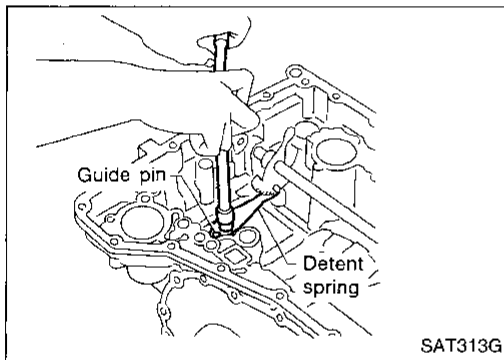
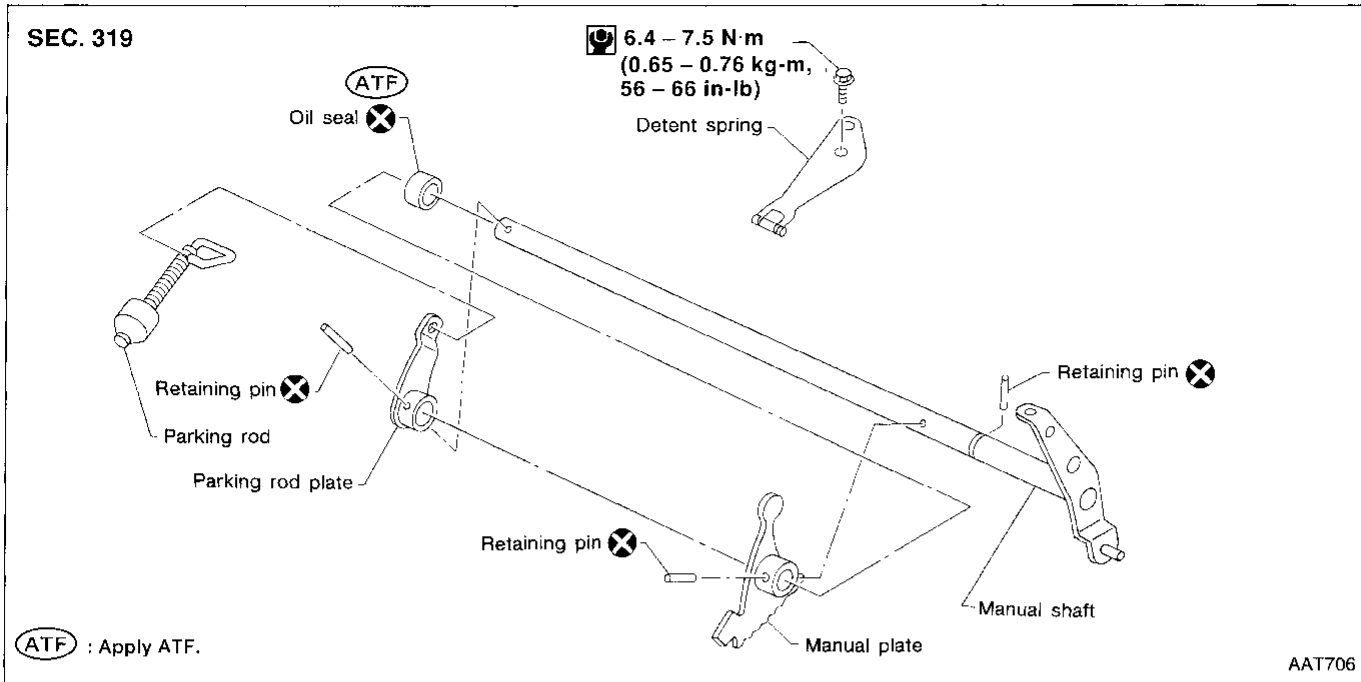

REMOVAL

1. Remove detent spring from transmission case.

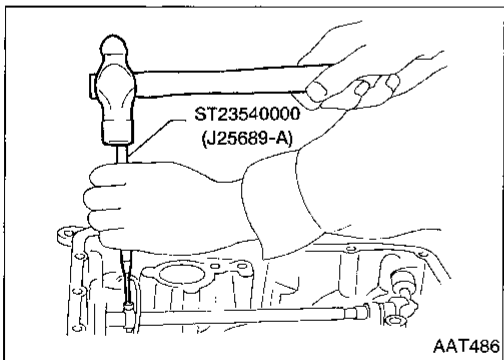

2. Drive out manual plate retaining pin.

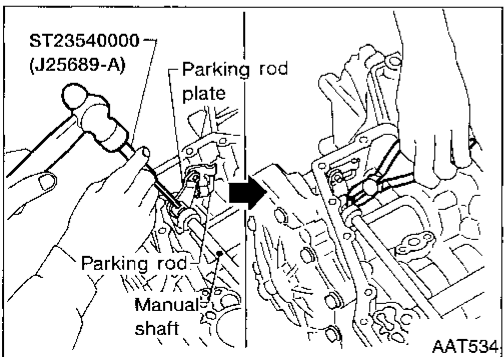

3. Drive and pull out parking rod plate retaining pin.
4. Remove parking rod plate from manual shaft.
5. Draw out parking rod from transmission case.

REPAIR FOR COMPONENT PARTS

Manual Shaft (Cont'd)

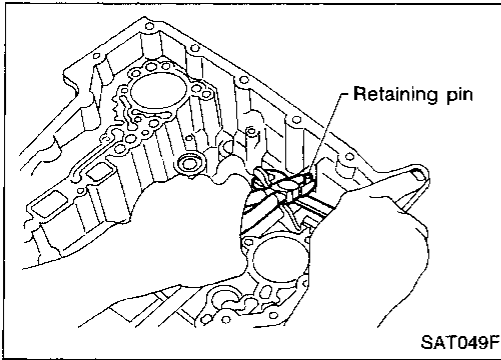

6. Pull out manual shaft retaining pin.
7. Remove manual shaft and manual plate from transmission case.

GI

MA

EM

LC

EC

FE

CL

MT

AT

FA

RA

BR

ST

RS

BT

HA

EL

IDX

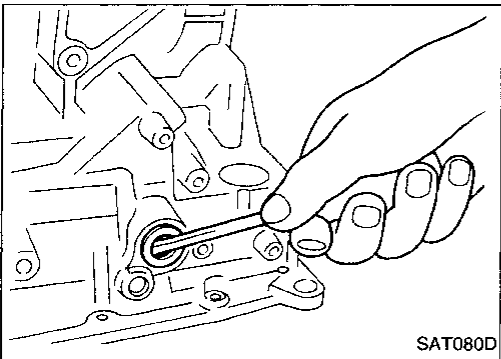

8. Remove manual shaft oil seal.

INSPECTION

- Check component parts for wear or damage. Replace if necessary.

AT

FA

RA

BR

ST

RS

BT

HA

EL

IDX

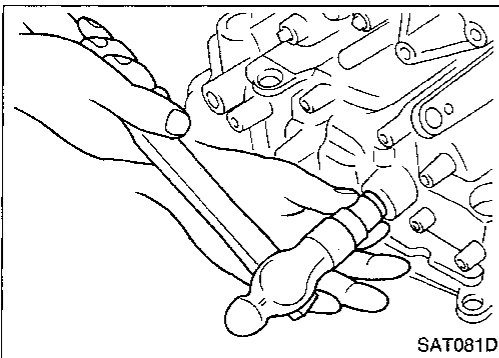

INSTALLATION

1. Install manual shaft oil seal.
 - **Apply ATF to outer surface of oil seal.**

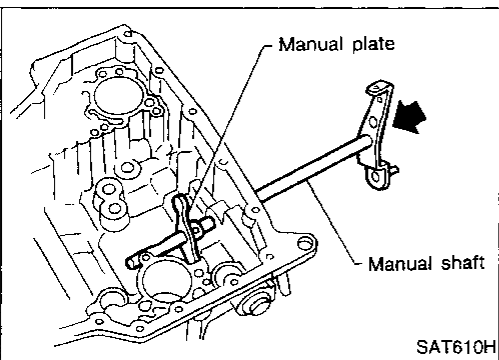

2. Install manual shaft and manual plate.

REPAIR FOR COMPONENT PARTS

Manual Shaft (Cont'd)

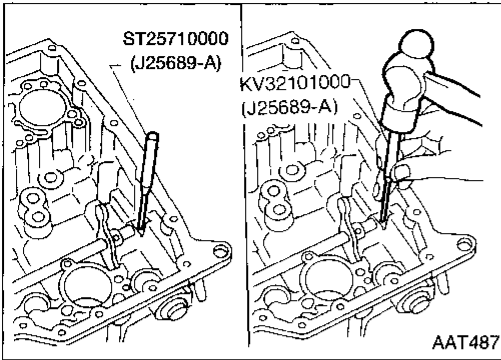

3. Align groove of manual shaft and hole of transmission case.
4. Install manual shaft retaining pin.

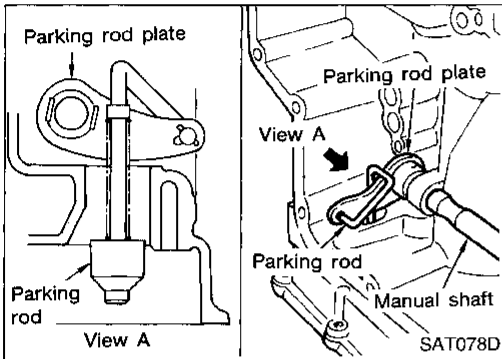

5. Install parking rod to parking rod plate.
6. Set parking rod assembly onto manual shaft.

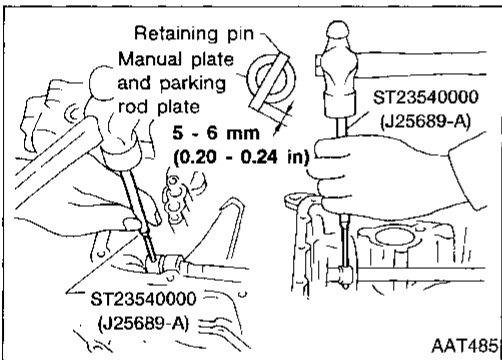

7. Drive in manual plate retaining pin and parking rod plate retaining pin.

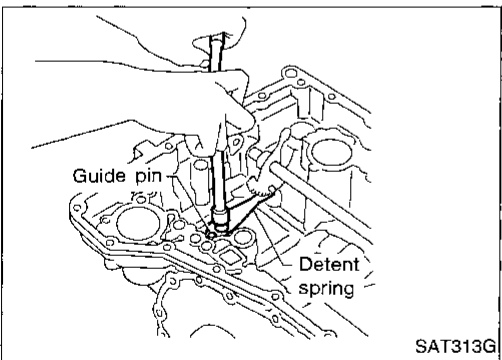

8. Install detent spring.

Oil Pump

SEC. 313

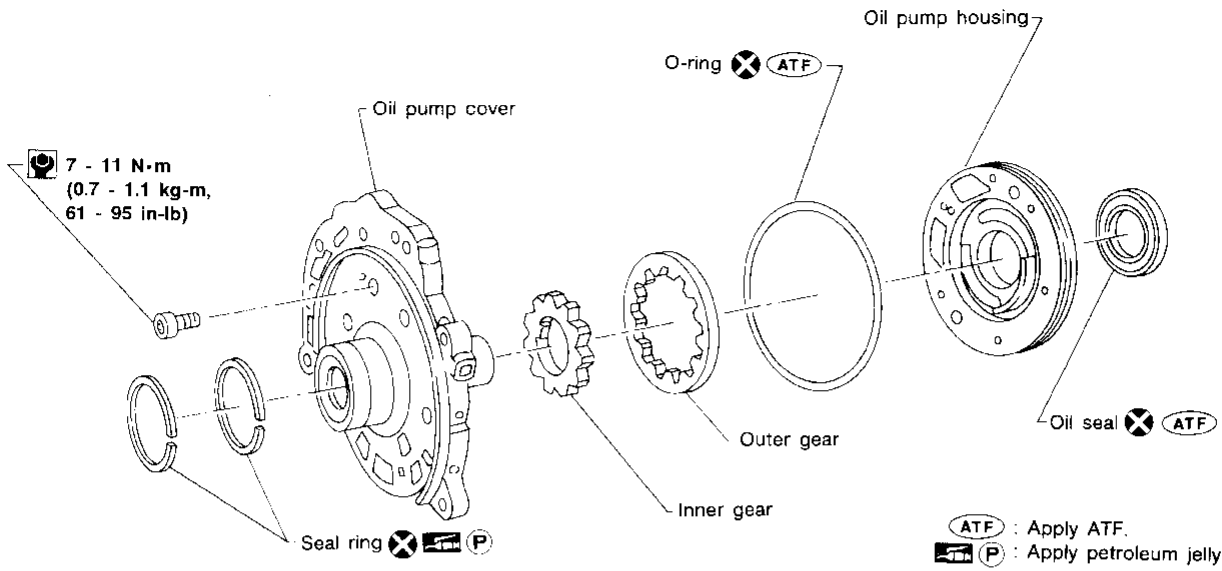

SAT698HA

GI
MA
EM
LC
EC
FE
CL
MT
AT
FA
RA
BR
ST
RS
BT
HA
EL
IDX

DISASSEMBLY

1. Remove seal rings.

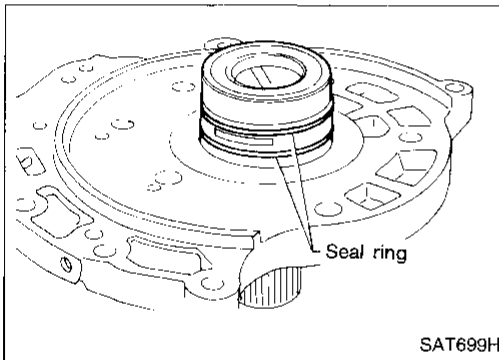

2. Loosen bolts in numerical order and remove oil pump cover.

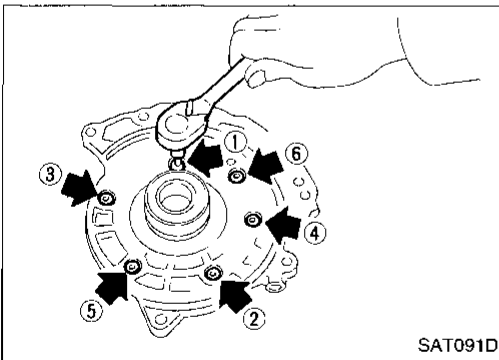

3. Remove inner and outer gear from oil pump housing.

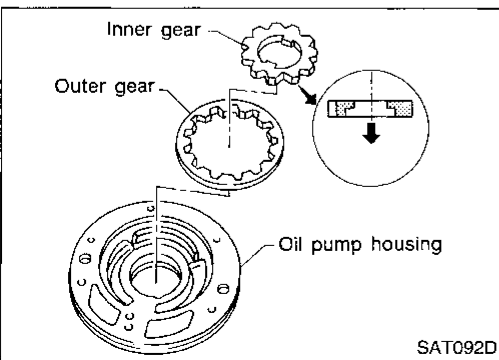

REPAIR FOR COMPONENT PARTS

Oil Pump (Cont'd)

4. Remove O-ring from oil pump housing.

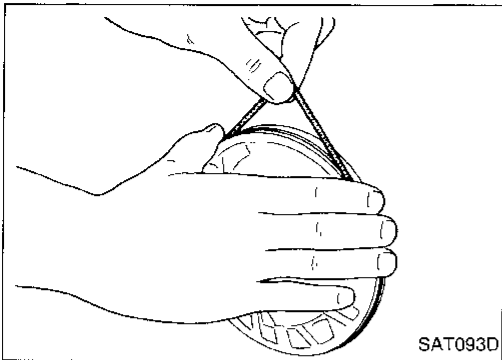

5. Remove oil pump housing oil seal.

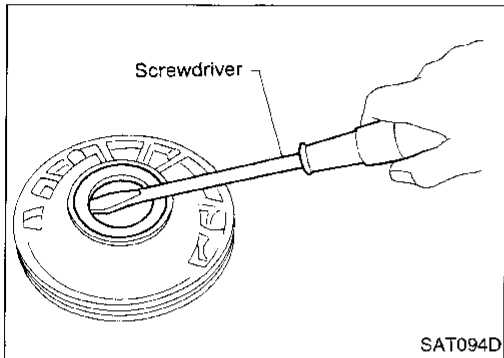

INSPECTION

Oil pump housing, oil pump cover, inner gear and outer gear

- Check for wear or damage.

Side clearance

- Measure side clearance of inner and outer gears in at least four places around each outside edge. Maximum measured values should be within specified range.

Standard clearance:

0.02 - 0.04 mm (0.0008 - 0.0016 in)

- If clearance is less than standard, select inner and outer gear as a set so that clearance is within specifications.

Inner and outer gear:

Refer to SDS, AT-297.

- If clearance is more than standard, replace whole oil pump assembly except oil pump cover.

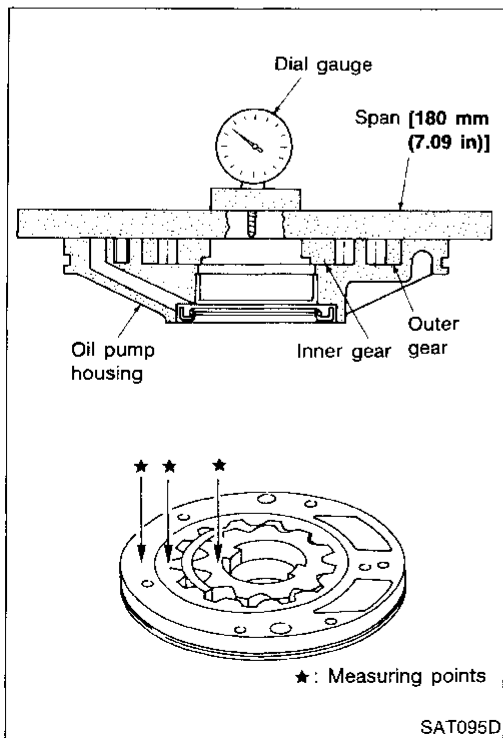

REPAIR FOR COMPONENT PARTS

Oil Pump (Cont'd)

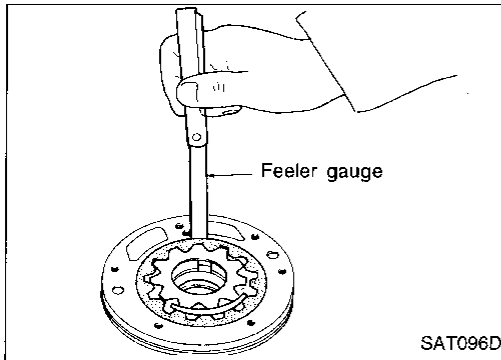

- Measure clearance between outer gear and oil pump housing.

Standard clearance:

0.08 - 0.15 mm (0.0031 - 0.0059 in)

Allowable limit:

0.15 mm (0.0059 in)

- If not within allowable limit, replace whole oil pump assembly except oil pump cover.

GI

MA

EM

EG

EC

FE

CL

MT

AT

FA

RA

BR

ST

RS

BT

HA

EL

IDX

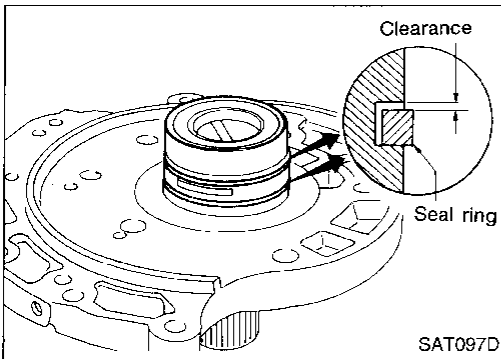

Seal ring clearance

- Install new seal rings onto oil pump cover.
- Measure clearance between seal ring and ring groove.

Standard clearance:

0.1 - 0.25 mm (0.0039 - 0.0098 in)

Allowable limit:

0.25 mm (0.0098 in)

- If not within allowable limit, replace oil pump cover assembly.

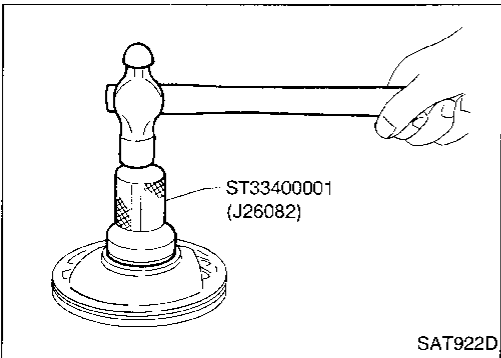

ASSEMBLY

1. Install oil seal on oil pump housing.

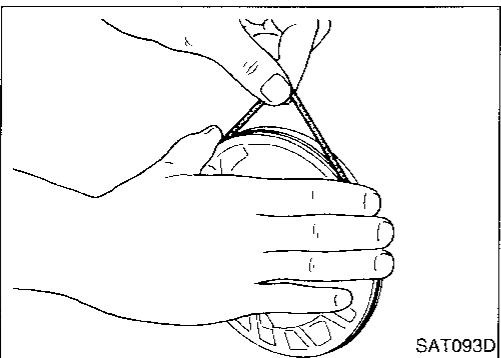

2. Install O-ring on oil pump housing.
 - Apply ATF to O-ring.

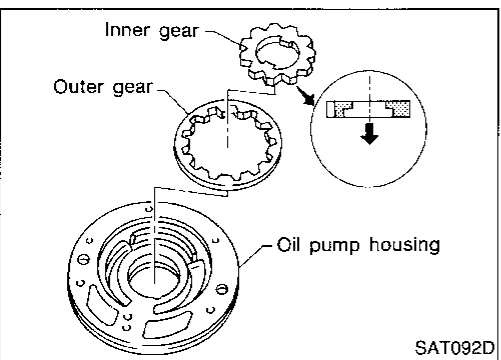

3. Install inner and outer gears on oil pump housing.
 - Take care with the direction of the inner gear.

REPAIR FOR COMPONENT PARTS

Oil Pump (Cont'd)

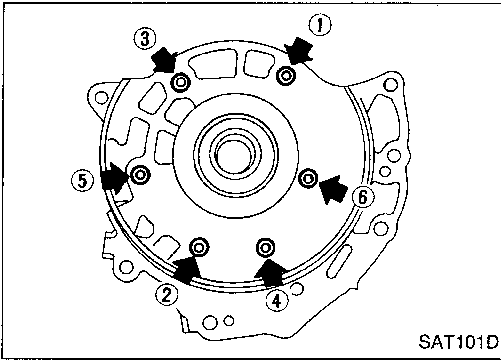

4. Install oil pump cover on oil pump housing.
 - a. Wrap masking tape around splines of oil pump cover assembly to protect seal. Position oil pump cover assembly on oil pump housing assembly, then remove masking tape.
 - b. Tighten bolts in numerical order.

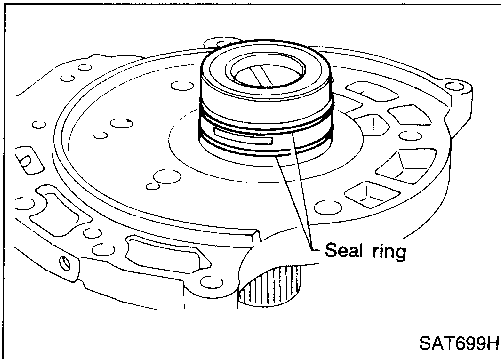

5. Install new seal rings carefully after packing ring groove with petroleum jelly.
 - **Do not spread gap of seal ring excessively while installing. It may deform the ring.**

REPAIR FOR COMPONENT PARTS

Control Valve Assembly

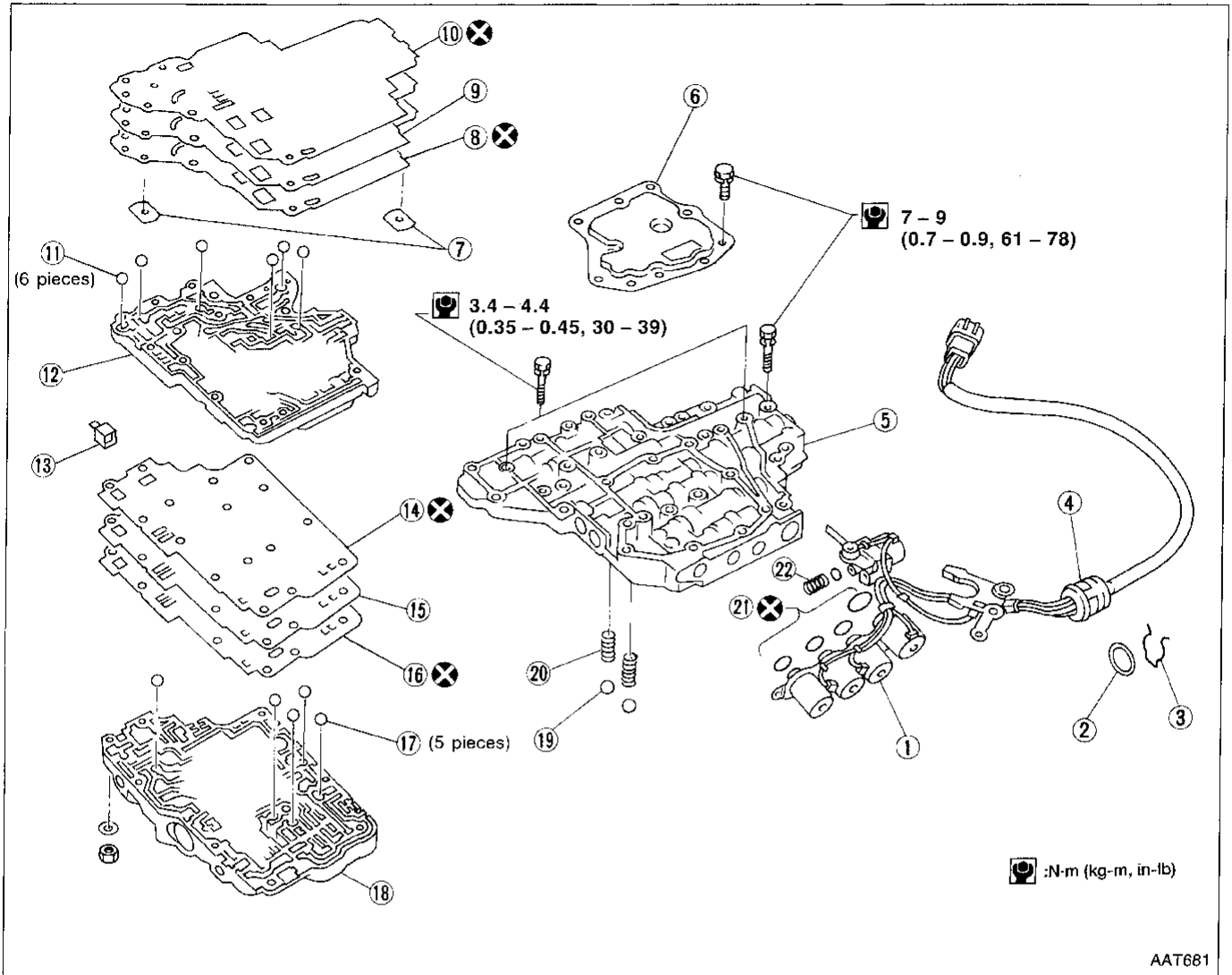

- | | | |
|---------------------------------|---------------------------------|---------------------------------------|
| ① Solenoid valve assembly | ⑨ Separating plate | ⑰ Steel ball |
| ② O-ring | ⑩ Lower separating gasket | ⑱ Control valve upper body |
| ③ Clip | ⑪ Steel ball | ⑲ Check ball |
| ④ Terminal body | ⑫ Control valve inter body | ⑳ Oil cooler relief valve spring |
| ⑤ Control valve lower body | ⑬ Pilot filter | ㉑ O-ring |
| ⑥ Oil strainer | ⑭ Upper inter separating gasket | ㉒ Line pressure solenoid valve spring |
| ⑦ Support plate | ⑮ Separating plate | |
| ⑧ Lower inter separating gasket | ⑯ Upper separating gasket | |

DISASSEMBLY

- Disassemble upper, inter and lower bodies.

Bolt length, number and location:

Bolt symbol	A	B	C	D	E	F
Bolt length "ℓ" mm (in)	13.5 (0.531)	58.0 (2.283)	40.0 (1.575)	66.0 (2.598)	33.0 (1.299)	78.0 (3.071)
Number of bolts	6	3	6	11	2	2

F: Reamer bolt with nut

GI
MA
EM
LC
EC
FE
CL
MT
AT
FA
RA
BR

ST
RS
BT
HA
EL

IDX

REPAIR FOR COMPONENT PARTS

Control Valve Assembly (Cont'd)

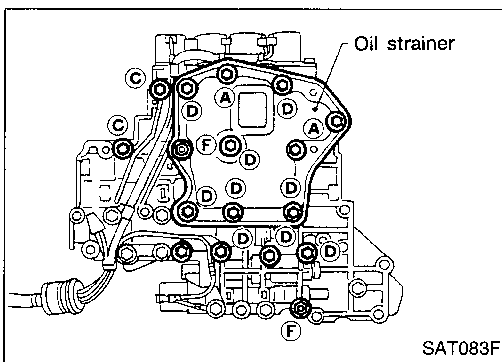
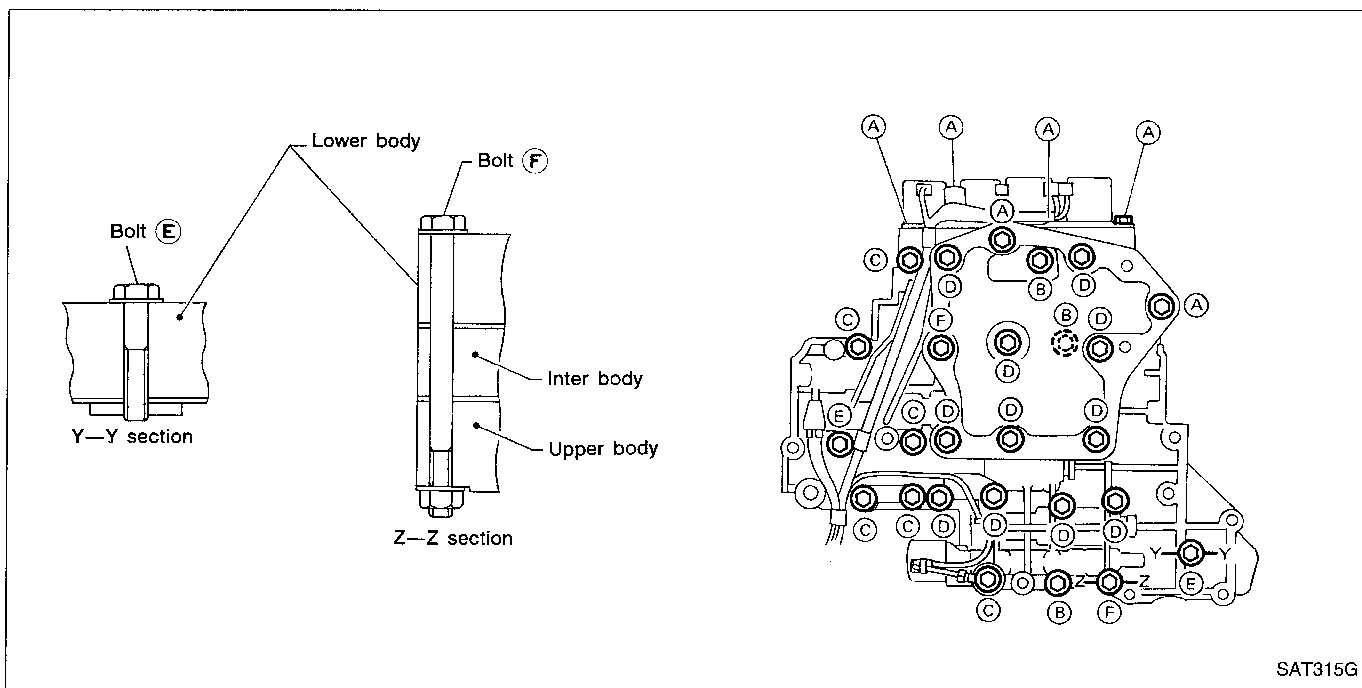

- a. Remove bolts (A), (D) and (F), and remove oil strainer from control valve assembly.

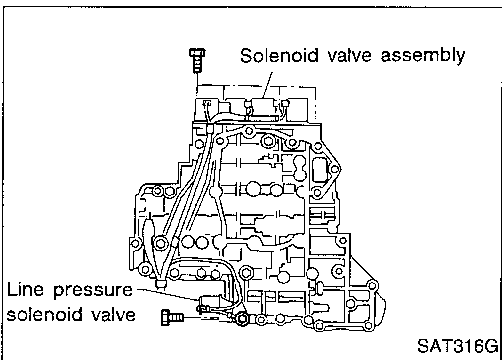

- b. Remove solenoid valve assembly and line pressure solenoid valve from control valve assembly.
 - **Be careful not to lose the line pressure solenoid valve spring.**

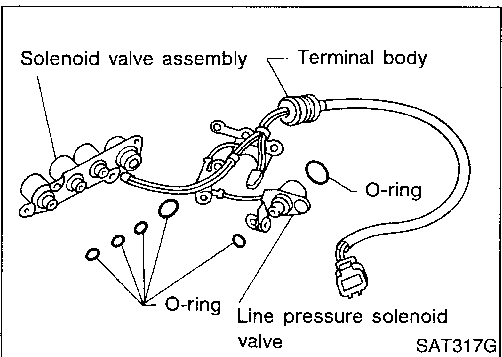

- c. Remove O-rings from solenoid valves and terminal body.

REPAIR FOR COMPONENT PARTS

Control Valve Assembly (Cont'd)

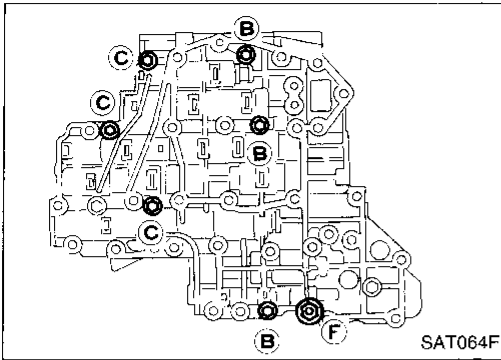

d. Place upper body facedown, and remove bolts (B), (C) and (F).

GI

MA

EM

LC

EC

FE

CL

MT

AT

FA

RA

BR

ST

RS

BT

HA

EL

IDX

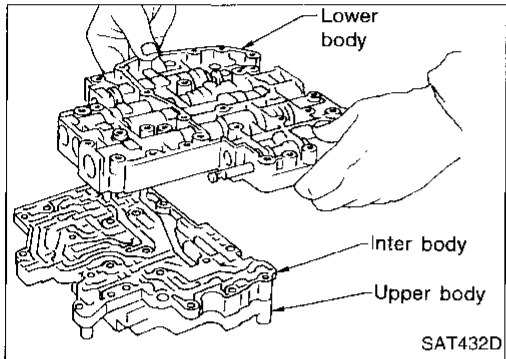

e. Remove lower body from inter body.

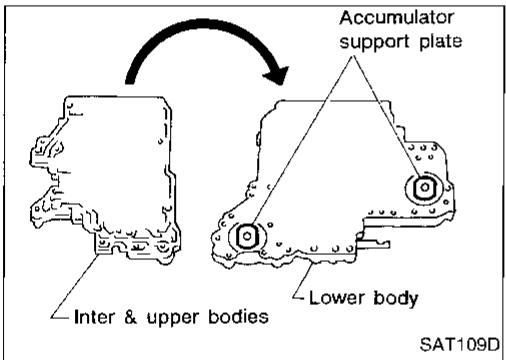

f. Turn over lower body, and accumulator support plates.

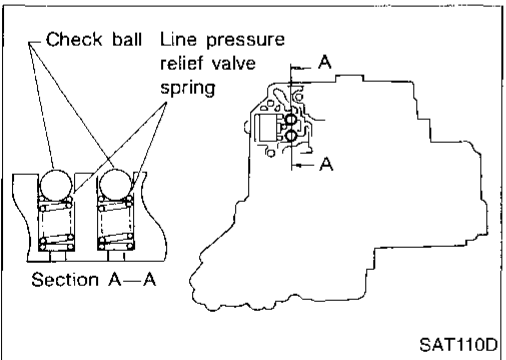

g. Remove bolts (E), separating plate and separating gaskets from lower body.

h. Remove steel balls and relief valve springs from lower body.

• **Be careful not to lose steel balls and relief valve springs.**

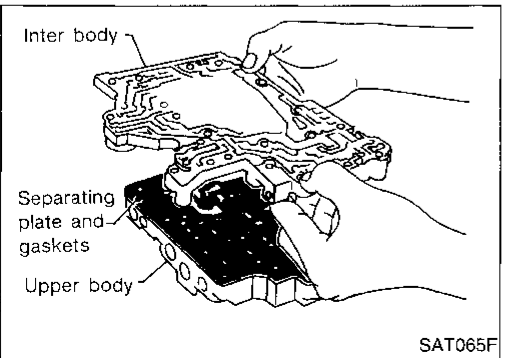

i. Remove inter body from upper body.

j. Remove pilot filter, separating plate and gaskets from upper body.

REPAIR FOR COMPONENT PARTS

Control Valve Assembly (Cont'd)

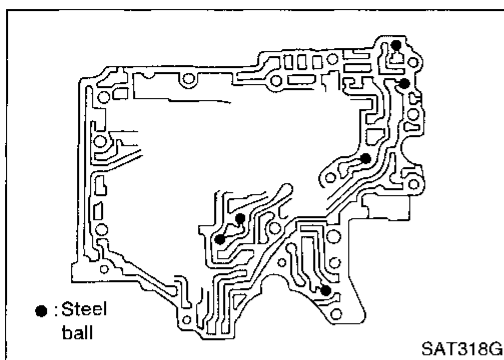

k. Check to see that steel balls are properly positioned in inter body and then remove them.

- **Be careful not to lose steel balls.**

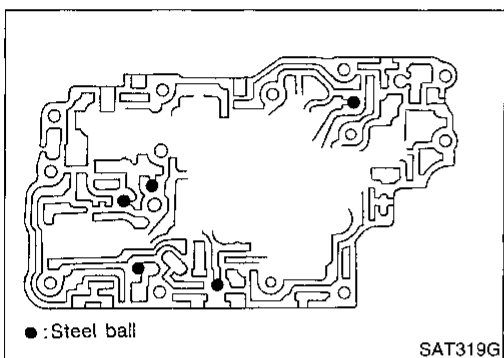

l. Check to see that steel balls are properly positioned in upper body and then remove them.

- **Be careful not to lose steel balls.**

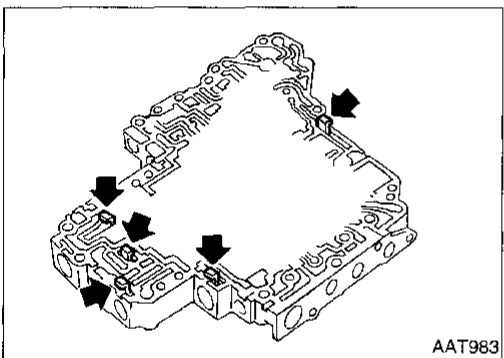

INSPECTION

Lower and upper bodies

- Check to see that retainer plates are properly positioned in lower body.

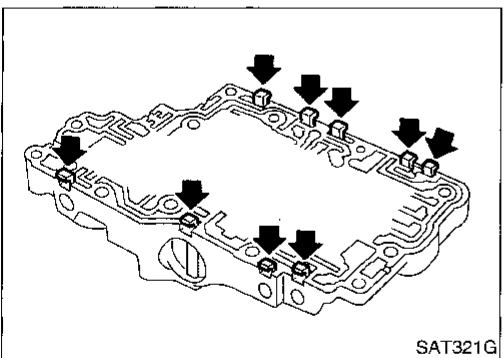

- Check to see that retainer plates are properly positioned in upper body.

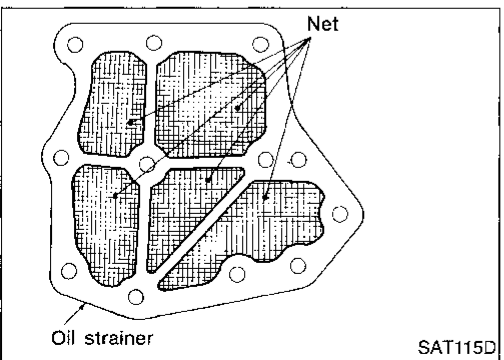

Oil strainer

- Check wire netting of oil strainer for damage.

REPAIR FOR COMPONENT PARTS

Control Valve Assembly (Cont'd)

Shift solenoid valves A and B, line pressure solenoid valve, torque converter clutch solenoid valve and overrun clutch solenoid valve

- Measure resistance. Refer to AT-135.

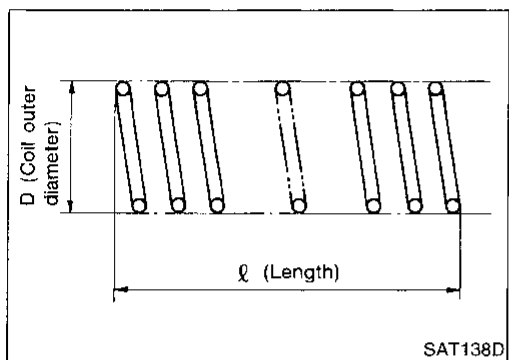
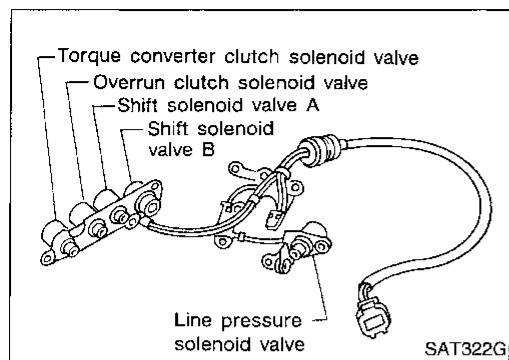

Oil cooler relief valve spring

- Check springs for damage or deformation.
- Measure free length and outer diameter.

Inspection standard:

Part No.	Unit: mm (in)	
	ℓ	D
31872 31X00	17.02 (1.6701)	8.0 (0.315)

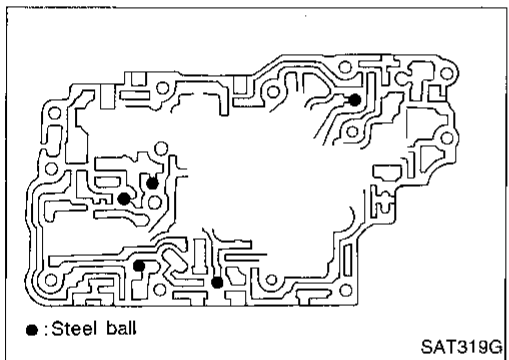

ASSEMBLY

1. Install upper, inter and lower body.
 - a. Place oil circuit of upper body face up. Install steel balls in their proper positions.

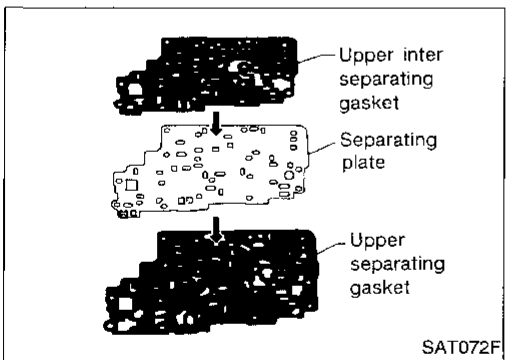

- b. Install upper separating gasket, upper inter separating gasket and upper separating plate in order shown in illustration.
 - **Always use new gaskets.**

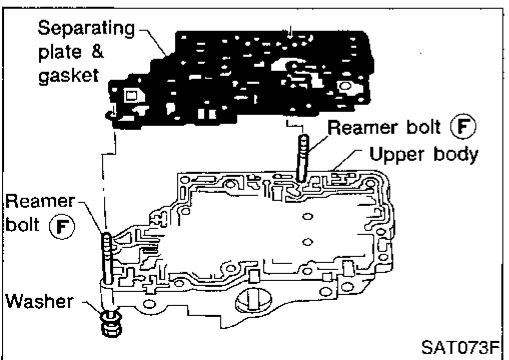

- c. Install reamer bolts (F) from bottom of upper body. Using reamer bolts as guides, install separating plate and gaskets as a seat.

REPAIR FOR COMPONENT PARTS

Control Valve Assembly (Cont'd)

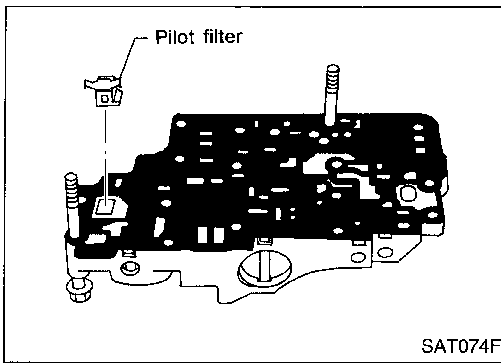

d. Install pilot filter.

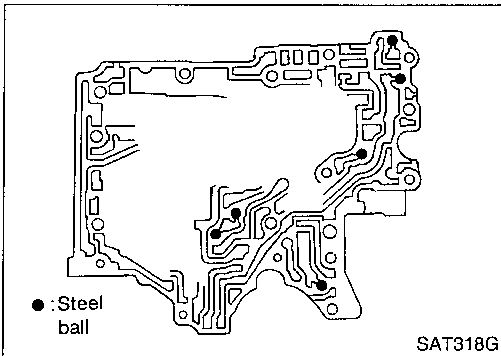

e. Place inter body as shown in the illustration. Install steel balls in their proper positions.

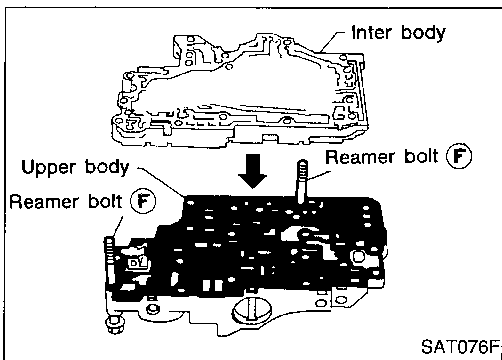

f. Install inter body on upper body using reamer bolts (F) as guides.

● **Be careful not to dislocate or drop steel balls.**

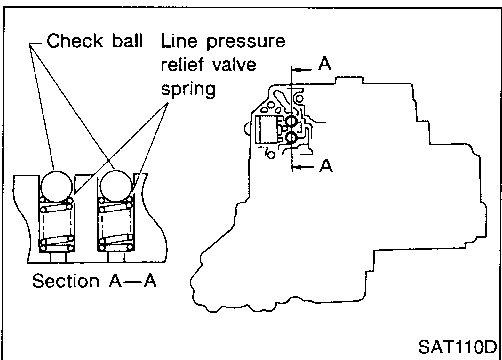

g. Install steel balls and relief valve springs in their proper positions in lower body.

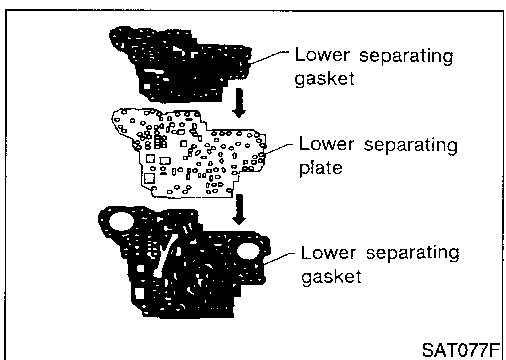

h. Install lower separating gasket, inner separating gasket and lower separating plate in order shown in the illustration.

REPAIR FOR COMPONENT PARTS

Control Valve Assembly (Cont'd)

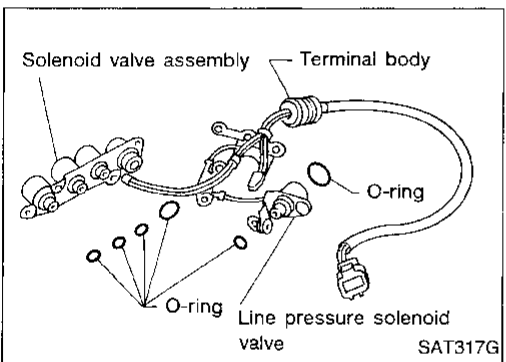
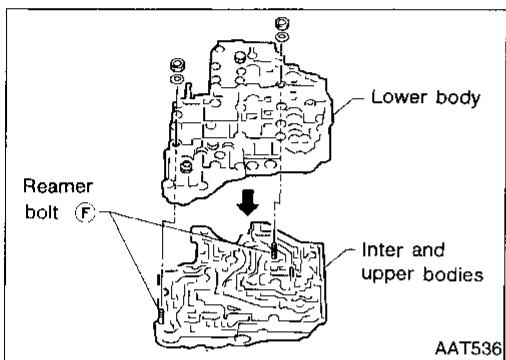
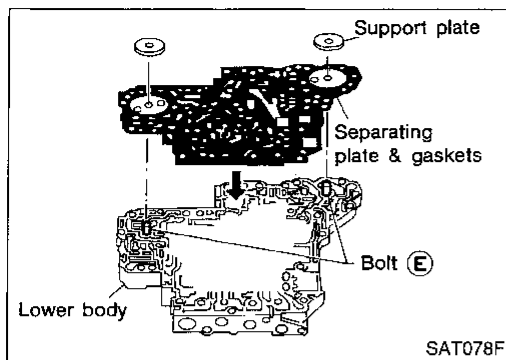

- i. Install bolts (E) from bottom of lower body. Using bolt (E) as guides, install separating plate and gaskets as a set.
- j. Install support plates on lower body.

- k. Install lower body on inter body using reamer bolts (F) as guides and tighten reamer bolts (F) slightly.

- 2. Install O-rings to solenoid valves and terminal body.
 - Apply ATF to O-rings.

- 3. Install and tighten bolts.

Bolt length, number and location:

Bolt symbol	(A)	(B)	(C)	(D)	(E)	(F)
Bolt length "l" mm (in)	13.5 (0.531)	58.0 (2.283)	44.0 (1.732)	66.0 (2.598)	33.0 (1.299)	78.0 (3.071)
Number of bolts	6	3	6	11	2	2

GI

MA

EM

LC

EC

FE

CL

MT

AT

FA

RA

BR

ST

RS

BT

HA

EL

IDX

REPAIR FOR COMPONENT PARTS

Control Valve Assembly (Cont'd)

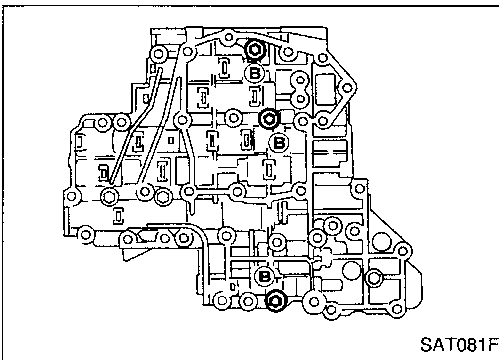
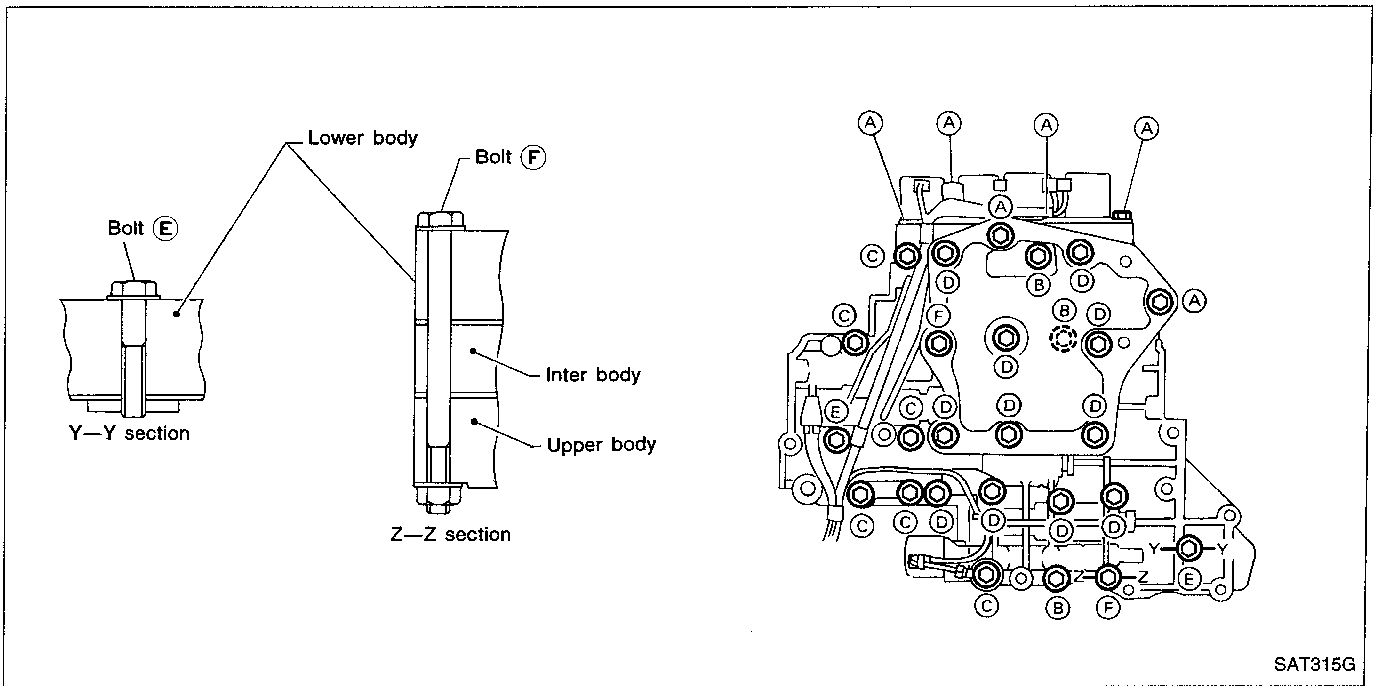

- a. Install and tighten bolts (B) to specified torque.
 ☐ : 7 - 9 N·m (0.7 - 0.9 kg-m, 61 - 78 in-lb)

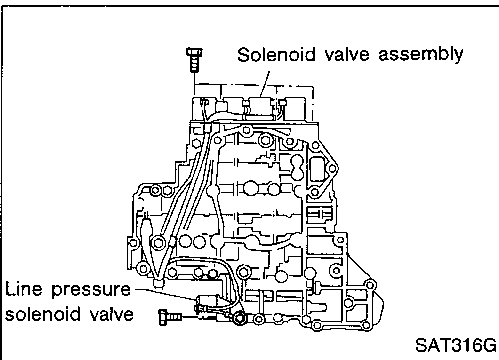

- b. Install solenoid valve assembly and line pressure solenoid valve to lower body.

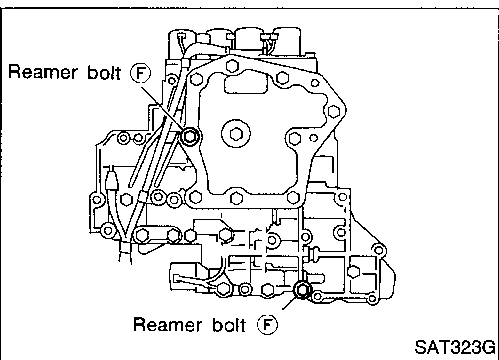

- c. Remove reamer bolts (F) and set oil strainer on control valve assembly.
 d. Reinstall reamer bolts (F) from lower body side.

REPAIR FOR COMPONENT PARTS

Control Valve Assembly (Cont'd)

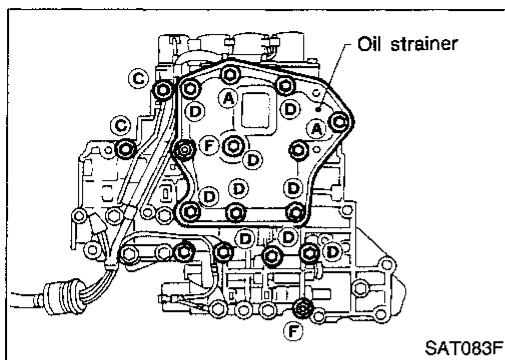

e. Tighten bolts (A), (C), (D) and (F) to specified torque.

: 7 - 9 N·m (0.7 - 0.9 kg-m, 61 - 78 in-lb)

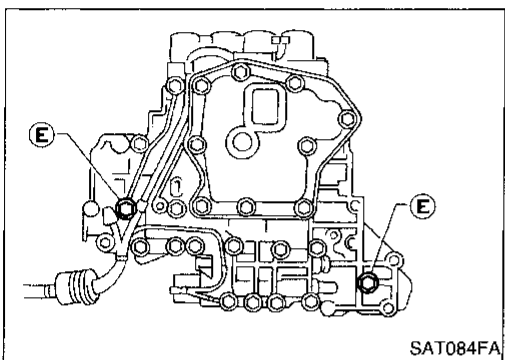

f. Tighten bolts (E) to specified torque.

: 3.4 - 4.4 N·m (0.35 - 0.45 kg-m, 30.4 - 39.1 in-lb)

GI

MA

EM

LC

EC

FE

CL

MT

AT

FA

RA

BR

ST

RS

BT

HA

EL

IDX

REPAIR FOR COMPONENT PARTS

Control Valve Upper Body

SEC. 317

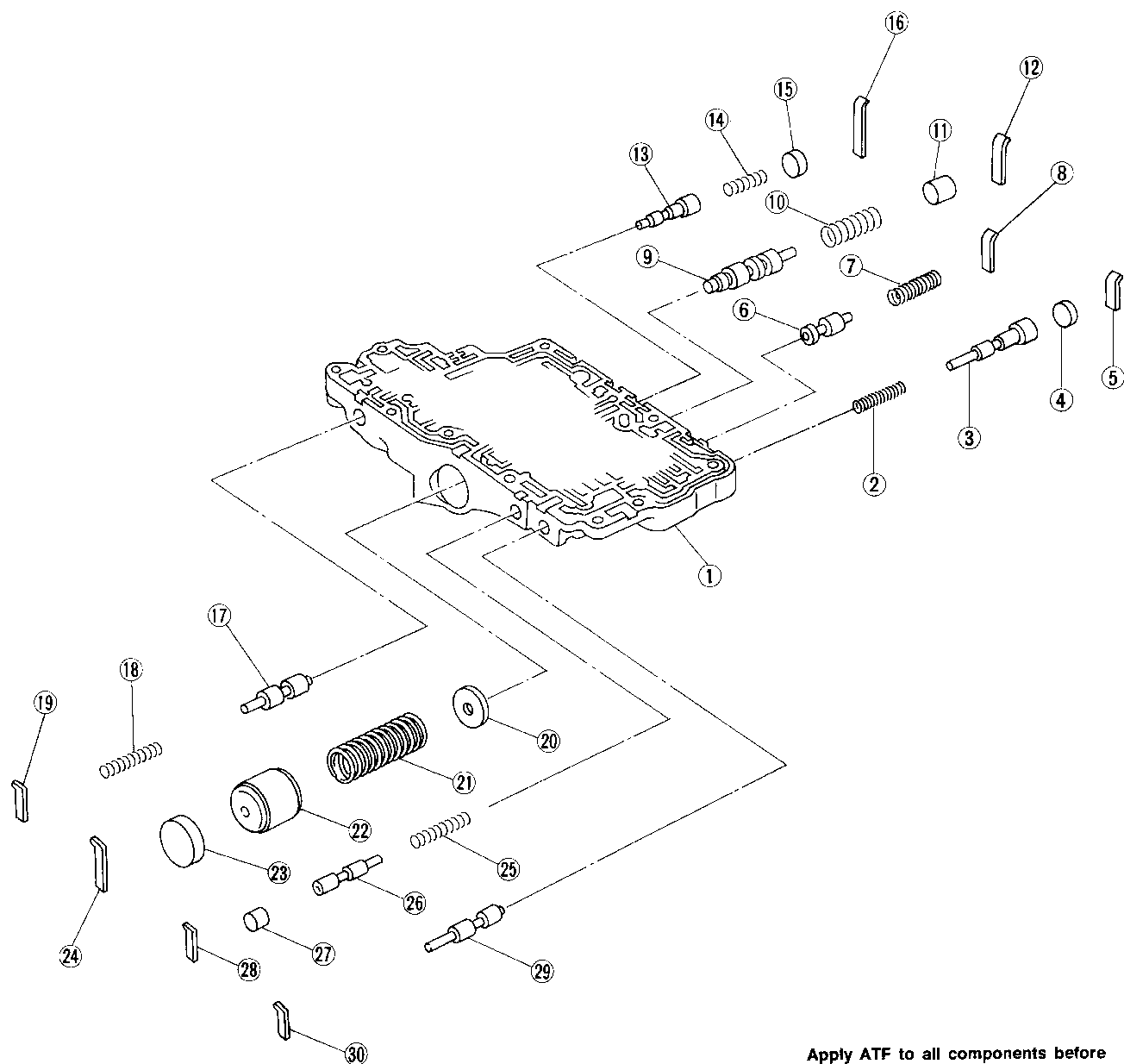

Apply ATF to all components before installation.

Numbers preceding valve springs correspond with those shown in SDS table on page AT-295.

AAT524

- | | | |
|---|----------------------------------|--------------------------|
| ① Control valve upper body | ⑪ Plug | ⑫ 1-2 accumulator piston |
| ② Return spring | ⑫ Retainer plate | ⑬ Plug |
| ③ Overrun clutch reducing valve | ⑬ 1-2 accumulator valve | ⑭ Retainer plate |
| ④ Plug | ⑭ Return spring | ⑮ Return spring |
| ⑤ Retainer plate | ⑮ Plug | ⑯ 1st reducing valve |
| ⑥ Torque converter relief valve | ⑯ Retainer plate | ⑰ Plug |
| ⑦ Return spring | ⑰ Pilot valve | ⑱ Retainer plate |
| ⑧ Retainer plate | ⑱ Return spring | ⑲ 2-3 timing valve |
| ⑨ Torque converter clutch control valve | ⑲ Retainer plate | ⑳ Retainer plate |
| ⑩ Return spring | ⑳ 1-2 accumulator retainer plate | |
| | ㉑ Return spring | |

REPAIR FOR COMPONENT PARTS

Control Valve Upper Body (Cont'd)

DISASSEMBLY

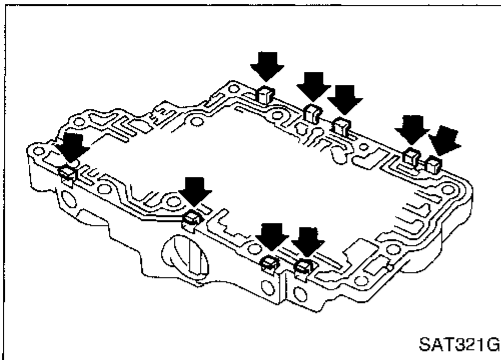

1. Remove valves at retainer plates.
 - Do not use a magnetic "hand".

GI

MA

EM

LC

EC

FE

CL

MT

AT

FA

RA

BR

ST

RS

BT

HA

EL

DX

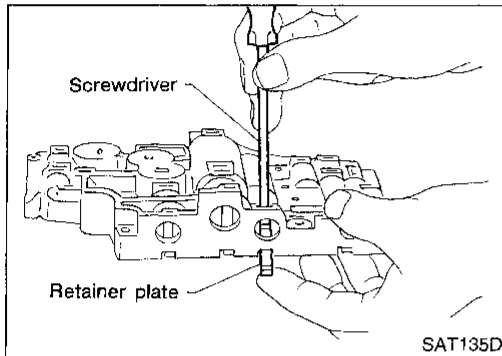

- a. Use a screwdriver to remove retainer plates.

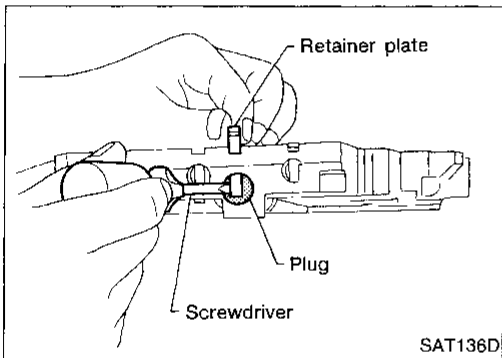

- b. Remove retainer plates while holding spring, plugs or sleeves.
 - Remove plugs slowly to prevent internal parts from jumping out.

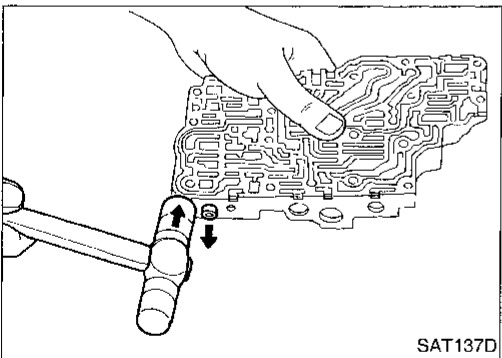

- c. Place mating surface of valve body face down, and remove internal parts.
 - If a valve is hard to remove, place valve body face down and lightly tap it with a soft hammer.
 - Be careful not to drop or damage valves and sleeves.

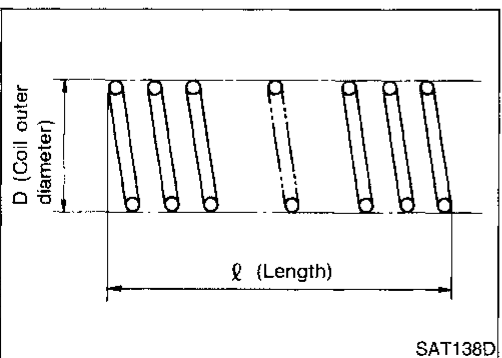

INSPECTION

Valve spring

- Measure free length and outer diameter of each valve spring. Also check for damage or deformation.

Inspection standard:

Refer to SDS, AT-295.

- Replace valve springs if deformed or fatigued.

Control valves

- Check sliding surfaces of valves, sleeves and plugs.

REPAIR FOR COMPONENT PARTS

Control Valve Upper Body (Cont'd)

ASSEMBLY

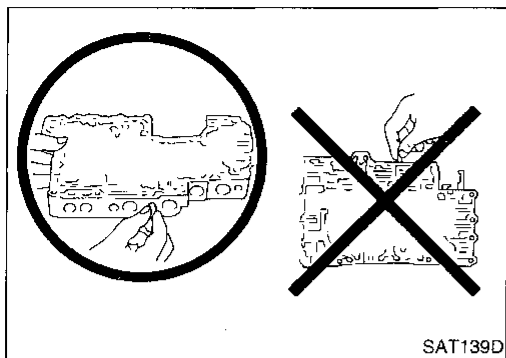

- Lay control valve body down when installing valves. Do not stand the control valve body upright.

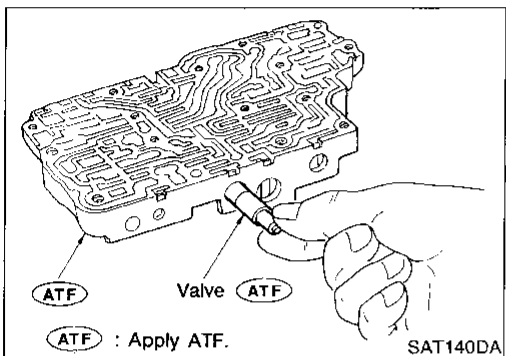

1. Lubricate the control valve body and all valves with ATF. Install control valves by sliding them carefully into their bores.

- Be careful not to scratch or damage valve body.

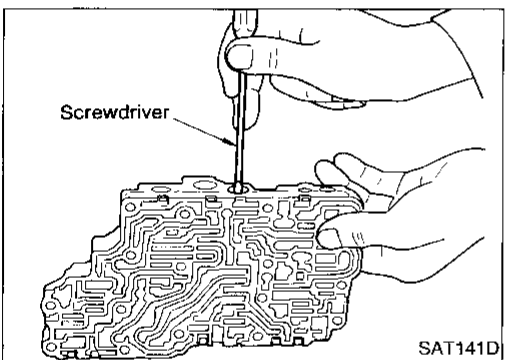

- Wrap a small screwdriver with vinyl tape and use it to insert the valves into their proper positions.

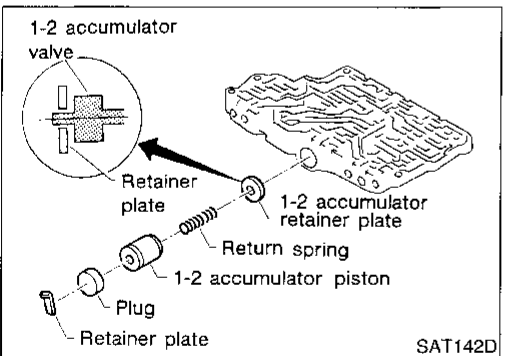

1-2 accumulator valve

- Install 1-2 accumulator valve. Align 1-2 accumulator retainer plate from opposite side of control valve body.
- Install return spring, 1-2 accumulator piston and plug.

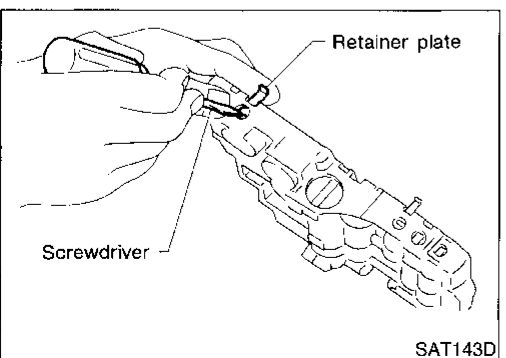

2. Install retainer plates
- Install retainer plate while pushing plug or return spring.

REPAIR FOR COMPONENT PARTS

Control Valve Upper Body (Cont'd)

Retainer plate

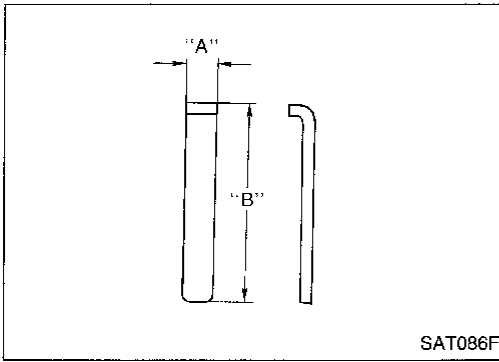

Unit: mm (in)

Name of control valve	Length A	Length B
Pilot valve	6.0 (0.236)	21.5 (0.846)
1-2 accumulator valve		38.5 (1.516)
1-2 accumulator piston valve		21.5 (0.846)
1st reducing valve		24.0 (0.945)
Overrun clutch reducing valve		21.5 (0.846)
Torque converter relief valve		28.0 (1.102)
Torque converter clutch control valve		21.5 (0.846)
2-3 timing valve		

- Install proper retainer plates.

GI

MA

EM

LC

EC

FE

CL

MT

AT

FA

RA

BR

ST

RS

BT

HA

EL

IDX

Control Valve Lower Body

SEC. 317

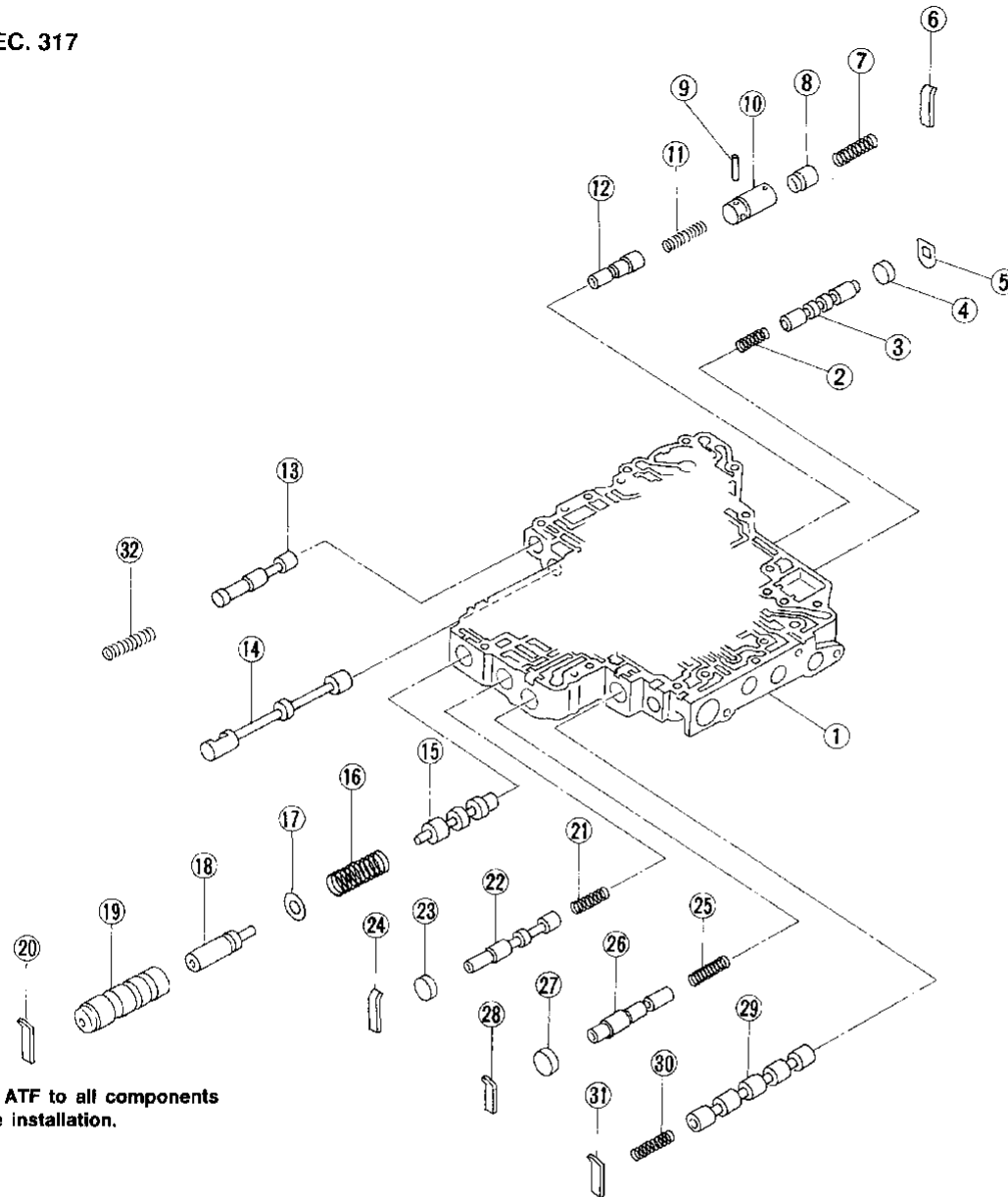

Apply ATF to all components before installation.

AAT946

Numbers preceding valve springs correspond with those shown in SDS table on page AT-295.

- | | | |
|----------------------------|--------------------------------|-----------------------------|
| ① Control valve lower body | ⑫ Pressure modifier valve | ⑳ Plug |
| ② Return spring | ⑬ Plug | ㉑ Retainer plate |
| ③ Shift valve B | ⑭ Manual valve | ㉒ Return spring |
| ④ Plug | ⑮ Pressure regulator valve | ㉓ Accumulator control valve |
| ⑤ Retainer plate | ⑯ Return spring | ㉔ Plug |
| ⑥ Retainer plate | ⑰ Spring seat | ㉕ Retainer plate |
| ⑦ Return spring | ⑱ Plug | ㉖ Shift valve A |
| ⑧ Piston | ㉒ Sleeve | ㉗ Return spring |
| ⑨ Parallel pin | ㉓ Retainer plate | ㉘ Retainer plate |
| ⑩ Sleeve | ㉔ Return spring | ㉙ Return spring |
| ⑪ Return spring | ㉕ Overrun clutch control valve | ㉚ Retainer plate |

REPAIR FOR COMPONENT PARTS

Control Valve Lower Body (Cont'd)

DISASSEMBLY

Remove valves at retainer plate.

For removal procedures, Refer to AT-231.

GI

MA

EM

LC

EC

FE

CL

MT

AT

FA

RA

BR

ST

RS

BT

HA

EL

IDX

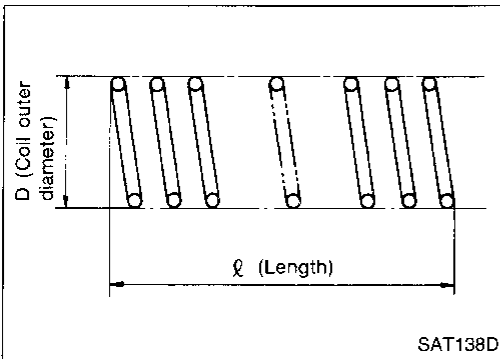
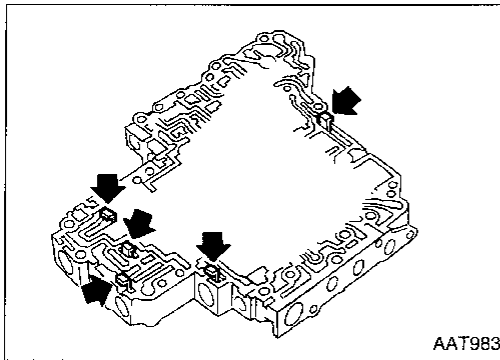

INSPECTION

Valve springs

- Check each valve spring for damage or deformation. Also measure free length and outer diameter.

Inspection standard:

Refer to SDS, AT-295.

- Replace valve springs if deformed or fatigued.

Control valves

- Check sliding surfaces of control valves, sleeves and plugs for damage.

ASSEMBLY

- Install control valves.
For installation procedures, refer to AT-232.

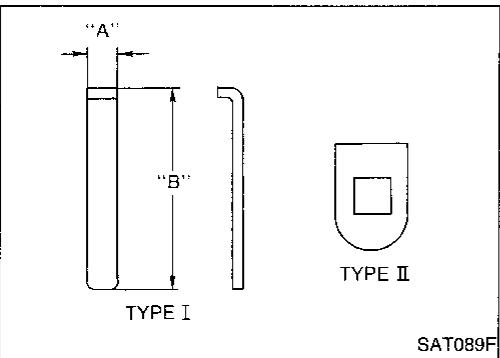
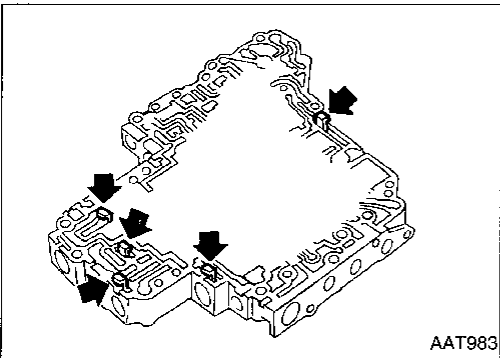

Retainer plate

Unit: mm (in)

Name of control valve and plug	Length A	Length B	Type
Pressure regulator valve	6.0 (0.236)	28.0 (1.102)	I
Accumulator control valve			
Shift valve A			
Overrun clutch control valve			
Pressure modifier valve			
Shift valve B	—	—	II

- Install proper retainer plates.

Reverse Clutch

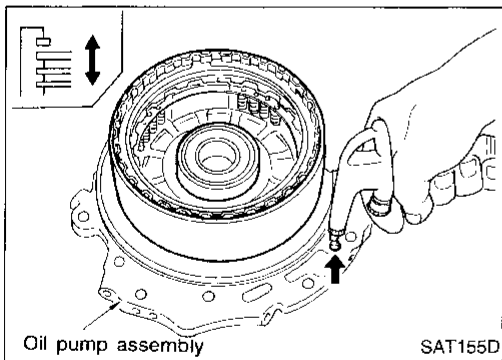
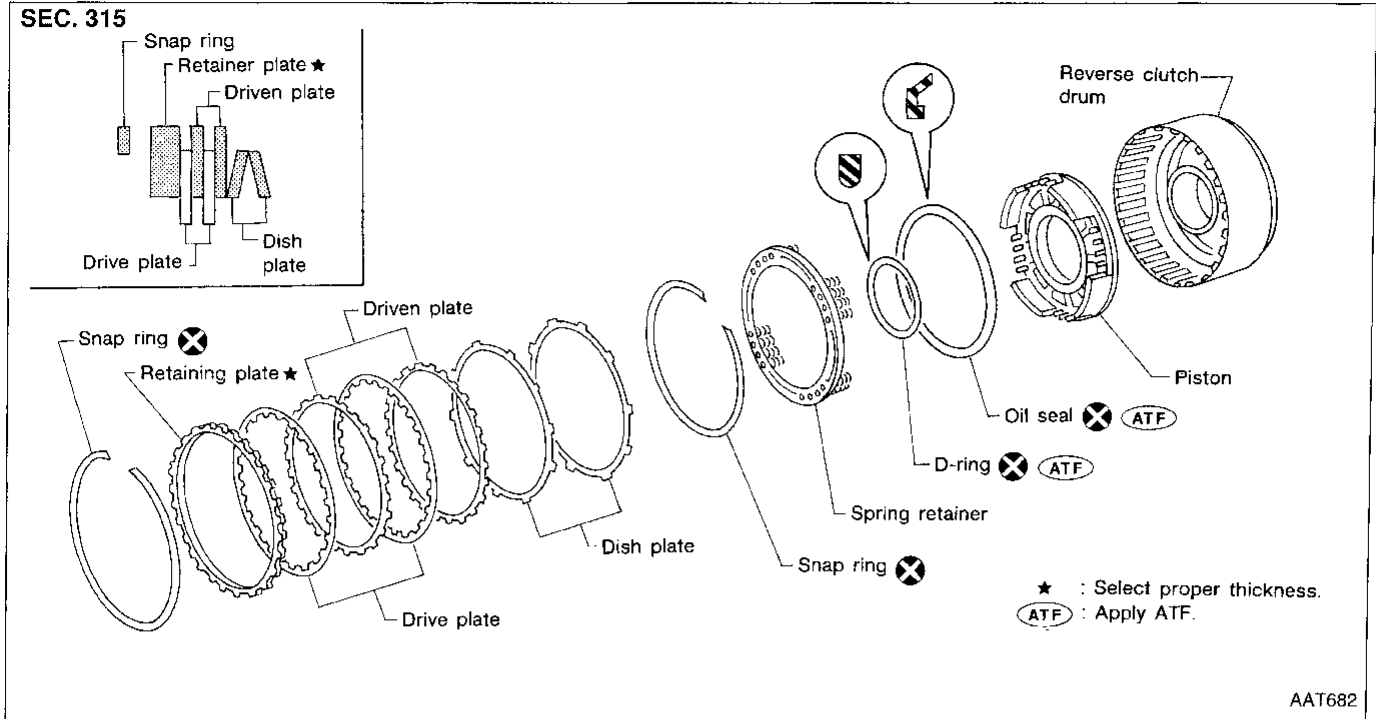

DISASSEMBLY

1. Check operation of reverse clutch.
 - a. Install seal ring onto drum support of oil pump cover and install reverse clutch assembly. Apply compressed air to oil hole.
 - b. Check to see that retaining plate moves to snap ring.
 - c. If retaining plate does not contact snap ring:
 - D-ring might be damaged.
 - Oil seal might be damaged.
 - Fluid might be leaking past piston check ball.
2. Remove snap ring.
3. Remove drive plates, driven plates, retaining plate, and dish plates.

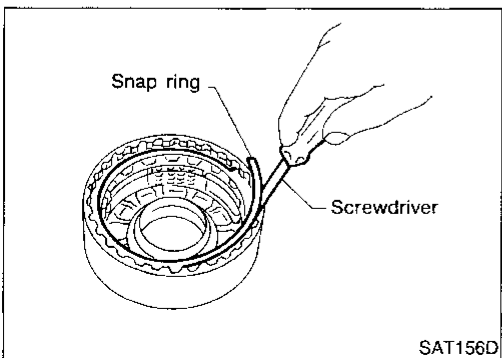

REPAIR FOR COMPONENT PARTS

Reverse Clutch (Cont'd)

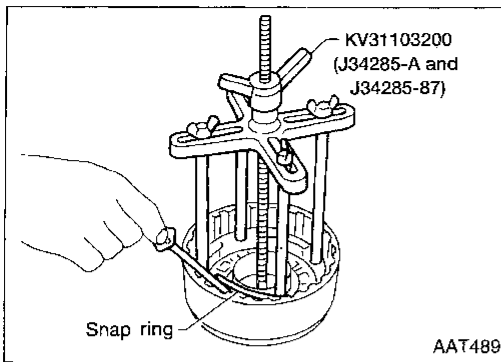

4. Set Tool on spring retainer and remove snap ring from reverse clutch drum while compressing return springs.
- **Set Tool directly above springs.**
- **Do not expand snap ring excessively.**
5. Remove spring retainer and return springs.

GI

MA

EM

LC

EC

FE

CL

MT

AT

FA

RA

BR

ST

RS

BT

HA

EL

IDX

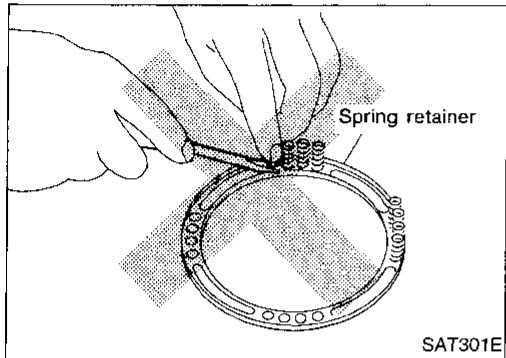

- **Do not remove return springs from spring retainer.**

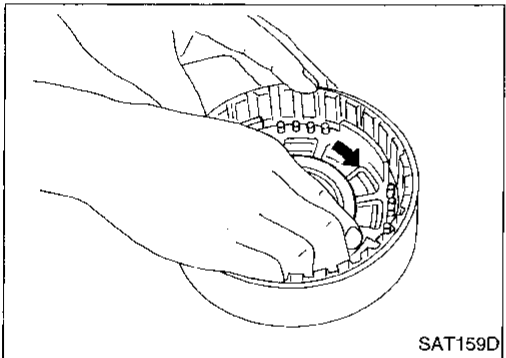

6. Remove piston from reverse clutch drum by turning it.

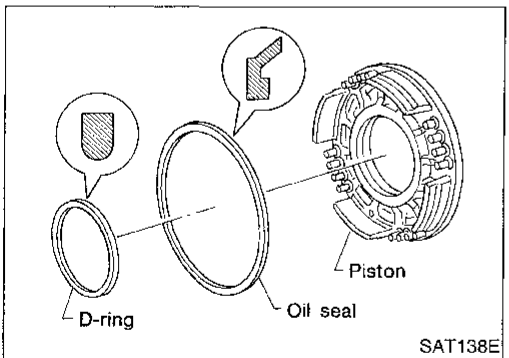

7. Remove D-ring and oil seal from piston.

INSPECTION

Reverse clutch snap ring, spring retainer and return springs

- Check for deformation, fatigue or damage.
- Replace if necessary.
- **When replacing spring retainer and return springs, replace them as a set.**

REPAIR FOR COMPONENT PARTS

Reverse Clutch (Cont'd)

Reverse clutch drive plates

- Check facing for burns, cracks or damage.
- Measure thickness of facing.

Thickness of drive plate:

Standard value: 2.0 mm (0.079 in)

Wear limit: 1.8 mm (0.071 in)

- If not within wear limit, replace.

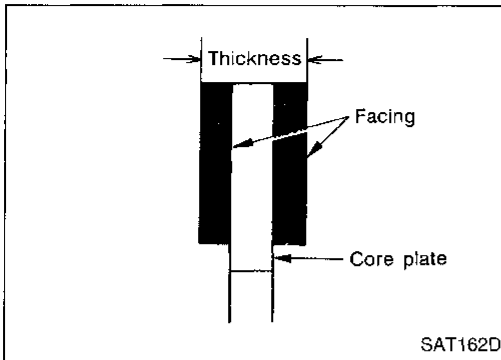

SAT162D

Reverse clutch dish plates

- Check for deformation or damage.
- Measure thickness of dish plate.

Thickness of dish plate "t": 2.8 mm (0.110 in)

- If deformed or fatigued, replace.

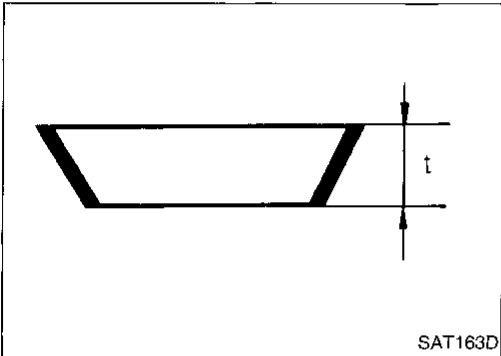

SAT163D

Reverse clutch piston

- Make sure check balls are not fixed.
- Apply compressed air to check ball oil hole opposite the return spring. Make sure that there is no air leakage.
- Apply compressed air to oil hole on return spring side to make sure air leaks past ball.

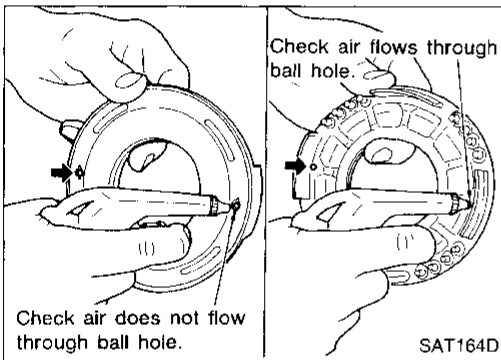

SAT164D

ASSEMBLY

1. Install D-ring and oil seal on piston.
 - Take care with the direction of the oil seal.
 - Apply ATF to both parts.

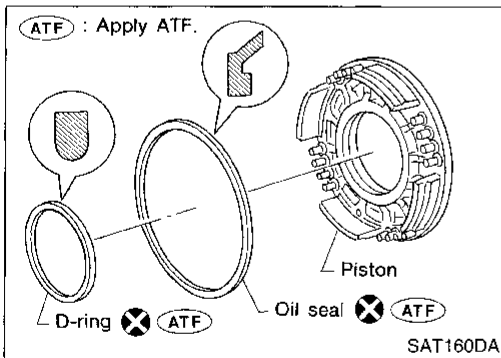

SAT160DA

2. Install piston assembly by turning it slowly.
 - Apply ATF to inner surface of drum.

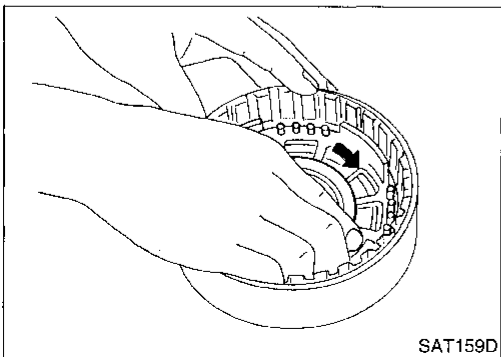

SAT159D

REPAIR FOR COMPONENT PARTS

Reverse Clutch (Cont'd)

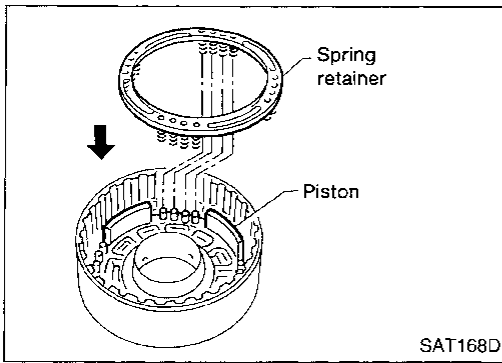

3. Install return springs and spring retainer on piston.

GI

MA

EM

LC

EC

FE

CL

MT

AT

FA

RA

BR

ST

RS

BT

HA

EL

IDX

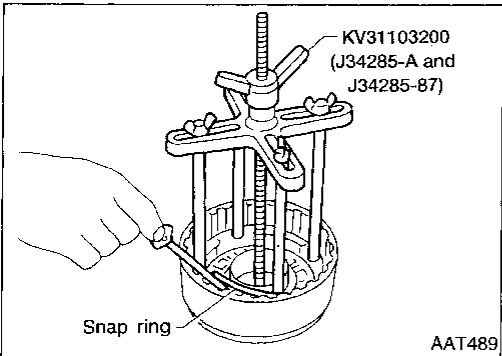

4. Set Tool on spring retainer and install snap ring while compressing return springs.

- Set Tool directly above return springs.

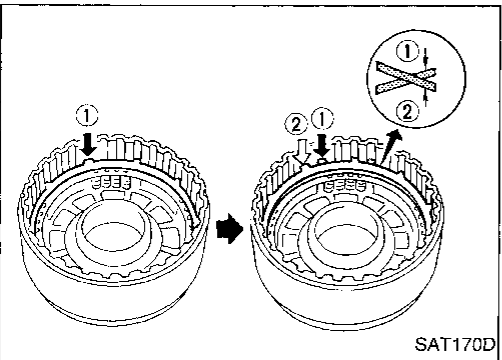

5. Install drive plates, driven plates, retaining plate and dish plates.

- Do not align the projections of any two dish plates.
- Take care with the order and direction of plates.

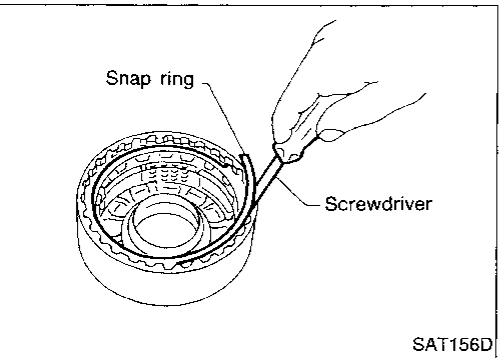

6. Install snap ring.

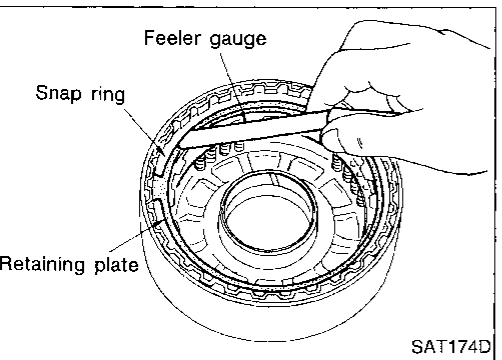

7. Measure clearance between retaining plate and snap ring. If not within allowable limit, select proper retaining plate.

Specified clearance:

Standard: 0.5 - 0.8 mm (0.020 - 0.031 in)

Allowable limit: 1.2 mm (0.047 in)

Retaining plate: Refer to SDS, AT-296.

REPAIR FOR COMPONENT PARTS

Reverse Clutch (Cont'd)

8. Check operation of reverse clutch.
Refer to AT-236.

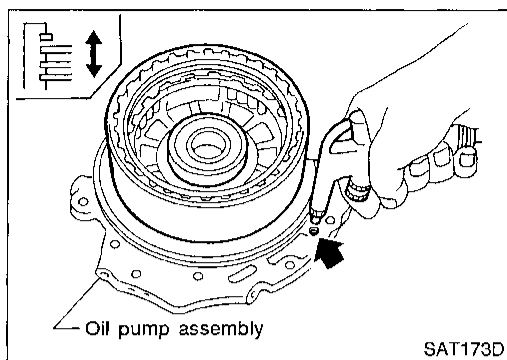

High Clutch

SEC. 315

For the number of clutch sheets (drive plates and driven plates), refer to the below cross-section.

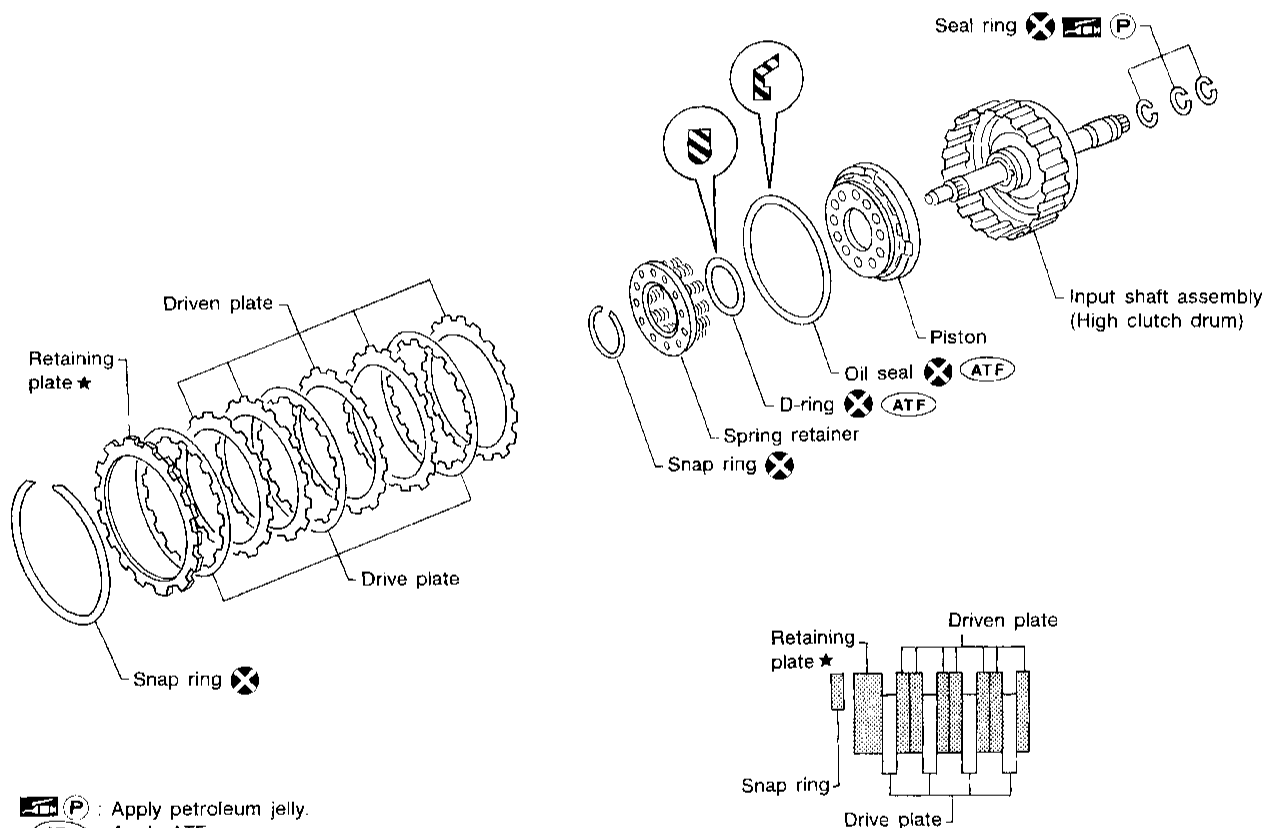

- : Apply petroleum jelly.
- : Apply ATF.
- ★ : Select proper thickness.

AAT212A

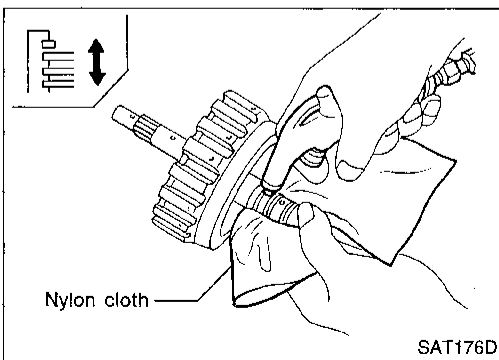

DISASSEMBLY

1. Check operation of high clutch.
 - a. Apply compressed air to oil hole of input shaft.
 - **Stop up a hole on opposite side of input shaft.**
 - b. Check to see that retaining plate moves to snap ring.
 - c. If retaining plate does not contact snap ring:
 - D-ring might be damaged.
 - Oil seal might be damaged.
 - Fluid might be leaking past piston check ball.

REPAIR FOR COMPONENT PARTS

High Clutch (Cont'd)

2. Remove seal rings from input shaft.

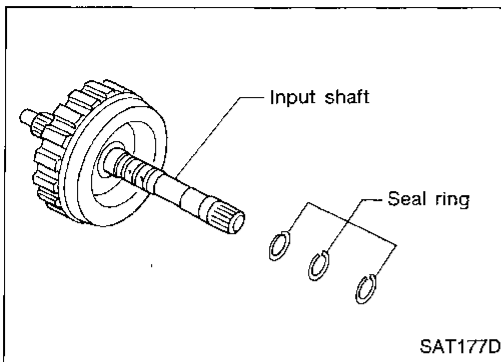

GI

MA

EM

LC

EC

FE

CL

MT

AT

FA

RA

BR

ST

RS

BT

HA

EL

IDX

3. Remove snap ring.

4. Remove drive plates, driven plates and retaining plate.

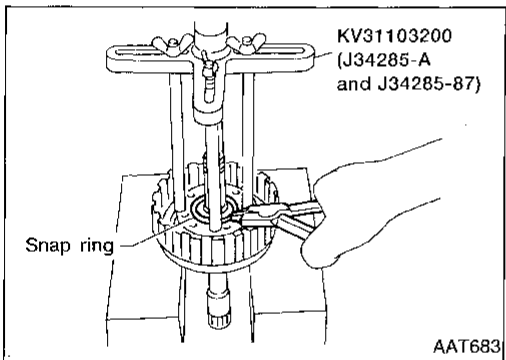
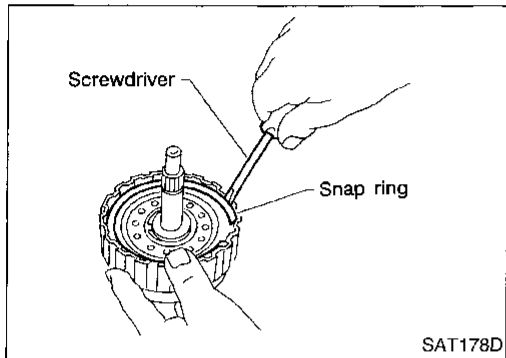

5. Set Tool on spring retainer and remove snap ring from high clutch drum while compressing return springs.

- **Set Tool directly above springs.**
- **Do not expand snap ring excessively.**

6. Remove spring retainer and return springs.

- **Do not remove return spring from spring retainer.**

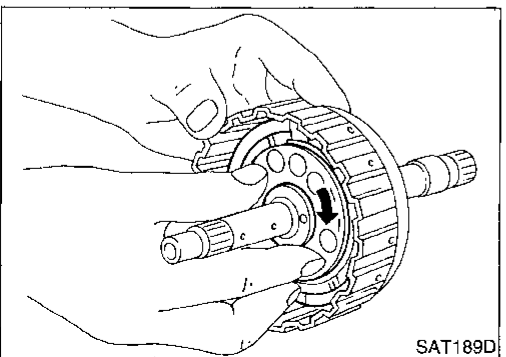
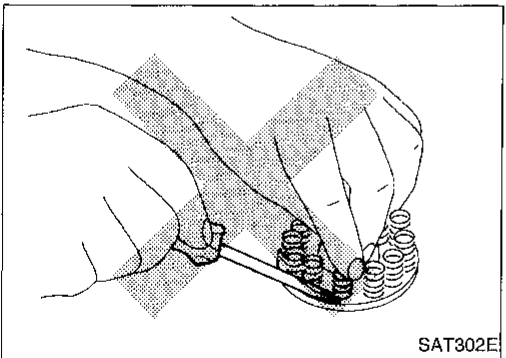

7. Remove piston from high clutch drum by turning it.

REPAIR FOR COMPONENT PARTS

High Clutch (Cont'd)

- Remove D-ring and oil seal from piston.

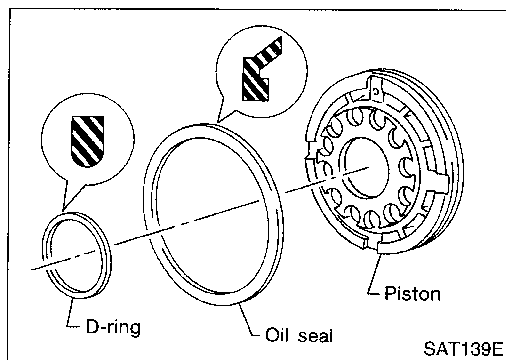

INSPECTION

Reverse clutch snap ring, spring retainer and return springs

- Check for deformation, fatigue or damage.
- Replace if necessary.
- When replacing spring retainer and return springs, replace them as a set.

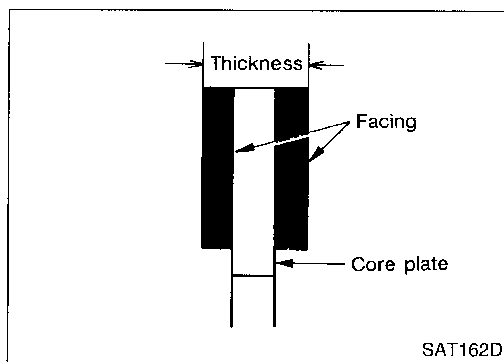

High clutch drive plates

- Check facing for burns, cracks or damage.
- Measure thickness of facing.

Thickness of drive plate:

Standard value: 1.6 mm (0.063 in)

Wear limit: 1.4 mm (0.055 in)

- If not within wear limit, replace.

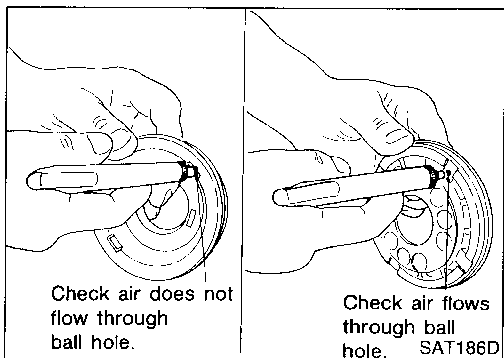

High clutch piston

- Make sure check balls are not fixed.
- Apply compressed air to check ball oil hole opposite the return spring. Make sure there is no air leakage.
- Apply compressed air to oil hole on return spring side to make sure air leaks past ball.

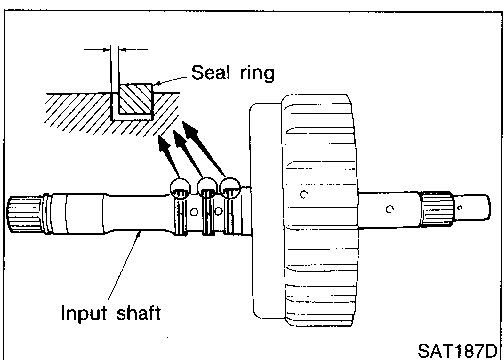

Seal ring clearance

- Install new seal rings onto input shaft.
- Measure clearance between seal ring and ring groove.

Standard clearance:

0.08 - 0.23 mm (0.0031 - 0.0091 in)

Allowable limit:

0.23 mm (0.0091 in)

- If not within wear limit, replace input shaft assembly.

REPAIR FOR COMPONENT PARTS

High Clutch (Cont'd)

ASSEMBLY

1. Install D-ring and oil seal on piston.
 - Take care with the direction of the oil seal.
 - Apply ATF to both parts.

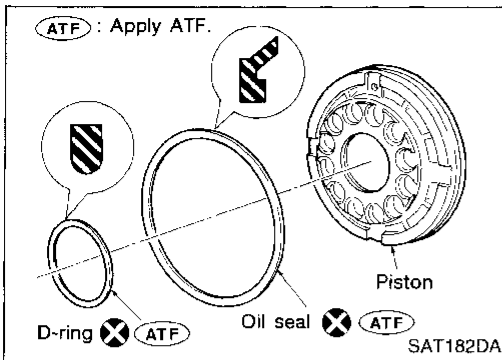

2. Install piston assembly by turning it slowly.
 - Apply ATF to inner surface of drum.

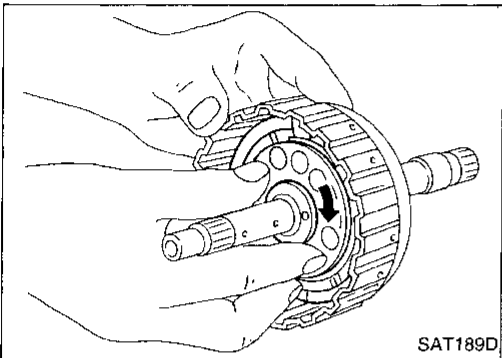

3. Install return springs and spring retainer on piston.

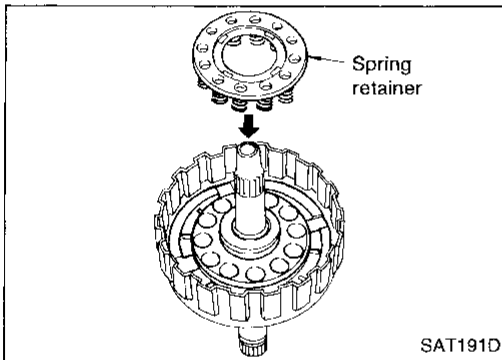

4. Set Tool on spring retainer and install snap ring while compressing return springs.
 - Set Tool directly above return springs.

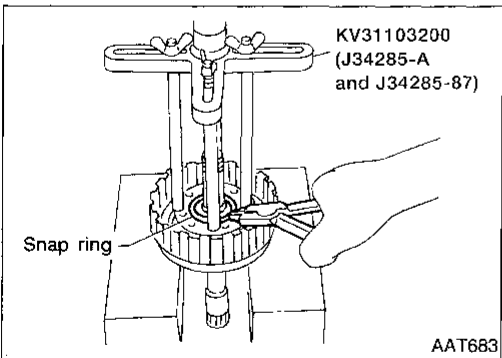

- Do not align snap ring gap with spring retainer stopper.

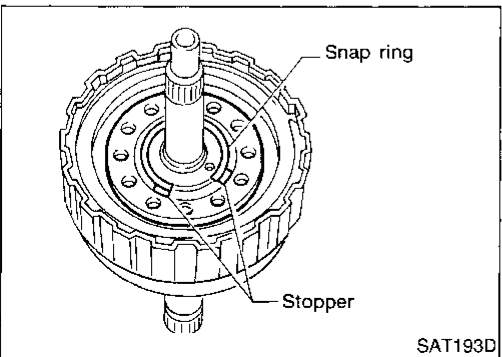

GI

MA

EM

LC

EC

FE

CL

MT

AT

FA

RA

BR

ST

RS

ET

HA

EL

IDX

REPAIR FOR COMPONENT PARTS

High Clutch (Cont'd)

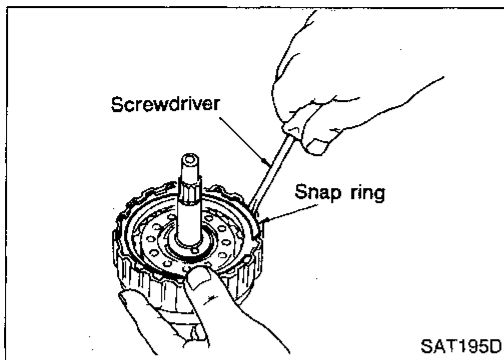

5. Install drive plates, driven plates and retaining plate. **Take care with the order and direction of plates.**
6. Install snap ring.

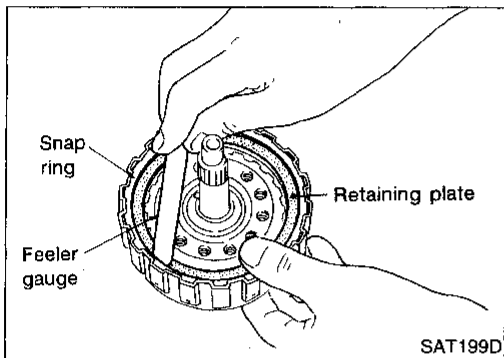

7. Measure clearance between retaining plate and snap ring. If not within allowable limit, select proper retaining plate.

Specified clearance:

Standard: 1.4 - 1.8 mm (0.055 - 0.071 in)

Allowable limit: 2.6 mm (0.102 in)

Retaining plate:

Refer to SDS, AT-296.

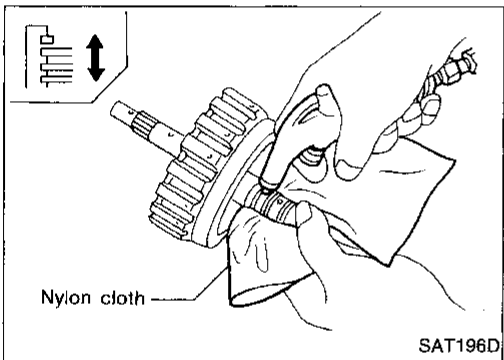

8. Check operation of high clutch. Refer to "DISASSEMBLY", "High Clutch", AT-240.

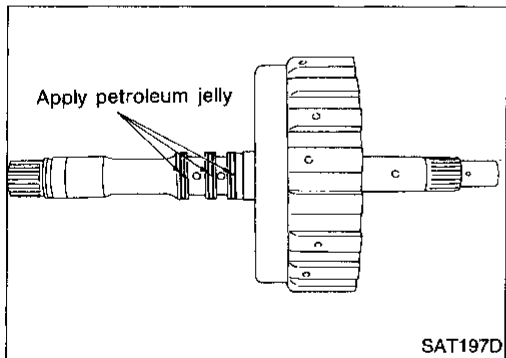

9. Install seal rings to input shaft.
 - **Apply petroleum jelly to seal rings.**

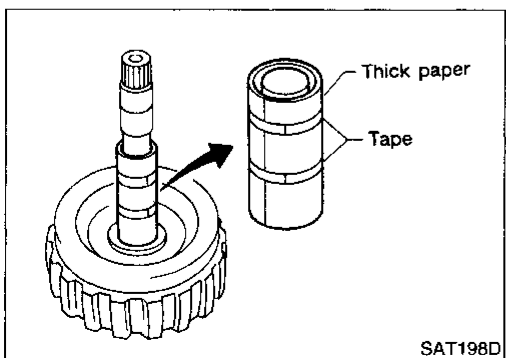

- **Roll paper around seal rings to prevent seal rings from spreading.**

Forward Clutch and Overrun Clutch

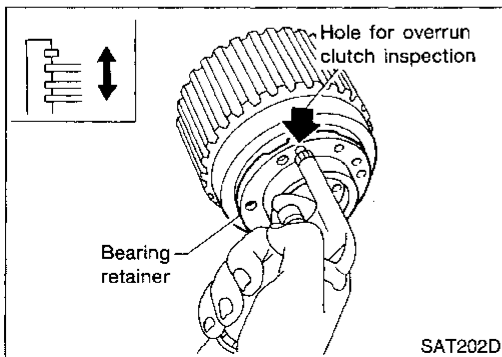
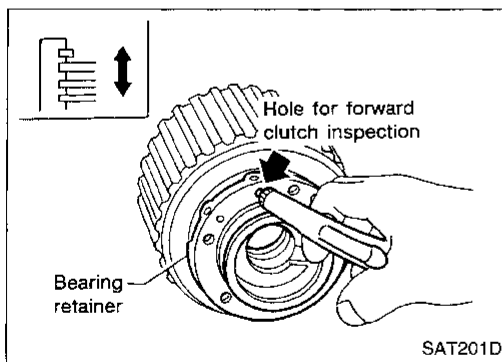
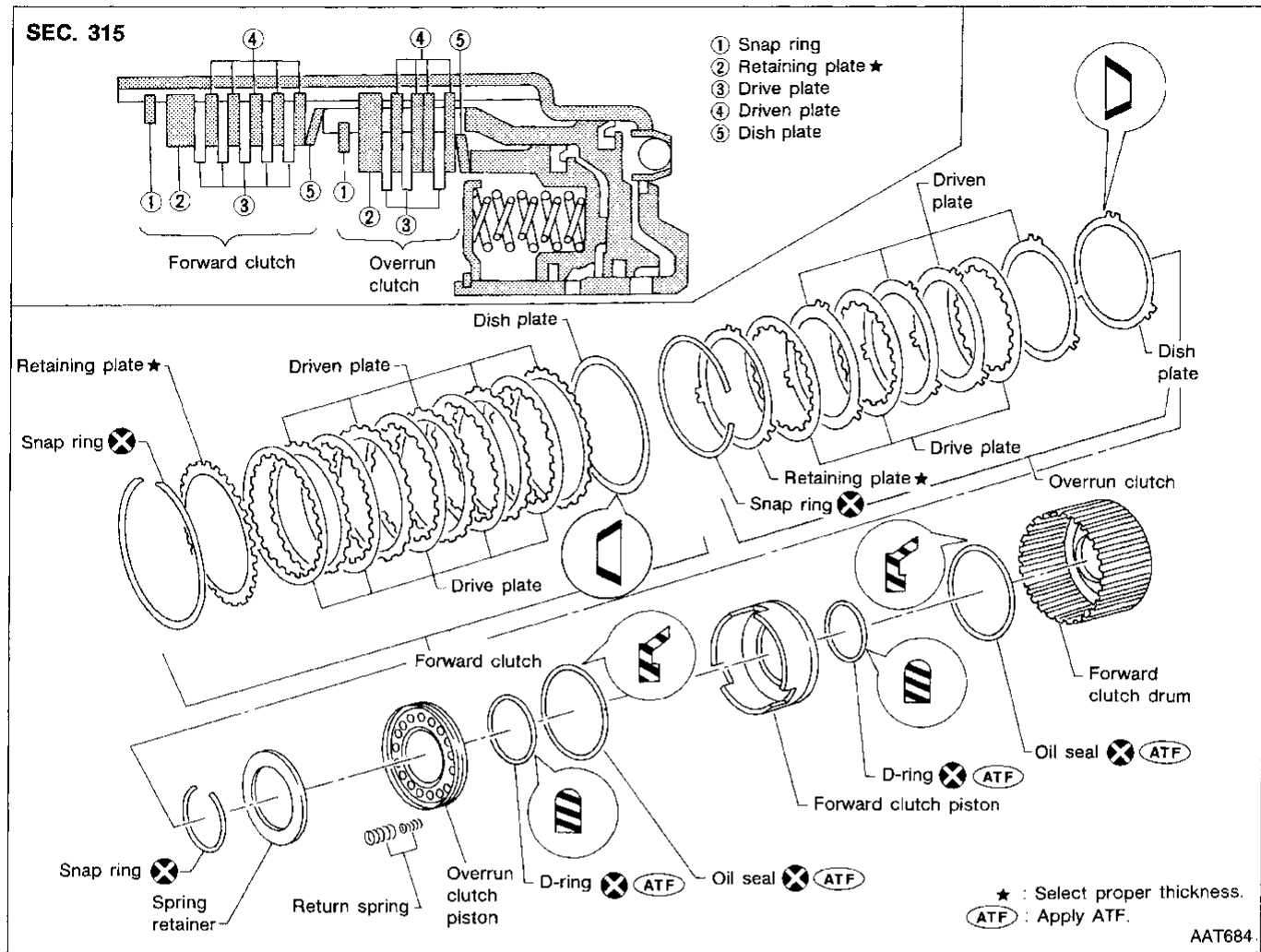

DISASSEMBLY

1. Check operation of forward clutch and overrun clutch.
 - a. Install bearing retainer on forward clutch drum.
 - b. Apply compressed air to oil hole of forward clutch drum.
 - c. Check to see that retaining plate moves to snap ring.
- d. If retaining plate does not contact snap ring:
 - D-ring might be damaged.
 - Oil seal might be damaged.
 - Fluid might be leaking past piston check ball.

GI
MA
EM
LC
EC
FE
CL
MT
AT
FA
RA
BR
ST
RS
BT
HA
EL
IDX

REPAIR FOR COMPONENT PARTS

Forward Clutch and Overrun Clutch (Cont'd)

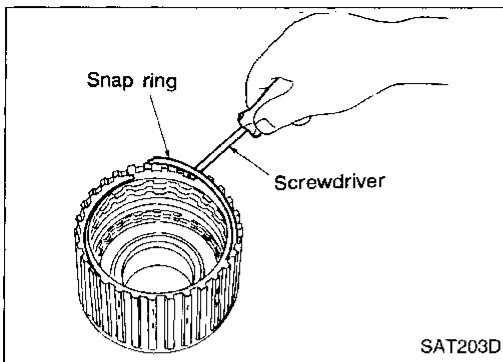

2. Remove snap ring for forward clutch.
3. Remove drive plates, driven plates, retaining plate and dish plate for forward clutch.

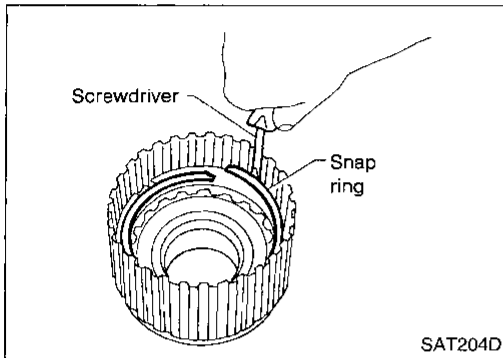

4. Remove snap ring for overrun clutch.
5. Remove drive plates, driven plates, retaining plate and dish plate for overrun clutch.

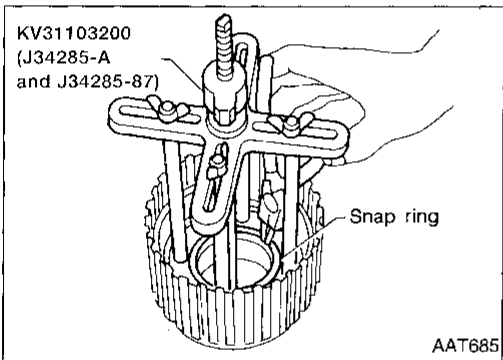

6. Set Tool on spring retainer and remove snap ring from forward clutch drum while compressing return springs.

- **Set Tool directly above return springs.**

- **Do not expand snap ring excessively.**

7. Remove spring retainer and return springs.

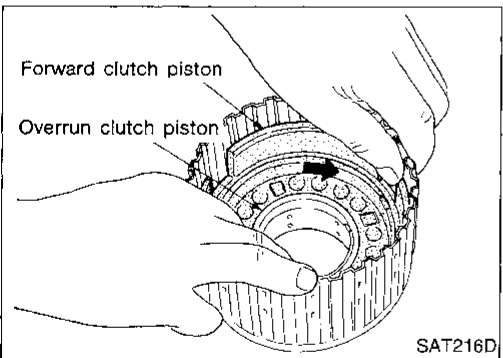

8. Remove forward clutch piston with overrun clutch piston from forward clutch drum by turning it.

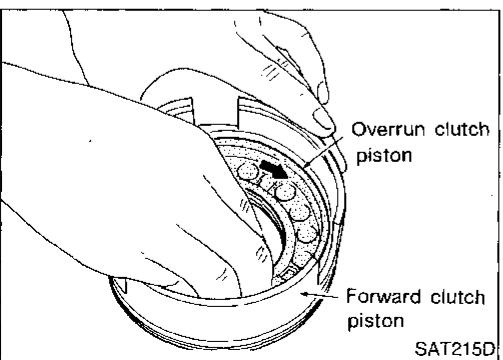

9. Remove overrun clutch piston from forward clutch piston by turning it.

REPAIR FOR COMPONENT PARTS

Forward Clutch and Overrun Clutch (Cont'd)

10. Remove D-rings and oil seals from forward clutch piston and overrun clutch piston.

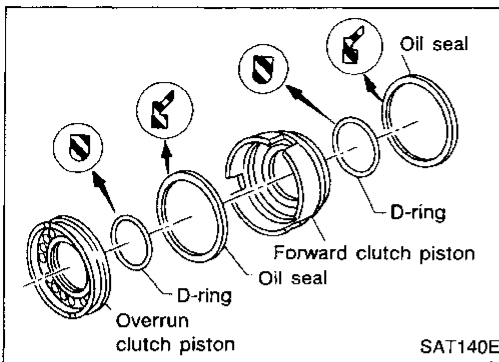

INSPECTION

Snap rings and spring retainer

- Check for deformation, fatigue or damage.

GI

MA

EM

LG

EC

PE

CL

MT

AT

FA

RA

BR

ST

RS

BT

HA

EL

IDX

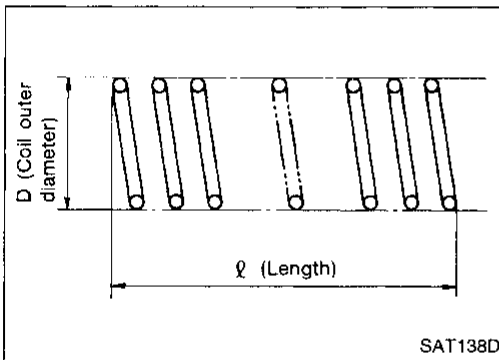

Forward clutch and overrun clutch return springs

- Check for deformation or damage.
- Measure free length and outer diameter.

Inspection standard:

Refer to SDS, AT-297.

- Replace if deformed or fatigued.

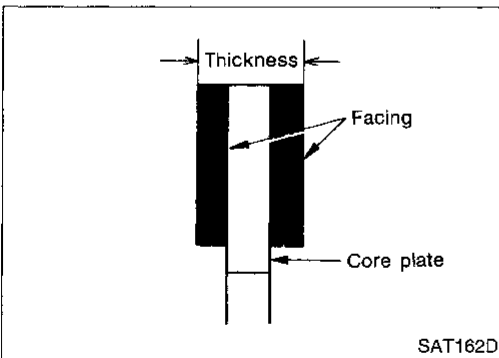

Forward clutch and overrun clutch drive plates

- Check facing for burns, cracks or damage.
- Measure thickness of facing.

Thickness of drive plate:

Forward clutch

Standard value: 1.8 mm (0.071 in)

Wear limit: 1.6 mm (0.063 in)

Overrun clutch

Standard value: 1.6 mm (0.063 in)

Wear limit: 1.4 mm (0.055 in)

- If not within wear limit, replace.

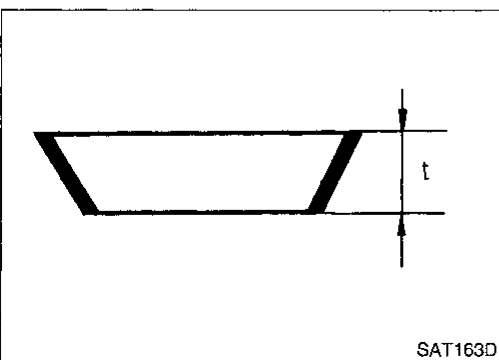

Forward clutch and overrun clutch dish plates

- Check for deformation or damage.
- Measure thickness of dish plate.

Thickness of dish plate "t":

Forward clutch: 2.5 mm (0.098 in)

Overrun clutch: 2.15 mm (0.0846 in)

- If deformed or fatigued, replace.

REPAIR FOR COMPONENT PARTS

Forward Clutch and Overrun Clutch (Cont'd)

Forward clutch drum

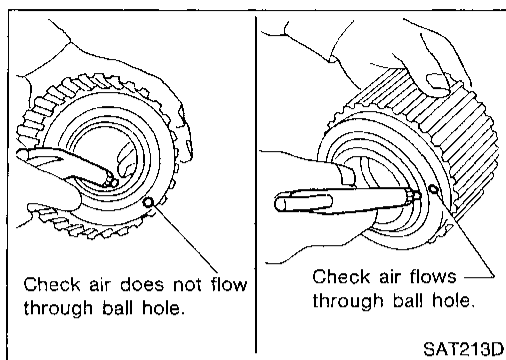

- Make sure check balls are not fixed.
- Apply compressed air to check ball oil hole from outside of forward clutch drum. Make sure air leaks past ball.
- Apply compressed air to oil hole from inside of forward clutch drum. Make sure there is no air leakage.

Overrun clutch piston

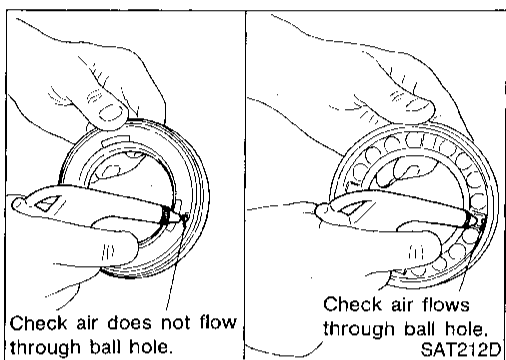

- Make sure check balls are not fixed.
- Apply compressed air to check ball oil hole opposite the return spring. Make sure there is no air leakage.
- Apply compressed air to oil hole on return spring side. Make sure air leaks past ball.

ASSEMBLY

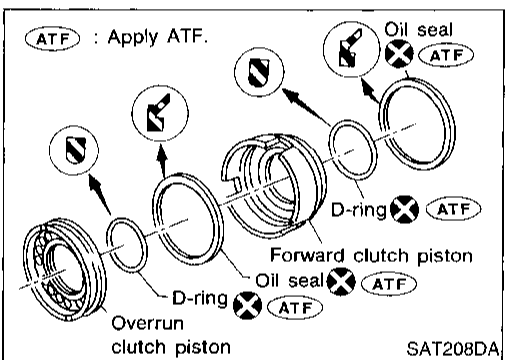

1. Install D-rings and oil seals on forward clutch piston and overrun clutch piston.

- Take care with direction of oil seal.
- Apply ATF to both parts.

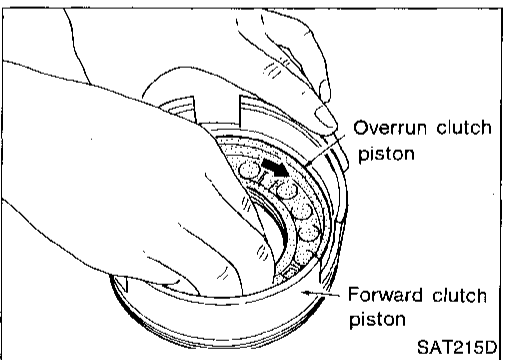

2. Install overrun clutch piston assembly on forward clutch piston while turning it slowly.

- Apply ATF to inner surface of forward clutch piston.

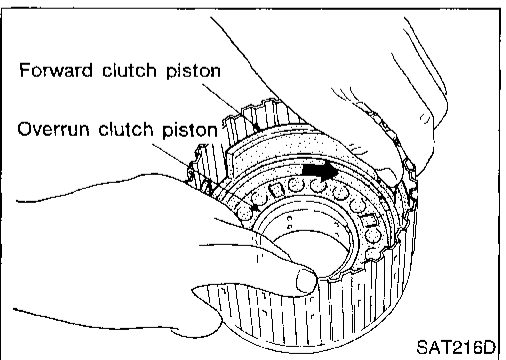

3. Install forward clutch piston assembly on forward clutch drum while turning it slowly.

- Apply ATF to inner surface of drum.

REPAIR FOR COMPONENT PARTS

Forward Clutch and Overrun Clutch (Cont'd)

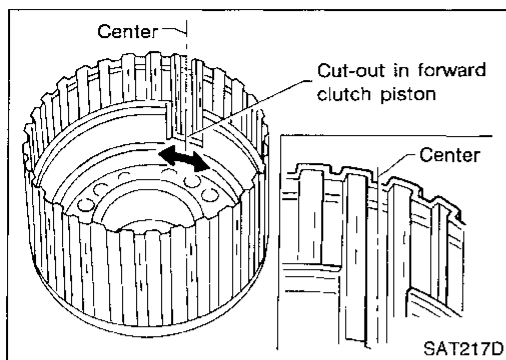

- Align notch in forward clutch piston with groove in forward clutch drum.

GI

MA

EM

LC

EC

FE

CL

MT

AT

FA

RA

BR

ST

RS

ET

HA

EL

IDX

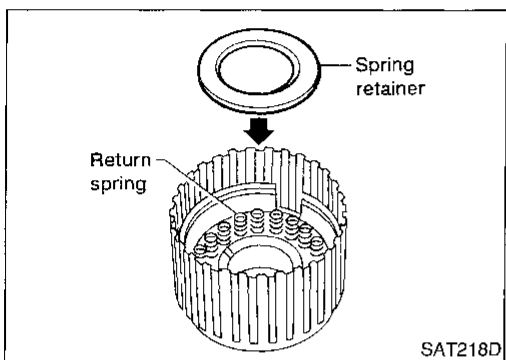

- Install return spring on piston.
- Install spring retainer on return springs.

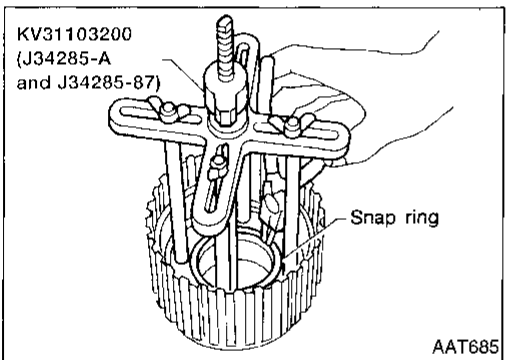

- Set Tool on spring retainer and install snap ring while compressing return springs.

- Set Tool directly above return springs.

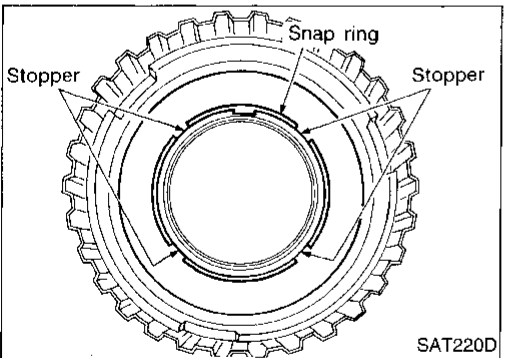

- Do not align snap ring gap with spring retainer stopper.

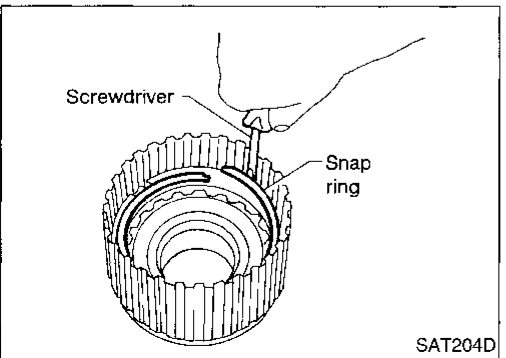

- Install drive plates, driven plates, retaining plate and dish plate for overrun clutch.
- Install snap ring for overrun clutch.

REPAIR FOR COMPONENT PARTS

Forward Clutch and Overrun Clutch (Cont'd)

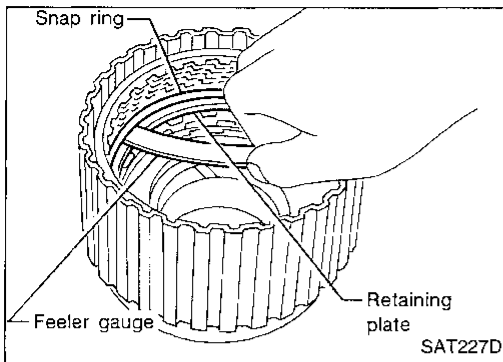

10. Measure clearance between overrun clutch retaining plate and snap ring.

If not within allowable limit, select proper retaining plate.

Specified clearance:

Standard: 1.0 - 1.4 mm (0.039 - 0.055 in)

Allowable limit: 2.0 mm (0.079 in)

Overrun clutch retaining plate:

Refer to SDS, AT-296.

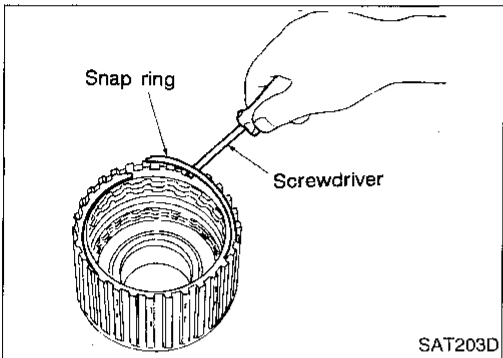

11. Install drive plates, driven plates, retaining plate and dish plate for forward clutch.

Take care with the order and direction of plates.

12. Install snap ring for forward clutch.

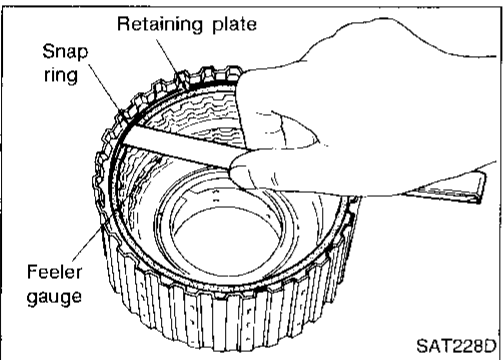

13. Measure clearance between forward clutch retaining plate and snap ring.

If not within allowable limit, select proper retaining plate.

Specified clearance:

Standard: 0.45 - 0.85 mm (0.0177 - 0.0335 in)

Allowable limit: 1.85 mm (0.0728 in)

Forward clutch retaining plate:

Refer to SDS, AT-296.

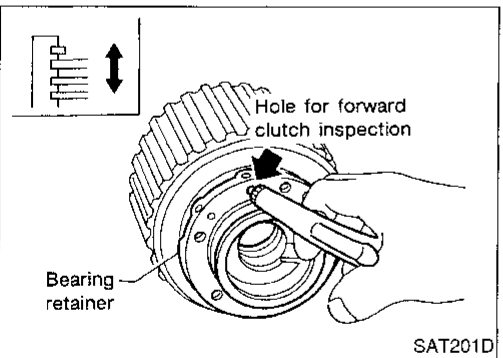

14. Check operation of forward clutch.

Refer to AT-245.

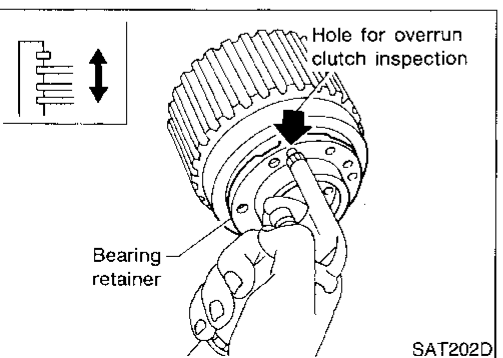

15. Check operation of overrun clutch.

Refer to "DISASSEMBLY" in "Forward Clutch and Overrun Clutch", AT-245.

Low & Reverse Brake

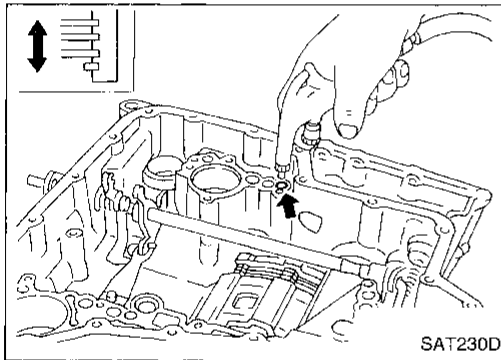
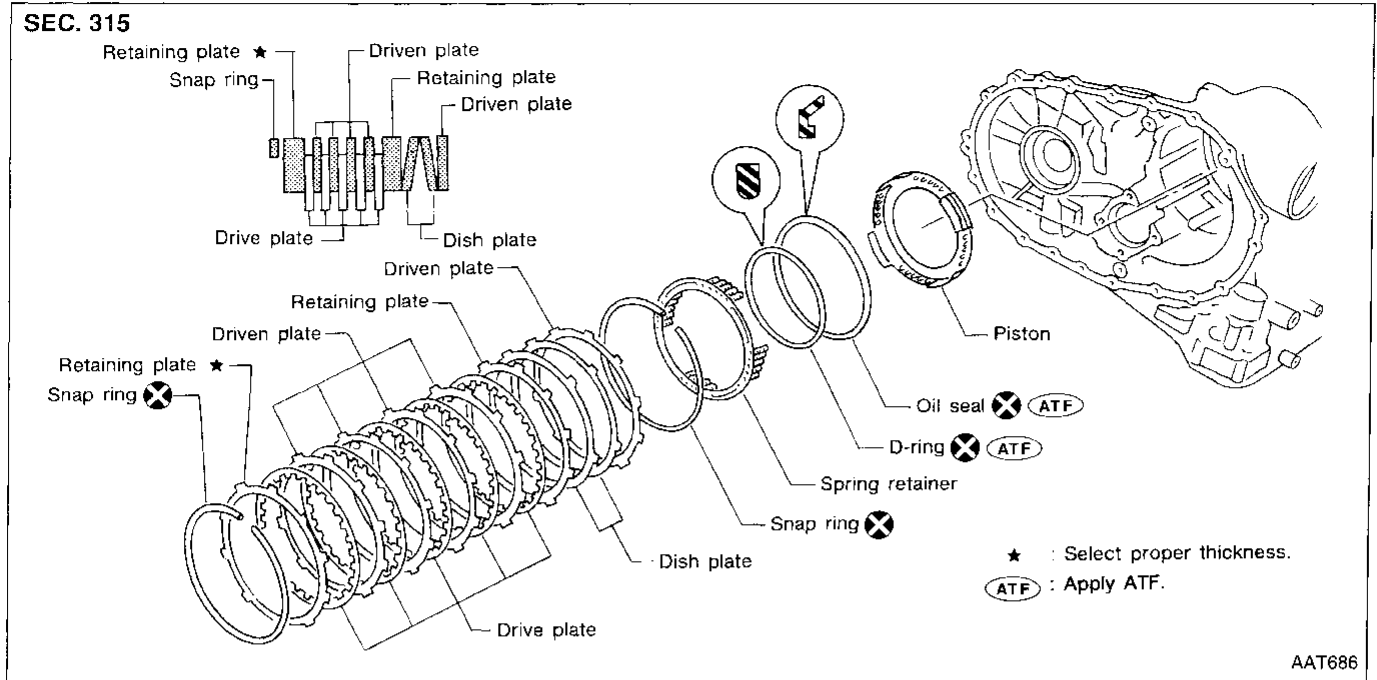

DISASSEMBLY

1. Check operation of low & reverse brake.
 - a. Apply compressed air to oil hole of transmission case.
 - b. Check to see that retaining plate moves to snap ring.
 - c. If retaining plate does not contact snap ring:
 - D-ring might be damaged.
 - Oil seal might be damaged.
 - Fluid might be leaking past piston check ball.

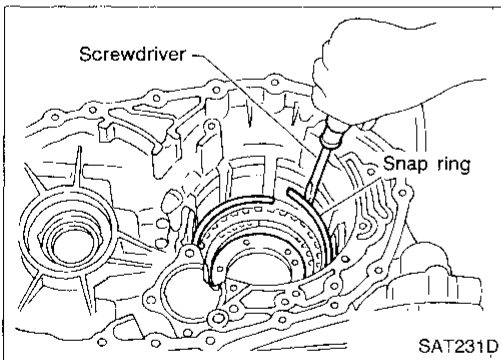

2. Stand transmission case.
3. Remove snap ring.
4. Remove drive plates, driven plates, retaining plate from transmission case.

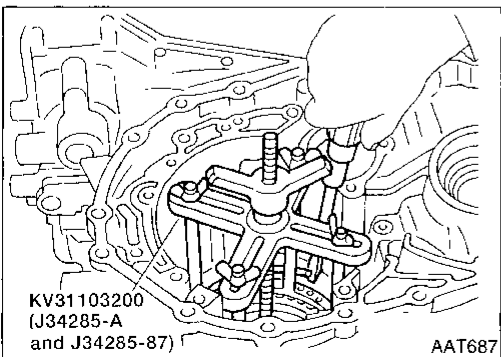

5. Set Tool on spring retainer and remove snap ring while compressing return springs.
 - **Set Tool directly above return springs.**
 - **Do not expand snap ring excessively.**
6. Remove spring retainer and return springs.

GI
MA
EM
LC
EC
FE
CL
MT
AT
FA
RA
BR
ST
RS
BT
HA
EL
IDX

REPAIR FOR COMPONENT PARTS

Low & Reverse Brake (Cont'd)

- Do not remove return springs from spring retainer.

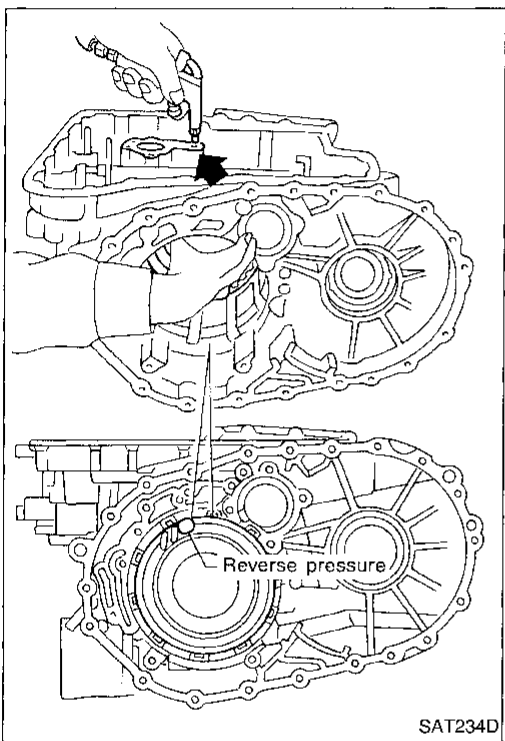
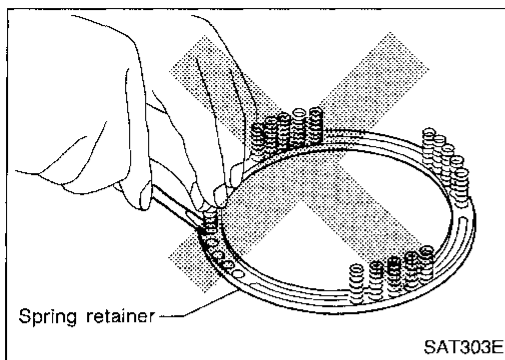

7. Apply compressed air to oil hole of transmission case while holding piston.
8. Remove piston from transmission case by turning it.

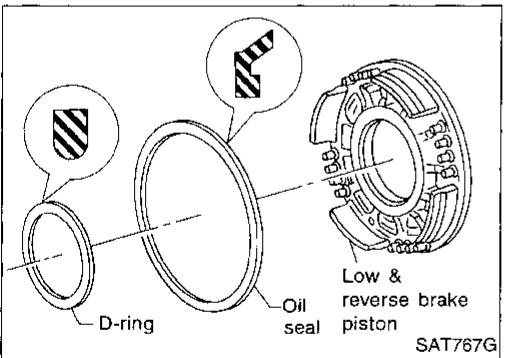

9. Remove D-ring and oil seal from piston.

INSPECTION

Low & reverse clutch snap ring, spring retainer and return springs

- Check for deformation, fatigue or damage.
- Replace if necessary.
- **When replacing spring retainer and return springs, replace them as a set.**

REPAIR FOR COMPONENT PARTS

Low & Reverse Brake (Cont'd)

Low & reverse brake drive plate

- Check facing for burns, cracks or damage.
- Measure thickness of facing.

Thickness of drive plate:

Standard value: 2.0 mm (0.079 in)

Wear limit: 1.8 mm (0.071 in)

- If not within wear limit, replace.

GI

MA

EM

LC

EC

FE

CL

MT

AT

FA

RA

BR

ST

RS

BT

HA

EL

IDX

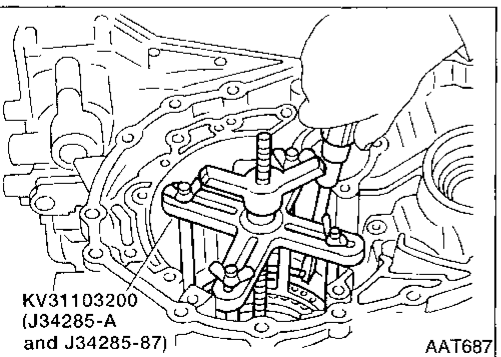
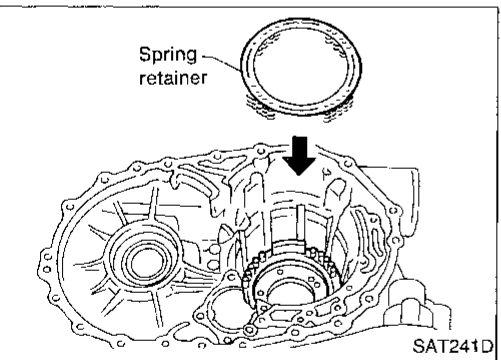
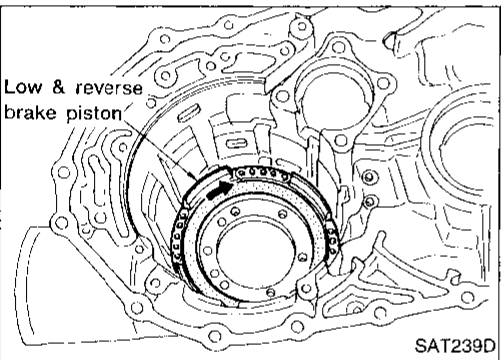
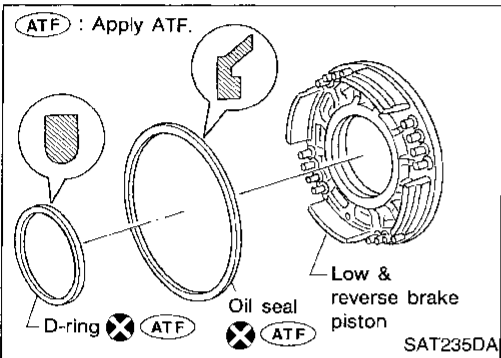
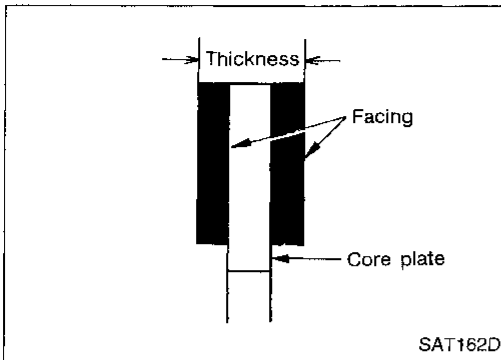

ASSEMBLY

1. Install D-ring and oil seal on piston.
 - Take care with the direction of the oil seal.
 - Apply ATF to both parts.
2. Stand transmission case.
3. Install piston assembly on transmission case while turning it slowly.
 - Apply ATF to inner surface of transmission case.
4. Install return springs and spring retainer on piston.
5. Install snap ring while compressing return springs.
 - Set Tool directly above return springs.

REPAIR FOR COMPONENT PARTS

Low & Reverse Brake (Cont'd)

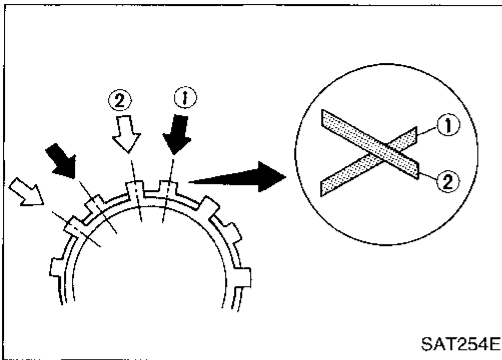

6. Install drive plates, driven plates, retaining plates and dished plates.
 - Do not align the projections on the two dished plates.
 - Make sure to put the plates in the correct order and direction.

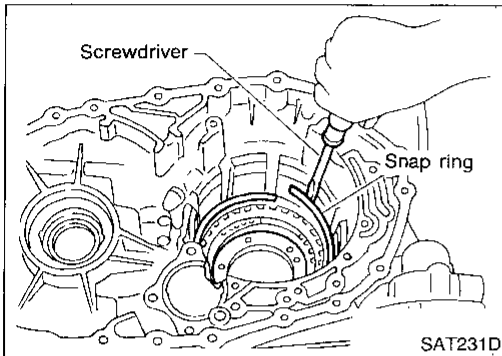

7. Install snap ring.

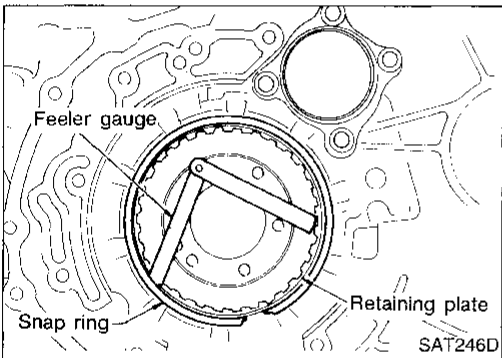

8. Measure clearance between retaining plate and snap ring. If not within allowable limit, select proper retaining plate (front side).

Specified clearance:

Standard: 1.4 - 1.8 mm (0.055 - 0.071 in)

**Allowable limit:
2.8 mm (0.110 in)**

**Retaining plate:
Refer to SDS, AT-297.**

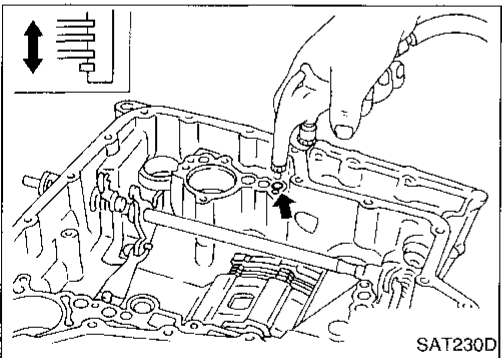

9. Check operation of low & reverse brake. Refer to "DISASSEMBLY", "Low & Reverse Brake", AT-251.

Rear Internal Gear, Forward Clutch Hub and Overrun Clutch Hub

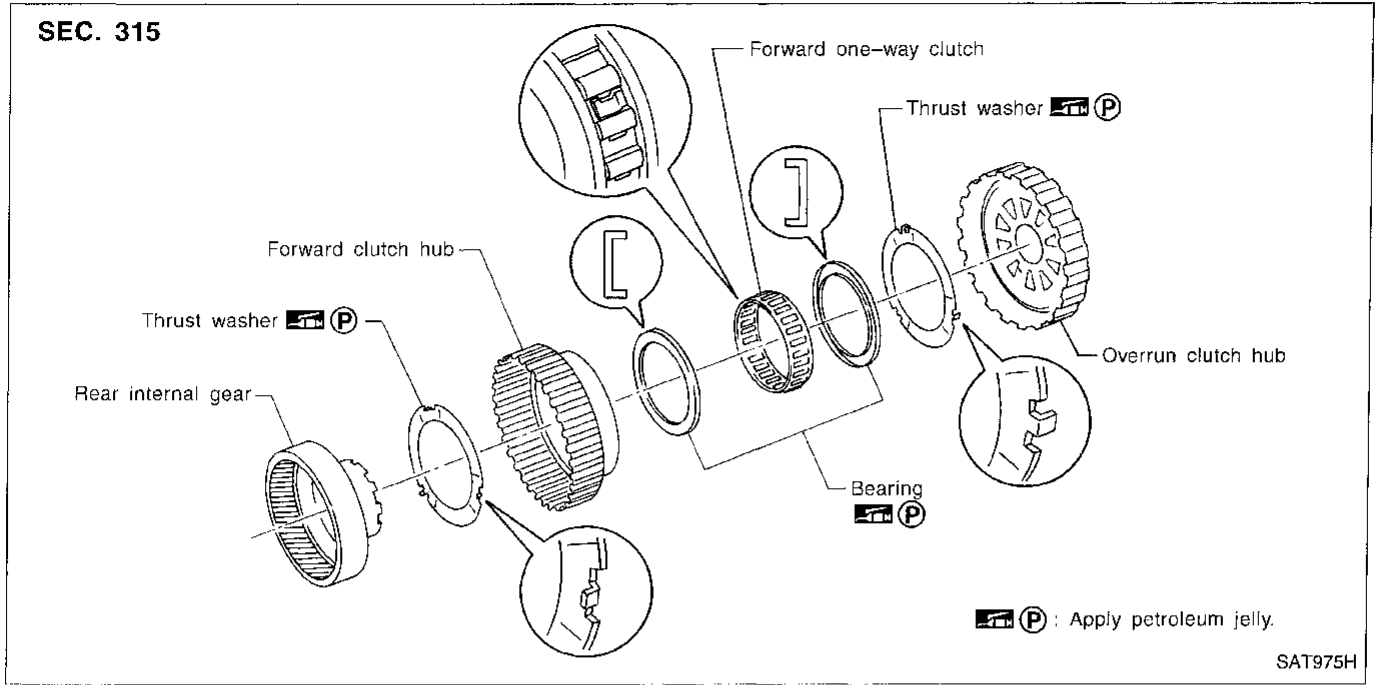

GI
MA
EM
LC
EC
FE
CL
MT

AT

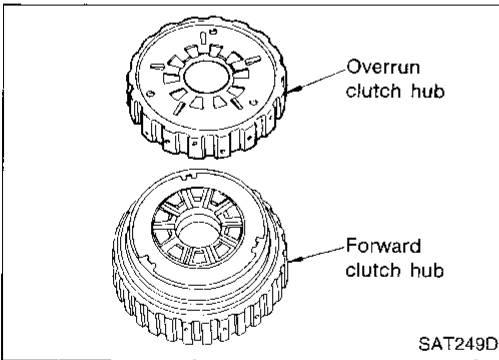

DISASSEMBLY

1. Remove snap ring from overrun clutch hub.
2. Remove overrun clutch hub from forward clutch hub.

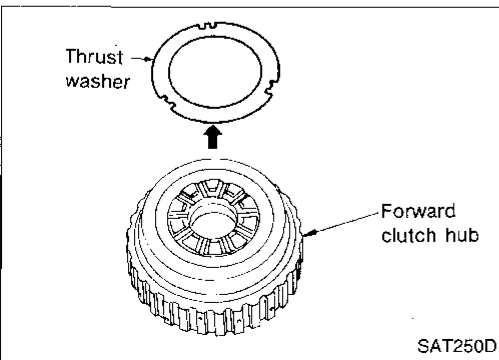

3. Remove thrust washer from forward clutch hub.

FA
RA
BR
ST
RS
BT
HA
EL
IDX

REPAIR FOR COMPONENT PARTS

Rear Internal Gear, Forward Clutch Hub and Overrun Clutch Hub (Cont'd)

4. Remove forward clutch hub from rear internal gear.

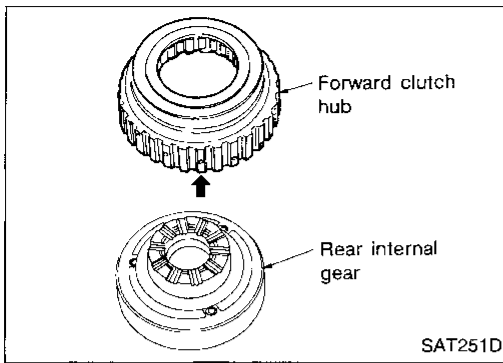

5. Remove end bearing from rear internal gear.

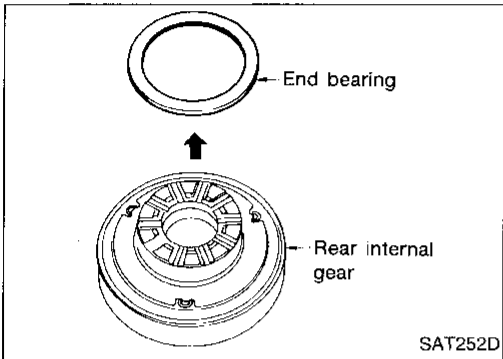

6. Remove thrust washer from rear internal gear.

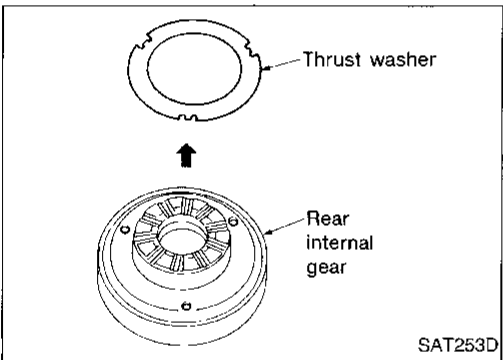

7. Remove end bearing from forward one-way clutch.

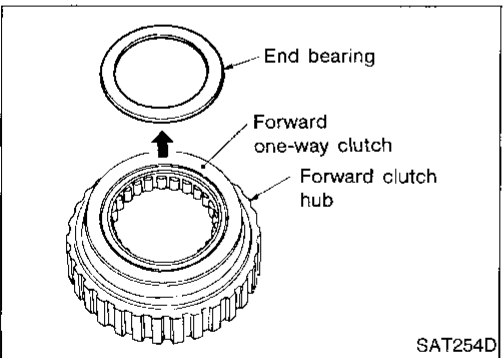

8. Remove one-way clutch from forward clutch hub.

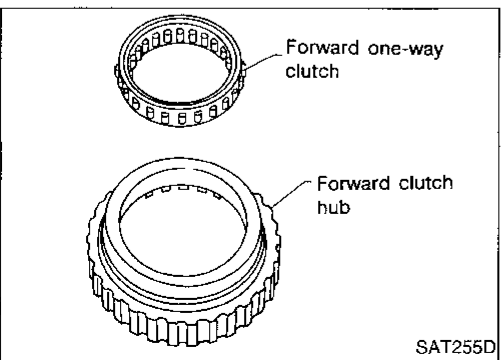

REPAIR FOR COMPONENT PARTS

Rear Internal Gear, Forward Clutch Hub and Overrun Clutch Hub (Cont'd)

INSPECTION

Rear internal gear, forward clutch hub and overrun clutch hub

- Check rubbing surfaces for wear or damage.

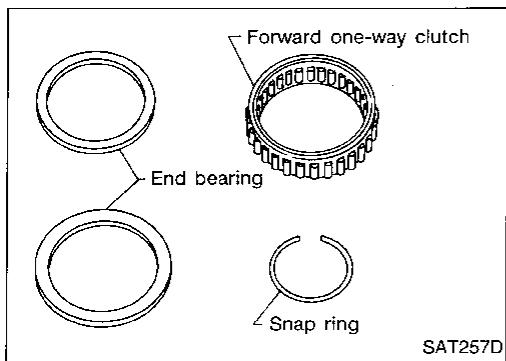
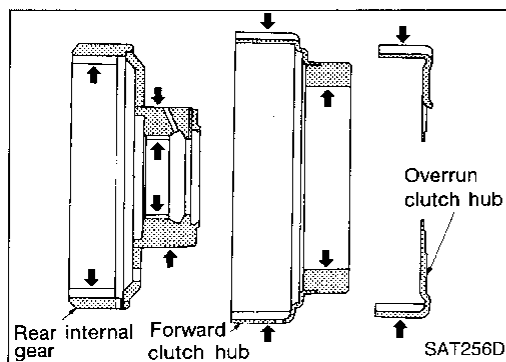

Snap ring, end bearings and forward one-way clutch

- Check snap ring and end bearings for deformation and damage.
- Check forward one-way clutch for wear and damage.

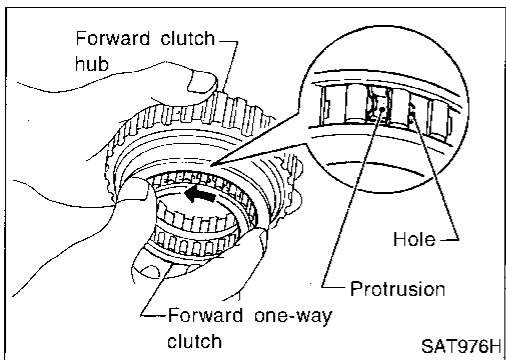

ASSEMBLY

1. Install forward one-way clutch on forward clutch.
 - Take care with the direction of forward one-way clutch.

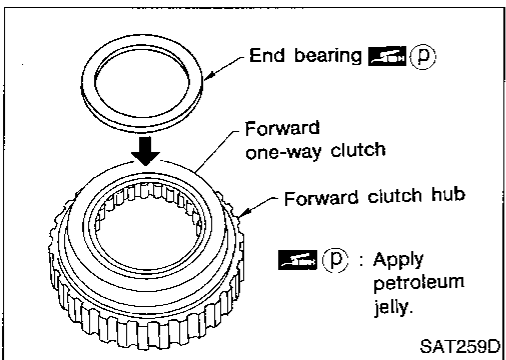

2. Install end bearing on forward one-way clutch.
 - Apply petroleum jelly to end bearing.

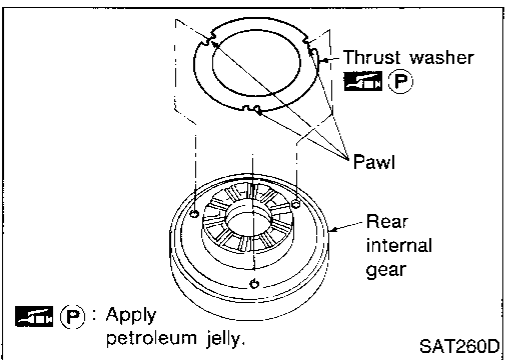

3. Install thrust washer on rear internal gear.
 - Apply petroleum jelly to thrust washer.
 - Align pawls of thrust washer with holes of rear internal gear.

REPAIR FOR COMPONENT PARTS

Rear Internal Gear, Forward Clutch Hub and Overrun Clutch Hub (Cont'd)

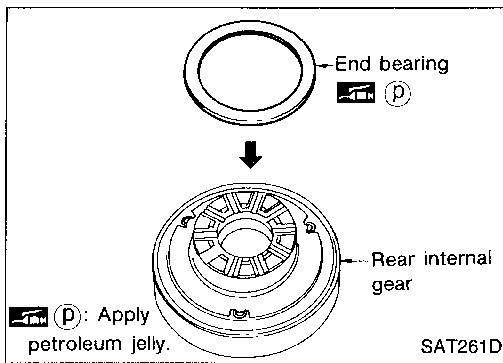

4. Install end bearing on rear internal gear.
 - Apply petroleum jelly to end bearing.

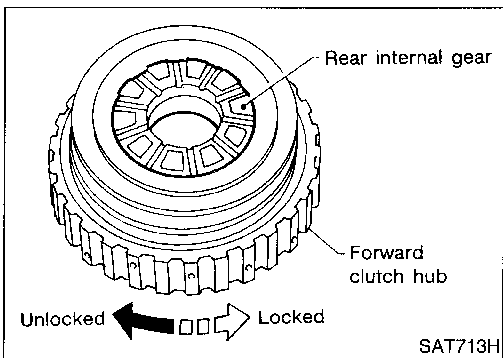

5. Install forward clutch hub on rear internal gear.
 - Check operation of forward one-way clutch. Hold rear internal gear and turn forward clutch hub. Check forward clutch hub for correct locking and unlocking directions.
 - If not as shown in illustration, check installation direction of forward one-way clutch.

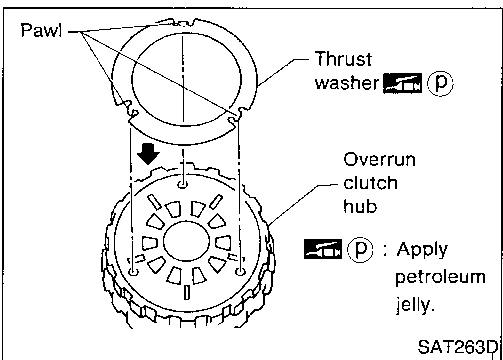

6. Install thrust washer and overrun clutch hub.
 - Apply petroleum jelly to thrust washer.
 - Align pawls of thrust washer with holes of overrun clutch hub.

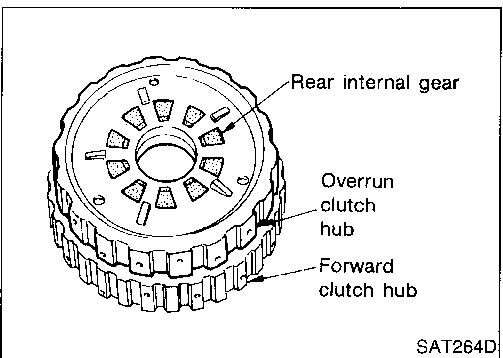

7. Install overrun clutch hub on rear internal gear.
 - Align projections of rear internal gear with holes of overrun clutch hub.

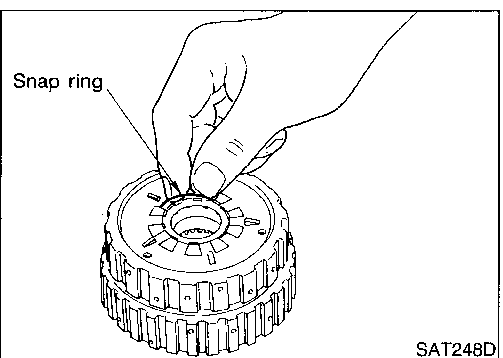

8. Install snap ring to groove of rear internal gear.

REPAIR FOR COMPONENT PARTS

Output Shaft, Idler Gear, Reduction Pinion Gear and Bearing Retainer (Cont'd)

3. Remove snap ring from bearing retainer.

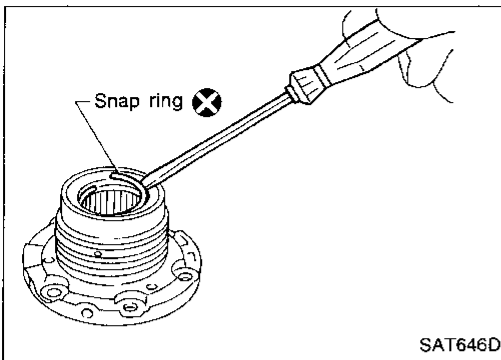

4. Remove needle bearing from bearing retainer.

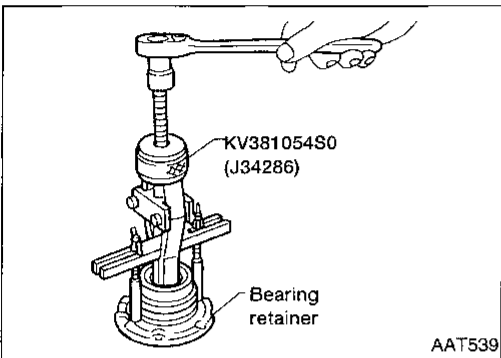

5. Remove idler gear bearing inner race from idler gear.

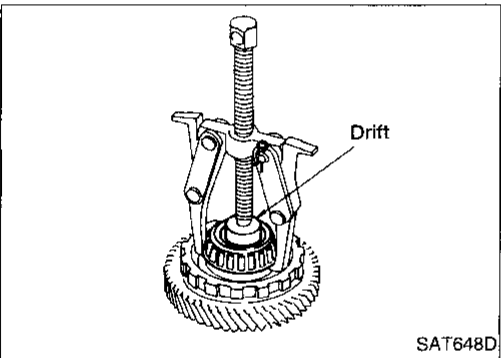

6. Remove idler gear bearing outer race from transmission case.

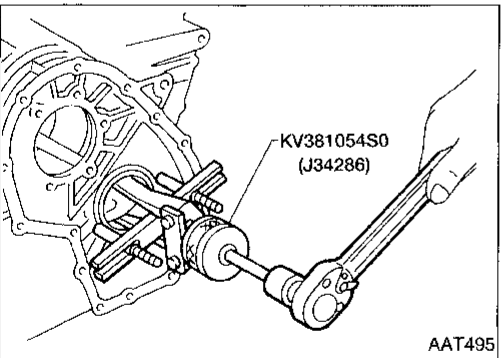

7. Press out reduction pinion gear bearing from reduction pinion gear.

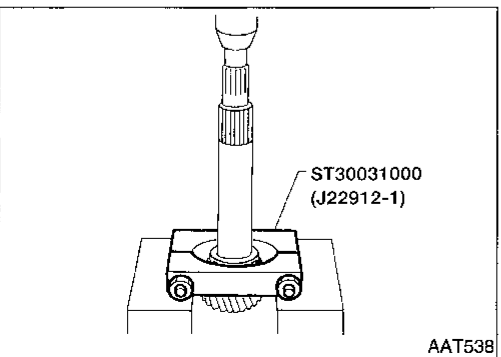

REPAIR FOR COMPONENT PARTS

Output Shaft, Idler Gear, Reduction Pinion Gear and Bearing Retainer (Cont'd)

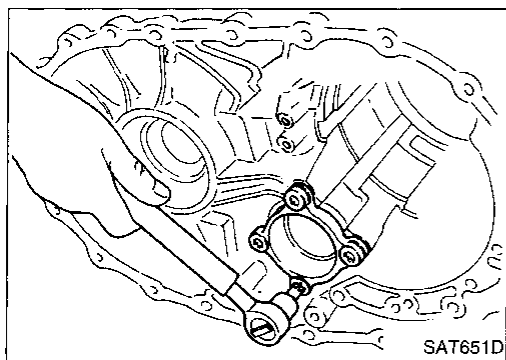

8. Remove reduction pinion gear bearing outer race from transmission case.

INSPECTION

Output shaft, idler gear and reduction pinion gear

- Check shafts for cracks, wear or bending.
- Check gears for wear, chips and cracks.

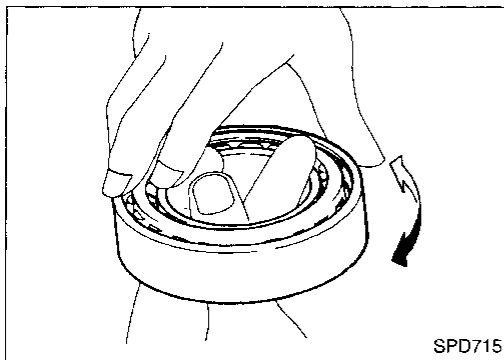

Bearing

- Make sure bearings roll freely and are free from noise, cracks, pitting or wear.
- **When replacing taper roller bearing, replace outer and inner race as a set.**

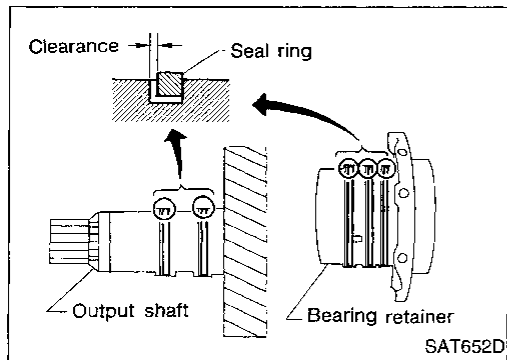

Seal ring clearance

- Install new seal rings to output shaft.
- Measure clearance between seal ring and ring groove of output shaft.

Standard clearance:

0.10 - 0.25 mm (0.0039 - 0.0098 in)

Allowable limit:

0.25 mm (0.0098 in)

- If not within allowable limit, replace output shaft.
- Install new seal rings to bearing retainer.
- Measure clearance between seal ring and ring groove of bearing retainer.

Standard clearance:

0.10 - 0.25 mm (0.0039 - 0.0098 in)

Allowable limit:

0.25 mm (0.0098 in)

- If not within allowable limit, replace bearing retainer.

REPAIR FOR COMPONENT PARTS

Output Shaft, Idler Gear, Reduction Pinion Gear and Bearing Retainer (Cont'd)

ASSEMBLY

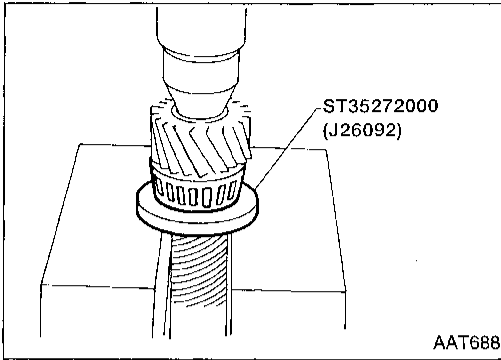

1. Press reduction pinion gear bearing on reduction pinion gear.

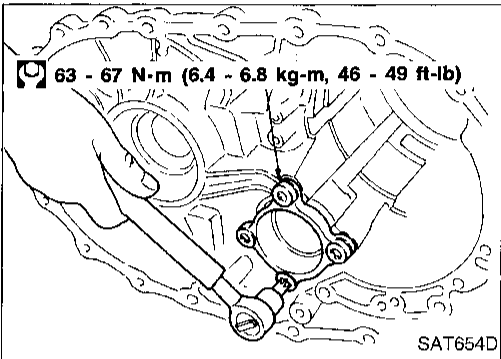

2. Install reduction pinion gear bearing outer race on transmission case.

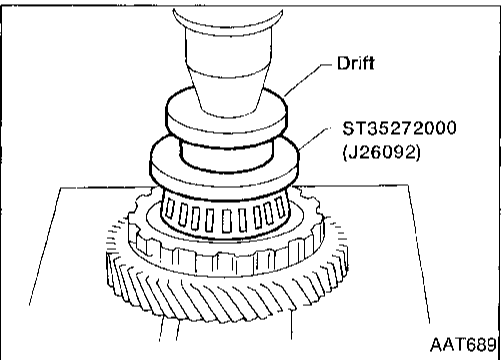

3. Press idler gear bearing inner race on idler gear.

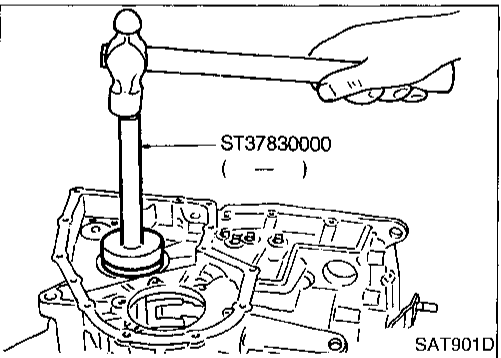

4. Install idler gear bearing outer race on transmission case.

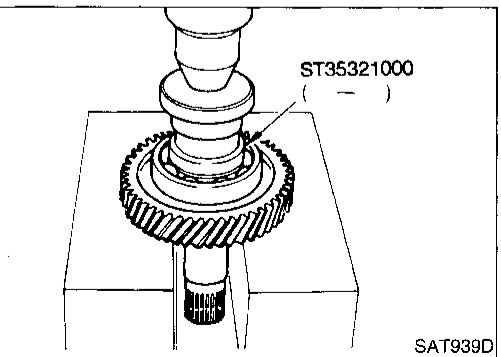

5. Press output shaft bearing on output shaft.

REPAIR FOR COMPONENT PARTS

Output Shaft, Idler Gear, Reduction Pinion Gear and Bearing Retainer (Cont'd)

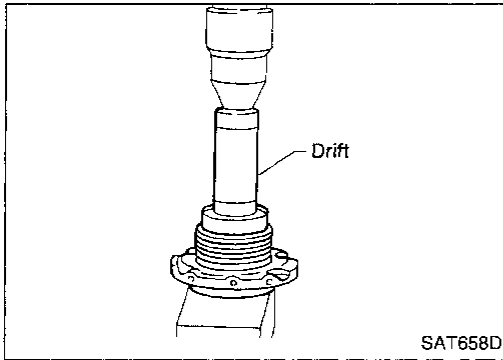

6. Press needle bearing on bearing retainer.

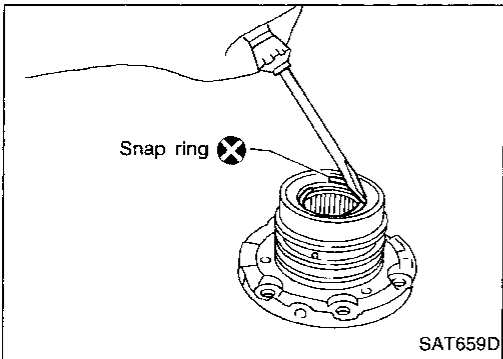

7. Install snap ring to bearing retainer.

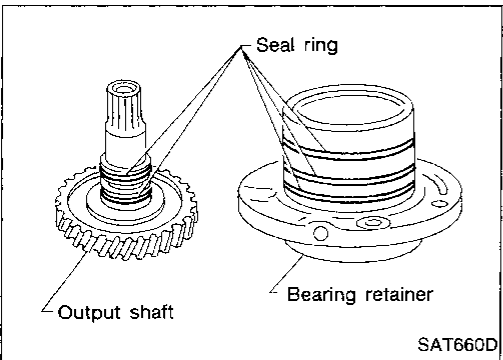

8. After packing ring grooves with petroleum jelly, carefully install new seal rings on output shaft and bearing retainer.

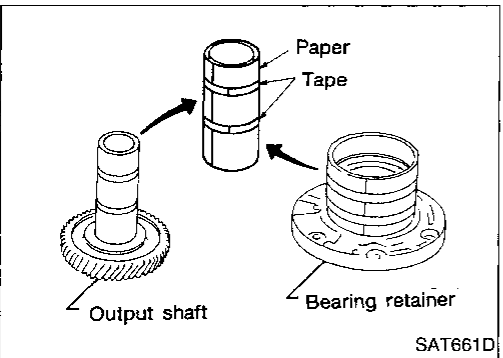

- Roll paper around seal rings to prevent seal rings from spreading.

GI

MA

EM

LC

EC

FE

CL

MT

AT

FA

RA

BR

ST

RS

BT

HA

EL

IDX

Band Servo Piston Assembly

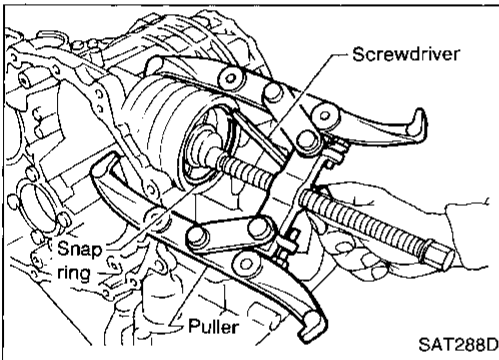
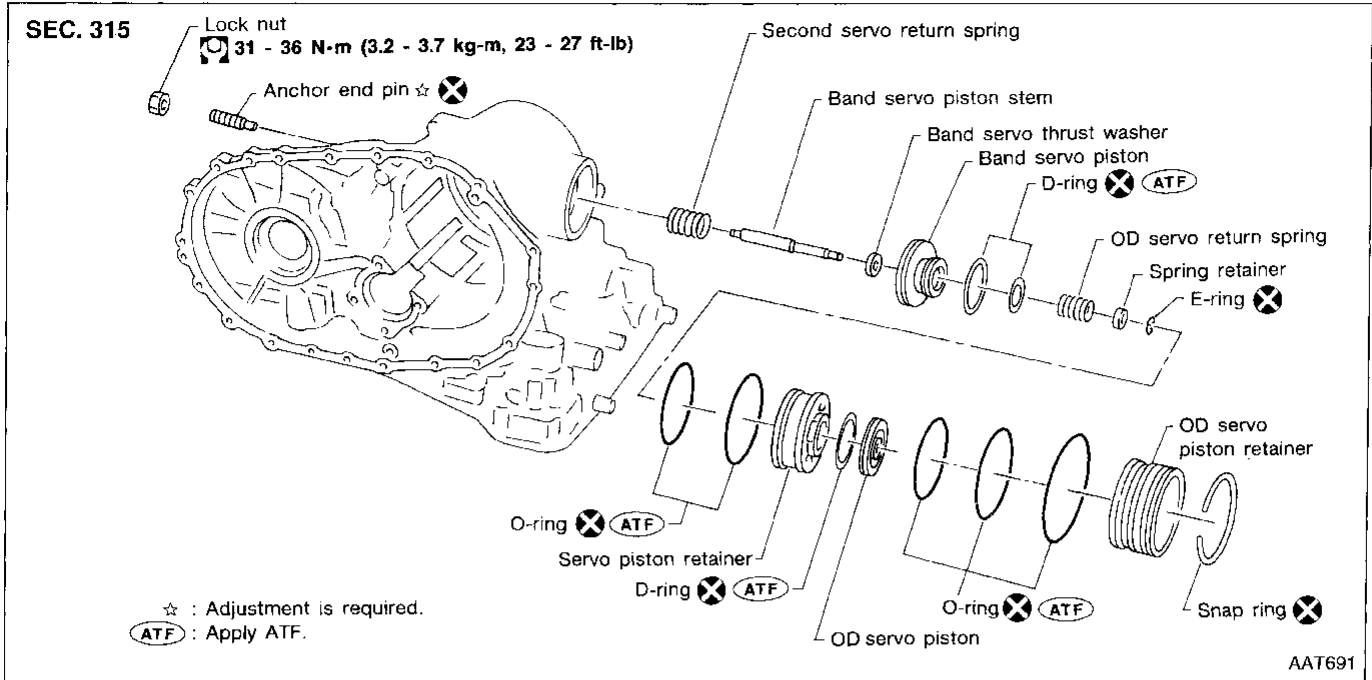

DISASSEMBLY

1. Remove band servo piston snap ring.

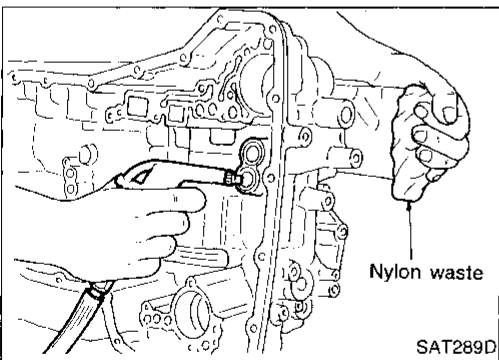

2. Apply compressed air to oil hole in transmission case to remove OD servo piston retainer and band servo piston assembly.

- Hold band servo piston assembly with a rag or nylon waste.

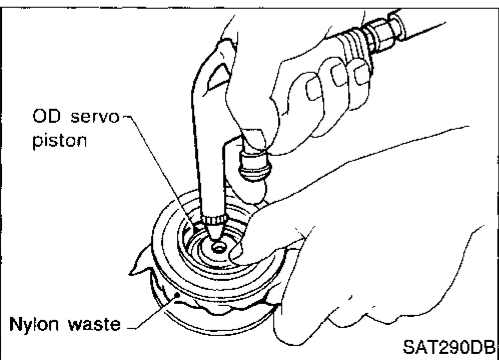

3. Apply compressed air to oil hole in OD servo piston retainer to remove OD servo piston from retainer.

- Hold OD servo piston while applying compressed air.

REPAIR FOR COMPONENT PARTS

Band Servo Piston Assembly (Cont'd)

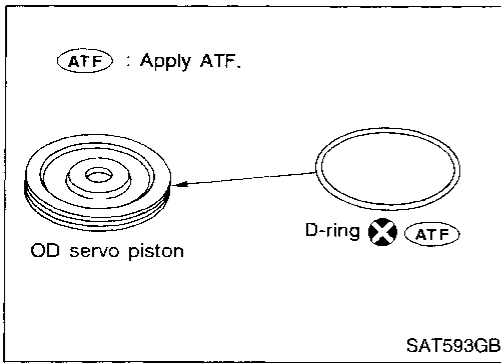

4. Remove D-ring from OD servo piston.

GI

MA

EM

LC

EC

FE

CL

MT

AT

FA

RA

BR

ST

RS

BT

HA

EL

IDX

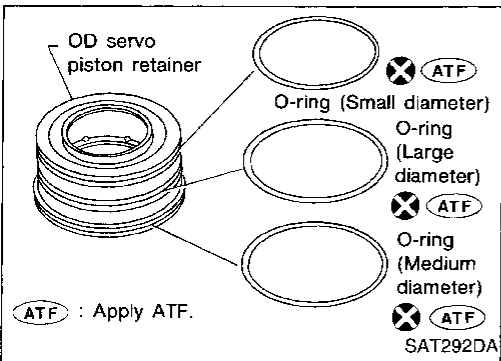

5. Remove O-rings from OD servo piston retainer.

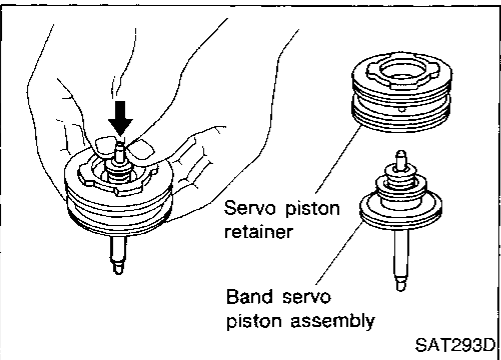

6. Remove band servo piston assembly from servo piston retainer by pushing it forward.

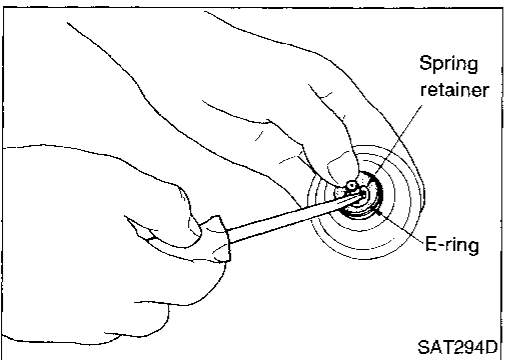

7. Place piston stem end on a wooden block. While pushing servo piston spring retainer down, remove E-ring.

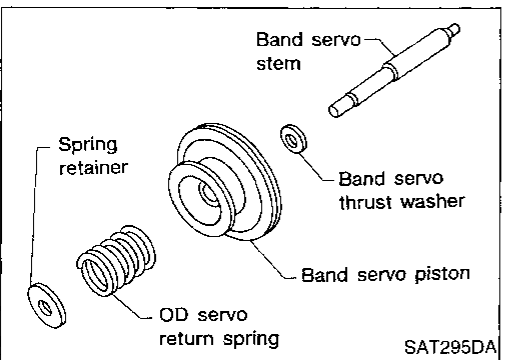

8. Remove OD servo return spring, band servo thrust washer and band servo piston stem from band servo piston.

REPAIR FOR COMPONENT PARTS

Band Servo Piston Assembly (Cont'd)

9. Remove O-rings from servo piston retainer.

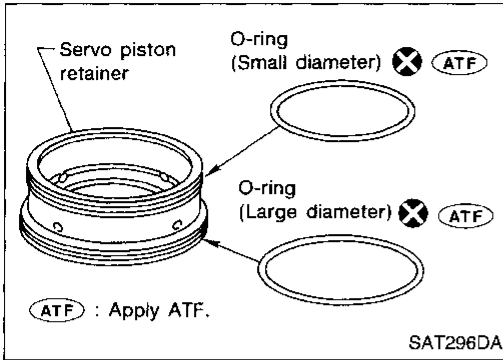

10. Remove D-rings from band servo piston.

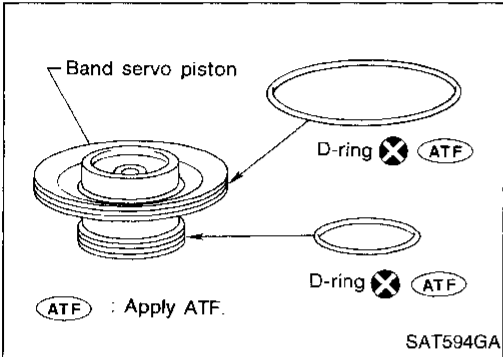

INSPECTION

Pistons, retainers and piston stem

- Check frictional surfaces for abnormal wear or damage.

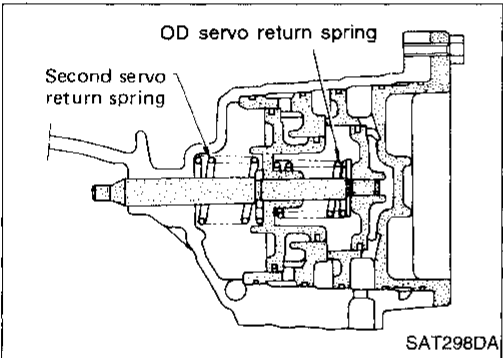

Return springs

- Check for deformation or damage.
- Measure free length and outer diameter.

Band servo inspection standard:
Refer to SDS, AT-300.

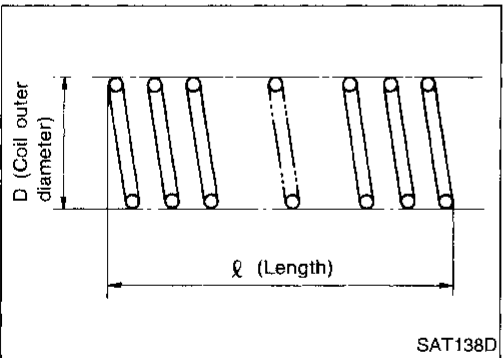

ASSEMBLY

1. Install D-rings to servo piston retainer.
 - Apply ATF to O-rings.
 - Pay attention to position of each O-ring.

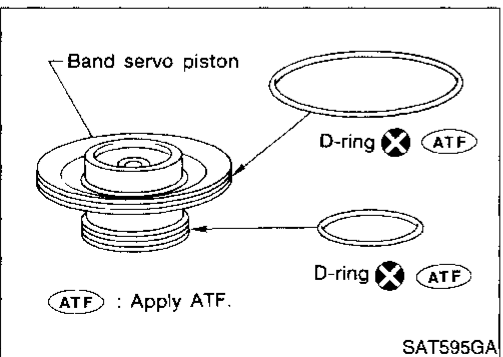

REPAIR FOR COMPONENT PARTS

Band Servo Piston Assembly (Cont'd)

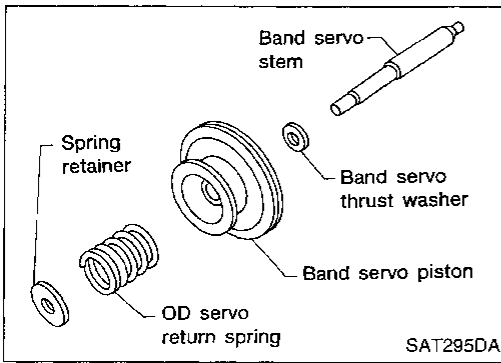

2. Install band servo piston stem, band servo thrust washer, OD servo return spring and spring retainer to band servo piston.

GI

MA

EM

LC

EC

FE

CL

MT

AT

FA

RA

BR

ST

RS

ET

HA

EL

IDX

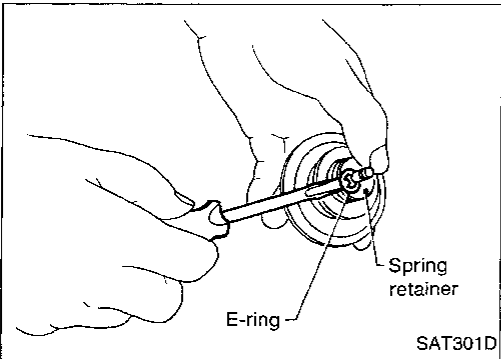

3. Place piston stem end on a wooden block. While pushing servo piston spring retainer down, install E-ring.

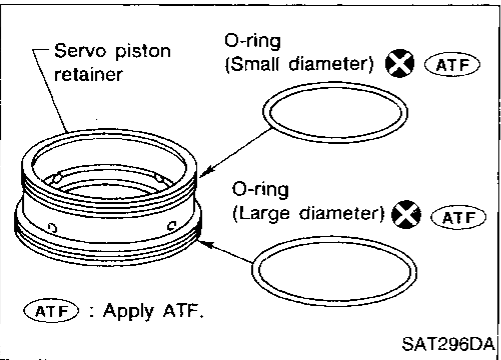

4. Install O-rings to servo piston retainer.
 - Apply ATF to O-rings.
 - Pay attention to the positions of the O-rings.

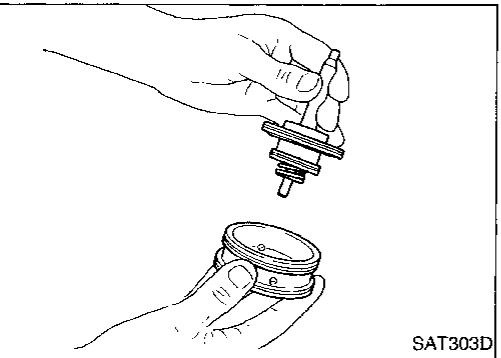

5. Install band servo piston assembly to servo piston retainer by pushing it inward.

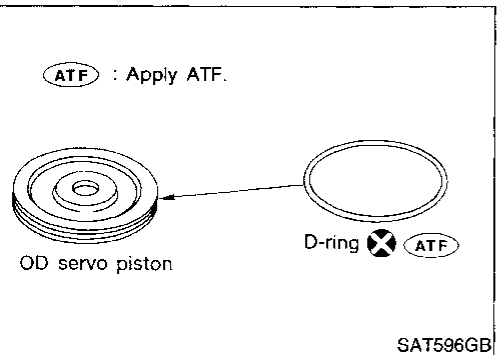

6. Install D-ring to OD servo piston.
 - Apply ATF to D-ring.

REPAIR FOR COMPONENT PARTS

Band Servo Piston Assembly (Cont'd)

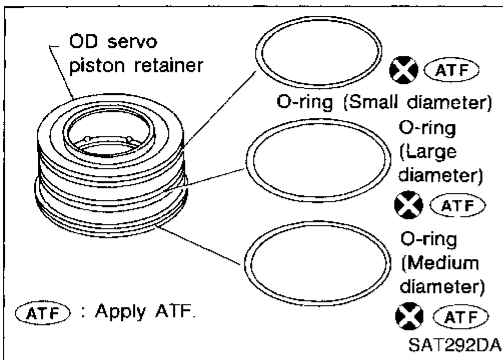

7. Install O-rings to OD servo piston retainer.
 - Apply ATF to O-rings.
 - Pay attention to the positions of the O-rings.

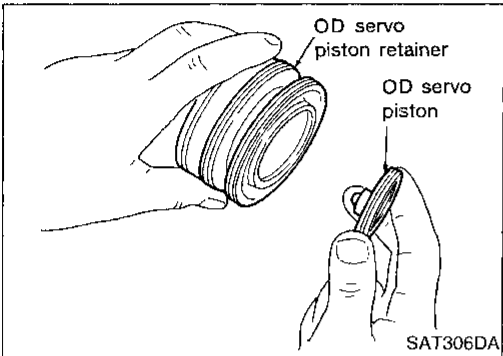

8. Install OD servo piston to OD servo piston retainer.

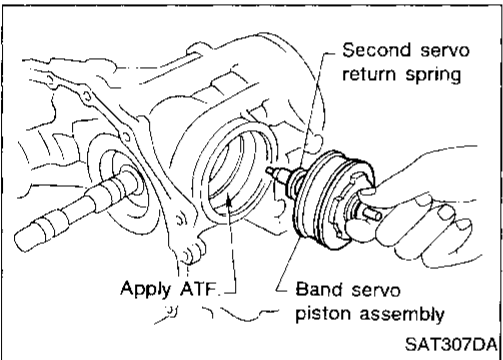

9. Install band servo piston assembly and 2nd servo return spring to transmission case.
 - Apply ATF to O-ring of band servo piston and transmission case.

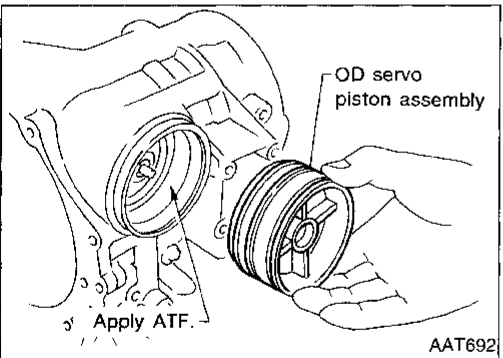

10. Install OD servo piston assembly to transmission case.
 - Apply ATF to O-ring of band servo piston and transmission case.

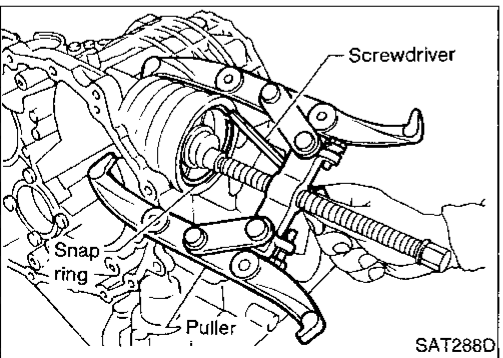

11. Install band servo piston snap ring to transmission case.

REPAIR FOR COMPONENT PARTS

Final Drive

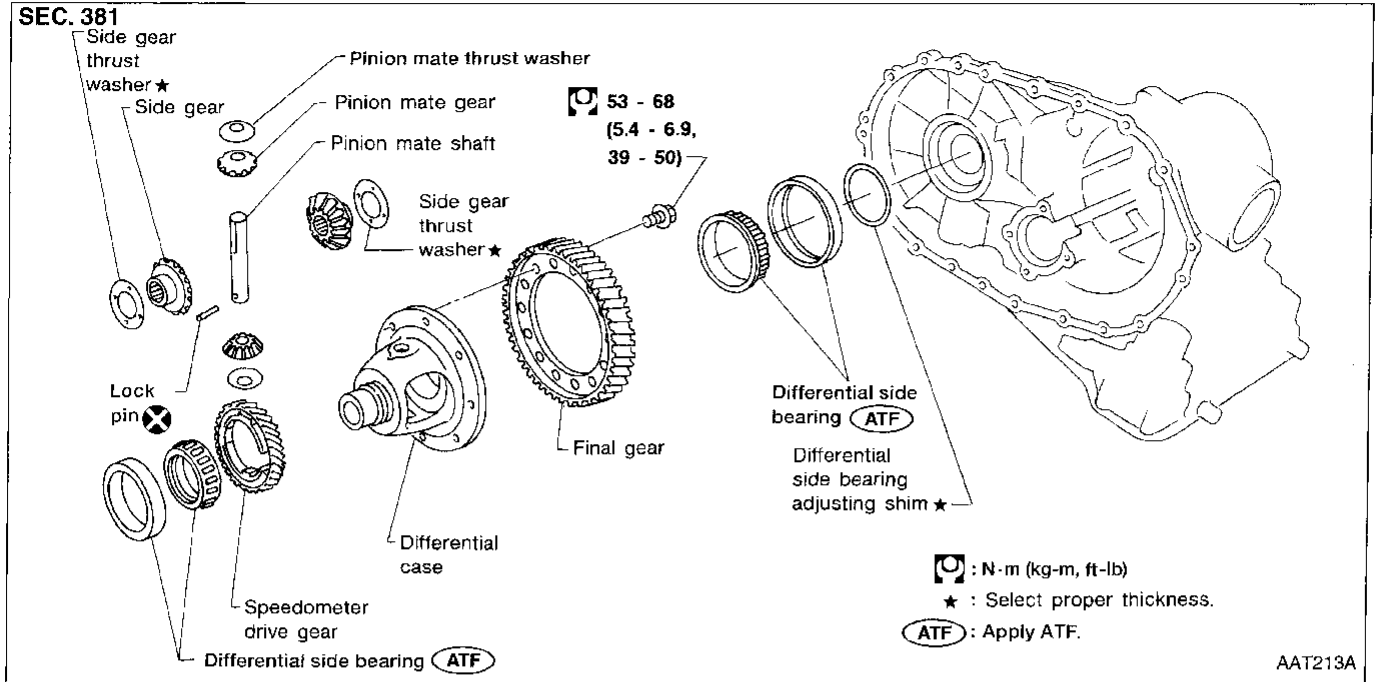

GI
MA
EM
LC
EC
FE
CL
MT
AT
FA
RA
BR
ST
RS
BT
HA
EL
IDX

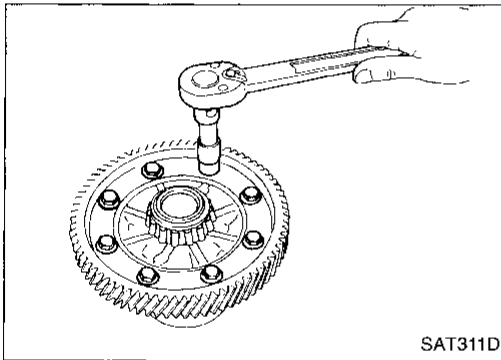

DISASSEMBLY

1. Remove final gear.

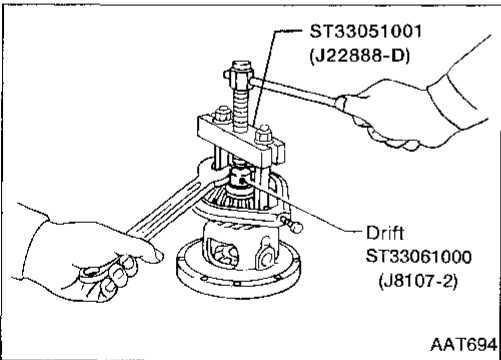

2. Press out differential side bearings.

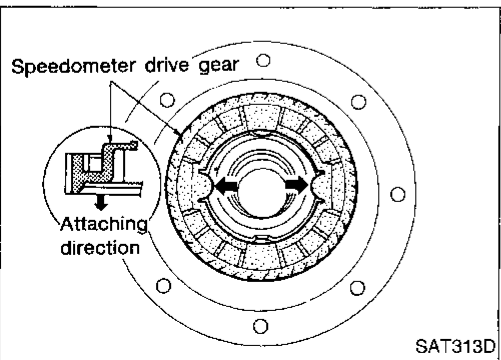

3. Remove speedometer drive gear.

REPAIR FOR COMPONENT PARTS

Final Drive (Cont'd)

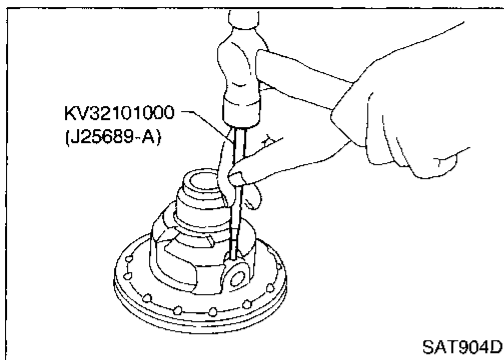

4. Drive out pinion mate shaft retaining pin.

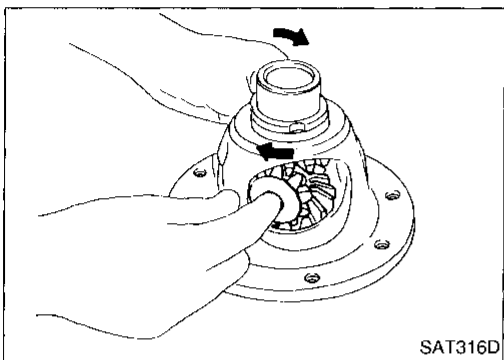

5. Draw out pinion mate shaft from differential case.
6. Remove pinion mate gears and side gears.

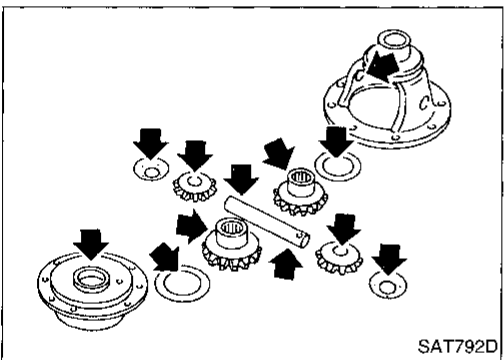

INSPECTION

Gear, washer, shaft and case

- Check mating surfaces of differential case, side gears, pinion mate gears and viscous coupling.
- Check washers for wear.

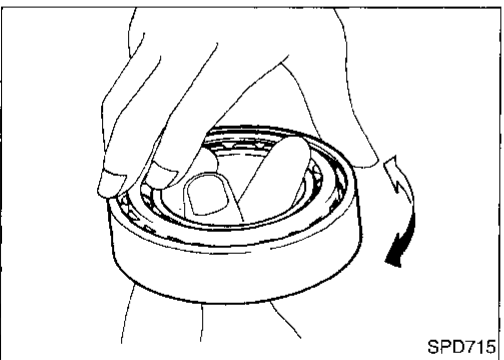

Bearings

- Make sure bearings roll freely and are free from noise, cracks, pitting or wear.
- **When replacing taper roller bearing, replace outer and inner race as a set.**

REPAIR FOR COMPONENT PARTS

Final Drive (Cont'd)

ASSEMBLY

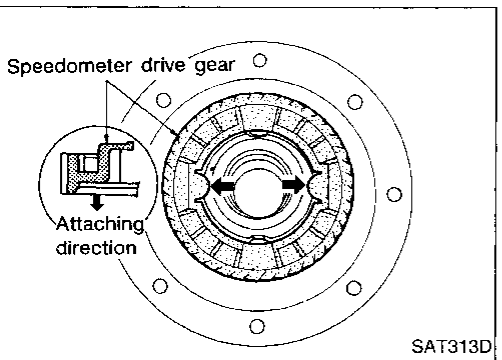
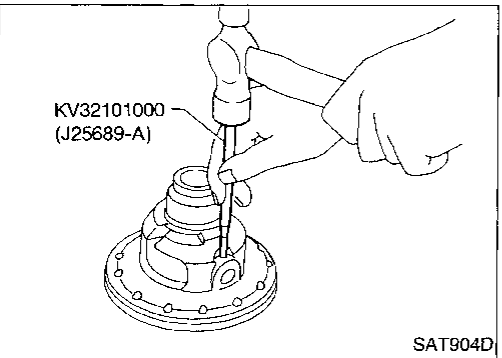
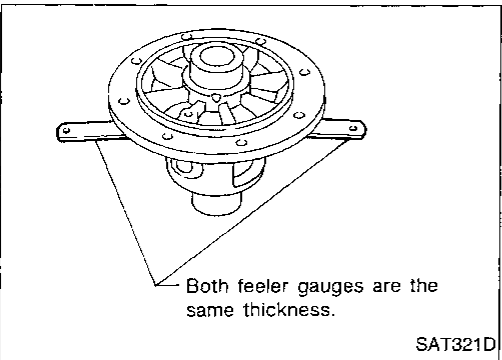
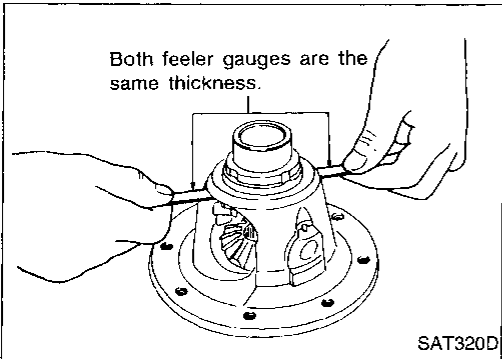
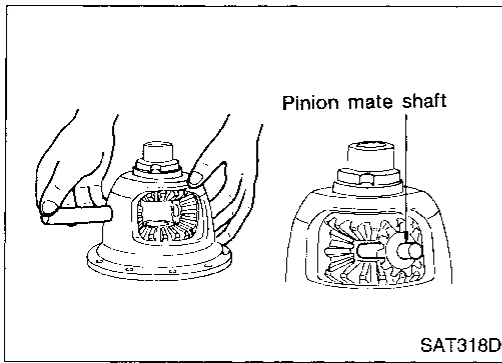

1. Install side gear and thrust washers in differential case.
2. Install pinion mate gears and thrust washers in differential case while rotating them.

- Apply ATF to any parts.

3. Measure clearance between side gear and differential case with washers.

Clearance between side gear and differential case with washers:

0.1 - 0.2 mm (0.004 - 0.008 in)

- If not within specification adjust clearance by changing thickness of side gear thrust washer.

Side gear thrust washers:

Refer to SDS, AT-298.

4. Install retaining pin.

- Make sure that retaining pin is flush with case.

5. Install speedometer drive gear on differential case.

- Align the projection of speedometer drive gear with the groove of differential case.

REPAIR FOR COMPONENT PARTS

Final Drive (Cont'd)

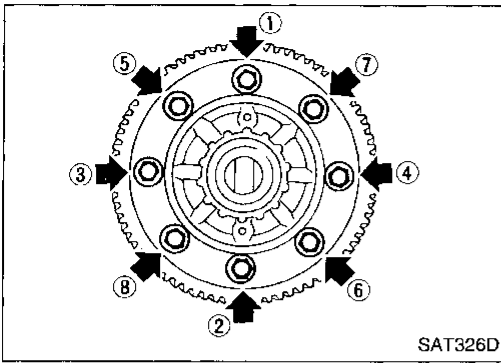

6. Install final gear and tighten fixing bolts in numerical order.

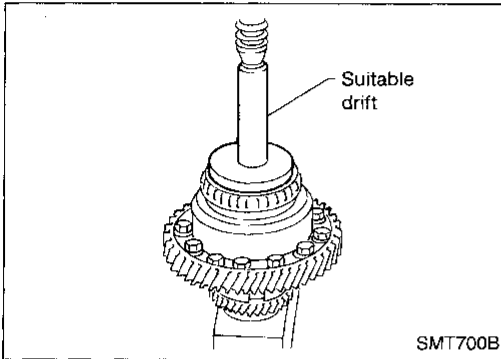

7. Press on differential side bearings.

ASSEMBLY

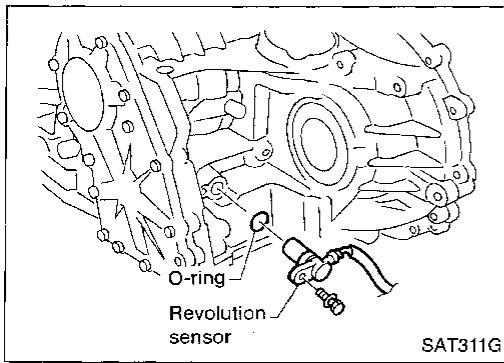

Assembly 1

1. Install revolution sensor onto transmission case.
Always use new sealing parts.

GI

MA

EM

LC

EC

FE

CL

MT

AT

FA

RA

BR

ST

RS

BT

HA

EL

IDX

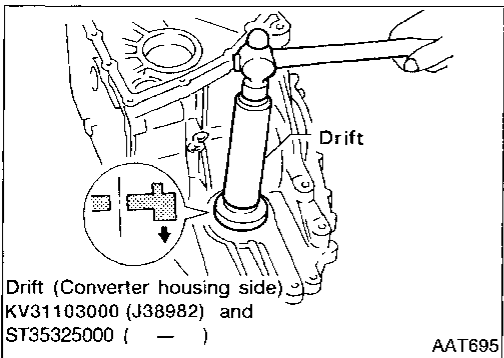

2. Install differential side oil seals on transmission case and converter housing, so that "A" and "B" are within specifications.

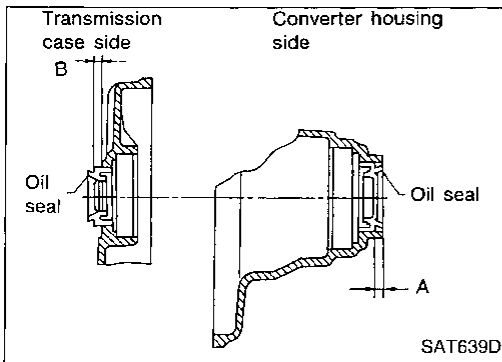

Unit: mm (in)

A	B
5.5 - 6.5 (0.217 - 0.256)	0.5 (0.020) or less

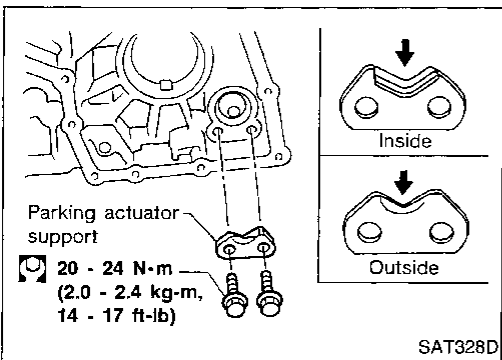

3. Install parking actuator support to transmission case.
• **Pay attention to direction of parking actuator support.**

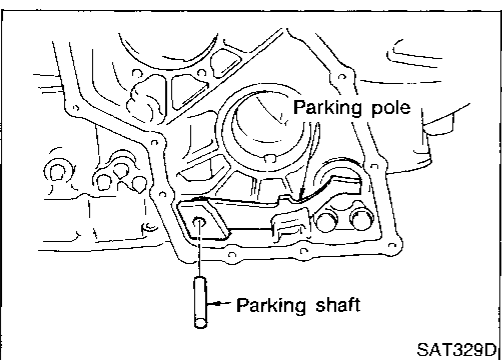

4. Install parking pawl on transmission case and fix it with parking shaft.

ASSEMBLY

Assembly 1 (Cont'd)

5. Install return spring.

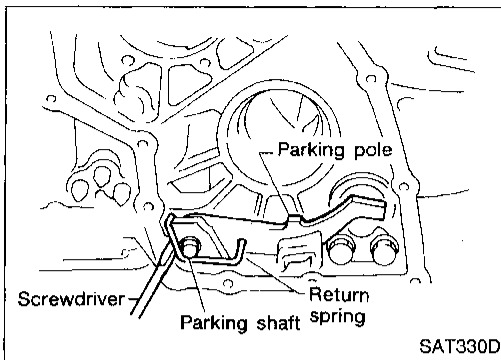

Adjustment 1

DIFFERENTIAL SIDE BEARING PRELOAD

1. Install differential side bearing outer race without adjusting shim on transmission case.
2. Install differential side bearing outer race on converter housing.

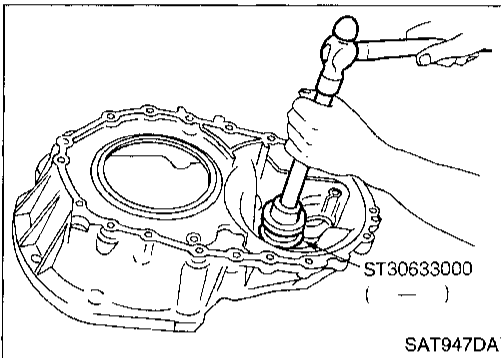

3. Place final drive assembly on transmission case.
4. Install transmission case on converter housing. Tighten transmission case fixing bolts (A) and (B) to the specified torque.

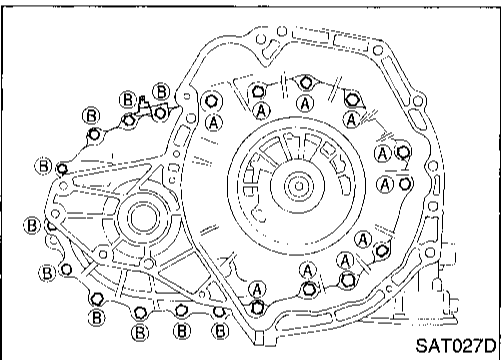

5. Attach dial indicator on differential case at transmission case side.
6. Insert Tool into differential side gear from converter housing.
7. Move Tool up and down and measure dial indicator deflection.

Differential side bearing preload "T":

0.04 mm - 0.09 mm (0.0016 in. - 0.0035 in.)

8. Select proper thickness of differential side bearing adjusting shim(s) using SDS table as a guide.

Differential side bearing adjusting shim:

Refer to SDS, AT-298.

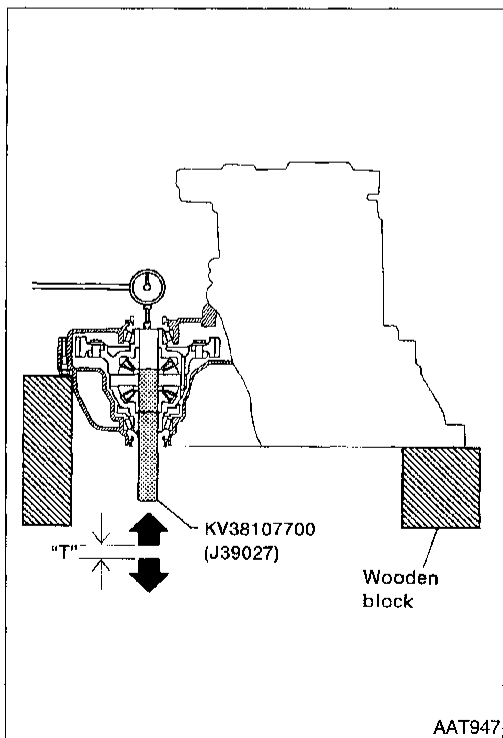

ASSEMBLY

Adjustment 1 (Cont'd)

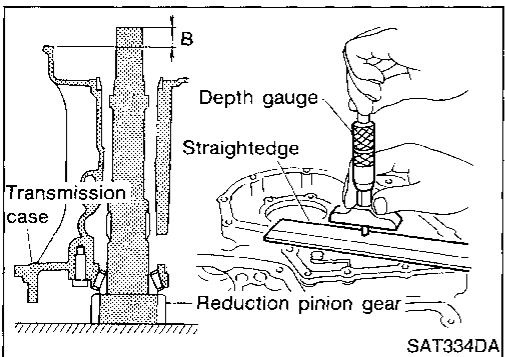
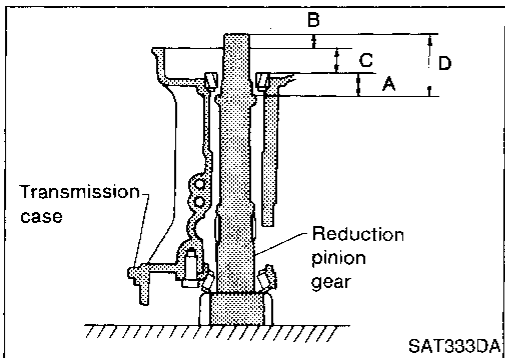
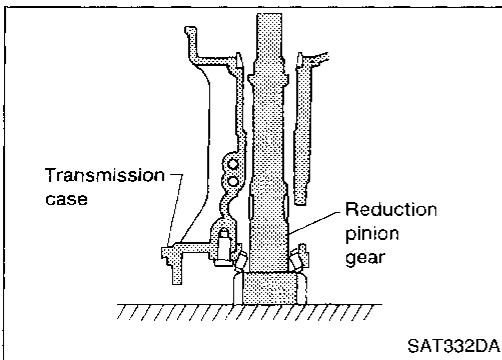
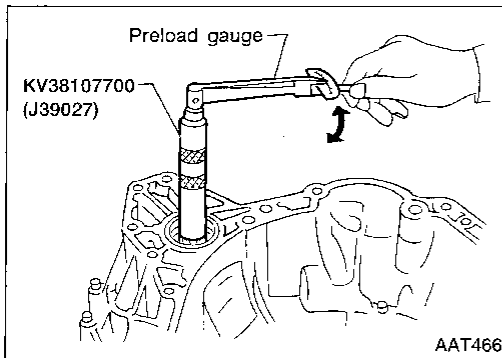
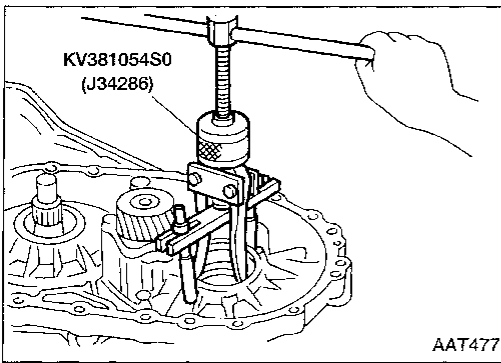

9. Remove converter housing from transmission case.
10. Remove final drive assembly from transmission case.
11. Remove differential side bearing outer race from transmission case.
12. Reinstall differential side bearing outer race and shim(s) selected from SDS table on transmission case.
13. Reinstall converter housing on transmission case and tighten transmission case fixing bolts to the specified torque.

14. Insert Tool into differential case and measure turning torque of final drive assembly.

- Turn final drive assembly in both directions several times to seat bearing rollers correctly.

Turning torque of final drive assembly (New bearing):

0.49 - 1.08 N·m (5.0 - 11.0 kg·cm, 4.3 - 9.5 in·lb)

- When old bearing is used again, turning torque will be slightly less than the above.
- Make sure torque is close to the specified range.

REDUCTION PINION GEAR BEARING PRELOAD

1. Remove transmission case and final drive assembly from converter housing.
2. Select proper thickness of reduction pinion gear bearing adjusting shim using the following procedures.
- a. Place reduction pinion gear on transmission case as shown.

- b. Place idler gear bearing on transmission case.
- c. Measure dimensions "B" "C" and "D" and calculate dimension "A".

$$A = D - (B + C)$$

"A": Distance between the surface of idler gear bearing inner race and the adjusting shim mating surface of reduction pinion gear.

- Measure dimension "B" between the end of reduction pinion gear and the surface of transmission case.
- Measure dimension "B" in at least two places.

ASSEMBLY

Adjustment 1 (Cont'd)

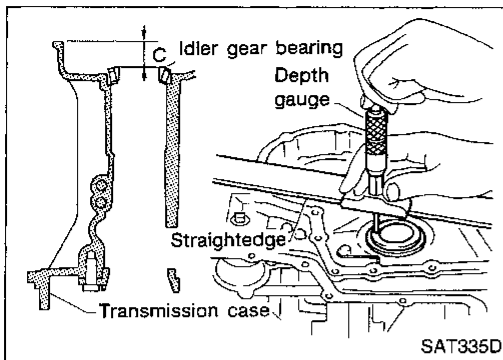

- Measure dimension "C" between the surface of idler gear bearing inner race and the surface of transmission case.
- Measure dimension "C" in at least two places.

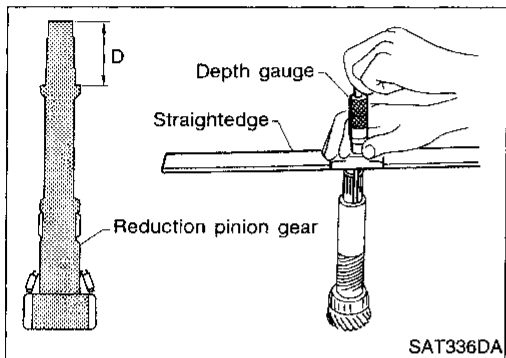

- Measure dimension "D" between the end of reduction pinion gear and the adjusting shim mating surface of reduction pinion gear.
- Measure dimension "D" in at least two places.
- Calculate dimension "A"
 $A = D - (B + C)$

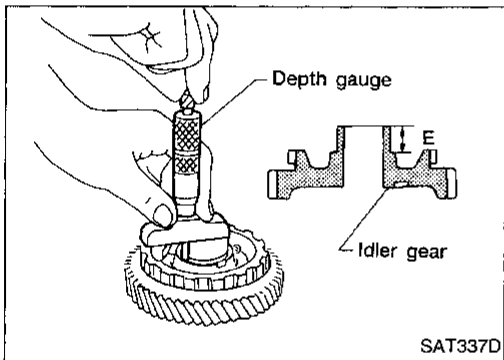

- d. Measure dimension "E" between the end of idler gear and the idler gear bearing inner race mating surface of idler gear.
- Measure dimension "E" in at least two places.

- e. Calculate "T" and select proper thickness of reduction pinion gear bearing adjusting shim using SDS table as a guide.

$$T = A - E$$

Reduction pinion gear bearing adjusting shim:

Refer to SDS, AT-299.

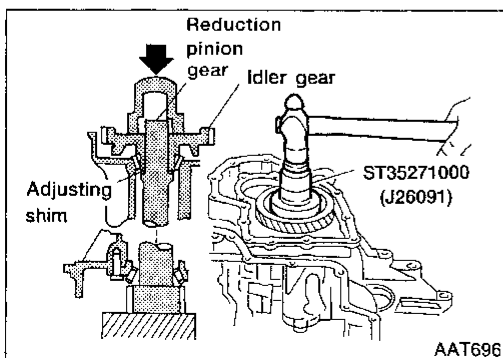

3. Install reduction pinion gear and reduction pinion gear bearing adjusting shim selected in step 2-e on transmission case.
 4. Press idler gear bearing inner race on idler gear.
 5. Press idler gear on reduction pinion gear.
- Press idler gear so that idler gear can be locked by parking pawl.

ASSEMBLY

Adjustment 1 (Cont'd)

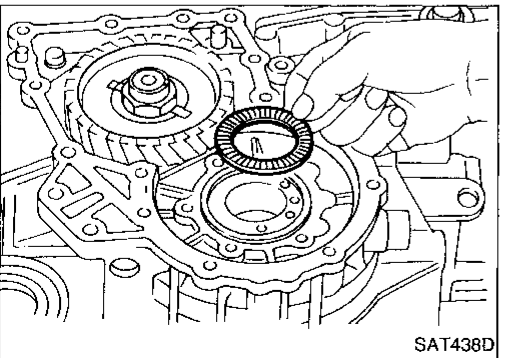
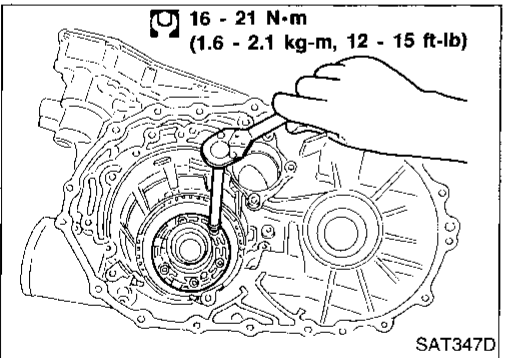
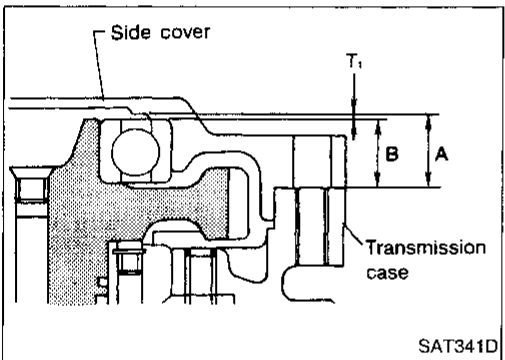
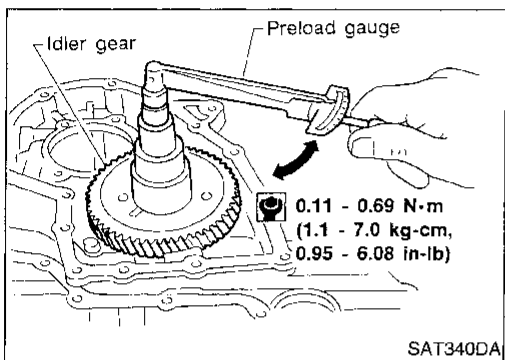
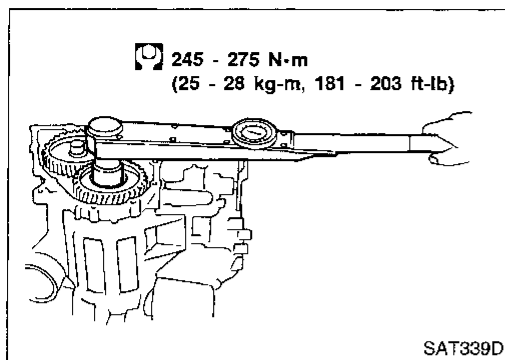

6. Tighten idler gear lock nut to the specified torque.
 - Lock idler gear with parking pawl when tightening lock nut.

GI

MA

EM

LC

7. Measure turning torque of reduction pinion gear.
 - When measuring turning torque, turn reduction pinion gear in both directions several times to seat bearing rollers correctly.

EC

Turning torque of reduction pinion gear:
0.11 - 0.69 N·m (1.1 - 7.0 kg-cm, 0.95 - 6.08 in-lb)

FE

CL

OUTPUT SHAFT END PLAY

MT

- Measure clearance between side cover and the end of the output shaft bearing.
- Select proper thickness of adjusting shim so that clearance is within specifications.

AT

FA

RA

1. Install bearing retainer for output shaft.

BR

ST

RS

BT

2. Install output shaft thrust needle bearing on bearing retainer.

HA

EL

IDX

ASSEMBLY

Adjustment 1 (Cont'd)

3. Install output shaft on transmission case.

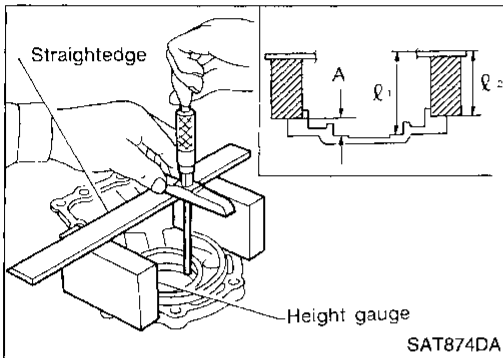
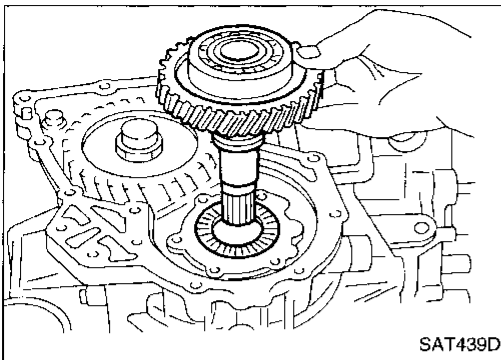

4. Measure dimensions " l_1 " and " l_2 " at side cover and then calculate dimension "A".

- Measure dimension " l_1 " and " l_2 " in at least two places.

"A": Distance between transmission case fitting surface and adjusting shim mating surface.

$$A = l_1 - l_2 \quad l_2: \text{Height of gauge}$$

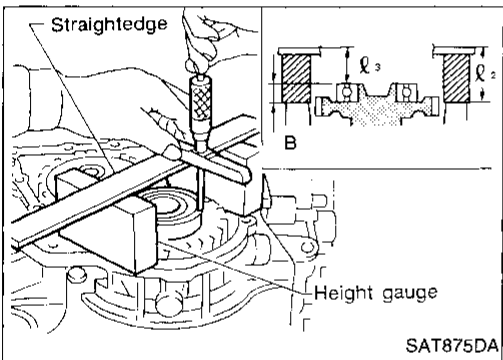

5. Measure dimensions " l_2 " and " l_3 " and then calculate dimension "B".

Measure " l_2 " and " l_3 " in at least two places.

"B": Distance between the end of output shaft bearing outer race and the side cover fitting surface of transmission case.

$$B = l_2 - l_3 \quad l_2: \text{Height of gauge}$$

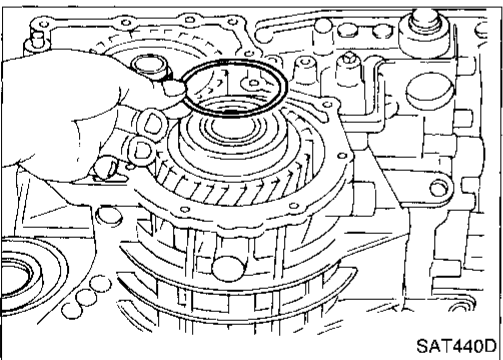

6. Select proper thickness of adjusting shim so that output shaft end play (clearance between side cover and output shaft bearing) is within specifications.

Output shaft end play (A - B):

0 - 0.5 mm (0 - 0.020 in)

Output shaft end play adjusting shim:

Refer to SDS, AT-300.

7. Install adjusting shim on output shaft bearing.

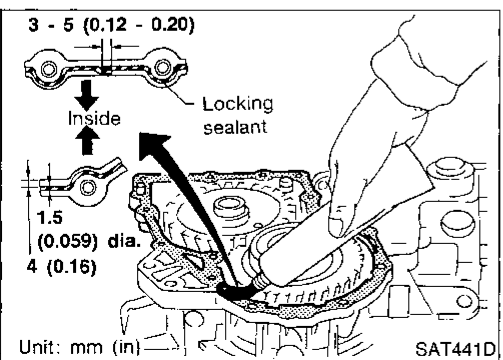

8. Apply locking sealant to transmission case as shown in illustration.

ASSEMBLY

Adjustment 1 (Cont'd)

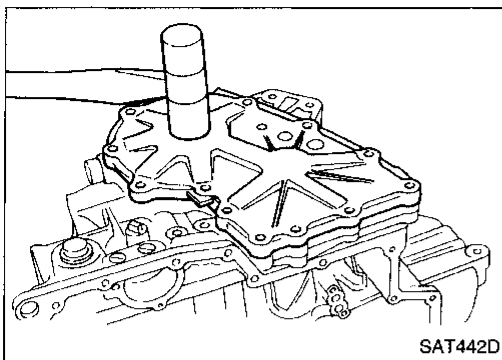

9. Install side cover on transmission case.
 - Apply locking sealant to the mating surface of transmission case.

GI

MA

EM

LC

EC

FE

CL

MT

AT

FA

RA

BR

ST

RS

BT

HA

EL

IDX

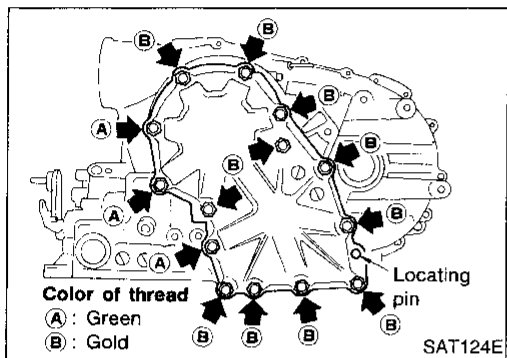

10. Tighten side cover fixing bolts to specified torque.
 - Do not mix bolts A and B.
 - Always replace bolts A as they are self-sealing bolts.

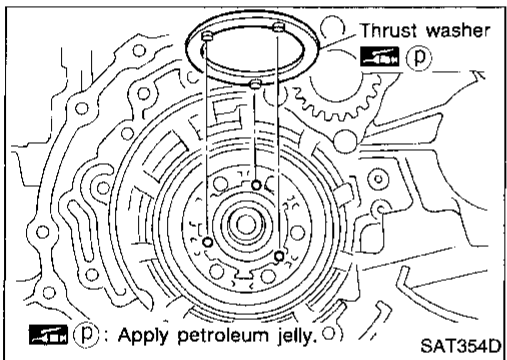

Assembly 2

1. Remove paper rolled around bearing retainer.
2. Install thrust washer on bearing retainer.
 - Apply petroleum jelly to thrust washer.

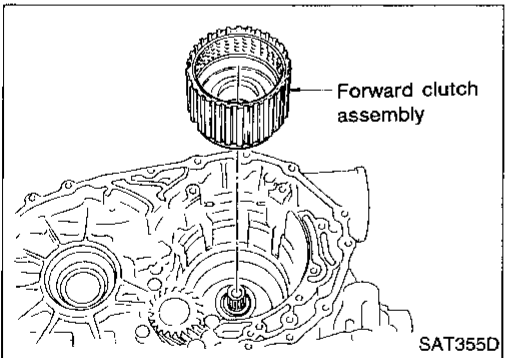

3. Install forward clutch assembly.
 - Align teeth of low & reverse brake drive plates before installing.
 - Make sure that bearing retainer seal rings are not spread.

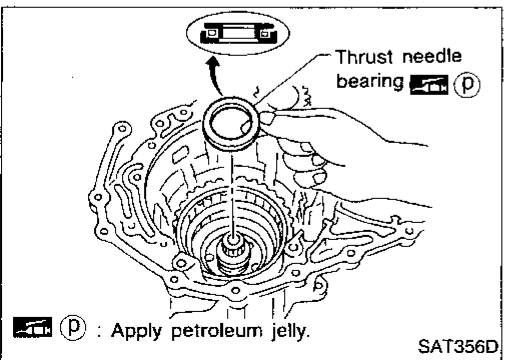

4. Install thrust needle bearing on bearing retainer.
 - Apply petroleum jelly to thrust bearing.
 - Pay attention to direction of thrust needle bearing.

ASSEMBLY

Assembly 2 (Cont'd)

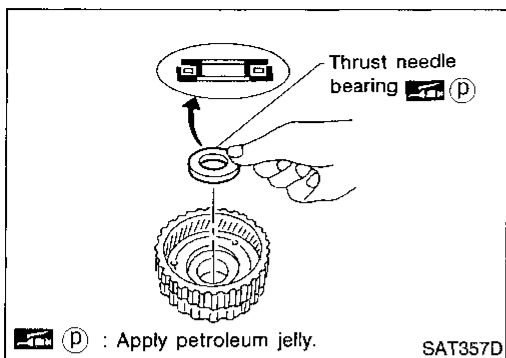

5. Install thrust needle bearing on rear internal gear.
 - Apply petroleum jelly to thrust needle bearing.
 - Pay attention to direction of thrust needle bearing.

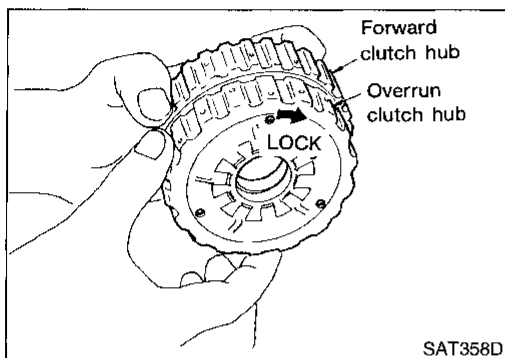

6. Hold forward clutch hub and turn overrun clutch hub. Check overrun clutch hub for directions of lock and unlock.
 - If not as shown in illustration, check installed direction of forward one-way clutch.

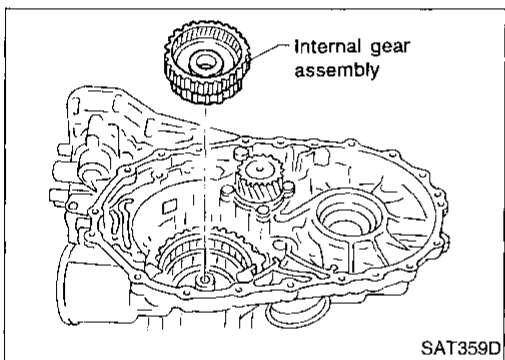

7. Install rear internal gear assembly.
 - Align teeth of forward clutch and overrun clutch drive plate.

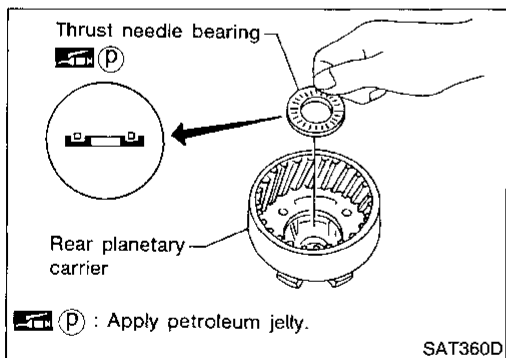

8. Install needle bearing on rear planetary carrier.
 - Apply petroleum jelly to needle bearing.
 - Pay attention to direction of needle bearing.

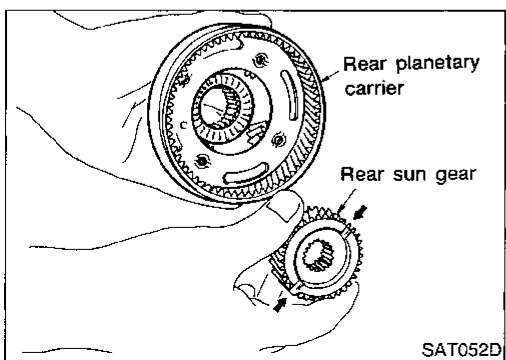

9. Install rear sun gear on rear planetary carrier.
 - Pay attention to direction of rear sun gear.

ASSEMBLY

Assembly 2 (Cont'd)

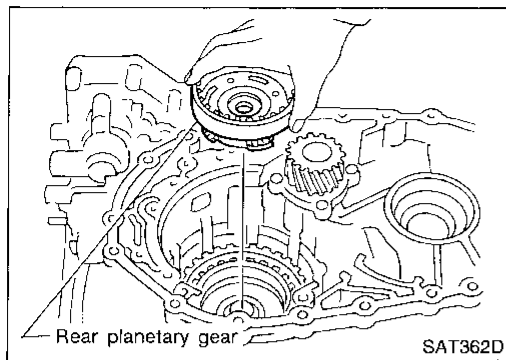

10. Install rear planetary carrier on transmission case.

GI

MA

EM

LC

EC

FE

CL

MT

AT

FA

RA

BR

ST

RS

BT

HA

EL

IDX

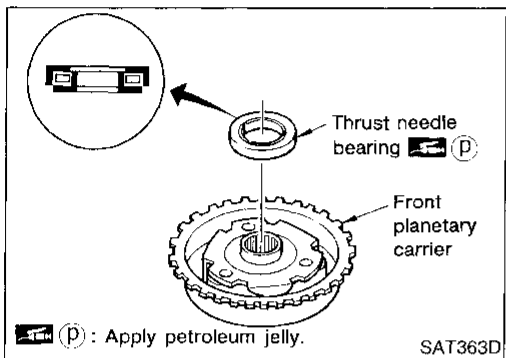

11. Install thrust needle bearing on front planetary carrier.

- Apply petroleum jelly to thrust needle bearing.
- Pay attention to direction of thrust needle bearing.

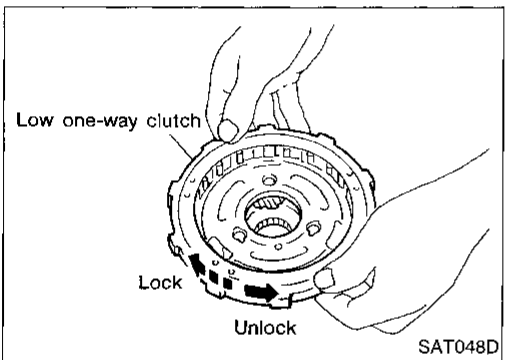

12. Install low one-way clutch to front planetary carrier by turning it in the direction of the arrow as shown.

13. While holding front planetary carrier, turn low one-way clutch. Check low one-way clutch for correct directions of lock and unlock.

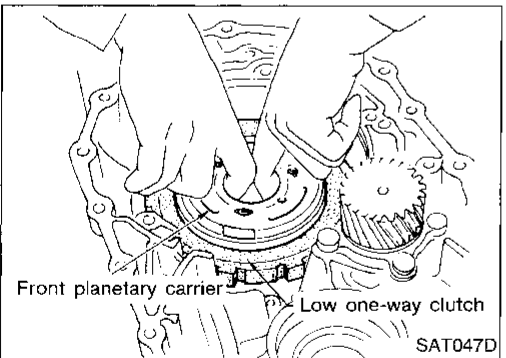

14. Install front planetary carrier assembly on transmission case.

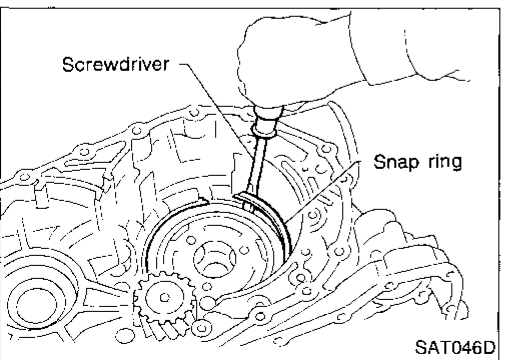

15. Install snap ring with screwdriver.

- Forward clutch and bearings must be correctly installed for snap ring to fit groove of transmission case.

ASSEMBLY

Assembly 2 (Cont'd)

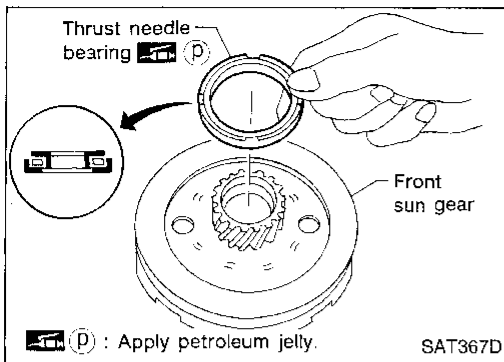

16. Install needle bearing on front sun gear.
- Apply petroleum jelly to needle bearing.
 - Pay attention to direction of needle bearing.

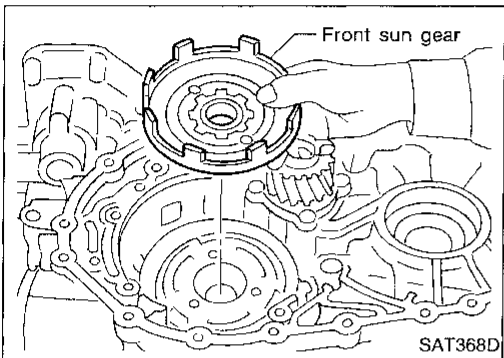

17. Install front sun gear on front planetary carrier.

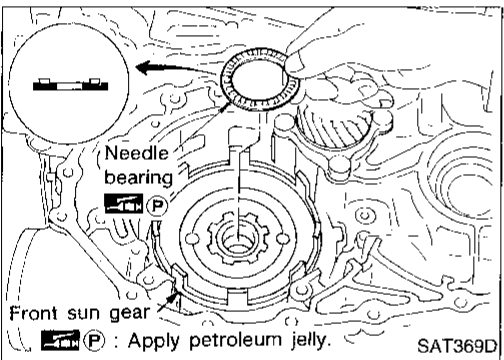

18. Install needle bearing on front sun gear.
- Apply petroleum jelly to needle bearing.
 - Pay attention to direction of needle bearing.

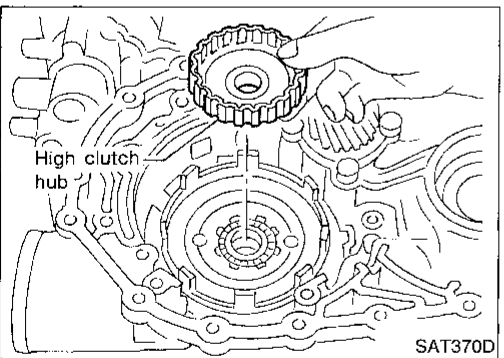

19. Install high clutch hub on front sun gear.

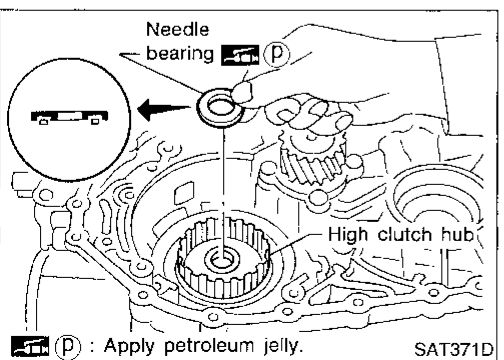

20. Install needle bearing on high clutch hub.
- Apply petroleum jelly to needle bearing.
 - Pay attention to direction of needle bearing.

ASSEMBLY

Assembly 2 (Cont'd)

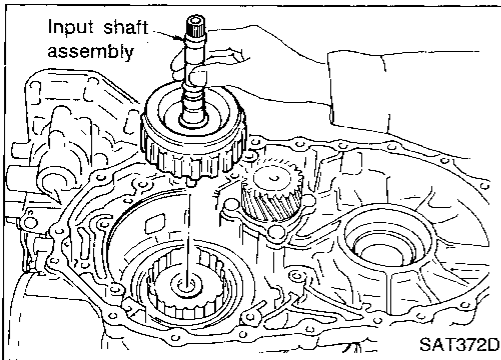

21. Remove paper rolled around input shaft.

22. Install input shaft assembly.

- **Align teeth of high clutch drive plates before installing.**

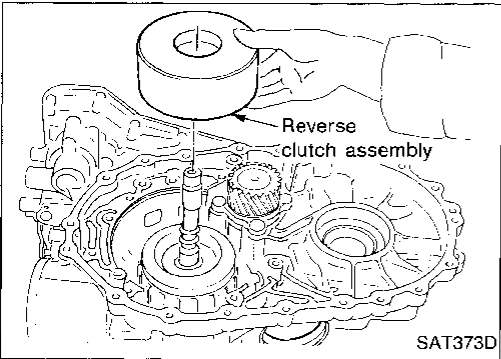

23. Install reverse clutch assembly.

- **Align teeth of reverse clutch drive plates before installing.**

Adjustment 2

When any parts listed below are replaced, adjust total end play and reverse clutch end play.

Part name	Total end play	Reverse clutch end play
Transmission case	●	●
Overrun clutch hub	●	●
Rear internal gear	●	●
Rear planetary carrier	●	●
Rear sun gear	●	●
Front planetary carrier	●	●
Front sun gear	●	●
High clutch hub	●	●
High clutch drum	●	●
Oil pump cover	●	●
Reverse clutch drum	—	●

ASSEMBLY

Adjustment 2 (Cont'd)

TOTAL END PLAY

- Measure clearance between reverse clutch drum and needle bearing for oil pump cover.
- Select proper thickness of bearing race so that end play is within specifications.

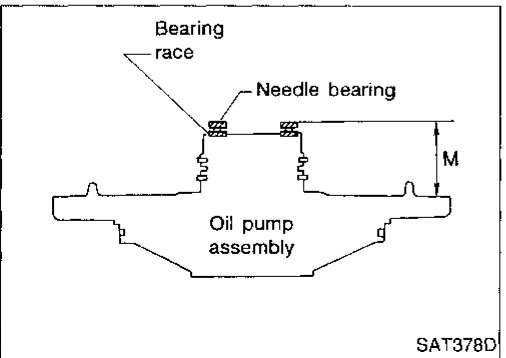
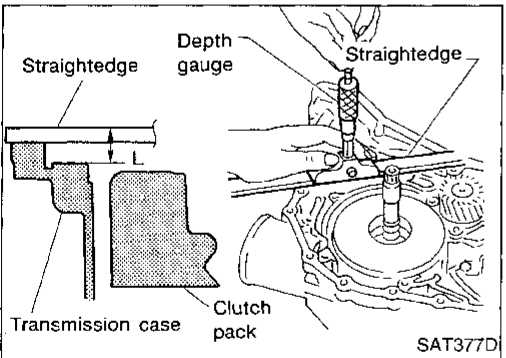
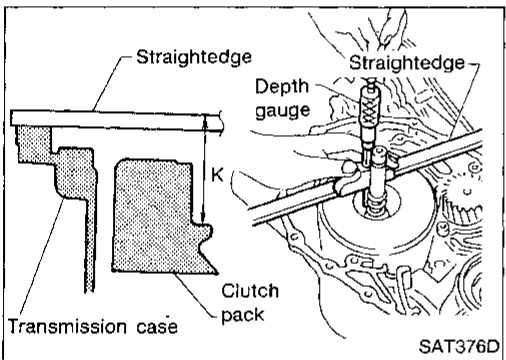
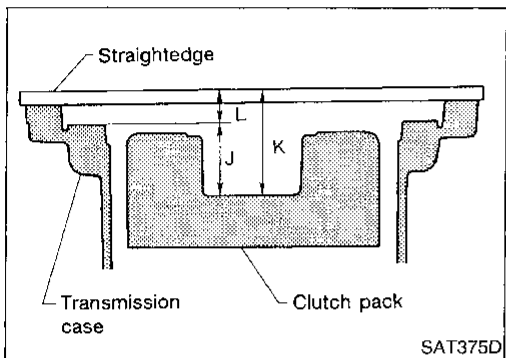
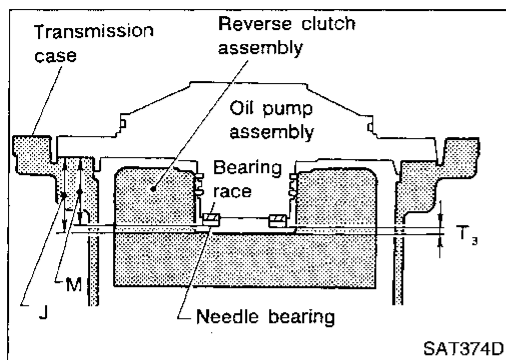

1. Measure dimensions "K" and "L" and then calculate dimension "J".

- a. Measure dimension "K".

- b. Measure dimension "L".
- c. Calculate dimension "J".

"J": Distance between oil pump fitting surface of transmission case and needle bearing mating surface of high clutch drum.

$$J = K - L$$

2. Measure dimension "M".
 - a. Place bearing race and needle bearing on oil pump assembly.

ASSEMBLY

Adjustment 2 (Cont'd)

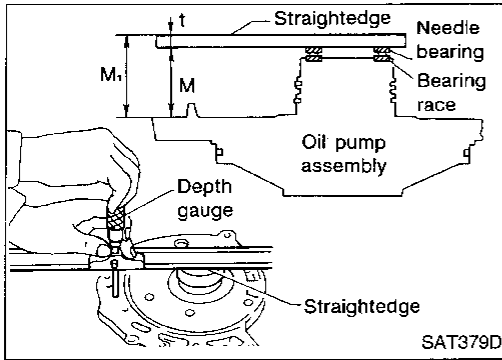

b. Measure dimension "M".

"M": Distance between transmission case fitting surface and needle bearing on oil pump cover.

"M₁": Indication of gauge.

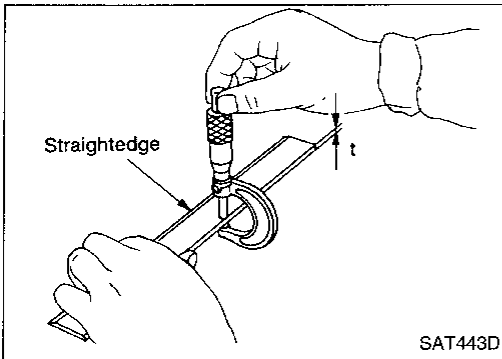

c. Measure thickness of straightedge "t".

$$M = M_1 - t$$

3. Adjust total end play "T₃".

$$T_3 = J - M$$

Total end play "T₃":

0.25 - 0.55 mm (0.0098 - 0.0217 in)

- Select proper thickness of bearing race so that total end play is within specifications.

Bearing races: Refer to SDS, AT-300.

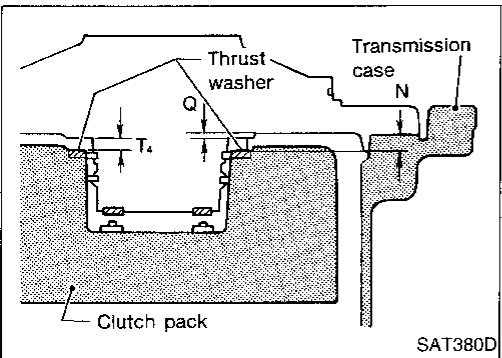

REVERSE CLUTCH END PLAY

- Measure clearance between oil pump cover and thrust washer for reverse clutch drum.
- Select proper thickness of thrust washer so that end play is within specifications.

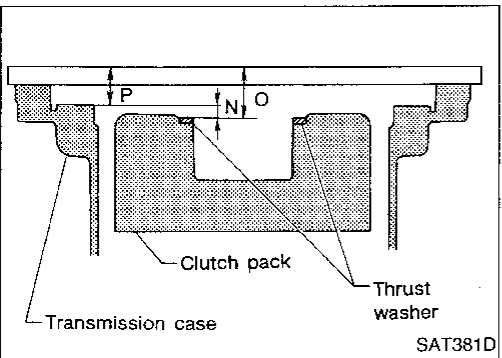

1. Measure dimensions "O" and "P" and then calculate dimension "N".

ASSEMBLY

Adjustment 2 (Cont'd)

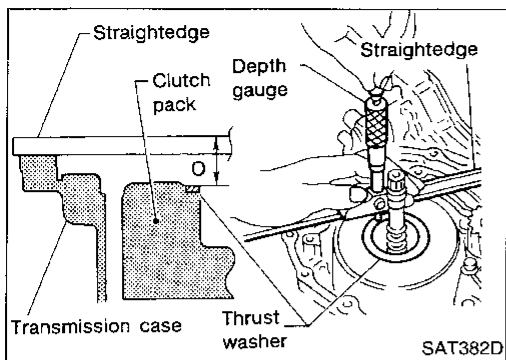

- Place thrust washer on reverse clutch drum.
- Measure dimension "O".

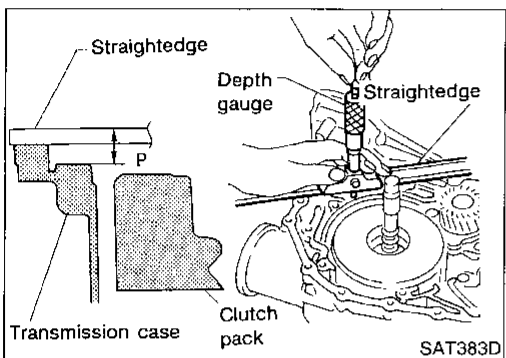

- Measure dimension "P".
- Calculate dimension "N".

"N": Distance between oil pump fitting surface of transmission case and thrust washer on reverse clutch drum.

$$N = O - P$$

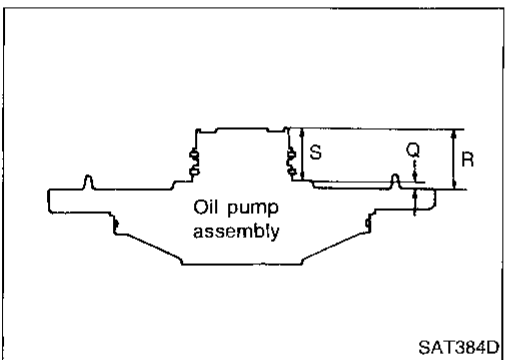

- Measure dimensions "R" and "S" and then calculate dimension "Q".

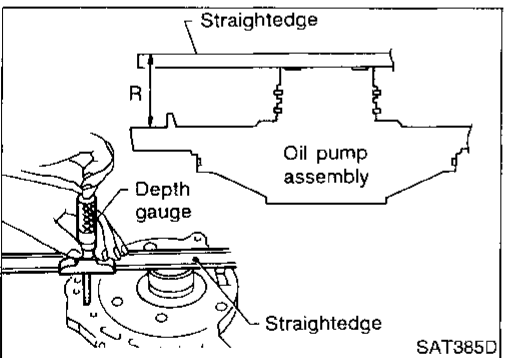

- Measure dimension "R".

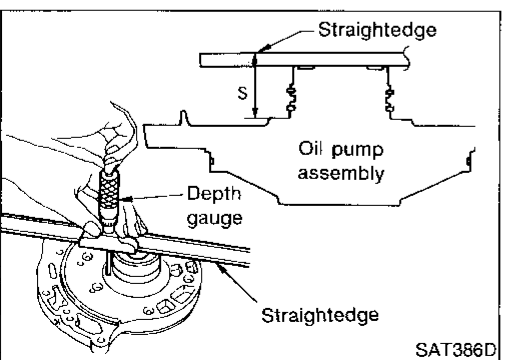

- Measure dimension "S".
- Calculate dimension "Q".

"Q": Distance between transmission case fitting surface and thrust washer mating surface.

$$Q = R - S$$

ASSEMBLY

Adjustment 2 (Cont'd)

- Adjust reverse clutch end play "T₄".

$$T_4 = N - Q$$

Reverse clutch end play:

0.65 - 1.00 mm (0.0256 - 0.0394 in)

- Select proper thickness of thrust washer so that reverse clutch end play is within specifications.
Thrust washer: Refer to SDS, AT-300.

GI

MA

EM

LC

EC

FE

CL

MT

AT

FA

RA

BR

ST

RS

BT

HA

EL

IDX

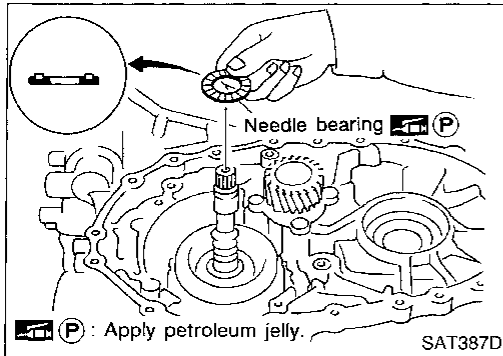

Assembly 3

- Remove reverse clutch assembly and install needle bearing on high clutch assembly.
 - Pay attention to direction of needle bearing.
- Install reverse clutch assembly.

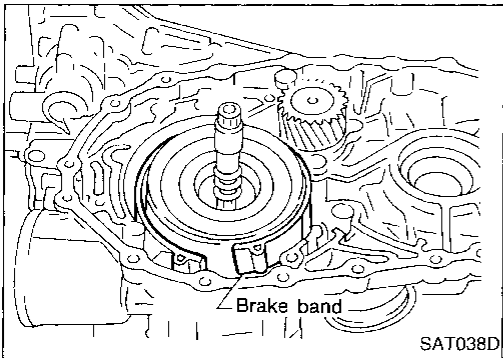

- Install anchor end pin and lock nut on transmission case.
- Place brake band on outside of reverse clutch drum. Tighten anchor end pin just enough so that brake band is evenly fitted on reverse clutch drum.

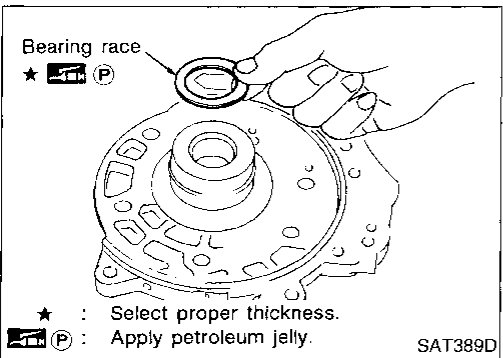

- Place bearing race selected in total end play adjustment step on oil pump cover.
 - Apply petroleum jelly to bearing race.

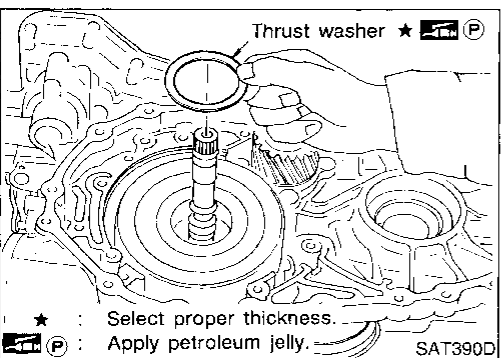

- Place thrust washer selected in reverse clutch end play step on reverse clutch drum.
 - Apply petroleum jelly to thrust washer.

ASSEMBLY

Assembly 3 (Cont'd)

7. Install oil pump assembly on transmission case.

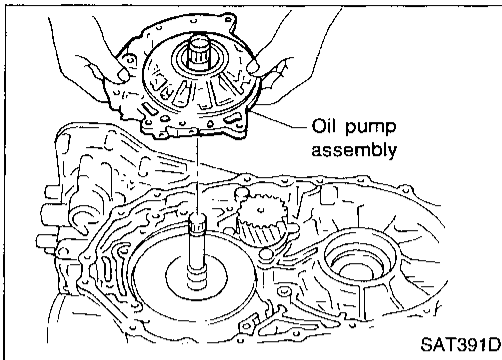

8. Tighten oil pump fixing bolts to specified torque.

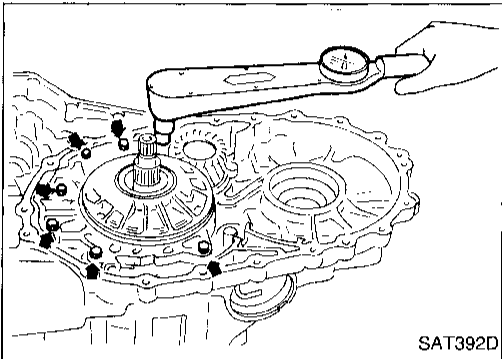

9. Install O-ring to input shaft.

- **Apply ATF to O-ring.**

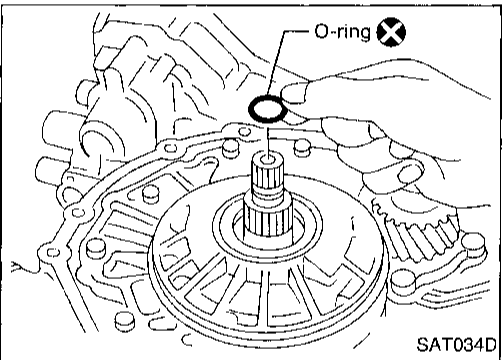

10. Adjust brake band.

- a. Tighten anchor end pin to specified torque.

Anchor end pin:

 : 3.9 - 5.9 N·m (0.4 - 0.6 kg-m, 35 - 52 in-lb)

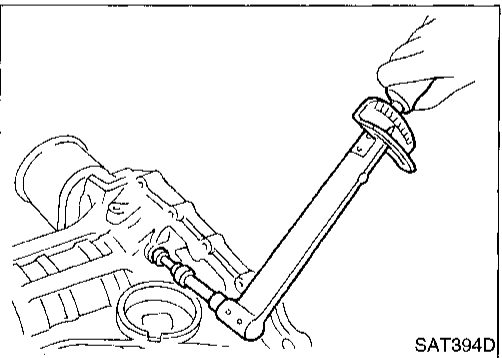

- b. Back off anchor end pin two and a half turns.

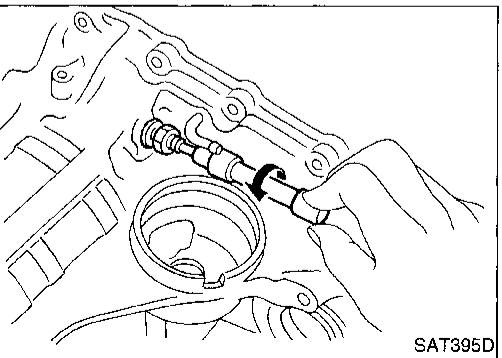

ASSEMBLY

Assembly 3 (Cont'd)

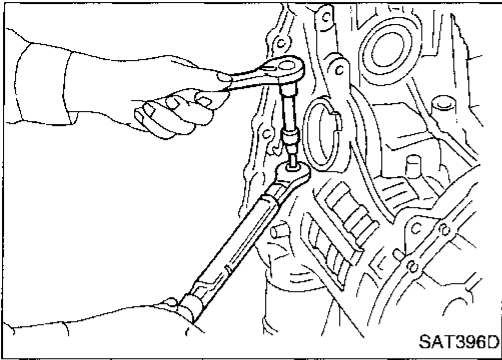

c. While holding anchor end pin, tighten lock nut.

GI
MA
EM

LC
EC

FE
CL

MT

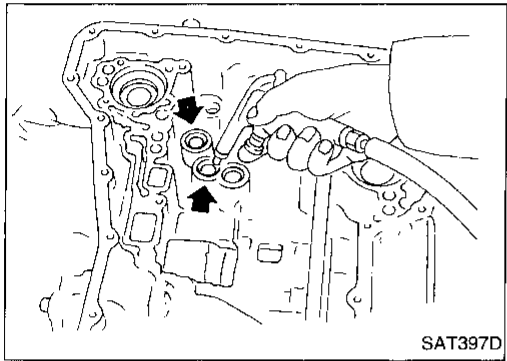

11. Apply compressed air to oil holes of transmission case and check operation of brake band.

AT

FA

RA

BR

ST

RS

BT

HA

EL

IDX

Assembly 4

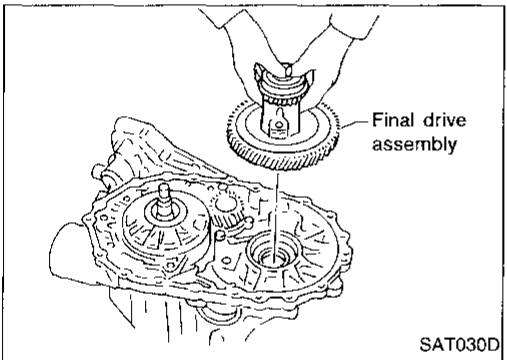

1. Install final drive assembly on transmission case.

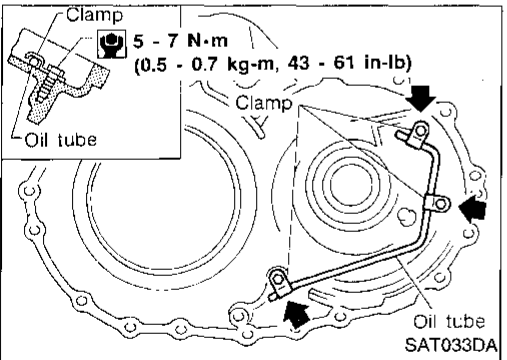

2. Install oil tube on converter housing.

ASSEMBLY

Assembly 4 (Cont'd)

3. Install O-ring on differential oil port of transmission case.

4. Install converter housing on transmission case.

- Apply locking sealant to mating surface of converter housing.

Bolt	Length mm (in)
(A)	32.8 (1.291)
(B)	40 (1.57)

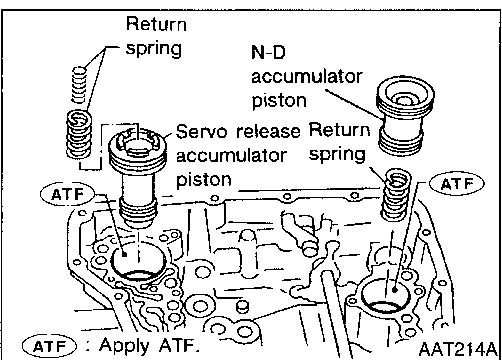
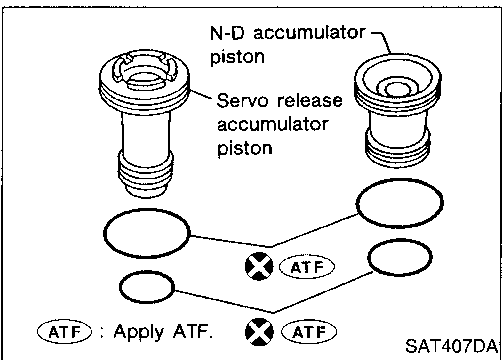
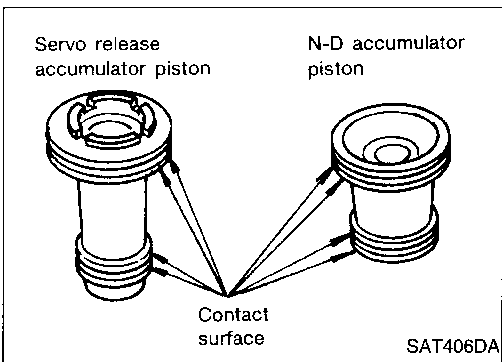
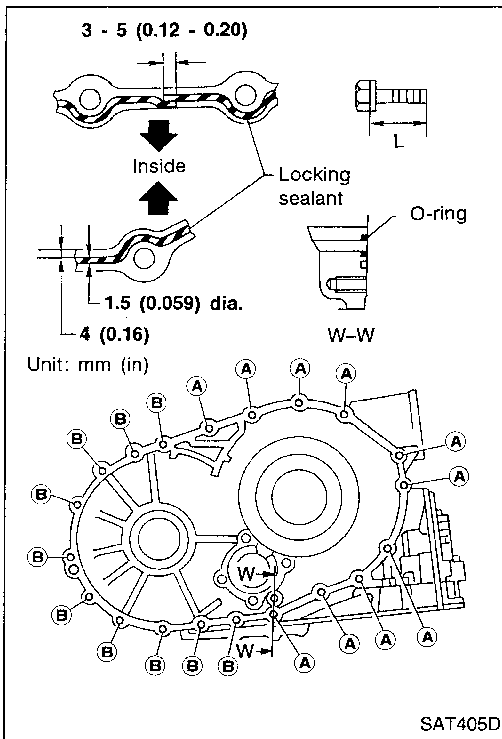

5. Install accumulator piston.

- a. Check contact surface of accumulator piston for damage.

b. Install O-rings on accumulator piston.

- Apply ATF to O-rings.

**Accumulator piston O-rings:
Refer to SDS, AT-300.**

c. Install accumulator pistons and return springs on transmission case.

- Apply ATF to inner surface of transmission case.

**Return springs:
Refer to SDS, AT-300.**

ASSEMBLY

Assembly 4 (Cont'd)

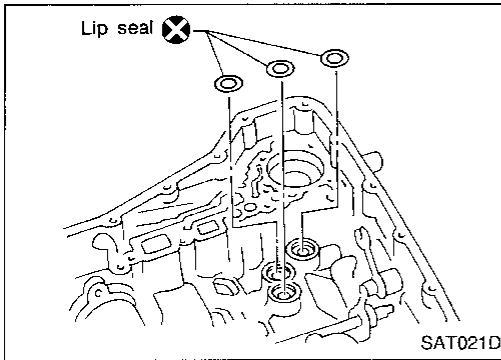

6. Install lip seals for band servo oil holes on transmission case.

- Apply petroleum jelly to lip seals.

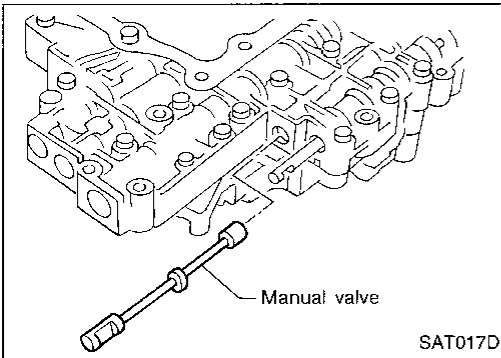
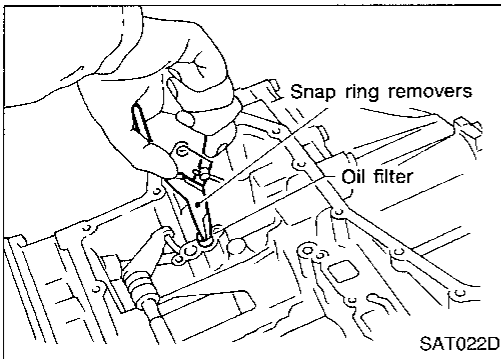

7. Install control valve assembly.

a. Insert manual valve into control valve assembly.

- Apply ATF to manual valve.

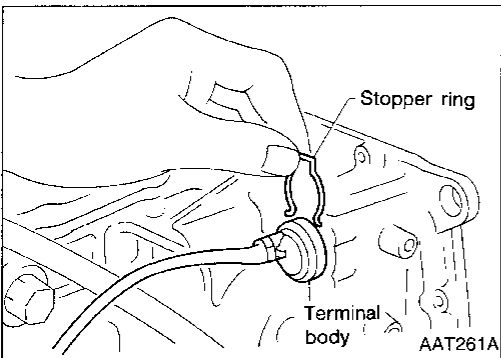

b. Pass solenoid harness through transmission case and install terminal body on transmission case by pushing it.

c. Install stopper ring to terminal body.

GI

MA

EM

LC

EC

FE

CL

MT

AT

FA

RA

BR

ST

RS

BT

HA

EL

IDX

ASSEMBLY

Assembly 4 (Cont'd)

d. Tighten bolts (A), (B) and (C).

 : 7 - 9 N·m (0.7 - 0.9 kg-m, 61 - 78 in-lb)

Bolt length, number and location

Bolt symbol	(A)	(B)	(C)
Bolt length "ℓ"  ℓ mm (in)	40.0 (1.575)	33.0 (1.299)	43.5 (1.713)
Number of bolts	5	6	2

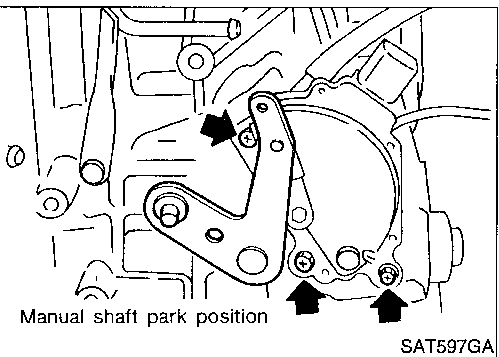
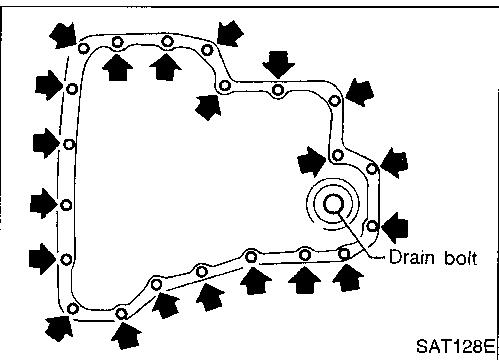
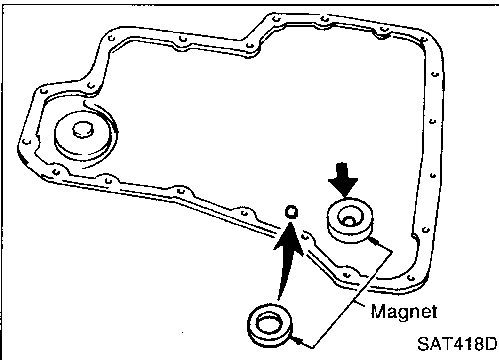
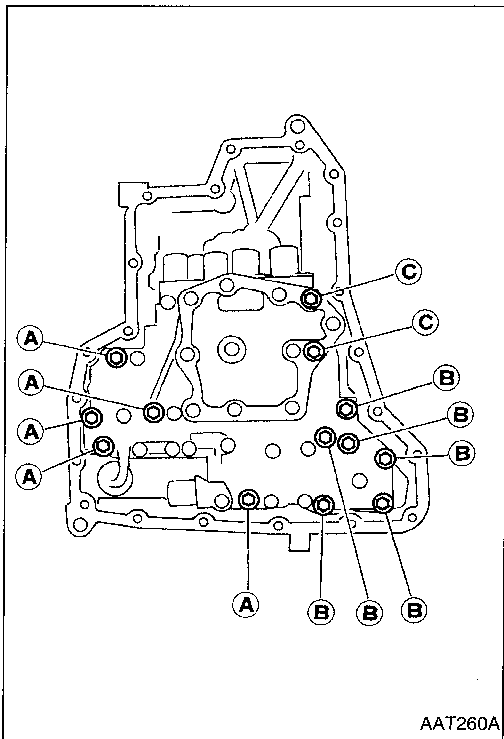

8. Install oil pan.
 - a. Attach magnet to oil pan.

- b. Install new oil pan gasket on transmission case.
- c. Install oil pan on transmission case.
 - **Always replace oil pan bolts as they are self-sealing bolts.**
 - **Tighten the four bolts in a criss-cross pattern to prevent dislocation of gasket.**
- d. Tighten drain plug to specified torque.

9. Install inhibitor switch.
 - a. Set manual shaft in "P" position.
 - b. Temporarily install inhibitor switch on manual shaft.
 - c. Move selector lever to "N" position.

ASSEMBLY

Assembly 4 (Cont'd)

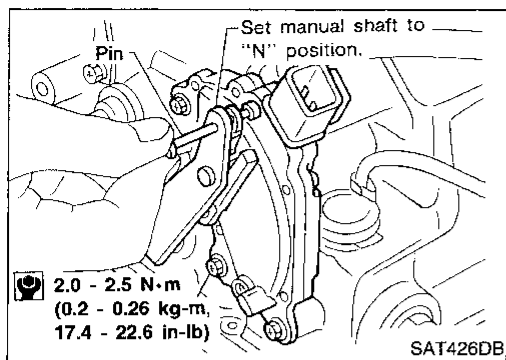

- d. Use a 4 mm (0.157 in) pin for this adjustment.
 - 1) Insert the pin straight into the manual shaft adjustment hole.
 - 2) Rotate inhibitor switch until the pin can also be inserted straight into hole in inhibitor switch.
- e. Tighten inhibitor switch fixing bolts.
- f. Remove pin from adjustment hole after adjusting inhibitor switch.

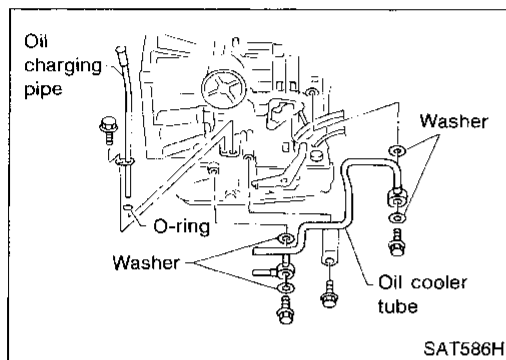

10. Install oil charging pipe and oil cooler tube to transmission case.

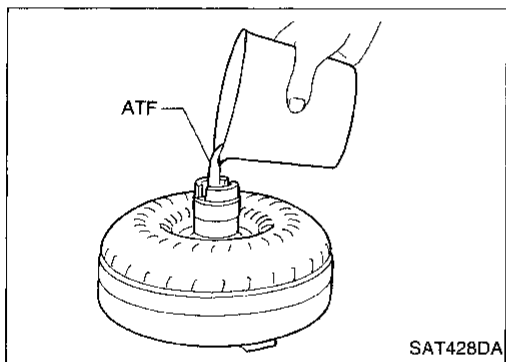

11. Install torque converter.
 - a. Pour ATF into torque converter.
 - **Approximately 1 liter (1 - 1/8 US qt, 7/8 Imp qt) of fluid is required for a new torque converter.**
 - **When reusing old torque converter, add the same amount of fluid as was drained.**

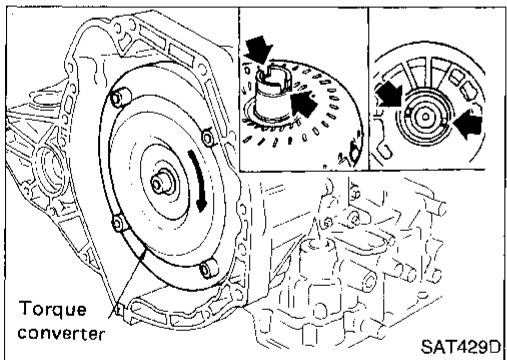

- b. Install torque converter while aligning notches of torque converter with notches of oil pump.

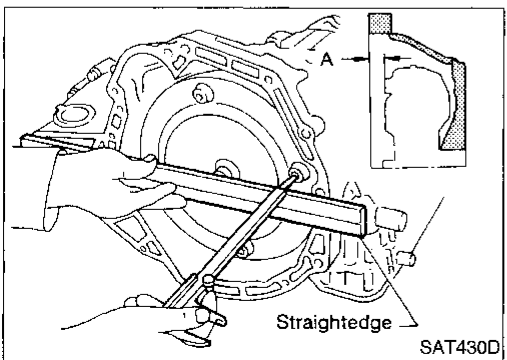

- c. Measure distance "A" to check that torque converter is in proper position.

Distance "A":
15.9 mm (0.626 in) or more

SERVICE DATA AND SPECIFICATIONS (SDS)

General Specifications

Engine	SR20DE		
Automatic transaxle model	RE4F03A		
Automatic transaxle assembly			
Model code number	36X09		
Transaxle gear ratio			
1st	2.861		
2nd	1.562		
3rd	1.000		
4th	0.697		
Reverse	2.310		
Final drive	3.827		
Recommended oil	Nissan Matic "D" (Continental U.S. and Alaska) or Genuine Nissan Automatic Transmission Fluid (Canada)*1		
Oil capacity	ℓ (US qt, Imp qt)	7.0 (7-3/8, 6-1/8)	

*1: Refer to MA section ("Fluids and Lubricants", "RECOMMENDED FLUIDS AND LUBRICANTS").

Specifications and Adjustments

SHIFT SCHEDULE

Vehicle speed when shifting gears

Throttle position	Shift pattern	Vehicle speed km/h (MPH)						
		D ₁ → D ₂	D ₂ → D ₃	D ₃ → D ₄	D ₄ → D ₃	D ₃ → D ₂	D ₂ → D ₁	1 ₂ → 1 ₁
Full throttle	Comfort	56 - 64 (35 - 40)	107 - 115 (66 - 71)	169 - 177 (105 - 110)	165 - 173 (103 - 108)	97 - 105 (60 - 65)	46 - 54 (29 - 34)	54 - 62 (34 - 39)
Half throttle	Comfort	29 - 37 (18 - 23)	64 - 72 (40 - 45)	110 - 118 (68 - 73)	74 - 82 (46 - 51)	37 - 45 (23 - 28)	9 - 17 (6 - 11)	54 - 62 (34 - 39)

Vehicle speed when performing lock-up

Throttle opening	OD switch	Shift pattern	Vehicle speed km/h (MPH)	
			Lock-up ON	Lock-up OFF
2/8	ON (D ₄)	Comfort	104 - 112 (65 - 70)	92 - 100 (57 - 62)
	OFF (D ₃)	Comfort	86 - 94 (53 - 58)	83 - 91 (52 - 57)

STALL REVOLUTION

1,850 - 2,150

LINE PRESSURE

Engine speed rpm	Line pressure kPa (kg/cm ² , psi)			
	R position	D position	2 position	1 position
Idle	902 (9.2, 131)	579 (5.9, 84)	598 (6.1, 87)	598 (6.1, 87)
Stall	1,706 (17.4, 247)	1,098 (11.2, 159)	1,098 (11.2, 159)	1,098 (11.2, 159)

SERVICE DATA AND SPECIFICATIONS (SDS)

Specifications and Adjustments (Cont'd)

CONTROL VALVES

Control valve and plug return springs

Unit: mm (in)

Parts		Part No.	Free length	Outer diameter	
Upper body	⑱	Pilot valve spring	31742-80X14	36.0 (1.417)	8.1 (0.319)
	⑭	1-2 accumulator valve spring	31742-80X10	20.5 (0.807)	7.0 (0.276)
	㉑	1-2 accumulator piston spring	31742-33X01	50.5 (1.988)	19.8 (0.780)
	㉕	1st reducing valve spring	31742-80X05	27.0 (1.063)	7.0 (0.276)
	②	Overrun clutch reducing valve spring	31742-80X06	37.5 (1.476)	7.0 (0.276)
	⑦	Torque converter relief valve spring	31742-33X00	31.0 (1.220)	8.9 (0.350)
	⑩	Torque converter clutch control valve	31742-80X17	39.5 (1.555)	11.0 (0.433)
	—	Oil cooler relief valve spring	31872-31X00	17.02 (0.6701)	8.0 (0.315)
Lower body	㉓	Plug spring	31742-80X11	17.0 (0.669)	10.7 (0.421)
	⑯	Pressure regulator valve spring	31742-80X13	45.0 (1.772)	15.0 (0.591)
	㉑	Overrun clutch control valve spring	31762-80X00	21.7 (0.854)	7.0 (0.276)
	㉕	Accumulator control valve spring	31742-80X02	22.0 (0.866)	6.5 (0.256)
	③⑩	Shift valve A spring	31762-80X00	21.7 (0.854)	7.0 (0.276)
	②	Shift valve B spring	31762-80X00	21.7 (0.854)	7.0 (0.276)
	⑦	Pressure modifier valve spring	31742-41X15	30.5 (1.201)	9.8 (0.386)
	⑪		31742-80X16	32.0 (1.260)	6.9 (0.272)

GI

MA

EM

LC

EC

FE

CL

MT

AT

FA

RA

BR

ST

RS

BT

HA

EL

IDX

SERVICE DATA AND SPECIFICATIONS (SDS)

Specifications and Adjustments (Cont'd)

CLUTCHES AND BRAKES

Reverse clutch			
Number of drive plates	2		
Number of driven plates	2		
Drive plate thickness mm (in)			
Standard	2.0 (0.079)		
Allowable limit	1.8 (0.071)		
Clearance mm (in)			
Standard	0.5 - 0.8 (0.020 - 0.031)		
Allowable limit	1.2 (0.047)		
Thickness of retaining plates	Thickness mm (in)	Part number	
	4.4 (0.173)	31537-31X00	
	4.6 (0.181)	31537-31X01	
	4.8 (0.189)	31537-31X02	
	5.0 (0.197)	31537-31X03	
	5.2 (0.205)	31537-31X04	
High clutch			
Number of drive plates	4		
Number of driven plates	6 + 1		
Drive plate thickness mm (in)			
Standard	1.6 (0.063)		
Allowable limit	1.4 (0.055)		
Clearance mm (in)			
Standard	1.4 - 1.8 (0.055 - 0.071)		
Allowable limit	2.6 (0.102)		
Thickness of retaining plates	Thickness mm (in)	Part number	
	3.8 (0.150)	31537-31 X11	
	4.0 (0.157)	31537-31 X12	
	4.2 (0.165)	31537-31 X13	
	4.4 (0.173)	31537-31 X14	
	4.6 (0.181)	31537-31 X15	
	4.8 (0.189)	31537-31 X16	
	5.0 (0.197)	31537-31 X17	

Forward clutch		
Number of drive plates	5	
Number of driven plates	5	
Drive plate thickness mm (in)		
Standard	1.8 (0.071)	
Allowable limit	1.6 (0.063)	
Clearance mm (in)		
Standard	0.45 - 0.85 (0.0177 - 0.0335)	
Allowable limit	1.85 (0.0728)	
Thickness of retaining plate	Thickness mm (in)	Part number
	3.6 (0.142)	31537-31X60
	3.8 (0.150)	31537-31X61
	4.0 (0.157)	31537-31X62
	4.2 (0.165)	31537-31X63
	4.4 (0.173)	31537-31X64
	4.6 (0.181)	31537-31X65
Overrun clutch		
Number of drive plates	3	
Number of driven plates	4	
Drive plate thickness mm (in)		
Standard	1.6 (0.063)	
Allowable limit	1.4 (0.055)	
Clearance mm (in)		
Standard	1.0 - 1.4 (0.039 - 0.055)	
Allowable limit	2.0 (0.079)	
Thickness of retaining plate	Thickness mm (in)	Part number
	3.6 (0.142)	31567-31X79
	3.8 (0.150)	31567-31X80
	4.0 (0.157)	31567-31X81
	4.2 (0.165)	31567-31X82
4.4 (0.173)	31567-31X83	

SERVICE DATA AND SPECIFICATIONS (SDS)

Specifications and Adjustments (Cont'd)

Model	RE4F03A	
Low & reverse brake		
Number of drive plates	5	
Number of driven plates	5	
Drive plate thickness mm (in)		
Standard	2.0 (0.079)	
Allowable limit	1.8 (0.071)	
Clearance mm (in)		
Standard	1.4 - 1.8 (0.055 - 0.071)	
Allowable limit	2.8 (0.110)	
Thickness of retaining plate	Thickness mm (in)	Part number
	3.6 (0.142)	31667-31X16
	3.8 (0.150)	31667-31X17
	4.0 (0.157)	31667-31X18
	4.2 (0.165)	31667-31X19
	4.4 (0.173)	31667-31X20
4.6 (0.181)	31667-31X21	
Brake band		
Anchor end pin tightening torque N·m (kg-m, in-lb)	3.9 - 5.9 (0.4 - 0.6, 35 - 52)	
Number of returning revolutions for anchor end pin	2.5±0.125	
Lock nut tightening torque N-m (kg-m, ft-lb)	31 - 36 (3.2 - 3.7, 23 - 27)	

Clutch and brake return springs

Unit: mm (in)

Parts		Free length	Outer diameter
Forward clutch (Over-run clutch) (16 pcs)	Outer	26.6 (1.047)	10.6 (0.417)
	Inner	26.3 (1.035)	7.7 (0.303)
Reverse clutch (16 pcs)		18.6 (0.732)	8.0 (0.315)
High clutch (12 pcs)		19.7 (0.776)	11.1 (0.437)
Low reverse brake (20 pcs)		25.1 (0.988)	7.6 (0.299)

OIL PUMP

Oil pump side clearance mm (in)	0.02 - 0.04 (0.0008 - 0.0016)	
Thickness of inner gears and outer gears	Inner gear	
	Thickness mm (in)	Part number
	9.99 - 10.00 (0.3933 - 0.3937)	31346-31X00
	9.98 - 9.99 (0.3929 - 0.3933)	31346-31X01
	9.97 - 9.98 (0.3925 - 0.3929)	31346-31X02
	Outer gear	
	Thickness mm (in)	Part number
	9.99 - 10.00 (0.3933 - 0.3937)	31347-31X00
	9.98 - 9.99 (0.3929 - 0.3933)	31347-31X01
	9.97 - 9.98 (0.3925 - 0.3929)	31347-31X02
Clearance between oil pump housing and outer gear mm (in)		
Standard	0.08 - 0.15 (0.0031 - 0.0059)	
Allowable limit	0.15 (0.0059)	
Oil pump cover seal ring clearance mm (in)		
Standard	0.1 - 0.25 (0.0039 - 0.0098)	
Allowable limit	0.25 (0.0098)	

INPUT SHAFT

Input shaft seal ring clearance mm (in)	
Standard	0.08 - 0.23 (0.0031 - 0.0091)
Allowable limit	0.23 (0.0091)

PLANETARY CARRIER

Clearance between planetary carrier and pinion washer mm (in)	
Standard	0.15 - 0.70 (0.0059 - 0.0276)
Allowable limit	0.80 (0.0315)

SERVICE DATA AND SPECIFICATIONS (SDS)

Specifications and Adjustments (Cont'd)

FINAL DRIVE

Differential side gear clearance

Clearance between side gear and differential case with washer mm (in)	0.1 - 0.2 (0.004 - 0.008)
--	---------------------------

Differential side gear thrust washers

Thickness mm (in)	Part number
0.75 - 0.80 (0.0295 - 0.0315)	38424-D2111
0.80 - 0.85 (0.0315 - 0.0335)	38424-D2112
0.85 - 0.90 (0.0335 - 0.0354)	38424-D2113
0.90 - 0.95 (0.0354 - 0.0374)	38424-D2114
0.95 - 1.00 (0.0374 - 0.0394)	38424-D2115

Bearing preload

Differential side bearing preload "T" mm (in)	0.04 - 0.09 (0.0016 - 0.0035)
---	-------------------------------

Turning torque

Turning torque of final drive assembly N-m (kg-cm, in-lb)	0.49 - 1.08 (5.0 - 11.0, 4.3 - 9.5)
--	-------------------------------------

Differential side bearing adjusting shims

Thickness mm (in)	Part number
0.40 (0.0157)	31499-21X07
0.44 (0.0173)	31499-21X08
0.48 (0.0189)	31499-21X09
0.52 (0.0205)	31499-21X10
0.56 (0.0220)	31499-21X11
0.60 (0.0236)	31499-21X12
0.64 (0.0252)	31499-21X13
0.68 (0.0268)	31499-21X14
0.72 (0.0283)	31499-21X15
0.76 (0.0299)	31499-21X16
0.80 (0.0315)	31499-21X17
0.84 (0.0331)	31499-21X18
0.88 (0.0346)	31499-21X19
0.92 (0.0362)	31499-21X20
1.44 (0.0567)	31499-21X21

Table for selecting differential side bearing adjusting shim(s)

Unit: mm (in)

Dial indicator deflection	Suitable shim(s)
0.31 - 0.35 (0.0122 - 0.0138)	0.40 (0.0157)
0.35 - 0.39 (0.0138 - 0.0154)	0.44 (0.0173)
0.39 - 0.43 (0.0154 - 0.0169)	0.48 (0.0189)
0.43 - 0.47 (0.0169 - 0.0185)	0.52 (0.0205)
0.47 - 0.51 (0.0185 - 0.0201)	0.56 (0.0220)
0.51 - 0.55 (0.0201 - 0.0217)	0.60 (0.0236)
0.55 - 0.59 (0.0217 - 0.0232)	0.64 (0.0252)
0.59 - 0.63 (0.0232 - 0.0248)	0.68 (0.0268)
0.63 - 0.67 (0.0248 - 0.0264)	0.72 (0.0283)
0.67 - 0.71 (0.0264 - 0.0280)	0.76 (0.0299)
0.71 - 0.75 (0.0280 - 0.0295)	0.80 (0.0315)
0.75 - 0.79 (0.0295 - 0.0311)	0.84 (0.0331)
0.79 - 0.83 (0.0311 - 0.0327)	0.88 (0.0346)
0.83 - 0.87 (0.0327 - 0.0343)	0.92 (0.0362)
0.87 - 0.91 (0.0343 - 0.0358)	0.48 (0.0189) + 0.48 (0.0189)
0.91 - 0.95 (0.0358 - 0.0374)	0.48 (0.0189) + 0.52 (0.0205)
0.95 - 0.99 (0.0374 - 0.0390)	0.52 (0.0205) + 0.52 (0.0205)
0.99 - 1.03 (0.0390 - 0.0406)	0.52 (0.0205) + 0.56 (0.0220)
1.03 - 1.07 (0.0406 - 0.0421)	0.56 (0.0220) + 0.56 (0.0220)
1.07 - 1.11 (0.0421 - 0.0437)	0.56 (0.0220) + 0.60 (0.0236)
1.11 - 1.15 (0.0437 - 0.0453)	0.60 (0.0236) + 0.60 (0.0236)
1.15 - 1.19 (0.0453 - 0.0469)	0.60 (0.0236) + 0.64 (0.0252)
1.19 - 1.23 (0.0469 - 0.0484)	0.64 (0.0252) + 0.64 (0.0252)
1.23 - 1.27 (0.0484 - 0.0500)	0.64 (0.0252) + 0.68 (0.0268)
1.27 - 1.31 (0.0500 - 0.0516)	0.68 (0.0268) + 0.68 (0.0268)
1.31 - 1.35 (0.0516 - 0.0531)	0.68 (0.0268) + 0.72 (0.0283)
1.35 - 1.39 (0.0531 - 0.0547)	1.44 (0.0567)
1.39 - 1.43 (0.0547 - 0.0563)	0.72 (0.0283) + 0.76 (0.0299)
1.43 - 1.47 (0.0563 - 0.0579)	0.76 (0.0299) + 0.76 (0.0299)
1.47 - 1.51 (0.0579 - 0.0594)	0.76 (0.0299) + 0.80 (0.0315)
1.51 - 1.55 (0.0594 - 0.0610)	0.80 (0.0315) + 0.80 (0.0315)
1.55 - 1.59 (0.0610 - 0.0626)	0.80 (0.0315) + 0.84 (0.0331)
1.59 - 1.63 (0.0626 - 0.0642)	0.84 (0.0331) + 0.84 (0.0331)
1.63 - 1.67 (0.0642 - 0.0657)	0.84 (0.0331) + 0.88 (0.0346)
1.67 - 1.71 (0.0657 - 0.0673)	0.88 (0.0346) + 0.88 (0.0346)
1.71 - 1.75 (0.0673 - 0.0689)	0.88 (0.0346) + 0.92 (0.0362)
1.75 - 1.79 (0.0689 - 0.0705)	0.92 (0.0362) + 0.92 (0.0362)
1.79 - 1.83 (0.0705 - 0.0720)	0.92 (0.0362) + 0.96 (0.0378)
1.83 - 1.87 (0.0720 - 0.0736)	0.96 (0.0378) + 0.96 (0.0378)
1.87 - 1.91 (0.0736 - 0.0752)	0.52 (0.0205) + 1.44 (0.0567)
1.91 - 1.95 (0.0752 - 0.0768)	0.56 (0.0220) + 1.44 (0.0567)

SERVICE DATA AND SPECIFICATIONS (SDS)

Specifications and Adjustments (Cont'd)

REDUCTION PINION GEAR

Bearing preload

Reduction pinion gear bearing preload mm (in)	0.05 (0.0020)
--	---------------

Turning torque

Turning torque of reduction pinion gear N-m (kg-cm, in-lb)	0.11 - 0.69 (1.1 - 7.0, 0.95 - 6.08)
---	--------------------------------------

Reduction pinion gear bearing adjusting shims

Thickness mm (in)	Part number
1.74 (0.0685)	31438-31X16
1.78 (0.0701)	31438-31X17
1.82 (0.0717)	31438-31X18
1.86 (0.0732)	31438-31X19
1.90 (0.0748)	31438-31X20
1.92 (0.0756)	31439-31X60
1.94 (0.0764)	31438-31X21
1.96 (0.0772)	31439-31X61
1.98 (0.0780)	31438-31X22
2.00 (0.0787)	31439-31X62
2.02 (0.0795)	31438-31X23
2.04 (0.0803)	31439-31X63
2.06 (0.0811)	31438-31X24
2.08 (0.0819)	31439-31X64
2.10 (0.0827)	31438-31X60
2.12 (0.0835)	31439-31X65
2.14 (0.0843)	31438-31X61
2.16 (0.0850)	31439-31X66
2.18 (0.0858)	31438-31X62
2.20 (0.0866)	31439-31X67
2.22 (0.0874)	31438-31X63
2.24 (0.0882)	31439-31X68
2.26 (0.0890)	31438-31X64
2.28 (0.0898)	31439-31X69
2.30 (0.0906)	31438-31X65
2.34 (0.0921)	31438-31X66
2.38 (0.0937)	31438-31X67
2.42 (0.0953)	31438-31X68
2.46 (0.0969)	31438-31X69
2.50 (0.0984)	31438-31X70
2.54 (0.1000)	31438-31X71
2.58 (0.1016)	31438-31X72
2.62 (0.1031)	31438-31X73
2.66 (0.1047)	31438-31X74

Table for selecting reduction pinion gear bearing adjusting shim

Unit: mm (in)	
Dimension "T"	Suitable shim(s)
1.77 - 1.81 (0.0697 - 0.0713)	1.74 (0.0685)
1.81 - 1.85 (0.0713 - 0.0728)	1.78 (0.0701)
1.85 - 1.89 (0.0728 - 0.0744)	1.82 (0.0717)
1.89 - 1.93 (0.0744 - 0.0760)	1.86 (0.0732)
1.93 - 1.96 (0.0760 - 0.0772)	1.90 (0.0748)
1.96 - 1.98 (0.0772 - 0.0780)	1.92 (0.0756)
1.98 - 2.00 (0.0780 - 0.0787)	1.94 (0.0764)
2.00 - 2.02 (0.0787 - 0.0795)	1.96 (0.0772)
2.02 - 2.04 (0.0795 - 0.0803)	1.98 (0.0780)
2.04 - 2.06 (0.0803 - 0.0811)	2.00 (0.0787)
2.06 - 2.08 (0.0811 - 0.0819)	2.02 (0.0795)
2.08 - 2.10 (0.0819 - 0.0827)	2.04 (0.0803)
2.10 - 2.12 (0.0827 - 0.0835)	2.06 (0.0811)
2.12 - 2.14 (0.0835 - 0.0843)	2.08 (0.0819)
2.14 - 2.16 (0.0843 - 0.0850)	2.10 (0.0827)
2.16 - 2.18 (0.0850 - 0.0858)	2.12 (0.0835)
2.18 - 2.20 (0.0858 - 0.0866)	2.14 (0.0843)
2.20 - 2.22 (0.0866 - 0.0874)	2.16 (0.0850)
2.22 - 2.24 (0.0874 - 0.0888)	2.18 (0.0858)
2.24 - 2.26 (0.0882 - 0.0890)	2.20 (0.0866)
2.26 - 2.28 (0.0890 - 0.0898)	2.22 (0.0874)
2.28 - 2.30 (0.0898 - 0.0906)	2.24 (0.0882)
2.30 - 2.32 (0.0906 - 0.0913)	2.26 (0.0890)
2.32 - 2.34 (0.0913 - 0.0921)	2.28 (0.0898)
2.34 - 2.37 (0.0921 - 0.0933)	2.30 (0.0906)
2.37 - 2.41 (0.0933 - 0.0949)	2.34 (0.0921)
2.41 - 2.45 (0.0949 - 0.0965)	2.38 (0.0937)
2.45 - 2.49 (0.0965 - 0.0980)	2.42 (0.0953)
2.49 - 2.53 (0.0980 - 0.0996)	2.46 (0.0969)
2.53 - 2.57 (0.0996 - 0.1012)	2.50 (0.0984)
2.57 - 2.61 (0.1012 - 0.1028)	2.54 (0.1000)
2.61 - 2.65 (0.1028 - 0.1043)	2.58 (0.1016)
2.65 - 2.69 (0.1043 - 0.1059)	2.62 (0.1031)
2.69 - 2.73 (0.1059 - 0.1075)	2.66 (0.1047)

GI
MA
EM
LC
EC
FE
CL
MT
AT
FA
RA
BR
ST
RS
BT
HA
EL
IDX

SERVICE DATA AND SPECIFICATIONS (SDS)

Specifications and Adjustments (Cont'd)

OUTPUT SHAFT

Seal ring clearance

Output shaft seal ring clearance mm (in)	
Standard	0.10 - 0.25 (0.0039 - 0.0098)
Allowable limit	0.25 (0.0098)

End play

Output shaft end play mm (in)	0 - 0.5 (0 - 0.020)
-------------------------------	---------------------

Output shaft adjusting shims

Thickness mm (in)	Part number
0.56 (0.0220)	31438-31X46
0.96 (0.0378)	31438-31X47
1.36 (0.0535)	31438-31X48

BEARING RETAINER

Seal ring clearance

Bearing retainer seal ring clearance mm (in)	
Standard	0.10 - 0.25 (0.0039 - 0.0098)
Allowable limit	0.25 (0.0098)

TOTAL END PLAY

Total end play mm (in)	0.25 - 0.55 (0.0098 - 0.0217)
------------------------	-------------------------------

Bearing race for adjusting total end play

Thickness mm (in)	Part number
0.6 (0.024)	31435-31X01
0.8 (0.031)	31435-31X02
1.0 (0.039)	31435-31X03
1.2 (0.047)	31435-31X04
1.4 (0.055)	31435-31X05
1.6 (0.063)	31435-31X06
1.8 (0.071)	31435-31X07
2.0 (0.079)	31435-31X08

REVERSE CLUTCH END PLAY

Reverse clutch end play mm (in)	0.65 - 1.00 (0.0256 - 0.0394)
---------------------------------	-------------------------------

Thrust washers for adjusting reverse clutch end play

Thickness mm (in)	Part number
0.65 (0.0256)	31508-31X00
0.80 (0.0315)	31508-31X01
0.95 (0.0374)	31508-31X02
1.10 (0.0433)	31508-31X03
1.25 (0.0492)	31508-31X04
1.40 (0.0551)	31508-31X05

ACCUMULATOR

O-ring

Unit: mm (in)

Accumulator	Diameter (Small)	Diameter (Large)
Servo release accumulator	26.9 (1.059)	44.2 (1.740)
N-D accumulator	34.6 (1.362)	39.4 (1.551)

Return spring

Unit: mm (in)

Accumulator		Free length	Outer diameter
Servo release accumulator spring	Outer	52.5 (2.067)	21.1 (0.831)
	Inner	52.0 (2.047)	13.1 (0.516)
N-D accumulator spring		43.5 (1.713)	28.0 (1.102)

BAND SERVO

Return spring

Unit: mm (in)

Return spring	Free length	Outer diameter
2nd servo return spring	32.5 (1.280)	25.9 (1.020)
OD servo return spring	31.0 (1.220)	21.7 (0.854)

REMOVAL AND INSTALLATION

Unit: mm (in)

Distance between end of converter housing and torque converter	15.9 (0.626) or more
--	----------------------