

SECTION **MT**

GI

MA

EM

LC

EC

FE

CL

MT

AT

FA

RA

BR

ST

RS

BT

HA

EL

IDX



CONTENTS

PREPARATION	2	DISASSEMBLY	14
Special Service Tools	2	REPAIR FOR COMPONENT PARTS	16
Commercial Service Tools	4	Input Shaft and Gears	16
NOISE, VIBRATION AND HARSHNESS (NVH)		Mainshaft and Gears	18
TROUBLESHOOTING	5	Final Drive	22
NVH Troubleshooting Chart	5	Shift Control Components	24
ON-VEHICLE SERVICE	6	Case Components	25
Replacing Oil Seal	6	ADJUSTMENT	27
Position Switch Check	7	Differential Side Bearing Preload	27
REMOVAL AND INSTALLATION	8	Mainshaft Bearing Preload	28
TRANSAXLE GEAR CONTROL	10	ASSEMBLY	29
MAJOR OVERHAUL	11	SERVICE DATA AND SPECIFICATIONS (SDS)	31
Case Components	11	General Specifications	31
Gear Components	12	SERVICE DATA AND SPECIFICATIONS (SDS)	32
Shift Control Components	13	Inspection and Adjustment	32

PREPARATION

Special Service Tools

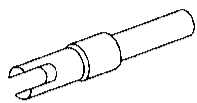
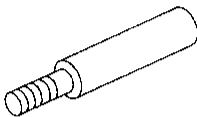
The actual shapes of Kent-Moore tools may differ from those of special service tools illustrated here.

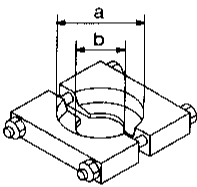
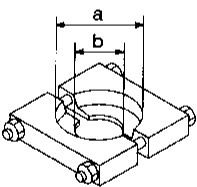
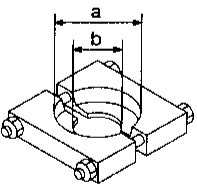
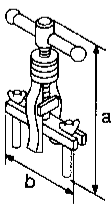
Tool number (Kent-Moore No.) Tool name	Description	Measuring turning torque of final drive assembly Measuring total turning torque Selecting differential side bearing adjusting shim (Use with KV38106000.)
KV38105900 (J33201) Preload adapter	NT087	
KV38106000 (J34291-A) Height gauge adapter (differential side bearing)	NT089	
KV32101000 (J25689-A) Pin punch	NT410	 a: 4 mm (0.16 in) dia.
ST22730000 (J25681) Puller	NT411	 a: 82 mm (3.23 in) dia. b: 30 mm (1.18 in) dia.
ST30031000 (J22912-01) Puller	NT411	 a: 90 mm (3.54 in) dia. b: 50 mm (1.97 in) dia.
ST30021000 (J22912-01) Puller	NT411	 a: 110 mm (4.33 in) dia. b: 68 mm (2.68 in) dia.
ST33290001 (J34286) Puller	NT414	 a: 250 mm (9.84 in) b: 160 mm (6.30 in)

PREPARATION

Special Service Tools (Cont'd)

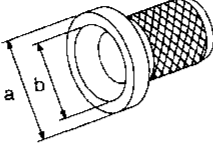
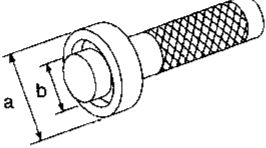
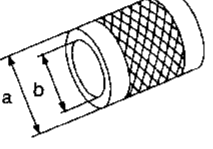
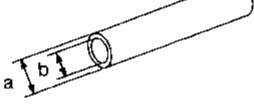
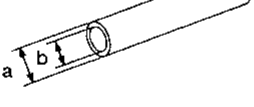
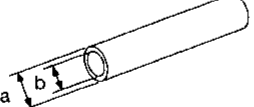
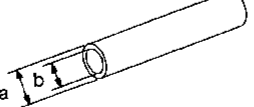
Tool number (Kent-Moore No.) Tool name	Description		
ST33400001 (J26082) Drift handle	 NT086	Installing differential oil seal a: 60 mm (2.36 in) dia. b: 47 mm (1.85 in) dia.	GI MA EM
KV38102100 (J25803-01) Drift	 NT084	Installing input shaft rear bearing a: 44 mm (1.73 in) dia. b: 24.5 mm (0.965 in) dia.	LC EC FE
ST33200000 (J26082) Drift	 NT091	Installing mainshaft front bearing outer race a: 60 mm (2.36 in) dia. b: 44.5 mm (1.752 in) dia.	CL MT
ST22350000 (J25678-01) Drift	 NT065	Installing input shaft front bearing a: 34 mm (1.34 in) dia. b: 28 mm (1.10 in) dia.	AT FA
ST22452000 (—) Drift	 NT065	Installing 1st & 2nd synchronizer a: 45 mm (1.77 in) dia. b: 36 mm (1.42 in) dia.	RA BR
ST37750000 (J25863-01) Drift	 NT065	Installing 5th main gear Installing 3rd & 4th synchronizer Installing input shaft oil seal Installing 5th synchronizer a: 40 mm (1.57 in) dia. b: 31 mm (1.22 in) dia.	ST RS BT
ST22360002 (J25679-01) Drift	 NT065	Installing mainshaft rear bearing inner race a: 29 mm (1.14 in) dia. b: 23 mm (0.91 in) dia.	HA EL IDX

PREPARATION

Special Service Tools (Cont'd)

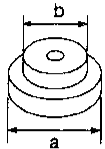
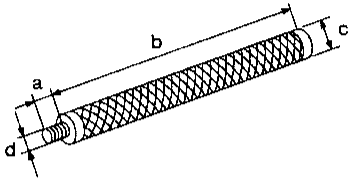
Tool number (Kent-Moore No.) Tool name	Description
ST30621000 (J25742-5) Drift	<div style="display: flex; align-items: center; justify-content: center;">  <div style="margin-left: 20px;"> <p>Installing differential side bearing outer race (Use with ST30611000.)</p> <p>a: 79 mm (3.11 in) dia. b: 59 mm (2.32 in) dia.</p> </div> </div> <p style="text-align: left; margin-left: 20px;">NT073</p>
ST30611000 (J25742-1) Drift handle	<div style="display: flex; align-items: center; justify-content: center;">  <div style="margin-left: 20px;"> <p>(Use with ST30621000.)</p> <p>a: 15 mm (0.59 in) b: 335 mm (13.19 in) c: 25 mm (0.98 in) dia. d: M12 x 1.5P</p> </div> </div> <p style="text-align: left; margin-left: 20px;">NT419</p>

Commercial Service Tools

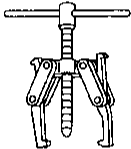
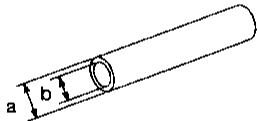
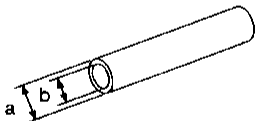
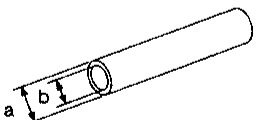
Tool name	Description
Puller	<div style="display: flex; align-items: center; justify-content: center;">  <div style="margin-left: 20px;"> <p>Removing input shaft front bearing</p> </div> </div> <p style="text-align: left; margin-left: 20px;">NT077</p>
Drift	<div style="display: flex; align-items: center; justify-content: center;">  <div style="margin-left: 20px;"> <p>Installing mainshaft front bearing inner race</p> <p>a: 31 mm (1.22 in) dia. b: 26 mm (1.02 in) dia.</p> </div> </div> <p style="text-align: left; margin-left: 20px;">NT065</p>
Drift	<div style="display: flex; align-items: center; justify-content: center;">  <div style="margin-left: 20px;"> <p>Installing differential side bearing inner race</p> <p>a: 56 mm (2.20 in) dia. b: 50.5 mm (1.988 in) dia.</p> </div> </div> <p style="text-align: left; margin-left: 20px;">NT065</p>
Drift	<div style="display: flex; align-items: center; justify-content: center;">  <div style="margin-left: 20px;"> <p>Installing striking rod oil seal</p> <p>a: 38 mm (1.50 in) dia. b: 32 mm (1.26 in) dia.</p> </div> </div> <p style="text-align: left; margin-left: 20px;">NT065</p>

NOISE, VIBRATION AND HARSHNESS (NVH) TROUBLESHOOTING

NVH Troubleshooting Chart

Use the chart below to help you find the cause of the problem. The numbers indicate the order of the inspection. If necessary, repair or replace these parts.

		Reference page												
		Refer to MA section ("Checking M/T Oil", "CHASSIS AND BODY MAINTENANCE").												
Symptom		Parts name												
		Oil (Level low)	Oil (Wrong)	Oil (Level too high)	Gasket (Damaged)	Oil seal (Worn or damaged)	O-ring (Worn or damaged)	Control rod (Worn)	Check plug return spring and check ball (Worn or damaged)	Shift fork (Worn)	Gear (Worn or damaged)	Bearing (Worn or damaged)	Baulk ring (Worn or damaged)	Insert spring (Damaged)
Symptom	Noise	1	2								3	3		
	Oil leakage		3	1	2	2	2							
	Hard to shift or will not shift		1	1				2					3	3
	Jumps out of gear							1	2	3	3			

GI
 MA
 EM
 LC
 EC
 FE
 CL
MT
 AT
 FA
 RA
 BR
 ST
 RS
 BT
 HA
 EL
 IDX

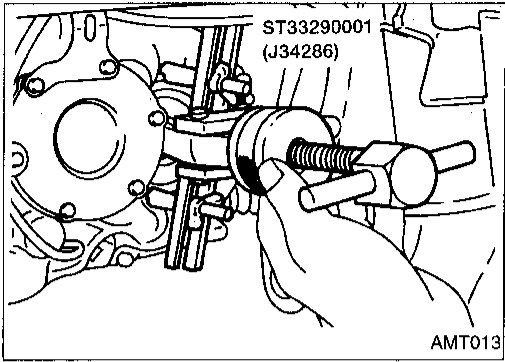

Replacing Oil Seal

DIFFERENTIAL OIL SEAL

1. Drain gear oil from transaxle.
2. Remove drive shafts. Refer to FA section ("Removal", "FRONT AXLE — Drive Shaft").
3. Remove differential oil seal.

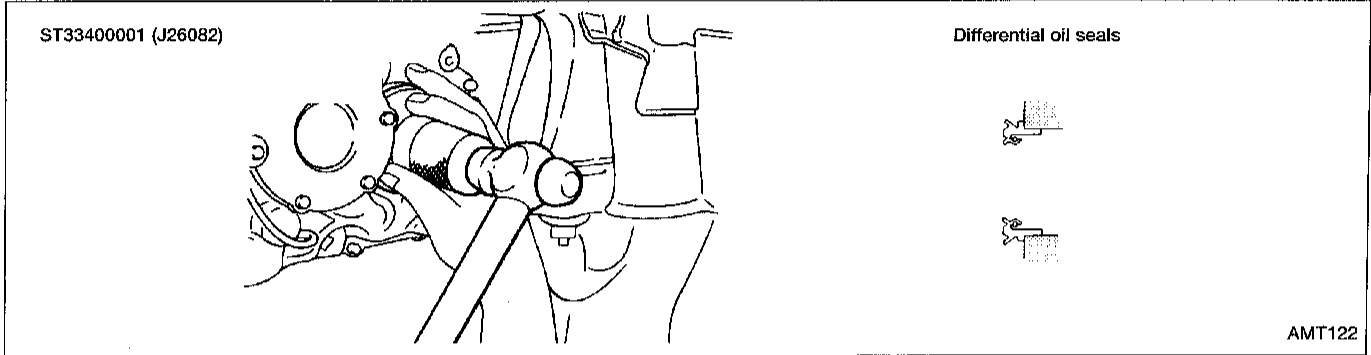

4. Install differential oil seal.
 - **Apply multi-purpose grease to seal lip of oil seal before installing.**
5. Install drive shafts. Refer to FA section ("Installation", "FRONT AXLE — Drive Shaft").

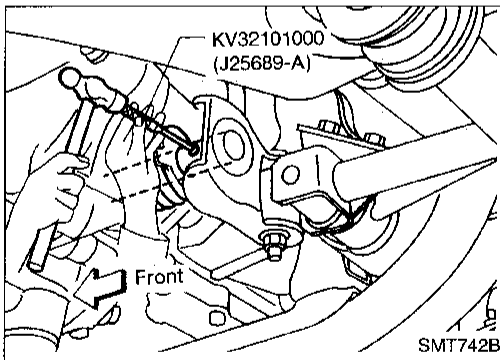

STRIKING ROD OIL SEAL

1. Remove transaxle control rod from yoke.
2. Remove retaining pin.
 - **Be careful not to damage boot.**

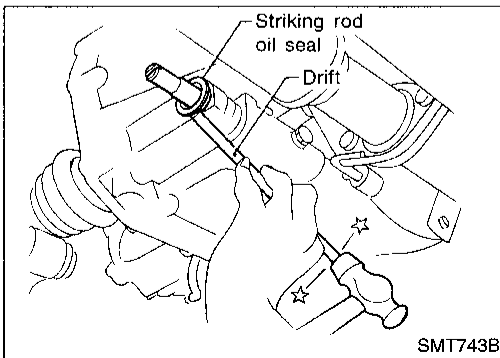

3. Remove striking rod oil seal.

ON-VEHICLE SERVICE

Replacing Oil Seal (Cont'd)

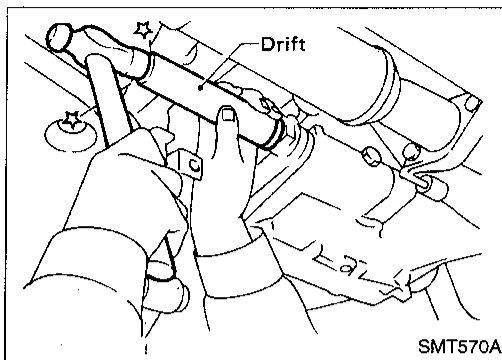

4. Install striking rod oil seal.

- Apply multi-purpose grease to seal lip of oil seal before installing.

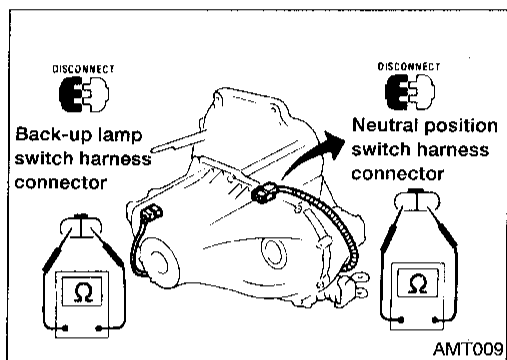

Position Switch Check

- Check continuity.

Switch	Gear position	Continuity
Back-up lamp switch	Reverse	Yes
	Except reverse	No
Neutral position switch	Neutral	Yes
	Except neutral	No

GI

MA

EM

LC

EC

FE

CL

MT

AT

FA

RA

BR

ST

RS

BT

HA

EL

IDX

REMOVAL AND INSTALLATION

Removal

CAUTION:

Before separating transaxle from engine, remove the crankshaft position sensor (OBD) from transaxle.

Be careful not to damage sensor edge or ring gear teeth.

1. Remove battery negative terminal.
2. Remove air cleaner housing.
3. Disconnect clutch control cable.
4. Disconnect back-up lamp switch, neutral position switch, vehicle speed sensor and ground harness connectors.
5. Remove starter motor from transaxle.
6. Remove crankshaft position sensor (OBD) from transaxle.
 - Be careful not to damage sensor tip.
7. Remove shift control rod from transaxle.
8. Drain gear oil from transaxle.
9. Remove drive shafts from transaxle. Refer to FA section ("Removal", "FRONT AXLE — Drive Shaft").
10. Support the transaxle with a jack.
11. Remove LH and rear mounts.
12. Remove bolts securing transaxle.
13. Lower transaxle.

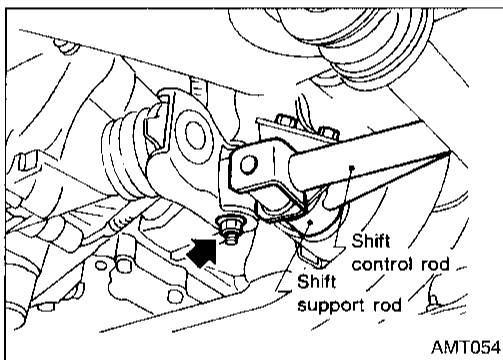
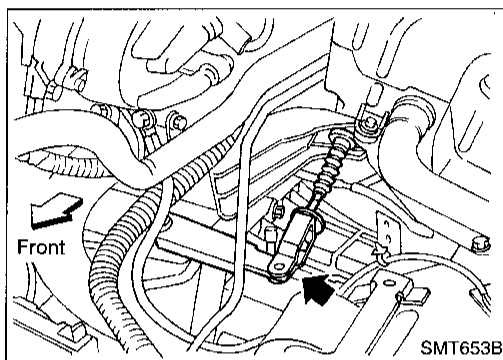

REMOVAL AND INSTALLATION

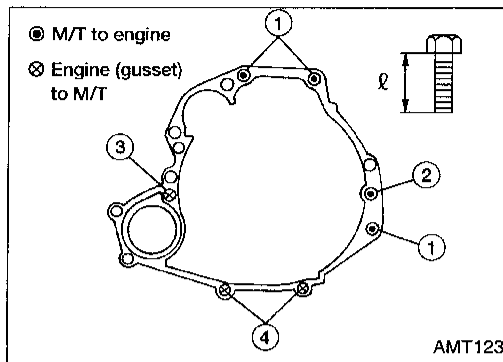

Installation

- Tighten starter motor to transaxle.
Ⓜ: **31 - 42 N·m (3.2 - 4.3 kg-m, 23 - 31 ft-lb)**
- Tighten LH and rear mounts to the specified torque. Refer to EM section (“ENGINE REMOVAL”).
- Install transaxle and any part removed.
- Check clutch cable adjustment. Refer to CL section (“Adjusting Clutch Pedal”, “INSPECTION AND ADJUSTMENT”).

Bolt No.	Tightening torque N·m (kg-m, ft-lb)	“L” mm (in)
①	30 - 40 (3.1 - 4.1, 22 - 30)	70 (2.76)
②	30 - 40 (3.1 - 4.1, 22 - 30)	85 (3.35)
③	30 - 40 (3.1 - 4.1, 22 - 30)	30 (1.18)
④	16 - 21 (1.6 - 2.1, 12 - 15)	25 (0.98)
Front gusset to engine	30 - 40 (3.1 - 4.1, 22 - 30)	20 (0.79)
Rear gusset to engine	16 - 21 (1.6 - 2.1, 12 - 15)	16 (0.63)

GI

MA

EM

LC

EC

FE

CL

MT

AT

FA

RA

BR

ST

RS

BT

HA

EL

IDX

TRANSAXLE GEAR CONTROL

SEC. 341

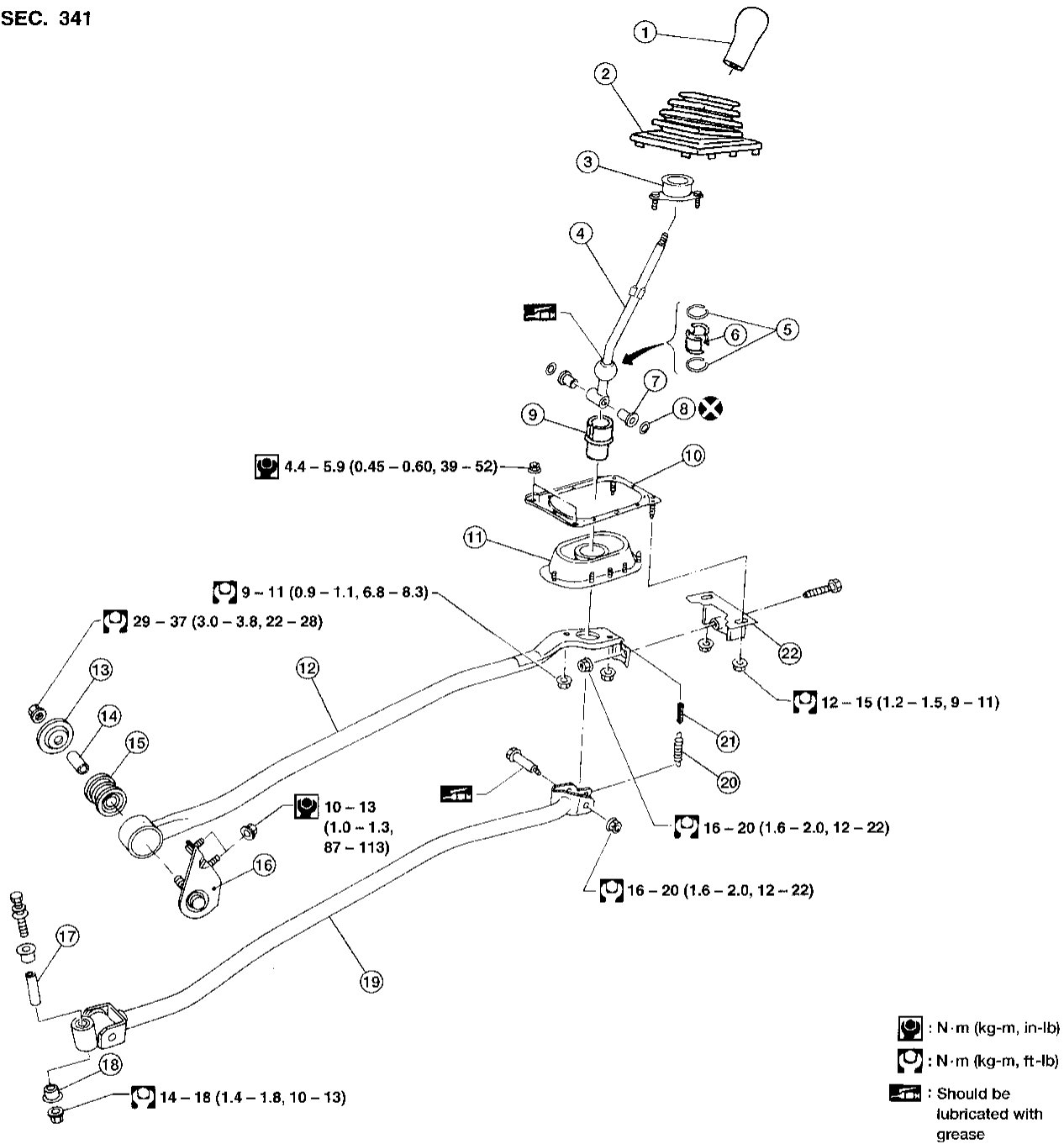

AMT124

- | | | |
|-----------------------|------------------------|------------------------|
| ① Shift lever knob | ⑨ Hand lever socket | ⑰ Collar |
| ② Boot | ⑩ Plate bolt | ⑱ Bushing |
| ③ Shift lever socket | ⑪ Transaxle hole cover | ⑲ Shift control rod |
| ④ Shift lever | ⑫ Support rod | ⑳ Return spring |
| ⑤ Bearing seat spring | ⑬ Plate | ㉑ Return spring rubber |
| ⑥ Seat | ⑭ Collar | ㉒ Holder bracket |
| ⑦ Bushing | ⑮ Bushing | |
| ⑧ O-ring | ⑯ Support rod bracket | |

MAJOR OVERHAUL

Case Components

SEC. 320

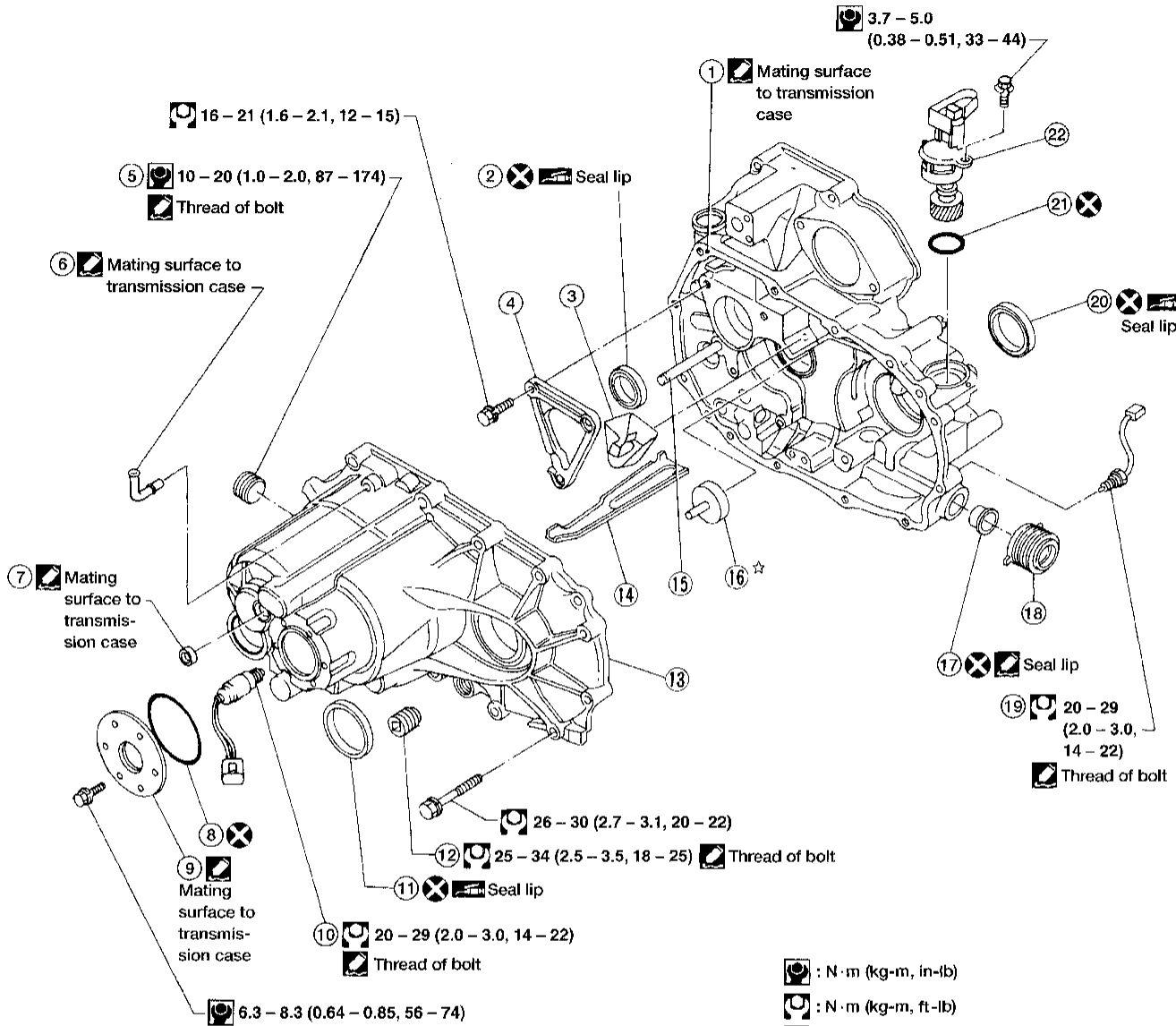

- ① Clutch housing
- ② Input shaft oil seal
- ③ Oil pocket
- ④ Bearing retainer
- ⑤ Filler plug
- ⑥ Air breather
- ⑦ Welch plug
- ⑧ O-ring

- ⑨ Case cover
- ⑩ Back-up lamp switch
- ⑪ Differential oil seal
- ⑫ Drain plug
- ⑬ Transmission case
- ⑭ Oil gutter
- ⑮ Reverse idler shaft

- ⑯ Oil channel
- ⑰ Striking rod oil seal
- ⑱ Boot
- ⑲ Neutral position switch
- ⑳ Differential oil seal
- ㉑ O-ring
- ㉒ Vehicle speed sensor

AMT125

MAJOR OVERHAUL

Gear Components

SEC. 322

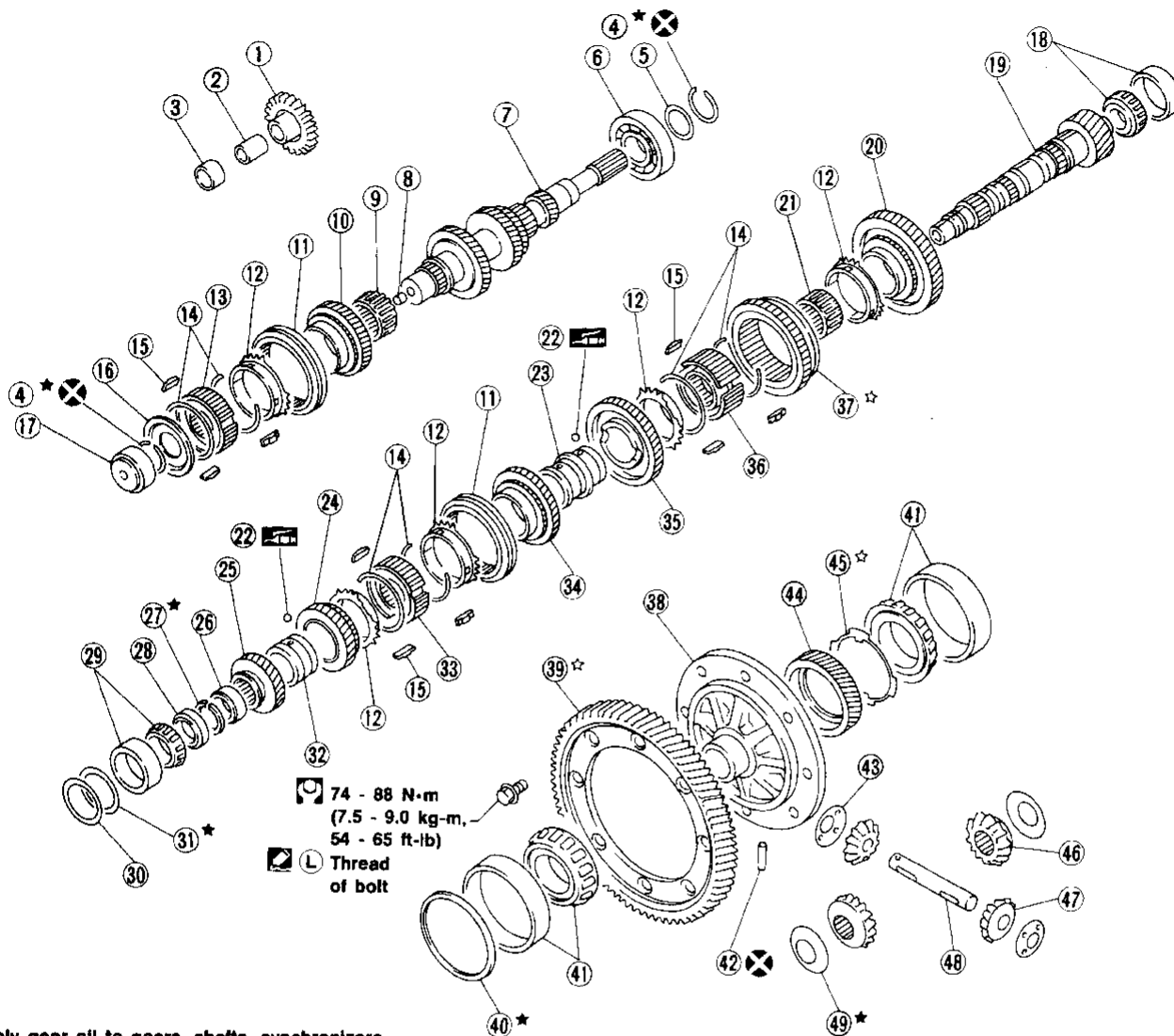

Apply gear oil to gears, shafts, synchronizers and bearings when assembling.

Ⓛ : Apply locking sealant.

☆ : Select proper thickness.

☆ : Pay attention to its direction.

AMT078

- | | | | |
|-----------------------------|----------------------------|---------------------------------------|---|
| ① Reverse idler gear | ⑭ Spread spring | ⑳ Mainshaft C-ring | ④⑨ Final gear |
| ② Reverse idler bushing | ⑮ Insert spring | ㉑ C-ring holder | ④⑩ Differential side bearing adjusting shim |
| ③ Reverse idler spacer | ⑯ 5th stopper | ㉒ Mainshaft rear bearing | ④⑪ Differential side bearing |
| ④ Snap ring | ⑰ Input shaft rear bearing | ⑳ Spacer | ④⑫ Lock pin |
| ⑤ Spacer | ⑱ Mainshaft front bearing | ㉓ Mainshaft bearing adjusting shim | ④⑬ Pinion mate thrust washer |
| ⑥ Input shaft front bearing | ⑲ Mainshaft | ㉔ 4th bushing | ④⑭ Speedometer drive gear |
| ⑦ Input shaft | ㉑ 1st main gear | ㉕ 3rd & 4th synchronizer hub | ④⑮ Speedometer stopper |
| ⑧ Oil plug | ㉒ 1st gear needle bearing | ㉖ 3rd main gear | ④⑯ Side gear |
| ⑨ 5th gear needle bearing | ㉓ Steel ball | ㉗ 2nd main gear | ④⑰ Pinion mate gear |
| ⑩ 5th input gear | ㉔ 2nd & 3rd bushing | ㉘ 1st & 2nd synchronizer hub | ④⑱ Pinion mate shaft |
| ⑪ Coupling sleeve | ㉕ 4th main gear | ㉙ Reverse main gear (Coupling sleeve) | ④⑲ Side gear thrust washer |
| ⑫ Baulk ring | ㉖ 5th main gear | ㉚ Differential case | |
| ⑬ 5th synchronizer hub | ㉗ Thrust washer | | |

MAJOR OVERHAUL

Shift Control Components

SEC. 328

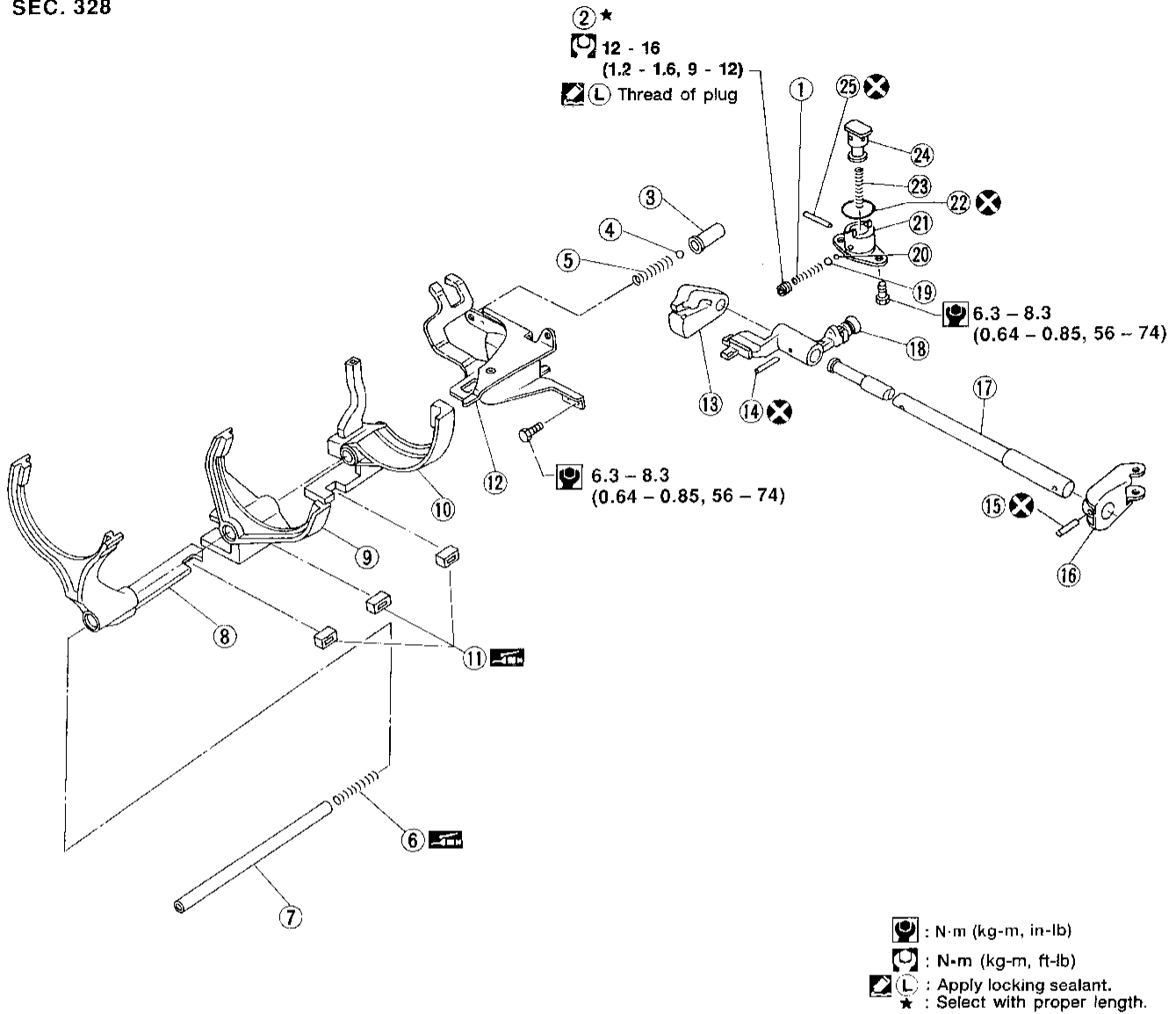

- ① Reverse check spring
- ② Reverse check plug
- ③ Check ball plug
- ④ Shift check ball
- ⑤ Shift check spring
- ⑥ Fork shaft support spring
- ⑦ Fork shaft
- ⑧ 5th shift fork
- ⑨ 3rd & 4th shift fork

- ⑩ 1st & 2nd shift fork
- ⑪ Shifter cap
- ⑫ Control bracket
- ⑬ Striking interlock
- ⑭ Retaining pin
- ⑮ Retaining pin
- ⑯ Striking rod

- ⑰ Striking lever
- ⑱ Check ball (Large)
- ⑲ Check ball (Small)
- ⑳ Check sleeve
- ㉑ O-ring
- ㉒ Select return spring
- ㉓ Check plunger
- ㉔ Stopper pin

AMT073

GI
 MA
 EM
 LC
 EC
 FE
 CL
MT

AT
 FA
 RA
 BR
 ST

RS
 BT

HA
 EL
 IDX

DISASSEMBLY

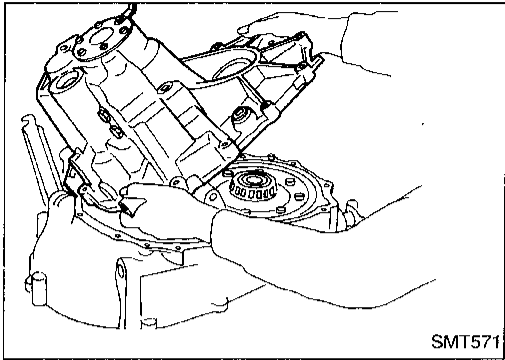

1. Remove transmission case while slightly tilting it to prevent 5th shift fork from interfering with case.

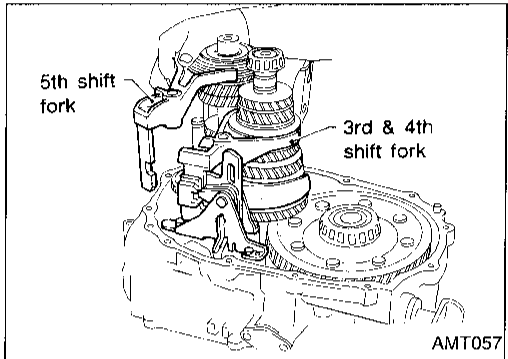

2. Draw out reverse idler spacer and fork shaft, then remove 5th and 3rd & 4th shift forks.
 - **Be careful not to lose shifter cap.**

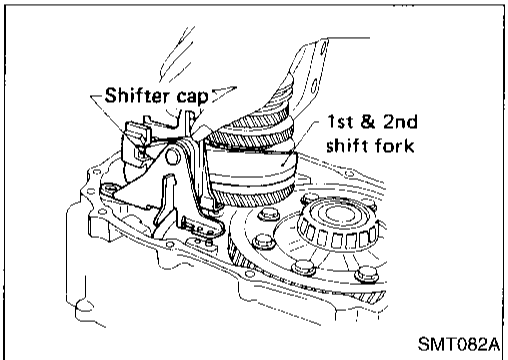

3. Remove control bracket with 1st & 2nd shift fork.
 - **Be careful not to lose shifter cap.**

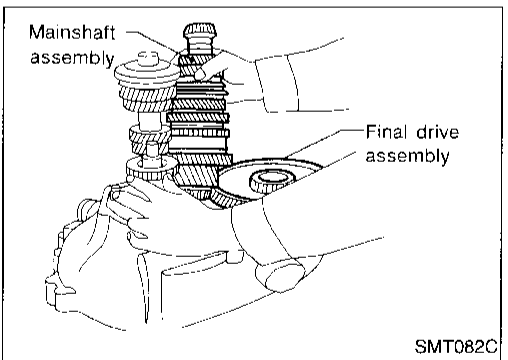

4. Remove gear components from clutch housing.
 - a. Remove mainshaft and final drive assembly.
 - **Always withdraw mainshaft straight out. Failure to do so can damage resin oil channel on clutch housing side.**

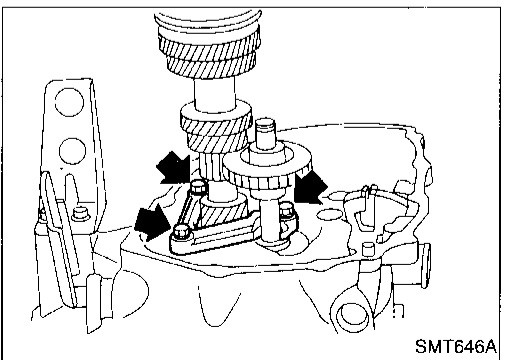

- b. Remove bearing retainer securing bolts.

DISASSEMBLY

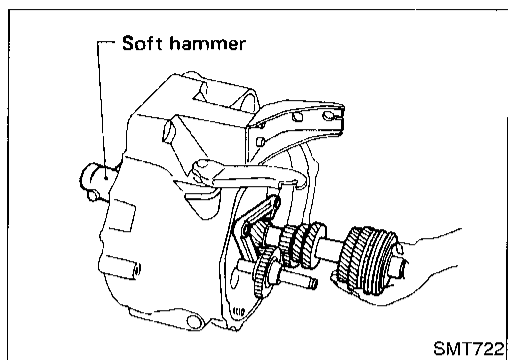

- c. Remove input shaft together with bearing retainer and reverse idler gear by tapping lightly.
 - Do not draw out reverse idler shaft from clutch housing because these fittings will be loose.
 - Be careful not to scratch oil seal lip with shaft spline when removing input shaft.

CI

MA

EM

LC

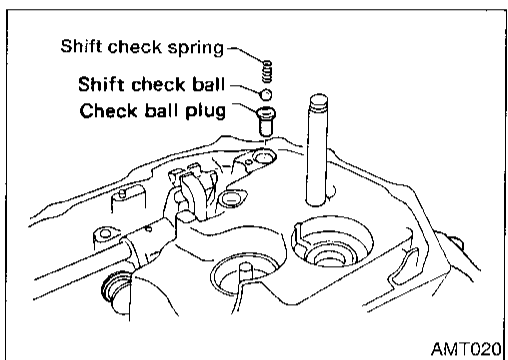

5. Remove oil pocket, shift check ball, shift check spring and check ball plug.

FC

FE

CL

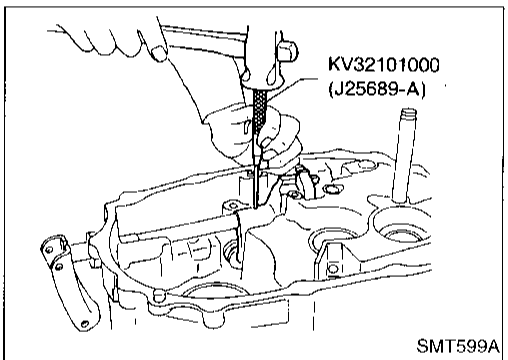

6. Drive retaining pin out of striking lever, then remove striking rod, striking lever and striking interlock.
 - Select a position where retaining pin does not interfere with clutch housing when removing retaining pin.

MT

AT

FA

RA

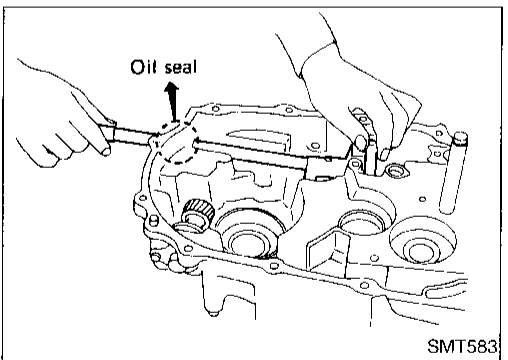

- Be careful not to damage oil seal lip, when removing striking rod. If necessary, tape edges of striking rod.

BR

SI

RS

BT

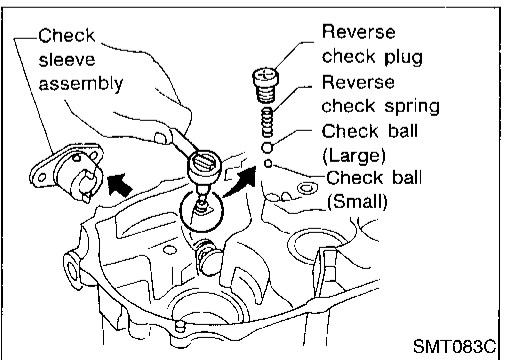

7. Remove reverse check plug, then detach reverse check spring and check balls.
8. Remove check sleeve assembly.

HA

EL

IDX

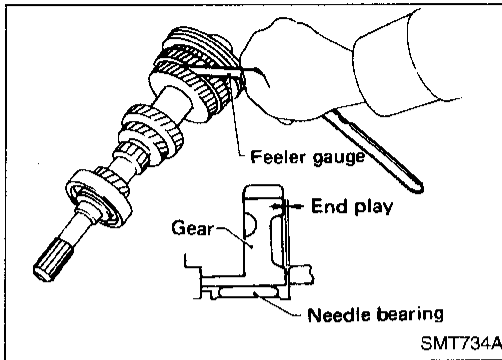

Input Shaft and Gears

DISASSEMBLY

1. Before disassembly, check 5th input gear end play.

Gear end play:

0.18 - 0.31 mm (0.0071 - 0.0122 in)

- If not within specification, disassemble and check contact surface of gear, shaft and hub. Then check clearance of snap ring groove. Refer to "ASSEMBLY", MT-17.

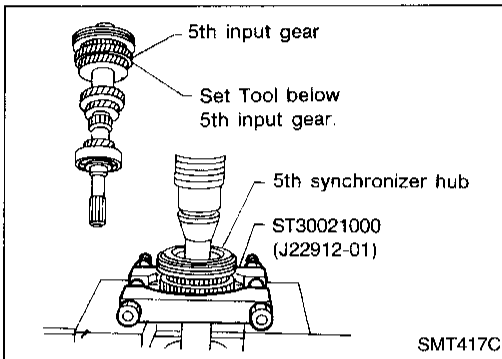

2. Remove snap ring and 5th stopper.
3. Remove 5th synchronizer, 5th input gear and 5th gear needle bearing.

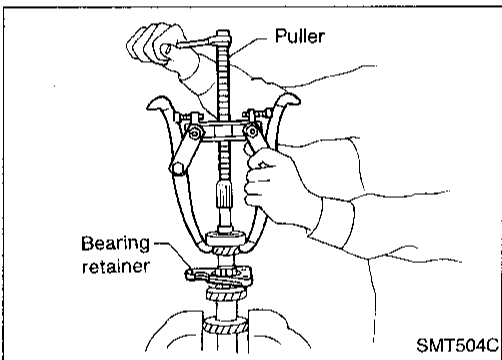

4. Remove snap ring of input shaft front bearing and spacer.
5. Pull out input shaft front bearing.
6. Remove bearing retainer.

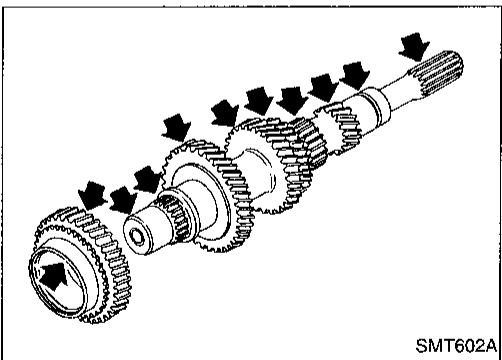

INSPECTION

Gear and shaft

- Check shaft for cracks, wear or bending.
- Check gears for excessive wear, chips or cracks.

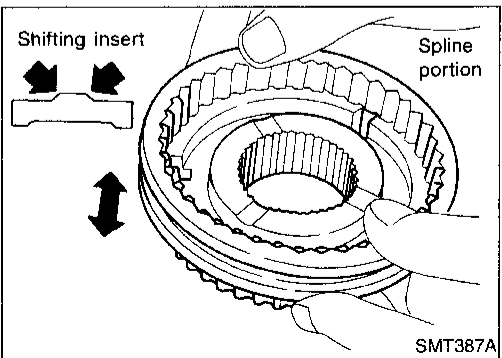

Synchronizer

- Check spline portion of coupling sleeves, hubs and gears for wear or cracks.
- Check baulk rings for cracks or deformation.
- Check shifting inserts for wear or deformation.

REPAIR FOR COMPONENT PARTS

Input Shaft and Gears (Cont'd)

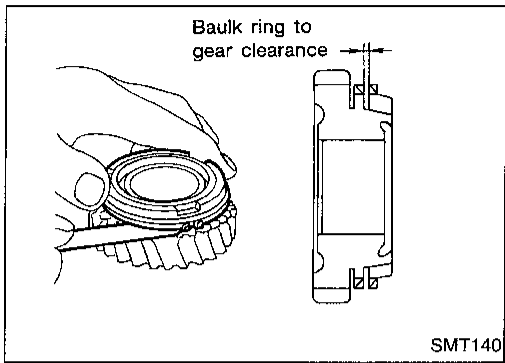

- Measure clearance between baulk ring and gear.
Clearance between baulk ring and gear:
Standard
 1.0 - 1.35 mm (0.0394 - 0.0531 in)
Wear limit
 0.7 mm (0.028 in)

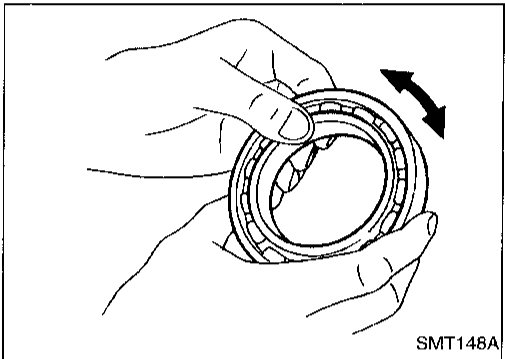

Bearing

- Make sure bearings roll freely and are free from noise, cracks, pitting or wear.

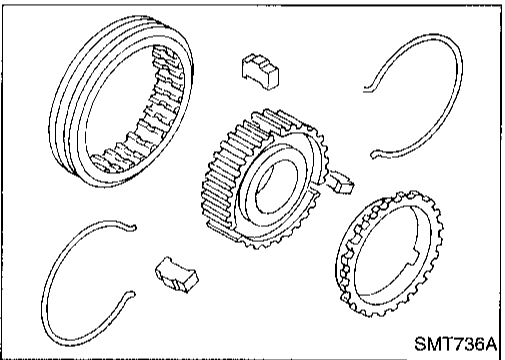

ASSEMBLY

1. Assemble 5th synchronizer.

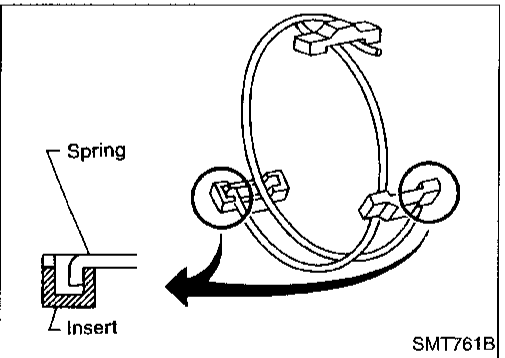

- Be careful not to hook front and rear ends of spread spring to the same insert.

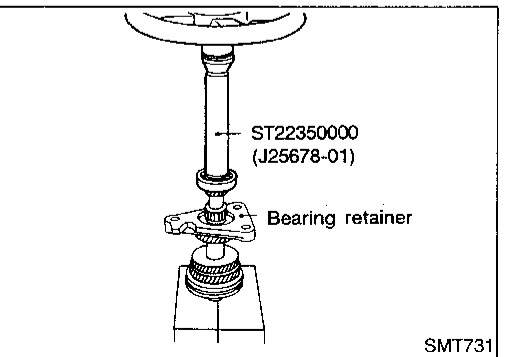

2. Install bearing retainer.
3. Press on input shaft front bearing.
4. Install spacer.

GI

MA

EM

LC

EC

FE

CL

MT

AT

FA

RA

BR

ST

RS

BT

HA

EL

IDX

REPAIR FOR COMPONENT PARTS

Input Shaft and Gears (Cont'd)

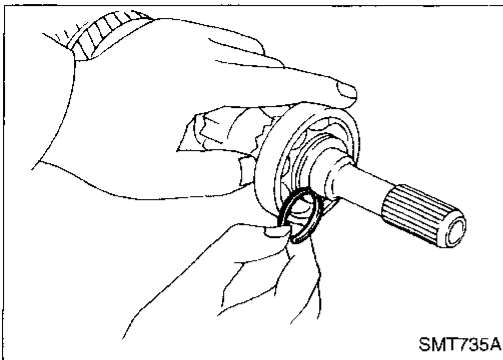

- Select and install snap ring that gives the proper clearance of groove in input shaft.

Allowable clearance of groove:

0 - 0.1 mm (0 - 0.004 in)

Snap ring of input shaft front bearing:

Refer to SDS, MT-32.

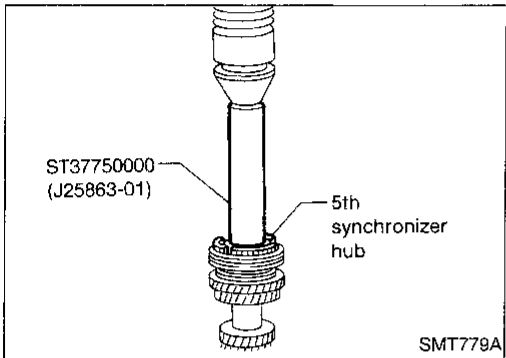

- Install 5th gear needle bearing, 5th input gear, 5th synchronizer and 5th stopper with Tool.
- Measure gear end play as the final check. Refer to "DISASSEMBLY", MT-16.

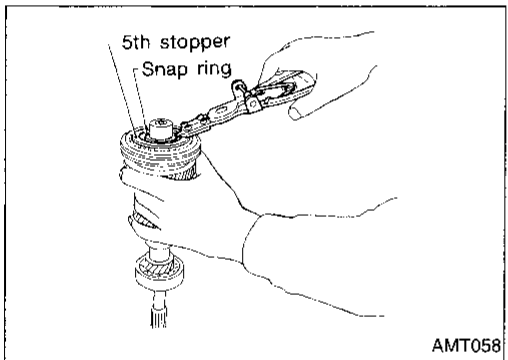

- Select and install snap ring that gives the proper clearance of groove in input shaft.

Allowable clearance of groove:

0 - 0.1 mm (0 - 0.004 in)

Snap ring of 5th synchronizer:

Refer to SDS, MT-32.

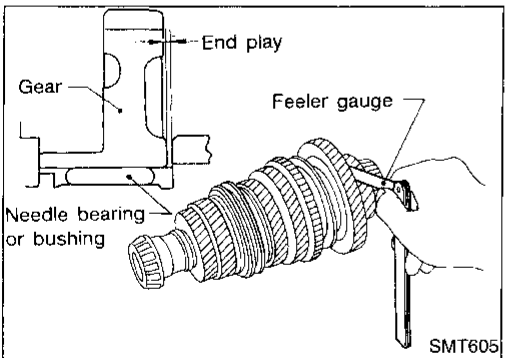

Mainshaft and Gears

DISASSEMBLY

- Before disassembly, measure gear end plays.

Gear end play:

1st main gear

0.18 - 0.31 mm (0.0071 - 0.0122 in)

2nd, 3rd, 4th main gear

0.20 - 0.30 mm (0.0079 - 0.0118 in)

- If end play is not within the specified limit, disassemble and check the parts. Refer to "ASSEMBLY", MT-20.

- Press out mainshaft front and rear bearing.

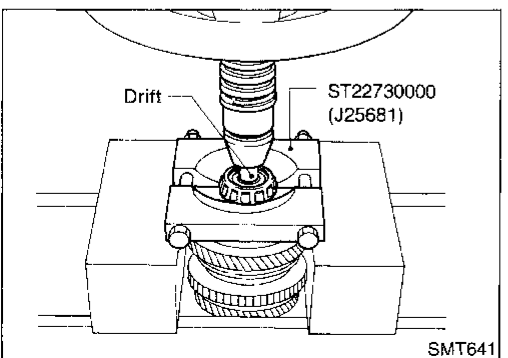

REPAIR FOR COMPONENT PARTS

Mainshaft and Gears (Cont'd)

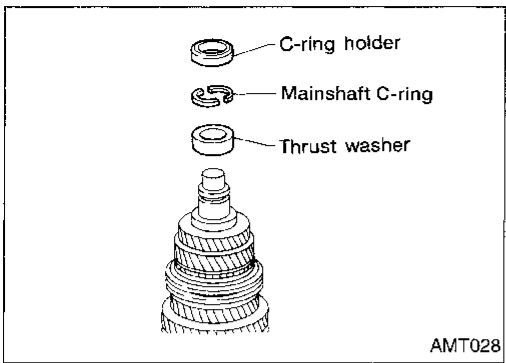

3. Remove C-ring holder, mainshaft C-rings and thrust washer.

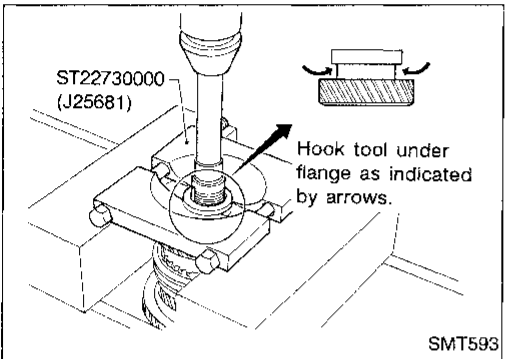

4. Press out 5th main gear.

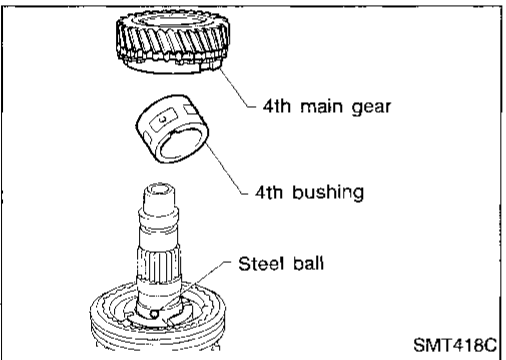

5. Remove 4th main gear, 4th bushing and steel ball.
● **Be careful not to lose steel ball.**

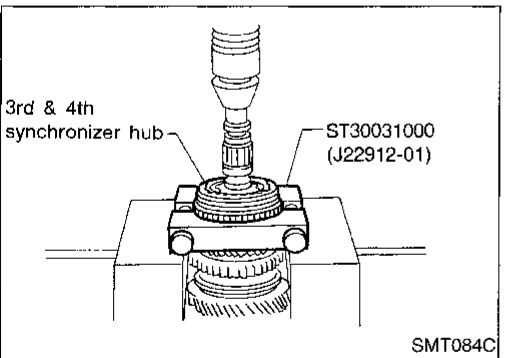

6. Remove 3rd & 4th synchronizer, 3rd main gear, 2nd & 3rd bushing, steel ball and 2nd main gear.
● **Be careful not to lose steel ball.**

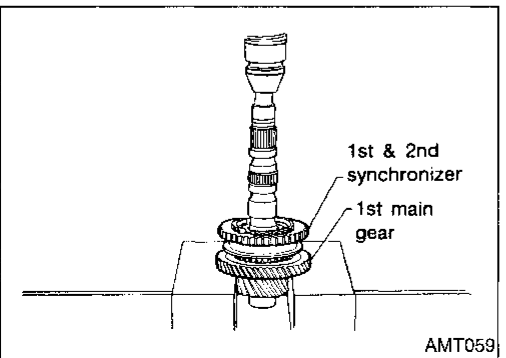

7. Remove 1st & 2nd synchronizer and 1st main gear, then remove 1st gear needle bearing.

GI

MA

EM

LC

EC

FE

CL

MT

AT

FA

RA

BR

ST

RS

BT

HA

EL

IDX

REPAIR FOR COMPONENT PARTS

Mainshaft and Gears (Cont'd)

INSPECTION

Gear and shaft

- Check shaft for cracks, wear or bending.
- Check gears for excessive wear, chips or cracks.

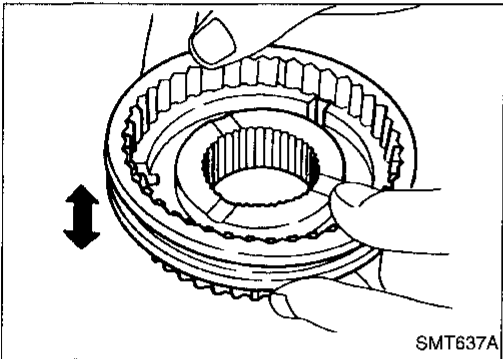
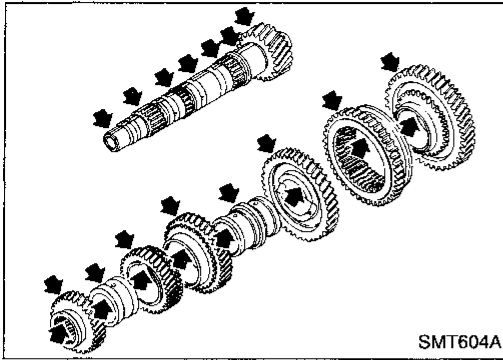

Synchronizer

- Check spline portion of coupling sleeves, hubs and gears for wear or cracks.
- Check baulk rings for cracks or deformation.
- Check insert springs for wear or deformation.

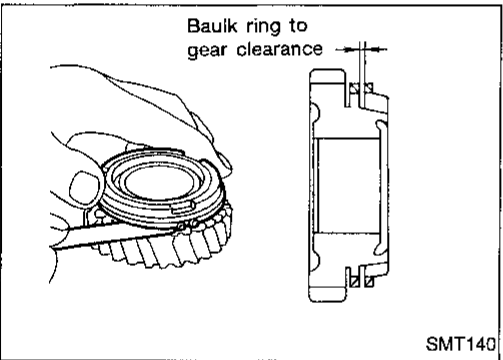

- Measure clearance between baulk ring and gear.
Clearance between baulk rings and 1st through 5th main gears:
Standard
1.0 - 1.35 mm (0.0394 - 0.0531 in)
Wear limit
0.7 mm (0.028 in)

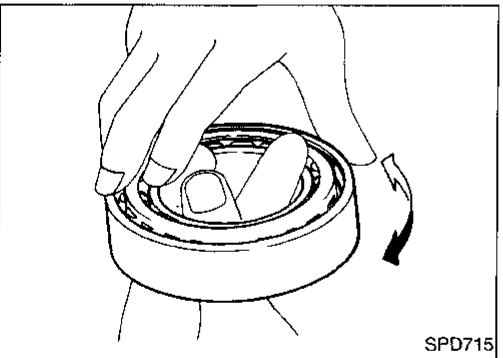

Bearing

- Make sure bearings roll freely and are free from noise, cracks, pitting or wear.
- **When replacing tapered roller bearing, replace outer and inner race as a set.**

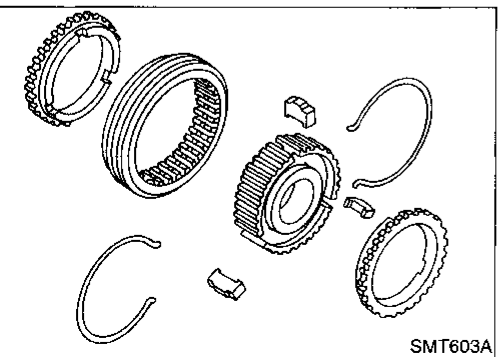

ASSEMBLY

1. Assemble 1st & 2nd and 3rd & 4th synchronizers.

REPAIR FOR COMPONENT PARTS

Mainshaft and Gears (Cont'd)

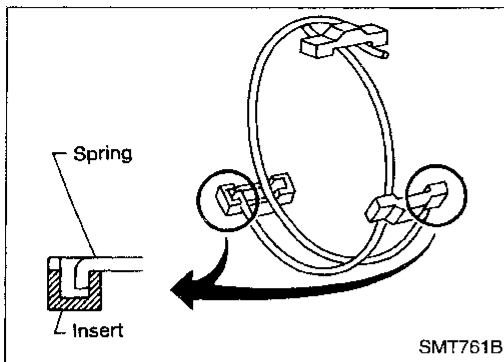

- Be careful not to hook front and rear ends of spread spring to the same insert.

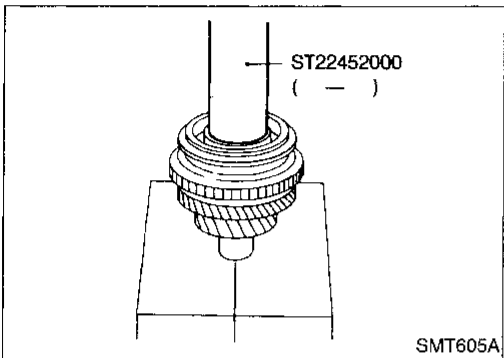

2. Install 1st gear needle bearing and 1st main gear.
3. Press on 1st & 2nd synchronizer.

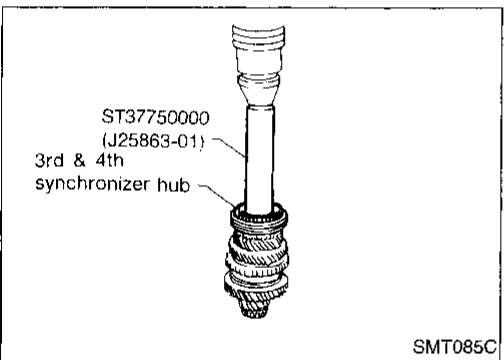

4. Install steel ball, 2nd main gear, 2nd & 3rd bushing, 3rd main gear and 3rd & 4th synchronizer.

- Apply multi-purpose grease to steel ball before installing it.
- 2nd & 3rd bushing has a groove in which steel ball fits.

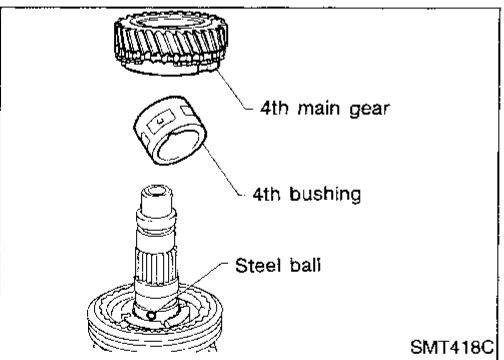

5. Install steel ball, 4th bushing and 4th main gear.
- Apply multi-purpose grease to steel ball before installing it.
 - 4th bushing has a groove in which steel ball fits.

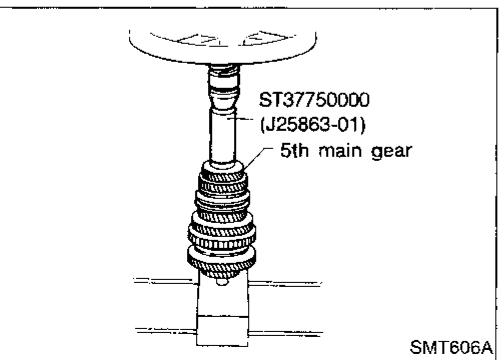

6. Press on 5th main gear.

GI

MA

EM

LC

EC

FE

CL

MT

AT

FA

RA

BR

ST

RS

BT

HA

EL

IDX

REPAIR FOR COMPONENT PARTS

Mainshaft and Gears (Cont'd)

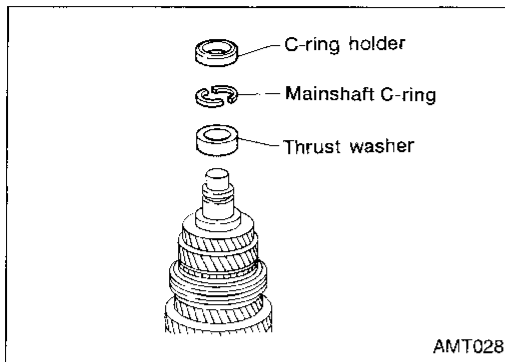

7. Install thrust washer.
8. Select and install mainshaft C-ring that gives proper clearance of groove in mainshaft.

Allowable clearance of groove:
0 - 0.1 mm (0 - 0.004 in)

Mainshaft C-ring:
Refer to SDS, MT-32.

9. Install C-ring holder.

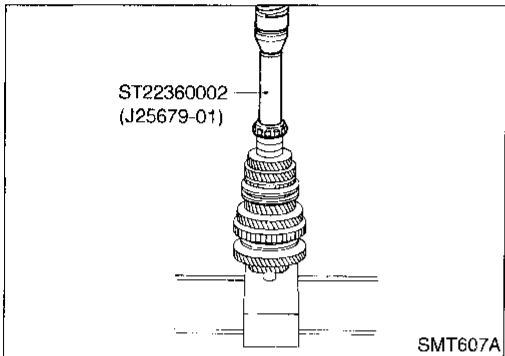

10. Press on mainshaft rear bearing.

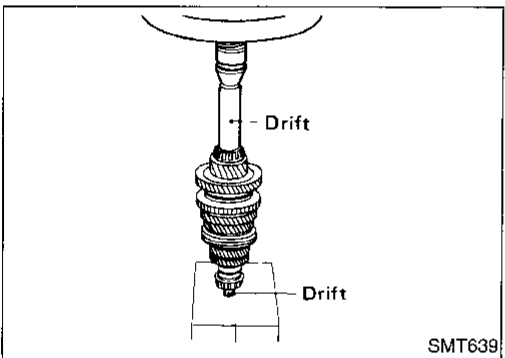

11. Press on mainshaft front bearing.
12. Measure gear end play as the final check. Refer to "DIS-ASSEMBLY", MT-18.

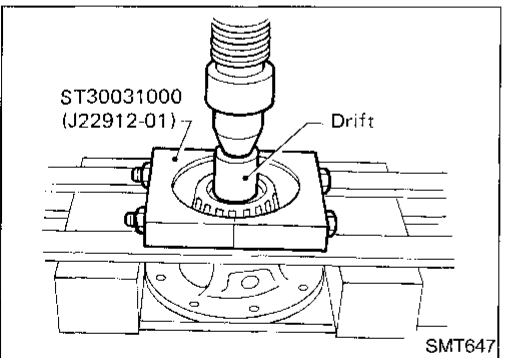

Final Drive

DISASSEMBLY

1. Remove final gear.
 2. Remove speedometer drive gear by cutting it.
 3. Press out differential side bearings.
- **Be careful not to mix up the right and left bearings.**

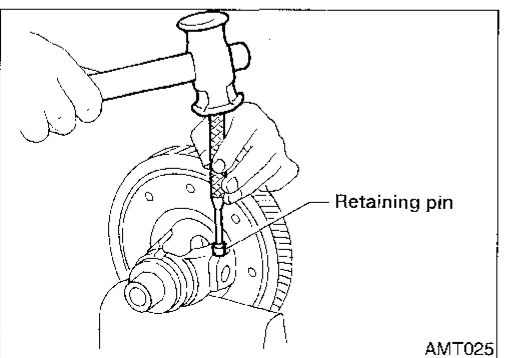

4. Drive out retaining pin and draw out pinion mate shaft.
5. Remove pinion mate gears and side gears.

REPAIR FOR COMPONENT PARTS

Final Drive (Cont'd)

INSPECTION

Gear, washer, shaft and case

- Check mating surfaces of differential case, side gears and pinion mate gears.
- Check washers for wear.

GI

MA

EM

LC

EC

FE

CL

MT

AT

FA

RA

BR

ST

RS

BT

HA

EL

IDX

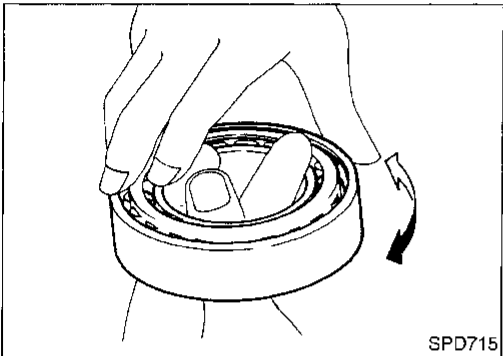
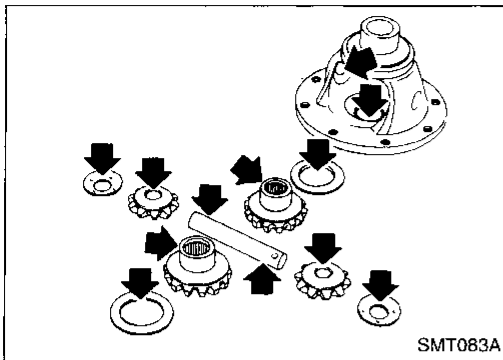

Bearing

- Make sure bearings roll freely and are free from noise, cracks, pitting or wear.
- **When replacing tapered roller bearing, replace outer and inner race as a set.**

ASSEMBLY

1. Attach side gear thrust washers to side gears and install in differential case.
2. Install pinion mate washers and pinion mate gears.

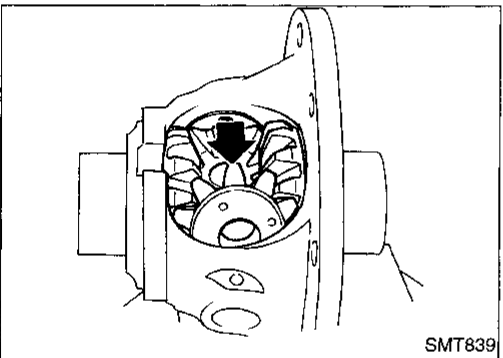

3. Insert pinion mate shaft.

- **When inserting, be careful not to damage pinion mate thrust washers.**

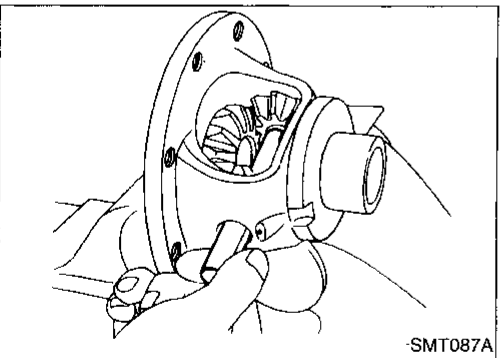

4. Measure clearance between side gear and differential case with washers following the procedure below:
 - a. Set Tool and dial indicator on side gear.

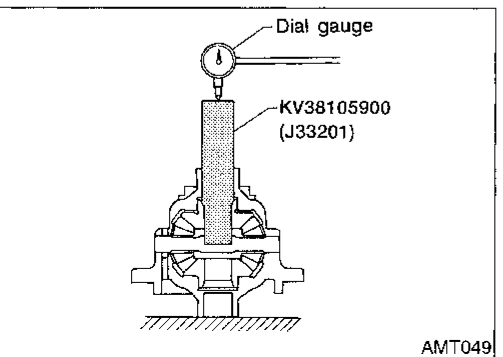

REPAIR FOR COMPONENT PARTS

Final Drive (Cont'd)

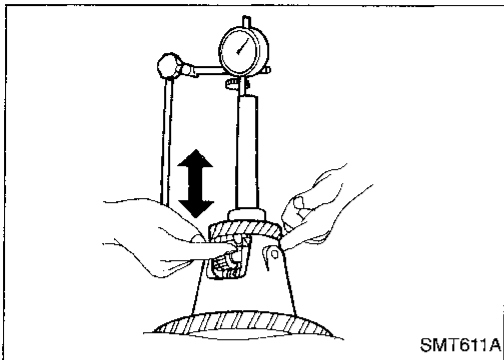

- b. Move side gear up and down to measure dial indicator deflection. Always measure indicator deflection on both side gears.

Clearance between side gear and differential case with washers:

0.1 - 0.2 mm (0.004 - 0.008 in) or less

- c. If not within specification, adjust clearance by changing thickness of side gear thrust washers.

Side gear thrust washer:

Refer to SDS, MT-32.

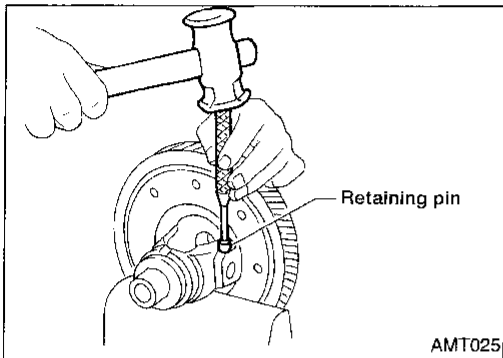

5. Install retaining pin.

- **Make sure that retaining pin is flush with case.**

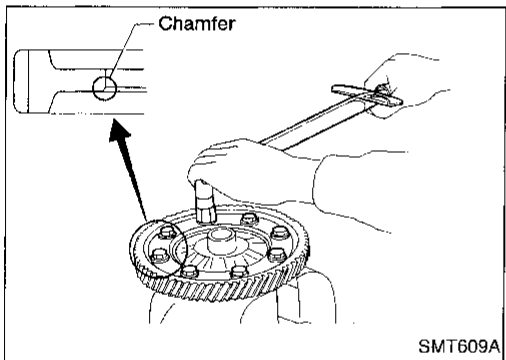

6. Install final gear.

- **Apply locking sealant to final gear fixing bolts before installing them.**

7. Install speedometer drive gear and stopper.

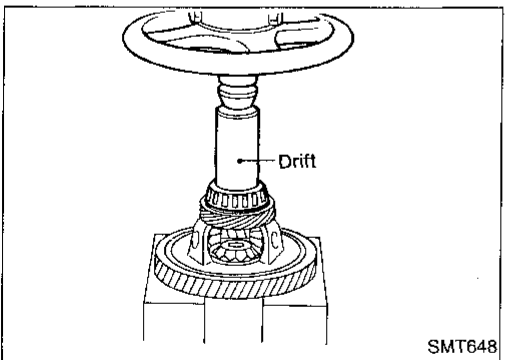

8. Press on differential side bearings.

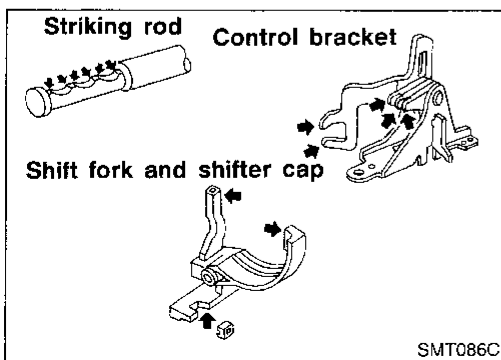

Shift Control Components

INSPECTION

- Check contact surface and sliding surface for wear, scratches, projections or other damage.

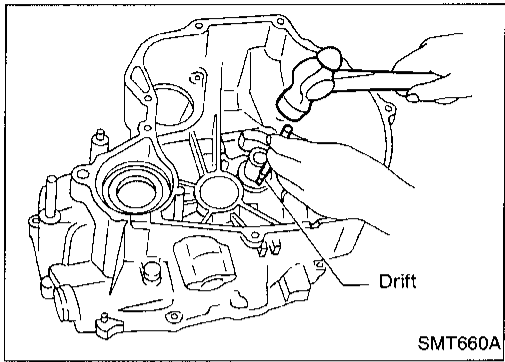

Case Components

Input shaft oil seal

1. Drive out input shaft oil seal.

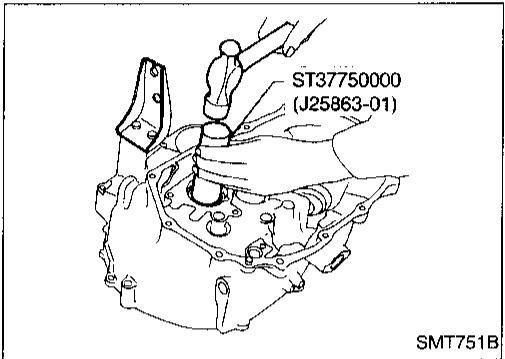

2. Install input shaft oil seal.

- Apply multi-purpose grease to seal lip of oil seal before installing.

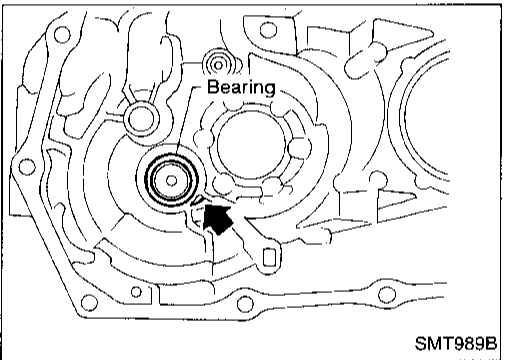

Input shaft rear bearing

1. Remove welch plug from transmission case.

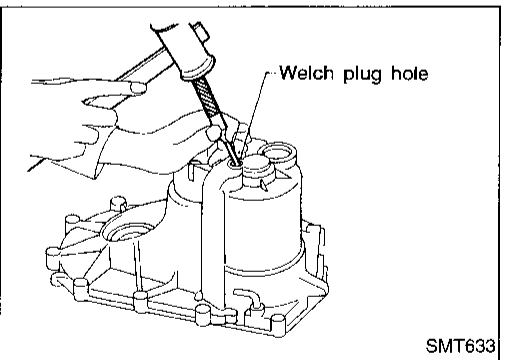

2. Remove input shaft rear bearing by tapping it from welch plug hole.

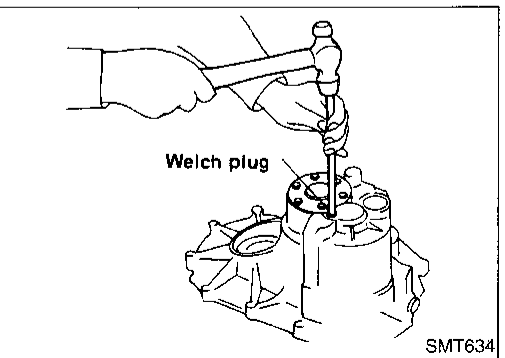

3. Install welch plug.

- Apply recommended sealant to mating surface of transmission case.

GI

MA

EM

LC

EC

FE

CL

MT

AT

FA

RA

BR

ST

RS

BT

HA

EL

IDX

REPAIR FOR COMPONENT PARTS

Case Components (Cont'd)

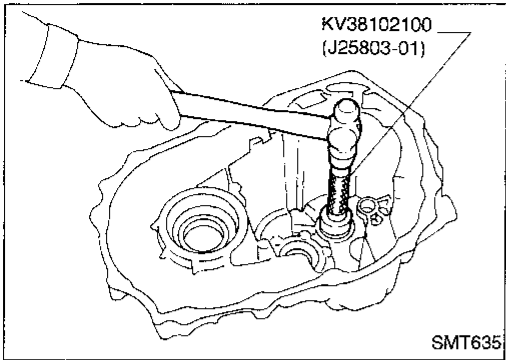

4. Install input shaft rear bearing.

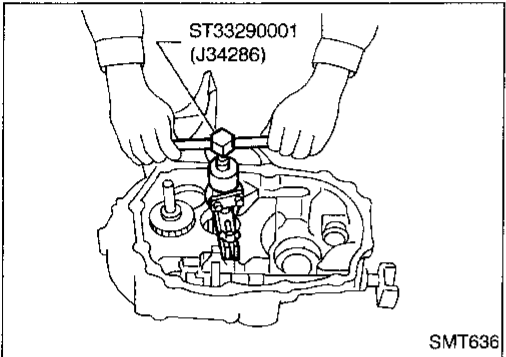

Mainshaft front bearing outer race and oil channel

1. Remove mainshaft front bearing outer race.
2. Remove oil channel.

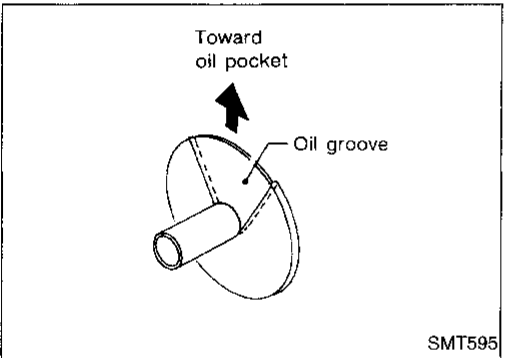

3. Install oil channel.
- **Ensure that the oil groove faces the oil pocket.**

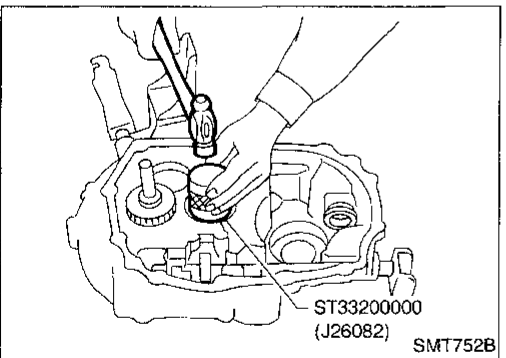

4. Install mainshaft front bearing outer race.

Differential side bearing outer race

- Refer to "Differential Side Bearing Preload", MT-27.

Mainshaft rear bearing outer race

- Refer to "Mainshaft Bearing Preload", MT-28.

ADJUSTMENT

Differential Side Bearing Preload

If any of the following parts are replaced, adjust differential side bearing preload.

- Differential case
- Differential side bearing
- Clutch housing
- Transmission case

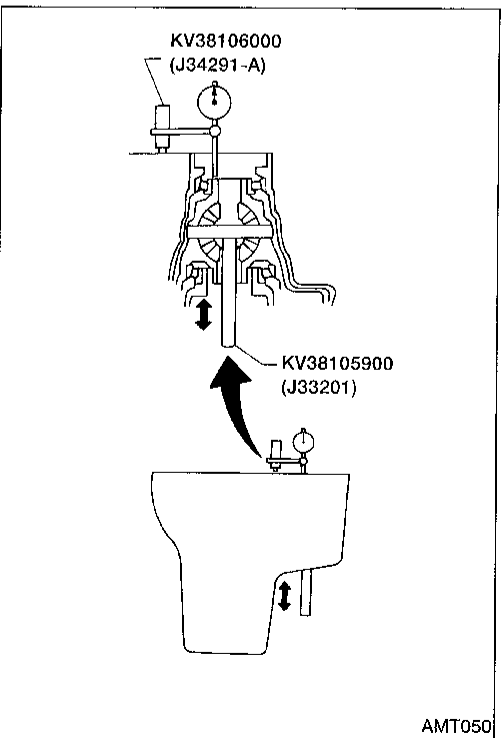
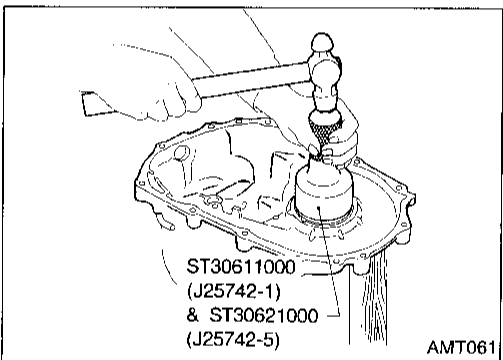
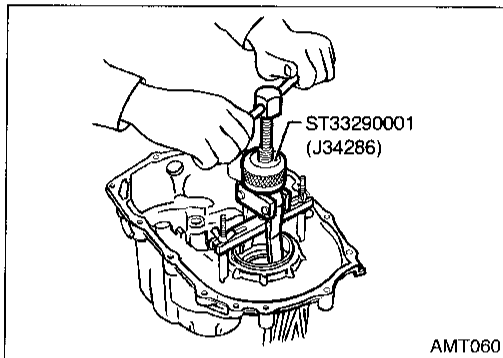

1. Remove differential side bearing outer race (transmission case side) and shim(s).

2. Install differential side bearing outer race without shim(s).
 3. Install final drive assembly on clutch housing.
 4. Install transmission case on clutch housing.
- **Tighten transmission case fixing bolts to the specified torque. Refer to MT-11.**

5. Set dial indicator on front end of differential case.
 6. Insert Tool all the way into differential side gear.
 7. Move Tool up and down and measure dial indicator deflection.
 8. Select shim considering bearing preload.
- **Suitable shim thickness = Dial indicator deflection + specified bearing preload**
 - **Differential side bearing adjusting shims and preload: Refer to SDS, MT-33.**
9. Install selected shim(s) and differential side bearing outer race.
 10. Check differential side bearing turning torque.
 - a. Install final drive assembly on clutch housing.
 - b. Install transmission case on clutch housing.
- **Tighten transmission case fixing bolts to the specified torque. Refer to MT-11.**

GI

MA

EM

LC

EC

FE

CL

MT

AT

FA

RA

BR

ST

RS

BT

HA

EL

IDX

ADJUSTMENT

Differential Side Bearing Preload (Cont'd)

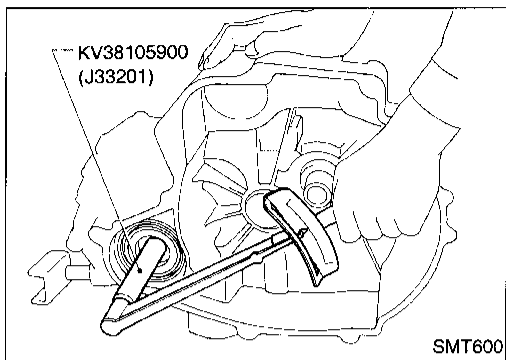

c. Measure turning torque of final drive assembly.

**Turning torque of final drive assembly
(New bearing):**

2.0 - 7.8 N·m (20 - 80 kg·cm, 17 - 69 in·lb)

- When old bearing is used again, turning torque will be slightly less than the above.
- Make sure torque is close to the specified range.
- Changes in turning torque of final drive assembly per revolution should be within 1.0 N·m (10 kg·cm, 8.7 in·lb) without binding.

Mainshaft Bearing Preload

If any of the following parts are replaced, adjust mainshaft bearing preload.

- Mainshaft
- Mainshaft bearings
- Clutch housing
- Transmission case

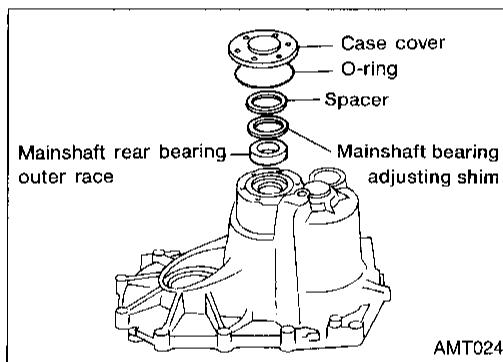

1. Remove case cover, O-ring, mainshaft bearing adjusting shim, spacer and mainshaft rear bearing outer race from transmission case.
 2. Install mainshaft assembly on clutch housing.
 3. Install transmission case on clutch housing.
- **Tighten transmission case fixing bolts to the specified torque. Refer to MT-11.**

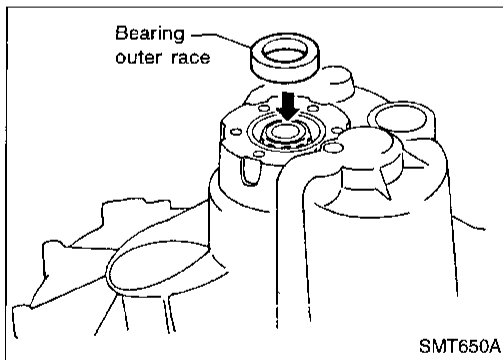

4. Install mainshaft rear bearing outer race on inner race.

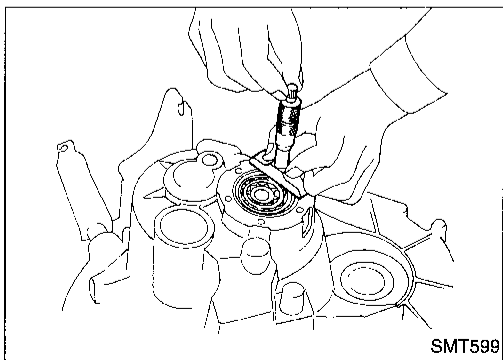

5. Measure distance from transmission case to bearing outer race.
- **Make sure that bearing is properly seated.**
6. Select shim. Refer to SDS, MT-33.
 7. Check total turning torque after assembling. Refer to "ASSEMBLY", MT-29.

ASSEMBLY

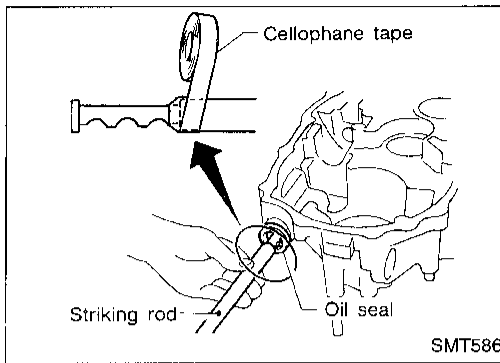

1. Install striking rod, lever and interlock.
 - **Tape edges of striking rod to avoid damaging oil seal lip during installation. When taped edges of striking rod are past the oil seal, remove tape.**

GI

MA

EM

LC

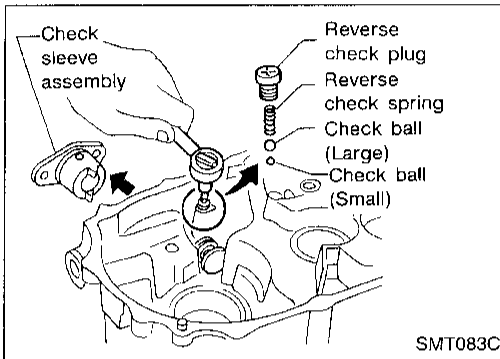

2. Install reverse check sleeve assembly.
3. Install check balls, reverse check spring and check plug.

EC

FE

CL

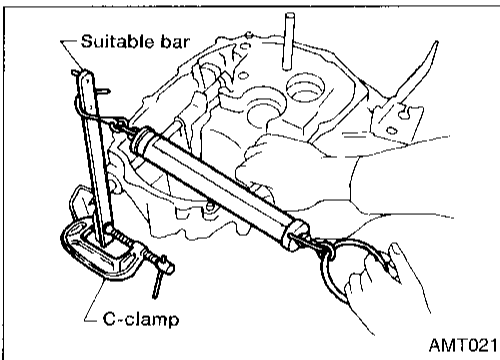

4. Check reverse check turning torque (At striking rod).
Reverse check turning torque (At striking rod):

Refer to SDS, MT-32.

- If not within specification, select another check plug having a different length and reinstall it.

Reverse check plug:

Refer to SDS, MT-32.

5. Install selected reverse check plug.
 - **Apply locking sealant to thread of plug before installing it.**

MT

AT

FA

RA

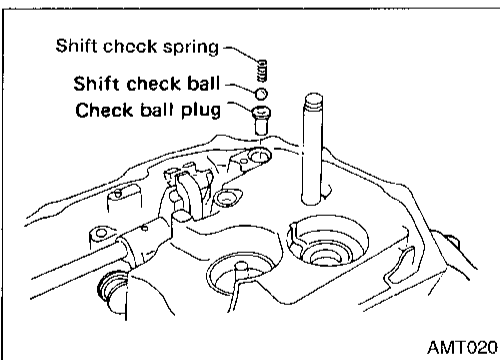

6. Install check ball plug, shift check ball and shift check spring.
7. Install oil pocket.

BR

ST

RS

BT

HA

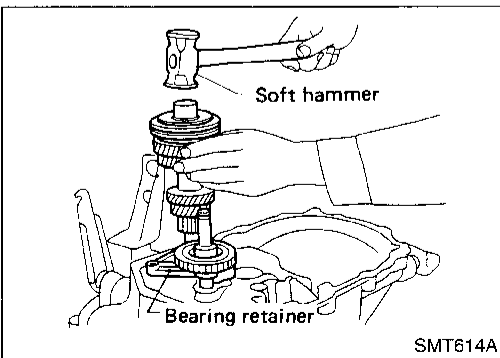

8. Install gear components onto clutch housing.
 - a. Install input shaft assembly and reverse idler gear.
 - **Be careful not to damage oil seal lip with splines of input shaft.**

EL

IDX

ASSEMBLY

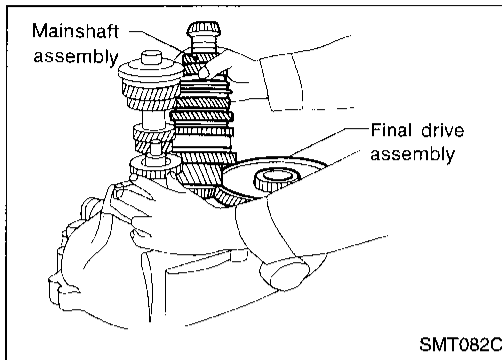

- b. Install final drive assembly.
 - c. Install mainshaft assembly.
- **Take care not to damage oil channel when inserting mainshaft into clutch housing.**

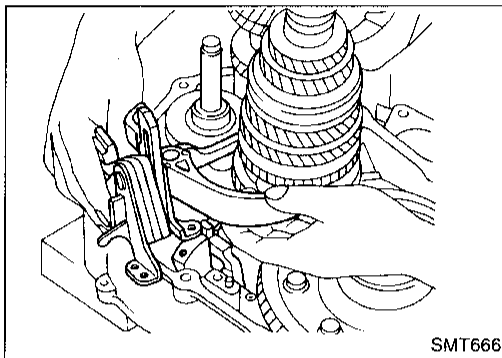

9. Apply grease to shifter caps, then install it to control bracket. Install control bracket with 1st & 2nd shift fork.
10. Install 3rd & 4th and 5th shift forks.

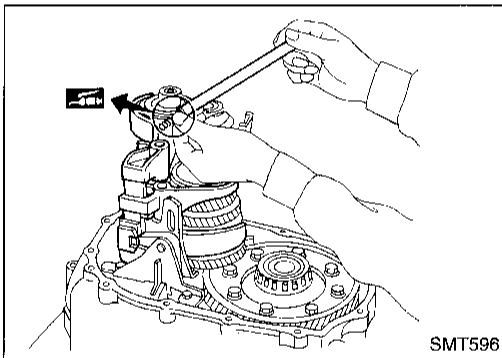

11. Insert fork shaft.
- **Apply multi-purpose grease to support spring before installing.**
12. Install reverse idler spacer.

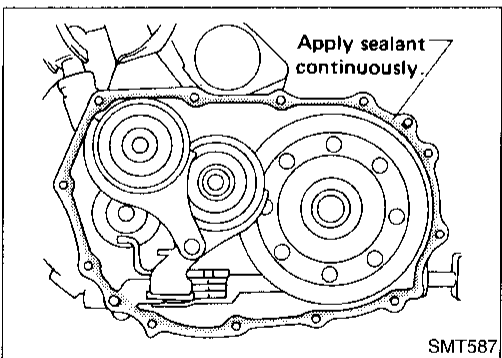

13. Apply recommended sealant to mating surface of clutch housing. Refer to MT-11.
14. Install transmission case on clutch housing.

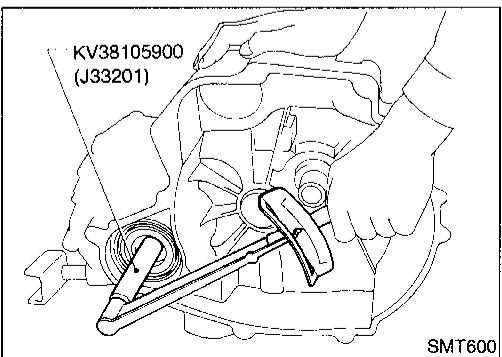

15. Measure total turning torque.
Total turning torque (New bearing):
3.9 - 13.7 N·m (40 - 140 kg-cm, 35 - 122 in-lb)
- **When old bearing is used again, turning torque will be slightly less than the above.**
 - **Make sure torque is close to the specified range.**

SERVICE DATA AND SPECIFICATIONS (SDS)

General Specifications

TRANSAXLE

Engine		GA16DE	
Transaxle model		RS5F31A	
Synchromesh type		Warner	
Shift pattern			
Gear ratio	1st	3.333	
	2nd	1.955	
	3rd	1.286	
	4th	0.926	
	5th	0.733	
	Reverse	3.417	
Number of teeth	Input gear	1	15
		2	22
		3	28
		4	41
		5	45
		Rev.	12
	Main gear	1	50
		2	43
		3	36
		4	38
		5	33
		Rev.	41
Reverse idler gear		30	
Oil level*	mm (in)	57 - 66 (2.24 - 2.60)	
Oil capacity (Reference)	(ℓ) (US pt, Imp pt)	2.9 - 3.2 (6-1/8 - 6-3/4, 5-1/8 - 5-5/8)	

*Refer to MA section ("Checking M/T Oil" - "CHASSIS AND BODY MAINTENANCE").

FINAL GEAR

Engine		GA16DE
Final gear ratio		3.789
Number of teeth	Final gear/Pinion	72/19
	Side gear/Pinion mate gear	16/10

SERVICE DATA AND SPECIFICATIONS (SDS)

Inspection and Adjustment

GEAR END PLAY

Gear	End play mm (in)
1st main gear	0.18 - 0.31 (0.0071 - 0.0122)
2nd main gear	0.20 - 0.30 (0.0079 - 0.0118)
3rd main gear	0.20 - 0.30 (0.0079 - 0.0118)
4th main gear	0.20 - 0.30 (0.0079 - 0.0118)
5th input gear	0.18 - 0.31 (0.0071 - 0.0122)

CLEARANCE BETWEEN BAULK RING AND GEAR

Unit: mm (in)

	Standard	Wear limit
1st & 2nd	1.0 - 1.35 (0.0394 - 0.0531)	0.7 (0.028)
3rd & 4th	1.0 - 1.35 (0.0394 - 0.0531)	0.7 (0.028)
5th	1.0 - 1.35 (0.0394 - 0.0531)	0.7 (0.028)

AVAILABLE CHECK PLUGS

Reverse check plug

Reverse check turning torque (At striking rod) N-m (kg-cm, in-lb)	4.9 - 7.4 (50 - 75, 43 - 65)
Thickness mm (in)	Part number
8.3 (0.327)	32188-M8001*
7.1 (0.280)	32188-M8002
7.7 (0.303)	32188-M8003
8.9 (0.350)	32188-M8004

* Standard size check plug

AVAILABLE SNAP RINGS

Input shaft front bearing

Allowable clearance	0 - 0.1 mm (0 - 0.004 in)
Thickness mm (in)	Part number
1.27 (0.0500)	32204-M8004
1.33 (0.0524)	32204-M8005
1.39 (0.0547)	32204-M8006
1.45 (0.0571)	32204-M8007

Input shaft 5th synchronizer hub

Allowable clearance	0 - 0.1 mm (0 - 0.004 in)
Thickness mm (in)	Part number
2.00 (0.0787)	32311-M8812
2.05 (0.0807)	32311-M8813
2.10 (0.0827)	32311-M8814
2.15 (0.0846)	32311-M8815
2.20 (0.0866)	32311-M8816
2.25 (0.0886)	32311-M8817
2.30 (0.0906)	32311-M8818

AVAILABLE C-RINGS

Mainshaft C-ring

Allowable clearance		0 - 0.1 mm (0 - 0.004 in)	
Thickness mm (in)	Part number	Thickness mm (in)	Part number
3.63 (0.1429)	32348-M8800	4.12 (0.1622)	32348-M8807
3.70 (0.1457)	32348-M8801	4.19 (0.1650)	32348-M8808
3.77 (0.1484)	32348-M8802	4.26 (0.1677)	32348-M8809
3.84 (0.1512)	32348-M8803	4.33 (0.1705)	32348-M8810
3.91 (0.1539)	32348-M8804	4.40 (0.1732)	32348-M8811
3.98 (0.1567)	32348-M8805	4.47 (0.1760)	32348-M8812
4.05 (0.1594)	32348-M8806	4.54 (0.1787)	32348-M8813

AVAILABLE WASHERS

Differential side gear thrust washer

Allowable clearance between side gear and differential case with washer	0.1 - 0.2 mm (0.004 - 0.008 in) or less
Thickness mm (in)	Part number
0.75 - 0.80 (0.0295 - 0.0315)	38424-D2111
0.80 - 0.85 (0.0315 - 0.0335)	38424-D2112
0.85 - 0.90 (0.0335 - 0.0354)	38424-D2113
0.90 - 0.95 (0.0354 - 0.0374)	38424-D2114
0.95 - 1.00 (0.0374 - 0.0394)	38424-D2115

SERVICE DATA AND SPECIFICATIONS (SDS)

Inspection and Adjustment (Cont'd)

AVAILABLE SHIMS

— MAINSHAFT AND DIFFERENTIAL SIDE BEARING PRELOAD AND ADJUSTING SHIM

Bearing preload (Reused bearing)

Unit: mm (in)

Mainshaft bearing	Differential side bearing
0.20 - 0.25 (0.0079 - 0.0098)	0.24 - 0.32 (0.0094 - 0.0126)

Turning torque (New bearing)

Unit: N·m (kg·cm, in·lb)

Final drive only	Total
2.0 - 7.8 (20 - 80, 17 - 69)	3.9 - 13.7 (40 - 140, 35 - 122)

Mainshaft bearing adjusting shims

Thickness mm (in)	Part number
0.10 (0.0039)	32137-M8000
0.15 (0.0059)	32137-M8001
0.20 (0.0079)	32137-M8002
0.25 (0.0098)	32137-M8003
0.30 (0.0118)	32137-M8004
0.35 (0.0138)	32137-M8005
0.40 (0.0157)	32137-M8006
0.45 (0.0177)	32137-M8007
0.50 (0.0197)	32137-M8008
0.55 (0.0217)	32137-M8009
0.60 (0.0236)	32137-M8010
0.65 (0.0256)	32137-M8011
0.70 (0.0276)	32137-M8012
0.75 (0.0295)	32137-M8013
0.80 (0.0315)	32137-M8014
0.85 (0.0335)	32137-M8015
0.90 (0.0354)	32137-M8016
0.95 (0.0374)	32137-M8017
1.00 (0.0394)	32137-M8018

Differential side bearing adjusting shims

Thickness mm (in)	Part number
0.44 (0.0173)	38454-M8000
0.48 (0.0189)	38454-M8001
0.56 (0.0220)	38454-M8003
0.60 (0.0236)	38454-M8004
0.64 (0.0252)	38454-M8005
0.68 (0.0268)	38454-M8006
0.72 (0.0283)	38454-M8007
0.76 (0.0299)	38454-M8008
0.80 (0.0315)	38454-M8009
0.84 (0.0331)	38454-M8010
0.88 (0.0346)	38454-M8011

GI

MA

EM

LC

EC

FE

CL

MT

AT

FA

RA

BR

ST

RS

BT

HA

EL

IDX