

SECTION BT

GI

MA

EM

LC

EG

FE

CL

MT

AT

FA

RA

BR

ST

RS

BT

HA

EL

IDX

CONTENTS

PRECAUTIONS AND PREPARATION..... 2
 Precautions 2
 Supplemental Restraint System (SRS)
 "AIR BAG" 2
 Clip and Fastener 2
BODY END 5
 Body Front End..... 5
 Sedan 5
 Removal — Front bumper assembly 5
 Coupe 5
 Removal — Front bumper assembly 5
 Sedan 6
 Coupe 7
 Body Rear End and Opener 8
DOOR..... 10
 Front Door..... 10
 Rear Door 12
INSTRUMENT PANEL 13
INTERIOR TRIM 16
 Side and Floor Trim 16
 Door Trim 19
 Roof Trim 21
 Trunk Room Trim 22
EXTERIOR 23
 ① Hood front seal 23
 ② ③ Cowl top seal and cowl top grille ... 23
 ④ Windshield side molding 23
 ⑤ Windshield upper molding 24
 ⑥ Drip weatherstrip..... 24
 ⑦ Body side welt 24
 ⑧ Door weatherstrip 24
 ⑨ Rear window upper molding and side
 molding 24

⑩ Rear window lower molding 24
 ⑪ Door sash molding..... 25
 ⑫ Rear door parting seal..... 25
 ⑬ Rear door corner molding..... 25
 ⑭ Door outside molding..... 25
 ⑮ Sunroof lid weatherstrip 26
 ⑯ Side guard molding..... 26
 ⑰ Trunk lid weatherstrip 26
 ⑱ Trunk lid finisher 26
 ⑲ Rear combination lamp..... 27
 ⑳ Fender and center mudguard 27
 ㉑ Rear air spoiler and high-mounted
 stop lamp 28
SEAT 29
 Front Seat 29
 Rear Seat 30
SUNROOF..... 31
 Removal 32
 Trouble Diagnoses 33
 Drain Hoses 34
 Weatherstrip..... 34
 Link And Wire Assembly..... 34
 Adjustment 35
WINDSHIELD AND WINDOWS 36
 Windshield and Rear Window 37
 Quarter Window 38
 Coupe 38
 Sedan 39
MIRROR..... 40
 Door Mirror..... 40
BODY ALIGNMENT..... 41
 Engine Compartment 41
 Underbody..... 43

★ For seat belt, refer to MA and RS section.
 ★ For wiring diagrams of body electrical systems, refer to EL section.

PRECAUTIONS AND PREPARATION

Precautions

- When removing or installing various parts, place a cloth or padding onto the vehicle body to prevent scratches.
- Handle trim, molding, instruments, grille, etc. carefully during removing or installing. Be careful not to soil or damage them.
- Apply sealing compound where necessary when installing parts.
- When applying sealing compound, be careful that the sealing compound does not protrude from parts.
- When replacing any metal parts (for example, body outer panel, members, etc.), be sure to take rust prevention measures.

Supplemental Restraint System (SRS) "AIR BAG"



The Supplemental Restraint System "Air Bag", used along with a seat belt, helps to reduce the risk or severity of injury to the driver and front passenger in a frontal collision. The Supplemental Restraint System consists of air bag modules (located in the center of the steering wheel and on the instrument panel on the passenger side), a diagnosis sensor unit, warning lamp, wiring harness and spiral cable. Information necessary to service the system safely is included in the **RS section** of this Service Manual.

WARNING:

- To avoid rendering the SRS inoperative, which could increase the risk of personal injury or death in the event of a collision which would result in air bag inflation, all maintenance should be performed by an authorized NISSAN dealer.
- Improper maintenance, including incorrect removal and installation of the SRS, can lead to personal injury caused by unintentional activation of the system.
- Do not use electrical test equipment on any circuit related to the SRS unless instructed to in this Service Manual. SRS wiring harnesses are covered with yellow insulation either just before the harness connectors or on the complete harness, for easy identification.



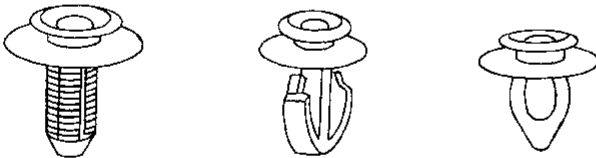
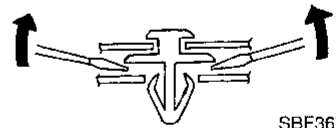

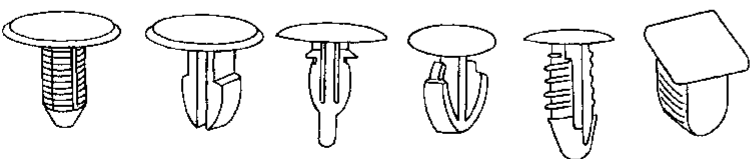
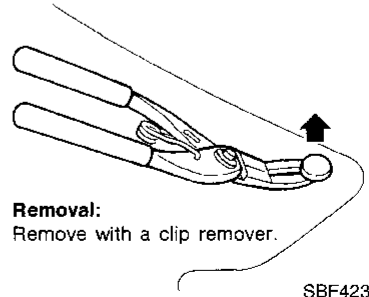



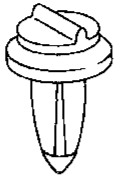
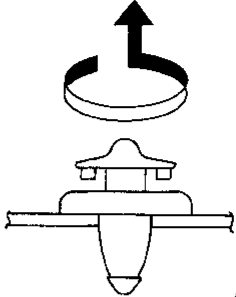

Clip and Fastener

- Clips and fasteners in BT section correspond to the following numbers and symbols.
- Replace any clips and/or fasteners which are damaged during removal or installation.

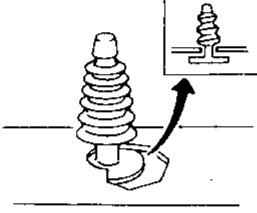
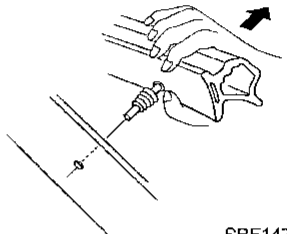
Symbol No.	Shapes	Removal & Installation
	 <p style="text-align: right;">SBF302H</p>	<p>Removal: Remove by bending up with flat-bladed screwdrivers or clip remover.</p>  <p style="text-align: right;">SBF367BA</p>
	 <p style="text-align: right;">SBT095</p>	<p>Removal: Remove with a clip remover.</p>  <p style="text-align: right;">SBF423H</p>

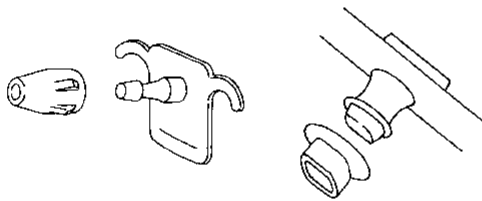
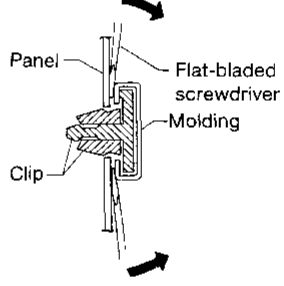
PRECAUTIONS AND PREPARATION

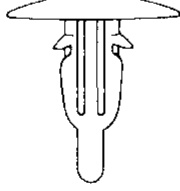
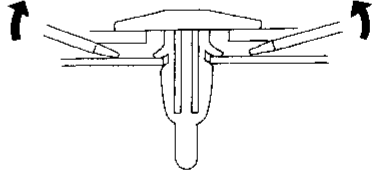
Clip and Fastener (Cont'd)

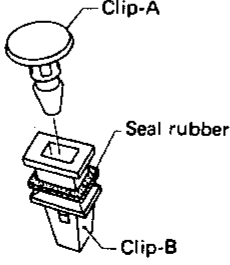
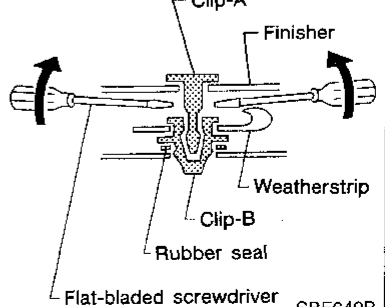
Symbol No.	Shapes	Removal & Installation
 		
 		<p>Removal:</p> 
 		
 		<p>Removal: Remove by bending up with a flat-bladed screwdriver or pliers.</p> 
 		<p>Removal:</p> 

GI

MA

EM

LC

EC

FE

CL

MT

AT

FA

RA

BR

ST

RS

BT











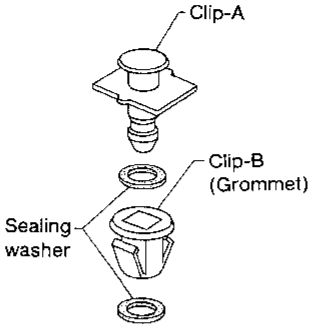
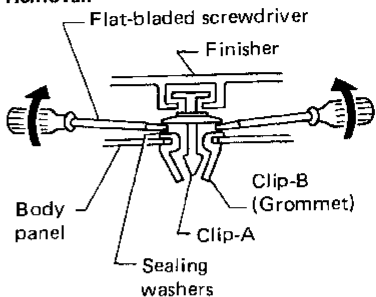

HA

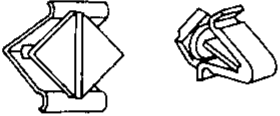
EL

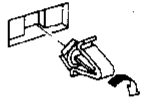
IDX

PRECAUTIONS AND PREPARATION

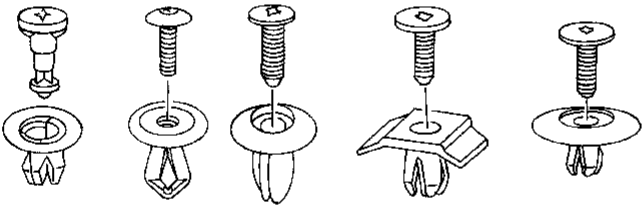
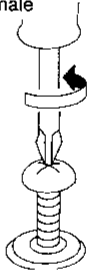
Clip and Fastener (Cont'd)

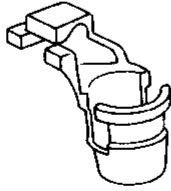
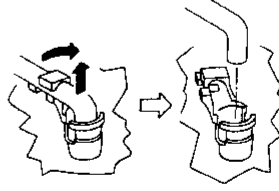
Symbol No.	Shapes	Removal & Installation
 		<p>Removal:</p>  <p>SBF151D</p> <p>SBF259G</p>
		<p>Removal:</p>  <p>Rotate 45° to remove.</p> <p>Installation:</p>  <p>Removal:</p>  <p>SBF145B</p> <p>SBF085B</p>
 		<p>Removal:</p> <ol style="list-style-type: none"> 1. Screw out with a Phillips screwdriver. 2. Remove female portion with flat-bladed screwdriver.  <p>SBF078B</p> <p>SBF992G</p>
		<p>Removal:</p> <p>Holder portion of clip must be spread out to remove rod.</p>  <p>SBF768B</p> <p>SBF770B</p>

Body Front End

- When removing or installing hood, place a cloth or other padding on front fender panels and cowl top. This prevents vehicle body from being scratched.
- Bumper fascia is made of plastic. Do not use excessive force and be sure to keep oil away from it.
- Hood adjustment: Adjust at hinge portion. **B**
- Hood lock adjustment: After adjusting, check hood lock control operation. Apply a coat of grease to hood lock engaging mechanism.
- Hood opener: Do not attempt to bend cable forcibly. Doing so increases effort required to unlock hood.

SEDAN

Removal — Front bumper assembly

- ① Remove screws securing left and right front fog lamps, and remove the lamps.
- ② Remove clips **CG101**, then remove the front grille. **A**
- ③ Remove clips **CS101** and screws located on front side of fender protector at wheel opening.
- ④ Remove two screws and two clips **CS101** securing upper side of front bumper fascia.
- ⑤ Remove seven screws, seven clips and air deflector.
- ⑥ Remove two screws securing lower side of front bumper fascia.
- ⑦ Pull out front bumper fascia and energy absorber.
- ⑧ Remove four bolts securing bumper reinforcement, then remove bumper reinforcement.
- ⑨ Remove four bolts and clip **CS101** securing front bumper side stays.
- ⑩ Remove front bumper side stays.

COUPE

Removal — Front bumper assembly

- ① Remove screws securing left and right front fog lamps, and remove the lamps.
- ② Remove clips **CG101**, then remove the front grille. **A**
- ③ Remove clips **CS101** and screws located on front side of fender protector at wheel opening.
- ④ Remove two screws and two clips **CS101** securing upper side of front bumper fascia.
- ⑤ Remove two screws securing lower side of front bumper fascia.
- ⑥ Pull out front bumper fascia and energy absorber.
- ⑦ Remove four bolts securing bumper reinforcement, then remove bumper reinforcement.
- ⑧ Remove four bolts and clip **CS101** securing front bumper side stays.
- ⑨ Remove front bumper side stays.

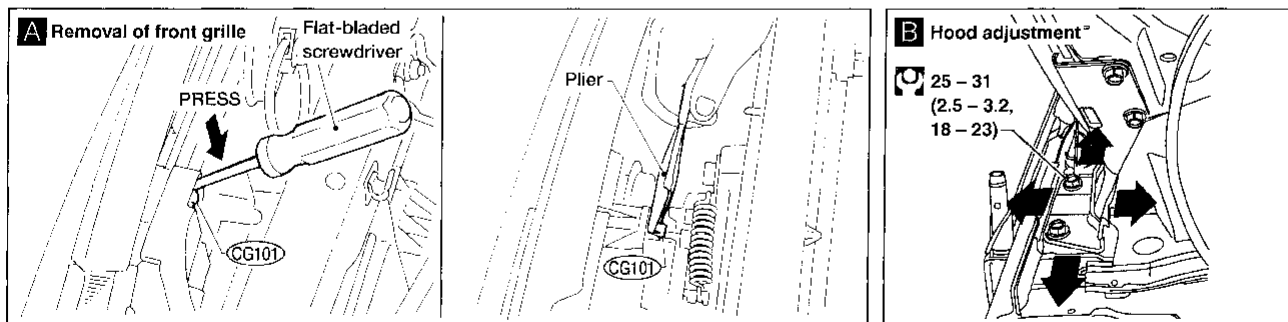

U : N·m (kg·m, ft·lb)

ABT336

BODY END

Body Front End (Cont'd)

SEDAN

SEC. 620 • 623 • 630

Hood lock adjustment

- Adjust hood so that hood primary lock meshes at a position 1 to 1.5 mm (0.039 to 0.059 in) lower than fender.
- After hood lock adjustment, adjust bumper rubber.
- When securing hood lock, ensure that it does not tilt. Striker must be positioned at the center of hood primary lock.
- After adjustment, ensure that hood primary and secondary lock operate properly.

Hood lock secondary latch hooking length

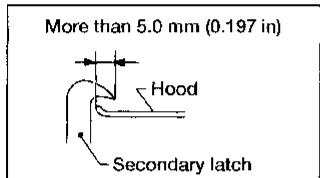

Bumper rubber adjustment

- Adjust so that hood is aligned with fender. At that time deflection is approximately 2 mm (0.08 in). [Bumper rubber free height is approximately 13 mm (0.51 in)]

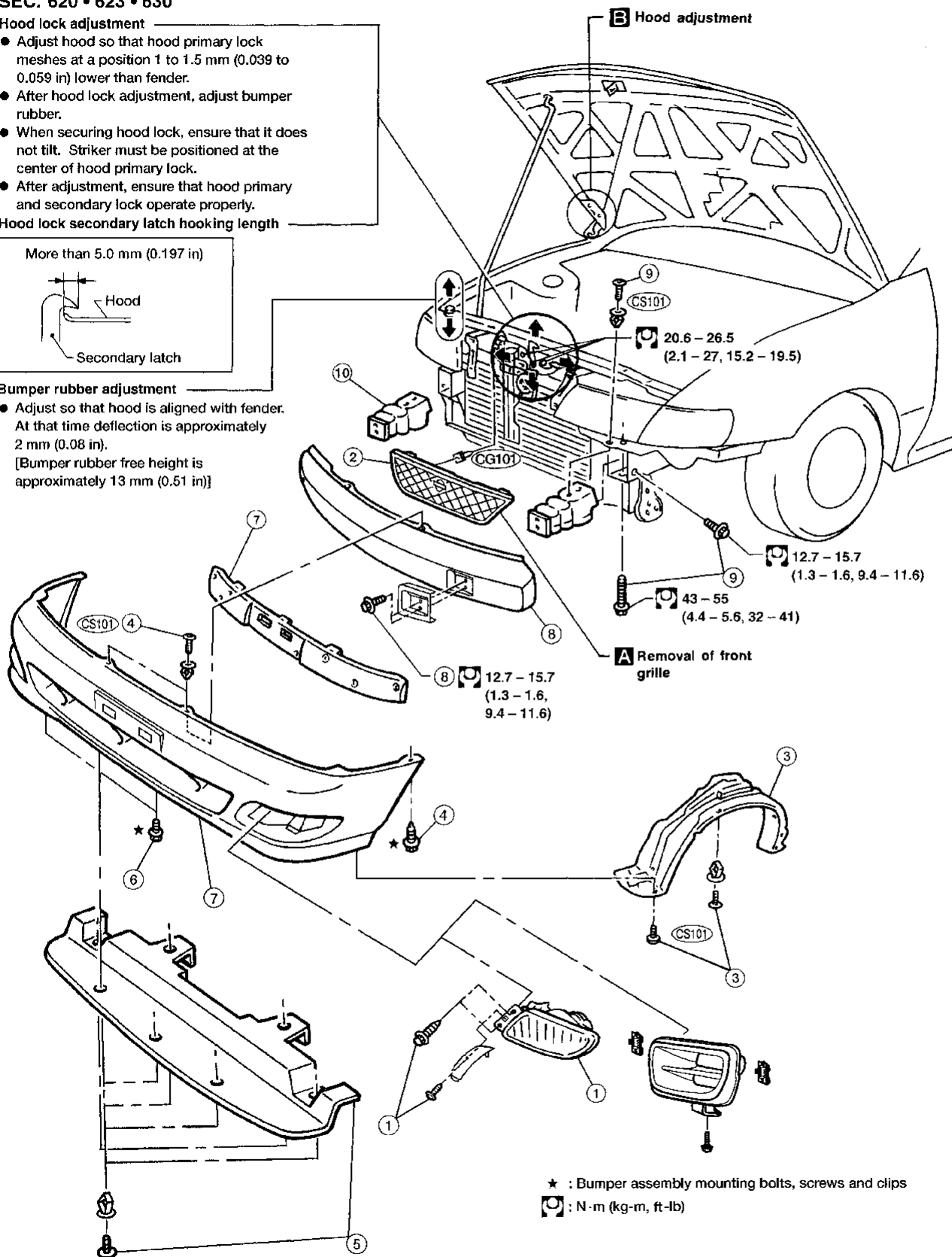

BODY END

Body Front End (Cont'd)

COUPE

Coupe

SEC. 620 • 623 • 630

Hood lock adjustment

- Adjust hood so that hood primary lock meshes at a position 1 to 1.5 mm (0.039 to 0.059 in) lower than fender.
- After hood lock adjustment, adjust bumper rubber.
- When securing hood lock, ensure that it does not tilt. Striker must be positioned at the center of hood primary lock.
- After adjustment, ensure that hood primary and secondary lock operate properly.

Hood lock secondary latch hooking length

More than 5.0 mm (0.197 in)

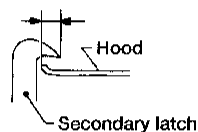

Bumper rubber adjustment

- Adjust so that hood is aligned with fender. At that time deflection is approximately 2 mm (0.08 in). [Bumper rubber free height is approximately 13 mm (0.51 in)]

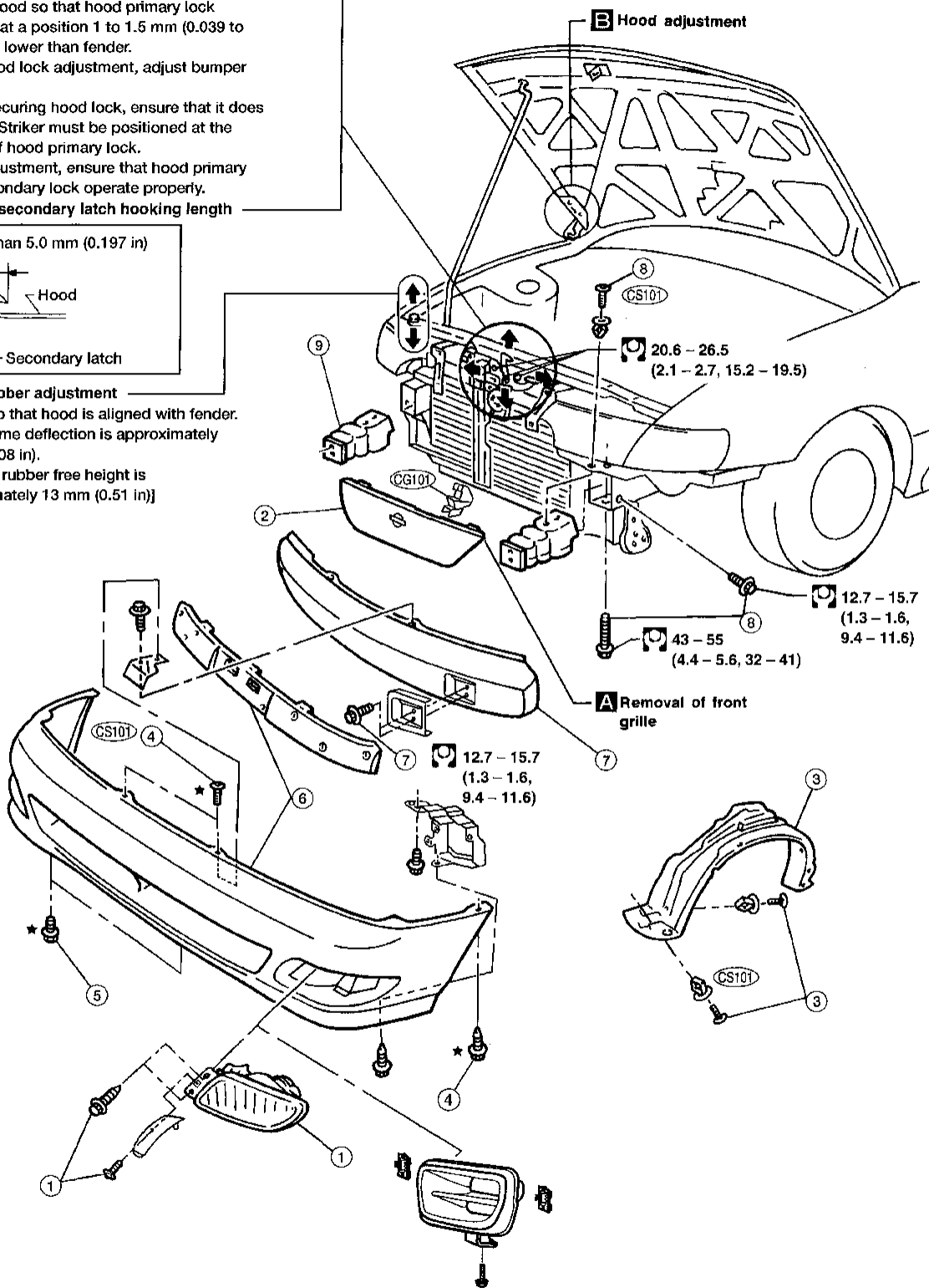

★ : Bumper assembly mounting bolts, screws and clips

Ⓔ : N·m (kg-m, ft-lb)

GI

MA

EM

LC

EC

FE

CL

MT

AT

FA

RA

BR

ST

RS

BT

HA

EL

IDX

Body Rear End and Opener

- When removing or installing trunk lid, place a cloth or other padding on rear fender panels. This prevents vehicle body from being scratched.
- Bumper fascia is made of plastic. Do not use excessive force and be sure to keep oil away from it.
- Trunk lid adjustment: Adjust at hinge-trunk lid portion for proper trunk lid fit.
- Trunk lid lock system adjustment: Adjust striker so that it is in the center of the lock. After adjustment, check trunk lid lock operation.
- Opener cable: Do not attempt to bend cable using excessive force.
- After installation, make sure that trunk lid and fuel filler lid open smoothly.

REMOVAL — Rear bumper assembly

- ① Remove four screws securing mudguards, then remove mudguards.
- ② Remove four bolts and one clip (CS101) from lower side of rear bumper fascia.
- ③ Remove two screws from each fender side.
- ④ Remove four clips (CS101) from upper side of rear bumper fascia.
- ⑤ Pull out rear bumper fascia.
- ⑥ Remove eight nuts securing bumper reinforcement, then remove bumper reinforcement.
- ⑦ Remove four bolts securing bumper side stays, then remove bumper side stays.

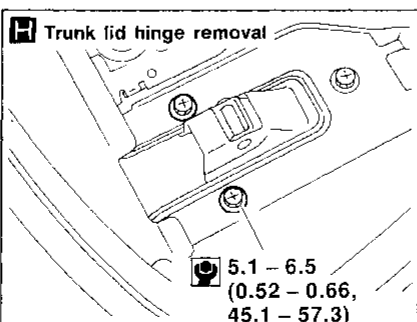
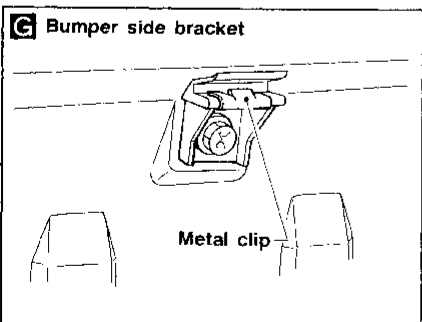
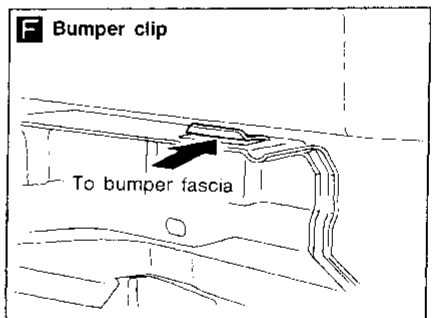
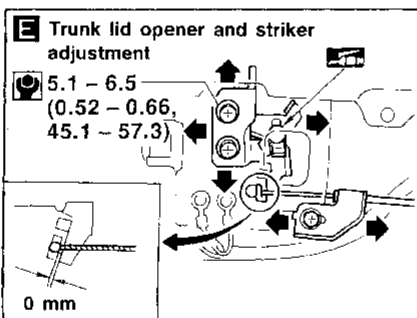
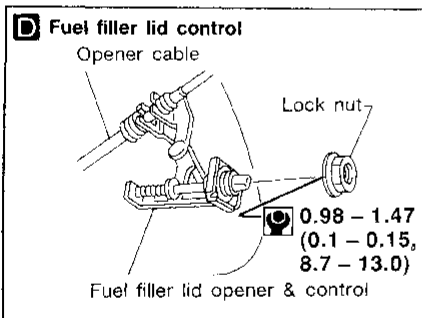
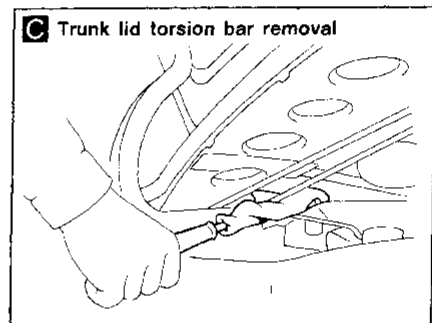
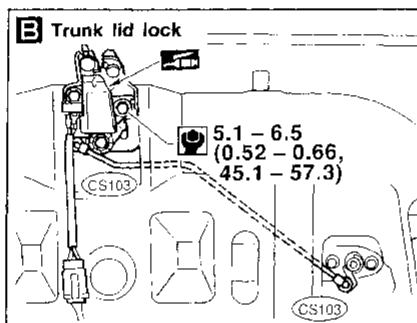
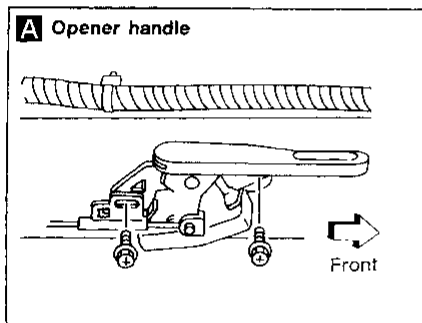

: N·m (kg·m, in·lb)

ABT092

DOOR

Front Door

- For removal of door trim, refer to BT-19.
- After adjusting door or door lock, check door lock operation.

Coupe

SEC. 800•803•805

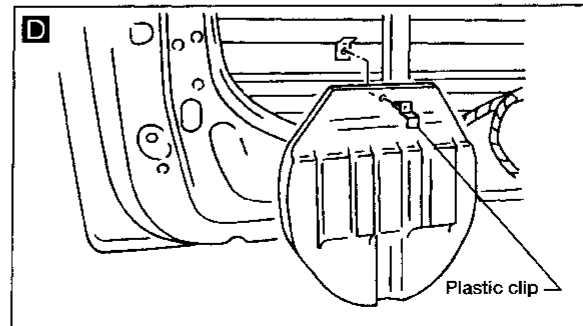
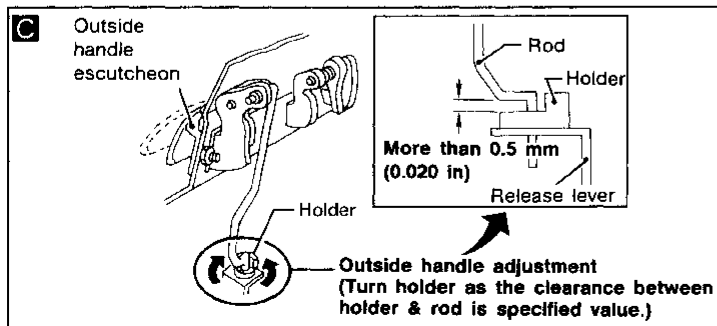
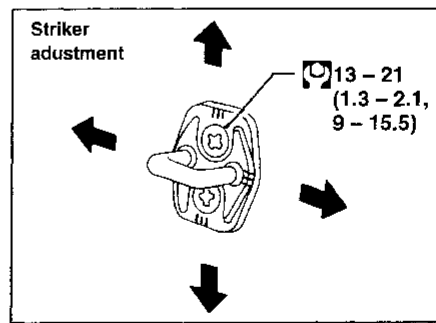
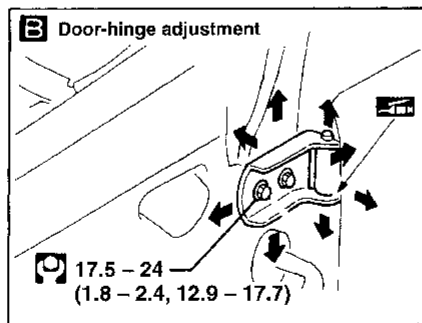
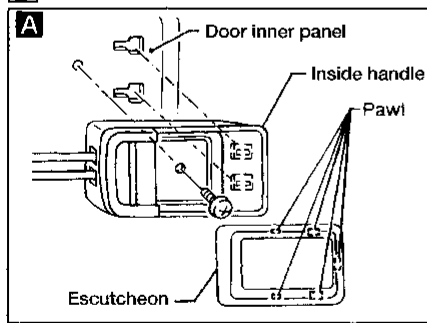
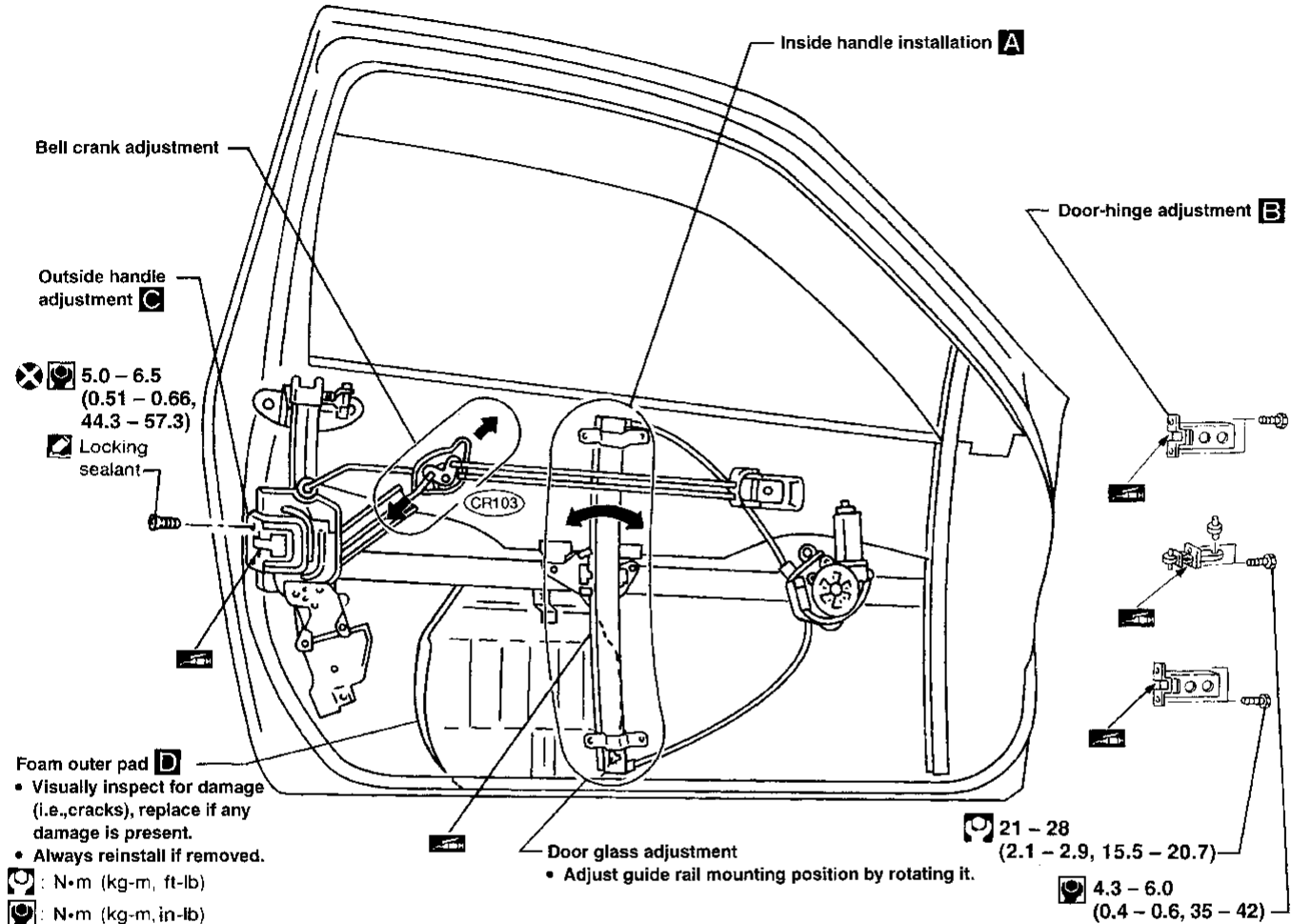

ABT283

DOOR

Front Door (Cont'd)

Sedan
SEC. 800-803-805

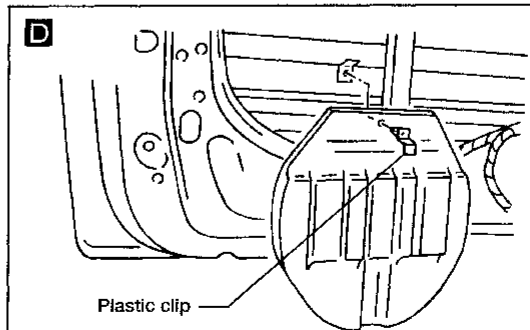
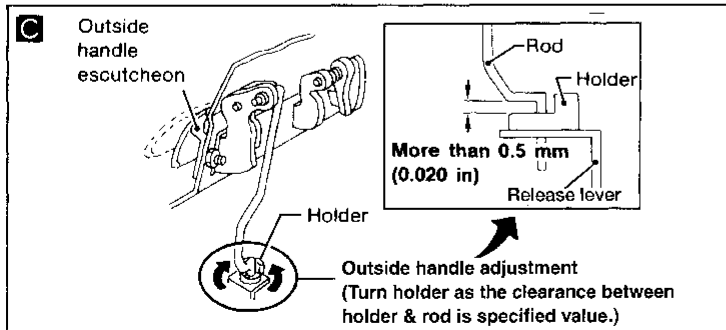
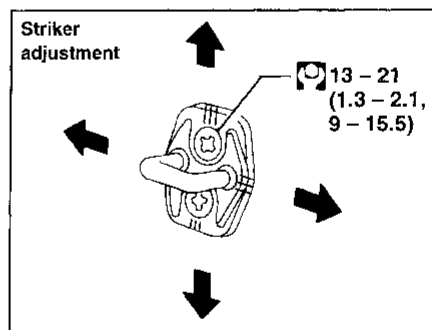
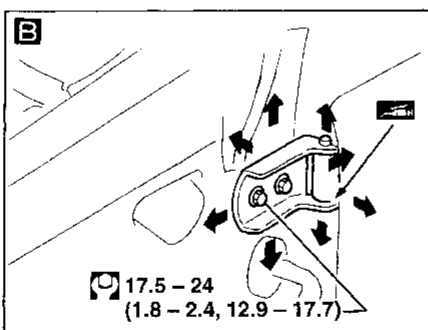
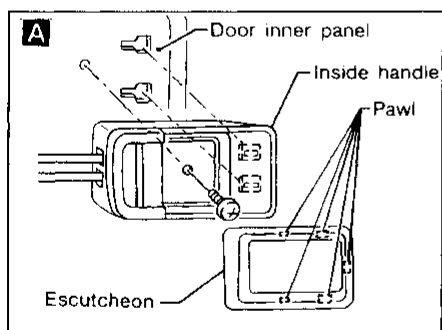
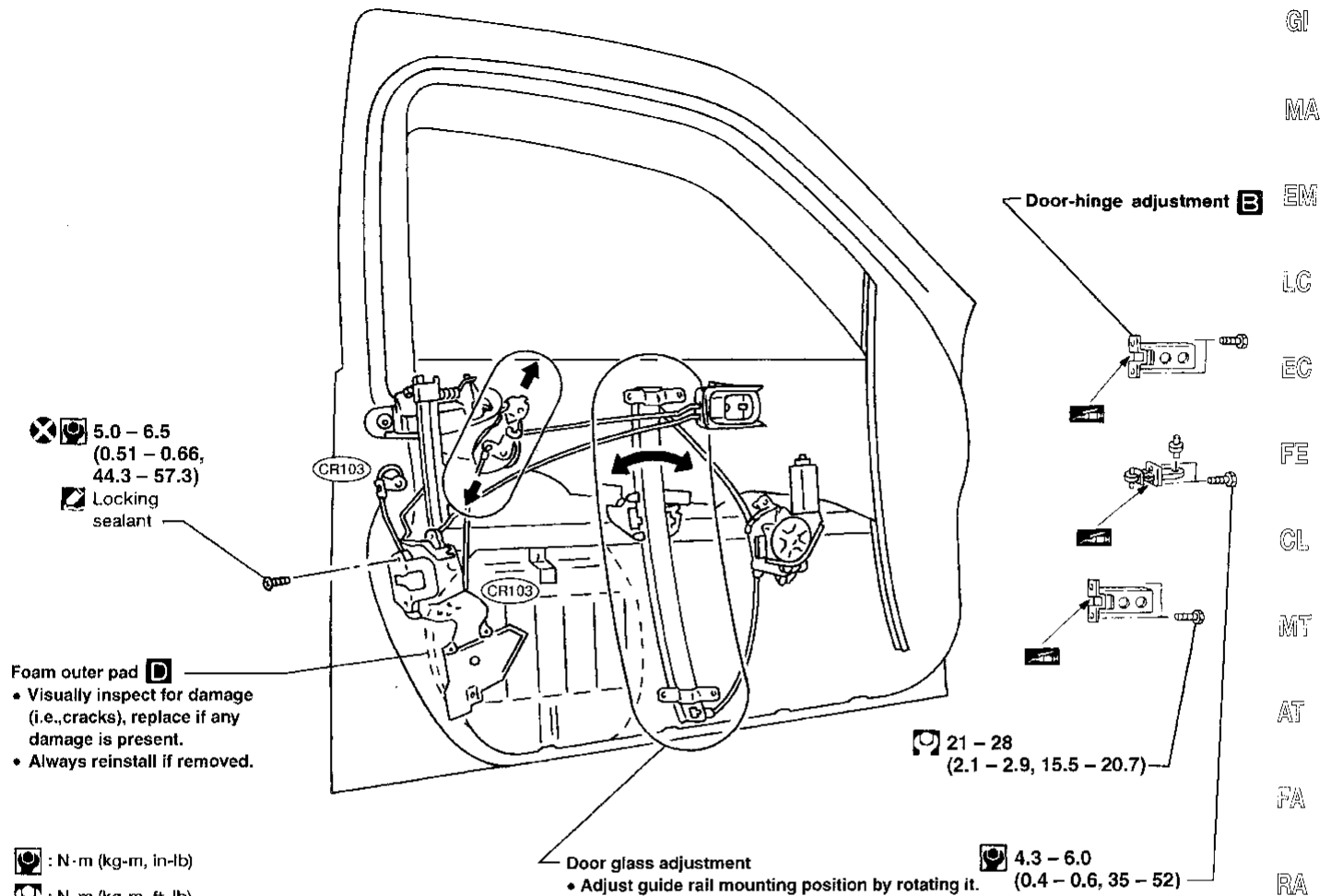

GI
MA
EM
LC
EC
FE
CL
MT
AT
FA
RA
BR
ST
RS
BT
HA
EL
IDX

DOOR

Rear Door

SEC. 820-823-825

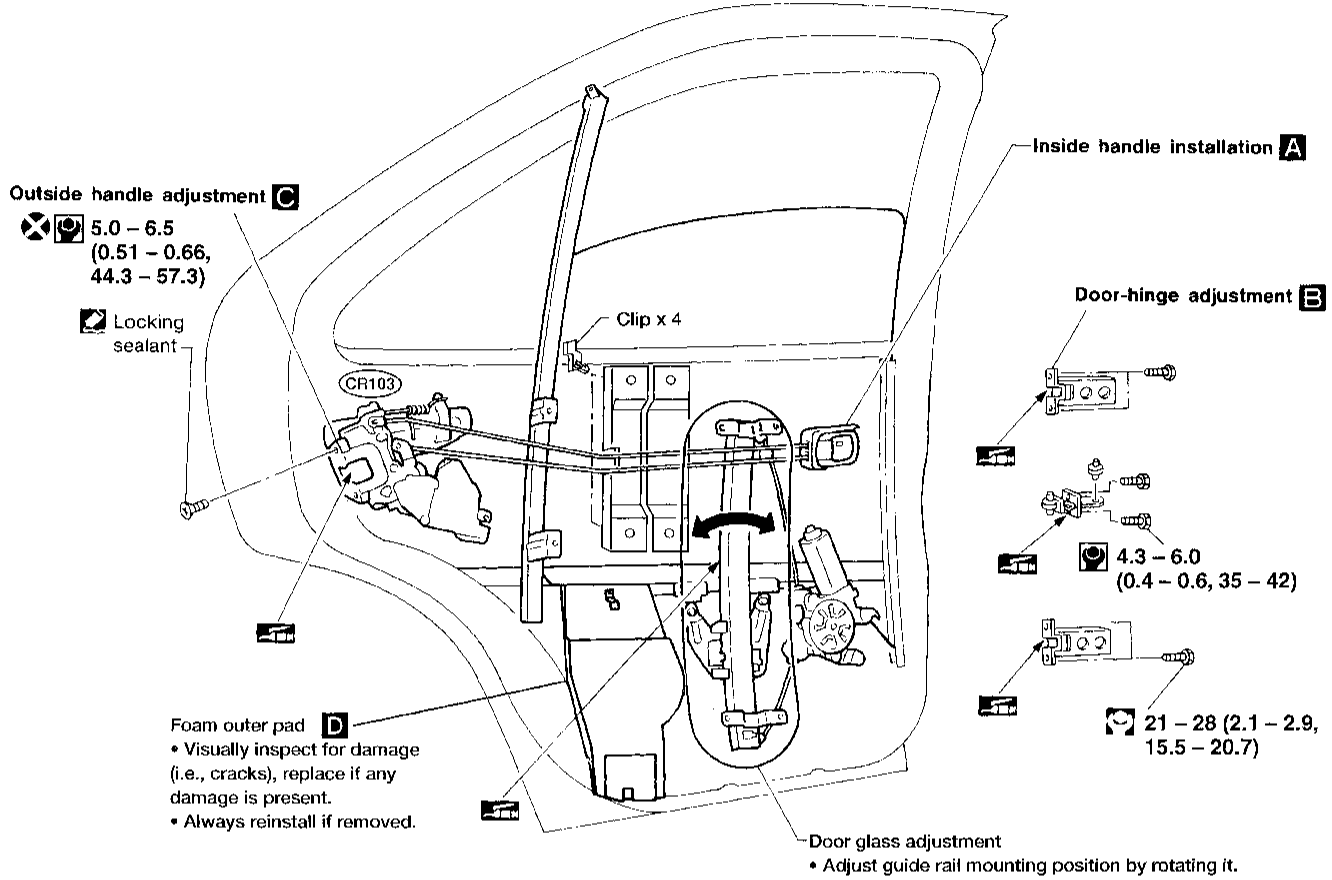

: N•m (kg-m, ft-lb)
 : N•m (kg-m, in-lb)

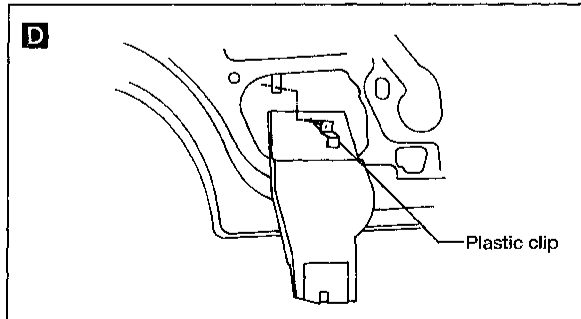
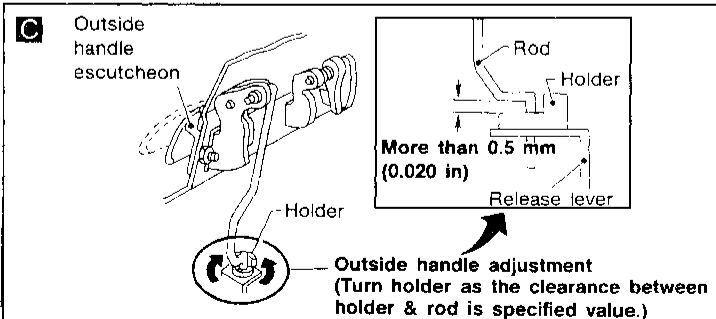
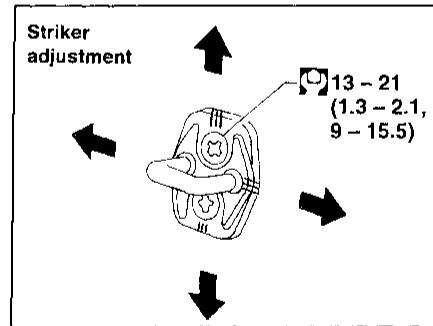
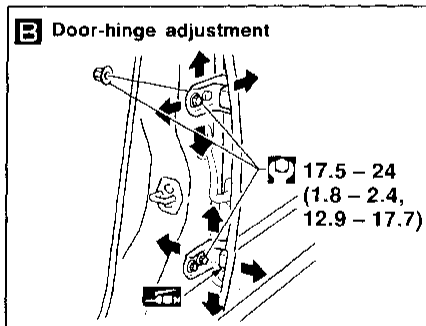
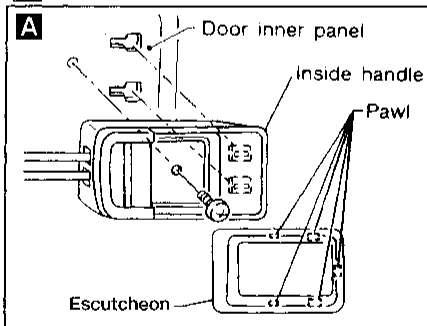

ABT285

INSTRUMENT PANEL

CAUTION:

- Disconnect both terminals from battery in advance.
- Disconnect air bag module connectors in advance.
- Be careful not to scratch pad and other parts.

REMOVAL — Instrument panel assembly

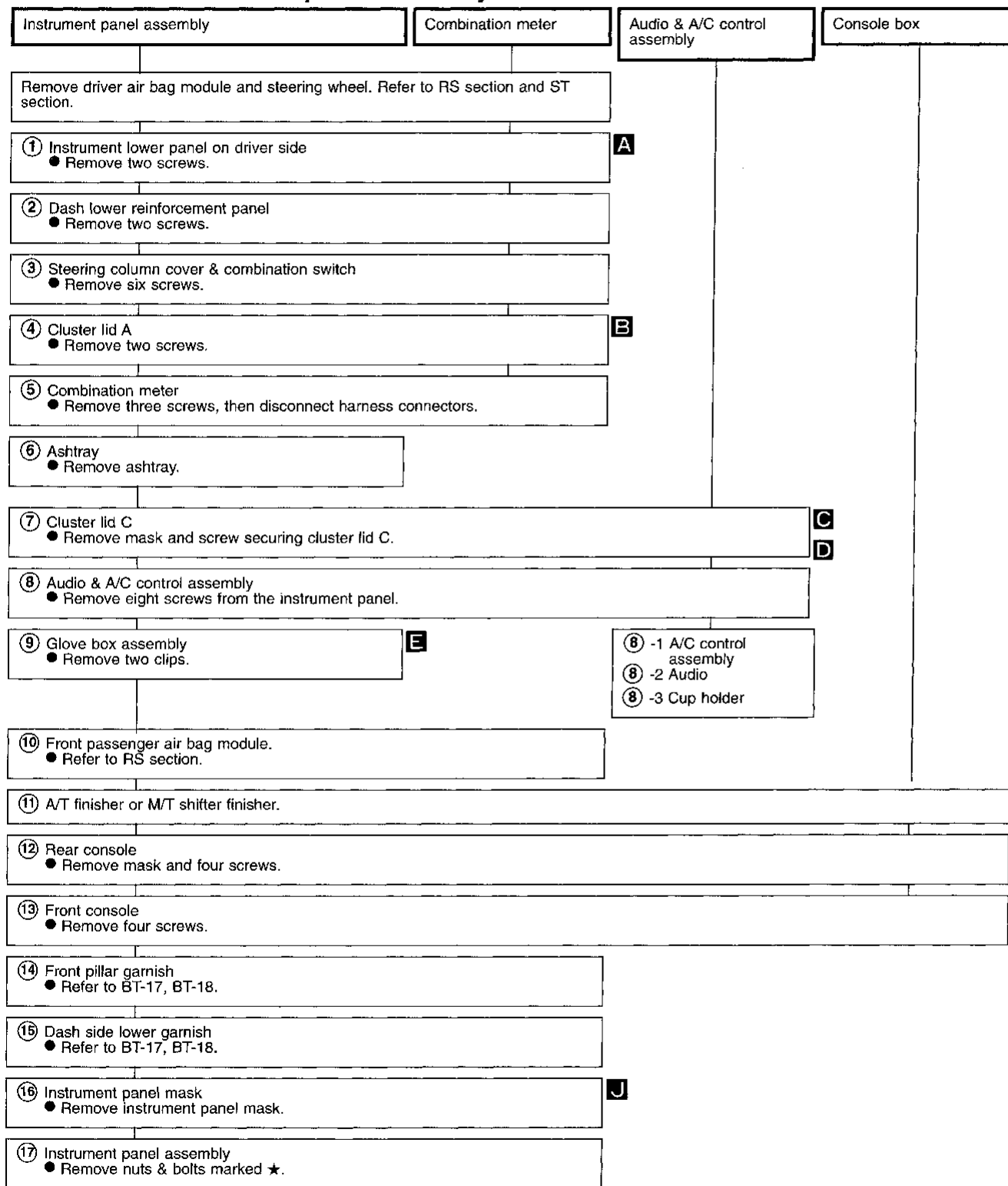

GI

MA

EM

LC

EC

FE

CL

MT

AT

FA

RA

BR

ST

RS

BT

HA

EL

IDX

INSTRUMENT PANEL

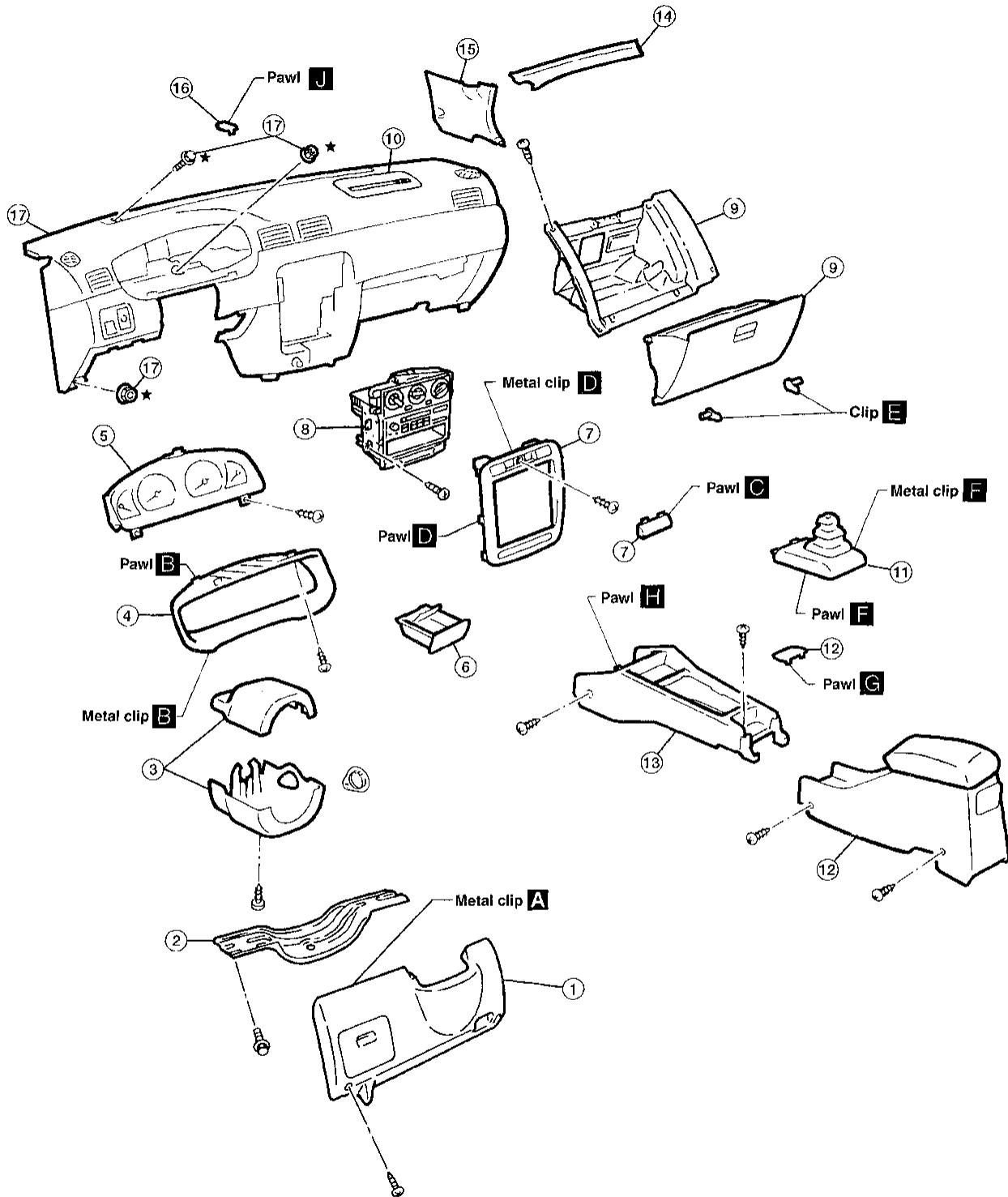

★ : Instrument panel assembly mounting bolts and nuts.

INSTRUMENT PANEL

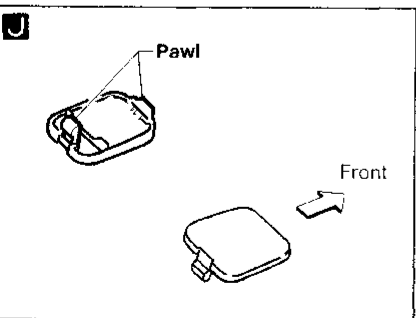
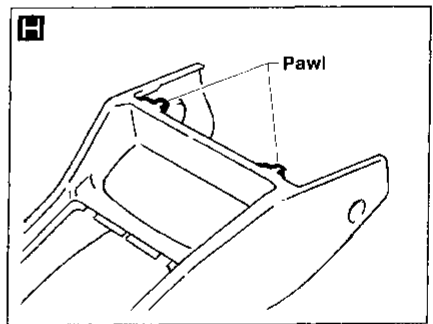
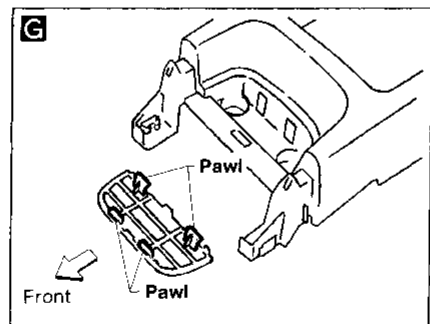
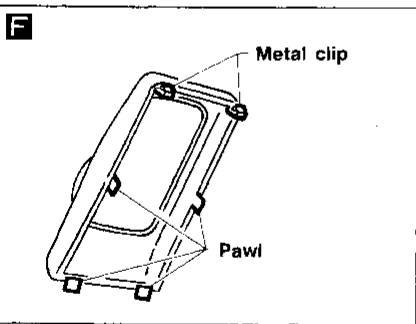
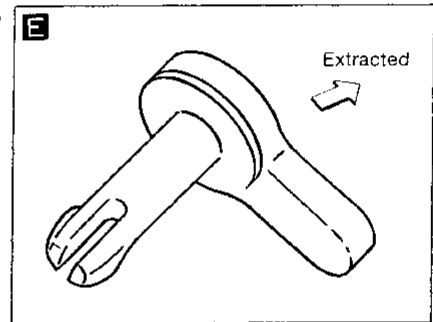
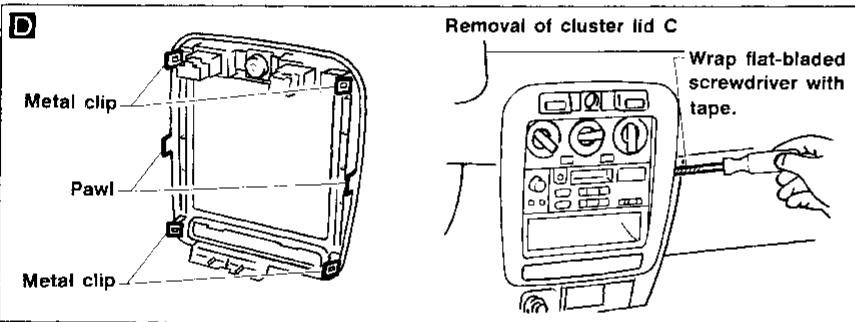
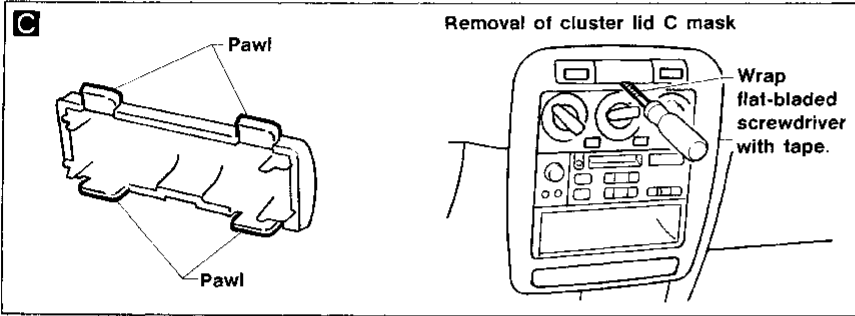
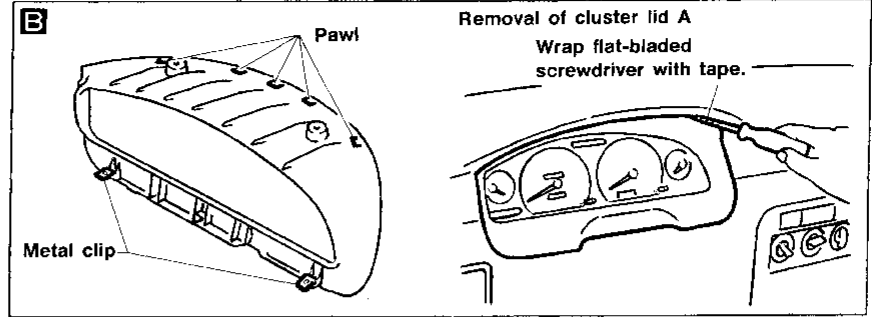
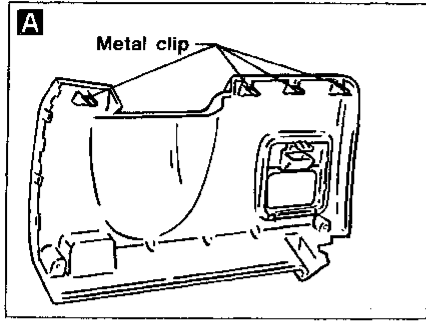

GI

MA

EM

LC

EC

FE

CL

MT

AT

FA

RA

BR

ST

RS

BT

HA

EL

IDX

Side and Floor Trim

CAUTION:

Wrap the tip of flat-bladed screwdriver with a cloth when removing metal clips from garnishes.

REMOVAL — Body side trim

Remove A/T finisher or M/T shift lever boot.

Remove front console and rear console. Refer to BT-13.

Remove front and rear seats.

- ① Remove kick plates.
- ② Remove dash side lower garnish. **A**
- ③ Remove body side welts.
- ④ Remove front pillar garnish. **B**
Remove front seat belt floor anchor bolt.
Remove rear seat belt floor anchor bolt.
- ⑤ Remove rear side finisher (for coupe).
Remove front seat belt pillar anchor cover and anchor bolt (for coupe). Refer to RS-4.
Remove center pillar lower garnish (for sedan).
Remove adjuster cover and pillar anchor bolt (for sedan). Refer to RS-5.
- ⑥ Remove center pillar upper garnish (for sedan). **C**
- ⑦ Remove rear pillar finisher (for coupe). **D**
Remove rear pillar garnish (for sedan). **E**
- ⑧ Remove parcel shelf.
- ⑨ Remove welt.
- ⑩ Remove rear seat back finishers. **F**
- ⑪ Remove floor carpet.

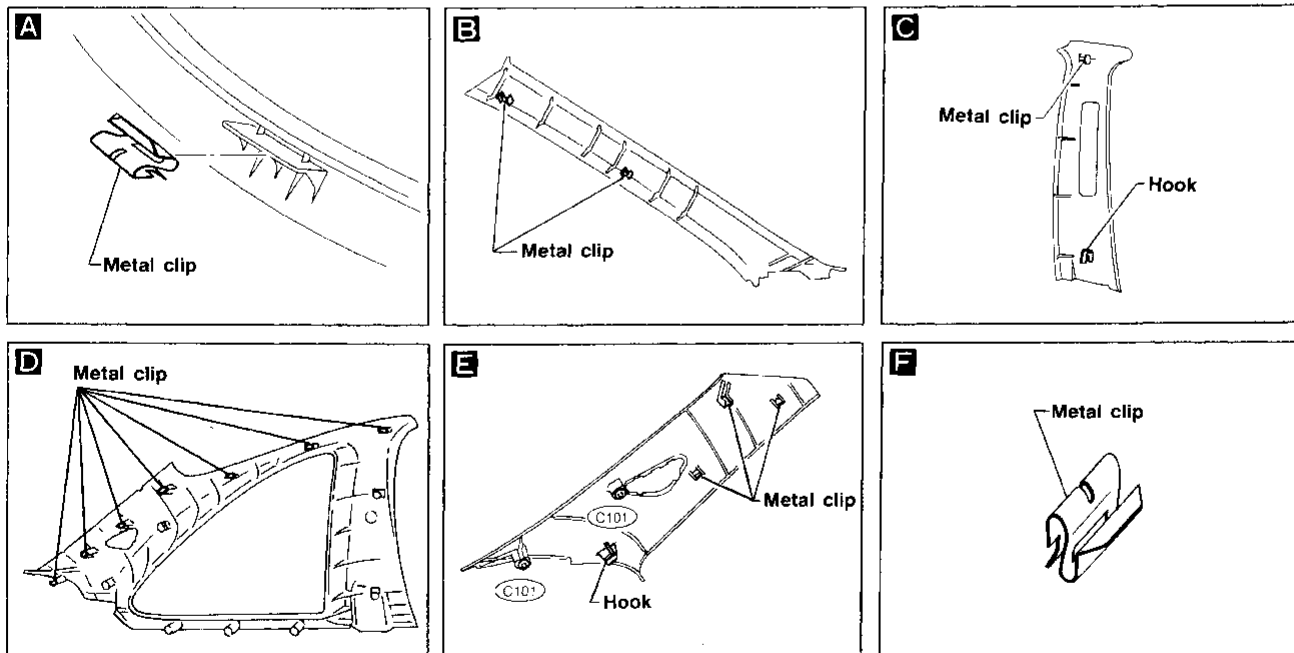

ABT036

INTERIOR TRIM

Side and Floor Trim (Cont'd)

Coupe

SEC. 749-769-799

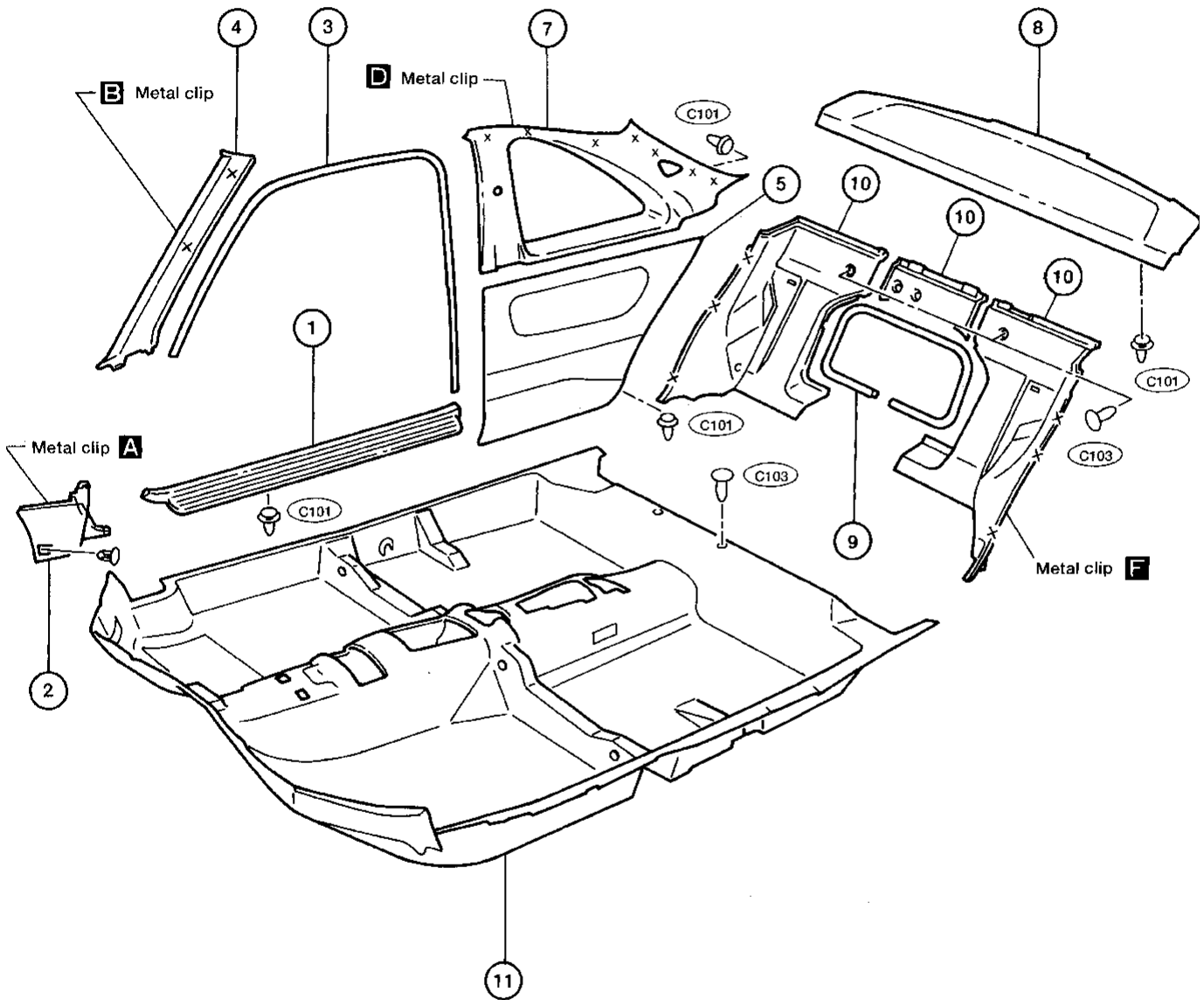

GI
MA
EM
LC
EC
FE
CL
MT
AT
FA
RA
BR
ST
RS
BT
HA
EL
IDX

X: Metal clips

ABT020

BT-17

1091

INTERIOR TRIM

Side and Floor Trim (Cont'd)

Sedan

SEC. 749-769-799

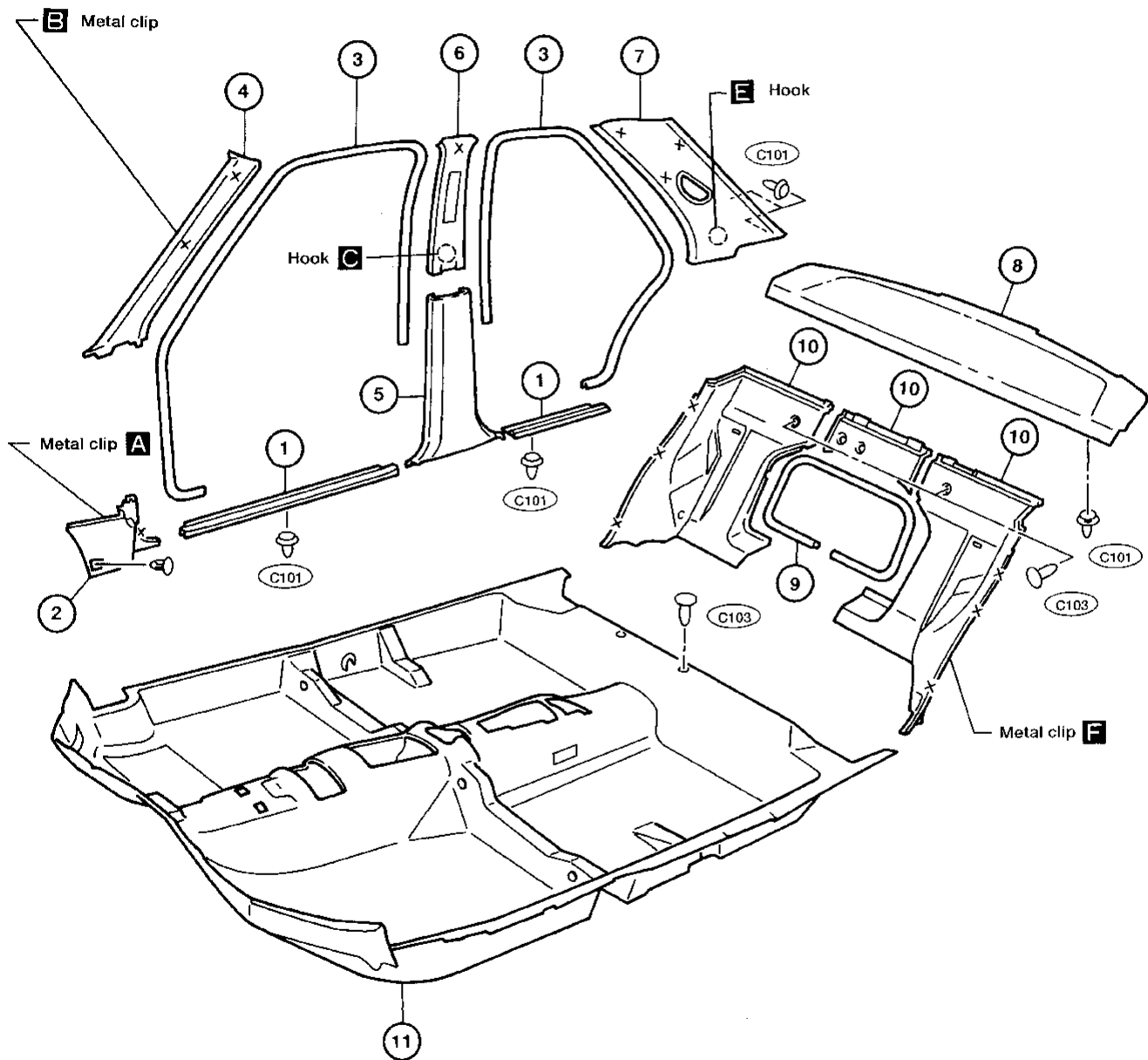

X: Metal clips

ABT024

INTERIOR TRIM

Door Trim

CAUTION:

Wrap the tip of a flat-bladed screwdriver with a cloth when prying pawls from door trim.

REMOVAL

- ① Remove inside handle escutcheon. **A**
- ② Remove power window switch(es), then disconnect the connector(s) (models equipped with power window). **B**
- **Do not lift the front of the power window switch assembly.**
Remove window regulator handle (models without power window). **C**
- ③ Remove screws and clips **(C103)**.
- ④ Lift out door trim.

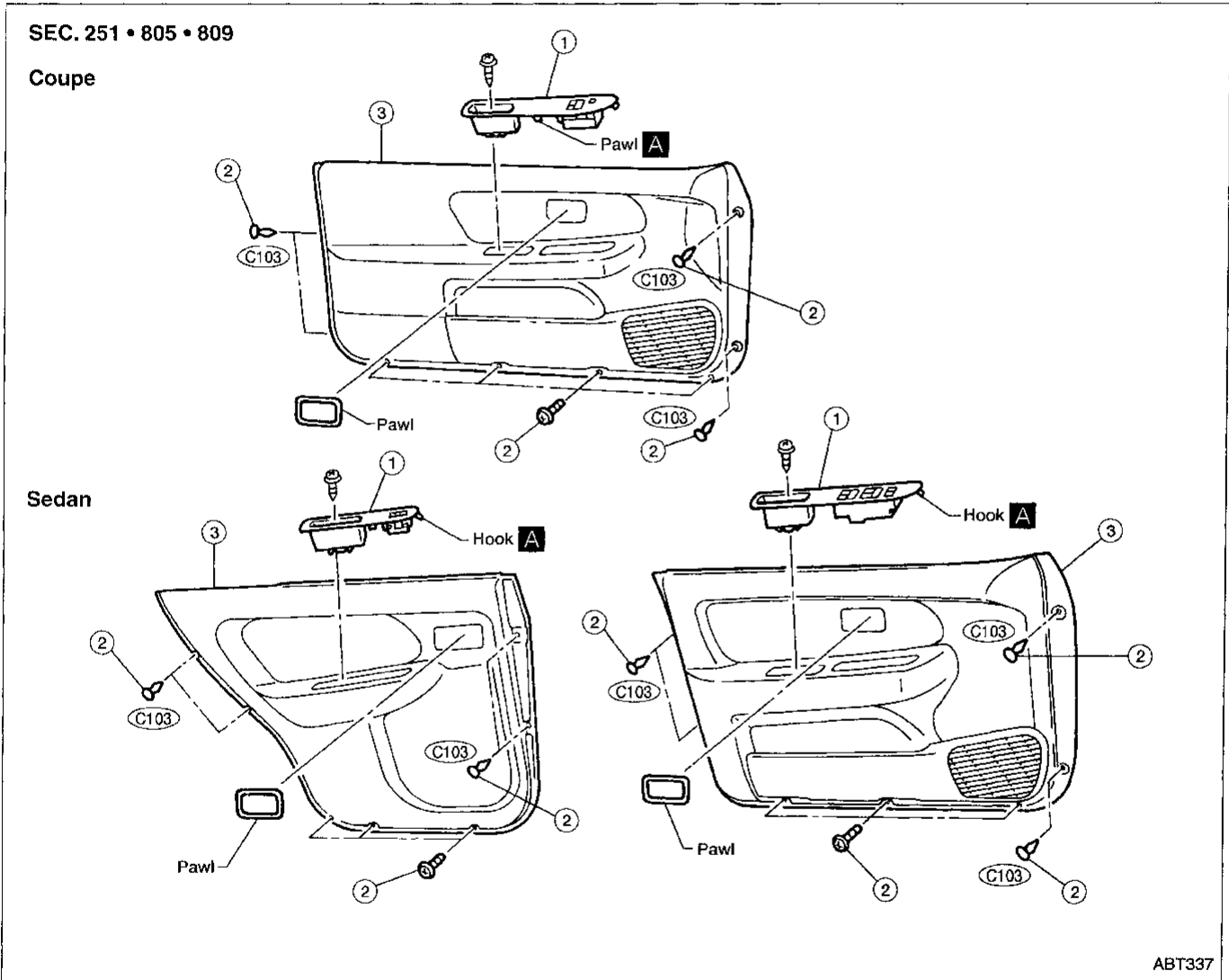

GI

MA

EM

LC

EC

FE

CL

MT

AT

FA

RA

BR

ST

RS

BT

HA

EL

IDX

INTERIOR TRIM

Door Trim (Cont'd)

A

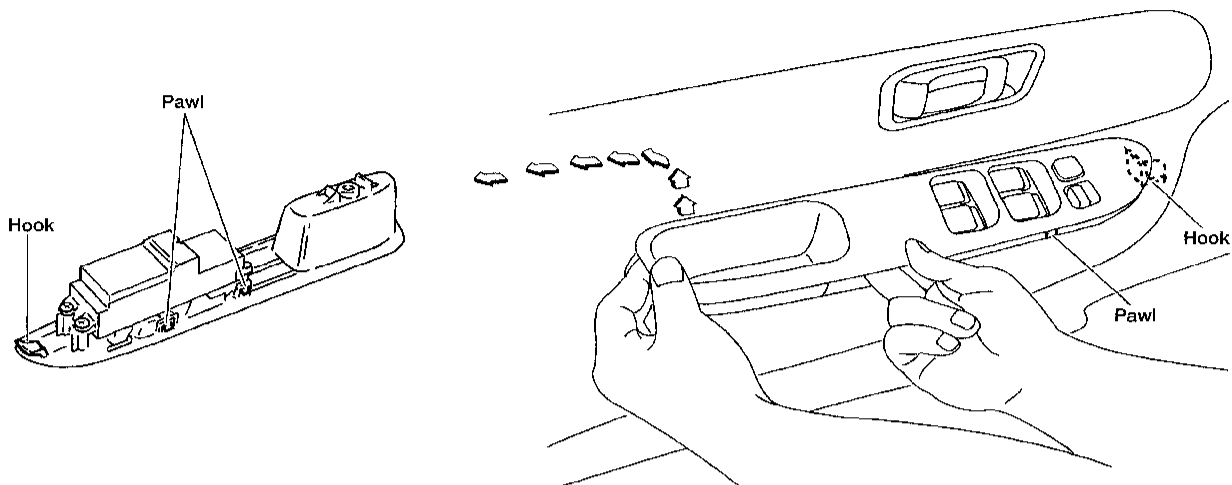

Lift the rear of the switch assembly and release pawls from door trim.
CAUTION: Do not lift switch assembly more than necessary to clear the door pull recess.
Slide the switch assembly rearward until the hook clears the edge of the door trim opening.

B Manual window regulator handle

Removal

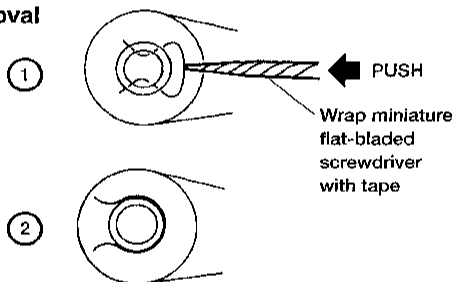

Push the regulator handle clip with a screwdriver, being careful not to scratch handle or door trim. Then remove the regulator handle from the regulator shaft.

Installation

Before installing, position the regulator handle clip as shown in figure 1.

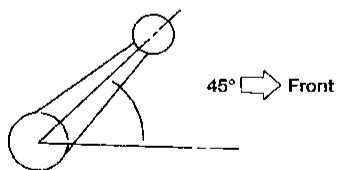

Push the regulator handle onto the regulator shaft. Install the regulator handle in place as shown in the figure with the window completely closed.

INTERIOR TRIM

Roof Trim

CAUTION:

- Disconnect both terminals from battery in advance.

REMOVAL

Remove driver air bag module and steering wheel. Refer to RS and ST section.

Fully tilt front right and left seatbacks backward.

Remove front pillar garnish. Refer to BT-16.

Remove rear pillar finisher (for coupe). Refer to BT-16.

Remove center pillar upper garnish and rear pillar garnish (for sedan). Refer to BT-16.

- ① Remove sun visors.
- ② Remove interior lamp.
- ③ Remove assist grips (if equipped) or coat hooks.
- ④ Remove sunroof welt.
- ⑤ Remove sunroof switch.
- ⑥ Remove clips attached to roof.
- ⑦ Take out headlining from the front passenger door.

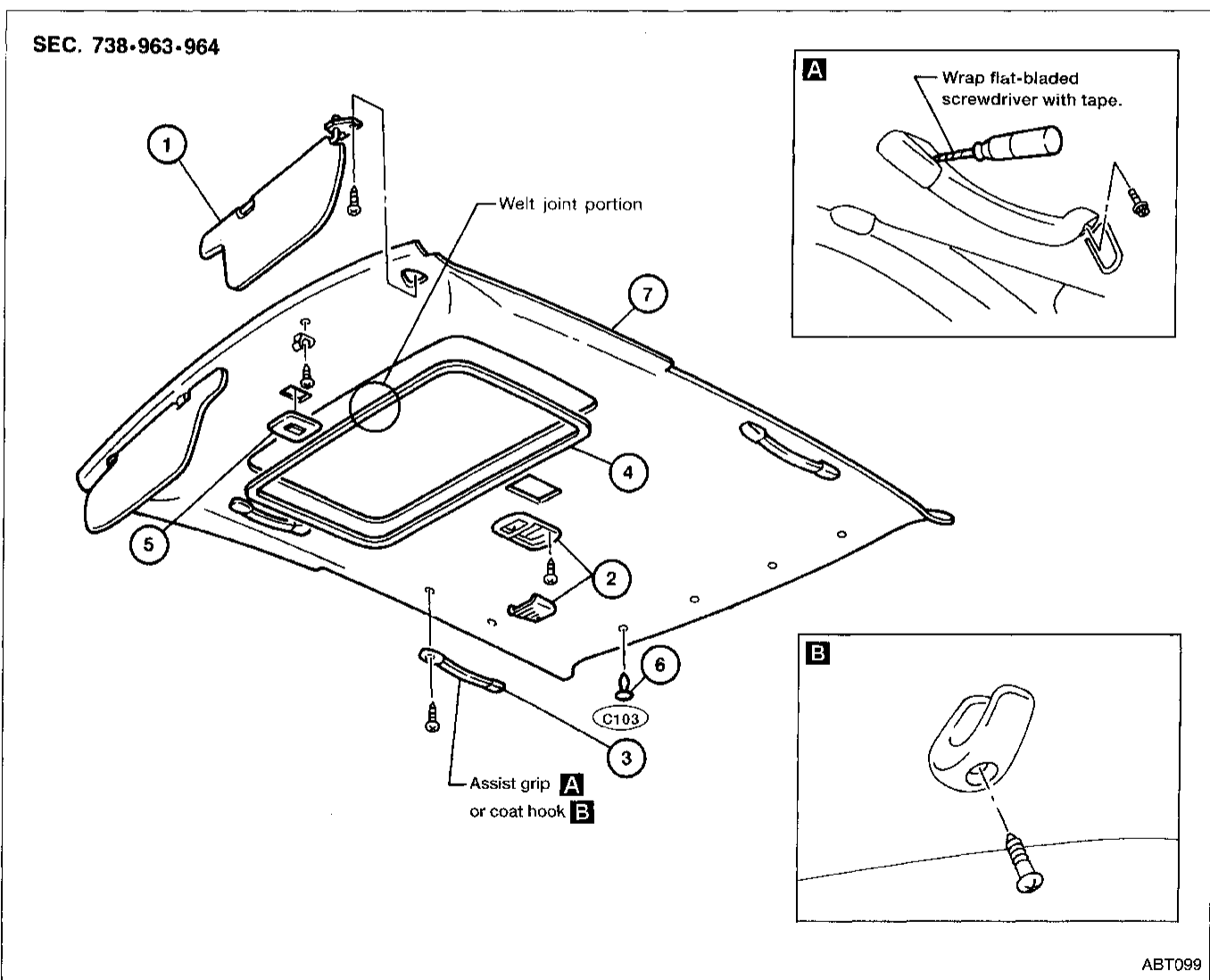

INTERIOR TRIM

Trunk Room Trim

SEC. 849

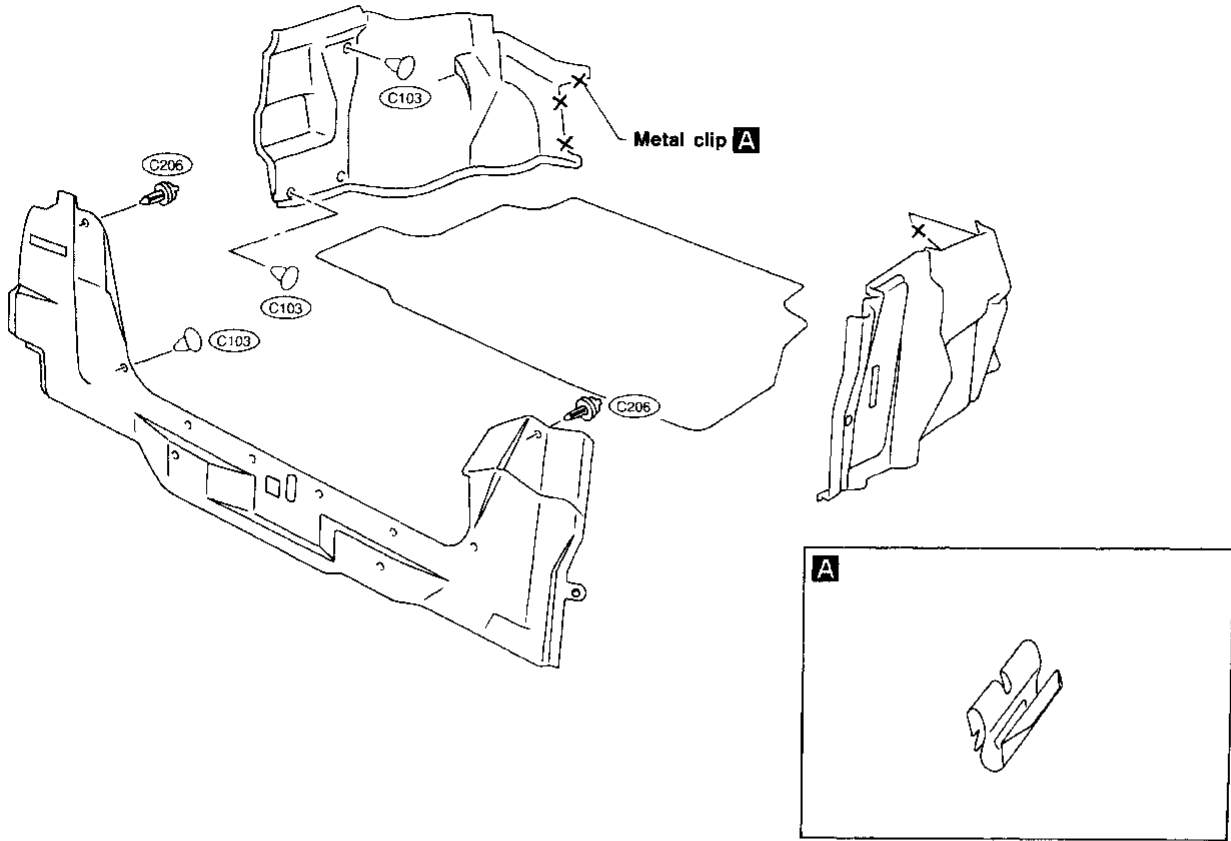

MBT009A

EXTERIOR

Coupe

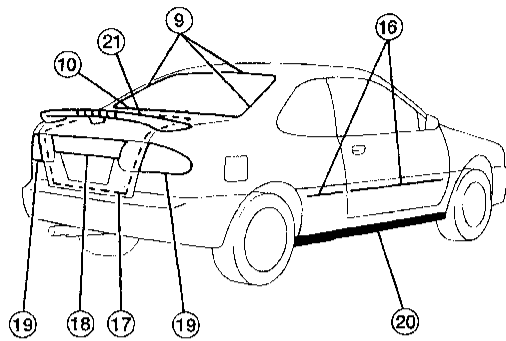
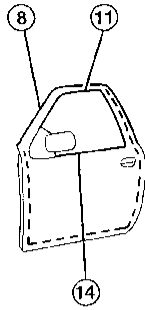
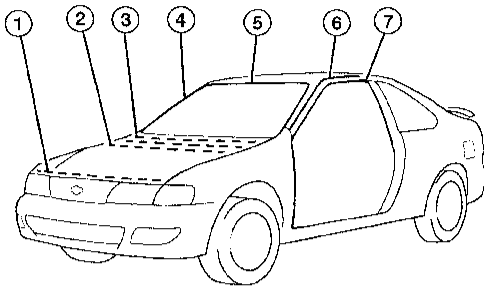

Sedan

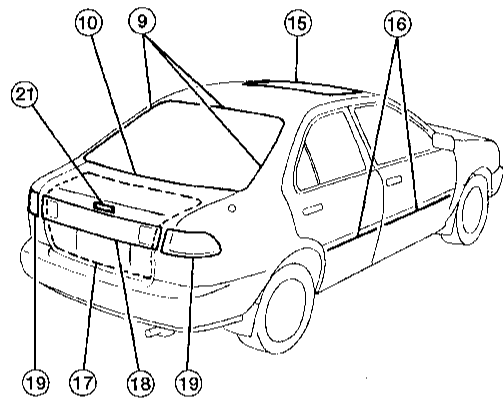
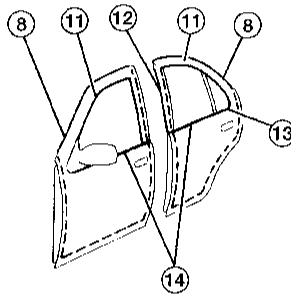
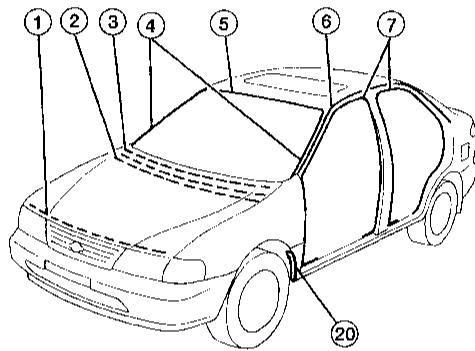

ABT281

① Hood front seal

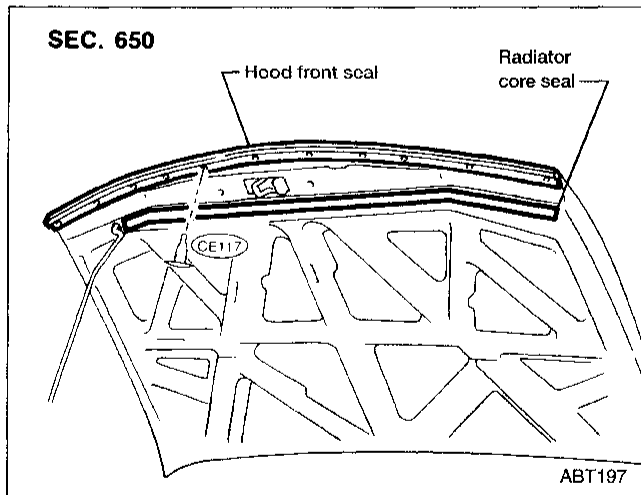

② ③ Cowl top seal and cowl top grille

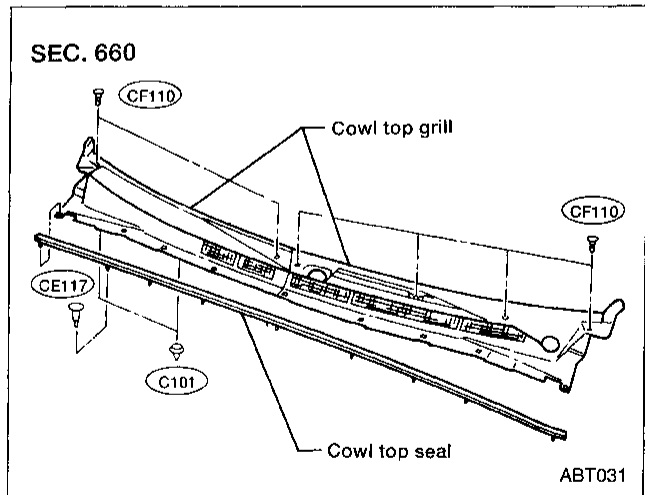

④ Windshield side molding

Mounted with screws.

GI
MA
EM
LC
EC
FE
CL
MT
AT
FA
RA
BR
ST
RS
BT
HA
EL
IDX

⑤ Windshield upper molding

SEC. 720

1. Cut off urethane adhesive at glass end.
2. Remove old urethane adhesive from panel surface.
3. Set molding fastener and apply primer to body panel, and apply urethane adhesive to body.

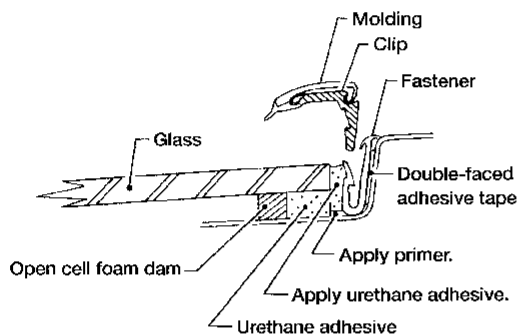
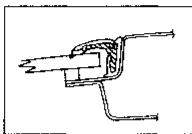

4. Install molding by aligning the molding mark located on center with vehicle center. Be sure to install tightly so that there is no gap around the corner.

ABT286

⑥ Drip weatherstrip

SEC. 720-767

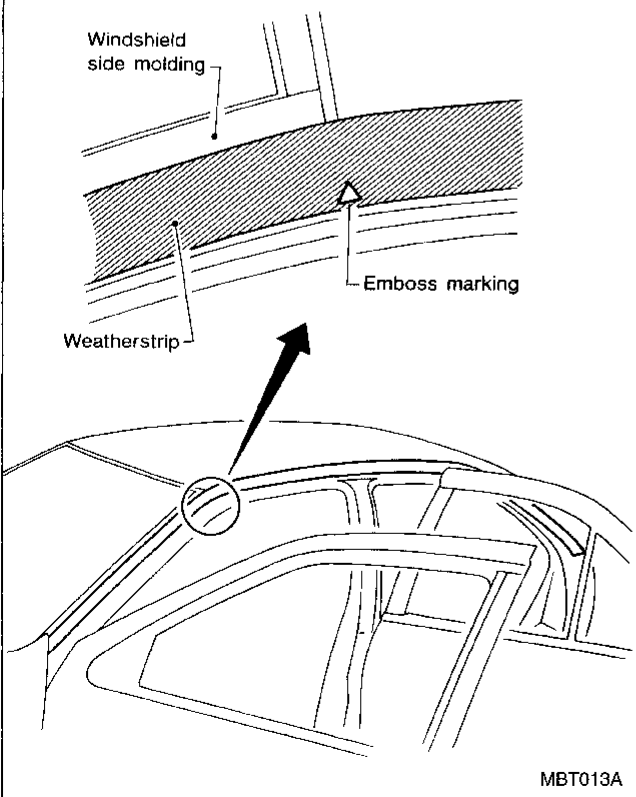

MBT013A

⑦ Body side welt

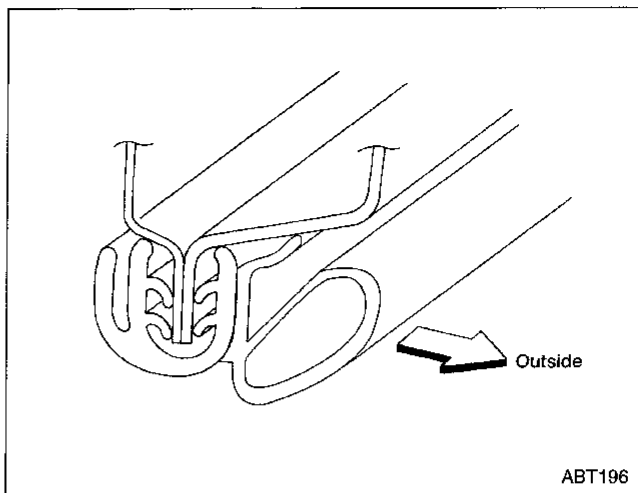

ABT196

⑧ Door weatherstrip

SEC. 800-820

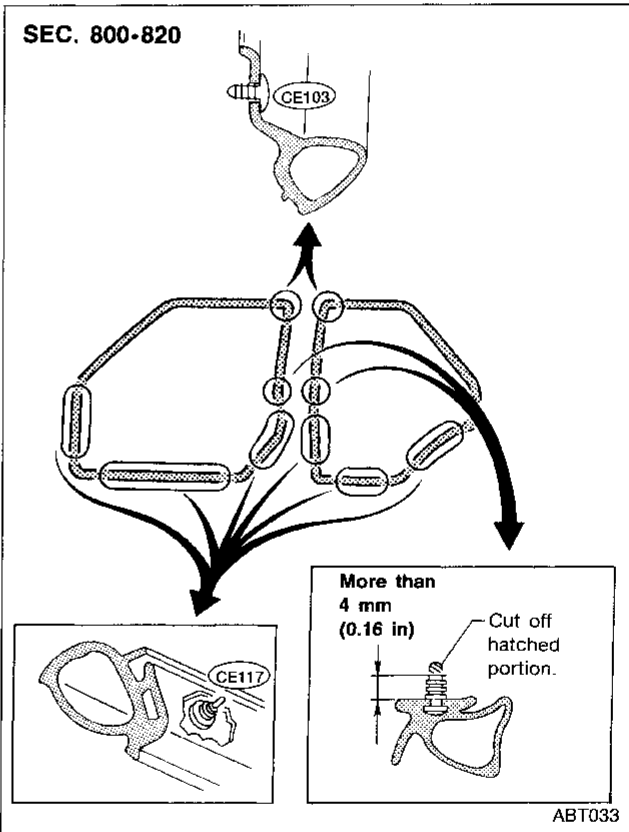

ABT033

⑨ Rear window upper molding and side molding

Basically the same as windshield upper molding. Refer to ⑤ Windshield upper molding.

⑩ Rear window lower molding

Mounted with screws.

11 Door sash molding

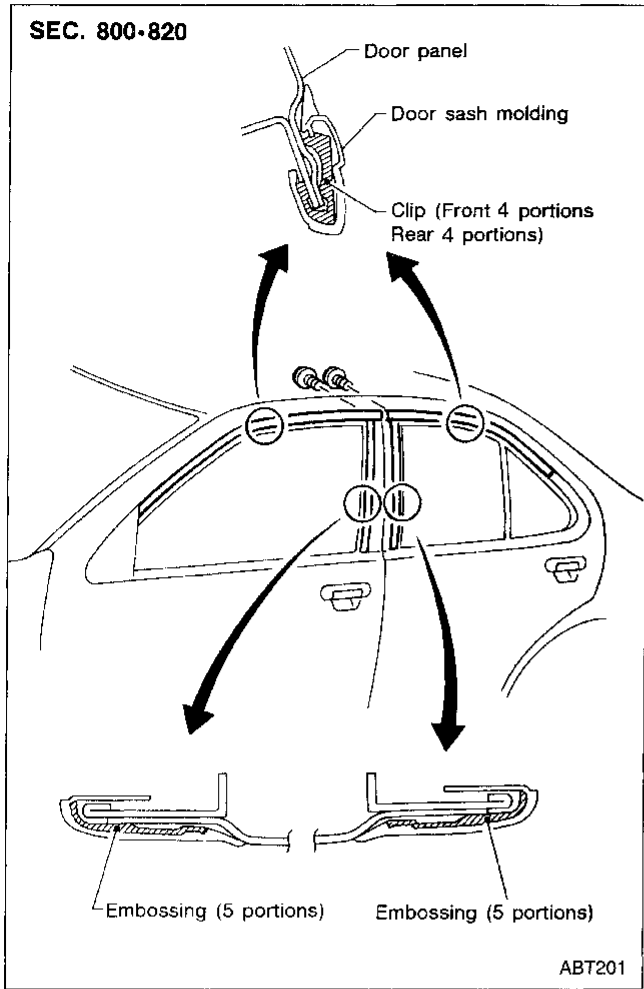

13 Rear door corner molding

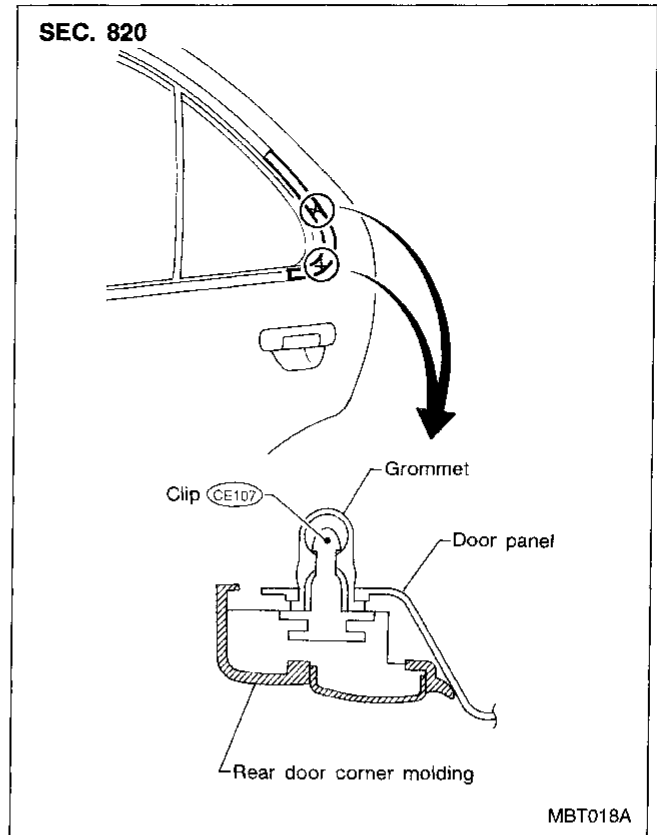

12 Rear door parting seal

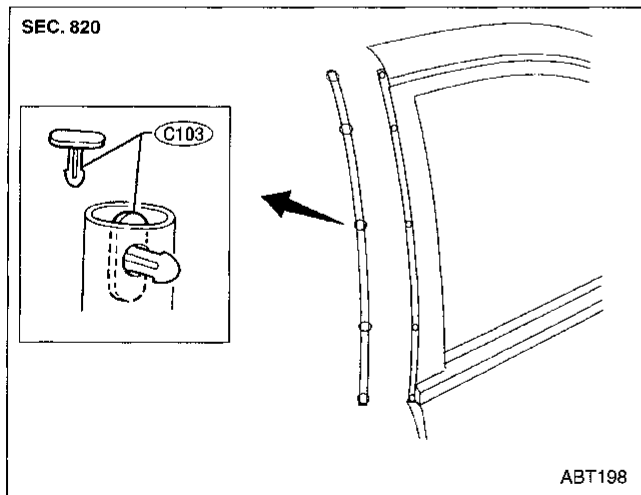

14 Door outside molding

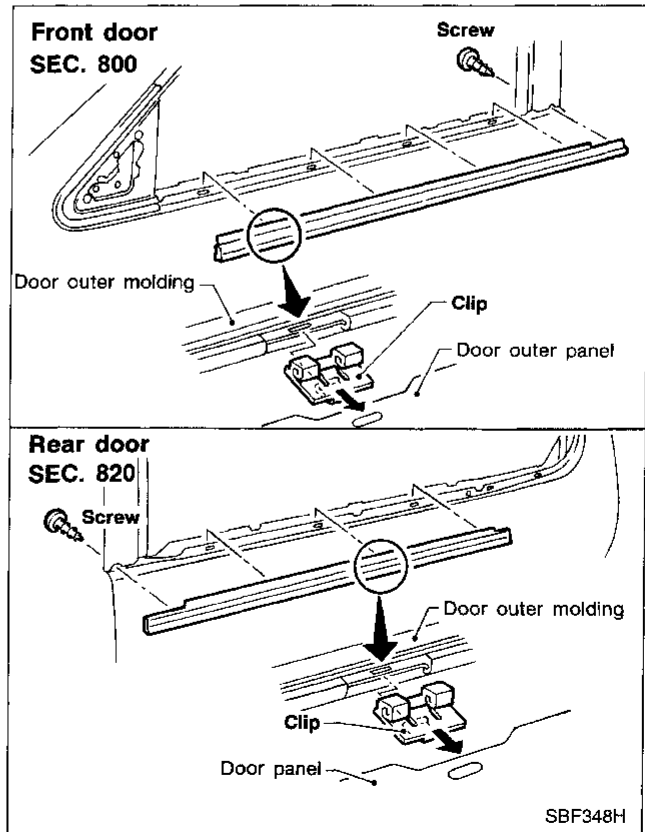

GI
MA
EM
LC
EC
FE
CL
MT
AT
FA
RA
BR
ST
RS
BT
HA
EL
IDX

15 Sunroof lid weatherstrip

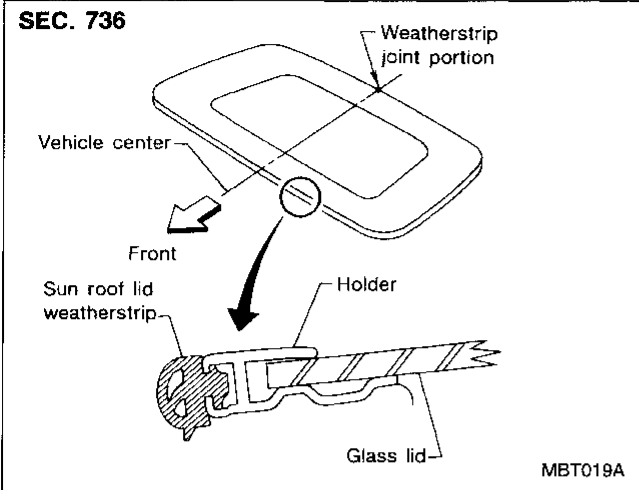

17 Trunk lid weatherstrip

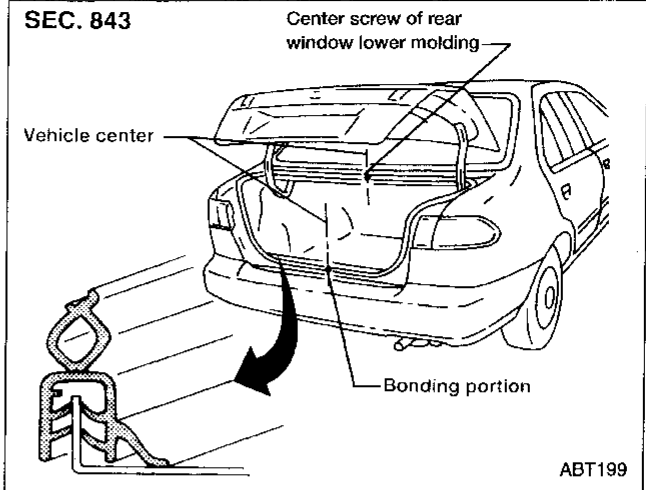

16 Side guard molding

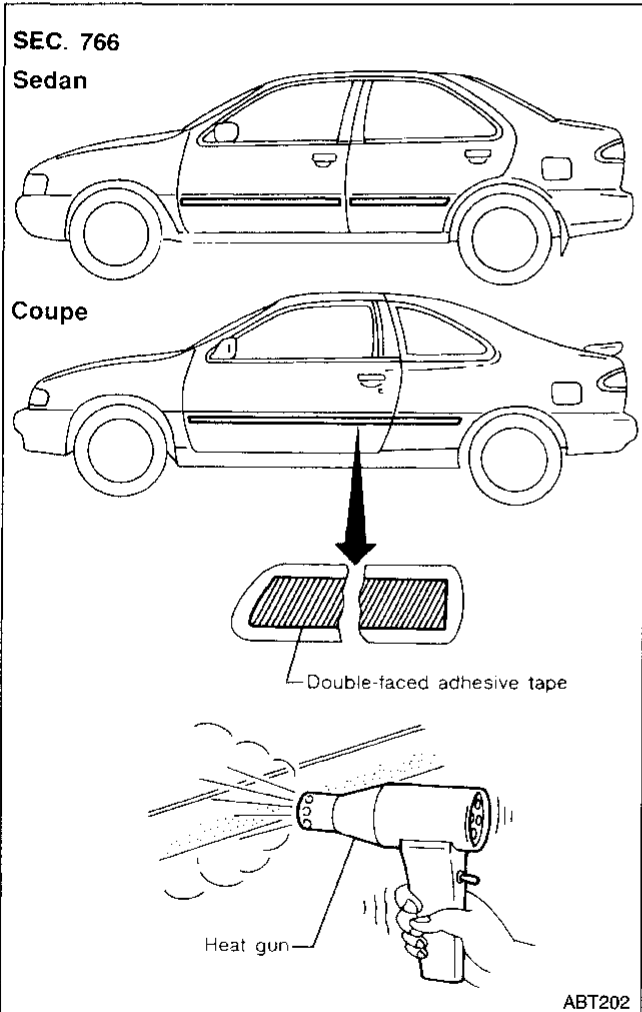

18 Trunk lid finisher

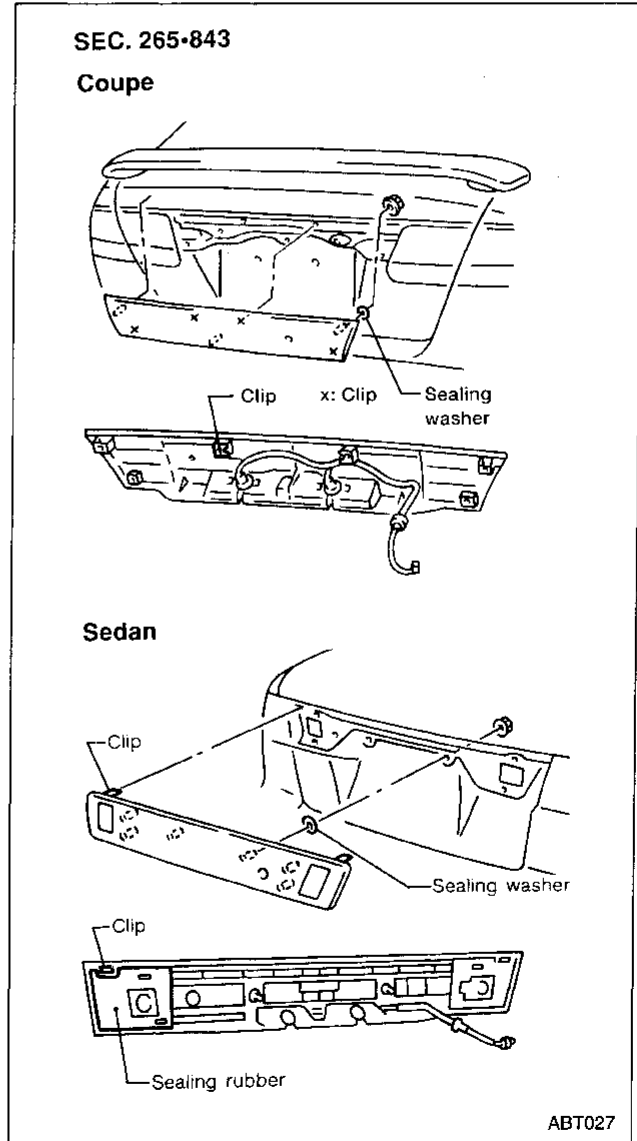

- With a vehicle coated with Hard Clear Coat, use double-faced 3M adhesive tape Product No. 4210 or equivalent, after priming with 3M primer Product No. N-200 or C-100 or equivalent.

19 Rear combination lamp

Rear combination lamps are installed with nuts and butyl sealant.

SEC. 265

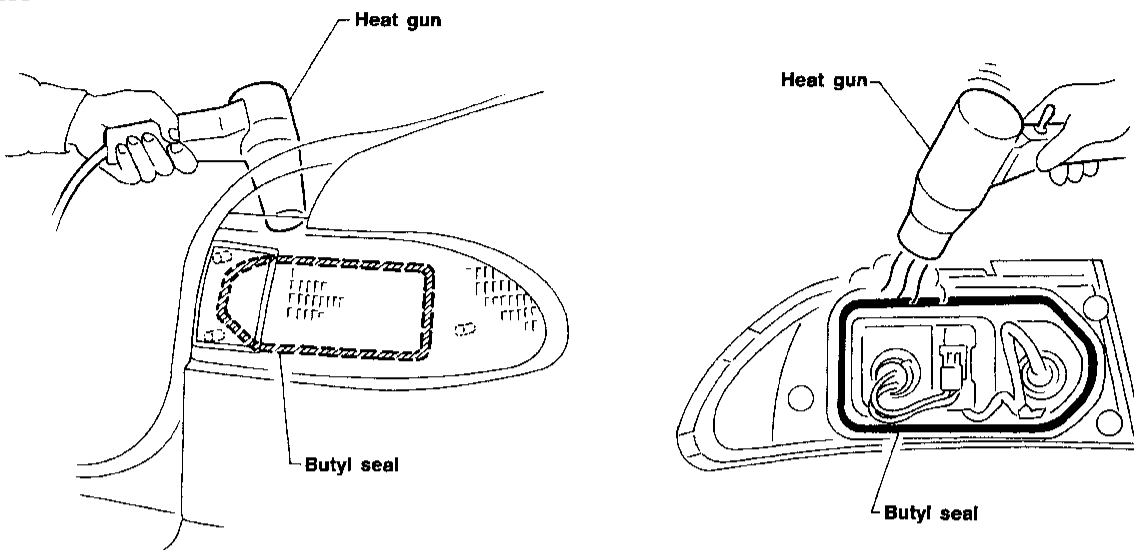

- Apply butyl seal evenly as it tends to become thin in the corners.
- Warm up lamp assembly area to a temperature of a little below 60°C (140°F).

MBT021A

20 Fender and center mudguard

SEC. 767

Sedan

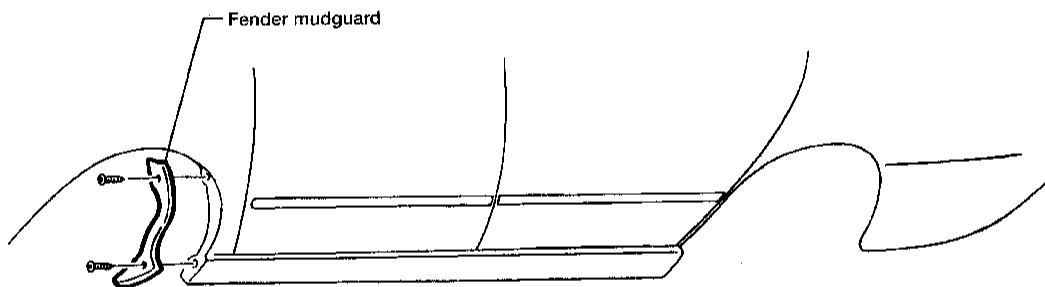

Coupe

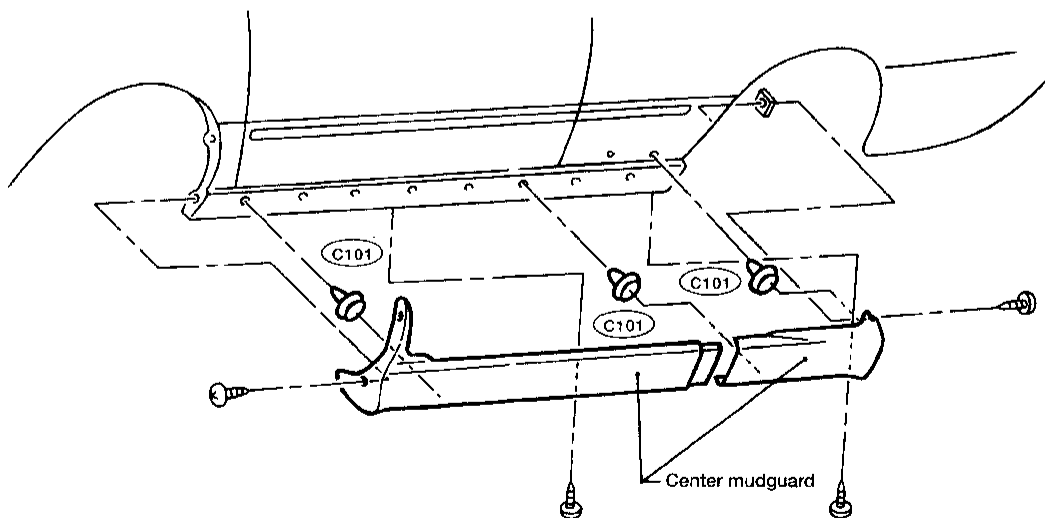

ABT040

GI
MA
EM
LC
EC
FE
CL
MT
AT
FA
RA
BR
ST
RS
BT
HA
EL
IDX

EXTERIOR

⑳ Rear air spoiler and high-mounted stop lamp

- When installing, make sure that there are no gaps or waves at ends of air spoiler.
- Before installing spoiler, clean and remove oil from surface where spoiler will be mounted.

SEC. 960

Sedan

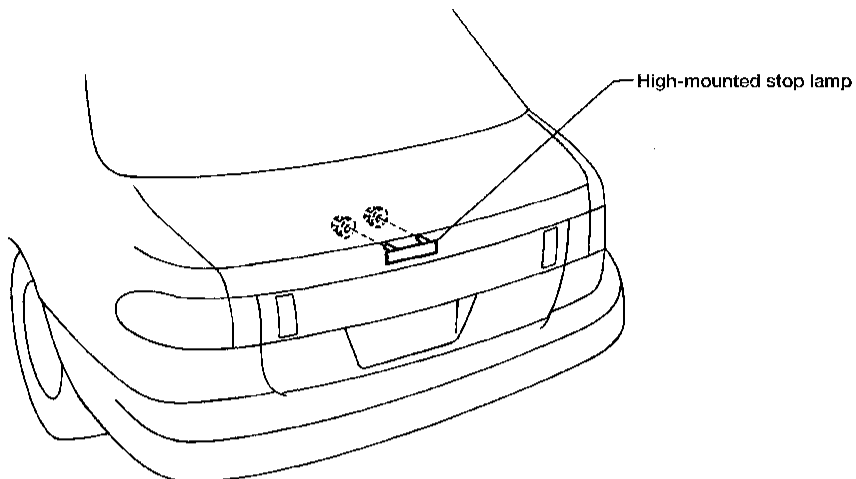

Coupe

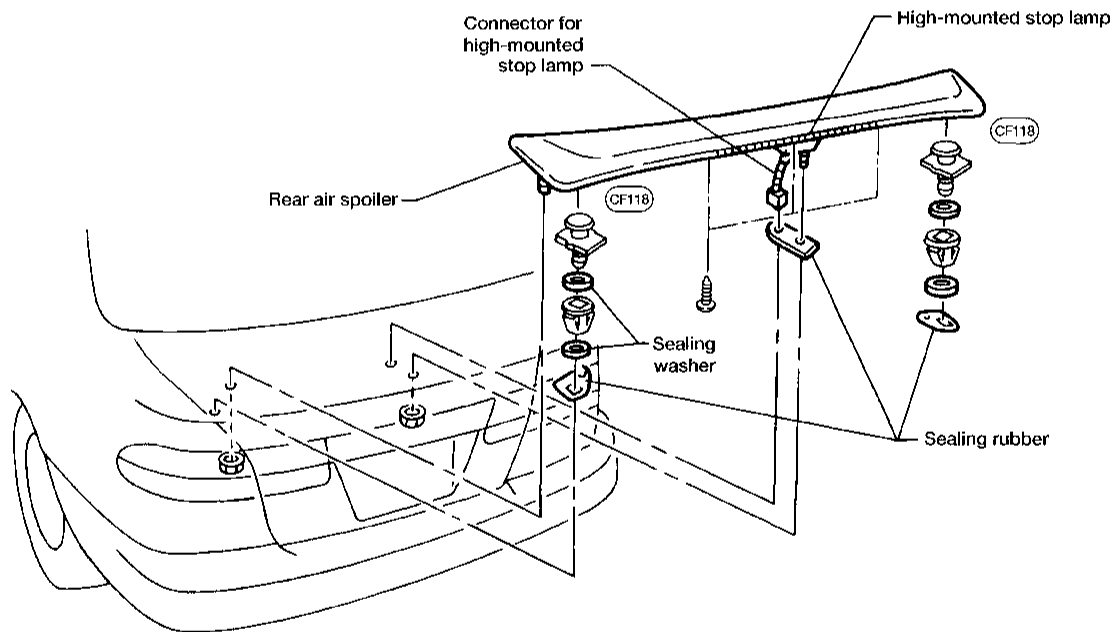

ABT282

SEAT

When removing or installing the seat trim, handle it carefully to keep dirt out and avoid damage.

Front Seat

SEC. 870

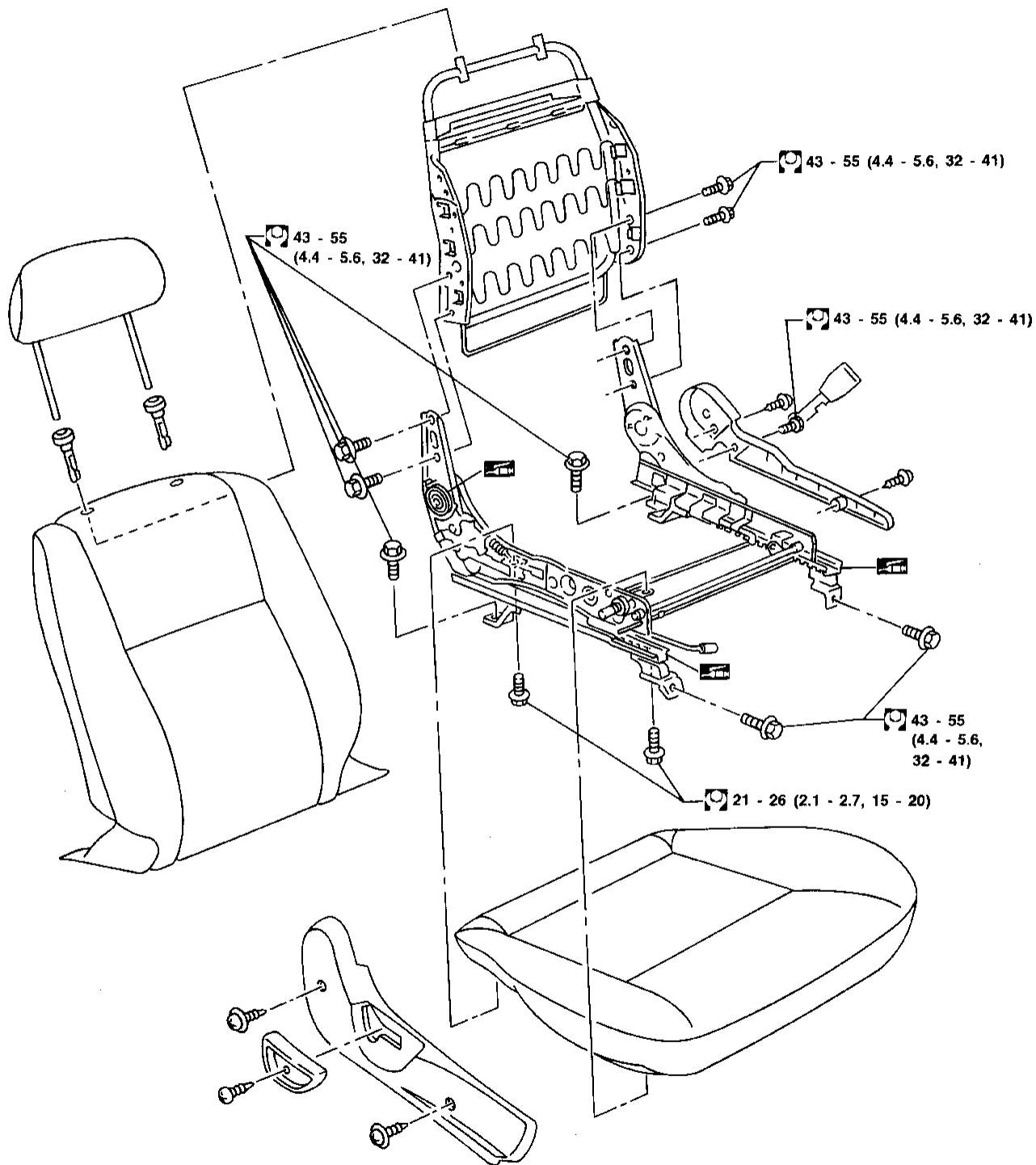

GI

MA

EM

LC

EC

FE

CL

MT

AT

FA

RA

BR

ST

RS

BT

HA

EL

IDX

N·m (kg-m, ft-lb)

ABT028

BT-29

1103

SEAT

Rear Seat

SEC. 880

Type 1 (Fixed type)

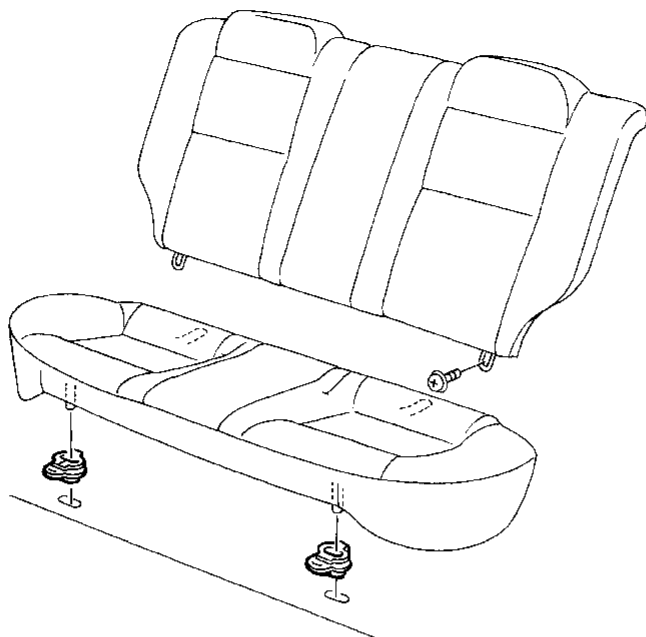

Type 2 (Folding type)

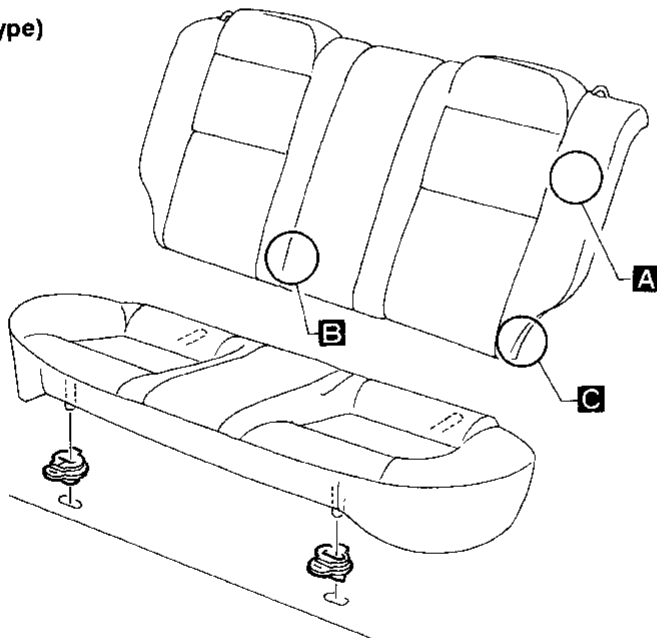

 : N·m (kg·m, ft·lb)

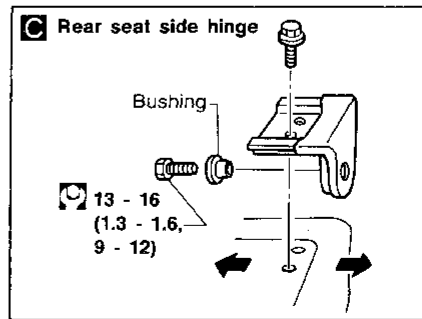
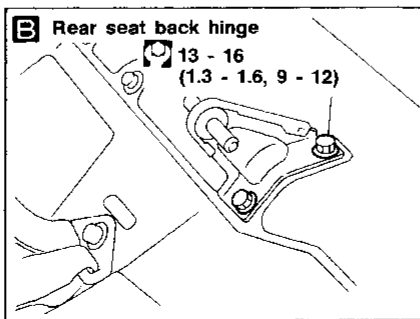
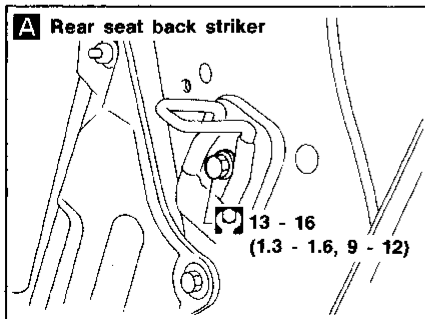

SUNROOF

SEC. 736

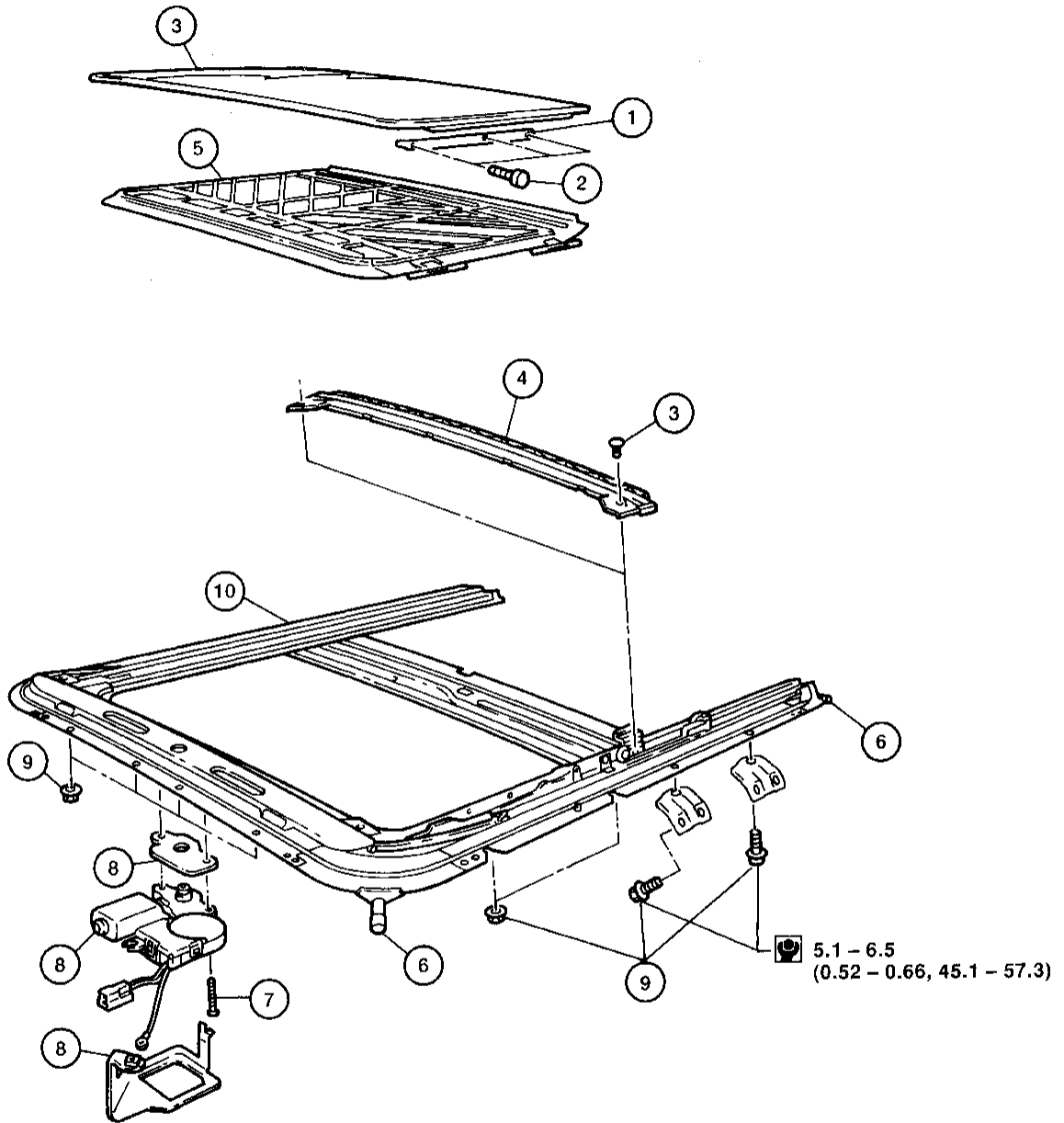

GI
MA
EM
LC
EC
FE
CL
MT
AT
FA
RA
BR
ST
RS
BT
HA
EL
IDX

: N·m (kg·m, in·lb)

ABT097

BT-31

Removal

- After any repair, check sunroof operation and lid alignment.
- Handle finisher plate and glass lid with care so not to cause damage.
- To ease installation, mark each point before removal.

CAUTION:

- **Always work with a helper.**

SUNROOF LID ASSEMBLY

Open sunroof shade.

Close sunroof lid.

- ① Remove side trim.
- ② Remove the six bolts securing sunroof lid assembly to sunroof assembly.

SHADE ASSEMBLY

- ③ After removing sunroof lid assembly, remove two screws securing drain channel.
- ④ Remove drain channel.
- ⑤ Remove shade assembly.

SUNROOF ASSEMBLY

Remove headlining. Refer to BT-21.

Disconnect interior lamp harness.

- ⑥ Disconnect front and rear drain hoses.
Remove assist grip brackets.
- ⑦ Remove screws securing sunroof motor to sunroof assembly.
- ⑧ Remove sunroof motor and bracket.
- ⑨ Remove nuts and bolts securing sunroof assembly to roof.
- ⑩ Remove sunroof assembly.

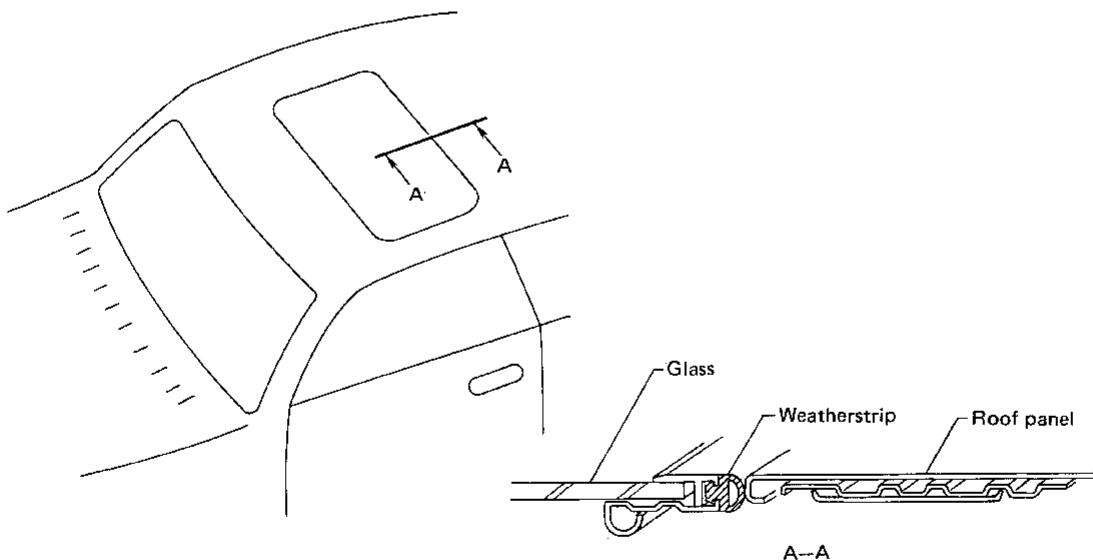

SBF918F

SUNROOF

Trouble Diagnoses

DIAGNOSTIC TABLE

NOTE: For "Wiring Diagram", refer to "ELECTRIC SUNROOF" in EL section.

		Check items (Components)				
		Wind deflector	Drain hoses	Weatherstrip	Link and wire assembly	Adjustment
	Reference page	BT-33	BT-34	BT-34	BT-34	BT-35
Symptom	Excessive wind noise	1		3		2
	Water leaks		2	3		1
	Sunroof rattles		4	2	3	1
	Excessive operation noise			2	3	1

The numbers in this table mean checking order.

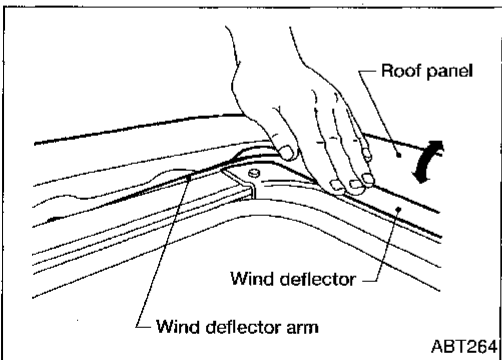
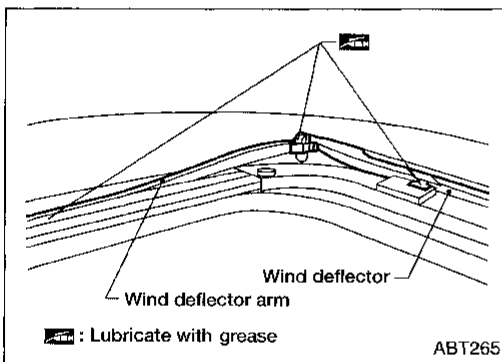

WIND DEFLECTOR

1. Open lid.
2. Check visually for proper installation.
3. Check to ensure a proper amount of grease has been applied to wind deflector connection points; apply if necessary.
4. Check that wind deflector is properly retracted by hand. If it is not, remove and visually check condition. If wind deflector is damaged, replace with new one. If wind deflector is not damaged, re-install properly.

GI

WA

EM

LC

EC

FE

CL

MT

AT

FA

RA

BR

ST

RS

BT

HA

EL

IDX

SUNROOF

Trouble Diagnoses (Cont'd)

DRAIN HOSES

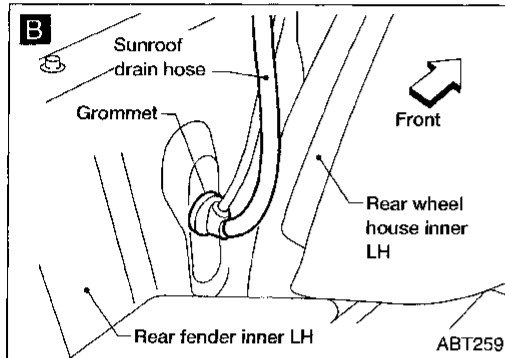
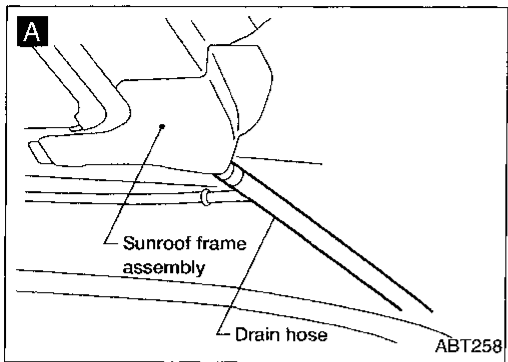

1. Remove headlining to access drain hose connections. Refer to "Roof Trim", "INTERIOR TRIM" (BT-21).
2. Check visually for proper connections, damage or deterioration. **A** (The figure shows only the front side.)

3. If leakage occurs around trunk room, remove trunk room side trim and check connecting area. Check for proper connection, damage. **B**
4. Remove drain hoses and check visually for any damage, cracks, or deterioration.
5. Pour water into drain hoses and find damaged portion.
- If any damaged portion is found at each step, replace the damaged part.

WEATHERSTRIP

- In case of leakage around lid, close lid and pour water over lid to find damaged or gap portion.
- If gap is between weatherstrip and roof panel, perform gap adjustment. Refer to procedure on BT-35.
- If gap is between weatherstrip and lid, or if weatherstrip is flattened, damaged or deteriorated, replace lid assembly. (Weatherstrip is not serviceable.)

LINK AND WIRE ASSEMBLY

NOTE:

Before replacing a suspect part, carefully ensure it is the source of noise being experienced.

1. Check link to determine if coating film has peeled off to such an extent that substrate is visible. Check also to determine if link is the source of noise. If it is, replace it.
2. Visually check to determine if a sufficient amount of petroleum jelly has been applied to wire or rail groove. If not, add petroleum jelly as required.
3. Check wire for any damage or deterioration. If damaged, replace wire.

SUNROOF

Adjustment

Install motor & limit SW assembly and sunroof rail assembly in the following sequence:

1. Arrange equal lengths of link and wire assemblies on both sides of sunroof opening.
2. Connect sunroof connector to sunroof switch and positive (+) power supply.
3. Set lid assembly to fully closed position **A** by operating CLOSE switch and TILT switch.
4. Fit outer side of lid assembly to the surface of roof on body outer panel.
5. Remove motor, and keep CLOSE switch pressed until motor pinion gear reaches the end of its rotating range.
6. Install motor.
7. Check that motor drive gear fits properly in wires.
8. Press TILT-UP switch to check lid assembly for normal tilting.
9. Check sunroof lid assembly for normal operations (tilt-up, tilt-down, open, and close).

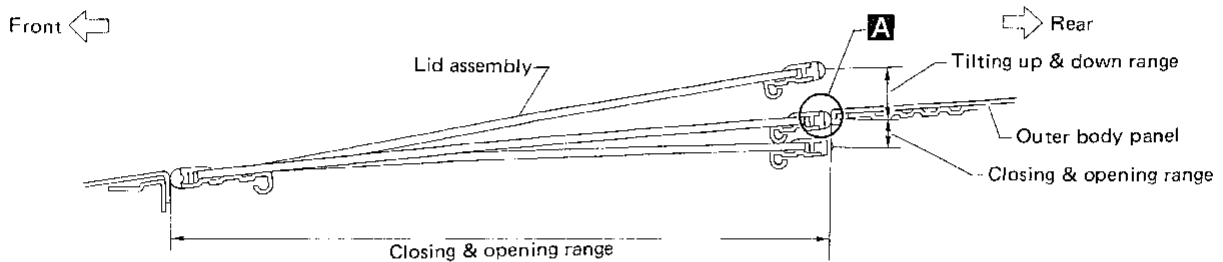

SBF920F

GI

MA

EM

LC

EC

FE

CL

MT

AT

FA

RA

BR

ST

RS

BT

HA

EL

IDX

WINDSHIELD AND WINDOWS

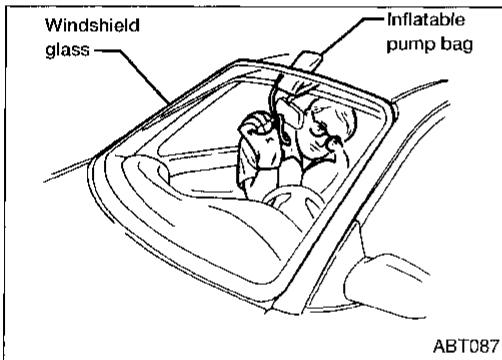
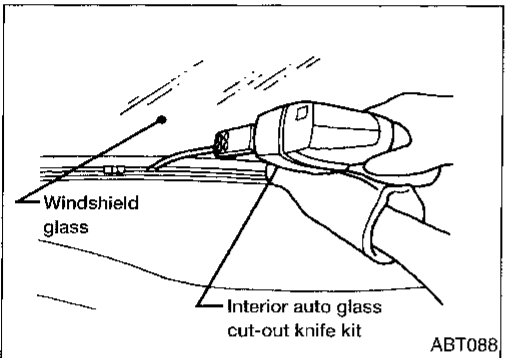
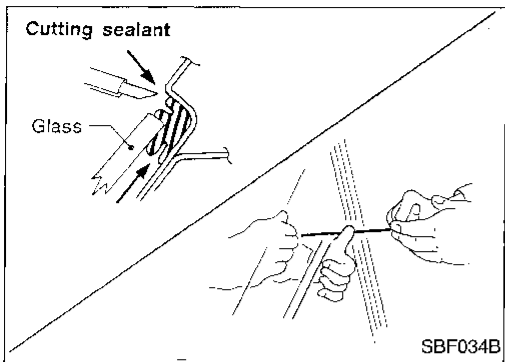

REMOVAL

After removing moldings, remove glass using piano wire or power cutting tool and an inflatable pump bag.

WARNING:

When cutting the glass from the vehicle, always wear safety glasses and heavy gloves to help prevent glass splinters from entering your eyes or cutting your hands.

CAUTION:

- Be careful not to scratch the glass when removing.
- Do not set or stand the glass on its edge. Small chips may develop into cracks.

INSTALLATION

- Use genuine Nissan Urethane Adhesive Kit or equivalent and follow the instructions furnished with it.
- While the urethane adhesive is curing, open a door window. This will prevent the glass from being forced out by passenger compartment air pressure when a door is closed.
- The molding must be installed securely so that it is in position and leaves no gap.
- Inform the customer that the vehicle should remain stationary until the urethane adhesive has completely cured (preferably 24 hours). Curing time varies with temperature and humidity.

WARNING:

- Keep heat and open flames away as primers and adhesive are flammable.
- The materials contained in the kit are harmful if swallowed, and may irritate skin and eyes. Avoid contact with the skin and eyes.
- Use in an open, well ventilated location. Avoid breathing the vapors. They can be harmful if inhaled. If affected by vapor inhalation, immediately move to an area with fresh air.
- Driving the vehicle before the urethane adhesive has completely cured may affect the performance of the windshield in case of an accident.

CAUTION:

- Do not use an adhesive which is past its usable term. Shelf life of this product is limited to six months after the date of manufacture. Carefully adhere to the expiration or manufacture date printed on the box.
- Keep primers and adhesive in a cool, dry place. Ideally, they should be stored in a refrigerator.
- Do not leave primers or adhesive cartridge unattended with their caps open or off.
- The vehicle should not be driven for at least 24 hours or until the urethane adhesive has completely cured. Curing time varies depending on temperature and humidities. The curing time will increase under higher temperatures and lower humidities.

Windshield and Rear Window

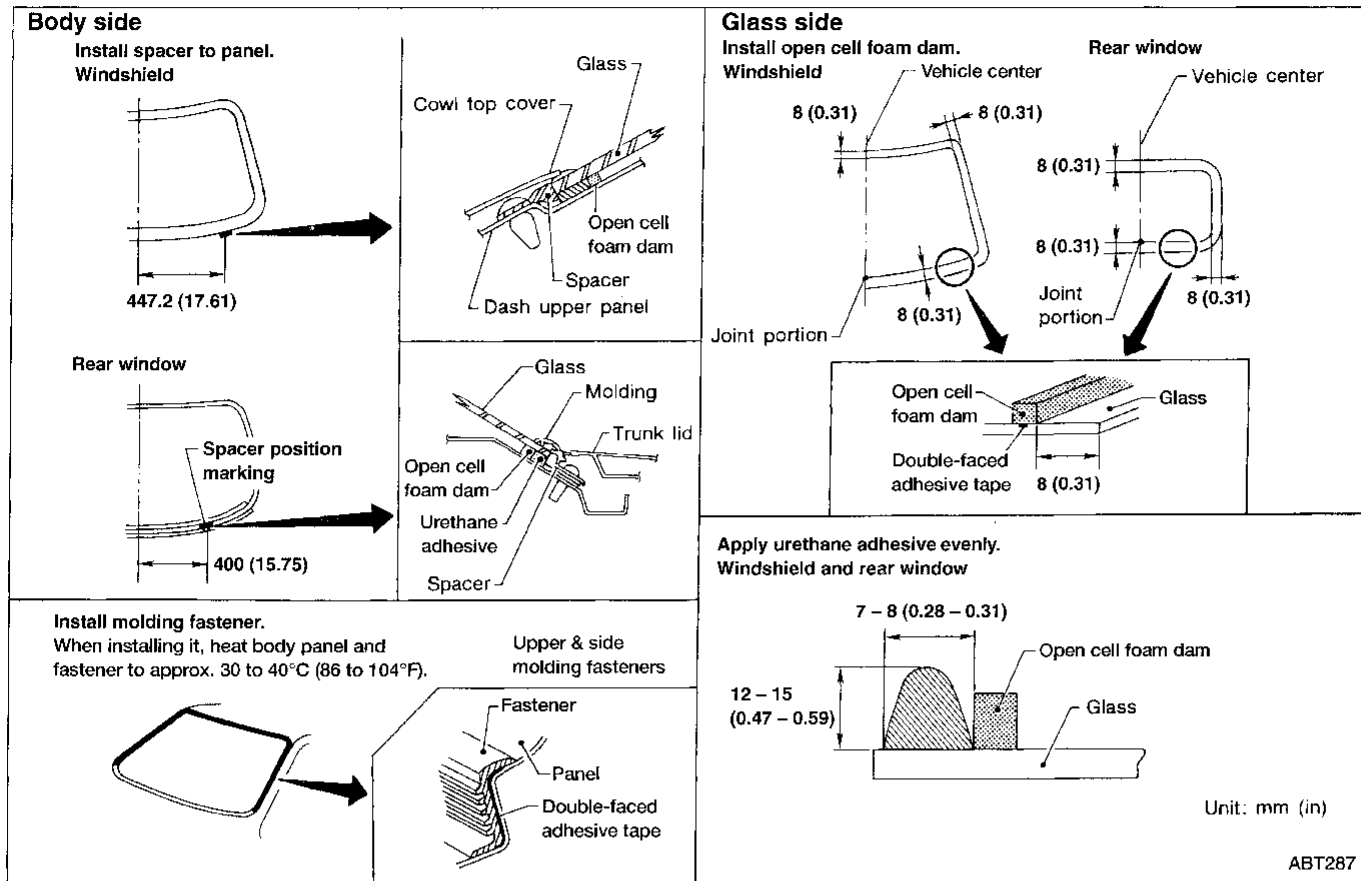

REPAIRING WATER LEAKS FOR WINDSHIELD

Leaks can be repaired without removing and reinstalling glass.

If water is leaking between caulking material and body or glass, determine the extent of leakage. This can be determined by applying water while pushing glass outward.

To stop the leak, apply primer and then sealant to the leak point.

GI
MA
EM
LC
EC
FE
CL
MT
AT
FA
RA
BR
ST
RS
BT
HA
EL
DX

Quarter Window

COUPE

Molded type window

During removal, be careful not to scratch molding when cutting sealant.
If molding is scratched, repair it.

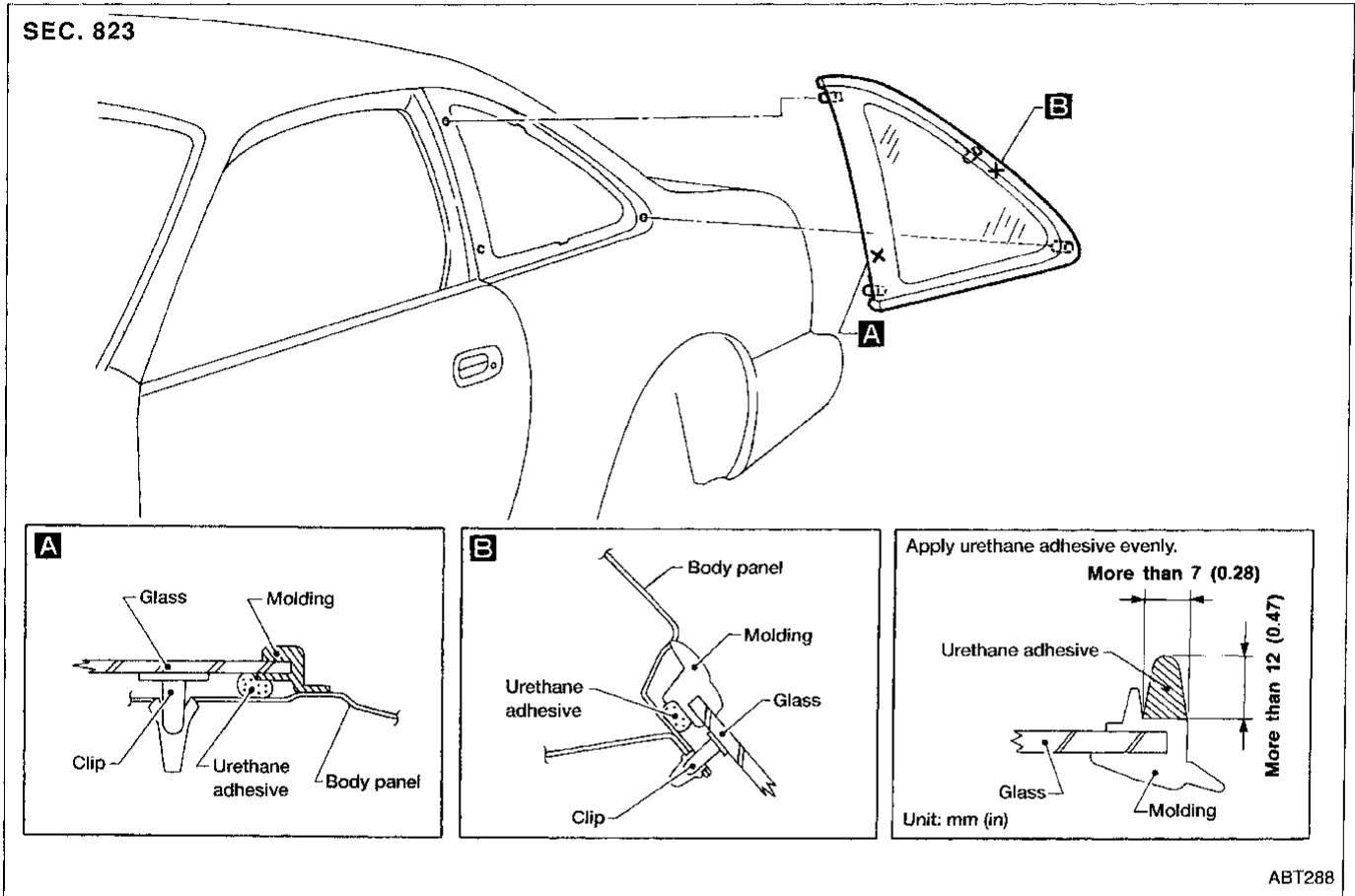

WINDSHIELD AND WINDOWS

Quarter Window (Cont'd)

SEDAN

Removal

Remove the rear door trim. For details, refer to BT-19.

Roll the rear window down.

- ① Remove two screws securing rear glass, then remove rear glass.
- ② Remove three screws securing rear door center sash, then remove rear door center sash.
- ③ Remove quarter glass.

SEC. 820-823-825

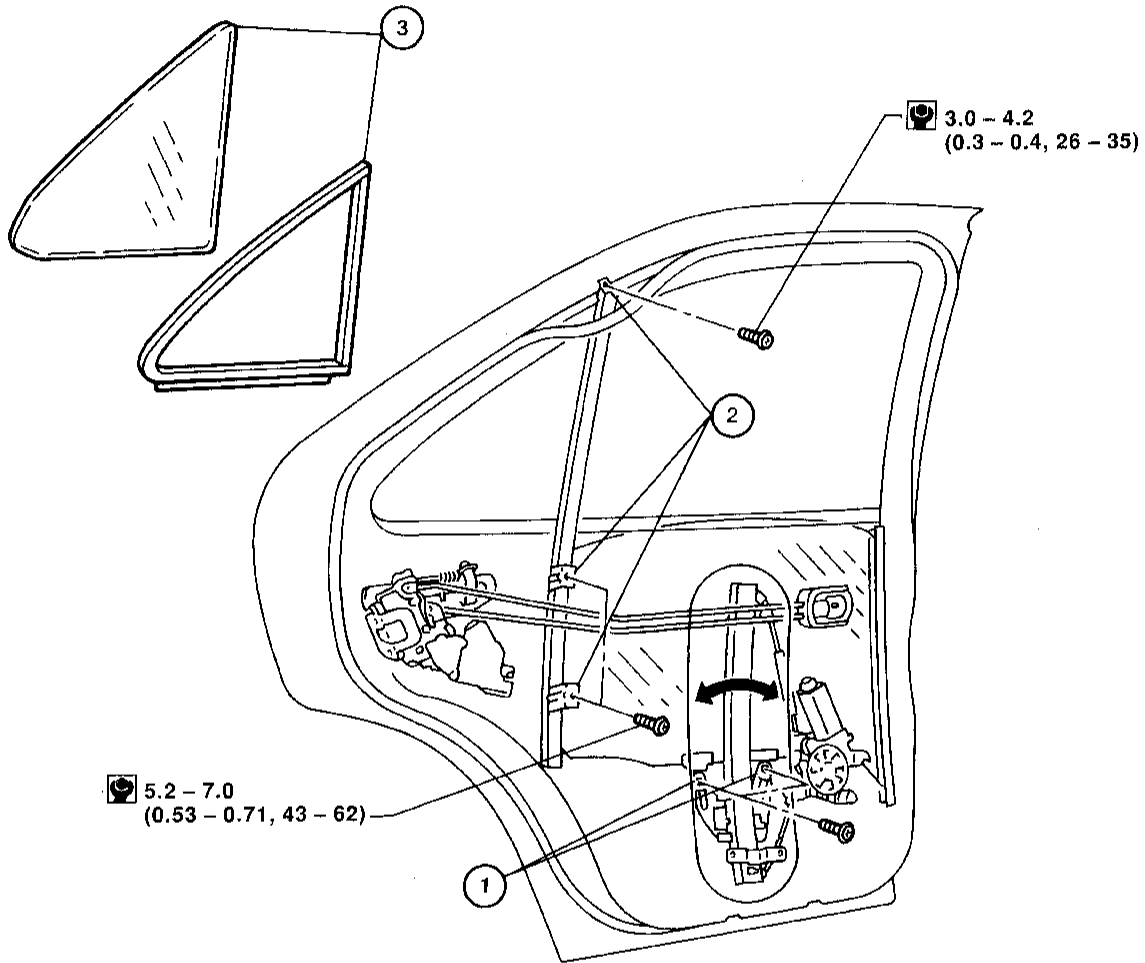

ABT098

GI
MA
EM
LC
EC
FE
CL
MT
AT
FA
RA
BR
ST
RS
BT
HA
EL
IDX

MIRROR

Door Mirror

CAUTION:

Be careful not to scratch door mirror body.

REMOVAL — Door mirror

Remove door trim. For details, refer to BT-19.

- ① Remove inner cover from front corner of door.
- ② Disconnect door mirror harness connector.
- ③ Remove three bolts securing door mirror assembly.

SEC. 963

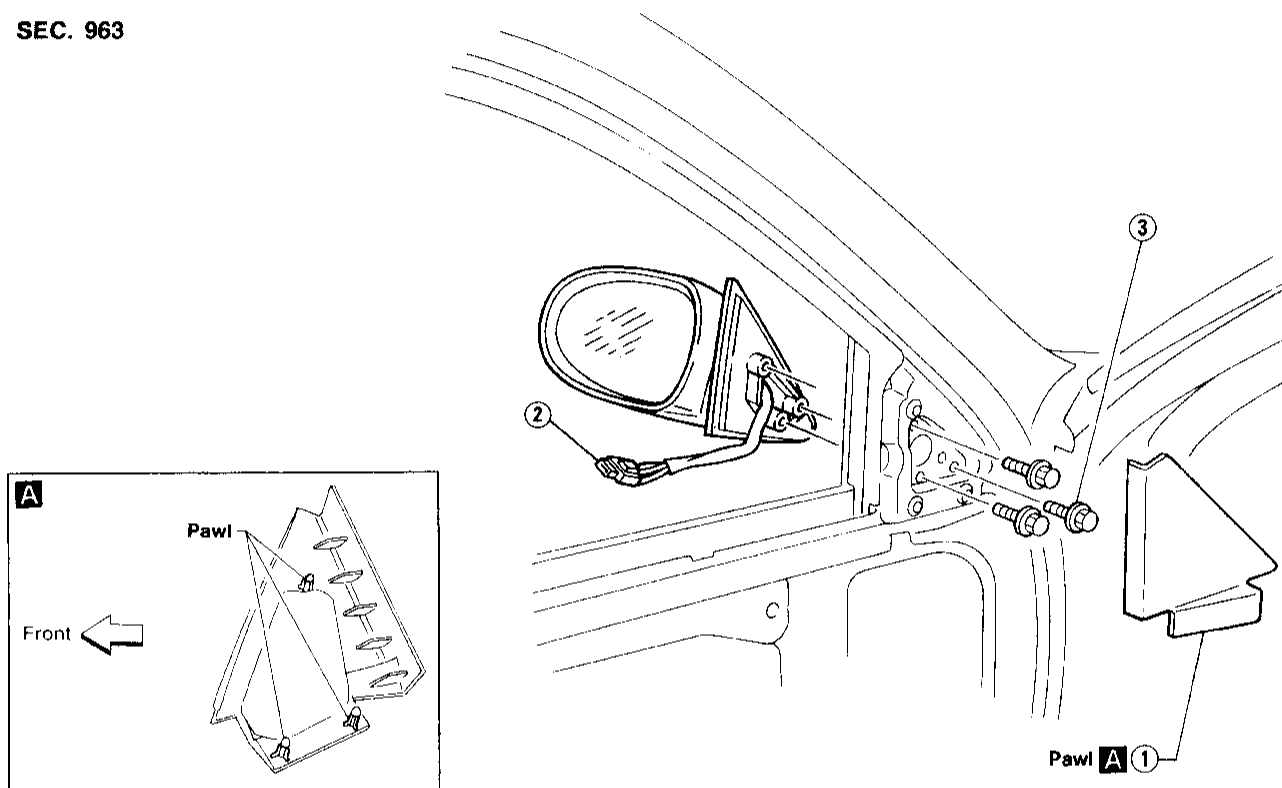

Mirror glass replacement

CAUTION:

Do not exceed specified temperature or time limit. Excess heat or duration may cause damage to the mirror housing.

• Removal

1. Use a heat lamp (at least 500 watts) to thoroughly warm the frame edge of the door mirror glass to approximately 70°C (159°F) for three minutes.

2. Insert a stiff blade scraper between the mirror glass and the frame. Pry the glass loose.
3. Remove any remaining adhesive (butyl tape) from the mounting surface on the frame.

• Installation

1. Install butyl/adhesive tape (2 pieces) on the frame.
2. Warm the mirror glass frame edge thoroughly with a heat lamp.
3. Position mirror glass on frame. Carefully press on the mirror glass to seat it in place.

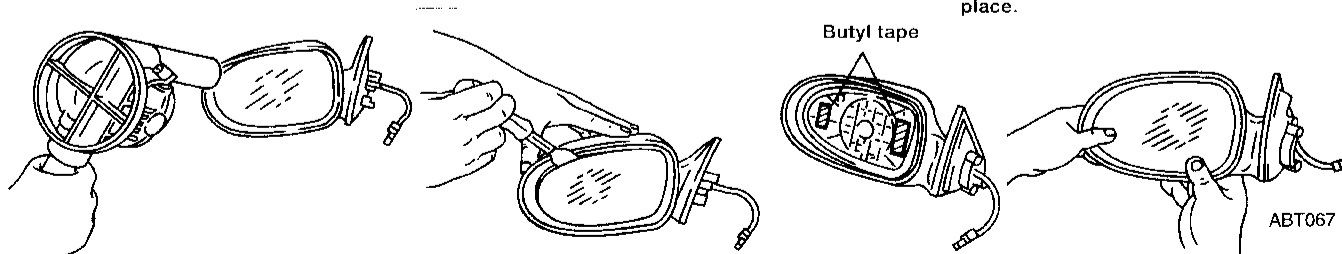

ABT067

BODY ALIGNMENT

- All dimensions indicated in figures are actual ones.
- When using a tracking gauge, adjust both pointers to equal length. Then check the pointers and gauge itself to make sure there is no free play.
- When a measuring tape is used, check to be sure there is no elongation, twisting or bending.
- Measurements should be taken at the center of the mounting holes.
- An asterisk (*) indicates the measuring point value is the same on both sides.
- The coordinates of the measurement points are the distances measured from the standard line of "X", "Y" and "Z".

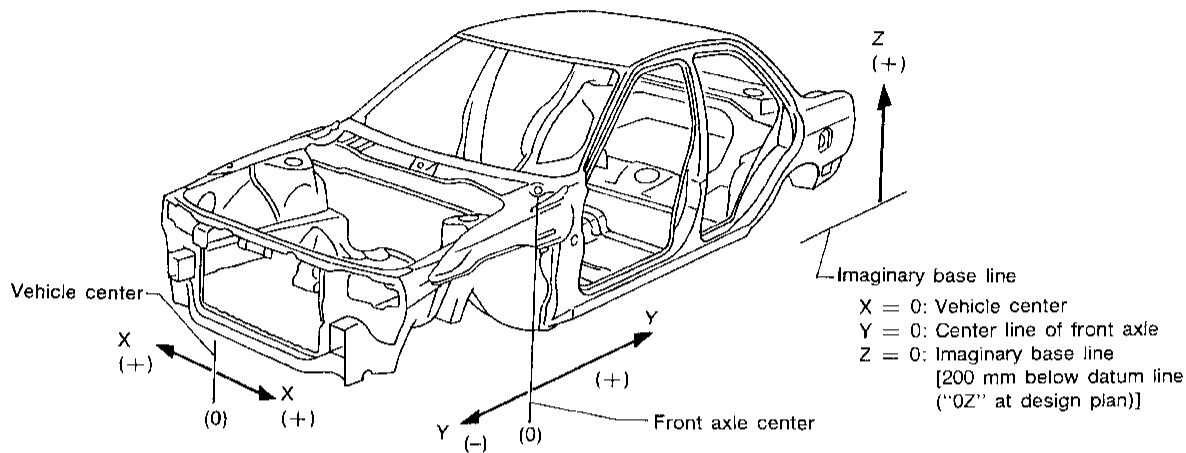

SBF874GC

Engine Compartment

MEASUREMENT

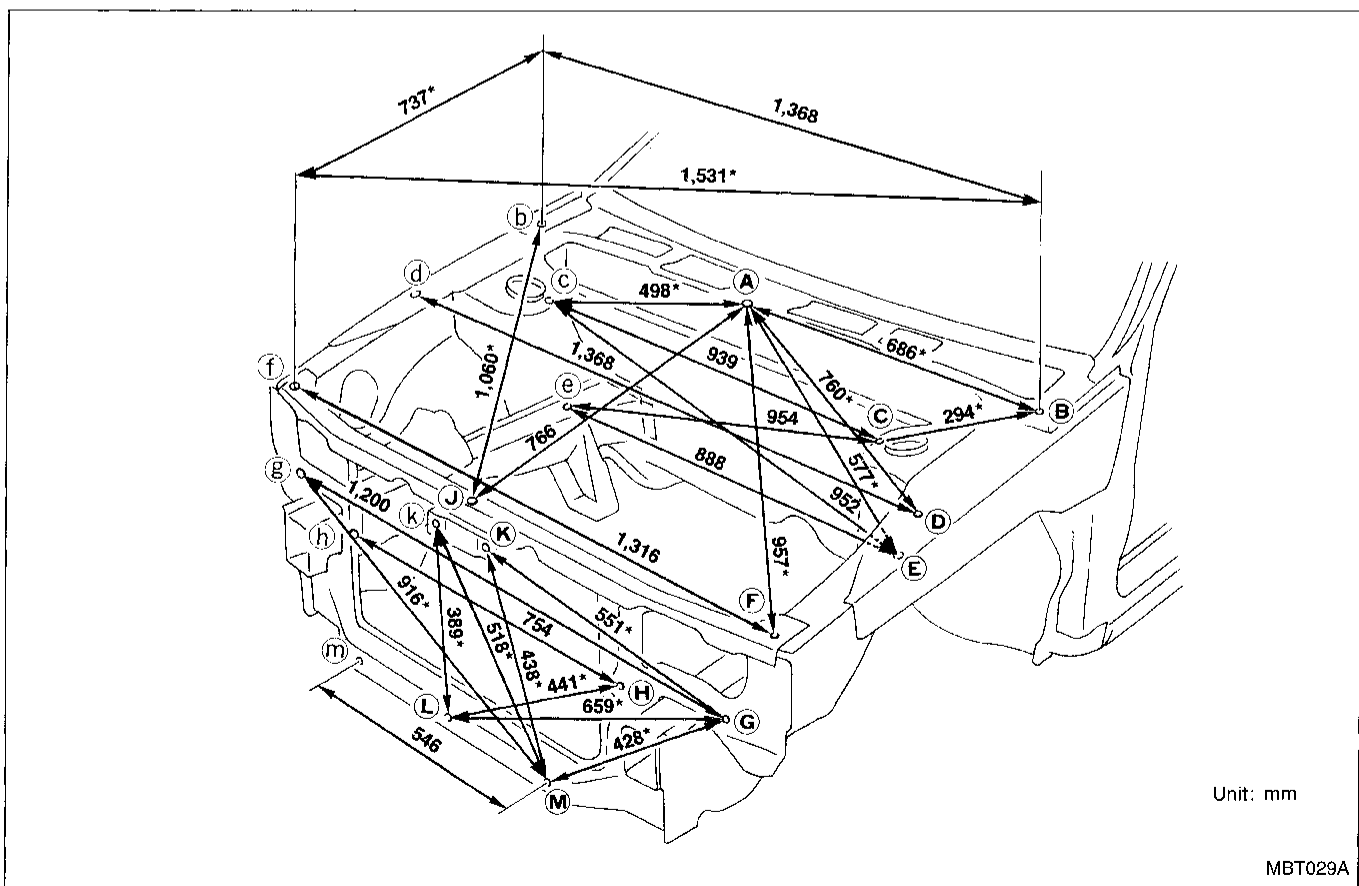

BT-41

GI

MA

EM

LC

EC

FE

CL

MT

AT

FA

RA

BR

ST

RS

BT

HA

EL

IDX

BODY ALIGNMENT

Engine Compartment (Cont'd)

MEASUREMENT POINTS

Unit: mm

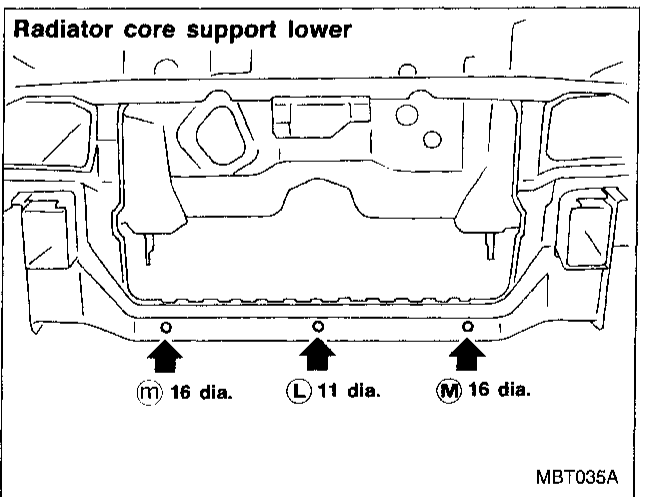
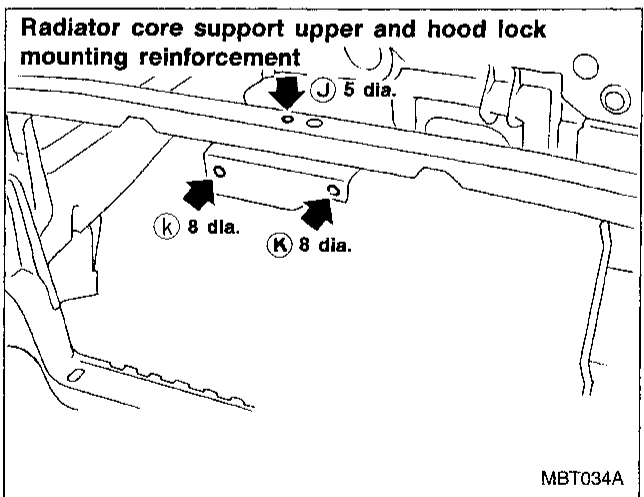
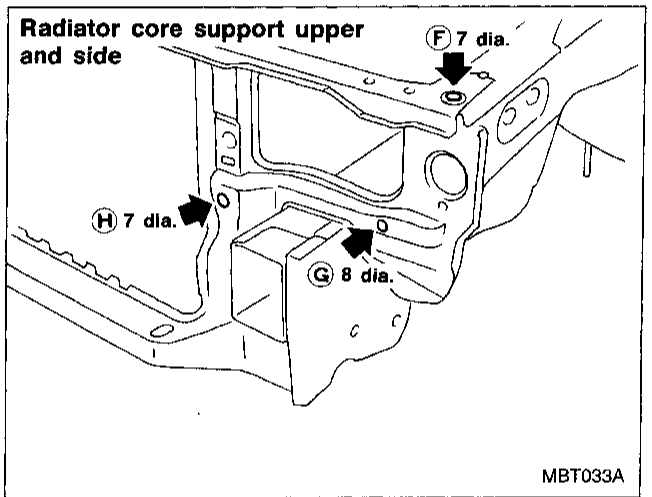
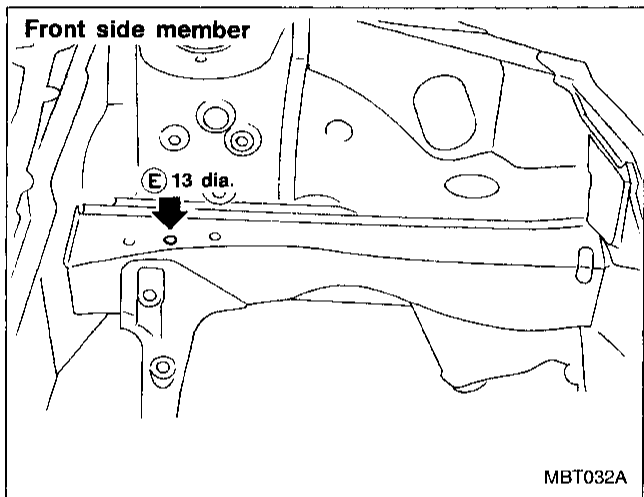
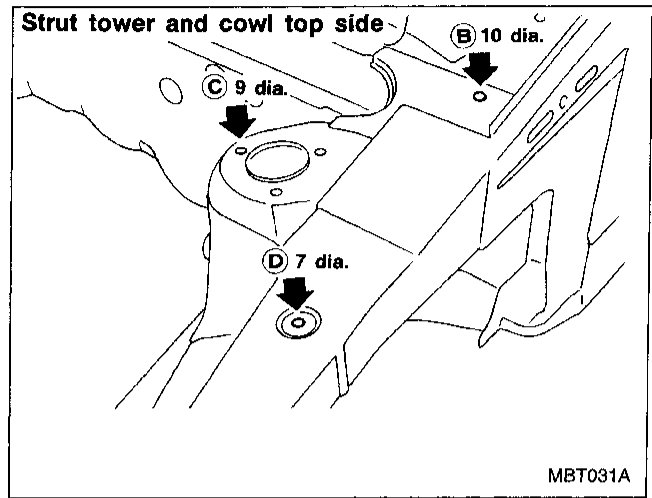
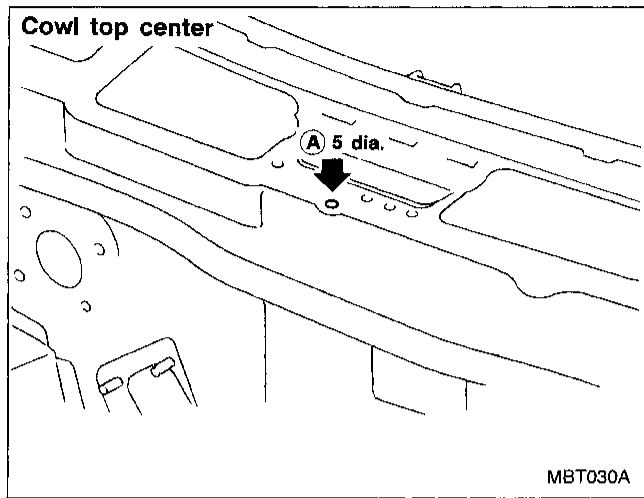

BODY ALIGNMENT

Underbody

MEASUREMENT

Unit: mm

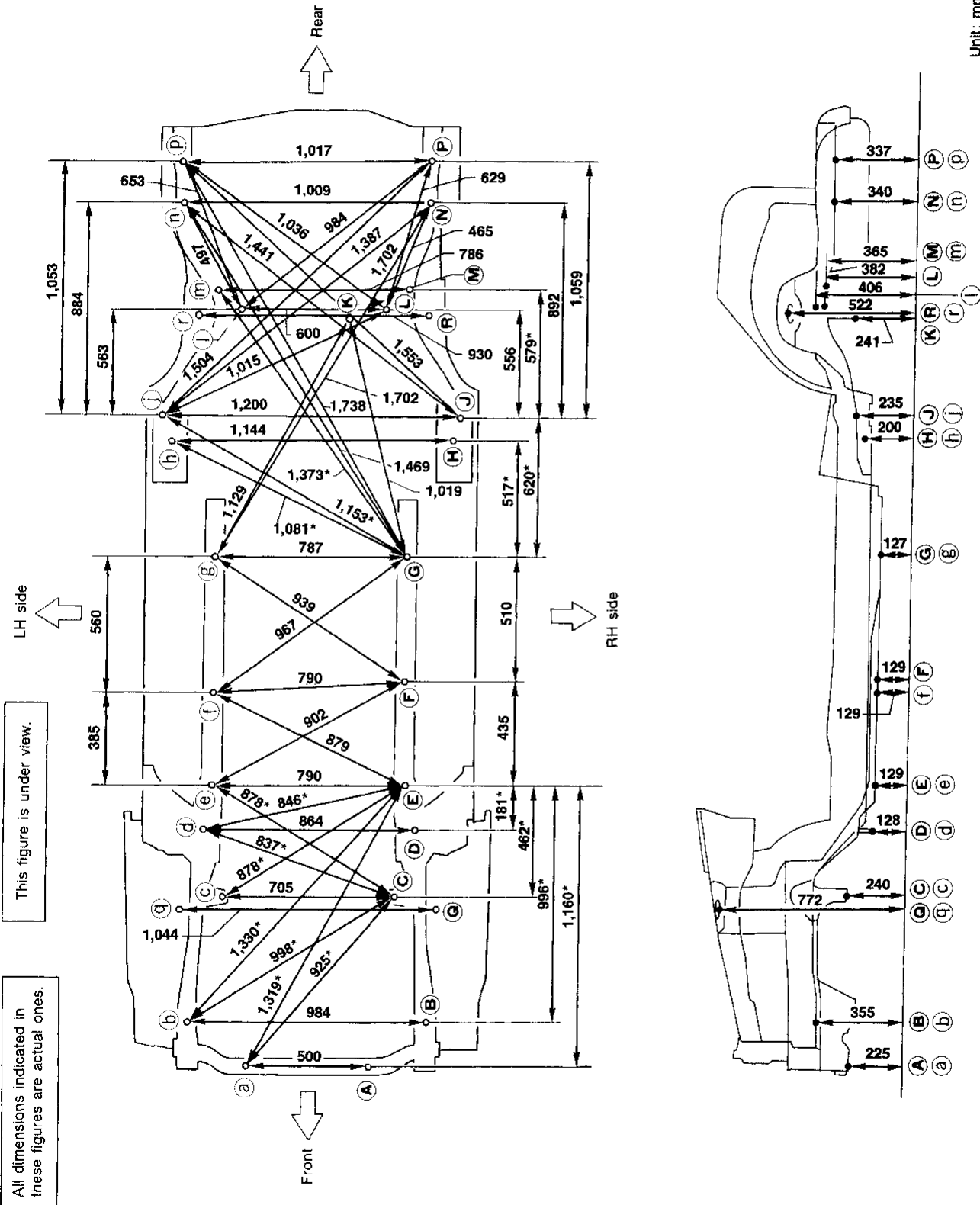

- GI
- MA
- EM
- LC
- EC
- FE
- CL
- MT
- AT
- FA
- RA
- BR
- ST
- RS
- BT**
- HA
- EL
- IDX

BODY ALIGNMENT

Underbody (Cont'd)

MEASUREMENT POINTS

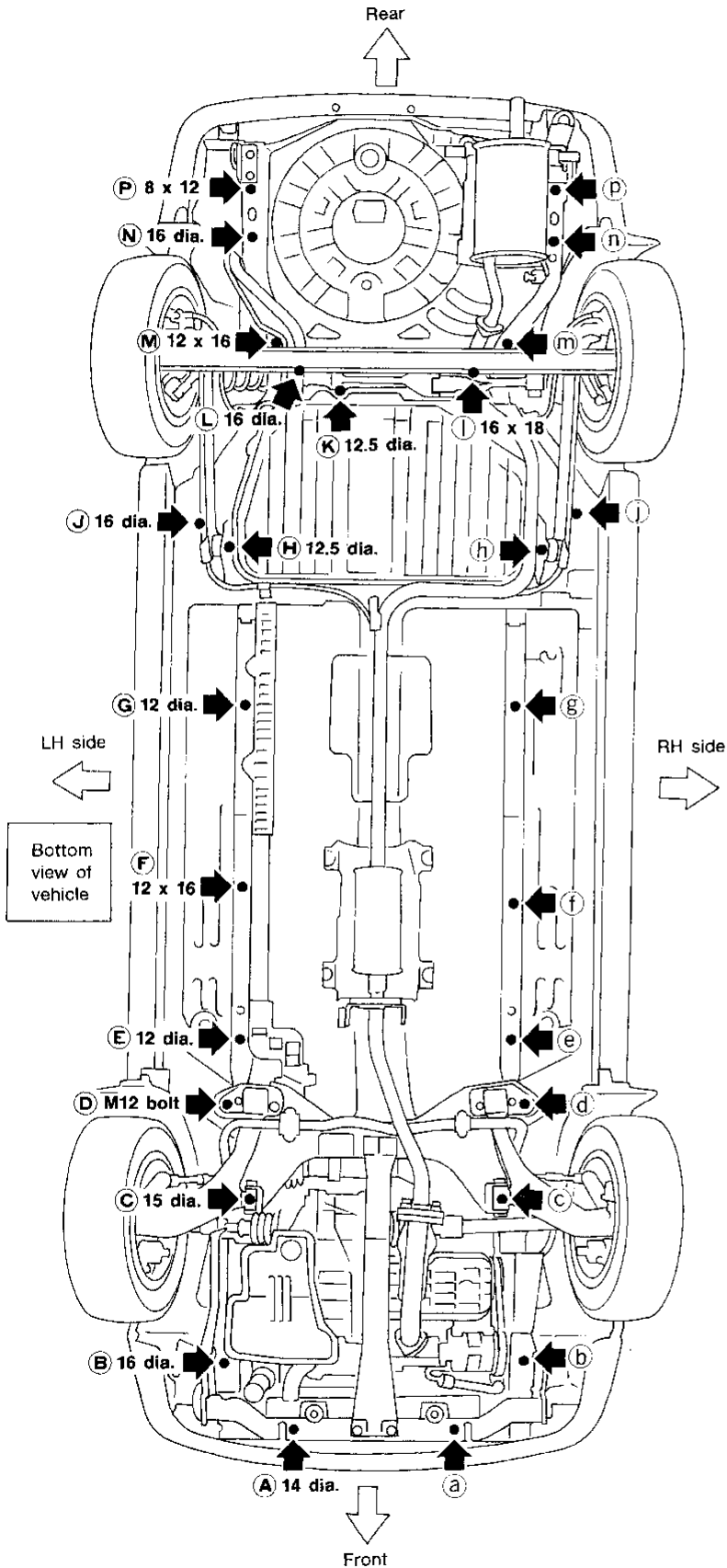

Front coordinates:	Rear coordinates:
Ⓐ, Ⓐ	Ⓔ, Ⓔ
X : 250	X : 393.5
Y : -632	Y : 1,460
Z : 224.8	Z : 126.9
Ⓑ, Ⓑ	Ⓕ, Ⓕ
X : 492	X : 572
Y : -450	Y : 1,940
Z : 355	Z : 200
Ⓒ, Ⓒ	Ⓖ, Ⓖ
X : 352.7	X : 600
Y : 69	Y : 2,035
Z : 240	Z : 235.2
Ⓓ, Ⓓ	Ⓚ, Ⓚ
X : 432	X : 150
Y : 338	Y : 2,487.9
Z : 128	Z : 241
Ⓔ, Ⓔ	Ⓛ, Ⓛ
X : 395	X : 300
Y : 515	Y : 2,480
Z : 129.2	Z : 381.8
Ⓕ, Ⓕ	Ⓜ, Ⓜ
X : 395	X : 393
Y : 950	Y : 2,560
Z : 129.2	Z : 365
Ⓖ, Ⓖ	Ⓝ, Ⓝ
X : 470	X : 470
Y : 2,911	Y : 2,911
Z : 339.6	Z : 339.6
Ⓝ, Ⓝ	Ⓟ, Ⓟ
X : 539	X : 539
Y : 2,911	Y : 2,911
Z : 339.6	Z : 339.6
Ⓟ, Ⓟ	Ⓠ, Ⓠ
X : 475	X : 475
Y : 3,082	Y : 3,082
Z : 335.8	Z : 335.8
Ⓠ, Ⓠ	Ⓡ, Ⓡ
X : 542	X : 542
Y : 3,082	Y : 3,082
Z : 335.8	Z : 335.8

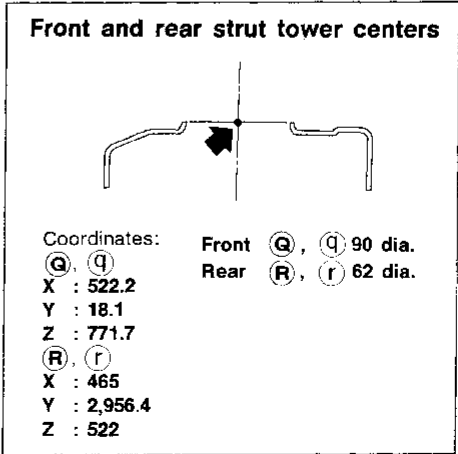

Unit: mm