

REAR AXLE & REAR SUSPENSION

SECTION **RA**

GI

MA

EM

LC

EC

FE

GL

MT

AT

FA

RA

BR

ST

RS

BT

HA

EL

IDX

CONTENTS

PRECAUTIONS AND PREPARATION	2	Coil Spring and Shock Absorber	10
Precautions	2	Removal.....	10
Special Service Tools.....	2	Disassembly	10
Commercial Service Tools	2	Inspection	10
REAR SUSPENSION SYSTEM	3	Assembly	11
ON-VEHICLE SERVICE	4	Torsion Beam, Lateral Link and Control Rod	11
Rear Axle and Rear Suspension Parts.....	4	Disassembly	11
Rear Wheel Bearing	4	Inspection	11
Rear Wheel Alignment	5	Rubber Bushing Replacement	12
REAR AXLE	6	Assembly	13
Wheel Hub	6	SERVICE DATA AND SPECIFICATIONS (SDS)	14
REAR SUSPENSION	8	General Specifications	14
Removal	9	Inspection and Adjustment.....	14
Installation	9		

PRECAUTIONS AND PREPARATION

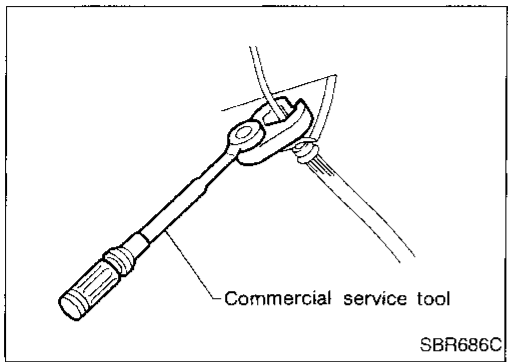

Precautions

- When installing rubber parts, final tightening must be carried out under unladen condition* with tires on ground.
- *: Fuel, radiator coolant and engine oil full. Spare tire, jack, hand tools and mats in designated positions.
- Use flare nut wrench when removing or installing brake tubes.
- After installing removed suspension components, check wheel alignment and adjust if necessary.
- Do not jack up at the trailing arm and lateral link.
- Always torque brake lines when installing.

Special Service Tools

The actual shapes of Kent-Moore tools may differ from those of special service tools illustrated here.

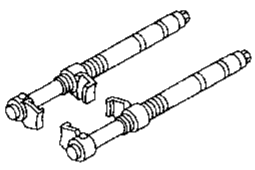
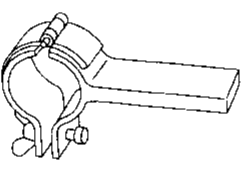
Tool number (Kent-Moore No.) Tool name	Description
HT71780000 (—) Spring compressor	 <p>Removing and installing coil spring</p> <p>NT144</p>
ST35652000 (—) Strut attachment	 <p>Fixing strut assembly</p> <p>NT145</p>

Commercial Service Tools

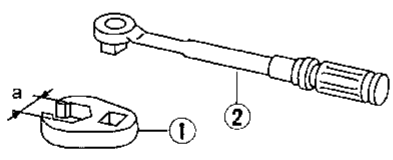
Tool name	Description
<ol style="list-style-type: none"> ① Flare nut crowfoot ② Torque wrench 	 <p>Removing and installing brake tubes</p> <p>NT360</p> <p>a: 10 mm (0.39 in)</p>

REAR SUSPENSION SYSTEM

SEC. 431

When installing each rubber part, final tightening must be carried out under unladen condition* with tires on ground.

* Fuel, radiator coolant and engine oil full.
Spare tire, jack, hand tools and mats in designated positions.

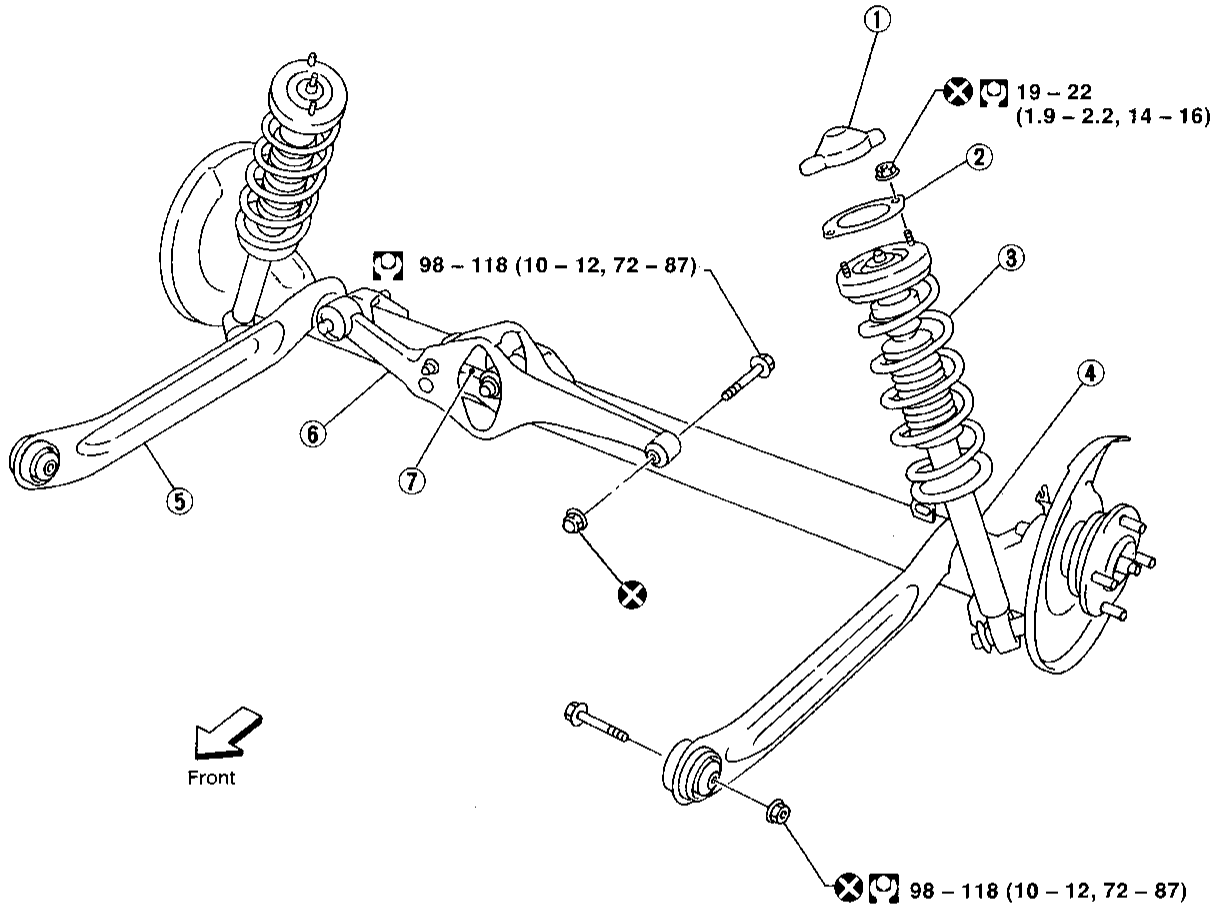

 : N·m (kg-m, ft-lb)

ARA060

- | | | |
|--------------------------------|------------------|----------------|
| ① Shock absorber cap | ④ Shock absorber | ⑥ Lateral link |
| ② Shock absorber mounting seal | ⑤ Torsion beam | ⑦ Control rod |
| ③ Coil spring | | |

GI

MA

EM

LC

EC

FE

CL

MT

AT

FA

RA

BR

ST

RS

BT

HA

EL

DX

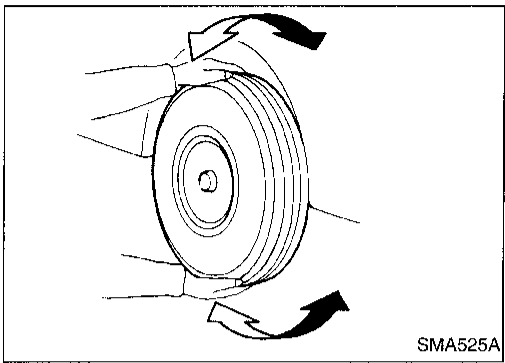

Rear Axle and Rear Suspension Parts

Check axle and suspension parts for excessive play, wear or damage.

- Shake each rear wheel to check for excessive play.

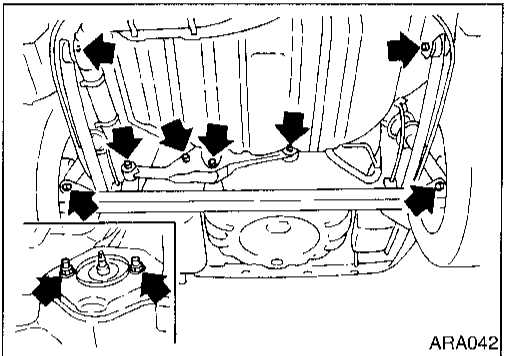

- Retighten all nuts and bolts to the specified torque.

Tightening torque:

Refer to RA-8.

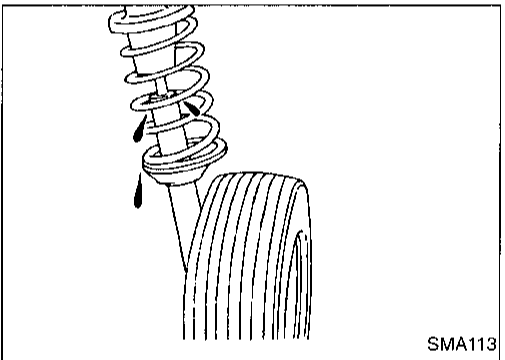

- Check shock absorber for oil leakage and damage.
- Check wheelarch height. Refer to FA section ("Front Axle and Front Suspension Parts", "ON-VEHICLE SERVICE").

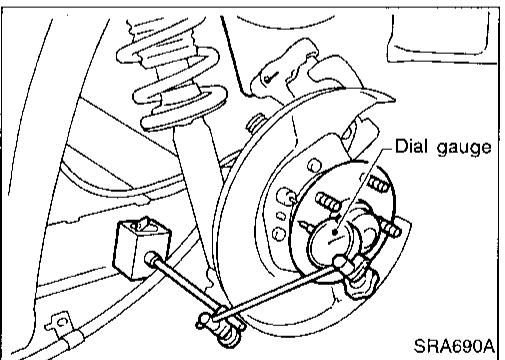

Rear Wheel Bearing

- Check axial end play.

Axial end play:

0.05 mm (0.0020 in) or less

- Check that wheel hub bearing operates smoothly.
- Check tightening torque of wheel bearing lock nut.
 \square : **187 - 255 N·m (19 - 26 kg·m, 138 - 188 ft·lb)**
- If axial end play is not within specification, or wheel bearing does not turn smoothly, replace wheel hub bearing assembly. Refer to RA-6.

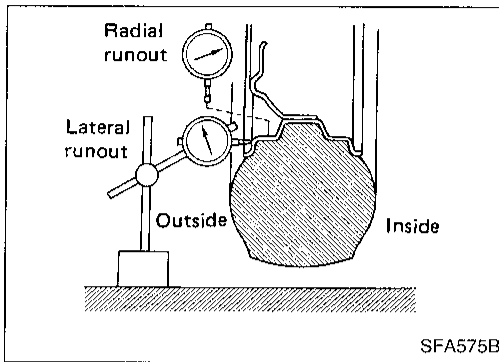

Rear Wheel Alignment

PRELIMINARY INSPECTION

Make following checks. Adjust, repair or replace if necessary.

- Check tires for wear and for proper inflation.
- Check rear wheel bearings for excessive play.
- Check wheel runout.

Wheel runout:

Refer to FA section ("Inspection and Adjustment", "SDS").

- Check that rear shock absorber works properly.
- Check rear axle and rear suspension parts for excessive play.
- Check vehicle posture (Unladen*).

*: Fuel, radiator coolant and engine oil full. Spare tire, jack, hand tools and mats in designated positions.

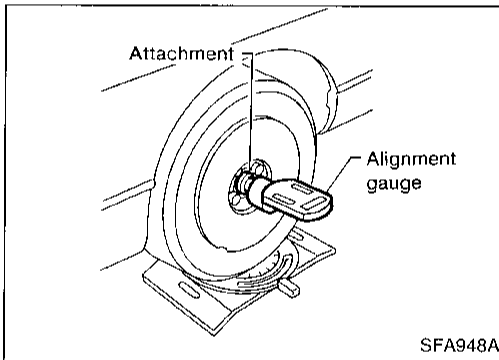

CAMBER

- **Camber is preset at factory and cannot be adjusted.**

Camber:

Refer to SDS, RA-14.

- If the camber is not within specification, inspect and replace any damaged or worn rear suspension parts.

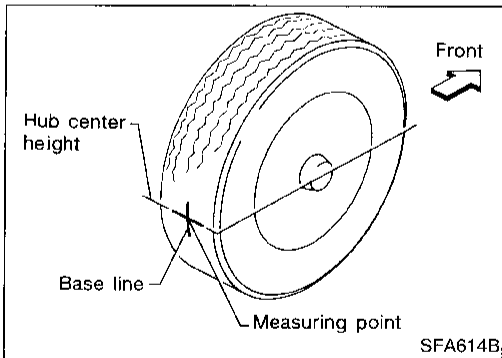

TOE-IN

Toe-in is preset at factory and cannot be adjusted.

Measure toe-in using following procedure. If out of specification, inspect and replace any damaged or worn rear suspension parts.

WARNING:

- Always perform following procedure on a flat surface.
- Make sure that no one is in front of the vehicle before pushing it.

1. Bounce rear of vehicle up and down to stabilize the posture.
2. Push the vehicle straight ahead about 5 m (16 ft).
3. Put a mark on base line of the tread (rear side) of both rear tires at the same height as hub center. This mark is a measuring point.
4. Measure distance "A" (rear side).
5. Push the vehicle slowly ahead to rotate the wheels 180 degrees (1/2 turn).

- If the wheels have rotated more than 180 degrees (1/2 turn), try the above procedure again from the beginning. Never push vehicle backward.

6. Measure distance "B" (front side).

Total toe-in:

Refer to SDS, RA-14.

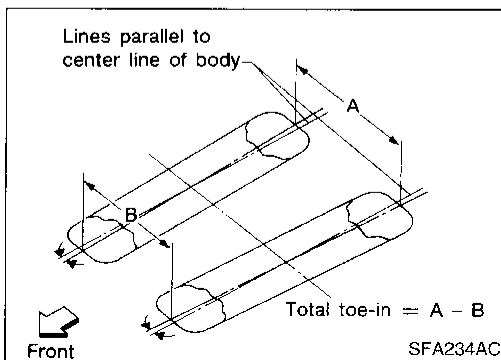

REAR AXLE

Wheel Hub

SEC. 430

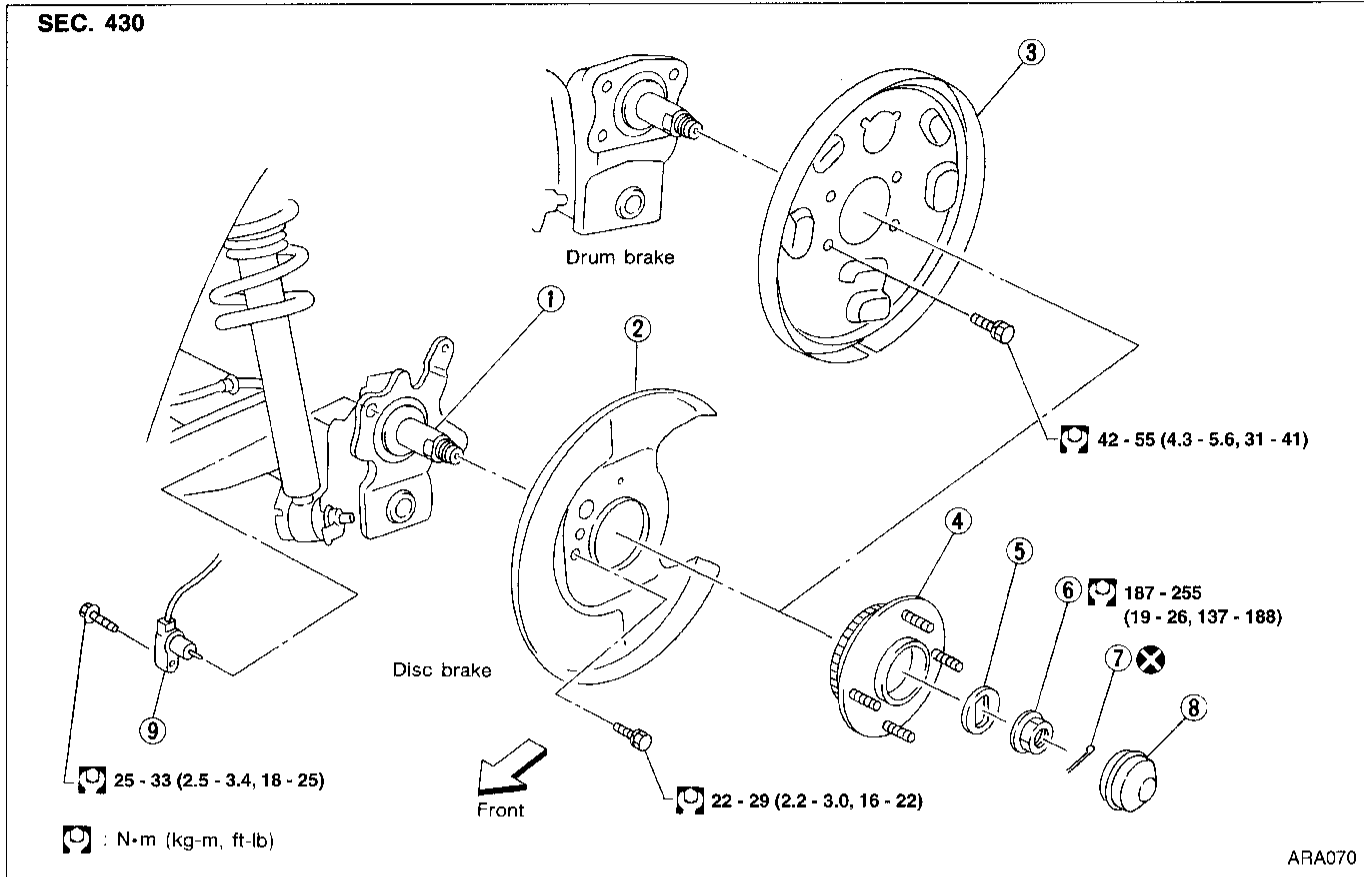

- ① Spindle
- ② Baffle plate
- ③ Back plate

- ④ Wheel hub bearing
- ⑤ Washer
- ⑥ Wheel bearing lock nut

- ⑦ Cotter pin
- ⑧ Hub cap
- ⑨ ABS sensor

REMOVAL

CAUTION:

- Before removing the wheel hub bearing assembly, disconnect the ABS wheel sensor from the assembly. Move it away from the hub assembly. Failure to do so may result in damage to the sensor wires and the sensor becoming inoperative.
- Wheel hub bearing does not require maintenance. If any of the following occurs, replace wheel hub bearing assembly.
 - (1) Growling noise is emitted from wheel hub bearing during operation.
 - (2) Wheel hub bearing drags or turns roughly. This occurs when turning wheel hub by hand after wheel bearing lock nut is tightened to specified torque.

REAR AXLE

Wheel Hub (Cont'd)

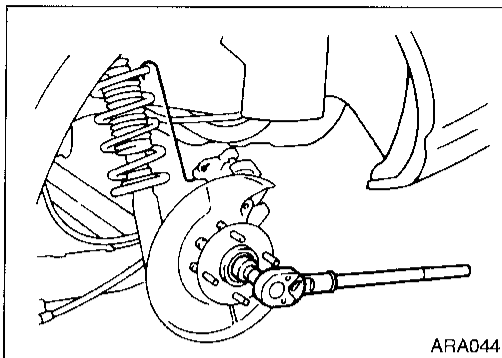

1. Remove brake caliper assembly.
 2. Remove wheel bearing lock nut.
 3. Remove brake rotor (models with disc brake) or brake drum (models with drum brakes).
 4. Remove wheel hub bearing from spindle.
- **Brake hose does not need to be disconnected from brake caliper.**
 - **Suspend caliper assembly with wire so as not to stretch brake hose.**
 - **Be careful not to depress brake pedal, or caliper piston will pop out.**
 - **Make sure brake hose is not twisted.**

GI

MA

EM

LC

EC

FE

CL

MT

AT

FA

RA

BR

ST

RS

BT

HA

EL

DX

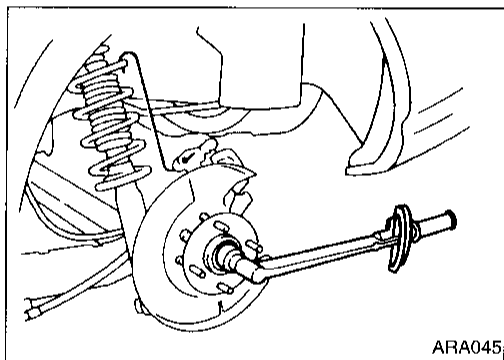

INSTALLATION

1. Install wheel hub bearing assembly.
2. Tighten wheel bearing lock nut.
Before tightening, apply oil to threaded portion of rear spindle and both sides of plain washer.
3. Check that wheel hub bearing operates smoothly.

: 187 - 255 N·m (19 - 26 kg·m, 137 - 188 ft·lb)

4. Check wheel hub bearing axial end play.
Axial end play:
0.05 mm (0.0020 in) or less

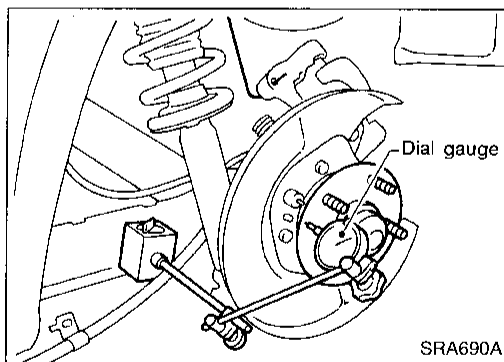

REAR SUSPENSION

SEC. 431

When installing each rubber part, final tightening must be carried out under unladen condition* with tires on ground.

* Fuel, radiator coolant and engine oil full.
Spare tire, jack, hand tools and mats in designated positions.

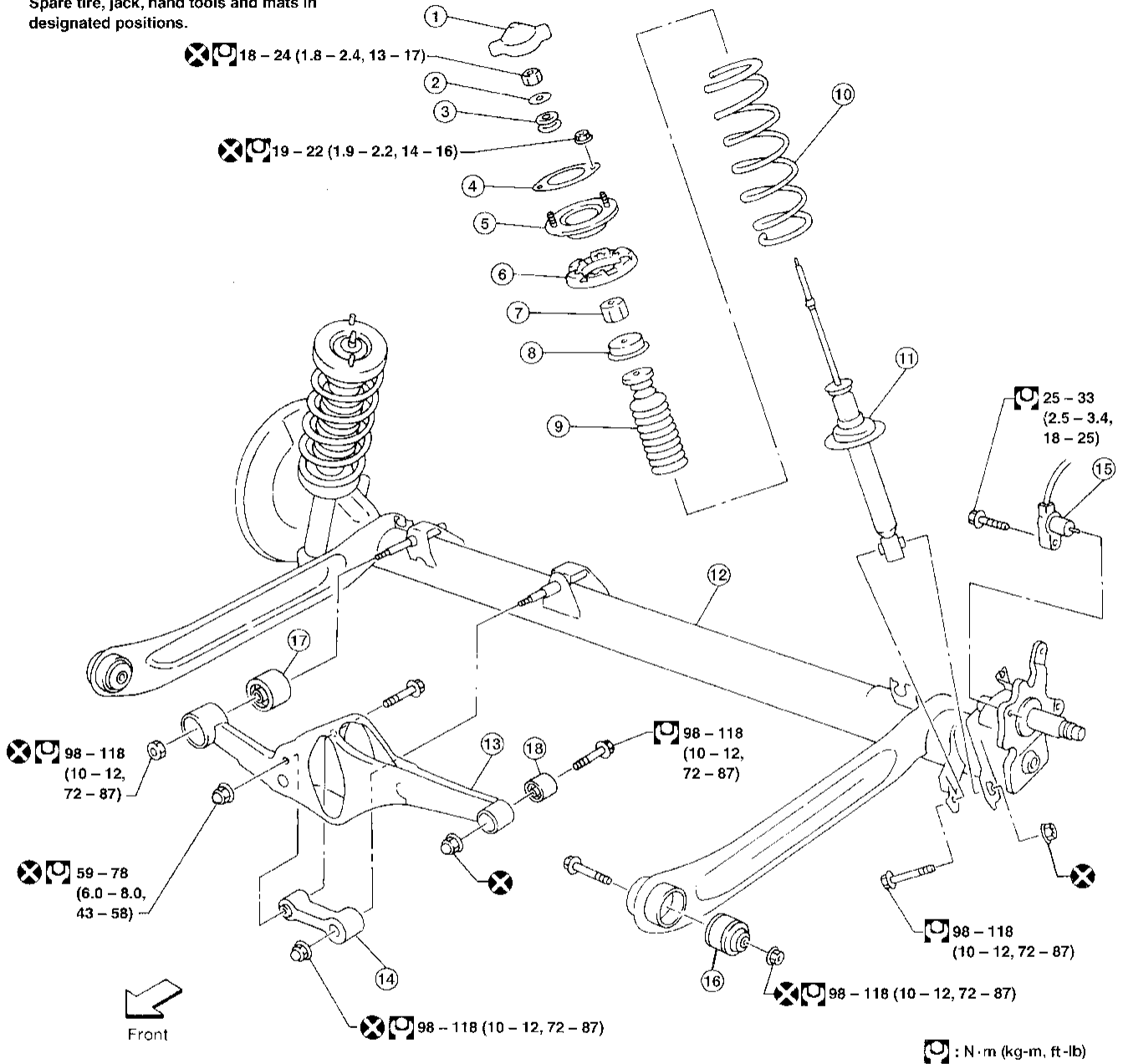

ARA073

- | | | |
|-----------------------------------|----------------------|------------------------------|
| ① Shock absorber cap | ⑦ Bushing | ⑬ Lateral link |
| ② Washer | ⑧ Bound bumper cover | ⑭ Control rod |
| ③ Bushing | ⑨ Bound bumper | ⑮ ABS sensor |
| ④ Shock absorber mounting seal | ⑩ Coil spring | ⑯ Trailing arm bushing |
| ⑤ Shock absorber mounting bracket | ⑪ Shock absorber | ⑰ Large lateral link bushing |
| ⑥ Upper spring seat rubber | ⑫ Torsion beam | ⑱ Small lateral link bushing |

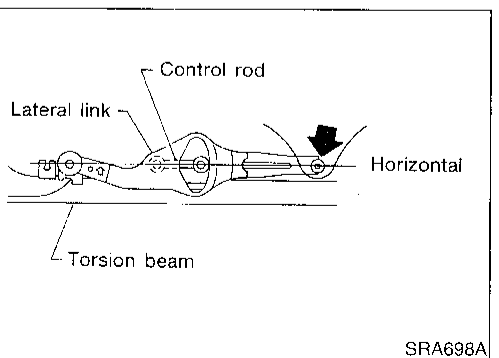
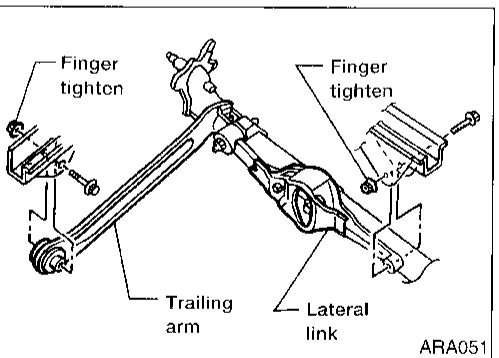
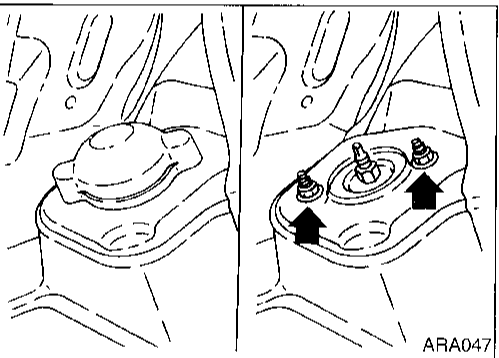
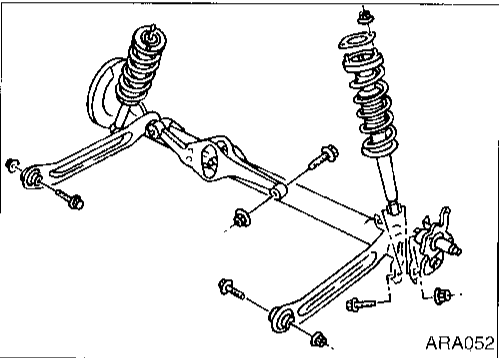
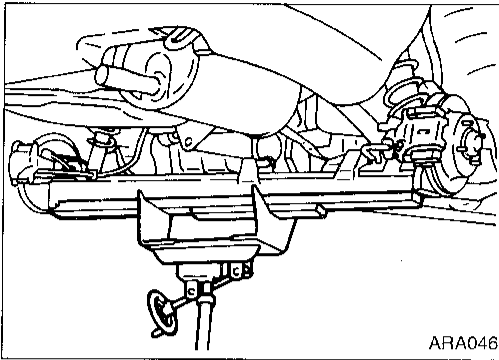

Removal

CAUTION:

- Before removing the rear suspension assembly, disconnect the ABS wheel sensor from the assembly. Failure to do so may result in damaged sensor wires and the sensor becoming inoperative.
 - Drain brake fluid before disconnecting brake lines.
1. Disconnect brake hydraulic lines and parking brake cables at toggle levers. (Models with drum brakes.)
 2. Disconnect brake hydraulic lines and parking brake cables from calipers and remove brake calipers and rotors. (Models with disc brakes.)
 3. Using a transmission jack, raise torsion beam a little, and remove nuts and bolts from the trailing arms, shock absorber assemblies (lower side) and lateral link.
 4. Lower transmission jack and remove suspension.
 5. Remove luggage compartment trim. Refer to BT section ("Trunk Trim", "INTERIOR TRIM").
 6. Remove shock absorber fixing nuts (upper side). Then pull out shock absorber assemblies.

Installation

CAUTION:

- Refill with new brake fluid DOT 3.
 - Never reuse drained brake fluid.
1. Attach torsion beam at trailing arm and lateral link to vehicle. Do not tighten bolts at this time.
 2. Using a transmission jack, place lateral link and control rod horizontally against torsion beam. Tighten lateral link on vehicle.
 3. Attach shock absorber assembly to vehicle. Then tighten the lower side of shock absorber assembly.
 4. Lower torsion beam to fully extended position. Remove transmission jack and tighten torsion beam, at trailing arm, to specified torque. Refer to RA-8.
 5. Install brake hydraulic lines and tighten flare nuts.
 - ☞: 15 - 18 N·m (1.5 - 1.8 kg·m, 11 - 13 ft·lb)

GI

MA

EM

LC

EC

FE

CL

MT

AT

FA

RA

BR

ST

RS

BT

HA

EL

DX

REAR SUSPENSION

Installation (Cont'd)

6. Bleed air. Refer to BR section ("Bleeding Procedure", "AIR BLEEDING").
7. Install ABS wheel sensor.

Coil Spring and Shock Absorber

REMOVAL

Remove shock absorber upper and lower fixing nuts.

WARNING:

Do not remove piston rod lock nut on vehicle.

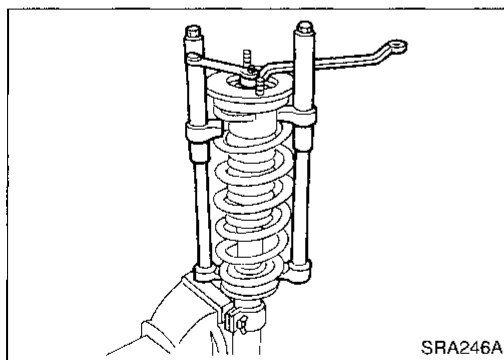
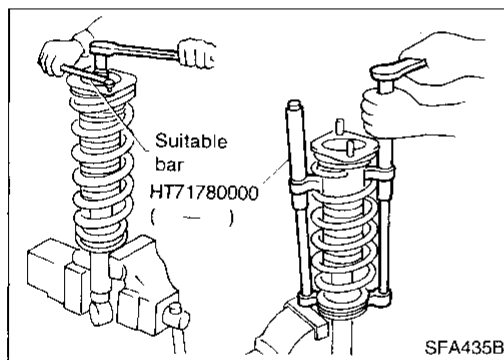

DISASSEMBLY

1. Set shock absorber in vise with attachment, then **loosen** piston rod lock nut.

WARNING:

Do not remove piston rod lock nut at this time.

2. Compress spring with Tool so that the shock absorber upper spring seat can be turned by hand.

3. Remove piston rod lock nut.

INSPECTION

Shock absorber assembly

- Check both compression and extension for smooth operation through a full stroke.
- Check for oil leakage on welded or gland packing portions.
- Check piston rod for cracks, deformation or other damage. Replace if necessary.

REAR SUSPENSION

Coil Spring and Shock Absorber (Cont'd)

Upper rubber seat and bushing

Check rubber parts for deterioration or cracks.
Replace if necessary.

GI

Coil spring

Check for cracks, deformation or other damage. Replace if necessary.

MA

EM

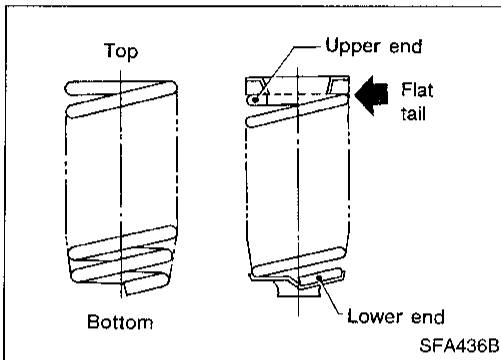

ASSEMBLY

- When installing coil spring, be careful not to reverse top and bottom direction. (Top end is flat.)
- When installing coil spring on shock absorber, it must be positioned as shown in figure.

LC

EC

FE

CL

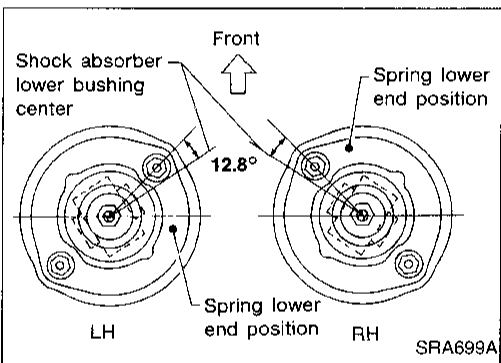

- Locate upper spring seat as shown.

MT

AT

FA

RA

BR

Torsion Beam, Lateral Link and Control Rod

DISASSEMBLY

- Remove torsion beam assembly. Refer to RA-9.
- Remove lateral link and control rod from torsion beam.

ST

RS

BT

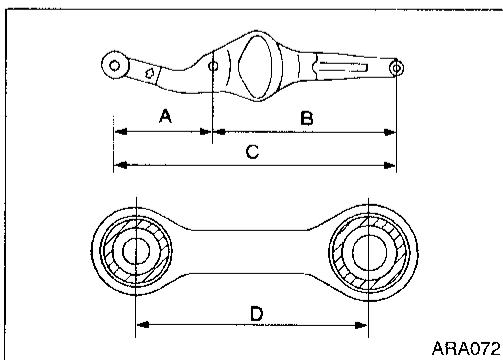

INSPECTION

- Check for cracks, distortion or other damage. Replace if necessary.

HA

EL

Standard length:

- A 207 - 208 mm (8.15 - 8.19 in)
- B 394 - 395 mm (15.51 - 15.55 in)
- C 601 - 603 mm (23.66 - 23.74 in)
- D 106 - 108 mm (4.17 - 4.25 in)

IDX

- Check all rubber parts for wear, cracks or deformation. Replace if necessary.

REAR SUSPENSION

Torsion Beam, Lateral Link and Control Rod (Cont'd)

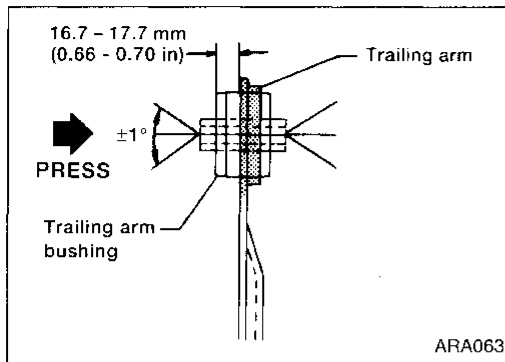

RUBBER BUSHING REPLACEMENT

Trailing arm

Trailing arm bushings are press fit and must be centered properly in trailing arm collars.

1. Press out old bushing from trailing arm collar.
 2. Press in new bushing until inside edge of bushing is 16.7 to 17.7 mm (0.66 to 0.70 in) from inside edge of trailing arm.
- Do not allow bushing to incline more than 1 degree.
 - During installation, do not allow trailing arm to bend or twist.

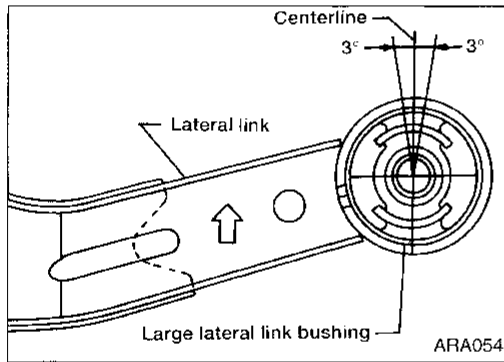

Lateral link

Lateral link bushings are press fit. The large lateral link bushing is directional and must be installed in a specific position.

1. Remove lateral link.
2. Press out bushings. Note installation position of large bushing before removing.
3. Press in small bushing until bushing is centered in lateral link collar.
4. Press in large bushing until bushing is centered in lateral link collar.
 - a. Position bushing on lateral link collar.
 - b. Angle between bushing centerline and collar centerline must be within 3 degrees as shown in illustration.

Control rod

Control rod bushings are not replaceable. If bushings are worn or damaged, replace control rod.

REAR SUSPENSION

Torsion Beam, Lateral Link and Control Rod (Cont'd)

ASSEMBLY

1. Temporarily assemble lateral link and control rod.
 - When installing the control rod, connect the end with the smaller inner diameter to the lateral link.

GI

MA

EM

LC

EC

FE

CL

MT

AT

FA

RA

BR

ST

RS

BT

HA

EL

IDX

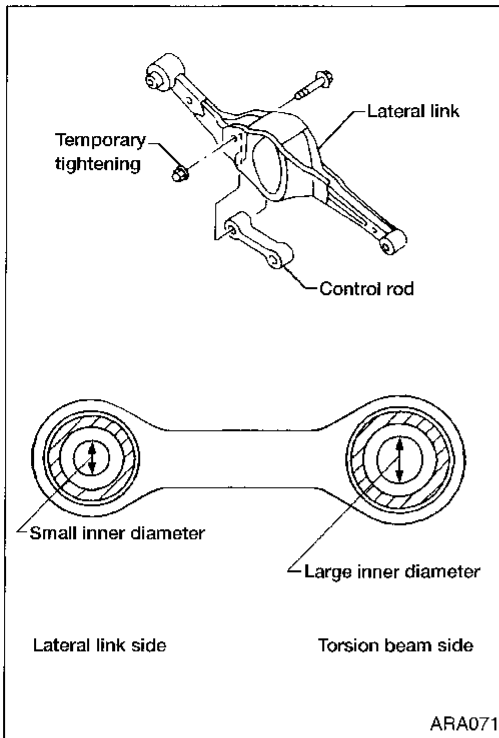

ARA071

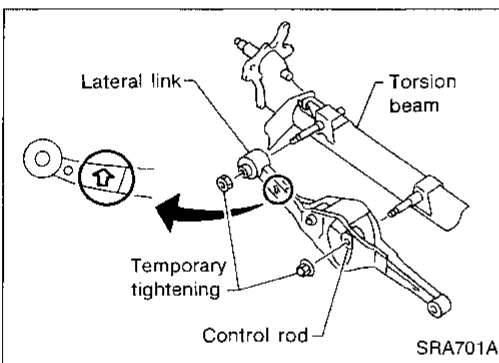

SRA701A

2. Temporarily install lateral link and control rod on torsion beam.
 - Install lateral link with the arrow upward.

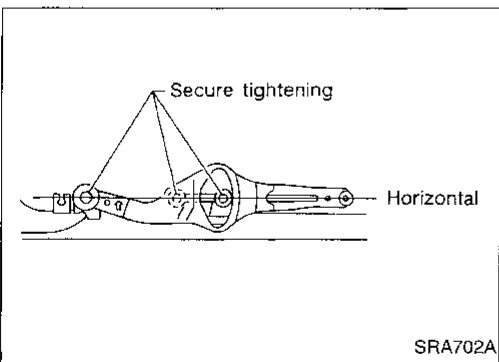

SRA702A

3. Ensure lateral link and control rod are horizontal against torsion beam, and tighten to the specified torque. Refer to RA-8.
4. Install torsion beam assembly. Refer to RA-9.

SERVICE DATA AND SPECIFICATIONS (SDS)

General Specifications

Shock absorber	Double-acting hydraulic
----------------	-------------------------

Inspection and Adjustment

WHEEL ALIGNMENT (Unladen*)

Camber	Minimum	-1°45' (-1.75°)
	Nominal	-1°00' (-1.00°)
	Maximum	-0°15' (-0.25°)
Degree minute (Decimal degree)		
Total toe-in	Minimum	-3 (-0.12)
	Nominal	1 (0.04)
	Maximum	5 (0.20)
Distance (A - B) mm (in)		
Angle (left plus right)	Minimum	-18' (-0.30°)
	Nominal	6' (0.10°)
	Maximum	30' (0.50°)
Degree minute (Decimal degree)		

*: Fuel, radiator coolant and engine oil full. Spare tire, jack, hand tools and mats in designated positions.

WHEEL BEARING

Wheel bearing axial end play mm (in)	0.05 (0.0020)
Wheel bearing lock nut tightening torque N·m (kg·m, ft·lb)	187 - 255 (19 - 26, 137 - 188)