

ENGINE LUBRICATION & COOLING SYSTEMS

SECTION **LC**

GI

MA

EM

LC

EC

PE

CL

MT

AT

FA

RA

BR

ST

RS

BT

HA

EL

IDX

CONTENTS

PRECAUTIONS	2
Liquid Gasket Application Procedure.....	2
PREPARATION	3
Special Service Tools.....	3

SR

ENGINE LUBRICATION SYSTEM	4
Lubrication Circuit	4
Oil Pressure Check	4
Oil Pump	5
Oil Filter.....	7
ENGINE COOLING SYSTEM	8
Cooling Circuit.....	8
System Check.....	8
Water Pump	9
Thermostat	10
Water Outlet.....	11
Radiator.....	12

GA

ENGINE LUBRICATION SYSTEM	13
----------------------------------------	----

Lubrication Circuit	13
Oil Pressure Check.....	14
Oil Pump	15
ENGINE COOLING SYSTEM	17
Cooling Circuit.....	17
System Check.....	17
Water Hose Drawing.....	18
Water Pump	20
Thermostat	21
Water Outlet.....	22
Radiator.....	23

SR, GA

ENGINE COOLING SYSTEM	24
Overheating Cause Analysis.....	24
SERVICE DATA AND SPECIFICATIONS (SDS)	25
Engine Lubrication System (SR)	25
Engine Cooling System (SR).....	25
Engine Lubrication System (GA)	25
Engine Cooling System (GA).....	25

PRECAUTIONS

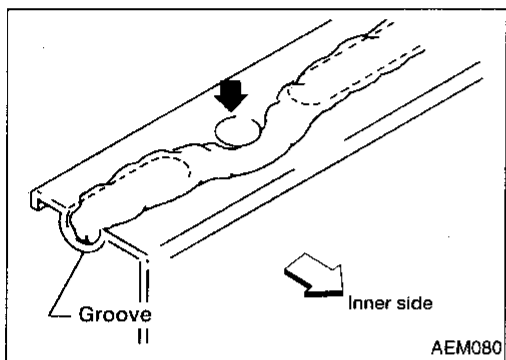
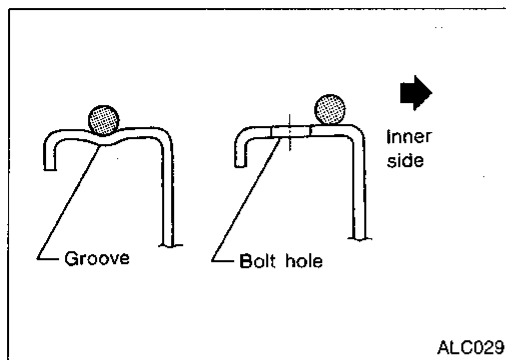

Liquid Gasket Application Procedure

- a. Use a scraper to remove all traces of old liquid gasket from mating surfaces and grooves. Also, completely clean any oil from these areas.
- b. Apply a continuous bead of liquid gasket to mating surfaces. (Use Genuine Liquid Gasket or equivalent.)
 - For oil pan, be sure liquid gasket diameter is 4.0 to 5.0 mm (0.157 to 0.197 in) for SR engine and 3.5 to 4.5 mm (0.138 to 0.177 in) for GA engine.
 - For areas except oil pan, be sure liquid gasket diameter is 2.0 to 3.0 mm (0.079 to 0.118 in).
- c. Apply liquid gasket around the inner side of bolt holes (unless otherwise specified).
- d. Assembly should be done within 5 minutes after coating.
- e. Wait at least 30 minutes before refilling engine oil and engine coolant.

PREPARATION

Special Service Tools

The actual shapes of Kent-Moore tools may differ from those of special service tools illustrated here.

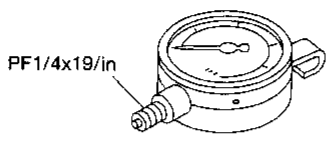
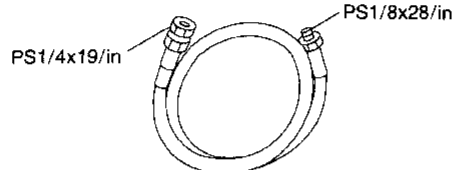
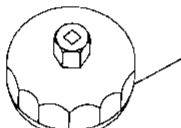
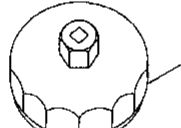
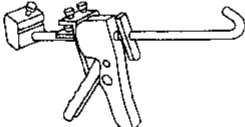
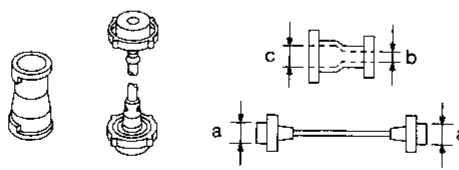
Tool number (Kent-Moore No.) Tool name	Description	Engine application		
		SR	GA	
ST25051001 (J25695-1) Oil pressure gauge	 <p>PF1/4x19/in</p> <p>NT558</p>	Measuring oil pressure	X	X
ST25052000 (J25695-2) Hose	 <p>PS1/4x19/in</p> <p>PS1/8x28/in</p> <p>NT559</p>	Adapting oil pressure gauge to cylinder block	X	X
KV10115801 (J38956) Oil filter wrench	 <p>14 faces, Inner span: 64.3 mm (2.531 in) (Face to opposite face)</p> <p>NT362</p>	Removing oil filter	X	—
KV10105900 (J34274) Oil filter wrench	 <p>15 faces Inner span 80 mm (3.15 in) (Face to opposite face)</p> <p>NT646</p>	Removing oil filter	—	X
WS39930000 (—) Tube presser	 <p>NT052</p>	Pressing the tube of liquid gasket	X	X
EG17650301 (J33984-A) Radiator cap tester adapter	 <p>NT564</p>	Adapting radiator cap tester to radiator filler neck	X	X

GI

MA

EM

LC

EC

FE

CL

MT

AT

FA

PA

BR

ST

RS

BT

HA

EL

IDX

Lubrication Circuit

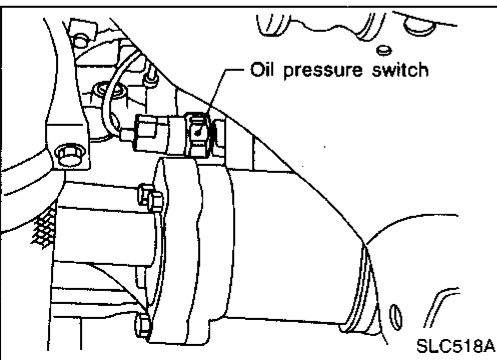
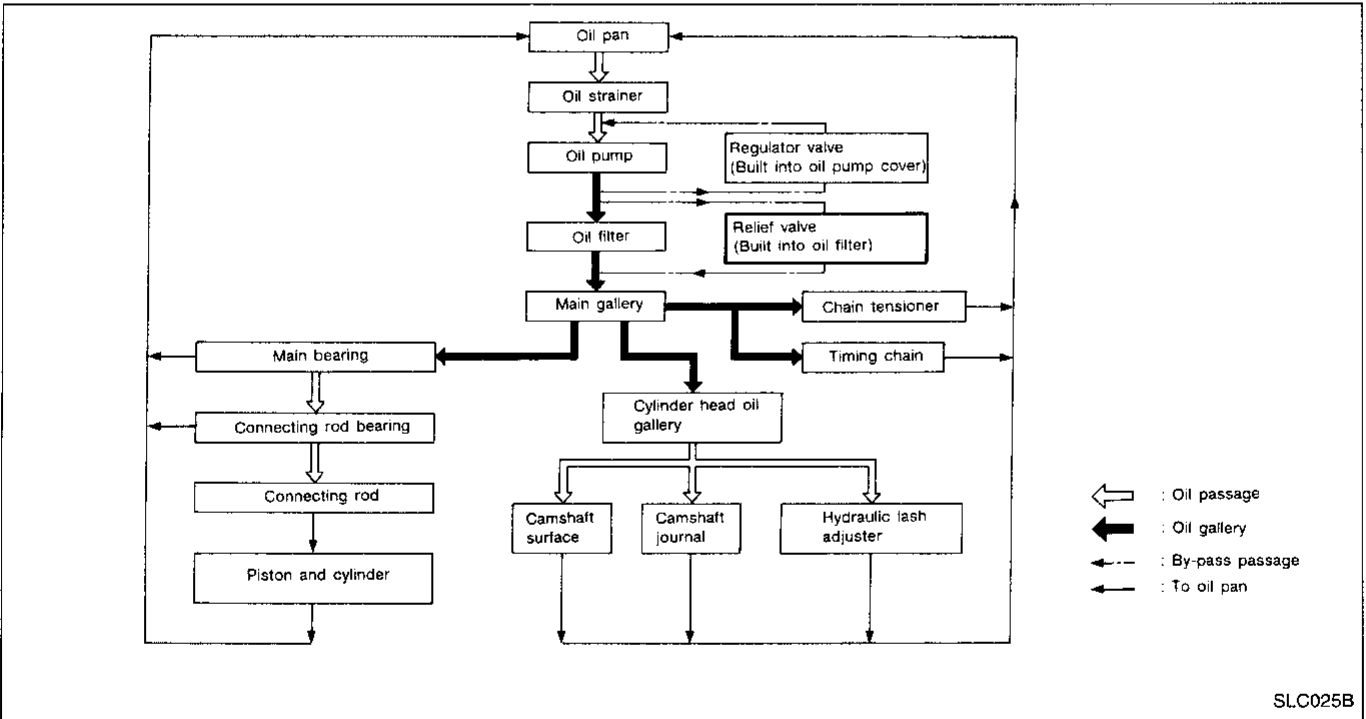
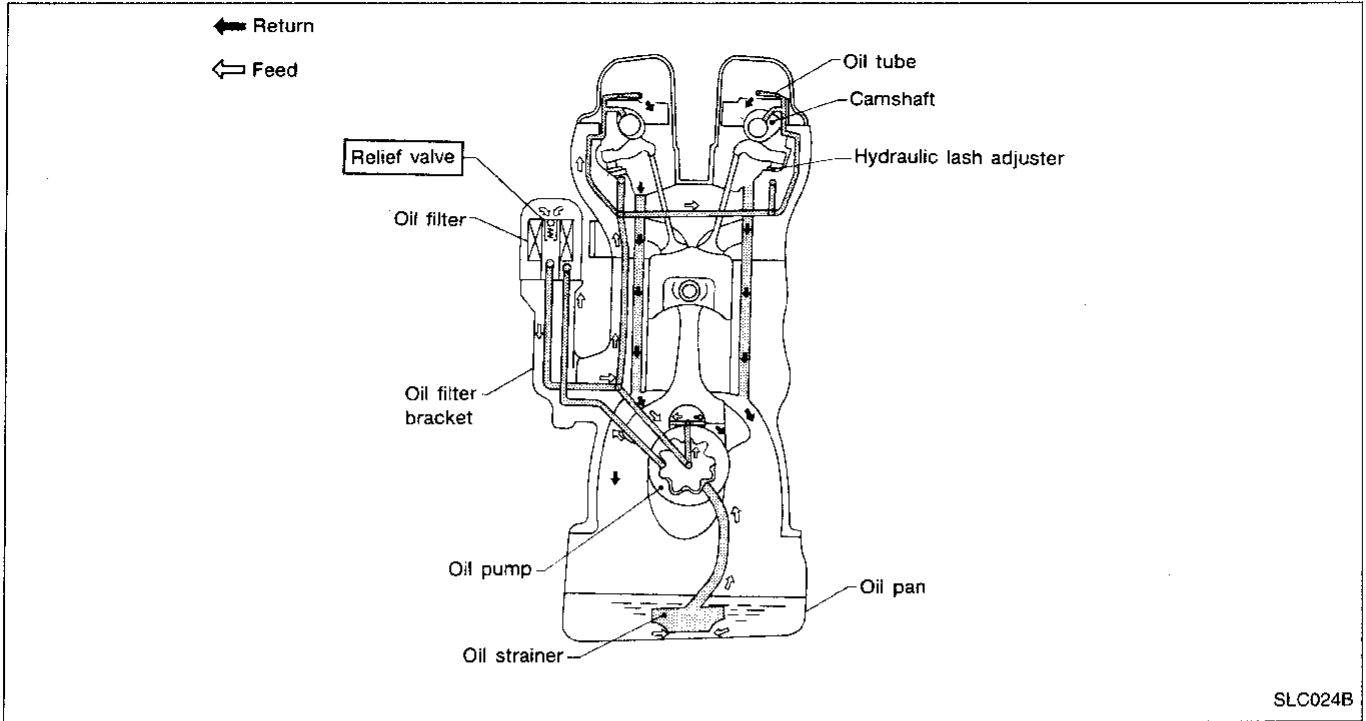

Oil Pressure Check

WARNING:

- Be careful not to burn yourself, as the engine and oil may be hot.
- For M/T models, put gearshift lever in Neutral "N" position. For A/T models, put selector lever in Park "P" position.

1. Check oil level.
2. Remove oil pressure switch.

Oil Pressure Check (Cont'd)

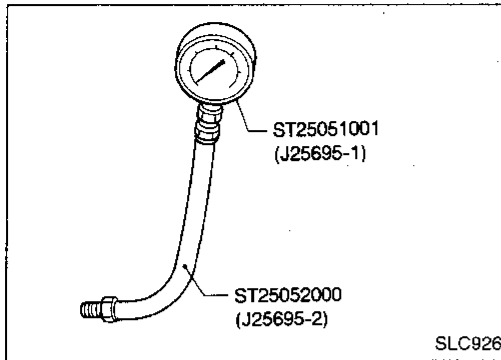

3. Install pressure gauge.
4. Start engine and warm it up to normal operating temperature.
5. Check oil pressure with engine running under no-load.

Engine speed rpm	Approximate discharge pressure kPa (kg/cm ² , psi)
Idle speed	More than 78 (0.8, 11)
3,200	314 - 392 (3.2 - 4.0, 46 - 57)

- **If difference is extreme, check oil passage and oil pump for oil leaks.**
6. Install oil pressure switch with sealant.

Oil Pump

REMOVAL

1. Remove drive belts.
2. Remove cylinder head. Refer to EM section ("Removal", "CYLINDER HEAD").
3. Remove oil pans. Refer to EM section ("Removal", "OIL PAN").
4. Remove oil strainer and baffle plate.
5. Remove front cover assembly.

DISASSEMBLY AND ASSEMBLY

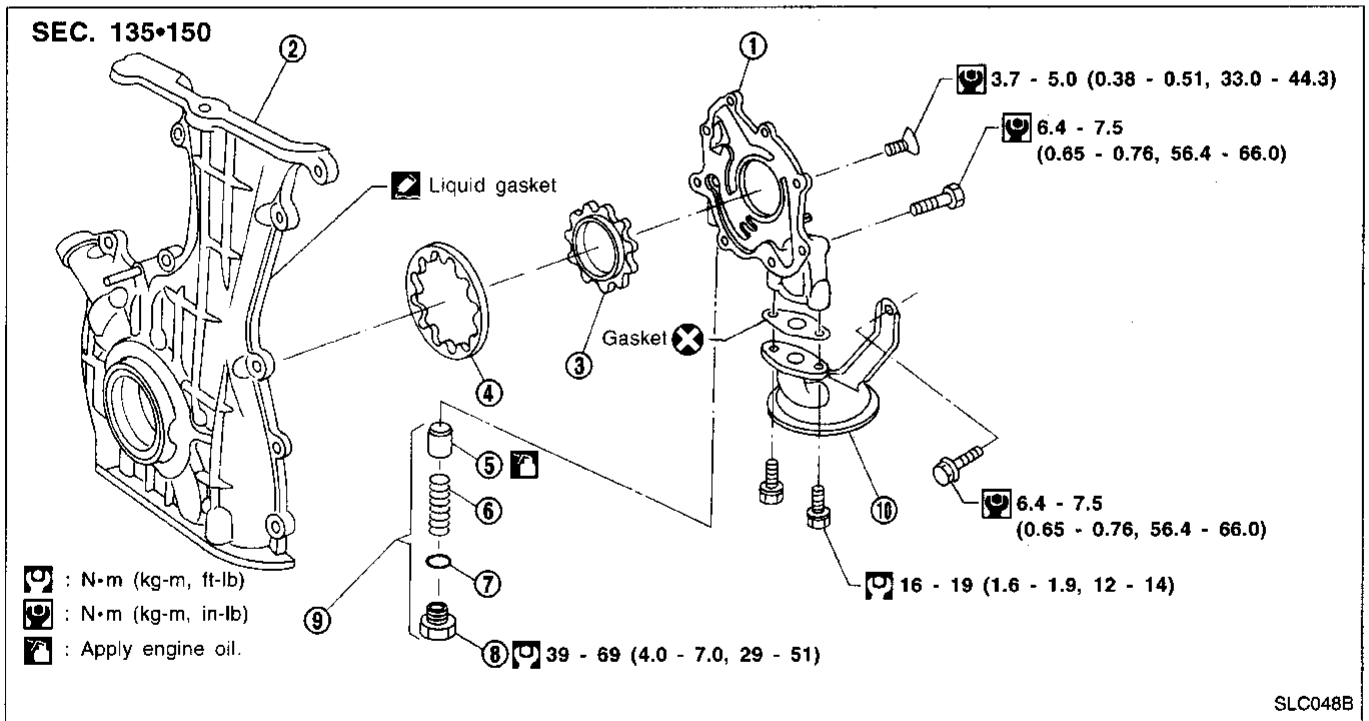

- | | | |
|------------------|-------------------|-------------------|
| ① Oil pump cover | ④ Outer gear | ⑦ Shim |
| ② Front cover | ⑤ Regulator valve | ⑧ Plug |
| ③ Inner gear | ⑥ Spring | ⑨ Regulator valve |
| | | ⑩ Oil strainer |

Oil Pump (Cont'd) INSPECTION

Using a feeler gauge, check the following clearances:

Standard clearance:

Unit: mm (in)

Body to outer gear radial clearance ①	0.114 - 0.200 (0.0045 - 0.0079)
Inner gear to outer gear tip clearance ②	Below 0.18 (0.0071)
Body to inner gear clearance ③	0.05 - 0.09 (0.0020 - 0.0035)
Body to outer gear axial clearance ④	0.05 - 0.11 (0.0020 - 0.0043)
Inner gear to brazed portion of housing clearance ⑤	0.045 - 0.091 (0.0018 - 0.0036)

- If the tip clearance (②) exceeds the limit, replace gear set.
- If body to gear clearances (① , ③ , ④ , ⑤) exceed the limit, replace front cover assembly.

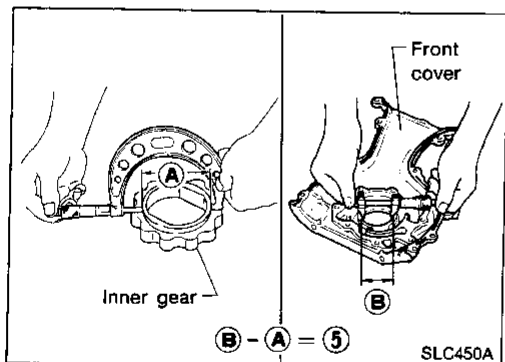
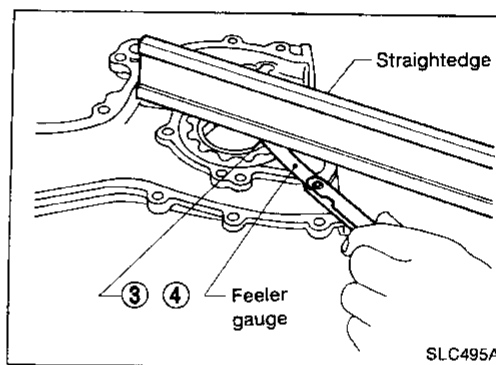
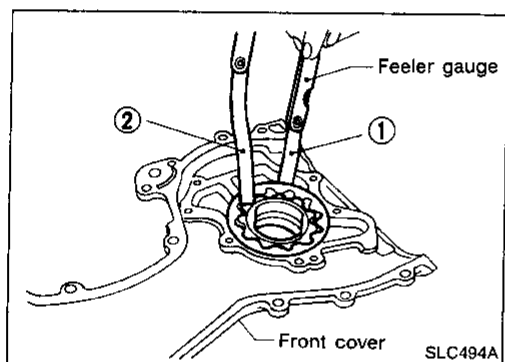

SLC854A

Oil Pump (Cont'd)

REGULATOR VALVE INSPECTION

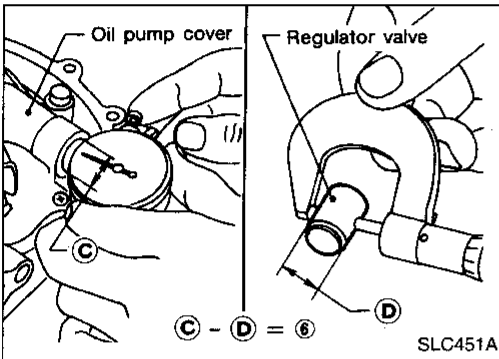
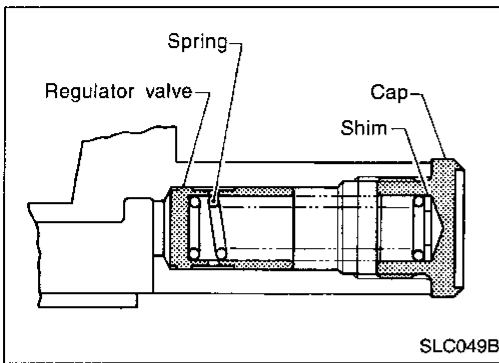

1. Visually inspect components for wear and damage.
 2. Check oil pressure regulator valve sliding surface and valve spring.
 3. Coat regulator valve with engine oil. Check that it falls smoothly into the valve hole by its own weight.
- **If damaged, replace regulator valve set or oil pump assembly.**

4. Check regulator valve to oil pump cover clearance.
- Clearance:**

⑥ : 0.040 - 0.097 mm (0.0016 - 0.0038 in)

- **If it exceeds the limit, replace oil pump cover.**

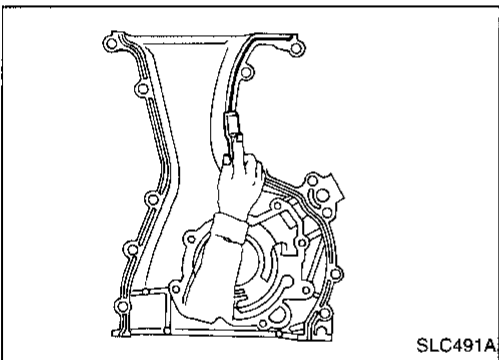

INSTALLATION

- **Always replace oil seal and O-ring with new ones. Refer to EM section ("OIL SEAL REPLACEMENT").**
- **When installing oil pump, apply engine oil to gears.**
- **Be sure that O-rings are properly fitted.**
- **Use a scraper to remove old liquid gasket from mating surface of front cover.**
- **Also remove traces of liquid gasket from mating surface of cylinder block.**

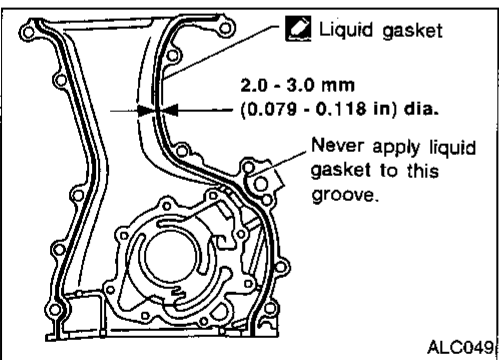

1. Apply a continuous bead of liquid gasket to mating surface of front cover assembly.
- **Use Genuine Liquid Gasket or equivalent.**
2. Installation is the reverse order of removal.

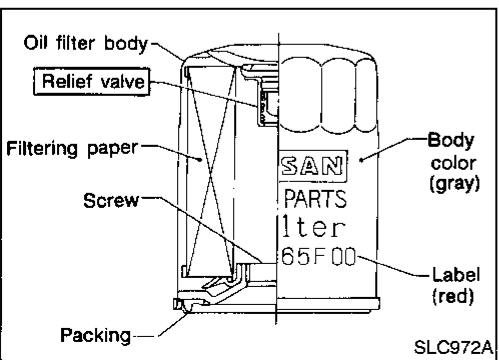

Oil Filter

The oil filter is a small, full-flow cartridge type and is provided with a relief valve.

- **The new and previous oil filter designs differ from each other and are not interchangeable.**
- **Use Tool KV10115801 (J38956) for removing oil filter.**

Cooling Circuit

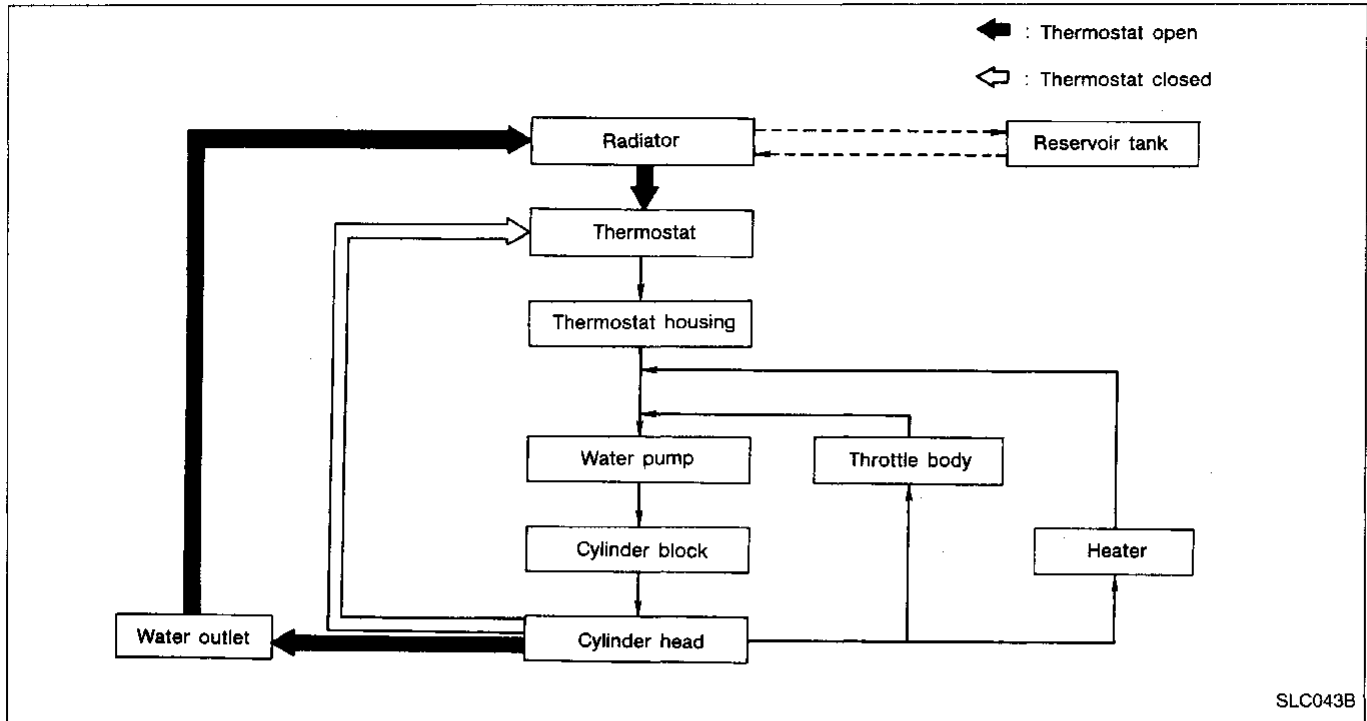

System Check

WARNING:

Never remove the radiator cap when the engine is hot. Serious burns could occur from high pressure coolant escaping from the radiator.

Wrap a thick cloth around the cap. Slowly turn it a quarter turn to allow built-up pressure to escape. Carefully remove the cap by turning it all the way.

CHECKING COOLING SYSTEM HOSES

Check hoses for the following:

- Improper attachment
- Leaks
- Cracks
- Damage
- Chafing
- Deterioration

CHECKING COOLING SYSTEM FOR LEAKS

To check for leakage, apply pressure to the cooling system with a tester.

Testing pressure:

157 kPa (1.6 kg/cm², 23 psi)

CAUTION:

Higher pressure than specified may cause radiator damage.

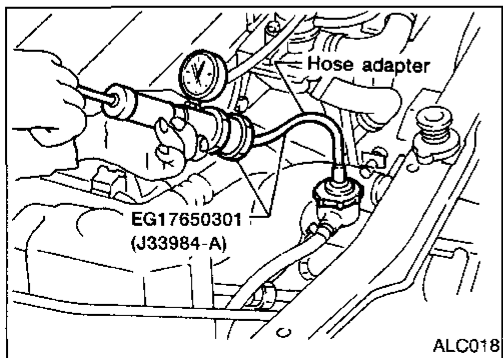

System Check (Cont'd) CHECKING RADIATOR CAP

To check radiator cap, apply pressure to cap with a tester.

Radiator cap relief pressure:

Standard

78 - 98 kPa (0.8 - 1.0 kg/cm², 11 - 14 psi)

Limit

59 - 98 kPa (0.6 - 1.0 kg/cm², 9 - 14 psi)

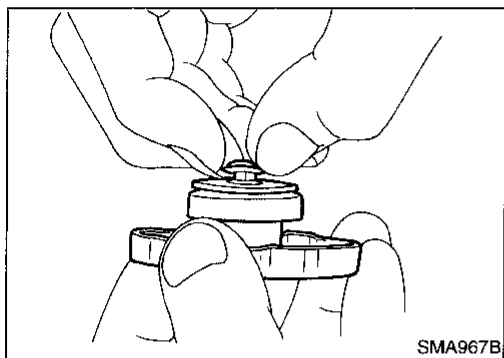
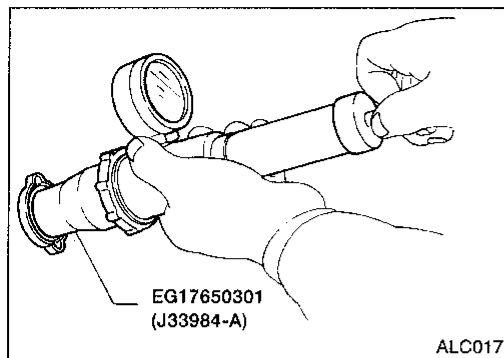

Pull the negative pressure valve to open it.
Check that it closes completely when released.

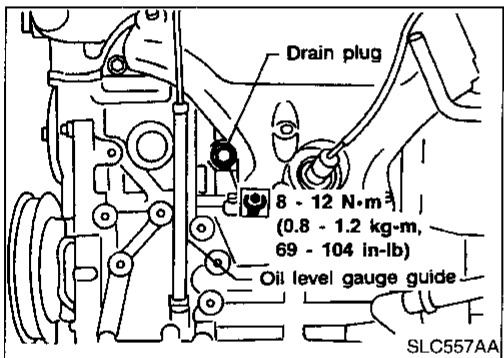

Water Pump

REMOVAL

1. Drain coolant from radiator and cylinder block.
Refer to MA section ("DRAINING ENGINE COOLANT", "Changing Engine Coolant").
2. Loosen water pump pulley bolts.
3. Remove drive belts.
4. Remove front RH wheel, engine side cover and front cover.
5. Remove three lower water pump bolts.

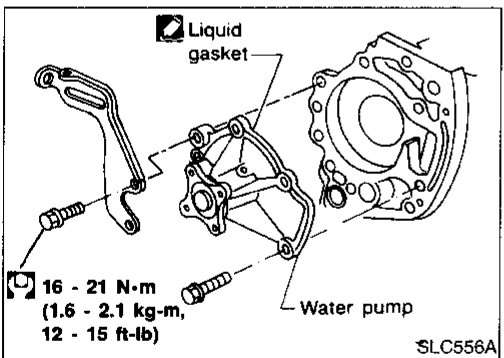

6. Position jack to support engine and remove front engine mount.
7. Remove remaining water pump bolt to remove water pump.

CAUTION:

- When removing water pump assembly, be careful not to get coolant on drive belt.
- Water pump cannot be disassembled and should be replaced as a unit.
- After installing water pump, connect hose and clamp securely, then check for leaks using radiator cap tester.

INSPECTION

- Check body assembly for rust or corrosion.
- Check for rough operation due to excessive end play.

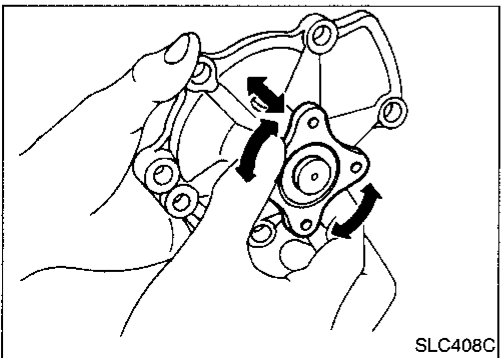

Water Pump (Cont'd)

INSTALLATION

1. Use a scraper to remove liquid gasket from water pump.
 - Also remove traces of liquid gasket from mating surface of cylinder block.

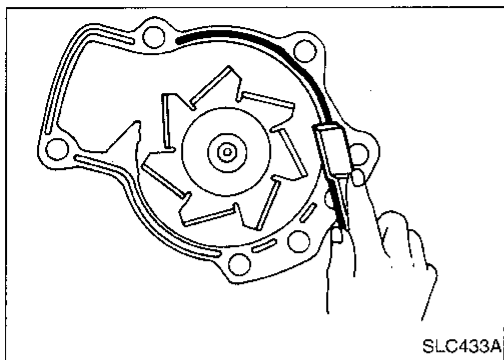

2. Apply a continuous bead of liquid gasket to mating surface of water pump.
 - Use Genuine Liquid Gasket or equivalent.

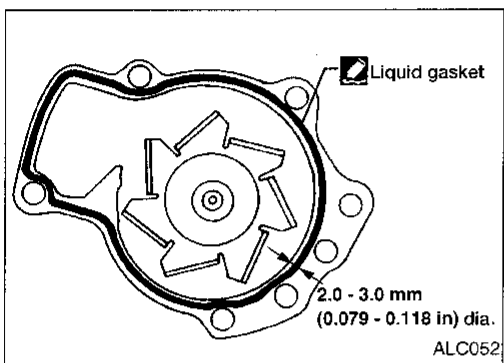

When filling radiator with coolant, refer to MA section ("REFILLING ENGINE COOLANT", "Changing Engine Coolant").

When installing drive belts, refer to MA section ("Checking Drive Belts", "ENGINE MAINTENANCE").

Thermostat

SEC. 210

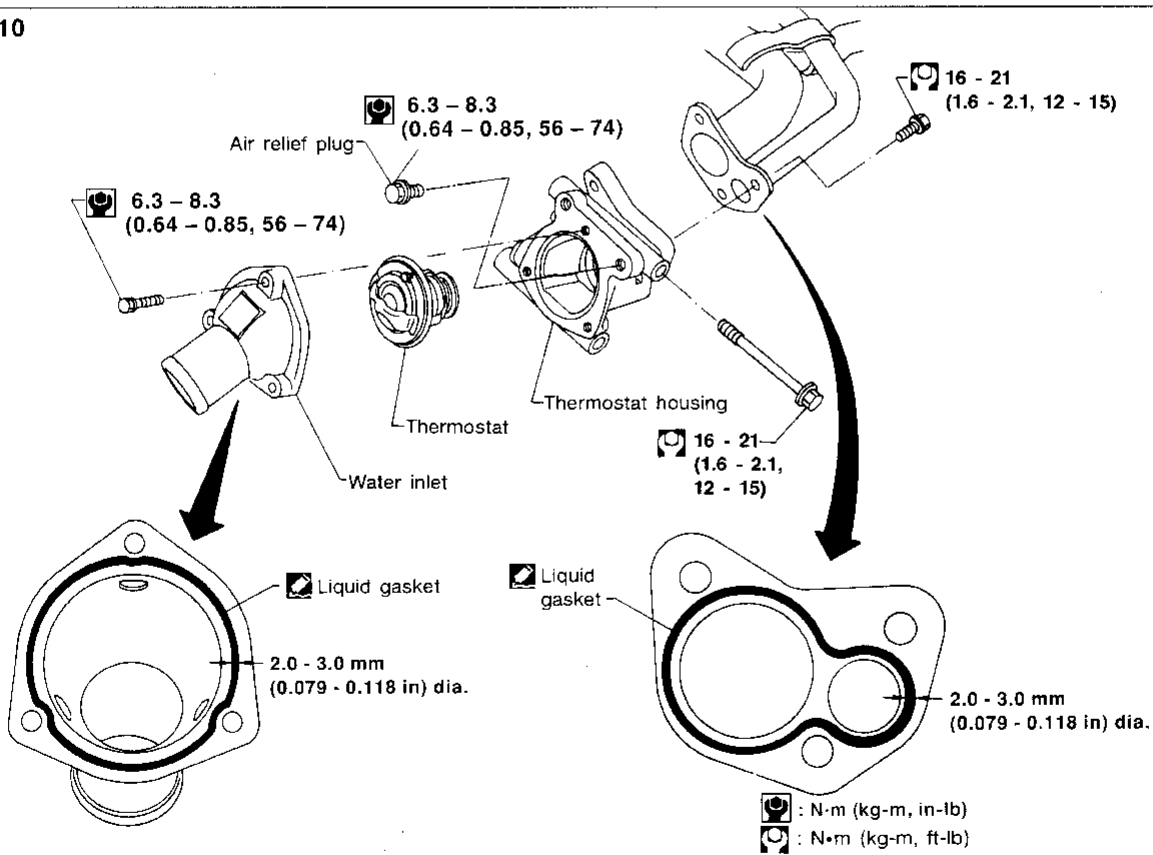

Thermostat (Cont'd)

Be careful not to spill coolant over engine compartment.
Use a rag to absorb coolant.

REMOVAL AND INSTALLATION

1. Drain engine coolant.
2. Remove lower radiator hose.
3. Remove water inlet, then take out thermostat.

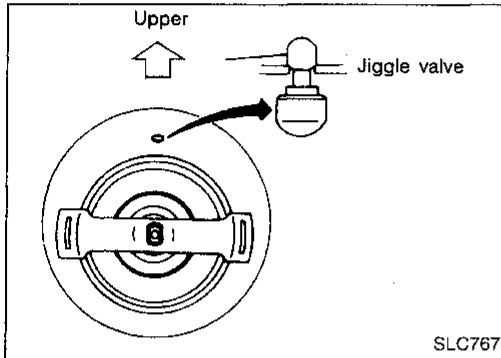

4. Install thermostat with jiggle valve or air bleeder at upper side.

- Apply a continuous bead of liquid gasket to mating surface of water inlet.
- After installation, run engine for a few minutes, and check for leaks.

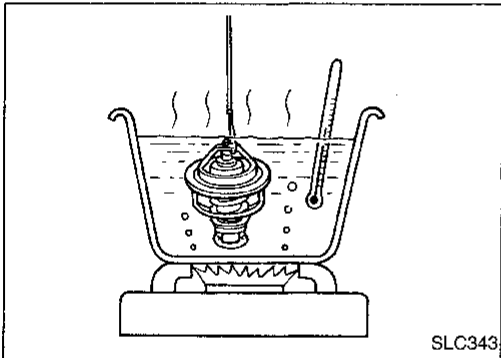

INSPECTION

1. Check for valve seating condition at normal room temperature. It should seat tightly.
2. Check valve opening temperature and valve lift.

Valve opening temperature	°C (°F)	76.5 (170)
Valve lift	mm/°C (in/°F)	More than 8/90 (0.31/194)

3. Then check if valve closes at 5°C (9°F) below valve opening temperature.

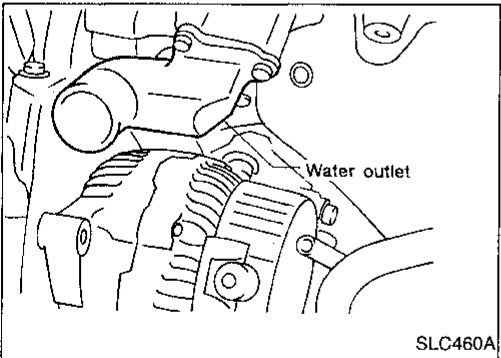

Water Outlet

INSPECTION

Visually inspect for water leaks. If there is leakage, apply liquid gasket.

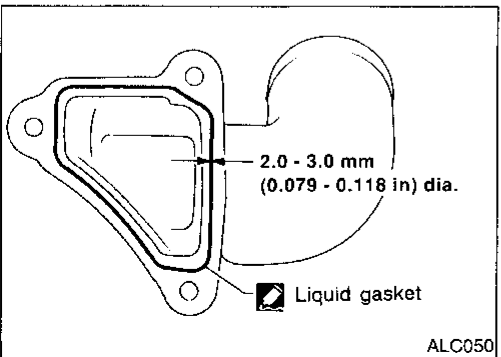

INSTALLATION

1. Use a scraper to remove old liquid gasket from water inlet.
 - Also remove traces of liquid gasket from mating surface of cylinder head.
2. Apply a continuous bead of liquid gasket to mating surface of water outlet.
 - Use Genuine Liquid Gasket or equivalent.

Radiator

SEC. 214

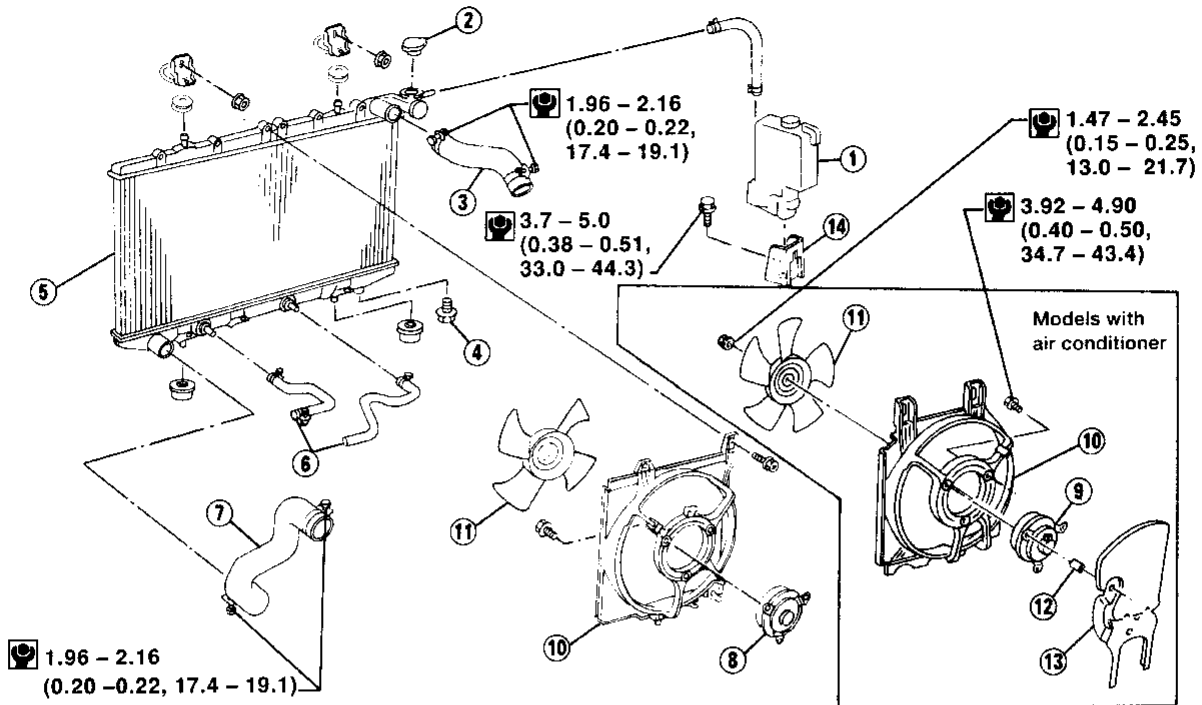

1.96 - 2.16
(0.20 - 0.22, 17.4 - 19.1)

: N·m (kg·m, in·lb)

ALC038

- | | | |
|-----------------------|---------------------------------|----------------------------|
| ① Reservoir tank | ⑥ Oil cooler hoses (A/T models) | ⑪ Cooling fan |
| ② Radiator cap | ⑦ Lower radiator hose | ⑫ Shield spacer |
| ③ Upper radiator hose | ⑧ Cooling fan motor-1 | ⑬ Cooling fan motor shield |
| ④ Radiator drain plug | ⑨ Cooling fan motor-2 | ⑭ Reservoir tank bracket |
| ⑤ Radiator | ⑩ Radiator shroud | |

Cooling fan control system

Cooling fans are controlled by the ECM. For details, refer to EC section ("Cooling Fan", "TROUBLE DIAGNOSIS FOR DTC P1900").

Refilling engine coolant

For details on refilling engine coolant, refer to MA section ("REFILLING ENGINE COOLANT", "Changing Engine Coolant").

Lubrication Circuit

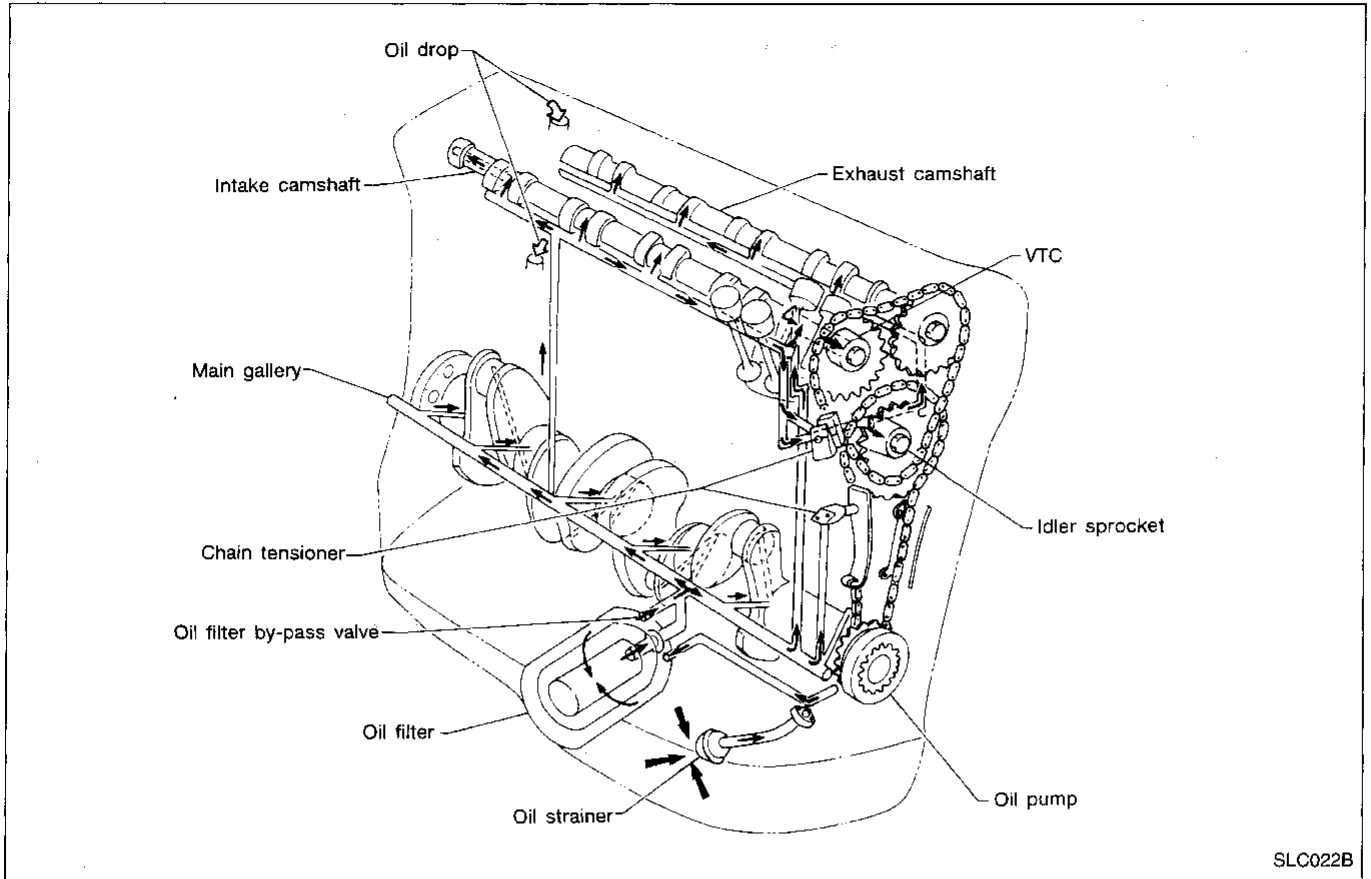

SLC022B

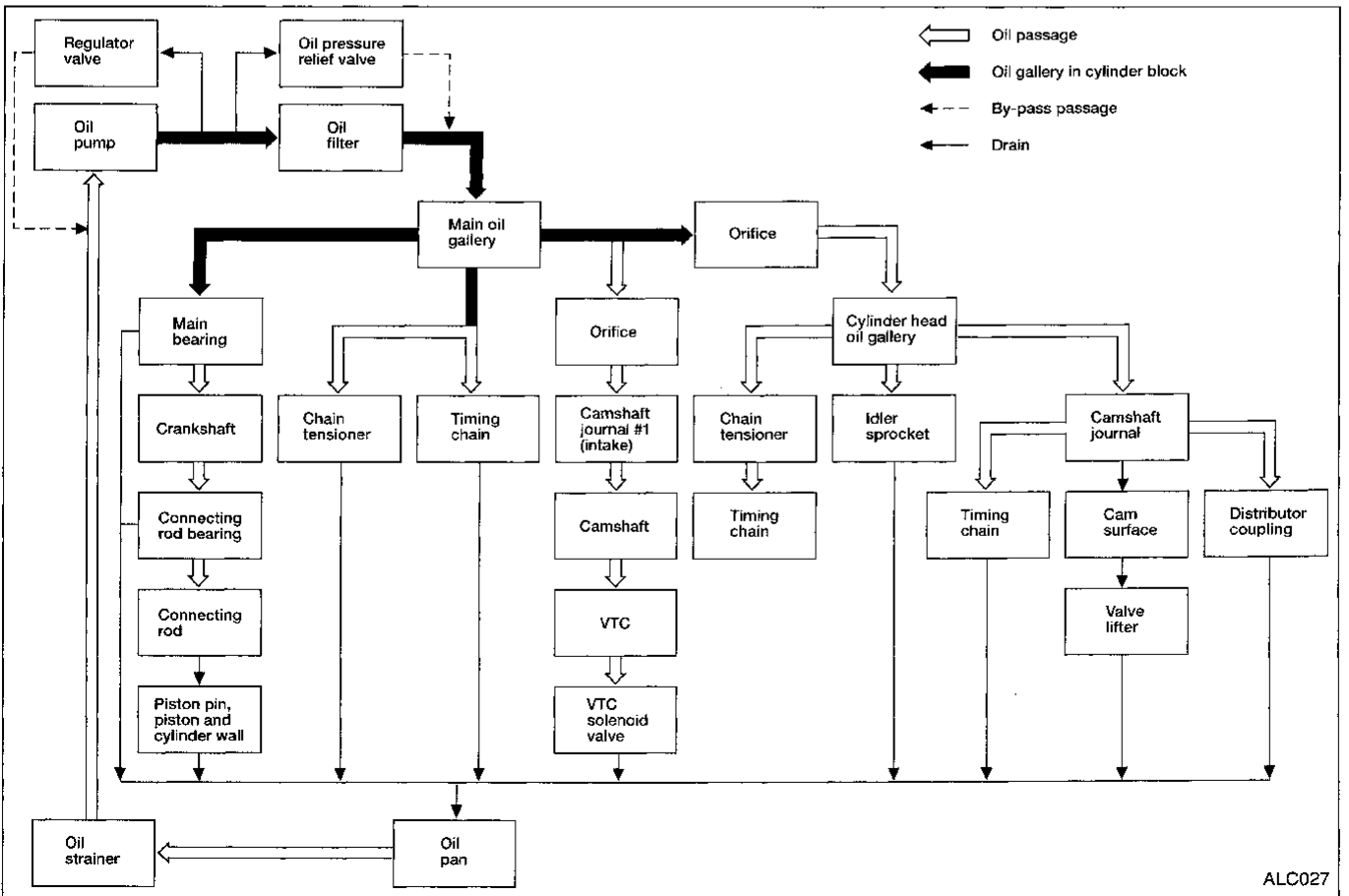

ALC027

GI
MA
EM
LC
EC
FE
CL
MT
AT
FA
RA
BR
ST
RS
BT
HA
EL
IDX

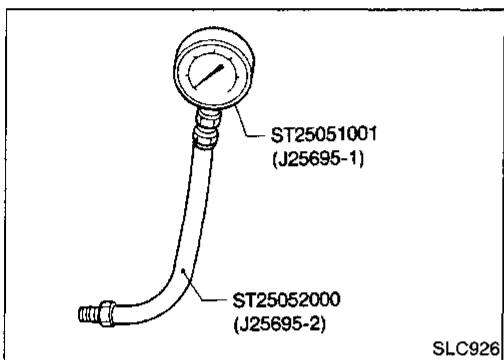
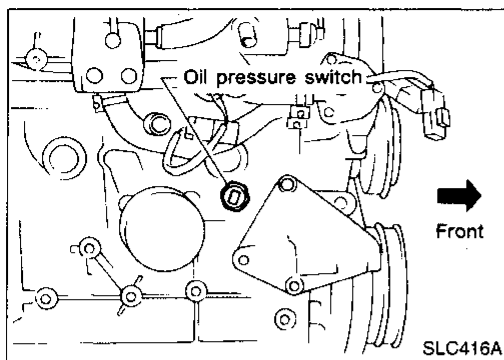

Oil Pressure Check

WARNING:

- Be careful not to burn yourself, as the engine and oil may be hot.
- For M/T models, put gearshift lever in Neutral “N” position. For A/T models, put selector lever in Park “P” position.

1. Check oil level.
2. Remove oil pressure switch.

3. Install pressure gauge.
4. Start engine and warm it up to normal operating temperature.
5. Check oil pressure with engine running under no-load.

Engine speed rpm	Approximate discharge pressure kPa (kg/cm ² , psi)
Idle speed	49 - 186 (0.5 - 1.9, 7 - 27)
3,000	343 - 441 (3.5 - 4.5, 50 - 64)

- If difference is extreme, check oil passage and oil pump for oil leaks.
6. Install oil pressure switch with sealant.

Oil Pump

REMOVAL AND INSTALLATION

- Always replace oil seal with a new one. Refer to EM section (“OIL SEAL REPLACEMENT”).
 - When installing oil pump, apply engine oil to gears.
 - Make sure that O-ring is fitted properly.
1. Drain engine oil.
 2. Remove drive belts.
 3. Remove cylinder head. Refer to EM section (“TIMING CHAIN”).
 4. Remove oil pan. Refer to EM section (“OIL PAN”).
 5. Remove oil strainer.
 6. Remove front cover.
 7. Install front cover. Refer to EM section (“TIMING CHAIN”).
 8. Reinstall any parts in reverse order of removal.

DISASSEMBLY AND ASSEMBLY

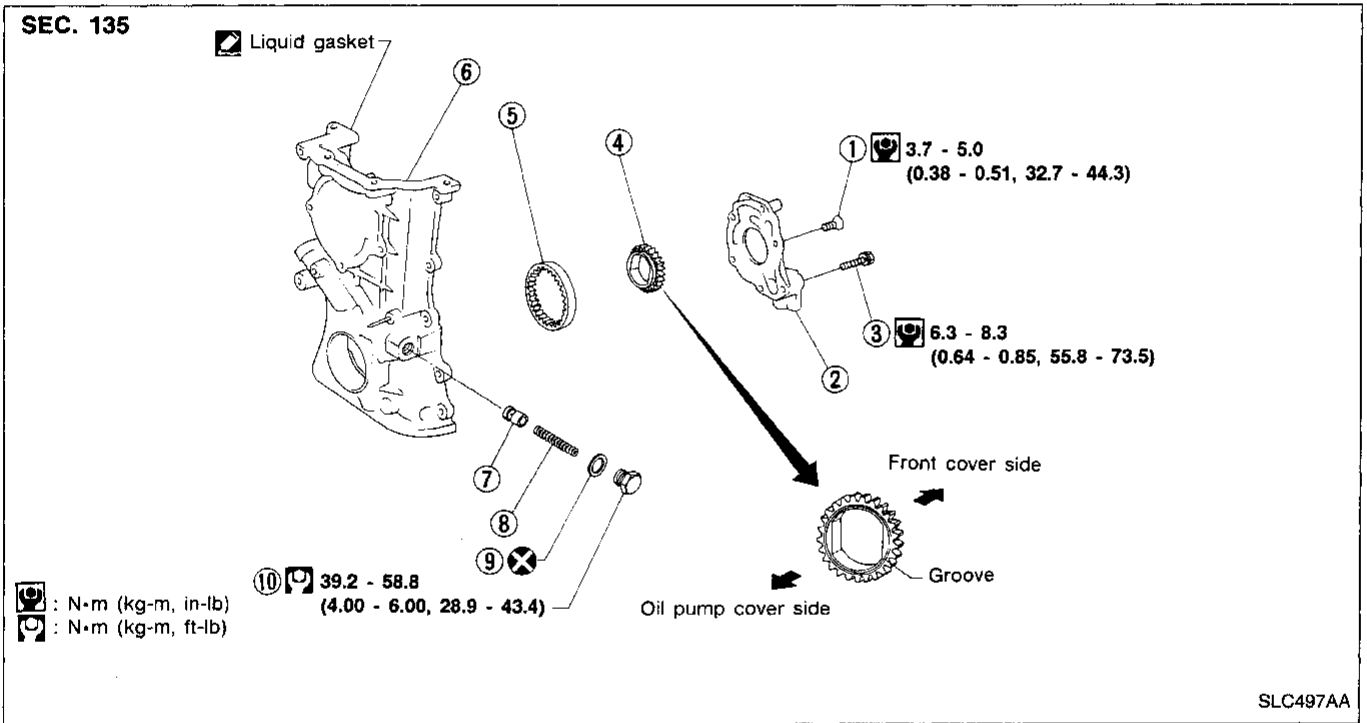

- | | | |
|------------------|-------------------|----------|
| ① Screw | ⑤ Outer gear | ⑧ Spring |
| ② Oil pump cover | ⑥ Front cover | ⑨ Washer |
| ③ Bolt | ⑦ Regulator valve | ⑩ Plug |
| ④ Inner gear | | |

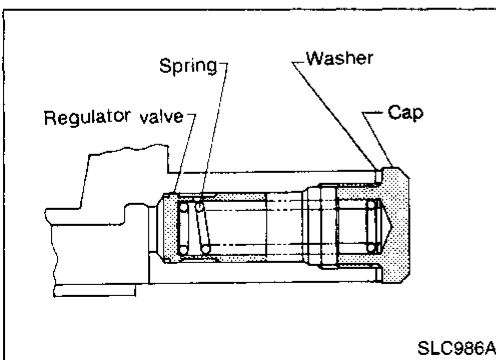

REGULATOR VALVE INSPECTION

1. Visually inspect components for wear and damage.
 2. Check oil pressure regulator valve sliding surface and valve spring.
 3. Coat regulator valve with engine oil. Check that it falls smoothly into the valve hole by its own weight.
- If damaged, replace regulator valve set or oil pump assembly.

Oil Pump (Cont'd)

OIL PRESSURE RELIEF VALVE INSPECTION

Inspect oil pressure relief valve for movement, cracks and breaks by pushing the ball. If replacement is necessary, remove valve by prying it out with suitable tool. Install a new valve in place by tapping it.

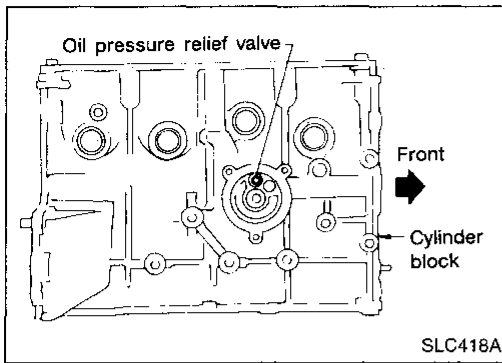

OIL PUMP INSPECTION

Using a feeler gauge, check the following clearances.

Standard clearance:

Unit: mm (in)

Body to outer gear radial clearance (1)	0.110 - 0.200 (0.0043 - 0.0079)
Inner gear to crescent clearance (2)	0.217 - 0.327 (0.0085 - 0.0129)
Outer gear to crescent clearance (3)	0.21 - 0.32 (0.0083 - 0.0126)
Body to inner gear clearance (4)	0.05 - 0.09 (0.0020 - 0.0035)
Body to outer gear axial clearance (5)	0.05 - 0.11 (0.0020 - 0.0043)
Inner gear to brazed portion of housing clearance (6)	0.045 - 0.091 (0.0018 - 0.0036)

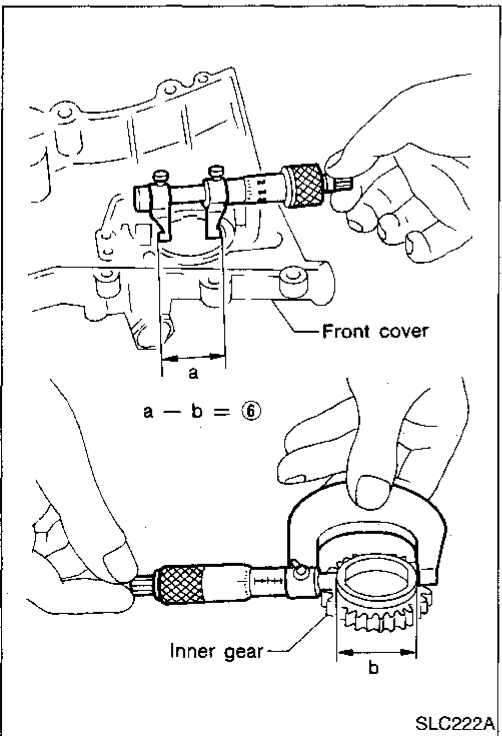
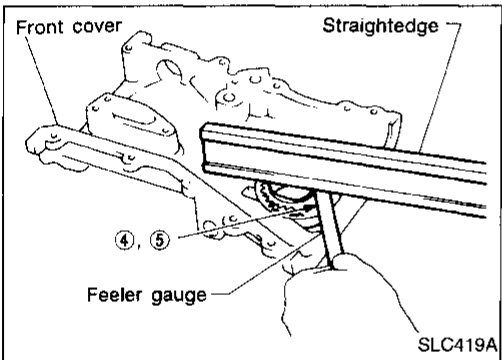
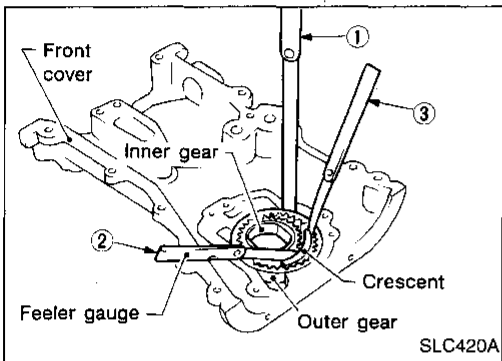

- If the tip clearance (2) exceeds the limit, replace gear set.
- If body to gear clearances (1 , 3 , 4 , 5 , 6) exceed the limit, replace front cover assembly.

Cooling Circuit

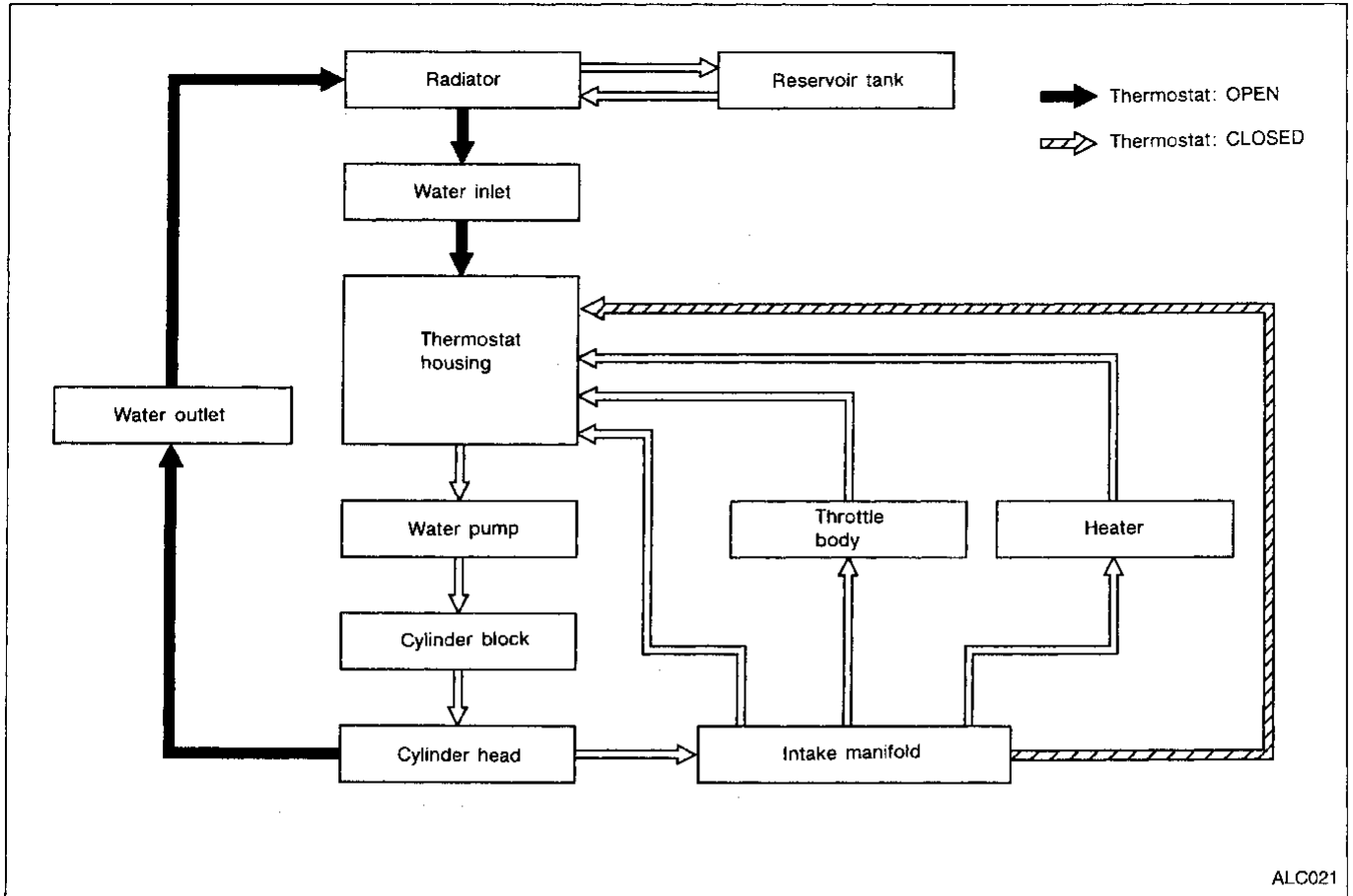

ALC021

System Check

WARNING:

Never remove the radiator cap when the engine is hot. Serious burns could occur from high pressure fluid escaping from the radiator.

Wrap a thick cloth around the cap. Slowly turn it a quarter turn to allow built-up pressure to escape. Carefully remove the cap by turning it all the way.

CHECKING COOLING SYSTEM HOSES

Check hoses for the following:

- Improper attachment
- Leaks
- Cracks
- Damage
- Chafing
- Deterioration

GI
MA
EM
LC
EC
FE
CL
MT
AT
FA
RA
BR
ST
RS
BT
HA
EL
IDX

Water Hose Drawing

SEC. 211

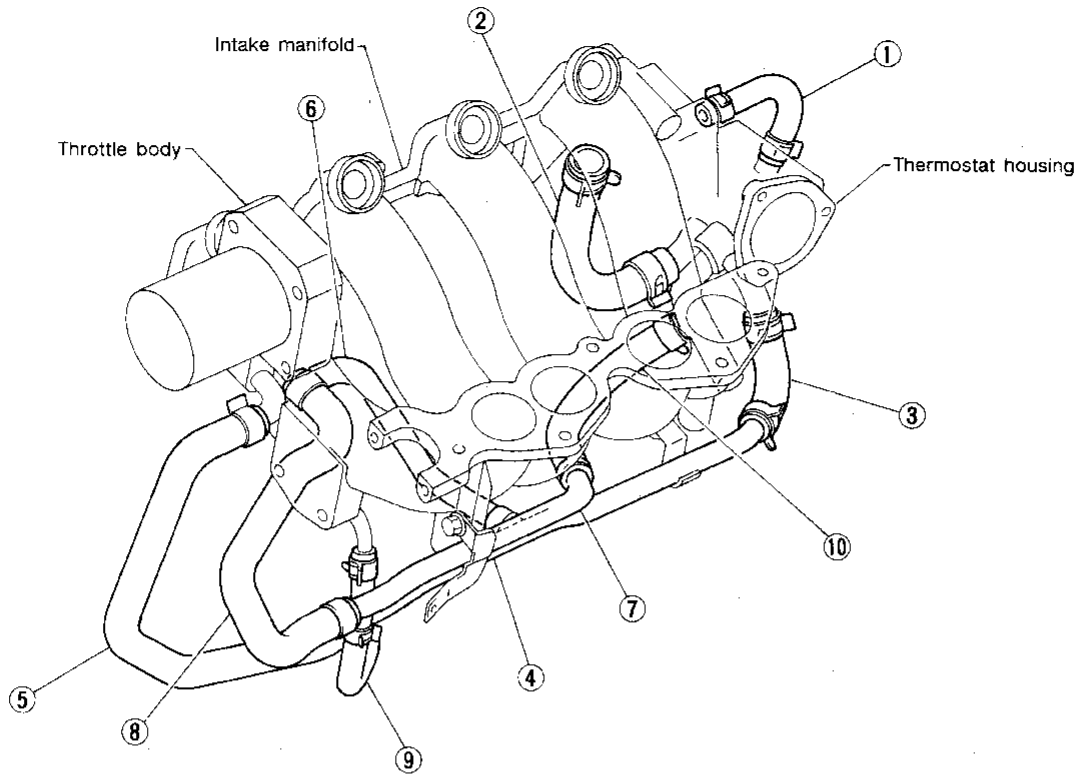

- | | | |
|-------------------------------------------------|---------------------------------------|------------------------------------------|
| ① Intake manifold to Thermostat housing (upper) | ④ Water pipe lower | ⑧ Throttle body to Water pipe upper |
| ② intake manifold to Thermostat housing (lower) | ⑤ Water pipe lower to Throttle body | ⑨ Intake manifold to Water pipe upper |
| ③ Water jacket to Water pipe lower | ⑥ Water pipe lower to Intake manifold | ⑩ Water pipe upper to Thermostat housing |
| | ⑦ Water pipe upper | |

ALC039

Water Hose Drawing (Cont'd)

CHECKING COOLING SYSTEM FOR LEAKS

To check for leakage, apply pressure to the cooling system with a tester.

Testing pressure:

157 kPa (1.6 kg/cm², 23 psi)

CAUTION:

Higher pressure than specified may cause radiator damage.

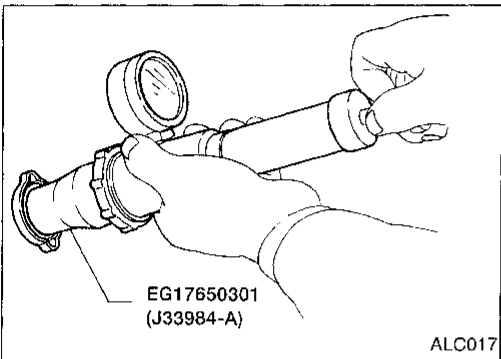
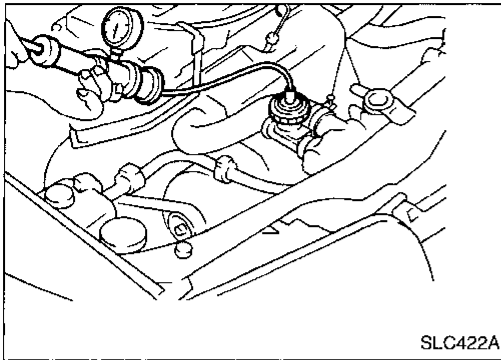

CHECKING RADIATOR CAP

To check radiator cap, apply pressure to cap with a tester.

Radiator cap relief pressure:

Standard

78 - 98 kPa (0.8 - 1.0 kg/cm², 11 - 14 psi)

Limit

59 - 98 kPa (0.6 - 1.0 kg/cm², 9 - 14 psi)

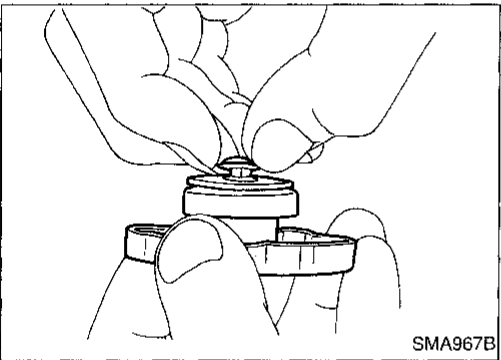

Pull the negative pressure valve to open it.

Check that it closes completely when released.

GI

MA

EM

LC

EC

FE

CL

MT

AT

FA

RA

BR

ST

RS

BT

HA

EL

IDX

Water Pump

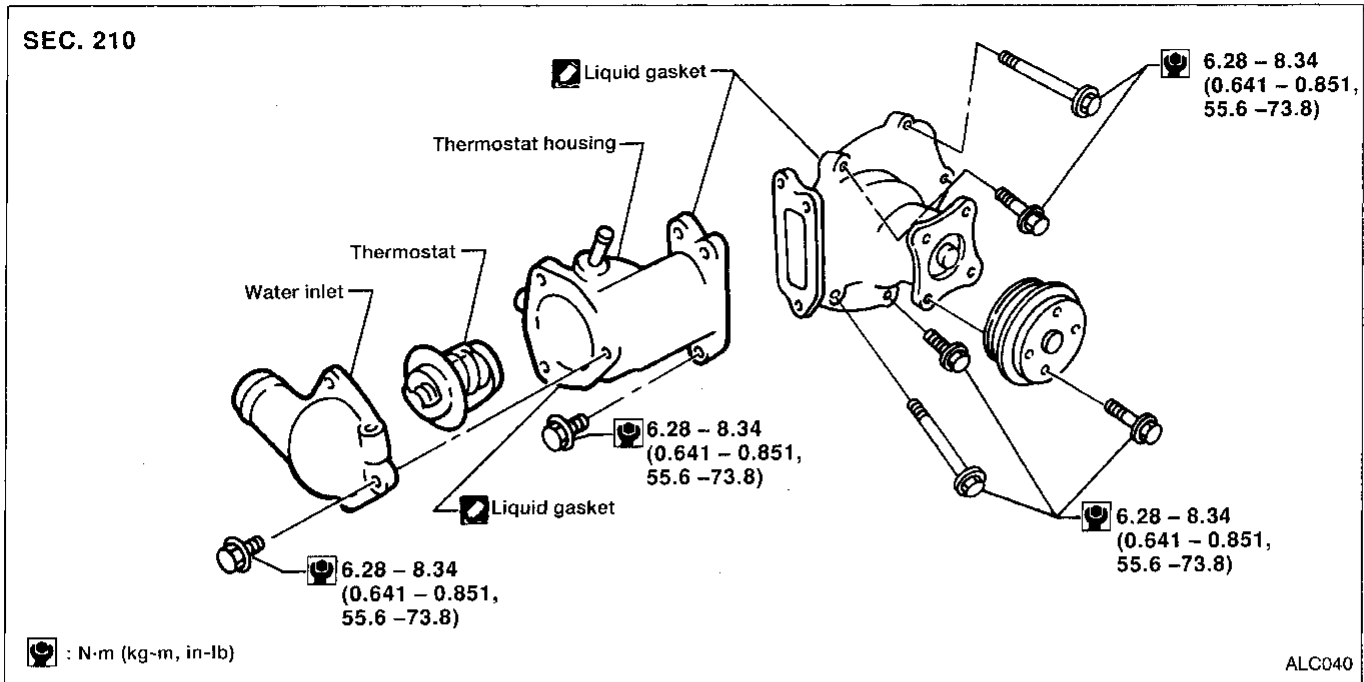

CAUTION:

- When removing water pump assembly, be careful not to get coolant on drive belt.
- Water pump cannot be disassembled and should be replaced as a unit.
- After installing water pump, connect hoses and clamps securely, then check for leaks using radiator cap tester.

REMOVAL

1. Drain coolant from radiator and cylinder block. Refer to MA section ("DRAINING ENGINE COOLANT", "Changing Engine Coolant").
2. Remove cylinder head front mounting bracket.
3. Loosen water pump pulley bolts.
4. Remove drive belts for power steering pump.
5. Remove water pump pulley.
6. Remove coolant hoses from water inlet and thermostat housing.
7. Remove water pump bolts.
8. Remove water pump with thermostat housing.

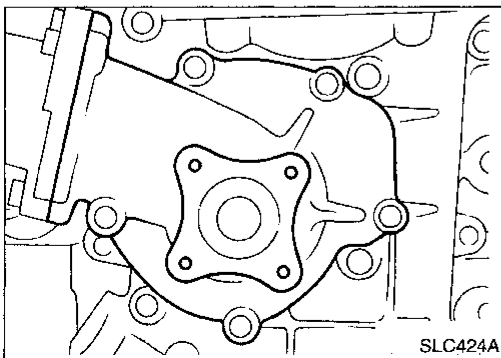

Water Pump (Cont'd)

INSPECTION

- Check body assembly and vane for rust or corrosion.
- Check for rough operation due to excessive end play.

GI
MA
EM

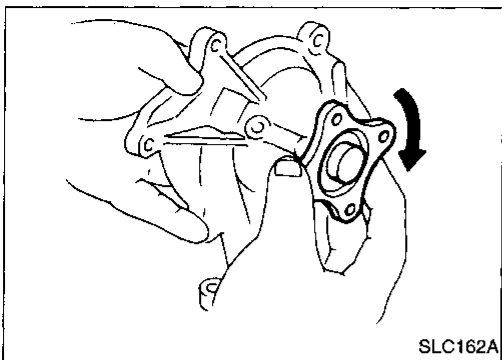

INSTALLATION

1. Use a scraper to remove liquid gasket from water pump and thermostat housing.
- Also remove old liquid gasket from mating surface of cylinder block.

LC
EC
FE

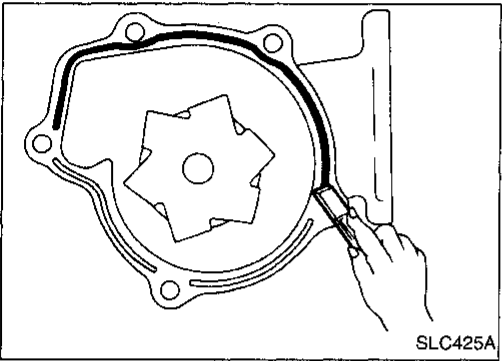

2. Apply a continuous bead of liquid gasket to mating surface of water pump.

- Use Genuine Liquid Gasket or equivalent.

When installing drive belts, refer to MA section ("Checking Drive Belts").

When filling radiator with coolant, refer to MA section ("REFILLING ENGINE COOLANT", "Changing Engine Coolant").

CL
MT

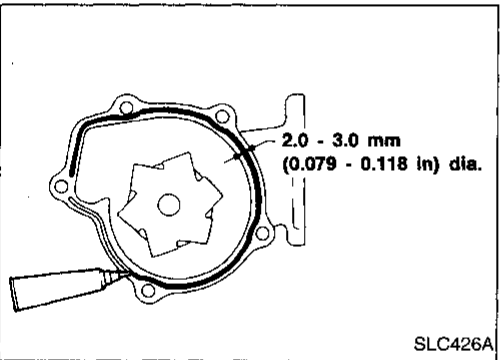

Thermostat

Be careful not to spill coolant over engine compartment. Use a rag to absorb coolant.

AT
FA
RA

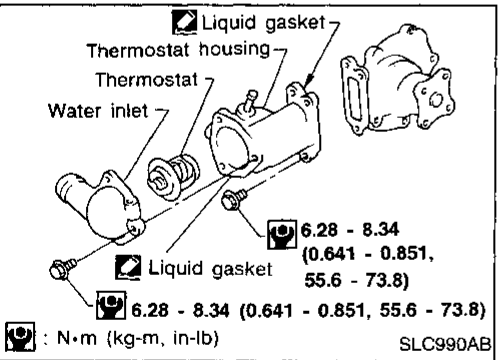

BR
ST

INSPECTION

1. Check for valve seating condition at normal room temperature. It should seat tightly.
2. Check valve opening temperature and valve lift.

Valve opening temperature	°C (°F)	76.5 (170)
Valve lift	mm/°C (in/°F)	More than 8/90 (0.31/194)

RS
BT

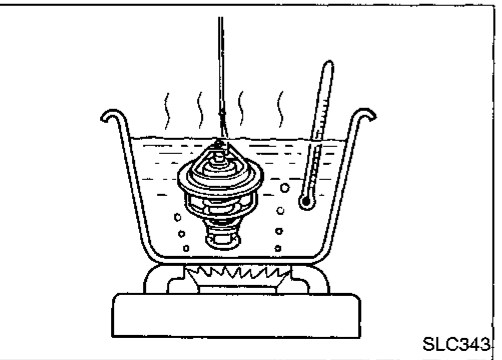

HA
EL

3. Then check if valve closes at 5°C (9°F) below valve opening temperature.

IDX

Thermostat (Cont'd) INSTALLATION

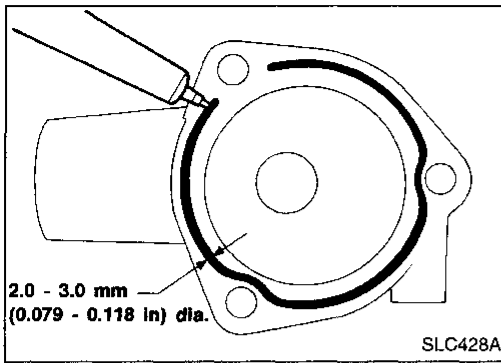

- When installing water inlet apply liquid gasket as shown.

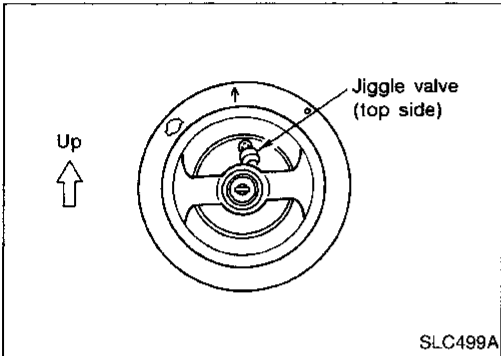

- Install thermostat with jiggle valve or air bleeder at upper side.

After installation, run engine for a few minutes, and check for leaks.

Water Outlet

INSPECTION

Visually inspect for water leaks. If there is leakage, apply liquid gasket.

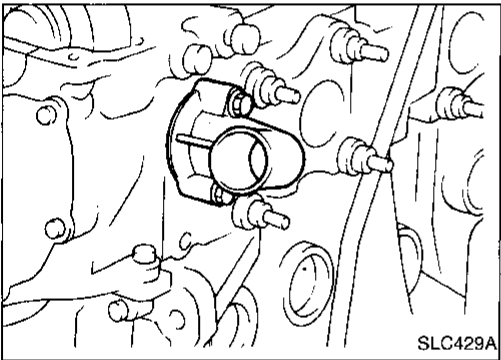

INSTALLATION

1. Use a scraper to remove old liquid gasket from water inlet.
- **Also remove traces of liquid gasket from mating surface of cylinder head.**
2. Apply a continuous bead of liquid gasket to mating surface of water outlet.
- **Use a Genuine Liquid Gasket or equivalent.**

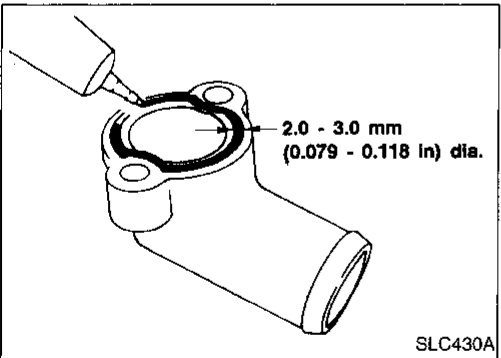

Radiator

SEC. 214

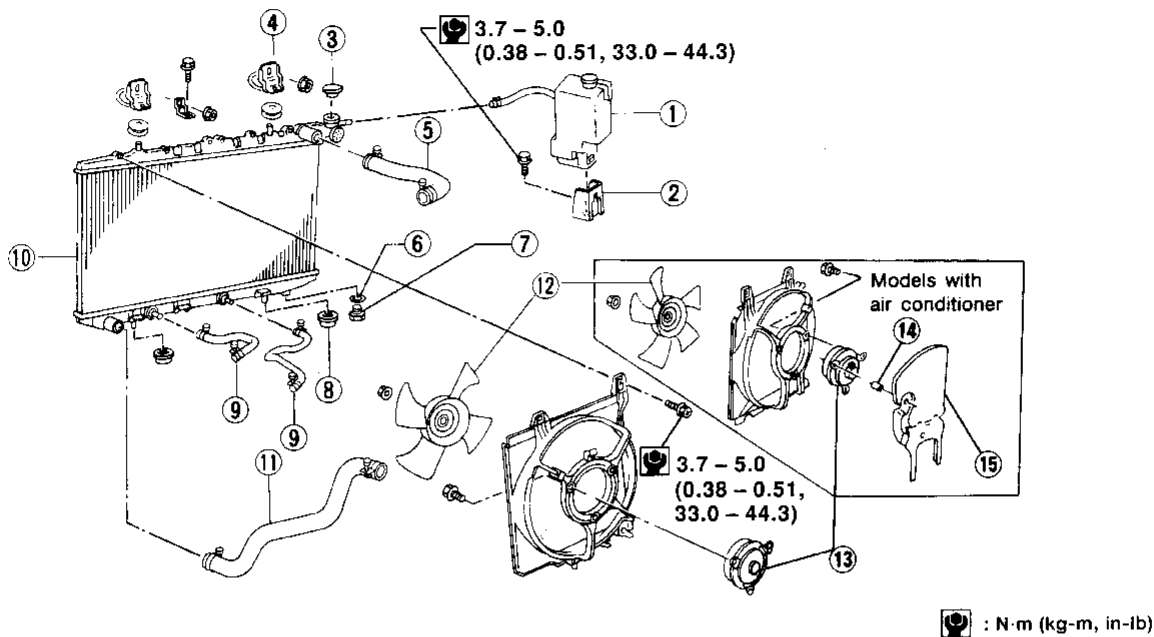

ALC041

- | | | |
|--------------------------|---------------------------------|----------------------------|
| ① Reservoir tank | ⑥ Washer | ⑪ Lower radiator hose |
| ② Reservoir tank bracket | ⑦ Radiator drain plug | ⑫ Cooling fan |
| ③ Radiator cap | ⑧ Mounting rubber | ⑬ Cooling fan motor |
| ④ Mounting bracket | ⑨ Oil cooler hoses (A/T models) | ⑭ Shield spacer |
| ⑤ Upper radiator hose | ⑩ Radiator | ⑮ Cooling fan motor shield |

Cooling fan control system

Cooling fans are controlled by the ECM. For details, refer to EC section ("Cooling Fan", "TROUBLE DIAGNOSIS FOR DTC P1900").

Refilling engine coolant

For details on refilling engine coolant, refer to MA section ("REFILLING ENGINE COOLANT", "Changing Engine Coolant").

GI
MA
EM
LC
EC
FE
CL
MT
AT
FA
RA
RS
BT
HA
EL
IDX

Overheating Cause Analysis

		Symptom	Check Items	
Cooling system parts malfunction	Poor heat transfer	Water pump malfunction	Worn or loose drive belt	---
		Thermostat stuck closed	---	
		Damaged fins	Dust contamination or paper clogging	
			Mechanical damage	
	Clogged radiator cooling tube	Excess foreign material (rust, dirt, sand, etc.)		
	Reduced air flow	Cooling fan does not operate	---	---
		High resistance to fan rotation		
		Damaged fan blades		
	Damaged radiator shroud	---	---	---
	Improper coolant mixture ratio	---	---	---
	Poor coolant quality	---	---	---
	Insufficient coolant	Coolant leaks	Cooling hose	Loose clamp
				Cracked hose
Water pump			Poor sealing	
Radiator cap			Loose	
			Poor sealing	
Radiator			O-ring for damage, deterioration or improper fitting	
		Cracked radiator tank		
	Cracked radiator core			
Reservoir tank	Cracked reservoir tank			
Overflowing reservoir tank	Exhaust gas leaks into cooling system	Cylinder head deterioration		
		Cylinder head gasket deterioration		
Except cooling system parts malfunction	---	Overload on engine	Abusive driving	High engine rpm under no load
				Driving in low gear for extended time
				Driving at extremely high speed
			Powertrain system malfunction	---
			Installed improper size wheels and tires	
	Dragging brakes			
	Improper ignition timing			
	Blocked or restricted air flow	Blocked bumper	---	---
		Blocked radiator grille	Installed car brassiere	
			Mud contamination or paper clogging	
Blocked radiator		---		
Blocked condenser		---		
Installed large fog lamp	---			

Engine Lubrication System (SR)

Oil pressure check

Engine speed rpm	Approximate discharge pressure kPa (kg/cm ² , psi)
Idle speed	More than 78 (0.8, 11)
3,200	314 - 392 (3.2 - 4.0, 46 - 57)

Regulator valve inspection

Unit: mm (in)

Regulator valve to oil pump cover clearance	0.040 - 0.097 (0.0016 - 0.0038)
---------------------------------------------	---------------------------------

Oil pump inspection

Unit: mm (in)

Body to outer gear radial clearance	0.114 - 0.200 (0.0045 - 0.0079)
Inner gear to outer gear tip clearance	Below 0.18 (0.0071)
Body to inner gear clearance	0.05 - 0.09 (0.0020 - 0.0035)
Body to outer gear axial clearance	0.05 - 0.11 (0.0020 - 0.0043)
Inner gear to brazed portion of housing clearance	0.045 - 0.091 (0.0018 - 0.0036)

Engine Cooling System (SR)

Thermostat

Valve opening temperature	°C (°F)	76.5 (170)
Valve lift	mm/°C (in/°F)	More than 8/90 (0.31/194)

Radiator

Unit: kPa (kg/cm², psi)

Cap relief pressure	Standard	78 - 98 (0.8 - 1.0, 11 - 14)
	Limit	59 - 98 (0.6 - 1.0, 9 - 14)
Leakage test pressure		157 (1.6, 23)

Engine Lubrication System (GA)

Oil pressure check

Engine speed rpm	Approximate discharge pressure kPa (kg/cm ² , psi)
Idle speed	49 - 186 (0.5 - 1.9, 7 - 27)
3,000	343 - 441 (3.5 - 4.5, 50 - 64)

Oil pump inspection

Unit: mm (in)

Body to outer gear radial clearance	0.110 - 0.200 (0.0043 - 0.0079)
Inner gear to crescent clearance	0.217 - 0.327 (0.0085 - 0.0129)
Outer gear to crescent clearance	0.21 - 0.32 (0.0083 - 0.0126)
Body to inner gear clearance	0.05 - 0.09 (0.0020 - 0.0035)
Body to outer gear axial clearance	0.05 - 0.11 (0.0020 - 0.0043)
Inner gear to brazed portion of housing clearance	0.045 - 0.091 (0.0018 - 0.0036)

Engine Cooling System (GA)

Thermostat

		Standard
Valve opening temperature	°C (°F)	76.5 (170)
Valve lift	mm/°C (in/°F)	More than 8/90 (0.31/194)

Radiator

Unit: kPa (kg/cm², psi)

Cap relief pressure	Standard	78 - 98 (0.8 - 1.0, 11 - 14)
	Limit	59 - 98 (0.6 - 1.0, 9 - 14)
Leakage test pressure		157 (1.6, 23)