

SECTION **EM**

CONTENTS

PRECAUTIONS	2
Parts Requiring Angular Tightening.....	2
Liquid Gasket Application Procedure.....	2
PREPARATION	3
Special Service Tools.....	3
Commercial Service Tools	6

SR

OUTER COMPONENT PARTS	7
COMPRESSION PRESSURE	10
OIL PAN	11
Removal	11
Installation	14
TIMING CHAIN	16
Removal	17
Inspection.....	21
Installation	21
OIL SEAL REPLACEMENT	30
Valve Oil Seal	30
Front Oil Seal.....	30
Rear Oil Seal	31
CYLINDER HEAD	32
Removal.....	33
Disassembly.....	33
Inspection.....	36
Cylinder Head Distortion	36
Camshaft Visual Check	36
Camshaft Runout.....	36
Camshaft Cam Height	36
Camshaft Journal Clearance	37
Camshaft End Play.....	37
Camshaft Sprocket Runout	38
Valve Guide Clearance.....	38
Valve Guide Replacement.....	38
Valve Seats.....	39
Replacing Valve Seat For Service Parts	40
Valve Dimensions	40

Valve Spring.....	40
Hydraulic Lash Adjuster.....	41
Rocker Arm, Shim And Rocker Arm Guide	41
Assembly.....	42
Installation	45
ENGINE REMOVAL	46
Removal	47
Installation	49
CYLINDER BLOCK	50
Disassembly	51
Piston And Crankshaft.....	51
Inspection.....	51
Piston And Piston Pin Clearance	51
Piston Ring Side Clearance	52
Piston Ring End Gap.....	52
Connecting Rod Bend And Torsion	52
Cylinder Block Distortion And Wear	53
Piston-To-Bore Clearance	53
Crankshaft	54
Bearing Clearance.....	55
Method A (Using bore gauge & micrometer)	55
Method B (Using Plastigage)	57
Connecting Rod Bushing Clearance (Small end).....	57
Replacement of Connecting Rod Bushing (Small end)	58
Replacement of Pilot Bushing (M/T) Or Pilot Converter (A/T).....	58
Flywheel/Drive Plate Runout	58
Assembly.....	59
Piston.....	59
Crankshaft	59

GA

OUTER COMPONENT PARTS	62
COMPRESSION PRESSURE	66

CONTENTS (Cont'd.)

<p>OIL PAN 67</p> <p style="padding-left: 20px;">Removal 67</p> <p style="padding-left: 20px;">Installation 68</p> <p>TIMING CHAIN 69</p> <p style="padding-left: 20px;">Removal 70</p> <p style="padding-left: 20px;">Inspection 73</p> <p style="padding-left: 20px;">Installation 73</p> <p>OIL SEAL REPLACEMENT 80</p> <p style="padding-left: 20px;">Valve Oil Seal 80</p> <p style="padding-left: 20px;">Front Oil Seal 80</p> <p style="padding-left: 20px;">Rear Oil Seal 81</p> <p>CYLINDER HEAD 82</p> <p style="padding-left: 20px;">Removal 83</p> <p style="padding-left: 20px;">Disassembly 83</p> <p style="padding-left: 20px;">Inspection 83</p> <p style="padding-left: 40px;">Cylinder Head Distortion 83</p> <p style="padding-left: 40px;">Camshaft Visual Check 83</p> <p style="padding-left: 40px;">Camshaft Runout 84</p> <p style="padding-left: 40px;">Camshaft Cam Height 84</p> <p style="padding-left: 40px;">Camshaft Journal Clearance 84</p> <p style="padding-left: 40px;">* Camshaft End Play 84</p> <p style="padding-left: 40px;">Camshaft Sprocket Runout 85</p> <p style="padding-left: 40px;">Valve Guide Clearance 85</p> <p style="padding-left: 40px;">Valve Guide Replacement 86</p> <p style="padding-left: 40px;">Valve Seats 87</p> <p style="padding-left: 40px;">Replacing Valve Seat For Service Parts 87</p> <p style="padding-left: 40px;">Valve Dimensions 87</p> <p style="padding-left: 40px;">Valve Spring 88</p> <p style="padding-left: 40px;">Valve Lifter 88</p> <p style="padding-left: 20px;">Assembly 89</p> <p style="padding-left: 20px;">Installation 89</p> <p>VALVE CLEARANCE 90</p> <p style="padding-left: 20px;">Checking 90</p> <p style="padding-left: 20px;">Adjusting 90</p> <p>ENGINE REMOVAL 93</p> <p style="padding-left: 20px;">Removal 94</p> <p style="padding-left: 20px;">Installation 96</p> <p>CYLINDER BLOCK 97</p> <p style="padding-left: 20px;">Disassembly 98</p> <p style="padding-left: 40px;">Piston And Crankshaft 98</p> <p style="padding-left: 20px;">Inspection 98</p> <p style="padding-left: 40px;">* Piston And Piston Pin Clearance 98</p> <p style="padding-left: 40px;">Piston Ring Side Clearance 99</p> <p style="padding-left: 40px;">Piston Ring End Gap 99</p> <p style="padding-left: 40px;">Connecting Rod Bend And Torsion 99</p> <p style="padding-left: 40px;">Cylinder Block Distortion And Wear 100</p> <p style="padding-left: 40px;">Piston-To-Bore Clearance 100</p> <p style="padding-left: 40px;">Crankshaft 101</p>	<p style="padding-left: 20px;">Bearing Clearance 102</p> <p style="padding-left: 40px;">Method A (Using bore gauge & micrometer) 102</p> <p style="padding-left: 40px;">Method B (Using Plastigage) 104</p> <p style="padding-left: 20px;">Connecting Rod Bushing Clearance (Small end) 104</p> <p style="padding-left: 20px;">Replacement of Connecting Rod Bushing (Small end) 104</p> <p style="padding-left: 20px;">Flywheel/Driveplate Runout 104</p> <p style="padding-left: 20px;">Assembly 105</p> <p style="padding-left: 20px;">Piston 105</p> <p style="padding-left: 20px;">Crankshaft 105</p>
<div style="display: flex; justify-content: space-around; align-items: center;"> <div style="border: 1px solid black; width: 100px; height: 15px;"></div> SR <div style="border: 1px solid black; width: 100px; height: 15px;"></div> </div>	
<p>SERVICE DATA AND SPECIFICATIONS (SDS) ... 108</p> <p style="padding-left: 20px;">General Specifications 108</p> <p style="padding-left: 20px;">Inspection and Adjustment 108</p> <p style="padding-left: 40px;">Compression Pressure 108</p> <p style="padding-left: 40px;">Cylinder Head 108</p> <p style="padding-left: 40px;">Valve 109</p> <p style="padding-left: 40px;">Camshaft And Camshaft Bearing 112</p> <p style="padding-left: 40px;">Cylinder Block 112</p> <p style="padding-left: 40px;">Piston, Piston Ring And Piston Pin 113</p> <p style="padding-left: 40px;">Connecting Rod 114</p> <p style="padding-left: 40px;">Crankshaft 114</p> <p style="padding-left: 40px;">Main Bearing 115</p> <p style="padding-left: 40px;">Connecting Rod Bearing 115</p> <p style="padding-left: 40px;">Miscellaneous Components 115</p>	
<div style="display: flex; justify-content: space-around; align-items: center;"> <div style="border: 1px solid black; width: 100px; height: 15px;"></div> GA <div style="border: 1px solid black; width: 100px; height: 15px;"></div> </div>	
<p>SERVICE DATA AND SPECIFICATIONS (SDS) ... 116</p> <p style="padding-left: 20px;">General Specifications 116</p> <p style="padding-left: 20px;">Inspection and Adjustment 116</p> <p style="padding-left: 40px;">Compression Pressure 116</p> <p style="padding-left: 40px;">Cylinder Head 116</p> <p style="padding-left: 40px;">Valve 116</p> <p style="padding-left: 40px;">Camshaft And Camshaft Bearing 119</p> <p style="padding-left: 40px;">Cylinder Block 119</p> <p style="padding-left: 40px;">Piston, Piston Ring And Piston Pin 120</p> <p style="padding-left: 40px;">Connecting Rod 120</p> <p style="padding-left: 40px;">Crankshaft 120</p> <p style="padding-left: 40px;">Main Bearing 121</p> <p style="padding-left: 40px;">Connecting Rod Bearing 121</p> <p style="padding-left: 40px;">Miscellaneous Components 121</p>	

PRECAUTIONS

Parts Requiring Angular Tightening

- Use an angle wrench for the final tightening of the following engine parts:
 - (1) Cylinder head bolts
 - (2) Main bearing cap bolts (SR engine only)
 - (3) Connecting rod cap nuts
- Do not use a torque value for final tightening.
- The torque value for these parts are for a preliminary step.
- Ensure thread and seat surfaces are clean and coated with engine oil.

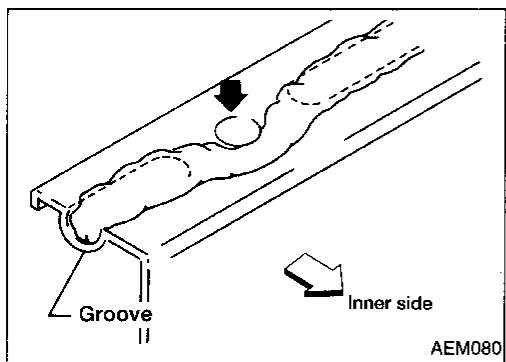
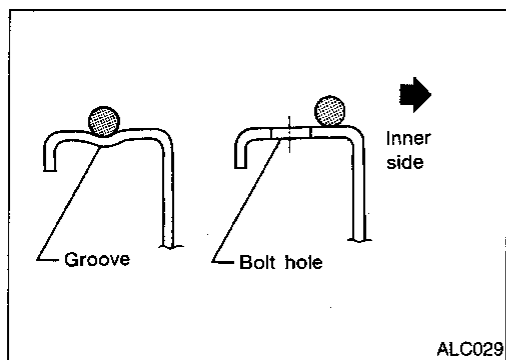

Liquid Gasket Application Procedure

- a. Use a scraper to remove old liquid gasket from mating surfaces and grooves. Also, completely clean any oil from these areas.
- b. Apply a continuous bead of liquid gasket to mating surfaces. (Use Genuine Liquid Gasket or equivalent.)
 - For oil pan, be sure liquid gasket diameter is 4.0 to 5.0 mm (0.157 to 0.197 in) for SR engine. Be sure liquid gasket diameter is 3.5 to 4.5 mm (0.138 to 0.177 in) for GA engine.
 - For areas except oil pan, be sure liquid gasket diameter is 2.0 to 3.0 mm (0.079 to 0.118 in).
- c. Apply liquid gasket around the inner side of bolt holes (unless otherwise specified).
- d. Assembly should be done within 5 minutes after coating.
- e. Wait at least 30 minutes before refilling engine oil and engine coolant.

PREPARATION

Special Service Tools

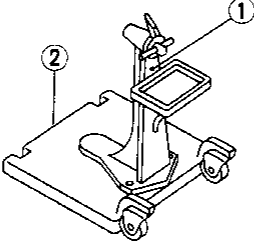
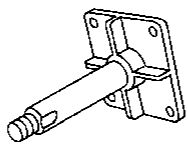
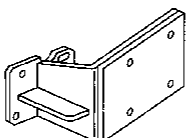
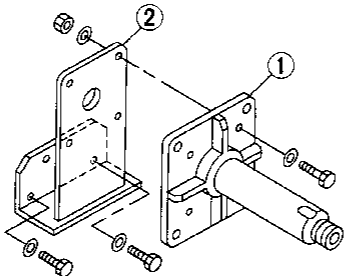
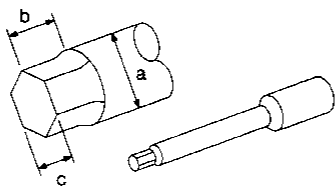
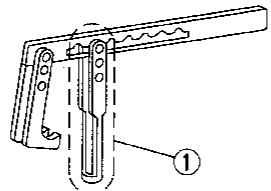

The actual shapes of Kent-Moore tools may differ from those of special service tools illustrated here.

Tool number (Kent-Moore No.) Tool name	Description	Engine application		
		SR	GA	
ST0501S000 (—) Engine stand assembly ① ST05011000 (—) Engine stand ② ST05012000 (—) Base	 NT042	Disassembling and assembling	X	X
KV10106500 (—) Engine stand shaft	 NT028		X	—
KV10115300 (—) Engine sub-attachment	 NT008		X	—
Engine attachment assembly ① KV10106500 (—) Engine attachment ② KV10113300 (—) Sub-attachment	 NT029	When overhauling engine	—	X
ST10120000 (J24239-01) Cylinder head bolt wrench	 NT583	Loosening and tightening cylinder head bolt a: 13 (0.51) dia. b: 12 (0.47) c: 10 (0.39) Unit: mm (in)	X	X
KV10116200 (J26336-B) Valve spring compressor ① KV10115900 (J26336-20) Attachment	 NT022	Disassembling valve mechanism	X	X

GI
 MA
EM
 LC
 EC
 FE
 CL
 MT
 AT
 FA
 RA
 BR
 ST
 RS
 BT
 HA
 EL
 IDX

PREPARATION

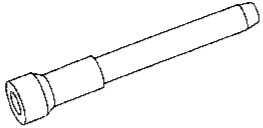
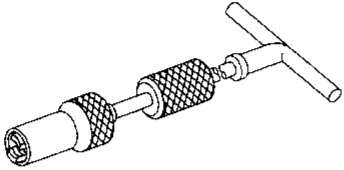
Special Service Tools (Cont'd)

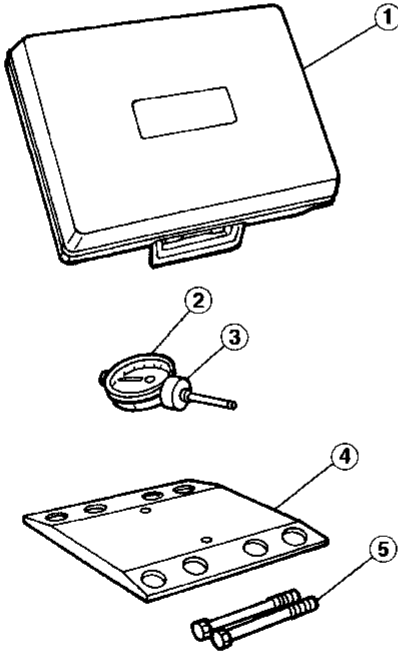
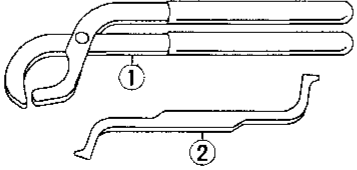
Tool number (Kent-Moore No.) Tool name	Description	Engine application		
		SR	GA	
KV10115600 (J38958) Valve oil seal drift	 NT024	Installing valve oil seal	X	X
KV10107902 (J38959) Valve oil seal puller	 NT011	Displacement valve lip seal	X	X
KV10115700 (J38957) Dial gauge stand	 NT012	Adjusting shims	X	—
(J38957-N) Valve shim gauge plate kit ① — (J35772) Plastic case ② — (J38957-8) Dial indicator ③ — (J38957-2) Collar ④ — (J38957-1) Plate ⑤ — (—) Hex bolts	 AEM239	Measuring valve shims	X	
KV101151S0 (J38972) Lifter stopper set ① KV10115110 (J38972-1) Camshaft pliers ② KV10115120 (J38972-2) Lifter stopper	 NT041	Changing shims	—	X

PREPARATION

Special Service Tools (Cont'd)

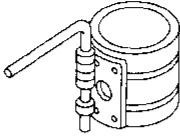
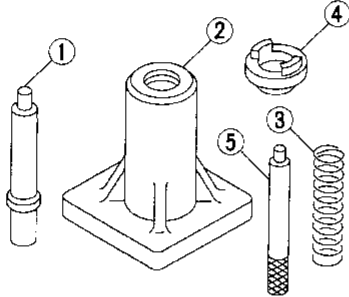
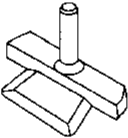
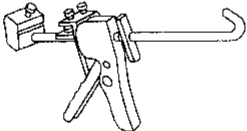
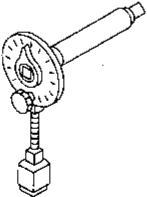
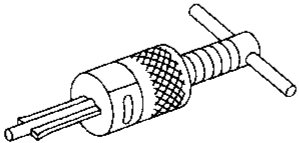
Tool number (Kent-Moore No.) Tool name	Description	Engine application			
		SR	GA		
EM03470000 (J8037) Piston ring compressor	 NT044	Installing piston assembly into cylinder bore	X	X	GI MA EM
KV10107400 (J26365-12, J26365) Piston pin press stand ① KV10107310 (—) Center shaft ② ST13040020 (—) Stand ③ ST13040030 (—) Spring ④ KV10107320 (—) Cap ⑤ ST13040050 (—) Drift	 NT013	Disassembling and assembling piston pin	X	X	LC EC FE CL MT AT
KV10111100 (J37228) Seal cutter	 NT046	Removing oil pan	X	X	FA RA
WS39930000 (—) Tube presser	 NT052	Pressing the tube of liquid gasket	X	X	BR ST
KV10112100 (BT-8653-A) Angle wrench	 NT014	Tightening bolts for bearing cap, cylinder head, etc.	X	X	RS BT HA
ST16610001 (J23907) Pilot bushing puller	 NT045	Removing pilot bushing	X	X	EL IDX

PREPARATION

Commercial Service Tools

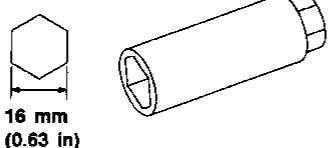
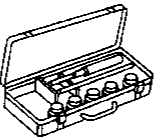
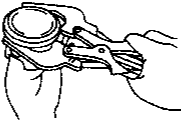
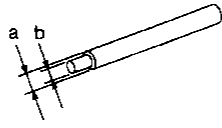
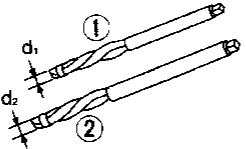
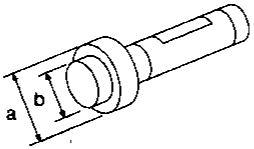
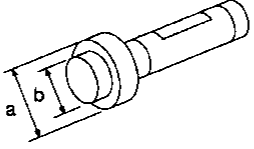
Tool name	Description	Engine application																						
		SR	GA																					
Spark plug wrench	 <p>16 mm (0.63 in)</p> <p>NT047</p>	Removing and installing spark plug	X	X																				
Valve seat cutter set	 <p>NT048</p>	Finishing valve seat dimensions	X	X																				
Piston ring expander	 <p>NT030</p>	Removing and installing piston ring	X	X																				
Valve guide drift	 <p>NT015</p> <table border="1" style="margin-left: auto; margin-right: auto;"> <thead> <tr> <th colspan="2">Diameter:</th> <th colspan="2">mm (in)</th> </tr> <tr> <th colspan="2"></th> <th colspan="2">Intake & Exhaust</th> </tr> <tr> <th colspan="2"></th> <th>GA16DE</th> <th>SR20DE</th> </tr> </thead> <tbody> <tr> <td>a</td> <td></td> <td>9.5 (0.374)</td> <td>9.5 (0.374)</td> </tr> <tr> <td>b</td> <td></td> <td>5.5 (0.217)</td> <td>5.0 (0.197)</td> </tr> </tbody> </table>	Diameter:		mm (in)				Intake & Exhaust				GA16DE	SR20DE	a		9.5 (0.374)	9.5 (0.374)	b		5.5 (0.217)	5.0 (0.197)	Removing and installing valve guide	X	X
Diameter:		mm (in)																						
		Intake & Exhaust																						
		GA16DE	SR20DE																					
a		9.5 (0.374)	9.5 (0.374)																					
b		5.5 (0.217)	5.0 (0.197)																					
Valve guide reamer	 <p>NT016</p> <table border="1" style="margin-left: auto; margin-right: auto;"> <thead> <tr> <th colspan="2">Diameter:</th> <th colspan="2">mm (in)</th> </tr> <tr> <th colspan="2"></th> <th colspan="2">Intake & Exhaust</th> </tr> <tr> <th colspan="2"></th> <th>GA16DE</th> <th>SR20DE</th> </tr> </thead> <tbody> <tr> <td>d₁</td> <td></td> <td>5.5 (0.217)</td> <td>6.0 (0.236)</td> </tr> <tr> <td>d₂</td> <td></td> <td>9.685 (0.3813)</td> <td>10.175 (0.4006)</td> </tr> </tbody> </table>	Diameter:		mm (in)				Intake & Exhaust				GA16DE	SR20DE	d ₁		5.5 (0.217)	6.0 (0.236)	d ₂		9.685 (0.3813)	10.175 (0.4006)	Reaming valve guide ① or hole for oversize valve guide ②	X	X
Diameter:		mm (in)																						
		Intake & Exhaust																						
		GA16DE	SR20DE																					
d ₁		5.5 (0.217)	6.0 (0.236)																					
d ₂		9.685 (0.3813)	10.175 (0.4006)																					
Front oil seal drift	 <p>NT049</p>	Installing front oil seal	X	X																				
Rear oil seal drift	 <p>NT049</p>	Installing rear oil seal	X	X																				

SEC. 140·150·210·220·221·233·493

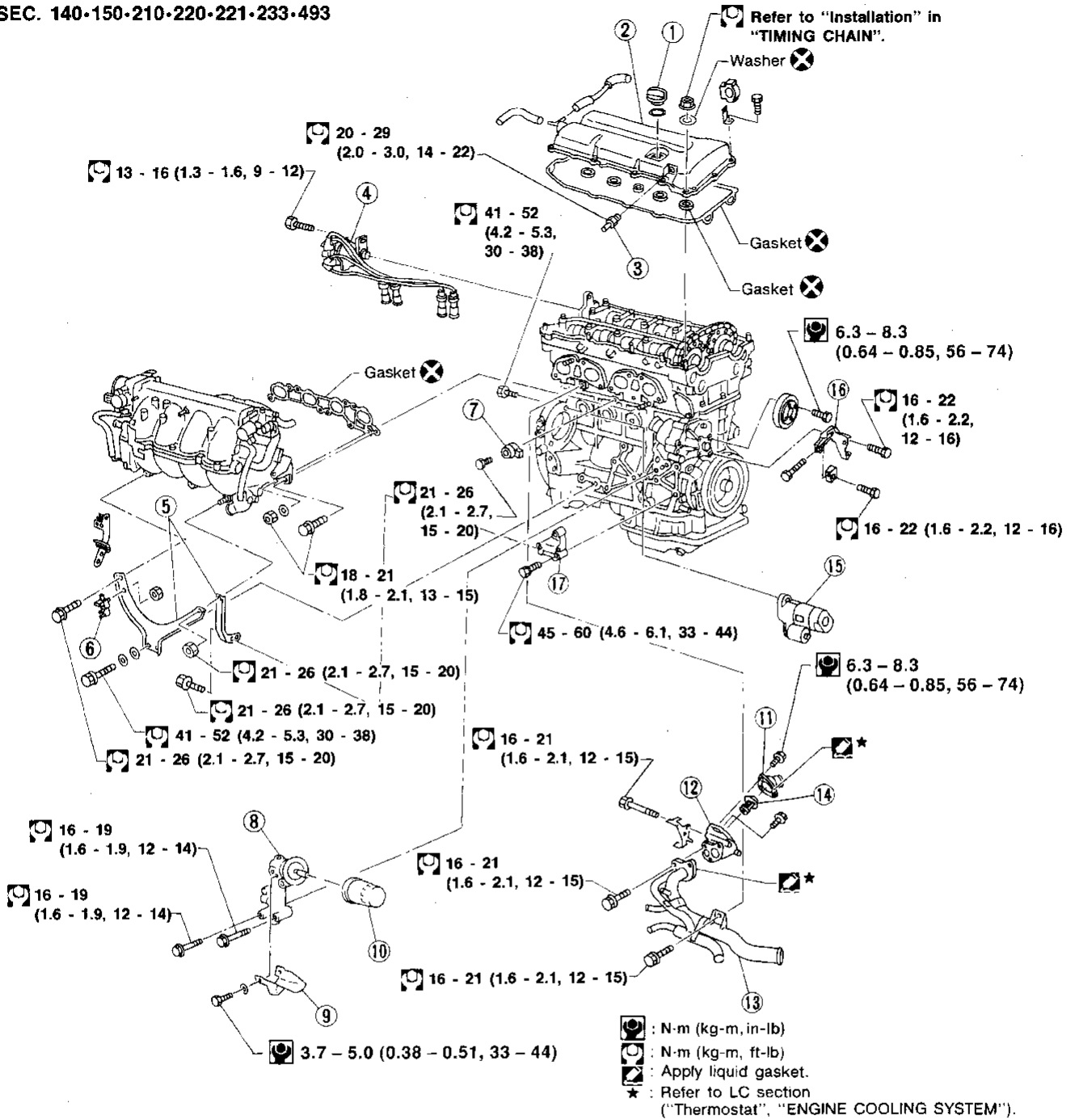

GI
MA
EM
LC
EC
FE
CL
MT
AT
FA
RA
BR
ST
RS
BT
HA
EL
IDX

- | | | |
|---|---|---|
| <p>① Oil filler cap</p> <p>② Rocker cover</p> <p>③ PCV valve</p> <p>④ Distributor</p> <p>⑤ Intake manifold supports</p> <p>⑥ EGR valve & EVAP canister purge control solenoid valve</p> | <p>⑦ Knock sensor</p> <p>⑧ Oil filter bracket</p> <p>⑨ Oil catcher</p> <p>⑩ Oil filter</p> <p>⑪ Water inlet</p> <p>⑫ Thermostat housing</p> | <p>⑬ Water pipe assembly</p> <p>⑭ Thermostat</p> <p>⑮ Starter motor</p> <p>⑯ Power steering oil pump adjusting bar</p> <p>⑰ Power steering oil pump bracket</p> |
|---|---|---|

AEM206

SEC. 140-146-147-148-163-164-210-226

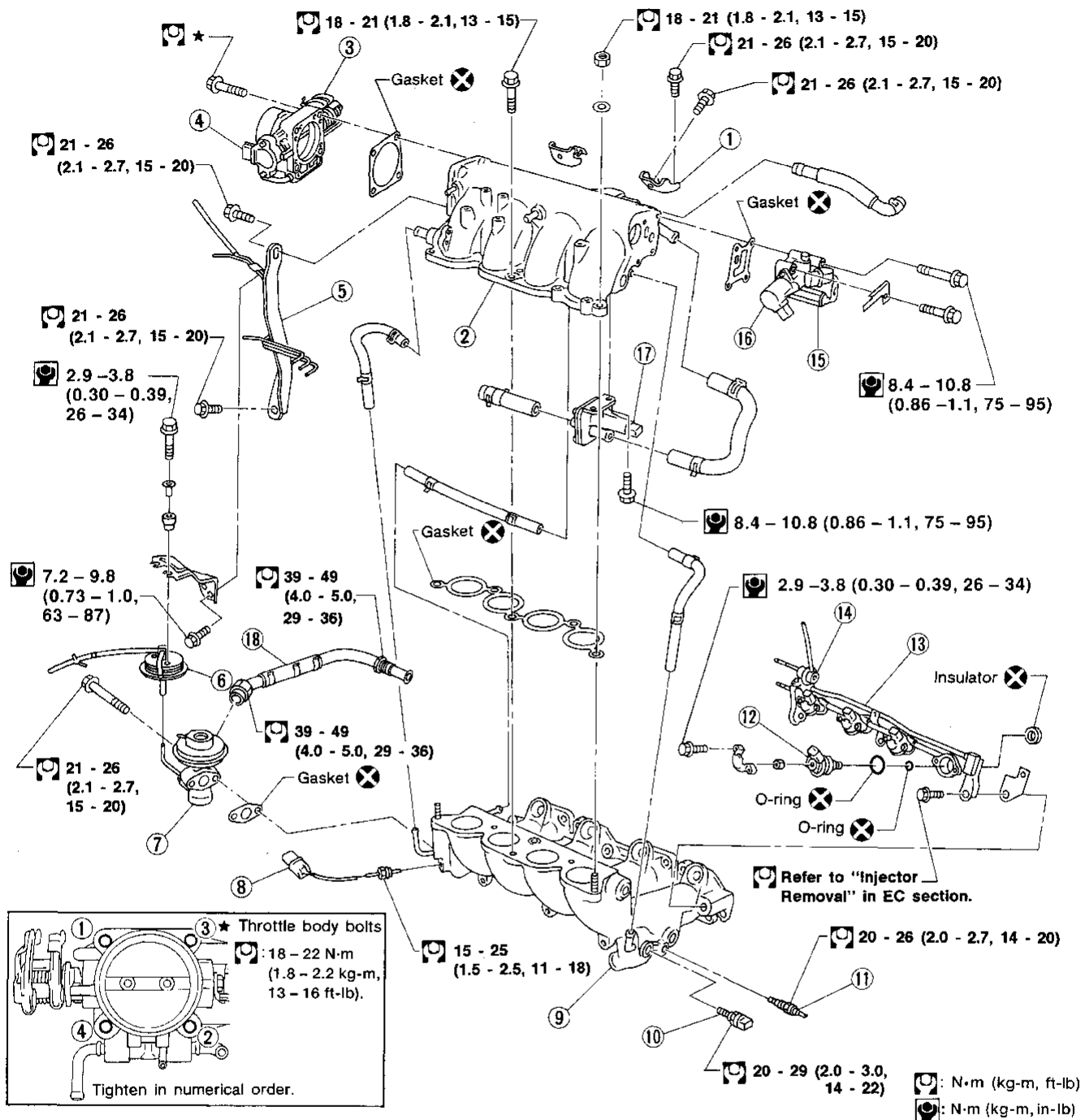

AEM207

- | | | |
|---|---|--|
| <ul style="list-style-type: none"> ① Intake manifold collector support ② Intake manifold collector ③ Throttle body ④ Throttle position sensor ⑤ Intake manifold collector support ⑥ EGRC-BPT valve ⑦ EGR valve | <ul style="list-style-type: none"> ⑧ EGR temperature sensor ⑨ Intake manifold ⑩ Engine coolant temperature sensor ⑪ Thermal transmitter ⑫ Injector ⑬ Fuel tube assembly | <ul style="list-style-type: none"> ⑭ Pressure regulator ⑮ IACV-FICD solenoid valve ⑯ IACV-AAC valve ⑰ IACV-air regulator ⑱ EGR tube |
|---|---|--|

SEC. 118-140-210-226-230-275

GI

MA

EM

LC

EC

FE

CL

WT

AT

FA

RA

BR

ST

RS

BT

HA

EL

IDX

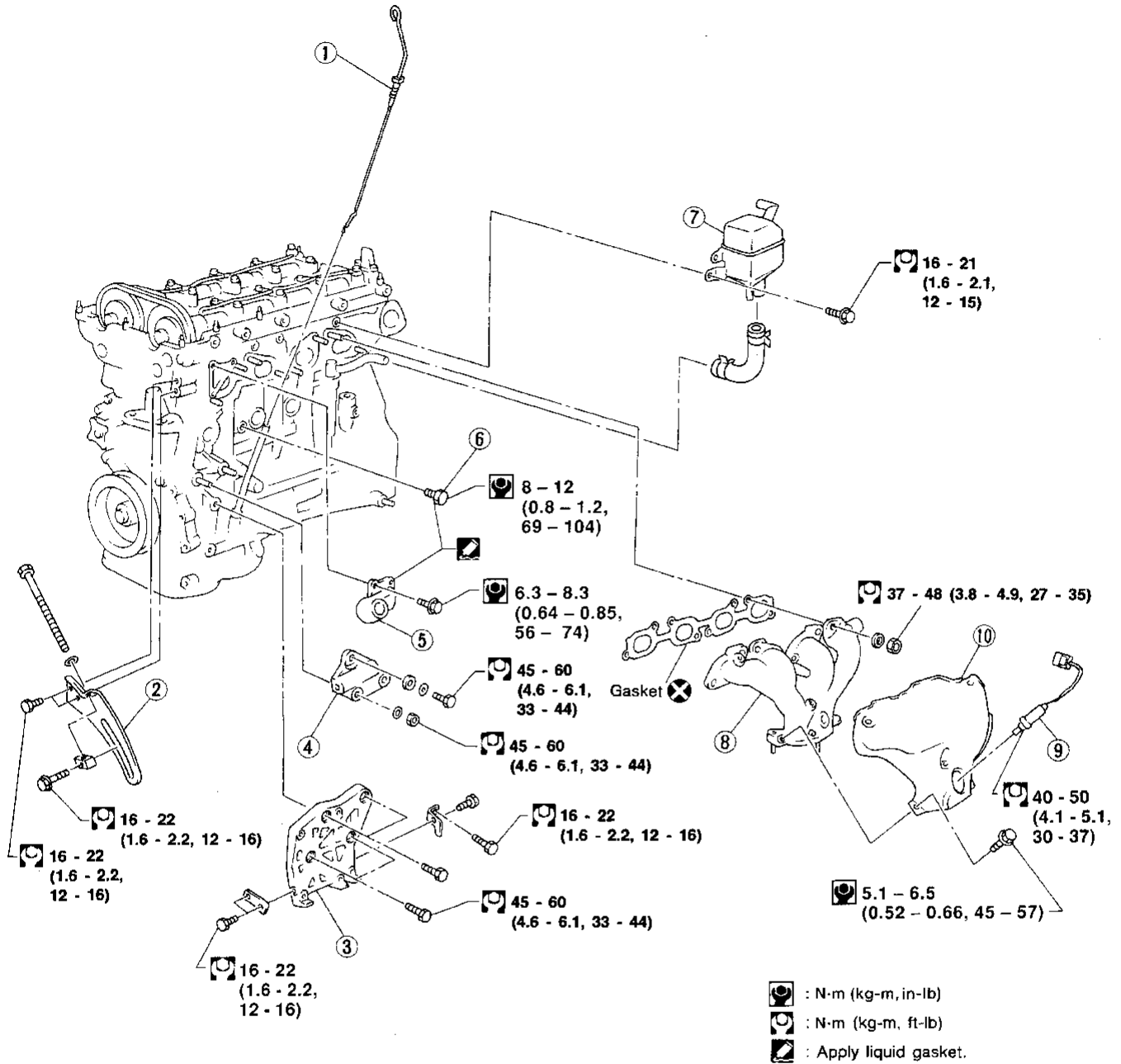

- ① Oil level gauge
- ② Generator adjusting bar
- ③ A/C compressor bracket
- ④ Generator bracket

- ⑤ Water outlet
- ⑥ Cylinder block drain plug
- ⑦ Crankcase ventilation oil separator

- ⑧ Exhaust manifold
- ⑨ Heated oxygen sensor
- ⑩ Exhaust manifold cover

AEM208

Measurement of Compression Pressure

1. Warm up engine.
2. Turn ignition switch off.
3. Release fuel pressure.
Refer to EC section ("Fuel Pressure Release", "BASIC SERVICE PROCEDURE").
4. Remove all spark plugs.
5. Disconnect distributor coil connector.

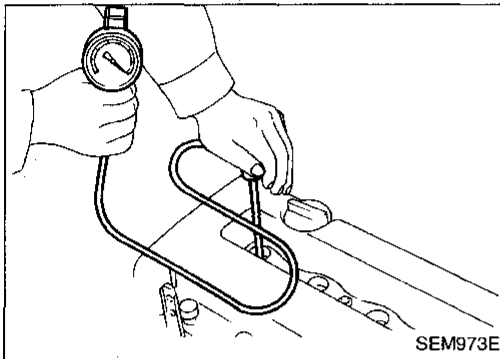

SEM973E

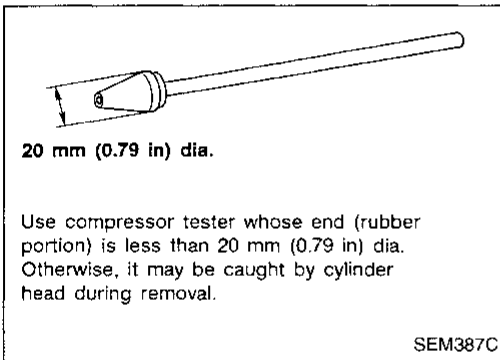

20 mm (0.79 in) dia.

Use compressor tester whose end (rubber portion) is less than 20 mm (0.79 in) dia. Otherwise, it may be caught by cylinder head during removal.

SEM387C

6. Attach a compression tester to No. 1 cylinder.
 7. Depress accelerator pedal fully to keep throttle valve wide open.
 8. Crank engine and record highest gauge indication.
 9. Repeat the measurement on each cylinder.
- **Always use a fully-charged battery to obtain specified engine speed.**

Compression pressure: kPa (kg/cm², psi)/rpm

Standard

1,226 (12.5, 178)/300

Minimum

1,030 (10.5, 149)/300

Difference limit between cylinders

98 (1.0, 14)/300

10. If compression in one or more cylinders is low:
 - a. Pour a small amount of engine oil into cylinders through spark plug holes.
 - b. Retest compression.
 - **If adding oil helps compression, piston rings may be worn or damaged. If so, replace piston rings after checking piston.**
 - **If pressure stays low, a valve may be sticking or seating improperly. Inspect and repair valve and valve seat. Refer to SDS, EM-110. If valve or valve seat is damaged excessively, replace them.**
 - **If compression stays low in two cylinders that are next to each other:**
 - a. **The cylinder head gasket may be leaking, or**
 - b. **Both cylinders may have valve component damage. Inspect and repair as necessary.**

SEC. 110

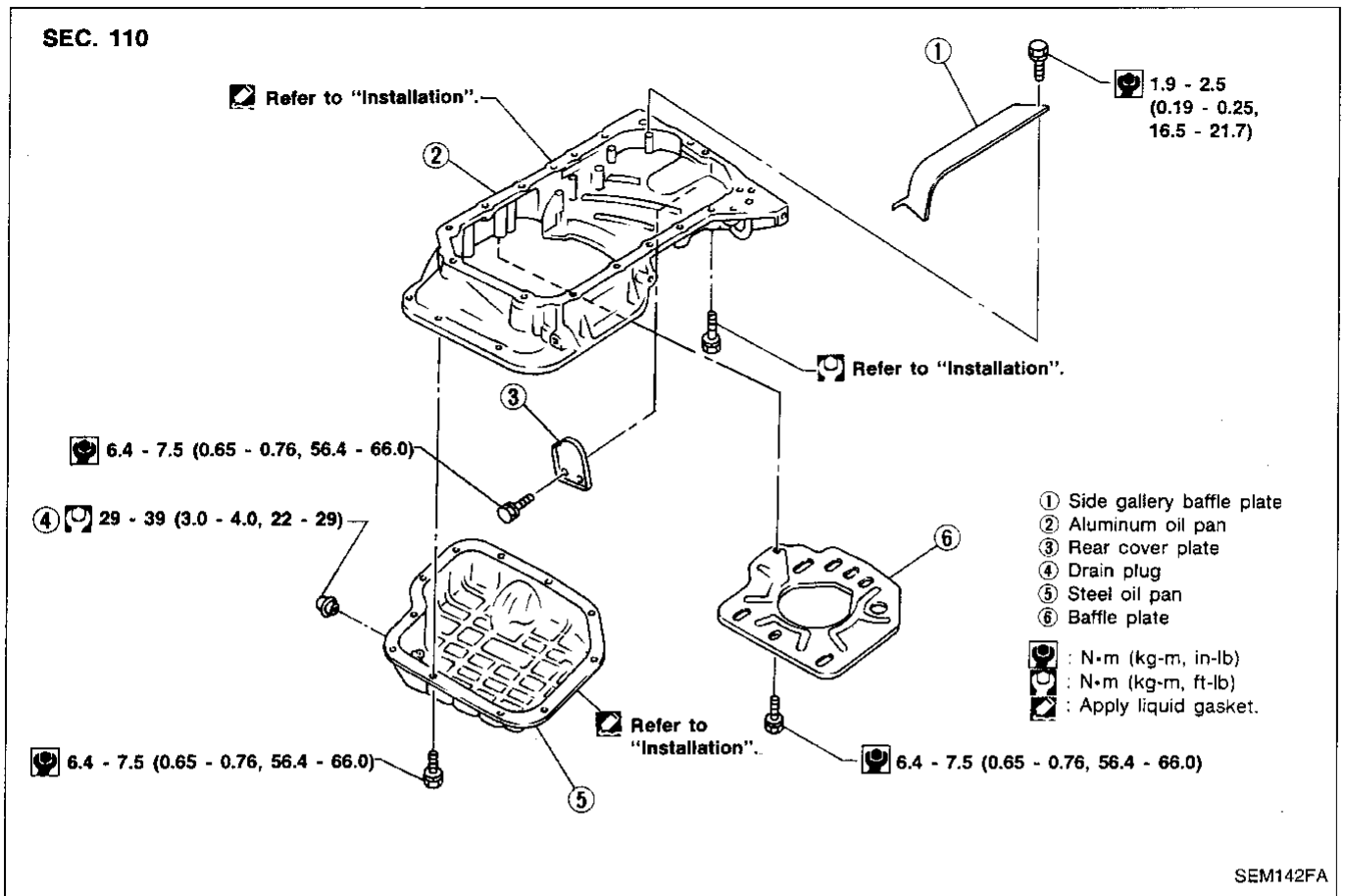

GI
MA
EM
LC
EC
FE
CL
MT
AT
FA
RA
BR
ST
RS
BT
HA
EL
IDX

Removal

1. Remove engine side cover.
2. Drain engine oil.
3. Remove steel oil pan bolts in numerical order.

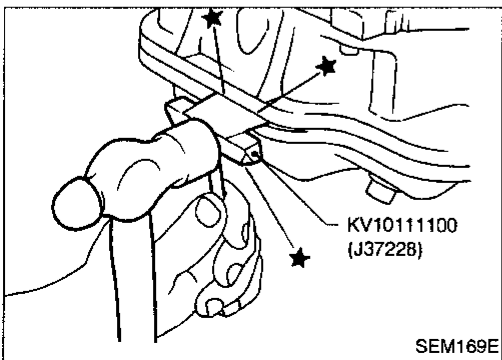
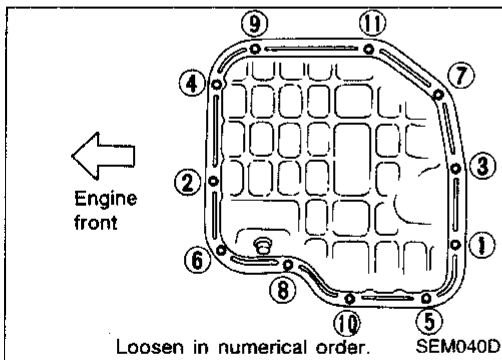

4. Remove steel oil pan.
 - a. Insert Tool between aluminum oil pan and steel oil pan.
 - Be careful not to damage aluminum mating surface.
 - Do not insert screwdriver, or oil pan flange will be damaged.

Removal (Cont'd)

- b. Slide Tool by tapping on the side of the Tool with a hammer.

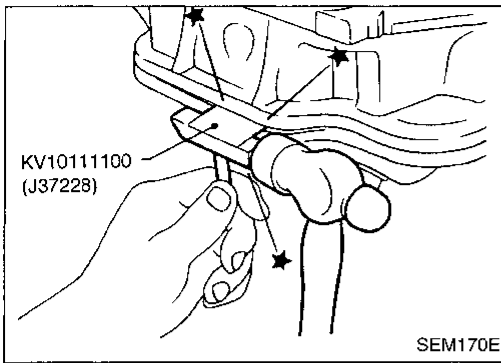

- 5. Remove baffle plate.

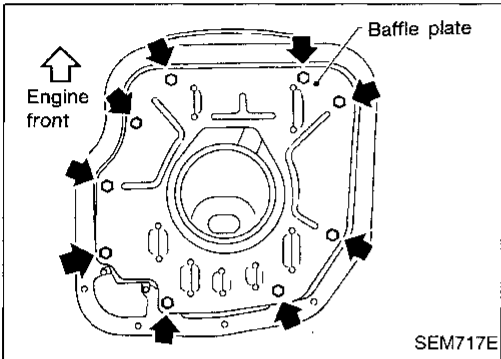

- 6. Remove front exhaust tube. Refer to FE section ("EXHAUST SYSTEM").
- 7. Set a suitable transmission jack under transaxle and lift engine with engine slinger.
- 8. Remove center member.
- 9. Remove A/T control cable.

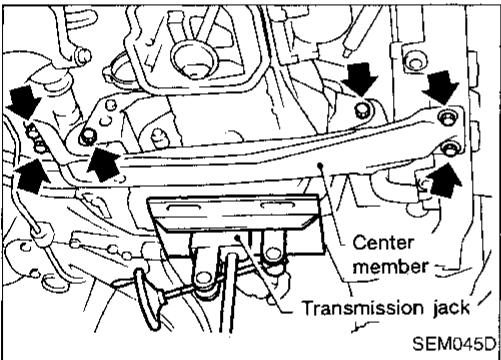

- 10. Remove A/C compressor gussets.

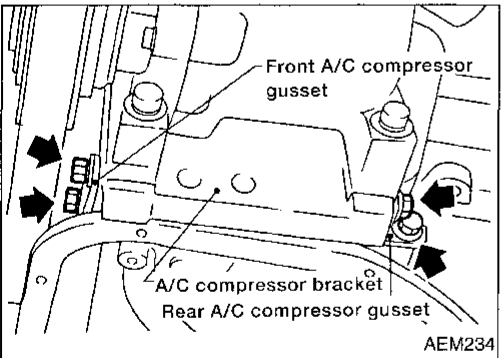

- 11. Remove rear cover plate.

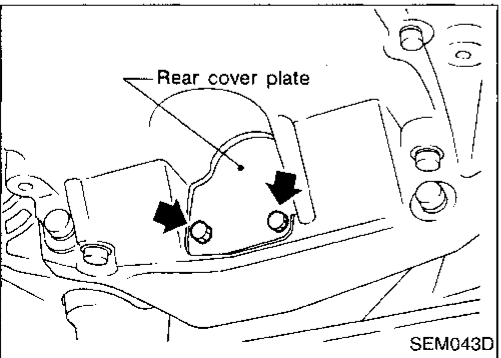

Removal (Cont'd)

12. Remove aluminum oil pan bolts in numerical order.

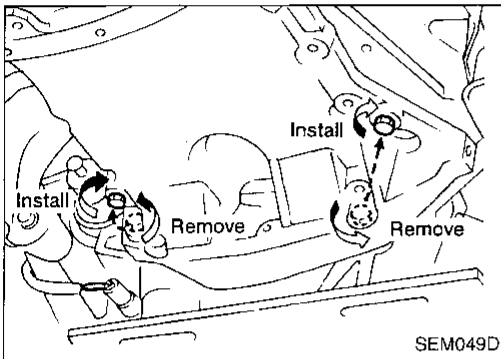
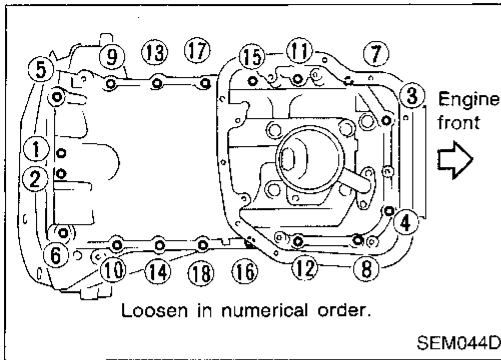

13. Remove two engine-to-transaxle bolts and install them into open bolt holes as shown. Tighten both bolts to separate aluminum oil pan from cylinder block.

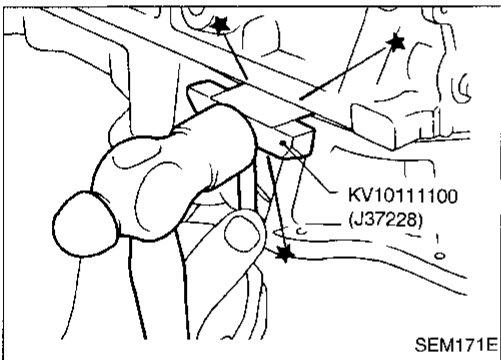

14. Remove aluminum oil pan.

- a. Insert Tool between cylinder block and aluminum oil pan.
 - Be careful not to damage aluminum mating surface.
 - Do not insert screwdriver, or oil pan flange will be damaged.

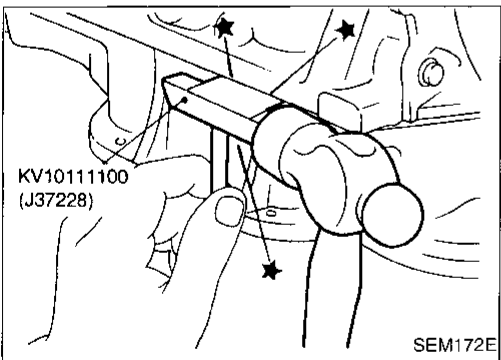

- b. Slide Tool by tapping on the side of the Tool with a hammer.

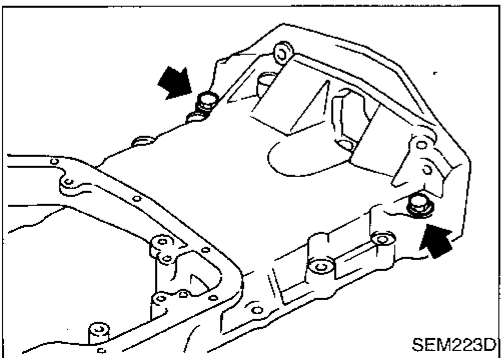

15. Remove the two engine-to-transaxle bolts previously installed in aluminum oil pan.

CI
MA
EM
LC
EC
FE
CL
MT
AT
FA
RA
BR
ST
RS
BT
HA
EL
IDX

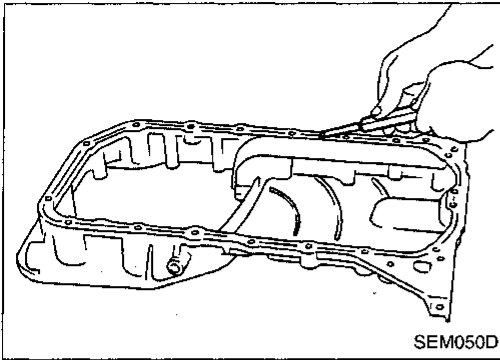

Installation

1. Install aluminum oil pan.
 - a. Use a scraper to remove old liquid gasket from mating surfaces.
 - Also remove old liquid gasket from mating surfaces of cylinder block and front cover.

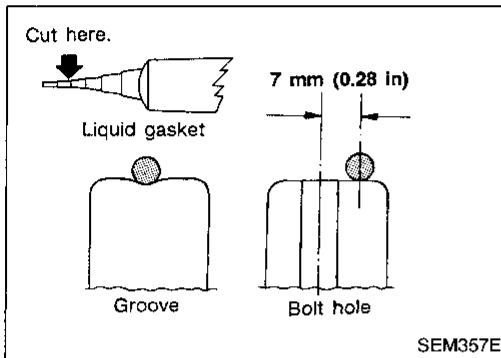

- b. Apply a continuous bead of liquid gasket to mating surface of aluminum oil pan.
 - Use Genuine Liquid Gasket or equivalent.
 - Apply to groove on mating surface.
 - Allow 7 mm (0.28 in) clearance around bolt holes.

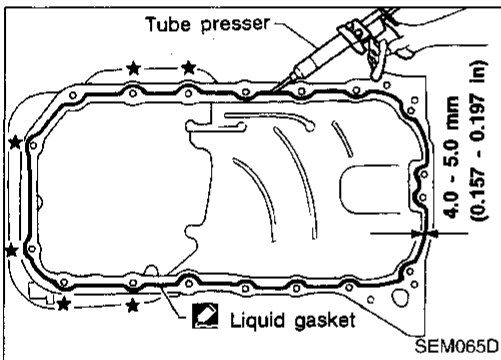

- For areas marked with "★", apply liquid gasket around the outer side of the bolt hole as shown.
- Be sure liquid gasket diameter is 4.0 to 5.0 mm (0.157 to 0.197 in).
- Attaching should be done within 5 minutes after coating.

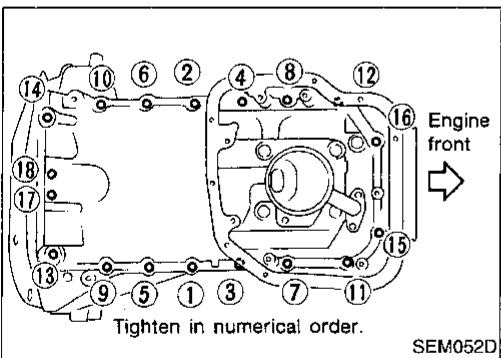

- c. Tighten nuts and bolts in numerical order.

Bolts ① - ⑬ :

⊞: 16 - 19 N·m (1.6 - 1.9 kg·m, 12 - 14 ft·lb)

Bolts ⑭ , ⑮ :

⊞: 6.4 - 7.5 N·m (0.65 - 0.76 kg·m, 56.4 - 66.0 in·lb)

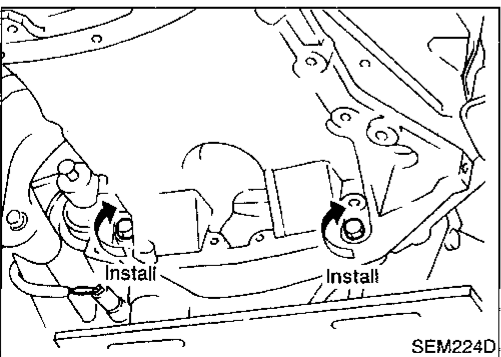

2. Install the two engine-to-transaxle bolts. For tightening torque, refer to MT or AT section ("REMOVAL AND INSTALLATION").
3. Install rear cover plate.

Installation (Cont'd)

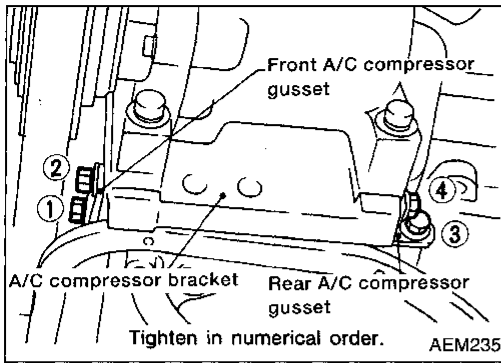

4. Install A/C compressor gussets.
5. Install A/T control cable.
6. Install center member.
7. Install front exhaust tube.
8. Install baffle plate.

GI

MA

EM

LC

EC

FE

CL

MT

AT

FA

RA

BR

ST

RS

BT

HA

EL

IDX

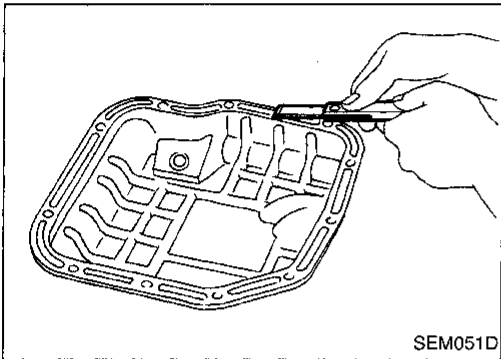

9. Install steel oil pan.
 - a. Use a scraper to remove old liquid gasket from mating surface of steel oil pan.
 - Also remove old liquid gasket from mating surface of aluminum oil pan.

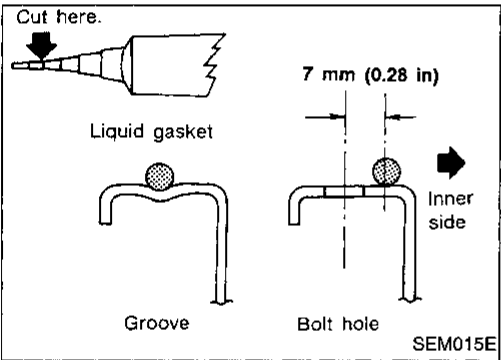

- b. Apply a continuous bead of liquid gasket to mating surface of steel oil pan.
 - Use Genuine Liquid Gasket or equivalent.
 - Apply to groove on mating surface.
 - Allow 7 mm (0.28 in) clearance around bolt hole.

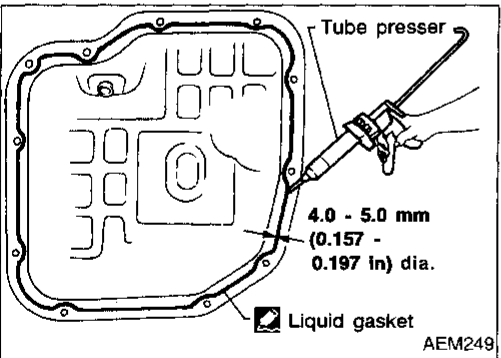

- Be sure liquid gasket diameter is 4.0 to 5.0 mm (0.157 to 0.197 in).
- Attaching should be done within 5 minutes after coating.

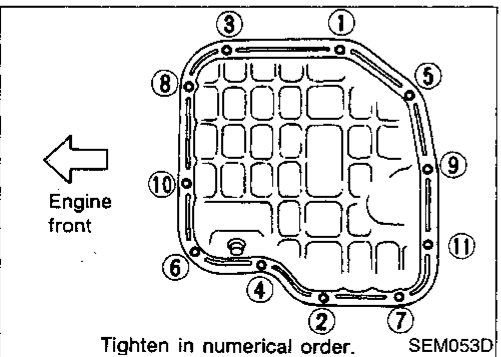

- c. Tighten bolts in numerical order as shown.
 - Wait at least 30 minutes before refilling engine oil.

TIMING CHAIN

SR

SEC. 120-130-135

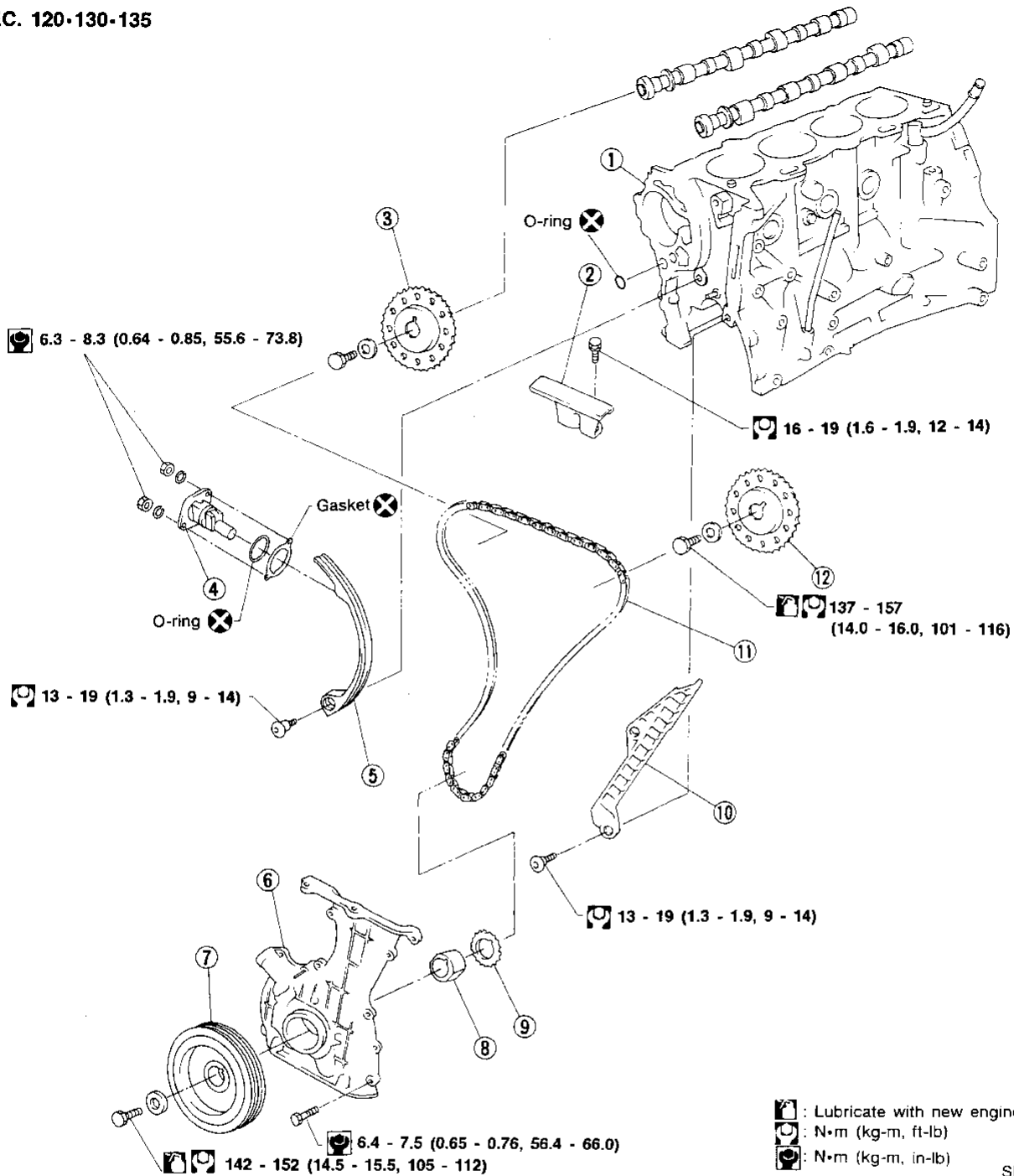

SEM718EC

- ① Cylinder block
- ② Chain guide
- ③ RH camshaft sprocket
- ④ Chain tensioner

- ⑤ Chain guide
- ⑥ Front cover
- ⑦ Crankshaft pulley
- ⑧ Oil pump drive spacer

- ⑨ Crankshaft sprocket
- ⑩ Chain guide
- ⑪ Timing chain
- ⑫ LH camshaft sprocket

CAUTION:

- After removing timing chain, do not turn crankshaft and camshaft separately, or valves will strike piston heads.
- When installing rocker arms, camshafts, chain tensioner, oil seals, or other sliding parts, lubricate contacting surfaces with new engine oil.
- Apply new engine oil to bolt threads and seat surfaces when installing cylinder head, camshaft sprockets, crankshaft pulley, and camshaft brackets.

Removal

1. Release fuel pressure.
Refer to EC section ("Fuel Pressure Release", "BASIC SERVICE PROCEDURE").
2. Remove engine under covers.
3. Remove front RH wheel and engine side cover.
4. Drain coolant by removing cylinder block drain plug and radiator drain cock. Refer to MA section ("DRAINING ENGINE COOLANT", "Changing Engine Coolant").
5. Remove radiator.
6. Remove air duct to intake manifold.
7. Remove drive belts and water pump pulley.
8. Remove alternator and power steering pump.
9. Disconnect the following parts:
 - Vacuum hoses
 - Fuel hoses
 - Wires
 - Harness
 - Connectors
10. Remove all spark plugs.
11. Remove rocker cover bolts in numerical order.
12. Remove rocker cover and oil separator.

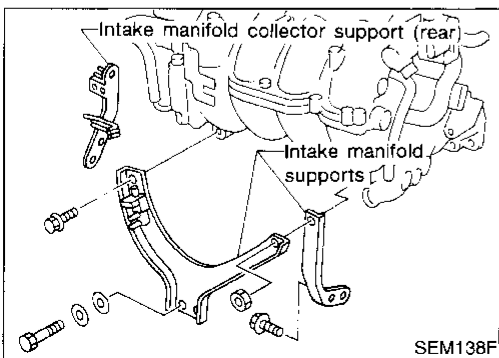
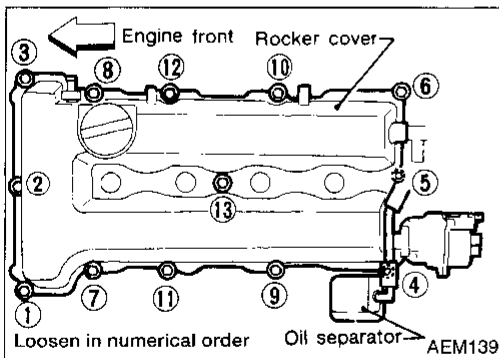

13. Remove intake manifold supports.

Removal (Cont'd)

14. Remove oil filter bracket and power steering oil pump bracket.

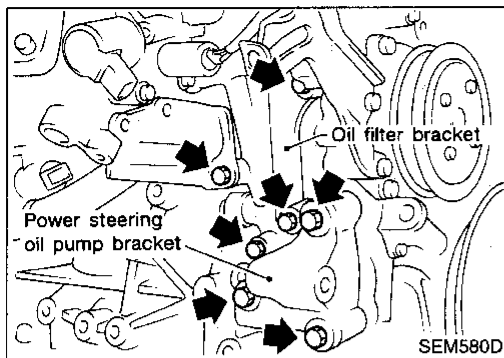

15. Set No. 1 piston at TDC of its compression stroke.

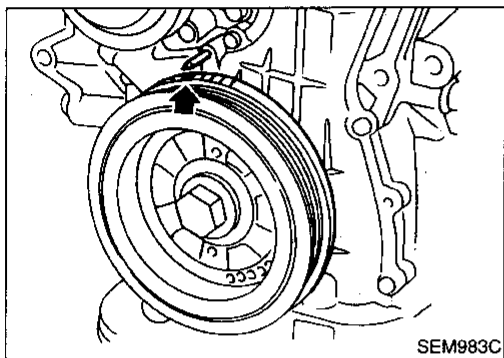

- Rotate crankshaft until mating mark on camshaft sprocket is set at position indicated in figure.

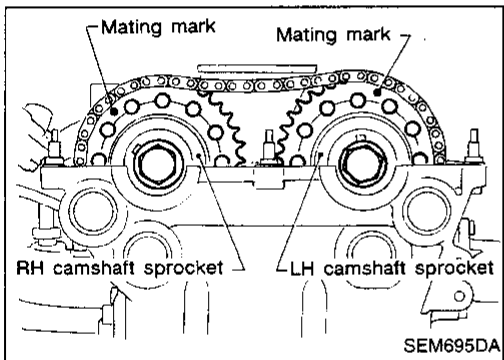

16. Remove chain tensioner.

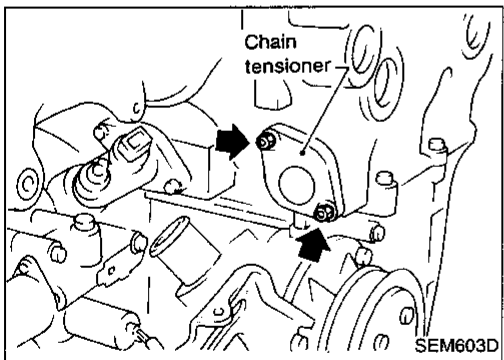

17. Remove distributor.
Do not turn rotor with distributor removed.

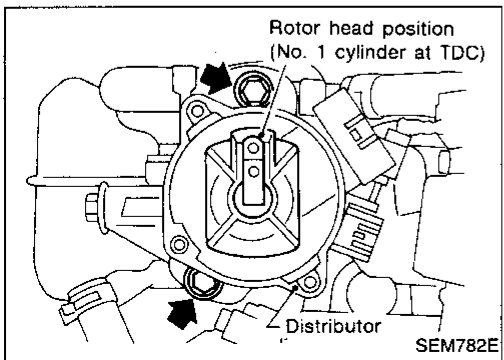

TIMING CHAIN

Removal (Cont'd)

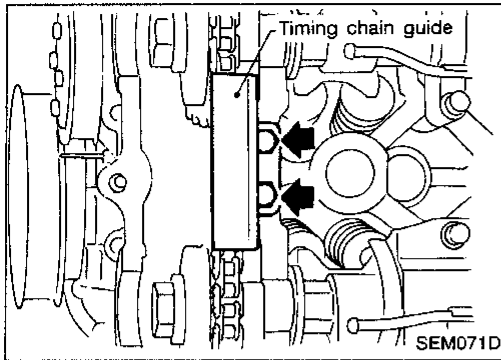

18. Remove timing chain guide.

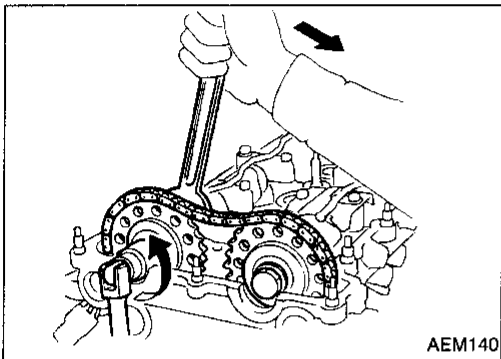

19. Remove camshaft sprockets.

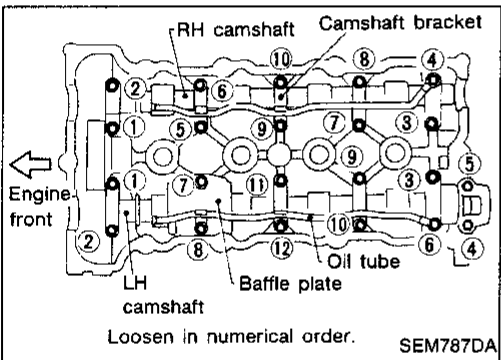

20. Remove oil tubes, baffle plate, camshaft brackets and camshafts.

- Mark these parts' original position for reassembly.

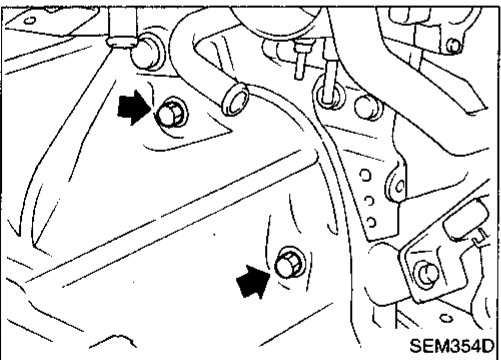

21. Remove starter motor.

22. Remove the following water hoses:

- Water hose for cylinder block.
- Water hoses for heater.

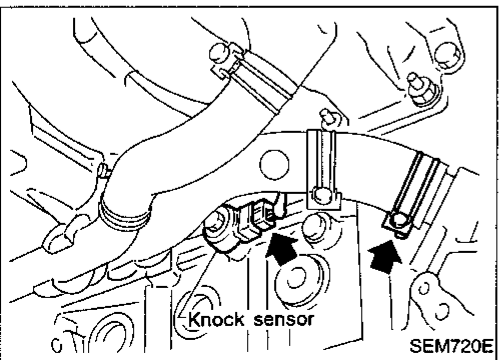

23. Remove knock sensor harness connector.

24. Remove EGR tube.

GI

MA

EM

LC

EC

FE

CL

MT

AT

FA

RA

BR

ST

RS

BT

HA

EL

IDX

Removal (Cont'd)

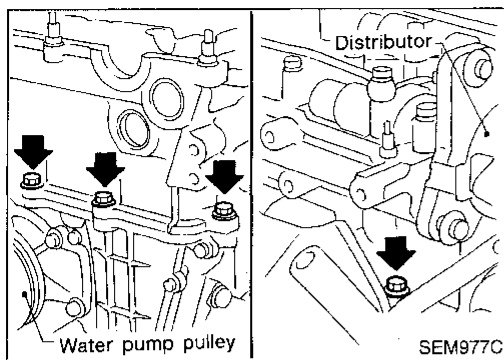

25. Remove cylinder head outside bolts.

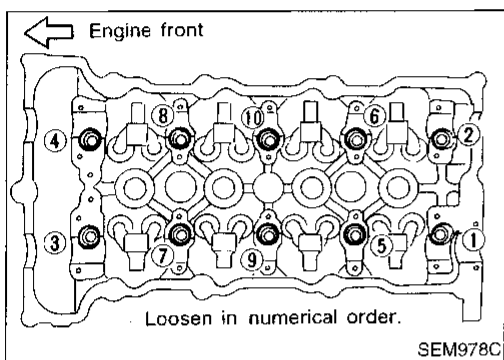

26. Remove cylinder head bolts.

• **Loosen cylinder head bolts in two or three steps.**

27. Remove cylinder head completely with intake and exhaust manifolds.

28. Remove oil pans.
Refer to EM-11.

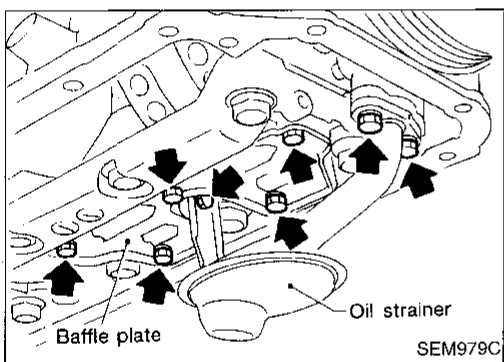

29. Remove oil strainer and baffle plate.

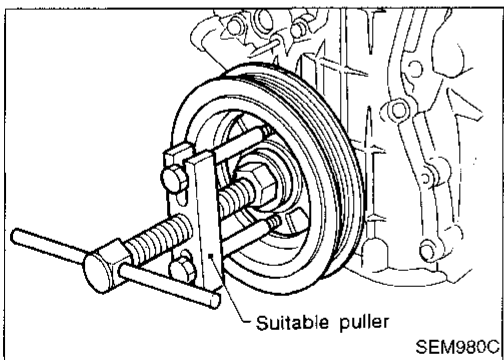

30. Remove crankshaft pulley.

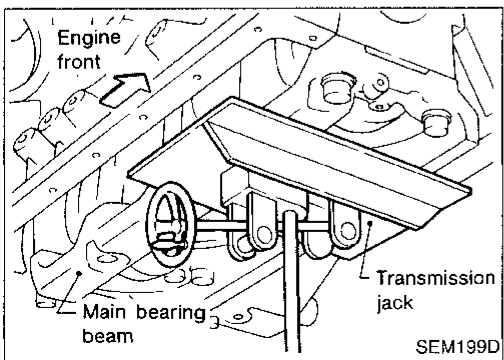

31. Set a suitable transmission jack under main bearing beam.

Removal (Cont'd)

32. Remove RH engine mounting.

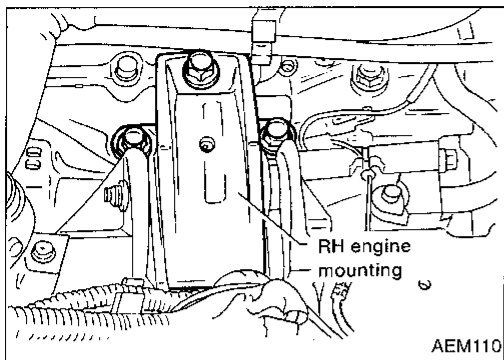

33. Remove front cover and oil pump drive spacer.

- Inspect for oil leakage at front oil seal. Replace seal if oil leak is present.

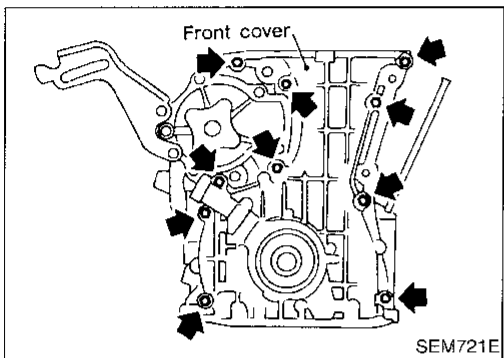

34. Remove timing chain guides and timing chain.

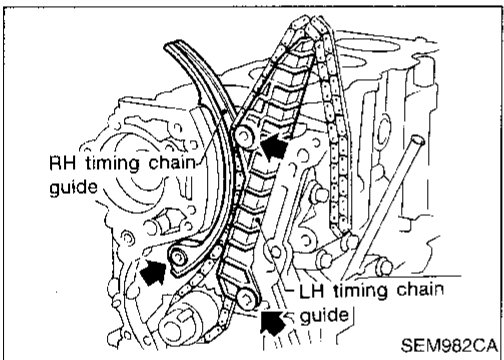

Inspection

Check for cracks and excessive wear at roller links. Replace chain if necessary.

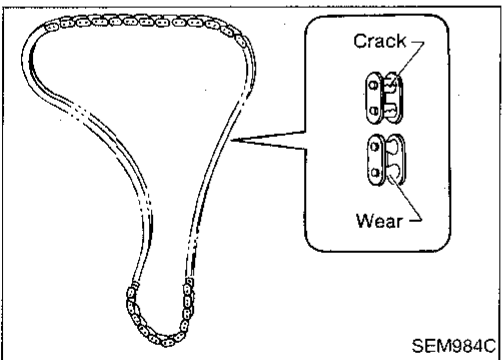

Installation

1. Install crankshaft sprocket on crankshaft.
 - Make sure that mating marks on crankshaft sprocket face front of engine.

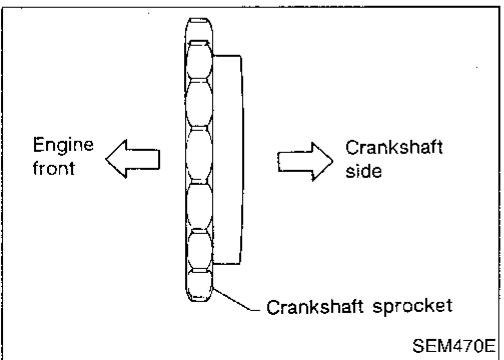

GI

MA

EM

LC

EC

FE

CL

MT

AT

FA

RA

BR

ST

RS

BT

HA

EL

IDX

Installation (Cont'd)

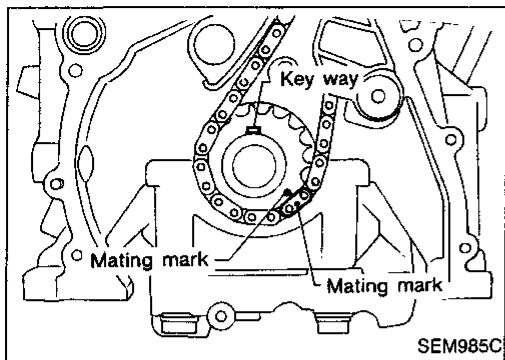

2. Position crankshaft so that No. 1 piston is set at TDC and key way is at 12 o'clock. Fit timing chain on crankshaft sprocket, aligning the mating marks.

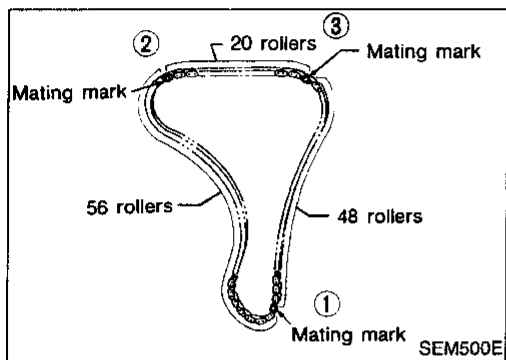

- Mating mark color on timing chain.

- ① : Gold
- ② , ③ : Silver

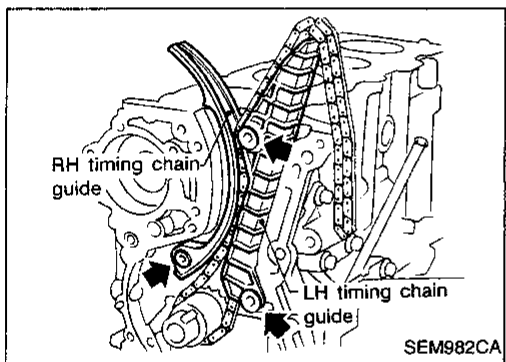

3. Install timing chain and timing chain guides.

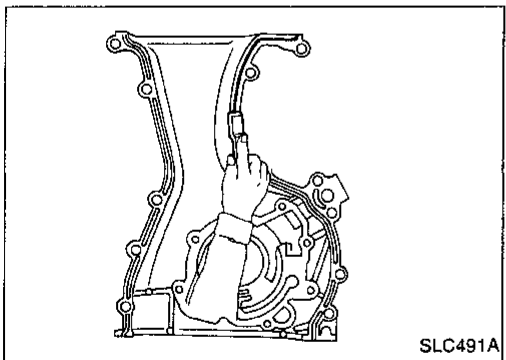

4. Use a scraper to remove old liquid gasket from mating surface of front cover.

- Also remove old liquid gasket from mating surface of cylinder block.

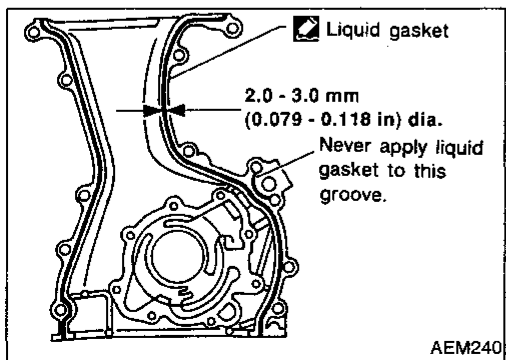

5. Apply a continuous bead of liquid gasket to front cover.

- Use Genuine Liquid Gasket or equivalent.
- Be sure to install new front oil seal in the right direction. Refer to EM-30.

Installation (Cont'd)

6. Install oil pump drive spacer and front cover.

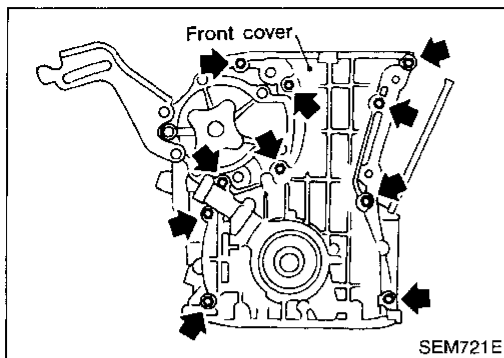

- Wipe off excessive liquid gasket.

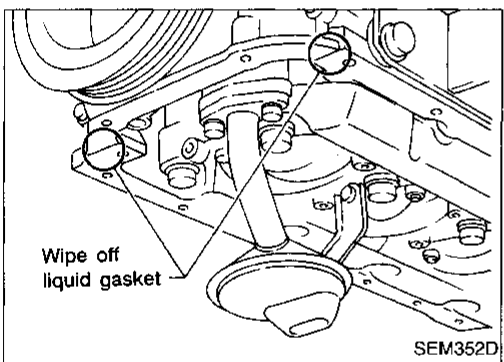
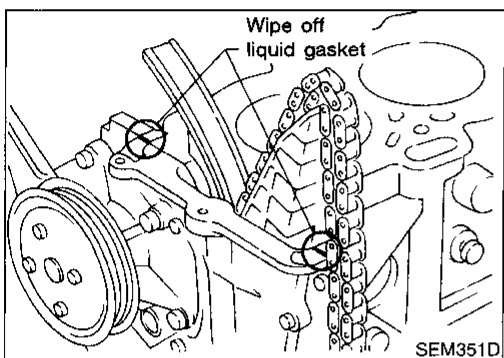

7. Install RH engine mounting.

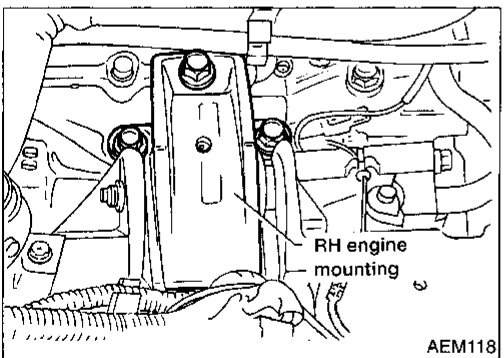

8. Install crankshaft pulley.
9. Set No. 1 piston at TDC of its compression stroke.

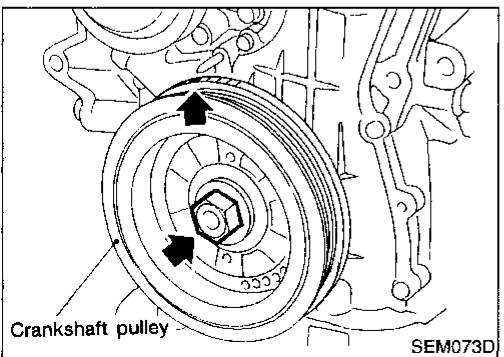

GI

MA

EM

LC

EC

FE

CL

MT

AT

FA

RA

BR

ST

RS

BT

HA

EL

IDX

TIMING CHAIN

Installation (Cont'd)

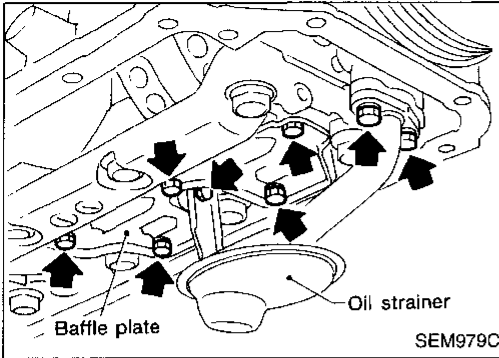

10. Install oil strainer and baffle plate.
11. Install aluminum oil pan.
Refer to EM-14.

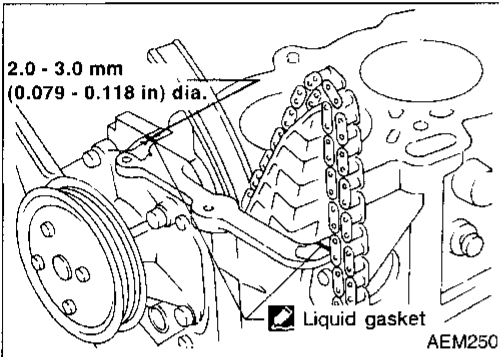

12. Before installing cylinder head gasket, apply liquid gasket as shown in the illustration.

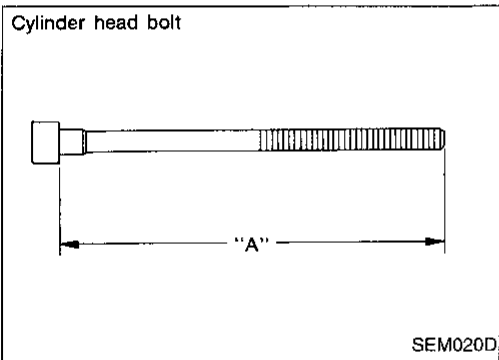

13. Install cylinder head completely with intake and exhaust manifolds.

- Apply engine oil to threads and seating surfaces of cylinder head bolts before installing them.
- Be sure to install washers between bolts and cylinder head.

CAUTION:

If cylinder head bolt exceeds limit of dimension "A", replace it.

Dimension "A":

158.2 mm (6.228 in)

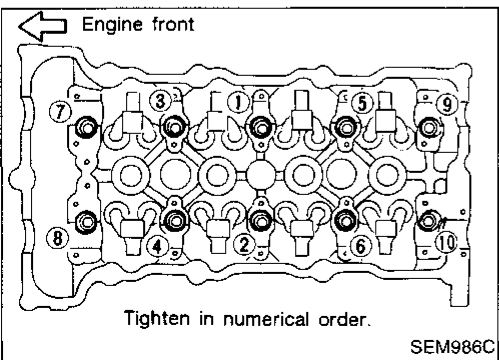
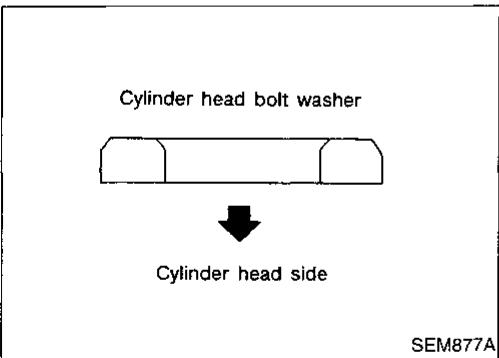

14. Tighten cylinder head bolts using the following procedure.
 - a. Tighten all bolts to 39 N·m (4.0 kg·m, 29 ft·lb).
 - b. Tighten all bolts to 78 N·m (8.0 kg·m, 58 ft·lb).
 - c. Loosen all bolts completely.
 - d. Tighten all bolts to 34 to 44 N·m (3.5 to 4.5 kg·m, 25 to 33 ft·lb).

TIMING CHAIN

Installation (Cont'd)

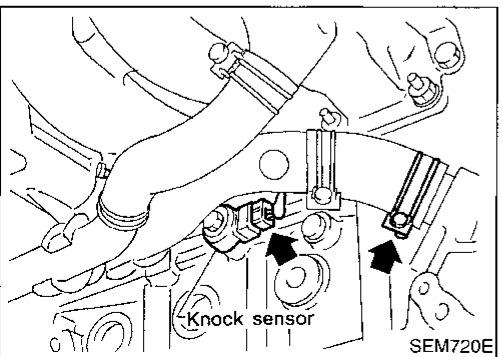
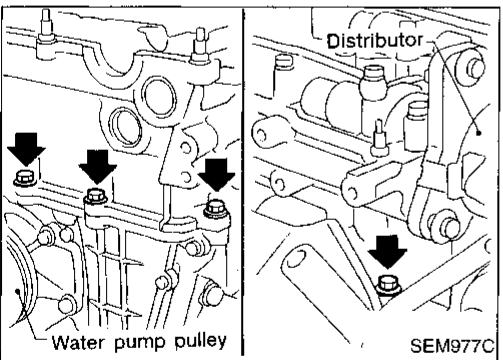
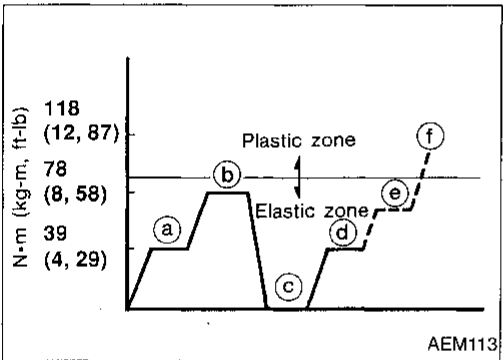
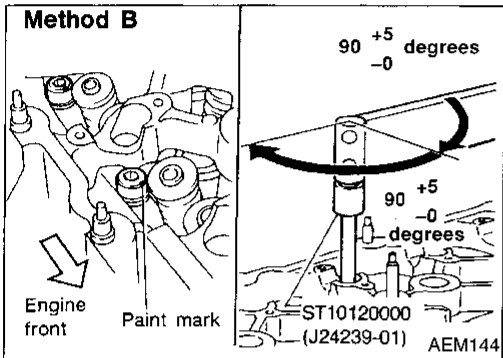
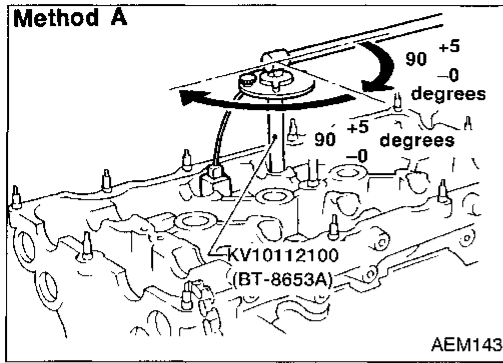

e. Method A: Turn all bolts 90 to 95 degrees clockwise with Tool or suitable angle wrench.

Method B: If an angle wrench is not available, mark all cylinder head bolts on the side facing engine front. Then, turn each cylinder head bolt 90 to 95 degrees clockwise.

f. Turn all bolts 90 to 95 degrees clockwise.

g. Ensure that paint mark on each bolt faces the rear of the engine. (Method B only)

Do not turn any bolt 180 to 190 degrees clockwise all at once.

	Tightening torque N-m (kg-m, ft-lb)
a.	39 (4.0, 29)
b.	78 (8.0, 58)
c.	0 (0, 0)
d.	34 - 44 (3.5 - 4.5, 25 - 33)
e.	90 - 95 degrees (90 degrees preferred)
f.	90 - 95 degrees (90 degrees preferred)

15. Install cylinder head outside bolts.

16. Install the following water hoses:

- Water hose for cylinder block.
- Water hoses for heater.

17. Install knock sensor harness connector.

GI

MA

EM

LC

EC

FE

CL

MT

AT

FA

RA

BR

ST

RS

BT

HA

EL

IDX

TIMING CHAIN

Installation (Cont'd)

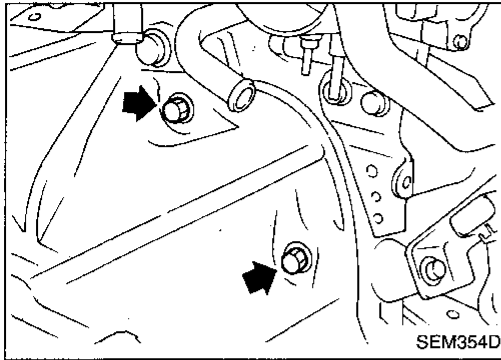

18. Install starter motor.

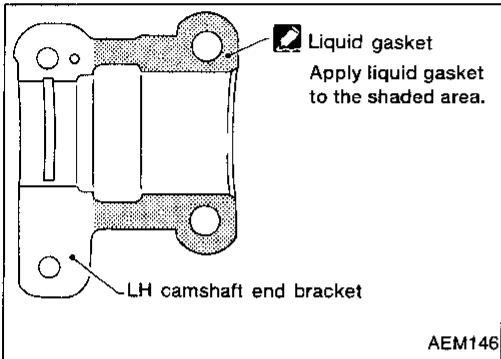

19. Remove old liquid gasket from mating surface of LH camshaft end bracket.

- Also remove old liquid gasket from mating surface of cylinder head.

20. Apply liquid gasket to mating surface of LH camshaft end bracket as shown in illustration.

- Use Genuine Liquid Gasket or equivalent.

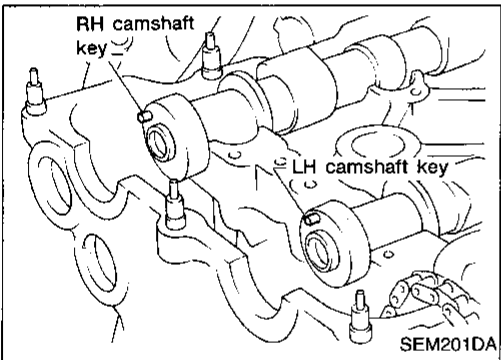

21. Install camshafts, camshaft brackets, oil tubes and baffle plate.

- Position camshaft.
- LH camshaft key at about 12 o'clock.
- RH camshaft key at about 12 o'clock.

Apply new engine oil to bearing and cam surfaces of camshafts before installing them.

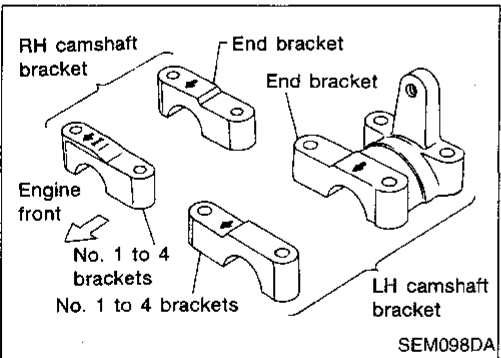

- Position camshaft brackets as shown in the illustration.

Apply new engine oil to threads and seating surfaces of camshaft bracket bolts before installing them.

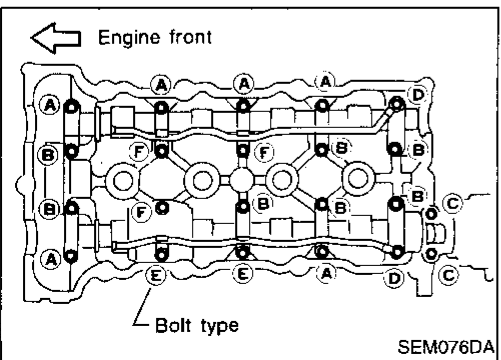

- Arrange bolts (Size and length).

(A) : M6 x 53.8mm (2.12 in.)

(B) : M6 x 37 mm (1.46 in.)

(C) : M8 x 35 mm (1.38 in.)

(D) : M6 x 64 mm (2.52 in.)

(E) : M6 x 55.3mm (2.18 in.)

(F) : M6 x 38.5mm (1.52 in.)

For (E) and (F), use with a washer.

TIMING CHAIN

Installation (Cont'd)

- Tightening procedure

STEP 1:

RH camshaft

Tighten bolts ⑨ - ⑩ in that order then tighten bolts ① - ⑧ in numerical order.

Ⓜ: 2 N-m (0.2 kg-m, 17 in-lb)

LH camshaft

Tighten bolts ⑪ - ⑫ in that order then tighten bolts ① - ⑩ in numerical order.

Ⓜ: 2 N-m (0.2 kg-m, 17 in-lb)

STEP 2:

Tighten bolts in numerical order.

Ⓜ: 6 N-m (0.6 kg-m, 52 in-lb)

STEP 3:

Tighten bolts in numerical order.

Bolt type ① ② ④ ⑤ ⑥

Ⓜ: 9.8 - 11.8 N-m
(1.0 - 1.2 kg-m, 7.2 - 8.7 ft-lb)

Bolt type ③

Ⓜ: 18 - 25 N-m
(1.8 - 2.6 kg-m, 13 - 19 ft-lb)

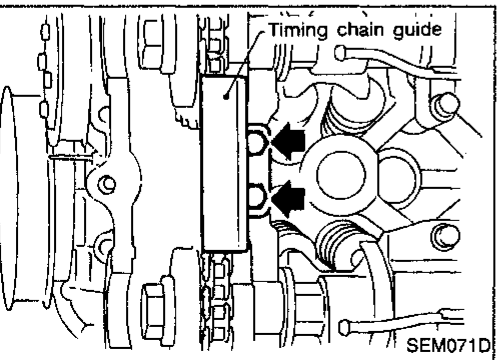
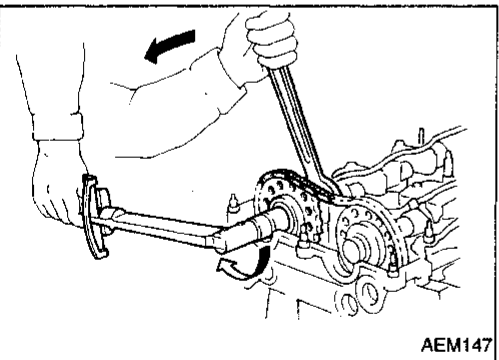
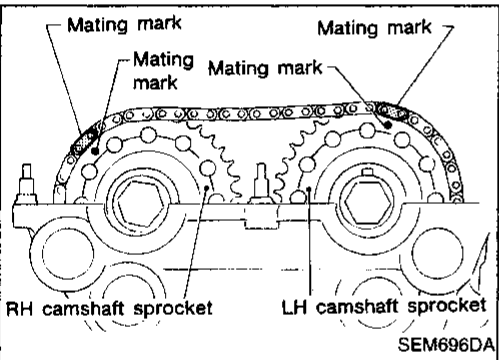
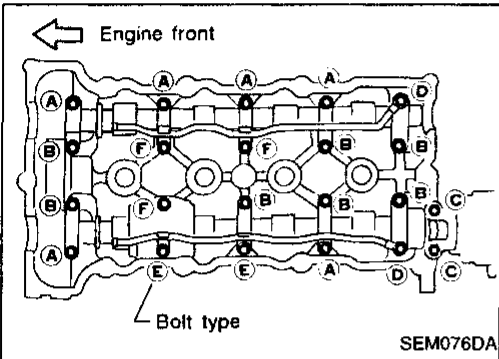
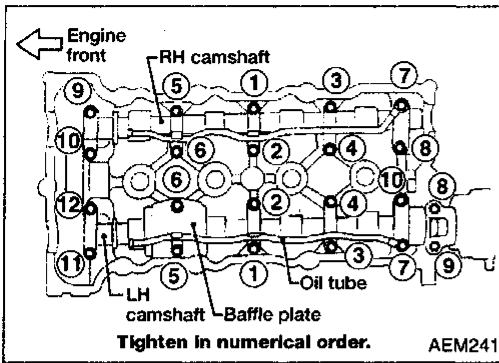

- 22. Install camshaft sprockets.

Line up mating marks on timing chain with mating marks on camshaft sprockets.

- Lock camshafts as shown in figure and tighten to specified torque.

Ⓜ: 137 - 157 N-m

(14.0 - 16.0 kg-m, 101 - 116 ft-lb)

Apply new engine oil to threads and seating surfaces of camshaft sprocket bolts before installing them.

- 23. Install timing chain guide.

CI

MA

EM

LC

EC

FE

CL

MT

AT

FA

RA

BR

ST

RS

BT

HA

EL

IDX

Installation (Cont'd)

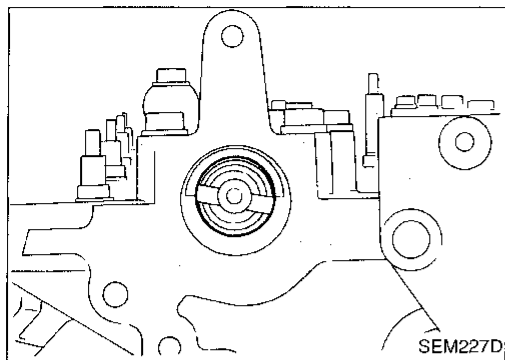

24. Install distributor.

- Make sure that position of camshaft is as shown in figure.

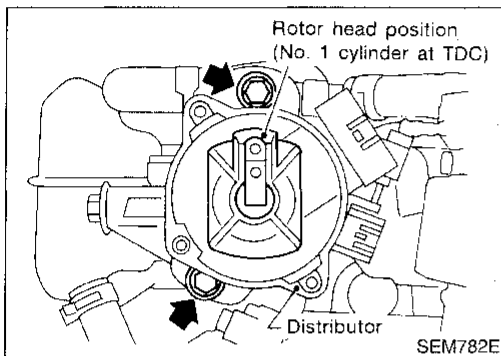

- Make sure that No. 1 piston is set at TDC and that distributor rotor is set at No. 1 cylinder spark position.

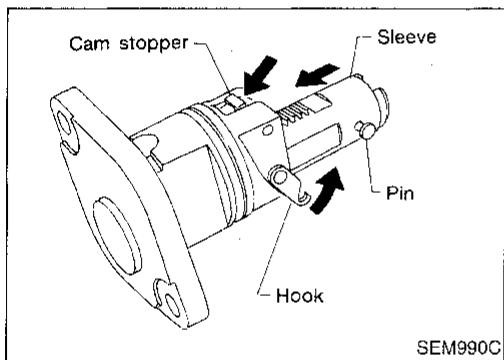

25. Install chain tensioner.

Make sure the camshaft sprockets are tightened completely.

Press cam stopper down and "press-in" sleeve until hook can be engaged on pin. When tensioner is bolted in position the hook will release automatically. Make sure arrow "A" points toward engine front.

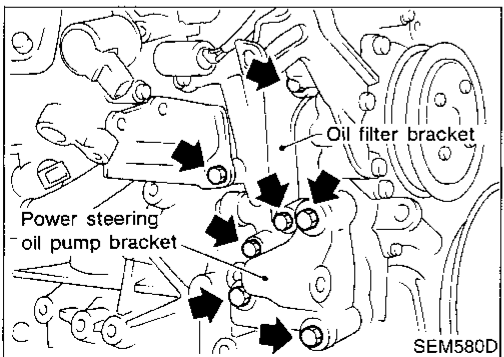
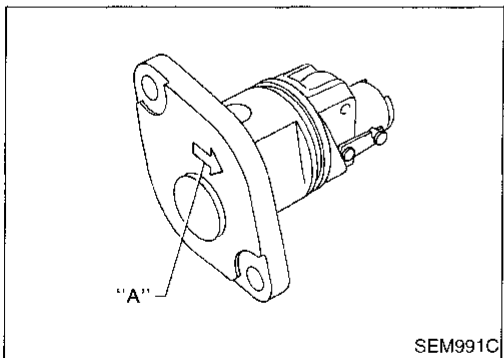

26. Install oil filter bracket and power steering oil pump bracket.

TIMING CHAIN

Installation (Cont'd)

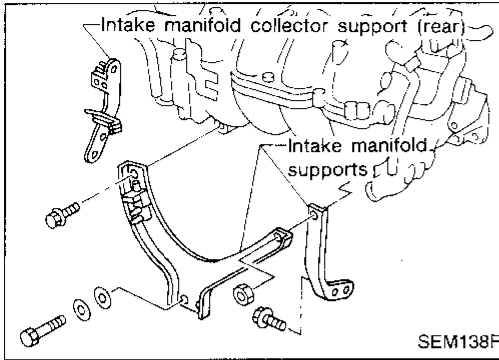

27. Install intake manifold supports.

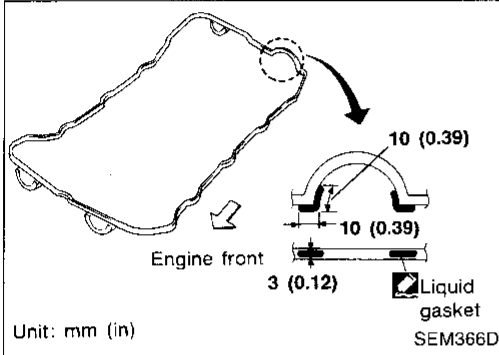

28. Remove old liquid gasket from mating surfaces of rocker cover and cylinder head.

29. Apply a continuous bead of liquid gasket to rocker cover gasket and cylinder head as shown in the illustrations.

- **Use Genuine Liquid Gasket or equivalent.**

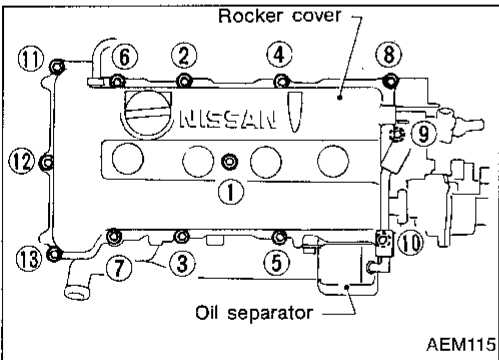
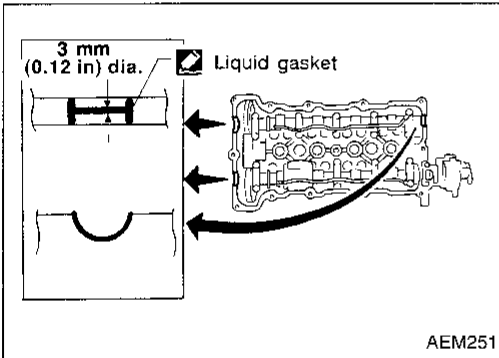

30. Install rocker cover and oil separator.

a. Tighten nuts ①, ⑩, ⑪, ⑬, ⑧ in that order to 4 N·m (0.4 kg-m, 35 in-lb).

b. Tighten nuts ① through ⑬ in numerical order to 8 to 10 N·m (0.8 to 1.0 kg-m, 69 to 87 in-lb).

31. Install the following parts:

- Spark plugs and leads
- Power steering pump
- Generator
- Water pump pulley and drive belts.

For adjusting drive belt deflection, refer to MA section ("Checking Drive Belts", "ENGINE MAINTENANCE").

- Radiator

Refit hoses and refill with coolant.

Refer to MA section ("REFILLING ENGINE COOLANT", "Changing Engine Coolant").

- Front RH wheel
- Engine under covers
- 32. Connect the following:
 - Vacuum hoses
 - Fuel hoses
 - Wire harnesses and connectors
 - Air duct to intake manifold

CI

MA

EM

LC

EC

FE

CL

MT

AT

FA

RA

BR

ST

RS

BT

HA

EL

IDX

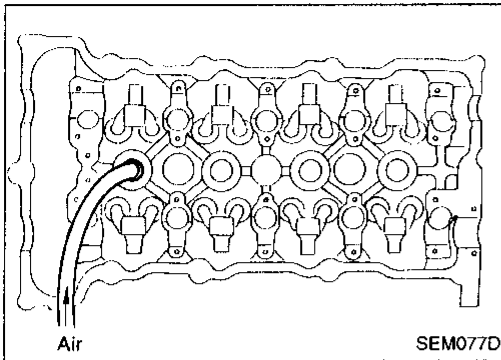

Valve Oil Seal

1. Remove accelerator wire.
2. Remove rocker cover and oil separator.
3. Remove camshafts and sprockets.
Refer to EM-16.
4. Remove spark plugs.
5. Install air hose adapter into spark plug hole and apply air pressure to hold valves in place. Apply a pressure of 490 kPa (5 kg/cm², 71 psi).
6. Remove rocker arm, rocker arm guide and shim.
7. Remove valve spring with Tool. Temporarily install camshaft as shown.

Piston concerned should be set at TDC to prevent valve from falling.

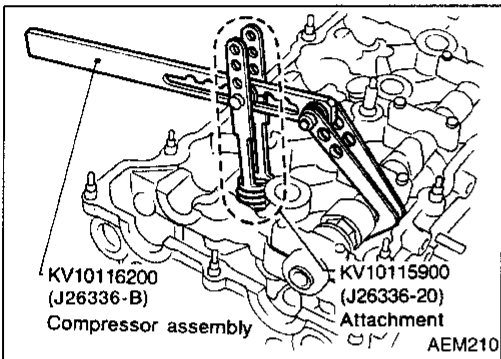

8. Remove valve oil seal with a suitable tool.

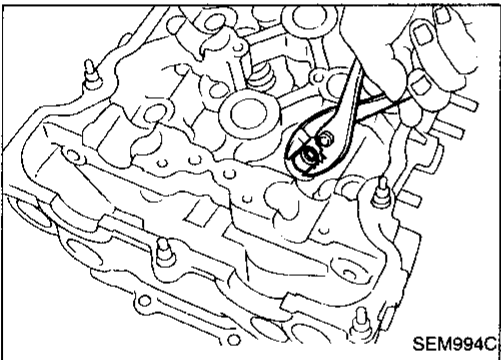

9. Apply new engine oil to new valve oil seal and install it with Tool.

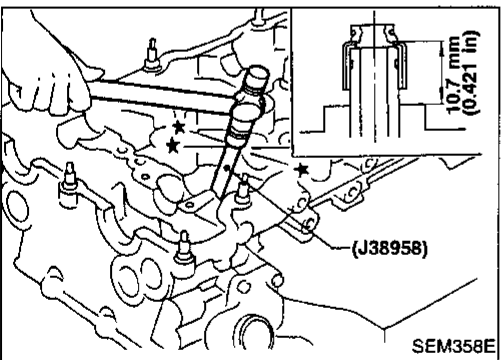

Front Oil Seal

1. Remove the following parts:
 - Engine under cover
 - Front RH wheel and engine side cover
 - Drive belts
 - Crankshaft pulley
2. Remove front oil seal.

Be careful not to scratch front cover.

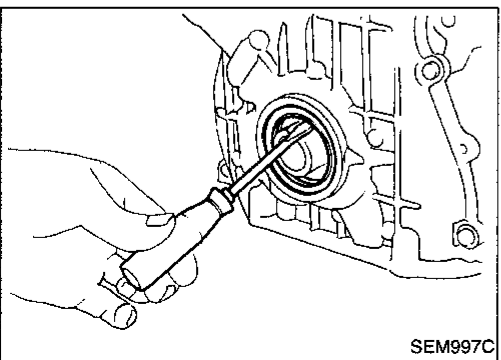

Front Oil Seal (Cont'd)

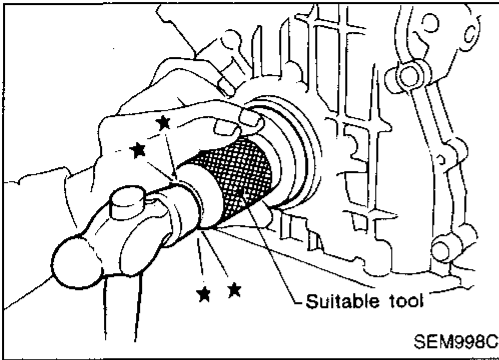

3. Apply new engine oil to new oil seal and install it using a suitable tool.

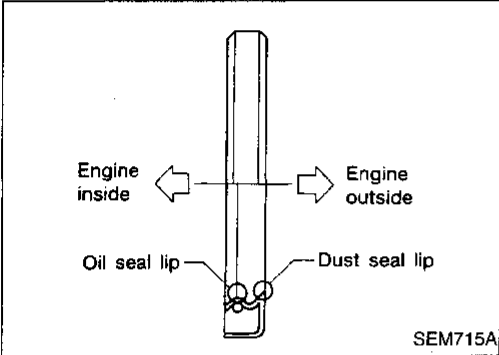

- Install new oil seal in the direction shown.

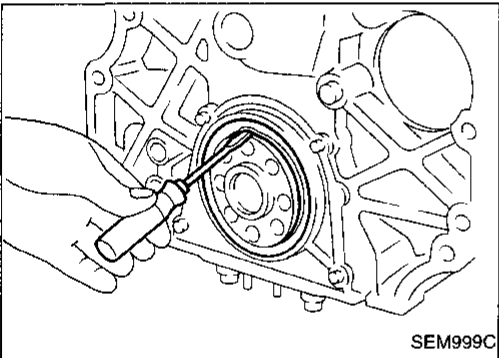

Rear Oil Seal

1. Remove transaxle. (Refer to MT or AT section.)
2. Remove flywheel or drive plate.
3. Remove rear oil seal.

Be careful not to scratch rear oil seal retainer.

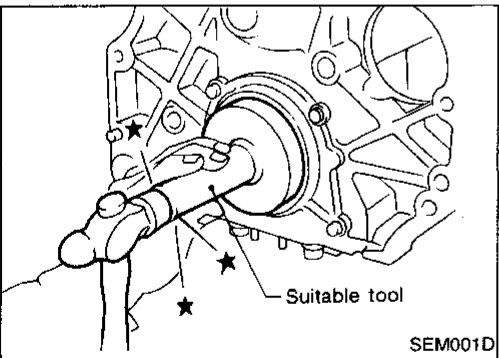

4. Apply new engine oil to new oil seal and install it using a suitable tool.

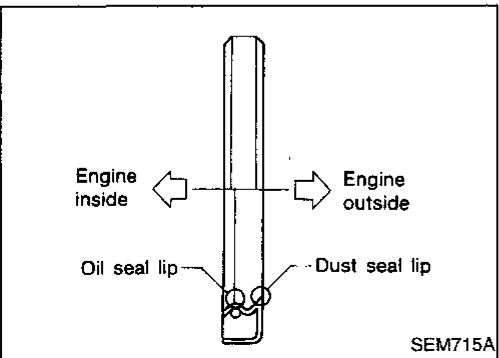

- Install new oil seal in the direction shown.

GI
MA
EM
LC
EC
FE
CL
MT
AT
FA
RA
BR
ST
RS
BT
HA
EL
IDX

SEC. 111-130

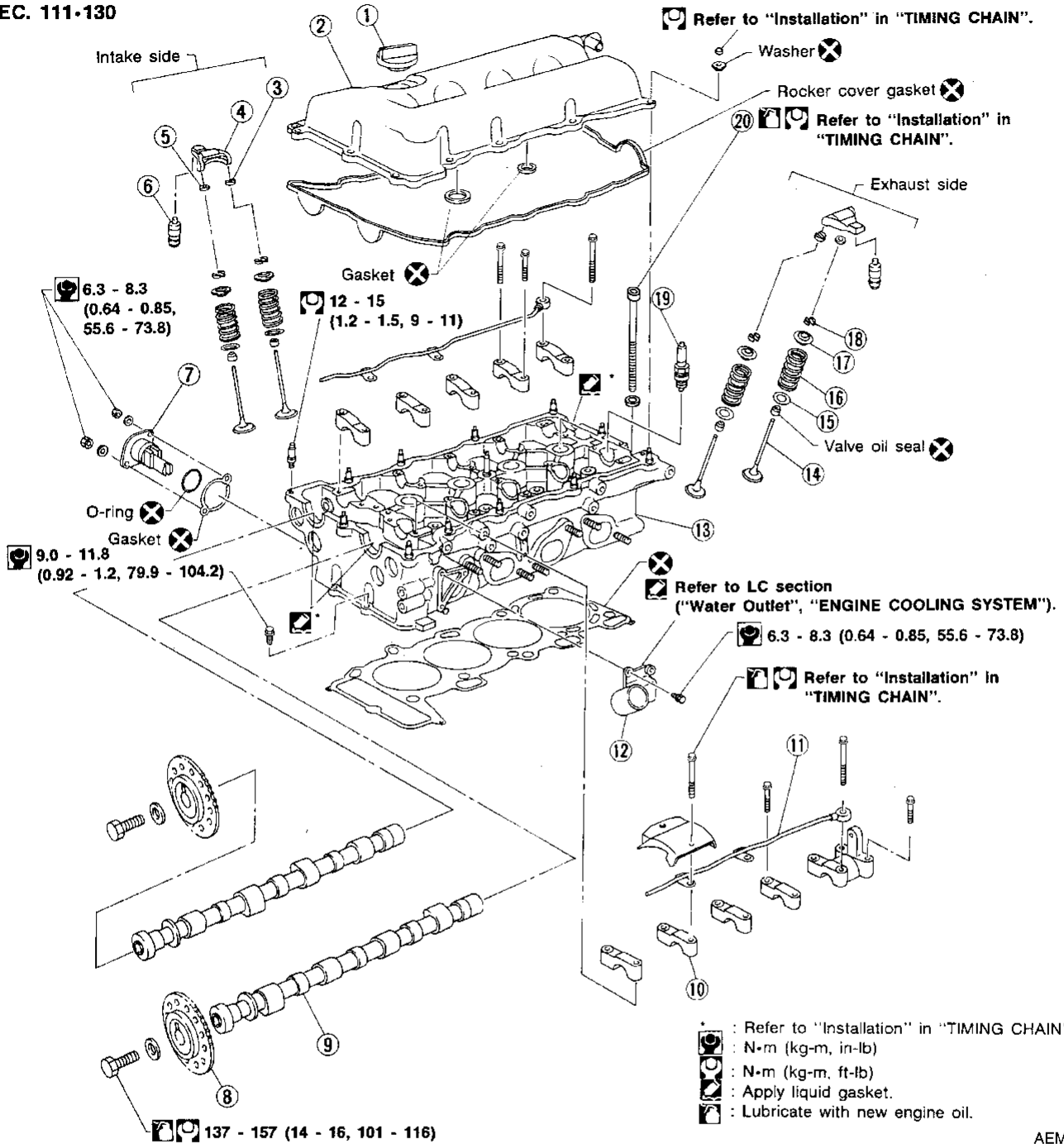

- | | | |
|---------------------------|---------------------|-------------------------|
| ① Oil filler cap | ⑧ Camshaft sprocket | ⑮ Valve spring seat |
| ② Rocker cover | ⑨ Camshaft | ⑯ Valve spring |
| ③ Rocker arm guide | ⑩ Camshaft bracket | ⑰ Valve spring retainer |
| ④ Rocker arm | ⑪ Oil tube | ⑱ Valve collet |
| ⑤ Shim | ⑫ Water outlet | ⑲ Spark plug |
| ⑥ Hydraulic lash adjuster | ⑬ Cylinder head | ⑳ Cylinder head bolt |
| ⑦ Chain tensioner | ⑭ Valve | |

AEM232

CAUTION:

- When installing rocker arms, camshaft and oil seal, lubricate contacting surfaces with new engine oil.
- When tightening cylinder head bolts, camshaft sprocket bolts and camshaft bracket bolts, lubricate bolt threads and seat surfaces with new engine oil.

CI
MA

EM

LC

EC

FE

CL

MT

AT

FA

RA

BR

ST

RS

BT

HA

EL

IDX

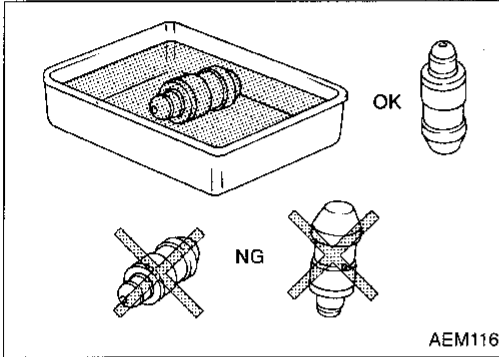

- If a hydraulic lash adjuster is kept on its side, there is a risk of air entering it. When hydraulic lash adjusters are removed, stand them straight up or soak them in new engine oil.
- Do not disassemble hydraulic lash adjusters.
- Attach tags to lash adjusters so as not to mix them up.

Removal

- The removal procedure is the same as for timing chain. Refer to EM-16.

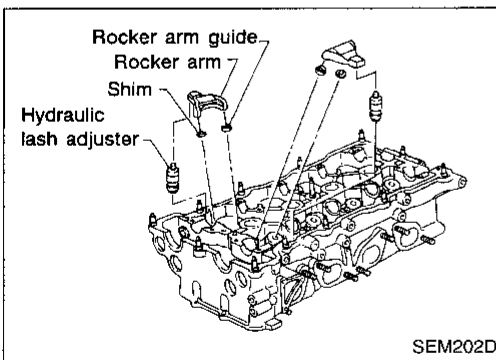

Disassembly

1. Remove rocker arms, shims, rocker arm guides and hydraulic lash adjusters from cylinder head.

CAUTION:

Keep parts in order so they can be installed in their original positions during assembly.

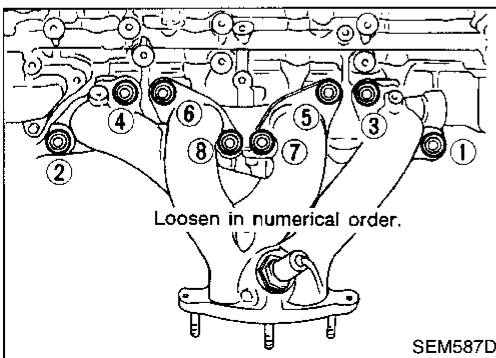

2. Remove exhaust manifold cover.
3. Remove exhaust manifold as shown.

Disassembly (Cont'd)

4. Remove water outlet.

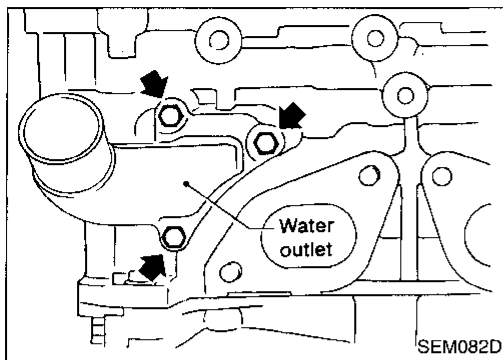

5. Remove intake manifold supports and intake manifold collector supports (both on rear and upper sides).

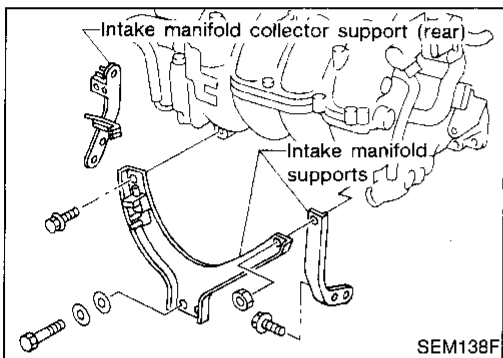

6. Remove fuel tube assembly. Refer to EC section ("Injector Removal and Installation", "BASIC SERVICE PROCEDURE").

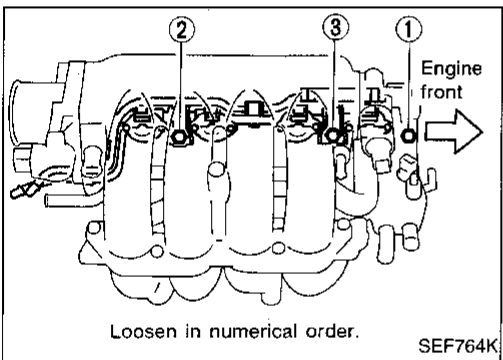

7. Remove intake manifold collector from intake manifold as shown.

8. Remove power steering oil pump bracket and oil filter bracket.

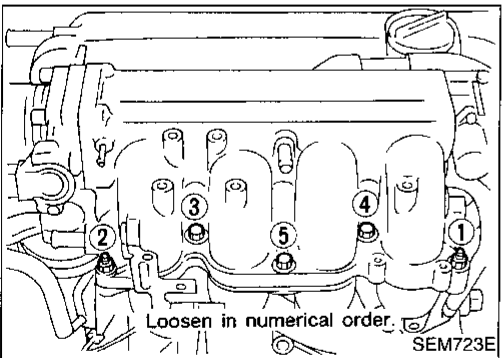

9. Remove intake manifold as shown.

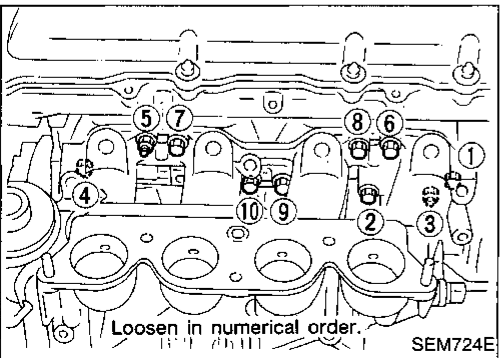

Disassembly (Cont'd)

10. Remove thermostat housing with water pipe.

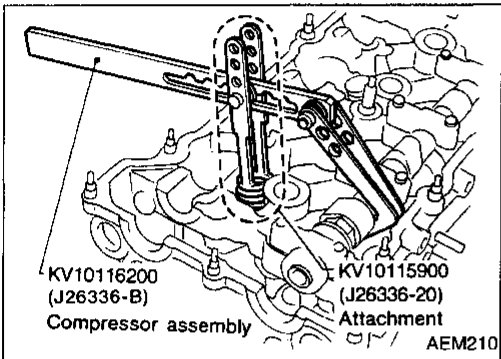
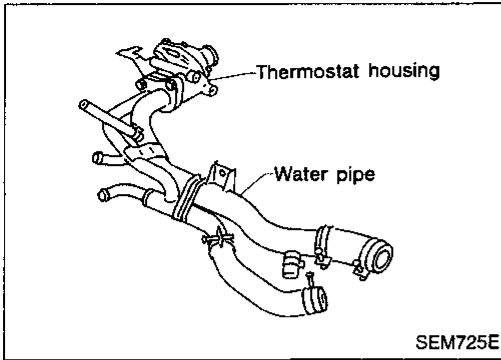

11. Remove valve components with Tool. Install camshaft temporarily as shown.

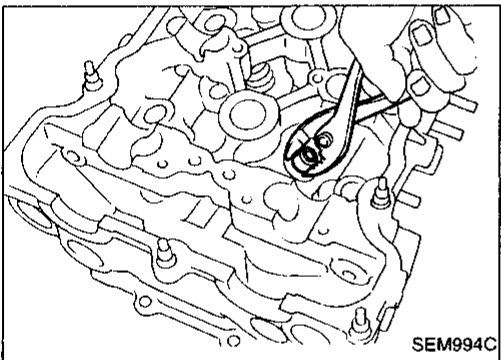

12. Remove valve oil seal with a suitable tool.

GI

MA

EM

LC

EC

FE

CL

MT

AT

FA

RA

BR

ST

RS

BT

HA

EL

IDX

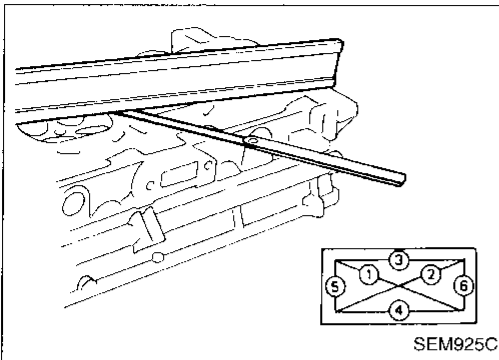

Inspection

CYLINDER HEAD DISTORTION

- Clean mating surface of cylinder head.
- Use a reliable straightedge and feeler gauge to check the flatness of cylinder head mating surface.
- Check along six positions shown in figure.

Head surface flatness:

Standard

Less than 0.03 mm (0.0012 in)

Limit

0.1 mm (0.004 in)

If beyond the specified limit, replace or resurface.

Resurfacing limit:

The limit for cylinder head resurfacing is determined by the amount of cylinder block resurfacing.

Amount of cylinder head resurfacing is "A".

Amount of cylinder block resurfacing is "B".

The maximum limit is as follows:

$$A + B = 0.2 \text{ mm (0.008 in)}$$

After resurfacing cylinder head, check that camshaft rotates freely by hand. If resistance is felt, cylinder head must be replaced.

Nominal cylinder head height:

136.9 - 137.1 mm (5.390 - 5.398 in)

CAMSHAFT VISUAL CHECK

Check camshaft for scratches, seizure and wear.

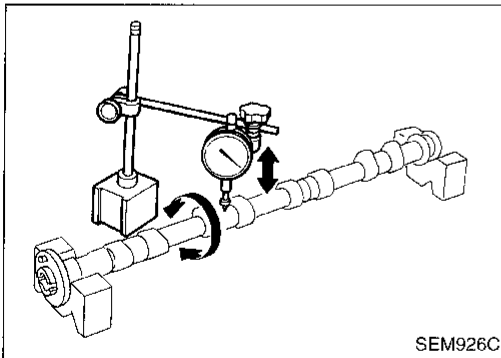

CAMSHAFT RUNOUT

1. Measure camshaft runout at the center journal.

Runout (Total indicator reading):

Standard

Less than 0.02 mm (0.0008 in)

Limit

0.1 mm (0.004 in)

2. If it exceeds the limit, replace camshaft.

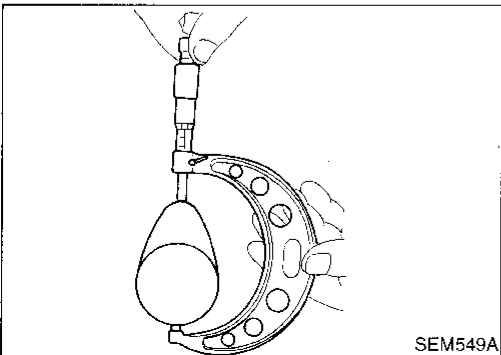

CAMSHAFT CAM HEIGHT

1. Measure camshaft cam height.

Standard cam height:

Intake

37.920 - 38.110 mm (1.4929 - 1.5004 in)

Exhaust

37.550 - 37.740 mm (1.4783 - 1.4858 in)

Cam height wear limit:

Intake & Exhaust

0.2 mm (0.008 in)

2. If wear is beyond the limit, replace camshaft.

Inspection (Cont'd)

CAMSHAFT JOURNAL CLEARANCE

1. Install camshaft bracket and tighten bolts. Refer to EM-26.
2. Measure inner diameter of camshaft bearing.

Standard inner diameter:

28.000 - 28.021 mm (1.1024 - 1.1032 in)

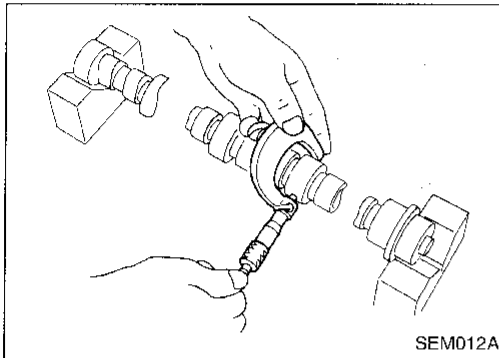
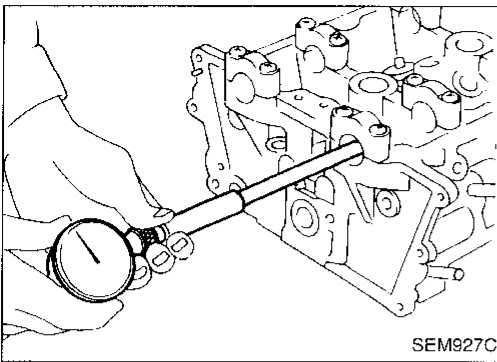

3. Measure outer diameter of camshaft journal.

Standard outer diameter:

27.935 - 27.955 mm (1.0998 - 1.1006 in)

4. Calculate camshaft journal clearance.

Camshaft journal clearance = standard inner diameter - standard outer diameter:

Standard

0.045 - 0.090 mm (0.0018 - 0.0035 in)

Limit

0.15 mm (0.0059 in)

5. If clearance exceeds the limit, replace camshaft and remeasure camshaft journal clearance.
 - If clearance still exceeds the limit after replacing camshaft, replace cylinder head.

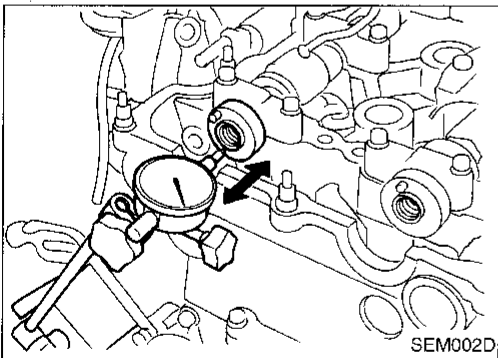

CAMSHAFT END PLAY

1. Install camshaft in cylinder head. Refer to EM-27.
2. Measure camshaft end play.

Camshaft end play:

Standard

0.055 - 0.139 mm (0.0022 - 0.0055 in)

Limit

0.20 mm (0.0079 in)

3. If end play exceeds the limit, replace camshaft and remeasure camshaft end play.
 - If end play still exceeds the limit after replacing camshaft, replace cylinder head.

GI

MA

EM

LC

EC

FE

CL

MT

AT

FA

PA

BR

ST

FS

BT

HA

EL

IDX

CYLINDER HEAD

Inspection (Cont'd)

CAMSHAFT SPROCKET RUNOUT

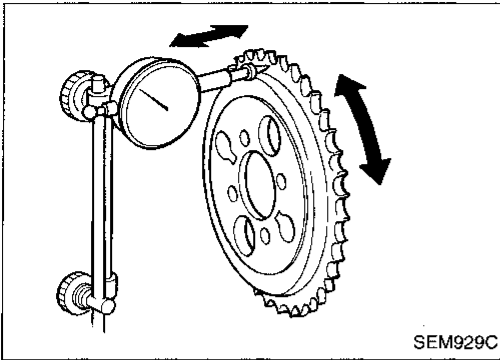

1. Install sprocket on camshaft.
2. Measure camshaft sprocket runout.
Runout (Total indicator reading):
Limit 0.25 mm (0.0098 in)
3. If it exceeds the limit, replace camshaft sprocket.

VALVE GUIDE CLEARANCE

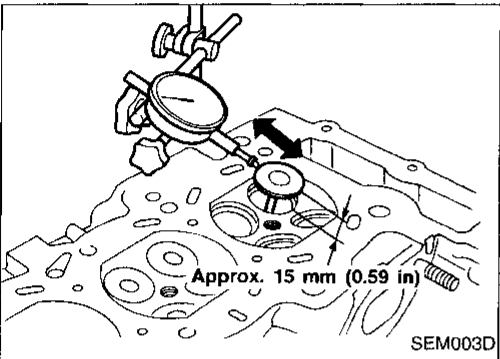

1. Measure valve deflection as shown in illustration. (Valve and valve guide mostly wear in this direction.)
Valve deflection limit (Dial gauge reading):
Intake & Exhaust
0.2 mm (0.008 in)

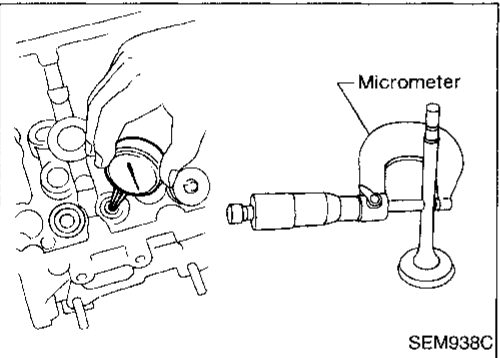

2. If it exceeds the limit, check valve to valve guide clearance.
 - a. Measure valve stem diameter and valve guide inner diameter.
 - b. Calculate valve to valve guide clearance.
Valve to valve guide clearance = valve guide inner diameter – valve stem diameter:
Standard
Intake 0.020 - 0.053 mm (0.0008 - 0.0021 in)
Exhaust 0.040 - 0.073 mm (0.0016 - 0.0029 in)
Limit
Intake 0.08 mm (0.0031 in)
Exhaust 0.1 mm (0.004 in)
 - c. If it exceeds the limit, replace valve and remeasure clearance.
 - If clearance still exceeds the limit after replacing valve, replace valve guide.

VALVE GUIDE REPLACEMENT

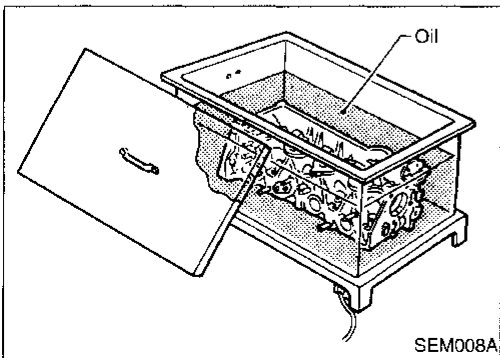

1. To remove valve guide, heat cylinder head to 110 to 130°C (230 to 266°F).

Inspection (Cont'd)

2. Press out valve guide or use a hammer and suitable tool.

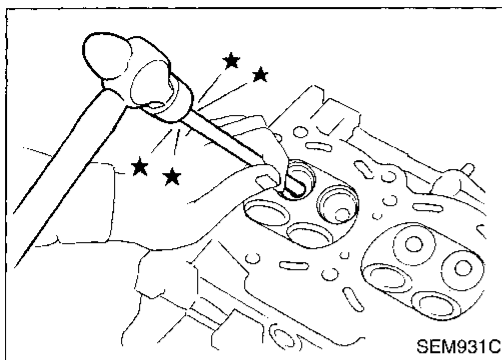

3. Ream cylinder head valve guide hole.

Valve guide hole diameter

(for service parts):

Intake & Exhaust

10.175 - 10.196 mm (0.4006 - 0.4014 in)

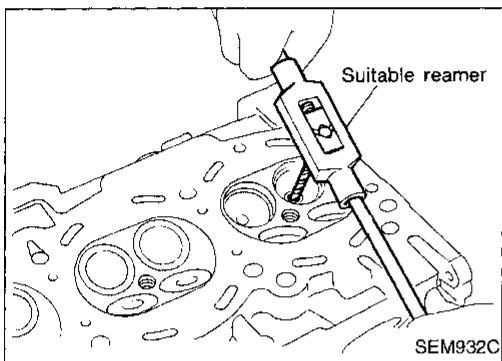

4. Heat cylinder head to 110 to 130°C (230 to 266°F) and press service valve guide into cylinder head.

Projection "L":

14.0 - 14.2 mm (0.551 - 0.559 in)

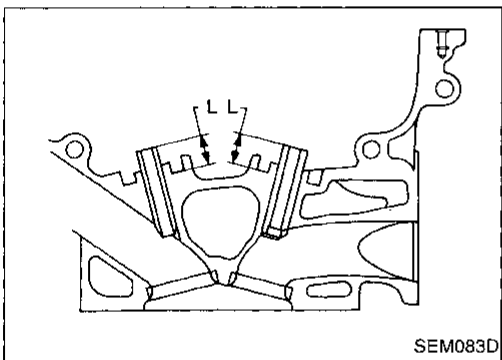

5. Ream valve guide.

Finished size:

Intake & Exhaust

6.000 - 6.018 mm (0.2362 - 0.2369 in)

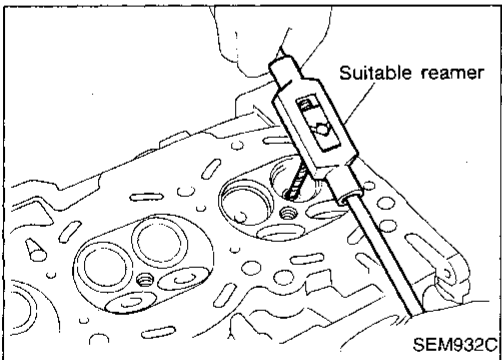

VALVE SEATS

Check valve seats for pitting at contact surface. Resurface or replace if excessively worn.

- Before repairing valve seats, check valve and valve guide for wear. If they have worn, replace them. Then correct valve seat.
- Use both hands to cut uniformly.

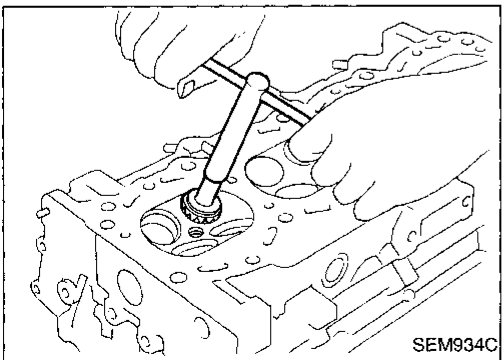

GI

MA

EM

LC

EC

FE

CL

MT

AT

FA

RA

BR

ST

RS

BT

HA

EL

IDX

CYLINDER HEAD

Inspection (Cont'd)

REPLACING VALVE SEAT FOR SERVICE PARTS

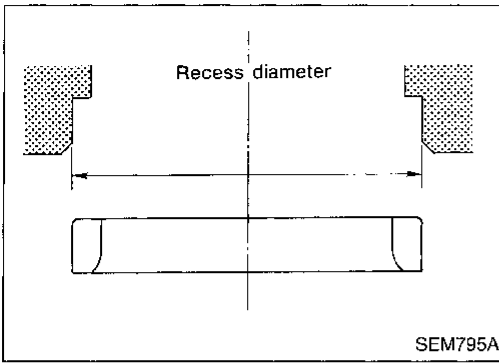

SEM795A

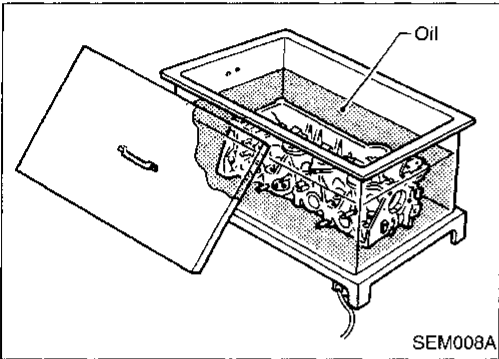

SEM008A

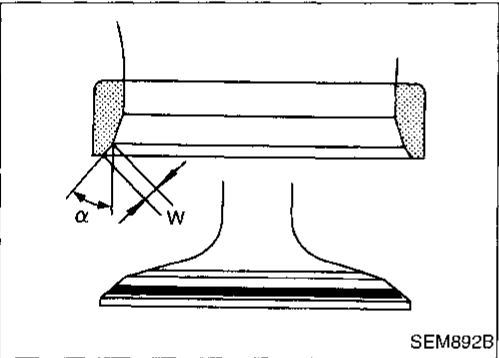

SEM892B

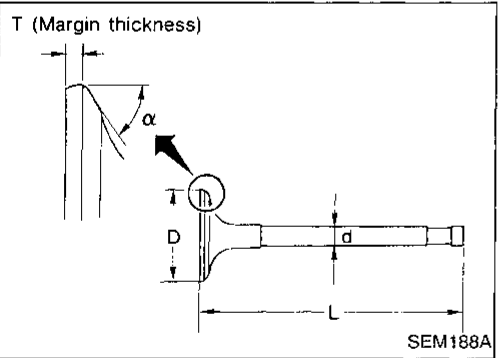

SEM188A

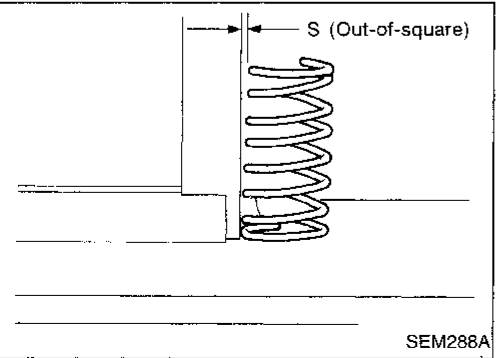

SEM288A

1. Bore out old seat until it collapses. Set machine depth stop so that boring cannot contact bottom face of seat recess in cylinder head.

2. Ream cylinder head recess.

Reaming bore for service valve seat

Oversize [0.5 mm (0.020 in)]:

Intake 35.500 - 35.516 mm (1.3976 - 1.3983 in)

Exhaust 31.500 - 31.516 mm (1.2402 - 1.2408 in)

Use the valve guide center for reaming to ensure valve seat will have the correct fit.

3. Heat cylinder head to 110 to 130°C (230 to 266°F).
4. Press fit valve seat until it seats on the bottom.

5. Cut or grind valve seat to the specified dimensions using a suitable tool. Refer to SDS, EM-110.

6. After cutting, lap valve seat with abrasive compound.

7. Check valve seating condition.

Seat face angle " α ":

44°53' - 45°07'

Contacting width "W":

Intake

1.05 - 1.35 mm (0.0413 - 0.0531 in)

Exhaust

1.25 - 1.55 mm (0.0492 - 0.0610 in)

VALVE DIMENSIONS

Check dimensions of each valve. Refer to SDS, EM-109.

When valve head has been worn down to 0.5 mm (0.020 in) in margin thickness, replace valve.

Grinding allowance for valve stem tip is 0.2 mm (0.008 in) or less.

VALVE SPRING

Squareness

1. Measure dimension "S".

Out-of-square "S":

Less than 2.2 mm (0.087 in)

2. If it exceeds the limit, replace spring.

CYLINDER HEAD

Inspection (Cont'd)

Pressure

Check valve spring pressure at specified spring height.

Pressure:

Standard

578.02 - 641.57 N (58.94 - 65.42 kg,
129.96 - 144.25 lb) at 30.0 mm (1.181 in)

Limit

More than 549.2 N (56.0 kg, 123.5 lb) at 30.0
mm (1.181 in)

If it exceeds the limit, replace spring.

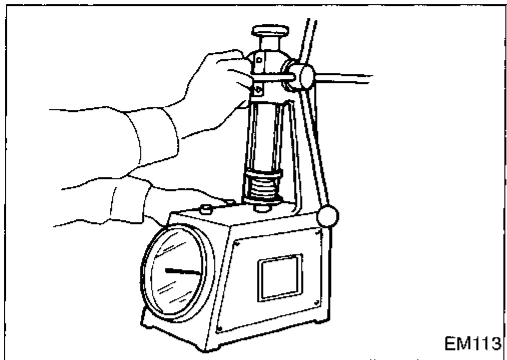

EM113

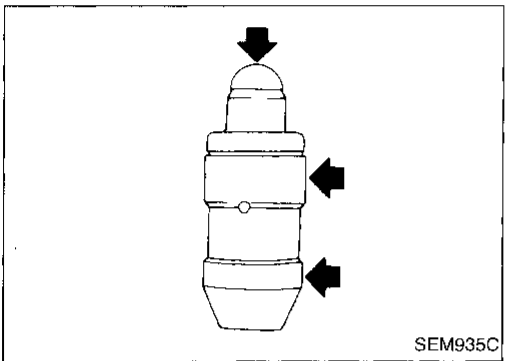

SEM935C

HYDRAULIC LASH ADJUSTER

1. Check contact and sliding surfaces for wear or score.

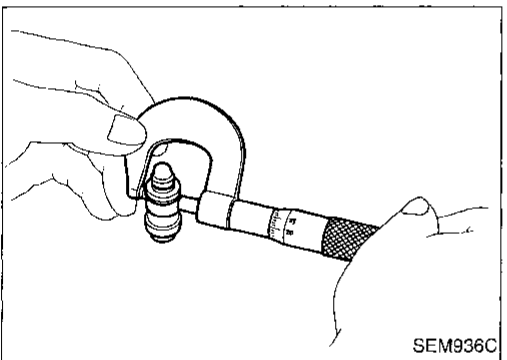

SEM936C

2. Check diameter of lash adjuster.

Outer diameter:

16.980 - 16.993 mm (0.6685 - 0.6690 in)

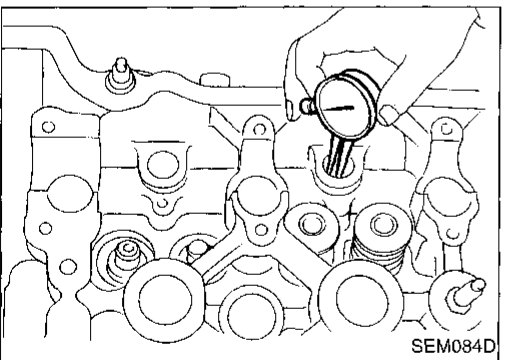

SEM084D

3. Check lash adjuster guide hole diameter.

Inner diameter:

17.000 - 17.020 mm (0.6693 - 0.6701 in)

Standard clearance between lash adjuster and
adjuster guide hole:

0.007 - 0.040 mm (0.0003 - 0.0016 in)

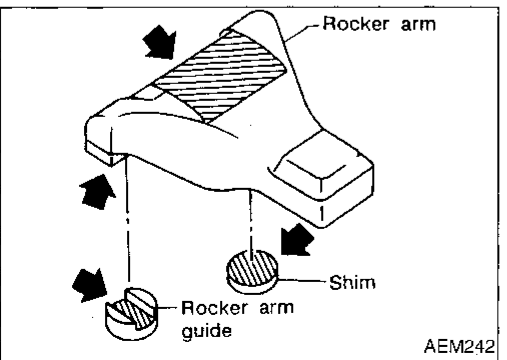

AEM242

ROCKER ARM, SHIM AND ROCKER ARM GUIDE

Check contact and sliding surfaces of rocker arms, shims and rocker arm guides for wear or score.

GI
MA
EM
LC
EC
FE
CL
MT
AT
FA
RA
BR
ST
RS
BT
HA
EL
IDX

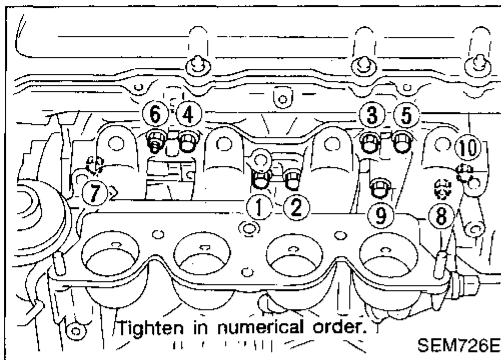

Assembly

1. Install intake manifold as shown.
2. Install fuel tube assembly.
Refer to EC section ("Injector Removal and Installation", "BASIC SERVICE PROCEDURE").

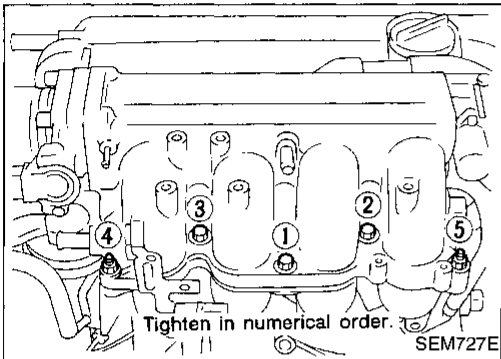

3. Install intake manifold collector to intake manifold as shown.
4. Install oil filter bracket and power steering oil pump bracket.

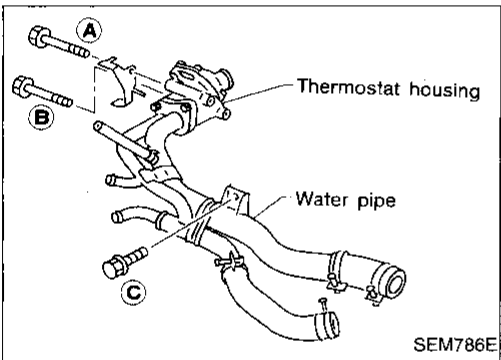

5. Install thermostat housing with water pipe using the following procedure.
 - a. Tighten bolt (A).
 ☐: 2 - 5 N·m (0.2 - 0.5 kg-m, 17 - 43 in-lb)
 - b. Tighten bolt (C).
 ☐: 16 - 21 N·m (1.6 - 2.1 kg-m, 12 - 15 ft-lb)
 - c. Tighten bolt (A).
 ☐: 16 - 21 N·m (1.6 - 2.1 kg-m, 12 - 15 ft-lb)
 - d. Tighten bolt (B).
 ☐: 16 - 21 N·m (1.6 - 2.1 kg-m, 12 - 15 ft-lb)

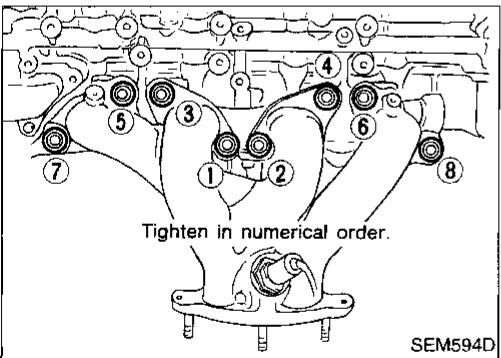

6. Install exhaust manifold.
 - Tighten exhaust manifold bolts in numerical order.
7. Install exhaust manifold cover.

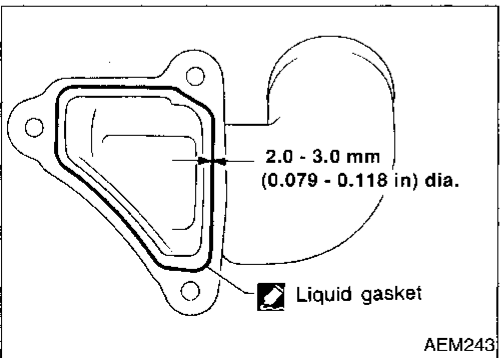

8. Install water outlet.
 - a. Remove old liquid gasket from mating surface of water outlet.
 - **Also remove old liquid gasket from mating surface of cylinder head.**
 - b. Apply a continuous bead of liquid gasket to mating surface of water outlet.
 - **Use Genuine Liquid Gasket or equivalent.**

Assembly (Cont'd)

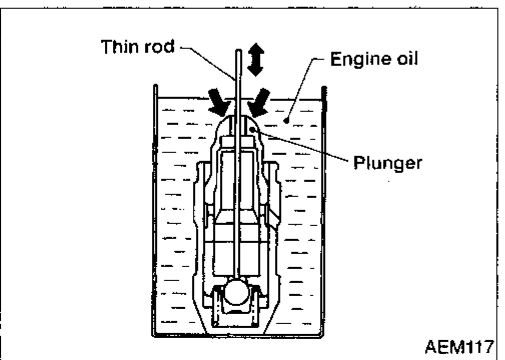
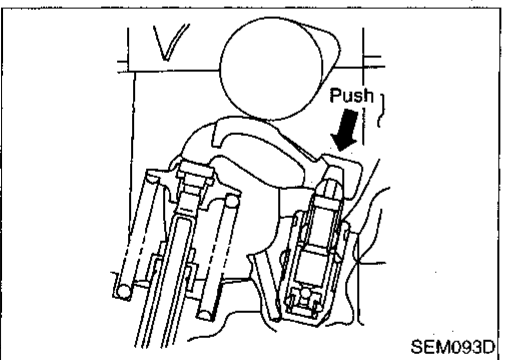
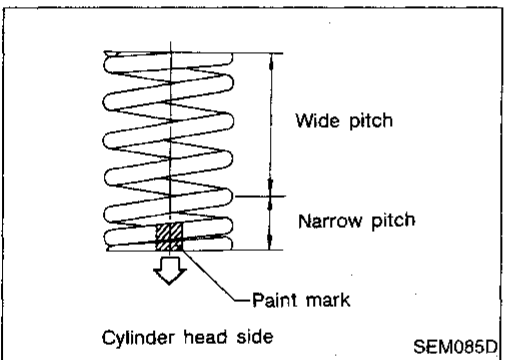
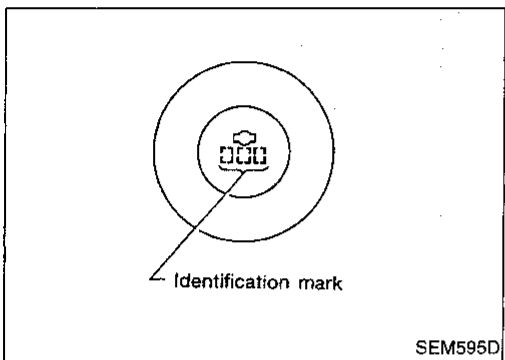
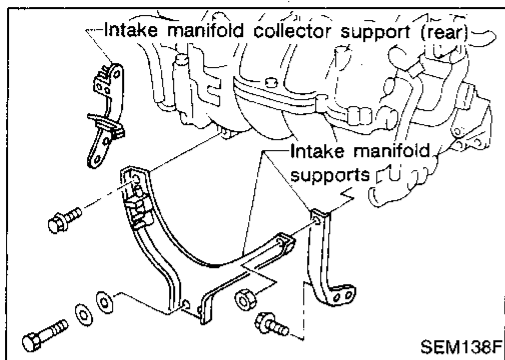

9. Install intake manifold supports and intake manifold collector supports.
10. Install EGR tube.
11. Install crankcase ventilation oil separator.

12. Install valve component parts.
 - Install valves, noting their identification marks as indicated in the table below.

	Identification mark
Intake valve	53J
Exhaust valve	64Y

- Always use new valve oil seal. Refer to EM-30.
- Before installing valve oil seal, install valve spring seat.
- Install valve spring (uneven pitch type) with its narrow pitched side (paint mark) toward cylinder head side.
- After installing valve components, use plastic hammer to lightly tap valve stem tip to assure a proper fit.

13. Check hydraulic lash adjusters.
 - a. Push on the rocker arm above the hydraulic lash adjuster. If it moves 1 mm (0.04 in) or more, there is air in the high pressure chamber of hydraulic lash adjuster. Noise will be emitted from hydraulic lash adjuster if engine is started without bleeding air.

- b. Remove hydraulic lash adjuster and dip in a container filled with new engine oil. While pushing plunger as shown in figure, lightly push check ball using a thin rod. Air is completely bled when plunger no longer moves.
- Air cannot be bled from this type of lash adjuster by running engine.**

GI

MA

EM

LC

EC

FE

CL

MT

AT

FA

RA

BR

ST

RS

BT

HA

EL

IDX

Assembly (Cont'd)

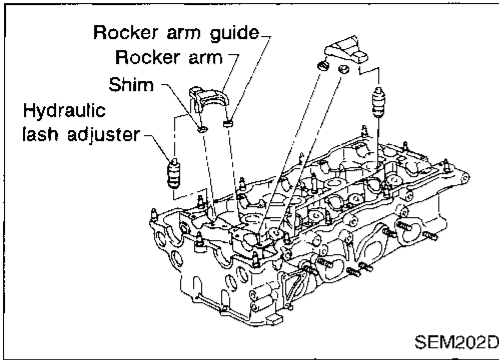

14. Remove camshafts, rocker arms and shims. For future reference, identify each shim with the cylinder it was removed from. Since the shims are reusable, it may not be necessary to replace all of the existing shims.

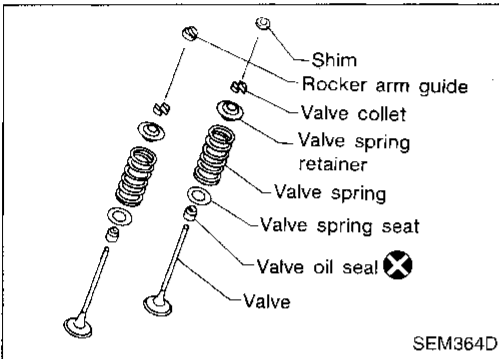

15. Before attempting any measurement, make sure the valve, valve spring, collet, retainer and rocker arm guide are properly installed in the head.

- **Always replace rocker arm guide with a new one.**

CAUTION:

Install parts in their original positions.

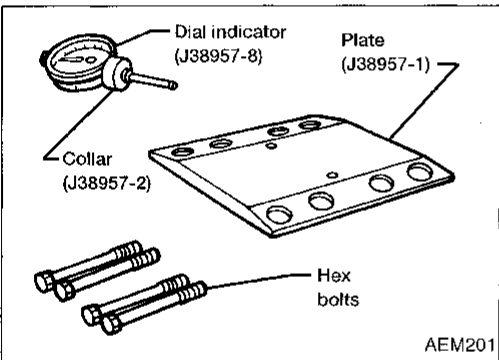

16. Install the J38957-1 gauge plate into the tapped holes at the cam journals and secure it to the head using two of the hex bolts supplied with the kit. (The two remaining bolts are spares.)

Assembly (Cont'd)

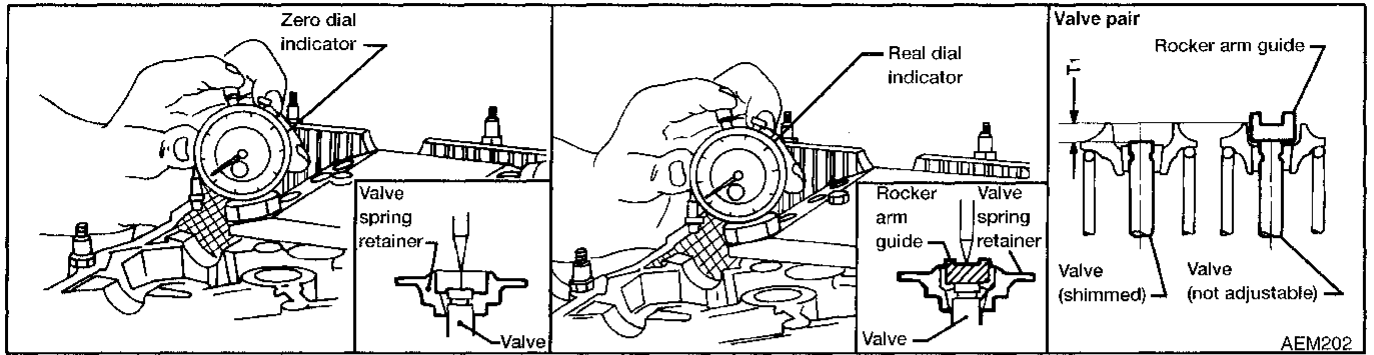

17. Place the J38957-2 collar on the J38957-8 dial indicator. Make sure the dished side of the collar is facing "up" (toward the dial indicator). Secure the collar to the dial indicator by tightening the set screw in the collar.
18. Place the indicator and collar over #1 cylinder intake valve shim side. Slide the tip of the dial indicator through the access hole and place it on the end of the valve stem. While resting the dial indicator collar on the gauge plate, "zero" the dial indicator.
19. Move the dial indicator and collar to the adjacent hole in the gauge plate and place the tip of the indicator in the center of the rocker arm guide. Write down the dial indicator reading. This measured distance between the valve stem end and the contact surface of the rocker arm guide is the "T₁" dimension.
20. Match the measured "T₁" dimension (in inches) to the available shim chart (in millimeters). Refer to SDS, EM-111. (The "T₁" dimension is equivalent to the thickness and size designation of the valve shim.) Select the closest size shim to the measured "T₁" dimension. For example, if the measured "T₁" dimension is 0.1154 in. use a 2.925 mm shim. Shims are available in 17 different thicknesses ranging from 2.800 mm (0.1102 in.) to 3.200 mm (0.1260 in.) and increase in increments of 0.025 mm (0.0010 in.).
21. Repeat this procedure on the remaining cylinders.

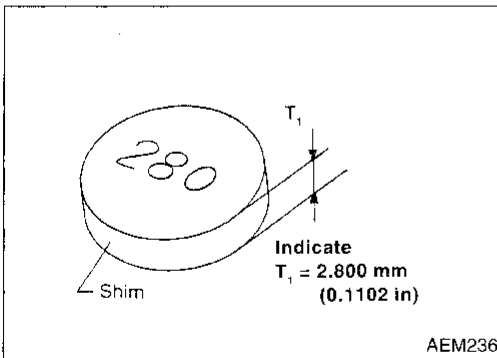

Installation

- The installation procedure is the same as for timing chain. Refer to EM-21.

GI
MA
EM
LC
EC
FE
CL
MT
AT
FA
RA
BR
ST
RS
BT
HA
EL
IDX

SEC. 112

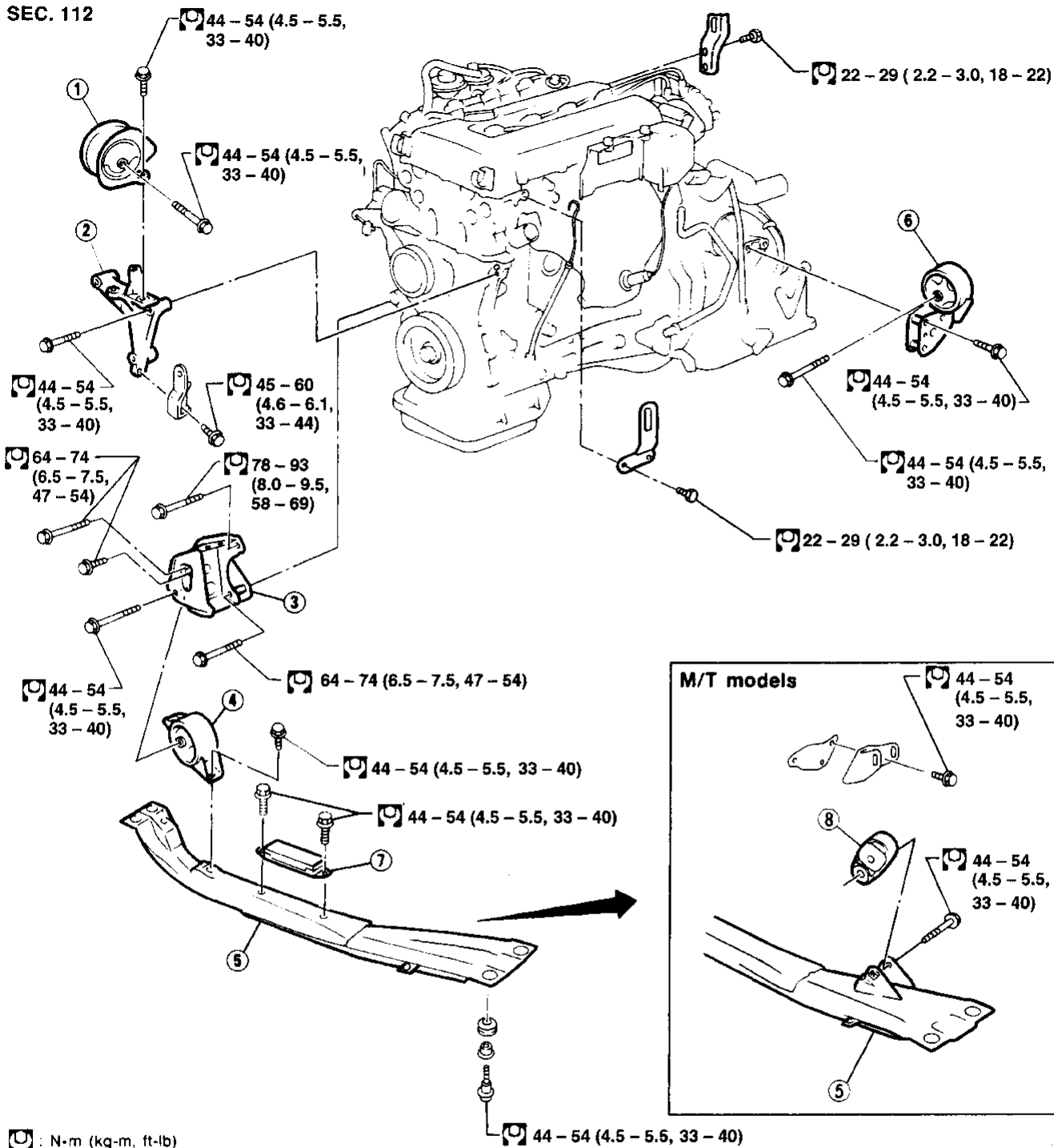

- ① Engine front mounting
- ② Mounting bracket
- ③ Rear engine mounting bracket

- ④ Rear insulator
- ⑤ Center member
- ⑥ LH engine mounting

- ⑦ Dynamic damper (A/T models)
- ⑧ Buffer

AEM231

WARNING:

- Position vehicle on a flat and solid surface.
- Place chocks at front and back of rear wheels.
- Do not remove engine until exhaust system has completely cooled off.

Otherwise, you may burn yourself and/or fire may break out in fuel line.

- Before disconnecting fuel hose, release pressure. Refer to EC section ("Fuel Pressure Release", "BASIC SERVICE PROCEDURE").
- Before removing front axle from transaxle, place safety stands under designated front supporting points. Refer to GI section ("Garage Jack and Safety Stand", "LIFTING POINTS AND TOW TRUCK TOWING").
- Be sure to lift engine and transaxle in a safe manner.
- For engines not equipped with engine slingers, attach proper slingers and bolts described in PARTS CATALOG.

CAUTION:

- When lifting engine, be sure to clear surrounding parts. Take special care near accelerator wire casing, brake lines and brake master cylinder.
- In lifting the engine, always use engine slingers in a safe manner.
- In removing drive shaft, be careful not to damage grease seal of transaxle.
- Before separating engine and transaxle, remove the crankshaft position sensor (OBD) from the assembly.
- Always take extra care not to damage edge of crankshaft position sensor (OBD) or ring gear teeth.

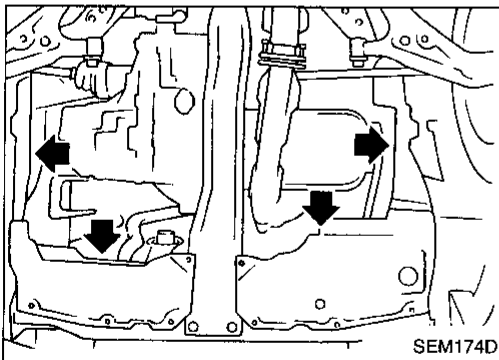
**Removal**

1. Remove engine under covers and engine side cover.
2. Drain coolant from both cylinder block and radiator. Refer to MA section ("DRAINING ENGINE COOLANT", "Changing Engine Coolant").
3. Drain engine oil.
4. Remove air cleaner assembly and duct.
5. Remove the battery and battery tray.
6. Disconnect the following:
 - Vacuum hoses
 - Heater hoses
 - A/T cooler hoses
 - Power steering hoses
 - Fuel lines
 - Wires
 - Harnesses and connectors
 - Throttle cable
 - ASCD cable
 - A/T control cable
7. Remove the cooling fans, radiator and recovery tank.
8. Remove front LH and RH wheels and drive shafts. Refer to FA section ("Drive Shaft", "FRONT AXLE").

Removal (Cont'd)

9. Remove front exhaust pipe.
10. Remove starter and intake manifold support.
11. Remove the drive belts.
12. Remove generator and adjusting bracket.
13. Remove power steering oil pump and A/C compressor.
14. Set a suitable transmission jack under transaxle. Lift engine with engine slinger.

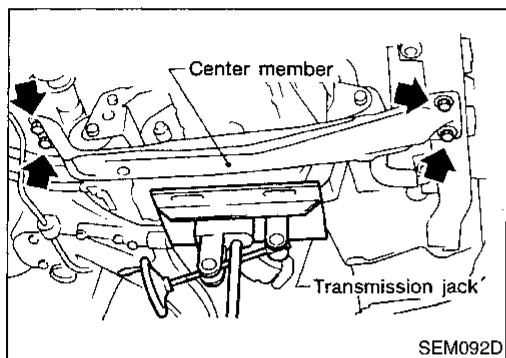

15. Remove center member.

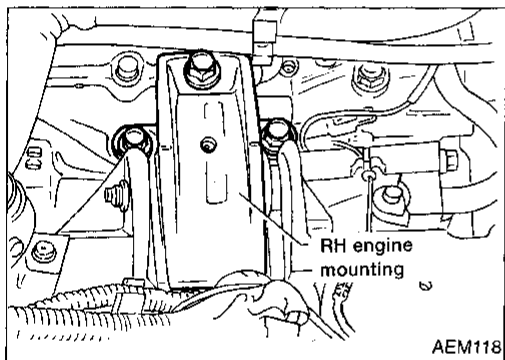

16. Remove engine mounting bolts from both sides, then slowly lower transmission jack.

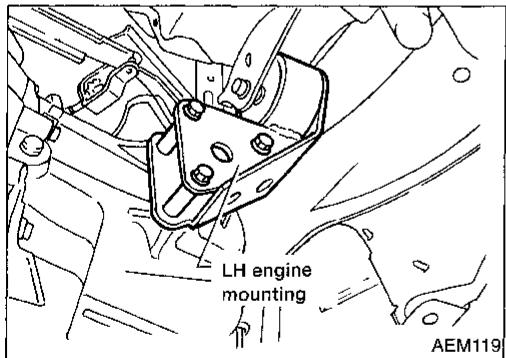

Removal (Cont'd)

17. Remove engine with transaxle as shown.

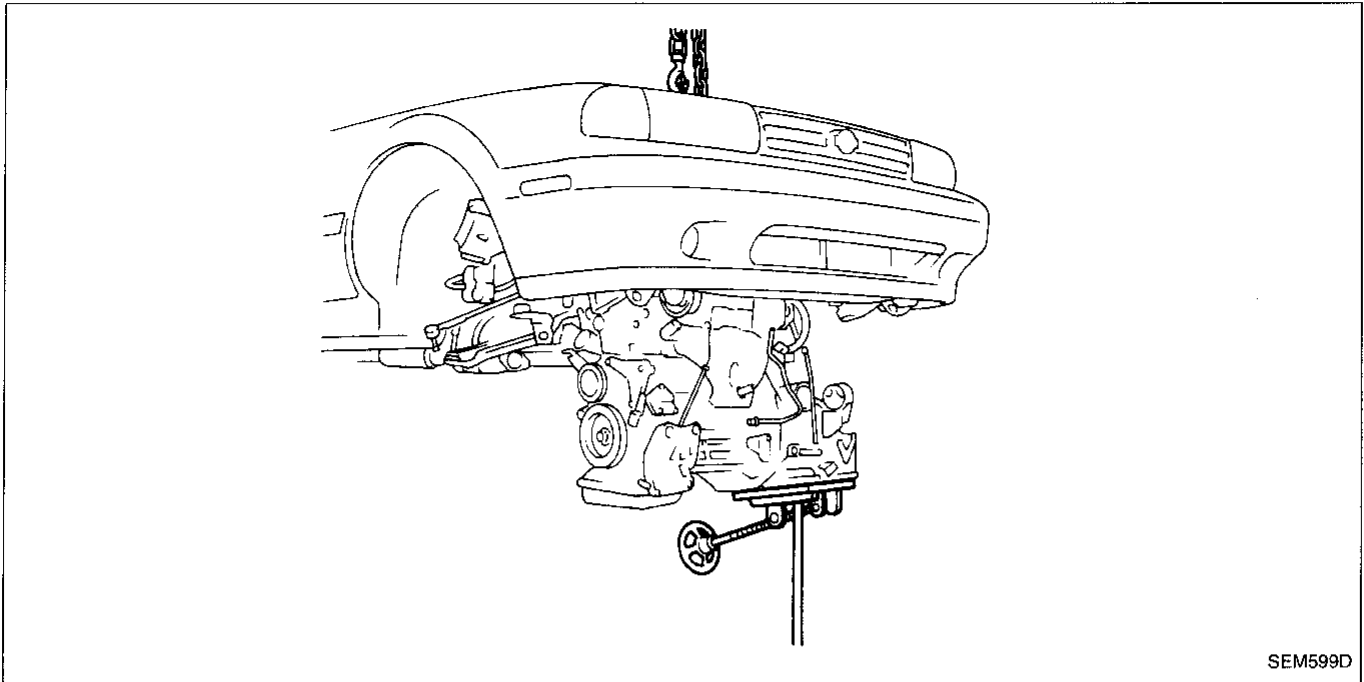

SEM599D

GI
MA
EM
LC
EC
FE
CL
MT
AT
FA
RA
BR
ST
RS
BT
HA
EL
IDX

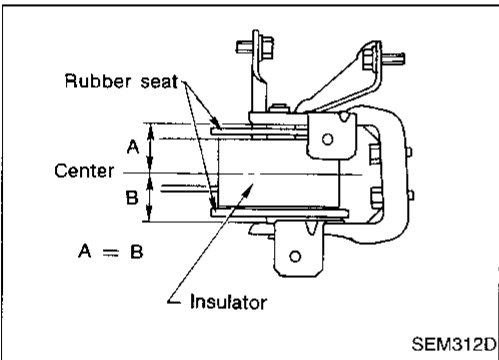

Installation

1. Install engine mounting bracket and fixing bolts. **Be sure that insulators are correctly positioned on the brackets.**
2. Carefully lower the engine onto engine mounting insulators.

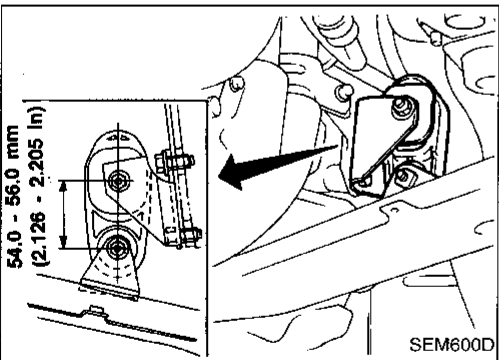

When installing the engine, adjust the height of the engine mounting as shown. (For M/T)

3. Install in the reverse order of removal.

SEC. 110-120-150

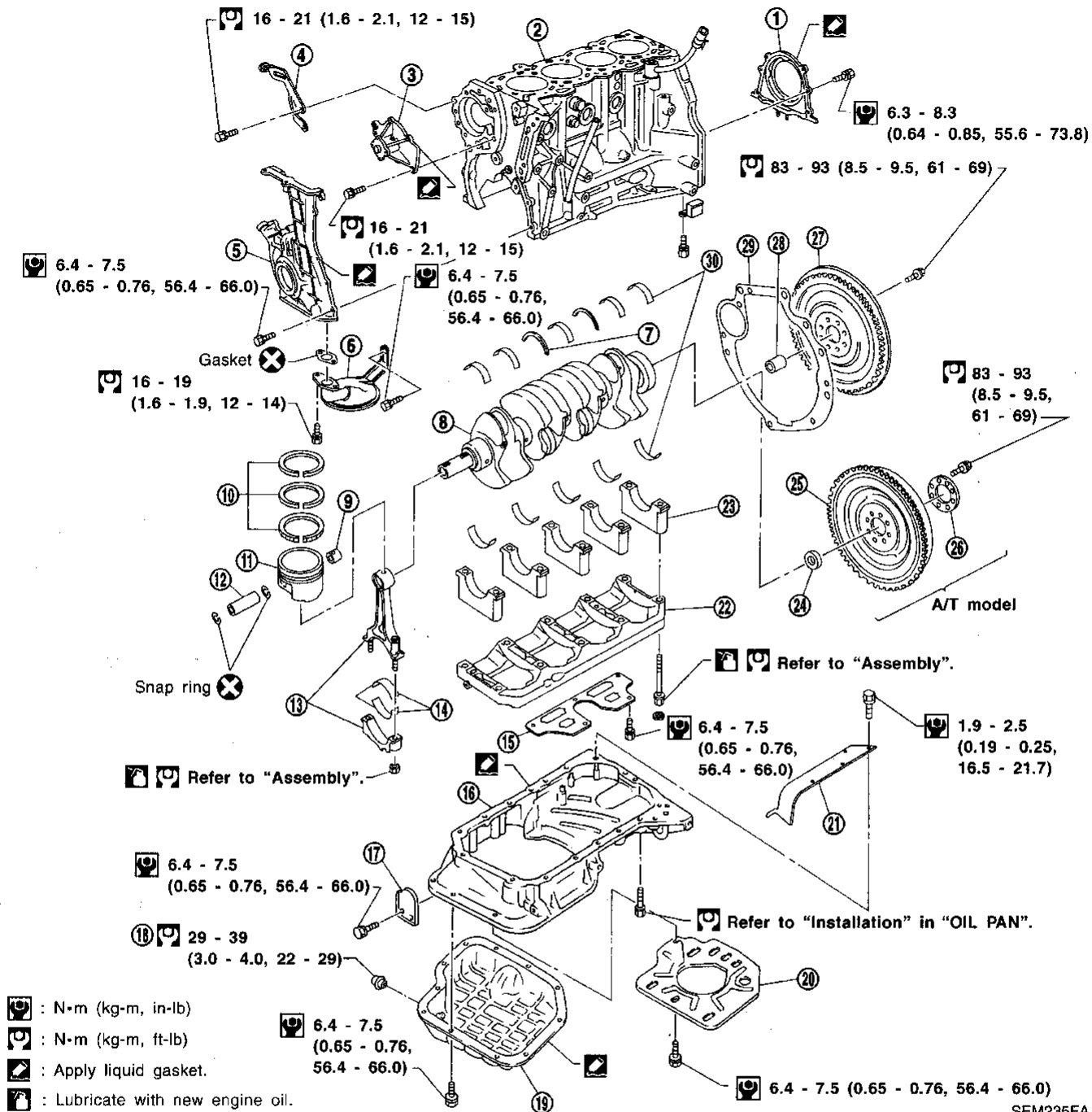

SEM235FA

- ① Rear oil seal retainer
- ② Cylinder block
- ③ Water pump
- ④ Power steering oil pump adjusting bar
- ⑤ Front cover with oil pump
- ⑥ Oil strainer
- ⑦ Thrust bearing
- ⑧ Crankshaft
- ⑨ Connecting rod bushing
- ⑩ Piston rings

- ⑪ Piston
- ⑫ Piston pin
- ⑬ Connecting rod
- ⑭ Connecting rod bearing
- ⑮ Baffle plate
- ⑯ Aluminum oil pan
- ⑰ Rear cover plate
- ⑱ Oil pan drain plug
- ⑲ Steel oil pan
- ⑳ Baffle plate

- ㉑ Side gallery baffle plate
- ㉒ Main bearing beam
- ㉓ Main bearing cap
- ㉔ Pilot converter
- ㉕ Drive plate
- ㉖ Reinforcement plate
- ㉗ Flywheel
- ㉘ Pilot bushing
- ㉙ Rear plate
- ㉚ Main bearing

CAUTION:

- When installing sliding parts (bearings, pistons, etc.), lubricate contacting surfaces with new engine oil.
- Place removed parts such as bearings and bearing caps in their proper order and direction.
- When installing connecting rod nuts and main bearing cap bolts, apply new engine oil to threads and seating surfaces.
- Do not allow any magnetic materials to contact the ring gear teeth of flywheel or drive plate.

GI
MA
EM

LC

EC

FE

CL

WT

AT

FA

RA

BR

ST

RS

BT

HA

EL

IDX

Disassembly

PISTON AND CRANKSHAFT

1. Place engine on engine stand (ST0501S000).
2. Remove cylinder head and timing chain. Refer to EM-16.
3. Remove oil pan. Refer to EM-11.
4. Remove pistons with connecting rods.
 - To disassemble piston and connecting rod, first remove snap rings. Heat piston to 60 to 70°C (140 to 158°F) then use piston pin press to remove pin.
 - **When piston rings are not replaced, make sure that piston rings are mounted in their original positions.**
 - **When replacing piston rings, if there is no punchmark, install with either side up.**
5. Remove rear oil seal retainer.
6. Remove main bearing beam, bearing cap and crankshaft as shown.
 - **Bolts should be loosened in two or three steps.**

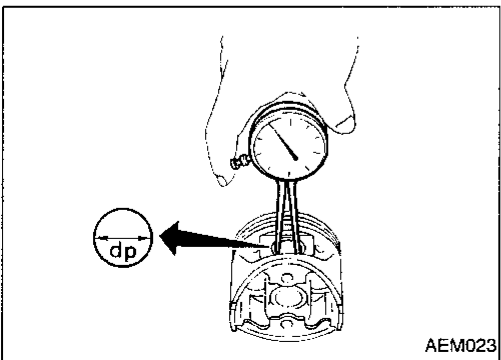
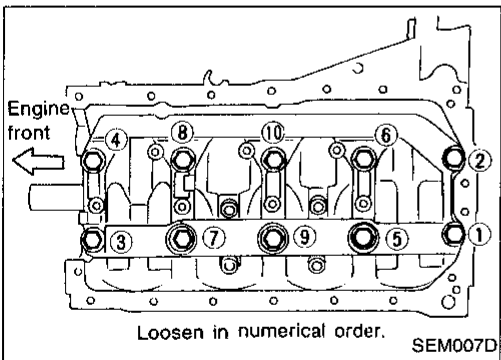
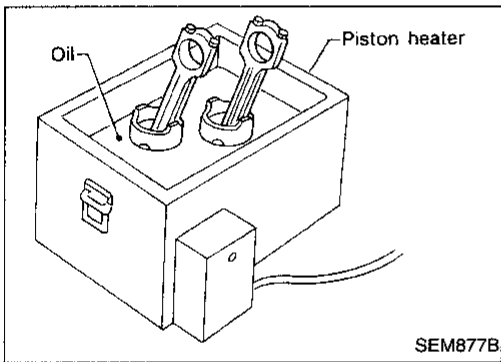
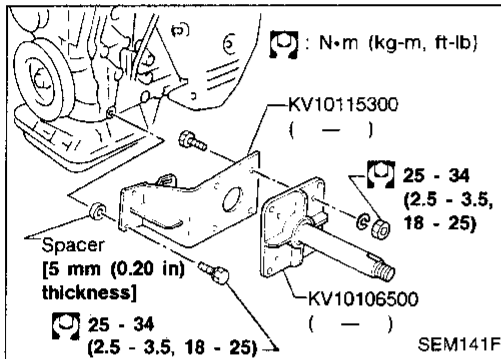

Inspection

PISTON AND PISTON PIN CLEARANCE

1. Measure inner diameter of piston pin hole "dp".
 - Standard diameter "dp":
21.987 - 21.999 mm (0.8656 - 0.8661 in)

Inspection (Cont'd)

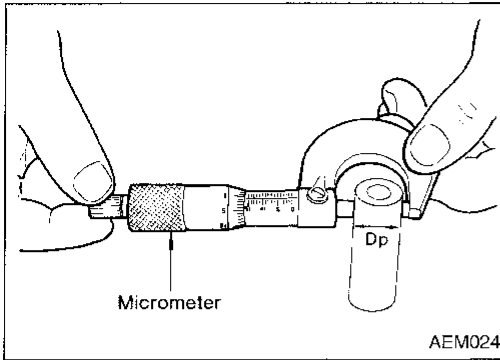

2. Measure outer diameter of piston pin "Dp".
Standard diameter "Dp":
21.989 - 22.001 mm (0.8657 - 0.8662 in)
3. Calculate interference fit of piston pin to piston.
Dp - dp: 0 - 0.004 (0 - 0.0002 in)
 If it exceeds the above value, replace piston assembly with pin.

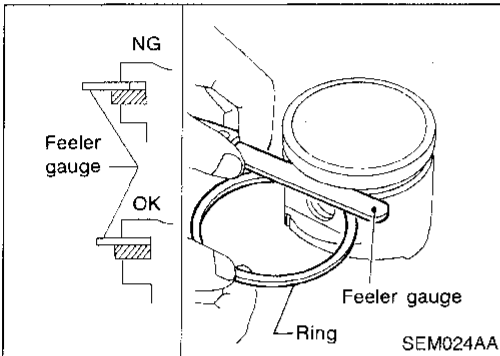

PISTON RING SIDE CLEARANCE

Side clearance:

Top ring
0.045 - 0.080 mm (0.0018 - 0.0031 in)

2nd ring
0.030 - 0.065 mm (0.0012 - 0.0026 in)

Max. limit of side clearance:

0.2 mm (0.008 in)

If out of specification, replace piston ring. If clearance exceeds maximum limit with new ring, replace piston.

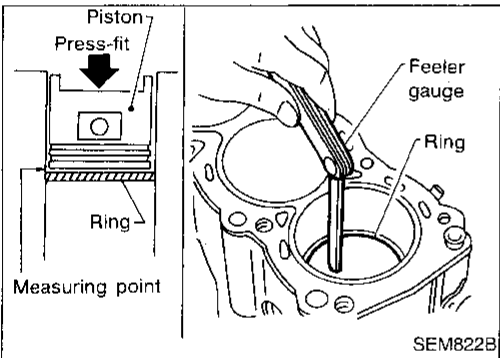

PISTON RING END GAP

End gap:

Top ring 0.20 - 0.30 mm (0.0079 - 0.0118 in)

2nd ring 0.35 - 0.50 mm (0.0138 - 0.0197 in)

Oil ring 0.20 - 0.60 mm (0.0079 - 0.0236 in)

Max. limit of ring gap:

1.0 mm (0.039 in)

If out of specification, replace piston ring. If gap exceeds maximum limit with a new ring, rebore cylinder and use oversized piston and piston rings. Refer to SDS, EM-113.

- When replacing the piston, check cylinder block surface for scratches or seizure. If scratches or seizure are found, hone or replace the cylinder block.

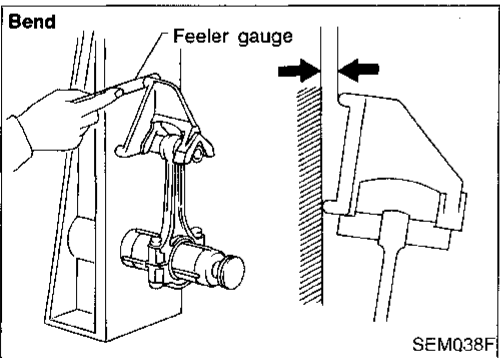

CONNECTING ROD BEND AND TORSION

Bend:

Limit 0.15 mm (0.0059 in)
per 100 mm (3.94 in) length

Torsion:

Limit 0.30 mm (0.0118 in)
per 100 mm (3.94 in) length

If it exceeds the limit, replace connecting rod assembly.

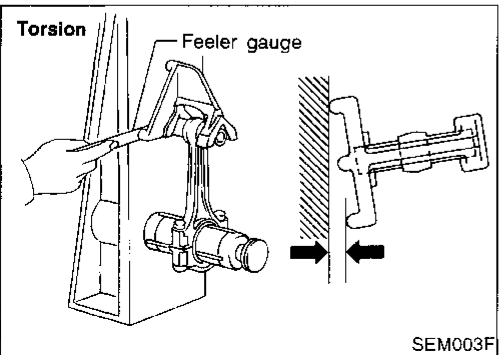

Inspection (Cont'd)

CYLINDER BLOCK DISTORTION AND WEAR

Clean upper surface of cylinder block.
Use a reliable straightedge and feeler gauge to check the flatness of cylinder block surface. Check along six positions shown in figure.

CI
MA
EM

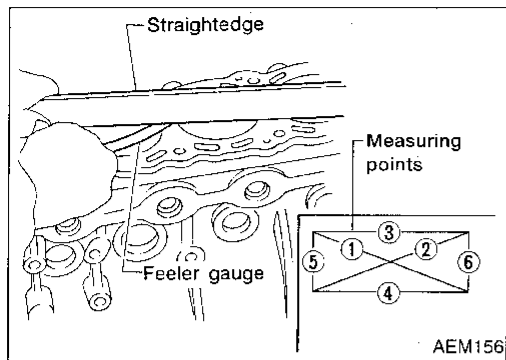

Block surface flatness:

Standard Less than 0.03 mm (0.0012 in)
Limit 0.10 mm (0.004 in)

If out of specification, resurface it.

The limit for cylinder block resurfacing is determined by the amount of cylinder head resurfacing.

Amount of cylinder head resurfacing is "A".
Amount of cylinder block resurfacing is "B".

The maximum limit is as follows:

$A + B = 0.2 \text{ mm (0.008 in)}$

Nominal cylinder block height from crankshaft center:

211.25 - 211.35 mm (8.3169 - 8.3208 in)

- If necessary, replace cylinder block.

LC
EC
FE
CL

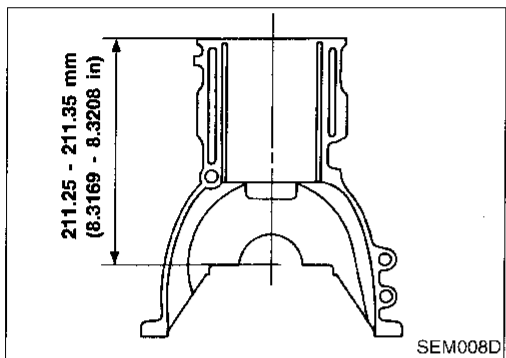

PISTON-TO-BORE CLEARANCE

- Using a bore gauge, measure cylinder bore for wear, out-of-round and taper.

Standard inner diameter:

86.000 - 86.030 mm (3.3858 - 3.3870 in)

Wear limit: 0.20 mm (0.0079 in)

Out-of-round (X - Y) standard: 0.015 mm (0.0006 in)

Taper (A - B and A - C) standard: 0.010 mm (0.0004 in)

If it exceeds the limit, rebore all cylinders. Replace cylinder block if necessary.

- Check for score and seizure. If seizure is found, hone it.
- If cylinder block and piston are replaced, match piston grade with grade number on cylinder block upper surface.

WT
AT
FA
RA
BR
ST
RS
BT

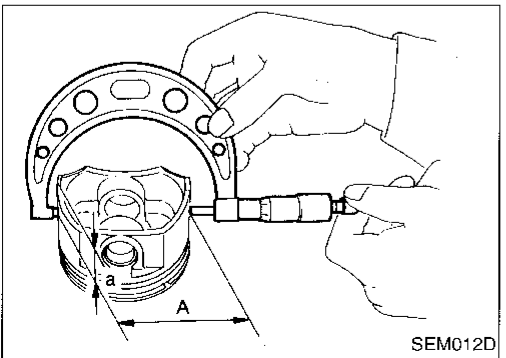
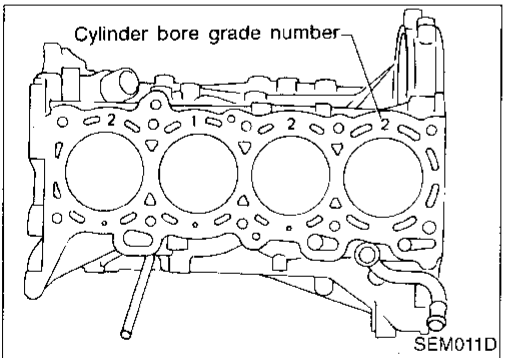
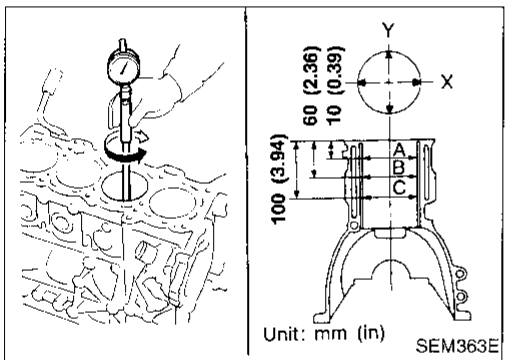

- Measure piston skirt diameter.
Piston diameter "A": Refer to SDS, EM-113.
Measuring point "a" (Distance from the bottom):
14.0 mm (0.551 in)
- Check that piston-to-bore clearance is within specification.
Piston-to-bore clearance = bore measurement "C" - Piston diameter "A":
0.010 - 0.030 mm (0.0004 - 0.0012 in)
- Determine piston oversize according to amount of cylinder wear.

HA
EL
IDX

Inspection (Cont'd)

Oversize pistons are available for service. Refer to SDS, EM-113.

- Cylinder bore size is determined by adding piston-to-bore clearance to piston diameter "A".

Rebored size calculation:

$$D = A + B - C$$

where,

D: Bored diameter

A: Piston diameter as measured

B: Piston-to-bore clearance

C: Honing allowance 0.02 mm (0.0008 in)

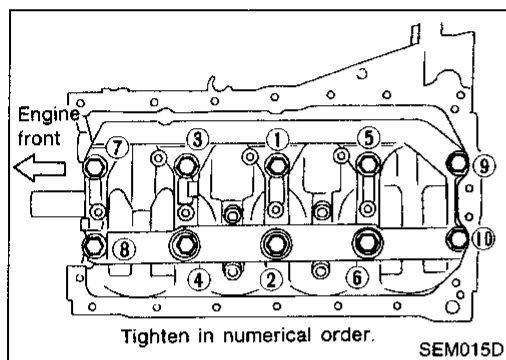

- Install main bearing caps and tighten bolts to 26 to 32 N·m (2.7 to 3.3 kg·m, 20 to 24 ft·lb) as shown. This will prevent distortion of cylinder bores. Otherwise, cylinder bores may be distorted in final assembly.

- Cut cylinder bores.

- When any cylinder needs boring, all other cylinders must also be bored.

- Do not cut too much out of cylinder bore at a time. Cut only 0.05 mm (0.0020 in) or so at a time.

- Hone cylinders to obtain specified piston-to-bore clearance.

- Measure finished cylinder bore for out-of-round and taper.

- Measurement should be done after cylinder bore cools down.

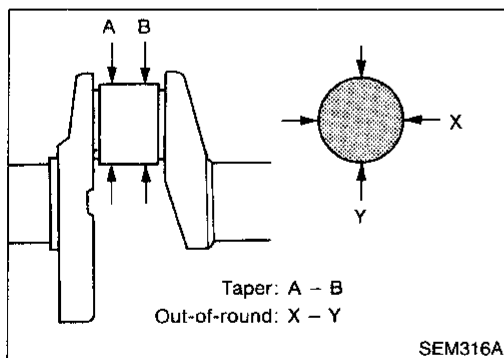

CRANKSHAFT

- Check crankshaft main and pin journals for score, wear or cracks.
- With a micrometer, measure journals for taper and out-of-round.

Out-of-round (X - Y):

Taper (A - B):

Main journal

Less than 0.005 mm (0.0002 in)

Pin journal

Less than 0.0025 mm (0.0001 in)

- Measure crankshaft runout.

Runout (Total indicator reading):

Less than 0.05 mm (0.0020 in)

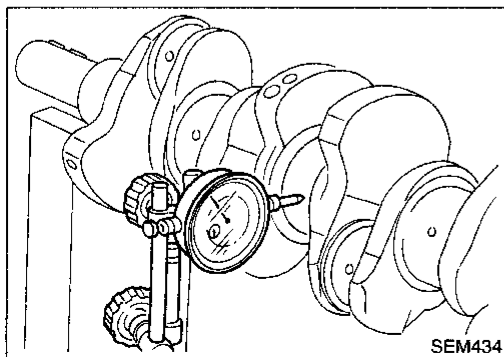

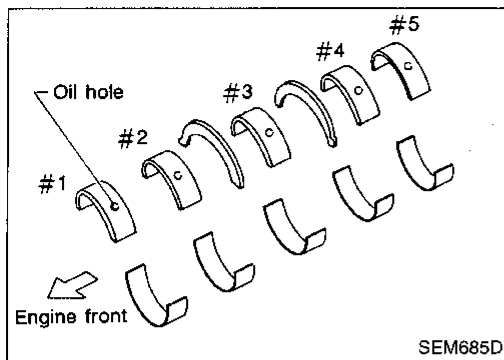

Inspection (Cont'd)

BEARING CLEARANCE

- Use Method A or Method B. Method A is preferred because it is more accurate.

Method A (Using bore gauge & micrometer)

Main bearing

1. Set main bearings in their proper positions on cylinder block and main bearing cap.
2. Install main bearing cap and main bearing beam to cylinder block.

Tighten all bolts in correct order in two or three stages. Refer to EM-60.

GI

MA

EM

LC

EC

FE

CL

MT

AT

FA

RA

BR

ST

RS

BT

HA

EL

IDX

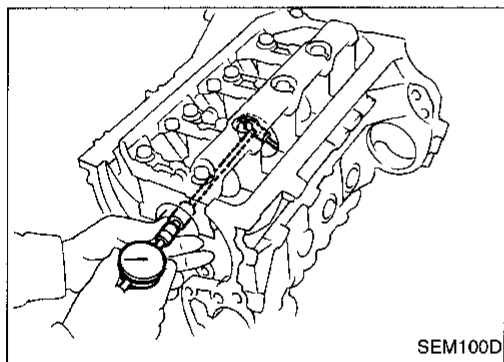

3. Measure inner diameter "A" of each main bearing.

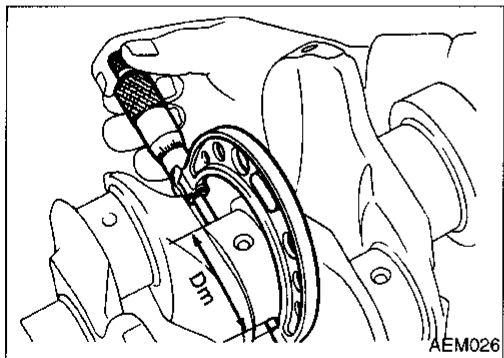

4. Measure outer diameter "Dm" of each crankshaft main journal.

5. Calculate main bearing clearance.

Main bearing clearance = A - Dm

Standard: 0.004 - 0.022 mm (0.0002 - 0.0009 in)

Limit: 0.050 mm (0.0020 in)

If it exceeds the limit, replace bearing.

- If clearance cannot be adjusted within the standard of any bearing, grind crankshaft main journal and use undersized bearing.

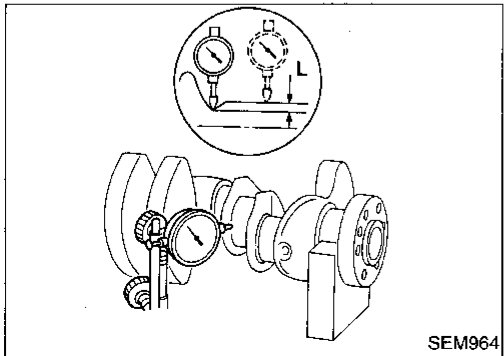

- When grinding crankshaft journal, confirm that "L" dimension in fillet roll is more than the specified limit.

"L": 0.1 mm (0.004 in)

- Refer to SDS, EM-114 for grinding crankshaft and available service parts.

Inspection (Cont'd)

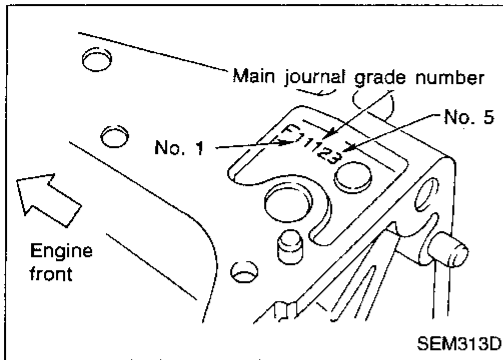

- If crankshaft is replaced, select thickness of main bearings as follows:
 - a. Grade number of each cylinder block main journal is punched on the respective cylinder block. These numbers are punched in either Arabic or Roman numerals.

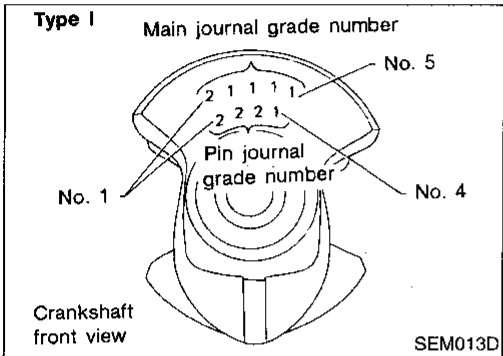

- b. Grade number of each crankshaft main journal is punched on the respective crankshaft. These numbers are punched in either Arabic or Roman numerals.
- c. Select main bearing with suitable thickness according to the following table.

How to select main bearings (Identification mark and color)

Crankshaft main journal grade number	Cylinder block main journal grade number			
	0	1	2	3
0	0 (A, Black)	1 (B, Brown)	2 (C, Green)	3 (D, Yellow)
1	1 (B, Brown)	2 (C, Green)	3 (D, Yellow)	4 (E, Blue)
2	2 (C, Green)	3 (D, Yellow)	4 (E, Blue)	5 (F, Pink)
3	3 (D, Yellow)	4 (E, Blue)	5 (F, Pink)	6 (G, No color)

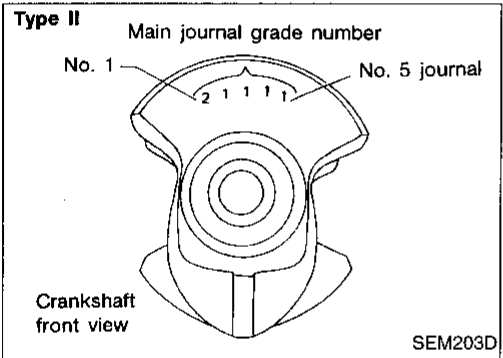

For example:

Cylinder block main journal grade number: 1

Crankshaft main journal grade number: 2

Main bearing grade number = 1 + 2

= 3 (D, Yellow)

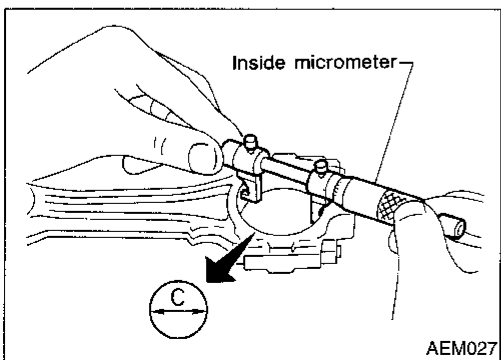

Connecting rod bearing (Big end)

1. Install connecting rod bearing to connecting rod and cap.
 2. Install connecting rod cap to connecting rod.
- Tighten bolts to the specified torque. Refer to EM-61.**
3. Measure inner diameter "C" of each bearing.

Inspection (Cont'd)

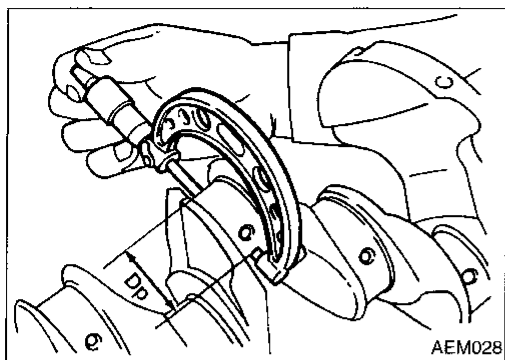

4. Measure outer diameter "Dp" of corresponding crankshaft pin journal.
5. Calculate connecting rod bearing clearance.

Connecting rod bearing clearance = C - Dp

Standard: 0.020 - 0.045 mm (0.0008 - 0.0018 in)

Limit: 0.065 mm (0.00256 in)

If it exceeds the limit, replace bearing.

- If clearance cannot be adjusted within the standard of any bearing, grind crankshaft journal and use undersized bearing. Refer to EM-55 for fillet roll remarks, grinding crankshaft and available service parts.

- If crankshaft is replaced with a new one, select connecting rod bearing according to the following table.

Connecting rod bearing grade number:

These numbers are punched in either Arabic or Roman numerals.

Crank pin grade number	Connecting rod bearing grade number
0	0
1	1
2	2

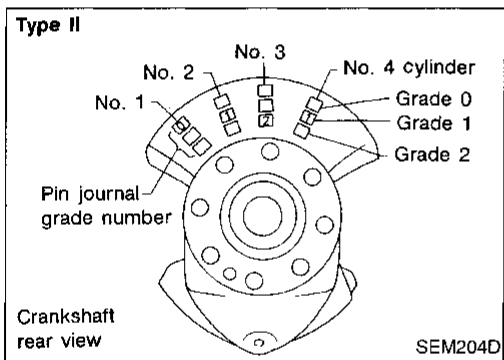
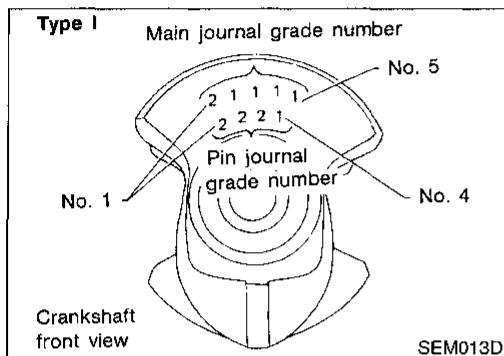

Identification color:

Grade 0; No color

Grade 1; Black

Grade 2; Brown

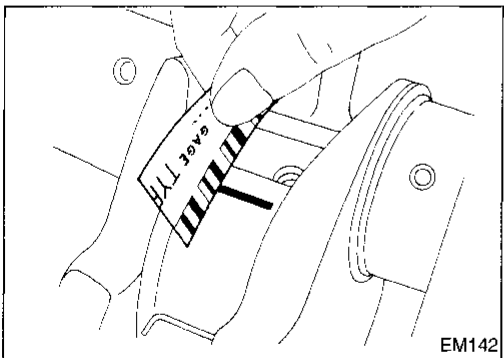

Method B (Using Plastigage)

CAUTION:

- Do not turn crankshaft or connecting rod while Plastigage is being inserted.
- If incorrect bearing clearance exists, use a thicker or undersized main bearing to ensure specified clearance.

CONNECTING ROD BUSHING CLEARANCE (Small end)

1. Measure inner diameter "C" of bushing.

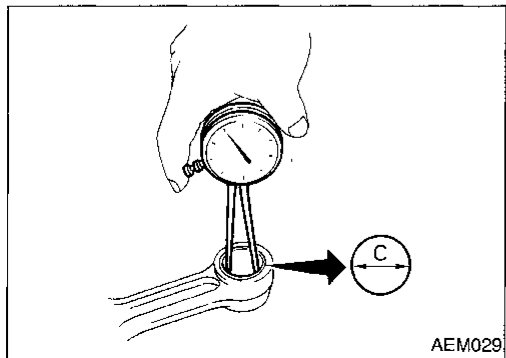

GI

MA

EM

LC

EC

FE

CL

MT

AT

FA

RA

BR

ST

RS

BT

HA

EL

IDX

Inspection (Cont'd)

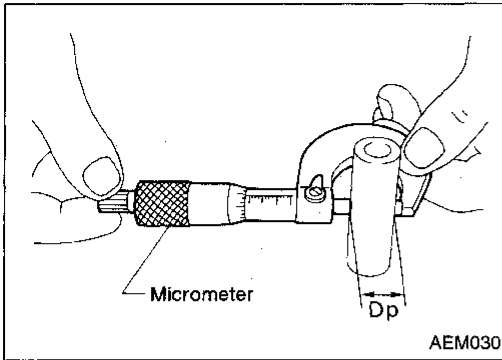

2. Measure outer diameter "Dp" of piston pin.
3. Calculate connecting rod bushing clearance.
Connecting rod bushing clearance = C - Dp

Standard:

0.005 - 0.017 mm (0.0002 - 0.0007 in)

Limit:

0.023 mm (0.0009 in)

If it exceeds the limit, replace connecting rod assembly or connecting rod bushing and/or piston set with pin.

REPLACEMENT OF CONNECTING ROD BUSHING (Small end)

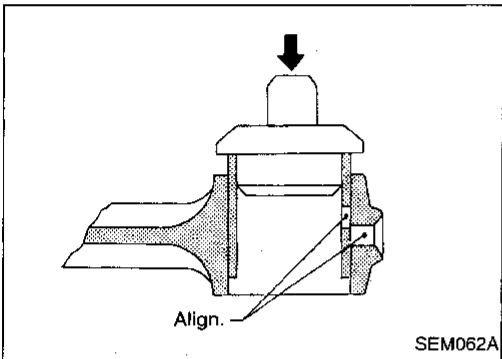

1. Drive in small end bushing until it is flush with end surface of rod.

Be sure to align the oil holes.

2. Ream the bushing so that clearance with piston pin is within specification.

Clearance between connecting rod bushing and piston pin:

0.005 - 0.017 mm (0.0002 - 0.0007 in)

REPLACEMENT OF PILOT BUSHING (M/T) OR PILOT CONVERTER (A/T)

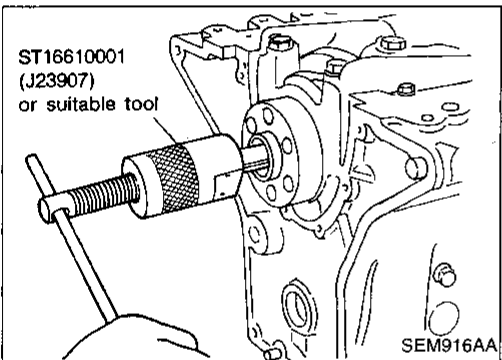

1. Remove pilot bushing or pilot converter using Tool or suitable tool.

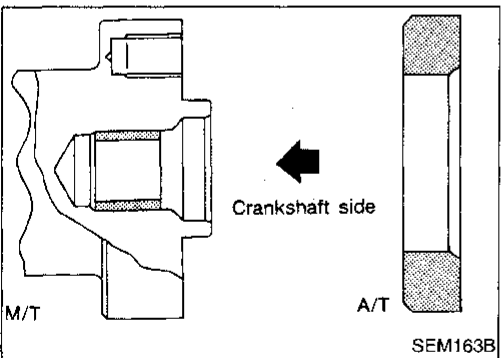

2. Install pilot bushing or pilot converter as shown.

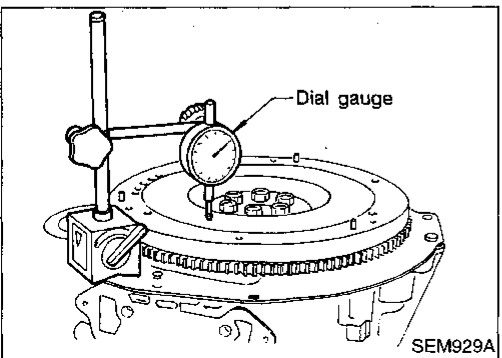

FLYWHEEL/DRIVE PLATE RUNOUT

Runout (Total indicator reading):

Flywheel (M/T model)

Less than 0.15 mm (0.0059 in)

Drive plate (A/T model)

Less than 0.20 mm (0.0079 in)

CAUTION:

Do not allow any magnetic materials to contact the ring gear teeth.

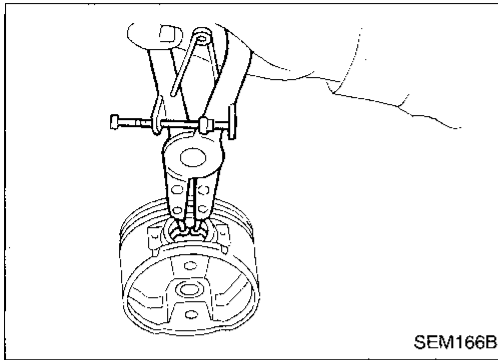

Assembly

PISTON

1. Install new snap ring on one side of piston pin hole.

GI

MA

EM

LC

EC

FE

CL

MT

AT

FA

RA

BR

ST

RS

BT

HA

EL

IDX

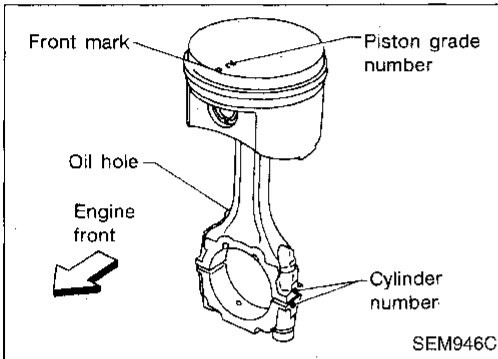

2. Heat piston to 60 to 70°C (140 to 158°F) and assemble piston, piston pin, connecting rod and new snap ring.

- Align the direction of piston and connecting rod.
- Numbers stamped on connecting rod and cap correspond to each cylinder.
- After assembly, make sure connecting rod swings smoothly.

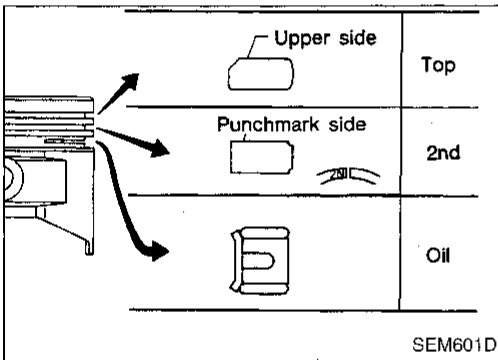

3. Set piston rings as shown.

CAUTION:

- When piston rings are not replaced, make sure that piston rings are mounted in their original positions.
- Install new piston rings either side up if there is no punch mark.

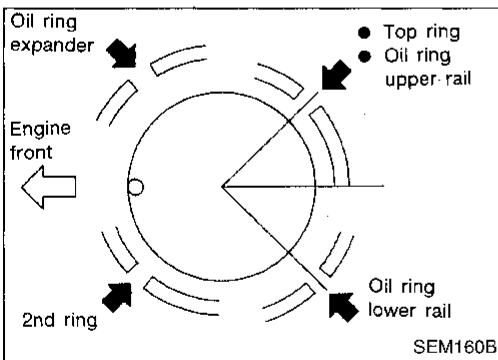

- Align piston rings so that end gaps are positioned as shown.

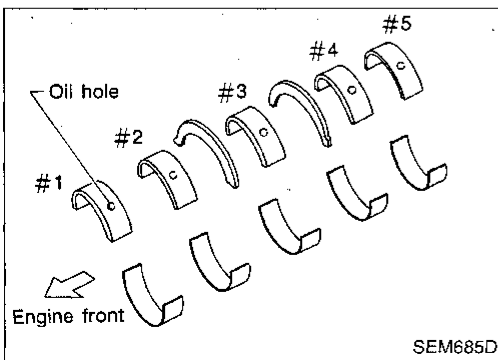

CRANKSHAFT

1. Set main bearings in their proper positions on cylinder block and main bearing cap.

- Confirm that correct main bearings are selected by using Method A or Method B. Refer to EM-55.
- Apply new engine oil to bearing surfaces.

Assembly (Cont'd)

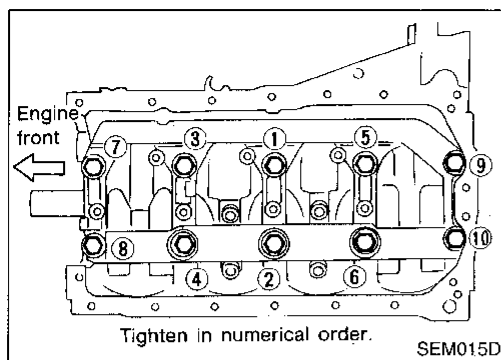

2. Install crankshaft, main bearing caps and beam, then tighten bolts to the specified torque.

- Prior to tightening bearing cap bolts, shift crankshaft back and forth to properly seat the bearing cap.
- Apply new engine oil to threads and seating surfaces of bearing cap bolts before installing them.
- Tightening procedure:

a. Tighten all bolts to 26 to 32 N-m (2.7 to 3.3 kg-m, 20 to 24 ft-lb).

b. Turn all bolts 75 to 80 degrees clockwise with Tool or suitable angle wrench.

c. Loosen all bolts completely.

d. Tighten all bolts to 32 to 38 N-m (3.3 to 3.9 kg-m, 24 to 28 ft-lb).

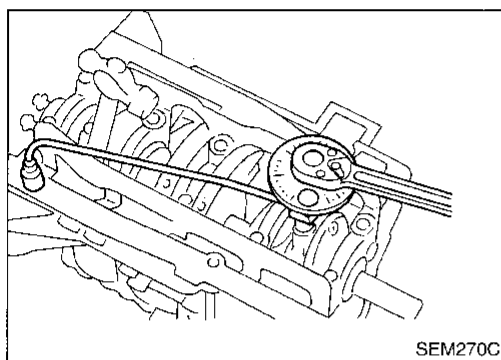

e. Turn all bolts 45 to 50 degrees clockwise with Tool or suitable angle wrench.

- If an angle wrench is not available, mark all bearing cap bolts on the side facing engine rear. Then, turn each bolt specified degrees clockwise. Confirm angle of degrees with a graduated, not by eye measurement.
- After securing bearing cap bolts, make sure crankshaft turns smoothly by hand.

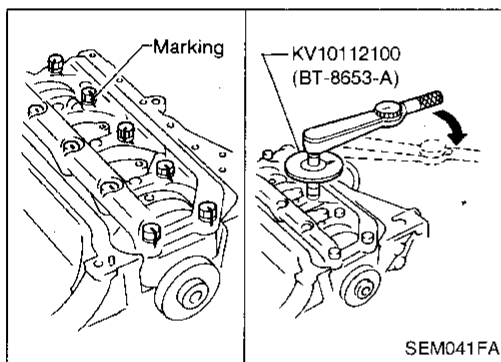

3. Measure crankshaft end play.

Crankshaft end play:

Standard

0.10 - 0.26 mm (0.0039 - 0.0102 in)

Limit

0.30 mm (0.0118 in)

If beyond the limit, replace thrust bearings with new ones.

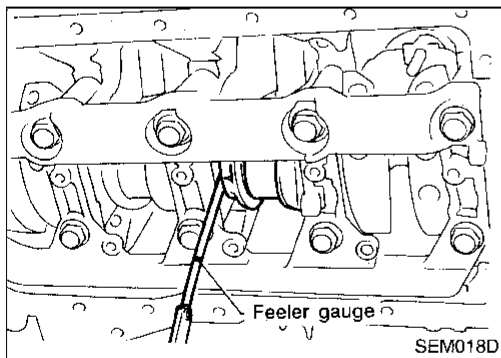

4. Install connecting rod bearings in connecting rods and connecting rod caps.

- Confirm that correct bearings are used. Refer to EM-56.
- Install bearings so that oil hole in connecting rod aligns with oil hole of bearing.
- Apply new engine oil to bolt threads and bearing surfaces.

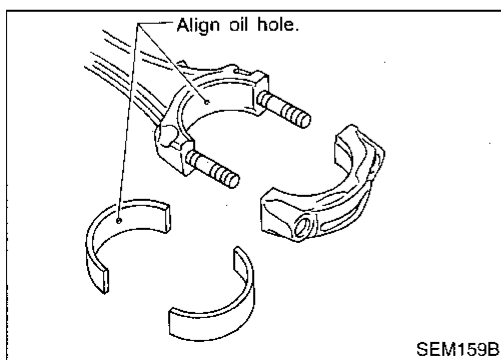

Assembly (Cont'd)

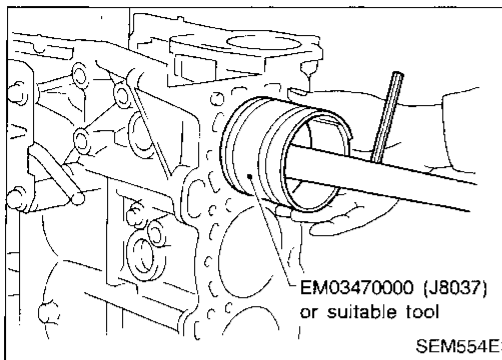

5. Install pistons with connecting rods.
 - a. Install them into corresponding cylinders with Tool.
 - **Make sure connecting rod does not scratch cylinder wall.**
 - **Make sure connecting rod bolts do not scratch crankshaft pin journals.**
 - **Arrange so that front mark on piston head faces engine front.**
 - **Apply new engine oil to piston rings and sliding surface of piston.**

GI

MA

EM

LC

EC

FE

CL

MT

AT

FA

RA

BR

ST

RS

BT

HA

EL

IX

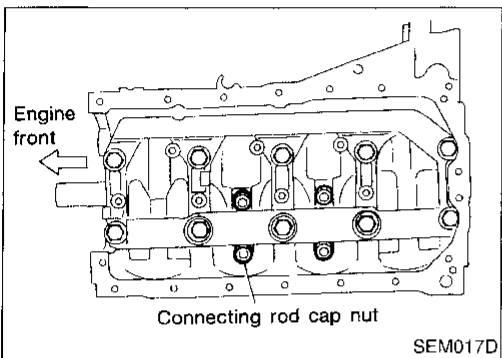

- b. Install connecting rod caps. Tighten connecting rod cap nuts using the following procedure:
 - 1) **Tighten nuts to 14 to 16 N-m (1.4 to 1.6 kg-m, 10 to 12 ft-lb).**
 - 2) **Turn all nuts 60 to 65 degrees clockwise. If an angle wrench is not available, tighten nuts to 38 to 44 N-m (3.9 to 4.5 kg-m, 28 to 33 ft-lb).**

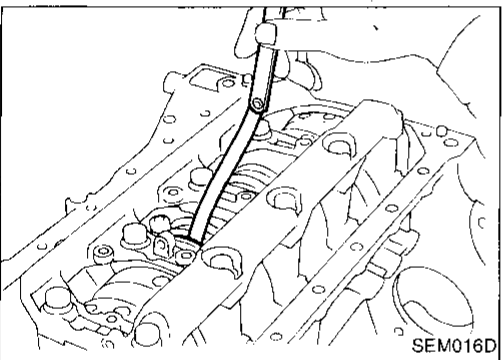

6. Measure connecting rod side clearance.

Connecting rod side clearance:

Standard
0.20 - 0.35 mm (0.0079 - 0.0138 in)

Limit
0.50 mm (0.0197 in)

If beyond the limit, replace connecting rod and/or crankshaft.

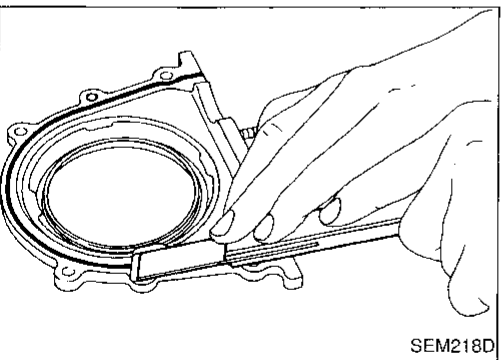

7. Install rear oil seal retainer.
 - a. Before installing rear oil seal retainer, remove old liquid gasket from mating surface.
 - Also remove old liquid gasket from mating surface of cylinder block.

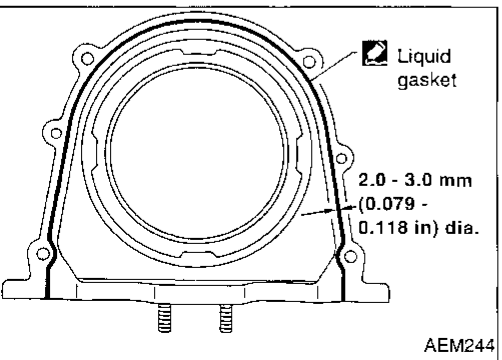

- b. Apply a continuous bead of liquid gasket to mating surface of rear oil seal retainer.
 - **Use Genuine Liquid Gasket or equivalent.**
 - **Apply around inner side of bolt holes.**

SEC. 130•140•150•210•211• 226•253

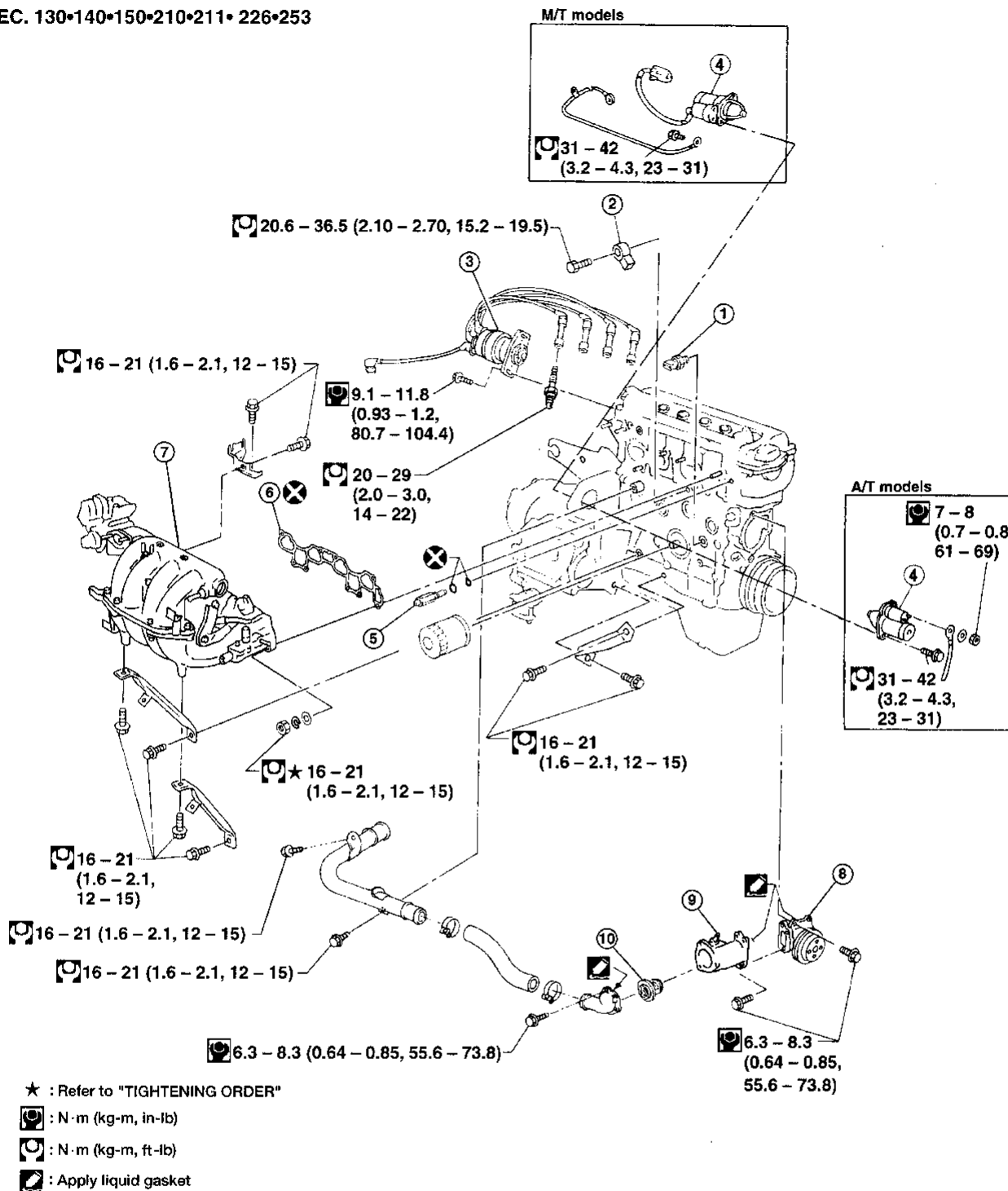

AEM199

- | | | |
|---|--------------------------|----------------------------|
| ① Oil pressure switch | ④ Starter motor | ⑦ Intake manifold assembly |
| ② Camshaft position sensor built into distributor | ⑤ VTC solenoid valve | ⑧ Water pump |
| ③ Distributor | ⑥ Intake manifold gasket | ⑨ Thermostat housing |
| | | ⑩ Thermostat |

SEC. 140•163•164•220

1st: ★ 9 - 11 (0.9 - 1.1, 69 - 95)

2nd: ★ 18 - 22 (1.8 - 2.2, 13 - 16)

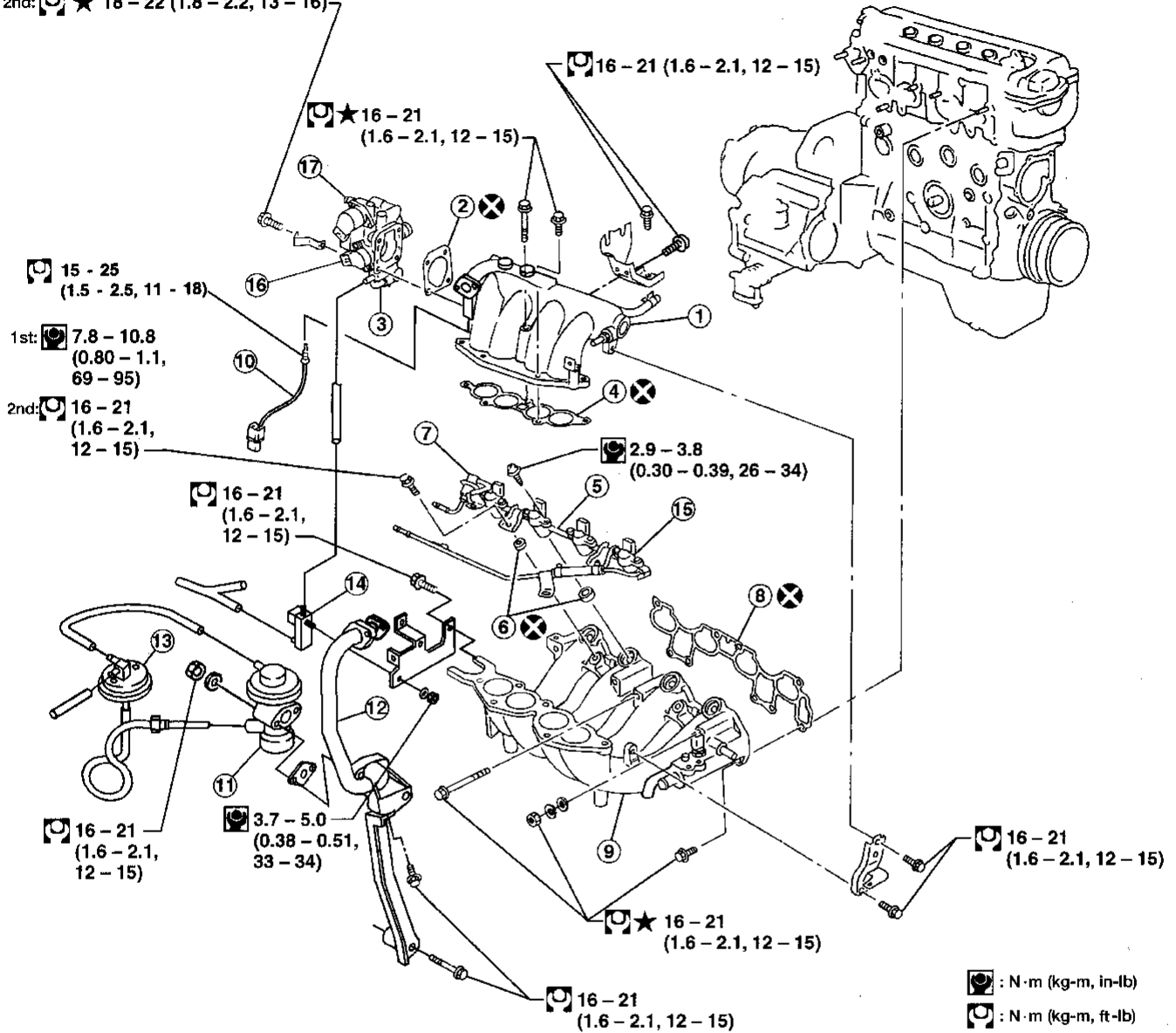

: N·m (kg·m, in·lb)
 : N·m (kg·m, ft·lb)
 ★ : Refer to "TIGHTENING ORDER"

AEM253

- | | | |
|-----------------------------|---------------------------|---|
| ① Intake manifold collector | ⑦ Fuel pressure regulator | ⑬ EGRC-BPT valve |
| ② Throttle body gasket | ⑧ Intake manifold gasket | ⑭ EGRC-solenoid valve |
| ③ Throttle body | ⑨ Intake manifold | ⑮ Fuel injector |
| ④ Collector gasket | ⑩ EGR temperature sensor | ⑯ Throttle position sensor |
| ⑤ Fuel tube assembly | ⑪ EGR valve | ⑰ IACV-AAC valve and IACV-FICD solenoid valve |
| ⑥ Insulator | ⑫ EGR guide | |

GI
 MA
EM
 LC
 EC
 FE
 CL
 MT
 AT
 FA
 RA
 BR
 ST
 RS
 BT
 HA
 EL
 IDX

SEC. 110•120•140•208•210•220•226•274•275

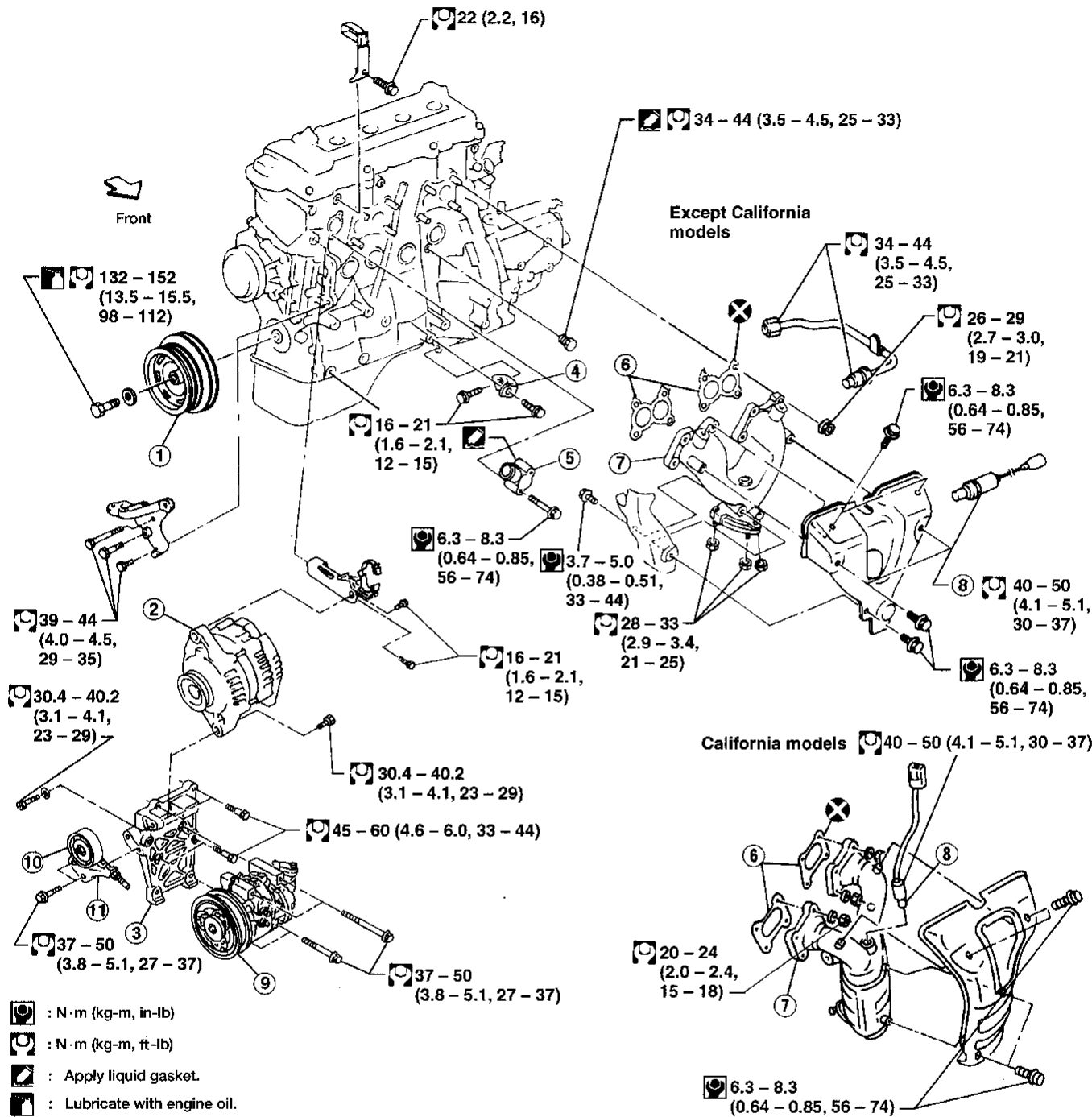

- | | | |
|--------------------------|---|---------------------|
| ① Crankshaft pulley | ⑥ Exhaust manifold gasket | ⑨ A/C compressor |
| ② Generator | ⑦ Exhaust manifold | ⑩ Idler pulley |
| ③ A/C compressor bracket | ⑧ Front heated oxygen sensor (M/T models for California and A/T models) | ⑪ Adjusting bracket |
| ④ Gusset | Front oxygen sensor (M/T models except for California) | |
| ⑤ Water outlet | | |

AEM200

★ Intake manifold collector nuts and bolts tightening order

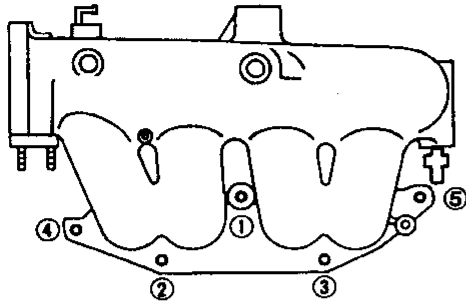

★ Throttle body parts tightening procedure

- 1) Tighten all bolts to 9 - 11 N·m (0.9 - 1.1 kg-m, 6.5 - 8.0 ft-lb)
 - 2) Tighten all bolts to 18 - 22 N·m (1.8 - 2.2 kg-m, 13 - 16 ft-lb)
- Make sure the direction of the gasket is as shown in figure.

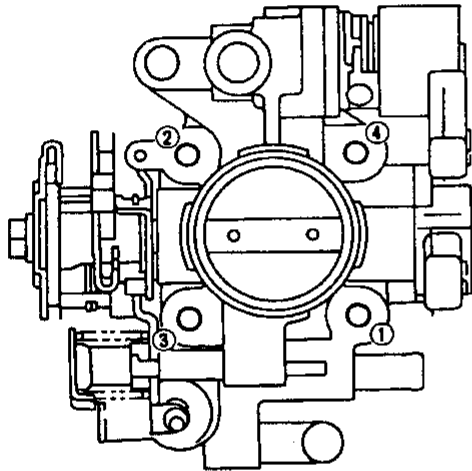

Tighten in numerical order

★ Intake manifold bolts and nuts tightening order

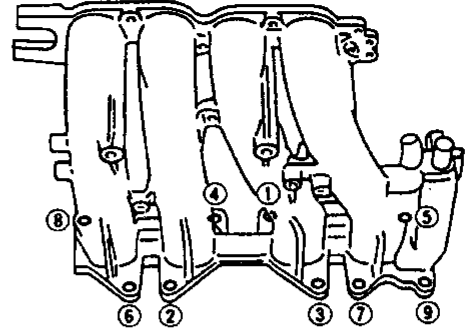

Tighten in numerical order

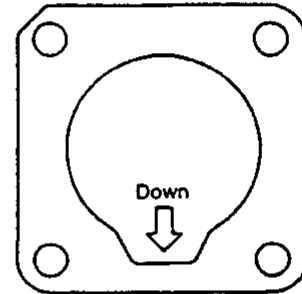

Gasket

AEM203

GI

MA

EM

LC

EC

FE

CL

MT

AT

FA

RA

BR

ST

RS

BT

HA

EL

IDX

Measurement of Compression Pressure

1. Warm up engine.
2. Turn ignition switch off.
3. Release fuel pressure.
Refer to EC section ("Fuel Pressure Release", "BASIC SERVICE PROCEDURE").
4. Remove all spark plugs.
5. Disconnect distributor coil connector.

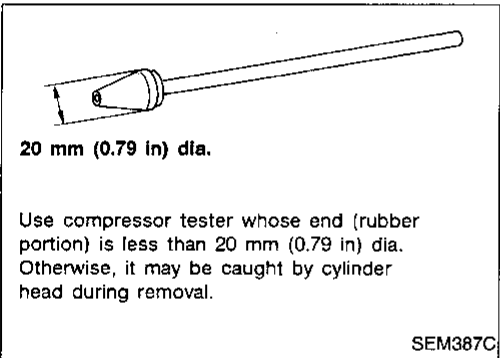
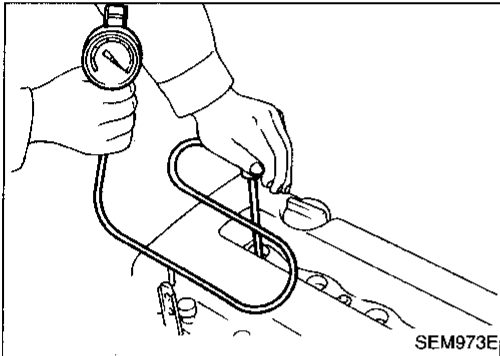

6. Attach a compression tester to No. 1 cylinder.
 7. Depress accelerator pedal fully to keep throttle valve wide open.
 8. Crank engine and record highest gauge indication.
 9. Repeat the measurement on each cylinder.
- **Always use a fully-charged battery to obtain specified engine speed.**

Compression pressure:

kPa (kg/cm², psi)/rpm

Standard

1,373 (14.0, 199)/350

Minimum

1,177 (12.0, 171)/350

Difference limit between cylinders

98 (1.0, 14)/350

10. If compression in one or more cylinders is low:
 - a. Pour a small amount of engine oil into cylinders through spark plug holes.
 - b. Re-test compression.
 - **If adding oil helps compression, piston rings may be worn or damaged. If so, replace piston rings after checking piston.**
 - **If pressure stays low, a valve may be sticking or seating improperly. Inspect and repair valve and valve seat. Refer to SDS, EM-118. If valve or valve seat is damaged excessively, replace them.**
 - **If compression stays low in two cylinders that are next to each other:**
 - a. The cylinder head gasket may be leaking, or
 - b. Both cylinders may have valve component damage. Inspect and repair as necessary.

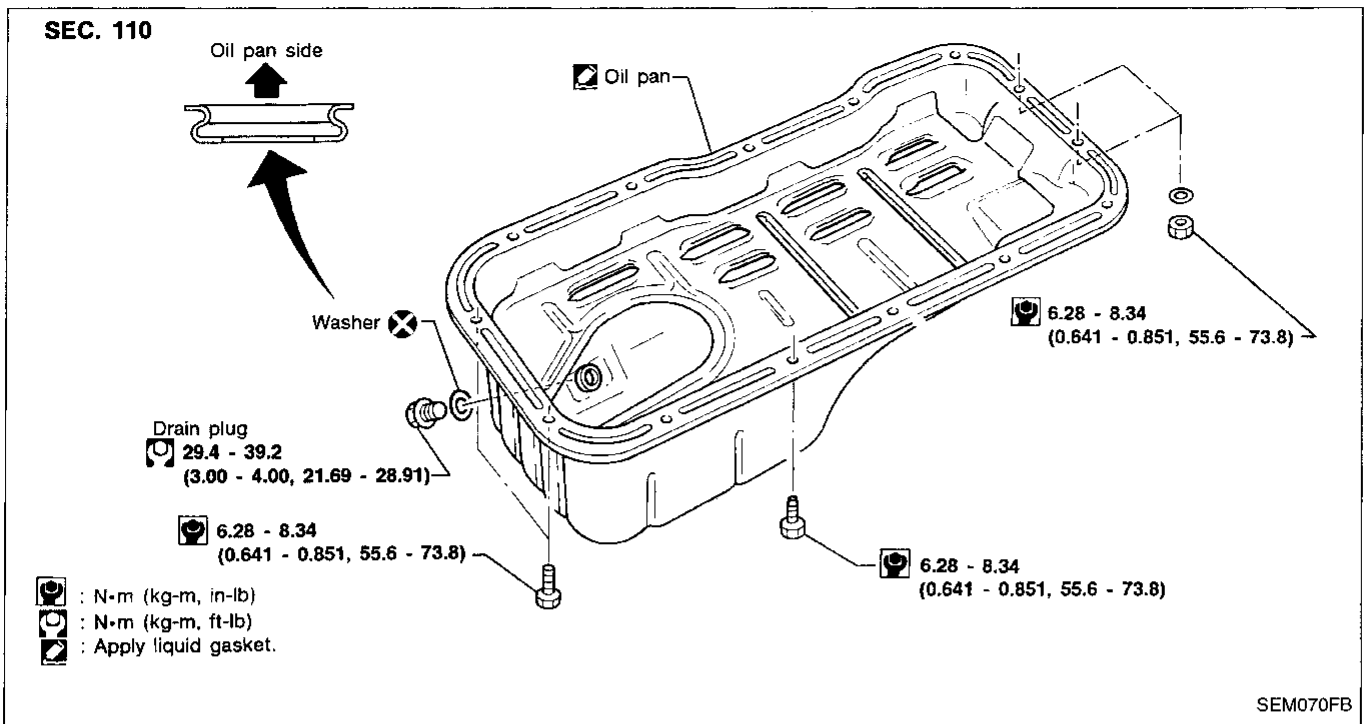

CI

MA

EM

LC

EC

FE

CL

MT

AT

FA

RA

BR

ST

RS

BT

HA

EL

IDX

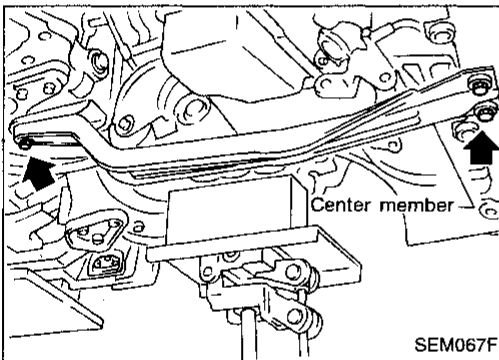

Removal

1. Remove engine RH side cover and under covers.
2. Drain engine oil.
3. Remove front exhaust tube.
Refer to FE section ("EXHAUST SYSTEM").
4. Set a suitable transmission jack under transaxle and lift engine with engine slinger.
5. Remove center member.

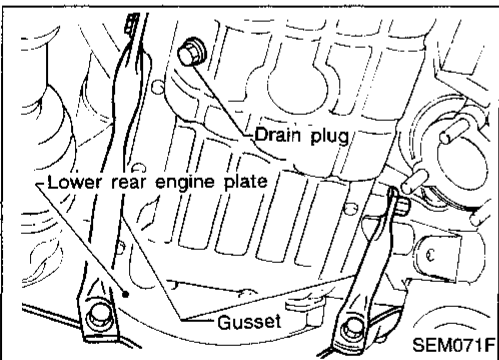

6. Remove front and rear engine gussets.
7. Remove rear plate cover (A/T models).

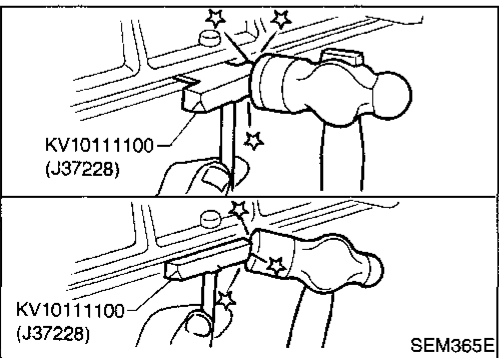

8. Remove oil pan.
 - a. Insert Tool between cylinder block and oil pan.
 - Be careful not to damage aluminum mating face.
 - Do not insert screwdriver, or oil pan flange will be damaged.
 - b. Slide Tool by tapping on the side of the Tool with a hammer.

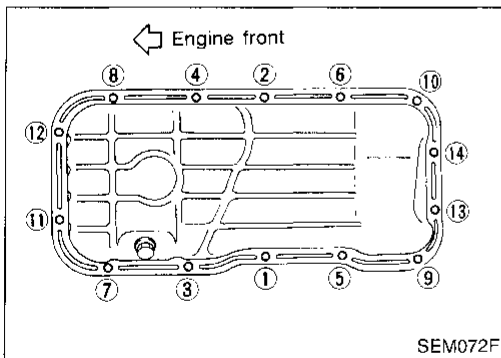
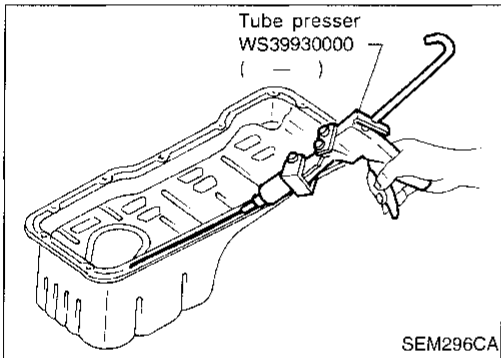
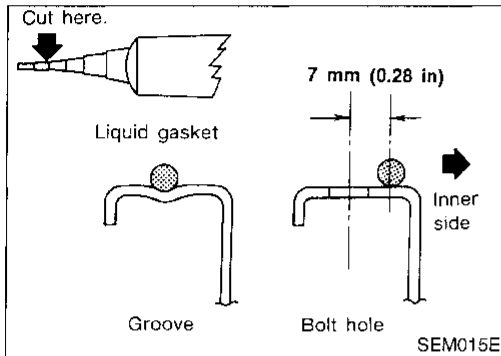
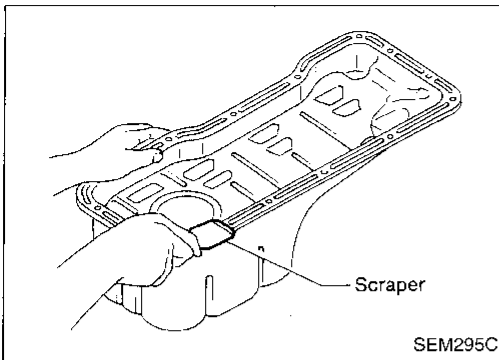

Installation

1. Use a scraper to remove old liquid gasket from mating surface of oil pan.
 - Also remove old liquid gasket from mating surface of cylinder block.

2. Apply a continuous bead of liquid gasket to mating surface of oil pan.

- Use Genuine Liquid Gasket or equivalent.
- Apply to groove on mating surface.
- Allow 7 mm (0.28 in) clearance around bolt holes.

- Be sure liquid gasket diameter is 3.5 to 4.5 mm (0.138 to 0.177 in).
- Attaching should be done within 5 minutes after coating.

3. Install oil pan.
 - Tighten oil pan nuts and bolts in the numerical order.
 - Wait at least 30 minutes before refilling engine oil.
4. Install parts in reverse order of removal.

SEC. 111-120-130-135

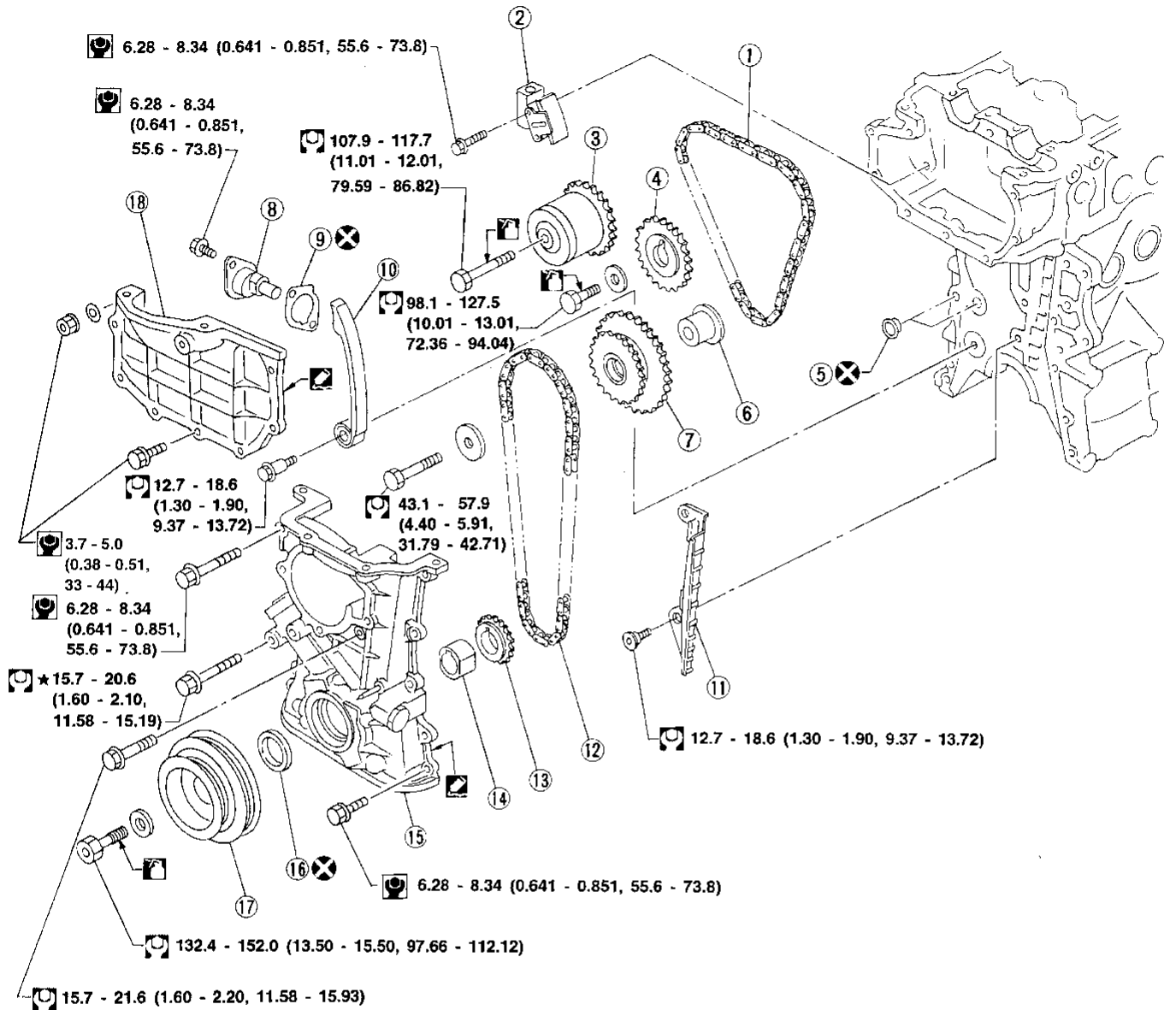

- : N·m (kg-m, in-lb)
- : N·m (kg-m, ft-lb)
- : Apply liquid gasket.
- : Lubricate with new engine oil.
- : Located on power steering pump adjusting bar

AEM237

- | | | |
|----------------------------------|-------------------------|-----------------------------|
| ① Upper timing chain | ⑦ Idler sprocket | ⑬ Crankshaft sprocket |
| ② Upper timing chain tensioner | ⑧ Lower chain tensioner | ⑭ Oil pump drive spacer |
| ③ VTC camshaft sprocket (Intake) | ⑨ Gasket | ⑮ Front cover |
| ④ Camshaft sprocket (Exhaust) | ⑩ Timing chain guide | ⑯ Oil seal |
| ⑤ O-ring | ⑪ Timing chain guide | ⑰ Crankshaft pulley |
| ⑥ Idler shaft | ⑫ Lower timing chain | ⑱ Cylinder head front cover |

GI

MA

EM

LC

EC

FE

CL

MT

AT

FA

RA

BR

ST

RS

BT

HA

EL

IDX

CAUTION:

- After removing timing chain, do not turn crankshaft and camshaft separately, or valves will strike piston heads.
- When installing camshafts, chain tensioner, oil seals, or other sliding parts, lubricate contacting surfaces with new engine oil.
- Apply new engine oil to bolt threads and seat surfaces when installing cylinder head, camshaft sprocket, crankshaft pulley, and camshaft brackets.

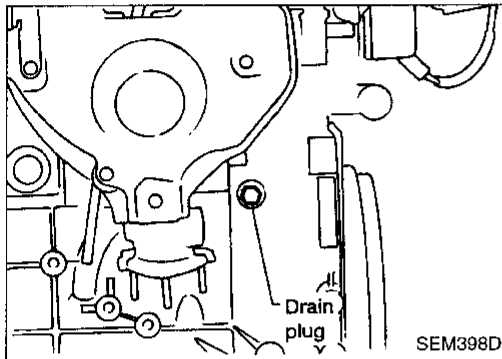
**Removal**

1. Drain engine coolant from radiator and cylinder block. Refer to MA section ("DRAINING ENGINE COOLANT", "Changing Engine Coolant").
 - Be careful not to spill coolant on drive belts.
2. Release fuel pressure. Refer to EC section ("Fuel Pressure Release", "BASIC SERVICE PROCEDURE").
3. Remove drive belts.
4. Remove power steering pulley and oil pump with bracket.
5. Remove air duct to intake manifold collector.
6. Remove front RH wheel.
7. Remove engine side cover.
8. Remove front under covers.
9. Remove front exhaust tube. Refer to FE section ("EXHAUST SYSTEM").

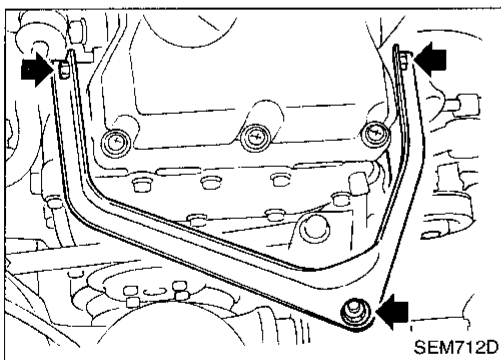

10. Remove cylinder head front mounting bracket.

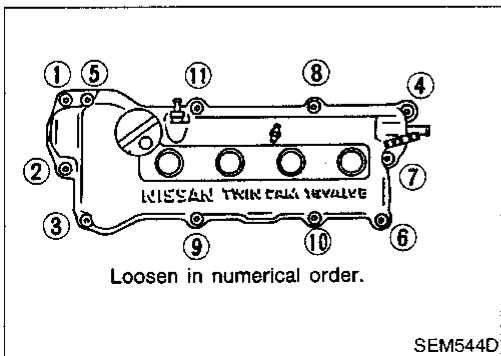

11. Remove rocker cover.
 - Loosen bolts in numerical order.
12. Remove distributor cap.
13. Remove all spark plugs.
14. Remove intake manifold support.

Removal (Cont'd)

15. Set No. 1 piston at TDC of compression stroke.

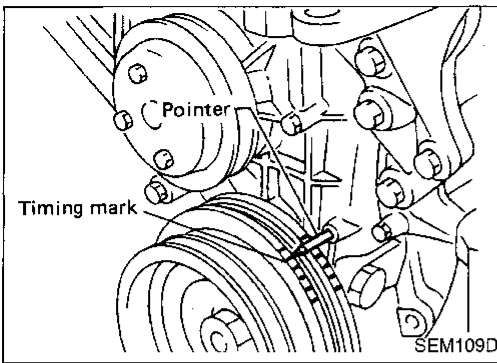

- **Make sure No. 1 cylinder is at TDC by looking at distributor rotor position.**

16. Remove distributor.

17. Remove cylinder head front cover.

18. Remove water pump pulley.

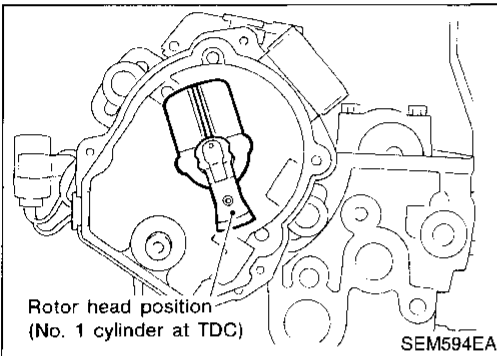

19. Remove thermostat housing.

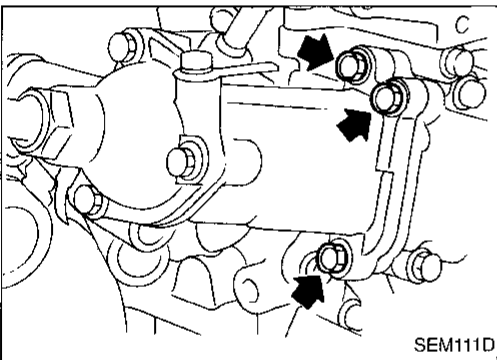

20. Remove lower chain tensioner.

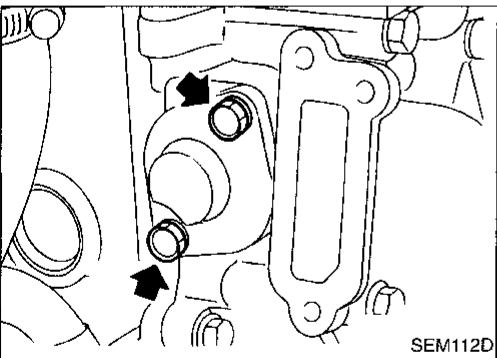

21. Remove upper chain tensioner and slack side timing chain guide.

22. Loosen idler sprocket bolt.

23. Remove camshaft sprocket bolts.

24. Remove camshaft sprockets.

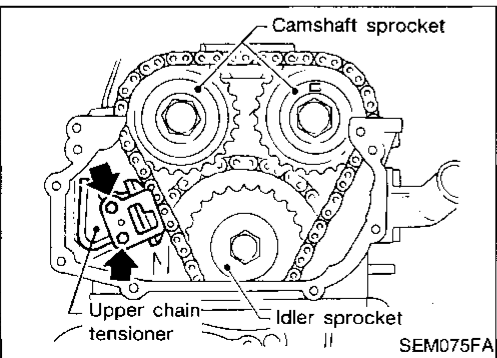

GI

MA

EM

LC

EC

FE

CL

MT

AT

FA

RA

BR

ST

RS

BT

HA

EL

IDX

Removal (Cont'd)

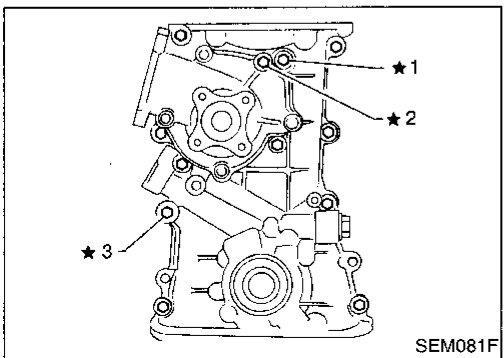
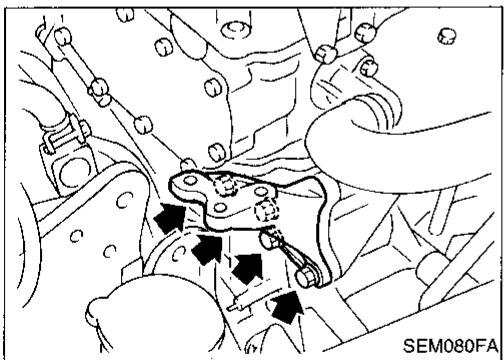
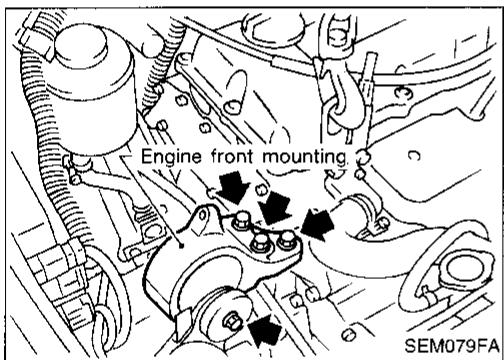
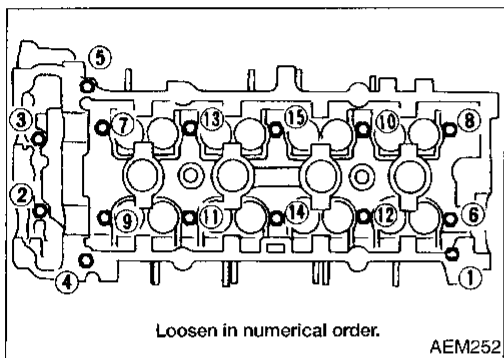
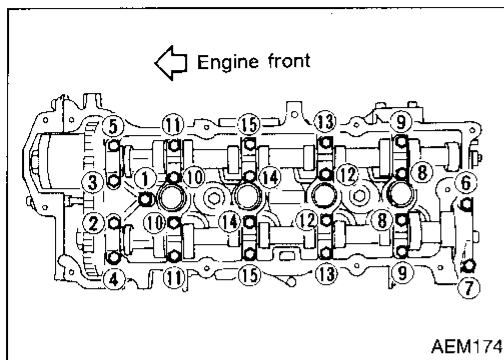

25. Remove camshaft brackets and camshafts.

- Mark these parts' original position for reassembly.
- Loosen cylinder head bolts in two or three steps.

26. Remove idler sprocket bolt.

27. Remove cylinder head with manifolds.

- Head warpage or cracking could result from removing in incorrect order.
- Loosen cylinder head bolts in two or three steps.

28. Remove idler sprocket shaft from rear side.

29. Remove upper timing chain.

30. Remove center member.

31. Remove oil pan. Refer to EM-67.

32. Remove oil strainer.

33. Remove crankshaft pulley.

34. Support engine with a suitable jack.

35. Remove engine front mounting.

36. Remove engine front mounting bracket.

37. Remove front cover bolts and front cover as shown.

CAUTION:

One bolt is located on water pump.

*1: Located on engine front mounting bracket

*2: Located on water pump

*3: Located on power steering oil pump adjusting bar

Removal (Cont'd)

38. Remove idler sprocket.
39. Remove lower timing chain.
40. Remove oil pump drive spacer.
41. Remove chain guides.
42. Remove crankshaft sprocket.

GI

MA

EM

LC

EC

FE

CL

MT

AT

FA

RA

BR

ST

RS

BT

HA

EL

IDX

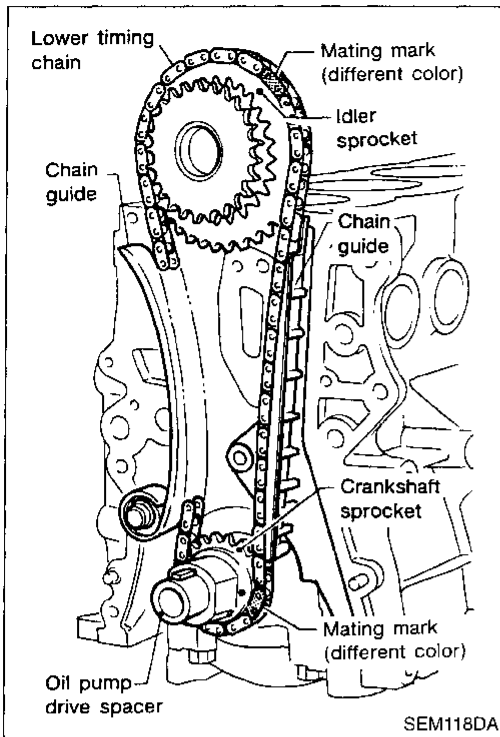

Inspection

Check for cracks and excessive wear at roller links. Replace if necessary.

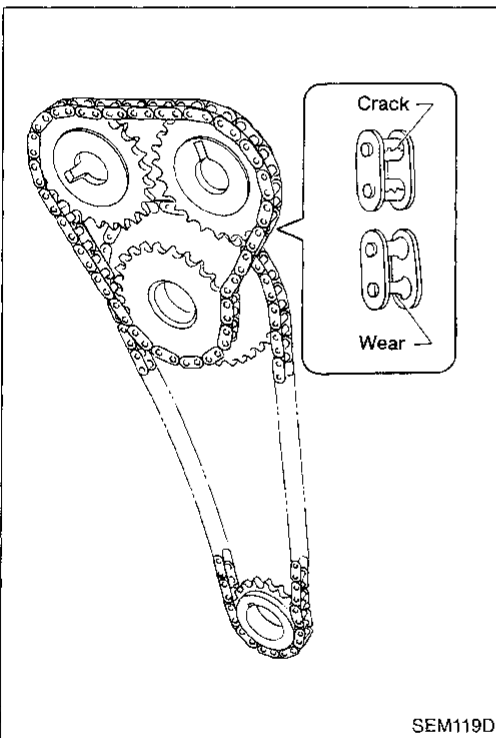

Installation

1. Position crankshaft so that No. 1 piston is at TDC and key way is at 12 o'clock.
 - a. Install crankshaft sprocket.
 - **Make sure mating marks on crankshaft sprocket face front of engine.**
 - b. Install oil pump drive spacer.

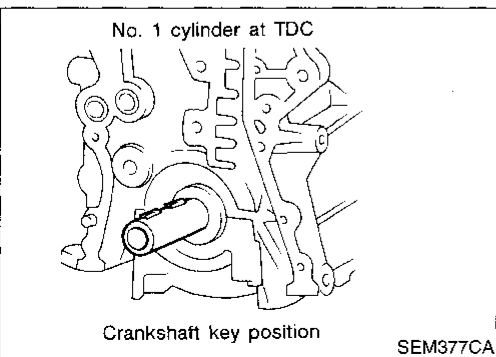

Installation (Cont'd)

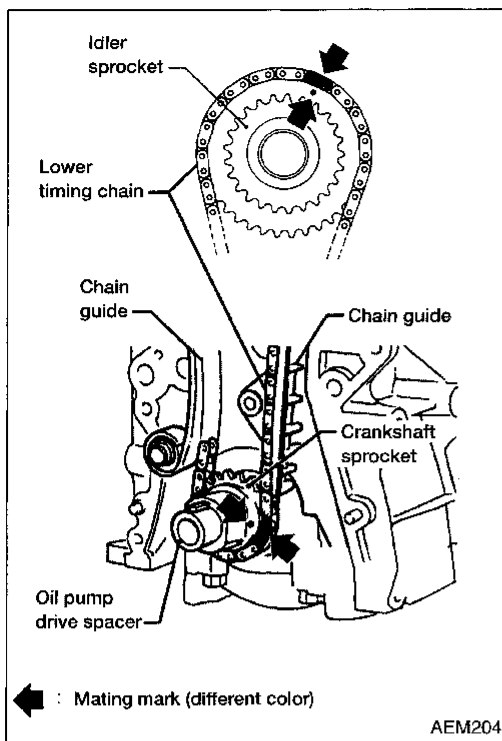

2. Install chain guides.
3. Install crankshaft sprocket and lower timing chain.
 - Set timing chain by aligning its mating mark with the one on crankshaft sprocket.
 - Make sure sprocket's mating mark faces engine front.
 - The number of links between the alignment marks are the same for the left and right sides, so either side can be used during alignment with the sprocket.

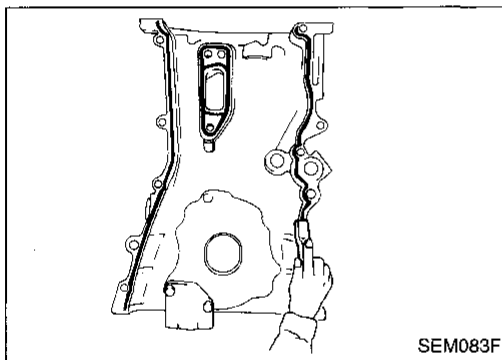

4. Install front cover.
 - a. Use a scraper to remove old liquid gasket from mating surface of front cover.
 - Also remove old liquid gasket from mating surface of cylinder block.

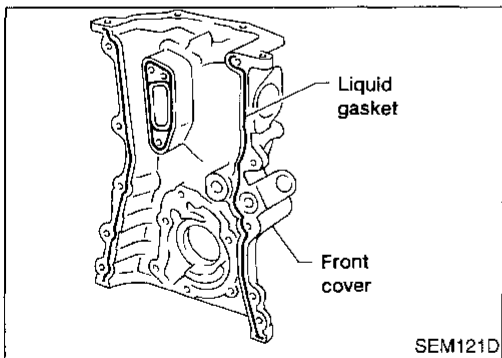

- c. Apply a continuous bead of liquid gasket to front cover.
 - Check alignment of mating marks on chain and crankshaft sprocket.
 - Align oil drive spacer with oil pump.
 - Put chain to the side of chain guide so that chain does not make contact with water seal area of front cover.
 - Make sure two O-rings are present.
 - Be careful not to damage oil seal when installing front cover.

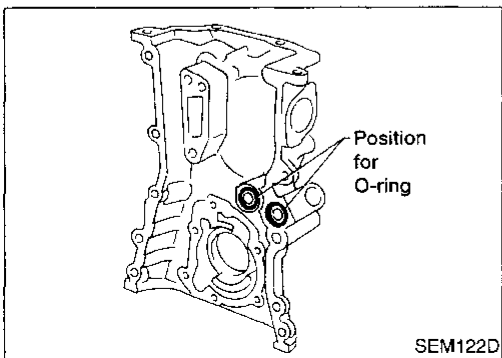

5. Install engine front mounting bracket and mounting.
6. Install oil strainer.
7. Install oil pan. Refer to EM-68.
8. Install crankshaft pulley.
9. Install center member.

Installation (Cont'd)

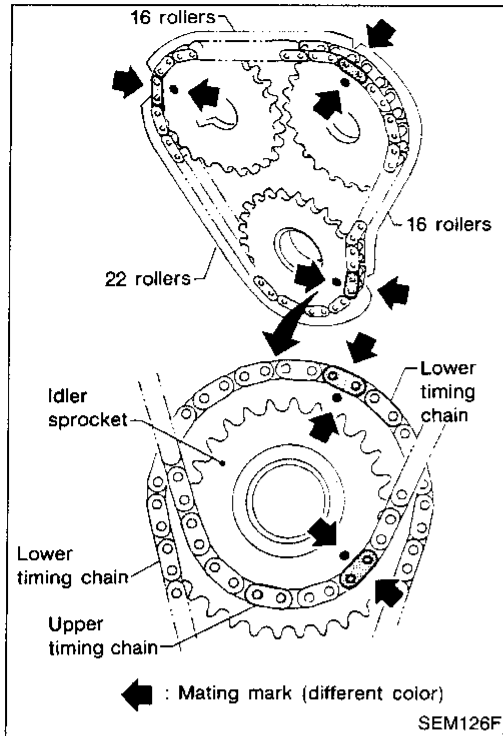

10. Set idler sprocket by aligning mating mark on larger sprocket with mating mark on lower timing chain.
11. Install upper timing chain and set it by aligning mating mark on the smaller sprocket with mating marks on upper timing chain.

- **Make sure sprocket's mating mark faces engine front.**
- 12. Install idler sprocket shaft from the rear side.

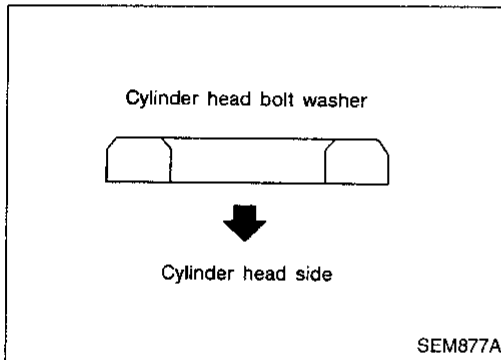

13. Install cylinder head with new gasket.
 - **Be sure to install washers between bolts and cylinder head.**
 - **Do not rotate crankshaft and camshaft separately, or valves will strike piston heads.**
 - **Apply new engine oil to cylinder head bolt threads and seat surfaces.**

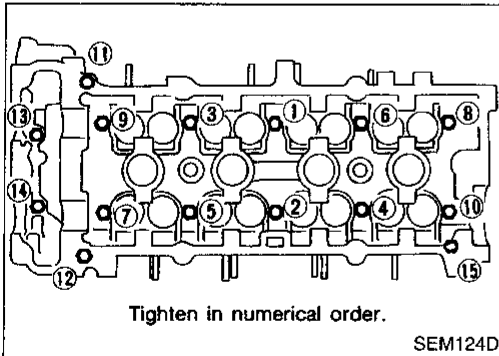

- **Tighten bolts in numerical order using the following procedure:**
 - a. **Tighten bolts to 29.4 N·m (3.00 kg-m, 21.69 ft-lb).**
 - b. **Tighten bolts to 58.8 N·m (6.00 kg-m, 43.37 ft-lb).**
 - c. **Loosen bolts completely.**
 - d. **Tighten bolts to 29.4 N·m (3.00 kg-m, 21.69 ft-lb).**
 - e. **Turn bolts 50 to 55 degrees clockwise. If angle wrench is not available, tighten bolts to 53.9 to 63.7 N·m (5.50 to 6.50 kg-m, 39.76 to 46.99 ft-lb).**
 - f. **Tighten bolts (11 - 15) to 6.3 to 8.3 N·m (0.64 to 0.85 kg-m, 55.8 to 73.5 in-lb).**

GI
 MA
 EM
 LC
 EC
 FE
 CL
 MT
 AT
 FA
 RA
 BR
 ST
 RS
 BT
 HA
 EL
 IDX

Installation (Cont'd)

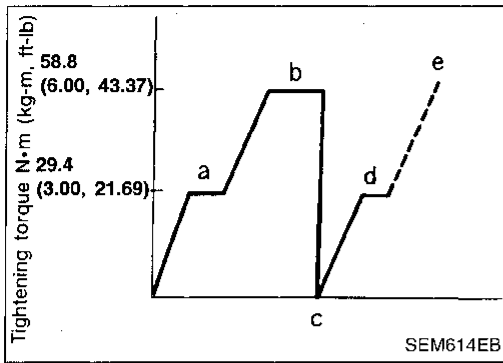

	Tightening torque N·m (kg-m, ft-lb)				
	a	b	c	d	e, f
Bolts (1) - (10)	29.4 (3.00, 21.69)	58.8 (6.00, 43.37)	0 (0, 0)	29.4 (3.00, 21.69)	50 - 55 degrees or 53.9 - 63.7 (5.50 - 6.50, 39.76 - 46.99)
Bolts (11) - (15)	—	—	—	—	6.3 - 8.3 (0.64 - 0.85, 55.8 - 73.5 [in-lb])

14. Install idler sprocket bolt.

- Apply new engine oil to bolt thread and seat surface.

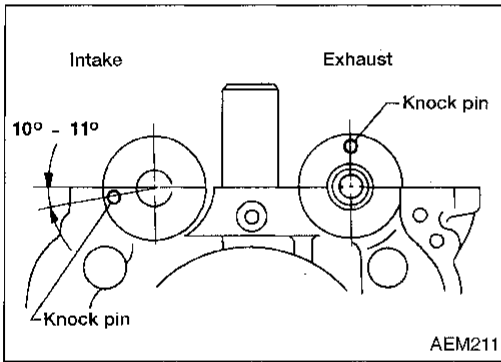

15. Install camshaft.

- Make sure camshafts are aligned as shown in figure.

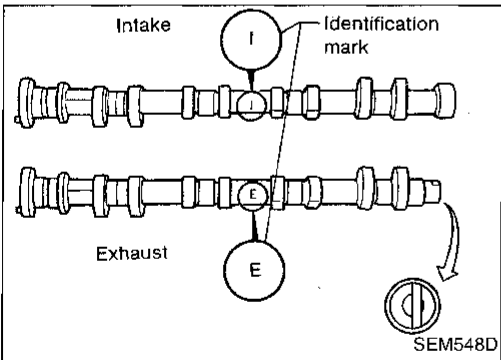

- Identification marks are present on camshafts.

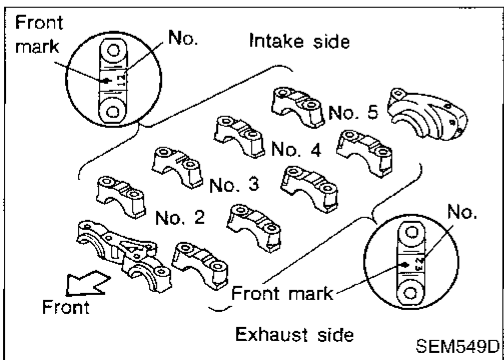

16. Install camshaft brackets and distributor bracket.

- Make sure camshaft brackets are aligned as shown in figure.

Installation (Cont'd)

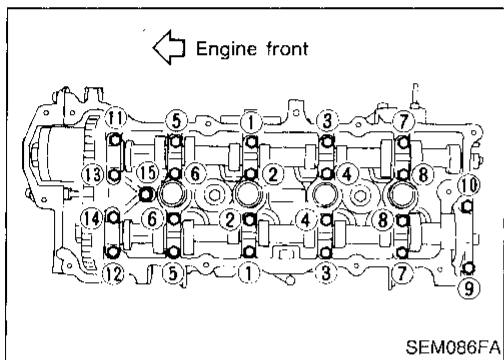
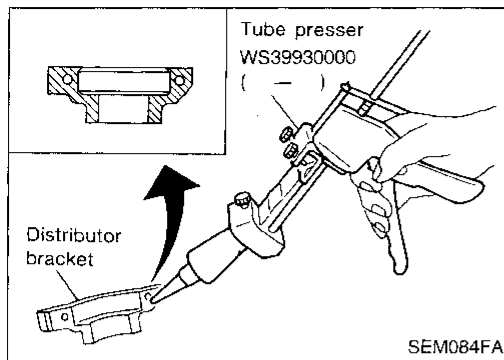

- Apply liquid gasket to distributor bracket as shown in the figure.

- Apply new engine oil to bolt threads and seat surfaces
- Tighten camshaft bracket bolts using the following procedure:
 - Set camshafts and camshaft brackets.
 - Tighten bolts ⑪ - ⑮, then ① - ⑩.
 Ⓜ: 2.0 N·m (0.204 kg-m, 17.7 in-lb)
 - Tighten bolts ① - ⑮.
 Ⓜ: 5.9 N·m (0.60 kg-m, 52.2 in-lb)
 - Tighten bolts ① - ⑭.
 Ⓜ: 9.0 - 11.8 N·m (0.92 - 1.20 kg-m, 6.7 - 8.7 ft-lb)
 - Tighten bolt ⑮.
 Ⓜ: 6.3 - 8.3 N·m (0.64 - 0.85 kg-m, 55.8 - 73.5 in-lb)
- If any part of valve assembly or camshaft is replaced, check valve clearance according to reference data. After completing assembly, check valve clearance. Refer to EM-90.

Reference data valve clearance (Cold):

Intake

0.25 - 0.33 mm (0.010 - 0.013 in)

Exhaust

0.32 - 0.40 mm (0.013 - 0.016 in)

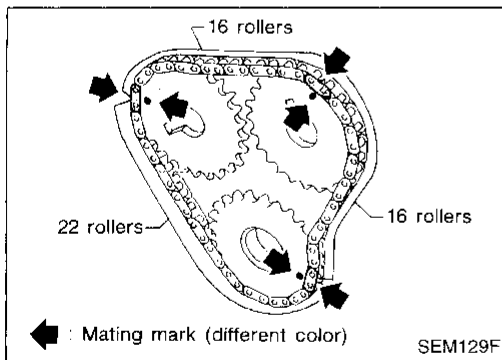

- Assemble camshaft sprocket with chain.
 - Set timing chain by aligning mating marks with those of camshaft sprockets.
 - Make sure sprocket's mating marks face engine front.
- Install camshaft sprocket bolts.
 - Apply new engine oil to bolt threads and seat surfaces.

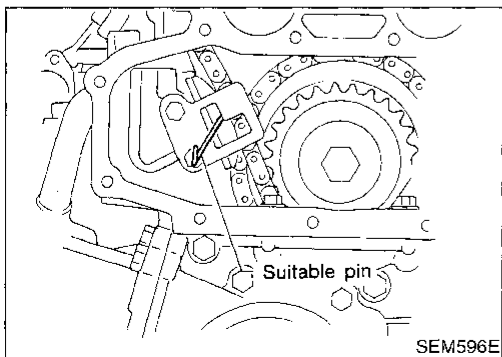

- Install upper chain tensioner.
 - Before installing chain tensioner, insert a suitable pin into pin hole of chain tensioner.
 - After installing chain tensioner, remove the pin.

Installation (Cont'd)

20. Install lower chain tensioner.

CAUTION:

- Check no problems occur when engine is rotated.
- Make sure that No. 1 piston is set at TDC on its compression stroke.

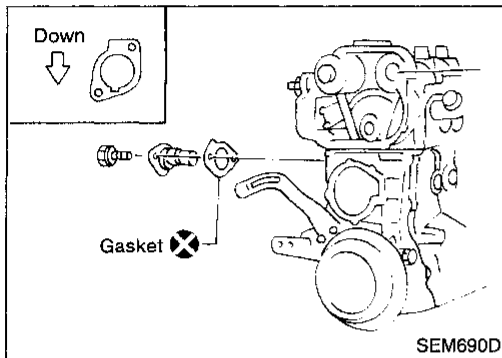
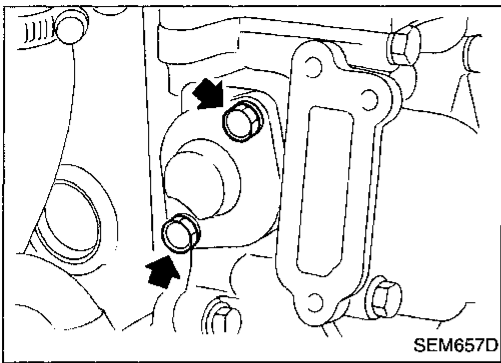

- Make sure gasket is facing proper direction before installing lower chain tensioner.

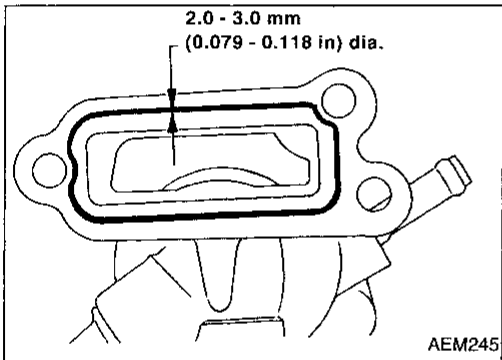

21. Apply liquid gasket to thermostat housing.

- Use Genuine Liquid Gasket or equivalent.

22. Install thermostat housing.

23. Install water pump pulley.

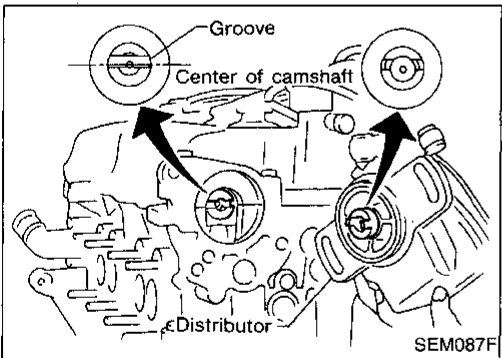

24. Install distributor.

- Make sure that position of camshaft is as shown in figure.

25. Install cylinder head front cover.

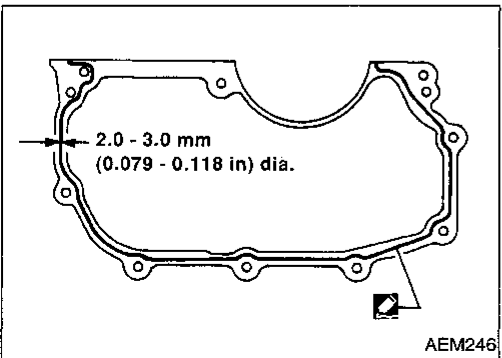

- Apply liquid gasket to cam sprocket cover gusset.
- Use Genuine Liquid Gasket or equivalent.

Installation (Cont'd)

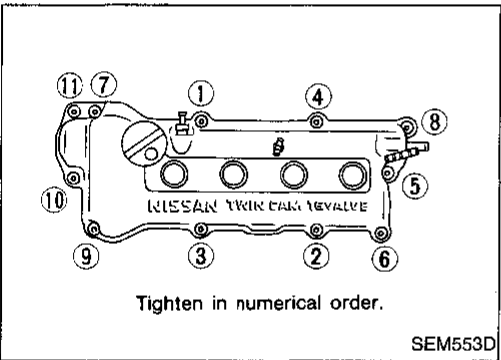
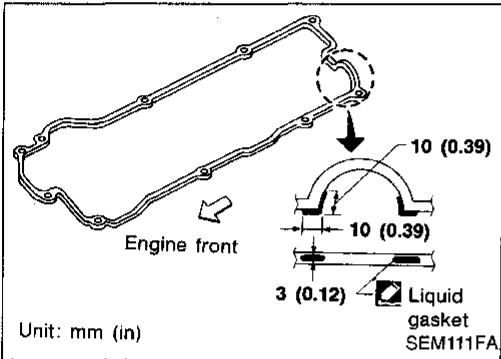
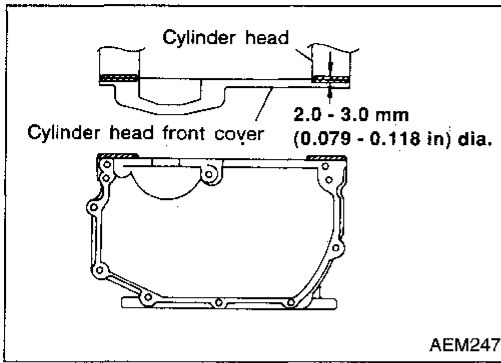

26. Apply liquid gasket to mating surfaces of cylinder head and cylinder head front covers shown in figure.

27. Apply liquid gasket to rocker cover gasket.
 • Use Genuine Liquid Gasket or equivalent.

28. Install rocker cover and tighten in numerical order as shown.
 29. Install the following parts:

- Spark plugs and leads
 - Cylinder head front mounting bracket
 - Front exhaust tube
 - Engine under cover
 - Engine side cover and RH wheel
 - Power steering oil pump and pulley with bracket
- To check power steering fluid, refer to MA section ("Checking Power Steering Fluid and Lines", "CHASSIS AND BODY MAINTENANCE").

• Drive belts
 For adjusting drive belt deflection, refer to MA section ("Checking Drive Belts", "ENGINE MAINTENANCE").

30. Connect the following:

- Vacuum hoses
- Fuel hoses
- Wire, harnesses and connectors
- Air duct to intake manifold
- Upper radiator hose and refill with coolant. Refer to MA section ("REFILLING ENGINE COOLANT", "Changing Engine Coolant").

GI

MA

EM

LC

EC

FE

CL

MT

AT

FA

RA

BR

ST

RS

BT

HA

EL

IDX

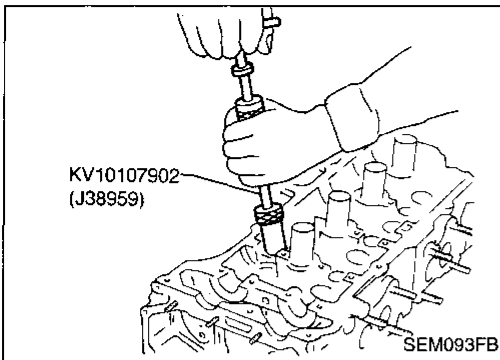

Valve Oil Seal

1. Remove rocker cover.
2. Remove camshaft.
3. Remove valve spring. Refer to EM-82.
4. Remove valve oil seal with Tool.

Piston concerned should be set at TDC to prevent valve from falling.

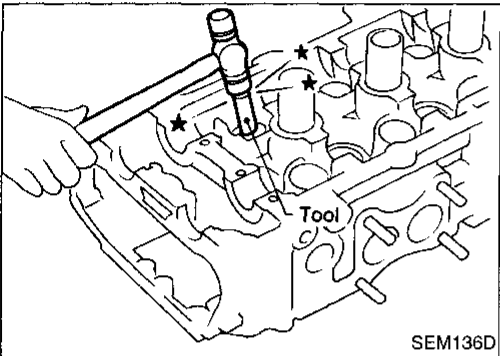

5. Apply new engine oil to new valve oil seal and install it with Tool.

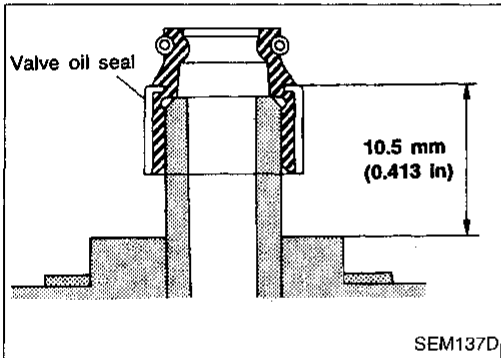

Front Oil Seal

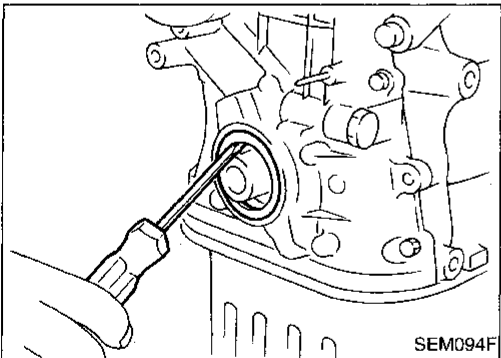

1. Remove the following parts:
 - Engine under cover
 - RH engine side cover
 - Generator and power steering drive belts
 - Crankshaft pulley
2. Remove front oil seal from front cover.
 - **Be careful not to damage oil seal portion.**
 - **Be careful not to scratch front cover.**

- Install new oil seal in the direction shown.

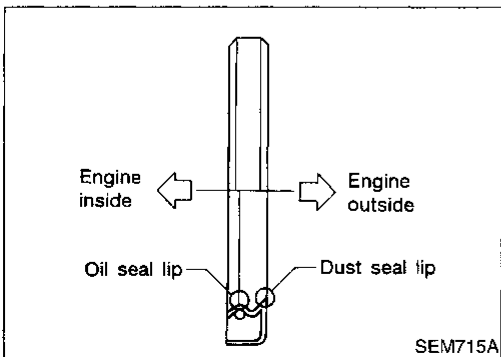

Front Oil Seal (Cont'd)

3. Apply new engine oil to new oil seal and install it using a suitable tool.

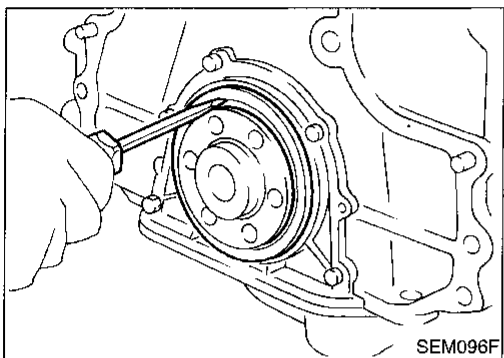
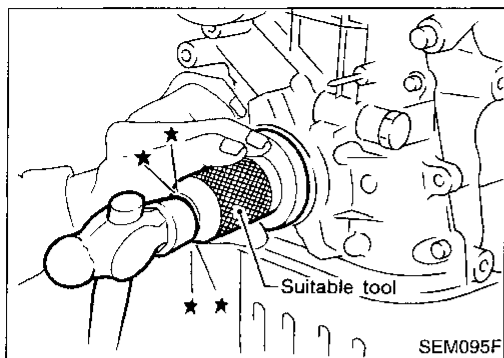

Rear Oil Seal

1. Remove flywheel or drive plate.
 2. Remove rear oil seal retainer.
 3. Remove traces of liquid gasket using scraper.
 4. Remove seal from rear oil seal retainer.
- **Be careful not to scratch rear oil seal retainer.**

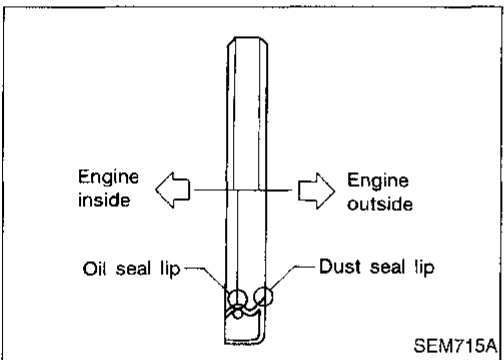

- Install new oil seal in the direction shown.

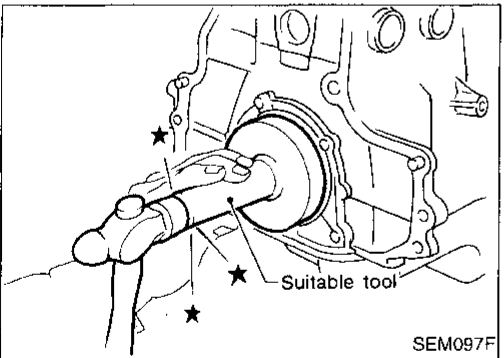

5. Apply new engine oil to new oil seal and install it using a suitable tool.

GI

MA

EM

LC

EC

FE

CL

MT

AT

FA

RA

BR

ST

RS

BT

HA

EL

IDX

SEC. 111-130

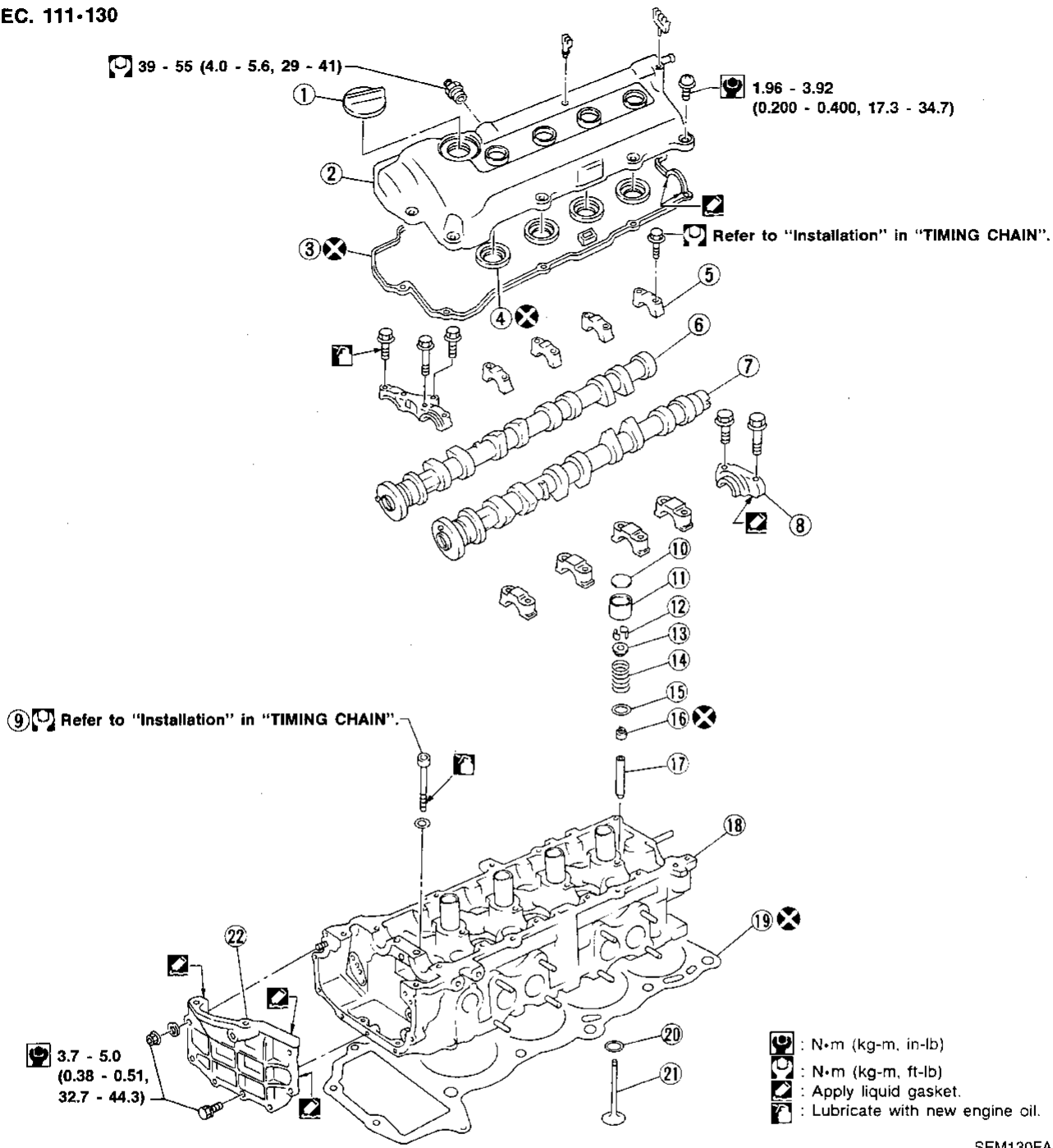

SEM130FA

- | | | |
|-----------------------|-------------------------|-----------------------------|
| ① Oil filler cap | ⑨ Cylinder head bolt | ⑰ Valve guide |
| ② Rocker cover | ⑩ Shim | ⑱ Cylinder head |
| ③ Rocker cover gasket | ⑪ Valve lifter | ⑲ Cylinder head gasket |
| ④ Oil seal | ⑫ Valve cotter | ⑳ Valve seat |
| ⑤ Camshaft bracket | ⑬ Valve spring retainer | ㉑ Valve |
| ⑥ Intake camshaft | ⑭ Valve spring | ㉒ Cylinder head front cover |
| ⑦ Exhaust camshaft | ⑮ Valve spring seat | |
| ⑧ Distributor bracket | ⑯ Valve oil seal | |

CAUTION:

- When installing camshaft and oil seal, lubricate contacting surfaces with new engine oil.
- When tightening cylinder head bolts, camshaft sprocket bolts and camshaft bracket bolts, lubricate bolt threads and seat surfaces with new engine oil.
- Attach tags to valve lifters so as not to mix them up.

Removal

- The removal procedure is the same as for timing chain. Refer to EM-70.

Disassembly

1. Remove valve components with Tool.
2. Remove valve oil seal with a suitable tool.

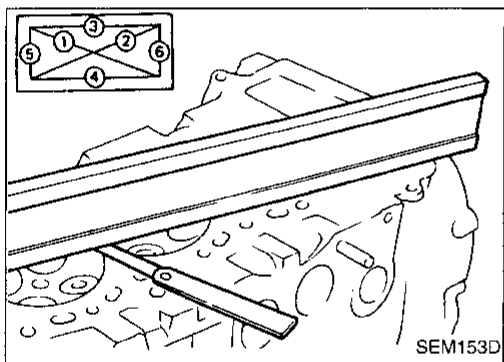
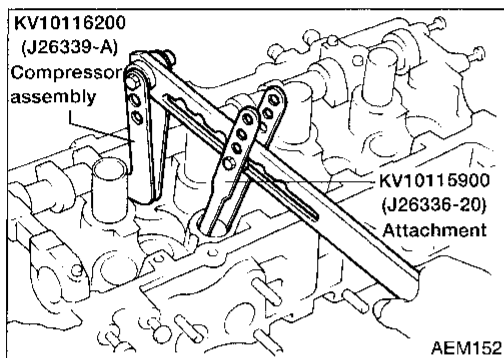

Inspection

CYLINDER HEAD DISTORTION

Clean surface of cylinder head.
 Use a reliable straightedge and feeler gauge to check the flatness of cylinder head surface.
 Check along six positions shown in figure.

Head surface flatness:

Standard: Less than 0.03 mm (0.0012 in)
Limit: 0.1 mm (0.004 in)

If beyond the specified limit, replace it or resurface it.

Resurfacing limit:

The limit for cylinder head resurfacing is determined by the amount of cylinder block resurfacing.

Amount of cylinder head resurfacing is "A".
Amount of cylinder block resurfacing is "B".

The maximum limit is as follows:

A + B = 0.2 mm (0.008 in)

After resurfacing cylinder head, check that camshaft rotates freely by hand. If resistance is felt, replace cylinder head.

Nominal cylinder head height:

117.8 - 118.0 mm (4.638 - 4.646 in)

CAMSHAFT VISUAL CHECK

Check camshaft for scratches, seizure and wear.

CI
MA

EM

LC

EC

FE

CL

MT

AT

FA

RA

BR

ST

RS

BT

TA

EL

IDX

CYLINDER HEAD**Inspection (Cont'd)****CAMSHAFT RUNOUT**

1. Measure camshaft runout at the center journal.

Runout (Total indicator reading):

Standard:

Less than 0.02 mm (0.0008 in)

Limit:

0.1 mm (0.004 in)

2. If it exceeds the limit, replace camshaft.

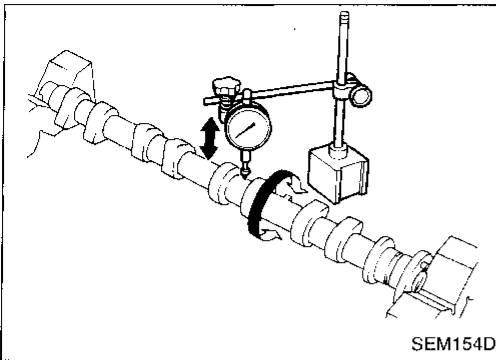

SEM154D

CAMSHAFT CAM HEIGHT

1. Measure camshaft cam height.

Standard cam height:

Intake

40.610 - 40.800 mm (1.5988 - 1.6063 in)

Exhaust

39.910 - 40.100 mm (1.5713 - 1.5787 in)

Cam wear limit:

0.20 mm (0.0079 in)

2. If wear is beyond the limit, replace camshaft.

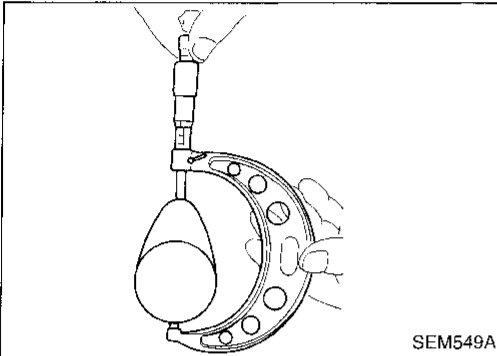

SEM549A

CAMSHAFT JOURNAL CLEARANCE

1. Install camshaft bracket and tighten bolts to the specified torque.

2. Measure inner diameter of camshaft bearing.

Standard inner diameter:

No. 1 bearing

28.000 - 28.021 mm (1.1024 - 1.1032 in)

No. 2 to No. 5 bearings

24.000 - 24.021 mm (0.9449 - 0.9457 in)

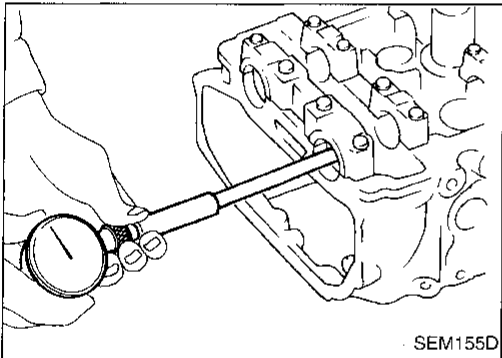

SEM155D

3. Measure outer diameter of camshaft journal.

Standard outer diameter:

No. 1 journal

27.935 - 27.955 mm (1.0998 - 1.1006 in)

No. 2 to No. 5 journals

23.935 - 23.955 mm (0.9423 - 0.9431 in)

4. If clearance exceeds the limit, replace camshaft and/or cylinder head.

Camshaft journal clearance:

Standard 0.045 - 0.086 mm (0.0018 - 0.0034 in)

Limit 0.15 mm (0.0059 in)

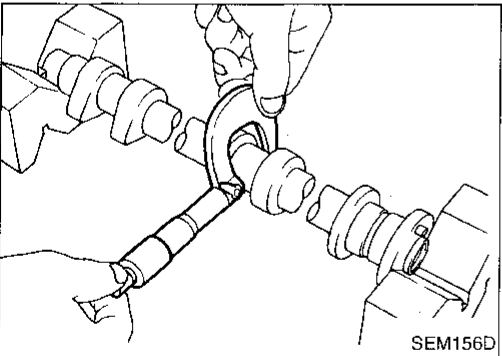

SEM156D

CAMSHAFT END PLAY

1. Install camshaft in cylinder head. Refer to EM-75.

2. Measure camshaft end play.

Camshaft end play:

Standard

0.115 - 0.188 mm (0.0045 - 0.0074 in)

Limit

0.20 mm (0.0079 in)

3. If limit is exceeded, replace camshaft and remeasure end play.

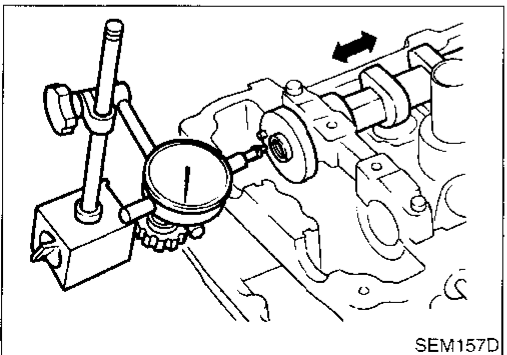

SEM157D

Inspection (Cont'd)

- If limit is still exceeded after replacing camshaft, replace cylinder head.

GI

MA

EM

LC

EC

EE

GL

MT

AT

FA

RA

BR

ST

BS

BT

HA

EL

DX

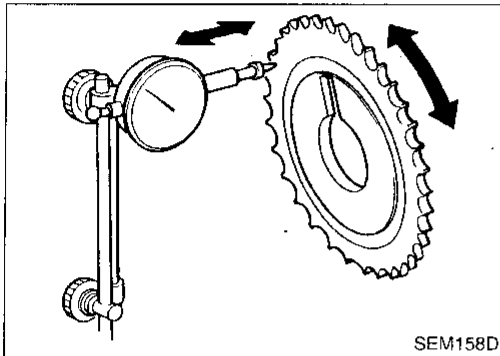

SEM158D

CAMSHAFT SPROCKET RUNOUT

1. Install sprocket on camshaft.
2. Measure camshaft sprocket runout.
Runout (Total indicator reading):
Limit 0.15 mm (0.0071 in)
3. If it exceeds the limit, replace camshaft sprocket.

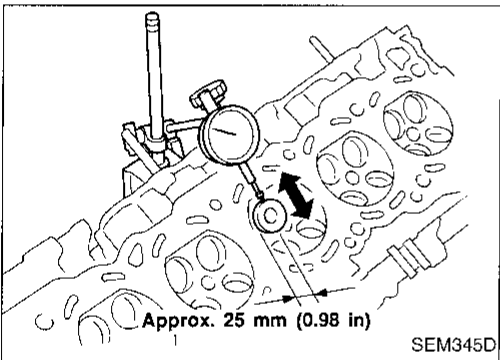

SEM345D

VALVE GUIDE CLEARANCE

1. Measure valve deflection as shown in figure. (Valve and valve guide mostly wear in this direction.)

Valve deflection limit (Dial gauge reading):
Intake & Exhaust
0.2 mm (0.008 in)

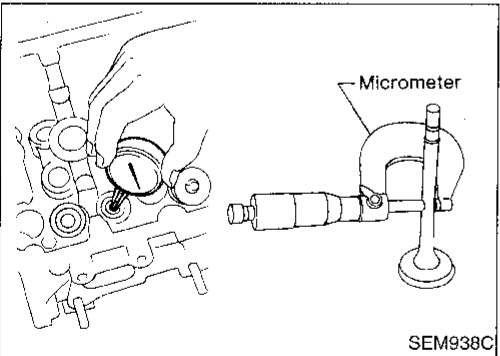

SEM938C

2. If it exceeds the limit, check valve to valve guide clearance.
 - a. Measure valve stem diameter and valve guide inner diameter.
 - b. Calculate valve to valve guide clearance.
Valve to valve guide clearance = valve guide inner diameter - valve stem diameter:
 - c. Check that clearance is within specification.

Unit: mm (in)

	Standard	Limit
Intake	0.020 - 0.050 (0.0008 - 0.0020)	0.1 (0.004)
Exhaust	0.040 - 0.070 (0.0016 - 0.0028)	0.1 (0.004)

- If it exceeds the limit, replace valve and remeasure clearance.
- **If limit is still exceeded after replacing valve, replace valve guide.**

Inspection (Cont'd)

VALVE GUIDE REPLACEMENT

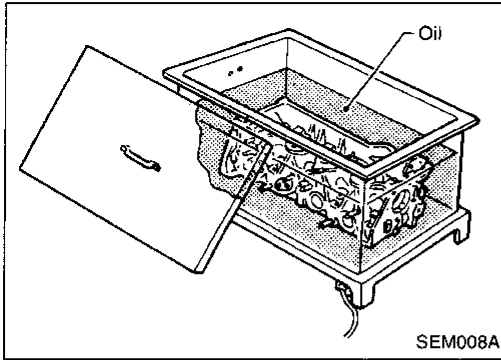

1. To remove valve guide, heat cylinder head to 110 to 120°C (230 to 248°F).

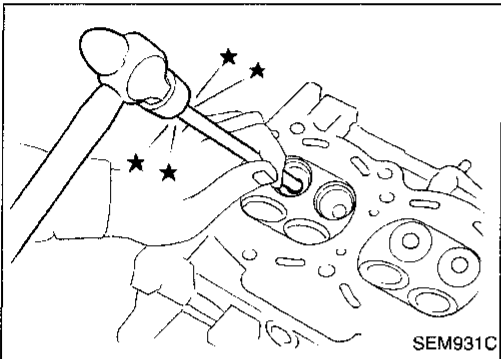

2. Drive out valve guide with a press [under a 20 kN (2 ton, 2.2 US ton, 2.0 Imp ton) pressure] or hammer and suitable tool.

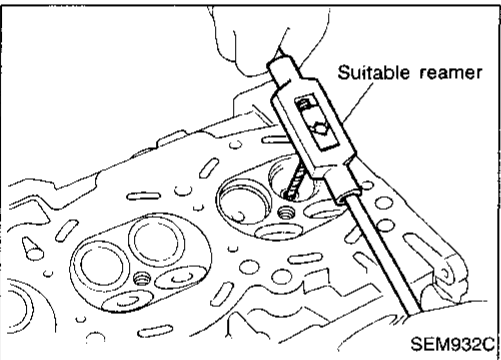

3. Ream cylinder head valve guide hole.

Valve guide hole diameter

(for service parts):

Intake & Exhaust

9.685 - 9.696 mm (0.3813 - 0.3817 in)

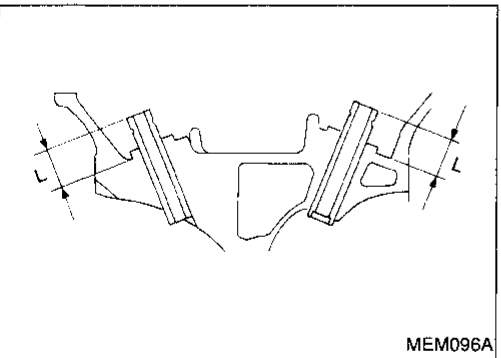

4. Heat cylinder head to 110 to 120°C (230 to 248°F) and press service valve guide into cylinder head.

Projection "L":

11.5 - 11.7 mm (0.453 - 0.461 in)

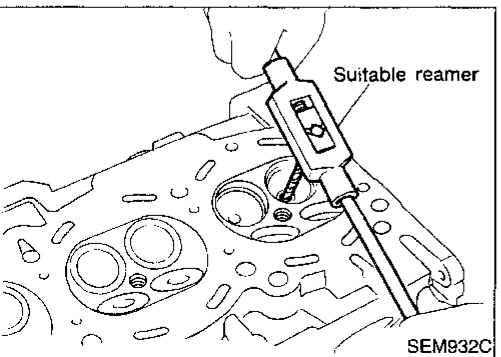

5. Ream valve guide.

Finished size:

Intake & Exhaust

5.500 - 5.515 mm (0.2165 - 0.2171 in)

Inspection (Cont'd)

VALVE SEATS

Check valve seats for pitting at contact surface. Resurface or replace if excessively worn.

- **Before repairing valve seats, check valve and valve guide for wear. If they have worn, replace them. Then correct valve seat.**
- **Use both hands to cut uniformly.**

GI

MA

EM

LC

EC

FE

CL

MT

AT

FA

RA

BR

ST

RS

BT

HA

EL

IDX

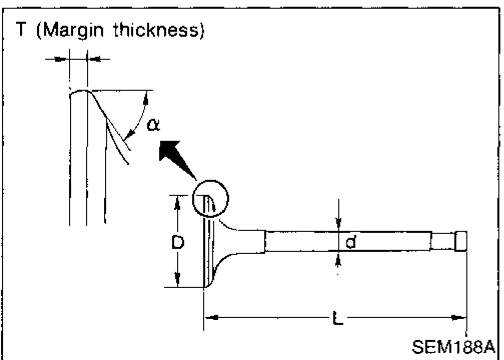
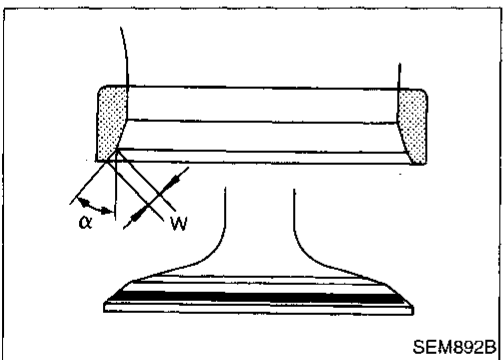
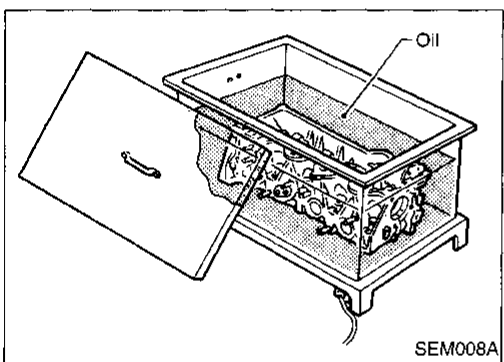
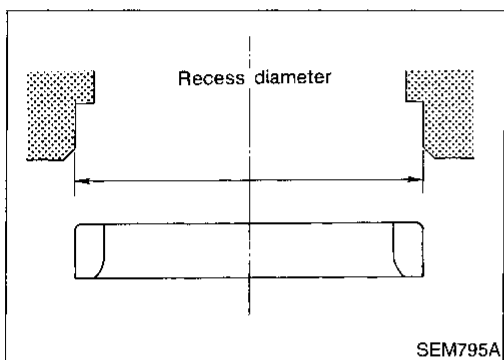
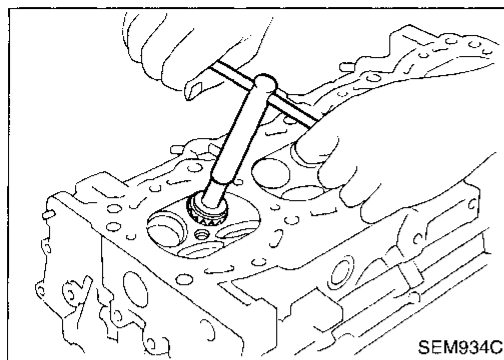

REPLACING VALVE SEAT FOR SERVICE PARTS

1. Bore out old seat until it collapses. Set machine depth stop so that boring cannot contact the bottom face of seat recess in cylinder head.
2. Ream cylinder head recess.

Reaming bore for service valve seat

Oversize [0.5 mm (0.020 in)]:

Intake 31.500 - 31.516 mm (1.2402 - 1.2408 in)

Exhaust 26.500 - 26.516 mm (1.0433 - 1.0439 in)

Use the valve guide center for reaming to ensure valve seat will have the correct fit.

3. Heat cylinder head to 110 to 120°C (230 to 248°F).
4. Press fit valve seat until it seats on the bottom.

5. Cut or grind valve seat using suitable tool to the specified dimensions as shown in SDS, EM-118.
6. After cutting, lap valve seat with abrasive compound.
7. Check valve seating condition.

Seat face angle " α ":

45°15' - 45°45' deg.

Contacting width "W":

Intake

1.06 - 1.34 mm (0.0417 - 0.0528 in)

Exhaust

1.20 - 1.68 mm (0.0472 - 0.0661 in)

VALVE DIMENSIONS

Check dimensions of each valve. Refer to SDS, EM-116 for dimensions.

When valve head has been worn down to 0.5 mm (0.020 in) in margin thickness, replace valve.

Grinding allowance for valve stem tip is 0.2 mm (0.008 in) or less.

Inspection (Cont'd)

VALVE SPRING

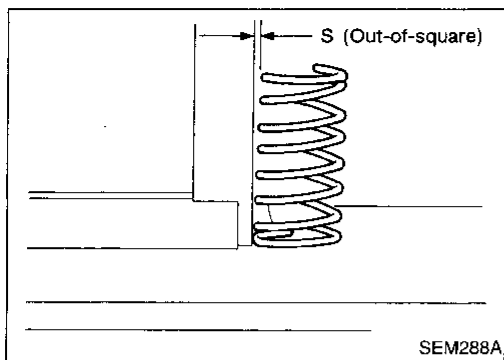

Squareness

1. Measure dimension "S".
Out-of-square "S":
Less than 1.80 mm (0.0709 in)
2. If it exceeds the limit, replace spring.

Pressure

Check valve spring pressure at specified spring height.

Pressure:

Standard

344.42 N (35.12 kg, 77.44 lb) at 25.26 mm (0.9945 in)

Limit

More than 330.41 N (33.69 kg, 74.31 lb) at 23.64 mm (0.9307 in)

If it exceeds the limit, replace spring.

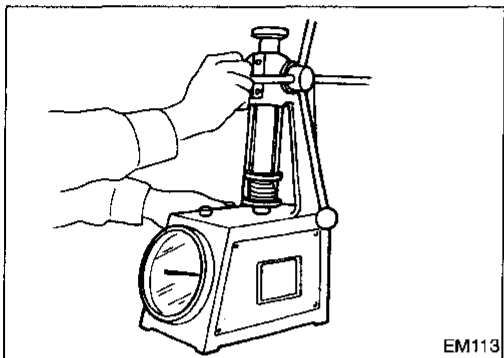

VALVE LIFTER

1. Check contact and sliding surfaces for wear or scratches.

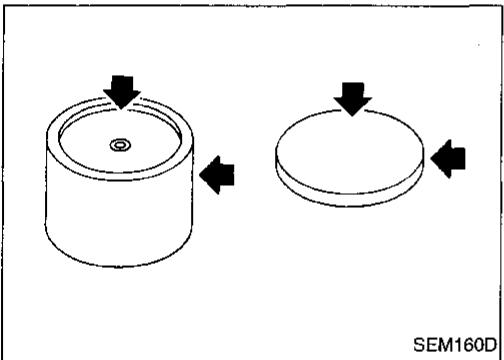

2. Check diameter of valve lifter and valve lifter guide bore.

Valve lifter diameter:

29.960 - 29.975 mm (1.1795 - 1.1801 in)

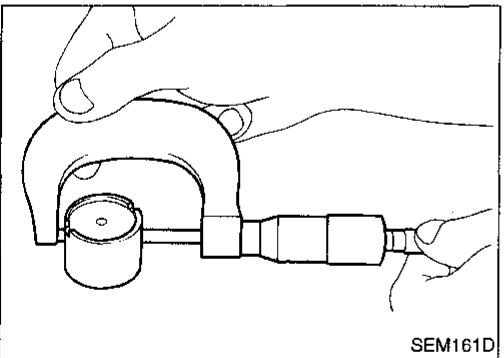

Lifter guide bore diameter:

30.000 - 30.021 mm (1.1811 - 1.1819 in)

Clearance between valve lifter and valve lifter guide:

0.025 - 0.061 mm (0.0010 - 0.0024 in)

If it exceeds the limit, replace valve lifter or cylinder head which exceeds the standard diameter tolerance.

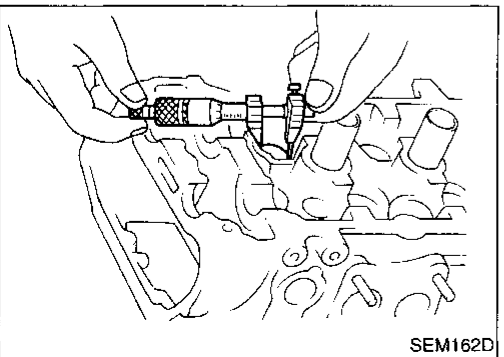

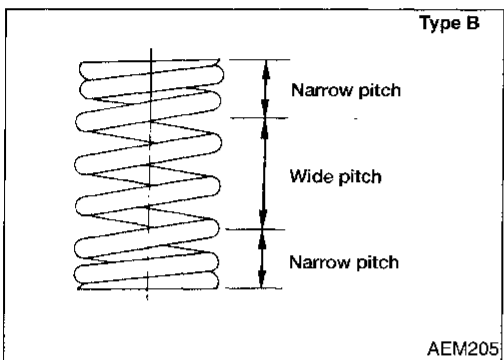
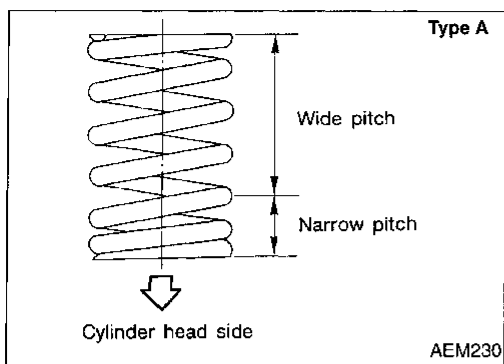

Assembly

1. Install valve component parts.
 - Always use new valve oil seal. Refer to EM-80.
 - Before installing valve oil seal, install valve spring seat.
 - After installing valve components, tap valve stem tip with a plastic hammer to assure a proper fit.
 - Install Type A valve spring (narrow pitch at one end of spring only) with narrow pitch end toward cylinder head.

- Install Type B valve spring (narrow pitch at both ends of spring) with either end toward cylinder head.

Installation

- The installation procedure is the same as for timing chain. Refer to EM-73.

GI

MA

EM

LC

EC

FE

CL

MT

AT

FA

RA

BR

ST

RS

BT

HA

EL

IDX

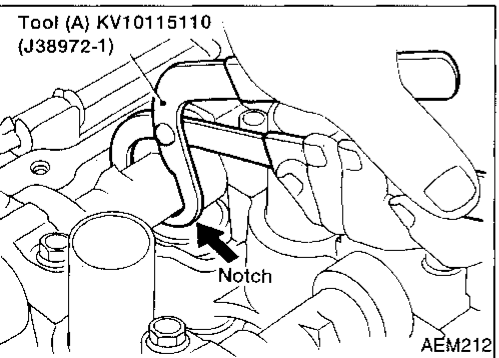
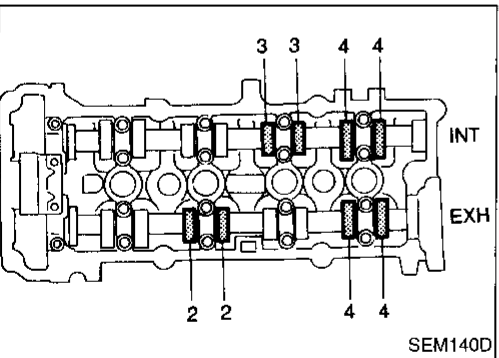
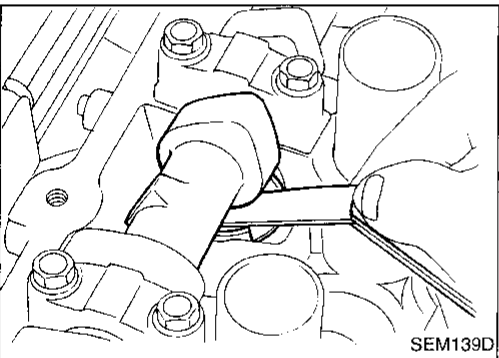
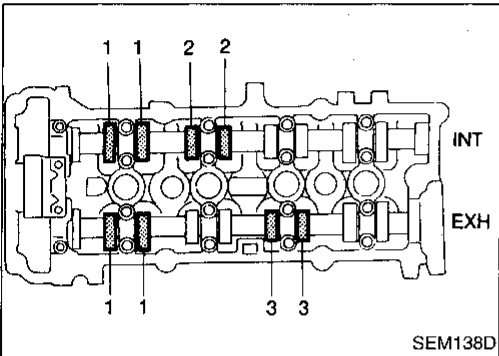
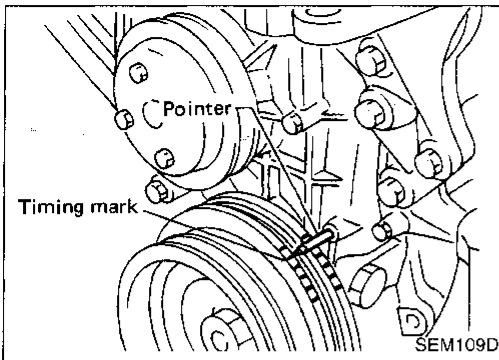

Checking

Check valve clearance while engine is warm and not running.

1. Remove rocker cover.
 2. Remove all spark plugs.
 3. Set No. 1 cylinder at TDC on its compression stroke.
 - Align pointer with TDC mark on crankshaft pulley.
 - Check that valve lifters on No. 1 cylinder are loose and valve lifters on No. 4 are tight.
- If not, turn crankshaft one revolution (360°) and align as described above.
4. Check only those valves shown in the figure.

- Using a feeler gauge, measure clearance between valve lifter and camshaft.
- Record any valve clearance measurements which are out of specification. They will be used later to determine the required replacement adjusting shim.

Valve clearance for checking (Hot):

Intake

0.21 - 0.49 mm (0.008 - 0.019 in)

Exhaust

0.30 - 0.58 mm (0.012 - 0.023 in)

5. Turn crankshaft one revolution (360°) and align mark on crankshaft pulley with pointer.
6. Check only those valves shown in the figure.
 - Use the same procedure as mentioned in step 4.
7. If all valve clearances are within specification, install the following parts:
 - Rocker cover
 - All spark plugs

Adjusting

Adjust valve clearance while engine is cold.

1. Turn crankshaft. Position cam lobe upward on camshaft for valve that must be adjusted.
2. Place Tool (A) around camshaft as shown in figure.

Before placing Tool (A), rotate notch toward center of cylinder head. (See figure.) This will simplify shim removal later.

CAUTION:

Be careful not to damage cam surface with Tool (A).

Adjusting (Cont'd)

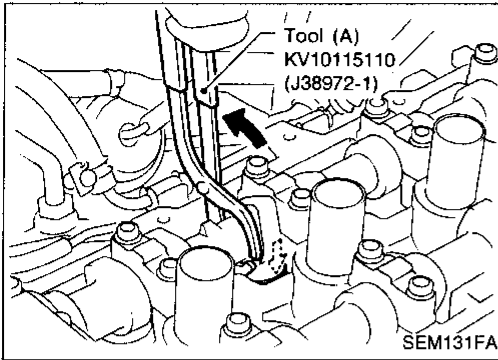

3. Rotate Tool (A) so that valve lifter is pushed down.

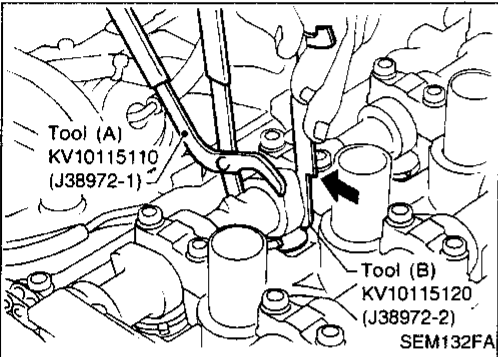

4. Place Tool (B) between camshaft and valve lifter to retain valve lifter.

CAUTION:

- Tool (B) must be placed as close to camshaft bracket as possible.
 - Be careful not to damage cam surface with Tool (B).
5. Remove Tool (A).

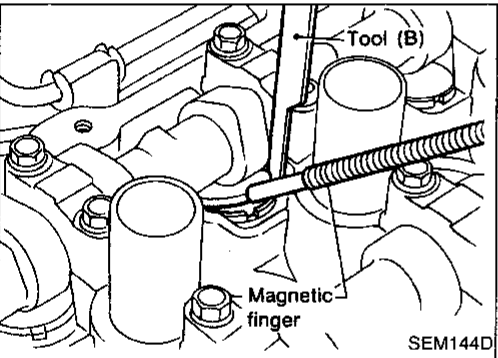

6. Remove adjusting shim using a small screwdriver and a magnetic finger.

7. Determine replacement adjusting shim size using the following formula.

- Use a micrometer to determine thickness of removed shim.
- Calculate thickness of new adjusting shim so valve clearance comes within specified values.

R = Thickness of removed shim

N = Thickness of new shim

M = Measured valve clearance

Intake:

$$N = R + [M - 0.37 \text{ mm (0.0146 in)}]$$

Exhaust:

$$N = R + [M - 0.40 \text{ mm (0.0157 in)}]$$

Shims are available in 50 sizes from 2.00 mm (0.0787 in) to 2.98 mm (0.1173 in), in steps of 0.02 mm (0.0008 in).

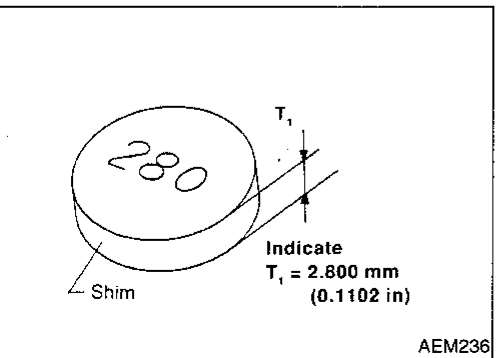
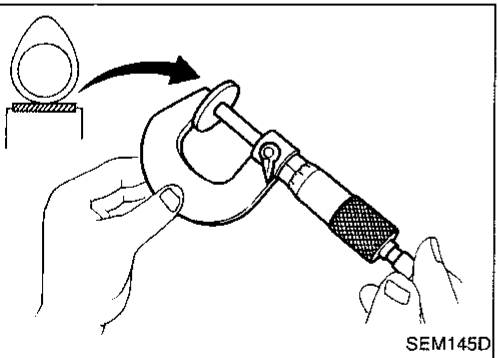

- Select the closest size shim to the calculated thickness. Refer to chart in SDS, EM117.

Adjusting (Cont'd)

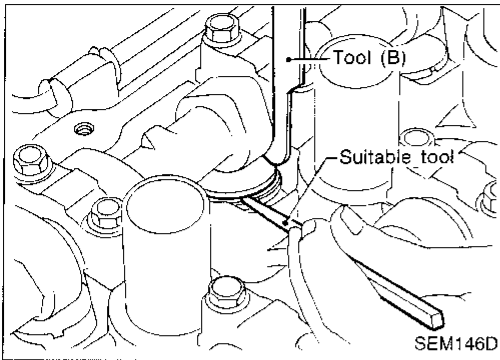

8. Install new shim using a suitable tool.

- Install with the surface on which the thickness is stamped facing down.

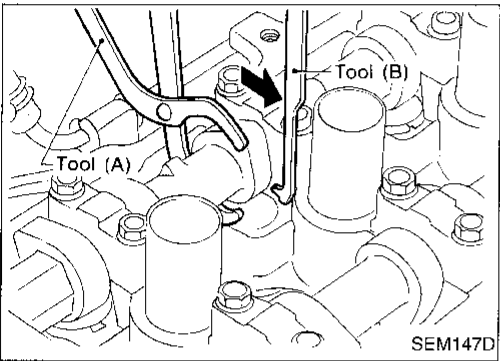

9. Place Tool (A) as explained in steps 2 and 3.

10. Remove Tool (B).

11. Remove Tool (A).

12. Recheck valve clearance.

Valve clearance:

Unit: mm (in)

	For adjusting		For checking
	Hot	Cold* (reference data)	Hot
Intake	0.32 - 0.40 (0.013 - 0.016)	0.25 - 0.33 (0.010 - 0.013)	0.21 - 0.49 (0.008 - 0.019)
Exhaust	0.37 - 0.45 (0.015 - 0.018)	0.32 - 0.40 (0.013 - 0.016)	0.30 - 0.58 (0.012 - 0.023)

*: At a temperature of approximately 20°C (68°F)

Whenever valve clearances are adjusted to cold specifications, check that the clearances satisfy hot specifications and adjust again if necessary.

SEC. 112

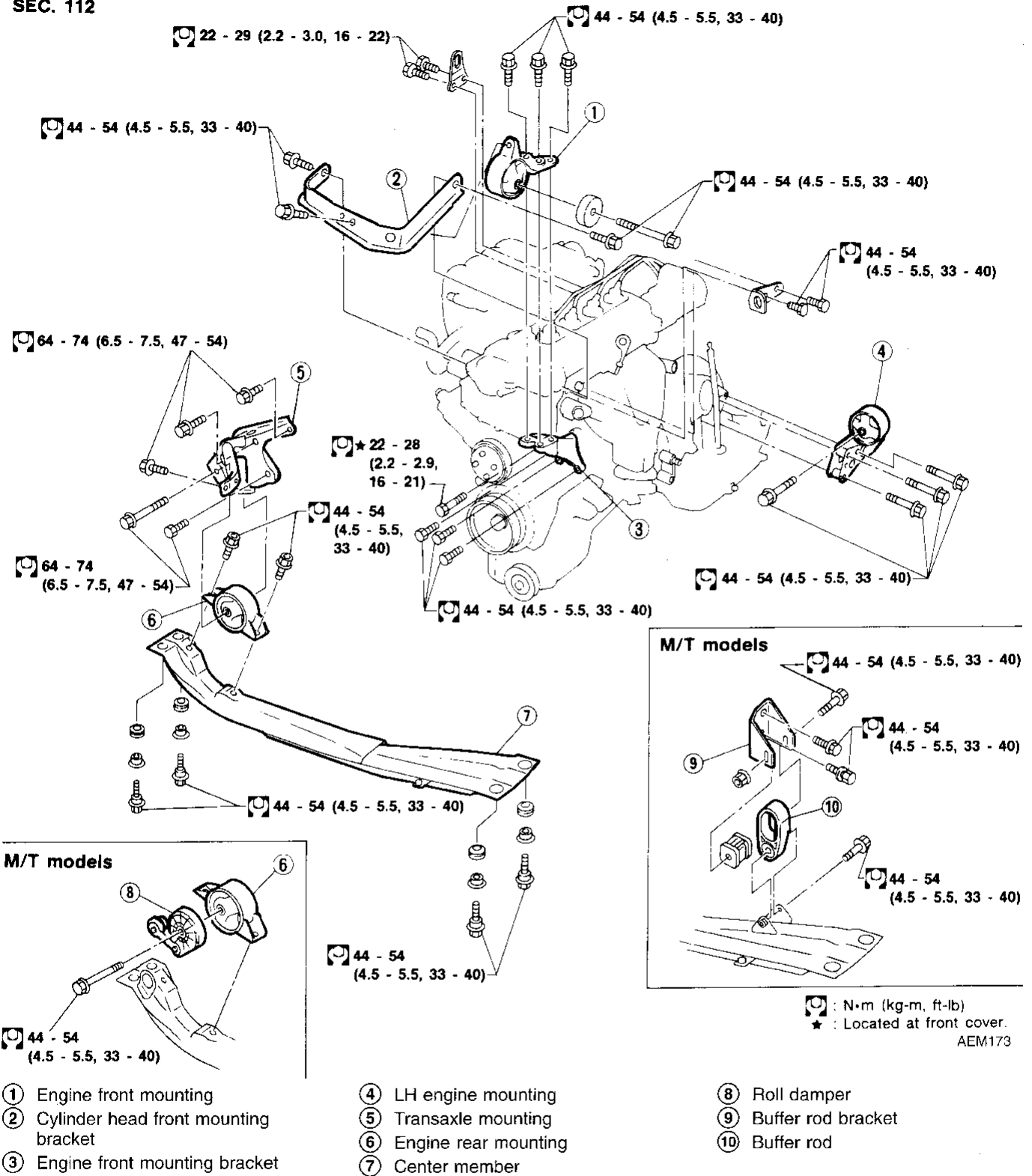

GI
MA
EM
LC
EC
FE
CL
WT
AT
FA
RA
BR
ST
RS
BT
HA
EL
IDX

WARNING:

- Position vehicle on a flat and solid surface.
- Place chocks at front and back of rear wheels.
- Do not remove engine until exhaust system has completely cooled off.
Otherwise, you may burn yourself and/or fire may break out in fuel line.
- Before disconnecting fuel hose, release pressure. Refer to EC section ("Fuel Pressure Release", "BASIC SERVICE PROCEDURE").
- Be sure to lift engine and transaxle in a safe manner.
- For engines not equipped with engine slingers, attach proper slingers and bolts described in PARTS CATALOG.

CAUTION:

- When lifting engine, be sure to clear surrounding parts. Take special care near accelerator wire casing, brake lines and brake master cylinder.
- In lifting the engine, always use engine slingers in a safe manner.
- In removing drive shaft, be careful not to damage grease seal of transaxle.

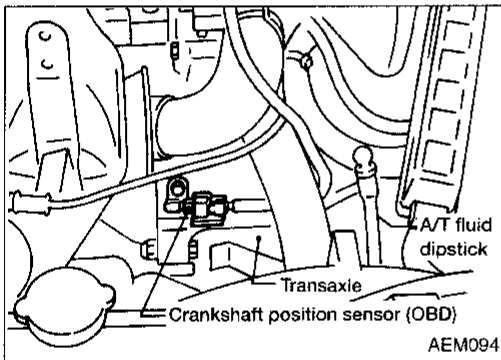

- Before separating engine and transaxle, remove crankshaft position sensor (OBD) from the assembly.
- Always take extra care not to damage edge of crankshaft position sensor (OBD), or ring gear teeth.

Engine cannot be removed separately from transaxle. Remove engine with transaxle as an assembly.

Removal

1. Drain coolant from radiator and cylinder block.
2. Drain oil.
3. Remove battery.
4. Remove coolant reservoir tank and bracket.
5. Remove drive belts.
6. Remove generator and air conditioner compressor from engine.
7. Remove power steering oil pump from engine and position aside.

Power steering oil pump does not need to be disconnected from power steering tubes.

Removal (Cont'd)

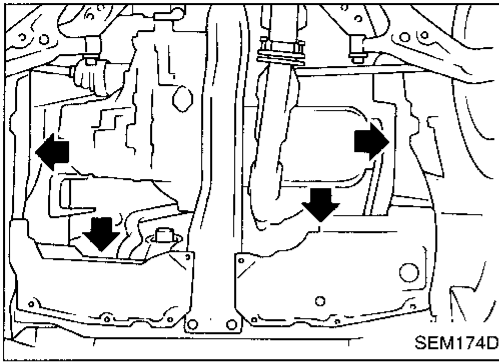

8. Remove the following parts:

- RH and LH front tires
- Under covers
- Splash covers
- RH and LH brake caliper assemblies

: 72 - 97 N·m (7.3 - 9.9 kg-m, 53 - 72 ft-lb)

Brake hose does not need to be disconnected from brake caliper assembly. Never depress brake pedal.

- RH & LH drive shaft. Refer to FA section ("Drive Shaft", "FRONT AXLE").

When removing drive shaft, be careful not to damage trans-axle side grease seal.

CI

MA

EM

LC

EC

FE

CL

MT

AT

FA

RA

BR

ST

RS

BT

HA

EL

IDX

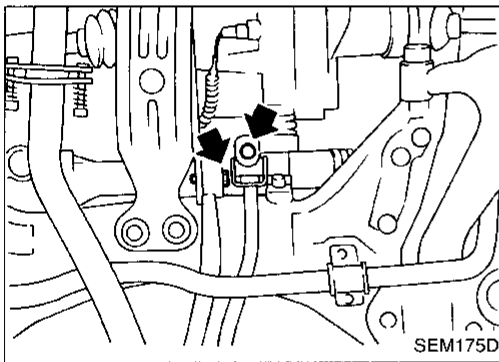

- Disconnect control rod and support rod from transaxle. (M/T models.)

Control rod:

: 14 - 18 N·m (1.4 - 1.8 kg-m, 10 - 13 ft-lb)

Support rod:

: 35 - 47 N·m (3.6 - 4.8 kg-m, 26 - 35 ft-lb)

- Disconnect control cable from transaxle. (A/T models.)

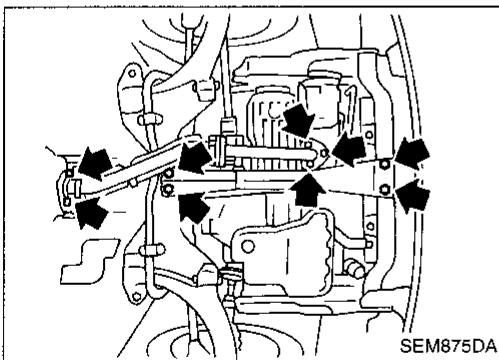

- Center member
- Front exhaust tube
- Stabilizer bar
- Cooling fan
- Radiator

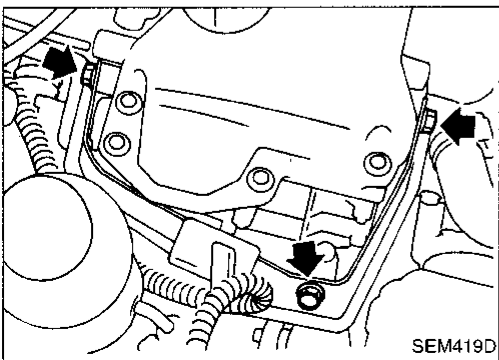

- Cylinder head front mounting bracket
- Remove air duct and disconnect wires, harness, pipes, hoses and so on.

9. Lift up engine slightly and disconnect or remove all engine mountings.

When lifting engine, be sure to clear surrounding parts. Take special care near brake tubes and brake master cylinder.

Removal (Cont'd)

10. Remove engine with transaxle as shown.

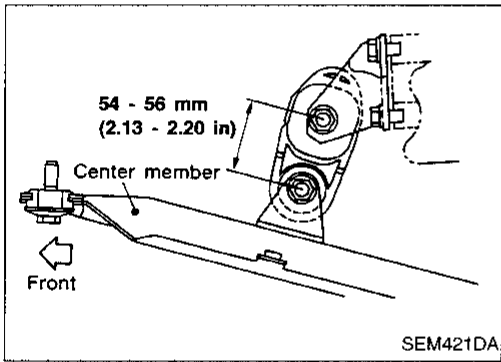
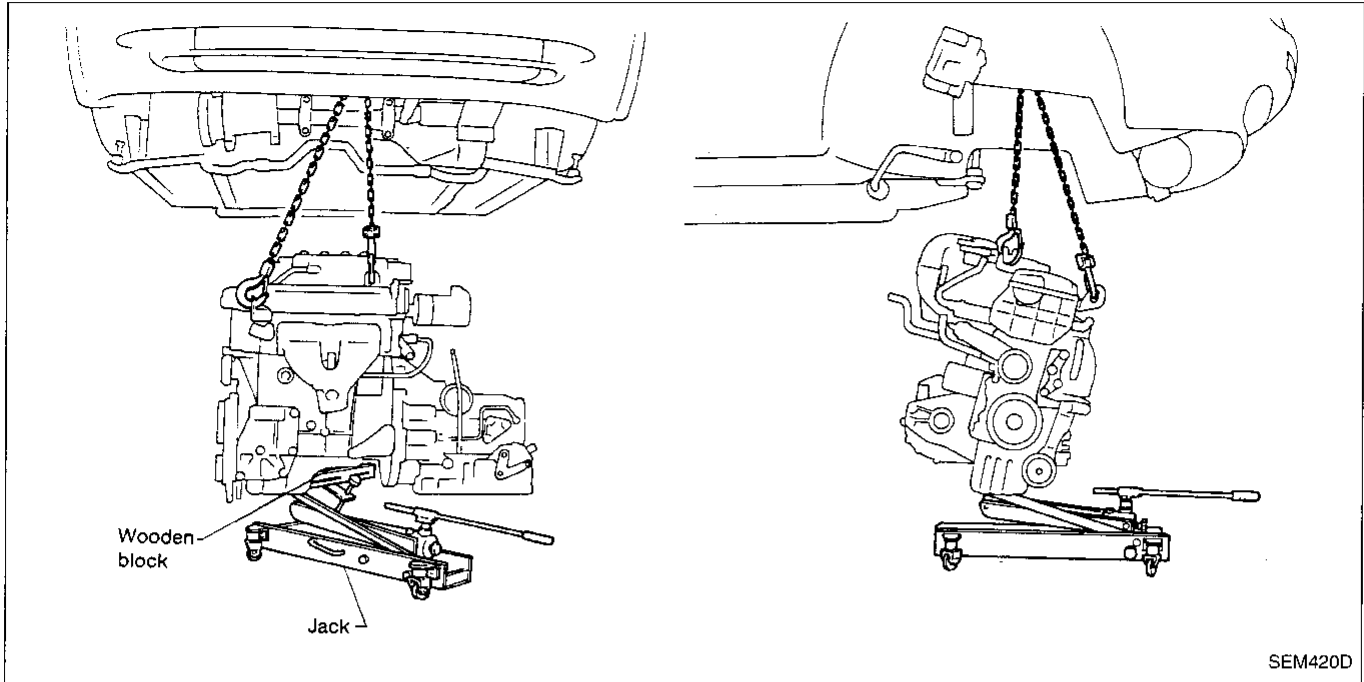

Installation

When installing the engine, adjust the height of buffer rod as shown. (For M/T.)

- Install in reverse order of removal.

SEC. 110-120

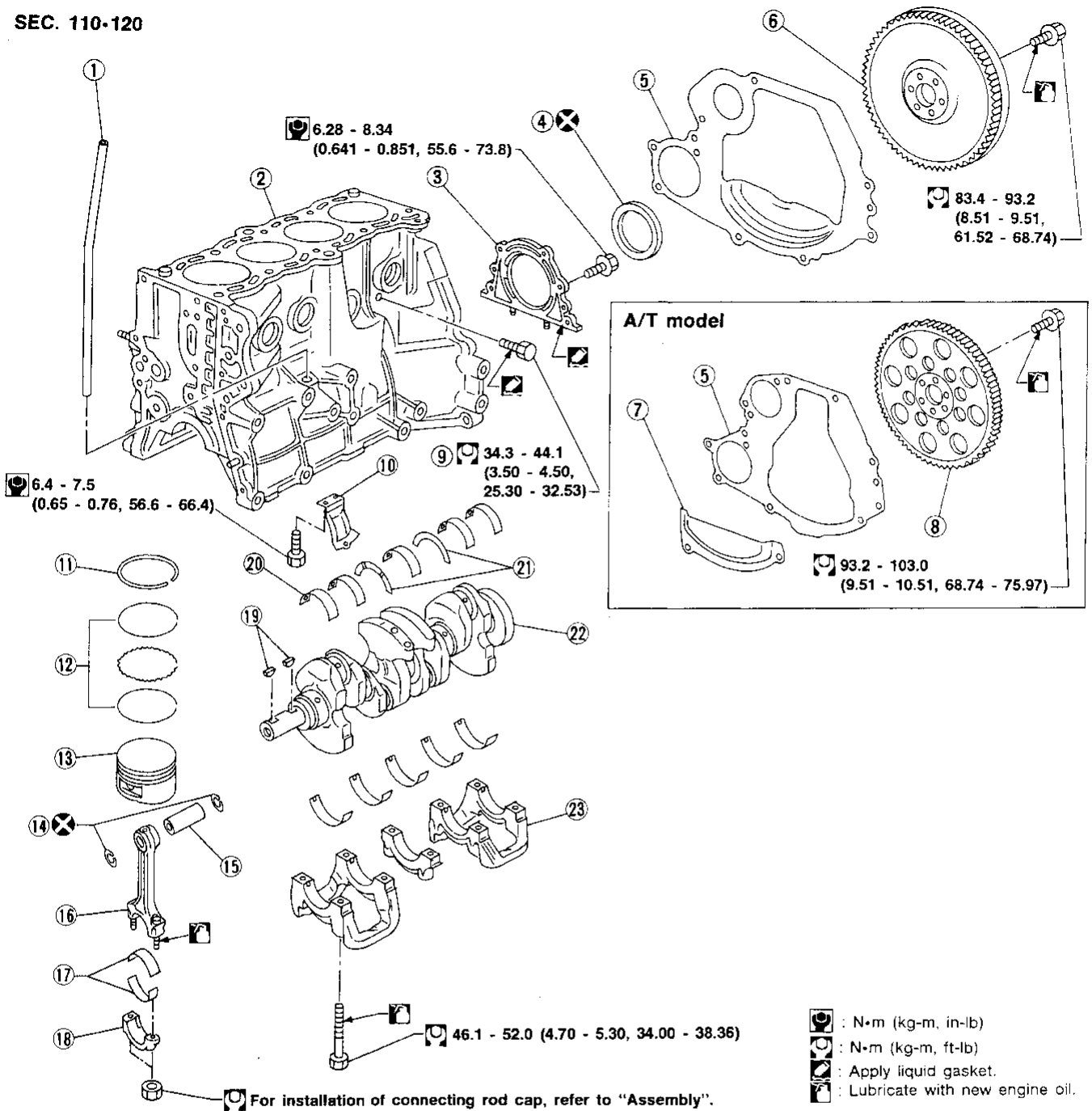

- ① Oil level gauge guide
- ② Cylinder block
- ③ Rear oil seal retainer
- ④ Rear oil seal
- ⑤ Rear plate
- ⑥ Flywheel
- ⑦ Rear plate cover
- ⑧ Drive plate

- ⑨ Drain plug
- ⑩ Buffer plate
- ⑪ Top ring
- ⑫ Oil ring
- ⑬ Piston
- ⑭ Snap ring
- ⑮ Piston pin
- ⑯ Connecting rod

- ⑰ Connecting rod bearing
- ⑱ Key
- ⑲ Main bearing
- ⑳ Thrust bearing
- ㉑ Crankshaft
- ㉒ Main bearing cap
- ㉓ Main bearing cap

GI
MA
EM
LC
EC
FE
CL
MT
AT
FA
RA
BR
ST
RS
BT
HA
EL
IDX

CAUTION:

- When installing sliding parts such as bearings and pistons, apply engine oil on the sliding surfaces.
- Place removed parts, such as bearings and bearing caps, in their proper order and direction.
- When installing connecting rod nuts and main bearing cap bolts, apply new engine oil to threads and seating surfaces of nuts.
- Do not allow any magnetic materials to contact the ring gear teeth of flywheel or drive plate, and rear plate.

Disassembly

PISTON AND CRANKSHAFT

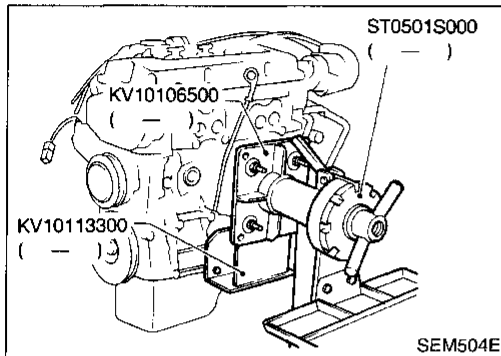

1. Place engine on a work stand.
2. Drain coolant and oil.
3. Remove timing chain.
Refer to EM-70.

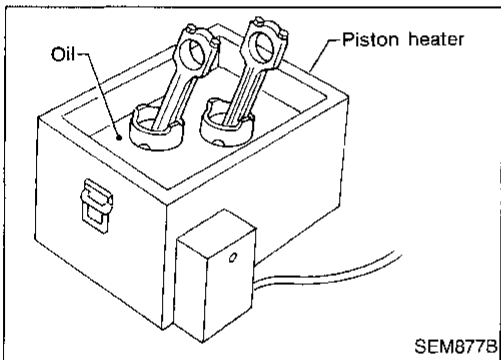

4. Remove pistons with connecting rod.
 - When disassembling piston and connecting rod, remove snap ring first. Then heat piston to 60 to 70°C (140 to 158°F) or use piston pin press stand at room temperature.

CAUTION:

- When piston rings are not replaced, make sure that piston rings are mounted in their original positions.
- When replacing piston rings, if there is no punch mark, install with either side up.

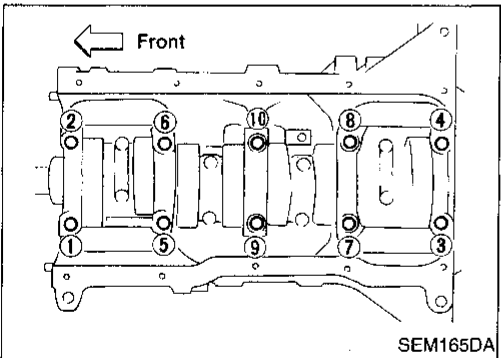

5. Loosen main bearing caps in numerical order as shown in figure.
6. Remove bearing caps, main bearings and crankshaft.
 - Before removing bearing caps, measure crankshaft end play. Refer to EM-106.
 - Bolts should be loosened in two or three steps.

Inspection

PISTON AND PISTON PIN CLEARANCE

1. Measure inner diameter of piston pin hole "dp".
Standard diameter "dp":
18.987 - 18.999 mm (0.7475 - 0.7480 in)

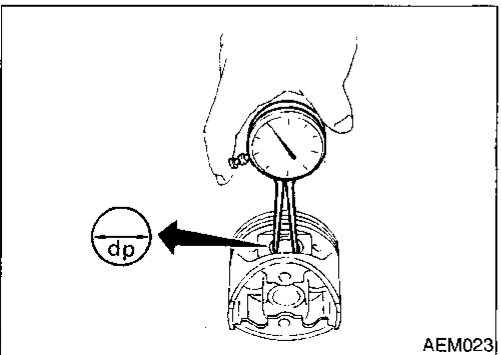

Inspection (Cont'd)

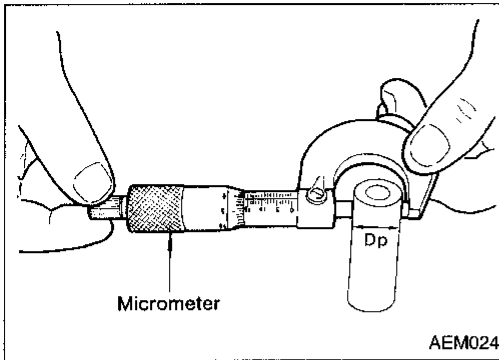

2. Measure outer diameter of piston pin "Dp".
Standard diameter "Dp":
18.989 - 19.001 mm (0.7476 - 0.7481 in)
3. Calculate piston pin clearance.
Dp - dp = -0.004 to 0 mm (-0.0002 to 0 in)
 If it exceeds the above value, replace piston assembly with pin.

CI

MA

EM

LC

EC

FE

CL

MT

AT

FA

RA

BR

ST

RS

BT

HA

EL

IDX

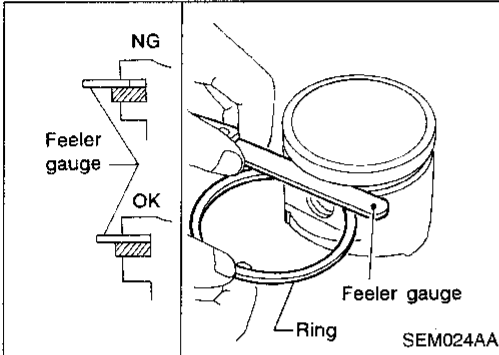

PISTON RING SIDE CLEARANCE

Side clearance:

Top ring

0.040 - 0.080 mm (0.0016 - 0.0031 in)

Max. limit of side clearance:

0.1 mm (0.004 in)

If out of specification, replace piston and/or piston ring assembly.

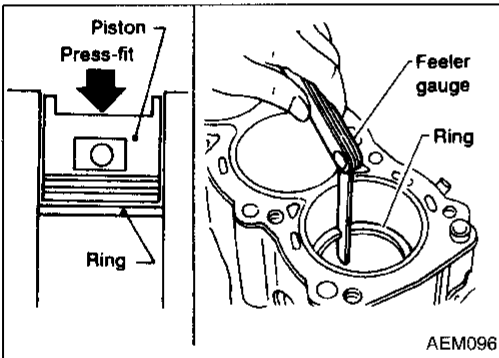

PISTON RING END GAP

End gap:

Top ring 0.20 - 0.40 mm (0.0079 - 0.0157 in)

Oil ring 0.20 - 0.60 mm (0.0079 - 0.0236 in)

Max. limit of ring gap:

Top ring 0.49 mm (0.0193 in)

Oil ring 0.69 mm (0.0272 in)

If out of specification, replace piston ring. If gap exceeds maximum limit with a new ring, rebore cylinder and use oversized piston and piston rings.

Refer to SDS, EM-120.

- When replacing the piston, check the cylinder block surface for scratches or seizure. If scratches or seizure is found, hone or replace the cylinder block.

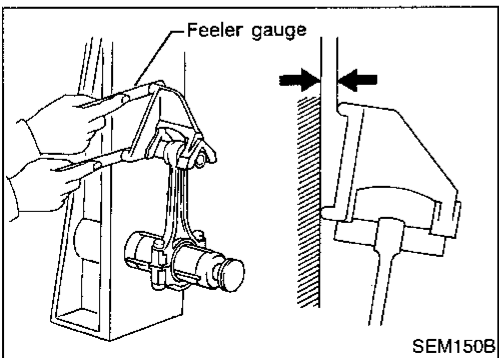

CONNECTING ROD BEND AND TORSION

Bend:

Limit 0.15 mm (0.0059 in)
per 100 mm (3.94 in) length

Torsion:

Limit 0.3 mm (0.012 in)
per 100 mm (3.94 in) length

If it exceeds the limit, replace connecting rod assembly.

CYLINDER BLOCK

Inspection (Cont'd)

GA

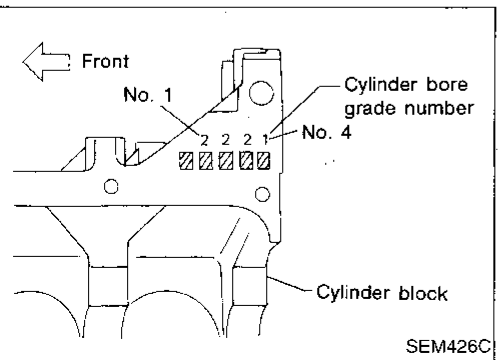
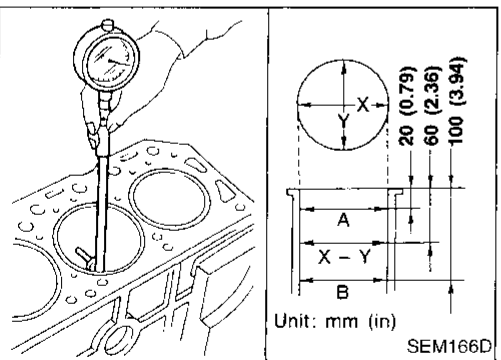
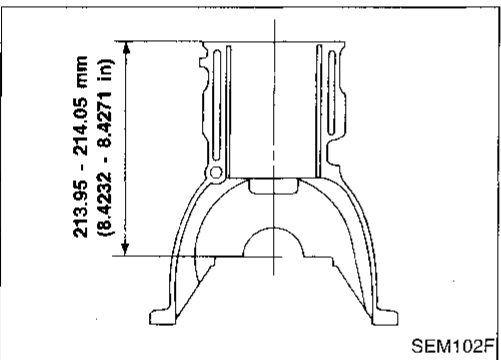
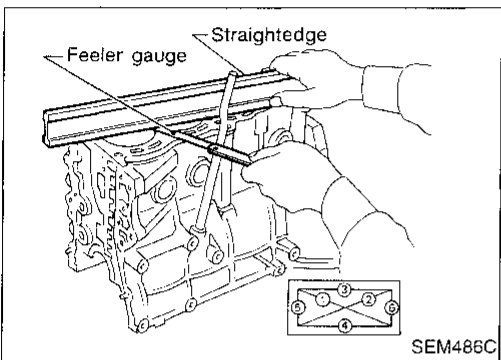
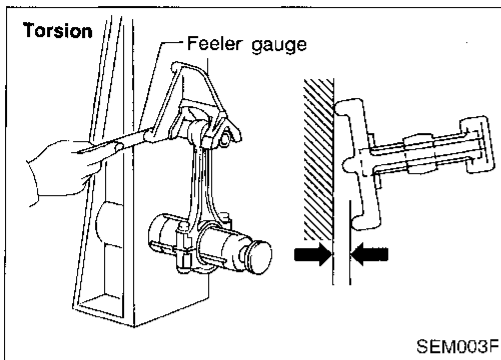

CYLINDER BLOCK DISTORTION AND WEAR

Clean upper surface of cylinder block. Use a reliable straightedge and feeler gauge to check the flatness of cylinder block surface. Check along six positions shown in figure.

Limit:

0.1 mm (0.004 in)

If out of specification, resurface it.

The limit for cylinder block resurfacing is determined by the amount of cylinder head resurfacing.

Amount of cylinder head resurfacing is "A".
Amount of cylinder block resurfacing is "B".

The maximum limit is as follows:

A + B = 0.2 mm (0.008 in)

Nominal cylinder block height
from crankshaft center:

213.95 - 214.05 mm (8.4232 - 8.4271 in)

If necessary, replace cylinder block.

PISTON-TO-BORE CLEARANCE

- Using a bore gauge, measure cylinder bore for wear, out-of-round and taper.

Standard inner diameter:

76.000 - 76.030 mm (2.9921 - 2.9933 in)

Wear limit: 0.2 mm (0.008 in)

If it exceeds the limit, rebore all cylinders. Replace cylinder block if necessary.

Out-of-round (X - Y) standard: 0.015 mm (0.0006 in)

Taper (A - B) standard: 0.01 mm (0.0004 in)

- Check for score and seizure. If seizure is found, hone it.

- If cylinder block or piston is replaced, match piston grade with grade number on cylinder block lower surface.

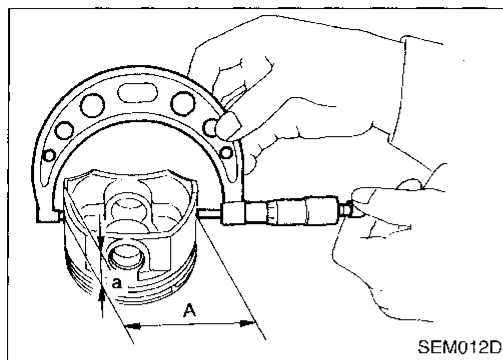

Inspection (Cont'd)

3. Measure piston skirt diameter.
Piston diameter "A":
 Refer to SDS, EM-120.
Measuring point "a" (Distance from the bottom):
 9.9 mm (0.390 in)
4. Check that piston-to-bore clearance is within specification.
Piston-to-bore clearance = cylinder bore measurement "B" - Piston diameter "A":
 0.015 - 0.035 mm (0.0006 - 0.0014 in)
5. Determine piston oversize according to amount of cylinder wear.

Oversize pistons are available for service. Refer to SDS EM-120.

6. Cylinder bore size is determined by adding piston-to-bore clearance to piston diameter "A".

Rebored size calculation:

$$D = A + B - C$$

where,

D: Bored diameter

A: Piston diameter as measured

B: Piston-to-bore clearance

C: Honing allowance 0.02 mm (0.0008 in)

7. Install main bearing caps and tighten bolts to the specified torque. This will prevent distortion of cylinder bores.
8. Cut cylinder bores.
 - **When any cylinder needs boring, all other cylinders must also be bored.**
 - **Do not cut too much out of cylinder bore at a time. Cut only 0.05 mm (0.0020 in) or so at a time.**
- 9.hone cylinders to obtain specified piston-to-bore clearance.
10. Measure finished cylinder bore for out-of-round and taper.
 - **Measurement should be done after cylinder bore cools down.**

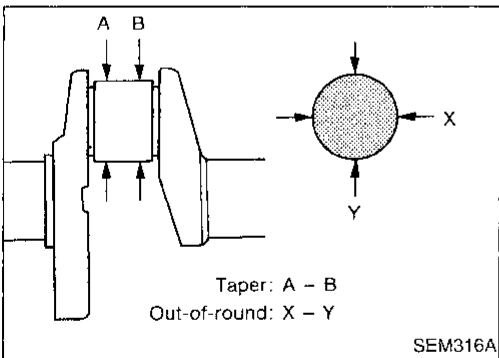

CRANKSHAFT

1. Check crankshaft main and pin journals for score, wear or cracks.
2. With a micrometer, measure journals for taper and out-of-round.

Out-of-round (X - Y):

Less than 0.005 mm (0.0002 in)

Taper (A - B):

Less than 0.005 mm (0.0002 in)

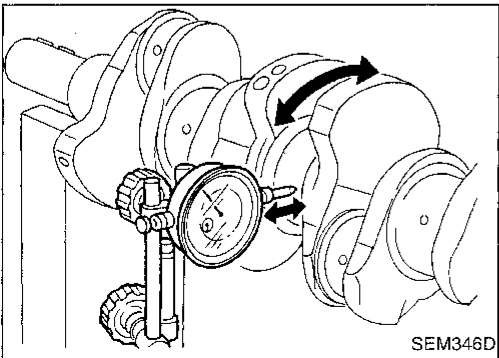

3. Measure crankshaft runout.

Runout (Total indicator reading):

Less than 0.05 mm (0.0002 in)

Inspection (Cont'd)

BEARING CLEARANCE

- Use Method A or Method B. Method A is preferred because it is more accurate.

Method A (Using bore gauge & micrometer)

Main bearing

1. Set main bearings in their proper positions on cylinder block and main bearing cap.
2. Install main bearing cap to cylinder block.
3. Measure inner diameter "A" of each main bearing.

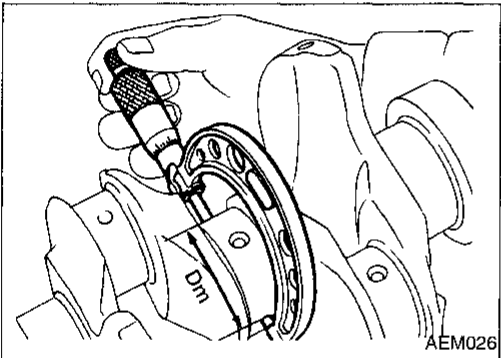
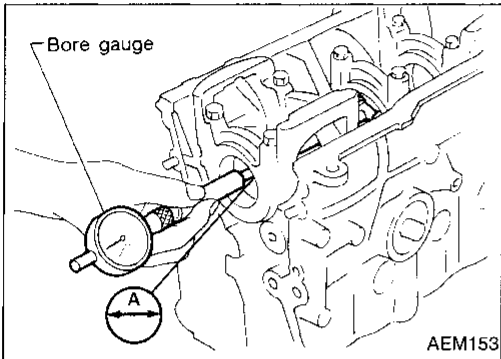
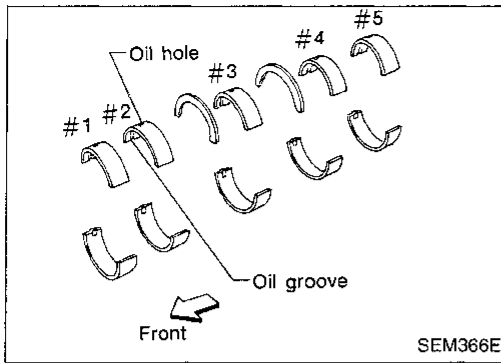

4. Measure outer diameter "Dm" of each main journal in crankshaft.
5. Calculate main bearing clearance.

Main bearing clearance = A - Dm

Standard: 0.018 - 0.042 mm (0.0007 - 0.0017 in)

Limit: 0.1 mm (0.004 in)

If it exceeds the limit, replace bearing.

If clearance cannot be adjusted within standard of any bearing, grind crankshaft journal and use undersized bearing.

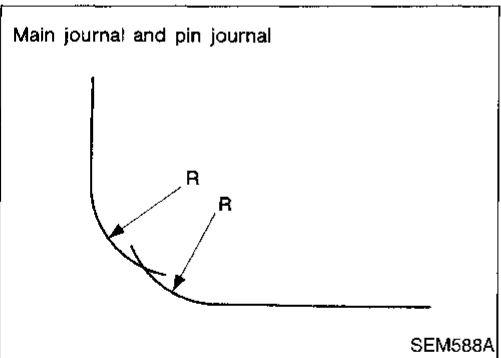

When grinding crank pin and crank journal:

- Grind until clearance is within specified standard bearing clearance.
- Fillets should be finished as shown in the figure.
R: 2.3 - 2.5 mm (0.091 - 0.098 in)

Refer to SDS, EM-121 for standard bearing clearance and available spare parts.

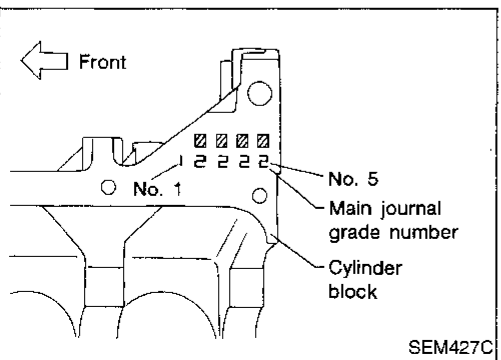

6. If the crankshaft or cylinder block is replaced, select thickness of main bearings as follows:
 - a. Grade number of each cylinder block main journal is punched on the respective cylinder block. These numbers are punched in either Arabic or Roman numerals.

Inspection (Cont'd)

- b. Grade number of each crankshaft main journal is punched on the respective crankshaft. These numbers are punched in either Arabic or Roman numerals.
- c. Select main bearing with suitable thickness according to the following table.

Main bearing grade color:

Crankshaft main journal grade number	Cylinder block main journal grade number		
	0	1	2
0	Black	Brown	Green
1	Brown	Green	Yellow
2	Green	Yellow	Blue

For example:

Cylinder block main journal grade number: 1
 Crankshaft main journal grade number: 2
 Main bearing grade number = 1 + 2 = Yellow

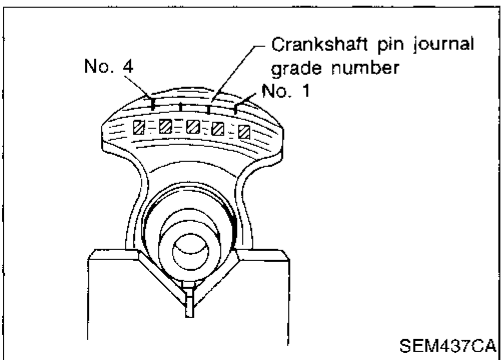
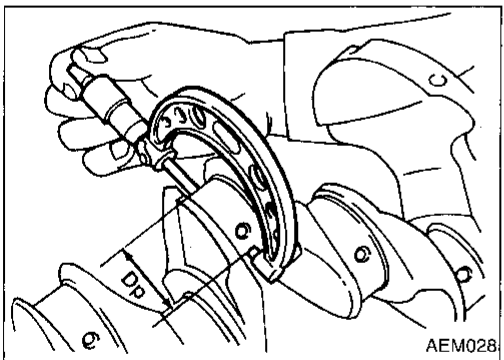
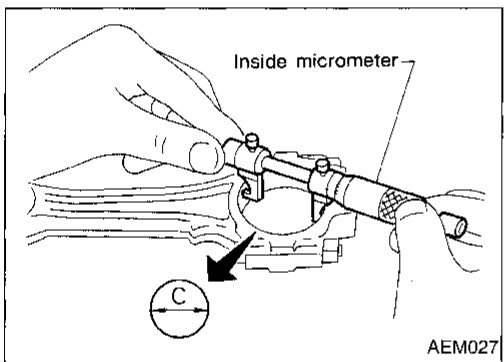
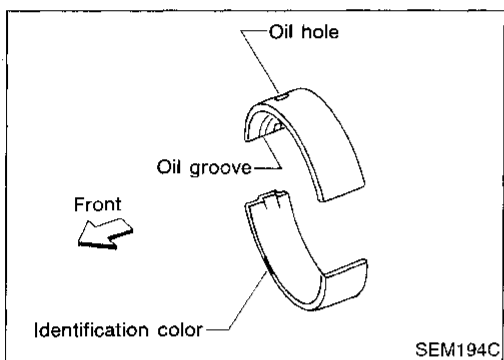
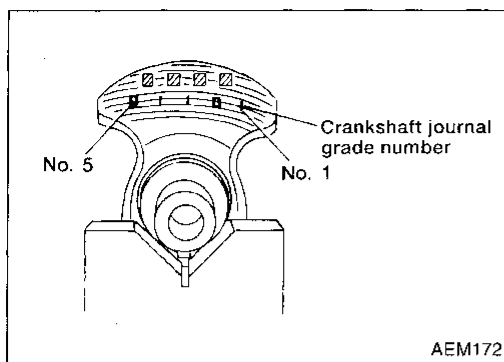

Connecting rod bearing (Big end)

1. Install connecting rod bearing to connecting rod and cap.
2. Install connecting rod cap to connecting rod.

Tighten bolts to the specified torque.

3. Measure inner diameter "C" of each bearing.

4. Measure outer diameter "Dp" of each crankshaft pin journal.
5. Calculate connecting rod bearing clearance.

$$\text{Connecting rod bearing clearance} = C - D_p$$

Standard: 0.010 - 0.035 mm (0.0004 - 0.0014 in)
Limit: 0.1 mm (0.004 in)

If it exceeds the limit, replace bearing.

If clearance cannot be adjusted using any standard bearing grade, grind crankshaft journal and use undersized bearing. Refer to step 5, EM-102.

- If a new bearing, crankshaft or connecting rod is replaced, select connecting rod bearing according to the following table.

Connecting rod bearing grade number:

These numbers are punched in either Arabic or Roman numerals.

Crankshaft pin journal grade number	Connecting rod bearing grade color
0	—
1	Brown
2	Green

Inspection (Cont'd)

Method B (Using Plastigage)

CAUTION:

- Do not turn crankshaft or connecting rod while Plastigage is being inserted.
- When bearing clearance exceeds the specified limit, ensure that the proper bearing has been installed. Then if excessive bearing clearance exists, use a thicker main bearing or undersized bearing so that the specified bearing clearance is obtained.

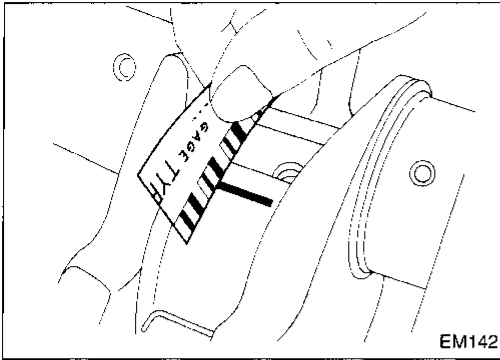

CONNECTING ROD BUSHING CLEARANCE (Small end)

1. Measure inner diameter "C" of bushing.

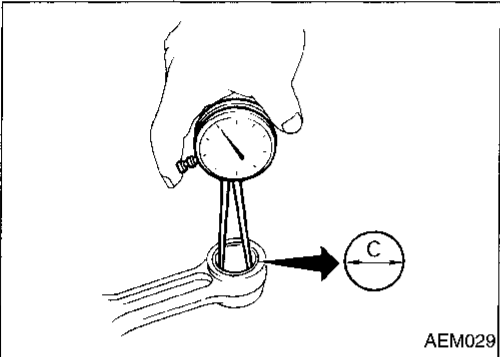

2. Measure outer diameter "Dp" of piston pin.
3. Calculate connecting rod bushing clearance.

$$\text{Connecting rod bushing clearance} = C - D_p$$

Standard:

0.005 - 0.017 mm (0.0002 - 0.0007 in)

Limit:

0.023 mm (0.0009 in)

If it exceeds the limit, replace connecting rod assembly or connecting rod bushing and/or piston pin.

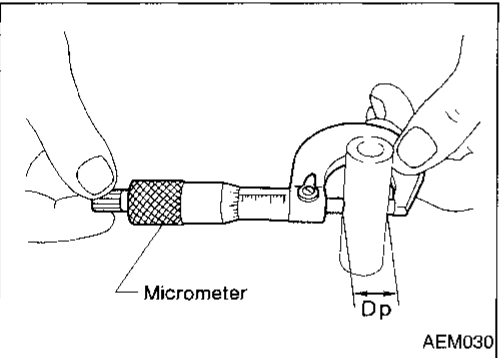

REPLACEMENT OF CONNECTING ROD BUSHING (Small end)

1. Drive in small end bushing until it is flush with end surface of rod.

Be sure to align the oil holes.

2. Ream the bushing so that clearance with piston pin is within specification.

Clearance between connecting rod bushing and piston pin: 0.005 - 0.017 mm (0.0002 - 0.0007 in)

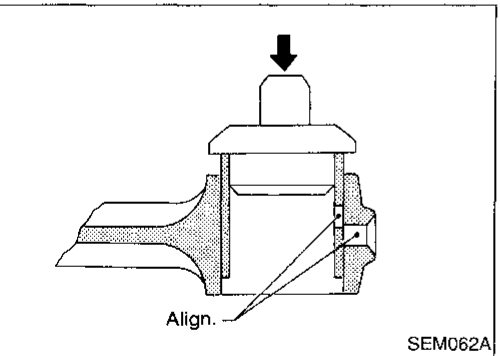

FLYWHEEL/DRIVEPLATE RUNOUT

Runout (Total indicator reading):

Flywheel (M/T models)

Less than 0.15 mm (0.0059 in)

Drive plate (A/T models)*

Less than 0.2 mm (0.008 in)

*Measuring points: Approximately 115 mm (4.53 in) from crankshaft center

CAUTION:

Do not allow any magnetic materials to contact the ring gear teeth and rear plate.

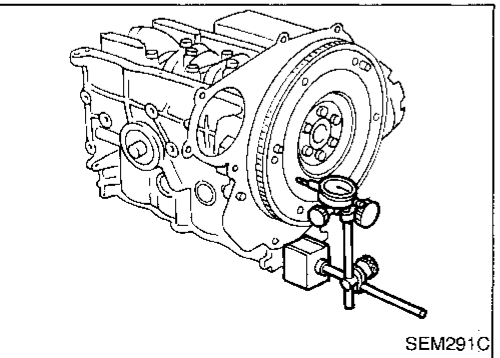

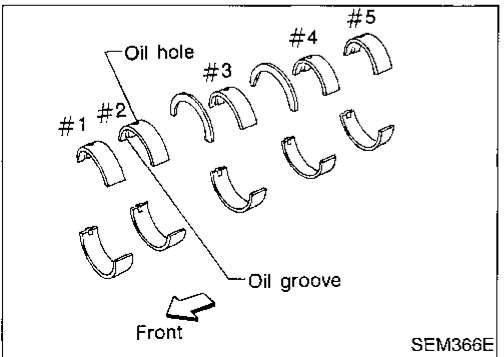
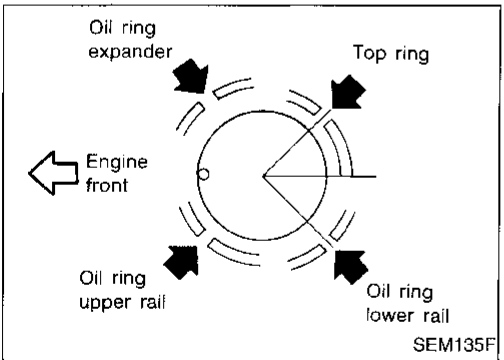
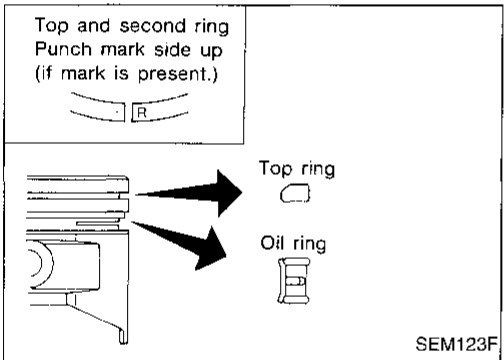
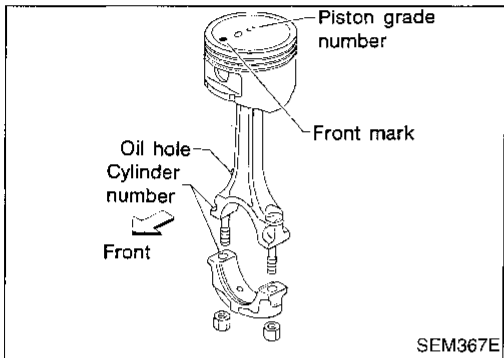
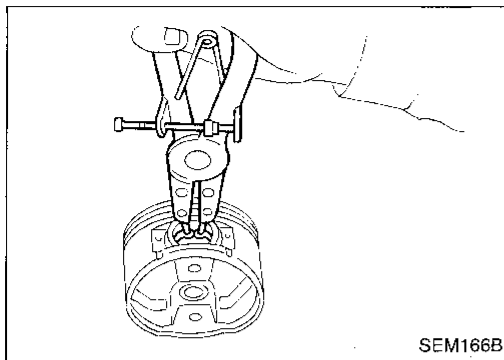

Assembly

PISTON

1. Install new snap ring on one side of piston pin hole.
2. Heat piston to 60 to 70°C (140 to 158°F) and assemble piston, piston pin, connecting rod and new snap ring.
 - Align the direction of piston and connecting rod.
 - Numbers stamped on connecting rod and cap correspond to each cylinder.
 - After assembly, make sure connecting rod swings smoothly.
3. Set piston rings as shown.

CAUTION:

- When piston rings are not replaced, make sure that piston rings are mounted in their original position.
 - When piston rings are being replaced and no punch mark is present, piston rings can be mounted with either side up.
-
- Align piston rings so that end gaps are positioned as shown.

CRANKSHAFT

1. Set main bearings in their proper positions on cylinder block and main bearing cap.
 - Confirm that correct main bearings are used. Refer to EM-101.

GI

MA

EM

LC

EC

FE

CL

MT

AT

FA

RA

BR

ST

RS

BT

HA

EL

IDX

CYLINDER BLOCK Assembly (Cont'd)

GA

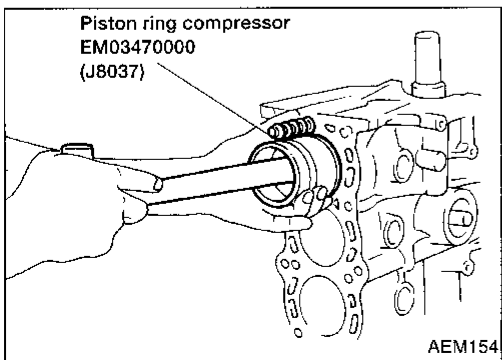
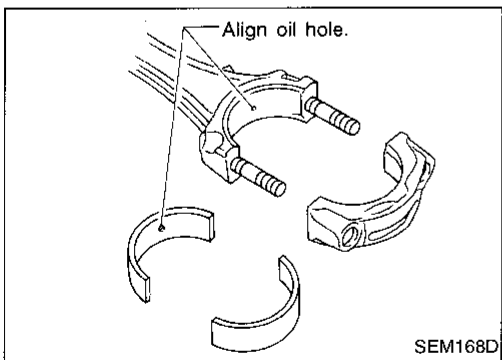
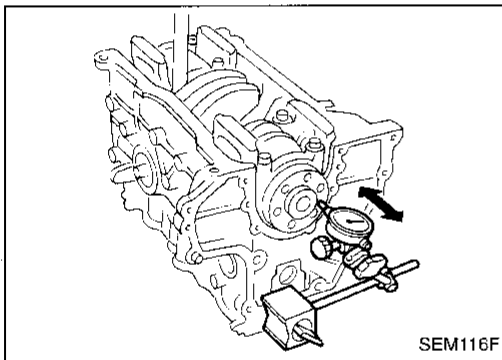
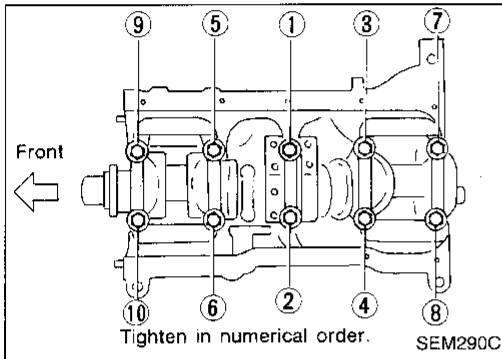
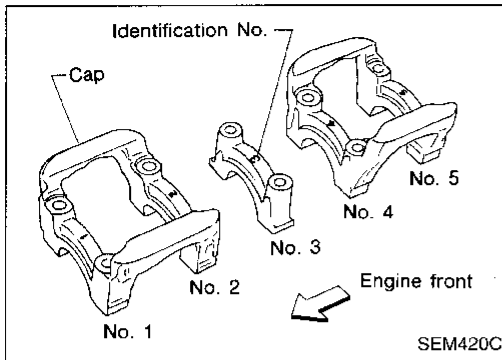

2. Install crankshaft and main bearing caps and tighten bolts to the specified torque.

- Apply new engine oil to the bolt thread and seat surface.
- Prior to tightening bearing cap bolts, place bearing cap in its proper position by shifting crankshaft in the axial direction.
- Tighten bearing cap bolts gradually in two or three stages. Start with center bearing and move outward as shown in figure.
- After securing bearing cap bolts, make sure crankshaft turns smoothly by hand.

3. Measure crankshaft end play.

Crankshaft end play:

Standard

0.060 - 0.180 mm (0.0024 - 0.0071 in)

Limit

0.3 mm (0.012 in)

If beyond the limit, replace thrust bearing with a new one.

4. Install connecting rod bearings in connecting rods and connecting rod caps.

- Confirm that correct bearings are used. Refer to EM-103.
- Install bearings so that oil hole in connecting rod aligns with oil hole of bearing.

5. Install pistons with connecting rods.

a. Install them into corresponding cylinders with Tool.

- Make sure connecting rod does not scratch cylinder wall.
- Make sure connecting rod bolts do not scratch crankshaft pin journals.
- Arrange so that front mark on piston head faces engine front.

Assembly (Cont'd)

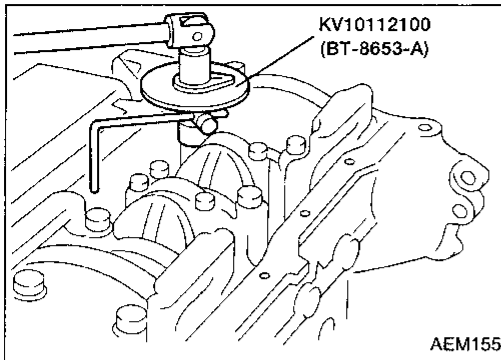

- b. Install connecting rod caps.
Apply new engine oil to bolt threads and nut seating surfaces.
Tighten connecting rod cap nuts in the following procedure:
- 1) Tighten to 13.72 to 15.68 N·m (1.399 to 1.599 kg-m, 10.120 - 11.566 ft-lb).
 - 2) Turn nuts to 35° to 40° degrees clockwise with an angle wrench. If an angle wrench is not available, tighten nuts to 23 to 28 N·m (2.3 to 2.9 kg-m, 17 to 21 ft-lb).

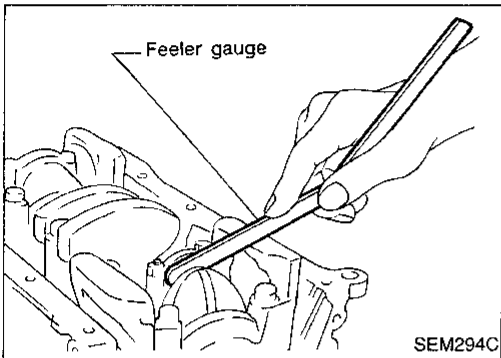

6. Measure connecting rod side clearance.

Connecting rod side clearance:

Standard

0.200 - 0.470 mm (0.0079 - 0.0185 in)

Limit

0.50 mm (0.0197 in)

If beyond the limit, replace connecting rod and/or crankshaft.

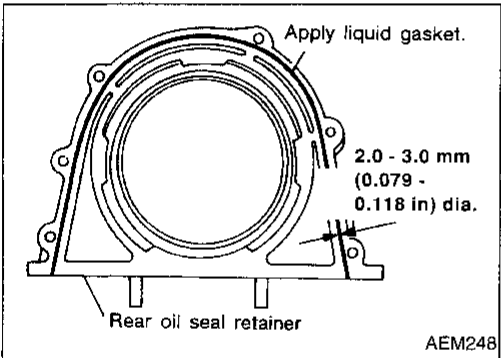

7. Install rear oil seal retainer.

- a. Before installing rear oil seal retainer, remove old liquid gasket from cylinder block and retainer.
 - b. Apply a continuous bead of liquid gasket to rear oil seal retainer.
- Apply around inner side of bolt holes.

GI

MA

EM

LC

EC

FE

CL

WT

AT

FA

RA

BR

ST

RS

BT

HA

EL

DX

General Specifications

Cylinder arrangement	In-line 4	
Displacement	cm ³ (cu in)	1,998 (121.92)
Bore and stroke	mm (in)	86 x 86 (3.39 x 3.39)
Valve arrangement	DOHC	
Firing order	1-3-4-2	
Number of piston rings	-	
Compression	2	
Oil	1	
Number of main bearings	5	
Compression ratio	9.5	

Valve timing

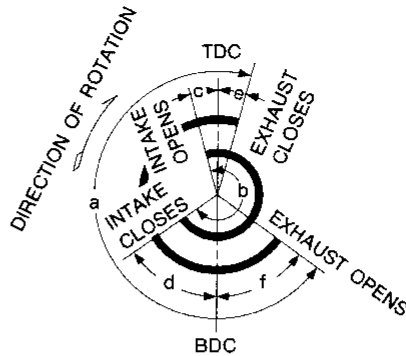

EM120
Unit: degree

a	b	c	d	e	f
240°	232°	5°	47°	3°	57°

Inspection and Adjustment

COMPRESSION PRESSURE

Unit: kPa (kg/cm², psi)/300 rpm

Compression pressure	
Standard	1,226 (12.5, 178)
Minimum	1,030 (10.5, 149)
Differential limit between cylinders	98 (1.0, 14)

CYLINDER HEAD

Unit: mm (in)

	Standard	Limit
Head surface distortion	Less than 0.03 (0.0012)	0.1 (0.004)

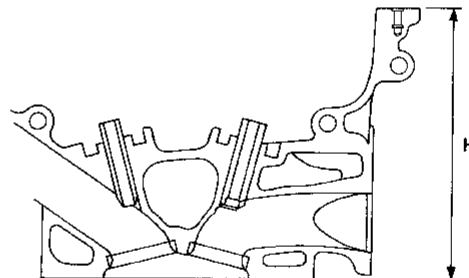

SEM043F

Nominal cylinder head height "H"	136.9 - 137.1 (5.390 - 5.398)
Resurfacing limit	0.2 (0.008)*

*Total amount of cylinder head resurfacing plus cylinder block resurfacing

Inspection and Adjustment (Cont'd)

Hydraulic lash adjuster (HLA)

VALVE

Unit: mm (in)

T (Margin thickness)

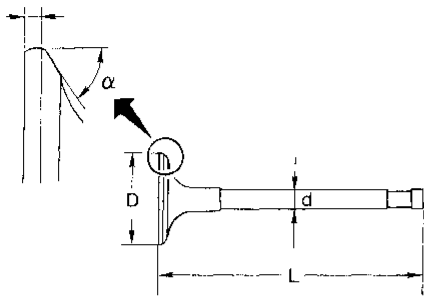

SEM188A

Valve head diameter "D"	
Intake	34.0 - 34.2 (1.339 - 1.346)
Exhaust	30.0 - 30.3 (1.181 - 1.193)
Valve length "L"	
Intake	101.19 - 101.61 (3.9839 - 4.0004)
Exhaust	102.11 - 102.53 (4.0201 - 4.0366)
Valve stem diameter "d"	
Intake	5.965 - 5.980 (0.2348 - 0.2354)
Exhaust	5.945 - 5.960 (0.2341 - 0.2346)
Valve seat angle "α"	
Intake	45°15' - 45°45'
Exhaust	
Valve margin "T"	
Intake	1.1 (0.043)
Exhaust	1.3 (0.051)
Valve margin "T" limit	More than 0.5 (0.020)
Valve stem end surface grinding limit	Less than 0.2 (0.008)

Valve spring

Free height	mm (in)	49.36 (1.9433)
Pressure N (kg, lb) at height mm (in)	Standard	578.02 - 641.57 (58.94 - 65.42, 129.96 - 144.25) at 30.0 (1.181)
	Limit	549.2 (56.0, 123.5) at 30.0 (1.181)
Out-of-square	mm (in)	Less than 2.2 (0.087)

Unit: mm (in)

HLA outer diameter	16.980 - 16.993 (0.6685 - 0.6690)
HLA guide hole diameter	17.000 - 17.020 (0.6693 - 0.6701)
Clearance between HLA and HLA guide hole	0.007 - 0.040 (0.0003 - 0.0016)

Valve guide

Unit: mm (in)

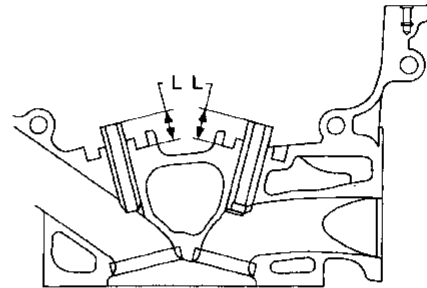

SEM083D

		Standard	Service
Valve guide			
Outer diameter	Intake	10.023 - 10.034 (0.3946 - 0.3950)	10.223 - 10.234 (0.4025 - 0.4029)
	Exhaust	10.023 - 10.034 (0.3946 - 0.3950)	10.223 - 10.234 (0.4025 - 0.4029)
Valve guide Inner diameter (Finished size)	Intake	6.000 - 6.018 (0.2362 - 0.2369)	
	Exhaust	6.000 - 6.018 (0.2362 - 0.2369)	
Cylinder head valve guide hole diameter	Intake	9.975 - 9.996 (0.3927 - 0.3935)	10.175 - 10.196 (0.4006 - 0.4014)
	Exhaust	9.975 - 9.996 (0.3927 - 0.3935)	10.175 - 10.196 (0.4006 - 0.4014)
Interference fit of valve guide		0.027 - 0.059 (0.0011 - 0.0023)	
		Standard	Limit
Stem to guide clearance	Intake	0.020 - 0.053 (0.0008 - 0.0021)	0.08 (0.0031)
	Exhaust	0.040 - 0.073 (0.0016 - 0.0029)	0.1 (0.004)
Valve deflection limit		0.2 (0.008)	
Projection length "L"		14.0 - 14.2 (0.551 - 0.559)	

Inspection and Adjustment (Cont'd)

Valve seat

Unit: mm (in)

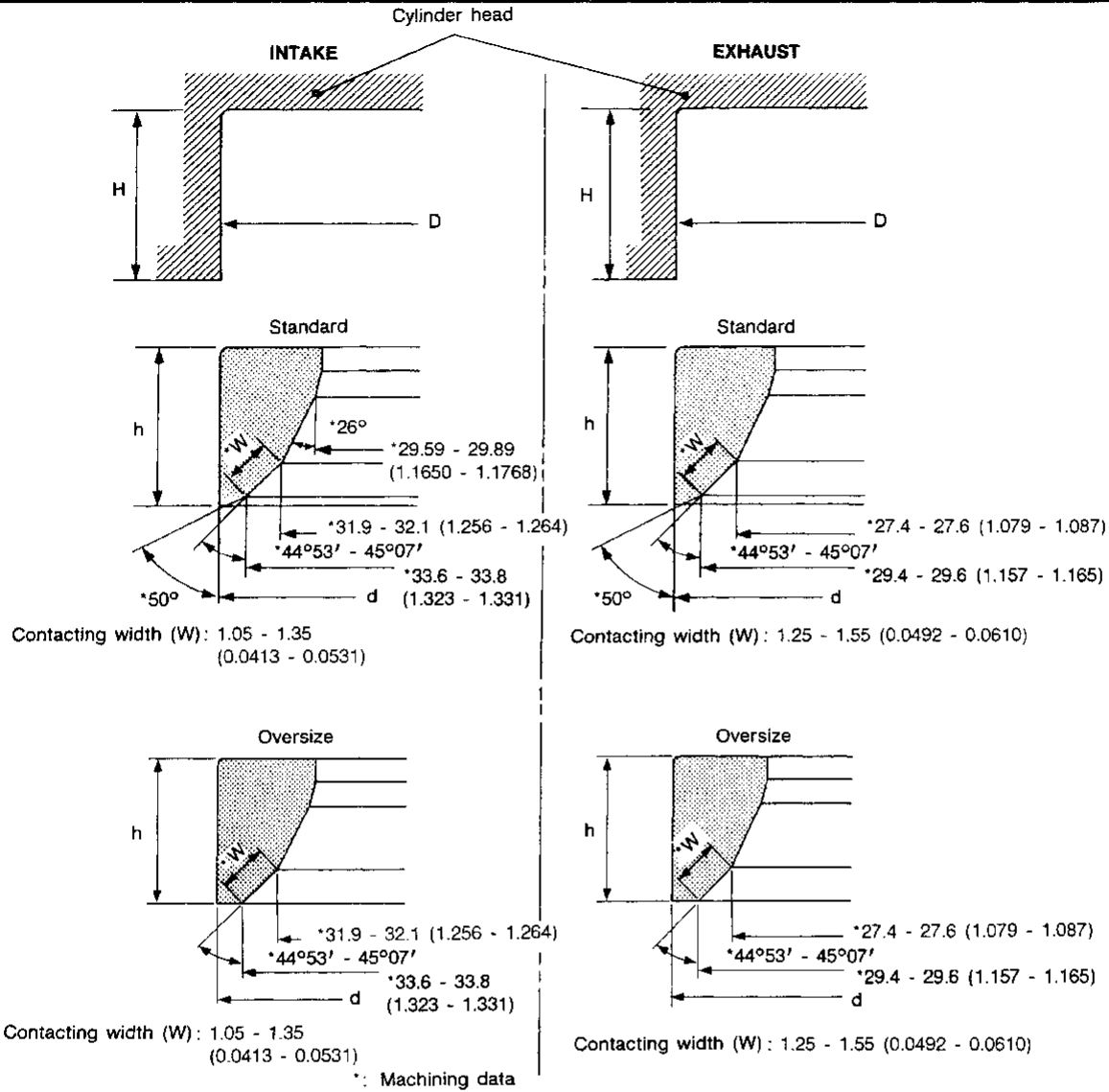

SEM651DB

		Standard	Service
Cylinder head seat recess diameter (D)	In.	35.000 - 35.016 (1.3780 - 1.3786)	35.500 - 35.516 (1.3976 - 1.3983)
	Ex.	31.000 - 31.016 (1.2205 - 1.2211)	31.500 - 31.516 (1.2402 - 1.2408)
Valve seat interference fit	In.	0.064 - 0.096 (0.0025 - 0.0038)	
	Ex.	0.064 - 0.096 (0.0025 - 0.0038)	
Valve seat outer diameter (d)	In.	35.080 - 35.096 (1.3811 - 1.3817)	35.580 - 35.596 (1.4008 - 1.4014)
	Ex.	31.080 - 31.096 (1.2236 - 1.2242)	31.580 - 31.596 (1.2433 - 1.2439)
Depth (H)	In.	6.25 (0.2461)	
	Ex.	6.25 (0.2461)	
Height (h)		6.2 - 6.3 (0.244 - 0.248)	5.4 - 5.5 (0.213 - 0.217)

Inspection and Adjustment (Cont'd)

Valve shim clearance adjustment

Unit: mm (in)

Valve shim clearance (cold)	
Intake & Exhaust	Less than 0.025 (0.001)
Shim thickness "T ₁ "	T ₁ ± 0.025 (0.001)

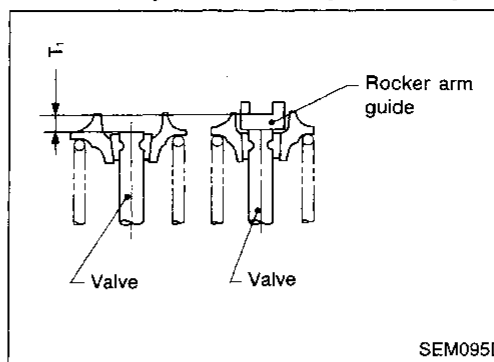

Available shim

Thickness mm (in)	Identification mark
2.800 (0.1102)	28 00
2.825 (0.1112)	28 25
2.850 (0.1122)	28 50
2.875 (0.1132)	28 75
2.900 (0.1142)	29 00
2.925 (0.1152)	29 25
2.950 (0.1161)	29 50
2.975 (0.1171)	29 75
3.000 (0.1181)	30 00
3.025 (0.1191)	30 25
3.050 (0.1201)	30 50
3.075 (0.1211)	30 75
3.100 (0.1220)	31 00
3.125 (0.1230)	31 25
3.150 (0.1240)	31 50
3.175 (0.1250)	31 75
3.200 (0.1260)	32 00

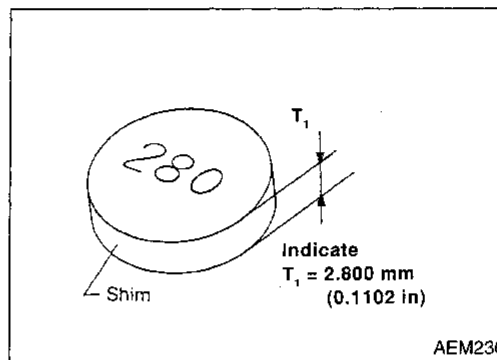

GI

MA

EM

LC

EC

FE

CL

MT

AT

FA

RA

BR

ST

RS

BT

HA

EL

IDX

Inspection and Adjustment (Cont'd)

CAMSHAFT AND CAMSHAFT BEARING

Unit: mm (in)

	Standard	Limit
Camshaft journal to bearing clearance	0.045 - 0.086 (0.0018 - 0.0034)	0.15 (0.0059)
Inner diameter of camshaft bearing	28.000 - 28.021 (1.1024 - 1.1032)	—
Outer diameter of camshaft journal	27.935 - 27.955 (1.0998 - 1.1006)	—
Camshaft runout [TIR*]	Less than 0.02 (0.0008)	0.1 (0.004)
Camshaft sprocket runout [TIR*]	Less than 0.25 (0.0098)	—
Camshaft end play	0.055 - 0.139 (0.0022 - 0.0055)	0.20 (0.0079)

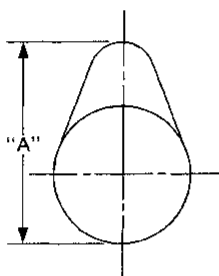

EM671

Cam height "A"

Intake	37.920 - 38.110 (1.4929 - 1.5004)
Exhaust	37.550 - 37.740 (1.4783 - 1.4858)
Wear limit of cam height	0.2 (0.008)
Valve lift	
Intake	8.6 (0.339)
Exhaust	9.2 (0.362)

*Total indicator reading

CYLINDER BLOCK

Unit: mm (in)

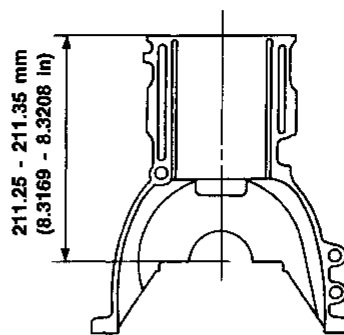

SEM964E

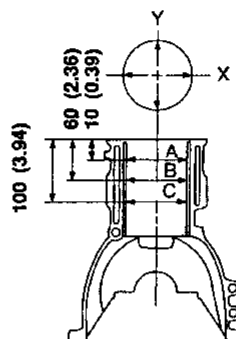

SEM686D

Surface flatness

Standard	Less than 0.03 (0.0012)
Limit	0.1 (0.004)

Cylinder bore

Inner diameter	
Standard	
Grade No. 1	86.000 - 86.010 (3.3858 - 3.3862)
Grade No. 2	86.010 - 86.020 (3.3862 - 3.3866)
Grade No. 3	86.020 - 86.030 (3.3866 - 3.3870)
Wear limit	0.20 (0.0079)

Out-of-round (X - Y) **Less than 0.015 (0.0006)**

Taper (A - B and A - C) **Less than 0.010 (0.0004)**

Difference in inner diameter between cylinders

Limit	Less than 0.05 (0.0020)
-------	-------------------------

Main journal inner diameter

Grade No. 0	58.944 - 58.950 (2.3206 - 2.3209)
Grade No. 1	58.950 - 58.956 (2.3209 - 2.3211)
Grade No. 2	58.956 - 58.962 (2.3211 - 2.3213)
Grade No. 3	58.962 - 58.968 (2.3213 - 2.3216)

Inspection and Adjustment (Cont'd)

PISTON, PISTON RING AND PISTON PIN

Piston ring

Piston

Unit: mm (in)

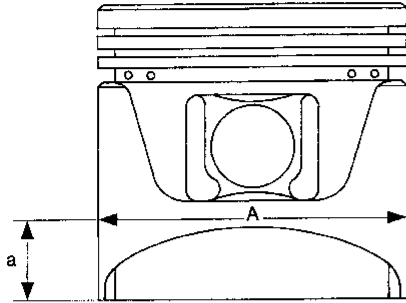

SEM750C

Piston skirt diameter "A"	
Standard	
Grade No. 1	85.980 - 85.990 (3.3850 - 3.3854)
Grade No. 2	85.990 - 86.000 (3.3854 - 3.3858)
Grade No. 3	86.000 - 86.010 (3.3858 - 3.3862)
0.20 (0.0079) over-size (Service)	86.180 - 86.210 (3.3929 - 3.3941)
"a" dimension	14.0 (0.551)
Piston clearance to cylinder block	0.010 - 0.030 (0.0004 - 0.0012)
Piston pin hole diameter	21.987 - 21.999 (0.8656 - 0.8661)

Unit: mm (in)

Side clearance		
Top		
Standard	0.045 - 0.080 (0.0018 - 0.0031)	
Limit	0.2 (0.008)	
2nd		
Standard	0.030 - 0.065 (0.0012 - 0.0026)	
Limit	0.2 (0.008)	
Ring gap		
Top		
Standard	0.20 - 0.30 (0.0079 - 0.0118)	
Limit	1.0 (0.039)	
2nd		
Standard	0.35 - 0.50 (0.0138 - 0.0197)	
Limit	1.0 (0.039)	
Oil		
Standard	0.20 - 0.60 (0.0079 - 0.0236)	
Limit	1.0 (0.039)	

Piston pin

Unit: mm (in)

Piston pin outer diameter	21.989 - 22.001 (0.8657 - 0.8662)
Interference fit of piston pin to piston	0 - 0.004 (0 - 0.0002)
Piston pin to connecting rod bushing clearance	
Standard	0.005 - 0.017 (0.0002 - 0.0007)
Limit	0.023 (0.0009)

* Values measured at ambient temperature of 20°C (68°F)

Inspection and Adjustment (Cont'd)

CONNECTING ROD

Unit: mm (in)

Center distance	136.30 (5.3661)
Bend [per 100 (3.94)]	
Limit	0.15 (0.0059)
Torsion [per 100 (3.94)]	
Limit	0.3 (0.012)
Connecting rod small end inner diameter	24.980 - 25.000 (0.9835 - 0.9843)
Piston pin bushing inner diameter*	22.000 - 22.012 (0.8661 - 0.8666)
Connecting rod big end inner diameter	51.000 - 51.013 (2.0079 - 2.0084)
Side clearance	
Standard	0.20 - 0.35 (0.0079 - 0.0138)
Limit	0.5 (0.020)

*After installing in connecting rod

CRANKSHAFT

Unit: mm (in)

Main journal dia. "Dm"		
Grade No. 0	54.974 - 54.980 (2.1643 - 2.1646)	
Grade No. 1	54.968 - 54.974 (2.1641 - 2.1643)	
Grade No. 2	54.962 - 54.968 (2.1639 - 2.1641)	
Grade No. 3	54.956 - 54.962 (2.1636 - 2.1639)	
Pin journal dia. "Dp"		
Grade No. 0	47.968 - 47.974 (1.8885 - 1.8887)	
Grade No. 1	47.962 - 47.968 (1.8883 - 1.8885)	
Grade No. 2	47.956 - 47.962 (1.8880 - 1.8883)	
Center distance "r"	42.96 - 43.04 (1.6913 - 1.6945)	
Out-of-round (X - Y)		
Standard	Main journal	Less than 0.005 (0.0002)
	Pin journal	Less than 0.0025 (0.0001)
Taper (A - B)		
Standard	Main journal	Less than 0.005 (0.0002)
	Pin journal	Less than 0.0025 (0.0001)
Runout [TIR]		
Standard		Less than 0.025 (0.0010)
Limit		Less than 0.05 (0.0020)
Free end play		
Standard		0.10 - 0.26 (0.0039 - 0.0102)
Limit		0.30 (0.0118)

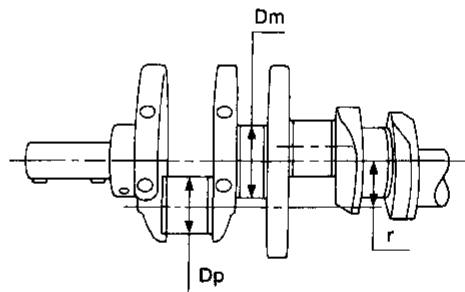

Out-of-round (X - Y)
Taper (A - B)

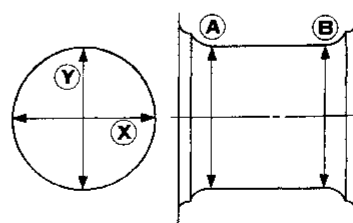

SEM954C

Inspection and Adjustment (Cont'd)

MAIN BEARING

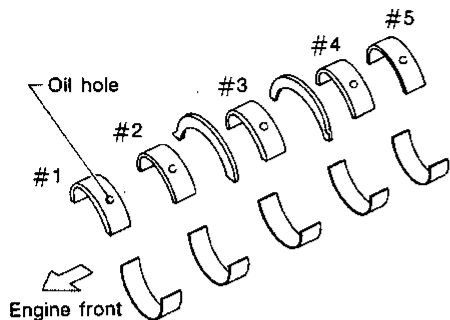

SEM685D

Standard

Unit: mm (in)

Grade number	Thickness "T"	Width "W"	Identification color (mark)
0	1.977 - 1.980 (0.0778 - 0.0780)	18.9 - 19.1 (0.744 - 0.752)	Black (A)
1	1.980 - 1.983 (0.0780 - 0.0781)		Brown (B)
2	1.983 - 1.986 (0.0781 - 0.0782)		Green (C)
3	1.986 - 1.989 (0.0782 - 0.0783)		Yellow (D)
4	1.989 - 1.992 (0.0783 - 0.0784)		Blue (E)
5	1.992 - 1.995 (0.0784 - 0.0785)		Pink (F)
6	1.995 - 1.998 (0.0785 - 0.0787)		No color (G)

Undersize

Unit: mm (in)

Undersize	Thickness "T"	Main journal diameter "Dm"
0.25 (0.0098)	2.109 - 2.117 (0.0830 - 0.0833)	Grind so that bearing clearance is the specified value.

CONNECTING ROD BEARING

Connecting rod bearing

Standard size

Unit: mm (in)

Grade number	Thickness "T"	Width "W"	Identification color (mark)
0	1.500 - 1.503 (0.0591 - 0.0592)	16.9 - 17.1 (0.665 - 0.673)	No color (A)
1	1.503 - 1.506 (0.0592 - 0.0593)		Black (B)
2	1.506 - 1.509 (0.0593 - 0.0594)		Brown (C)

Undersize

Unit: mm (in)

Undersize	Thickness "T"	Crank pin journal diameter "Dp"
0.08 (0.0031)	1.541 - 1.549 (0.0607 - 0.0610)	Grind so that bearing clearance is the specified value.
0.12 (0.0047)	1.561 - 1.569 (0.0615 - 0.0618)	
0.25 (0.0098)	1.626 - 1.634 (0.0640 - 0.0643)	

Bearing clearance

Unit: mm (in)

Main bearing clearance	
Standard	0.004 - 0.022 (0.0002 - 0.0009)
Limit	0.05 (0.0020)
Connecting rod bearing clearance	
Standard	0.020 - 0.045 (0.0008 - 0.0018)
Limit	0.065 (0.00256)

MISCELLANEOUS COMPONENTS

Unit: mm (in)

Camshaft sprocket runout limit [TIR]	0.25 (0.0098)
Flywheel runout limit [TIR]	0.15 (0.0059)
Drive plate runout limit [TIR]	0.2 (0.008)

General Specifications

Engine	GA16DE	
Classification	Gasoline	
Cylinder arrangement	4, in-line	
Displacement	cm ³ (cu in)	1,597 (97.45)
Bore × stroke	mm (in)	76.0 × 88.0 (2.992 × 3.465)
Valve arrangement	DOHC	
Firing order	1-3-4-2	
Number of piston rings		
Compression	1	
Oil	1	
Number of main bearings	5	
Compression ratio	9.9	

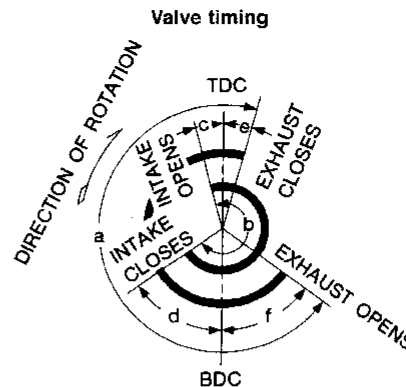

EM120
Unit: degree

a	b	c	d	e	f
222	236	-12	68	0	42

Inspection and Adjustment

COMPRESSION PRESSURE

Unit: kPa (kg/cm², psi)/350 rpm

Standard	1,373 (14.0, 199)
Minimum	1,177 (12.0, 171)
Difference limit between cylinders	98 (1.0, 14)

CYLINDER HEAD

Unit: mm (in)

	Standard	Limit
Head surface flatness	Less than 0.03 (0.0012)	0.1 (0.004)
Height	117.8 - 118.0 (4.638 - 4.646)	—

Valve head diameter "D"	Intake	29.9 - 30.2 (1.177 - 1.189)
	Exhaust	24.9 - 25.2 (0.980 - 0.992)
Valve length "L"	Intake	92.00 - 92.5 (3.6220 - 3.6417)
	Exhaust	92.37 - 92.87 (3.6366 - 3.6563)
Valve stem diameter "d"	Intake	5.465 - 5.480 (0.2152 - 0.2157)
	Exhaust	5.445 - 5.460 (0.2144 - 0.2150)
Valve face angle "α"	45°15' - 45°45'	
Valve margin "T" limit	0.9 - 1.1 (0.035 - 0.043)	
Valve stem end surface grinding limit	0.2 (0.008)	

VALVE

Unit: mm (in)

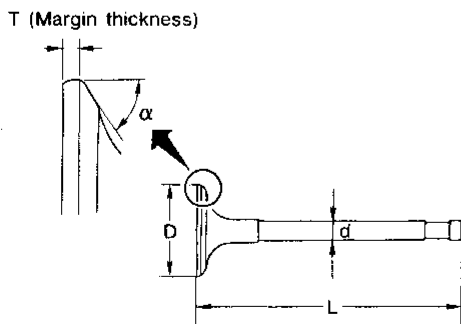

SEM188A

Valve clearance

Unit: mm (in)

	For adjusting		For checking
	Hot	Cold* (reference data)	Hot
Intake	0.32 - 0.40 (0.013 - 0.016)	0.25 - 0.33 (0.010 - 0.013)	0.21 - 0.49 (0.008 - 0.019)
Exhaust	0.37 - 0.45 (0.015 - 0.018)	0.32 - 0.40 (0.013 - 0.016)	0.30 - 0.58 (0.012 - 0.023)

*: At a temperature of approximately 20°C (68°F)

Whenever valve clearances are adjusted to cold specifications, check that the clearances satisfy hot specifications and adjust again if necessary.

Inspection and Adjustment (Cont'd)

Available shims

Thickness mm (in)	Identification mark
2.00 (0.0787)	200
2.02 (0.0795)	202
2.04 (0.0803)	204
2.06 (0.0811)	206
2.08 (0.0819)	208
2.10 (0.0827)	210
2.12 (0.0835)	212
2.14 (0.0843)	214
2.16 (0.0850)	216
2.18 (0.0858)	218
2.20 (0.0866)	220
2.22 (0.0874)	222
2.24 (0.0882)	224
2.26 (0.0890)	226
2.28 (0.0898)	228
2.30 (0.0906)	230
2.32 (0.0913)	232
2.34 (0.0921)	234
2.36 (0.0929)	236
2.38 (0.0937)	238
2.40 (0.0945)	240
2.42 (0.0953)	242
2.44 (0.0961)	244
2.46 (0.0969)	246
2.48 (0.0976)	248
2.50 (0.0984)	250
2.52 (0.0992)	252
2.54 (0.1000)	254
2.56 (0.1008)	256
2.58 (0.1016)	258
2.60 (0.1024)	260
2.62 (0.1031)	262
2.64 (0.1039)	264
2.66 (0.1047)	266
2.68 (0.1055)	268
2.70 (0.1063)	270
2.72 (0.1071)	272
2.74 (0.1079)	274
2.76 (0.1087)	276
2.78 (0.1094)	278
2.80 (0.1102)	280
2.82 (0.1110)	282
2.84 (0.1118)	284

Thickness mm (in)	Identification mark
2.86 (0.1126)	286
2.88 (0.1134)	288
2.90 (0.1142)	290
2.92 (0.1150)	292
2.94 (0.1157)	294
2.96 (0.1165)	296
2.98 (0.1173)	298

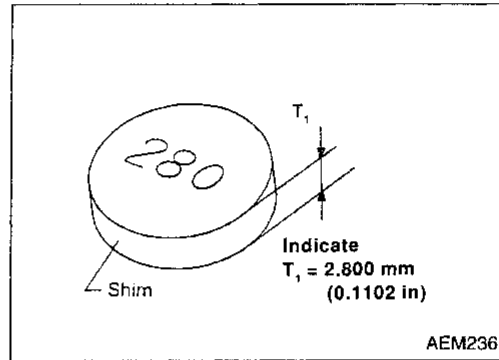

GI

MA

EM

LC

EC

FE

CL

MT

AT

FA

RA

BR

ST

RS

BT

HA

EL

IDX

Inspection and Adjustment (Cont'd)

Valve seat

Unit: mm (in)

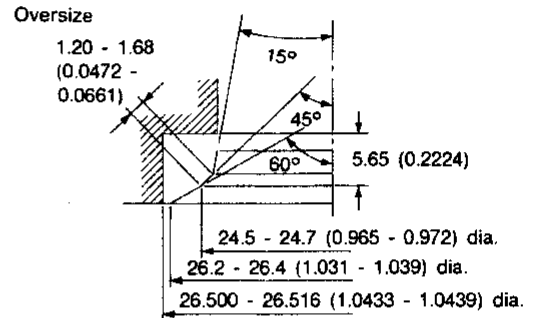
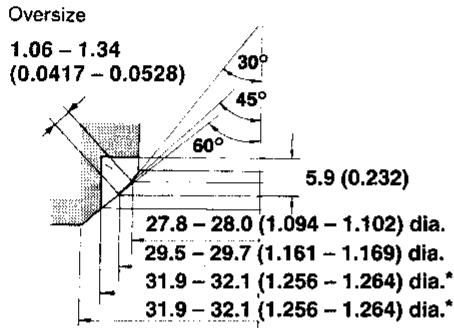
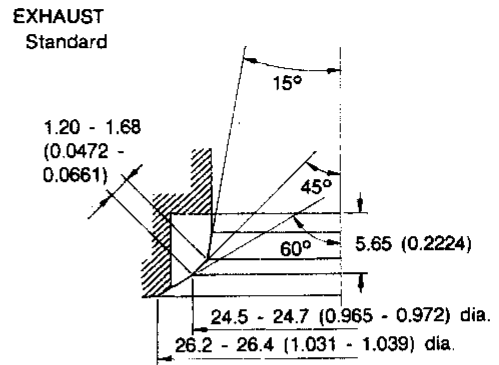
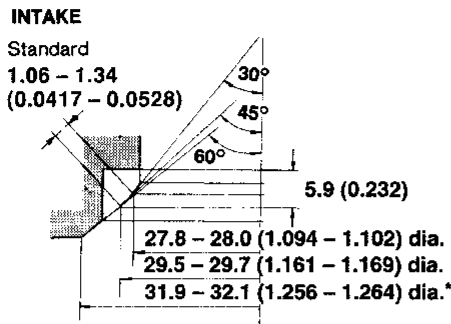

* Cylinder head machining data

AEM233

SEM124F

Valve guide

Unit: mm (in)

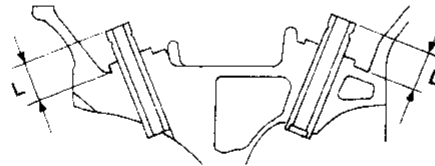

MEM096A

	Intake		Exhaust	
	Standard	Service	Standard	Service
Valve guide				
Outer diameter	9.523 - 9.534 (0.3749 - 0.3754)	9.723 - 9.734 (0.3828 - 0.3832)	9.523 - 9.534 (0.3749 - 0.3754)	9.723 - 9.734 (0.3828 - 0.3832)
Valve guide Inner diameter [Finished size]	5.500 - 5.515 (0.2165 - 0.2171)		5.500 - 5.515 (0.2165 - 0.2171)	
Cylinder head valve guide hole diameter	9.475 - 9.496 (0.3730 - 0.3739)	9.685 - 9.696 (0.3813 - 0.3817)	9.475 - 9.496 (0.3730 - 0.3739)	9.685 - 9.696 (0.3813 - 0.3817)
Interference fit of valve guide	0.027 - 0.059 (0.0011 - 0.0023)	0.027 - 0.049 (0.0011 - 0.0019)	0.027 - 0.059 (0.0011 - 0.0023)	0.027 - 0.049 (0.0011 - 0.0019)
Stem to guide clearance	0.020 - 0.050 (0.0008 - 0.0020)		0.040 - 0.070 (0.0016 - 0.0028)	
Valve deflection limit (Dial gauge reading)	0.2 (0.008)			
Projection length "L"	11.5 - 11.7 (0.453 - 0.461)			

Inspection and Adjustment (Cont'd)

Valve spring

Unit: mm (in)

Free height	mm (in)	41.19 (1.6217)
Pressure N (kg, lb) at height mm (in)	Standard	344.42 (35.12, 77.44) at 25.26 (0.9945)
	Limit	330.41 (33.69, 74.31) at 23.64 (0.9307)
Out-of-square	mm (in)	Less than 1.80 (0.0709)

Valve lifter

Unit: mm (in)

Valve lifter outside diameter	29.960 - 29.975 (1.1795 - 1.1801)
Lifter guide inside diameter	30.000 - 30.021 (1.1811 - 1.1819)
Clearance between lifter and lifter guide	0.025 - 0.061 (0.0010 - 0.0024)

CAMSHAFT AND CAMSHAFT BEARING

Unit: mm (in)

Cam height "A"	Intake	40.610 - 40.800 (1.5988 - 1.6063)
	Exhaust	39.910 - 40.100 (1.5713 - 1.5787)
Cam wear limit		0.20 (0.0079)

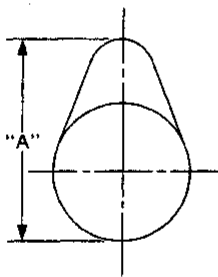

EM671

		Standard	Limit
Camshaft journal to bearing clearance		0.045 - 0.086 (0.0018 - 0.0034)	0.15 (0.0059)
Inner diameter of camshaft bearing	No. 1	28.000 - 28.021 (1.1024 - 1.1032)	—
	No. 2 to No. 5	24.000 - 24.021 (0.9449 - 0.9457)	
Outer diameter of camshaft journal	No. 1	27.935 - 27.955 (1.0998 - 1.1006)	—
	No. 2 to No. 5	23.935 - 23.955 (0.9423 - 0.9431)	
Camshaft runout [TIR*]		Less than 0.02 (0.0008)	0.1 (0.004)
Camshaft end play		0.115 - 0.188 (0.0045 - 0.0074)	0.20 (0.0079)

*: Total indicator reading

CYLINDER BLOCK

Unit: mm (in)

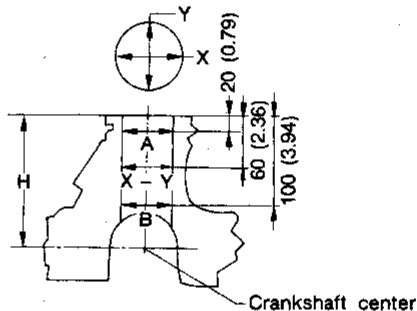

Crankshaft center

		Standard	Limit
Surface flatness		Less than 0.03 (0.0012)	0.1 (0.004)
Height "H" (nominal)		213.95 - 214.05 (8.4232 - 8.4271)	—
Standard			
Inner diameter			0.2 (0.008)
Grade No. 1	76.000 - 76.010 (2.9921 - 2.9925)		
Grade No. 2	76.010 - 76.020 (2.9925 - 2.9929)		
Grade No. 3	76.020 - 76.030 (2.9929 - 2.9933)		
Out-of-round (X - Y)		Less than 0.015 (0.0006)	—
Taper (A - B)		Less than 0.010 (0.0004)	—

Inspection and Adjustment (Cont'd)

PISTON, PISTON RING AND PISTON PIN

Piston

Unit: mm (in)

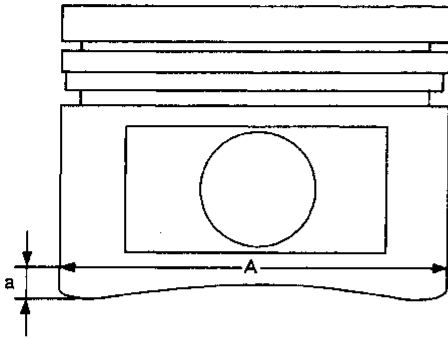

SEM125F

Piston skirt diameter "A"		
Standard		
Grade No. 1	75.975 - 75.985 (2.9911 - 2.9915)	
Grade No. 2	75.985 - 75.995 (2.9915 - 2.9919)	
Grade No. 3	75.995 - 76.005 (2.9919 - 2.9923)	
0.5 (0.020) oversize (service)	76.475 - 76.505 (3.0108 - 3.0120)	
1.0 (0.039) oversize (service)	76.975 - 77.005 (3.0305 - 3.0317)	
"a" dimension	9.9 (0.390)	
Piston pin hole inner diameter	18.987 - 18.999 (0.7475 - 0.7480)	
Piston pin outer diameter	18.989 - 19.001 (0.7476 - 0.7481)	
Piston to bore clearance	0.015 - 0.035 (0.0006 - 0.0014)	

Piston ring

Unit: mm (in)

		Standard	Limit
Side clearance	Top	0.040 - 0.080 (0.0016 - 0.0031)	0.1 (0.004)
	Oil	0.20 - 0.40 (0.0079 - 0.0157)	0.49 (0.0193)
End gap	Top	0.20 - 0.40 (0.0079 - 0.0157)	0.49 (0.0193)
	Oil	0.20 - 0.60 (0.0079 - 0.0236)	0.69 (0.0272)

Piston pin

Unit: mm (in)

Piston pin outer diameter	18.989 - 19.001 (0.7476 - 0.7481)
Piston pin to piston clearance	- 0.004 to 0 (- 0.0002 to 0)
Piston pin to connecting rod, bushing clearance	0.005 - 0.017 (0.0002 - 0.0007)

CONNECTING ROD

Unit: mm (in)

Center distance	140.45 - 140.55 (5.5295 - 5.5335)	
Bend limit [per 100 (3.94)]	0.15 (0.0059)	
Torsion limit [per 100 (3.94)]	0.3 (0.012)	
Connecting rod bushing inner diameter* (small end)	19.000 - 19.012 (0.7480 - 0.7485)	
Connecting rod big end inner diameter	43.000 - 43.013 (1.6929 - 1.6934)	
Side clearance	Standard	0.20 - 0.47 (0.0079 - 0.0185)
	Limit	0.50 (0.0197)

*: After installing in connecting rod

CRANKSHAFT

Unit: mm (in)

Main journal dia. "Dm"		
Grade No. 0	49.956 - 49.964 (1.9668 - 1.9671)	
Grade No. 1	49.948 - 49.956 (1.9665 - 1.9668)	
Grade No. 2	49.940 - 49.948 (1.9661 - 1.9665)	
Pin journal dia. "Dp"		
Grade No. 0	39.968 - 39.974 (1.5735 - 1.5738)	
Grade No. 1	39.962 - 39.968 (1.5733 - 1.5735)	
Grade No. 2	39.956 - 39.962 (1.5731 - 1.5733)	
Center distance "r"	43.95 - 44.05 (1.7303 - 1.7342)	
Out-of-round (X - Y)		
Standard	Less than 0.005 (0.0002)	
Taper (A - B)		
Standard	Less than 0.005 (0.0002)	
Runout [TIR*]		
Standard	Less than 0.05 (0.0020)	
Free end play		
Standard	0.060 - 0.180 (0.0024 - 0.0071)	
Limit	0.3 (0.012)	

*: Total indicator reading

Inspection and Adjustment (Cont'd)

MAIN BEARING

Undersize

Standard

Unit: mm (in)

Grade No.	Thickness "T" mm (in)	Identification color
0	1.827 - 1.831 (0.0719 - 0.0721)	Black
1	1.831 - 1.835 (0.0721 - 0.0722)	Brown
2	1.835 - 1.839 (0.0722 - 0.0724)	Green
3	1.839 - 1.843 (0.0724 - 0.0726)	Yellow
4	1.843 - 1.847 (0.0726 - 0.0727)	Blue

Thickness "T"	
0.25 (0.0098)	1.960 - 1.964 (0.0772 - 0.0773)
0.50 (0.0197)	2.085 - 2.089 (0.0821 - 0.0822)

GI

MA

EM

LC

EC

FE

CONNECTING ROD BEARING

Connecting rod bearing

Unit: mm (in)

	Grade No.	Thickness	Identification color or number
Standard	0	1.505 - 1.508 (0.0593 - 0.0594)	--
	1	1.508 - 1.511 (0.0594 - 0.0595)	Brown
	2	1.511 - 1.514 (0.0595 - 0.0596)	Green
Undersize	0.08 (0.0031)	1.542 - 1.546 (0.0607 - 0.0609)	8
	0.12 (0.0047)	1.562 - 1.566 (0.0615 - 0.0617)	12
	0.25 (0.0098)	1.627 - 1.631 (0.0641 - 0.0642)	25

CL

MT

AT

FA

RA

Bearing clearance

Unit: mm (in)

Main bearing clearance	
Standard	0.018 - 0.042 (0.0007 - 0.0017)
Limit	0.1 (0.004)
Connecting rod bearing clearance	
Standard	0.010 - 0.035 (0.0004 - 0.0014)
Limit	0.1 (0.004)

MISCELLANEOUS COMPONENTS

Unit: mm (in)

Flywheel Runout [TIR*]	Less than 0.15 (0.0059)
Drive plate Runout [TIR*]	Less than 0.2 (0.008)
Camshaft sprocket Runout [TIR*]	Less than 0.15 (0.0059)

*: Total indicator reading

BR

ST

RS

BT

HA

EL

IDX