

SECTION **EL**

CONTENTS

PRECAUTIONS	2	Steering Switch/Check	42
Supplemental Restraint System (SRS) "AIR BAG"	2	HEADLAMP	43
HARNES CONNECTOR	3	System Description (For USA)	43
Description	3	Wiring Diagram (For USA) –H/LAMP–	44
STANDARDIZED RELAY	4	Trouble Diagnoses (For USA)	45
Description	4	System Description (For Canada)	46
POWER SUPPLY ROUTING	6	Operation (Daytime light system for Canada)	47
Schematic	6	Schematic (For Canada)	48
Wiring Diagram –POWER–	7	Wiring Diagram (For Canada) –DTRL–	49
Fuse	16	Trouble Diagnoses (For Canada)	52
Fusible Link	16	Bulb Replacement	54
Circuit Breaker	16	Aiming Adjustment	54
BATTERY	17	EXTERIOR LAMP	55
How to Handle Battery	17	Back-up Lamp/Wiring Diagram –BACK/L–	55
Methods of Preventing Discharge	17	License, Tail and Stop Lamps/Wiring Diagram –TAIL/L–	56
Checking Electrolyte Level	17	Front Fog Lamp/System Description	58
Specific Gravity Check	18	Front Fog Lamp/Wiring Diagram –F/FOG–	59
Charging The Battery	19	Turn Signal and Hazard Warning Lamps/System Description	60
Voltage chart	20	Turn Signal and Hazard Warning Lamps/Wiring Diagram –TURN–	62
Service Data and Specifications (SDS)	20	Turn Signal and Hazard Warning Lamps/Trouble Diagnoses	64
STARTING SYSTEM	21	Combination Flasher Unit Check	65
System Description	21	Bulb Specifications	65
Wiring Diagram –START–	24	INTERIOR LAMP	66
Starter	28	Illumination/System Description	66
Pinion/Clutch Check	32	Illumination/Wiring Diagram –ILL–	68
Service Data and Specifications (SDS)	32	Interior and Trunk Room Lamps/System Description	70
CHARGING SYSTEM	33	Interior and Trunk Room Lamps/Wiring Diagram –INT/L–	72
System Description	33	METERS AND GAUGES/WITH TACHOMETER	74
Wiring Diagram –CHARGE–	34	System Description	74
Trouble Diagnoses	35	Combination Meter	75
Generator	36	Speedometer, Tachometer, Temp. and Fuel Gauges/Wiring Diagram –METER–	76
Diode Check	37		
Disassembly and Assembly	38		
Service Data and Specifications (SDS)	39		
COMBINATION SWITCH	40		
Combination Switch/Check	40		
Combination Switch/Replacement	41		

CONTENTS (Cont'd.)

Inspection/Fuel Gauge and Water Temperature Gauge	77	Wiring Diagram –D/LOCK–.....	129
Inspection/Tachometer	78	Trouble Diagnoses	132
Inspection/Speedometer and Vehicle Speed Sensor.....	79	Main Power Supply And Ground Circuit Check.....	132
METERS AND GAUGES/WITHOUT TACHOMETER	80	Electrical Components Inspection	132
System Description	80	Diagnostic Procedure	133
Combination Meter.....	81	DOOR MIRROR	135
Speedometer, Temp. and Fuel Gauges/Wiring Diagram –METER–.....	82	Wiring Diagram –MIRROR–	135
Inspection/Fuel Gauge and Water Temperature Gauge	83	SUNROOF	136
Inspection/Speedometer and Vehicle Speed Sensor.....	84	System Description	136
METERS AND GAUGES	85	Wiring Diagram –SROOF–	137
Fuel Tank Gauge Unit Check	85	HORN AND LIGHTER	138
Fuel Warning Lamp Sensor Check.....	85	REAR WINDOW DEFOGGER	139
Thermal Transmitter Check	85	System Description	139
Oil Pressure Switch Check	86	Wiring Diagram –DEF–.....	140
Vehicle Speed Sensor Signal Check.....	86	Trouble Diagnoses	142
WARNING LAMPS AND CHIME	87	Diagnostic Procedure	142
Warning Lamps/System Description.....	87	Electrical Components Inspection	144
Warning Lamps/Schematic	88	Filament Check	144
Warning Lamps/Wiring Diagram –WARN–.....	90	Filament Repair.....	145
Warning Chime/System Description	96	AUDIO	147
Warning Chime/Wiring Diagram –CHIME–.....	98	System Description	147
Warning Chime/Trouble Diagnoses	100	Schematic	148
Symptom Chart.....	100	Wiring Diagram –AUDIO–.....	149
Preliminary Check	101	Trouble Diagnoses	150
Main Power Supply And Ground Circuit Check.....	103	MULTI-REMOTE CONTROL SYSTEM	152
Diagnostic Procedures	104	System Description	152
Diode Check	109	Wiring Diagram –MULTI–	154
Warning Chime Check.....	109	Schematic	158
WIPER AND WASHER	110	Input/Output Operation Signal	159
System Description	110	Smart Entrance Control Unit	159
Wiring Diagram –WIPER–	112	Trouble Diagnoses	160
Trouble Diagnoses	115	Trouble Symptom	160
Diagnostic Procedures	115	Diagnostic Procedures	161
Wiper Installation and Adjustment	117	Replacing Remote Controller or Control Unit.....	166
Washer Nozzle Adjustment.....	118	AUTOMATIC SPEED CONTROL DEVICE (ASCD)	167
POWER WINDOW	119	System Description	167
System Description	119	Component Parts and Harness Connector Location.....	169
Component Layout.....	122	Schematic	170
Wiring Diagram –WINDOW–	124	Wiring Diagram –ASCD–	171
Trouble Diagnoses	126	Trouble Diagnoses	178
POWER DOOR LOCK	127	Symptom Chart.....	178
System Description	127	Diagnostic Procedures	179
Schematic	128	ASCD Wire Adjustment	186
		Electrical Components Inspection	187
		ASCD actuator/ASCD pump	187
		ASCD main switch	188
		ASCD steering switch	188

CONTENTS (Cont'd.)

<p>ASCD cancel switch and stop lamp switch..... 188</p> <p>ASCD clutch pedal position switch (For M/T models) 188</p> <p>Inhibitor switch (For A/T models) 188</p> <p>Vehicle speed sensor 189</p> <p>THEFT WARNING SYSTEM 190</p> <p> System Description 190</p> <p> Component Parts and Harness Connector Location..... 193</p> <p> Schematic 194</p> <p> Wiring Diagram –THEFT– 195</p> <p> Trouble Diagnoses 204</p> <p> System Operation Check 204</p> <p> Power Supply And Ground Circuit Check 207</p> <p> Diagnostic Procedures 208</p> <p> Electrical Components Inspection 220</p> <p>LOCATION OF ELECTRICAL UNITS 223</p> <p> Engine Compartment 223</p> <p> Passenger Compartment 224</p> <p>HARNESS LAYOUT 225</p> <p> How To Read Harness Layout..... 225</p> <p> Outline 226</p> <p> 2-Door 226</p> <p> 4-Door 226</p> <p> Engine Room Harness..... 227</p> <p> Passenger Compartment..... 227</p> <p> Engine Compartment..... 228</p> <p> Main Harness 230</p> <p> Body Harness 232</p> <p> 2-Door 232</p> <p> 4-Door 233</p> <p> Engine Control Harness..... 234</p> <p> GA Engine 234</p>	<p>SR Engine 235</p> <p>Engine Harness No. 2 and Generator Harness . 236</p> <p>GA Engine 236</p> <p>SR Engine 237</p> <p>Room Lamp Harness..... 238</p> <p> 2-Door..... 238</p> <p> 4-Door..... 238</p> <p>Air Bag Harness..... 239</p> <p>Tail Harness 240</p> <p> 2-Door..... 240</p> <p> 4-Door..... 240</p> <p>Front Door Harness (2-Door)..... 241</p> <p> Left..... 241</p> <p> Right 241</p> <p>Front Door Harness (4-Door)..... 242</p> <p> Left..... 242</p> <p> Right 242</p> <p>Rear Door Harness (4-Door) 243</p> <p> Left..... 243</p> <p> Right 243</p> <p>SUPER MULTIPLE JUNCTION (SMJ)... Foldout page</p> <p> Installation..... Foldout page</p> <p> Terminal Arrangement..... Foldout page</p> <p>JOINT CONNECTOR (J/C) Foldout page</p> <p> Location..... Foldout page</p> <p> Terminal Arrangement..... Foldout page</p> <p>HYBRID ELECTRIC CONTROL UNIT (HEC)..... Foldout page</p> <p> Construction and Terminal Arrangement Foldout page</p> <p>FUSE BLOCK/FUSIBLE LINK AND FUSE BOX Foldout page</p> <p> Fuse Arrangement Foldout page</p> <p>CONTROL UNITS..... Foldout page</p>
--	---

When you read wiring diagrams:

- Read GI section, "HOW TO READ WIRING DIAGRAMS".

When you perform trouble diagnoses, read GI section, "HOW TO FOLLOW FLOW CHART IN TROUBLE DIAGNOSES" and "HOW TO PERFORM EFFICIENT DIAGNOSIS FOR AN ELECTRICAL INCIDENT".

WIRING DIAGRAM REFERENCE CHART

ECCS (Ignition system).....	EC SECTION
AUTOMATIC TRANSAXLE CONTROL SYSTEM, SHIFT LOCK SYSTEM.....	AT SECTION
ABS.....	BR SECTION
HEATER AND AIR CONDITIONING	HA SECTION

PRECAUTIONS

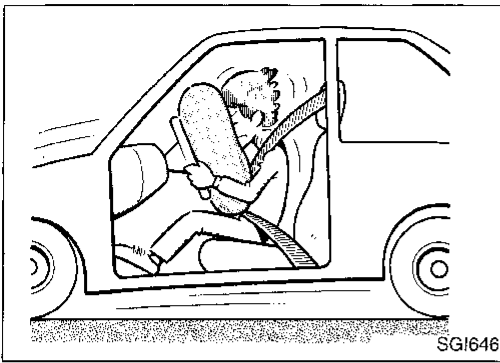

Supplemental Restraint System (SRS) "AIR BAG"

The Supplemental Restraint System "Air Bag", used along with a seat belt, helps to reduce the risk or severity of injury to the driver and front passenger in a frontal collision. The Supplemental Restraint System consists of air bag modules (located in the center of the steering wheel and on the instrument panel on the passenger side), a diagnosis sensor unit, warning lamp, wiring harness and spiral cable. Information necessary to service the system safely is included in the **RS section** of this Service Manual.

WARNING:

- To avoid rendering the SRS inoperative, which could increase the risk of personal injury or death in the event of a collision which would result in air bag inflation, all maintenance must be performed by an authorized NISSAN dealer.
- Improper maintenance, including incorrect removal and installation of the SRS, can lead to personal injury caused by unintentional activation of the system.
- All SRS electrical wiring harnesses and connectors are covered with yellow outer insulation. Do not use electrical test equipment on any circuit related to the SRS.

HARNESS CONNECTOR

Description

HARNESS CONNECTOR

- All harness connectors have been designed to prevent accidental looseness or disconnection.
- The connector can be disconnected by pushing or lifting the locking section.

CAUTION:

Do not pull the harness when disconnecting the connector.

[Example]

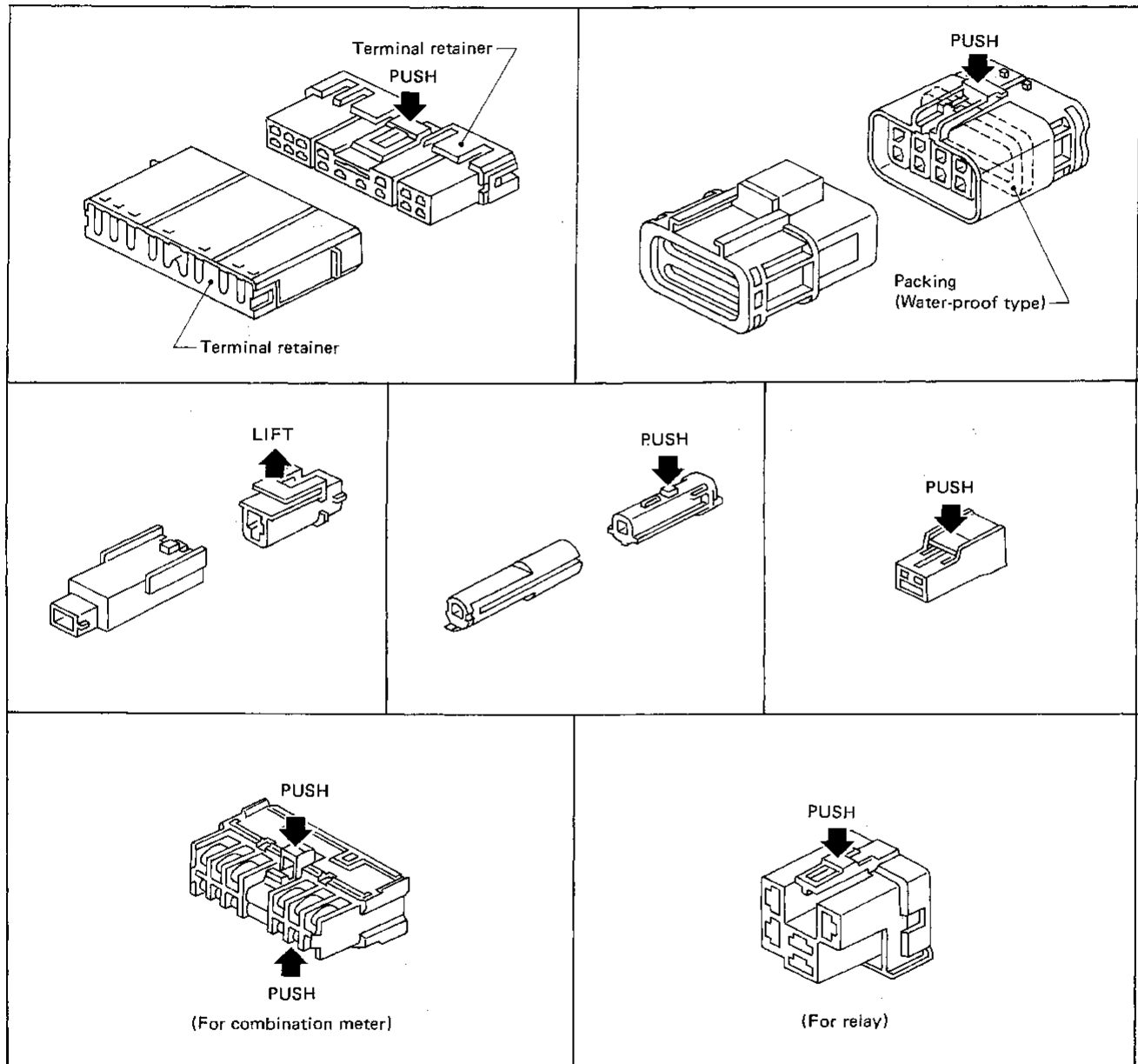

GI
MA
EM
LC
EC
FE
CL
MT
AT
FA
RA
BR
ST
RS
BT
HA
EL
IDX

SEL769D

STANDARDIZED RELAY

Description

NORMAL OPEN, NORMAL CLOSED AND MIXED TYPE RELAYS

Relays can mainly be divided into three types: normal open, normal closed and mixed type relays.

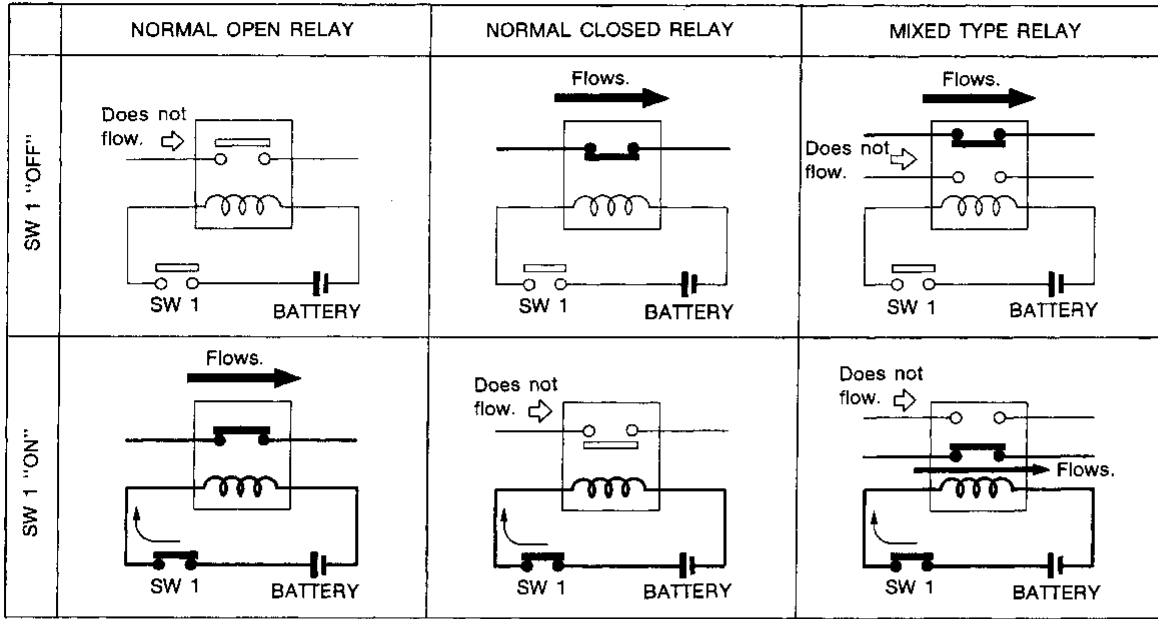

SEL881H

TYPE OF STANDARDIZED RELAYS

1M 1 Make 2M 2 Make
 1T 1 Transfer 1M-1B 1 Make 1 Break

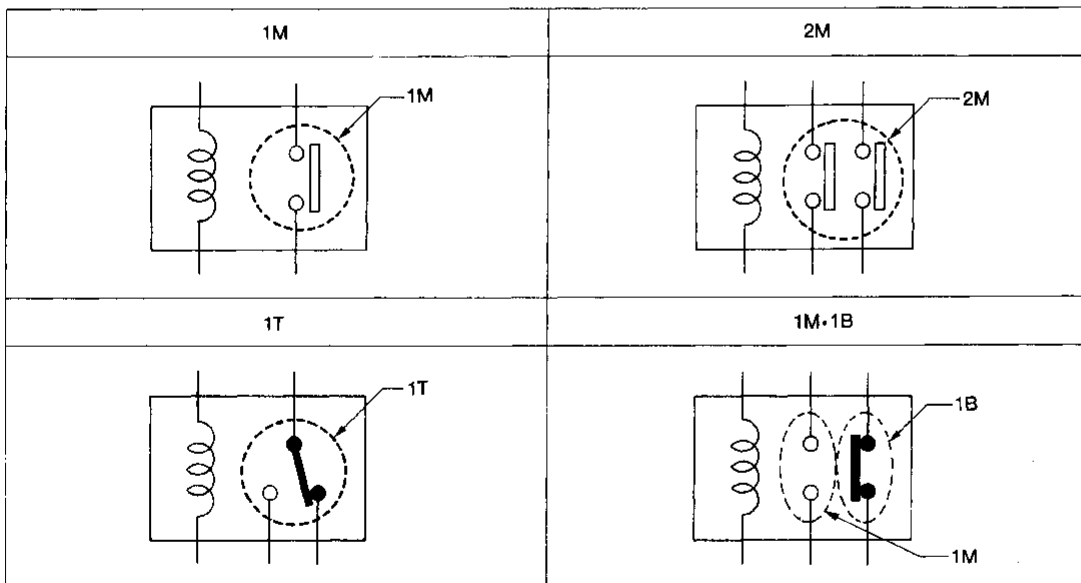

SEL882H

STANDARDIZED RELAY

Description (Cont'd)

GI

MA

EM

LC

EC

FE

CL

MT

AT

FA

RA

BR

ST

RS

BT

HA

EL

IDX

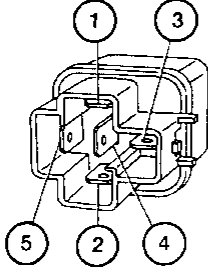
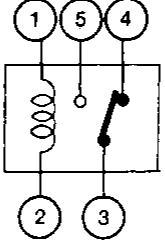
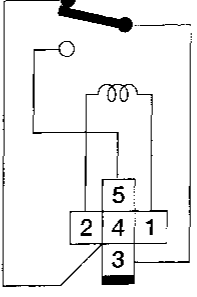
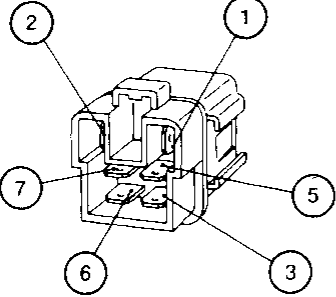
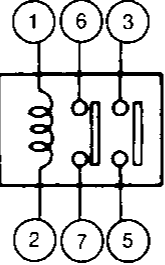
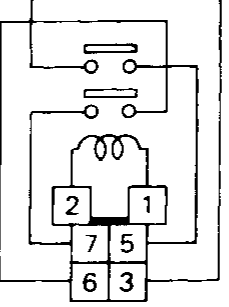
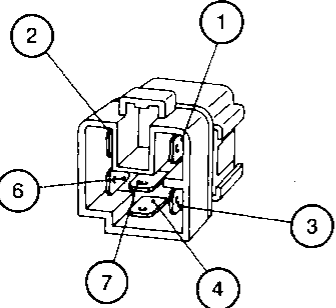
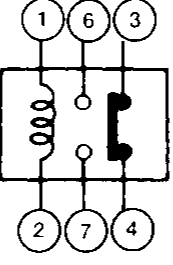
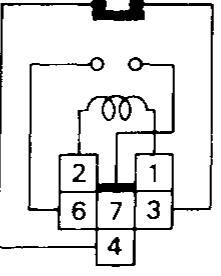
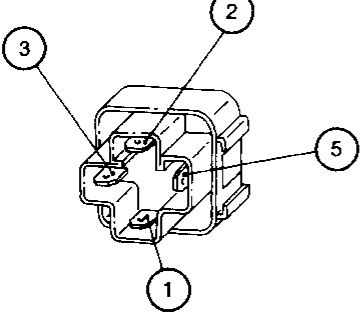
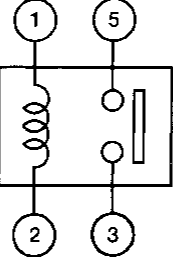
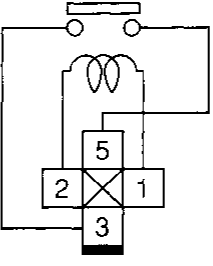
Type	Outer view	Circuit	Connector symbol and connection	Case color
1T				BLACK
2M				BROWN
1M-1B				GRAY
1M				BLUE

POWER SUPPLY ROUTING

Schematic

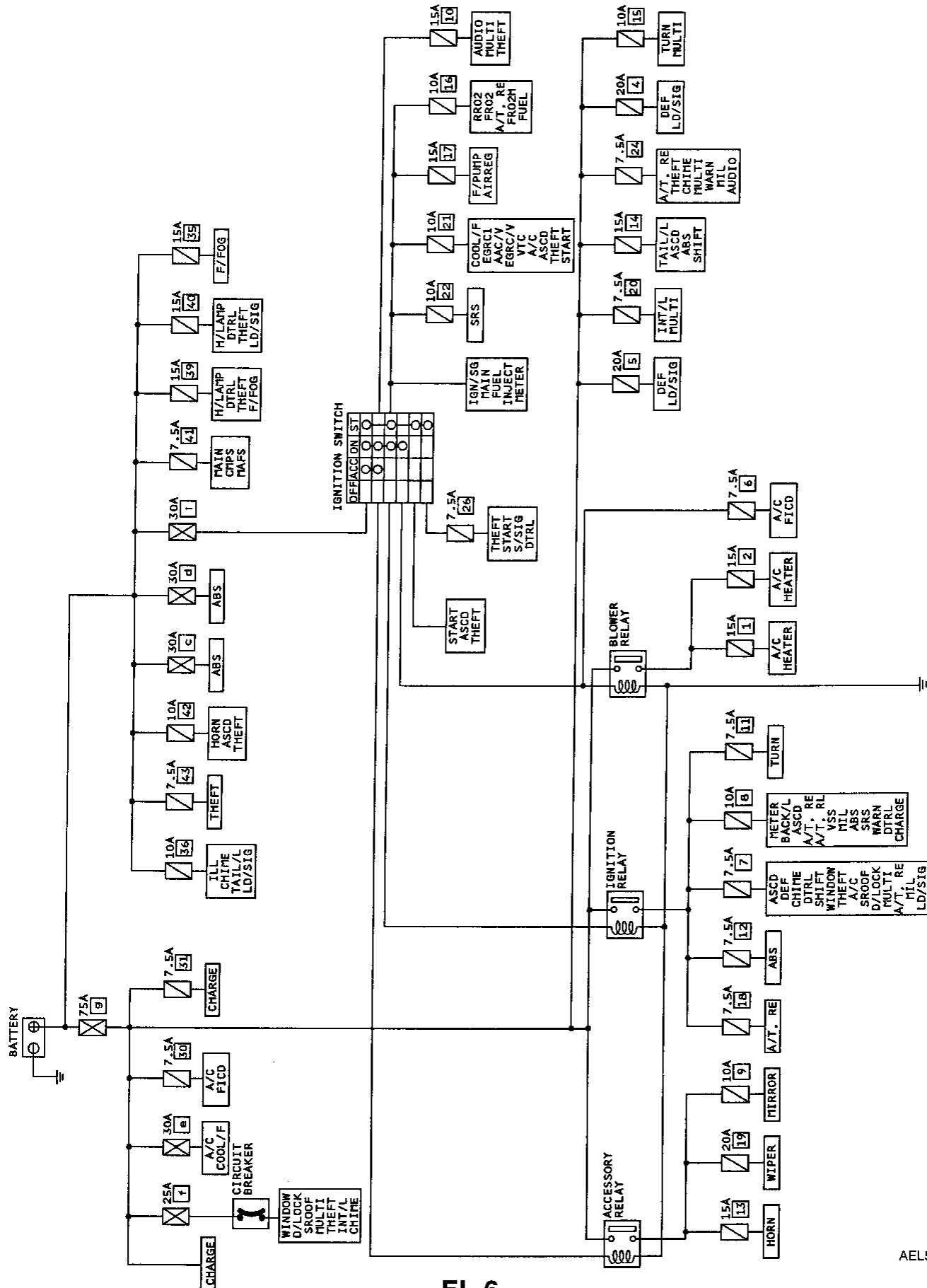

EL-6

AEL588

POWER SUPPLY ROUTING

Wiring Diagram -POWER-

EL-POWER-01

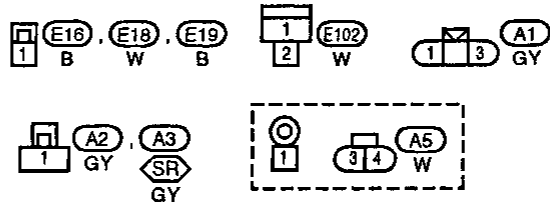
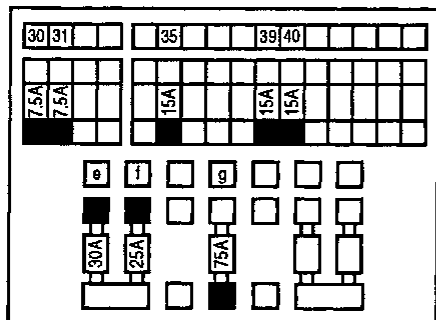
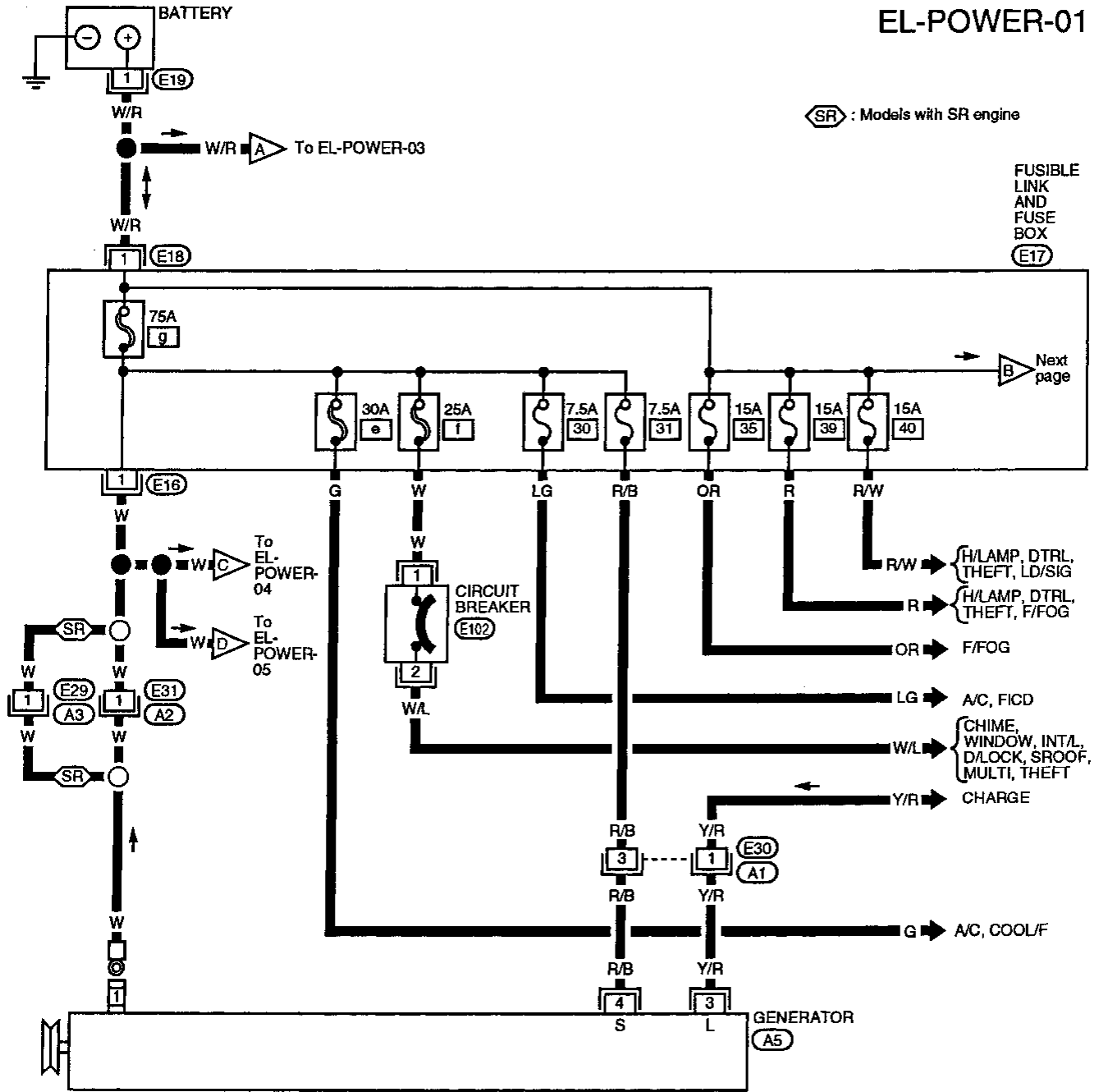

GI
NA
EM
LC
EC
FE
CL
MT
AT
FA
RA
BR
ST
RS
BT
HA
EL
IDX

POWER SUPPLY ROUTING

Wiring Diagram -POWER- (Cont'd)

EL-POWER-02

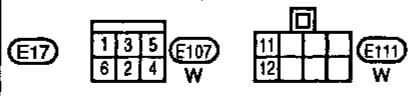
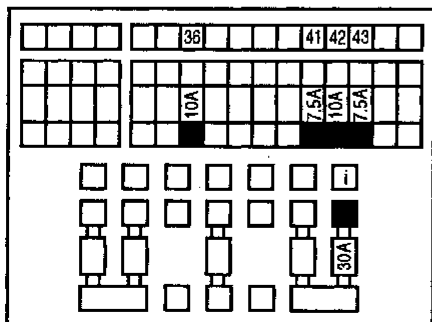
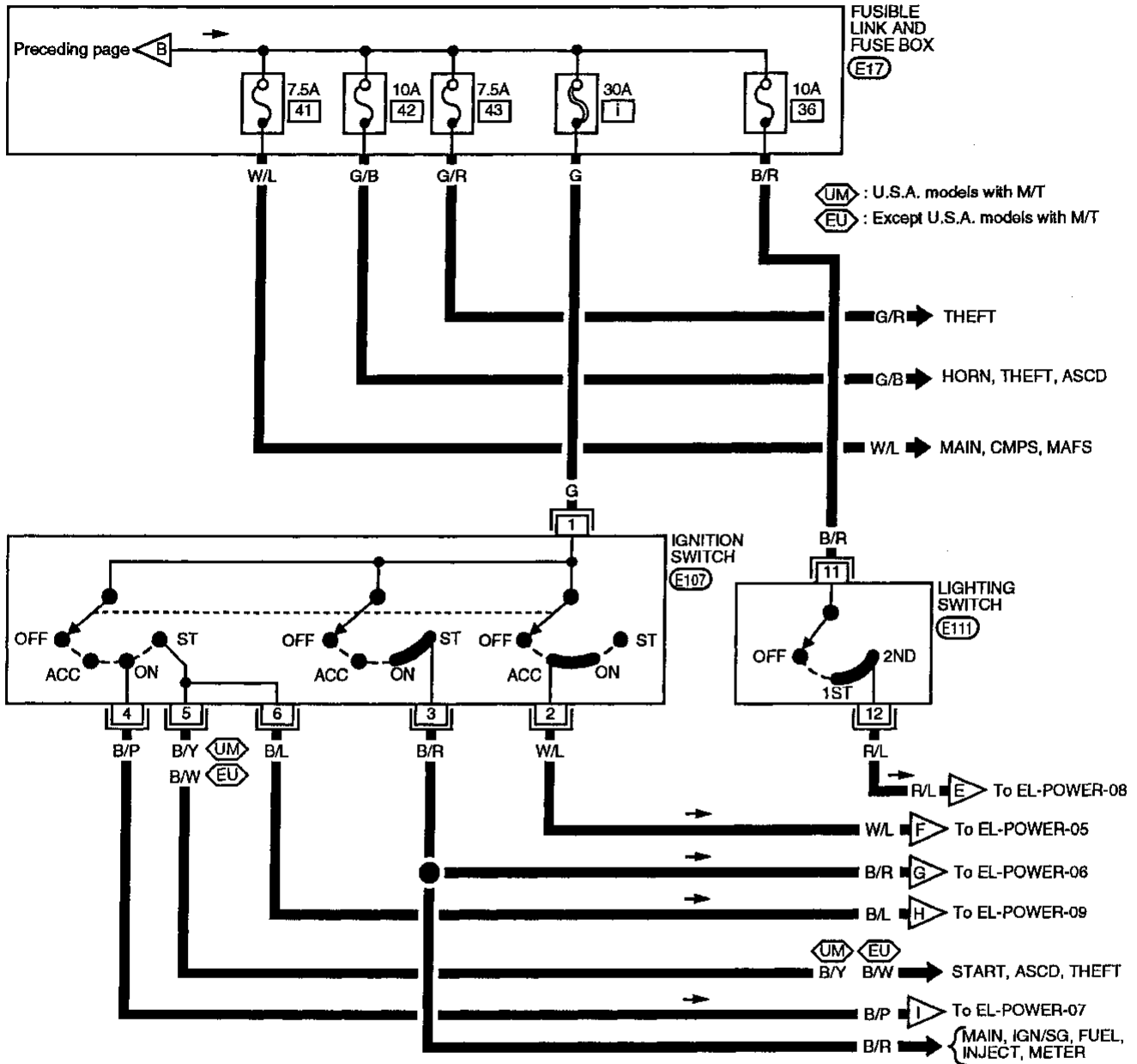

POWER SUPPLY ROUTING

Wiring Diagram -POWER- (Cont'd)

EL-POWER-03

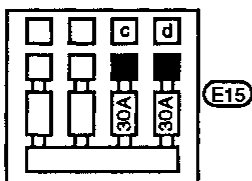
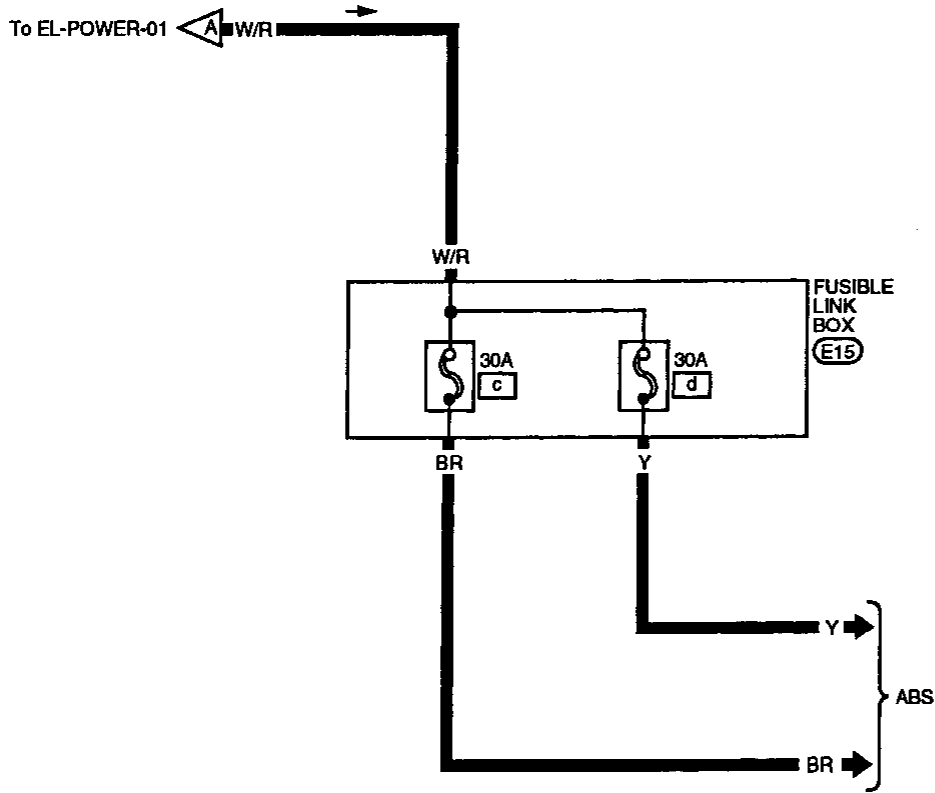

GI
MA
EM
LC
EC
FE
CL
MT
AT
FA
RA
BR
ST
RS
BT
HA
EL
IDX

POWER SUPPLY ROUTING

Wiring Diagram -POWER- (Cont'd)

EL-POWER-05

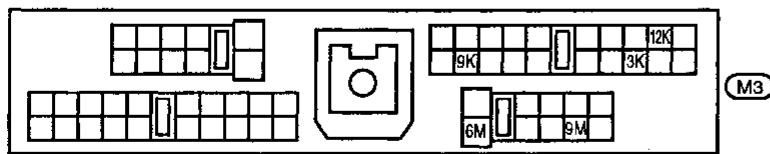
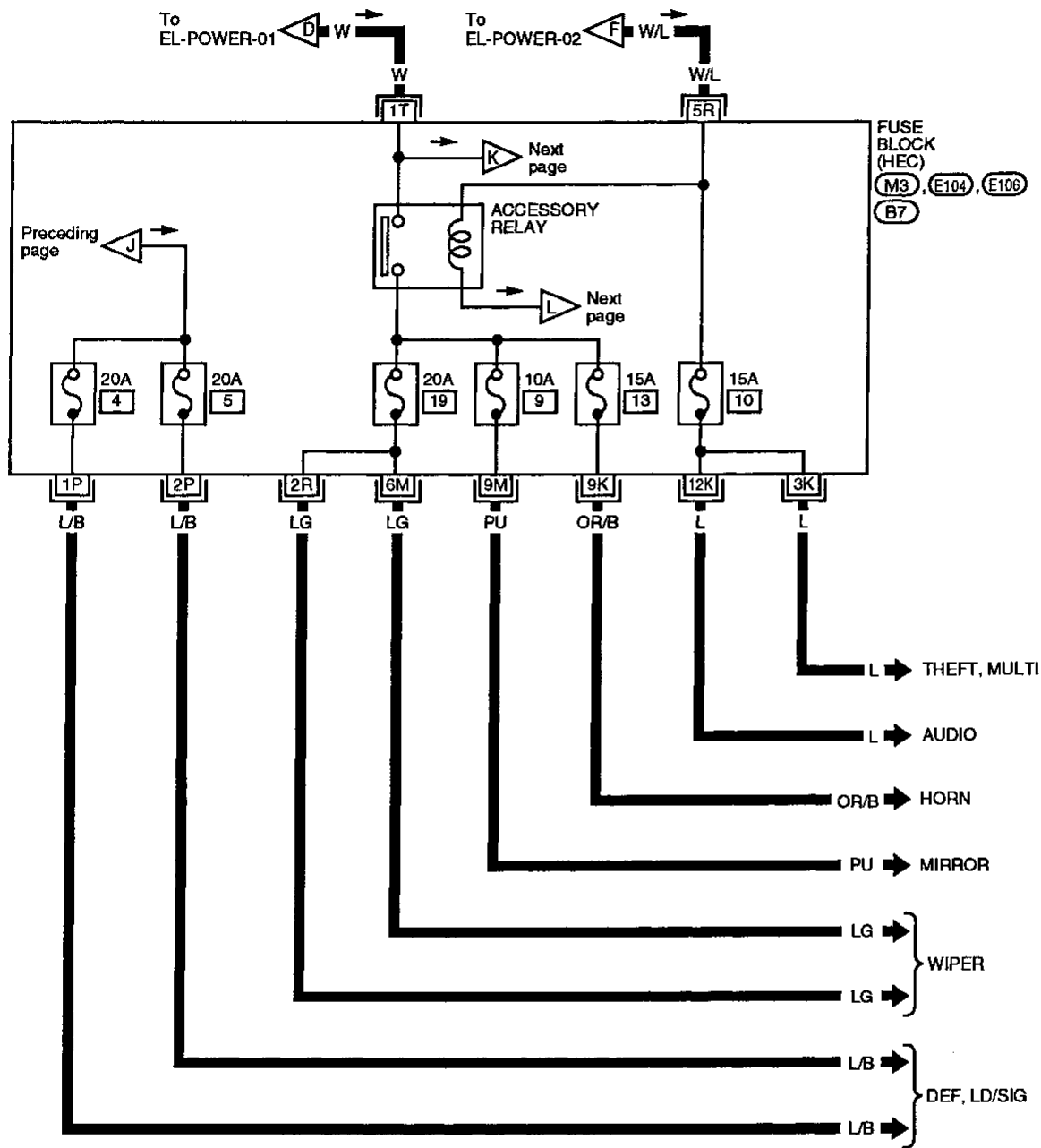

POWER SUPPLY ROUTING

Wiring Diagram -POWER- (Cont'd)

EL-POWER-06

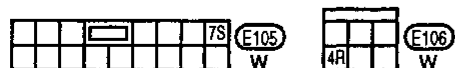
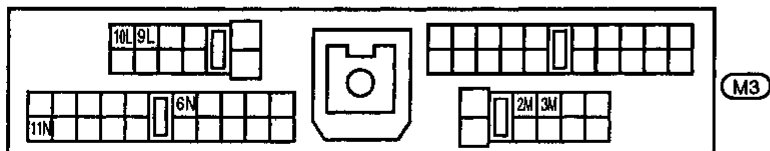
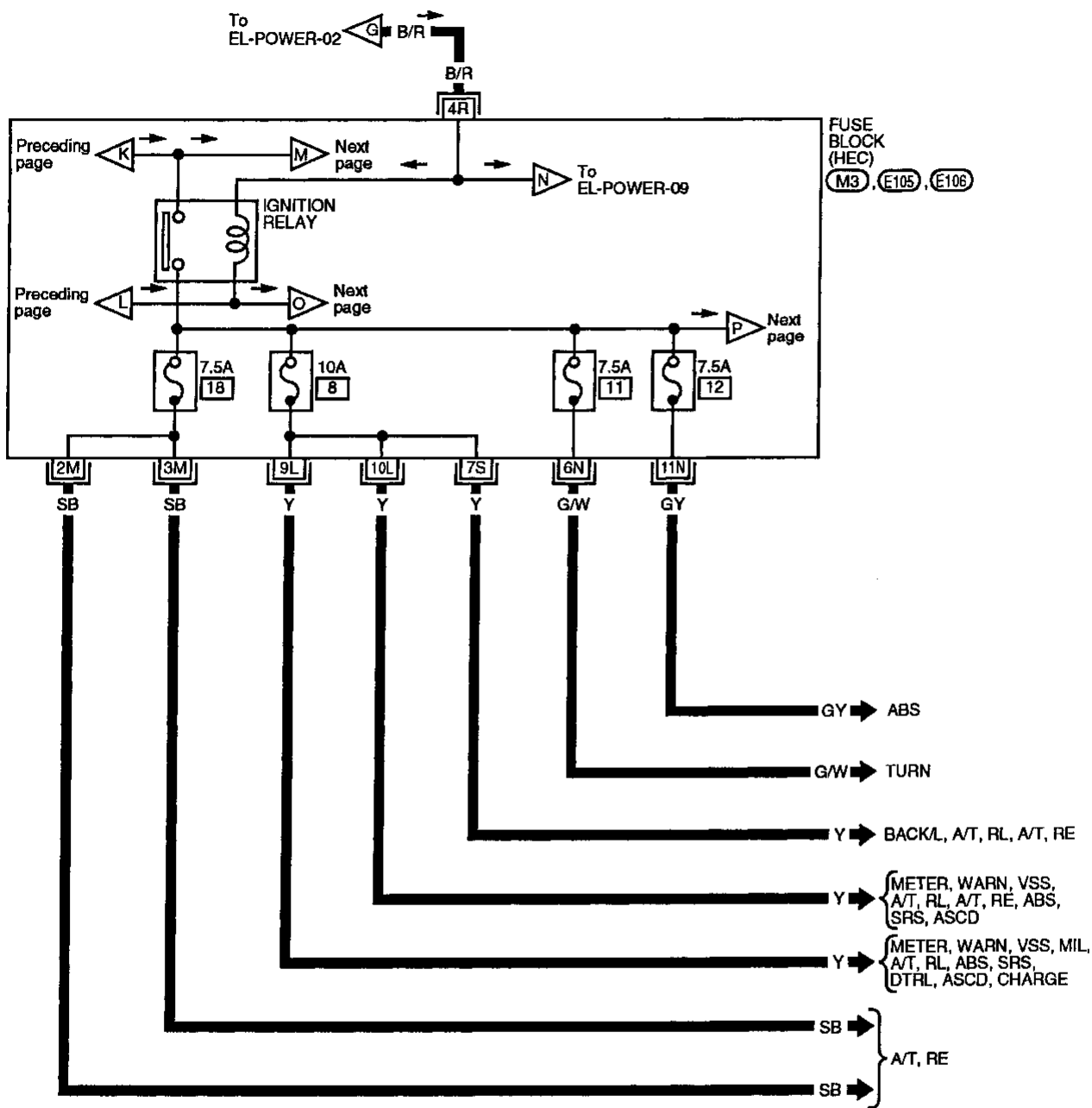

POWER SUPPLY ROUTING

Wiring Diagram -POWER- (Cont'd)

EL-POWER-08

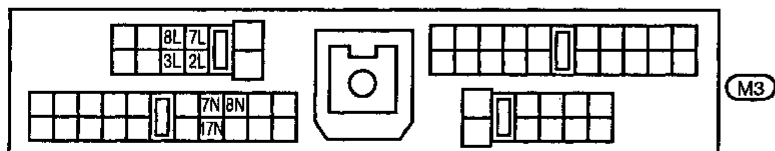
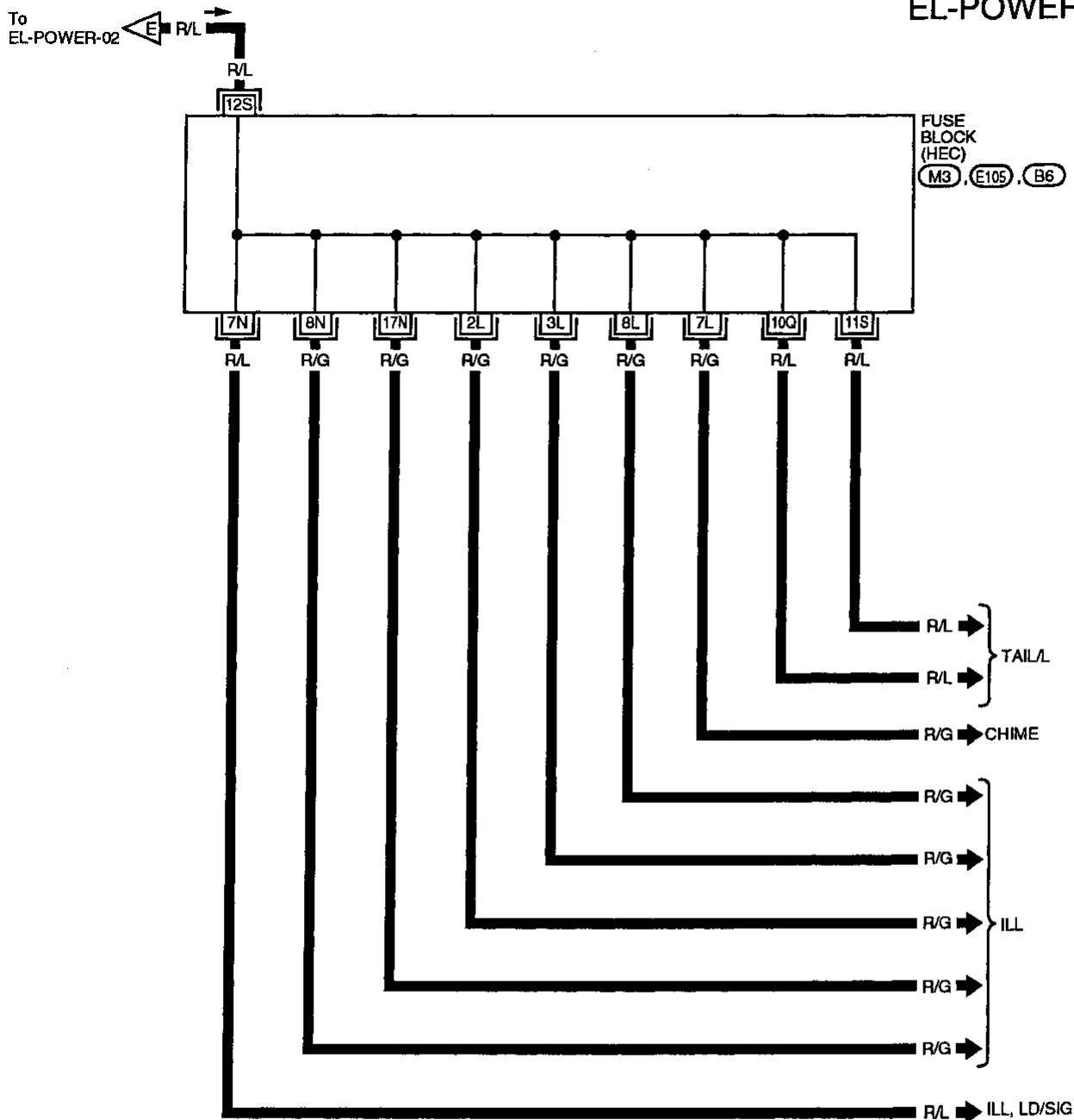

POWER SUPPLY ROUTING

Wiring Diagram -POWER- (Cont'd)

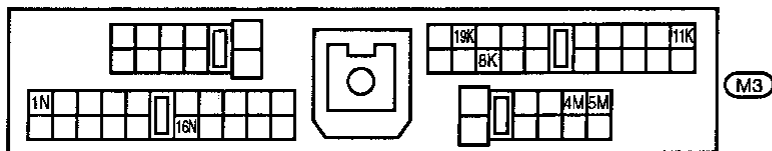
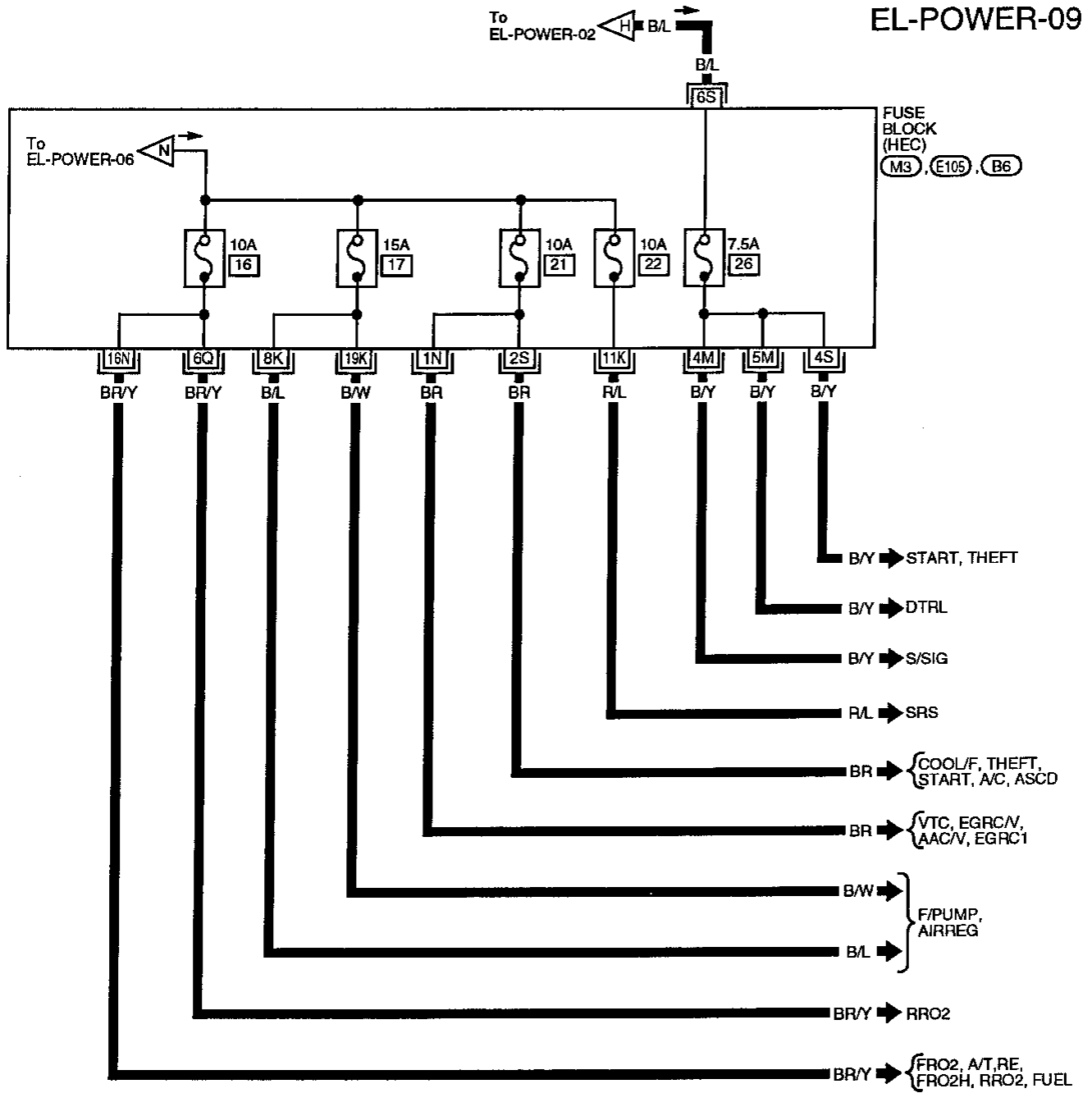

POWER SUPPLY ROUTING

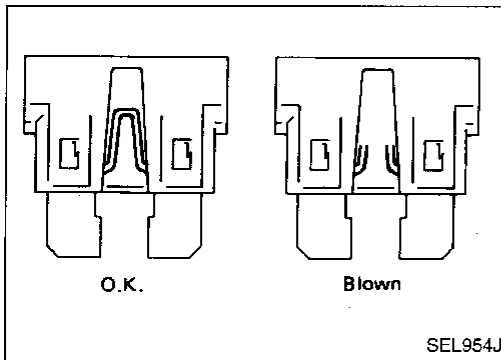

Fuse

- If fuse is blown, be sure to eliminate cause of problem before installing new fuse.
- Use fuse of specified rating. Never use fuse of more than specified rating.
- Do not partially install fuse; always insert it into fuse holder properly.
- Remove fuse for radio (clock) if vehicle is not used for a long period of time.

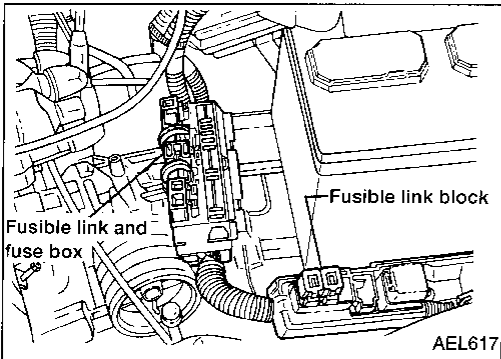

Fusible Link

A melted fusible link can be detected either by visual inspection or by feeling with finger tip. If its condition is questionable, use circuit tester or test lamp.

CAUTION:

- If fusible link should melt, it is possible that a critical circuit (power supply or large current carrying circuit) is shorted. In such a case, carefully check these circuits and eliminate cause of problem.
 - Never wrap outside of fusible link with vinyl tape.
- Important: Never let fusible link touch any other wiring harness, vinyl or rubber parts.

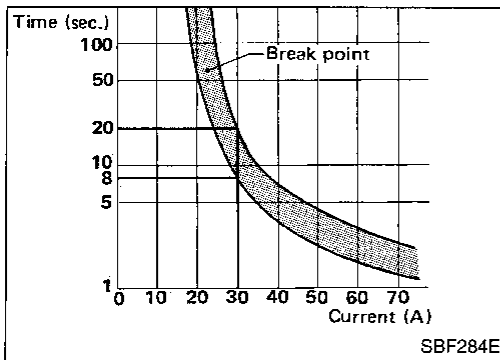

Circuit Breaker

For example, when current is 30A, the circuit is broken within 8 to 20 seconds.

Circuit breakers are used in the following systems:

- Power door lock
- Power window
- Power sun roof

BATTERY

CAUTION:

- If it becomes necessary to start engine with booster battery and jumper cables, use a 12-volt booster battery.
- After connecting battery cables, ensure that they are tightly clamped to battery terminals for good contact.

GI

MA

EM

LC

EG

FE

CL

MT

AT

FA

RA

BR

ST

RS

BT

HA

EL

IDX

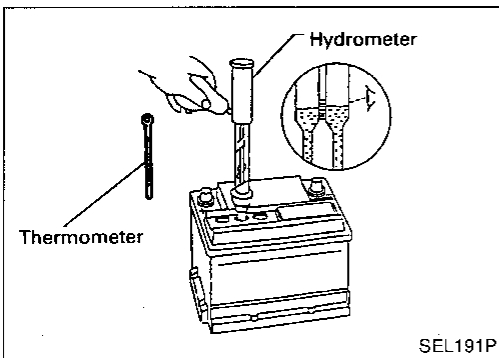
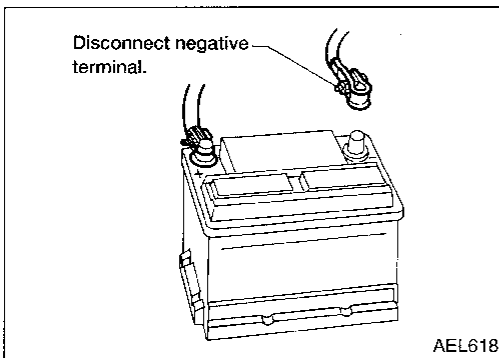
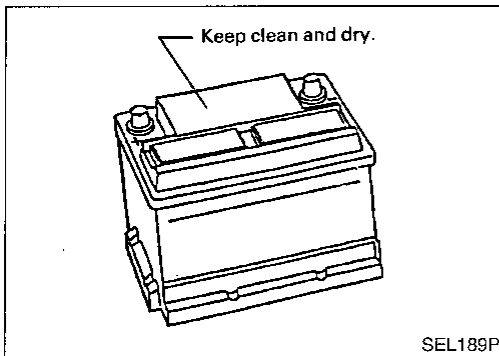

How to Handle Battery

METHODS OF PREVENTING DISCHARGE

The following precautions must be taken to prevent over-discharging a battery.

- The battery surface (particularly its top) should always be kept clean and dry.
- The terminal connections should be clean and tight.
- **During every routine maintenance, check the electrolyte level.** This also applies to batteries designated as "low maintenance" and "maintenance-free".
- When the vehicle is not going to be used over a long period of time, disconnect the negative battery terminal.

- Check the condition of the battery. Periodically check the specific gravity of the electrolyte. Keep a close check on charge condition to prevent over-discharge.

CHECKING ELECTROLYTE LEVEL

WARNING:

Do not allow battery fluid to come in contact with skin, eyes, fabrics, or painted surfaces. After touching a battery, do not touch or rub your eyes until you have thoroughly washed your hands. If acid contacts eyes, skin or clothing, immediately flush with water for 15 minutes and seek medical attention.

Normally the battery does not require additional water. However, when battery is used under severe conditions, adding distilled water may be necessary during battery life.

BATTERY

How to Handle Battery (Cont'd)

- Remove the cell plug using a suitable tool.
- Add distilled water up to the MAX level.

SULPHATION

A battery (with specific gravity less than 1.100) will completely discharge when left unattended for a long period of time. This will result in sulphation on the cell plates.

A sulphated battery may sometimes be brought back into service by a slow charge, 12 hours or more. A capacity test should be run after the battery is charged to ensure the battery is not damaged.

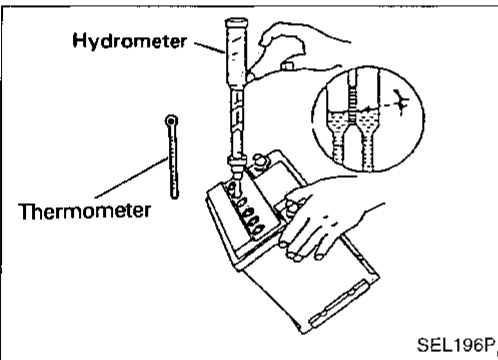
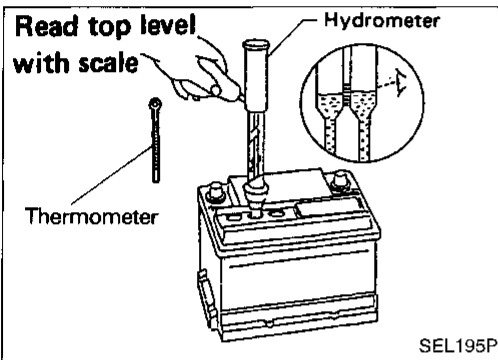
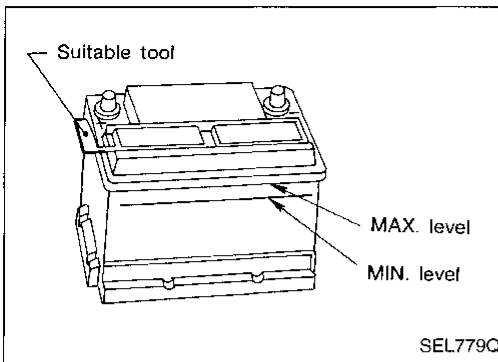

SPECIFIC GRAVITY CHECK

- Read hydrometer and thermometer readings at eye level.

- When electrolyte level is too low, tilt battery case for easy measurement.

- Use the chart below to correct your hydrometer reading according to electrolyte temperature.

Hydrometer temperature correction

Battery electrolyte temperature °C (°F)	Add to specific gravity reading	Battery electrolyte temperature °C (°F)	Add to specific gravity reading
71 (160)	0.032	21 (70)	-0.004
66 (150)	0.028	16 (60)	-0.008
60 (140)	0.024	10 (50)	-0.012
54 (129)	0.020	4 (39)	-0.016
49 (120)	0.016	-1 (30)	-0.020
43 (110)	0.012	-7 (20)	-0.024
38 (100)	0.008	-12 (10)	-0.028
32 (90)	0.004	-18 (0)	-0.032
27 (80)	0		

Corrected specific gravity	Approximate charge condition	Corrected specific gravity	Approximate charge condition
1.260 - 1.280	Fully charged	1.170 - 1.190	1/4 charged
1.230 - 1.250	3/4 charged	1.140 - 1.160	Almost discharged
1.200 - 1.220	1/2 charged	1.110 - 1.130	Completely discharged

BATTERY

How to Handle Battery (Cont'd)

CHARGING THE BATTERY

CAUTION:

- Do not “quick charge” a fully discharged battery. GI
- Keep the battery away from open flame while it is being charged.
- When connecting the charger, connect the leads first, then turn on the charger. Do not turn on the charger first, as this may cause a spark. MA
- If battery electrolyte temperature rises above 60°C (140°F), stop charging. Always charge battery at a temperature below 60°C (140°F). EM

Charging rates:

Amps	Time	
50	1 hour	EC
25	2 hours	
10	5 hours	FE
5	10 hours	

Do not charge at more than 50 ampere rate.

Note: The ammeter reading on your battery charger will automatically decrease as the battery charges. This indicates that the voltage of the battery is increasing normally as the state of charge improves. The charging amps indicated above are referred to as initial charge rate. CL

- If, after charging, the specific gravity of any two cells varies more than .050, the battery should be replaced. MT
- After the battery is charged, always perform a “capacity test” as follows, to assure that the battery is serviceable. AT

MEMORY RESET

If the battery is disconnected or goes dead the following items must be reset:

- Radio AM and FM preset RA
- Radio Clock BR

ST

PS

BT

HA

EL

IX

BATTERY

How to Handle Battery (Cont'd)

- Check battery type and determine the specified current using the following table.

Fig. 1 DISCHARGING CURRENT (Load tester)

Group Size	Current (A)
21F (USA)	245
24F (Canada)	275

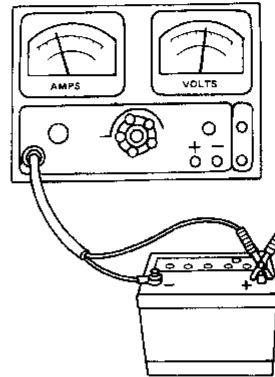

SEL008Z

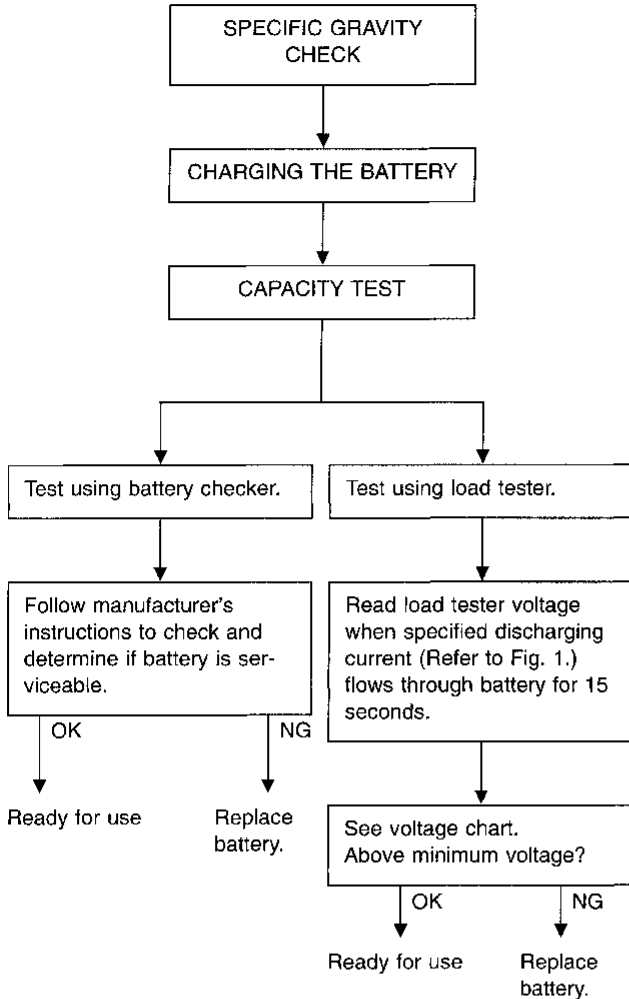

Voltage chart

Estimated electrolyte temperature °C (°F)	Minimum voltage under 15 second load
21 (70)	9.6
16 (60)	9.5
10 (50)	9.4
4 (40)	9.3
-1 (30)	9.1
-7 (20)	8.9
-12 (10)	8.7
-18 (0)	8.5

Service Data and Specifications (SDS)

Applied area		USA	Canada
Group size		21F	24F
Capacity	V-AH	12-60	12-65
Cold cranking current (For reference value)	A	490	550
Reserve capacity	Minutes	88	113

System Description

M/T models for USA

Power is supplied at all times:

- to ignition switch terminal ①
- through 30A fusible link (letter **I** , located in the fusible link and fuse box).

With the ignition switch in the START position, power is supplied:

- through terminal ⑤ of the ignition switch
- to clutch interlock relay terminal ③.

Power is also supplied:

- to the 7.5A fuse (No. 26 , located in the fuse block [HEC]).

For models with theft warning system

With the ignition switch in the ON or START position, power is supplied:

- through 10A fuse (No. 21 , located in the fuse block [HEC])
- to theft warning relay terminal ①.

With the ignition switch in the START position, power is supplied:

- through 7.5A fuse (No. 26 , located in the fuse block [HEC])
- to theft warning relay terminal ③
- through theft warning relay terminal ④
- to clutch interlock relay terminal ①.

If the theft warning system is triggered, terminal ② of the theft warning relay is grounded and power to the clutch interlock relay is interrupted.

For models without theft warning system

With the ignition switch in the START position, power is supplied:

- through 7.5A fuse (No. 26 , located in the fuse block [HEC])
- to clutch interlock relay terminal ①.

Ground is supplied to clutch interlock relay terminal ②, when the clutch pedal is depressed through the clutch pedal position switch and body grounds **(M43)**, **(M44)** and **(M60)**.

The clutch interlock relay is energized and power is supplied:

- from terminal ⑤ of the clutch interlock relay
- to terminal ① of the starter motor windings.

The starter motor plunger closes and provides a closed circuit between the battery and the starter motor. The starter motor is grounded to the engine block. With power and ground supplied, cranking occurs and the engine starts.

M/T models for Canada

Power is supplied at all times:

- to ignition switch terminal ①
- through 30A fusible link (letter **I** , located in the fusible link and fuse box).

For models with theft warning system

With the ignition switch in the ON or START position, power is supplied:

- through 10A fuse (No. 21 , located in the fuse block [HEC])
- to theft warning relay terminal ①

With the ignition switch in the START position, power is supplied:

- to theft warning relay terminal ③
- through theft warning relay terminal ④
- to terminal ① of the starter motor windings.

If the theft warning system is triggered, terminal ② of the theft warning relay is grounded and power to the starter is interrupted.

For models without theft warning system

With the ignition switch in the START position, power is supplied:

- from ignition switch terminal ⑤
- directly to terminal ① of the starter motor windings.

The starter motor plunger closes and provides a closed circuit between the battery and the starter motor. The starter motor is grounded to the engine block. With power and ground supplied, cranking occurs and the engine starts.

GI

MA

EM

LC

EC

FE

CL

MT

AT

FA

RA

BH

ST

RS

BT

HA

EL

DX

STARTING SYSTEM

System Description (Cont'd)

A/T models

Power is supplied at all times:

- through 30A fusible link (letter **I** , located in the fusible link and fuse box)
- to ignition switch terminal **①**.

For models with theft warning system (and with ASCD)

Power is supplied:

- through 10A fuse (No. **21** , located in the fuse block [HEC])
- to theft warning relay terminal **①**
- to theft warning relay terminal **③**
- through theft warning relay terminal **④**
- to inhibitor relay terminal **①**.

If the theft warning system is triggered, terminal **②** of the theft warning relay is grounded and power to the inhibitor relay is interrupted.

When the theft warning system is not triggered and the ignition switch is in the START position, power is supplied:

- from ignition switch terminal **⑤**
- to inhibitor relay terminal **⑥**.

With the selector lever in the "P" or "N" position, ground is supplied:

- from inhibitor switch terminal **①**
- to inhibitor relay terminal **②**
- through inhibitor switch terminal **②**
- to body grounds **E13** and **E25**.

The inhibitor relay is energized, and power is supplied:

- from inhibitor relay terminal **⑦**
- to terminal **①** of the starter motor windings.

The starter motor plunger closes and provides a closed circuit between the battery and starter motor. The starter motor is grounded to the engine block. With power and ground supplied, cranking occurs and the engine starts.

For models without theft warning system

Power is supplied:

- through 10A fuse (No. **21** , located in the fuse block [HEC])
- to inhibitor relay terminal **①**.

With the ignition switch in the START position, power is supplied:

- from ignition switch terminal **⑤**
- to inhibitor relay terminal **⑥** (models with ASCD)
- to inhibitor relay terminal **③** (models without ASCD).

With the selector lever in the "P" or "N" position, ground is supplied:

- from inhibitor switch terminal **①**
- to inhibitor relay terminal **②**
- through inhibitor switch terminal **②**
- to body grounds **E13** and **E25**.

The inhibitor relay is energized and power is supplied:

- from inhibitor relay terminal **⑦** (models with ASCD)
- from inhibitor relay terminal **⑤** (models without ASCD)
- to terminal **①** of the starter motor windings.

The starter motor plunger closes and provides a closed circuit between the battery and starter motor. The starter motor is grounded to the engine block. With power and ground supplied, cranking occurs and the engine starts.

STARTING SYSTEM

NOTE

GI

MA

EM

LC

EC

FE

CL

MT

AT

FA

RA

BR

ST

RS

BT

HA

EL

IDX

STARTING SYSTEM

Wiring Diagram -START-

M/T models for USA

EL-START-01

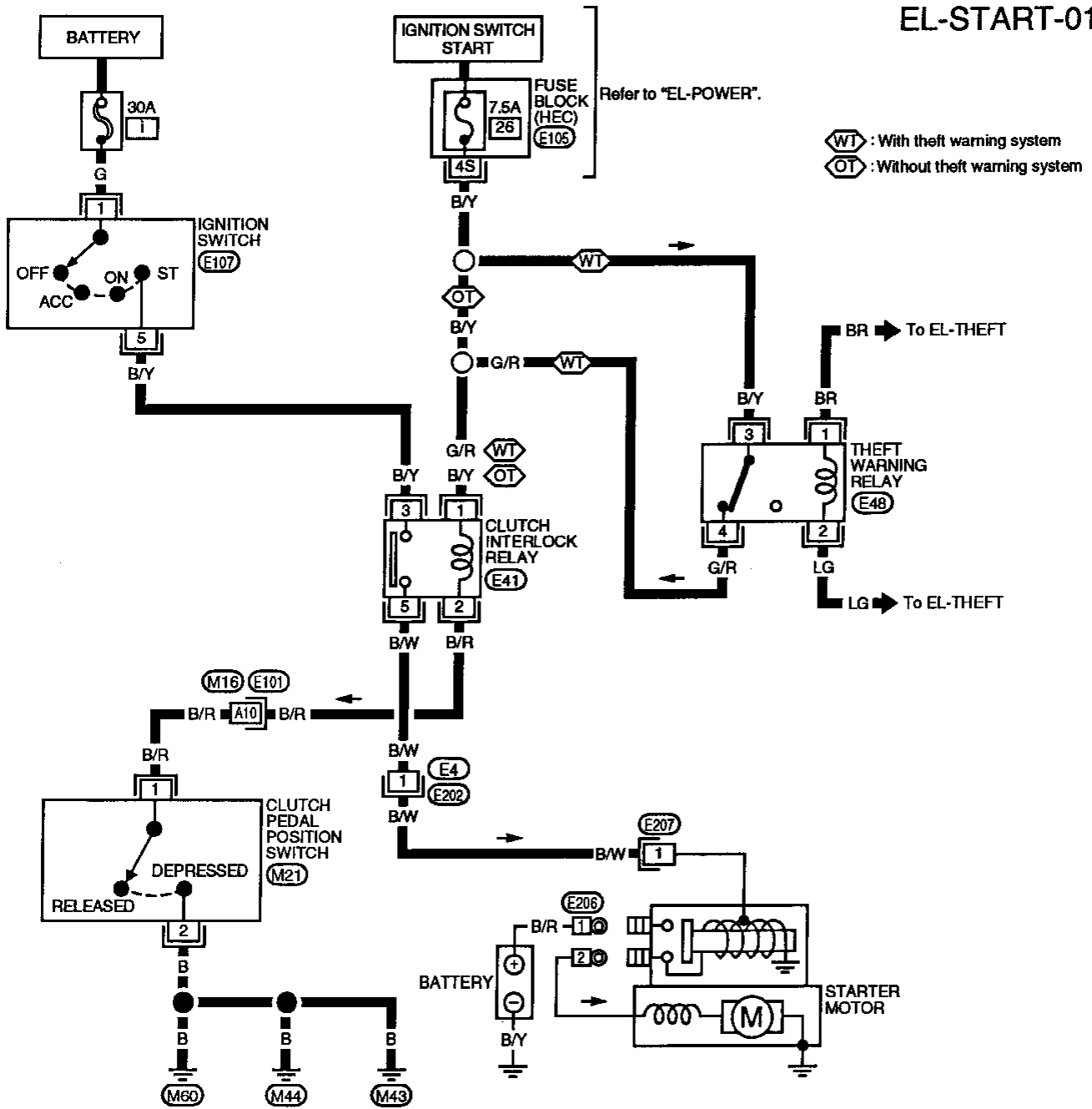

Refer to last page (Foldout page).

(M16), (E101)

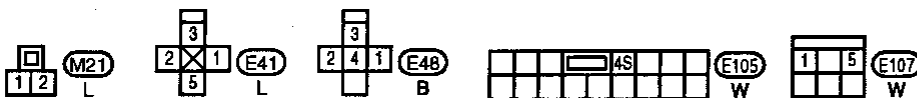

STARTING SYSTEM

Wiring Diagram -START- (Cont'd)

M/T models for Canada

EL-START-02

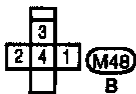
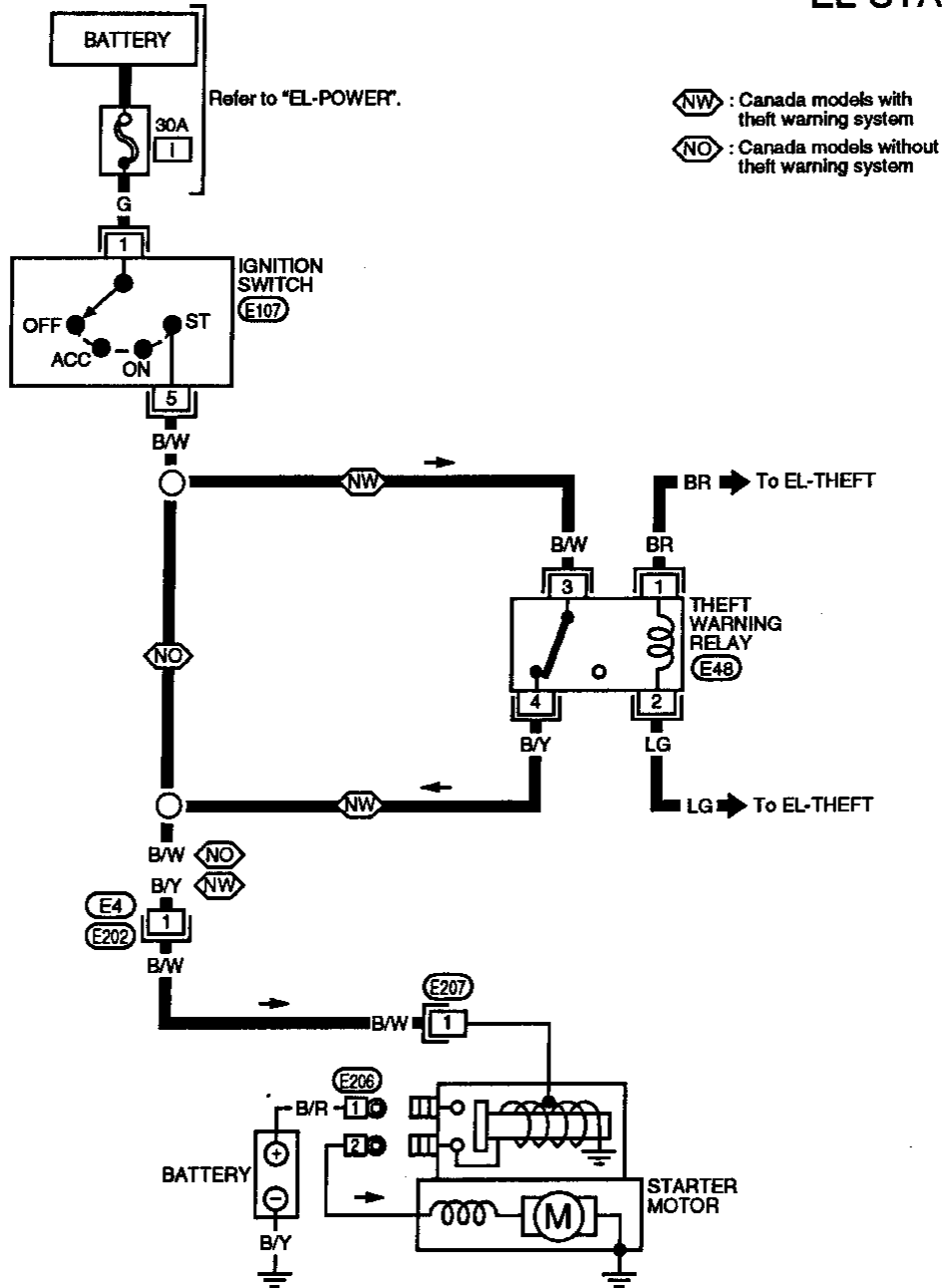

GI

MA

EM

LC

EC

FE

CL

MT

AT

FA

RA

BR

ST

RS

BT

HA

EL

IDX

STARTING SYSTEM

Wiring Diagram -START- (Cont'd)

A/T models

EL-START-03

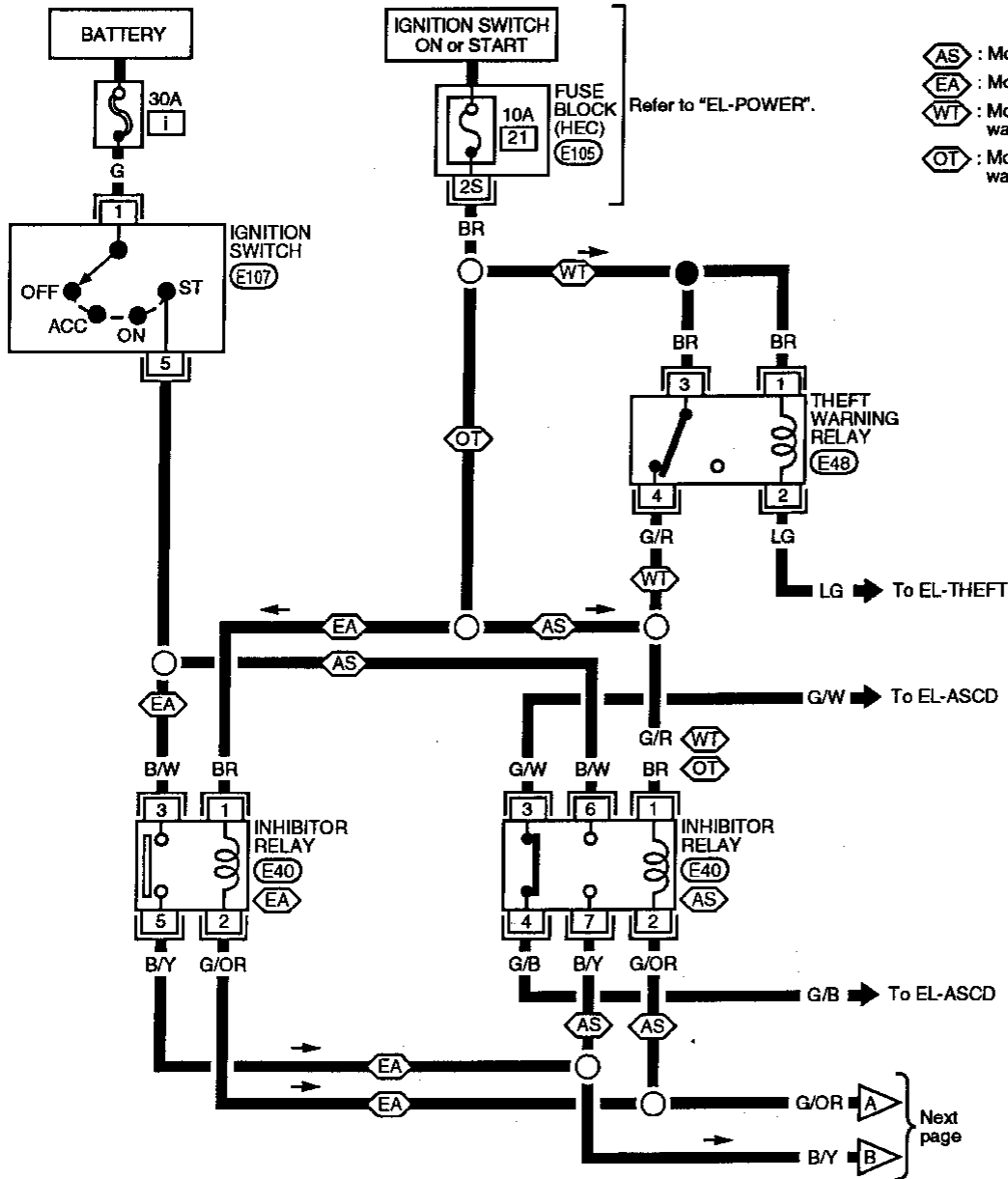

- ⬡ AS : Models with ASCD
- ⬡ EA : Models without ASCD
- ⬡ WT : Models with theft warning system
- ⬡ OT : Models without theft warning system

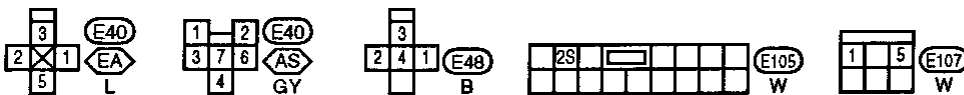

STARTING SYSTEM

Wiring Diagram -START- (Cont'd)

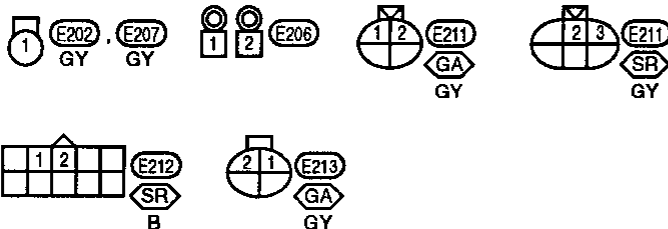
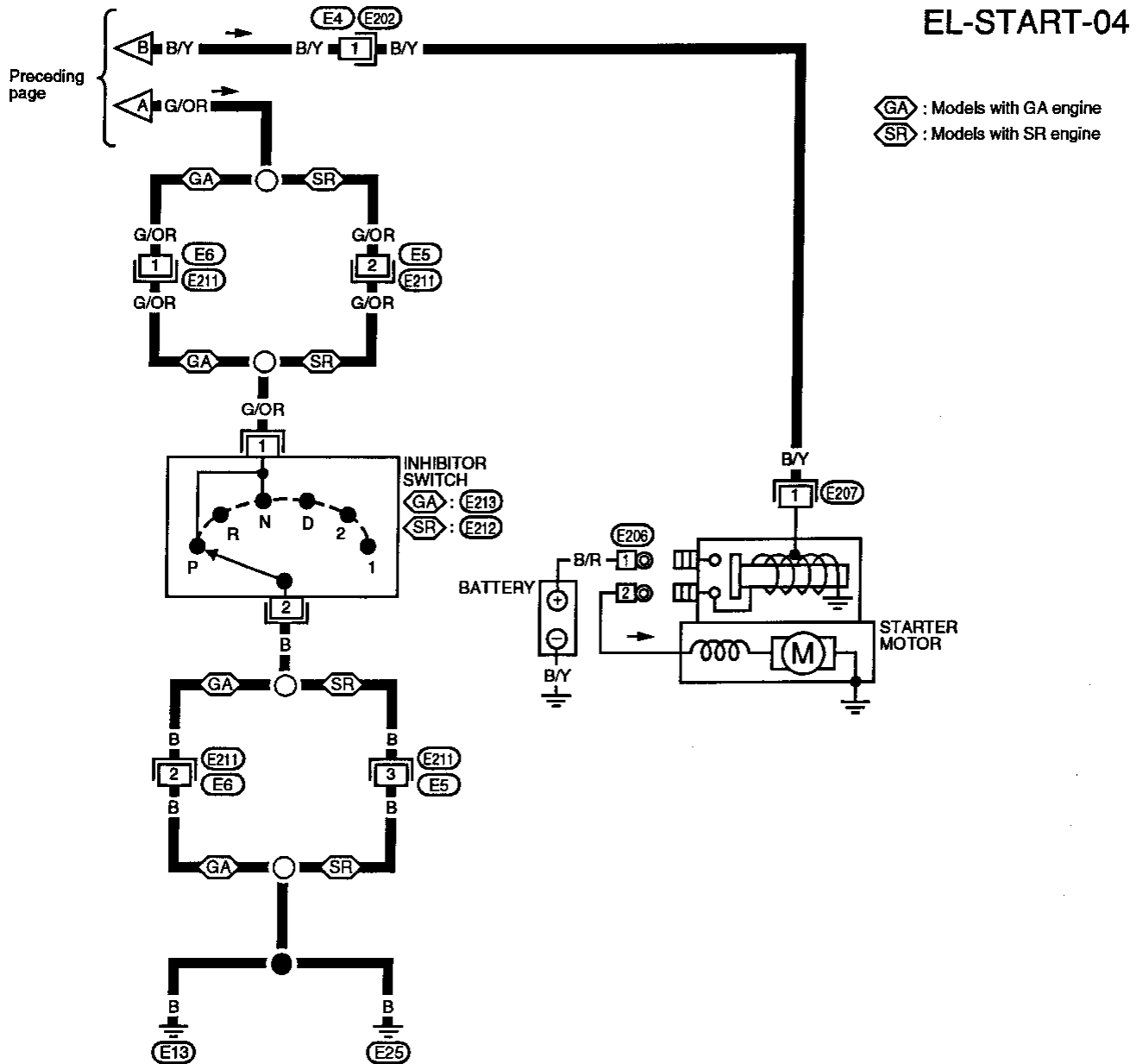

GI
MA
EM
LC
EC
FE
CL
MT
AT
FA
RA
BR
ST
RS
BT
HA
EL
IDX

STARTING SYSTEM

Starter

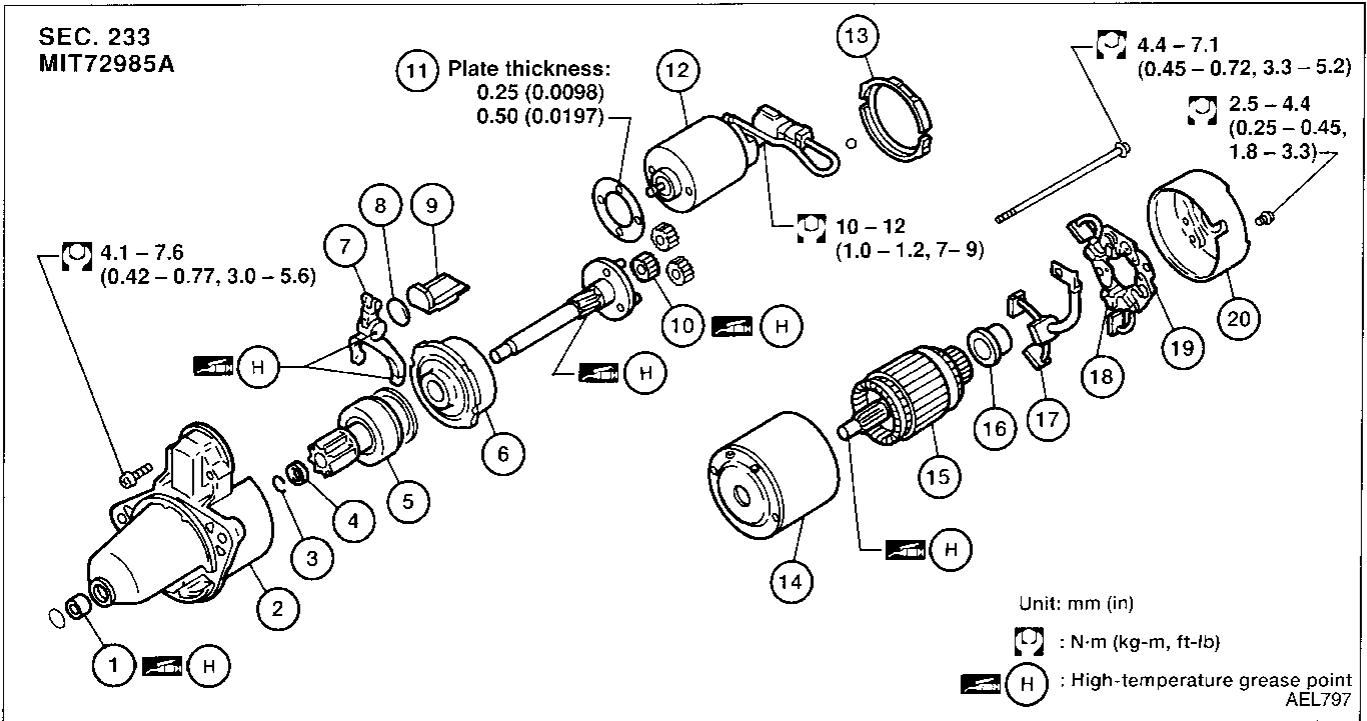

- ① Sleeve bearing
- ② Gear case
- ③ Stopper clip
- ④ Pinion stopper
- ⑤ Pinion assembly
- ⑥ Internal gear
- ⑦ Shift lever

- ⑧ Plate
- ⑨ Packing
- ⑩ Planetary gear
- ⑪ Adjusting plate
- ⑫ Magnetic switch assembly
- ⑬ Packing
- ⑭ Yoke

- ⑮ Armature
- ⑯ Bearing
- ⑰ Brush (+)
- ⑱ Brush spring
- ⑲ Brush holder
- ⑳ Rear cover

STARTING SYSTEM

Starter (Cont'd)

SEC. 233
S114-701C

 6.4 - 8.3
(0.65 - 0.85,
4.7 - 6.1)

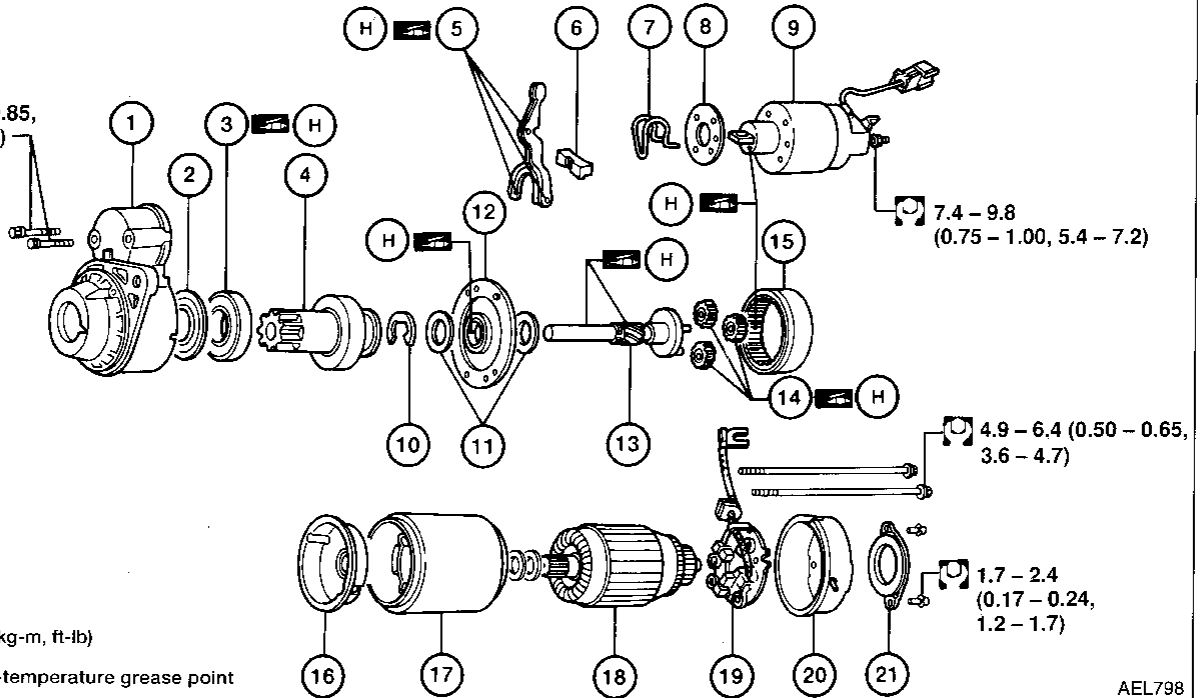

 : N-m (kg-m, ft-lb)

 H : High-temperature grease point

AEL798

- ① Gear case
- ② Bearing cover
- ③ Ball bearing
- ④ Pinion assembly
- ⑤ Shift lever
- ⑥ Dust cover
- ⑦ Torsion spring

- ⑧ Adjusting plate
- ⑨ Magnetic switch assembly
- ⑩ E-ring
- ⑪ Thrust washer
- ⑫ Center bracket
- ⑬ Pinion shaft
- ⑭ Planetary gear

- ⑮ Internal gear
- ⑯ Center bracket
- ⑰ Yoke assembly
- ⑱ Armature
- ⑲ Brush holder assembly
- ⑳ Rear cover
- ㉑ Dust cover

GI

MA

EM

LC

EC

FE

CL

MT

AT

FA

RA

BR

ST

RS

BT

HA

EL

IDX

STARTING SYSTEM

Starter (Cont'd)

SEC. 233
MZT49283ZC

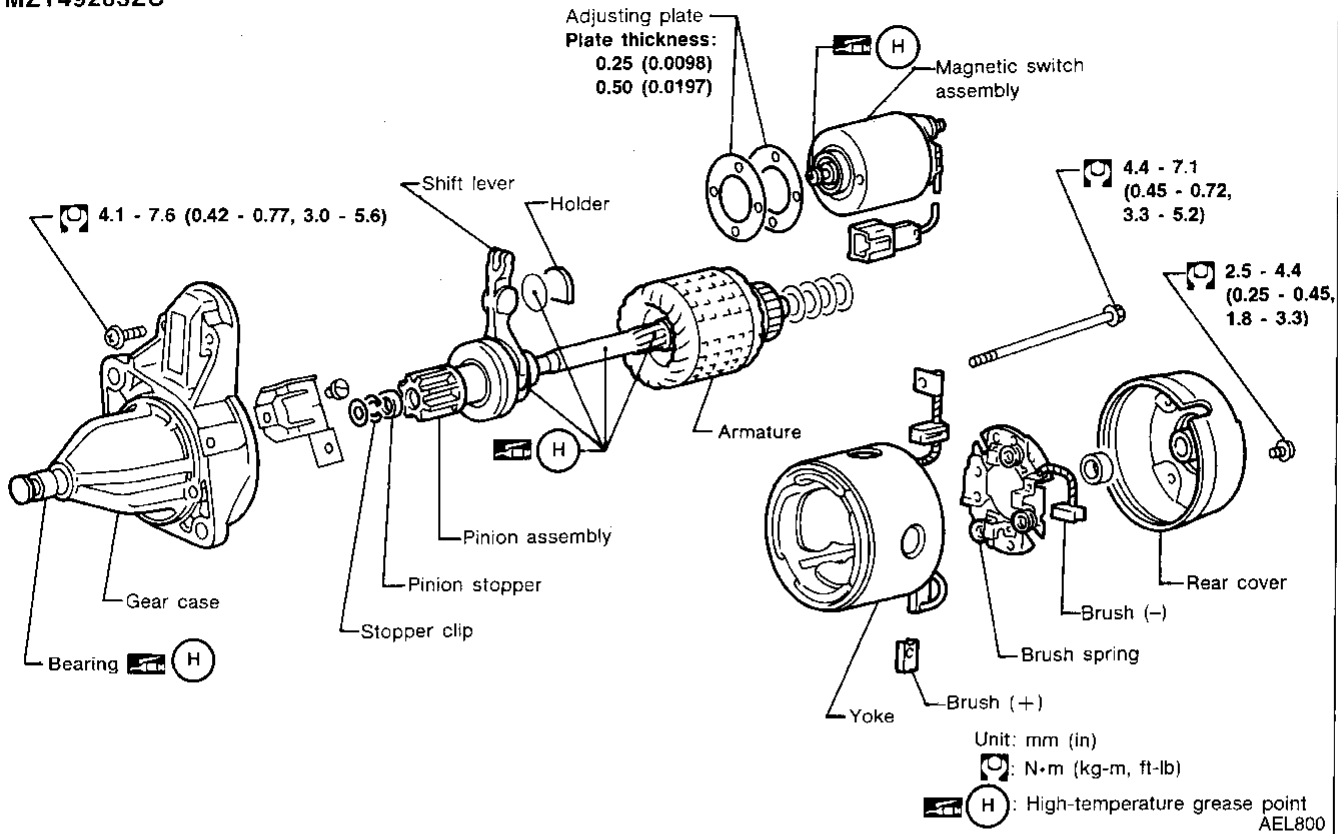

SEC. 233
S114-802A

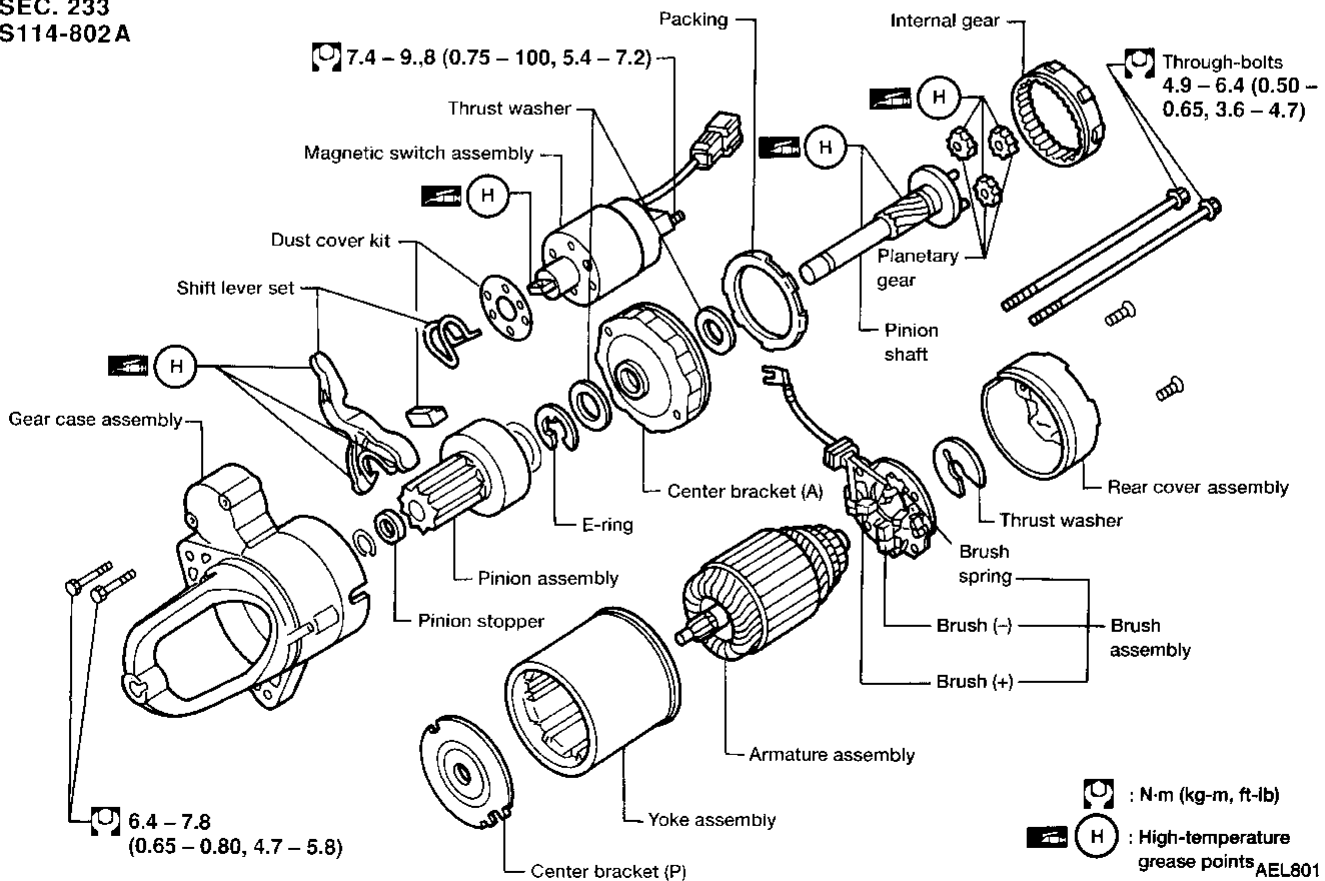

STARTING SYSTEM

Starter (Cont'd)

SEC.233
MOT80281ZC

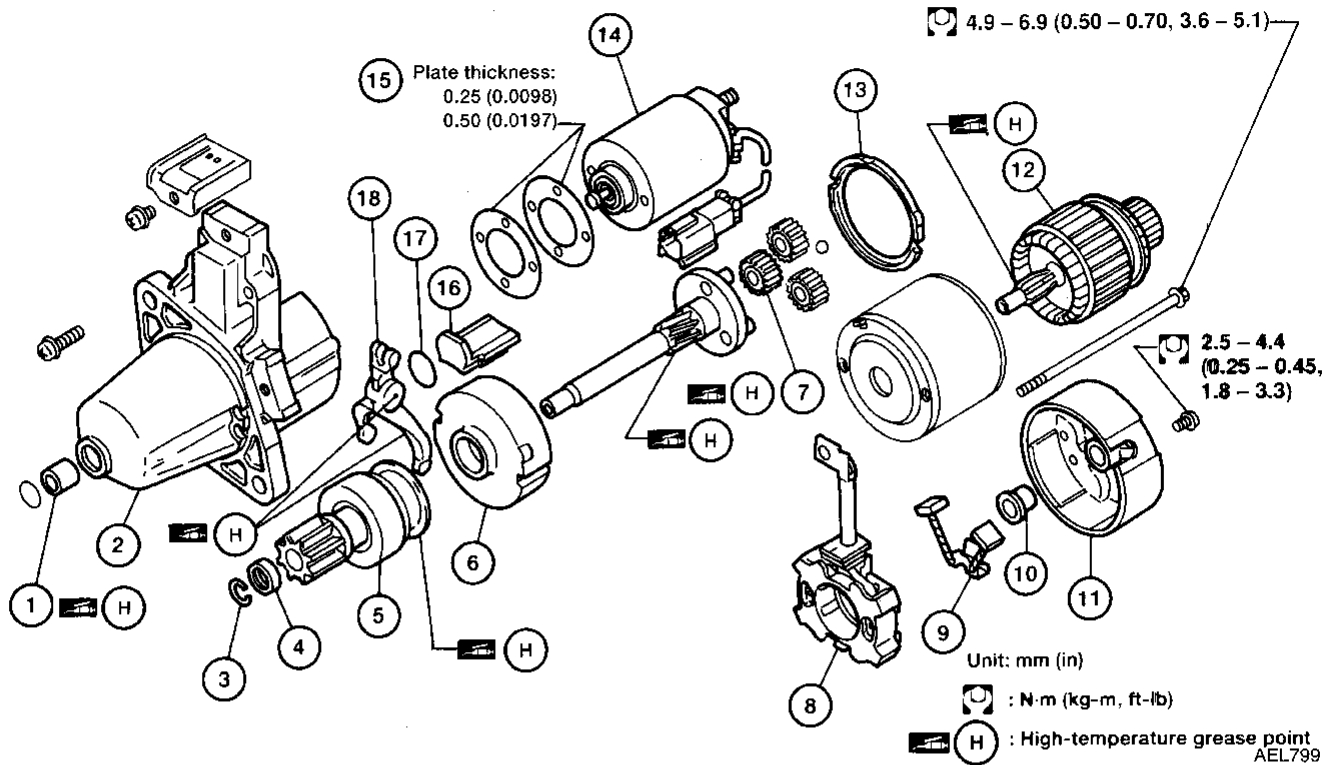

- ① Sleeve bearing
- ② Gear case
- ③ Stopper clip
- ④ Pinion stopper
- ⑤ Pinion assembly
- ⑥ Internal gear

- ⑦ Planetary gear
- ⑧ Brush holder
- ⑨ Brush
- ⑩ Bearing
- ⑪ Rear cover
- ⑫ Armature

- ⑬ Packing
- ⑭ Magnetic switch assembly
- ⑮ Adjusting plate
- ⑯ Packing
- ⑰ Plate
- ⑱ Shift lever

GI
MA
EM
LG
EC
FE
CL
MT
AT
FA
RA
BR
ST
RS
ET
HA
EL
IDX

STARTING SYSTEM

Pinion/Clutch Check

1. Inspect pinion teeth.
 - Replace pinion if teeth are worn or damaged. (Also check condition of ring gear teeth.)
2. Inspect reduction gear teeth.
 - Replace reduction gear if teeth are worn or damaged. (Also check condition of armature shaft gear teeth.)
3. Check to see if pinion locks in one direction and rotates smoothly in the opposite direction.
 - If it locks or rotates in both directions, or unusual resistance is evident, replace.

Service Data and Specifications (SDS)

STARTER

Type	MOT80281ZC	M2T42983ZC	S114-802A	S114-701C	M1T72985A
	MITSUBISHI		HITACHI		MITSUBISHI
	Reduction	Non-reduction	Reduction		
Applied model	GA with M/T		GA with A/T	SR	
	Federal	California			
System voltage	V 12				
No-load					
Terminal voltage	V 11.0	11.5	11.0		
Current	A 90 Max	53 Max	90 Max		
Motor revolution	rpm 2750 Min.	6000 Min.	2750 Min.	2950 Min.	3000 Min.
Minimum diameter of commutator	mm (in) 28.8 (1.134)	31.4 (1.236)	28.0 (1.102)	32.0 (1.260)	28.8 (1.134)
Minimum length of brush	mm (in) 7.0 (0.276)	11.5 (0.453)	10.5 (0.413)	11.0 (0.433)	12.0 (0.472)
Brush spring tension	N (kg, lb) 11.8 - 23.5 (1.2 - 2.4, 2.7 - 5.3)	13.7 - 25.5 (1.4 - 2.6, 3.1 - 5.7)	14.7 - 17.7 (1.5 - 1.8, 3.3 - 4.0)	17.7 - 21.6 (1.8 - 2.2, 4.0 - 4.9)	13.7 - 25.5 (1.4 - 2.6, 3.1 - 5.7)
Clearance of bearing metal and armature shaft	mm (in) 0.2 (0.0078) Max	0.2 (0.0078) Max	—	0.03 - 0.3 (0.0012 - 0.0118)	0.2 (0.0078) Max
Clearance between Pinion front edge and Pinion stopper	mm (in) 0.5 - 2.0 (0.019 - 0.079)	0.5 - 2.0 (0.019 - 0.079)	0.3 - 2.5 (0.012 - 0.098)	0.05 - 1.5 (0.0020 - 0.0591)	0.5 - 2.0 (0.019 - 0.079)

CHARGING SYSTEM

System Description*

The generator provides DC voltage to operate the vehicle's electrical system and to keep the battery charged. The voltage output is controlled by the IC regulator.

GI

Power is supplied at all times to generator terminal (S) through:

- 7.5A fuse (No. 31), located in the fusible link and fuse box.

MA

Terminal (B) of the generator supplies current to charge the battery and operate the vehicles electrical system. Voltage output at this terminal is controlled by the amount of voltage detected by the IC regulator at terminal (S). The charging circuit is protected by the 75A fusible link (letter G), located in the fusible link and fuse box).

EM

LC

Terminal (E) of the generator supplies ground through body ground (A4).

EC

With the ignition switch in the ON or START position, power is supplied:

- through 10A fuse (No. 8), located in the fuse block [HEC]
- to combination meter terminal (41) (34) for the charge warning lamp.

FE

Ground is supplied to terminal (35) (33) of the combination meter through terminal (L) of the generator. With power and ground supplied, the charge warning lamp will illuminate. When the generator is providing sufficient voltage the ground is opened and the charge warning lamp will go off.

CL

If the charge warning lamp illuminates with the engine running, a fault is indicated. Refer to "Trouble Diagnoses", "CHARGING SYSTEM" (EL-35).

MT

*: Terminal numbers in () are for models without tachometer.

AT

FA

RA

BR

ST

RS

BT

HA

EL

IDX

CHARGING SYSTEM

Wiring Diagram -CHARGE-

EL-CHARGE-01

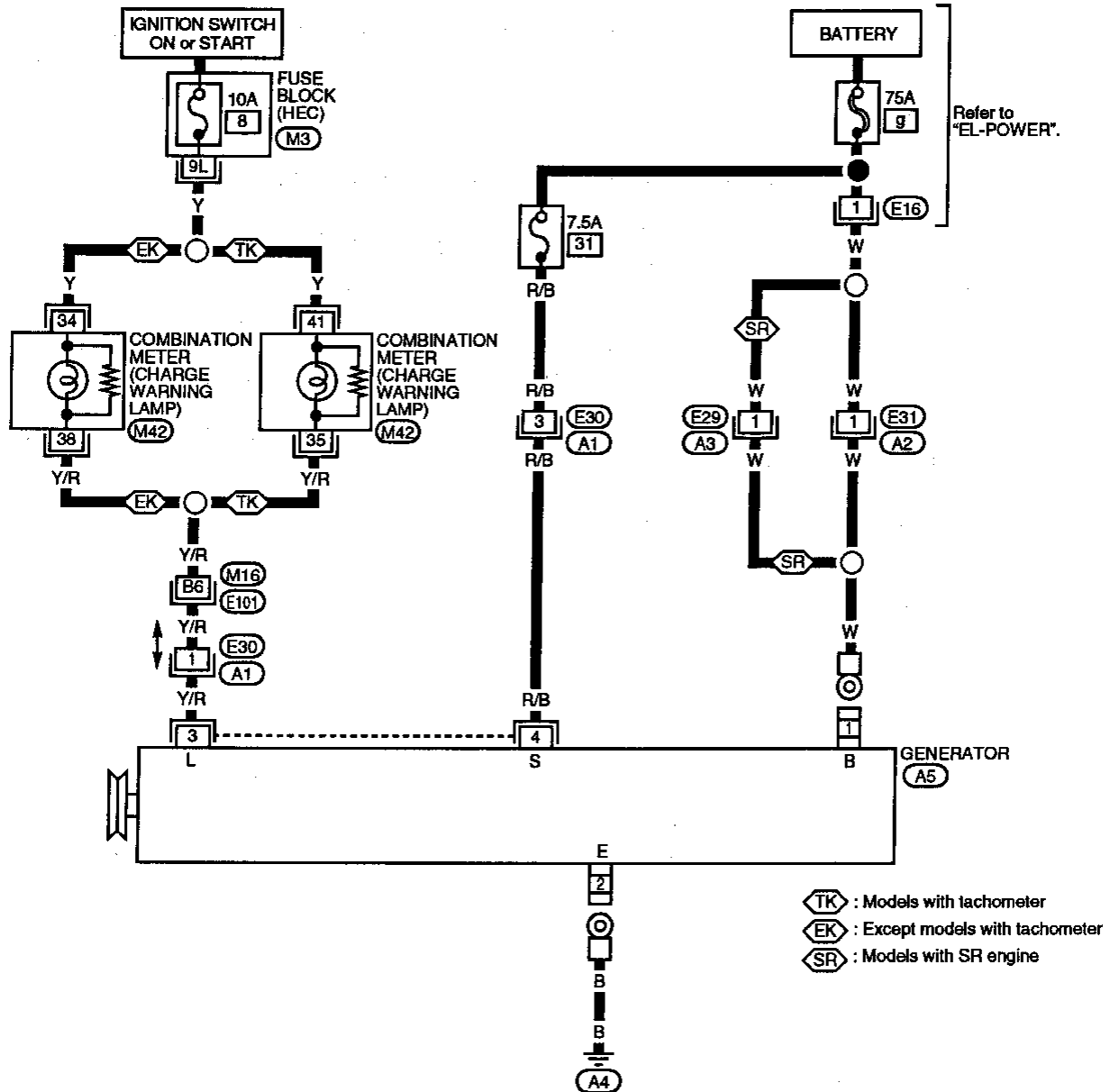

Refer to last page (Foldout page).

(M16) (E101)

(M3)

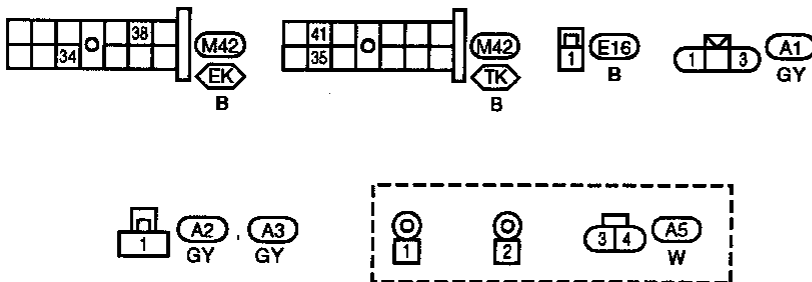

CHARGING SYSTEM

Trouble Diagnoses

Before conducting a generator test, make sure that the battery is fully charged. A 30-volt voltmeter and suitable test probes are necessary for the test. The generator can be checked easily by referring to the Inspection Table.

Before starting diagnosis, inspect the fusible link.

WITH IC REGULATOR

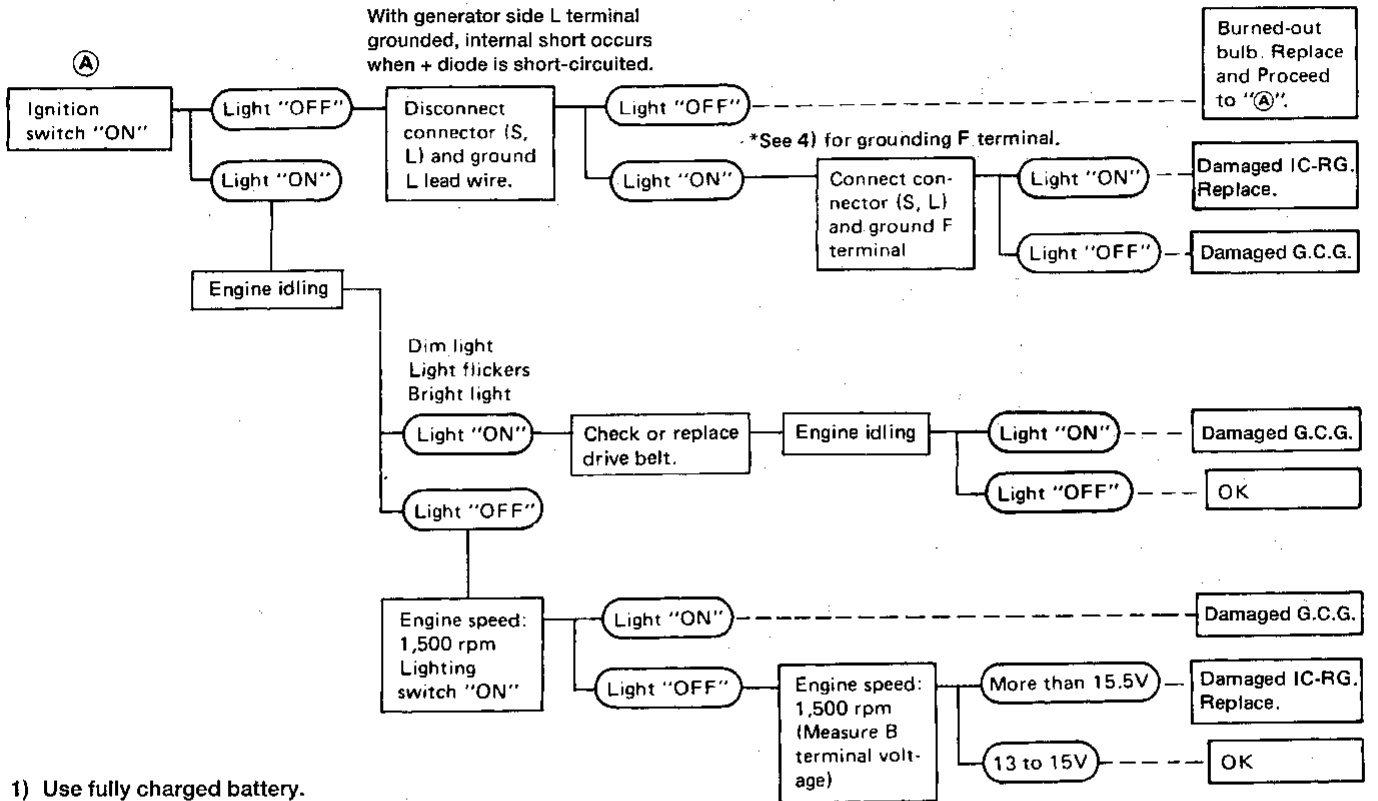

- 1) Use fully charged battery.
- 2) Light : Charge warning light
G.C.G. : Generator parts except IC regulator
IC-RG : IC regulator
OK : IC-generator is in good condition.
- 3) When reaching "Damaged G.C.G.", remove generator from vehicle and disassemble, inspect and correct or replace faulty parts.
- 4) *Method of grounding F terminal (HITACHI make only)

Gasoline engine model

Contact tip of wire with brush and attach wire to generator body.

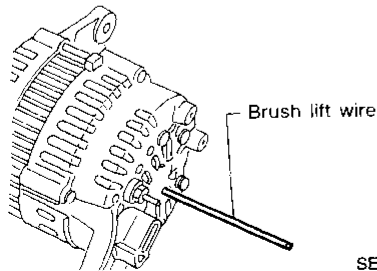

SEL030Z

- 5) Terminals "S", "L", "B" and "E" are marked on rear cover of generator.

CHARGING SYSTEM

Generator

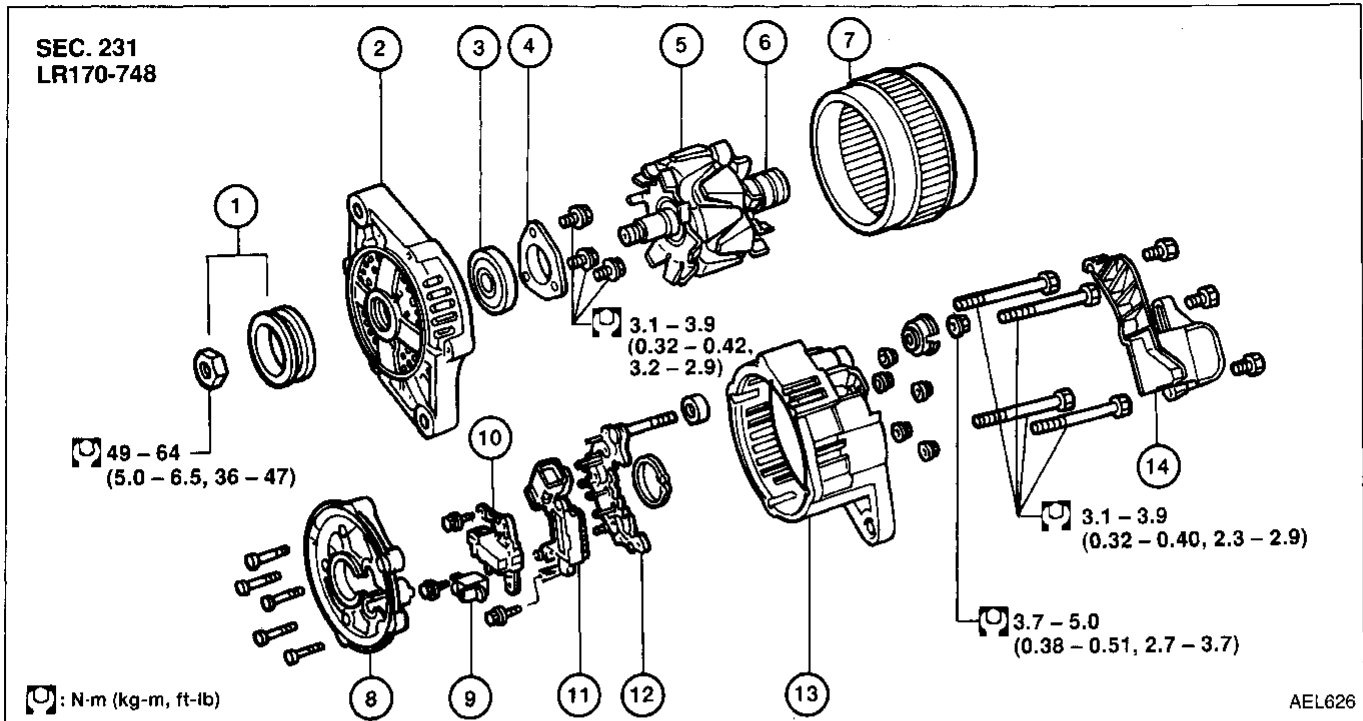

- | | | |
|-------------------|------------------|---|
| ① Pulley assembly | ⑥ Slip ring | ⑪ IC regulator assembly |
| ② Front cover | ⑦ Stator | ⑫ Diode assembly |
| ③ Front bearing | ⑧ Fan guide | ⑬ Rear cover |
| ④ Retainer | ⑨ Condenser | ⑭ Rear cover protector
(A/T models only) |
| ⑤ Rotor | ⑩ Brush assembly | |

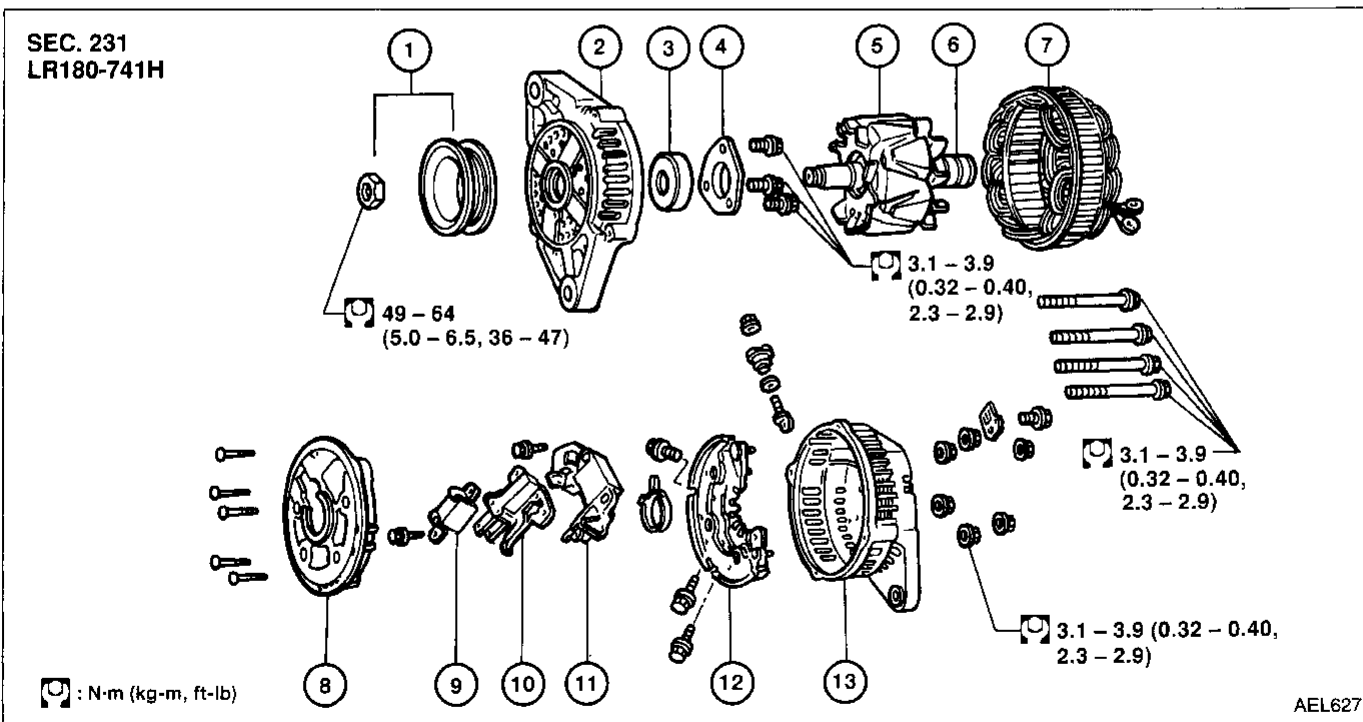

- | | | |
|-------------------|-------------|-------------------------|
| ① Pulley assembly | ⑥ Slip ring | ⑩ Brush assembly |
| ② Front cover | ⑦ Stator | ⑪ IC regulator assembly |
| ③ Front bearing | ⑧ Fan guide | ⑫ Diode assembly |
| ④ Retainer | ⑨ Condenser | ⑬ Rear cover |
| ⑤ Rotor | | |

CHARGING SYSTEM

Diode Check

MAIN DIODES

- In order to check diodes, they must be unsoldered from the stator.
- Use an ohmmeter to check condition of diodes as indicated in chart below.
- If any of the test results are not satisfactory, replace diode assembly.

	Ohmmeter probes		Judgement
	Positive ⊕	Negative ⊖	
Diodes check (Positive side)	Positive diode plate	Diode terminals	Diode conducts in only one direction.
	Diode terminals	Positive diode plate	
Diodes check (Negative side)	Negative diode plate	Diode terminals	Diode conducts in only one direction.
	Diode terminals	Negative diode plate	

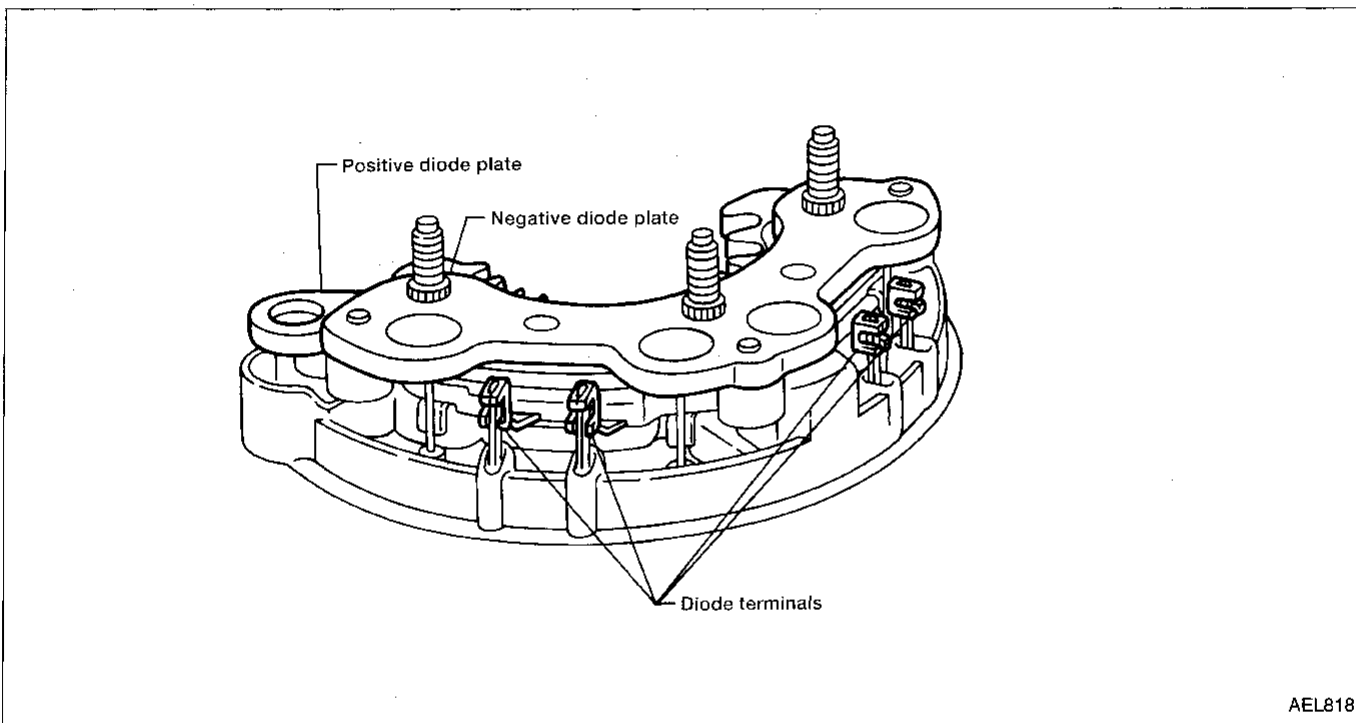

GI

MA

EM

LC

EC

FE

CL

MT

AT

FA

RA

BR

ST

RS

BT

HA

EL

IDX

CHARGING SYSTEM

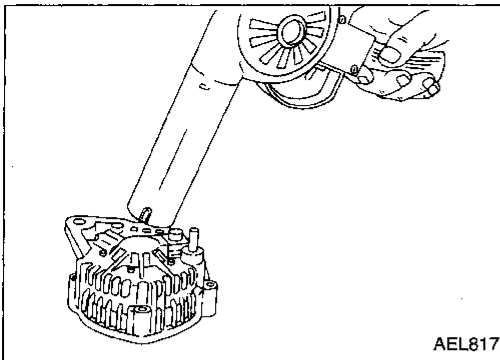

AEL817

Disassembly and Assembly

1. Remove rear cover.
 - Heat rear cover, using heat gun, to 50°C (90°F) above room temperature to prevent bearing damage.

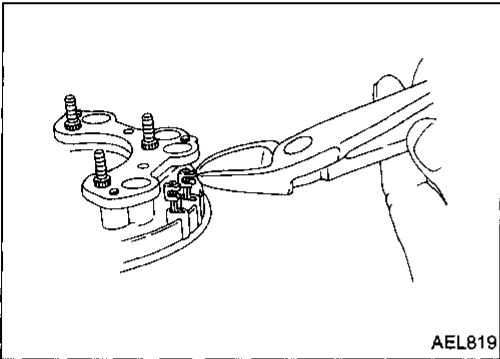

AEL819

2. Disconnect stator/diode.
 - Cut diode terminals.
 - Unsolder stator coil leads.

CAUTION:

Unsolder stator coil leads as fast as possible to avoid damaging diodes.

3. Remove stator and rotor.
4. Remove bearing retainer and bearing.
5. Assemble in reverse of disassembly.

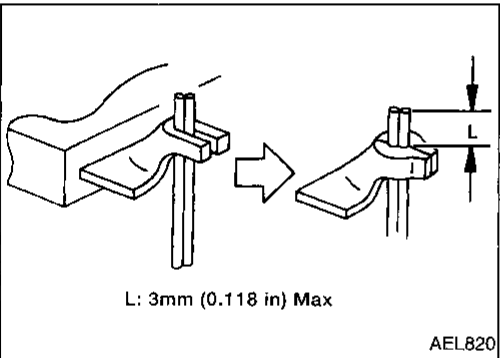

AEL820

- Insert stator coil lead into lower portion of diode terminal.
- Using pliers, crimp diode terminal around stator coil lead.
- Be sure stator coil leads do not protrude more than 3 mm (0.118 in.) past diode terminal.

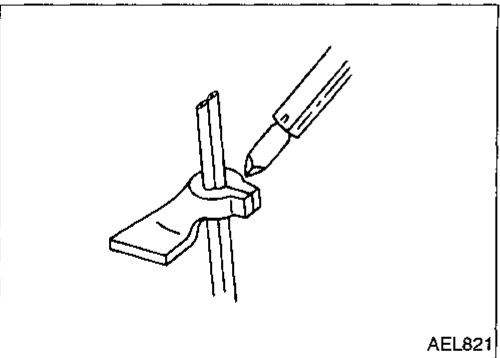

AEL821

- Solder stator coil lead and diode terminals.

CAUTION:

Solder stator coil leads and diode terminals as fast as possible to avoid damaging diodes. Use 9/1 Pb/Sn solder in assembly.

CHARGING SYSTEM

Service Data and Specifications (SDS)

GENERATOR

Type		LR180-741H	LR170-748
		HITACHI	HITACHI
Applied model		SR20DE	GA16DE
Nominal rating	V-A	12-80	12-70
Ground polarity		Negative	
Minimum revolution under no-load (When 13.5 volts is applied)	rpm	Less than 1,000	Less than 1,000
Hot output current	A/rpm	More than 23/1,300 More than 63/2,500 More than 77/5,000	More than 22/1,300 More than 50/2,500 More than 67/5,000
Regulated output voltage	V	14.1 - 14.7	
Minimum length of brush	mm (in)	6.0 (0.236)	6.0 (0.236)
Brush spring pressure	N (g, oz)	1,000 - 3,432 (102 - 350, 3.60 - 12.34)	1,000 - 3,432 (102 - 350, 360 - 12.34)
Slip ring minimum outer diameter	mm (in)	More than 26.0 (1.024)	More than 26.0 (1.024)
Rotor (Field coil) resistance	Ω	2.6 - 2.7	2.5 - 2.6

GI
MA
EM
LC
EC
FE
CL
MT
AT
FA
RA
BR
ST
RS
BT
HA
EL
IDX

COMBINATION SWITCH

Combination Switch/Check

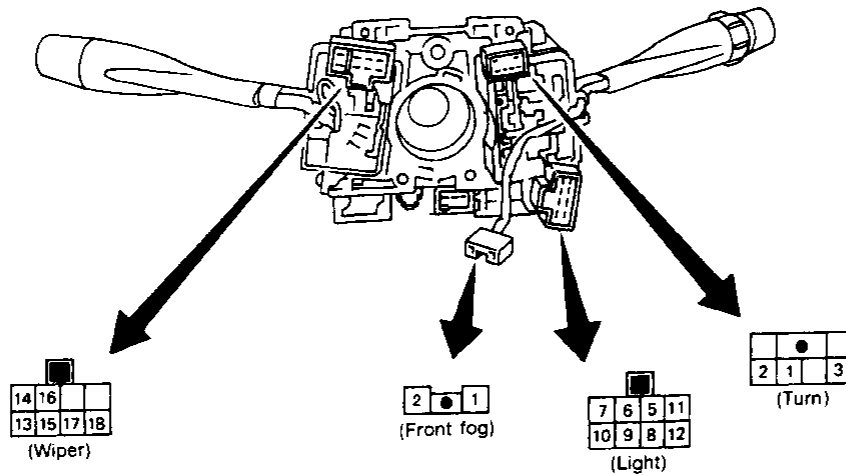
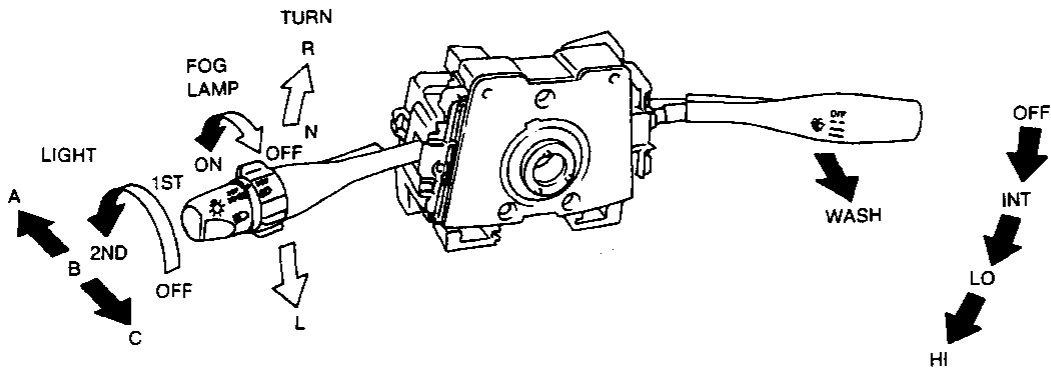

LIGHTING SWITCH

	OFF			1ST			2ND		
	A	B	C	A	B	C	A	B	C
5			○		○	○	○	○	○
6			○		○	○			
7									○
8			○		○	○	○	○	○
9			○		○	○			
10									○
11					○	○	○	○	○
12					○	○	○	○	○

WIPER SWITCH

	OFF	INT	LO	HI	WASH
	13	○	○		
14	○	○			
15		○			
16				○	
17		○	○	○	○
18					○

TURN SIGNAL SWITCH

	R	N	L
	1	○	
2	○		
3			○

FRONT FOG LAMP SWITCH

	OFF	ON
	2	
1		○

COMBINATION SWITCH

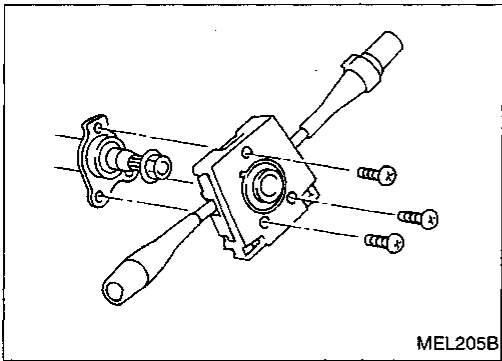
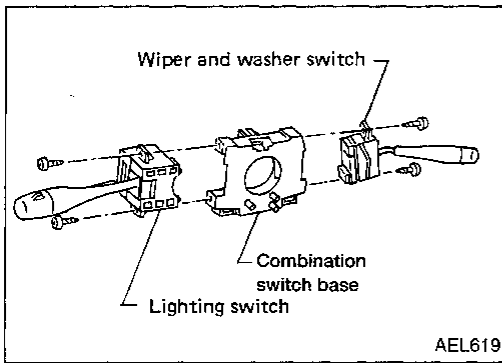

Combination Switch/Replacement

- Each switch can be replaced without removing combination switch base.
- To remove combination switch base, remove base attaching screws.

GI

MA

EM

LC

EC

FE

CL

MT

AT

FA

RA

BR

ST

RS

BT

HA

EL

IDX

COMBINATION SWITCH

Steering Switch/Check

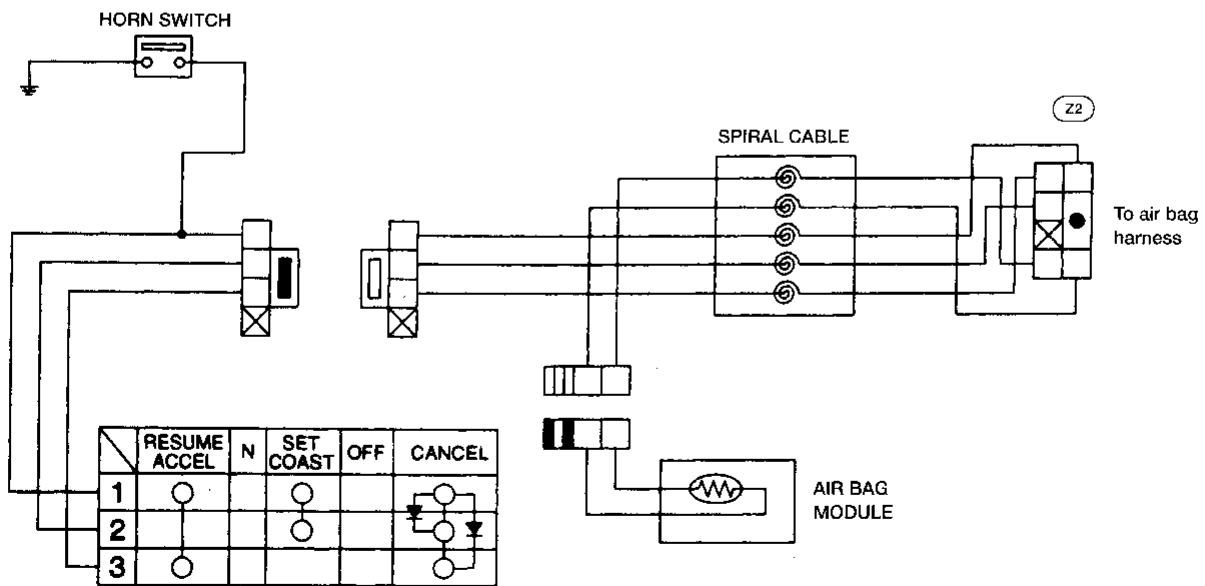
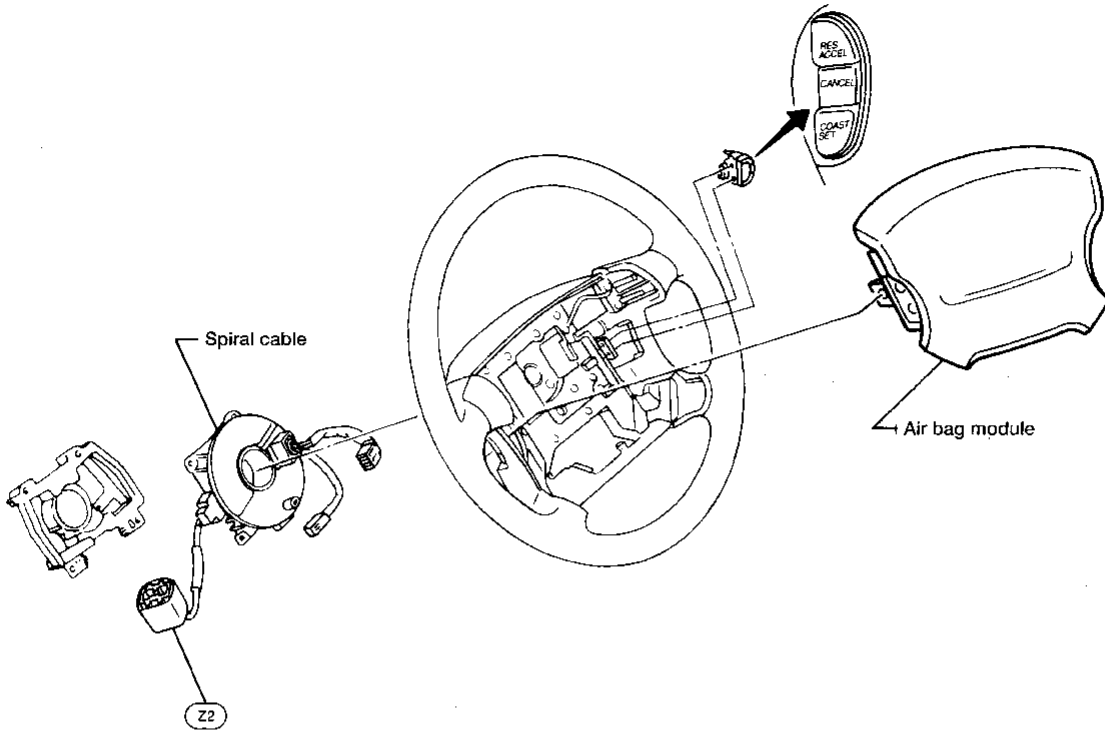

HEADLAMP

System Description (For USA)*

The headlamps are controlled by the lighting switch which is built into the combination switch. Power is supplied at all times:

- to lighting switch terminal ⑤
- through 15A fuse (No. ③⑨ , located in the fusible link and fuse box), and
- to lighting switch terminal ⑧
- through 15A fuse (No. ④① , located in the fusible link and fuse box).

Low beam operation

When the lighting switch is turned to the 2ND position and placed in LOW ("B") position, power is supplied:

- from lighting switch terminal ⑩
- to terminal ② of the LH headlamp, and
- from lighting switch terminal ⑦
- to terminal ② of the RH headlamp.

Terminal ③ of each headlamp supplies ground through body grounds ①⑩③ and ①②⑤. With power and ground supplied, the headlamp(s) will illuminate.

High beam operation/flash-to-pass operation

When the lighting switch is placed in the 2ND position and placed in HIGH ("A") or Pass ("C") position, power is supplied:

- from lighting switch terminal ⑥
- to terminal ① of the RH headlamp, and
- from lighting switch terminal ⑨
- to terminal ① of the LH headlamp, and
- to combination meter terminal ⑬ (⑫) for the HI BEAM indicator.

Ground is supplied to terminal ⑱ (⑲) of the combination meter through body grounds ①④③, ①④④ and ①⑤①.

With power and ground supplied, the high beams and the HI BEAM indicator illuminate.

Theft warning system

The theft warning system will flash the high beams if the system is triggered. Refer to "System Description", "THEFT WARNING SYSTEM", (EL-190).

*: Terminal numbers in () are for models without tachometer.

GI
MA
EM
LC
EC
FE
CL
MT
AT
FA
RA
BR
ST
RS
BT
HA
EL
IDX

HEADLAMP

Wiring Diagram (For USA) -H/LAMP-

EL-H/LAMP-01

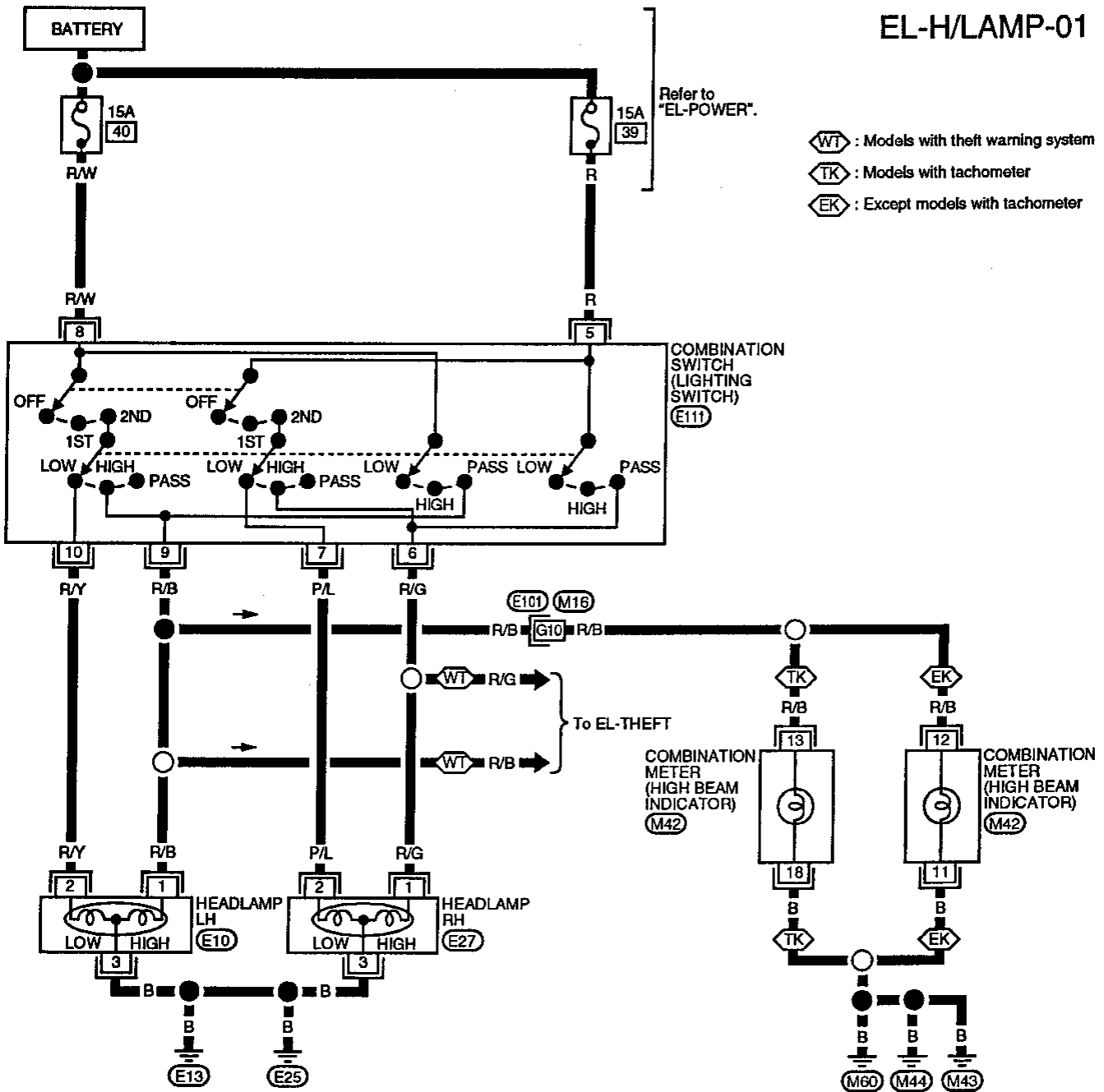

Refer to "EL-POWER".

- ⬡ WT : Models with theft warning system
- ⬡ TK : Models with tachometer
- ⬡ EK : Except models with tachometer

COMBINATION SWITCH (LIGHTING SWITCH) (E11)

To EL-THEFT

COMBINATION METER (HIGH BEAM INDICATOR) (M42)

COMBINATION METER (HIGH BEAM INDICATOR) (M42)

Refer to last page (Foldout page).
 (M16) . (E10)

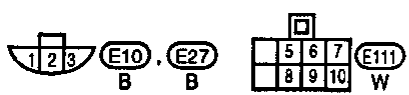
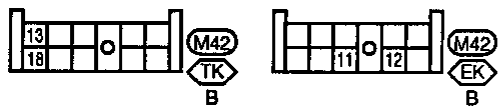

HEADLAMP

Trouble Diagnoses (For USA)

Symptom	Possible cause	Repair order
LH headlamps do not operate.	<ol style="list-style-type: none"> 1. Bulb 2. Grounds (E13) and (E25) 3. 15A fuse 4. Lighting switch 	<ol style="list-style-type: none"> 1. Check bulb. 2. Check grounds (E13) and (E25). 3. Check 15A fuse (No. 40), located in fusible link and fuse box). Verify battery positive voltage is present at terminal (8) of lighting switch. 4. Check lighting switch.
RH headlamps do not operate.	<ol style="list-style-type: none"> 1. Bulb 2. Grounds (E13) and (E25) 3. 15A fuse 4. Lighting switch 	<ol style="list-style-type: none"> 1. Check bulb. 2. Check grounds (E13) and (E25). 3. Check 15A fuse (No. 39), located in fusible link and fuse box). Verify battery positive voltage is present at terminal (5) of lighting switch. 4. Check lighting switch.
LH high beam does not operate, but LH low beam operates.	<ol style="list-style-type: none"> 1. Bulb 2. Open in LH high beam circuit 3. Lighting switch 	<ol style="list-style-type: none"> 1. Check bulb. 2. Check R/B wire between lighting switch and LH headlamp for an open circuit. 3. Check lighting switch.
LH low beam does not operate, but LH high beam operates.	<ol style="list-style-type: none"> 1. Bulb 2. Open in LH low beam circuit 3. Lighting switch 	<ol style="list-style-type: none"> 1. Check bulb. 2. Check R/Y wire between lighting switch and LH headlamp for an open circuit. 3. Check lighting switch.
RH high beam does not operate, but RH low beam operates.	<ol style="list-style-type: none"> 1. Bulb. 2. Open in RH high beam circuit 3. Lighting switch. 	<ol style="list-style-type: none"> 1. Check bulb. 2. Check R/G wire between lighting switch and RH headlamp for an open circuit. 3. Check lighting switch.
RH low beam does not operate, but RH high beam operates.	<ol style="list-style-type: none"> 1. Bulb 2. Open in RH low beam circuit 3. Lighting switch 	<ol style="list-style-type: none"> 1. Check bulb. 2. Check P/L wire between lighting switch and RH headlamp for an open circuit. 3. Check lighting switch.
High beam indicator does not work.	<ol style="list-style-type: none"> 1. Bulb 2. Grounds (M43), (M44) and (M60) 3. Open in high beam circuit 	<ol style="list-style-type: none"> 1. Check bulb in combination meter. 2. Check grounds (M43), (M44) and (M60). 3. Check R/B wire between lighting switch and combination meter for an open circuit.

G1

MA

EM

LC

EC

FE

CL

MT

AT

FA

FA

BR

ST

RS

BT

HA

EL

IDX

System Description (For Canada)

The headlamp system for Canada vehicles contains a daytime light control unit. This unit activates the high beam headlamps at approximately half illumination whenever the engine is running. If the parking brake is applied before the engine is started, daytime lights will not be illuminated. The daytime lights will illuminate once the parking brake is released. Thereafter, the daytime lights will continue to operate when the parking brake is applied. For location of daytime light control unit, refer to EL-224.

Power is supplied at all times:

- through 15A fuse (No. 39 , located in the fusible link and fuse box)
- to daytime light control unit terminal ② and
- to lighting switch terminal ⑤.

Power is also supplied at all times:

- through 15A fuse (No. 40 , located in the fusible link and fuse box)
- to daytime light control unit terminal ③ and
- to lighting switch terminal ⑧.

With the ignition switch in the ON or START position, power is supplied:

- through 7.5A fuse (No. 7 , located in the fuse block [HEC])
- to daytime light control unit terminal ⑫.

Ground is supplied to daytime light control unit terminal ⑨ through body grounds M43 , M44 and M60 .

HEADLAMP OPERATION

Low beam operation

When the lighting switch is moved to the 2ND position and placed in LOW ("B") position (low beam operation), power is supplied:

- from lighting switch terminal ⑦
- to RH headlamp terminal ②.

Ground is supplied to RH headlamp terminal ③ through body grounds E13 and E25 .

Also, when the lighting switch is moved to the 2ND position and placed in LOW ("B") position (low beam operation), power is supplied:

- from lighting switch terminal ⑩
- to LH headlamp terminal ②.

Ground is supplied:

- to LH headlamp terminal ③
- from daytime light control unit terminal ⑦
- through daytime light control unit terminal ⑨
- through body grounds M43 , M44 and M60 .

With power and ground supplied, the low beam headlamps illuminate.

High beam operation/Flash-to-pass operation

When the lighting switch is moved to the 2ND position and placed in HIGH ("A") or Pass ("C") position, power is supplied:

- from lighting switch terminal ⑥
- to RH headlamp terminal ①, and
- from lighting switch terminal ⑨
- to daytime light control unit terminal ⑤
- through daytime light control unit terminal ⑥
- to LH headlamp terminal ①.

Ground is supplied in the same manner as low beam operation.

With power and ground supplied, the high beam headlamps illuminate.

HEADLAMP

System Description (For Canada) (Cont'd)

DAYTIME LIGHT OPERATION

With the engine running and the lighting switch in the OFF position, power is supplied:

- to daytime light control unit terminal ③
- through daytime light control unit terminal ⑥
- to LH headlamp terminal ①
- through LH headlamp terminal ③
- to daytime light control unit terminal ⑦
- through daytime light control unit terminal ⑧
- to RH headlamp terminal ①.

Ground is supplied to RH headlamp terminal ③ through body grounds (E13) and (E25).

Because the high beam headlamps are now wired in series, they operate at half illumination.

Operation (Daytime light system for Canada)

The headlamps' high beams automatically turn on after starting the engine with the lighting switch in "OFF" or "1st" position. Lighting switch operations other than the above are the same as conventional light systems.

Engine		With engine stopped									With engine running									
		OFF			1ST			2ND			OFF			1ST			2ND			
Lighting switch		A	B	C	A	B	C	A	B	C	A	B	C	A	B	C	A	B	C	
Headlamp	High beam	X	X	○	X	X	○	○	X	○	△*	△*	○	△*	△*	○	○	○	X	○
	Low beam	X	X	X	X	X	X	X	○	X	X	X	X	X	X	X	X	○	X	○
Front side marker and tail lamp		X	X	X	○	○	○	○	○	○	X	X	X	○	○	○	○	○	○	○
License and instrument illumination lamp		X	X	X	○	○	○	○	○	○	X	X	X	○	○	○	○	○	○	○

○: Lamp "ON"

X: Lamp "OFF"

△: Lamp dims.

□: Added functions

*: When starting the engine with the parking brake released, the daytime light will come ON.

When starting the engine with the parking brake pulled, the daytime light won't come ON.

HEADLAMP

Schematic (For Canada)

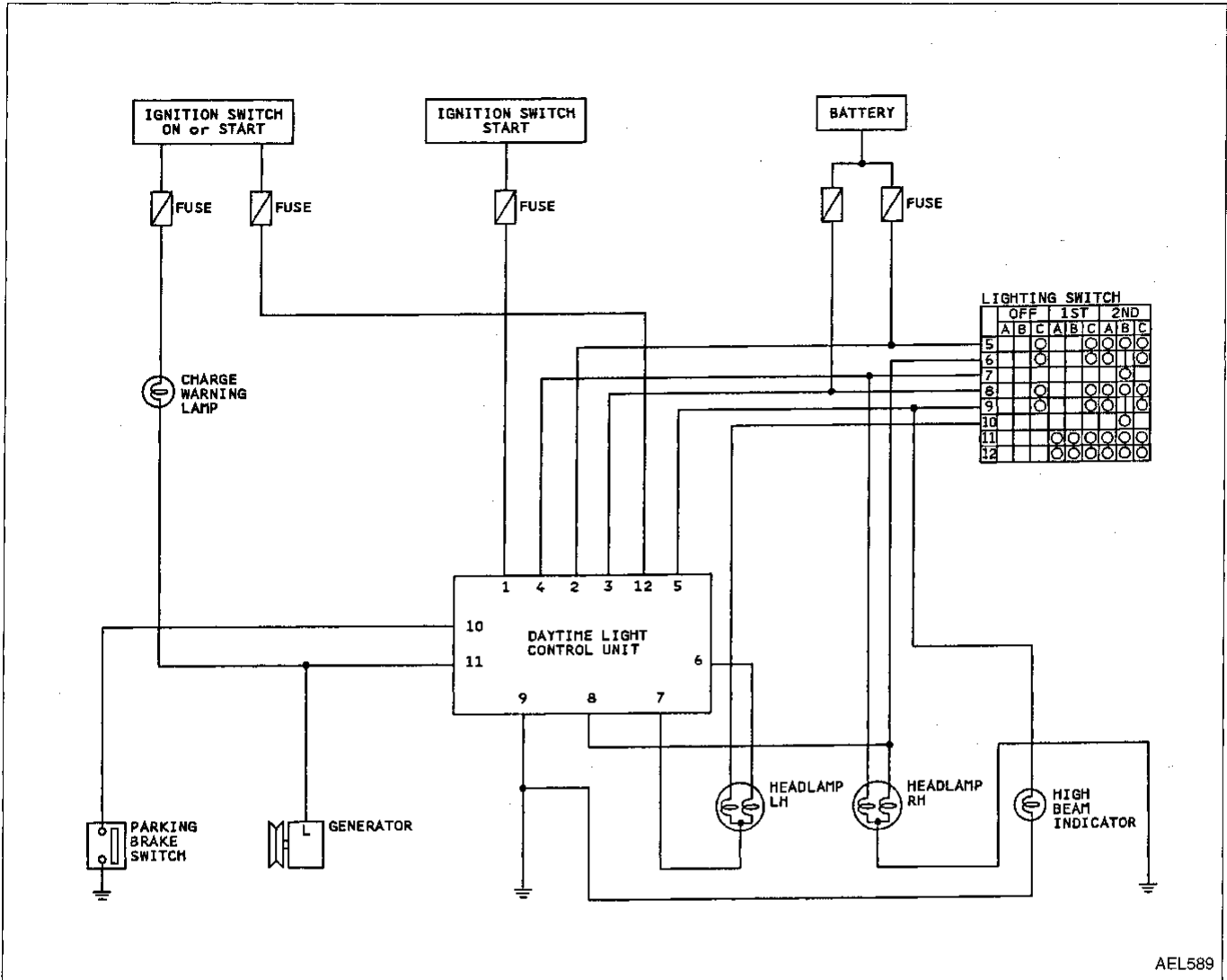

AEL589

HEADLAMP

Wiring Diagram (For Canada) -DTRL-

EL-DTRL-01

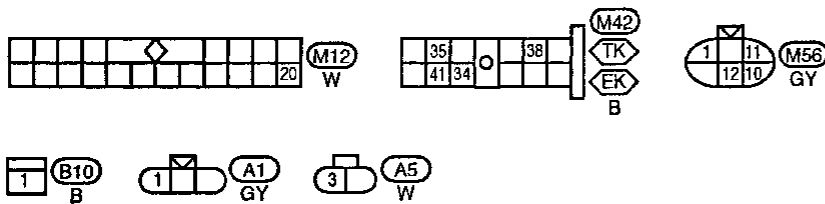
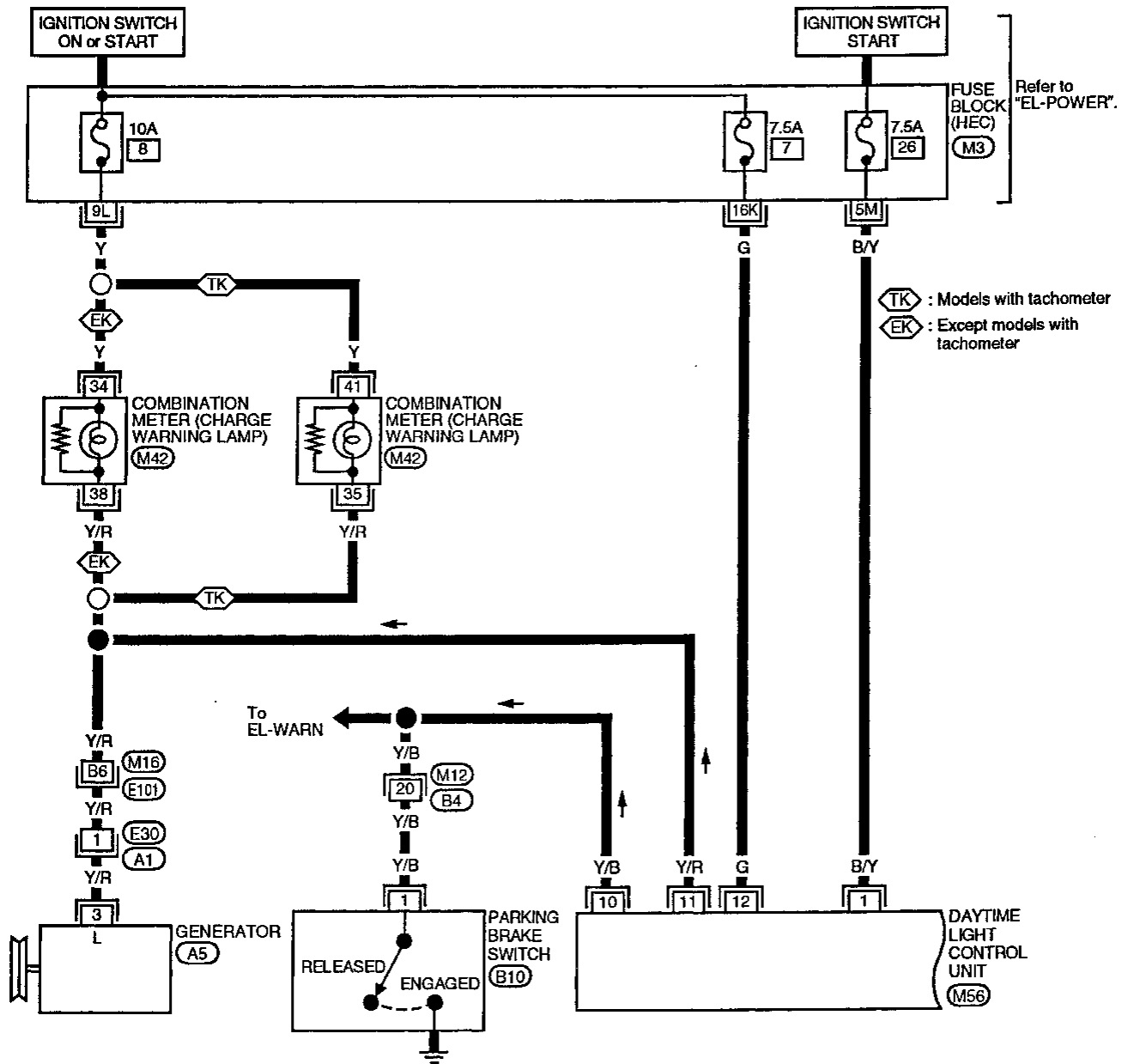

Refer to last page (Foldout page).

M16, E101
M3

GI
MA
EM
LC
EC
FE
CL
MT
AT
FA
RA
BR
ST
RS
BT
HA
EL
IDX

HEADLAMP

Wiring Diagram (For Canada) -DTRL- (Cont'd)

EL-DTRL-02

WT : Models with theft warning system

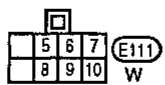
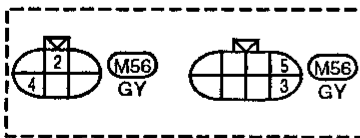
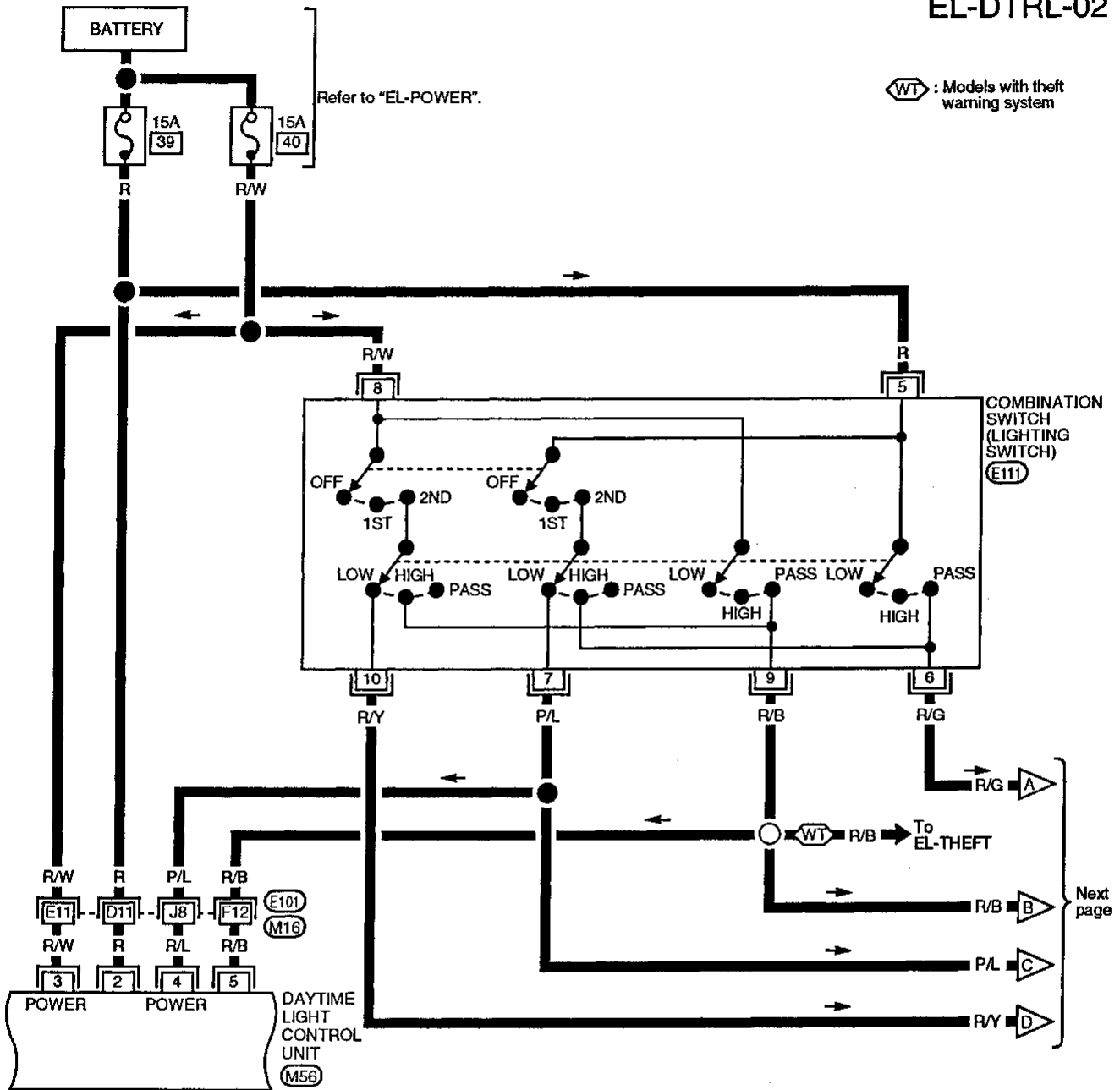

Refer to last page (Foldout page).
(M16), (E101)

HEADLAMP

Wiring Diagram (For Canada) -DTRL- (Cont'd)

EL-DTRL-03

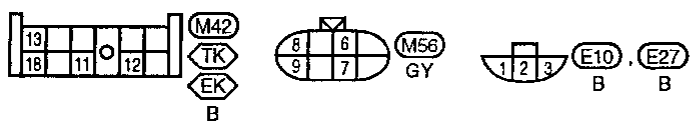
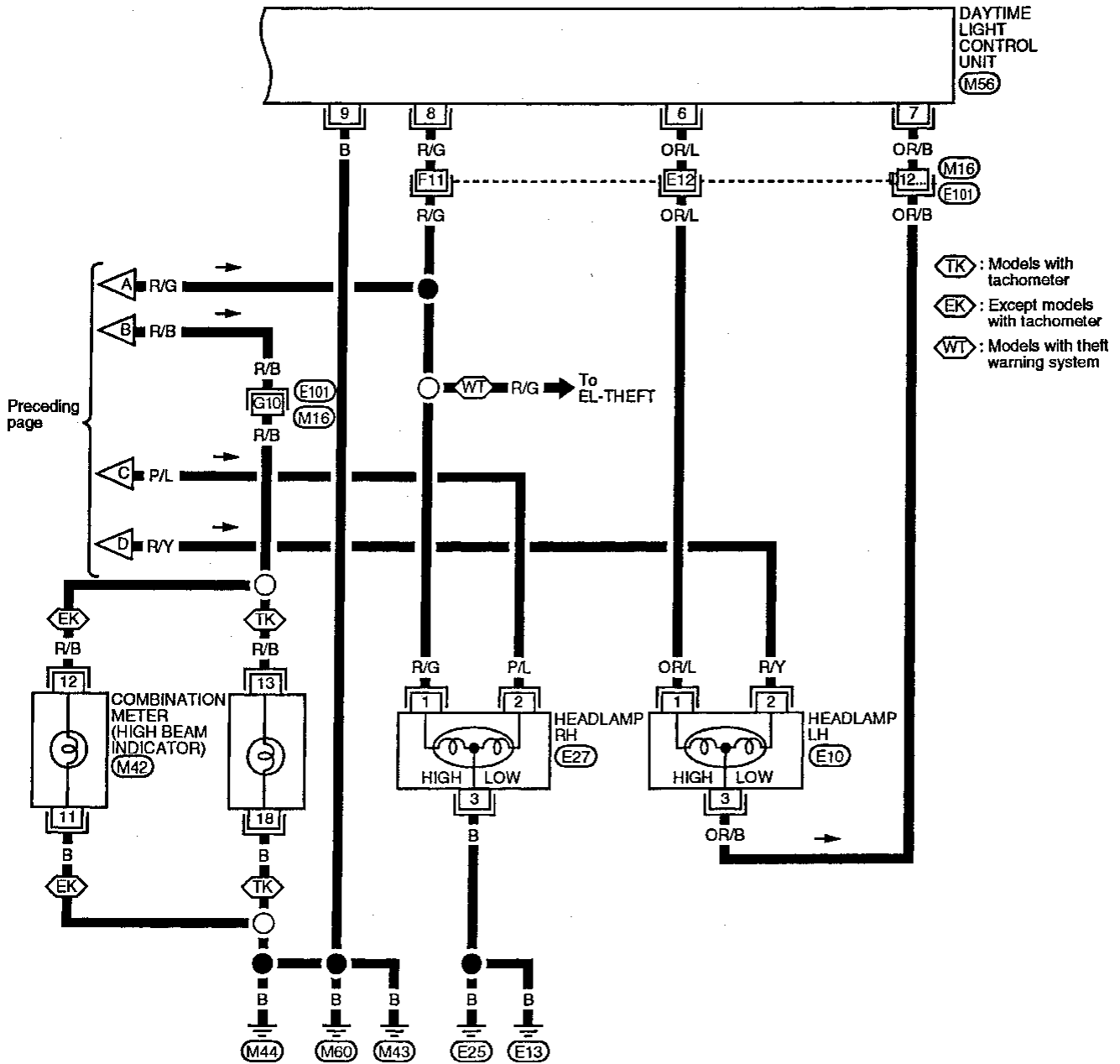

Refer to last page (Foldout page).
(M16) (E101)









GI
 MA
 EM
 LC
 EC
 FE
 CL
 MT
 AT
 FA
 RA
 BR
 ST
 RS
 BT
 HA
EL
 IDX

HEADLAMP

Trouble Diagnoses (For Canada)





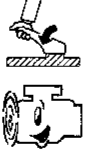
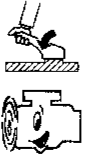

DAYTIME LIGHT CONTROL MODULE INSPECTION TABLE

(Data are reference values.)

Terminal No.	Item	Condition	Judgement standard
1	Start signal	 When turning ignition switch to "ST"	Battery positive voltage
		 When turning ignition switch to "ON" from "ST"	1V or less
		 When turning ignition switch to "OFF"	1V or less
2	Power source	 When turning ignition switch to "ON"	Battery positive voltage
		 When turning ignition switch to "OFF"	Battery positive voltage
3	Power source	 When turning ignition switch to "ON"	Battery positive voltage
		 When turning ignition switch to "OFF"	Battery positive voltage
4	Lighting switch (Lo beam)	When turning lighting switch to "HEAD" (2nd position)	Battery positive voltage
5	Lighting switch (Hi beam)	When turning lighting switch to "HI BEAM"	Battery positive voltage
		When turning lighting switch to "FLASH TO PASS"	Battery positive voltage
6	LH hi beam	When turning lighting switch to "HI BEAM"	Battery positive voltage
		 When releasing parking brake with engine running and turning lighting switch to "OFF" (day-time light operation) CAUTION: Block wheels and ensure selector lever is in "N" or "P" position.	Battery positive voltage
7	LH headlamp control (ground)	When lighting switch is turned to "HEAD"	1V or less
		 When releasing parking brake with engine running and turning lighting switch to "OFF" (day-time light operation) CAUTION: Block wheels and ensure selector lever is in "N" or "P" position.	Approx. half battery voltage
8	RH hi beam	When turning lighting switch to "HI BEAM"	Battery positive voltage
		 When releasing parking brake with engine running and turning lighting switch to "OFF" (day-time light operation) CAUTION: Block wheels and ensure selector lever is in "N" or "P" position.	Approx. half battery voltage

HEADLAMP

Trouble Diagnoses (For Canada) (Cont'd)

Ter- minal No.	Item	Condition		Judgement standard
9	Ground		—	—
10	Parking brake switch		When parking brake is released	Battery positive voltage
			When parking brake is set	1.5V or less
11	Alternator		When turning ignition switch to "ON"	1V or less
			When engine is running	Battery positive voltage
			When turning ignition switch to "OFF"	1V or less
12	Power source		When turning ignition switch to "ON"	Battery positive voltage
			When turning ignition switch to "ST"	Battery positive voltage
			When turning ignition switch to "OFF"	1V or less

GI
MA
EM
LC
EC
FE
CL
MT
AI
FA
RA
BR
ST
RS
BT
HA
EL
IDX

HEADLAMP

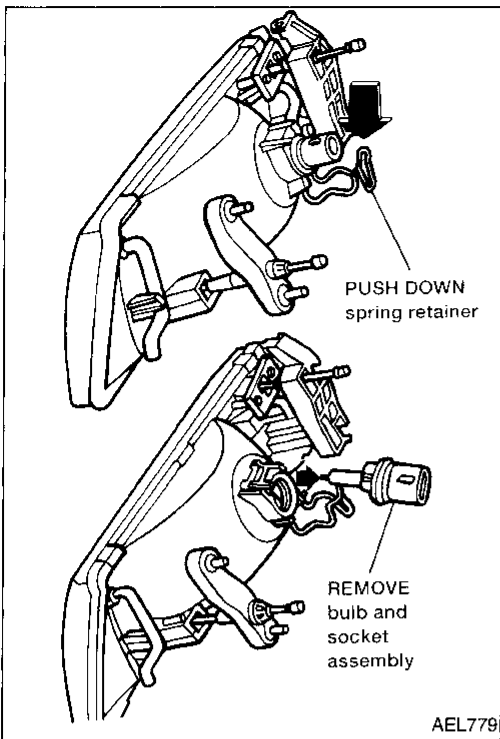

Bulb Replacement

The headlamp is a semi-sealed beam type which uses a replaceable halogen bulb. The bulb can be replaced from the engine compartment side without removing the headlamp body.

- **Grasp only the plastic base when handling the bulb. Never touch the glass envelope.**

1. Disconnect the battery cable.
2. If removing the right-hand (passenger side) headlamp bulb, it is necessary to first reposition the engine coolant reservoir.
3. Disconnect the electrical connector from the bulb.
4. Push down spring retainer.
5. Pull out the headlamp bulb and socket as an assembly. Do not shake or rotate the bulb when removing it. Do not handle the glass envelope.

CAUTION:

Do not leave headlamp reflector without bulb for a long period of time. Dust, moisture, smoke, etc. entering headlamp body may affect the performance of the headlamp. Remove headlamp bulb from the headlamp reflector just before a replacement bulb is installed.

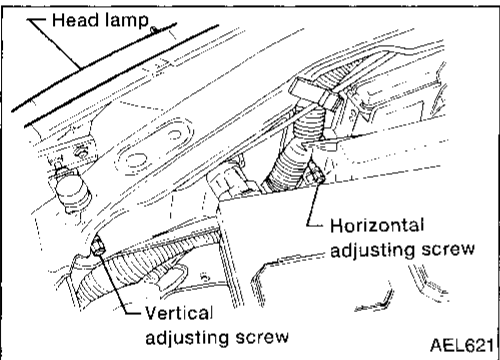

Aiming Adjustment

When performing headlamp aiming adjustment, use an aiming machine, aiming wall screen or headlamp tester. Aimers should be in good repair, calibrated and operated according to their operation manuals. Before performing aiming adjustment, make sure of the following:

- Keep all tires inflated to correct pressure.
- Place vehicle on level ground.
- See that vehicle is unloaded (except for full levels of coolant, engine oil and fuel, and spare tire, jack, and tools). Have the driver or equivalent weight placed in driver's seat.

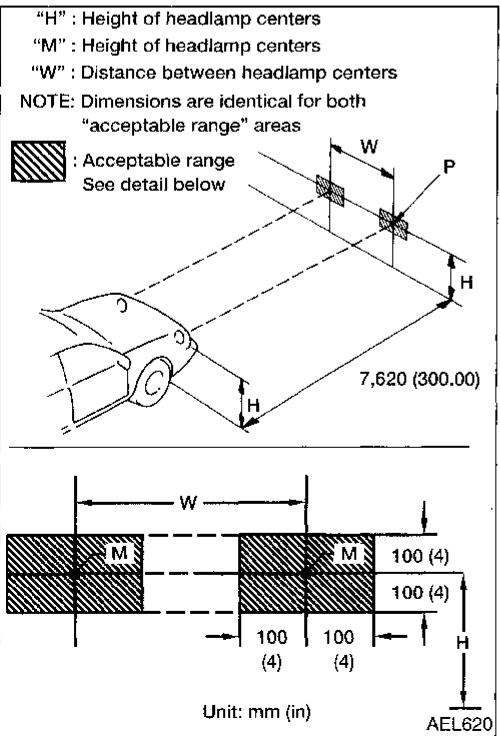

LOW BEAM

1. Open the hood.
2. **Vertical (Up and Down)**
 Adjust headlamp by turning adjusting screw so that main axis of light "M" is within acceptable range.
3. **Horizontal (Left to Right)**
 Adjust headlamp by turning adjusting screw so that main axis of light "M" is parallel with vehicle center line.

EXTERIOR LAMP

Back-up Lamp/Wiring Diagram -BACK/L-

EL-BACK/L-01

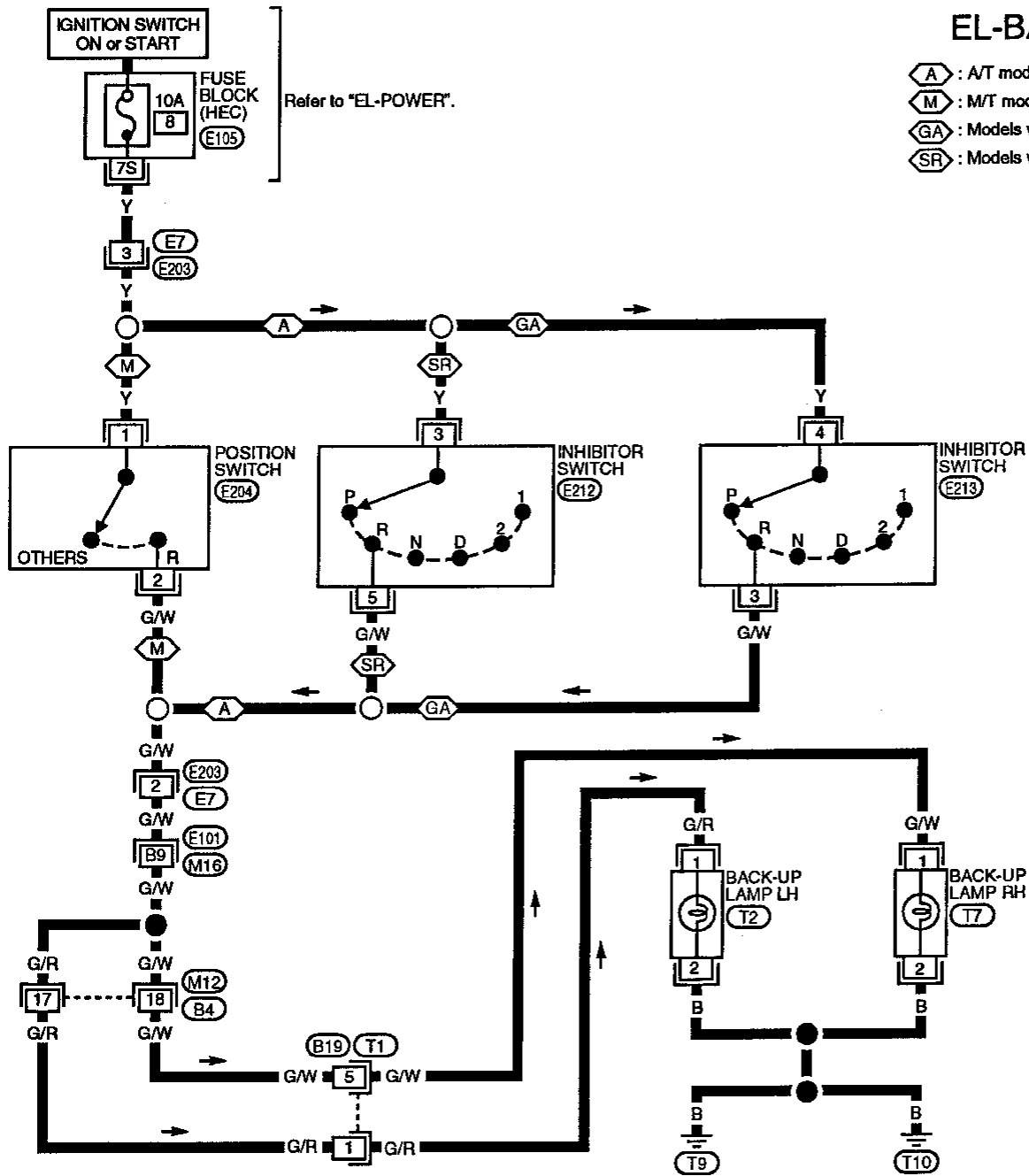

Refer to last page (Foldout page).
M16, E101

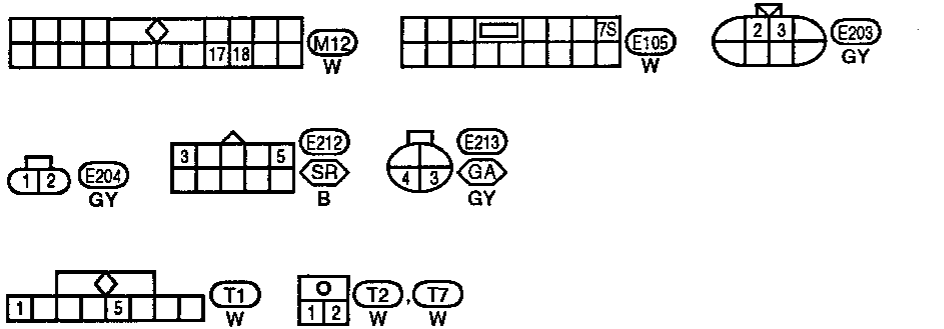

CI
MA
EM
LC
EC
FE
CL
MT
AT
FA
RA
BR
ST
RS
BT
HA
EL
IDX

EXTERIOR LAMP

License, Tail and Stop Lamps/Wiring Diagram -TAIL/L-

EL-TAIL/L-01

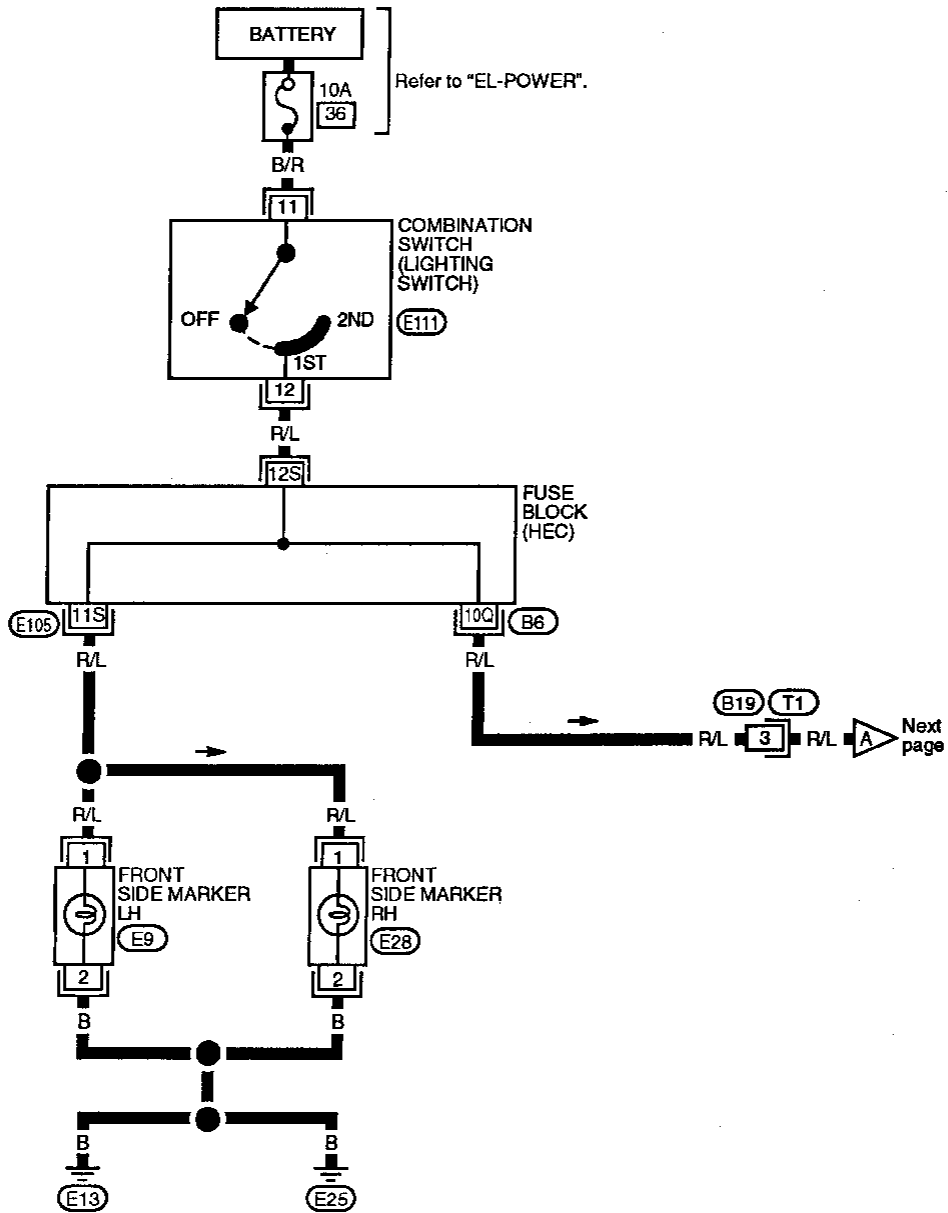

EXTERIOR LAMP

License, Tail and Stop Lamps/Wiring Diagram -TAIL/L- (Cont'd)

EL-TAIL/L-02

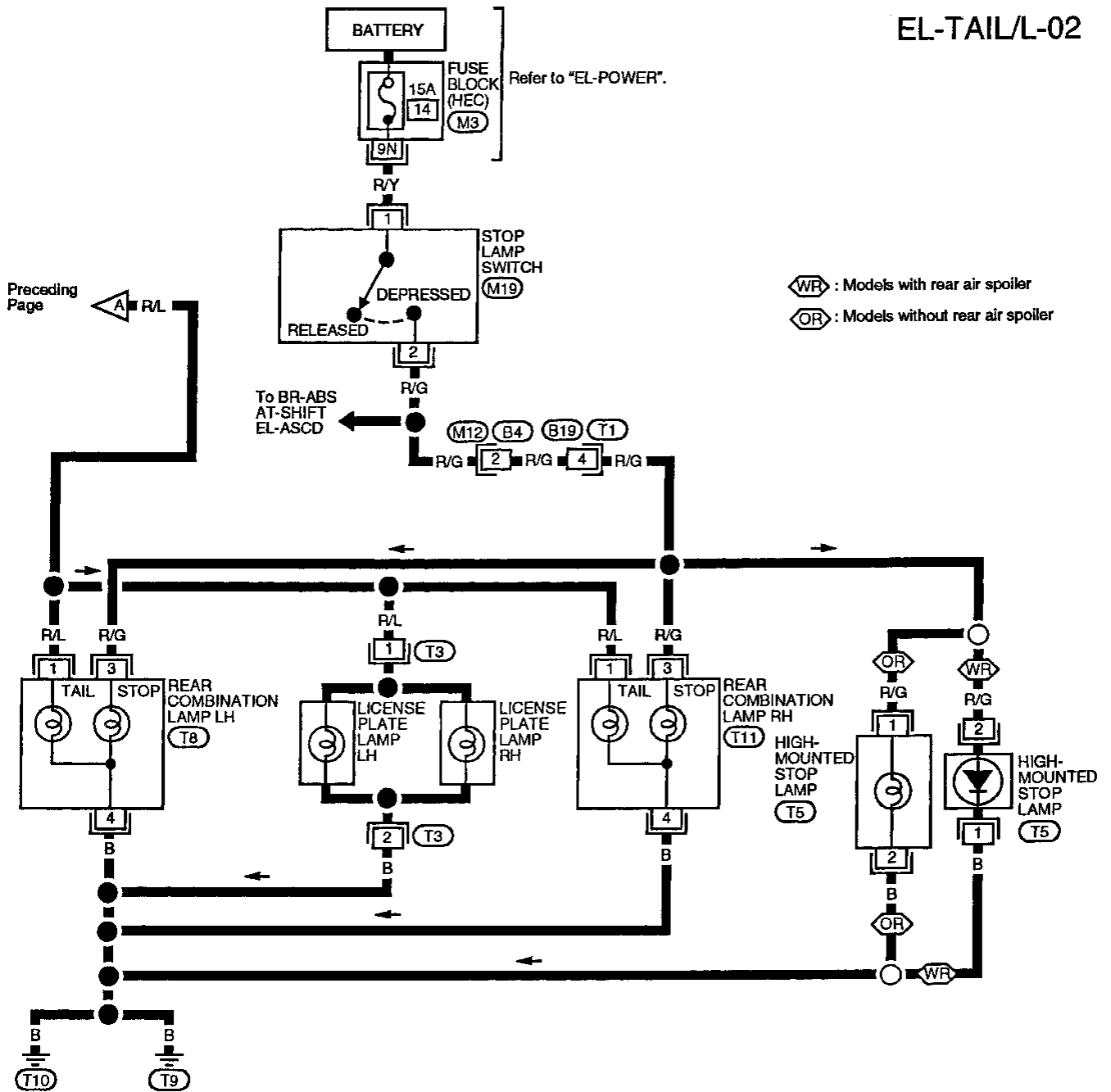

WR : Models with rear air spoiler
OR : Models without rear air spoiler

Preceding Page

Refer to last page (Foldout page).

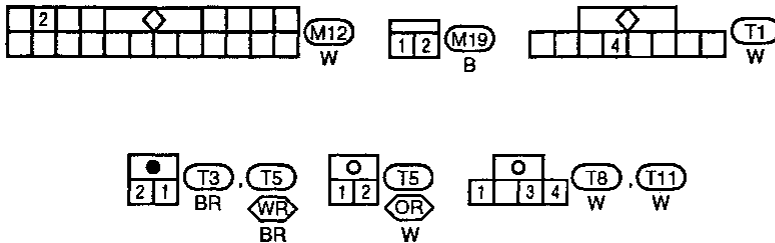

GI
MA
EM
LC
EC
FE
CL
MT
AT
FA
RA
BR
ST
RS
BT

HA

EL

IDX

Front Fog Lamp/System Description

Power is supplied at all times to front fog lamp relay terminal ③ through:

- 15A fuse (No. ③⑤ , located in the fusible link and fuse box).

With the lighting switch in the 2ND position and LOW ("B") position, power is supplied:

- through 15A fuse (No. ③⑨ , located in the fusible link and fuse box)
- to lighting switch terminal ⑤
- through terminal ⑦ of the lighting switch
- to front fog lamp relay terminal ①.

Fog lamp operation

The front fog lamp switch is built into the combination switch. The lighting switch must be in the 2ND position and LOW ("B") position for fog lamp operation.

With the front fog lamp switch in the ON position:

- ground is supplied to front fog lamp relay terminal ② through the front fog lamp switch and body grounds ①③ and ①⑤.

The front fog lamp relay is energized and power is supplied:

- from front fog lamp relay terminal ⑤
- to terminal ① of each front fog lamp.

Ground is supplied to terminal ② of each front fog lamp through body grounds ①③ and ①⑤.

With power and ground supplied, the front fog lamps illuminate.

EXTERIOR LAMP

Front Fog Lamp/Wiring Diagram -F/FOG-

EL-F/FOG-01

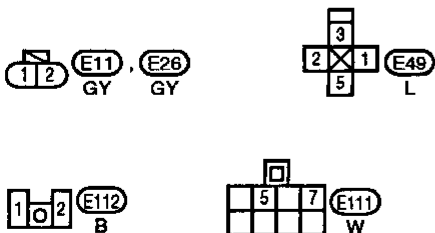
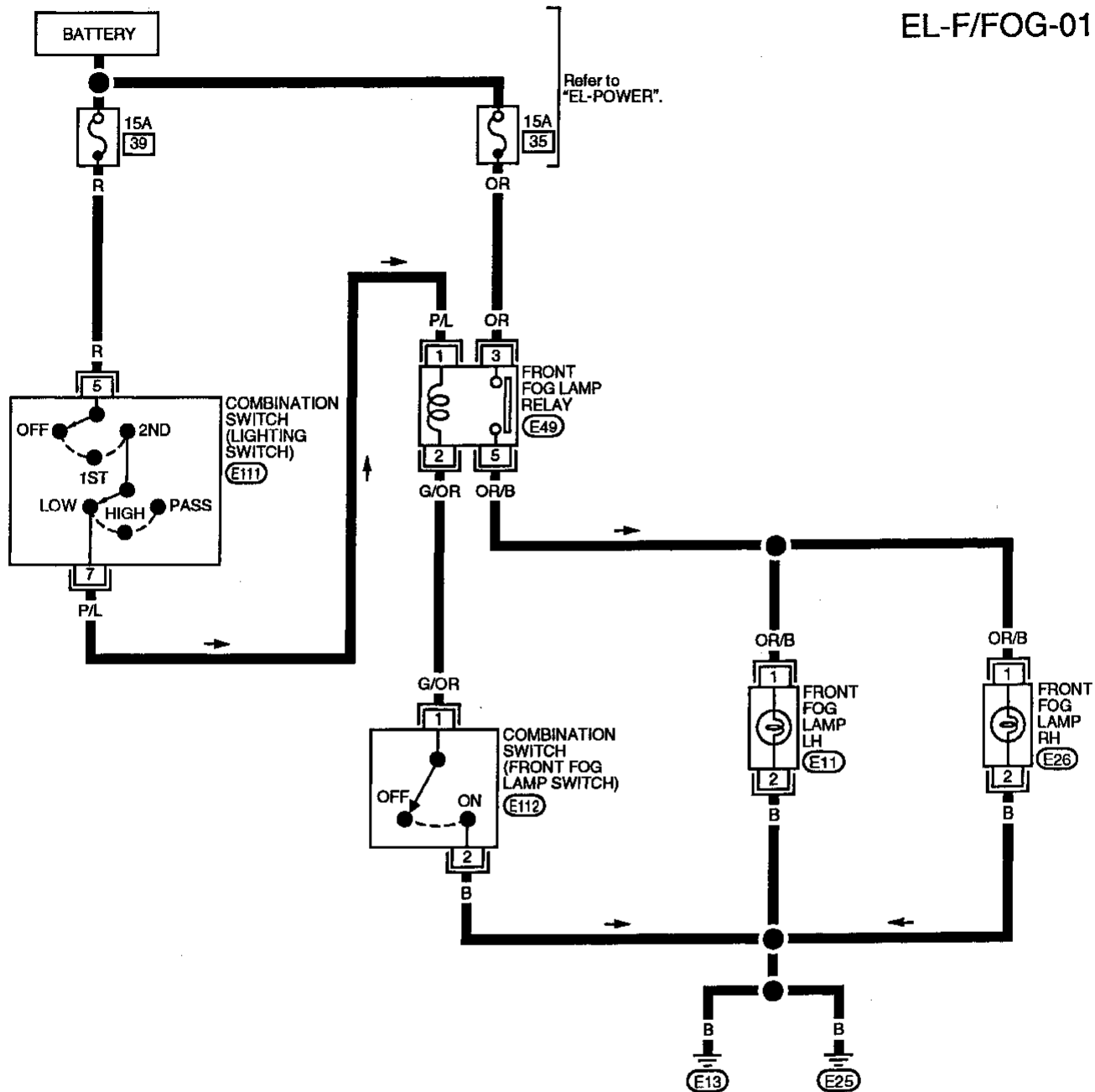

CI
MA
EM
LC
EC
FE
CL
WT
AT
FA
RA
BR
ST
RS
BT
HA

EL

IDX

EXTERIOR LAMP

Turn Signal and Hazard Warning Lamps/System Description*

TURN SIGNAL OPERATION

With the hazard switch in the OFF position and the ignition switch in the ON or START position, power is supplied:

- through 7.5A fuse (No. 111), located in the fuse block [HEC])
- to hazard switch terminal ②
- through terminal ① of the hazard switch
- to combination flasher unit terminal ①
- through terminal ③ of the combination flasher unit
- to turn signal switch terminal ①.

Ground is supplied to combination flasher unit terminal ② through body grounds (M43), (M44) and (M60).

LH turn

When the turn signal switch is moved to the LH position, power is supplied from turn signal switch terminal ③ to:

- front turn signal lamp LH terminal ③
- rear combination lamp LH terminal ②, and
- combination meter terminal ⑯ (17).

Ground is supplied to the front turn signal lamp LH terminal ② through body grounds (E13) and (E25).

Ground is supplied to the rear combination lamp LH terminal ④ through body grounds (T9) and (T10).

Ground is supplied to combination meter terminal 27 (28) through body grounds (M43), (M44) and (M60).

With power and grounds supplied, the combination flasher unit controls the flashing of the LH turn signal lamps.

RH turn

When the turn signal switch is moved to the RH position, power is supplied from turn signal switch terminal ② to:

- front turn signal lamp RH terminal ③
- rear combination lamp RH terminal ②, and
- combination meter terminal 26 (27).

Ground is supplied to the front turn signal lamp RH terminal ② through body grounds (E13) and (E25).

Ground is supplied to the rear combination lamp RH terminal ④ through body grounds (T9) and (T10).

Ground is supplied to combination meter terminal 27 (28) through body grounds (M43), (M44) and (M60).

With power and grounds supplied, the combination flasher unit controls the flashing of the RH turn signal lamps.

HAZARD LAMP OPERATION

Power is supplied at all times to hazard switch terminal ③ through:

- 10A fuse (No. 15), located in the fuse block [HEC]).

With the hazard switch in the ON position, power is supplied:

- through terminal ① of the hazard switch
- to combination flasher unit terminal ①
- through terminal ③ of the combination flasher unit
- to hazard switch terminal ④.

Ground is supplied to combination flasher unit terminal ② through body grounds (M43), (M44) and (M60).

Power is supplied through terminal ⑤ of the hazard switch to:

- front turn signal lamp LH terminal ③
- rear combination lamp LH terminal ②, and
- combination meter terminal ⑯ (17).

Power is supplied through terminal ⑥ of the hazard switch to:

- front turn signal lamp RH terminal ③
- rear combination lamp RH terminal ②, and
- combination meter terminal 26 (27).

Ground is supplied to terminal ② of the front turn signal lamps through body grounds (E13) and (E25).

Ground is supplied to terminal ④ of the rear combination lamps through body grounds (T9) and (T10).

Ground is supplied to combination meter terminal 27 (28) through body grounds (M43), (M44) and (M60).

With power and ground supplied, the combination flasher unit controls the flashing of the hazard warning lamps.

*: Terminal numbers in () are for models without tachometer.

EXTERIOR LAMP

Turn Signal and Hazard Warning Lamps/System Description* (Cont'd)

WITH MULTI-REMOTE CONTROL SYSTEM

Power is supplied at all times:

- through 10A fuse (No. 15), located in the fuse block [HEC]
- to multi-remote control relay-1 terminals ①, ⑥ and ③
- to multi-remote control relay-2 terminal ①.

Ground is supplied to multi-remote control relays-1, -2 terminal ②, when the multi-remote control system is triggered, through the smart entrance control unit.

Refer to EL-152 "MULTI-REMOTE CONTROL SYSTEM".

The multi-remote control relays-1, -2 are energized.

Power is disconnected to the turn signal switch.

Power is supplied through terminal ⑤ of the multi-remote control relay-1:

- to front turn signal lamp LH terminal ③
- to rear combination lamp LH terminal ②
- to combination meter terminal ⑩ (17).

Power is supplied through terminal ⑦ of the multi-remote control relay-1:

- to front turn signal lamp RH terminal ③
- to rear combination lamp RH terminal ②
- to combination meter terminal ⑲ (27).

Ground is supplied to terminal ② of each front turn signal lamp through body grounds E13 and E25.

Ground is supplied to terminal ④ of the rear combination lamps through body grounds T9 and T10.

Ground is supplied to combination meter terminal ⑳ (28) through body grounds M43, M44 and M60.

With power and ground supplied, the smart entrance control unit controls the flashing of the hazard warning lamps.

*: Terminal numbers in () are for models without tachometer.

GI

MA

EM

LC

EC

FE

CL

MT

AT

FA

RA

BR

ST

RS

BT

HA

EL

IDX

EXTERIOR LAMP

Turn Signal and Hazard Warning Lamps/Wiring Diagram -TURN-

EL-TURN-01

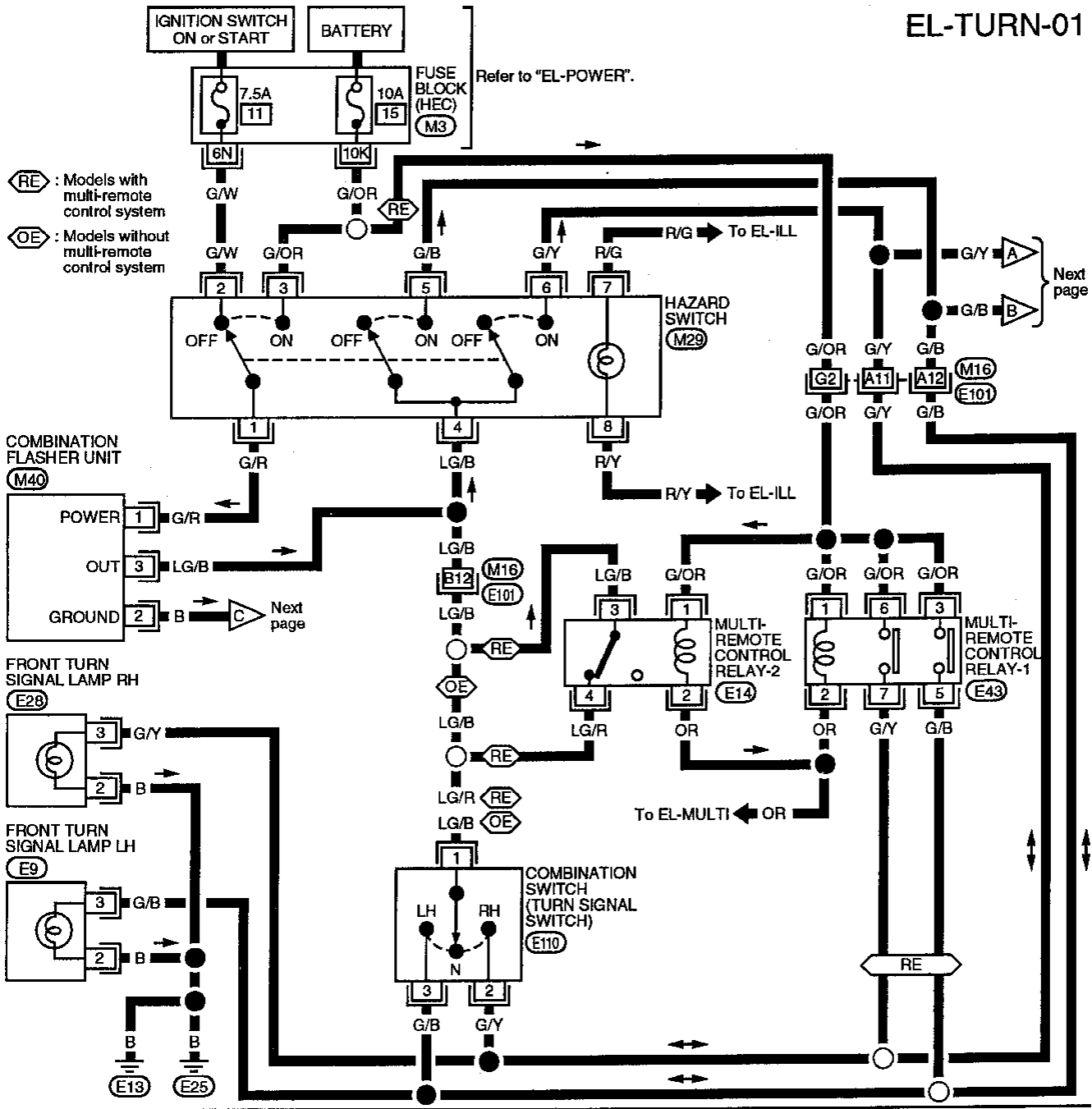

Refer to last page (Foldout page).

(M16), (E101)
(M3)

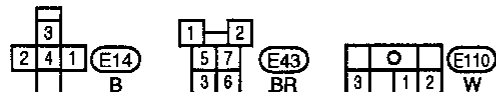
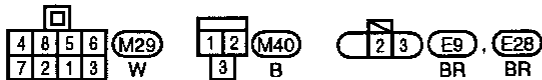

EXTERIOR LAMP

Turn Signal and Hazard Warning Lamps/Wiring Diagram -TURN- (Cont'd)

EL-TURN-02

TK : Models with tachometer
 EK : Except models with tachometer

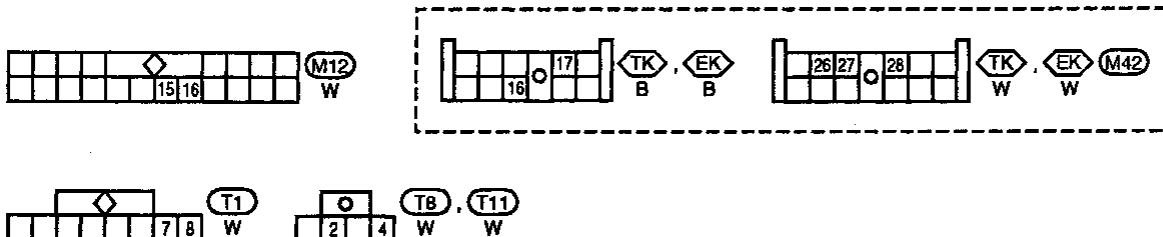
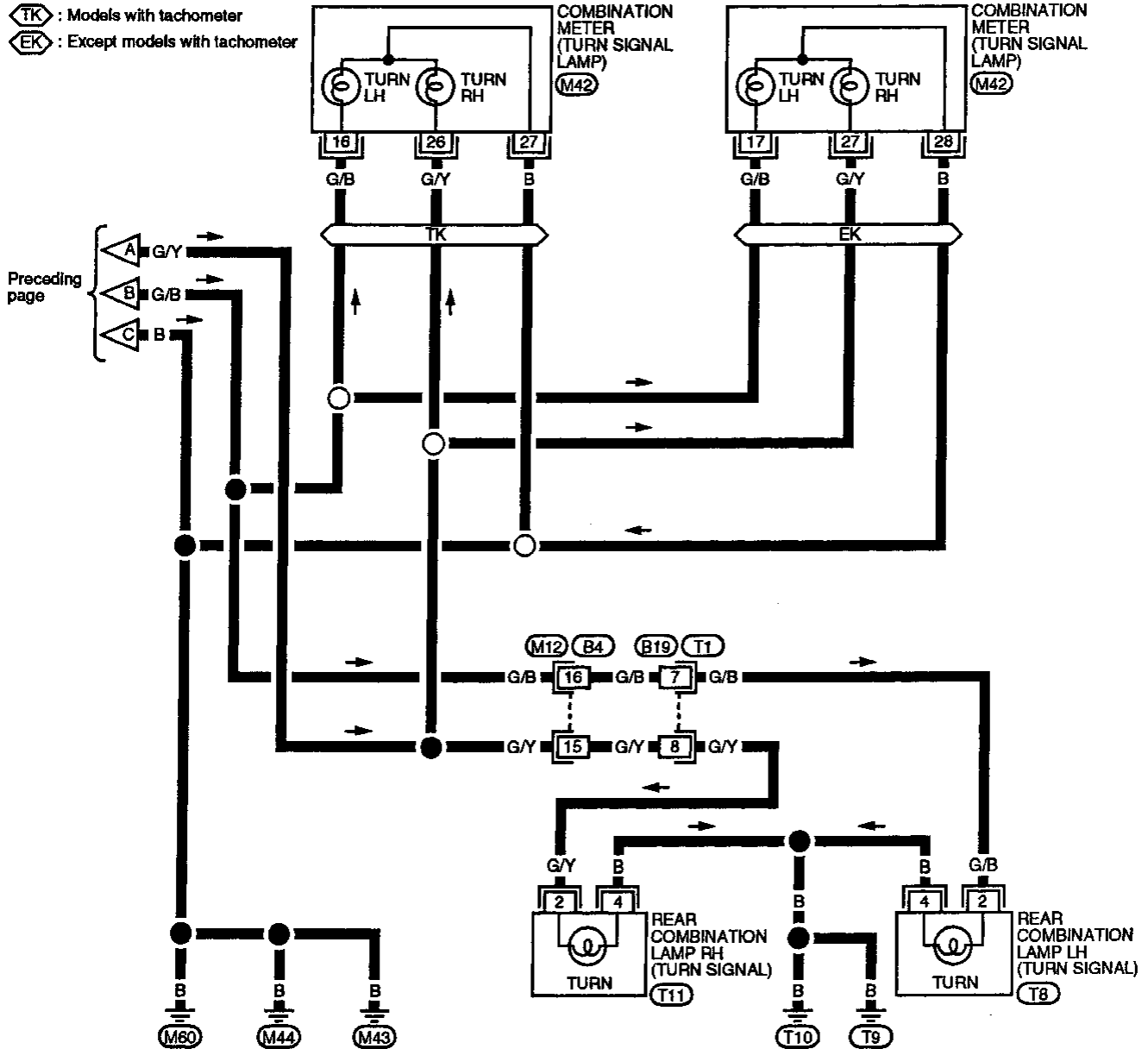

GI
 MA
 EM
 LC
 EC
 FE
 CL
 MT
 AT
 FA
 RA
 BR
 ST
 RS
 BT
 HA
EL
 IDX

EXTERIOR LAMP

Turn Signal and Hazard Warning Lamps/Trouble Diagnoses

Symptom	Possible cause	Repair order
Turn signal and hazard warning lamps do not operate.	<ol style="list-style-type: none"> 1. Hazard switch 2. Combination flasher unit 3. Open in combination flasher unit circuit 	<ol style="list-style-type: none"> 1. Check hazard switch. 2. Refer to combination flasher unit check. 3. Check wiring to combination flasher unit for open circuit.
Turn signal lamps do not operate but hazard warning lamps operate.	<ol style="list-style-type: none"> 1. 7.5A fuse 2. Hazard switch 3. Turn signal switch 4. Open in turn signal switch circuit 	<ol style="list-style-type: none"> 1. Check 7.5A fuse (No. 11 , located in fuse block [HEC]). Turn ignition switch ON and verify battery positive voltage is present at terminal 2 of hazard switch. 2. Check hazard switch. 3. Check turn signal switch. 4. Check LB/G wire between combination flasher unit and turn signal switch for open circuit.
Hazard warning lamps do not operate but turn signal lamps operate.	<ol style="list-style-type: none"> 1. 10A fuse 2. Hazard switch 3. Open in hazard switch circuit 	<ol style="list-style-type: none"> 1. Check 10A fuse (No. 15 , located in fuse block [HEC]). Verify battery positive voltage is present at terminal 3 of hazard switch. 2. Check hazard switch. 3. Check LG/B wire between combination flasher unit and hazard switch for open circuit.
Front turn signal lamp LH or RH does not operate.	<ol style="list-style-type: none"> 1. Bulb 2. Grounds E13 and E25 	<ol style="list-style-type: none"> 1. Check bulb. 2. Check grounds E13 and E25.
Rear turn signal lamp LH or RH does not operate.	<ol style="list-style-type: none"> 1. Bulb 2. Grounds T9 and T10 	<ol style="list-style-type: none"> 1. Check bulb. 2. Check grounds T9 and T10.
LH and RH turn indicators do not operate.	<ol style="list-style-type: none"> 1. Ground 	<ol style="list-style-type: none"> 1. Check grounds M43, M44 and M60.
LH or RH turn indicator does not operate.	<ol style="list-style-type: none"> 1. Bulb 	<ol style="list-style-type: none"> 1. Check bulb in combination meter.

EXTERIOR LAMP

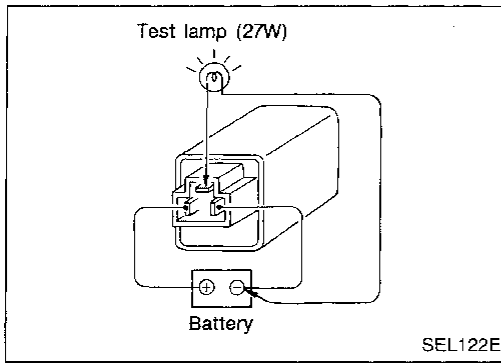

Combination Flasher Unit Check

- Before checking, ensure that bulbs meet specifications.
- Connect a battery and test lamp to the combination flasher unit, as shown. Combination flasher unit is properly functioning if it blinks when power is supplied to the circuit.

Bulb Specifications

	Wattage (12 volt)	Bulb No.	
Headlamp (Semi-sealed beam)			EC
High/Low	65/45	9004	FE
Front combination lamp	27/8	1157NA	
Front fog lamp	35	H3 (Special)	CL
Rear combination lamp			
Turn signal	27	1156	MT
Stop/Tail	27/8	1157	
Back-up (SENTRA)	13	912	AT
Back-up (200SX)	27	1156	
License plate lamp	5	168	FA
High-mounted stop lamp	13	912	
Trunk lid-mounted stop lamp	13	912	RA
Interior lamp	8		
Trunk room lamp	3.4	158	BR

GI
MA
EM
LC
EC
FE
CL
MT
AT
FA
RA
ST
RS
BT
HA
EL
IDX

INTERIOR LAMP

Illumination/System Description

Power is supplied at all times:

- through 10A fuse (No. 36, located in the fusible link and fuse box)
- to lighting switch terminal 11.

The lighting switch must be in the 1ST or 2ND position for illumination.

The illumination control switch is a thumbwheel that controls the amount of current to the illumination system. As the amount of current increases, the illumination becomes brighter.

The following chart shows the power and ground connector terminals for the components included in the illumination system.

Component	Power terminal	Ground terminal
Radio	8	7
Fan switch	1	2
A/T device indicator*	3	6
Hazard switch	7	8
Main power window and door lock switch*	3	4
Combination meter	40 (18)**	39 (13)**
ASCD main switch*	5	6
Rear window defogger switch	5	6
Illumination control switch	1	2 and 3

* If equipped.

** Terminal numbers in () are for models without tachometer.

The ground for all of the components is controlled through terminals 2 and 3 of the illumination control switch and body grounds M43, M44 and M60.

INTERIOR LAMP

NOTE

GI

MA

EM

LC

EC

FE

CL

WT

AT

FA

RA

BR

ST

RS

BT

HA

EL

IDX

INTERIOR LAMP

Illumination/Wiring Diagram -ILL-

EL-ILL-01

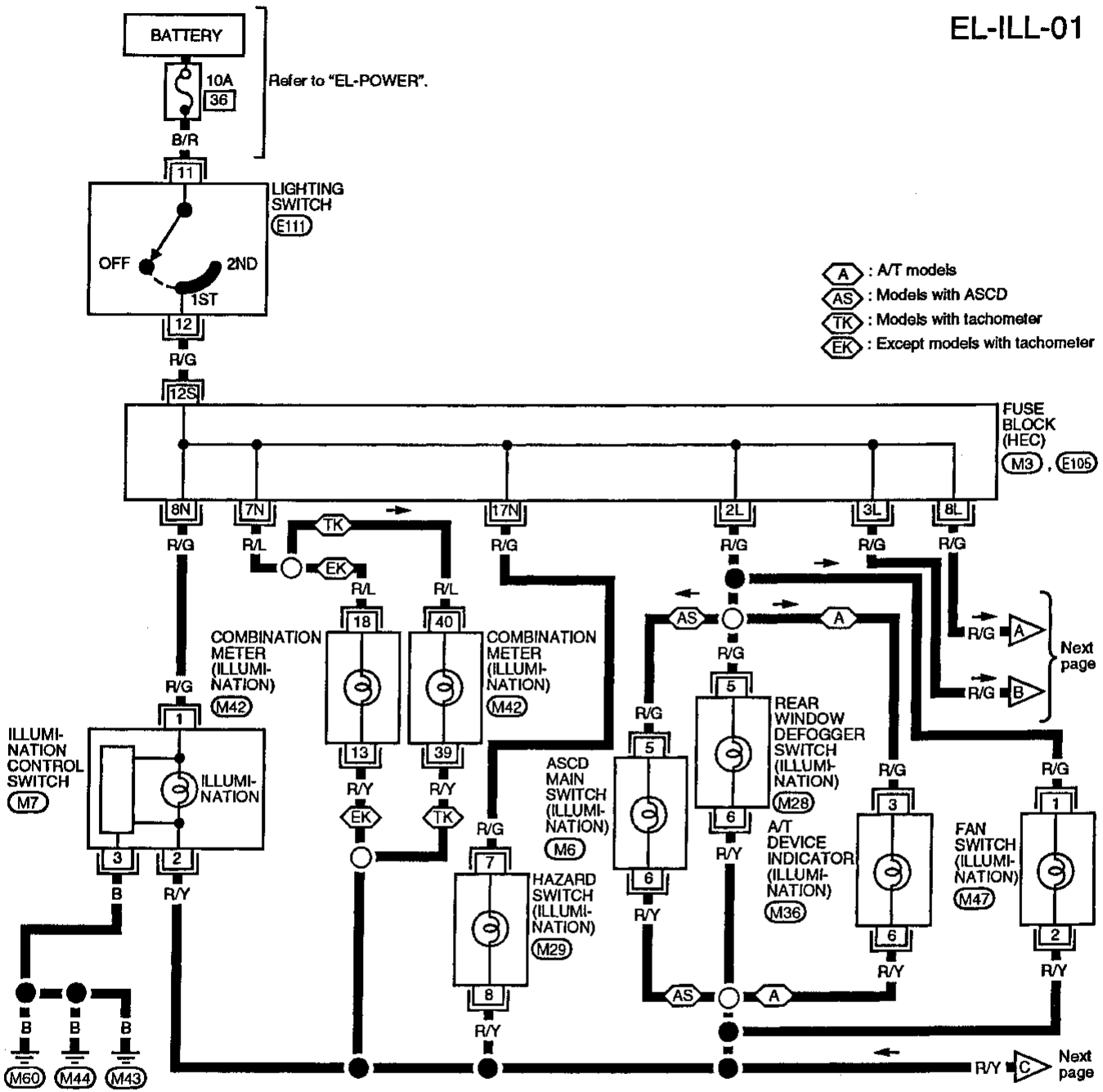

Refer to last page (Foldout page).

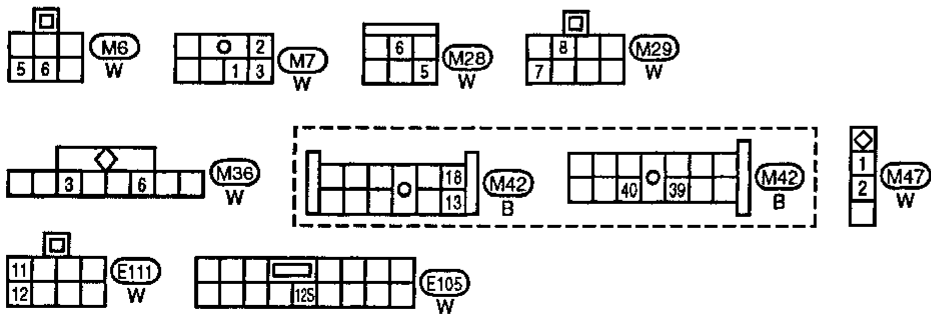

INTERIOR LAMP

Illumination/Wiring Diagram –ILL– (Cont'd)

EL-ILL-02

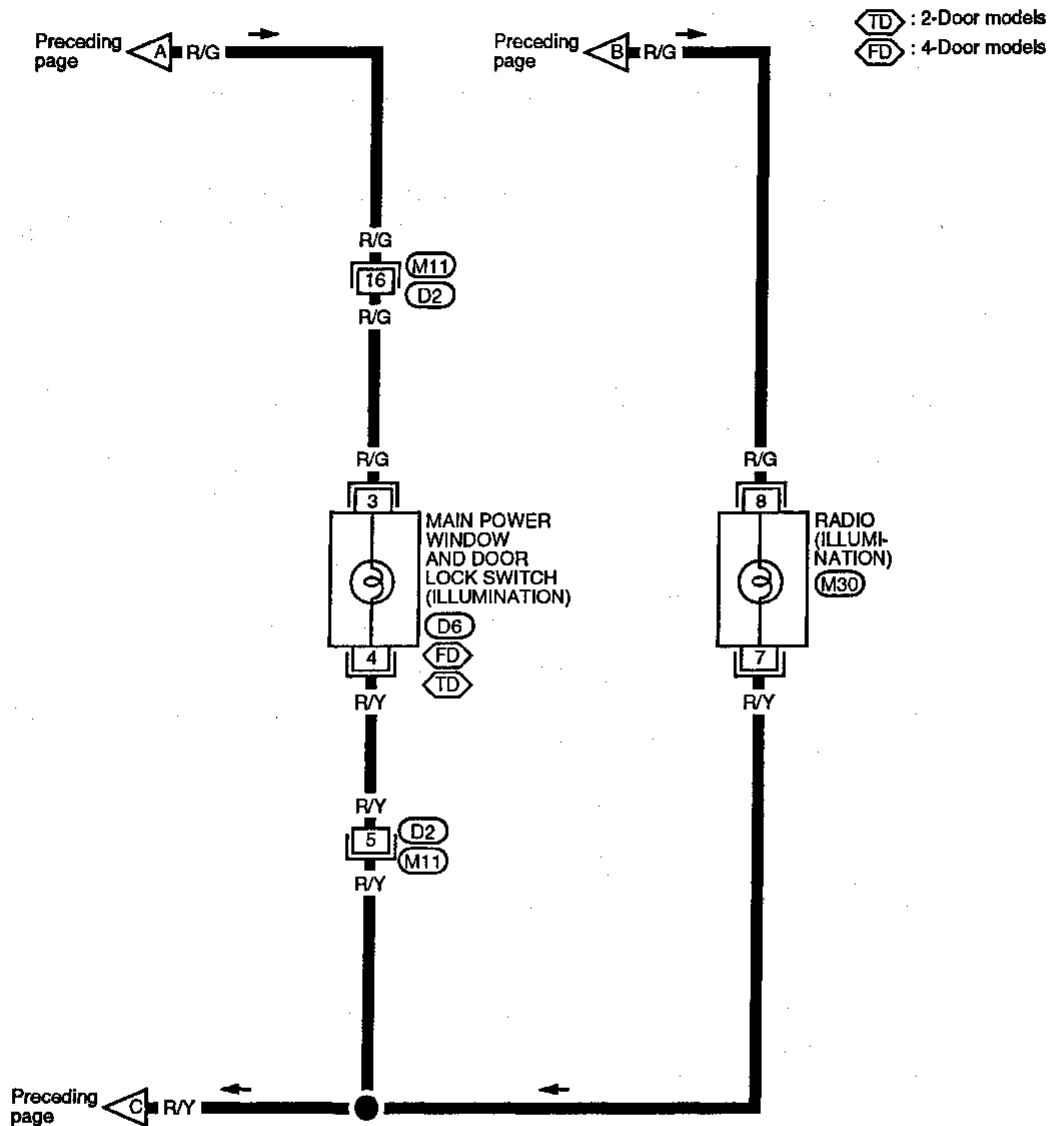

TD : 2-Door models
FD : 4-Door models

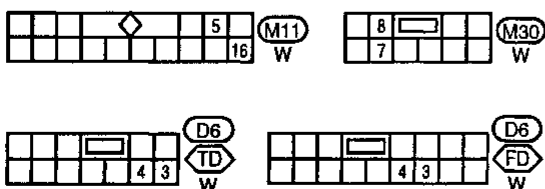

GI
MA
EM
LC
EC
FE
CL
MT
AT
FA
RA
BR
ST
RS
BT
HA
EL
IDX

INTERIOR LAMP

Interior and Trunk Room Lamps/System Description

Power is supplied at all times:

- through 7.5A fuse (No. 20 , located in the fuse block [HEC])
- to interior lamp terminal ①
- to trunk room lamp terminal ①.

Models with multi-remote control system

Power is supplied at all times:

- through 25A fusible link (letter f , located in the fusible link and fuse box)
- to circuit breaker terminal ①
- through circuit breaker terminal ②
- to smart entrance control unit terminal ① for multi-remote control system.

Ground is supplied to smart entrance control unit terminal ⑩ through body grounds M43 , M44 and M60 .

INTERIOR LAMP

Switch operation

With the interior lamp switch in the ON position, ground is supplied through screw terminal on interior lamp assembly to body to turn interior lamp ON.

When a door switch is set to OPEN (door is open) with the interior lamp switch in the DOOR position, ground is supplied:

- to interior lamp terminal ②
- through front door switch LH terminal ② or
- through any other door switch terminal ①.

The interior lamp will not illuminate if the interior lamp switch is in the OFF position.

Interior lamp control by multi-remote control system

The smart entrance control unit receives a remote control signal from multi-remote controller to turn interior lamp ON when the doors are unlocked. Ground is then supplied:

- to interior lamp terminal ②
- through smart entrance control unit terminal ⑨,
- through smart entrance control unit terminal ⑩ and
- through body grounds M43 , M44 and M60 .

With power and ground supplied, the interior lamp turns ON.

TRUNK ROOM LAMP

When the trunk room lamp switch is set to OPEN (trunk is opened), ground is supplied:

- to trunk room lamp terminal ②
- through trunk room switch terminal ①,
- through trunk room lamp switch terminal ② and
- through body grounds T9 and T10 .

With power and ground supplied, the trunk room lamp turns ON.

INTERIOR LAMP

NOTE

GI

MA

EM

LC

EC

FE

CL

MT

AT

FA

RA

BR

ST

RS

BT

HA

EL

IDX

INTERIOR LAMP

Interior and Trunk Room Lamps/Wiring Diagram -INT/L-

EL-INT/L-01

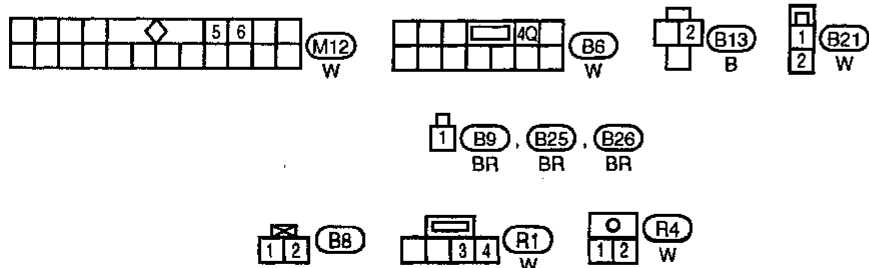
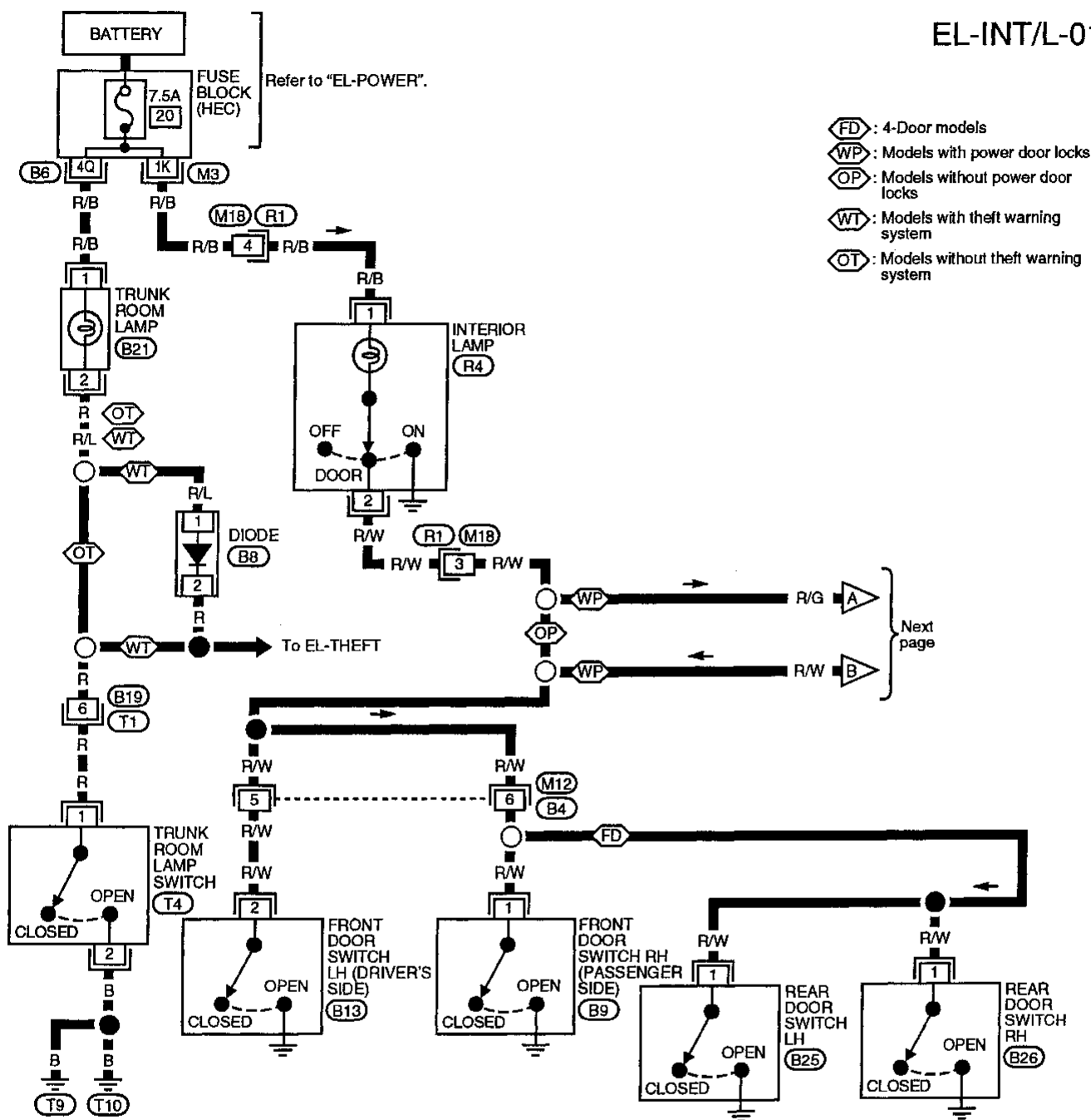

Refer to last page (Foldout page).

M3

INTERIOR LAMP

Interior and Trunk Room Lamps/Wiring Diagram -INT/L- (Cont'd)

EL-INT/L-02

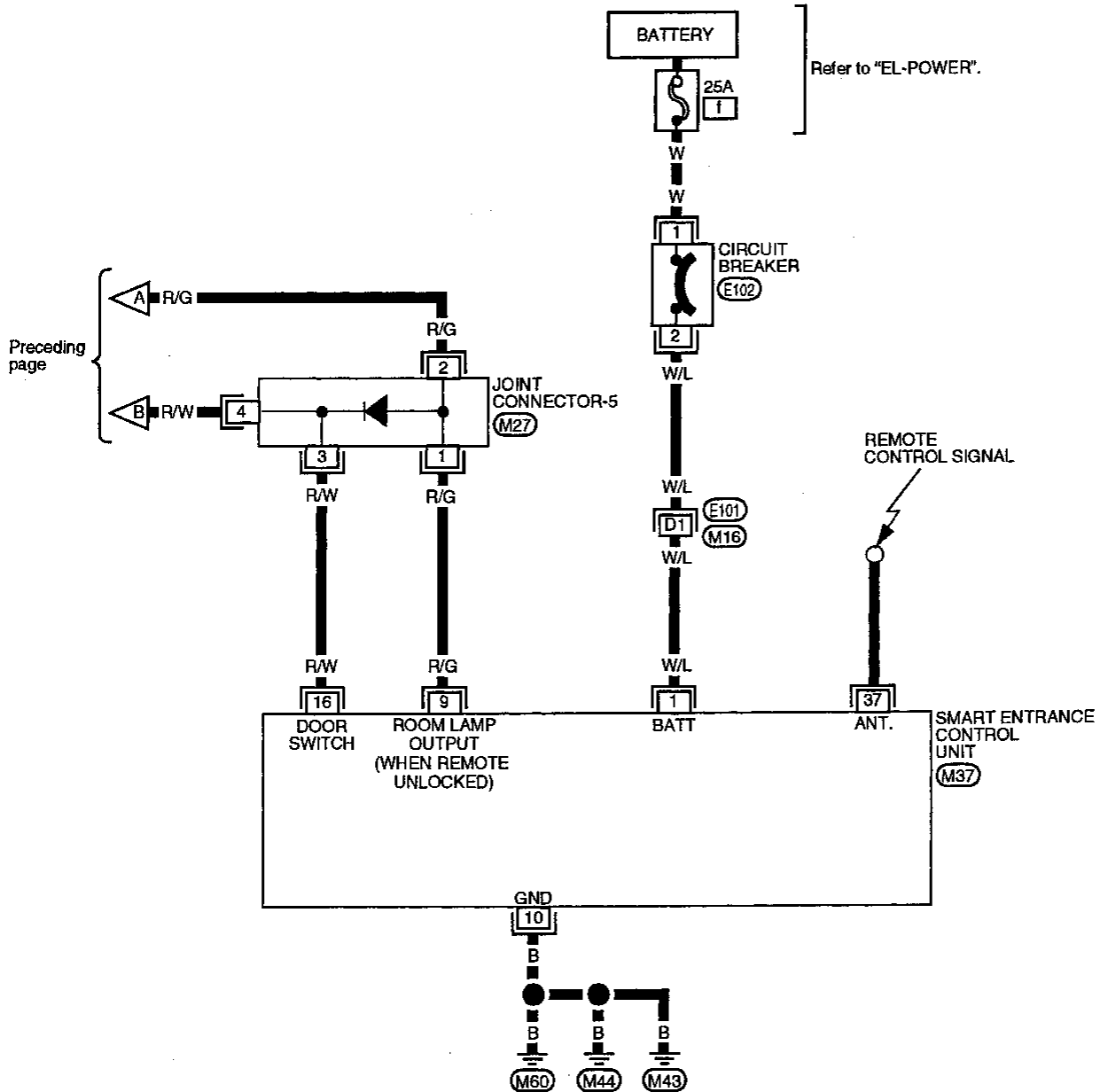

Preceding page

Refer to "EL-POWER".

Refer to last page (Foldout page).



(M16), (E101)
(M37)

GI
MA
EM
LC
EC
FE
CL
MT
AT
FA
RA
BR
ST
RS
BT
HA
EL
IDX

System Description

With the ignition switch in the ON or START position, power is supplied:

- through 10A fuse (No. 8), located in the fuse block [HEC]
- to combination meter terminal 41 for the water temperature gauge,
- to combination meter terminal 22 for the tachometer and speedometer
- to combination meter terminal 10 for the fuel gauge.

Ground is supplied:

- to combination meter terminal 28
- through body grounds M43, M44 and M60.

The water temperature gauge indicates the engine coolant temperature. The reading on the gauge is based on the resistance of the thermal transmitter.

As the temperature of the coolant increases, the resistance of the thermal transmitter decreases. A variable ground is supplied to terminal 42 of the combination meter for the water temperature gauge. The needle on the gauge moves from "C" to "H".

The tachometer indicates engine speed in revolutions per minute (rpm).

The tachometer is regulated by a signal:

- from terminal 3 of the ECM (ECCS control module)
- to combination meter terminal 29 for the tachometer.

The fuel gauge indicates the approximate fuel level in the fuel tank.

The fuel gauge is regulated by a variable ground signal supplied:

- to combination meter terminal 14 for the fuel gauge
- from terminal 1 of the fuel tank gauge unit
- through terminal 3 of the fuel tank gauge unit
- through body grounds B14 and B17.

The vehicle speed sensor provides a voltage signal to the combination meter for the speedometer.

The voltage is supplied:

- to combination meter terminals 30 and 24 for the speedometer
- from terminals 1 and 2 of the vehicle speed sensor.

The speedometer converts the voltage into the vehicle speed displayed.

METERS AND GAUGES/WITH TACHOMETER

Combination Meter

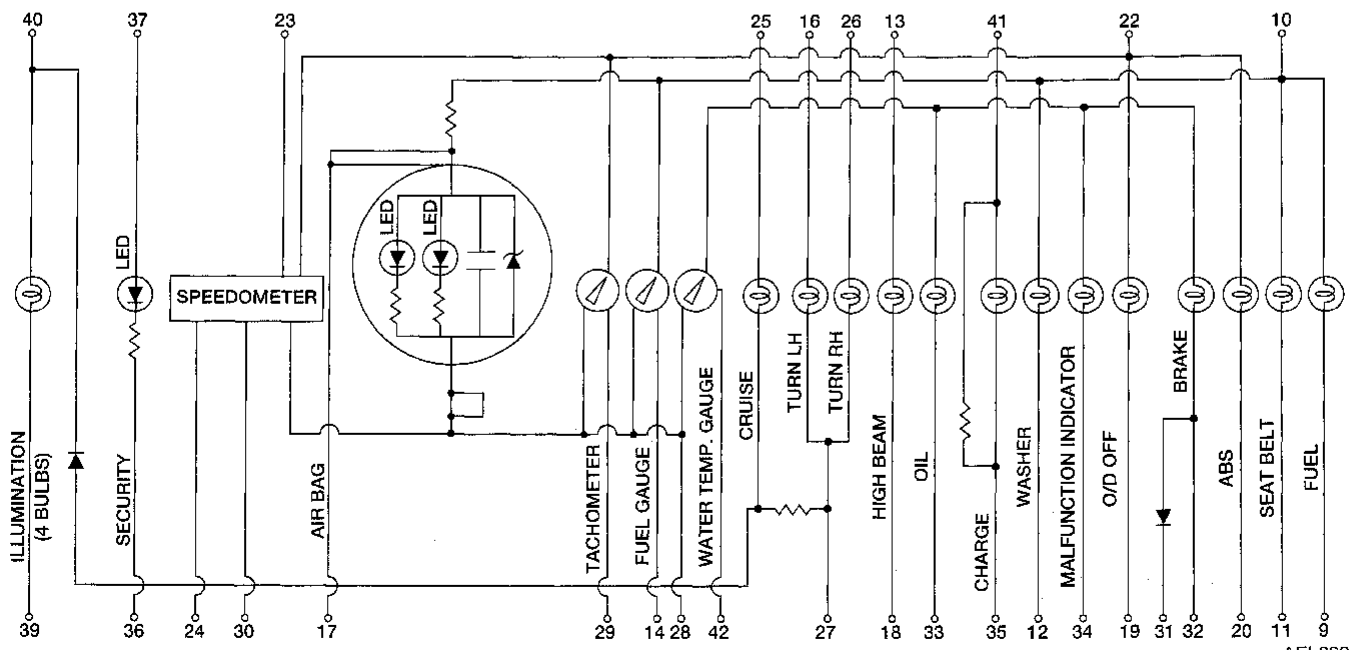
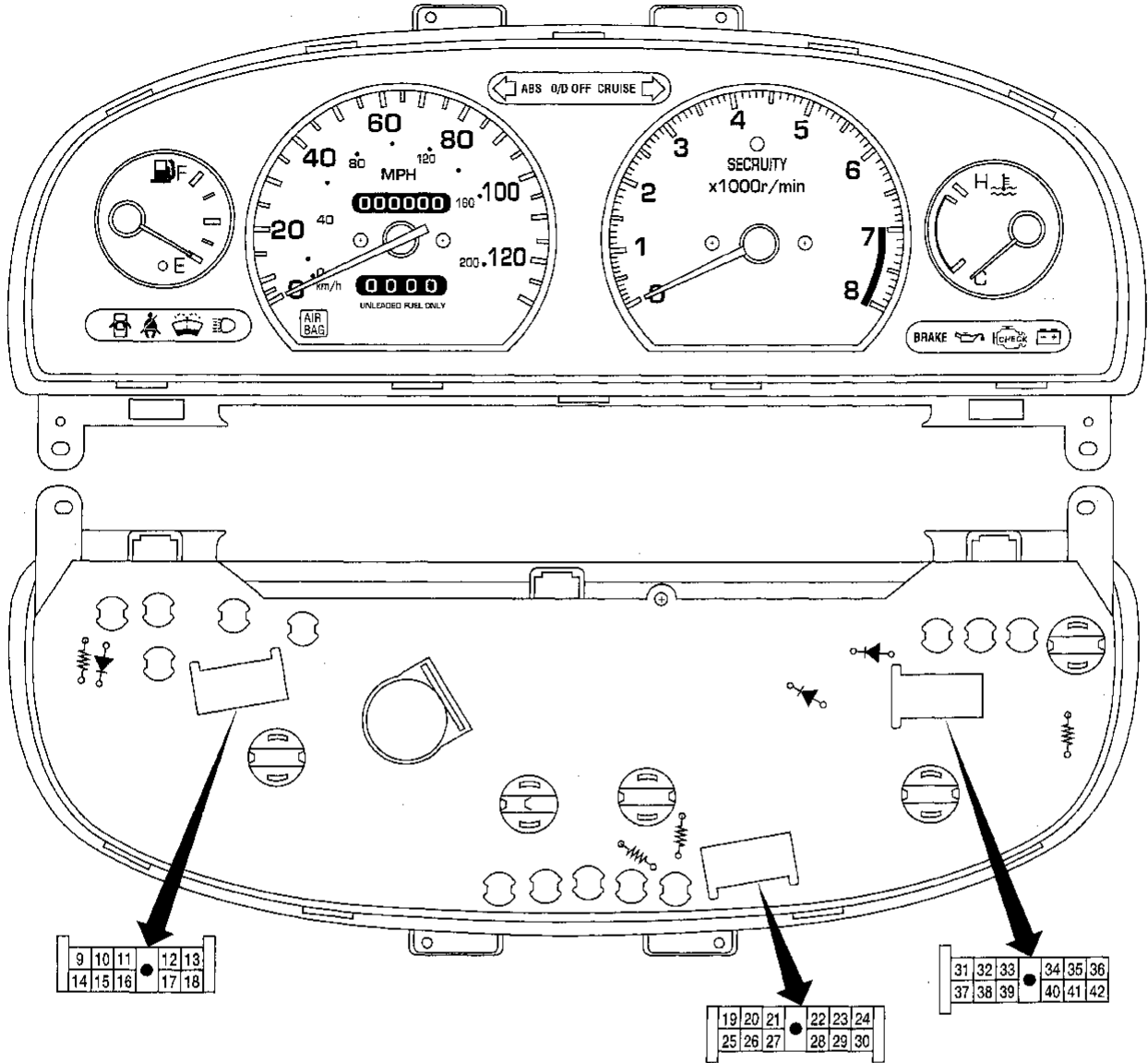

GI
MA
EM
LC
EC
FE
CL
MT
AT
FA
RA
BR
ST
RS
BT
HA
EL
IDX

METERS AND GAUGES/WITH TACHOMETER

Speedometer, Tachometer, Temp. and Fuel Gauges/Wiring Diagram -METER-

EL-METER-01

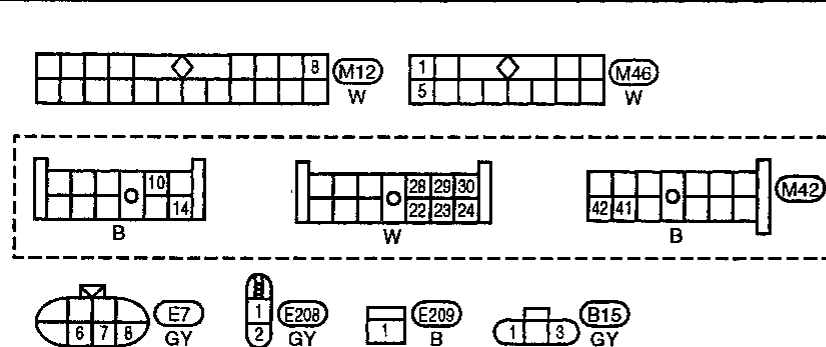
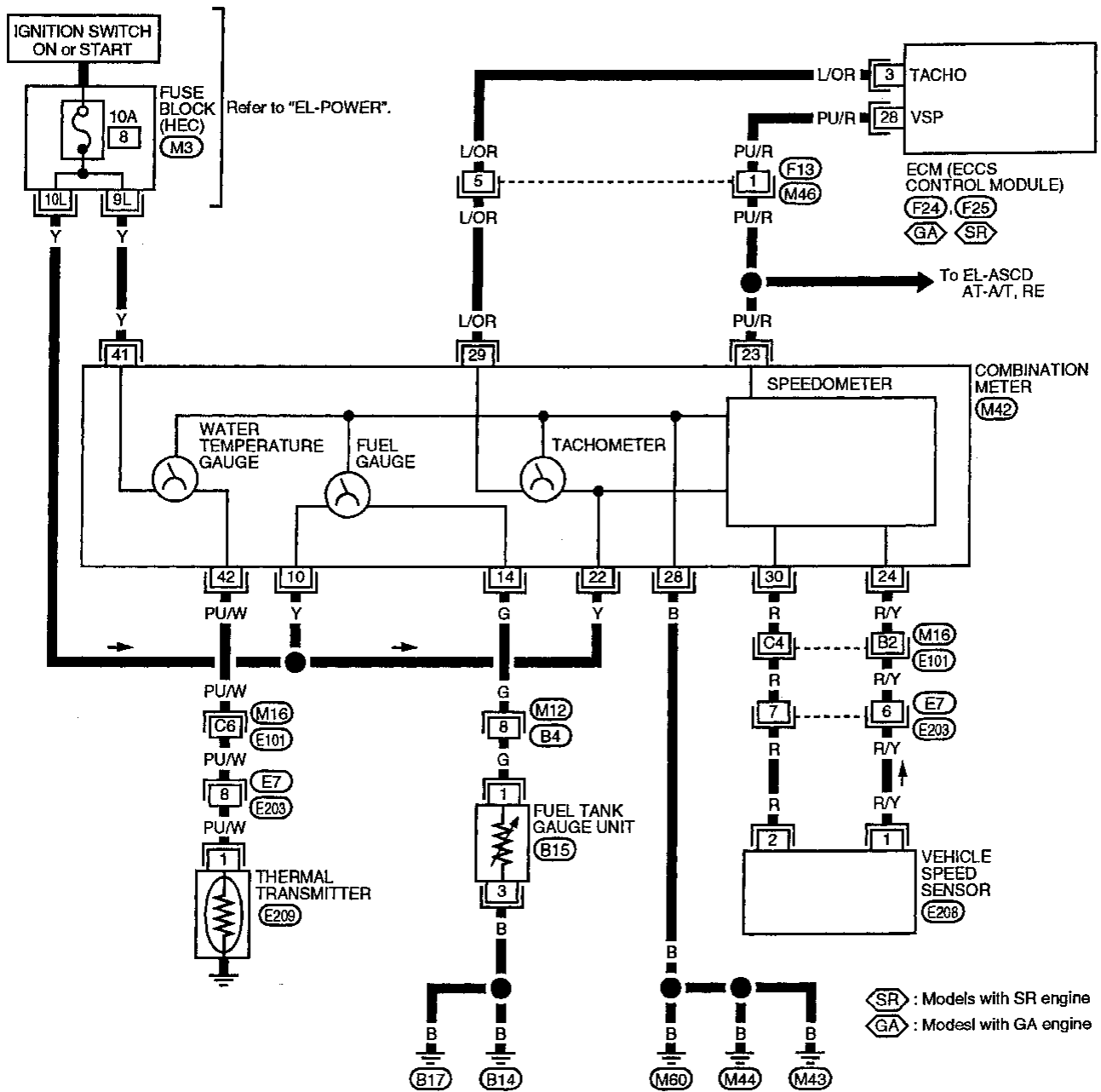

Refer to last page (Foldout page).

- M3
- M16, E101
- F24, F25
- GA, SR

METERS AND GAUGES/WITH TACHOMETER

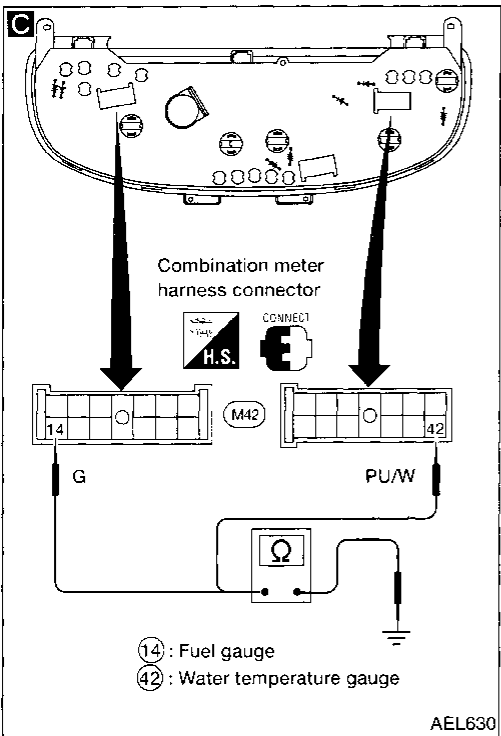
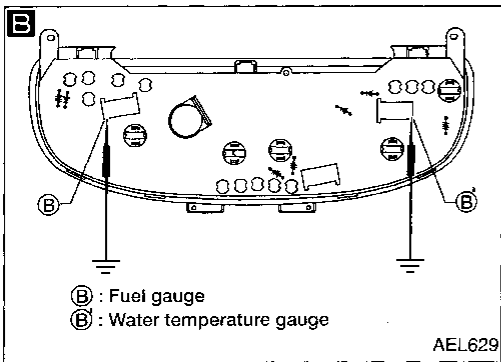
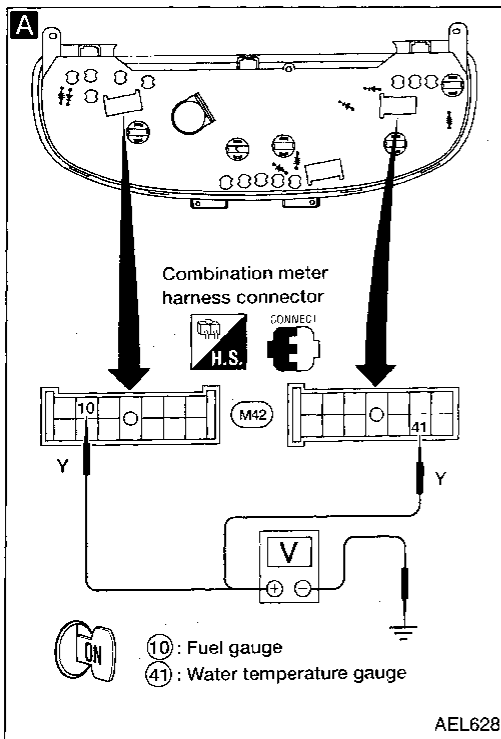

Inspection/Fuel Gauge and Water Temperature Gauge

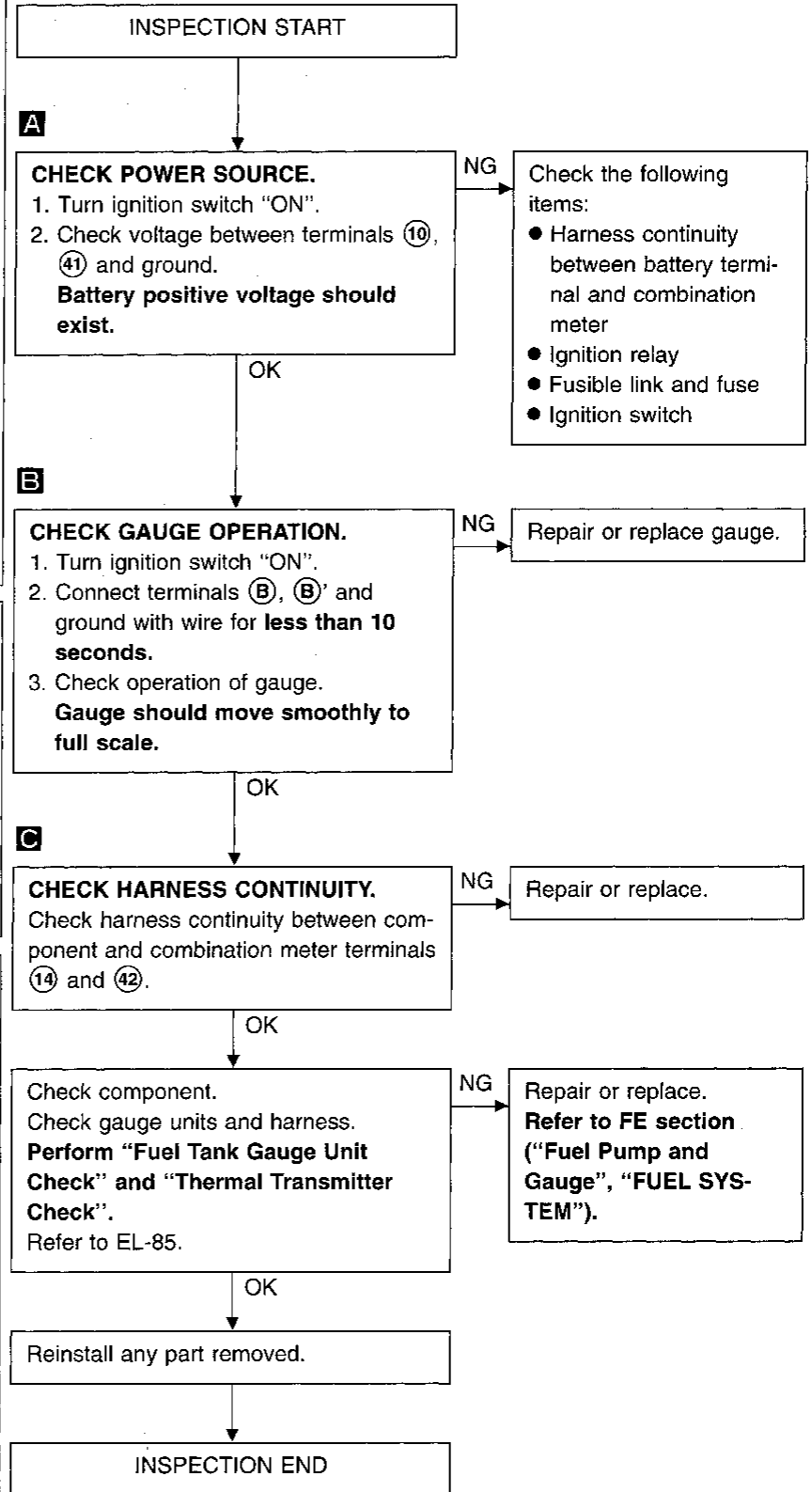

GI
MA
EM
LC
EC
FE
CL
MT
AT
FA
RA
BR
ST
RS
BT
HA
EL
IDX

METERS AND GAUGES/WITH TACHOMETER

Inspection/Tachometer

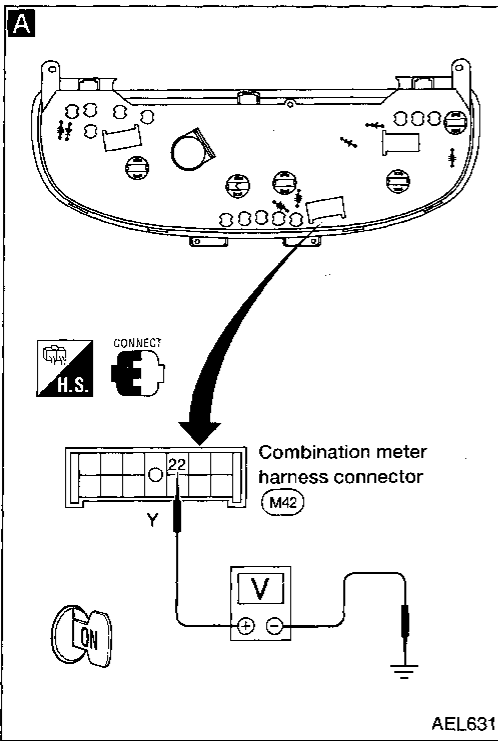

INSPECTION START

A

CHECK POWER SOURCE.

1. Turn ignition switch "ON".
2. Check voltage between terminal (22) and ground.

Battery voltage should exist.

NG

Check the following items:

- Harness continuity between battery terminal and combination meter
- Ignition relay
- Fusible link and fuse
- Ignition switch

OK

B

CHECK ECM OUTPUT.

1. Start engine.
2. Check voltage between terminals (28) and (29) at idle and 2,000 rpm.

Higher rpm = Higher voltage
Lower rpm = Lower voltage
Voltage should change with rpm.

NG

Check harness and connector between ECM and combination meter, or check ground.

OK

Replace tachometer.

INSPECTION END

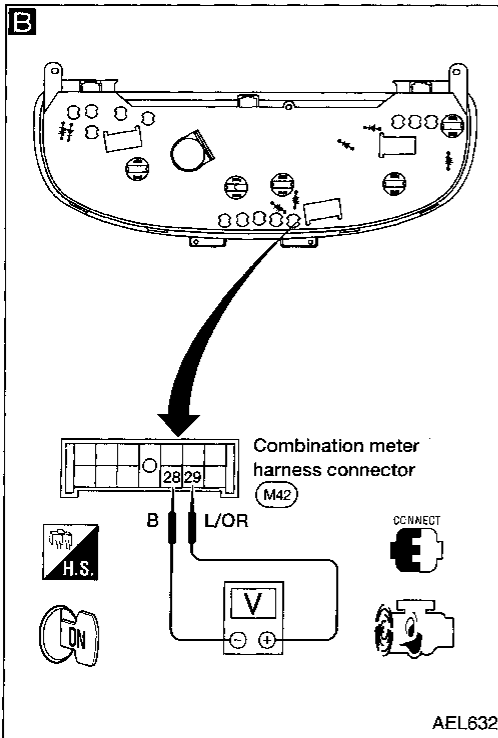

METERS AND GAUGES/WITH TACHOMETER

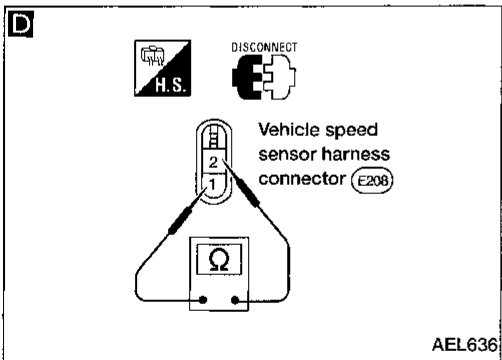
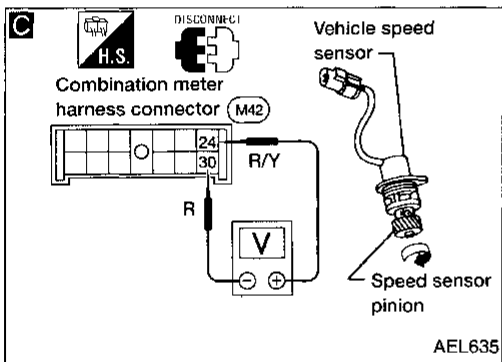
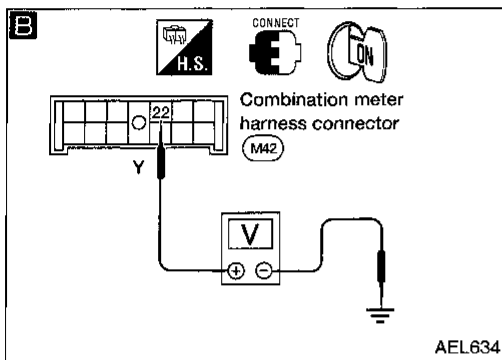
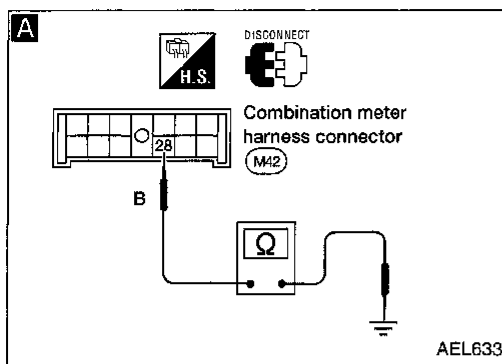

Inspection/Speedometer and Vehicle Speed Sensor

SYMPTOM: Speedometer stays at 0 km/h (0 MPH).

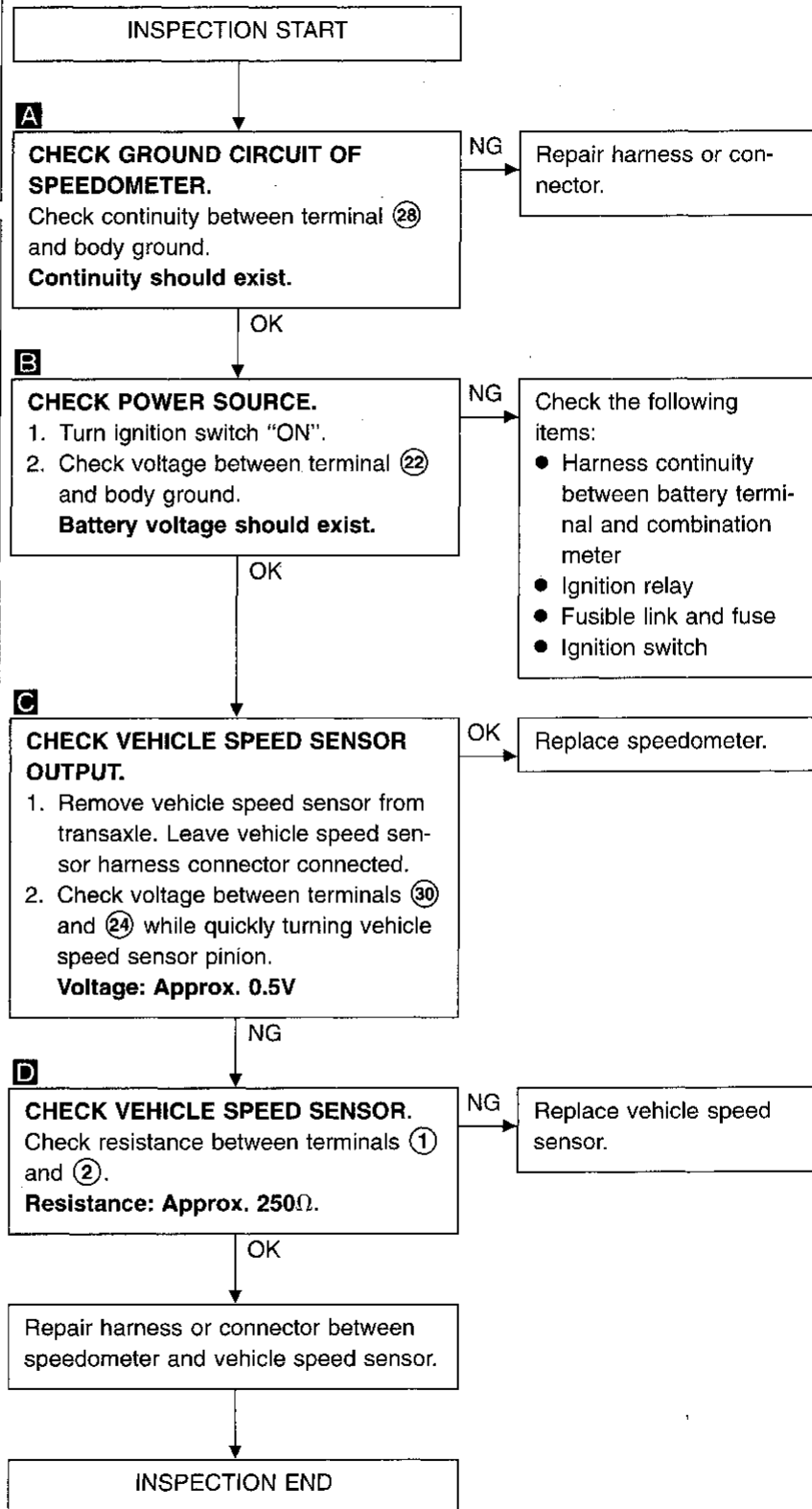

GI

MA

EM

LC

EC

FE

CL

MT

AT

FA

RA

BR

ST

RS

BT

HA

EL

IDX

System Description

With the ignition switch in the ON or START position, power is supplied:

- through 10A fuse (No. 8), located in the fuse block [HEC]
- to combination meter terminal 34 for the water temperature gauge, fuel gauge and speedometer.

Ground is supplied:

- to combination meter terminal 30
- through body grounds M43, M44 and M60.

The water temperature gauge indicates the engine coolant temperature. The reading on the gauge is based on the resistance of the thermal transmitter.

As the temperature of the coolant increases, the resistance of the thermal transmitter decreases. A variable ground is supplied to terminal 29 of the combination meter for the water temperature gauge. The needle on the gauge moves from "C" to "H".

The fuel gauge indicates the approximate fuel level in the fuel tank.

The fuel gauge is regulated by a variable ground signal supplied:

- to combination meter terminal 24 for the fuel gauge
- from terminal 1 of the fuel tank gauge unit
- through terminal 3 of the fuel tank gauge unit
- through body grounds B14 and B17.

The vehicle speed sensor provides a voltage signal to the combination meter for the speedometer.

The voltage is supplied:

- to combination meter terminals 23 and 22 for the speedometer
- from terminals 1 and 2 of the vehicle speed sensor.

The speedometer converts the voltage into the vehicle speed displayed.

METERS AND GAUGES/WITHOUT TACHOMETER

Combination Meter

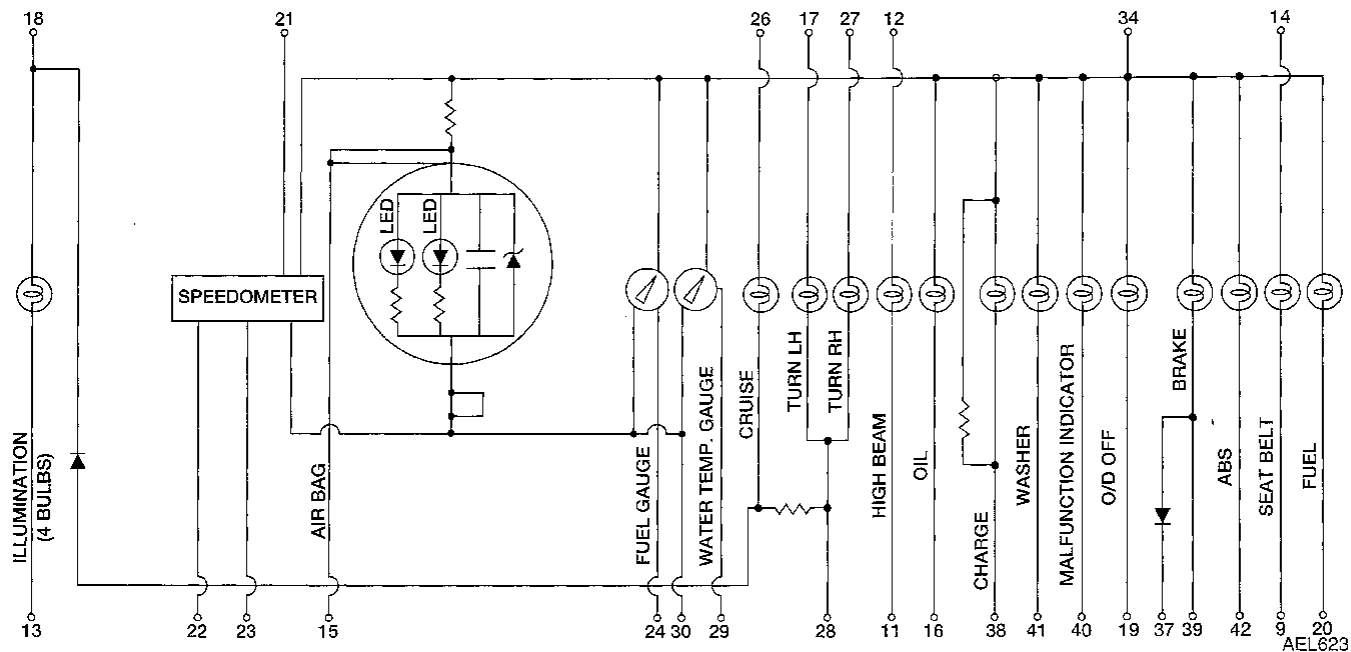
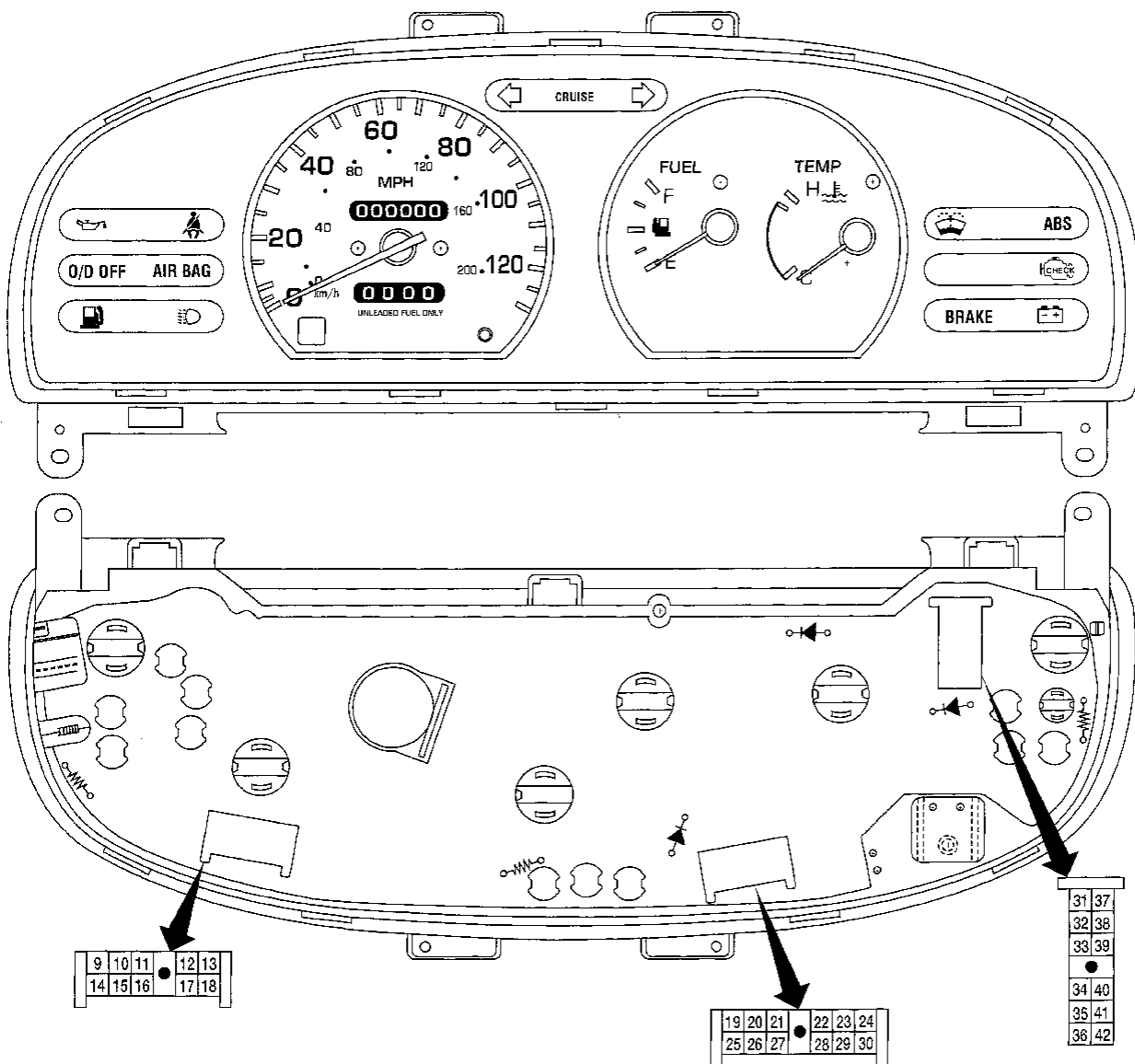

EL-81

GI
MA
EM
LC
EC
FE
CL
MT
AT
FA
RA
BR
ST
RS
BT
HA
EL
IDX

Speedometer, Temp. and Fuel Gauges/Wiring Diagram -METER-

EL-METER-02

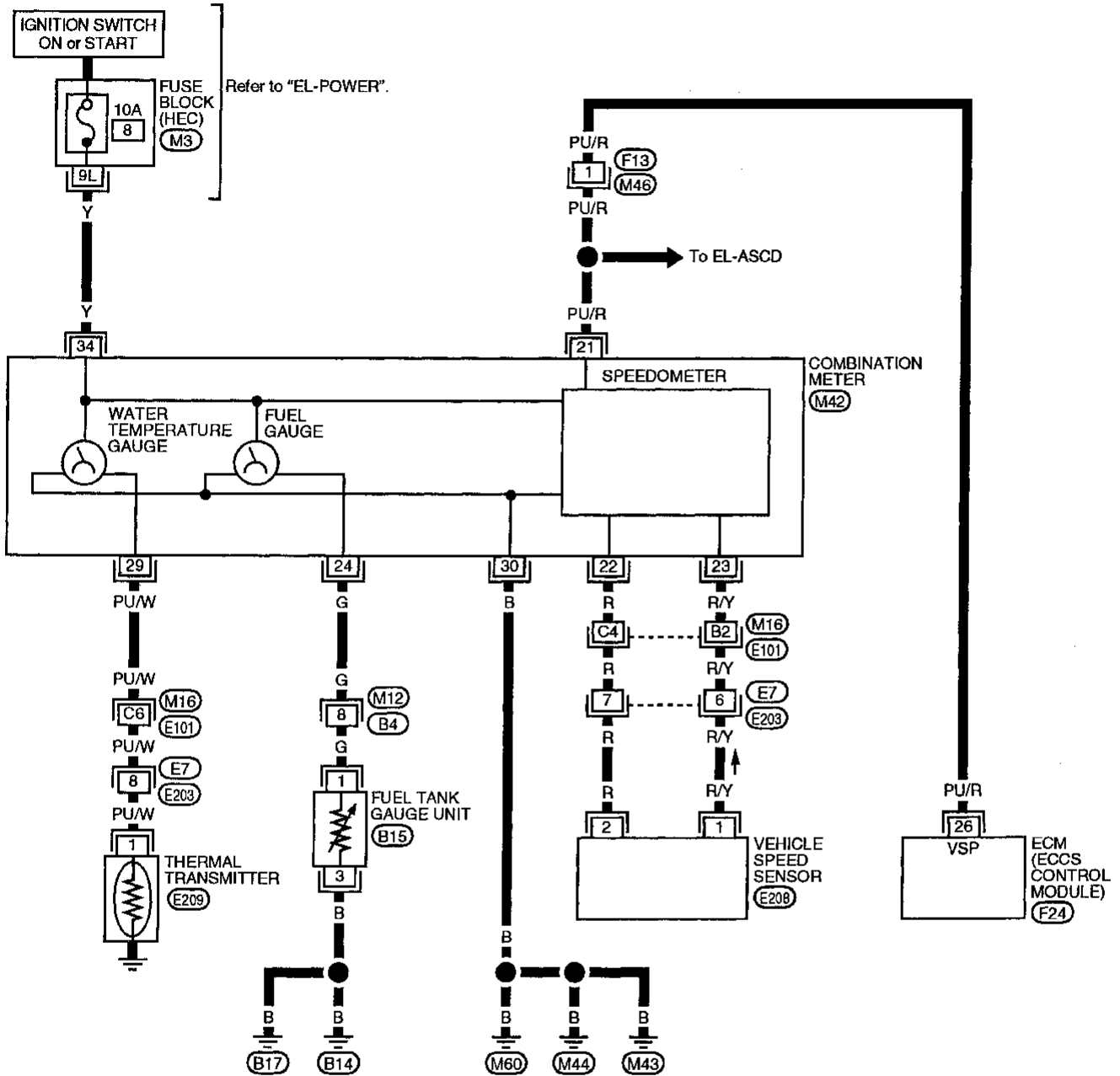

Refer to last page (Foldout page).

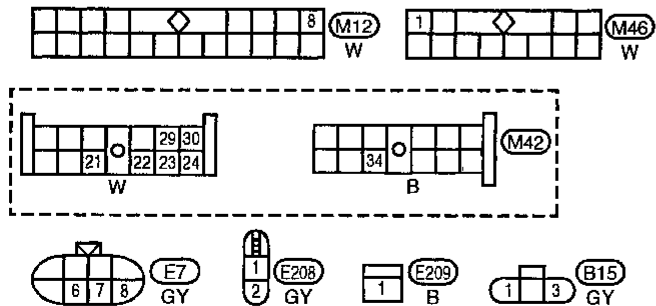

- (M3)
- (M16), (E101)
- (F24)

METERS AND GAUGES/WITHOUT TACHOMETER

GL
MA
EM
LC
EC
FE
CL
MT
AT
FA
RA
BR
ST
RS
BT
HA
EL
IDX

Inspection/Fuel Gauge and Water Temperature Gauge

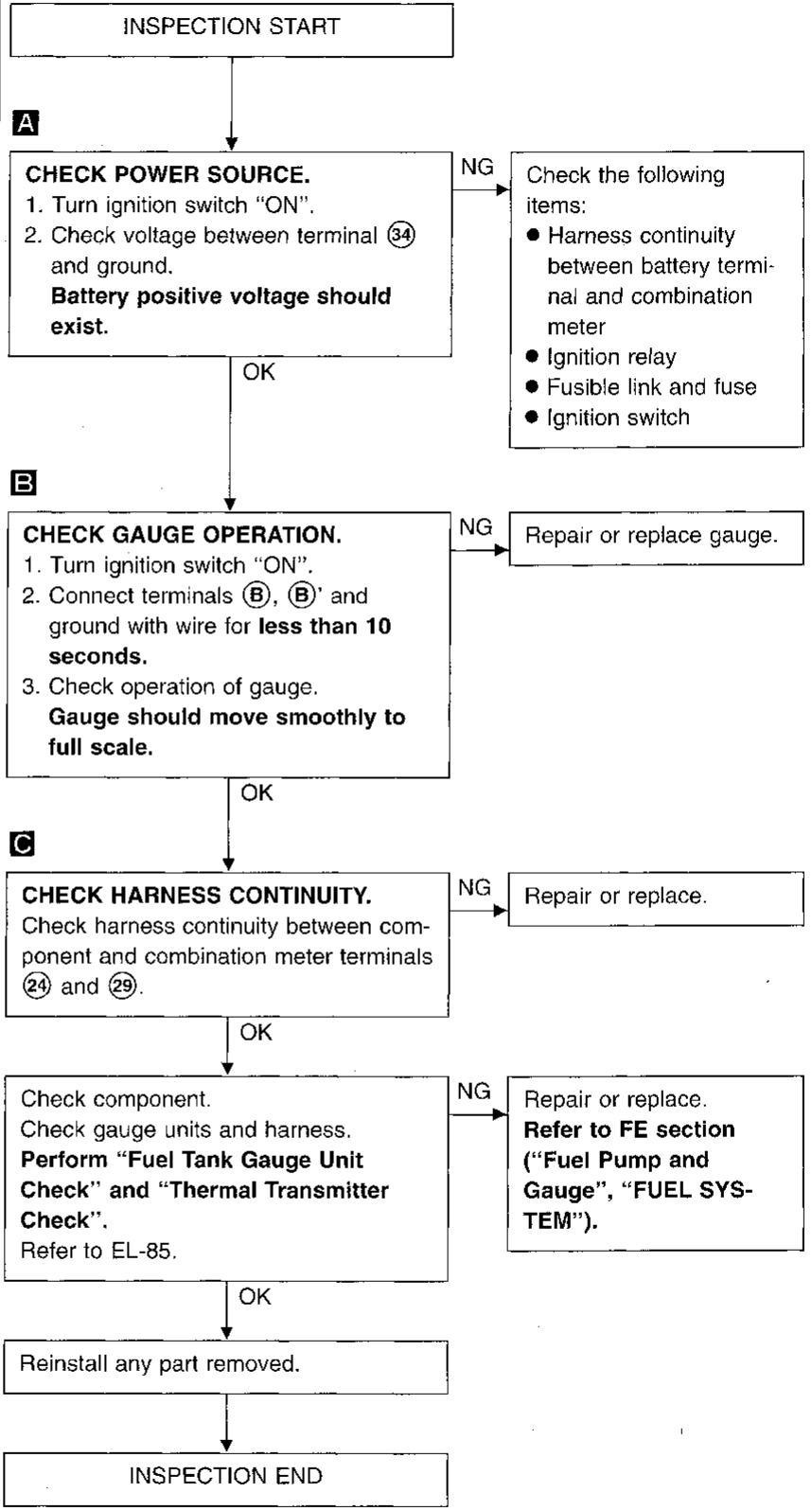
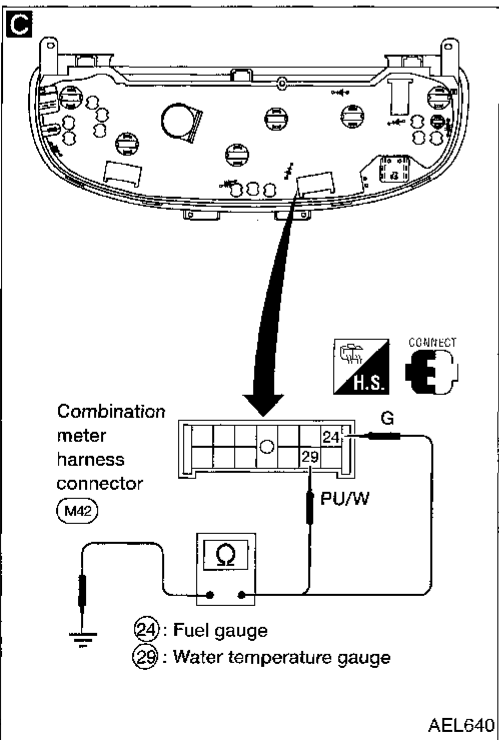
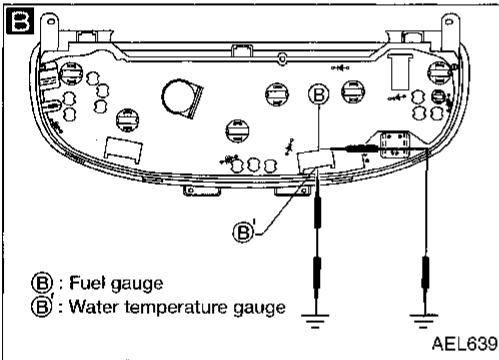
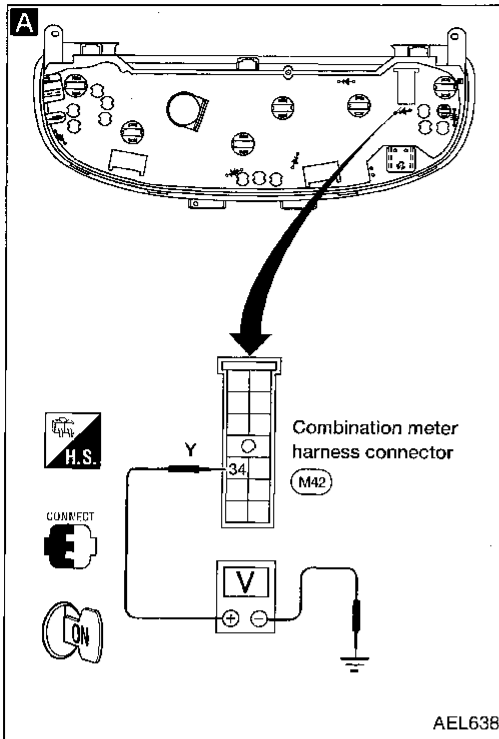

Inspection/Speedometer and Vehicle Speed Sensor

SYMPTOM: Speedometer stays at 0 km/h (0 MPH).

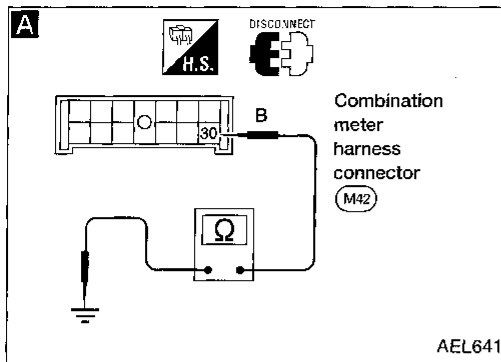

INSPECTION START

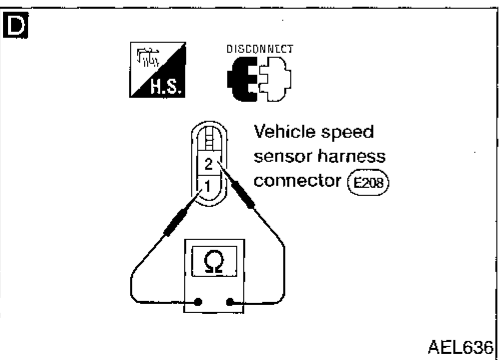
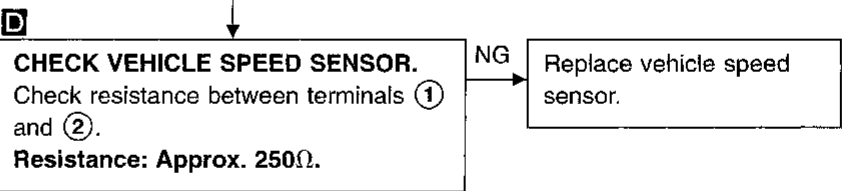
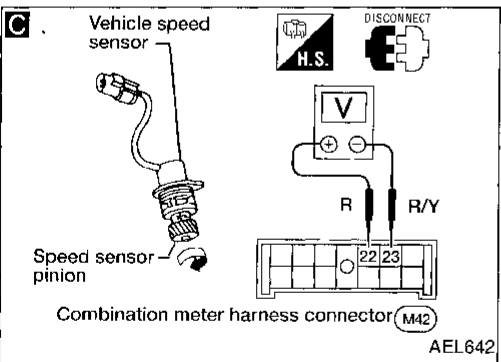
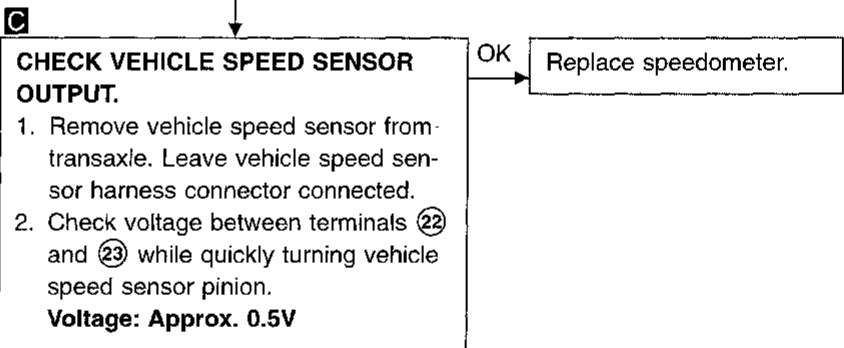
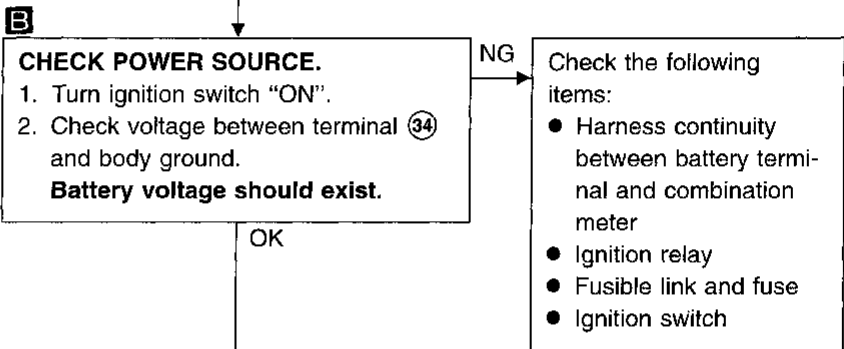
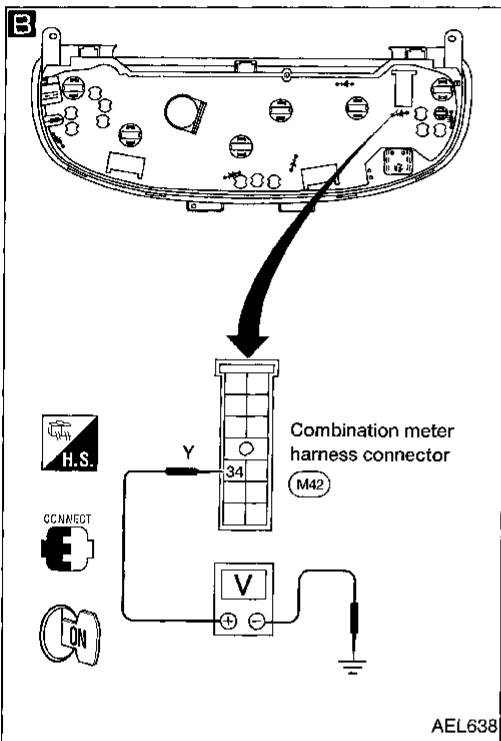
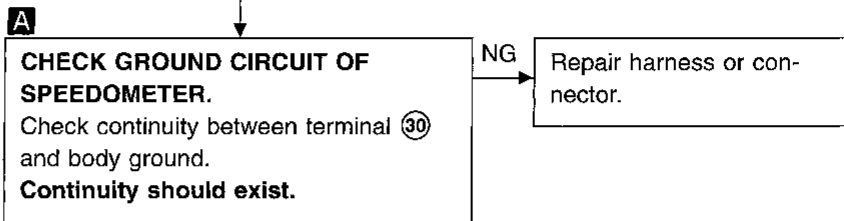

Repair harness or connector between speedometer and vehicle speed sensor.

INSPECTION END

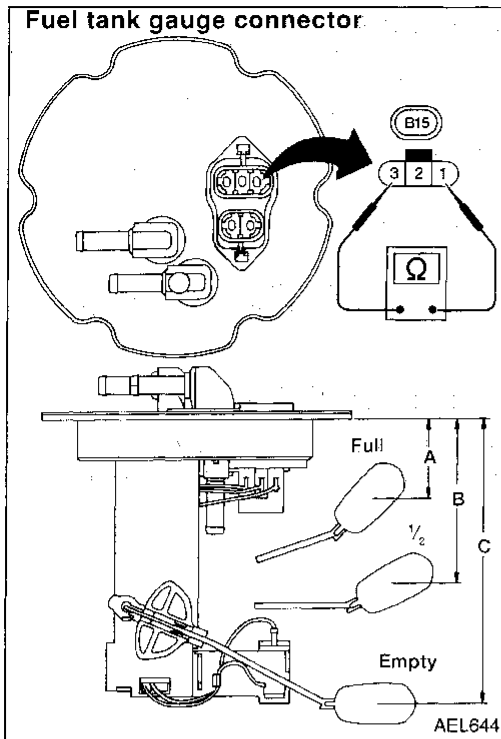

Fuel Tank Gauge Unit Check

- For removal, refer to FE section ("Fuel Pump and Gauge", "FUEL SYSTEM").

Check the resistance between terminals ① and ③.

Ohmmeter		Float position		Resistance value (Ω)
(+)	(-)	mm (in)		
①	③	A	Full	35.8 (1.409)
		B	1/2	85.9 (3.382)
		C	Empty	128.8 (5.071)
				Approx. 4.5 - 6
				Approx. 31.5 - 33.5
				Approx. 80 - 83

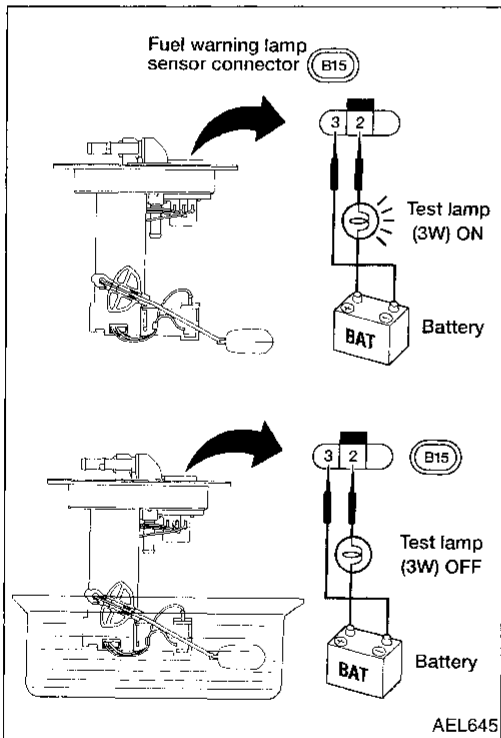

Fuel Warning Lamp Sensor Check

- It will take a short time for the bulb to light.

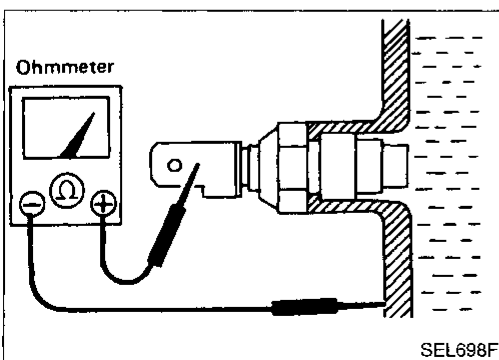

Thermal Transmitter Check

Check the resistance between the terminals of thermal transmitter and body ground.

Water temperature	Resistance
60°C (140°F)	Approx. 70 - 90 Ω
100°C (212°F)	Approx. 21 - 24 Ω

METERS AND GAUGES

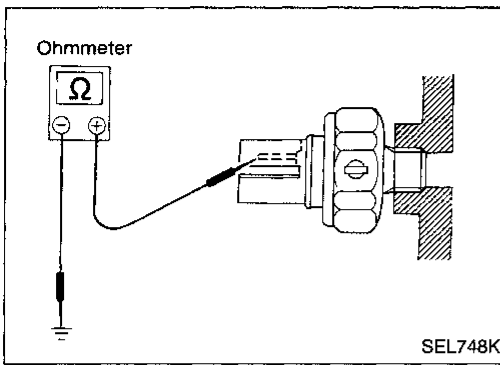

Oil Pressure Switch Check

	Oil pressure kPa (kg/cm ² , psi)	Continuity
Engine start	More than 10 - 20 (0.1 - 0.2, 1.4 - 2.8)	NO
Engine stop	Less than 10 - 20 (0.1 - 0.2, 1.4 - 2.8)	YES

Check the continuity between the terminals of oil pressure switch and body ground.

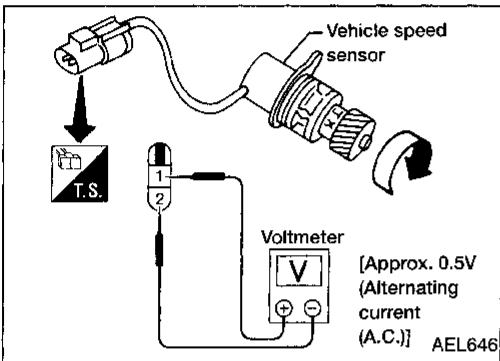

Vehicle Speed Sensor Signal Check

1. Remove vehicle speed sensor from transaxle.
2. Turn vehicle speed sensor pinion quickly and measure voltage across terminals ① and ②.

WARNING LAMPS AND CHIME

Warning Lamps/System Description*

If equipped with theft warning system, power is supplied at all times:

- through 7.5A fuse (No. 24 , located in the fuse block [HEC])
- to combination meter terminal 37 for the security lamp.

Ground for the security lamp is supplied when the system is activated:

- to combination meter terminal 36
- from terminal 2 of the smart entrance control unit.

With the ignition switch in the ON or START position, power is supplied:

- through 10A fuse (No. 8 , located in the fuse block [HEC])
- to combination meter terminal 10 (34) for the air bag warning lamp
- to combination meter terminal 22 (14) and
- to combination meter terminal 41.

Ground is supplied for each of the warning lamps through different terminals of the combination meter.

For details of power and ground terminals for the warning lamps in the combination meter, refer to "Combination Meter", "METERS AND GAUGES/WITH TACHOMETER" or "METERS AND GAUGES/WITHOUT TACHOMETER".

*: Terminal numbers in () are for models without tachometer.

GI

MA

EM

LC

EC

FE

CL

MT

AT

FA

RA

BR

ST

RS

BT

HA

EL

IDX

WARNING LAMPS AND CHIME

Warning Lamps/Schematic

MODELS WITH TACHOMETER

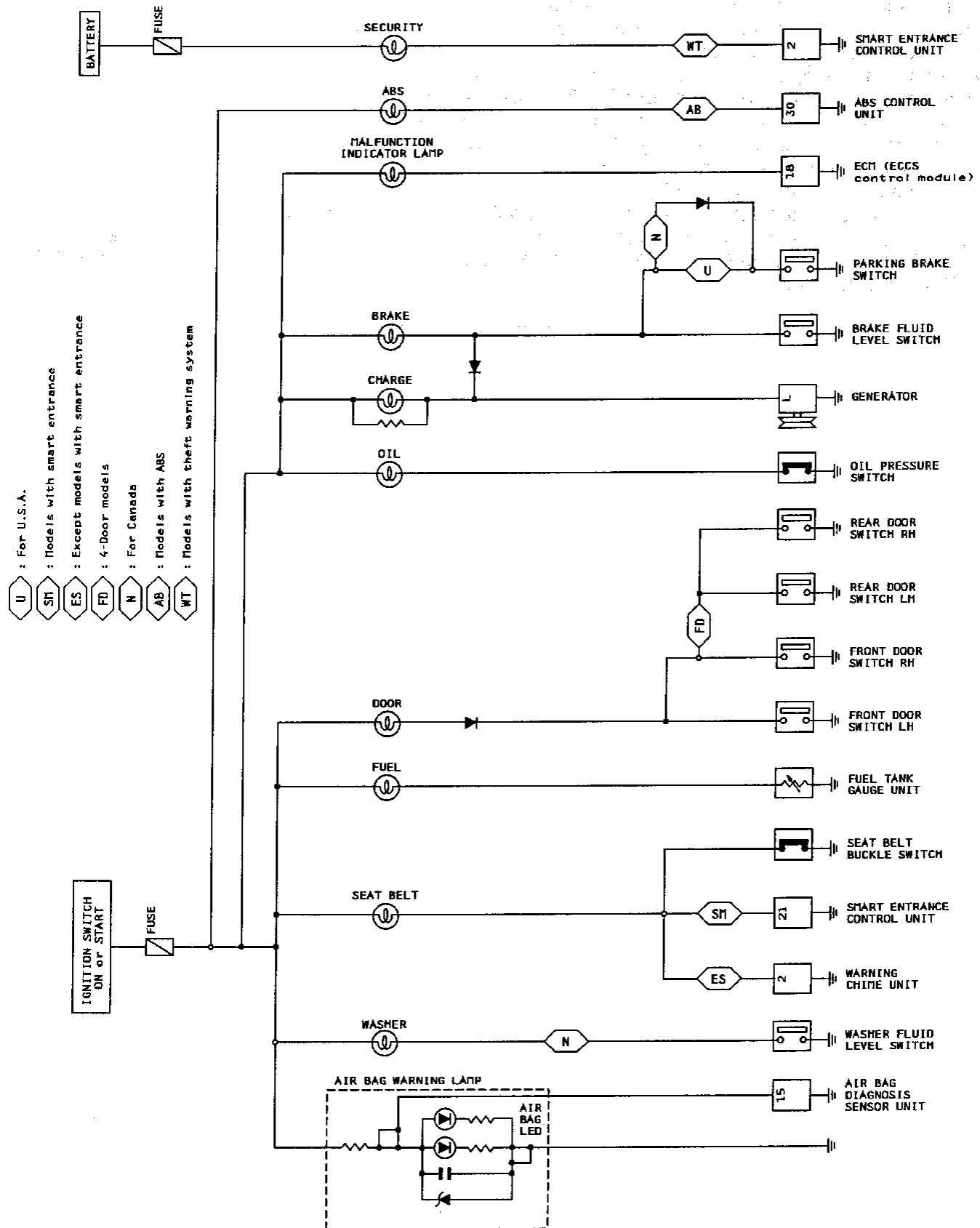

WARNING LAMPS AND CHIME

Warning Lamps/Schematic (Cont'd)

MODELS WITHOUT TACHOMETER

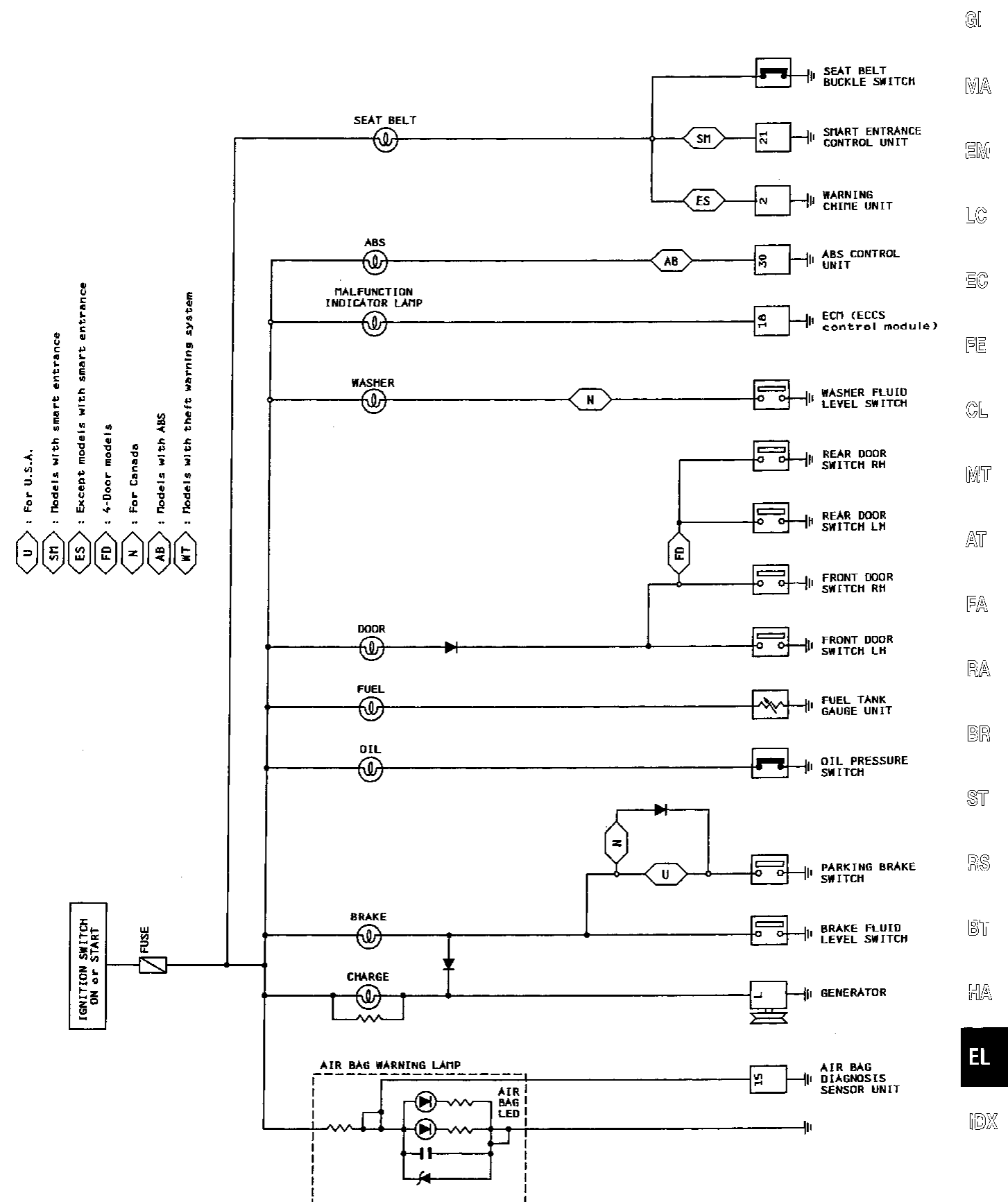

GI
WA
EM
LC
EC
FE
CL
MT
AT
FA
RA
BR
ST
RS
BT
HA
EL
IDX

WARNING LAMPS AND CHIME

Warning Lamps/Wiring Diagram -WARN-

MODELS WITH TACHOMETER

EL-WARN-01

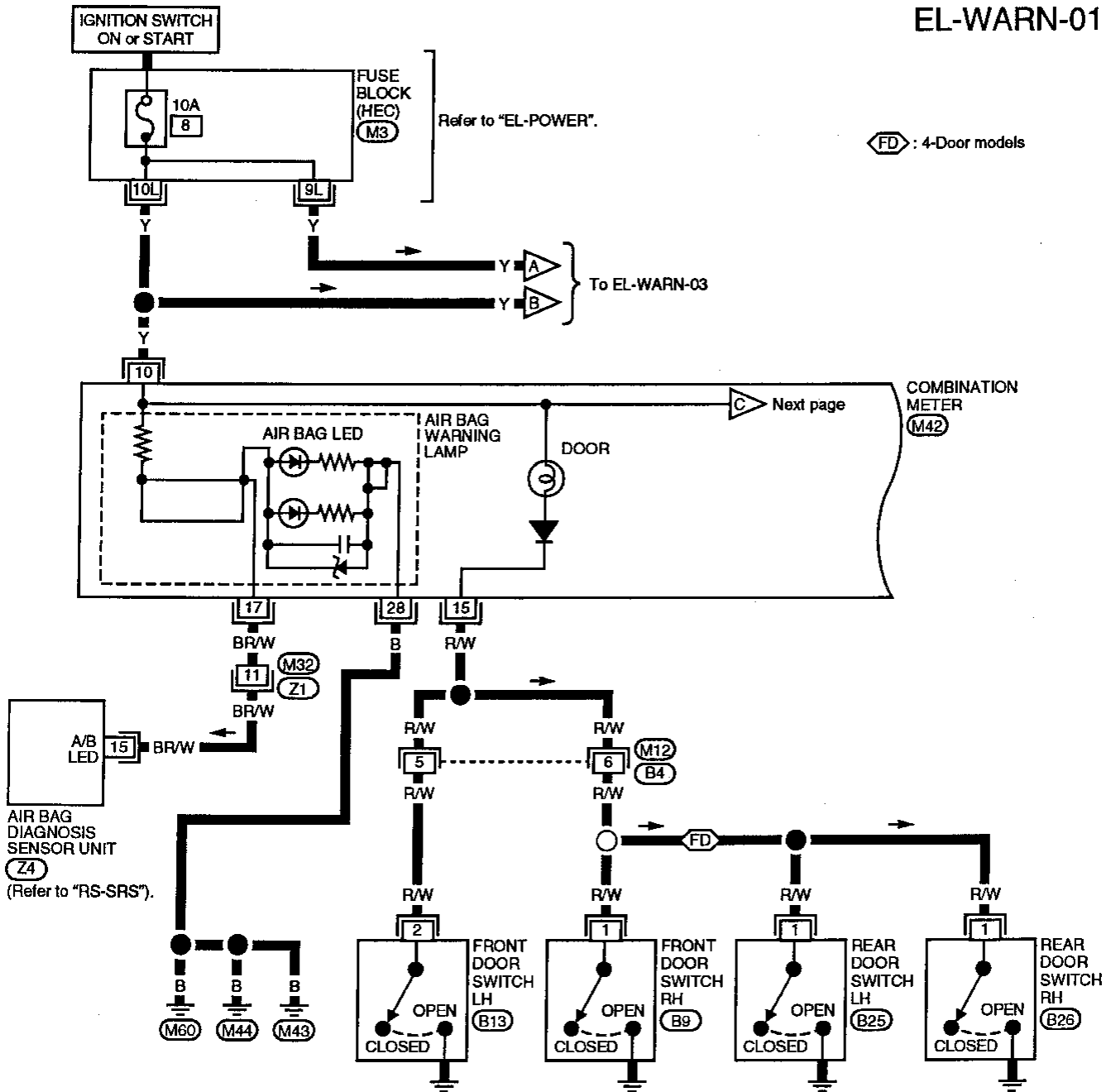

FD: 4-Door models

Next page
COMBINATION METER (M42)

A/B LED
AIR BAG DIAGNOSIS SENSOR UNIT (Z4)
(Refer to "RS-SRS").

Refer to last page (Foldout page).
(M3)

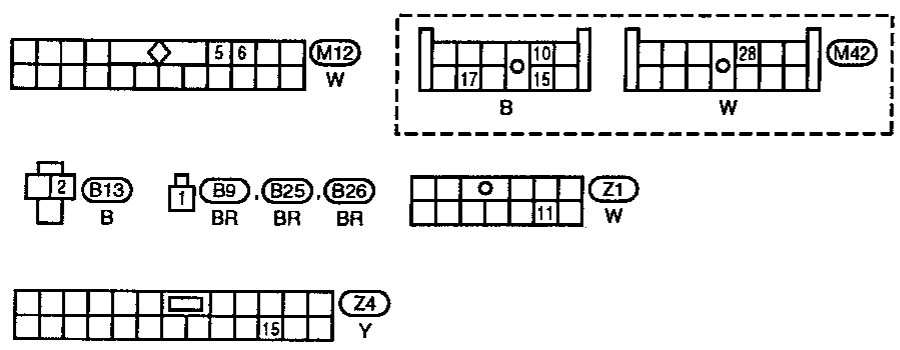

WARNING LAMPS AND CHIME

Warning Lamps/Wiring Diagram –WARN– (Cont'd)

EL-WARN-03

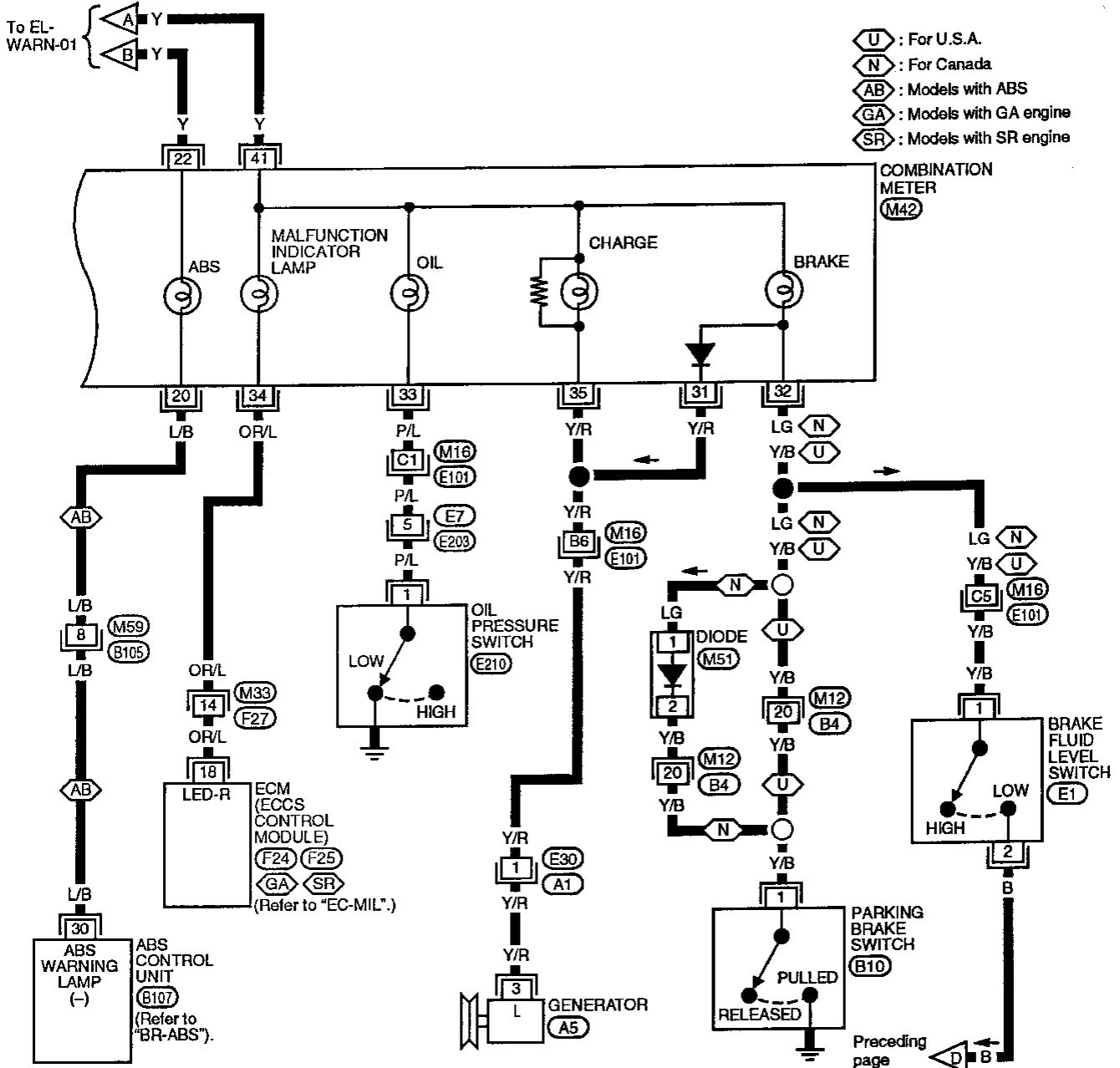

Refer to last page (Foldout page).

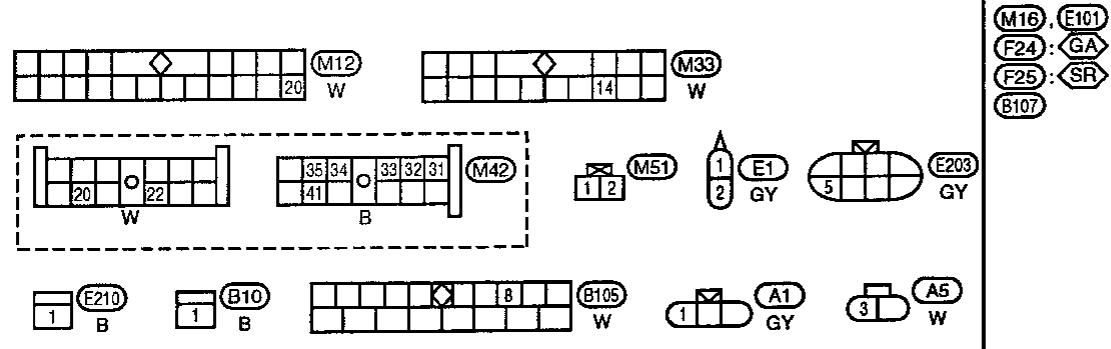

WARNING LAMPS AND CHIME

Warning Lamps/Wiring Diagram -WARN- (Cont'd)

MODELS WITHOUT TACHOMETER

EL-WARN-04

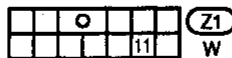
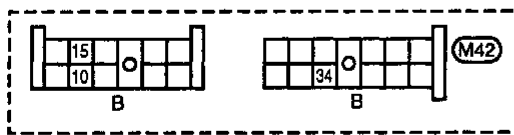
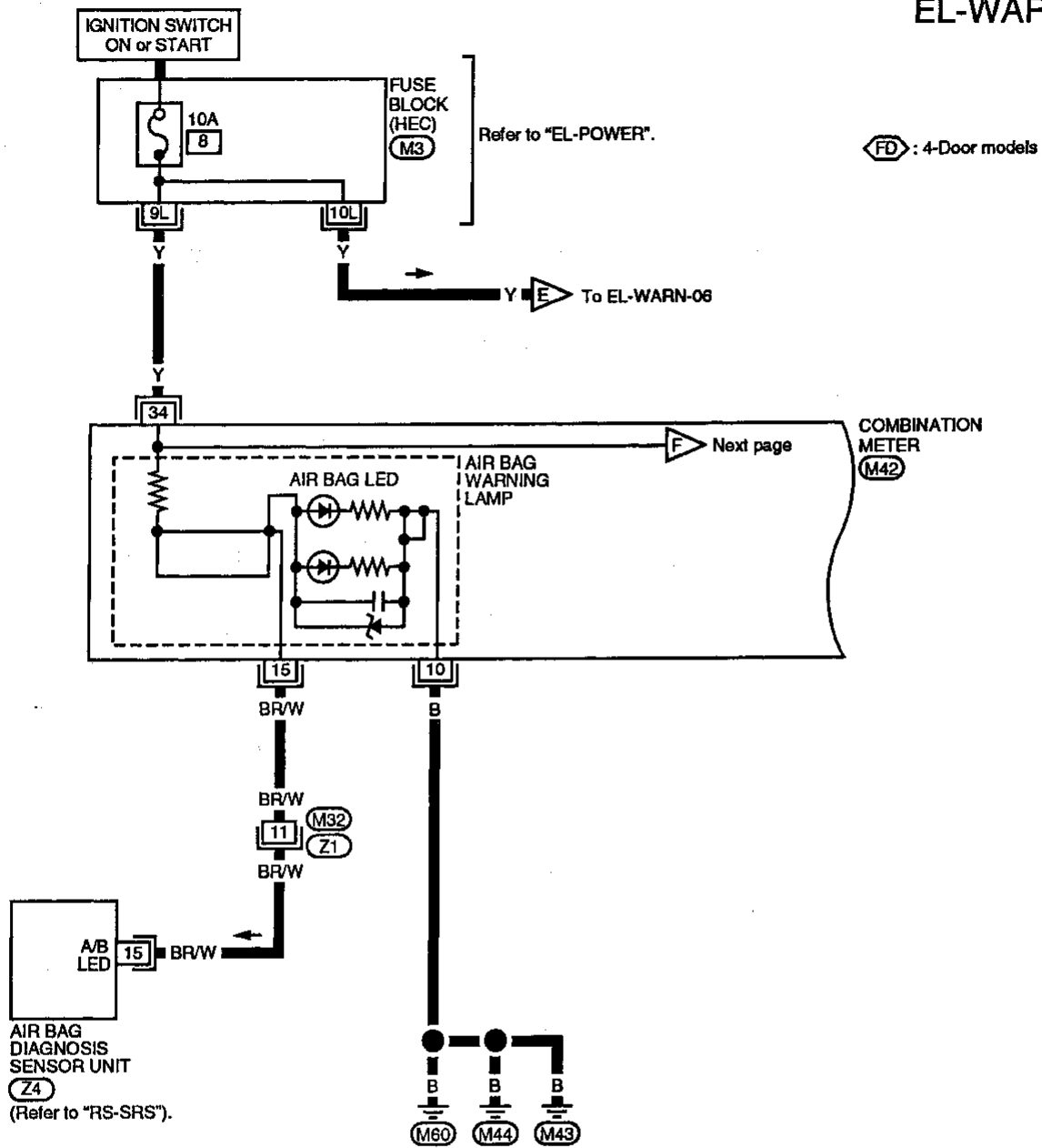

Refer to last page (Foldout page).

M3

GI

MA

EM

LC

EC

FE

CL

MT

AT

FA

RA

BR

ST

RS

BT

HA

EL

IDX

WARNING LAMPS AND CHIME

Warning Lamps/Wiring Diagram -WARN- (Cont'd)

EL-WARN-05

- U : For U.S.A.
- N : For Canada
- AB : Models with ABS

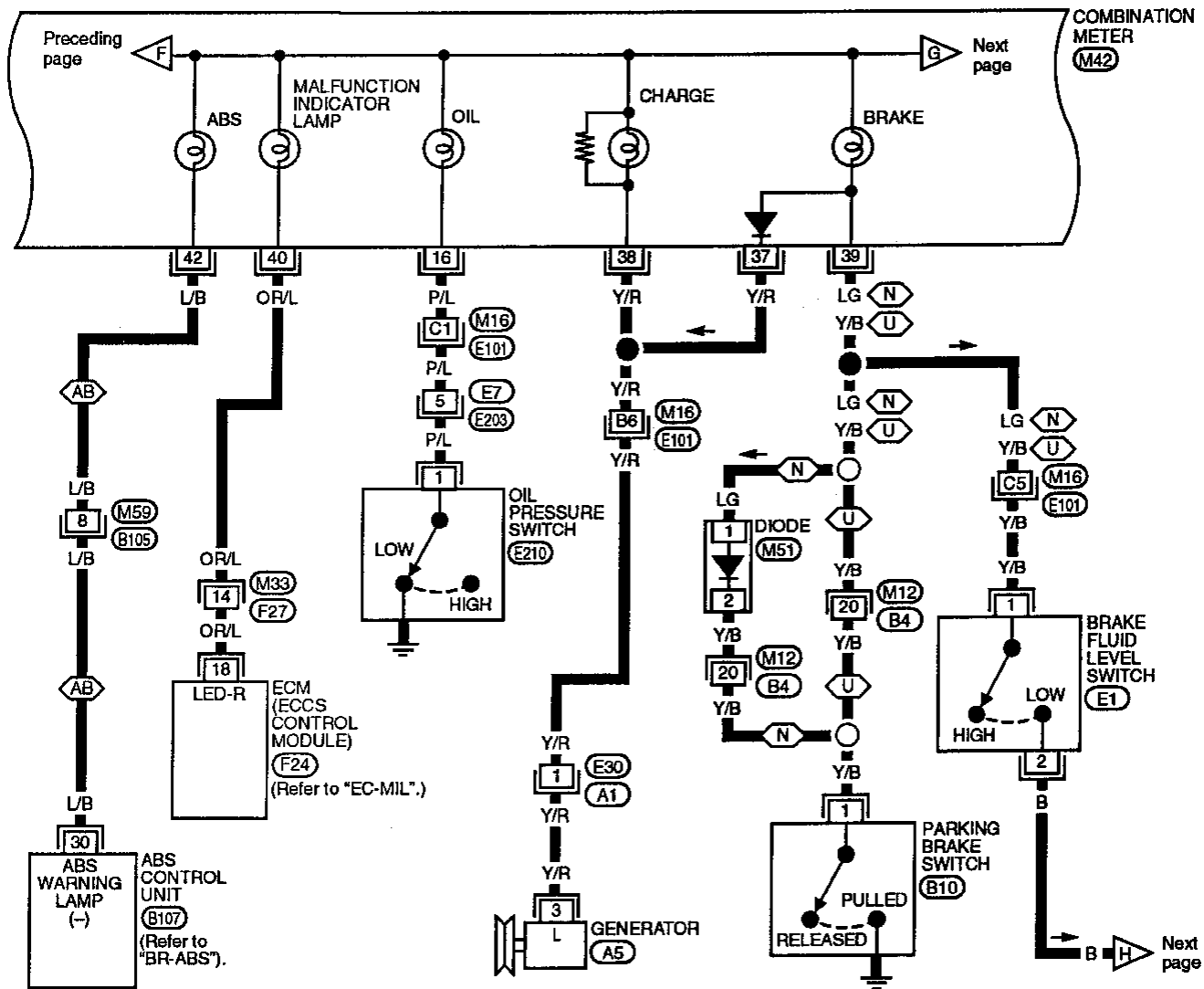

Refer to last page (Foldout page).

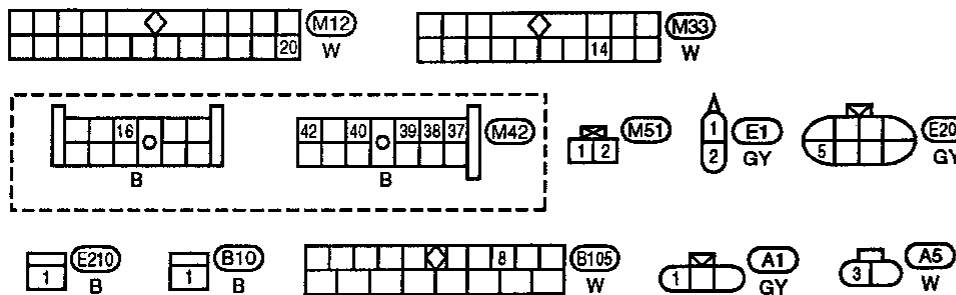

AEL574-E

WARNING LAMPS AND CHIME

Warning Lamps/Wiring Diagram -WARN- (Cont'd)

EL-WARN-06

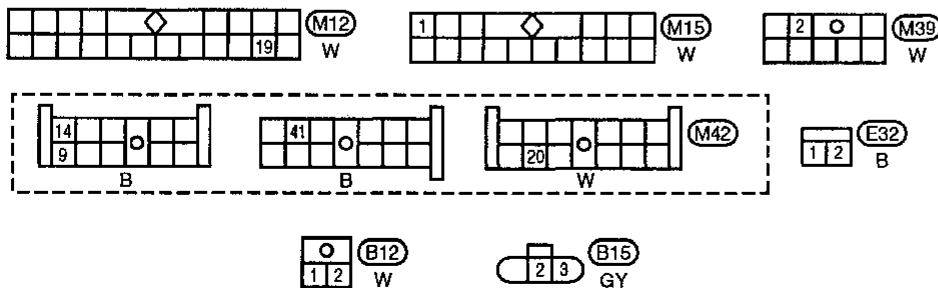
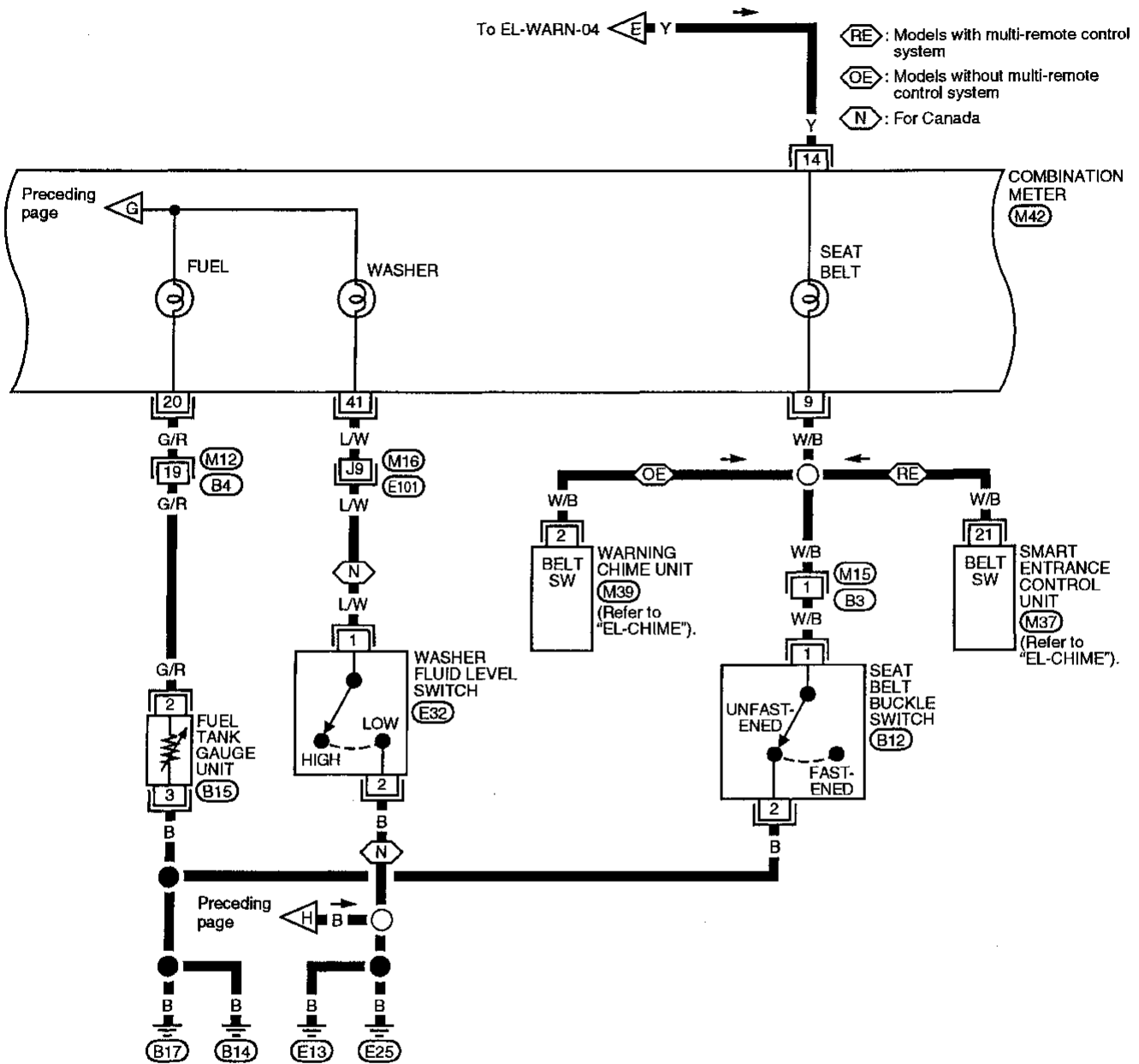

Refer to last page (Foldout page).
(M16, E101)

G1
 NA
 EM
 LC
 EC
 FE
 CL
 MT
 AT
 FA
 RA
 BR
 ST
 RS
 BT
 HA
 EL
 IDX

Warning Chime/System Description

MODELS WITH POWER DOOR LOCKS

The warning chime is controlled by the smart entrance control unit.

Power is supplied at all times:

- through 7.5A fuse (No. 24 , located in the fuse block [HEC])
- to warning chime terminal ③
- to key switch terminal ①.

Power is supplied at all times:

- through 10A fuse (No. 36 , located in the fusible link and fuse box)
- to lighting switch terminal ⑪.

Power is supplied at all times:

- through 25A fusible link (letter f , located in the fusible link and fuse box)
- to circuit breaker terminal ①
- through circuit breaker terminal ②
- to smart entrance control unit terminal ①.

With the ignition switch in the ON or START position, power is supplied:

- through 7.5A fuse (No. 7 , located in the fuse block [HEC])
- to smart entrance control unit terminal ⑪.

Ground is supplied to smart entrance control unit terminal ⑩ through body grounds M43 , M44 and M60 .

When a signal, or combination of signals, is received by the smart entrance control unit, ground is supplied:

- through smart entrance control unit terminal ⑳
- to warning chime terminal ①.

With power and ground supplied, the warning chime will sound.

Ignition key warning chime

With the key in the ignition switch in the OFF or ACC position, and the driver's door open, the warning chime will sound. A battery positive voltage is supplied:

- from key switch terminal ②
- to smart entrance control unit terminal ⑳.

Ground is supplied:

- to smart entrance control unit terminal ⑮
- from front door switch LH terminal ①.

Front door switch LH terminal ③ is grounded through body grounds B14 and B17 .

Light warning chime

With ignition switch OFF, or ACC driver's door open, and lighting switch in 1ST or 2ND position, the warning chime will sound. A battery positive voltage is supplied:

- from lighting switch terminal ⑫
- to smart entrance control unit terminal ⑳

Ground is supplied:

- to smart entrance control unit terminal ⑮
- from front door switch LH terminal ①.

Front door switch LH terminal ③ is grounded through body grounds B14 and B17 .

Seat belt warning chime

With ignition switch turned ON and seat belt unfastened (seat belt switch ON), warning chime will sound for approximately 6 seconds.

Ground is supplied:

- to smart entrance control unit terminal ⑳
- from seat belt switch terminal ①.

Seat belt switch terminal ② is grounded through body grounds B14 and B17 .

MODELS WITHOUT POWER DOOR LOCKS

The warning chime is controlled by the warning chime unit.

Power is supplied at all times:

- through 7.5A fuse (No. 24 , located in the fuse block [HEC])

WARNING LAMPS AND CHIME

Warning Chime/System Description (Cont'd)

- to key switch terminal ①.

Power is supplied at all times:

- through 10A fuse (No. 36 , located in the fusible link and fuse box)
- to lighting switch terminal ⑪.

With the ignition switch in the ON or START position, power is supplied:

- through 7.5A fuse (No. 7 , located in the fuse block [HEC])
- to warning chime unit terminal ①.

Ground is supplied to warning chime unit terminal ⑧ through body grounds M43 , M44 and M60 .

When a signal, or combination of signals, is received by the warning chime unit, the warning chime will sound.

Ignition key warning chime

With the key in the ignition switch in the OFF or ACC position, and the driver's door open, the warning chime will sound. A battery positive voltage is supplied:

- from key switch terminal ②
- to warning chime unit terminal ⑤.

Ground is supplied:

- to warning chime unit terminal ⑦
- from front door switch LH terminal ①.

Front door switch LH terminal ③ is grounded through body grounds B14 and B17 .

Light warning chime

With ignition switch OFF or ACC, driver's door open, and lighting switch in 1ST or 2ND position, warning chime will sound. A battery positive voltage is supplied:

- from lighting switch terminal ⑫
- to warning chime unit terminal ④.

Ground is supplied:

- to warning chime unit terminal ⑦
- from front door switch LH terminal ①.

Front door switch LH terminal ③ is grounded through body grounds B14 and B17 .

Seat belt warning chime

With ignition switch turned ON and seat belt unfastened (seat belt switch ON), warning chime will sound for approximately 6 seconds.

Ground is supplied:

- to warning chime unit terminal ②
- from seat belt switch terminal ①.

Seat belt switch terminal ② is grounded through body grounds B14 and B17 .

GI
MA
EM
LC
EC
FE
CL
MT
AT
FA
RA
BR
ST
RS
BT
HA
EL
IDX

WARNING LAMPS AND CHIME

Warning Chime/Wiring Diagram -CHIME-

MODELS WITH POWER DOOR LOCKS

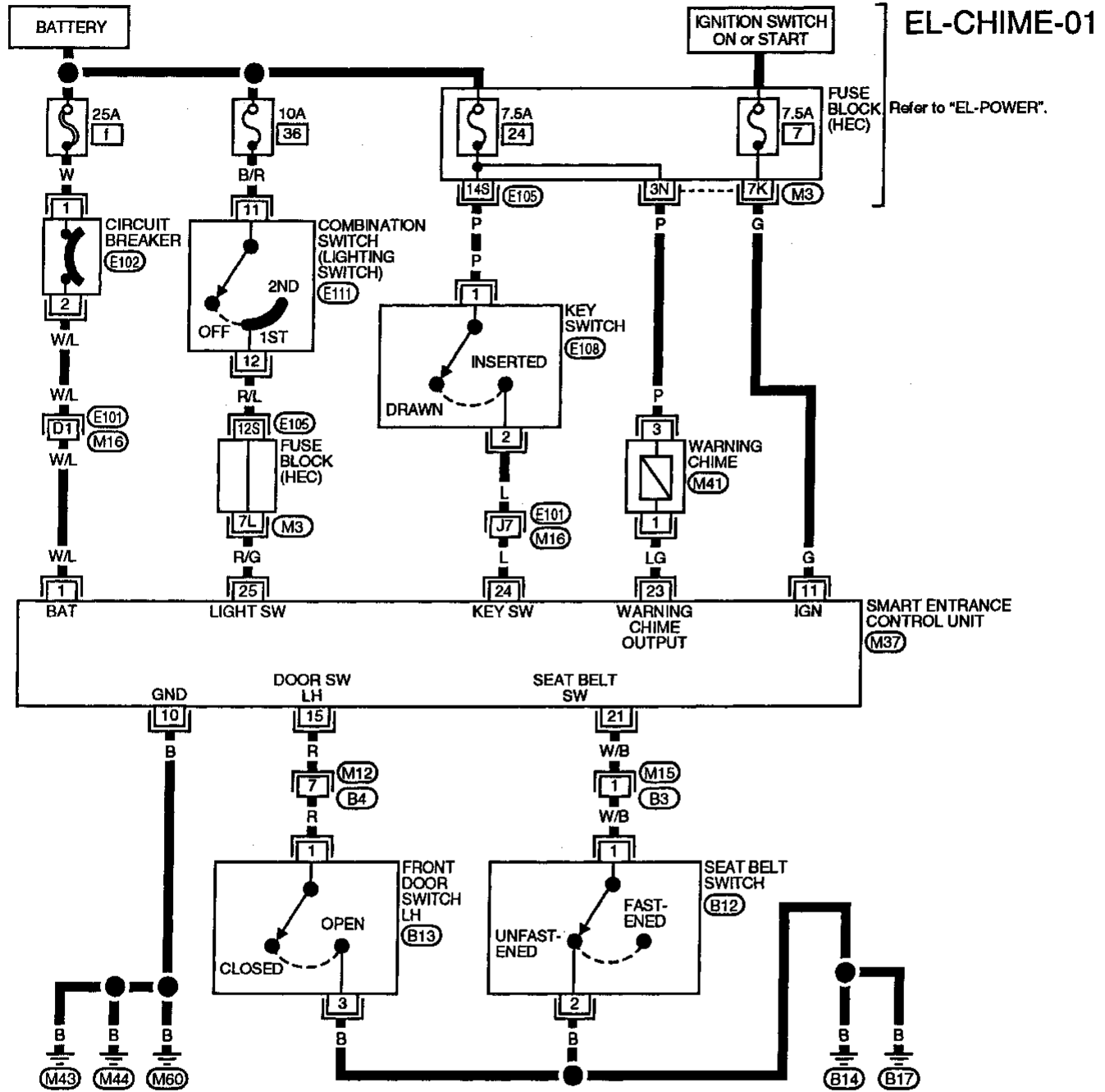

Refer to last page (Foldout page).

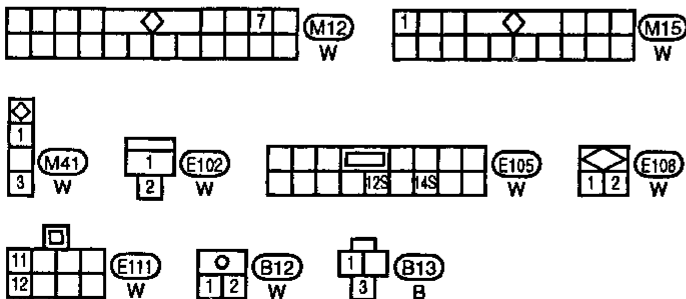

WARNING LAMPS AND CHIME

Warning Chime/Trouble Diagnoses

SYMPTOM CHART

Models with power door locks

PROCEDURE	Preliminary Check			Main Power Supply and Ground Circuit Check	Diagnostic Procedure		
	EL-101	EL-101	EL-101		EL-104	EL-106	EL-108
SYMPTOM	Preliminary check 1	Preliminary check 2	Preliminary check 3	Main power supply and Ground circuit	Diagnostic Procedure 1	Diagnostic Procedure 2	Diagnostic Procedure 3
Light warning chime does not activate.	○			○	○		
Ignition key warning chime does not activate.		○		○		○	
Seat belt warning chime does not activate.			○	○			○

Models without power door locks

PROCEDURE	Preliminary Check			Main Power Supply and Ground Circuit Check	Diagnostic Procedure		
	EL-102	EL-102	EL-102		EL-105	EL-107	EL-108
SYMPTOM	Preliminary check 1	Preliminary check 2	Preliminary check 3	Main power supply and Ground circuit	Diagnostic Procedure 1	Diagnostic Procedure 2	Diagnostic Procedure 3
Light warning chime does not activate.	○			○	○		
Ignition key warning chime does not activate.		○		○		○	
Seat belt warning chime does not activate.			○	○			○

WARNING LAMPS AND CHIME

Warning Chime/Trouble Diagnoses (Cont'd)

PRELIMINARY CHECK

Models with power door locks

Preliminary check 1

- Light warning chime does not activate.

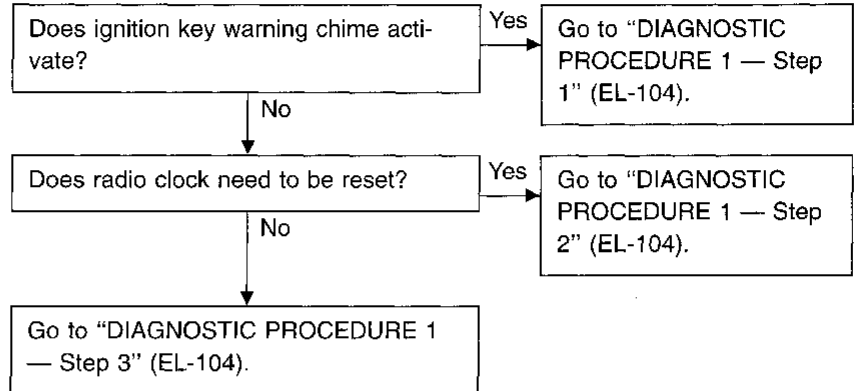

Preliminary check 2

- Ignition key warning chime does not activate.

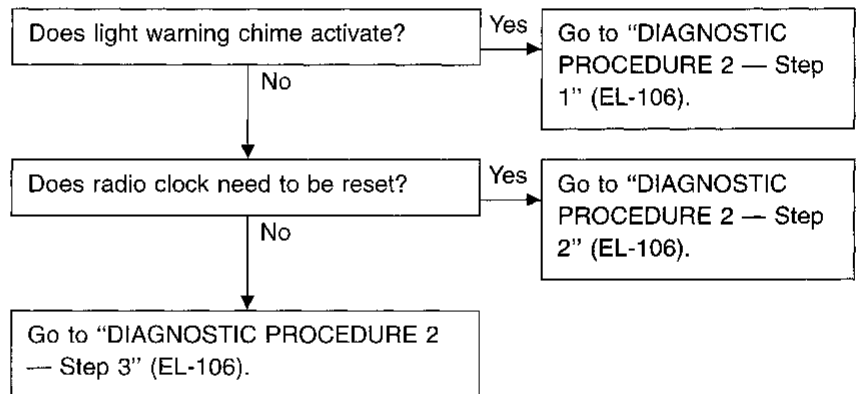

Preliminary check 3

- Seat belt warning chime does not activate.

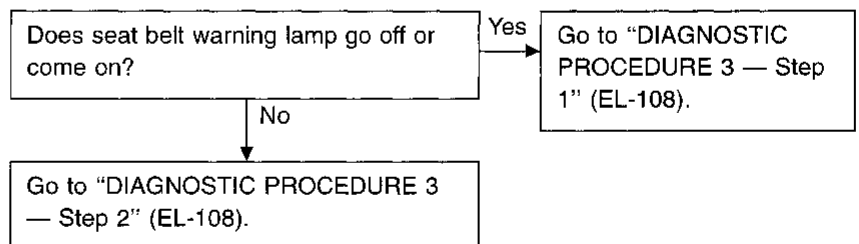

GI
MA
EM
LC
EC
FE
CL
MT
AT
EA
RA
BR
ST
RS
BT
HA
EL
IDX

WARNING LAMPS AND CHIME

Warning Chime/Trouble Diagnoses (Cont'd)

Models without power door locks

Preliminary check 1

- Light warning chime does not activate.

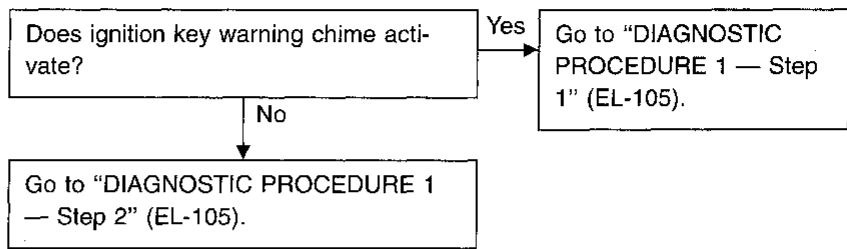

Preliminary check 2

- Ignition key warning chime does not activate.

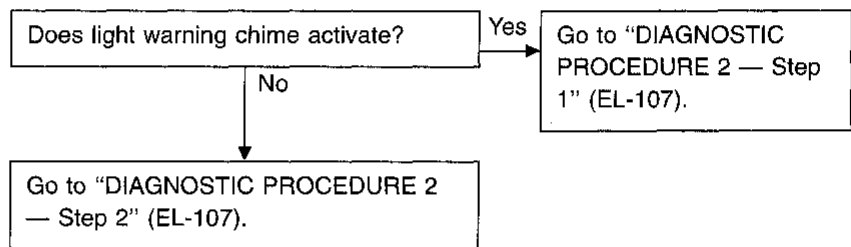

Preliminary check 3

- Seat belt warning chime does not activate.

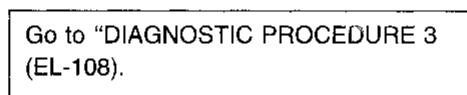

WARNING LAMPS AND CHIME

Warning Chime/Trouble Diagnoses (Cont'd)

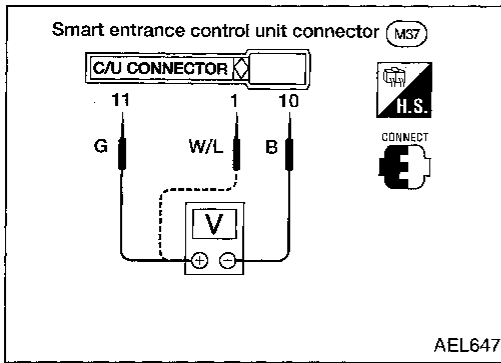

MAIN POWER SUPPLY AND GROUND CIRCUIT CHECK

Main power supply

- Models with power door locks

Terminals	Battery voltage existence condition		
	Ignition switch position		
	OFF	ACC	ON
①① - ①⑩	No	No	Yes
① - ①⑩	Yes	Yes	Yes

GI

MA

EM

LC

EC

FE

CL

MT

AT

FA

RA

BR

ST

RS

BT

HA

EL

IDX

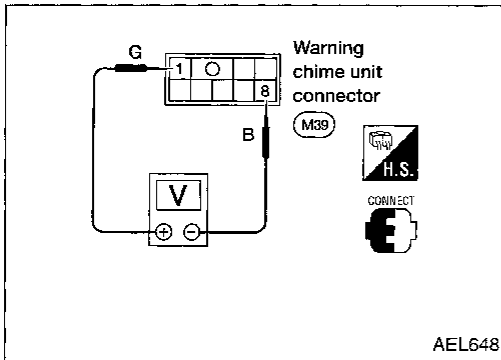

- Models without power door locks

Terminals	Battery voltage existence condition		
	Ignition switch position		
	OFF	ACC	ON
① - ⑧	No	No	Yes

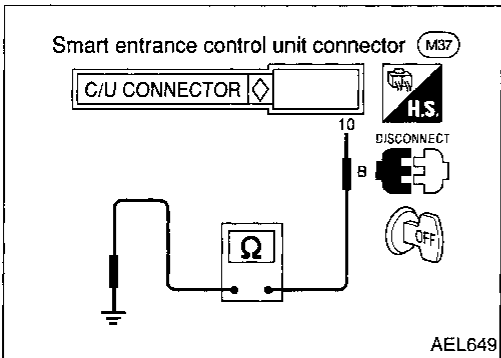

Ground circuit

- Models with power door locks

Terminals	Continuity
①⑩ - Ground	Yes

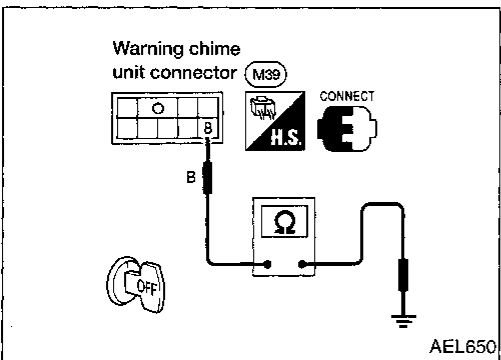

- Models without power door locks

Terminals	Continuity
⑧ - Ground	Yes

WARNING LAMPS AND CHIME

Warning Chime/Trouble Diagnoses (Cont'd)

DIAGNOSTIC PROCEDURE 1

SYMPTOM: Light warning chime does not activate.

- Perform "Preliminary check 1" before referring to the following flow chart.

Models with power door locks

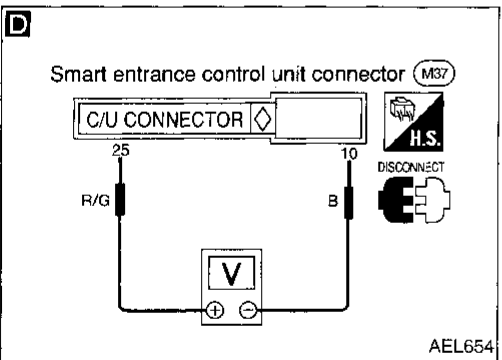
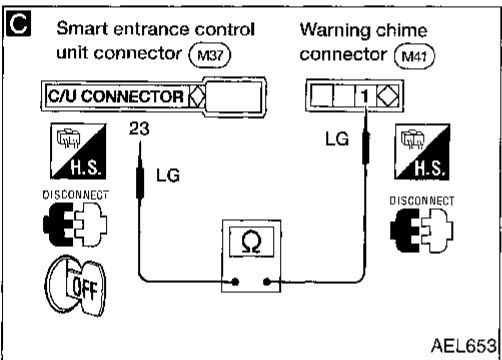
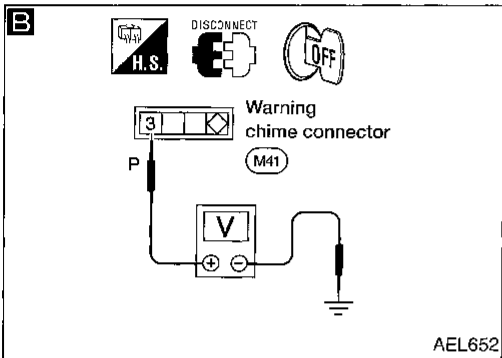
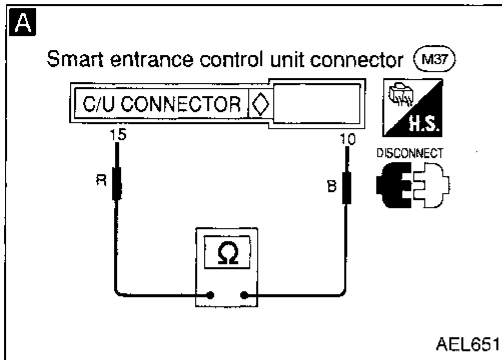

A Step 3

DOOR SWITCH INPUT SIGNAL CHECK.

Check continuity between control unit harness terminals (15) and (10).

Condition of driver's door	Continuity
LH door is closed.	No
LH door is open.	Yes

- NG
- Check door switch. (Refer to EL-220.)
 - Check harness continuity between control unit harness terminal (15) and LH door switch harness terminal (1). **Continuity should exist.**
 - Check harness continuity between LH door switch harness terminal (3) and body ground. **Continuity should exist.**

OK

B Step 2

WARNING CHIME POWER SUPPLY CHECK.

Measure voltage between warning chime harness terminal (3) and body ground. **Battery voltage should exist.**

NG

Check 7.5A fuse (24), harness and connector.

OK

C

WARNING CHIME OUTPUT SIGNAL CHECK.

Check continuity between warning chime harness terminal (1) and control unit harness terminal (23). **Continuity should exist.**

NG

Repair harness or connectors.

OK

WARNING CHIME CHECK

Refer to EL-109.

NG

Replace warning chime.

OK

D Step 1

LIGHTING SWITCH INPUT SIGNAL CHECK.

Measure voltage between control unit harness terminals (25) and (10).

Condition	Voltage [V]
Lighting switch is ON.	Approx. 12
Lighting switch is OFF.	0

- NG
- Check lighting switch.
 - Check harness continuity between control unit harness terminal (25) and lighting switch harness terminal (12). **Continuity should exist.**
 - Measure voltage between lighting switch harness terminal (11) and body ground. **Battery voltage should exist.**

OK

Replace control unit.

WARNING LAMPS AND CHIME

Warning Chime/Trouble Diagnoses (Cont'd)

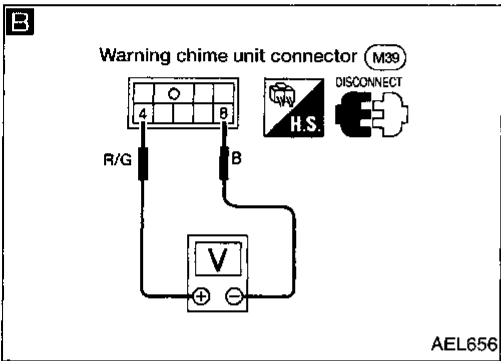
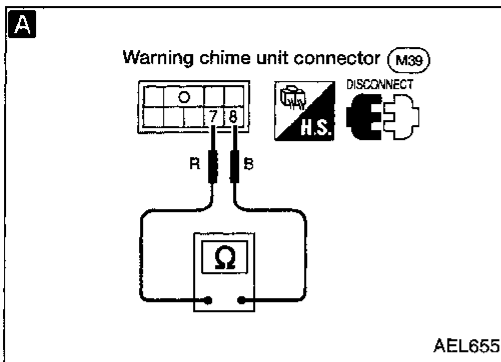

Models without power door locks

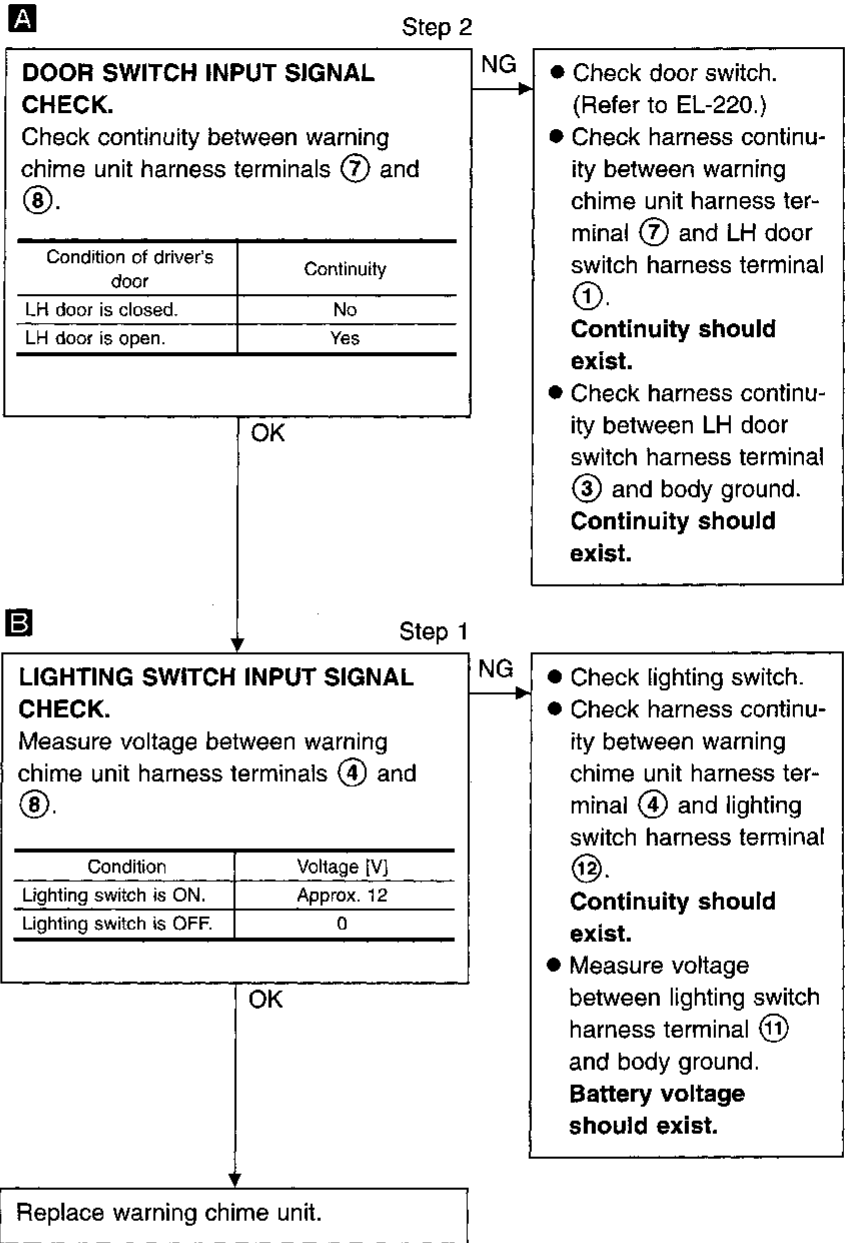

GI
MA
EM
LC
EC
FE
CL
MT
AT
FA
RA
BR
ST
RS
BT
HA
EL
IDX

WARNING LAMPS AND CHIME

Warning Chime/Trouble Diagnoses (Cont'd)

DIAGNOSTIC PROCEDURE 2

SYMPTOM: Ignition key warning chime does not activate.

- Perform "Preliminary check 2" before referring to the following flow chart.

Models with power door locks

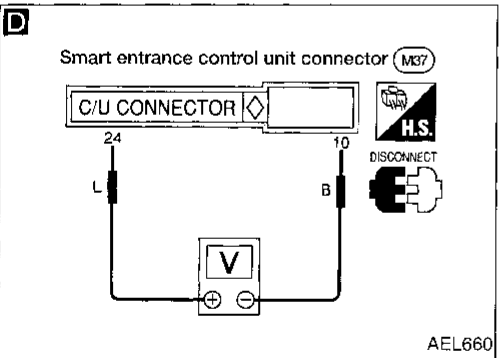
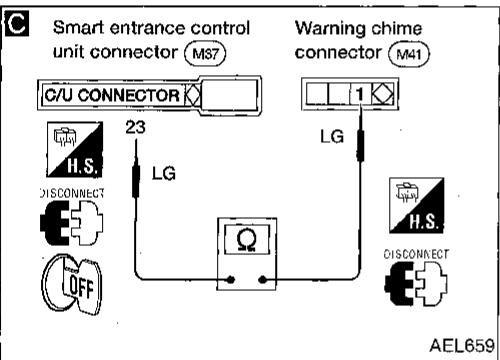
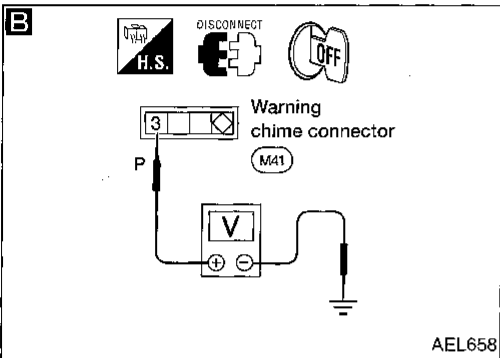
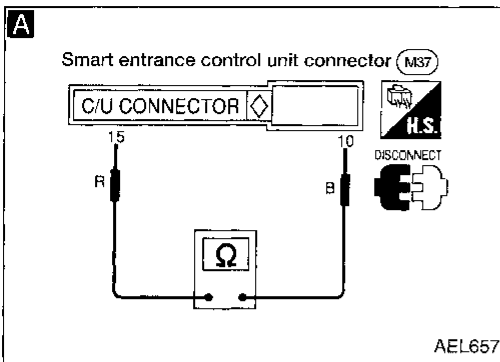

Step 3

A DOOR SWITCH INPUT SIGNAL CHECK.
Check continuity between control unit harness terminals (15) and (10).

Condition of driver's door	Continuity
LH door is closed.	No
LH door is open.	Yes

• Check door switch. (Refer to EL-220.)
• Check harness continuity between control unit harness terminal (15) and LH door switch harness terminal (1). **Continuity should exist.**
• Check harness continuity between LH door switch harness terminal (3) and body ground. **Continuity should exist.**

Step 2

B WARNING CHIME POWER SUPPLY CHECK.
Measure voltage between warning chime harness terminal (3) and body ground. **Battery voltage should exist.**

Check 7.5A fuse (24), harness and connector.

Step 1

D IGNITION KEY SWITCH INPUT SIGNAL CHECK.
Measure voltage between control unit harness terminals (24) and (10).

Condition	Voltage [V]
Key is inserted.	Approx. 12
Key is pulled.	0

• Check ignition key switch.
• Check harness continuity between control unit harness terminal (24) and key switch harness terminal (2). **Continuity should exist.**
• Measure voltage between key switch harness terminal (1) and body ground. **Battery voltage should exist.**

Replace control unit.

NG: Repair harness or connectors.
NG: Replace warning chime.

WARNING LAMPS AND CHIME

Warning Chime/Trouble Diagnoses (Cont'd)

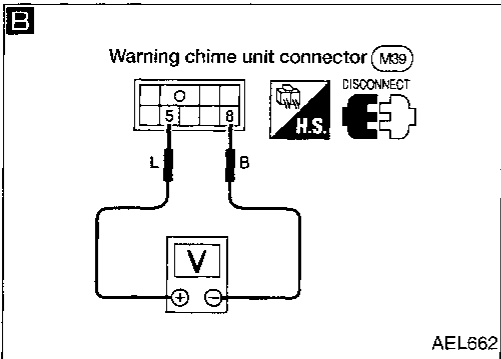
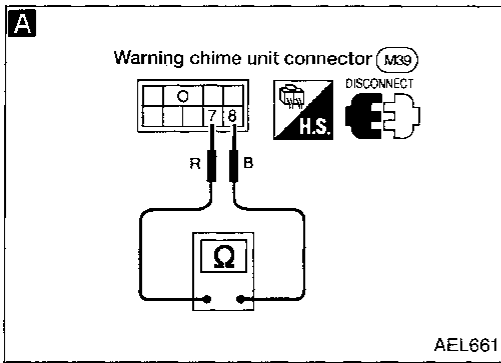

Models without power door locks

A

Step 2

DOOR SWITCH INPUT SIGNAL CHECK.

Check continuity between warning chime unit harness terminals ⑦ and ⑧.

Condition of driver's door	Continuity
LH door is closed.	No
LH door is open.	Yes

NG

- Check door switch. (Refer to EL-220.)
- Check harness continuity between warning chime unit harness terminal ⑦ and LH door switch harness terminal ①.

Continuity should exist.

- Check harness continuity between LH door switch harness terminal ③ and body ground.

Continuity should exist.

OK

B

Step 1

IGNITION KEY SWITCH INPUT SIGNAL CHECK.

Measure voltage between warning chime unit harness terminals ⑤ and ⑧.

Condition	Voltage [V]
Key is inserted.	Approx. 12
Key is pulled.	0

NG

- Check ignition key switch.
- Check harness continuity between warning chime unit harness terminal ⑤ and key switch harness terminal ②.

Continuity should exist.

- Measure voltage between key switch harness terminal ① and body ground.

Battery voltage should exist.

OK

Replace warning chime unit.

GI
MA
EM
LG
EC
FE
CL
MT
AT
FA
RA
BR
ST
RS
BT
HA
EL
DX

WARNING LAMPS AND CHIME

Warning Chime/Trouble Diagnoses (Cont'd)

DIAGNOSTIC PROCEDURE 3

SYMPTOM: Seat belt warning chime does not activate.

- Perform "Preliminary check 3" before referring to the following flow chart.

Models with power door locks

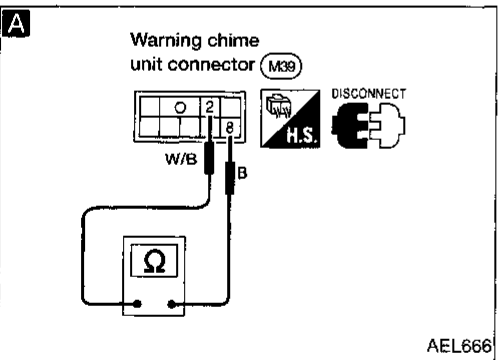
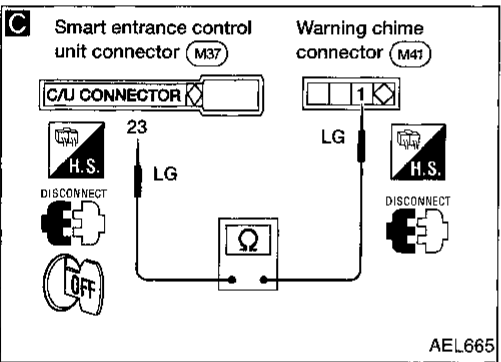
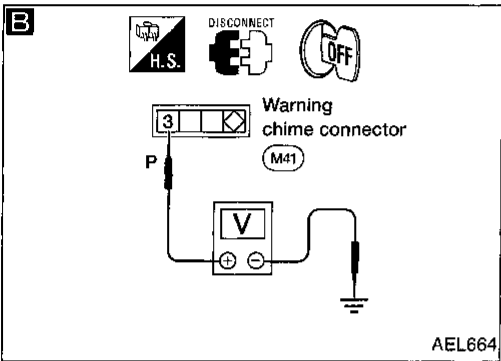
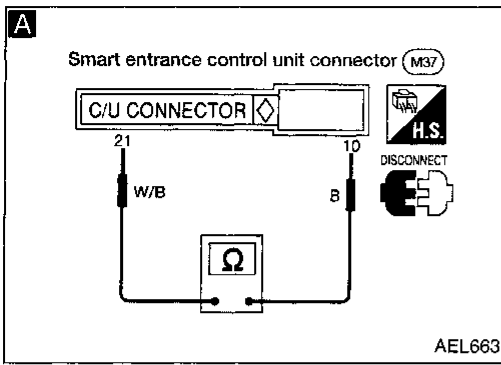

Step 2

SEAT BELT SWITCH INPUT SIGNAL CHECK.

Check continuity between control unit harness terminals (21) and (10).

Condition	Continuity
Unfastened	Yes
Fastened	No

- NG
- Check seat belt switch.
 - Check harness continuity between control unit harness terminal (21) and seat belt switch harness terminal (1). **Continuity should exist.**
 - Check harness continuity between seat belt switch harness terminal (2) and body ground. **Continuity should exist.**

Step 1

WARNING CHIME POWER SUPPLY CHECK.

Measure voltage between warning chime harness terminal (3) and body ground. **Battery voltage should exist.**

- NG
- Check 7.5A fuse (24) harness and connector.

WARNING CHIME OUTPUT SIGNAL CHECK.

Check continuity between warning chime harness terminal (1) and control unit harness terminal (23). **Continuity should exist.**

- NG
- Repair harness or connectors.

WARNING CHIME CHECK. Refer to EL-109.

- NG
- Replace warning chime.

Replace control unit.

Models without power door locks

SEAT BELT SWITCH INPUT SIGNAL CHECK. Check continuity between warning chime unit harness terminals (2) and (8).

Condition	Continuity
Unfastened	Yes
Fastened	No

- NG
- Check seat belt switch.
 - Check harness continuity between warning chime unit harness terminal (2) and seat belt switch harness terminal (1). **Continuity should exist.**
 - Check harness continuity between seat belt switch harness terminal (2) and body ground. **Continuity should exist.**

Replace warning chime unit.

WARNING LAMPS AND CHIME

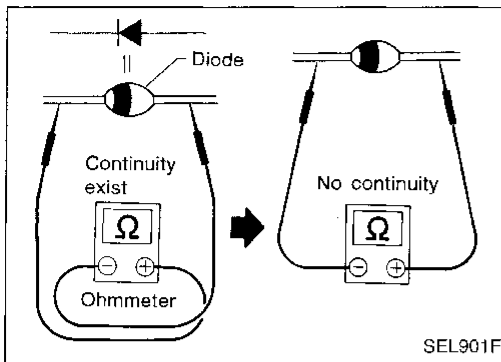

Diode Check

- Check continuity using an ohmmeter.
- Diode is functioning properly if test results are as shown in the figure at left.

NOTE: Specification may vary depending on the type of tester. Before performing this inspection, be sure to refer to the instruction manual for the tester being used.

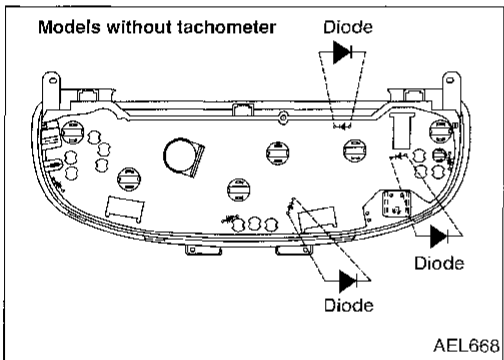
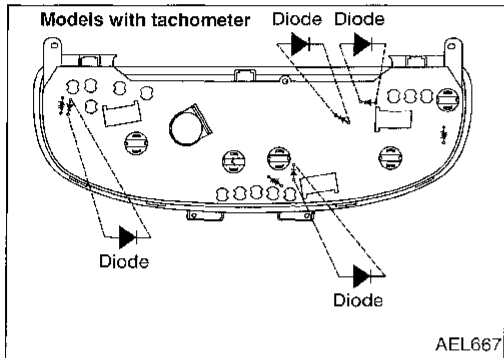

- Diodes for warning lamps are built into the combination meter printed circuit.

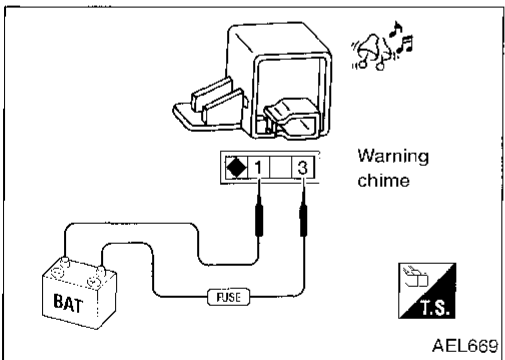

Warning Chime Check

Supply battery voltage to warning chime as shown in the illustration.

Warning chime should operate.

GI

MA

EM

LC

EC

FE

CL

WT

AT

FA

BA

BR

ST

RS

BT

MA

EL

IDX

System Description

WIPER OPERATION

The wiper switch is controlled by a lever built into the combination switch.

There are three wiper switch positions:

- LO speed
- HI speed
- INT (with Intermittent)

With the ignition switch in the ACC or ON position, power is supplied:

- through 20A fuse (No. 19, located in the fuse block [HEC])
- to wiper motor terminal 6
- to wiper amplifier terminal 5 (with intermittent).

Ground is supplied to wiper amplifier terminal 3 through body grounds M43, M44 and M60 (with intermittent).

Low and high speed wiper operation

Ground is supplied to wiper switch terminal 17 through body grounds E13 and E25.

When the wiper switch is placed in the LO position, ground is supplied:

- through terminal 14 of the wiper switch
- to wiper motor terminal 2.

With power and ground supplied, the wiper motor operates at low speed.

When the wiper switch is placed in the HI position, ground is supplied:

- through terminal 16 of the wiper switch
- to wiper motor terminal 1.

With power and ground supplied, the wiper motor operates at high speed.

Auto stop operation (with intermittent)

With wiper switch turned OFF, wiper motor will continue to operate until wiper arms reach windshield base.

When wiper arms are not located at base of windshield with wiper switch OFF, ground is provided:

- from terminal 14 of the wiper switch
- to wiper motor terminal 2, in order to continue wiper motor operation at low speed.

Ground is also supplied:

- through terminal 13 of the wiper switch
- to wiper amplifier terminal 2
- through terminal 7 of the wiper amplifier
- to wiper motor terminal 5
- through terminal 4 of the wiper motor, and
- through body grounds M43, M44 and M60.

When wiper arms reach base of windshield, wiper motor terminals 5 and 6 are connected instead of terminals 5 and 4. Wiper motor will then stop wiper arms at the PARK position.

Auto stop operation (without intermittent)

With wiper switch turned OFF, wiper motor will continue to operate until wiper arms reach windshield base.

When wiper arms are not located at base of windshield with wiper switch OFF, ground is provided:

- from terminal 14 of the wiper switch
- to wiper motor terminal 2, in order to continue wiper motor operation at low speed.

Ground is also supplied:

- through terminal 13 of the wiper switch
- to wiper motor terminal 5
- through terminal 4 of the wiper motor, and
- through body grounds M43, M44 and M60.

When wiper arms reach base of windshield, wiper motor terminals 5 and 6 are connected instead of terminals 5 and 4. Wiper motor will then stop wiper arms at the PARK position.

Intermittent operation

The wiper motor operates the wiper arms one time at low speed at an interval of approximately 7 seconds. This feature is controlled by the intermittent wiper amplifier.

When the wiper switch is placed in the INT position, ground is supplied:

- to wiper amplifier terminal 1

WIPER AND WASHER

System Description (Cont'd)

- from wiper switch terminal ⑮
- through body grounds ①E13 and ①E25, and
- to wiper motor terminal ②
- through the wiper switch terminal ⑭
- to wiper switch terminal ⑬
- through wiper amplifier terminal ②
- to wiper amplifier terminal ③
- through body grounds ①M43, ①M44 and ①M60.

WASHER OPERATION

With the ignition switch in the ACC or ON position, power is supplied:

- through 20A fuse (No. ⑱, located in the fuse block [HEC])
- to washer motor terminal ①.

When the lever is pulled to the WASH position, ground is supplied:

- to washer motor terminal ②, and
- to wiper amplifier terminal ⑥ (with intermittent)
- from terminal ⑱ of the wiper switch
- through terminal ⑰ of the wiper switch, and
- through body grounds ①E13 and ①E25.

With power and ground supplied, the washer motor operates.

If equipped with intermittent wipers, the wiper motor is activated when the lever is pulled to WASH for 1 second or more. The motor operates at low for approximately 3 seconds. This feature is controlled by the wiper amplifier in the same manner as the intermittent operation.

GI

MA

EM

LC

EC

FE

CL

MT

AT

FA

RA

BR

ST

RS

BT

HA

EL

IDX

WIPER AND WASHER

Wiring Diagram -WIPER-

MODELS WITH INTERMITTENT WIPERS

EL-WIPER -01

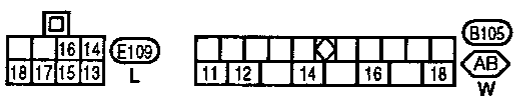
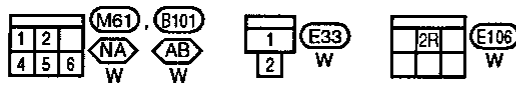
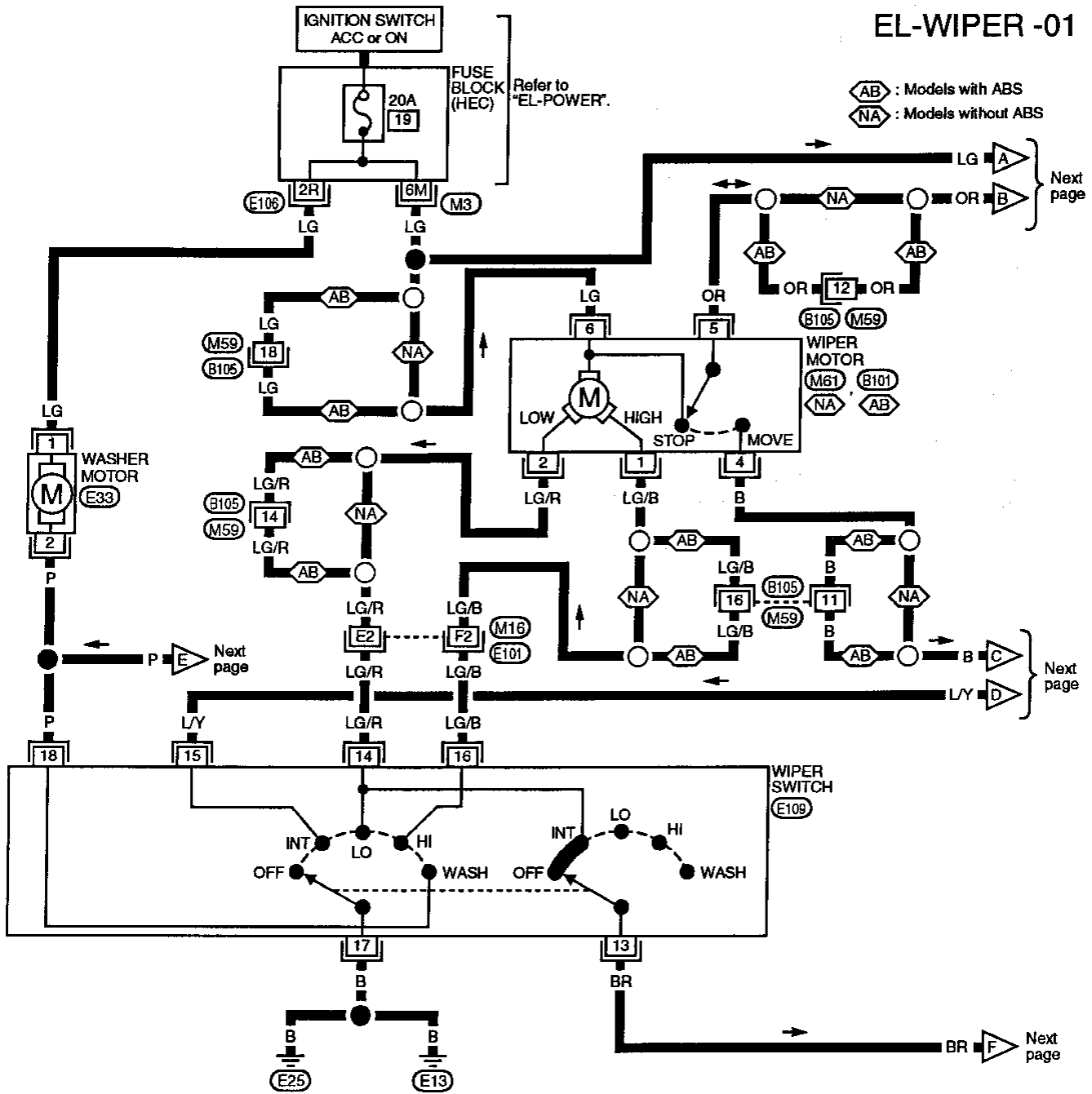

Refer to last page (Foldout page).

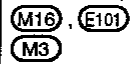

WIPER AND WASHER

Wiring Diagram -WIPER- (Cont'd)

EL-WIPER -02

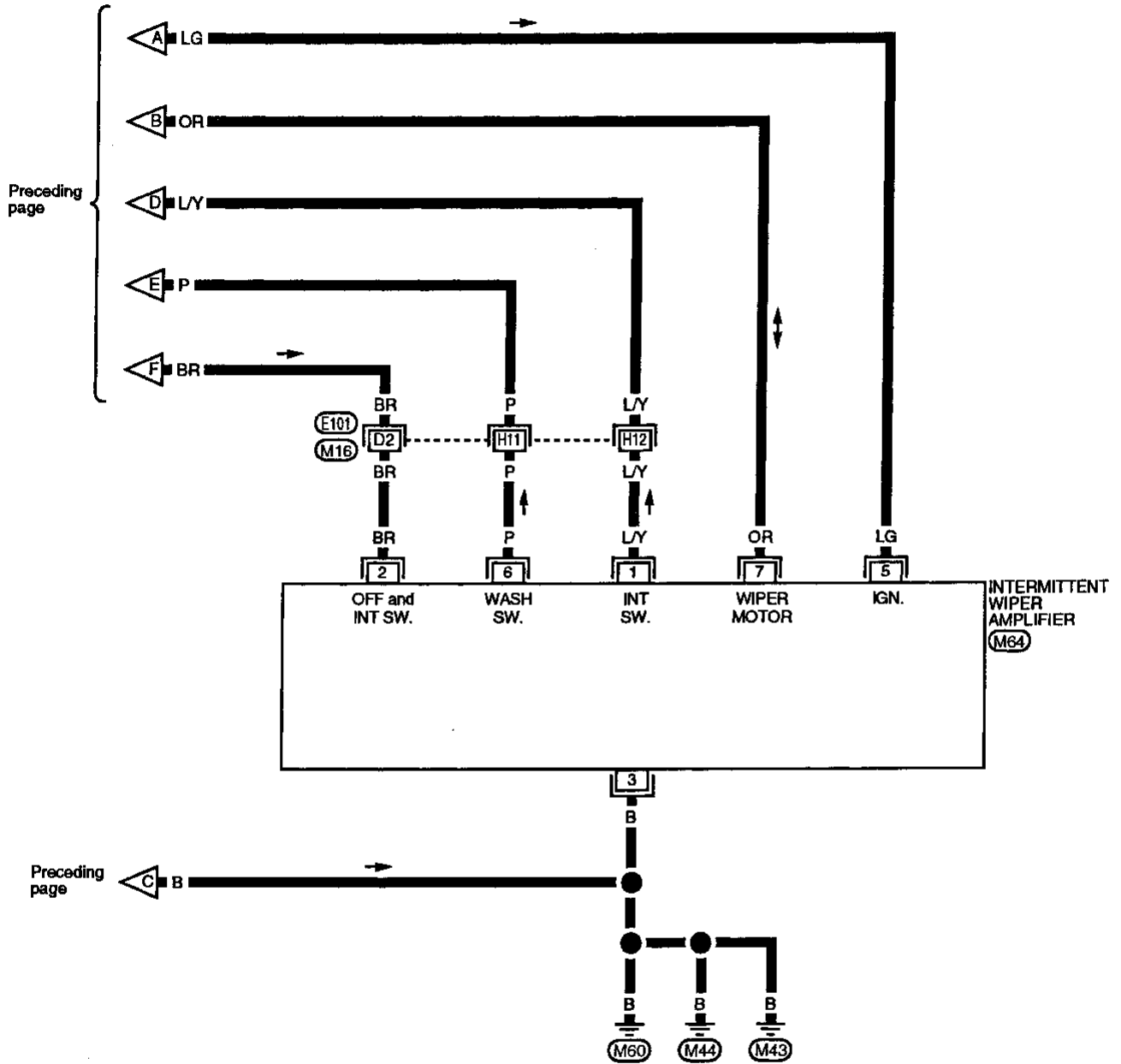

Preceding page

Preceding page

Refer to last page (Foldout page).
M16, E101

	3	2	1	(M64) W
	7	6	5	

GI
MA
EM
LC
EC
FE
CL
MT
AT
FA
RA
BR
ST
RS
BT
HA
EL
IDX

Trouble Diagnoses

DIAGNOSTIC PROCEDURE 1

SYMPTOM: Intermittent wiper does not operate.

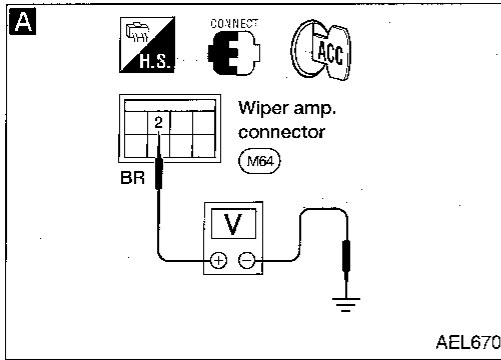

A

WIPER AMP. OUTPUT SIGNAL CHECK.
 1. Turn ignition switch to "ACC".
 2. Move wiper switch to "INT" or "OFF".
 3. Measure voltage between wiper amp. harness terminal ② and body ground.

Condition of wiper switch	Voltage [V]
OFF	Approx. 12
INT	Pointer swings from 0 to 12 every 7 seconds

OK → Check wiper motor.

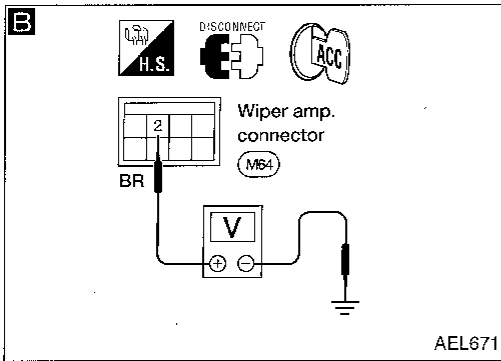

B

VOLTAGE CHECK.
 Measure voltage between wiper amp. harness terminal ② and body ground. **Battery voltage should exist.**

NG →

- Check wiper switch.
- Check wiper motor.
- Check harness continuity between wiper amp. harness terminal ② and wiper switch harness terminal ⑬. **Continuity should exist.**
- Check harness continuity between wiper switch harness terminal ⑭ and wiper motor harness terminal ②. **Continuity should exist.**

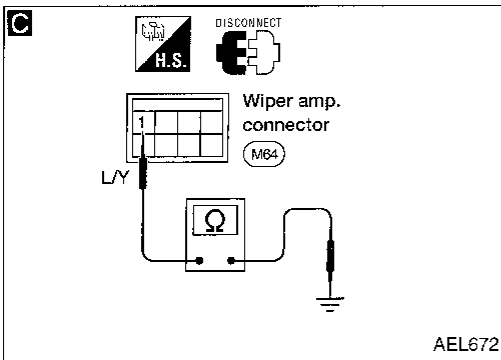

C

INTERMITTENT SWITCH INPUT SIGNAL CHECK.
 Check harness continuity between wiper amp. harness terminal ① and body ground.

Condition of wiper switch	Continuity
OFF	No
INT	Yes

NG →

- Check wiper switch.
- Check harness continuity between wiper amp. harness terminal ① and wiper switch harness terminal ⑮. **Continuity should exist.**
- Check harness continuity between wiper switch harness terminal ⑰ and body ground. **Continuity should exist.**

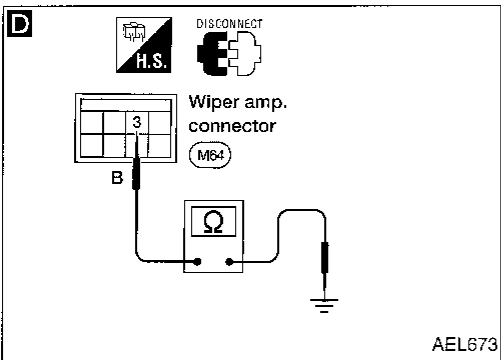

D

WIPER AMP. GROUND CIRCUIT CHECK.
 Check harness continuity between wiper amp. harness terminal ③ and body ground. **Continuity should exist.**

NG → Repair harness or connector.

OK →

Replace wiper amp.

CI
 MA
 EM
 LC
 EC
 FE
 CL
 MT
 AT
 FA
 RA
 BR
 ST
 RS
 BT
 HA
 EL
 IDX

WIPER AND WASHER

Trouble Diagnoses (Cont'd)

DIAGNOSTIC PROCEDURE 2

SYMPTOM: Wiper and washer activate individually but not in combination.

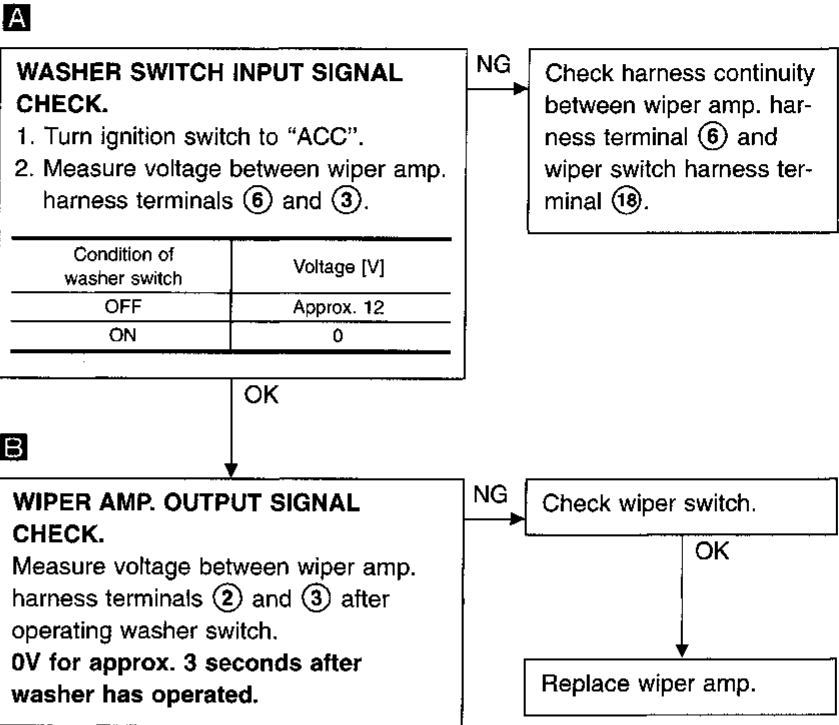
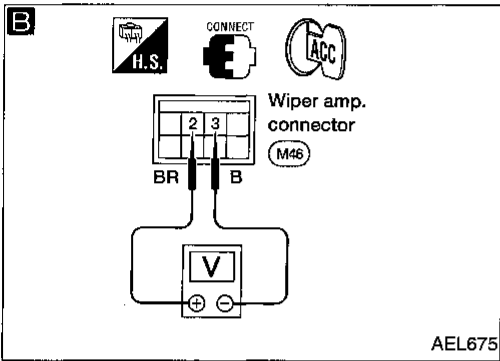
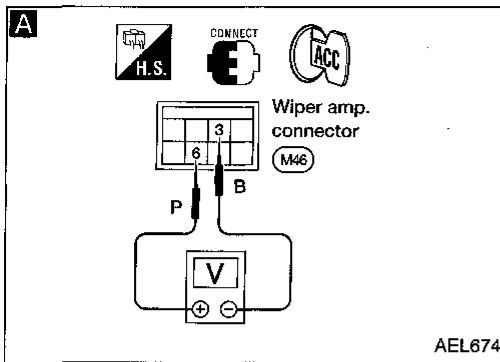

Wiper Installation and Adjustment

1. Turn ignition ON.
2. Prior to wiper arm installation, turn on wiper switch and then turn it "OFF". Allow wiper to operate until its Auto Stop position is reached before turning ignition OFF.
3. Lift the blade up and then set it down onto glass surface. Set the blade center to clearance "L" just before tightening nut.
4. Eject washer fluid. Turn on wiper switch to operate wiper motor and then turn it "OFF".
5. Ensure that wiper blades stop within clearance "L".

Clearance "L": 27 - 41 mm (1.06 - 1.61 in)

- Tighten windshield wiper arm nuts to specified torque.

Windshield wiper:

21 - 26 N·m (2.1 - 2.7 kg-m, 15 - 20 ft-lb)

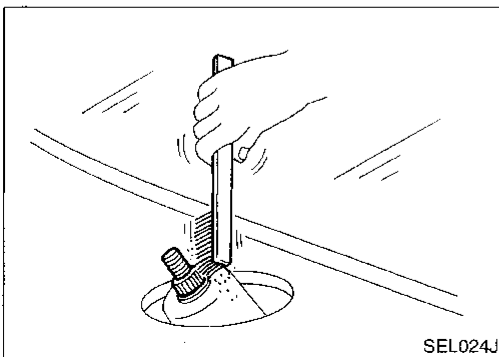
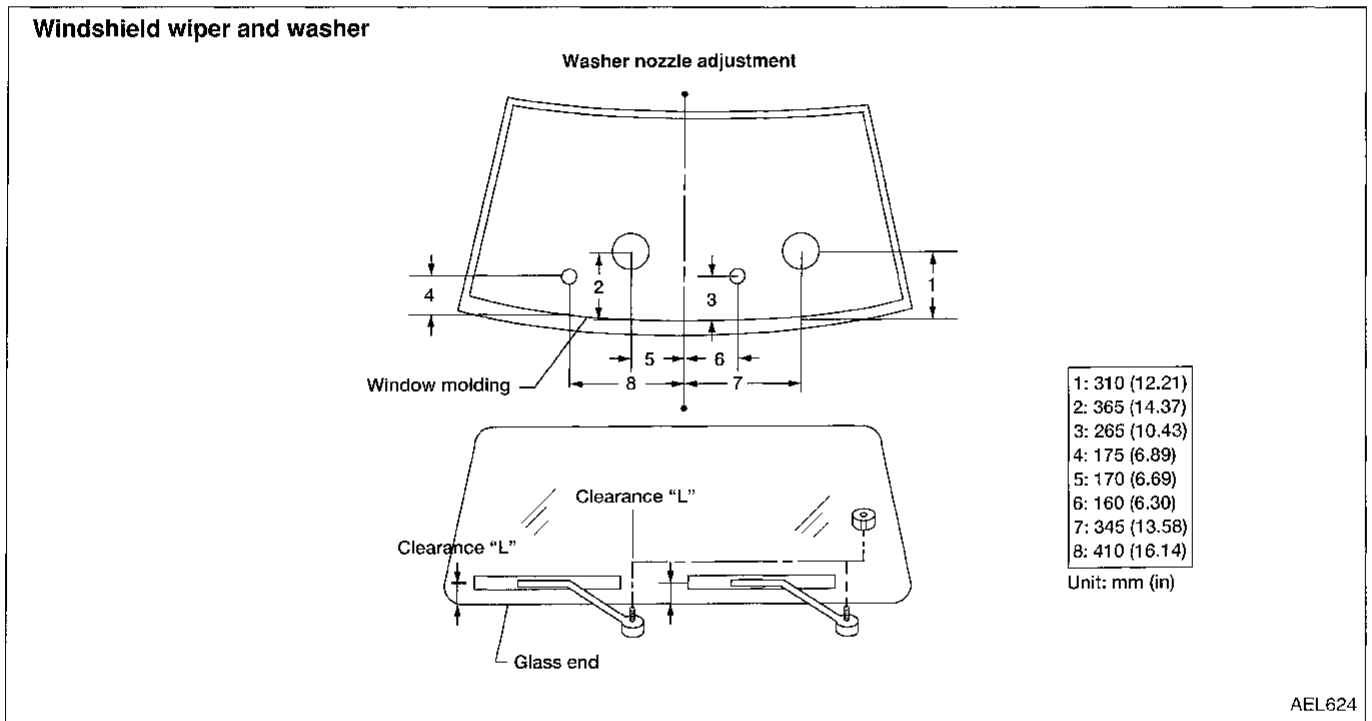

- Before reinstalling wiper arm, clean up the pivot area as illustrated. This will reduce possibility of wiper arm looseness.

WIPER AND WASHER

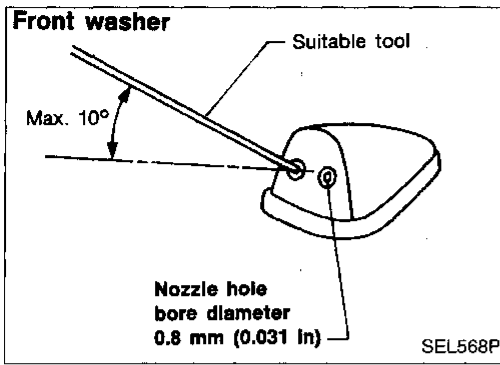

Washer Nozzle Adjustment

- Adjust washer nozzle with suitable tool as shown in the figure at left.

Adjustable range: $\pm 10^\circ$

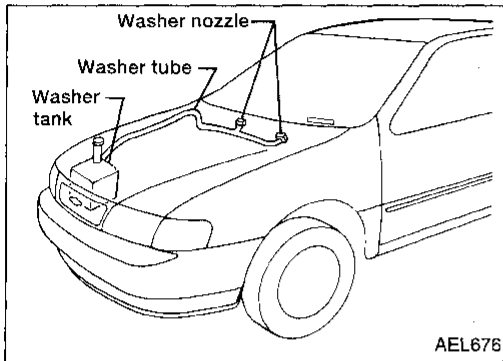

System Description

Power is supplied at all times:

- from 25A fusible link (letter **f** , located in the fusible link and fuse box)
- to circuit breaker terminal ①
- through circuit breaker terminal ②
- to power window relay terminal ③.

With the ignition switch in ON or START position, power is supplied:

- from 7.5A fuse (No. **7** , located in the fuse block [HEC])
- to power window relay terminal ①.

Ground is supplied to power window relay terminal ②:

- through body grounds **M43** , **M44** and **M60** .

The power window relay is energized and power is supplied:

- through terminal ⑤ of the power window relay
- to main power window and door lock switch terminal ①
- to power window switch (front RH) terminal ⑤
- to power window switch (rear LH) terminal ⑤, and
- to power window switch (rear RH) terminal ⑤.

Ground is supplied

- to main power window and door lock switch terminal ⑤
- through body grounds **M43** , **M44** and **M60** .

MANUAL OPERATION

Front door LH

WINDOW UP

When the main power window switch front LH is pressed in the up position, power is supplied:

- to front power window motor LH terminal ②
- through main power window and door lock switch terminal ⑬.

Ground is supplied:

- to front power window motor LH terminal ①
- through main power window and door lock switch terminal ⑮.

Then, the motor raises the window until the switch is released.

WINDOW DOWN

When the main power window switch front LH is pressed in the down position, power is supplied:

- to front power window motor LH terminal ①
- through main power window and door lock switch terminal ⑮.

Ground is supplied:

- to front power window motor LH terminal ②
- through main power window and door lock switch terminal ⑬.

Then, the motor lowers the window until the switch is released.

Except front LH door

FRONT DOOR RH

NOTE:

Figures in parentheses () refer to terminal Nos. arranged in order when the UP or DOWN section of power window switch is pressed.

Operation by main switch

Power is supplied:

- through main power window and door lock switch terminal (⑭, ⑬)
- to power window switch (front RH) terminal (③, ④).

The subsequent operations are the same as those outlined under "Operation by sub-switches".

Operation by sub-switches

Power is supplied:

- through power window switch (front RH) terminal (①, ②)
- to power window motor (front RH) terminal (②, ①).

Ground is supplied:

- to power window motor (front RH) terminal (①, ②)

GI

MA

EM

LC

EC

FE

CL

MT

AT

FA

RA

BR

ST

RS

BT

HA

EL

IDX

POWER WINDOW

System Description (Cont'd)

- through power window switch (front RH) terminal (②, ①)
- to power window switch (front RH) terminal (④, ③)
- through main power window and door lock switch terminal (⑬, ⑭)
- to main power window and door lock switch terminal (⑤)
- through body grounds (M43), (M44) and (M60).

Then, the motor raises or lowers the window until the switch is released.

REAR DOOR LH

NOTE:

Figures in parentheses () refer to terminal Nos. arranged in order when the UP or DOWN section of power window switch is pressed.

Operation by main switch

Power is supplied:

- through main power window and door lock switch terminal (⑫, ⑪)
- to power window switch (rear LH) terminal (③, ④).

The subsequent operations are the same as those outlined under "Operation by sub-switches".

Operation by sub-switches

Power is supplied:

- through power window switch (rear LH) terminal (①, ②)
- to power window motor (rear LH) terminal (②, ①).

Ground is supplied:

- to front power window motor (rear LH) terminal (①, ②)
- through power window switch (rear LH) terminal (②, ①)
- to power window switch (rear LH) terminal (④, ③)
- through main power window and door lock switch terminal (⑪, ⑫)
- to main power window and door lock switch terminal (⑤)
- through body grounds (M43), (M44) and (M60).

Then, the motor raises or lowers the window until the switch is released.

REAR DOOR RH

NOTE:

Figures in parentheses () refer to terminal Nos. arranged in order when the UP or DOWN section of power window switch is pressed.

Operation by main switch

Power is supplied:

- through main power window and door lock switch terminal (⑩, ⑨)
- to power window switch (rear RH) terminal (③, ④).

The subsequent operations are the same as those outlined under "Operation by sub-switches".

Operation by sub-switches

Power is supplied:

- through power window switch (rear RH) terminal (①, ②)
- to power window motor (rear RH) terminal (②, ①).

Ground is supplied:

- to front power window motor (rear RH) terminal (①, ②)
- through power window switch (rear RH) terminal (②, ①)
- to power window switch (rear RH) terminal (④, ③)
- through main power window and door lock switch terminal (⑨, ⑩)
- to main power window and door lock switch terminal (⑤)
- through body grounds (M43), (M44) and (M60).

Then, the motor raises or lowers the window until the switch is released.

AUTO FEATURE

The AUTO feature enables the driver to lower the driver's window without holding the window switch down.

The AUTO feature only operates on the driver's window downward movement.

When the main power window switch (front LH) is pressed and released in the AUTO position, ground signal is supplied:

- to front power window motor LH terminal (②)
- through main power window and door lock switch terminal (⑯).

POWER WINDOW

System Description (Cont'd)

Power is supplied:

- to front power window motor LH terminal ①
 - through main power window and door lock switch terminal ⑮.
- Then, the front door LH window will travel to the fully open position.

GI

LOCK FEATURE

The power window lock is designed to lock-out window operation to all windows except the front door LH window.

MA

Pressing the lock switch to the lock position disconnects the ground from the main power window and door lock switch. This prevents the power window motors from operating.

EM

LC

EC

FE

CL

MT

AT

FA

RA

BR

ST

RS

BT

HA

EL

IDX

POWER WINDOW

Component Layout

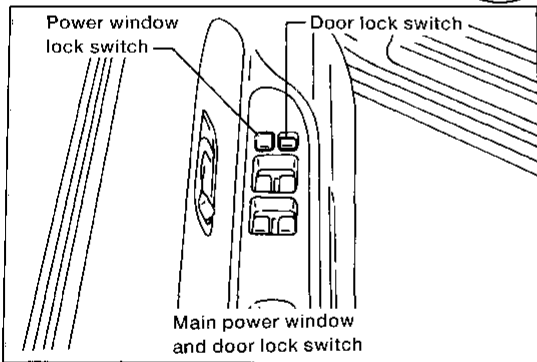
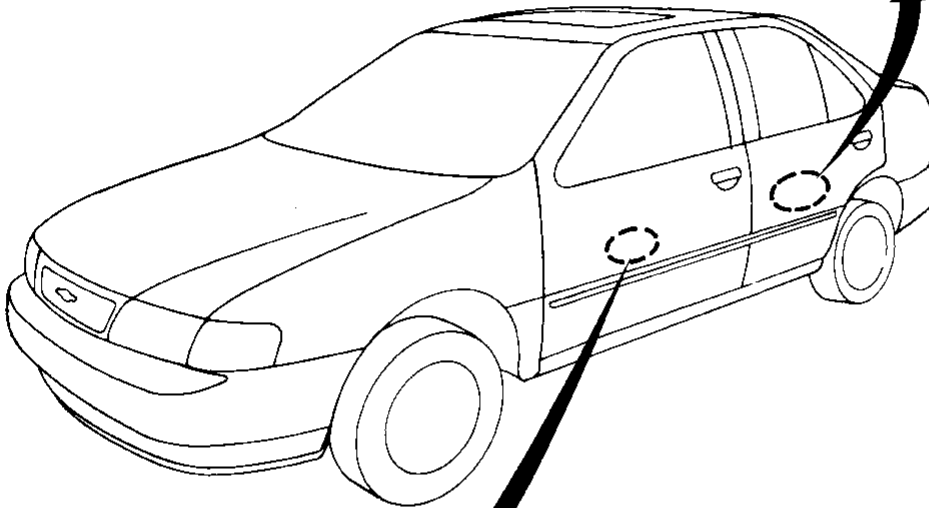
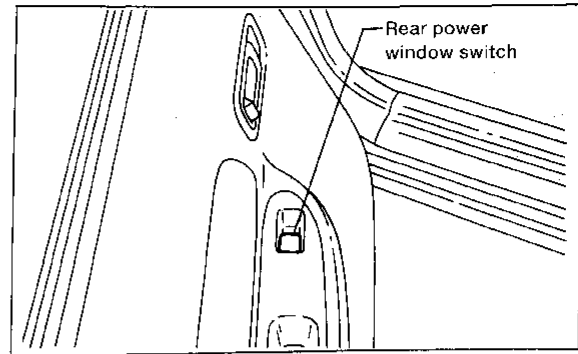

Rear door

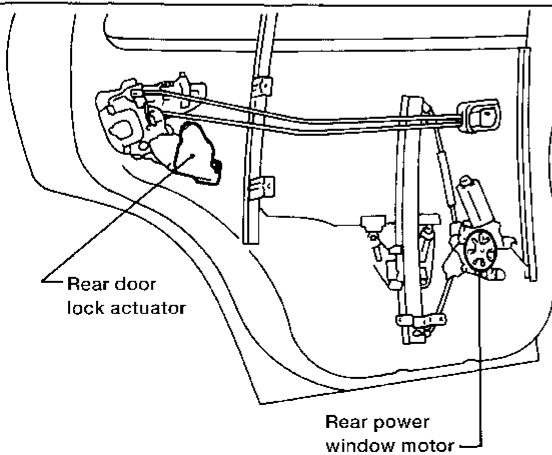

Front door

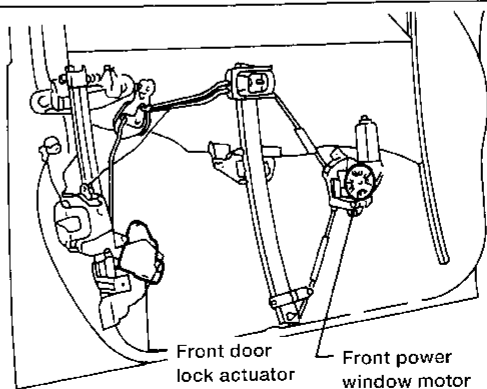

POWER WINDOW

NOTE

GI

MA

EM

LC

EC

FE

CL

MT

AT

FA

RA

BR

ST

RS

BT

HA

EL

IDX

POWER WINDOW

Wiring Diagram -WINDOW-

EL-WINDOW-01

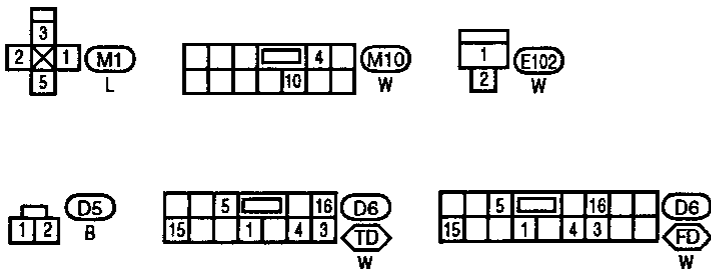
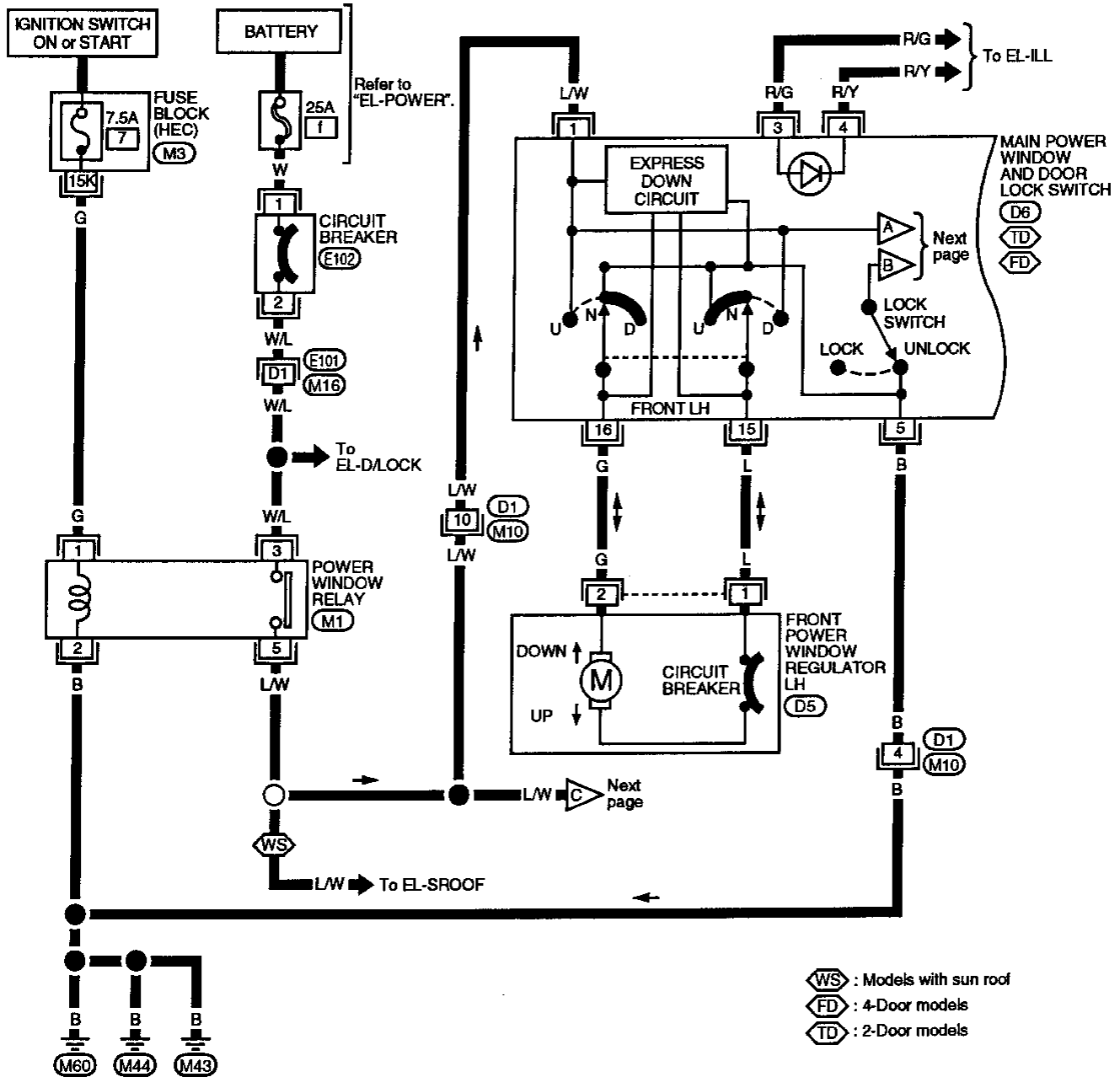

Refer to last page (Foldout page).

M16, E101
 M3

POWER WINDOW

Wiring Diagram -WINDOW- (Cont'd)

EL-WINDOW-02

FD : 4-Door models
TD : 2-Door models

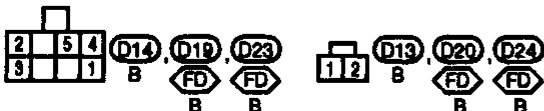
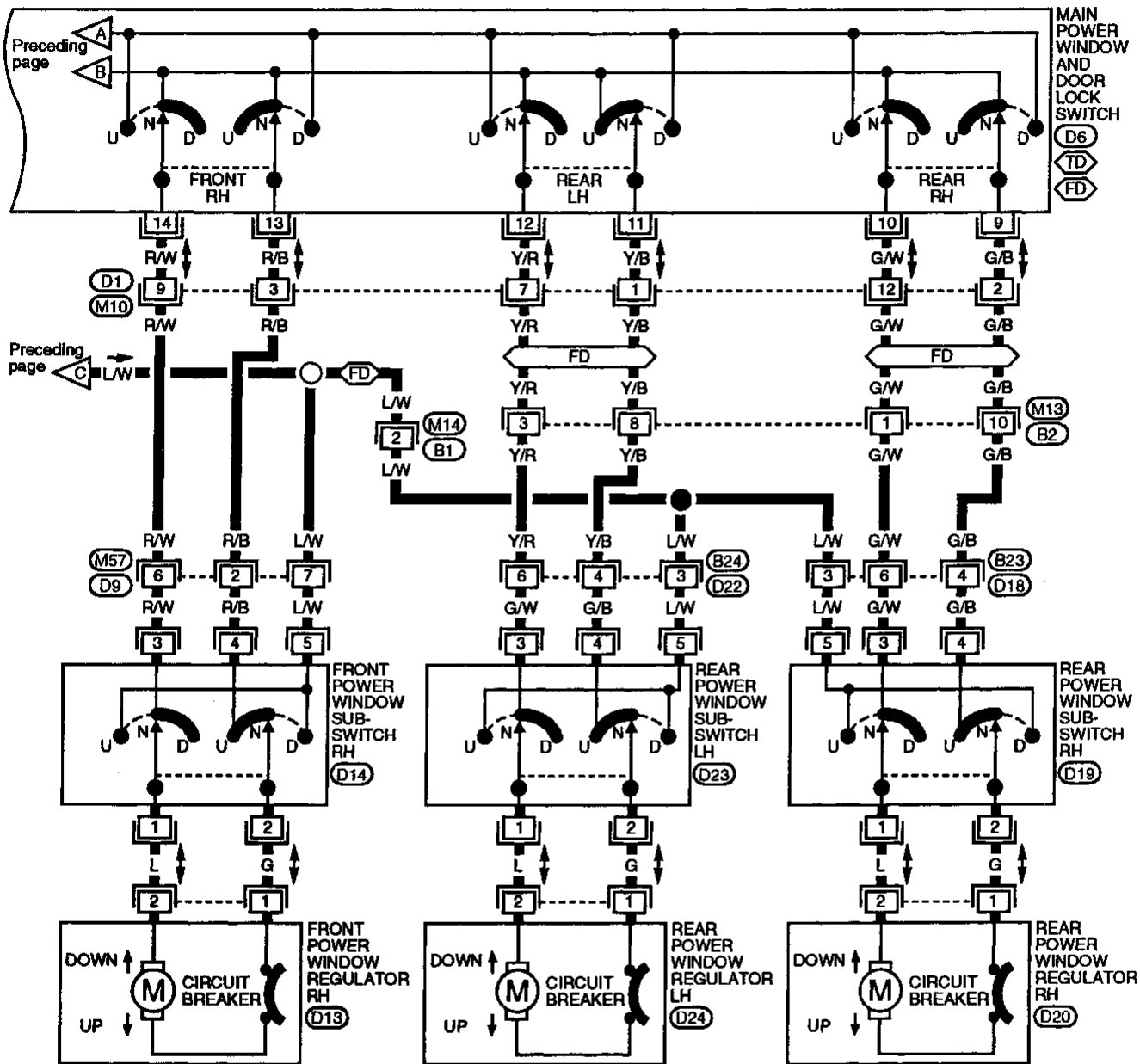

POWER WINDOW

Trouble Diagnoses

Symptom	Possible causes	Repair order
None of the power windows can be operated from any switch.	<ol style="list-style-type: none"> 1. 7.5A fuse and 25A fusible link and circuit breaker. 2. Grounds (M43), (M44) and (M60). 3. Power window relay. 4. Open/short in main power window and door lock switch circuit. 	<ol style="list-style-type: none"> 1. Check 7.5A fuse (No. 7), located in fuse block [HEC]) and 25A fusible link (letter f), located in the fusible link and fuse box) and the circuit breaker. Turn ignition switch ON and verify battery positive voltage is present at terminal ① of main power window switch and terminal ⑤ of any other switches. 2. Check grounds (M43), (M44) and (M60). 3. Check power window relay. 4. Check L/W wire between power window relay and main power window door lock switch for open/short circuit.
Driver side power window cannot be operated but other windows can be operated.	<ol style="list-style-type: none"> 1. Driver side (front LH) power window motor circuit. 2. Driver side (front LH) power window motor. 	<ol style="list-style-type: none"> 1. Check driver side (front LH) power window motor circuit. 2. Check driver side (front LH) power window motor.
One or more passenger power windows cannot be operated.	<ol style="list-style-type: none"> 1. Power window switches (front RH, rear LH and RH). 2. Power window motors (front RH, rear LH and RH). 3. Main power window and door lock switch. 4. Power window circuits. 	<ol style="list-style-type: none"> 1. Check power window switches (front RH, rear LH and RH). 2. Check power window motors (front RH, rear LH and RH). 3. Check main power window and door lock switch. 4. Check wires between main power window and door lock switch and power window switches and motors for open/short circuits.
One or more passenger power windows cannot be operated by main switch but can be operated by passenger's switches.	<ol style="list-style-type: none"> 1. Main power window and door lock switch. 	<ol style="list-style-type: none"> 1. Check main power window and door lock switch.

POWER DOOR LOCK

System Description

Power is supplied at all times:

- through 25A fusible link (letter **f** , located in the fusible link and fuse box)
- to circuit breaker terminal ①
- through circuit breaker terminal ②
- to smart entrance control unit terminal ①.

Ground is supplied to smart entrance control unit terminal ⑩ through body grounds **(M43)** , **(M44)** and **(M60)** .

INPUT

When the door lock & unlock switch LH is in LOCK position, ground signal is supplied:

- to smart entrance control unit terminal ⑩
- through door lock & unlock switch LH terminal ⑦
- to door lock & unlock switch LH terminal ⑤
- through body grounds **(M43)** , **(M44)** and **(M60)** .

When the door lock & unlock switch RH is in LOCK position, ground signal is supplied:

- to smart entrance control unit terminal ⑩
- through door lock & unlock switch RH terminal ①
- to door lock & unlock switch RH terminal ②
- through body grounds **(M43)** , **(M44)** and **(M60)** .

When the door lock & unlock switch LH is in UNLOCK position, ground signal is supplied:

- to smart entrance control unit terminal ⑩
- through door lock & unlock switch LH terminal ⑧
- to door lock & unlock switch LH terminal ⑤
- through body grounds **(M43)** , **(M44)** and **(M60)** .

When the door lock & unlock switch RH is in UNLOCK position, ground signal is supplied:

- to smart entrance control unit terminal ⑩
- through door lock & unlock switch RH terminal ③
- to door lock & unlock switch RH terminal ②
- through body grounds **(M43)** , **(M44)** and **(M60)** .

OUTPUT

Unlock

Power is supplied:

- from smart entrance control unit terminal ③
- to front door lock actuator LH terminal ①
- from smart entrance control unit terminal ②
- to all other door lock actuators terminal ①.

Ground is supplied:

- from smart entrance control unit terminal ④,
- to all door lock actuators terminal ③.

With power and ground supplied, the door lock actuators move to the unlocked position.

Lock

Power is supplied:

- from smart entrance control unit terminal ④
- to all door lock actuators terminal ③.

Ground is supplied:

- from smart entrance control unit terminal ③
- to front door lock actuator LH terminal ①
- from smart entrance control unit terminal ②.
- to all other door lock actuators terminal ①.

With power and ground supplied, the door lock actuators move to the locked position.

G1

MA

EM

LC

EC

FE

CL

MT

AT

FA

RA

BR

ST

RS

BT

HA

EL

IDX

POWER DOOR LOCK

Schematic

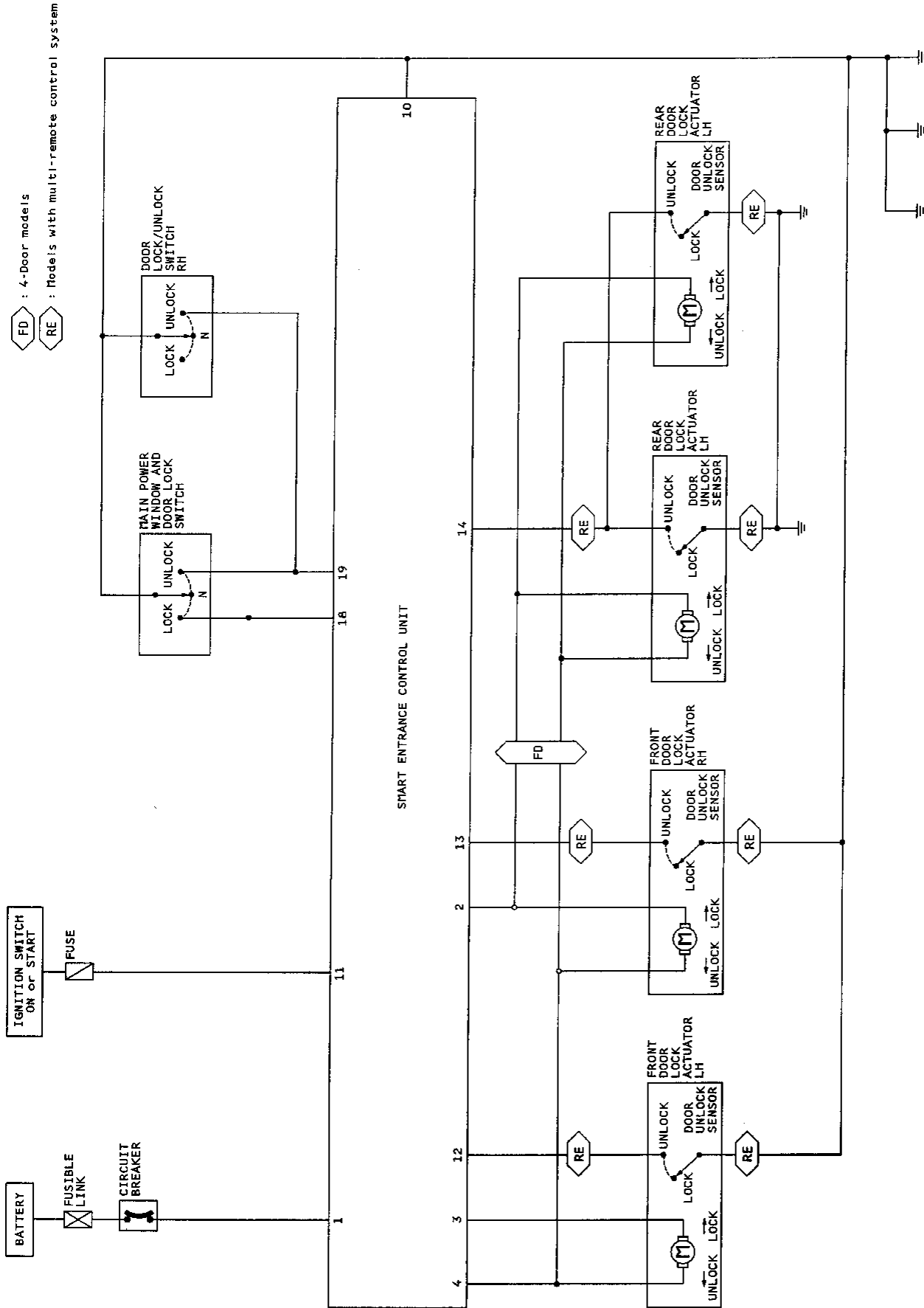

POWER DOOR LOCK

Wiring Diagram -D/LOCK-

EL-D/LOCK-01

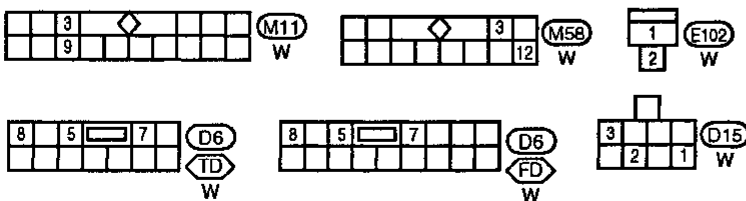
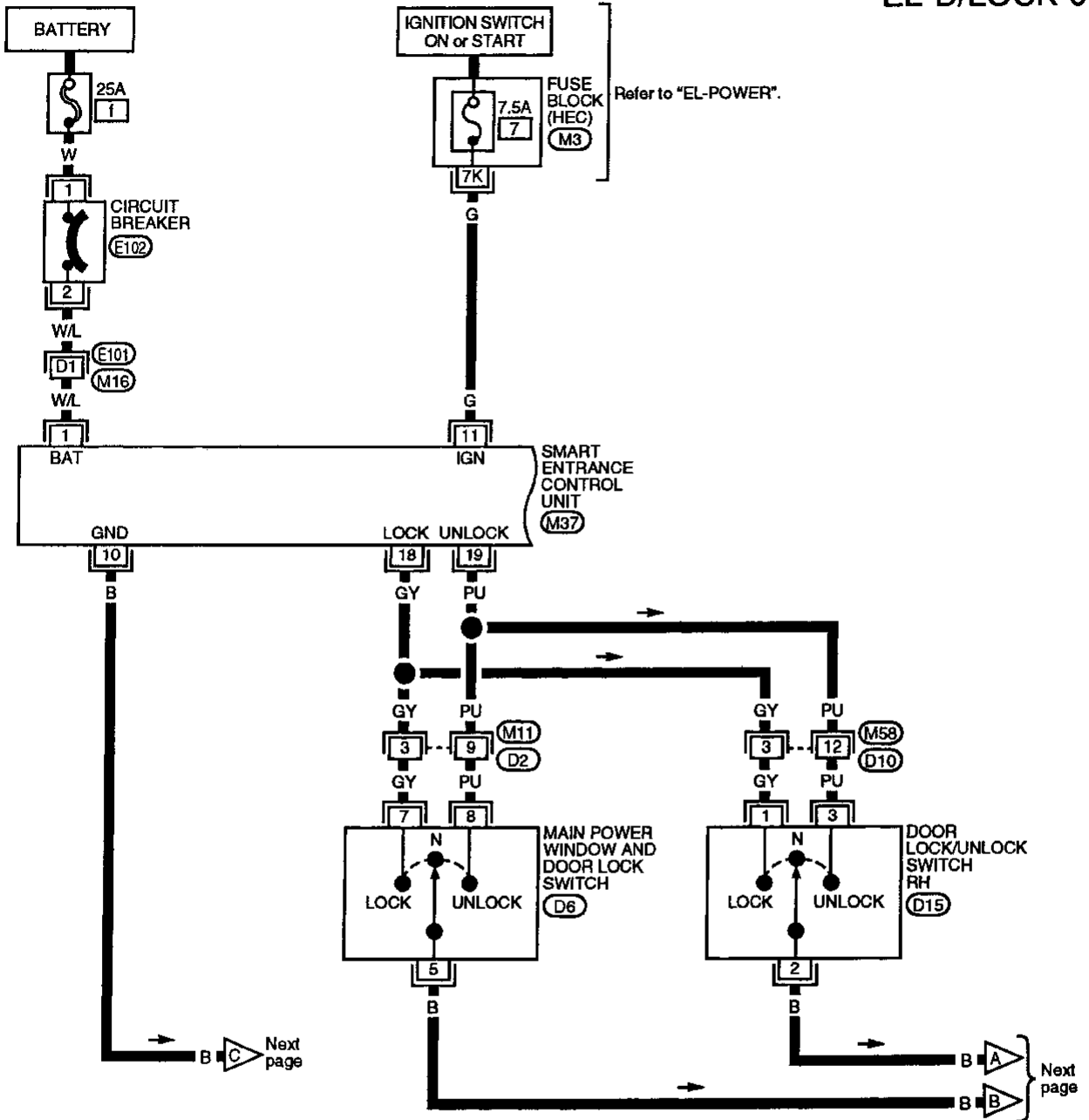

Refer to last page (Foldout page).

- (M16), (E101)
- (M3)
- (M37)

GI
MA
EM
LC
EC
FE
CL
MT
AT
FA
RA
BR
ST
RS
BT

HA
EL
IDX

POWER DOOR LOCK

Wiring Diagram -D/LOCK- (Cont'd)

EL-D/LOCK-02

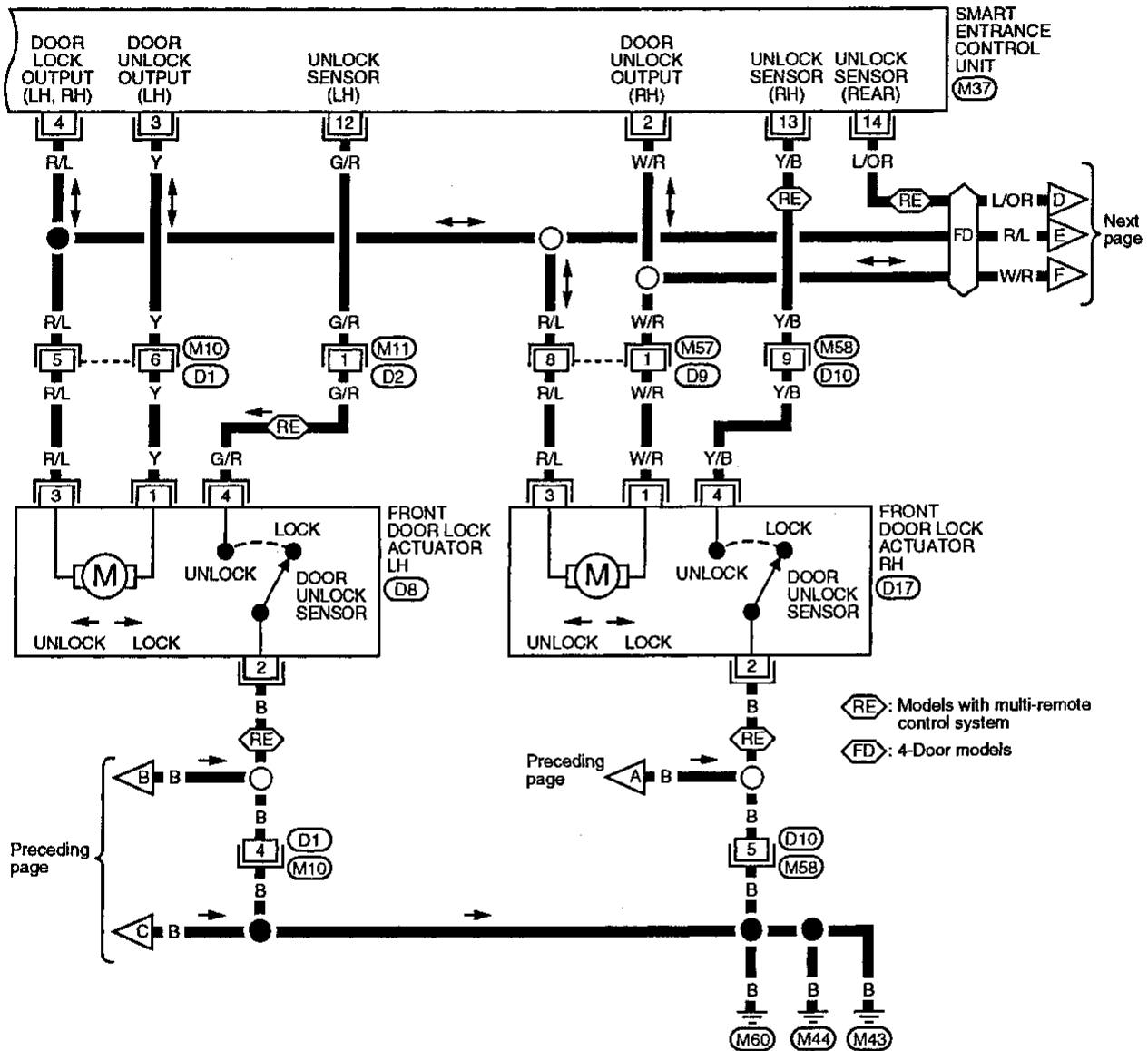

Refer to last page (Foldout page).
 (M37)

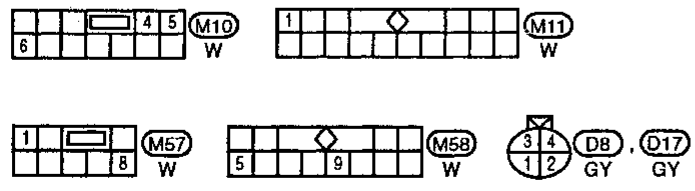

POWER DOOR LOCK

Wiring Diagram -D/LOCK- (Cont'd)

EL-D/LOCK-03

RE: Models with multi-remote control system

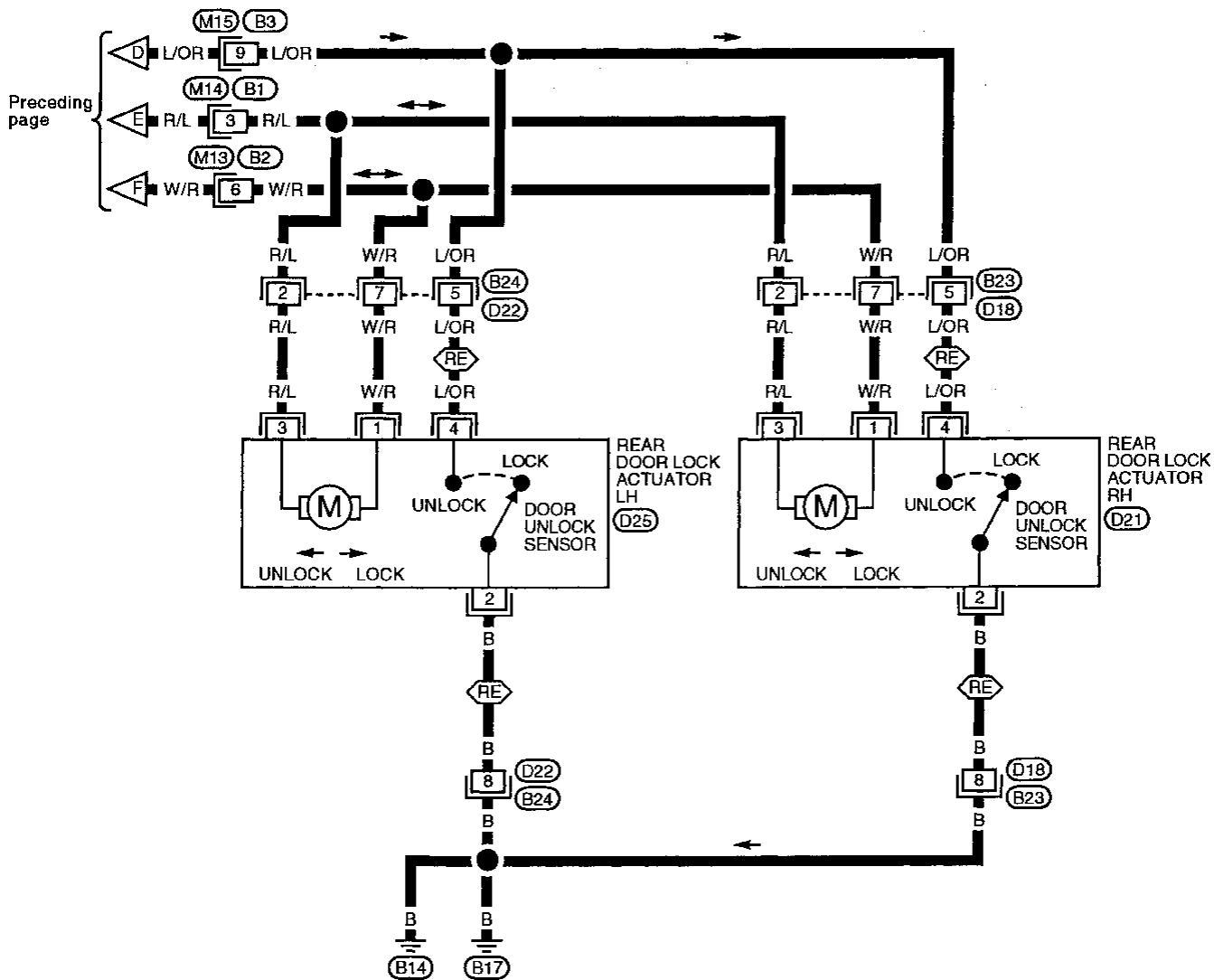

GI

MA

EM

LC

EC

FE

CL

MT

AT

FA

RA

BR

ST

RS

BT

HA

EL

IDX

POWER DOOR LOCK

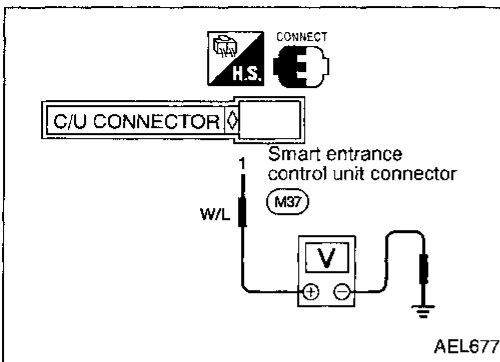

Trouble Diagnoses

MAIN POWER SUPPLY AND GROUND CIRCUIT CHECK

Main power supply for smart entrance control unit (SECU)

Terminals	Battery voltage existence
① - Ground (GND)	Yes

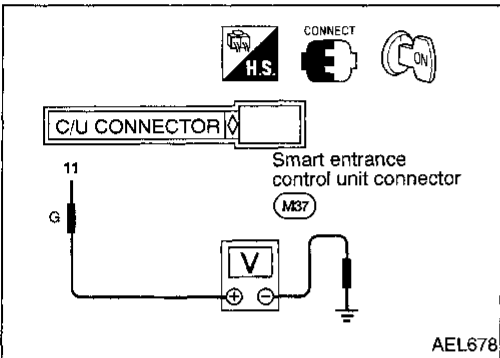

Main power supply while ignition switch is "ON" or "START" position

Terminals	Battery voltage existence
⑪ - Ground	Yes

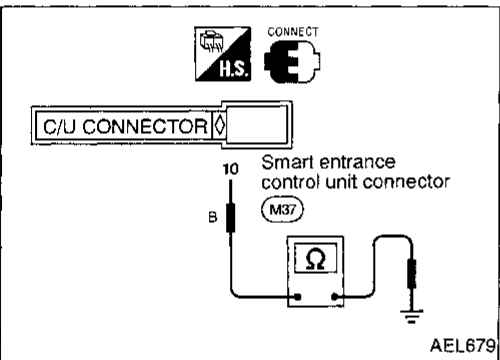

Ground circuit for smart entrance control unit

Terminals	Continuity
⑩ - Ground	Yes

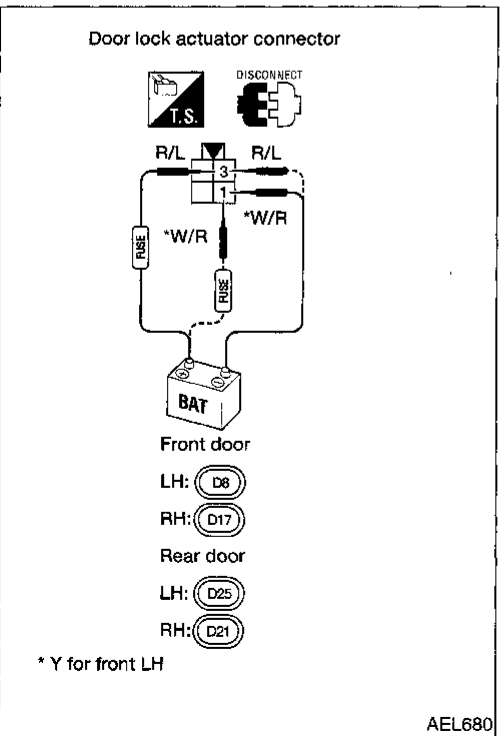

ELECTRICAL COMPONENTS INSPECTION

Power door lock motor

Door lock condition	Terminals	
	⊕	⊖
Unlocked → Locked	③	①
Locked → Unlocked	①	③

POWER DOOR LOCK

Trouble Diagnoses (Cont'd)

DIAGNOSTIC PROCEDURE

SYMPTOM: Power door locks cannot be operated by door lock/unlock switches.

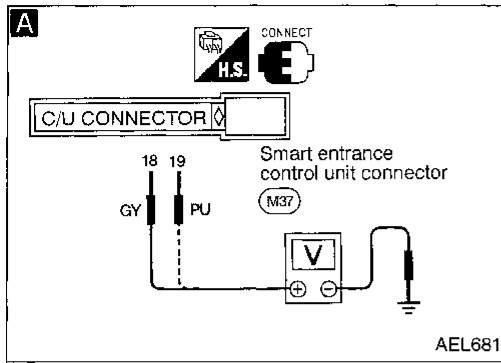

A

CHECK SIGNAL OF DOOR LOCK/UNLOCK SWITCH.

OK → **A** (Go to next page.)

Door lock/unlock switch (LH or RH) operation	Terminals	Voltage (V)
Lock	(18) - GND	12 → 0 → 12
Unlock	(19) - GND	12 → 0 → 12

NG

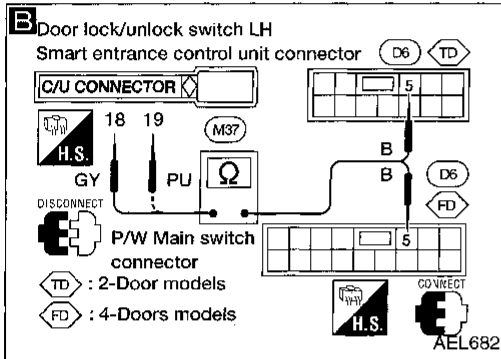

B C

CHECK HARNESS CONTINUITY.

OK → Repair ground harness of door lock/unlock switch.

1. Disconnect control unit connector.
2. Check continuity.

B Door lock/unlock switch LH

Operation	Terminals	Continuity
Lock	(18) - (5)	Yes
Unlock	(19) - (5)	

NG

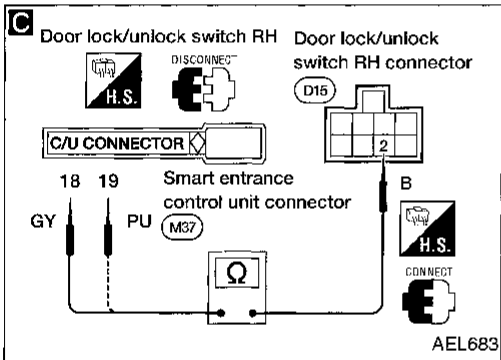

C Door lock/unlock switch RH

Operation	Terminals	Continuity
Lock	(18) - (2)	Yes
Unlock	(19) - (2)	

NG

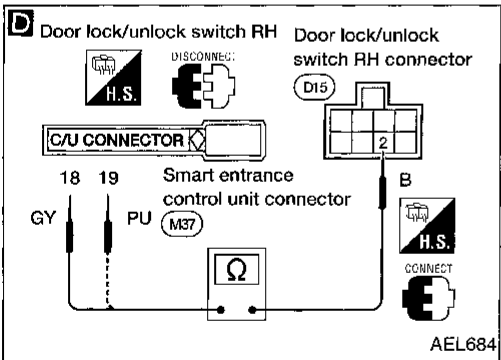

D E

CHECK DOOR LOCK/UNLOCK SWITCHES.

OK → Repair harness between door lock/unlock switch and control unit connector.

D Door lock/unlock switch LH

Operation	Terminals	Continuity
Lock	(7) - (5)	Yes
Unlock	(8) - (5)	

NG

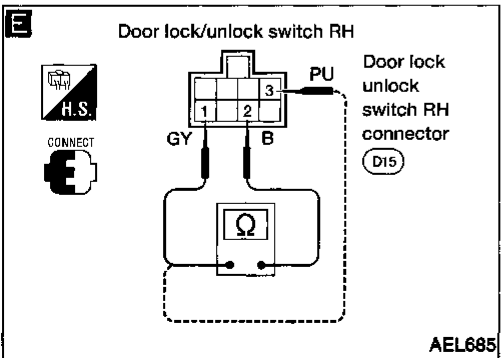

E Door lock/unlock switch RH

Operation	Terminals	Continuity
Lock	(1) - (2)	Yes
Unlock	(3) - (2)	

NG

Replace door lock/unlock switch.

GI
MA
EM
LC
EC
FE
CL
MT
AT
FA
RA
BR
ST
RS
BT
HA
EL
IDX

POWER DOOR LOCK

Trouble Diagnoses (Cont'd)

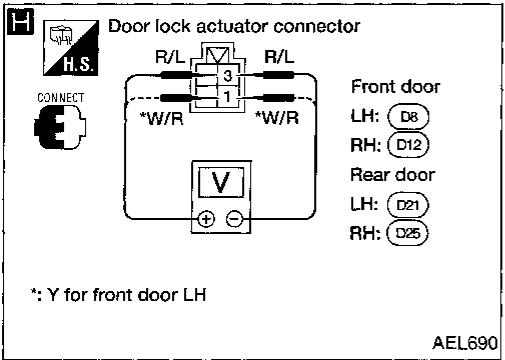
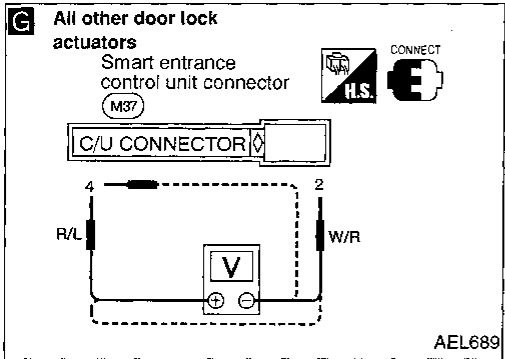
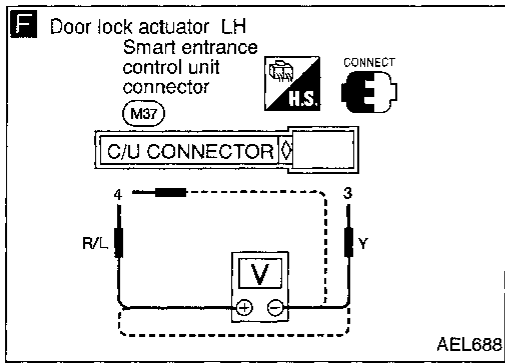

(A)

F G

CHECK DOOR LOCK ACTUATOR CIRCUIT.
Check voltage for door lock motor.

F Front door lock actuator LH

Door lock/ unlock switch operation	Termi- nals		Voltage (V)
	⊕	⊖	
Lock	④	③	Battery voltage
Unlock	③	④	

NG → Replace smart entrance control unit.

G All other door lock actuators

Door lock/ unlock switch operation	Termi- nals		Voltage (V)
	⊕	⊖	
Lock	④	②	Battery voltage
Unlock	②	④	

OK

CHECK VOLTAGE FOR DOOR LOCK MOTOR.

Door lock/ unlock switch operation	Termi- nals		Voltage (V)
	⊕	⊖	
Lock	③	①	Battery voltage
Unlock	①	③	

NG → Repair harness between control unit connector and door lock actuator.

OK

Go to power door lock motor in ELECTRICAL COMPONENTS INSPECTION. (See page EL-132.)

NG → Replace defective power door lock motor.

OK

Check system again.

DOOR MIRROR

Wiring Diagram -MIRROR-

EL-MIRROR-01

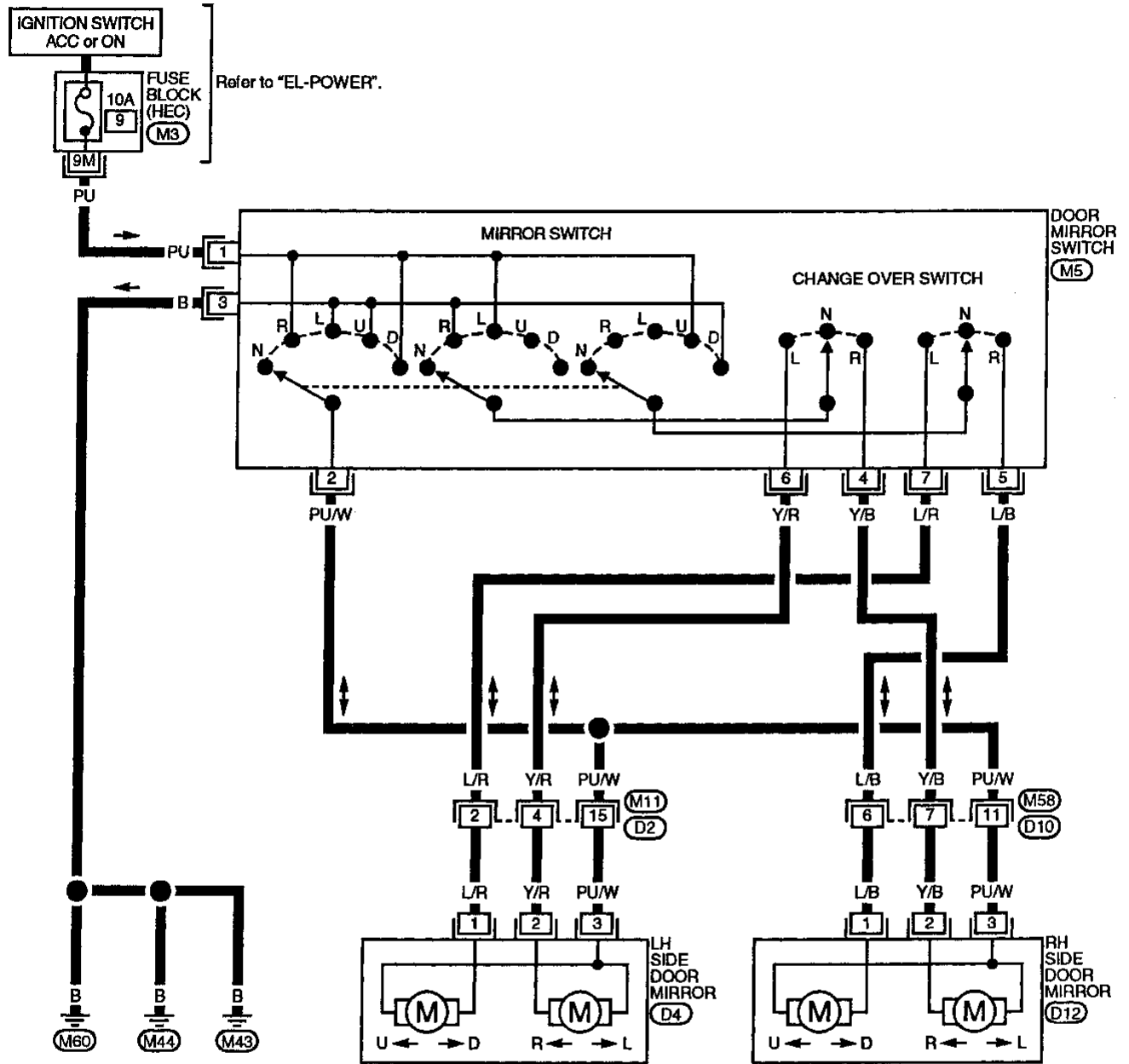

Refer to last page (Foldout page).



GI

MA

EM

LC

EC

FE

CL

MT

AT

FA

RA

BR

ST

RS

BT

HA

EL

IDX

System Description

POWER

Power is supplied to the sunroof motor assembly by the sunroof relay, or power window relay, if equipped. When the ignition switch is turned ON the relay is energized. The power circuit is protected by the circuit breaker. The sunroof motor assembly has an independent ground circuit.

TILT AND SLIDE OPERATION

The sunroof is controlled by the sunroof switch. With sunroof in closed position, depressing UP/CLOSE switch will tilt rear of sunroof up. The sunroof will stop when the switch is released, or when the sunroof reaches its maximum tilt position.

The sunroof will tilt down when in tilt up position and DOWN/OPEN switch is depressed. The sunroof will stop when switch is released, or when sunroof is fully closed.

With sunroof in closed position, pressing DOWN/OPEN switch will cause sunroof to slide open. The sunroof will slide open until switch is released or until it is all the way open. The sunroof will close when in open position, and UP/CLOSE switch is depressed. The sunroof will slide until switch is released, or when sunroof is fully closed.

All automatic operations in sunroof are controlled by internal limit switches located in sunroof motor assembly.

Wiring Diagram -SROOF-

EL-SROOF-01

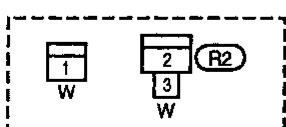
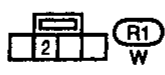
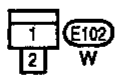
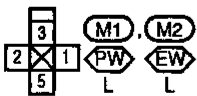
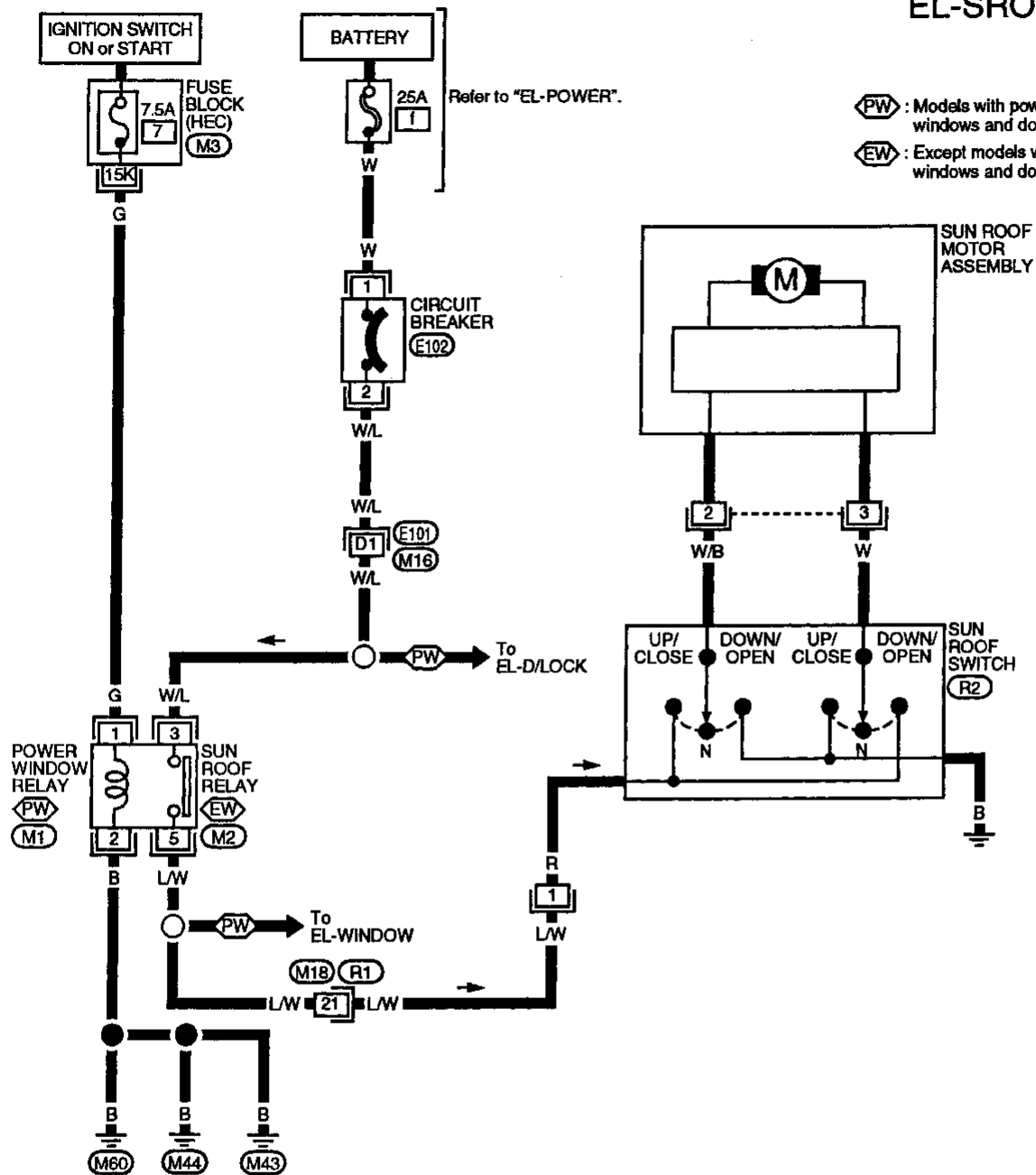

Refer to last page (Foldout page).

(M16) (E101) (M3)

GI
MA
EM
LC
EC
FE
CL
MT
AT
FA
RA
BR
ST
RS
BT
HA
EL
IDX

HORN AND LIGHTER

Wiring Diagram -HORN-

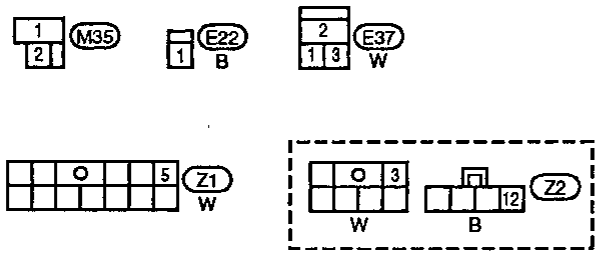
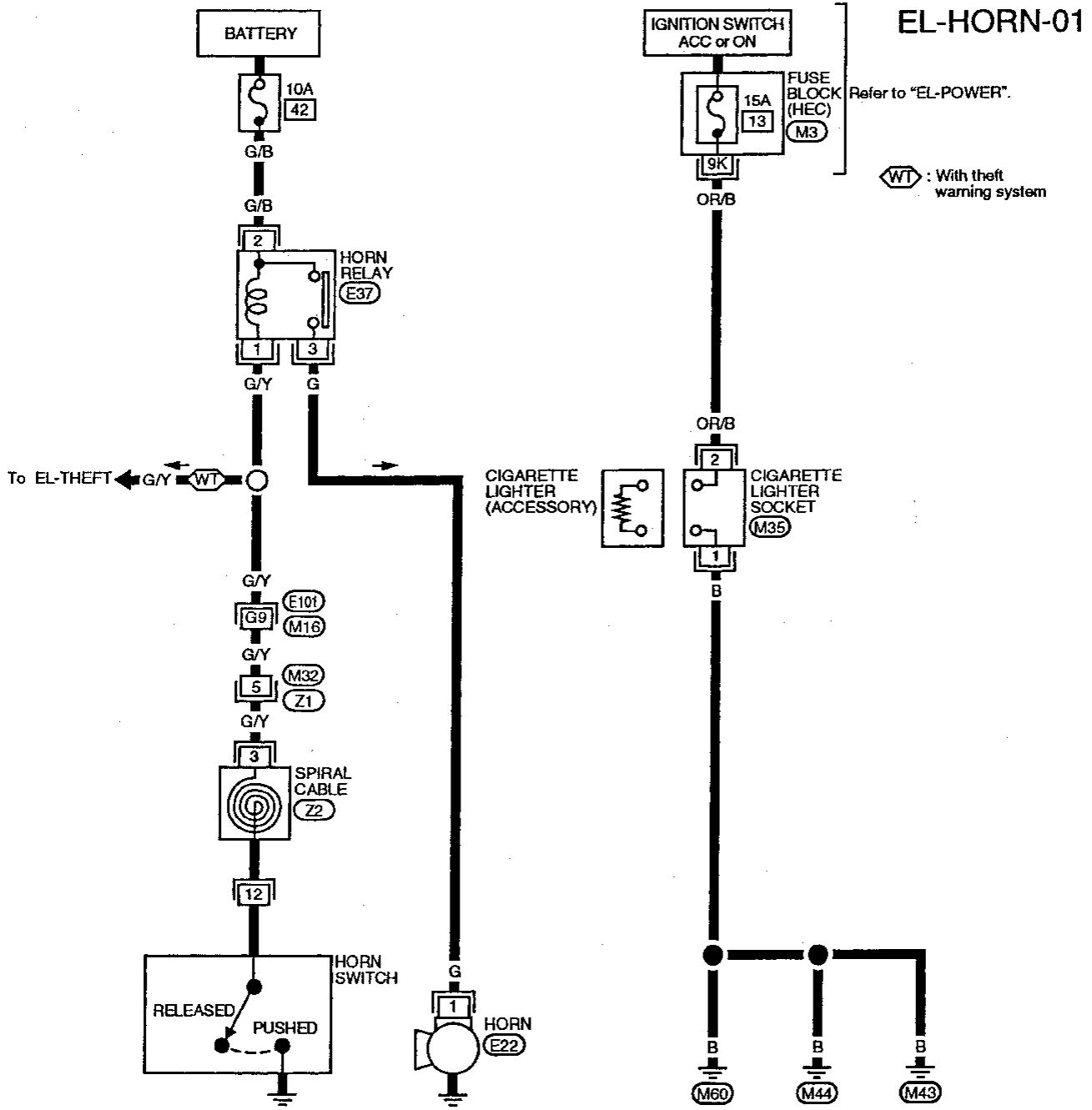

Refer to last page (Foldout page).
 (M16), (E101)
 (M3)

REAR WINDOW DEFOGGER

System Description

If equipped with power door locks the rear defogger system is controlled by the smart entrance control unit. If not equipped with power door locks the rear defogger system is controlled by the rear window defogger timer. The rear window defogger operates for approximately 15 minutes.

Power is supplied at all times:

- through 20A fuse (No. ④ , located in the fuse block [HEC])
- to rear window defogger relay terminal ③ and
- through 20A fuse (No. ⑤ , located in the fuse block [HEC])
- to rear window defogger relay terminal ⑥.

With the ignition switch in the ON or START position, power is supplied:

- through 7.5A fuse (No. ⑦ , located in the fuse block [HEC])
- to rear window defogger relay terminal ① and
- to smart entrance control unit terminal ⑪ (models with power door lock), or
- to rear window defogger timer terminal ① (models without power door lock).

Ground is supplied to terminal ② of the rear window defogger switch through body grounds M43 , M44 and M60 .

When the rear window defogger switch is activated, ground is supplied:

- through terminal ① of the rear window defogger switch
- to smart entrance control unit terminal ⑳ (models with power door lock) or
- to rear window defogger timer terminal ③ (models without power door lock).

Terminal ⑳ of the smart entrance control unit (models with power door lock) or terminal ② of the rear window defogger timer (models without power door lock) then supplies ground to the rear window defogger relay terminal ②.

With power and ground supplied, the rear window defogger relay is energized.

Power is supplied:

- through terminals ⑤ and ⑦ of the rear window defogger relay
- to rear window defogger terminal ①.

The rear window defogger has an independent ground.

With power and ground supplied, the rear window defogger filaments heat and defog the rear window.

When the system is activated, the rear window defogger indicator illuminates in the rear window defogger switch.

Power is supplied:

- to terminal ③ of the rear window defogger switch
- from terminal ⑦ of the rear window defogger relay.

Terminal ④ of the rear window defogger switch is grounded through body grounds M43 , M44 and M60 .

GI

MA

EM

LC

EC

FE

CL

MT

AT

FA

RA

BR

ST

RS

BT

HA

EL

IDX

REAR WINDOW DEFOGGER

Wiring Diagram -DEF- (Cont'd)

EL-DEF-02

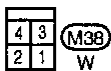
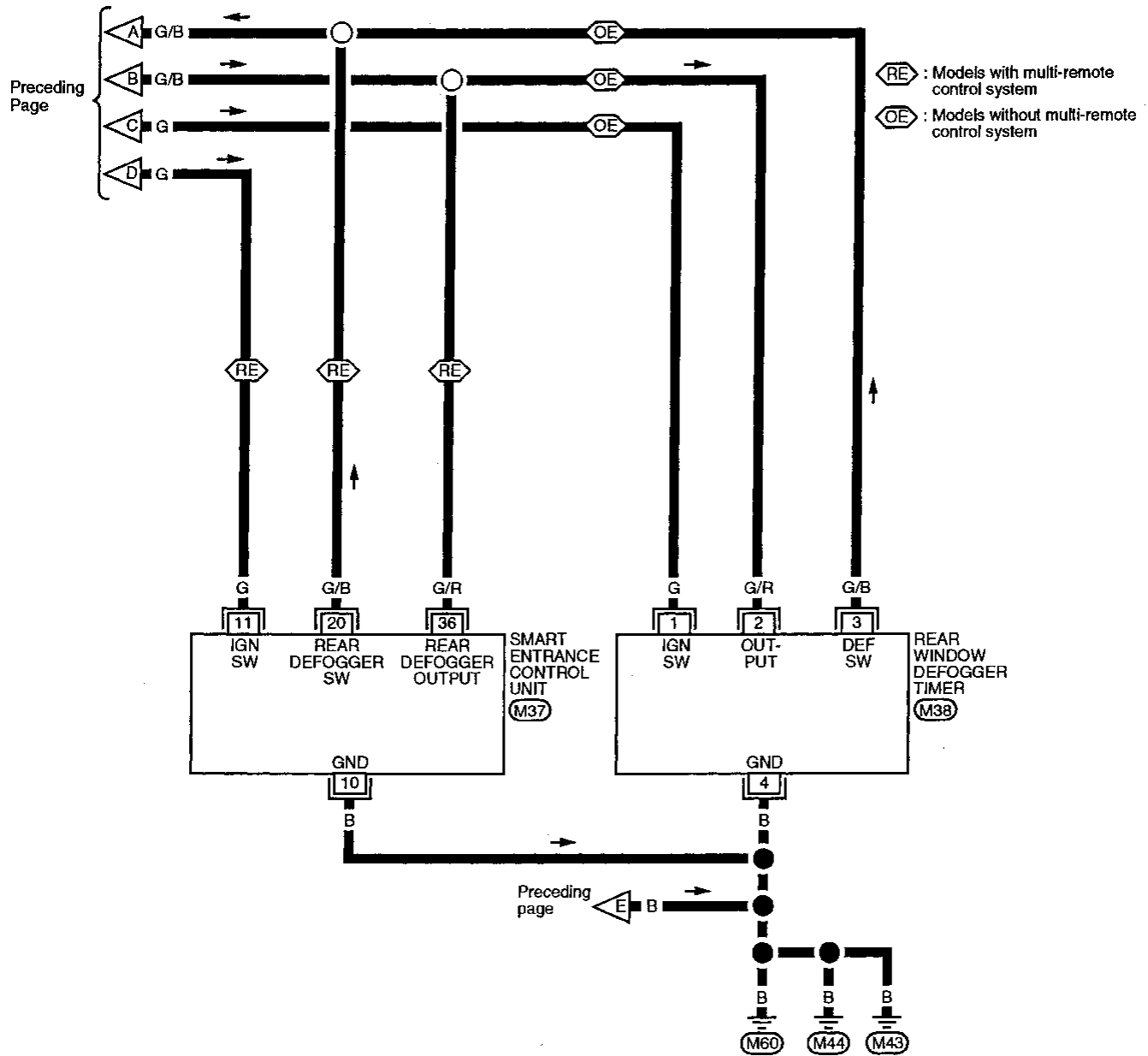

Refer to last page (Foldout page).

M37

GI

MA

EM

LC

EC

FE

CL

MT

AT

FA

RA

BR

ST

RS

BT

HA

EL

IDX

REAR WINDOW DEFOGGER

Trouble Diagnoses

DIAGNOSTIC PROCEDURE

SYMPTOM: Rear defogger does not activate, or does not go off after activating.

Models with power door lock

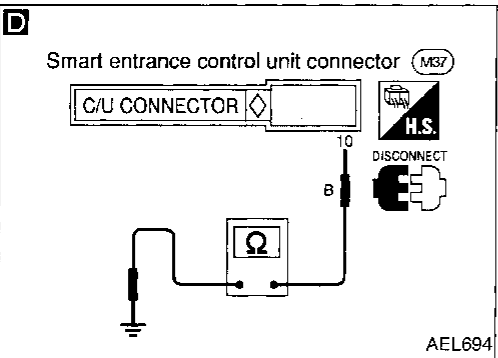
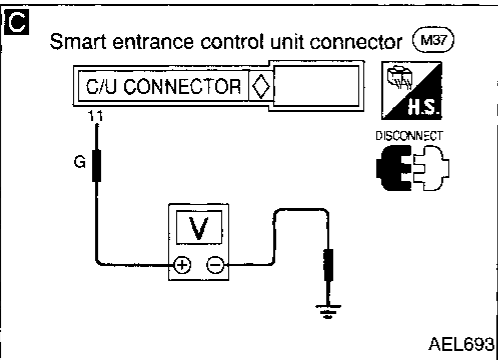
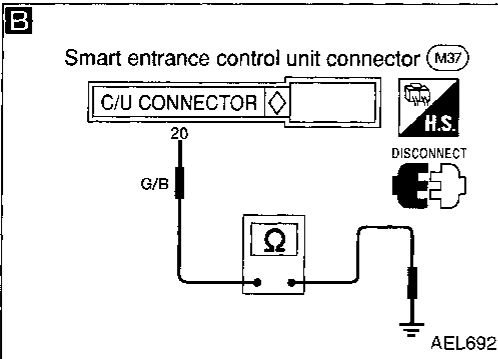
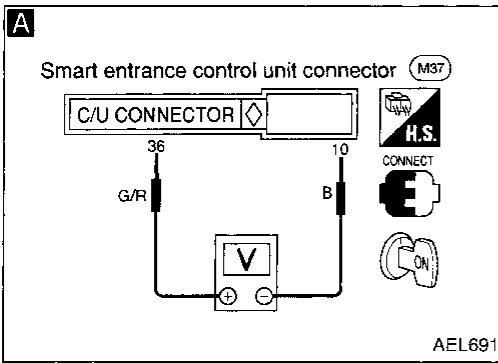

A

REAR WINDOW DEFOGGER OUTPUT SIGNAL CHECK.

Measure voltage between control unit harness terminals (36) and (10).

Condition	Voltage [V]
Rear defogger switch is "OFF".	Approx. 12
Rear defogger switch is "ON".	0

- OK
- Check rear window defogger relay. (Refer to EL-144.)
 - Check rear window defogger circuit.
 - Check rear window defogger filament. (Refer to EL-144.)

NG

B

REAR WINDOW DEFOGGER SWITCH INPUT SIGNAL CHECK.

Check continuity between control unit harness terminal (20) and body ground.

Condition of defogger switch	Continuity
Rear defogger switch is pushed.	Yes
Rear defogger switch is released.	No

- NG
- Check rear window defogger switch. (Refer to EL-144.)
 - Check continuity between control unit harness terminal (20) and rear window defogger switch harness terminal (1).
 - Continuity should exist.**
 - Check continuity between rear window defogger switch harness terminal (2) and body ground.
 - Continuity should exist.**

OK

C

IGNITION INPUT SIGNAL CHECK.

Check voltage between control unit harness terminal (11) and body ground.

Condition	Voltage [V]
Ignition switch is "ON".	Approx. 12
Ignition switch is "OFF".	0

- NG
- Repair harness or connectors.

OK

D

CONTROL UNIT GROUND CIRCUIT CHECK.

Check continuity between control unit harness terminal (10) and body ground.

Continuity should exist.

- NG
- Repair harness or connectors.

OK

Replace control unit.

REAR WINDOW DEFOGGER

Trouble Diagnoses (Cont'd)

Models without power door lock

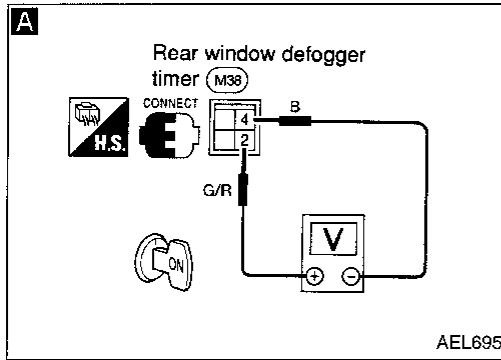

A

REAR WINDOW DEFOGGER OUTPUT SIGNAL CHECK.
Measure voltage between rear window defogger timer harness terminals ② and ④.

Condition	Voltage [V]
Rear defogger switch is "OFF".	Approx. 12
Rear defogger switch is "ON".	0

- OK
- Check rear window defogger relay. (Refer to EL-144.)
 - Check rear window defogger circuit.
 - Check rear window defogger filament. (Refer to EL-144.)

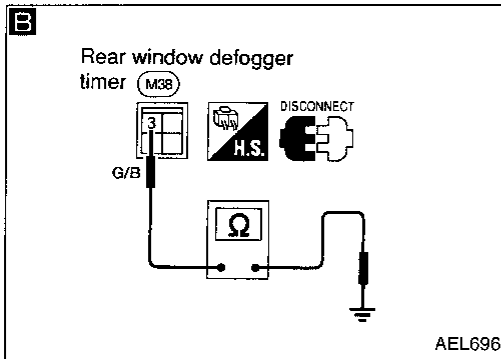

B

REAR WINDOW DEFOGGER SWITCH INPUT SIGNAL CHECK.
Check continuity between rear window defogger timer harness terminal ③ and body ground.

Condition of defogger switch	Continuity
Rear defogger switch is pushed.	Yes
Rear defogger switch is released.	No

- NG
- Check rear window defogger switch. (Refer to EL-144.)
 - Check continuity between rear window defogger timer harness terminal ③ and rear window defogger switch harness terminal ①. **Continuity should exist.**
 - Check continuity between rear window defogger switch harness terminal ② and body ground. **Continuity should exist.**

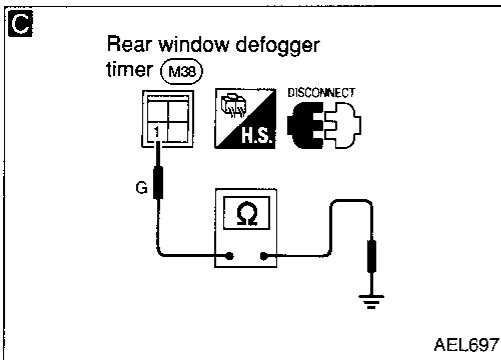

C

IGNITION INPUT SIGNAL CHECK.
Check voltage between rear window defogger timer harness terminal ① and body ground.

Condition	Voltage [V]
Ignition switch is "ON".	Approx. 12
Ignition switch is "OFF".	0

- NG
- Repair harness or connectors.

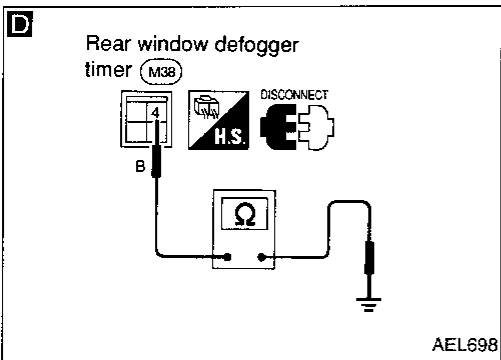

D

CONTROL UNIT GROUND CIRCUIT CHECK.
Check continuity between rear window defogger timer harness terminal ④ and body ground. **Continuity should exist.**

- NG
- Repair harness or connectors.

OK

Replace control unit.

CI
MA
EM
LC
EC
FE
CL
MT
AT
FA
RA
BR
ST
RS
BT
HA
EL
IDX

REAR WINDOW DEFOGGER

Trouble Diagnoses (Cont'd)

ELECTRICAL COMPONENTS INSPECTION

Rear window defogger relay

Check continuity between terminals ③ and ⑤, ⑥ and ⑦.

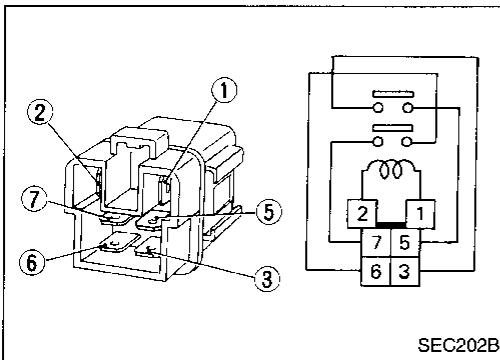

Condition	Continuity
12V direct current supply between terminals ① and ②	Yes
No current supply	No

Rear window defogger switch

Check continuity between terminals when rear window defogger switch is pushed and released.

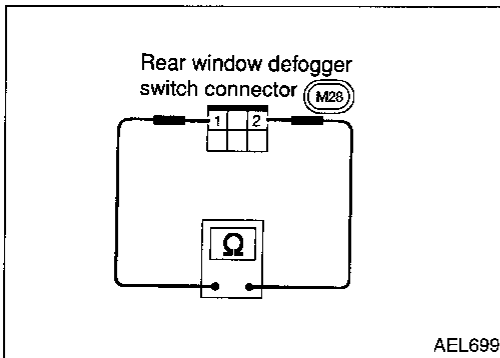

Terminals	Condition	Continuity
① - ②	Rear window defogger switch is pushed	Yes
	Rear window defogger switch is released	No

Filament Check

- When measuring voltage, wrap tin foil around the top of the negative probe. Press the foil against the wire with your finger. Otherwise, the element may be damaged.

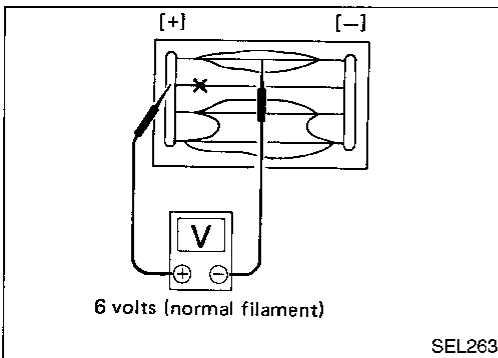
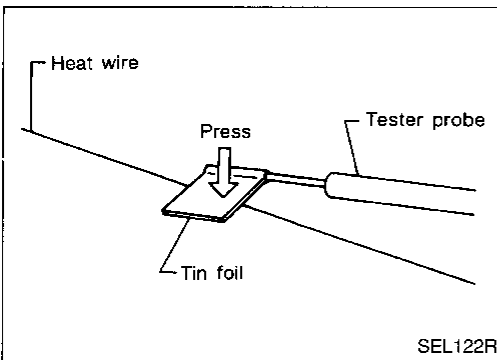

- Attach probe circuit tester (in volt range) to middle portion of each filament.

REAR WINDOW DEFOGGER

Filament Check (Cont'd)

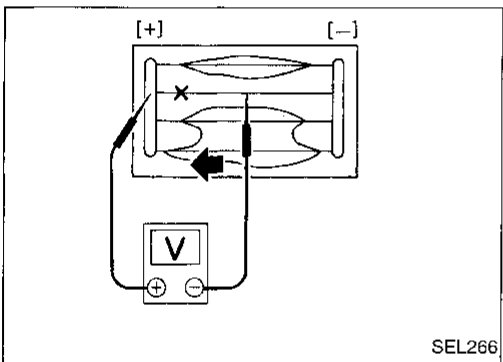
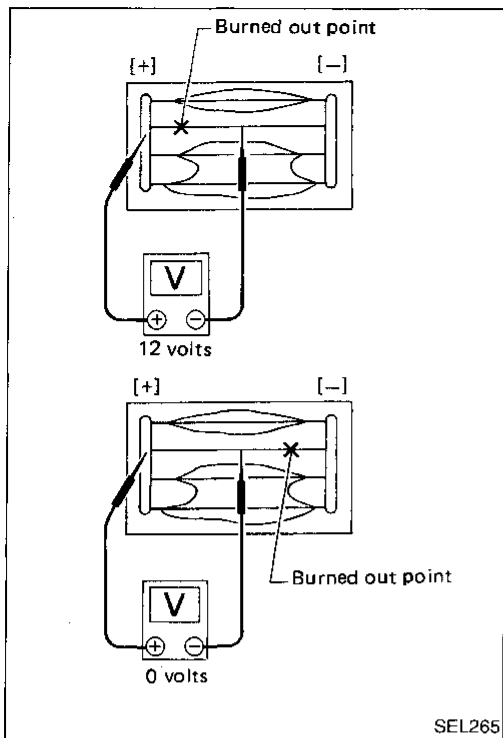

2. If a filament is burned out, circuit tester registers 0 or 12 volts.

3. To locate burned out point, move probe to left and right along filament. Tester needle swings abruptly at the burned point.

Filament Repair

REPAIR EQUIPMENT

1. Conductive silver composition (Dupont No. 4817 or equivalent)
2. Ruler 30 cm (11.8 in) long
3. Drawing pen
4. Heat gun
5. Alcohol
6. Cloth

REPAIRING PROCEDURE

1. Wipe broken heat wire and its surrounding area clean with a cloth dampened in alcohol.
2. Apply a small amount of conductive silver composition to tip of drawing pen.

Shake silver composition container before use.

3. Place ruler on glass along broken line. Deposit conductive silver composition on break with drawing pen. Slightly overlap existing heat wire on both sides [preferably 5 mm (0.20 in)] of the break.

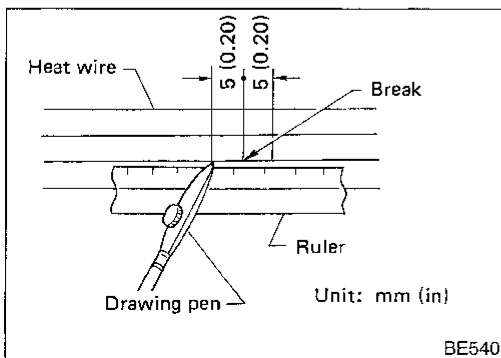

GI

MA

EM

LC

EC

FE

CL

MT

AT

FA

RA

BR

ST

RS

BT

HA

EL

IDX

REAR WINDOW DEFOGGER

Filament Repair (Cont'd)

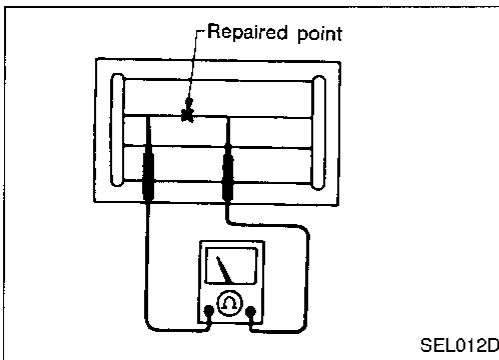

4. After repair has been completed, check repaired wire for continuity. This check should be conducted 10 minutes after silver composition is deposited.

Do not touch repaired area while test is being conducted.

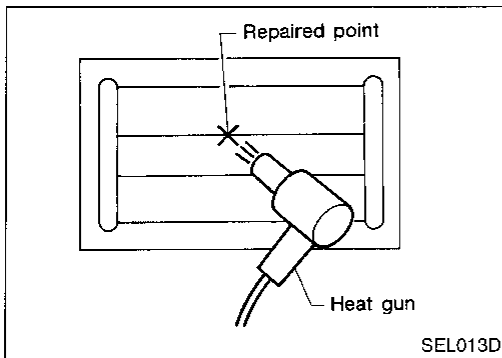

5. Apply a constant stream of hot air directly to the repaired area for approximately 20 minutes with a heat gun. A minimum distance of 3 cm (1.2 in) should be kept between repaired area and hot air outlet. If a heat gun is not available, let the repaired area dry for 24 hours.

System Description

Refer to Owner's Manual for audio system operating instructions.

Power is supplied at all times:

- through 7.5A fuse (No. 24 , located in the fuse block [HEC])
- to radio/radio and cassette player terminal 6.

With the ignition switch in the ACC or ON position, power is supplied:

- through 15A fuse (No. 10 , located in the fuse block [HEC])
- to radio/radio and cassette player terminal 10.

Ground is supplied through the case of the radio/radio and cassette player.

When the system is on, audio signals are supplied:

- through radio/radio and cassette player terminals 1, 2, 3, 4, 13, 14, 15 and 16
- to the front and rear speakers.

GI

MA

EM

LC

EC

FE

CL

MT

AT

FA

RA

BR

ST

RS

BT

HA

EL

IDX

Schematic

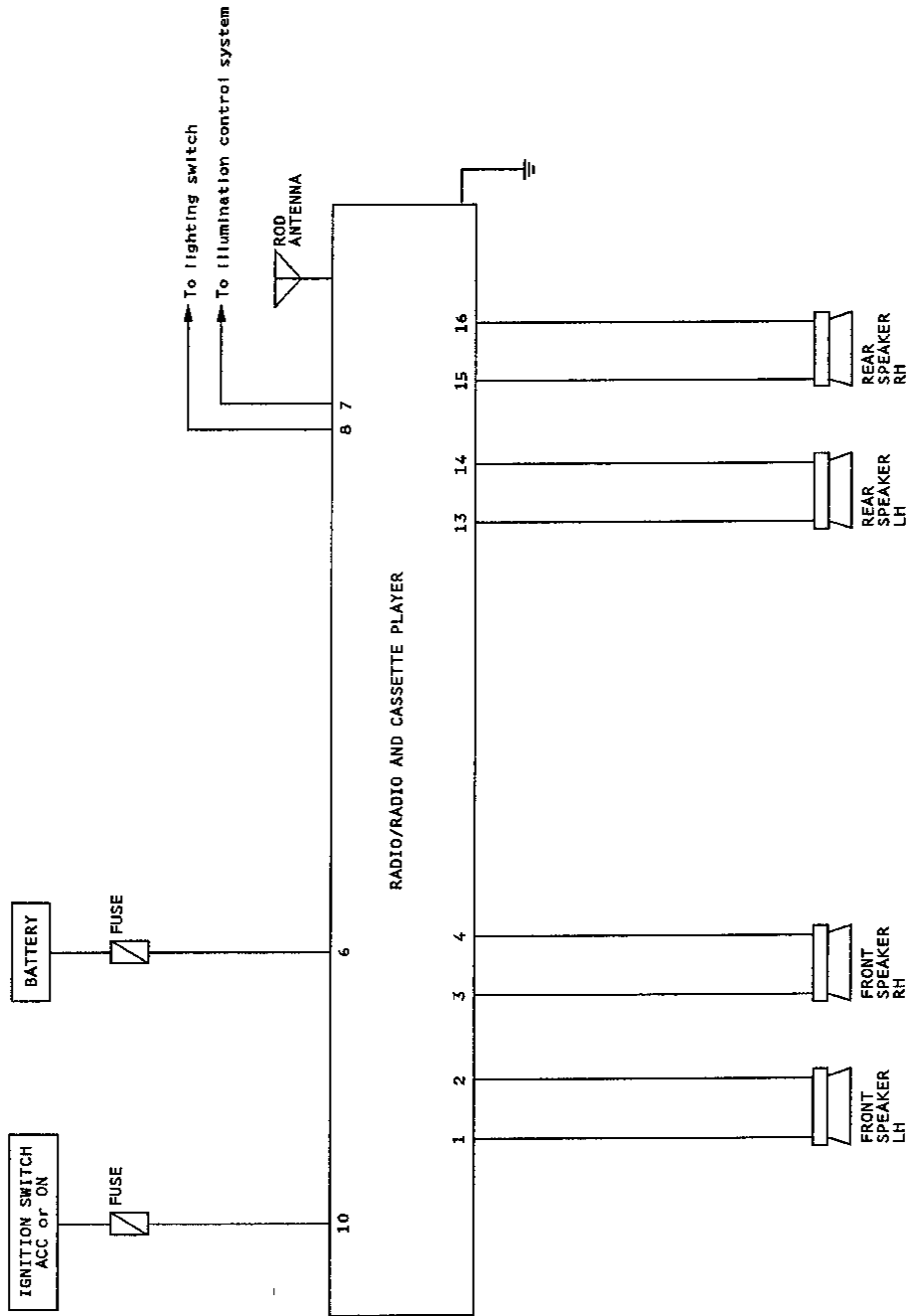

AUDIO

Wiring Diagram -AUDIO-

EL-AUDIO-01

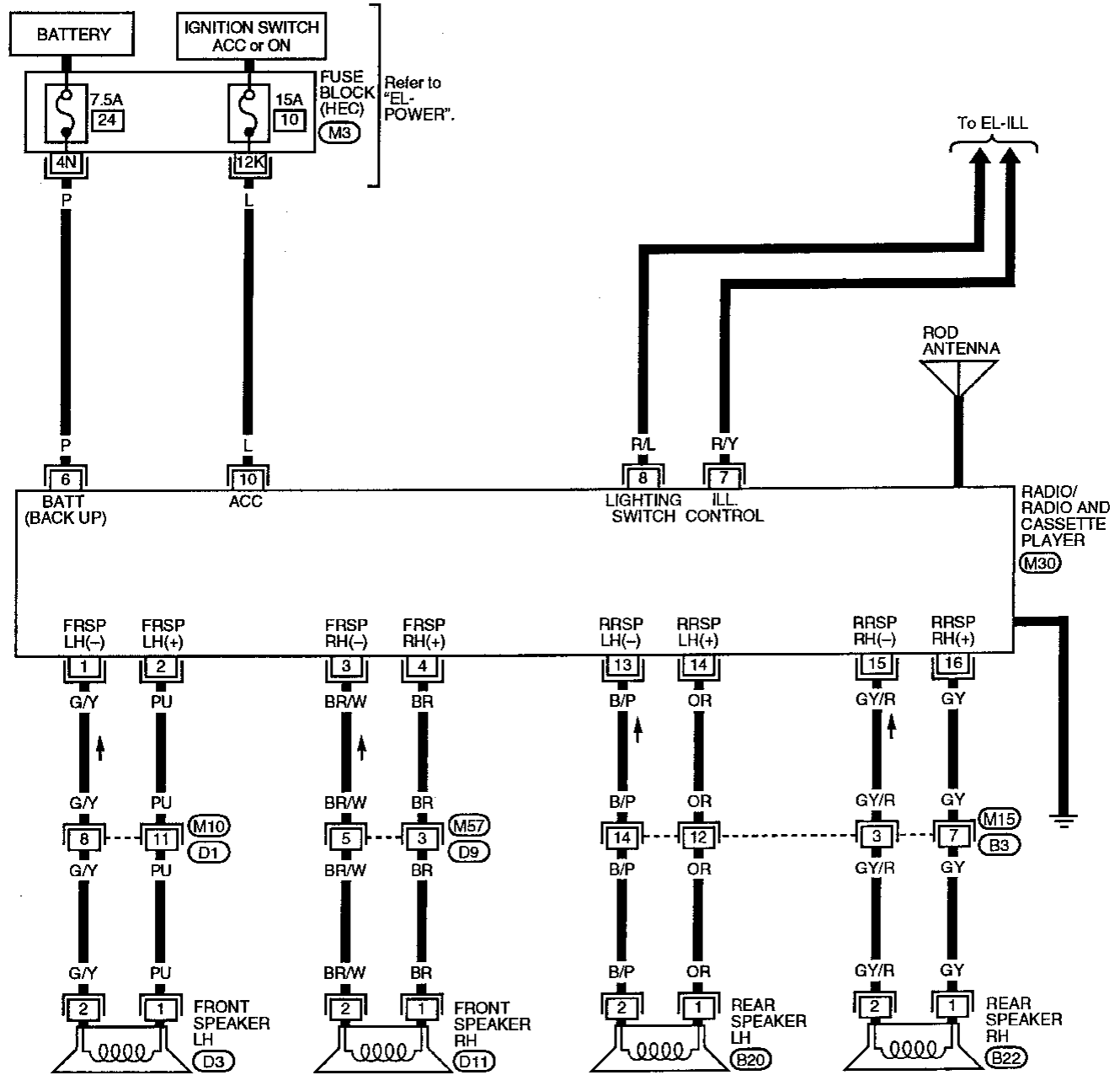

Refer to last page (Foldout page).

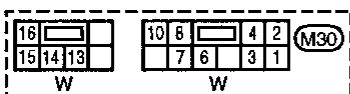
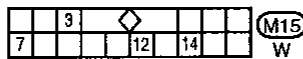

M3

GI
HA
EM
LC
EC
FE
CL
MT
AT
FA
RA
BR
ST
RS
BT
HA
EL
ICX

AUDIO

Trouble Diagnoses

Symptom	Possible causes	Repair order
Radio inoperative (no digital display and no sound from speakers).	<ol style="list-style-type: none"> 1. 15A fuse 2. Poor radio case ground 3. Radio 	<ol style="list-style-type: none"> 1. Check 15A fuse (No. 10 , located in fuse block [HEC]). Turn ignition switch ON and verify battery positive voltage is present at terminal 10 of radio. 2. Check radio case ground. 3. Remove radio for repair.
Radio controls are operational, but no sound is heard from any speaker.	<ol style="list-style-type: none"> 1. Radio output 2. Radio 	<ol style="list-style-type: none"> 1. Check radio output voltages. 2. Remove radio for repair.
Radio presets are lost when ignition switch is turned OFF.	<ol style="list-style-type: none"> 1. 7.5A fuse 2. Radio 	<ol style="list-style-type: none"> 1. Check 7.5A fuse (No. 24 , located in fuse block [HEC]) and verify battery positive voltage is present at terminal 6 of radio. 2. Remove radio for repair.
Rear speakers are inoperative.	<ol style="list-style-type: none"> 1. Radio output 2. Radio 	<ol style="list-style-type: none"> 1. Check radio output voltages. 2. Remove radio for repair.
Front speakers are inoperative.	<ol style="list-style-type: none"> 1. Radio output 2. Radio 	<ol style="list-style-type: none"> 1. Check radio output voltages. 2. Remove radio for repair.
Individual speaker is noisy or inoperative.	<ol style="list-style-type: none"> 1. Speaker 2. Radio output 3. Speaker circuit 4. Radio 	<ol style="list-style-type: none"> 1. Check speaker. 2. Check radio output voltages. 3. Check wires for open or short between radio and speaker. 4. Remove radio for repair.
AM stations are weak or noisy (FM stations OK).	<ol style="list-style-type: none"> 1. Antenna 2. Poor radio ground 3. Radio 	<ol style="list-style-type: none"> 1. Check antenna. 2. Check radio ground. 3. Remove radio for repair.
FM stations are weak or noisy (AM stations OK).	<ol style="list-style-type: none"> 1. Antenna 2. Radio 	<ol style="list-style-type: none"> 1. Check antenna. 2. Remove radio for repair.
Radio generates noise in AM and FM modes with engine running.	<ol style="list-style-type: none"> 1. Poor radio ground 2. Loose or missing ground bonding straps. 3. Ignition condenser 4. Generator 5. Ignition coil or secondary wiring 6. Radio 	<ol style="list-style-type: none"> 1. Check radio ground. 2. Check ground bonding straps. 3. Replace ignition condenser. 4. Check generator. 5. Check ignition coil and secondary wiring. 6. Remove radio for repair.
Radio generates noise in AM and FM modes with accessories on (switch pops and motor noise).	<ol style="list-style-type: none"> 1. Poor radio ground 2. Antenna 3. Accessory ground 4. Faulty accessory 	<ol style="list-style-type: none"> 1. Check radio ground. 2. Check antenna. 3. Check accessory ground. 4. Replace accessory.

AUDIO

Trouble Diagnoses (Cont'd)

SPEAKER INSPECTION

1. Disconnect speaker harness connector.
2. Measure the resistance between speaker terminals ① and ②.
 - The resistance should be 2-4 Ω
3. Using jumper wires, momentarily connect a 9V battery between speaker terminals ① and ②.
 - A momentary hum or pop should be heard

GI

MA

EM

LC

EC

FE

CL

MT

AT

FA

RA

BR

ST

RS

BT

HA

EL

IDX

ANTENNA INSPECTION

Using a jumper wire, clip an auxiliary ground between antenna and body.

- If reception improves, check antenna ground (at body surface)
- If reception does not improve, check main feeder cable for short circuit or open circuit.

RADIO INSPECTION

All voltage inspections are made with:

- Ignition switch ON or ACC
- Radio ON
- Radio connected (If removed for inspection, supply a ground to the case using a jumper wire.)

Radio voltages

Terminal	Voltage (V)
1	5 - 7.5
2	5 - 7.5
3	5 - 7.5
4	5 - 7.5
6	10.8 - 15.6
7	—
8	—
9	—
10	10.8 - 15.6
11	—
12	—
13	5 - 7.5
14	5 - 7.5
15	5 - 7.5
16	5 - 7.5

System Description

Power is supplied at all times:

- from 25A fusible link (letter **F** , located in the fusible link and fuse box)
- to circuit breaker terminal **①**
- through circuit breaker terminal **②**
- to smart entrance control unit terminal **①**.

Power is supplied at all times:

- from 7.5A fuse (No. **20** , located in the fuse block [HEC])
- to interior lamp terminal **①**.

Power is supplied at all times:

- from 7.5A fuse (No. **24** , located in the fuse block [HEC])
- to key switch terminal **①**.

Power is supplied at all times:

- from 10A fuse (No. **15** , located in the fuse block [HEC])
- to multi-remote control relay-1 terminal **①**
- to multi-remote control relay-1 terminal **⑥**
- to multi-remote control relay-1 terminal **③**
- to multi-remote control relay-2 terminal **①**.

With the ignition switch in the ACC or ON position, power is supplied:

- from 7.5A fuse (No. **10** , located in the fuse block [HEC])
- to smart entrance control unit terminal **17**.

Terminal **⑩** of the smart entrance control unit is grounded through body grounds **(M43)** , **(M44)** and **(M60)** .

INPUTS

When the key switch is ON (ignition key is inserted in key cylinder), power is supplied:

- through key switch terminal **②**
- to smart entrance control unit terminal **24**.

When any door switch is OPEN, ground is supplied:

- to smart entrance control unit terminal **16**
- through front door switch LH terminal **②**, or
- through any other door switch terminal **①**.

When the front door lock actuator LH (door unlock sensor) is UNLOCKED, ground is supplied:

- to smart entrance control unit terminal **12**
- through front door lock actuator LH (door unlock sensor) terminal **④**
- to front door lock actuator LH (door unlock sensor) terminal **②**
- through body grounds **(M43)** , **(M44)** and **(M60)** .

When the front door lock actuator RH (door unlock sensor) is UNLOCKED, ground is supplied:

- to smart entrance control unit terminal **13**
- through front door lock actuator RH (door unlock sensor) terminal **④**
- to front door lock actuator RH (door unlock sensor) terminal **②**
- through body grounds **(M43)** , **(M44)** and **(M60)** .

When either rear door lock actuator (door unlock sensor) is UNLOCKED, ground is supplied:

- to smart entrance control unit terminal **14**
- through either rear door lock actuator (door unlock sensor) terminal **④**
- to either rear door lock actuator (door unlock sensor) terminal **②**
- through body grounds **(B14)** and **(B17)** .

Remote controller signal is input:

- through window antenna
- to smart entrance control unit terminal **37**.

The multi-remote control system controls operation of the:

- power door lock
- interior lamp
- panic alarm
- hazard lamp
- ID code entry.

MULTI-REMOTE CONTROL SYSTEM

System Description (Cont'd)

OPERATING PROCEDURE

Power door lock operation

When the following input signals are both supplied:

- key switch OFF (when ignition key is not inserted in key cylinder);
- door switches CLOSED (when all the doors are closed); smart entrance control unit locks all the doors with input of LOCK signal from remote controller. When key switch is OFF (when ignition key is not inserted in key cylinder), smart entrance control unit unlocks the doors with input of UNLOCK signal from remote controller.

Refer to "POWER DOOR LOCK" (EL-127) and "THEFT WARNING SYSTEM" (EL-190).

Interior lamp operation

When the following input signals are both supplied:

- key switch OFF (when ignition key is not inserted in key cylinder);
- door switches CLOSED (when all the doors are closed); multi-remote control system turns on interior lamp (for 30 seconds) with input of UNLOCK signal from remote controller. For detailed description, refer to "Interior and Trunk Room Lamps/System Description" (EL-70).

Panic alarm operation

When key switch is OFF (when ignition key is not inserted in key cylinder), the multi-remote control system turns on and off horn and headlamps intermittently with the input of a PANIC ALARM signal from the remote controller.

For detailed description, refer to "System Description", "THEFT WARNING SYSTEM" (EL-190).

Hazard lamp operation

When the following input signals are all supplied:

- key switch OFF (when ignition key is not inserted in key cylinder);
- door switches CLOSED (when all the doors are closed)
- door lock actuator (door unlock sensor) LOCKED (when all the doors are locked);

multi-remote control system outputs the following ground signals with input of LOCK signal from remote controller:

- to multi-remote control relay-1 terminal ②
- to multi-remote control relay-2 terminal ②
- through smart entrance control unit terminal ⑦.

As a result, multi-remote control relay-1 and multi-remote control relay-2 are energized and hazard warning lamps flash on and off.

For detailed description refer to "Turn Signal and Hazard Warning Lamps/System Description" (EL-60).

GI
MA
EM
LC
EC
FE
CL
MT
AT
FA
RA
BR
ST
RS
BT
HA
EL
IDX

MULTI-REMOTE CONTROL SYSTEM

Wiring Diagram -MULTI-

EL-MULTI-01

(FD) : 4-Door models

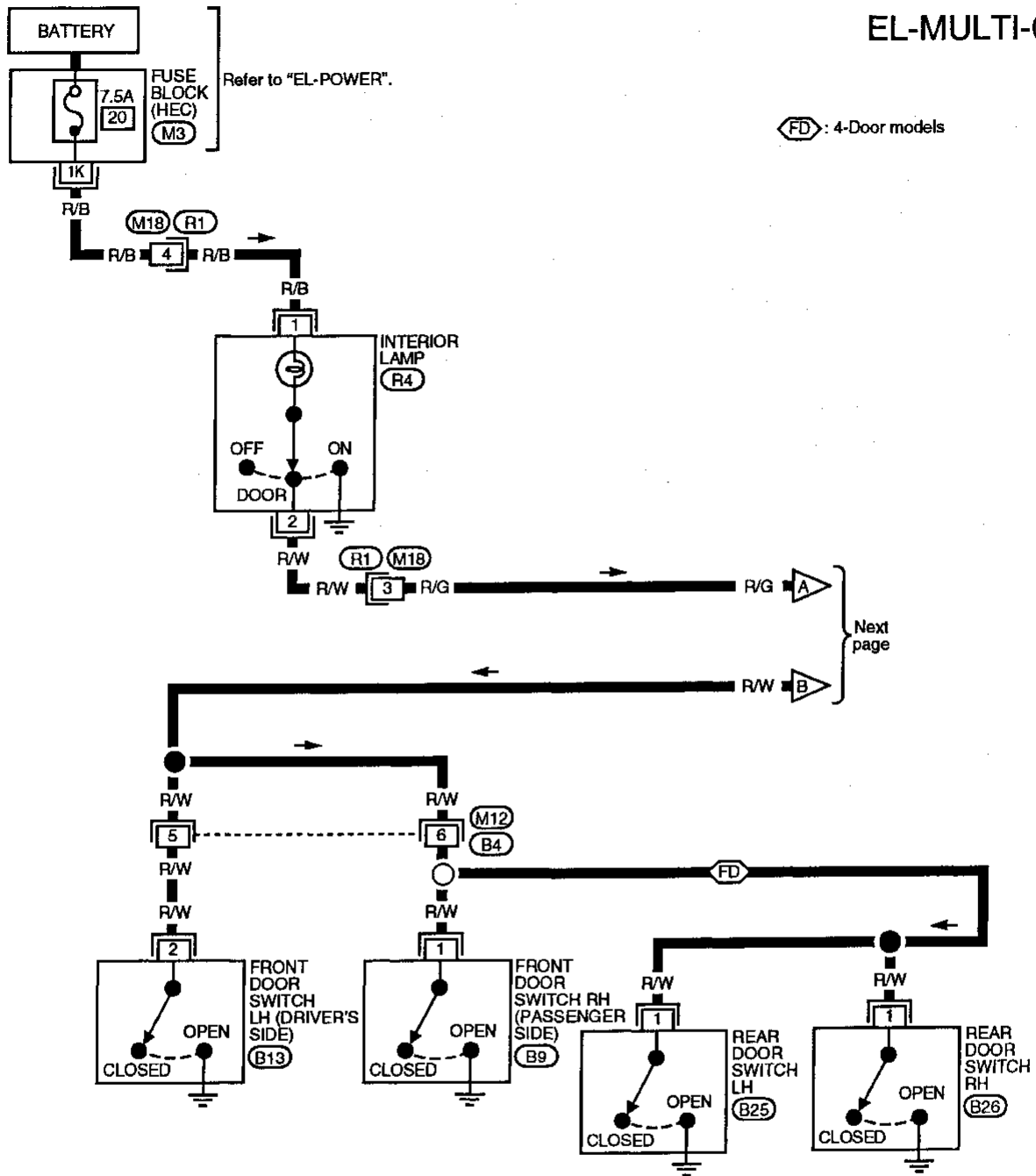

Next page

Refer to last page (Foldout page).

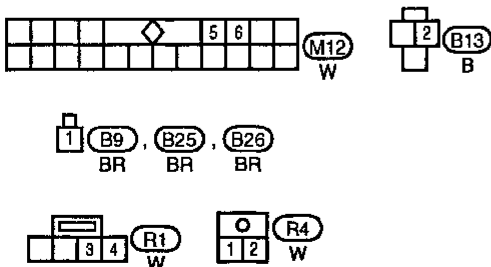

(M3)

MULTI-REMOTE CONTROL SYSTEM

Wiring Diagram -MULTI- (Cont'd)

EL-MULTI-02

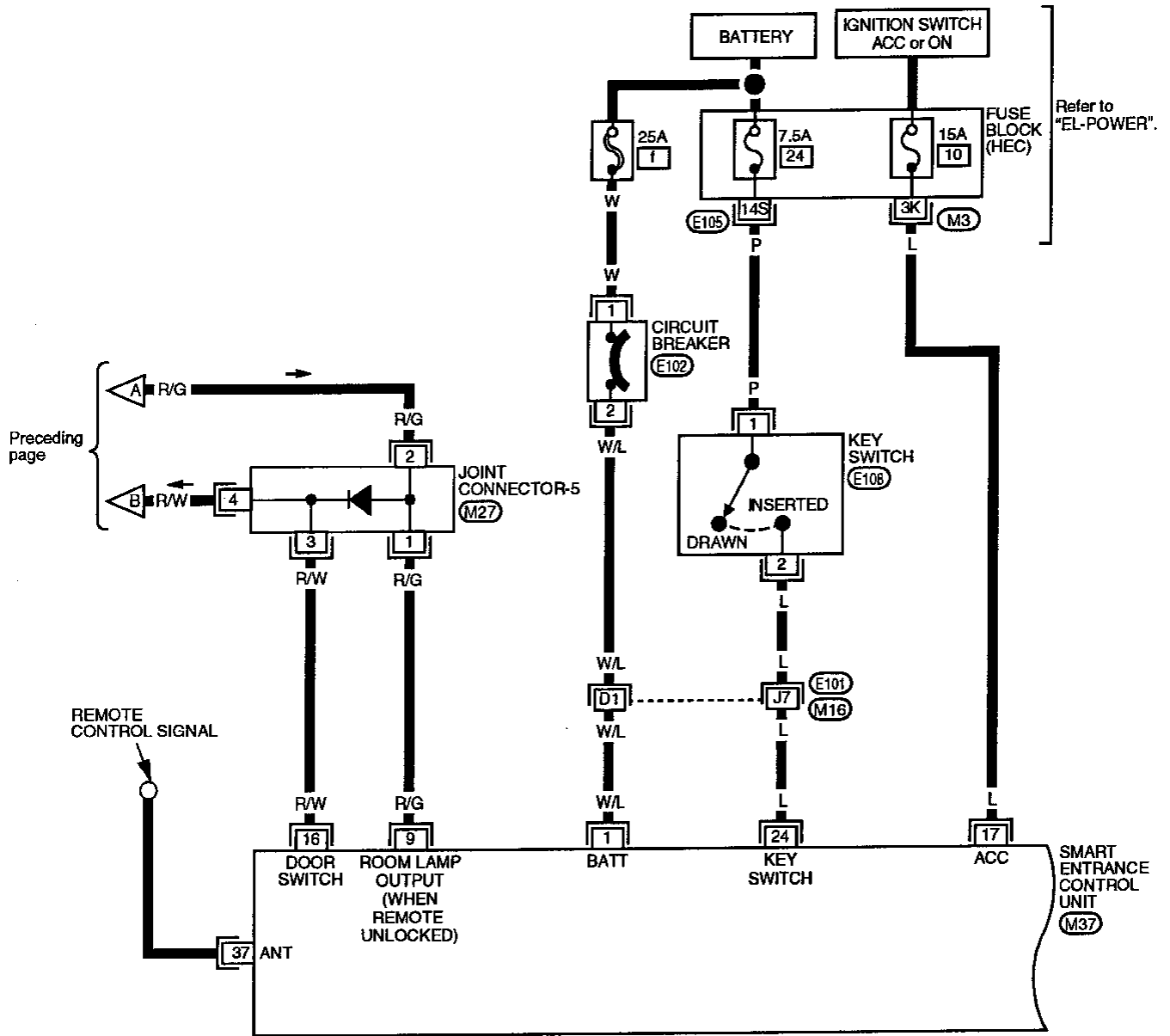

Preceding page

Refer to "EL-POWER".

Refer to last page (Foldout page).

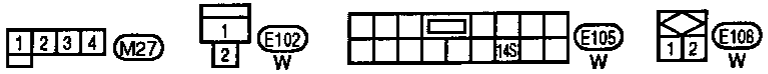

- (M16) , (E101)
- (M3)
- (M37)

GI
MA
EM
LC
EC
FE
CL
MT
AT
FA
RA
BR
ST
RS
BT
HA
EL
IDX

MULTI-REMOTE CONTROL SYSTEM

Wiring Diagram -MULTI- (Cont'd)

EL-MULTI-03

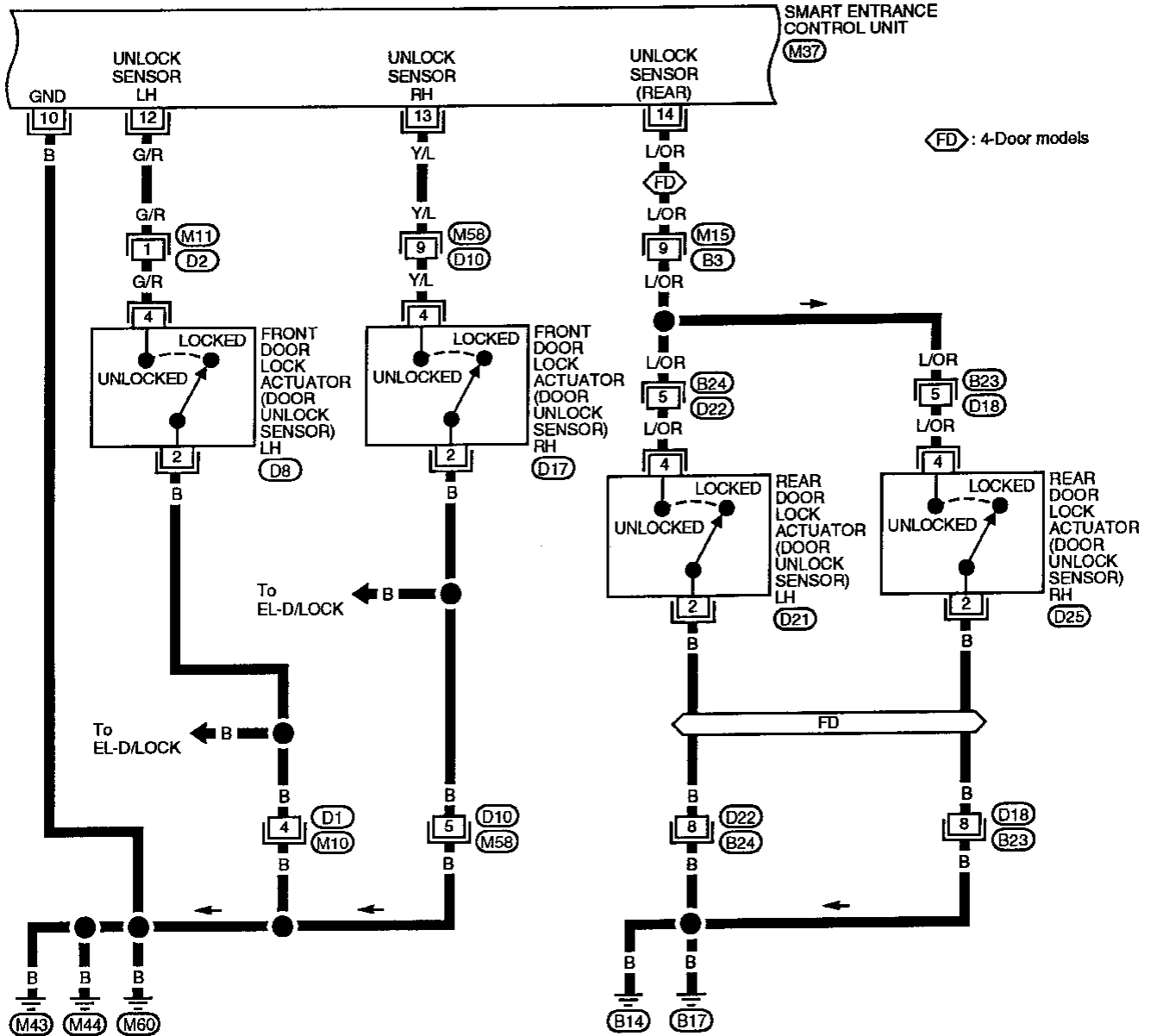

Refer to last page (Foldout page).

(M37)

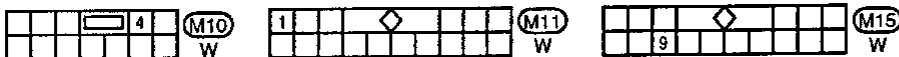

MULTI-REMOTE CONTROL SYSTEM

Wiring Diagram -MULTI- (Cont'd)

EL-MULTI-04

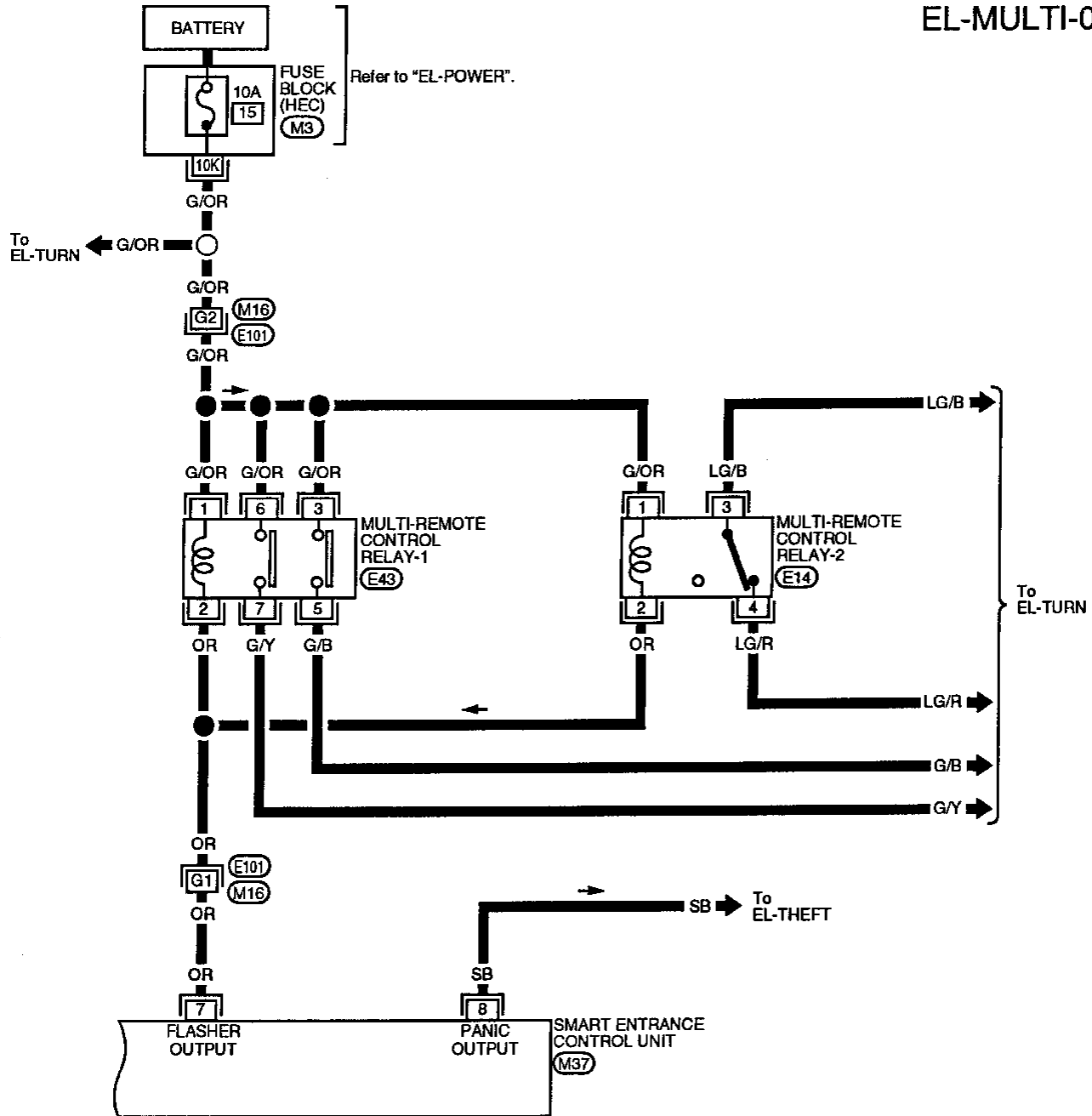

Refer to last page (Foldout page).

- (M16), (E101)
- (M3)
- (M37)

GI
MA
EM
LC
EC
FE
CL
MT
AT
FA
RA
BR
ST
RS
BT
HA
EL
IDX

MULTI-REMOTE CONTROL SYSTEM

Schematic

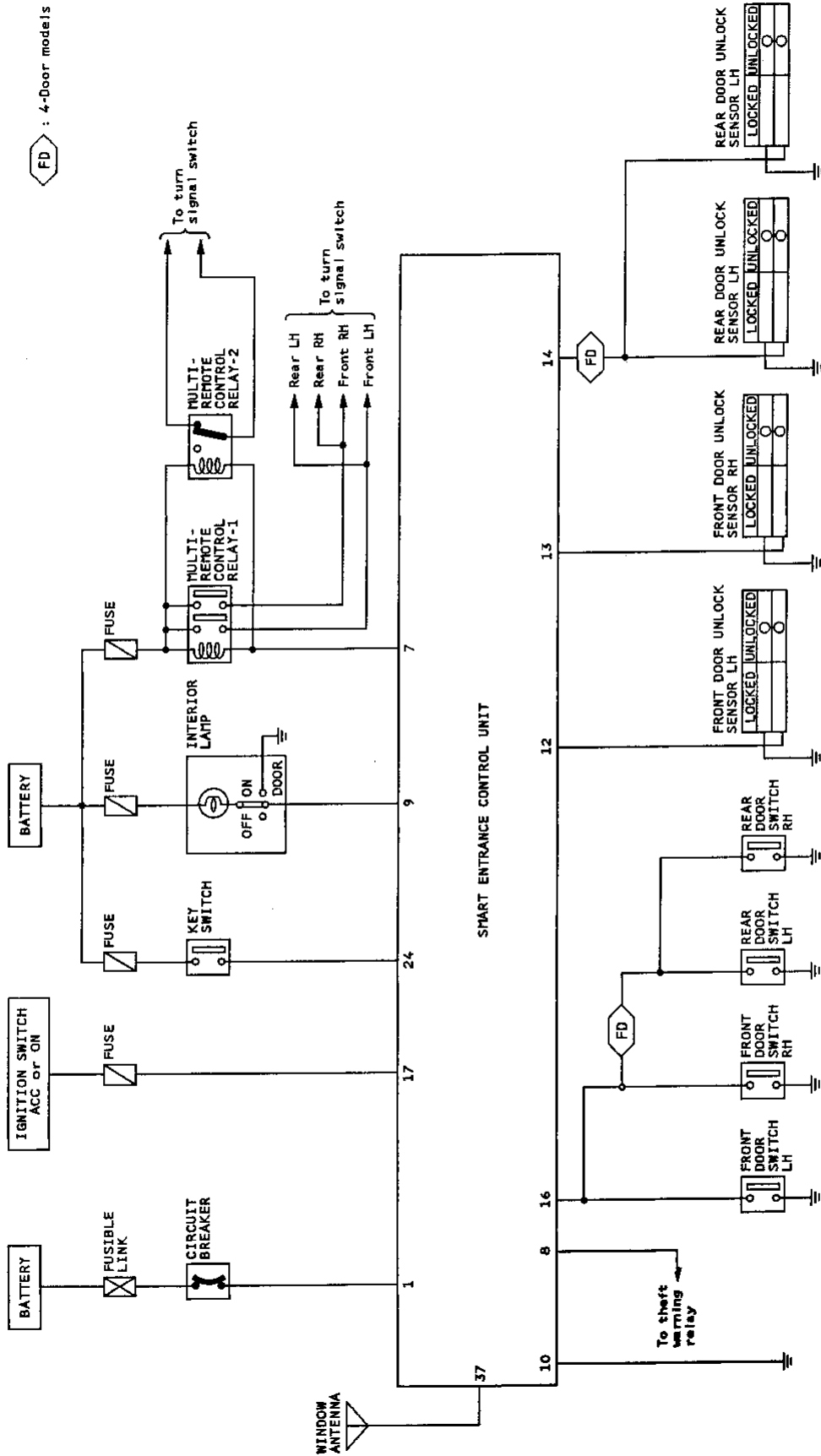

MULTI-REMOTE CONTROL SYSTEM

Input/Output Operation Signal

SMART ENTRANCE CONTROL UNIT

Terminal No.	Connections	Operated condition	Voltage (V) (Approximate values)
1	Power source (C/B)	—	12V
2	Passenger and rear door lock actuators	Door lock & unlock switch	Unlocked
3	Driver door lock actuator		Free
4	All door lock actuators	Door lock & unlock switch	Locked
			Free
7	Multi-remote control relay -1, -2	When doors are locked using remote controller	12V → 0V
8	Theft warning relay	When panic alarm is operated using remote controller	12V → 0V
9	Interior lamp	When interior lamp is operated using remote controller. (Lamp switch in "DOOR" position)	12V → 0V
10	Ground	—	—
11	Ignition switch (ON)	"ON" position	12V
12	Driver door unlock sensor	Driver door: Locked → Unlocked	12V → 0V
13	Passenger door unlock sensor	Passenger door: Locked → Unlocked	12V → 0V
14	Rear door unlock sensors	Either rear door: Locked → unlocked	12V → 0V
15	Driver door switch	OFF (Closed) → ON (Open)	12V → 0V
16	All door switches	OFF (Closed) → ON (Open)	12V → 0V
17	Ignition switch (ACC)	"ACC" position	12V
18	Door lock & unlock switches	Neutral → Locks	12V → 0V
19	Door lock & unlock switches	Neutral → Unlocks	12V → 0V
20	Rear window defogger switch	OFF → ON	12V → 0V
21	Seat belt switch	Unfasten → Fasten	0V → 12V
23	Warning chime	OFF → ON	12V → 0V
24	Ignition key switch (Insert)	IGN key inserted → IGN key removed from IGN key cylinder	12V → 0V
25	Headlamp switch (1ST)	1ST, 2ND positions: ON → OFF	12V → 0V
26	Trunk switch	ON (Open) → OFF (Closed)	0V → 12V
27	Trunk key unlock switch	OFF (Neutral) → ON (Unlocked)	12V → 0V
28	Door key cylinders tamper switch	OFF → ON	12V → 0V
29	Hood open signal	ON (Open) → OFF (Closed)	0V → 12V
30	Door key cylinder lock switch	OFF (Neutral) → ON (Locked)	12V → 0V
31	Door key cylinder lock switch	OFF (Neutral) → ON (Unlocked)	12V → 0V
32	Theft warning relay (Starter cut)	OFF → ON	12V → 0V
33	Theft warning indicator	Goes off → Illuminates	12V → 0V
36	Rear defogger relay	OFF → ON	12V → 0V
37	Multi-remote antenna	—	—

MULTI-REMOTE CONTROL SYSTEM

Trouble Diagnoses

TROUBLE SYMPTOM

- All functions of remote control system do not operate.

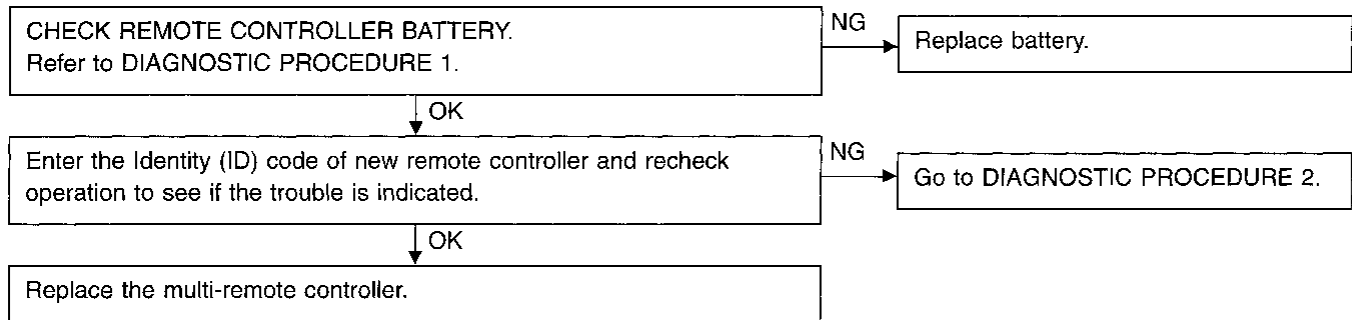

- Some functions of multi-remote controller do not operate.

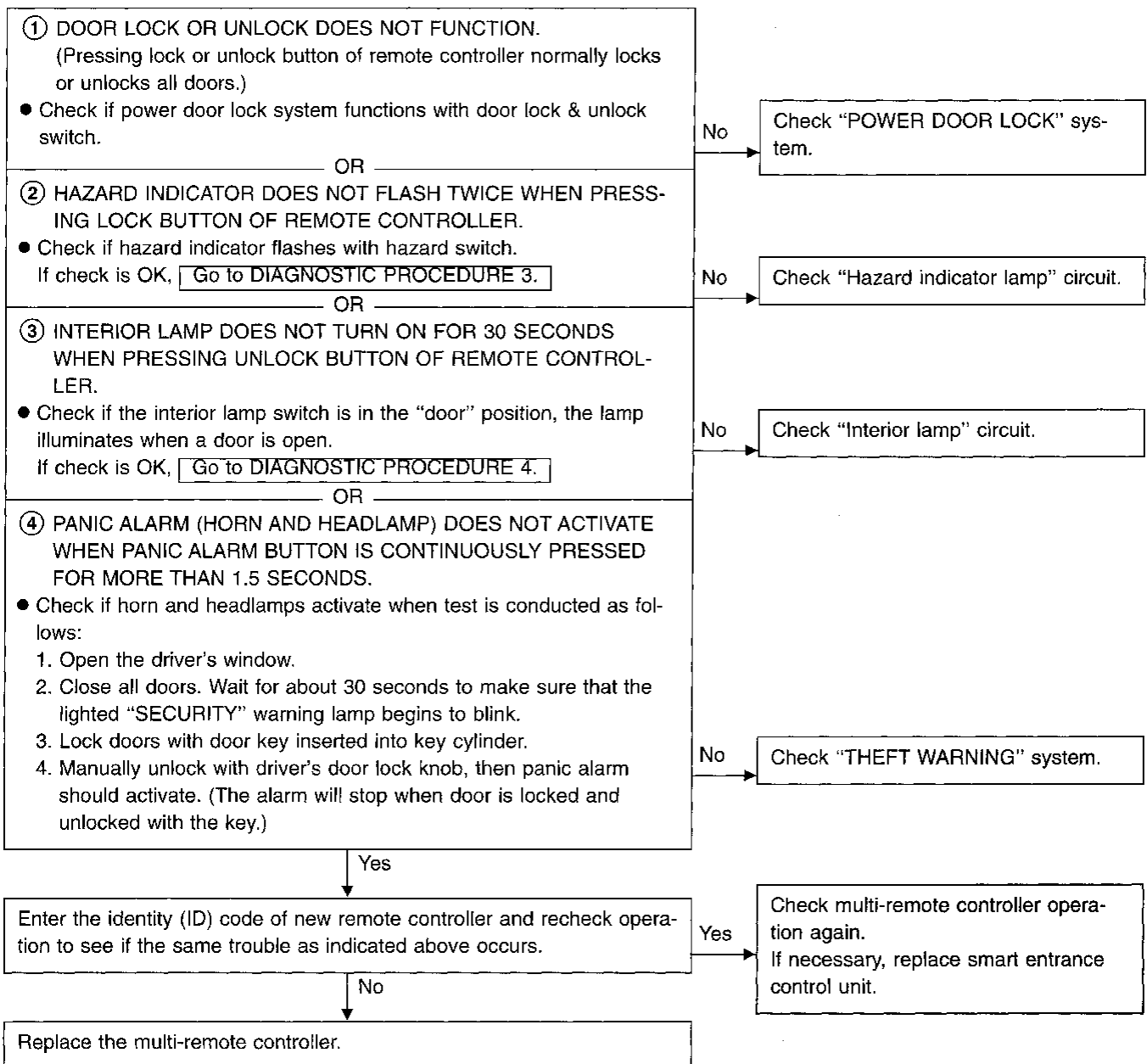

Note: The multi-remote control system does not activate with the ignition key inserted in the ignition key cylinder.

MULTI-REMOTE CONTROL SYSTEM

Trouble Diagnoses (Cont'd)

DIAGNOSTIC PROCEDURE 1

Check remote controller battery.

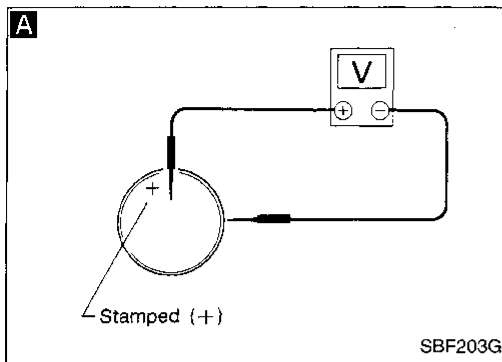

A

CHECK REMOTE CONTROLLER BATTERY.

Remove battery and measure voltage across battery positive and negative terminals ⊕ and ⊖.

Measuring terminal		Standard value
⊕	⊖	
Battery positive terminal ⊕	Battery negative terminal ⊖	3V or more

Note:

Remote controller does not function if battery is not set correctly.

GI

MA

EM

LC

EC

FE

CL

MT

AT

FA

RA

BR

ST

RS

BT

HA

EL

IDX

DIAGNOSTIC PROCEDURE 2

All remote controls do not function even if remote controller is operated properly.

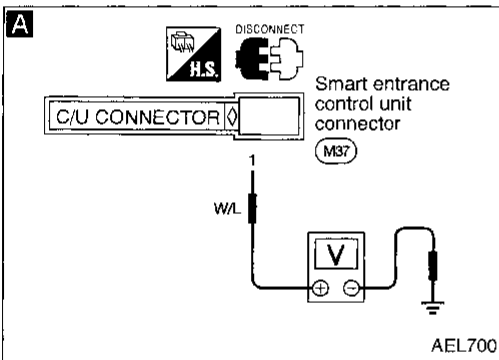

A

CHECK MAIN POWER SUPPLY AND GROUND CIRCUIT.

1. Remove key from ignition.
2. Disconnect connector from control unit. Check voltage across control unit terminal ① and GND. **Battery voltage should exist.**

NG → Check power supply harness.

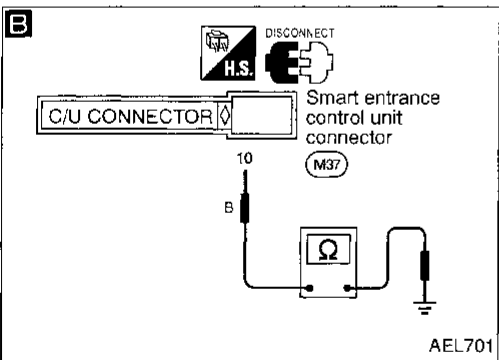

B

CHECK GROUND CONTINUITY.

Check continuity between terminal ⑩ and GND. **Continuity should exist.**

NG → Check GND harness.

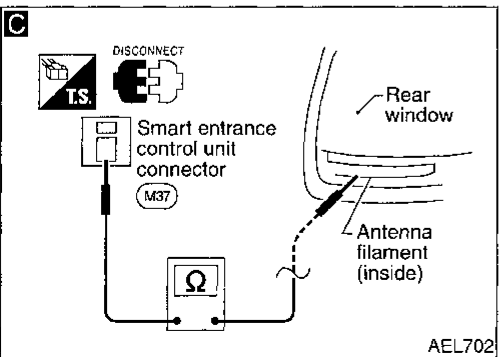

C

CHECK ANTENNA CIRCUIT.

Disconnect 1-pin connector from control unit. Check continuity between terminal on 1-pin harness connector and filament on the rear window. **Continuity should exist.**

NG → Check antenna circuit. (Refer to "Filament Repair", "REAR WINDOW DEFOGGER".)

OK → **A**
(Go to next page.)

MULTI-REMOTE CONTROL SYSTEM

Trouble Diagnoses (Cont'd)

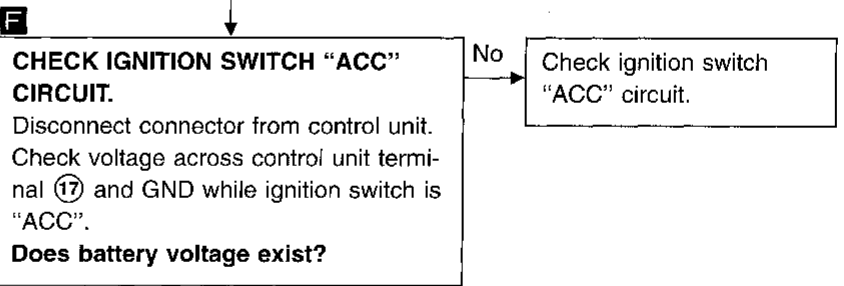
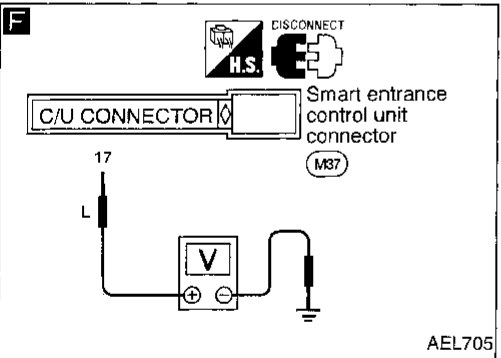
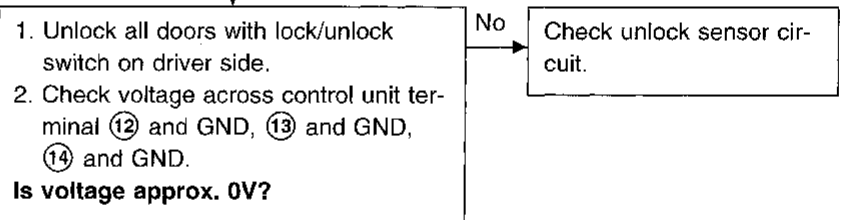
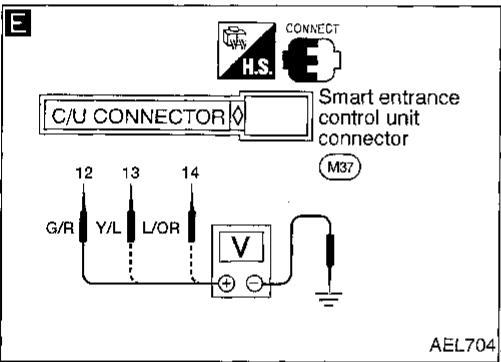
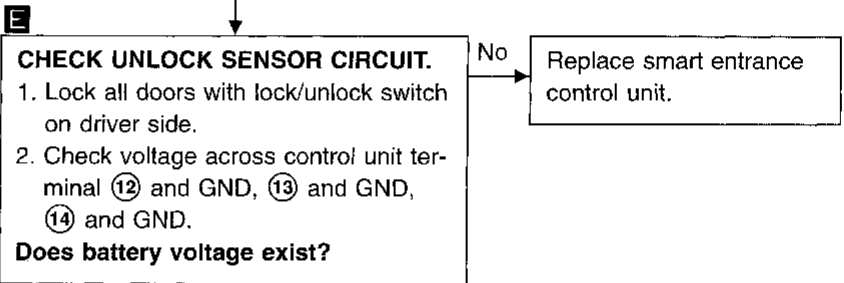
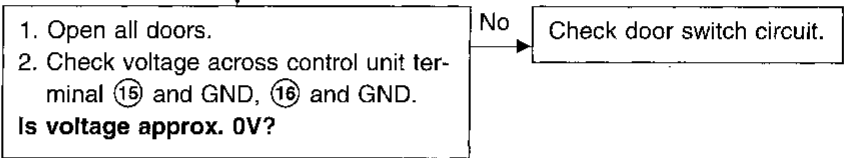
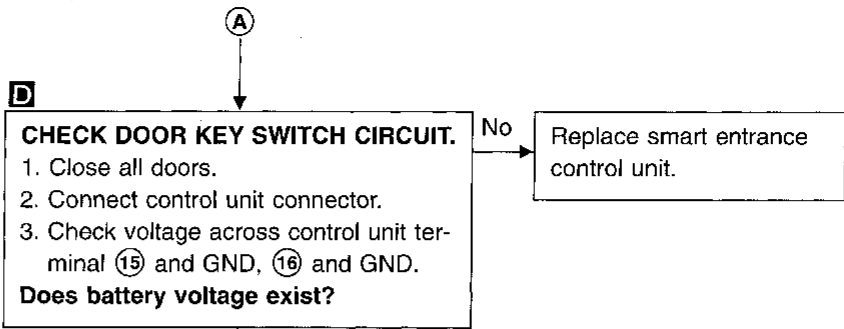
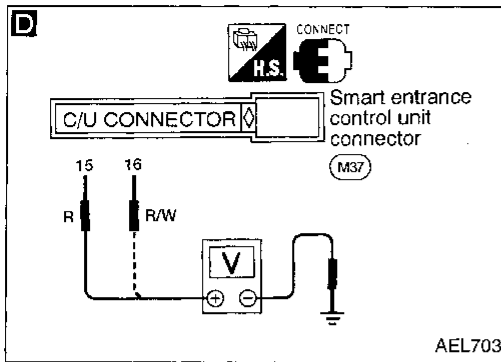

Check operation parts in multi-remote control system for function.

MULTI-REMOTE CONTROL SYSTEM

Trouble Diagnoses (Cont'd)

DIAGNOSTIC PROCEDURE 3

Hazard indicator does not flash twice when pressing lock button of remote controller. Everything else functions.

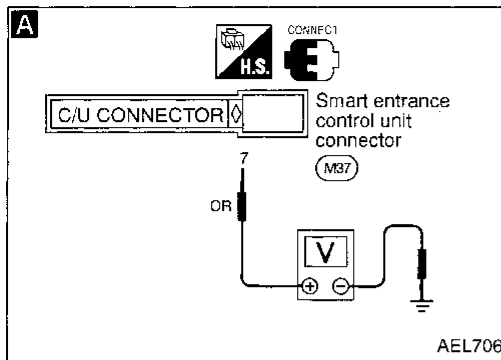

A

CHECK HAZARD INDICATOR FLASHING CIRCUIT.
Check voltage across control unit terminal ⑦ and GND.
Does battery voltage exist?

Yes → (A) (Go to next page.)

No ↓

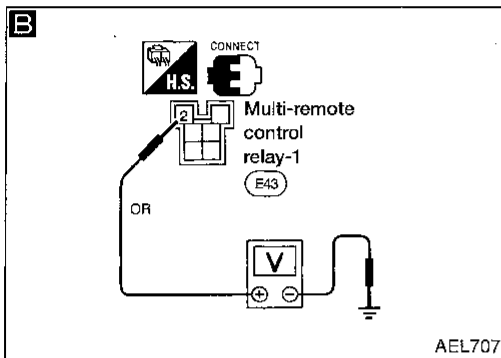

B

CHECK VOLTAGE.
Check voltage across multi-remote control relay-1 terminal ② and GND.
Does battery voltage exist?

Yes →

No ↓

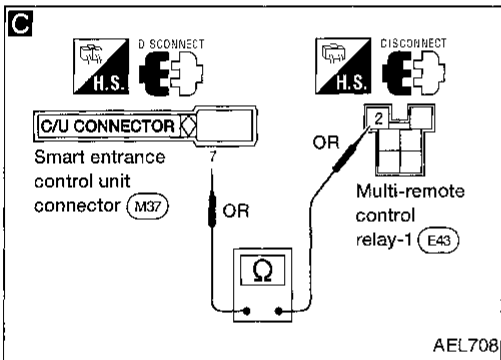

C

CHECK CONTINUITY.
1. Disconnect connectors from control unit and multi-remote control relay-1.
2. Check continuity between terminal ⑦ of control unit connector and ② of multi-remote control relay-1 connector.
Does continuity exist?

No ↓

Yes →

Check system again.

Repair harness between control unit connector and multi-remote control relay-1 connector.

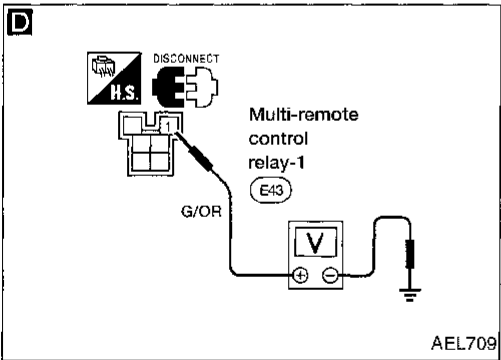

D

CHECK RELAY POWER CIRCUIT.
Disconnect connector from multi-remote control relay-1.
Check voltage across multi-remote control relay-1 terminal ① and GND.
Does battery voltage exist?

No →

Yes ↓

Repair power supply harness for multi-remote control relay-1.

Replace multi-remote control relay-1.

GI
MA
EM
LC
EC
FE
CL
WT
AT
FA
RA
BR
ST
RS
BT
HA
EL
IDX

MULTI-REMOTE CONTROL SYSTEM

Trouble Diagnoses (Cont'd)

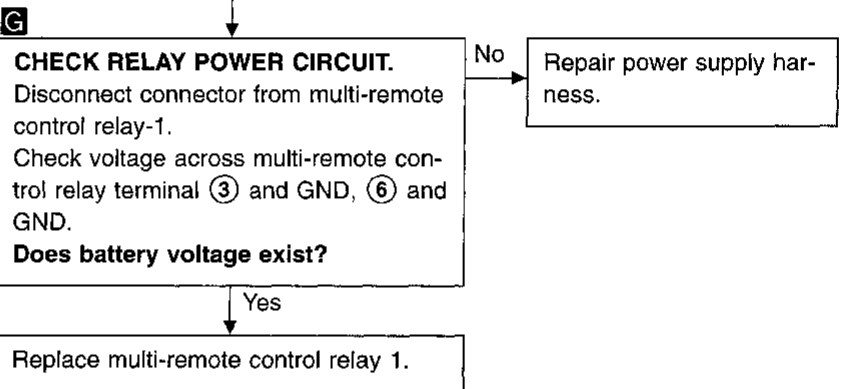
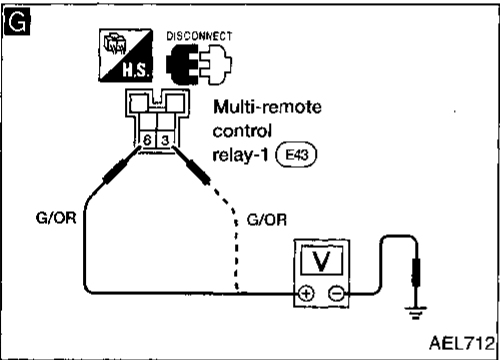
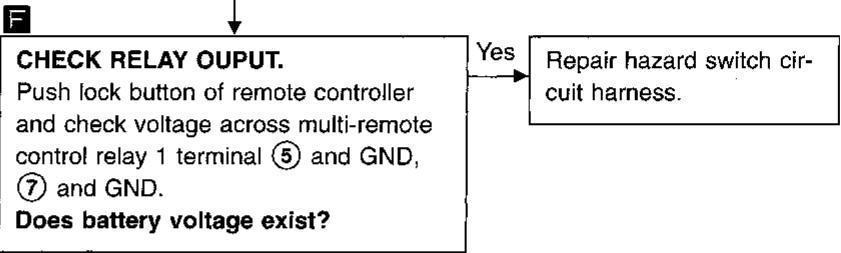
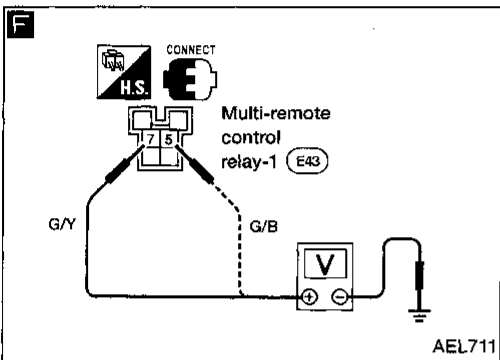
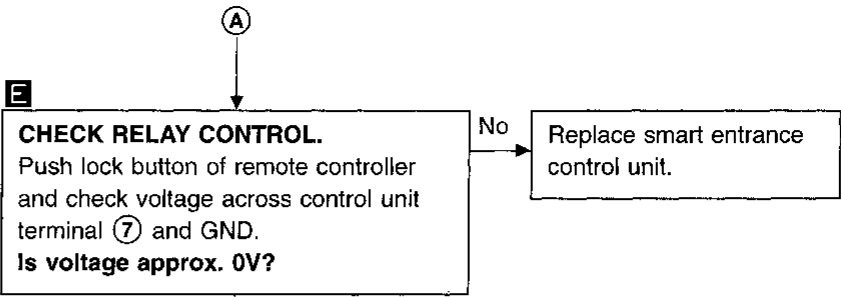
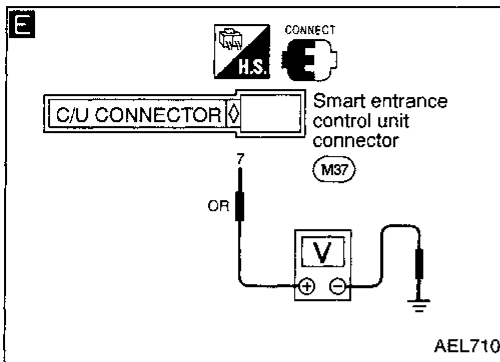

MULTI-REMOTE CONTROL SYSTEM

Trouble Diagnoses (Cont'd)

DIAGNOSTIC PROCEDURE 4

Interior lamp does not turn on for 30 seconds when pressing unlock button of remote controller. Everything else functions.

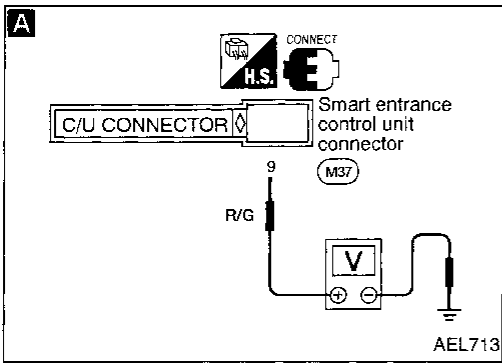

A

CHECK INTERIOR LAMP CIRCUIT.

When interior lamp switch is in "DOOR" position, check voltage across control unit terminal ⑨ and GND.

Does battery voltage exist?

No

Repair harness between control unit connector and interior lamp connector.

Yes

CHECK VOLTAGE.

Push unlock button of remote controller and check voltage across control unit terminal ⑨ and GND.

Is voltage approx. 0V?

No

Replace smart entrance control unit.

Yes

Check system again.

GI

MA

EM

LC

EC

FE

CL

MT

AT

FA

RA

BR

ST

RS

BT

HA

EL

IDX

Replacing Remote Controller or Control Unit

If the remote controller or the control unit needs to be replaced or if an additional remote controller needs to be set, enter the identity (ID) code manually.

ID Code Entry Procedure

To enter the ID code, follow this procedure:

“Setting mode”:

Three steps must be followed to establish the “setting mode”.

1. Close and lock all doors.
 2. Insert and remove the key from the ignition more than six times within 10 seconds. (The hazard warning lamp will then flash twice.)
- **At this time, the original ID codes are eliminated.**
3. Turn ignition key to “ACC” position.

ID code entry:

4. Push the lock button on the new remote controller once.
- **At this time, the new ID code is entered. (The hazard warning lamp will then flash twice.)**
5. To enter additional remote controllers (including the original) unlock, then lock, the driver’s door with the door lock/unlock switch LH (in main power window switch).
 6. Push lock button on the new additional remote controller once.
 7. This ID code entry enable state and setting mode remain until the driver’s door is opened.

NOTE

- **If the same ID code already exists in memory, the entry is canceled, and no ID code will be entered.**
- **Entry of maximum four ID codes is allowed and any attempt to enter more will be ignored.**
- **Any ID codes entered after termination of the “setting” mode will not be accepted. Additionally, remote control signals will be inhibited when an ID code has not been entered during “setting” mode.**

AUTOMATIC SPEED CONTROL DEVICE (ASCD)

System Description*

Refer to Owner's Manual for ASCD operating instructions.

When the ignition switch is in the ON or START position, power is supplied:

- through 7.5A fuse (No. 7), located in the fuse block [HEC]
- to ASCD main switch terminal ① and
- to ASCD hold relay terminal ⑤.

When ASCD main switch is in the ON position, power is supplied:

- from terminal ② of the ASCD main switch
- to ASCD control unit terminal ④ and
- from terminal ③ of the ASCD main switch
- to ASCD hold relay terminal ①.

Ground is supplied:

- to ASCD hold relay terminal ②
- through body grounds M43, M44 and M60.

With power and ground supplied, the ASCD hold relay is activated, and power is supplied:

- from terminal ③ of the ASCD hold relay
- to ASCD control unit terminal ④ and
- to ASCD clutch pedal position switch terminal ① (M/T models) or
- to inhibitor relay terminal ③ (A/T models).

Power remains supplied to ASCD control unit terminal ④ when the ASCD main switch is released to the N (neutral) position.

Ground is supplied:

- to ASCD control unit terminal ③
- through body grounds M43, M44 and M60.

Inputs

At this point, the system is ready to activate or deactivate, based on inputs from the following:

- speedometer in the combination meter
- stop lamp switch
- ASCD steering switch
- inhibitor relay (A/T models)
- ASCD clutch pedal position switch (M/T models)
- ASCD cancel switch.

A vehicle speed input is supplied:

- to ASCD control unit terminal ⑦
- from terminal ②③ (②①) of the combination meter.

Power is supplied at all times:

- through 15A fuse (No. 14), located in the fuse block [HEC]
- to stop lamp switch terminal ①.

When the brake pedal is depressed, power is supplied:

- from terminal ② of the stop lamp switch
- to ASCD control unit terminal ⑩.

Power is supplied at all times:

- through 10A fuse (No. 42), located in the fusible link and fuse box)
- to horn relay terminal ②
- through terminal ① of the horn relay
- to ASCD steering switch terminal ⑫.

When the SET/COAST button is depressed, power is supplied:

- from terminal ⑭ of the ASCD steering switch
- to ASCD control unit terminal ②.

When the RESUME/ACCEL button is depressed, power is supplied:

- from terminal ⑬ of the ASCD steering switch
- to ASCD control unit terminal ①.

When the CANCEL button is depressed, power is supplied:

- to ASCD control unit terminals ① and ②.

When the system is activated, power is supplied:

- to ASCD control unit terminal ⑤.

*: Terminal numbers in () are for models without tachometer.

GI

MA

EM

LC

EC

FE

CL

MT

AT

FA

RA

BR

ST

RS

BT

HA

EL

IDX

AUTOMATIC SPEED CONTROL DEVICE (ASCD)

System Description* (Cont'd)

Power is interrupted when:

- the shift lever is placed in "P" or "N" (A/T models)
- the clutch pedal is depressed (M/T models) or
- the brake pedal is depressed.

Outputs

The ASCD actuator controls the throttle drum via the ASCD wire based on inputs from the ASCD control unit. The ASCD actuator consists of a vacuum motor, an air valve, and a release valve.

Power is supplied:

- from terminal ⑧ of the ASCD control unit
- to ASCD actuator terminal ①.

Ground is supplied to the vacuum motor:

- from terminal ⑨ of the ASCD control unit
- to ASCD actuator terminal ④.

Ground is supplied to the air valve:

- from terminal ⑩ of the ASCD control unit
- to ASCD actuator terminal ②.

Ground is supplied to the release valve:

- from terminal ⑭ of the ASCD control unit
- to ASCD actuator terminal ③.

When the system is activated, power is supplied:

- from terminal ⑬ of the ASCD control unit
- to combination meter terminal ⑳ (⑲) and
- to A/T control unit terminal ⑳ (A/T models with SR engine).

Ground is supplied:

- to combination meter terminal ⑳ (⑲)
- through body grounds M43, M44 and M60.

With power and ground supplied, the CRUISE indicator illuminates.

When the RESUME/ACCEL button is depressed, a signal is sent:

- from terminal ⑫ of the ASCD control unit
- to A/T control unit terminal ④① (A/T models with SR engine), or
- to A/T control valve terminal ② (A/T models with GA engine).

When this occurs, overdrive is cancelled.

*: Terminal numbers in () are for models without tachometer.

AUTOMATIC SPEED CONTROL DEVICE (ASCD)

Component Parts and Harness Connector Location

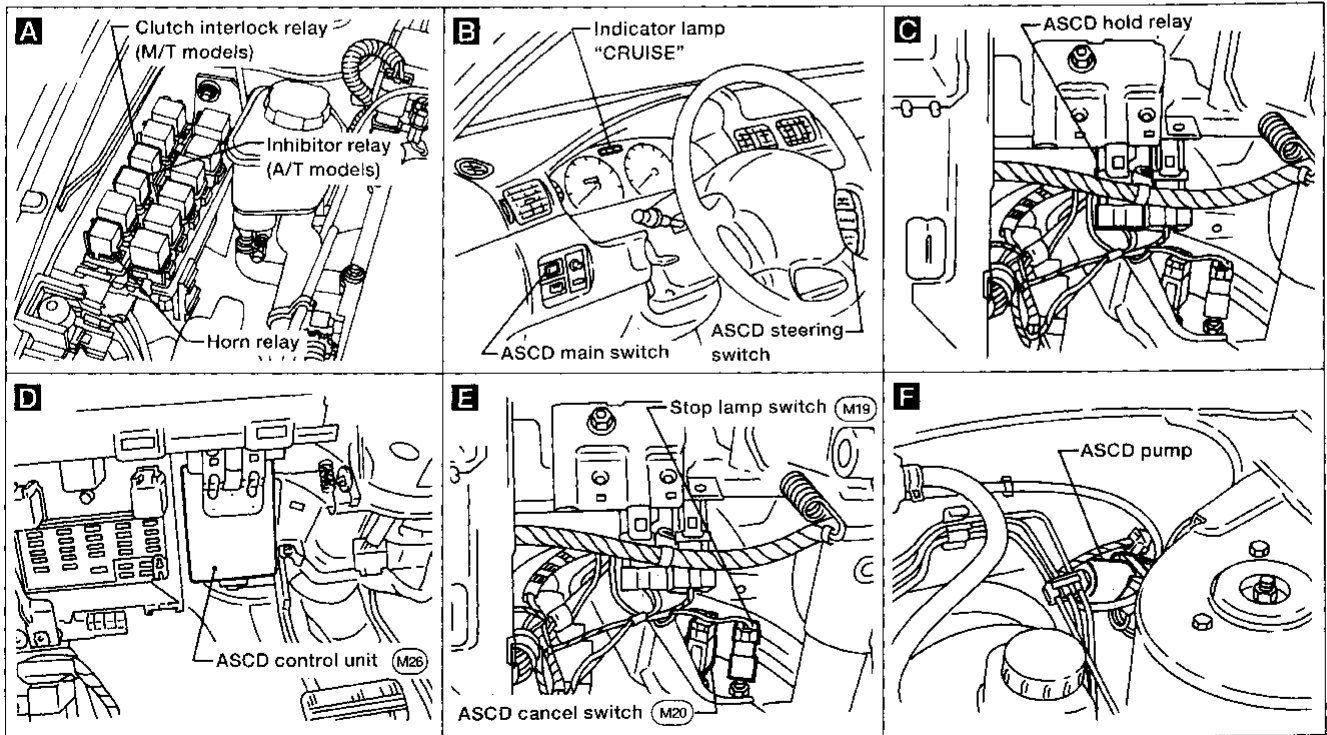
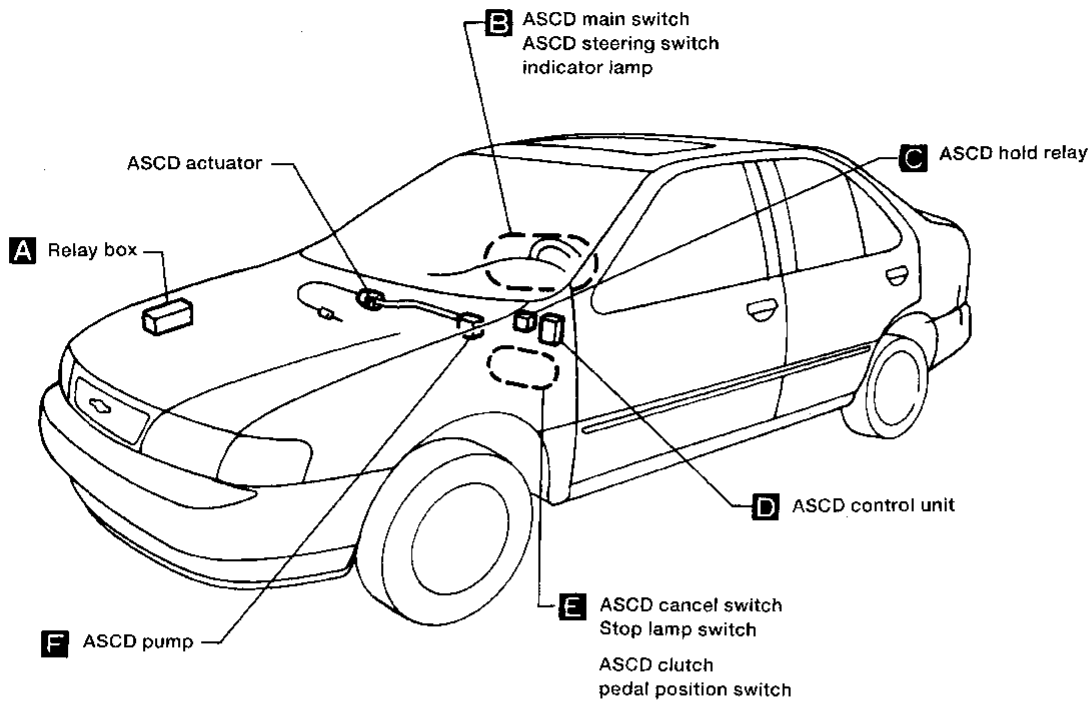

GI
MA
EM
LC
EC
FE
CL
MT
AT
FA
RA
BR
ST
RS
BT
HA
EL
IDX

AUTOMATIC SPEED CONTROL DEVICE (ASCD)

Schematic

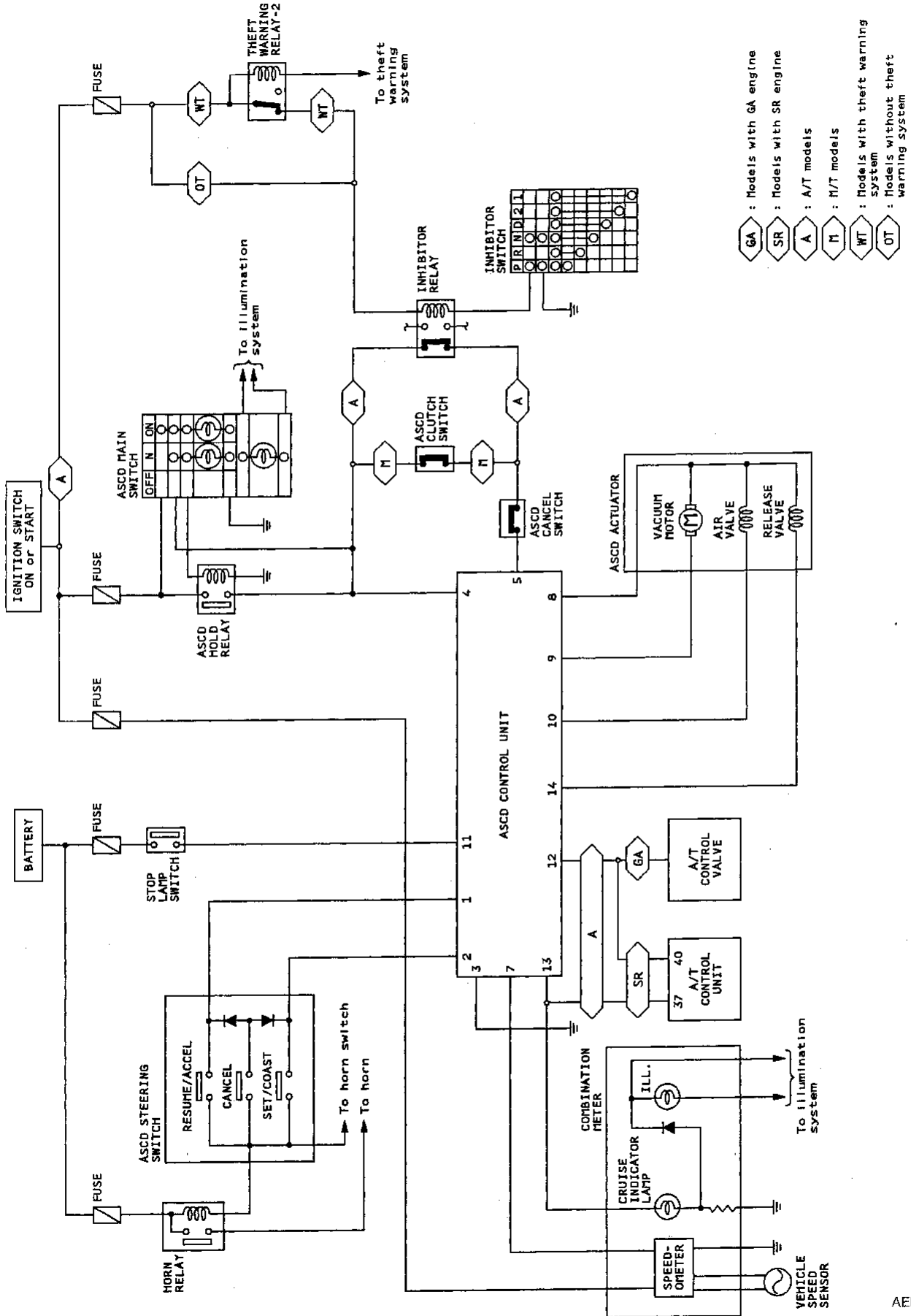

AUTOMATIC SPEED CONTROL DEVICE (ASCD)

Wiring Diagram -ASCD-

EL-ASCD-01

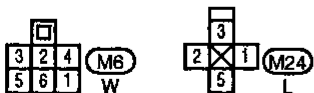
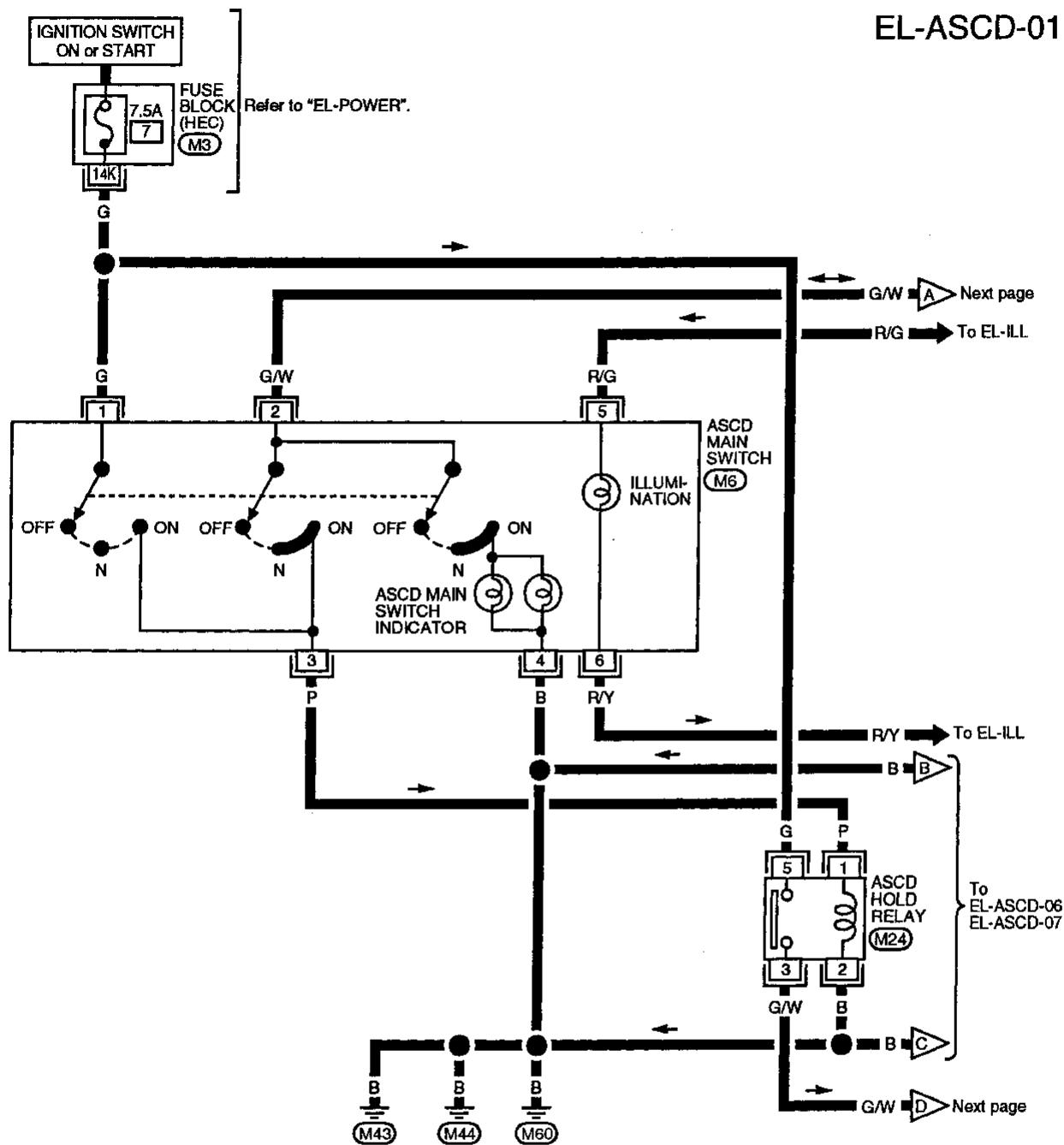

Refer to last page (Foldout page).
M3

GI
 MA
 EM
 LC
 EC
 FE
 CL
 MT
 AT
 FA
 RA
 BR
 ST
 RS
 BT
 HA
 EL
 IDX

AUTOMATIC SPEED CONTROL DEVICE (ASCD)

Wiring Diagram -ASCD- (Cont'd)

EL-ASCD-02

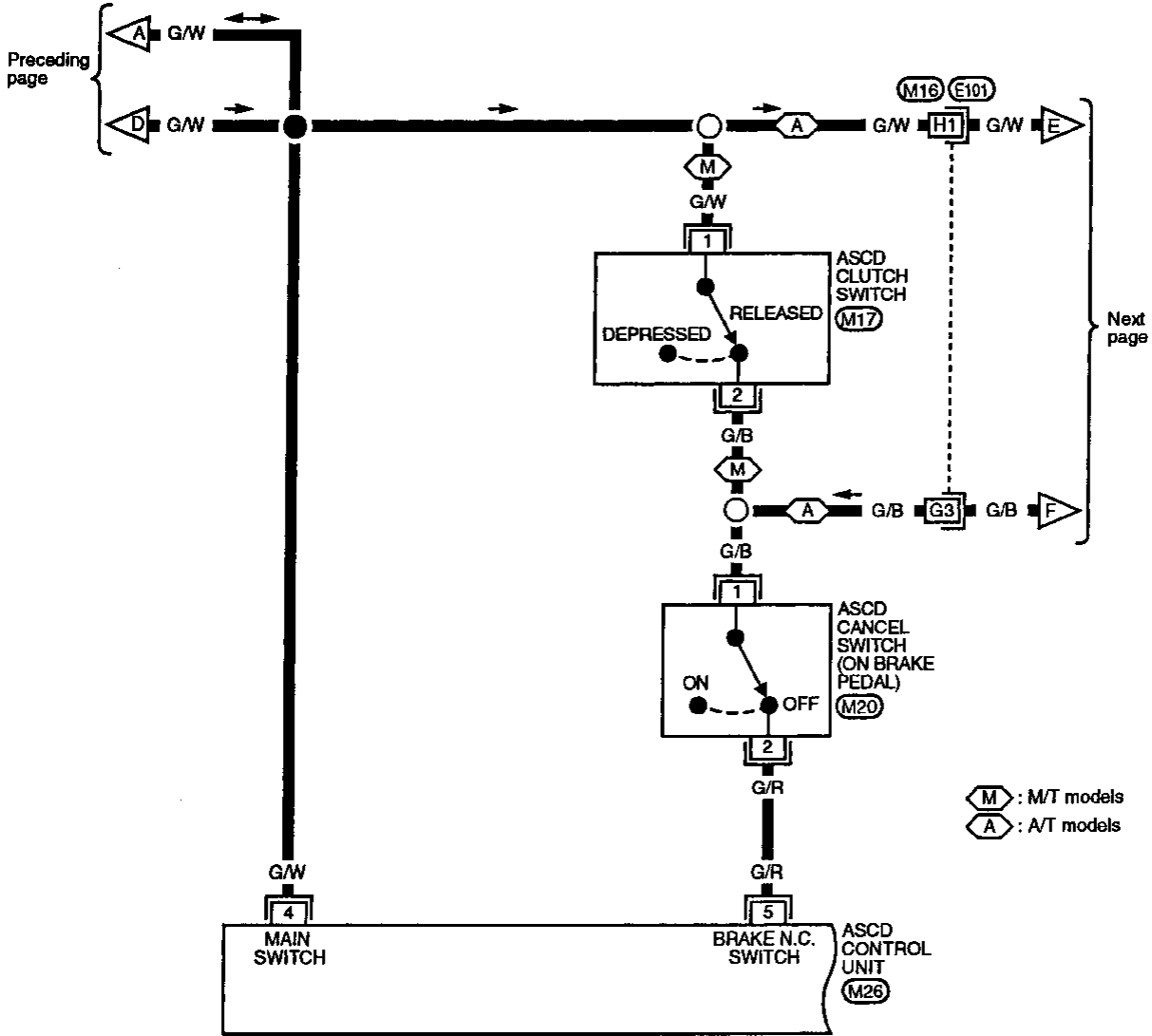

M : M/T models
A : A/T models

Refer to last page (Foldout page).
M16 , E101

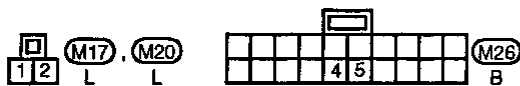

AUTOMATIC SPEED CONTROL DEVICE (ASCD)

Wiring Diagram -ASCD- (Cont'd)

EL-ASCD-04

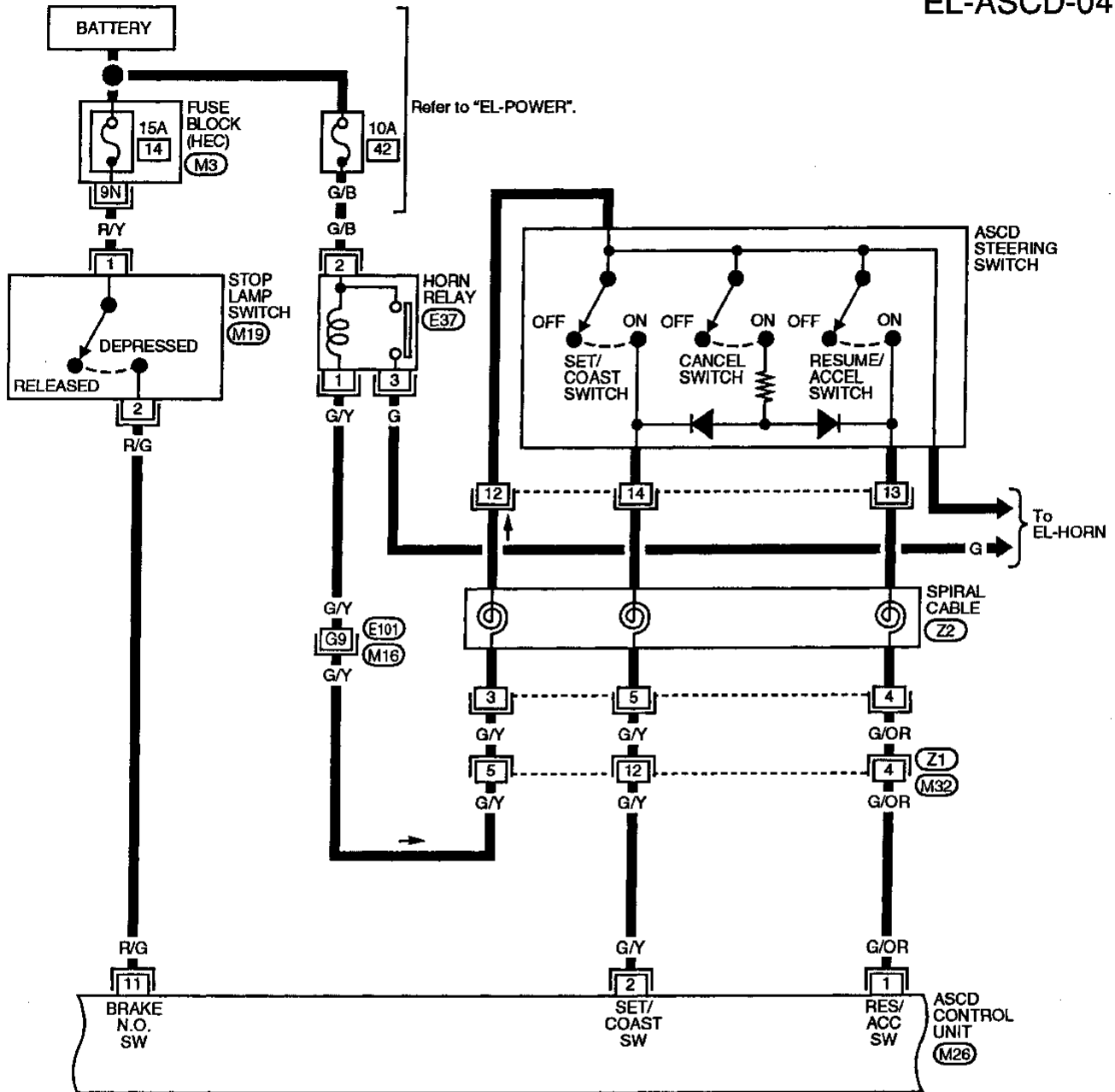

Refer to last page (Foldout page).

(M19), (E101)

(M3)

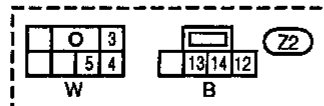
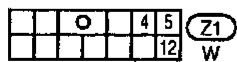
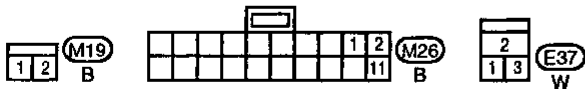

AUTOMATIC SPEED CONTROL DEVICE (ASCD)

Wiring Diagram -ASCD- (Cont'd)

EL-ASCD-05

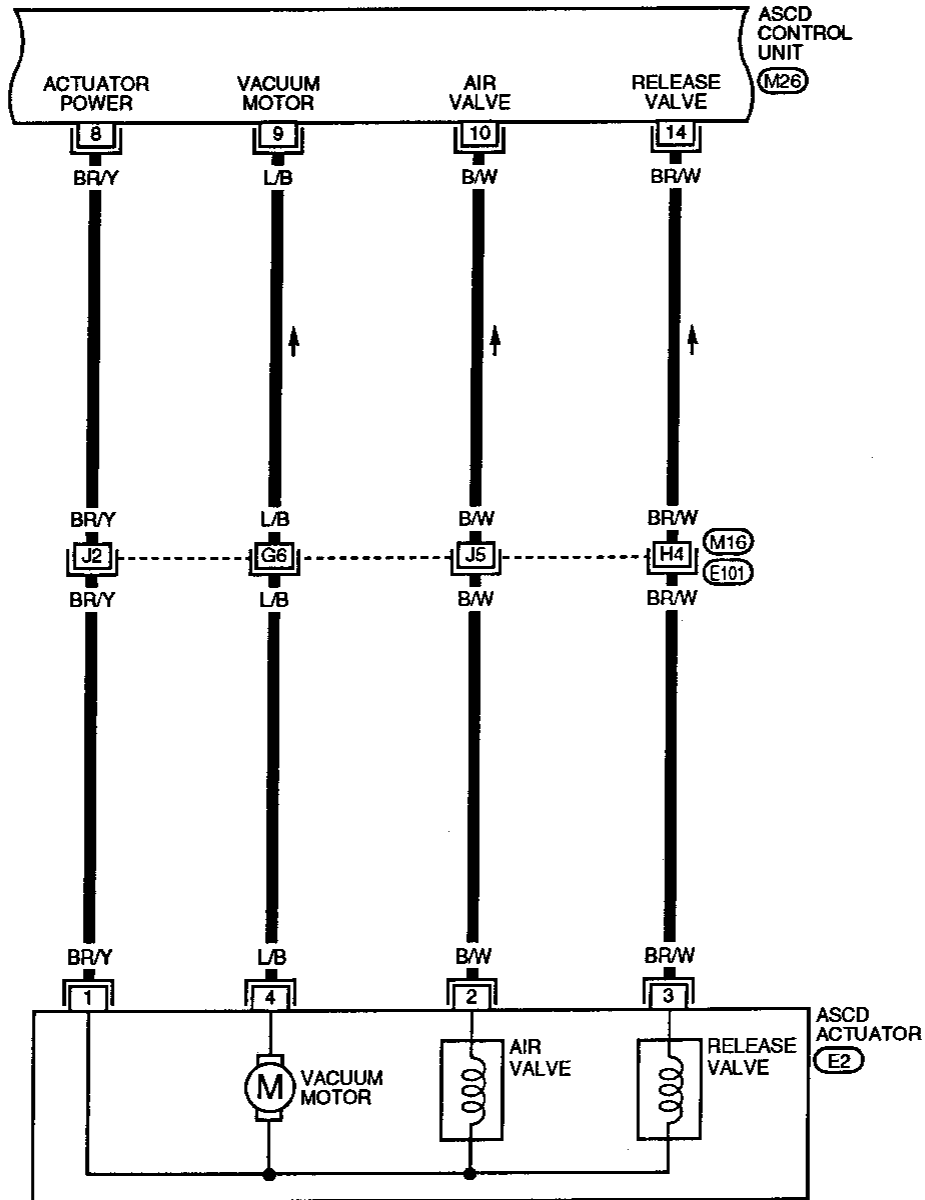

Refer to last page (Foldout page).
 (M16) . (E101)



CI
 MA
 EM
 LC
 EC
 FE
 CL
 MT
 AT
 FA
 RA
 BR
 ST
 RS
 BT
 FA
 EL
 IOX

AUTOMATIC SPEED CONTROL DEVICE (ASCD)

Wiring Diagram -ASCD- (Cont'd)

MODELS WITH TACHOMETER

EL-ASCD-06

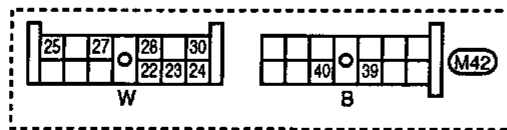
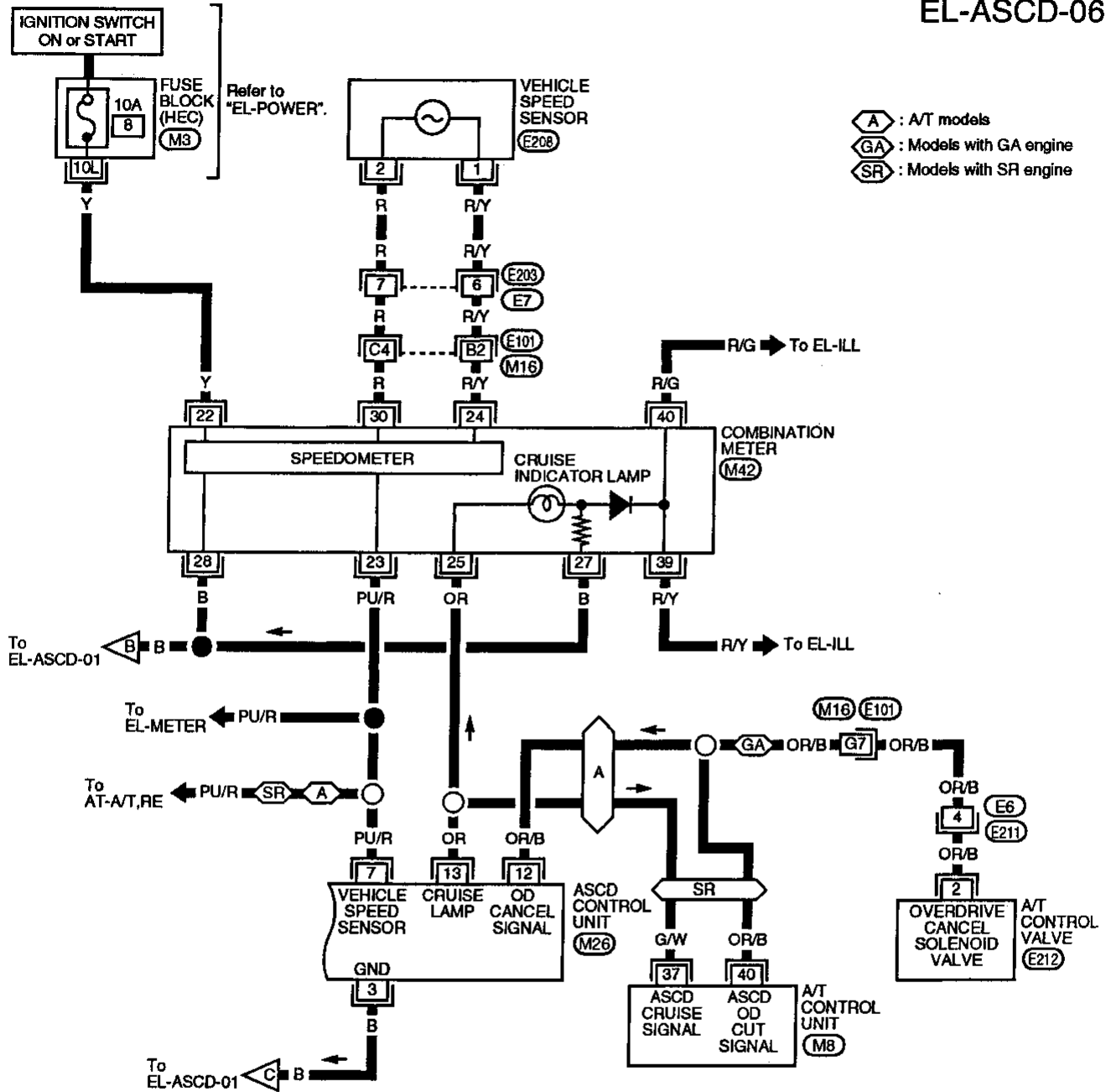

Refer to last page (Foldout page).

- M16 , E101
- M3
- M8

AUTOMATIC SPEED CONTROL DEVICE (ASCD)

Wiring Diagram -ASCD- (Cont'd)

MODELS WITHOUT TACHOMETER

EL-ASCD-07

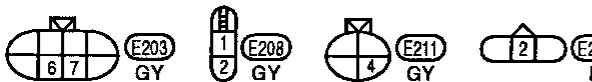
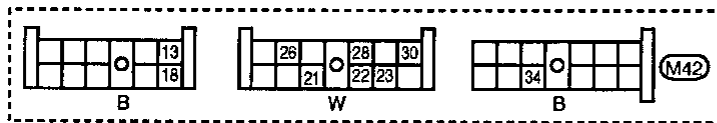
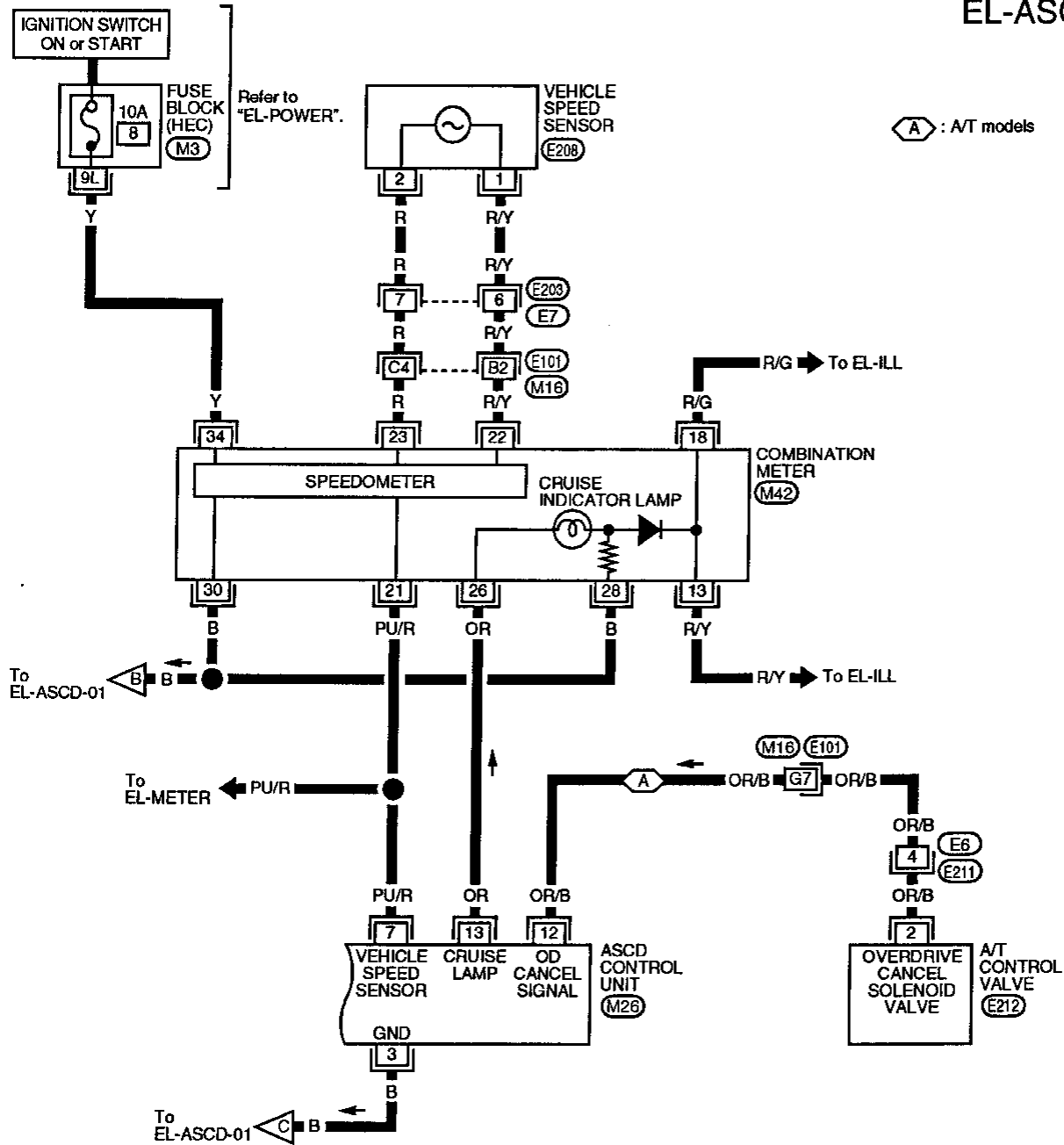

Refer to last page (Foldout page).

M16, E101
M3

GI

MA

EM

LC

EC

FE

CL

MT

AT

FA

RA

BR

ST

RS

BT

HA

EL

IDX

AUTOMATIC SPEED CONTROL DEVICE (ASCD)

Trouble Diagnoses

SYMPTOM CHART

PROCEDURE	Diagnostic Procedure								—	Electrical Components Inspection						
REFERENCE PAGE	EL-179	EL-181	EL-181	EL-181	EL-182	EL-183	EL-184	EL-185	EL-186	EL-187	EL-188	EL-188	EL-188	EL-188	EL-188	EL-189
SYMPTOM	Diagnostic Procedure 1	Diagnostic Procedure 2	Diagnostic Procedure 3	Diagnostic Procedure 4	Diagnostic Procedure 5	Diagnostic Procedure 6	Diagnostic Procedure 7	Diagnostic Procedure 8	ASCD Wire Adjustment	ASCD actuator/ASCD pump	ASCD main switch	ASCD steering switch	ASCD cancel switch and stop lamp switch	Clutch pedal position switch (M/T models)	Inhibitor switch (A/T models)	Vehicle speed sensor
ASCD control unit cannot be set properly.	○									○	○	○	○	○	○	○
Engine hunts.		○							○	○						
Large difference between set speed and actual vehicle speed.			○						○	○						
Deceleration is greatest immediately after ASCD has been set.				○					○	○						
ACCEL switch will not operate.	○				○							○				
RESUME switch will not operate.	○					○						○	○	○		
Set speed cannot be cancelled.							○		○	○			○	○		
"CRUISE" indicator lamp blinks.								○		○		○	○			

AUTOMATIC SPEED CONTROL DEVICE (ASCD)

Trouble Diagnoses (Cont'd)

DIAGNOSTIC PROCEDURE 1

SYMPTOM: ASCD control cannot be set.

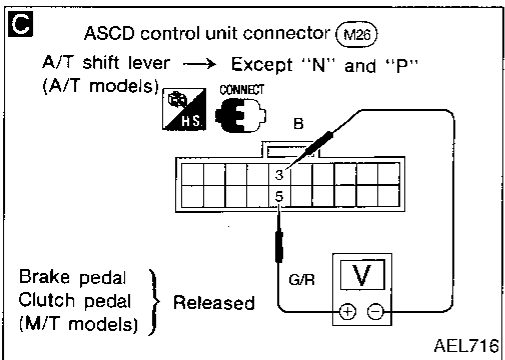
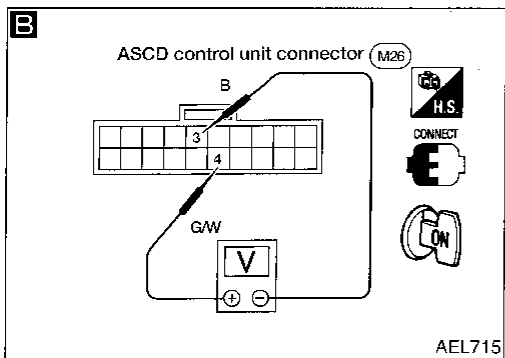
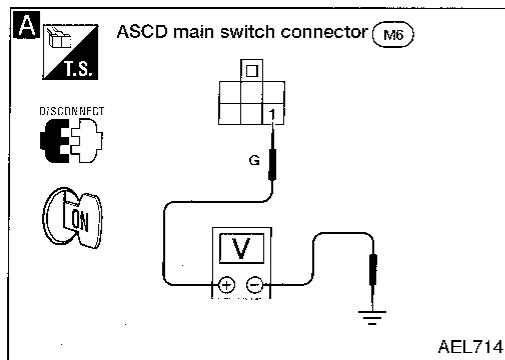

Turn ASCD main switch "OFF" and "ON" to make sure indicator illuminates.

A **CHECK POWER SUPPLY FOR ASCD MAIN SWITCH.**

1. Disconnect switch harness connector.
2. Does approx. 12 volts exist between switch harness terminal ① and body ground?

No → Check fuse and harness.

Yes → Check ASCD main switch. Refer to EL-188. Check ASCD hold relay.

B **CHECK POWER SUPPLY CIRCUIT FOR ASCD CONTROL UNIT.**

1. Turn ASCD main switch "ON".
2. Check voltage between ASCD control unit harness terminals ④ and ③.

Battery positive voltage should exist.

NG → Check continuity between ASCD control unit harness terminal ④ and ASCD hold relay terminal ③.

C **CHECK CUT-OFF CIRCUIT FOR ASCD CONTROL UNIT.**

Check voltage between ASCD control unit harness terminals ⑤ and ③.

Battery positive voltage should exist.

NG → Check ASCD cancel switch, ASCD clutch pedal position switch (M/T models) and inhibitor switch (A/T models). Refer to EL-188. Check inhibitor relay (A/T models).

Ⓐ (Next page)

GI
MA
EM
LG
EC
FE
CL
MT
AT
FA
RA
BR
ST
RS
BT
FA
EL
IDX

AUTOMATIC SPEED CONTROL DEVICE (ASCD)

Trouble Diagnoses (Cont'd)

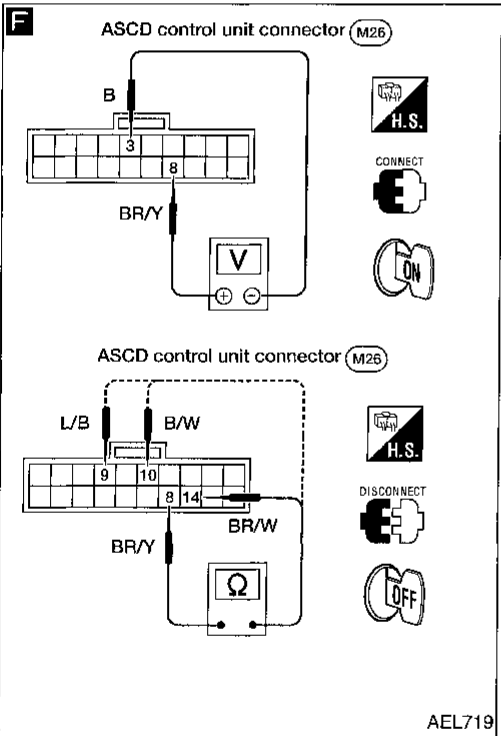
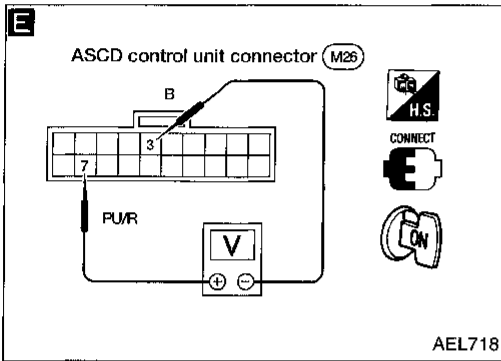
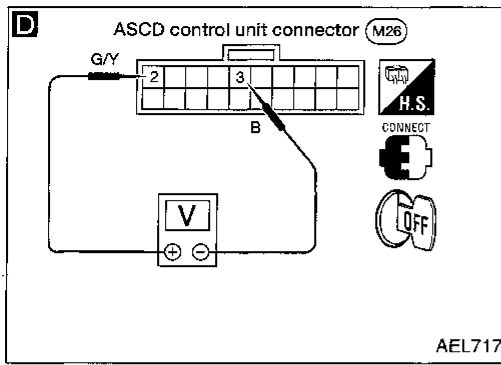

A

D **CHECK SET/COAST SWITCH CIRCUIT FOR ASCD CONTROL UNIT.**

1. Turn and keep on SET/COAST switch of ASCD steering switch.
2. Check voltage between ASCD control unit harness terminals ② and ③.

Battery positive voltage should exist.

NG → Does horn work?

No → Check fuse and horn relay.

Yes → Check ASCD steering switch. Refer to EL-188.

OK →

E **CHECK VEHICLE SPEED SENSOR CIRCUIT.**

1. Apply wheel chocks and jack up front of vehicle.
2. Connect voltmeter between ASCD control unit harness terminals ⑦ and ③.
3. Slowly turn front wheel.
4. Check deflection of voltmeter pointer.

NG → Check vehicle speed sensor. Refer to EL-189.

OK →

Check ASCD actuator/ASCD pump. Refer to EL-187.

NG → Replace ASCD actuator assembly.

OK →

F **CHECK ASCD ACTUATOR/ASCD PUMP CIRCUIT.**

1. Check voltage between ASCD control unit harness terminals ⑧ and ③. **Voltage is 0V.**
2. Disconnect ASCD control unit connector.
3. Measure resistance between ASCD control unit harness terminals ⑧ and ⑨, ⑩, ⑭.

Terminals	Resistance [Ω]	
⑧	⑨	Approx. 8 - 45
	⑩	Approx. 65
	⑭	Approx. 65

NG → Repair short or open circuit in ASCD actuator/ASCD pump harness.

OK →

Replace ASCD control unit.

AUTOMATIC SPEED CONTROL DEVICE (ASCD)

Trouble Diagnoses (Cont'd)

DIAGNOSTIC PROCEDURE 2

SYMPTOM: Engine hunts.

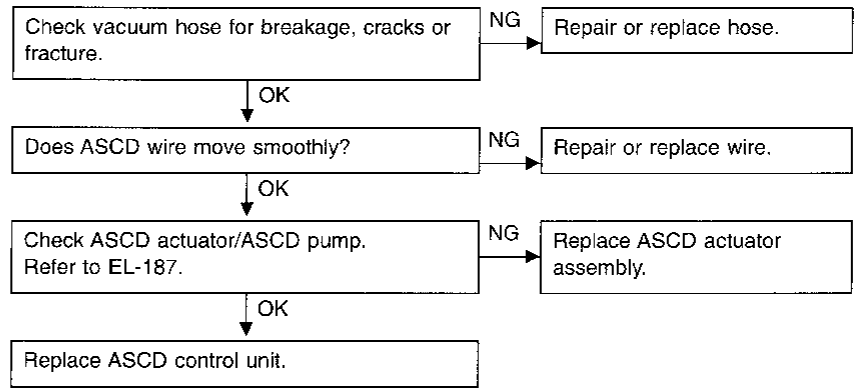

CI

MA

EM

LC

EC

DIAGNOSTIC PROCEDURE 3

SYMPTOM: Large difference between set vehicle speed and actual speed.

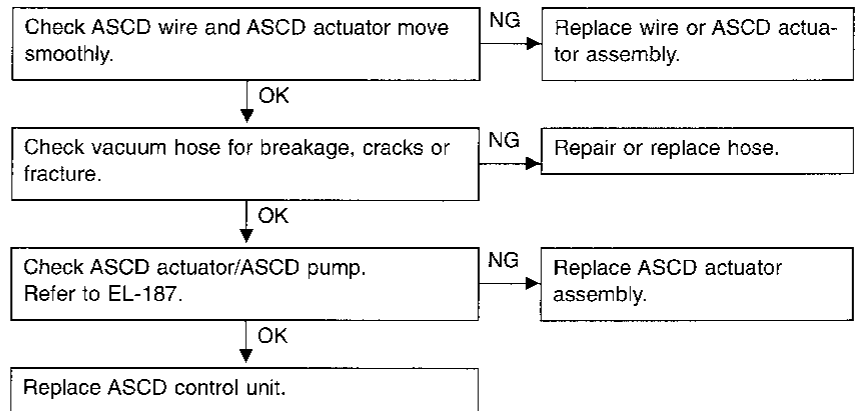

FE

CL

MT

AT

FA

RA

DIAGNOSTIC PROCEDURE 4

SYMPTOM: Deceleration is greatest immediately after ASCD has been set.

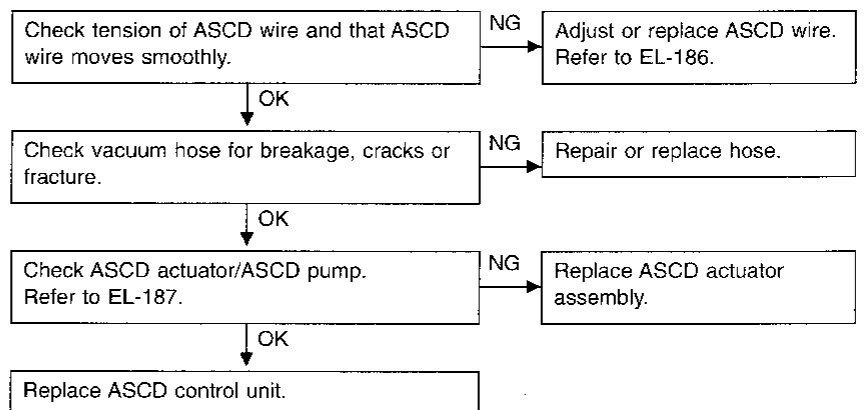

BR

ST

RS

BT

HA

EL

DX

AUTOMATIC SPEED CONTROL DEVICE (ASCD)

Trouble Diagnoses (Cont'd)

DIAGNOSTIC PROCEDURE 5

SYMPTOM: ACCEL switch will not operate.

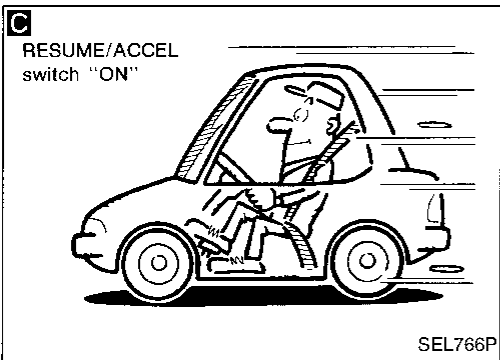
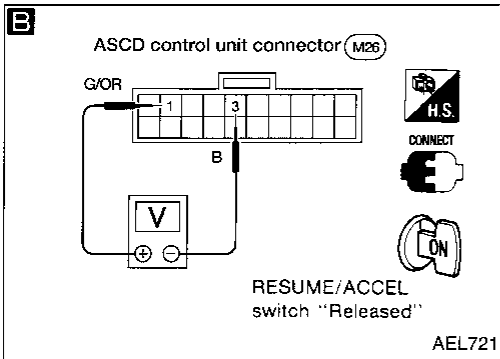
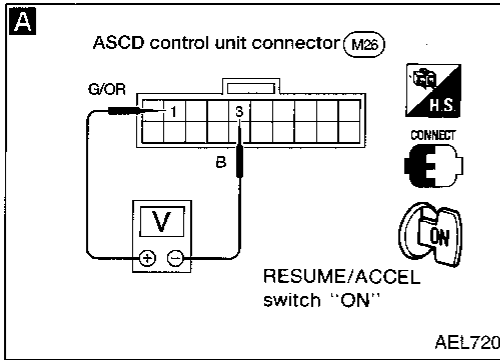

Check constant-speed function for operating using SET/COAST switch.

NG → Perform "DIAGNOSTIC PROCEDURE 1". Refer to EL-179.

OK

A

CHECK ACCEL SIGNAL.
Check voltage between ASCD control unit harness terminals ① and ③ after turning on and holding RESUME/ACCEL switch.
Battery positive voltage should exist.

NG → Check ASCD steering switch. Refer to EL-188.

OK

B

Check voltage between ASCD control unit harness terminals ① and ③ after releasing RESUME/ACCEL switch.
Voltage is 0V.

NG → Check ASCD steering switch. Refer to EL-188.

OK

C

CHECK IF ACCEL IS NOW FUNCTIONING.
Does vehicle accelerate when RESUME/ACCEL switch is turned on?

No → Replace ASCD control unit.

Yes

Does vehicle maintain the new (faster) speed when RESUME/ACCEL switch is released?

No → Replace ASCD control unit.

Yes

System is OK.

AUTOMATIC SPEED CONTROL DEVICE (ASCD)

Trouble Diagnoses (Cont'd)

DIAGNOSTIC PROCEDURE 6

SYMPTOM: RESUME switch will not operate.

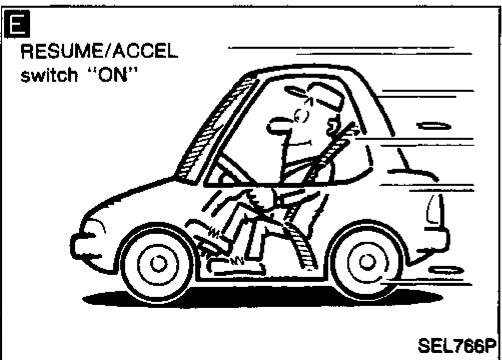
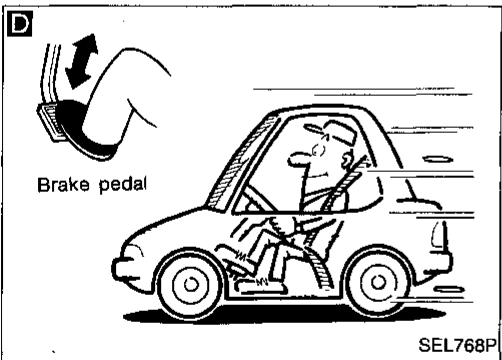
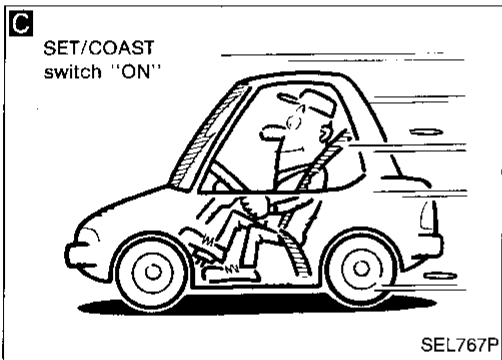
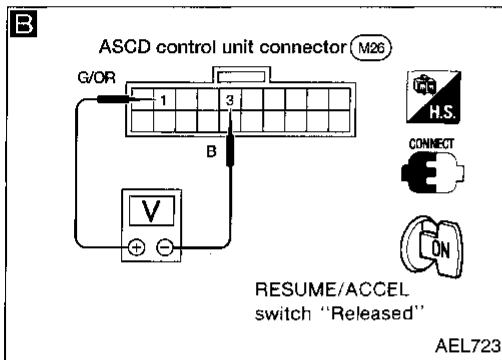
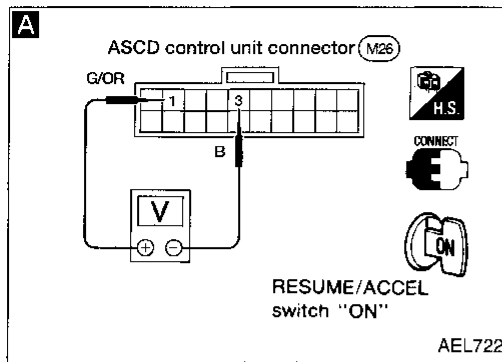

Check constant-speed function for operation using SET/COAST switch.

NG → Perform "DIAGNOSTIC PROCEDURE 1". Refer to EL-179.

OK ↓

A

CHECK RESUME SIGNAL.
Check voltage between ASCD control unit harness terminals ① and ③ after turning on and holding RESUME/ACCEL switch.

Battery positive voltage should exist.

NG → Check ASCD steering switch. Refer to EL-188.

OK ↓

B

Check voltage between ASCD control unit harness terminals ① and ③ after releasing RESUME/ACCEL switch.

Voltage is 0V.

NG → Check ASCD steering switch. Refer to EL-188.

OK ↓

C

CHECK IF RESUME IS NOW FUNCTIONING.
Set vehicle speed at 80 km/h (50 MPH) by turning on SET/COAST switch.

OK ↓

D

While cruising at set speed, depress and release brake pedal.

OK ↓

Does speed control disengage and "CRUISE" lamp turn off?

No → Check stop lamp switch, ASCD cancel switch and ASCD clutch pedal position switch (M/T models). Refer to EL-188.

Yes ↓

E

Above 48 km/h (30 MPH), press and release RESUME/ACCEL switch.

OK ↓

Does vehicle return to previously set speed [80 km/h (50 MPH)]?

No → Replace ASCD control unit.

Yes ↓

System is OK.

GI
MA
EM
LC
EC
FE
CL
MT
AT
FA
RA
BR
ST
RS
BT
HA
EL
IDX

AUTOMATIC SPEED CONTROL DEVICE (ASCD)

Trouble Diagnoses (Cont'd)

DIAGNOSTIC PROCEDURE 7

SYMPTOM: Set speed cannot be cancelled.

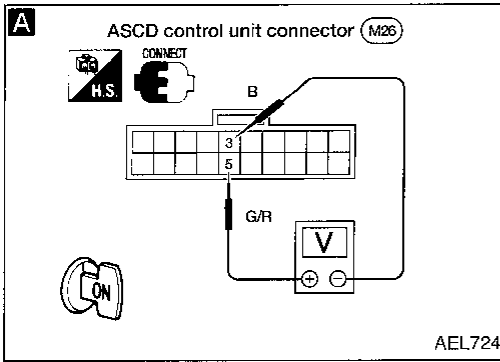

A

CHECK ASCD CANCEL, CLUTCH PEDAL POSITION, INHIBITOR SWITCH CIRCUIT.

1. Turn ASCD main switch on.
2. Check voltage between ASCD control unit harness terminals ⑤ and ③.

Conditions			Voltage [V]
ASCD cancel switch	Depressed		0
	Released		Approx. 12
M/T clutch pedal position switch	Depressed		0
	Released		Approx. 12
A/T	A/T shift lever position is at any position except N or P.		Approx. 12
	A/T shift lever position is at N or P.		0

NG → Check ASCD cancel, clutch pedal position, and inhibitor switch. Refer to EL-188.

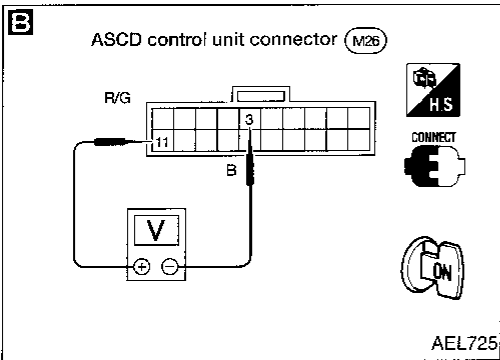

B

CHECK STOP LAMP SWITCH CIRCUIT.

Check voltage between ASCD control unit harness terminals ⑪ and ③.

Condition		Voltage [V]
Stop lamp switch	Depressed	Approx. 12
	Released	0

NG → Check stop lamp switch. Refer to EL-188.

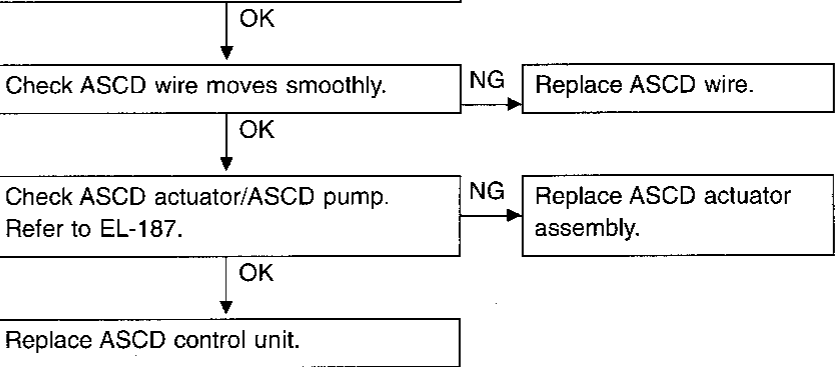

AUTOMATIC SPEED CONTROL DEVICE (ASCD)

Trouble Diagnoses (Cont'd)

DIAGNOSTIC PROCEDURE 8

SYMPTOM: "CRUISE" indicator lamp blinks.

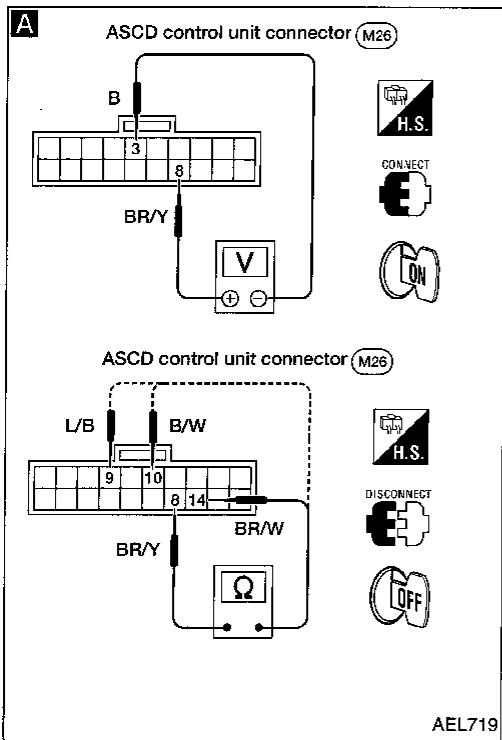
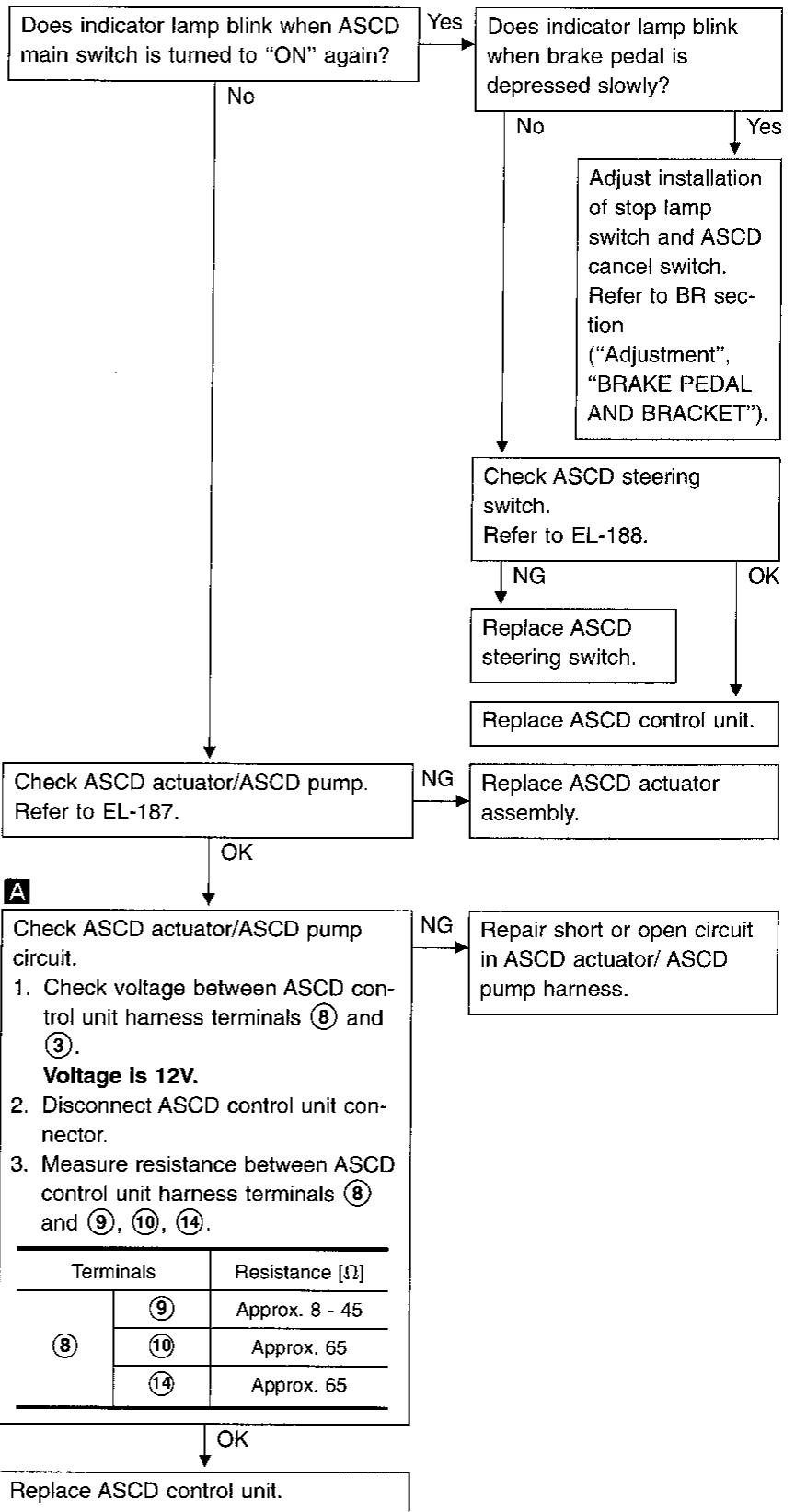

AEL719

Terminals	Resistance [Ω]	
⑧	⑨	Approx. 8 - 45
	⑩	Approx. 65
	⑭	Approx. 65

AUTOMATIC SPEED CONTROL DEVICE (ASCD)

Trouble Diagnoses (Cont'd) ASCD WIRE ADJUSTMENT

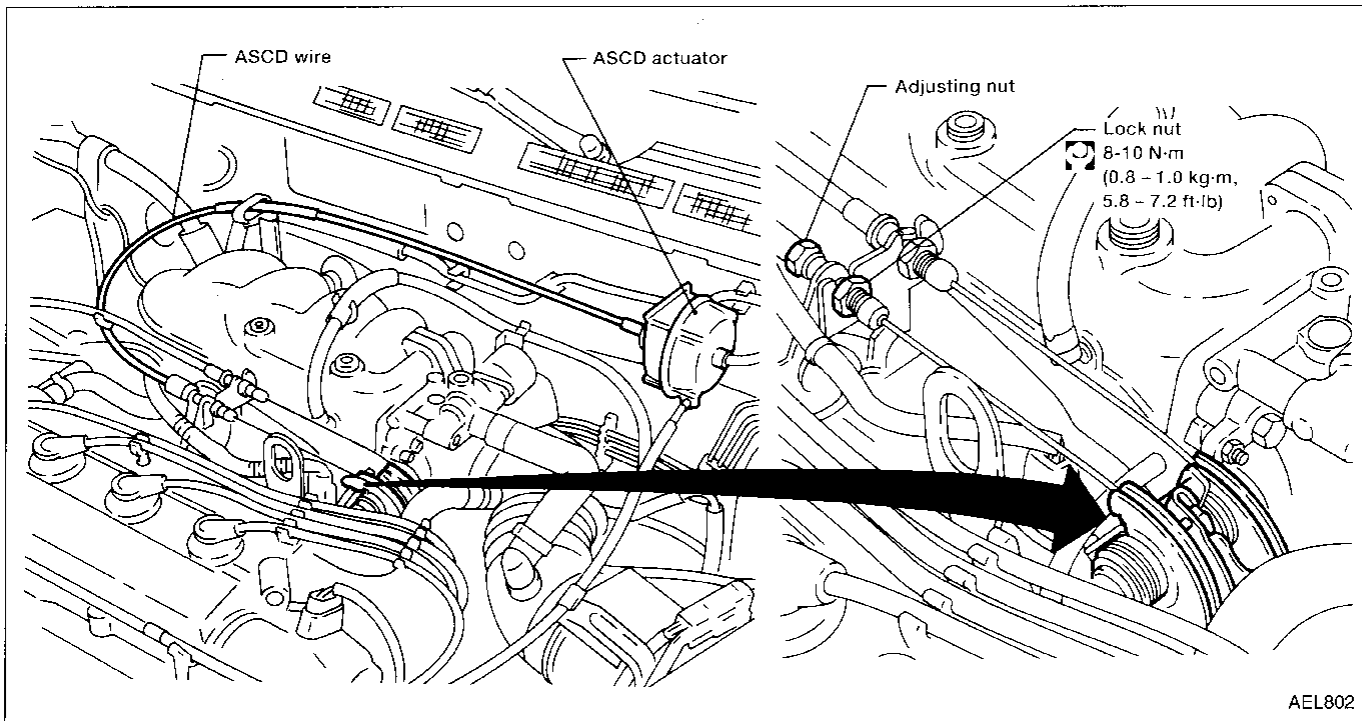

CAUTION:

- Be careful not to twist ASCD wire when removing it.
- Do not overly tighten ASCD wire during adjustment.

Confirm that accelerator wire is properly adjusted.

- For accelerator cable adjustment, refer to FE section ("Adjusting Accelerator Cable", "ACCELERATOR CONTROL SYSTEM").

Adjust the ASCD wire as follows:

1. Loosen lock nut and tighten adjusting nut until throttle drum starts to move.
2. From that position turn back adjusting nut 0.5 to 1 turn, and secure lock nut.

(This prevents a delay in the operation of the ASCD.)

- For ASCD cancel switch adjustment, refer to BR and CL sections ("Adjustment", "BRAKE PEDAL AND BRACKET" and "Adjusting Clutch Pedal", "INSPECTION AND ADJUSTMENT", respectively).

AUTOMATIC SPEED CONTROL DEVICE (ASCD)

Trouble Diagnoses (Cont'd)

ELECTRICAL COMPONENTS INSPECTION

ASCD actuator/ASCD pump

1. Disconnect ASCD actuator/ASCD pump connector.
2. Check ASCD actuator/ASCD pump operations as shown.

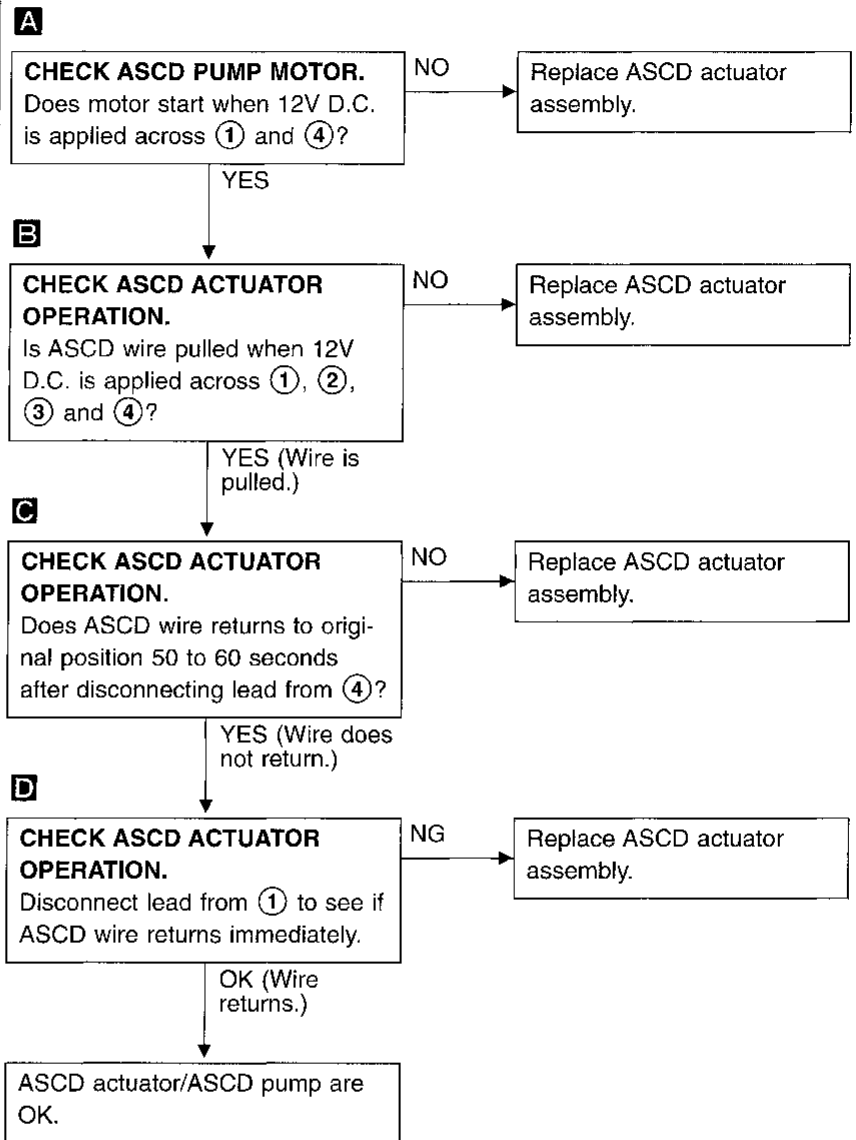
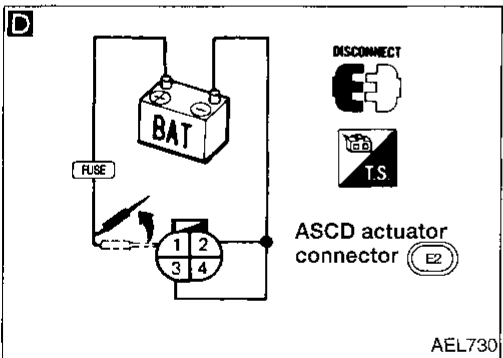
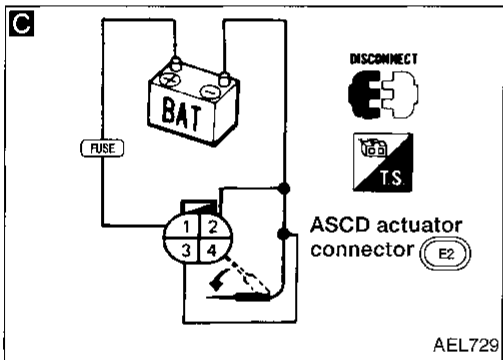
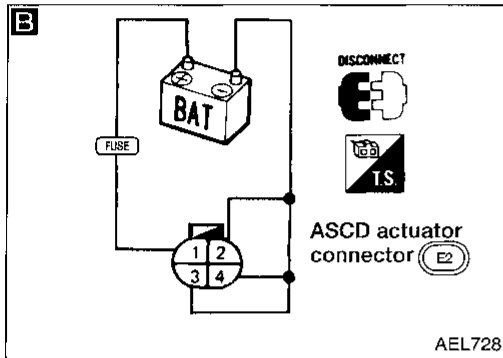
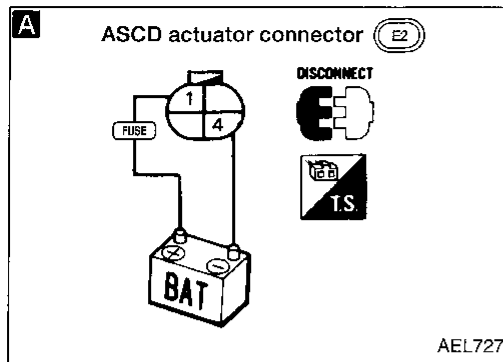

GI
MA
EM
LC
EC
FE
CL
MT
AT
FA
PA
BR
ST
RS
BT
HA
EL
IDX

AUTOMATIC SPEED CONTROL DEVICE (ASCD)

Trouble Diagnoses (Cont'd)

ASCD main switch

Check continuity between terminals by pushing switch to each position.

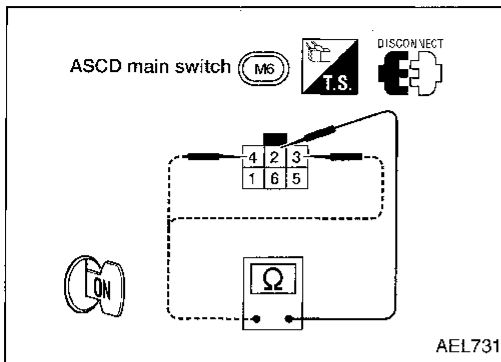

AEL731

Switch position	Terminal					
	1	2	3	4	5	6
ON	○	○	○	○		
N		○	○	○		ILL. ○
OFF						

ASCD steering switch

Check continuity between terminals by pushing each button.

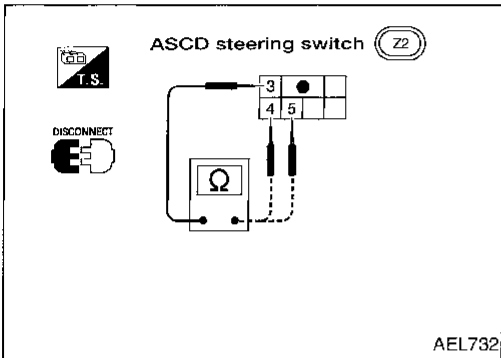

AEL732

Button	Terminal		
	3	5	4
SET/COAST	○	○	
RESUME/ACCEL	○		○
CANCEL	○	▶	○
	○	▶	○

ASCD cancel switch and stop lamp switch

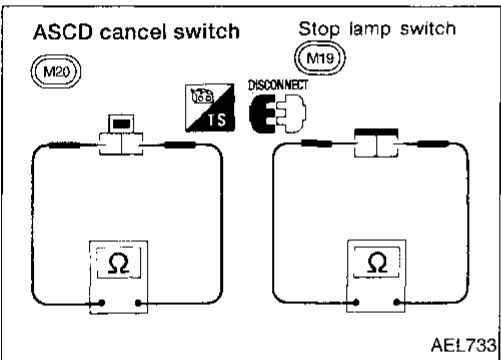

AEL733

Condition	Continuity	
	ASCD cancel switch	Stop lamp switch
When brake pedal is depressed	No	Yes
When brake pedal is released	Yes	No

Check each switch after adjusting brake pedal — refer to BR section (“Adjustment”, “BRAKE PEDAL AND BRACKET”).

ASCD clutch pedal position switch (For M/T models)

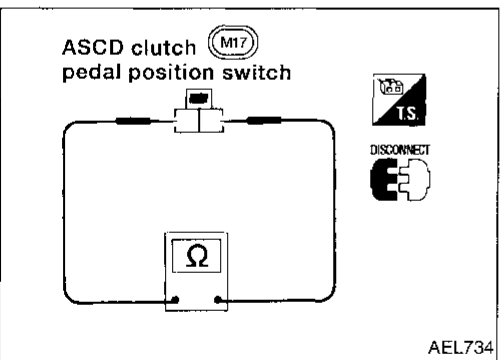

AEL734

Condition	Continuity
When clutch pedal is depressed	No
When clutch pedal is released	Yes

Check switch after adjusting clutch pedal — refer to CL section (“Adjusting Clutch Pedal”, “INSPECTION AND ADJUSTMENT”).

Inhibitor switch (For A/T models)

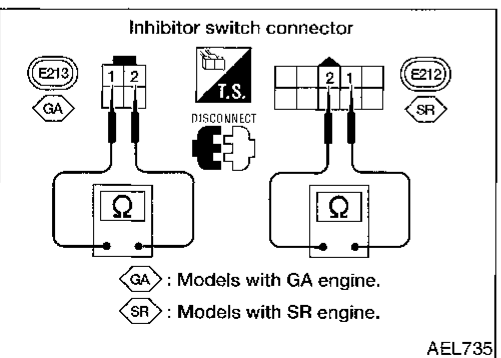

AEL735

Shift lever position	Terminal	
	1	2
“P”	○	○
“N”	○	○
Except “N” or “P”		

AUTOMATIC SPEED CONTROL DEVICE (ASCD)

Trouble Diagnoses (Cont'd)

Vehicle speed sensor

- 1 Remove vehicle speed sensor from transaxle.
- 2 Turn vehicle speed sensor pinion quickly and measure voltage across terminals ② and ①.

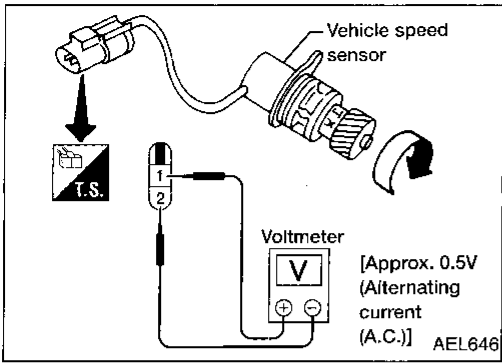

GI

MA

EM

LC

EC

FE

CL

MT

AT

FA

RA

BR

ST

RS

BT

HA

EL

IDX

THEFT WARNING SYSTEM

System Description

Refer to Owner's Manual for theft warning system operating instructions.

Power is supplied at all times:

- through 30A fusible link (letter **I** , located in the fusible link and fuse box)
- to ignition switch terminal **①**.

With the ignition switch in the ON or START position, power is supplied:

- through 10A fuse (No. **21** , located in the fuse block [HEC])
- to theft warning relay terminals **①** and **③** (A/T models)
- to theft warning relay terminal **①** (M/T models for U.S.A. and Canada).

With the ignition switch in the START position, power is supplied:

- from terminal **⑤** of the ignition switch
- to clutch interlock relay terminal **③** (M/T models for U.S.A.) or
- to theft warning relay terminal **③** (M/T models for Canada)
- to inhibitor relay terminal **⑥** (A/T models).

With the ignition switch in the START position, power is supplied:

- through 7.5A fuse (No. **26** , located in the fuse block [HEC])
- to theft warning relay terminal **③** (M/T models for U.S.A.).

Power is supplied at all times:

- through 7.5A fuse (No. **43** , located in the fusible link and fuse box)
- to horn relay-2 terminals **①** and **③**.

Power is supplied at all times:

- through 25A fusible link (letter **f** , located in the fusible link and fuse box)
- to circuit breaker terminal **①**
- through circuit breaker terminal **②**
- to smart entrance control unit terminal **①**.

Power is supplied at all times:

- through 15A fuses (No. **39** and **40** , located in the fusible link and fuse box)
- to theft warning lamp relay terminals **③** and **⑥**.

Power is supplied at all times:

- through 10A fuse (No. **42** , located in the fusible link and fuse box)
- to horn relay terminal **②**.

Power is supplied at all times:

- through 7.5A fuse (No. **24** , located in the fuse block [HEC])
- to security indicator lamp terminal **③7**
- to key switch terminal **①**.

With the ignition switch in the ON or START position, power is supplied:

- through 7.5A fuse (No. **7** , located in the fuse block [HEC])
- to smart entrance control unit terminal **⑪**.

With the ignition switch in the ACC or ON position, power is supplied:

- through 15A fuse (No. **10** , located in the fuse block [HEC])
- to smart entrance control unit terminal **⑰**.

Ground is supplied:

- to smart entrance control unit terminal **⑩**
- through body grounds **M43** , **M44** and **M60** .

THEFT WARNING SYSTEM ACTIVATION (Without key or remote controller used to lock doors)

The operation of the theft warning system is controlled by the doors, hood and trunk lid.

To activate the theft warning system, the ignition key must be removed, doors, hood and trunk closed, and the doors locked.

When a door is open, smart entrance control unit terminal **⑯** receives a ground signal from door switches.

When a door is unlocked, smart entrance control unit terminal **⑫** , **⑬** or **⑭** receives a ground signal:

- from terminal **④** of all the door unlock sensors
- through body grounds **M43** , **M44** and **M60** .

When the hood is open, smart entrance control unit terminal **⑲** receives a ground signal:

- from terminal **①** of the hood switch
- through body grounds **E13** and **E25** .

THEFT WARNING SYSTEM

System Description (Cont'd)

When the trunk lid is open, smart entrance control unit terminal ②⑥ receives a ground signal:

- from terminal ① of the trunk room lamp switch
- through body grounds ①⑨ and ①⑩.

If none of the described conditions exist, the theft warning system will activate automatically.

THEFT WARNING SYSTEM ACTIVATION (With key or remote controller used to lock doors)

If the key or remote controller is used to lock doors, terminal ③⑩ receives a ground signal:

- from terminal ① of the door key cylinder switch LH
- from terminal ② of the door key cylinder switch RH
- through body grounds ①④③, ①④④ and ①⑥①.

If this signal is received by the smart entrance control unit, the theft warning system will activate automatically.

With the theft warning system activated, smart entrance control unit terminal ③③ supplies ground to of the security indicator lamp.

The security lamp will illuminate for approximately 30 seconds and then go out.

THEFT WARNING SYSTEM OPERATION

The theft warning system is triggered by:

- opening a door or the trunk lid without using the key
- opening the hood
- tampering with the key cylinder in the door.

Once the theft warning system has been activated, it will be triggered if the smart entrance control unit receives a ground signal at terminal ①⑤, ①⑥, ②⑥ or ②⑨. Also, when a door key tamper signal is received at the smart entrance control unit, the system will be triggered. The headlamps flash and the horn sounds intermittently, and the starting system is interrupted.

When a door key cylinder switch has been tampered with, smart entrance control unit terminal ②⑧ receives a ground signal:

- from terminal ③ of the front LH or RH key cylinder switch
- through body grounds ①④③, ①④④ and ①⑥①.

If the theft warning system is triggered, ground is supplied:

- from terminal ③② of the smart entrance control unit
- to theft warning relay terminal ②.

With power and ground supplied, power to the clutch interlock relay (M/T models for U.S.A.), inhibitor relay (A/T models) or starter motor (M/T models for Canada) is interrupted. The starter motor will not crank and the engine will not start.

When the theft warning system is triggered, ground is supplied intermittently:

- from terminal ⑧ of the smart entrance control unit
- to theft warning lamp relay terminal ② and
- to horn relay-2 terminal ②.

The headlamps flash and the horn sounds intermittently.

The alarm automatically turns off after 2 or 3 minutes but will reactivate if the vehicle is tampered with again.

THEFT WARNING SYSTEM DEACTIVATION

To deactivate the theft warning system, a door or the trunk lid must be unlocked with the key or remote controller.

When the key is used to unlock a door, smart entrance control unit terminal ③① receives a ground signal:

- from terminal ② of the LH key cylinder switch
- from terminal ① of the RH key cylinder switch.

When the key is used to unlock the trunk lid, smart entrance control unit terminal ②⑦ receives a ground signal from terminal ① of the trunk key cylinder switch.

When the smart entrance control unit receives either one of these signals, the theft warning system is deactivated.

GI
MA
EM
LC
EC
FE
CL
MT
AT
FA
RA
BR
ST
RS
BT
HA
EL
IDX

THEFT WARNING SYSTEM

System Description (Cont'd)

PANIC ALARM OPERATION

Multi-remote control system may or may not operate theft warning system (horn and headlamps) as required.

When the multi-remote control system is triggered, ground is supplied intermittently:

- from smart entrance control unit terminal ⑧
- to theft warning lamp relay terminal ② and
- to horn relay-2 terminal ②.

The headlamp flashes and the horn sounds intermittently:

The alarm automatically turns off after 30 seconds or when smart entrance control unit receives any signal from multi-remote controller.

THEFT WARNING SYSTEM

Component Parts and Harness Connector Location

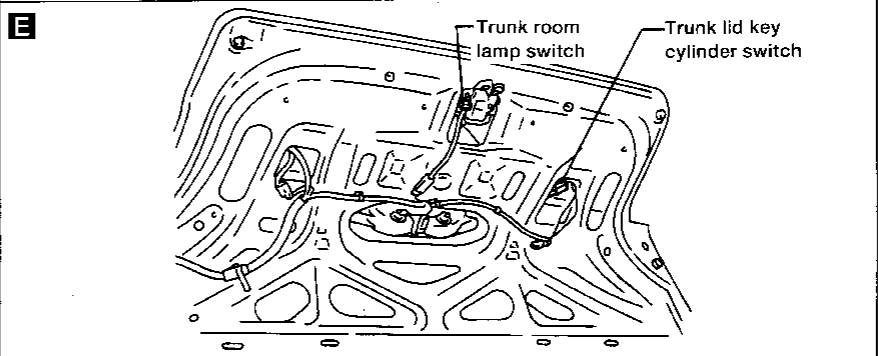
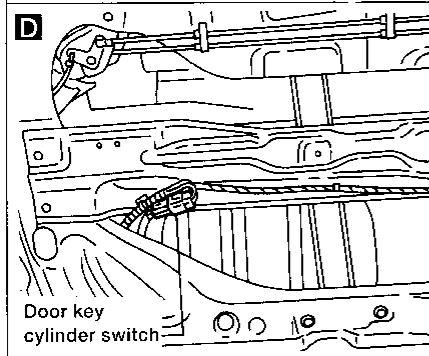
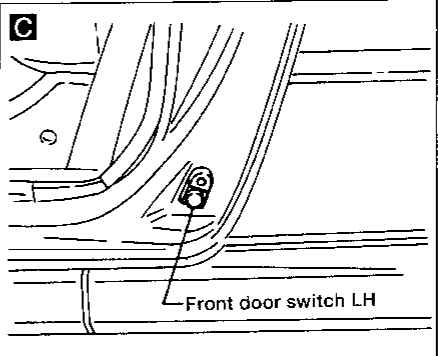
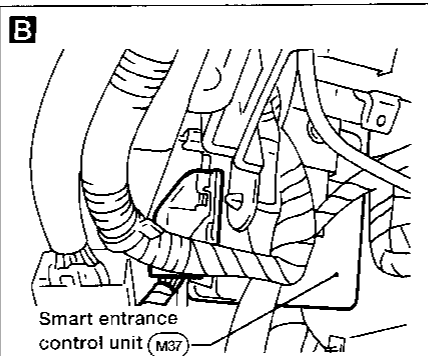
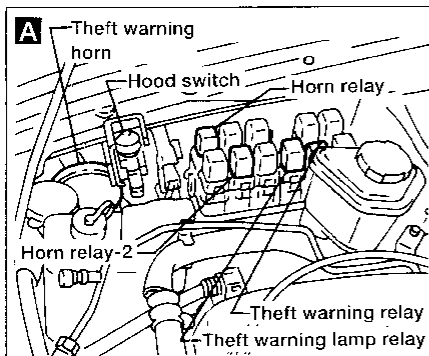
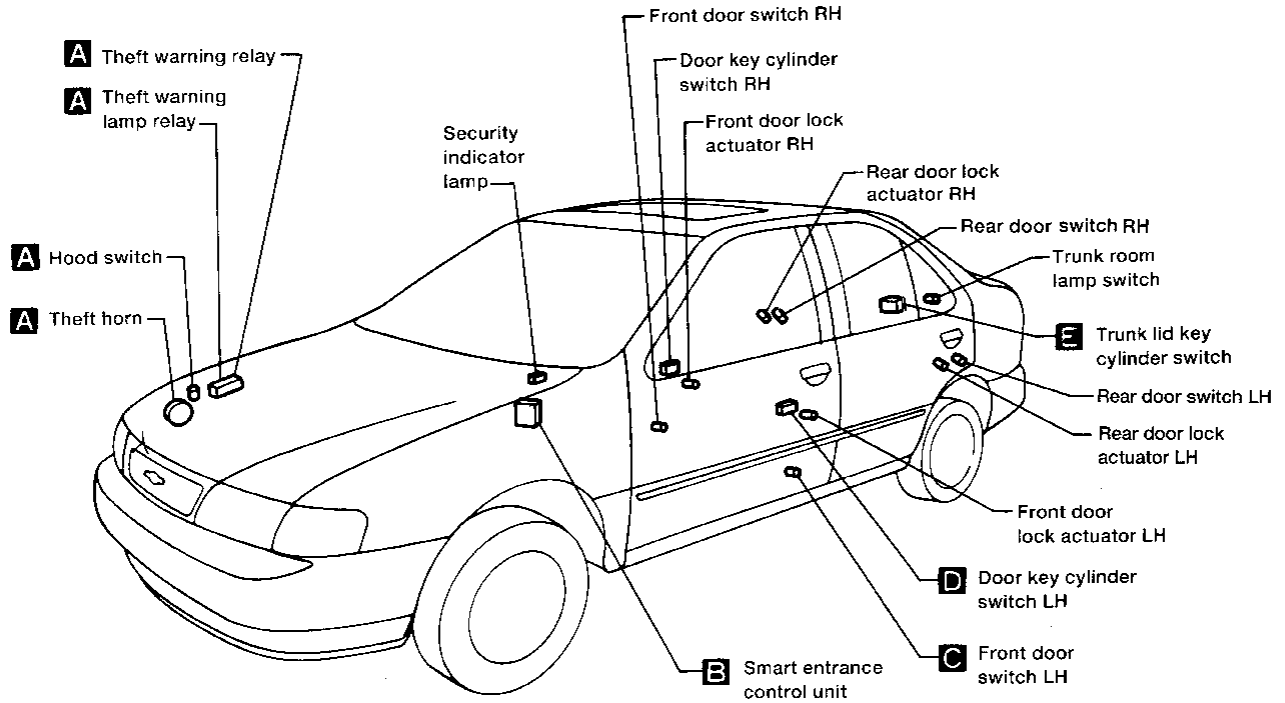

GI
MA
EM
LC
EC
FE
CL
MT
AT
FA
RA
BR
ST
RS
BT
HA
EL
IDX

THEFT WARNING SYSTEM

Schematic

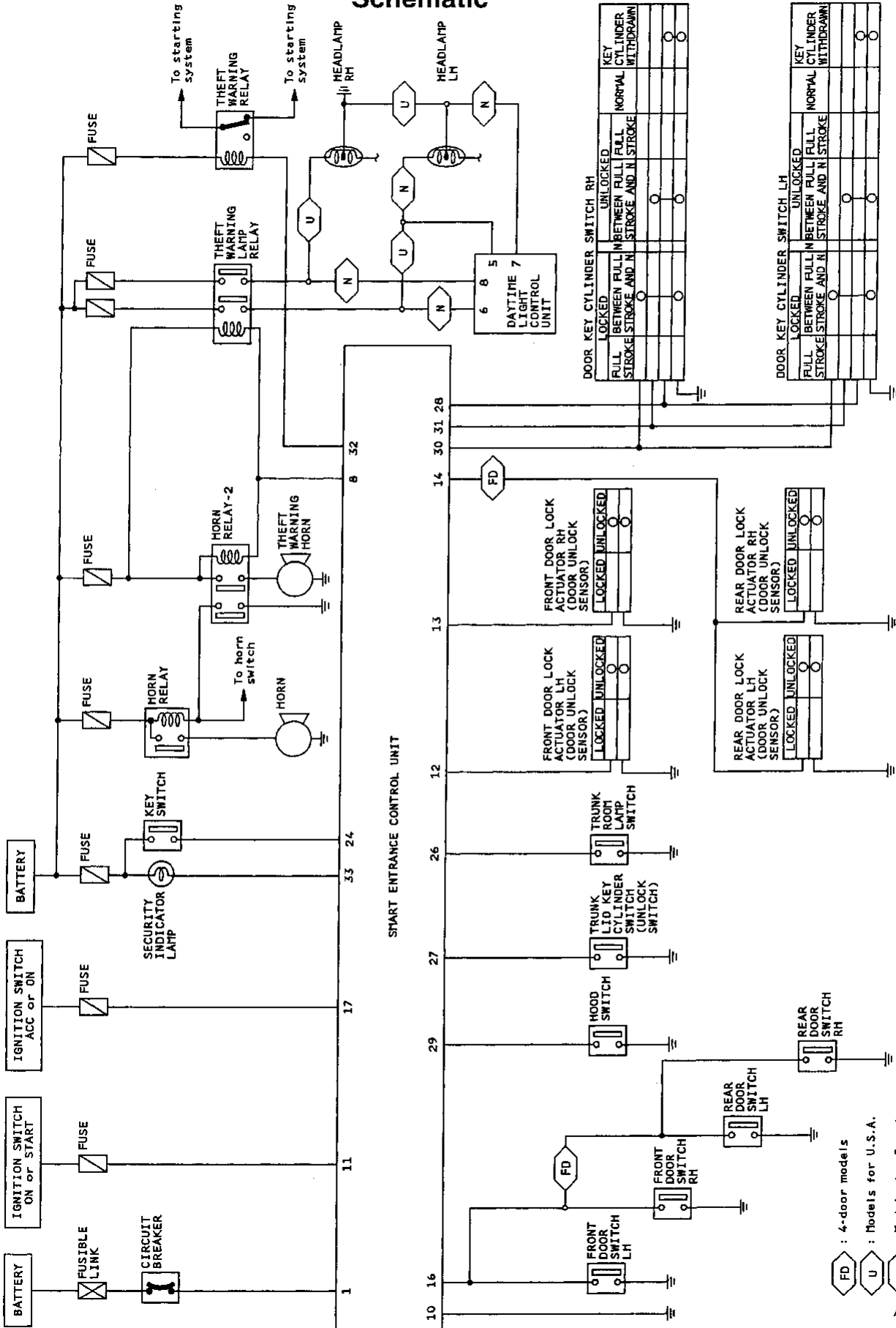

EL-194

AEL597

THEFT WARNING SYSTEM

Wiring Diagram -THEFT- (Cont'd)

EL-THEFT-02

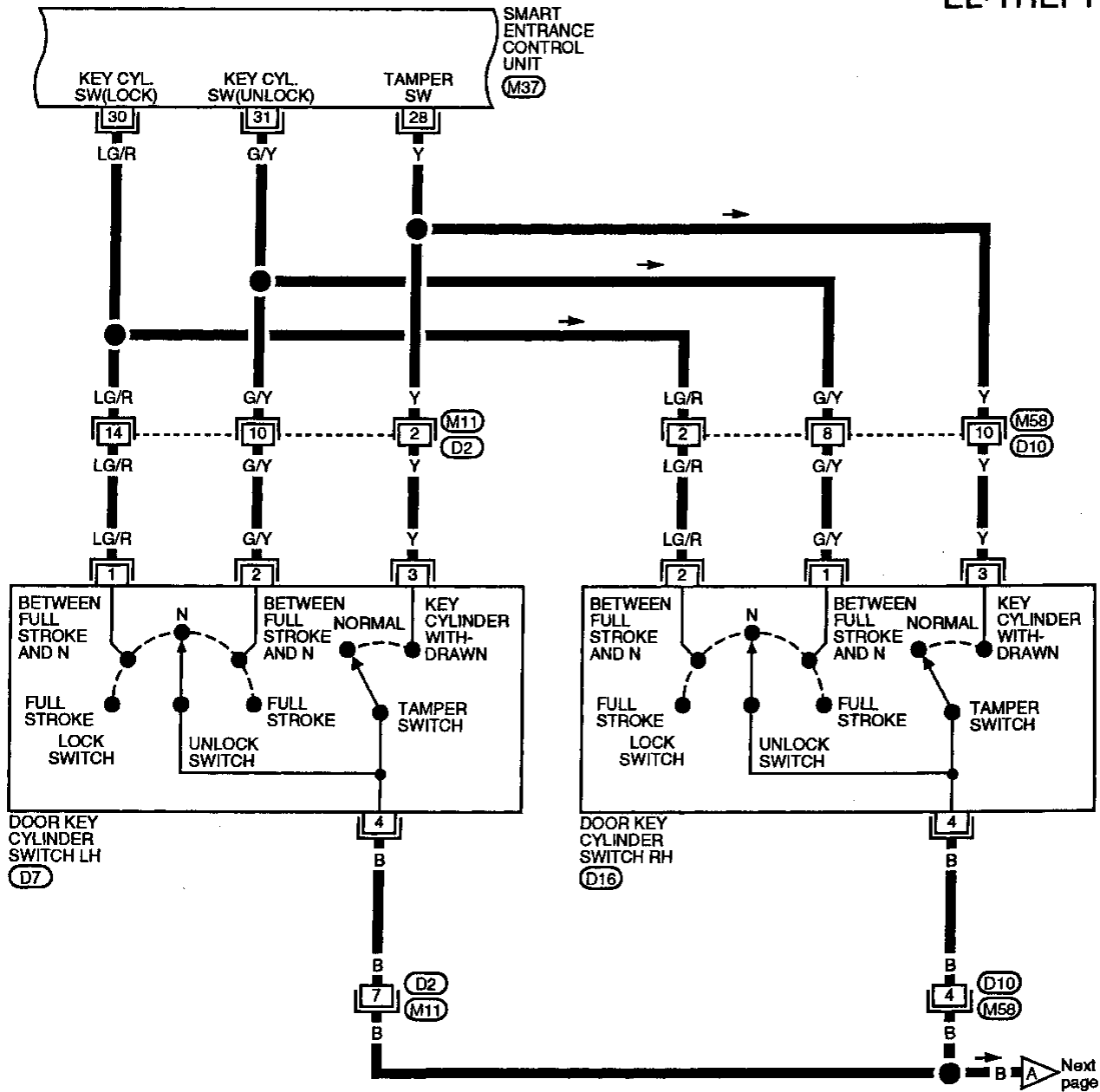

Refer to last page (Foldout page).

(M37)

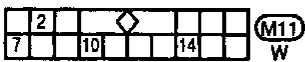

THEFT WARNING SYSTEM

Wiring Diagram -THEFT- (Cont'd)

EL-THEFT-03

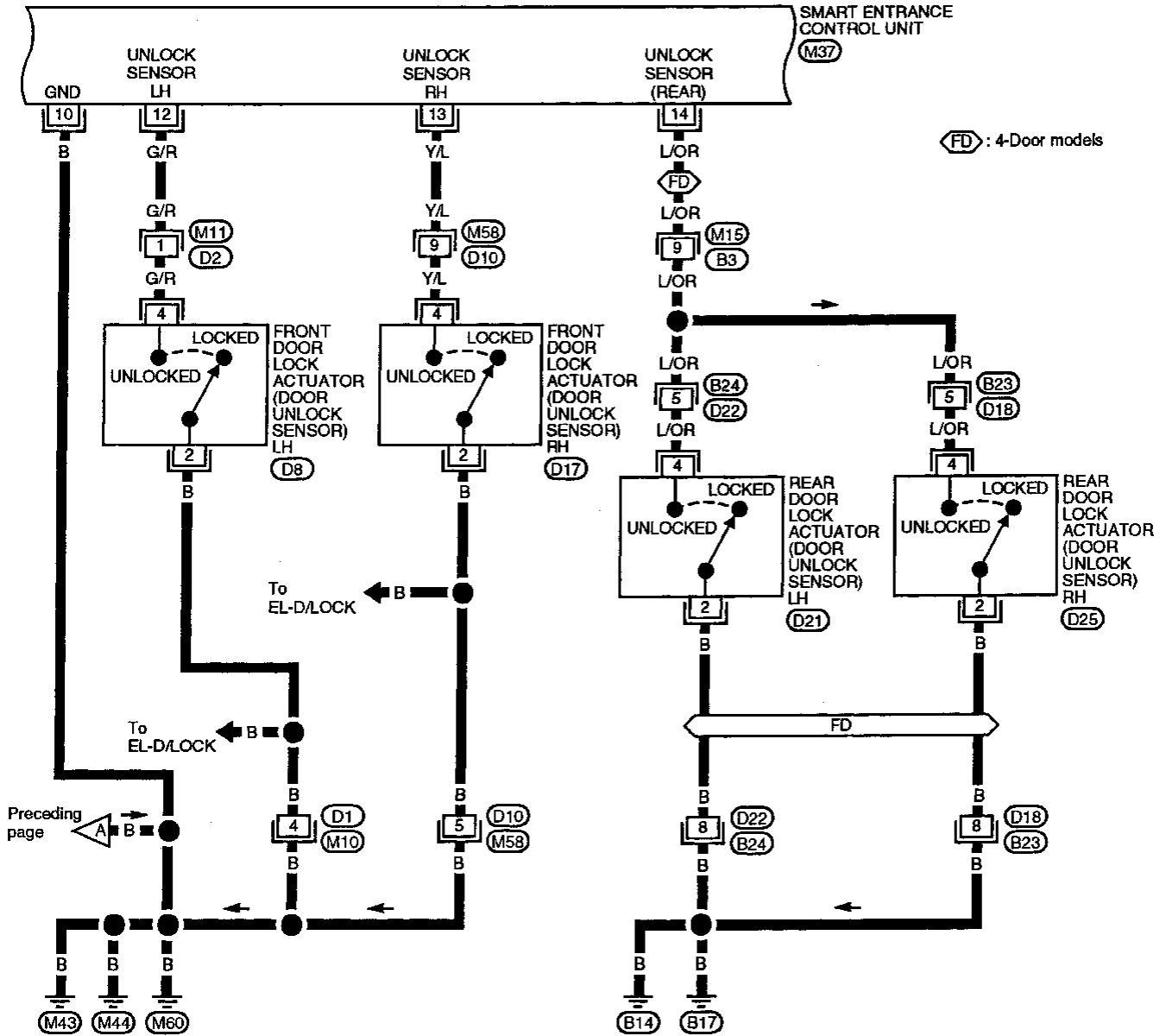

Refer to last page (Foldout page).
M37

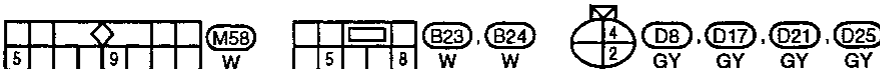

GI
MA
EM
LC
EC
FE
CL
MT
AT
FA
RA
BR
ST
RS
BT
HA
EL
DX

THEFT WARNING SYSTEM

Wiring Diagram -THEFT- (Cont'd)

EL-THEFT-05

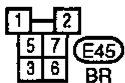
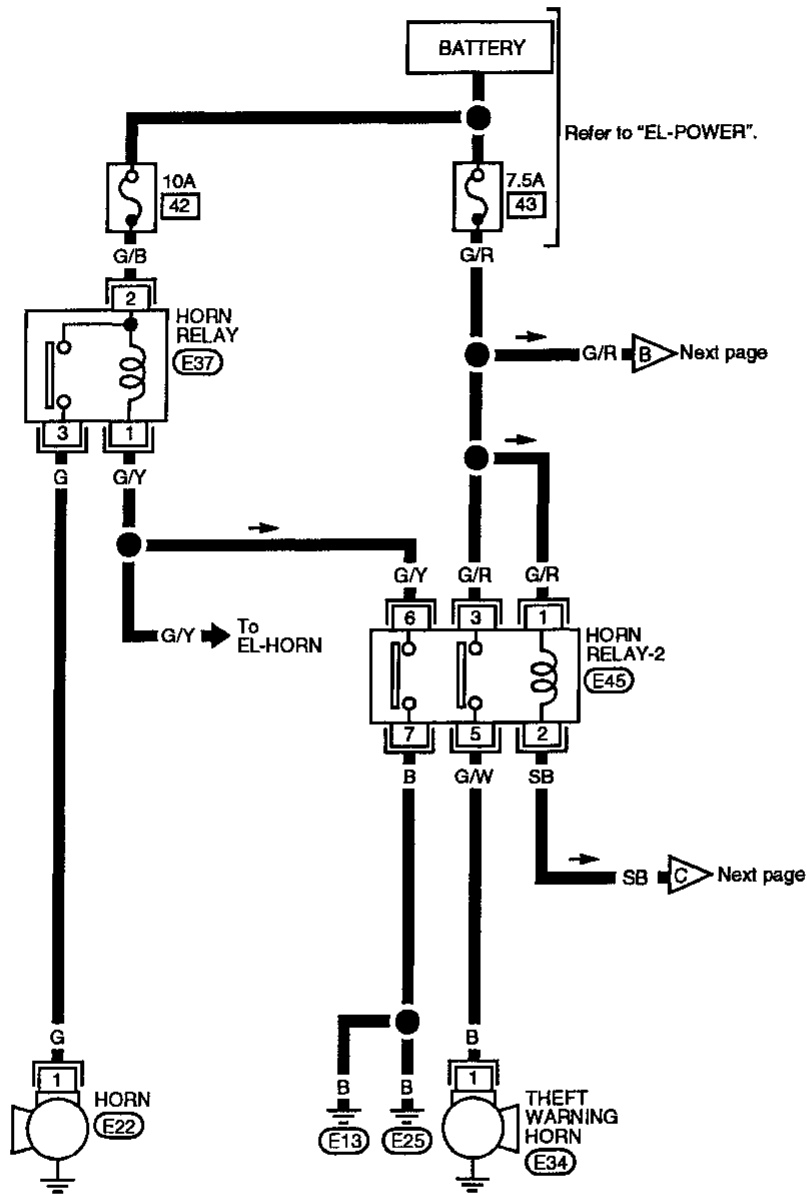

GI
MA
EM
LC
EC
FE
CL
MT
AT
FA
RA
BR
ST
RS
BT
HA
EL
IDX

THEFT WARNING SYSTEM

Wiring Diagram -THEFT- (Cont'd)

EL-THEFT-06

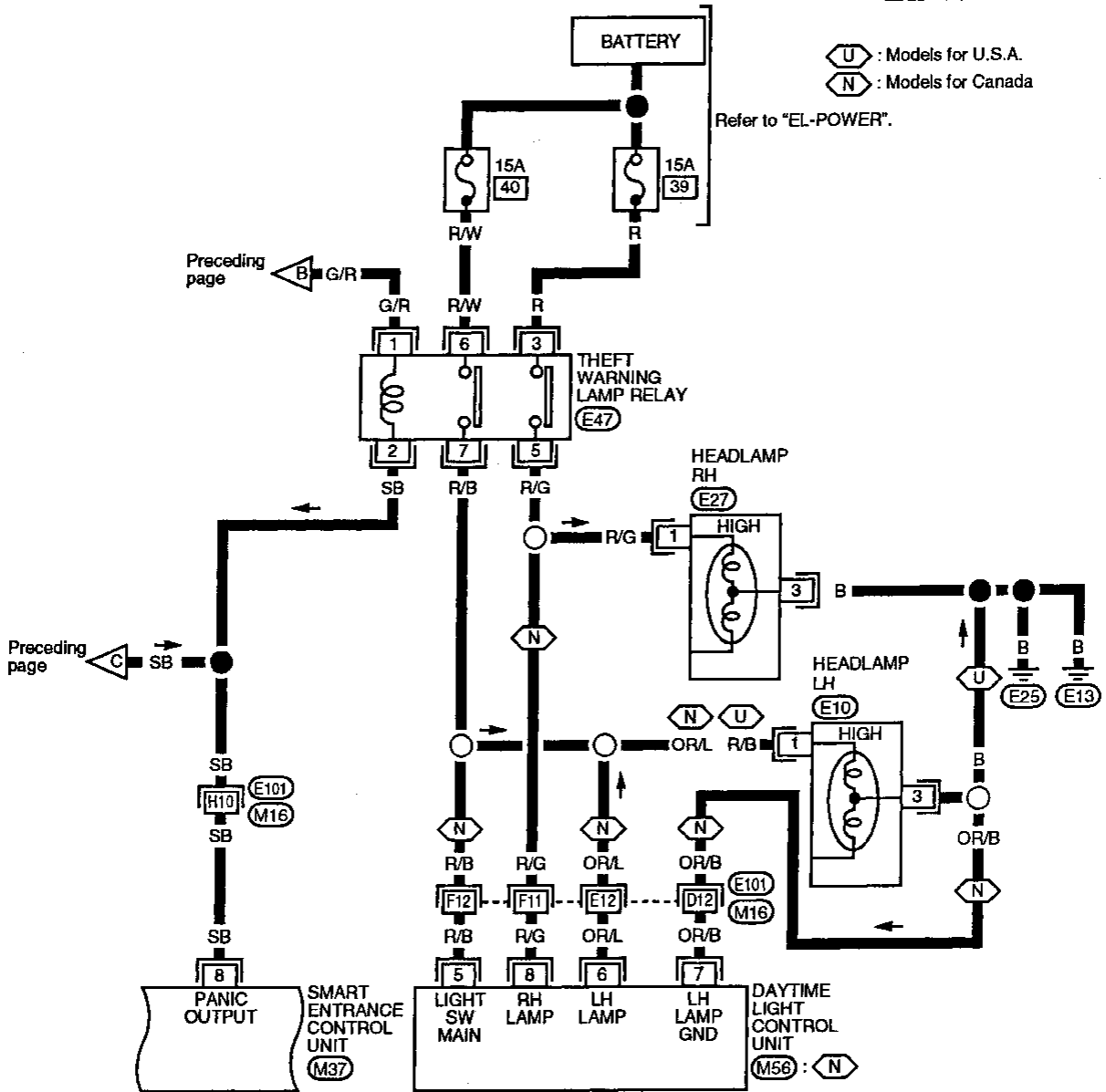

Refer to last page (Foldout page).

M16 , E101

M37

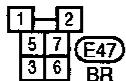
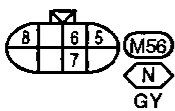

THEFT WARNING SYSTEM

Wiring Diagram -THEFT- (Cont'd)

A/T MODELS

EL-THEFT-07

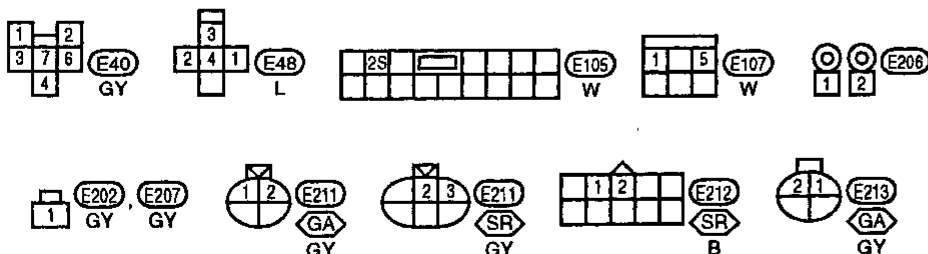
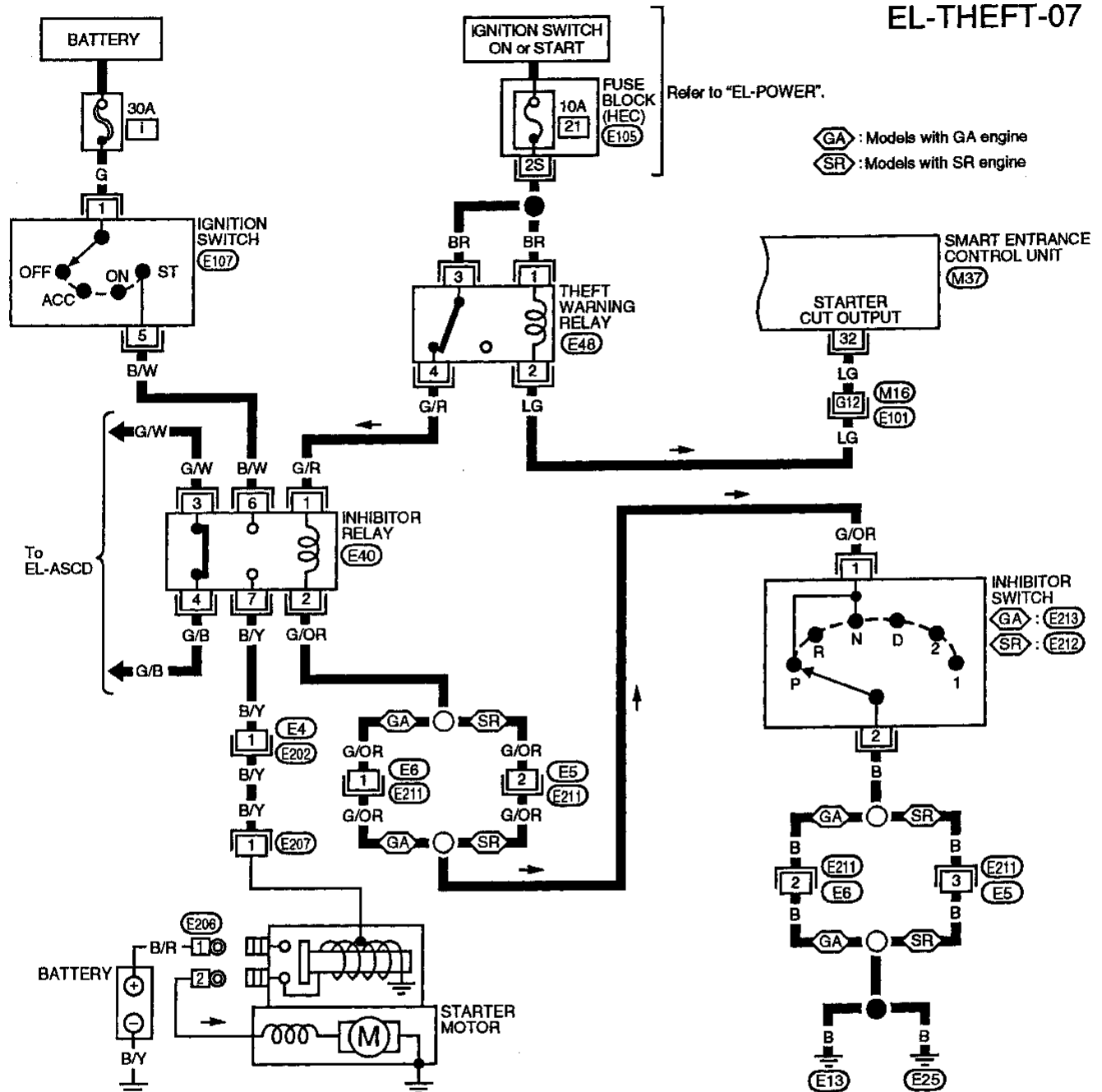

THEFT WARNING SYSTEM

Wiring Diagram -THEFT- (Cont'd)

M/T MODELS FOR CANADA

EL-THEFT-09

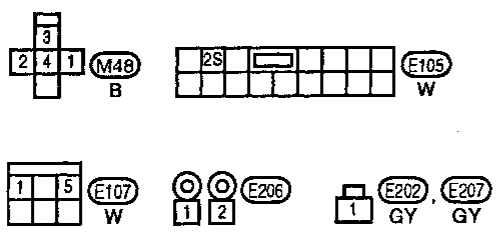
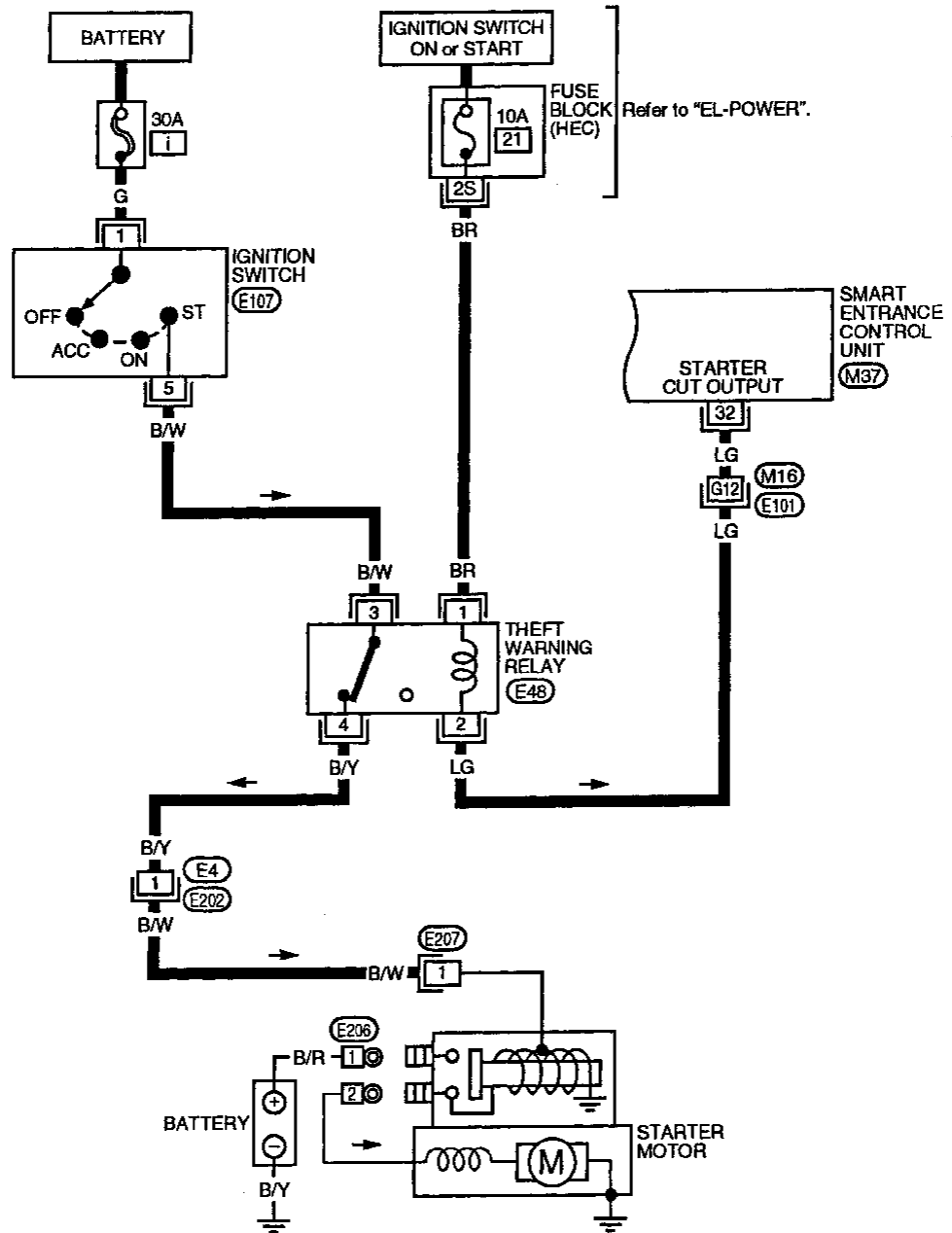

Refer to last page (Foldout page).
 (M16), (E101)
 (M37)

GI
 MA
 EM
 LG
 EC
 FE
 CL
 MT
 AT
 FA
 RA
 BR
 ST
 RS
 BT
 HA
 EL
 IDX

THEFT WARNING SYSTEM

Trouble Diagnoses

SYSTEM OPERATION CHECK

The system operation is canceled by turning ignition switch to "ACC" at any step in the following:

- A step between START and ARMED, or
- In the ARMED phase

in the following flow chart.

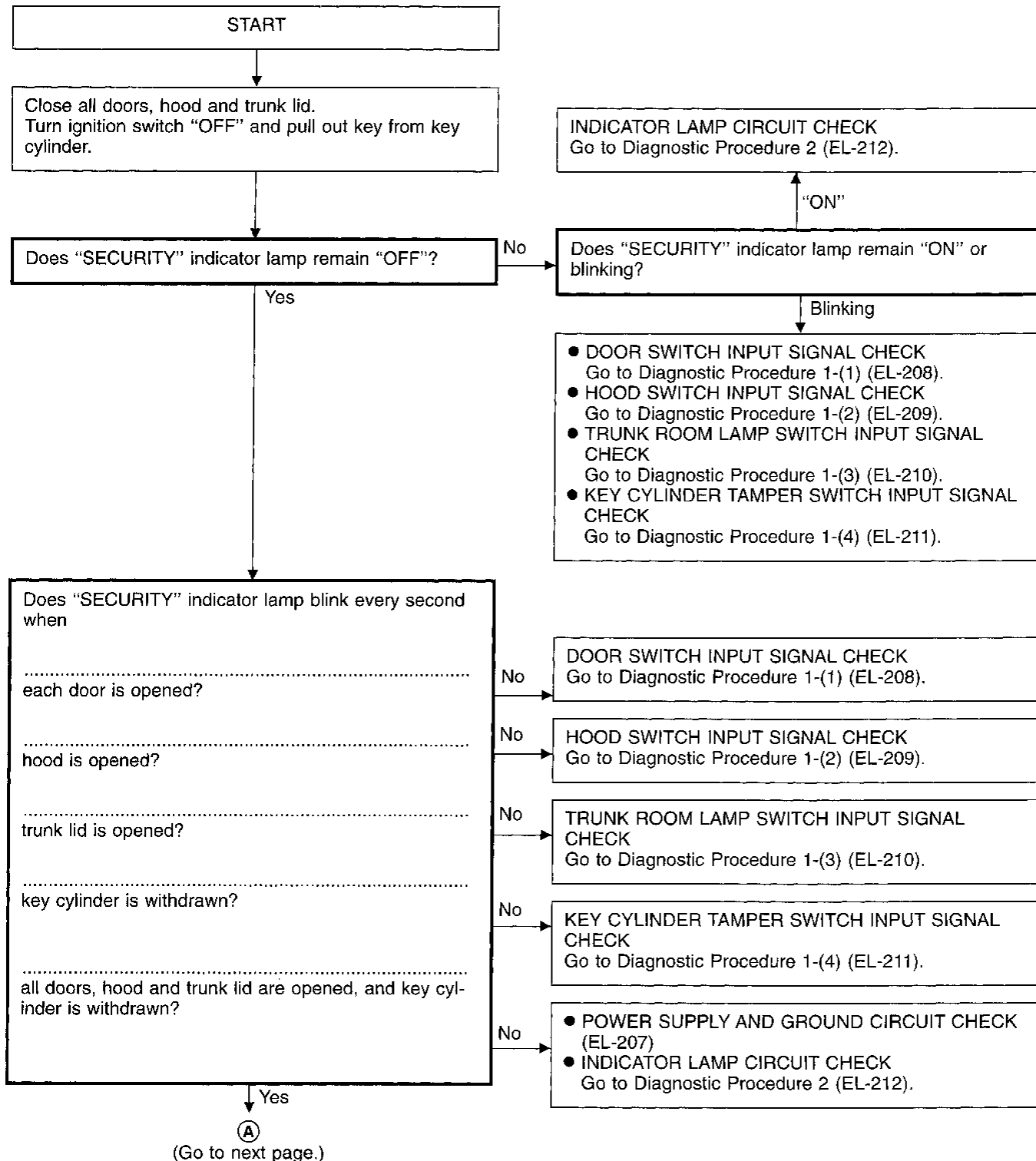

THEFT WARNING SYSTEM

Trouble Diagnoses (Cont'd)



GI
MA
EM
LC
EC
FE
CL
MT
AT
FA
RA
BR
ST
RS
BT
HA
EL
IDX

THEFT WARNING SYSTEM

Trouble Diagnoses (Cont'd)

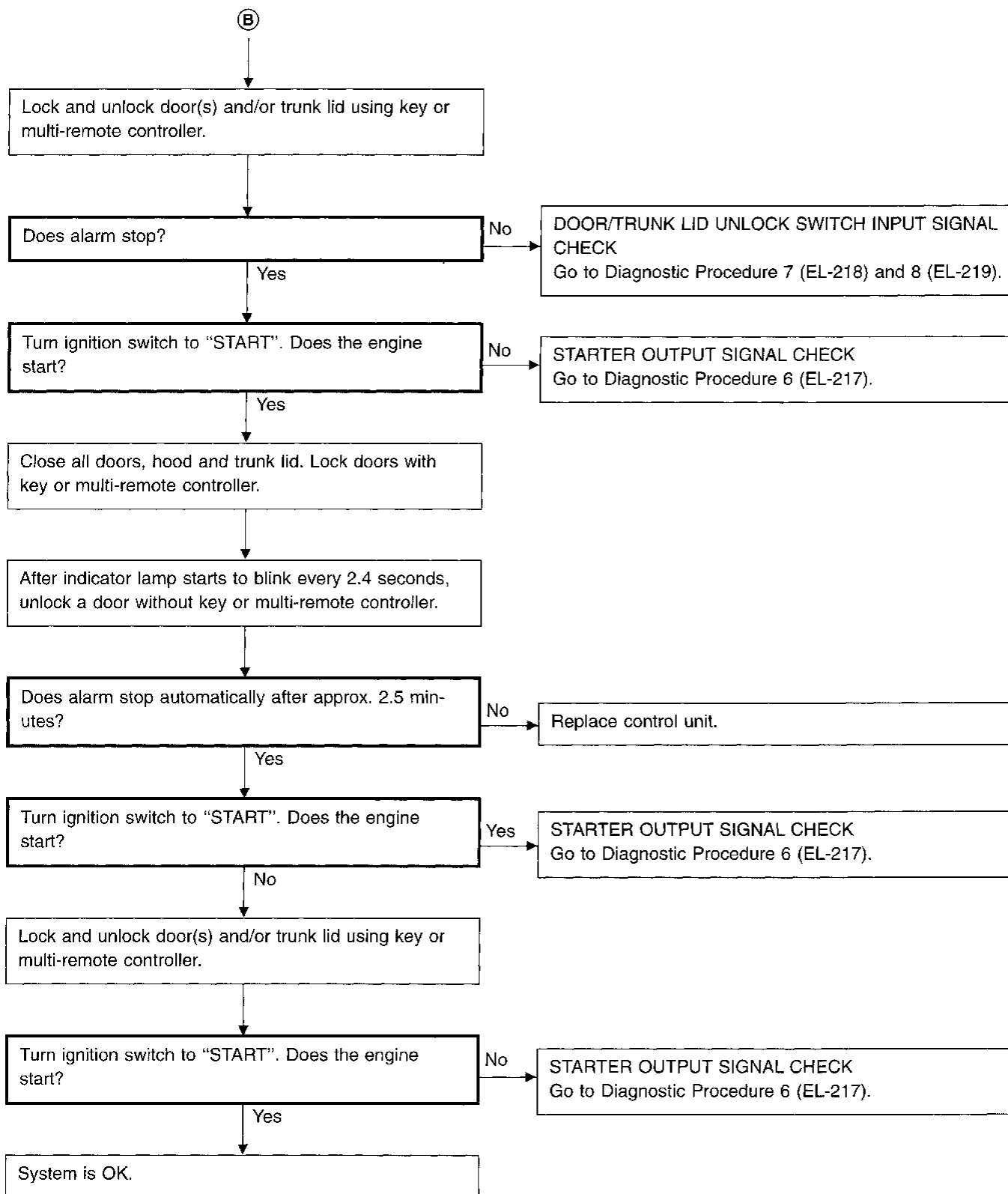

THEFT WARNING SYSTEM

Trouble Diagnoses (Cont'd)

POWER SUPPLY AND GROUND CIRCUIT CHECK

Main power supply circuit check

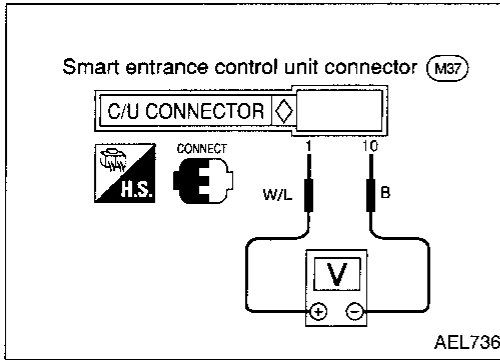

Terminals	Ignition switch position		
	OFF	ACC	ON
① - ⑩	Battery voltage	Battery voltage	Battery voltage

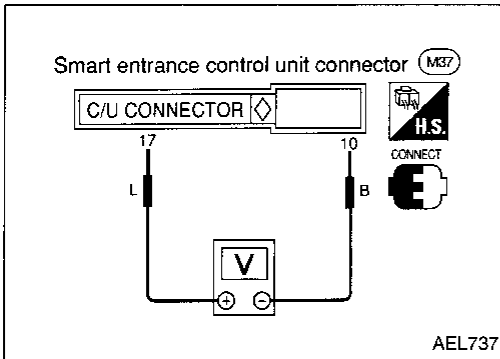

Power supply circuit check for system cancel

Terminals	Ignition switch position		
	OFF	ACC	ON
⑬ - ⑩	0V	Battery voltage	Battery voltage

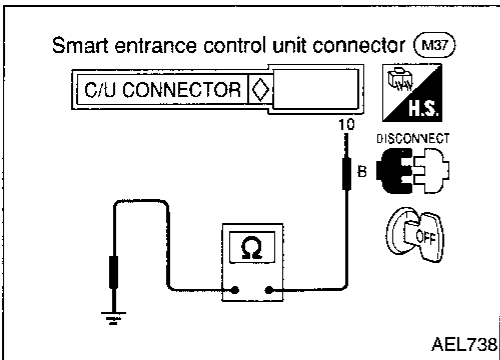

Ground circuit check

Terminals	Continuity
⑩ - Ground	Yes

GI
MA
EM
LC
EC
FE
CL
MT
AT
FA
RA
BR
ST
RS
BT
HA
EL
IDX

THEFT WARNING SYSTEM

Trouble Diagnoses (Cont'd)

DIAGNOSTIC PROCEDURE 1

SYMPTOM:

- Indicator lamp does not blink or
- Indicator lamp remains blinking every second.

Diagnostic procedure 1-(1)

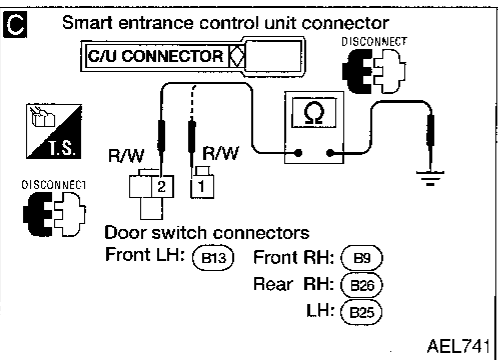
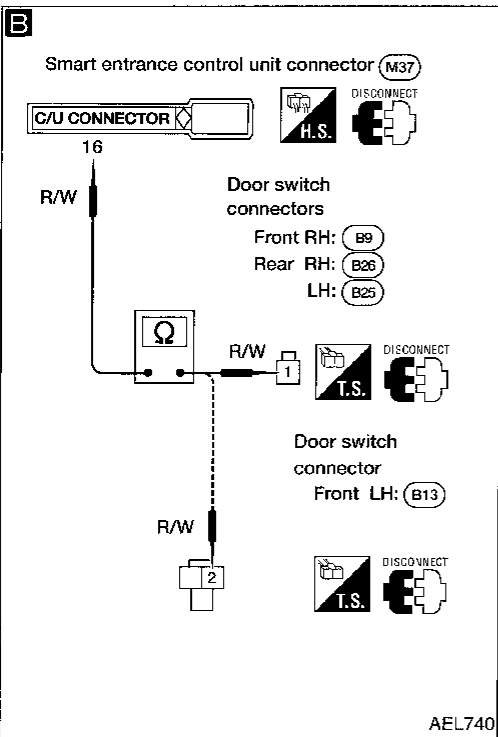
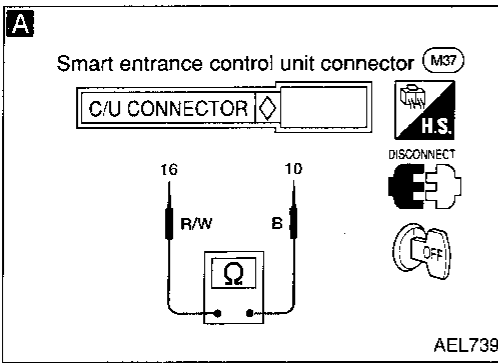

A

DOOR SWITCH INPUT SIGNAL CHECK.

Check continuity between control unit harness terminals (16) and (10).

Condition	Continuity between (16) and (10)
LH door is closed.	No
LH door is opened.	Yes
<hr/>	
Condition	Continuity between (16) and (10)
RH door is closed.	No
RH door is opened.	Yes
<hr/>	
Condition	Continuity between (16) and (10)
Rear LH, RH door is closed.	No
Rear LH, RH door is opened.	Yes

OK → Go to Diagnostic Procedure 2 (EL-212).

NG

Door switch check. Refer to "Electrical Components Inspection" (EL-220).

NG → Replace door switch.

B

DOOR SWITCH CIRCUIT CHECK.

• Check harness continuity between control unit harness terminal (16) and door switch harness terminal.
Continuity should exist.

NG → Repair harness or connectors.

C

CHECK CONTINUITY.

Check harness continuity between door switch harness terminal and body ground. (Before checking harness continuity, control unit harness connector should be disconnected.)
Continuity should not exist.

NG → Repair harness. (Short circuit exists between control unit harness terminal (16) and door switch harness terminals.)

OK

Check the connections at each connector.

THEFT WARNING SYSTEM

Trouble Diagnoses (Cont'd)

Diagnostic procedure 1-(2)

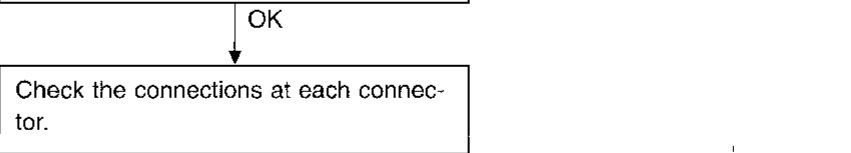
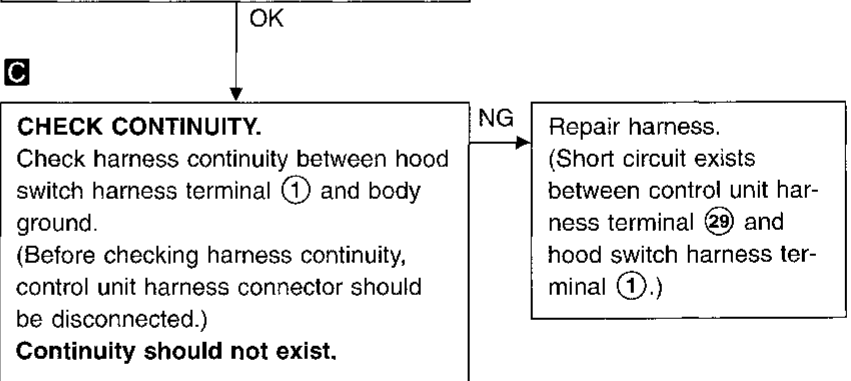
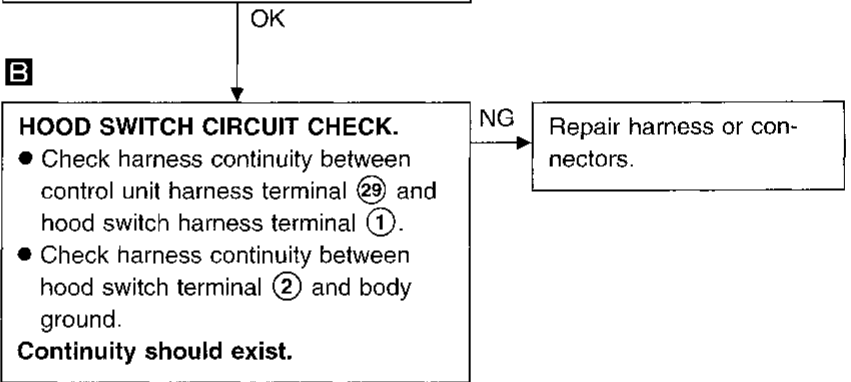
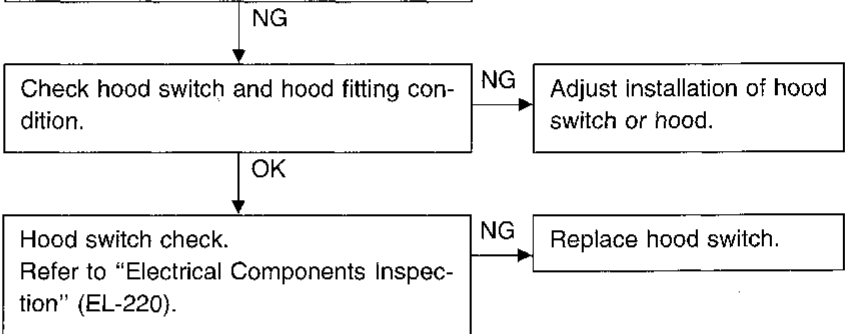
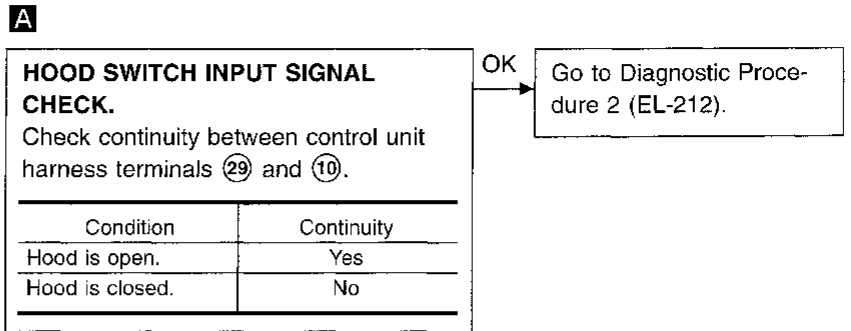
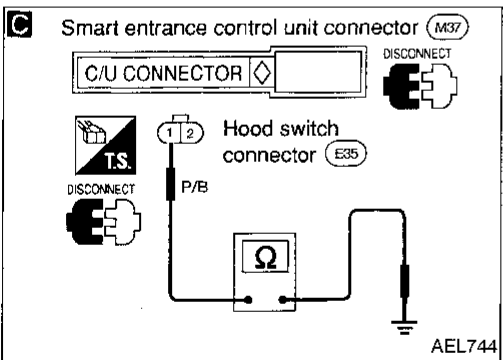
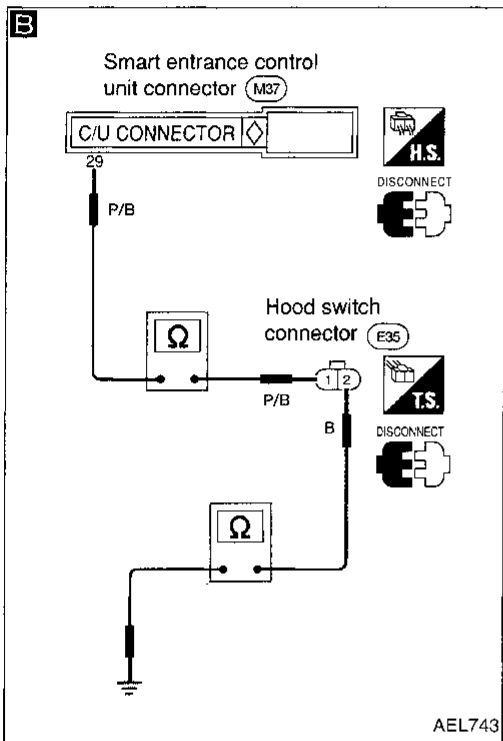
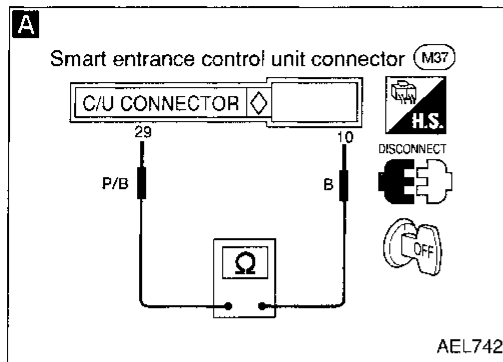

GI

MA

EM

LG

EG

FE

CL

MT

AT

FA

RA

BR

ST

RS

BT

HA

EL

IDX

THEFT WARNING SYSTEM

Trouble Diagnoses (Cont'd)

Diagnostic procedure 1-(3)

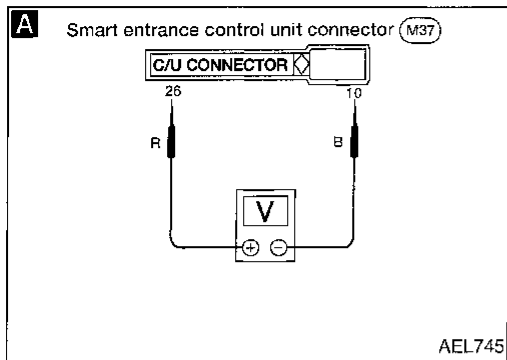

A

TRUNK ROOM LAMP SWITCH INPUT SIGNAL CHECK.
Check voltage between control unit harness terminals (26) and (10).

Condition	Voltage
Trunk lid is open.	Approx. 0V
Trunk lid is closed.	Approx. 12V

OK → Go to Diagnostic Procedure 2 (EL-212).

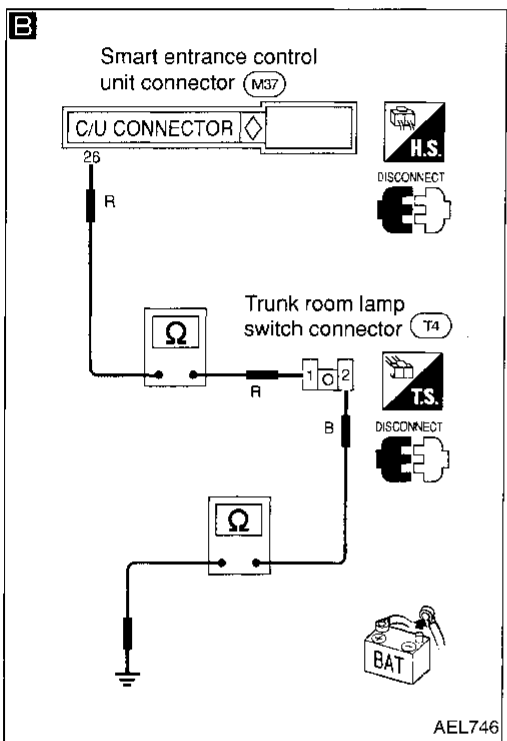

NG → Replace trunk room lamp switch.

OK →

B

TRUNK ROOM LAMP SWITCH CIRCUIT CHECK.

- Check harness continuity between control unit harness terminal (26) and trunk room lamp switch harness terminal (1). (Before checking harness continuity, the battery negative terminal should be disconnected.)
- Check harness continuity between trunk room lamp switch harness terminal (2) and body ground.

Continuity should exist.

NG → Repair harness or connectors.

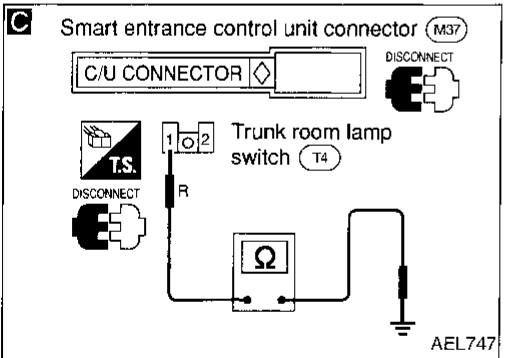

C

CHECK CONTINUITY.
Check harness continuity between trunk room lamp switch harness terminal (1) and body ground. (Before checking harness continuity, control unit harness connector should be disconnected.)

Continuity should not exist.

NG → Repair harness. (Short circuit exists between control unit harness terminal (26) and trunk room lamp switch harness terminal (1).)

OK → Check the connections at each connector.

THEFT WARNING SYSTEM

Trouble Diagnoses (Cont'd)

Diagnostic procedure 1-(4)

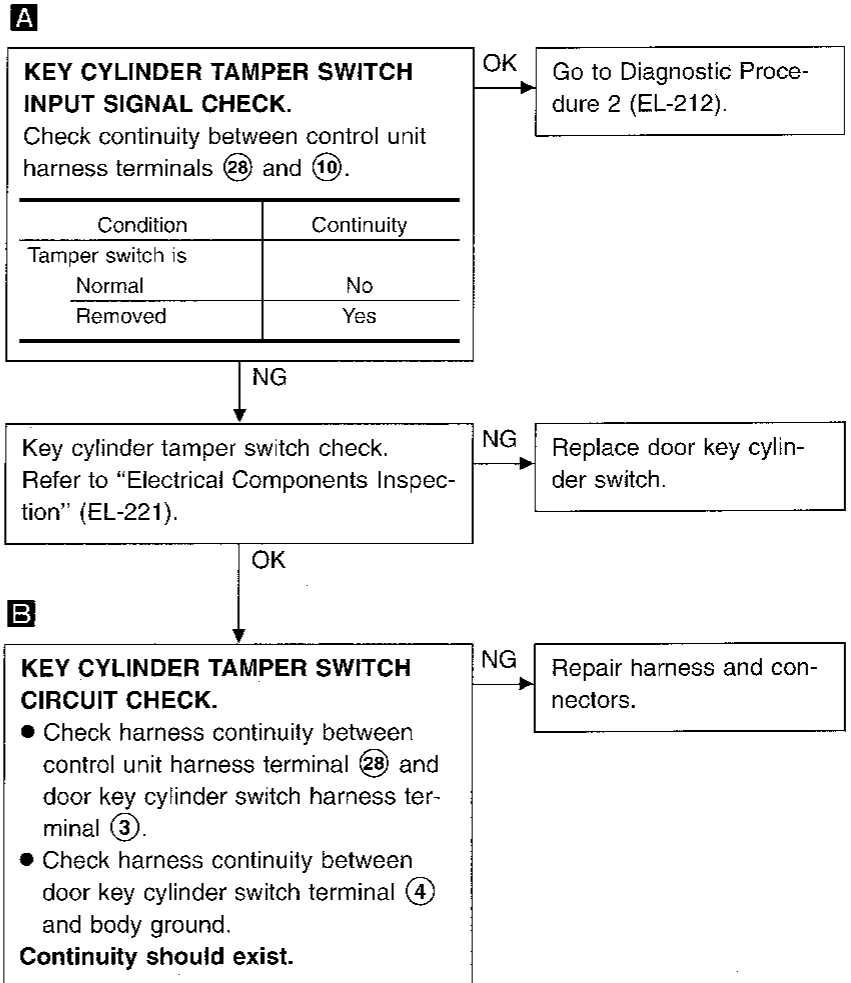
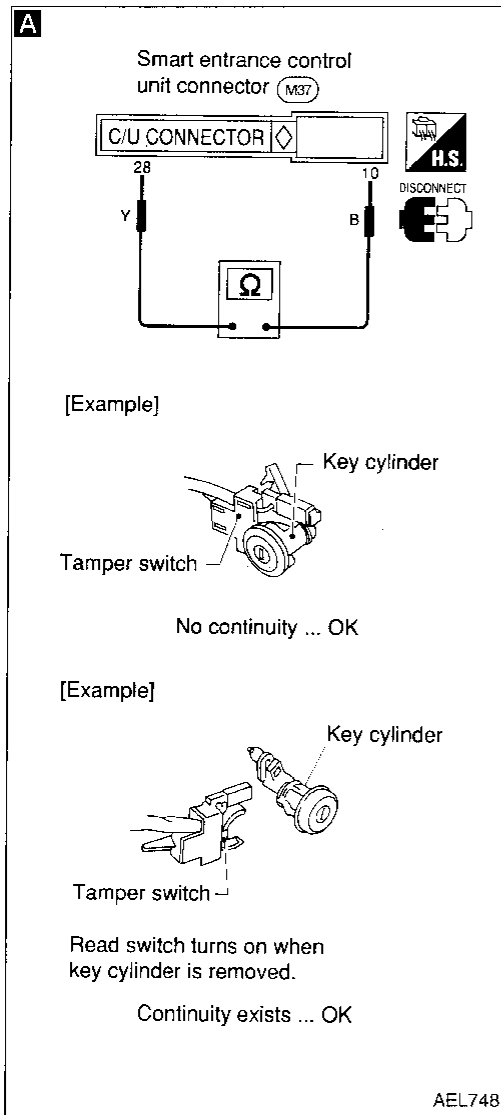

(Next page)

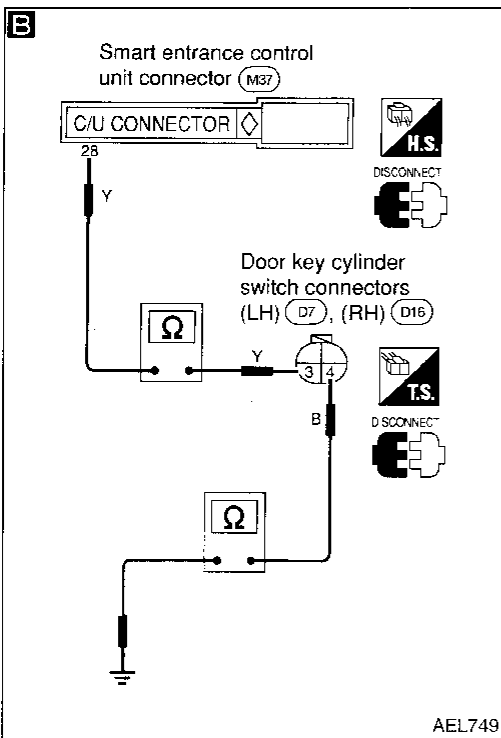

GI
MA
EM
LC
EC
FE
CL
MT
AT
FA
RA
BR
ST
RS
BT
HA
EL
IDX

THEFT WARNING SYSTEM

Trouble Diagnoses (Cont'd)

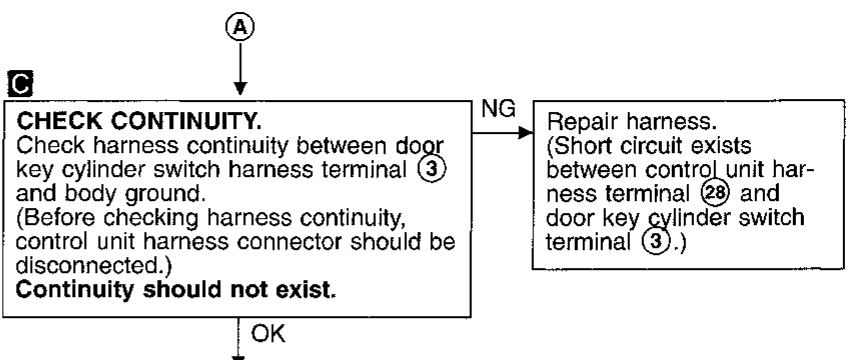
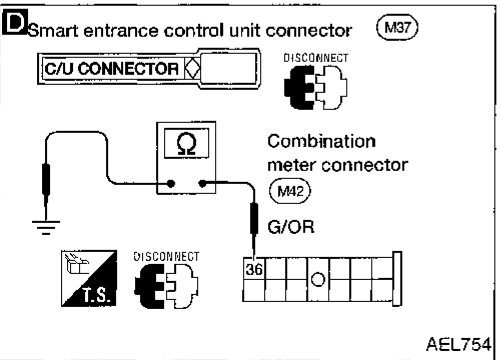
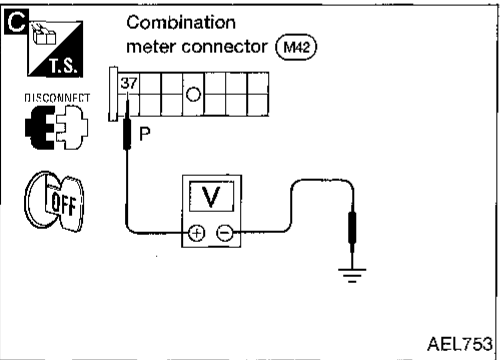
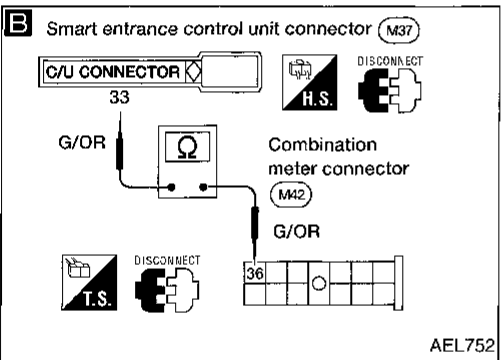
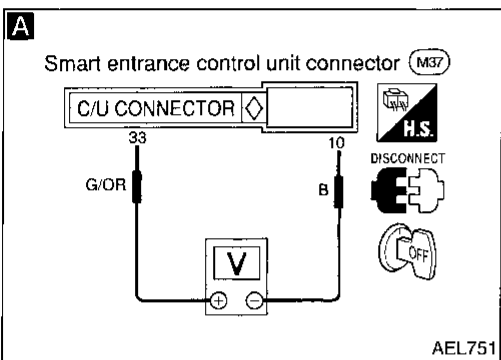
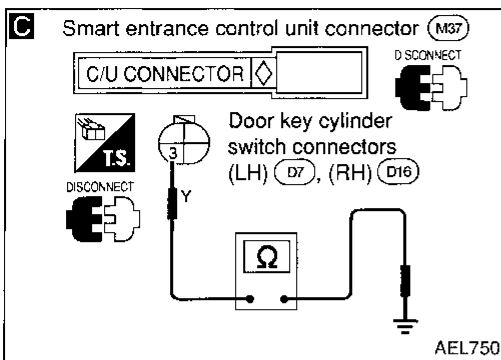

Check the connections at each connector.

DIAGNOSTIC PROCEDURE 2
SYMPTOM: • Indicator lamp does not blink or
• Indicator lamp remains "ON".

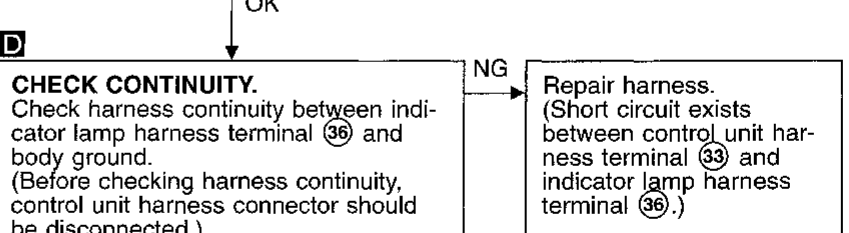
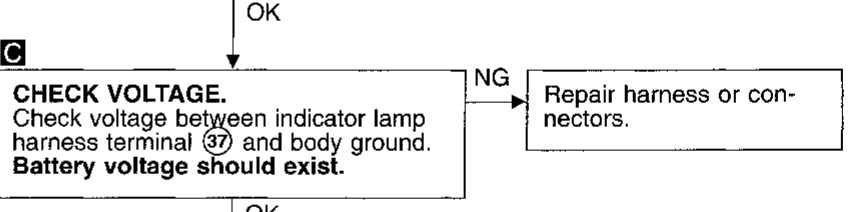
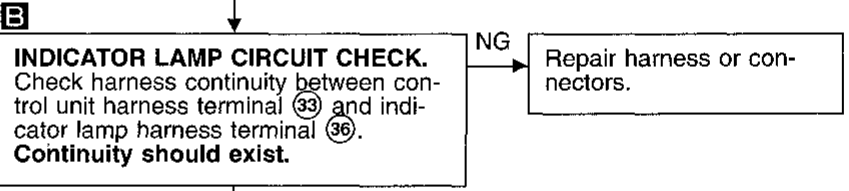
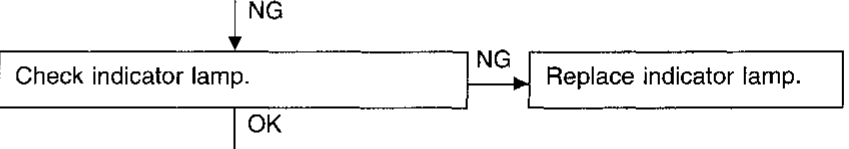
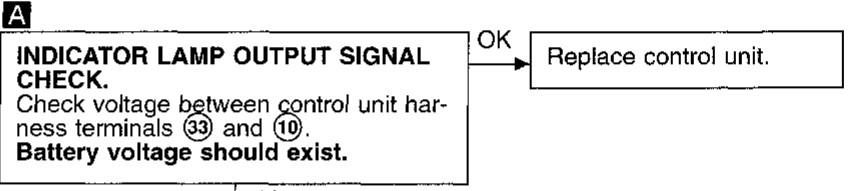

Check the connections at each connector.

Replace control unit.

THEFT WARNING SYSTEM

Trouble Diagnoses (Cont'd)

DIAGNOSTIC PROCEDURE 3

SYMPTOM: Indicator lamp does not come on.

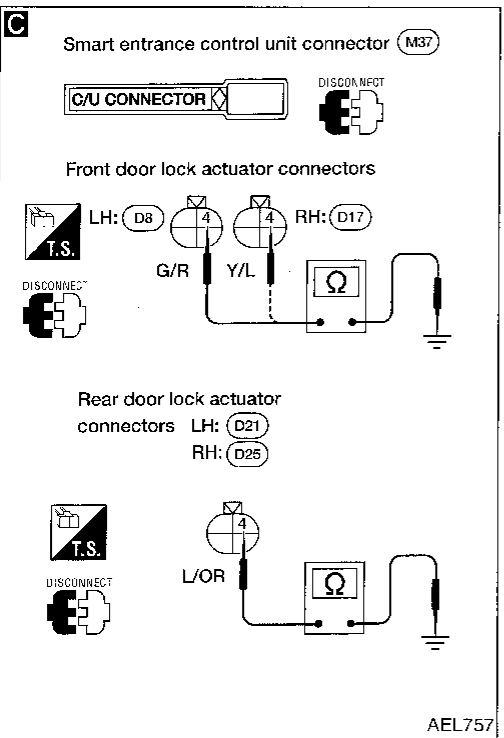
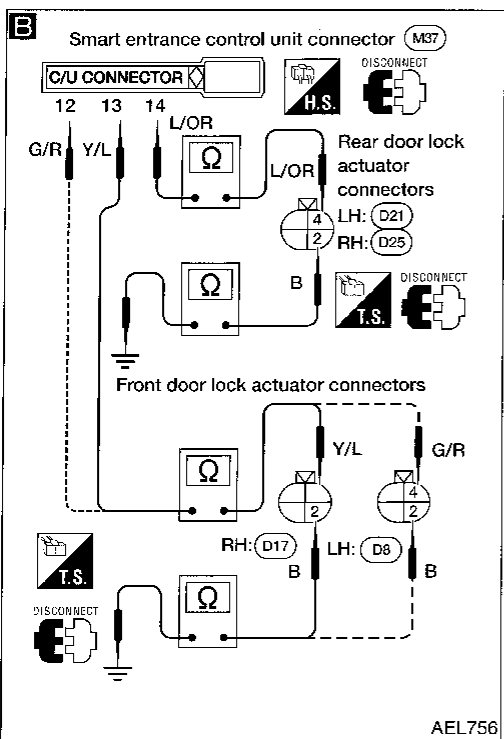
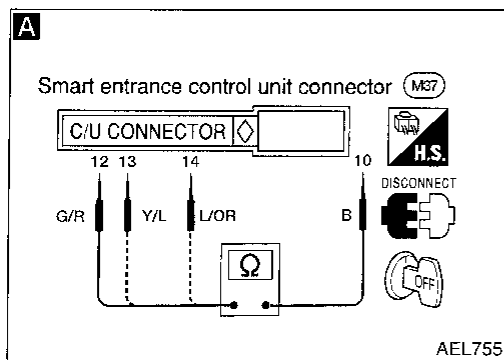

A

DOOR UNLOCK SENSOR INPUT SIGNAL CHECK.

Check continuity between control unit harness terminals ⑫ or ⑬ or ⑭ and ⑩.

Condition	Continuity between ⑫ and ⑩
LH door is locked.	No
LH door is unlocked.	Yes

Condition	Continuity between ⑬ and ⑩
RH door is locked.	No
RH door is unlocked.	Yes

Condition	Continuity between ⑭ and ⑩
LH, RH door is locked.	No
LH, RH door is unlocked.	Yes

NG

Door unlock sensor check. Refer to "Electrical Components Inspection" (EL-221).

OK

B

DOOR UNLOCK SENSOR CIRCUIT CHECK.

- Check harness continuity between control unit harness terminal ⑫, ⑬ or ⑭ and door actuator terminal ④.
 - Check harness continuity between door lock actuator harness terminal ② and body ground.
- Continuity should exist.**

OK

C

CHECK CONTINUITY.

Check harness continuity between door lock actuator harness terminal ④ and body ground. (Before checking harness continuity, control unit harness connector should be disconnected.)

Continuity should not exist.

OK

Check the connections at each connector.

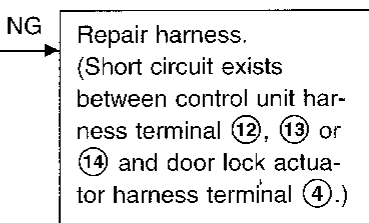
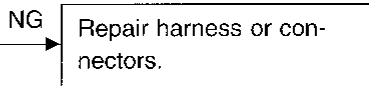
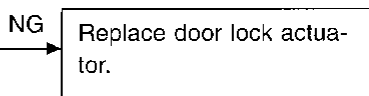
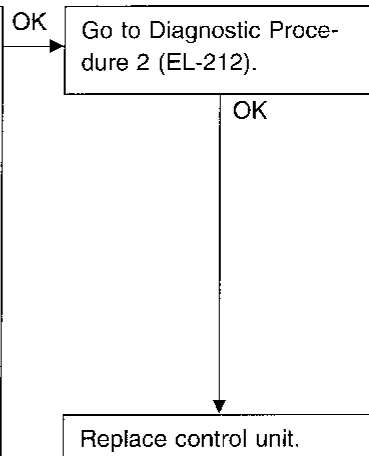

GI
IA
EM
LC
FC
FE
CL
MT
AT
FA
RA
BR
ST
RS
BT
HA
EL
DX

THEFT WARNING SYSTEM

Trouble Diagnoses (Cont'd)

DIAGNOSTIC PROCEDURE 4

SYMPTOM: Indicator lamp does not come on.

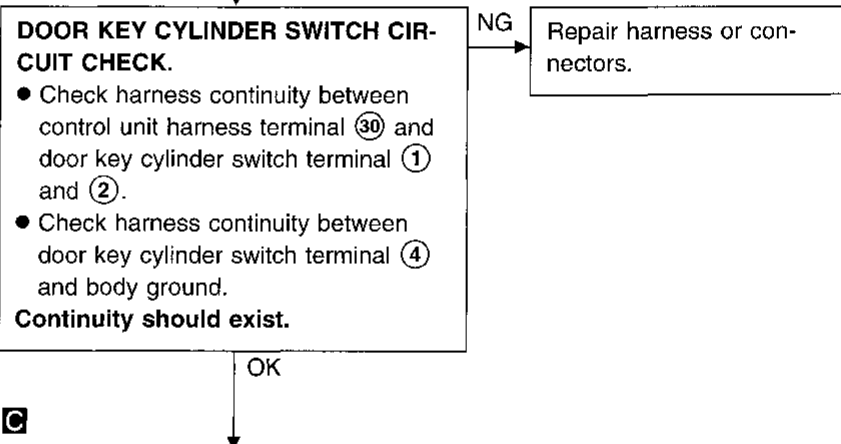
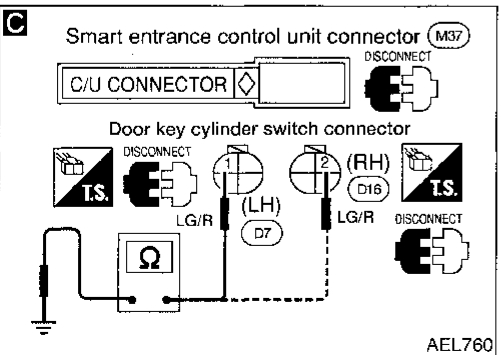
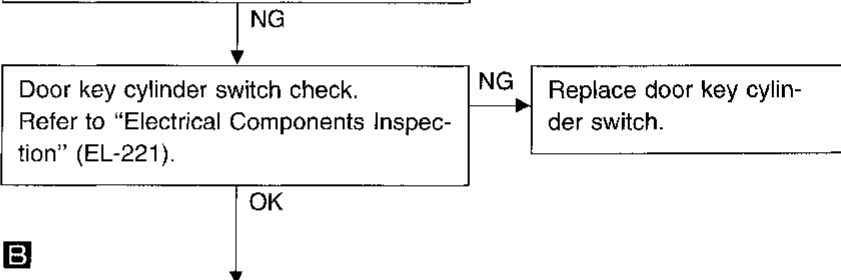
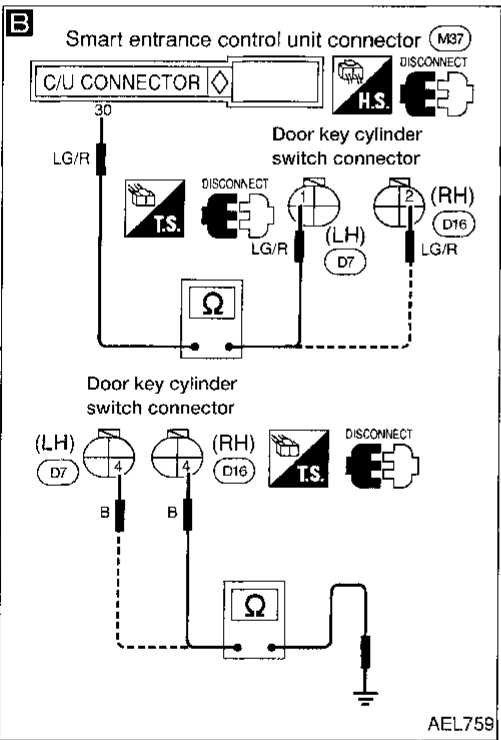
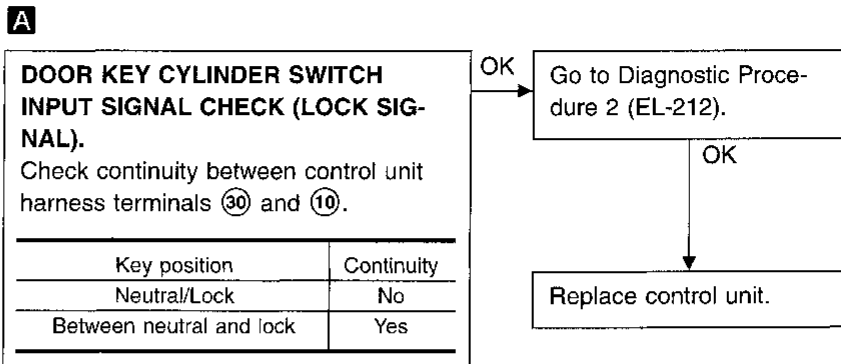
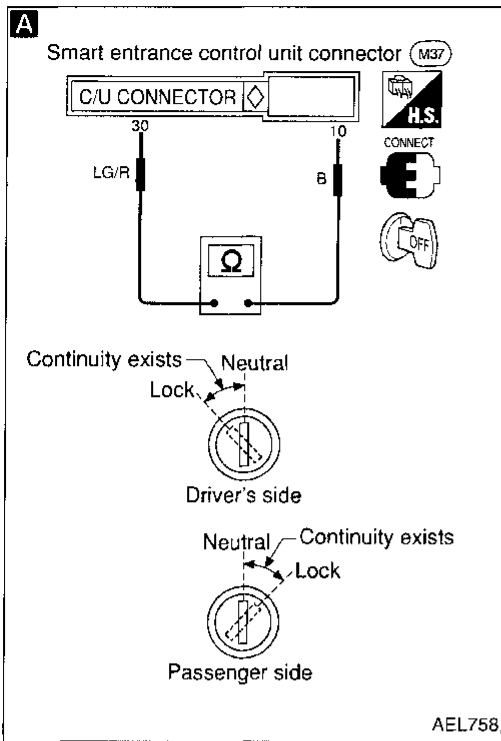

THEFT WARNING SYSTEM

Trouble Diagnoses (Cont'd)

DIAGNOSTIC PROCEDURE 5

SYMPTOM: Alarm does not operate.

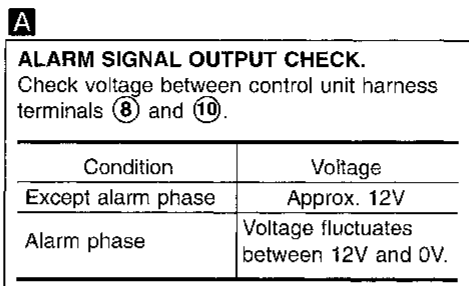
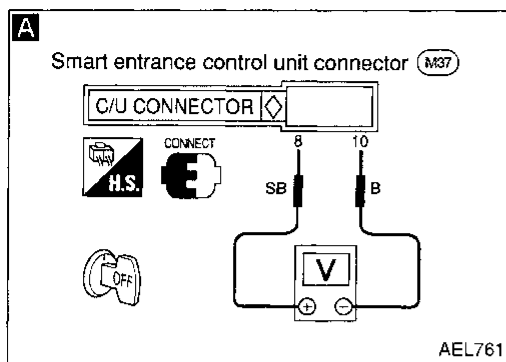

- Check the following:
- Harness continuity between control unit harness terminal (8) and theft warning lamp relay harness terminal (2).
 - Harness continuity between fuse and theft warning lamp relay harness terminal (1).
 - Harness continuity between fuse and horn relay harness terminal (2).
 - Harness continuity between control unit harness terminal (8) and horn relay-2 harness terminal (2).
 - Harness continuity between fuse and horn relay-2 harness terminal (1).
 - Theft warning lamp relay. Refer to "Electrical Components Inspection" (EL-222).
 - Horn relay-2 and horn relay. Refer to "Electrical Components Inspection" (EL-222).

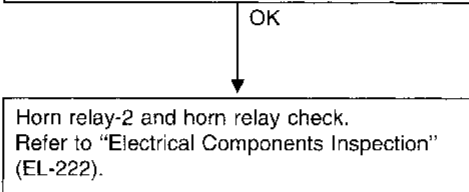
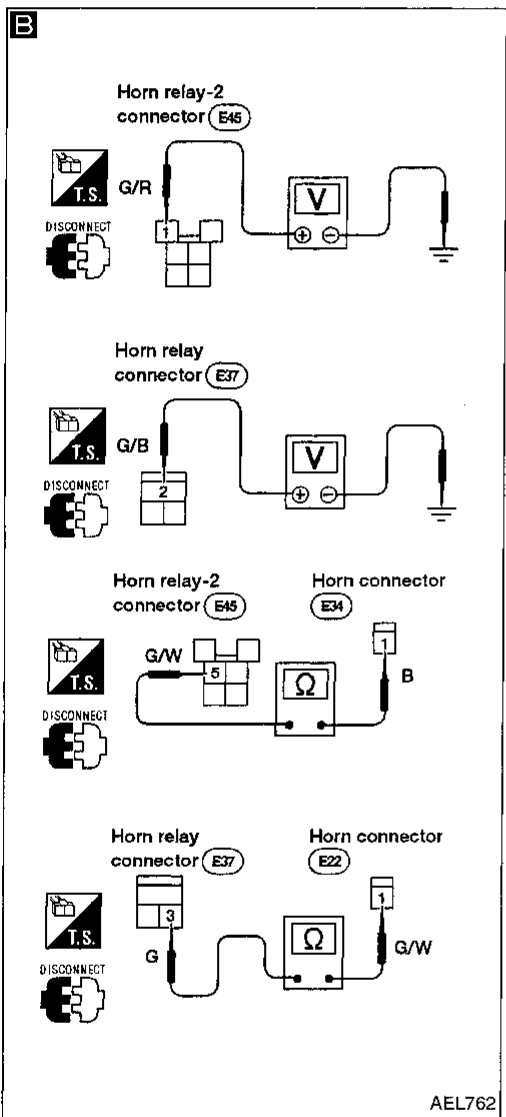

Replace relays.

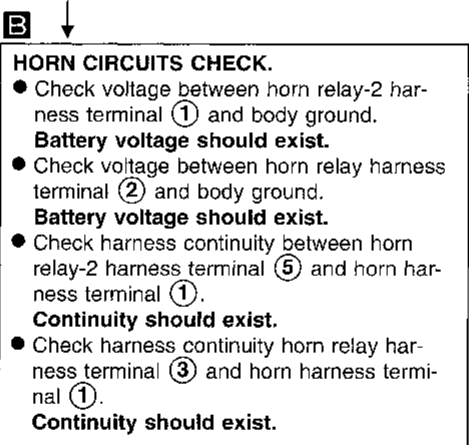

Repair harness or connectors.

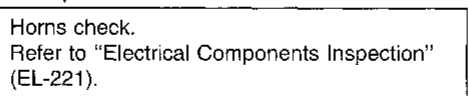

Replace horns.

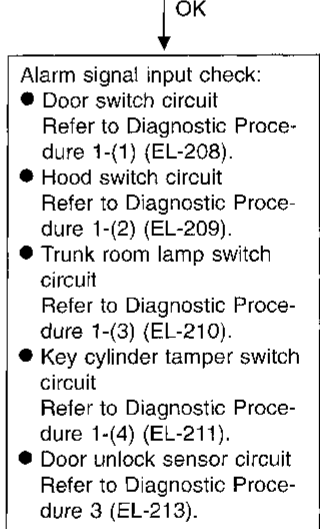

OK

Replace control unit.

(Next page)

GI
MA
EM
LC
EC
FE
CL
MT
AT
FA
RA
BR
ST
RS
BT
HA
EL
JDX

THEFT WARNING SYSTEM

Trouble Diagnoses (Cont'd)

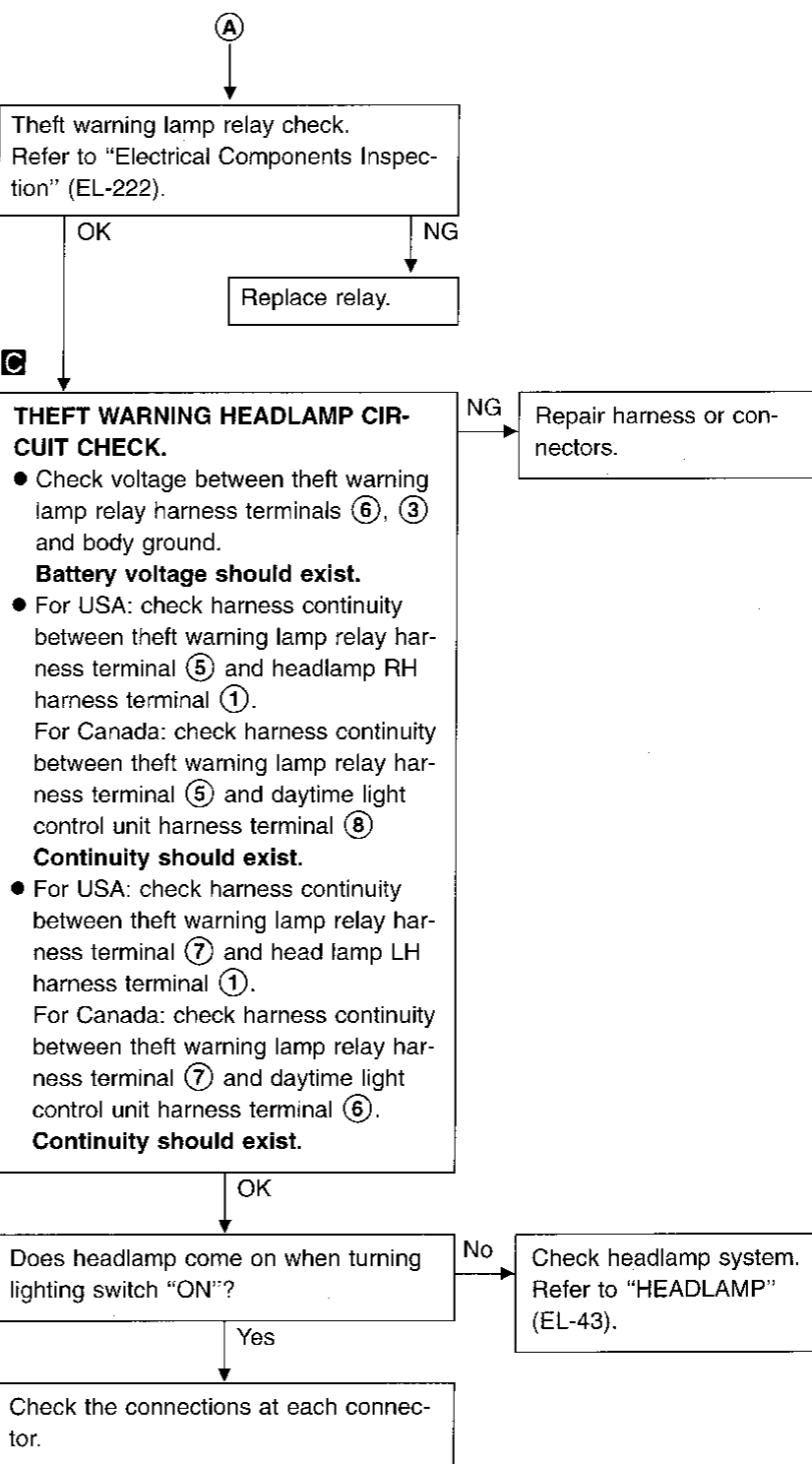
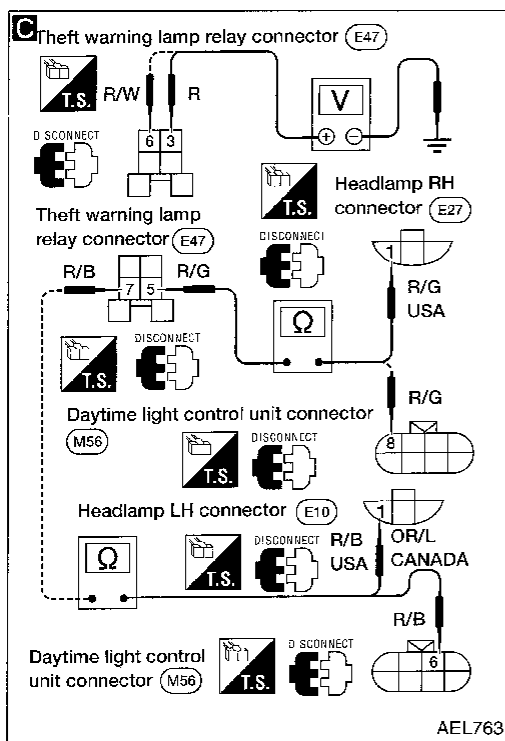

THEFT WARNING SYSTEM

Trouble Diagnoses (Cont'd)

DIAGNOSTIC PROCEDURE 6

SYMPTOM: • **STARTER MOTOR** can be operated. (Starter killed phase) or
 • **STARTER MOTOR** cannot be operated after the theft warning system is deactivated.

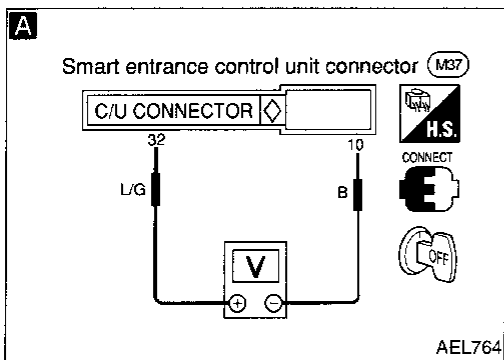

A

STARTER MOTOR KILL OUTPUT SIGNAL CHECK.

Check voltage between control unit harness terminals ③② and ①⑩.

Condition	Voltage
Except starter killed phase	Approx. 12V
Starter killed phase	0V

NG

Check the following.

- Harness continuity between control unit harness terminal ③② and theft warning relay harness terminal ②.
- Harness continuity between theft warning relay harness terminal ① and fuse.
- Theft warning relay. Refer to "Electrical Components Inspection" (EL-222).

OK

OK

Theft warning relay check.
 Refer to "Electrical Components Inspection" (EL-222).

Replace control unit.

OK

NG

Replace relay.

Check the connections at each connector.

GI

MA

EM

LC

EC

FE

CL

MT

AT

FA

RA

BR

ST

RS

BT

HA

EL

IDX

THEFT WARNING SYSTEM

Trouble Diagnoses (Cont'd)

DIAGNOSTIC PROCEDURE 7

SYMPTOM: Alarm does not stop even if stop signal is given.

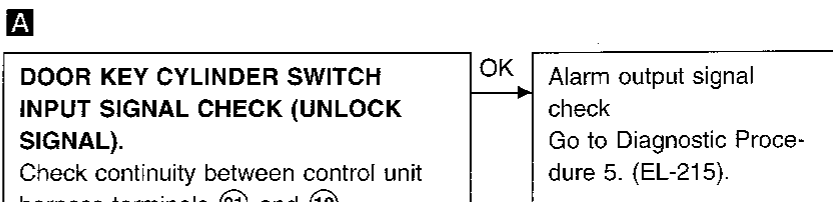
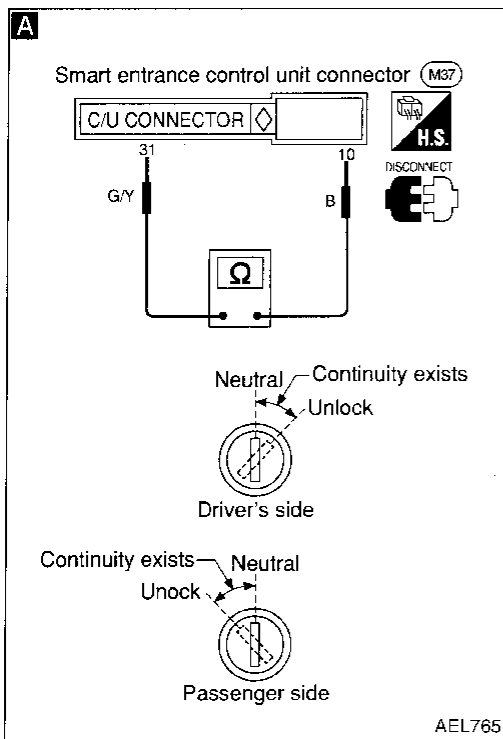

Key position	Continuity
Neutral/Unlock	No
Between neutral and unlock	Yes

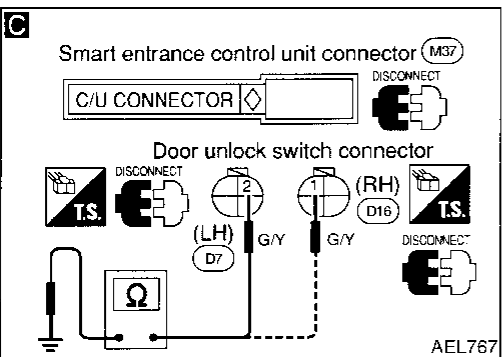
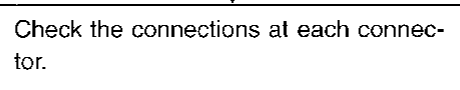
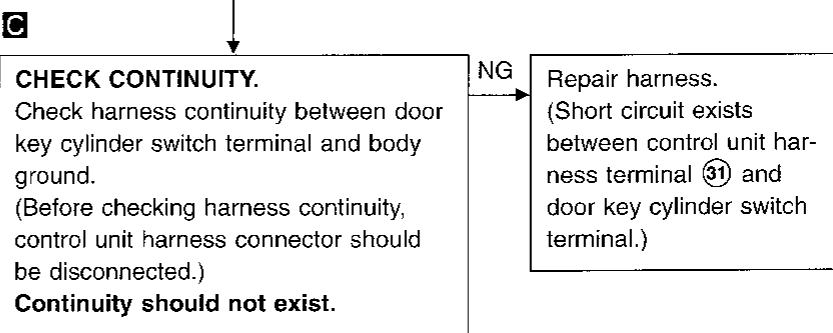
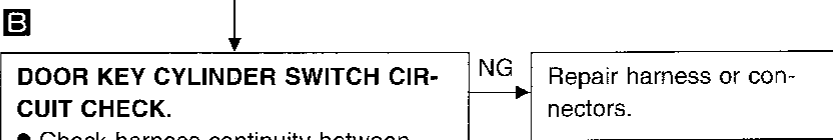
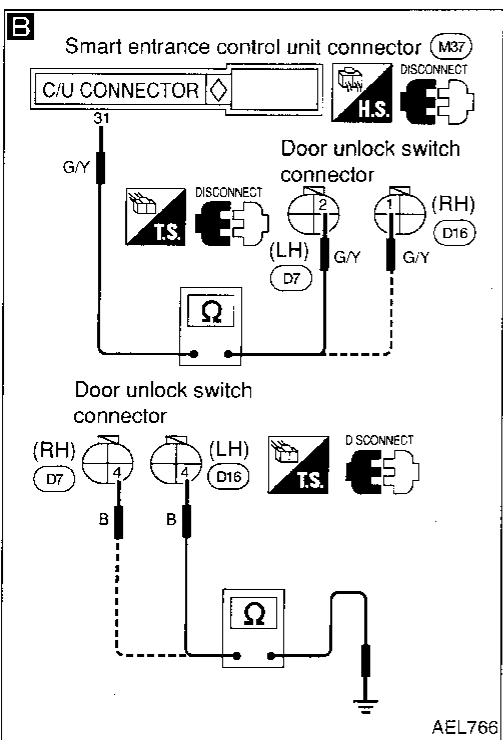
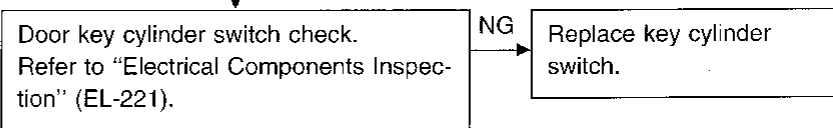

THEFT WARNING SYSTEM

Trouble Diagnoses (Cont'd)

DIAGNOSTIC PROCEDURE 8

SYMPTOM: Alarm does not stop even if stop signal is given.

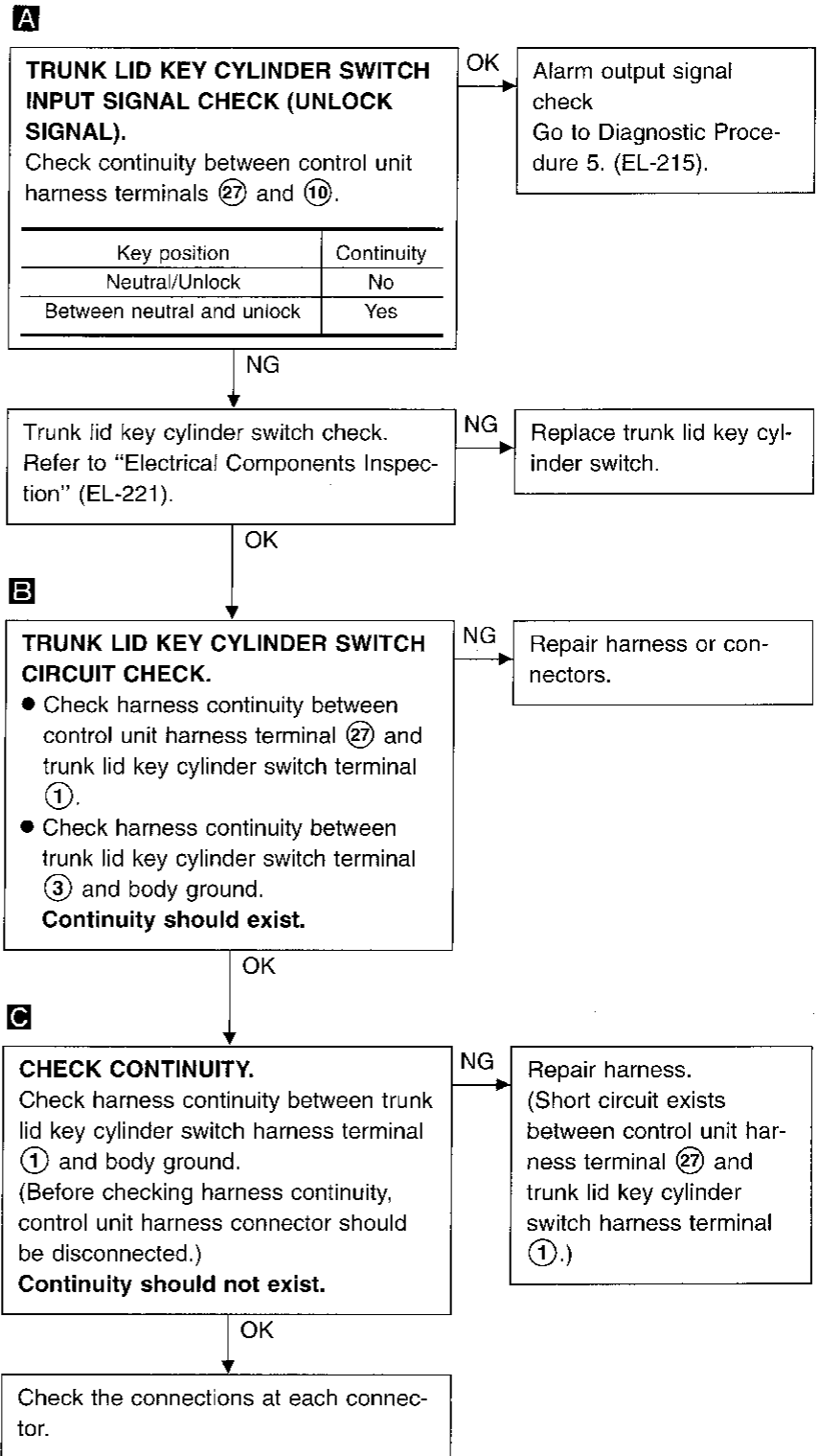
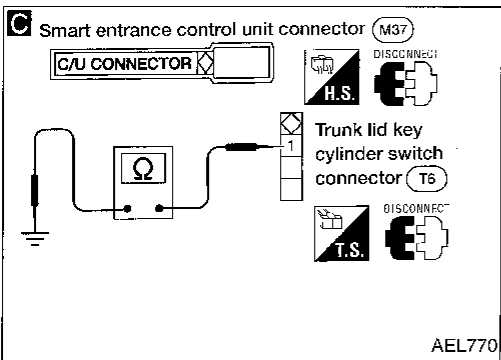
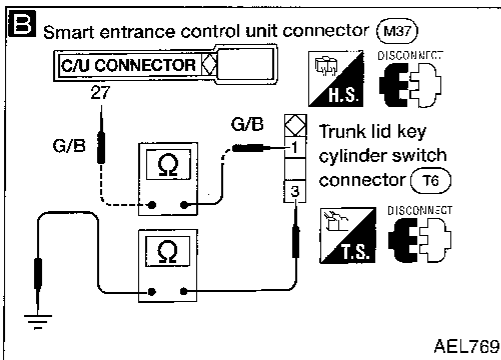
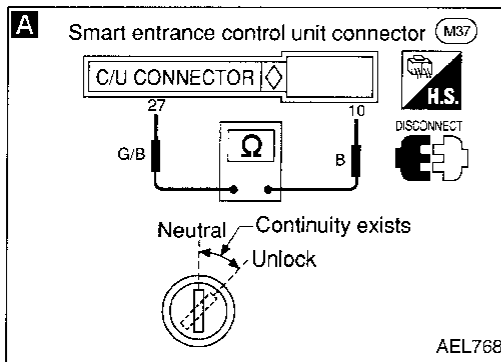

CI
MA
EM
LC
EC
FE
CL
MT
AT
FA
RA
BR
ST
RS
BT
HA
EL
IDX

THEFT WARNING SYSTEM

Trouble Diagnoses (Cont'd)

ELECTRICAL COMPONENTS INSPECTION

Door switches

Check continuity between terminals when door switch is pushed and released.

Terminal No.	Condition	Continuity
RH: ① - body ground	Door switch is pushed.	No
LH: ② - body ground		
Rear RH, LH: ① - body ground	Door switch is released.	Yes

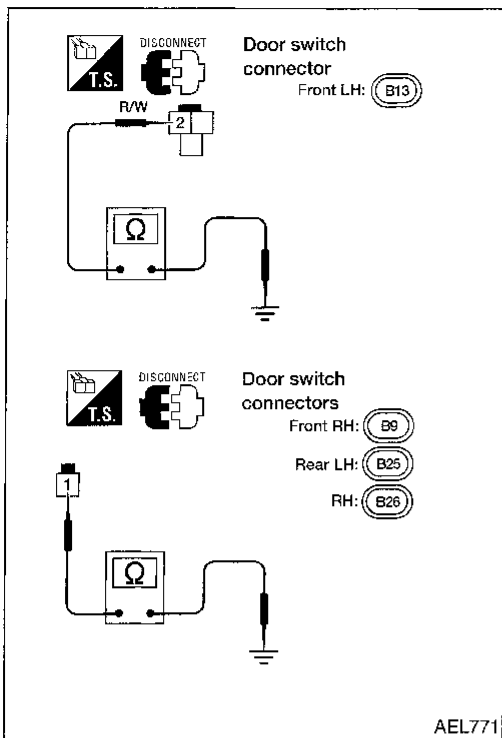

Hood switch

Check continuity between terminals when hood switch is pushed and released.

Terminal No.	Condition	Continuity
① - ②	Hood switch is pushed.	No
	Hood switch is released.	Yes

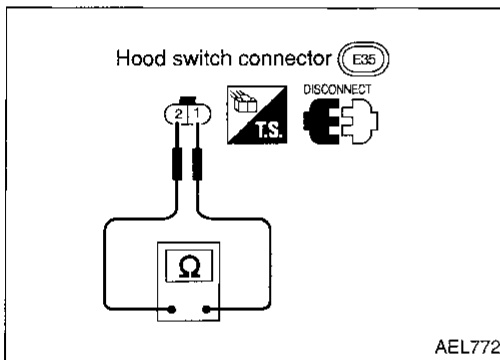

Trunk room lamp switch

Check continuity between terminals when trunk lid is closed and opened.

Terminal No.	Condition	Continuity
① - ②	Trunk lid is closed.	No
	Trunk lid is opened.	Yes

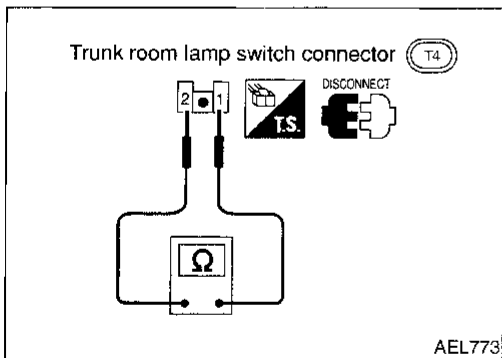

THEFT WARNING SYSTEM

Trouble Diagnoses (Cont'd)

Key cylinder tamper switch, door lock switch and door unlock switch

• Door key cylinder switch

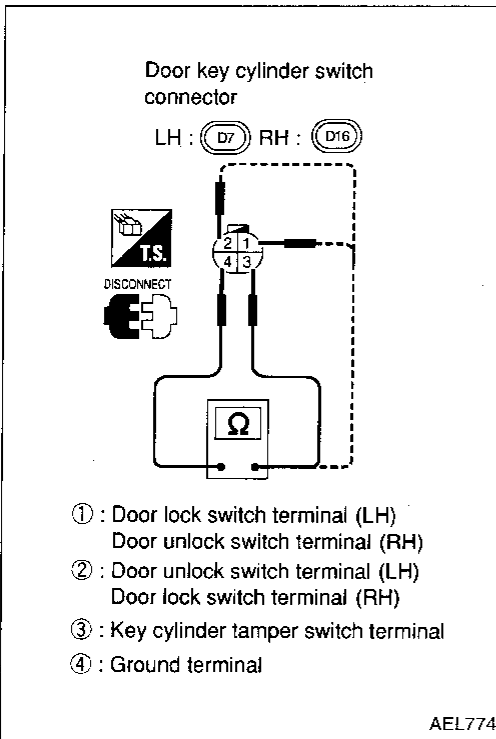

	Terminal No.	Condition	Continuity
Tamper switch	③ - ④	Key cylinder is installed.	No
		Key cylinder is removed.	Yes
Door lock switch	RH: ② - ④ LH: ① - ④	Key position is neutral or lock.	No
		Key position is between neutral and lock.	Yes
Door unlock switch	RH: ① - ④ LH: ② - ④	Key position is neutral or unlock.	No
		Key position is between neutral and unlock.	Yes

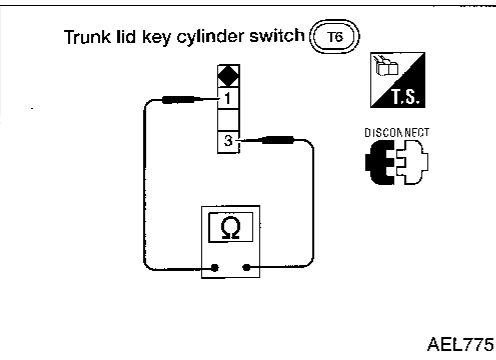

• Trunk lid key cylinder switch (unlock switch)

	Terminal No.	Condition	Continuity
① - ③		Key position is neutral.	No
		Key position is unlock.	Yes

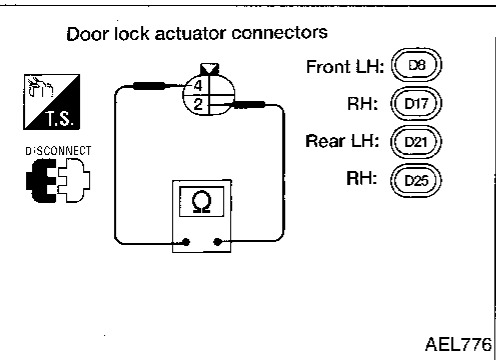

• Door lock actuator (Door unlock sensor)

	Terminal No.	Condition	Continuity
④ - ②		Door is locked.	No
		Door is unlocked.	Yes

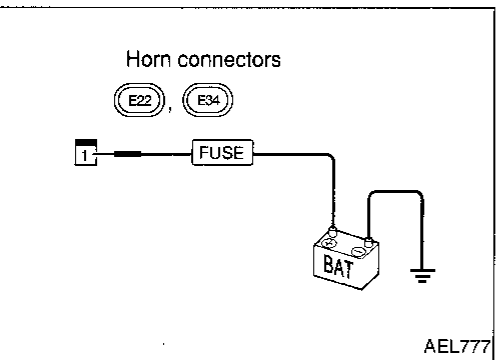

Horns

Supply horn terminal with battery voltage and check horn operation.

THEFT WARNING SYSTEM

Trouble Diagnoses (Cont'd)

Theft warning lamp relay

Check continuity between terminals ③ and ⑤, ⑥ and ⑦.

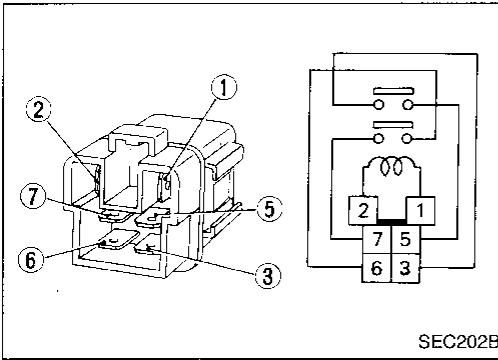

SEC202B

Condition	Continuity
12V direct current supply between terminals ① and ②	Yes
No current supply	No

Theft warning relay

Check continuity between terminals ③ and ④.

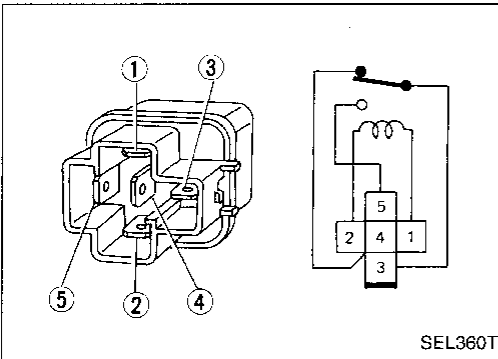

SEL360T

Condition	Continuity
12V direct current supply between terminals ① and ②	No
No current supply	Yes

Horn relay

Check continuity between terminals ② and ③.

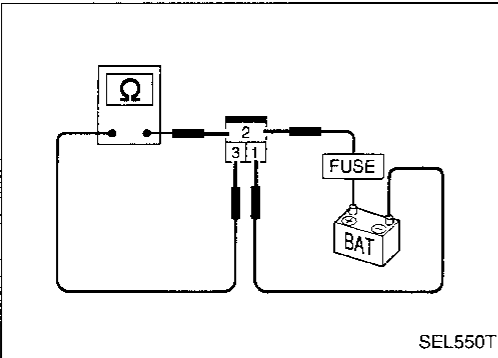

SEL550T

Condition	Continuity
12V direct current supply between terminals ① and ②	Yes
No current supply	No

Horn relay-2

Check continuity between terminals ③ and ⑤, ⑥ and ⑦.

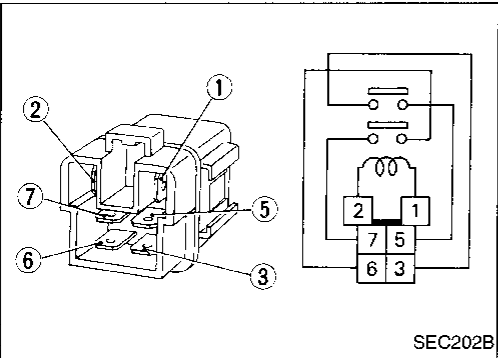

SEC202B

Condition	Continuity
12V direct current supply between terminals ① and ②	Yes
No current supply	No

LOCATION OF ELECTRICAL UNITS

Engine Compartment

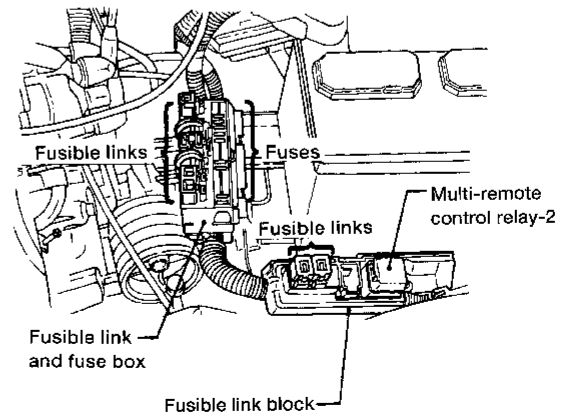
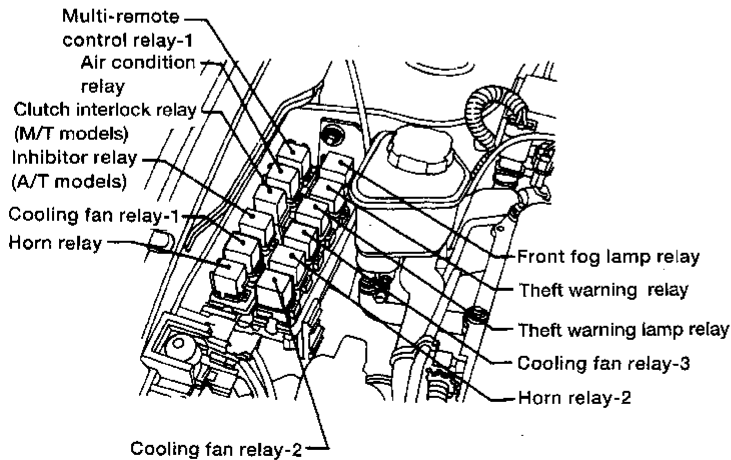
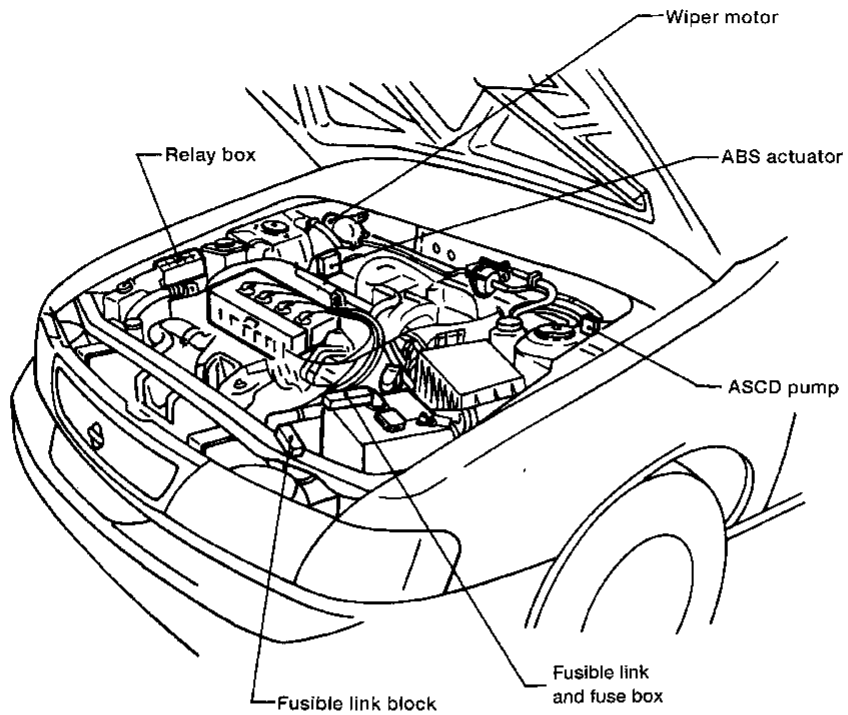

CI
MA
EM
LC
EC
FE
CL
MT
AT
FA
RA
BR
ST
RS
BT
HA
EL
IDX

LOCATION OF ELECTRICAL UNITS

Passenger Compartment

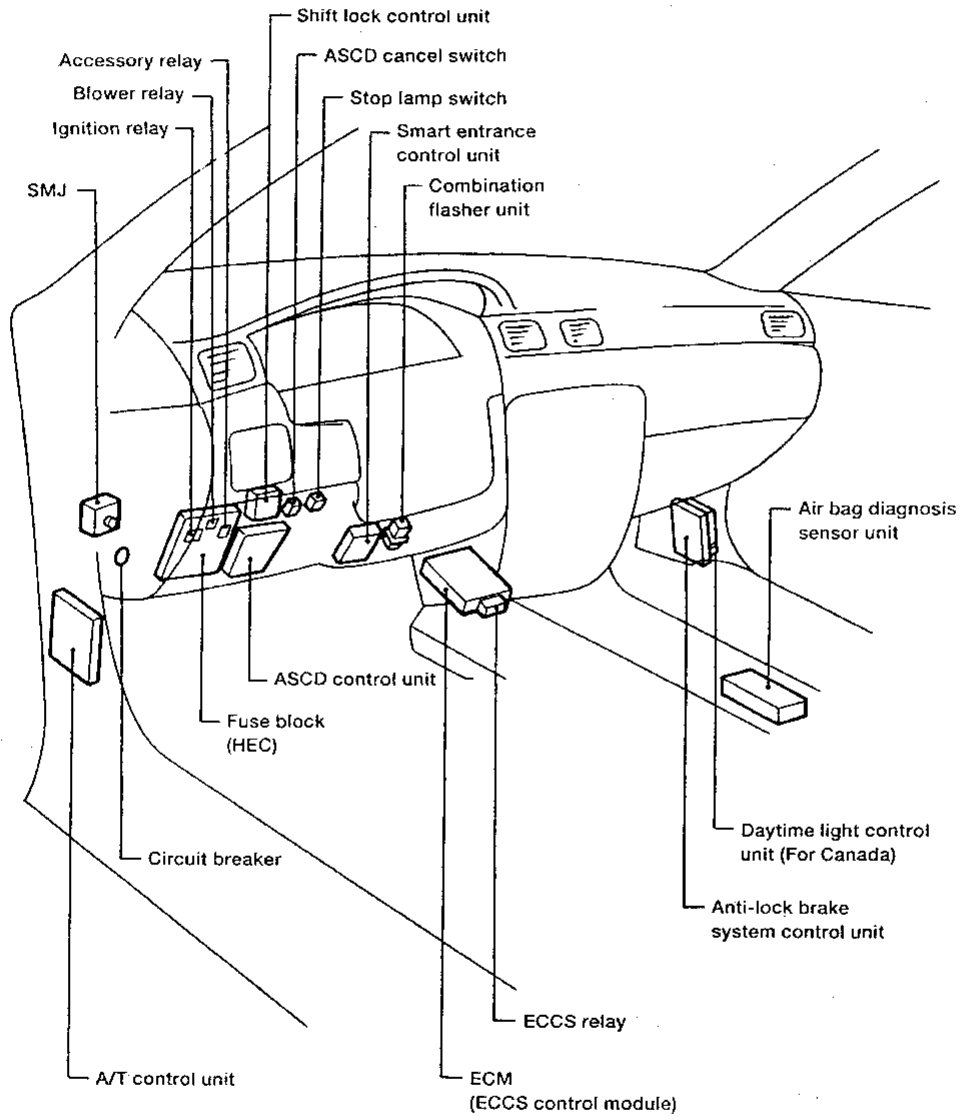

HARNES LAYOUT

How To Read Harness Layout

Example:

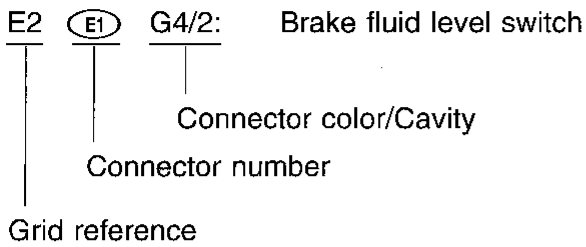

The following Harness Layouts use a map style grid to help locate connectors on the drawings:

- Engine Room Harness (Engine Compartment)
- Main Harness
- Body Harness

To use the grid reference

- 1) Find the desired connector number on the connector list.
- 2) Find the grid reference.
- 3) On the drawing, find the crossing of the grid reference letter column and number row.
- 4) Find the connector number in the crossing zone.
- 5) Follow the line (if used) to the connector.

CONNECTOR SYMBOL

Main symbol of connector (In Harness Layout) are indicated in the below.

Connector type	Water proof type		Standard type	
	Male	Female	Male	Female
<ul style="list-style-type: none"> • Cavity: Less than 4 • Relay connector 				
<ul style="list-style-type: none"> • Cavity: From 5 to 8 				
<ul style="list-style-type: none"> • Cavity: More than 9 				
<ul style="list-style-type: none"> • Ground: terminal etc. 	—			

GI

MA

EM

LC

EC

FE

CL

MT

AT

FA

RA

BR

ST

RS

BT

HA

EL

IDX

HARNESSES LAYOUT

Outline

2-DOOR

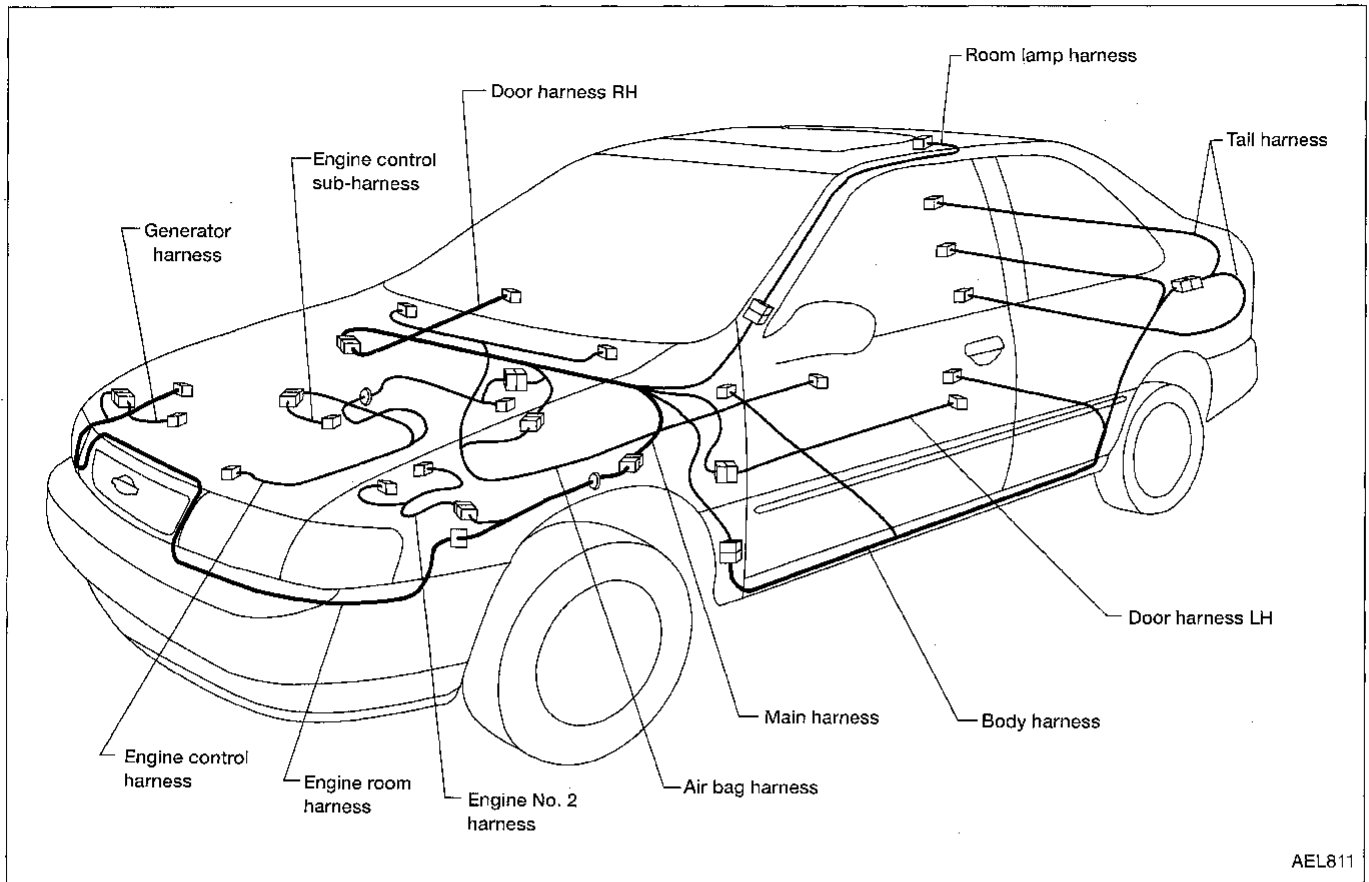

4-DOOR

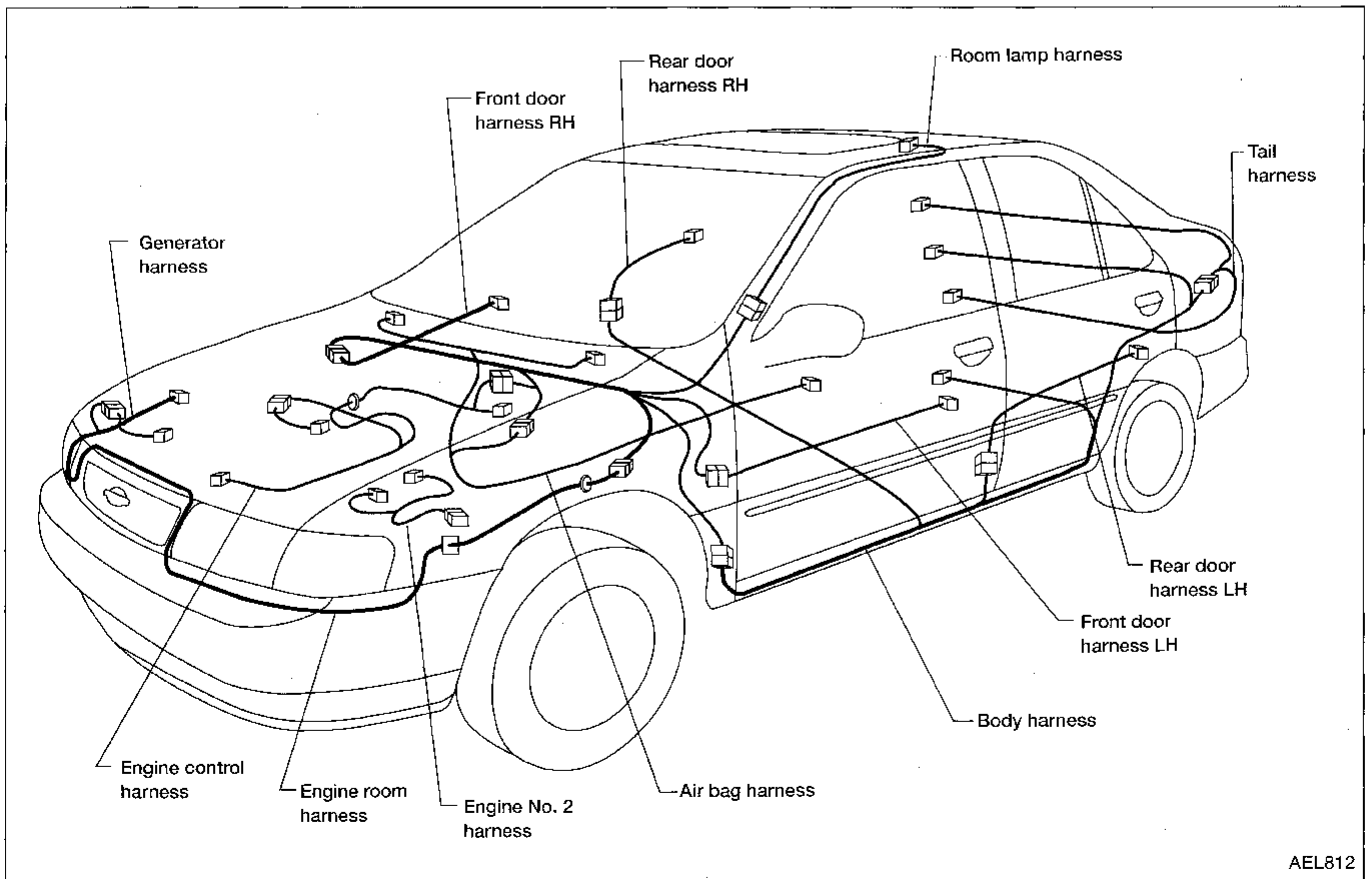

HARNESS LAYOUT

Engine Room Harness

PASSENGER COMPARTMENT

- * E101 SMJ : To (M16)
- E102 W/2 : Circuit breaker
- E103 W/6 : Joint connector-3
- E104 B/2 : Fuse block (HEC)
- * E105 W/16 : Fuse block (HEC)
- E106 W/6 : Fuse block (HEC)
- * E107 W/6 : Ignition switch
- E108 W/2 : Key switch
- E109 L/8 : Wiper switch
- E110 W/6 : Turn signal switch
- E111 W/8 : Lighting switch
- E112 B/2 : Front fog lamp switch

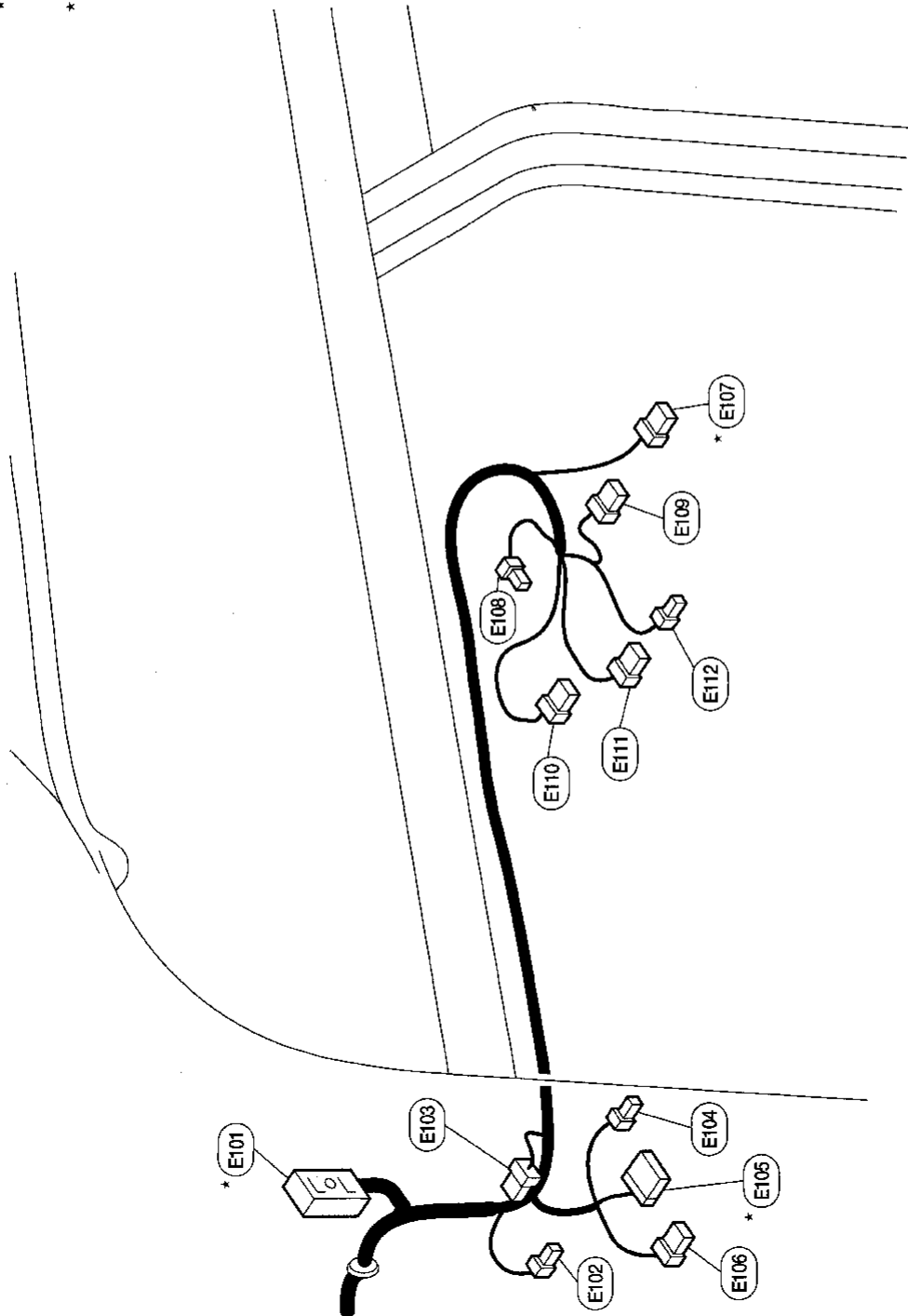

* : Be sure to connect and lock the connectors securely after repair work.
 Failure to do so may cause the on-board diagnostic system to light up the MIL as an open circuit detection.

- GI
- MA
- EM
- LC
- EC
- FE
- CL
- MT
- AT
- FA
- RA
- BR
- ST
- RS
- BT
- HA
- EL
- IDX

HARNESS LAYOUT

Engine Room Harness (Cont'd)

ENGINE COMPARTMENT

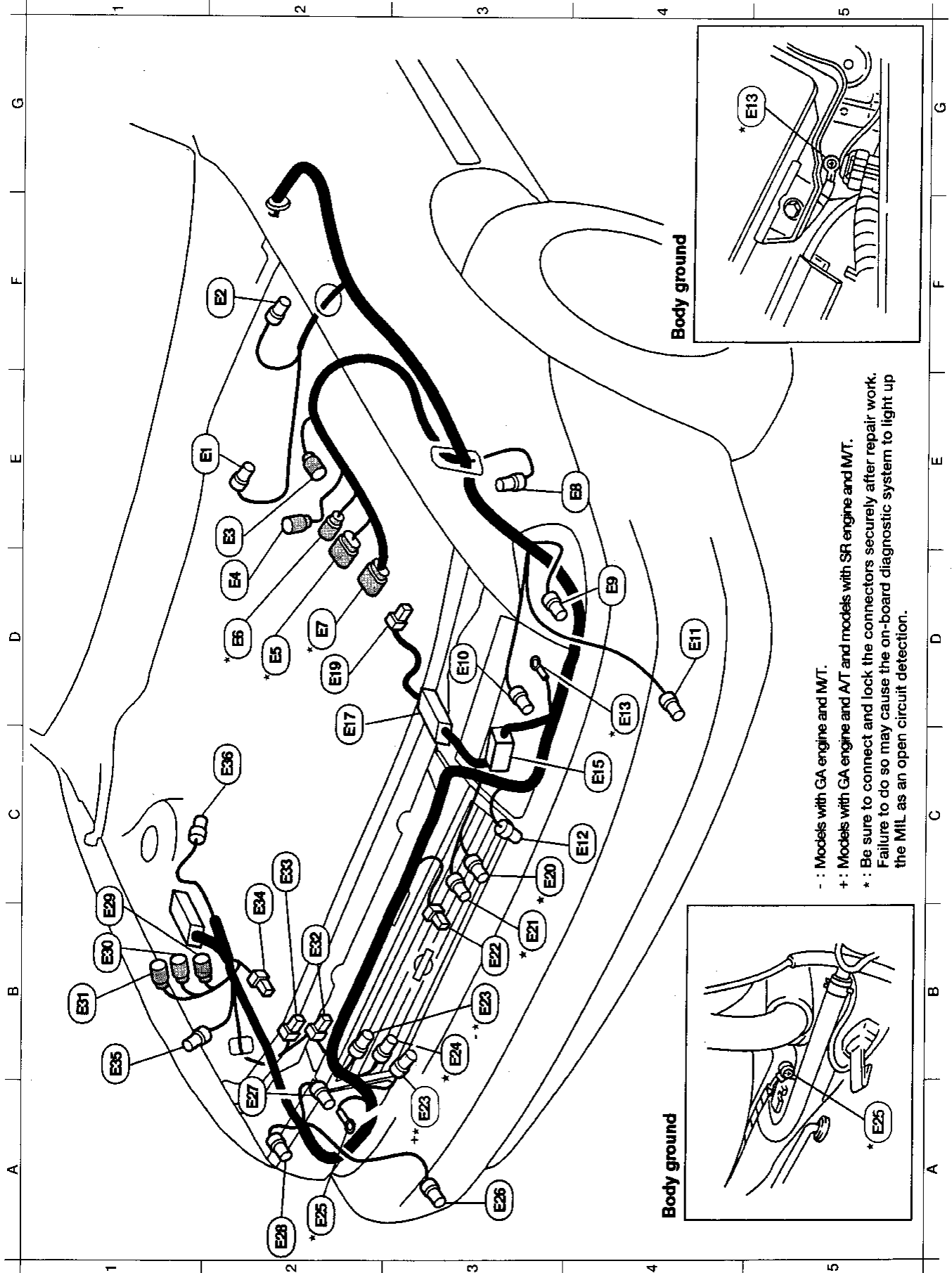

- : Models with GA engine and MT.
- + : Models with GA engine and AT and models with SR engine and MT.
- * : Be sure to connect and lock the connectors securely after repair work. Failure to do so may cause the on-board diagnostic system to light up the MIL as an open circuit detection.

HARNESS LAYOUT

Engine Room Harness (Cont'd)

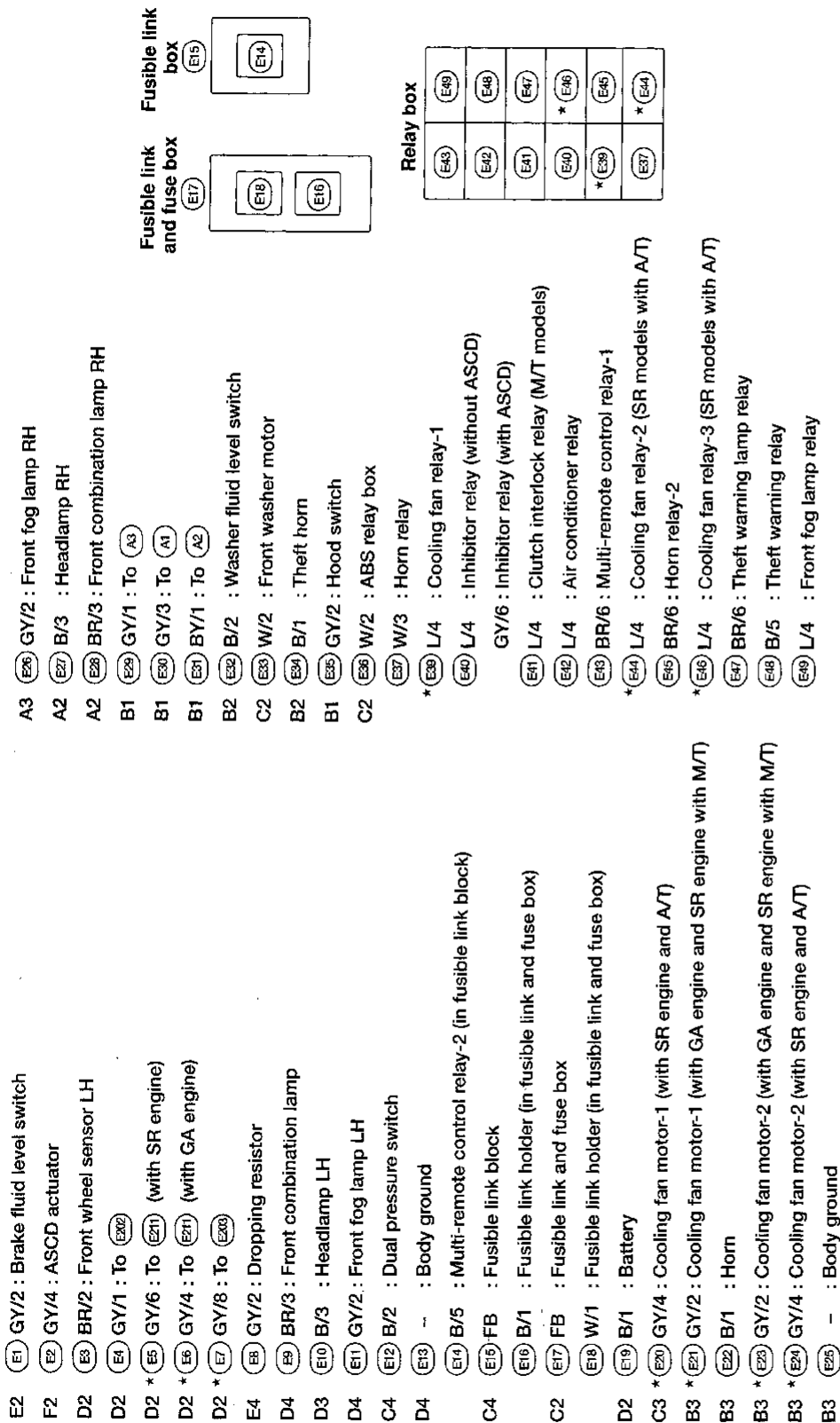

* : Be sure to connect and lock the connectors securely after repair work. Failure to do so may cause the on-board diagnostic system to light up the MIL as an open circuit detection.

GI
MA
EM
LC
EC
FE
CL
MT
AT
FA
RA
BR
ST
RS
BT
HA
EL
IDX

HARNESS LAYOUT

Main Harness

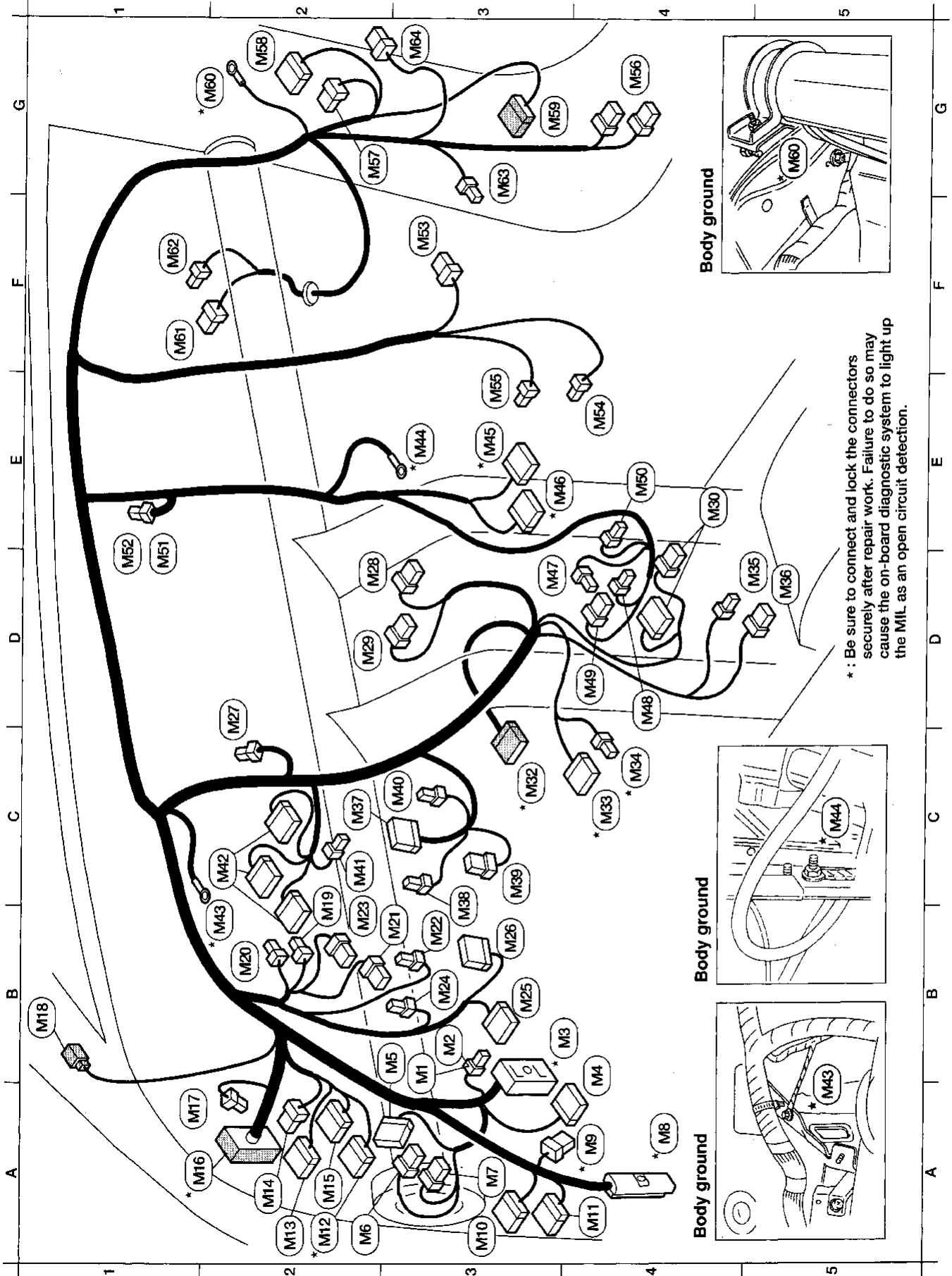

*: Be sure to connect and lock the connectors securely after repair work. Failure to do so may cause the on-board diagnostic system to light up the MIL as an open circuit detection.

HARNES LAYOUT

Main Harness (Cont'd)

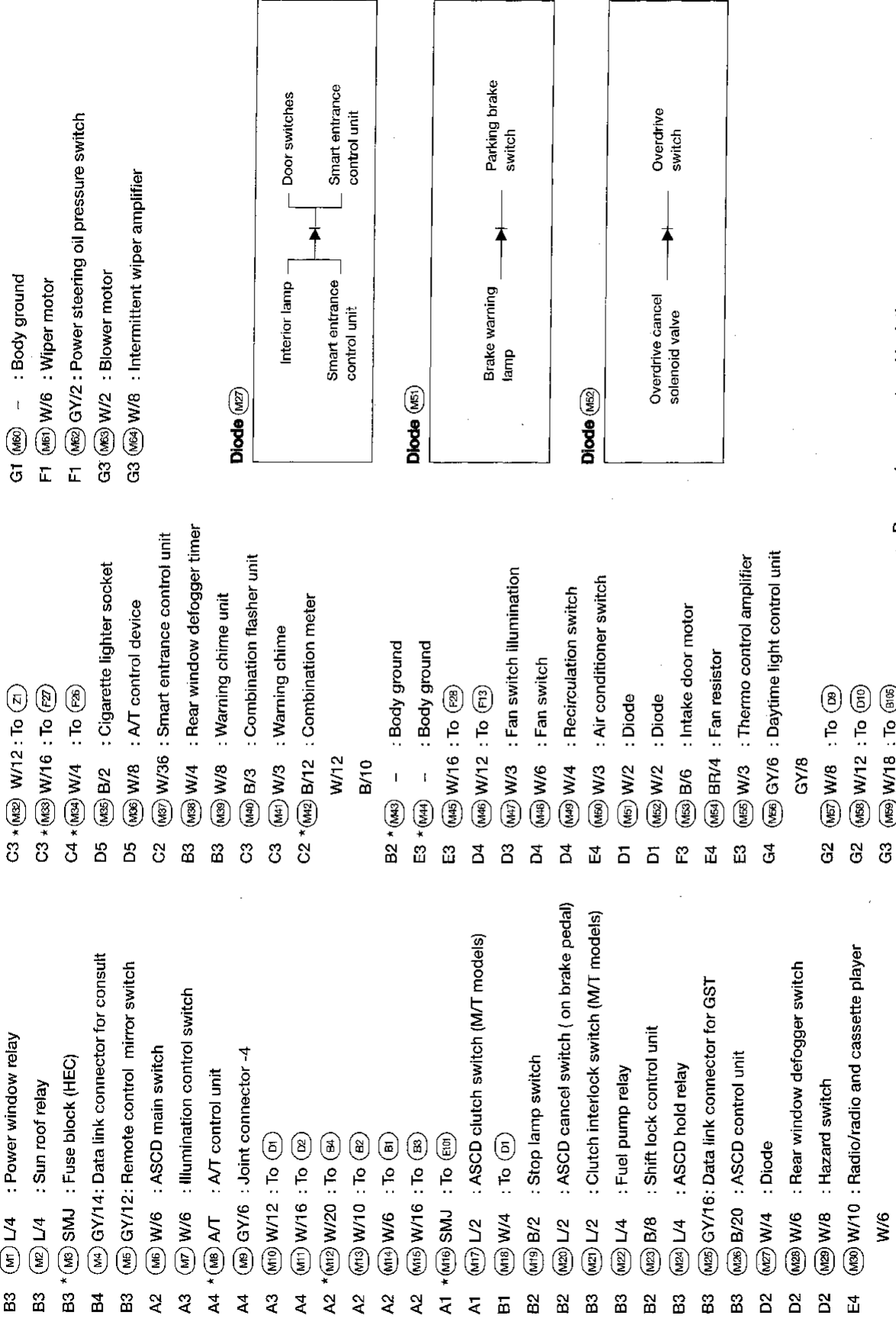

* : Be sure to connect and lock the connectors securely after repair work. Failure to do so may cause the on-board diagnostic system to light up the MIL as an open circuit detection.

CL MA EM LC EC FE CL MT AT FA RA BR ST PS BT HA EL IDX

HARNES LAYOUT

2-DOOR

Body Harness

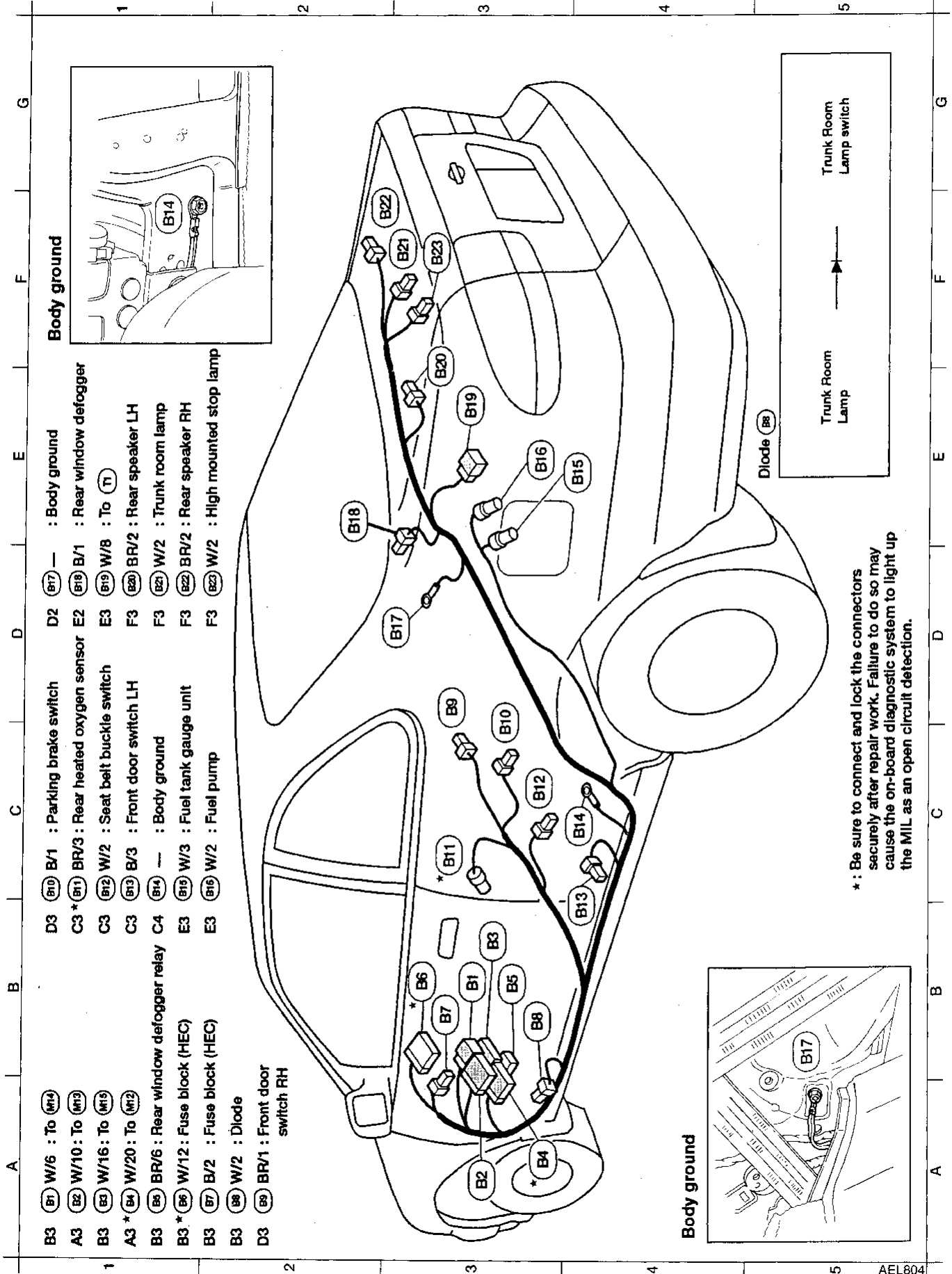

- B3 (B1) W/6 : To (M14)
- A3 (B2) W/10 : To (M12)
- B3 (B3) W/16 : To (M15)
- A3 * (B4) W/20 : To (M12)
- B3 (B6) BR/6 : Rear window defogger relay
- B3 * (B6) W/12 : Fuse block (HEC)
- B3 (B7) B/2 : Fuse block (HEC)
- B3 (B8) W/2 : Diode
- D3 (B9) BR/1 : Front door switch RH
- D3 (B10) B/1 : Parking brake switch
- C3 * (B11) BR/3 : Rear heated oxygen sensor
- C3 (B12) W/2 : Seat belt buckle switch
- C3 (B13) B/3 : Front door switch LH
- C4 (B14) — : Body ground
- E3 (B15) W/3 : Fuel tank gauge unit
- E3 (B16) W/2 : Fuel pump
- D2 (B17) — : Body ground
- E2 (B18) B/1 : Rear window defogger
- E3 (B19) W/8 : To (T1)
- F3 (B20) BR/2 : Rear speaker LH
- F3 (B21) W/2 : Trunk room lamp
- F3 (B22) BR/2 : Rear speaker RH
- F3 (B23) W/2 : High mounted stop lamp

* : Be sure to connect and lock the connectors securely after repair work. Failure to do so may cause the on-board diagnostic system to light up the MIL as an open circuit detection.

HARNESS LAYOUT

Body Harness (Cont'd)

4-DOOR

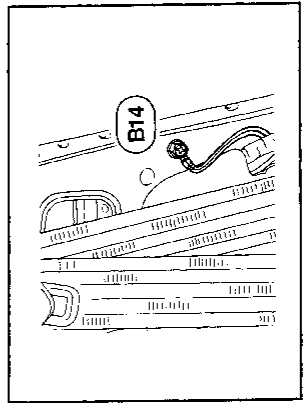
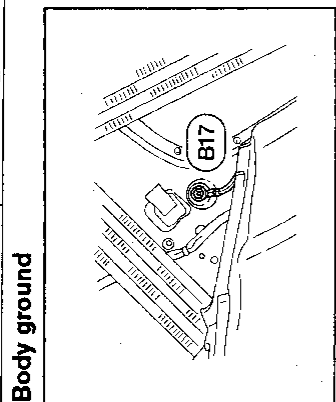
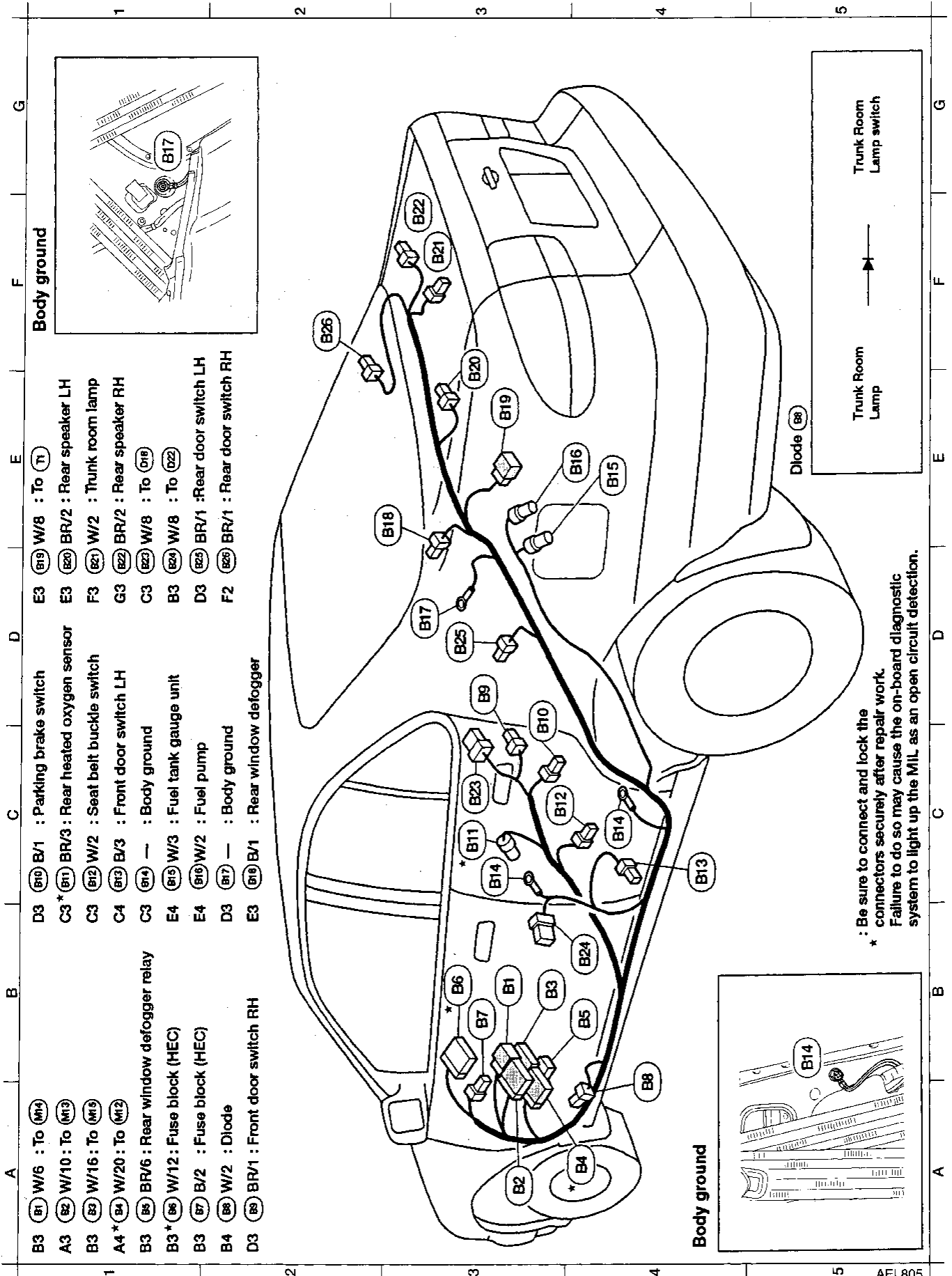

- B3 (B1) W/6 : To (M4)
- A3 (B2) W/10 : To (M3)
- B3 (B3) W/16 : To (M5)
- A4 * (B4) W/20 : To (M2)
- B3 (B6) BR/6 : Rear window defogger relay
- B3 * (B6) W/12 : Fuse block (HEC)
- B3 (B7) B/2 : Fuse block (HEC)
- B4 (B8) W/2 : Diode
- D3 (B9) BR/1 : Front door switch RH
- D3 (B10) B/1 : Parking brake switch
- C3 * (B1) BR/3 : Rear heated oxygen sensor
- C3 (B12) W/2 : Seat belt buckle switch
- C4 (B13) B/3 : Front door switch LH
- C3 (B14) — : Body ground
- E4 (B15) W/3 : Fuel tank gauge unit
- E4 (B16) W/2 : Fuel pump
- D3 (B17) — : Body ground
- E3 (B19) B/1 : Rear window defogger
- E3 (B19) W/8 : To (T1)
- E3 (B20) BR/2 : Rear speaker LH
- F3 (B21) W/2 : Trunk room lamp
- G3 (B22) BR/2 : Rear speaker RH
- C3 (B23) W/8 : To (C19)
- B3 (B24) W/8 : To (D22)
- D3 (B25) BR/1 : Rear door switch LH
- F2 (B26) BR/1 : Rear door switch RH

* : Be sure to connect and lock the connectors securely after repair work. Failure to do so may cause the on-board diagnostic system to light up the MIL as an open circuit detection.

1 2 3 4 5

A B C D E F G

GI
MA
EM
LC
EC
FE
CL
MT
AT
FA
RA
BR
ST
RS
BT
HA
EL
IDX

Body ground

Body ground

Trunk Room Lamp

Trunk Room Lamp switch

Diode (B8)

AEL805

Engine Control Harness

GA ENGINE

- * F1 GY/3 : Front heated oxygen sensor (Except Non-California models with M/T)
- * F2 B/1 : Front oxygen sensor (Non-California models with M/T)
- * F3 GY/2 : Crankshaft position sensor
- * F4 GY/2 : Distributor GY/6
- * F6 GY/2 : Resistor
- * F7 BR/4 : Mass air flow sensor
- * F8 GY/2 : Intake air temperature sensor
- * F9 BR/5 : IACV-AAC and FICD solenoid valve
- * F10 BR/3 : Throttle position sensor
- * F11 GY/2 : EGR temperature sensor
- * F12 — : Engine ground
- * F13 W/12: To M46
- * F14 L/4 : ECCS relay
- * F15 G/2 : EGR valve and canister control solenoid valve
- * F16 B/2 : Injector No. 1
- * F17 B/2 : Injector No. 2
- * F18 B/2 : Injector No. 3
- * F19 B/2 : Injector No. 4
- * F20 GY/2 : Engine coolant temperature sensor
- * F21 GY/2 : To knock sensor
- * F22 B/2 : Valve timing control solenoid valve
- * F23 — : Engine ground
- * F24 SMJ : ECM (ECCS control module)
- * F25 GY/3 : Rear heated oxygen sensor (Models for California)
- * F26 W/4 : To M34
- * F27 W/16: To M33
- * F28 GY/6 : Joint connector - 1
- * F29 GY/6 : Joint connector - 2

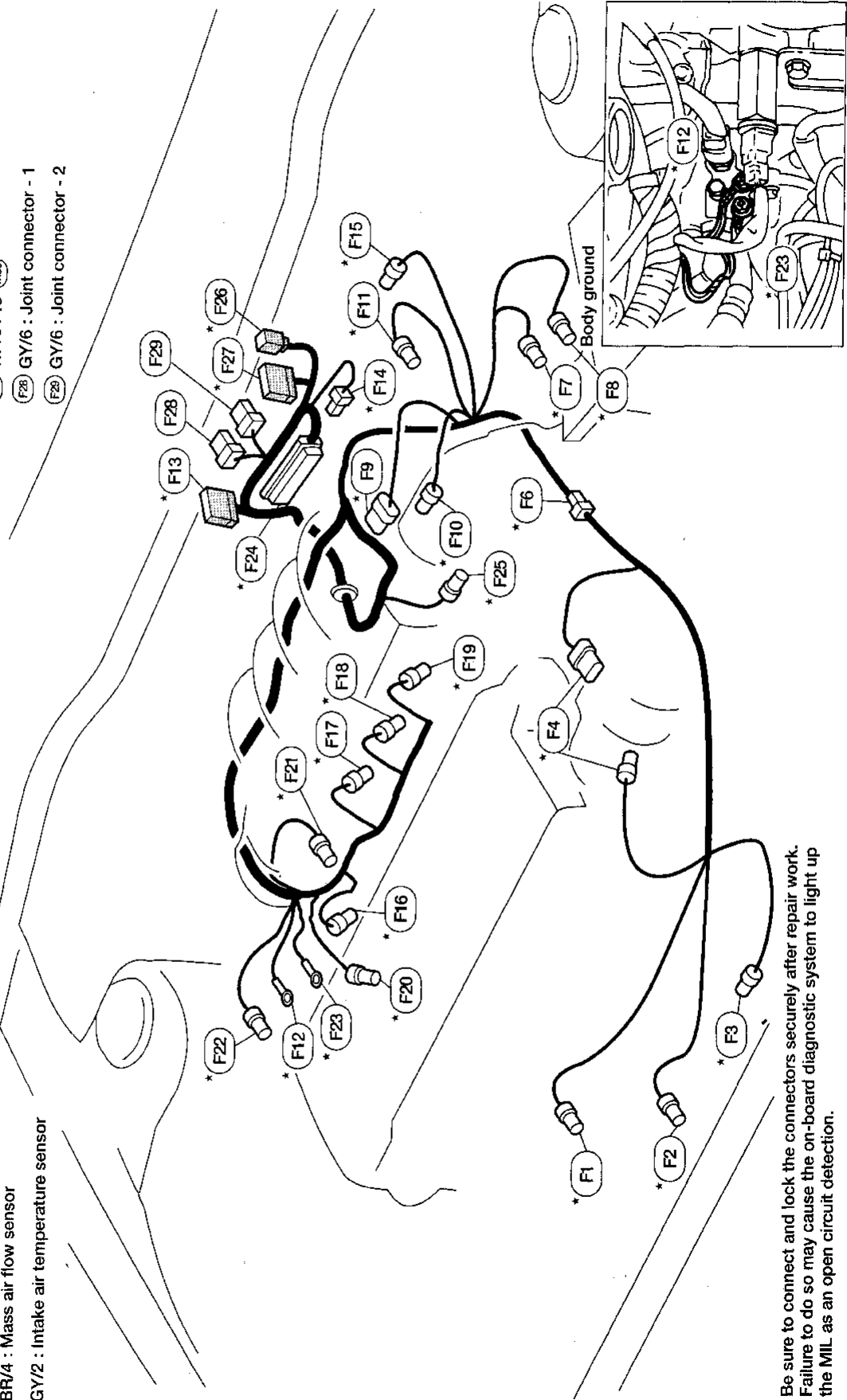

* : Be sure to connect and lock the connectors securely after repair work. Failure to do so may cause the on-board diagnostic system to light up the MIL as an open circuit detection.

HARNESS LAYOUT

Engine Control Harness (Cont'd)

SR ENGINE

- * (F1) GY/3 : Front heated oxygen sensor
- * (F2) GY/2 : Crankshaft position sensor
- * (F4) GY/2 : Distributor
- GY/6
- * (F5) GY/5 : To (E213)
- * (F6) GY/2 : Resistor
- * (F7) BR/4 : Mass air flow sensor
- * (F8) GY/2 : Intake air temperature sensor
- * (F9) BR/8 : To terminal cord assembly (A/T models)
- * (F10) BR/3 : Throttle position sensor (M/T models)
- * (F11) GY/2 : EGR temperature sensor
- * (F12) — : Engine ground
- * (F13) W/12 : To (M46)
- * (F14) L/4 : ECCS relay
- * (F15) GY/3 : Revolution sensor (A/T models)
- * (F16) GY/3 : Throttle position sensor (A/T models)
- * (F17) GY/4 : Throttle position switch (A/T models)
- * (F18) — : Engine ground
- * (F19) BR/2 : IACV-AAC valve
- * (F20) GY/2 : IAC-FICD solenoid valve
- * (F21) GY/8 : To (F51)
- * (F22) GY/2 : IACV-air regulator
- * (F23) GY/6 : Joint connector-1
- * (F24) GY/6 : Joint connector-2
- * (F25) SMJ : ECM (ECCS control module)
- * (F26) W/4 : To (M24)
- * (F27) W/16 : To (M33)
- * (F28) W/16 : To (M36)
- * (F29) GY/8 : To (F51)
- * (F30) GY/8 : To (F51)
- * (F31) B/2 : Injector No. 1
- * (F32) B/2 : Injector No. 2
- * (F33) B/2 : Injector No. 3
- * (F34) B/2 : Injector No. 4
- * (F35) B/2 : Injector No. 4
- * (F36) B/2 : Knock sensor

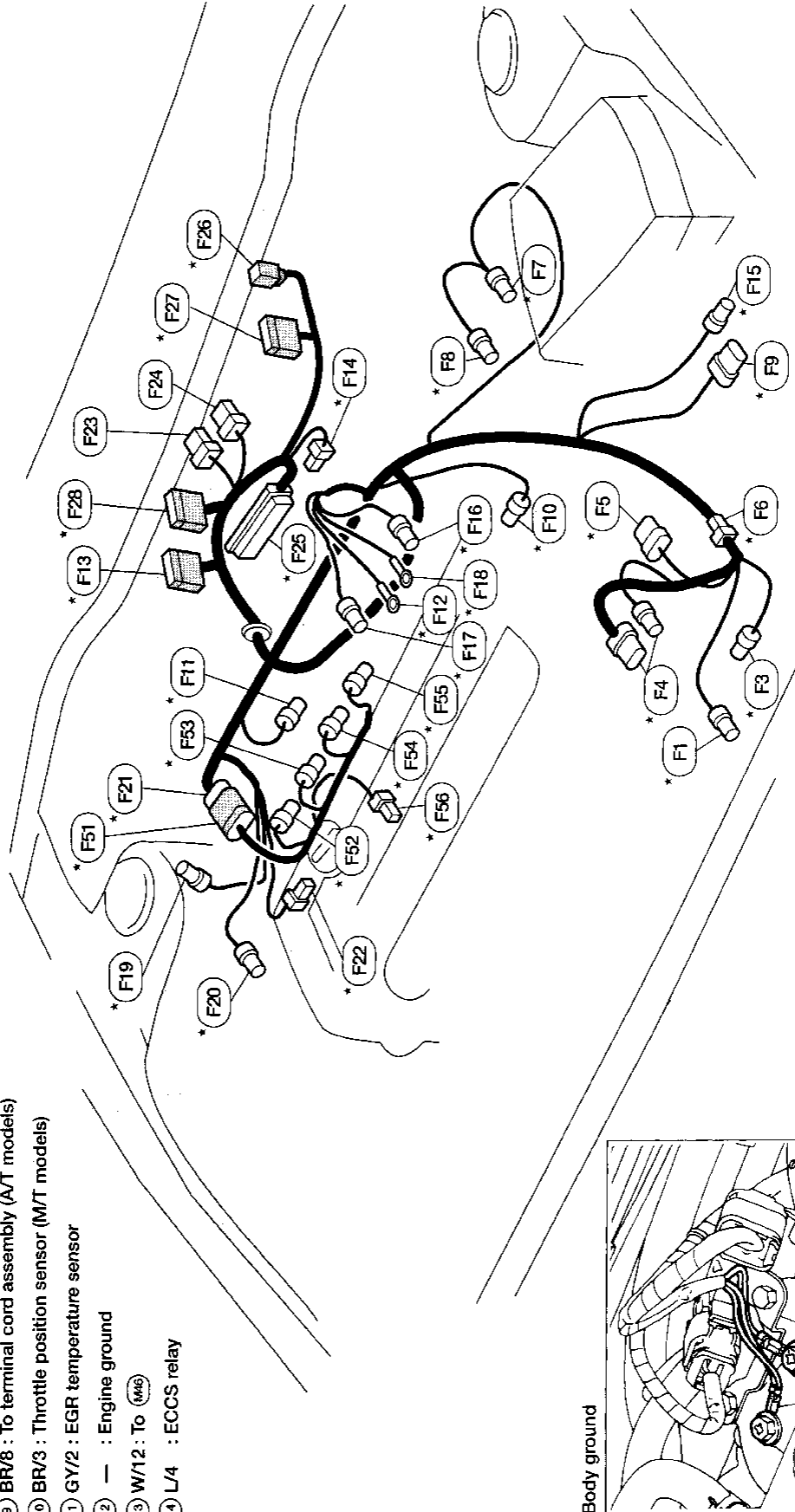

* : Be sure to connect and lock the connectors securely after repair work. Failure to do so may cause the on-board diagnostic system to light up the MIL as an open circuit detection.

- CI
- MA
- EM
- LC
- EC
- FE
- CL
- MT
- AT
- FA
- RA
- BR
- ST
- RS
- BT
- HA
- EL**
- IDX

HARNES LAYOUT

Engine Harness No. 2 and Generator Harness

GA ENGINE

- Engine No. 2 harness**
- (E201) — : Battery
 - (E202) GY/1 : To (E4)
 - * (E203) GY/8 : To (E7)
 - (E204) GY/2 : Back-up lamp switch (Models with M/T)
 - * (E205) B/2 : Neutral switch (Models with M/T)
 - (E206) — : Starter motor
 - (E207) GY/1 : Starter motor
 - * (E208) GY/2 : Vehicle speed sensor
 - (E209) B/1 : Thermal transmitter
 - (E210) B/1 : Engine oil pressure switch
 - (E211) GY/4 : To (E6)
 - (E212) B/3 : Overdrive cancel solenoid valve and torque converter clutch solenoid valve (Models with A/T)
 - * (E213) GY/4 : Inhibitor switch
- Generator harness**
- (A1) GY/3 : To (E30)
 - (A2) GY/1 : To (E31)
 - (A4) — : Body ground
 - (A5) — : Generator
 - : W/2
 - (A6) B/1 : A/C compressor

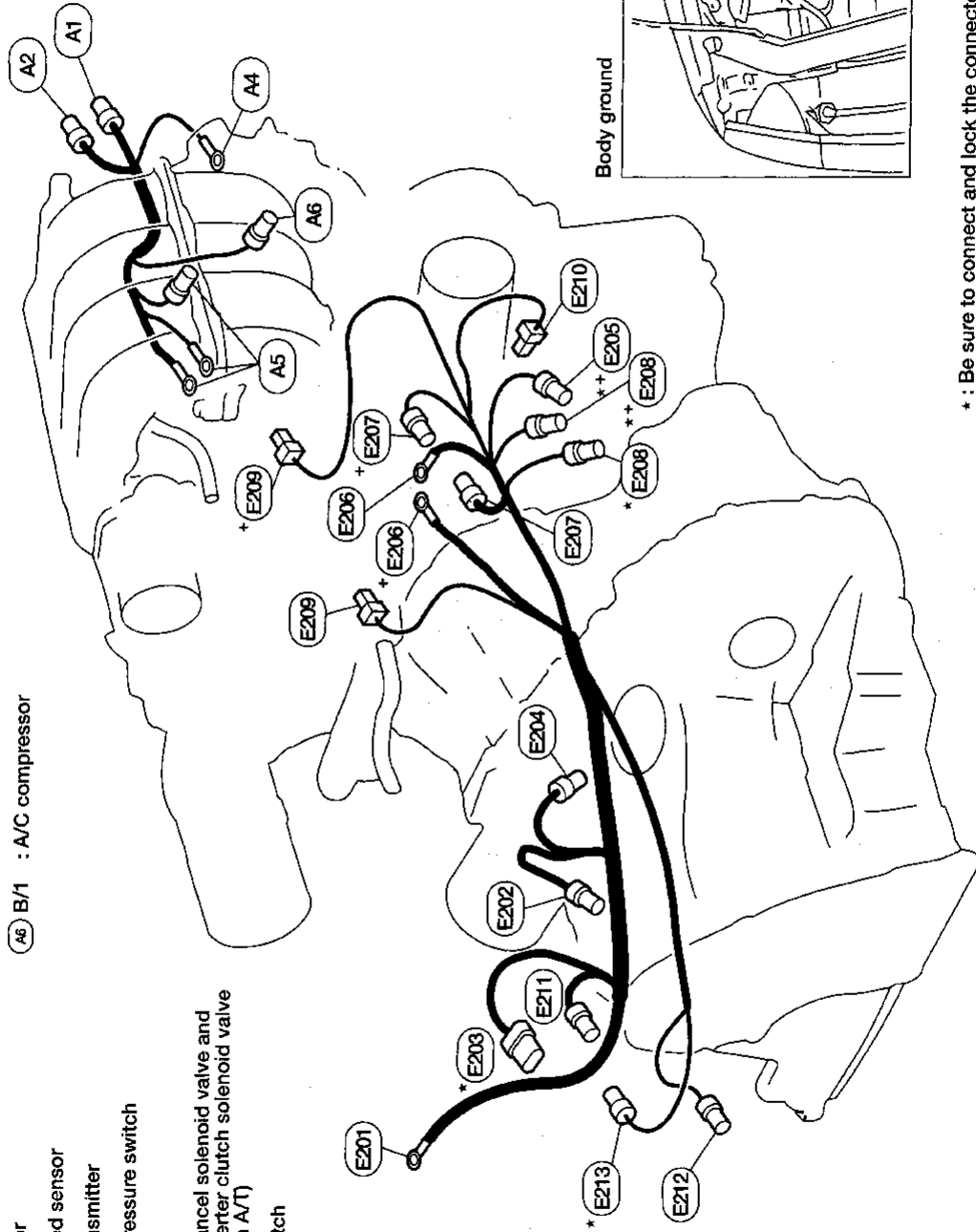

* : Be sure to connect and lock the connectors securely after repair work. Failure to do so may cause the on-board diagnostic system to light up the MIL as an open circuit detection.

+ Harness routing for models with M/T

HARNESS LAYOUT

Engine Harness No. 2 and Generator Harness (Cont'd)

SR ENGINE

Generator harness

- (A1) GY/3 : To (E30)
- (A2) GY/1 : To (E31)
- (A3) GY/1 : To (E28)
- (A4) — : Body ground
- (A5) — : Generator
- (A6) B/1 : A/C compressor

- * (E213) GY/5 : To (F5)
- * (E214) B/2 : EGR and canister control solenoid valve
- * (E215) GY/2 : Engine coolant temperature sensor

- Engine No. 2 harness
- (E201) — : Battery
- (E202) GY/1 : To (E4)
- * (E203) GY/8 : To (E7)
- (E204) GY/2 : Back-up lamp switch (Models with M/T)
- * (E205) B/2 : Neutral switch (Models with M/T)
- (E206) — : Starter motor
- (E207) GY/1 : Starter motor
- * (E208) GY/2 : Vehicle speed sensor
- (E209) B/1 : Thermal transmitter
- (E210) B/1 : Engine oil pressure switch
- * (E211) GY/6 : To (E5)
- (E212) B/10 : Inhibitor switch (Models with A/T)

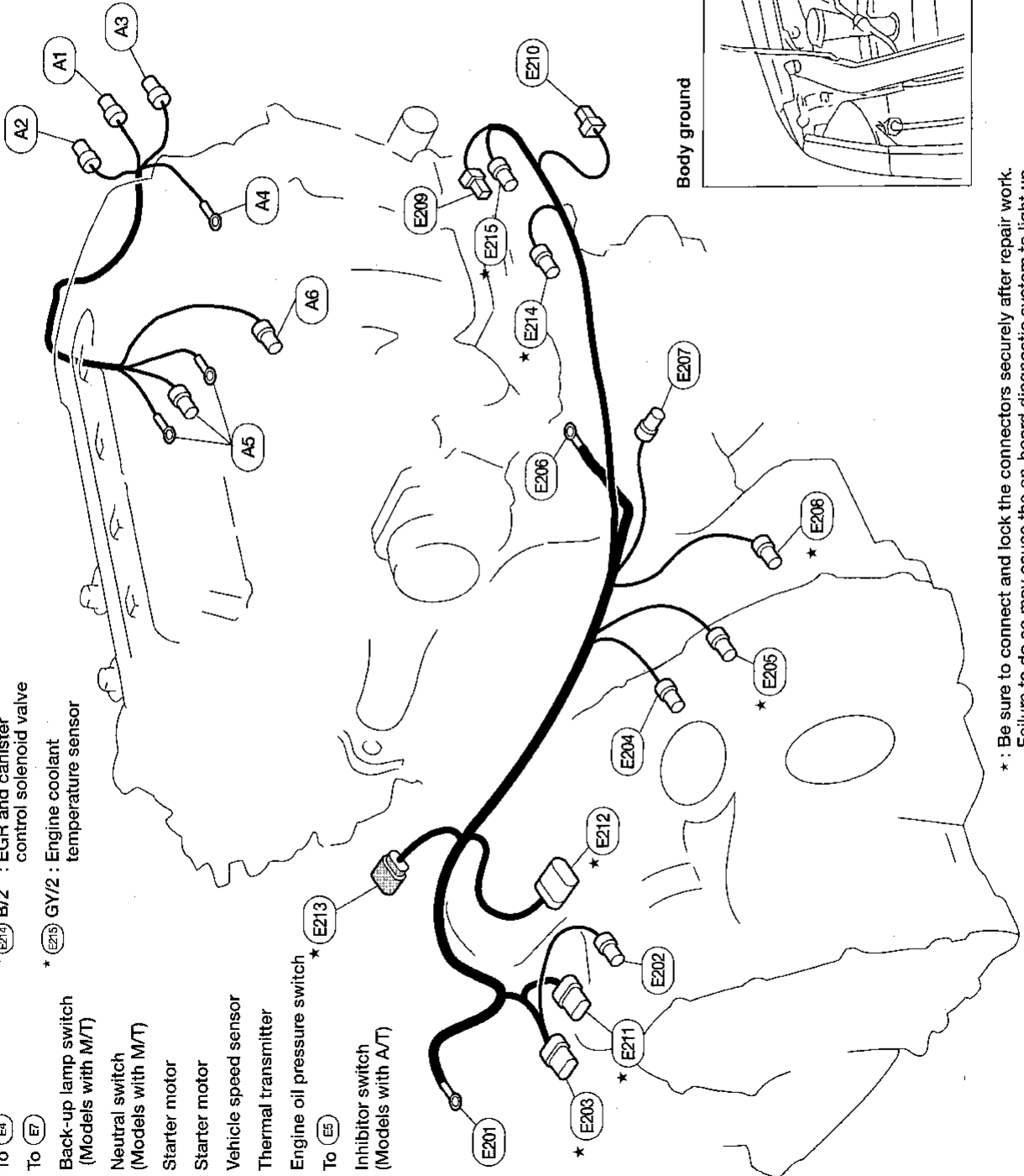

* : Be sure to connect and lock the connectors securely after repair work. Failure to do so may cause the on-board diagnostic system to light up the MIL as an open circuit detection.

GI
MA
EM
LC
EC
FE
CL
WT
AT
FA
RA
BR
ST
RS
BT
HA
EL
IDX

HARNES LAYOUT

Room Lamp Harness

2-DOOR

- (R1) W/4 : To (M18)
- (R2) W/1 : Sun roof assembly
- (R4) W/2 : Interior lamp

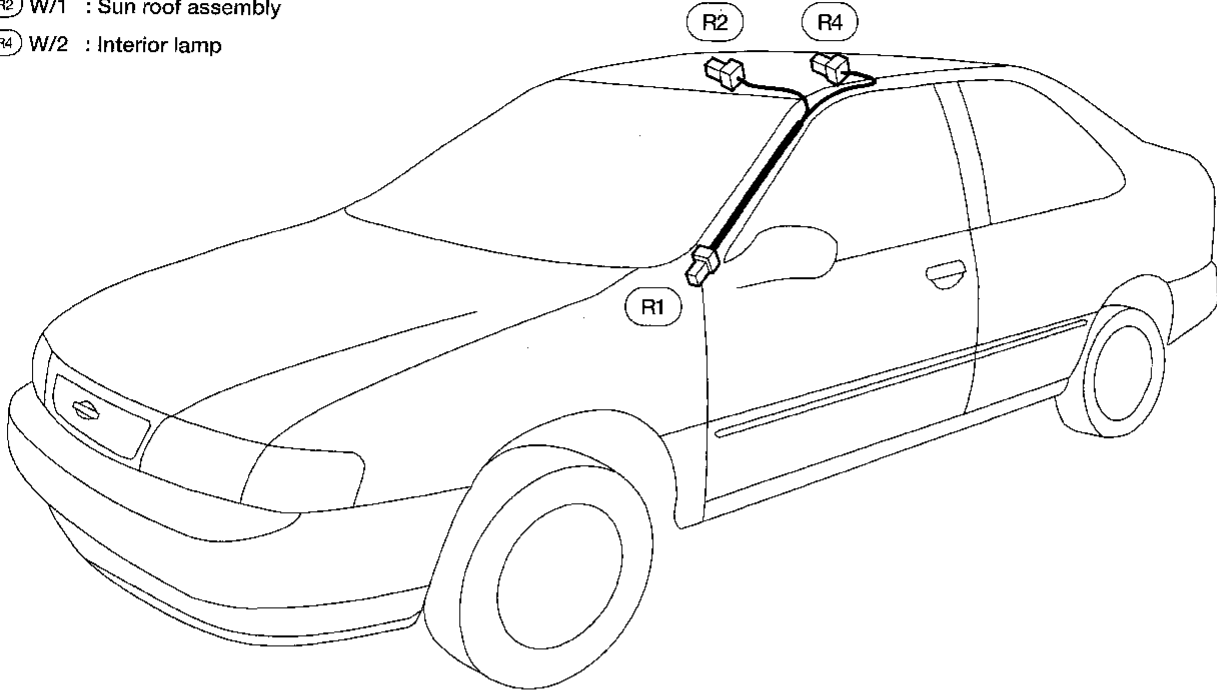

AEL808

4-DOOR

- (R1) W/4 : To (M18)
- (R2) W/1 : Sun roof assembly
- (R4) W/2 : Interior lamp

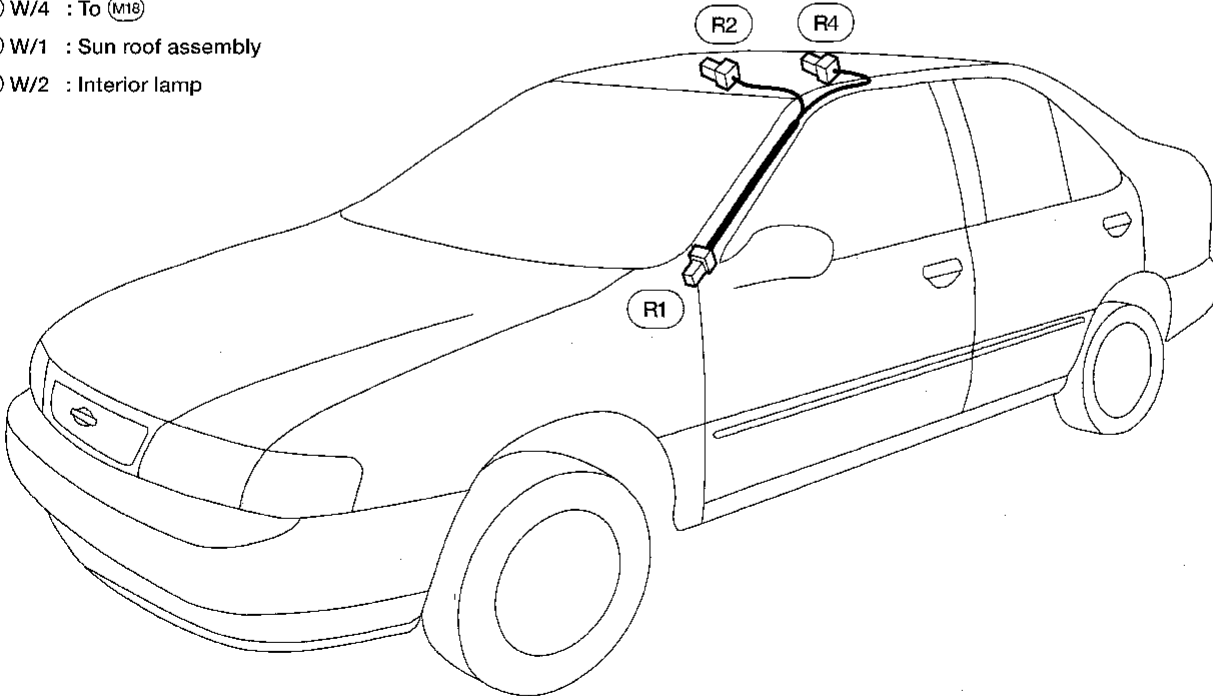

AEL809

HARNESS LAYOUT

Air Bag Harness

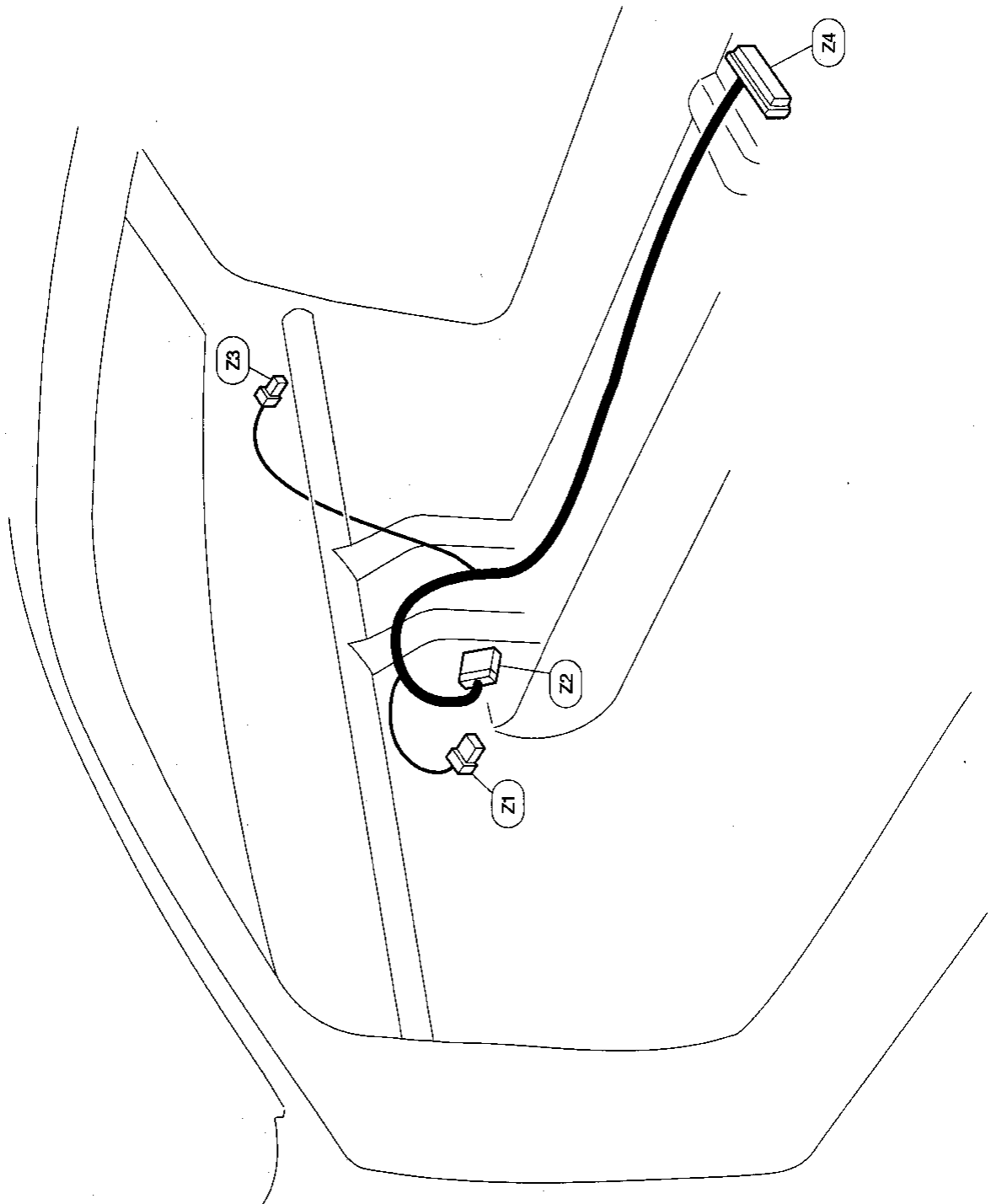

- ① W/12 : To (M32)
- ② W/6 : Air bag module LH
- ③ W/2 : Air bag module RH
- ④ Y/24 : Air bag diagnosis sensor unit

- GI
- MA
- EM
- LC
- EC
- FE
- CL
- MT
- AT
- FA
- RA
- BR
- ST
- RS
- BT
- HA
- EL**
- IDX

HARNESS LAYOUT

Tail Harness

2-DOOR

- | | |
|------------------------------------|--|
| (T1) W/8 : To (B19) | (T6) W/3 : Trunk lid key cylinder switch |
| (T2) W/2 : Back-up lamp LH | (T7) W/2 : Back-up lamp RH |
| (T3) BR/2 : License lamp | (T8) W/4 : Rear combination lamp LH |
| (T4) B/2 : Trunk room lamp switch | (T9) — : Body ground |
| (T5) BR/2 : High mounted stop lamp | (T10) — : Body ground |
| | (T11) W/4 : Rear combination lamp RH |

Body ground

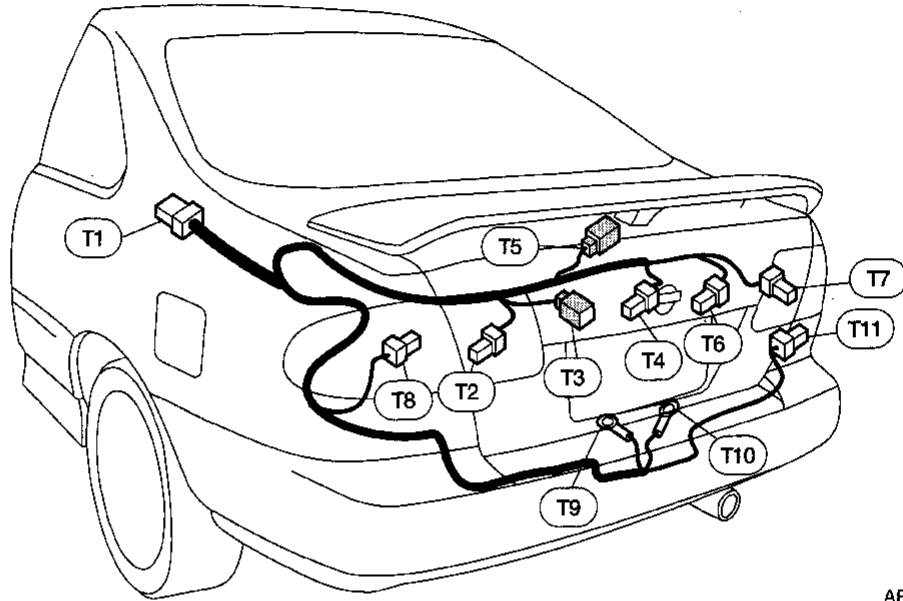
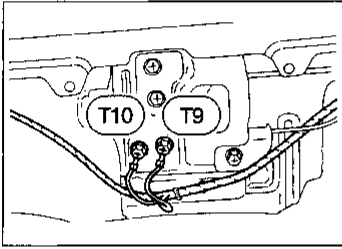

AEL806

4-DOOR

- | | |
|--|--------------------------------------|
| (T1) W/8 : To (B19) | (T7) W/2 : Back-up lamp RH |
| (T2) W/2 : Back-up lamp LH | (T8) W/4 : Rear combination lamp LH |
| (T3) BR/2 : License lamp | (T9) — : Body ground |
| (T4) B/2 : Trunk room lamp switch | (T10) — : Body ground |
| (T5) W/2 : High mounted stop lamp | (T11) W/4 : Rear combination lamp RH |
| (T6) W/3 : Trunk lid key cylinder switch | |

Body ground

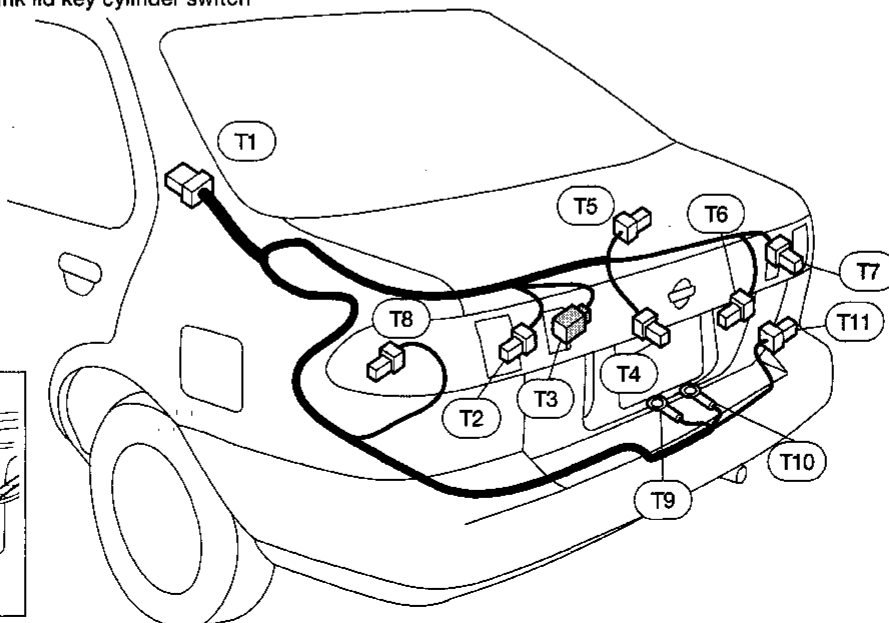
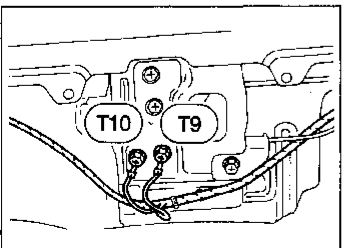

AEL807

HARNESS LAYOUT

LEFT

Front Door Harness (2-Door)

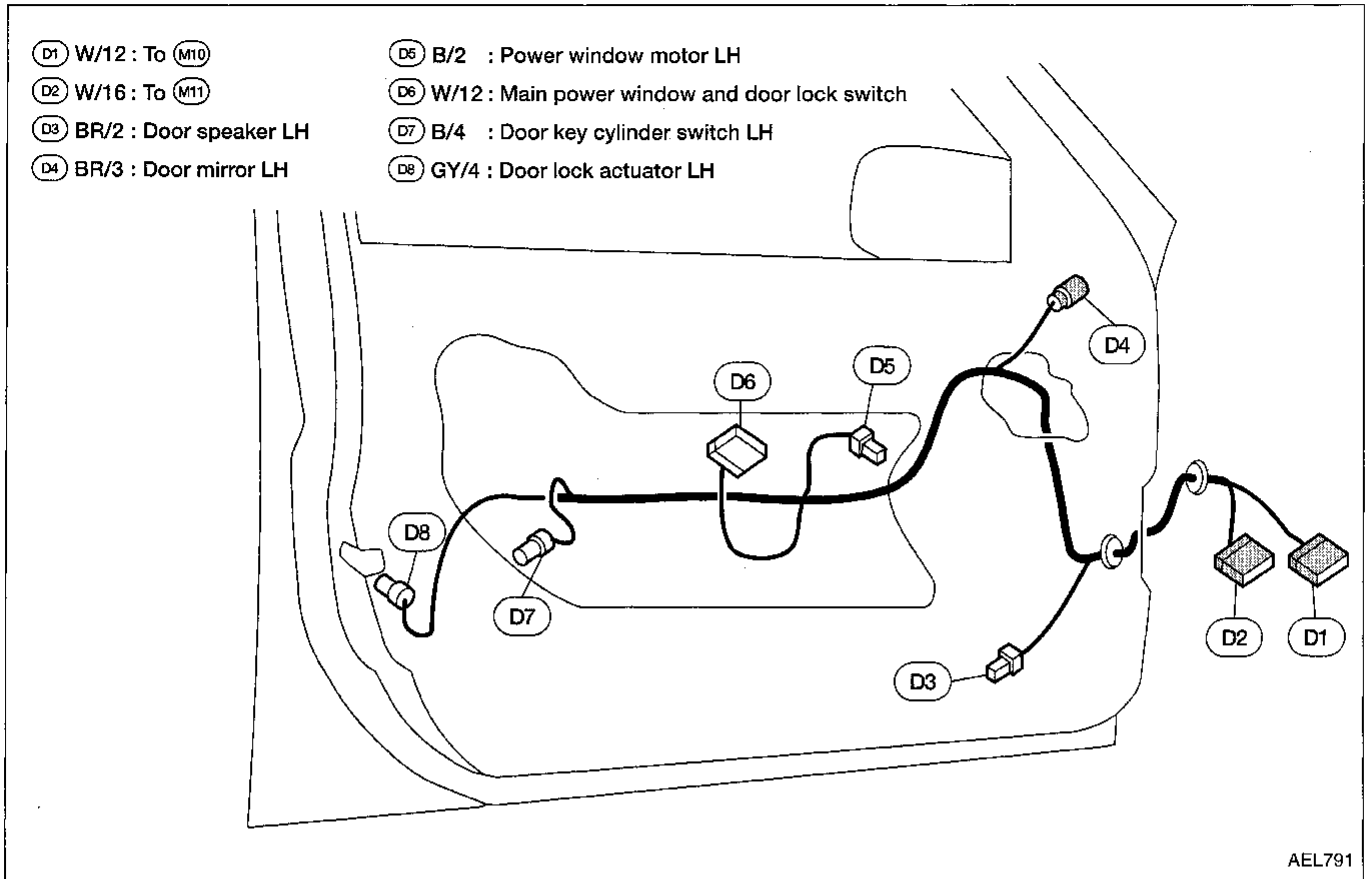

RIGHT

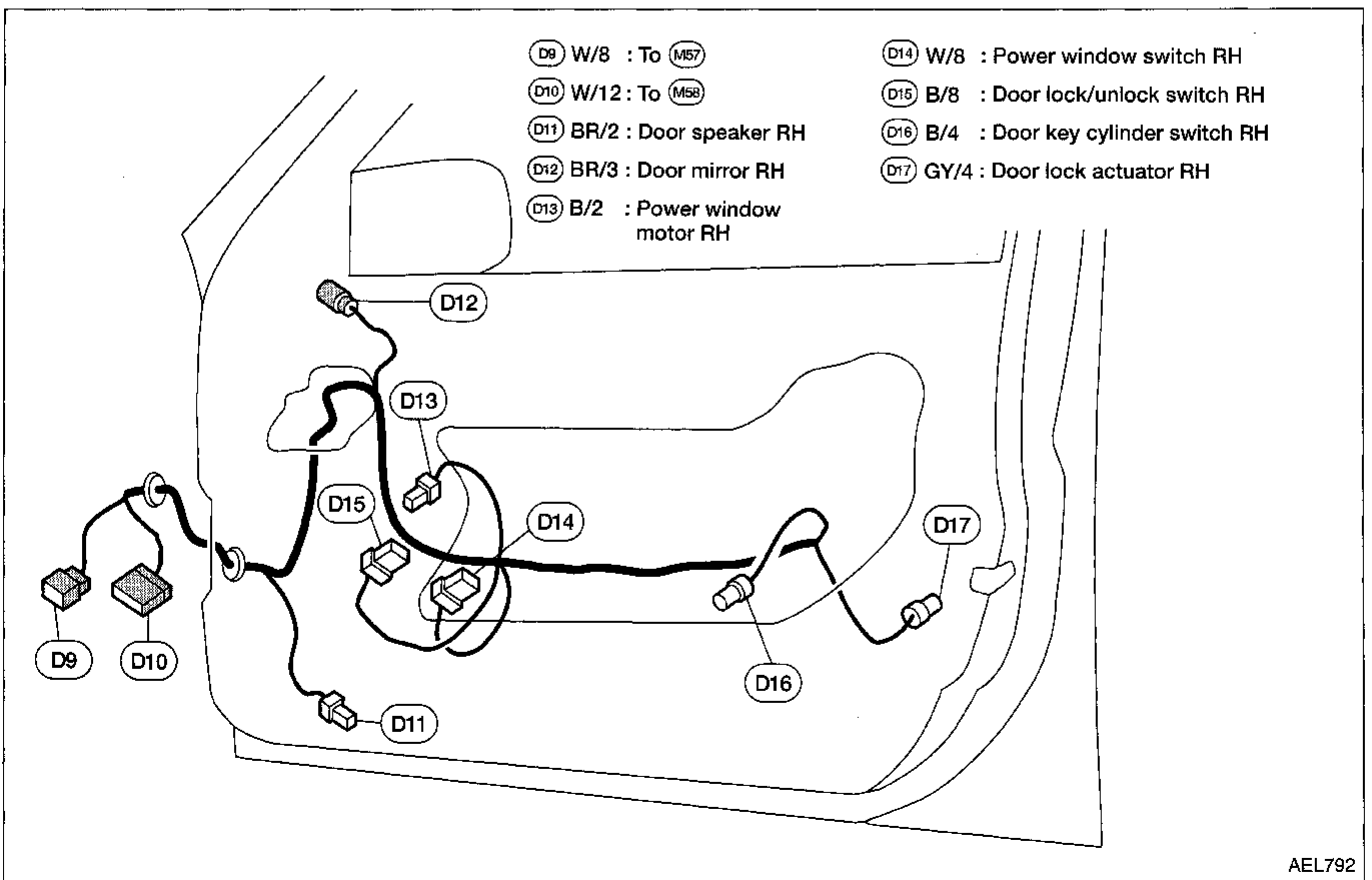

GI
MA
EM
LC
EC
FE
CL
MT
AT
FA
RA
BR
ST
RS
BT
HA
EL
IDX

HARNESS LAYOUT

Front Door Harness (4-Door)

LEFT

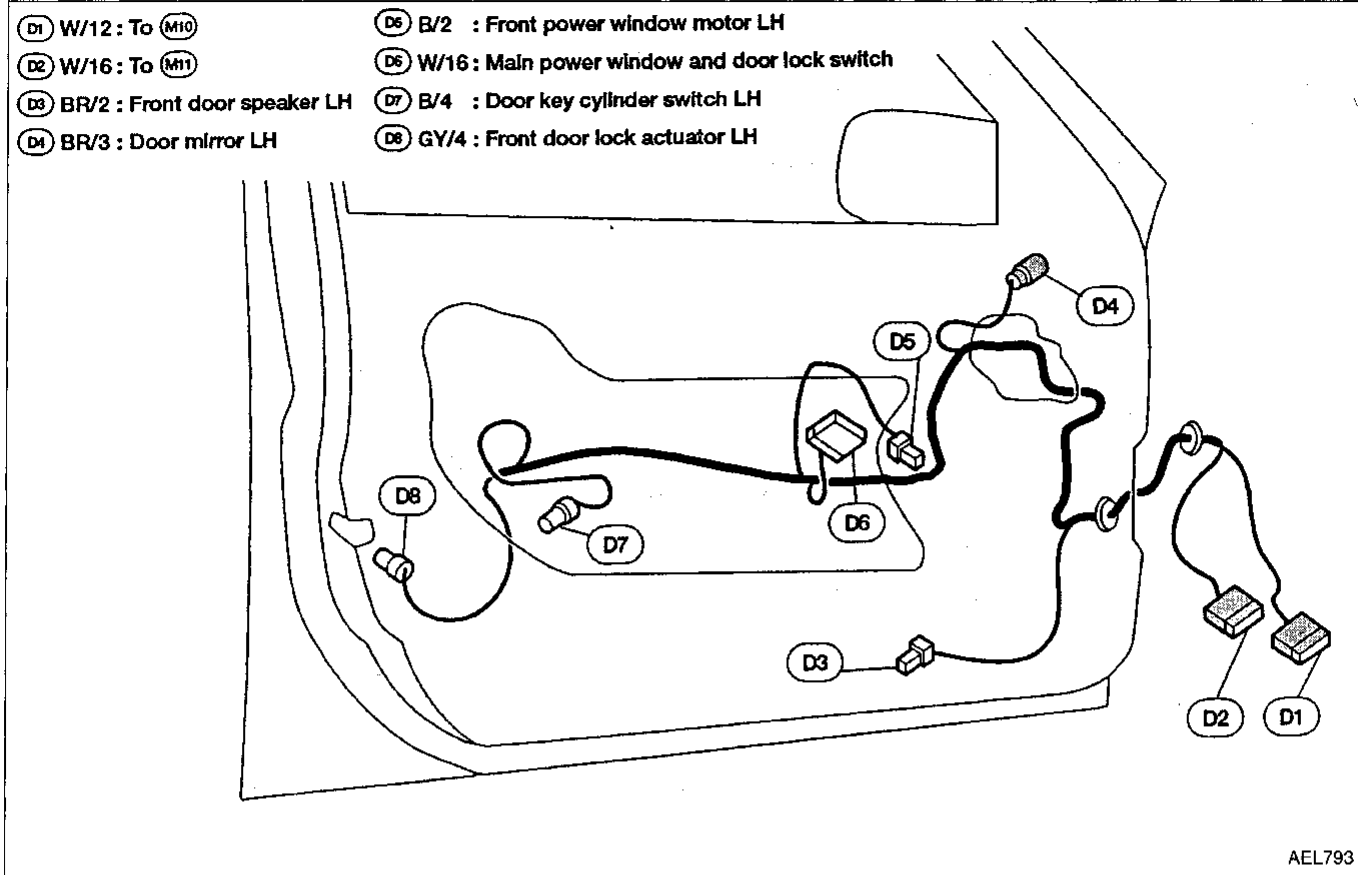

RIGHT

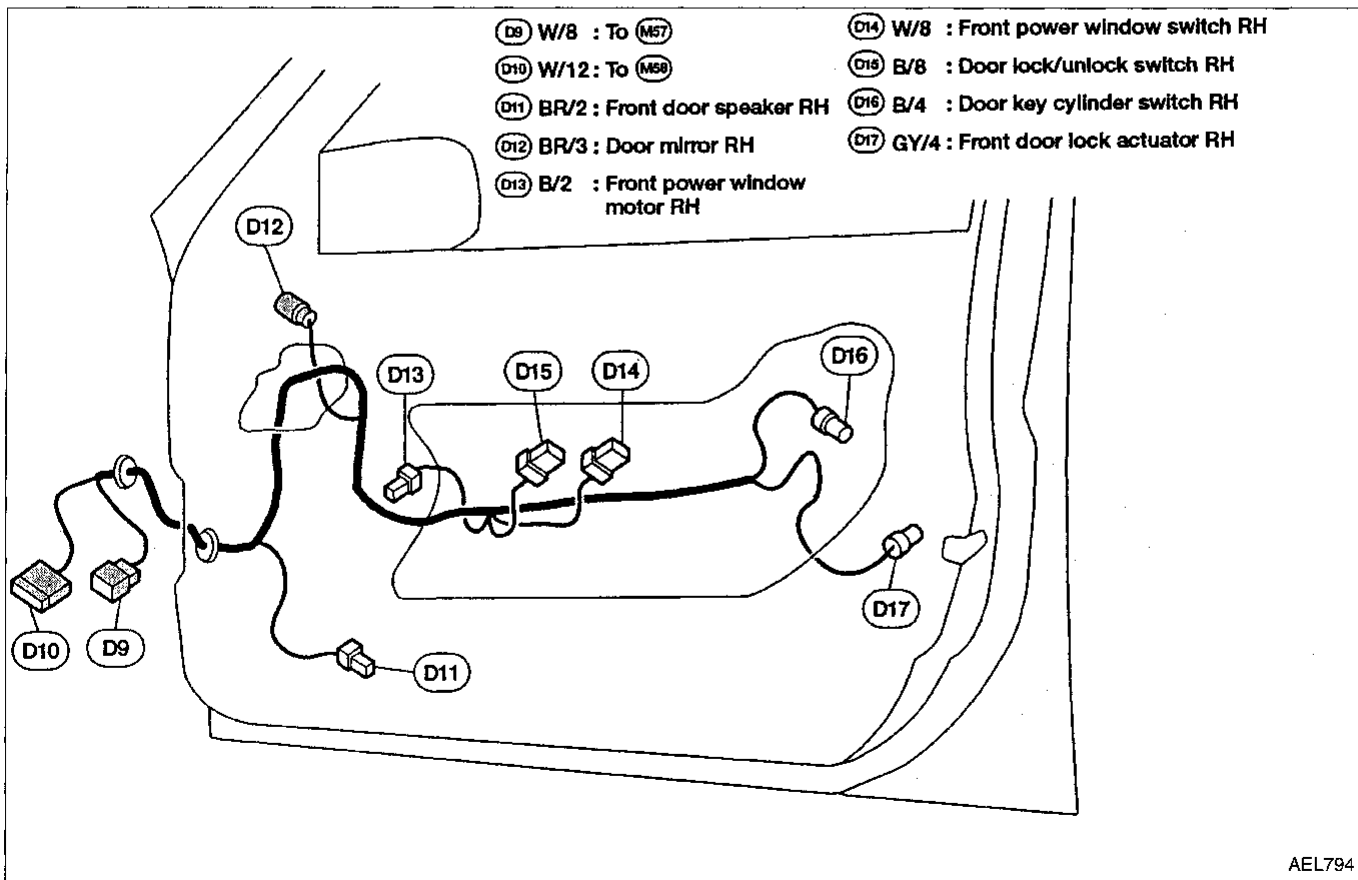

HARNESS LAYOUT

LEFT

Rear Door Harness (4-Door)

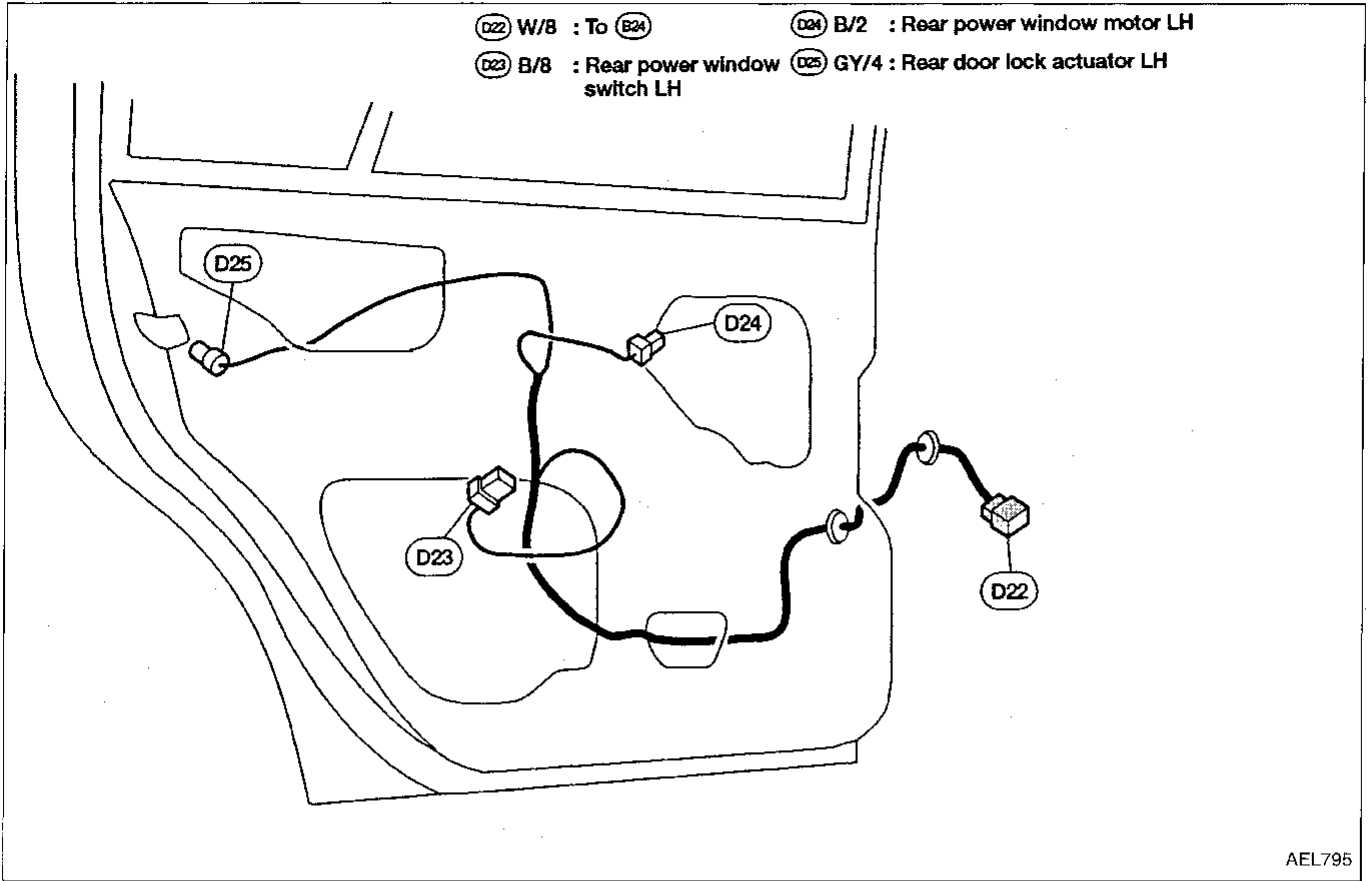

RIGHT

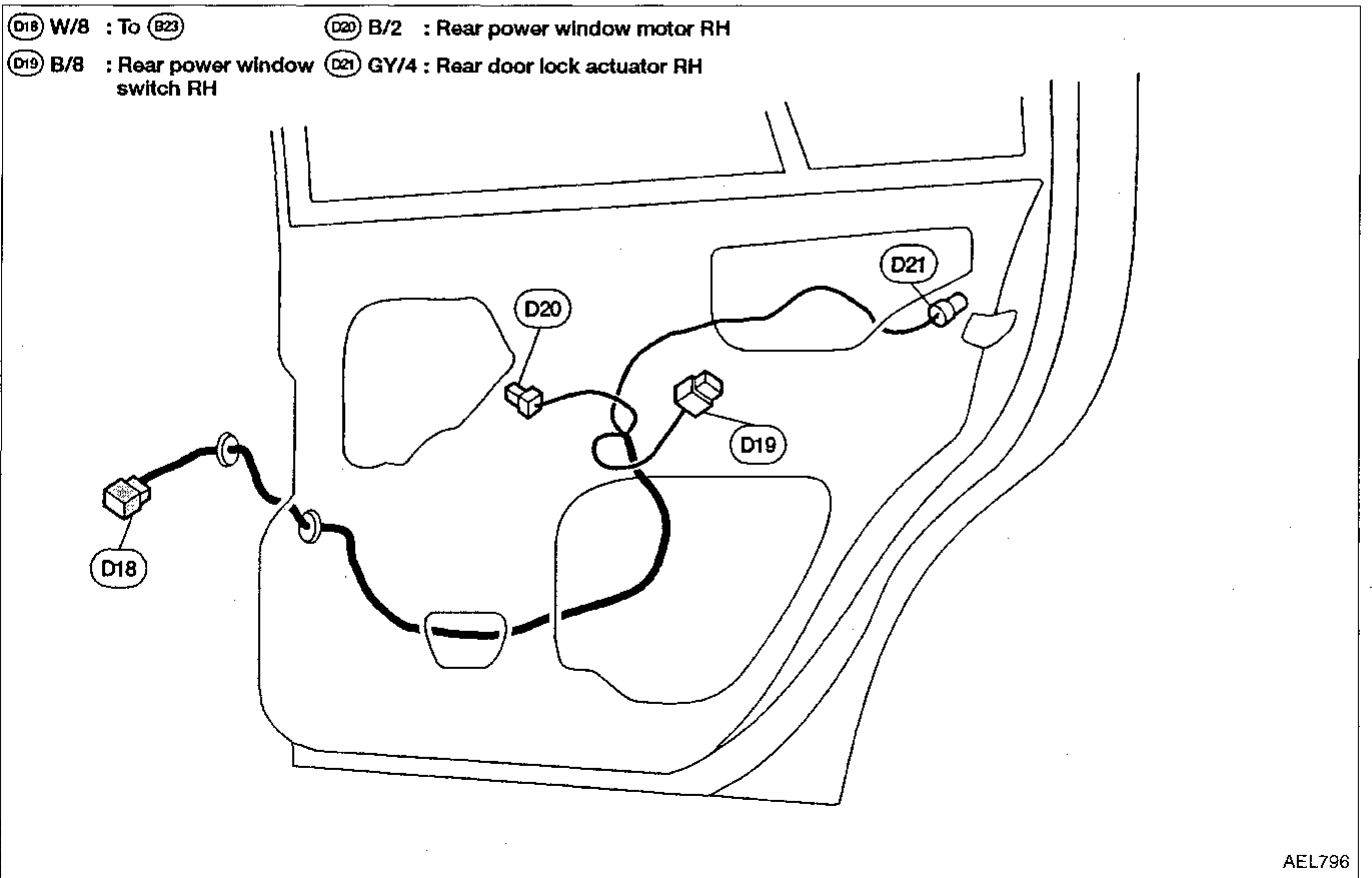

GI
MA
EM
LC
EC
FE
CL
MT
AT
FA
RA
BR
ST
RS
BT
HA
EL
IDX