

SECTION CL

GI
MA
EM
LC
EC
FE
CL
MT
AT
FA
RA
BR
ST
RS
BT
HA
EL
IDX

CONTENTS

PRECAUTIONS AND PREPARATION	2	Clutch Cover and Flywheel.....	7
Precaution.....	2	Inspection And Adjustment.....	7
Special Service Tools.....	2	Flywheel Inspection.....	7
CLUTCH SYSTEM	3	Installation.....	7
INSPECTION AND ADJUSTMENT	4	SERVICE DATA AND SPECIFICATIONS (SDS)	8
Adjusting Clutch Pedal.....	4	General Specifications.....	8
CLUTCH RELEASE MECHANISM	5	Clutch Control System.....	8
Removal And Installation.....	5	Clutch Disc.....	8
Inspection.....	5	Clutch Cover.....	8
Lubrication.....	5	Inspection and Adjustment.....	8
CLUTCH DISC AND CLUTCH COVER	6	Clutch Pedal.....	8
Clutch Disc.....	6	Clutch Disc.....	8
Inspection.....	6	Clutch Cover.....	8
Installation.....	6		

PRECAUTIONS AND PREPARATION

Precaution

WARNING:

After cleaning the clutch disc, wipe it with a dust collector.
Do not use compressed air.

Special Service Tools

*: Special tool or commercial equivalent

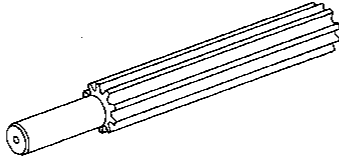
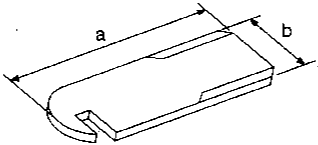
Tool number (Kent-Moore No.) Tool name	Description
KV30101000* (J33213) Clutch aligning bar	 <p>NT061</p> <p>Installing clutch cover and clutch disc</p>
ST20050240* (—) Diaphragm spring adjusting wrench	 <p>NT404</p> <p>Adjusting unevenness of clutch cover diaphragm spring</p> <p>a: 150 mm (5.91 in) b: 25 mm (0.98 in)</p>

CLUTCH SYSTEM

SEC. 300-307-465

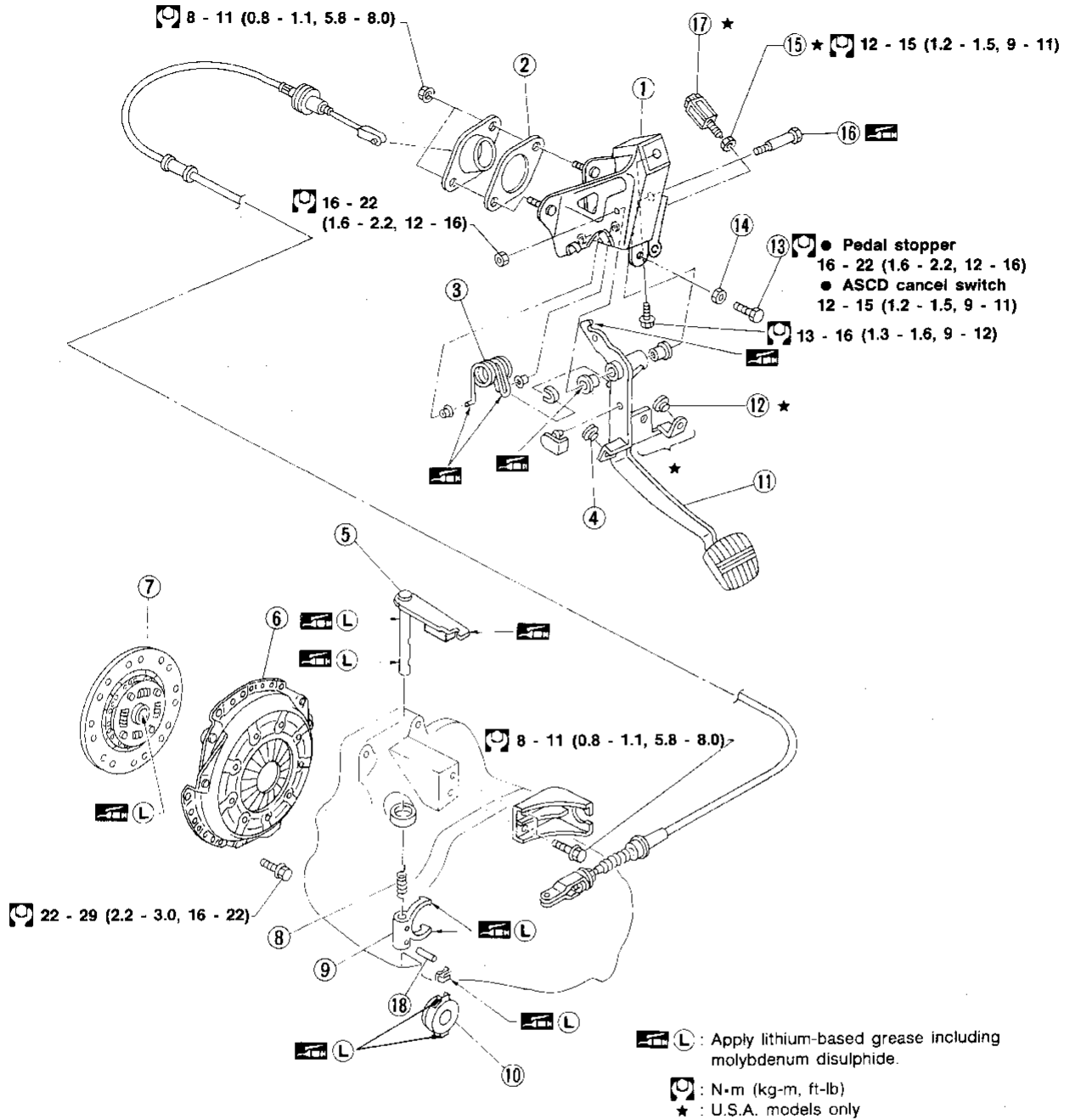

- ① Clutch pedal bracket
- ② Insulator
- ③ Assist spring
- ④ Stopper rubber
- ⑤ Withdrawal lever
- ⑥ Clutch cover

- ⑦ Clutch disc
- ⑧ Return spring
- ⑨ Clutch lever
- ⑩ Release bearing
- ⑪ Clutch pedal
- ⑫ Stopper rubber

- ⑬ Pedal stopper or ASCD cancel switch
- ⑭ Lock nut
- ⑮ Lock nut
- ⑯ Fulcrum pin
- ⑰ Clutch interlock switch
- ⑱ Spring pin

ACL018

GI
MA
EM
LC
EC
FE
CL
MT
AT
FA
RA
BR
ST
RS
BT
HA
EL
IDX

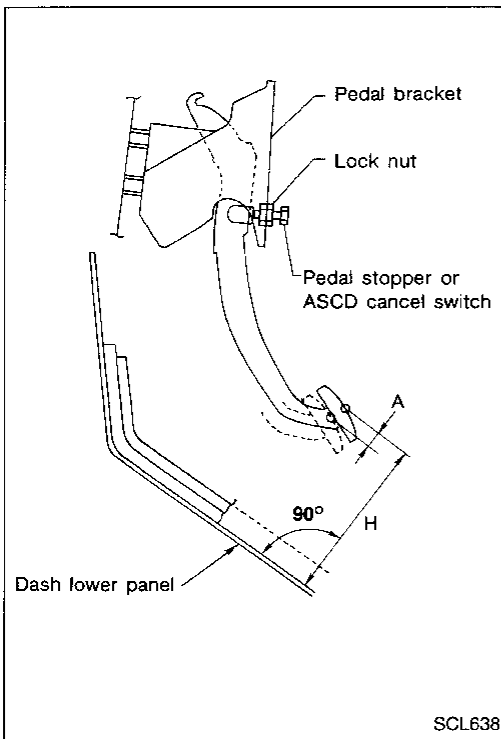

Adjusting Clutch Pedal

1. Adjust pedal height with pedal stopper or ASCD cancel switch.

Pedal height "H":
153 - 163 mm (6.02 - 6.42 in)

2. Adjust withdrawal lever play "B" according to the following procedure.

- a. Push withdrawal lever by hand until resistance is felt, and then tighten adjusting nut.
- b. Turn back adjusting nut 2.5 to 3.5 turns, and then tighten lock nut.

Withdrawal lever play "B":
2.5 - 3.5 mm (0.098 - 0.138 in)

Lock nut:
⊗: 3 - 4 N·m (0.3 - 0.4 kg-m, 2.2 - 2.9 ft-lb)

3. As a final check, measure pedal free play at center of pedal pad.

Pedal free travel "A":
10.8 - 15.1 mm (0.425 - 0.594 in)

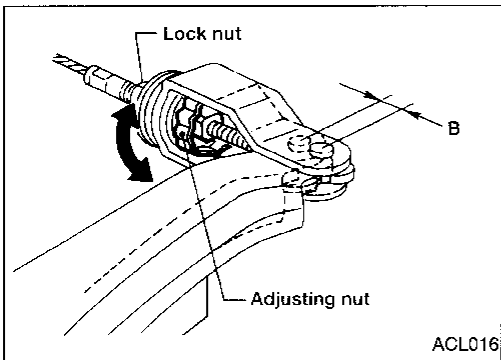

—FOR USA MODELS—

4. Adjust clearance "C" shown in the figure while fully depressing clutch pedal.

Clearance "C":
0.3 - 1.0 mm (0.012 - 0.039 in)

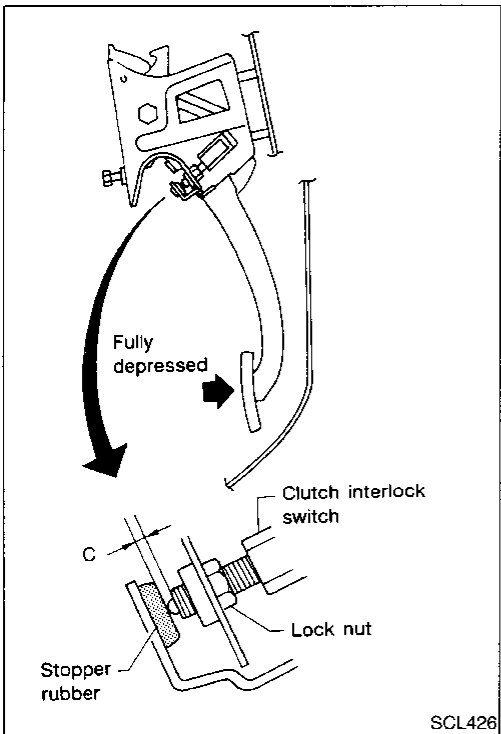

CLUTCH RELEASE MECHANISM

SEC. 321

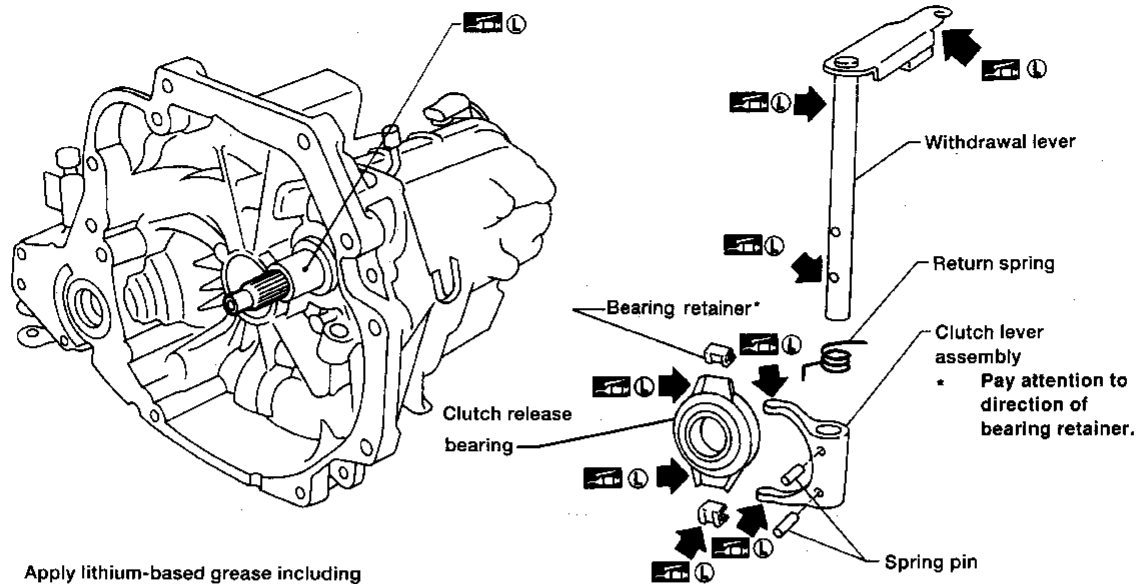

: Apply lithium-based grease including molybdenum disulphide.

ACL015

GI
MA
EM
LC
EC
FE
CL

MT

AT

FA

RA

BR

ST

RS

BT

HA

EL

IDX

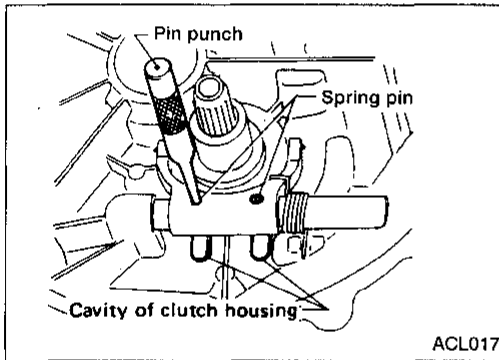

ACL017

REMOVAL AND INSTALLATION

- Remove release bearing by pulling bearing retainers outward.
- Align spring pin with cavity of clutch housing and tap out spring pin.

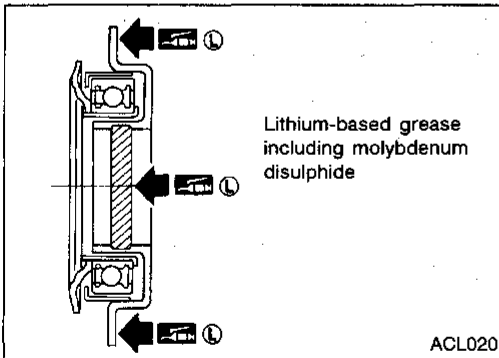

ACL020

INSPECTION

Check the following items, and replace if necessary.

- Release bearing, to see that it rolls freely and is free from noise, cracks, pitting or wear
- Release sleeve and withdrawal lever rubbing surface, for wear, rust or damage

LUBRICATION

- Apply recommended grease to contact surface and rubbing surface.
- **Too much lubricant may damage clutch disc facing.**

CLUTCH DISC AND CLUTCH COVER

SEC. 300

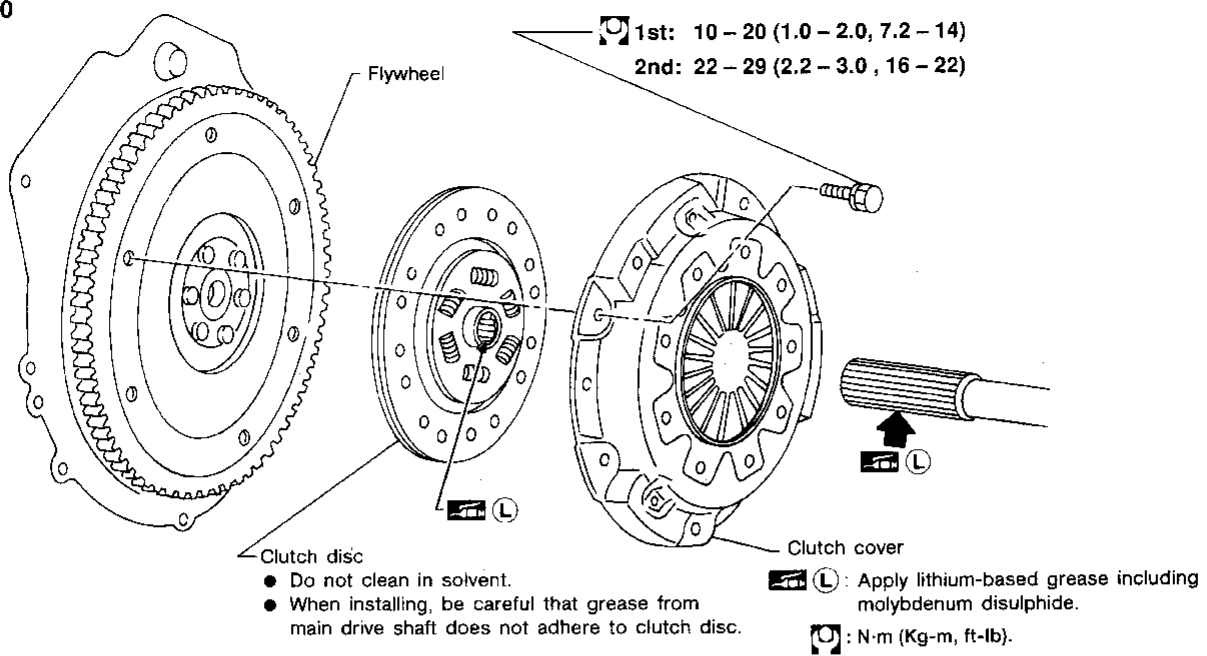

ACL019

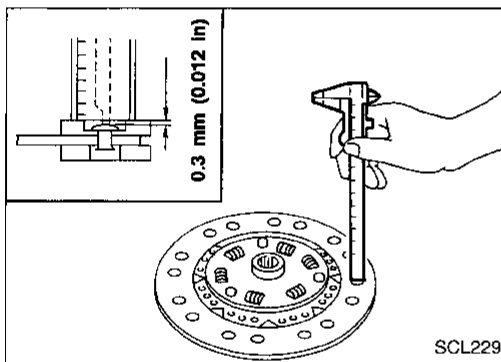

Clutch Disc

INSPECTION

Check the following items, and replace if necessary.

- Clutch disc, for burns, discoloration, oil or grease leakage
- Clutch disc, for wear of facing

**Wear limit of facing surface to rivet head:
0.3 mm (0.012 in)**

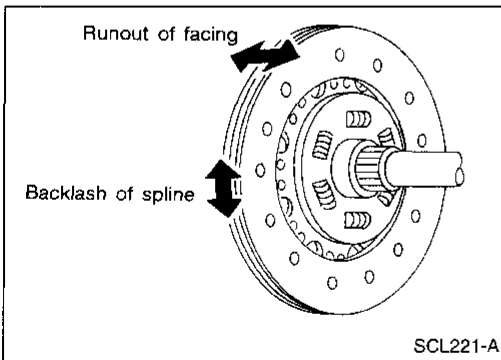

- Clutch disc, for backlash of spline and runout of facing
Maximum backlash of spline (at outer edge of disc):

MODEL 190 0.8 mm (0.031 in)

MODEL 215 0.9 mm (0.035 in)

Runout limit:

1.0 mm (0.039 in)

Distance of runout check point (from hub center):

MODEL 190 90 mm (3.54 in)

MODEL 215 102.5 mm (4.04 in)

INSTALLATION

- Apply recommended grease to contact surface of splines.
- **Too much lubricant may damage clutch disc facing.**

CLUTCH DISC AND CLUTCH COVER

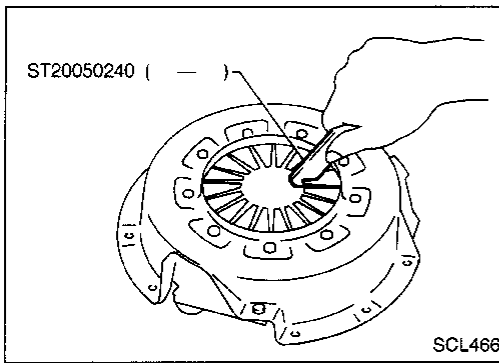

Clutch Cover and Flywheel

INSPECTION AND ADJUSTMENT

- Check clutch cover, installed on vehicle, for uneven diaphragm spring toe height.
Uneven limit:
0.7 mm (0.028 in)
- If out of limit, adjust the height with Tool.

GI

MA

EM

LC

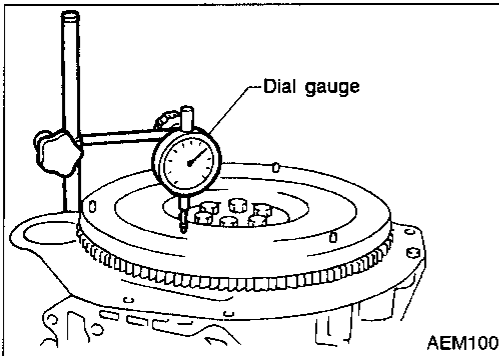

FLYWHEEL INSPECTION

CAUTION:

Do not allow any magnetic materials to contact the ring gear teeth.

- Inspect contact surface of flywheel for slight burns or discoloration. Clean flywheel with emery paper.
- Check flywheel runout.

Maximum allowable runout:

Refer to EM section ("Inspection", "CYLINDER BLOCK").

EC

FE

CL

MT

AT

FA

RA

BR

ST

RS

BT

HA

EL

IDX

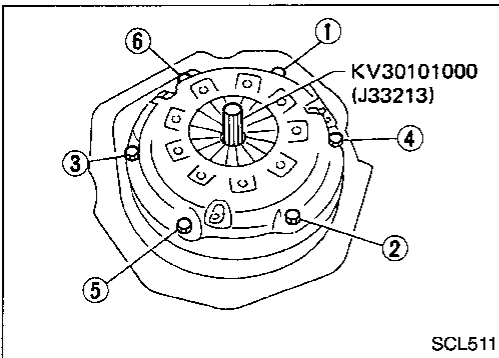

INSTALLATION

- Insert Tool into clutch disc hub when installing clutch cover and disc.
- Be careful not to allow grease to contaminate clutch facing.
- Tighten bolts in numerical order, in two steps.

First step:

: 10 - 20 N·m (1.0 - 2.0 kg·m, 7.2 - 14 ft·lb)

Final step:

: 22 - 29 N·m (2.2 - 3.0 kg·m, 16 - 22 ft·lb)

SERVICE DATA AND SPECIFICATIONS (SDS)

General Specifications

CLUTCH CONTROL SYSTEM

Type of clutch control	Mechanical type
------------------------	-----------------

CLUTCH DISC

Unit: mm (in)

Engine	GA16DE	SR20DE
Model	190	215
Facing size (Outer dia. x inner dia. x thickness)	190 x 132 x 3.5 (7.48 x 5.20 x 0.138)	215 x 140 x 3.5 (8.46 x 5.51 x 0.138)
Thickness of disc assembly with load	7.6 - 8.0 (0.315 - 0.331) with 3,825 N (390 kg, 860 lb)	7.6 - 8.0 (0.299 - 0.315) with 3,923 N (400 kg, 882 lb)

CLUTCH COVER

Engine	GA16DE	SR20DE
Model	190	215
Full-load N (kg, lb)	3,825 (390, 860)	4,413 (450, 992)

Inspection and Adjustment

CLUTCH PEDAL

Unit: mm (in)

Pedal height "H" ¹	153 - 163 (6.02 - 6.42)
Pedal free travel "A" (at pedal pad)	10.8 - 15.1 (0.425 - 0.594)
Withdrawal lever play "B"	2.5 - 3.5 (0.098 - 0.138)
Clearance "C" (between pedal stopper rubber and clutch inter- lock switch) ²	0.3 - 1.0 (0.012 - 0.039)

¹: Measured from surface of dash lower panel to surface of pedal pad.

²: Clutch pedal fully depressed.

CLUTCH COVER

Unit: mm (in)

Model	190	215
Diaphragm spring height	29 - 31 (1.14 - 1.22)	30.5 - 32.5 (1.201 - 1.280)
Uneven limit of diaphragm spring toe height	0.7 (0.028)	

CLUTCH DISC

Unit: mm (in)

Model	190	215
Wear limit of facing surface to rivet head	0.3 (0.012)	
Runout limit of facing	1.0 (0.039)	
Distance of runout check point (from hub center)	90 (3.54)	102.5 (4.04)
Maximum backlash of spline (at outer edge of disc)	0.8 (0.031)	0.9 (0.035)