

A  
EM  
C  
D  
E  
F  
G  
H  
I  
J  
K  
L  
M  
N  
O  
P

# SECTION **EM**

## ENGINE MECHANICAL

### CONTENTS

<p><b>SYMPTOM DIAGNOSIS</b> ..... 3</p> <p><b>NOISE, VIBRATION AND HARSHNESS (NVH) TROUBLESHOOTING</b> ..... 3</p> <p style="padding-left: 20px;">NVH Troubleshooting Chart .....3</p> <p><b>PRECAUTION</b> ..... 5</p> <p><b>PRECAUTIONS</b> ..... 5</p> <p><b>FOR USA AND CANADA</b> .....5</p> <p style="padding-left: 20px;">FOR USA AND CANADA : Precaution for Procedure without Cowl Top Cover .....5</p> <p style="padding-left: 20px;">FOR USA AND CANADA : Precaution Necessary for Steering Wheel Rotation After Battery Disconnect .....5</p> <p style="padding-left: 20px;">FOR USA AND CANADA : Precaution for Supplemental Restraint System (SRS) "AIR BAG" and "SEAT BELT PRE-TENSIONER" .....5</p> <p style="padding-left: 20px;">FOR USA AND CANADA :</p> <p style="padding-left: 40px;">Draining Engine Coolant .....6</p> <p style="padding-left: 20px;">FOR USA AND CANADA :</p> <p style="padding-left: 40px;">Disconnecting Fuel Piping .....6</p> <p style="padding-left: 20px;">FOR USA AND CANADA :</p> <p style="padding-left: 40px;">Removal and Disassembly .....6</p> <p style="padding-left: 20px;">FOR USA AND CANADA :</p> <p style="padding-left: 40px;">Inspection, Repair and Replacement .....6</p> <p style="padding-left: 20px;">FOR USA AND CANADA :</p> <p style="padding-left: 40px;">Assembly and Installation .....6</p> <p style="padding-left: 20px;">FOR USA AND CANADA :</p> <p style="padding-left: 40px;">Parts Requiring Angle Tightening .....6</p> <p style="padding-left: 20px;">FOR USA AND CANADA : Liquid Gasket .....7</p> <p><b>FOR MEXICO</b> .....8</p> <p style="padding-left: 20px;">FOR MEXICO : Precaution for Procedure without Cowl Top Cover .....8</p> <p style="padding-left: 20px;">FOR MEXICO : Precaution Necessary for Steering Wheel Rotation After Battery Disconnect .....8</p> <p style="padding-left: 20px;">FOR MEXICO : Precaution for Supplemental Restraint System (SRS) "AIR BAG" and "SEAT BELT PRE-TENSIONER" .....8</p>	<p style="padding-left: 20px;">FOR MEXICO : Draining Engine Coolant ..... 9</p> <p style="padding-left: 20px;">FOR MEXICO : Disconnecting Fuel Piping ..... 9</p> <p style="padding-left: 20px;">FOR MEXICO : Removal and Disassembly ..... 9</p> <p style="padding-left: 20px;">FOR MEXICO :</p> <p style="padding-left: 40px;">Inspection, Repair and Replacement ..... 9</p> <p style="padding-left: 20px;">FOR MEXICO : Assembly and Installation ..... 9</p> <p style="padding-left: 20px;">FOR MEXICO :</p> <p style="padding-left: 40px;">Parts Requiring Angle Tightening ..... 9</p> <p style="padding-left: 20px;">FOR MEXICO : Liquid Gasket .....10</p> <p><b>PREPARATION</b> .....11</p> <p><b>PREPARATION</b> .....11</p> <p style="padding-left: 20px;">Special Service Tools .....11</p> <p style="padding-left: 20px;">Commercial Service Tools .....12</p> <p><b>ON-VEHICLE MAINTENANCE</b> .....15</p> <p><b>DRIVE BELTS</b> .....15</p> <p style="padding-left: 20px;">Exploded View .....15</p> <p style="padding-left: 20px;">Checking .....15</p> <p style="padding-left: 20px;">Tension Adjustment .....15</p> <p style="padding-left: 20px;">Removal and Installation .....15</p> <p><b>AIR CLEANER FILTER</b> .....17</p> <p style="padding-left: 20px;">Removal and Installation .....17</p> <p><b>SPARK PLUG</b> .....18</p> <p style="padding-left: 20px;">Exploded View .....18</p> <p style="padding-left: 20px;">Removal and Installation .....18</p> <p style="padding-left: 20px;">Inspection .....19</p> <p><b>CAMSHAFT VALVE CLEARANCE</b> .....20</p> <p style="padding-left: 20px;">Inspection and Adjustment .....20</p> <p><b>COMPRESSION PRESSURE</b> .....23</p> <p style="padding-left: 20px;">Inspection .....23</p> <p><b>ON-VEHICLE REPAIR</b> .....25</p> <p><b>DRIVE BELT AUTO-TENSIONER</b> .....25</p> <p style="padding-left: 20px;">Exploded View .....25</p> <p style="padding-left: 20px;">Removal and Installation .....25</p>
--	---

<b>AIR CLEANER AND AIR DUCT .....</b>	<b>27</b>	<b>ENGINE ASSEMBLY .....</b>	<b>61</b>
Exploded View .....	27	Exploded View .....	61
Removal and Installation .....	27	Removal and Installation .....	61
Inspection .....	28	Inspection .....	65
<b>INTAKE MANIFOLD .....</b>	<b>29</b>	<b>DISASSEMBLY AND ASSEMBLY .....</b>	<b>66</b>
Exploded View .....	29	<b>ENGINE STAND SETTING .....</b>	<b>66</b>
Removal and Installation .....	29	Setting .....	66
Inspection .....	31	<b>ENGINE UNIT .....</b>	<b>68</b>
<b>EXHAUST MANIFOLD AND THREE WAY</b>		Disassembly .....	68
<b>CATALYST .....</b>	<b>32</b>	Assembly .....	68
Exploded View .....	32	<b>TIMING CHAIN .....</b>	<b>69</b>
Removal and Installation .....	32	Exploded View .....	69
Inspection .....	33	Removal and Installation .....	70
<b>OIL PAN (LOWER) .....</b>	<b>34</b>	Inspection .....	77
Exploded View .....	34	<b>CYLINDER HEAD .....</b>	<b>79</b>
Removal and Installation .....	34	Exploded View .....	79
Inspection .....	36	Removal and Installation .....	80
<b>OIL PAN (UPPER) AND OIL STRAINER .....</b>	<b>37</b>	Disassembly and Assembly .....	81
Exploded View .....	37	Inspection .....	85
Removal and Installation .....	37	<b>CYLINDER BLOCK .....</b>	<b>88</b>
Inspection .....	39	Exploded View .....	88
<b>IGNITION COIL, SPARK PLUG AND ROCK- ER COVER .....</b>	<b>40</b>	Disassembly and Assembly .....	89
Exploded View .....	40	Inspection .....	96
Removal and Installation .....	40	<b>HOW TO SELECT PISTON AND BEARING ..</b>	<b>105</b>
<b>FUEL INJECTOR AND FUEL TUBE .....</b>	<b>43</b>	Description .....	105
Exploded View .....	43	Piston .....	105
Removal and Installation .....	43	Connecting Rod Bearing .....	106
Inspection .....	46	Main Bearing .....	108
<b>CAMSHAFT .....</b>	<b>48</b>	<b>SERVICE DATA AND SPECIFICATIONS (SDS) .....</b>	<b>112</b>
Exploded View .....	48	<b>SERVICE DATA AND SPECIFICATIONS (SDS) .....</b>	<b>112</b>
Removal and Installation .....	48	General Specification .....	112
Inspection .....	53	Drive belt .....	112
<b>OIL SEAL .....</b>	<b>58</b>	Spark Plug .....	112
<b>VALVE OIL SEAL .....</b>	<b>58</b>	Intake Manifold .....	113
VALVE OIL SEAL : Removal and Installation .....	58	Exhaust Manifold .....	113
<b>FRONT OIL SEAL .....</b>	<b>58</b>	Camshaft .....	113
FRONT OIL SEAL : Removal and Installation .....	59	Cylinder Head .....	115
<b>REAR OIL SEAL .....</b>	<b>59</b>	Cylinder Block .....	117
REAR OIL SEAL : Removal and Installation .....	59	Main Bearing .....	121
<b>REMOVAL AND INSTALLATION .....</b>	<b>61</b>	Connecting Rod Bearing .....	122

# NOISE, VIBRATION AND HARSHNESS (NVH) TROUBLESHOOTING

< SYMPTOM DIAGNOSIS >

## SYMPTOM DIAGNOSIS

### NOISE, VIBRATION AND HARSHNESS (NVH) TROUBLESHOOTING

#### NVH Troubleshooting Chart

INFOID:000000004231377

A

EM

C

D

E

F

G

H

I

J

K

L

M

N

O

P

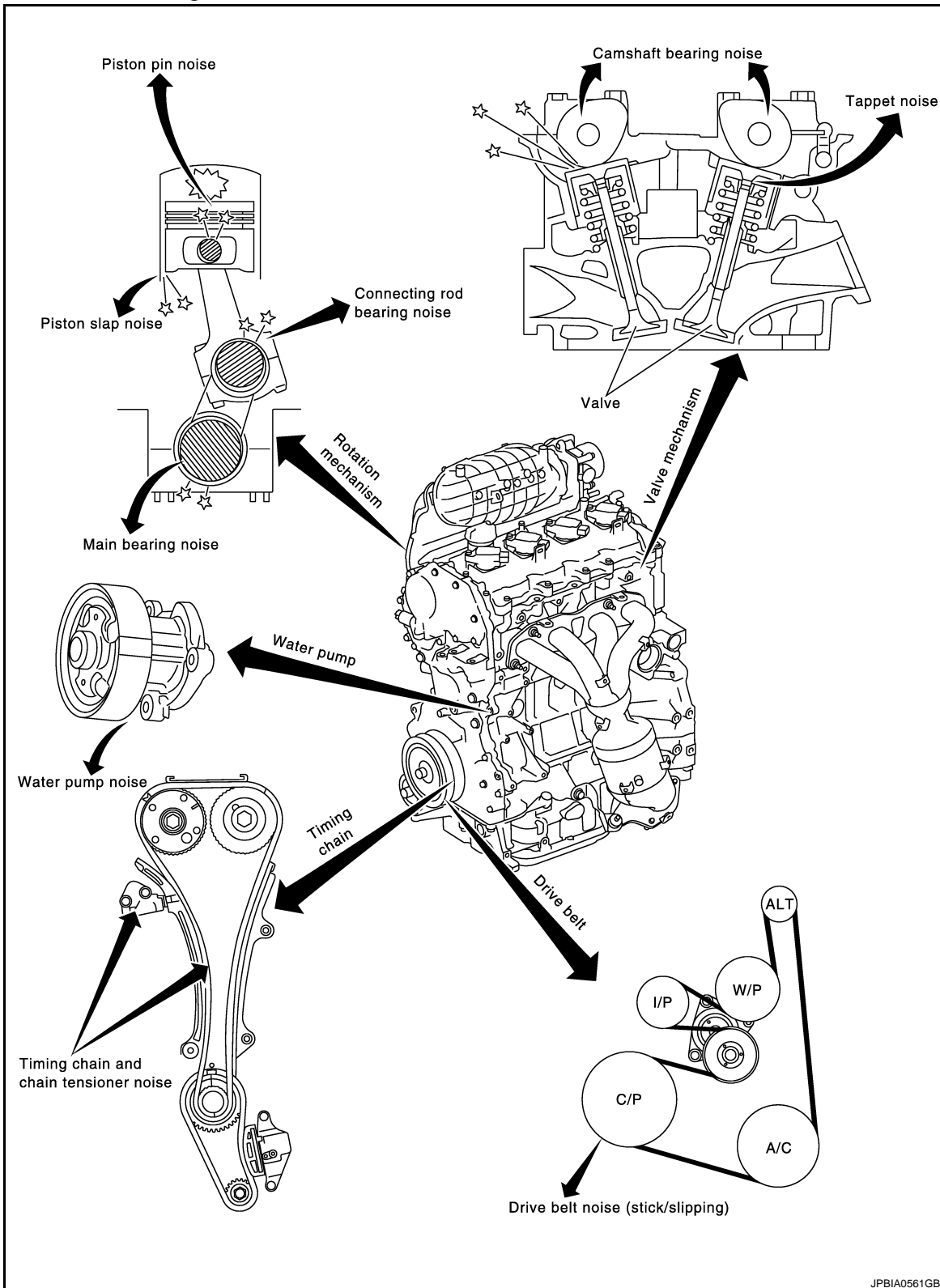

1. Locate the area where noise occurs.
2. Confirm the type of noise.
3. Specify the operating condition of engine.

# NOISE, VIBRATION AND HARSHNESS (NVH) TROUBLESHOOTING

## < SYMPTOM DIAGNOSIS >

4. Check specified noise source.

If necessary, repair or replace these parts.

Location of noise	Type of noise	Operating condition of engine						Source of noise	Check item	Reference page
		Before warm-up	After warm-up	When starting	When idling	When racing	While driving			
Top of engine Rocker cover Cylinder head	Ticking or clicking	C	A	—	A	B	—	Tappet noise	Valve clearance	<a href="#">EM-20</a>
	Rattle	C	A	—	A	B	C	Camshaft bearing noise	Camshaft journal oil clearance Camshaft runout	<a href="#">EM-113</a>
Crankshaft pulley Cylinder block (Side of engine) Oil pan	Slap or knock	—	A	—	B	B	—	Piston pin noise	Piston to piston pin oil clearance Connecting rod bushing oil clearance	<a href="#">EM-117</a>
	Slap or rap	A	—	—	B	B	A	Piston slap noise	Piston to cylinder bore clearance Piston ring side clearance Piston ring end gap Connecting rod bend and torsion	<a href="#">EM-117</a>
	Knock	B	A	C	B	B	B	Connecting rod bearing noise	Connecting rod bushing oil clearance Connecting rod bearing oil clearance	<a href="#">EM-117</a> <a href="#">EM-122</a>
	Knock	B	A	—	A	B	C	Main bearing noise	Main bearing oil clearance Crankshaft runout	<a href="#">EM-121</a> <a href="#">EM-117</a>
Front of engine Front cover	Tapping or ticking	A	A	—	B	B	B	Timing chain and chain tensioner noise	Timing chain cracks and wear Timing chain tensioner operation	<a href="#">EM-77</a> <a href="#">EM-69</a>
Front of engine	Squeaking or fizzing	A	B	—	B	B	B	Drive belt (Sticking or slipping)	Drive belt deflection	<a href="#">EM-15</a>
	Creaking	A	B	A	B	A	B	Drive belt (Slipping)	Idler pulley bearing operation	
	Squall Creak	A	B	—	B	A	B	Water pump noise	Water pump operation	<a href="#">CO-24, "Inspection"</a>

A: Closely related B: Related C: Sometimes related —: Not related

# PRECAUTIONS

< PRECAUTION >

## PRECAUTION

### PRECAUTIONS FOR USA AND CANADA

#### FOR USA AND CANADA : Precaution for Procedure without Cowl Top Cover

INFOID:000000004300769

When performing the procedure after removing cowl top cover, cover the lower end of windshield with urethane, etc.

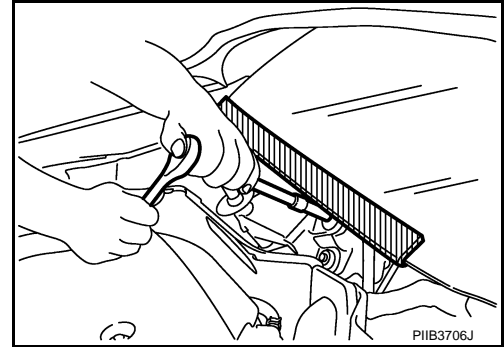

#### FOR USA AND CANADA : Precaution Necessary for Steering Wheel Rotation After Battery Disconnect

INFOID:000000004300770

##### NOTE:

- This Procedure is applied only to models with Intelligent Key system and NVIS/IVIS (NISSAN/INFINITI VEHICLE IMMOBILIZER SYSTEM - NATS).
- Remove and install all control units after disconnecting both battery cables with the ignition knob in the "LOCK" position.
- Always use CONSULT-III to perform self-diagnosis as a part of each function inspection after finishing work. If DTC is detected, perform trouble diagnosis according to self-diagnostic results.

For models equipped with the Intelligent Key system and NVIS/IVIS, an electrically controlled steering lock mechanism is adopted on the key cylinder.

For this reason, if the battery is disconnected or if the battery is discharged, the steering wheel will lock and steering wheel rotation will become impossible.

If steering wheel rotation is required when battery power is interrupted, follow the procedure below before starting the repair operation.

##### OPERATION PROCEDURE

1. Connect both battery cables.

##### NOTE:

Supply power using jumper cables if battery is discharged.

2. Use the Intelligent Key or mechanical key to turn the ignition switch to the "ACC" position. At this time, the steering lock will be released.
3. Disconnect both battery cables. The steering lock will remain released and the steering wheel can be rotated.
4. Perform the necessary repair operation.
5. When the repair work is completed, return the ignition switch to the "LOCK" position before connecting the battery cables. (At this time, the steering lock mechanism will engage.)
6. Perform a self-diagnosis check of all control units using CONSULT-III.

#### FOR USA AND CANADA : Precaution for Supplemental Restraint System (SRS) "AIR BAG" and "SEAT BELT PRE-TENSIONER"

INFOID:000000004300771

The Supplemental Restraint System such as "AIR BAG" and "SEAT BELT PRE-TENSIONER", used along with a front seat belt, helps to reduce the risk or severity of injury to the driver and front passenger for certain types of collision. This system includes seat belt switch inputs and dual stage front air bag modules. The SRS system uses the seat belt switches to determine the front air bag deployment, and may only deploy one front air bag, depending on the severity of a collision and whether the front occupants are belted or unbelted.

# PRECAUTIONS

## < PRECAUTION >

Information necessary to service the system safely is included in the “SRS AIRBAG” and “SEAT BELT” of this Service Manual.

### **WARNING:**

- **To avoid rendering the SRS inoperative, which could increase the risk of personal injury or death in the event of a collision which would result in air bag inflation, all maintenance must be performed by an authorized NISSAN/INFINITI dealer.**
- **Improper maintenance, including incorrect removal and installation of the SRS, can lead to personal injury caused by unintentional activation of the system. For removal of Spiral Cable and Air Bag Module, see the “SRS AIRBAG”.**
- **Never use electrical test equipment on any circuit related to the SRS unless instructed to in this Service Manual. SRS wiring harnesses can be identified by yellow and/or orange harnesses or harness connectors.**

## FOR USA AND CANADA : Draining Engine Coolant

INFOID:000000004231381

Drain engine coolant and engine oil when the engine is cooled.

## FOR USA AND CANADA : Disconnecting Fuel Piping

INFOID:000000004231382

- Before starting work, check no fire or spark producing items are in the work area.
- Release fuel pressure before disconnecting and disassembly.
- After disconnecting pipes, plug openings to stop fuel leakage.

## FOR USA AND CANADA : Removal and Disassembly

INFOID:000000004231383

- When instructed to use SST, use specified tools. Always be careful to work safely, avoid forceful or uninstructed operations.
- Exercise maximum care to avoid damage to mating or sliding surfaces.
- Dowel pins are used for several parts alignment. When replacing and reassembling parts with dowel pins, check that dowel pins are installed in the original position.
- Cover openings of engine system with a tape or equivalent, if necessary, to seal out foreign materials.
- Mark and arrange disassembly parts in an organized way for easy troubleshooting and reassembly.
- When loosening nuts and bolts, as a basic rule, start with the one furthest outside, then the one diagonally opposite, and so on. If the order of loosening is specified, do exactly as specified. Power tools may be used in the step.

## FOR USA AND CANADA : Inspection, Repair and Replacement

INFOID:000000004231384

Before repairing or replacing, thoroughly inspect parts. Inspect new replacement parts in the same way, and replace if necessary.

## FOR USA AND CANADA : Assembly and Installation

INFOID:000000004231385

- Use torque wrench to tighten bolts or nuts to specification.
- When tightening nuts and bolts, as a basic rule, equally tighten in several different steps starting with the ones in center, then ones on inside and outside diagonally in this order. If the order of tightening is specified, do exactly as specified.
- Replace with new gasket, packing, oil seal or O-ring.
- Thoroughly wash, clean, and air-blow each part. Carefully check engine oil or engine coolant passages for any restriction and blockage.
- Avoid damaging sliding or mating surfaces. Completely remove foreign materials such as cloth lint or dust. Before assembly, oil sliding surfaces well.
- Release air within route when refilling after draining engine coolant.
- After repairing, start the engine and increase engine speed to check engine coolant, fuel, engine oil, and exhaust gases for leakage.

## FOR USA AND CANADA : Parts Requiring Angle Tightening

INFOID:000000004231386

- Use the angle wrench [SST: KV10112100 (BT8653-A)] for the final tightening of the following engine parts:
  - Cylinder head bolts
  - Main bearing cap bolts
  - Connecting rod cap bolts

# PRECAUTIONS

## < PRECAUTION >

- Crankshaft pulley bolt (No the angle wrench is required as bolt flange is provided with notches for angle tightening)
- Do not use a torque value for final tightening.
- The torque value for these parts are for a preliminary step.
- Ensure thread and seat surfaces are clean and coated with engine oil.

## FOR USA AND CANADA : Liquid Gasket

INFOID:000000004231387

### REMOVAL OF LIQUID GASKET SEALING

- After removing mounting nuts and bolts, separate the mating surface using the seal cutter (SST) and remove old liquid gasket sealing.

#### CAUTION:

**Be careful not to damage the mating surfaces.**

- Tap the seal cutter to insert it (1), and then slide it (2) by tapping on the side as shown in the figure.
- In areas where the seal cutter (SST) is difficult to use, use a plastic hammer to lightly tap the parts, to remove it.

#### CAUTION:

**If for some unavoidable reason tool such as a screwdriver is used, be careful not to damage the mating surfaces.**

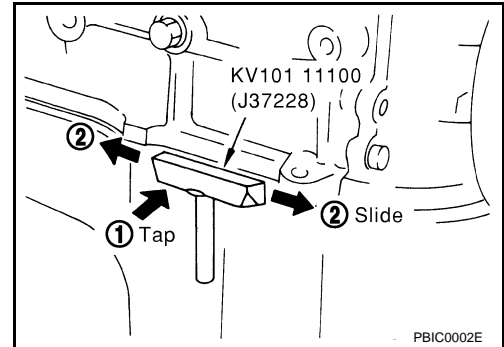

### LIQUID GASKET APPLICATION PROCEDURE

1. Using a scraper, remove old liquid gasket adhering to the liquid gasket application surface and the mating surface.
  - Remove liquid gasket completely from the groove of the liquid gasket application surface, mounting bolts, and bolt holes.
2. Wipe the liquid gasket application surface and the mating surface with white gasoline (lighting and heating use) to remove adhering moisture, grease and foreign materials.

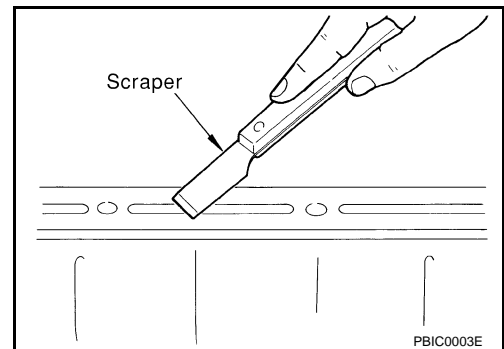

3. Attach liquid gasket tube to the tube presser (commercial service tool).  
**Use Genuine RTV Silicone Sealant or equivalent. Refer to [GI-17, "Recommended Chemical Products and Sealants"](#).**
4. Apply liquid gasket without breaks to the specified location with the specified dimensions.
  - If there is a groove for liquid gasket application, apply liquid gasket to the groove.

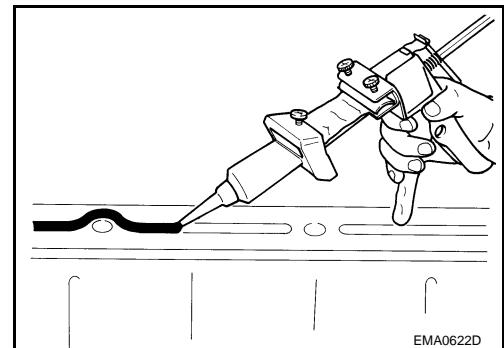

- As for bolt holes, normally apply liquid gasket inside the holes. Occasionally, it should be applied outside the holes. Check to read the text of this manual.
- Within five minutes of liquid gasket application, install the mating component.
- If liquid gasket protrudes, wipe it off immediately.
- Do not retighten mounting bolts or nuts after the installation.
- After 30 minutes or more have passed from the installation, fill engine oil and engine coolant.

#### CAUTION:

**If there are specific instructions in this manual, observe them.**

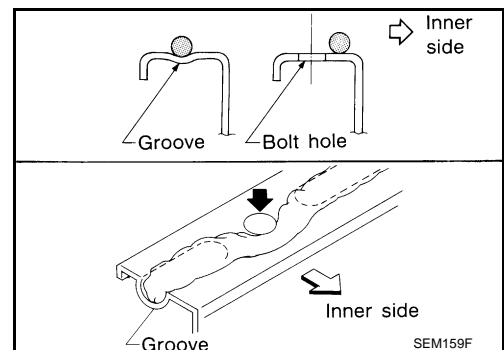



# PRECAUTIONS

< PRECAUTION >

## FOR MEXICO

### FOR MEXICO : Precaution for Procedure without Cowl Top Cover

INFOID:000000004300772

When performing the procedure after removing cowl top cover, cover the lower end of windshield with urethane, etc.

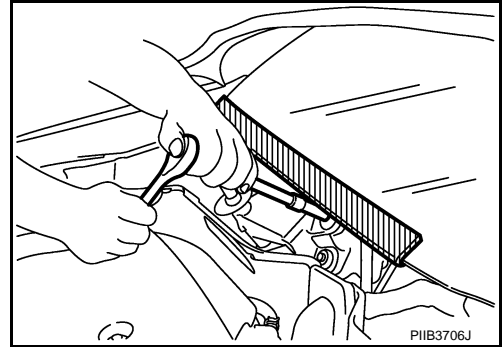

### FOR MEXICO : Precaution Necessary for Steering Wheel Rotation After Battery Disconnect

INFOID:000000004300773

#### NOTE:

- This Procedure is applied only to models with Intelligent Key system and NVIS/IVIS (NISSAN/INFINITI VEHICLE IMMOBILIZER SYSTEM - NATS).
- Remove and install all control units after disconnecting both battery cables with the ignition knob in the "LOCK" position.
- Always use CONSULT-III to perform self-diagnosis as a part of each function inspection after finishing work. If DTC is detected, perform trouble diagnosis according to self-diagnostic results.

For models equipped with the Intelligent Key system and NVIS/IVIS, an electrically controlled steering lock mechanism is adopted on the key cylinder.

For this reason, if the battery is disconnected or if the battery is discharged, the steering wheel will lock and steering wheel rotation will become impossible.

If steering wheel rotation is required when battery power is interrupted, follow the procedure below before starting the repair operation.

#### OPERATION PROCEDURE

1. Connect both battery cables.

#### NOTE:

Supply power using jumper cables if battery is discharged.

2. Use the Intelligent Key or mechanical key to turn the ignition switch to the "ACC" position. At this time, the steering lock will be released.
3. Disconnect both battery cables. The steering lock will remain released and the steering wheel can be rotated.
4. Perform the necessary repair operation.
5. When the repair work is completed, return the ignition switch to the "LOCK" position before connecting the battery cables. (At this time, the steering lock mechanism will engage.)
6. Perform a self-diagnosis check of all control units using CONSULT-III.

### FOR MEXICO : Precaution for Supplemental Restraint System (SRS) "AIR BAG" and "SEAT BELT PRE-TENSIONER"

INFOID:000000004300774

The Supplemental Restraint System such as "AIR BAG" and "SEAT BELT PRE-TENSIONER", used along with a front seat belt, helps to reduce the risk or severity of injury to the driver and front passenger for certain types of collision. Information necessary to service the system safely is included in the "SRS AIRBAG" and "SEAT BELT" of this Service Manual.

#### WARNING:

- To avoid rendering the SRS inoperative, which could increase the risk of personal injury or death in the event of a collision which would result in air bag inflation, all maintenance must be performed by an authorized NISSAN/INFINITI dealer.



# PRECAUTIONS

## < PRECAUTION >

- **Improper maintenance, including incorrect removal and installation of the SRS, can lead to personal injury caused by unintentional activation of the system. For removal of Spiral Cable and Air Bag Module, see the “SRS AIRBAG”.**
- **Do not use electrical test equipment on any circuit related to the SRS unless instructed to in this Service Manual. SRS wiring harnesses can be identified by yellow and/or orange harnesses or harness connectors.**

A

EM

### FOR MEXICO : Draining Engine Coolant

INFOID:000000004231391

Drain engine coolant and engine oil when the engine is cooled.

C

### FOR MEXICO : Disconnecting Fuel Piping

INFOID:000000004231392

- Before starting work, check no fire or spark producing items are in the work area.
- Release fuel pressure before disconnecting and disassembly.
- After disconnecting pipes, plug openings to stop fuel leakage.

D

E

### FOR MEXICO : Removal and Disassembly

INFOID:000000004231393

- When instructed to use SST, use specified tools. Always be careful to work safely, avoid forceful or uninstructed operations.
- Exercise maximum care to avoid damage to mating or sliding surfaces.
- Dowel pins are used for several parts alignment. When replacing and reassembling parts with dowel pins, check that dowel pins are installed in the original position.
- Cover openings of engine system with a tape or equivalent, if necessary, to seal out foreign materials.
- Mark and arrange disassembly parts in an organized way for easy troubleshooting and reassembly.
- When loosening nuts and bolts, as a basic rule, start with the one furthest outside, then the one diagonally opposite, and so on. If the order of loosening is specified, do exactly as specified. Power tools may be used in the step.

F

G

H

### FOR MEXICO : Inspection, Repair and Replacement

INFOID:000000004231394

Before repairing or replacing, thoroughly inspect parts. Inspect new replacement parts in the same way, and replace if necessary.

I

J

### FOR MEXICO : Assembly and Installation

INFOID:000000004231395

- Use torque wrench to tighten bolts or nuts to specification.
- When tightening nuts and bolts, as a basic rule, equally tighten in several different steps starting with the ones in center, then ones on inside and outside diagonally in this order. If the order of tightening is specified, do exactly as specified.
- Replace with new gasket, packing, oil seal or O-ring.
- Thoroughly wash, clean, and air-blow each part. Carefully check engine oil or engine coolant passages for any restriction and blockage.
- Avoid damaging sliding or mating surfaces. Completely remove foreign materials such as cloth lint or dust. Before assembly, oil sliding surfaces well.
- Release air within route when refilling after draining engine coolant.
- After repairing, start the engine and increase engine speed to check engine coolant, fuel, engine oil, and exhaust gases for leakage.

K

L

M

N

### FOR MEXICO : Parts Requiring Angle Tightening

INFOID:000000004231396

- Use the angle wrench [SST: KV10112100 (BT8653-A)] for the final tightening of the following engine parts:
  - Cylinder head bolts
  - Main bearing cap bolts
  - Connecting rod cap bolts
  - Crankshaft pulley bolt (No the angle wrench is required as bolt flange is provided with notches for angle tightening)
- Do not use a torque value for final tightening.
- The torque value for these parts are for a preliminary step.
- Ensure thread and seat surfaces are clean and coated with engine oil.

O

P

# PRECAUTIONS

< PRECAUTION >

## FOR MEXICO : Liquid Gasket

INFOID:000000004231397

### REMOVAL OF LIQUID GASKET SEALING

- After removing mounting nuts and bolts, separate the mating surface using the seal cutter (SST) and remove old liquid gasket sealing.

**CAUTION:**

**Be careful not to damage the mating surfaces.**

- Tap the seal cutter to insert it (1), and then slide it (2) by tapping on the side as shown in the figure.
- In areas where the seal cutter (SST) is difficult to use, use a plastic hammer to lightly tap the parts, to remove it.

**CAUTION:**

**If for some unavoidable reason tool such as a screwdriver is used, be careful not to damage the mating surfaces.**

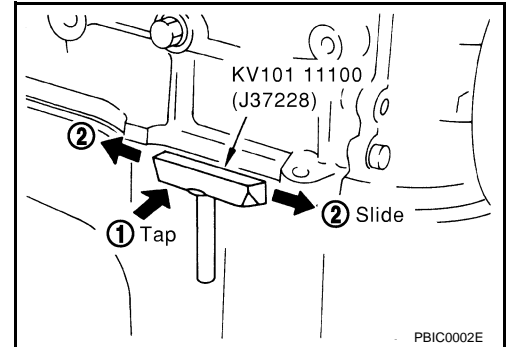

### LIQUID GASKET APPLICATION PROCEDURE

1. Using a scraper, remove old liquid gasket adhering to the liquid gasket application surface and the mating surface.
  - Remove liquid gasket completely from the groove of the liquid gasket application surface, mounting bolts, and bolt holes.
2. Wipe the liquid gasket application surface and the mating surface with white gasoline (lighting and heating use) to remove adhering moisture, grease and foreign materials.

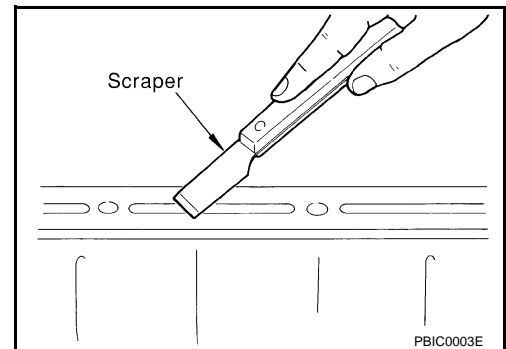

3. Attach liquid gasket tube to the tube presser (commercial service tool).

**Use Genuine RTV Silicone Sealant or equivalent. Refer to [GI-17, "Recommended Chemical Products and Sealants"](#).**
4. Apply liquid gasket without breaks to the specified location with the specified dimensions.
  - If there is a groove for liquid gasket application, apply liquid gasket to the groove.

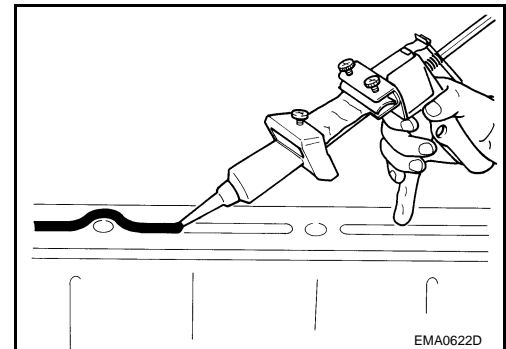

- As for bolt holes, normally apply liquid gasket inside the holes. Occasionally, it should be applied outside the holes. Check to read the text of this manual.
- Within five minutes of liquid gasket application, install the mating component.
- If liquid gasket protrudes, wipe it off immediately.
- Do not retighten mounting bolts or nuts after the installation.
- After 30 minutes or more have passed from the installation, fill engine oil and engine coolant.

**CAUTION:**

**If there are specific instructions in this manual, observe them.**

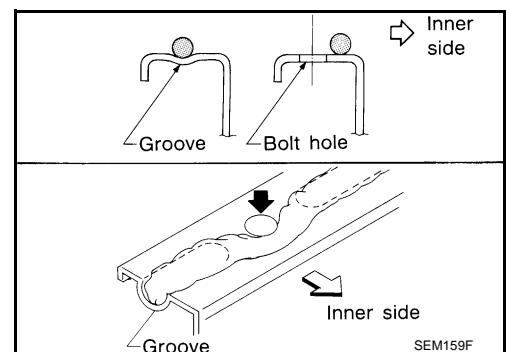

# PREPARATION

< PREPARATION >

## PREPARATION

### PREPARATION

#### Special Service Tools

INFOID:000000004231398

A

EM

The actual shapes of Kent-Moore tools may differ from those of special service tools illustrated here.

Tool number (Kent-Moore No.) Tool name	Description
KV10111100 (J-37228) Seal cutter	Removing oil pan and timing chain case
KV10116200 (J-26336-A) Valve spring compressor 1. KV10115900 (J-26336-20) Attachment 2. KV10109220 ( — ) Adapter	Disassembling and assembling valve mechanism Part (1) is a component of KV10116200 (J-26336-A), but Part (2) is not so.
KV10112100 (BT8653-A) Angle wrench	Tightening bolts for bearing cap, cylinder head, etc.
KV10117100 (J-3647-A) Heated oxygen sensor wrench	Loosening or tightening air fuel ratio sensor and heated oxygen sensor with 22 mm (0.87 in) hexagon nut
KV10107902 (J-38959) Valve oil seal puller 1. KV10116100 Valve oil seal puller adapter	Removing valve oil seal
KV10115600 (J-38958) Valve oil seal drift	Installing valve oil seal <b>Use side A.</b> <b>a: 20 (0.79) dia.</b> <b>d: 8 (0.31) dia.</b> <b>b: 13 (0.51) dia.</b> <b>e: 10.7 (0.421) dia.</b> <b>c: 10.3 (0.406) dia.</b> <b>f: 5 (0.20) dia.</b> Unit: mm (in)

C

D

E

F

G

H

I

J

K

L

M

N

O

P

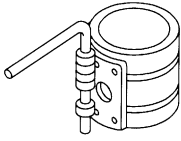
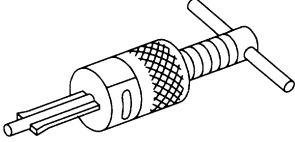

# PREPARATION

## < PREPARATION >

Tool number (Kent-Moore No.) Tool name	Description
EM03470000 (J-8037) Piston ring compressor <div data-bbox="683 317 862 457" style="text-align: center;">  </div> <div data-bbox="850 470 906 485" style="text-align: center;">S-NT044</div>	Installing piston assembly into cylinder bore
ST16610001 (J-23907) Pilot bushing puller <div data-bbox="626 569 919 709" style="text-align: center;">  </div> <div data-bbox="850 722 906 737" style="text-align: center;">S-NT045</div>	Removing pilot converter

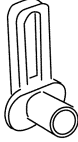
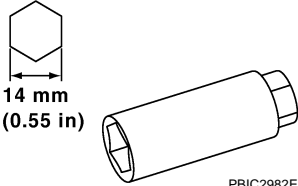

## Commercial Service Tools

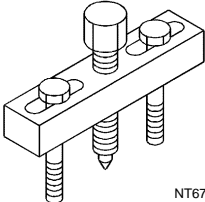
INFOID:000000004231399

(Kent-Moore No.) Tool name	Description
(J-45488) Quick connector release <div data-bbox="745 989 821 1129" style="text-align: center;">  </div> <div data-bbox="850 1148 922 1163" style="text-align: center;">PBIC0198E</div>	Removing fuel tube quick connectors in engine room
( — ) Spark plug wrench <div data-bbox="626 1226 922 1409" style="text-align: center;">  </div> <div data-bbox="850 1400 922 1415" style="text-align: center;">PBIC2982E</div>	Removing and installing spark plug
( — ) Pulley holder <div data-bbox="623 1514 922 1619" style="text-align: center;">  </div> <div data-bbox="850 1652 922 1667" style="text-align: center;">ZZA1010D</div>	Crankshaft pulley removing and installing
( — ) Pulley puller <div data-bbox="680 1719 883 1919" style="text-align: center;">  </div> <div data-bbox="850 1904 894 1919" style="text-align: center;">NT676</div>	Removing crankshaft pulley

# PREPARATION

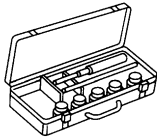
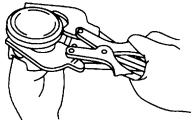
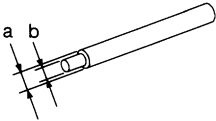
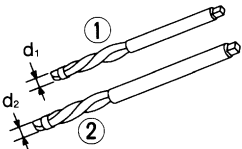
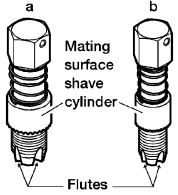
## < PREPARATION >

(Kent-Moore No.) Tool name	Description
( — ) Valve seat cutter set   S-NT048	Finishing valve seat dimensions
( — ) Piston ring expander   S-NT030	Removing and installing piston ring
( — ) Valve guide drift   S-NT015	Removing and installing valve guide <b>Intake and Exhaust:</b> <b>a: 9.5 mm (0.374 in) dia.</b> <b>b: 5.5 mm (0.217 in) dia.</b>
( — ) Valve guide reamer   S-NT016	1: Reaming valve guide inner hole 2: Reaming hole for oversize valve guide <b>Intake and Exhaust:</b> <b>d1: 6.0 mm (0.236 in) dia.</b> <b>d2: 10.2 mm (0.402 in) dia.</b>
(J-43897-18) (J-43897-12) Oxygen sensor thread cleaner   AEM488	Reconditioning the exhaust system threads before installing a new air fuel ratio sensor and heated oxygen sensor (Use with anti-seize lubricant shown below.) <b>a : J-43897-18 [18 mm (0.71 in) dia.]</b> <b>b : J-43897-12 [12 mm (0.47 in) dia.]</b>
( — ) Anti-seize lubricant (Permatex 133AR or equivalent meeting MIL specification MIL-A-907)   AEM489	Lubricating oxygen sensor thread cleaning tool when reconditioning exhaust system threads

A

EM

C

D

E

F

G

H

I

J

K

L

M

N

O

P

# PREPARATION

## < PREPARATION >

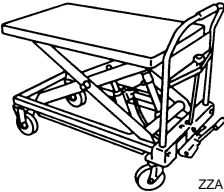
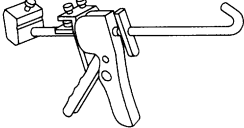
(Kent-Moore No.) Tool name	Description
( — ) Manual lift table caddy  ZZA1210D	Removing and installing engine
( — ) Tube presser  S-NT052	Pressing the tube of liquid gasket

# DRIVE BELTS

< ON-VEHICLE MAINTENANCE >

## ON-VEHICLE MAINTENANCE

### DRIVE BELTS

#### Exploded View

INFOID:000000004231400

A

EM

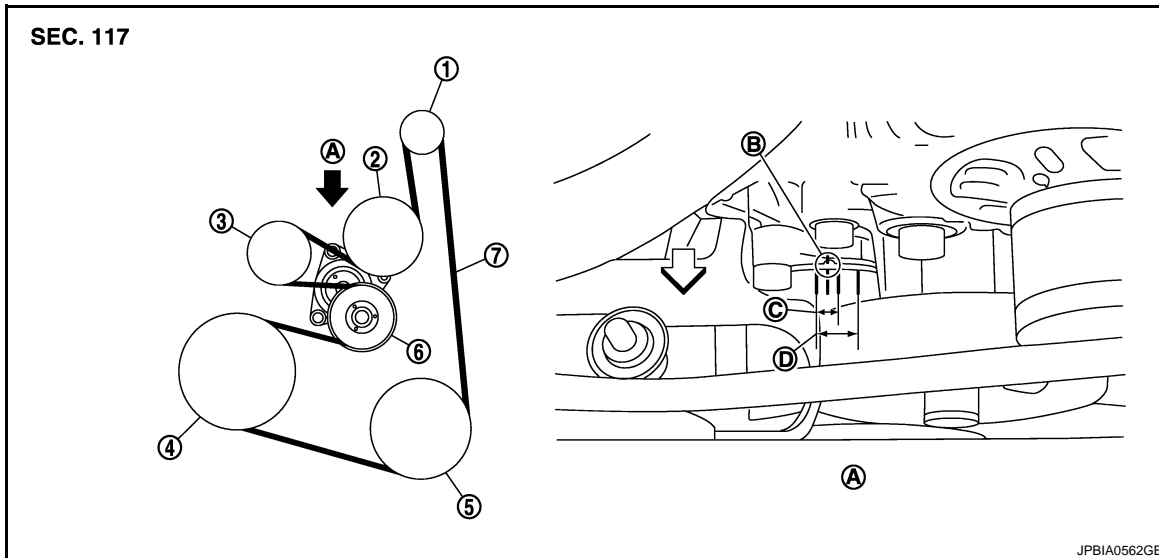

C

D

E

F

G

H

- |                      |                   |                              |
|----------------------|-------------------|------------------------------|
| 1. Alternator        | 2. Water pump     | 3. Idler pulley              |
| 4. Crankshaft pulley | 5. A/C compressor | 6. Drive belt auto-tensioner |
| 7. Drive belt        |                   |                              |
- A. View A                      B. Indicator (notch on the fixed side)      C. Range when new drive belt is installed
- D. Possible use range
- ⇐ : Engine front

I

J

#### Checking

INFOID:000000004231401

#### **WARNING:**

**Be sure to perform this step when the engine is stopped.**

- Check that the indicator (notch on fixed side) of drive belt auto-tensioner is within the possible use range (between four line notches on moving side).

K

L

M

N

O

P

#### **NOTE:**

- Check the drive belt auto-tensioner indication when the engine is cold.
- When new drive belt is installed, the indicator (notch on fixed side) should be within the range (C) in the figure.
- Visually check entire drive belt for wear, damage or cracks.
- If the indicator (notch on fixed side) is out of the possible use range or belt is damaged, replace drive belt.

#### Tension Adjustment

INFOID:000000004231402

Refer to : [EM-112, "Drive belt"](#).

#### Removal and Installation

INFOID:000000004231403

#### REMOVAL

1. Remove front wheel and tire (RH).
2. Remove front fender protector (RH). Refer to [EXT-22, "Exploded View"](#).



# DRIVE BELTS

## < ON-VEHICLE MAINTENANCE >

3. Hold the hexagonal part in center of drive belt auto-tensioner pulley with a box wrench securely. Then move the wrench handle in the direction of arrow (loosening direction of tensioner).

**CAUTION:**

- Avoid placing hand in a location where pinching may occur if the holding tool accidentally comes off.
- Never loosen the hexagonal part in center of drive belt auto-tensioner pulley (Never turn it counterclockwise). If turned counterclockwise, the complete drive belt auto-tensioner must be replaced as a unit, including the pulley.

4. Insert a rod approximately 6 mm (0.24 in) in diameter such as short-length screwdriver into the hole of the retaining boss to fix drive belt auto-tensioner pulley.
5. Loosen drive belt from water pump pulley in sequence, and remove it.

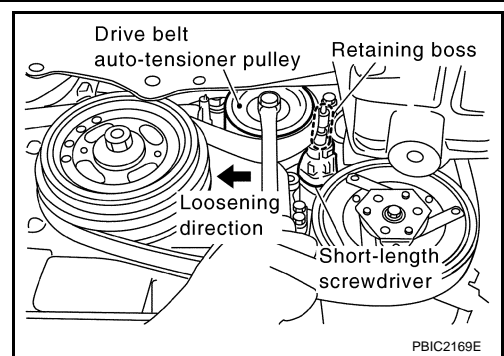

## INSTALLATION

1. Hold the hexagonal part in center of drive belt auto-tensioner pulley with a box wrench securely. Then move the wrench handle in the direction of arrow (loosening direction of tensioner).

**CAUTION:**

- Avoid placing hand in a location where pinching may occur if the holding tool accidentally comes off.
- Never loosen the hexagonal part in center of drive belt auto-tensioner pulley (Never not turn it counterclockwise). If turned counterclockwise, the complete drive belt auto-tensioner must be replaced as a unit, including the pulley.

2. Insert a rod approximately 6 mm (0.24 in) in diameter such as short-length screwdriver into the hole of retaining boss to fix drive belt auto-tensioner pulley.
3. Hook drive belt onto all pulleys except for water pump, and then onto water pump pulley finally.

**CAUTION:**

- Confirm drive belt is completely set to pulleys.
- Check for engine oil, working fluid and engine coolant are not adhered to drive belt and each pulley groove.

4. Release drive belt auto-tensioner, and apply tension to drive belt.
5. Turn crankshaft pulley clockwise several times to equalize tension between each pulley.
6. Confirm tension of drive belt at indicator (notch on fixed side) is within the possible use range. Refer to [EM-15. "Exploded View"](#).

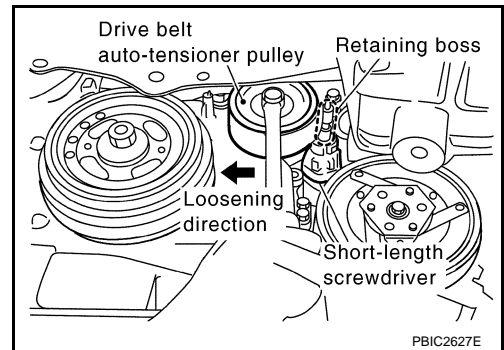

# AIR CLEANER FILTER

< ON-VEHICLE MAINTENANCE >

## AIR CLEANER FILTER

### Removal and Installation

INFOID:000000004231404

#### REMOVAL

1. Push the tabs (A) of both ends of the air cleaner cover (1) into the inside (B).
2. Pull up the air cleaner cover forward (C) and remove it.

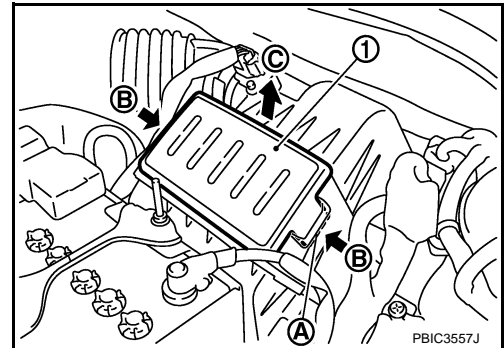

3. Remove the air cleaner filter (1) and holder (2) assembly from the air cleaner case.
4. Remove the air cleaner filter from the holder.

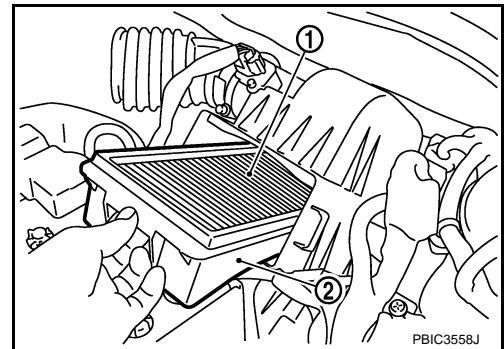

#### INSTALLATION

Install in the reverse order of removal.

A

EM

C

D

E

F

G

H

I

J

K

L

M

N

O

P

# SPARK PLUG

< ON-VEHICLE MAINTENANCE >

## SPARK PLUG

Exploded View

INFOID:000000004231405

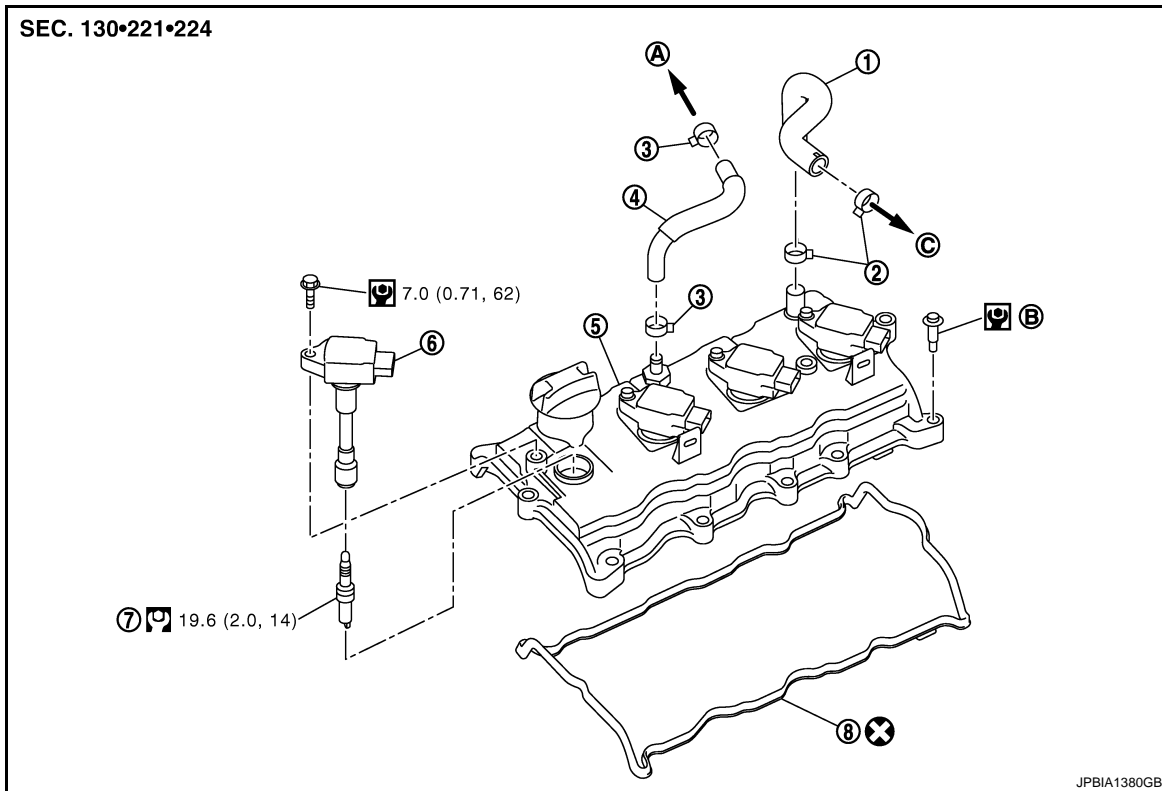

- |                       |                                   |                                       |
|-----------------------|-----------------------------------|---------------------------------------|
| 1. Fresh air hose     | 2. Clamp                          | 3. Clamp                              |
| 4. PCV hose           | 5. Rocker cover                   | 6. Ignition coil                      |
| 7. Spark plug         | 8. Rocker cover gasket            |                                       |
| A. To intake manifold | B. Refer to <a href="#">EM-40</a> | C. To air duct and resonator assembly |
- Refer to [GI-4, "Components"](#) for symbols in the figure.

## Removal and Installation

INFOID:000000004231406

### REMOVAL

1. Remove ignition coil. Refer to [EM-40, "Removal and Installation"](#).
2. Remove spark plug with spark plug wrench (commercial service tool).

**CAUTION:**  
Never drop or shock spark plug.

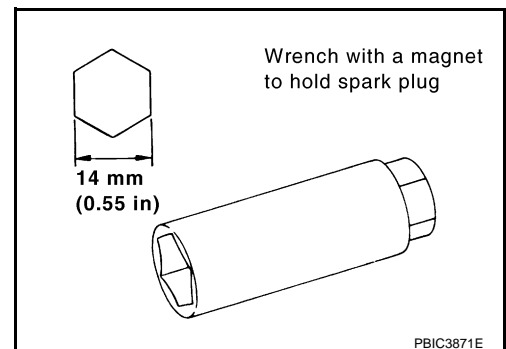

### INSTALLATION

Install in the reverse order of removal.

# SPARK PLUG

< ON-VEHICLE MAINTENANCE >

## Inspection

INFOID:000000004231407

### INSPECTION AFTER REMOVAL

Use standard type spark plug for normal condition.

Spark plug (standard) : Refer to [EM-112. "Spark Plug"](#).

#### CAUTION:

- Never drop or shock spark plug.
- Never use wire brush for cleaning.
- If plug tip is covered with carbon, spark plug cleaner may be used.

Cleaner air pressure: Less than 588 kPa (6 kg/cm<sup>2</sup>, 85 psi)

Cleaning time: Less than 20 seconds

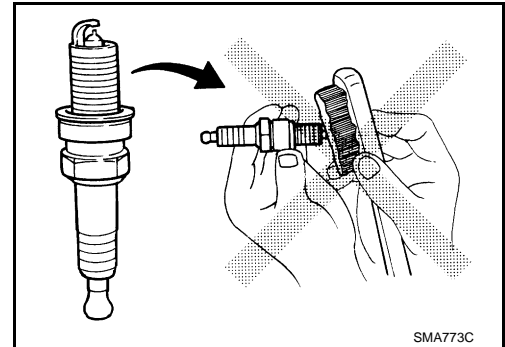

- Checking and adjusting plug gap is not required between change intervals.

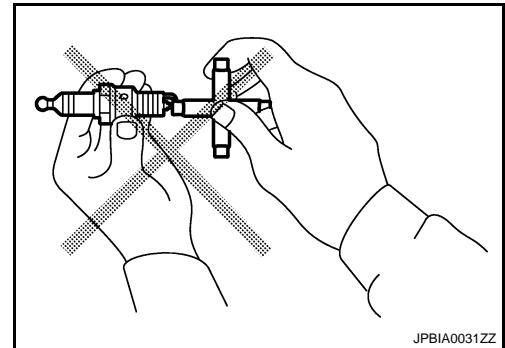

A

EM

C

D

E

F

G

H

I

J

K

L

M

N

O

P

# CAMSHAFT VALVE CLEARANCE

< ON-VEHICLE MAINTENANCE >

## CAMSHAFT VALVE CLEARANCE

### Inspection and Adjustment

INFOID:000000004231408

#### INSPECTION

Perform inspection as follows after removal, installation or replacement of camshaft or valve-related parts, or if there is unusual engine conditions regarding valve clearance.

1. Start the engine and warm it up.
2. Stop the engine.
3. Remove rocker cover. Refer to [EM-40, "Exploded View"](#).
4. Remove splash guard on RH fender protector.
5. Measure the valve clearance with the following procedure:
  - a. Set No. 1 cylinder at TDC of its compression stroke.
    - Rotate crankshaft pulley clockwise and align TDC mark to timing indicator on front cover.
    - At the same time, check that both intake and exhaust cam noses of No. 1 cylinder face outside as shown in the figure.
    - If they do not face outside, rotate crankshaft pulley once more (360 degrees) and align as shown in the figure.

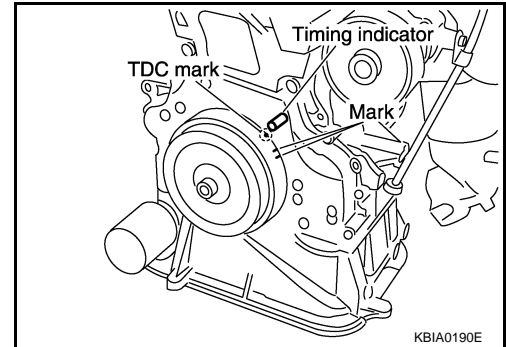

- b. Use a feeler gauge, measure the clearance between valve lifter and camshaft.

**Valve clearance** : Refer to [EM-113, "Camshaft"](#).

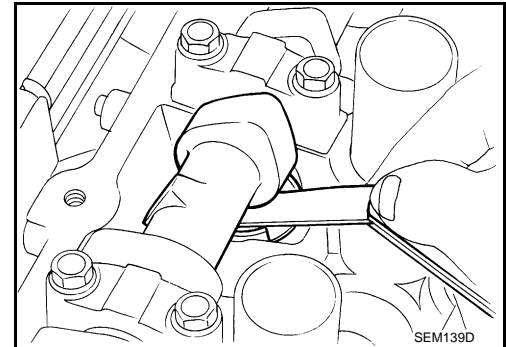

- By referring to the figure, measure the valve clearances at locations marked "x" as shown in the table below (locations indicated with black arrow in the figure) with a feeler gauge.
- No. 1 cylinder compression TDC

Measuring position		No. 1 CYL.	No. 2 CYL.	No. 3 CYL.	No. 4 CYL.
No. 1 cylinder at compression TDC	INT	x	x		
	EXH	x		x	

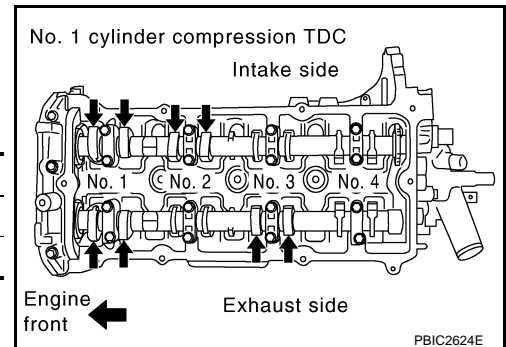

# CAMSHAFT VALVE CLEARANCE

## < ON-VEHICLE MAINTENANCE >

- c. Rotate crankshaft pulley one revolution (360 degrees) and align TDC mark to timing indicator on front cover.

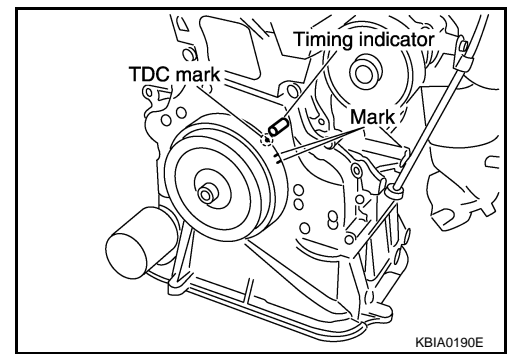

- By referring to the figure, measure the valve clearance at locations marked “x” as shown in the table below (locations indicated with black arrow in the figure) with a feeler gauge.
- No. 4 cylinder compression TDC

Measuring position		No. 1 CYL.	No. 2 CYL.	No. 3 CYL.	No. 4 CYL.
No. 4 cylinder at compression TDC	INT			×	×
	EXH		×		×

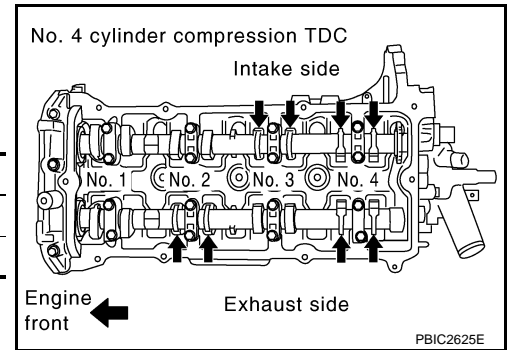

6. If out of standard, perform adjustment. Refer to “ADJUSTMENT”.

### ADJUSTMENT

- Perform adjustment depending on selected head thickness of valve lifter.
1. Remove camshaft. Refer to [EM-48. "Exploded View"](#).
  2. Remove valve lifters at the locations that are out of the standard.
  3. Measure the center thickness of the removed valve lifters with a micrometer (A).

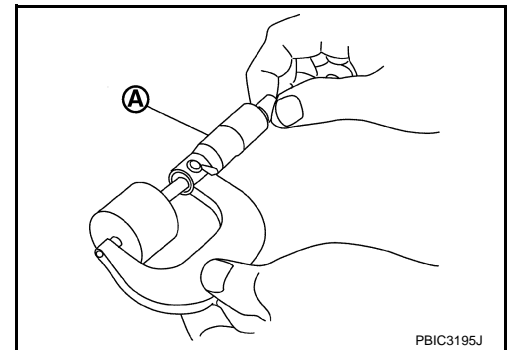

4. Use the equation below to calculate valve lifter thickness for replacement.

**Valve lifter thickness calculation:**  $t = t_1 + (C_1 - C_2)$

**t** = Valve lifter thickness to be replaced

**t<sub>1</sub>** = Removed valve lifter thickness

**C<sub>1</sub>** = Measured valve clearance

**C<sub>2</sub>** = Standard valve clearance:

**Intake** : 0.28 mm (0.011 in)

**Exhaust** : 0.30 mm (0.012 in)

## CAMSHAFT VALVE CLEARANCE

### < ON-VEHICLE MAINTENANCE >

- Thickness of new valve lifter (B) can be identified by stamp mark (A) on the reverse side (inside the cylinder). Stamp mark "788" indicates 7.88 mm (0.3102 in) in thickness.

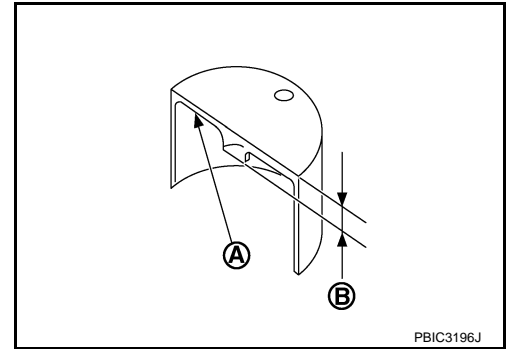

#### NOTE:

Available thickness of valve lifter: 26 sizes range 7.88 to 8.38 mm (0.3102 to 0.3299 in) in steps of 0.02 mm (0.0008 in) (when manufactured at factory). Refer to [EM-113, "Camshaft"](#).

5. Install the selected valve lifter.
6. Install camshaft. Refer to [EM-48, "Exploded View"](#).
7. Manually rotate crankshaft pulley a few rotations.
8. Check that valve clearances for cold engine are within specifications by referring to the specified values. Refer to "INSPECTION".
9. Install all removed parts in the reverse order of removal.
10. Warm up the engine, and check for unusual noise and vibration.



# COMPRESSION PRESSURE

< ON-VEHICLE MAINTENANCE >

## COMPRESSION PRESSURE

### Inspection

INFOID:000000004231409

1. Warm up engine thoroughly. Then, stop it.
2. Release fuel pressure. Refer to [EC-489, "Inspection"](#) (for California), [EC-1279, "Inspection"](#) (for Mexico) or [EC-923, "Inspection"](#) (Except for California and Mexico).
3. Disconnect fuel pump fuse to avoid fuel injection during measurement. Refer to [EC-32, "Component Parts Location"](#) (for California), [EC-942, "Component Parts Location"](#) (for Mexico) or [EC-509, "Component Parts Location"](#) (Except for California and Mexico).
4. Remove ignition coil and spark plug from each cylinder. Refer to [EM-40, "Exploded View"](#).
5. Connect engine tachometer (not required in use of CONSULT-III).
6. Install compression tester with adapter onto spark plug hole.

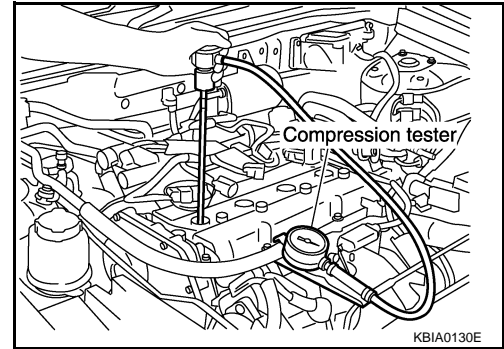

- Use the adapter whose picking up end inserted to spark plug hole is smaller than 20 mm (0.79 in) in diameter. Otherwise, it may be caught by cylinder head during removal.

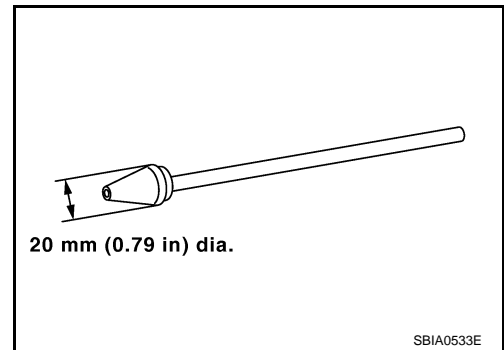

7. With accelerator pedal fully depressed, turn ignition switch to "START" for cranking. When the gauge pointer stabilizes, read the compression pressure and engine rpm. Perform these steps to check each cylinder.

**Compression pressure** : Refer to [EM-112, "General Specification"](#).

#### **CAUTION:**

**Always use a fully charged battery to obtain specified engine speed.**

- If the engine speed is out of specified range, check battery liquid for proper gravity. Check engine speed again with normal battery gravity.
- If compression pressure is below minimum value, check valve clearances and parts associated with combustion chamber (valve, valve seat, piston, piston ring, cylinder bore, cylinder head, cylinder head gasket). After the checking, measure the compression pressure again.
- If some cylinder has low compression pressure, pour small amount of engine oil into the spark plug hole of the cylinder to recheck it for compression.
  - If the added engine oil improves the compression, piston rings may be worn out or damaged. Check piston rings and replace if necessary.
  - If the compression pressure remains at low level despite the addition of engine oil, valves may be malfunctioning. Check valves for damage. Replace valve or valve seat accordingly.
- If two adjacent cylinders have respectively low compression pressure and their compression remains low even after the addition of engine oil, gaskets are leaking. In such a case, replace cylinder head gaskets.

## COMPRESSION PRESSURE

### < ON-VEHICLE MAINTENANCE >

---

8. After inspection is completed, install removed parts.
9. Start engine, and confirm that engine runs smoothly.
10. Perform trouble diagnosis. If DTC appears, erase it. Refer to [EC-116. "Description"](#) (for California), [EC-1012. "Description"](#) (for Mexico) or [EC-587. "Description"](#) (Except for California and Mexico).

# DRIVE BELT AUTO-TENSIONER

< ON-VEHICLE REPAIR >

## ON-VEHICLE REPAIR

### DRIVE BELT AUTO-TENSIONER

Exploded View

INFOID:000000004231410

A

EM

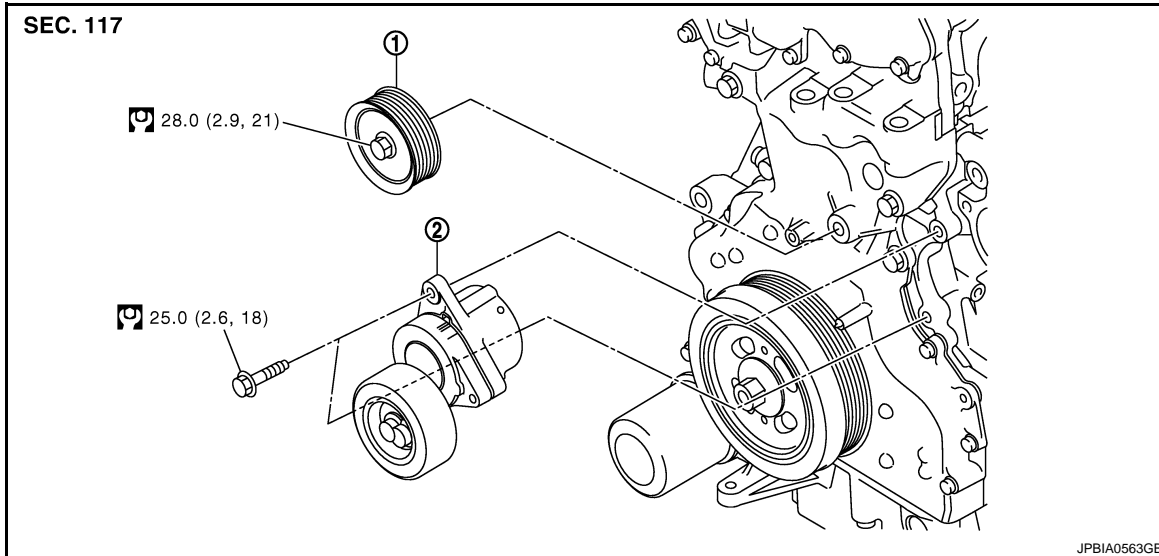

1. Idler pulley
2. Drive belt auto-tensioner

Refer to [GI-4, "Components"](#) for symbols in the figure.

## Removal and Installation

INFOID:000000004231411

### Removal

#### CAUTION:

The complete drive belt auto-tensioner must be replaced as a unit, including the pulley.

1. Remove front wheel and tire (RH).
2. Remove front fender protector (RH).
3. Remove drive belt. Refer to [EM-15, "Removal and Installation"](#).
4. Support the bottom surface of engine using a transmission jack, and loosen engine mounting insulator bolts (RH). Refer to [EM-61, "Exploded View"](#).

#### CAUTION:

Never remove the bolts (No. 4, 5) as shown in the figure.

← : Vehicle front

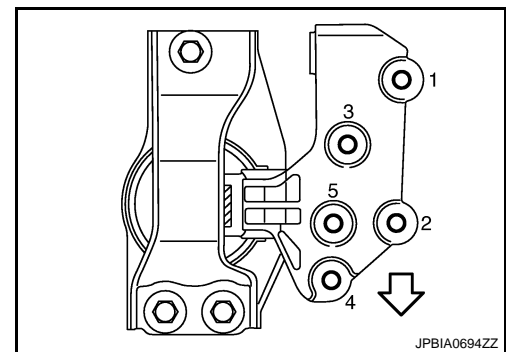

5. Remove idler pulley.
6. Release the fixed drive belt auto-tensioner pulley.
7. Remove drive belt auto-tensioner.

#### CAUTION:

C

D

E

F

G

H

I

J

K

L

M

N

O

P

## DRIVE BELT AUTO-TENSIONER

< ON-VEHICLE REPAIR >

---

Never loosen the hexagonal part in center of drive belt auto-tensioner pulley (Never turn it counterclockwise). If turned counterclockwise, the complete drive belt auto-tensioner must be replaced as a unit, including the pulley.

Installation

Note the following, and install in the reverse order of removal.

**CAUTION:**

- When installing drive belt auto-tensioner, be careful not to interfere with water pump pulley.
- If there is damage greater than peeled paint, replace drive belt auto-tensioner.
- Never swap the pulley between new and old drive belt auto-tensioner.

# AIR CLEANER AND AIR DUCT

< ON-VEHICLE REPAIR >

## AIR CLEANER AND AIR DUCT

### Exploded View

INFOID:000000004231412

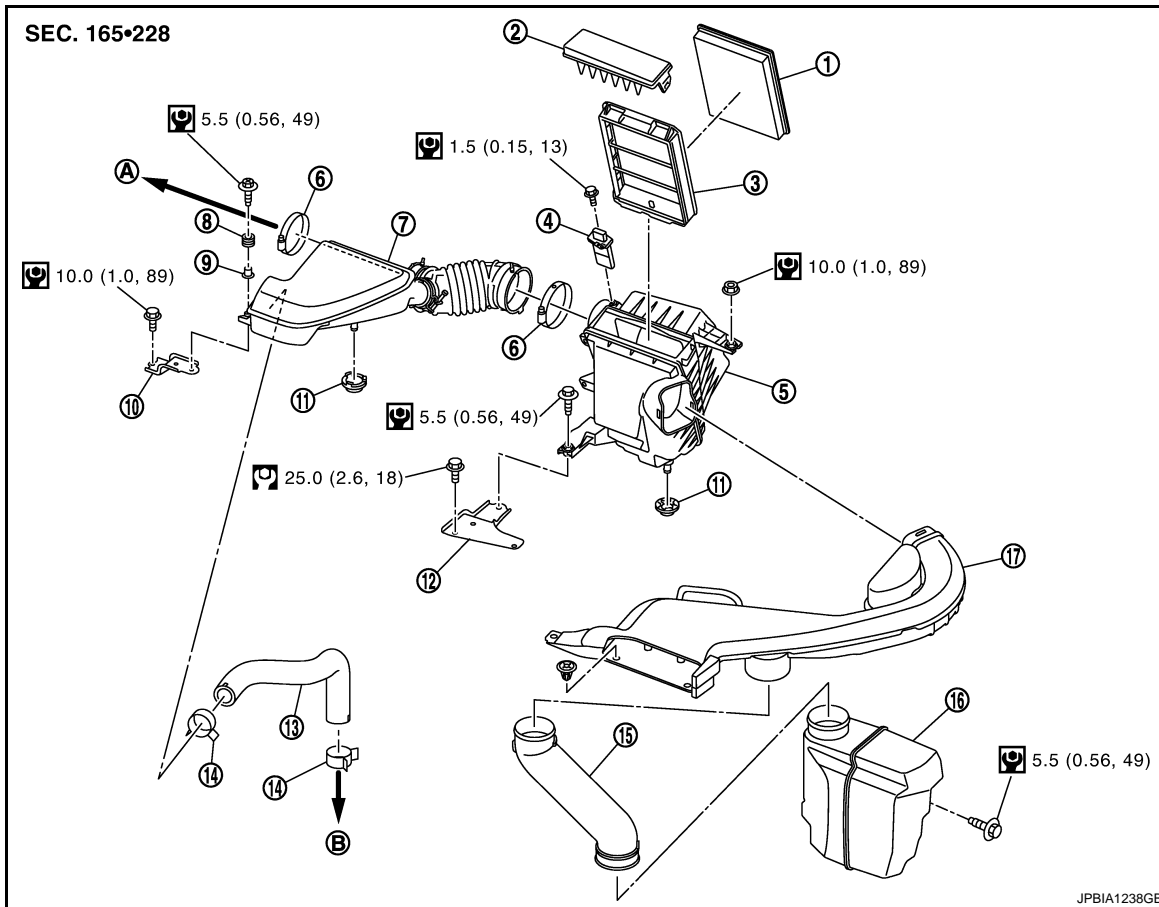

- |  |                      |              |
|--|----------------------|--------------|
| 1. Air cleaner filter                    | 2. Air cleaner cover | 3. Holder    |
| 4. Mass air flow sensor                  | 5. Air cleaner case  | 6. Clamp     |
| 7. Air duct and resonator assembly       | 8. Grommet           | 9. Collar    |
| 10. Bracket                              | 11. Grommet          | 12. Bracket  |
| 13. Fresh air hose                       | 14. Clamp            | 15. Air duct |
| 16. Resonator                            | 17. Air duct (inlet) |              |
| A. To electric throttle control actuator | B. To rocker cover   |              |

Refer to [GI-4, "Components"](#) for symbols in the figure.

### Removal and Installation

INFOID:000000004231413

#### REMOVAL

##### NOTE:

Mass air flow sensor is removable under the car-mounted condition.

1. Remove air duct (inlet).
2. Remove battery. Refer to [PG-92, "Exploded View"](#).

## AIR CLEANER AND AIR DUCT

### < ON-VEHICLE REPAIR >

3. Disconnect harness connectors (A) and then remove bracket (1).
4. Disconnect mass air flow sensor harness connector.
5. Disconnect fresh air hose.
6. Remove air cleaner case and mass air flow sensor assembly, air duct and resonator assembly and air duct disconnecting their joints.
  - Add marks if necessary for easier installation.
7. Remove mass air flow sensor from air cleaner case, if necessary.

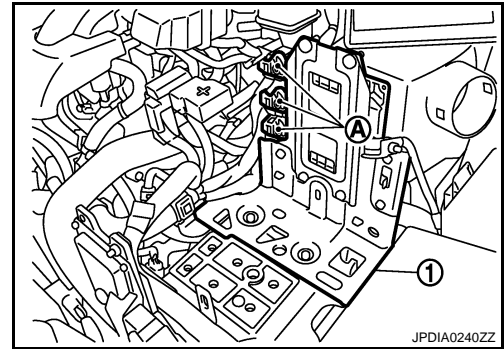

#### **CAUTION:**

**Handle the mass air flow sensor with the following cares.**

- **Never shock the mass air flow sensor.**
- **Never disassemble the mass air flow sensor.**
- **Never touch the sensor of the mass air flow sensor.**

### INSTALLATION

Note the following, and install in the reverse order of removal.

- Align marks. Attach each joint. Screw clamps firmly.

### Inspection

INFOID:000000004231414

### INSPECTION AFTER REMOVAL

Inspect air duct and resonator assembly for crack or tear.

- If anything found, replace air duct and resonator assembly.

# INTAKE MANIFOLD

< ON-VEHICLE REPAIR >

## INTAKE MANIFOLD

### Exploded View

INFOID:000000004231415

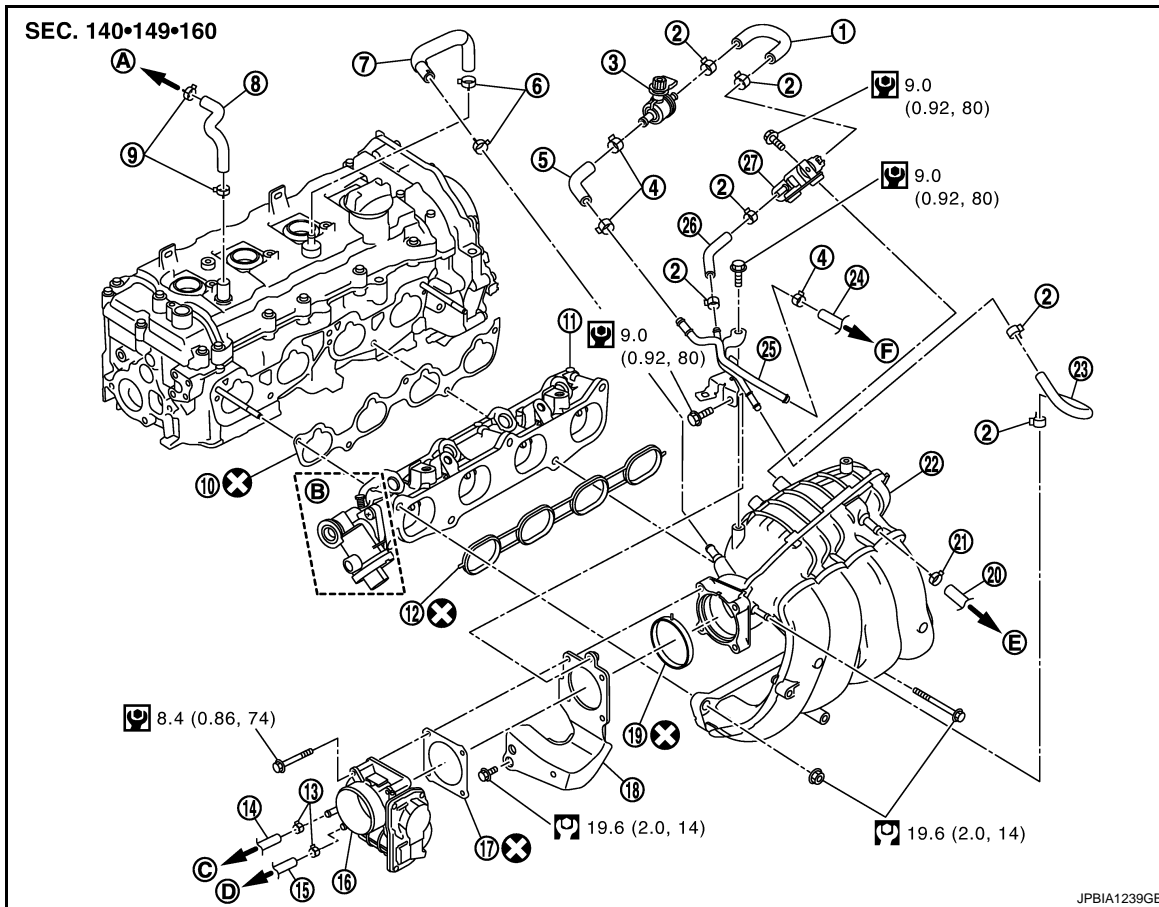

- |  |                             |   |
|--|-----------------------------|---|
| 1. EVAP hose                           | 2. Clamp                    | 3. EVAP service port                                  |
| 4. Clamp                               | 5. EVAP hose                | 6. Clamp  |
| 7. PCV hose                            | 8. Fresh air hose           | 9. Clamp  |
| 10. Gasket                             | 11. Intake manifold adapter | 12. Gasket  |
| 13. Clamp                              | 14. Water hose              | 15. Water hose  |
| 16. Electric throttle control actuator | 17. Gasket                  | 18. Intake manifold support                           |
| 19. Gasket                             | 20. Vacuum hose             | 21. Clamp   |
| 22. Intake manifold                    | 23. EVAP hose               | 24. EVAP hose   |
| 25. EVAP tube                          | 26. EVAP hose               | 27. EVAP canister purge volume control solenoid valve |
- A. To air duct  
 B. For California  
 C. To heater pipe  
 D. To water outlet  
 E. To brake booster  
 F. To vacuum pipe (canister)

Refer to [GI-4, "Components"](#) for symbols in the figure.

### Removal and Installation

INFOID:000000004231416

#### REMOVAL

1. Release fuel pressure. Refer to [EC-489, "Inspection"](#) (for California), [EC-1279, "Inspection"](#) (for Mexico) or [EC-923, "Inspection"](#) (Except for California and Mexico).
2. Remove cowl top cover. Refer to [EXT-20, "Exploded View"](#).
3. Remove air cleaner case and mass air flow sensor assembly and air duct and resonator assembly. Refer to [EM-27, "Exploded View"](#).



# INTAKE MANIFOLD

## < ON-VEHICLE REPAIR >

4. Remove electric throttle control actuator with the following procedure:
  - a. Disconnect harness connector.
  - b. Loosen mounting bolts in reverse order as shown in the figure, and remove electric throttle control actuator and gasket.

### CAUTION:

- Handle carefully to avoid any shock to electric throttle control actuator.
- Never disassemble.

### NOTE:

- When removing only intake manifold, move electric throttle control actuator without disconnecting the water hose.

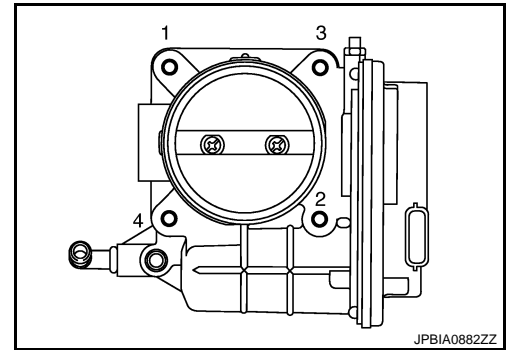

5. Disconnect harness, vacuum hose and PCV hose from intake manifold, and move them aside.
6. Remove intake manifold support.
7. Disconnect harness connector from tumble control valve motor. (For California)
8. Loosen mounting bolts and nuts in reverse order as shown in the figure, and remove intake manifold and gasket.

⇐ : Engine front

### CAUTION:

Cover engine openings to avoid entry of foreign materials.

### NOTE:

Disregard No. 6 when loosening.

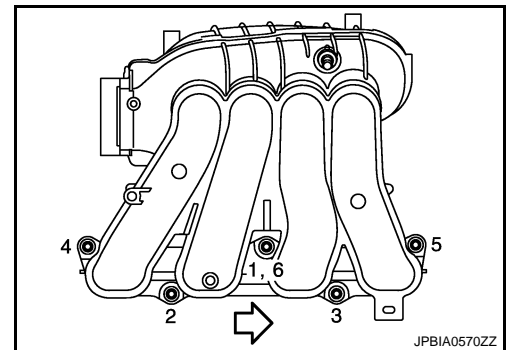

9. Disconnect sub-harness from fuel injector. Refer to [EM-43. "Exploded View"](#).
10. Remove fuel tube and fuel injector assembly from intake manifold adaptor. Refer to [EM-43. "Exploded View"](#).
11. Remove EVAP canister purge volume control solenoid valve from intake manifold, if necessary.

## INSTALLATION

Note the following, and install in the reverse order of removal.

### Intake Manifold

- If stud bolts were removed, install them and tighten to the specified torque below.

 : 9.4 N·m (0.96 kg·m, 83 in·lb)

- Tighten in numerical order as shown in the figure.

⇐ : Engine front

### NOTE:

No. 6 means double tightening of bolt No. 1.

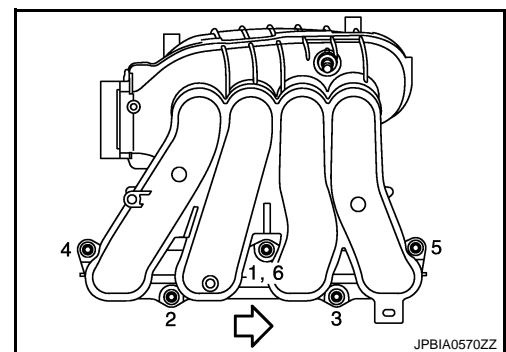

### Electric Throttle Control Actuator

# INTAKE MANIFOLD

## < ON-VEHICLE REPAIR >

- Tighten mounting bolts equally and diagonally in several steps and in numerical order as shown in the figure.
- Perform the "Throttle Valve Closed Position Learning" when harness connector of electric throttle control actuator is disconnected. Refer to [EC-27, "THROTTLE VALVE CLOSED POSITION LEARNING : Description"](#) (for California), [EC-938, "THROTTLE VALVE CLOSED POSITION LEARNING : Description"](#) (for Mexico) or [EC-504, "THROTTLE VALVE CLOSED POSITION LEARNING : Description"](#) (Except for California and Mexico).
- Perform the "Idle Air Volume Learning" and "Throttle Valve Closed Position Learning" when electric throttle control actuator is replaced. Refer to [EC-27, "IDLE AIR VOLUME LEARNING : Description"](#) (for California), [EC-938, "IDLE AIR VOLUME LEARNING : Description"](#) (for Mexico) or [EC-504, "IDLE AIR VOLUME LEARNING : Description"](#) (Except for California and Mexico).

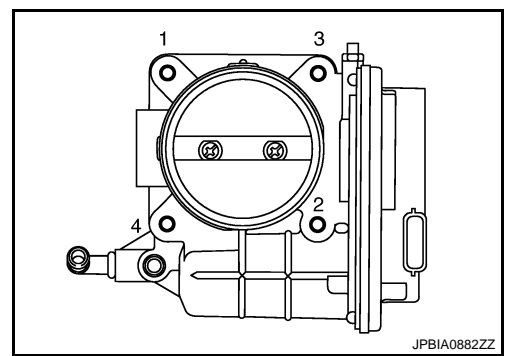

## Inspection

INFOID:000000004231417

### INSPECTION AFTER REMOVAL

#### Surface Distortion

- Using straightedge (A) and feeler gauge (B), check the surface distortion of both the intake manifold adaptor mating surface.

**Limit** : Refer to [EM-113, "Intake Manifold"](#).

- If it exceeds the limit, replace intake manifold adaptor.

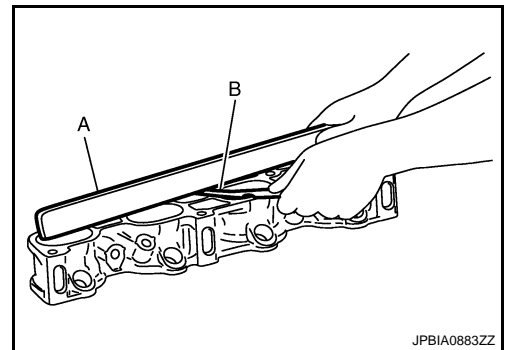

A  
EM  
C  
D  
E  
F  
G  
H  
I  
J  
K  
L  
M  
N  
O  
P

# EXHAUST MANIFOLD AND THREE WAY CATALYST

< ON-VEHICLE REPAIR >

## EXHAUST MANIFOLD AND THREE WAY CATALYST

Exploded View

INFOID:000000004231418

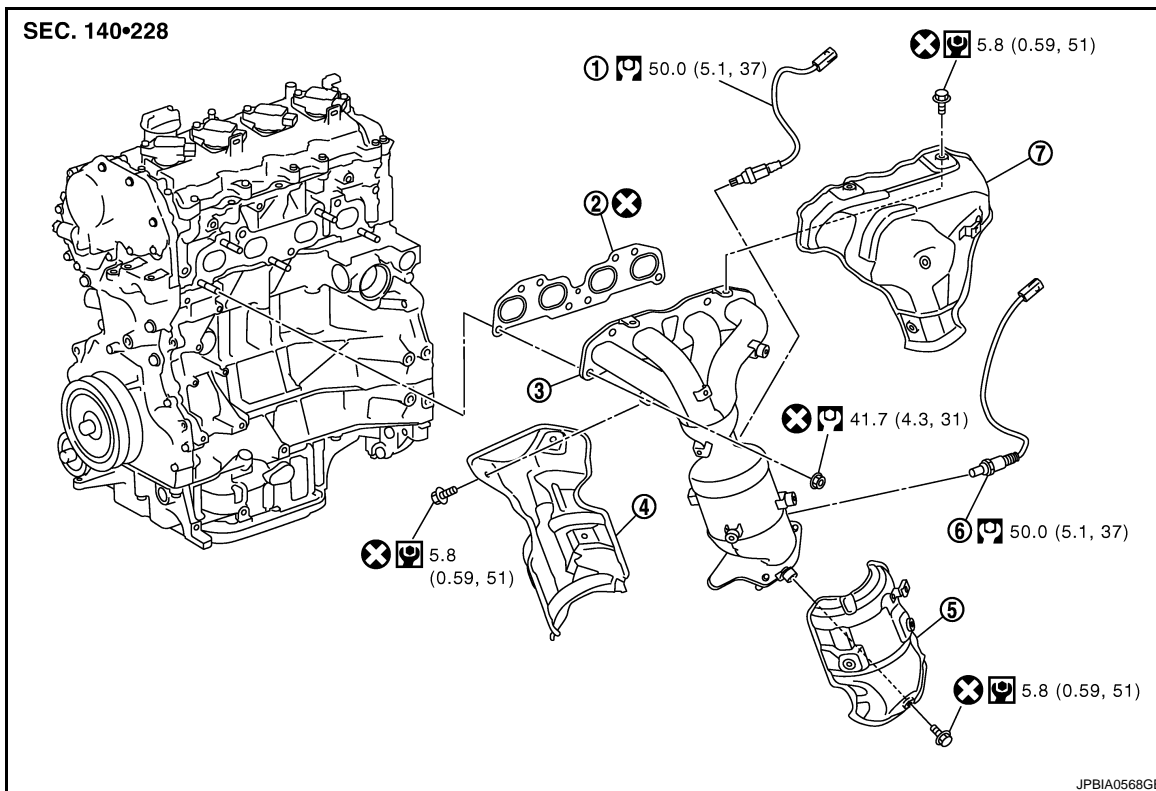

- |                                   |                                   |   |
|-----------------------------------|-----------------------------------|---|
| 1. Air fuel ratio sensor 1        | 2. Gasket                         | 3. Exhaust manifold and three way catalyst assembly |
| 4. Three way catalyst cover       | 5. Exhaust manifold cover (lower) | 6. Heated oxygen sensor 2                           |
| 7. Exhaust manifold cover (upper) |                                   |   |

Refer to [GI-4, "Components"](#) for symbols in the figure.

## Removal and Installation

INFOID:000000004231419

### Removal

- Remove air fuel ratio sensor 1 and heated oxygen sensor 2 with the following procedure:
  - Disconnect harness connector of air fuel ratio sensor 1 and heated oxygen sensor 2 and harness from bracket and middle clamp.
  - Using heated oxygen sensor wrench [SST: KV10117100 (J-3647-A)] (A), remove air fuel ratio sensor 1 (1).

#### CAUTION:

- Be careful not to damage air fuel ratio sensor 1 and heated oxygen sensor 2.
- Discard any air fuel ratio sensor 1 and heated oxygen sensor 2 which has been dropped onto a hard surface such as a concrete floor. Replace with a new one.

#### NOTE:

This figure shows air fuel ratio sensor 1 as an example.

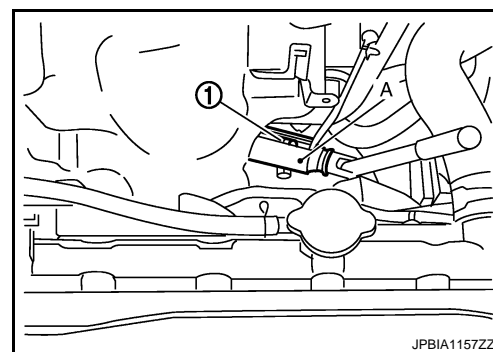

JPBIA1157ZZ

- Remove exhaust front tube. Refer to [EX-5, "Exploded View"](#).
- Remove alternator. Refer to [CHG-19, "Exploded View"](#).
- Remove exhaust manifold cover (upper).

# EXHAUST MANIFOLD AND THREE WAY CATALYST

## < ON-VEHICLE REPAIR >

- Loosen nuts in reverse order as shown in the figure to remove exhaust manifold and three way catalyst assembly.

← : Engine front

### NOTE:

Disregard No. 6 to 10 when loosening.

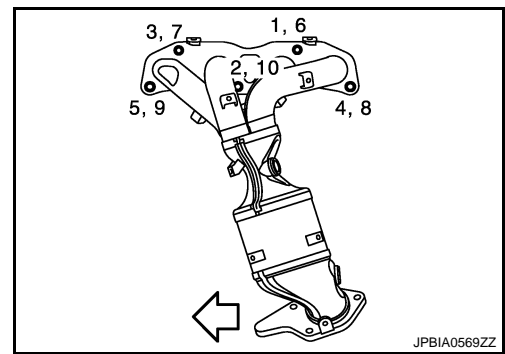

- Remove gasket.

### CAUTION:

Cover engine openings to avoid entry of foreign materials.

- Remove exhaust manifold cover (lower) and three way catalyst cover from exhaust manifold and three way catalyst assembly.

## Installation

Note the following, and install in the reverse order of removal.

### EXHAUST MANIFOLD

- If stud bolts were removed, install them and tighten to the specified torque below.

 : 14.7 N·m (1.5 kg·m, 11 ft·lb)

- Tighten nuts in numerical order as shown in the figure.

← : Engine front

### NOTE:

No. 6 to 10 mean double tightening of bolts No. 1 and 5.

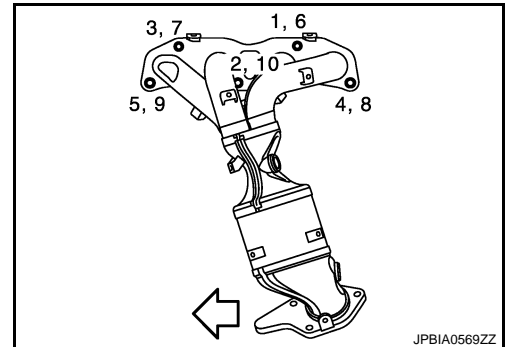

### HEATED OXYGEN SENSOR

#### CAUTION:

- Before installing a new air fuel ratio sensor 1 and heated oxygen sensor 2, clean exhaust system threads using heated oxygen sensor thread cleaner and apply anti-seize lubricant (commercial service tool: J-43897-18 or J-43897-12).
- Never over torque the air fuel ratio sensor 1 and heated oxygen sensor 2. Doing so may cause damage to the air fuel ratio sensor 1 and heated oxygen sensor 2, resulting in the "MIL" coming on.

## Inspection

INFOID:000000004231420

### INSPECTION AFTER REMOVAL

#### Surface Distortion

- Check the surface distortion of the exhaust manifold mating surface with a straightedge and a feeler gauge.

Limit : Refer to [EM-113, "Exhaust Manifold"](#).

- If it exceeds the limit, replace exhaust manifold.

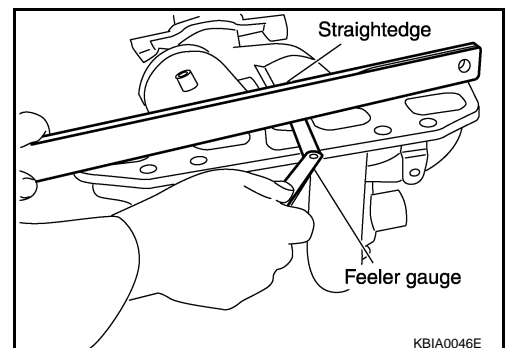

# OIL PAN (LOWER)

< ON-VEHICLE REPAIR >

## OIL PAN (LOWER)

Exploded View

INFOID:000000004231421

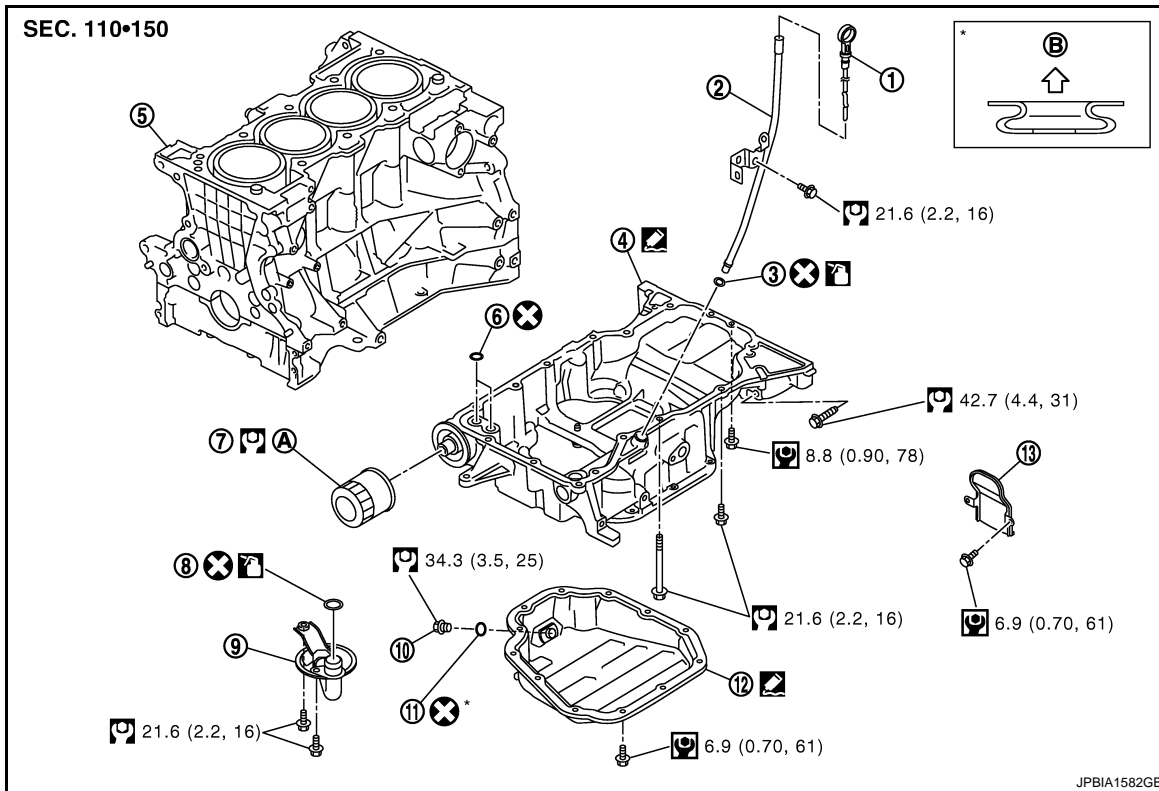

JPBIA1582GB

- |                                  |                          |                     |
|----------------------------------|--------------------------|---------------------|
| 1. Oil level gauge               | 2. Oil level gauge guide | 3. O-ring           |
| 4. Oil pan (upper)               | 5. Cylinder block        | 6. O-ring           |
| 7. Oil filter                    | 8. O-ring                | 9. Oil strainer     |
| 10. Drain plug                   | 11. Drain plug washer    | 12. Oil pan (lower) |
| 13. Rear plate cover             |                          |                     |
| A. Refer to <a href="#">LU-8</a> | B. Oil pan side          |                     |

Refer to [GI-4. "Components"](#) for symbols in the figure.

## Removal and Installation

INFOID:000000004231422

### REMOVAL

#### **WARNING:**

**To avoid the danger of being scalded, never drain the engine oil when the engine is hot.**

1. Drain engine oil. Refer to [LU-6. "Draining"](#).
2. Remove oil pan (lower) with the following procedure:
  - a. Loosen mounting bolts in the reverse order as shown in the figure.

⇐ : Engine front

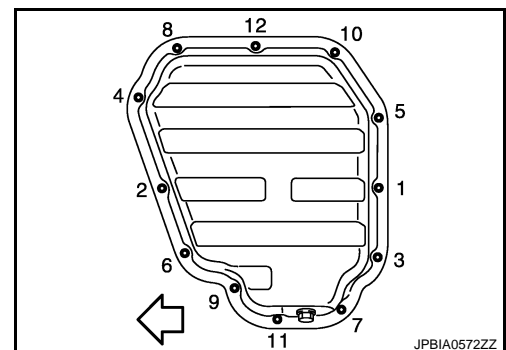

JPBIA0572ZZ

## OIL PAN (LOWER)

### < ON-VEHICLE REPAIR >

- b. Insert seal cutter (SST) between oil pan (upper) and oil pan (lower).

**CAUTION:**

**Be careful not to damage the mating surface.**

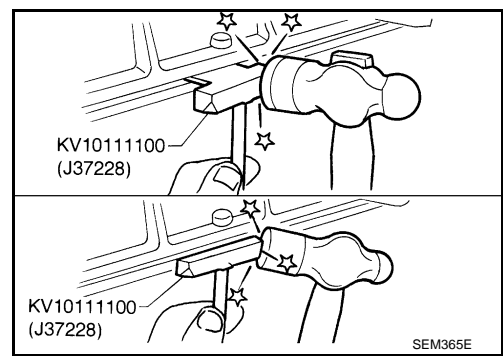

### INSTALLATION

1. Install oil pan (lower) with the following procedure:
- a. Use a scraper to remove old liquid gasket from mating surfaces.
- Also remove old liquid gasket from mating surface of oil pan (upper).
  - Remove old liquid gasket from the bolt holes and threads.

**CAUTION:**

**Never scratch or damage the mating surface when cleaning off liquid gasket.**

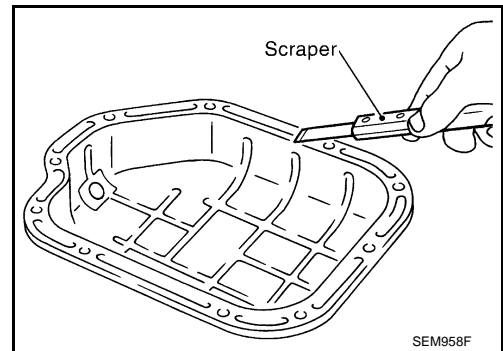

- b. Apply a continuous bead of liquid gasket with a tube presser (commercial service tool) as shown in the figure.

↶ : Engine front

**a** :  $\phi 4.0 - 5.0$  mm (0.157 - 0.197 in)

Use Genuine RTV Silicone Sealant or equivalent. Refer to [GI-17, "Recommended Chemical Products and Sealants"](#).

**CAUTION:**

**Attaching should be done within 5 minutes after liquid gasket application.**

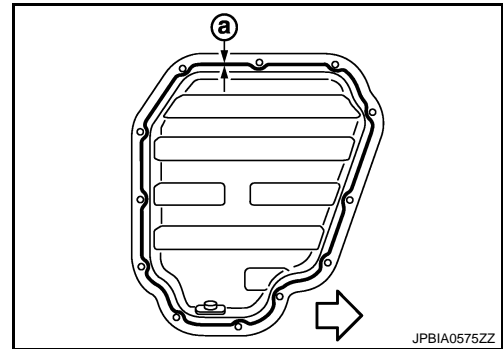

- c. Tighten bolts in numerical order as shown in the figure.

↶ : Engine front

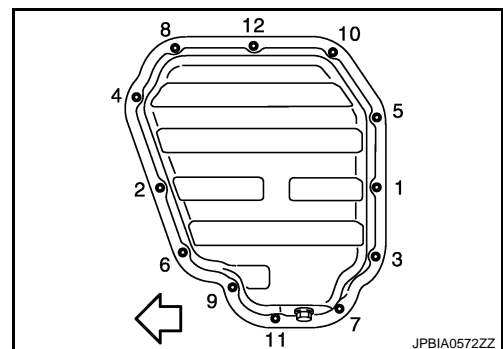

2. Install oil pan drain plug.
- Refer to the figure of components of former page for installation direction of drain plug washer. Refer to [EM-34, "Exploded View"](#).

3. Install in the reverse order of removal after this step.

**NOTE:**

Pour engine oil at least 30 minutes after oil pan is installed.

## OIL PAN (LOWER)

< ON-VEHICLE REPAIR >

---

### Inspection

INFOID:000000004231423

#### INSPECTION AFTER INSTALLATION

1. Check engine oil level and adjust engine oil. Refer to [LU-5. "Inspection"](#).
2. Start engine, and check there is no leakage of engine oil.
3. Stop engine and wait for 10 minutes.
4. Check engine oil level again. Refer to [LU-5. "Inspection"](#).



# OIL PAN (UPPER) AND OIL STRAINER

< ON-VEHICLE REPAIR >

## OIL PAN (UPPER) AND OIL STRAINER

### Exploded View

INFOID:000000004231424

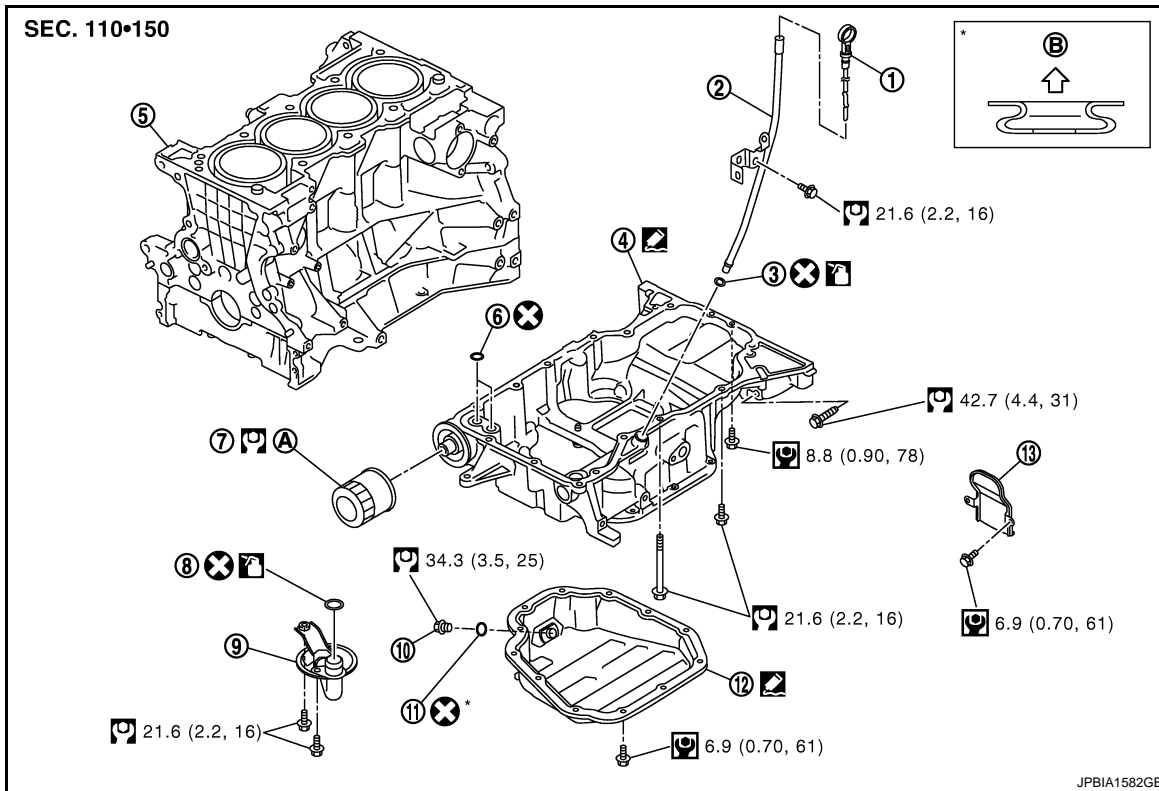

- |                      |                          |                     |
|----------------------|--------------------------|---------------------|
| 1. Oil level gauge   | 2. Oil level gauge guide | 3. O-ring           |
| 4. Oil pan (upper)   | 5. Cylinder block        | 6. O-ring           |
| 7. Oil filter        | 8. O-ring                | 9. Oil strainer     |
| 10. Drain plug       | 11. Drain plug washer    | 12. Oil pan (lower) |
| 13. Rear plate cover |                          |                     |
- A. Refer to [LU-8](#)                      B. Oil pan side

Refer to [GI-4, "Components"](#) for symbols in the figure.

### Removal and Installation

INFOID:000000004231425

#### REMOVAL

#### **WARNING:**

**To avoid the danger of being scalded, never drain the engine oil when the engine is hot.**

1. Remove undercover.
2. Drain engine oil. Refer to [LU-6, "Draining"](#).
3. Remove oil pan (lower). Refer to [EM-34, "Removal and Installation"](#).
4. Remove oil level gauge and guide.
5. Disconnect steering lower joint at steering gear assembly side, and release steering lower shaft. Refer to [ST-11, "Exploded View"](#).
6. Disconnect steering outer sockets from steering knuckle. Refer to [ST-14, "Exploded View"](#).
7. Remove rear torque rod. Refer to [EM-61, "Exploded View"](#).
8. Remove stabilizer connecting rod. Refer to [FSU-16, "Exploded View"](#).
9. Remove front suspension member. Refer to [FSU-18, "Exploded View"](#).
10. Remove A/C compressor without disconnecting A/C piping, and temporarily fasten it on vehicle with a rope. Refer to [HA-43, "Exploded View"](#).

# OIL PAN (UPPER) AND OIL STRAINER

## < ON-VEHICLE REPAIR >

11. Remove oil strainer.
12. Remove oil pan (upper) with the following procedure:
  - a. Loosen bolts in the reverse order as shown in the figure.

⇐ : Engine front

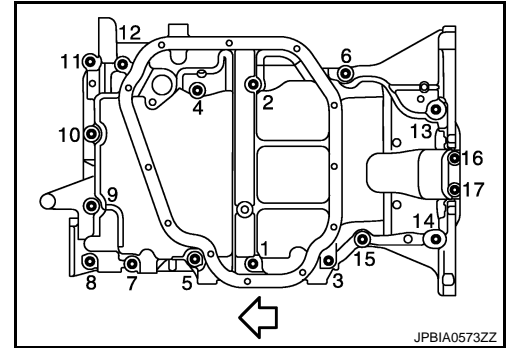

- b. Insert seal cutter (SST) between oil pan (upper) and lower cylinder block, and slide it by tapping on the side of the tool with a hammer.

**CAUTION:**

**Be careful not to damage the mating surface.**

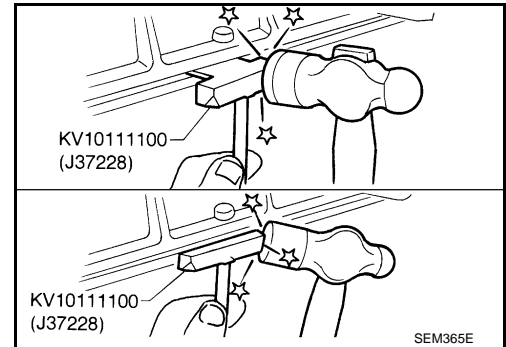

13. Remove O-rings at front cover side.

## INSTALLATION

1. Install oil pan (upper) with the following procedure:
  - a. Use a scraper to remove old liquid gasket from mating surfaces.
    - Also remove the old liquid gasket from mating surface of cylinder block.
    - Remove old liquid gasket from the bolt holes and threads.

**CAUTION:**

**Never scratch or damage the mating surfaces when cleaning off old liquid gasket.**

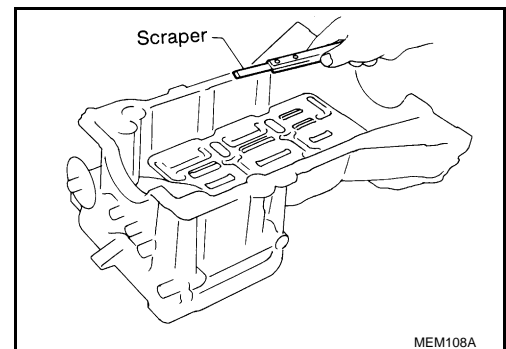

- b. Apply a continuous bead of liquid gasket with a tube presser (commercial service tool) as shown in the figure.

⇐ : Engine front

**a** :  $\phi 4.0 - 5.0$  mm (0.157 - 0.197 in)

Use Genuine RTV Silicone Sealant or equivalent. Refer to [GI-17, "Recommended Chemical Products and Sealants"](#).

**CAUTION:**

- For bolt holes with ▲ marks (3 locations), apply liquid gasket out side the holes.
- Attaching should be done within 5 minutes after liquid gasket application.

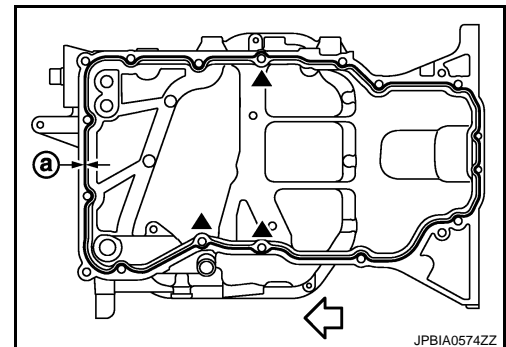

- c. Install new O-rings at front cover side.

**CAUTION:**

**Install avoiding misalignment of O-rings.**

# OIL PAN (UPPER) AND OIL STRAINER

## < ON-VEHICLE REPAIR >

- d. Tighten bolts in numerical order as shown in the figure.

← : Engine front

### NOTE:

Refer to the following for locating bolts.

<b>M6 × 20 mm (0.79 in)</b>	<b>: No. 16, 17</b>
<b>M8 × 25 mm (0.98 in)</b>	<b>: No. 4, 6, 11, 13, 14, 15</b>
<b>M8 × 60 mm (2.36 in)</b>	<b>: No. 7, 8, 9, 10</b>
<b>M8 × 100 mm (3.94 in)</b>	<b>: No. 1, 2, 3, 5, 12</b>

**Tightening torque** : Refer to [EM-37, "Exploded View"](#).

2. Install oil strainer.
3. Install front suspension member. Refer to [FSU-18, "Exploded View"](#).
4. Install oil pan (lower). Refer to [EM-34, "Removal and Installation"](#).
5. Install oil pan drain plug.
  - Refer to the figure of components of former page for installation direction of washer. Refer to [EM-37, "Exploded View"](#).
6. Install in the reverse order of removal after this step.

### NOTE:

Pour engine oil at least 30 minutes after oil pan is installed.

## Inspection

INFOID:000000004231426

## INSPECTION AFTER INSTALLATION

1. Check engine oil level and adjust engine oil. Refer to [LU-5, "Inspection"](#).
2. Start engine, and check there is no leakage of engine oil.
3. Stop engine and wait for 10 minutes.
4. Check engine oil level again. Refer to [LU-5, "Inspection"](#).

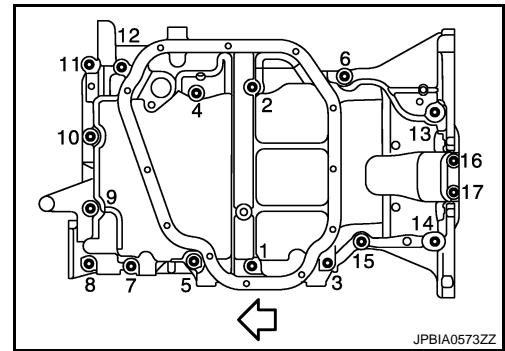

A

EM

C

D

E

F

G

H

I

J

K

L

M

N

O

P

# IGNITION COIL, SPARK PLUG AND ROCKER COVER

< ON-VEHICLE REPAIR >

## IGNITION COIL, SPARK PLUG AND ROCKER COVER

Exploded View

INFOID:000000004231427

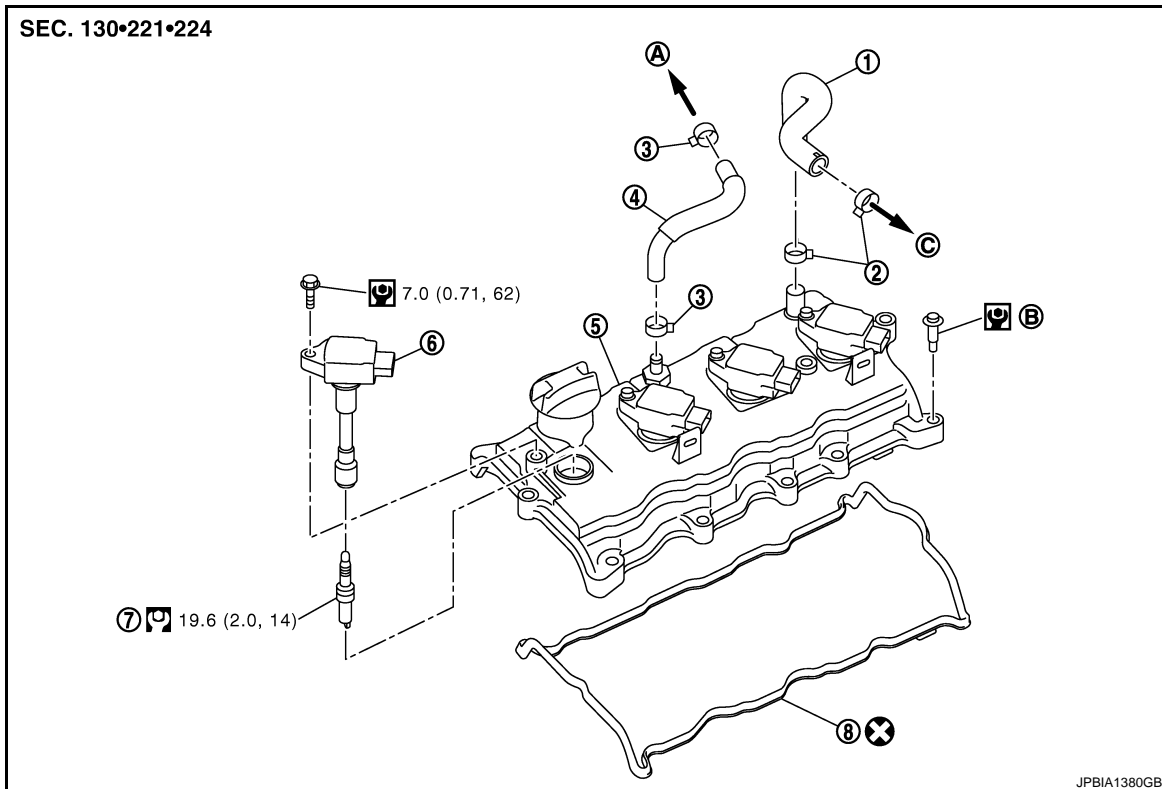

- |                       |                                   |                  |
|-----------------------|-----------------------------------|------------------|
| 1. Fresh air hose     | 2. Clamp                          | 3. Clamp         |
| 4. PCV hose           | 5. Rocker cover                   | 6. Ignition coil |
| 7. Spark plug         | 8. Rocker cover gasket            |                  |
| A. To intake manifold | B. Refer to <a href="#">EM-40</a> | C. To air duct   |

Refer to [GI-4, "Components"](#) for symbols in the figure.

## Removal and Installation

INFOID:000000004231428

### REMOVAL

1. Remove air duct and resonator assembly. Refer to [EM-27, "Exploded View"](#).
2. Remove electric throttle control actuator without disconnecting water hose. Refer to [EM-29, "Exploded View"](#).
3. Loosen intake manifold mounting bolts and nuts.
4. Remove intake manifold. Refer to [EM-29, "Exploded View"](#).
5. Disconnect harness connector from ignition coil.
6. Support the bottom surface of engine using a transmission jack.
7. Remove ground cable and harness from engine mounting bracket.
8. Remove ignition coil.  
**CAUTION:**
  - Never drop or shock ignition coil.
  - Never disassemble ignition coil.
9. Disconnect PCV hose from rocker cover.
10. Remove engine mounting insulator (RH). Refer to [EM-61, "Exploded View"](#).
11. Remove engine mounting bracket. Refer to [EM-69, "Exploded View"](#).
12. Remove PCV valve and O-ring from rocker cover, if necessary.

# IGNITION COIL, SPARK PLUG AND ROCKER COVER

## < ON-VEHICLE REPAIR >

13. Remove oil filler cap from rocker cover, if necessary.
14. Loosen bolts in the reverse order shown in the figure.

← : Engine front

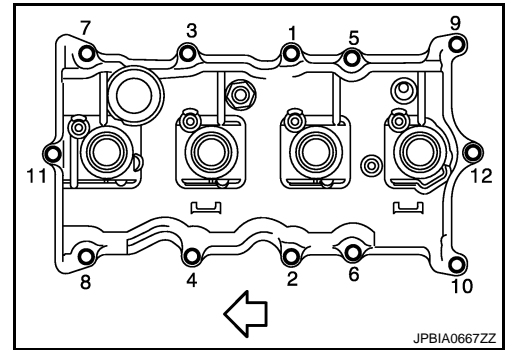

15. Remove rocker cover gasket from rocker cover.
16. Use scraper to remove all traces of liquid gasket from cylinder head and camshaft bracket (No. 1).  
**CAUTION:**  
**Never scratch or damage the mating surface when cleaning off old liquid gasket.**

## INSTALLATION

1. Apply liquid gasket to the position shown in the figure (4 places of cylinder head front and back) with the following procedure:
  - a. Refer to figure "a" to apply liquid gasket to joint part of camshaft bracket (No. 1) and cylinder head.
  - b. Refer to figure "b" to apply liquid gasket in 90 degrees to figure "a".

**Use Genuine RTV Silicone Sealant or equivalent. Refer to GI-17, "Recommended Chemical Products and Sealants".**

**CAUTION:**  
**Attaching should be done within 5 minutes after liquid gasket application.**

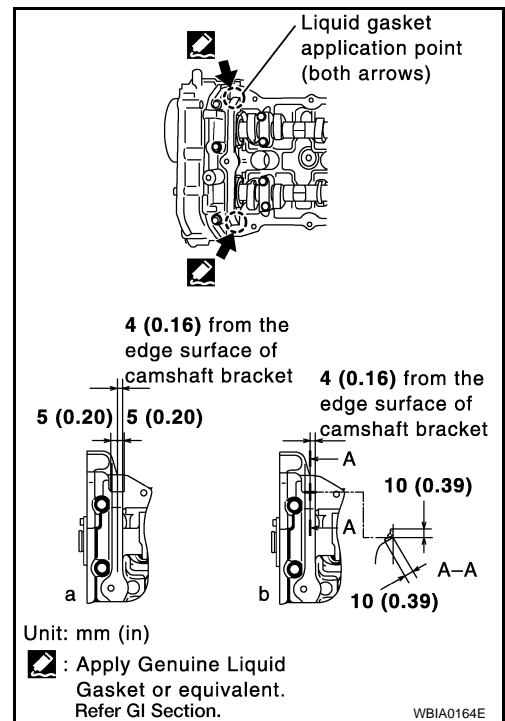

2. Install rocker cover gasket to rocker cover.
3. Install rocker cover.
  - Check if rocker cover gasket is not dropped from the installation groove of rocker cover.
4. Tighten bolts in two steps separately in numerical order as shown in the figure.

← : Engine front

**1st step** : 1.96 N·m (0.2 kg·m, 17 in·lb)

**2nd step** : 8.33 N·m (0.85 kg·m, 74 in·lb)

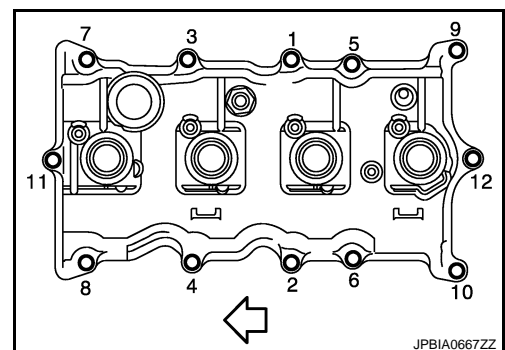

## IGNITION COIL, SPARK PLUG AND ROCKER COVER

< ON-VEHICLE REPAIR >

---

5. Install engine mounting bracket. Refer to [EM-69, "Exploded View"](#).
6. Install engine mounting insulator (RH). Refer to [EM-61, "Exploded View"](#).
7. Install in the reverse order of removal after this step.

# FUEL INJECTOR AND FUEL TUBE

< ON-VEHICLE REPAIR >

## FUEL INJECTOR AND FUEL TUBE

### Exploded View

INFOID:000000004231429

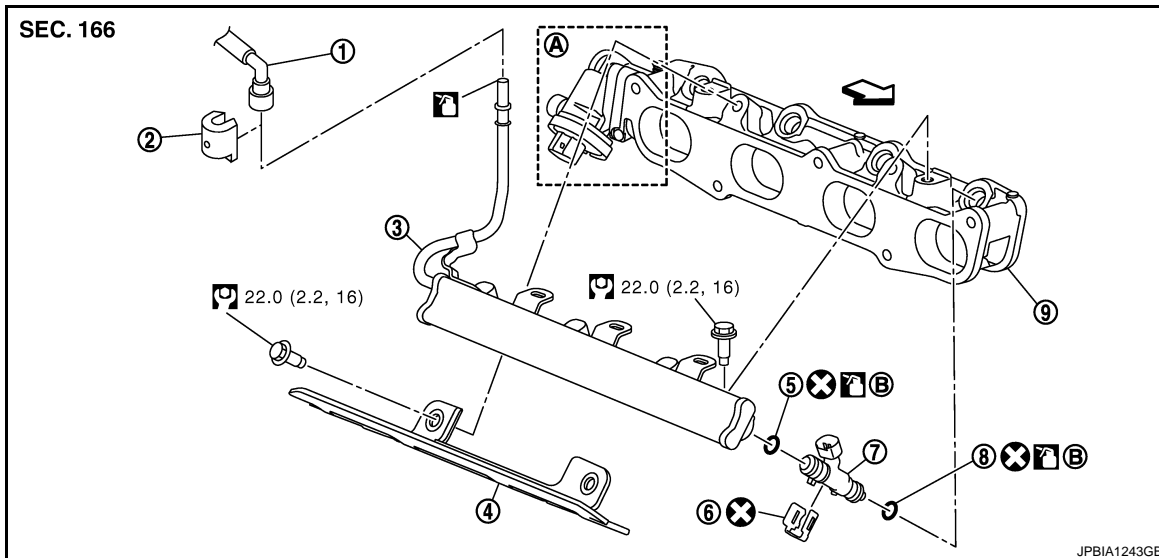

- |                        |                                   |                            |
|------------------------|-----------------------------------|----------------------------|
| 1. Fuel feed hose      | 2. Quick connector cap            | 3. Fuel tube               |
| 4. Fuel tube protector | 5. O-ring                         | 6. Clip                    |
| 7. Fuel injector       | 8. O-ring                         | 9. Intake manifold adapter |
| A. For California      | B. Refer to <a href="#">EM-43</a> |                            |

↶ : Engine front

Refer to [GI-4, "Components"](#) for symbols in the figure.

### CAUTION:

Never remove or disassemble parts unless instructed in the figure.

### Removal and Installation

INFOID:000000004231430

#### REMOVAL

### WARNING:

- Put a "CAUTION: FLAMMABLE" sign in the work shop.
- Be sure to work in a well ventilated area and furnish work shop with a CO2 fire extinguisher.
- Never smoke while servicing fuel system. Keep open flames and sparks away from the work area.

1. Release fuel pressure. Refer to [EC-489, "Inspection"](#) (for California), [EC-1279, "Inspection"](#) (for Mexico) or [EC-923, "Inspection"](#) (Except for California and Mexico).
2. Remove air cleaner case, mass air flow sensor and air duct assembly. Refer to [EM-27, "Exploded View"](#).
3. Disconnect quick connector (A) with the following procedure:

1 : Fuel feed hose

↶ : Vehicle front

### CAUTION:

Disconnect quick connector by using quick connector release, not by picking out retainer tabs.

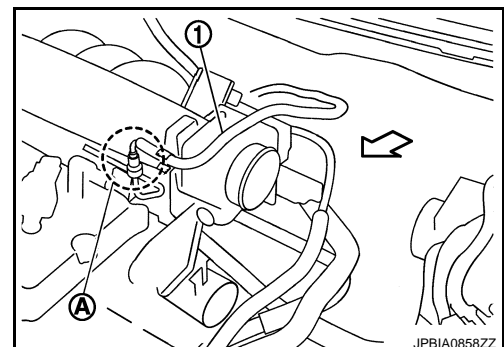

# FUEL INJECTOR AND FUEL TUBE

## < ON-VEHICLE REPAIR >

- a. Remove quick connector cap.

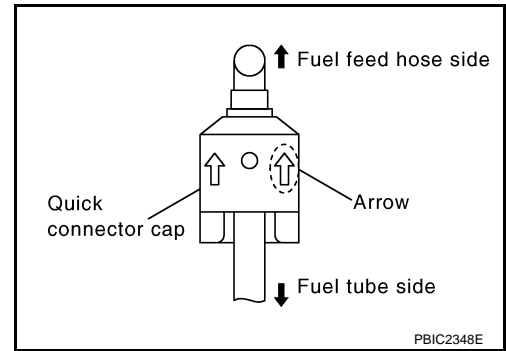

- b. With the sleeve side of quick connector release facing quick connector, install quick connector release onto fuel tube.  
 c. Insert quick connector release into quick connector until sleeve contacts and goes no further. Hold quick connector release on that position.

**CAUTION:**

Inserting quick connector release hard will not disconnect quick connector. Hold quick connector release where it contacts and goes no further.

- d. Draw and pull out quick connector straight from fuel tube.

**CAUTION:**

- Pull quick connector holding "A" position in the figure.
- Never pull with lateral force applied. O-ring inside quick connector may be damaged.
- Prepare container and cloth beforehand as fuel will leakage out.
- Avoid fire and sparks.
- Keep parts away from heat source. Especially, be careful when welding is performed around them.
- Never expose parts to battery electrolyte or other acids.
- Never bend or twist connection between quick connector and fuel feed hose during installation/removal.
- To keep clean the connecting portion and to avoid damage and foreign materials, cover them completely with plastic bags or something similar.

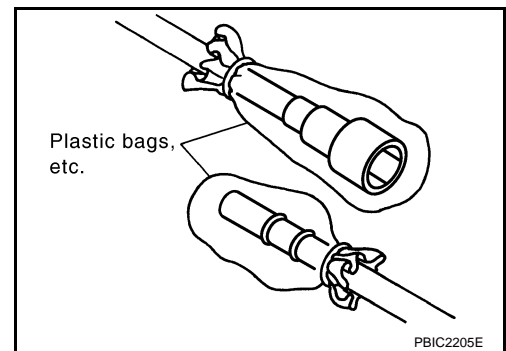
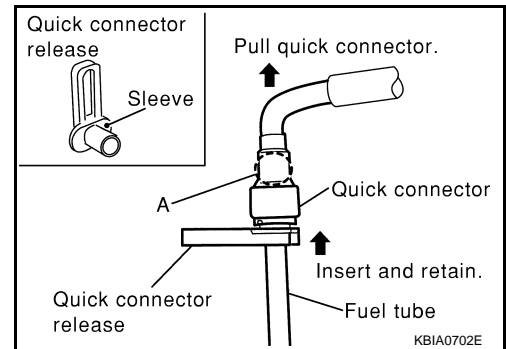

4. Remove intake manifold. Refer to [EM-29, "Exploded View"](#).  
 5. Disconnect sub-harness for fuel injector.  
 6. Remove fuel tube and fuel injector assembly.
- Loosen mounting bolts in the reverse order as shown in the figure.

⇐ : Engine front

**CAUTION:**

- When removing, be careful to avoid any interference with fuel injector.
- Use a shop cloth to absorb any fuel leakage from fuel tube.

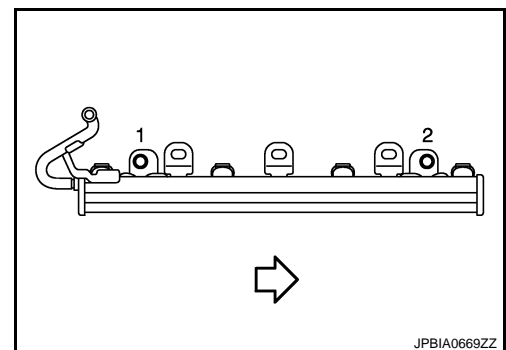



# FUEL INJECTOR AND FUEL TUBE

## < ON-VEHICLE REPAIR >

7. Remove fuel injector from fuel tube with the following procedure:
  - a. Open and remove clip (1).
  - b. Remove fuel injector (2) from fuel tube (3) by pulling straight.

**CAUTION:**

- Be careful with remaining fuel that may go out from fuel tube.
- Be careful not to damage fuel injector nozzle during removal.
- Never bump or drop fuel injector.
- Never disassemble fuel injector.

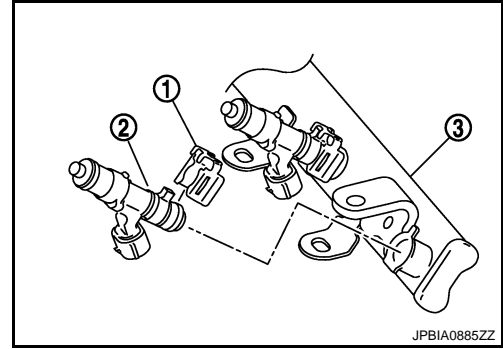

## INSTALLATION

1. Note the following, and install O-rings to fuel injector.

**CAUTION:**

- Upper and lower O-rings are different. Be careful not to confuse them.

**Except for California:**

Fuel tube side : Blue

Nozzle side : Brown

**For California:**

Fuel tube side : Black

Nozzle side : Green

- Handle O-ring with bare hands. Never wear gloves.
  - Lubricate O-ring with new engine oil.
  - Never clean O-ring with solvent.
  - Check that O-ring and its mating part are free of foreign material.
  - When installing O-ring, be careful not to scratch it with tool or fingernails. Also be careful not to twist or stretch O-ring. If O-ring was stretched while it was being attached, never insert it quickly into fuel tube.
  - Insert O-ring straight into fuel tube. Never decenter or twist it.
2. Install fuel injector to fuel tube with the following procedure:

**Except for California:**

2 : O-ring (Blue)

4 : O-ring (Brown)

**For California:**

2 : O-ring (Black)

4 : O-ring (Green)

- a. Insert clip (3) into clip mounting groove (F) on fuel injector (5).
    - Insert clip so that protrusion (E) of fuel injector matches cutout (C) of clip.
- CAUTION:**
- Never reuse clip. Replace it with a new one.
  - Be careful to keep clip from interfering with O-ring. If interference occurs, replace O-ring.
- b. Insert fuel injector into fuel tube with clip attached.
    - Insert it while matching it to the axial center.
    - Insert fuel injector so that protrusion (A) of fuel tube (1) matches cutout (B) of clip.
    - Check that fuel tube flange (G) is securely fixed in flange fixing groove (D) on clip.

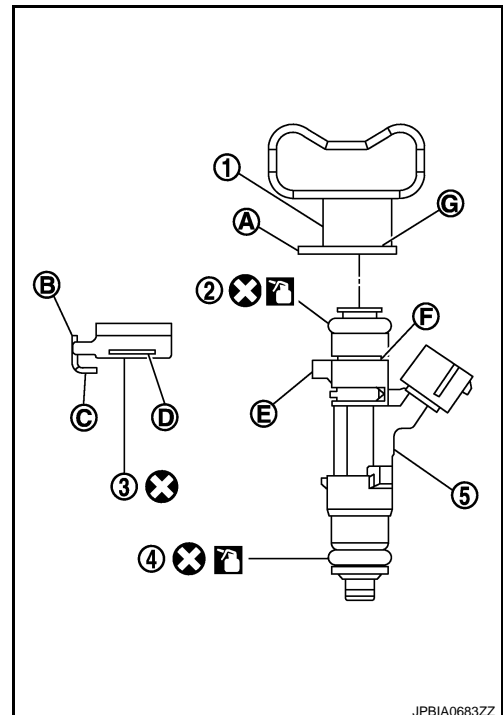

# FUEL INJECTOR AND FUEL TUBE

## < ON-VEHICLE REPAIR >

- c. Check that install in complete by checking that fuel injector does not rotate or come off.
3. Install fuel tube and fuel injector assembly with the following procedure:
  - a. Insert the tip of each fuel injector into intake manifold adapter.
  - b. Tighten mounting bolts in numerical order as shown in the figure.

↔ : Engine front

4. Connect sub-harness for fuel injector.

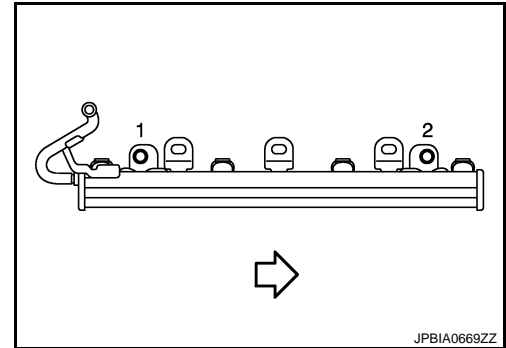

5. Install intake manifold. Refer to [EM-29, "Exploded View"](#).
6. Note the following, and connect quick connector to install fuel feed hose.
  - a. Check the connection for foreign material and damage.
  - b. Align center to insert quick connector straightly into fuel tube.

### NOTE:

The figure shows engine side as an example.

- Insert fuel tube into quick connector until the top spool on fuel tube is inserted completely and the second level spool is positioned slightly below quick connector bottom end.

### CAUTION:

- Hold "A" position in the figure when inserting fuel tube into quick connector.
- Carefully align center to avoid inclined insertion to prevent damage to O-ring inside quick connector.
- Insert until you hear a "click" sound and actually feel the engagement.
- To avoid misidentification of engagement with a similar sound, be sure to perform the next step.

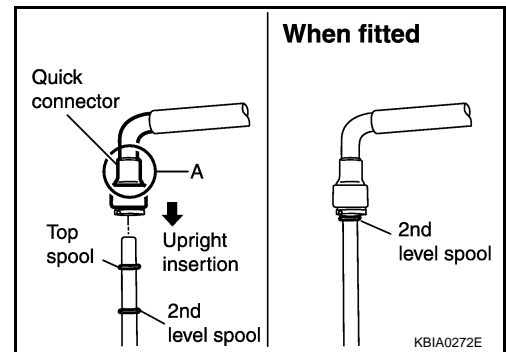

- c. Before clamping fuel feed hose with hose clamps, pull quick connector hard by hand holding "A" position. Check it is completely engaged (connected) so that it does not come out from fuel feed tube.
- d. Install quick connector cap to quick connector connection.
  - Install so that the arrow mark on the side faces up.

### CAUTION:

- Check that quick connector and fuel tube are securely fit into quick connector cap installation groove.
- If quick connector cap cannot be installed smoothly, quick connector may have not been installed correctly. Check connection again.

7. Install fuel feed hose to hose clamp.
8. Install in the reverse order of removal after this step.

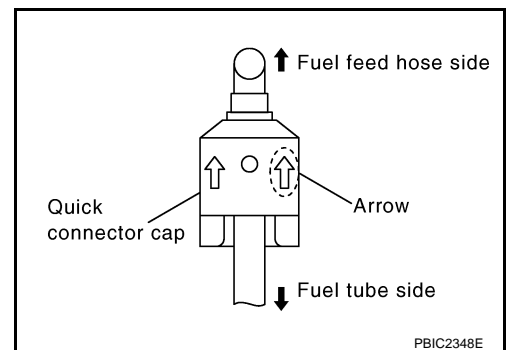

## Inspection

### INSPECTION AFTER INSTALLATION

#### Check on Fuel Leakage

1. Turn ignition switch "ON" (with the engine stopped). With fuel pressure applied to fuel piping, check there are no fuel leakage at connection points.

### NOTE:

Use mirrors for checking at points out of clear sight.

INFOID:000000004231431

## FUEL INJECTOR AND FUEL TUBE

< ON-VEHICLE REPAIR >

---

2. Start the engine. With engine speed increased, check again that there are no fuel leakage at connection points.

**CAUTION:**

**Never touch the engine immediately after stopped, as the engine becomes extremely hot.**

A

EM

C

D

E

F

G

H

I

J

K

L

M

N

O

P

# CAMSHAFT

< ON-VEHICLE REPAIR >

## CAMSHAFT

### Exploded View

INFOID:000000004231432

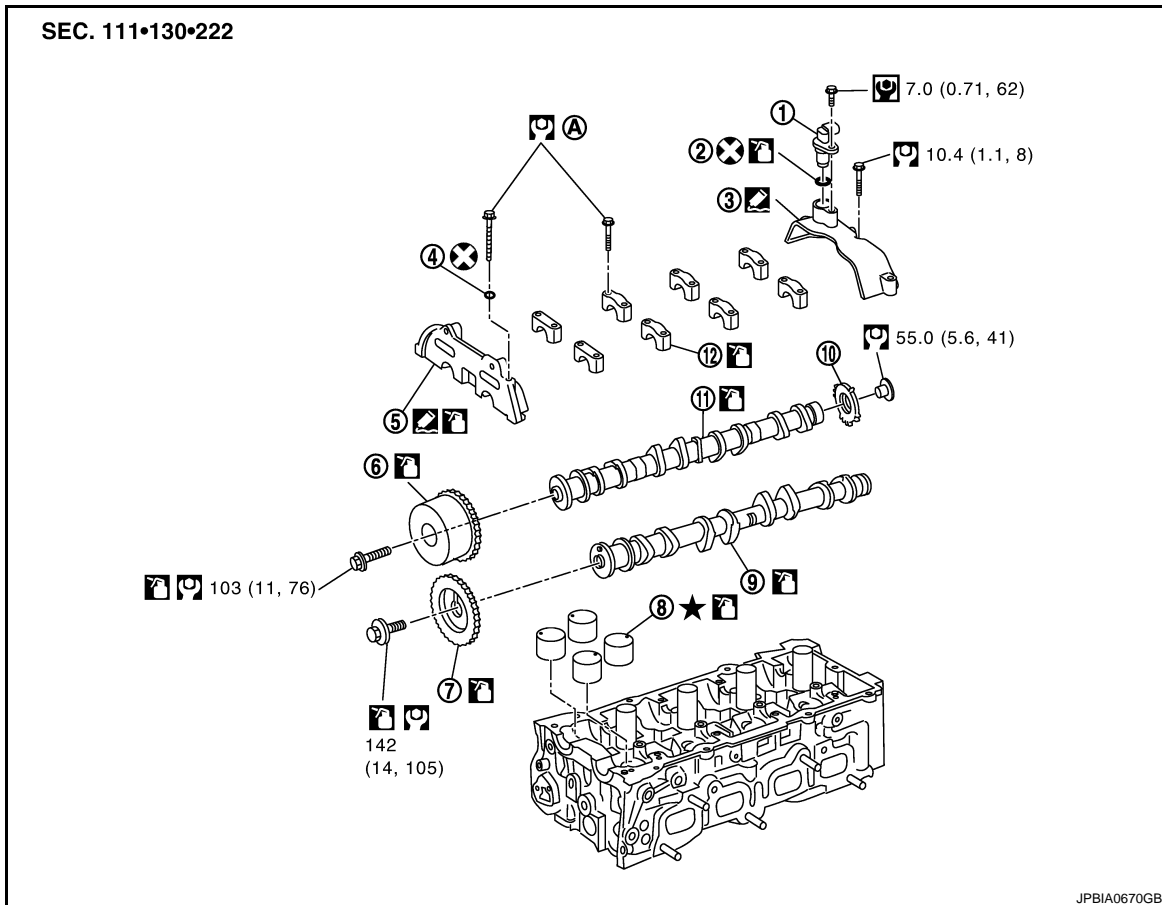

- |                                     |                             |                                     |
|-------------------------------------|-----------------------------|-------------------------------------|
| 1. Camshaft position sensor (PHASE) | 2. O-ring                   | 3. Camshaft position sensor bracket |
| 4. Seal washer                      | 5. Camshaft bracket (No. 1) | 6. Camshaft sprocket (INT)          |
| 7. Camshaft sprocket (EXH)          | 8. Valve lifter             | 9. Camshaft (EXH)                   |
| 10. Signal plate                    | 11. Camshaft (INT)          | 12. Camshaft bracket (No. 2 to 5)   |

A. Refer to [EM-48](#)

Refer to [GI-4, "Components"](#) for symbols in the figure.

## Removal and Installation

INFOID:000000004231433

### REMOVAL

#### NOTE:

This section describes removal/installation procedure of camshaft without removing front cover. If front cover is removed or installed, removal of camshaft bracket (No. 1) is easier before step 9 and install in easier after step 4. Regarding removal and installation of front cover, refer to [EM-69, "Exploded View"](#).

1. Release fuel pressure. Refer to [EC-489, "Inspection"](#) (for California), [EC-1279, "Inspection"](#) (for Mexico) or [EC-923, "Inspection"](#) (Except for California and Mexico).
2. Remove the following parts.
  - Intake manifold: Refer to [EM-29, "Exploded View"](#).
  - Rocker cover: Refer to [EM-40, "Removal and Installation"](#).
3. Remove camshaft position sensor (PHASE).

#### CAUTION:

- Handle carefully to avoid dropping and shocks.
- Never disassemble.

# CAMSHAFT

## < ON-VEHICLE REPAIR >

- **Never allow metal powder to adhere to magnetic part at sensor tip.**
- **Never place sensor in a location where it is exposed to magnetism.**

- Remove camshaft position sensor bracket.
  - Loosen mounting bolts in the reverse order as shown in the figure.

← : Engine front

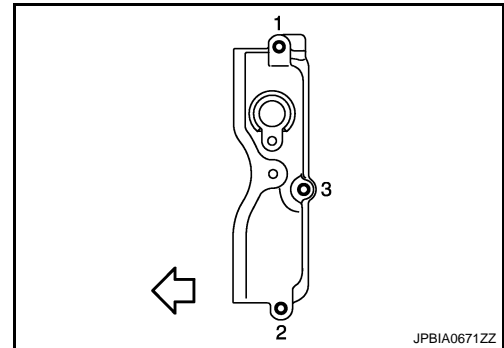

- Remove intake valve timing control cover with the following procedure:
  - Disconnect intake valve timing control solenoid valve harness connector.
  - Remove intake valve timing control solenoid valve, if necessary.
  - Loosen bolts in the reverse order as shown in the figure.
  - Use a seal cutter [SST: KV10111100 (J-37228)] or equivalent tool to cut liquid gasket for removal.

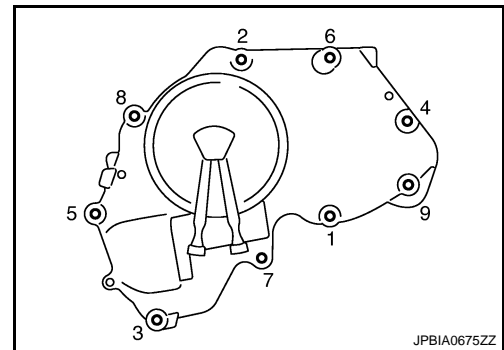

- Pull chain guide between camshaft sprockets out through front cover.
- Set No. 1 cylinder at TDC on its compression stroke with the following procedure:
  - Open splash guard on RH undercover.
  - Rotate crankshaft pulley clockwise and align TDC mark to timing indicator on front cover.

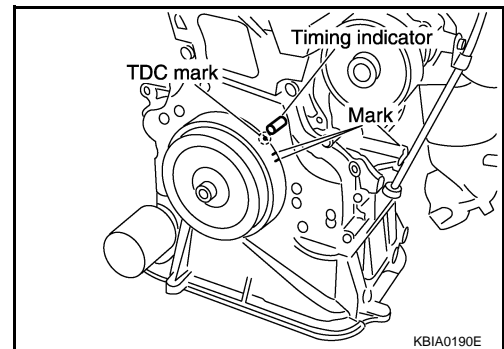

- At the same time, check that the mating marks on camshaft sprockets are located as shown in the figure.
  - If not, rotate crankshaft pulley one more turn to align mating marks to the positions in the figure.

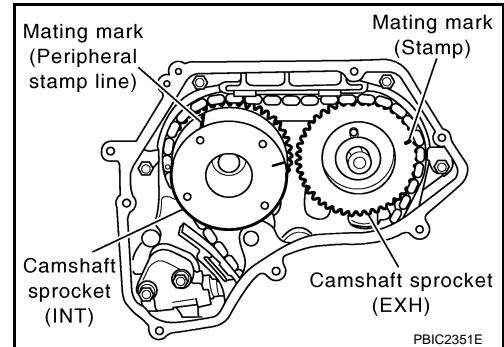

- Remove camshaft sprockets with the following procedure:
  - Line up the mating marks on camshaft sprockets, and paint indelible mating marks on timing chain link plate.

A

EM

C

D

E

F

G

H

I

J

K

L

M

N

O

P

# CAMSHAFT

## < ON-VEHICLE REPAIR >

- b. Push in chain tensioner plunger. Insert a stopper pin into hole on chain tensioner body to secure chain tensioner plunger and remove chain tensioner.

**NOTE:**

Use approximately 0.5 mm (0.020 in) dia. hard metal pin as a stopper pin.

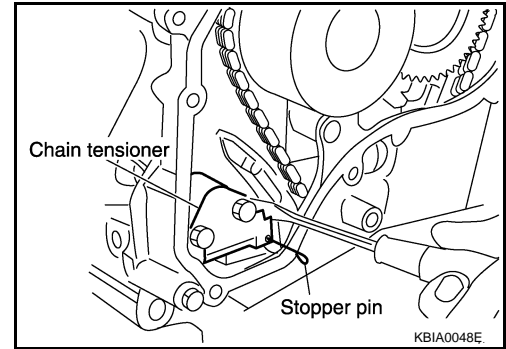

- c. Secure hexagonal part of camshaft with a wrench. Loosen camshaft sprocket mounting bolts and remove camshaft sprockets.

**CAUTION:**

**Never rotate crankshaft or camshaft while timing chain is removed. It causes interference between valve and piston.**

**NOTE:**

Chain tension holding work is not necessary. Crankshaft sprocket and timing chain do not disconnect structurally while front cover is attached.

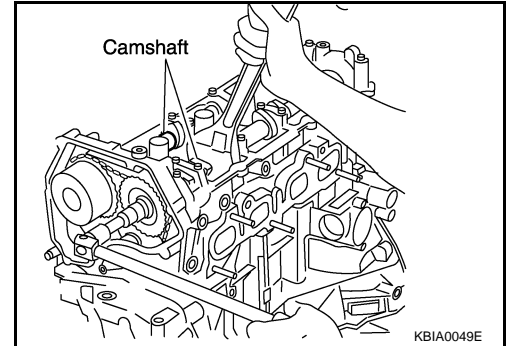

9. Loosen mounting bolts in the reverse order as shown in the figure, and remove camshaft brackets and camshafts.

- Remove camshaft bracket (No. 1) by slightly tapping it with a plastic hammer.

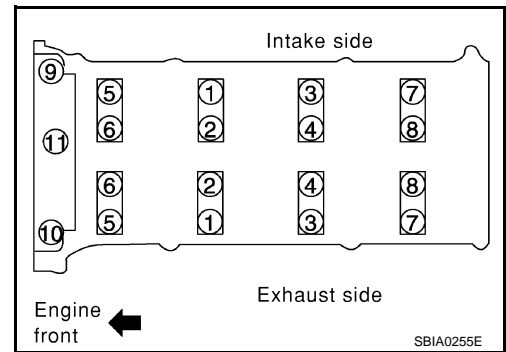

10. Remove valve lifters.

- Identify installation positions, and store them without mixing them up.

## INSTALLATION

1. Install valve lifters.
  - Install them in the original positions.
2. Install camshafts.
  - Distinction between intake and exhaust camshafts is performed with the different shapes of rear end.

- 1 : Camshaft (EXH)
- 2 : Camshaft (INT)

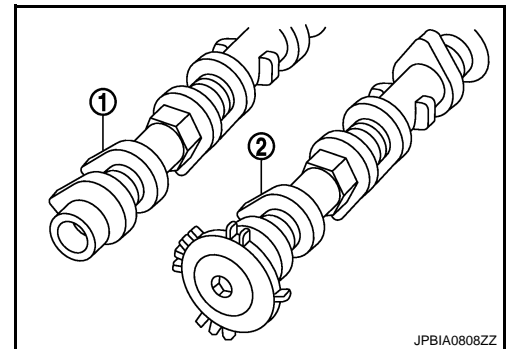

# CAMSHAFT

## < ON-VEHICLE REPAIR >

- Install camshafts so that camshaft dowel pins on the front side are positioned as shown in the figure.

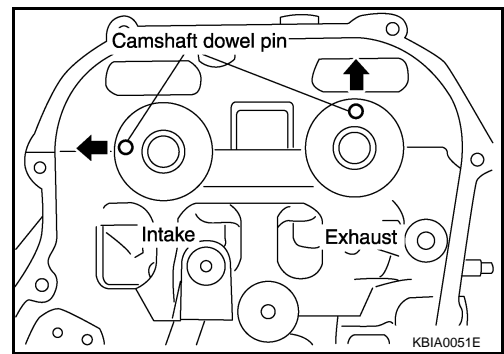

3. Install camshaft brackets with the following procedure:
  - a. Remove foreign material completely from camshaft bracket backside and from cylinder head installation face.
  - b. Install camshaft brackets (No. 2 to 5) aligning the identification marks on upper surface as shown in the figure.

**NOTE:**

Install so that identification mark can be correctly read when viewed from the exhaust side.

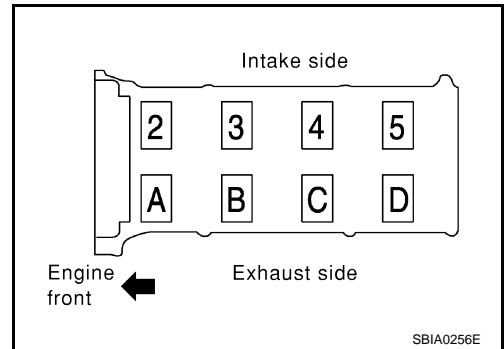

- c. Install camshaft bracket (No. 1) with the following procedure:
  - i. Apply liquid gasket to camshaft bracket (No. 1) as shown in the figure.

**Use Genuine RTV Silicone Sealant or equivalent. Refer to GI-17, "Recommended Chemical Products and Sealants".**

**CAUTION:**

After installation, be sure to wipe off any excessive liquid gasket leaking from part "A".

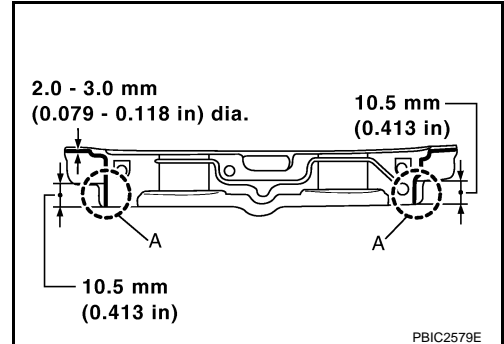

- ii. Apply liquid gasket to camshaft bracket (No. 1) contact surface on the front cover backside.

1 : Front cover

a :  $\phi 3.4 - 4.4$  mm (0.134 - 0.173 in)

**Use Genuine RTV Silicone Sealant or equivalent. Refer to GI-17, "Recommended Chemical Products and Sealants".**

- Apply liquid gasket to the outside of bolt hole on front cover.

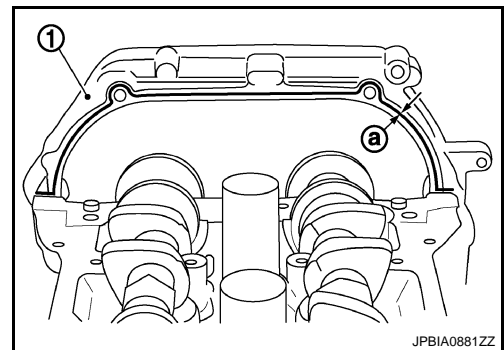

# CAMSHAFT

## < ON-VEHICLE REPAIR >

- iii. For camshaft bracket (No. 1) near installation position, and install it without disturbing the liquid gasket applied to the surfaces.

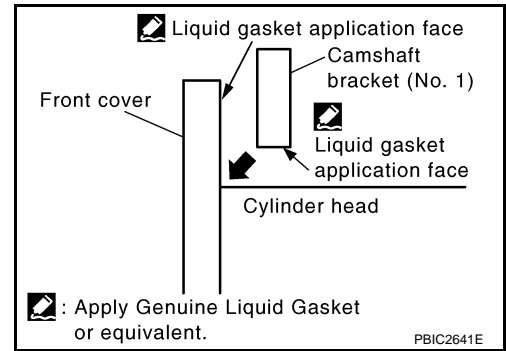

4. Tighten mounting bolts of camshaft brackets in the following steps, in numerical order as shown in the figure.

- a. Tighten No. 9 to 11 in numerical order.

 : 2.0 N·m (0.20 kg·m, 1 ft·lb)

- b. Tighten No. 1 to 8 in numerical order.

 : 2.0 N·m (0.20 kg·m, 1 ft·lb)

- c. Tighten all bolts in numerical order.

 : 5.9 N·m (0.60 kg·m, 4 ft·lb)

- d. Tighten all bolts in numerical order.

 : 10.4 N·m (1.1 kg·m, 8 ft·lb)

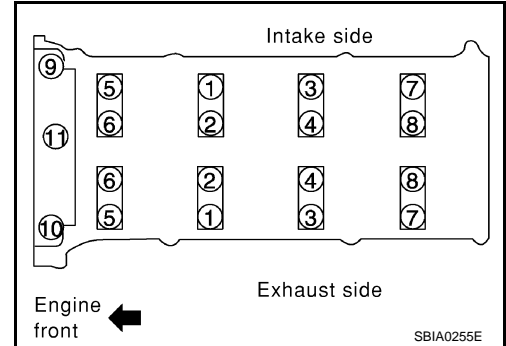

### CAUTION:

After tightening mounting bolts of camshaft brackets, be sure to wipe off excessive liquid gasket from the parts listed below.

- Mating surface of rocker cover.
- Mating surface of front cover. (When installed without front cover)

5. Install camshaft sprockets.

- Install them by aligning the mating marks on each camshaft sprocket with the ones painted on timing chain link plate during removal.

### CAUTION:

- Aligned mating marks could slip. Therefore, after matching them, hold the timing chain in place by hand.
- Before and after installing chain tensioner, check again that mating marks have not slipped.

### NOTE:

Before installation of chain tensioner, it is possible to re-match the marks on timing chain with the ones on each sprocket.

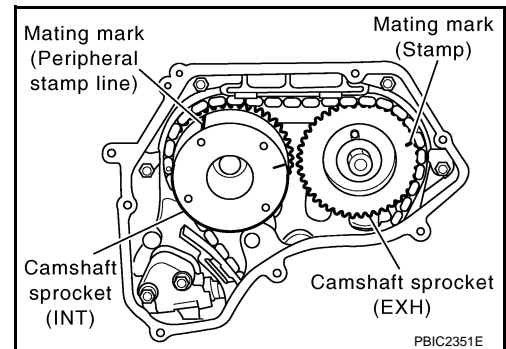

6. Install chain tensioner.

### CAUTION:

After installation, pull the stopper pin off completely, and check that chain tensioner plunger is released.

7. Install chain guide.

8. Install intake valve timing control cover with the following procedure:

- Install intake valve timing control solenoid valve to intake valve timing control cover if removed.
- Install oil rings to the camshaft sprocket (INT) insertion points on backside of intake valve timing control cover.
- Install new O-ring to front cover.



# CAMSHAFT

## < ON-VEHICLE REPAIR >

- d. Apply liquid gasket with a tube presser (commercial service tool) to intake valve timing control cover as shown in the figure.

**a** :  $\phi 3.4 - 4.4 \text{ mm}$  (0.134 – 0.173 in)

Use Genuine RTV Silicone Sealant or equivalent. Refer to [GI-17, "Recommended Chemical Products and Sealants"](#).

**CAUTION:**

Attaching should be done within 5 minutes after liquid gasket application.

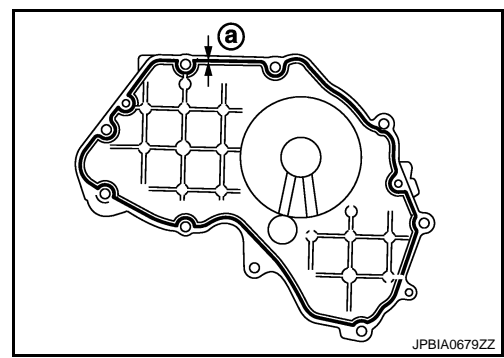

- e. Tighten mounting bolts in numerical order as shown in the figure.

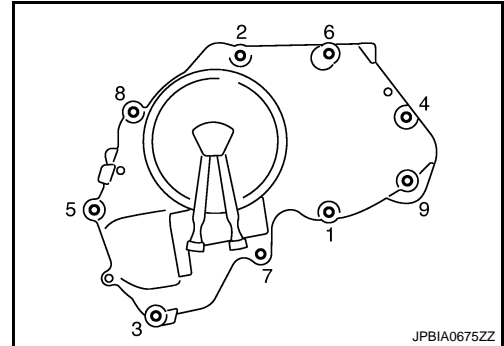

9. Install camshaft position sensor bracket.

- a. Apply liquid gasket with a tube presser (commercial service tool) to camshaft position sensor bracket as shown in the figure.

← : Engine front

**a** :  $\phi 2.0 - 3.0 \text{ mm}$  (0.079 – 0.118 in)

**b** : 10.5 mm (0.413 in)

Use Genuine RTV Silicone Sealant or equivalent. Refer to [GI-17, "Recommended Chemical Products and Sealants"](#).

**CAUTION:**

- After installation, be sure to wipe off any excessive liquid gasket leaking from part "b".
- Attaching should be done within 5 minutes after liquid gasket application.

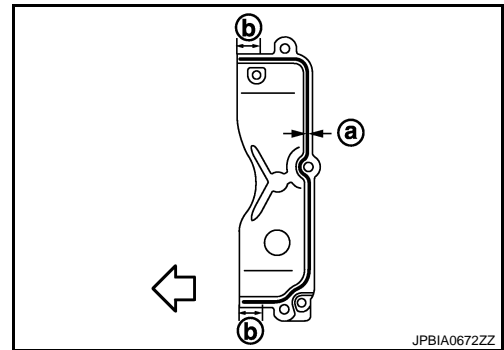

- b. Tighten mounting bolts in numerical order as shown in the figure.

← : Engine front

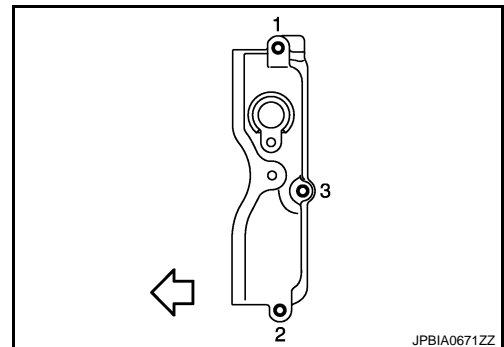

10. Install camshaft position sensor (PHASE).

11. Inspect and adjust valve clearance. Refer to [EM-20, "Inspection and Adjustment"](#).

12. Install in the reverse order of removal after this step.

## Inspection

### INSPECTION AFTER REMOVAL

#### Camshaft Runout

1. Put V-block on a precise flat table, and support No. 2 and 5 journal of camshaft.

**CAUTION:**

INFOID:000000004231434

# CAMSHAFT

## < ON-VEHICLE REPAIR >

**Never support No. 1 journal (on the side of camshaft sprocket) because it has a different diameter from the other four locations.**

2. Set dial indicator (A) vertically to No. 3 journal.
3. Turn camshaft to one direction with hands, and measure the camshaft runout on dial indicator. (Total indicator reading)

**Standard: Refer to [EM-113, "Camshaft"](#).**

4. If out of the standard, replace camshaft.

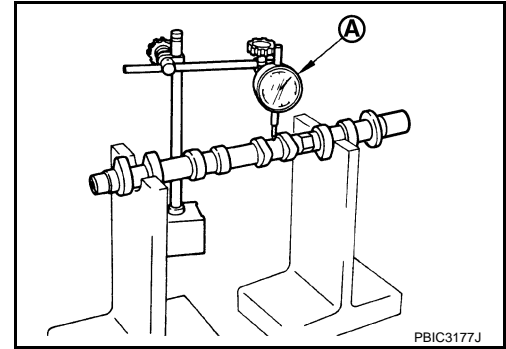

### Camshaft Cam Height

1. Measure the camshaft cam height with a micrometer (A).

**Standard and Limit: Refer to [EM-113, "Camshaft"](#).**

2. If it exceeds the limit, replace camshaft.

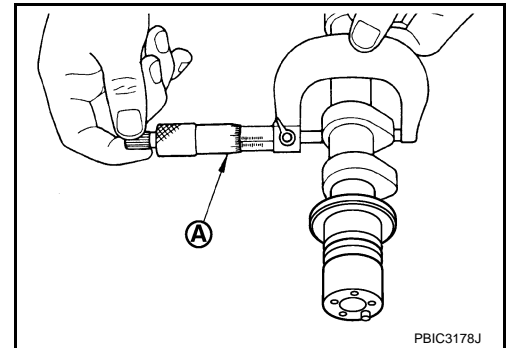

### Camshaft Journal Oil Clearance

#### **CAMSHAFT JOURNAL DIAMETER**

Measure the outer diameter of camshaft journal with a micrometer (A).

**Standard: Refer to [EM-113, "Camshaft"](#).**

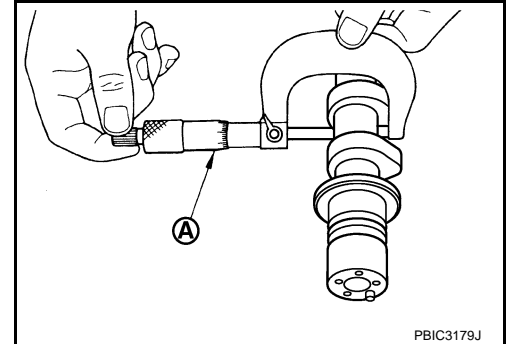

#### **CAMSHAFT BRACKET INNER DIAMETER**

- Tighten camshaft bracket bolts with specified torque. Refer to [EM-48, "Removal and Installation"](#).
- Measure the inner diameter of camshaft bracket with an inside micrometer.

**Standard: Refer to [EM-113, "Camshaft"](#).**

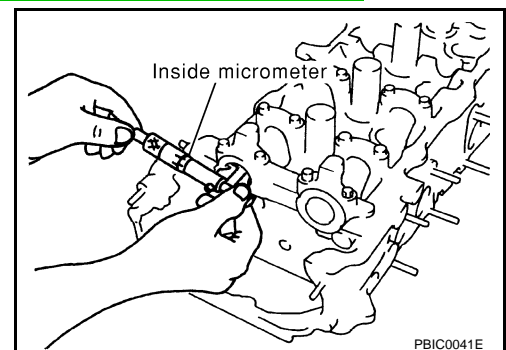

#### **CAMSHAFT JOURNAL OIL CLEARANCE**

- (Oil clearance) = (Camshaft bracket inner diameter) – (Camshaft journal diameter)

**Standard: Refer to [EM-113, "Camshaft"](#).**

# CAMSHAFT

## < ON-VEHICLE REPAIR >

- If out of the standard, replace either or both camshaft and cylinder head.

### NOTE:

Camshaft bracket cannot be replaced as a single part, because it is machined together with cylinder head. Replace whole cylinder head assembly.

### Camshaft End Play

1. Install camshaft in cylinder head. Refer to [EM-48, "Removal and Installation"](#).
2. Install dial indicator in thrust direction on front end of camshaft. Read the end play of dial indicator when camshaft is moved forward/backward (in direction to axis).

**Standard:** Refer to [EM-113, "Camshaft"](#).

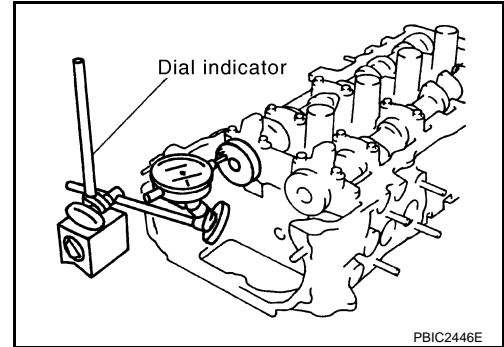

- Measure the following parts if out of the standard.
  - Dimension "A" for camshaft No. 1 journal

**Standard** : 25.800 - 25.848 mm (1.0157 - 1.0176 in)

- Dimension "B" for cylinder head No. 1 journal

**Standard** : 25.660 - 25.685 mm (1.0102 - 1.0112 in)

- Refer to the standards above, and then replace camshaft and/or cylinder head.

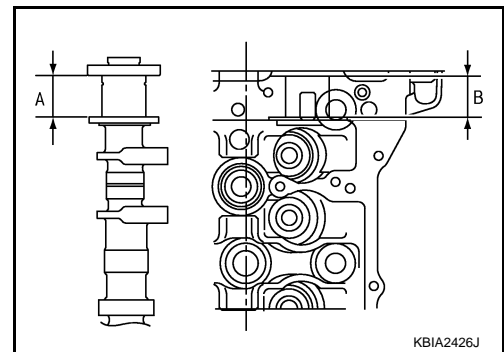

### Camshaft Sprocket Runout

1. Put V-block on precise flat table, and support No. 2 and 5 journals of camshaft.

### CAUTION:

**Never support No. 1 journal (on the side of camshaft sprocket) because it has a different diameter from the other four locations.**

2. Measure the camshaft sprocket runout with a dial indicator. (Total indicator reading)

**Limit:** Refer to [EM-113, "Camshaft"](#).

- If it exceeds the limit, replace camshaft sprocket.

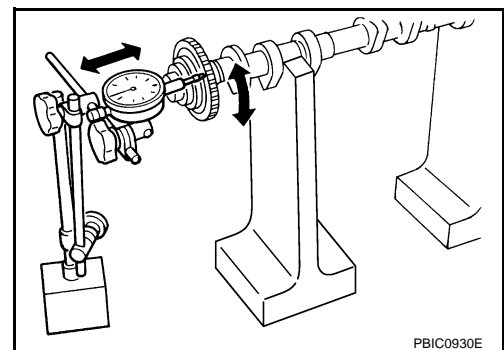

### Valve Lifter

Check if surface of valve lifter has any wear or cracks.

- If anything above is found, replace valve lifter. Refer to [EM-113, "Camshaft"](#).

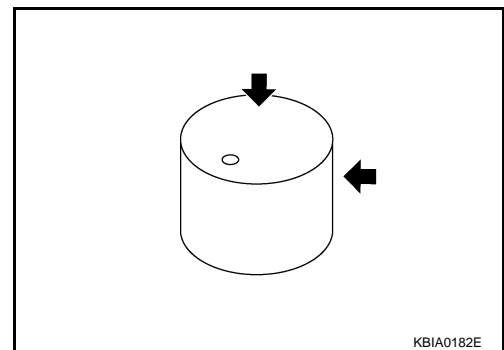

# CAMSHAFT

## < ON-VEHICLE REPAIR >

### Valve Lifter Clearance

#### VALVE LIFTER OUTER DIAMETER

- Measure the outer diameter of valve lifter with a micrometer (A).

Standard: Refer to [EM-113, "Camshaft"](#).

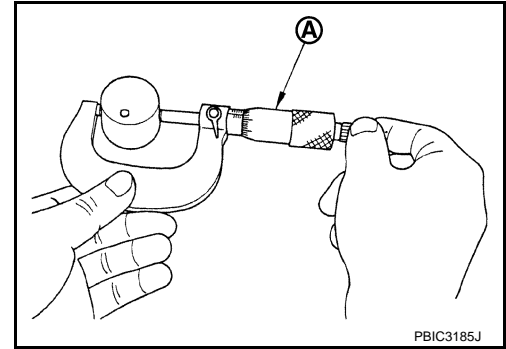

#### VALVE LIFTER HOLE DIAMETER

Measure the diameter of valve lifter hole of cylinder head with an inside micrometer.

Standard: Refer to [EM-113, "Camshaft"](#).

#### VALVE LIFTER CLEARANCE

- (Valve lifter clearance) = (Valve lifter hole diameter) – (Valve lifter outer diameter)

Standard: Refer to [EM-113, "Camshaft"](#).

- If out of the standard, referring to the each standard of valve lifter outer diameter and valve lifter hole diameter, replace either or both valve lifter and cylinder head.

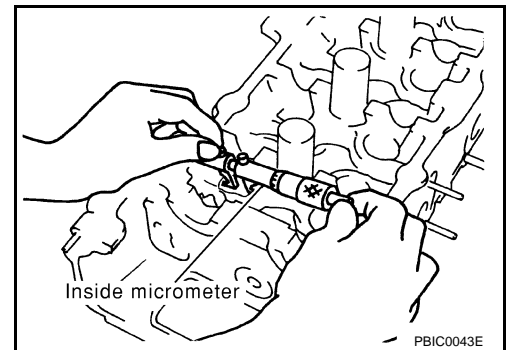

## INSPECTION AFTER INSTALLATION

Inspection of Camshaft Sprocket (INT) Oil Groove

### CAUTION:

- Perform this inspection only when DTC P0011 is detected in self-diagnostic results of CONSULT-III and it is directed according to inspection procedure of EC section. Refer to [EC-132, "Diagnosis Procedure"](#) (for California), [EC-1028, "Diagnosis Procedure"](#) (for Mexico) or [EC-603, "Diagnosis Procedure"](#) (Except for California and Mexico).
- Check when engine is cold so as to prevent burns from the splashing engine oil.

1. Check engine oil level. Refer to [LU-5, "Inspection"](#).
2. Perform the following procedure so as to prevent the engine from being unintentionally started while checking.
  - a. Release the fuel pressure. Refer to [EC-489, "Inspection"](#) (for California), [EC-1279, "Inspection"](#) (for Mexico) or [EC-923, "Inspection"](#) (Except for California and Mexico).
  - b. Disconnect ignition coil and injector harness connectors. Refer to [EM-40, "Exploded View"](#).
3. Remove intake valve timing control solenoid valve. Refer to [EM-69, "Exploded View"](#).
4. Crank engine, and then check that engine oil comes out from intake valve timing control solenoid valve hole. End crank after checking.

### WARNING:

Be careful not to touch rotating parts. (drive belts, idler pulley, and crankshaft pulley, etc.)

### CAUTION:

- Prevent splashing by using a shop cloth so as to prevent the worker from injury from engine oil and so as to prevent engine oil contamination.
- Prevent splashing by using a shop cloth so as to prevent engine oil from being splashed to engine and vehicle. Especially, be careful no to apply engine oil to rubber parts of drive belts, engine mounting insulator, etc. Wipe engine oil off immediately if it is splashed.

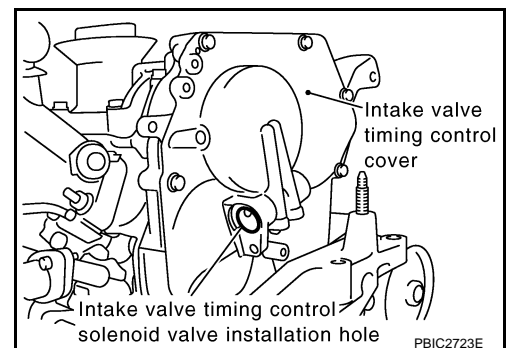

# CAMSHAFT

## < ON-VEHICLE REPAIR >

- Clean oil groove between oil strainer and intake valve timing control solenoid valve. Refer to [LU-2, "Engine Lubrication System"](#).
5. Remove components between intake valve timing control solenoid valve and camshaft sprocket (INT), and then check each oil groove for clogging.
    - Clean oil groove if necessary. Refer to [LU-2, "Engine Lubrication System"](#).
  6. After inspection, install removed parts in the reverse order.

A

EM

C

D

E

F

G

H

I

J

K

L

M

N

O

P

# OIL SEAL

< ON-VEHICLE REPAIR >

## OIL SEAL

### VALVE OIL SEAL

#### VALVE OIL SEAL : Removal and Installation

INFOID:000000004231435

#### REMOVAL

1. Remove camshafts. Refer to [EM-48, "Exploded View"](#).
2. Remove valve lifters. Refer to [EM-48, "Exploded View"](#).
3. Rotate crankshaft, and set piston whose valve oil seal is to be removed to TDC. This will prevent valve from dropping into cylinder.

**CAUTION:**

**When rotating crankshaft, be careful to avoid scarring front cover with timing chain.**

4. Remove valve collet.
  - Compress valve spring with valve spring compressor, attachment and adapter [SST: KV10116200 (J-26336-A)] (A). Remove valve collet with a magnet hand.

**CAUTION:**

**When working, be careful not to damage valve lifter holes.**

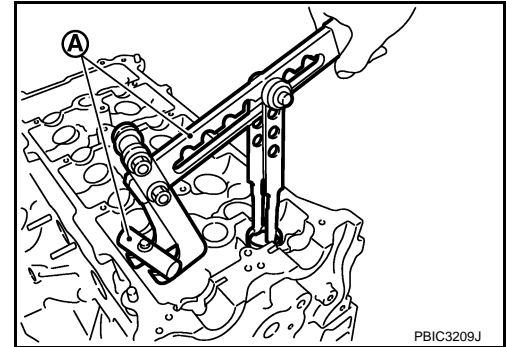

5. Remove valve spring retainer and valve spring.

**CAUTION:**

**Never remove valve spring seat from valve spring.**

6. Remove valve oil seal with a valve oil seal puller (SST).

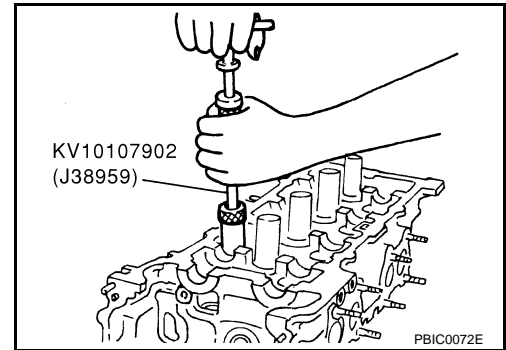

#### INSTALLATION

1. Apply new engine oil to valve oil seal joint surface and seal lip.
2. Press in valve oil seal to the height "H" shown in the figure with a valve oil seal drift (SST).

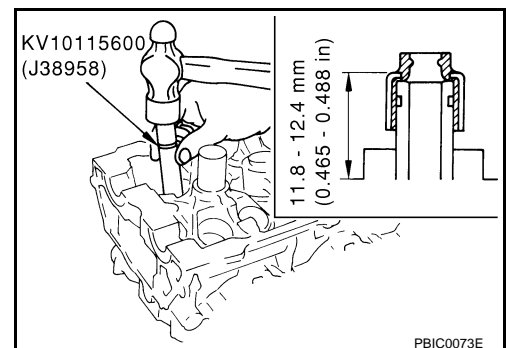

3. Install in the reverse order of removal after this step.

## FRONT OIL SEAL

# OIL SEAL

< ON-VEHICLE REPAIR >

## FRONT OIL SEAL : Removal and Installation

INFOID:000000004231436

### REMOVAL

1. Remove the following parts.
  - Under cover
  - Front fender protector: Refer to [EXT-22, "Exploded View"](#).
  - Drive belt: Refer to [EM-15, "Removal and Installation"](#).
  - Crankshaft pulley: Refer to [EM-69, "Exploded View"](#).
2. Remove front oil seal with a suitable tool.

#### CAUTION:

Be careful not to damage front cover and crankshaft.

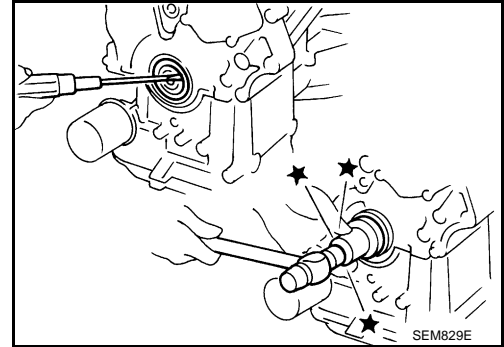

### INSTALLATION

1. Apply new engine oil to new front oil seal joint surface and seal lip.
2. Install front oil seal so that each seal lip is oriented as shown in the figure.

- A : Dust seal lip
- B : Oil seal lip
- ← : Engine outside
- : Engine inside

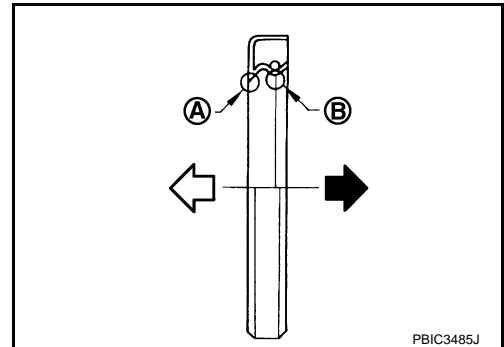

- Press-fit front oil seal until it is flush with front end surface of front cover using a suitable drift with outer diameter 56 mm (2.20 in) and inner diameter 48 mm (1.89 in).

#### CAUTION:

- Be careful not to damage front cover and crankshaft.
- Press-fit oil seal straight to avoid causing burrs or tilting.

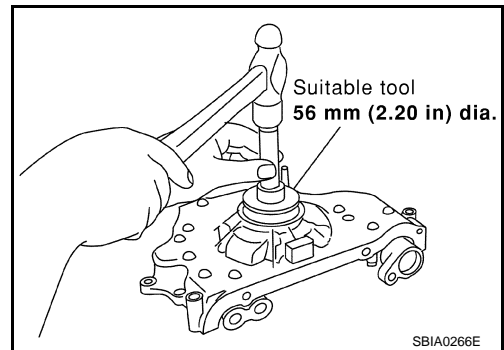

3. Install in the reverse order of removal after this step.

## REAR OIL SEAL

### REAR OIL SEAL : Removal and Installation

INFOID:000000004231437

### REMOVAL

1. Remove transaxle assembly. Refer to [TM-210, "2WD : Exploded View"](#) (2WD models) or [TM-214, "AWD : Exploded View"](#) (AWD models).
2. Remove drive plate. Refer to [EM-88, "Exploded View"](#).
3. Remove rear oil seal with a suitable tool.

#### CAUTION:

# OIL SEAL

## < ON-VEHICLE REPAIR >

**Be careful not to damage crankshaft and cylinder block.**

### INSTALLATION

1. Apply new engine oil to new rear oil seal joint surface and seal lip.
2. Install rear oil seal so that each seal lip is oriented as shown in the figure.

- A : Dust seal lip
- B : Oil seal lip
- ⇐ : Engine outside
- ➡ : Engine inside

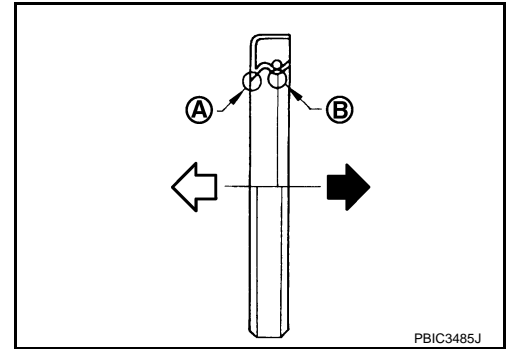

- Press in rear oil seal (1) to the position as shown in the figure.

- A : Rear end surface of cylinder block

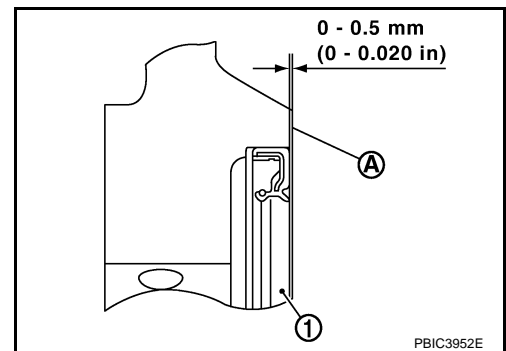

- Press-fit rear oil seal with a suitable drift [outer diameter 102 mm (4.02 in), inner diameter 86 mm (3.39 in)].

#### **CAUTION:**

- **Be careful not to damage crankshaft and cylinder block.**
- **Press-fit oil seal straight to avoid causing burrs or tilting.**
- **Never touch grease applied onto oil seal lip.**

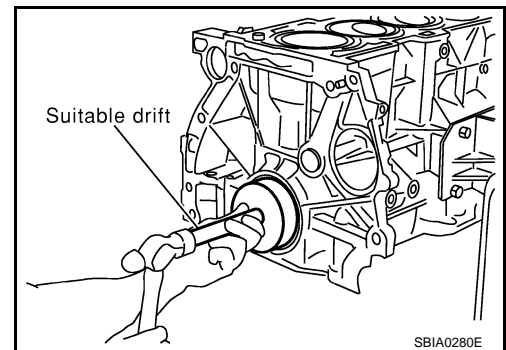

3. Install in the reverse order of removal after this step.



# ENGINE ASSEMBLY

< REMOVAL AND INSTALLATION >

## REMOVAL AND INSTALLATION

### ENGINE ASSEMBLY

Exploded View

INFOID:000000004231438

A

EM

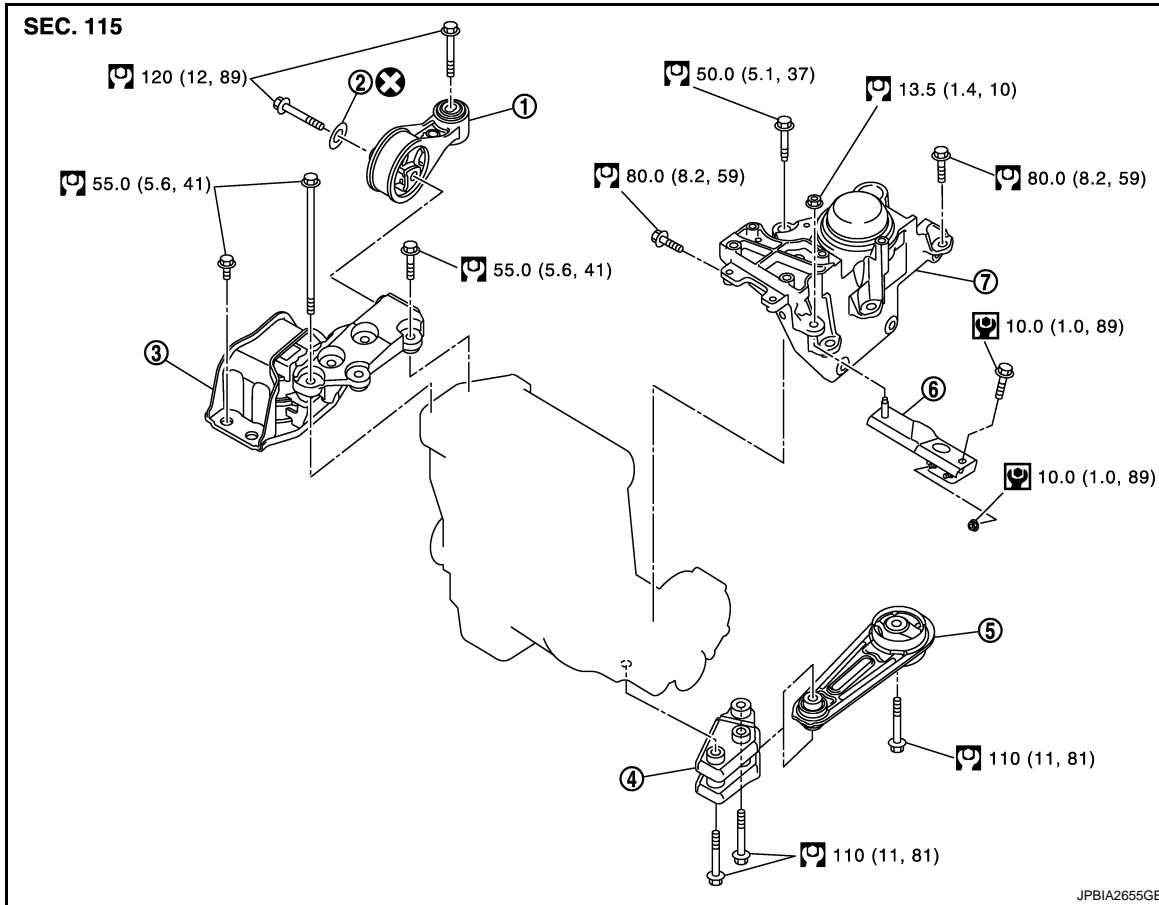

C

D

E

F

G

H

I

J

K

L

M

N

O

P

- |                                   |                    |                                   |
|-----------------------------------|--------------------|-----------------------------------|
| 1. Upper torque rod               | 2. Washer          | 3. Engine mounting insulator (RH) |
| 4. Rear engine mounting bracket   | 5. Rear torque rod | 6. Engine mounting stay           |
| 7. Engine mounting insulator (LH) |                    |                                   |

Refer to [GI-4, "Components"](#) for symbols in the figure.

### Removal and Installation

INFOID:000000004231439

#### WARNING:

- Situate the vehicle on a flat and solid surface.
- Place chocks at front and back of rear wheels.
- Attach proper slingers and bolts described in PARTS CATALOG if engine slingers are not equipped.

#### CAUTION:

- Always be careful to work safely, avoid forceful or uninstructed operations.
- Never start working until exhaust system and coolant are cool enough.
- If items or work required are not covered by the engine section, refer to the applicable sections.
- Always use the support point specified for lifting.
- Use either 2-pole lift type or separate type lift as best you can. If board-on type is used for unavoidable reasons, support at the rear axle jacking point with a transmission jack or similar tool before starting work, in preparation for the backward shift of center of gravity.
- For supporting points for lifting and jacking point at rear axle, refer to [GI-32, "Garage Jack and Safety Stand and 2-Pole Lift"](#).

### REMOVAL

# ENGINE ASSEMBLY

## < REMOVAL AND INSTALLATION >

---

### Outline

Remove the engine and the transaxle assembly from the vehicle downward. Separate the engine and the transaxle.

### Preparation

1. Release fuel pressure. Refer to [EC-489, "Inspection"](#) (for California), [EC-1279, "Inspection"](#) (for Mexico) or [EC-923, "Inspection"](#) (Except for California and Mexico).
2. Drain engine coolant from radiator. Refer to [CO-9, "Draining"](#).  
**CAUTION:**
  - Perform this step when the engine is cold.
  - Never spill engine coolant on drive belt.
3. Remove the following parts.
  - Air duct and air cleaner case assembly: Refer to [EM-27, "Exploded View"](#).
  - Battery and battery tray: Refer to [PG-92, "Exploded View"](#).
  - Engine undercover
  - Radiator hose (upper and lower) and cooling fan assembly: Refer to [CO-15, "Exploded View"](#).
  - Front road wheels and tires
  - Front fender protector (RH and LH): Refer to [EXT-22, "Exploded View"](#).
  - Exhaust front tube: Refer to [EX-5, "Exploded View"](#).

### Engine Room LH

1. Disconnect all connections of engine harness around the engine mounting insulator (LH), and then temporarily secure the engine harness into the engine side.  
**CAUTION:**  
**Protect connectors using a resin bag against foreign materials during the operation.**
2. Disconnect fuel feed hose at engine side. Refer to [EM-43, "Exploded View"](#).
3. Disconnect heater hoses. Refer to [CO-25, "Exploded View"](#).
4. Disconnect control cable from transaxle. Refer to [TM-181, "Exploded View"](#).
5. Remove ground cable at transaxle side.
6. Disconnect CVT fluid cooler hose. Refer to [TM-207, "FLUID COOLER : Exploded view"](#).

### Engine Room RH

1. Remove alternator. Refer to [CHG-19, "Exploded View"](#).
2. Disconnect vacuum hose from intake manifold. Refer to [EM-29, "Exploded View"](#).
3. Remove A/C compressor without disconnecting A/C piping, and temporarily fasten it on vehicle with a rope. Refer to [HA-43, "Exploded View"](#).

### Vehicle inside

Disconnect steering lower joint at steering gear assembly side, and release steering lower shaft. Refer to [ST-11, "Exploded View"](#).

### Vehicle Underbody

1. Remove front wheel sensor (LH and RH) for ABS from steering knuckle. Refer to [BRC-65, "FRONT WHEEL SENSOR : Exploded View"](#).
2. Remove brake caliper assembly with piping connected from steering knuckle. Temporarily secure it on the vehicle side with a rope to avoid load on it. Refer to [BR-36, "BRAKE CALIPER ASSEMBLY : Exploded View"](#).
3. Disconnect steering outer sockets from steering knuckle. Refer to [ST-14, "Exploded View"](#).
4. Remove transverse link from steering knuckle. Refer to [FSU-13, "Exploded View"](#).
5. Remove drive shafts (LH and RH). Refer to [FAX-18, "Exploded View"](#) (2WD models) or [FAX-42, "Exploded View"](#) (AWD models).
6. Remove propeller shaft. Refer to [DLN-85, "Exploded View"](#) (AWD models).
7. Remove stabilizer connecting rod. Refer to [FSU-16, "Exploded View"](#).
8. Remove rear torque rod.
9. Remove front suspension member. Refer to [FSU-18, "Exploded View"](#).
10. Preparation for the separation work of transaxle is as follows:
  - Remove transaxle joint bolts which pierce at oil pan (upper) lower rear side. Refer to [EM-37, "Exploded View"](#).

# ENGINE ASSEMBLY

## < REMOVAL AND INSTALLATION >

### Removal

1. Use a manual lift table caddy (commercial service tool) or equivalently rigid tool such as a transmission jack. Securely support bottom of the engine and the transaxle assembly.

**CAUTION:**

**Put a piece of wood or an equivalent as the supporting surface, secure a completely stable condition.**

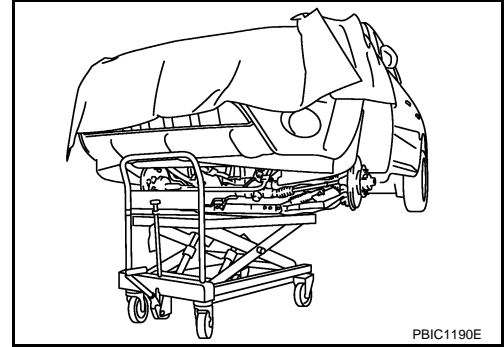

2. Remove upper torque rod.
3. Remove engine mounting insulator bolts (RH).
  - Loosen the mounting bolts in the reverse order as shown in the figure.

← : Vehicle front

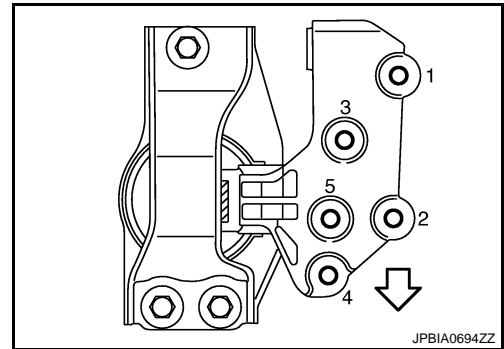

4. Remove engine mounting insulator bolts (LH).
  - Loosen the mounting bolts in the reverse order as shown in the figure.

← : Vehicle front

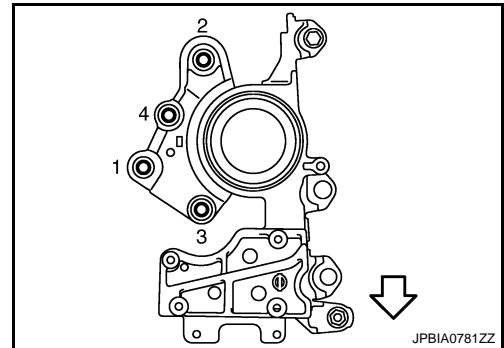

5. Remove engine mounting stay.
6. Carefully lower jack, or raise lift to remove the engine and the transaxle assembly. When performing work, observe the following caution.

**CAUTION:**

- Check that no part interferes with the vehicle side.
- Before and during this lifting, always check if any harnesses are left connected.
- During the removal, always be careful to prevent the vehicle from falling off the lift due to changes in the center of gravity.
- If necessary, support the vehicle by setting jack or suitable tool at the rear.

### Separation

1. Install engine slingers into front left of cylinder head and rear right of cylinder head.

A  
EM  
C  
D  
E  
F  
G  
H  
I  
J  
K  
L  
M  
N  
O  
P

# ENGINE ASSEMBLY

## < REMOVAL AND INSTALLATION >

- Use alternator bracket mounting bolt holes for the front side.

⇐ : Engine front

### Slinger bolts

Cylinder head side (A):  : 28.0 N·m (2.9 kg-m, 21 ft-lb)

Front cover side (B):  : 45.0 N·m (4.6 kg-m, 33 ft-lb)

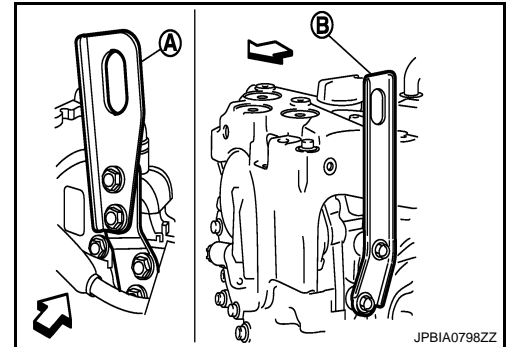

2. Remove starter motor. Refer to [STR-15, "2WD : Exploded View"](#) (2WD models) or [STR-17, "AWD : Exploded View"](#) (AWD models).
3. Lift with a hoist and separate the engine from the transaxle assembly. Refer to [TM-210, "2WD : Exploded View"](#) (2WD models) or [TM-214, "AWD : Exploded View"](#) (AWD models).

## INSTALLATION

Note the following, and install in the reverse order of removal.

### CAUTION:

- **Never allow engine oil to get on engine mounting insulator. Be careful not to damage engine mounting insulator.**
- **Check that each mounting insulator is seated properly, and tighten mounting nuts and bolts.**

### Preparation

1. Install the engine mounting insulator (RH) to the body temporarily.
2. Install the upper torque rod to the body side bracket temporarily.
3. Install the engine mounting stay to the body and tighten. (specified torque)
4. Install the engine mounting insulator (LH) to the body as follows:
  - a. Tighten the bolt No. 1, and the nut No. 8 as shown in the figure. (temporarily)

⇐ : Vehicle front

- b. Tighten the bolts No. 2, 3, 4 in numerical order as shown in the figure. (specified torque)
- c. Tighten the bolts No. 5, 6, 7 in numerical order as shown in the figure. (specified torque)
- d. Tighten the bolt No. 1 as shown in the figure. (specified torque)
- e. Tighten the nut No. 8 as shown in the figure. (specified torque)
5. Install the rear bracket to the transaxle and tighten. (specified torque)

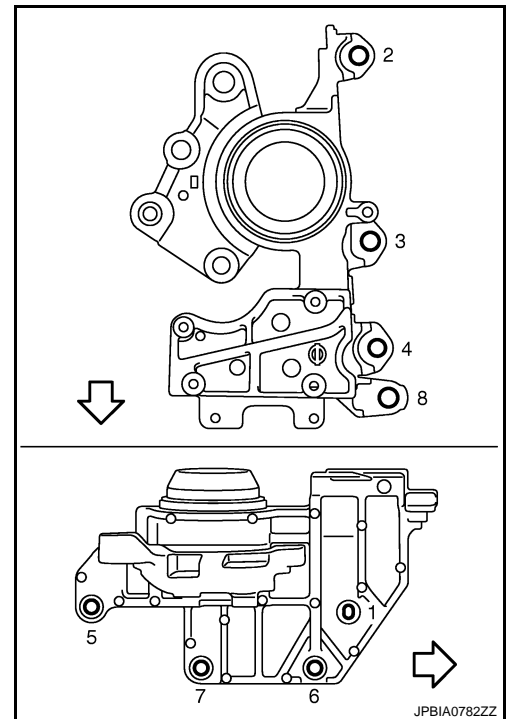

### Installation

1. Install the engine mounting insulator bolts (LH) to the transaxle and tighten as follows:

# ENGINE ASSEMBLY

## < REMOVAL AND INSTALLATION >

- a. Tighten the bolt No. 1, 2 in numerical order as shown in the figure. (temporarily)

↔ : Vehicle front

- b. Tighten the bolts No. 3, 4 in numerical order as shown in the figure. (specified torque)
- c. Tighten the bolt No. 1, 2 in numerical order as shown in the figure. (specified torque)

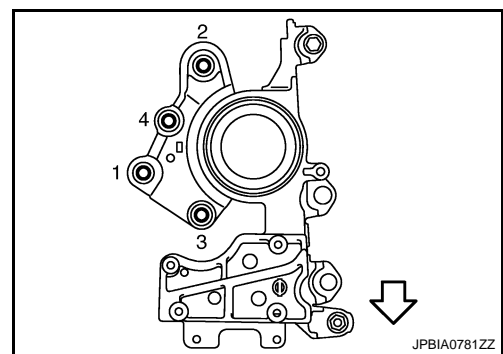

2. Install the engine mounting insulator bolts (RH) to the engine and tighten as follows:

- a. Tighten the bolt No. 1 as shown in the figure. (temporarily)

↔ : Vehicle front

- b. Tighten the bolts No. 2, 3, 4, 5 in numerical order as shown in the figure. (specified torque)
- c. Tighten the bolt No. 1 as shown in the figure. (specified torque)
3. Install the rear torque rod and tighten. (specified torque)
4. Tighten the upper torque rod. (specified torque)

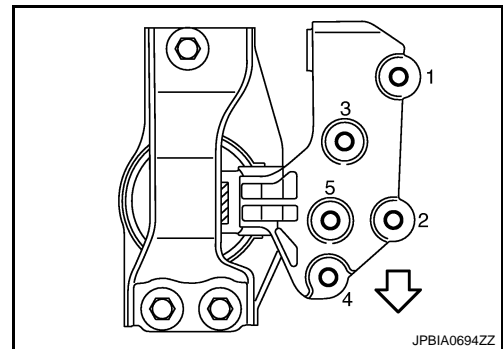

INFOID:000000004231440

## Inspection

### INSPECTION AFTER INSTALLATION

#### Inspection for Leakage

The following are procedures for checking fluids leakage, lubricates leakage, and exhaust gases leakage.

- Before starting engine, check oil/fluid levels including engine coolant and engine oil. If less than required quantity, fill to the specified level. Refer to [MA-17. "FOR NORTH AMERICA : Fluids and Lubricants"](#) (Except for Mexico) or [MA-18. "FOR MEXICO : Fluids and Lubricants"](#) (for Mexico).
- Use procedure below to check for fuel leakage.
  - Turn ignition switch "ON" (with engine stopped). With fuel pressure applied to fuel piping, check for fuel leakage at connection points.
  - Start engine. With engine speed increased, check again for fuel leakage at connection points.
- Run engine to check for unusual noise and vibration.
- Warm up engine thoroughly to check there is no leakage of fuel, exhaust gases, or any oil/fluids including engine oil and engine coolant.
- Bleed air from lines and hoses of applicable lines, such as in cooling system.
- After cooling down engine, again check oil/fluid levels including engine oil and engine coolant. Refill to the specified level, if necessary.

Summary of the inspection items:

Items	Before starting engine	Engine running	After engine stopped
Engine coolant	Level	Leakage	Level
Engine oil	Level	Leakage	Level
Other oils and fluid*	Level	Leakage	Level
Fuel	Leakage	Leakage	Leakage
Exhaust gases	—	Leakage	—

\*: Transmission/transaxle/CVT fluid, power steering fluid, brake fluid, etc.

# ENGINE STAND SETTING

< DISASSEMBLY AND ASSEMBLY >

## DISASSEMBLY AND ASSEMBLY

### ENGINE STAND SETTING

#### Setting

INFOID:000000004231441

#### NOTE:

Explained here is how to disassemble with engine stand supporting transaxle surface. When using different type of engine stand, note with difference in steps and etc.

1. Remove the engine and the transaxle assembly from the vehicle, and separate the transaxle from the engine. Refer to [EM-61, "Exploded View"](#).
2. Install engine to engine stand with the following procedure:
  - a. Remove drive plate.
    - Secure drive plate with a stopper plate and use a suitable tool to remove mounting bolts.

Drive plate : Size E20

#### CAUTION:

- Never disassemble them.
- Never place them with signal plate facing down.
- When handling signal plate, take care not to damage or scratch them.
- Handle signal plate in a manner that prevents them from becoming magnetized.

#### NOTE:

The flywheel, two block construction, allows movement in response to transaxle side pressure, or when twisted in its rotation direction. Therefore, some amount of noise is normal.

- b. Remove pilot converter using pilot bushing puller (SST) or suitable tool.

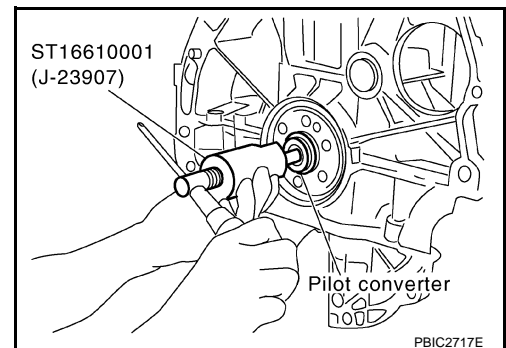
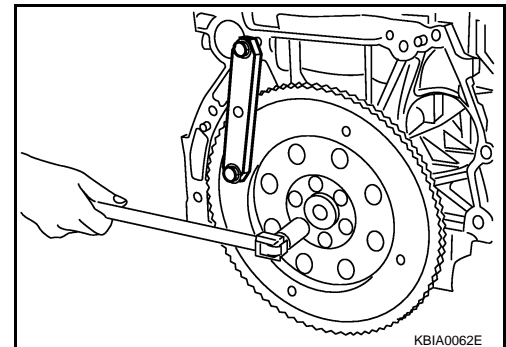

- c. Lift the engine with a hoist to install it onto widely use engine stand.

#### CAUTION:

- Use the engine stand that has a load capacity [approximately 135 kg (298 lb) or more] large enough for supporting the engine weight.
- If the load capacity of stand is not adequate, remove the following parts beforehand to reduce the potential risk of overturning stand.
  - Intake manifold: Refer to [EM-29, "Exploded View"](#).
  - Exhaust manifold: Refer to [EM-32, "Exploded View"](#).
  - Rocker cover: Refer to [EM-40, "Exploded View"](#).

#### NOTE:

# ENGINE STAND SETTING

## < DISASSEMBLY AND ASSEMBLY >

The figure shows an example of widely used engine stand (A) that can support mating surface of transaxle with drive plate removed.

**CAUTION:**

**Before removing the hanging chains, check the engine stand is stable and there is no risk of overturning.**

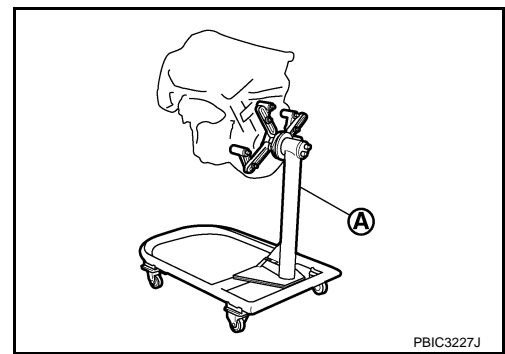

3. Drain engine oil. Refer to [LU-6, "Draining"](#).

**CAUTION:**

**Be sure to clean drain plug and install with new washer.**

4. Drain engine coolant by removing water drain plug from inside of the engine.

**Tightening torque** : Refer to [EM-88, "Exploded View"](#).

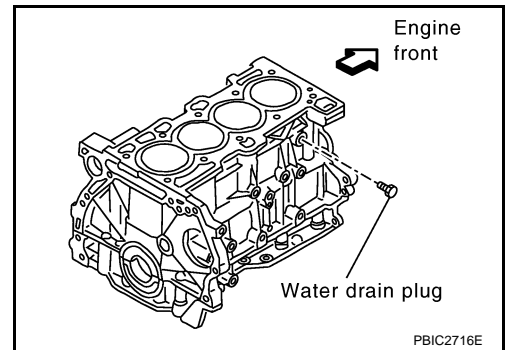

A  
EM  
C  
D  
E  
F  
G  
H  
I  
J  
K  
L  
M  
N  
O  
P

# ENGINE UNIT

< DISASSEMBLY AND ASSEMBLY >

## ENGINE UNIT

---

### Disassembly

INFOID:000000004231442

1. Remove intake manifold. Refer to [EM-29, "Exploded View"](#).
2. Remove exhaust manifold. Refer to [EM-32, "Exploded View"](#).
3. Remove oil pan (lower). Refer to [EM-34, "Exploded View"](#).
4. Remove oil pan (upper). Refer to [EM-37, "Exploded View"](#).
5. Remove oil cooler. Refer to [LU-9, "Exploded View"](#).
6. Remove ignition coil, spark plug and rocker cover. Refer to [EM-40, "Exploded View"](#).
7. Remove fuel injector and fuel tube. Refer to [EM-43, "Exploded View"](#).
8. Remove timing chain. Refer to [EM-69, "Exploded View"](#).
9. Remove camshaft. Refer to [EM-48, "Exploded View"](#).
10. Remove water inlet. Refer to [CO-25, "Exploded View"](#).
11. Remove water outlet. Refer to [CO-25, "Exploded View"](#).
12. Remove cylinder head. Refer to [EM-79, "Exploded View"](#).

### Assembly

INFOID:000000004231443

Assembly is the reverse order of disassembly.



# TIMING CHAIN

< DISASSEMBLY AND ASSEMBLY >

## TIMING CHAIN

Exploded View

INFOID:000000004231444

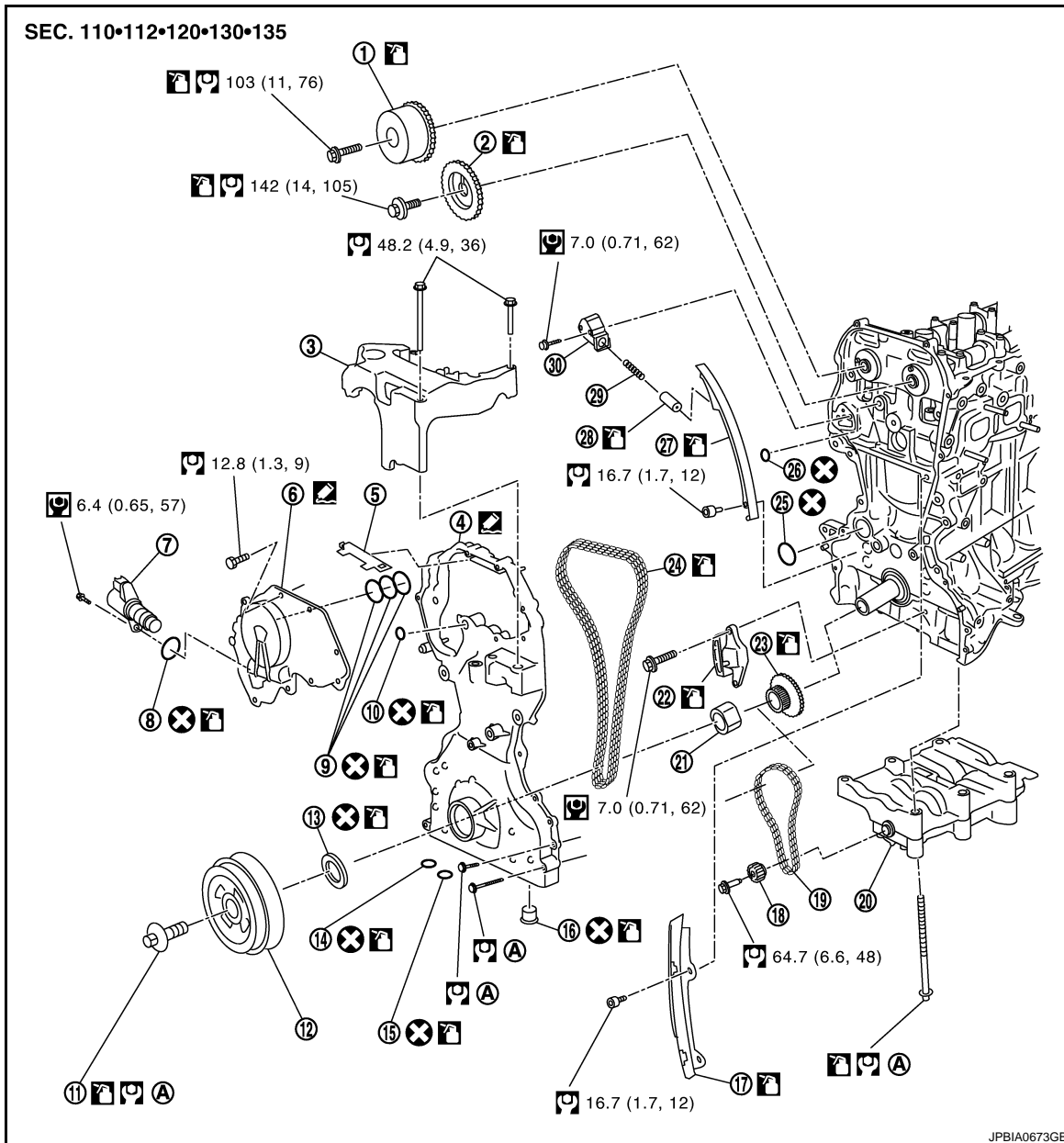

- |   |                                |                                      |
|---|--------------------------------|--------------------------------------|
| 1. Camshaft sprocket (INT)                    | 2. Camshaft sprocket (EXH)     | 3. Engine mounting bracket           |
| 4. Front cover                                | 5. Chain guide                 | 6. Intake valve timing control cover |
| 7. Intake valve timing control solenoid valve | 8. O-ring                      | 9. O-ring                            |
| 10. O-ring                                    | 11. Crankshaft pulley bolt     | 12. Crankshaft pulley                |
| 13. Front oil seal                            | 14. O-ring                     | 15. O-ring                           |
| 16. O-ring                                    | 17. Timing chain tension guide | 18. Balancer unit sprocket           |
| 19. Balancer unit timing chain                | 20. Balancer unit              | 21. Oil pump drive spacer            |
| 22. Balancer unit timing chain tensioner      | 23. Crankshaft sprocket        | 24. Timing chain                     |
| 25. O-ring                                    | 26. O-ring                     | 27. Timing chain slack guide         |
| 28. Chain tensioner plunger                   | 29. Spring                     | 30. Chain tensioner                  |

# TIMING CHAIN

## < DISASSEMBLY AND ASSEMBLY >

A. Refer to [EM-70](#)

Refer to [GI-4, "Components"](#) for symbols in the figure.

## Removal and Installation

INFOID:000000004231445

### REMOVAL

1. Remove the following parts.
  - PCV hose: Refer to [EM-29, "Exploded View"](#).
  - Intake manifold: Refer to [EM-29, "Exploded View"](#).
  - Ignition coil: Refer to [EM-40, "Exploded View"](#).
  - Drive belt: Refer to [EM-15, "Removal and Installation"](#).
  - Drive belt auto-tensioner: Refer to [EM-25, "Exploded View"](#).
2. Remove engine mounting bracket.
3. Remove rocker cover. Refer to [EM-40, "Exploded View"](#).
4. Remove oil pan (lower). Refer to [EM-34, "Exploded View"](#).
5. Remove oil pan (upper), and oil strainer. Refer to [EM-37, "Exploded View"](#).
6. Remove intake valve timing control cover.
  - Loosen bolts in the reverse order as shown in the figure.
  - Use a seal cutter [SST: KV10111100 (J-37228)] or equivalent tool to cut liquid gasket for removal.

### CAUTION:

**Be careful not to damage mounting surface.**

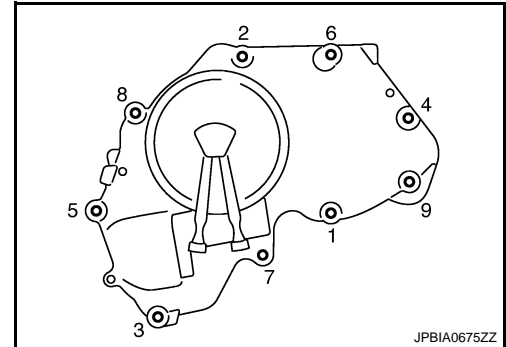

7. Pull chain guide between camshaft sprockets out through front cover.
8. Set No. 1 cylinder at TDC on its compression stroke with the following procedure:
  - a. Rotate crankshaft pulley clockwise and align TDC mark to timing indicator on front cover.

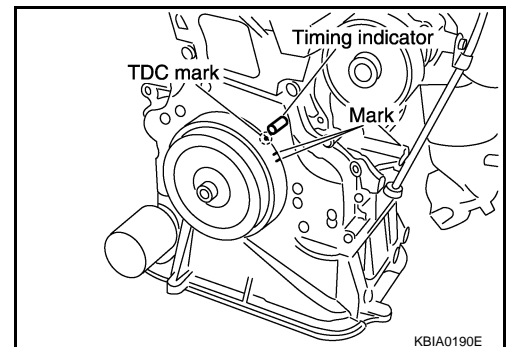

- b. At the same time, check that the mating marks on camshaft sprockets are located as shown in the figure.
  - If not, rotate crankshaft pulley one more turn to align mating marks to the positions in the figure.

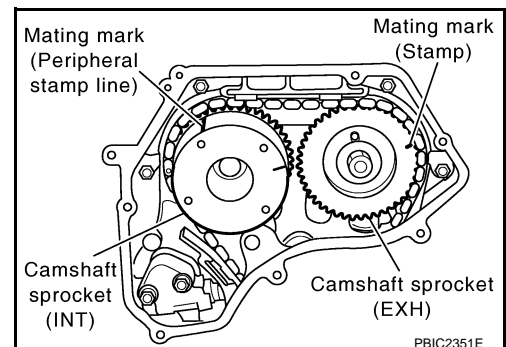

9. Remove crankshaft pulley with the following procedure:

# TIMING CHAIN

## < DISASSEMBLY AND ASSEMBLY >

- a. Fix crankshaft pulley with a pulley holder (commercial service tool), loosen crankshaft pulley bolt, and locate bolt seating surface at 10 mm (0.39 in) from its original position.

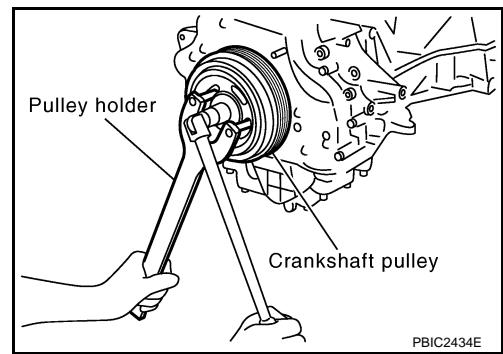

- b. Attach a pulley puller (commercial service tool) in the M 6 thread hole on crankshaft pulley, and remove crankshaft pulley.

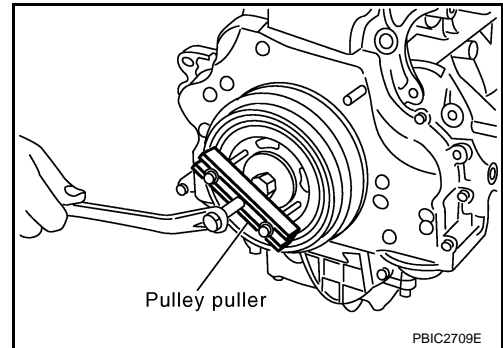

10. Remove front cover with the following procedure:

- a. Loosen mounting bolts in the reverse order as shown in the figure, and remove them.

- A : Dowel pin  
B : Dowel pin hole

- b. Use a seal cutter [SST: KV10111100 (J-37228)] or equivalent tool to cut liquid gasket for removal.

**CAUTION:**

**Be careful not to damage mounting surface.**

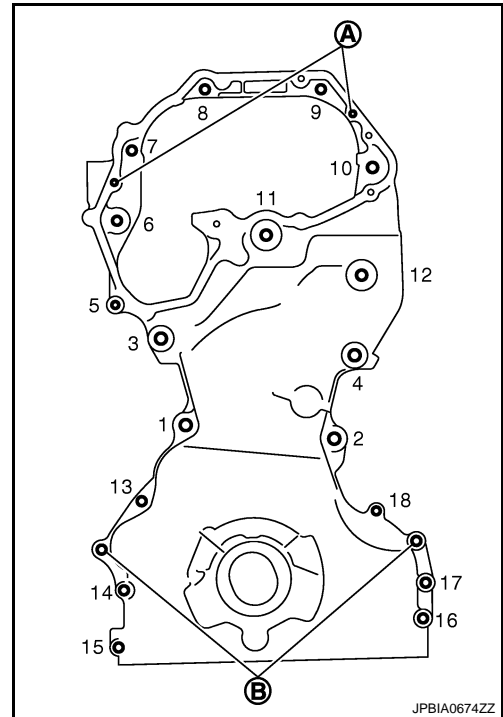

11. If front oil seal needs to be replaced, lift it with a suitable tool, and remove it.

**CAUTION:**

**Be careful not to damage front cover.**

12. Remove timing chain and camshaft sprockets with the following procedure:

A  
EM  
C  
D  
E  
F  
G  
H  
I  
J  
K  
L  
M  
N  
O  
P

# TIMING CHAIN

## < DISASSEMBLY AND ASSEMBLY >

- a. Push in chain tensioner plunger. Insert a stopper pin into hole on chain tensioner body to secure chain tensioner plunger and remove chain tensioner.

**NOTE:**

Use approximately 0.5 mm (0.020 in) dia. hard metal pin as a stopper pin.

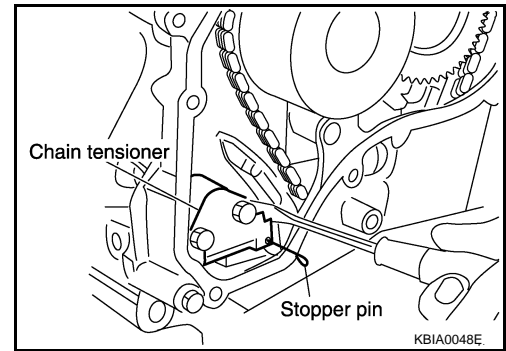

- b. Secure hexagonal part of camshaft with a wrench. Loosen camshaft sprocket mounting bolts and remove timing chain and camshaft sprockets.

**CAUTION:**

Never rotate crankshaft or camshaft while timing chain is removed. It causes interference between valve and piston.

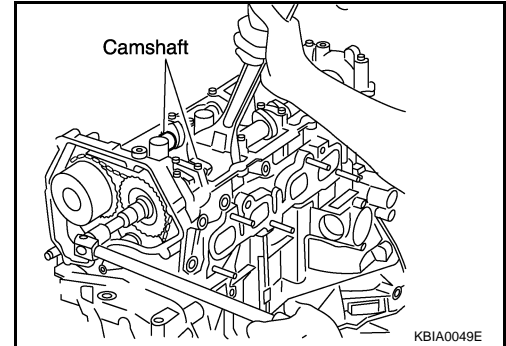

13. Remove timing chain slack guide, timing chain tension guide and oil pump drive spacer.

14. Remove balancer unit timing chain tensioner with the following procedure:

- a. Press stopper tab (A) in the direction shown in the figure to push the timing chain slack guide (B) toward balancer unit timing chain tensioner (1).

- The slack guide is released by pressing the stopper tab. As the result, the slack guide can be moved.

- b. Insert a stopper pin (D) into tensioner body hole (C) to secure the timing chain slack guide.

**NOTE:**

Use a hard metal pin with the diameter of approximately 1.2 mm (0.047 in) as a stopper pin.

- c. Remove balancer unit timing chain tensioner.

- When the holes on lever and tensioner body cannot be aligned, align these holes by slightly moving the slack guide.

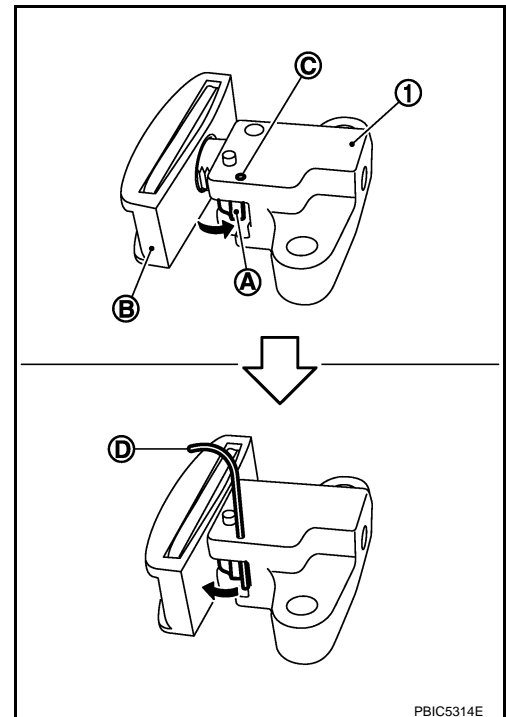

15. Remove balancer unit timing chain and crankshaft sprocket.

# TIMING CHAIN

## < DISASSEMBLY AND ASSEMBLY >

16. Loosen mounting bolts in the reverse order as shown in the figure, and remove balancer unit.

← : Engine front

**CAUTION:**

**Never disassemble balancer unit.**

**NOTE:**

Use TORX socket (size E14).

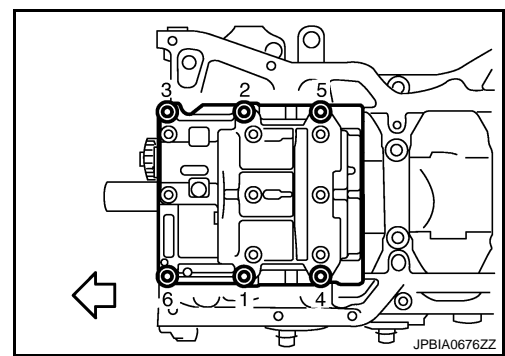

A

EM

C

D

## INSTALLATION

**NOTE:**

The figure shows the relationship between the mating mark on each timing chain and that on the corresponding sprocket, with the components installed.

1. Check that crankshaft key points straight up.

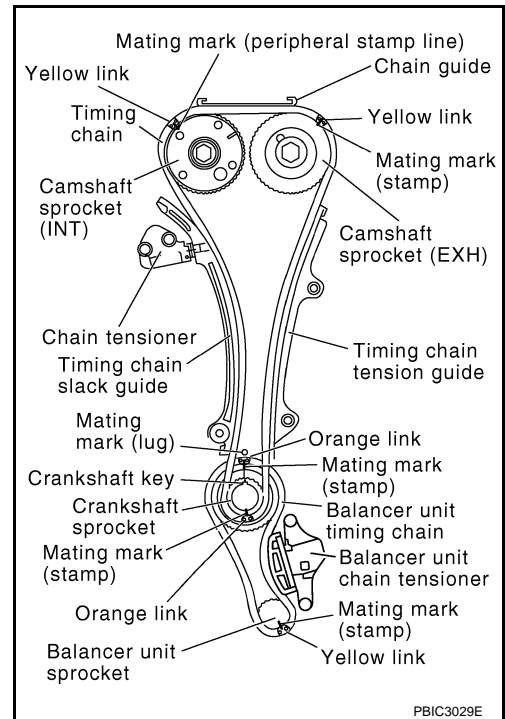

E

F

G

H

I

J

K

2. Tighten mounting bolts in numerical order as shown in the figure with the following procedure, and install balancer unit.

← : Engine front

**CAUTION:**

**If mounting bolts are reused, check their outer diameter before installation. Refer to [EM-77, "Inspection"](#).**

- Apply new engine oil to threads and seat surfaces of mounting bolts.
- Tighten No. 1 to 5 bolts.

 : 42.0 N-m (4.3 kg-m, 31 ft-lb)

- Tighten No. 6 bolt.

 : 36.0 N-m (3.7 kg-m, 27 ft-lb)

- Turn No. 1 to 5 bolts 120 degrees clockwise (angle tightening).

**CAUTION:**

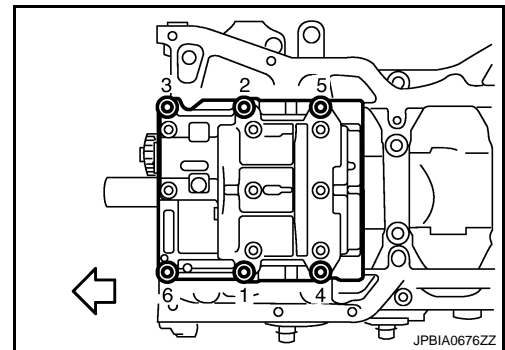

L

M

N

O

P

# TIMING CHAIN

## < DISASSEMBLY AND ASSEMBLY >

Use the angle wrench [SST: KV10112100 (BT8653-A)] (A) to check tightening angle. Never make judgment by visual inspection.

- e. Turn No. 6 bolt 90 degrees clockwise (angle tightening).
- f. Completely loosen all bolts.

 : 0 N·m (0 kg·m, 0 ft·lb)

**CAUTION:**

In this step, loosen bolts in the reverse order as shown in the figure.

- g. Repeat step b to e.

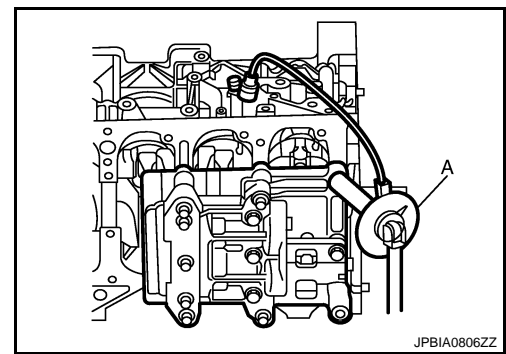

JPBIA0806ZZ

3. Install crankshaft sprocket and balancer unit timing chain.
  - Check that crankshaft sprocket is positioned with mating marks on cylinder block and crankshaft sprocket meeting at the top.
  - Install it by aligning mating marks on each sprocket and balancer unit timing chain.

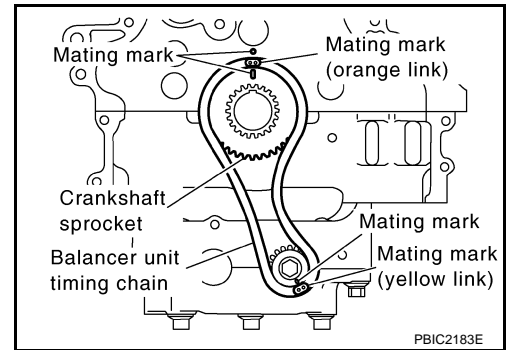

PBIC2183E

4. Install balancer unit timing chain tensioner.
  - Be careful not to let mating marks of each sprocket and timing chain slip.
  - After installation, check the mating marks have not slipped, then remove stopper pin and release tensioner sleeve.

5. Install timing chain and related parts.
  - Install by aligning mating marks on each sprocket and timing chain.
  - Before and after installing chain tensioner, check again to check that mating marks have not slipped.
  - After installing chain tensioner, remove stopper pin, and check that tensioner moves freely.

**CAUTION:**

- For the following note, after the mating marks are aligned, keep them aligned by holding them with a hand.
- To avoid skipped teeth, never rotate crankshaft and camshaft until front cover is installed.

**NOTE:**

Before installing chain tensioner, it is possible to change the position of mating mark on timing chain for that on each sprocket for alignment.

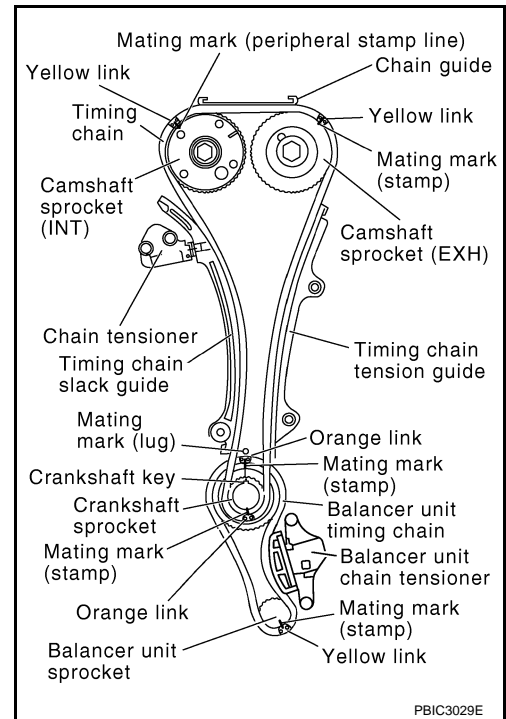

PBIC3029E

6. Install front oil seal to front cover. Refer to [EM-59. "FRONT OIL SEAL : Removal and Installation"](#).
7. Install front cover with the following procedure:
  - a. Install O-rings to cylinder head and cylinder block.

# TIMING CHAIN

## < DISASSEMBLY AND ASSEMBLY >

- b. Apply a continuous bead of liquid gasket with a tube presser (commercial service tool) to front cover as shown in the figure.

- G** : Dowel pin hole  
**a** : 35.7 mm (1.406 in)  
**b** :  $\phi 4.8 - 5.8$  mm (0.189 - 0.228 in)  
**c** :  $\phi 3.4 - 4.4$  mm (0.134 - 0.173 in)  
**d** : 179.6 mm (7.07 in)  
**e** : 35.5 mm (1.398 in)  
**f** : 31.3 mm (1.232 in)

Use Genuine RTV Silicone Sealant or equivalent. Refer to [GI-17, "Recommended Chemical Products and Sealants"](#).

**CAUTION:**

- For bolt holes with ▲ marks (5 locations), apply liquid gasket out side the holes.
- Attaching should be done within 5 minutes after coating.

**NOTE:**

Application instruction differs depending on the position.

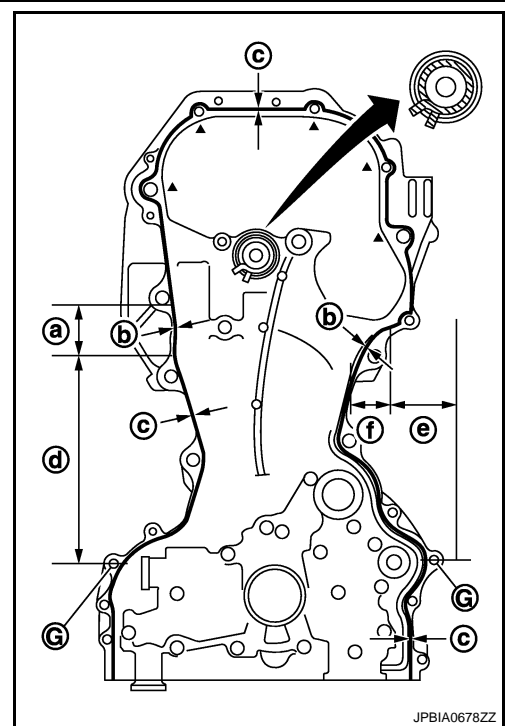

- c. Check that mating marks of timing chain and each sprocket are still aligned. Then install front cover.

**CAUTION:**

**Be careful not to damage front oil seal by interference with front end of crankshaft.**

- d. Tighten mounting bolts in numerical order as shown in the figure.  
 e. After all bolts are tightened, retighten them to specified torque in numerical order as shown in the figure.

- A : Dowel pin  
 B : Dowel pin hole

**CAUTION:**

**Be sure to wipe off any excessive liquid gasket leaking to surface for fitting oil pan.**

**Tightening torque**

- M10 bolt** : 49.0 N·m (5.0 kg·m, 36 ft·lb)  
**M6 bolt** : 12.8 N·m (1.3 kg·m, 9 ft·lb)

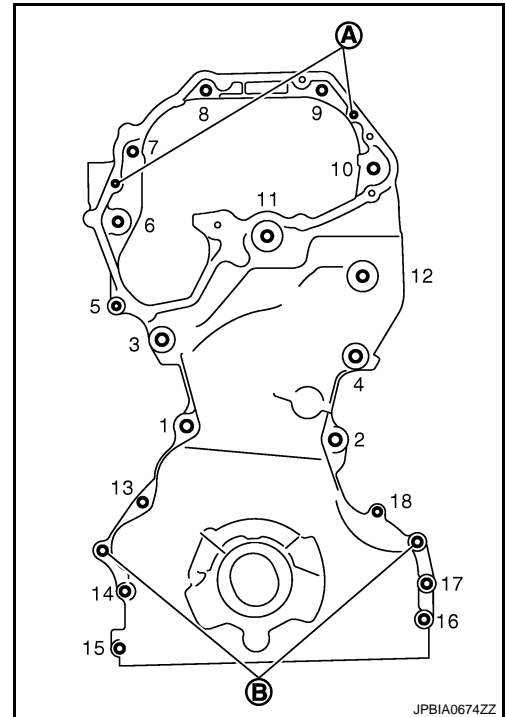

8. Install chain guide between camshaft sprockets.  
 9. Install intake valve timing control cover with the following procedure:  
 a. Install intake valve timing control solenoid valves to intake valve timing control cover if removed.  
 b. Install new oil rings to the camshaft sprocket (INT) insertion points on backside of intake valve timing control cover.  
 c. Install new O-ring to front cover.



## TIMING CHAIN

### < DISASSEMBLY AND ASSEMBLY >

- d. Apply a continuous bead of liquid gasket with a tube presser (commercial service tool) to intake valve timing control cover as shown in the figure.

**a** :  $\phi 3.4 - 4.4 \text{ mm}$  (0.134 – 0.173 in)

Use Genuine RTV Silicone Sealant or equivalent. Refer to [GI-17, "Recommended Chemical Products and Sealants"](#).

**CAUTION:**

Attaching should be done within 5 minutes after liquid gasket application.

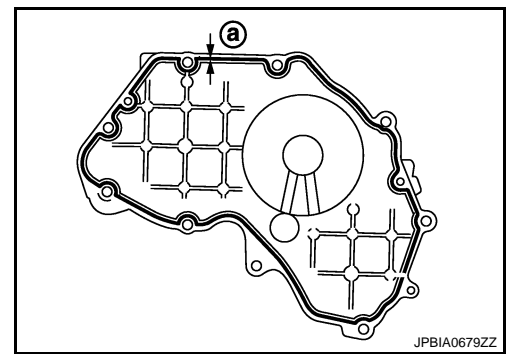

- e. Tighten mounting bolts in numerical order as shown in the figure.

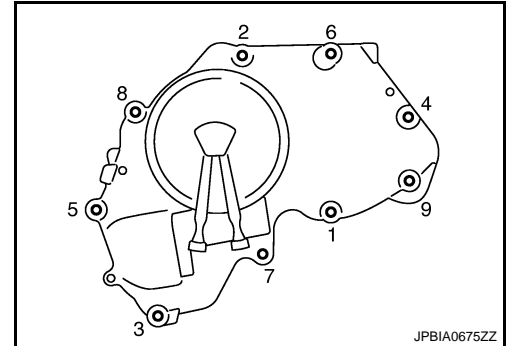

10. Insert crankshaft pulley by aligning with crankshaft key.
- When inserting crankshaft pulley with a plastic hammer, tap on its center portion (not circumference).
- CAUTION:**  
Install protecting front oil seal lip section from any damage.
11. Tighten crankshaft pulley bolt.
- Secure crankshaft pulley with a pulley holder (commercial service tool), and tighten crankshaft pulley bolt.
  - Perform angle tightening with the following procedure:
- a. Apply new engine oil to thread and seat surfaces of crankshaft pulley bolt.
- b. Tighten crankshaft pulley bolt.

 : 42.1 N·m (4.3 kg·m, 31 ft·lb)

- c. Put a paint mark on crankshaft pulley, mating with any one of six easy to recognize angle marks on bolt flange.
- d. Turn another 60 degrees clockwise (angle tightening).
- Check the tightening angle with movement of one angle mark.

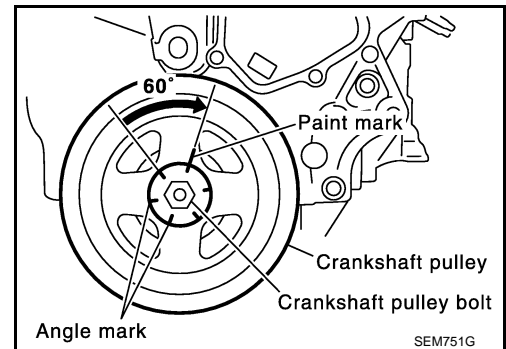

12. Install the following parts:
- Oil pan (upper) and oil strainer: Refer to [EM-37, "Exploded View"](#).
  - Oil pan (lower): Refer to [EM-34, "Exploded View"](#).
  - Rocker cover: Refer to [EM-40, "Exploded View"](#).
13. Install the engine mounting bracket to the engine as follow:



# TIMING CHAIN

## < DISASSEMBLY AND ASSEMBLY >

- a. Tighten the bolts No. 3, 5 as shown in the figure. (temporarily)

← : Engine front

- b. Tighten the bolts in numerical order as shown in the figure. (specified torque)

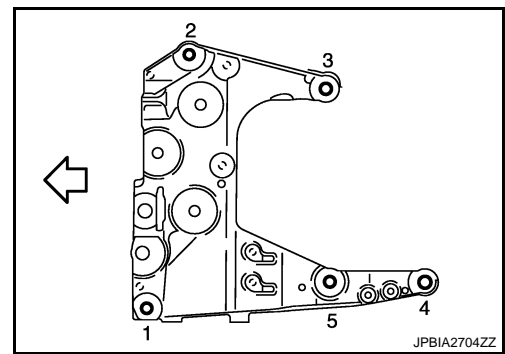

14. Install all removed parts in the reverse order of removal.

## Inspection

INFOID:000000004231446

## INSPECTION AFTER REMOVAL

### Timing Chain

Check timing chain for cracks and any excessive wear at the roller links of timing chain. Replace timing chain if necessary.

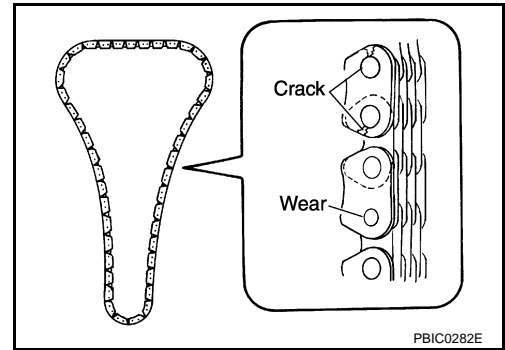

### Balancer Unit Mounting Bolt Outer Diameter

- Measure the outer diameters ("d1", "d2") at two positions as shown in the figure.
- If reduction appears in "A" range, regard it as "d2".

**Limit ("d1"–"d2") : 0.15 mm (0.0059 in)**

- If it exceeds the limit (large difference in dimensions), replace it with a new one.

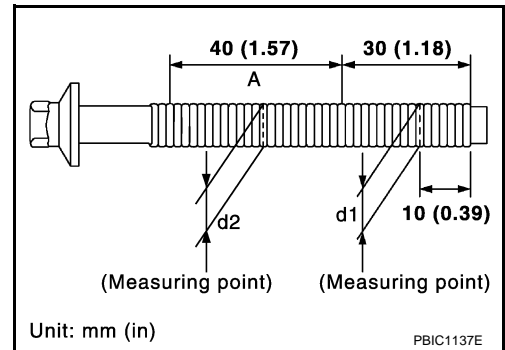

## INSPECTION AFTER INSTALLATION

### Inspection for Leakage

The following are procedures for checking fluids leakage and lubricates leakage.

- Before starting engine, check oil/fluid levels including engine coolant and engine oil. If less than required quantity, fill to the specified level. Refer to [MA-17. "FOR NORTH AMERICA : Fluids and Lubricants"](#) (Except for Mexico) or [MA-18. "FOR MEXICO : Fluids and Lubricants"](#) (for Mexico).
- Use procedure below to check for fuel leakage.
  - Turn ignition switch "ON" (with engine stopped). With fuel pressure applied to fuel piping, check for fuel leakage at connection points.
  - Start engine. With engine speed increased, check again for fuel leakage at connection points.
- Run engine to check for unusual noise and vibration.
- Warm up engine thoroughly to check there is no leakage of fuel, or any oil/fluids including engine oil and engine coolant.
- Bleed air from lines and hoses of applicable lines, such as in cooling system.
- After cooling down engine, again check oil/fluid levels including engine oil and engine coolant. Refill to the specified level, if necessary.

## TIMING CHAIN

### < DISASSEMBLY AND ASSEMBLY >

Summary of the inspection items:

Items	Before starting engine	Engine running	After engine stopped
Engine coolant	Level	Leakage	Level
Engine oil	Level	Leakage	Level
Other oils and fluid*	Level	Leakage	Level
Fuel	—	Leakage	—

\*: Transmission/transaxle/CVT fluid, power steering fluid, brake fluid, etc.

# CYLINDER HEAD

< DISASSEMBLY AND ASSEMBLY >

## CYLINDER HEAD

Exploded View

INFOID:000000004231447

REMOVAL

A

EM

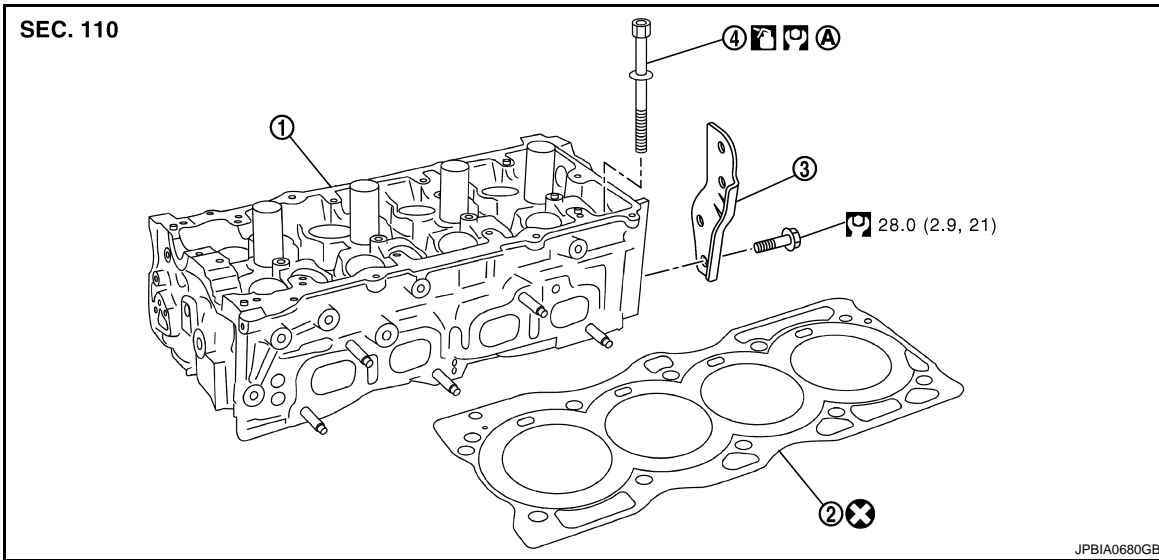

- 1. Cylinder head assembly
- 2. Cylinder head gasket
- 3. Engine rear lower slinger

4. Cylinder head bolt

A. Refer to [EM-80](#)

Refer to [GI-4, "Components"](#) for symbols in the figure.

DISASSEMBLY

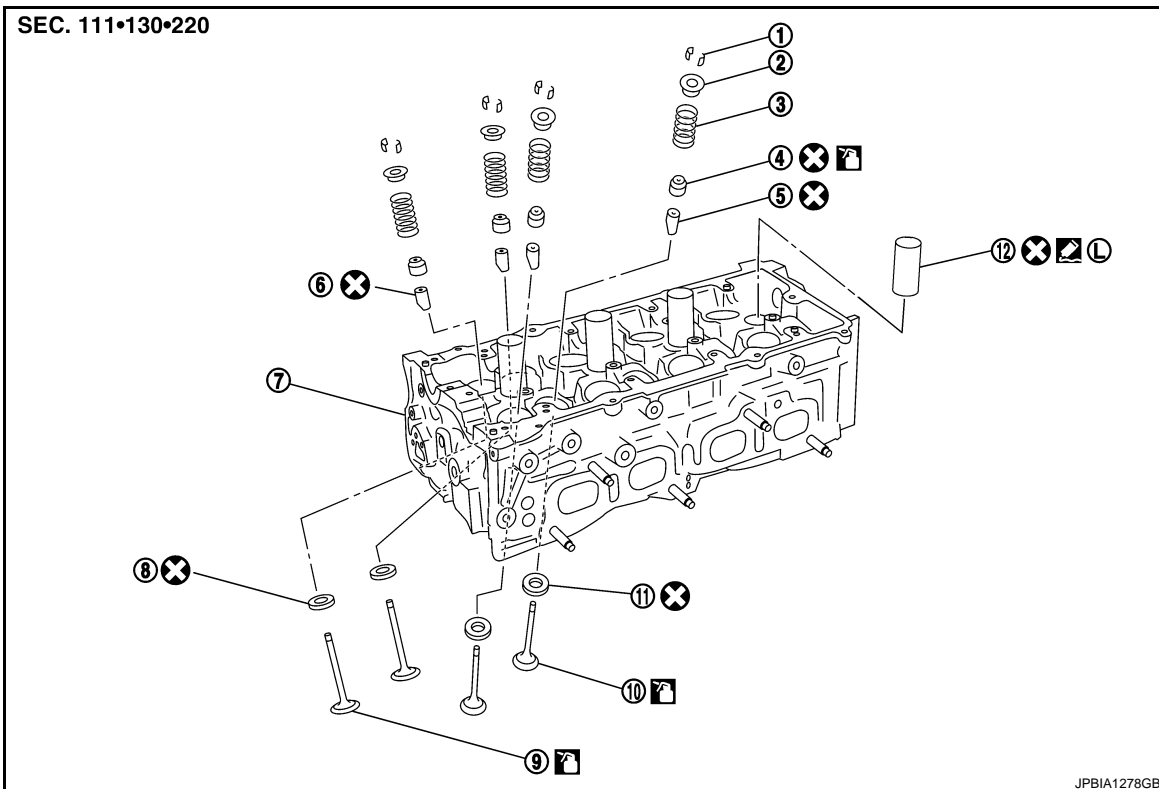

C

D

E

F

G

H

I

J

K

L

M

N

O

P

# CYLINDER HEAD

## < DISASSEMBLY AND ASSEMBLY >

- |                   |                          |  |
|-------------------|--------------------------|--|
| 1. Valve collet   | 2. Valve spring retainer | 3. Valve spring (with valve spring seat) |
| 4. Valve oil seal | 5. Valve guide (EXH)     | 6. Valve guide (INT)                     |
| 7. Cylinder head  | 8. Valve seat (INT)      | 9. Valve (INT)                           |
| 10. Valve (EXH)   | 11. Valve seat (EXH)     | 12. Spark plug tube                      |

: Apply genuine high strength thread locking sealant or equivalent.  
Refer to [GI-4, "Components"](#) for symbols not described on the above.

## Removal and Installation

INFOID:000000004231448

### REMOVAL

1. Release fuel pressure. Refer to [EC-489, "Inspection"](#) (for California), [EC-1279, "Inspection"](#) (for Mexico) or [EC-923, "Inspection"](#) (Except for California and Mexico).
2. Drain engine coolant and engine oil. Refer to [CO-9, "Draining"](#) and [LU-6, "Draining"](#).
3. Remove the following components and related parts.
  - Exhaust manifold and three way catalyst assembly: Refer to [EM-32, "Removal and Installation"](#).
  - Intake manifold and fuel tube assembly: Refer to [EM-29, "Removal and Installation"](#) and [EM-43, "Exploded View"](#).
  - Water control valve and water control valve housing (water outlet): Refer to [CO-25, "Exploded View"](#).

#### NOTE:

Can be removed and installed even when assembled with cylinder head.

4. Remove front cover and timing chain. Refer to [EM-69, "Exploded View"](#).
5. Remove camshafts. Refer to [EM-48, "Removal and Installation"](#).
6. Securely support bottom of cylinder block with a jack or equivalent tool, and release the hoist that was supporting it.
7. Remove cylinder head loosening bolts in the reverse order as shown in the figure.
  - Using TORX socket (size E20), loosen cylinder head bolts.
8. Remove cylinder head gasket.

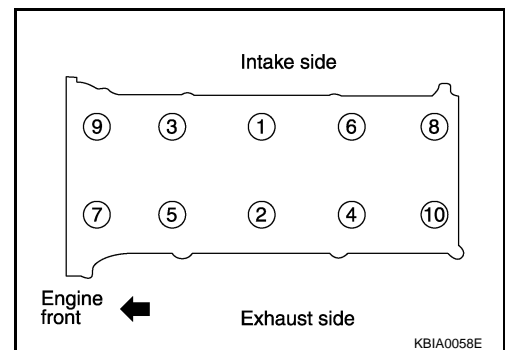

### INSTALLATION

1. Install cylinder head gasket.
2. Tighten cylinder head bolts in numerical order as shown in the figure with the following procedure, and install cylinder head.

#### CAUTION:

**If cylinder head bolts are reused, check their outer diameters before installation. Refer to [EM-85, "Inspection"](#).**

- a. Apply new engine oil to threads and seating surface of mounting bolts.
- b. Tighten all bolts.

 : **50.0 N·m (5.1 kg·m, 37 ft·lb)**

- c. Turn all bolts 60 degrees clockwise (angle tightening).
- d. Completely loosen.

 : **0 N·m (0 kg·m, 0 ft·lb)**

#### CAUTION:

**In this step, loosen bolts in the reverse order of that indicated in the figure.**

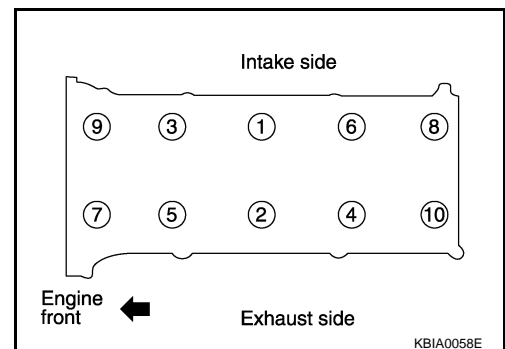

# CYLINDER HEAD

## < DISASSEMBLY AND ASSEMBLY >

- e. Tighten all bolts.

 : 39.2 N-m (4.0 kg-m, 29 ft-lb)

- f. Turn all bolts 75 degrees clockwise (angle tightening).  
g. Turn all bolts 75 degrees clockwise again (angle tightening).

**CAUTION:**

Check and confirm the tightening angle by using an angle wrench (SST) or protractor. Avoid judgment by visual inspection without the tool.

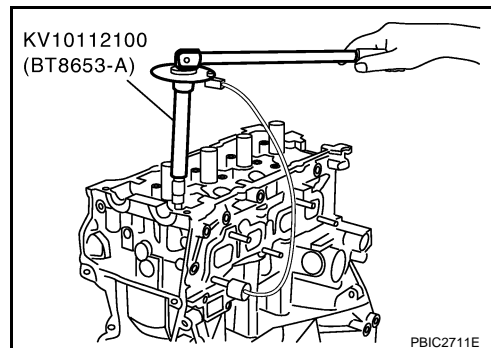

3. Install in the reverse order of removal after this step.

## Disassembly and Assembly

INFOID:000000004231449

### DISASSEMBLY

1. Remove spark plug with spark plug wrench (commercial service tool).
  2. Remove spark plug tube, if necessary.
    - Using pliers, remove it from cylinder head.
- CAUTION:**
- Be careful not to damage cylinder head.
  - Never remove spark plug tube if not necessary. Once removed, spark plug tube cannot be reused because of deformation.
3. Remove valve lifter.
    - Identify installation positions, and store them without mixing them up.
  4. Remove valve collet.
    - Compress valve spring with valve spring compressor, attachment and adapter [SST: KV10116200 (J-26336-A)] (A). Remove valve collet with a magnet hand (B).

**CAUTION:**

When working, be careful not to damage valve lifter holes.

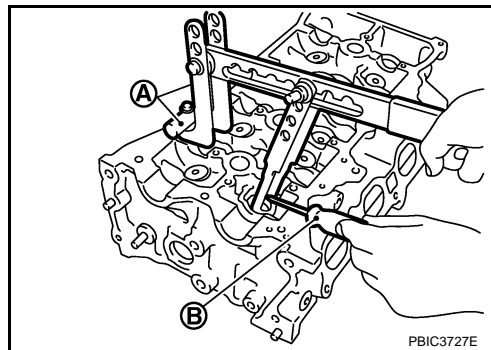

5. Remove valve spring retainer and valve spring (with valve spring seat).

**CAUTION:**  
Never remove valve spring seat from valve spring.
6. Push valve stem to combustion chamber side, and remove valve.
  - Identify installation positions, and store them without mixing them up.

# CYLINDER HEAD

## < DISASSEMBLY AND ASSEMBLY >

7. Remove valve oil seal with a valve oil seal puller (SST).

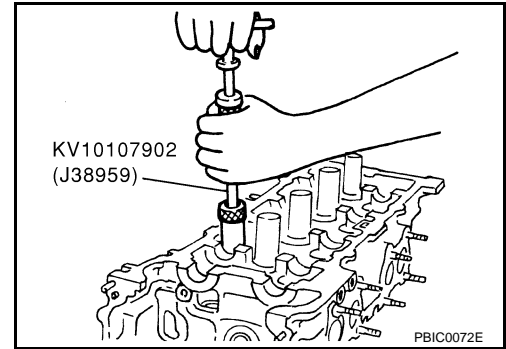

8. Remove valve seat, if valve seat must be replaced.
- Bore out old seat until it collapses. Boring should not continue beyond the bottom face of the seat recess in cylinder head. Set the machine depth stop to ensure this. Refer to [EM-115, "Cylinder Head"](#).

**CAUTION:**

**Prevent to scratch cylinder head by excessive boring.**

9. Remove valve guide, if valve guide must be replaced.
- a. To remove valve guide, heat cylinder head to 110 to 130°C (230 to 266°F) by soaking in heated oil (A).

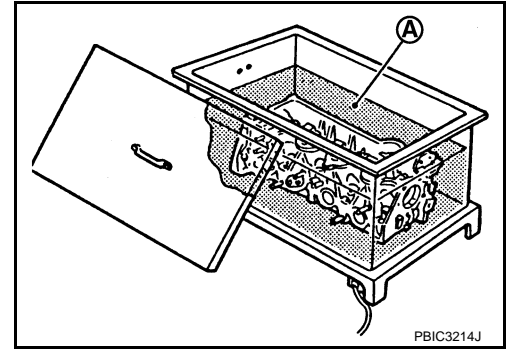

- b. Drive out valve guide with a press [under a 20 kN (2 ton, 2.2 US ton, 2.0 Imp ton) pressure] or hammer and suitable tool.

**CAUTION:**

**Cylinder head contains heat, when working, wear protective equipment to avoid getting burned.**

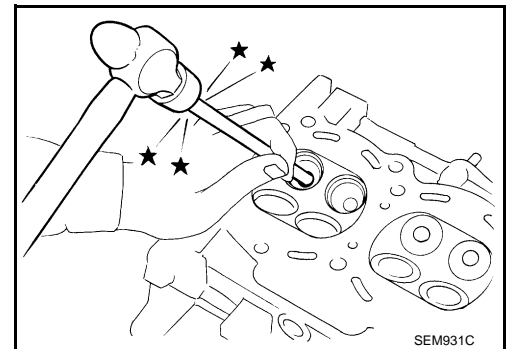

## ASSEMBLY

1. Install valve guide if removed.

**CAUTION:**

**Replace with oversize [0.2 mm (0.008 in)] valve guide.**

- a. Ream cylinder head valve guide hole with a valve guide reamer (commercial service tool) (A).

**For service parts : Oversize [0.2 mm (0.008 in)]**

**Refer to [EM-115, "Cylinder Head"](#).**

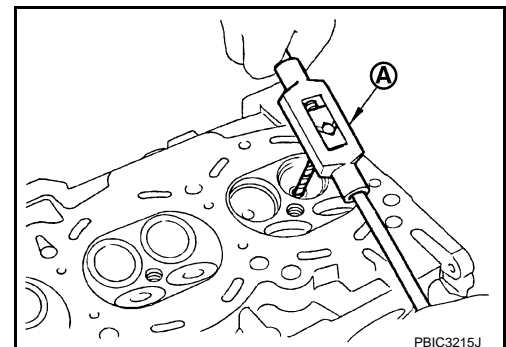

# CYLINDER HEAD

## < DISASSEMBLY AND ASSEMBLY >

- b. Heat cylinder head to 110 to 130°C (230 to 266°F) by soaking in heated oil (A).

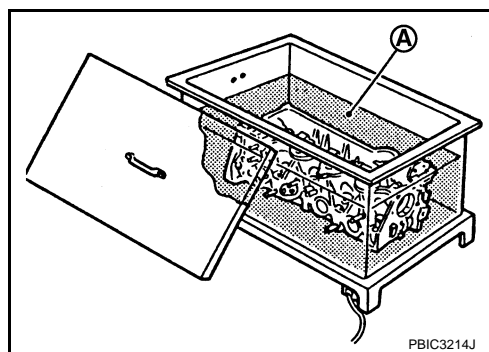

- c. Press valve guide from camshaft side to dimensions as shown in the figure.

**Projection "H"** : Refer to [EM-115, "Cylinder Head"](#).

**CAUTION:**

Cylinder head contains heat, when working, wear protective equipment to avoid getting burned.

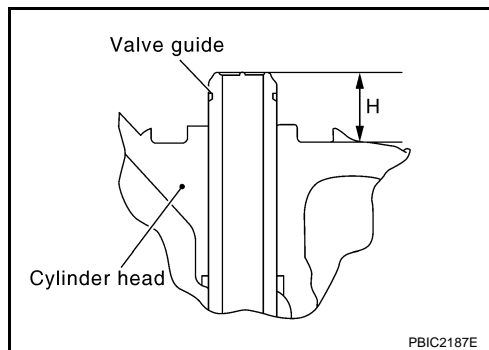

- d. Apply reamer finish to valve guide with a valve guide reamer (commercial service tool) (A).

**Standard** : Refer to [EM-115, "Cylinder Head"](#).

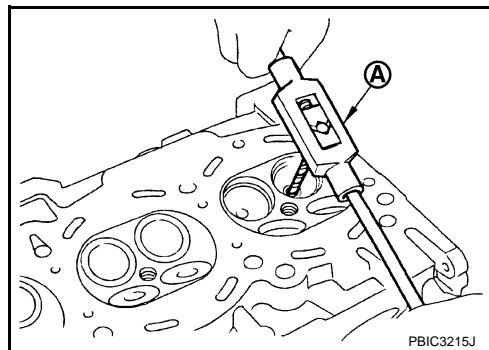

2. Install valve seat if removed.

**CAUTION:**

Replace with **oversize [0.5 mm (0.020 in)] valve seat.**

- a. Ream cylinder head (1) recess diameter for service valve seat.

2 : Valve seat

**For service parts** : **Oversize [0.5 mm (0.020 in)]**

Refer to [EM-115, "Cylinder Head"](#).

- Be sure to ream in circles concentric to the valve guide center. This will enable valve seat to fit correctly.

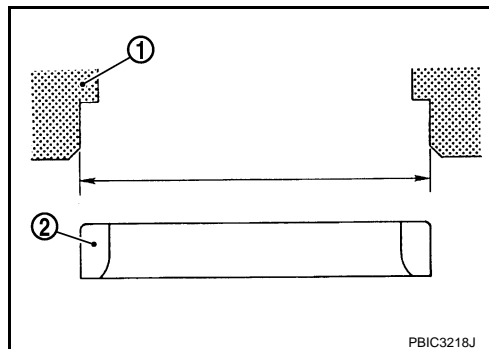

A  
EM  
C  
D  
E  
F  
G  
H  
I  
J  
K  
L  
M  
N  
O  
P

# CYLINDER HEAD

## < DISASSEMBLY AND ASSEMBLY >

- b. Heat cylinder head to 110 to 130°C (230 to 266°F) by soaking in heated oil (A).

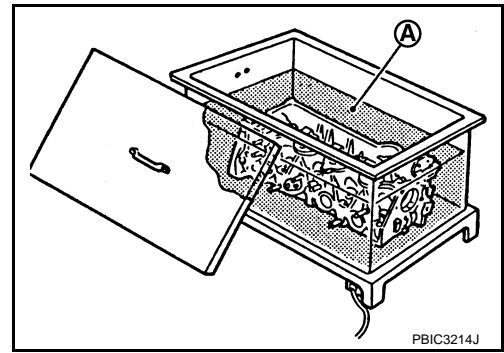

- c. Provide valve seats cooled well with dry ice. Press-fit valve seat into cylinder head.

**CAUTION:**

- Avoid directly touching cold valve seats.
- Cylinder head contains heat, when working, wear protective equipment to avoid getting burned.

- d. Using valve seat cutter set (commercial service tool) or valve seat grinder, finish valve seat to the specified dimensions. For dimensions, refer to [EM-115, "Cylinder Head"](#).

**CAUTION:**

When using valve seat cutter, firmly grip the cutter handle with both hands. Then, press on the contacting surface all around the circumference to cut in a single drive. Improper pressure on with the cutter or cutting many different times may result in stage valve seat.

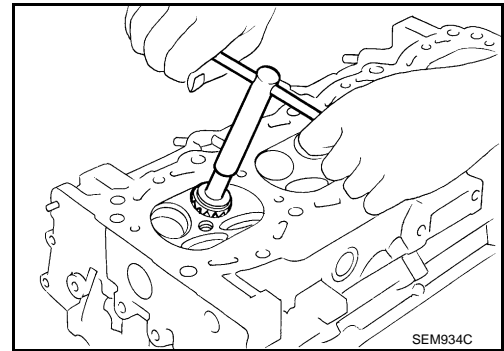

- e. Using compound, grind to adjust valve fitting.  
f. Check again for normal contact. Refer to [EM-85, "Inspection"](#).

3. Install valve oil seal.

- Install with a valve oil seal drift (SST) to match dimension in the figure.

**NOTE:**

Dimension "H" is height that measured before installing valve spring (with valve spring seat).

**Height "H" : 11.8 - 12.4 mm (0.465 - 0.488 in)**

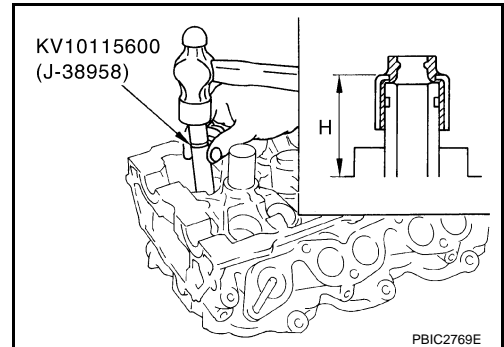

4. Install valve.  
• Install larger diameter to intake side.

5. Install valve spring (with valve spring seat).  
• Install smaller pitch (valve spring seat side) to cylinder head side.  
• Confirm identification color of valve spring.

**Intake : Pink**

**Exhaust : Yellowish green**

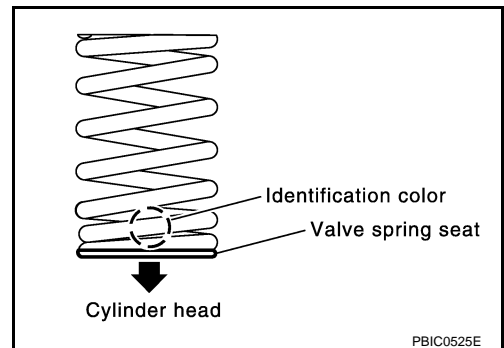

6. Install valve spring retainer.



# CYLINDER HEAD

## < DISASSEMBLY AND ASSEMBLY >

7. Install valve collet.
  - Compress valve spring with a valve spring compressor, attachment and adapter [SST: KV10116200 (J-26336-A)] (A). Install valve collet with a magnet hand (B).

**CAUTION:**

**When working, be careful not to damage valve lifter holes.**

- Tap valve stem edge lightly with a plastic hammer after installation to check its installed condition.

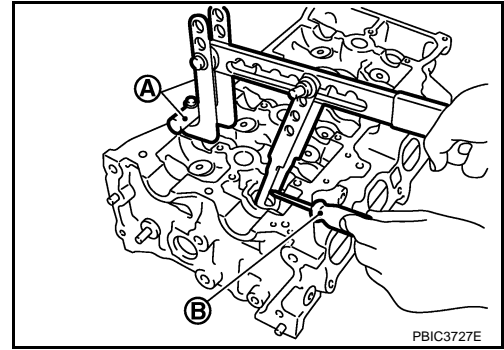

8. Install valve lifter.
  - Install it in the original position.
9. Install spark plug tube if removed.
  - Press-fit it into cylinder head with the following procedure:
    - a. Remove old thread locking sealant from cylinder head side installation hole.
    - b. Apply thread locking sealant all round on spark plug tube within approximately 12 mm (0.47 in) width from edge of spark plug tube on the press-fit side.  
**Use Genuine RTV Silicone Sealant or equivalent. Refer to GI-17. "Recommended Chemical Products and Sealants".**
    - c. Using a suitable tool, press-fit spark plug tube so that height is as same as "H" shown in the figure.

**Standard press-fit height "H":**

**41.2 - 42.2 mm (1.622 - 1.661 in)**

**CAUTION:**

- **When press-fitting, be careful not to deform spark plug tube.**
- **After press-fitting, wipe off any protruding thread locking sealant on top surface of cylinder head.**

10. Install spark plug with spark plug wrench (commercial service tool).

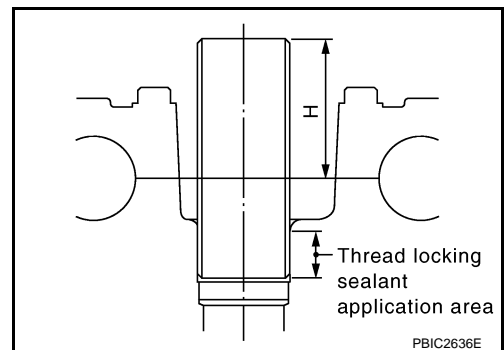

## Inspection

INFOID:000000004231450

### INSPECTION AFTER REMOVAL

#### Cylinder Head Bolts Outer Diameter

- Cylinder head bolts are tightened by plastic zone tightening method. Whenever the size difference between "A" and "B" exceeds the limit, replace them with new one.

c : 55.0 mm (2.165 in)

d : 12.0 mm (0.472 in)

**Limit ("B"-"A") : 0.23 mm (0.0091 in)**

- If reduction of outer diameter appears in a position other than "d2", use it as "d2" point.

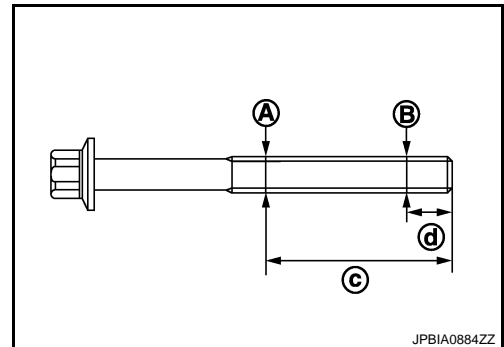

#### Cylinder Head Distortion

**NOTE:**

When performing this inspection, cylinder block distortion should be also checking. Refer to [EM-96. "Inspection"](#).

1. Using a scraper, wipe off oil, scale, gasket, sealant and carbon deposits from surface of cylinder head.

**CAUTION:**

**Never allow gasket fragments to enter engine oil or engine coolant passages.**

# CYLINDER HEAD

## < DISASSEMBLY AND ASSEMBLY >

2. At each of several locations on bottom surface of cylinder head, measure the distortion in six directions.

**Limit** : Refer to [EM-115, "Cylinder Head"](#).

- If it exceeds the limit, replace cylinder head.

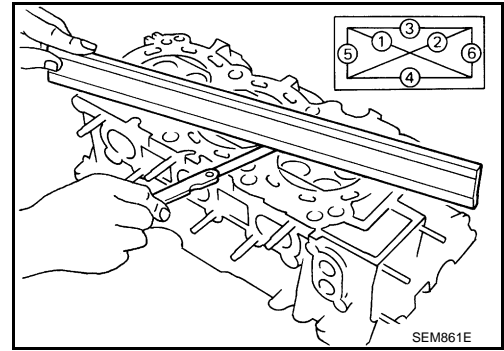

## VALVE DIMENSIONS

- Check dimensions of each valve. For dimensions, refer to [EM-115, "Cylinder Head"](#).
- If dimensions are out of the standard, replace valve.

## VALVE GUIDE CLEARANCE

Valve Stem Diameter

Measure the diameter of valve stem with a micrometer (A).

**Standard** : Refer to [EM-115, "Cylinder Head"](#).

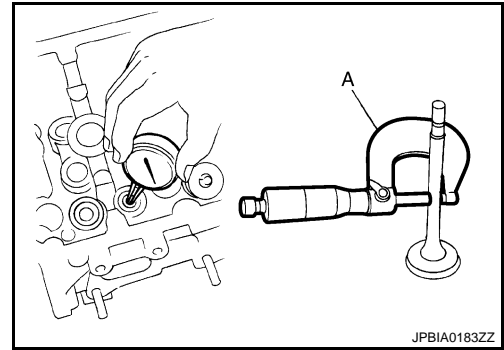

Valve Guide Inner Diameter

Measure the inner diameter of valve guide with a bore gauge.

**Standard** : Refer to [EM-115, "Cylinder Head"](#).

Valve Guide Clearance

(Valve guide clearance) = (Valve guide inner diameter) – (Valve stem diameter).

**Standard and Limit** : Refer to [EM-115, "Cylinder Head"](#).

- If it exceeds the limit, replace valve guide and/or valve. When valve guide must be replaced. Refer to [EM-81, "Disassembly and Assembly"](#).

## VALVE SEAT CONTACT

- After confirming that the dimensions of valve guides and valves are within specifications, perform this procedure.
- Apply prussian blue (or white lead) onto contacting surface of valve seat to check the condition of the valve contact on the surface.
- Check if the contact area band is continuous all around the circumference.
- If not, grind to adjust valve fitting and check again. If the contacting surface still has NG conditions (B) even after the recheck, replace valve seat. Refer to [EM-81, "Disassembly and Assembly"](#).

A : OK

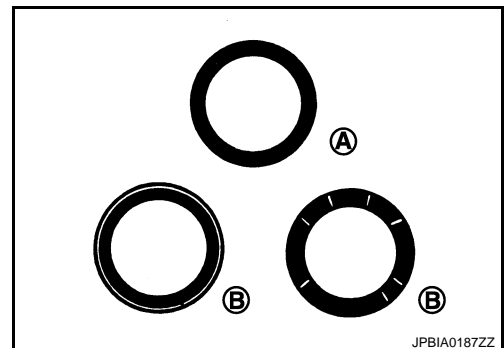

# CYLINDER HEAD

## < DISASSEMBLY AND ASSEMBLY >

### VALVE SPRING SQUARENESS

- Set try square (A) along the side of valve spring and rotate the spring. Measure the maximum clearance between the top of valve spring and try square.

B : Contact

**CAUTION:**

**Never remove valve spring seat from valve spring.**

**Limit** : Refer to [EM-115, "Cylinder Head"](#).

- If it exceeds the limit, replace valve spring (with valve spring seat).

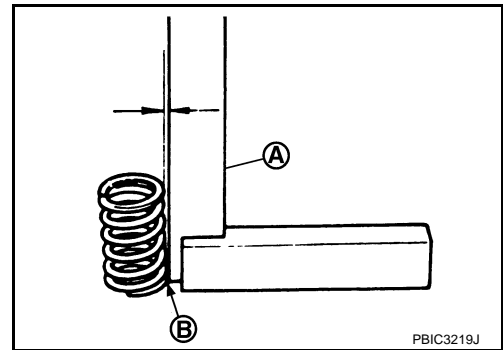

### VALVE SPRING DIMENSIONS AND VALVE SPRING PRESSURE LOAD

- Check valve spring pressure with valve spring seat installed at the specified spring height.

**CAUTION:**

**Never remove valve spring seat from valve spring.**

**Standard** : Refer to [EM-115, "Cylinder Head"](#).

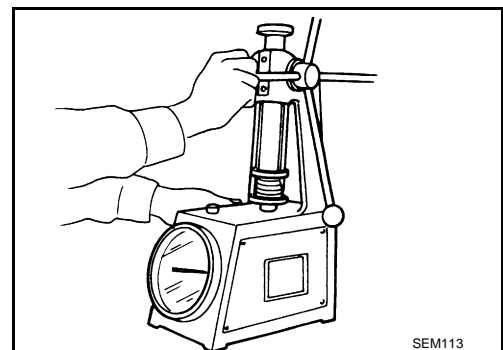

- If the installation load or load with valve open is out of the standard, replace valve spring (with valve spring seat).

### INSPECTION AFTER INSTALLATION

#### Inspection for Leakage

The following are procedures for checking fluids leakage, lubricates leakage, and exhaust gases leakage.

- Before starting engine, check oil/fluid levels including engine coolant and engine oil. If less than required quantity, fill to the specified level. Refer to [MA-17, "FOR NORTH AMERICA : Fluids and Lubricants"](#) (Except for Mexico) or [MA-18, "FOR MEXICO : Fluids and Lubricants"](#) (for Mexico).
- Use procedure below to check for fuel leakage.
  - Turn ignition switch "ON" (with engine stopped). With fuel pressure applied to fuel piping, check for fuel leakage at connection points.
  - Start engine. With engine speed increased, check again for fuel leakage at connection points.
- Run engine to check for unusual noise and vibration.
- Warm up engine thoroughly to check there is no leakage of fuel, exhaust gases, or any oil/fluids including engine oil and engine coolant.
- Bleed air from lines and hoses of applicable lines, such as in cooling system.
- After cooling down engine, again check oil/fluid levels including engine oil and engine coolant. Refill to the specified level, if necessary.

Summary of the inspection items:

Items	Before starting engine	Engine running	After engine stopped
Engine coolant	Level	Leakage	Level
Engine oil	Level	Leakage	Level
Other oils and fluid*	Level	Leakage	Level
Fuel	Leakage	Leakage	Leakage
Exhaust gases	—	Leakage	—

\*: Transmission/transaxle/CVT fluid, power steering fluid, brake fluid, etc.

# CYLINDER BLOCK

< DISASSEMBLY AND ASSEMBLY >

## CYLINDER BLOCK

Exploded View

INFOID:000000004231451

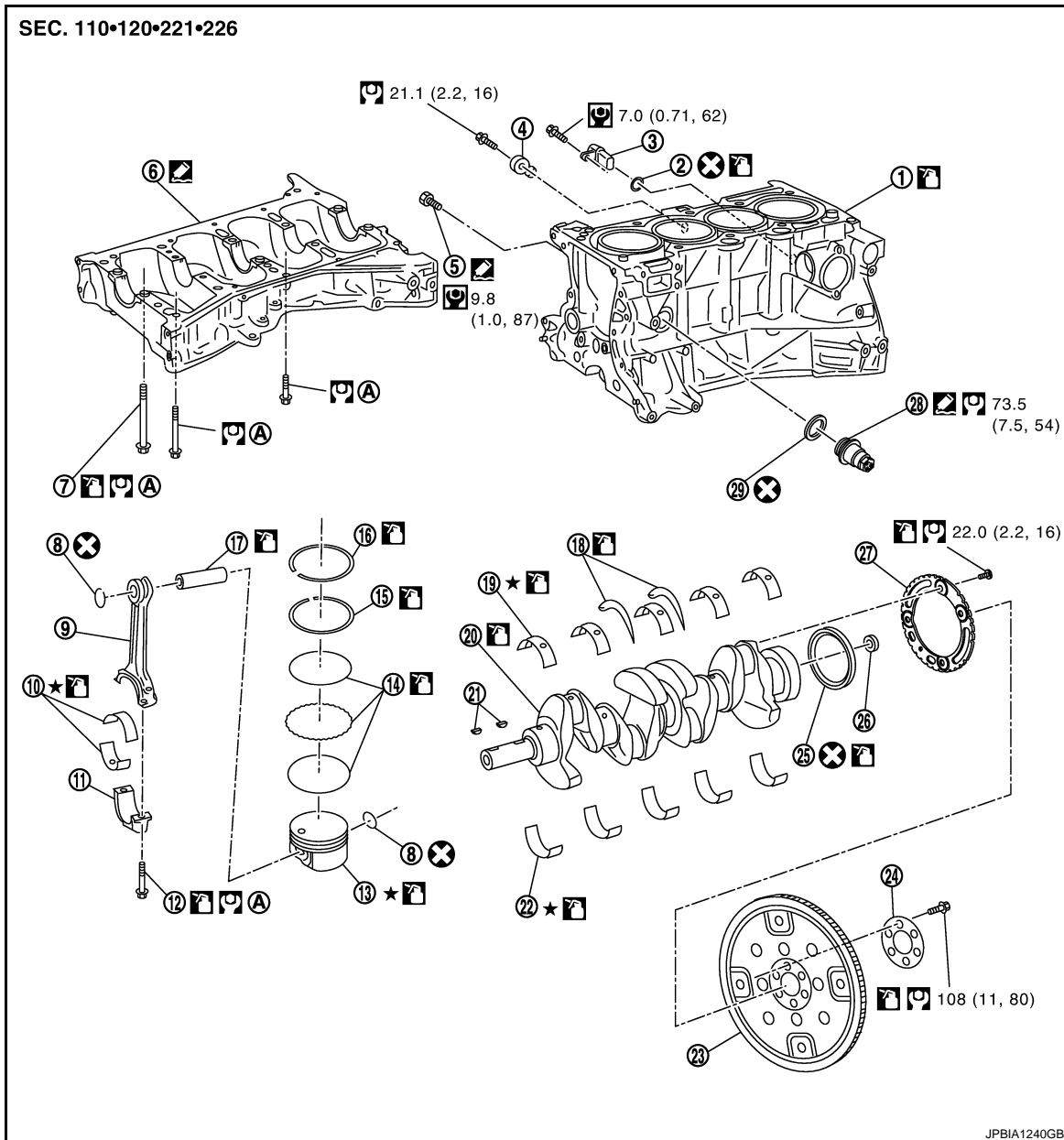

- |  |                                |                                     |
|--|--------------------------------|-------------------------------------|
| 1. Cylinder block                      | 2. O-ring                      | 3. Crankshaft position sensor (POS) |
| 4. Knock sensor                        | 5. Water drain plug            | 6. Lower cylinder block             |
| 7. Lower cylinder block mounting bolt  | 8. Snap ring                   | 9. Connecting rod                   |
| 10. Connecting rod bearing             | 11. Connecting rod bearing cap | 12. Connecting rod bolt             |
| 13. Piston                             | 14. Oil ring                   | 15. Second ring                     |
| 16. Top ring                           | 17. Piston pin                 | 18. Thrust bearing                  |
| 19. Main bearing (upper)               | 20. Crankshaft                 | 21. Crankshaft key                  |
| 22. Main bearing (lower)               | 23. Drive plate                | 24. Reinforcement plate             |
| 25. Rear oil seal                      | 26. Pilot converter            | 27. Signal plate                    |
| 28. Cylinder block heater (for Canada) | 29. O-ring (for Canada)        |                                     |

A. Refer to [EM-89](#)

Refer to [GI-4, "Components"](#) for symbols in the figure.

# CYLINDER BLOCK

< DISASSEMBLY AND ASSEMBLY >

## Disassembly and Assembly

INFOID:000000004231452

### DISASSEMBLY

1. Remove cylinder head. Refer to [EM-79, "Exploded View"](#).
2. Remove knock sensor.

**CAUTION:**

**Carefully handle knock sensor avoiding shocks.**

3. Remove crankshaft position sensor (POS).

**CAUTION:**

- Avoid impacts such as a dropping.
- Never disassemble.
- Keep it away from metal particles.
- Never place sensor in a location where it is exposed to magnetism.

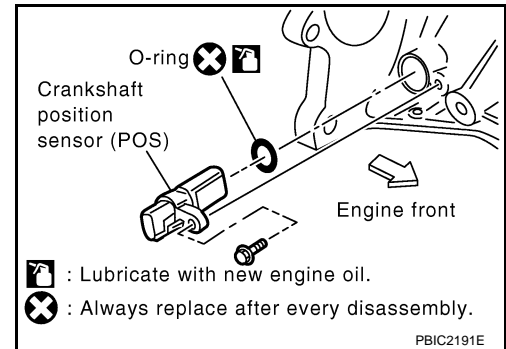

4. Remove piston and connecting rod assembly with the following procedure:
  - Before removing piston and connecting rod assembly, check the connecting rod side clearance. Refer to [EM-96, "Inspection"](#).
- a. Position crankshaft pin corresponding to connecting rod to be removed onto the bottom dead center.
- b. Remove connecting rod cap.
- c. Using a hammer handle or similar tool, push piston and connecting rod assembly out to the cylinder head side.

**CAUTION:**

**Be careful not to damage the cylinder wall, resulting from an interference of the connecting rod big end.**

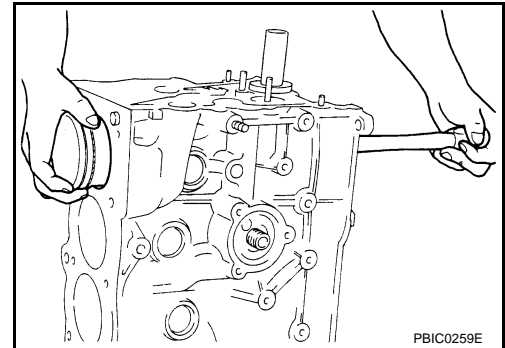

5. Remove connecting rod bearings.

**CAUTION:**

**When removing them, note the installation position. Keep them in the correct order.**

6. Remove piston rings from piston.
  - Use a piston ring expander (commercial service tool) (A).

**CAUTION:**

- When removing piston rings, be careful not to damage the piston.
- Be careful not to damage piston rings by expanding them excessively.

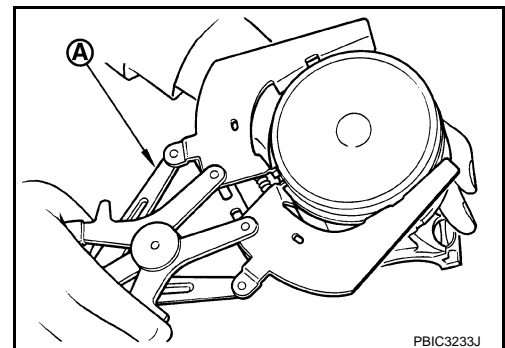

7. Remove piston from connecting rod with the following procedure:

## CYLINDER BLOCK

### < DISASSEMBLY AND ASSEMBLY >

- a. Using snap ring pliers (A), remove snap ring.

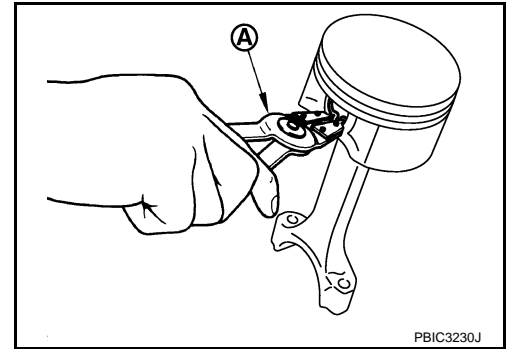

- b. Heat piston to 60 to 70°C (140 to 158°F) with an industrial use drier (A) or equivalent.

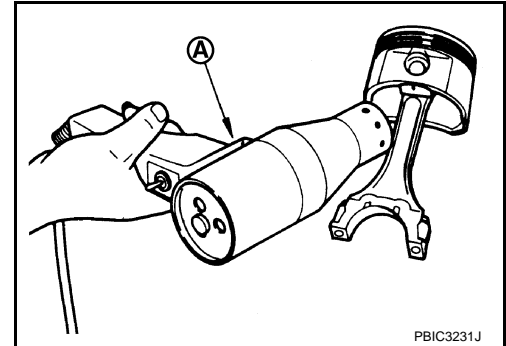

- c. Push out piston pin with stick of outer diameter approximately 19 mm (0.75 in).

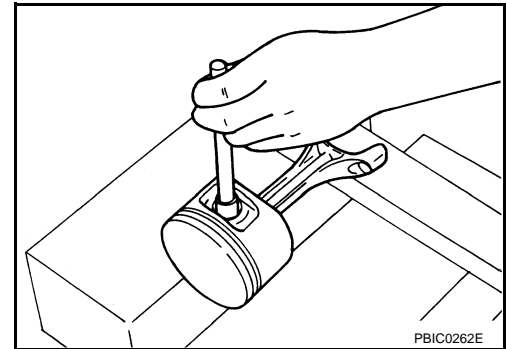

8. Remove lower cylinder block mounting bolts.
- Loosen them in the reverse order as shown in the figure, and remove them.
  - Use TORX socket (size E14) for bolts No. 1 to 10.
  - Before loosening lower cylinder block mounting bolts, measure crankshaft end play. Refer to [EM-96, "Inspection"](#).

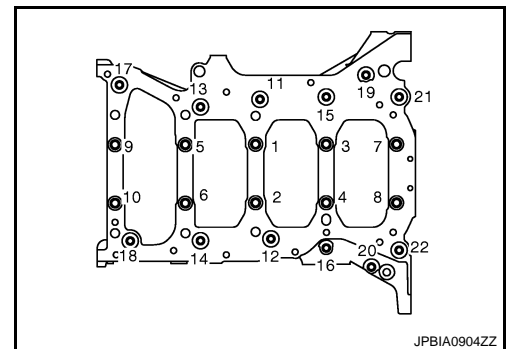

9. Remove lower cylinder block.
- Use a seal cutter [SST: KV10111100 (J-37228)] or equivalent tool to cut liquid gasket for removal.

**CAUTION:**

**Be careful not to damage the mounting surface.**

10. Remove crankshaft.

**CAUTION:**

# CYLINDER BLOCK

## < DISASSEMBLY AND ASSEMBLY >

- Be careful not damage or deform signal plate mounted on crankshaft.
- When setting crankshaft on a flat floor surface, use a block of wood to avoid interference between signal plate and the floor surface.
- Never remove signal plate unless it is necessary to do so.

**NOTE:**

When removing or installing signal plate, use TORX socket (size T30).

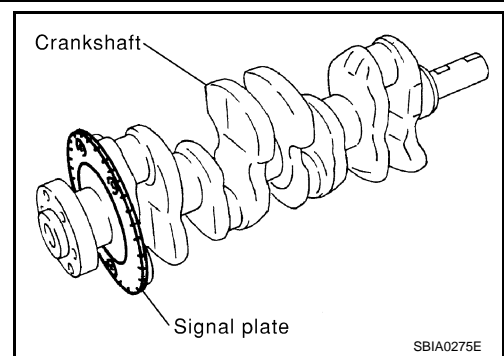

11. Pull rear oil seal out from rear end of crankshaft.

**NOTE:**

When replacing rear oil seal without removing lower cylinder block, use a screwdriver to pull it out from between crankshaft and cylinder block.

**CAUTION:**

Be careful not to damage crankshaft and cylinder block.

12. Remove main bearings and thrust bearings from cylinder block and lower cylinder block.

**CAUTION:**

Identify installation positions, and store them without mixing them up.

## ASSEMBLY

1. Fully air-blow engine coolant and engine oil passages in cylinder block, cylinder bore and crankcase to remove any foreign material.

**CAUTION:**

Use a goggle to protect your eye.

2. Install each plug to cylinder block as shown in the figure.

- Apply liquid gasket to the thread of water drain plug "A".

Use Genuine RTV Silicone Sealant or equivalent. Refer to [GI-17. "Recommended Chemical Products and Sealants"](#).

**NOTE:**

Do not apply liquid gasket to the thread of plug "B".

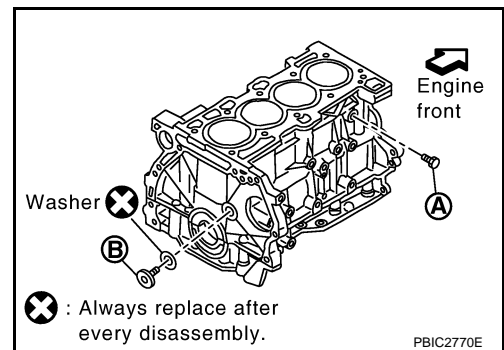

- Tighten each plug as specified below.

Part	Washer	Tightening torque
A	No	9.8 N·m (1.0 kg·m, 87 in·lb)
B	Yes	53.9 N·m (5.5 kg·m, 40 ft·lb)

3. Install oil jet.

- Insert oil jet dowel pin (A) into cylinder block dowel pin hole, and tighten mounting bolts.

← : Engine front

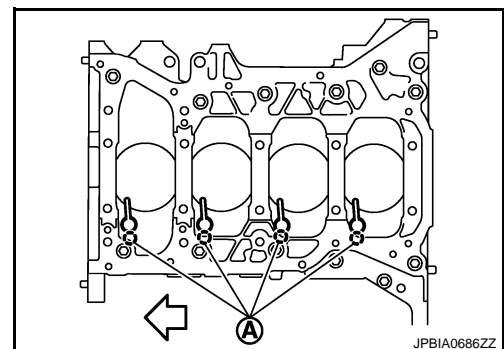

4. Install main bearings and thrust bearings with the following procedure:

- a. Remove dust, dirt, and engine oil on the bearing mating surfaces of cylinder block and lower cylinder block.



# CYLINDER BLOCK

## < DISASSEMBLY AND ASSEMBLY >

- b. Install thrust bearings to the both sides of the No. 3 journal housing on cylinder block.
- Install thrust bearings with the oil groove facing crankshaft arm (outside).

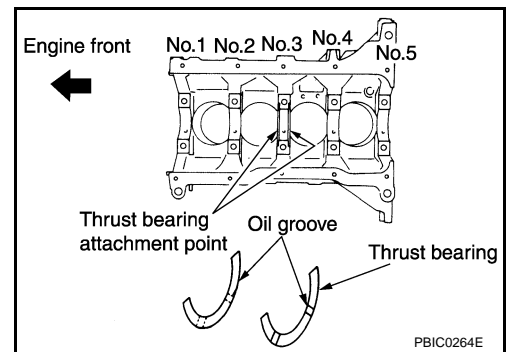

- c. Install the main bearings paying attention to the direction.
- Main bearing with an oil hole and groove goes on cylinder block. The one without them goes on lower cylinder block.
  - Only main bearing (on cylinder block) for No. 3 journal has different specifications.
  - Before installing main bearings, apply new engine oil to the bearing surface (inside). Do not apply new engine oil to the back surface, but thoroughly clean it.
  - When installing, align main bearing stopper to the notch.
  - Ensure the oil holes on cylinder block and those on the corresponding bearing are aligned.

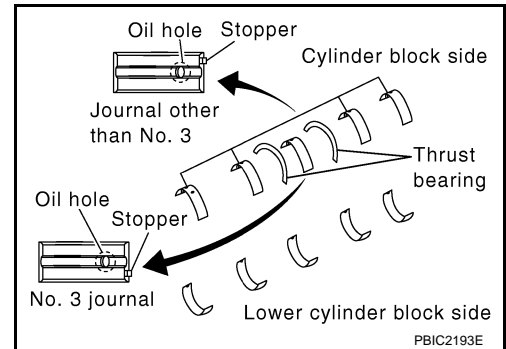

5. Install signal plate to crankshaft if removed.
- a. Position crankshaft and signal plate using a dowel pin, and tighten mounting bolts.

- 1 : Signal plate
- 2 : Crankshaft
- A : Dowel pin (used to position the signal plate)

- b. Remove dowel pin.

**CAUTION:**

**Be sure to remove dowel pin.**

**NOTE:**

Dowel pin of crankshaft and signal plate is provided as a set for each. If dowel pin is not available (when reusing crankshaft and signal), use M6 bolt [length 10 mm (0.39 in) or more] as a substitute.

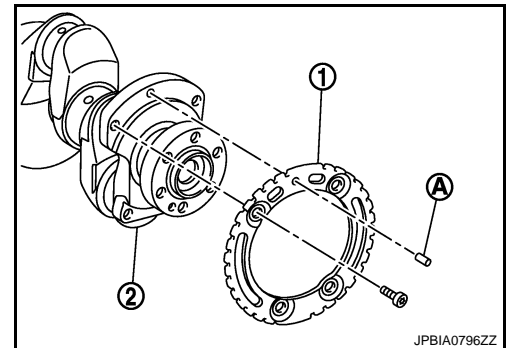

6. Install crankshaft to cylinder block.
- While turning crankshaft by hand, check that it turns smoothly.
7. Install lower cylinder block with the following procedure:

- a. Apply liquid gasket with a tube presser (commercial service tool) to lower cylinder block as shown in the figure.

- B : Apply liquid gasket to an end
- a :  $\phi 3.5 - 4.0$  mm (0.138 - 0.157 in)

**Use Genuine RTV Silicone Sealant or equivalent. Refer to [GI-17, "Recommended Chemical Products and Sealants"](#).**

**CAUTION:**

**After liquid gasket is applied, rear oil seal installation must be finished within 5 minutes. Therefore, the following procedure must be performed quickly.**

**NOTE:**

Lower cylinder block cannot be replaced as a single part, because it is machined together with cylinder block.

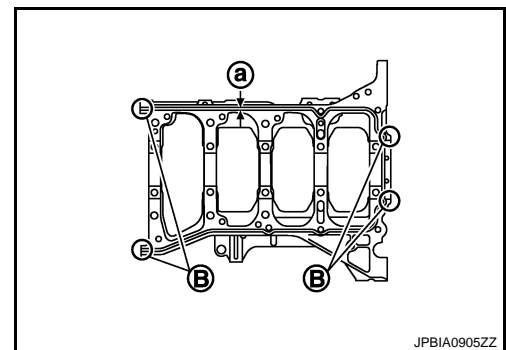

- b. Tighten lower cylinder block mounting bolts with the following procedure:



# CYLINDER BLOCK

## < DISASSEMBLY AND ASSEMBLY >

- i. Apply new engine oil to threads and seat surfaces of mounting bolts.
- ii. Tighten M8 bolts in numerical order from No. 11 to 22 in the figure.

 : 25.1 N·m (2.6 kg·m, 19 ft·lb)

### NOTE:

There are more processes to complete the tightening of mounting bolts. However stop procedure here to install rear oil seal.

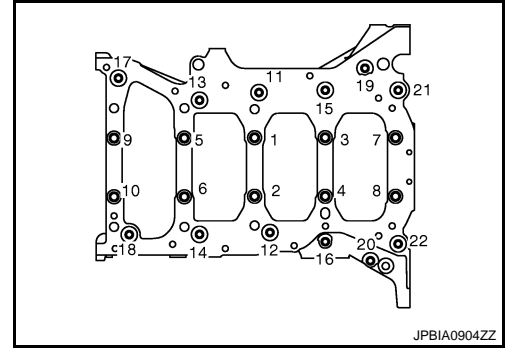

- c. Install rear oil seal. Refer to [EM-59. "REAR OIL SEAL : Removal and Installation"](#).
- d. Restart tightening of lower cylinder block mounting bolts with the following procedure:
  - i. Tighten M10 bolts in numerical order from No. 1 to 10.

 : 39.2 N·m (4.0 kg·m, 29 ft·lb)

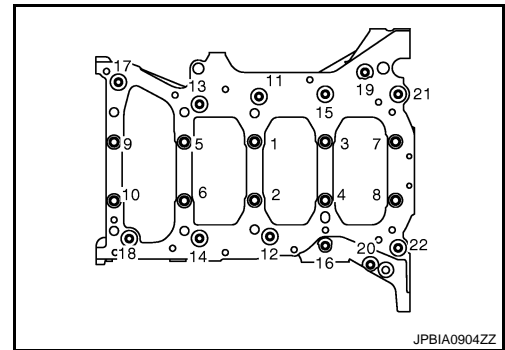

- ii. Turn M10 bolts 60 degrees clockwise (angle tightening) in order from No. 1 to 10 in the figure.

### CAUTION:

Check and confirm the tightening angle by using an angle wrench [SST: KV10112100 (BT8653-A)] (A) or protractor. Avoid judgment by visual inspection without the tool.

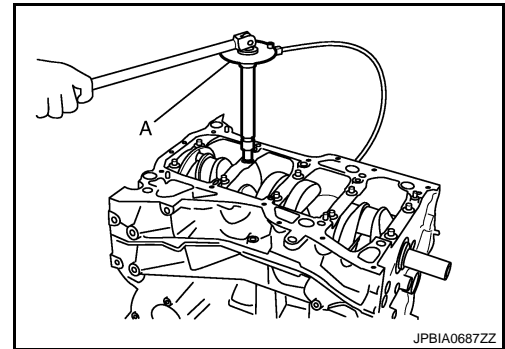

- After installing mounting bolts, check that crankshaft can be rotated smoothly by hand.
  - Wipe off completely any protruding liquid gasket on front side of engine.
  - Check crankshaft end play. Refer to [EM-96. "Inspection"](#).
8. Install piston to connecting rod with the following procedure:
    - a. Using snap ring pliers, install new snap ring to the groove of the piston rear side.
      - Insert it fully into groove to install.
    - b. Assemble piston to connecting rod.
      - Using an industrial use drier or similar tool, heat the piston until the piston pin can be pushed in by hand without excess force [approximately 60 to 70°C (140 to 158°F)]. From the front to the rear, insert piston pin into piston and connecting rod.

# CYLINDER BLOCK

## < DISASSEMBLY AND ASSEMBLY >

- Assemble so that the front mark on the piston head and the oil holes and the cylinder number on connecting rod are positioned as shown in the figure.
- c. Install new snap ring to the groove of the piston front side.
- Insert it fully into groove to install.
  - After installing, check that connecting rod moves smoothly.

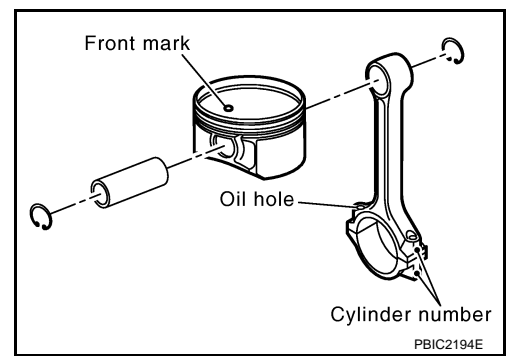

9. Using a piston ring expander (commercial service tool), install piston rings.

### CAUTION:

#### Be careful not to damage piston.

- Position each ring with the gap as shown in the figure referring to the piston front mark.
- Install second ring with the stamped surface facing upward.

#### Stamped mark:

Top ring : —  
Second ring : 2 K

#### NOTE:

If there is no stamped mark on piston ring, no specific orientation is required for installation.

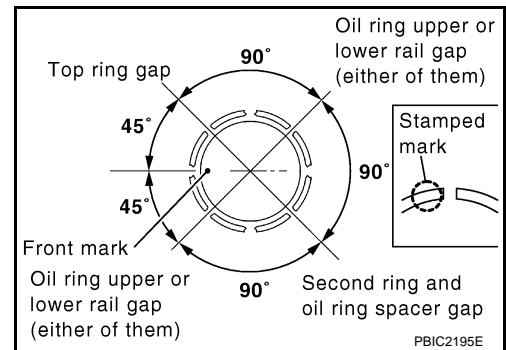

10. Install connecting rod bearings to connecting rod and connecting rod cap.

- When installing connecting rod bearings, apply new engine oil to the bearing surface (inside). Do not apply new engine oil to the back surface, but thoroughly clean it.
- When installing, align the connecting rod bearing stopper protrusion with the cutout of connecting rod and connecting rod cap to install.
- Ensure the oil hole on connecting rod and that on the corresponding bearing are aligned.

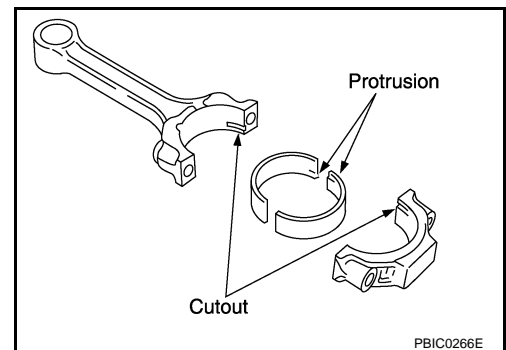

11. Install piston and connecting rod assembly to crankshaft.

- Position crankshaft pin corresponding to connecting rod to be installed onto the bottom dead center.
- Apply new engine oil sufficiently to the cylinder bore, piston and crankshaft pin.
- Match the cylinder position with the cylinder number on connecting rod to install.
- Using a piston ring compressor [SST: EM03470000 (J-8037)] (A) or suitable tool, install piston with the front mark on the piston head facing the front of the engine.

### CAUTION:

Be careful not to damage the cylinder wall and crankshaft pin, resulting from an interference of the connecting rod big end.

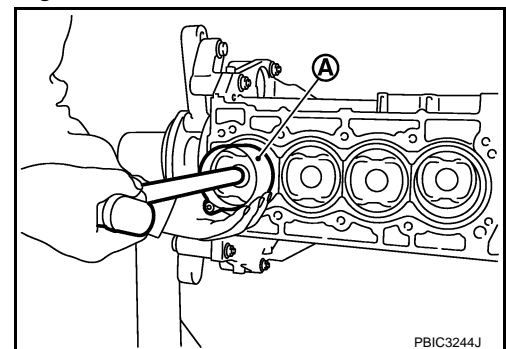

# CYLINDER BLOCK

## < DISASSEMBLY AND ASSEMBLY >

12. Install connecting rod cap.
- Match the stamped cylinder number marks on connecting rod with those on connecting rod cap to install.

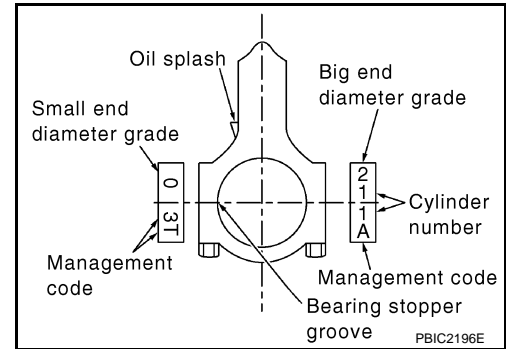

13. Tighten connecting rod bolt with the following procedure:
- Apply new engine oil to the threads and seats of connecting rod bolts.
  - Tighten bolts.

 : 27.4 N·m (2.8 kg-m, 20 ft-lb)

- Completely loosen bolts.

 : 0 N·m (0 kg-m, 0 ft-lb)

- Tighten bolts.

 : 19.6 N·m (2.0 kg-m, 14 ft-lb)

- Then turn all bolts 90 degrees clockwise (angle tightening).

**CAUTION:**

Check and confirm the tightening angle by using an angle wrench [SST: KV10112100 (BT8653-A)] (A) or protractor. Avoid judgment by visual inspection without the tool.

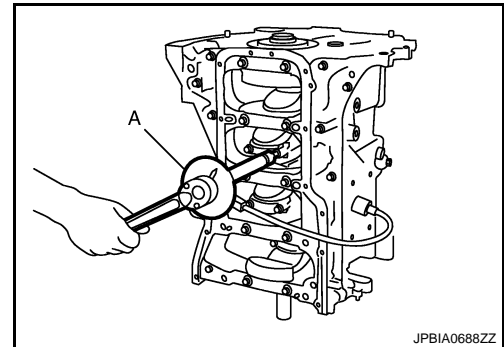

- After tightening connecting rod bolts, check that crankshaft rotates smoothly.
- Check the connecting rod side clearance. Refer to [EM-96, "Inspection"](#).

14. Install drive plate.

**CAUTION:**

Check that dowel pin is installed at the rear end of crankshaft.

- When installing drive plate to crankshaft, check that align crankshaft side dowel pin with drive plate side dowel pin hole correctly.

**CAUTION:**

If these are not aligned correctly, engine runs roughly and "MIL" turns on.

- Secure crankshaft with a stopper plate, and tighten mounting bolts crosswise over several times.

# CYLINDER BLOCK

## < DISASSEMBLY AND ASSEMBLY >

- Install drive plate (1), reinforcement plate (2) and pilot converter (3) as shown in the figure.

A : Crankshaft rear end  
B : Rounded  
C : Chamfered

- Using a suitable tool of 33 mm (1.30 in) in diameter, press-fit pilot converter into the end of crankshaft until it stops.

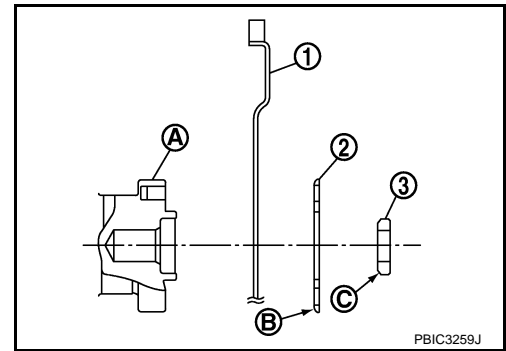

### 15. Install knock sensor.

- Install knock sensor with harness connector facing lower left as shown in the figure.

#### **CAUTION:**

- **Never tighten mounting bolts while holding the harness connector.**
- **If any impact by dropping is applied to knock sensor, replace it with a new one.**

#### **NOTE:**

- Check that there is no foreign material on the cylinder block mating surface and the back surface of knock sensor.
- Check that knock sensor does not interfere with other parts.

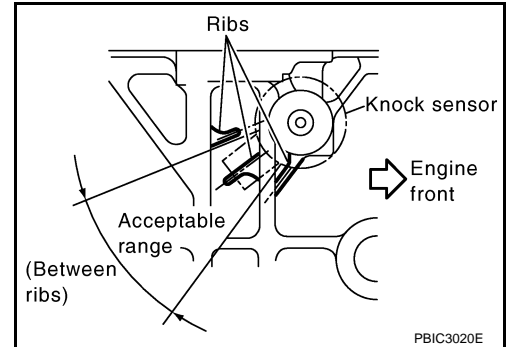

### 16. Install crankshaft position sensor (POS).

### 17. Assemble in the reverse order of disassembly after this step.

## Inspection

INFOID:000000004231453

### CRANKSHAFT END PLAY

- Measure the clearance between thrust bearings and crankshaft arm when crankshaft is moved fully forward or backward with a dial indicator (A).

**Standard and Limit : Refer to [EM-117, "Cylinder Block"](#).**

- If the measured value exceeds the limit, replace thrust bearings, and measure again. If it still exceeds the limit, replace crankshaft also.

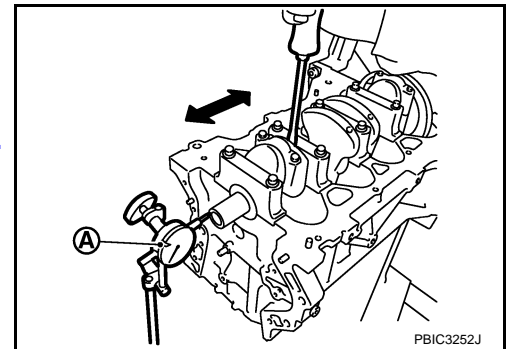

### CONNECTING ROD SIDE CLEARANCE

- Measure the side clearance between connecting rod and crankshaft arm with a feeler gauge (A).

**Standard and Limit : Refer to [EM-117, "Cylinder Block"](#).**

- If the measured value exceeds the limit, replace connecting rod, and measure again. If it still exceeds the limit, replace crankshaft also.

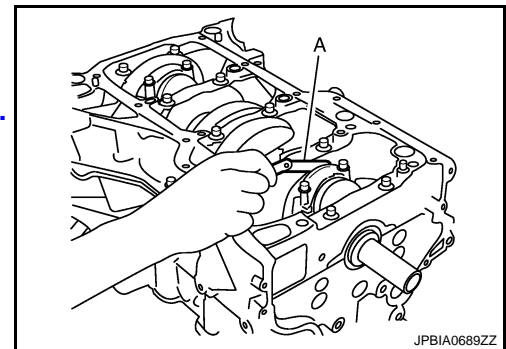

### PISTON TO PISTON PIN OIL CLEARANCE

Piston Pin Hole Diameter

# CYLINDER BLOCK

## < DISASSEMBLY AND ASSEMBLY >

Measure the inner diameter of piston pin hole with an inside micrometer (A).

**Standard** : Refer to [EM-117, "Cylinder Block"](#).

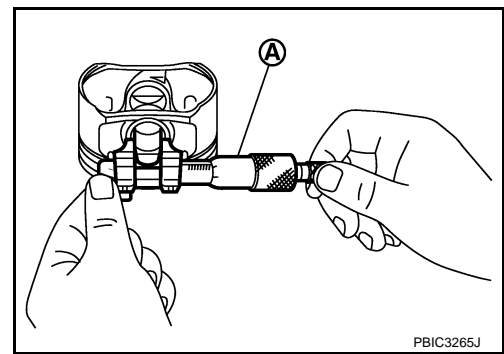

Piston Pin Outer Diameter

Measure the outer diameter of piston pin with a micrometer (A).

**Standard** : Refer to [EM-117, "Cylinder Block"](#).

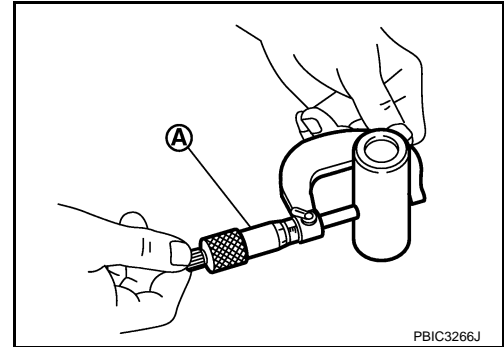

Piston to Piston Pin Oil Clearance

(Piston to piston pin oil clearance) = (Piston pin hole diameter) – (Piston pin outer diameter)

**Standard** : Refer to [EM-117, "Cylinder Block"](#).

- If oil clearance is out of the standard, replace piston and piston pin assembly.
- When replacing piston and piston pin assembly, refer to [EM-105, "Piston"](#).

### NOTE:

- Piston is available together with piston pin as assembly.
- Piston pin (piston pin hole) grade is provided only for the parts installed at the plant. For service parts, no grades can be selected. (Only grade "0" is available.)

## PISTON RING SIDE CLEARANCE

- Measure the side clearance of piston ring and piston ring groove with a feeler gauge.

**Standard and Limit** : Refer to [EM-117, "Cylinder Block"](#).

- If the measured value exceeds the limit, replace piston ring, and measure again. If it still exceeds the limit, replace piston also.

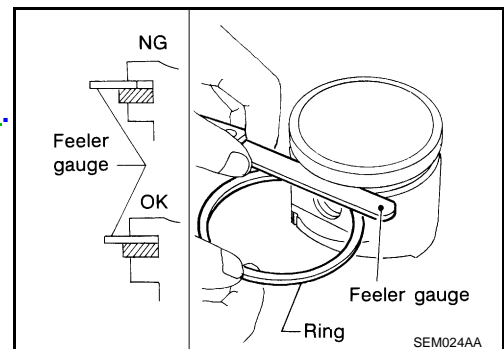

## PISTON RING END GAP

- Check that cylinder bore inner diameter is within specification. Refer to "Cylinder Bore Inner Diameter".

# CYLINDER BLOCK

## < DISASSEMBLY AND ASSEMBLY >

- Lubricate with new engine oil to piston (1) and piston ring (2), and then insert (A) piston ring until middle of cylinder (B) with piston, and measure piston ring end gap with a feeler gauge (C).

**Standard and Limit** : Refer to [EM-117, "Cylinder Block"](#).

- If the measured value exceeds the limit, replace piston ring, and measure again. If it still exceeds the limit, rebore cylinder and use oversized piston and piston rings.

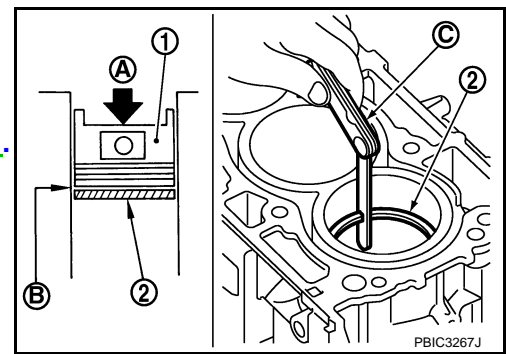

## CONNECTING ROD BEND AND TORSION

- Check with a connecting rod aligner.

A : Bend  
B : Torsion  
C : Feeler gauge

**Bend and Torsion** : Refer to [EM-117, "Cylinder Block"](#).

- If it exceeds the limit, replace connecting rod assembly.

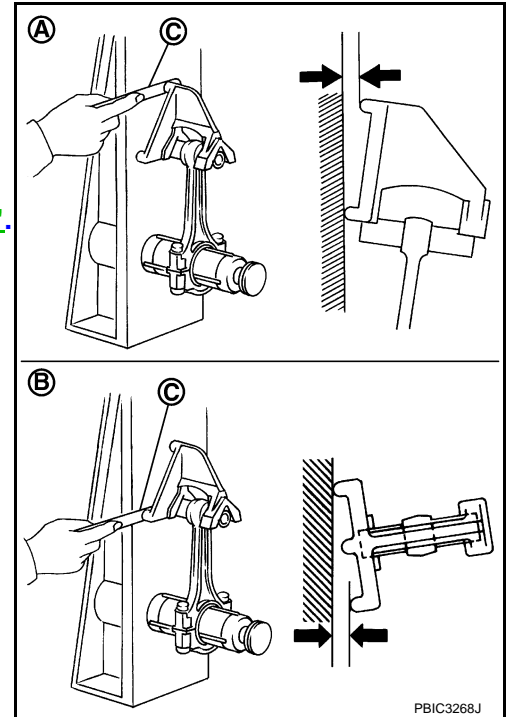

## CONNECTING ROD BIG END DIAMETER

- Install connecting rod cap (1) without connecting rod bearing installed, and tightening connecting rod bolts to the specified torque. Refer to [EM-89, "Disassembly and Assembly"](#) for the tightening procedure.

2 : Connecting rod  
A : Example  
B : Measuring direction of inner diameter

- Measure the inner diameter of connecting rod big end with an inside micrometer.

**Standard** : Refer to [EM-117, "Cylinder Block"](#).

- If out of the standard, replace connecting rod assembly.

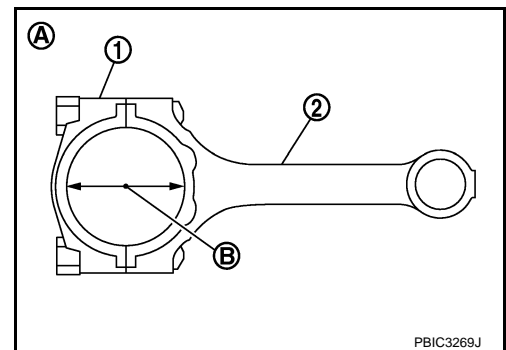

## CONNECTING ROD BUSHING OIL CLEARANCE

Connecting Rod Bushing Inner Diameter

# CYLINDER BLOCK

## < DISASSEMBLY AND ASSEMBLY >

Measure the inner diameter of connecting rod bushing with an inside micrometer (A).

**Standard** : Refer to [EM-117, "Cylinder Block"](#).

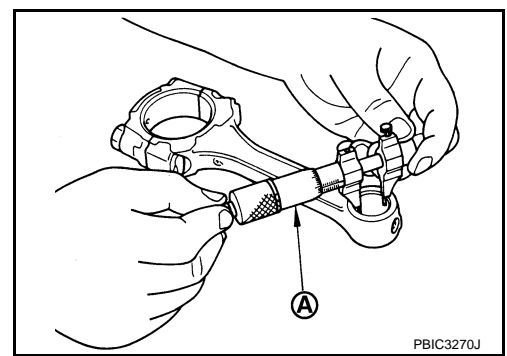

Piston Pin Outer Diameter

Measure the outer diameter of piston pin with a micrometer (A).

**Standard** : Refer to [EM-117, "Cylinder Block"](#).

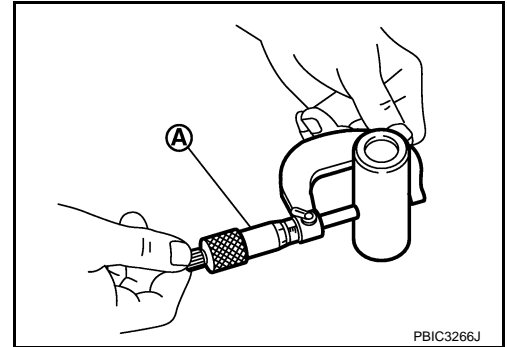

Connecting Rod Bushing Oil Clearance

(Connecting rod bushing oil clearance) = (Connecting rod bushing inner diameter) – (Piston pin outer diameter)

**Standard** : Refer to [EM-117, "Cylinder Block"](#).

- If the measured value is out of the standard. Replace connecting rod assembly and/or piston and piston pin assembly.
- If replacing piston and piston pin assembly. Refer to [EM-105, "Piston"](#).
- If replacing connecting rod assembly. Refer to [EM-106, "Connecting Rod Bearing"](#) to select connecting rod bearing.

## CYLINDER BLOCK DISTORTION

- Using a scraper, remove gasket on the cylinder block surface, and also remove engine oil, scale, carbon, or other contamination.

### CAUTION:

**Be careful not to allow gasket flakes to enter engine oil or engine coolant passages.**

- Measure the distortion on the cylinder block upper face at some different points in six directions with a straight edge (A) and feeler gauge (B).

**Limit** : Refer to [EM-117, "Cylinder Block"](#).

- If it exceeds the limit, replace cylinder block.

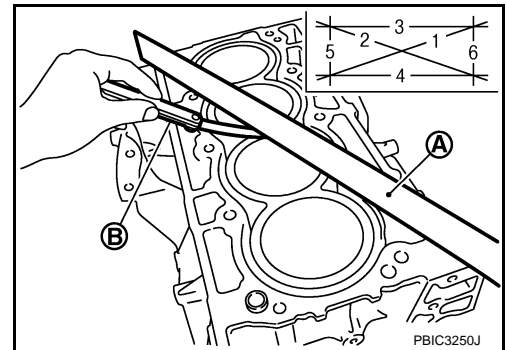

## MAIN BEARING HOUSING INNER DIAMETER

- Install lower cylinder block without main bearings installed, and tighten lower cylinder block mounting bolts to the specified torque. Refer to [EM-89, "Disassembly and Assembly"](#) for the tightening procedure.



# CYLINDER BLOCK

## < DISASSEMBLY AND ASSEMBLY >

- Measure the inner diameter of main bearing housing with a bore gauge.

**Standard** : Refer to [EM-117, "Cylinder Block"](#).

- If out of the standard, replace cylinder block (1) and lower cylinder block (2) assembly.

**NOTE:**

Cylinder block cannot be replaced as a single, because it is machined together with lower cylinder block.

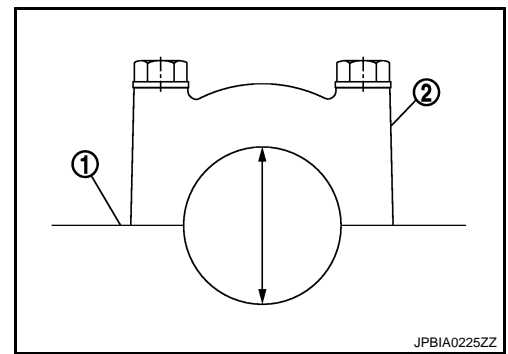

JPBIA0225ZZ

## PISTON TO CYLINDER BORE CLEARANCE

### Cylinder Bore Inner Diameter

- Using a bore gauge, measure the cylinder bore for wear, out-of-round and taper at six different points on each cylinder. ("X" and "Y" directions at "A", "B" and "C") ("Y" is in longitudinal direction of engine)

**NOTE:**

When determining cylinder bore grade, measure the cylinder bore at "B" position.

**Standard:**

**Cylinder bore inner diameter**

: Refer to [EM-117, "Cylinder Block"](#).

**Limit:**

**Out-of-round (Difference between "X" and "Y")**

**Taper (Difference between "A" and "B")**

: Refer to [EM-117, "Cylinder Block"](#).

- If the measured value exceeds the limit, or if there are scratches and/or seizure on the cylinder inner wall, hone or re-bore the cylinder inner wall.
- Oversize piston is provided. When using oversize piston, rebore the cylinder so that the clearance of the piston to cylinder bore satisfies the standard.

**CAUTION:**

**When using oversize piston, use it for all cylinders with oversize piston rings.**

**Oversize (O/S): 0.2 mm (0.008 in)**

### Piston Skirt Diameter

Measure the outer diameter of piston skirt with a micrometer (A).

**Standard** : Refer to [EM-117, "Cylinder Block"](#).

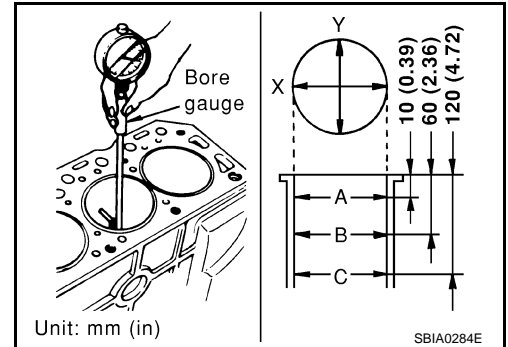

Unit: mm (in)

SBIA0284E

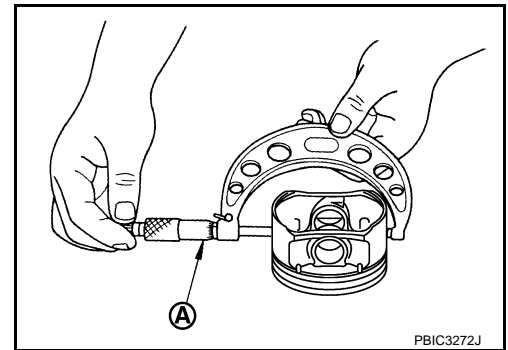

PBIC3272J

### Piston to Cylinder Bore Clearance



# CYLINDER BLOCK

## < DISASSEMBLY AND ASSEMBLY >

Calculate by piston skirt diameter and cylinder bore inner diameter (direction "X", position "B").  
(Clearance) = (Cylinder bore inner diameter) – (Piston skirt diameter)

**Standard and Limit** : Refer to [EM-117, "Cylinder Block"](#).

- If it exceeds the limit, replace piston and piston pin assembly. Refer to [EM-105, "Piston"](#).

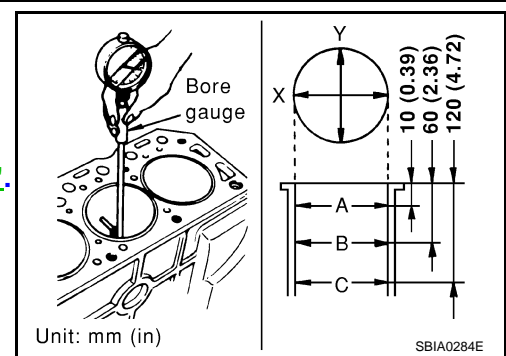

## Reboring Cylinder Bore

1. Cylinder bore size is determined by adding piston to cylinder bore clearance to piston skirt diameter.

**Rebored size calculation:  $D = A + B - C$**

**where,**

**A: Piston diameter as measured**

**B: Piston - to - cylinder bore clearance (standard value)**

**C: Honing allowance 0.02 mm (0.0008 in)**

**D: Bored diameter**

2. Install lower cylinder block, and tighten mounting bolts to the specified torque. Otherwise, cylinder bores may be distorted in final assembly. Refer to [EM-89, "Disassembly and Assembly"](#) for the tightening procedure.

3. Cut cylinder bores.

### NOTE:

- When any cylinder needs boring, all other cylinders must also be bored.
- Do not cut too much out of cylinder bore at a time. Cut only 0.05 mm (0.0020 in) or so in diameter at a time.

4. Hone cylinders to obtain specified piston to cylinder bore clearance.

5. Measure the finished cylinder bore for out-of-round and taper.

### NOTE:

Measurement should be done after cylinder bore cools down.

## CRANKSHAFT MAIN JOURNAL DIAMETER

- Measure the outer diameter of crankshaft main journals with a micrometer (A).

**Standard** : Refer to [EM-117, "Cylinder Block"](#).

- If out of the standard, measure the main bearing oil clearance. Then use undersize bearing. Refer to [EM-108, "Main Bearing"](#).

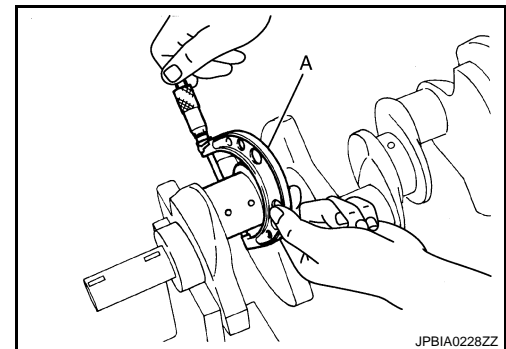

## CRANKSHAFT PIN JOURNAL DIAMETER

- Measure the outer diameter of crankshaft pin journal with a micrometer.

**Standard** : Refer to [EM-117, "Cylinder Block"](#).

- If out of the standard, measure the connecting rod bearing oil clearance. Then use undersize bearing. Refer to [EM-106, "Connecting Rod Bearing"](#).

## OUT-OF-ROUND AND TAPER OF CRANKSHAFT

# CYLINDER BLOCK

## < DISASSEMBLY AND ASSEMBLY >

- Measure the dimensions at four different points as shown in the figure on each main journal and pin journal with a micrometer.
- Out-of-round is indicated by the difference in dimensions between "X" and "Y" at "A" and "B".
- Taper is indicated by the difference in dimension between "A" and "B" at "X" and "Y".

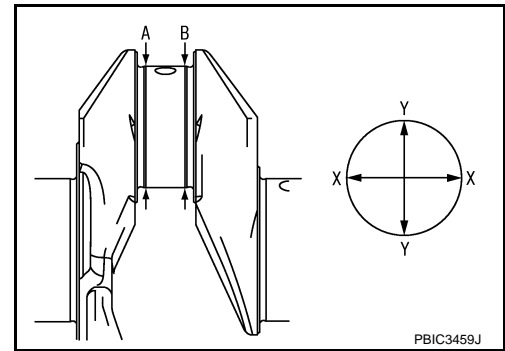

### Limit:

**Out-of-round (Difference between "X" and "Y")**

**Taper (Difference between "A" and "B")**

: Refer to [EM-117, "Cylinder Block"](#).

- If the measured value exceeds the limit, correct or replace crankshaft.
- If corrected, measure the bearing oil clearance of the corrected main journal and/or pin journal. Then select main bearing and/or connecting rod bearing. Refer to [EM-122, "Connecting Rod Bearing"](#) and/or [EM-121, "Main Bearing"](#).

## CRANKSHAFT RUNOUT

- Place a V-block on a precise flat table to support the journals on the both end of the crankshaft.
- Place a dial indicator straight up on the No. 3 journal.
- While rotating crankshaft, read the movement of the pointer on the dial indicator. (Total indicator reading)

**Limit** : Refer to [EM-117, "Cylinder Block"](#).

- If it exceeds the limit, replace crankshaft.

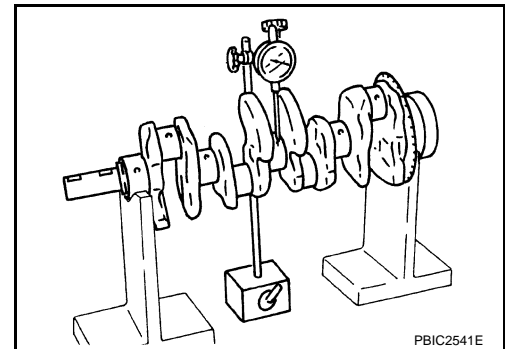

## CONNECTING ROD BEARING OIL CLEARANCE

### Method by Calculation

- Install connecting rod bearings (2) to connecting rod (3) and cap, and tighten connecting rod bolts to the specified torque. Refer to [EM-89, "Disassembly and Assembly"](#) for tightening procedure.

- 1 : Connecting rod bearing cap
- A : Example
- B : Inner diameter measuring direction

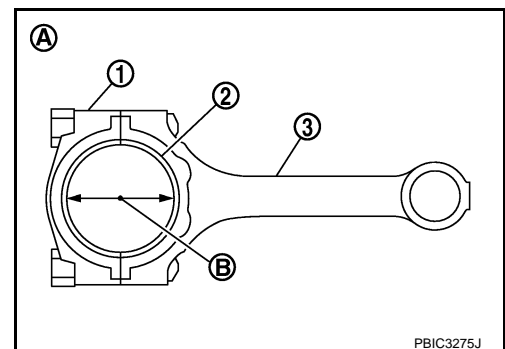

- Measure the inner diameter of connecting rod bearing with an inside micrometer.  
(Bearing oil clearance) = (Connecting rod bearing inner diameter) – (Crankshaft pin journal diameter)

**Standard and Limit** : Refer to [EM-122, "Connecting Rod Bearing"](#).

- If clearance exceeds the limit, select proper connecting rod bearing according to connecting rod big end diameter and crankshaft pin journal diameter to obtain specified bearing oil clearance. Refer to [EM-106, "Connecting Rod Bearing"](#).

### Method of Using Plastigage

- Remove engine oil and dust on crankshaft pin and the surfaces of each bearing completely.
- Cut a plastigage slightly shorter than the bearing width, and place it in crankshaft axial direction, avoiding oil holes.
- Install connecting rod bearings to connecting rod and cap, and tighten connecting rod bolts to the specified torque. Refer to [EM-89, "Disassembly and Assembly"](#) for the tightening procedure.

# CYLINDER BLOCK

## < DISASSEMBLY AND ASSEMBLY >

### CAUTION:

#### Never rotate crankshaft.

- Remove connecting rod cap and bearing, and using the scale on the plastigage bag, measure the plastigage width.

### NOTE:

The procedure when the measured value exceeds the limit is same as that described in the "Method by Calculation".

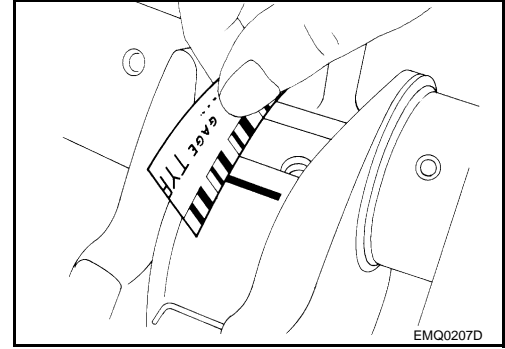

## MAIN BEARING OIL CLEARANCE

### Method by Calculation

- Install main bearings (3) to cylinder block (1) and lower cylinder block (2), and tighten lower cylinder block mounting bolts to the specified torque. Refer to [EM-89, "Disassembly and Assembly"](#) for the tightening procedure.

A : Example

B : Inner diameter measuring direction

- Measure the inner diameter of main bearing with a bore gauge.  
(Bearing oil clearance) = (Main bearing inner diameter) – (Crankshaft main journal diameter)

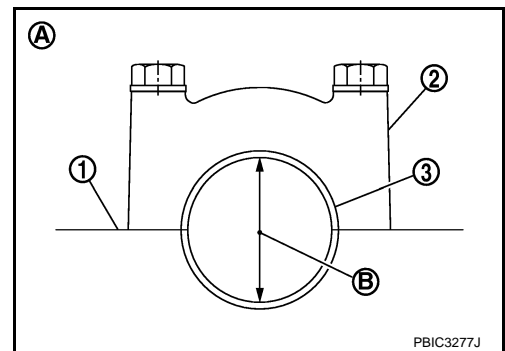

**Standard and Limit** : Refer to [EM-121, "Main Bearing"](#).

- If clearance exceeds the limit, select proper main bearing according to main bearing inner diameter and crankshaft main journal diameter to obtain specified bearing oil clearance. Refer to [EM-89, "Disassembly and Assembly"](#).

### Method of Using Plastigage

- Remove engine oil and dust on crankshaft main journal and the surfaces of each bearing completely.
- Cut a plastigage slightly shorter than the bearing width, and place it in crankshaft axial direction, avoiding oil holes.
- Install main bearings to cylinder block and lower cylinder block, and tighten lower cylinder block mounting bolts to the specified torque. Refer to [EM-89, "Disassembly and Assembly"](#) for the tightening procedure.

### CAUTION:

#### Never rotate crankshaft.

- Remove lower cylinder block and bearings, and using the scale on the plastigage bag, measure the plastigage width.

### NOTE:

The procedure when the measured value exceeds the limit is same as that described in the "Method by Calculation".

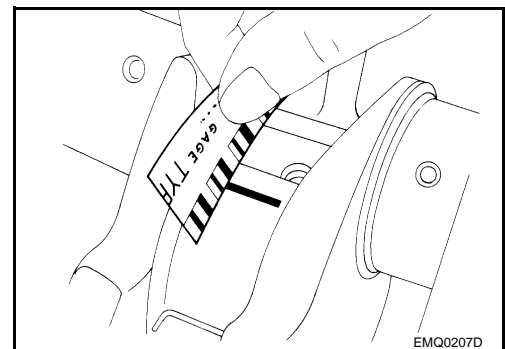

## MAIN BEARING CRUSH HEIGHT

# CYLINDER BLOCK

## < DISASSEMBLY AND ASSEMBLY >

- When lower cylinder block is removed after being tightened to the specified torque with main bearings (1) installed, the tip end of bearing must protrude (B). Refer to [EM-89, "Disassembly and Assembly"](#) for the tightening procedure.

A : Example

**Standard: There must be crush height.**

- If the standard is not met, replace main bearings.

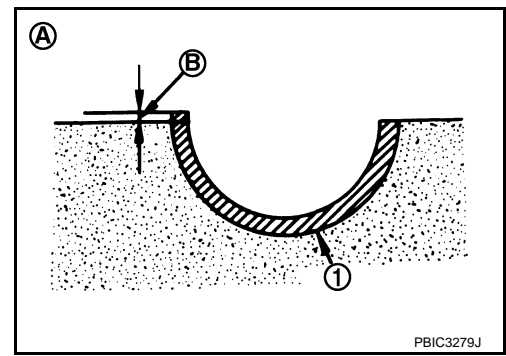

## CONNECTING ROD BEARING CRUSH HEIGHT

- When connecting rod bearing cap is removed after being tightened to the specified torque with connecting rod bearings (1) installed, the tip end of bearing must protrude (B). Refer to [EM-89, "Disassembly and Assembly"](#) for the tightening procedure.

A : Example

**Standard: There must be crush height.**

- If the standard is not met, replace connecting rod bearings.

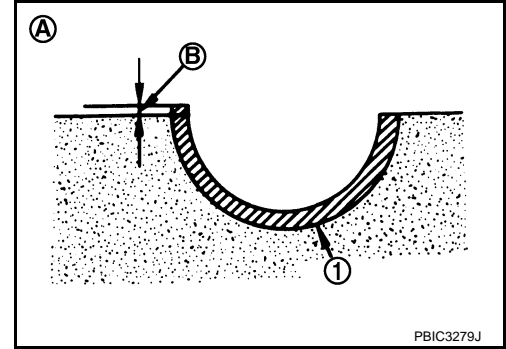

## LOWER CYLINDER BLOCK MOUNTING BOLT OUTER DIAMETER

- Perform only with M10 bolts.
- Measure the outer diameters ("d1", "d2") at two positions as shown in the figure.
- If reduction appears in "A" range, regard it as "d2".

**Limit ("d1" – "d2"): 0.13 mm (0.0051 in)**

- If it exceeds the limit (a large difference in dimensions), replace lower cylinder block mounting bolt with a new one.

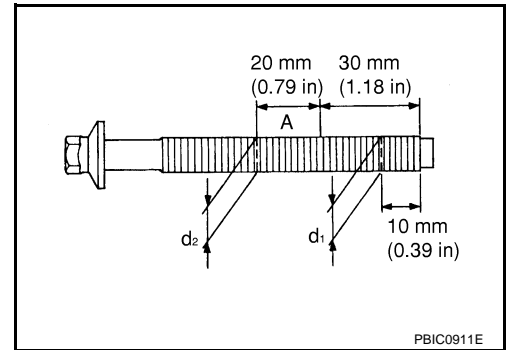

## CONNECTING ROD BOLT OUTER DIAMETER

- Measure the outer diameter "d" at position as shown in the figure.
- If reduction appears in a position other than "d", regard it as "d".

**Limit: 7.75 mm (0.3051 in)**

- When "d" exceeds the limit (when it becomes thinner), replace connecting rod bolt with a new one.

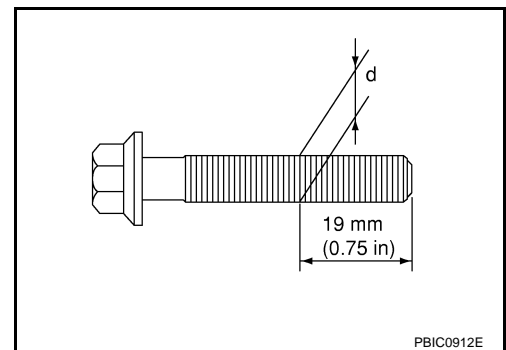

# HOW TO SELECT PISTON AND BEARING

< DISASSEMBLY AND ASSEMBLY >

## HOW TO SELECT PISTON AND BEARING

### Description

INFOID:000000004231454

Selection points	Selection parts	Selection items	Selection methods
Between cylinder block and crankshaft	Main bearing	Main bearing grade (bearing thickness)	Determined by match of cylinder block bearing housing grade (inner diameter of housing) and crankshaft journal grade (outer diameter of journal)
Between crankshaft and connecting rod	Connecting rod bearing	Connecting rod bearing grade (bearing thickness)	Combining service grades for connecting rod big end diameter and crankshaft pin outer diameter determine connecting rod bearing selection.
Between cylinder block and piston	Piston and piston pin assembly (piston is available together with piston pin as an assembly.)	Piston grade (piston outer diameter)	Piston grade = cylinder bore grade (inner diameter of bore)
Between piston and connecting rod*	—	—	—

\*For the service parts, the grade for fitting cannot be selected between piston pin and connecting rod. (Only grade "0" is available.) The information at the shipment from the plant is described as a reference.

- The identification grade stamped on each part is the grade for the dimension measured in new condition. This grade cannot apply to reused parts.
- For reused or repaired parts, measure the dimension accurately. Determine the grade by comparing the measurement with the values of each selection table.
- For details of the measurement method of each part, the reuse standards and the selection method of the selective fitting parts, refer to the text.

### Piston

INFOID:000000004231455

#### WHEN NEW CYLINDER BLOCK IS USED

- Check the cylinder bore grade on rear left side of cylinder block, and select piston of the same grade.
- If there is a corrected stamp mark on the cylinder block, use it as a correct reference.

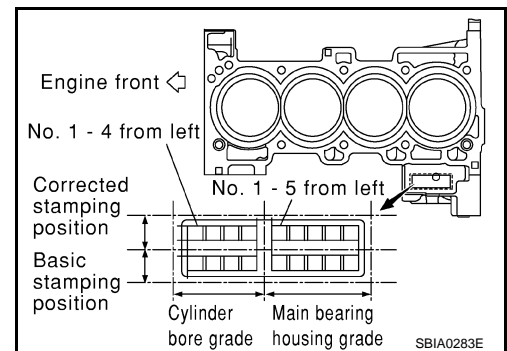

#### WHEN CYLINDER BLOCK IS REUSED

1. Measure the cylinder bore inner diameter. Refer to [EM-96, "Inspection"](#).
2. Determine the bore grade by comparing the measurement with the values under the cylinder bore inner diameter of the "Piston Selection Table".

# HOW TO SELECT PISTON AND BEARING

## < DISASSEMBLY AND ASSEMBLY >

3. Select piston of the same grade.

- A : Identification code
- B : Piston grade number
- C : Front mark
- D : Piston pin bore grade number

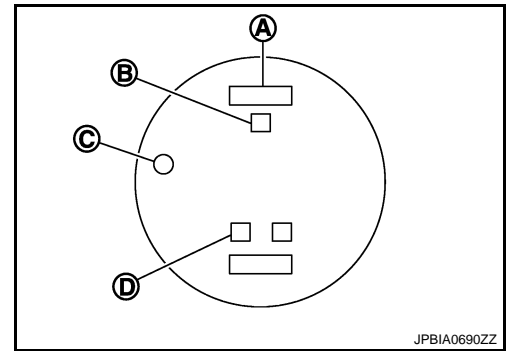

## PISTON SELECTION TABLE

Unit: mm (in)

Grade number (Mark)	2 (or no mark)	3
Cylinder bore Inner diameter	89.010 - 89.020 (3.5043 - 3.5047)	89.020 - 89.030 (3.5047 - 3.5051)
Piston skirt diameter	88.990 - 89.000 (3.5035 - 3.5039)	89.000 - 89.010 (3.5039 - 3.5043)

### NOTE:

- There is no piston grade “1”.
- Piston is available together with piston pin as an assembly.
- The piston pin (piston pin hole) grade is provided only for the parts installed at the plant. For service parts, no grades can be selected. (Only grade “0” is available.)

## Connecting Rod Bearing

INFOID:000000004231456

### WHEN NEW CONNECTING ROD AND CRANKSHAFT ARE USED

1. Apply connecting rod big end diameter grade stamped on connecting rod side face to the row in the “Connecting Rod Bearing Selection Table”.

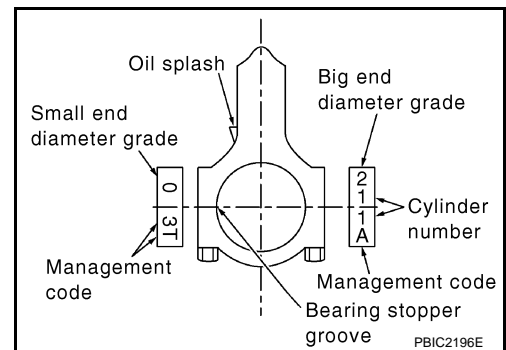

2. Apply crankshaft pin journal diameter grade stamped on crankshaft front side to the column in the “Connecting Rod Bearing Selection Table”.

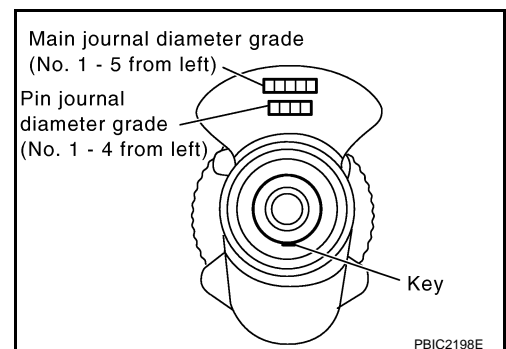

3. Read the symbol at the cross point of selected row and column in the “Connecting Rod Bearing Selection Table”.
4. Apply the symbol obtained to the “Connecting Rod Bearing Grade Table” to select connecting rod bearing.

### WHEN CRANKSHAFT AND CONNECTING ROD ARE REUSED

1. Measure the dimensions of the connecting rod big end diameter and crankshaft pin journal diameter individually. Refer to [EM-96, "Inspection"](#).

# HOW TO SELECT PISTON AND BEARING

## < DISASSEMBLY AND ASSEMBLY >

2. Apply the measured dimension to the "Connecting Rod Bearing Selection Table".
3. Read the symbol at the cross point of selected row and column in the "Connecting Rod Bearing Selection Table".
4. Apply the symbol obtained to the "Connecting Rod Bearing Grade Table" to select connecting rod bearing.

### CONNECTING ROD BEARING SELECTION TABLE

Connecting rod big end diameter Crankshaft pin journal diameter		Mark												
		0	1	2	3	4	5	6	7	8	9	A	B	C
Mark	Outer diameter Unit: mm (in)	Inner diameter Unit: mm (in)												
		48.000 - 48.001 (1.8898 - 1.8898)	48.001 - 48.002 (1.8898 - 1.8898)	48.002 - 48.003 (1.8898 - 1.8899)	48.003 - 48.004 (1.8899 - 1.8899)	48.004 - 48.005 (1.8899 - 1.8900)	48.005 - 48.006 (1.8900 - 1.8900)	48.006 - 48.007 (1.8900 - 1.8900)	48.007 - 48.008 (1.8900 - 1.8901)	48.008 - 48.009 (1.8901 - 1.8901)	48.009 - 48.010 (1.8901 - 1.8902)	48.010 - 48.011 (1.8902 - 1.8902)	48.011 - 48.012 (1.8902 - 1.8902)	48.012 - 48.013 (1.8902 - 1.8903)
A	44.974 - 44.973 (1.7706 - 1.7706)	0	0	0	0	01	01	01	1	1	1	12	12	12
B	44.973 - 44.972 (1.7706 - 1.7705)	0	0	0	01	01	01	1	1	1	12	12	12	2
C	44.972 - 44.971 (1.7705 - 1.7705)	0	0	01	01	01	1	1	1	12	12	12	2	2
D	44.971 - 44.970 (1.7705 - 1.7705)	0	01	01	01	1	1	1	12	12	12	2	2	2
E	44.970 - 44.969 (1.7705 - 1.7704)	01	01	01	1	1	1	12	12	12	2	2	2	23
F	44.969 - 44.968 (1.7704 - 1.7704)	01	01	1	1	1	12	12	12	2	2	2	23	23
G	44.968 - 44.967 (1.7704 - 1.7704)	01	1	1	1	12	12	12	2	2	2	23	23	23
H	44.967 - 44.966 (1.7704 - 1.7703)	1	1	1	12	12	12	2	2	2	23	23	23	3
J	44.966 - 44.965 (1.7703 - 1.7703)	1	1	12	12	12	2	2	2	23	23	23	3	3
K	44.965 - 44.964 (1.7703 - 1.7702)	1	12	12	12	2	2	2	23	23	23	3	3	3
L	44.964 - 44.963 (1.7702 - 1.7702)	12	12	12	2	2	2	23	23	23	3	3	3	34
M	44.963 - 44.962 (1.7702 - 1.7702)	12	12	2	2	2	23	23	23	3	3	3	34	34
N	44.962 - 44.961 (1.7702 - 1.7701)	12	2	2	2	23	23	23	3	3	3	34	34	34
P	44.961 - 44.960 (1.7701 - 1.7701)	2	2	2	23	23	23	3	3	3	34	34	34	4
R	44.960 - 44.959 (1.7701 - 1.7700)	2	2	23	23	23	3	3	3	34	34	34	4	4
S	44.959 - 44.958 (1.7700 - 1.7700)	2	23	23	23	3	3	3	34	34	34	4	4	4
T	44.958 - 44.957 (1.7700 - 1.7700)	23	23	23	3	3	3	34	34	34	4	4	4	4
U	44.957 - 44.956 (1.7700 - 1.7699)	23	23	3	3	3	34	34	34	4	4	4	4	4

JPBIA0797GB

### CONNECTING ROD BEARING GRADE TABLE

**Connecting rod bearing grade table** : Refer to [EM-122, "Connecting Rod Bearing"](#).

#### UNDERSIZE BEARINGS USAGE GUIDE

- When the specified connecting rod bearing oil clearance is not obtained with standard size connecting rod bearings, use undersize (US) bearings.
- When using undersize (US) bearing, measure the connecting rod bearing inner diameter with bearing installed, and grind the crankshaft pin so that the connecting rod bearing oil clearance satisfies the standard.

**CAUTION:**



# HOW TO SELECT PISTON AND BEARING

< DISASSEMBLY AND ASSEMBLY >

In grinding crankshaft pin to use undersize bearings, keep the fillet R [1.5 - 1.7 mm (0.059 - 0.067 in)].

Bearing under-size table

: Refer to [EM-122](#), "[Connecting Rod Bearing](#)".

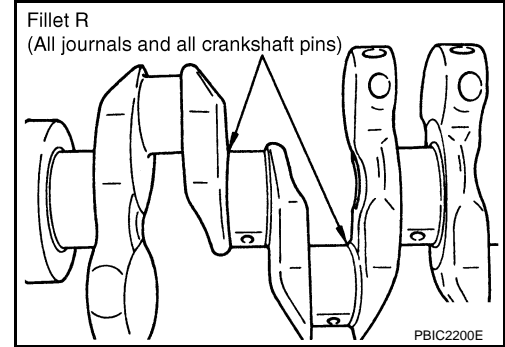

INFOID:000000004231457

## Main Bearing

### WHEN NEW CYLINDER BLOCK AND CRANKSHAFT ARE USED

1. "Main Bearing Selection Table" rows correspond to main bearing housing grade on rear left side of cylinder block.
  - If there is a corrected stamp mark on cylinder block, use it as a correct reference.

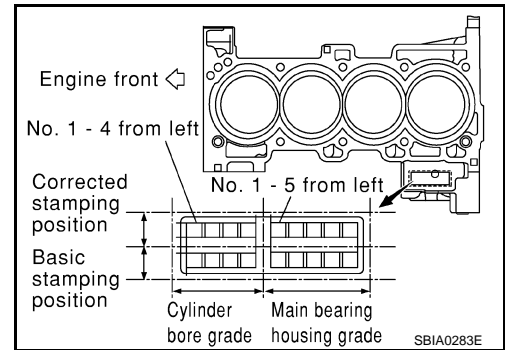

2. Apply main journal diameter grade stamped on crankshaft front side to column in the "Main Bearing Selection Table".

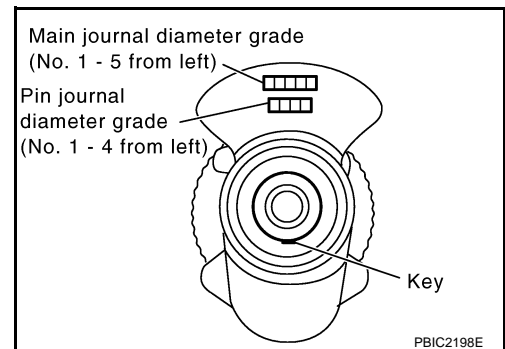

3. Read the symbol at the cross point of selected row and column in the "Main Bearing Selection Table".

**CAUTION:**

There are two main bearing selection tables. One is for odd-numbered journals (No. 1, 3 and 5) and the other is for even-numbered journals (No. 2 and 4). Make certain to use the appropriate table. This is due to differences in the specified clearances.

4. Apply the symbol obtained to the "Main Bearing Grade Table" to select main bearing.

**NOTE:**

Service part is available as a set of both upper and lower.

### WHEN CYLINDER BLOCK AND CRANKSHAFT ARE REUSED

1. Measure the dimensions of the cylinder block main bearing housing inner diameter and crankshaft main journal diameter individually. Refer to [EM-96](#), "[Inspection](#)".

2. Apply the measured dimension to the "Main Bearing Selection Table".

3. Read the symbol at the cross point of selected row and column in the "Main Bearing Selection Table".

**CAUTION:**

There are two main bearing selection tables. One is for odd-numbered journals (No. 1, 3 and 5) and the other is for even-numbered journals (No. 2 and 4). Make certain to use the appropriate table. This is due to differences in the specified clearances.

4. Apply the symbol obtained to the "Main Bearing Grade Table" to select main bearing.





# HOW TO SELECT PISTON AND BEARING

< DISASSEMBLY AND ASSEMBLY >

## MAIN BEARING SELECTION TABLE (No. 2 and 4 journals)

Cylinder block main bearing housing inner diameter	Crankshaft main journal diameter	Mark	Mark																											
			A	B	C	D	E	F	G	H	J	K	L	M	N	P	R	S	T	U	V	W	X	Y	4	7				
		Inner diameter Unit: mm (in)																												
		Outer diameter Unit: mm (in)																												
A	54.979 - 54.978 (2.1645 - 2.1645)	0 0																												
B	54.978 - 54.977 (2.1645 - 2.1644)	0 0																												
C	54.977 - 54.976 (2.1644 - 2.1644)	0 0																												
D	54.976 - 54.975 (2.1644 - 2.1644)	0 0																												
E	54.975 - 54.974 (2.1644 - 2.1643)	0 0																												
F	54.974 - 54.973 (2.1643 - 2.1643)	0 0																												
G	54.973 - 54.972 (2.1643 - 2.1642)	0 0																												
H	54.972 - 54.971 (2.1642 - 2.1642)	0 0																												
J	54.971 - 54.970 (2.1642 - 2.1642)	0 0																												
K	54.970 - 54.969 (2.1642 - 2.1641)	0 0																												
L	54.969 - 54.968 (2.1641 - 2.1641)	0 0																												
M	54.968 - 54.967 (2.1641 - 2.1641)	0 0																												
N	54.967 - 54.966 (2.1641 - 2.1640)	0 0																												
P	54.966 - 54.965 (2.1640 - 2.1640)	0 0																												
R	54.965 - 54.964 (2.1640 - 2.1639)	0 0																												
S	54.964 - 54.963 (2.1639 - 2.1639)	0 0																												
T	54.963 - 54.962 (2.1639 - 2.1639)	0 0																												
U	54.962 - 54.961 (2.1639 - 2.1638)	0 0																												
V	54.961 - 54.960 (2.1638 - 2.1638)	0 0																												
W	54.960 - 54.959 (2.1638 - 2.1637)	0 0																												
X	54.959 - 54.958 (2.1637 - 2.1637)	0 0																												
Y	54.958 - 54.957 (2.1637 - 2.1637)	0 0																												
4	54.957 - 54.956 (2.1637 - 2.1636)	0 0																												
7	54.956 - 54.955 (2.1636 - 2.1636)	0 0																												

PBIC2202E

## MAIN BEARING GRADE TABLE (ALL JOURNALS)

Main bearing grade table (All journals) : Refer to [EM-121, "Main Bearing"](#).

### USE UNDERSIZE BEARING USAGE GUIDE

- When the specified main bearing oil clearance is not obtained with standard size main bearings, use undersize (US) bearing.
- When using undersize (US) bearing, measure the main bearing inner diameter with bearing installed, and grind main journal so that the main bearing oil clearance satisfies the standard.

### CAUTION:

In grinding crankshaft main journal to use undersize bearings, keep fillet R [1.5 - 1.7 mm (0.059 - 0.067 in)].

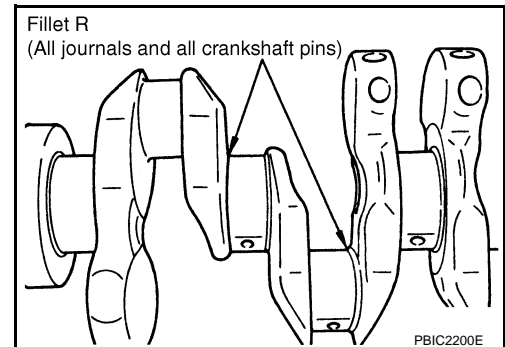

# HOW TO SELECT PISTON AND BEARING

< DISASSEMBLY AND ASSEMBLY >

---

**Bearing undersize table** : Refer to [EM-121, "Main Bearing"](#).

A

EM

C

D

E

F

G

H

I

J

K

L

M

N

O

P

# SERVICE DATA AND SPECIFICATIONS (SDS)

< SERVICE DATA AND SPECIFICATIONS (SDS)

## SERVICE DATA AND SPECIFICATIONS (SDS)

### SERVICE DATA AND SPECIFICATIONS (SDS)

#### General Specification

INFOID:000000004231458

#### GENERAL SPECIFICATIONS

Cylinder arrangement	In-line 4	
Displacement	cm <sup>3</sup> (cu in)	2,488 (151.82)
Bore and stroke	mm (in)	89.0 x 100.0 (3.504 x 3.940)
Valve arrangement	DOHC	
Firing order	1-3-4-2	
Number of piston rings	Compression	2
	Oil	1
Compression ratio	9.6	
Compression pressure kPa (kg/cm <sup>2</sup> , psi)/250 rpm	Standard	1,412 (14.4, 204.7)
	Minimum	1,216 (12.4, 176.3)
	Differential limit between cylinders	100 (1.0, 14.5)

Unit: degree

Valve timing ◁ : Intake valve ◀ : Exhaust valve						
	PBIC5304E	a	b	c	d	e
Except for California	220	232	12 (-28) ATDC	64 (24) ABDC	10	30
For California	224	236	8 (-32) ATDC	64 (24) ABDC	8	36

( ) : Valve timing control "ON"

#### Drive belt

INFOID:000000004231459

#### DRIVE BELT

Tension of drive belt	Belt tension is not necessary, as it is automatically adjusted by drive belt auto-tensioner.
-----------------------	--

#### Spark Plug

INFOID:000000004231460

#### SPARK PLUG

Unit: mm (in)

Make	NGK
Standard type	DILKAR6A-11
Spark plug gap (Nominal)	1.1 (0.043)

# SERVICE DATA AND SPECIFICATIONS (SDS)

## < SERVICE DATA AND SPECIFICATIONS (SDS)

### Intake Manifold

INFOID:000000004231461

#### INTAKE MANIFOLD

Unit: mm (in)

Items		Limit
Surface distortion	Intake manifold adaptor	0.1 (0.004)

### Exhaust Manifold

INFOID:000000004231462

#### EXHAUST MANIFOLD

Unit: mm (in)

Items		Limit
Surface distortion	Exhaust manifold	0.3 (0.012)

### Camshaft

INFOID:000000004231463

#### CAMSHAFT

Unit: mm (in)

Items		Standard		Limit
Camshaft journal oil clearance		0.045 - 0.086 (0.0018 - 0.0034)		—
Camshaft bracket inner diameter	No. 1	28.000 - 28.021 (1.1024 - 1.1032)		—
	No. 2, 3, 4, 5	23.500 - 23.521 (0.9252 - 0.9260)		—
Camshaft journal diameter	No. 1	27.935 - 27.955 (1.0998 - 1.1006)		—
	No. 2, 3, 4, 5	23.435 - 23.455 (0.9226 - 0.9234)		—
Camshaft end play		0.115 - 0.188 (0.0045 - 0.0074)		—
Camshaft cam height "A"	Intake	Except for California	44.815 - 45.005 (1.7644 - 1.7718)	0.2 (0.008)*1
		For California	45.015 - 45.205 (1.7722 - 1.7797)	
	Exhaust	43.975 - 44.165 (1.7313 - 1.7388)		
Camshaft runout [TIR*2]		Less than 0.02 mm (0.0008)		—
Camshaft sprocket runout [TIR*2]		—		0.15 (0.0059)

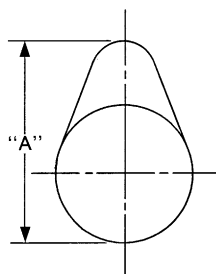

SEM671

\*1: Cam wear limit

\*2: Total indicator reading

### VALVE LIFTER

Unit: mm (in)

Items	Standard
Valve lifter outer diameter	33.98 - 33.99 (1.3378 - 1.3382)

## SERVICE DATA AND SPECIFICATIONS (SDS)

### < SERVICE DATA AND SPECIFICATIONS (SDS)

Valve lifter hole diameter	34.000 - 34.021 (1.3386 - 1.3394)
Valve lifter clearance	0.013 - 0.044 (0.0005 - 0.0017)

### VALVE CLEARANCE

Unit: mm (in)

Items	Cold	Hot* (reference data)
Intake	0.24 - 0.32 (0.009 - 0.013)	0.304 - 0.416 (0.012 - 0.016)
Exhaust	0.26 - 0.34 (0.010 - 0.013)	0.308 - 0.432 (0.012 - 0.017)

\*: Approximately 80°C (176°F)

### AVAILABLE VALVE LIFTER

Unit: mm (in)

Thickness	Identification (stamped) mark
7.88 (0.3102)	788
7.90 (0.3110)	790
7.92 (0.3118)	792
7.94 (0.3126)	794
7.96 (0.3134)	796
7.98 (0.3142)	798
8.00 (0.3150)	800
8.02 (0.3157)	802
8.04 (0.3165)	804
8.06 (0.3173)	806
8.08 (0.3181)	808
8.10 (0.3189)	810
8.12 (0.3197)	812
8.14 (0.3205)	814
8.16 (0.3213)	816
8.18 (0.3220)	818
8.20 (0.3228)	820
8.22 (0.3236)	822
8.24 (0.3244)	824
8.26 (0.3252)	826
8.28 (0.3260)	828
8.30 (0.3268)	830
8.32 (0.3276)	832
8.34 (0.3283)	834
8.36 (0.3291)	836

# SERVICE DATA AND SPECIFICATIONS (SDS)

## < SERVICE DATA AND SPECIFICATIONS (SDS)

Thickness	Identification (stamped) mark
8.38 (0.3299)	838

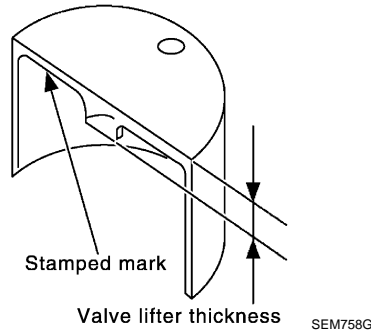

### Cylinder Head

INFOID:000000004231464

### CYLINDER HEAD

Unit: mm (in)

Items	Standard	Limit
Head surface distortion	Less than 0.03 (0.0012)	0.1 (0.004)
Normal cylinder head height "H"	129.3 - 129.5 (5.09 - 5.10)	—

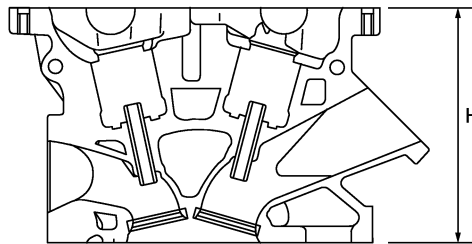

PBIC0924E

### VALVE DIMENSIONS

Unit: mm (in)

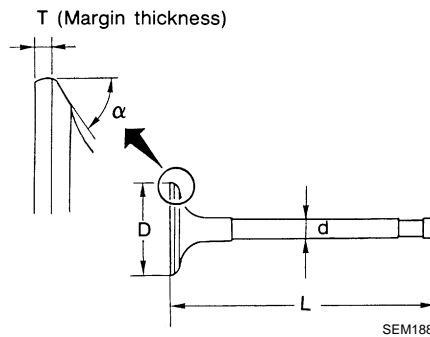

Valve head diameter "D"	Intake	35.5 - 35.8 (1.398 - 1.409)
	Exhaust	30.3 - 30.6 (1.193 - 1.205)
Valve length "L"	Intake	96.84 (3.8126)
	Exhaust	97.9 (3.854)
Valve stem diameter "d"	Intake	5.965 - 5.980 (0.2348 - 0.2354)
	Exhaust	5.955 - 5.970 (0.2344 - 0.2350)

# SERVICE DATA AND SPECIFICATIONS (SDS)

## < SERVICE DATA AND SPECIFICATIONS (SDS)

Valve seat angle "α"	Intake	45°15' - 45°45'
	Exhaust	
Valve margin "T"	Intake	1.1 (0.043)
	Exhaust	1.4 (0.055)
Valve margin "T" limit		0.5 (0.020)
Valve stem end surface grinding limit		0.2 (0.008)

### VALVE GUIDE

Unit: mm (in)

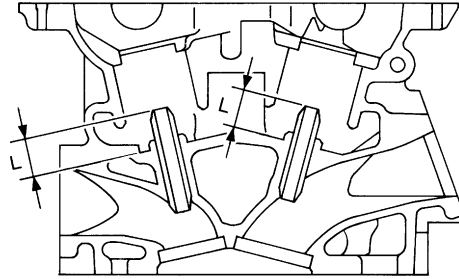

SEM950E

Items		Standard	Oversize (Service) [0.2 (0.008)]
Valve guide	Outer diameter	10.023 - 10.034 (0.3946 - 0.3950)	10.223 - 10.234 (0.4025 - 0.4029)
	Inner diameter (Finished size)	6.000 - 6.018 (0.2362 - 0.2369)	
Cylinder head valve guide hole diameter		9.975 - 9.996 (0.3927 - 0.3935)	10.175 - 10.196 (0.4006 - 0.4014)
Interference fit of valve guide		0.027 - 0.059 (0.0011 - 0.0023)	
Items		Standard	Limit
Valve guide clearance	Intake	0.020 - 0.053 (0.0008 - 0.0021)	0.08 (0.0031)
	Exhaust	0.030 - 0.063 (0.0012 - 0.0025)	0.09 (0.0035)
Projection length "L"	Intake	10.1 - 10.3 (0.398 - 0.406)	
	Exhaust	10.0 - 10.4 (0.394 - 0.409)	

### VALVE SEAT

Unit: mm (in)

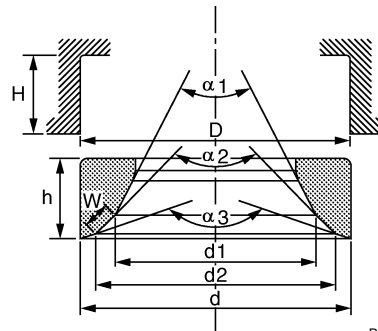

PBIC2745E

Items		Standard	Oversize (Service) [0.5 (0.020)]
Cylinder head seat recess diameter "D"	Intake	36.500 - 36.516 (1.4370 - 1.4376)	37.000 - 37.016 (1.4567 - 1.4573)
	Exhaust	31.500 - 31.516 (1.2402 - 1.2408)	32.000 - 32.016 (1.2598 - 1.2605)
Valve seat outer diameter "d"	Intake	36.597 - 36.613 (1.4408 - 1.4415)	37.097 - 37.113 (1.4605 - 1.4611)
	Exhaust	31.600 - 31.616 (1.2441 - 1.2447)	32.100 - 32.116 (1.2638 - 1.2644)



# SERVICE DATA AND SPECIFICATIONS (SDS)

## < SERVICE DATA AND SPECIFICATIONS (SDS)

Valve seat interference fit	Intake	0.081 - 0.113 (0.0032 - 0.0044)	
	Exhaust	0.084 - 0.116 (0.0033 - 0.0046)	
Diameter "d1"*1	Intake	33.5 (1.319)	
	Exhaust	28.0 (1.102)	
Diameter "d2"*2	Intake	34.8 - 35.3 (1.370 - 1.390)	
	Exhaust	29.6 - 30.1 (1.165 - 1.185)	
Angle "α1"	Intake	60°	
	Exhaust	60°	
Angle "α2"	Intake	88°45' - 90°15'	
	Exhaust	88°45' - 90°15'	
Angle "α3"	Intake	120°	
	Exhaust	120°	
Contacting width "W"*3	Intake	0.99 - 1.35 (0.0390 - 0.0531)	
	Exhaust	1.19 - 1.55 (0.0469 - 0.0610)	
Height "h"	Intake	5.9 - 6.0 (0.232 - 0.236)	5.0 - 5.1 (0.197 - 0.201)
	Exhaust	5.9 - 6.0 (0.232 - 0.236)	4.91 - 5.01 (0.1933 - 0.1972)
Depth "H"	6.0 (0.236)		

\*1: Diameter made by intersection point of conic angles "α1" and "α2"

\*2: Diameter made by intersection point of conic angles "α2" and "α3"

\*3: Machining data

## VALVE SPRING

Items	Intake	Exhaust
Free height	43.72 - 43.92 mm (1.7213 - 1.7291 in)	45.29 - 45.49 mm (1.7831 - 1.7909 in)
Installation height	35.30 mm (1.3898 in)	35.30 mm (1.3898 in)
Installation load	151 - 175 N (15.4 - 17.9 kg, 34 - 39 lb)	151 - 175 N (15.4 - 17.9 kg, 34 - 39 lb)
Height during valve open	25.30 mm (0.9961 in)	26.76 mm (1.0535 in)
Load with valve open	351 - 394 N (35.8 - 40.2 kg, 79 - 89 lb)	318 - 362 N (32.4 - 36.9 kg, 71 - 81 lb)
Identification color	Pink	Yellowish green
Out-of-Square	1.9 mm (0.075 in)	

## Cylinder Block

INFOID:000000004231465

## CYLINDER BLOCK

Unit: mm (in)

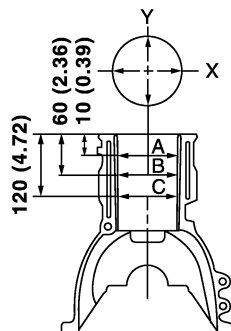

PBIC0281E

Surface distortion	Limit	0.1 (0.004)
--------------------	-------	-------------

## SERVICE DATA AND SPECIFICATIONS (SDS)

### < SERVICE DATA AND SPECIFICATIONS (SDS)

Cylinder bore	Inner diameter	Standard	Grade No. 2	89.010 - 89.020 (3.5043 - 3.5047)
			Grade No. 3	89.020 - 89.030 (3.5047 - 3.5051)
		Wear limit		0.2 (0.008)
Out-of-round (Difference between "X" and "Y")		Limit	0.015 (0.0006)	
Taper (Difference between "A" and "C")			0.01 (0.0004)	
Main bearing housing inner diameter grade			Grade No. A	58.944 - 58.945 (2.3206 - 2.3207)
			Grade No. B	58.945 - 58.946 (2.3207 - 2.3207)
			Grade No. C	58.946 - 58.947 (2.3207 - 2.3207)
			Grade No. D	58.947 - 58.948 (2.3207 - 2.3208)
			Grade No. E	58.948 - 58.949 (2.3208 - 2.3208)
			Grade No. F	58.949 - 58.950 (2.3208 - 2.3209)
			Grade No. G	58.950 - 58.951 (2.3209 - 2.3209)
			Grade No. H	58.951 - 58.952 (2.3209 - 2.3209)
			Grade No. J	58.952 - 58.953 (2.3209 - 2.3210)
			Grade No. K	58.953 - 58.954 (2.3210 - 2.3210)
			Grade No. L	58.954 - 58.955 (2.3210 - 2.3211)
			Grade No. M	58.955 - 58.956 (2.3211 - 2.3211)
			Grade No. N	58.956 - 58.957 (2.3211 - 2.3211)
			Grade No. P	58.957 - 58.958 (2.3211 - 2.3212)
			Grade No. R	58.958 - 58.959 (2.3212 - 2.3212)
			Grade No. S	58.959 - 58.960 (2.3212 - 2.3213)
			Grade No. T	58.960 - 58.961 (2.3213 - 2.3213)
Grade No. U	58.961 - 58.962 (2.3213 - 2.3213)			
Grade No. V	58.962 - 58.963 (2.3213 - 2.3214)			
Grade No. W	58.963 - 58.964 (2.3214 - 2.3214)			
Grade No. X	58.964 - 58.965 (2.3214 - 2.3215)			
Grade No. Y	58.965 - 58.966 (2.3215 - 2.3215)			
Grade No. 4	58.966 - 58.967 (2.3215 - 2.3215)			
Grade No. 7	58.967 - 58.968 (2.3215 - 2.3216)			
Difference in inner diameter between cylinders		Standard	Less than 0.03 (0.0012)	

### AVAILABLE PISTON

Unit: mm (in)

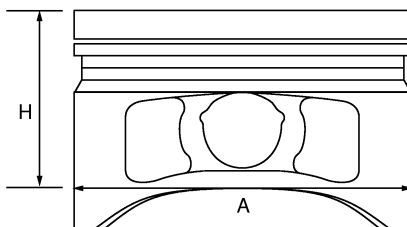

PBIC0188E

Piston skirt diameter "A"	Standard	Grade No. 2	88.990 - 89.000 (3.5035 - 3.5039)
		Grade No. 3	89.000 - 89.010 (3.5039 - 3.5043)
		Oversize (Service) [0.20 (0.008)]	89.180 - 89.210 (3.5110 - 3.5122)
Piston height "H" dimension			37.5 (1.476)
Piston pin hole diameter	Grade No. 0	19.993 - 19.999 (0.7871 - 0.7874)	
	Grade No. 1	19.999 - 20.005 (0.7874 - 0.7876)	
Piston to cylinder bore clearance	Standard	0.010 - 0.030 (0.0004 - 0.0012)	
	Limit	0.08 (0.0031)	

### PISTON RING

# SERVICE DATA AND SPECIFICATIONS (SDS)

## < SERVICE DATA AND SPECIFICATIONS (SDS)

Unit: mm (in)

Items	Standard	Limit
Side clearance	Top	0.040 - 0.080 (0.0016 - 0.0031)
	2nd	0.030 - 0.070 (0.0012 - 0.0028)
	Oil ring	0.045 - 0.125 (0.0018 - 0.0049)
End gap	Top	0.23 - 0.33 (0.0091 - 0.0130)
	2nd	0.33 - 0.48 (0.0130 - 0.0189)
	Oil (rail ring)	0.20 - 0.45 (0.0079 - 0.0177)

### PISTON PIN

Unit: mm (in)

Items	Standard	Limit
Piston pin outer diameter	Grade No. 0	19.989 - 19.995 (0.7870 - 0.7872)
	Grade No. 1	19.995 - 20.001 (0.7872 - 0.7874)
Piston to piston pin oil clearance	0.002 - 0.006 (0.0001 - 0.0002)	—
Connecting rod bushing oil clearance	0.005 - 0.017 (0.0002 - 0.0007)	0.030 (0.0012)

### CONNECTING ROD

Unit: mm (in)

Center distance		143.00 - 143.10 (5.63 - 5.63)
Bend [per 100 (3.94)]	Limit	0.15 (0.0059)
Torsion [per 100 (3.94)]	Limit	0.3 (0.012)
Connecting rod bushing inner diameter*	Grade No. 0	20.000 - 20.006 (0.7874 - 0.7876)
	Grade No. 1	20.006 - 20.012 (0.7876 - 0.7879)
Side clearance	Standard	0.20 - 0.35 (0.0079 - 0.0138)
	Limit	0.5 (0.020)
Connecting rod big end diameter	Grade No. 0	48.000 - 48.001 (1.8898 - 1.8898)
	Grade No. 1	48.001 - 48.002 (1.8898 - 1.8898)
	Grade No. 2	48.002 - 48.003 (1.8898 - 1.8899)
	Grade No. 3	48.003 - 48.004 (1.8899 - 1.8899)
	Grade No. 4	48.004 - 48.005 (1.8899 - 1.8900)
	Grade No. 5	48.005 - 48.006 (1.8900 - 1.8900)
	Grade No. 6	48.006 - 48.007 (1.8900 - 1.8900)
	Grade No. 7	48.007 - 48.008 (1.8900 - 1.8901)
	Grade No. 8	48.008 - 48.009 (1.8901 - 1.8901)
	Grade No. 9	48.009 - 48.010 (1.8901 - 1.8902)
	Grade No. A	48.010 - 48.011 (1.8902 - 1.8902)
	Grade No. B	48.011 - 48.012 (1.8902 - 1.8902)
Grade No. C	48.012 - 48.013 (1.8902 - 1.8903)	

\*: After installing in connecting rod

### CRANKSHAFT

# SERVICE DATA AND SPECIFICATIONS (SDS)

## < SERVICE DATA AND SPECIFICATIONS (SDS)

Unit: mm (in)

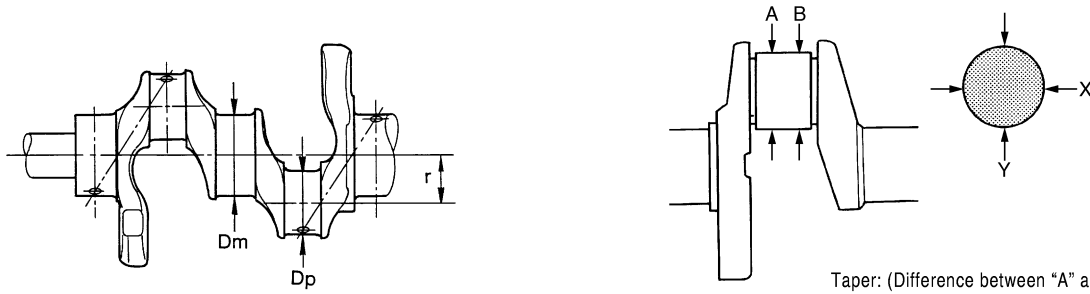

SEM645

SBIA0535E

Taper: (Difference between "A" and "B")  
Out-of-round: (Difference between "X" and "Y")

Center distance "r"		49.96 - 50.04 (1.9669 - 1.9701)
Out-of-round (Difference between "X" and "Y")	Limit	0.005 (0.0002)
Taper (Difference between "A" and "B")	Limit	0.005 (0.0002)
Runout [TIR*]	Limit	0.05 (0.0020)
Crankshaft end play	Standard	0.10 - 0.26 (0.0039 - 0.0102)
	Limit	0.3 (0.012)
Pin journal diameter grade. "Dp"	Grade No. A	44.974 - 44.973 (1.7706 - 1.7706)
	Grade No. B	44.973 - 44.972 (1.7706 - 1.7705)
	Grade No. C	44.972 - 44.971 (1.7705 - 1.7705)
	Grade No. D	44.971 - 44.970 (1.7705 - 1.7705)
	Grade No. E	44.970 - 44.969 (1.7705 - 1.7704)
	Grade No. F	44.969 - 44.968 (1.7704 - 1.7704)
	Grade No. G	44.968 - 44.967 (1.7704 - 1.7704)
	Grade No. H	44.967 - 44.966 (1.7704 - 1.7703)
	Grade No. J	44.966 - 44.965 (1.7703 - 1.7703)
	Grade No. K	44.965 - 44.964 (1.7703 - 1.7702)
	Grade No. L	44.964 - 44.963 (1.7702 - 1.7702)
	Grade No. M	44.963 - 44.962 (1.7702 - 1.7702)
	Grade No. N	44.962 - 44.961 (1.7702 - 1.7701)
	Grade No. P	44.961 - 44.960 (1.7701 - 1.7701)
	Grade No. R	44.960 - 44.959 (1.7701 - 1.7700)
	Grade No. S	44.959 - 44.958 (1.7700 - 1.7700)
	Grade No. T	44.958 - 44.957 (1.7700 - 1.7700)
Grade No. U	44.957 - 44.956 (1.7700 - 1.7699)	
Main journal diameter grade. "Dm"	Grade No. A	54.979 - 54.978 (2.1645 - 2.1645)
	Grade No. B	54.978 - 54.977 (2.1645 - 2.1644)
	Grade No. C	54.977 - 54.976 (2.1644 - 2.1644)
	Grade No. D	54.976 - 54.975 (2.1644 - 2.1644)
	Grade No. E	54.975 - 54.974 (2.1644 - 2.1643)
	Grade No. F	54.974 - 54.973 (2.1643 - 2.1643)
	Grade No. G	54.973 - 54.972 (2.1643 - 2.1642)
	Grade No. H	54.972 - 54.971 (2.1642 - 2.1642)
	Grade No. J	54.971 - 54.970 (2.1642 - 2.1642)
	Grade No. K	54.970 - 54.969 (2.1642 - 2.1641)
	Grade No. L	54.969 - 54.968 (2.1641 - 2.1641)
	Grade No. M	54.968 - 54.967 (2.1641 - 2.1641)
	Grade No. N	54.967 - 54.966 (2.1641 - 2.1640)
	Grade No. P	54.966 - 54.965 (2.1640 - 2.1640)
	Grade No. R	54.965 - 54.964 (2.1640 - 2.1639)
	Grade No. S	54.964 - 54.963 (2.1639 - 2.1639)
	Grade No. T	54.963 - 54.962 (2.1639 - 2.1639)
	Grade No. U	54.962 - 54.961 (2.1639 - 2.1638)
	Grade No. V	54.961 - 54.960 (2.1638 - 2.1638)
	Grade No. W	54.960 - 54.959 (2.1638 - 2.1637)
Grade No. X	54.959 - 54.958 (2.1637 - 2.1637)	
Grade No. Y	54.958 - 54.957 (2.1637 - 2.1637)	
Grade No. 4	54.957 - 54.956 (2.1637 - 2.1636)	
Grade No. 7	54.956 - 54.955 (2.1636 - 2.1636)	

# SERVICE DATA AND SPECIFICATIONS (SDS)

## < SERVICE DATA AND SPECIFICATIONS (SDS)

\*: Total indicator reading

### Main Bearing

INFOID:000000004231466

### MAIN BEARING

Unit: mm (in)

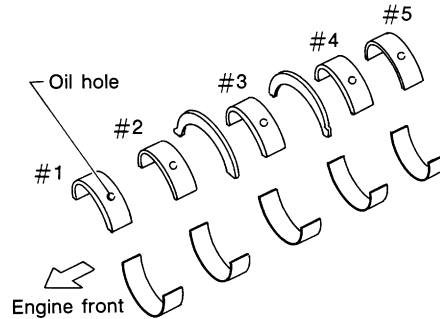

SEM685D

Grade number		Thickness	Identification color	Remarks
0		1.973 - 1.976 (0.0777 - 0.0778)	Black	Grade and color are the same for upper and lower bearings.
1		1.976 - 1.979 (0.0778 - 0.0779)	Brown	
2		1.979 - 1.982 (0.0779 - 0.0780)	Green	
3		1.982 - 1.985 (0.0780 - 0.0781)	Yellow	
4		1.985 - 1.988 (0.0781 - 0.0783)	Blue	
5		1.988 - 1.991 (0.0783 - 0.0784)	Pink	
6		1.991 - 1.994 (0.0784 - 0.0785)	Purple	
7		1.994 - 1.997 (0.0785 - 0.0786)	White	
01	UPR	1.973 - 1.976 (0.0777 - 0.0778)	Black	Grade and color are different for upper and lower bearings.
	LWR	1.976 - 1.979 (0.0778 - 0.0779)	Brown	
12	UPR	1.976 - 1.979 (0.0778 - 0.0779)	Brown	
	LWR	1.979 - 1.982 (0.0779 - 0.0780)	Green	
23	UPR	1.979 - 1.982 (0.0779 - 0.0780)	Green	
	LWR	1.982 - 1.985 (0.0780 - 0.0781)	Yellow	
34	UPR	1.982 - 1.985 (0.0780 - 0.0781)	Yellow	
	LWR	1.985 - 1.988 (0.0781 - 0.0783)	Blue	
45	UPR	1.985 - 1.988 (0.0781 - 0.0783)	Blue	
	LWR	1.988 - 1.991 (0.0783 - 0.0784)	Pink	
56	UPR	1.988 - 1.991 (0.0783 - 0.0784)	Pink	
	LWR	1.991 - 1.994 (0.0784 - 0.0785)	Purple	
67	UPR	1.991 - 1.994 (0.0784 - 0.0785)	Purple	
	LWR	1.994 - 1.997 (0.0785 - 0.0786)	White	

### UNDERSIZE

Unit: mm (in)

Items	Thickness	Main journal diameter
0.25 (0.0098)	2.106 - 2.114 (0.0829 - 0.0832)	Grind so that bearing clearance is the specified value.

### MAIN BEARING OIL CLEARANCE

## SERVICE DATA AND SPECIFICATIONS (SDS)

### < SERVICE DATA AND SPECIFICATIONS (SDS)

Unit: mm (in)

Main bearing oil clearance	Standard	No. 1, 3 and 5	0.012 - 0.022 (0.0005 - 0.0009)
		No. 2 and 4	0.018 - 0.028 (0.0007 - 0.0011)
	Limit		0.1 (0.004)

### Connecting Rod Bearing

INFOID:000000004231467

### CONNECTING ROD BEARING

Unit: mm (in)

Grade number	Thickness	Identification color	Remarks
0	1.493 - 1.496 (0.0588 - 0.0589)	Black	Grade and color are the same for upper and lower bearings.
1	1.496 - 1.499 (0.0589 - 0.0590)	Brown	
2	1.499 - 1.502 (0.0590 - 0.0591)	Green	
3	1.502 - 1.505 (0.0591 - 0.0593)	Yellow	
4	1.505 - 1.508 (0.0593 - 0.0594)	Blue	
01	UPR	1.493 - 1.496 (0.0588 - 0.0589)	Grade and color are different for upper and lower bearings.
	LWR	1.496 - 1.499 (0.0589 - 0.0590)	
12	UPR	1.496 - 1.499 (0.0589 - 0.0590)	
	LWR	1.499 - 1.502 (0.0590 - 0.0591)	
23	UPR	1.499 - 1.502 (0.0590 - 0.0591)	
	LWR	1.502 - 1.505 (0.0591 - 0.0593)	
34	UPR	1.502 - 1.505 (0.0591 - 0.0593)	
	LWR	1.505 - 1.508 (0.0593 - 0.0594)	

### UNDERSIZE

Unit: mm (in)

Items	Thickness	Crank pin journal diameter
0.25 (0.0098)	1.622 - 1.630 (0.0639 - 0.0642)	Grind so that bearing clearance is the specified value.

### CONNECTING ROD BEARING OIL CLEARANCE

Unit: mm (in)

Items	Standard	Limit
Connecting rod bearing oil clearance	0.035 - 0.045 (0.0014 - 0.0018)	0.1 (0.004)