

SECTION **PG**

POWER SUPPLY, GROUND & CIRCUIT ELEMENTS

CONTENTS

POWER SUPPLY ROUTING	2	REAR DOOR HARNESS	48
Schematic	2	Wiring Diagram Codes (Cell Codes)	49
Wiring Diagram — POWER —	3	ELECTRICAL UNITS LOCATION	53
BATTERY POWER SUPPLY—IGNITION SW. IN		Electrical Units Location	53
ANY POSITION	3	ENGINE COMPARTMENT	54
ACCESSORY POWER SUPPLY — IGNITION		PASSENGER COMPARTMENT	55
SW. IN “ACC” OR “ON”	8	LUGGAGE COMPARTMENT	59
IGNITION POWER SUPPLY — IGNITION SW.		HARNESS CONNECTOR	60
IN “ON” AND/OR “START”	10	Description	60
Fuse	14	HARNESS CONNECTOR (TAB-LOCKING	
Fusible Link	14	TYPE)	60
Circuit Breaker	14	HARNESS CONNECTOR (SLIDE-LOCKING	
GROUND	15	TYPE)	61
Ground Distribution	15	HARNESS CONNECTOR (LEVER LOCKING	
MAIN HARNESS	15	TYPE)	62
ENGINE ROOM HARNESS	18	ELECTRICAL UNITS	63
ENGINE HARNESS	22	Terminal Arrangement	63
ENGINE CONTROL HARNESS	23	SMJ (SUPER MULTIPLE JUNCTION)	65
BODY HARNESS	24	Terminal Arrangement	65
BODY NO. 2 HARNESS	27	STANDARDIZED RELAY	68
HARNESS	31	Description	68
Harness Layout	31	NORMAL OPEN, NORMAL CLOSED AND	
HOW TO READ HARNESS LAYOUT	31	MIXED TYPE RELAYS	68
OUTLINE	32	TYPE OF STANDARDIZED RELAYS	68
MAIN HARNESS	33	FUSE BLOCK - JUNCTION BOX (J/B) NO. 1	70
ENGINE ROOM HARNESS	36	Terminal Arrangement	70
ENGINE HARNESS	39	FUSE BLOCK - JUNCTION BOX (J/B) NO. 2	71
ENGINE CONTROL HARNESS	40	Terminal Arrangement	71
BODY HARNESS AND REAR CONTROL HAR-		FUSE, FUSIBLE LINK AND RELAY BLOCK (J/B)..	72
NESS	42	Terminal Arrangement	72
BODY NO. 2 HARNESS	44	FUSE, FUSIBLE LINK AND RELAY BOX	73
ROOM LAMP HARNESS	46	Terminal Arrangement	73
FRONT DOOR HARNESS	47		

A
B
C
D
E
F
G
H
I
J
L
M

PG

POWER SUPPLY ROUTING

Wiring Diagram — POWER — BATTERY POWER SUPPLY— IGNITION SW. IN ANY POSITION

NKS001LK

PG-POWER-01

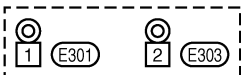
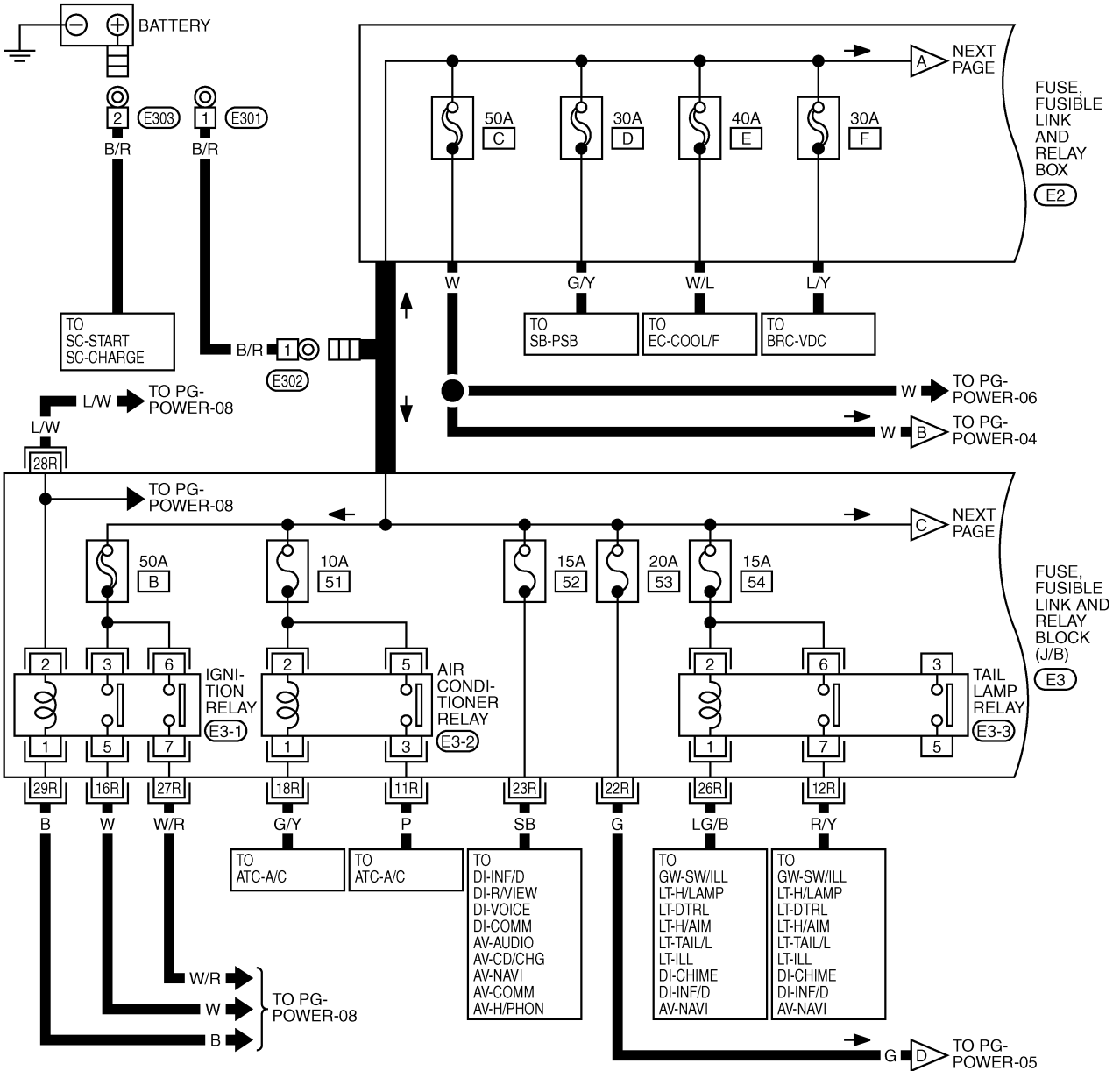

*: THIS CONNECTOR IS NOT SHOWN IN "HARNESS LAYOUT".

REFER TO THE FOLLOWING.

E3 - FUSE, FUSIBLE LINK AND RELAY BLOCK (J/B)

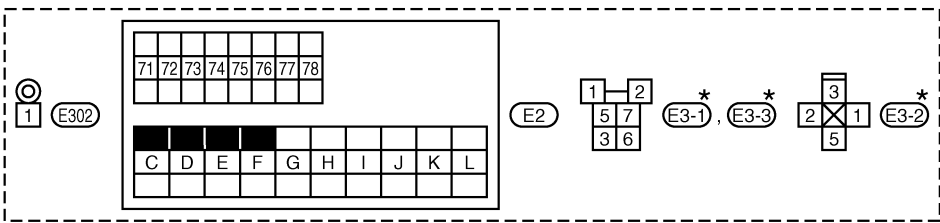
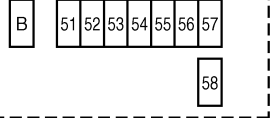

TKWM3842E

POWER SUPPLY ROUTING

PG-POWER-02

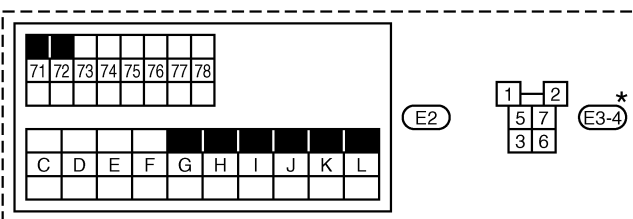
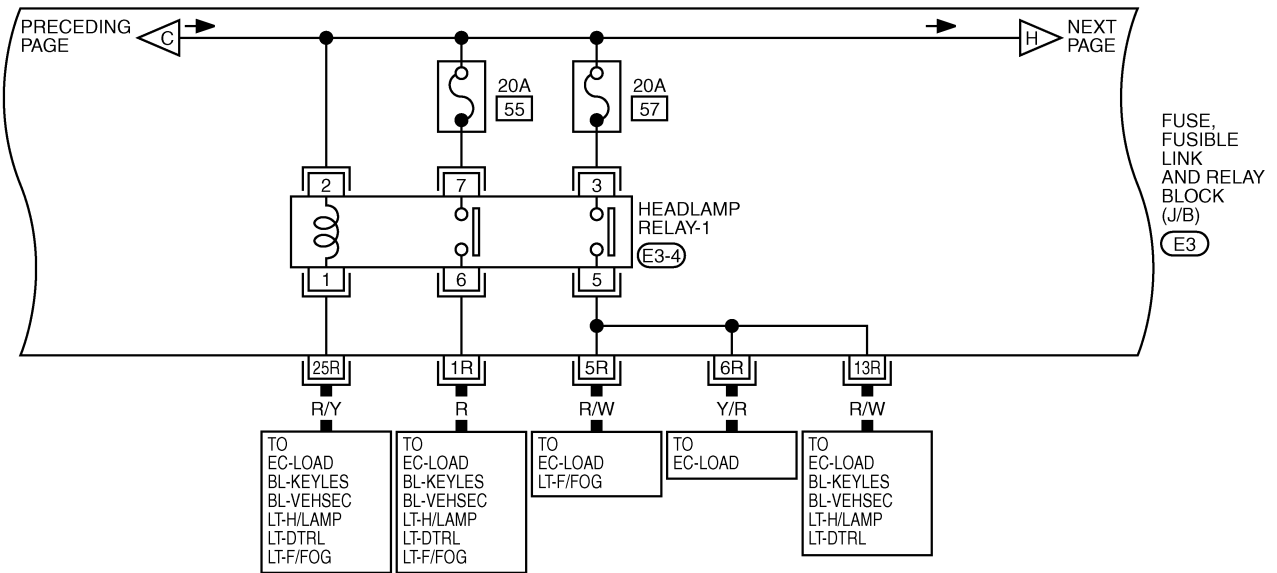
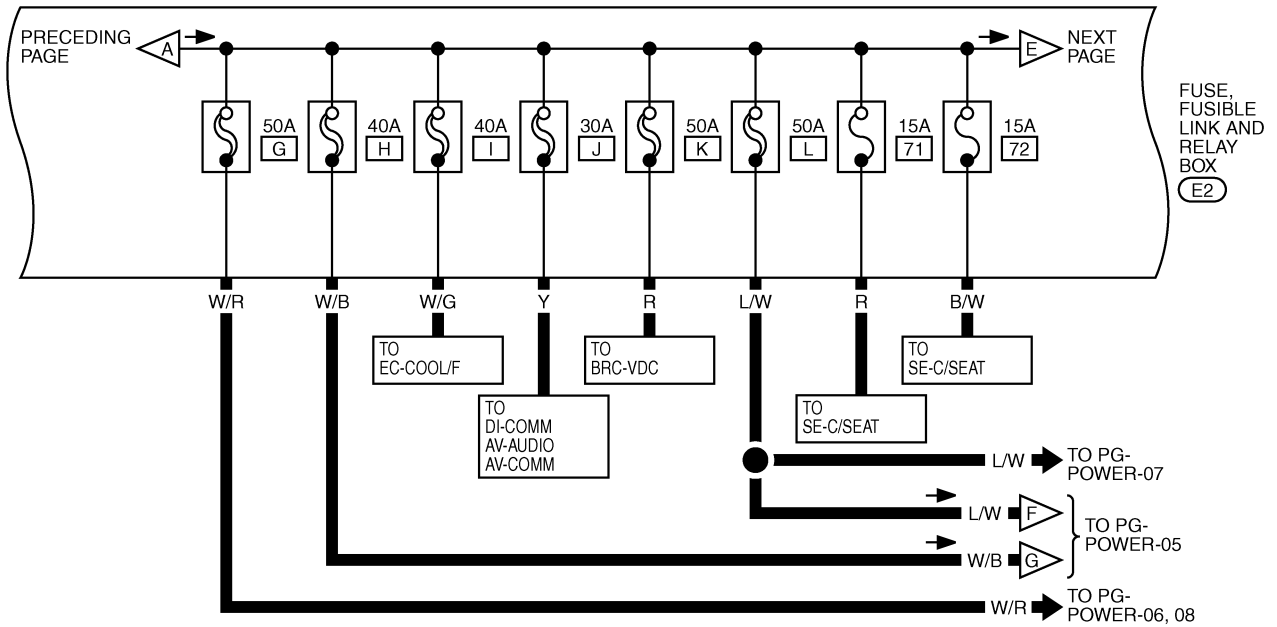

*: THIS CONNECTOR IS NOT SHOWN IN "HARNES LAYOUT".

REFER TO THE FOLLOWING.

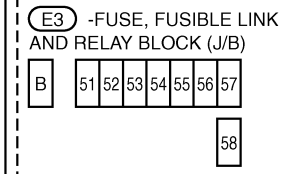

TKWM3843E

POWER SUPPLY ROUTING

PG-POWER-03

U : FOR U.S.A.

C : FOR CANADA

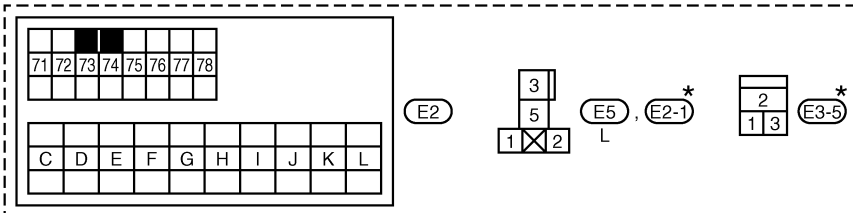
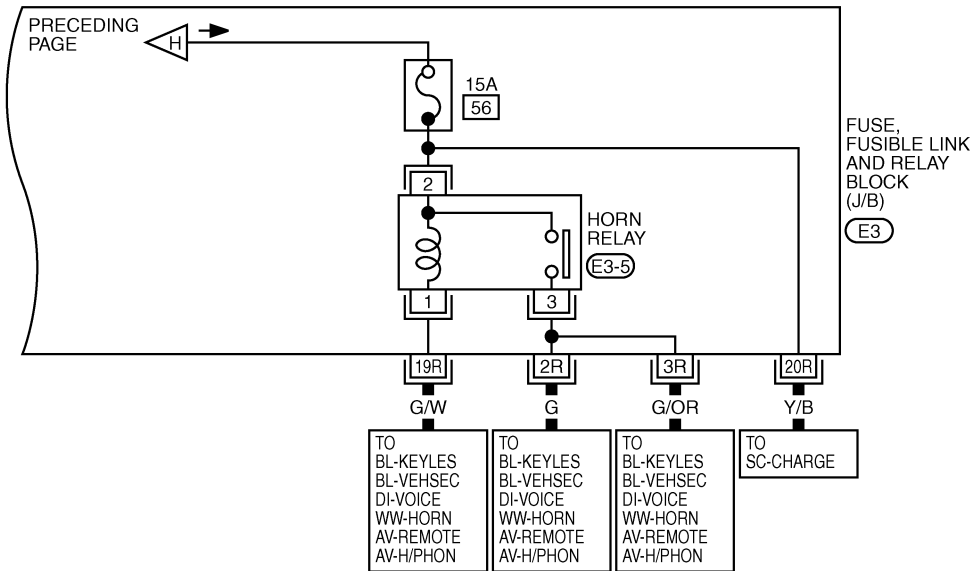
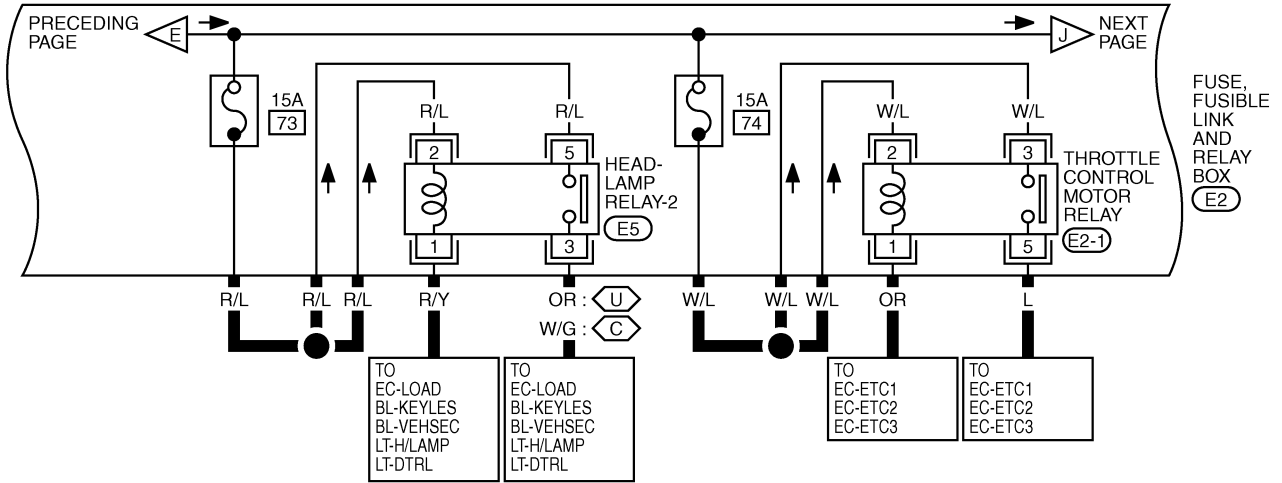

REFER TO THE FOLLOWING.

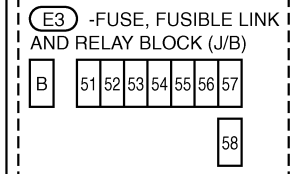

*: THIS CONNECTOR IS NOT SHOWN IN "HARNESS LAYOUT".

TKWM3844E

POWER SUPPLY ROUTING

PG-POWER-05

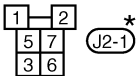
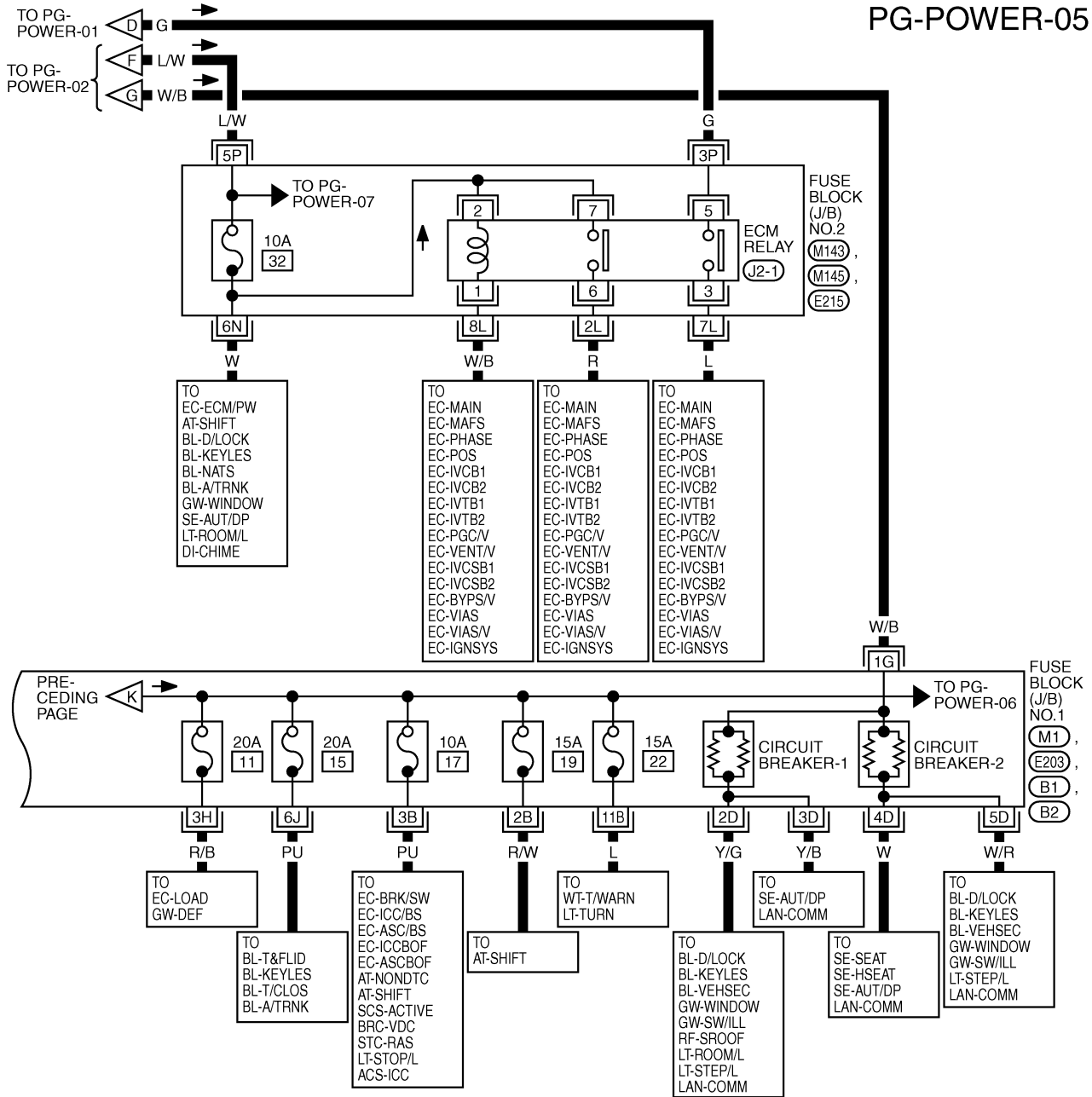

*: THIS CONNECTOR IS NOT SHOWN IN "HARNESS LAYOUT".

REFER TO THE FOLLOWING.

(M1), (E203), (B1), (B2) - FUSE BLOCK-JUNCTION BOX (J/B) NO.1

1	2	3	4	5	6	7	8	9	10	11
12	13	14	15	16	17	18	19	20	21	22

(M143), (M145), (E215) - FUSE BLOCK-JUNCTION BOX (J/B) NO.2

31	32	33	34	35	36	37	38
----	----	----	----	----	----	----	----

TKWM3846E

POWER SUPPLY ROUTING

ACCESSORY POWER SUPPLY — IGNITION SW. IN “ACC” OR “ON”

PG-POWER-06

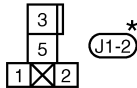
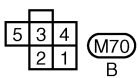
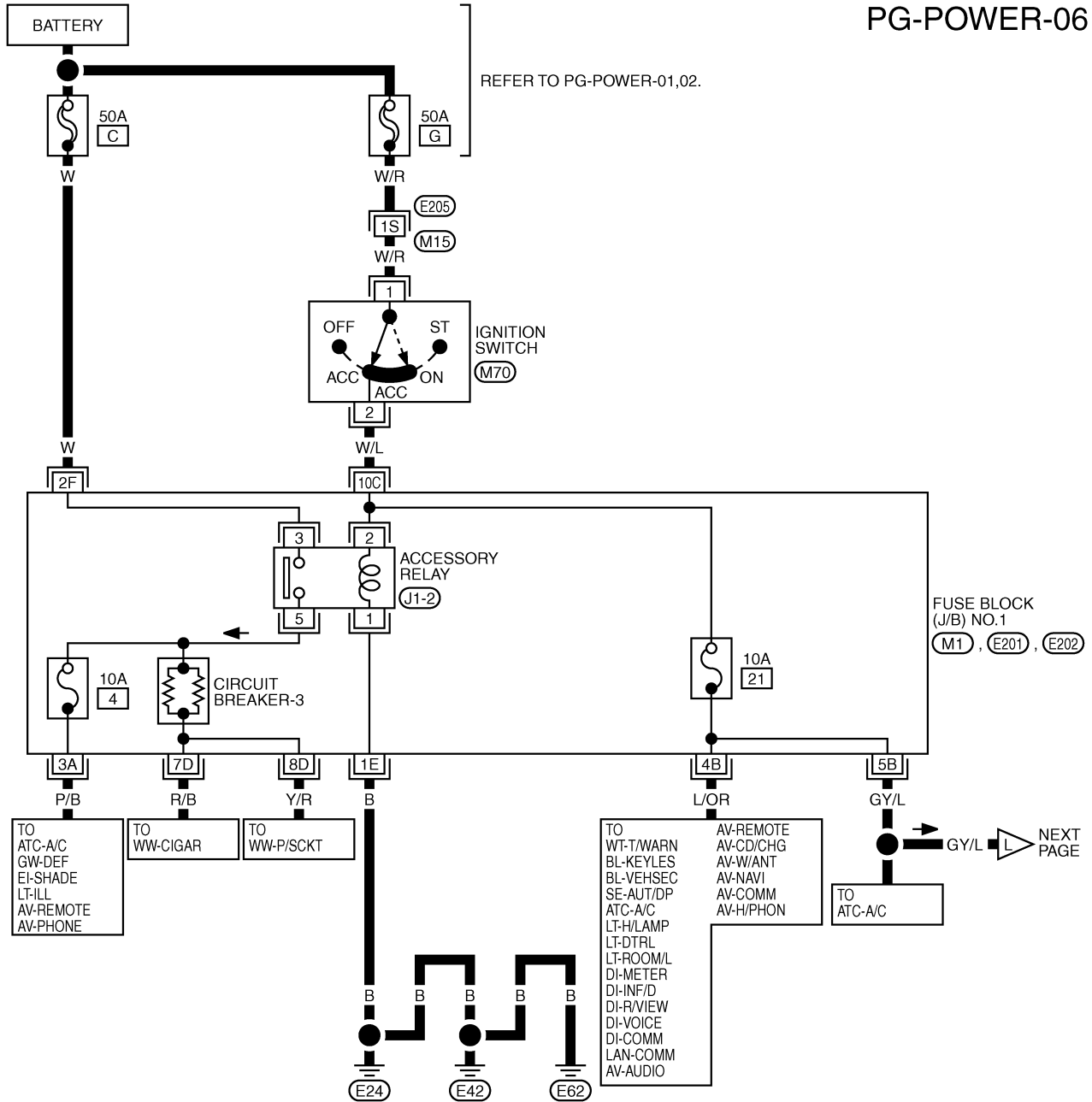

*: THIS CONNECTOR IS NOT SHOWN IN "HARNESS LAYOUT".

REFER TO THE FOLLOWING.

(E205) -SUPER MULTIPLE JUNCTION (SMJ)

(M1), (E201), (E202) -FUSE BLOCK-JUNCTION BOX (J/B) NO.1

1	2	3	4	5	6	7	8	9	10	11
12	13	14	15	16	17	18	19	20	21	22

TKWM3847E

POWER SUPPLY ROUTING

PG-POWER-07

A
B
C
D
E
F
G
H
I
J
PG
L
M

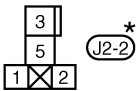
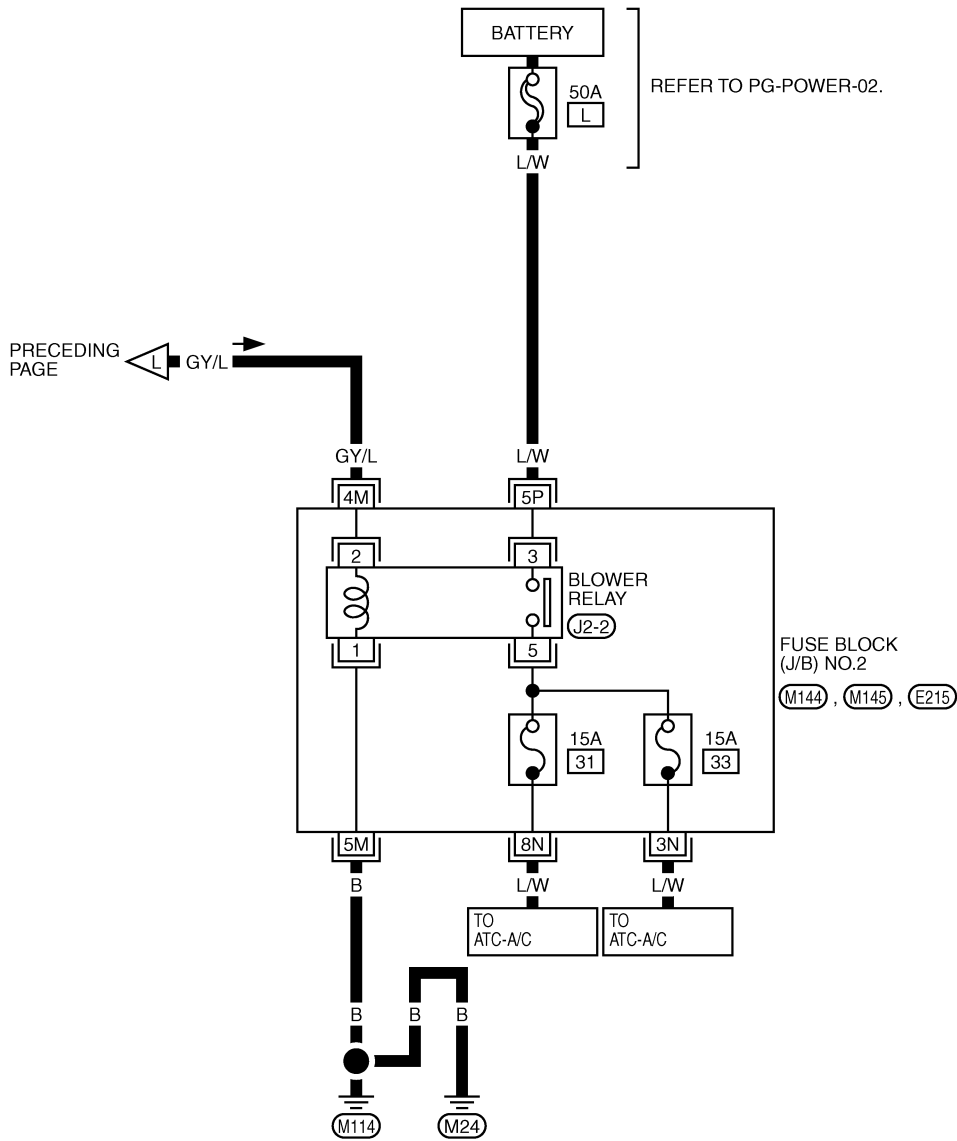

*: THIS CONNECTOR IS NOT SHOWN IN "HARNESS LAYOUT".

REFER TO THE FOLLOWING.

(M144), (M145), (E215) -FUSE
BLOCK-JUNCTION BOX
(J/B) NO.2

31	32	33	34	35	36	37	38
----	----	----	----	----	----	----	----

TKWM1449E

POWER SUPPLY ROUTING

PG-POWER-09

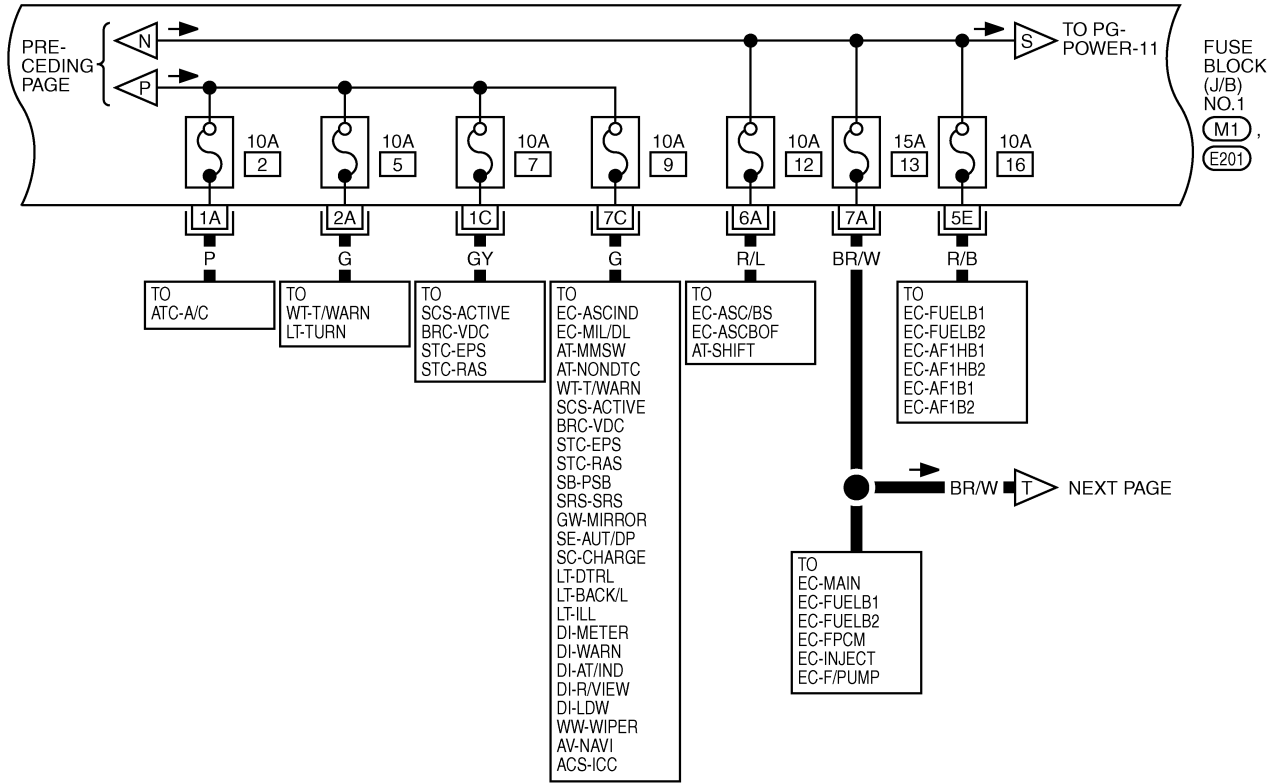

REFER TO THE FOLLOWING.

M1, E201 -FUZE BLOCK-
JUNCTION BOX (J/B) NO.1

1	2	3	4	5	6	7	8	9	10	11
12	13	14	15	16	17	18	19	20	21	22

TKWM3849E

POWER SUPPLY ROUTING

PG-POWER-10

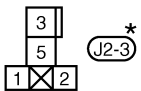
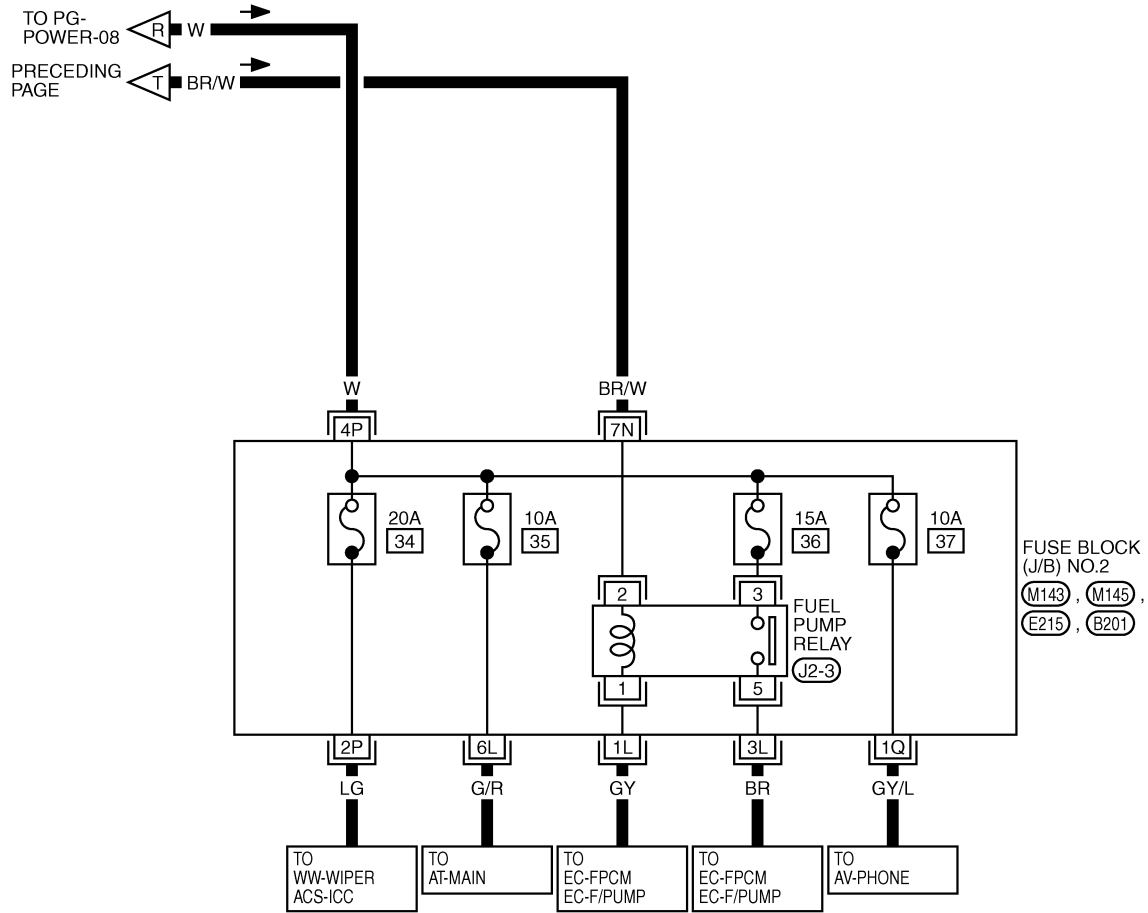

*: THIS CONNECTOR IS NOT SHOWN IN "HARNESS LAYOUT".

REFER TO THE FOLLOWING.

M143, M145, E215, B201
- FUSE BLOCK-JUNCTION BOX (J/B) NO.2

31 32 33 34 35 36 37 38

TKWM3850E

POWER SUPPLY ROUTING

PG-POWER-11

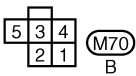
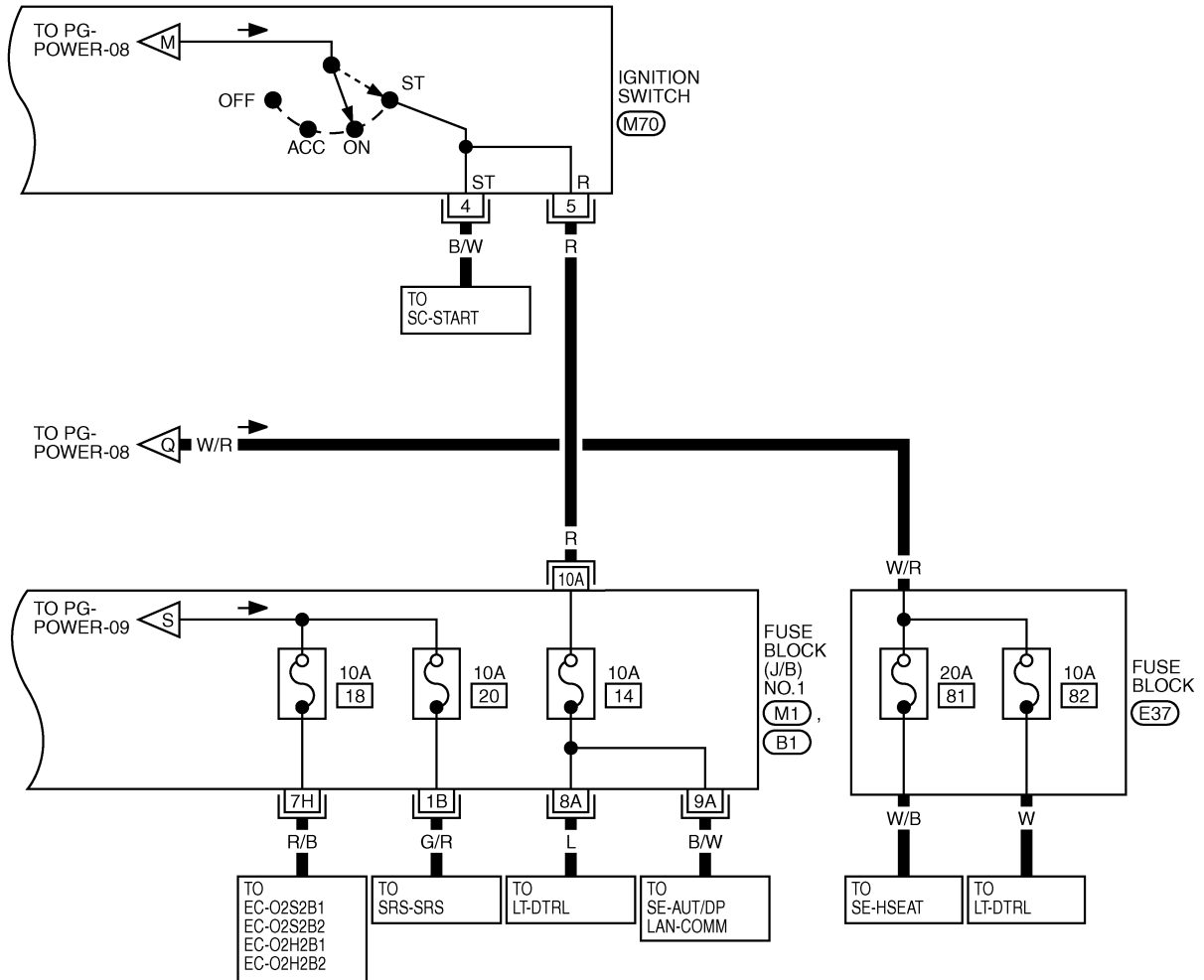

REFER TO THE FOLLOWING.

(M1), (B1) - FUSE BLOCK-JUNCTION BOX (J/B) NO.1

1	2	3	4	5	6	7	8	9	10	11
12	13	14	15	16	17	18	19	20	21	22

TKWM3851E

POWER SUPPLY ROUTING

Fuse

NKS001LL

- If fuse is blown, be sure to eliminate cause of malfunction before installing new fuse.
- Use fuse of specified rating. Never use fuse of more than specified rating.
- Do not partially install fuse; always insert it into fuse holder properly.
- Remove fuse for "ELECTRICAL PARTS (BAT)" if vehicle is not used for a long period of time.

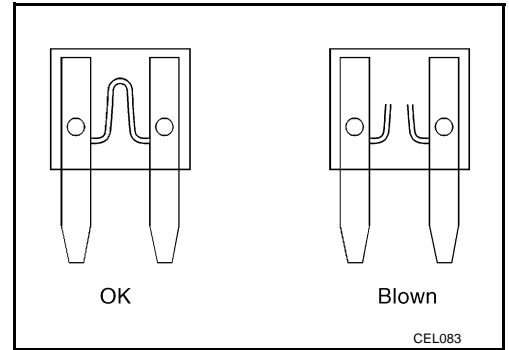

Fusible Link

NKS001LM

A melted fusible link can be detected either by visual inspection or by feeling with finger tip. If its condition is questionable, use circuit tester or test lamp.

CAUTION:

- If fusible link should melt, it is possible that critical circuit (power supply or large current carrying circuit) is shorted. In such a case, carefully check and eliminate cause of malfunction.
- Never wrap outside of fusible link with vinyl tape. Important: Never let fusible link touch any other wiring harness, vinyl or rubber parts.

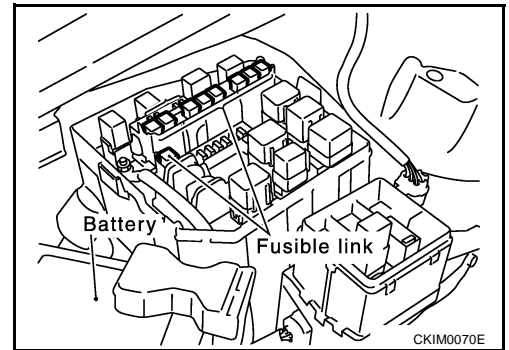

Circuit Breaker

NKS001LN

The PTC thermistor generates heat in response to current flow. The temperature (and resistance) of the thermistor element varies with current flow. Excessive current flow will cause the element's temperature to rise. When the temperature reaches a specified level, the electrical resistance will rise sharply to control the circuit current. Reduced current flow will cause the element to cool. Resistance falls accordingly and normal circuit current flow is allowed to resume.

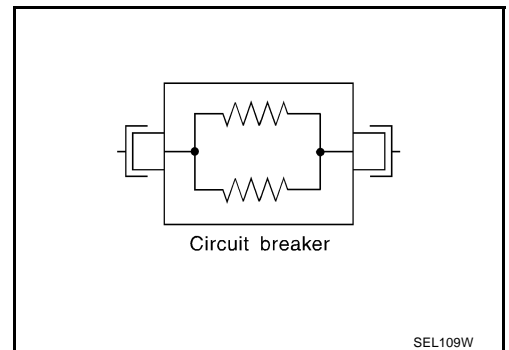

GROUND

GROUND

PFP:00011

Ground Distribution MAIN HARNESS

NKS001LO

A
B
C
D
E
F
G
H
I
J
PG
L
M

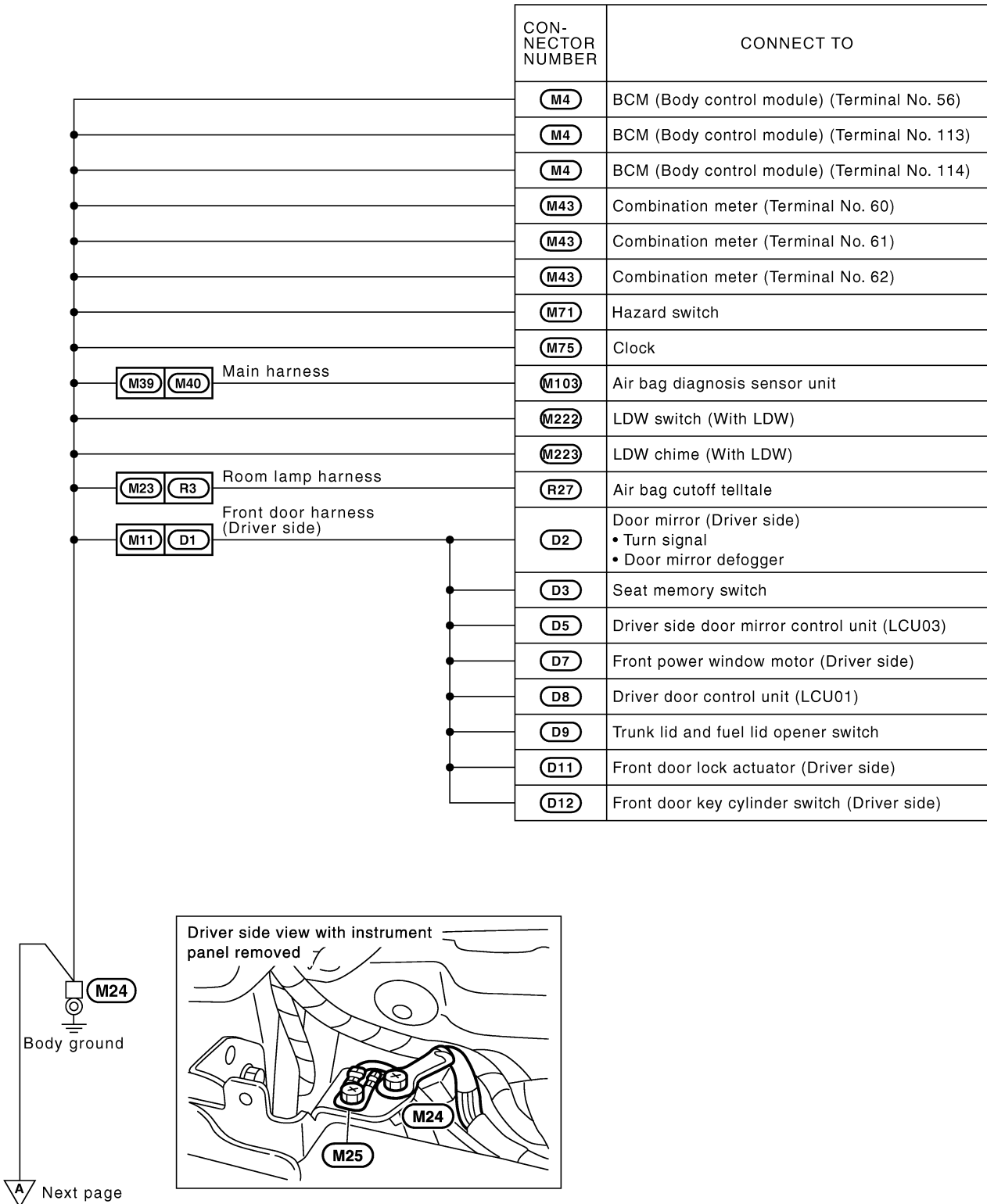

GROUND

A Preceding page

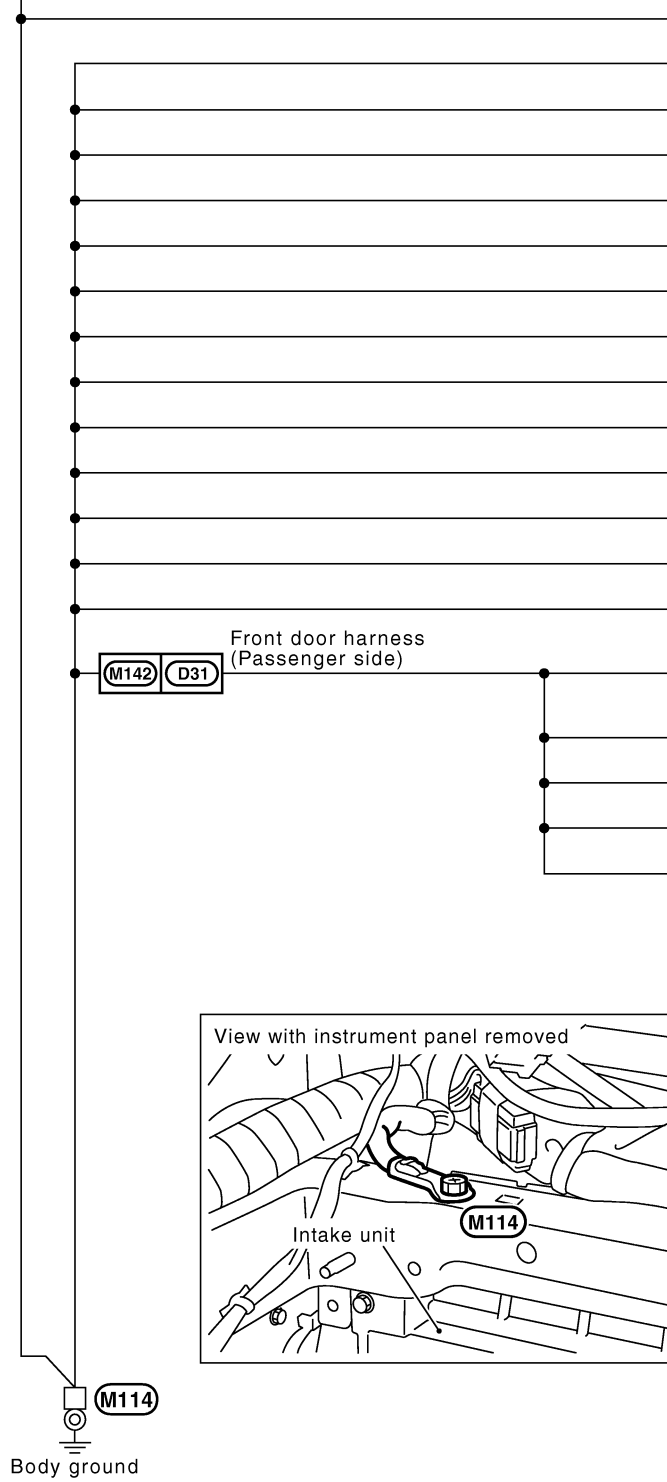

CON-NECTOR NUMBER	CONNECT TO
M22	ICC warning chime (With LDW and ICC)
M82	Display (Terminal No. 22)
M82	Display (Terminal No. 24)
M83	Multifunction switch
M91	Combination flasher unit
M92	Front cigarette lighter socket
M96	Handset (Option)
M97	A/T device
M100	Front power socket
M102	Console box lamp
M106	Mode door motor (Passenger side)
M107	Air mix door motor (Passenger side)
M109	CD auto changer
M144	Fuse block (J/B) No. 2 • Blower relay
D32	Door mirror (Passenger side) • Turn signal • Door mirror defogger
D35	Passenger side door mirror control unit (LCU04)
D37	Front power window motor (Passenger side)
D39	Passenger door control unit
D41	Front door lock actuator (Passenger side)

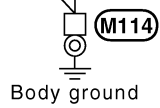
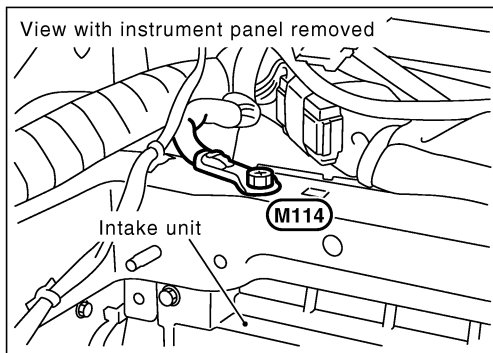

CKIM0611E

GROUND

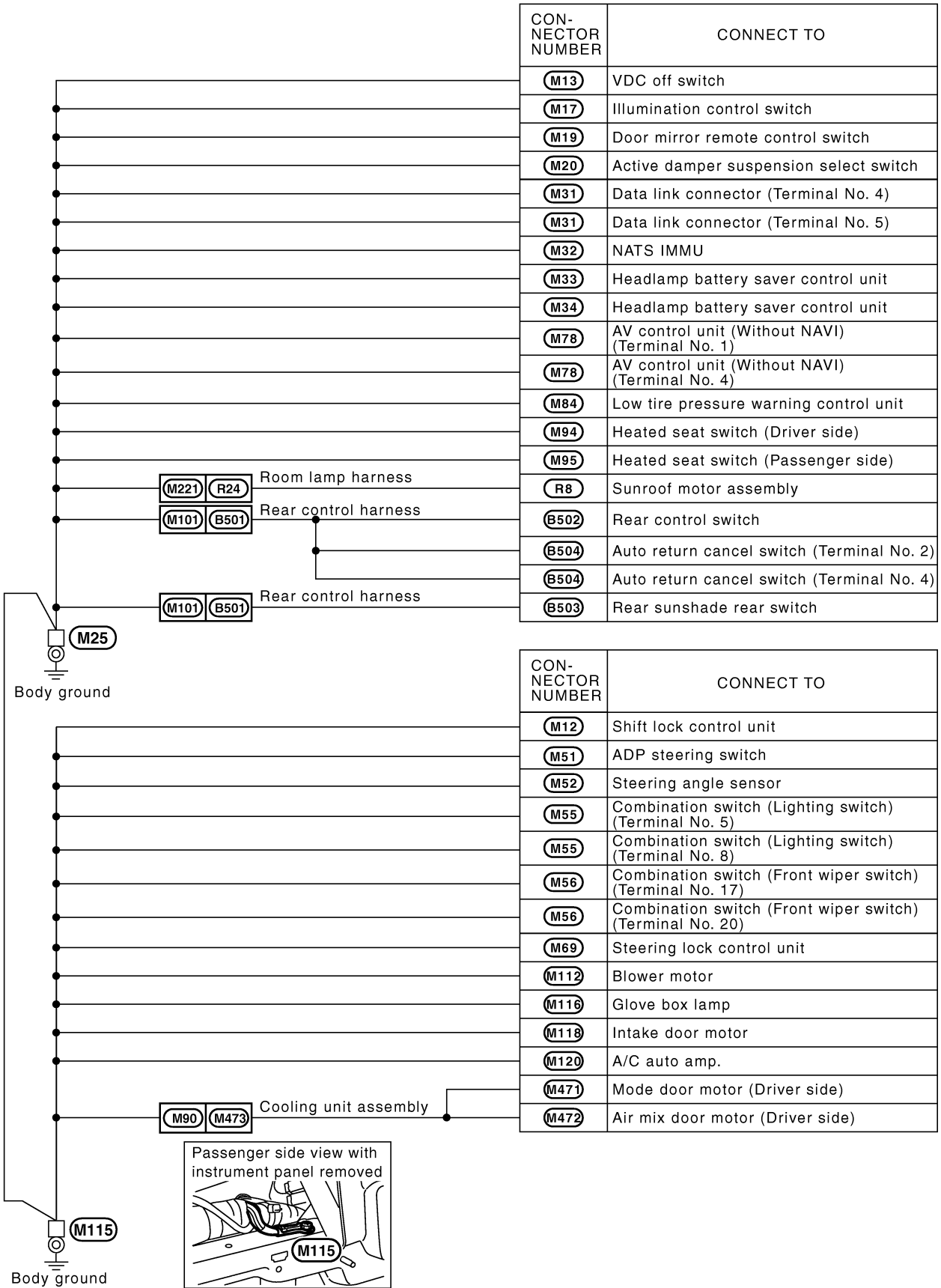

A
B
C
D
E
F
G
H
I
J
PG
L
M

CKIM0612E

GROUND

ENGINE ROOM HARNESS

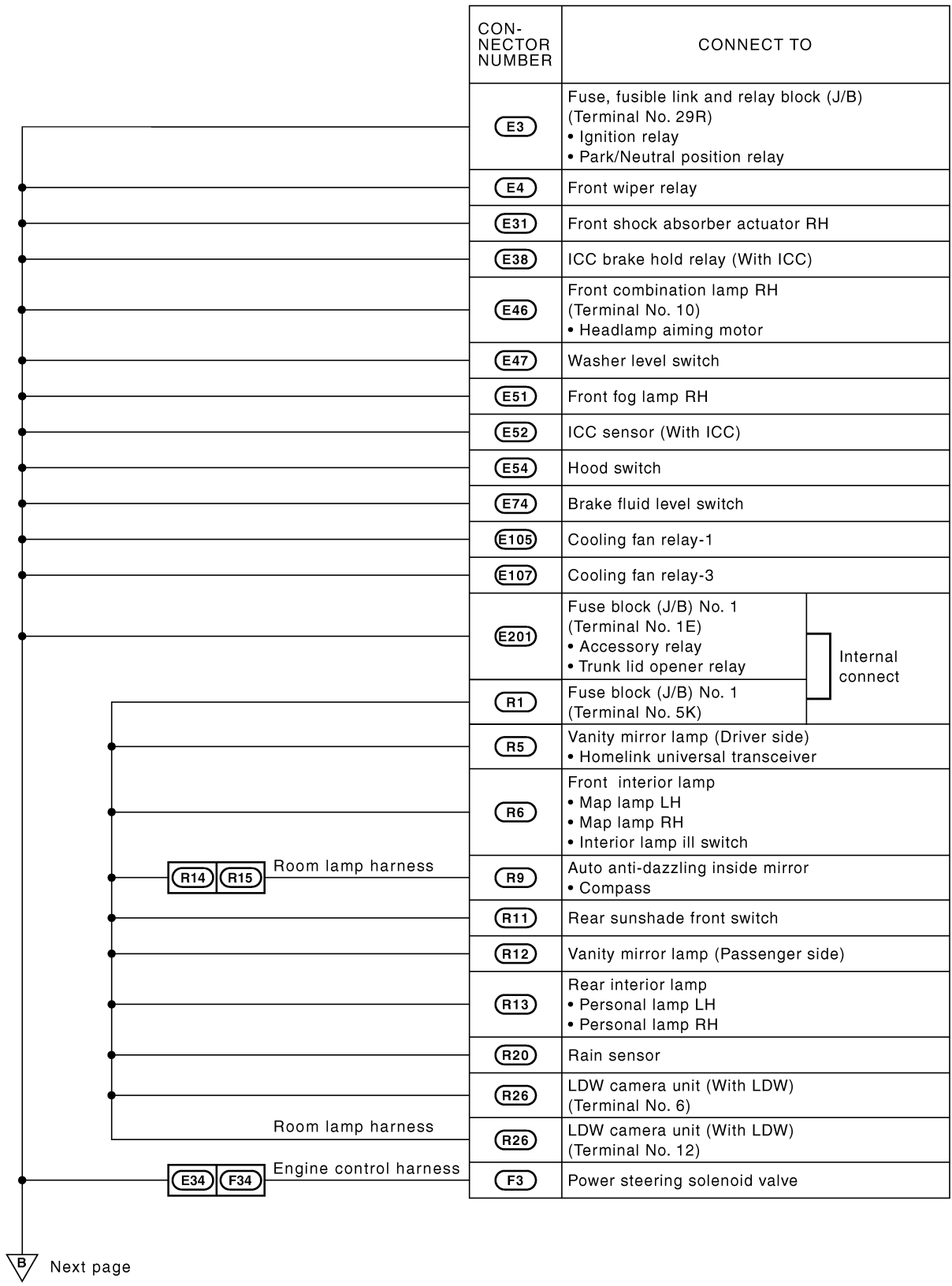

CKIM0613E

GROUND

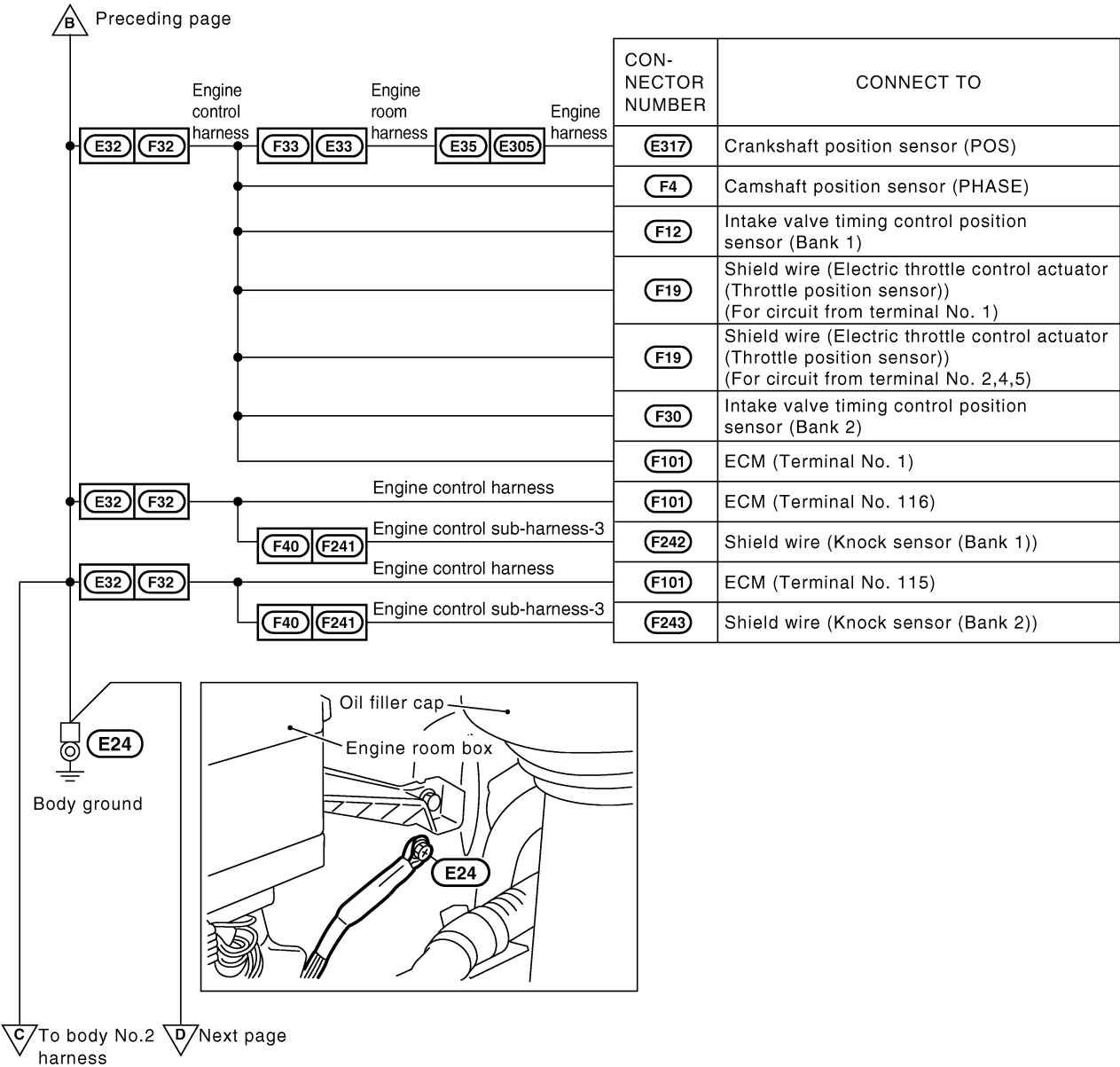

A
B
C
D
E
F
G
H
I
J
L
M

PG

CKIM0614E

GROUND

△ Preceding page

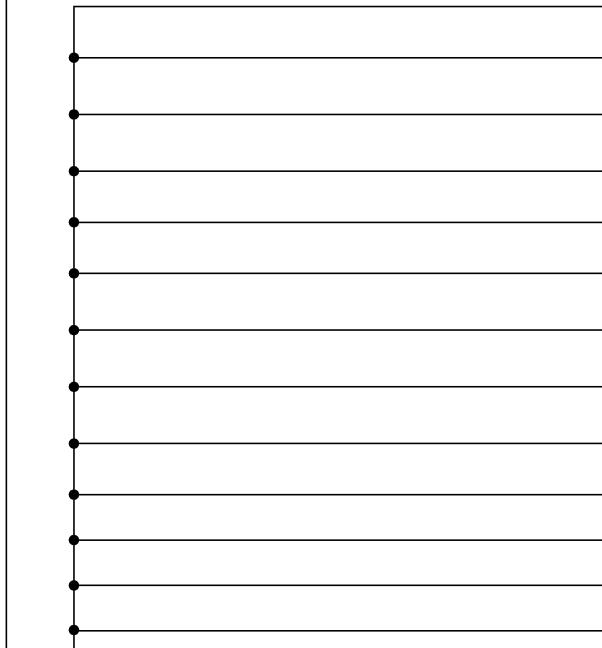
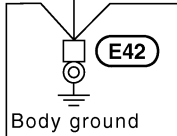
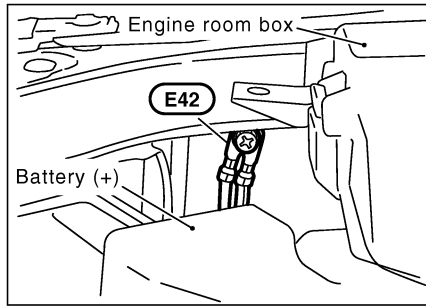

CON-NECTOR NUMBER	CONNECT TO
E45	Front combination lamp RH (Terminal No. 8) • Headlamp
E65	Front combination lamp LH (Terminal No. 6) • Parking
E26	Daytime light control unit
E45	Front combination lamp RH (Terminal No. 2) • Turn signal
E45	Front combination lamp RH (Terminal No. 6) • Parking
E46	Front combination lamp RH (Terminal No. 16) • Side marker
E61	Front shock absorber actuator LH
E65	Front combination lamp LH (Terminal No. 2) • Turn signal
E65	Front combination lamp LH (Terminal No. 8) • Headlamp
E66	Front combination lamp LH (Terminal No. 10) • Headlamp aiming motor
E66	Front combination lamp LH (Terminal No. 16) • Side marker
E71	Front fog lamp LH
E75	Front wiper motor
E103	Cooling fan motor-1 (Terminal No. 3)
E103	Cooling fan motor-1 (Terminal No. 4)

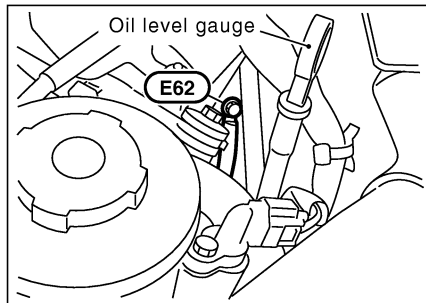
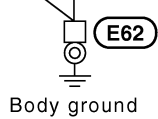

CKIM0615E

GROUND

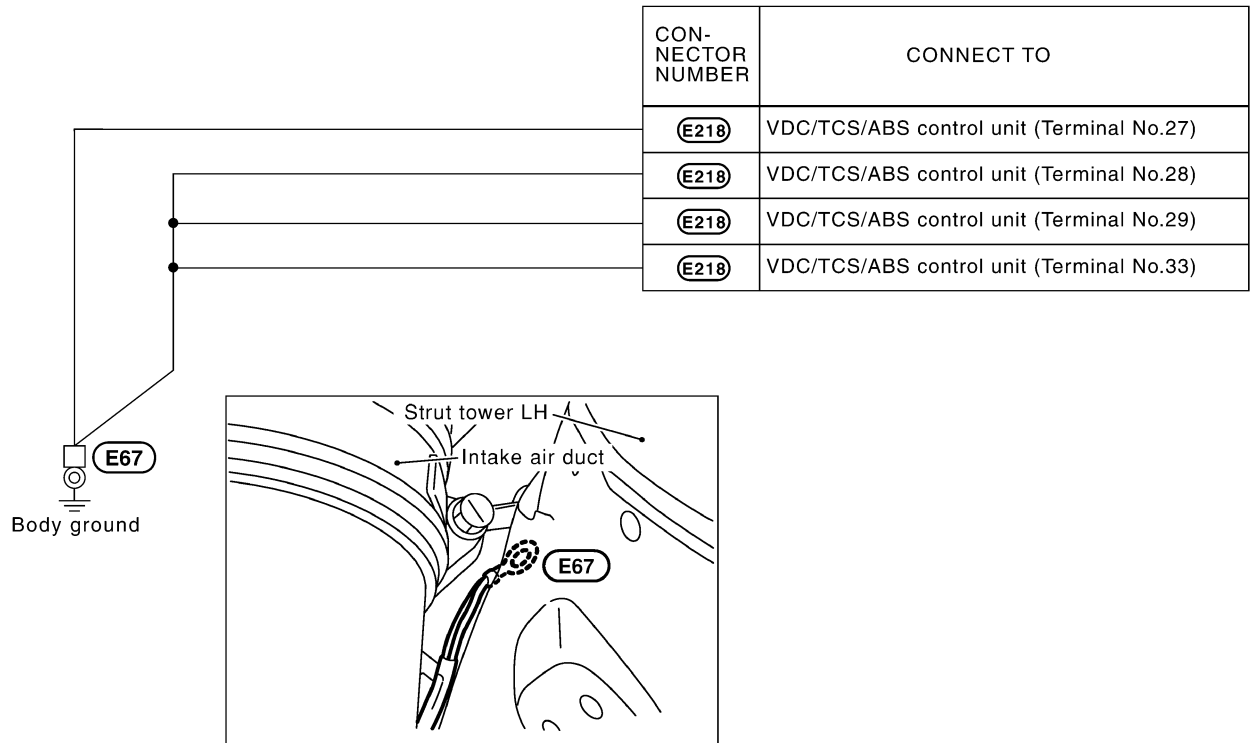
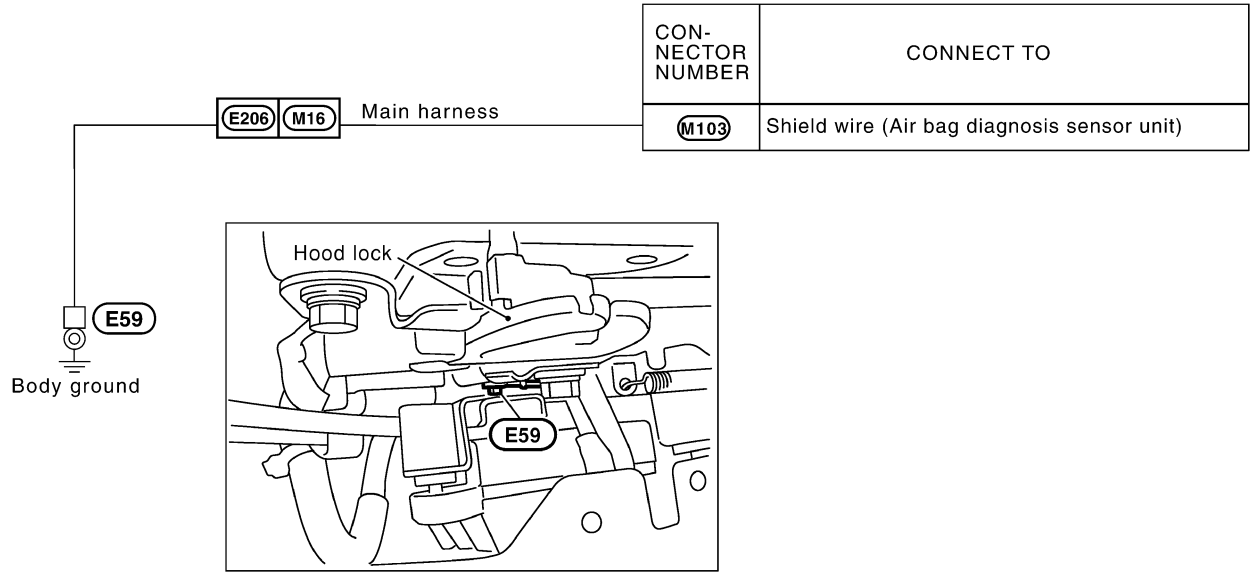

CKIM0156E

A
B
C
D
E
F
G
H
I
J
PG
L
M

GROUND

ENGINE HARNESS

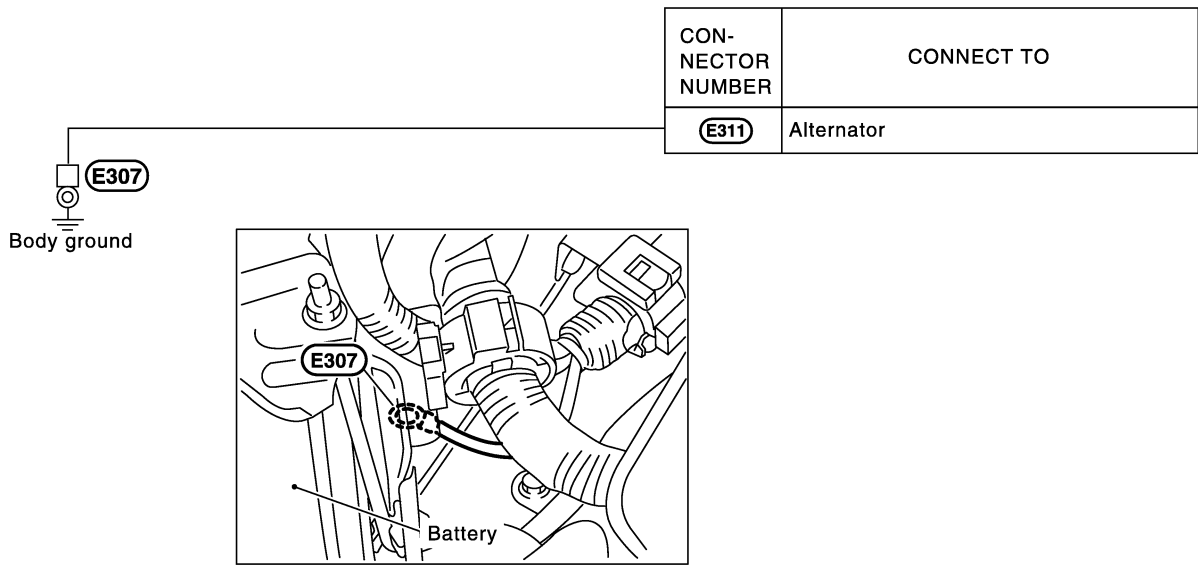

CKIM0018E

GROUND

ENGINE CONTROL HARNESS

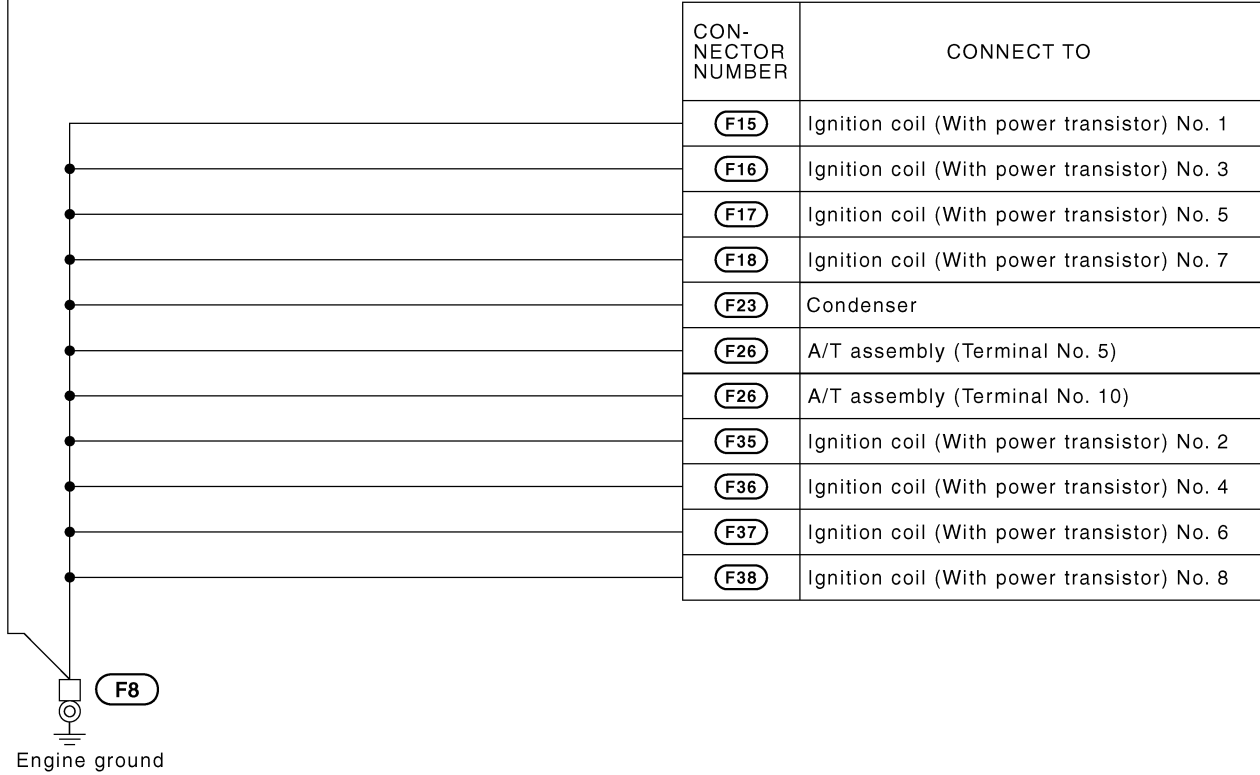
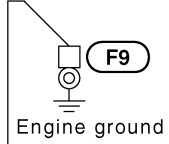
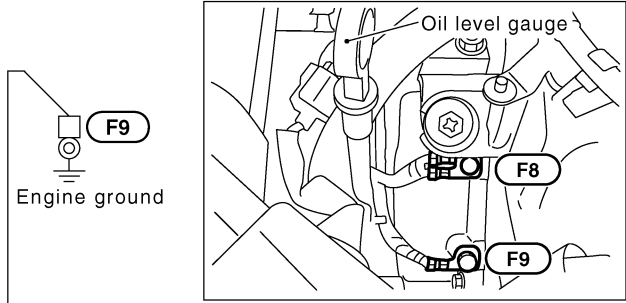

A
B
C
D
E
F
G
H
I
J
PG
L
M

CKIM0331E

GROUND

BODY HARNESS

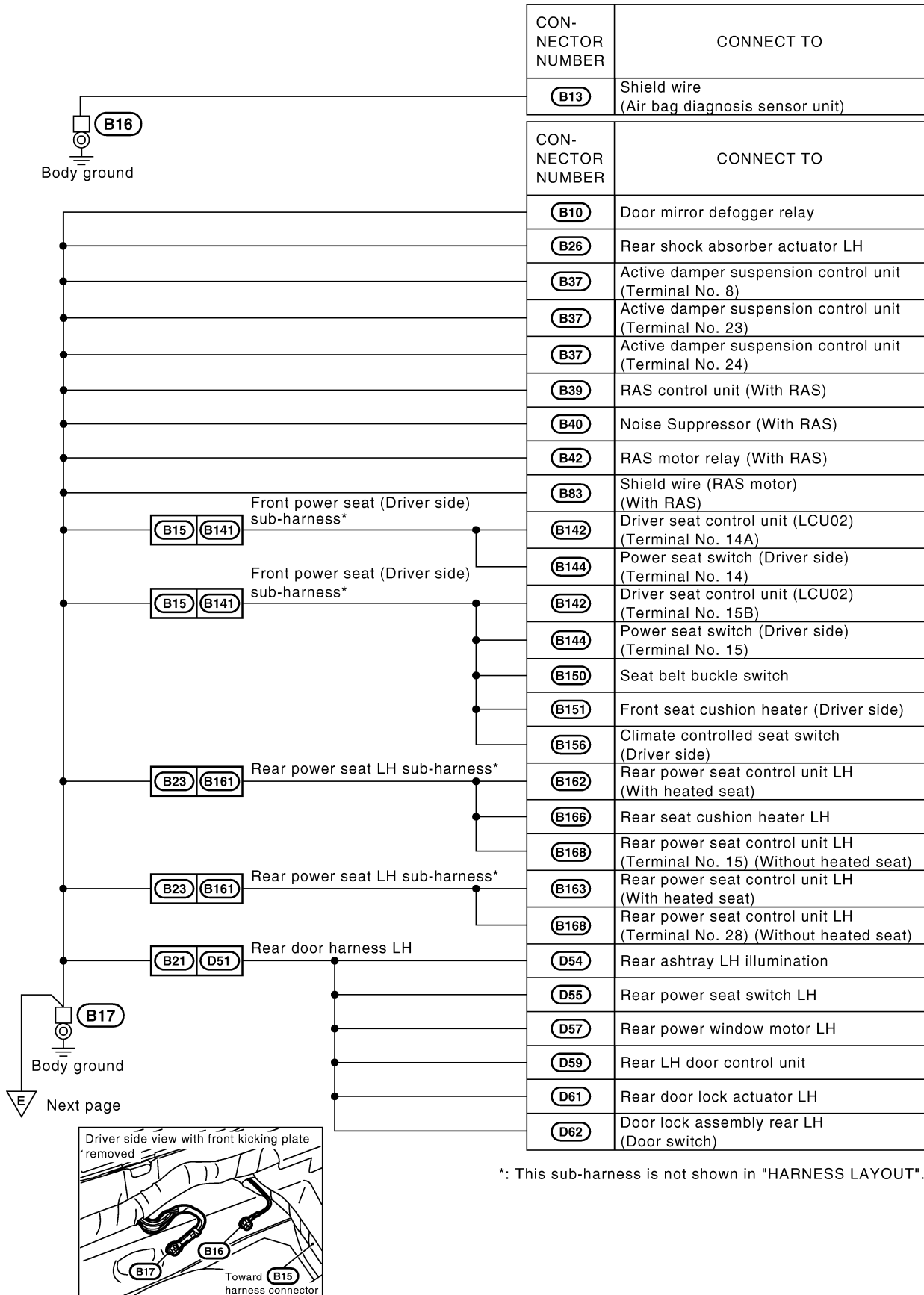

*: This sub-harness is not shown in "HARNES LAYOUT".

CKIM0616E

GROUND

△ E Preceding page

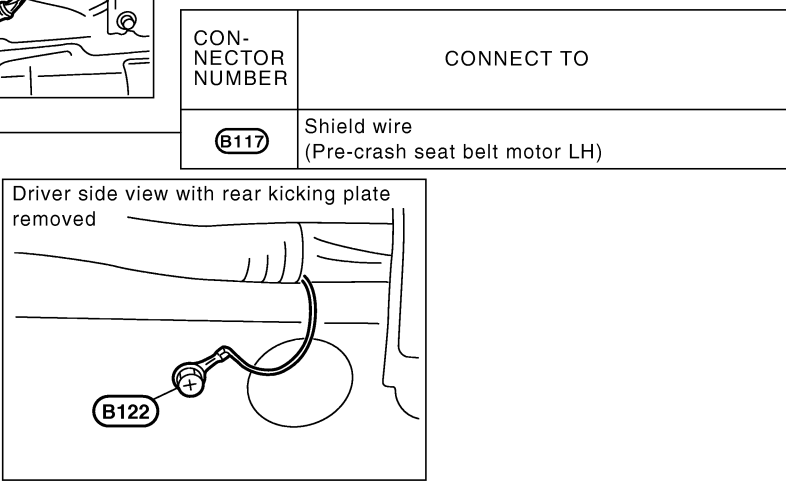
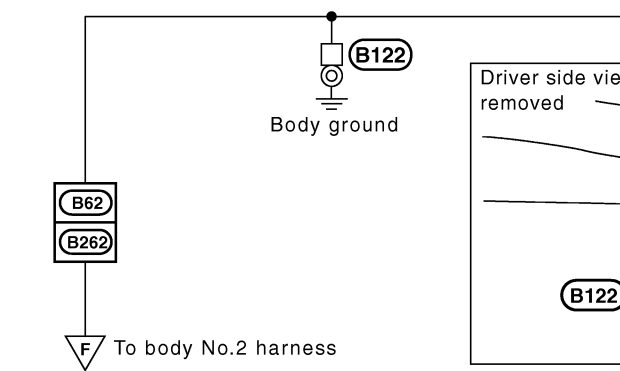
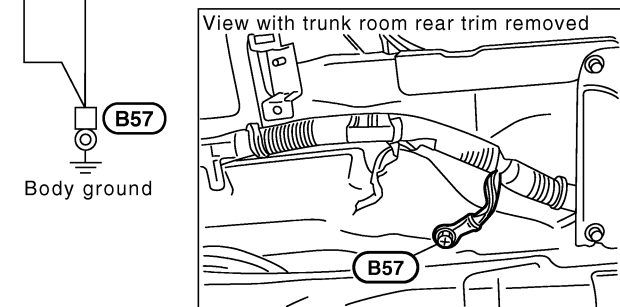
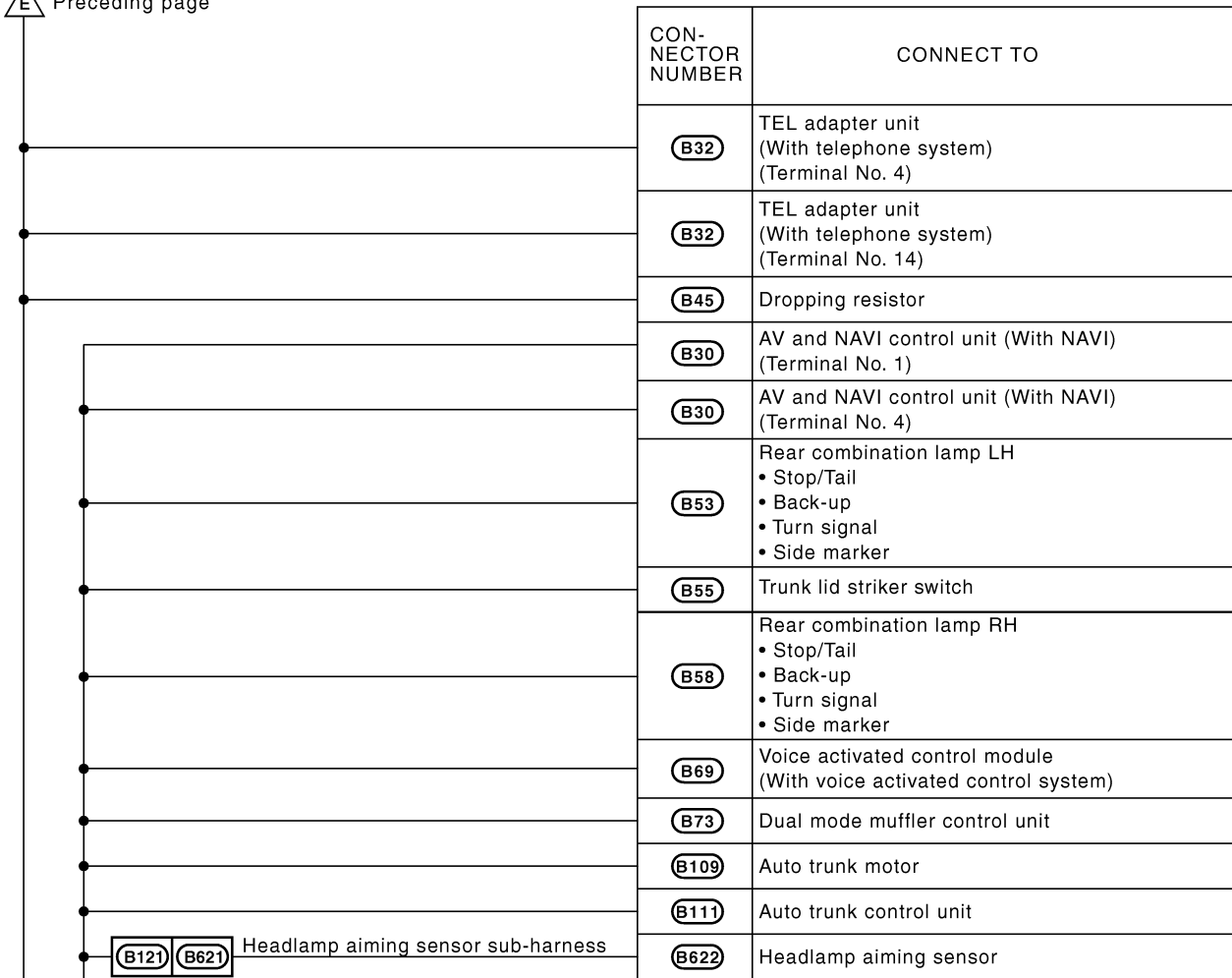

A
B
C
D
E
F
G
H
I
J
PG
L
M

CKIM0617E

GROUND

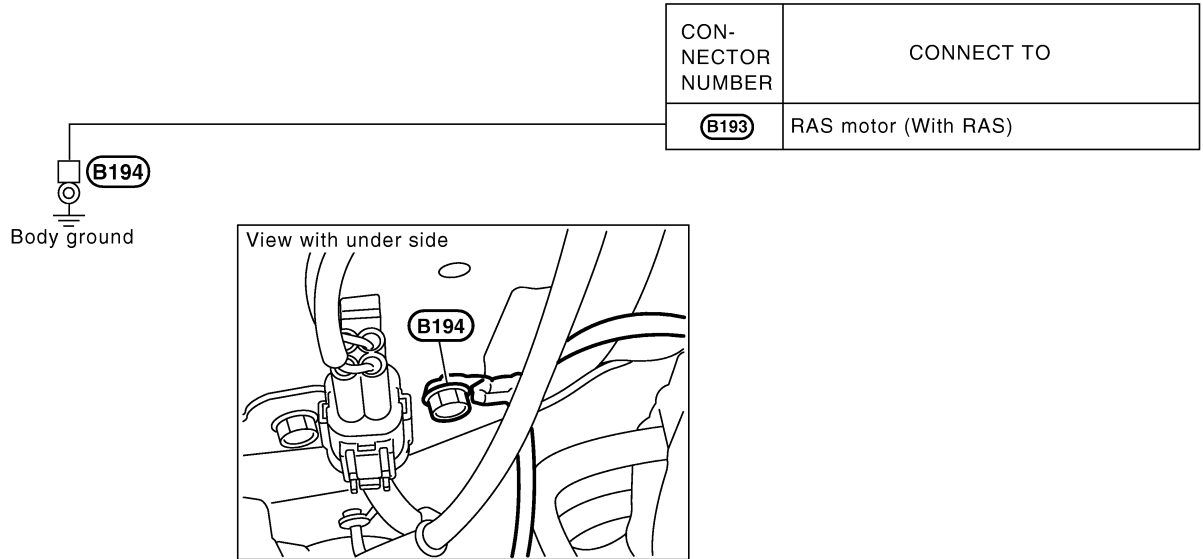

CKIM0618E

GROUND

BODY NO. 2 HARNESS

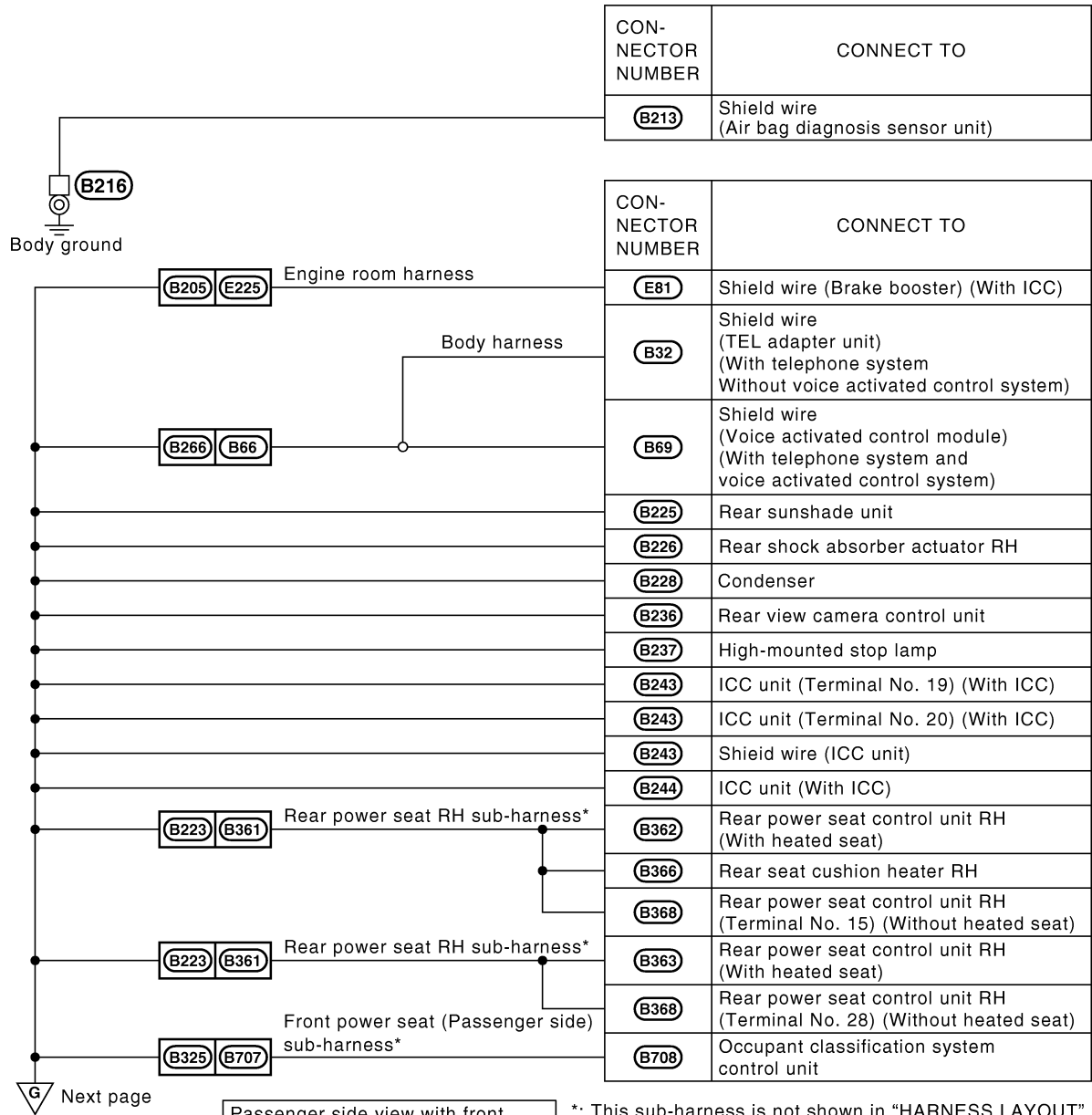

Next page

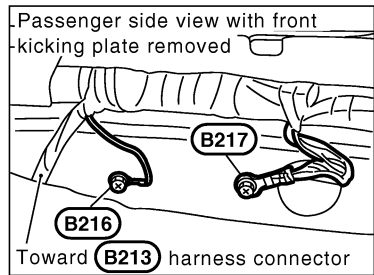

*: This sub-harness is not shown in "HARNESS LAYOUT".

A
B
C
D
E
F
G
H
I
J
PG
L
M

CKIM0619E

GROUND

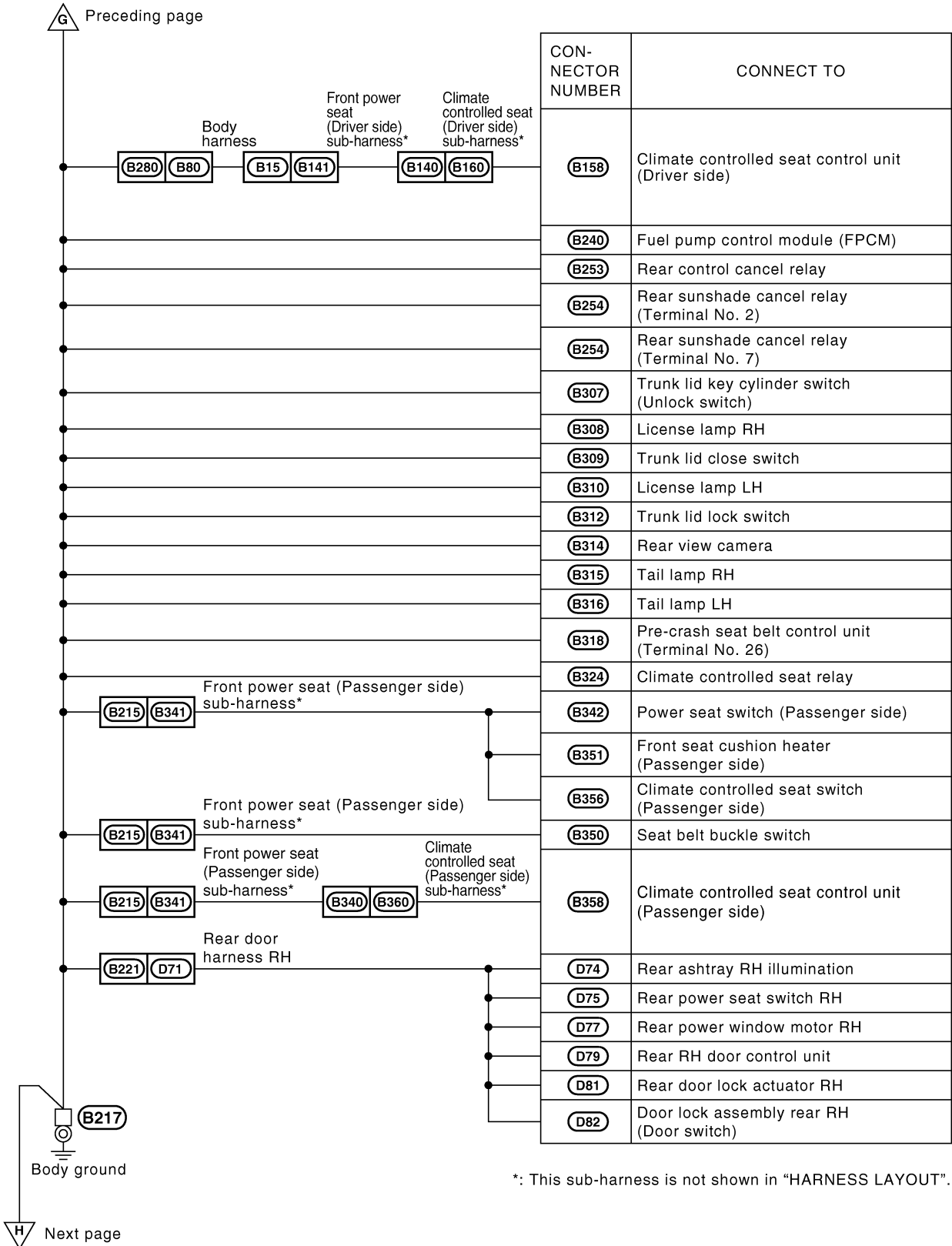

CKIM0620E

GROUND

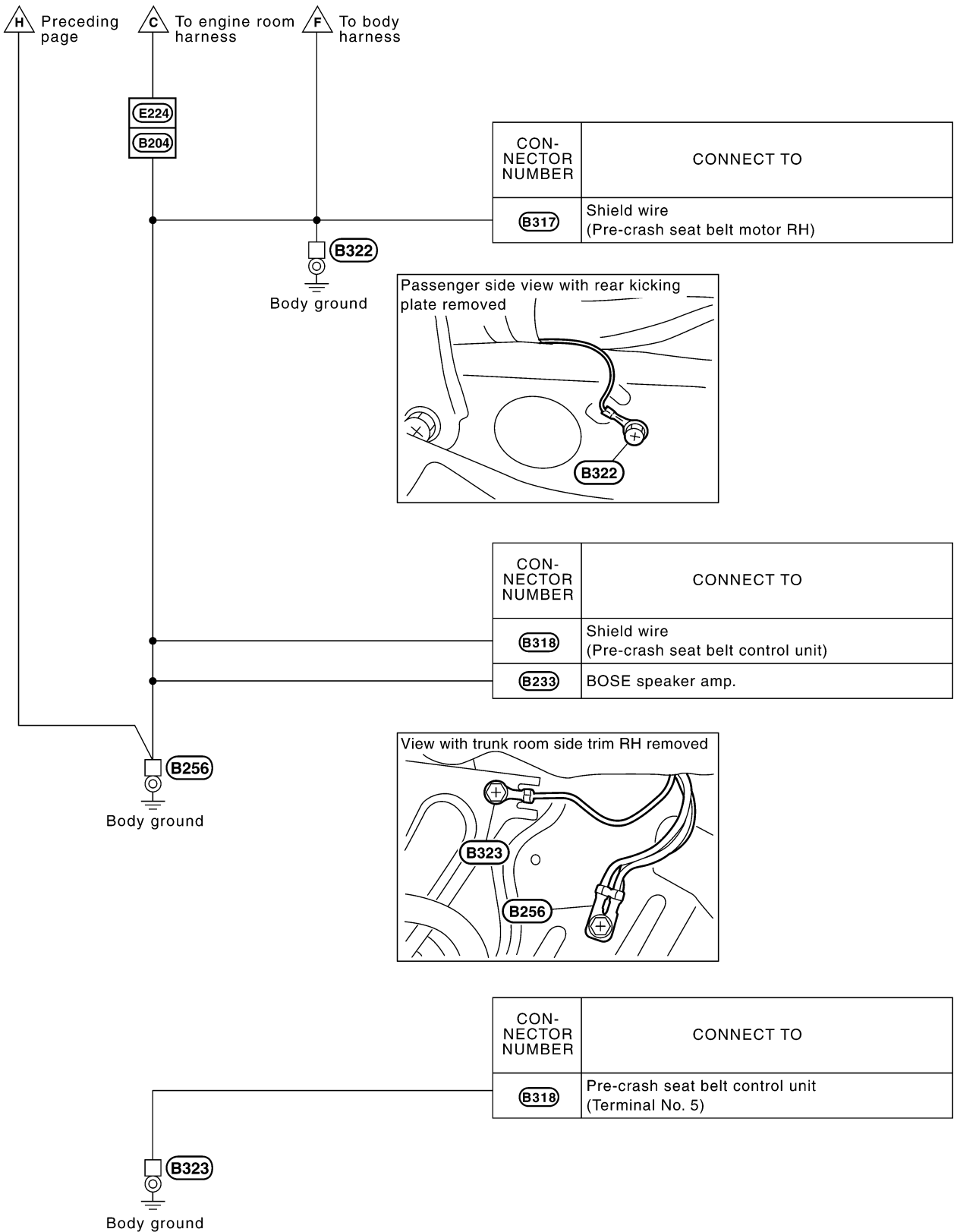

A
B
C
D
E
F
G
H
I
J
PG
L
M

CKIM0336E

GROUND

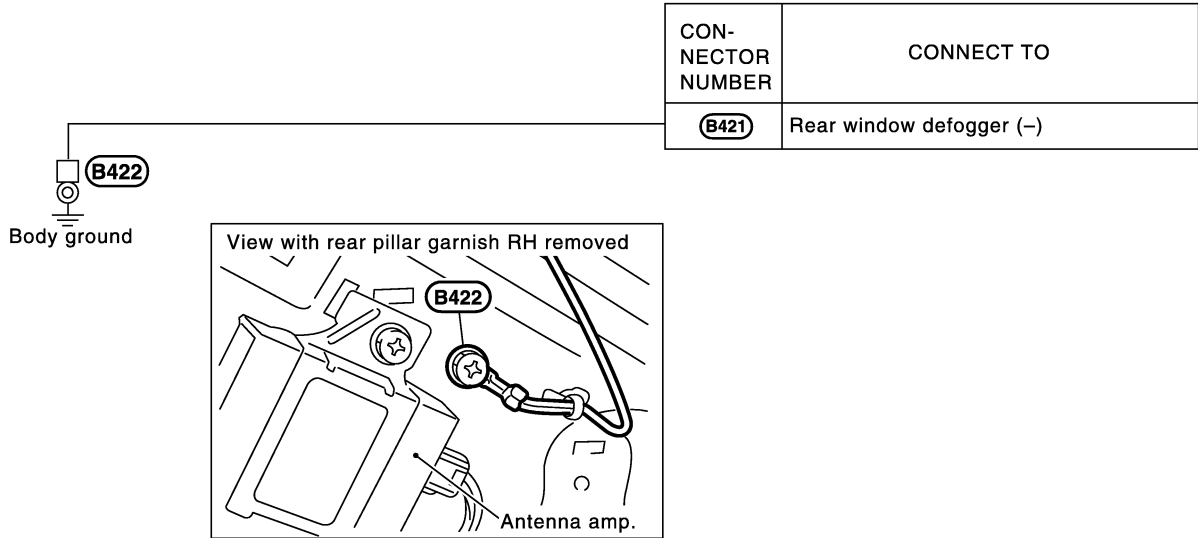

CKIM0024E

HARNESS

PPF:00011

Harness Layout

NKS001LP

HOW TO READ HARNESS LAYOUT

The following Harness Layouts use a map style grid to help locate connectors on the figures:

- Main Harness
- Engine Room Harness (Engine Compartment)
- Engine Control Harness
- Body Harness and Rear Control Harness
- Body No. 2 Harness

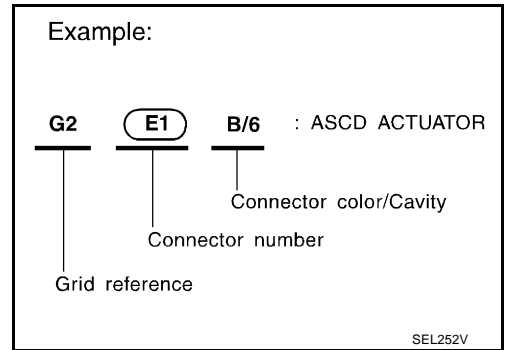

To Use the Grid Reference

1. Find the desired connector number on the connector list.
2. Find the grid reference.
3. On the figure, find the crossing of the grid reference letter column and number row.
4. Find the connector number in the crossing zone.
5. Follow the line (if used) to the connector.

CONNECTOR SYMBOL

Main symbols of connector (in Harness Layout) are indicated in the below.

Connector type	Water proof type		Standard type	
	Male	Female	Male	Female
<ul style="list-style-type: none"> • Cavity: Less than 4 • Relay connector 				
<ul style="list-style-type: none"> • Cavity: From 5 to 8 				
<ul style="list-style-type: none"> • Cavity: More than 9 	—	—		
<ul style="list-style-type: none"> • Ground terminal etc. 	—			

SKIA0404E

A
B
C
D
E
F
G
H
I
J
PG
L
M

HARNESS

OUTLINE

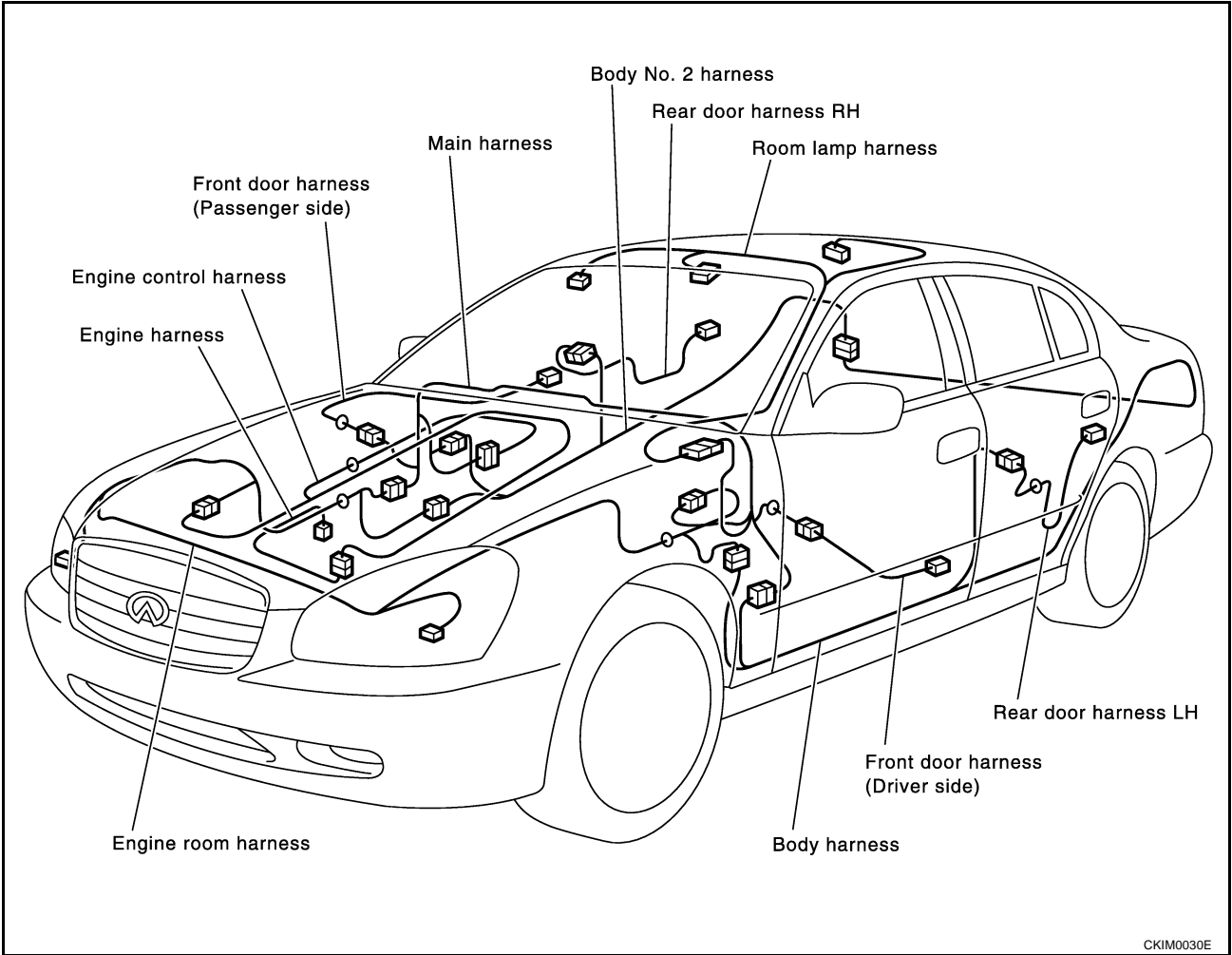

HARNESS

MAIN HARNESS

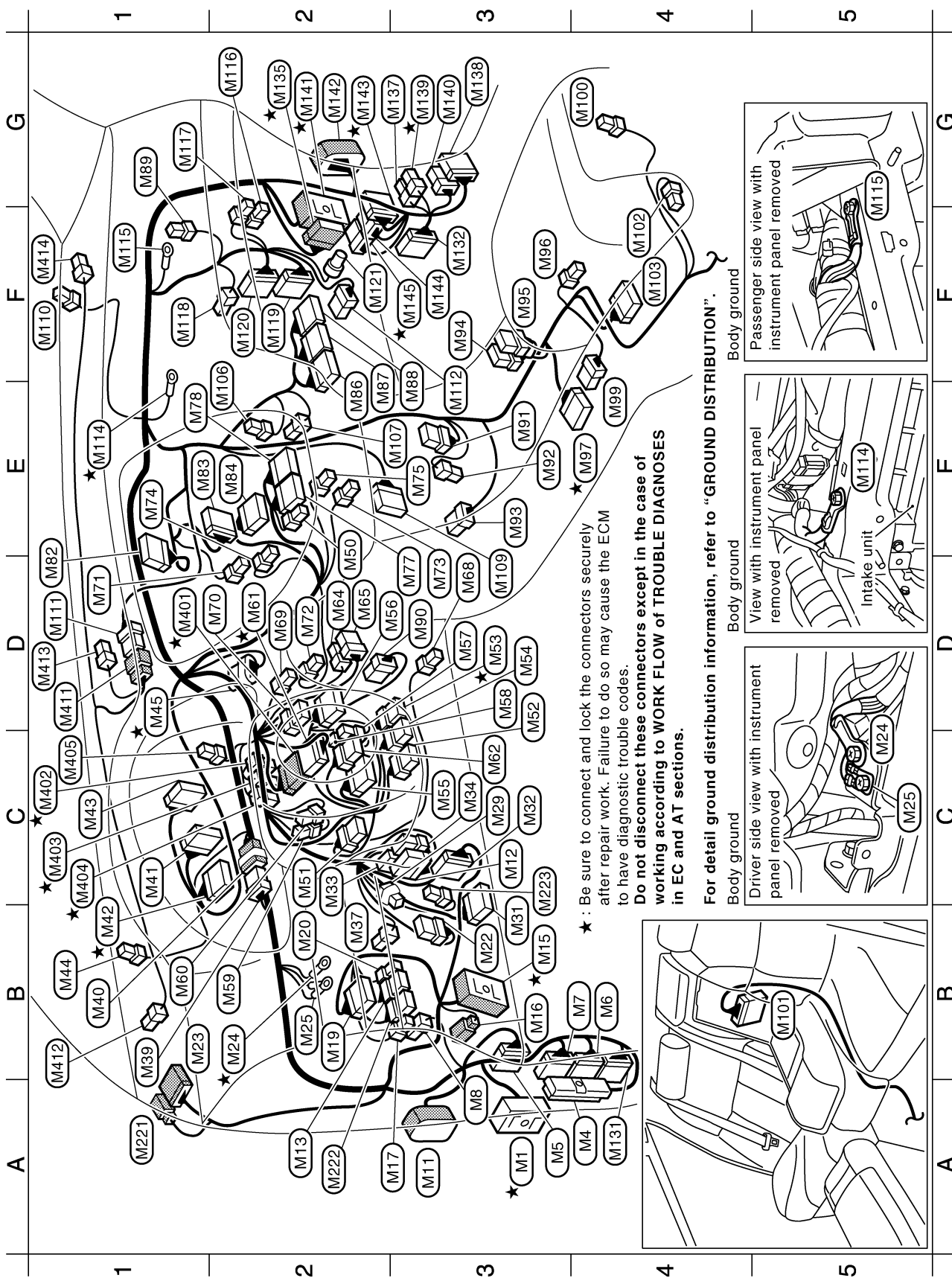

★ : Be sure to connect and lock the connectors securely after repair work. Failure to do so may cause the ECM to have diagnostic trouble codes.
Do not disconnect these connectors except in the case of working according to WORK FLOW of TROUBLE DIAGNOSES in EC and AT sections.

For detail ground distribution information, refer to "GROUND DISTRIBUTION".

Body ground

Body ground

Body ground

Passenger side view with instrument panel removed

View with instrument panel removed
Intake unit

Driver side view with instrument panel removed

PG

TKIM0541E

Main harness

D1	(M82)	GY/24 : Display
E1	(M83)	W/20 : Multifunction switch
E2	(M84)	W/16 : Low tire pressure warning control unit
E2	(M86)	W/12 : Audio unit
E2	(M87)	W/16 : Audio unit
E3	(M88)	W/12 : Audio unit
G1	(M89)	BR/2 : Antenna amp. (Via sub-harness)
D3	(M90)	W/6 : Cooling unit assembly
E3	(M91)	W/8 : Combination flasher unit
E3	(M92)	W/3 : Front cigarette lighter socket
E3	(M93)	Br/6 : Rear vent door motor
F3	(M94)	W/6 : Heated seat switch (Driver side)
F3	(M95)	BR/6 : Heated seat switch (Passenger side)
F3	(M96)	W/4 : Handset (Option)
E4	(M97)	W/16 : A/T device
E4	(M99)	B/6 : Yaw rate/Side G sensor
G4	(M100)	B/2 : Front power socket
B5	(M101)	W/24 : To (B501)
F4	(M102)	W/2 : Console box lamp
F4	(M103)	Y/28 : Air bag diagnosis sensor unit
E2	(M106)	W/3 : Mode door motor (Passenger side)
E3	(M107)	W/3 : Air mix door motor (Passenger side)
D3	(M109)	W/16 : CD auto changer
F1	(M110)	W/3 : Optical sensor
D1	(M111)	W/6 : To (M411)
E3	(M112)	W/6 : Blower motor
E1	(M114)	— : Body ground
F1	(M115)	— : Body ground
G2	(M116)	W/2 : Glove box lamp
G1	(M117)	W/2 : Trunk lid opener cancel switch
F1	(M118)	W/3 : Intake door motor
F2	(M119)	GY/20 : A/C auto amp.
F2	(M120)	GY/16 : A/C auto amp.
F2	(M121)	Y/4 : Front passenger air bag module
A4	(M131)	BR/24 : To (B31)
F3	(M132)	W/24 : To (E222)
G2	(M135)	SMJ : To (F105)
G3	(M137)	W/3 : To (B207)
G3	(M138)	BR/24 : To (B208)

G3	(M139)	W/4 : To (B209)
G3	(M140)	GY/6 : To (B210)
G2	(M141)	SMJ : To (B211)
G2	(M142)	SMJ : To (D31)
G2	(M143)	W/10 : Fuse block (J/B) No.2
F3	(M144)	W/8 : Fuse block (J/B) No.2
F3	(M145)	W/8 : Fuse block (J/B) No.2
A1	(M221)	W/2 : To (R24)
A2	(M222)	GY/6 : LDW switch
C3	(M223)	BR/4 : LDW chime

Main sub-harness-1

D1	(M401)	W/10 : To (M61)
C1	(M402)	W/4 : Stop lamp switch
C1	(M403)	BR/2 : ASCD brake switch (Without ICC)
C1	(M404)	BR/2 : ICC brake switch (With ICC)
C1	(M405)	B/4 : Brake pedal stroke sensor

Main sub-harness-2

D1	(M411)	W/6 : To (M111)
B1	(M412)	BR/2 : Instrument speaker LH
D1	(M413)	BR/2 : Instrument speaker center
F1	(M414)	BR/2 : Instrument speaker RH

★ : Be sure to connect and lock the connectors securely after repair work.
 Failure to do so may cause the ECM to have diagnostic trouble codes.
Do not disconnect these connectors except in the case of working according to WORK FLOW of TROUBLE DIAGNOSES in EC and AT sections.

A
B
C
D
E
F
G
H
I
J
L
M
PG

C1	E1	— : Engine room box
A1	E2	— : Fuse, fusible link and relay box
C1	E3	SMJ : Fuse, fusible link and relay block (J/B)
A1	E4	B/5 : Front wiper relay
A1	E5	L/4 : Headlamp relay-2
D2	E20	GY/2 : Front wheel sensor RH
D1	E21	DGY/8 : VDC actuator
E1	E22	SB/8 : VDC actuator
E2	E23	B/2 : VDC actuator
D1	E24	— : Body ground
D3	E26	SB/8 : Daytime light control unit
D2	E27	SB/6 : Daytime light control unit
D2	E28	SB/4 : Daytime light control unit
D1	E31	GY/6 : Front shock absorber actuator RH
C3	E32	SB/8 : To F32
D2	E33	GY/10 : To F33
C2	E34	G/10 : To F34
C2	E35	GY/9 : To E305
B2	E37	— : Fuse block
B2	E38	GY/6 : ICC brake hold relay (With ICC)
B2	E42	— : Body ground
B3	E43	B/1 : Horn low
B2	E45	DGY/8 : Front combination lamp RH
B2	E46	SB/8 : Front combination lamp RH
B3	E47	BR/2 : Washer level switch
B3	E48	GY/2 : Front washer pump
B3	E49	B/3 : Refrigerant pressure sensor
B3	E51	B/2 : Front fog lamp RH
C4	E52	GY/6 : ICC sensor (With ICC)
C3	E54	GY/2 : Hood switch
D3	E55	GY/2 : VDC relay box
D3	E56	DGY/8 : VDC relay box
D3	E57	B/2 : VDC relay box
C3	E58	B/2 : Ambient sensor
C3	E59	— : Body ground
C3	E60	Y/2 : Crash zone sensor
E2	E61	GY/6 : Front shock absorber actuator LH
E3	E62	— : Body ground

E3	E63	B/1 : Horn high
E4	E65	DGY/8 : Front combination lamp LH
E4	E66	SB/8 : Front combination lamp LH
F2	E67	— : Body ground
E2	E70	GY/2 : Front wheel sensor LH
E4	E71	B/2 : Front fog lamp LH
G2	E72	— : Relay box-3
F2	E74	GY/2 : Brake fluid level switch
F2	E75	SB/6 : Front wiper motor
E2	E81	GY/6 : Brake booster
E2	E82	B/3 : Brake pressure sensor
C3	E103	SB/4 : Cooling fan motor-1
B3	E104	SB/4 : Cooling fan motor-2
B2	E105	BR/6 : Cooling fan relay-1
A2	E106	L/4 : Cooling fan relay-2
A3	E107	L/4 : Cooling fan relay-3
A2	E108	L/4 : Front fog lamp relay
A2	E109	B/5 : Front wiper rain relay

} (With ICC)

★ : Be sure to connect and lock the connectors securely after repair work.
 Failure to do so may cause the ECM to have diagnostic trouble codes.
Do not disconnect these connectors except in the case of working according to WORK FLOW of TROUBLE DIAGNOSES in EC and AT sections.

A
B
C
D
E
F
G
H
I
J

PG

L
M

HARNESS

Passenger Compartment

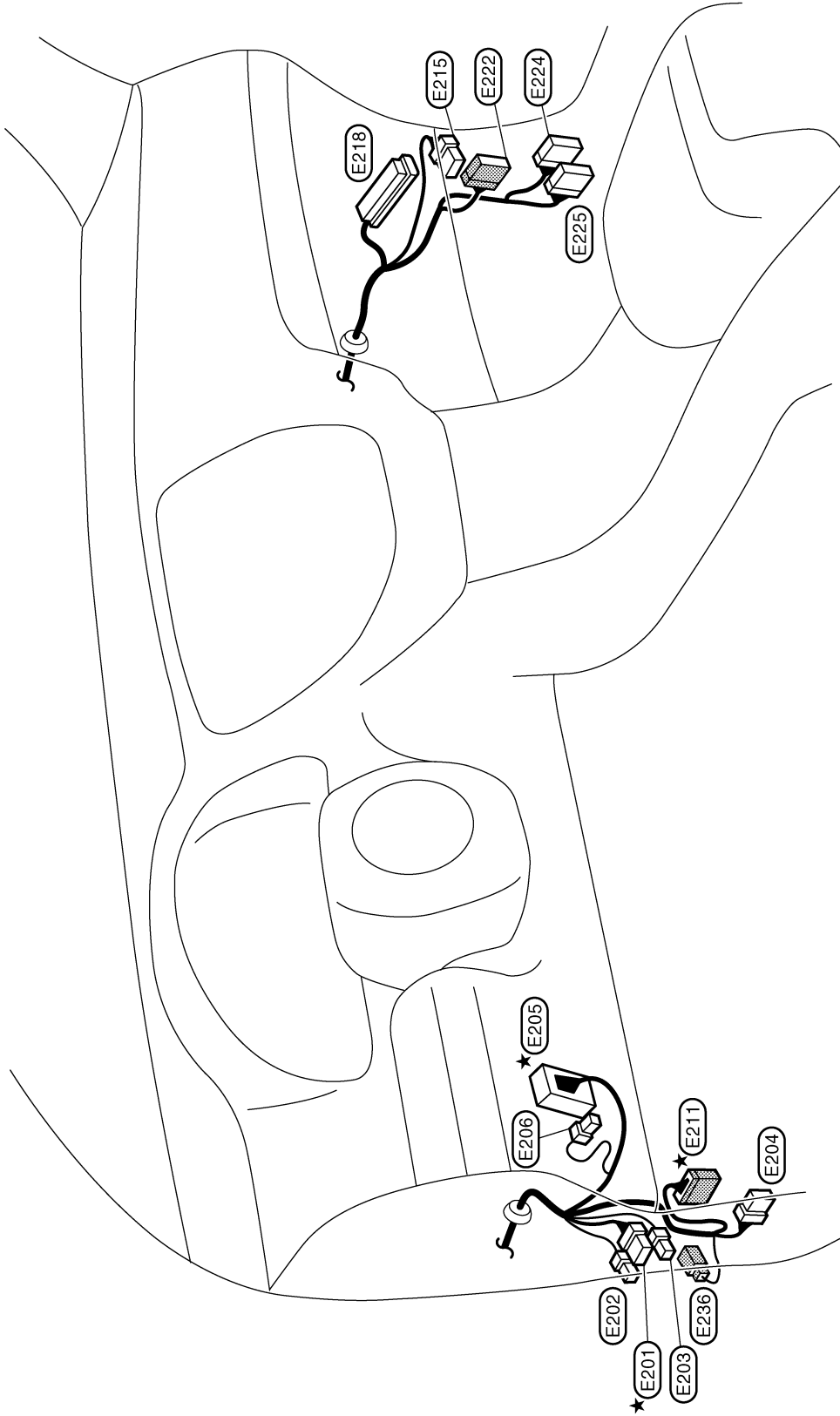

- E222 W/24 : To M132
- E224 W/12 : To B204
- E225 W/20 : To B205 (With ICC)
- E236 GY/1 : To B9 (With RAS)

- ★ E201 W/8 : Fuse block (J/B) No. 1
- E202 W/4 : Fuse block (J/B) No. 1
- E203 W/4 : Fuse block (J/B) No. 1
- E204 BR/8 : BCM (Body control module)
- ★ E205 SMJ : To M15
- E206 Y/4 : To M16
- ★ E211 W/20 : To B11
- E215 W/6 : Fuse block (J/B) No. 2
- E218 SMJ : VDC/TCS/ABS control unit

★ : Be sure to connect and lock the connectors securely after repair work.
 Failure to do so may cause the ECM to have diagnostic trouble codes.
Do not disconnect these connectors except in the case of working according to WORK FLOW of TROUBLE DIAGNOSES in EC and AT sections.

TKIM0545E

HARNESS

ENGINE CONTROL HARNESS

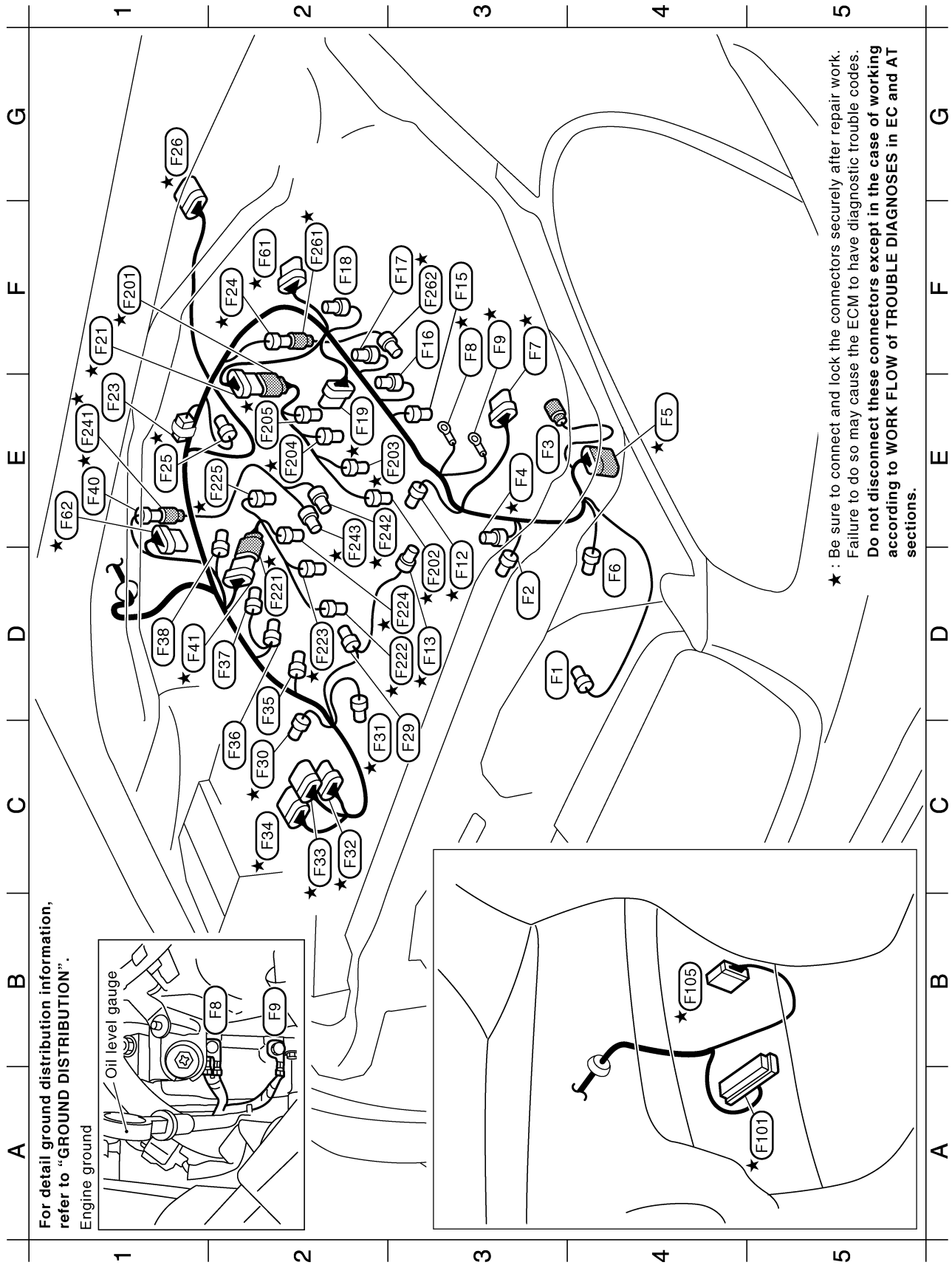

For detail ground distribution information, refer to "GROUND DISTRIBUTION".

Engine ground

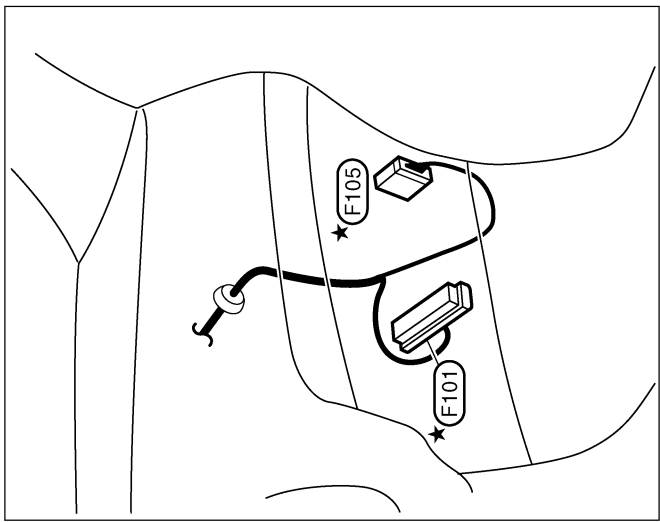
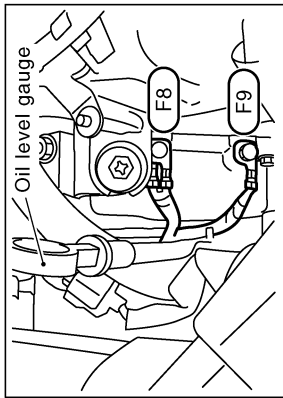

* : Be sure to connect and lock the connectors securely after repair work. Failure to do so may cause the ECM to have diagnostic trouble codes. Do not disconnect these connectors except in the case of working according to WORK FLOW of TROUBLE DIAGNOSES in EC and AT sections.

TKIM0546E

Engine control harness

D3	(F1)	GY/1 : Oil pressure switch
D3	(F2)	B/1 : Compressor (Magnet clutch)
E3	(F3)	BR/2 : Power steering solenoid valve
E3	(F4)	B/3 : Camshaft position sensor (PHASE)
E4	(F5)	GY/10 : To (E315)
D4	(F6)	B/2 : Compressor (ECV solenoid valve)
F3	(F7)	B/6 : Mass air flow sensor
F3	(F8)	— : Engine ground
F3	(F9)	— : Engine ground
D3	(F12)	B/3 : Intake valve timing control position sensor (Bank 1)
D3	(F13)	G/2 : Intake valve timing control solenoid valve (Bank 1)
F3	(F15)	GY/3 : Ignition coil (With power transistor) No.1
F3	(F16)	GY/3 : Ignition coil (With power transistor) No.3
F3	(F17)	GY/3 : Ignition coil (With power transistor) No.5
F2	(F18)	GY/3 : Ignition coil (With power transistor) No.7
E2	(F19)	G/6 : Electric throttle control actuator
F1	(F21)	G/6 : To (F201)
E1	(F23)	GY/2 : Condenser
F2	(F24)	SB/2 : To (F261)
E1	(F25)	L/2 : EVAP canister purge volume control solenoid valve
G1	(F26)	G/10 : A/T assembly
C3	(F29)	B/2 : VIAS control solenoid valve
C2	(F30)	B/3 : Intake valve timing control position sensor (Bank 2)
C2	(F31)	G/2 : Intake valve timing control solenoid valve (Bank 2)
C2	(F32)	SB/8 : To (E32)
C2	(F33)	GY/10 : To (E33)
C2	(F34)	G/10 : To (E34)
D2	(F35)	GY/3 : Ignition coil (With power transistor) No.2
C2	(F36)	GY/3 : Ignition coil (With power transistor) No.4
D2	(F37)	GY/3 : Ignition coil (With power transistor) No.6
D1	(F38)	GY/3 : Ignition coil (With power transistor) No.8
E1	(F40)	DGY/4 : To (F241)
D1	(F41)	G/6 : To (F221)
F2	(F61)	B/6 : Air fuel ratio (A/F) sensor 1 (Bank 1)
E1	(F62)	B/6 : Air fuel ratio (A/F) sensor 1 (Bank 2)
A5	(F101)	SMJ : ECM
B4	(F105)	SMJ : To (M135)

Engine control sub-harness-1

F1	(F201)	G/6 : To (F21)
D3	(F202)	GY/2 : Fuel injector No.1
E3	(F203)	GY/2 : Fuel injector No.3
E2	(F204)	GY/2 : Fuel injector No.5
E2	(F205)	GY/2 : Fuel injector No.7

Engine control sub-harness-2

D2	(F221)	G/6 : To (F41)
D3	(F222)	GY/2 : Fuel injector No.2
D2	(F223)	GY/2 : Fuel injector No.4
D3	(F224)	GY/2 : Fuel injector No.6
E2	(F225)	GY/2 : Fuel injector No.8

Engine control sub-harness-3

E1	(F241)	B/4 : To (F40)
E2	(F242)	L/2 : Knock sensor (Bank 1)
E2	(F243)	L/2 : Knock sensor (Bank 2)

Engine control sub-harness-4

F2	(F261)	SB/2 : To (F24)
F3	(F262)	GY/2 : Engine coolant temperature sensor

★ : Be sure to connect and lock the connectors securely after repair work. Failure to do so may cause the ECM to have diagnostic trouble codes. **Do not disconnect these connectors except in the case of working according to WORK FLOW of TROUBLE DIAGNOSES in EC and AT sections.**

HARNESS

BODY HARNESS AND REAR CONTROL HARNESS

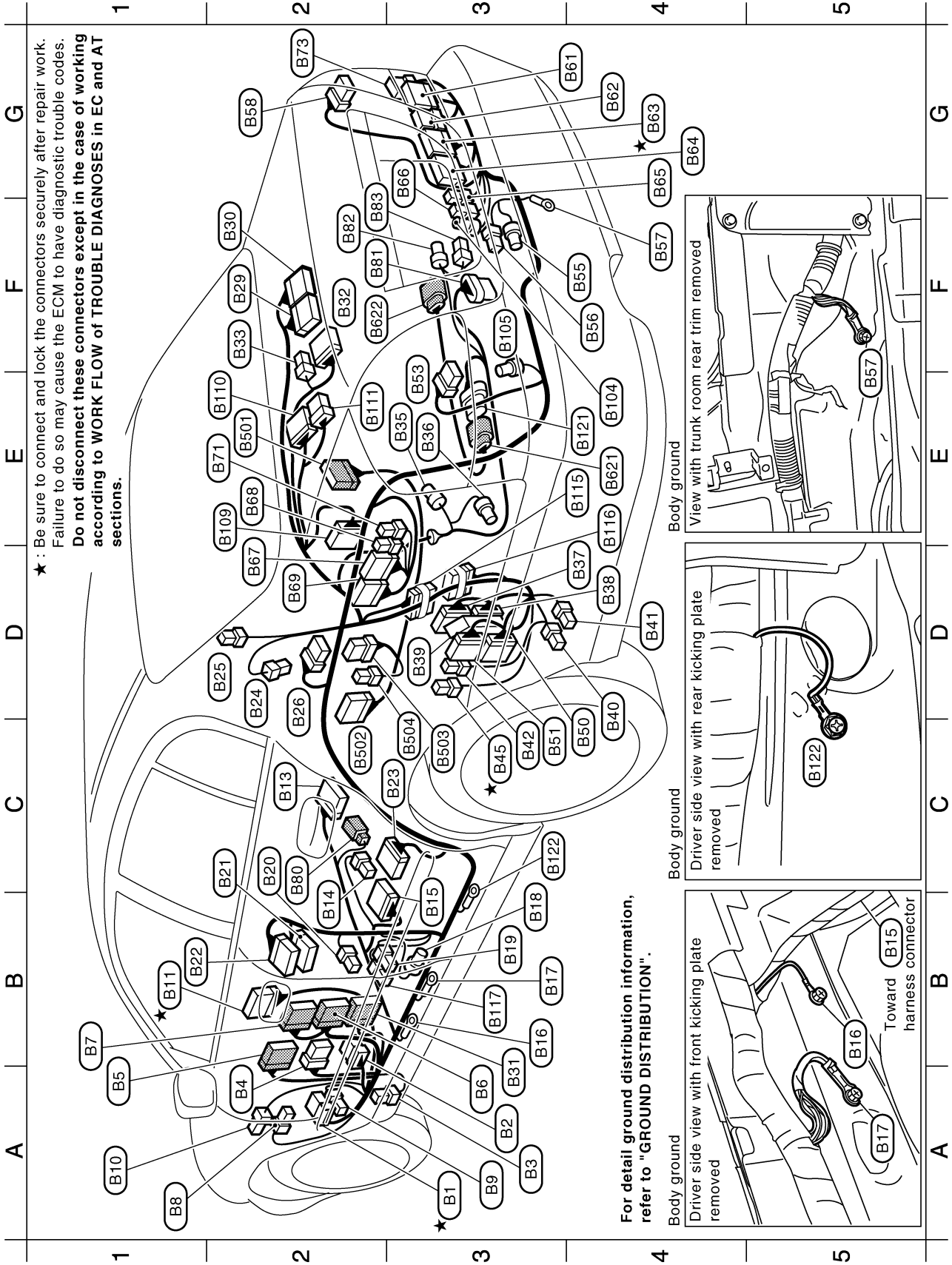

★: Be sure to connect and lock the connectors securely after repair work. Failure to do so may cause the ECM to have diagnostic trouble codes. Do not disconnect these connectors except in the case of working according to WORK FLOW of TROUBLE DIAGNOSES in EC and AT sections.

For detail ground distribution information, refer to "GROUND DISTRIBUTION".

Body ground

Driver side view with front kicking plate removed

Body ground

Driver side view with rear kicking plate removed

Body ground

View with trunk room rear trim removed

Body harness

A3	★ B1	W/8 : Fuse block (J/B) No.1	
A3	B2	W/6 : Fuse block (J/B) No.1	
A3	B3	W/3 : Front vertical G sensor	
A2	B4	W/8 : BCM (Body control module)	
A1	B5	SMJ : To M5	
A3	B6	GY/24 : To M6	
B1	B7	W/24 : To M7	
A1	B8	BR/6 : Rear window defogger and door mirror defogger relay	
A3	B9	W/1 : To E236 (With RAS)	
A1	B10	L/4 : Door mirror defogger relay	
B1	★ B11	W/20 : To E211	
C2	B13	Y/12 : Air bag diagnosis sensor unit	
B2	B14	Y/2 : Front LH side air bag module	
B3	B15	W/10 : Front power seat (Driver side) (Via sub-harness)	
B3	B16	— : Body ground	
B3	B17	— : Body ground	
B3	B18	Y/2 : LH side air bag (Satellite) sensor	
B3	B19	Y/2 : Front LH seat belt pre-tensioner	
C2	B20	W/3 : Front door switch (Driver side)	
C2	B21	W/15 : To D51	
B1	B22	GY/15 : To D51 (With rear power seat)	
C3	B23	W/18 : Rear power seat LH (Via sub-harness)	
D2	B24	Y/2 : LH side curtain air bag module	
D2	B25	W/1 : Condenser (Rear window defogger)	
D2	B26	W/6 : Rear shock absorber actuator LH	
F2	B29	GY/24 : AV and NAVI control unit	} (With NAVI)
F2	B30	W/24 : AV and NAVI control unit	
A3	B31	BR/24 : To M131	
F2	B32	W/32 : TEL adapter unit	} (With telephone system)
F2	B33	GY/3 : TEL adapter unit	
E3	B35	SB/4 : Rear wheel sensor	
E3	B36	GY/2 : Dual mode muffler actuator	
D4	B37	W/24 : Active damper suspension control unit	
D4	B38	GY/24 : Active damper suspension control unit	
D3	B39	W/40 : RAS control unit	
D4	B40	W/2 : Noise suppressor	} (With RAS)
D4	B41	W/3 : Noise suppressor	
C3	B42	L/4 : RAS motor relay	
C3	★ B45	W/2 : Dropping resistor	
C4	B50	W/16 : Satellite radio tuner	} (With satellite radio)
C3	B51	W/16 : Satellite radio tuner	

E3	B53	W/6 : Rear combination lamp LH	
F4	B55	GY/2 : Trunk lid striker switch	
F4	B56	W/4 : Trunk closure control unit	
F4	B57	— : Body ground	
G2	B58	W/6 : Rear combination lamp RH	
G4	B61	W/12 : To B261	
G4	B62	BR/8 : To B262	
G4	B63	W/10 : To B263	
G4	B64	W/16 : To B264	
G4	B65	W/2 : To E285 (With ICC)	
G3	B66	W/3 : To E266	
D2	B67	W/12 : Voice activated control module	} (With telephone system and voice activated control system)
E2	B68	GY/3 : Voice activated control module	
D2	B69	W/22 : Voice activated control module	} (With voice activated control system)
E2	B71	GY/3 : Voice activated control module	
G2	B73	W/6 : Dual mode muffler control unit	
C2	B80	W/4 : To B280 (With climate controlled seat)	
F2	B81	SB/6 : Rear wheel steering angle sensor	} (With RAS)
F2	B82	B/2 : RAS motor	
F2	B83	B/1 : RAS motor	
E4	B104	BR/2 : Auto trunk buzzer-1	
F3	B105	BR/2 : Auto trunk buzzer-2	
E2	B109	W/10 : Auto trunk motor	
E2	B110	W/16 : Auto trunk control unit	
E2	B111	W/6 : Auto trunk control unit	
E4	B115	W/16 : Jumping connector (For satellite radio tuner)	} (Without satellite radio)
E4	B116	W/16 : Jumping connector (For satellite radio tuner)	
B3	B117	W/2 : Pre-crash seat belt motor LH	
E4	B121	BR/8 : To B621	
C3	B122	— : Body ground	

Rear control harness

E2	B501	W/24 : To M101	
C2	B502	W/12 : Rear control switch	
C3	B503	W/6 : Rear sunshade rear switch	
C3	B504	W/4 : Auto return cancel switch	

Headlamp aiming sensor sub-harness

E4	B621	BR/8 : To B121	
F2	B622	GY/6 : Headlamp aiming sensor	

★ : Be sure to connect and lock the connectors securely after repair work. Failure to do so may cause the ECM to have diagnostic trouble codes. **Do not disconnect these connectors except in the case of working according to WORK FLOW of TROUBLE DIAGNOSES in EC and AT sections.**

HARNESS

BODY NO. 2 HARNESS

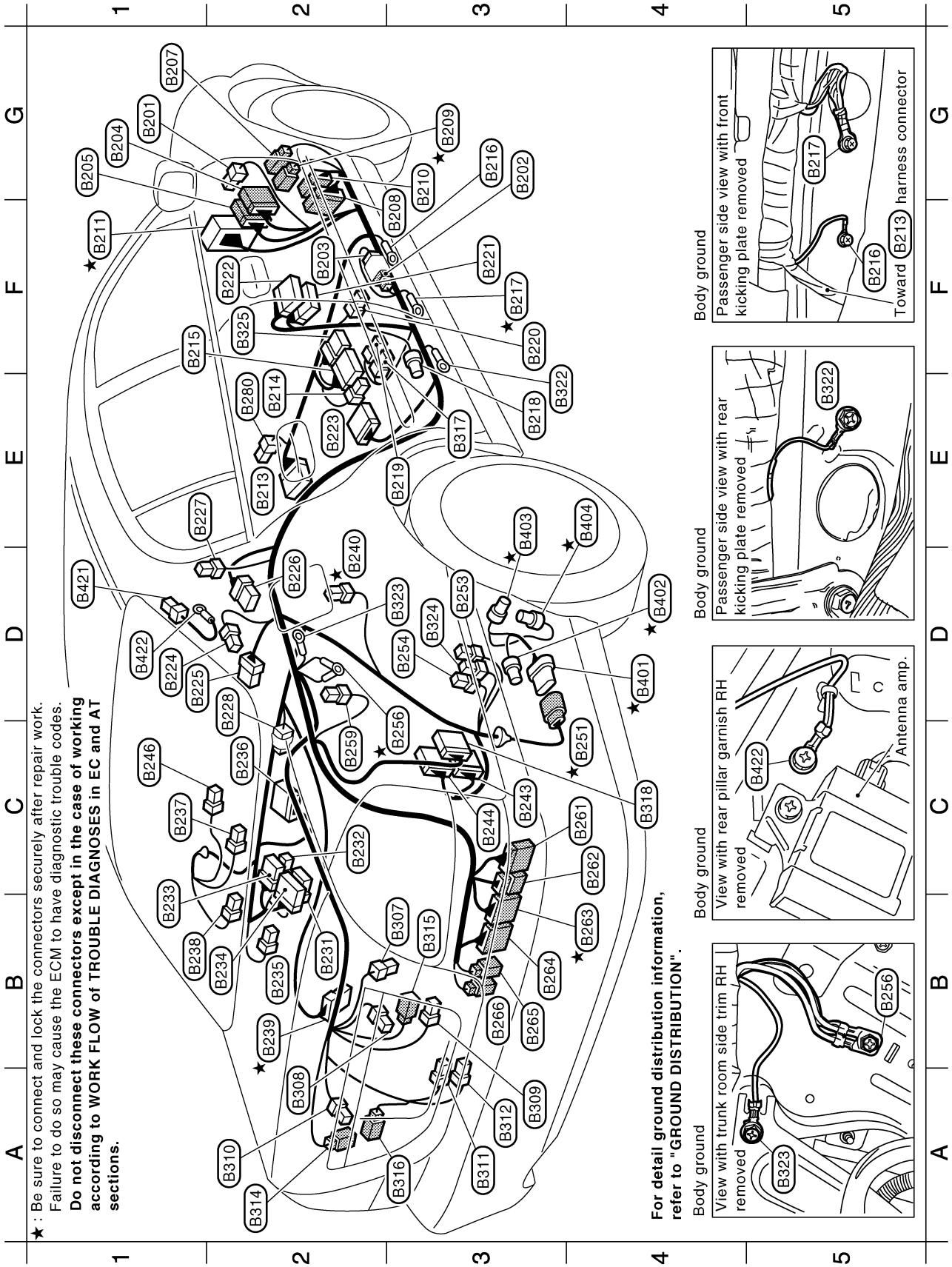

★ : Be sure to connect and lock the connectors securely after repair work.
 Failure to do so may cause the ECM to have diagnostic trouble codes.
 Do not disconnect these connectors except in the case of working
 according to WORK FLOW of TROUBLE DIAGNOSES in EC and AT
 sections.

For detail ground distribution information,
 refer to "GROUND DISTRIBUTION".

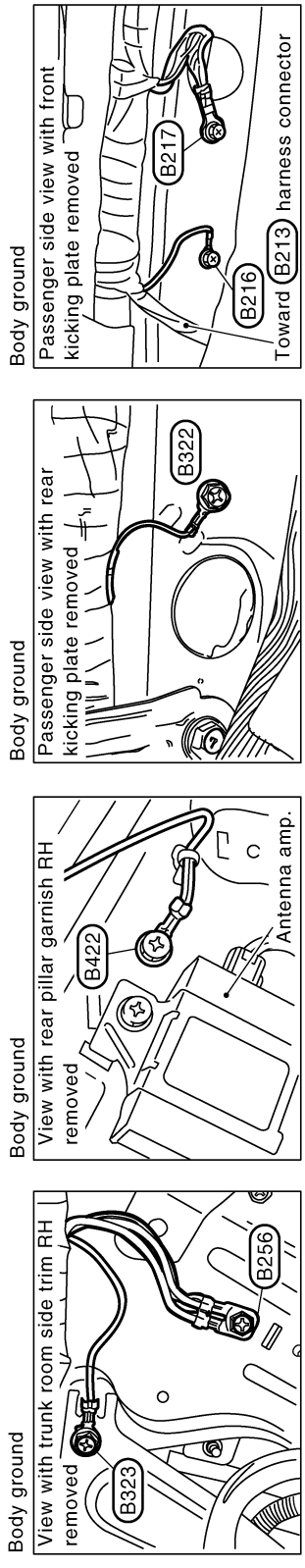

Body No. 2 harness

G1	(B201)	W/4 : Fuse block (J/B) No.2
G3	(B202)	W/3 : To (B203)
F2	(B203)	W/3 : To (B202)
G1	(B204)	W/12 : To (E224)
G1	(B205)	W/20 : To (E225) (With ICC)
G1	(B207)	W/3 : To (M137)
F3	(B208)	BR/24 : To (M138)
G3	(B209)	W/4 : To (M139)
G3	(B210)	GY/6 : To (M140)
F1	(B211)	SMJ : To (M141)
E2	(B213)	Y/12 : Air bag diagnosis sensor unit
E2	(B214)	Y/2 : Front RH side air bag module
F1	(B215)	W/10 : Front power seat (Passenger side) (Via sub-harness)
G3	(B216)	— : Body ground
F3	(B217)	— : Body ground
E3	(B218)	Y/2 : RH side air bag (Satellite) sensor
E3	(B219)	Y/2 : Front RH seat belt pre-tensioner
F3	(B220)	W/3 : Front door switch (Passenger side)
F3	(B221)	W/15 : To (D71)
F2	(B222)	GY/15 : To (D71) (With rear power seat)
E2	(B223)	W/18 : Rear power seat RH (Via sub-harness)
D1	(B224)	Y/2 : RH side curtain air bag module
D1	(B225)	W/6 : Rear sunshade unit
D2	(B226)	W/6 : Rear shock absorber actuator RH
E1	(B227)	W/3 : Rear vertical G sensor
D2	(B228)	GY/2 : Condenser
B2	(B231)	B/6 : BOSE speaker amp.
C2	(B232)	W/4 : BOSE speaker amp.
B1	(B233)	LG/8 : BOSE speaker amp.
B2	(B234)	B/24 : BOSE speaker amp.
B2	(B235)	W/2 : Woofer
C2	(B236)	W/16 : Rear view camera control unit
C1	(B237)	W/2 : High-mounted stop lamp
B1	(B238)	W/2 : Trunk room lamp
B2	(B239)	W/6 : Fuel level sensor unit and fuel pump
D2	(B240)	W/4 : Fuel pump control module (FPCM)
C3	(B243)	W/24 : ICC unit } (With ICC)
C3	(B244)	GY/24 : ICC unit }
C1	(B246)	W/4 : Remote keyless entry receiver
C4	(B251)	SB/8 : To (B401)

D3	(B253)	L/4 : Rear control cancel relay
D3	(B254)	BR/6 : Rear sunshade cancel relay
C3	(B256)	— : Body ground
C2	(B259)	W/4 : Fuel lid opener actuator
C4	(B261)	W/12 : To (B61)
C4	(B262)	BR/8 : To (B62)
B4	(B263)	W/10 : To (B63)
B3	(B264)	W/16 : To (B64)
B3	(B265)	W/2 : To (B65) (With ICC)
B3	(B266)	W/3 : To (B66)
E2	(B280)	W/4 : To (B80) (With climate controlled seat)
B3	(B307)	W/3 : Trunk lid key cylinder switch (Unlock switch)
A2	(B308)	BR/2 : License lamp RH
A3	(B309)	W/2 : Trunk lid close switch
A2	(B310)	BR/2 : License lamp LH
A3	(B311)	B/2 : Trunk lid opener actuator
A3	(B312)	W/2 : Trunk lid lock switch
A2	(B314)	W/4 : Rear view camera
B3	(B315)	GY/2 : Tail lamp RH
A3	(B316)	GY/2 : Tail lamp LH
E3	(B317)	W/2 : Pre-crash seat belt motor RH
C4	(B318)	W/26 : Pre-crash seat belt control unit
E3	(B322)	— : Body ground
D3	(B323)	— : Body ground
D3	(B324)	BR/6 : Climate controlled seat relay
F2	(B325)	W/8 : Front power seat (Passenger side) (Via sub-harness)

Body No. 2 sub-harness-1

D4	(B401)	SB/8 : To (B251)
C4	(B402)	B/2 : EVAP canister vent control valve
E3	(B403)	BR/3 : EVAP control system pressure sensor
E4	(B404)	G/2 : Vacuum cut valve bypass valve

Body No. 2 sub-harness-2

D1	(B421)	B/1 : Rear window defogger (-)
D1	(B422)	— : Body ground

★ : Be sure to connect and lock the connectors securely after repair work.
 Failure to do so may cause the ECM to have diagnostic trouble codes.
Do not disconnect these connectors except in the case of working according to WORK FLOW of TROUBLE DIAGNOSES in EC and AT sections.

A
B
C
D
E
F
G
H
I
J
K
L
M
N
O
P
Q
R
S
T
U
V
W
X
Y
Z
PG

HARNESS

ROOM LAMP HARNESS

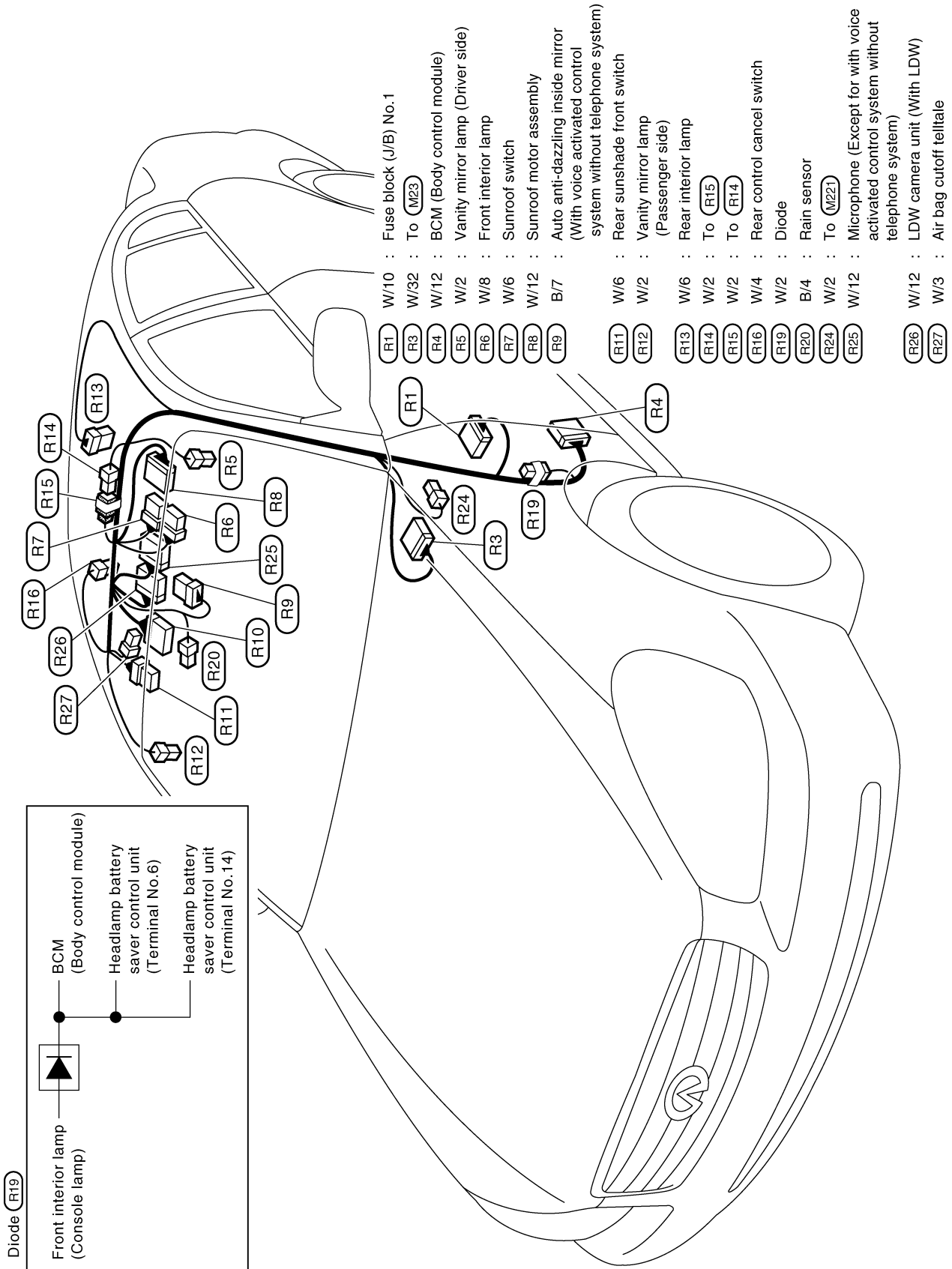

TKIM0552E

HARNESS

FRONT DOOR HARNESS

LH Side

- (D1) SMJ : To (M11)
- (D2) BR/16 : Door mirror (Driver side)
- (D3) W/8 : Seat memory switch
- (D4) GY/2 : Power window main switch illumination
- (D5) W/10 : Driver side door mirror control unit (LCU03)
- (D6) W/2 : Front door speaker LH
- (D7) W/6 : Front power window motor (Driver side)
- (D8) W/18 : Driver door control unit (LCU01)
- (D9) W/3 : Trunk lid and fuel lid opener switch
- (D10) W/2 : Front step lamp (Driver side)
- (D11) SB/4 : Front door lock actuator (Driver side)
- (D12) BR/3 : Front door key cylinder switch (Driver side)

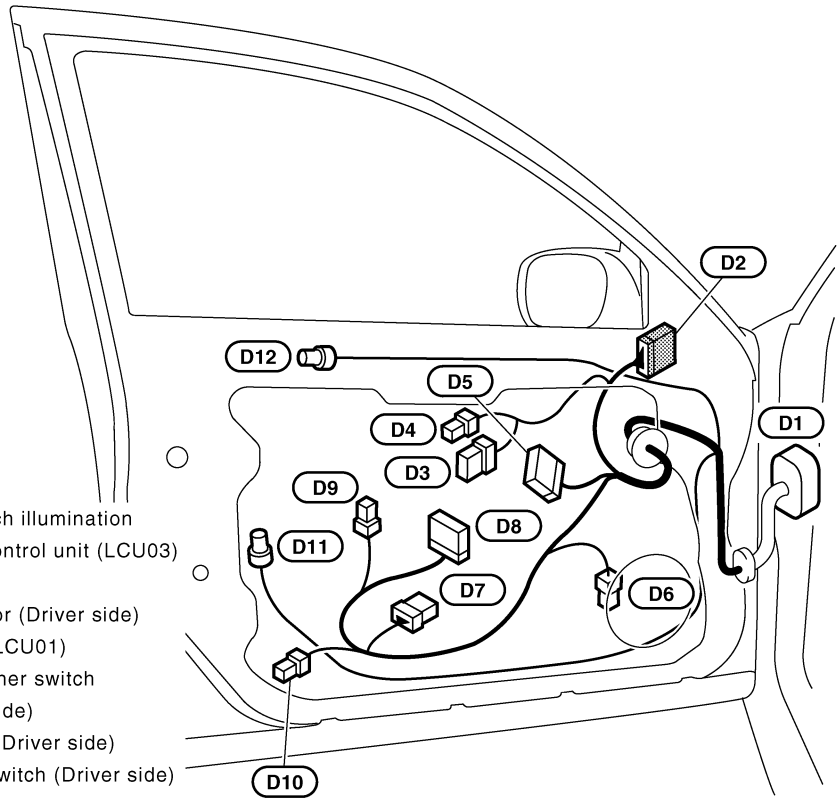

TKIM0229E

RH Side

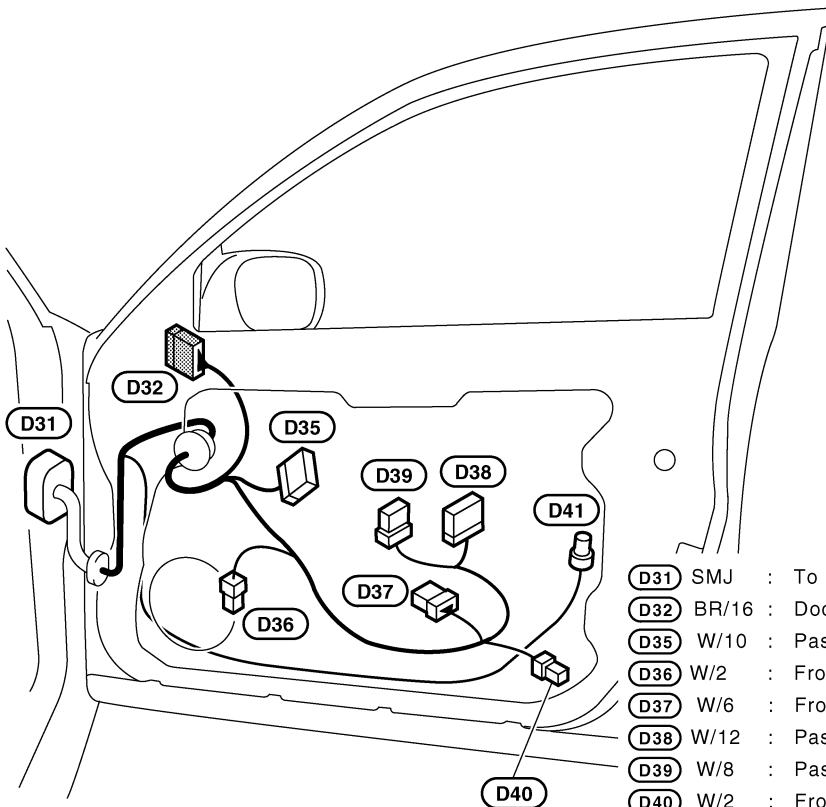

- (D31) SMJ : To (M142)
- (D32) BR/16 : Door mirror (Passenger side)
- (D35) W/10 : Passenger side door mirror control unit (LCU04)
- (D36) W/2 : Front door speaker RH
- (D37) W/6 : Front power window motor (Passenger side)
- (D38) W/12 : Passenger door control unit
- (D39) W/8 : Passenger door control unit
- (D40) W/2 : Front step lamp (Passenger side)
- (D41) SB/4 : Front door lock actuator (Passenger side)

TKIM0138E

A
B
C
D
E
F
G
H
I
J
PG
L
M

HARNESS

REAR DOOR HARNESS

LH Side

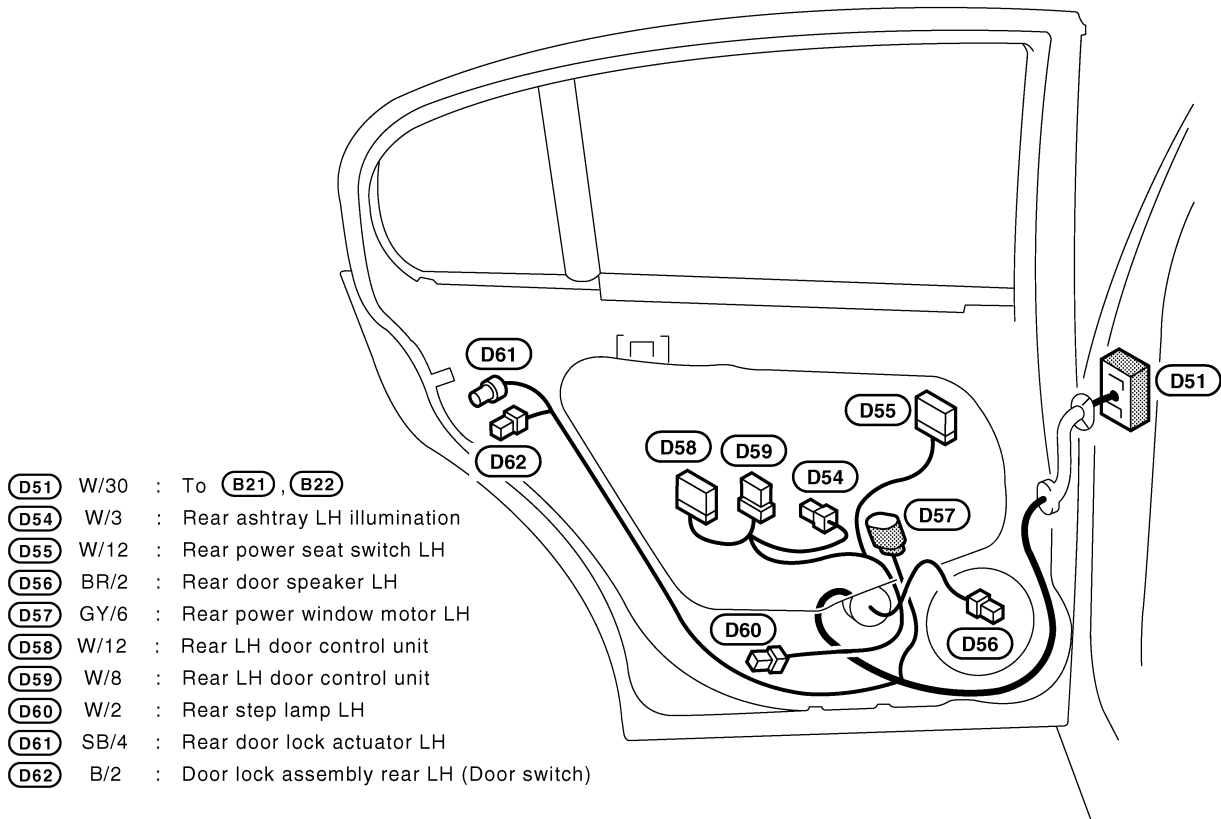

TKIM0139E

RH Side

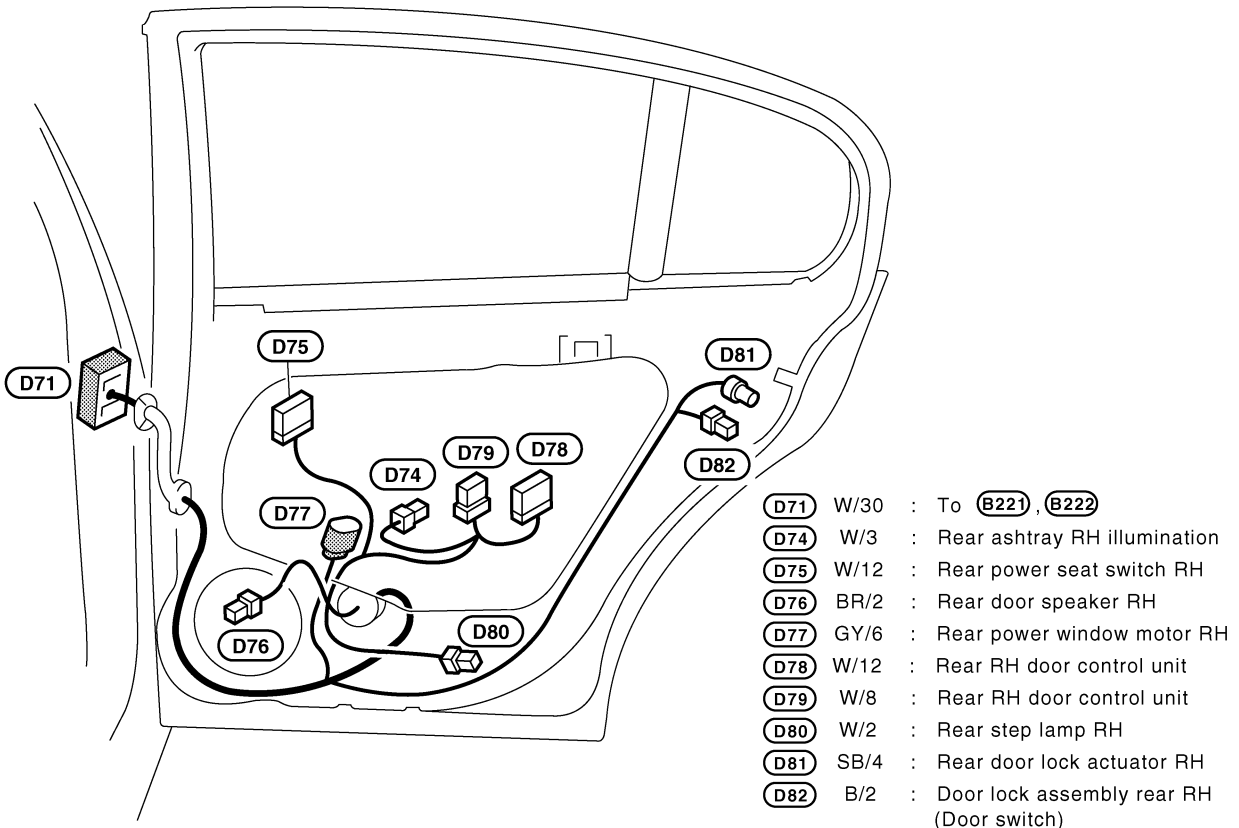

TKIM0140E

HARNESS

Wiring Diagram Codes (Cell Codes)

NKS002RJ

Use the chart below to find out what each wiring diagram code stands for. Refer to the wiring diagram code in the alphabetical index to find the location (page number) of each wiring diagram.

Code	Section	Wiring Diagram Name
A/C	ATC	Air Conditioner
A/TRNK	BL	Auto Trunk System
ACTIVE	SCS	Active Damper Suspension System
AF1B1	EC	Air Fuel Ratio Sensor 1 Bank 1
AF1B2	EC	Air Fuel Ratio Sensor 1 Bank 2
AF1HB1	EC	Air Fuel Ratio Sensor 1 Heater Bank 1
AF1HB2	EC	Air Fuel Ratio Sensor 1 Heater Bank 2
APPS1	EC	Accelerator Pedal Position Sensor
APPS2	EC	Accelerator Pedal Position Sensor
APPS3	EC	Accelerator Pedal Position Sensor
ASC/BS	EC	Automatic Speed Control Device (ASCD) Brake Switch
ASC/SW	EC	Automatic Speed Control Device (ASCD) Steering Switch
ASCBOF	EC	Automatic Speed Control Device (ASCD) Brake Switch
ASCIND	EC	Automatic Speed Control Device (ASCD) Indicator
AT/IND	DI	A/T Indicator Lamp
AUDIO	AV	Audio
AUT/DP	SE	Automatic Drive Positioner - IVMS
BACK/L	LT	Back-Up Lamp
BRK/SW	EC	Brake Switch
BYPS/V	EC	Vacuum Cut Valve Bypass Valve
C/SEAT	SE	Climate Controlled Seat
CAN	AT	CAN Communication Line
CAN	EC	CAN Communication Line
CAN	LAN	CAN System
CD/CHG	AV	CD Auto Changer
CHARGE	SC	Charging System
CHIME	DI	Warning Chime
CIGAR	WW	Cigarette Lighter
CLOCK	DI	Clock
COMM	AV	Audio Visual Communication Line
COMM	DI	Communication Line
COMM	LAN	IVMS - Communication Check, Power Supply & Ground
COMPAS	DI	Compass
COOL/F	EC	Cooling Fan Control
D/LOCK	BL	Power Door Lock - IVMS
DEF	GW	Rear Window Defogger
DTRL	LT	Headlamp - With Daytime Light System
ECM/PW	EC	ECM Power Supply for Back-Up
ECTS	EC	Engine Coolant Temperature Sensor
EPS	STC	Electronic Controlled Power Steering System
ETC1	EC	Electric Throttle Control Function

HARNESS

Code	Section	Wiring Diagram Name
ETC2	EC	Electric Throttle Control Motor Relay
ETC3	EC	Electric Throttle Control Motor
F/FOG	LT	Front Fog Lamp
F/PUMP	EC	Fuel Pump
FPCM	EC	Fuel Pump Control Module
FTS	AT	A/T Fluid Temperature Sensor Circuit
FTTS	EC	Fuel Tank Temperature Sensor
FUELB1	EC	Fuel Injection System Function (Bank 1)
FUELB2	EC	Fuel Injection System Function (Bank 2)
H/AIM	LT	Headlamp Aiming Control System
H/LAMP	LT	Headlamp
H/PHON	AV	Hands Free Telephone
HORN	WW	Horn
HSEAT	SE	Heated Seat
I/MIRR	GW	Inside Mirror (Auto-Anti Dazzling Mirror)
IATS	EC	Intake Air Temperature Sensor
ICC	ACS	Intelligent Cruise Control System
ICC/BS	EC	ICC Brake Switch
ICC/SW	EC	ICC Steering Switch
ICCB0F	EC	ICC Brake Switch
IGNSYS	EC	Ignition System
ILL	LT	Illumination
INF/D	DI	Vehicle Information and Integrated Switch System
INJECT	EC	Injector
INT/L	LT	Vanity Mirror and Trunk Room Lamps
IVCB1	EC	Intake Valve Timing Control Solenoid Valve Bank 1
IVCB2	EC	Intake Valve Timing Control Solenoid Valve Bank 2
IVCSB1	EC	Intake Valve Timing Control Position Sensor Bank 1
IVCSB2	EC	Intake Valve Timing Control Position Sensor Bank 2
IVTB1	EC	Intake Valve Timing Control System (Bank 1)
IVTB2	EC	Intake Valve Timing Control System (Bank 2)
KEYLES	BL	Remote Keyless Entry System-IVMS
KS	EC	Knock Sensor
LDW	DI	Lane Departure Warning System
LOAD	EC	Electrical Load Signal
MAFS	EC	Mass Air Flow Sensor
MAIN	AT	Transmission Control Module Power Supply
MAIN	EC	Main Power Supply and Ground Circuit
METER	DI	Speedometer, Tachometer, Temp., Oil and Fuel Gauges
MIL/DL	EC	MIL & Data Link Connector
MIRR/L	LT	Door Mirror Lamp
MIRROR	GW	Door Mirror
MMSW	AT	Manual Mode Switch
NATS	BL	Nissan Anti-Theft System

HARNESS

Code	Section	Wiring Diagram Name	
NAVI	AV	Navigation System	A
NONDTC	AT	Non-Detective Items	
O2H2B1	EC	Heated Oxygen Sensor 2 Heater Bank 1	B
O2H2B2	EC	Heated Oxygen Sensor 2 Heater Bank 2	
O2S2B1	EC	Heated Oxygen Sensor 2 Bank 1	C
O2S2B2	EC	Heated Oxygen Sensor 2 Bank 2	
P/SCKT	WW	Power Socket	
PGC/V	EC	EVAP Canister Purge Volume Control Solenoid Valve	D
PHASE	EC	Camshaft Position Sensor (PHASE)	
PHONE	AV	Telephone	
PNP/SW	AT	Park/Neutral Position Switch	E
PNP/SW	EC	Park/Neutral Position Switch	
POS	EC	Crankshaft Position Sensor (CKPS) (POS)	F
POWER	PG	Power Supply Routing	
PRE/SE	EC	EVAP Control System Pressure Sensor	
PS/SEN	EC	Power Steering Pressure Sensor	G
PSB	SB	Pre-Crash Seat Belt	
R/VIEW	DI	Rear View Camera Control System	H
RAS	STC	Rear Active Steer	
REMOTE	AV	Audio (Remote Control Switch)	
ROOM/L	LT	Interior Room Lamp - IVMS	I
RP/SEN	EC	Refrigerant Pressure Sensor	
SEAT	SE	Power Seat	
SEN/PW	EC	Sensor Power Supply	J
SHADE	EI	Rear Sunshade	
SHIFT	AT	A/T Shift Lock System	PG
SROOF	RF	Sunroof	
SRS	SRS	Supplemental Restraint System	
START	SC	Starting System	L
STEP/L	LT	Step Lamp - IVMS	
STOP/L	LT	Stop Lamp	M
STSIG	AT	Start Signal Circuit	
SW/ILL	GW	Power Window Switch Illumination - IVMS	
T&FLID	BL	Trunk Lid and Fuel Lid Opener	
T/CLOS	BL	Trunk Closure System	
T/WARN	WT	Low Tire Pressure Warning System	
TAIL/L	LT	Parking, License and Tail Lamps	
TPS1	EC	Throttle Position Sensor (Sensor1)	
TPS2	EC	Throttle Position Sensor (Sensor2)	
TPS3	EC	Throttle Position Sensor	
TRNSCV	BL	Homelink Universal Transceiver	
TURN	LT	Turn Signal and Hazard Warning Lamp	
VDC	BRC	Vehicle Dynamics Control System	
VEHSEC	BL	Vehicle Security System - IVMS	

HARNESSES

Code	Section	Wiring Diagram Name
VENT/V	EC	EVAP Canister Vent Control Valve
VEXH	EX	Variable Exhaust Muffler Control System
VIAS	EC	Variable Induction Air Control System
VIAS/V	EC	VIAS Control Solenoid Valve
VOICE	DI	Voice Activation System
VSSA/T	AT	Vehicle Speed Sensor A/T (Revolution Sensor)
W/ANT	AV	Audio Antenna
WARN	DI	Warning Lamps
WINDOW	GW	Power Window - IVMS
WIPER	WW	Front Wiper and Washer

ELECTRICAL UNITS LOCATION

ELECTRICAL UNITS LOCATION

PFP:25230

Electrical Units Location

NKS001LR

Use parts code, if applicable, and chassis number to find correct parts number in parts catalog. Parts codes are shown in figure.

NOTE:

Parts codes in figure are those in effect at the time of the first service manual edition. Information might not be maintained in the timely manner. Always confirm correct parts code using appropriate parts catalog.

A

B

C

D

E

F

G

H

I

J

PG

L

M

ELECTRICAL UNITS LOCATION

ENGINE COMPARTMENT

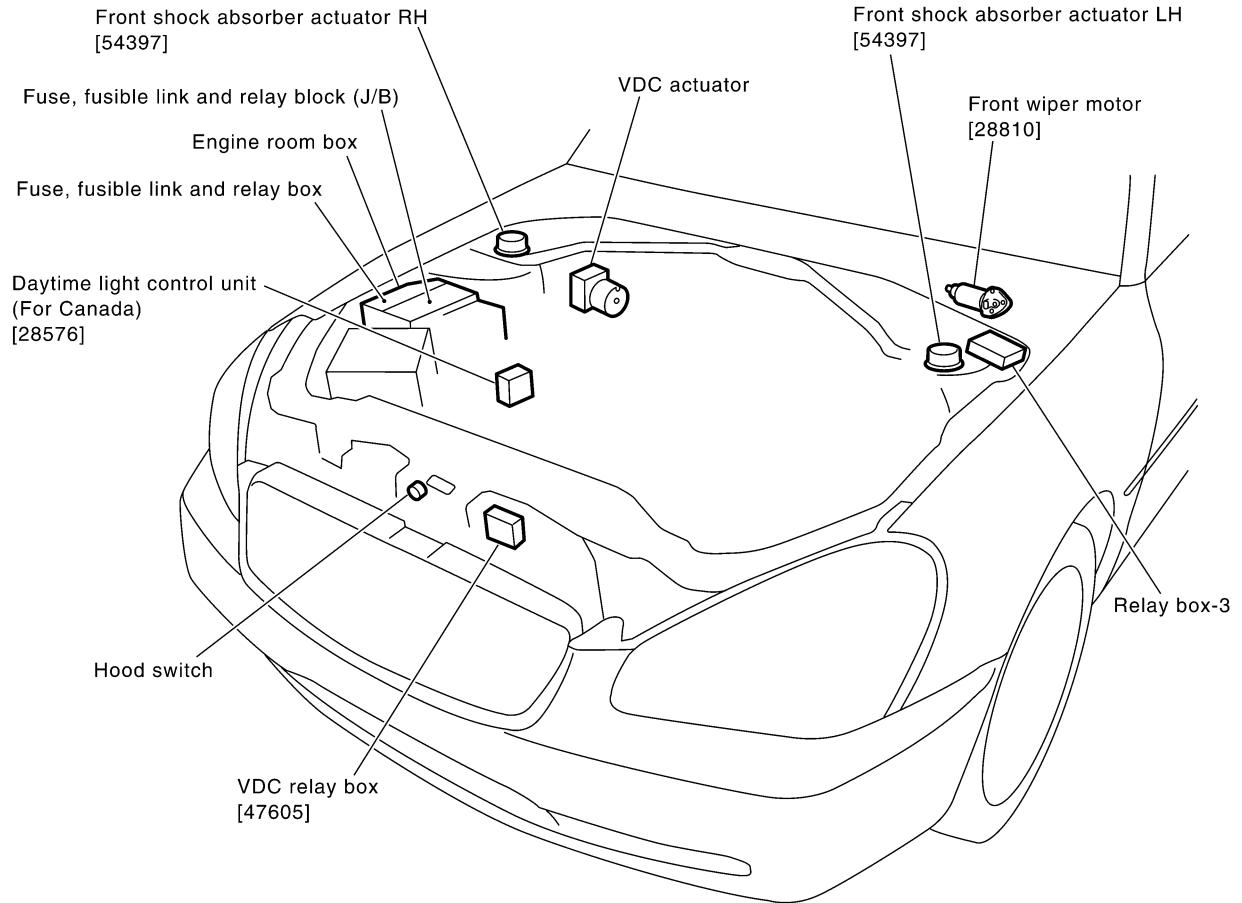

ENGINE ROOM BOX

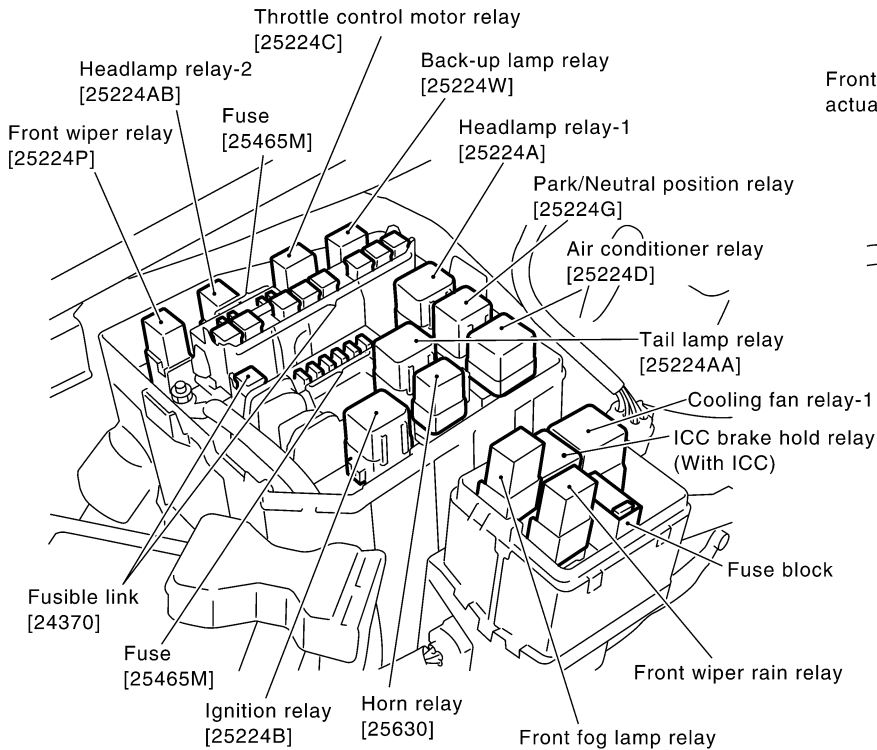

RELAY BOX-3

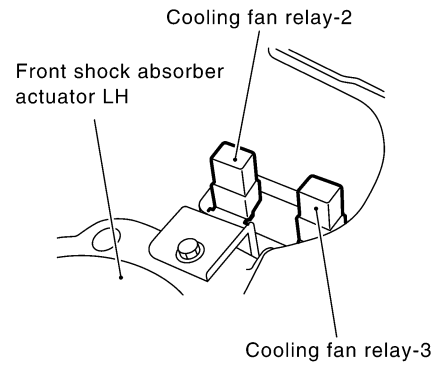

CKIM0337E

ELECTRICAL UNITS LOCATION

PASSENGER COMPARTMENT

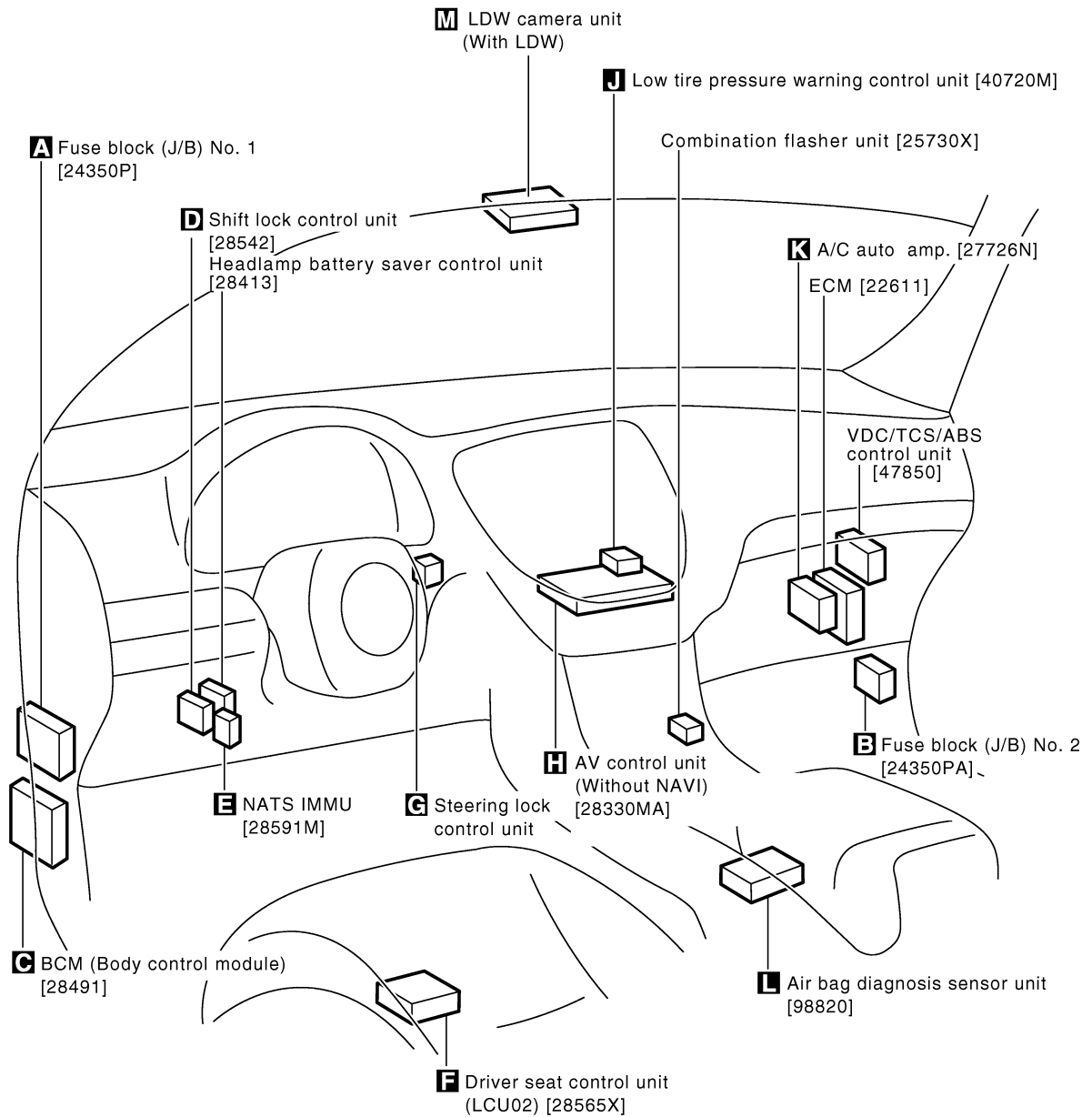

A
B
C
D
E
F
G
H
I
J
PG
L
M

PG

CKIM0623E

ELECTRICAL UNITS LOCATION

A Dash side LH

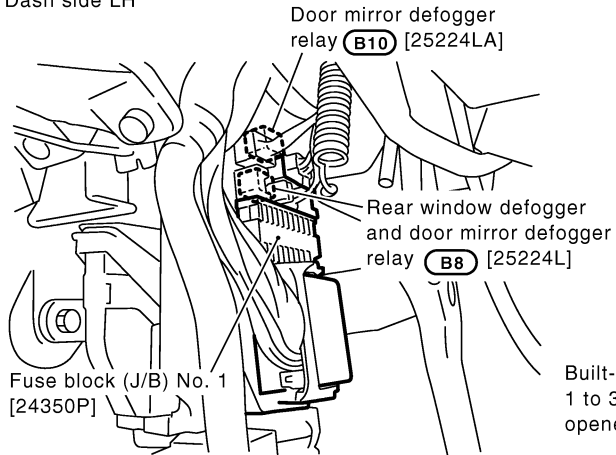

In back of the fuse block (J/B) No. 1

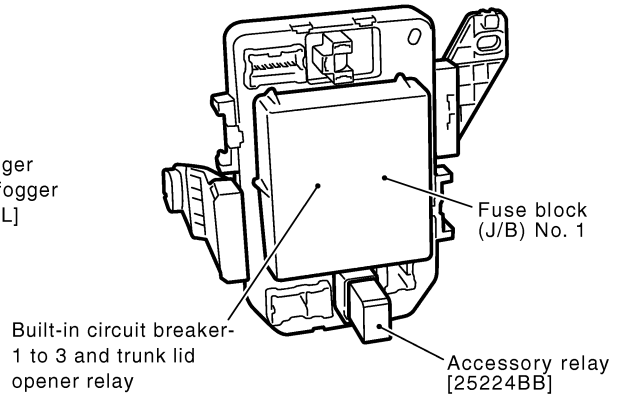

B Dash side RH

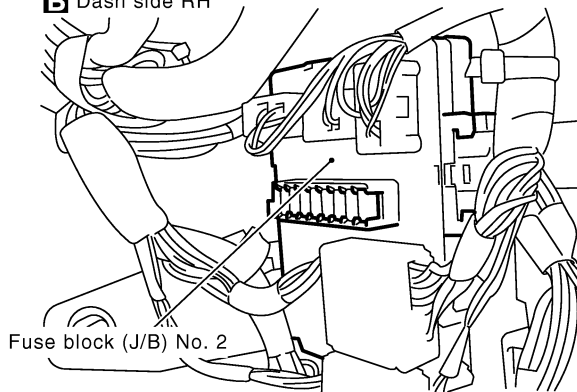

In back of the fuse block (J/B) No. 2

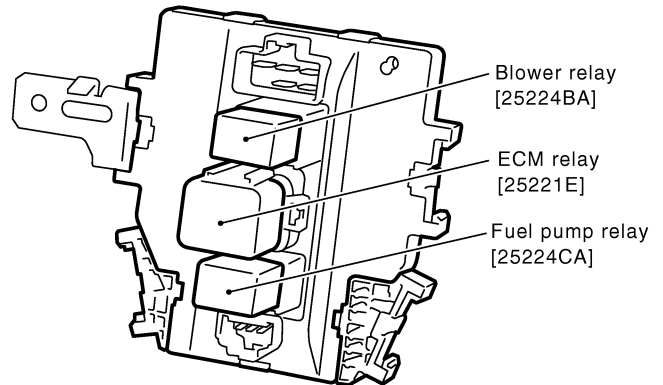

CKIM0624E

ELECTRICAL UNITS LOCATION

<p>C Dash side LH</p> <p>BCM (M4), (E204), (B4), (R4)</p>	<p>D Driver side view with lower instrument panel removed</p> <p>Headlamp battery saver control unit (M33), (M34)</p> <p>Shift lock control unit (M12)</p> <p>Data link connector (M31)</p>	<p>E Driver side view with lower instrument panel removed</p> <p>NATS IMMU (M32)</p> <p>Data link connector (M31)</p>
<p>F Under driver's seat</p> <p>Driver seat control unit (LCU02)</p> <p>(B142), (B143)</p> <p>Front ↑</p>	<p>G</p> <p>Steering lock control unit (M69)</p> <p>Key switch</p>	<p>H View with instrument panel center removed</p> <p>AV control unit (M50), (M77), (M78)</p> <p>Clock</p>
<p>J View with instrument panel center removed</p> <p>Combination flasher unit (M91)</p> <p>Low tire pressure warning control unit (M84)</p>	<p>K Behind lower instrument panel on passenger side</p> <p>ECM (F101)</p> <p>A/C auto amp. (M119), (M120)</p> <p>VDC/TCS/ABS control unit (E218)</p>	<p>L View with console box removed</p> <p>Air bag diagnosis sensor unit (M103), (B13), (B213)</p> <p>Front ←</p>
<p>M Map lamp garnish removed</p> <p>LDW camera unit (R26)</p> <p>Room mirror</p>		

A
B
C
D
E
F
G
H
I
J
L
M

PG

CKIM0625E

ELECTRICAL UNITS LOCATION

Rear power seat control unit RH [28565]

B362, **B363** : With heated seat

B368 : Without heated seat

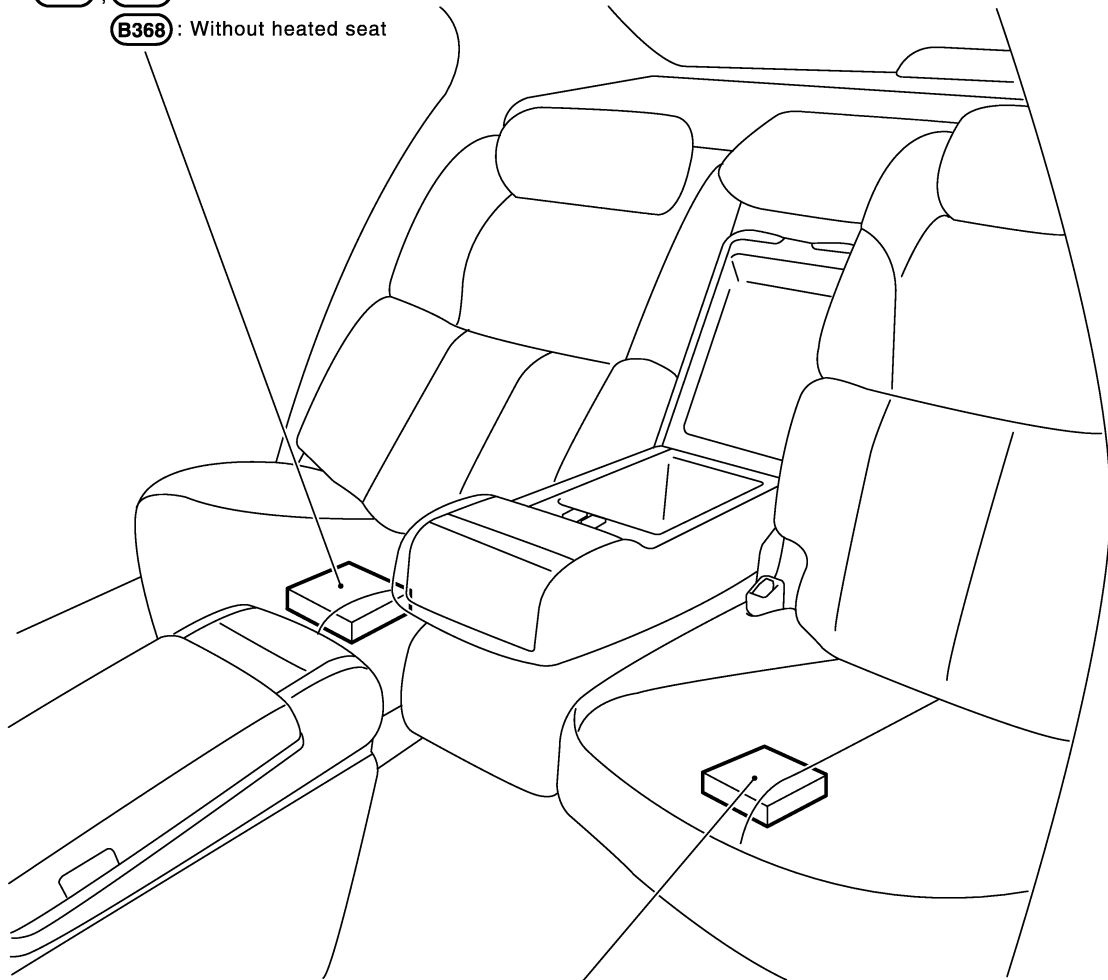

Rear power seat control unit LH [28565X]

B162, **B163** : With heated seat

B168 : Without heated seat

CKIM0028E

ELECTRICAL UNITS LOCATION

LUGGAGE COMPARTMENT

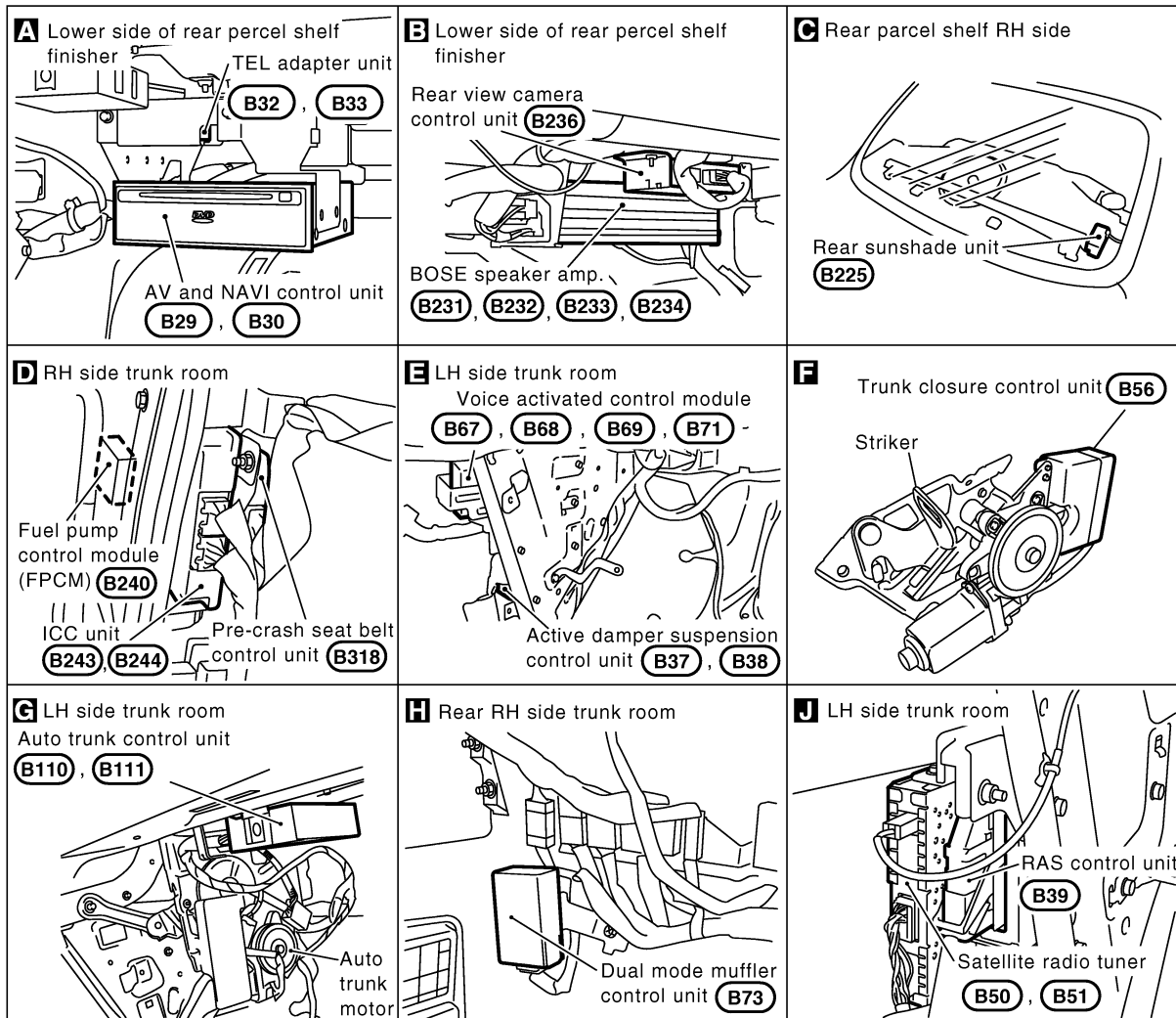
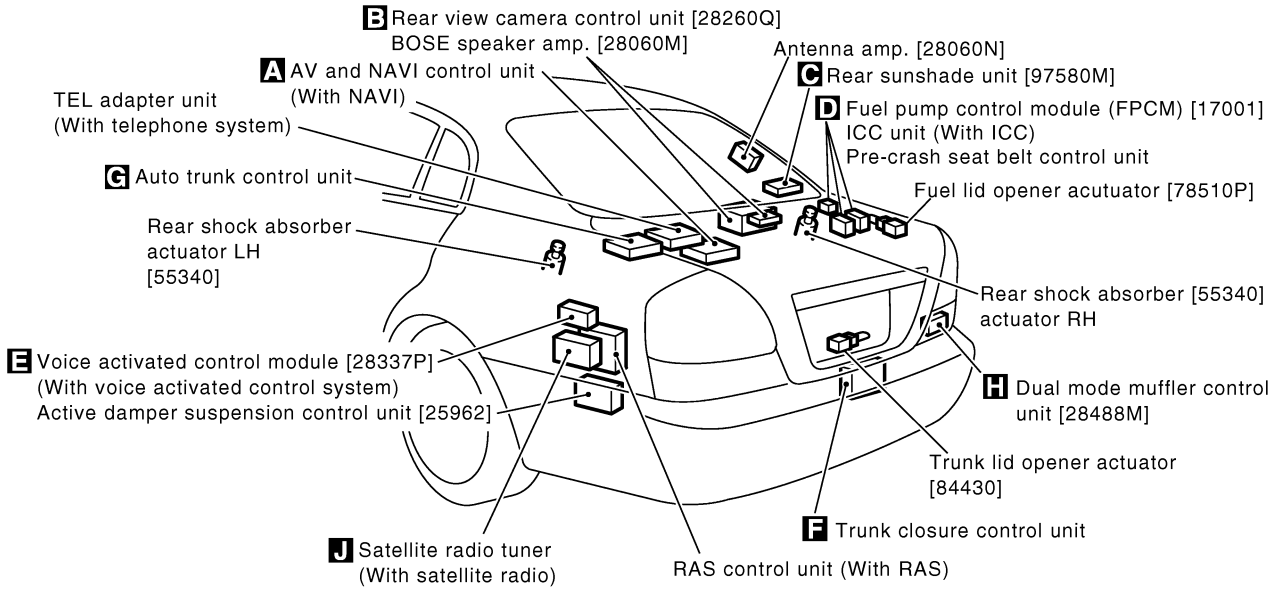

CKIM0626E

HARNESS CONNECTOR

PFP:00011

NKS001LS

HARNESS CONNECTOR

Description

HARNESS CONNECTOR (TAB-LOCKING TYPE)

- The tab-locking type connectors help prevent accidental looseness or disconnection.
- The tab-locking type connectors are disconnected by pushing or lifting the locking tab(s). Refer to the figure below.

Refer to the next page for description of the slide-locking type connector.

CAUTION:

Never pull the harness or wires when disconnecting the connector.

[Example]

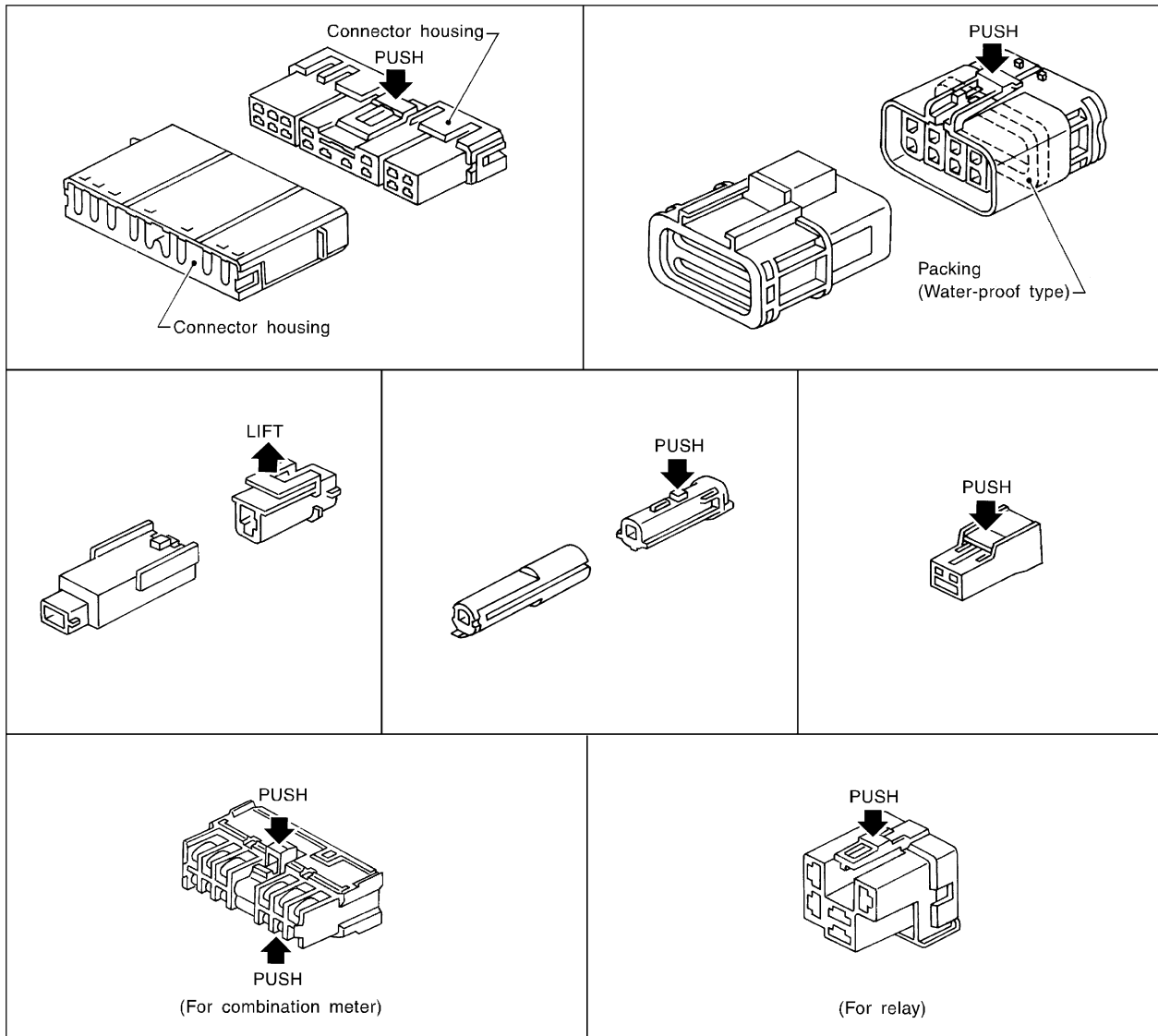

SEL769DA

HARNESS CONNECTOR

HARNESS CONNECTOR (SLIDE-LOCKING TYPE)

- A new style slide-locking type connector is used on certain systems and components, especially those related to OBD.
- The slide-locking type connectors help prevent incomplete locking and accidental looseness or disconnection.
- The slide-locking type connectors are disconnected by pushing or pulling the slider. Refer to the figure below.

CAUTION:

- **Never pull the harness or wires when disconnecting the connector.**
- **Be careful not to damage the connector support bracket when disconnecting the connector.**

[Example]

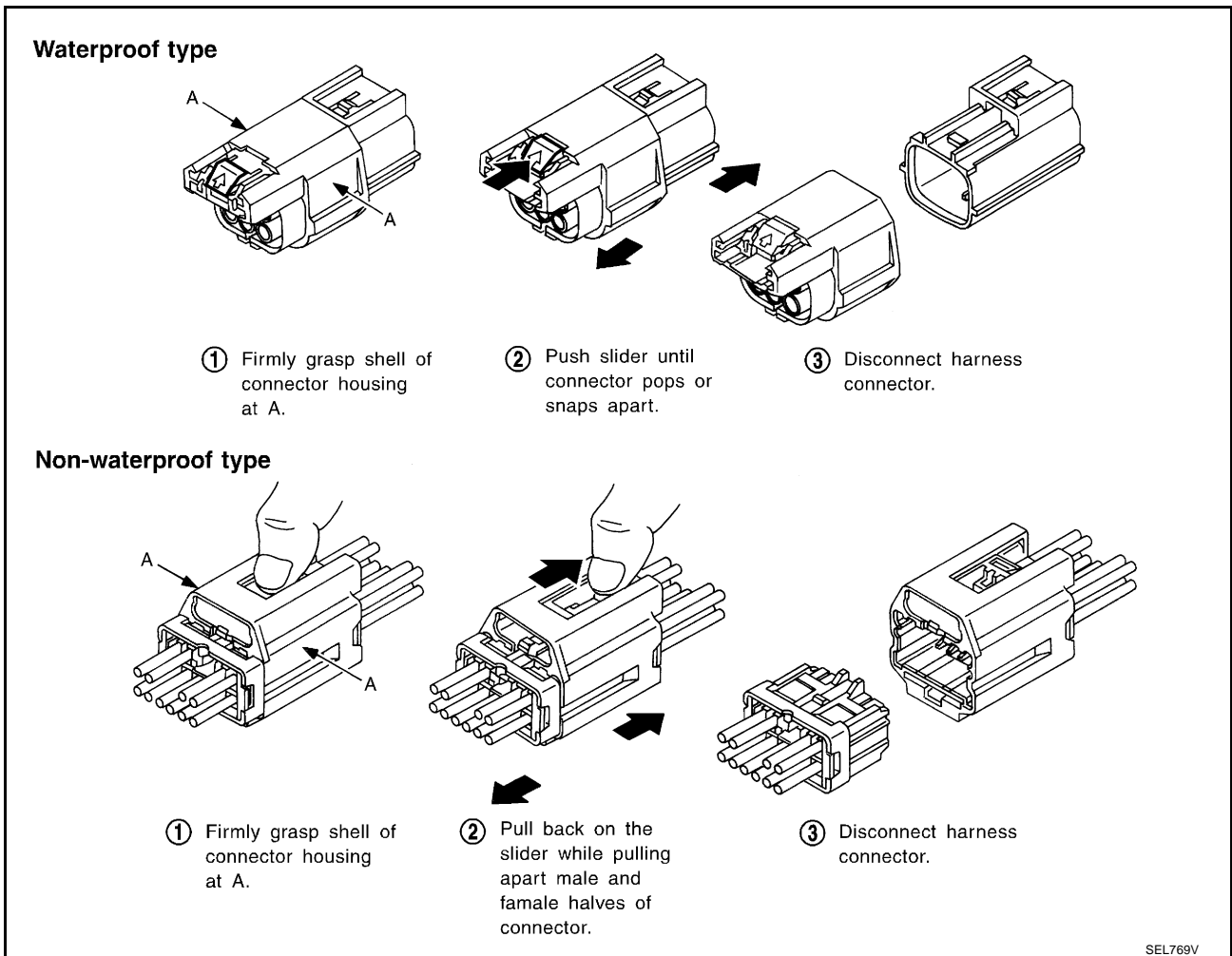

A
B
C
D
E
F
G
H
I
J
PG
L
M

HARNESS CONNECTOR

HARNESS CONNECTOR (LEVER LOCKING TYPE)

- Lever locking type harness connectors are used on certain control units and control modules such as ECM, ABS actuator and electric unit (control unit), etc.
- Lever locking type harness connectors are also used on super multiple junction (SMJ) connectors.
- Always confirm the lever is fully locked in place by moving the lever as far as it will go to ensure full connection.

CAUTION:

Always confirm the lever is fully released (loosened) before attempting to disconnect or connect these connectors to avoid damage to the connector housing or terminals.

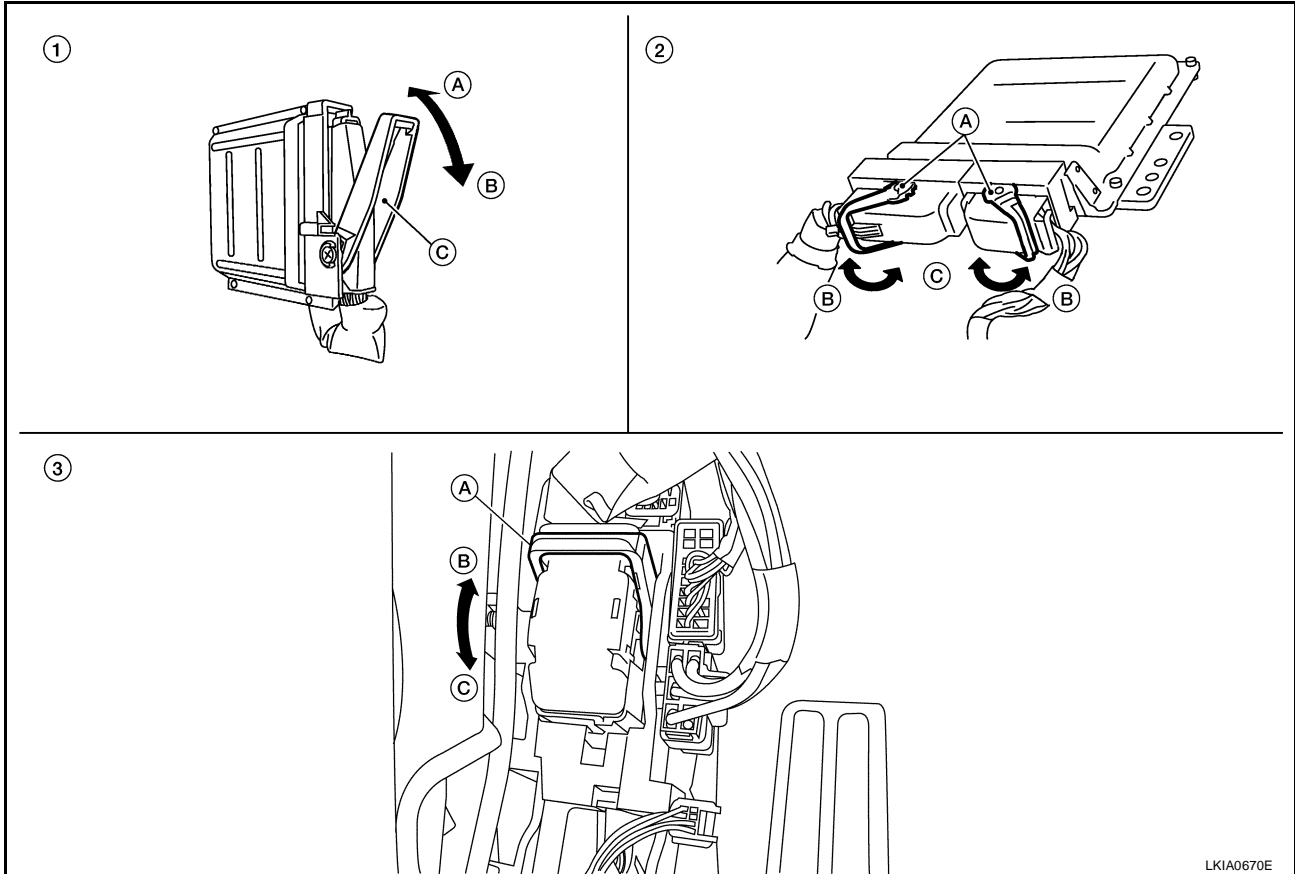

LKIA0670E

- | | | |
|-----------------------------------|----------------------------------|------------------|
| 1. Control unit with single lever | 2. Control unit with dual levers | 3. SMJ connector |
| A. Fasten | A. Levers | A. Lever |
| B. Loosen | B. Fasten | B. Fasten |
| C. Lever | C. Loosen | C. Loosen |

ELECTRICAL UNITS

PPF:23710

ELECTRICAL UNITS

Terminal Arrangement

NKS001LT

ECM

F101

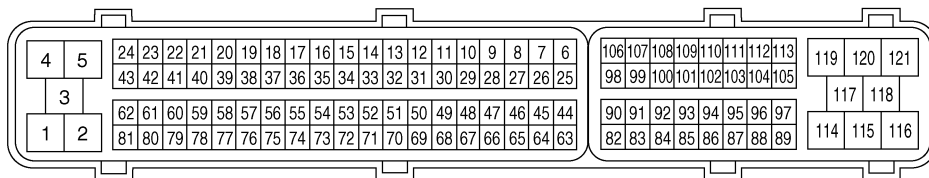

(Black)



A/C AUTO AMP.

M119

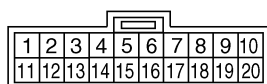

(Gray)

M120

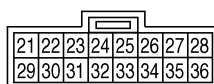

(Gray)



VDC/TCS/ABS CONTROL UNIT

E218

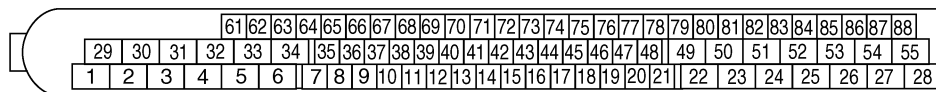

(Black)



A
B
C
D
E
F
G
H
I
J
PG
L
M

PG

CKIM0341E

ELECTRICAL UNITS

BCM (BODY CONTROL MODULE)

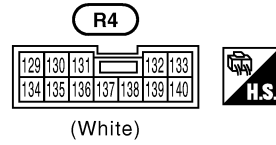
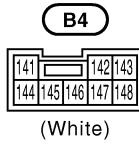
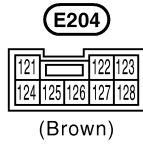
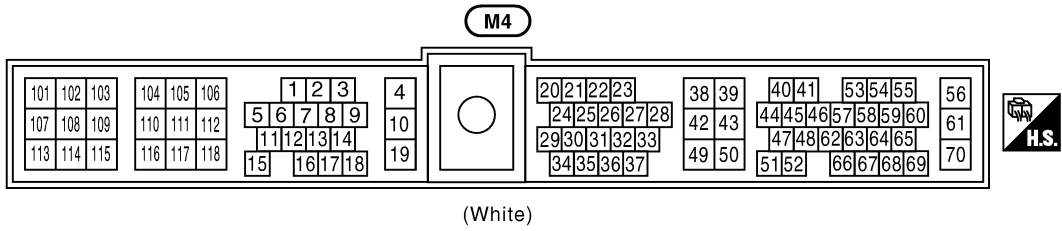

ICC UNIT

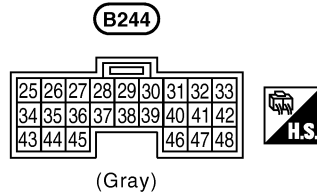
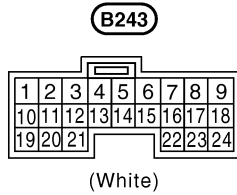

RAS CONTROL UNIT

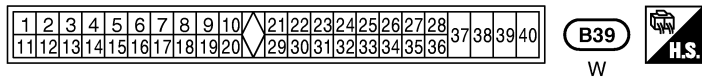

SMJ (SUPER MULTIPLE JUNCTION)

SMJ (SUPER MULTIPLE JUNCTION) Terminal Arrangement

PFP:B4341

NKS001LU

A
B
C
D
E
F
G
H
I
J
PG
L
M

MAIN HARNESS

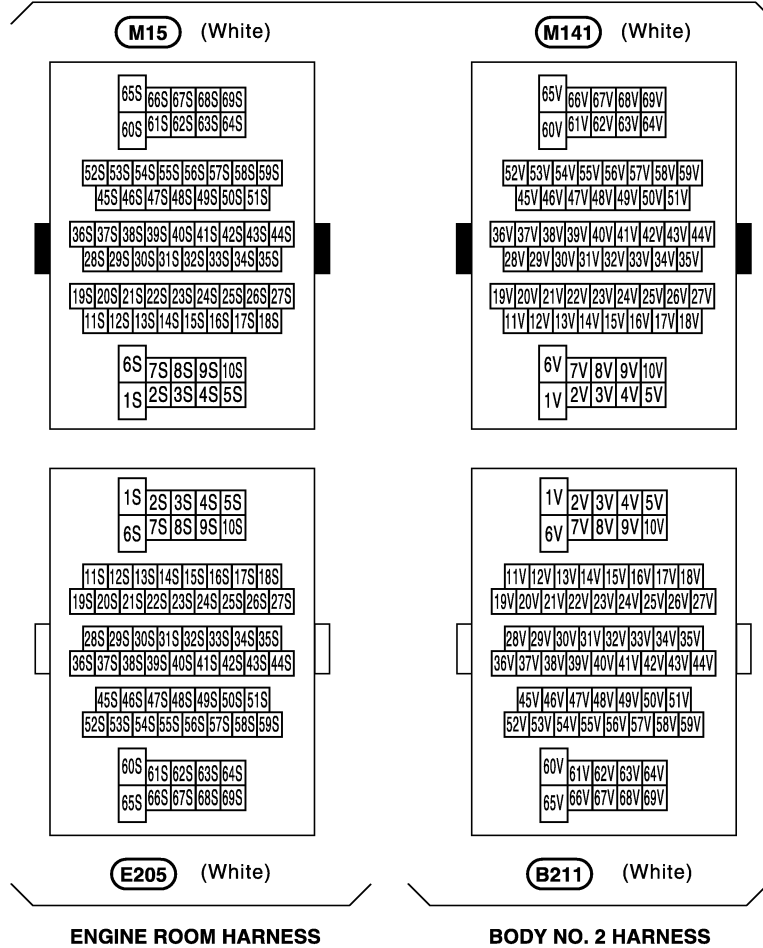

SMJ (SUPER MULTIPLE JUNCTION)



MAIN HARNESS

M5 (White)

1U	2U	3U	4U	5U	11U	12U	13U	14U	15U	16U	17U	18U	19U	20U	30U	31U	32U	33U	34U	35U	36U	37U	38U				
6U	7U	8U	9U	10U	21U	22U	23U	24U	25U	26U	27U	28U	29U	39U	40U	41U	42U	43U	44U	45U	46U						

6U	7U	8U	9U	10U	21U	22U	23U	24U	25U	26U	27U	28U	29U	39U	40U	41U	42U	43U	44U	45U	46U		
1U	2U	3U	4U	5U	11U	12U	13U	14U	15U	16U	17U	18U	19U	20U	30U	31U	32U	33U	34U	35U	36U	37U	38U

B5 (White)

BODY HARNESS



MAIN HARNESS

M135 (White)

6T	7T	8T	9T	10T	21T	22T	23T	24T	25T	26T	27T	28T	29T	39T	40T	41T	42T	43T	44T	45T	46T		
1T	2T	3T	4T	5T	11T	12T	13T	14T	15T	16T	17T	18T	19T	20T	30T	31T	32T	33T	34T	35T	36T	37T	38T

1T	2T	3T	4T	5T	11T	12T	13T	14T	15T	16T	17T	18T	19T	20T	30T	31T	32T	33T	34T	35T	36T	37T	38T
6T	7T	8T	9T	10T	21T	22T	23T	24T	25T	26T	27T	28T	29T	39T	40T	41T	42T	43T	44T	45T	46T		

F105 (White)

ENGINE CONTROL HARNESS



MAIN HARNESS

M11 (White)

20W	21W	22W	23W	24W	25W	26W	27W	36W	37W	38W	39W		
11W	12W	13W	14W	15W	16W	17W	18W	19W	32W	33W	34W	35W	
1W	2W	3W	4W	5W	6W	7W	8W	9W	10W	28W	29W	30W	31W

M142 (White)

20X	21X	22X	23X	24X	25X	26X	27X	36X	37X	38X	39X		
11X	12X	13X	14X	15X	16X	17X	18X	19X	32X	33X	34X	35X	
1X	2X	3X	4X	5X	6X	7X	8X	9X	10X	28X	29X	30X	31X

D1 (White)

11W	12W	13W	14W	15W	16W	17W	18W	19W	28W	29W	30W	31W	
20W	21W	22W	23W	24W	25W	26W	27W	32W	33W	34W	35W		
1W	2W	3W	4W	5W	6W	7W	8W	9W	10W	36W	37W	38W	39W

D31 (White)

11X	12X	13X	14X	15X	16X	17X	18X	19X	28X	29X	30X	31X	
20X	21X	22X	23X	24X	25X	26X	27X	32X	33X	34X	35X		
1X	2X	3X	4X	5X	6X	7X	8X	9X	10X	36X	37X	38X	39X

FRONT DOOR HARNESS (DRIVER SIDE)

FRONT DOOR HARNESS (PASSENGER SIDE)

CKIM0062E

SMJ (SUPER MULTIPLE JUNCTION)

A
B
C
D
E
F
G
H
I
J
PG
L
M

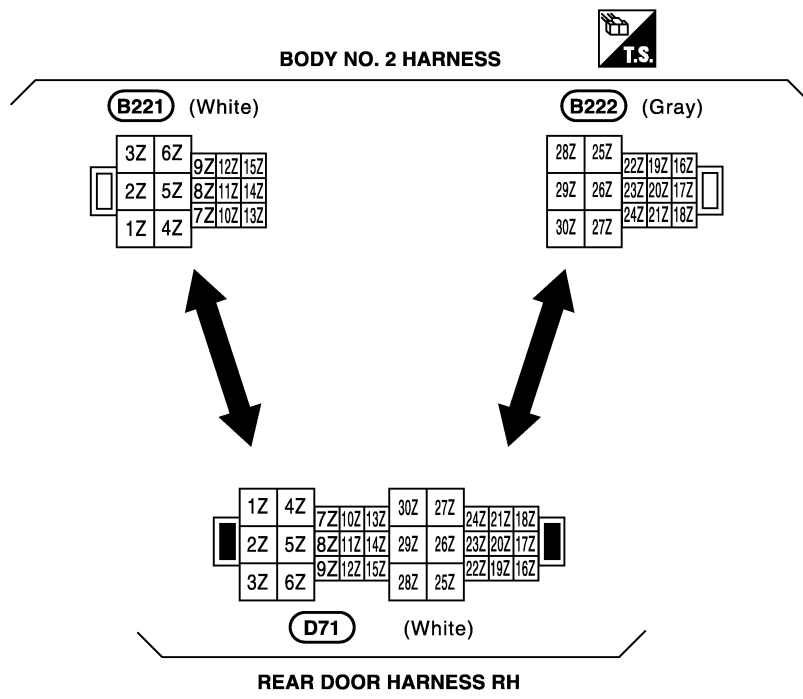
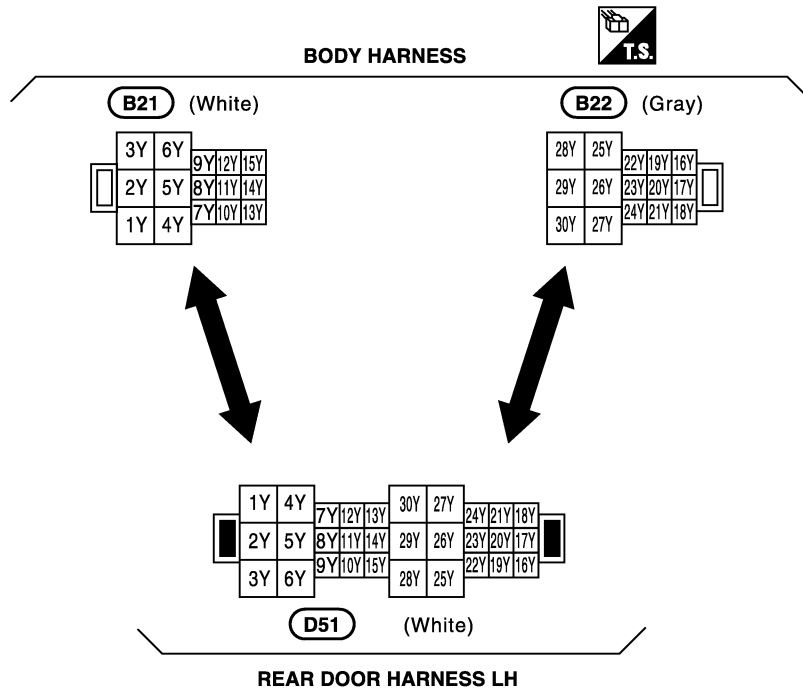

CKIM0063E

STANDARDIZED RELAY

PFP:00011

NKS001LV

STANDARDIZED RELAY

Description NORMAL OPEN, NORMAL CLOSED AND MIXED TYPE RELAYS

Relays can mainly be divided into three types: normal open, normal closed and mixed type relays.

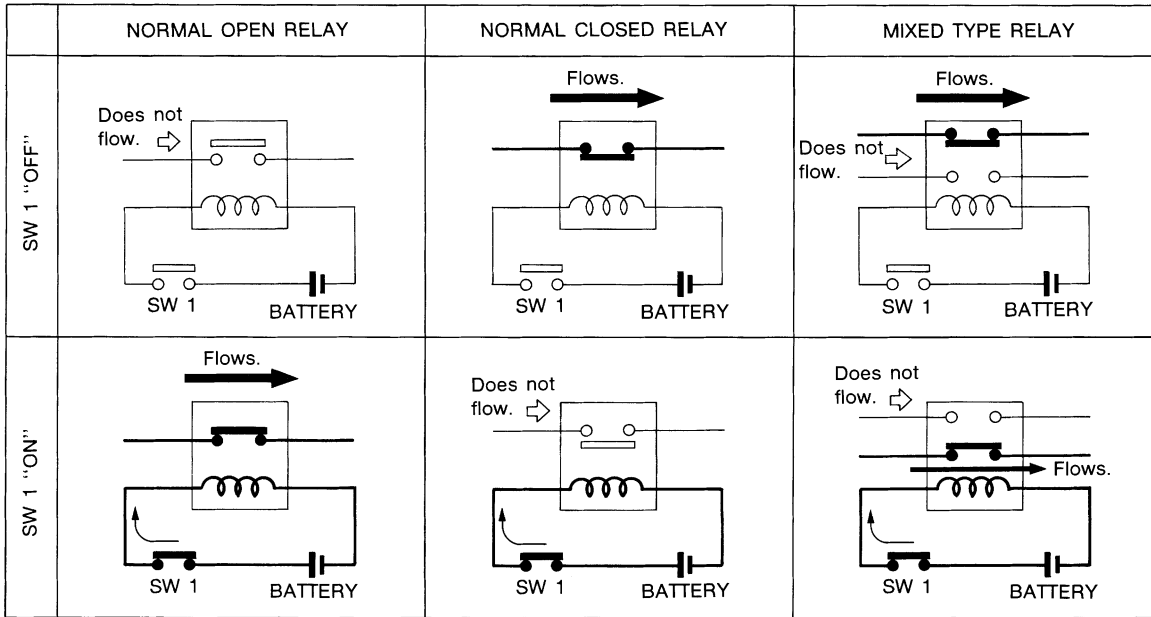

SEL881H

TYPE OF STANDARDIZED RELAYS

- 1M 1 Make
- 2M 2 Make
- 1T 1 Transfer
- 1M·1B 1 Make 1 Break

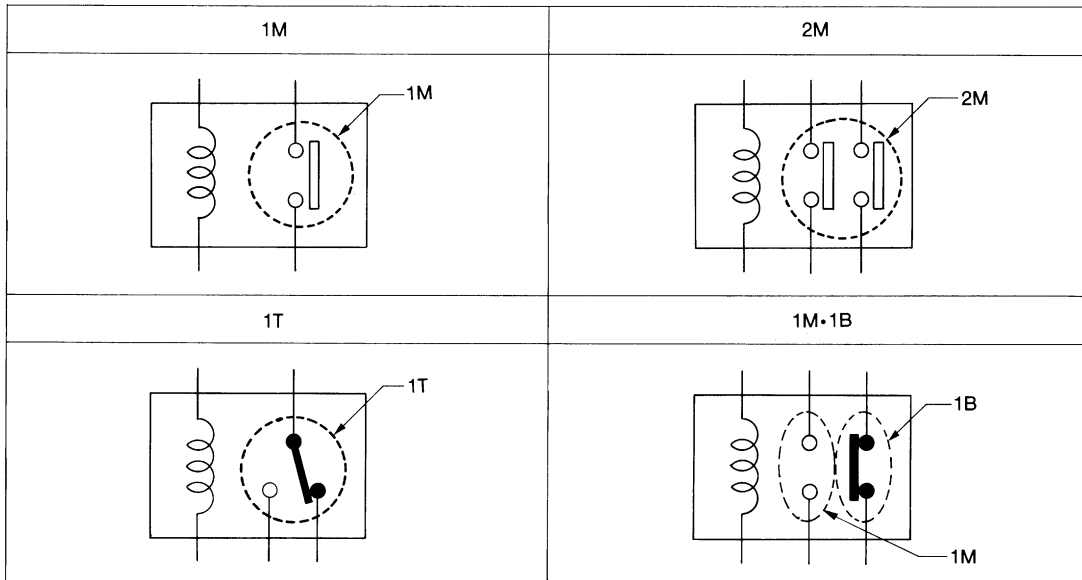

SEL882H

STANDARDIZED RELAY

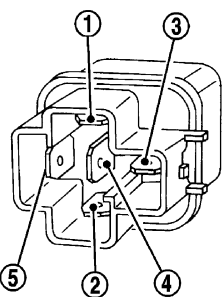
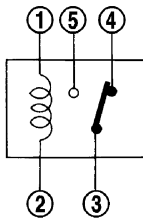
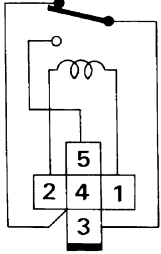
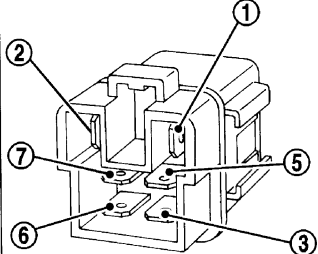
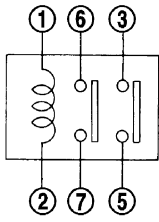
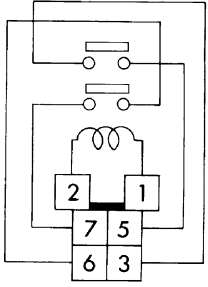
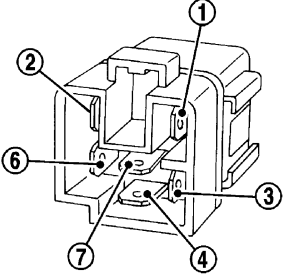
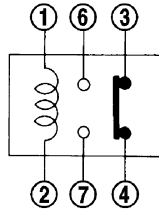
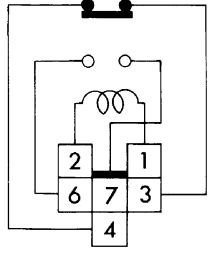
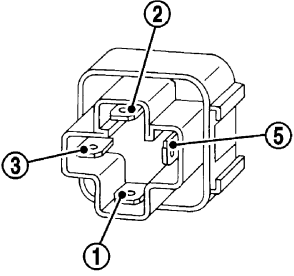
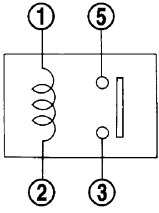
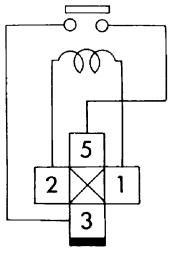
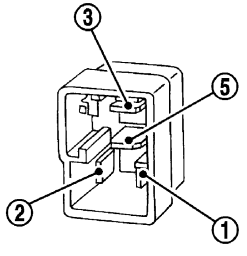
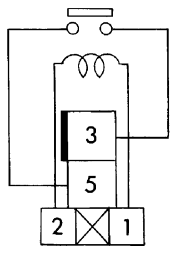
Type	Outer view	Circuit	Connector symbol and connection	Case color
1T				BLACK
2M				BROWN
1M•1B				GRAY
1M				BLUE
				

The arrangement of terminal numbers on the actual relays may differ from those shown above.

SEL188W

A
B
C
D
E
F
G
H
I
J
PG
L
M

FUSE BLOCK - JUNCTION BOX (J/B) NO. 1

FPF:24350

NKS001LW

FUSE BLOCK - JUNCTION BOX (J/B) NO. 1

Terminal Arrangement

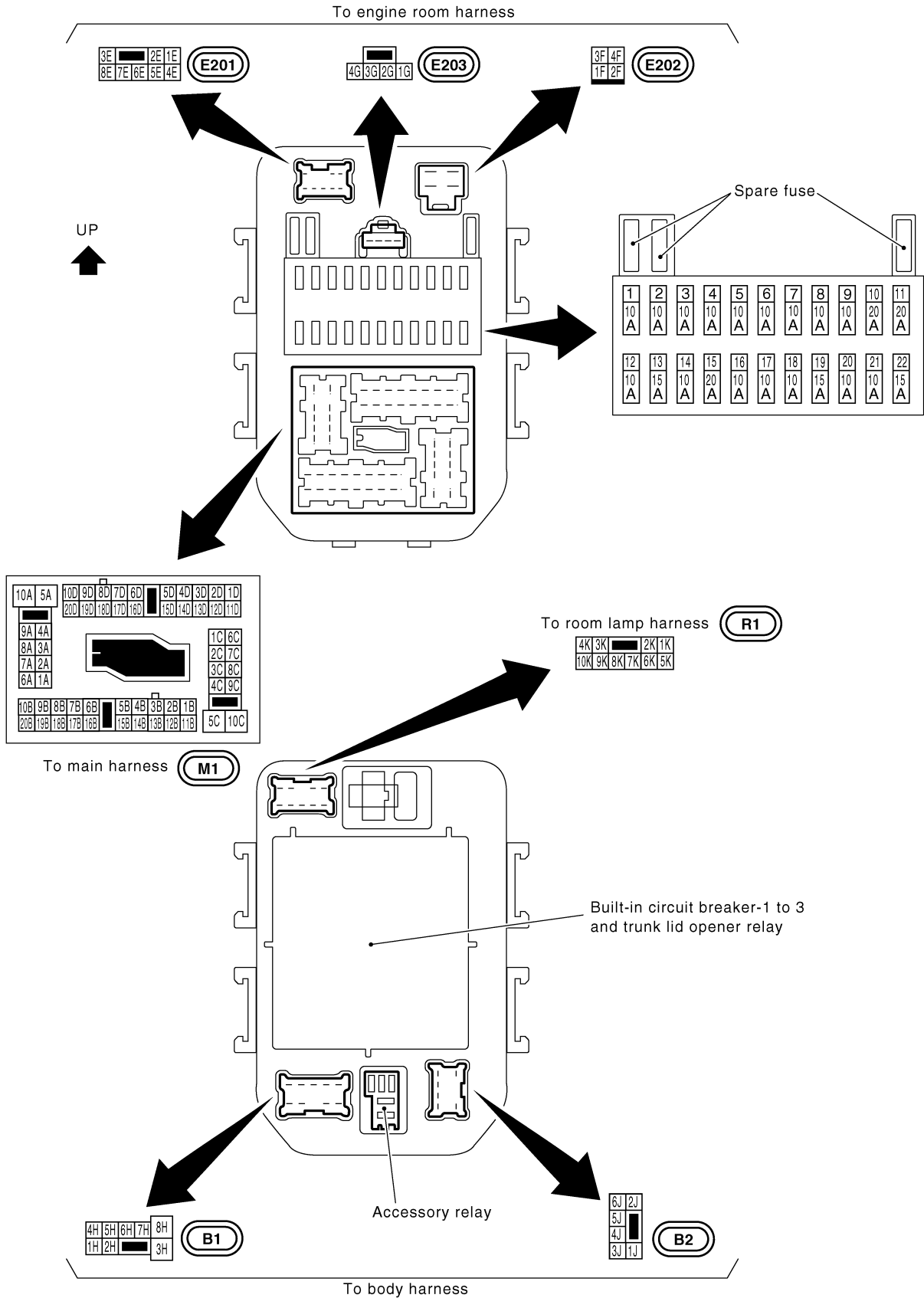

CKIM0343E

FUSE BLOCK - JUNCTION BOX (J/B) NO. 2

FUSE BLOCK - JUNCTION BOX (J/B) NO. 2 Terminal Arrangement

PFP:24350

NKS001LX

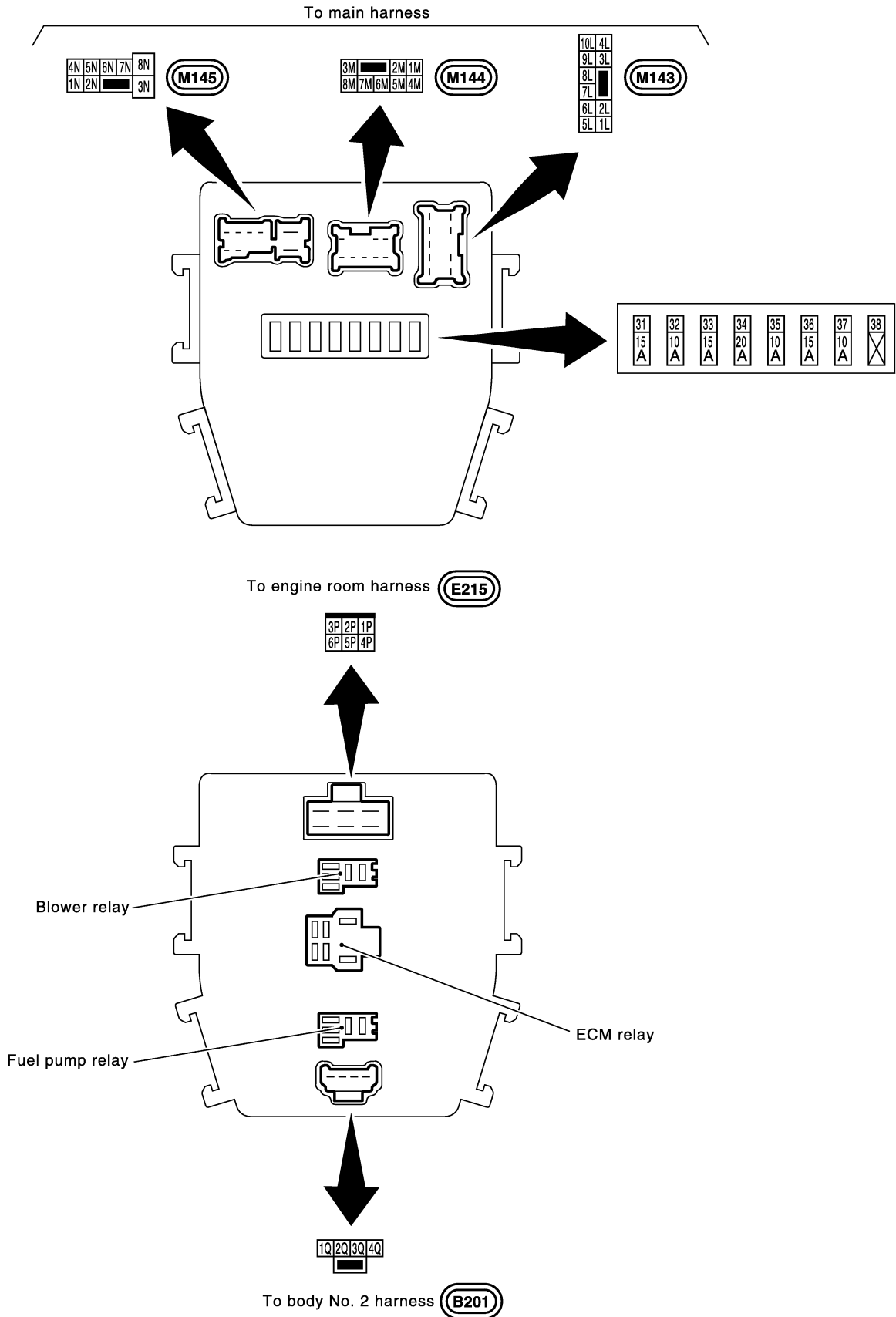

A
B
C
D
E
F
G
H
I
J
PG
L
M

FUSE, FUSIBLE LINK AND RELAY BLOCK (J/B)

PFP:24382

NKS001LY

FUSE, FUSIBLE LINK AND RELAY BLOCK (J/B)

Terminal Arrangement

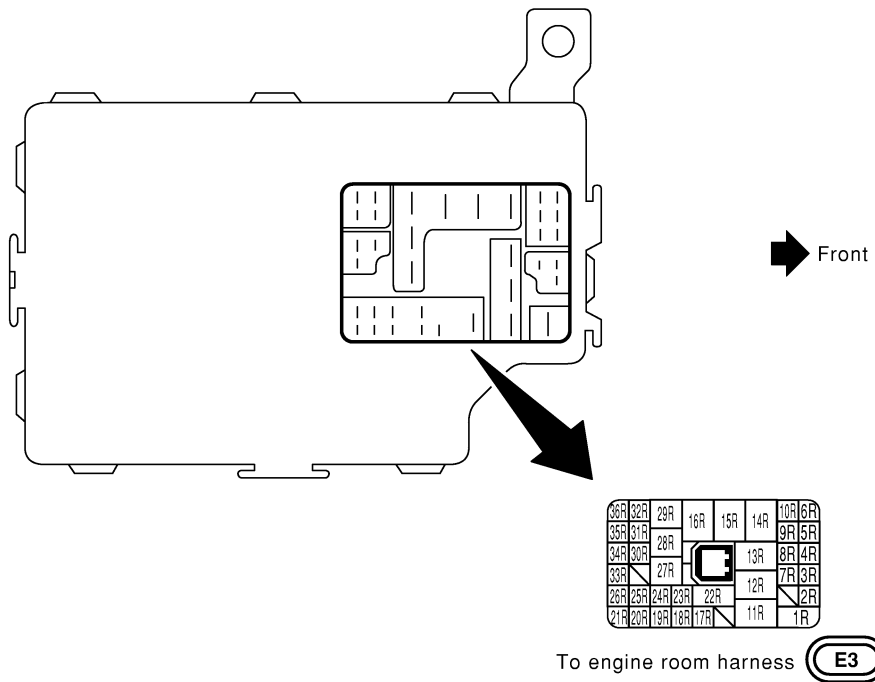
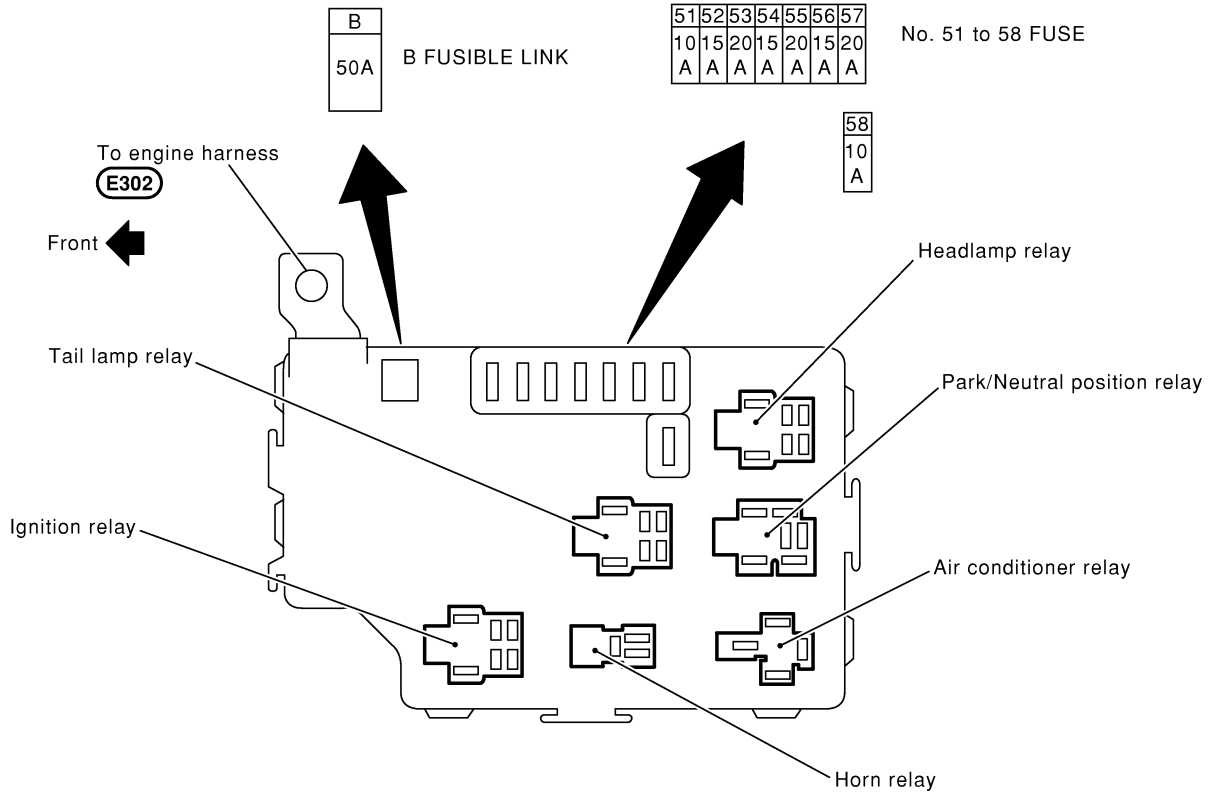

CKIM0066E

FUSE, FUSIBLE LINK AND RELAY BOX

FUSE, FUSIBLE LINK AND RELAY BOX

PFP:24382

Terminal Arrangement

NKS001LZ

A
B
C
D
E
F
G
H
I
J
PG
L
M

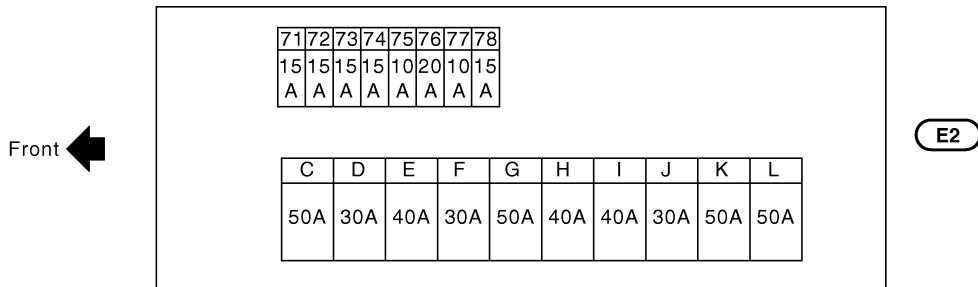
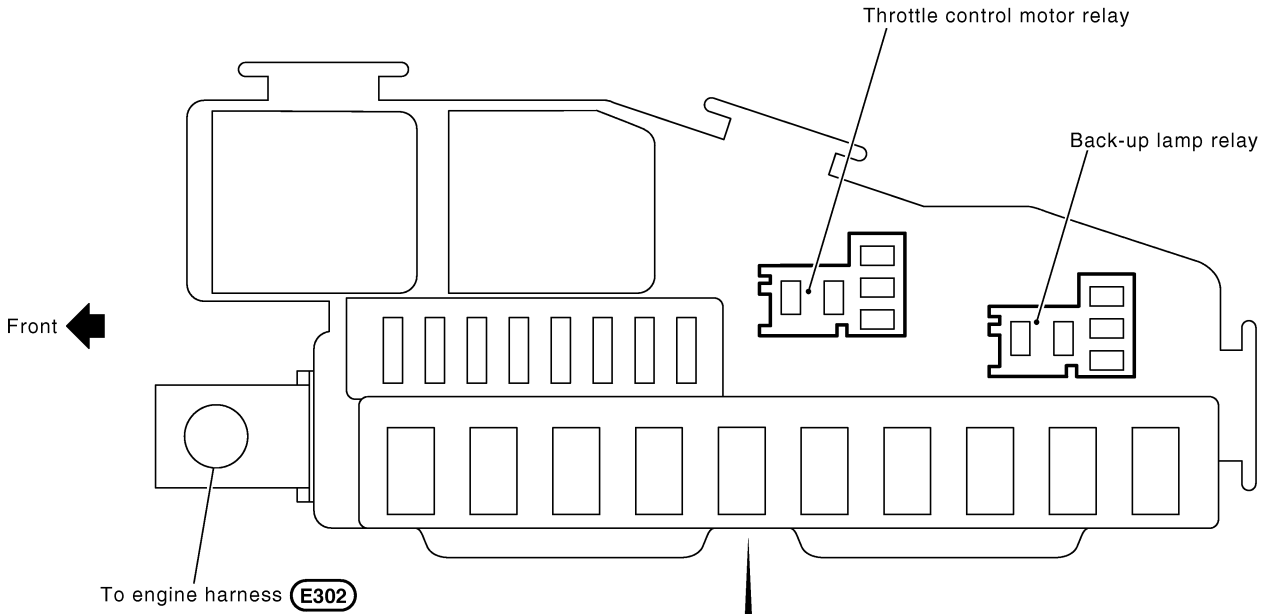

C to L FUSIBLE LINK
No. 71 to 78 FUSE

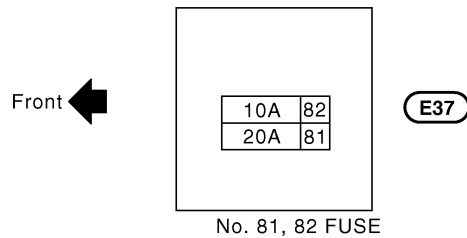

CKIM0629E

FUSE, FUSIBLE LINK AND RELAY BOX
