

A

SECTION LU

LU

ENGINE LUBRICATION SYSTEM

C

CONTENTS

D

E

PRECAUTIONS	2	OIL PUMP	10	F
Precautions for Liquid Gasket	2	Removal and Installation	10	
LIQUID GASKET APPLICATION PROCEDURE....	2	REMOVAL	10	
PREPARATION	3	INSTALLATION	10	G
Special Service Tools	3	INSPECTION AFTER INSTALLATION	10	
Commercial Service Tools	3	Disassembly and Assembly	11	
LUBRICATION SYSTEM	4	DISASSEMBLY	11	H
Lubrication Circuit	4	INSPECTION AFTER DISASSEMBLY	11	
System Drawing	5	ASSEMBLY	12	
ENGINE OIL	6	SERVICE DATA AND SPECIFICATIONS (SDS)	13	I
Inspection	6	Standard and Limit	13	
ENGINE OIL LEVEL	6	OIL PRESSURE	13	
ENGINE OIL APPEARANCE	6	OIL PUMP	13	J
ENGINE OIL LEAKAGE	6	REGULATOR VALVE	13	
OIL PRESSURE CHECK	6	ENGINE OIL CAPACITY	13	
Changing Engine Oil	7	Tightening Torque	13	K
OIL FILTER	9			L
Removal and Installation	9			M
REMOVAL	9			
INSTALLATION	9			
INSPECTION AFTER INSTALLATION	9			

PRECAUTIONS

PRECAUTIONS

PFP:00001

Precautions for Liquid Gasket LIQUID GASKET APPLICATION PROCEDURE

EBS011WG

1. Remove old liquid gasket adhering to the liquid gasket application surface and the mating surface.
 - Remove liquid gasket completely from the liquid gasket application surface, mounting bolts, and bolt holes.
2. Wipe the liquid gasket application surface and the mating surface with white gasoline (lighting and heating use) to remove adhering moisture, grease and foreign materials.
3. Attach liquid gasket tube to tube presser (SST).

Use Genuine RTV Silicone Sealant or equivalent. Refer to [GI-46, "RECOMMENDED CHEMICAL PRODUCTS AND SEALANTS"](#) .

- Within five minutes of liquid gasket application, install the mating component.
- If liquid gasket protrudes, wipe it off immediately.
- Do not retighten mounting bolts or nuts after the installation.
- After 30 minutes or more have passed from the installation, fill engine oil and engine coolant.

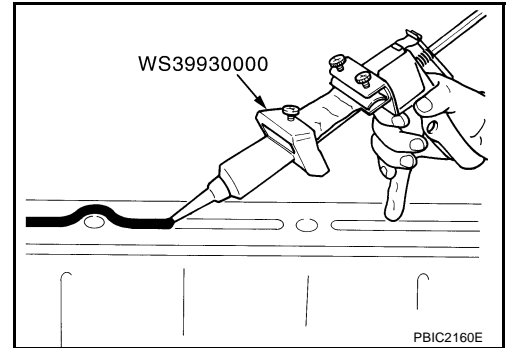

PREPARATION

PREPARATION

PPF:00002

Special Service Tools

EBS0024S

The actual shapes of Kent-Moore tools may differ from those of special service tools illustrated here.

Tool number (Kent-Moore No.) Tool name	Description
ST25051001 (J25695-1) Oil pressure gauge	Measuring oil pressure Maximum measuring range: 2,452 kPa (25 kg/cm², 356 psi)
ST25052000 (J25695-2) Hose	Adapting oil pressure gauge to cylinder block
KV10115801 (J38956) Oil filter wrench	Removing and installing oil filter a: 64.3 mm (2.531 in)
WS39930000 (—) Tube presser	Pressing the tube of liquid gasket

Commercial Service Tools

EBS003GF

Tool name	Description
Deep socket	Removing and installing oil pressure switch Deep socket 27 mm (1.06 in)
Power tool	Loosening bolts and nuts

LUBRICATION SYSTEM

LUBRICATION SYSTEM

PFP:15010

Lubrication Circuit

EBS001KC

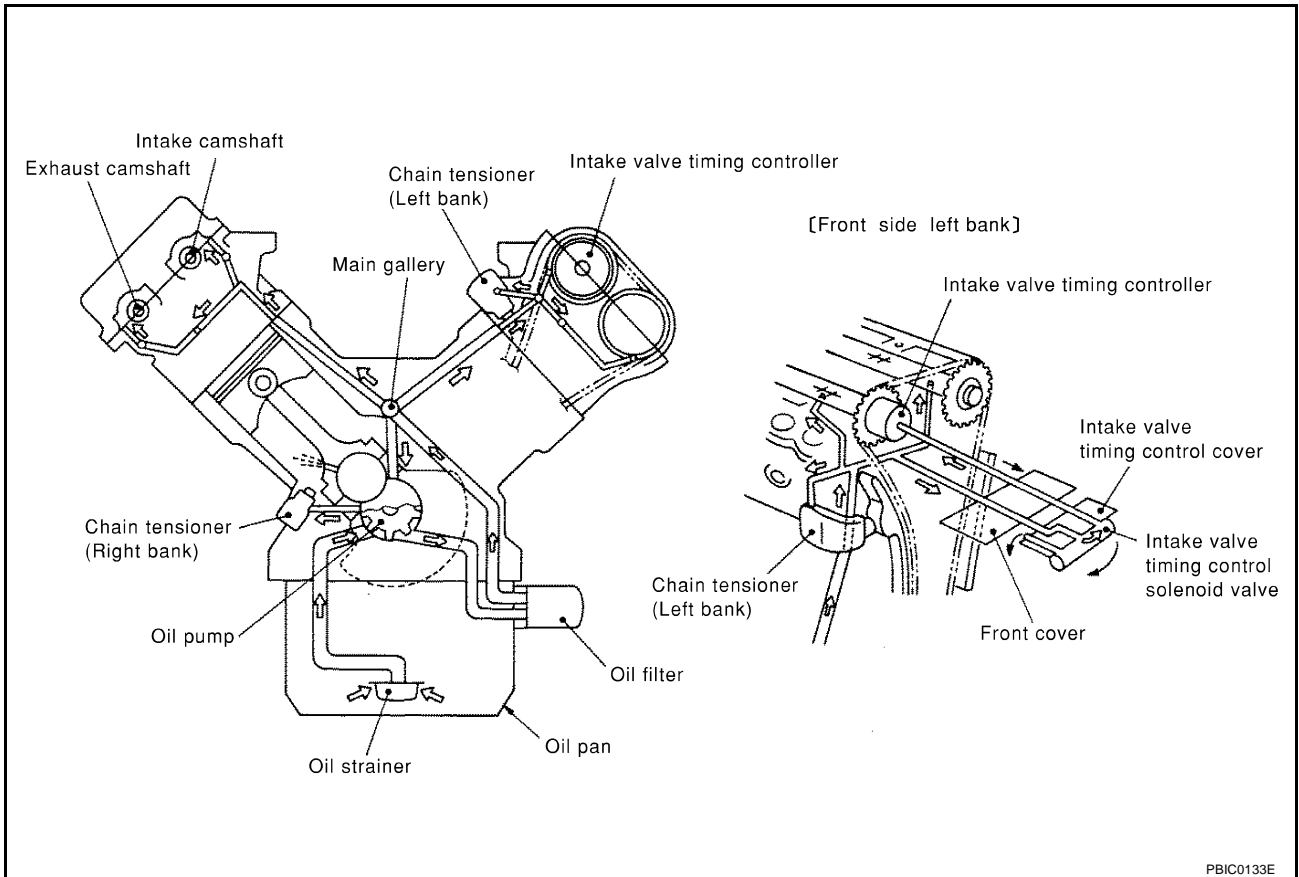

PBIC0133E

LUBRICATION SYSTEM

System Drawing

EBS0024T

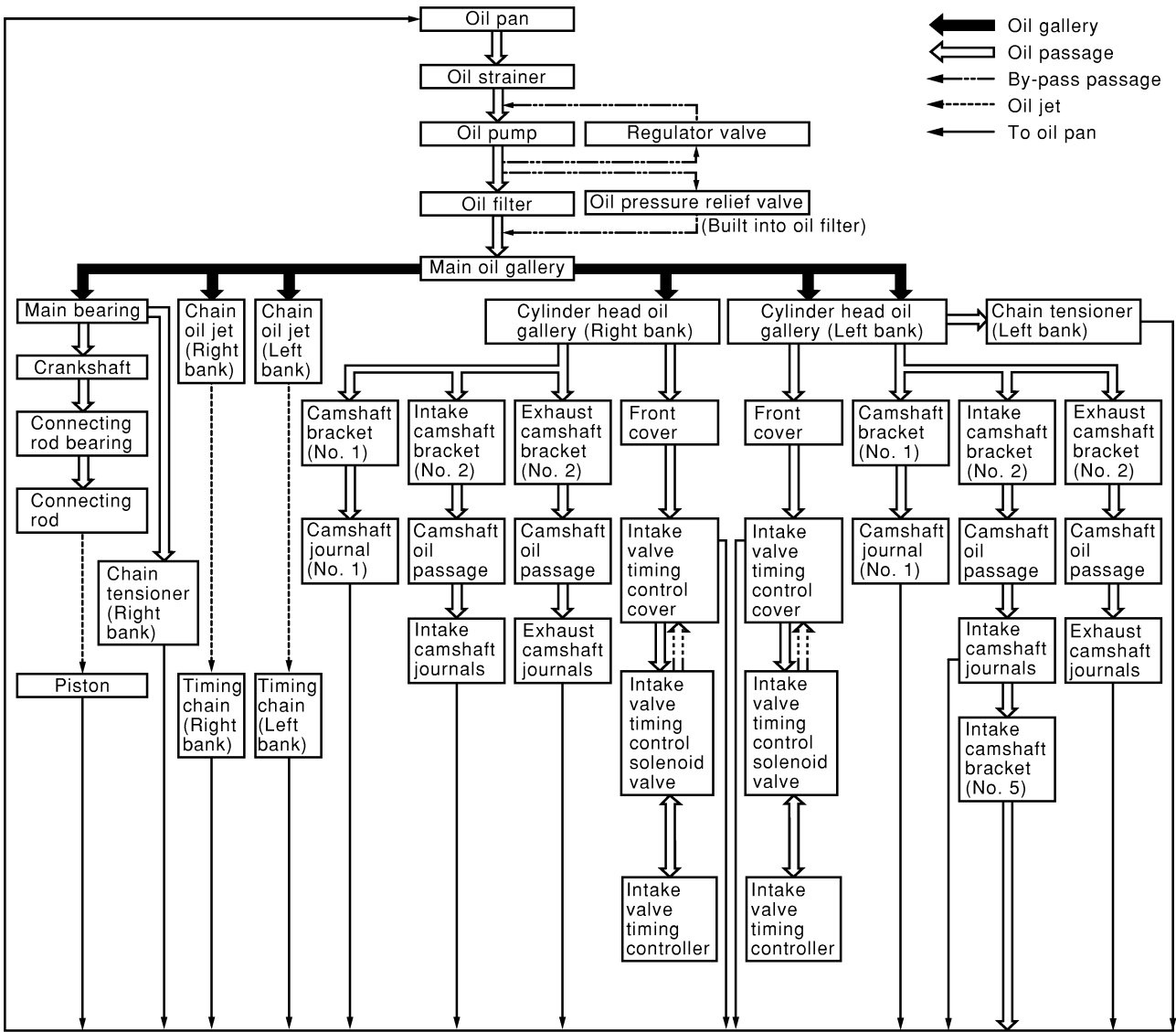

PBIC0134E

A
LU
C
D
E
F
G
H
I
J
K
L
M

ENGINE OIL

ENGINE OIL

PFP:KLA92

Inspection ENGINE OIL LEVEL

EBS0024U

NOTE:

Before starting engine, check the oil level. If engine is already started, stop it and allow 15 minutes before checking.

1. Put vehicle horizontally.
2. Pull out oil level gauge and wipe it clean.
3. Insert oil level gauge and check that the engine oil level is within the range shown in the figure.
4. If it is out of range, adjust it.

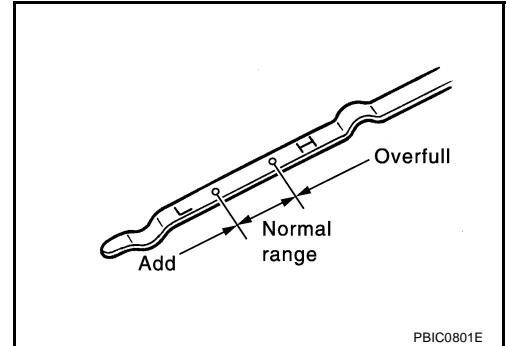

ENGINE OIL APPEARANCE

- Check engine oil for a white milky appearance or excessive contamination.
- If engine oil is milky, it is highly probable that it is contaminated with engine coolant. Repair the broken parts.

ENGINE OIL LEAKAGE

Check for engine oil leakage around the following area.

- Oil pan
- Oil pan drain plug
- Oil pressure switch
- Oil filter
- Intake valve timing control cover
- Intake valve timing control solenoid valve
- Front cover
- Mating surface between cylinder block and cylinder head
- Mating surface between cylinder head and rocker cover
- Crank oil seal (front and rear)

OIL PRESSURE CHECK

WARNING:

- **Be careful not to burn yourself, as engine oil is hot.**
 - **Engine oil pressure check should be done in "Parking position".**
1. Check engine oil level. Refer to [LU-6, "ENGINE OIL LEVEL"](#).
 2. Remove engine undercover with power tool.
 3. Disconnect oil pressure switch harness connector.
 4. Remove oil pressure switch using the deep socket (commercial service tool).

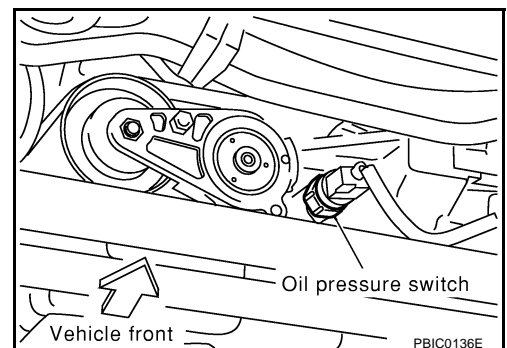

ENGINE OIL

5. Install oil pressure gauge and hose [SST].

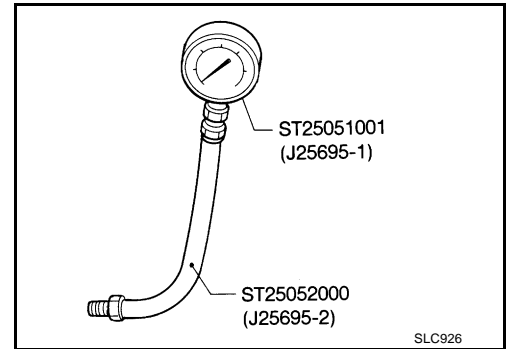

6. After warming up engine, check that engine oil pressure corresponding to the engine speed is produced.

NOTE:

When engine oil temperature is low, the engine oil pressure becomes high.

Engine oil pressure [Engine oil temperature at 80 °C (176 °F)]

Engine speed (rpm)	Idle speed	2,000
Oil pressure kPa (kg/cm ² , psi)	98 (1.0, 14) or more	294 (3.0, 43) or more

If difference is extreme, check the oil passage and oil pump for engine oil leaks.

7. After checking, install oil pressure switch as follows.
- Remove old liquid gasket adhering to oil pressure switch and engine.
 - Apply thread sealant and tighten oil pressure switch to the specification.
Use Genuine Thread Sealant or equivalent. Refer to [GI-46, "RECOMMENDED CHEMICAL PRODUCTS AND SEALANTS"](#) .

Oil pressure switch:

: 12.3 - 17.2 N·m (1.25 - 1.75 kg·m, 10 - 12 ft·lb)

Changing Engine Oil

EBS0024V

WARNING:

- Be careful not to burn yourself, as engine oil is hot.
- Prolonged and repeated contact with used engine oil may cause skin cancer; try to avoid direct skin contact with used engine oil. If skin contact is made, wash thoroughly with soap or hand cleaner as soon as possible.

- Remove engine undercover with power tool.
- Warm up engine, and check for engine oil leakage from engine components.
- Stop engine and wait for 15 minutes.
- Loosen oil filler cap, then remove drain plug.
- Drain engine oil.
- Install drain plug with new washer. Refer to [EM-24, "OIL PAN AND OIL STRAINER"](#) .

CAUTION:

- Be sure to clean drain plug and install with new washer.

Oil pan drain plug:

 : 29.4 - 39.2 N·m (3.0 - 4.0 kg·m, 22 - 28 ft·lb)

7. Refill with new engine oil.

Engine oil specification and viscosity:

Refer to [MA-10, "RECOMMENDED FLUIDS AND LUBRICANTS"](#) .

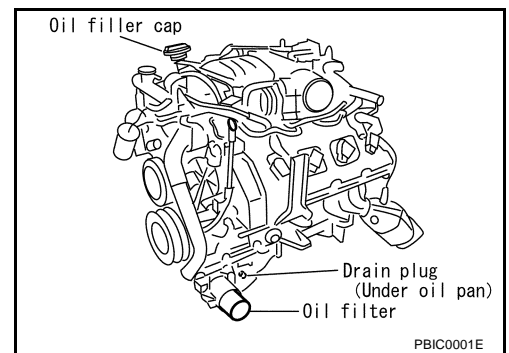

ENGINE OIL

Engine oil capacity (Approximate):

Unit: ℓ (US qt, Imp qt)

Drain and refill	With oil filter change	5.6 (5-7/8, 4-7/8)
	without oil filter change	5.0 (5-1/4, 4-3/8)
Dry engine (engine overhaul)		6.7 (7-1/8, 5-7/8)

CAUTION:

- **The refill capacity depends on the engine oil temperature and drain time. Use these specifications for reference only.**
 - **Always use oil level gauge to determine when the proper amount of engine oil is in engine.**
8. Warm up engine and check area around drain plug and oil filter for oil leakage.
 9. Stop engine and wait for 15 minutes.
 10. Check the engine oil level. Refer to [LU-6, "Inspection"](#) .

OIL FILTER

OIL FILTER

PFP:15208

Removal and Installation

EBS0024W

REMOVAL

1. Open oil filter installation/removal cover on engine undercover.
2. Using the oil filter wrench (SST), remove oil filter.

CAUTION:

- Oil filter is provided with a relief valve.
Use genuine NISSAN oil filter or equivalent.
- Be careful not to get burned when engine and engine oil are hot.
- When removing, prepare a shop cloth to absorb any engine oil leakage or spillage.
- Do not allow engine oil to adhere to drive belts.
- Completely wipe off any engine oil that adhere to engine and vehicle.

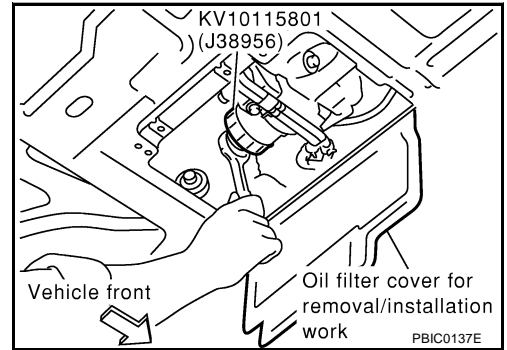

INSTALLATION

1. Remove foreign materials adhering to the oil filter installation surface.
2. Apply engine oil to the oil seal circumference of new oil filter.

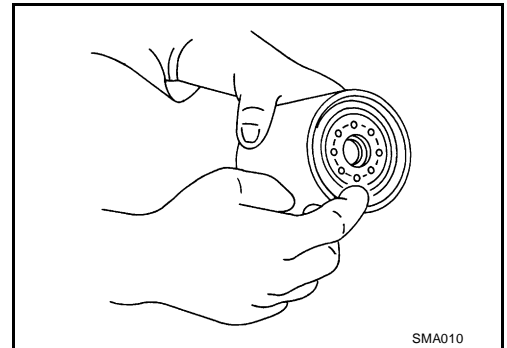

3. Screw oil filter manually until it touches the installation surface, then tighten it by 2/3 turn. Or tighten to specification.

Oil filter:

: 14.7 - 20.6 N·m (1.5 - 2.1 kg·m, 11 - 15 ft·lb)

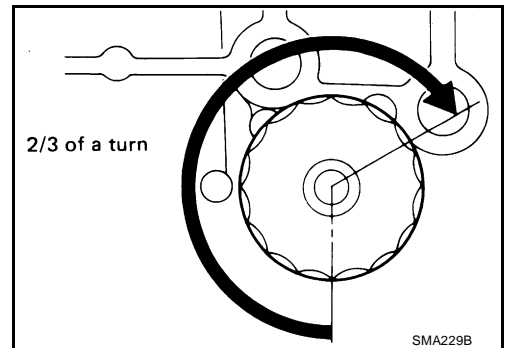

INSPECTION AFTER INSTALLATION

1. After warming up engine, check for engine oil leakage.
2. Stop engine and wait for 15 minutes.
3. Check engine oil level and add engine oil. Refer to [LU-6, "ENGINE OIL"](#).

OIL PUMP

OIL PUMP

PFP:15010

Removal and Installation

EBS00240

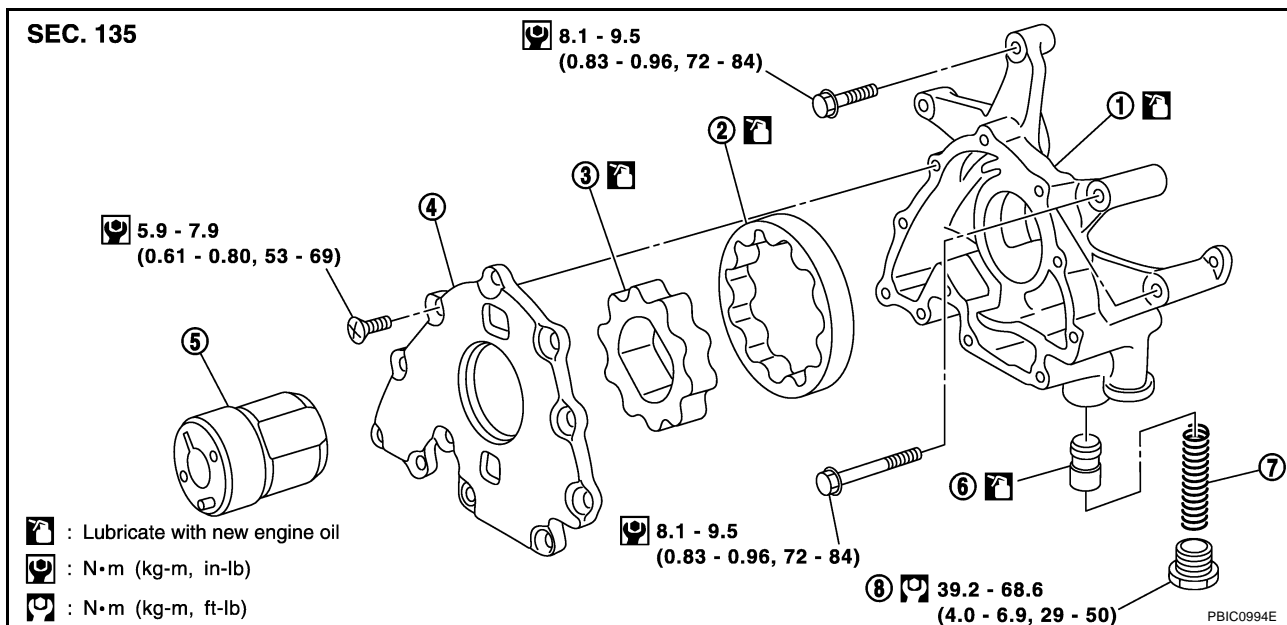

- | | | |
|---------------------|--------------------------|--------------------|
| 1. Oil pump body | 2. Outer rotor | 3. Inner rotor |
| 4. Oil pump cover | 5. Oil pump drive spacer | 6. Regulator valve |
| 7. Regulator spring | 8. Regulator plug | |

REMOVAL

- Remove front cover.
Refer to [EM-37, "Removal and Installation"](#).
- Remove oil pump drive spacer.
 - Set bolts in the two bolt holes [M6 x 1.0 mm (0.039 in)] on the front surface. Using a small puller, remove oil pump drive spacer from crankshaft.

NOTE:

The dimension between the centers of the two bolt holes is 33 mm (1.30 in).
In the figure, the commercial steering puller is used.

- Remove oil pump.

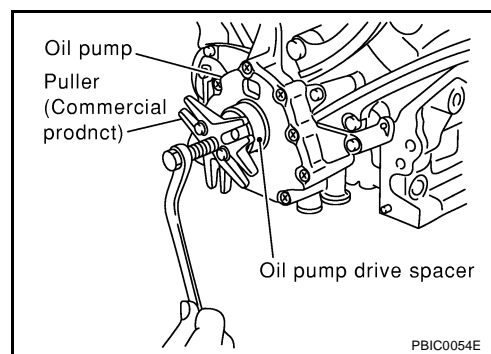

INSTALLATION

- Install oil pump.
- Install oil pump drive spacer as follows.
 - When inserting oil pump drive spacer, align crankshaft key and the flat face of inner rotor.
 - If they are not aligned, rotate inner rotor by hand.
 - Make sure that the each part is aligned. Using a tool such as a plastic hammer, tap lightly until it reaches the end.
- Install in the reverse order of removal.

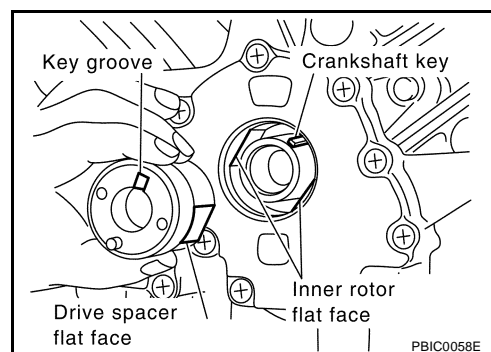

INSPECTION AFTER INSTALLATION

- Start engine, and check there is no leak of engine oil.
- Check level of engine oil, and add engine oil. Refer to [LU-6, "ENGINE OIL"](#).

OIL PUMP

EBS0024L

Disassembly and Assembly DISASSEMBLY

1. Remove oil pump cover.
2. Remove inner rotor and outer rotor from oil pump body.
3. After removing regulator plug, remove regulator spring and regulator valve.

INSPECTION AFTER DISASSEMBLY

Clearance of Oil Pump Parts

- Measure clearance with feeler gauge.
Clearance between outer rotor and oil pump body (position 1)
Standard : 0.114 - 0.200 mm (0.0045 - 0.0079 in)
Tip clearance between inner rotor and outer rotor (position 2)
Standard : Below 0.180 mm (0.0071in)
- Measure clearance with feeler gauge and straightedge.
Side clearance between inner rotor and oil pump body (position 3)
Standard : 0.030 - 0.070 mm (0.0012 - 0.0028 in)
Side clearance between outer rotor and oil pump body (position 4)
Standard : 0.030 - 0.090 mm (0.0012 - 0.0035 in)
- Calculate the clearance between inner rotor and oil pump body as follows.
 - Measure the outer diameter of protruded portion of inner rotor (Position 5)
 - Measure the inner diameter of oil pump body with inside micrometer (Position 6)
 - (Clearance) = (Inner diameter of oil pump body) – (Outer diameter of inner rotor)
Standard : 0.045 - 0.091 mm (0.0018 - 0.0036 in)
- If out of the standard, replace oil pump assembly.

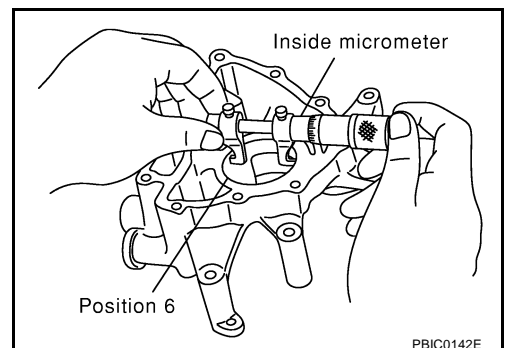
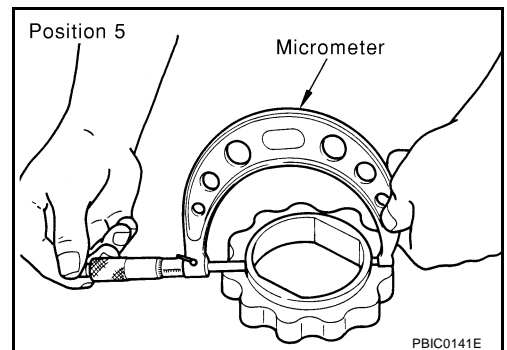
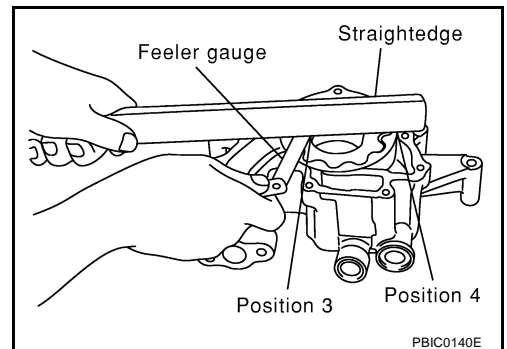
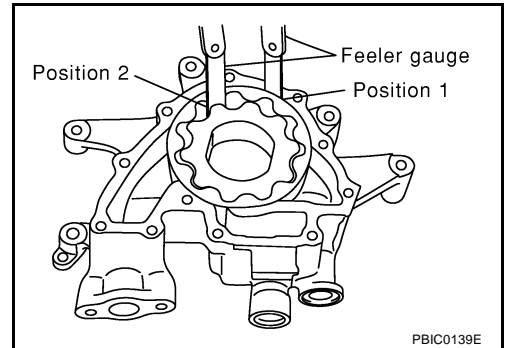

OIL PUMP

Regulator Valve Clearance

(Clearance) = D1 (Valve hole diameter) – D2 (Outer diameter of valve)

Standard : 0.040 - 0.097 mm (0.0016 - 0.0038 in)

- If out of the standard, replace oil pump assembly.

CAUTION:

- Coat regulator valve with engine oil.
- Check that it falls smoothly into the regulator valve hole by its own weight.

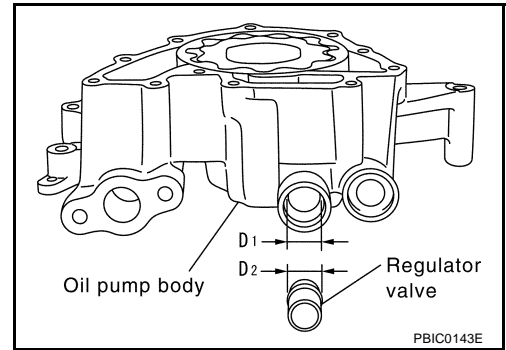

ASSEMBLY

Installation is in the reverse order of removal.

- Install inner rotor and outer rotor with the punched marks on the oil pump cover side.

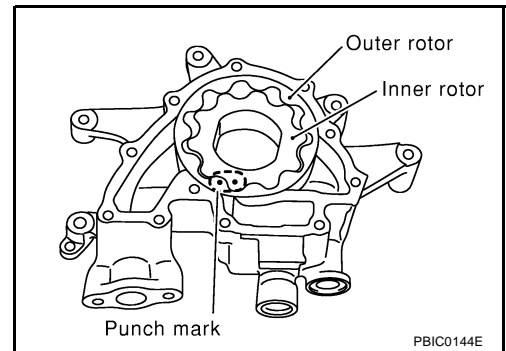

SERVICE DATA AND SPECIFICATIONS (SDS)

SERVICE DATA AND SPECIFICATIONS (SDS)

PFP:00030

Standard and Limit OIL PRESSURE

EBS003Q7

Engine speed rpm	Approximate discharge pressure kPa (kg/cm ² , psi)
Idle speed 2,000	98 (1.0, 14) or more 294 (3.0, 43) or more

OIL PUMP

Unit: mm (in)

Oil pump body to outer rotor radial clearance	0.114 - 0.200 (0.0045 - 0.0079)
Inner rotor to outer rotor tip clearance	Below 0.180 (0.0071)
Oil pump body to inner rotor side clearance	0.030 - 0.070 (0.0012 - 0.0028)
Oil pump body to outer rotor side clearance	0.030 - 0.090 (0.0012 - 0.0035)
Inner rotor to brazed portion of housing clearance	0.045 - 0.091 (0.0018 - 0.0036)

REGULATOR VALVE

Unit: mm (in)

Regulator valve to oil pump body clearance	0.040 - 0.097 (0.0016 - 0.0038)
--	---------------------------------

ENGINE OIL CAPACITY

Unit: ℓ (US qt, Imp qt)

With oil filter change	5.6 (5-7/8, 4-7/8)
Without oil filter change	5.0 (5-1/4, 4-3/8)
Dry engine (engine overhaul)	6.7 (7-1/8, 5-7/8)

Tightening Torque

EBS002NE

Unit: N·m (kg-m, ft-lb)
Unit: N·m (kg-m, in-lb)*

Oil pressure switch	12.3 - 17.2 (1.25 - 1.75, 10 - 12)
Oil pan drain plug	29.4 - 39.2 (3.0 - 4.0, 22 - 28)
Oil filter	14.7 - 20.6 (1.5 - 2.1, 11 - 15)
Oil pump body	8.1 - 9.5 (0.83 - 0.96, 72 - 84)*
Oil pump cover	5.9 - 7.9 (0.61 - 0.80, 53 - 69)*
Regulator plug	39.2 - 68.6 (4.0 - 6.9, 29 - 50)

SERVICE DATA AND SPECIFICATIONS (SDS)
