

SECTION **RFD**
REAR FINAL DRIVE

A
B
C

RFD

CONTENTS

E

PREPARATION	2	BLY	13	F
Special Service Tools	2	REMOVAL OF DRIVE PINION ASSEMBLY	14	
Commercial Service Tools	4	DISASSEMBLY OF DIFFERENTIAL CASE		
NOISE, VIBRATION AND HARSHNESS (NVH)		ASSEMBLY	15	G
TROUBLESHOOTING	5	INSPECTION	16	
NVH Troubleshooting Chart	5	ADJUSTMENT OF DIFFERENTIAL CASE	17	H
FRONT OIL SEAL	6	SIDE BEARING PRELOAD	17	
Removal and Installation	6	PINION GEAR HEIGHT	19	
REMOVAL	6	TOOTH CONTACT	22	
INSTALLATION	6	ASSEMBLY OF DIFFERENTIAL CASE ASSEM-		
SIDE OIL SEAL	8	BLY	23	I
Removal and Installation	8	INSTALLATION OF DRIVE PINION ASSEMBLY..	24	
REMOVAL	8	INSTALLATION OF DIFFERENTIAL CASE		
INSTALLATION	8	ASSEMBLY	25	J
REAR FINAL DRIVE ASSEMBLY	10	SERVICE DATA AND SPECIFICATIONS (SDS)	28	
Removal and Installation	10	General Specifications	28	
REMOVAL	10	Ring Gear Runout	28	K
INSTALLATION	10	Side Gear Adjustment	28	
Components	11	AVAILABLE SIDE GEAR THRUST WASHERS...	28	
R200 2-PINION	11	Drive Pinion Height Adjustment	29	
Pre-Inspection	12	AVAILABLE PINION HEIGHT ADJUSTING		
TOTAL PRELOAD	12	WASHERS	29	L
RING GEAR TO DRIVE PINION BACKLASH ...	12	Drive Pinion Preload Adjustment	29	
RING GEAR RUNOUT	12	Side Bearing Preload Adjustment	29	M
TOOTH CONTACT	12	SIDE BEARING ADJUSTING WASHERS	29	
Disassembly and Assembly	13	Total Preload Adjustment	29	
REMOVAL OF DIFFERENTIAL CASE ASSEM-				

PREPARATION

PFP:00002

EDS000YG



PREPARATION

Special Service Tools

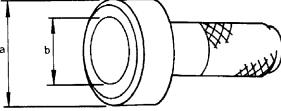
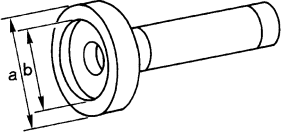
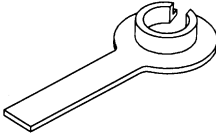
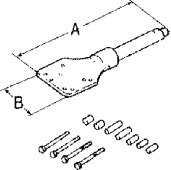
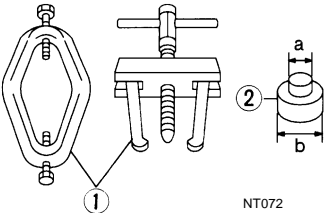
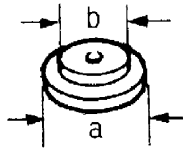
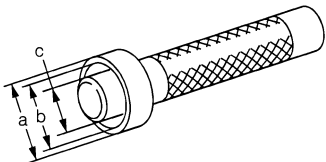
The actual shapes of Kent-Moore tools may differ from those of special service tools illustrated here.

Tool name Tool number (Kent-Moore No.)	Description
<p>Drift ST30720000 (J25405) a: 77 mm (3.03 in) dia. b: 55 mm (2.17 in) dia.</p>  <p style="text-align: right; font-size: small;">ZZA0811D</p>	<p>Installing front oil seal</p>
<p>Drift KV38100200 (J26233) a: 65 mm (2.56 in) dia. b: 49 mm (1.93 in) dia.</p>  <p style="text-align: right; font-size: small;">ZZA1143D</p>	<p>Installing final drive side oil seal</p>
<p>Protector KV38107900 (J39352)</p>  <p style="text-align: right; font-size: small;">S-NT129</p>	<p>Installing final drive side flange</p>
<p>Attachment KV38100800 (J25604-01) a: 541 mm (21.30 in) b: 200 mm (7.87 in)</p>  <p style="text-align: right; font-size: small;">SDIA0267E</p>	<p>Fixing unit assembly</p>
<p>Differential side bearing puller set ST3306S001 (-) 1.ST3305S001 (-) 2.ST33061000 (J8107-2) a: 28.5 mm (1.122 in) dia. b: 38 mm (1.50 in) dia.</p>  <p style="text-align: right; font-size: small;">NT072</p>	<p>Removing and installing side bearing</p>
<p>Drift ST30613000 (J25742-3) a: 72 mm (2.83 in) dia. b: 48 mm (1.89 in) dia.</p>  <p style="text-align: right; font-size: small;">ZZA0810D</p>	<p>Installing pinion front and bearing outer race</p>
<p>Drift KV38100300 (J25523) a: 54 mm (2.13 in) dia. b: 46 mm (1.81 in) dia. c: 32 mm (1.26 in) dia.</p>  <p style="text-align: right; font-size: small;">ZZA1046D</p>	<p>Installing side bearing</p>

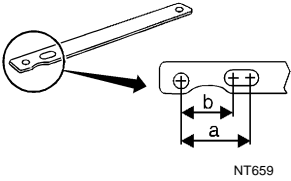
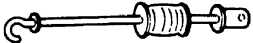
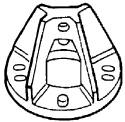
PREPARATION

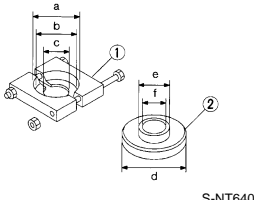
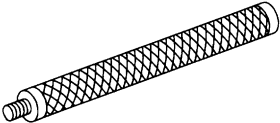
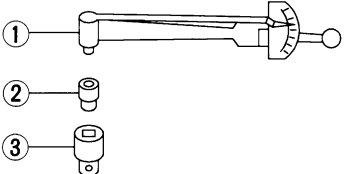
Tool name Tool number (Kent-Moore No.)	Description	
<p>Drive pinion flange wrench KV40104000 (-) a : 85 mm (3.35 in) dia. b : 65 mm (2.56 in) dia.</p>	 <p style="text-align: center;">NT659</p>	<p style="text-align: center;">A</p> <p style="text-align: center;">B</p> <p style="text-align: center;">C</p>
<p>Sliding hammer ST36230000 (J25840-A)</p>	 <p style="text-align: center;">ZZA0803D</p>	<p style="text-align: center;">RFD</p> <p style="text-align: center;">E</p>
<p>Axle Stand KV40104100 (-)</p>	 <p style="text-align: center;">ZZA0804D</p>	<p style="text-align: center;">F</p> <p style="text-align: center;">G</p>
<p>Sliding hammer HT72400000 (-)</p>	 <p style="text-align: center;">S-NT125</p>	<p style="text-align: center;">H</p> <p style="text-align: center;">I</p> <p style="text-align: center;">J</p>
<p>Drive pinion rear inner race puller set ST3090S000 (-) 1. ST30031000 (J22912-01) Puller 2. ST30901000 (-) Base Equivalent tool (J26010-01) a : 90 mm (3.54 in) dia. b : 80 mm (3.15 in) dia. c : 50 mm (1.97 in) dia. d : 79 mm (3.11 in) dia. e : 45 mm (1.77 in) dia. f : 35 mm (1.38 in) dia.</p>	 <p style="text-align: center;">S-NT640</p>	<p style="text-align: center;">K</p> <p style="text-align: center;">L</p> <p style="text-align: center;">M</p>
<p>Drift ST30611000 (J25742-1)</p>	 <p style="text-align: center;">S-NT090</p>	<p style="text-align: center;">Installing pinion rear bearing outer race (Use with ST30613000)</p>
<p>Preload gauge ST3127S000 (see J25765-A) 1. GG91030000 Torque wrench (J25765) 2. HT62940000 (-) Socket adapter (1/2") 3. HT62900000 (-) Socket adapter (3/8")</p>	 <p style="text-align: center;">NT124</p>	<p style="text-align: center;">Measuring pinion bearing preload and total preload</p>

PREPARATION

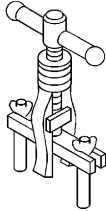
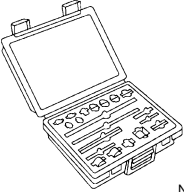
Tool name Tool number (Kent-Moore No.)	Description
<p data-bbox="161 321 459 378">Side bearing outer race puller ST33290001 (J34286)</p>  <p data-bbox="847 442 890 459">NT713</p>	<p data-bbox="999 336 1182 363">Removing oil seal</p>
<p data-bbox="161 576 515 604">Differential shim selection (J34309)</p>  <p data-bbox="847 676 890 693">NT134</p>	<p data-bbox="999 576 1382 604">Adjusting bearing preload gear height</p>

Commercial Service Tools

EDS000YH

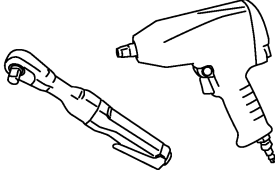
<p data-bbox="137 889 244 917">Power tool</p>  <p data-bbox="898 1002 970 1019">PBIC0190E</p>	
--	--

FRONT OIL SEAL

PFP:38189

EDS000YJ

FRONT OIL SEAL

Removal and Installation

REMOVAL

1. Remove the propeller shaft. Refer to [PR-3, "REAR PROPELLER SHAFT"](#) .
2. Put a mark on the end of the drive pinion corresponding to the C position mark on the final drive companion flange.

CAUTION:

- For matching mark, use paint. Never damage drive pinion.
- The mark C on the final drive companion flange indicates the maximum vertical runout position.

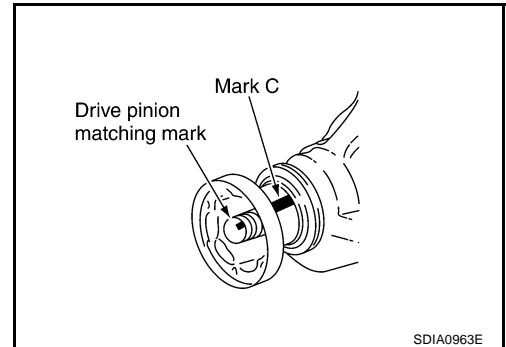

3. Using the drive pinion flange wrench, Remove drive pinion nut.

Tool number : KV40104000 (-)

4. Using the puller, remove the companion flange.

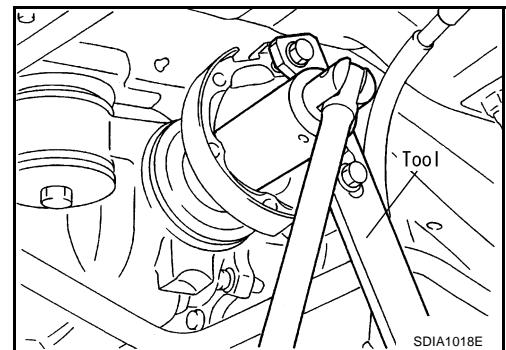

5. Using the side bearing outer race puller, remove oil seal.

Tool number : ST33290001 (J34286)

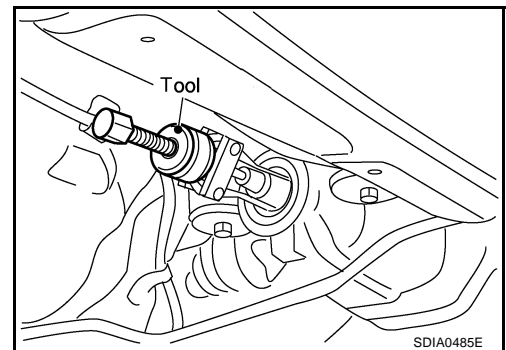

INSTALLATION

1. Apply multi-purpose grease to sealing lips of oil seal. Press front oil seal into carrier with tool.

Tool number : ST30720000 (J25405)

NOTE:

- When installing the oil seal, be careful not to get it inclined.
- Discard the old oil seal. Always replace with new one.

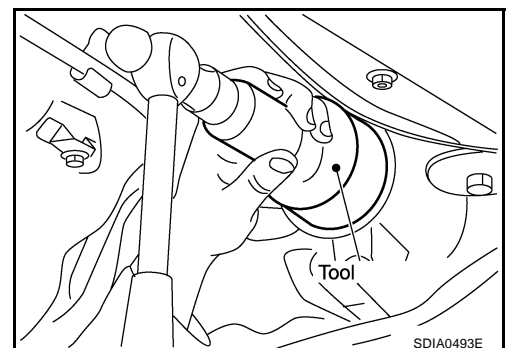

FRONT OIL SEAL

- Align the matching mark of drive pinion with the matching mark C of companion flange, then install the companion flange.

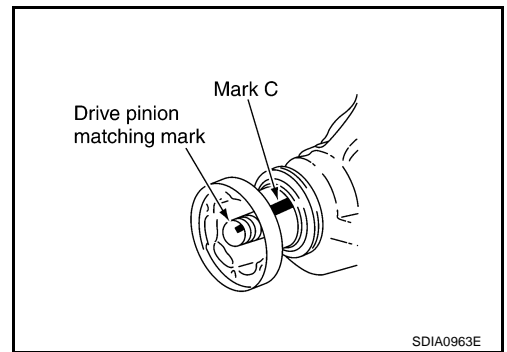

- Apply oil or grease on the screw part of drive pinion and the seating surface of drive pinion nut.
- Install drive pinion nut with tool.

Tool number : KV40104000 (-)

 : 147 - 323N-m (15.0 - 32.0 kg-m, 109 - 238 ft-lb)

CAUTION:

The drive pinion nut is not reusable. Never reuse drive pinion nut.

- Install propeller shaft. Refer to [PR-3, "REAR PROPELLER SHAFT"](#) .

A
B
C

RFD

E
F

G

H

I

J

K

L

M

SIDE OIL SEAL

PFP:33142

EDS000YK

SIDE OIL SEAL

Removal and Installation REMOVAL

1. Remove side flange with the following procedure for press-fitting.
 - a. Remove rear ABS wheel sensor. Refer to [BRC-67, "WHEEL SENSORS"](#).
 - b. Remove drive shaft and axle assembly. Refer to [RAX-9, "REAR DRIVE SHAFT"](#) and [RAX-5, "WHEEL HUB"](#).
 - c. Install Axle stand to both side flange.
Tool number A : KV40104100 (-)
 - d. Using a sliding hammer, pull out the side flange.
Tool number B : ST3623000 (J25840-A)

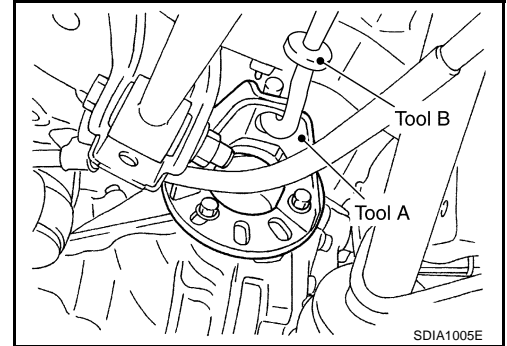

Model	Circular clip installation position
R200	Final drive side

2. Remove oil seal using a flat-bladed screwdriver.

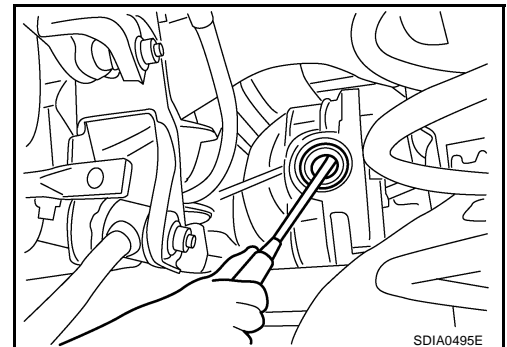

INSTALLATION

1. Apply multi-purpose grease to sealing lips of oil seal.
2. Using the drift, press-fit oil seal so that its surface comes face to face with the end surface of the case.
Tool number : KV38100200 (J26233)
CAUTION:
 - When installing the oil seal be careful not to get it inclined.
 - Discard the old oil seal. Always replace with new one.
3. Align the installing position of the ABS wheel sensor.

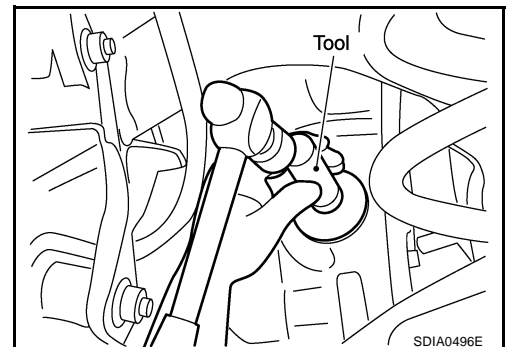

SIDE OIL SEAL

4. Install the side flange with the following procedure.

a. Attach the protector to side oil seal.

Tool number : KV38107900 (J39352)

b. After the side flange is inserted and the serrated part of side gear has engaged the serrated part of flange, remove the protector.

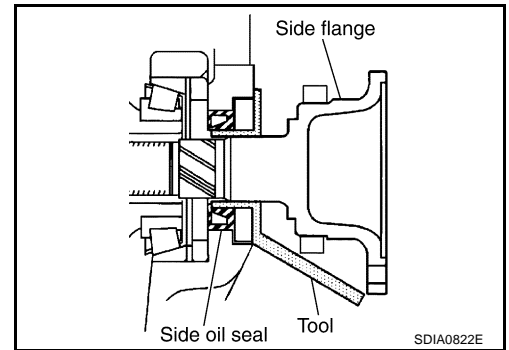

c. Put suitable drift on the center of side flange, then drive it until sound changes.

NOTE:

When installation is completed, driving sound of the side flange turns into a sound which seems to affect the whole final drive.

5. Confirm that the dimension of the side flange installation (Measurement A) in the illustration comes into the following, then install the drive shaft.

Measurement A : Approx. 326 - 328 mm (12.83 - 12.91 in)

6. Align the installing position of the ABS wheel sensor. Refer to [BRC-67, "WHEEL SENSORS"](#) .

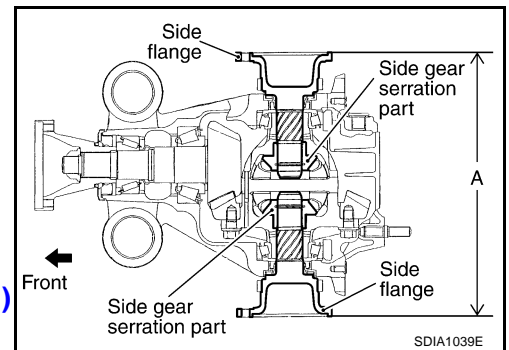

A
B
C

RFD

E
F
G

H

I

J

K

L

M

REAR FINAL DRIVE ASSEMBLY

PFP:38300

REAR FINAL DRIVE ASSEMBLY

Removal and Installation

EDS000YL

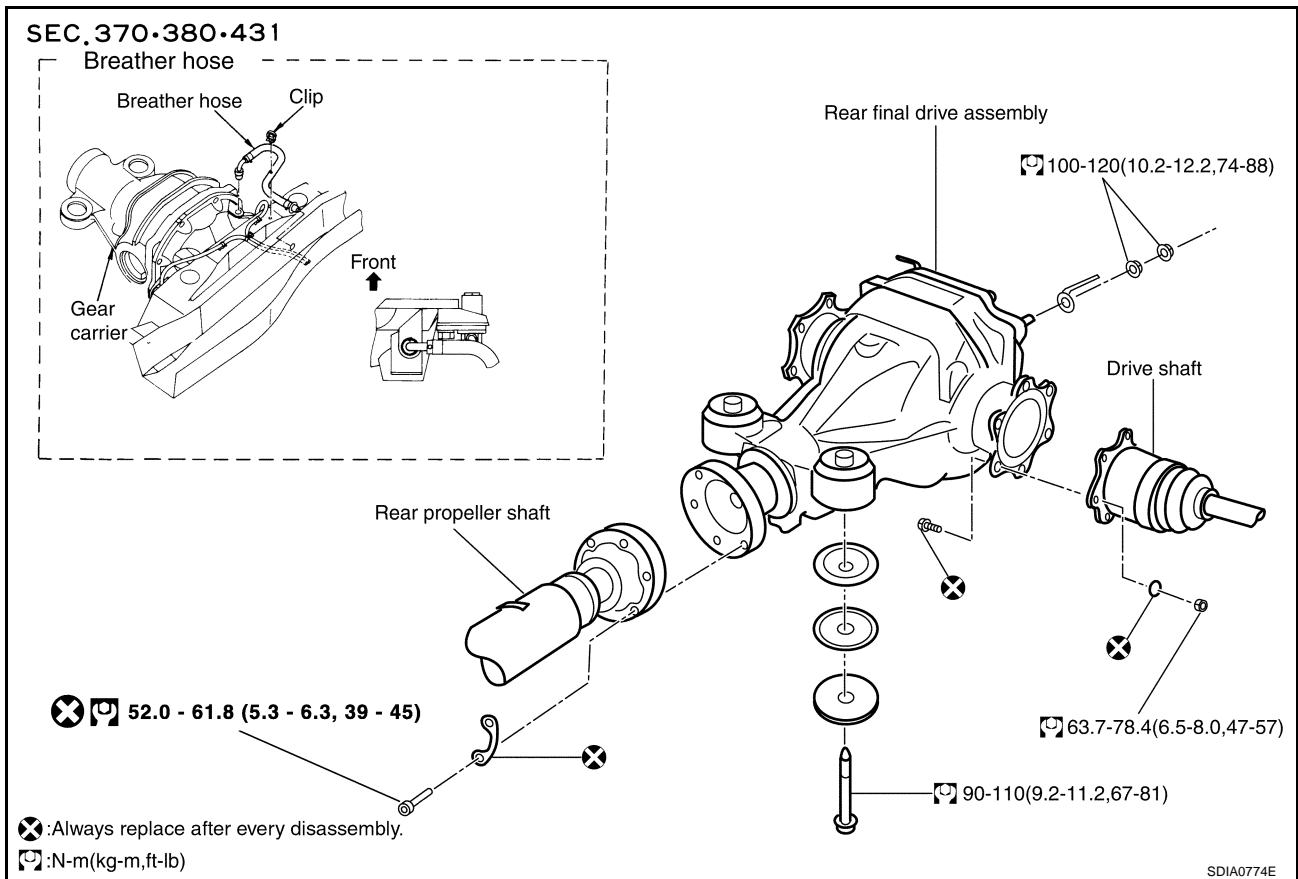

REMOVAL

1. Remove exhaust center tube with power tool. Refer to [EX-4, "REMOVAL"](#).
2. Remove rear stabilizer bar with power tool. Refer to [RSU-16, "REMOVAL"](#).
3. Remove rear propeller shaft from the final drive. Refer to [PR-3, "REMOVAL"](#).
4. Remove rear drive shaft from final drive. Then suspend it by wire etc. with power tool.
5. Remove breather hose from the final drive.
6. Remove rear wheel sensor. Refer to [BRC-67, "REMOVAL"](#).
7. Place a transmission jack on the final drive.

CAUTION:

Do not place a transmission jack on the rear cover (aluminum case).

8. Remove the mounting bolts and nuts connecting to the suspension member, and remove the rear final drive.

INSTALLATION

Install in the reverse order of removal.

CAUTION:

After installation, check the final drive oil level.

REAR FINAL DRIVE ASSEMBLY

EDS000YM

Components R200 2-PINION

A
B
C
RFD
E
F
G
H
I
J
K
L
M

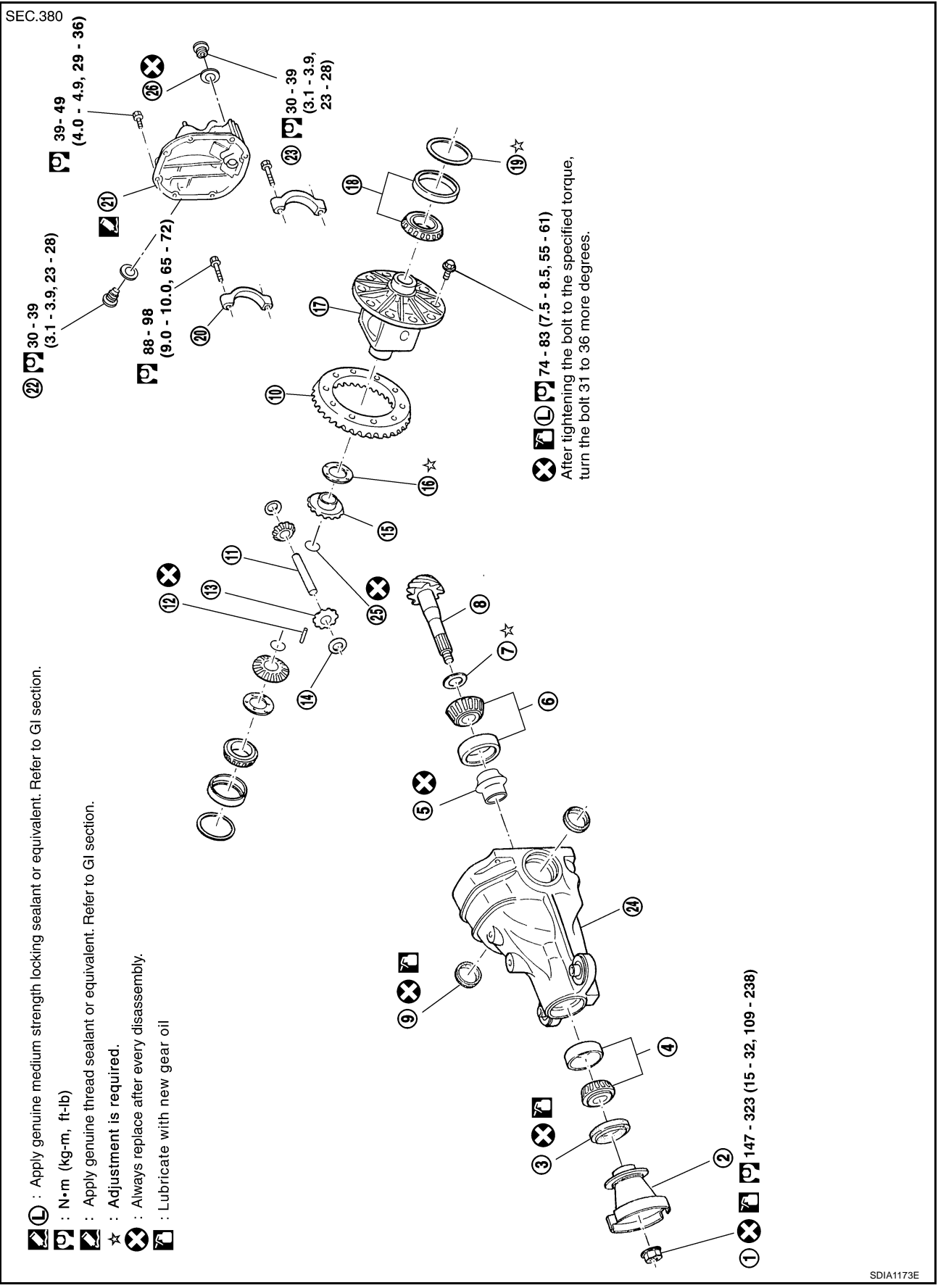

SDIA1173E

REAR FINAL DRIVE ASSEMBLY

- | | | |
|-----------------------------------|---|------------------------|
| 1. Drive pinion nut | 2. Companion flange (Rebro joint type) | 3. Front oil seal |
| 4. Pinion front bearing | 5. Pinion bearing adjusting spacer (Collapsible spacer) | 6. Pinion rear bearing |
| 7. Pinion height adjusting washer | 8. Drive pinion | 9. Side oil seal |
| 10. Ring gear | 11. Pinion mate shaft | 12. Lock pin |
| 13. Pinion mate gear | 14. Pinion mate thrust washer | 15. Side gear |
| 16. Side gear thrust washer | 17. Differential case | 18. Side bearing |
| 19. Side bearing adjusting washer | 20. Bearing cap | 21. Rear cover |
| 22. Filler plug | 23. Drain plug | 24. Gear carrier |
| 25. Circular clip | 26. Gasket | |

Pre-Inspection

EDS000YN

Before disassembling final drive, perform the following inspection.

TOTAL PRELOAD

1. Turn drive pinion in both directions several times to set bearing rollers.
2. Check total preload with Tool.

Tool number : ST3127S000 (see J25765-A)

Total preload : 2.84 - 3.75 N·m (0.29 - 0.38 kg·m, 26 - 33 in·lb)

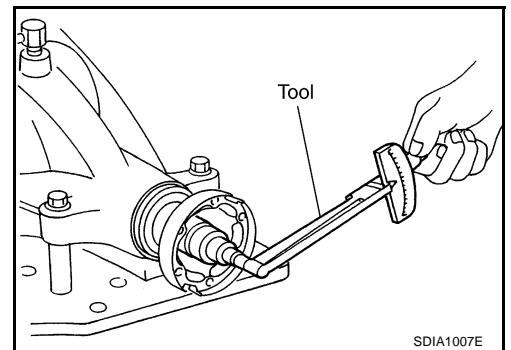

RING GEAR TO DRIVE PINION BACKLASH

Check ring gear to drive pinion backlash with a dial indicator at several points.

Ring gear backlash:

0.10 - 0.15 mm (0.0039 - 0.0059 in)

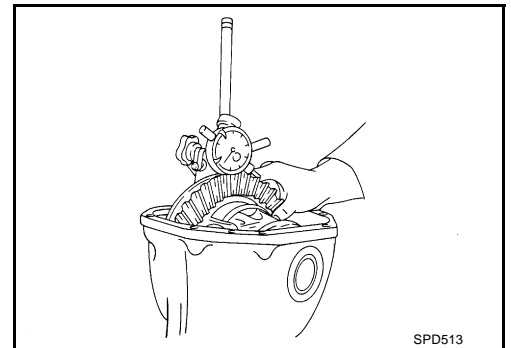

RING GEAR RUNOUT

Check runout of ring gear with a dial indicator.

Runout limit: 0.05 mm (0.0020 in) less

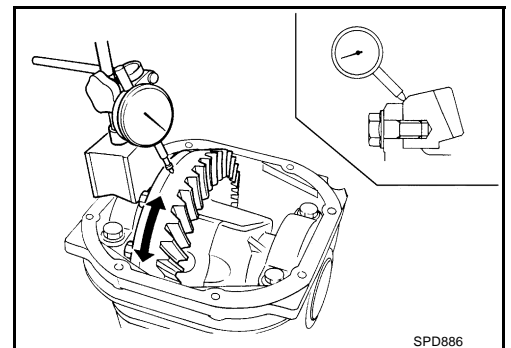

TOOTH CONTACT

Check tooth contact. Refer to [RFD-12, "TOOTH CONTACT"](#).

REAR FINAL DRIVE ASSEMBLY

Disassembly and Assembly REMOVAL OF DIFFERENTIAL CASE ASSEMBLY

EDS000YO

1. Using two 45 mm (1.77 in) spacers, mount carrier on Tool.

Tool number: KV38100800 (J25604-01)

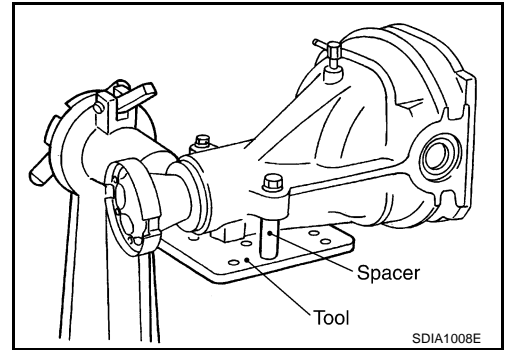

2. For proper reinstallation, paint match marks on one side of the bearing cap.
Bearing caps are line-board during manufacture. Replace them in their proper positions.

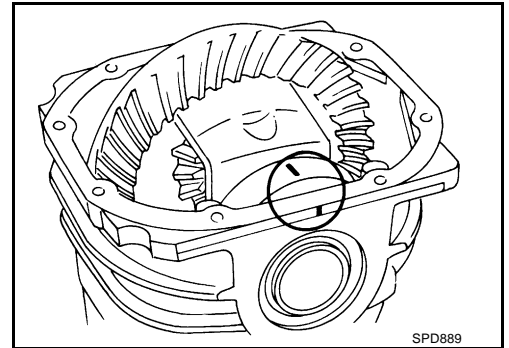

3. Remove bearing caps.

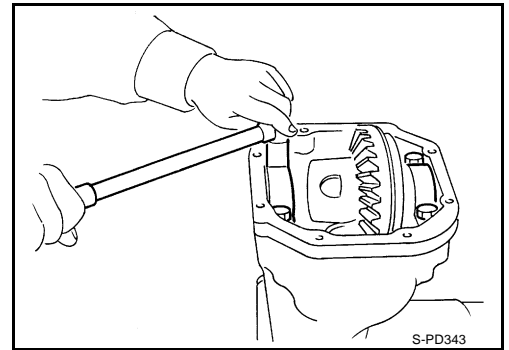

4. Lift differential case assembly out with Tool.

Tool number: HT72400000 (-)

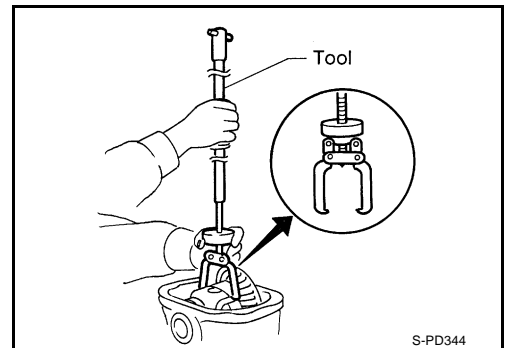

A
B
C
RFD
E
F
G
H
I
J
K
L
M

REAR FINAL DRIVE ASSEMBLY

- Keep the side bearing outer races together with inner race. Do not mix them up. Also, keep adjusting washers together with bearings.

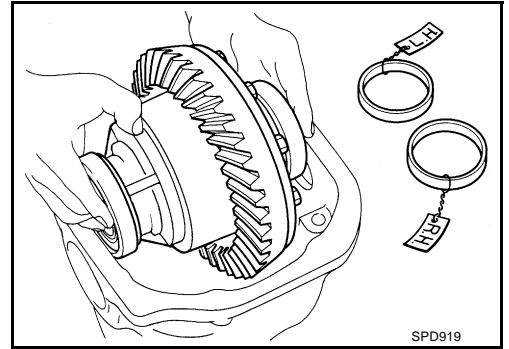

REMOVAL OF DRIVE PINION ASSEMBLY

1. Put matchmarks on companion flange and drive pinion with paint.

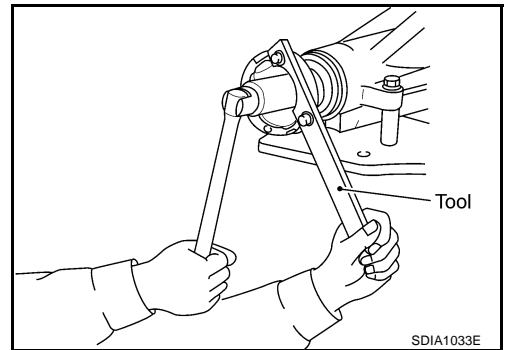

2. Loosen drive pinion nut and pull off companion flange.

Tool number: KV40104000 (-)

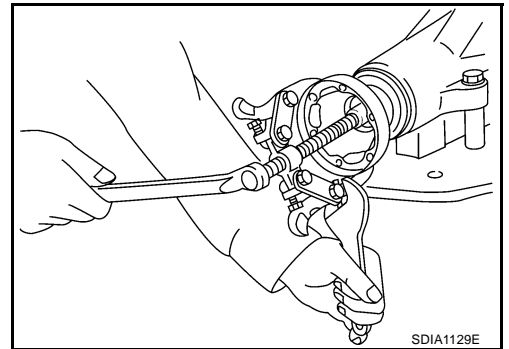

3. Take out drive pinion (together with rear bearing inner race, pinion bearing adjusting spacer).
4. Remove front oil seal. Refer to [RFD-6, "FRONT OIL SEAL"](#).
5. Remove pinion front bearing inner race.
6. Remove side oil seal. Refer to [RFD-8, "SIDE OIL SEAL"](#).

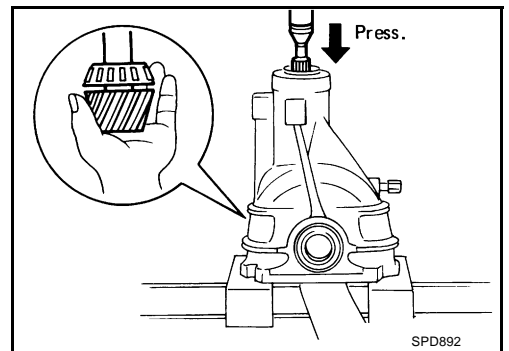

REAR FINAL DRIVE ASSEMBLY

7. Remove pinion bearing outer races with a brass drift.

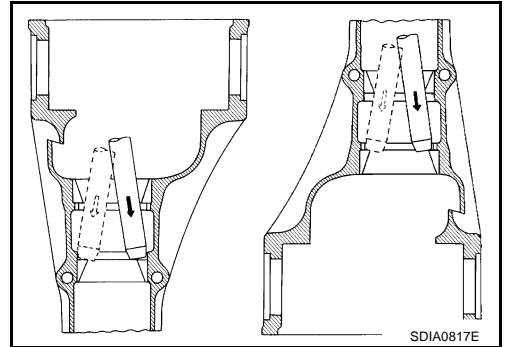

8. Remove pinion rear bearing inner race and drive pinion height adjusting washer with Tool.

Tool number: ST30031000 (J22912-01)

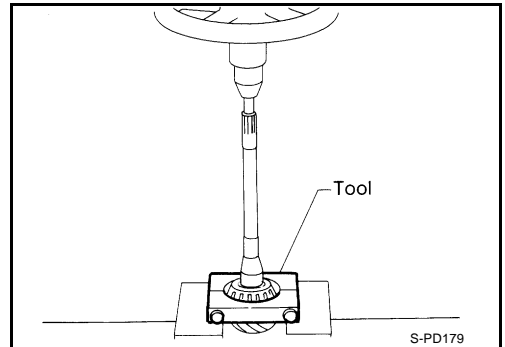

DISASSEMBLY OF DIFFERENTIAL CASE ASSEMBLY

1. Remove side bearing inner race.
To prevent damage to bearing, engage puller jaws in groove.

Tool number:

A ST3305S001 (-)

B ST33061000 (J8107-2)

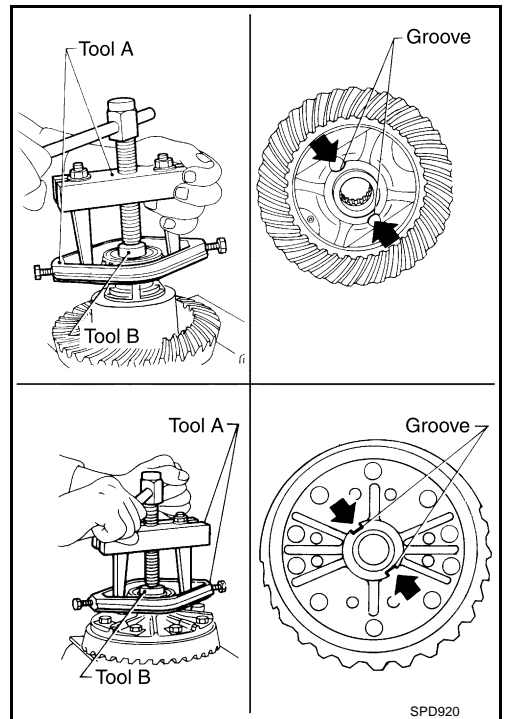

A
B
C
RFD
E
F
G
H
I
J
K
L
M

REAR FINAL DRIVE ASSEMBLY

- Be careful not to confuse left- and right-hand parts.

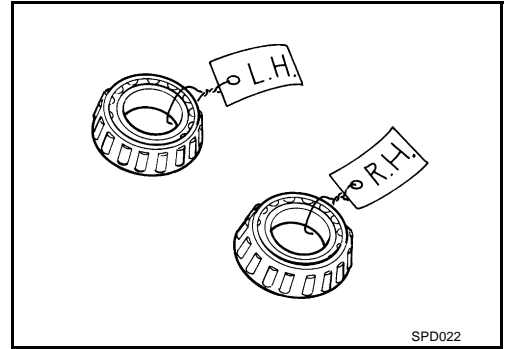

2. Loosen ring gear bolts in a criss-cross fashion.
3. Tap ring gear off the differential case with a soft hammer.
 - Tap evenly all around to keep ring gear from binding.

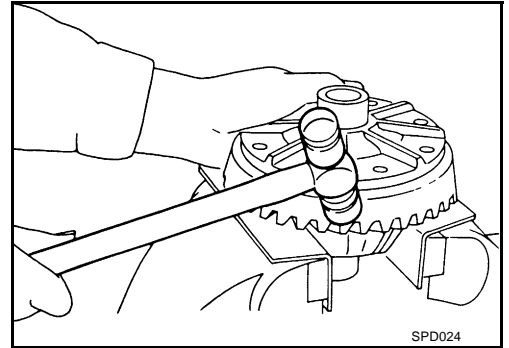

4. Drive out pinion mate shaft lock pin with punch from ring gear side.

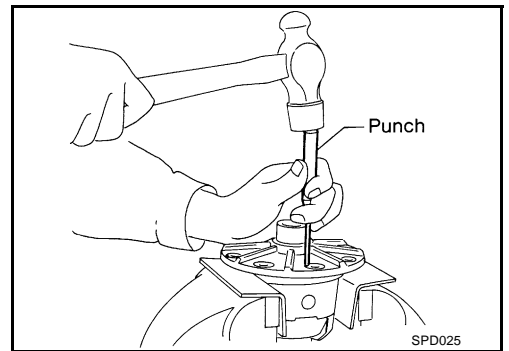

INSPECTION

Contact Surfaces

1. Clean the disassembled parts in suitable solvent and blow dry with compressed air.
2. If following surfaces are found to be burred or scratched, smooth with oil stone.
 - Differential case
 - Side gear
 - Pinion mate gear
 - Pinion mate shaft

Bearing

1. Thoroughly clean bearing.
2. Check bearings for wear, scratches, pitting or flaking. Check tapered roller bearing for smooth rotation. If damaged, replace outer race and inner race as a set.

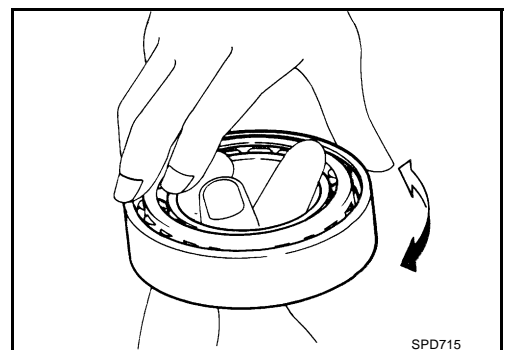

REAR FINAL DRIVE ASSEMBLY

ADJUSTMENT OF DIFFERENTIAL CASE

Thrust Washer Selection

1. Install side gears, pinion mate gears, thrust washers into differential case.

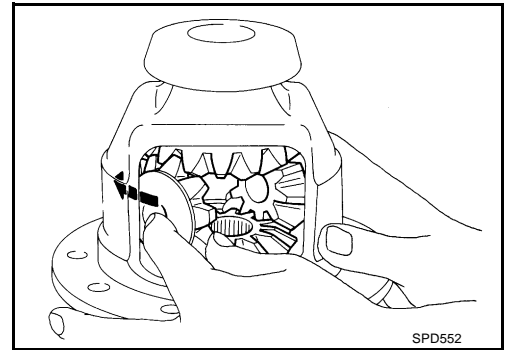

2. Fit pinion mate shaft to differential case so that it meets lock pin holes.

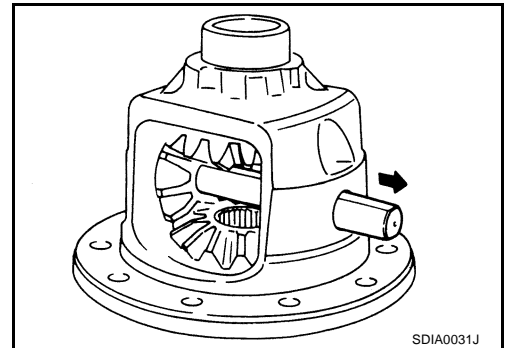

3. Adjust clearance between rear face of side gear and thrust washer by selecting side gear thrust washer. Refer to [RFD-28](#), "[AVAILABLE SIDE GEAR THRUST WASHERS](#)". Use two feeler gauges to prevent leaning of side gear as showing, figure.

Clearance between side gear thrust washer and differential case

: 0.20mm (0.0079 in) less

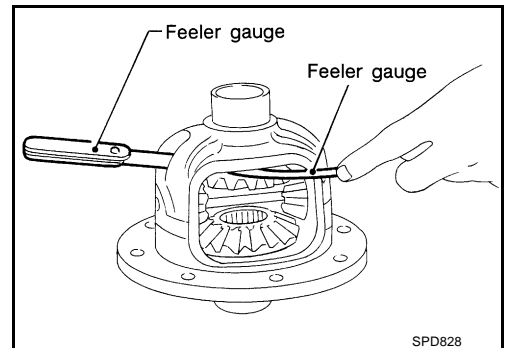

SIDE BEARING PRELOAD

A selection of carrier side bearing adjusting washers is required for successful completion of this procedure.

1. Make sure all parts are clean. Also, make sure the bearings are well lubricated with light oil or DEXRON™ type automatic transmission fluid.
2. Place the differential carrier, with side bearings and bearing races installed, into the final drive housing.

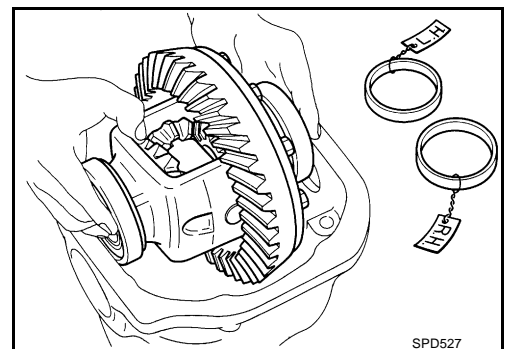

A
B
C
RFD
E
F
G
H
I
J
K
L
M

REAR FINAL DRIVE ASSEMBLY

3. Insert left and right side bearing adjusting washers in place between side bearings and carrier.

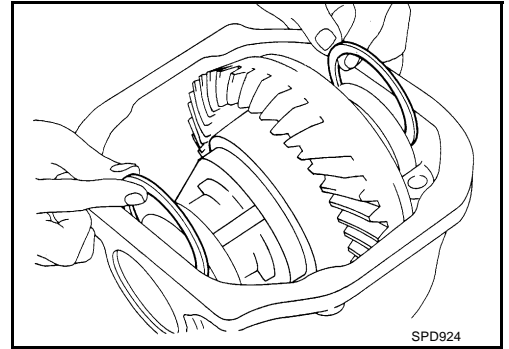

4. Install the side bearing caps in their correct locations and torque the bearing cap retaining bolts.

 : 88 - 98 N-m (9.0 - 9.9kgm, 65 - 72 ft-lb)

5. Turn the carrier several times to seat the bearings.

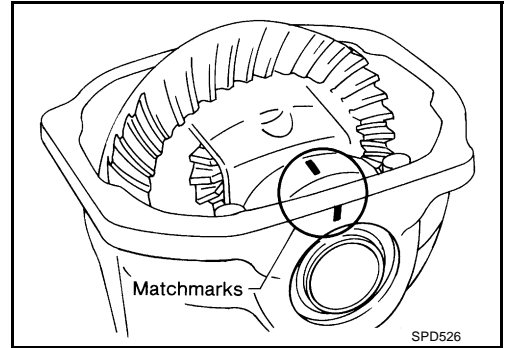

6. Measure the turning torque of the carrier at the ring gear retaining bolts with a spring gauge, J-8129.

Specification

**:34.2 - 39.2 N (3.5 - 4 kg, 7.7 - 8.8 lb)
of pulling force at the ring gear bolt**

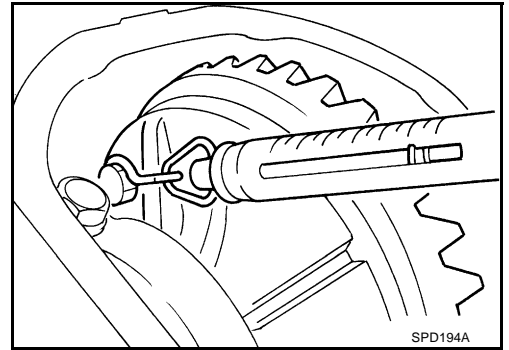

7. If the turning torque is not within the specifications, correct the torque as follows:

- If the turning torque is less than the specified range, install washers of greater thickness.
- If the turning torque is greater than the specification, install thinner washers.
- See the SDS section for washer dimensions and part numbers.

8. Record the total amount of washer thickness required for the correct carrier side bearing preload.

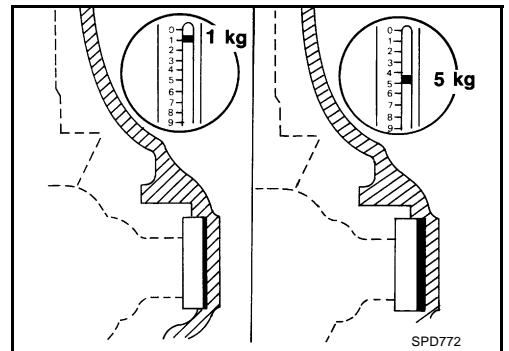

9. Remove the carrier from the final drive housing. Save the selected washers for later use during the assembly of the final drive unit.

Tool number: HT72400000 (-)

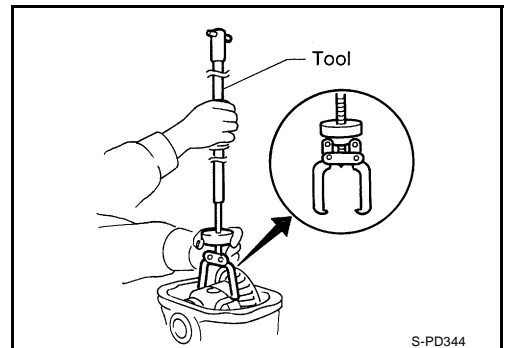

REAR FINAL DRIVE ASSEMBLY

PINION GEAR HEIGHT

1. Make sure all parts are clean and that the bearings are well lubricated.
2. Assemble the pinion gear bearings into the pinion preload shim selector Tool, J34309.

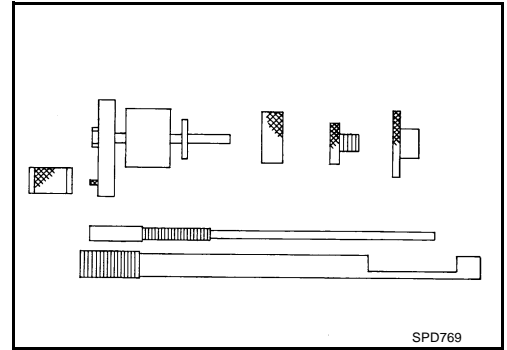

- Pinion front bearing; make sure the J34309-3 pinion front bearing seat is secured tightly against the J34309-2 gauge anvil. Then turn the pinion front bearing pilot, J34309-5, to secure the bearing in its proper position.
- Rear pinion bearing; the pinion rear bearing pilot, J34309-8, is used to center the pinion rear bearing only. The pinion rear bearing locking seat, J34309-4, is used to lock the bearing to the assembly.
- Installation of J34309-9 and J34309-16; place a suitable 2.5 mm (0.098 in) thick plain washer between J34309-9 and J34309-16. Both surfaces of J34309-9 and J34309-16 must be parallel with a clearance of 2.5 mm (0.098 in).

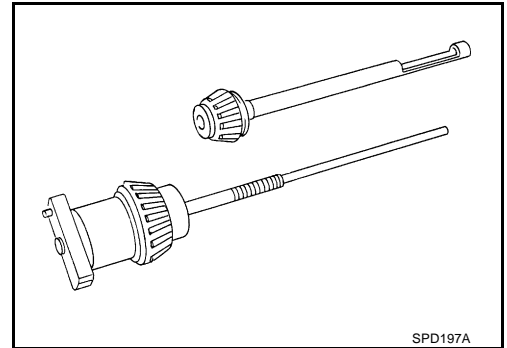

3. Install the pinion rear bearing inner race into the final drive housing. Then place the pinion preload shim selector Tool, J34309-1, gauge screw assembly.

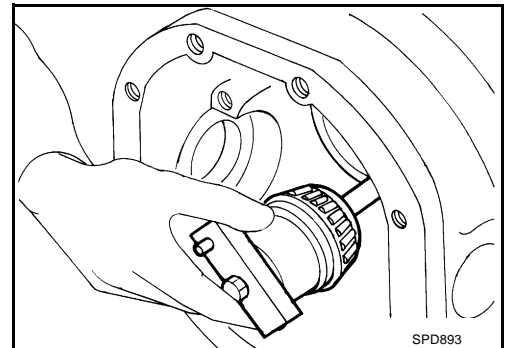

4. Assemble the front pinion bearing inner race and the J34309-2 gauge anvil. Assemble them together with the J34309-1 gauge screw in the final drive housing. Make sure that the pinion height gauge plate, J34309-16, will turn a full 360 degrees. Tighten the two sections together by hand.

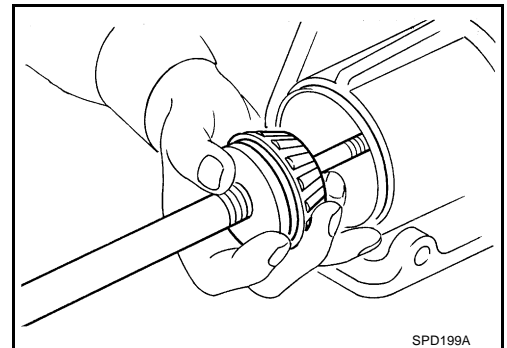

A
B
C
RFD
E
F
G
H
I
J
K
L
M

REAR FINAL DRIVE ASSEMBLY

5. Turn the assembly several times to seat the bearings.

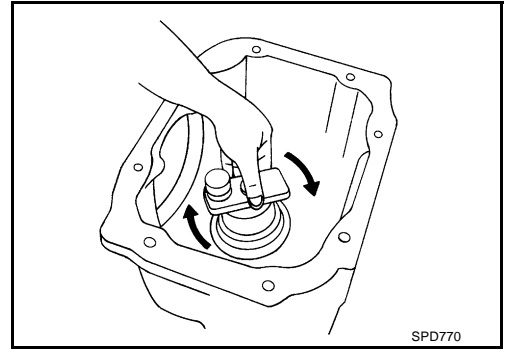

6. Measure the turning torque at the end of the J34309-2 gauge anvil using torque wrench J-25765A.

Turning torque specification

: 1.0 - 1.3 N·m (0.11 - 0.13 kg·m, 9 - 11 in·lb)

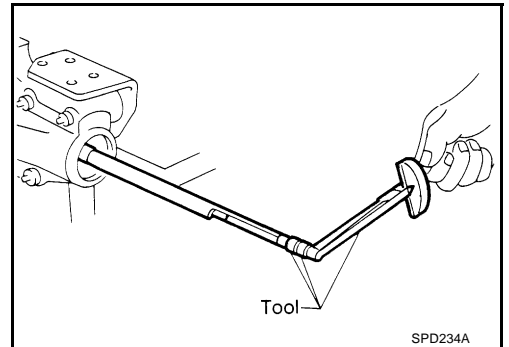

7. Place the J34309-11 "R200A" pinion height adapter onto the gauge plate and tighten it by hand.

CAUTION:

Make sure all machined surfaces are clean.

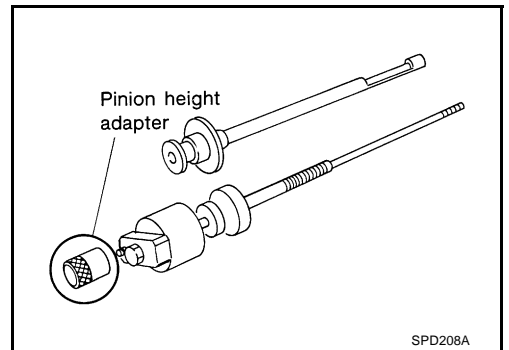

Pinion Height Adjusting Washer Selection

1. Now, position the side bearing discs, J25269-4, and arbor firmly into the side bearing bores. Install the bearing caps and tighten the cap bolts to proper torque.

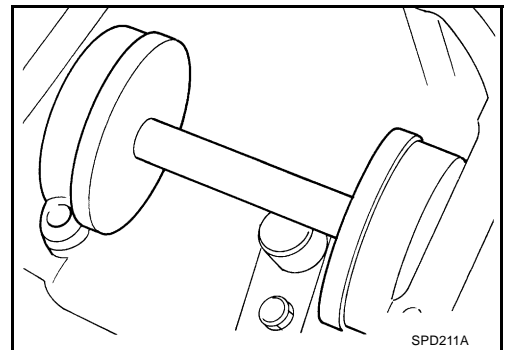

REAR FINAL DRIVE ASSEMBLY

2. Select the correct standard pinion height adjusting washer thickness. Select by using a standard gauge of 3 mm (0.12 in) and your J34309-101 feeler gauge. Measure the distance between the J34309-11 pinion height adapter including the standard gauge and the arbor.

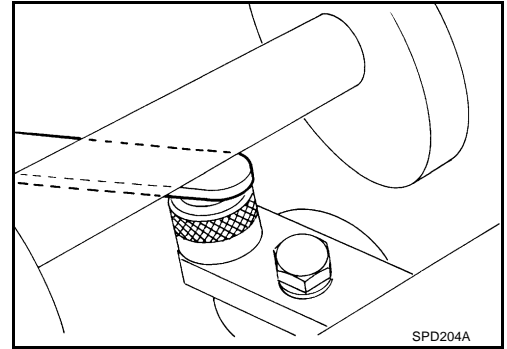

3. Write down your exact measurement (the value of feeler gauge).

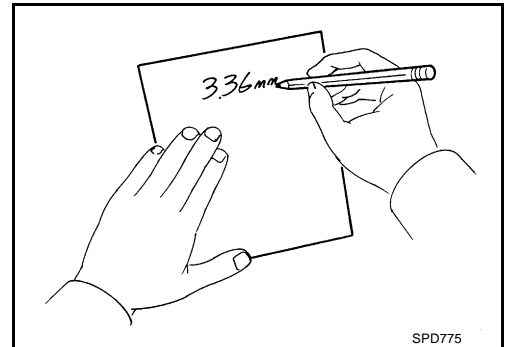

4. Correct the pinion height washer size by referring to the "pinion head number".

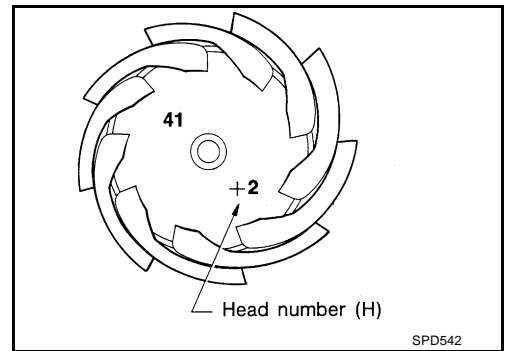

There are two numbers painted on the drive pinion. The first one refers to the drive pinion and ring gear as a matched set. This number should be the same as the number on the ring gear. The second number is the "pinion head height number". It refers to the ideal pinion height from standard for quietest operation. Use the following chart to determine the correct pinion height washer.

Pinion head height number	Add or remove from the standard pinion height washer thickness measurement
- 6	Add 0.06 mm (0.0024 in)
- 5	Add 0.05 mm (0.0020 in)
- 4	Add 0.04 mm (0.0016 in)
- 3	Add 0.03 mm (0.0012 in)
- 2	Add 0.02 mm (0.0008 in)
- 1	Add 0.01 mm (0.0004 in)
0	Use the selected washer thickness
+1	Subtract 0.01 mm (0.0004 in)
+2	Subtract 0.02 mm (0.0008 in)
+3	Subtract 0.03 mm (0.0012 in)
+4	Subtract 0.04 mm (0.0016 in)
+5	Subtract 0.05 mm (0.0020 in)
+6	Subtract 0.06 mm (0.0024 in)

5. Select the correct Drive pinion height adjusting washer as follows. Refer to [RFD-29, "AVAILABLE PINION HEIGHT ADJUSTING WASHERS"](#).

A
B
C
RFD
E
F
G
H
I
J
K
L
M

REAR FINAL DRIVE ASSEMBLY

6. Remove the J34309 pinion preload shim selector Tool from the final drive housing. Then disassemble to retrieve the pinion bearings.

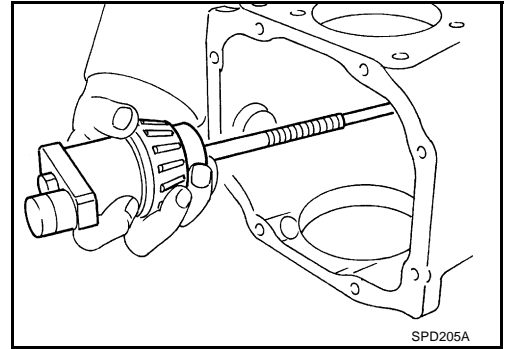

TOOTH CONTACT

Checking gear tooth contact pattern is necessary to verify correct relationship between ring gear and drive pinion.

Ring gears which are not positioned in proper arrangement may be noisy and/or have a short life. Check gear tooth contact pattern to obtain the best contact for low noise and long life.

1. Thoroughly clean ring gear and drive pinion teeth.
2. Lightly apply a mixture of powdered ferric oxide and oil or the equivalent. Apply it to 3 or 4 teeth of ring gear drive side.

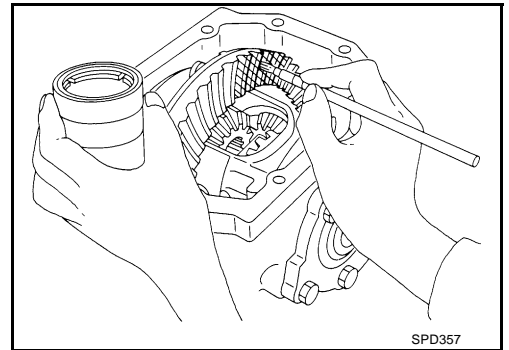

3. Hold companion flange steady by hand and rotate the ring gear in both directions.

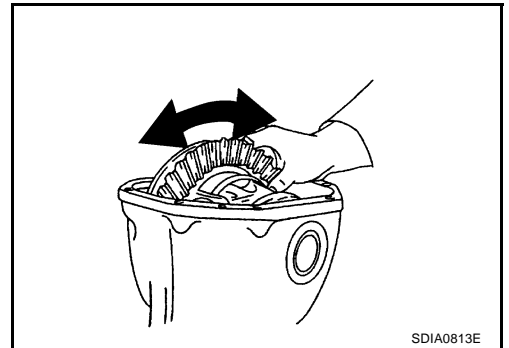

REAR FINAL DRIVE ASSEMBLY

Usually the pattern will be correct if washers are correctly calculated and the backlash is correct. However, in rare cases, trial and error processes may be employed to obtain a correct pattern. The tooth pattern is the best indication of how well a differential has been set up.

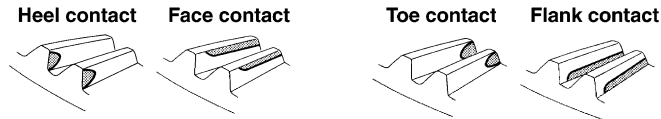

To correct, increase thickness of pinion height adjusting washer in order to bring drive pinion close to ring gear.

To correct, reduce thickness of pinion height adjusting washer in order to make drive pinion go away from ring gear.

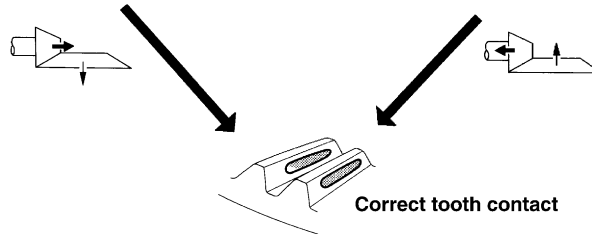

When adjustment is completed, be sure to wipe off completely the ferric oxide and oil or their equivalent.

SDIA0821E

ASSEMBLY OF DIFFERENTIAL CASE ASSEMBLY

1. Install pinion mate shaft lock pin with a punch. Make sure lock pin is flush with case.

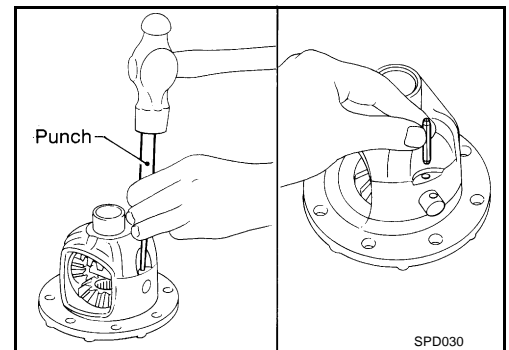

2. Place differential case on ring gear.
3. Apply genuine medium strength locking sealant or equivalent. Refer to [MA-11, "RECOMMENDED FLUIDS AND LUBRICANTS"](#) to ring gear bolts, and install them.

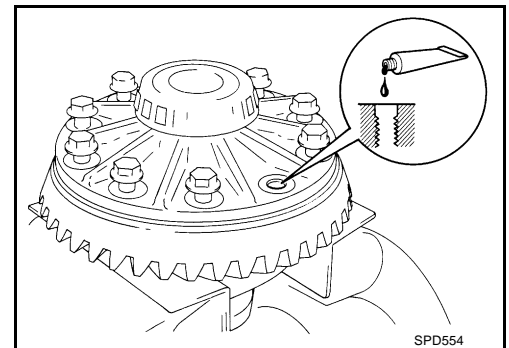

4. Press-fit side bearing inner race on differential case with Tool.

Tool number : A KV38100300 (J25523)
: B ST33061000 (J18107-2)

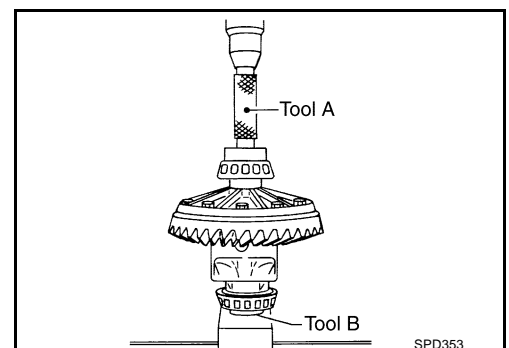

A
B
C
RFD
E
F
G
H
I
J
K
L
M

REAR FINAL DRIVE ASSEMBLY

INSTALLATION OF DRIVE PINION ASSEMBLY

1. Press-fit front and rear bearing outer races with Tools.

Tool number : A Suitable tool
: B ST30611000 (J25742-1)
: C ST30613000 (J25742-3)

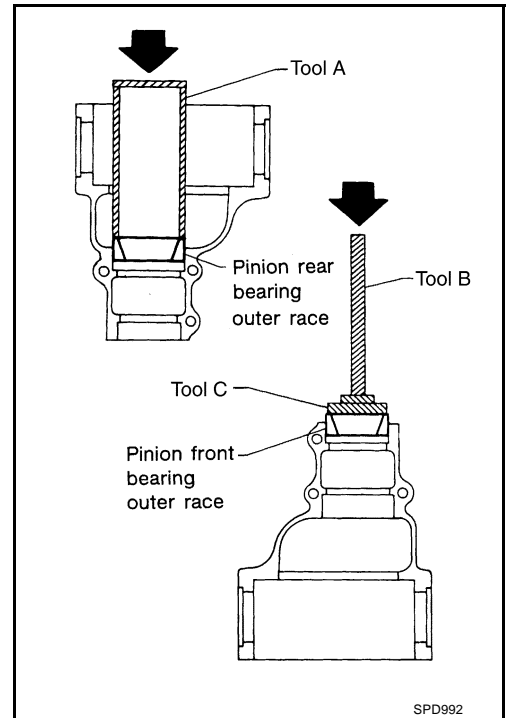

2. Select pinion height adjusting washer. Refer to [RFD-29, "AVAILABLE PINION HEIGHT ADJUSTING WASHERS"](#)
3. Install selected pinion height adjusting washer in drive pinion. Using press and Tool, press-fit pinion rear bearing inner race into it.

Tool number : ST30901000 (-)

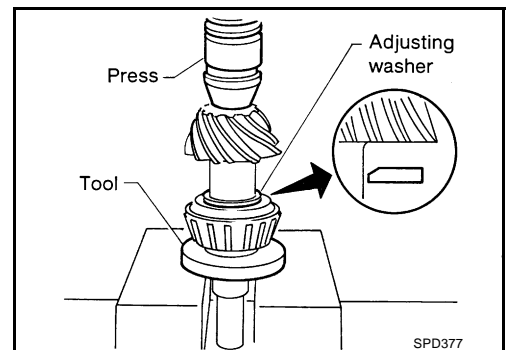

4. Set drive pinion assembly (as shown in figure) in differential carrier and install drive pinion, with press and suitable tool. Stop when drive pinion touches bearing. Apply multi-purpose grease to pinion rear bearing inner race and pinion front bearing inner race.

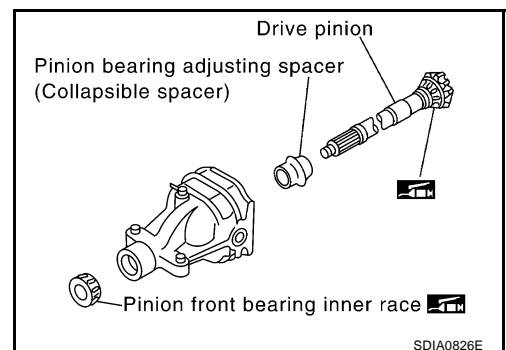

REAR FINAL DRIVE ASSEMBLY

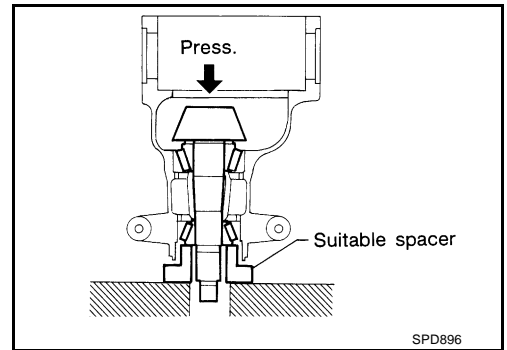

A
B
C

RFD

5. Install front oil seal with Tool. Refer to [RFD-6, "Removal and Installation"](#) .

Tool number : ST30720000 (J25405)

6. Install companion flange, and tighten pinion nut to minimum. Ascertain that threaded portion of drive pinion and drive pinion nut are free from oil or grease.

Tool number : KV40104000 (-)

CAUTION:

The drive pinion nut is not reusable. Never reuse drive pinion nut.

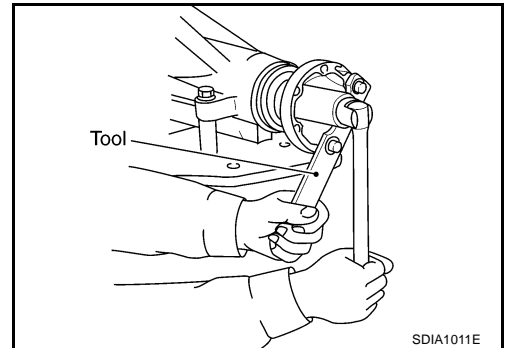

E
F
G
H

7. Tighten the drive pinion nut by very small degrees until the specified preload is achieved, when checking the preload, turn drive pinion in both directions several times.

Tool number
: ST3127S000 (See J25765-A)

Pinion bearing preload
: 2.65 - 3.23 N·m (0.27 - 0.32 kg·m, 24 - 28 in·lb)

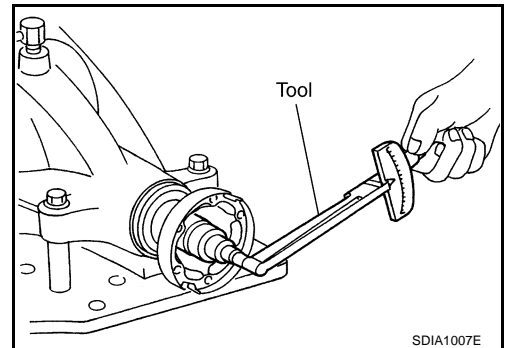

I
J
K
L

- If pinion bearing preload is too small, tighten the Drive pinion nut more.
- If pinion bearing preload is too great, replace pinion bearing adjusting spacer.

M

INSTALLATION OF DIFFERENTIAL CASE ASSEMBLY

1. Select side bearing adjusting washer. Refer to [RFD-29, "SIDE BEARING ADJUSTING WASHERS"](#) .
2. Install differential case assembly with side bearing outer races into gear carrier.

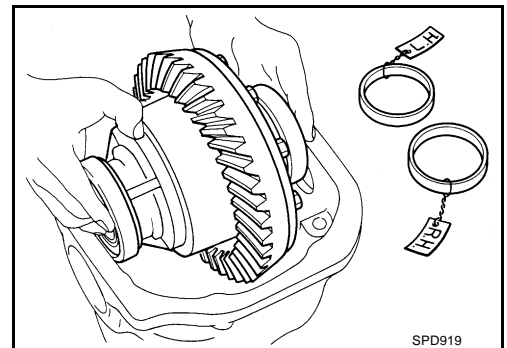

REAR FINAL DRIVE ASSEMBLY

3. Insert left and right side bearing adjusting washers in place between side bearings and carrier.

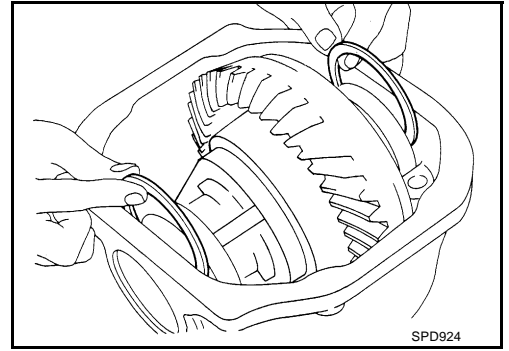

4. Align mark on bearing cap with that on gear carrier and install bearing cap on gear carrier.

 : 88 - 98 N·m (9.0 - 9.9kg-m, 65 - 72 ft-lb)

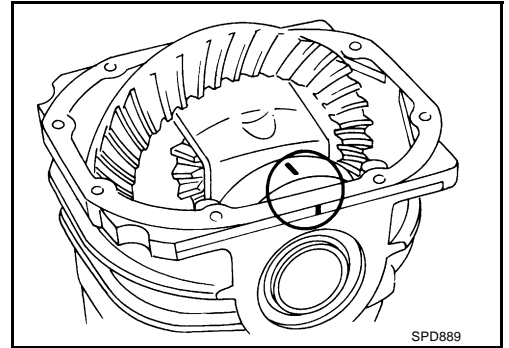

5. Install side oil seal. Refer to [RFD-8, "Removal and Installation"](#).

Tool number : KV38100200 (J26233)

6. Measure ring gear-to-drive pinion backlash with a dial indicator at several point.

Ring gear backlash

: 0.10 - 0.15 mm (0.0039 - 0.0059 in) less

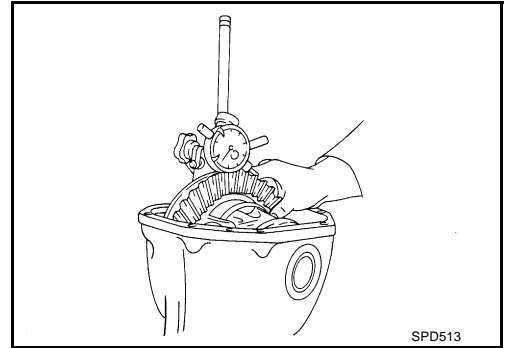

- If backlash is too small, adjustment of washer thickness is required. Decrease thickness of left shim and increase thickness of right by the same amount. If backlash is too great, reverse the above procedure.

Never change the total amount of washers as it will change the bearing preload.

7. Check total preload with Tool.

Tool number : ST3127S000 (See J25765-A)

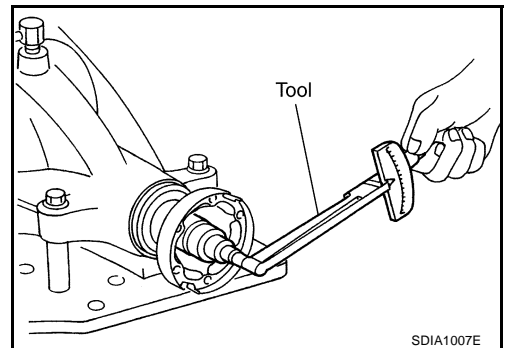

When checking preload, turn drive pinion in both directions several times to seat bearing rollers correctly.

Total preload : 2.84 - 3.75 N·m (0.29 - 0.38 kg-m, 26 - 33 in-lb)

REAR FINAL DRIVE ASSEMBLY

- If preload is too great, remove the same amount of washer to each side.
- If preload is too small, add the same amount of washer to each side.

Never add or remove a different number of washers for each side. Difference in number of washers will change ring gear to drive pinion backlash.

8. Recheck ring gear to drive pinion backlash. Increase or decrease in thickness of shims will cause change to ring gear to pinion backlash.
 - Check whether the backlash varies excessively in different places. Foreign matter may be caught between the ring gear and the differential case causing the trouble.
 - The backlash can vary greatly even when the ring gear runout is within a specified range. In that case, replace the hypoid gear set or differential case.
9. Check runout of ring gear with a dial indicator.

Runout limit : 0.05 mm (0.0020 in) less

10. Check tooth contact.
Refer to [RFD-12, "TOOTH CONTACT"](#) .

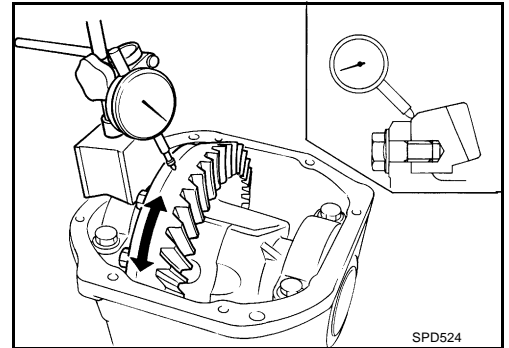

11. Install rear cover. Apply liquid sealant to rear cover side and install gear carrier.

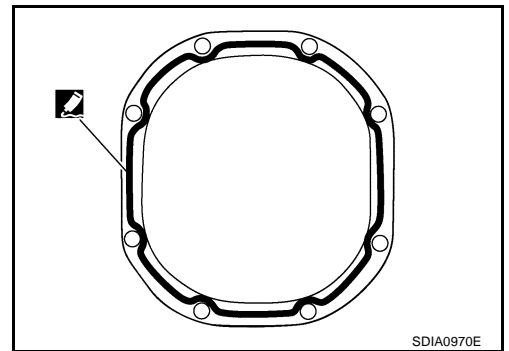

A
B
C
RFD
E
F
G
H
I
J
K
L
M

SERVICE DATA AND SPECIFICATIONS (SDS)

SERVICE DATA AND SPECIFICATIONS (SDS)

PFP:00030

General Specifications

EDS000YP

Applied model	VK45DE engine
	5A / T
Final drive model	R200 (2 – pinion)
Gear ratio	3.133
Number of teeth (Ring gear / drive pinion)	47 / 15
Oil capacity (Approx.) ℓ (US pt, Imp pt)	1.4 liter (3 US pt, 2 - 1/2 Imp pt)

Ring Gear Runout

EDS000YQ

Unit: mm (in)

Type	R200
Ring gear runout limit	0.05 (0.0020) less

Side Gear Adjustment

EDS000YR

Unit: mm (in)

Type	R200
Clearance limit between side gear and differential case mm (in)	0.20 (0.0079) less

AVAILABLE SIDE GEAR THRUST WASHERS

Unit: mm (in)

Type	R200	
	Thickness	Part number
Thrust washer	0.75 (0.0295)	38424 0C000
	0.78 (0.0307)	38424 0C001
	0.81 (0.0319)	38424 0C002
	0.84 (0.0331)	38424 0C003
	0.87 (0.0343)	38424 0C004
	0.90 (0.0350)	38424 0C005
	0.93 (0.0366)	38424 0C006

SERVICE DATA AND SPECIFICATIONS (SDS)

Drive Pinion Height Adjustment AVAILABLE PINION HEIGHT ADJUSTING WASHERS

EDS000YS

Unit: mm (in)

Type	R200, R200V			
	Thickness	Part number	Thickness	Part number
Adjusting washer	3.05 (0.1201)	38154 0C000	3.29 (0.1295)	38154 0C008
	3.08 (0.1213)	38154 0C001	3.32 (0.1307)	38154 0C009
	3.11 (0.1224)	38154 0C002	3.35 (0.1319)	38154 0C010
	3.14 (0.1236)	38154 0C003	3.38 (0.1331)	38154 0C011
	3.17 (0.1248)	38154 0C004	3.41 (0.1343)	38154 0C012
	3.20 (0.1260)	38154 0C005	3.44 (0.1354)	38154 0C013
	3.23 (0.1272)	38154 0C006	3.47 (0.1366)	38154 0C014
	3.26 (0.1283)	38154 0C007	3.50 (0.1378)	38154 0C015

Drive Pinion Preload Adjustment

EDS000YT

Type	R200
Drive pinion preload	2.65 – 3.23 N·m (0.27 – 0.32 kg–m, 24 – 28 in lb)

Side Bearing Preload Adjustment

EDS000YU

Type	R200
Side bearing preload <Reference>	0.20 – 0.52 N·m (0.02 – 0.05 kg–m, 2 – 4 in lb)
Torque by spring gauge	34.2 – 39.2 N (3.5 – 4 kg, 7.7 – 8.8 lb)

SIDE BEARING ADJUSTING WASHERS

Unit: mm (in)

Type	R200			
	Thickness	Part number	Thickness	Part number
Adjusting washer	2.00 (0.0787)	38453 N3100	2.35 (0.0925)	38453 N3107
	2.05 (0.0807)	38453 N3101	2.40 (0.0945)	38453 N3108
	2.10 (0.0827)	38453 N3102	2.45 (0.0965)	38453 N3109
	2.15 (0.0846)	38453 N3103	2.50 (0.0984)	38453 N3110
	2.20 (0.0866)	38453 N3104	2.55 (0.1004)	38453 N3111
	2.25 (0.0886)	38453 N3105	2.60 (0.1024)	38453 N3112
	2.30 (0.0906)	38453 N3106	2.65 (0.1043)	38453 N3113

Total Preload Adjustment

EDS000YV

Type	R200
Total preload with oil seal	2.84 – 3.75 N·m (0.29 – 0.38 kg–m, 26 – 33 in lb)
Ring gear to drive pinion backlash	0.10 – 0.15 mm (0.0039 – 0.0059 in)

SERVICE DATA AND SPECIFICATIONS (SDS)
