

SECTION **BRC**

BRAKE CONTROL SYSTEM

A
B
C
D
E
BRC
G
H
I
J
K
L
M

CONTENTS

PRECAUTIONS 3	CONSULT-II Functions 26
Precautions for Supplemental Restraint System (SRS) "AIR BAG" and "SEAT BELT PRE-TENSIONER" 3	CONSULT-II MAIN FUNCTION 26
Precautions for Brake System 3	SELF-DIAGNOSIS 27
Precautions for Brake Control 3	DATA MONITOR 30
Diagnosis Precaution 4	ACTIVE TEST 32
CAN SYSTEM 4	For Fast and Accurate Diagnosis 36
Precaution for Harness Repair 4	PRECAUTIONS FOR DIAGNOSIS 36
CAN SYSTEM 4	Basic Inspection 38
PREPARATION 5	BASIC INSPECTION 1: BRAKE FLUID LEVEL AND LEAK INSPECTION 38
Special Service Tools 5	BASIC INSPECTION 2: INSPECTION FOR LOOSENESS OF POWER SYSTEM TERMINALS 38
Commercial Service Tools 5	BASIC INSPECTION 3: INSPECTION OF ABS WARNINGLAMP, VDC OFF INDICATOR LAMP, AND SLIP INDICATOR LAMP 38
ON-VEHICLE SERVICE 6	Inspection 1 Wheel Sensor System 39
Adjustment of Steering Angle Sensor Neutral Position 6	INSPECTION PROCEDURE 39
SYSTEM DESCRIPTION 7	Inspection 2 Engine System 41
Fail-Safe 7	Inspection 3 VDC/TCS/ABS Control Unit System... 41
ABS SYSTEM 7	Inspection 4 Pressure Sensor and Circuit Between Pressure Sensor and VDC/TCS/ABS Control Unit.. 42
VDC/TCS SYSTEM 7	Inspection 5 Steering Angle Sensor and Circuit Between Steering Angle Sensor and VDC/TCS/ABS Control Unit 43
Hydraulic Circuit Diagram 7	Inspection 6 Yaw Rate/Side G-Sensor and Circuit Between Yaw Rate/Side G-Sensor and VDC/TCS/ABS Control Unit 45
ABS Function 7	Inspection 7 Solenoid, VDC Switching Valve, and Circuits 46
TCS Function 8	Inspection 8 Actuator Motor, Motor Relay, and Circuit 48
VDC Function 8	Inspection 9 Actuator Relay and Circuit 50
System Diagram 8	Inspection 10 Stop Lamp Switch and Circuit 52
CAN COMMUNICATION 9	Inspection 11 VDC/TCS/ABS Control Unit Power Circuit 53
System Description 9	Inspection 12 When "SHIFT POSITION ERROR" Appears in Self-Diagnosis Results Display 55
FOR VDC MODELS 9	Inspection 13 When "EMERGENCY BRAKE" Appears on Self-Diagnosis Results Display 55
FOR ICC MODELS 10	
TROUBLE DIAGNOSIS 12	
How to Proceed With Diagnosis 12	
BASIC CONCEPT 12	
DIAGNOSIS FLOWCHART 13	
ASKING COMPLAINTS 14	
EXAMPLE OF DIAGNOSIS SHEET 14	
Component Installation Location 15	
Schematic 16	
Wiring Diagram — VDC — 17	
Control Unit Input/Output Signal Standard 25	
STANDARDS BY CONSULT-II 25	

Inspection 14 When "STEERING ANGLE SENSOR HAS NOT BEEN CORRECTED" Appears on Self-Diagnosis Results Display	56	TCS/ABS Operation.	66
Inspection 15 Brake Fluid Level in Reservoir Tank, Communication Circuit Between VDC/TCS/ABS Control Unit and Brake Fluid Level Sensor	56	WHEEL SENSORS	67
Inspection 16 CAN Communications Lines, VDC/TCS/ABS Control Unit and Steering Angle Sensor System	57	Removal and Installation	67
Inspecting Components	58	REMOVAL	67
VDC OFF SWITCH	58	INSTALLATION	67
VDC RELAY BOX	58	VDC/TCS/ABS CONTROL UNIT	68
VDC/TCS/ABS ACTUATOR	59	Removal and Installation	68
Symptom 1 ABS Works Frequently.	61	REMOVAL	68
Symptom 2 Unexpected Pedal Reaction	61	INSTALLATION	68
Symptom 3 Long Stopping Distance	62	SENSOR ROTOR	69
Symptom 4 ABS Does Not Work.	63	Removal and Installation	69
Symptom 5 Pedal Vibration and Noise	63	REMOVAL	69
Symptom 6 VDC OFF Indicator Lamp Does Not Illuminate.	65	INSTALLATION	69
Symptom 7 SLIP Indicator Lamp Does Not Illuminate.	65	VDC/TCS/ABS ACTUATOR	70
Symptom 8 Vehicle Behaves Jerkily During VDC/		Removal and Installation	70
		G SENSOR	71
		Removal and Installation	71
		REMOVAL	71
		INSTALLATION	71
		STEERING ANGLE SENSOR	72
		Removal and Installation	72
		REMOVAL	72
		INSTALLATION	72

PRECAUTIONS

PRECAUTIONS

PF0:00001

Precautions for Supplemental Restraint System (SRS) “AIR BAG” and “SEAT BELT PRE-TENSIONER”

EFS00285

The Supplemental Restraint System such as “AIR BAG” and “SEAT BELT PRE-TENSIONER”, used along with a front seat belt, helps to reduce the risk or severity of injury to the driver and front passenger for certain types of collision. This system includes seat belt switch inputs and dual stage front air bag modules. The SRS system uses the seat belt switches to determine the front air bag deployment, and may only deploy one front air bag, depending on the severity of a collision and whether the front occupants are belted or unbelted. Information necessary to service the system safely is included in the SRS and SB section of this Service Manual.

WARNING:

- To avoid rendering the SRS inoperative, which could increase the risk of personal injury or death in the event of a collision which would result in air bag inflation, all maintenance must be performed by an authorized NISSAN/INFINITI dealer.
- Improper maintenance, including incorrect removal and installation of the SRS, can lead to personal injury caused by unintentional activation of the system. For removal of Spiral Cable and Air Bag Module, see the SRS section.
- Do not use electrical test equipment on any circuit related to the SRS unless instructed to in this Service Manual. SRS wiring harnesses can be identified by yellow and/or orange harness connectors.

Precautions for Brake System

EFS00209

- Recommended fluid is brake fluid “DOT 3”.
- Never reuse drained brake fluid.
- Be careful not to splash brake fluid on painted areas such as body. If brake fluid is splashed, wipe it off and flush area with water immediately.
- Never use mineral oils such as gasoline or kerosene to clean. They will ruin rubber parts and cause improper operation.
- Using a flare nut torque wrench, securely tighten brake tube flare nuts.
- Brake system is an important safety part. If a brake fluid leak is detected, always disassemble the affected part. If a malfunction is detected, replace part with a new one.
- Before working, turn ignition switch OFF and disconnect electrical connectors of VDC actuator and control module or battery terminals.
- When installing brake piping, be sure to check torque.

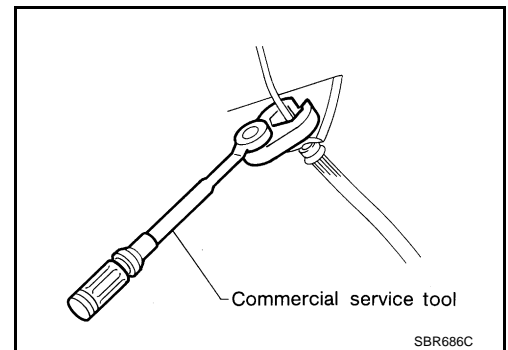

Precautions for Brake Control

EFS0020A

- During ABS, TCS and VDC operations of sudden deceleration and turn, brake pedal lightly vibrates and a mechanical noise may be heard. This is normal.
- Just after starting vehicle after ignition switch ON, brake pedal may vibrate or motor operating noise may be heard from engine compartment. This is a normal status of operation check.
- Stopping distance may be longer than that of vehicles without ABS when vehicle drives on rough, gravel, or snow-covered (fresh, deep snow) roads.
- When an error is indicated by ABS or another warning lamp, collect all necessary information from customer (what symptoms are present under what conditions) and check for simple causes before starting diagnostic servicing. Besides electrical system inspection, check booster operation, brake fluid level, and oil leaks.
- If tire size and type are used in an improper combination, or brake pads are not Genuine NISSAN parts, stopping distance or steering stability may deteriorate.
- If there is a radio, antenna, or antenna lead-in wire (including wiring) near control module, ABS function may have a malfunction or error.

PRECAUTIONS

- If aftermarket parts (car stereo, CD player, etc.) have been installed, check for incidents such as harness pinches, open circuits, and improper wiring.
- If non-standard suspension parts (shock absorber, strut, spring, bushing, etc.) and reinforcements (roll bar, tower bar, etc.) are attached, or if suspension parts deteriorate significantly, VDC may not operate normally and VDC warning lamp may turn on.
- If non-standard engine components (muffler, etc.) are attached, VDC may not operate normally and VDC warning lamp may turn on.
- When driving on a steep slope (as a bank), VDC may not operate normally and VDC warning lamp may turn on. In this case, start engine to resume the normal screen. This is normal.

Diagnosis Precaution CAN SYSTEM

EFS0020B

- Do not apply voltage of 7.0V or higher to terminal to be measured.
- Maximum open terminal voltage of tester in use shall be 7.0V or lower.
- Before checking harnesses, turn ignition switch to OFF and disconnect battery negative cable.

Precaution for Harness Repair CAN SYSTEM

EFS0020C

- Area to be repaired shall be soldered, and wrapped with a tape (be sure that fraying of twisted wire shall be within 110 mm 4.33 in)).

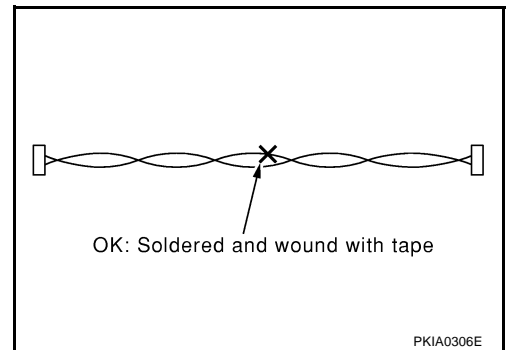

- Do not make a bypass connection to repaired area. (If it is done, branch part will be removed and characteristics of twisted wire will be lost.)

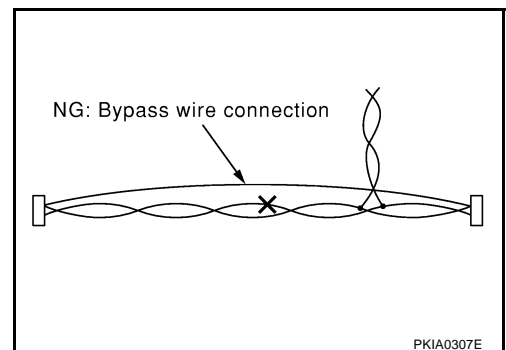

PREPARATION

PREPARATION

PFP:00002

Special Service Tools

EFS00288

The actual shapes of Kent-Moore tools may differ from those of special service tools illustrated here.

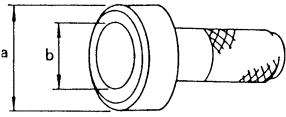
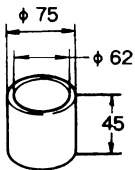
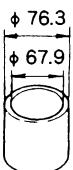
Tool number (Kent-Moore No.) Tool name	Description
<p>ST3072 000 (J25405) Drift a: 76.5 mm (3.012 in) dia. b: 55.0 mm (2.17 in) dia.</p>  <p style="text-align: right; font-size: small;">ZZC0760D</p>	Installing rear sensor rotor.
<p>ST2786 3000 (—) Drift</p>  <p style="text-align: right; font-size: small;">ZZC1307D</p>	Installing rear sensor rotor.
<p>KV401 04710 (—) Drift</p>  <p style="text-align: right; font-size: small;">ZZC1082D</p>	Installing rear sensor rotor.

A
B
C
D
E
BRC
G
H
I
J
K
L
M

Commercial Service Tools

EFS0020D

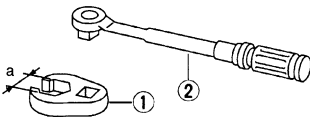
Tool name	Description
<p>1. Flare nut crowfoot a: 10 mm (0.39 in) 2. Torque wrench</p>  <p style="text-align: right; font-size: small;">S-NT360</p>	Removing and installing each brake piping

ON-VEHICLE SERVICE

PFP:00000

Adjustment of Steering Angle Sensor Neutral Position

EFS0020E

In case of doing work that applies to the list below, make sure to adjust neutral position of steering angle sensor before running vehicle.

Situation	Adjustment of Steering Angle Sensor Neutral Position
Removing/Installing VDC/TCS/ABS control unit	-
Replacing VDC/TCS/ABS control unit	-
Removing/Installing steering angle sensor	×
Removing/Installing steering components	×
Removing/Installing suspension components	×
Removing/Installing the same tire to the same position	-
Change 4 tires to new ones	-
Change some of 4 tires to new ones (not 4 tires)	-
Tire rotation	-
Adjusting wheel alignment	×

×: Required

-: Not required

CAUTION:

To adjust neutral position of steering angle sensor, make sure to use CONSULT-II. (Adjustment cannot be done without CONSULT-II.)

1. Stop vehicle with front wheels in straight-ahead position.
2. Connect CONSULT-II and CONSULT-II converter to data link connector on vehicle, and turn ignition switch ON (do not start engine).
3. Touch "VDC", "WORK SUPPORT" and "ST ANG SEN ADJUSTMENT" on CONSULT-II screen in this order.

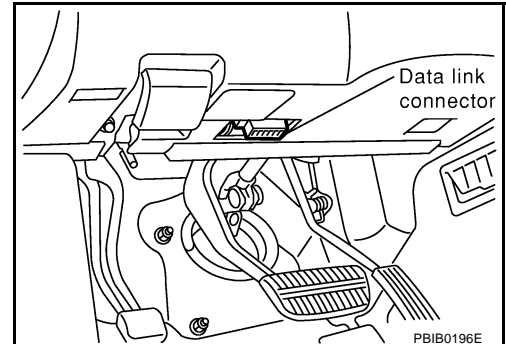

4. Touch "START".

CAUTION:

Do not touch steering wheel while adjusting steering angle sensor.

5. After approximately 10 seconds, touch "END". (After approximately 60 seconds, it ends automatically.)
6. Turn ignition switch OFF, then turn it ON again.

CAUTION:

Be sure to carry out above operation.

7. Run vehicle with front wheels in straight-ahead position, then stop.
8. Select "DATA MONITOR", "ECU INPUT SIGNALS", and "STEERING ANGLE SIGNAL" on CONSULT-II screen. Then check that "STEERING ANGLE SIGNAL" is within 0 ± 2.5 deg. If value is more than specification, repeat steps 1 to 5.
9. Erase memory of VDC/TCS/ABS control unit and ECM.
10. Turn ignition switch to OFF.



SYSTEM DESCRIPTION

SYSTEM DESCRIPTION

PF0:00000

Fail-Safe ABS SYSTEM

EFS0020F

If a malfunction occurs in electrical system, ABS warning lamp, VDC OFF indicator lamp, and SLIP indicator lamp in combination meter turn ON. In this condition, fail-safe function puts VDC/TCS/ABS and EBD into one of following conditions.

1. Only EBD operates. Same condition as that of models without VDC/TCS/ABS.
2. VDC/TCS/ABS and EBD do not operate. All 4 wheels operate as normal brakes.

NOTE:

In step 1 shown above, self-diagnosis when ignition switch is turned ON and when vehicle starts at initial time is carried out. ABS self-diagnosis noise may be heard as usual.

VDC/TCS SYSTEM

If a malfunction occurs in electrical system, VDC OFF indicator lamp and SLIP indicator lamp in combination meter turn on. In this condition, VDC/TCS will be deactivated and it becomes equal to that of models without VDC/TCS. However, ABS is controlled normally.

If a malfunction occurs in throttle control system, VDC/TCS control will be deactivated and only ABS control will operate normally.

CAUTION:

If fail-safe mode is initiated, carry out self-diagnosis for VDC/TCS/ABS control system.

Hydraulic Circuit Diagram

EFS0020G

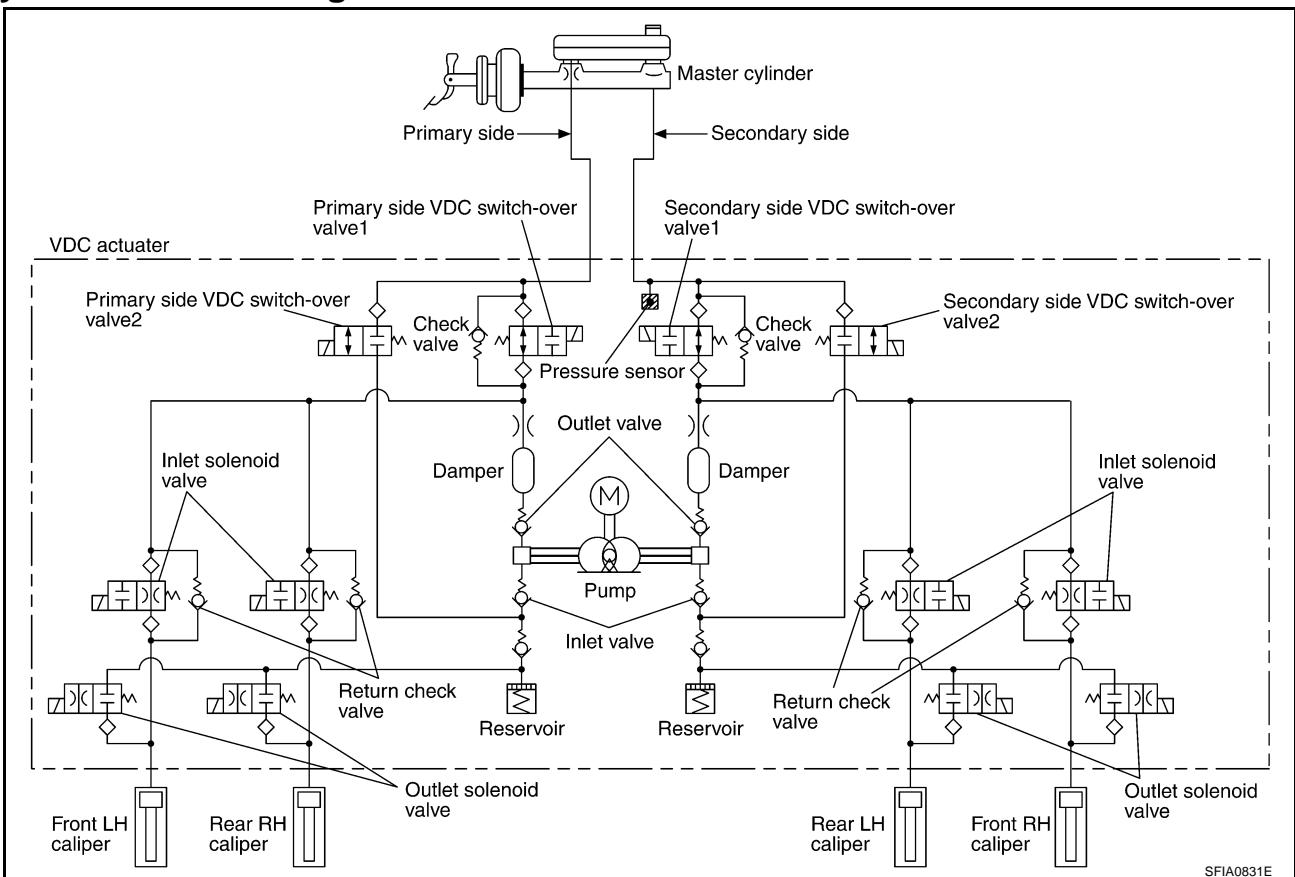

SFIA0831E

ABS Function

EFS0020H

1. During ABS operation, brake pedal lightly vibrates and a mechanical noise may be heard. This is normal.
2. When starting engine, or just after starting vehicle, brake pedal may vibrate or motor operating noises may be heard from engine compartment. This is a normal status of operation check.
3. Stopping distance may be longer than that of vehicles without ABS when vehicle drives on rough, gravel, or snow-covered (fresh, deep snow) roads.
4. EBD is integrated in VDC/TCS/ABS system.

SYSTEM DESCRIPTION

TCS Function

EFS0020I

1. VDC/TCS/ABS control unit detects a spin at drive wheels by comparing wheel speed signals from all 4 wheels. At this time, output from control unit controls brake fluid pressure to both LH and RH rear wheels while cutting fuel to engine and closing throttle valve to reduce engine torque. Furthermore, throttle position is continuously controlled to insure appropriate engine torque at all times.
2. Depending on road circumstances, driver may have a sluggish feel. This is normal, because optimum traction has highest priority under TCS operation.
3. When vehicle is passing through a road where surface friction coefficient varies, downshifting or depressing accelerator pedal fully may activate TCS temporarily.
4. During TCS operation, it informs driver of system operation by flashing SLIP indicator lamp.

VDC Function

EFS0020J

1. In addition to TCS/ABS function, VDC detects driver's steering operation amount and brake pedal travel from steering angle sensor and pressure sensor. Using information from yaw rate/side G-sensor and wheel sensor, VDC judges driving condition (conditions of under steer and over steer) to improve stability by controlling brake application to 4 wheels and engine output.
2. SLIP indicator lamp flashes to inform driver of VDC operation.
3. During VDC operation, body and brake pedal lightly vibrate and mechanical noises may be heard. This is normal.
4. If vehicle is rotated on turn table, or rolled and rocked on ship, ABS warning lamp, VDC OFF indicator lamp, and SLIP indicator lamp may turn ON. In this case, start engine on normal road again. If ABS warning lamp, VDC OFF indicator lamp, and SLIP indicator lamp turn OFF after restart, it is normal.
5. When driving in steep slope such as bank, ABS warning lamp, VDC OFF indicator lamp, and SLIP indicator lamp may turn ON. In this case, start engine on normal road again. If ABS warning lamp, VDC OFF indicator lamp, and SLIP indicator lamp turn OFF after restart, it is normal.

System Diagram

EFS0020K

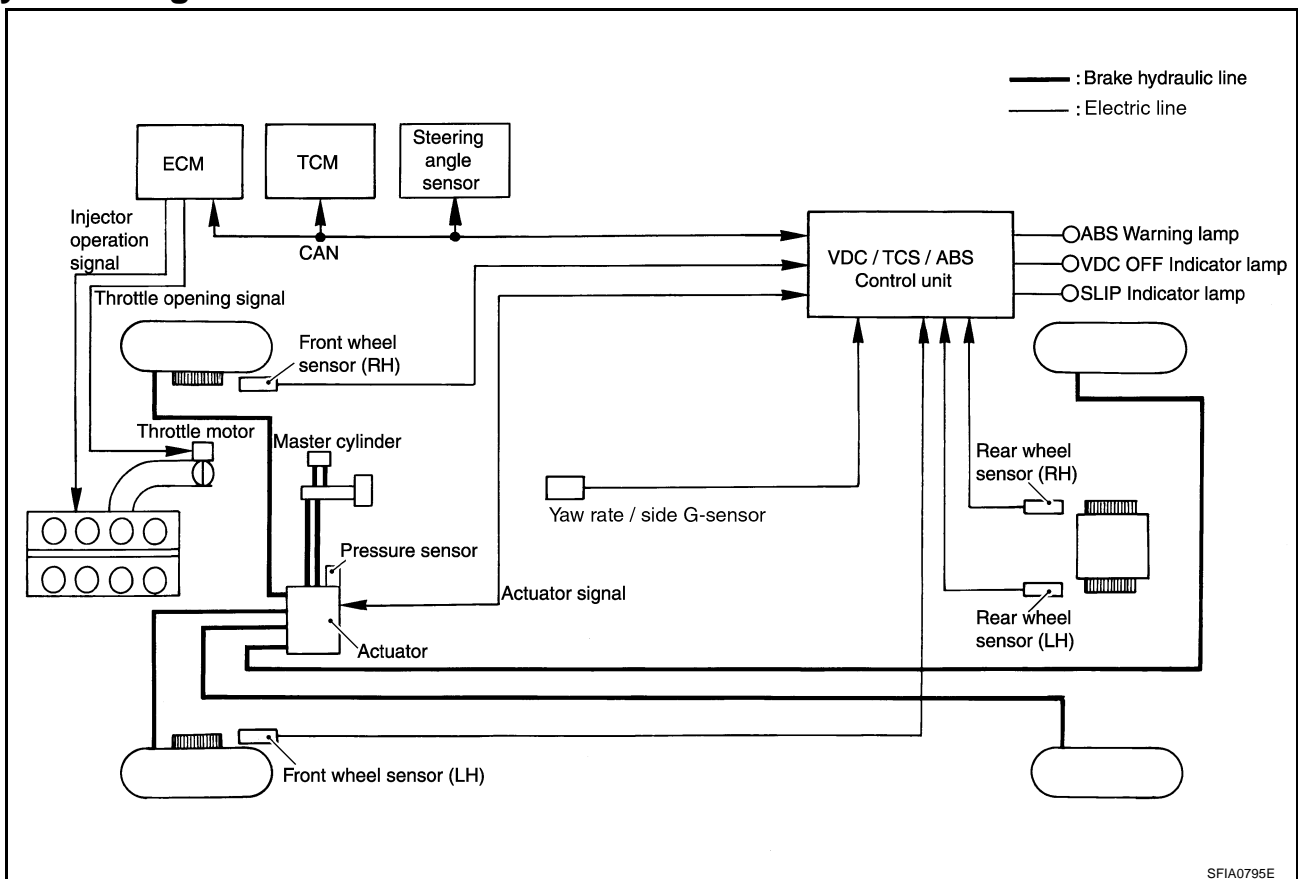

CAN COMMUNICATION

CAN COMMUNICATION

PPF:23710

System Description

EPS00587

CAN (Controller Area Network) is a serial communication line for real time application. It is an on-vehicle multiplex communication line with high data communication speed and excellent error detection ability. Many electronic control units are equipped onto a vehicle, and each control unit shares information and links with other control units during operation (not independent). In CAN communication, control units are connected with 2 communication lines (CAN H line, CAN L line) allowing a high rate of information transmission with less wiring. Each control unit transmits/receives data but selectively reads required data only.

FOR VDC MODELS

System Diagram

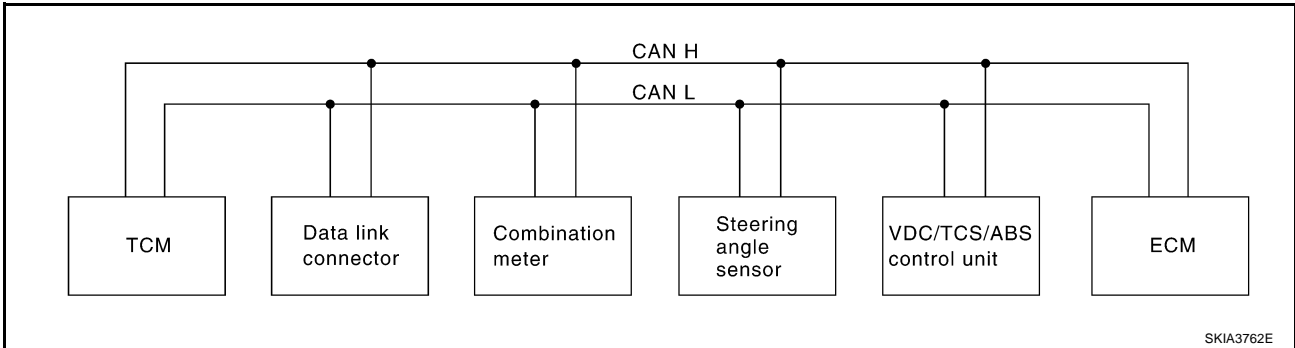

Input/Output Signal Chart

T: Transmit R: Receive

Signals	TCM	Combination meter	Steering angle sensor	VDC/TCS/ABS control unit	ECM
Engine speed signal	R	R		R	T
Engine coolant temperature signal	R	R			T
Accelerator pedal position signal	R			R	T
Engine torque signal	R			R	T
Battery voltage signal	R				T
Closed throttle position signal	R				T
Wide open throttle position signal	R				T
Lock-up prohibition signal	R				T
Torque-down permission signal	R				T
Fuel consumption monitor signal		R			T
Lock-up signal	T				R
Hard deceleration signal	T				R
Torque-down signal	T				R
Power mode indicator signal	T				R
A/T fluid temperature warning lamp signal	T	R			R
Current gear position signal	T	R		R	R
	R	T			
Next gear position signal	T			R	R
Shift change signal	T			R	R
Shift pattern signal	T				R
VDC system control signal				T	R
VDC operation signal				T	R
Stop lamp switch signal	R			T	
Steering wheel angle sensor signal	R		T	R	R

CAN COMMUNICATION

Signals	TCM	Combination meter	Steering angle sensor	VDC/TCS/ABS control unit	ECM
Air conditioner switch signal		T			R
Headlamp switch signal		T			R
Rear window defogger switch signal		T			R
OD cancel switch signal	R	T		R	
Brake switch signal	R	T			
Power mode switch signal	R	T			
Vehicle speed signal	R	R		T	
	R	T			R
	T				R

FOR ICC MODELS System Diagram

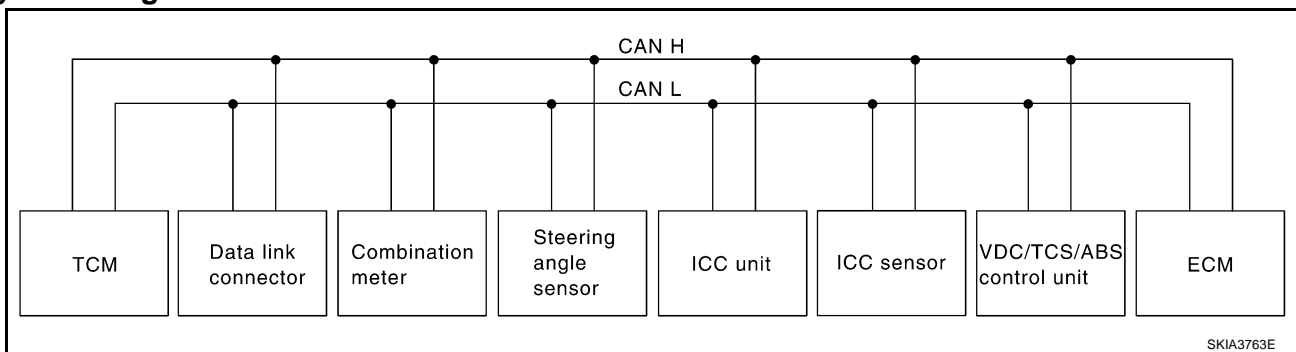

Input/Output Signal Chart

T: Transmit R: Receive

Signals	TCM	Combination meter	Steering angle sensor	ICC unit	ICC sensor	VDC/TCS/ABS control unit	ECM
ICC system display signal		R		T			
ICC sensor signal				R	T		
Engine speed signal	R	R		R		R	T
Engine coolant temperature signal	R	R					T
Accelerator pedal position signal	R					R	T
Engine torque signal	R					R	T
Battery voltage signal	R						T
Closed throttle position signal	R			R			T
Lock-up prohibition signal	R						T
Torque-down permission signal	R						T
Fuel consumption monitor signal		R					T
Lock-up signal	T						R
Hard deceleration signal	T						R
Torque-down signal	T						R
Power mode indicator signal	T						R
A/T fluid temperature warning lamp signal	T	R					R
Current gear position signal	T	R				R	R
	R	T					
Next gear position signal	T					R	R

CAN COMMUNICATION

Signals	TCM	Combina- tion meter	Steering angle sensor	ICC unit	ICC sen- sor	VDC/ TCS/ABS control unit	ECM
Shift change signal	T					R	R
Shift pattern signal	T			R			R
VDC system control signal						T	R
VDC operation signal				R		T	R
Stop lamp switch signal	R					T	
Steering wheel angle sensor signal	R		T			R	R
Air conditioner switch signal		T					R
Headlamp switch signal		T					R
Rear window defogger switch signal		T					R
OD cancel switch signal	R	T				R	
Brake switch signal	R	T					
Power mode switch signal	R	T					
Vehicle speed signal	R	R		R		T	
	R	T					R
	T			R			R

A
B
C
D
E
BRC
G
H
I
J
K
L
M

TROUBLE DIAGNOSIS

TROUBLE DIAGNOSIS

PFP:00004

How to Proceed With Diagnosis BASIC CONCEPT

EFS001Z4

- Most important point to perform diagnosis is to understand systems (control and mechanism) in vehicle thoroughly.
- It is also important to clarify customer complaints before inspection.
First of all, reproduce symptom, and understand it fully.
Ask customer about his/her complaints carefully. In some cases, it will be necessary to check symptom by driving vehicle with customer.

NOTE:

Customers are not professionals. Do not assume “maybe customer means...” or “maybe customer mentioned this symptom”.

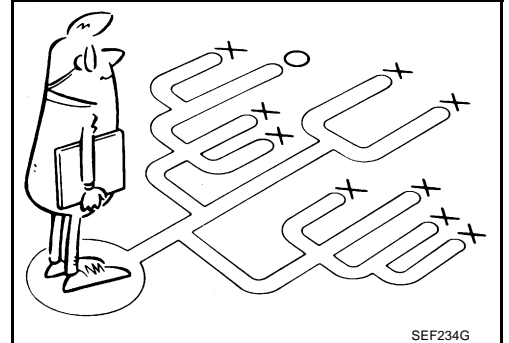

SEF234G

- It is essential to check symptoms right from beginning in order to repair a malfunction completely.
For an intermittent malfunction, it is important to reproduce symptom based on interview with customer and past examples. Do not perform inspection on ad hoc basis. Most intermittent malfunctions are caused by poor contacts. In this case, it will be effective to shake suspected harness or connector by hand. When repairs are performed without any symptom check, no one can judge if malfunction has actually been eliminated.
- After diagnosis, make sure to carry out “erase memory”. Refer to [BRC-27, "SELF-DIAGNOSIS"](#).
- For an intermittent malfunction, move harness or harness connector by hand to check poor contact or false open circuit.
- Always read “GI General Information” to confirm general precautions.

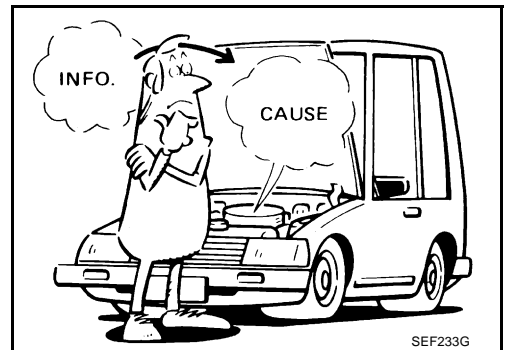

SEF233G

TROUBLE DIAGNOSIS

DIAGNOSIS FLOWCHART

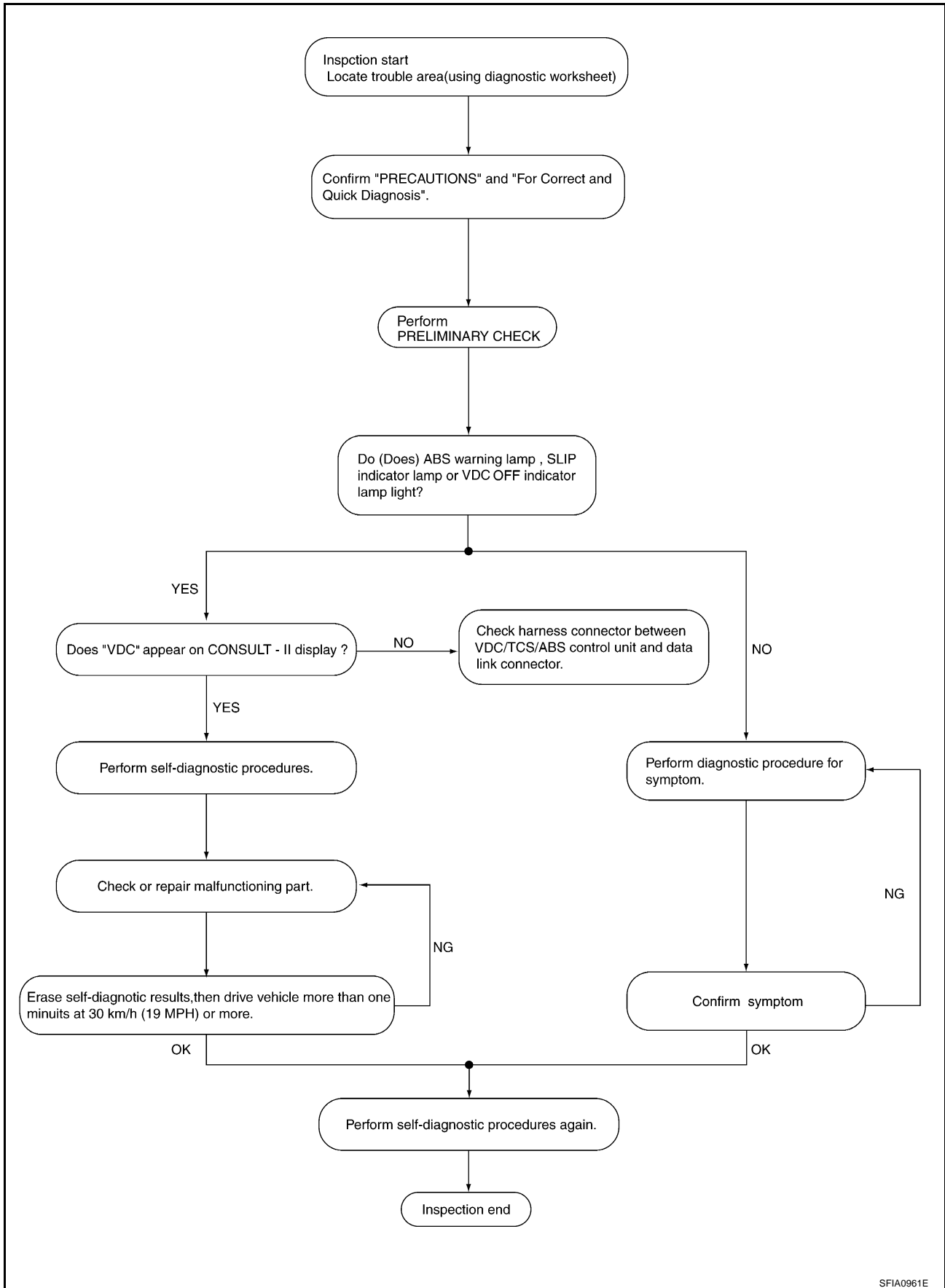

A

B

C

D

E

BRC

G

H

I

J

K

L

M

SFIA0961E

TROUBLE DIAGNOSIS

ASKING COMPLAINTS

- Complaints against malfunction vary depending on each person. It is important to clarify customer complaints.
- Ask customer about what symptoms are present and under what conditions. Use information to reproduce symptom while driving.
- It is also important to use diagnosis sheet so as not to miss information.

KEY POINTS

WHAT Vehicle model
WHEN Date, Frequencies
WHERE Road conditions
HOW Operating conditions,
 Weather conditions,
 Symptoms

SBR339B

EXAMPLE OF DIAGNOSIS SHEET

Customer name MR/MS	Model & Year	VIN	
Engine #	Trans.	Mileage	
Incident Date	Manuf. Date	In Service Date	
Symptoms	<input type="checkbox"/> Noise and vibration (from engine compartment) <input type="checkbox"/> Noise and vibration (from axle)	<input type="checkbox"/> Warning / Indicator activate	<input type="checkbox"/> Firm pedal operation <input type="checkbox"/> Large stroke pedal operation
	<input type="checkbox"/> TCS does not work (Rear wheels slip when accelerating)	<input type="checkbox"/> ABS does not work. (wheels slip when braking)	<input type="checkbox"/> Lack of sense of acceleration
Engine conditions	<input type="checkbox"/> When starting <input type="checkbox"/> After starting		
Road conditions	<input type="checkbox"/> Low friction road (<input type="checkbox"/> Snow <input type="checkbox"/> Gravel <input type="checkbox"/> Other) <input type="checkbox"/> Bumps / potholes		
Driving conditions	<input type="checkbox"/> Full-acceleration <input type="checkbox"/> High speed cornering <input type="checkbox"/> Vehicle speed: Greater than 10 km/h (6 MPH) <input type="checkbox"/> Vehicle speed: 10 km/h (6 MPH) or less <input type="checkbox"/> Vehicle is stopped		
Applying brake conditions	<input type="checkbox"/> Suddenly <input type="checkbox"/> Gradually		
Other conditions	<input type="checkbox"/> Operation of electrical equipment <input type="checkbox"/> Shift change <input type="checkbox"/> Other descriptions		

SFIA0791E

TROUBLE DIAGNOSIS

Component Installation Location

EFS001Z5

A
B
C
D
E
BRC
G
H
I
J
K
L
M

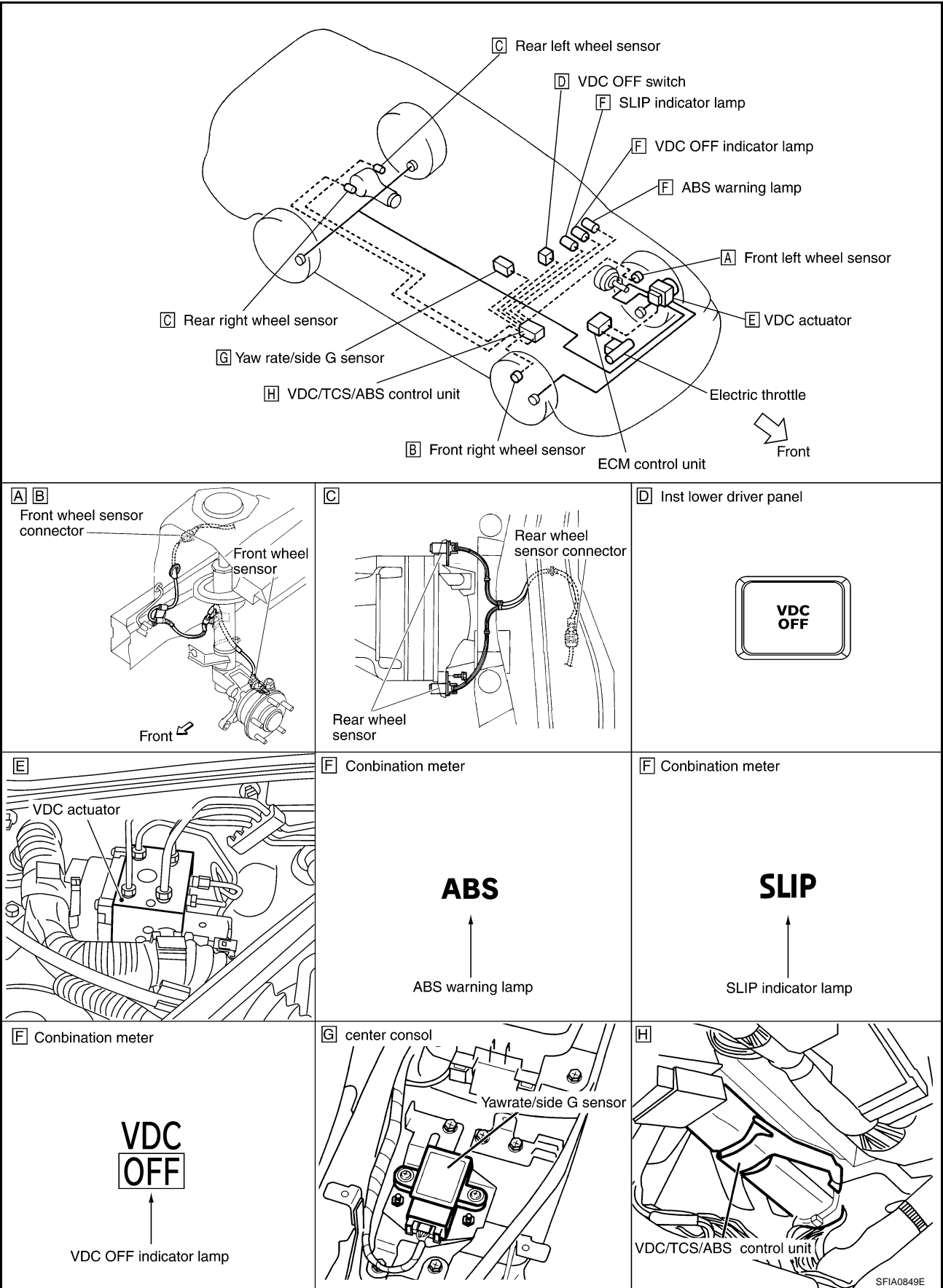

TROUBLE DIAGNOSIS

Schematic

EFS001Z6

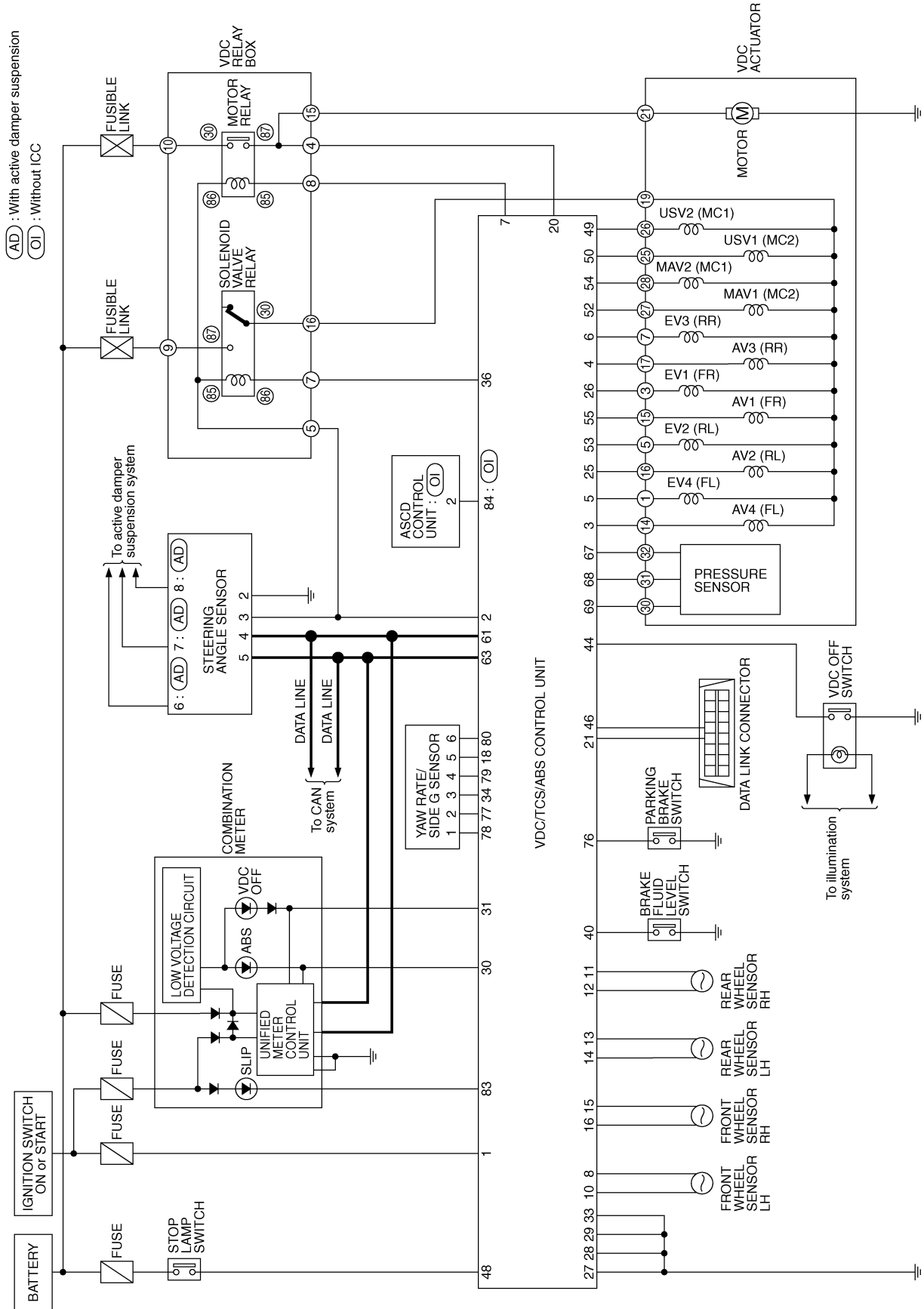

TFWM0023E

TROUBLE DIAGNOSIS

Wiring Diagram — VDC —

EFS001Z7

BRC-VDC-01

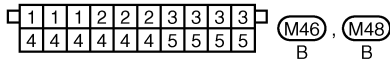
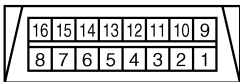
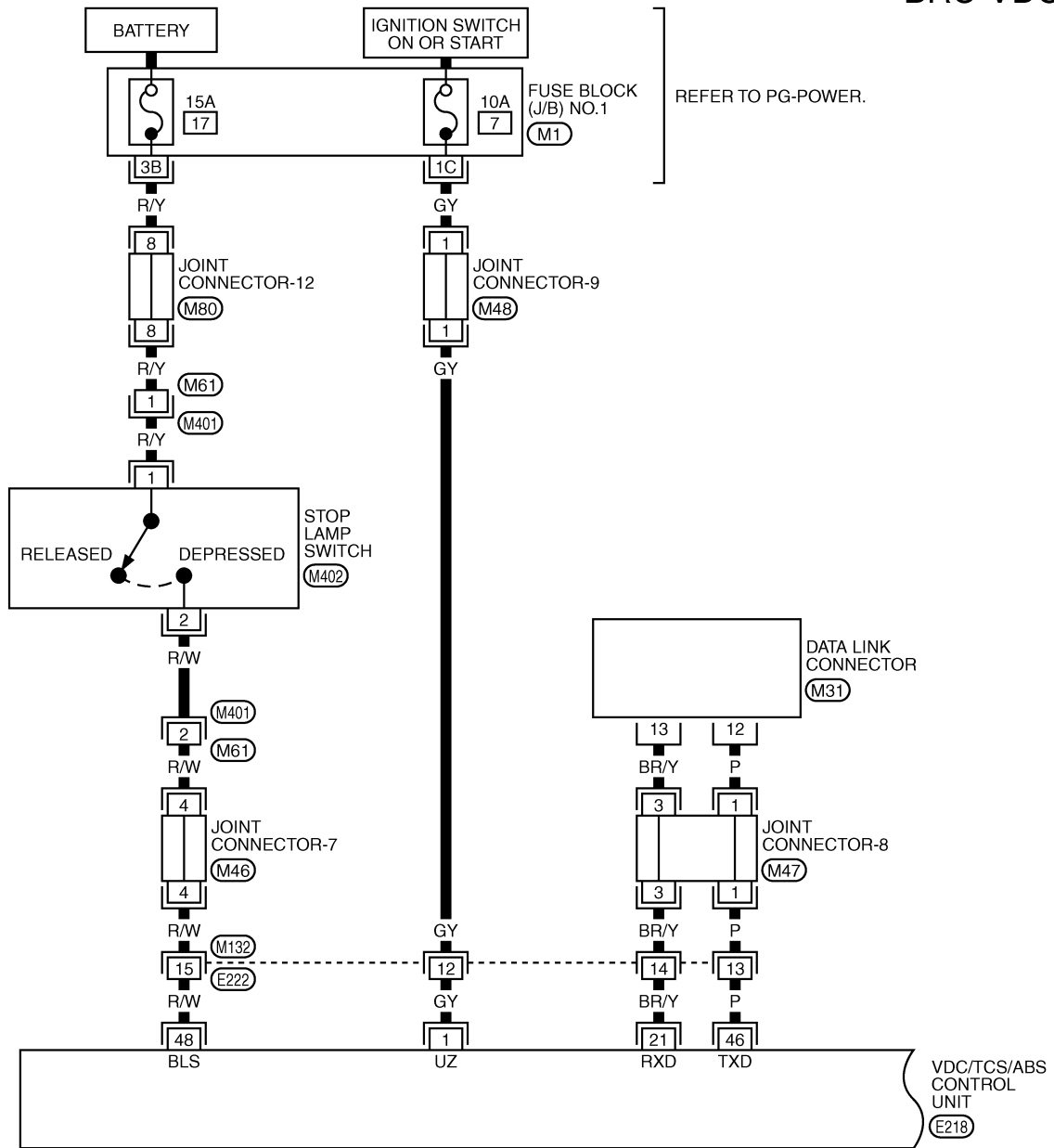

REFER TO THE FOLLOWING.

(M1) - FUSE BLOCK-JUNCTION BOX (J/B) NO.1

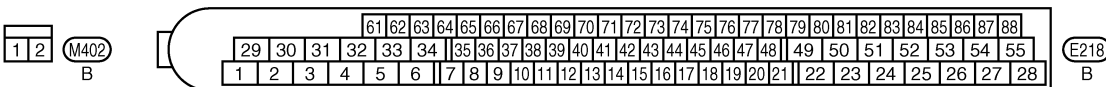
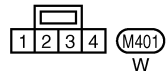
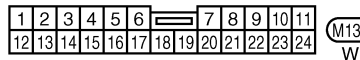
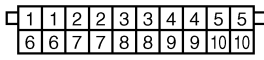
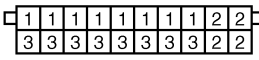

TFWM0024E

TROUBLE DIAGNOSIS

BRC-VDC-02

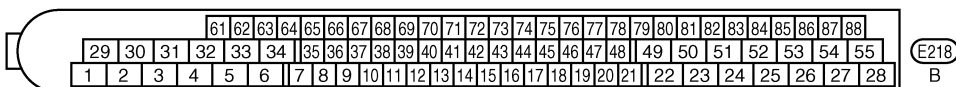
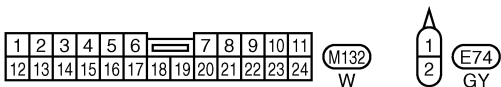
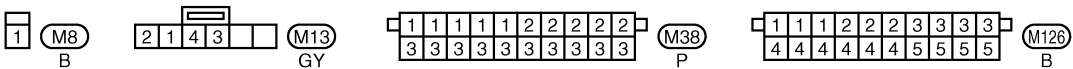
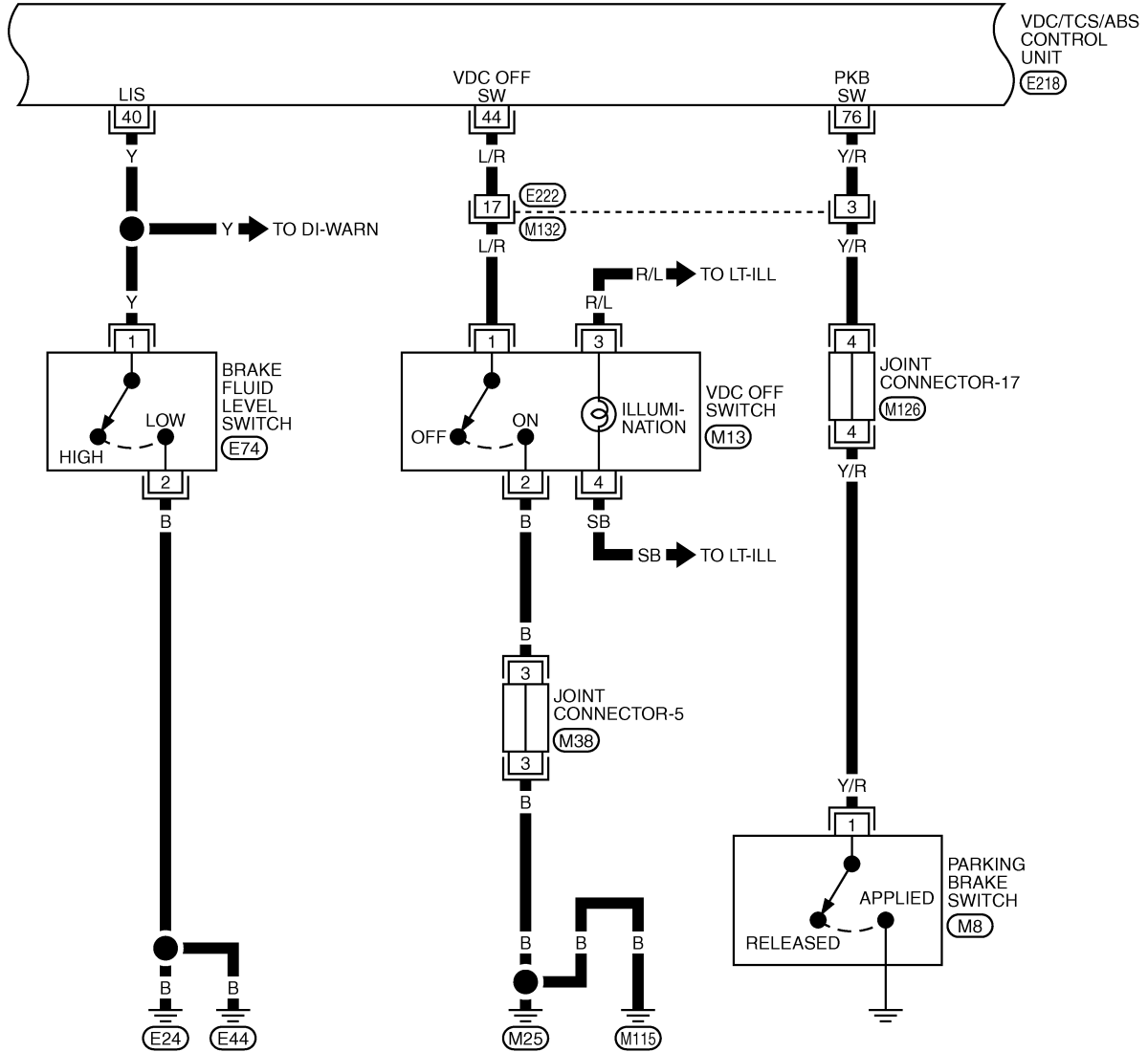

TFWM0025E

TROUBLE DIAGNOSIS

BRC-VDC-03

⬡ : WITHOUT ICC

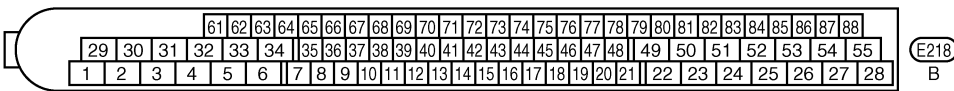
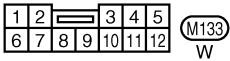
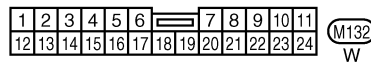
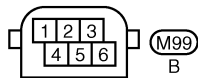
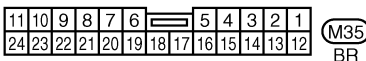
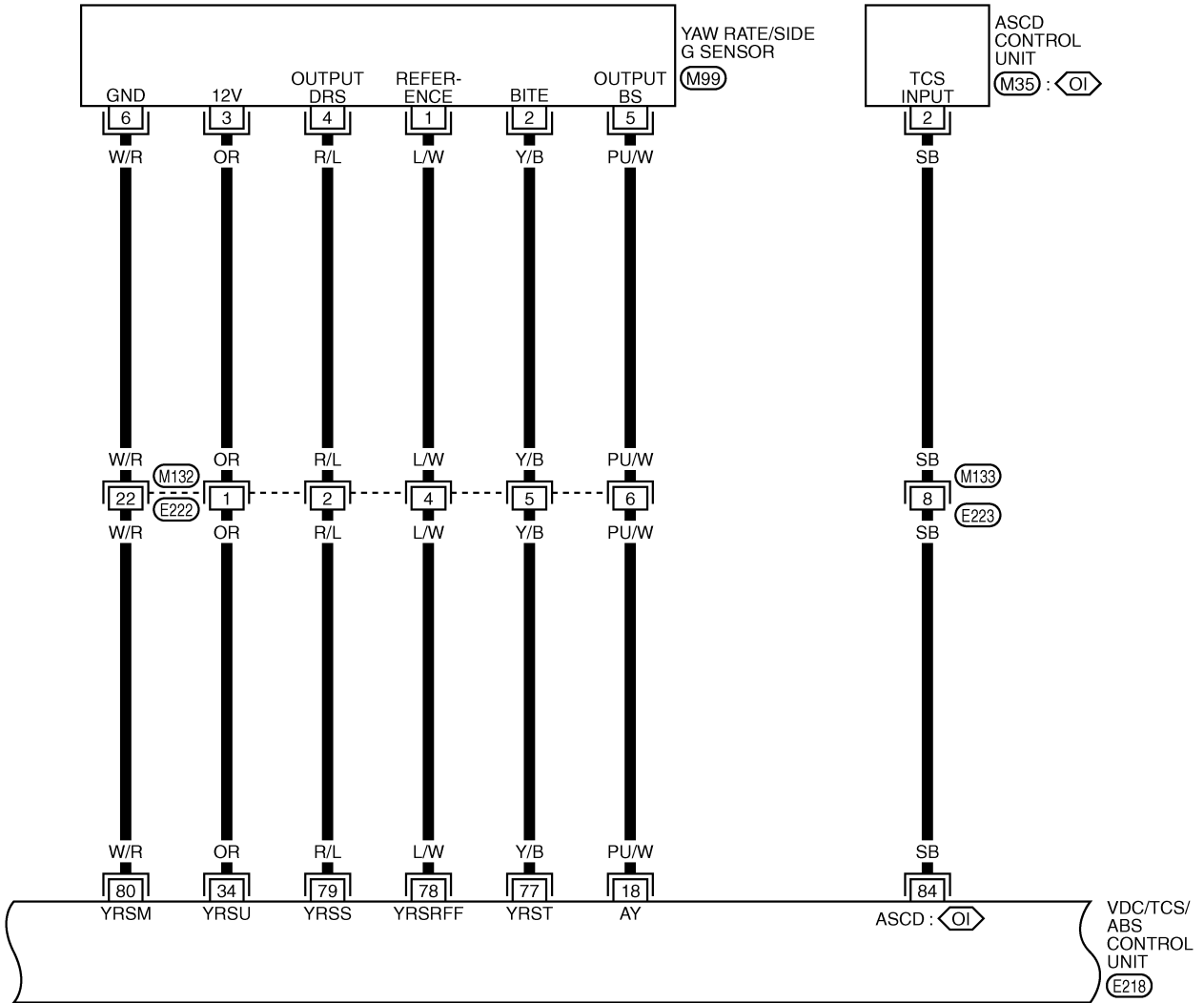

TFWM0026E

TROUBLE DIAGNOSIS

BRC-VDC-04

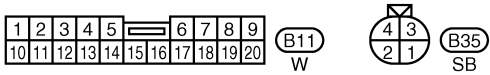
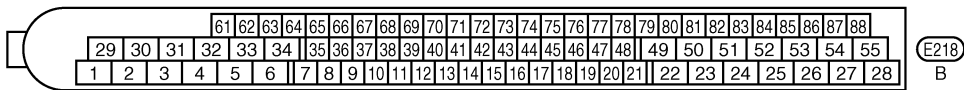
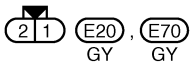
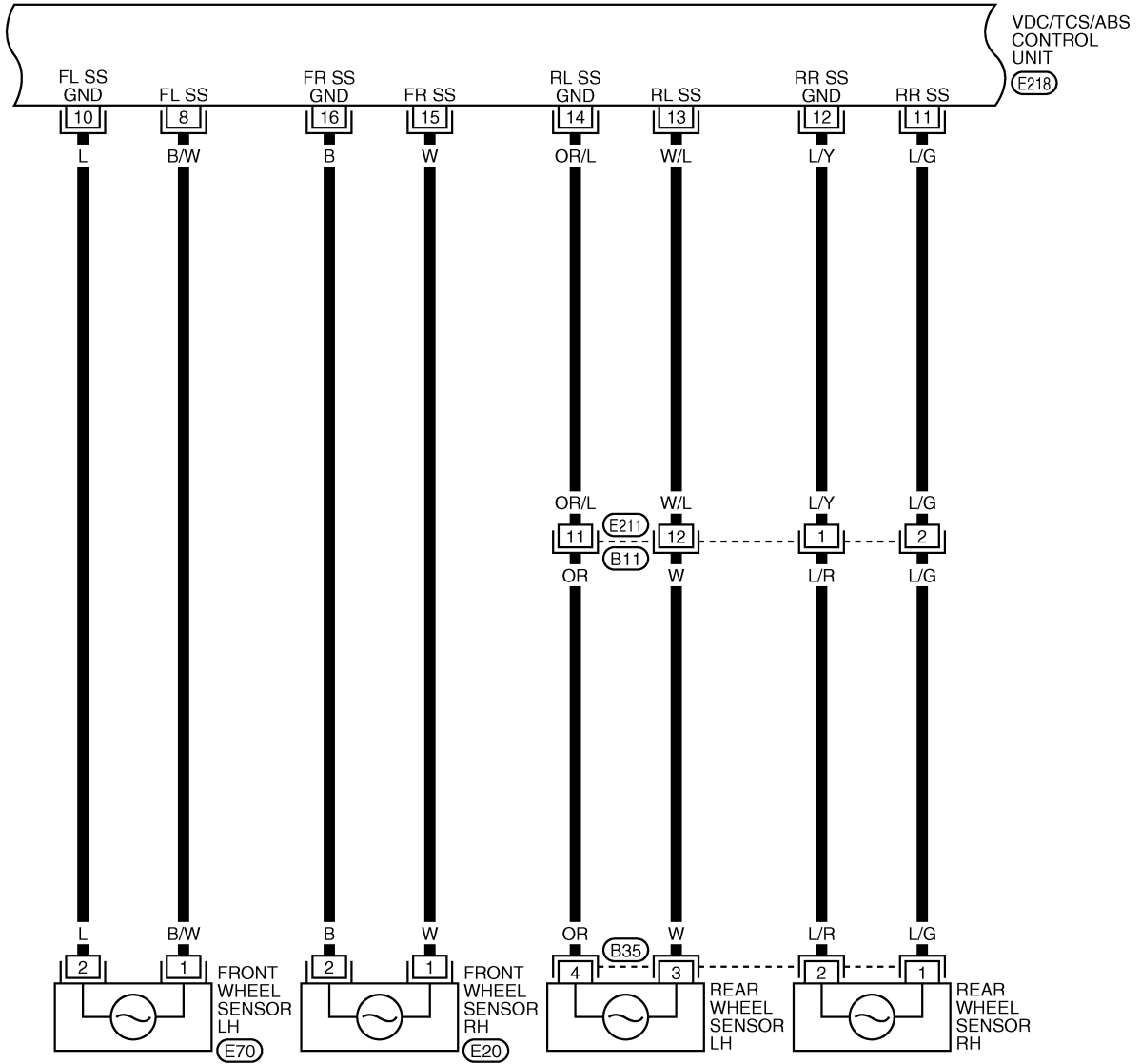

TFWM0005E

TROUBLE DIAGNOSIS

BRC-VDC-05

▬ : DATA LINE

◊(AD) : WITH ACTIVE DAMPER SUSPENSION

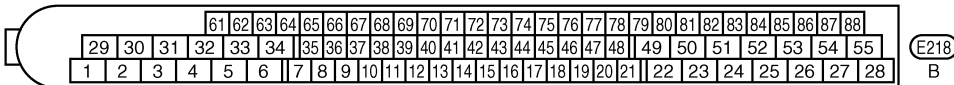
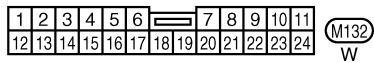
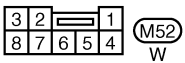
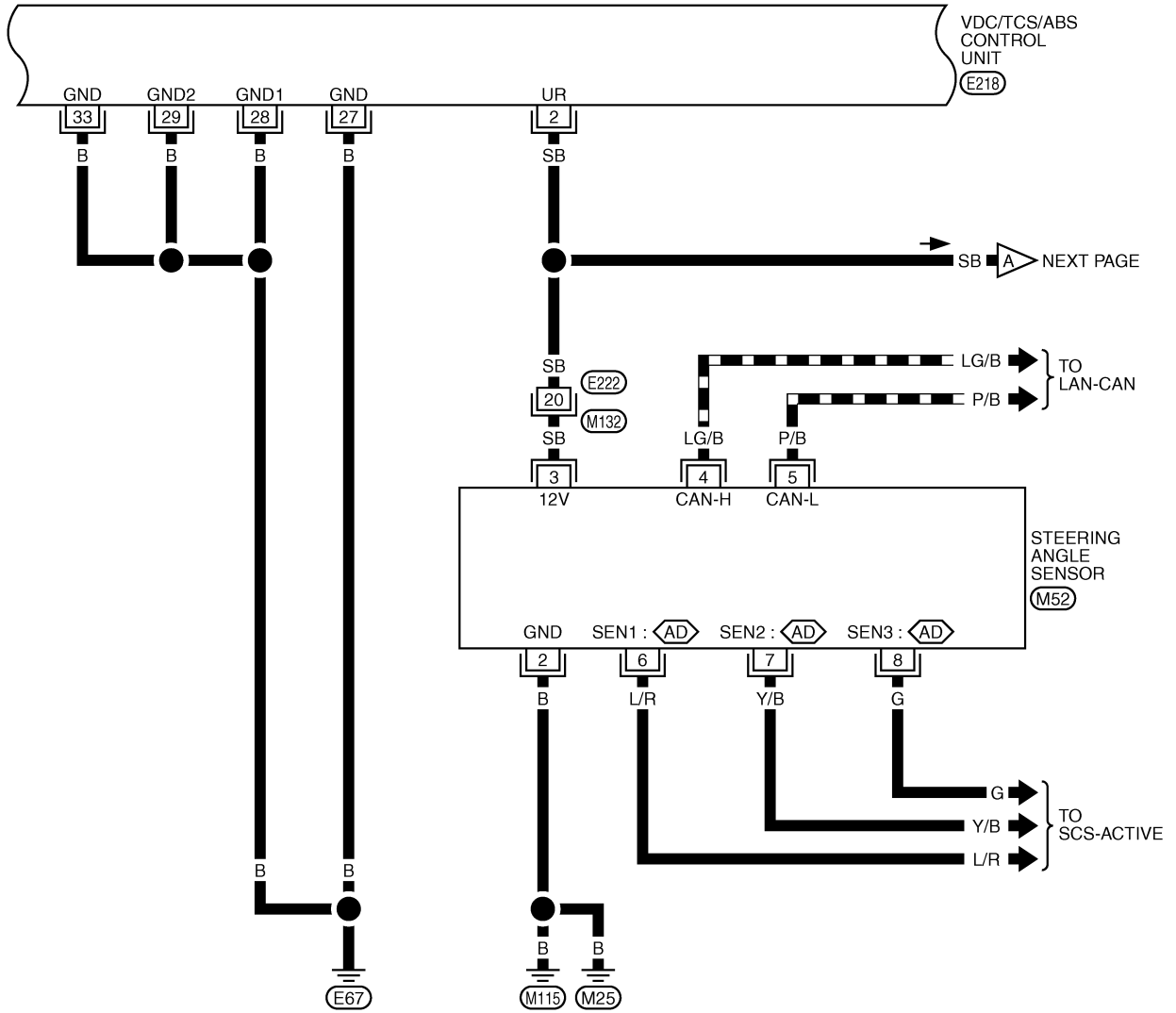

TFWM0027E

TROUBLE DIAGNOSIS

BRC-VDC-06

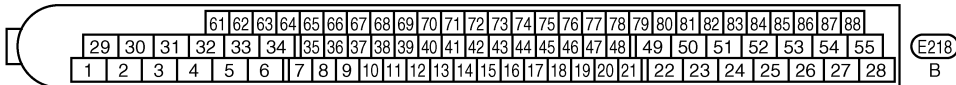
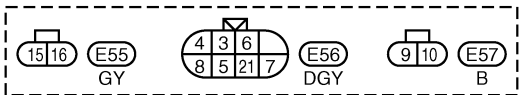
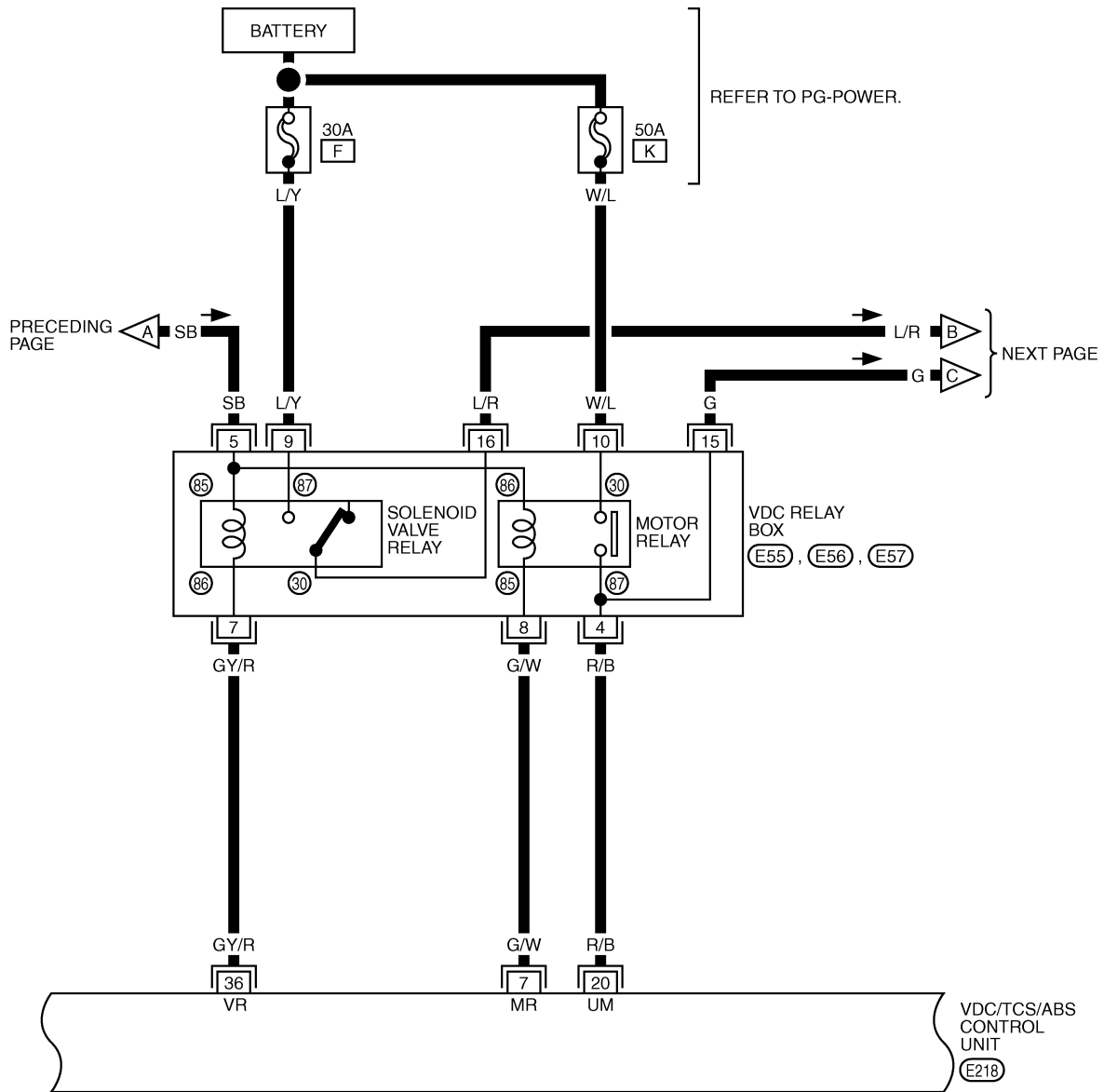

TFWM0028E

TROUBLE DIAGNOSIS

BRC-VDC-07

A
B
C
D
E
G
H
I
J
K
L
M

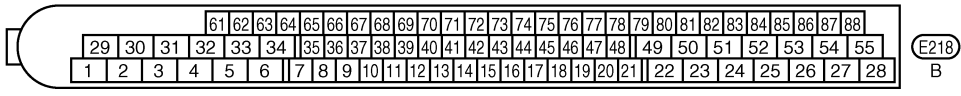
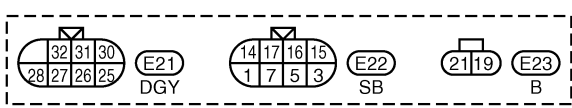
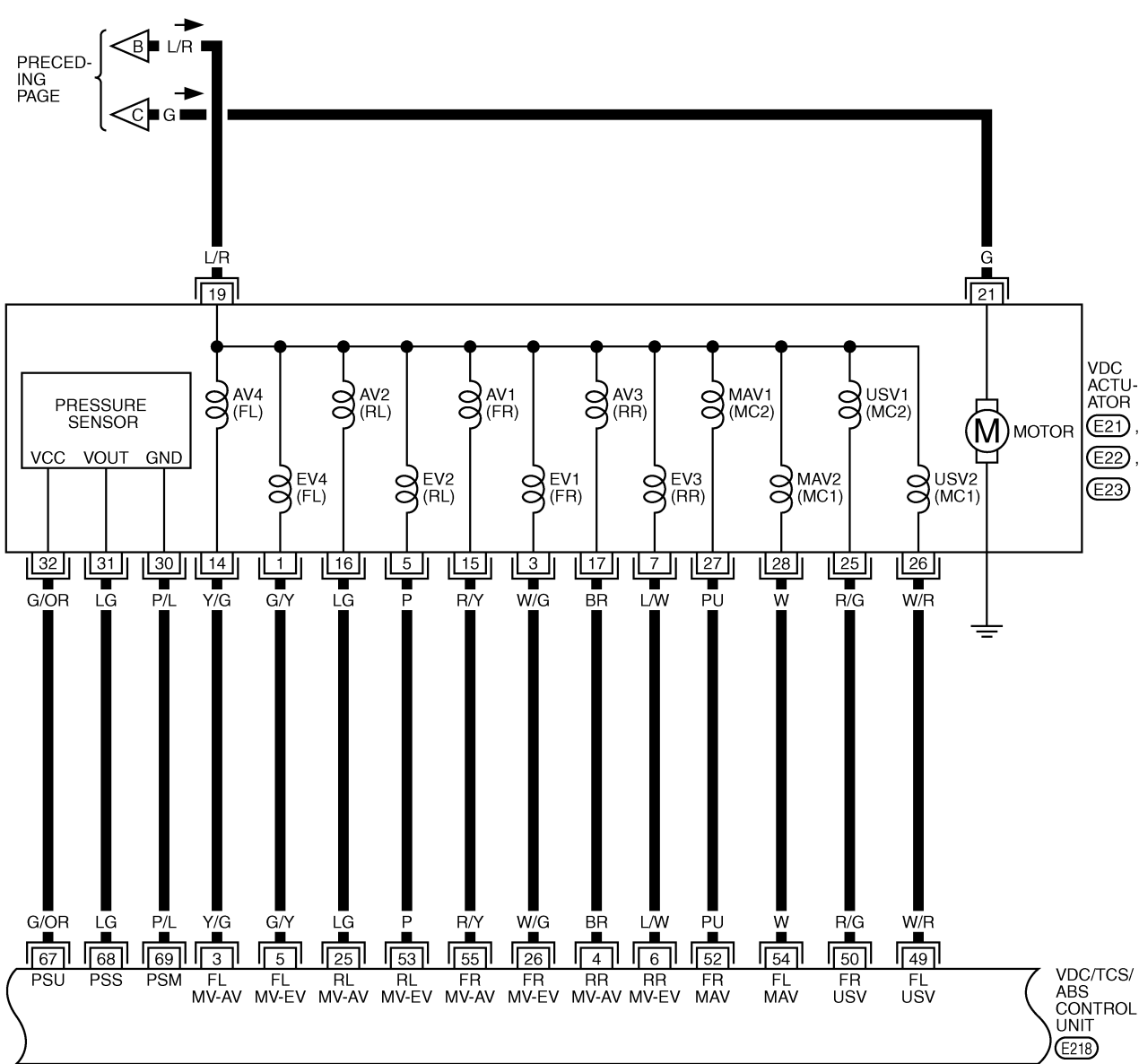

TFWM0008E

TROUBLE DIAGNOSIS

BRC-VDC-08

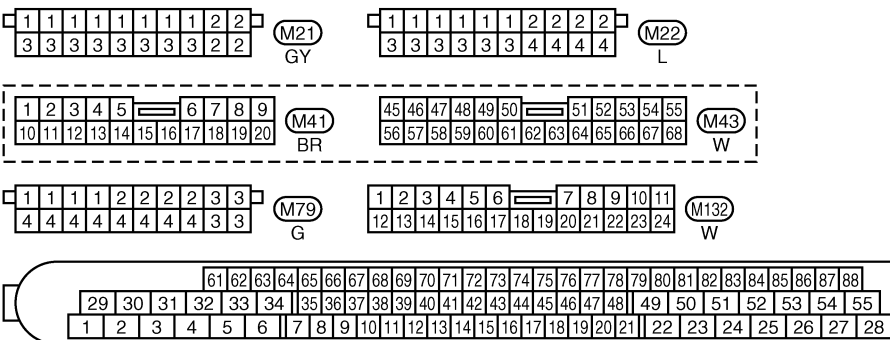
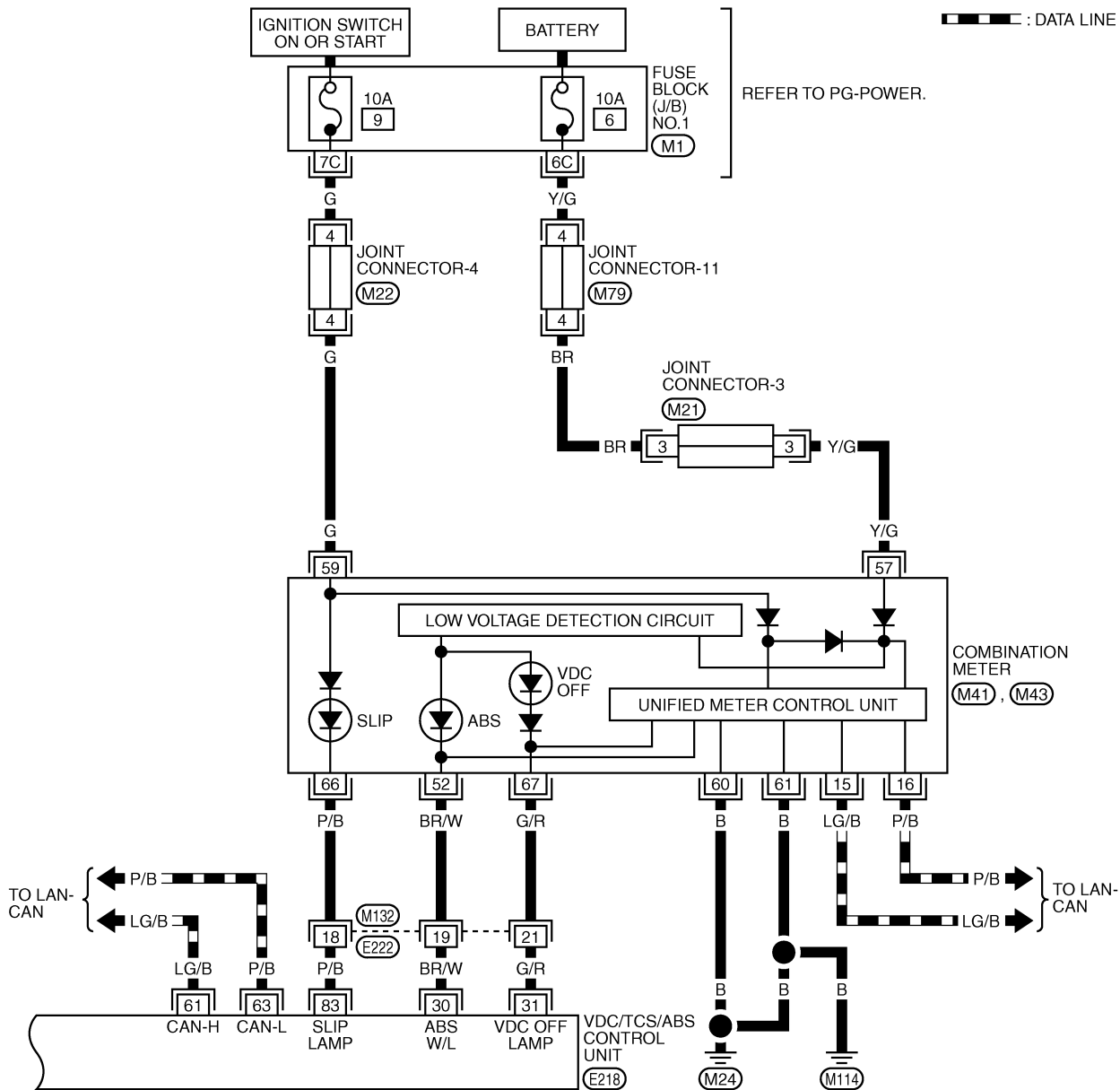

REFER TO THE FOLLOWING.
 (M1) -FUSE BLOCK-JUNCTION BOX (J/B) NO.1

TFWM0031E

TROUBLE DIAGNOSIS

Control Unit Input/Output Signal Standard STANDARDS BY CONSULT-II

EFS001Z8

CAUTION:

Items displayed are data calculated by control unit and may indicate normal operation even if output circuit (harness) is open or shorted.

Monitor item	Display content	Data monitor		Note: Error inspection checklist
		Condition	Reference value in normal operation	
GEAR POSITION	A/T gear position	1:1st gear 2:2nd gear 3:3rd gear 4:4th gear 5:5th gear		—
VHCL SPEED	Wheel speed	Vehicle stopped	0 [km/h (MPH)]	Wheel sensor circuit [Inspection 1] BRC-39
		Vehicle running (Note 1)	Almost in accordance with speedometer display (within ±10%)	
THRTL OPENING	Throttle actuator opening/closing is displayed (linked with accelerator pedal).	Accelerator pedal not depressed (ignition switch is ON)	0%	Communication circuit between VDC/TCS/ABS control unit and ECM
		Depress accelerator pedal (ignition switch is ON)	0 to 100%	
ENGINE RPM	With engine running	With engine stopped	0 rpm	Engine speed signal circuit
		Engine running	Almost in accordance with tachometer display	
STEERING ANGLE SIG	Steering angle detected by steering angle sensor	Straight-ahead	Approx. 0 deg	Steering angle sensor and circuit [Inspection 5] BRC-43
		Steering wheel turned	-720 to 720 deg	
YAW RATE SEN	Yaw rate detected by yaw rate sensor	Vehicle stopped	Approx. 0 d/s	Yaw rate sensor and circuit [Inspection 6] BRC-45
		Vehicle running	-70 to 70 d/s	
SIDE G-SEN	Transverse G detected by side G-sensor	Vehicle stopped	Approx. 0 m/s ²	Side G-sensor and circuit [Inspection 6] BRC-45
		Vehicle running	-24.3 to 24.1 m/s ²	
PRESS SENSOR	Brake fluid pressure detected by pressure sensor	With ignition switch turned ON and brake pedal released	Approx. 0 bar	Pressure sensor and circuit [Inspection 4] BRC-42
		With ignition switch turned ON and brake pedal depressed	-40 to 300 bar	
ABS CONT VOLT	Battery voltage supplied to VDC/TCS/ABS control unit	Ignition switch ON	10 to 16V	VDC/TCS/ABS control unit power supply and ground circuits [Inspection 11] BRC-53
STOP LAMP SW	Brake pedal operation	Brake pedal depressed	ON	Stop lamp switch circuit [Inspection 10] BRC-52
		Brake pedal not depressed	OFF	
PARK BRAKE SW	Parking brake status	Parking brake depressed	ON	Parking brake switch circuit
		Parking brake not depressed	OFF	
OFF SW	OFF switch ON/OFF status	VDC OFF switch ON (When VDC OFF indicator lamp is ON)	ON	VDC OFF switch circuit
		VDC OFF switch OFF (When VDC OFF indicator lamp is OFF)	OFF	

TROUBLE DIAGNOSIS

Monitor item	Display content	Data monitor		Note: Error inspection checklist
		Condition	Reference value in normal operation	
ABS WARN LAMP	ABS warning lamp ON condition (Note 2)	ABS warning lamp ON	ON	ABS warning lamp harness
		ABS warning lamp OFF	OFF	
VDC OFF LAMP	VDC OFF indicator lamp status (Note 3)	When VDC OFF indicator lamp is ON	ON	VDC OFF indicator lamp circuit
		When VDC OFF indicator lamp is OFF	OFF	
EV SIGNAL AV SIGNAL	Solenoid valve operation	Actuator (solenoid) is active ("ACTIVE TEST" with CONSULT-II) or actuator relay is inactive (in fail-safe mode).	ON	Solenoid and circuit [Inspection 7] BRC-46
		When actuator (solenoid) is not active and actuator relay is active (ignition switch ON).	OFF	
USV SIGNAL MAV SIGNAL	VDC switch-over valve status	When actuator (switch-over valve) is active ("ACTIVE TEST" with CONSULT-II) or actuator relay is inactive (when in fail-safe mode).	ON	Switch-over valve and circuit [Inspection 7] BRC-46
		When actuator (switch-over valve) is not active and actuator relay is active (ignition switch ON).	OFF	
M/R OUTPUT	Actuator motor and motor relay status (ON/OFF)	When actuator motor and motor relay are active ("ACTIVE TEST" with CONSULT-II).	ON	Actuator motor, motor relay, and circuit [Inspection 8] BRC-48
		When actuator motor and motor relay are inactive.	OFF	

Note 1: Confirm tire pressure is normal.

Note 2: ON/OFF timing of ABS warning lamp

ON: For approximately 1 seconds after ignition switch is turned ON, or when a malfunction is detected.

OFF: Approximately 1 seconds after ignition switch is turned ON (when system is in normal operation).

Note 3: ON/OFF timing of VDC OFF indicator lamp

ON: For approximately 1 seconds after ignition switch is turned ON, or when a malfunction is detected and VDC OFF switch is ON.

OFF: Approximately 1 seconds after ignition switch is turned ON (when system is in normal operation.) And when VDC OFF switch is OFF.

CONSULT-II Functions CONSULT-II MAIN FUNCTION

EF5001Z9

In a diagnosis function (main function), there are "WORK SUPPORT", "SELF-DIAGNOSTIC RESULTS", "DATA MONITOR", "CAN DIAG SUPPORT MNTR", "ACTIVE TEST", "FUNCTION TEST", "ECU PART NUMBER".

Diagnostic test mode	Function	Reference
WORK SUPPORT	This mode enables a technician to adjust some devices faster and more accurately by following the indications on CONSULT-II.	BRC-6, "Adjustment of Steering Angle Sensor Neutral Position"
SELF-DIAGNOSTIC RESULTS	Self-diagnostic results can be read and erased quickly.	BRC-27, "SELF-DIAGNOSIS"
DATA MONITOR	Input/Output data in the VDC/TCS/ABS control unit can be read.	BRC-30, "DATA MONITOR"

TROUBLE DIAGNOSIS

Diagnostic test mode	Function	Reference
CAN DIAG SUPPORT MNTR	The results of transmit / receive diagnostic of CAN communication can be read.	—
ACTIVE TEST	Diagnostic Test Mode in which CONSULT-II drives some actuators apart from the VDC/TCS/ABS control unit and also shifts some parameters in a specified range.	BRC-32, "ACTIVE TEST"
FUNCTION TEST	Performed by CONSULT-II instead of a technician to determine whether each system is "OK" or "NG".	—
ECU PART NUMBER	VDC/TCS/ABS control unit part number can be read.	—

SELF-DIAGNOSIS

Description

If a malfunction is detected in system, ABS warning lamp, VDC OFF indicator lamp, and SLIP indicator lamp on meter turn on. In this case, perform self-diagnosis as follows:

Operation Procedure

1. Perform [BRC-38, "Basic Inspection"](#) using information from customer.
2. After ignition switch is turned OFF, connect CONSULT-II and CONSULT-II CONVERTER to data link connector (data link connector is on lower instrument cover).
3. Start engine and drive at approximately 30 km/h (19 MPH) for approximately 1 minute.
4. After stopping vehicle, with engine still idling, touch "START (NISSAN BASED VHCL)", "VDC", and "SELF-DIAG RESULTS" on CONSULT-II screen in this order.

CAUTION:

Just after starting engine, or turning ignition switch ON, "VDC" may not be displayed on system selection screen even if "START (NISSAN BASED VHCL)" is touched. In this case, start self-diagnosis again from step 2. If it cannot be shown after several attempts, VDC/TCS/ABS control unit may have malfunctioned. Repair or replace control unit.

5. Self-diagnosis result is displayed. (If necessary, touch "PRINT" to print self-diagnosis result.)
 - When "NO FAILURE" is shown, check ABS warning lamp, VDC OFF indicator lamp, SLIP indicator lamp. Refer to [BRC-36, "For Fast and Accurate Diagnosis"](#).
 - CONSULT-II self-diagnosis results are displayed without regard to occurrence timing. In some cases later ones (timing value is small) appear on next screen.
6. Go to appropriate "Inspection" chart according to "Display Item List", and repair or replace as necessary.
7. Start engine and drive at approximately 30 km/h (19 MPH) for approximately 1 minute.

CAUTION:

● **Check again to make sure that there is no malfunction on other parts.**

8. Turn ignition switch OFF to prepare for erasing memory.
9. Start engine and touch "START (NISSAN BASED VHCL)", "VDC", "SELF-DIAGNOSIS RESULTS", and "ERASE MEMORY" on CONSULT-II screen in this order to erase memory.

CAUTION:

If memory cannot be erased, go to step 6.

10. Drive vehicle at approximately 30 km/h (19 MPH) and check that ABS warning lamp, VDC OFF indicator lamp, and SLIP indicator lamp stay off.

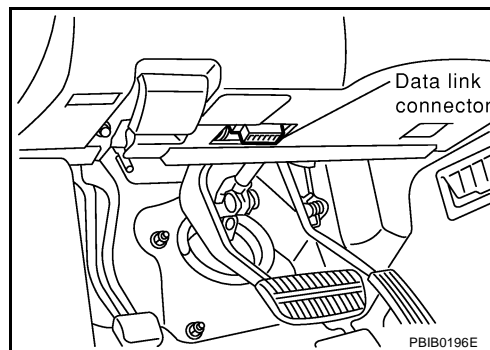

TROUBLE DIAGNOSIS

Display Item List

Malfunction system	Malfunction detecting condition	Check system
FR LH SENSOR- 1	Circuit of front LH wheel sensor is open	Wheel sensor and circuit [Inspection 1] Note 1 BRC-39
RR RH SENSOR- 1	Circuit of rear RH wheel sensor is open	
FR RH SENSOR- 1	Circuit of front RH wheel sensor is open	
RR LH SENSOR- 1	Circuit of rear LH wheel sensor is open	
FR LH SENSOR- 2	Circuit of front LH wheel sensor is shorted, or sensor power voltage is unusual. Control unit cannot identify sensor pulses, because of large gap between wheel sensor and sensor rotor.	
RR RH SENSOR- 2	Circuit of rear RH wheel sensor is shorted, or sensor power voltage is unusual. Control unit cannot identify sensor pulses, because of large gap between wheel sensor and sensor rotor.	
FR RH SENSOR- 2	Circuit of front RH wheel sensor is shorted, or sensor power voltage is unusual. Control unit cannot identify sensor pulses, because of large gap between wheel sensor and sensor rotor.	
RR LH SENSOR- 2	Circuit of rear LH wheel sensor is shorted, or sensor power voltage is unusual. Control unit cannot identify sensor pulses, because of large gap between wheel sensor and sensor rotor.	Actuator relay and circuit [Inspection 9] BRC-50
MAIN RELAY	During ABS actuator relay operation with OFF, when actuator relay turns ON or when control line for relay is shorted to ground. During ABS actuator relay operation with ON, when actuator relay turns OFF or when control line for relay is open.	
STOP LAMP SW	Stop lamp switch circuit is open.	Stop lamp switch and circuit [Inspection 10] BRC-52
PRESS SEN CIRCUIT	Pressure sensor signal line is open or shorted, or pressure sensor is malfunctioning.	Pressure sensor and circuit [Inspection 4] BRC-42
ST ANGLE SEN CIRCUIT	Neutral position of steering angle sensor is dislocated, or steering angle sensor is malfunctioning.	Steering angle sensor and circuit [Inspection 5] BRC-43
YAW RATE SENSOR	Yaw rate sensor has generated an error, or yaw rate sensor signal line is open or shorted.	Yaw rate/Side G-sensor and circuit [Inspection 6] BRC-45
FR LH IN ABS SOL	Circuit of front LH IN ABS solenoid is open or shorted, or control line is open or shorted to power supply or ground.	Solenoid and circuit [Inspection 7] BRC-46
FR LH OUT ABS SOL	Circuit of front LH OUT ABS solenoid is open or shorted, or control line is open or shorted to power supply or ground.	
RR RH IN ABS SOL	Circuit of rear RH IN ABS solenoid is open or shorted, or control line is open or shorted to power supply or ground.	
RR RH OUT ABS SOL	Circuit of rear RH OUT ABS solenoid is open or shorted, or control line is open or shorted to power supply or ground.	
FR RH IN ABS SOL	Circuit of front RH IN ABS solenoid is open or shorted, or control line is open or shorted to power supply or ground.	
FR RH OUT ABS SOL	Circuit of front RH OUT ABS solenoid is open or shorted, or control line is open or shorted to power supply or ground.	
RR LH IN ABS SOL	Circuit of rear LH IN ABS solenoid is open or shorted, or control line is open or shorted to power supply or ground.	
RR LH OUT ABS SOL	Circuit of rear LH OUT ABS solenoid is open or shorted, or control line is open or shorted to power supply or ground.	

TROUBLE DIAGNOSIS

Malfunction system	Malfunction detecting condition	Check system	
PRIMARY SIDE USV CIRCUIT	Circuit of primary-side VDC switch-over valve 1 is open or shorted, or control line is open or shorted to power supply or ground.	VDC switch-over valve and circuit [Inspection 7] BRC-46	A
SECONDARY SIDE USV CIRCUIT	Circuit of secondary-side VDC switch-over valve 1 is open or shorted, or control line is open or shorted to power supply or ground.		B
PRIMARY SIDE HSV CIRCUIT	Circuit of primary-side VDC switch-over valve 2 is open or shorted, or control line is open or shorted to power supply or ground.		C
SECONDARY SIDE HSV CIRCUIT	Circuit of secondary-side VDC switch-over valve 2 is open or shorted, or control line is open or shorted to power supply or ground.		D
PUMP MOTOR ACTUATOR RLY	During actuator motor operation with ON, when actuator motor turns OFF or when control line for actuator motor relay is open.	Actuator motor, motor relay, and circuit [Inspection 8] BRC-48	E
	During actuator motor operation with OFF, when actuator motor turns ON or when control line for relay is shorted to ground.		
LOW POWER VOLTAGE	VDC/TCS/ABS control unit power voltage is too low.	VDC/TCS/ABS control unit power supply and ground circuits [Inspection 11] BRC-53	BRC
ST ANGLE SEN SIGNAL	Neutral position correction of steering angle sensor is not finished.	Neutral position adjustment of steering angle sensor [Inspection 14] BRC-56	G
ST ANG SEN COM CIR	CAN communication line or steering angle sensor has generated an error.	Steering angle sensor and CAN communication line [Inspection 16] BRC-57	H
SIDE G-SEN CIRCUIT	Side G-sensor is malfunctioning, or signal line of side G-sensor is open or shorted.	Yaw rate/Side G-sensor and circuit [Inspection 6] BRC-45	I
EMERGENCY BRAKE	VDC/TCS/ABS control unit malfunction (pressure increase is too much or too little.)	VDC/TCS/ABS control unit [Inspection 13] BRC-55	J
CONTROLLER FAILURE	Internal malfunction of VDC/TCS/ABS control unit	VDC/TCS/ABS control unit [Inspection 3] BRC-41	K
SHIFT POSITION ERROR	P-position switch stuck to ON or TCM internal malfunction, VDC/TCS/ABS control unit internal malfunction.	TCM and circuit VDC/TCS/ABS control unit and circuit [Inspection 12] BRC-55	L
CAN COMM CIRCUIT	<ul style="list-style-type: none"> ● CAN communication line is open or shorted. ● VDC/TCS/ABS control unit internal malfunction ● Battery voltage for EMC is suddenly interrupted for approximately 0.5 seconds or more. 	Communication line between VDC/TCS/ABS control unit and other control units [Inspection 16] Note 2 BRC-57	M

TROUBLE DIAGNOSIS

Malfunction system	Malfunction detecting condition	Check system
BR FLUID LEVEL LOW	<ul style="list-style-type: none"> Brake fluid level drops or communication line between VDC/TCS/ABS control unit and brake fluid level sensor is open or shorted. 	<ul style="list-style-type: none"> Communication line between VDC/TCS/ABS control unit and brake fluid sensor, and brake warning lamp Reservoir tank fluid level [Inspection 15] BRC-56
ENGINE SIGNAL 2-6	<ul style="list-style-type: none"> Major engine component is malfunctioning. 	Engine system [Inspection 2] BRC-41

Note 1. If wheel sensor 2 for each wheel is indicated, check control unit power supply voltage in addition to wheel sensor circuit check.

Note 2. If multiple malfunctions are detected including CAN communication line [U1000], perform diagnosis for CAN communication line first.

DATA MONITOR

- For details of data monitor function, refer to “CONSULT-II Instruction Manual”.

Operation Procedure

- Turn ignition switch OFF.
- Connect CONSULT-II to and CONSULT-II CONVERTER data link connector.
- Turn ignition switch ON.
- Touch “START (NISSAN BASED VHCL)” on display.
- Touch “VDC” on display.

NOTE:

Just after starting engine, or turning ignition switch ON, “VDC” may not be displayed on system selection screen even if “START (NISSAN BASED VHCL)” is touched. In this case, start self-diagnosis again from step 2.

- Touch “DATA MONITOR”.
- Return to monitor item selection screen, and touch any of “CONTROL UNIT INPUT ITEM”, “MAIN ITEM” or “ITEM MENU SELECTION”. Refer to [BRC-30, "Display Item List"](#).
- Touch “START”.
- Screen of data monitor is displayed.

Display Item List

Item (Unit)	Monitor item selection			Remarks
	ECU input signals	Main item (Monitor item selection)	selection from menu	
GEAR POSITION	×	×	×	Gear position judged by PNP switch signal is displayed.
VHCL SPEED FR	×	×	×	Wheel speed calculated by front RH wheel sensor signal is displayed.
VHCL SPEED FL	×	×	×	Wheel speed calculated by front LH wheel sensor signal is displayed.
VHCL SPEED RR	×	×	×	Wheel speed calculated by rear RH wheel sensor signal is displayed.
VHCL SPEED RL	×	×	×	Wheel speed calculated by rear LH wheel sensor signal is displayed.
ABS CONT VOLT (V)	×	×	×	Voltage supplied to VDC/TCS/ABS control unit is displayed.
THRTL OPENING (%)	×	×	×	Throttle actuator opening/closing status judged by CAN communication signal is displayed.

TROUBLE DIAGNOSIS

Item (Unit)	Monitor item selection			Remarks
	ECU input signals	Main item (Monitor item selection)	selection from menu	
ENGINE RPM (rpm)	×	×	×	Engine speed judged by CAN communication signal is displayed.
STR ANGLE SIG (deg)	×	-	×	Steering angle detected by steering angle sensor is displayed.
YAW RATE SEN (d/s)	×	-	×	Yaw rate detected by yaw rate sensor is displayed.
SIDE G-SEN(m/s ²)	×	-	×	Transverse acceleration detected by side G-sensor is displayed.
PRESS SENSOR (bar)	×	-	×	Brake fluid pressure detected by pressure sensor is displayed.
STOP LAMP SW (ON/OFF)	×	×	×	Stop lamp switch (ON/OFF) status is displayed.
PARK BRAKE SW (ON/OFF)	×	-	×	Parking brake switch (ON/OFF) status is displayed.
OFF SW (ON/OFF)	×	-	×	VDC OFF switch (ON/OFF) status is displayed.
ABS WARN LAMP (ON/OFF)	-	×	×	ABS warning lamp (ON/OFF) status is displayed.
EV SIGNAL FL (ON/OFF)	-	×	×	Front LH IN ABS solenoid (ON/OFF) status is displayed.
AV SIGNAL FL (ON/OFF)	-	×	×	Front LH OUT ABS solenoid (ON/OFF) status is displayed.
EV SIGNAL RR (ON/OFF)	-	×	×	Rear RH IN ABS solenoid (ON/OFF) status is displayed.
AV SIGNAL RR (ON/OFF)	-	×	×	Rear RH OUT ABS solenoid (ON/OFF) status is displayed.
EV SIGNAL FR (ON/OFF)	-	×	×	Front RH IN ABS solenoid (ON/OFF) status is displayed.
AV SIGNAL FR (ON/OFF)	-	×	×	Front RH OUT ABS solenoid (ON/OFF) status is displayed.
EV SIGNAL RL (ON/OFF)	-	×	×	Rear LH IN ABS solenoid (ON/OFF) status is displayed.
AV SIGNAL RL (ON/OFF)	-	×	×	Rear LH OUT ABS solenoid (ON/OFF) status is displayed.
VDC OFF LAMP (ON/OFF)	-	×	×	OFF Lamp (ON/OFF) status is displayed.
USV SIGNAL P [FL-RR] (ON/OFF)	-	×	×	Primary-side USV solenoid valve (ON/OFF) status is displayed.
USV SIGNAL S [FR-RL] (ON/OFF)	-	×	×	Secondary-side USV solenoid valve (ON/OFF) status is displayed.
MAV SIGNAL P [FL-RR] (ON/OFF)	-	×	×	Primary-side HSV solenoid valve (ON/OFF) status is displayed.
MAV SIGNAL S [FR-RL] (ON/OFF)	-	×	×	Secondary-side HSV solenoid valve (ON/OFF) status is displayed.
M/R OUTPUT (ON/OFF)	-	×	×	Front motor relay activation signal (ON/OFF) status is displayed.

×: Applicable
 -: Not applicable

A
B
C
D
E
BRC
G
H
I
J
K
L
M

TROUBLE DIAGNOSIS

ACTIVE TEST

Operation Procedure

CAUTION:

- Do not perform active test while driving vehicle.
 - Make sure to completely bleed air from brake system.
 - Active test cannot be performed when ABS warning lamp is on.
1. Connect CONSULT-II and CONSULT-II CONVERTER data link connector and start engine.
 2. Touch "START" on display.
 3. Touch "VDC" and "ACTIVE TEST".

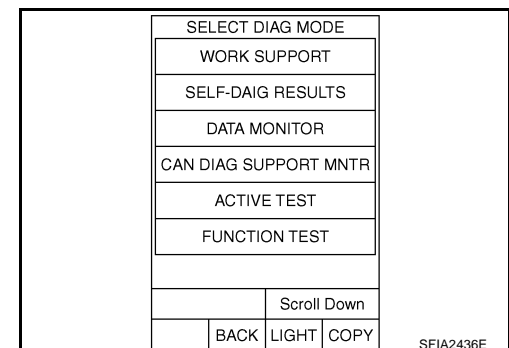
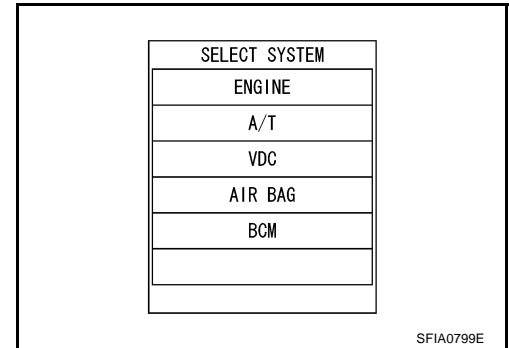

4. Test item selection screen is displayed.
5. Touch necessary test item.

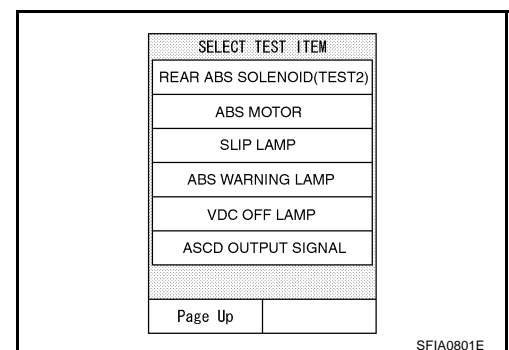

6. Touch "START" with "MAIN SIGNALS" line inverted.

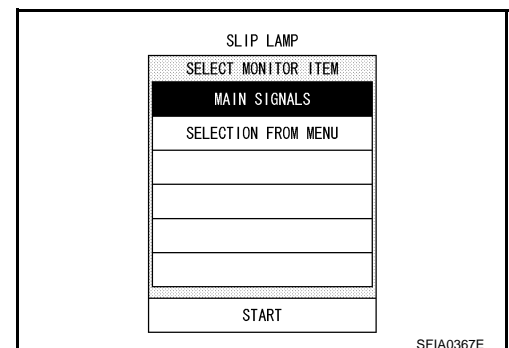

TROUBLE DIAGNOSIS

Solenoid Valve Operation Chart

Operation		ABS solenoid valve			ABS solenoid valve (ACT)		
		UP	KEEP	DOWN	UP	ACT UP	ACT KEEP
FR RH ABS SOLENOID	EV SIGNAL FR (IN)	OFF	ON	ON	OFF	OFF	OFF
	AV SIGNAL FR (OUT)	OFF	OFF	ON*	OFF	OFF	OFF
	USV SIGNAL S	OFF	OFF	OFF	OFF	ON	ON
	MAV SIGNAL S	OFF	OFF	OFF	OFF	ON*	OFF
FR LH ABS SOLENOID	EV SIGNAL FL (IN)	OFF	ON	ON	OFF	OFF	OFF
	AV SIGNAL FL (OUT)	OFF	OFF	ON*	OFF	OFF	OFF
	USV SIGNAL S	OFF	OFF	OFF	OFF	ON	ON
	MAV SIGNAL S	OFF	OFF	OFF	OFF	ON*	OFF
RR RH ABS SOLENOID	EV SIGNAL RR (IN)	OFF	ON	ON	OFF	OFF	OFF
	AV SIGNAL RR (OUT)	OFF	OFF	ON*	OFF	OFF	OFF
	USV SIGNAL P	OFF	OFF	OFF	OFF	ON	ON
	MAV SIGNAL P	OFF	OFF	OFF	OFF	ON*	OFF
RR LH ABS SOLENOID	EV SIGNAL RL (IN)	OFF	ON	ON	OFF	OFF	OFF
	AV SIGNAL RL (OUT)	OFF	OFF	ON*	OFF	OFF	OFF
	USV SIGNAL P	OFF	OFF	OFF	OFF	ON	ON
	MAV SIGNAL P	OFF	OFF	OFF	OFF	ON*	OFF

*: ON for 1 to 2 seconds after the touch, and then OFF

NOTE:

- If active test is performed with brake pedal depressed, pedal stroke may change. This is normal.
- "TEST STOP" is displayed approximately 6 seconds after operation starts.
- After "TEST STOP" is displayed, to perform test again, repeat step 6.

VDC OFF Indicator Lamp

Touch "ON" and "OFF" on the screen. Check that VDC OFF indicator lamp operates as shown in table below.

Operation	ON	OFF
VDC OFF indicator lamp	ON	OFF

NOTE:

If "OFF" is touched on screen during active test, VDC OFF indicator lamp, SLIP indicator lamp, and ABS warning lamp all turn ON for a moment. This is normal.

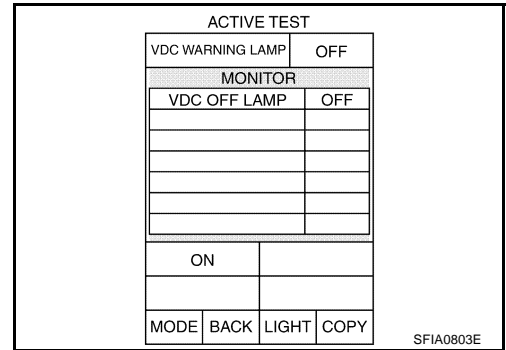

ABS Motor

Touch "ON" and "OFF" on the screen. Check that ABS motor relay operates as shown in table below.

Operation	ON	OFF
M/R OUTPUT	ON	OFF

NOTE:

- If active test is performed with brake pedal depressed, pedal stroke may change. This is normal.
- "TEST STOP" is displayed approximately 10 seconds after operation starts.

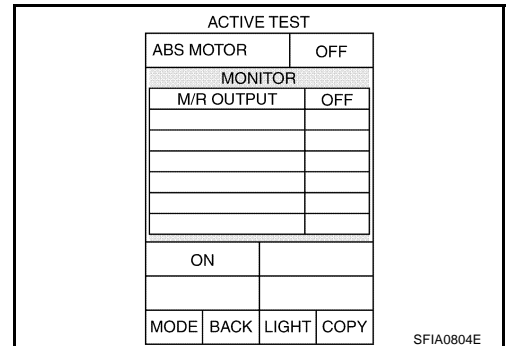

TROUBLE DIAGNOSIS

SLIP Indicator Lamp

Touch "ON" and "OFF" on the screen. Check that SLIP indicator lamp operates as shown in table below.

Operation	ON	OFF
SLIP indicator lamp	ON	OFF

NOTE:

If "OFF" is touched on screen during active test, VDC OFF indicator lamp, SLIP indicator lamp, and ABS warning lamp all turn ON for a moment. This is normal.

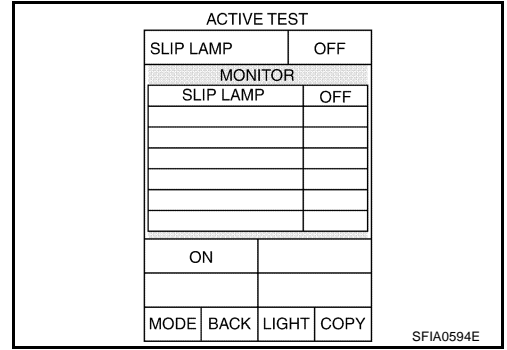

A
B
C
D

ABS Warning Lamp

Touch "ON" and "OFF" on the screen. Check that ABS warning lamp operates as shown in table below.

Operation	ON	OFF
ABS warning lamp	ON	OFF

NOTE:

If "OFF" is touched on screen during active test, VDC OFF indicator lamp, SLIP indicator lamp, and ABS warning lamp all turn ON for a moment. This is normal.

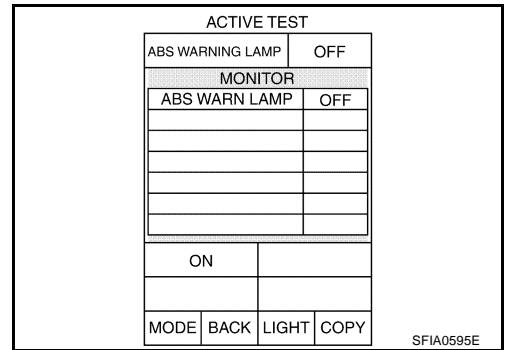

BRC

G
H
I
J
K
L
M

ASCD Output

Touch "ON" and "OFF" on the screen. Check that ASCD output is as shown in table below.

Operation	ON	OFF
ASCD output	ON	OFF

TROUBLE DIAGNOSIS

For Fast and Accurate Diagnosis

EFS001ZA

PRECAUTIONS FOR DIAGNOSIS

- Before performing diagnosis, always read General Information (GI) to confirm general precautions.
- If VDC/TCS/ABS control unit, steering angle sensor, steering system parts, suspension system parts, or tires have been replaced, or if alignment has been adjusted, be sure to adjust neutral position of steering angle sensor before driving.
- When replacing VDC/TCS/ABS control unit, be sure labels on control units are same color.
- After diagnosis is finished, be sure to erase memory. Refer to [BRC-27, "SELF-DIAGNOSIS"](#) .
- When checking continuity and voltage between units, be sure to check for disconnection, looseness, bend, or collapse of connector terminals. If any non-standard condition is found, repair or replace connector terminals.
- For intermittent symptoms, possible cause is malfunction in harness, harness connector, or terminals. Move harness, harness connector, and terminals to check for poor connections.
- If a circuit tester is used for the check, be careful not to forcibly extend any connector terminal.
- To use CONSULT-II to perform self-diagnosis of VDC/TCS/ABS control unit, active tests, or work support, first stop work, then connect CONSULT-II and CONSULT-II CONVERTER to data link connector and select "VDC".
- CONSULT-II self-diagnosis results are displayed without regard to occurrence timing. In some cases later ones (timing value is small) appear on the next screen.
- While self-diagnosis results of CONSULT-II shows an error, if CONSULT-II active test is performed, an engine system error may be indicated. In this case, start engine to resume normal screen.
- VDC/TCS/ABS system electronically controls brake operation and engine output. Following symptoms may be caused by normal operations:

Symptom	Symptom description	Result
Motor operation noise	This is noise of motor inside VDC actuator. Slight noise may occur during VDC, TCS, and ABS operation.	Normal
	Just after engine starts, motor operating noise may be heard. This is a normal status of the system operation check.	
System operation check noise	When the engine starts, slight "click" noise may be heard from engine compartment. This is normal and is part of system operation check.	Normal
TCS operation (SLIP lamp ON)	TCS may activate momentarily if wheel speed changes when driving over location where friction coefficient varies, when downshifting, or when fully depressing accelerator pedal.	Normal Cancel VDC/TCS function for the inspection on a chassis dynamometer.
	For inspection of speedometer or other instruments, press VDC OFF SW to turn VDC/TCS function off.	
	When accelerator pedal is depressed on a chassis dynamometer (fixed front-wheel type), vehicle speed will not increase. This is not normal. It is result of TCS being activated by stationary front wheels. Warning lamp may also illuminate to indicate "sensor system error". This is also normal, and is the result of the stationary front wheels being detected. To be certain, restart engine, and drive vehicle at 30 km/h or above. Check that warning lamp does not illuminate.	
ABS operation (Longer stopping distance)	On roads with low friction coefficients, such as snowy roads or gravel roads, vehicles with ABS may require a longer stopping distance. Therefore, when driving on such roads, avoid overconfidence and keep speed sufficiently low.	Normal
Insufficient feeling of acceleration	Depending on road conditions, driver may feel that feeling of acceleration is insufficient. This is because traction control, which controls engine and brakes to achieve optimal traction, has the highest priority (for safety). As a result, there may be times when acceleration is slightly less than usual for the same accelerator pedal operation.	Normal

TROUBLE DIAGNOSIS

ON and OFF Timing for ABS Warning Lamp, VDC OFF Indicator Lamp, and SLIP Indicator Lamp

x: ON -: OFF

Condition	ABS warning lamp	VDC OFF indicator lamp	SLIP indicator lamp	Remarks
Ignition SW OFF	-	-	-	—
For Approx. 1 seconds after ignition SW is turned ON	x	x	x	—
Approx. 1 seconds after ignition switch ON	-	-	-	Turns OFF 1 seconds after engine starts.
VDC OFF SW is turned ON. (VDC function is OFF.)	-	x	-	—
There is a VDC/TCS/ABS error.	x	x	x	—
	x	x	-	There is a VDC/TCS/ABS control unit error. (Power or ground malfunction)
When VDC/TCS is not functioning normally.	-	x	x	—

A

B

C

D

E

BRC

G

H

I

J

K

L

M

TROUBLE DIAGNOSIS

Basic Inspection

EFS001ZB

BASIC INSPECTION 1: BRAKE FLUID LEVEL AND LEAK INSPECTION

1. Check fluid level in brake reservoir tank. If fluid level is low, refill brake fluid.
2. Check for leakage in brake piping and around VDC actuator. If leakage or seepage is found, check as follows.
 - If VDC actuator connector is loose, tighten piping to specified torque. Then inspect again and confirm that there is no leakage.
 - If connection flare nuts or screws of VDC actuator are damaged, replace damaged parts. Then inspect again and confirm that there is no leakage.
 - If there is leakage or seepage at any location other than VDC actuator connections, wipe away leakage or seepage with clean cloth. Then inspect again and confirm that there is no leakage.
 - If there is leakage from VDC actuator, wipe away leakage or seepage with clean cloth. Then inspect again. If there is leakage or seepage, replace VDC actuator unit.

CAUTION:

ABS actuator body cannot be disassembled.

3. Check brake disc rotor and pads.

BASIC INSPECTION 2: INSPECTION FOR LOOSENESS OF POWER SYSTEM TERMINALS

Check battery for looseness on battery positive/negative terminals and ground connection. If looseness is detected, tighten piping to the specified torque. Check that battery voltage does not drop and alternator is normal.

BASIC INSPECTION 3: INSPECTION OF ABS WARNING LAMP, VDC OFF INDICATOR LAMP, AND SLIP INDICATOR LAMP

1. Check that ABS warning lamp illuminates for approximately 1 seconds when ignition switch is turned ON. If it does not illuminate, inspect ABS warning lamp and circuit, and inspect combination meter.
2. Check that VDC OFF indicator lamp illuminates for approximately 1 seconds when ignition switch is turned ON. If it does not illuminate, inspect VDC OFF indicator lamp and circuit, and inspect combination meter.
3. Check that SLIP indicator lamp illuminates for approximately 1 seconds when ignition switch is turned ON. If it does not turn on, check SLIP indicator lamp and circuit.
4. With engine running, turn VDC OFF switch ON and OFF. Check that VDC OFF indicator lamp turns ON and OFF. If indicator lamp does not turn ON and OFF according to switch operation, inspect VDC OFF switch and circuit.
5. With VDC OFF switch OFF (not operating), check that VDC OFF indicator lamp turns OFF 2 seconds after engine starts. If VDC OFF indicator lamp does not turn OFF after 10 seconds have passed since engine-start, perform self-diagnosis of VDC/TCS/ABS control unit.

TROUBLE DIAGNOSIS

Inspection 1 Wheel Sensor System

EFS001ZC

INSPECTION PROCEDURE

First use CONSULT-II self-diagnosis results to determine positions of malfunctioning wheel sensors. Then inspect parts and determine which parts to replace.

1. STARTING INSPECTION

Perform self-diagnosis.

OK or NG

- OK >> Inspection is completed.
- NG >> GO TO 2.

SELF-DIAG RESULTS	
DTC RESULTS	TIME
RR RH SENSOR-1 [C1101]	0

SFIA0625E

2. CHECKING CONNECTOR

Disconnect VDC/TCS/ABS control unit connector E218 and connector E70 (FR-LH), E20 (FR-RH), B35 (RR-RH, LH) of wheel sensor where malfunction was detected. Check for deformation of terminals and incomplete joining of connectors. Then reconnect connector. Also check that interference with other parts has not cut wheel sensor cables.

Drive vehicle at 30 km/h(19MPH) or above for at least 1.0minute. Did ABS warning lamp turn OFF?

- YES >> Inspection is completed.
- NO >> GO TO 3.

TROUBLE DIAGNOSIS

3. CHECKING WHEEL SENSOR CIRCUIT

1. Disconnect VDC/TCS/ABS control unit connector E218 and wheel sensor connector E70 (FR-LH), E20 (FR-RH), B35 (RR-RH, LH)

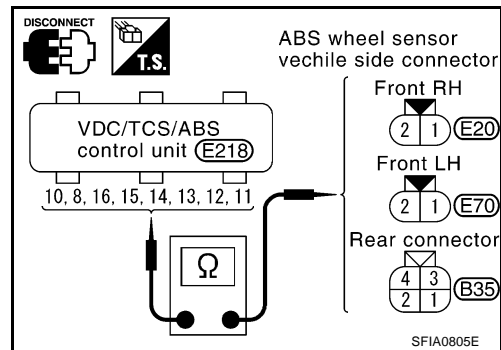

2. Check resistance between terminals. (Check resistance when steering wheel is turned right and left, and when sensor harness inside wheel house is moved.)

Wheel	Power system		Signal system	
	Control unit	Wheel sensor	Control unit	Wheel sensor
Front RH wheel	15 (W)	1 (W)	16 (B)	2 (B)
Front LH wheel	8 (B/W)	1 (B/W)	10 (L)	2 (L)
Rear RH wheel	11 (L/G)	1 (L/G)	12 (L/Y)	2 (L/R)
Rear LH wheel	13 (W/L)	3 (W)	14 (OR/L)	4 (OR)

Resistance value

Power system : 0 - 0.5 Ω

Signal system : 0 - 0.5 Ω

OK or NG

OK >> GO TO 4.

NG >> Repair harness and connectors between VDC/TCS/ABS control unit and wheel sensor.

4. TIRE INSPECTION

Check air pressure, wear, and size.

Are air pressure, wear, and size within standards?

YES >> GO TO 5.

NO >> Adjust air pressure or replace tire.

5. SENSOR ROTOR INSPECTION

Check for damage to sensor rotor teeth and surface of rubber.

OK or NG

OK >> GO TO 6.

NG >> Replace sensor rotor.

6. POWER SUPPLY CHECK FOR CONTROL UNIT SENSOR

1. Connect VDC/TCS/ABS control unit connector E218.
2. Check voltage between wheel sensor harness connector E70 terminal 1 (B/W), E20 terminal 1 (W), B35 terminal 1 (L/G), 3 (W) and body ground.

Voltage : Approx. 8V or more

OK or NG

OK >> Replace wheel sensor.

NG >> Replace VDC/TCS/ABS control unit.

TROUBLE DIAGNOSIS

Inspection 2 Engine System

EFS001ZD

Inspection Procedure

1. CHECKING SELF-DIAGNOSIS RESULTS (1)

Check self-diagnosis results.

Self-diagnosis results
CONSULT-II display items
Engine system 2
Engine system 3
Engine system 4
Engine system 5
Engine system 6

Do self-diagnosis results indicate anything other than the above?

YES >> Perform repair or replacement for the item indicated.

NO >> GO TO 2.

2. CHECKING SELF-DIAGNOSIS RESULTS (2)

1. Perform ECM self-diagnosis. Repair or replace items indicated, then perform ECM self-diagnosis again.

2. Perform VDC/TCS/ABS control unit self-diagnosis again.

OK or NG

OK >> Inspection is completed.

NG >> Repair or replace items indicated. Then perform self-diagnosis again.

Inspection 3 VDC/TCS/ABS Control Unit System

EFS001ZE

Inspection Procedure

1. CHECKING SELF-DIAGNOSIS RESULTS

Check self-diagnosis results.

Self-diagnosis results
CONSULT-II display items
ABS controller

Does anything other than "ABS CONTROLLER" appear on self-diagnosis display?

YES >> Repair or replace items indicated. Then perform self-diagnosis again.

NO >> Replace VDC/TCS/ABS control unit. Then perform VDC/TCS/ABS control unit self-diagnosis again.

TROUBLE DIAGNOSIS

Inspection 4 Pressure Sensor and Circuit Between Pressure Sensor and VDC/TCS/ABS Control Unit

EF5001ZF

Inspection Procedure

1. CHECKING SELF-DIAGNOSIS RESULTS (1)

Check self-diagnosis results.

Self-diagnosis results
CONSULT-II display items
Pressure sensor system

Does "PRESSURE SENSOR" appear on self-diagnosis display?

- YES >> GO TO 2.
 NO >> Inspection is completed.

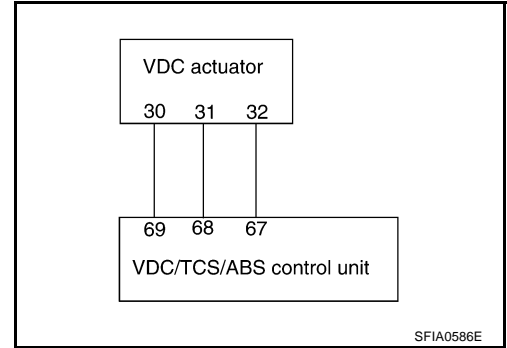

2. CHECKING SELF-DIAGNOSIS RESULTS (2)

1. Disconnect pressure sensor VDC actuator connector E21 and VDC/TCS/ABS control unit connectors E218. Then reconnect them securely.
2. Perform VDC/TCS/ABS control unit self-diagnosis again.

OK or NG

- OK >> Poor connection of connectors. Repair or replace suspect connector. Perform self-diagnosis again.
 NG >> GO TO 3.

3. CHECKING PRESSURE SENSOR CIRCUIT

1. Disconnect VDC actuator connector E21 pressure sensor and VDC/TCS/ABS control unit connector E218.
2. Check continuity between VDC/TCS/ABS control unit harness connector E218 and VDC actuator pressure sensor harness connector E21.

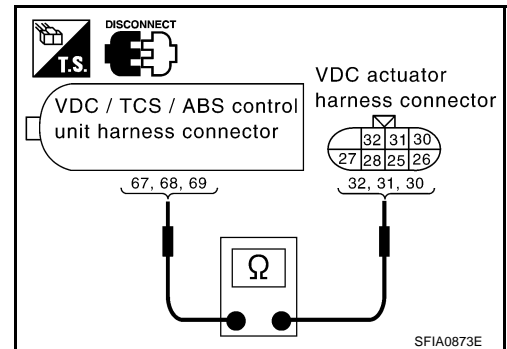

VDC/TCS/ABS control unit (Harness connector E218)	Pressure sensor (VDC actuator harness connector E21)	Continuity
69 (P/L)	30 (P/L)	Yes
68 (LG)	31 (LG)	Yes
67 (G/OR)	32 (G/OR)	Yes

OK or NG

- OK >> GO TO 4.
 NG >> Open or short in harness. Repair or replace the suspect harness.

TROUBLE DIAGNOSIS

4. CHECKING PRESSURE SENSOR

Check pressure sensor value on "DATA MONITOR".

Condition	Data monitor display
Brake pedal depressed	Positive value
When brake pedal is released.	Approx. 0 bar

OK or NG

- OK >> Perform VDC/TCS/ABS control unit self-diagnosis again.
- NG >> Pressure sensor malfunction. Replace VDC actuator (inside pressure sensor).

Inspection 5 Steering Angle Sensor and Circuit Between Steering Angle Sensor and VDC/TCS/ABS Control Unit

EFS001ZG

Inspection Procedure

1. CHECKING SELF-DIAGNOSIS RESULTS

Check self-diagnosis results.

Self-diagnosis results
CONSULT-II display items
Steering angle sensor system

Also perform Inspection 1 for the CAN communication system.

Does "STEERING ANGLE SENSOR" appear on self-diagnosis display?

- YES >> GO TO 2.
- NO >> Inspection is completed.

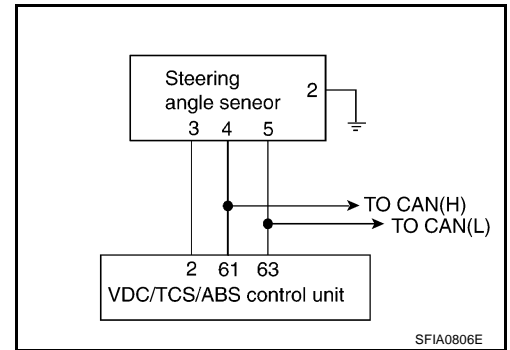

2. CHECKING STEERING ANGLE SENSOR CIRCUIT

- Disconnect VDC/TCS/ABS control unit connector E218 and steering angle sensor connector M52.
- Check continuity between VDC/TCS/ABS control unit harness connector E218 and steering angle sensor harness connector M52.

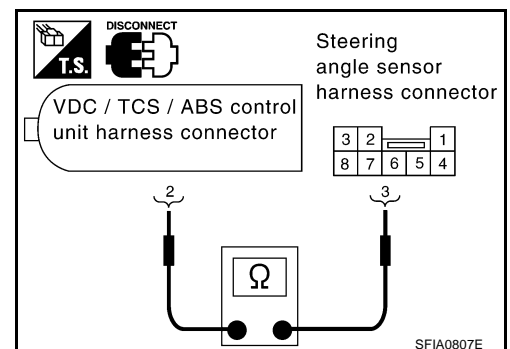

VDC/TCS/ABS control unit (Harness connector E218)	Steering angle sensor (Harness connector M52)	Continuity
2 (SB)	3 (SB)	Yes

OK or NG

- OK >> GO TO 3.
- NG >> Open or short in harness. Repair or replace suspect harness.

TROUBLE DIAGNOSIS

3. DATA MONITOR CHECK

Execute "DATA MONITOR" for "STEERING ANGLE SIGNAL". Check that results are normal.

Steering condition	Data monitor
Driving straight	-5 deg to +5 deg
Turned 90°to right	Approx. +90 deg
Turned 90°to left	Approx. -90 deg

OK or NG

- OK >> Perform VDC/TCS/ABS control unit self-diagnosis again.
- NG >> Replace spiral cable (steering angle sensor) and adjust neutral position of steering angle sensor. Refer to [BRC-6, "Adjustment of Steering Angle Sensor Neutral Position"](#).

TROUBLE DIAGNOSIS

Inspection 6 Yaw Rate/Side G-Sensor and Circuit Between Yaw Rate/Side G-Sensor and VDC/TCS/ABS Control Unit

EF5001ZH

Inspection Procedure

1. CHECKING SELF-DIAGNOSIS RESULTS (1)

Check self-diagnosis results.

Self-diagnosis results
CONSULT-II display items
Yaw rate sensor system
Side G-sensor system

CAUTION:

If vehicle is on turn-table at entrance to parking garage, or on other moving surface, VDC OFF indicator lamp may illuminate and CONSULT-II self-diagnosis may indicate yaw rate sensor system malfunction. However, in this case there is no malfunction in yaw rate sensor system. Take vehicle off of turn-table or other moving surface, and start engine. Results will return to normal.

Do "YAW RATE SENSOR SYSTEM" and "SIDE G-SENSOR SYSTEM" appear on self-diagnosis display?

YES >> GO TO 2.

NO >> Inspection is completed.

2. CHECKING SELF-DIAGNOSIS RESULTS (2)

1. Disconnect yaw rate/side G-sensor harness connector M99 and VDC/TCS/ABS control unit harness connector E218.
2. Check continuity between VDC/TCS/ABS control unit harness connector E218 and yaw rate/side G-sensor harness connector M99.

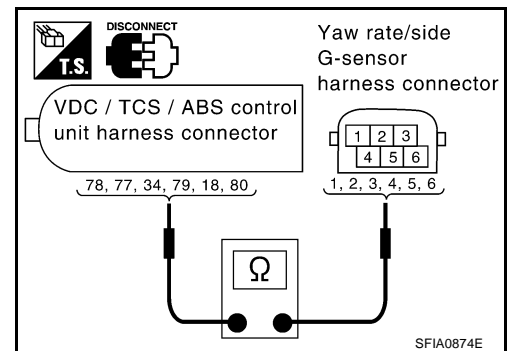
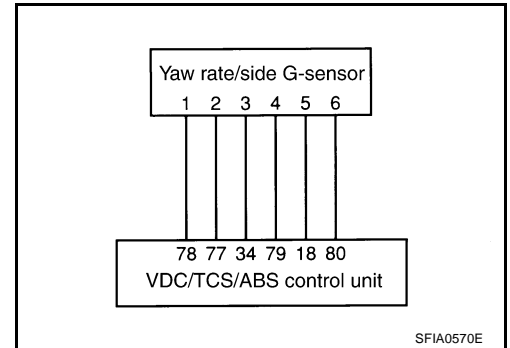

VDC/TCS/ABS control unit (Harness connector E218)	Yaw rate/ Side G-sensor (Harness connector M99)	Continuity
78 (L/W)	1 (L/W)	Yes
77 (Y/B)	2 (Y/B)	Yes
34 (OR)	3 (OR)	Yes
79 (R/L)	4 (R/L)	Yes
18 (PU/W)	5 (PU/W)	Yes
80 (W/R)	6 (W/R)	Yes

OK or NG

OK >> GO TO 3.

NG >> Open or short in harness. Repair or replace suspect harness.

TROUBLE DIAGNOSIS

3. CHECKING YAW RATE/SIDE G-SENSOR CIRCUIT

Check "DATA MONITOR" for yaw rate /side G-sensor. Check that results are normal.

Vehicle condition	Yaw rate sensor (Data monitor standard)	Side G-sensor (Data monitor standard)
Stopped	- 4 to +4 deg/s	- 1.1 to +1.1 m/s ²
Turning right	Negative value	Negative value
Turning left	Positive value	Positive value

OK or NG

OK >> Perform VDC/TCS/ABS control unit self-diagnosis again.

NG >> Malfunction of yaw rate/side G-sensor. Replace sensor and perform VDC/TCS/ABS control unit self-diagnosis again.

Inspection 7 Solenoid, VDC Switching Valve, and Circuits

EF50023W

Inspection Procedure

1. CHECKING SELF-DIAGNOSIS RESULTS (1)

Check self-diagnosis results.

Self-diagnosis results
CONSULT-II display items
Front LH inlet ABS solenoid system
Front LH outlet ABS solenoid system
Rear RH inlet ABS solenoid system
Rear RH outlet ABS solenoid system
Front RH inlet ABS solenoid system
Front RH outlet ABS solenoid system
Rear LH inlet ABS solenoid system
Rear LH outlet ABS solenoid system
Primary USV solenoid system
Secondary USV solenoid system
Primary MAV solenoid system
Secondary MAV solenoid system

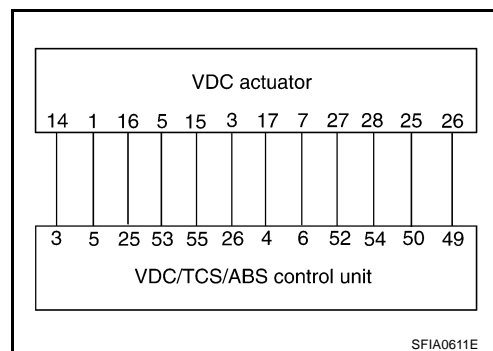

Do above items appear on self-diagnosis results display?

YES >> GO TO 2.

NO >> Inspection is completed.

2. CHECKING SELF-DIAGNOSIS RESULTS (2)

1. Disconnect VDC/TCS/ABS control unit connector E218 and VDC actuator connector E21, E22, E23. Then reconnect them securely.

2. Reconnect connectors securely and perform self-diagnosis again.

Do any self-diagnosis items appear?

YES >> GO TO 3.

NO >> Poor connection. Repair or replace applicable connector.

TROUBLE DIAGNOSIS

3. CHECKING SOLENOID CIRCUIT

1. Disconnect VDC actuator connector E21, E22 and VDC/TCS/ABS control unit connector E218.
2. Check continuity between VDC/TCS/ABS control unit harness connector E218 and VDC actuator harness connector E21, E22.

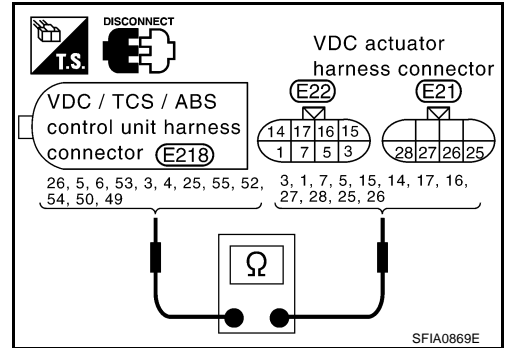

VDC/TCS/ABS control unit (Harness connector E218)	VDC actuator (Harness connector E21, E22)	Continuity
26 (W/G)	3 (W/G)	Yes
5 (G/Y)	1 (G/Y)	Yes
6 (L/W)	7 (L/W)	Yes
53 (P)	5 (P)	Yes
55 (R/Y)	15 (R/Y)	Yes
3 (Y/G)	14 (Y/G)	Yes
4 (BR)	17 (BR)	Yes
25 (LG)	16 (LG)	Yes
52 (PU)	27 (PU)	Yes
54 (W)	28 (W)	Yes
50 (R/G)	25 (R/G)	Yes
49 (W/R)	26 (W/R)	Yes

OK or NG

OK >> GO TO 4.

NG >> Open or short in harness between VDC/TCS/ABS control unit and VDC actuator

TROUBLE DIAGNOSIS

4. CHECKING ACTUATOR SOLENOID

1. Disconnect VDC actuator connector.
2. Check resistance of VDC actuator solenoid.

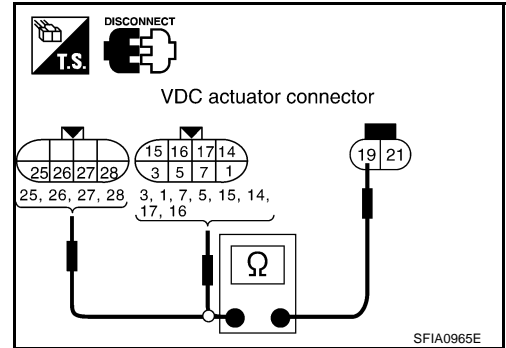

VDC actuator (Actuator side connector)	VDC actuator (Actuator side connector)	Resistance value
7	19	6.0 - 11 Ω
3	19	6.0 - 11 Ω
5	19	6.0 - 11 Ω
1	19	6.0 - 11 Ω
17	19	3.0 - 5.0 Ω
15	19	3.0 - 5.0 Ω
16	19	3.0 - 5.0 Ω
14	19	3.0 - 5.0 Ω
27	19	3.0 - 5.0 Ω
28	19	3.0 - 5.0 Ω
25	19	6.0 - 11 Ω
26	19	6.0 - 11 Ω

OK or NG

- OK >> Perform VDC/TCS/ABS control unit self-diagnosis again.
 NO >> Replace VDC actuator assembly.

Inspection 8 Actuator Motor, Motor Relay, and Circuit

EFS001ZJ

Inspection Procedure

1. CHECKING SELF-DIAGNOSIS RESULTS (1)

Check self-diagnosis results.

Self-diagnosis results
CONSULT-II display items
Pump motor, motor relay system

Do "PUMP MOTOR" and "MOTOR RELAY SYSTEM" appear in self-diagnosis results display?

- YES >> GO TO 2.
 NO >> Inspection is completed.

TROUBLE DIAGNOSIS

2. CHECKING SELF-DIAGNOSIS RESULTS (2)

1. Disconnect VDC/TCS/ABS control unit connector E218 and VDC relay box connector E55, E56, E57. Then reconnect them securely.
2. Reconnect connectors securely and perform self-diagnosis again.

Do any self-diagnosis items appear?

YES >> GO TO 3.

NO >> Poor connection. Repair or replace applicable connector.

3. CHECKING ABS MOTOR AND MOTOR RELAY POWER SYSTEM

1. Disconnect VDC relay box connector E57.
2. Check voltage between VDC relay box harness connector E57 and body ground.

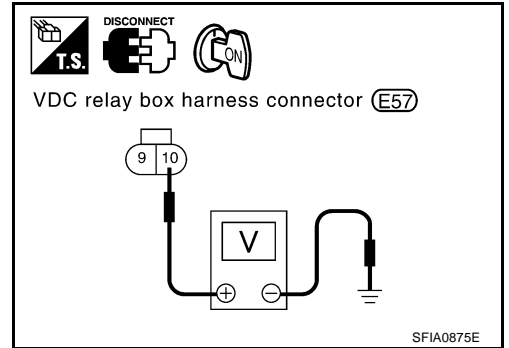

VDC relay box (Harness connector E57)	Body ground	Voltage
10 (W/L)	—	Battery voltage (Approx. 12V)

OK or NG

OK >> GO TO 4.

NG >> ● Check fuse 50A.

- Check that there is continuity between battery and relay unit terminal No. 10 (W/L).

4. CHECKING ABS MOTOR AND MOTOR RELAY CIRCUIT

1. Disconnect VDC/TCS/ABS control unit E218 and VDC relay box connector E56.
2. Check continuity between VDC/TCS/ABS control unit harness connector E218 and VDC relay box harness connector E56.

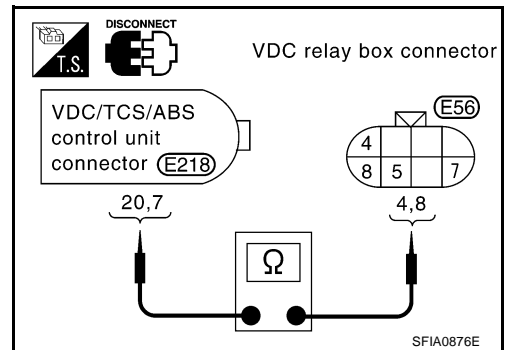

VDC/TCS/ABS control unit (Harness connector E218)	VDC relay box (Harness connector E56)	Continuity
20 (R/B)	4 (R/B)	Yes
7 (G/W)	8 (G/W)	Yes

OK or NG

OK >> GO TO 5.

NG >> Open or short in harness between VDC/TCS/ABS control unit and relay unit/actuator

TROUBLE DIAGNOSIS

5. CHECKING MOTOR RELAY UNIT

Check motor relay as a unit. Refer to [BRC-58, "VDC RELAY BOX"](#) .

OK or NG

- OK >> Check VDC/TCS/ABS control unit power circuit.
- NG >> Replace motor relay.

Inspection 9 Actuator Relay and Circuit

EFS001ZK

Inspection Procedure

1. CHECKING SELF-DIAGNOSIS RESULTS (1)

Check self-diagnosis results.

Self-diagnosis results
CONSULT-II display items
Actuator relay circuit

Does "ACTUATOR RELAY CIRCUIT" appear on self-diagnosis results display?

- YES >> GO TO 2.
- NO >> Inspection is completed.

2. CHECKING SELF-DIAGNOSIS RESULTS (2)

1. Disconnect VDC/TCS/ABS control unit connector E218 and VDC relay box connector E55, E56, E57. Then reconnect it securely.
2. Perform VDC/TCS/ABS control unit self-diagnosis again.

Do any self-diagnosis items appear?

- YES >> GO TO 3.
- NO >> Poor connection. Repair or replace applicable connector.

3. CHECKING VDC/TCS/ABS CONTROL UNIT GROUND CIRCUIT

Check continuity between VDC/TCS/ABS control unit harness connector E218 and body ground.

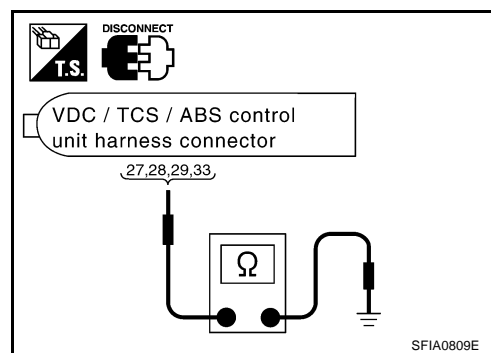

VDC/TCS/ABS control unit (Harness connector E218)	Body ground	Continuity
27 (B)	—	Yes
28 (B)	—	Yes
29 (B)	—	Yes
33 (B)	—	Yes

OK or NG

- OK >> GO TO 4.
- NG >> Poor connection of VDC/TCS/ABS control unit, or harness malfunction.

TROUBLE DIAGNOSIS

4. CHECKING ACTUATOR RELAY POWER SYSTEM

1. Disconnect VDC relay box connector E57.
2. Check voltage between VDC relay box harness connector E57 and body ground.

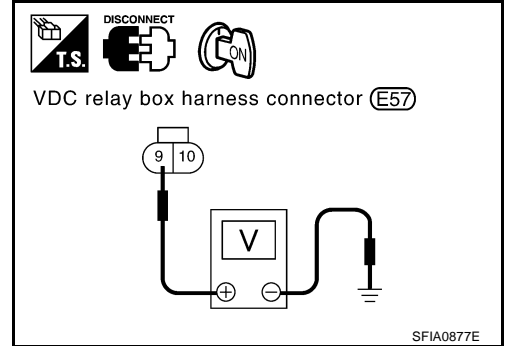

VDC relay box (Harness connector E57)	Body ground	Voltage
9 (L/Y)	—	Battery voltage (Approx. 12V)

OK or NG

OK >> GO TO 5.

NG >> ● Check fuse 30A.

- Check continuity between battery and relay unit terminal No. 9. If it is not OK, replace fuse or harness.

5. CHECKING ACTUATOR RELAY POWER CIRCUIT

1. Disconnect VDC/TCS/ABS control unit connector E218 and VDC relay box connector E56.
2. Check continuity between VDC/TCS/ABS control unit harness connector E218 and VDC relay box harness connector E56.

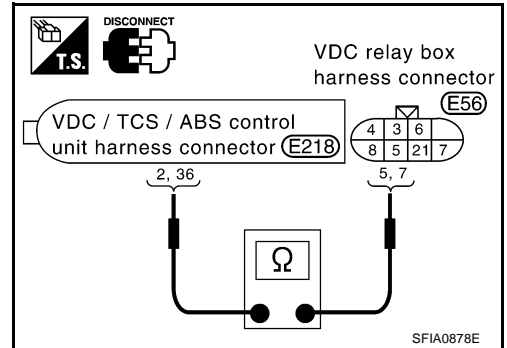

VDC/TCS/ABS control unit (Harness connector E218)	VDC relay box (Harness connector E56)	Continuity
2 (SB)	5 (SB)	Yes
36 (GY/R)	7 (GY/R)	Yes

OK or NG

OK >> GO TO 6.

NG >> Open or short in harness between VDC/TCS/ABS control unit and VDC relay box.

6. CHECKING ACTUATOR RELAY UNIT

Check actuator relay as a unit. Refer to [BRC-58, "VDC RELAY BOX"](#).

OK or NG

OK >> Check VDC/TCS/ABS control unit power circuit.

NG >> Replace actuator relay.

TROUBLE DIAGNOSIS

EFS001ZL

Inspection 10 Stop Lamp Switch and Circuit

Inspection Procedure

1. CHECKING SELF-DIAGNOSIS RESULTS

Check self-diagnosis results.

Self-diagnosis results
CONSULT-II display items
Stop lamp switch system

Does "STOP LAMP SW SYSTEM" appear in self-diagnosis results display?

- YES >> GO TO 2.
- NO >> Inspection is completed.

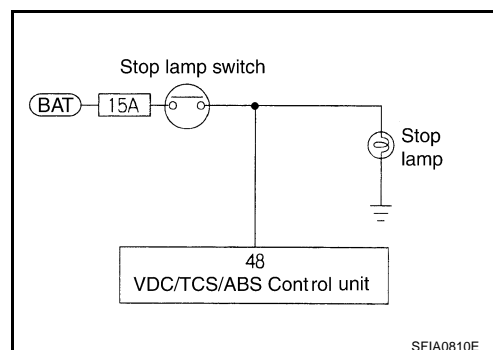

2. CHECKING STOP LAMP

1. Disconnect stop lamp switch connector M402 and VDC/TCS/ABS control unit connector E218.
2. Reconnect connectors securely.
3. Start engine.
4. Repeat pumping brake pedal carefully several times, then perform self-diagnosis again.

Do any self-diagnosis items appear?

- YES >> GO TO 3.
- NO >> Poor connection. Repair or replace applicable connector.

3. CHECKING STOP LAMP SWITCH CIRCUIT

1. Disconnect stop lamp switch connector M402 and VDC/TCS/ABS control unit connector E218.
2. Check continuity between stop lamp switch harness connector M402 and VDC/TCS/ABS control unit harness connector E218.

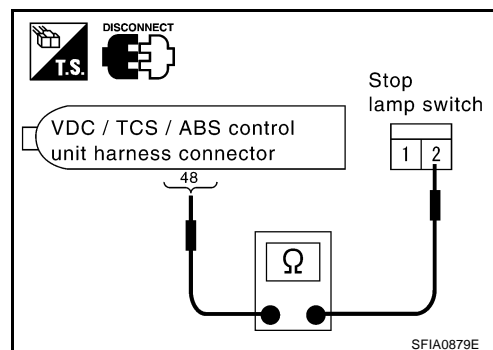

VDC/TCS/ABS control unit (Harness connector E218)	Stop lamp switch (Harness connector M402)	Continuity
48 (R/W)	2 (R/W)	Yes

OK or NG

- OK >> Perform VDC/TCS/ABS control unit self-diagnosis again.
- NG >> Open or short in harness between VDC/TCS/ABS control unit and stop lamp switch

TROUBLE DIAGNOSIS

Inspection 11 VDC/TCS/ABS Control Unit Power Circuit

EFS001ZM

Inspection Procedure

1. CHECKING SELF-DIAGNOSIS RESULT

Check self-diagnosis results.

Self-diagnosis results
CONSULT-II display items
Low battery voltage

Does "LOW BATTERY VOLTAGE" appear in self-diagnosis results display?

- YES >> GO TO 2.
- NO >> Inspection is completed.

2. STARTING INSPECTION

1. Disconnect VDC/TCS/ABS control unit connector E218. Then reconnect it securely.
2. Perform self-diagnosis.

Do any self-diagnosis items appear?

- YES >> GO TO 3.
- NO >> Poor connection. Repair or replace applicable connector.

3. CHECKING VDC/TCS/ABS CONTROL UNIT POWER SYSTEM (1)

1. Disconnect VDC/TCS/ABS control unit connector E218.
2. Turn ignition switch ON (but do not start engine).
3. Check voltage between VDC/TCS/ABS control unit harness connector E218 and body ground.

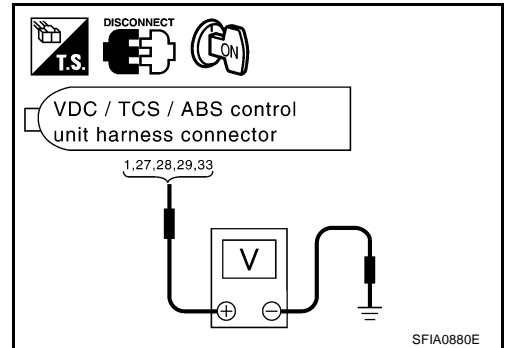

VDC/TCS/ABS control unit (Harness connector E218)	Body ground	Voltage
1 (GY)	—	Battery voltage (Approx. 12V)

OK or NG

- OK >> GO TO 4.
- NG >> GO TO 5.

TROUBLE DIAGNOSIS

4. CHECKING VDC/TCS/ABS CONTROL UNIT GROUND CIRCUIT

Check continuity between VDC/TCS/ABS control unit harness connector E218 and body ground .

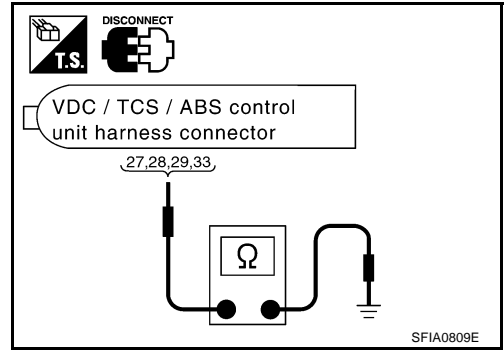

VDC/TCS/ABS control unit (Harness connector E218)	Body ground	Continuity
27 (B)	—	Yes
28 (B)	—	Yes
29 (B)	—	Yes
33 (B)	—	Yes

OK or NG

- OK >> Perform VDC/TCS/ABS control unit self-diagnosis again.
- NG >> Poor installation of VDC/TCS/ABS control unit, or harness malfunction

5. CHECKING VDC/TCS/ABS CONTROL UNIT POWER SYSTEM (2)

1. Check fuse 10A.
2. Disconnect VDC/TCS/ABS control unit connector E218 and positive battery terminal.
3. Check continuity between battery positive terminal and VDC/TCS/ABS control unit harness connector E218.

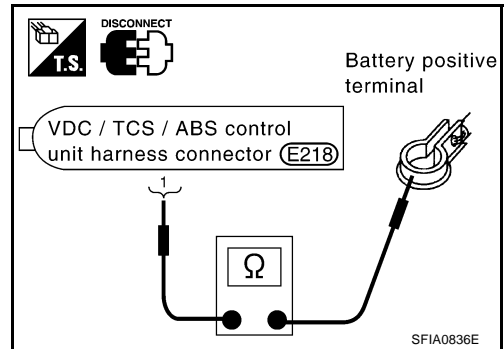

VDC/TCS/ABS control unit (Harness connector E218)	Positive battery terminal	Continuity
1 (GY)	—	Yes

OK or NG

- OK >> Check for non-standard conditions in battery (terminal looseness, low voltage, etc.) And alternator.
- NG >>
 - Replace fuse 10A.
 - Open or short in harness.

TROUBLE DIAGNOSIS

Inspection 12 When “SHIFT POSITION ERROR” Appears in Self-Diagnosis Results Display

EFS001ZN

Inspection Procedure

1. CHECKING SELF-DIAGNOSIS RESULTS

Check self-diagnosis results.

Self-diagnosis results
CONSULT-II display items
Shift position error

Does “SHIFT POSITION ERROR” appear in self-diagnosis results display?

YES >> GO TO 2.

NO >> Inspection is completed.

2. DATA MONITOR CHECK

1. Connect CONSULT-II. Start engine.
2. In “DATA MONITOR” select “ITEM MENU” and then check P position.

Selector lever position	Position (data monitor)
P position	ON
Other than P position.	OFF

OK or NG

OK >> Perform VDC/TCS/ABS control unit self-diagnosis again.

NG >> GO TO 3.

3. CHECKING A/T INHIBITOR SWITCH

Perform A/T inhibitor switch inspection. Refer to [AT-106, "DTC P0705 PARK/NEUTRAL POSITION SWITCH"](#)

Do any self-diagnosis items appear?

YES >> Repair indicated items and perform VDC/TCS/ABS control unit self-diagnosis again.

NO >> Perform VDC/TCS/ABS control unit self-diagnosis again.

Inspection 13 When “EMERGENCY BRAKE” Appears on Self-Diagnosis Results Display

EFS001ZO

Inspection Procedure

1. CHECKING SELF-DIAGNOSIS RESULTS

Check self-diagnosis results.

Self-diagnosis results
CONSULT-II display items
Emergency brake

If anything other than “EMERGENCY BRAKE” appears in self-diagnosis results display, follow the instructions in the note below.

NOTE:

“EMERGENCY BRAKE” is displayed when a malfunction is detected in the control unit itself. If this display item appears, replace control unit.

Does “EMERGENCY BRAKE” appear on self-diagnosis results display?

>> Replace VDC/TCS/ABS control unit, and perform self-diagnosis again.

TROUBLE DIAGNOSIS

Inspection 14 When “STEERING ANGLE SENSOR HAS NOT BEEN CORRECTED” Appears on Self-Diagnosis Results Display

EFS001ZP

Inspection Procedure

1. CHECKING SELF-DIAGNOSIS RESULTS (1)

Check self-diagnosis results.

Self-diagnosis results
CONSULT-II display items
Steering angle sensor has not been corrected.

Does anything besides “STEERING ANGLE SENSOR HAS NOT BEEN CORRECTED” appear on self-diagnosis results display?

- YES >> Inspect and repair indicated items. Then perform self-diagnosis again.
NO >> Perform adjustment of steering angle sensor neutral position. Then GO TO 2.

2. CHECKING SELF-DIAGNOSIS RESULTS (2)

1. Turn ignition switch OFF, and ON to erase self-diagnosis results, and perform VDC/TCS/ABS control unit self-diagnosis again.

Does anything appear on self-diagnosis results display?

- YES >> Replace steering angle sensor. Then perform adjustment of neutral position and perform self-diagnosis again.
NO >> Inspection is completed.

Inspection 15 Brake Fluid Level in Reservoir Tank, Communication Circuit Between VDC/TCS/ABS Control Unit and Brake Fluid Level Sensor

SFIA0230E

Inspection Procedure

1. CHECKING SELF-DIAGNOSIS RESULTS (1)

Check self-diagnosis results.

Self-diagnosis results
CONSULT-II display items
Brake fluid level switch

Does brake warning lamp turn on?

- YES >> Check pad for wear. Check brake fluid for leakage.
NO >> GO TO 2.

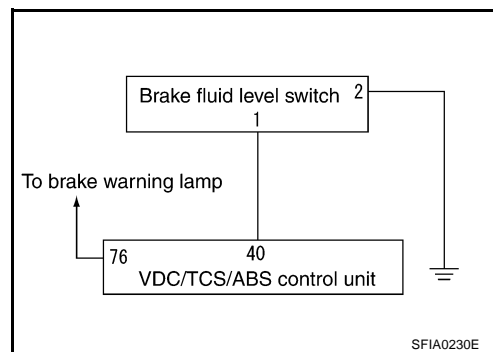

2. CHECKING SELF-DIAGNOSIS RESULTS (2)

1. Disconnect brake fluid level switch connector E74 and VDC/TCS/ABS control unit connector E218.
2. Reconnect connectors securely, then perform VDC/TCS/ABS control unit self-diagnosis again.

Does anything appear on self-diagnosis results display?

- YES >> Poor connector connections. Repair or replace connectors.
NO >> GO TO 3.

TROUBLE DIAGNOSIS

3. CHECKING CIRCUIT BETWEEN BRAKE FLUID LEVEL SENSOR AND VDC/TCS/ABS CONTROL UNIT

1. Disconnect brake fluid level switch connector E74 and VDC/TCS/ABS control unit connector E218.
2. Check continuity between brake fluid level sensor harness connector E74 and VDC/TCS/ABS control unit harness connector E218.

VDC/TCS/ABS control unit (Harness connector E218)	Brake fluid level switch (Harness connector E74)	Continuity
40 (Y)	1 (Y)	Yes

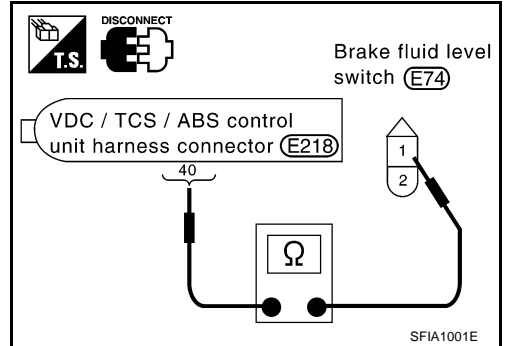

3. Check continuity between VDC/TCS/ABS control unit harness connector E218 and body ground.

VDC/TCS/ABS control unit (Harness connector E218)	Body ground	Continuity
40 (Y)	—	No

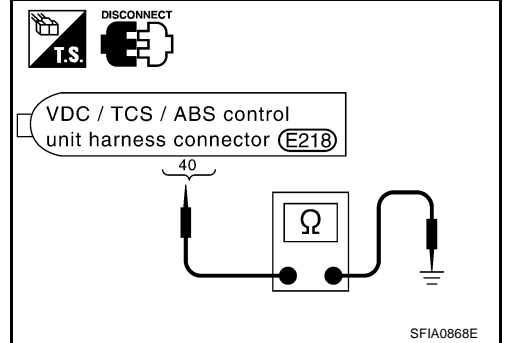

OK or NG

- OK >> Perform VDC/TCS/ABS control unit self-diagnosis again.
- NG >> Open or short in harness. Repair or replace suspect harness.

Inspection 16 CAN Communications Lines, VDC/TCS/ABS Control Unit and Steering Angle Sensor System

EF5001ZR

Inspection Procedure

1. CHECKING SELF-DIAGNOSIS RESULTS (1)

Check self-diagnosis results.

Self-diagnosis results
CONSULT-II display items
CAN communication system
Steering angle sensor communication line

Do self-diagnosis results indicate anything other than the above?

- YES >> Repair or replace the indication item.
- NO >> GO TO 2.

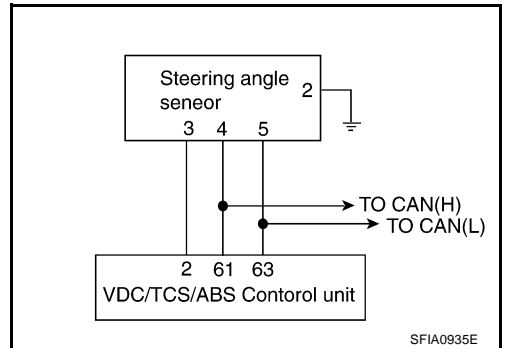

2. CHECKING CONNECTORS AND HARNESS BETWEEN VDC/TCS/ABS CONTROL UNIT AND STEERING ANGLE SENSOR

1. Disconnect battery negative terminal.
2. Turn ignition switch OFF.
3. Disconnect VDC/TCS/ABS control unit connector E218 and steering angle sensor connector M52.
4. Check for open circuit and short circuits in harness between VDC/TCS/ABS control unit harness connector E218 and steering angle sensor harness connector M52.

OK or NG

- OK >> GO TO 3.
- NG >> Harness connector malfunction. Repair or replace.

TROUBLE DIAGNOSIS

3. CHECKING SELF-DIAGNOSIS RESULTS (2)

1. Connect VDC/TCS/ABS control unit and steering angle sensor connector.
2. Connect battery negative terminal. Turn ignition switch ON.
3. Erase self-diagnosis results. Then start engine and perform self-diagnosis.

Does only "STEERING ANGLE SENSOR COMMUNICATION SYSTEM" appear on self-diagnosis results display?

- YES >> Check spiral cable (Replace steering angle sensor and adjust steering angle sensor neutral position. Refer to [BRC-6, "Adjustment of Steering Angle Sensor Neutral Position"](#) .)
- NO >> GO TO 4.

4. CHECK CONNECTOR

1. Turn ignition switch OFF and disconnect VDC/TCS/ABS control unit connector and steering angle sensor connector. Check terminal for deformation, disconnection, looseness, and so on. If any malfunction is found, repair or replace terminal.
2. Securely reconnect connectors and perform self-diagnosis.

Self-diagnostic results

CAN COMM CIRCUIT

ST ANG SEN COM CIR

Is above displayed in the self-diagnosis item?

- YES >> Print out self-diagnostic results and go to [LAN-21, "CAN COMMUNICATION"](#) .
- NO >> Connector terminal connection is loose, damaged, open or shorted.

Inspecting Components

VDC OFF SWITCH

- Disconnect VDC OFF switch connector. Check continuity between terminal No. 1 and terminal No. 2.

No. 1 to No. 2:

Pressing switch will establish continuity, releasing it will break continuity.

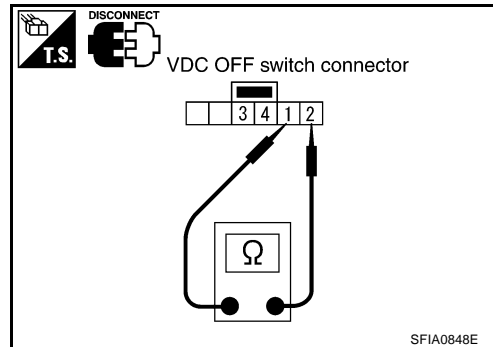

VDC RELAY BOX

Disconnect VDC relay box connector. Check continuity, resistance value, and insulation between any pair of terminals in VDC relay box.

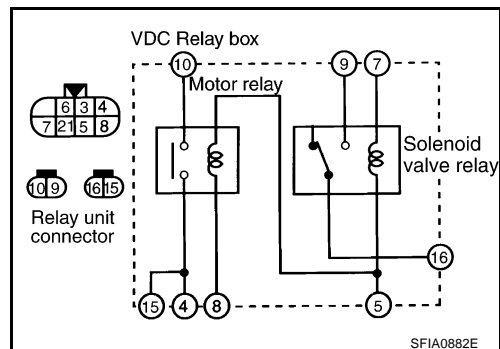

TROUBLE DIAGNOSIS

Continuity, Resistance

Item	VDC relay box								Condition			
	16	2	4	1	9	4	15	10		5	7	8
Solenoid valve relay	○ — X — ○					○ — ○			Open (0V)			Between terminal No. 5 and No. 7 Open (0V)
	○ — ○					○ — ○			12V			
Motor relay						○ — ○						—
						○ — X — ○			Open (0V)			Between terminal No. 5 and No. 8 Open (0V)
						○ — ○			12V			Between terminal No. 5 and No. 8 Add 12V
Relay coil						○ — W — ○			Approx. 100 Ω			—
						○ — W — ○			Approx. 80 Ω			—

○ — ○ : Conductivity ○ — ○ : Open between terminals (0V) ○ — W — ○ : Resistance between terminals is 100 Ω
 ○ — X — ○ : Not conductivity ○ — 12V — ○ : Add 12V between terminals

SFIA0582E

VDC/TCS/ABS ACTUATOR

Disconnect actuator connectors. Check continuity and resistance value between any pair of terminals on the actuator.

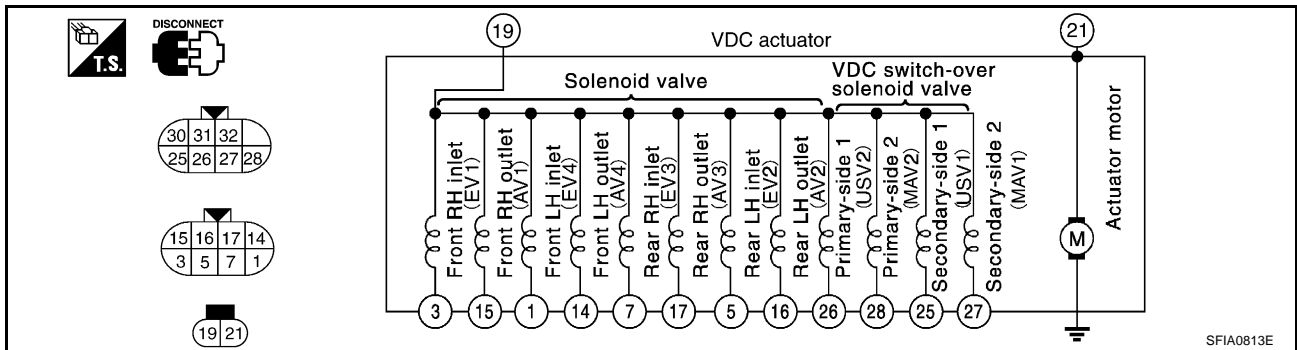









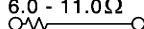
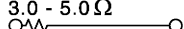
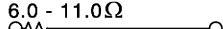

SFIA0813E

CAUTION:
Make sure actuator motor is correctly grounded.

TROUBLE DIAGNOSIS

Continuity, resistance

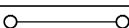
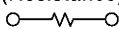
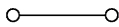
Item	VDC actuator connector terminal number	Condition
	19 3 15 1 14 7 17 5 16 26 25 28 27 21 Body ground	
Solenoid valve	6.0 - 11.0Ω  3.0 - 5.0Ω  6.0 - 11.0Ω  3.0 - 5.0Ω  6.0 - 11.0Ω  3.0 - 5.0Ω  6.0 - 11.0Ω  3.0 - 5.0Ω 	Check the resistance
VDC switch-over solenoid valve	6.0 - 11.0Ω  6.0 - 11.0Ω  3.0 - 5.0Ω  3.0 - 5.0Ω 	
Actuator motor		—
(Resistance)  : Continuity: Yes  : Continuity: Yes		

SFIA0814E

TROUBLE DIAGNOSIS

Actuator Operation Inspection

1. Connect E56 and E57 terminals of actuator to 15 and 16 terminals of VDC relay box.
2. Measure motor voltage (No. 4 (R/B) terminal to body ground) with oscilloscope. Then check motor reverse voltage occasioned time. Motor reverse voltage occasioned time is more than 0.1 sec.

CAUTION:

- The above check should be performed after motor relay unit inspection to make sure relay operates normally.
- Limit actuator drive motor operation to 4 seconds or less to prevent heating.
- Motor counter electromotive force duration is based on the time at an ambient temperature of 20°C with 12V battery voltage. If battery voltage or the ambient temperature is lower, time will be slightly shorter.

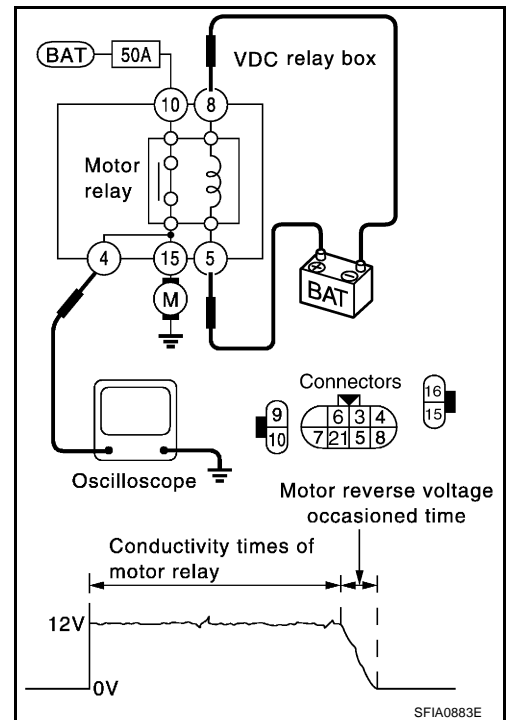

Symptom 1 ABS Works Frequently.

Inspection Procedure

1. STARTING INSPECTION

Inspect wheel sensor system.

- Sensor mounting inspection
- Sensor pick-up inspection for iron chips
- Sensor rotor inspection (e.g. Number of teeth, damaged teeth)
- Sensor connector engagement inspection

OK or NG

- OK >> GO TO 2.
- NG >> Repair wheel sensor and rotor system.

2. CHECKING FOR LOOSENESS

Check for looseness of front and rear axle. Refer to front axle [FAX-4, "WHEEL BEARING INSPECTION"](#), rear axle [RAX-5, "WHEEL BEARING INSPECTION"](#).

OK or NG

- OK >> GO TO [BRC-61, "Symptom 2 Unexpected Pedal Reaction"](#).
- NG >> Axle inspection and repair

Symptom 2 Unexpected Pedal Reaction

Inspection Procedure

1. BRAKE PEDAL STROKE INSPECTION

Check brake pedal stroke.

Is stroke excessively long?

- YES >> Check bleeding and brake system.
- NO >> GO TO 2.

TROUBLE DIAGNOSIS

2. CHECKING PEDAL FORCE

Check that brake is effective with pedal depressed.

Is pedal heavy, but effective?

- YES >> Normal
- NO >> GO TO 3.

3. CONNECTOR AND PERFORMANCE INSPECTION

Disconnect actuator relay unit connector to deactivate ABS function. Check that brake is effective.

Is brake effective?

- YES >> GO TO 4.
- NO >> Brake line inspection

4. CHECKING ABS WARNING LAMP INDICATION

Check that ABS warning lamp illuminates.

OK or NG

- OK >> Execute self-diagnosis.
- NG >> GO TO 5.

5. CHECKING WHEEL SENSORS

Inspect wheel sensor system.

- Sensor mounting inspection
- Check sensor pick-up for adhering iron chips.
- Sensor rotor inspection (e.g. Number of teeth, damaged teeth)
- Sensor connector engagement inspection

OK or NG

- OK >> Normal
- NG >> Repair wheel sensor and rotor system.

Symptom 3 Long Stopping Distance

EFS001ZV

Inspection Procedure

1. STARTING INSPECTION

Check that stopping distance increases only on snowy roads and gravel roads.

OK or NG

- OK >> May be longer than for vehicles without ABS.
- NG >> GO TO 2.

2. CHECKING PERFORMANCE

Disconnect actuator VDC relay box to deactivate ABS function.

Is stopping distance still long?

- YES >> ● Brake line air bleeding
 - Brake line inspection
- NO >> GO TO 3.

3. CHECKING ABS WARNING LAMP INDICATION

Check that ABS warning lamp illuminates.

OK or NG

- OK >> Perform self-diagnosis.
- NG >> GO TO 4.

4. CHECKING WHEEL SENSORS

Inspect wheel sensor system.

- Sensor mounting inspection
- Check sensor pick-up for adhering iron chips.
- Sensor rotor inspection (e.g. Number of teeth, damaged teeth)
- Sensor connector engagement inspection

OK or NG

OK >> Normal

NG >> Repair wheel sensor and rotor system.

Symptom 4 ABS Does Not Work.

EFS001ZW

Inspection Procedure

1. CHECKING ABS WARNING LAMP INDICATION

Check that ABS warning lamp illuminates.

OK or NG

OK >> Perform self-diagnosis.

NG >> GO TO 2.

2. CHECKING WHEEL SENSORS

Inspect wheel sensor system.

- Sensor mounting inspection
- Check sensor pick-up for adhering iron chips.
- Sensor rotor inspection (e.g. Number of teeth, damaged teeth)
- Sensor connector engagement inspection

OK or NG

OK >> Normal

NG >> Repair wheel sensor and rotor system.

Symptom 5 Pedal Vibration and Noise

EFS001ZX

Inspection Procedure

1. INSPECTION (1)

Check brake system for pedal vibration or noise at engine start.

OK or NG

OK >> Perform self-diagnosis.

NG >> GO TO 2.

2. INSPECTION (2)

Check for vibration during soft braking (just placing foot on pedal).

CAUTION:

ABS may activate in conditions such as those listed below, when wheel speed changes.

- Gear shifting
- Turning at high speed
- Passing through gusts of wind

OK or NG

OK >> GO TO 3.

NG >> Normal

TROUBLE DIAGNOSIS

3. INSPECTION (3)

Does vibration occur during normal braking?

CAUTION:

In addition to activation for sudden braking, ABS may activate in conditions such as those listed below.

- Roads with low surface μ
- Turning at high speed
- Passing through gusts of wind

OK or NG

OK >> GO TO 4.

NG >> Normal

4. INSPECTION (4)

Check for vibration when engine speed is increased while vehicle is stopped.

OK or NG

OK >> GO TO 5.

NG >> ● Normal.

CAUTION:

Vibration may occur when vehicle is stopped.

5. INSPECTION (5)

Check for vibration when switches of electrical components are operated.

OK or NG

OK >> Check for any wireless devices, antennas, or antenna lead near control unit (including wiring).

NG >> GO TO 6.

6. CHECKING ABS WARNING LAMP INDICATION

Confirm ABS warning lamp turns on.

OK or NG

OK >> Execute self-diagnosis.

NG >> GO TO 7.

7. CHECKING WHEEL SENSORS

Inspect wheel sensor system.

- Sensor mounting inspection
- Sensor pick-up inspection for iron chips (e.g. Number of teeth, damaged teeth)
- Sensor connector engagement inspection
- Inspection of wheel sensor circuit

OK or NG

OK >> Normal

NG >> Repair wheel sensor and rotor system.

TROUBLE DIAGNOSIS

Symptom 6 VDC OFF Indicator Lamp Does Not Illuminate.

EFS00287

Inspection Procedure

1. CHECKING VDC OFF INDICATOR LAMP POWER CIRCUIT

- Disconnect VDC/TCS/ABS control unit connector.
- Check that voltage between VDC/TCS/ABS control unit harness terminal and ground is battery voltage (Approx. 12V).

OK or NG ?

- OK >> Malfunction of VDC/TCS/ABS control unit. Repair or replace control unit.
NG >> Malfunction in combination meter system. Inspect combination meter system.

Symptom 7 SLIP Indicator Lamp Does Not Illuminate.

EFS001ZZ

Inspection Procedure

1. CHECKING FOR BURNED-OUT SLIP INDICATOR LAMP BULB

Check that there is continuity between meter power terminal and SLIP indicator lamp terminal.

OK or NG

- OK >> GO TO 2.
NG >> Open or short in SLIP indicator lamp or combination meter circuit

2. CHECKING SLIP INDICATOR LAMP POWER CIRCUIT

Disconnect meter connector. Check that voltage between meter harness terminal and body ground is battery voltage (Approx. 12V).

OK or NG

- OK >> GO TO 3.
NG >> ● Fuse inspection
- Check harness and connectors between fuse block and meter.
 - Inspect power system (battery, ignition switch circuit).

3. CHECKING SLIP INDICATOR LAMP HARNESS

1. Disconnect VDC/TCS/ABS control unit and meter vehicle-side harness connectors.
2. Check for open circuit or short circuits in harness between meter and VDC/TCS/ABS control unit.

OK or NG

- OK >> GO TO 4.
NG >> Open or short in harness. Repair or replace suspect harness.

4. CHECKING SLIP INDICATOR LAMP CONNECTOR

Check VDC/TCS/ABS control unit and meter harness connectors.

OK or NG

- OK >> Reconnect connectors and perform self-diagnosis. There is an intermediate connector in vehicle harness. Be sure to refer to vehicle wiring diagram when performing inspection.
NG >> Connector open, shorted or damaged. Repair or replace connector.

A
B
C
D
E
G
H
I
J
K
L
M

BRC

TROUBLE DIAGNOSIS

Symptom 8 Vehicle Behaves Jerkily During VDC/TCS/ABS Operation.

EFS0027V

Inspection Procedure

1. CHECKING CONNECTORS

1. Disconnect VDC/TCS/ABS control unit, ECM and A/T control unit connectors.
2. Check connectors for terminal damage or loose connection. Then reconnect them securely.

Is inspection result OK?

- OK >> GO TO 2.
NG >> Connector open, shorted or damaged. Repair or replace connector.

2. SYMPTOM CHECK

Check if the vehicle jerks during VDC/TCS/ABS control.

OK or NG

- OK >> Inspection END.
NG >> GO TO 3.

3. ECM SELF-DIAGNOSIS RESULT ITEM CHECK

Perform the ECM self-diagnosis.

Does self-diagnosis results display?

- YES >> GO TO [EC-74, "TROUBLE DIAGNOSIS"](#) .
NO >> GO TO 4.

4. A/T SELF-DIAGNOSIS RESULT ITEM CHECK

Perform the A/T self-diagnosis.

Does self-diagnosis results display?

- YES >> GO TO [AT-42, "TROUBLE DIAGNOSIS"](#) .
NO >> GO TO 5.

5. CHECKING ENGINE SPEED SIGNAL

On CONSULT-II, execute "DATA MONITOR" for VDC/TCS/ABS control unit.

Is engine speed at idle 400 rpm or higher?

- OK >> GO TO 7.
NG >> GO TO 6.

6. CHECKING SELF-DIAGNOSIS RESULTS (1)

Perform VDC/TCS/ABS control unit self-diagnosis.

Self-diagnosis results
CONSULT-II display items
"CAN COMM" (CAN communication)
"ST ANGLE SEN CIRCUIT" (Steering angle sensor communication line)

Is the result of self-diagnosis "CAN COMM" or "ST ANGLE SEN CIRCUIT"?

- YES >> GO TO inspection 16 CAN Communications, VDC/TCS/ABS Control Unit and Steering Angle Sensor System. Refer to [BRC-57](#) .
NO >> Replace VDC/TCS/ABS control unit.

7. CHECKING SELF-DIAGNOSIS RESULTS (2)

Perform VDC/TCS/ABS control unit self-diagnosis.

Does anything appear on self-diagnosis results display?

- YES >> Repair or replace parts at location indicated.
NO >> Inspection END.

WHEEL SENSORS

WHEEL SENSORS

PFP:47910

Removal and Installation

EFS00201

A
B
C
D
E
BRC
G
H
I
J
K
L
M

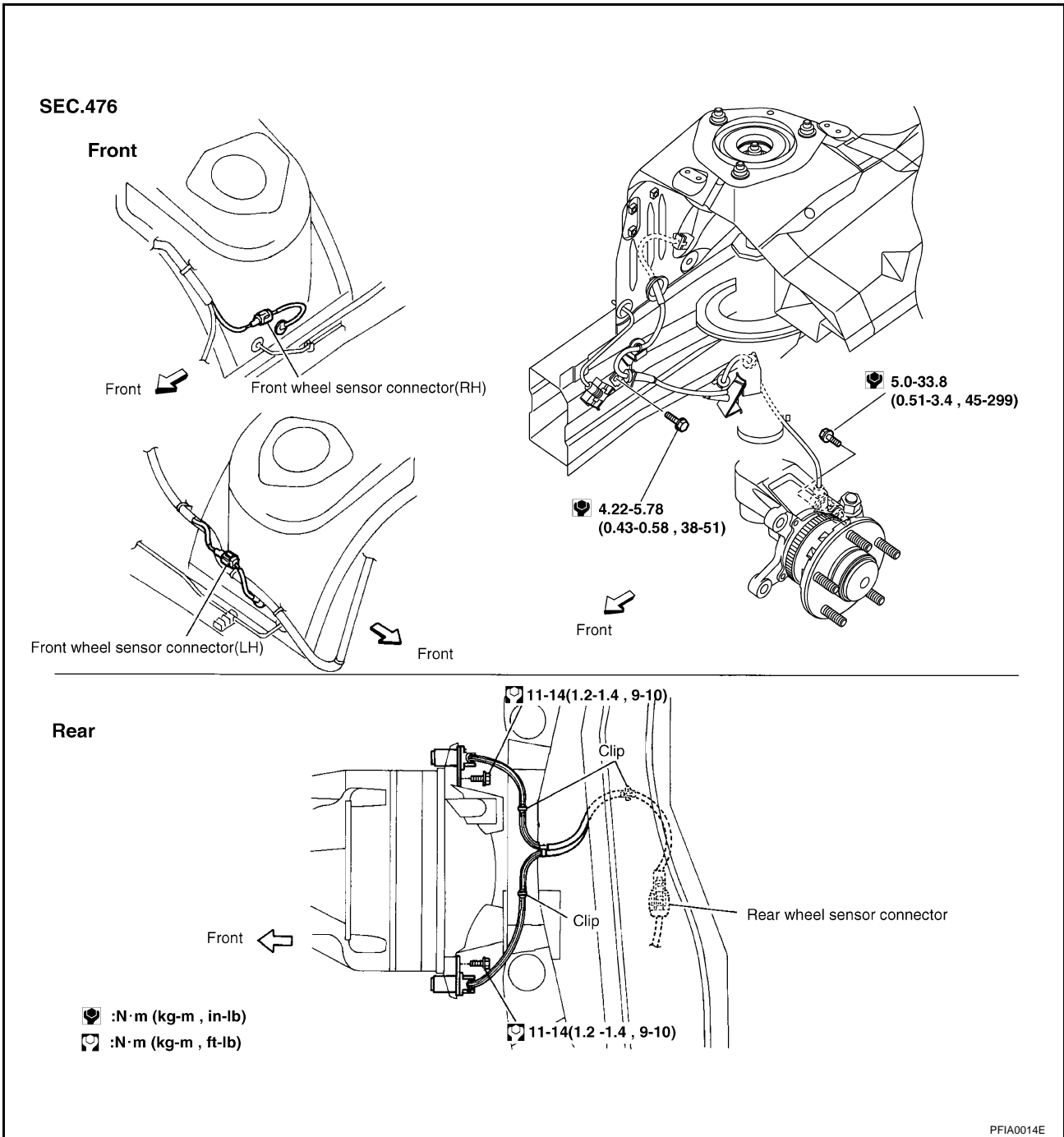

REMOVAL

Be careful of the following.

CAUTION:

When removing the sensor, do not rotate it, if possible, and also do not forcibly pull the sensor harness.

INSTALLATION

Be careful of the following. Tighten the mounting bolts and nuts to the specified torque.

- When installing, check that there is no foreign material such as iron chips on the pick-up and mounting hole of the sensor, and check that no foreign material has been caught in the sensor rotor motor. Remove any foreign material to clean the mount.

VDC/TCS/ABS CONTROL UNIT

VDC/TCS/ABS CONTROL UNIT

PFP:47660

Removal and Installation

EFS0020N

REMOVAL

1. Remove instrument lower panel, glove box and instrument assist panel. Refer to [IP-10, "INSTRUMENT PANEL ASSEMBLY"](#).
2. Remove VDC/TCS/ABS control unit.

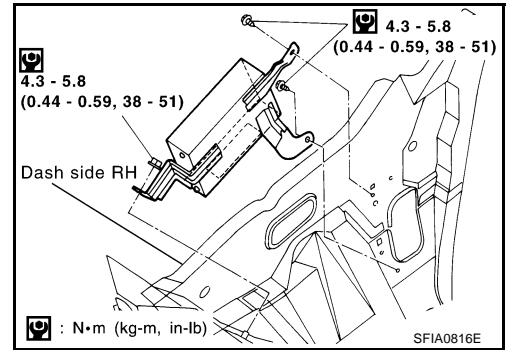

INSTALLATION

Install in the reverse order of removal.

SENSOR ROTOR

SENSOR ROTOR

PPF:47970

Removal and Installation

EF500200

Front

Refer to [FAX-4, "FRONT WHEEL HUB AND KNUCKLE"](#) in "FAX" section.

Rear

Follow procedure below to remove rear sensor rotor.

- Remove side flange. Refer to [RFD-8, "SIDE OIL SEAL"](#) in "RFD" section.
- Using a bearing replacer (special service tool) and puller (commercial service tool), remove sensor rotor from the companion flange.

INSTALLATION

Front

Refer to [FAX-4, "FRONT WHEEL HUB AND KNUCKLE"](#) in "FAX" section.

Rear

Follow procedure below to install rear sensor rotor.

- Using a drift (special service tool), press rear sensor rotor onto the side flange.
- Install side flange.

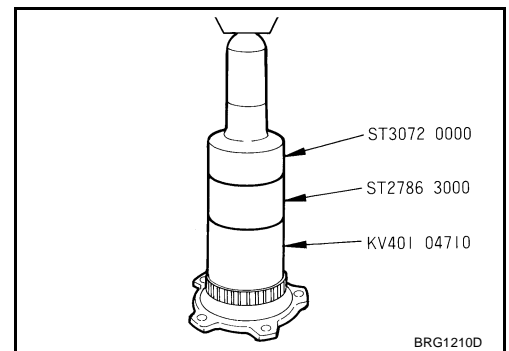

A

B

C

D

E

BRC

G

H

I

J

K

L

M

VDC/TCS/ABS ACTUATOR

PFP:47660

VDC/TCS/ABS ACTUATOR

Removal and Installation

EFS0020P

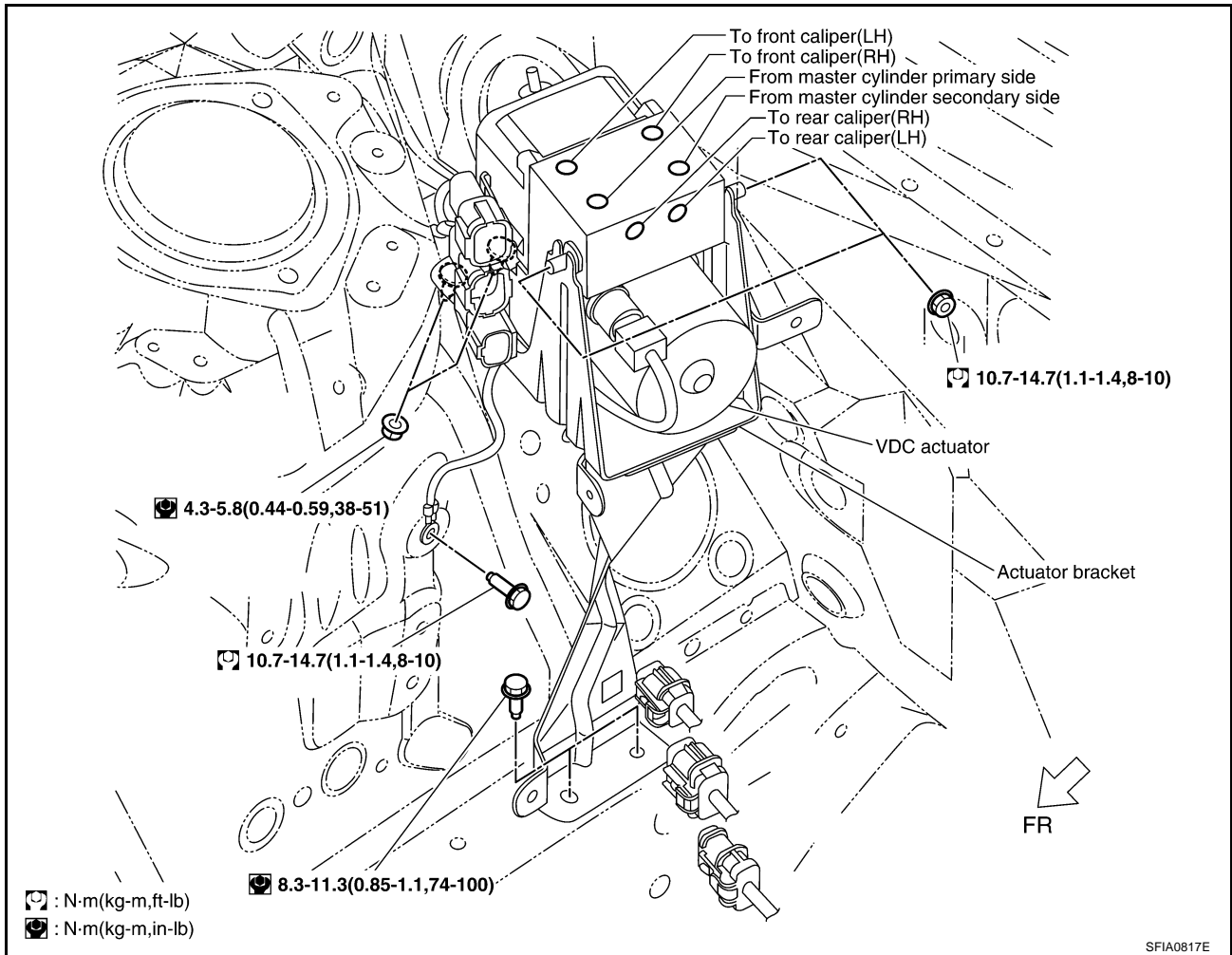

Pay attention to the following when removing actuator.

CAUTION:

- Before servicing, disconnect battery cables.
- To remove brake tube, use a flare nut wrench to prevent flare nuts and brake tube from being damaged. To install, use flare nut wrench (commercial service tool).
- Do not remove and install actuator by holding harness.
- After work is completed, bleed air from brake piping. Refer to [BR-10. "Bleeding Brake System"](#) .
- Be sure to securely connect the ground cable.

G SENSOR

G SENSOR

PFP:47930

Removal and Installation

EFS00200

REMOVAL

1. Install center console. Refer to [IP-10, "INSTRUMENT PANEL ASSEMBLY"](#).
2. Remove harness connector.
3. Remove installation bolts. Remove yaw rate/side G-sensor.

CAUTION:

Do not drop or strike the yaw rate/side G-sensor, because it has little endurance to impact.

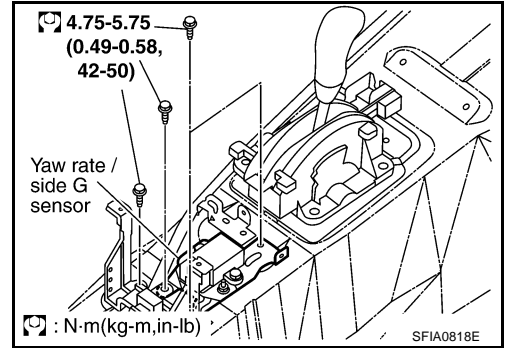

INSTALLATION

To install, follow procedure for removal in reverse order.

CAUTION:

Do not drop or strike the yaw rate/side G-sensor, because it has little endurance to impact.

A
B
C
D
E
BRC
G
H
I
J
K
L
M

STEERING ANGLE SENSOR

STEERING ANGLE SENSOR

PFP:25554

Removal and Installation

EFS003XJ

REMOVAL

1. Remove spiral cable assembly. Refer to [SRS-42, "SPIRAL CABLE"](#) .
2. Remove steering angle sensor from spiral cable assembly.

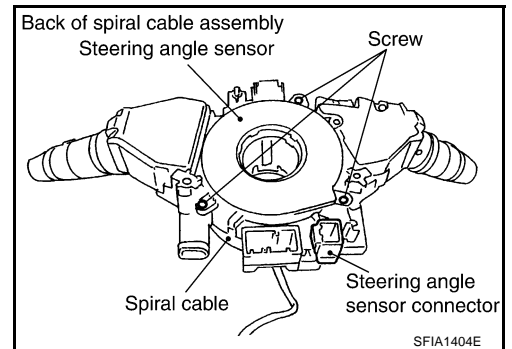

INSTALLATION

Install in the reverse order of removal.

NOTE:

After work, make sure to adjust neutral position of steering angle sensor. Refer to [BRC-6, "Adjustment of Steering Angle Sensor Neutral Position"](#) .