

# BODY & TRIM

# SECTION BT

GI  
MA  
EM  
LC  
EC  
FE  
AT  
PD  
FA  
RA  
ST  
RS  
**BT**  
HA  
EL  
IDX

## CONTENTS

<b>PRECAUTIONS</b> .....	2	Side and Floor Trim .....	26
Service Notice.....	2	Door Trim .....	28
Supplemental Restraint System (SRS) "AIR BAG" and "SEAT BELT PRE-TENSIONER" .....	2	Roof Trim .....	30
<b>PREPARATION</b> .....	3	Trunk Room Trim .....	32
Special Service Tools .....	3	<b>EXTERIOR</b> .....	33
Commercial Service Tools .....	3	<b>SEAT</b> .....	42
<b>SQUEAK AND RATTLE TROUBLE DIAGNOSES</b> .....	4	Front Seat.....	42
Work Flow .....	4	Heated Seat.....	43
Generic Squeak and Rattle Troubleshooting .....	6	Active Head Restraint.....	43
Diagnostic Worksheet .....	8	Rear Seat.....	44
<b>GENERAL SERVICING</b> .....	10	<b>SUNROOF</b> .....	45
Clip and Fastener .....	10	Adjustment.....	45
<b>BODY END</b> .....	13	Removal.....	45
Body Front End.....	13	Trouble Diagnoses.....	49
Body Rear End and Opener.....	16	<b>WINDSHIELD AND WINDOWS</b> .....	53
<b>DOOR</b> .....	19	Windshield and Rear Window .....	54
Front Door.....	19	<b>MIRROR</b> .....	55
Front Door Limit Switch Reset .....	20	Door Mirror.....	55
Rear Door .....	21	<b>BODY ALIGNMENT</b> .....	56
<b>INSTRUMENT PANEL</b> .....	22	Engine Compartment.....	56
<b>INTERIOR TRIM</b> .....	26	Underbody .....	58

- ★ For seat belt, refer to MA and RS section.
- ★ For wiring diagrams of body electrical systems, refer to EL section.

## Service Notice

- When removing or installing various parts, place a cloth or padding onto the vehicle body to prevent scratches.
- Handle trim, molding, instruments, grille, etc. carefully during removing or installing. Be careful not to soil or damage them.
- Apply sealing compound where necessary when installing parts.
- When applying sealing compound, be careful that the sealing compound does not protrude from parts.
- When replacing any metal parts (for example body outer panel, members, etc.), be sure to take rust prevention measures.

## Supplemental Restraint System (SRS) “AIR BAG” and “SEAT BELT PRE-TENSIONER”

The Supplemental Restraint System such as “AIR BAG” and “SEAT BELT PRE-TENSIONER” used along with a seat belt, helps to reduce the risk or severity of injury to the driver and front passenger for certain types of collision. The SRS system composition which is available to INFINITI Q45 is as follows:

- For a frontal collision  
The Supplemental Restraint System consists of driver air bag module (located in the center of the steering wheel), front passenger air bag module (located on the instrument panel on passenger side), seat belt pre-tensioners, a diagnosis sensor unit, warning lamp, wiring harness and spiral cable.
- For a side collision  
The Supplemental Restraint System consists of front side air bag module (located in the outer side of front seat), satellite sensor, diagnosis sensor unit (one of components of air bags for a frontal collision), wiring harness, warning lamp (one of components of air bags for a frontal collision).

Information necessary to service the system safely is included in the **RS section** of this Service Manual.

### **WARNING:**

- **To avoid rendering the SRS inoperative, which could increase the risk of personal injury or death in the event of a collision which would result in air bag inflation, all maintenance should be performed by an authorized INFINITI dealer.**
- **Improper maintenance, including incorrect removal and installation of the SRS, can lead to personal injury caused by intentional activation of the system. For removal of Spiral Cable and Air Bag Module, see the RS section.**
- **Do not use electrical test equipment on any circuit related to the SRS unless instructed to in this Service Manual. Spiral cable and wiring harnesses (except satellite sensor and side air bag module) covered with yellow insulation tape either just before the harness connectors or for the complete harness are related to the SRS.**

# PREPARATION

## Special Service Tools

The actual shapes of Kent-Moore tools may differ from those of special service tools illustrated here.

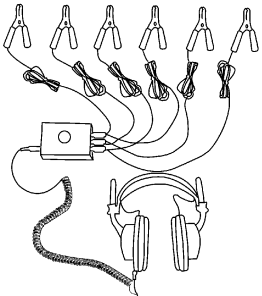
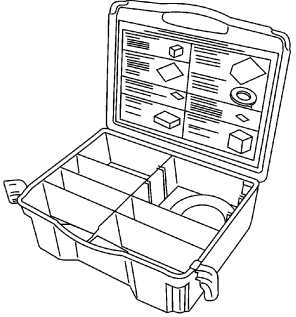
Tool number (Kent-Moore No.) Tool name	Description	
— (J-39570) Chassis ear	Locating the noise    SBT839	GI MA EM LC EC
— (J-43980) Nissan Squeak and Rattle kit	Repairing the cause of noise    SBT840	FE AT PD FA RA

## Commercial Service Tools

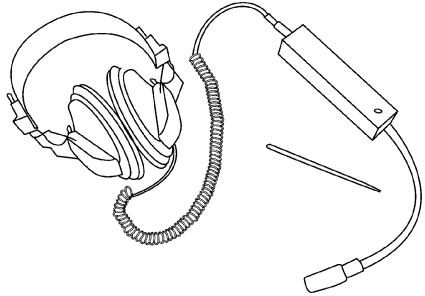
Tool name	Description	
Engine ear	Locating the noise    SBT841	BR ST RS <b>BT</b> HA EL

IDX

## Work Flow

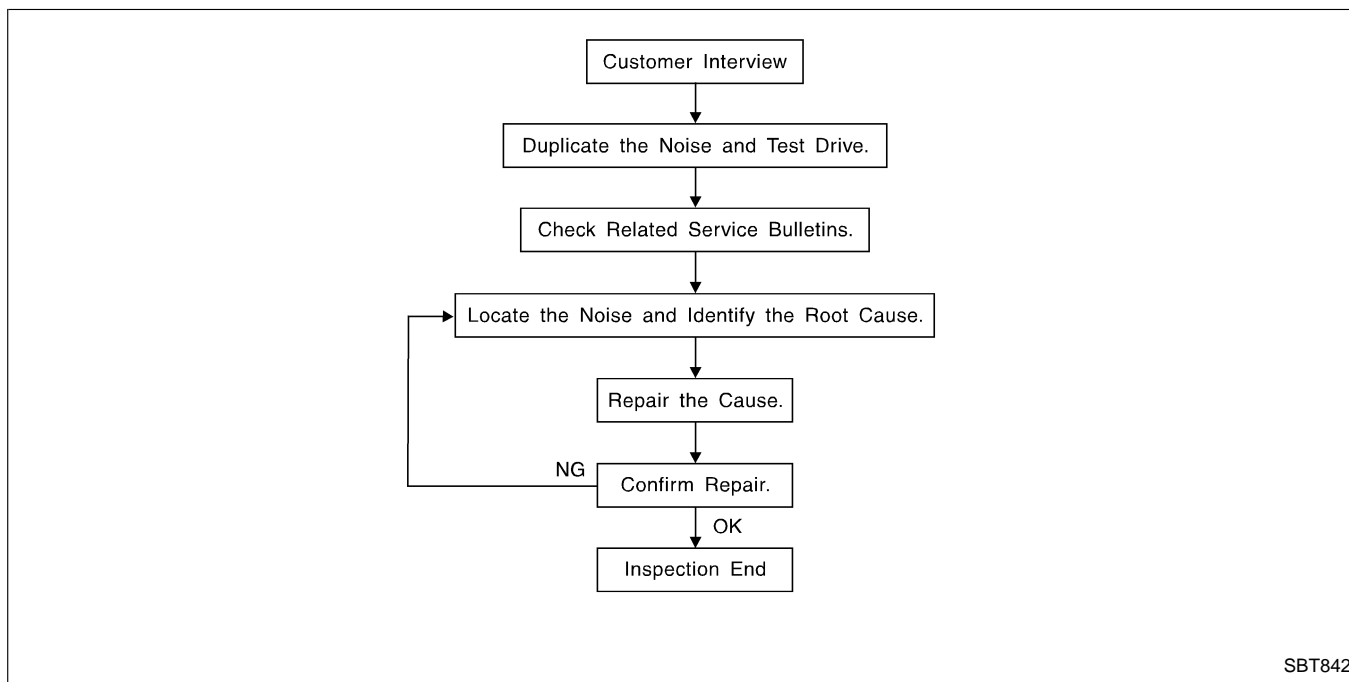

### CUSTOMER INTERVIEW

Interview the customer, if possible, to determine the conditions that exist when the noise occurs. Use the Diagnostic Worksheet during the interview to document the facts and conditions when the noise occurs and any customer's comments; refer to BT-8. This information is necessary to duplicate the conditions that exist when the noise occurs.

- The customer may not be able to provide a detailed description or the location of the noise. Attempt to obtain all the facts and conditions that exist when the noise occurs (or does not occur).
- If there is more than one noise in the vehicle, be sure to diagnose and repair the noise that the customer is concerned about. This can be accomplished by test driving the vehicle with the customer.
- After identifying the type of noise, isolate the noise in terms of its characteristics. The noise characteristics are provided so the customer, service adviser and technician are all speaking the same language when defining the noise.
- Squeak — (Like tennis shoes on a clean floor)  
Squeak characteristics include the light contact/fast movement/brought on by road conditions/hard surfaces = higher pitch noise/softer surfaces = lower pitch noises/edge to surface = chirping
- Creak — (Like walking on an old wooden floor)  
Creak characteristics include firm contact/slow movement/twisting with a rotational movement/pitch dependent on materials/often brought on by activity.
- Rattle — (Like shaking a baby rattle)  
Rattle characteristics include the fast repeated contact/vibration or similar movement/loose parts/missing clip or fastener/incorrect clearance.
- Knock — (Like a knock on a door)  
Knock characteristics include hollow sounding/sometimes repeating/often brought on by driver action.
- Tick — (Like a clock second hand)  
Tick characteristics include gentle contacting of light materials/loose components/can be caused by driver action or road conditions.
- Thump — (Heavy, muffled knock noise)  
Thump characteristics include softer knock/dead sound often brought on by activity.
- Buzz — (Like a bumble bee)  
Buzz characteristics include high frequency rattle/firm contact.
- Often the degree of acceptable noise level will vary depending upon the person. A noise that you may judge as acceptable may be very irritating to the customer.
- Weather conditions, especially humidity and temperature, may have a great effect on noise level.

## Work Flow (Cont'd)

### DUPLICATE THE NOISE AND TEST DRIVE

If possible, drive the vehicle with the customer until the noise is duplicated. Note any additional information on the Diagnostic Worksheet regarding the conditions or location of the noise. This information can be used to duplicate the same conditions when you confirm the repair.

If the noise can be duplicated easily during the test drive, to help identify the source of the noise, try to duplicate the noise with the vehicle stopped by doing one or all of the following:

- 1) Close a door. GI
- 2) Tap or push/pull around the area where the noise appears to be coming from. MA
- 3) Rev the engine. EM
- 4) Use a floor jack to recreate vehicle "twist". EM
- 5) At idle, apply engine load (electrical load, half-clutch on M/T model, drive position on A/T model). EM
- 6) Raise the vehicle on a hoist and hit a tire with a rubber hammer. EM
  - Drive the vehicle and attempt to duplicate the conditions the customer states exist when the noise occurs. LC
  - If it is difficult to duplicate the noise, drive the vehicle slowly on an undulating or rough road to stress the vehicle body. LC

### CHECK RELATED SERVICE BULLETINS

After verifying the customer concern or symptom, check ASIST for Technical Service Bulletins (TSBs) related to that concern or symptom. EC

If a TSB relates to the symptom, follow the procedure to repair the noise. FE

### LOCATE THE NOISE AND IDENTIFY THE ROOT CAUSE

1. Narrow down the noise to a general area. To help pinpoint the source of the noise, use a listening tool (Chassis Ear: J-39570, Engine Ear: J-39565 and mechanics stethoscope). AT
2. Narrow down the noise to a more specific area and identify the cause of the noise by: PD
  - removing the components in the area that you suspect the noise is coming from. FA  
**Do not use too much force when removing clips and fasteners, otherwise clips and fastener can be broken or lost during the repair, resulting in the creation of new noise.**
  - tapping or pushing/pulling the component that you suspect is causing the noise. RA  
**Do not tap or push/pull the component with excessive force, otherwise the noise will be eliminated only temporarily.**
  - feeling for a vibration with your hand by touching the component(s) that you suspect is (are) causing the noise. BR
  - placing a piece of paper between components that you suspect are causing the noise. BR
  - looking for loose components and contact marks. ST  
Refer to "Generic Squeak and Rattle Troubleshooting", BT-6.

### REPAIR THE CAUSE

- If the cause is a loose component, tighten the component securely. RS
- If the cause is insufficient clearance between components: BT
  - separate components by repositioning or loosening and retightening the component, if possible.
  - insulate components with a suitable insulator such as urethane pads, foam blocks, felt cloth tape or urethane tape. A Nissan Squeak and Rattle Kit (J-43980) is available through your authorized Nissan Parts Department. HA

#### CAUTION:

**Do not use excessive force as many components are constructed of plastic and may be damaged. Always check with the Parts Department for the latest parts information.**

The following materials are contained in the Nissan Squeak and Rattle Kit (J-43980). Each item can be ordered separately as needed. EL

URETHANE PADS [1.5 mm (0.059 in) thick] IDX

Insulates connectors, harness, etc.

76268-9E005: 100 x 135 mm (3.94 x 5.31 in)/76884-71L01: 60 x 85 mm (2.36 x 3.35 in)/76884-71L02: 15 x 25 mm (0.59 x 0.98 in)

INSULATOR (Foam blocks)

Insulates components from contact. Can be used to fill space behind a panel.

73982-9E000: 45 mm (1.77 in) thick, 50 x 50 mm (1.97 x 1.97 in)/73982-50Y00: 10 mm (0.39 in) thick, 50 x 50 mm (1.97 x 1.97 in)

INSULATOR (Light foam block)

80845-71L00: 30 mm (1.18 in) thick, 30 x 50 mm (1.18 x 1.97 in)

## Work Flow (Cont'd)

### FELT CLOTH TAPE

Used to insulate where movement does not occur. Ideal for instrument panel applications.  
68370-4B000: 15 x 25 mm (0.59 x 0.98 in) pad/68239-13E00: 5 mm (0.20 in) wide tape roll  
The following materials, not found in the kit, can also be used to repair squeaks and rattles.

### UHMW (TEFLON) TAPE

Insulates where slight movement is present. Ideal for instrument panel applications.

### SILICONE GREASE

Used in place of UHMW tape that will be visible or not fit.

Note: Will only last a few months.

### SILICONE SPRAY

Use when grease cannot be applied.

### DUCT TAPE

Use to eliminate movement.

## CONFIRM THE REPAIR

Confirm that the cause of a noise is repaired by test driving the vehicle. Operate the vehicle under the same conditions as when the noise originally occurred. Refer to the notes on the Diagnostic Worksheet.

## Generic Squeak and Rattle Troubleshooting

Refer to Table of Contents for specific component removal and installation information.

### INSTRUMENT PANEL

Most incidents are caused by contact and movement between:

1. The cluster lid A and instrument panel
2. Acrylic lens and combination meter housing
3. Instrument panel to front pillar garnish
4. Instrument panel to windshield
5. Instrument panel mounting pins
6. Wiring harnesses behind the combination meter
7. A/C defroster duct and duct joint

These incidents can usually be located by tapping or moving the components to duplicate the noise or by pressing on the components while driving to stop the noise. Most of these incidents can be repaired by applying felt cloth tape or silicon spray (in hard to reach areas). Urethane pads can be used to insulate wiring harness.

### CAUTION:

**Do not use silicone spray to isolate a squeak or rattle. If you saturate the area with silicone, you will not be able to recheck the repair.**

### CENTER CONSOLE

Components to pay attention to include:

1. Shifter assembly cover to finisher
2. A/C control unit and cluster lid C
3. Wiring harnesses behind audio and A/C control unit

The instrument panel repair and isolation procedures also apply to the center console.

### DOORS

Pay attention to the:

1. Finisher and inner panel making a slapping noise
2. Inside handle escutcheon to door finisher
3. Wiring harnesses tapping
4. Door striker out of alignment causing a popping noise on starts and stops

Tapping or moving the components or pressing on them while driving to duplicate the conditions can isolate many of these incidents. You can usually insulate the areas with felt cloth tape or insulator foam blocks from the Nissan Squeak and Rattle Kit (J-43980) to repair the noise.

### TRUNK

Trunk noises are often caused by a loose jack or loose items put into the trunk by the owner.

In addition look for:

1. Trunk lid bumpers out of adjustment

# SQUEAK AND RATTLE TROUBLE DIAGNOSES

## Generic Squeak and Rattle Troubleshooting (Cont'd)

2. Trunk lid striker out of adjustment
3. The trunk lid torsion bars knocking together
4. A loose license plate or bracket

Most of these incidents can be repaired by adjusting, securing or insulating the item(s) or component(s) causing the noise.

GI

### SUNROOF/HEADLINER

MA

Noises in the sunroof/headliner area can often be traced to one of the following:

1. Sunroof lid, rail, linkage or seals making a rattle or light knocking noise
2. Sunvisor shaft shaking in the holder
3. Front or rear windshield touching headliner and squeaking

EM

Again, pressing on the components to stop the noise while duplicating the conditions can isolate most of these incidents. Repairs usually consist of insulating with felt cloth tape.

LC

### SEATS

EC

When isolating seat noises it's important to note the position the seat is in and the load placed on the seat when the noise is present. These conditions should be duplicated when verifying and isolating the cause of the noise.

Cause of seat noise include:

FE

1. Headrest rods and holders
2. A squeak between the seat pad cushion and frame
3. The rear seat back lock and bracket

AT

These noises can be isolated by moving or pressing on the suspected components while duplicating the conditions under which the noise occurs. Most of these incidents can be repaired by repositioning the component or applying urethane tape to the contact area.

PD

### UNDERHOOD

FA

Some interior noises may be caused by components under the hood or on the engine wall. The noise is then transmitted into the passenger compartment.

Causes of transmitted underhood noises include:

RA

1. Any component mounted to the engine wall
2. Components that pass through the engine wall
3. Engine wall mounts and connectors
4. Loose radiator mounting pins
5. Hood bumpers out of adjustment
6. Hood striker out of adjustment

BR

ST

These noises can be difficult to isolate since they cannot be reached from the interior of the vehicle. The best method is to secure, move or insulate one component at a time and test drive the vehicle. Also, engine RPM or load can be changed to isolate the noise. Repairs can usually be made by moving, adjusting, securing, or insulating the component causing the noise.

RS

**BT**

HA

EL

IDX

## Diagnostic Worksheet



INFINITI®

### SQUEAK & RATTLE DIAGNOSTIC WORKSHEET

Dear Infiniti Customer:

We are concerned about your satisfaction with your Infiniti vehicle. Repairing a squeak or rattle sometimes can be very difficult. To help us fix your Infiniti right the first time, please take a moment to note the area of the vehicle where the squeak or rattle occurs and under what conditions. You may be asked to take a test drive with a service advisor or technician to ensure we confirm the noise you are hearing.

#### I. WHERE DOES THE NOISE COME FROM? (circle the area of the vehicle)

The illustrations are for reference only, and may not reflect the actual configuration of your vehicle.

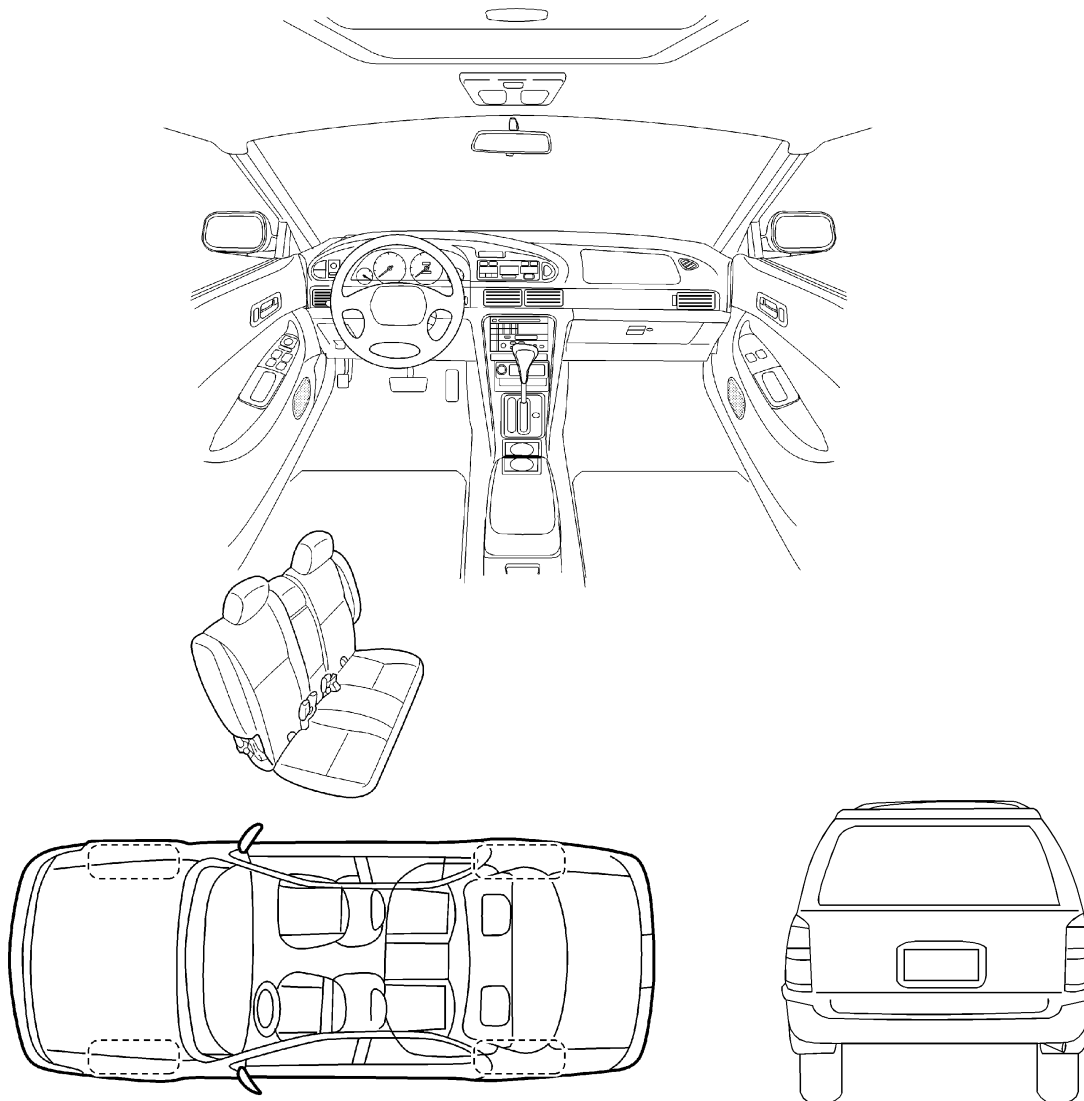

Continue to the back of the worksheet and briefly describe the location of the noise or rattle. In addition, please indicate the conditions which are present when the noise occurs.



# SQUEAK AND RATTLE TROUBLE DIAGNOSES

## Diagnostic Worksheet (Cont'd)

### SQUEAK & RATTLE DIAGNOSTIC WORKSHEET- page 2

**Briefly describe the location where the noise occurs:**

---



---



---

**II. WHEN DOES IT OCCUR? (check the boxes that apply)**

- |  |   |
|--|---|
| <input type="checkbox"/> anytime                             | <input type="checkbox"/> after sitting out in the sun |
| <input type="checkbox"/> 1 <sup>st</sup> time in the morning | <input type="checkbox"/> when it is raining or wet    |
| <input type="checkbox"/> only when it is cold outside        | <input type="checkbox"/> dry or dusty conditions      |
| <input type="checkbox"/> only when it is hot outside         | <input type="checkbox"/> other: _____                 |

**III. WHEN DRIVING:**

- through driveways
- over rough roads
- over speed bumps
- only at about \_\_\_\_ mph
- on acceleration
- coming to a stop
- on turns : left, right or either (circle)
- with passengers or cargo
- other: \_\_\_\_\_
- after driving \_\_\_\_ miles or \_\_\_\_ minutes

**IV. WHAT TYPE OF NOISE?**

- squeak (like tennis shoes on a clean floor)
- creak (like walking on an old wooden floor)
- rattle (like shaking a baby rattle)
- knock (like a knock on a door)
- tick (like a clock second hand)
- thump (heavy, muffled knock noise)
- buzz (like a bumble bee)

**TO BE COMPLETED BY DEALERSHIP PERSONNEL**

**Test Drive Notes:**

---



---

	<u>YES</u>	<u>NO</u>	<u>Initials of person performing</u>
Vehicle test driven with customer	<input type="checkbox"/>	<input type="checkbox"/>	_____
- Noise verified on test drive	<input type="checkbox"/>	<input type="checkbox"/>	_____
- Noise source located and repaired	<input type="checkbox"/>	<input type="checkbox"/>	_____
- Follow up test drive performed to confirm repair	<input type="checkbox"/>	<input type="checkbox"/>	_____

VIN: \_\_\_\_\_ Customer Name: \_\_\_\_\_

W.O. #: \_\_\_\_\_ Date: \_\_\_\_\_

**This form must be attached to Work Order**

GI

MA

EM

LC

EC

FE

AT

PD

FA

RA

BR

ST

RS

BT

HA





EL

IDX

# GENERAL SERVICING

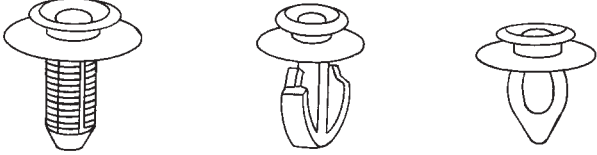

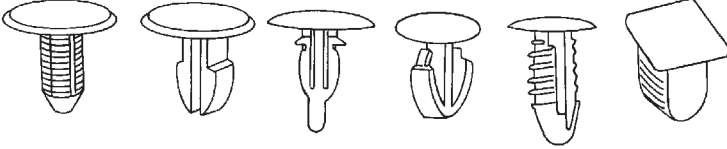
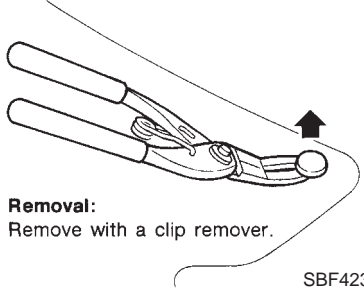

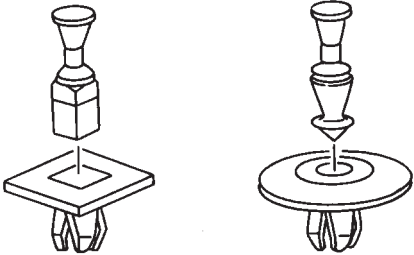
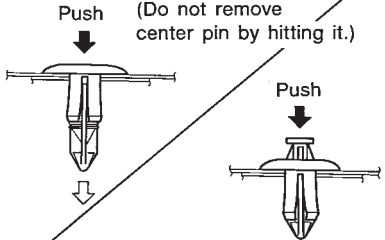
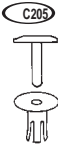
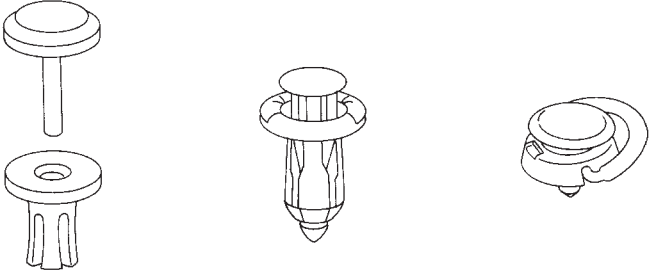
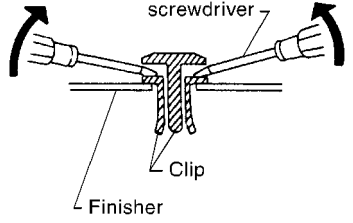



## Clip and Fastener

- Clips and fasteners in BT section correspond to the following numbers and symbols.
- Replace any clips and/or fasteners which are damaged during removal or installation.

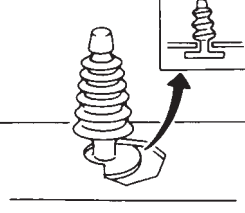
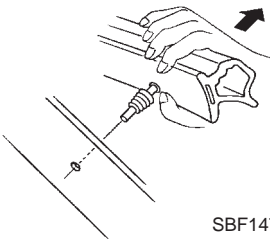
Symbol No.	Shapes	Removal & Installation
	 <p style="text-align: right;">SBF302H</p>	<p><b>Removal:</b> Remove by bending up with flat-bladed screwdrivers or clip remover.</p>  <p style="text-align: right;">SBF367BA</p>
	 <p style="text-align: right;">SBT095</p>	<p><b>Removal:</b> Remove with a clip remover.</p>  <p style="text-align: right;">SBF423H</p>
	 <p style="text-align: right;">SBF258G</p>	<p>Push center pin to catching position. (Do not remove center pin by hitting it.)</p>  <p><b>Installation:</b></p> <p style="text-align: right;">SBF708E</p>
	 <p style="text-align: right;">MBT080A</p>	<p><b>Removal:</b></p>  <p style="text-align: right;">SBF638CA</p>

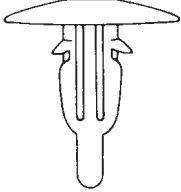
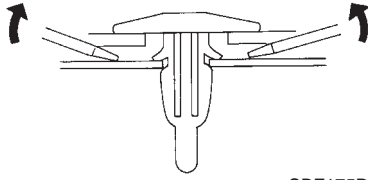
# GENERAL SERVICING

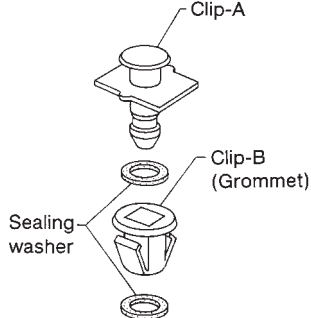
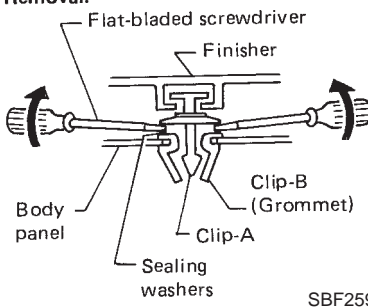
## Clip and Fastener (Cont'd)

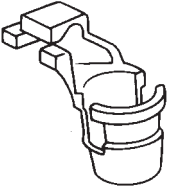
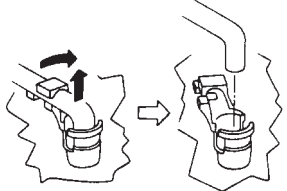
Symbol No.	Shapes	Removal & Installation
 		<p><b>Removal:</b></p>  <p style="text-align: right;">SBF104B <span style="float: right;">SBF147B</span></p>
 		<p><b>Removal:</b> Remove by bending up with a flat-bladed screwdriver or pliers.</p>  <p style="text-align: right;">SBF174D <span style="float: right;">SBF175DA</span></p>
 		<p><b>Removal:</b></p>  <p style="text-align: right;">SBF151D <span style="float: right;">SBF259G</span></p>
 		<p><b>Removal:</b> Holder portion of clip must be spread out to remove rod.</p>  <p style="text-align: right;">SBF768B <span style="float: right;">SBF770B</span></p>

GI  
MA  
EM  
LC  
EC  
FE  
AT  
PD  
FA  
RA  
BR  
ST  
RS  
BT  
HA  
EL  
IDX

# GENERAL SERVICING

## Clip and Fastener (Cont'd)

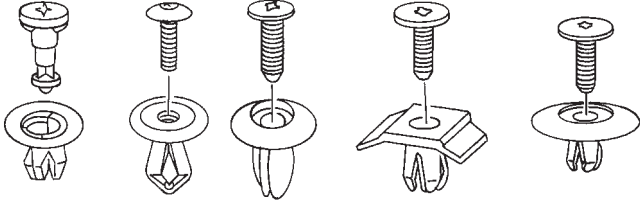
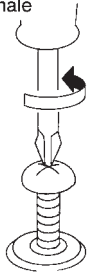
Symbol No.	Shapes	Removal & Installation
	 <p style="text-align: right;">SBF078B</p>	<p><b>Removal:</b></p> <ol style="list-style-type: none"> <li>1. Screw out with a Phillips screwdriver.</li> <li>2. Remove female portion with flat-bladed screwdriver.</li> </ol>  <p style="text-align: right;">SBF992G</p>

## Body Front End

- When removing or installing hood, place a cloth or other padding on the front fender panels and cowl top. This prevents vehicle body from being scratched.
- Bumper fascia is made of plastic. Do not use excessive force and be sure to keep oil away from it.
- Hood adjustment: Adjust at hinge portion.
- Hood lock adjustment: After adjusting, check hood lock control operation. Apply a coat of grease to hood locks engaging mechanism.
- Hood opener: Do not attempt to bend cable forcibly. Doing so increases effort required to unlock hood.

### WARNING:

- **Be careful not to scratch hood stay when installing hood. A scratched stay may cause gas leakage.**
- **The contents of the hood stay are under pressure. Do not take apart, puncture, apply heat or allow fire near it.**

### REMOVAL — Front bumper assembly

- ① Remove screws and clips securing left and right sides of front fender protector. **A**
- ② Remove bolts securing bumper fascia to engine undercover. **B**
- ③ Remove clips securing air guide. **C**
- ④ Remove bolts securing left and right front fenders to bumper fascia. **D**
- ⑤ Remove clip securing bumper fascia to upper center bumper retainer. **E**
- ⑥ Remove bolts securing upper center bumper retainer to left and right upper bumper retainer. **F**
- ⑦ Extract bumper fascia assembly. Then disconnect fog lamp connector.
- ⑧ Remove bolts securing upper center bumper retainer to left and right bumper side stay. **G**
- ⑨ Remove nuts securing bumper reinforcement to left and right bumper stay. **H**
- ⑩ Remove bolts and clips securing bumper side stay to bumper stay. **I**
- ⑪ Remove bolts and nuts securing bumper stay. **J**
- ⑫ Remove bolts securing bumper bracket to bumper stay. **K**
- ⑬ Remove fog lamp bracket cover. **L**
- ⑭ Remove nuts securing fog lamp assembly. **M**

GI

MA

EM

LC

EC

FE

AT

PD

FA

RA

BR

ST

RS

BT

HA

EL

IDX

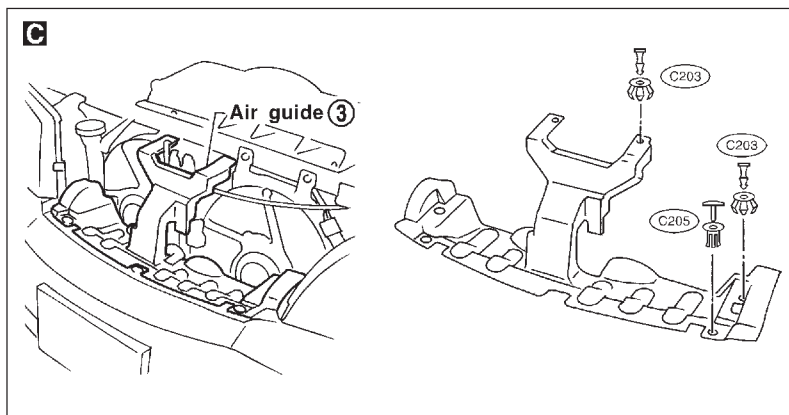
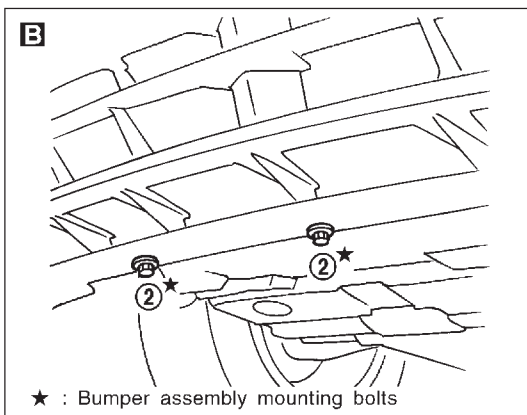
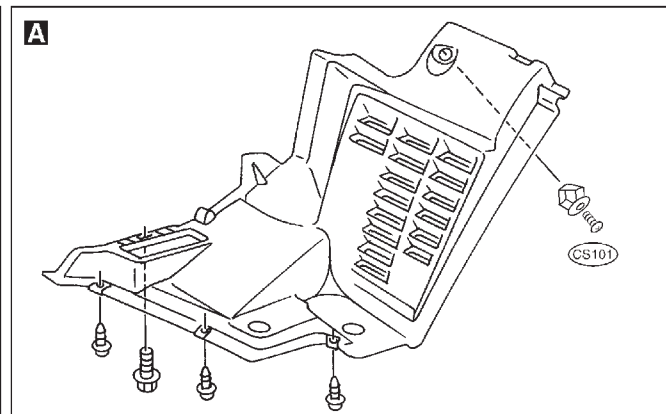
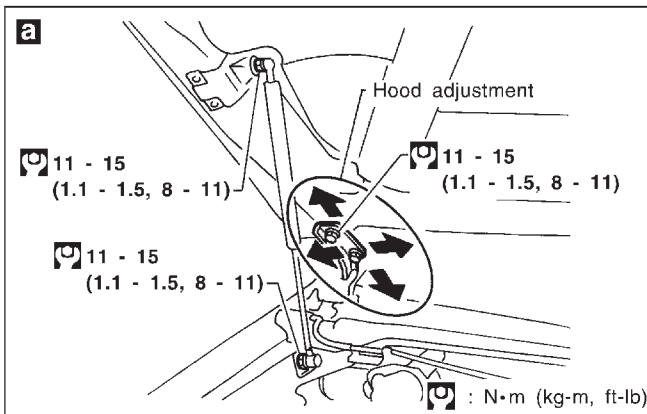

SBT324

# BODY END

## Body Front End (Cont'd)

### SEC. 263•620•630•650

#### Hood lock adjustment

- Adjust hood so that hood primary lock meshes at a position 1 to 1.5 mm (0.039 to 0.059 in) lower than fender.
- After hood lock adjustment, adjust bumper rubber.
- When securing hood lock, ensure it does not tilt. Striker must be positioned at the center of hood primary lock.
- After adjustment, ensure that hood primary and secondary lock operate properly.

#### Hood lock secondary latch hooking length

More than 5.0 mm (0.197 in)

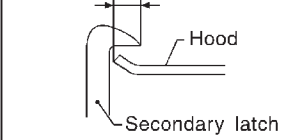

#### Bumper rubber adjustment

- Adjust so that hood is aligned with fender. At that time deflection is approx. 2 mm (0.08 in).
- [Bumper rubber free height is approx. 13 mm (0.51 in).]

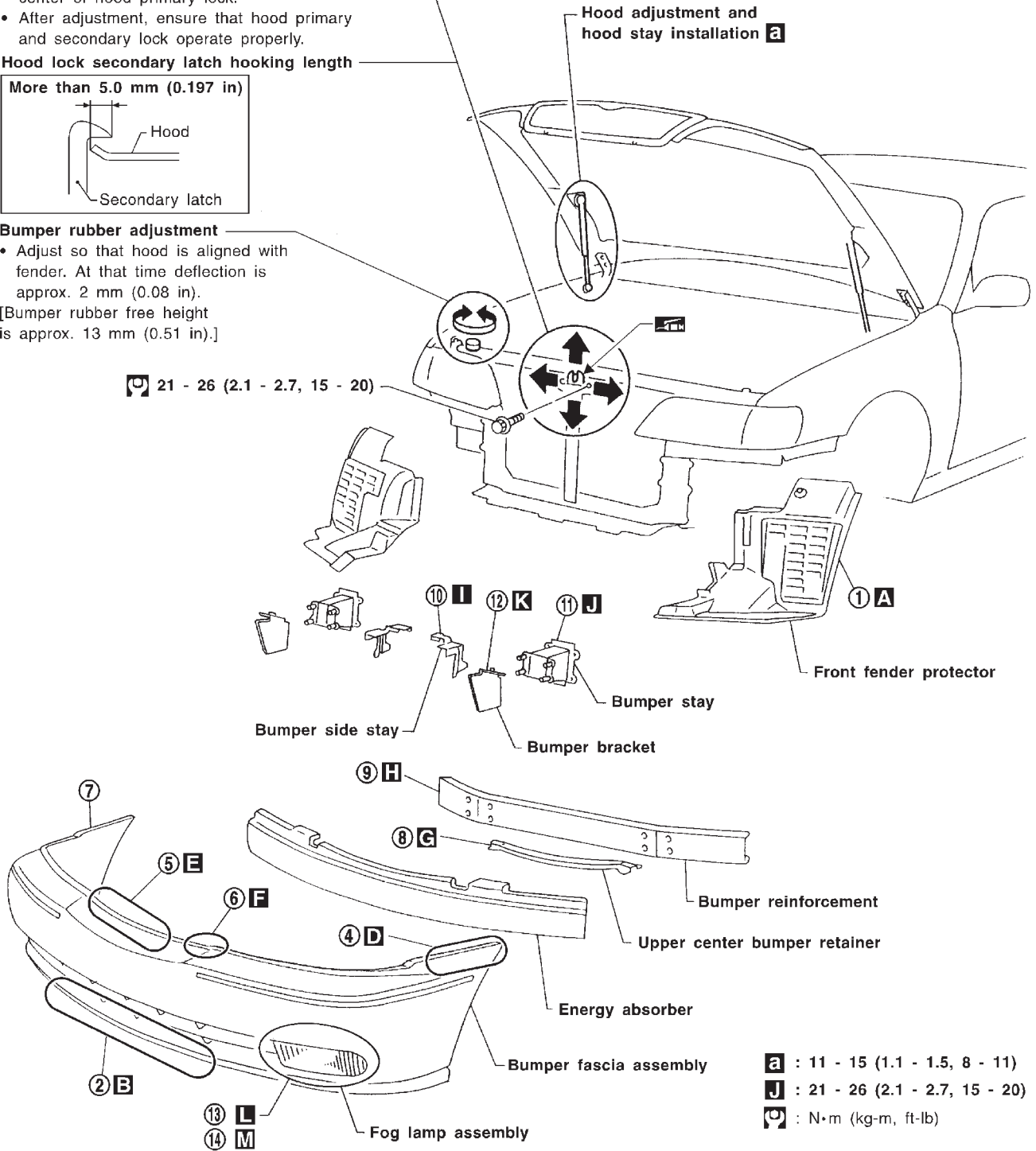

- a** : 11 - 15 (1.1 - 1.5, 8 - 11)
- J** : 21 - 26 (2.1 - 2.7, 15 - 20)
- Ⓢ** : N•m (kg-m, ft-lb)

# BODY END

## Body Front End (Cont'd)

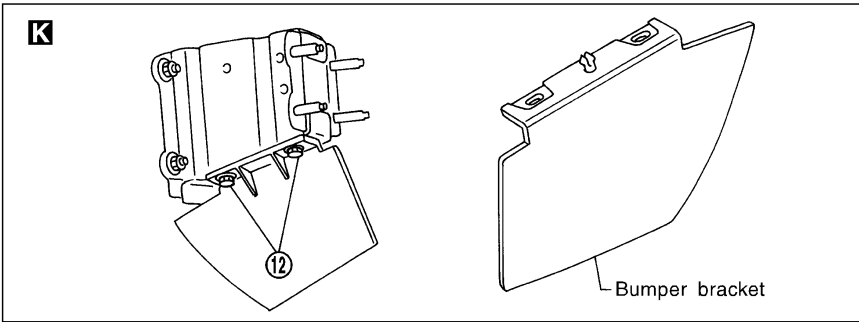
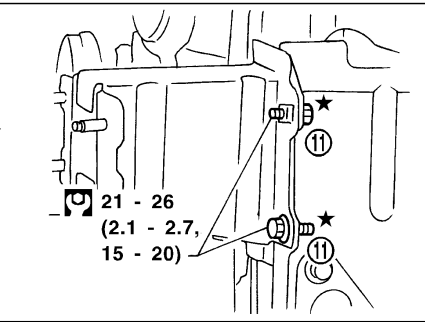
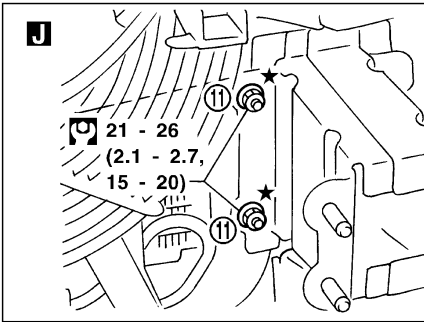
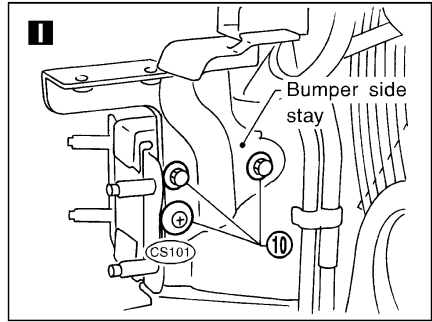
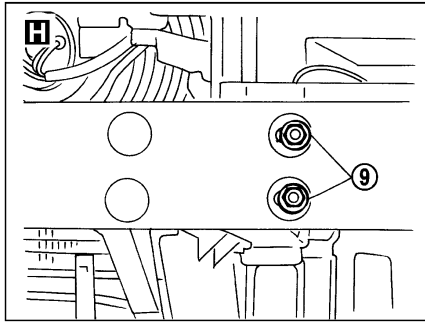
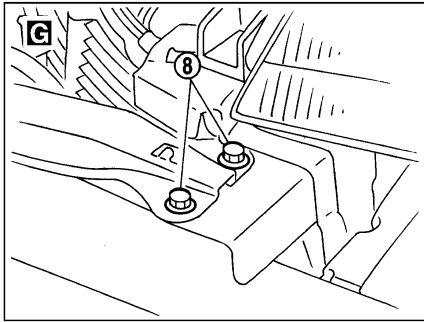
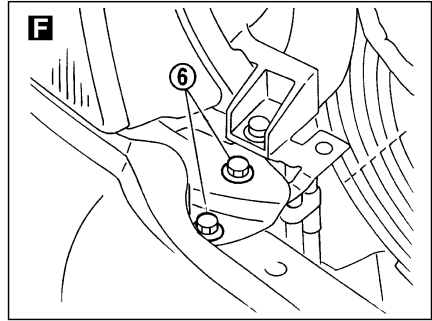
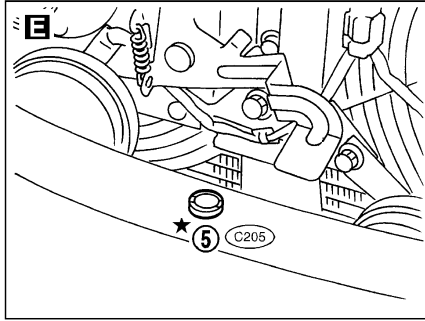
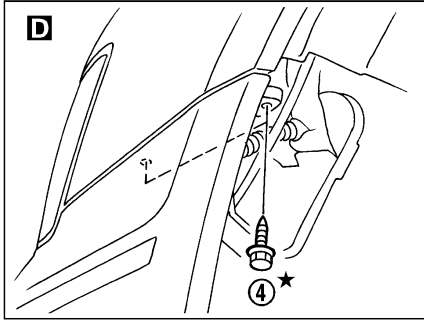

**9** : N·m (kg-m, ft-lb)  
 ★ : Bumper assembly mounting bolts, nuts and clips

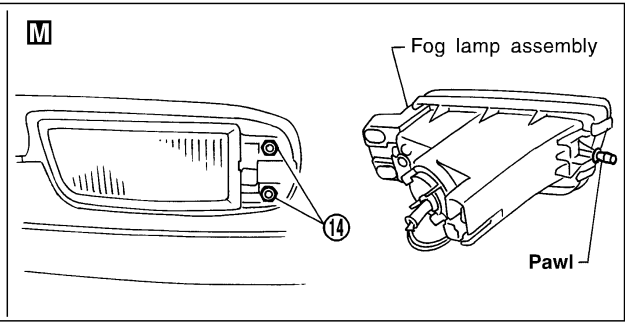
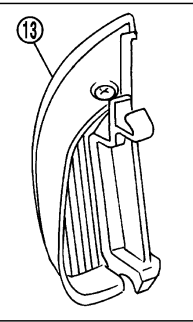
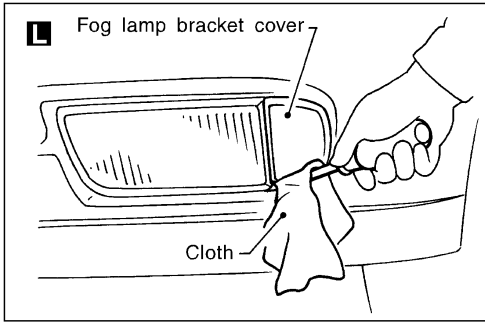

For **a** and **A - C**, refer to BT-13

GI  
 MA  
 EM  
 LC  
 EC  
 FE  
 AT  
 PD  
 FA  
 RA  
 BR  
 ST  
 RS  
 BT  
 HA  
 EL  
 IDX

## Body Rear End and Opener

- When removing or installing trunk lid, place a cloth or other padding on the rear fender panels. This prevents vehicle body from being scratched.
- Bumper fascia is made of plastic. Do not use excessive force and be sure to keep oil away from it.
- Trunk lid adjustment: Adjust at hinge-trunk lid portion for proper trunk lid fit.
- Trunk lid lock system adjustment: Adjust striker so that it is in the center of the lock. After adjustment, check trunk lid lock operation.
- After installation, make sure that trunk lid and fuel filler lid open smoothly.
- ★ **For Wiring Diagram, refer to “TRUNK LID OPENER” in EL section.**

### REMOVAL — Rear bumper assembly

- ① Remove clips securing left and right chipping protectors.
- ② Remove bolts securing left and right rear fenders to bumper fascia. **F**
- ③ Remove bolts securing bumper side stay to bumper fascia. **G**
- ④ Remove clips securing bumper fascia bracket to bumper fascia. **H**
- ⑤ Remove trunk room trim. Refer to “Trunk Room Trim” in “INTERIOR TRIM” for details, BT-32.
- ⑥ Working from inside trunk, remove bolts and nuts securing left and right rear fenders to bumper fascia. **I**, **J**
- ⑦ Remove bumper sight shield assembly. **K**
- ⑧ Remove clips securing bumper fascia. **L**
- ⑨ Extract bumper fascia assembly.
- ⑩ Working from inside trunk, remove left and right plugs from floor and then remove bumper reinforcement mounting bolts. **M**
- ⑪ Extract bumper reinforcement. **N**

### REMOVAL — Back up lamp assembly

- a. Remove trunk lid trim. Refer to “Trunk Room Trim” in “INTERIOR TRIM” for details, BT-32.
- b. Remove trunk lid finisher. Refer to “Trunk lid finisher” in “EXTERIOR” for details, BT-40.
- c. Remove license plate finisher. Refer to “License plate finisher” in “EXTERIOR” for details, BT-38.
- d. Remove back up lamp assembly.



# BODY END

## Body Rear End and Opener (Cont'd)

SEC. 767•843•850

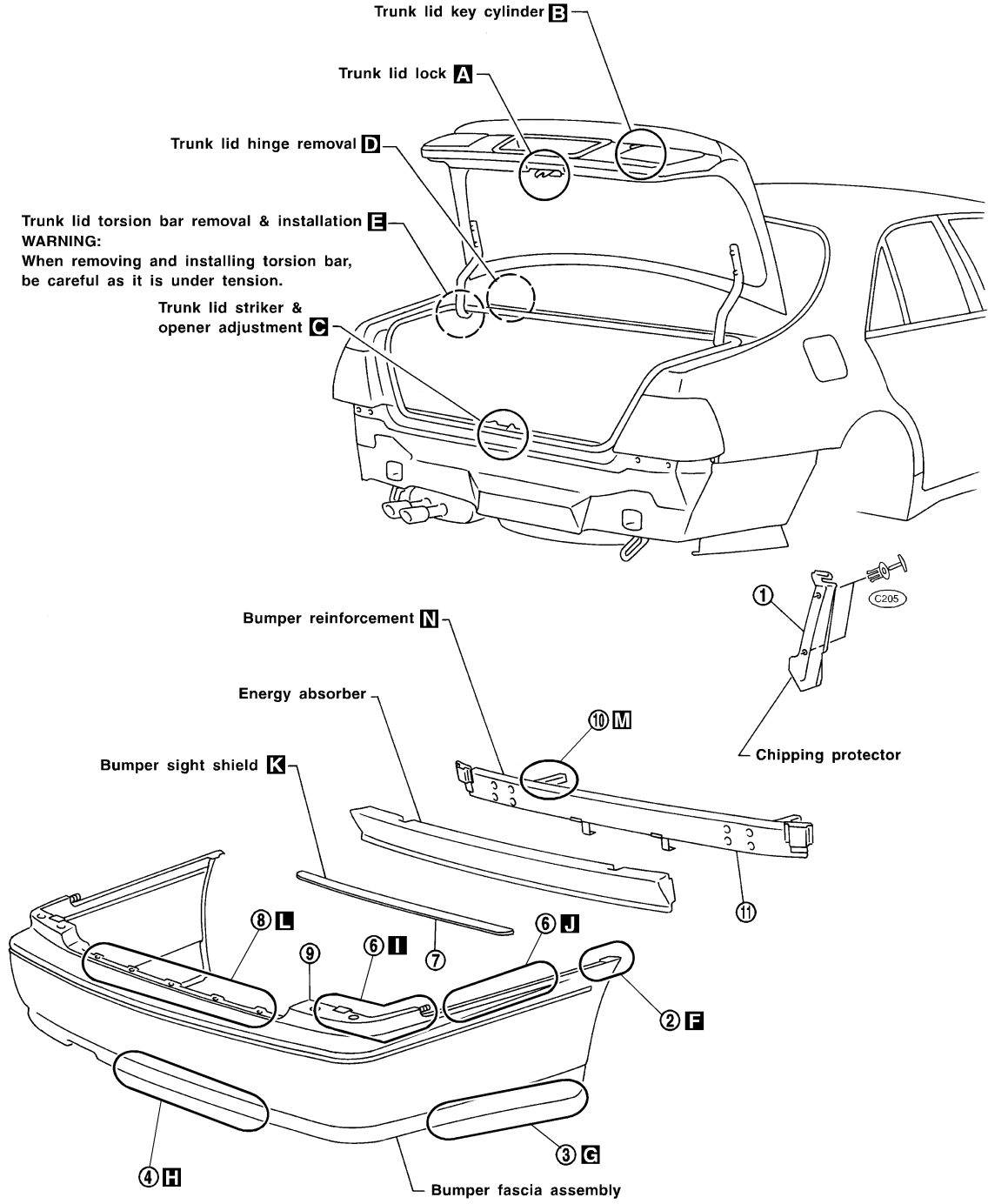

GI  
MA  
EM  
LC  
EC  
FE  
AT  
PD  
FA  
RA  
BR  
ST  
RS  
BT  
HA  
EL  
IDX

- I** : 5.1 - 6.5 N•m (0.52 - 0.66 kg-m, 45.1 - 57.3 in-lb)
- J** : 5.1 - 6.5 N•m (0.52 - 0.66 kg-m, 45.1 - 57.3 in-lb)
- M** : 77 - 98 (7.9 - 10.0, 57 - 72)
- N** : 13 - 16 (1.3 - 1.6, 9 - 12)
- U** : N•m (kg-m, ft-lb)

# BODY END

## Body Rear End and Opener (Cont'd)

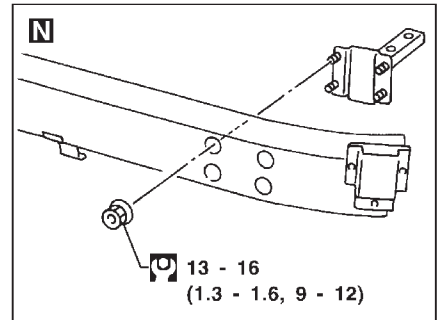
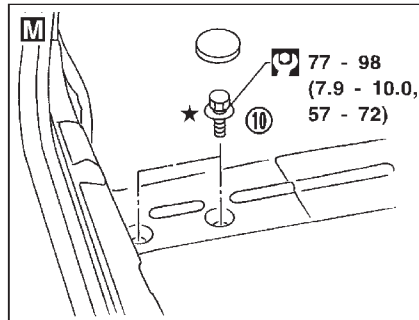
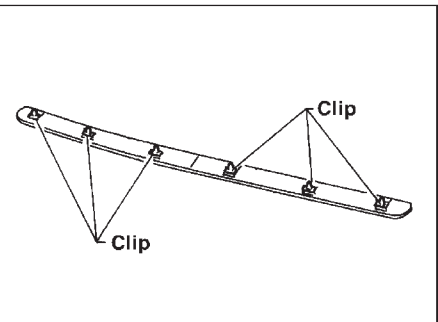
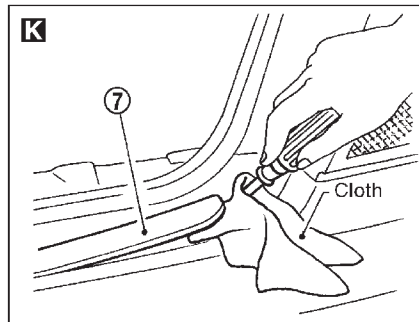
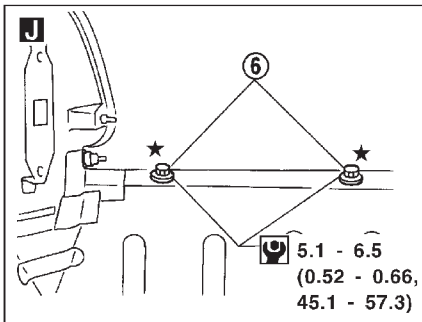
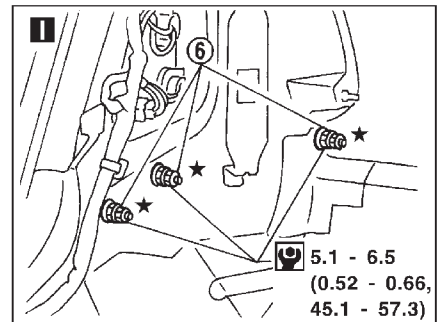
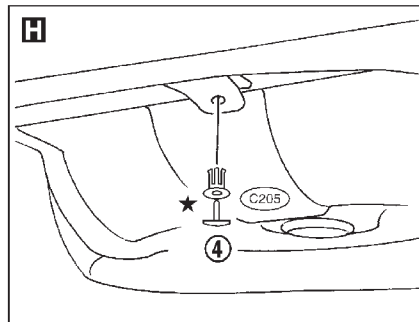
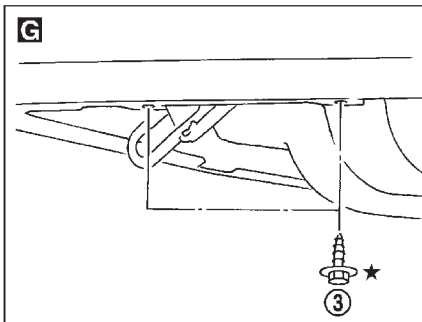
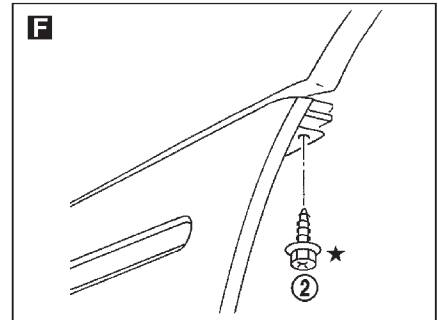
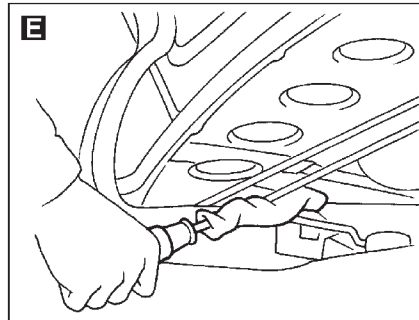
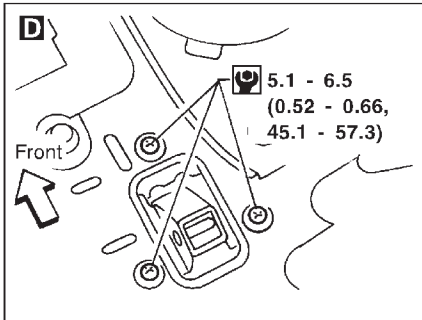
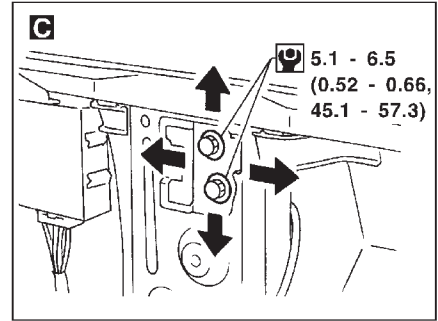
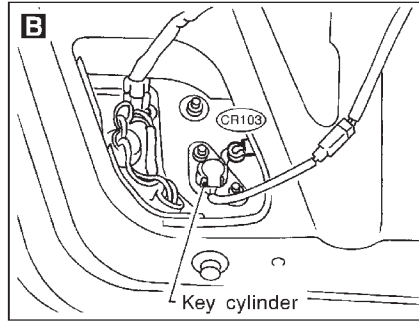
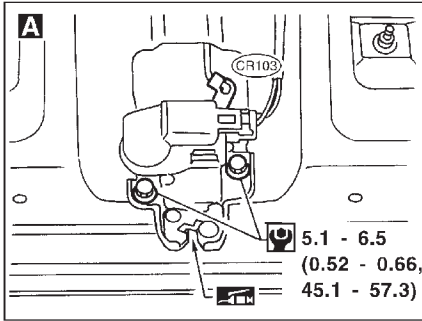

: N•m (kg-m, in-lb)  
 : N•m (kg-m, ft-lb)

★ : Bumper assembly mounting bolts, nuts and clips



## Front Door Limit Switch Reset

### RESET CONDITIONS

After each of the following operations are performed, reset the limit switch (with built-in motor).

- Regulator removal and installation
- Removal of motor from regulator
- Operation of regulator as a single unit
- Door glass removal and installation
- Glass run removal and installation

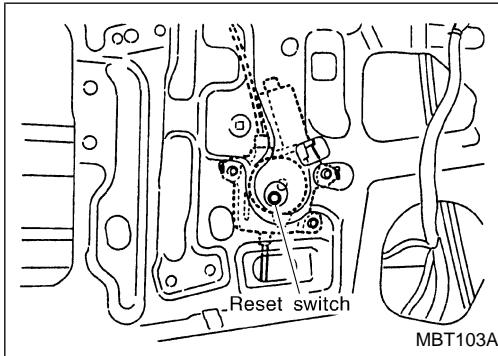

### RESET PROCEDURES

After installing parts, proceed as follows:

1. Close the door window completely.
2. Press the reset switch and open the door window completely.
3. Release the reset switch. After making sure the reset switch has returned to the original position, close the door window completely.
4. The limit switch is now reset.

#### **CAUTION:**

**Be sure to manually open or close the door window. (Do not use the automatic open-close procedures.)**

## Rear Door

SEC. 820•823•825

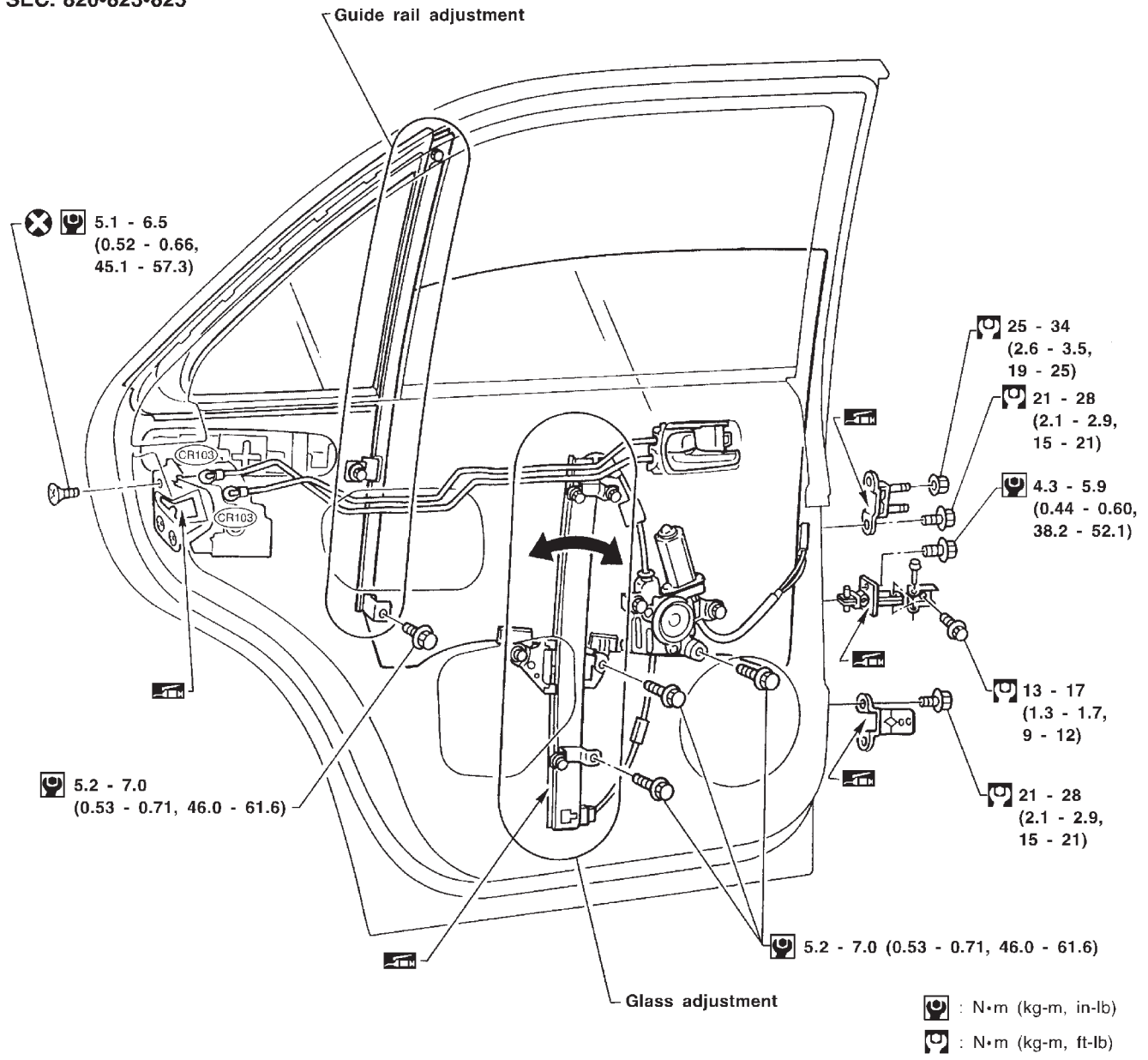

GI  
MA  
EM  
LC  
EC  
FE  
AT  
PD  
FA  
RA  
BR  
ST  
RS  
BT  
HA  
EL  
IDX

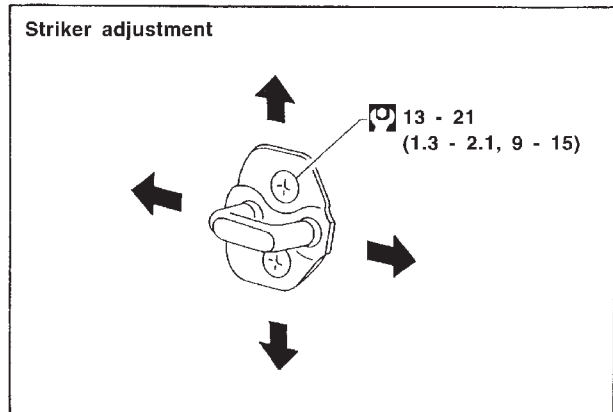
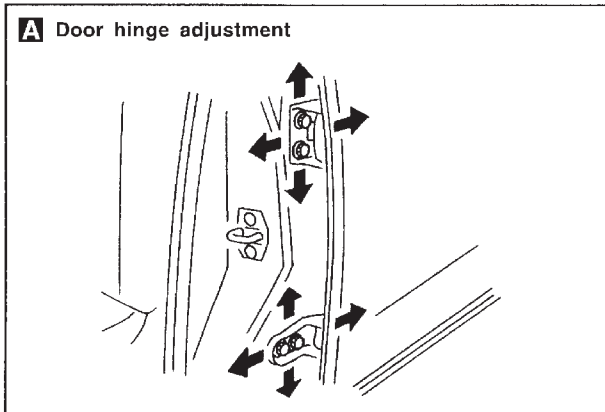

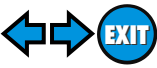

**CAUTION:**

- Disconnect both battery cables in advance.
- Disconnect air bag system line in advance.
- Never tamper with or force air bag lid open, as this may adversely affect air bag performance.
- Be careful not to scratch pad and other parts.

# INSTRUMENT PANEL

## REMOVAL — Instrument panel assembly

Instrument panel assembly	Combination meter	Audio & A/C control	Console box	
Remove air bag module (driver) and steering wheel. Refer to "SUPPLEMENTAL RESTRAINT SYSTEM" in RS section for details.				GI
Remove dash side lower finishers. Refer to "Side and Floor Trim" in "INTERIOR TRIM" for details, BT-26.				MA
① Steering column cover and combination switch ● Remove screws.				EM
② Instrument lower panel on driver side ● Remove screws and bolts then disconnect harness connectors and in-vehicle sensor duct.				LC
③ Instrument lower reinforcement ● Remove bolts.				EC
	Steering column mounting nuts. Refer to "STEERING WHEEL AND STEERING COLUMN" in ST section for details.			FE
④ Cluster lid A ● Remove screws.				AT
⑤ Steering lock escutcheon ● Remove screws.				PD
⑥ Cluster lid D				FA
⑦ Combination meter ● Remove screws then disconnect harness connectors.				RA
⑧ Instrument lower cover on passenger side ● Then disconnect passenger air bag module connector.				BR
⑨ Glove box assembly ● Remove screws. ● Then disconnect harness connectors.				ST
⑩ Instrument panel reinforcement ● Remove screws.				RS
⑪ Passenger air bag module ● Refer to "SUPPLEMENTAL RESTRAINT SYSTEM" in RS section for details.				BT
⑫ Center ventilation grille ● Pull out with a miniature flat-bladed screwdriver.				HA
⑬ Lock console				EL
⑭ Card pocket assembly ● Remove screws.				IDX
⑮ Console A/T finisher				
⑯ Audio, cluster lid C and A/C control unit ● Remove screws from the instrument panel.				
⑰ Console box assembly ● Remove screws then disconnect harness connectors.				
⑱ Defroster grille ● Then remove sunload sensor.				
⑲ Sunload sensor ● Then disconnect harness connector.				
⑳ Front pillar garnish ● Refer to "Side and Floor Trim" in "INTERIOR TRIM" for details, BT-26.				
㉑ Instrument panel and pads ● Remove bolts. ● Disconnect SMJ of instrument harness. Note: Remove instrument panel and pads with instrument harness.				

# INSTRUMENT PANEL

SEC. 248•272•280•487•680•685•969

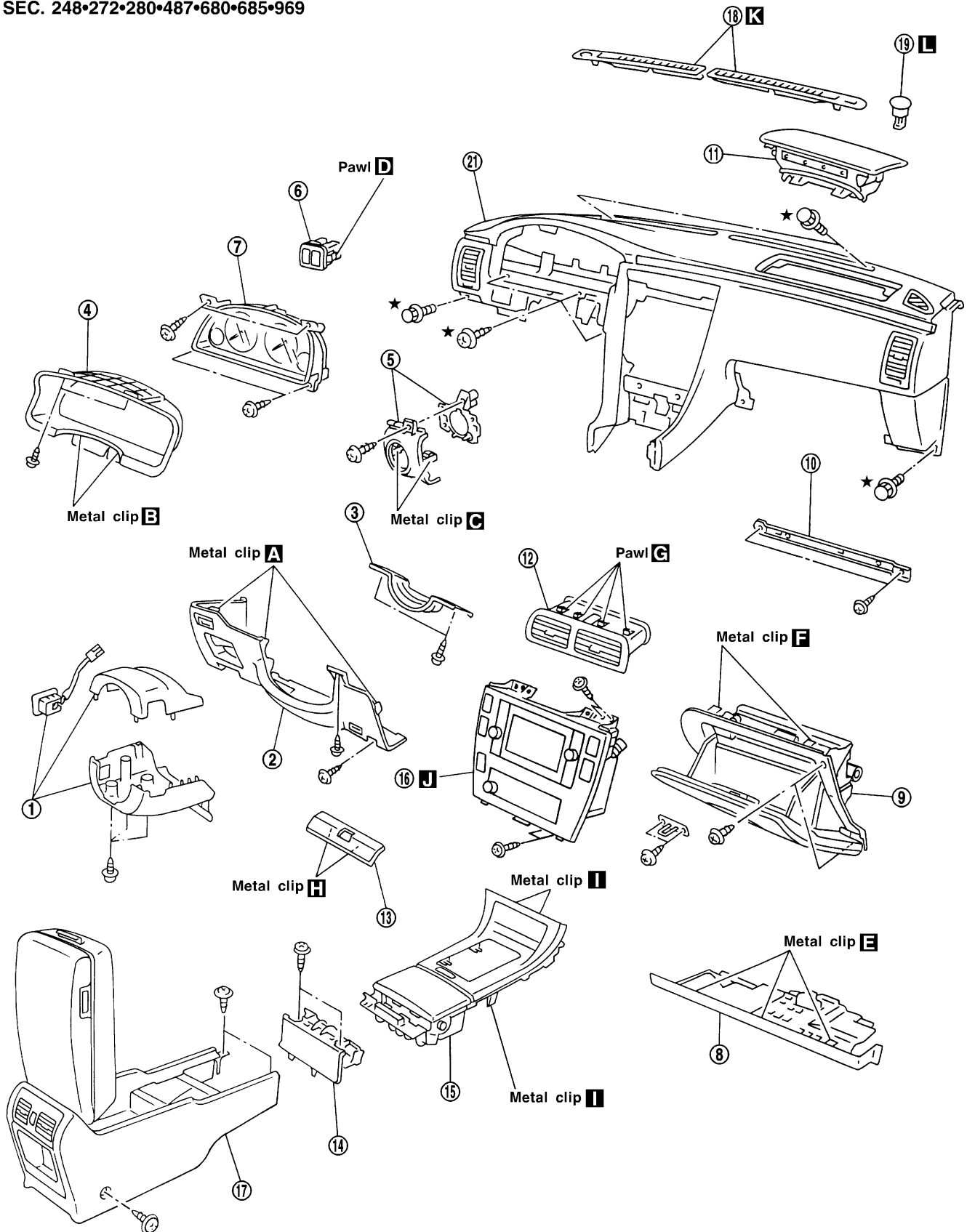



GI  
MA  
EM  
LC  
EC  
FE  
AT  
PD  
FA  
RA  
BR  
ST  
RS  
BT  
HA  
EL  
IDX

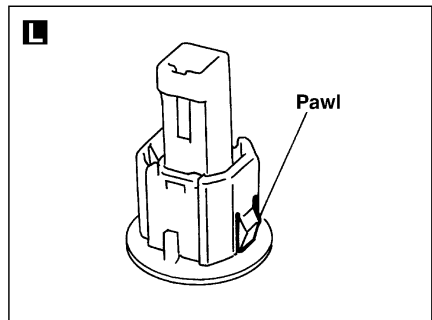
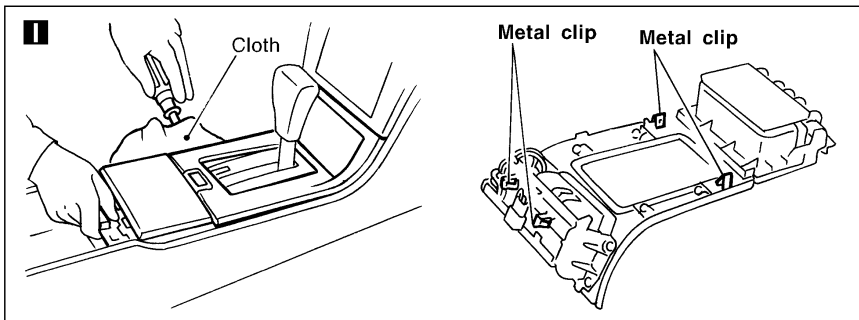
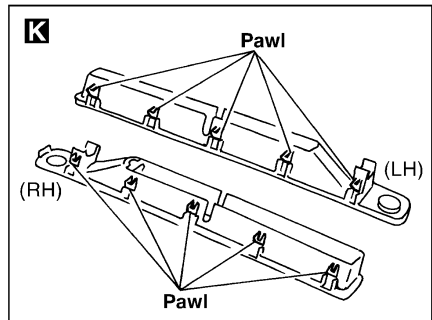
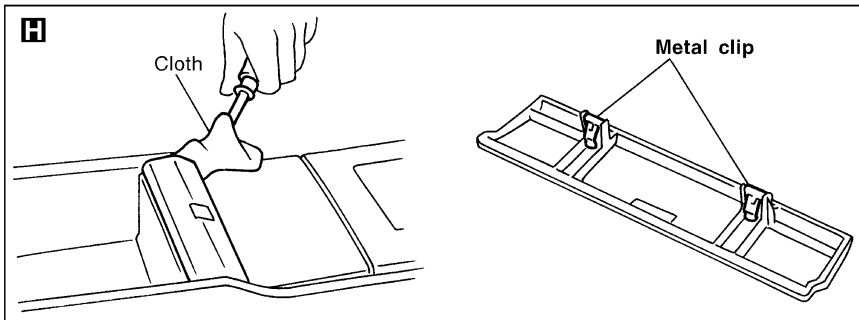
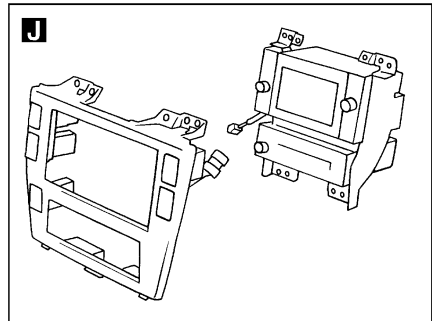
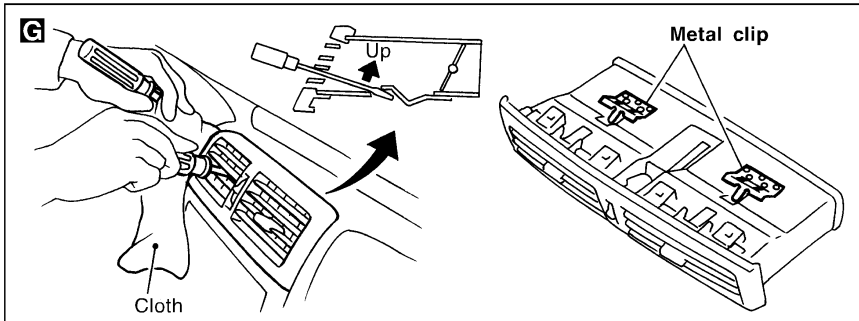
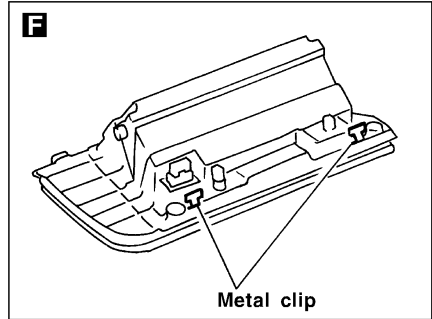
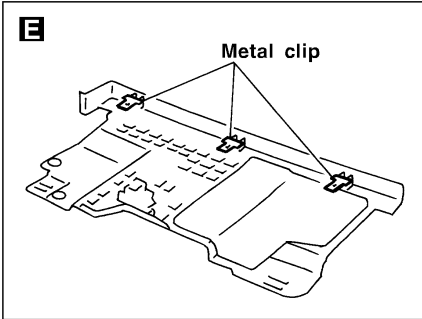
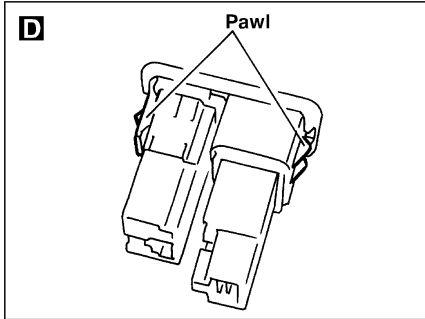
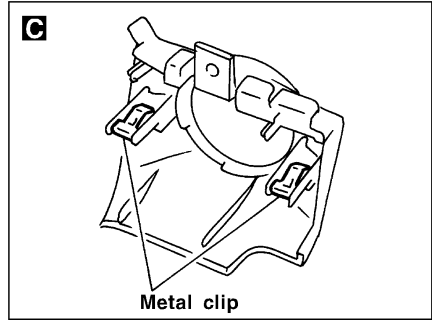
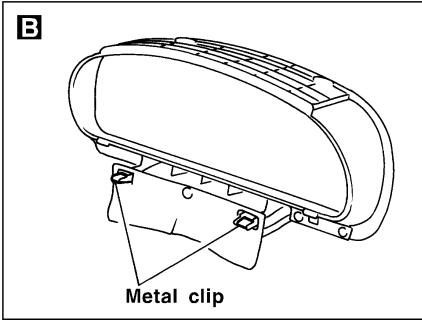
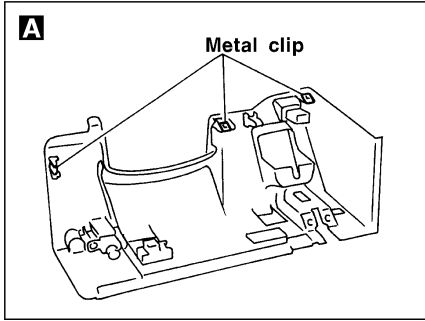

# INTERIOR TRIM

## Side and Floor Trim

### CAUTION:

Wrap the tip of flat-bladed screwdriver with a cloth when removing metal clips from garnishes.

### REMOVAL — Body side trim

- ① Remove front and rear seats. Refer to "SEAT" for details, BT-42.
- ② Remove front and rear seat belts. Refer to "SEAT BELTS" in RS section for details.
- ③ Remove front and rear kicking plates. **B**
- ④ Remove dash side lower finishers.
- ⑤ Remove front and rear body side welts.
- ⑥ Remove front pillar garnishes. **C**
- ⑦ Remove center pillar lower garnishes. **D**
- ⑧ Remove center pillar upper garnishes.
- ⑨ Remove rear pillar garnishes. **E**
- ⑩ Remove high-mounted stop lamp cover and high-mounted stop lamp.
- ⑪ Remove rear parcel shelf. **F**

SEC. 746•769•799

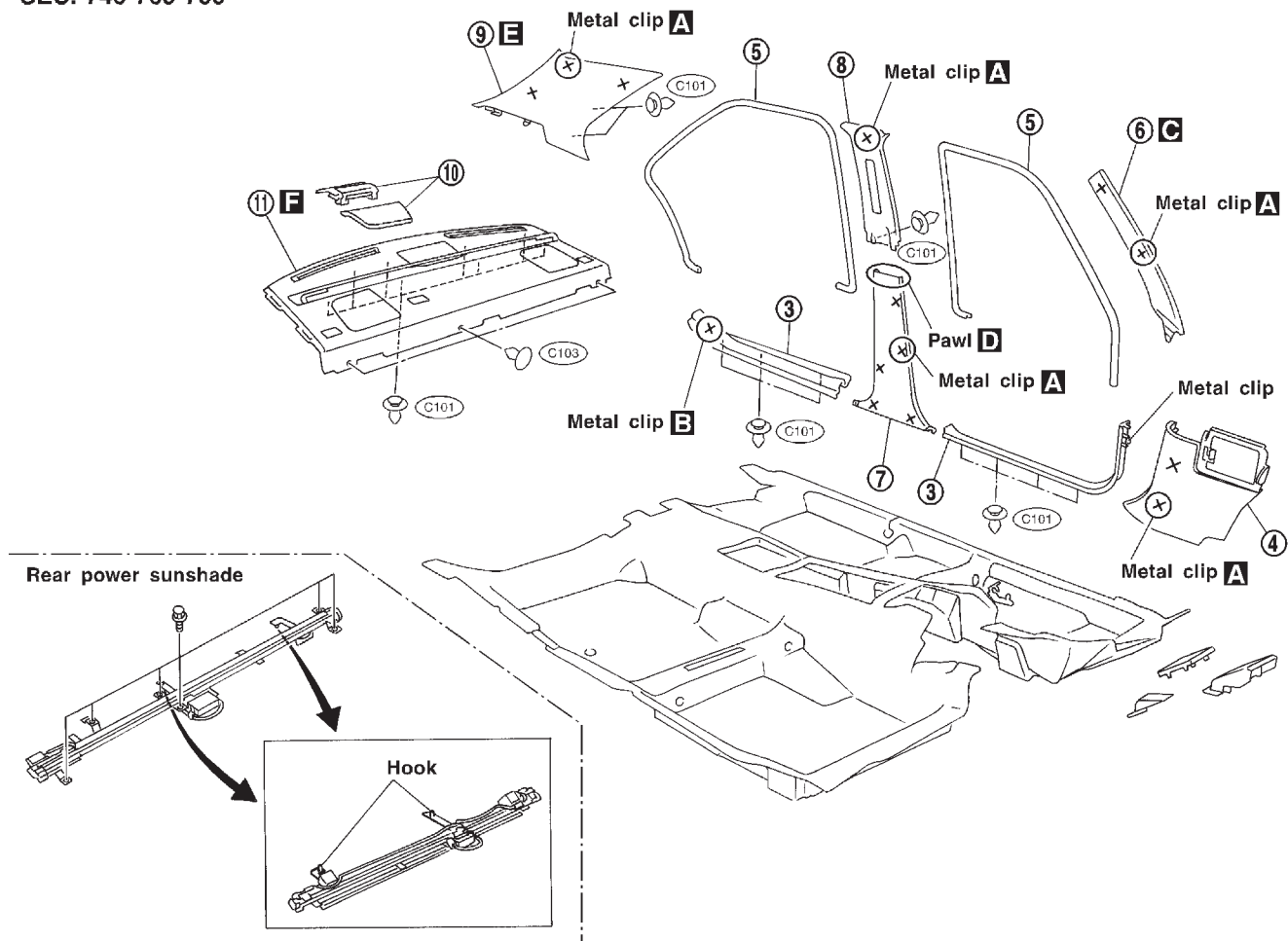

SBT667

# INTERIOR TRIM

## Side and Floor Trim (Cont'd)

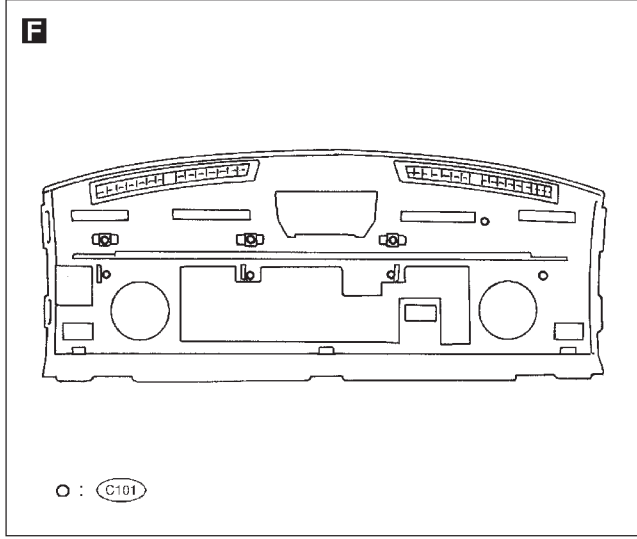
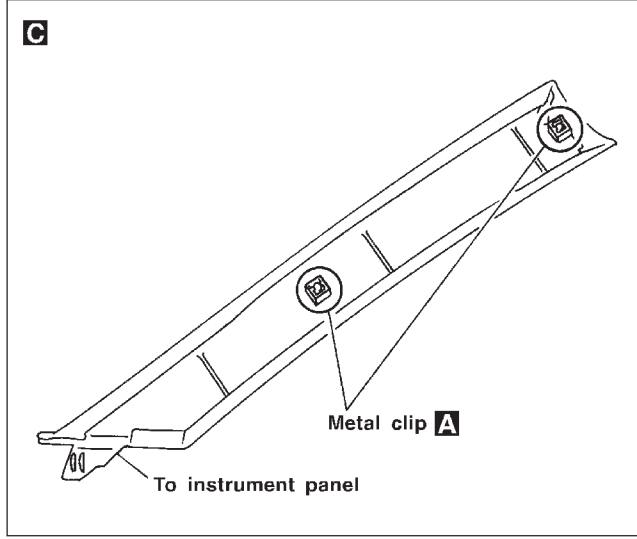
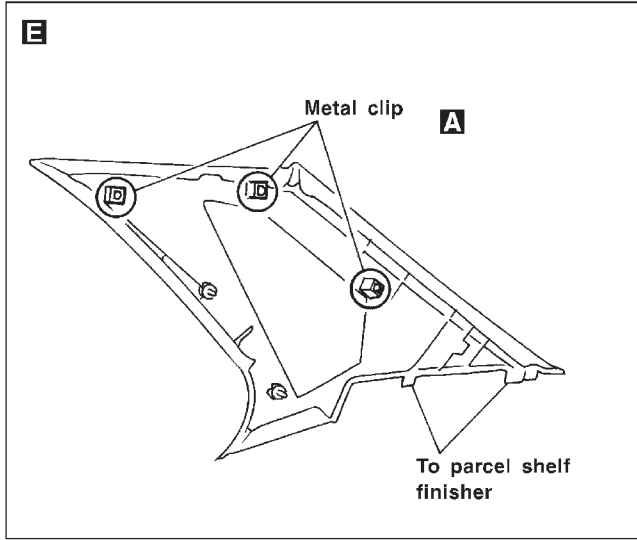
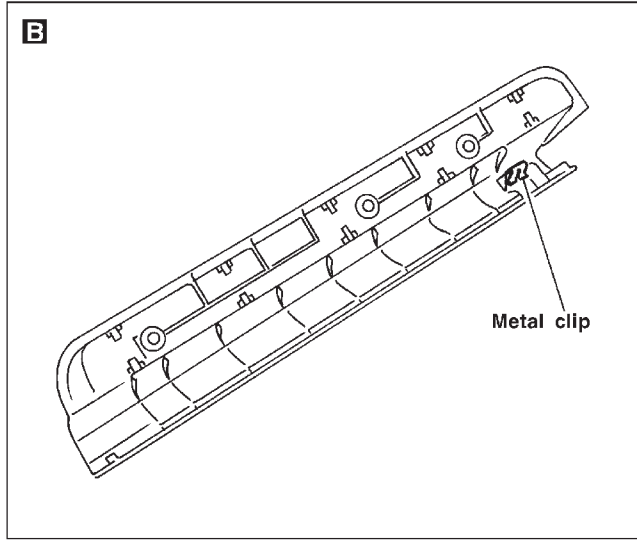
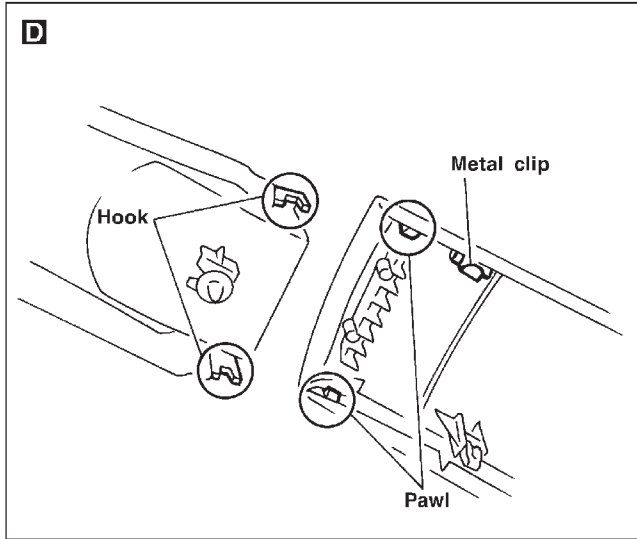
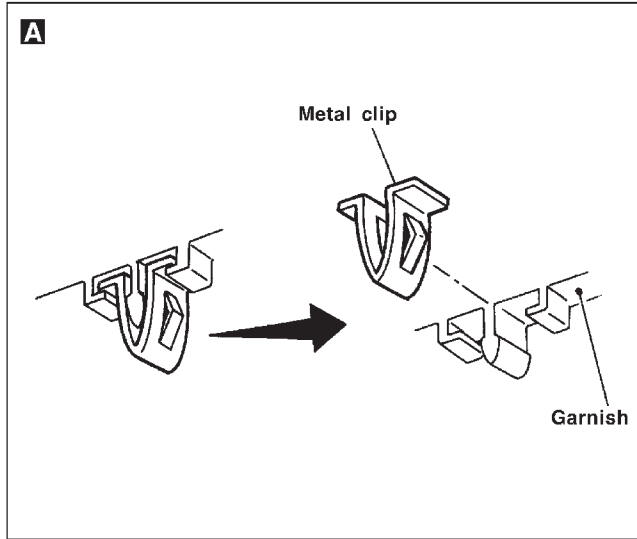

- GI
- MA
- EM
- LC
- EC
- FE
- AT
- PD
- FA
- RA
- BR
- ST
- RS
- BT**
- HA
- EL
- IDX

## Door Trim

### REMOVAL — Door trim

#### Front door trim

- ① Remove inside handle escutcheon, then disconnect auto drive positioner connector. **A**
- ② Remove door armrest. **B**
- ③ Remove power window switches, then disconnect the connectors. **C**
- ④ Remove door step lamp, then disconnect step lamp connector. **D**
- ⑤ Remove bolts securing door finisher.
- ⑥ Pull on door finisher to remove clip from door panel and remove door finisher, then disconnect trunk lid and fuel lid opener switch connector.

#### Rear door trim

- ⑦ Remove inside handle escutcheon. **E**
- ⑧ Remove door armrest. **F**
- ⑨ Remove ash tray, then remove screw securing power window switch.
- ⑩ Remove power window switch, then disconnect power window switch connector. **G**
- ⑪ Remove door step lamp, then disconnect step lamp connector. **D**
- ⑫ Remove bolts securing door finisher.
- ⑬ Pull on door finisher to remove clips from door panel and remove door finisher.

SEC. 251•809•828

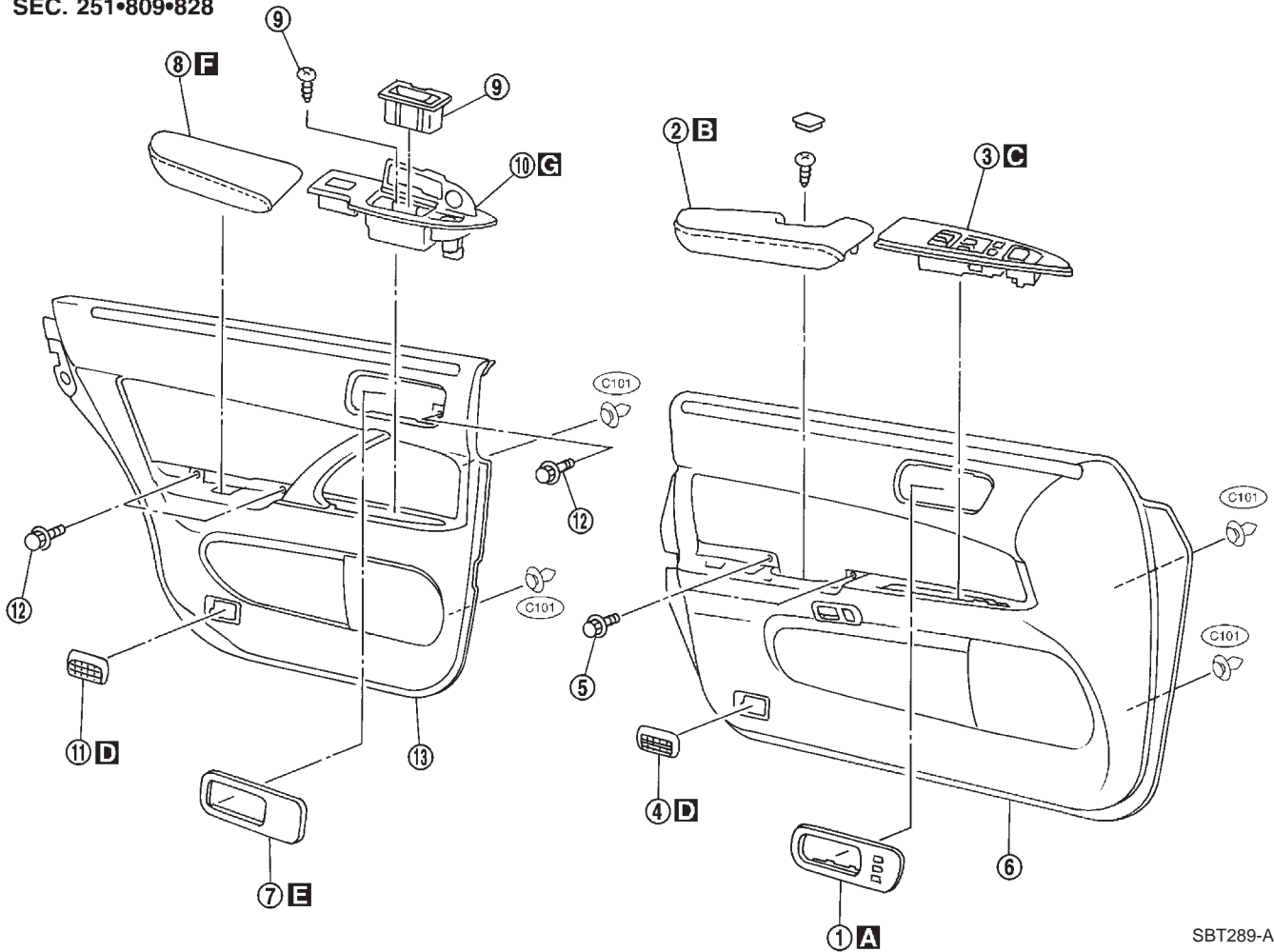

SBT289-A

# INTERIOR TRIM

## Door Trim (Cont'd)

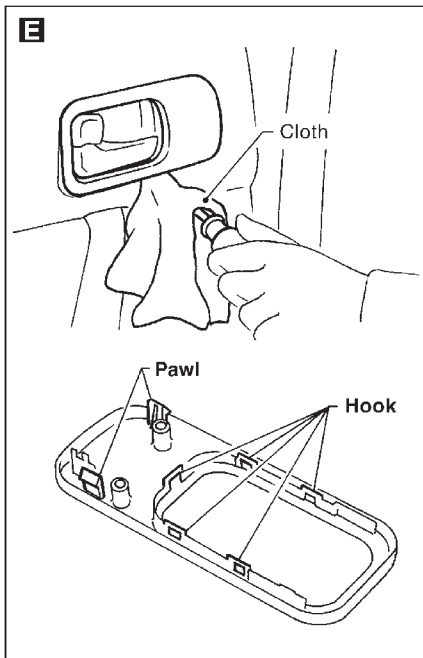
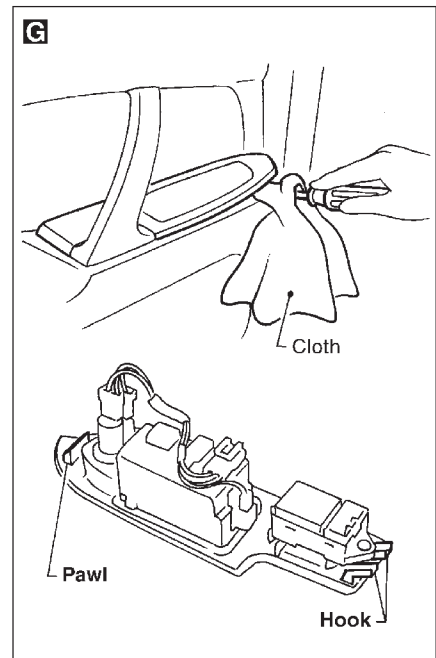
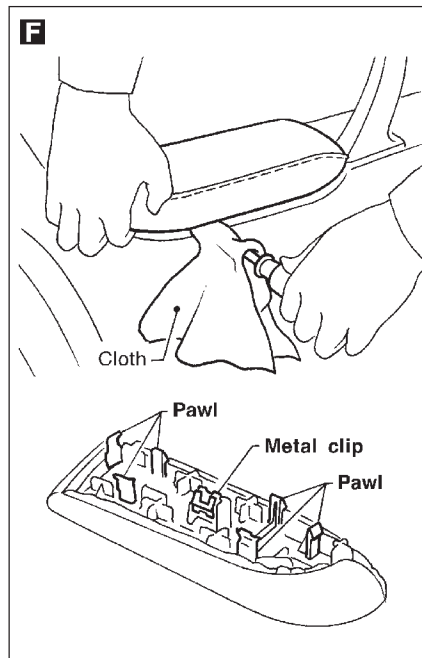
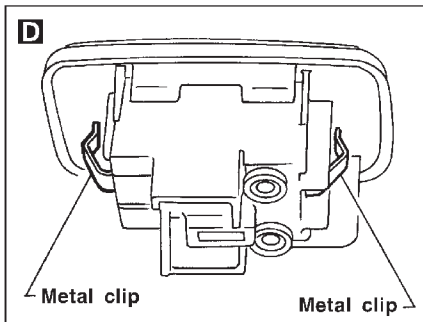
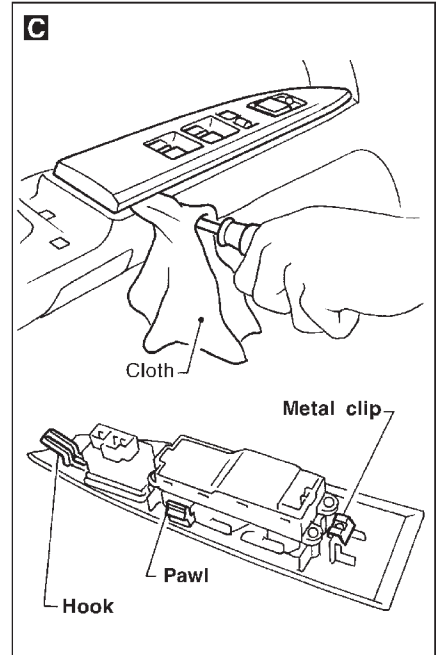
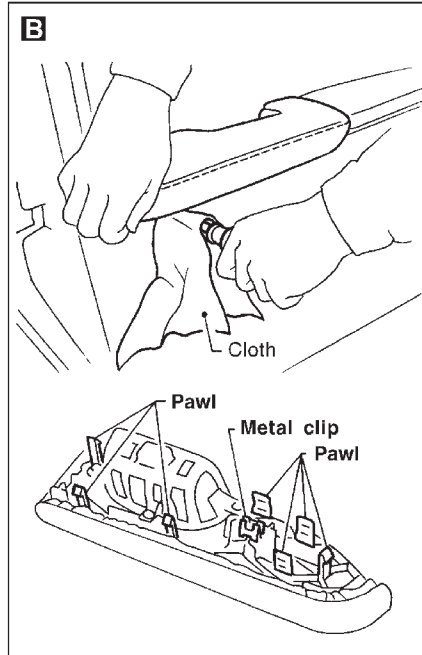
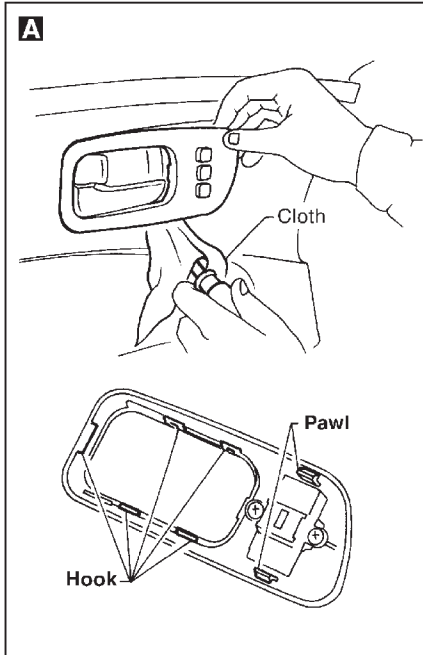

GI  
MA  
EM  
LC  
EC  
FE  
AT  
PD  
FA  
RA  
BR  
ST  
RS  
BT  
HA  
EL  
IDX

# INTERIOR TRIM

## Roof Trim

### REMOVAL — Headlining

- ① Remove front and rear seats. Refer to “SEAT” for details, BT-42.
- ② Remove instrument panel. Refer to “INSTRUMENT PANEL” for details, BT-22.
- ③ Remove front and rear seat belts. Refer to “SEAT BELTS” in RS section for details.
- ④ Remove body side trim. Refer to “Side and Floor Trim” in “INTERIOR TRIM” for details, BT-26.
- ⑤ Remove sunroof switch or spot lamp switch. **A**
- ⑥ Remove inside mirror assembly. **B**
- ⑦ Remove sun visors. **C**
- ⑧ Remove personal lamps. **D**
- ⑨ Remove assist grips. **E**
- ⑩ Remove metal clips securing headlining.
- ⑪ Remove headlining.

SEC. 264•728•963•964

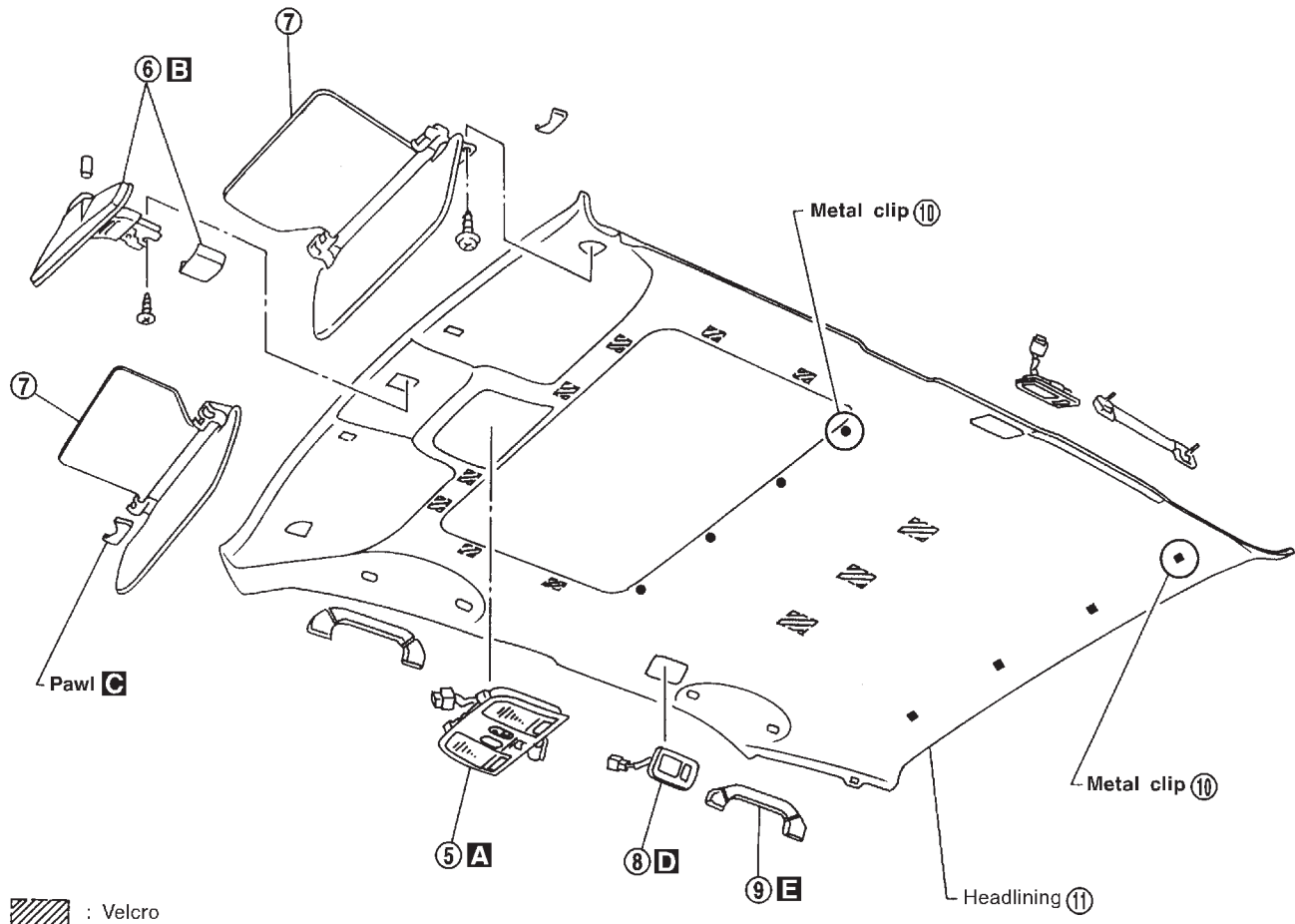

SBT291-B

# INTERIOR TRIM

## Roof Trim (Cont'd)

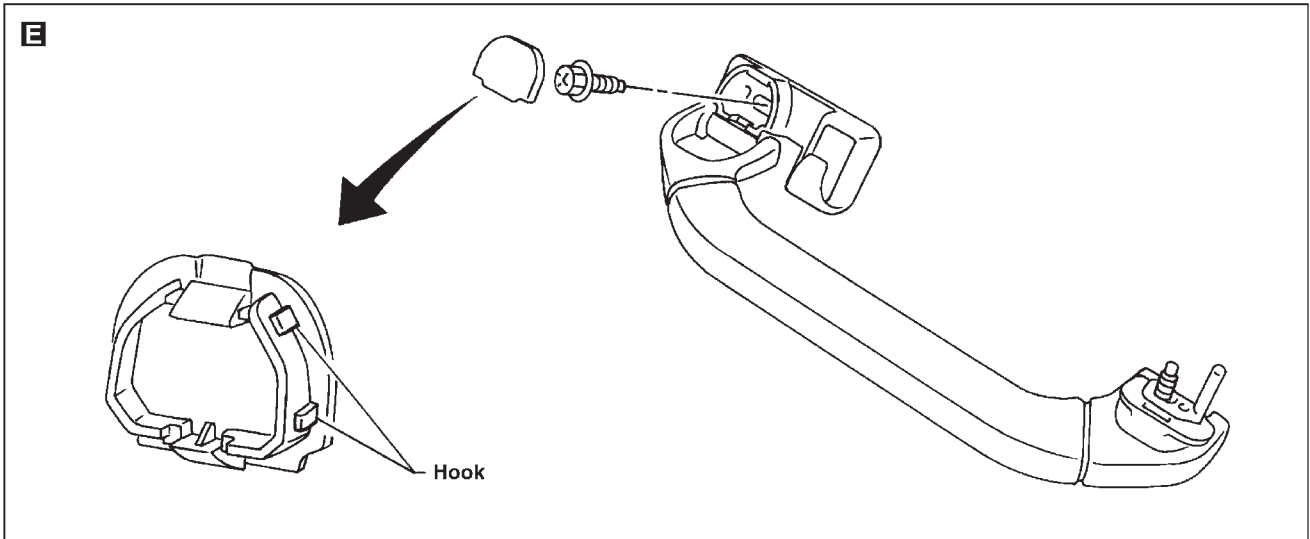
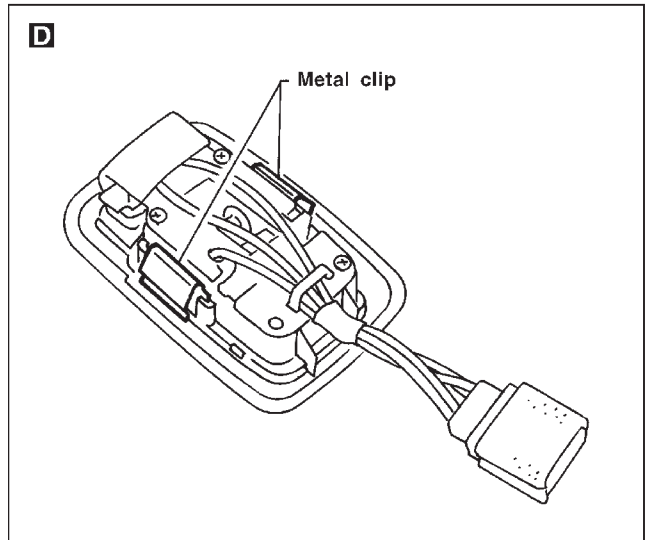
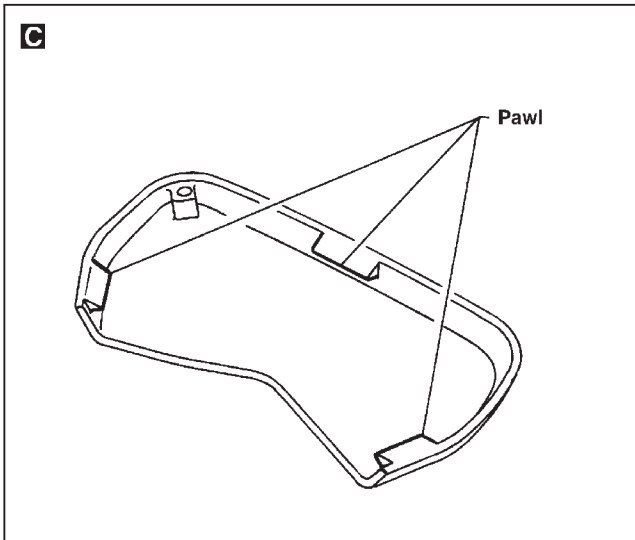
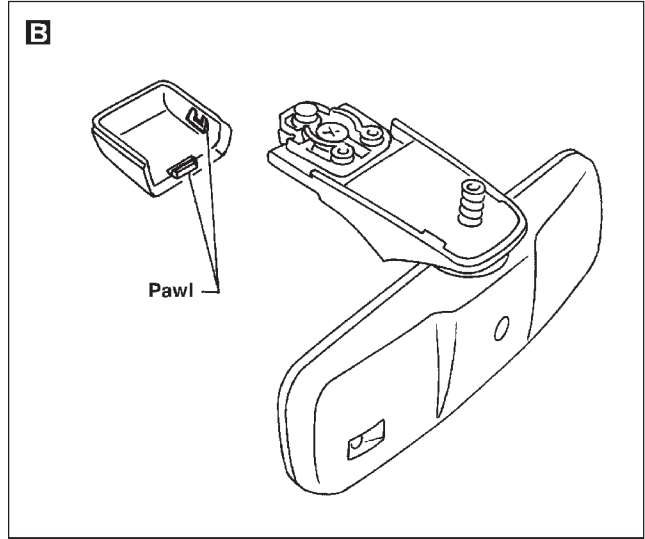
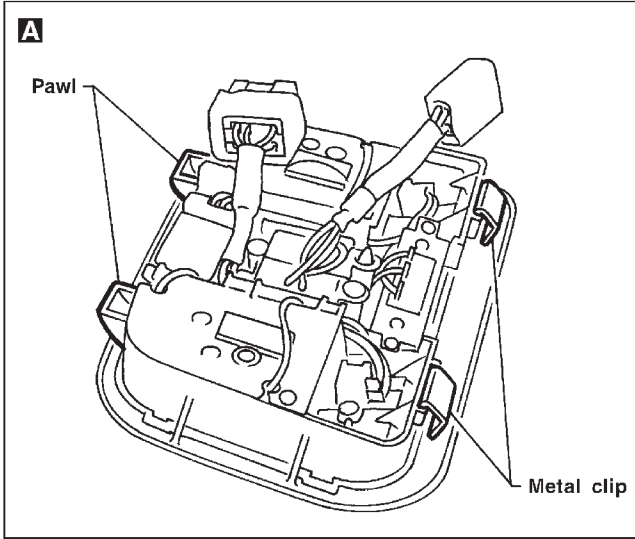

GI  
MA  
EM  
LC  
EC  
FE  
AT  
PD  
FA  
RA  
BR  
ST  
RS  
**BT**  
HA  
EL  
IDX

# INTERIOR TRIM

## Trunk Room Trim

SEC. 849

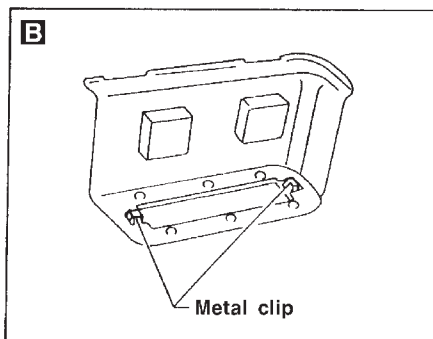
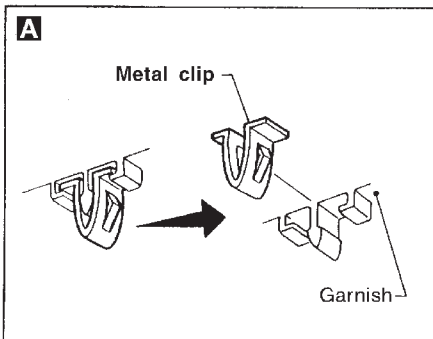
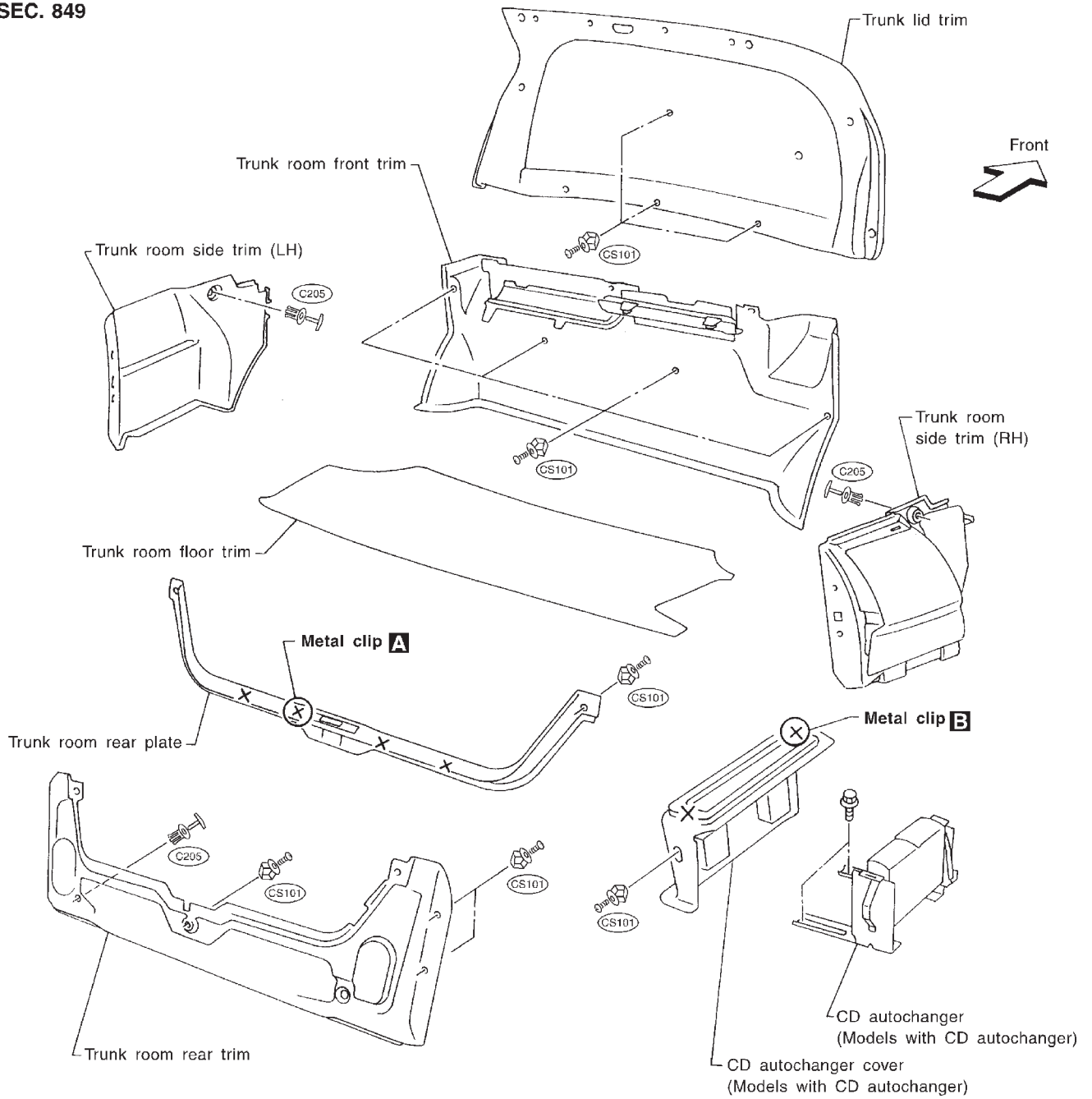



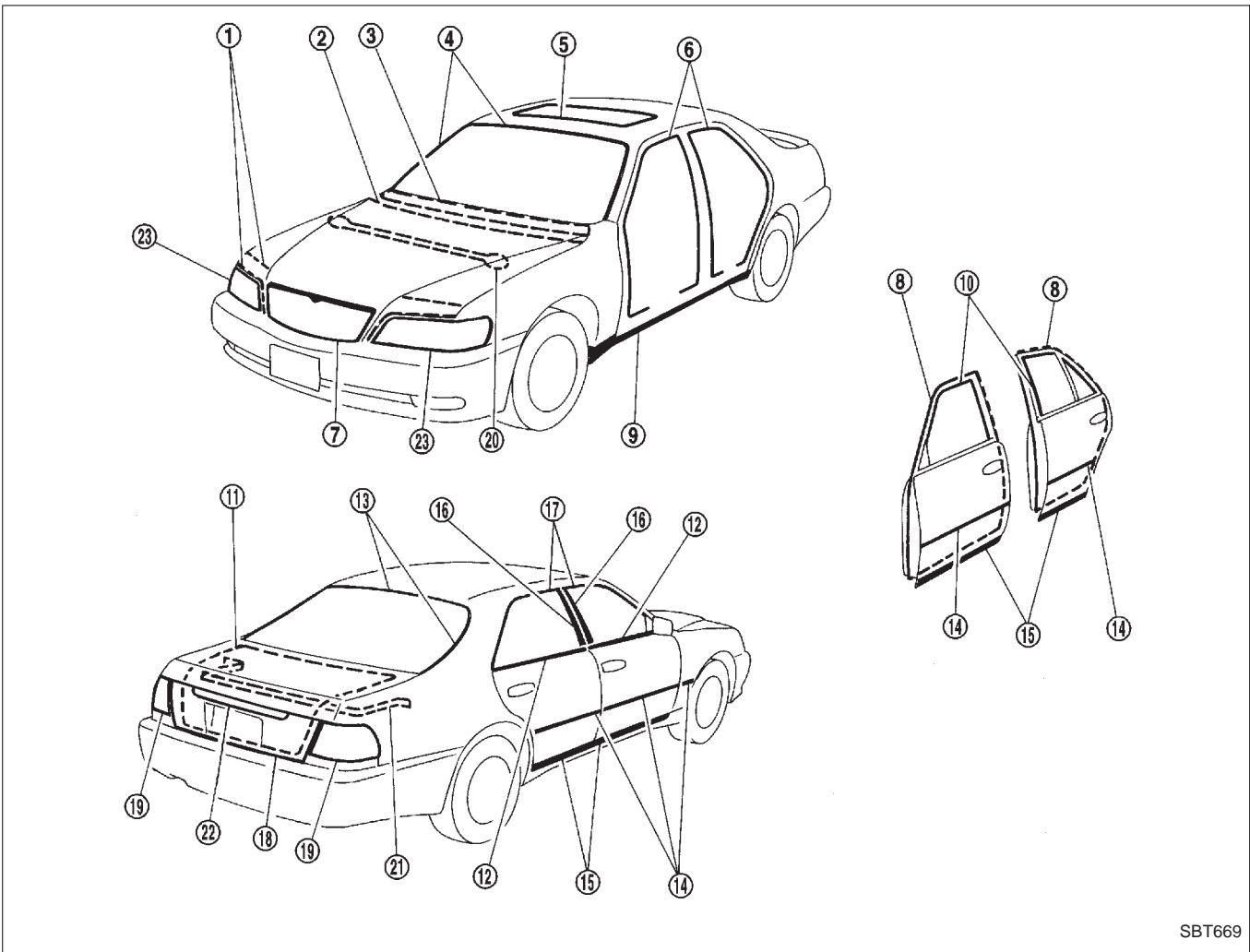

SBT669

① Hood front sealing rubber

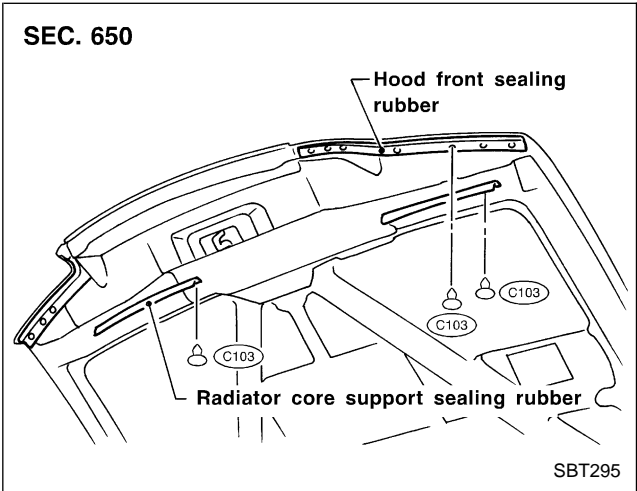

② ③ Cowl top seal and cowl top grille

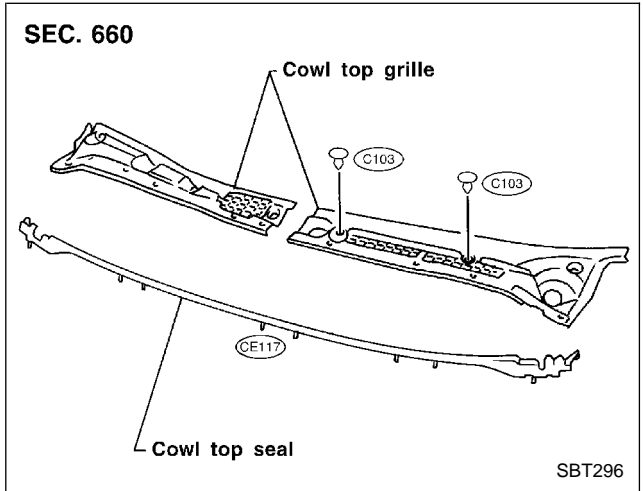

GI  
MA  
EM  
LC  
EC  
FE  
AT  
PD  
FA  
RA  
BR  
ST  
RS  
BT  
HA  
EL  
IDX

## ④ Front windshield molding

### SEC. 720

1. Cut off urethane adhesive at glass end.
2. Remove old urethane adhesive from panel surface.
3. Set molding fastener and apply primer to body panel, and apply urethane adhesive to body.

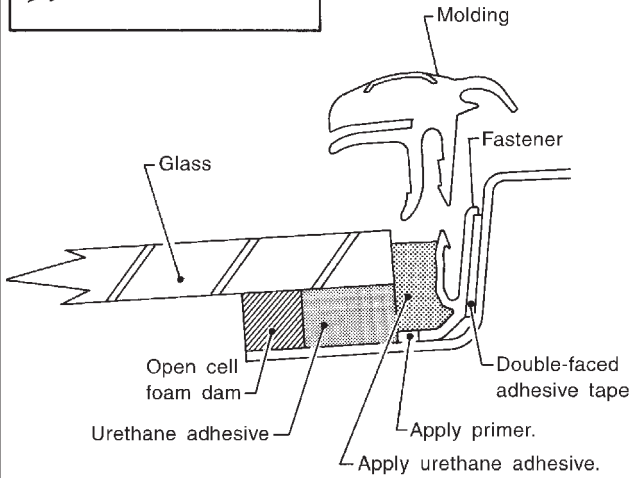
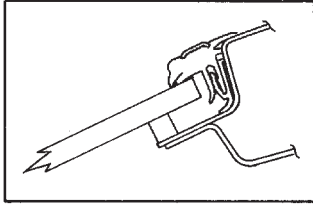

4. Install molding by aligning the molding mark located on center with vehicle center. Be sure to install tightly so that there is no gap around the corner.

SBT297-C

## ⑥ Body side welt

### SEC. 769

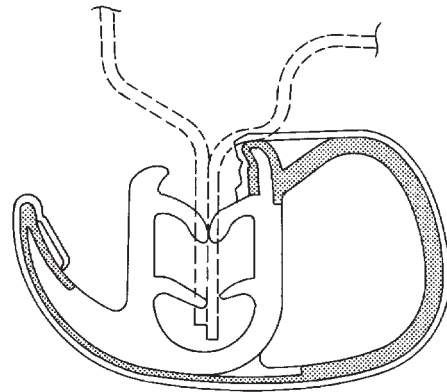

SBT299

## ⑦ Front hood grille

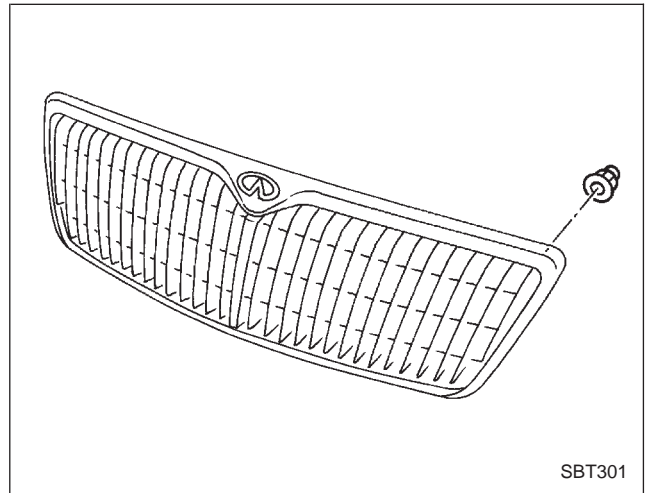

SBT301

## ⑤ Sunroof lid weatherstrip

### SEC. 736

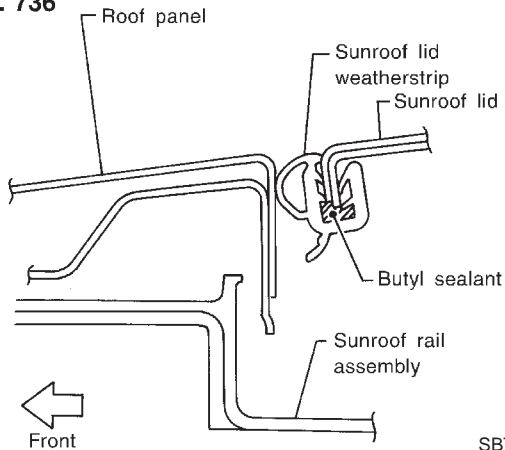

SBT298

## ⑧ Door weatherstrip

### SEC. 800•820

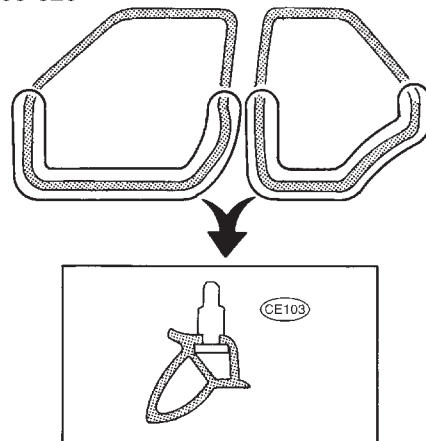

SBT300-A

⑨ Mudguard center

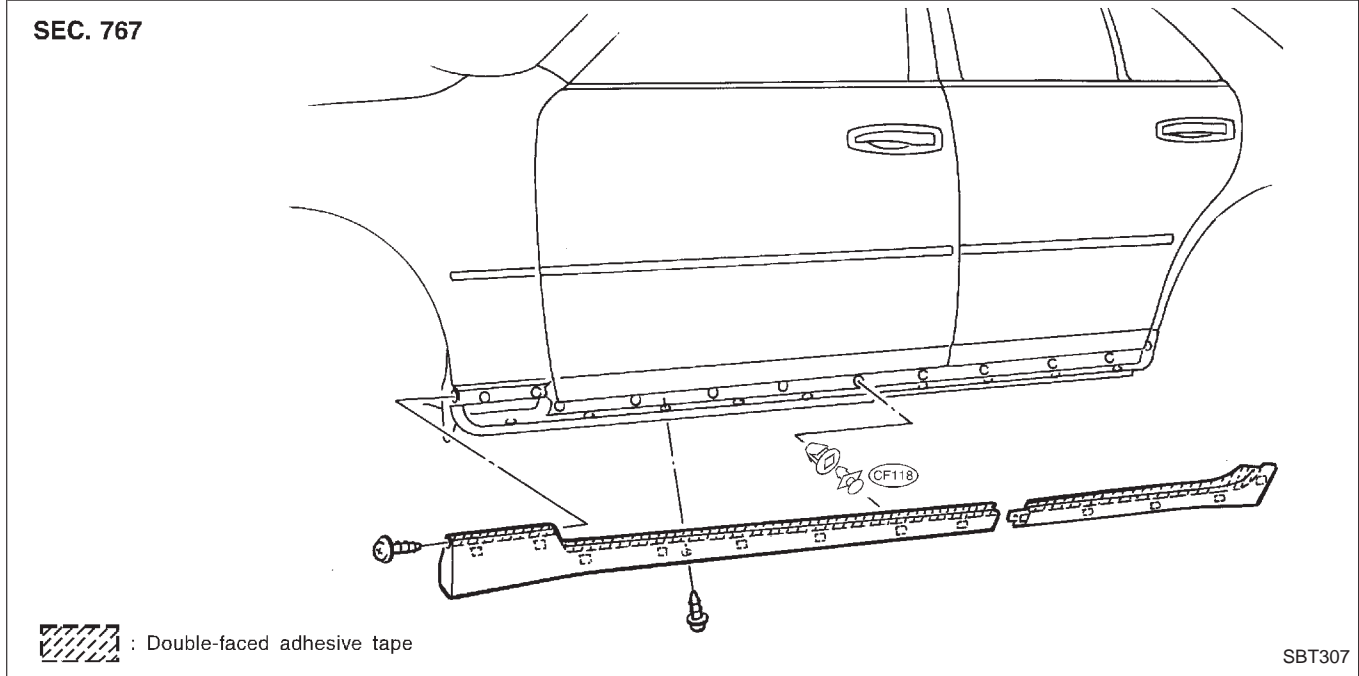

- With a vehicle coated with Hard Clear Coat, use double-faced 3M adhesive tape Product No. 4210 or equivalent, after priming with 3M primer Product No. N-200 or C-100 or equivalent.

⑩ Sash cover inner

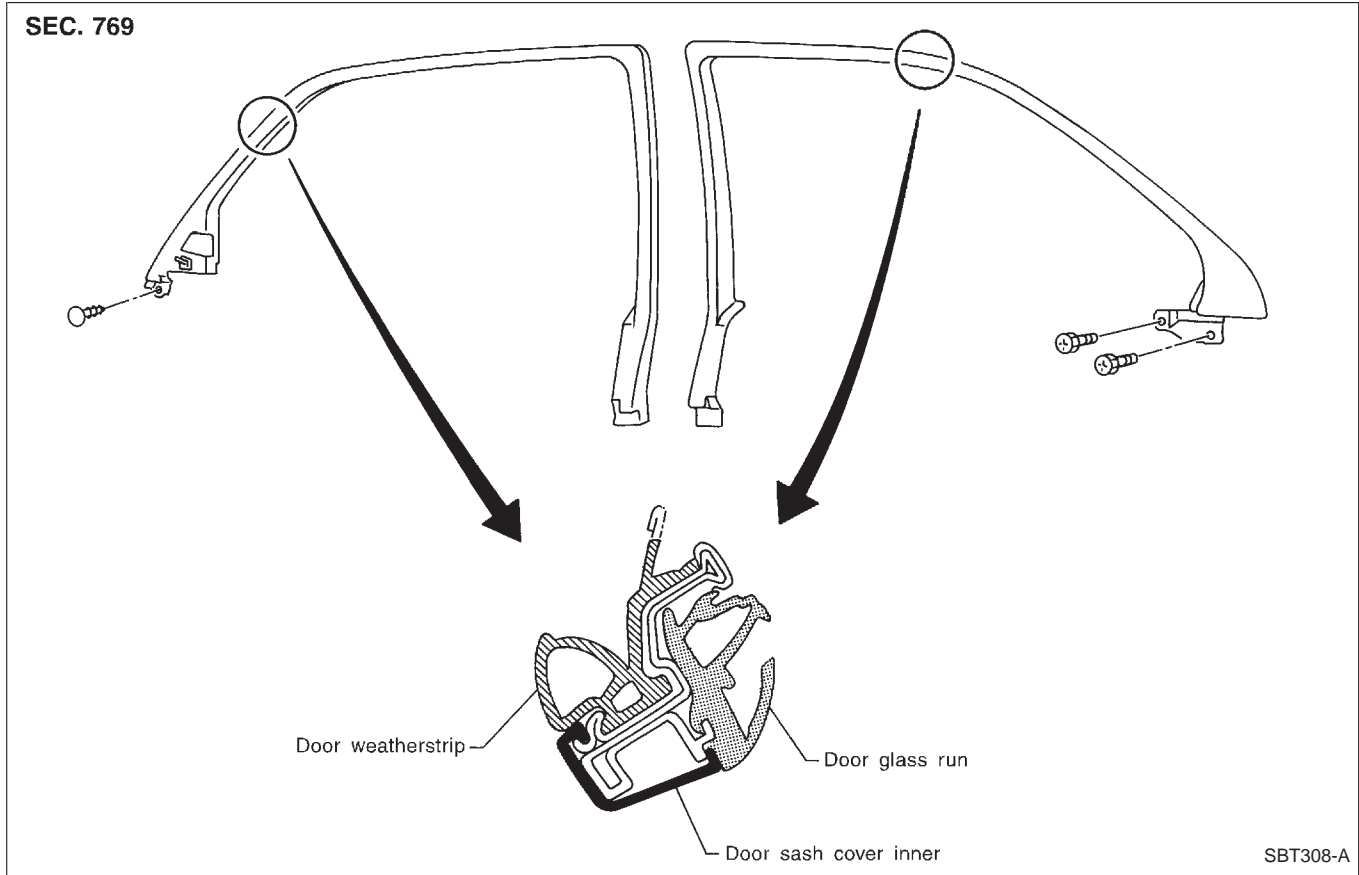

GI  
MA  
EM  
LC  
EC  
FE  
AT  
PD  
FA  
RA  
BR  
ST  
RS  
BT  
HA  
EL  
IDX

## ⑪ Trunk lid weatherstrip

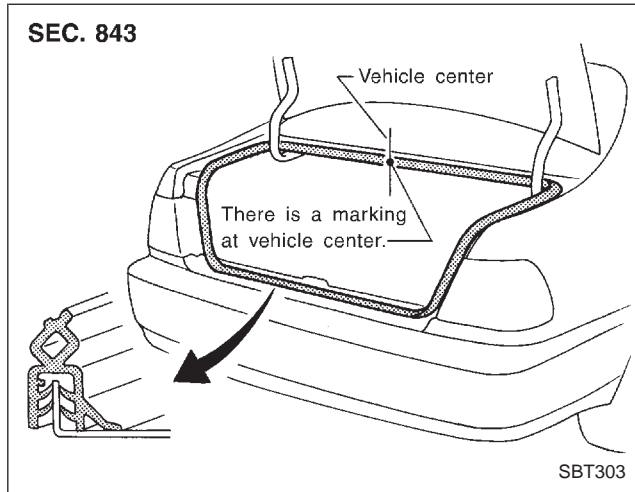

## ⑫ Door outside molding

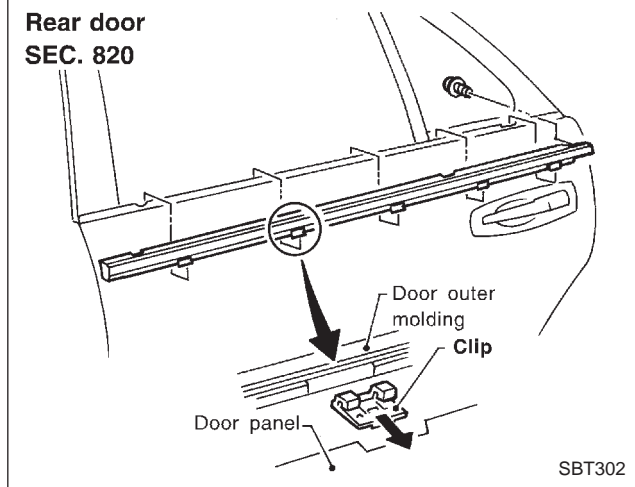
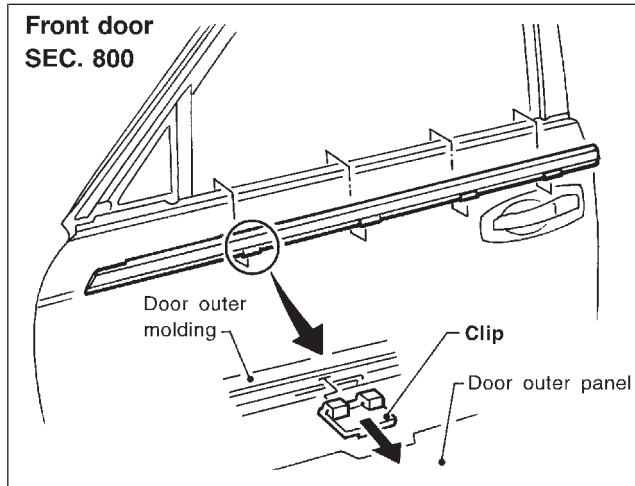

## ⑬ Rear window molding

Basically the same as front windshield molding. Refer to ④ Front windshield molding.

## ⑭ Side guard molding

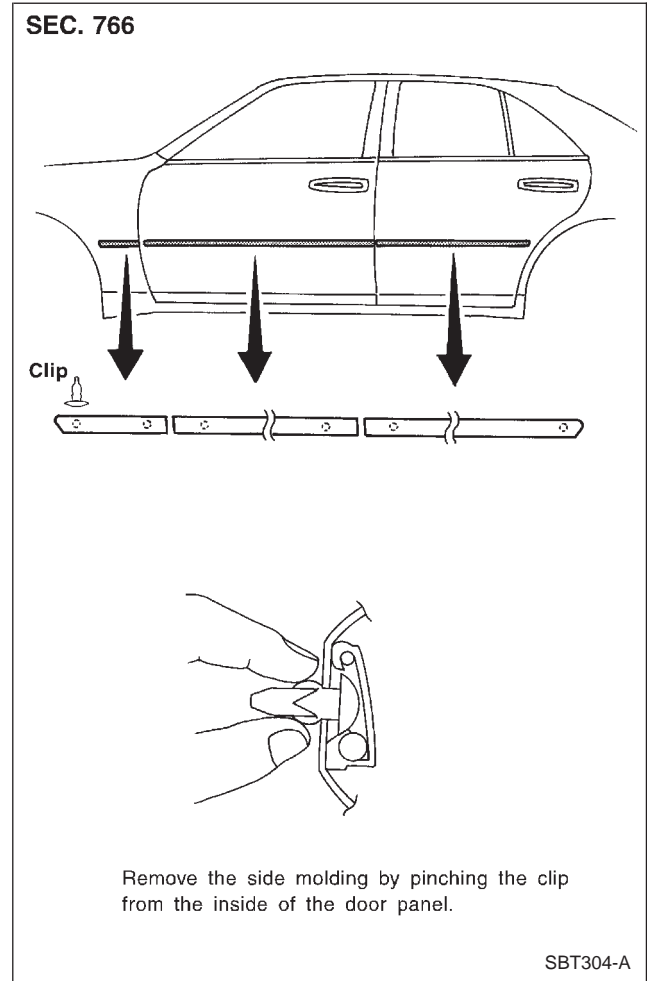

15 Lower molding

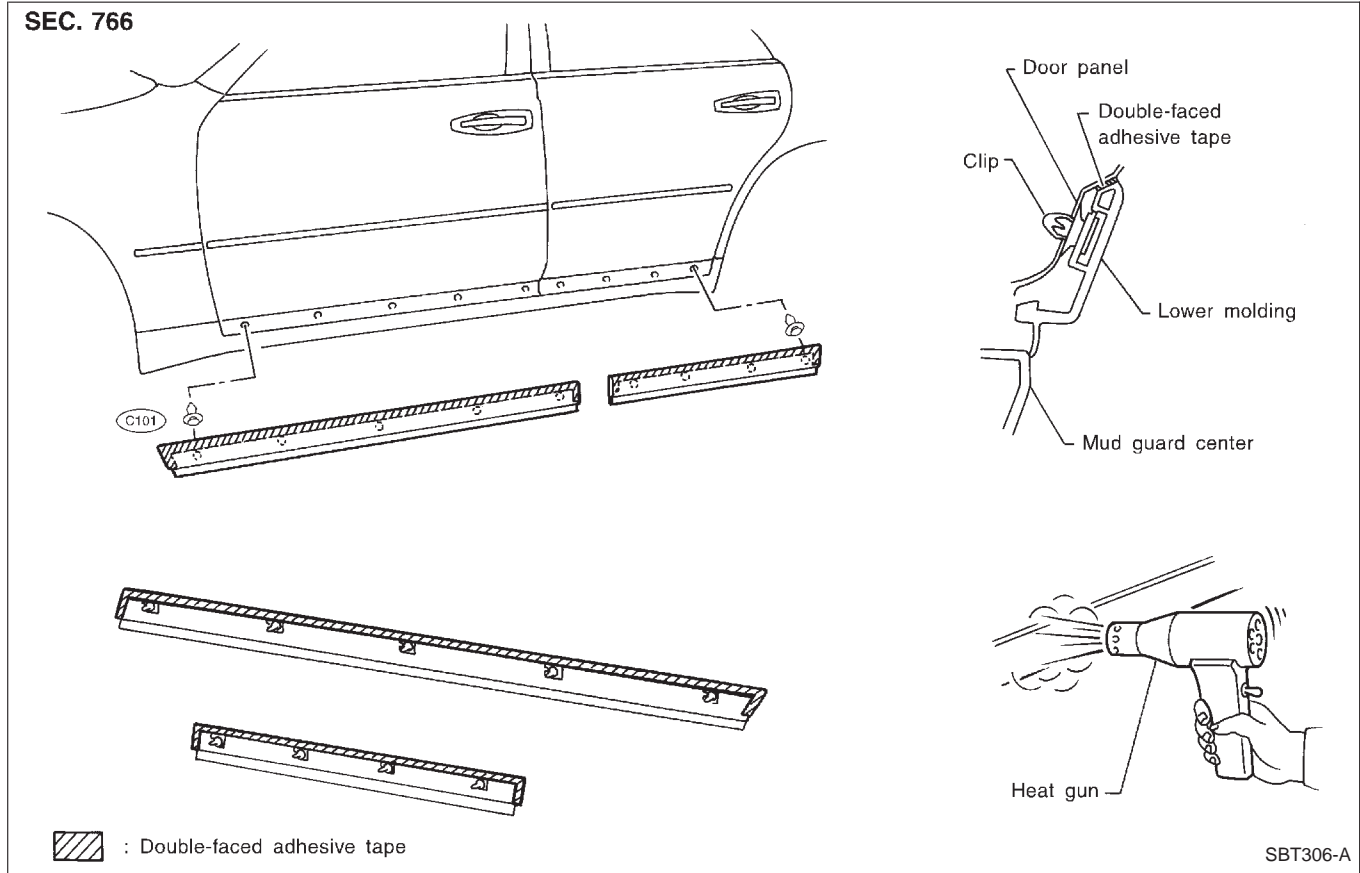

- With a vehicle coated with Hard Clear Coat, use double-faced 3M adhesive tape Product No. 4210 or equivalent, after priming with 3M primer Product No. N-200 or C-100 or equivalent.

16 Center sash molding

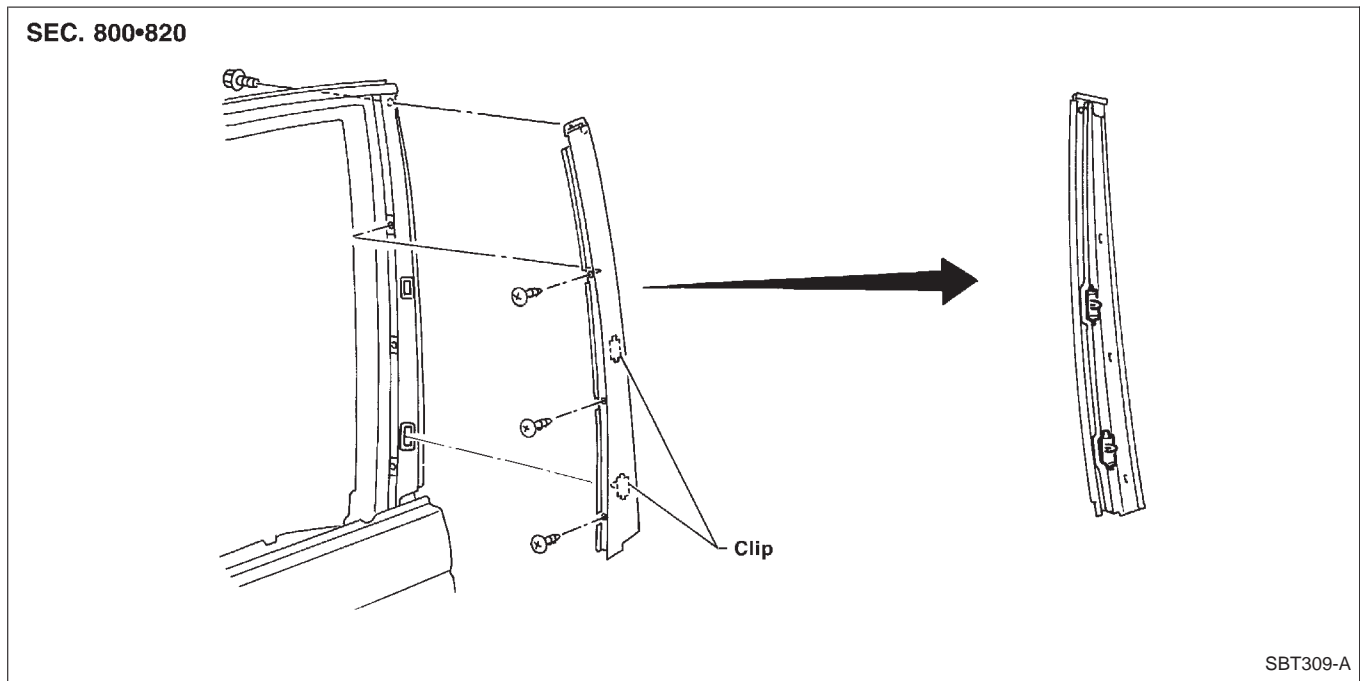

GI  
MA  
EM  
LC  
EC  
FE  
AT  
PD  
FA  
RA  
BR  
ST  
RS  
BT  
HA  
EL  
IDX

## 17 Door sash molding

SEC. 800•820

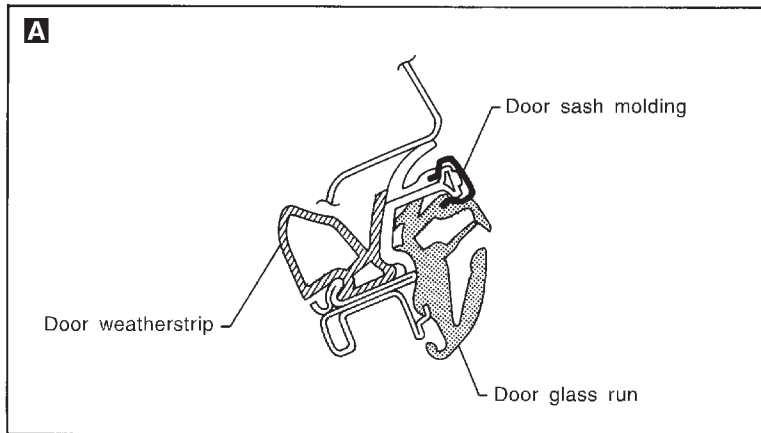
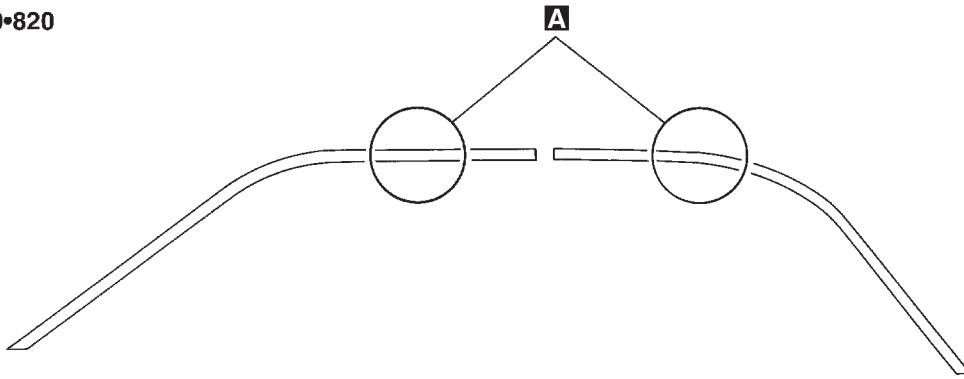

SBT305-A

## 18 License plate finisher

SEC. 843

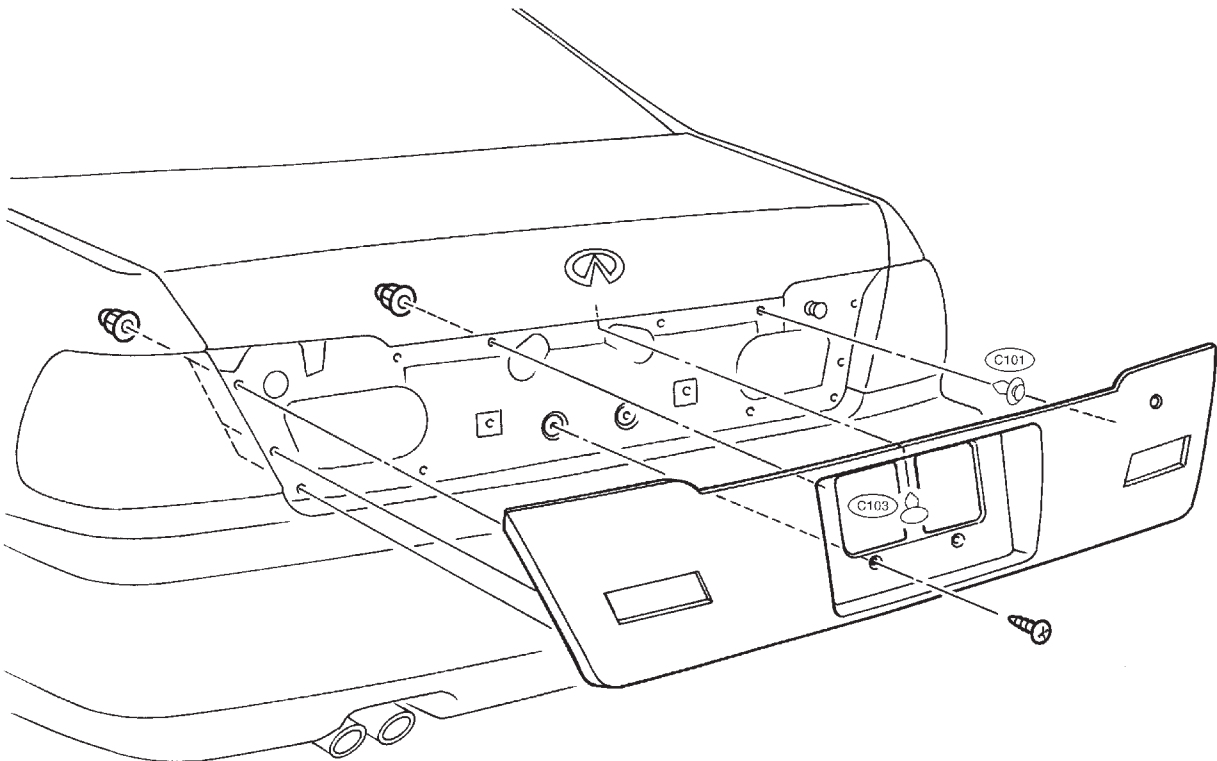

SBT670

## 19 Rear combination lamp

- Rear combination lamps are installed with nuts and butyl seal.

### SEC. 265

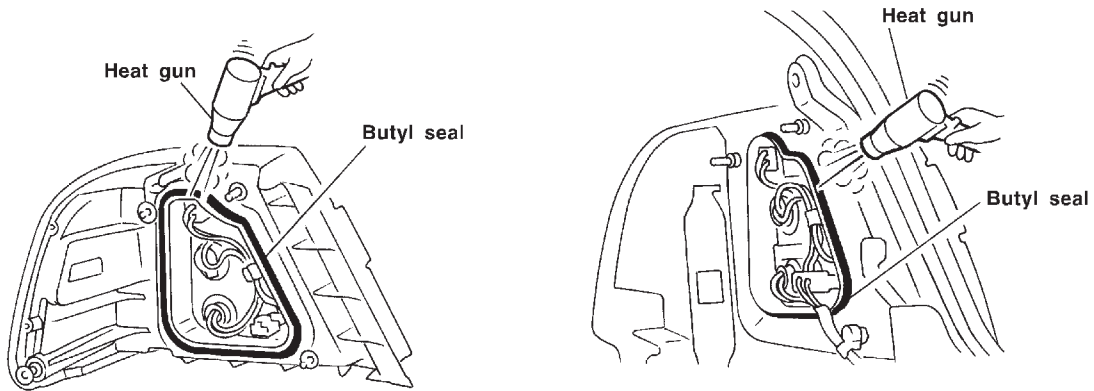

- Warm up lamp assembly area to a temperature of a little below 60°C (140°F).

- Apply butyl seal evenly as it tends to become thin in the corners.
- Warm up lamp assembly area to a temperature of a little below 60°C (140°F).

SBT672

## 20 Front tower bar

### SEC. 401

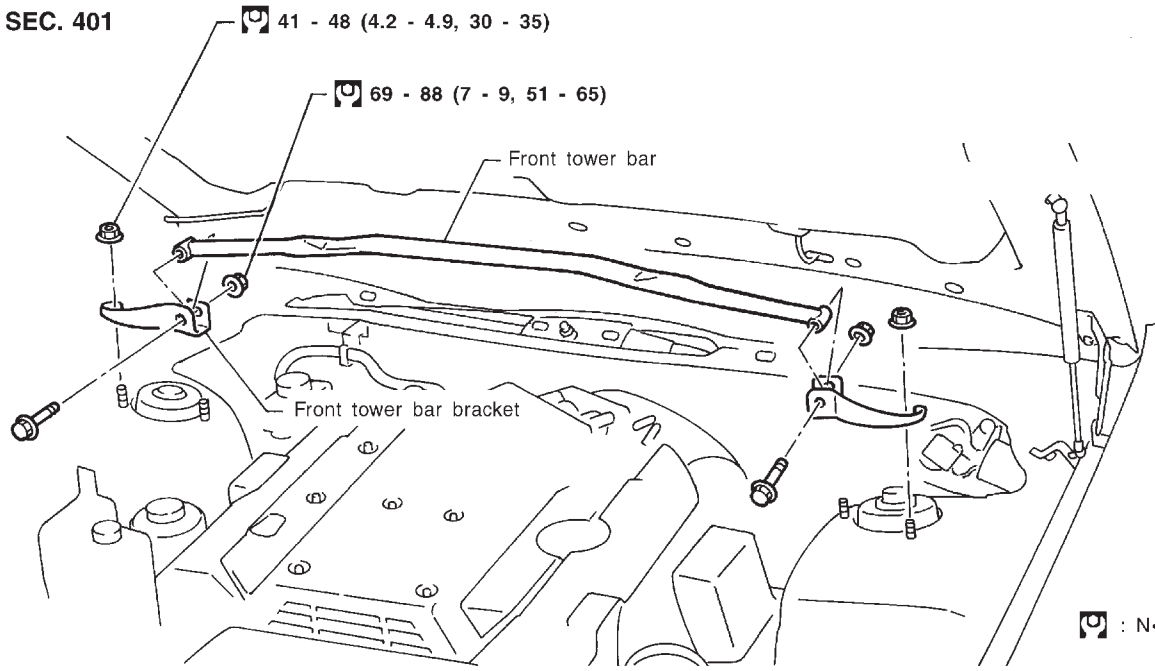

SBT378

### CAUTION:

Do not remove front tower bar assembly while vehicle is jacked up with wheels on.

GI

MA

EM

LC

EC

FE

AT

PD

FA

RA

BR

ST

RS

BT

HA

EL

IDX

21 Rear tower bar

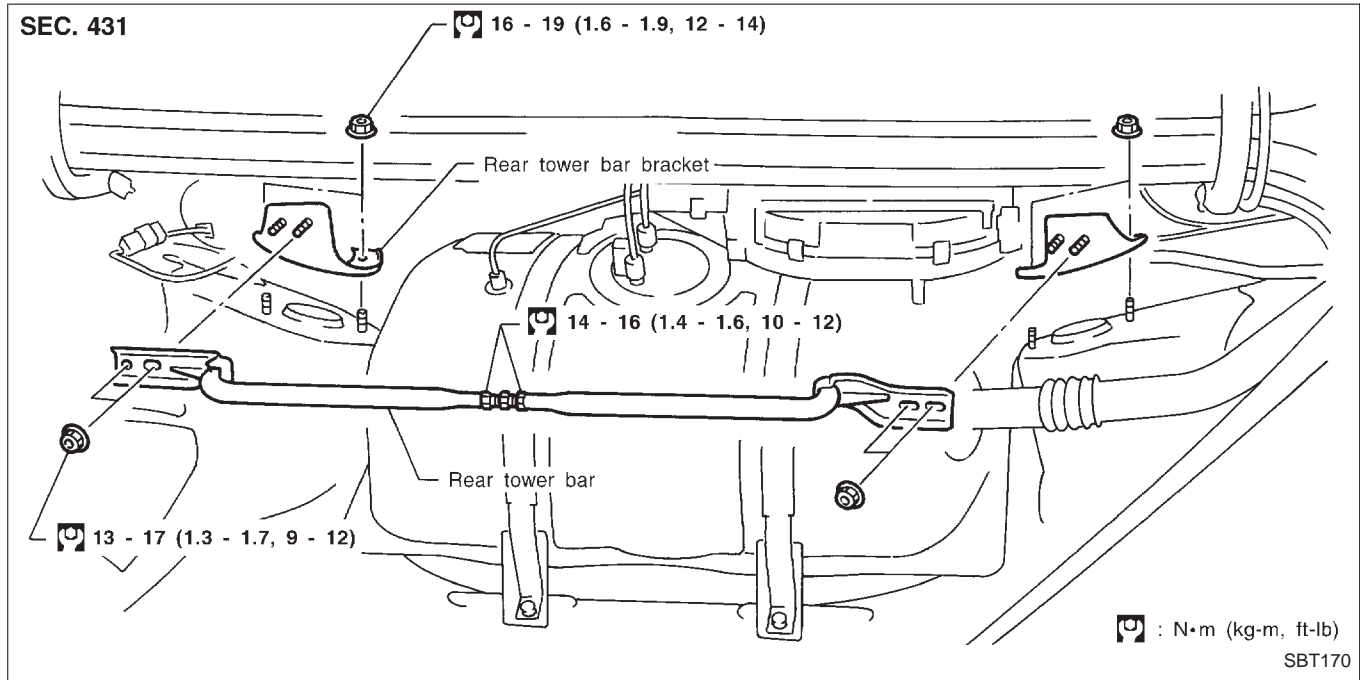

**CAUTION:**

Do not remove rear tower bar assembly while vehicle is jacked up with wheels on.

22 Trunk lid finisher

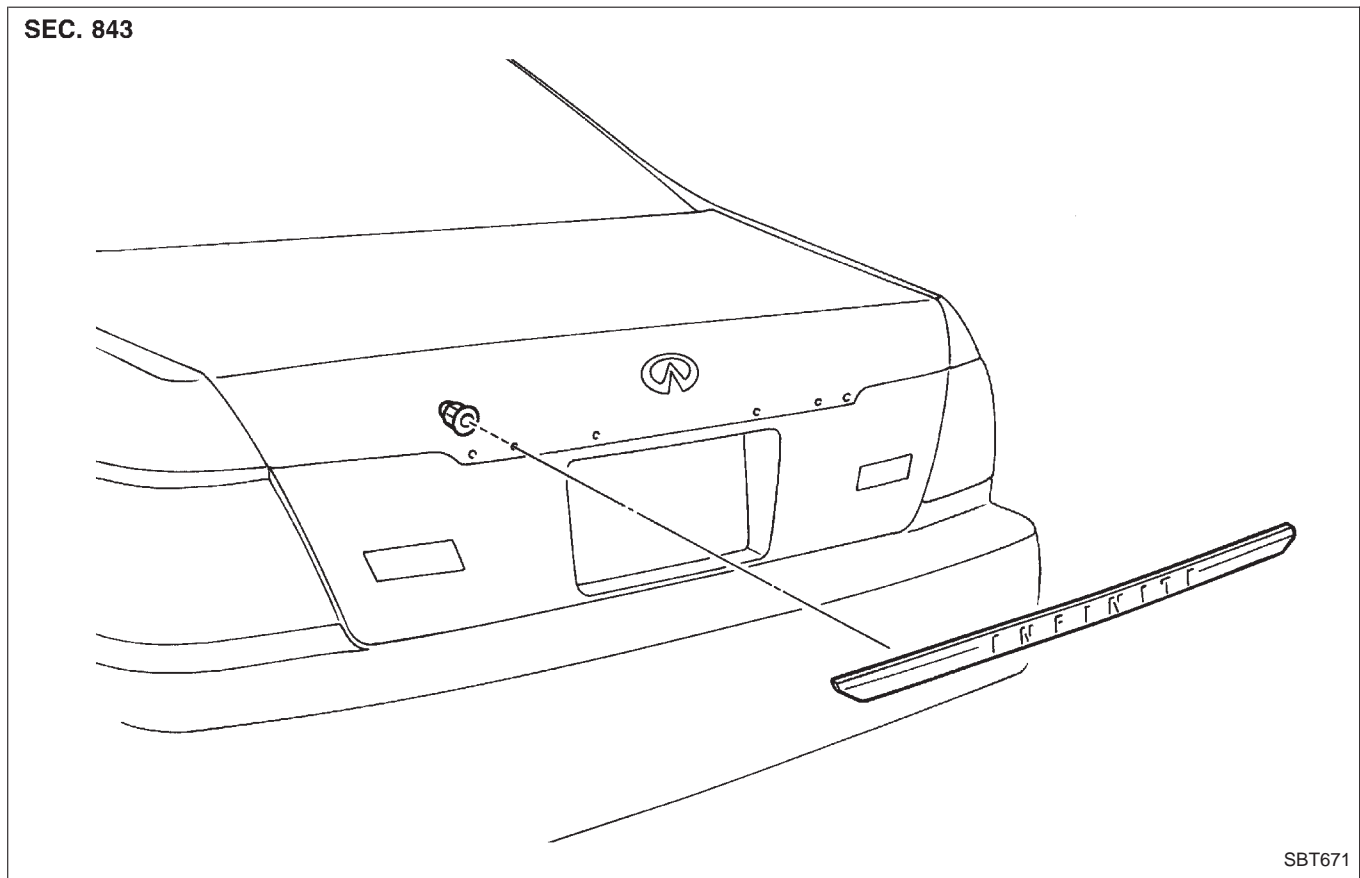



23 Headlamp

a. Remove bolts.

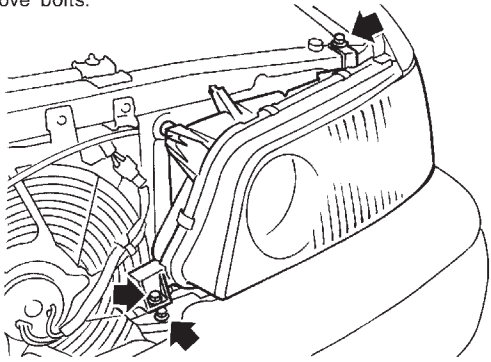

b. Remove nuts.

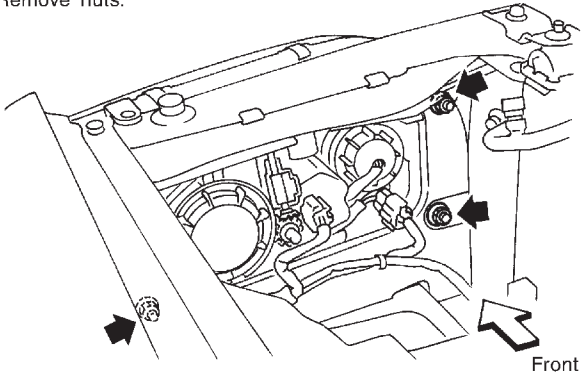

c. Pull forward, then lift up to move.

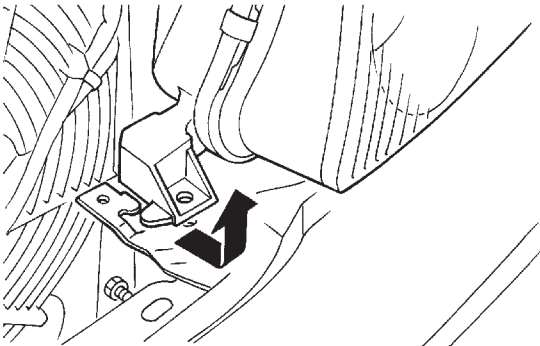

d. Remove carefully because fender may prevent easy removal.

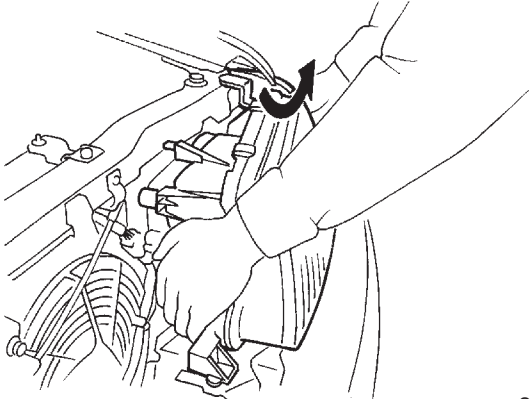

SBT673

- GI
- MA
- EM
- LC
- EC
- FE
- AT
- PD
- FA
- RA
- BR
- ST
- RS
- BT**
- HA
- EL
- IDX

- When removing or installing the seat trim, carefully handle it to keep dirt out and avoid damage.
- ★ For Wiring Diagram, refer to “POWER SEAT” in EL section.

### Front Seat

**CAUTION:**

- Before removing the front seat, turn the ignition switch off, disconnect both battery cables and wait at least 3 minutes.
- When checking the power seat circuit for continuity using a circuit tester, do not confuse its connector with the side air bag module connector. Such an error may cause the air bag to deploy.
- Do not drop, tilt, or bump the side air bag module installed in the seat. Always handle it with care.

### POWER SEAT (WITH SIDE AIR BAG MODULE)

SEC. 868•870

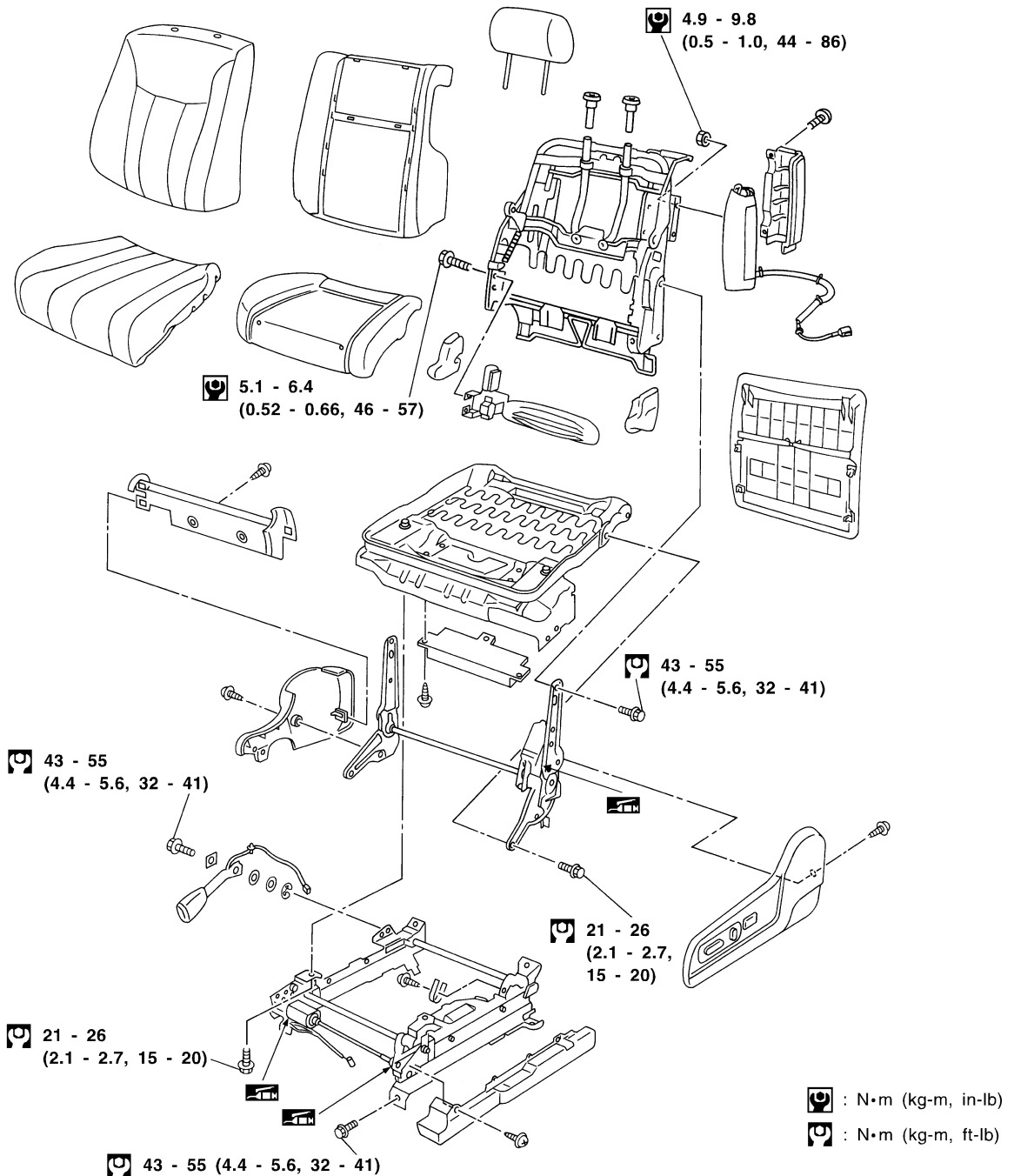

## Heated Seat

- When handling seat, be extremely careful not to scratch heating unit.
- To replace heating unit, seat trim and pad should be separated.
- Do not use any organic solvent, such as thinner, benzene, alcohol, gasoline, etc. to clean trims.
- ★ For Wiring Diagram, refer to “HEATED SEAT” in EL section.

GI

MA

EM

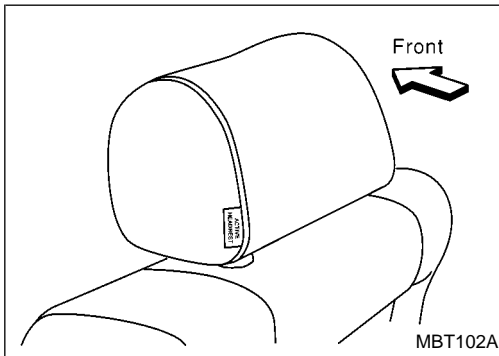

## Active Head Restraint

The active head restraint system is designed so that the headrest instantaneously moves towards the front upper direction by utilizing the force at the seatback during a rear-end collision. As a result, the occupant's head is protected from being overextended, reducing the chance for neck injury as much as possible.

Seat with active head restraint have the labels shown in figures at left.

LC

EC

FE

AT

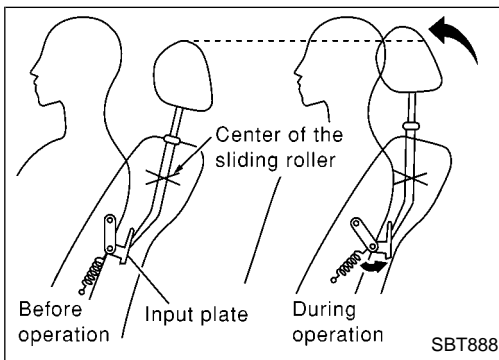

## OPERATION OUTLINE

When the seatback receives a sharp backward force during a rear-end collision, the input plate moves with the link rotating center as a pivot. The headrest will then move towards the front upper direction with the center of the sliding roller as a pivot.

As the backward force on the seat back is eliminated, spring tension returns the headrest to its original position.

PD

FA

RA

BR

ST

RS

BT

HA

EL

IDX

- When removing or installing the seat trim, carefully handle it to keep dirt out and avoid damage.

### Rear Seat

SEC. 880

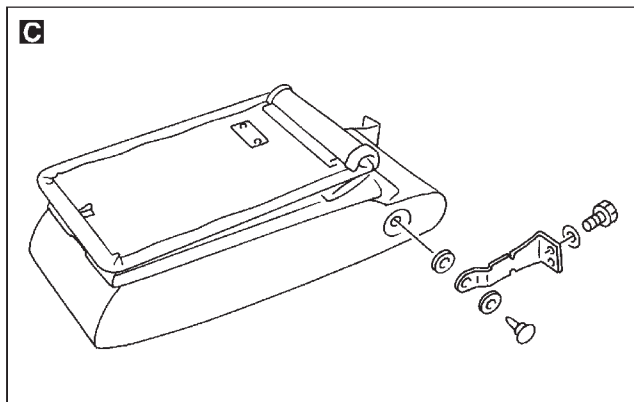
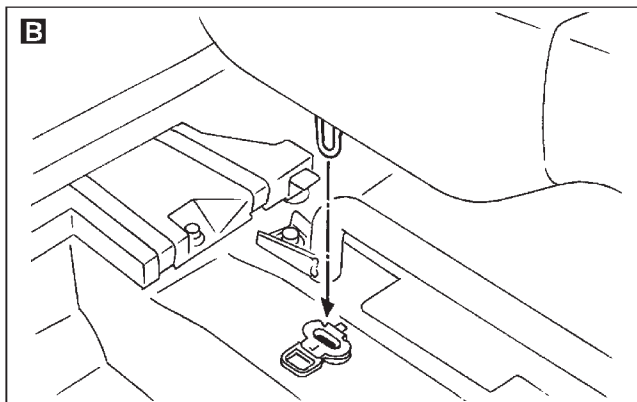
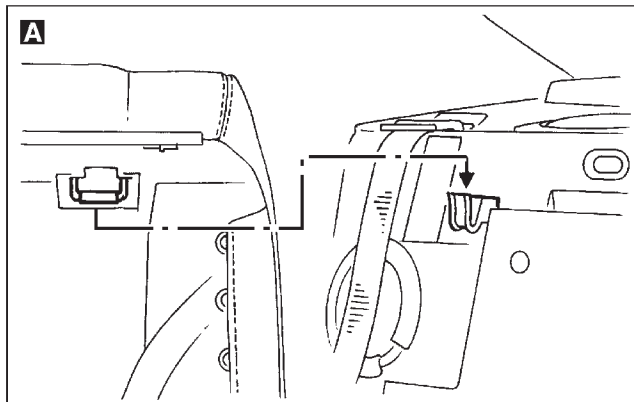
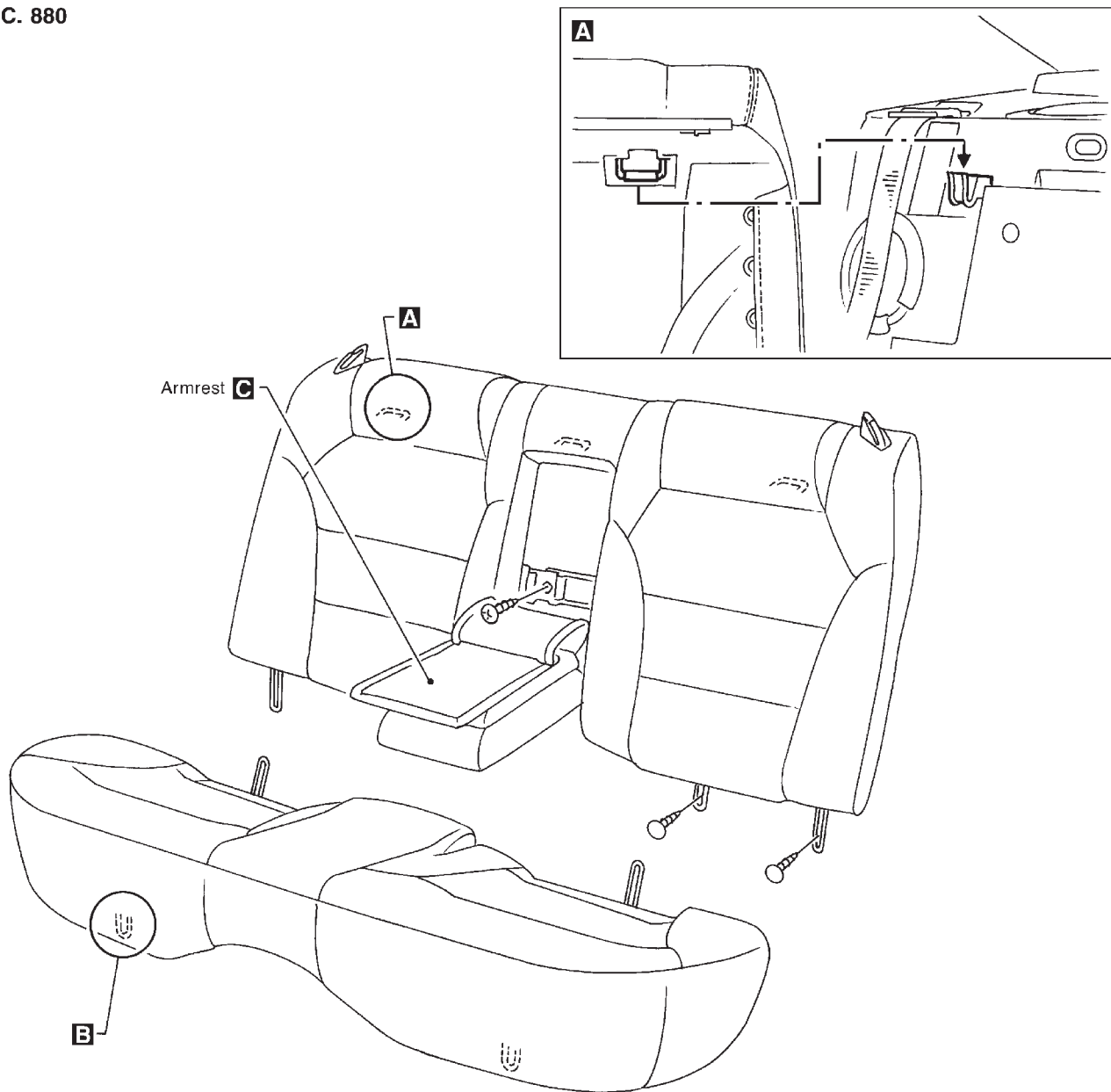

## Adjustment

**Install motor & limit SW assembly and sunroof rail assembly in the following sequence:**

1. Arrange equal lengths of link and wire assemblies on both sides of sunroof opening.
2. Connect sunroof connector to sunroof switch and positive (+) power supply.
3. Set lid assembly to fully closed position **A** by operating OPEN switch and TILT switch.
4. Fit outer side of lid assembly to the surface of roof on body outer panel.
5. Remove motor, and keep OPEN switch pressed until motor pinion gear reaches the end of its rotating range.
6. Install motor.
7. Check that motor drive gear fits properly in wires.
8. Press TILT-UP switch to check lid assembly for normal tilting.
9. Check sunroof lid assembly for normal operations (tilt-up, tilt-down, open, and close).

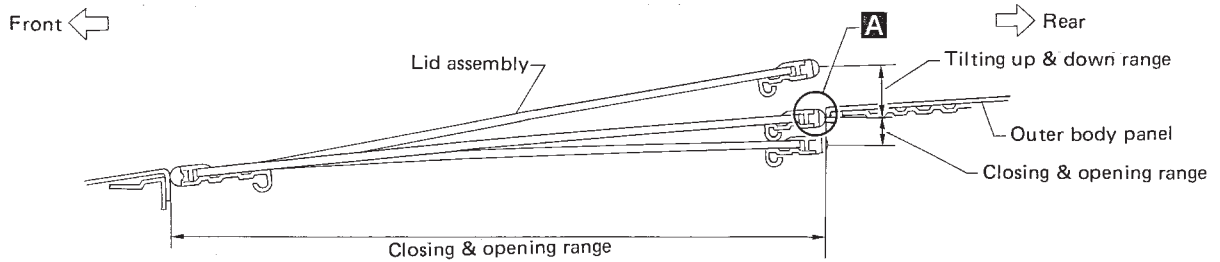

SBF920F

## Removal

- After any adjustment, check sunroof operation and lid alignment.
- Handle finisher plate and glass lid with care so not to cause damage.
- It is desirable for easy installation to mark each point before removal.

**CAUTION:**  
Always work with a helper.

GI

MA

EM

LC

EC

FE

AT

PD

FA

RA

BR

ST

RS

**BT**

HA

EL

IDX

# SUNROOF

## Removal (Cont'd)

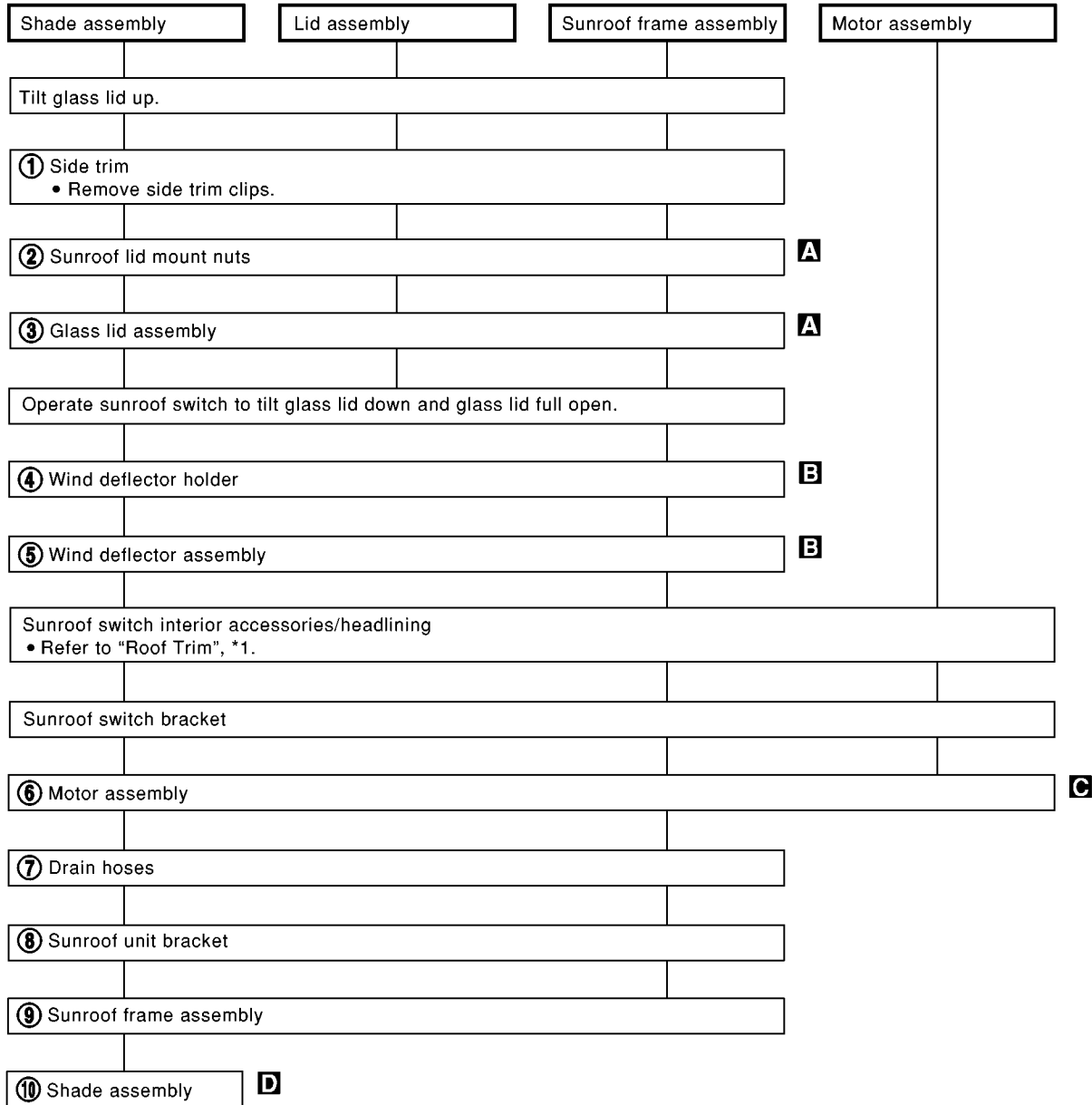

★ For Wiring Diagram, refer to (\*2), "POWER SUNROOF" for details.

SBT838

\*1 BT-30

\*2 Refer to EL section.

# SUNROOF

## Removal (Cont'd)

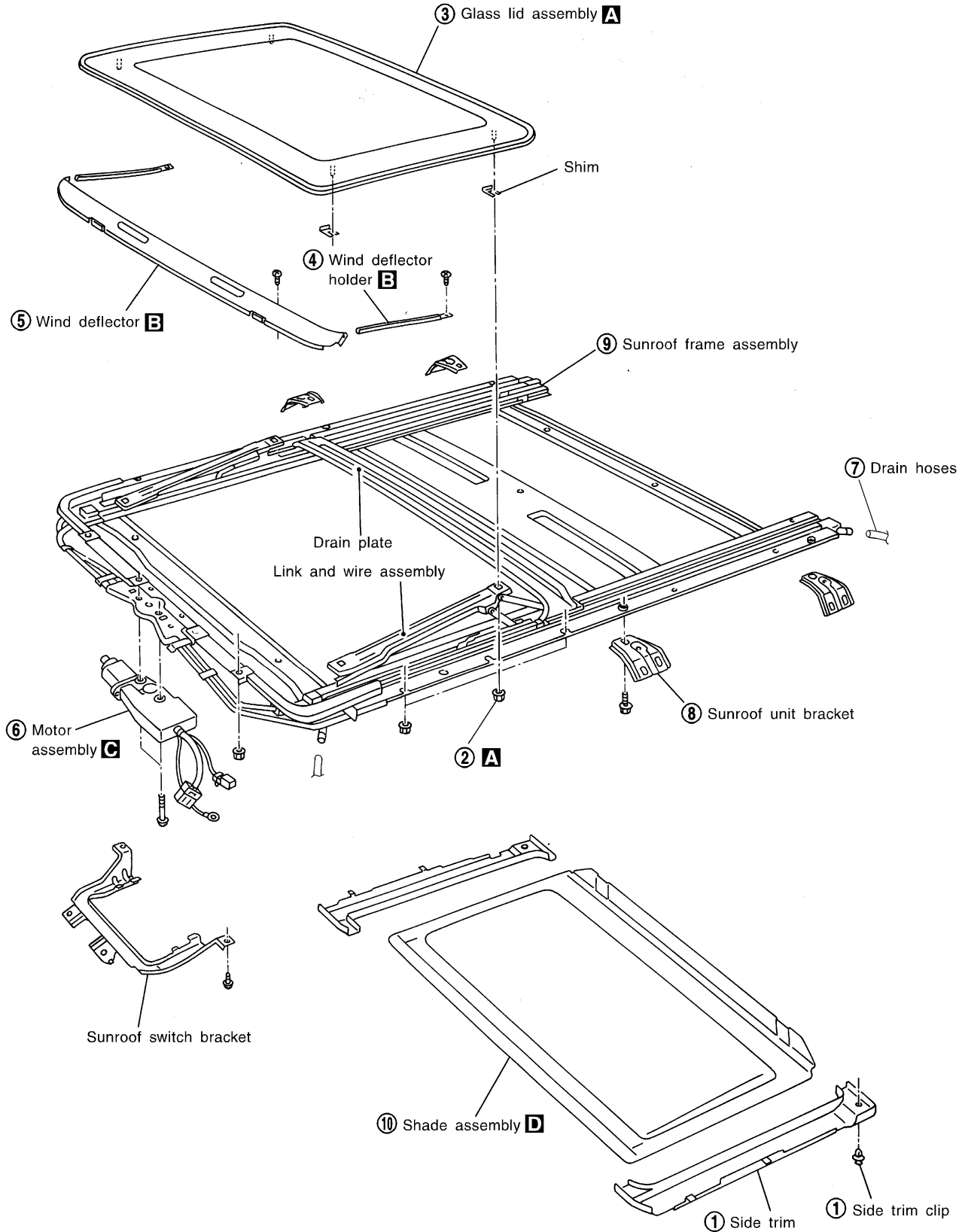

GI  
MA  
EM  
LC  
EC  
FE  
AT  
PD  
FA  
RA  
BR  
ST  
RS  
**BT**  
HA  
EL  
IDX

# SUNROOF

## Removal (Cont'd)

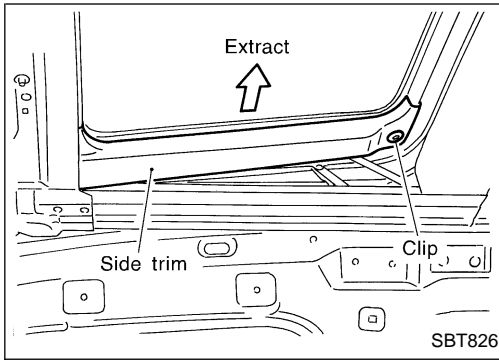

**A** Record the number of shims placed between glass lid assembly and link and wire assembly. Remove securing nuts and glass lid assembly.

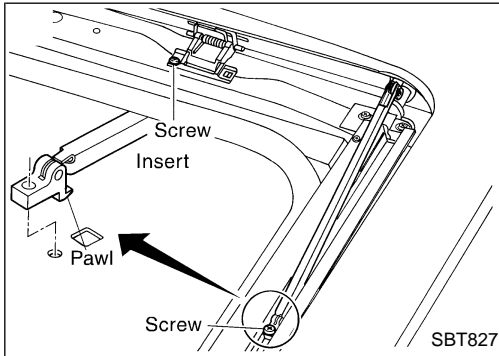

**B** Remove screws from left and right sides of each wind deflector holder. Extract pawls through rail holes, then remove left and right sides of wind deflector holder. Remove screws from front end of sunroof unit. Extract pawls through frame holes, then remove wind deflector from frame assembly.

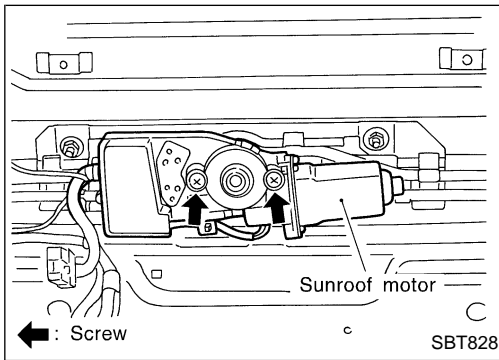

**C**

### CAUTION:

- Before removing sunroof motor, make sure that sunroof is fully closed.
- After removing sunroof motor, never attempt to rotate sunroof motor as a single unit.

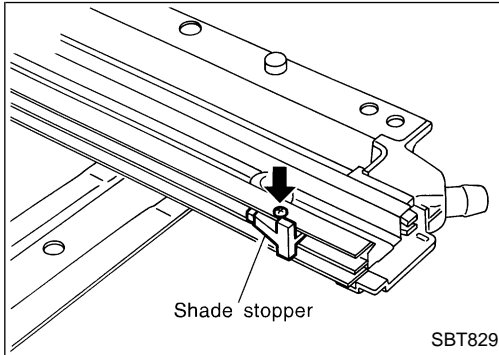

**D** Remove shade stoppers (2 points) from rear end of sunroof frame assembly. Remove sun shade from rear end of sunroof frame assembly.



## Trouble Diagnoses

### DIAGNOSTIC TABLE

NOTE: For diagnosing electric problem, refer to "ELECTRIC SUNROOF" in EL section.

		Check items (Components)				
		Wind deflector	Adjustment	Drain hoses	Weatherstrip	Link and wire assembly
	Reference page	BT-49	BT-50	BT-51	BT-51	BT-52
Symptom	Excessive wind noise	1	2		3	
	Water leaks		1	2	3	
	Sunroof rattles		1	4	2	3
	Excessive operation noise		1		2	3

The numbers in this table mean checking order.

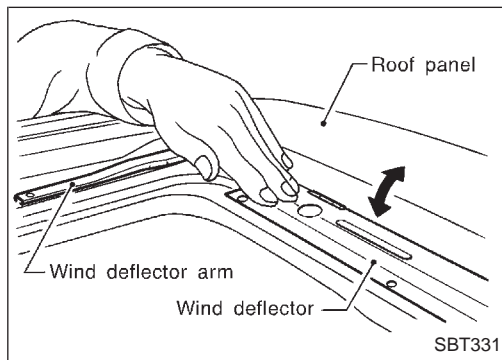

### WIND DEFLECTOR

1. Open lid.
2. Check visually for proper installation.
3. Check to ensure a proper amount of petroleum jelly has been applied to wind deflector connection points; apply if necessary.
4. Check that wind deflector is properly retracted by hand. If it is not, remove and visually check condition. (Refer to removal procedures, BT-45.) If wind deflector is damaged, replace with new one. If wind deflector is not damaged, re-install properly.

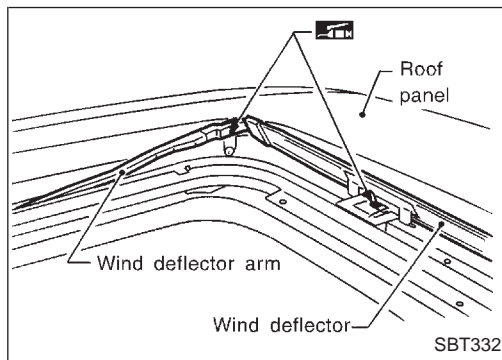

GI  
MA  
EM  
LC  
EC  
FE  
AT  
PD  
FA  
RA  
BR  
ST  
RS  
BT  
HA  
EL  
IDX

# SUNROOF

## Trouble Diagnoses (Cont'd) ADJUSTMENT

SEC. 736

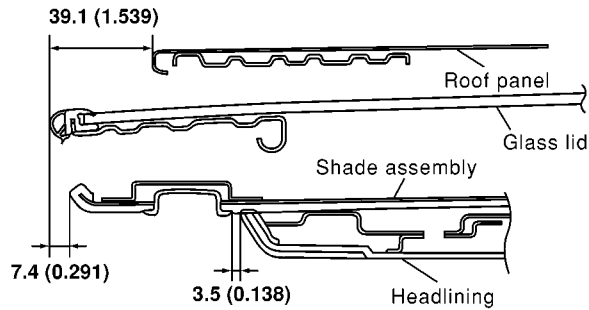
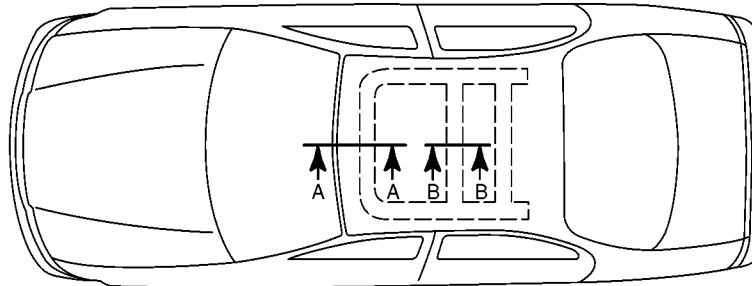

B - B (When sunroof is open)

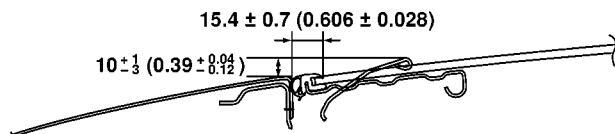

Unit: mm (in)

A - A

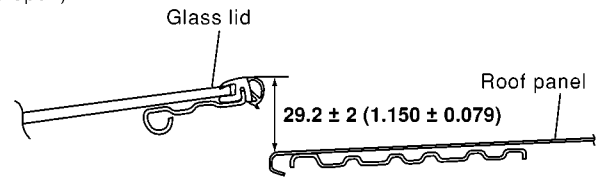

B - B (When sunroof is tilted up)

SBT886

If any gap or height difference between glass lid and roof is found, check glass lid fit and adjust as follows:

### Gap Adjustment

1. Open shade assembly.
2. Tilt glass lid up then remove side trim.
3. Loosen glass lid securing nuts (3 each on left and right sides), then tilt glass lid down.
4. Adjust glass lid from outside of vehicle so it resembles "A-A" as shown in the figure above.
5. Tilt glass lid up and down until it is adjusted to "B-B" as shown in the figure above.
6. After adjusting glass lid, tilt glass lid up and tighten nuts.
7. Tilt glass lid up and down several times to check that it moves smoothly.

### Height Difference Adjustment

1. Tilt glass lid up and down.
2. Check height difference between roof panel and glass lid to see if it is as "A-A" as shown in the figure above.
3. If necessary, adjust it by using one of following procedures.
  - Adjust by adding or removing adjustment shim(s) between glass lid and link assembly.
  - If glass lid protrudes above roof panel, add shim(s) or plain washer(s) at sunroof mounting bracket or stud bolt locations to adjust sunroof installation as required.

# SUNROOF

## Trouble Diagnoses (Cont'd)

### DRAIN HOSES

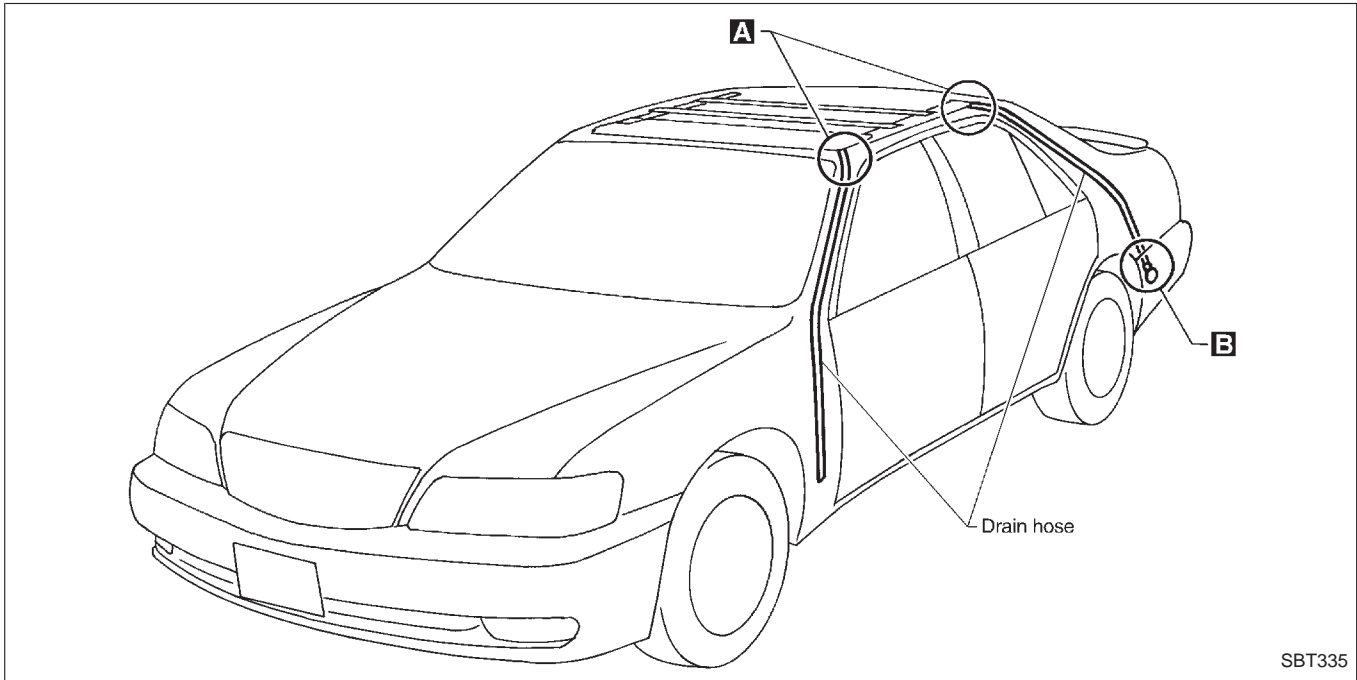

SBT335

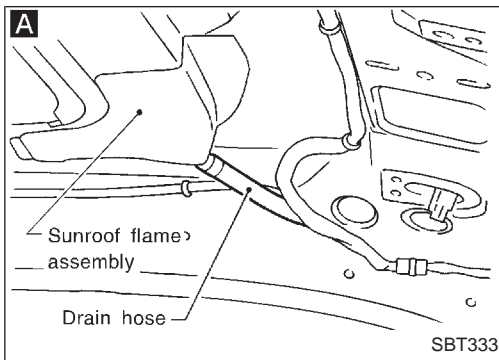

SBT333

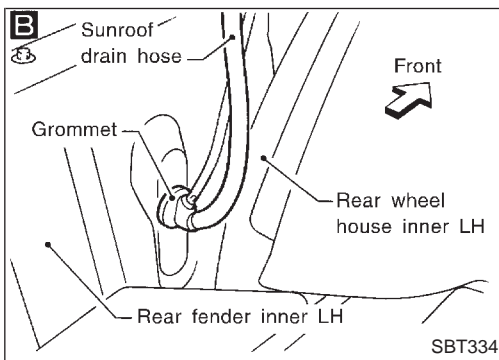

SBT334

1. Remove headlining to access drain hose connections. (Refer to "REMOVAL — Headlining" in "INTERIOR TRIM", BT-30, for detail.)
2. Check visually for proper connections, damage or deterioration. **A** (The figure shows only the front side.)

3. If leakage occurs around trunk room, remove trunk room side trim and check connecting area. Check for proper connection, damage or tear. **B**
4. Remove drain hoses and check visually for any damage, cracks, or deterioration.
5. Pour water into drain hoses and find damaged portion.
  - If any damaged portion is found at each step, replace the damaged part.

### WEATHERSTRIP

- In the case of leakage around lid, close lid and pour water over lid to find damaged or gap portion.
1. Remove lid assembly. (Refer to removal procedures, BT-45, for details.)
  2. Visually check weatherstrip for proper installation. If a gap exists between lid and weatherstrip, check for sufficient amount of butyl seal. If required, remove weatherstrip and apply butyl seal.
- Refer to "EXTERIOR" (BT-34), for details.

GI  
MA  
EM  
LC  
EC  
FE  
AT  
PD  
FA  
RA  
BR  
ST  
RS  
BT  
HA  
EL

IDX

## Trouble Diagnoses (Cont'd)

3. Check weatherstrip visually for any damage, deterioration, or flattening.
  - If any damage is found, replace weatherstrip.

### **CAUTION:**

**Do not remove weatherstrip except when replacing, or filling up butyl seal.**

## LINK AND WIRE ASSEMBLY

### **NOTE:**

**Before replacing a suspect part, carefully ensure it is the source of noise being experienced.**

1. Check link to determine if coating film has peeled off to such an extent that substrate is visible. Check also to determine if link is the source of noise. If it is, replace it.
2. Visually check to determine if a sufficient amount of petroleum jelly has been applied to wire or rail groove. If not, add petroleum jelly as required.
3. Check wire for any damage or deterioration. If any damage is found, replace wire.

# WINDSHIELD AND WINDOWS

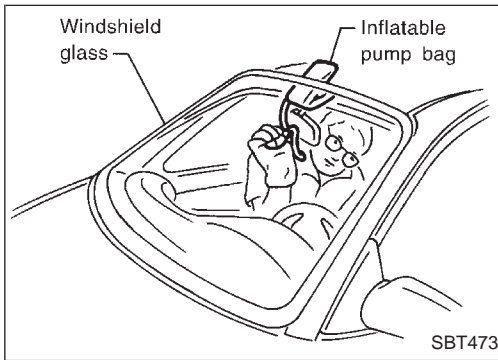
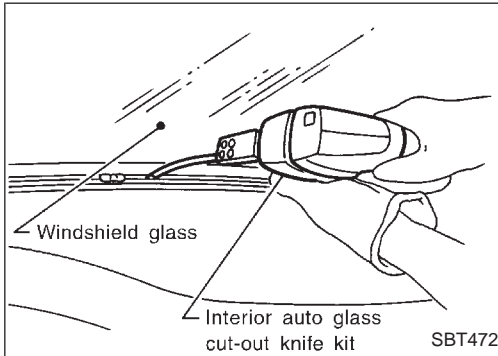
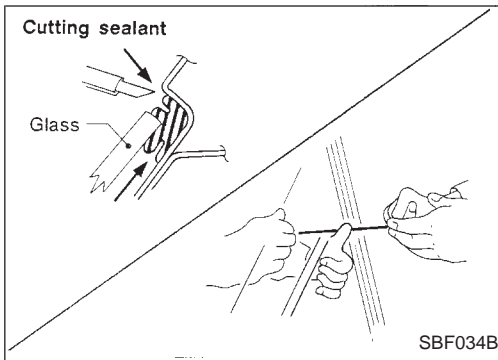

## REMOVAL

After removing moldings, remove glass using piano wire or power cutting tool and an inflatable pump bag.

### WARNING:

When cutting the glass from the vehicle, always wear safety glasses and heavy gloves to help prevent glass splinters from entering your eyes or cutting your hands.

### CAUTION:

- Be careful not to scratch the glass when removing.
- Do not set or stand the glass on its edge. Small chips may develop into cracks.

## INSTALLATION

- Use a genuine Nissan Urethane Adhesive Kit or equivalent and follow the instructions furnished with it.
- While the urethane adhesive is curing, open a door window. This will prevent the glass from being forced out by passenger compartment air pressure when a door is closed.
- The molding must be installed securely so that it is in position and leaves no gap.
- Inform the customer that the vehicle should remain stationary until the urethane adhesive has completely cured (preferably 24 hours). Curing time varies with temperature and humidity.

### WARNING:

- Keep heat and open flames away as primers and adhesive are flammable.
- The materials contained in the kit are harmful if swallowed, and may irritate skin and eyes. Avoid contact with the skin and eyes.
- Use in an open, well ventilated location. Avoid breathing the vapors. They can be harmful if inhaled. If affected by vapor inhalation, immediately move to an area with fresh air.
- Driving the vehicle before the urethane adhesive has completely cured may affect the performance of the windshield in case of an accident.

### CAUTION:

- Do not use an adhesive which is past its usable term. Shelf life of this product is limited to six months after the date of manufacture. Carefully adhere to the expiration or manufacture date printed on the box.
- Keep primers and adhesive in a cool, dry place. Ideally, they should be stored in a refrigerator.
- Do not leave primers or adhesive cartridge unattended with their caps open or off.
- The vehicle should not be driven for at least 24 hours or until the urethane adhesive has completely cured. Curing time varies depending on temperature and humidities. The curing time will increase under higher temperatures and lower humidities.

GI

MA

EM

LC

EC

FE

AT

PD

FA

RA

BR

ST

RS

BT

HA

EL

IDX

## Windshield and Rear Window

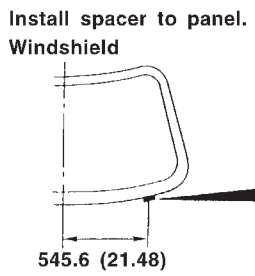
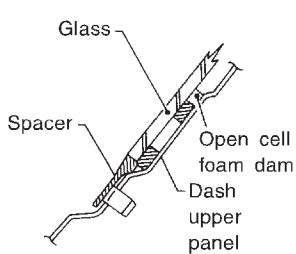
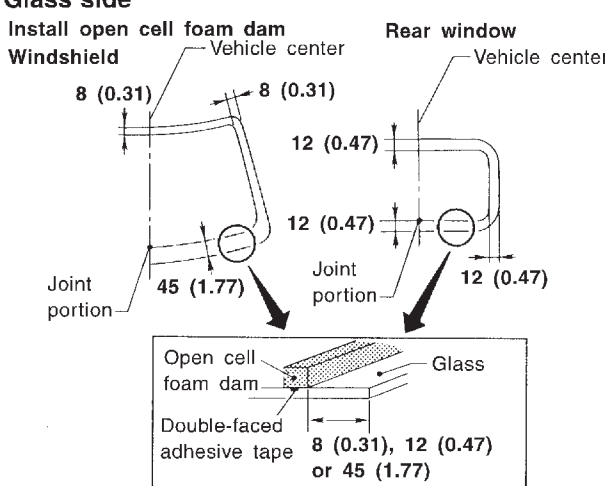
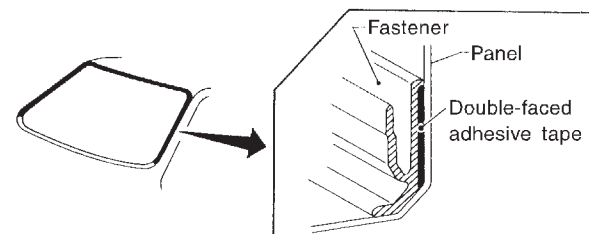
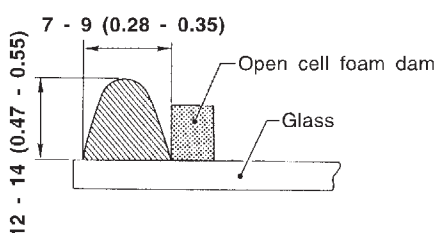
<p><b>Body side</b></p> <p>Install spacer to panel. Windshield</p>  <p style="text-align: center;">545.6 (21.48)</p> 	<p><b>Glass side</b></p> <p>Install open cell foam dam Windshield</p>  <p style="text-align: center;">8 (0.31), 12 (0.47) or 45 (1.77)</p>
<p><b>Install molding fastener.</b> When installing it, heat body panel and fastener to approx. 30 to 40°C (86 to 104°F).</p> 	<p><b>Apply urethane adhesive evenly.</b> Windshield and rear window</p>  <p style="text-align: right;">Unit: mm (in)</p>

SBT317-A

### REPAIRING WATER LEAKS FOR WINDSHIELD

Leaks can be repaired without removing and reinstalling glass.

**If water is leaking between urethane adhesive material and body or glass, determine the extent of leakage. This can be done by applying water to the windshield area while pushing glass outward.**

To stop the leak, apply primer (if necessary) and then urethane adhesive to the leak point.

# MIRROR

## Door Mirror

**CAUTION:**

Be careful not to scratch door rearview mirror body.

★ For Wiring Diagram, refer to “POWER DOOR MIRROR” in EL section.

**REMOVAL — Door mirror**

- ① Remove door trim. Refer to “Door Trim” in “INTERIOR TRIM” for details, BT-28.
- ② Remove sash cover inner. Refer to “Sash cover inner” in “EXTERIOR” for details, BT-35.
- ③ Remove bolt securing side speaker, then remove side speaker assembly. Disconnect side speaker harness connector.
- ④ Disconnect door mirror harness connector.
- ⑤ Remove bolts securing door mirror, then remove door mirror assembly.

GI  
MA  
EM  
LC  
EC  
FE  
AT  
PD  
FA  
RA  
BR  
ST  
RS  
BT  
HA  
EL  
IDX

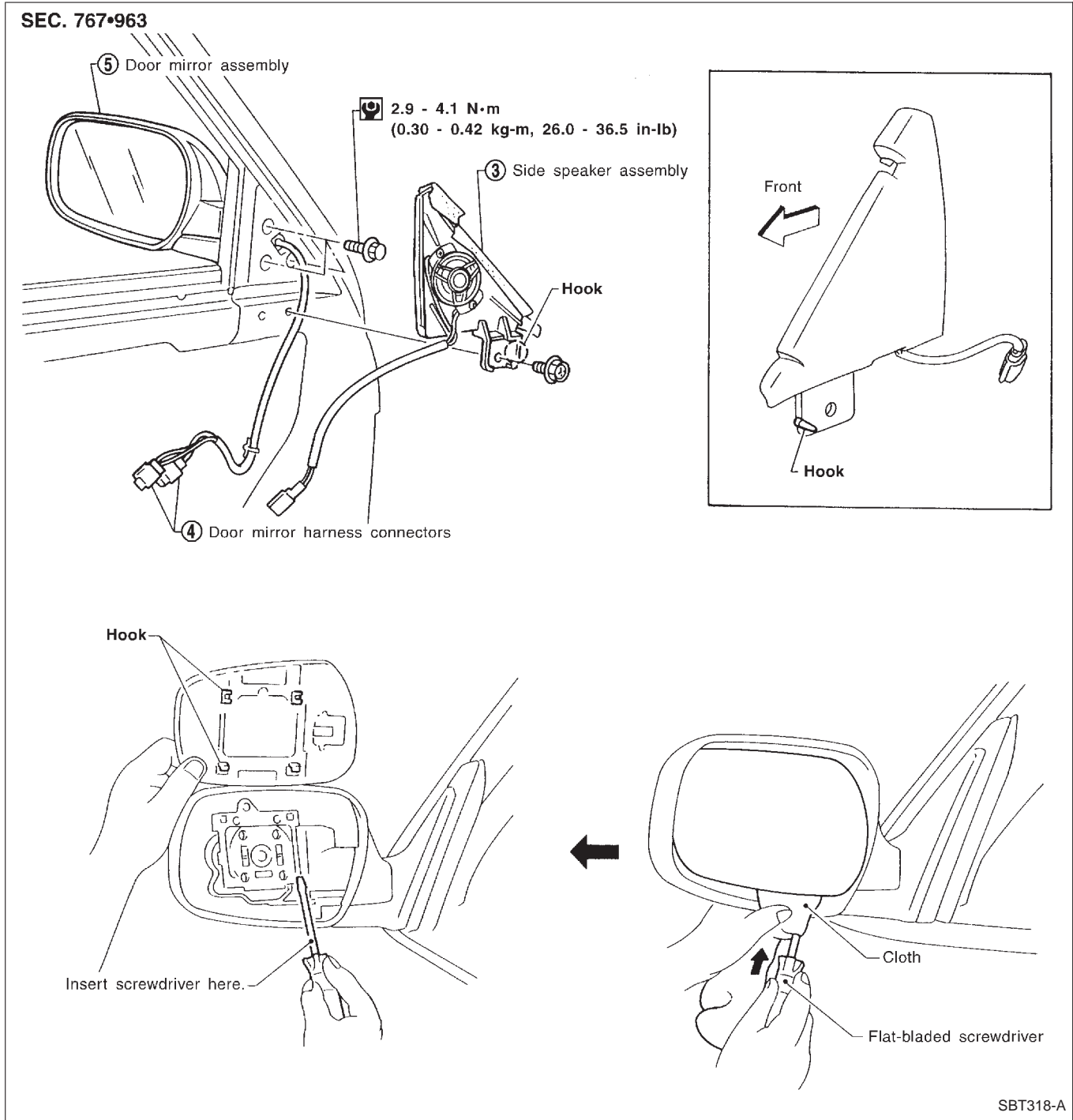

# BODY ALIGNMENT

- All dimensions indicated in figures are actual ones.
- When using a tracking gauge, adjust both pointers to equal length. Then check the pointers and gauge itself to make sure there is no free play.
- When a measuring tape is used, check to be sure there is no elongation, twisting or bending.
- Measurements should be taken at the center of the mounting holes.
- An asterisk (\*) following the value at the measuring point indicates that the measuring point on the other side is symmetrically the same value.
- The coordinates of the measurement points are the distances measured from the standard line of "X", "Y" and "Z".

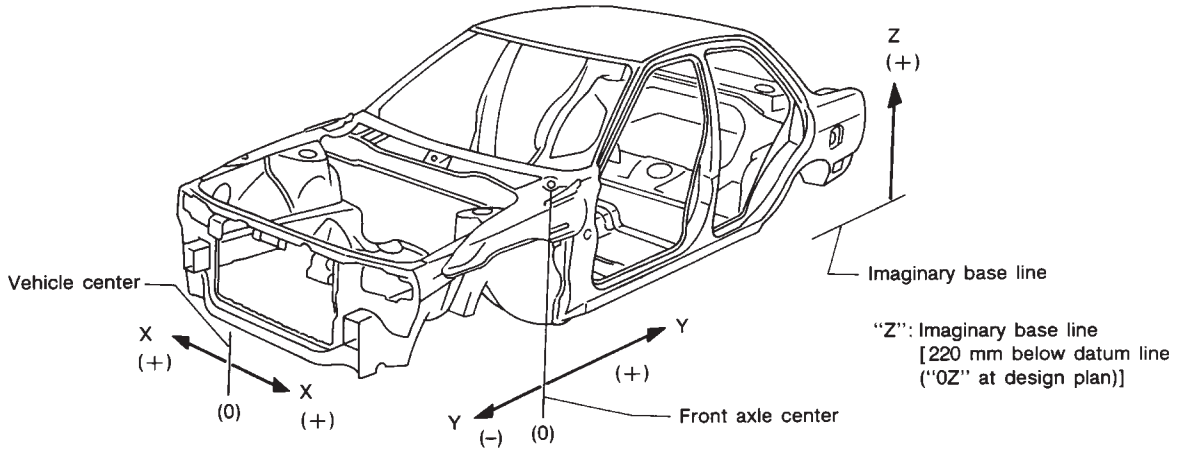

SBF874GE

## Engine Compartment

### MEASUREMENT

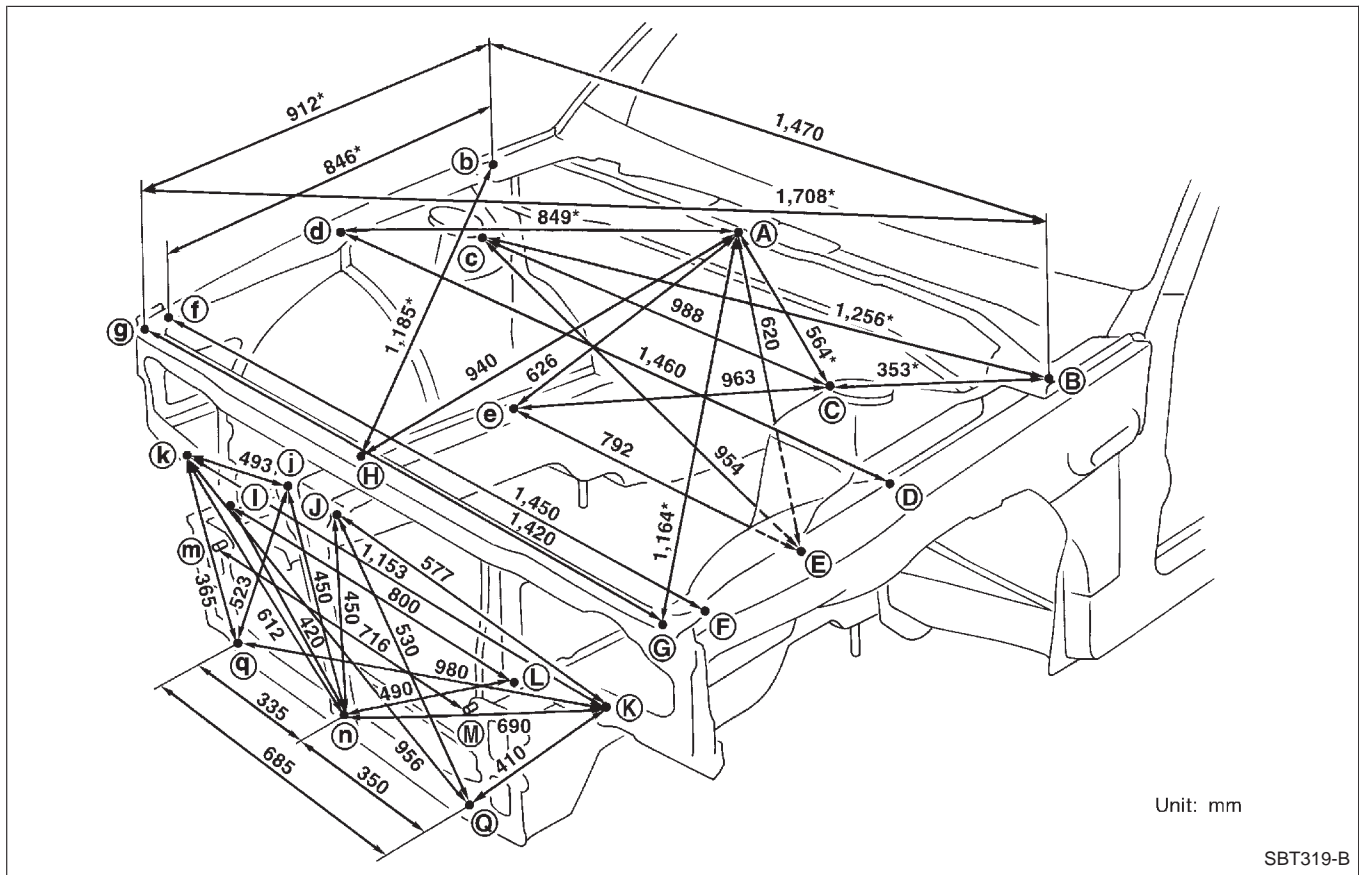



# BODY ALIGNMENT

## Engine Compartment (Cont'd)

### MEASUREMENT POINTS

Unit: mm

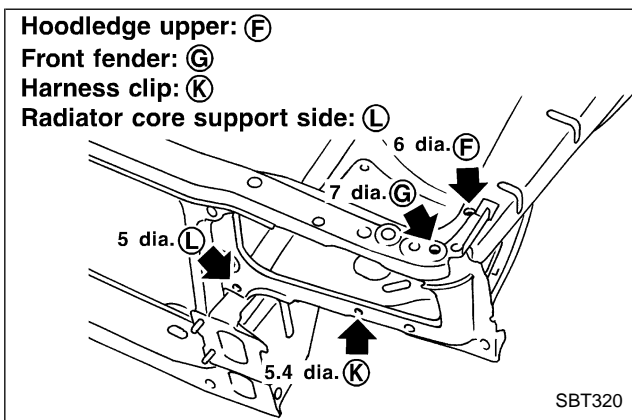
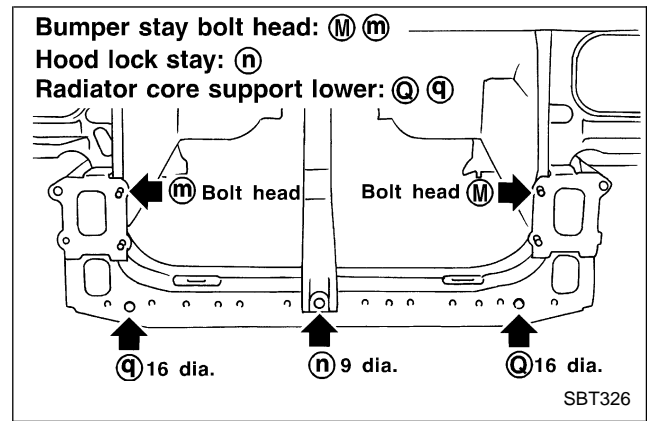
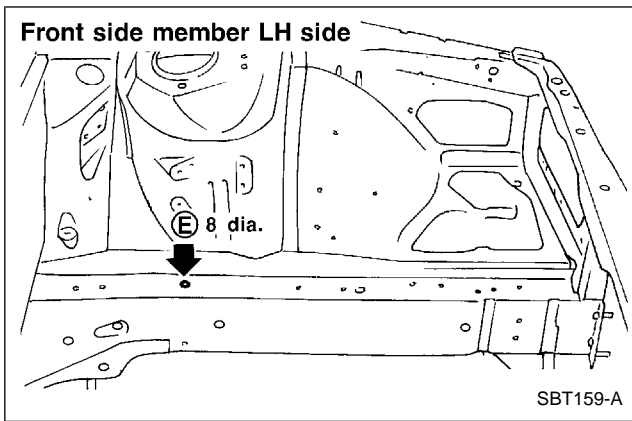
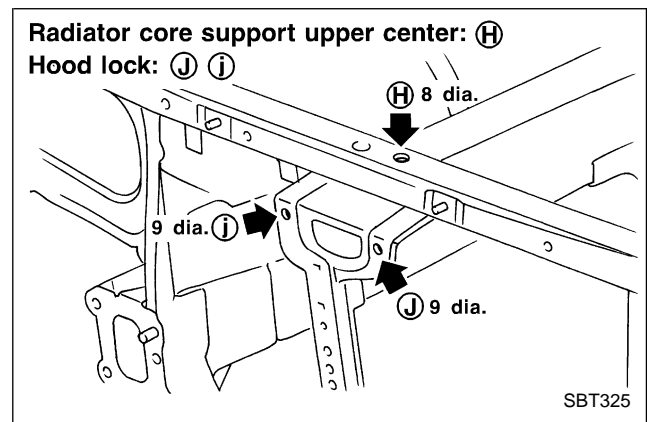
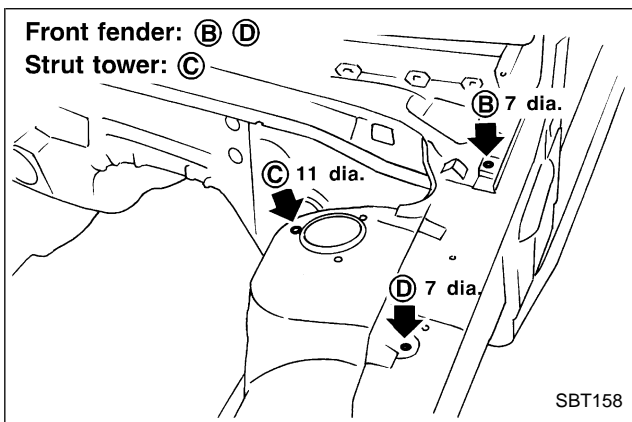
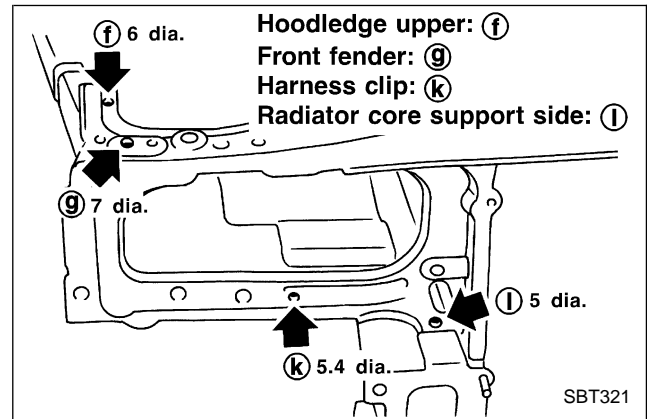
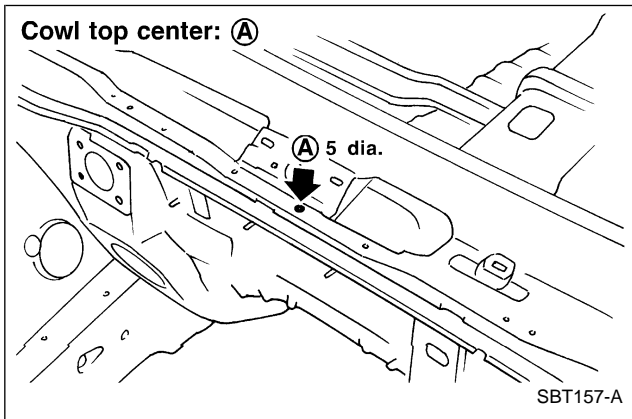

GI  
MA  
EM  
LC  
EC  
FE  
AT  
PD  
FA  
RA  
BR  
ST  
RS  
BT  
HA  
EL  
IDX

# BODY ALIGNMENT

## Underbody

### MEASUREMENT

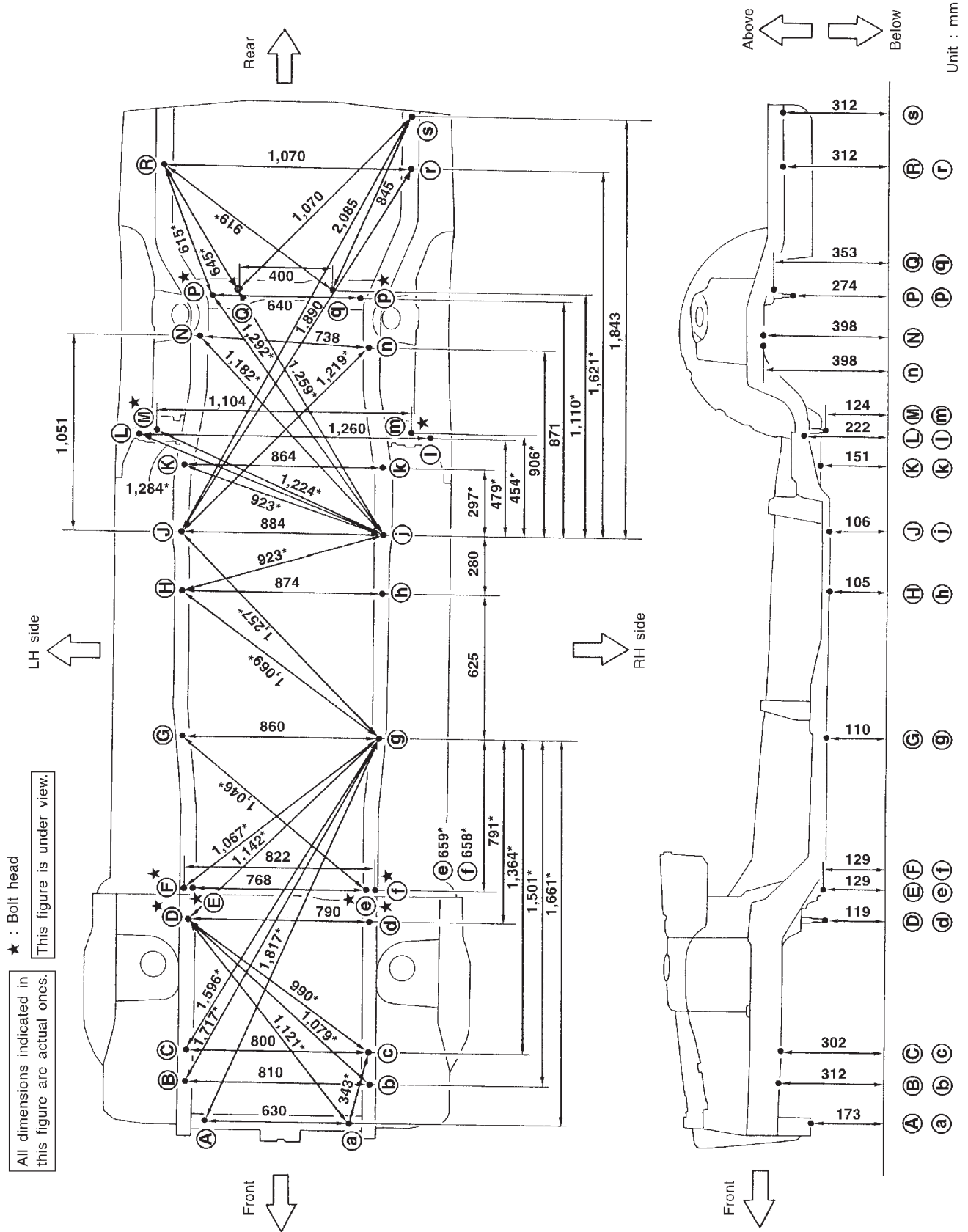

# BODY ALIGNMENT

## Underbody (Cont'd)

### MEASUREMENT POINTS

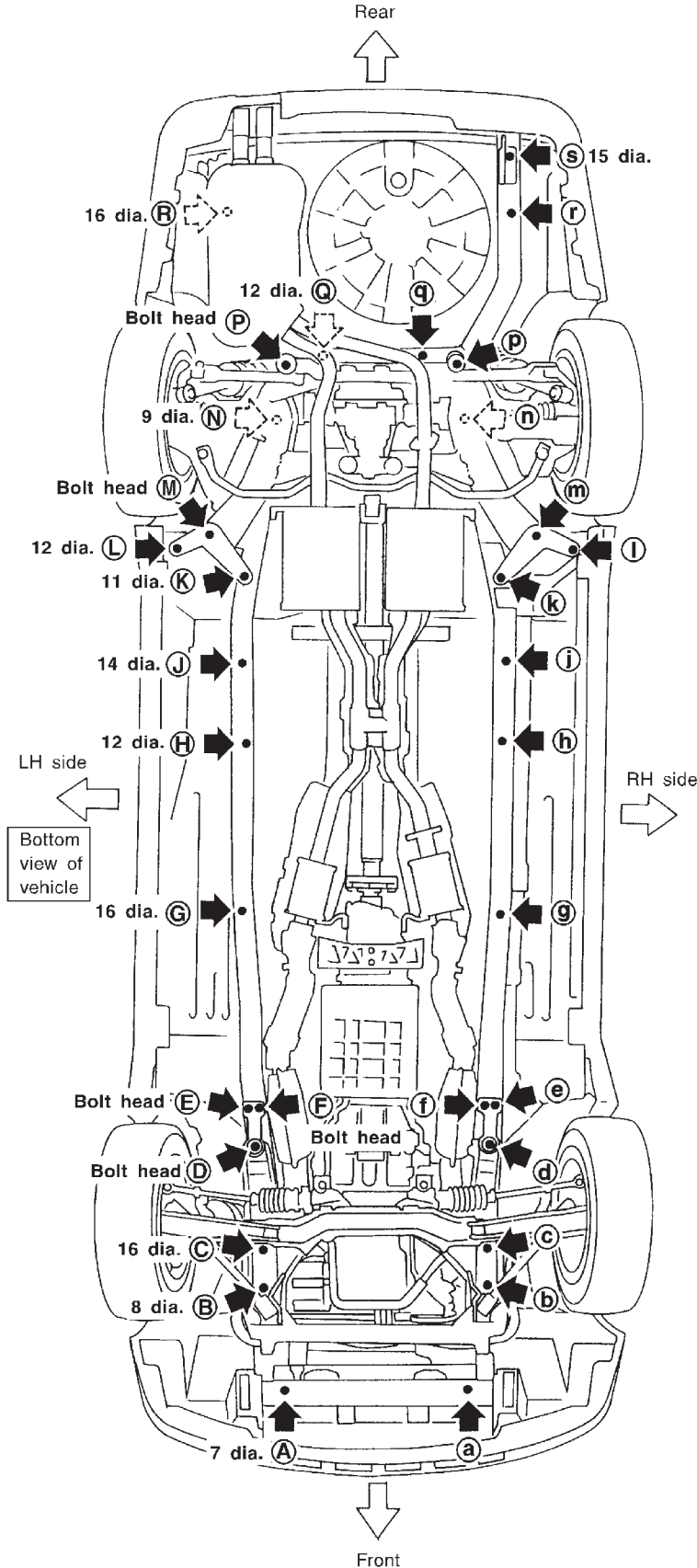

Coordinates:

<b>(A, a)</b> X: 315 Y: -596 Z: 173	<b>(G, g)</b> X: 430 Y: 1,060 Z: 110.4	<b>(N)</b> X: 376 Y: 2,820 Z: 397.7
<b>(B, b)</b> X: 405 Y: -427 Z: 311.9	<b>(H, h)</b> X: 437 Y: 1,685 Z: 104.8	<b>(n)</b> X: 361 Y: 2,782 Z: 397.7
<b>(C, c)</b> X: 400 Y: -290 Z: 302	<b>(J, j)</b> X: 442 Y: 1,965 Z: 106.2	<b>(P, p)</b> X: 320 Y: 2,995 Z: 274.1
<b>(D, d)</b> X: 395 Y: 270 Z: 119	<b>(K, k)</b> X: 432 Y: 2,258 Z: 151.2	<b>(Q, q)</b> X: 200 Y: 3,020 Z: 352.9
<b>(E, e)</b> X: 384 Y: 403.2 Z: 128.8	<b>(L, l)</b> X: 630 Y: 2,390 Z: 221.5	<b>(R, r)</b> X: 535 Y: 3,570 Z: 311.6
<b>(F, f)</b> X: 411 Y: 402.7 Z: 128.8	<b>(M, m)</b> X: 552 Y: 2,375 Z: 124.2	<b>(S)</b> X: 537.7 Y: 3,794 Z: 311.6

#### Front and rear strut tower centers

Coordinates:

<b>(T, t)</b> X: 543 Y: 71.5 Z: 800
<b>(U, u)</b> X: 454 Y: 2,877.2 Z: 667.7



Front: **(T, t)** 106 dia.  
Rear: **(U, u)** 84 dia.

Unit: mm

GI

MA

EM

LC

EC

FE

AT

PD

FA

RA

BR

ST

RS

**BT**

HA

EL

IDX

## NOTES