

ACCELERATOR CONTROL, FUEL & EXHAUST SYSTEMS

SECTION **FE**

CONTENTS

ACCELERATOR CONTROL SYSTEM	2	FUEL SYSTEM	3
Adjusting Accelerator Wire	2	EXHAUST SYSTEM	4

GI

MA

EM

LC

EC

FE

AT

PD

FA

RA

BR

ST

RS

BT

HA

EL

IDX

ACCELERATOR CONTROL SYSTEM

CAUTION:

- When removing accelerator wire, make a mark to indicate lock nut's initial position.
- Check that throttle valve opens fully when accelerator pedal is fully depressed. Also check that it returns to idle position when pedal is released.
- Check accelerator control parts for improper contact with any adjacent parts.
- When connecting accelerator wire, be careful not to twist or scratch wire.
- Refer to "AUTOMATIC SPEED CONTROL DEVICE (ASCD)" in EL section for ASCD wire adjustment.

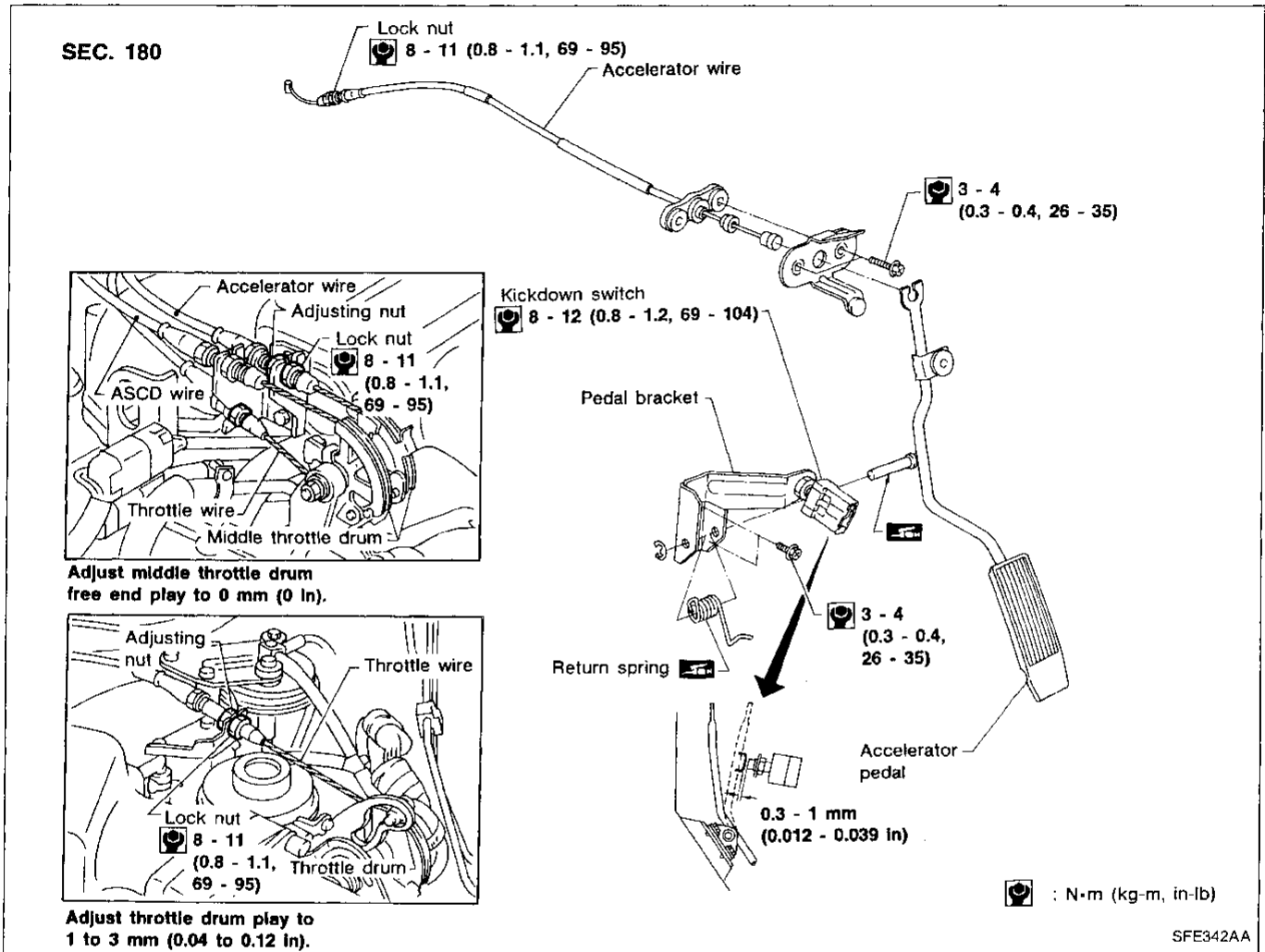

Adjusting Accelerator Wire

MIDDLE THROTTLE DRUM ADJUSTMENT

1. Loosen lock nut, and tighten adjusting nut until middle throttle drum starts to move.
2. Fasten adjusting nut with lock nut.

THROTTLE DRUM ADJUSTMENT

1. Loosen lock nut, and tighten adjusting nut until throttle drum starts to move.
2. From that position turn back adjusting nut 1.5 to 2 turns, and fasten it with lock nut.

FUEL SYSTEM

WARNING:

When replacing fuel line parts, be sure to observe the following:

- Put a "CAUTION: FLAMMABLE" sign in workshop.
- Be sure to furnish workshop with a CO₂ fire extinguisher.
- Do not smoke while servicing fuel system. Keep open flames and sparks away from work area.
- Be sure to disconnect battery ground cable before conducting operations.
- Drain fuel from Fuel Tank and put drained fuel in an explosion-proof container and put lid on securely.

CAUTION:

- Before disconnecting fuel hose, release fuel pressure from fuel line. Refer to "Changing Fuel Filter" in MA section.
- Do not disconnect any fuel line unless absolutely necessary.
- Plug hose and pipe openings to prevent entry of dust or dirt.
- Always replace O-ring and clamps with new ones.
- Do not kink or twist hose and tube when they are installed.
- Do not tighten hose clamps excessively to avoid damaging hoses.
- Tighten bolts to specified torque.
- When installing fuel check valve, be careful of its designated direction. (Refer to "EVAPORATIVE EMISSION SYSTEM" in EC section.)
- After installation, run engine and check for fuel leaks at connections.
- Use only a genuine fuel filler cap as a replacement.

SEC. 172

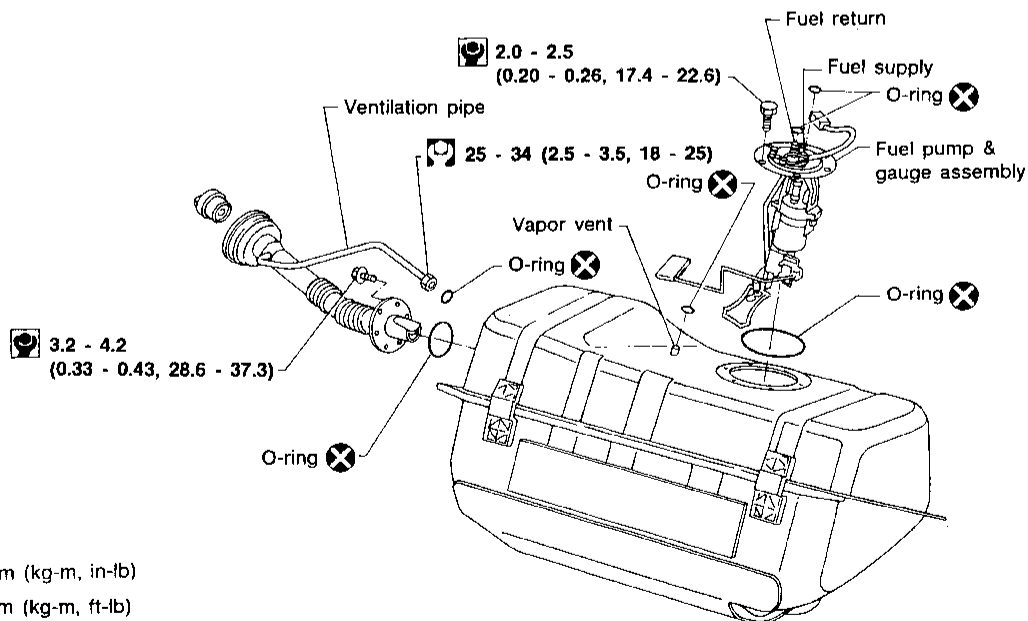
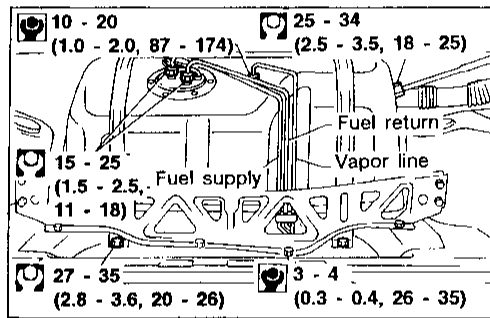

SFE331AA

EXHAUST SYSTEM

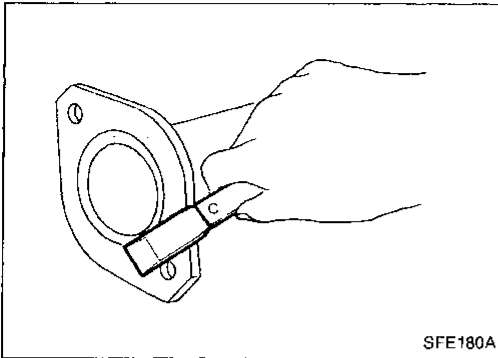

SFE180A

CAUTION:

- Always replace exhaust gaskets with new ones when reassembling. If gasket is left on flange surface, scrape off completely as shown at left.
- With engine running, check all tube connections for exhaust gas leaks, and entire system for unusual noises.
- Check to ensure that mounting brackets and mounting insulators are installed properly free from undue stress. Improper installation could result in excessive noise or vibration.
- For removal and installation of rear heated oxygen sensor, refer to "TROUBLE DIAGNOSIS FOR DTC P0136 and P0256" in EC section.
- Discard any heated oxygen sensor which has been dropped from a height of more than 0.5 m (19.7 in) onto a hard surface such as a concrete floor; use a new one.

SEC. 200

