

HEATER & AIR CONDITIONER

SECTION **HA**

CONTENTS

PRECAUTIONS AND PREPARATION 2	TROUBLE DIAGNOSES22	
Supplemental Restraint System "AIR BAG" and "SEAT BELT PRE-TENSIONER" 2	Contents.....22	
Introduction 3	Wiring Diagram58	AT
Identification..... 3	SYSTEM DESCRIPTION86	
Precautions for Working with HFC-134a (R-134a) 4	Overview of Control System.....86	PD
General Refrigerant Precautions 4	Control System Input Components86	
Precautions for Refrigerant Connection 5	Control System Automatic Amplifier (Auto amp.).....91	FA
Precautions for Servicing Compressor..... 6	Control System Output Components.....92	
Special Service Tools..... 6	SERVICE PROCEDURES 103	RA
HFC-134a (R-134a) Service Tools and Equipment..... 7	HFC-134a (R-134a) Service Procedure..... 103	
Precautions for Service Equipment 9	Maintenance of Oil Quantity in Compressor 105	BR
DESCRIPTION11	Refrigerant Lines 107	
Refrigeration Cycle.....11	Compressor Mounting 108	ST
V-6 Variable Displacement Compressor.....12	Belt Tension 108	
Component Layout.....16	Engine Idling Speed (When A/C is ON)..... 108	RS
Discharge Air Flow17	Compressor — Model V-6 (CALSONIC make) 109	
Introduction18	Compressor Clutch 109	BT
Features.....18	SERVICE DATA AND SPECIFICATIONS (SDS) 112	
Control Operation19	General Specifications.....112	
	Inspection and Adjustment..... 112	

When you read wiring diagrams:

- Read GI section, "HOW TO READ WIRING DIAGRAMS".
- See EL section, "POWER SUPPLY ROUTING" for power distribution circuit.

When you perform trouble diagnoses, read GI section, "HOW TO FOLLOW FLOW CHART IN TROUBLE DIAGNOSES".

GI

WA

EM

LC

EF &
EC

FE

AT

PD

FA

RA

BR

ST

RS

BT

HA

EL

IDX

Supplemental Restraint System “AIR BAG” and “SEAT BELT PRE-TENSIONER”

The Supplemental Restraint System “Air Bag” and “Seat Belt Pre-tensioner”, used along with a seat belt, help to reduce the risk or severity of injury to the driver and front passenger in a frontal collision. The Supplemental Restraint System consists of air bag modules (located in the center of the steering wheel and on the instrument panel on the passenger side), seat belt pre-tensioners, a diagnosis sensor unit, warning lamp, wiring harness and spiral cable. Information necessary to service the system safely is included in the **RS section** of this Service Manual.

WARNING:

- **To avoid rendering the SRS inoperative, which could increase the risk of personal injury or death in the event of a collision which would result in air bag inflation, all maintenance must be performed by an authorized INFINITI dealer.**
- **Improper maintenance, including incorrect removal and installation of the SRS, can lead to personal injury caused by unintentional activation of the system.**
- **All SRS electrical wiring harnesses and connectors are covered with yellow outer insulation. Do not use electrical test equipment on any circuit related to the SRS.**

PRECAUTIONS AND PREPARATION

Introduction

To prevent the ozone layer from being destroyed, the HFC-134a (R-134a) refrigerant has replaced the previously used CFC-12 (R-12).

R-134a and R-12 refrigerants, lubricants, service tools, etc. are not interchangeable. They have different physical properties and characteristics.

Always service the HFC-134a (R-134a) air conditioning system using the specified tools, lubricant and refrigerant, observing the following precautions:

Identification

IDENTIFICATION LABEL FOR VEHICLE

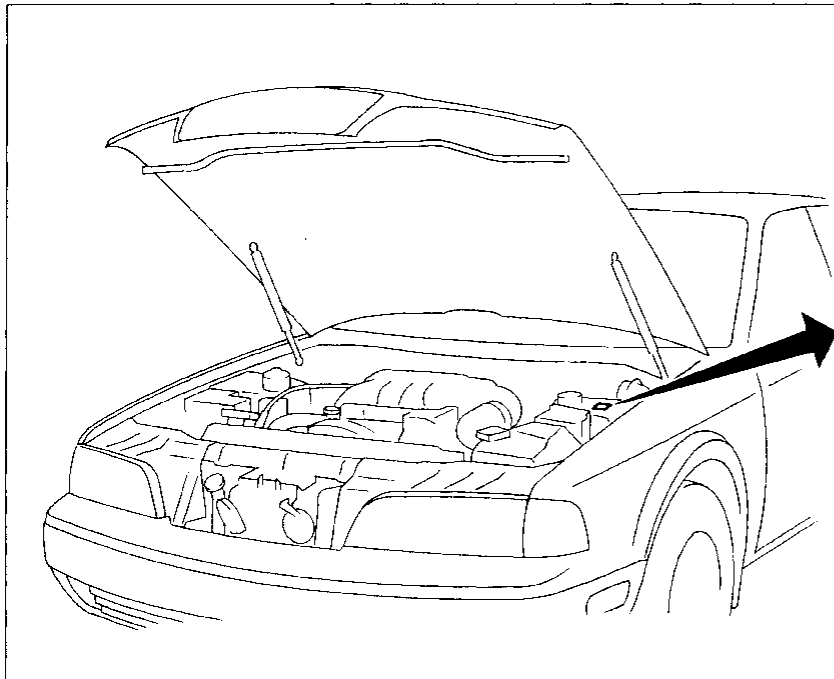

AIR CONDITIONER		
	REFRIGERANT	COMPRESSOR LUBRICANT
TYPE (PART NO.)	HFC-134a (R-134a)	△1
AMOUNT	△3	△2

CAUTION PRÉCAUTION

- REFRIGERANT UNDER HIGH PRESSURE.
- SYSTEM TO BE SERVICED BY QUALIFIED PERSONNEL.
- IMPROPER SERVICE METHODS MAY CAUSE PERSONAL INJURY.
- CONSULT SERVICE MANUAL.
- THIS AIR CONDITIONER SYSTEM COMPLIES WITH SAE J-639.

NISSAN MOTOR CO., LTD. Tokyo, Japan

△1 : Lubricant type and service part number
 △2 : Amount of lubricant
 △3 : Amount of refrigerant

SHA599E

PARTS IDENTIFICATION

1. Compressor label

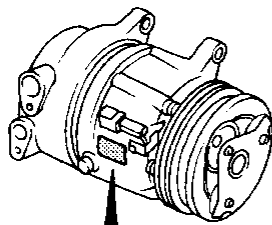

CALSONIC	
PART NO.	○○○○○ ○○○○
SER. NO.	○○○○○ ○○○○
TYPE V6-16 REFRIG. HFC-134a	
OIL DH-PS: 200 cm ³ (7 fl oz)	
[NISSAN PART NO. KLH00-PAGS0]	
LEAK TEST HIGH SIDE: 30 kg/cm ² G [430 P.S.I.G.]	
LOW SIDE: 15 kg/cm ² G [215 P.S.I.G.]	
HFC-134a 用 USE FOR HFC-134a	
MFD. CALSONIC CORP.	MADE IN JAPAN

2. Other component parts label

HFC-134a label

HFC-134a 用
USE FOR HFC-134a

Base color: Light blue

HFC-用
134a
USE FOR
HFC-134a

Part name	Identification
1. Compressor	Compressor label
2. Cooling unit	HFC-134a label
3. Expansion valve	Stamp
4. Condenser	HFC-134a label
5. Liquid tank	HFC-134a label

3. Service valves (suction/discharge)

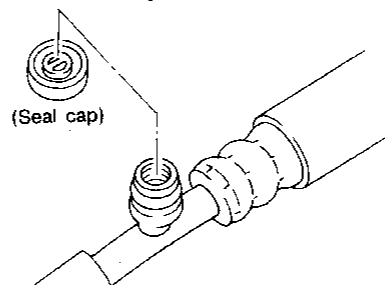

The service valves are specially designed for the HFC-134a (R-134a) system. Those for the CFC-12 (R-12) system are different in size and configuration. Refer to "PREPARATION".

SHA600E

PRECAUTIONS AND PREPARATION

Precautions for Working with HFC-134a (R-134a)

WARNING:

- CFC-12 (R-12) refrigerant and HFC-134a (R-134a) refrigerant are not compatible. These refrigerants must never be mixed, even in the smallest amounts. If the refrigerants are mixed, compressor failure is likely to occur.
- Use only specified lubricant for the HFC-134a (R-134a) A/C system and HFC-134a (R-134a) components. If lubricant other than that specified is used, compressor failure is likely to occur.
- The specified HFC-134a (R-134a) lubricant rapidly absorbs moisture from the atmosphere. The following handling precautions must be observed:
 - a: When removing refrigerant components from a vehicle, immediately cap (seal) the component to minimize the entry of moisture from the atmosphere.
 - b: When installing refrigerant components to a vehicle, do not remove the caps (unseal) until just before connecting the components. Connect all refrigerant loop components as quickly as possible to minimize the entry of moisture into system.
 - c: Only use the specified lubricant from a sealed container. Immediately reseal containers of lubricant. Without proper sealing, lubricant will become moisture saturated and should not be used.
 - d: Avoid breathing A/C refrigerant and lubricant vapor or mist. Exposure may irritate eyes, nose and throat. Remove R-134a from the A/C system, using certified service equipment meeting requirements of SAE J2210 (R-134a recycling equipment), or J2209 (R-134a recovery equipment). If accidental system discharge occurs, ventilate work area before resuming service. Additional health and safety information may be obtained from refrigerant and lubricant manufacturers.
 - e: Do not allow lubricant (Nissan A/C System Oil Type S) to come in contact with styrofoam parts. Damage may result.

General Refrigerant Precautions

WARNING:

- Do not release refrigerant into the air. Use approved recovery/recycling equipment to capture the refrigerant every time an air conditioning system is discharged.
- Always wear eye and hand protection (goggles and gloves) when working with any refrigerant or air conditioning system.
- Do not store or heat refrigerant containers above 52°C (125°F).
- Do not heat a refrigerant container with an open flame; if container warming is required, place the bottom of the container in a warm pail of water.
- Do not intentionally drop, puncture, or incinerate refrigerant containers.
- Keep refrigerant away from open flames: poisonous gas will be produced if refrigerant burns.
- Refrigerant will displace oxygen, therefore be certain to work in well ventilated areas to prevent suffocation.
- Do not introduce compressed air to any refrigerant container or refrigerant component.

PRECAUTIONS AND PREPARATION

Precautions for Refrigerant Connection

WARNING:

Make sure all refrigerant is discharged into the recycling equipment and the pressure in the system is less than atmospheric pressure. Then gradually loosen the discharge side hose fitting and remove it.

CAUTION:

When replacing or cleaning refrigerant cycle components, observe the following.

- When the compressor is removed, store it in the same position as it is when mounted on the car. Failure to do so will cause lubricant to enter the low pressure chamber.
- When connecting tubes, always use a torque wrench and a back-up wrench.
- After disconnecting tubes, immediately plug all openings to prevent entry of dirt and moisture.
- When installing an air conditioner in the vehicle, connect the pipes as the final stage of the operation. Do not remove the seal caps of pipes and other components until just before required for connection.
- Allow components stored in cool areas to warm to working area temperature before removing seal caps. This prevents the condensation from forming inside A/C components.
- Thoroughly remove moisture from the refrigeration system before charging the refrigerant.
- Always replace used O-rings.
- When connecting tube, apply lubricant to portions shown in illustration. Be careful not to apply lubricant to threaded portion.

Lubricant name: Nissan A/C System Oil Type S

Part number: KLH00-PAGS0

- O-ring must be closely attached to inflated portion of tube.
- After inserting tube into union until O-ring is no longer visible, tighten nut to specified torque.
- After connecting line, conduct leak test and make sure that there is no leakage from connections. When the gas leaking point is found, disconnect that line and replace the O-ring. Then tighten connections of seal seat to the specified torque.

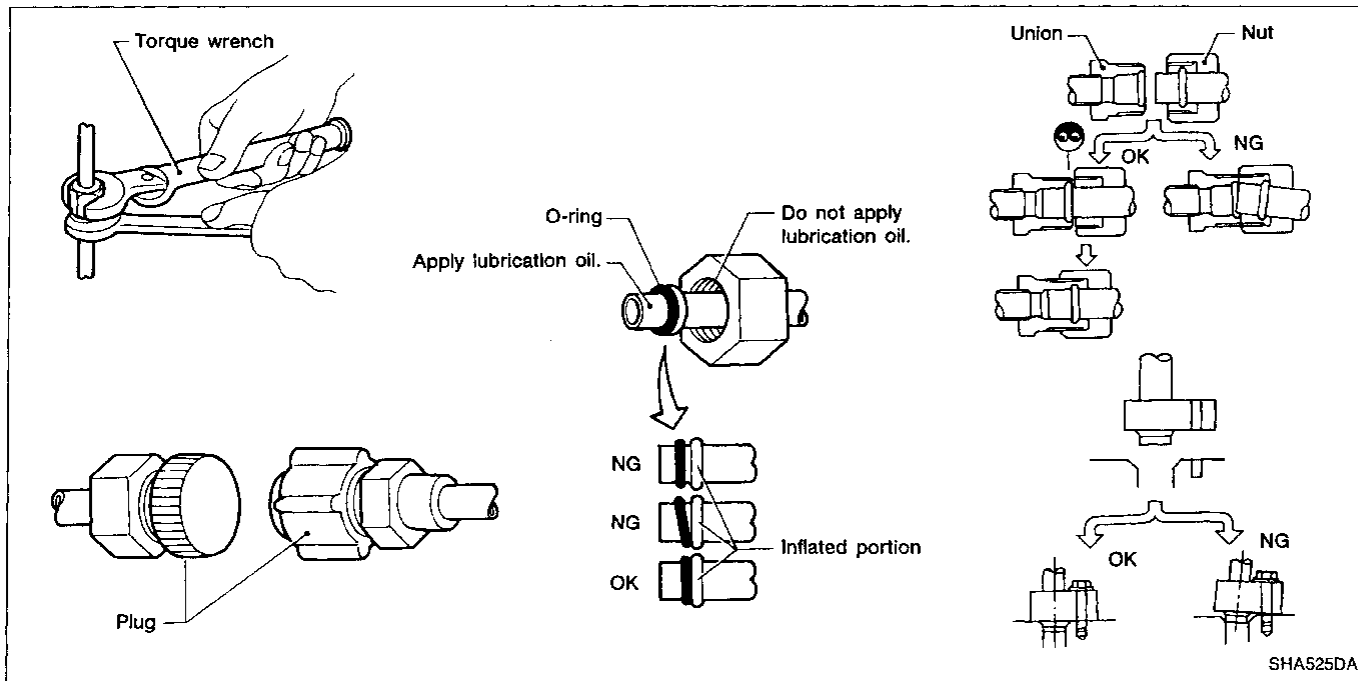

PRECAUTIONS AND PREPARATION

Precautions for Servicing Compressor

- Plug all openings to prevent moisture and foreign matter from entering.
- When the compressor is removed, store it in the same position as it is when mounted on the car.
- When replacing or repairing compressor, follow "Maintenance of Oil Quantity in Compressor" exactly. Refer to HA-105.
- Remove lubricant from new compressor so that the lubricant quantity is equal to that of removed compressor. See HA-105.
- Keep friction surfaces between clutch and pulley clean. If the surface is contaminated, with lubricant, wipe it off by using a clean waste cloth moistened with thinner.
- After compressor service operation, turn the compressor shaft by hand more than five turns in both directions. This will equally distribute lubricant inside the compressor. After the compressor is installed, let the engine idle and operate the compressor for one hour.
- After replacing the compressor magnet clutch, apply voltage to the new one and check for normal operation.

Special Service Tools

Tool number (Kent-Moore No.) Tool name	Description
KV99106100 (J-41260) Clutch disc wrench	<div style="display: flex; justify-content: space-between;"> <div data-bbox="410 961 467 987">NT232</div> <div data-bbox="540 804 852 972"> </div> <div data-bbox="982 793 1218 823">Removing center bolt</div> </div> <div style="display: flex; justify-content: space-around; margin-top: 20px;"> <div data-bbox="492 1010 670 1182"> </div> <div data-bbox="735 1010 914 1182"> </div> </div> <p data-bbox="410 1186 706 1323">When replacing the magnet clutch in the above compressor, use a clutch disc wrench with the pin side on the clutch disc to remove it.</p> <p data-bbox="722 1186 982 1323">When replacing the magnet clutch in the above compressor, use a clutch disc wrench with the flat side on the clutch disc to remove it.</p> <div style="text-align: center; margin-top: 20px;"> <p data-bbox="657 1333 706 1354">Pin</p> <p data-bbox="722 1417 901 1438">Clutch disc wrench</p> </div> <div data-bbox="410 1470 467 1491">NT233</div>
KV99232340 (J-38874) or KV992T0001 (—) Clutch disc puller	<div style="display: flex; justify-content: space-between;"> <div data-bbox="410 1711 467 1732">NT234</div> <div data-bbox="540 1528 768 1711"> </div> <div data-bbox="982 1507 1218 1537">Removing clutch disc</div> </div>
KV99106200 (J-41261) Pulley installer	<div style="display: flex; justify-content: space-between;"> <div data-bbox="410 1921 467 1942">NT235</div> <div data-bbox="630 1791 727 1906"> </div> <div data-bbox="982 1749 1153 1778">Installing pulley</div> </div>

PRECAUTIONS AND PREPARATION

HFC-134a (R-134a) Service Tools and Equipment

Never mix HFC-134a refrigerant and/or its specified lubricant with CFC-12 (R-12) refrigerant and/or its lubrication oil.

Separate and non-interchangeable service equipment must be used for each type of refrigerant/lubricant.

Refrigerant container fittings, service hose fittings and service equipment fittings (equipment which handles refrigerant and/or lubricant) are different between CFC-12 (R-12) and HFC-134a (R-134a). This is to avoid mixed use of the refrigerants/lubricant.

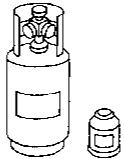
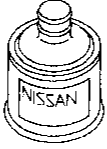
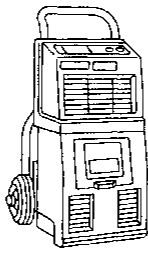
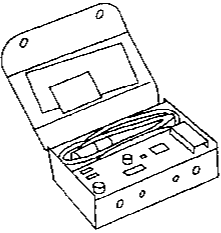
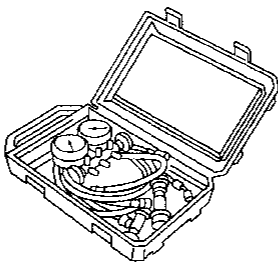

Adapters that convert one size fitting to another must never be used: refrigerant/lubricant contamination will occur and compressor failure will result.

CI
 MA
 EM
 LC
 EF & EC
 FE
 AT
 PD
 FA
 RA
 BR
 ST
 RS
 BT
 HA
 EL
 IDX

Tool number (Kent-Moore No.) Tool name	Description	Note
HFC-134a (R-134a) refrigerant	 NT196	Container color: Light blue Container marking: HFC-134a (R-134a) Fitting size: Thread size ● large container 1/2"-16 ACME
KLH00-PAGS0 (—) Nissan A/C System Oil Type S	 NT197	Type: Poly alkylene glycol oil (PAG), type S Application: HFC-134a (R-134a) swash plate (piston) compressors (Nissan only) Lubricity: 40 ml (1.4 US fl oz, 1.4 Imp fl oz)
(J-39500-INF) Recovery/Recycling equipment (ACR4)	 NT195	Function: Refrigerant Recovery and Recycling and Recharging
(J-39400) Electrical leak detector	 NT198	Power supply: ● DC 12 V (Cigarette lighter)
(J-39183) Manifold gauge set (with hoses and couplers)	 NT199	Identification: ● The gauge face indicates R-134a. Fitting size: Thread size ● 1/2"-16 ACME

PRECAUTIONS AND PREPARATION

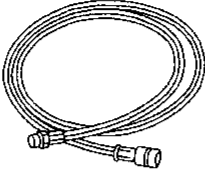
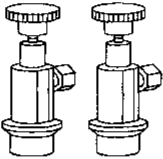
HFC-134a (R-134a) Service Tools and Equipment (Cont'd)

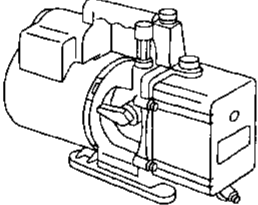
Tool number (Kent-Moore No.) Tool name	Description	Note
Service hoses <ul style="list-style-type: none"> ● High side hose (J-39501-72) ● Low side hose (J-39502-72) ● Utility hose (J-39476-72) 	 NT201	Hose color: <ul style="list-style-type: none"> ● Low hose: Blue with black stripe ● High hose: Red with black stripe ● Utility hose: Yellow with black stripe or green with black stripe Hose fitting to gauge: <ul style="list-style-type: none"> ● 1/2"-16 ACME
Service couplers <ul style="list-style-type: none"> ● High side coupler (J-39500-20) ● Low side coupler (J-39500-24) 	 NT202	Hose fitting to service hose: <ul style="list-style-type: none"> ● M14 x 1.5 fitting is optional or permanently attached.
(J-39650) Refrigerant weight scale	 NT200	For measuring of refrigerant Fitting size: Thread size <ul style="list-style-type: none"> ● 1/2"-16 ACME
(J-39649) Vacuum pump (Including the isolator valve)	 NT203	Capacity: <ul style="list-style-type: none"> ● Air displacement: 4 CFM ● Micron rating: 20 microns ● Oil capacity: 482 g (17 oz) Fitting size: Thread size <ul style="list-style-type: none"> ● 1/2"-16 ACME

PRECAUTIONS AND PREPARATION

Precautions for Service Equipment

RECOVERY/RECYCLING EQUIPMENT

Be certain to follow the manufacturers instructions for machine operation and machine maintenance. Never introduce any refrigerant other than that specified into the machine.

ELECTRONIC LEAK DETECTOR

Be certain to follow the manufactures instructions for tester operation and tester maintenance.

VACUUM PUMP

The lubricant contained inside the vacuum pump is not compatible with the specified lubricant for HFC-134a (R-134a) A/C systems. The vent side of the vacuum pump is exposed to atmospheric pressure. So the vacuum pump lubricant may migrate out of the pump into the service hose. This is possible when the pump is switched off after evacuation (vacuuming) and hose is connected to it.

To prevent this migration, use a manual valve placed near the hose-to-pump connection, as follows.

- Usually vacuum pumps have a manual isolator valve as part of the pump. Close this valve to isolate the service hose from the pump.
- For pumps without an isolator, use a hose equipped with a manual shut-off valve near the pump end. Close the valve to isolate the hose from the pump.
- If the hose has an automatic shut off valve, disconnect the hose from the pump. As long as the hose is connected, the valve is open and lubricant may migrate.

Some one-way valves open when vacuum is applied and close under a no vacuum condition. Such valves may restrict the pump's ability to pull a deep vacuum and are not recommended.

MANIFOLD GAUGE SET

Be certain that the gauge face indicates R-134a or 134a. Be sure the gauge set has 1/2"-16 ACME threaded connections for service hoses. Confirm the set has been used only with refrigerant HFC-134a (R-134a) along with specified lubricant.

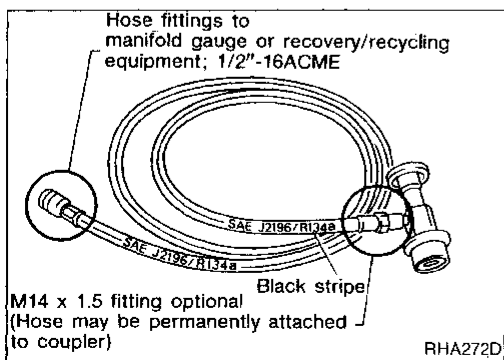
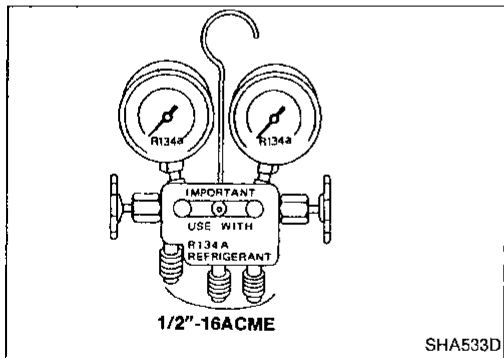
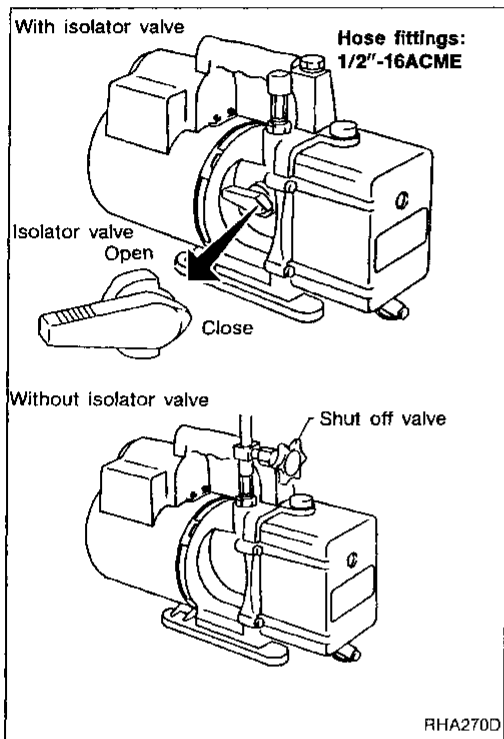

SERVICE HOSES

Be certain that the service hoses display the markings described (colored hose with black stripe). All hoses must include positive shut off devices (either manual or automatic) near the end of the hoses opposite the manifold gauge.

PRECAUTIONS AND PREPARATION

Precautions for Service Equipment (Cont'd)

SERVICE COUPLERS

Never attempt to connect HFC-134a (R-134a) service couplers to an CFC-12 (R-12) A/C system. The HFC-134a (R-134a) couplers will not properly connect to the CFC-12 (R-12) system. However, if an improper connection is attempted, discharging and contamination can occur.

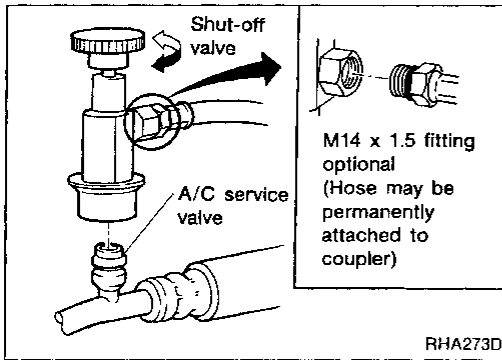

Shut off valve rotation	A/C service valve
Clockwise	Open
Counterclockwise	Close

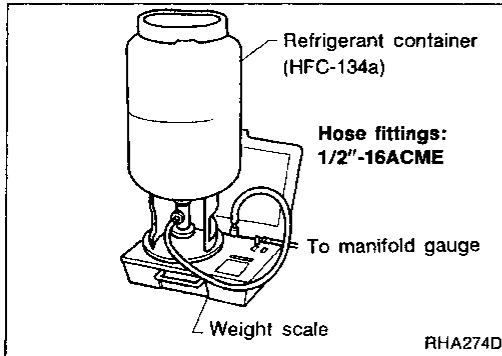

REFRIGERANT WEIGHT SCALE

Verify that no refrigerant other than R-134a and specified lubricant have been used with the scale. If the scale controls refrigerant flow electronically, the hose fitting must be 1/2"-16 ACME.

CHARGING CYLINDER

Using a charging cylinder is not recommended. Refrigerant may be vented into air from cylinder's top valve when filling the cylinder with refrigerant. Also, the accuracy of the cylinder is generally less than that of an electronic scale or of quality recycle/recharge equipment.

DESCRIPTION

Refrigeration Cycle

REFRIGERANT FLOW

The refrigerant flow is in the standard pattern. Refrigerant flows through the compressor, condenser, liquid tank, evaporator, and back to the compressor.

The refrigerant evaporation through the evaporator coil is controlled by an externally equalized expansion valve, located inside the evaporator case.

FREEZE PROTECTION

Under normal operating conditions, when the AUTO is switched on, the compressor runs continuously, and the evaporator pressure, and therefore temperature, is controlled by the V-6 variable displacement compressor to prevent freeze up.

REFRIGERANT SYSTEM PROTECTION

Triple-pressure switch

The triple pressure switch is located on the liquid tank. If the system pressure rises or falls out of specifications, the switch opens to interrupt compressor clutch operation. Triple-pressure switch closes to turn on the cooling fan to reduce system pressure.

Pressure relief valve

The refrigerant system is protected by a pressure relief valve. The valve is located on the bottom of the compressor. When refrigerant system pressure increases abnormally [over 3,727 kPa (38 kg/cm², 540 psi)], the relief valve's port opens. The valve then releases refrigerant into the atmosphere.

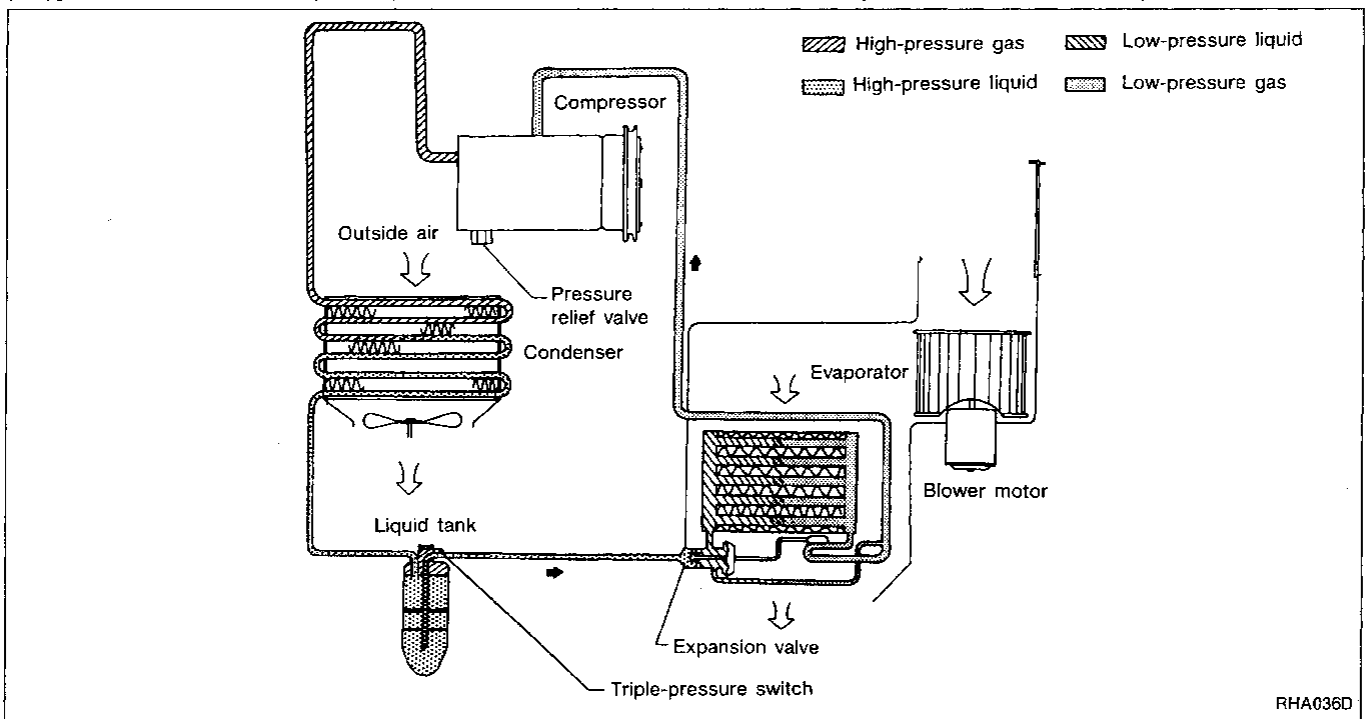

V-6 Variable Displacement Compressor

GENERAL INFORMATION

1. The V-6 variable compressor differs from previous units. The vent temperatures of the V-6 variable compressor do not drop too far below 5°C (41°F) when:
 - evaporator intake air temperature is less than 20°C (68°F)
 - engine is running at speeds less than 1,500 rpm.This is because the V-6 compressor provides a means of “capacity” control.
2. The V-6 variable compressor provides refrigerant control under varying conditions. When ambient temperatures are low, it may not produce high refrigerant pressure discharge (compared to previous units).
3. A “clanking” sound may occasionally be heard during refrigerant charge. The sound indicates that the tilt angle of the swash plate has changed and is not a problem.
4. For air conditioning systems with the V-6 compressor, the clutch remains engaged unless: the system main switch, fan switch or ignition switch is turned OFF. When ambient (outside) temperatures are low or when the amount of refrigerant is insufficient, the clutch is disengaged to protect the compressor.
5. A constant range of suction pressure is maintained when engine speed is greater than a certain value. It normally ranges from 147 to 177 kPa (1.5 to 1.8 kg/cm², 21 to 26 psi) under varying conditions.
In previous compressors, however, suction pressure was reduced with increases in engine speed.

DESCRIPTION

V-6 Variable Displacement Compressor (Cont'd)

DESCRIPTION

General

The variable compressor is basically a swash plate type that changes piston stroke in response to the required cooling capacity.

The tilt of the swash plate allows the piston's stroke to change so that refrigerant discharge can be continuously changed from 10.5 to 165 cm³ (0.641 to 10.07 cu in).

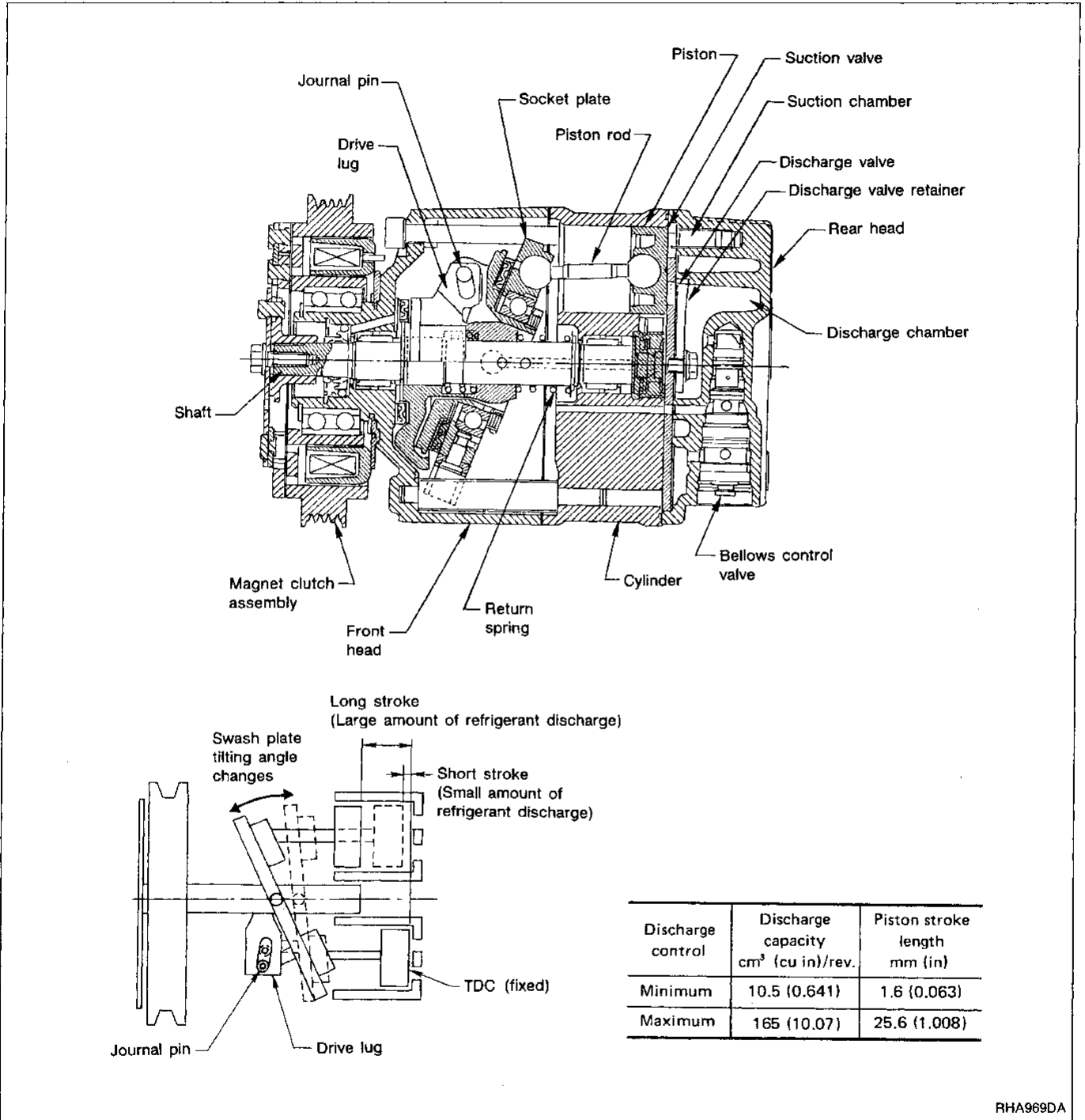

GI
 MA
 EM
 LC
 EF & EC
 FE
 AT
 PD
 FA
 RA
 BR
 ST
 RS
 BT
HA
 EL
 IDX

DESCRIPTION

V-6 Variable Displacement Compressor (Cont'd)

Operation

1. Operation control valve

Operation control valve is located in the suction port (low-pressure) side, and opens or closes in response to changes in refrigerant suction pressure.

Operation of the valve controls the internal pressure of the crankcase.

The angle of the swash plate is controlled between the crankcase's internal pressure and the piston cylinder pressure.

2. Maximum cooling

Refrigerant pressure on the low-pressure side increases with an increase in heat loads.

When this occurs, the control valve's bellows compress to open the low-pressure side valve and close the high-pressure side valve.

This causes the following pressure changes:

- the crankcase's internal pressure to equal the pressure on the low-pressure side;
- the cylinder's internal pressure to be greater than the crankcase's internal pressure.

Under this condition, the swash plate is set to the maximum stroke position.

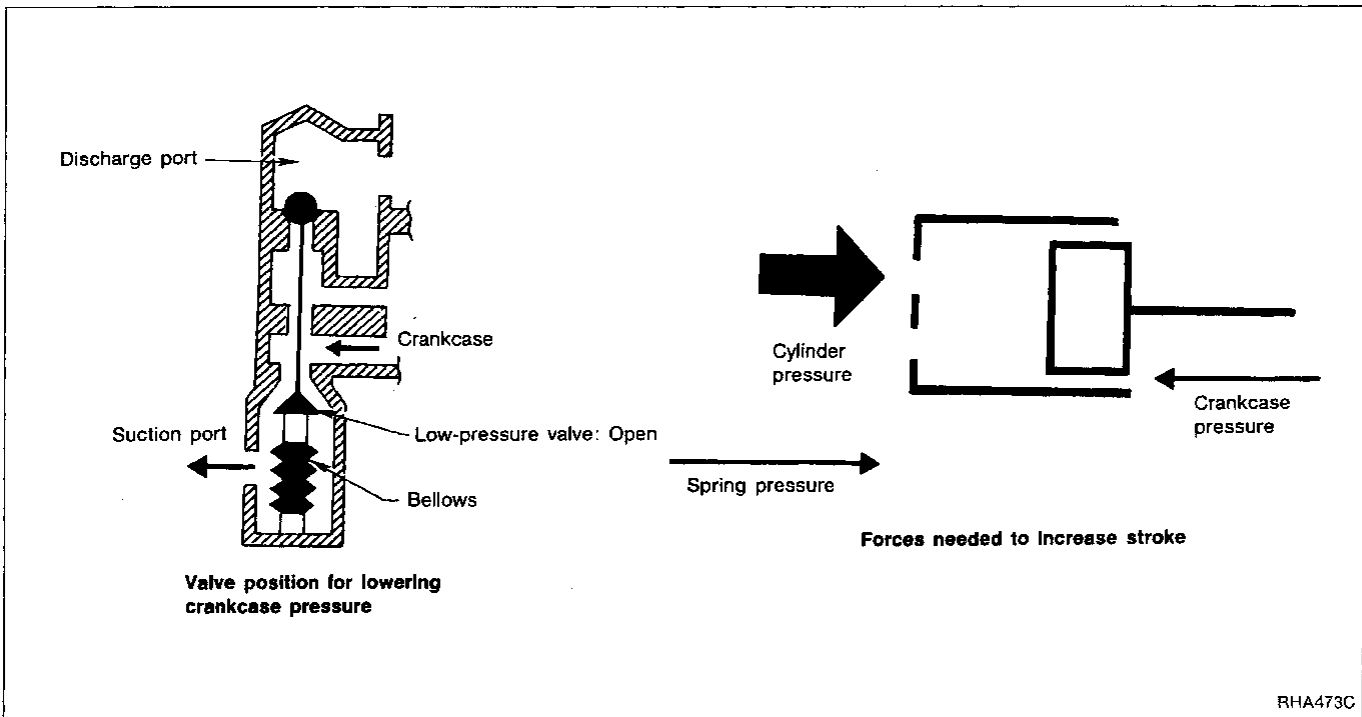

DESCRIPTION

V-6 Variable Displacement Compressor (Cont'd)

3. Capacity control

- Refrigerant pressure on suction side is low during high speed driving or when ambient or interior temperature is low.
- The bellows expands when refrigerant pressure on the suction pressure side drops below approximately 177 kPa (1.8 kg/cm², 26 psi).

Since suction pressure is low, it makes the suction port close and the discharge port open. Thus, crankcase pressure becomes high as high pressure enters the crankcase.

- The force acts around the journal pin near the swash plate, and is generated by the pressure difference before and behind the piston.

The drive lug and journal pin are located where the piston generates the highest pressure. Piston pressure is between suction pressure P_s and discharge pressure P_d , which is near suction pressure P_s . If crankcase pressure P_c rises due to capacity control, the force around the journal pin makes the swash plate angle decrease and also the piston stroke decrease. In other words, crankcase pressure increase triggers pressure difference between the piston and the crankcase. The pressure difference changes the angle of the swash plate.

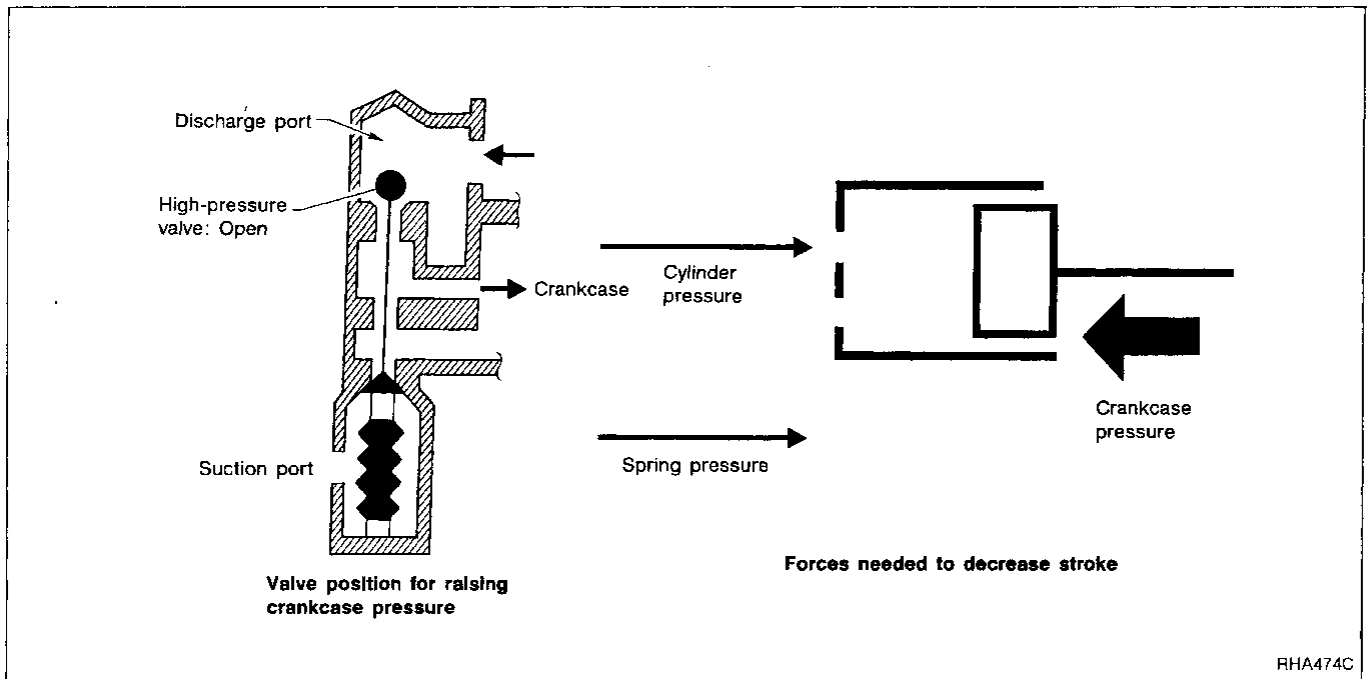

DESCRIPTION

Component Layout

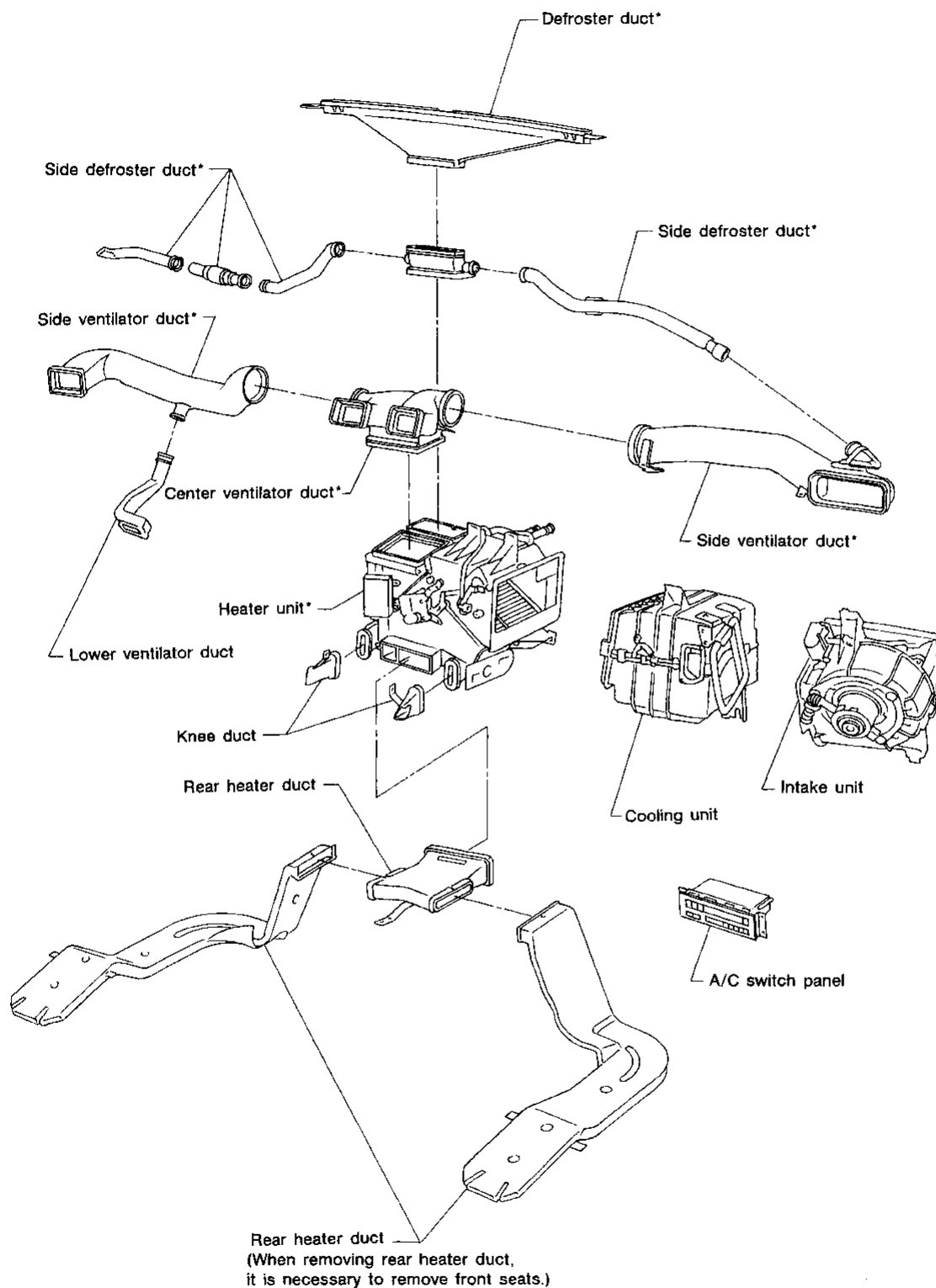

*: For removal, it is necessary to remove instrument assembly.

DESCRIPTION

Discharge Air Flow

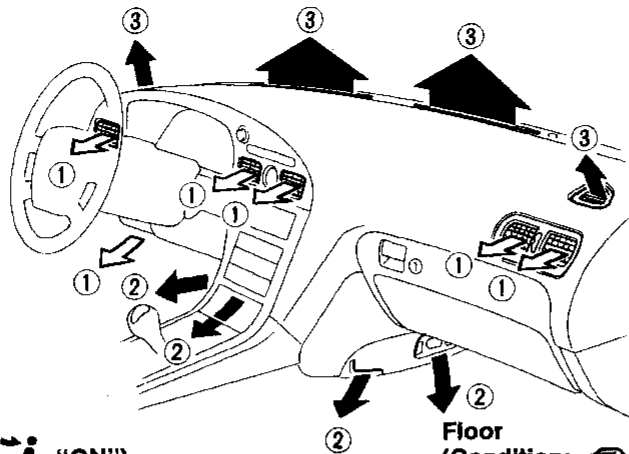

Ventilation
(Condition: and "ON")

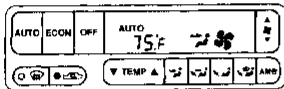

Floor
(Condition: "OFF" and "ON")

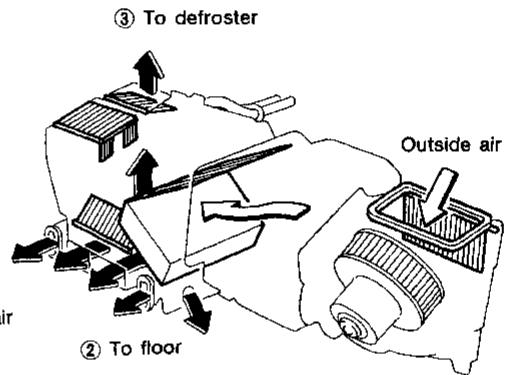
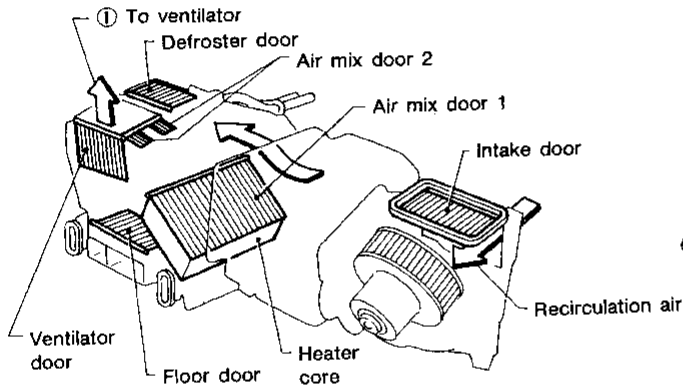
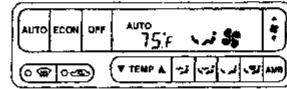

Bi-level
(Condition: "OFF" and "ON")

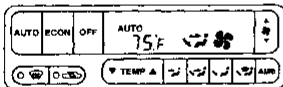

(1) To ventilator

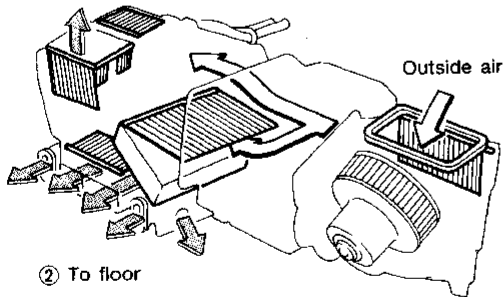

Defroster
(Condition: "ON")

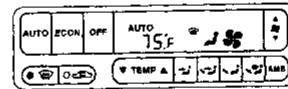

(3) To defroster

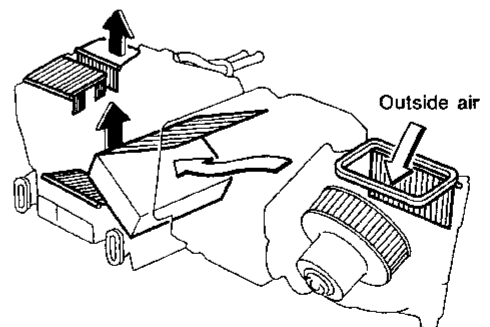

- : Air passed through heater core
- : Mixed air (+)
- : Air not passed through heater core

GI
MA
EM
LC
EF &
EC
FE
AT
PD
FA
RA
BR
ST
RS
BT
HA
EL
IDX

Introduction

The Automatic Temperature Control (ATC) system provides automatic regulation of the vehicles interior temperature. The operator selects "set temperature", on which the regulation is based, regardless of the outside temperature changes. This is done by utilizing a microcomputer, also referred to as the automatic amplifier, which receives input signals from several sensors. The automatic amplifier uses these input signals (including the set temperature) to automatically control the ATC system's outlet air volume, air temperature, and air distribution.

Features

Air mix door control

The air mix door is automatically controlled so that in-vehicle temperature will reach, and be maintained at the operator selected "set temperature". For a given set temperature, the air mix door position will depend on: Ambient temperature, in-vehicle temperature, amount of sunload, and intake air temperature.

Fan speed control

Blower speed is automatically controlled based on temperature setting, ambient temperature, in-vehicle temperature, intake air temperature, amount of sunload and air mix door position.

With FAN switch set to "AUTO", the blower motor starts to gradually increase air flow volume.

When engine coolant temperature is low, the blower motor operation is delayed to prevent cool air from flowing.

Intake door control

The intake door position will be determined by: Ambient temperature, in-vehicle temperature, and whether the compressor is on or off.

Outlet door control

The outlet door position will be determined by: Ambient temperature, in-vehicle temperature, intake air temperature, and amount of sunload.

Compressor clutch control

The compressor operation (ON-OFF) is automatically controlled by the ambient sensor to prevent compressor damage in very cold ambient temperatures.

Recirculation switch

When RECIRC switch is pressed, intake door is fixed at RECIRC position.

Self-diagnostic system

The self-diagnostic system consists of five steps. Each step can be accessed by pushing the switches on the automatic amplifier.

STEP 1: Checks L.E.D.s and segments of the display.

STEP 2: Checks each sensor circuit for open or short circuit.

STEP 3: Checks mode door position.

STEP 4: Checks operation of each actuator.

STEP 5: Checks temperature detected by each sensor.

AUXILIARY TRIMMER MECHANISM: Set temperature trimmer.

Memory function

With ignition switch turned OFF, the auto amplifier stores in memory the set temperature and inputs of various switches. When the ignition switch is turned ON, the system begins operation with the information stored in memory. The system, then immediately compensates for the actual operating conditions.

Refrigeration cycle

Refer to page HA-11 for the description of the refrigeration cycle.

DESCRIPTION

Control Operation

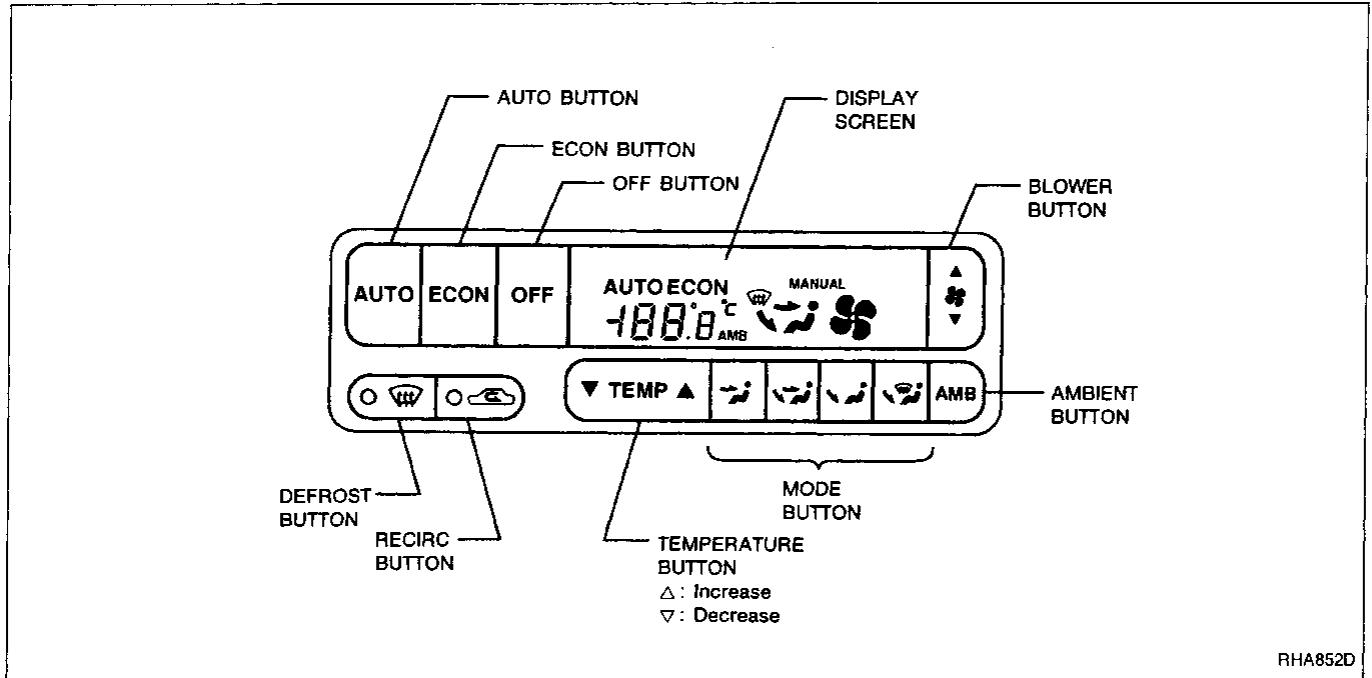

DISPLAY SCREEN

Displays the operational status of the system.

AUTO BUTTON

The compressor, air inlet door, air mix door, outlet doors, and blower speed are automatically controlled so that the in-vehicle temperature will reach, and be maintained at the set temperature selected by the operator.

ECON BUTTON

Fully automatic control with the compressor off. With the compressor off, the system will not remove heat (cool) or de-humidify. The system will maintain the in-vehicle temperature at the set temperature when the set temperature is above the ambient (outside) temperature.

TEMPERATURE INCREASE/DECREASE BUTTON





Increases or decreases the set temperature.

OFF BUTTON

The compressor and blower are off, the air inlet door is set to the outside air position. Then, the air outlet doors are set to the foot (70% foot and 30% defrost) position. In the off position the ATC system uses the vehicle's "flow through" ventilation. It tries to maintain the interior temperature based on the last set temperature of the system.

BLOWER BUTTON

Manual control of the blower speed. Four speeds are available for manual control (as shown on the display screen):

low , medium low , medium high , high 

MODE BUTTON

Manual control of the air discharge outlets. There selections are available (as shown on the display screen):

face , bi-level , foot , foot/defroster 

DESCRIPTION

Control Operation (Cont'd)

AMBIENT BUTTON

Shows the ambient (outside) air temperature on the display screen for 5 seconds.

RECIRC BUTTON

Positions the air inlet door to the recirculation position.

DEFROST BUTTON

Positions the air discharge doors to the defrost position. Also positions the air inlet door to the outside air position. The compressor operates at ambient temperature approx. 6°C (43°F) or above.

DESCRIPTION

NOTE

GI

MA

EM

LC

EF &
EC

FE

AT

PD

FA

RA

BR

ST

RS

BT

HA

EL

IDX

TROUBLE DIAGNOSES

Contents

How to Perform Trouble Diagnoses for Quick and Accurate Repair	HA-24
Operational Check	HA-25
Symptom Chart	HA-28
Self-diagnosis	HA-30
INTRODUCTION AND GENERAL DESCRIPTION	HA-30
STEP BY STEP PROCEDURE	HA-31
HOW TO INTERPRET THE RESULTS	HA-34
STEP 1: Checks L.E.D.s and segments	HA-34
STEP 2: Checks each sensor circuit for open or short circuit	HA-34
STEP 3: Checks mode door position	HA-35
STEP 4: Checks operation of each actuator	HA-36
STEP 5: Checks temperature detected by sensors, and detects multiplex communication error	HA-37
AUXILIARY MECHANISM: Temperature setting trimmer	HA-39
Preliminary Check	HA-40
PRELIMINARY CHECK 1 (Air outlet does not change.)	HA-40
PRELIMINARY CHECK 2 (Intake door does not change.)	HA-41
PRELIMINARY CHECK 3 (Insufficient cooling)	HA-42
PRELIMINARY CHECK 4 (Insufficient heating)	HA-43
PRELIMINARY CHECK 5 (Blower motor operation is malfunctioning.)	HA-44
PRELIMINARY CHECK 6 (Magnet clutch does not engage.)	HA-45
PRELIMINARY CHECK 7 (Discharged air temperature does not change.)	HA-46
PRELIMINARY CHECK 8 (Noise)	HA-47
Performance Test Diagnoses	HA-48
INSUFFICIENT COOLING	HA-48
Performance Chart	HA-50
TEST CONDITION	HA-50
TEST READING	HA-50
Trouble Diagnoses for Abnormal Pressure	HA-51
A/C Component Layout	HA-55
Circuit Diagram for Quick Pinpoint Check	HA-57
Wiring Diagram	HA-58
Main Power Supply and Ground Circuit Check	HA-60
Diagnostic Procedure 1 SYMPTOM: Ambient sensor circuit is open. (21 is indicated on auto amp. as a result of conducting Self-diagnosis STEP 2.)	HA-61
Diagnostic Procedure 2 SYMPTOM: In-vehicle sensor circuit is open. (22 is indicated on auto amp. as a result of conducting Self-diagnosis STEP 2.)	HA-62
Diagnostic Procedure 3 SYMPTOM: Water temperature sensor circuit is open. (23 is indicated on auto amp. as a result of conducting Self-diagnosis STEP 2.)	HA-63
Diagnostic Procedure 4 SYMPTOM: Intake sensor circuit is open. (24 is indicated on auto amp. as a result of conducting Self-diagnosis STEP 2.)	HA-64

TROUBLE DIAGNOSES

Contents (Cont'd)

Diagnostic Procedure 5	
SYMPTOM: Sunload sensor circuit is open. (25 is indicated on auto amp. as a result of conducting Self-diagnosis STEP 2.)	HA-65
Diagnostic Procedure 6	
SYMPTOM: PBR circuit is open. (26 is indicated on auto amp. as a result of conducting Self-diagnosis STEP 2.)	HA-66
Diagnostic Procedure 7	
SYMPTOM: Thermal transmitter circuit is open. (27 is indicated on auto amp. as a result of conducting Self-diagnosis STEP 2.)	HA-67
Diagnostic Procedure 8	
SYMPTOM: Ambient sensor circuit is shorted. (28 is indicated on auto amp. as a result of conducting Self-diagnosis STEP 2.)	HA-68
Diagnostic Procedure 9	
SYMPTOM: In-vehicle sensor circuit is shorted. (29 is indicated on auto amp. as a result of conducting Self-diagnosis STEP 2.)	HA-68
Diagnostic Procedure 10	
SYMPTOM: Water temperature sensor circuit is shorted. (23 is indicated on auto amp. as a result of conducting Self-diagnosis STEP 2.)	HA-69
Diagnostic Procedure 11	
SYMPTOM: Intake sensor circuit is shorted. (24 is indicated on auto amp. as a result of conducting Self-diagnosis STEP 2.)	HA-69
Diagnostic Procedure 12	
SYMPTOM: Sunload sensor circuit is shorted. (25 is indicated on auto amp. as a result of conducting Self-diagnosis STEP 2.)	HA-70
Diagnostic Procedure 13	
SYMPTOM: PBR circuit is shorted. (26 is indicated on auto amp. as a result of conducting Self-diagnosis STEP 2.)	HA-71
Diagnostic Procedure 14	
SYMPTOM: Thermal transmitter circuit is shorted. (27 is indicated on auto amp. as a result of conducting Self-diagnosis STEP 2.)	HA-72
Diagnostic Procedure 15	
SYMPTOM: Mode door motor does not operate normally.	HA-73
Diagnostic Procedure 16	
SYMPTOM: Intake door motor does not operate normally.	HA-75
Diagnostic Procedure 17	
SYMPTOM: Air mix door motor does not operate normally.	HA-77
Diagnostic Procedure 18	
SYMPTOM: Blower motor operation is malfunctioning under out of Starting Fan Speed Control.	HA-78
Diagnostic Procedure 19	
SYMPTOM: Magnet clutch does not engage after performing Preliminary Check 6.	HA-80
Diagnostic Procedure 20	
SYMPTOM: Self-diagnosis cannot be performed.	HA-82
Electrical Components Inspection	HA-83
Control Linkage Adjustment	HA-84

GI

MA

EM

LC

EF &
EC

FE

AT

PD

FA

RA

BR

ST

RS

BT

HA

EL

IDX

TROUBLE DIAGNOSES

How to Perform Trouble Diagnoses for Quick and Accurate Repair

WORK FLOW

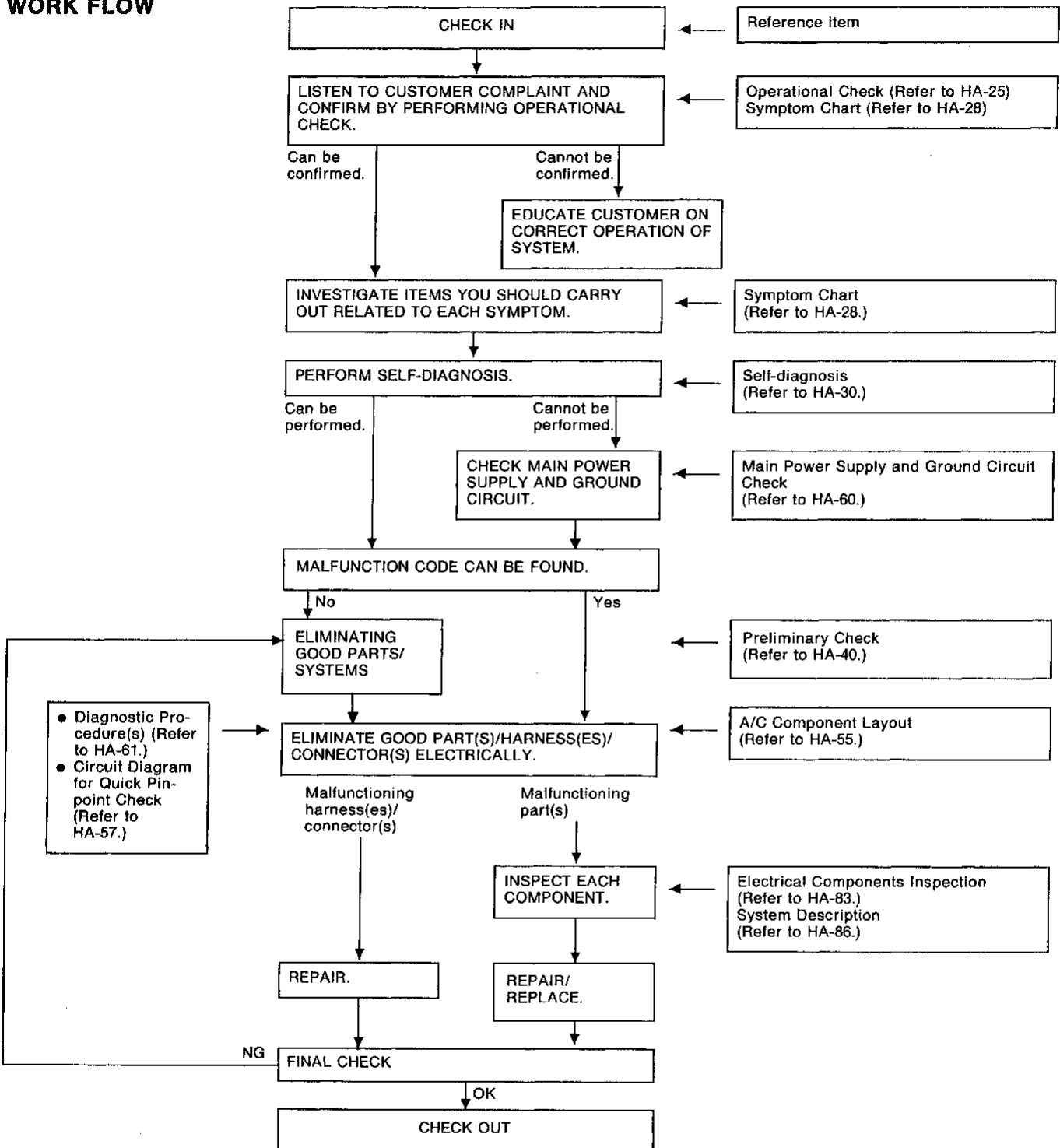

Operational Check

The purpose of the operational check is to confirm that the system operates as it should. The systems which will be checked are the blower, mode (discharge air), ambient display, intake air, defrost, econ, auto, temperature decrease, temperature increase, and the memory function.

CONDITIONS:

Engine running at normal operating temperature.

PROCEDURE:

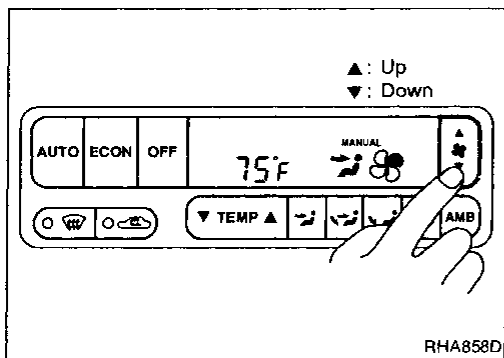

1. Check blower

- 1) Press FAN switch (▲: Up) one time. MANUAL should appear on the display. Blower should operate on low speed, and the fan symbol should have one blade lit ().
- 2) Press FAN switch one more time.
- 3) Continue checking blower speed and fan symbol until all four speeds have been checked.
- 4) Leave blower on high speed.
- 5) Press FAN switch (▼: Down) one time. Blower should operate in third speed.
- 6) Continue checking blower speed and fan symbol until all three speeds have been checked.

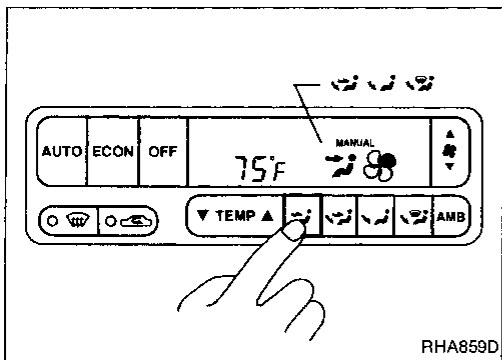

2. Check discharge air

- 1) Press the () switch. Display should show air to the face.
- 2) Confirm that all discharge air comes out the face vents.
- 3) Press () switch. Display should show air to face and foot (bi-level).
- 4) Confirm that discharge air comes out the face and foot vents.
- 5) Press () switch. Display should show air to foot.
- 6) Confirm that discharge air comes mostly from the foot outlets, with some air from the defroster outlets.
- 7) Press () switch. Display should show air to foot and defrost.
- 8) Confirm that discharge air comes mostly from the defrost vents, with some air from the foot outlets.

TROUBLE DIAGNOSES

Operational Check (Cont'd)

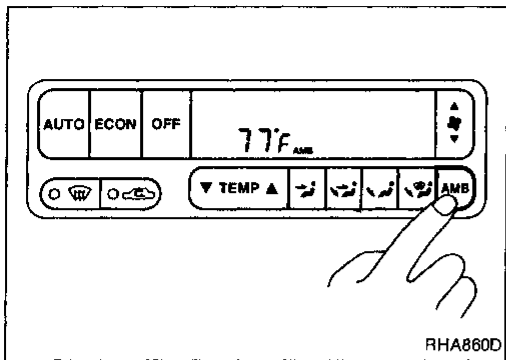

3. Check ambient display

Press the AMB button.

Display should show the outside (ambient) temperature for approximately 5 seconds.

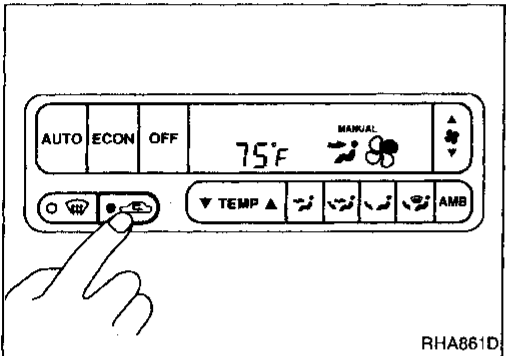

4. Check recirc

- 1) Press RECIRC button.
RECIRC indicator should illuminate.
- 2) Listen for intake door position change (you should hear blower sound change slightly).

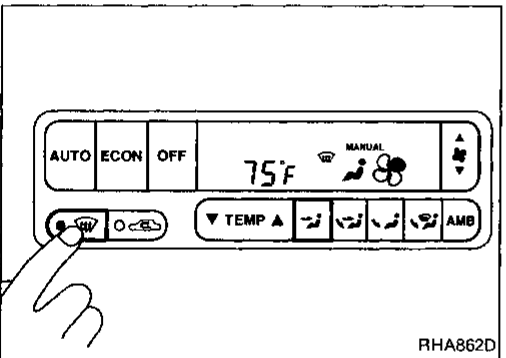

5. Check defrost

- 1) Press defrost button.
- 2) Check that RECIRC is canceled.
The discharge air should be coming only from the defrost vents.
- 3) Confirm that the compressor clutch is engaged (visual inspection).
The display should indicate AUTO, MANUAL, and defrost ().

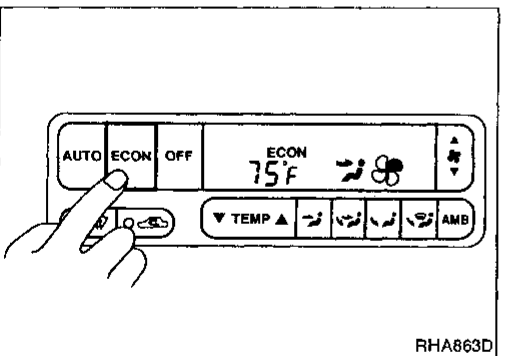

6. Check ECON mode

- 1) Press ECON button.
Defrost should be canceled.
Discharge air outlet will depend on ambient, in-vehicle, and set temperatures.
Display should indicate ECON (no AUTO, no MANUAL).
- 2) Confirm that the compressor clutch is not engaged (visual inspection).

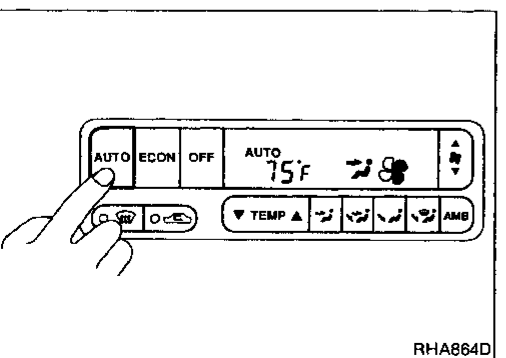

7. Check AUTO mode

- 1) Press AUTO button.
- 2) Confirm that the compressor clutch engages (audio or visual inspection).
Display should indicate AUTO (no ECON, no MANUAL).
(Discharge air will depend on ambient, in-vehicle, and set temperatures).

TROUBLE DIAGNOSES

Operational Check (Cont'd)

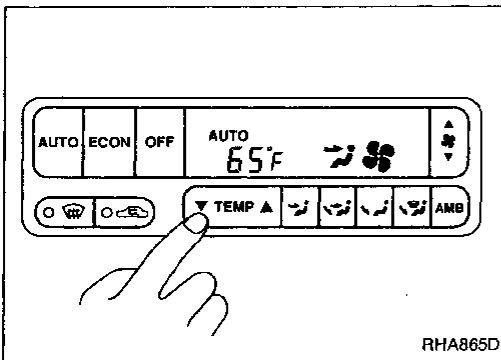

8. Check temperature decrease

- 1) Press the temperature decrease button until 18°C (65°F) is displayed.
- 2) Check for cold air at discharge air outlets.

GI

MA

EM

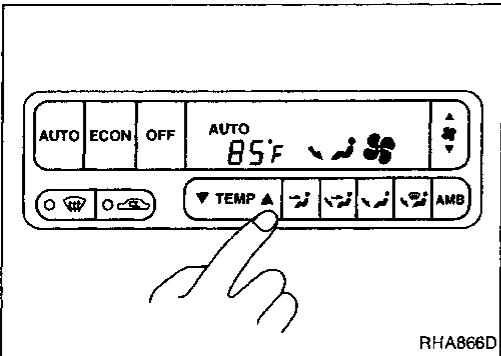

9. Check temperature increase

- 1) Press the temperature increase button until 32°C (85°F) is displayed.
- 2) Listen for changes in blower speed as set temperature changes.
- 3) Check for hot air at discharge air outlets.

LC

EF &
EC

FE

AT

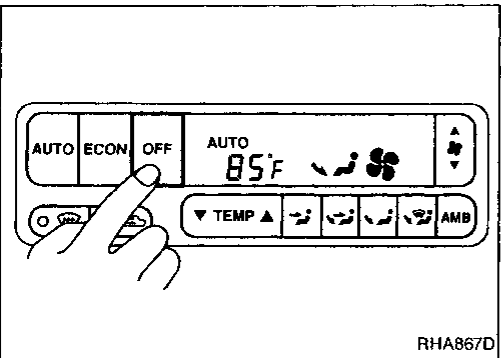

10. Check memory function

- 1) Press off button.
- 2) Turn the ignition off.
- 3) Wait 15 seconds.
- 4) Turn the ignition on.
- 5) Press the AUTO button.
- 6) Confirm that the set temperature remained at 32°C (85°F).

PD

FA

RA

BR

ST

RS

BT

HA

EL

IDX

TROUBLE DIAGNOSES

Symptom Chart

DIAGNOSTIC TABLE





PROCEDURE		Self-diagnosis					Preliminary Check								Diagnostic Procedure														
SYMPTOM	DIAGNOSTIC ITEM AND REFERENCE PAGE	STEP 1 (HA-30, 34)	STEP 2 (HA-30, 34)	STEP 3 (HA-30, 35)	STEP 4 (HA-30, 36)	STEP 5 (HA-30, 37)	AUXILIARY MECHANISM (HA-39)	Preliminary Check 1 (HA-40)	Preliminary Check 2 (HA-41)	Preliminary Check 3 (HA-42)	Preliminary Check 4 (HA-43)	Preliminary Check 5 (HA-44)	Preliminary Check 6 (HA-45)	Preliminary Check 7 (HA-46)	Preliminary Check 8 (HA-47)	Diagnostic Procedure 1 (HA-61)	Diagnostic Procedure 2 (HA-62)	Diagnostic Procedure 3 (HA-63)	Diagnostic Procedure 4 (HA-64)	Diagnostic Procedure 5 (HA-65)	Diagnostic Procedure 6 (HA-66)	Diagnostic Procedure 7 (HA-67)	Diagnostic Procedure 8 (HA-68)	Diagnostic Procedure 9 (HA-68)	Diagnostic Procedure 10 (HA-68)	Diagnostic Procedure 11 (HA-69)	Diagnostic Procedure 12 (HA-70)	Diagnostic Procedure 13 (HA-71)	
Air outlet does not change.		1	2					5																					
Intake door does not change.		1	2					6																					
Insufficient cooling										1																			
Insufficient heating											1																		
Blower motor operation is malfunctioning.		1	2									3																	
Magnet clutch does not engage.		1	2										3																
Discharged air temperature does not change.		1	2											3															
Noise															1														
Result of self-diagnosis STEP 2	21 Ambient sensor circuit is open.	1	2			3										4													
	22 In-vehicle sensor circuit is open.	1	2			3											4												
	23 Water temperature sensor circuit is open.	1	2															3											
	24 Intake sensor circuit is open.	1	2			3														4									
	25 Sunload sensor circuit is open.	1	2																		3								
	26 PBR circuit is open.	1	2																			3							
	27 Thermal transmitter circuit is open.	1	2																				3						
	21 Ambient sensor circuit is shorted.	1	2			3																		4					
	22 In-vehicle sensor circuit is shorted.	1	2			3																				4			
	23 Water temperature sensor circuit is shorted.	1	2																								3		
	24 Intake sensor circuit is shorted.	1	2			3																						4	
	25 Sunload sensor circuit is shorted.	1	2																									3	
	26 PBR circuit is shorted.	1	2																										3
	27 Thermal transmitter circuit is shorted.	1	2																										
Mode door motor does not operate normally.		1	2	3	4																								
Intake door motor does not operate normally.		1	2		3																								
Air mix door motor does not operate normally.		1	2		3																								
Blower motor operation is malfunctioning under out of Starting Fan Speed Control.		1	2									3																	
Magnet clutch does not operate after performing Preliminary Check 6.		1	2										3																
Self-diagnosis cannot be performed.																													

1, 2: The number means checking order.

○: As for checking order, refer to each flow chart. (It depends on malfunctioning portion.)

Self-diagnosis

INTRODUCTION AND GENERAL DESCRIPTION

The self-diagnostic system diagnoses sensors, door motors, blower motor and multiplex communication errors, etc. by system line. Refer to applicable sections (items) for details. Shifting from normal control to the self-diagnostic system is done as follows. Start the engine (turn the ignition switch from "OFF" to "ON"). And press  switch for at least 5 seconds. The  switch must be pressed within 10 seconds after starting the engine (ignition switch is turned "ON"). This system will be canceled by either pressing  switch or turning ignition switch "OFF". Shifting from one step to another is accomplished by means of pushing  (HOT) or  (COLD) switch, as required.

Additionally shifting from STEP 5 to AUXILIARY MECHANISM is accomplished by means of pushing  (fan up) switch.

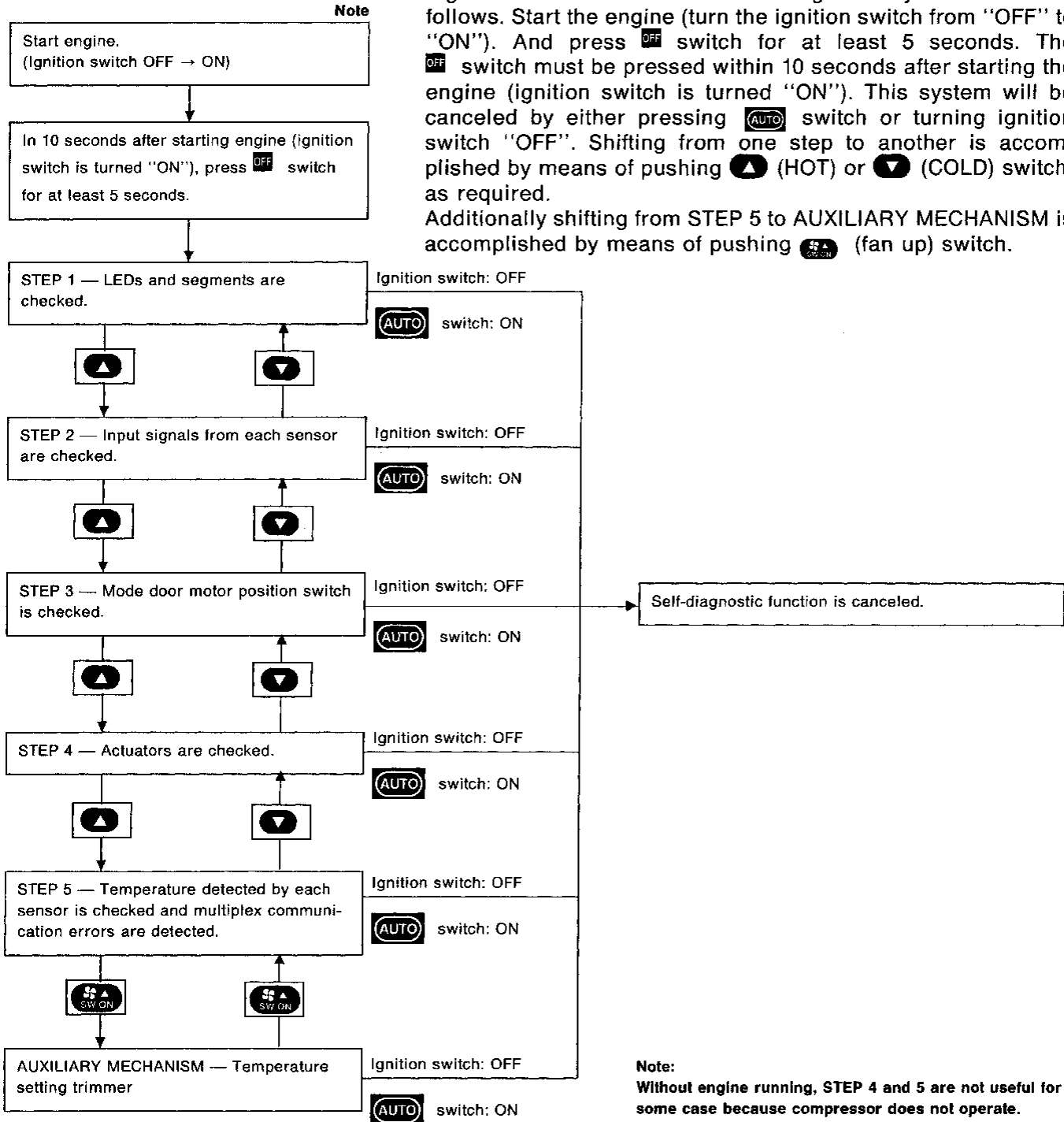

Note:
Without engine running, STEP 4 and 5 are not useful for some case because compressor does not operate.

TROUBLE DIAGNOSES

Self-diagnosis (Cont'd)

STEP BY STEP PROCEDURE

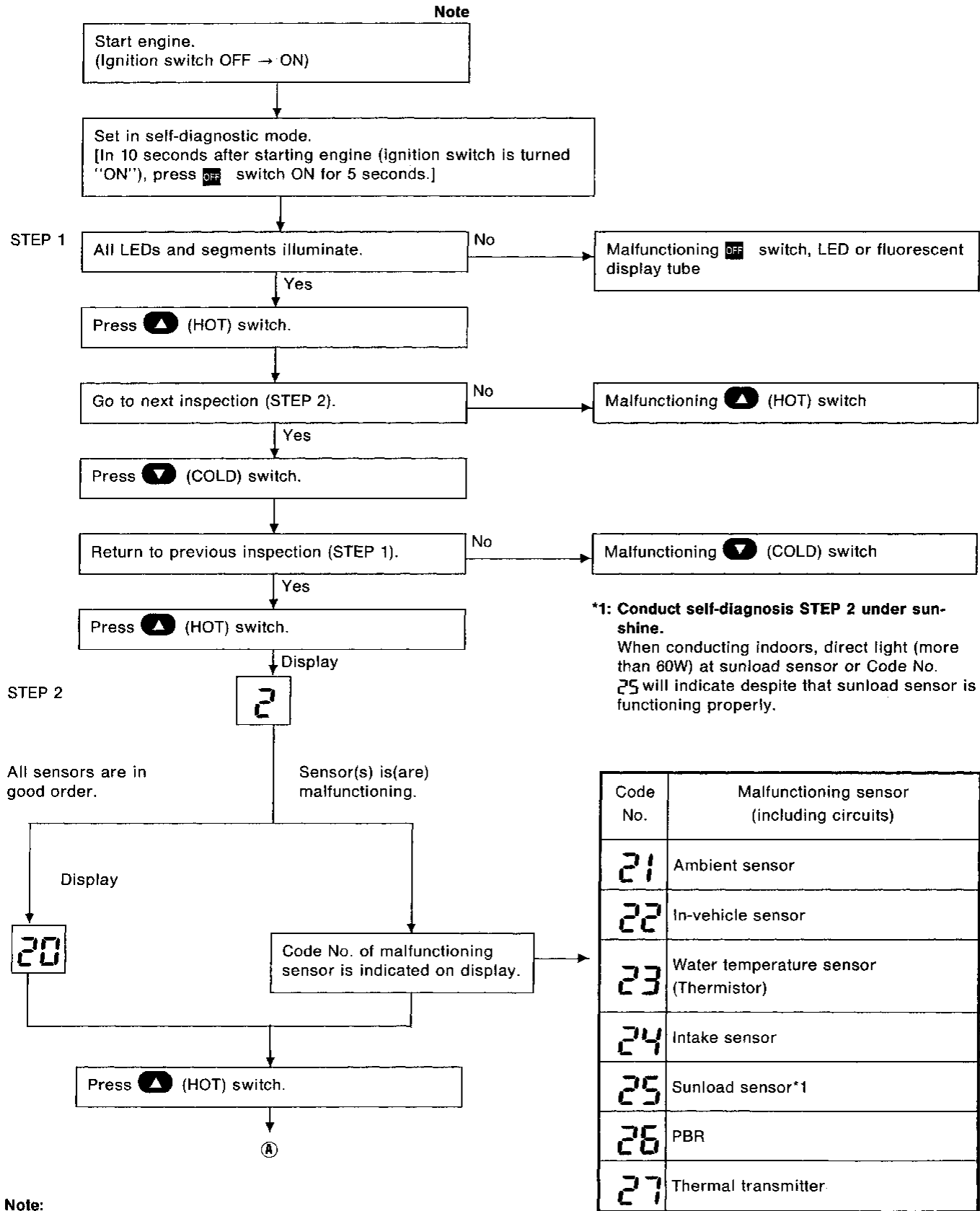

Note:
Without engine running, STEP 4 and 5 are not useful for some case because compressor does not operate.

GI
 MA
 EM
 LC
 EF & EC
 FE
 AT
 PD
 FA
 RA
 BR
 ST
 RS
 BT
 HA
 EL
 IDX

TROUBLE DIAGNOSES

Self-diagnosis (Cont'd)

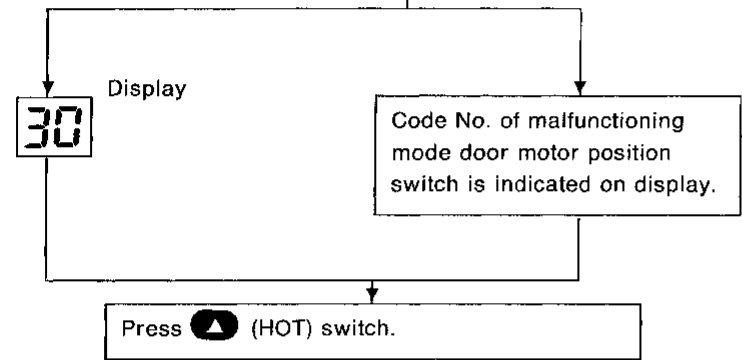
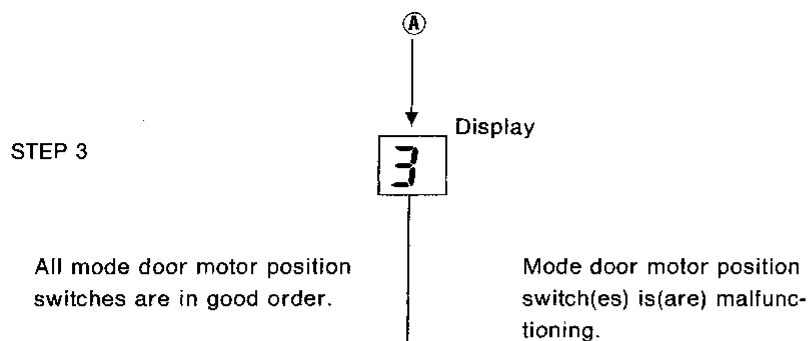

Code No.	Malfunctioning mode door motor position switch (including circuits)
31	VENT
32	B/L
33	B/L
34	FOOT/DEF 1
35	FOOT/DEF 2
36	DEF

STEP 4

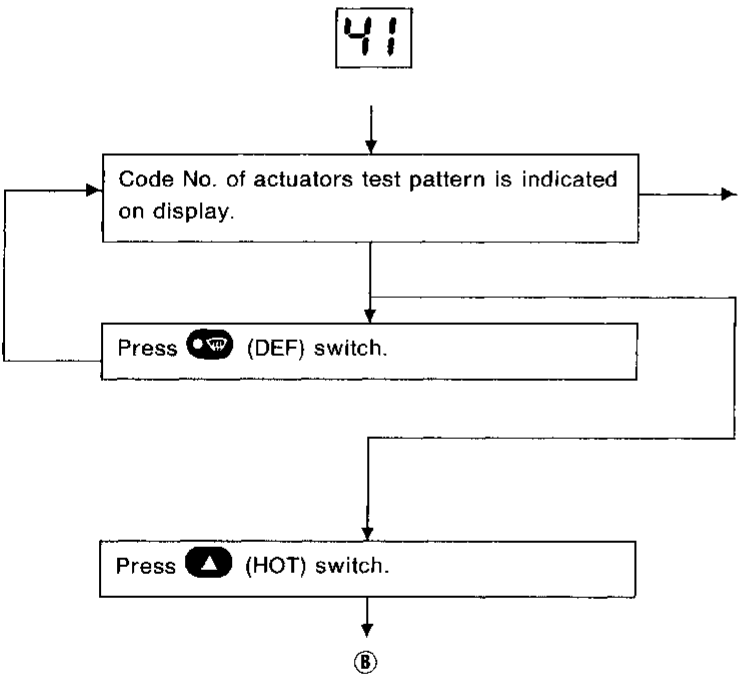

Code No.	Actuators test pattern				
	Mode door	Intake door	Air mix door	Blower motor	Compressor
41	VENT	REC	Full Cold	4 - 5V	ON
42	B/L 1	REC	Full Cold	9 - 11V	ON
43	B/L 2	20% FRE	Full Hot	7 - 9V	ON
44	D/F 1	FRE	Full Hot	7 - 9V	OFF
45	D/F 2	FRE	Full Hot	7 - 9V	OFF
46	DEF	FRE	Full Hot	10 - 12V	ON

TROUBLE DIAGNOSES

Self-diagnosis (Cont'd)

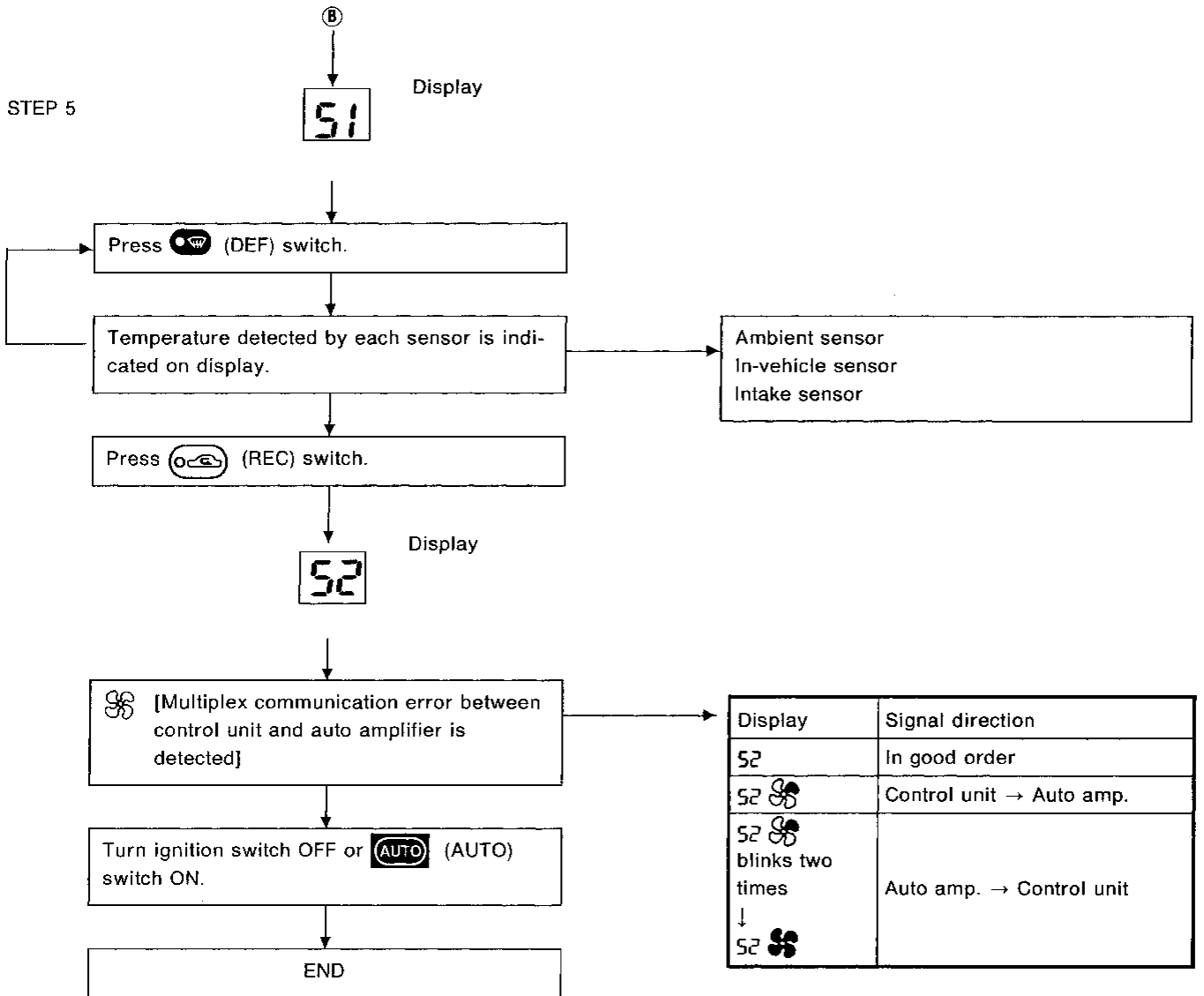

GI

MA

EM

LC

EF &
EC

FE

AT

PD

FA

RA

BR

ST

RS

BT

HA

EL

IDX

TROUBLE DIAGNOSES

Self-diagnosis (Cont'd)

HOW TO INTERPRET THE RESULTS

STEP 1: Checks LEDs and segments

When switch's LED and segments are functioning properly in STEP 1, LED and display will come on.

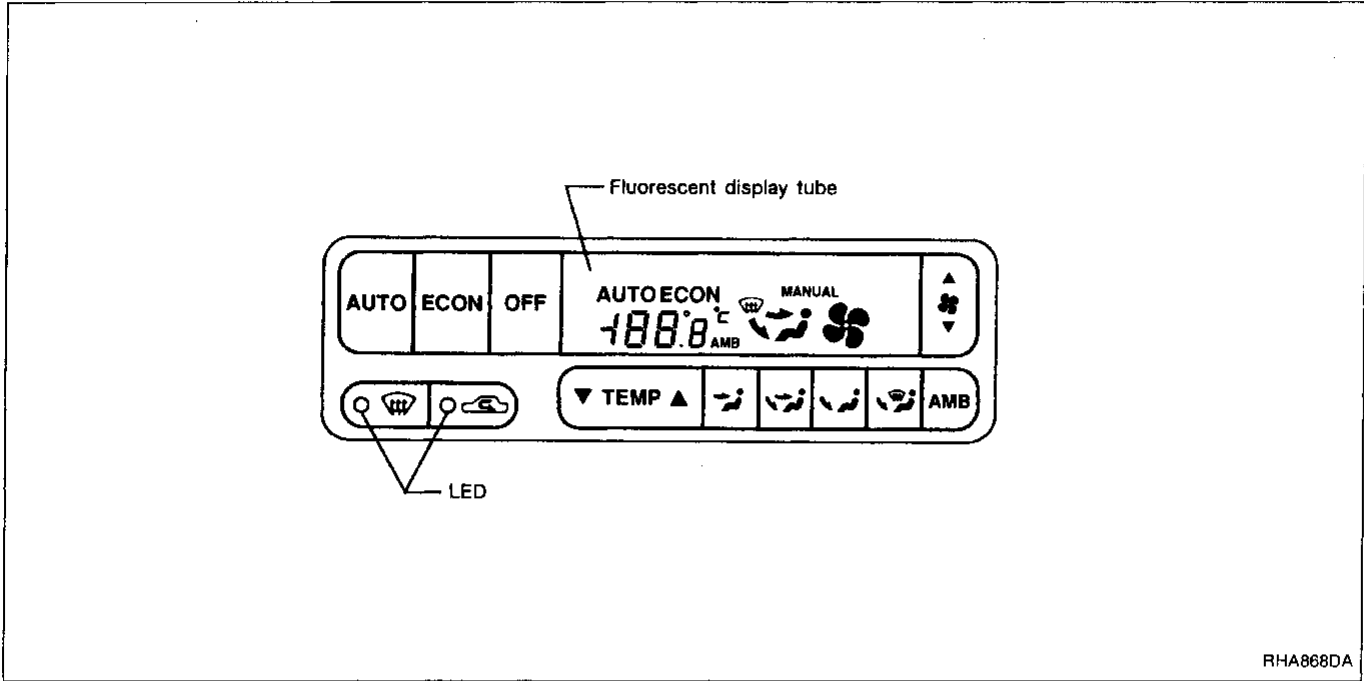

RHA868DA

Display malfunction

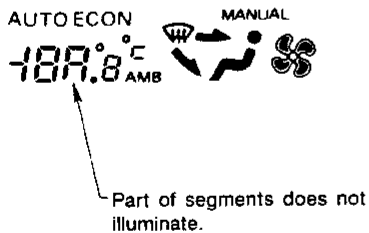

RHA502A

If LEDs or segments malfunction, LED does not come on or display shows incomplete segment.

Display (when all sensors are in good order)

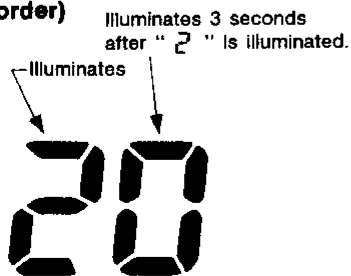

RHA970D

STEP 2: Checks each sensor circuit for open or short circuit

Display shows "2" in STEP 2 mode.

When all sensors are in good order, display shows "20".

It takes approximately 3 seconds to check all sensors.

TROUBLE DIAGNOSES

Self-diagnosis (Cont'd)

Display (when sensor malfunctions)

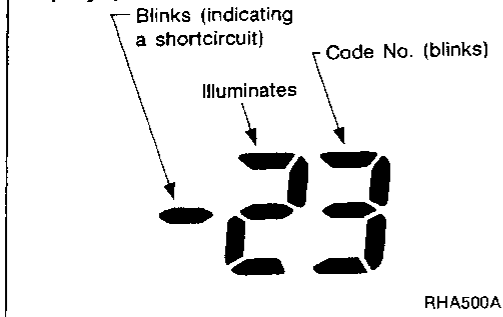

If a sensor is malfunctioning, the corresponding code No. blinks on display. A short circuit is identified by a blinking “-” mark preceding mode number.

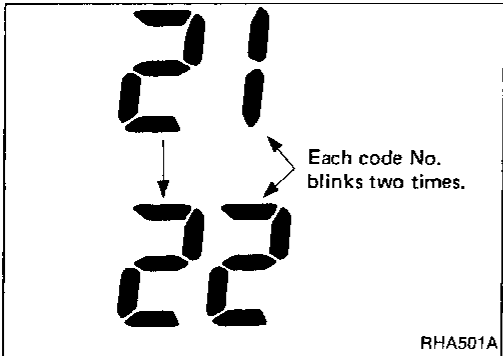

If two or more sensors malfunction, corresponding code Nos. respectively blink two times.

Sensors and abnormalities

If a circuit is opened or shorted, display shows its code No. when input corresponds with any of following conditions.

Code No.	Sensor	Open circuit	Short circuit
21	Ambient sensor	Less than -41.9°C (-43°F)	Greater than 100°C (212°F)
22	In-vehicle sensor	Less than -41.9°C (-43°F)	Greater than 100°C (212°F)
23	Water temperature sensor	Less than -25.6°C (-14°F)	Greater than 150°C (302°F)
24	Intake sensor	Less than -41.9°C (-43°F)	Greater than 100°C (212°F)
25	Sunload sensor*2	Less than 0.0152 mA	Greater than 0.545 mA
26	PBR*1	Greater than 50%	Less than 30%
27	Thermal transmitter	Greater than 11.5V	Less than 2.2V

*1: "50%" and "30%" refer to percentage with respect to full stroke of air mix door. (Full cold: 0%, Full hot: 100%)

*2: Conduct self-diagnosis STEP 2 under sunshine.

When conducting indoors, direct light (more than 60W) at sunload sensor.

Display (when all doors are in good order)

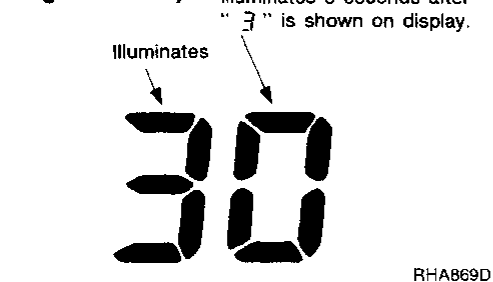

STEP 3: Checks mode door position

Display shows “3” in STEP 3 mode.

When all doors are in good order, display will then show “30”.

It takes approximately 3 seconds to check all mode doors.

TROUBLE DIAGNOSES

Self-diagnosis (Cont'd)

Display (when a door is out of order)

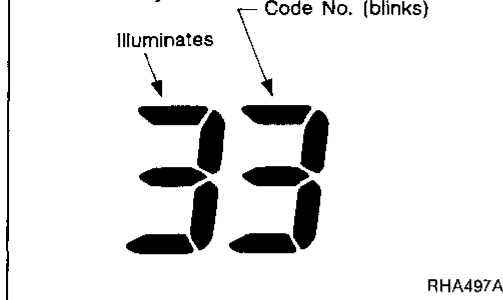

When abnormalities are detected, display shows a code No. corresponding with malfunctioning part.

Code No.	31	32	33	34	35	36
Malfunctioning part	VENT	B/L 1	B/L 2	F/D 1	F/D 2	DEF

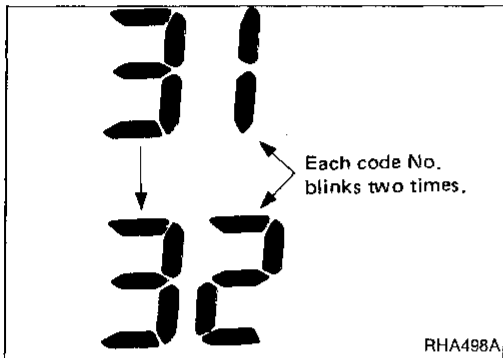

If two or more mode doors are out of order, corresponding code numbers respectively blink two times.

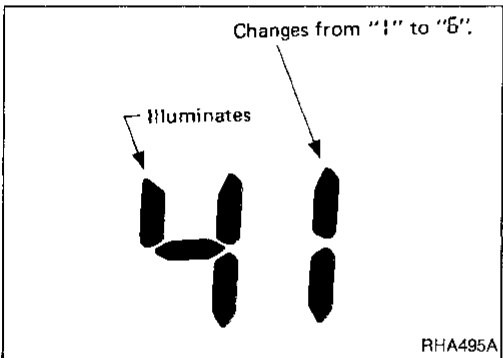

If any mode door motor position switch is malfunctioning, mode door motor will also malfunction.

STEP 4: Checks operation of each actuator

Display shows "41" in STEP 4 mode.

When  (DEF) switch is pressed one time, display shows "42". Thereafter, each time the switch is pressed, display advances one number at a time, up to "46", then returns to "41".

During inspection in STEP 4 mode, auto amplifier will forcefully transmit an output to the affected actuators. The corresponding code Nos. are shown on display as indicated in table below.

Checks must be made visually, by listening to any noise, or by touching air outlets with your hand, etc. for improper operation.

Code No.	41	42	43	44	45	46
Actuator						
Mode door	VENT	B/L 1	B/L 2	F/D 1	F/D 2	DEF
Intake door	REC	REC	20% FRE	FRE	FRE	FRE
Air mix door	Full Cold	Full Cold	Full Hot	Full Hot	Full Hot	Full Hot
Blower motor	4 - 5 V	9 - 11 V	7 - 9 V	7 - 9 V	7 - 9 V	10 - 12 V
Compressor	ON	ON	ON	OFF	OFF	ON

Operating condition of each actuator cannot be checked by indicators.





TROUBLE DIAGNOSES

Self-diagnosis (Cont'd)

STEP 5: Checks temperature detected by sensors, and detects multiplex communication error

Checks temperature detected by sensors.

Display shows "51" in STEP 5 mode.

- When  (DEF) switch is pressed one time, display shows temperature detected by ambient sensor.
- When  (DEF) switch is pressed second time, display shows temperature detected by in-vehicle sensor.
- When  (DEF) switch is pressed third time, display shows temperature detected by intake sensor.
- When  (DEF) switch is pressed fourth time, display returns to original presentation "51".

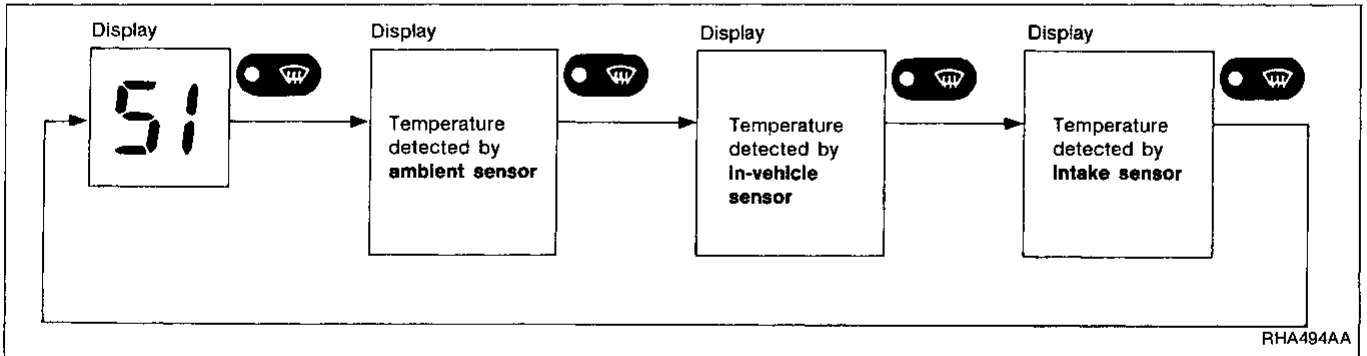
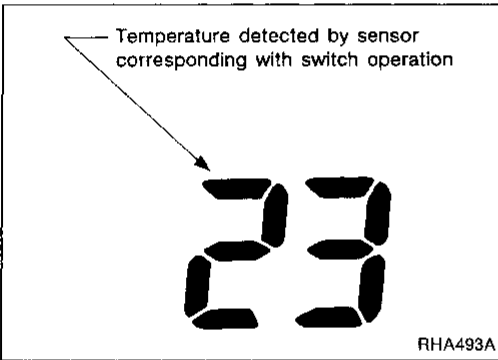
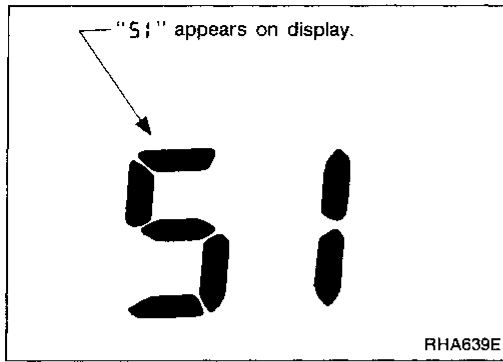

If temperature shown on display greatly differs from actual temperature, check sensor circuit at first. Then inspect sensor itself according to the procedures described in **Control System Input Components (HA-86)**.

GI
MA
EM
LC
EF &
EC
FE
AT
PD
FA
RA
BR
ST
RS
BT
HA

TROUBLE DIAGNOSES

Self-diagnosis (Cont'd)

Detects multiplex communication error

Display shows "52" in STEP 5 mode.
 [Multiplex communication error between control unit and auto amplifier is detected]

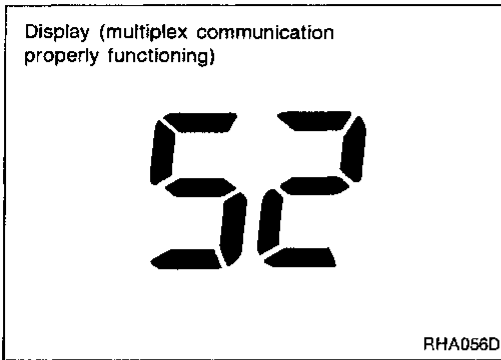

Display	Signal direction
52	In good order
52	Control unit → auto amplifier
52 blinks two times ↓	Auto amplifier → control unit
52	

CAUTION:

The auto amplifier memorizes any communication error in the system in a normal control with battery connected. When there is an error, display will be as shown above. When plural errors occur, the display of each error will blink two times for 0.5 second intervals.

If a communication error is displayed, follow the flow chart below to judge if the error occurred in the past or is currently happening.

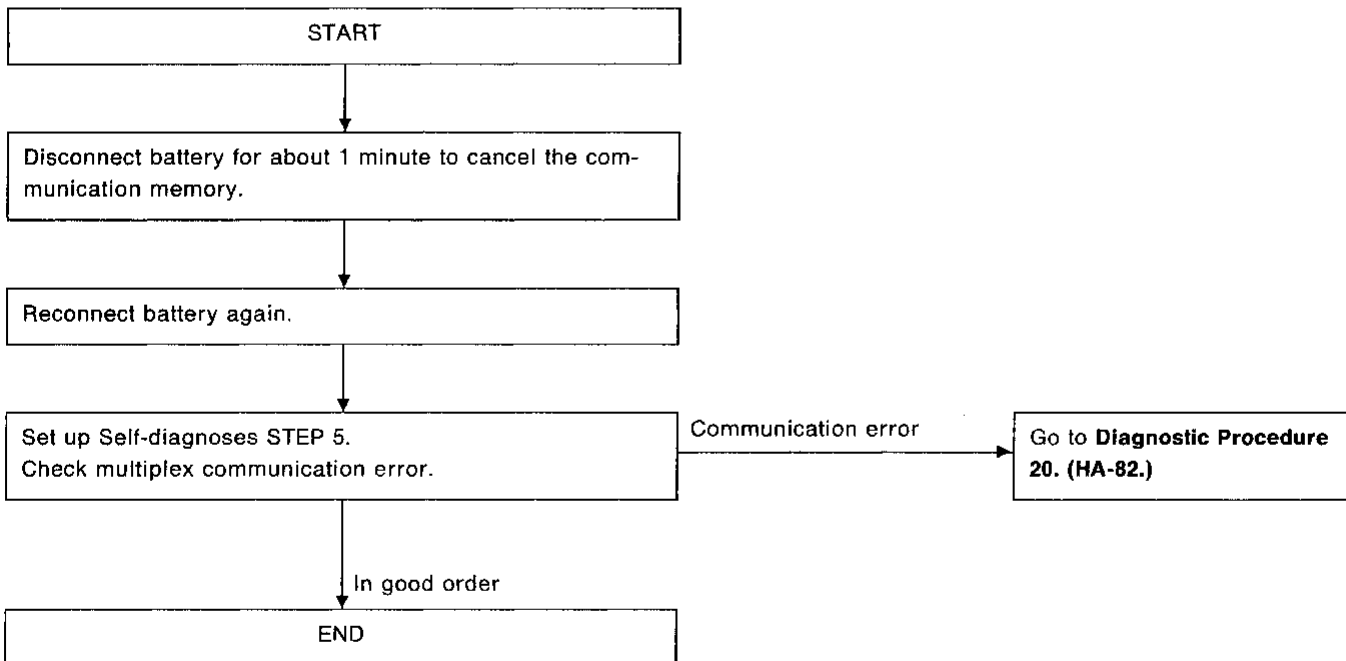

TROUBLE DIAGNOSES



Self-diagnosis (Cont'd)

AUXILIARY MECHANISM: Temperature setting trimmer

This trimmer compensates for differences between temperature setting (displayed digitally) and temperature felt by driver in a range of $\pm 3^{\circ}\text{C}$ ($\pm 6^{\circ}\text{F}$).

Operating procedures for this trimmer are as follows:

Starting with STEP 5 under "Self-diagnostic mode", press

 (fan up) switch to set air conditioning system in auxiliary mode. Then, press either  (HOT) or  (COLD) switch as desired. Temperature will change at a rate of 0.5°C (1°F) each time a switch is pressed.

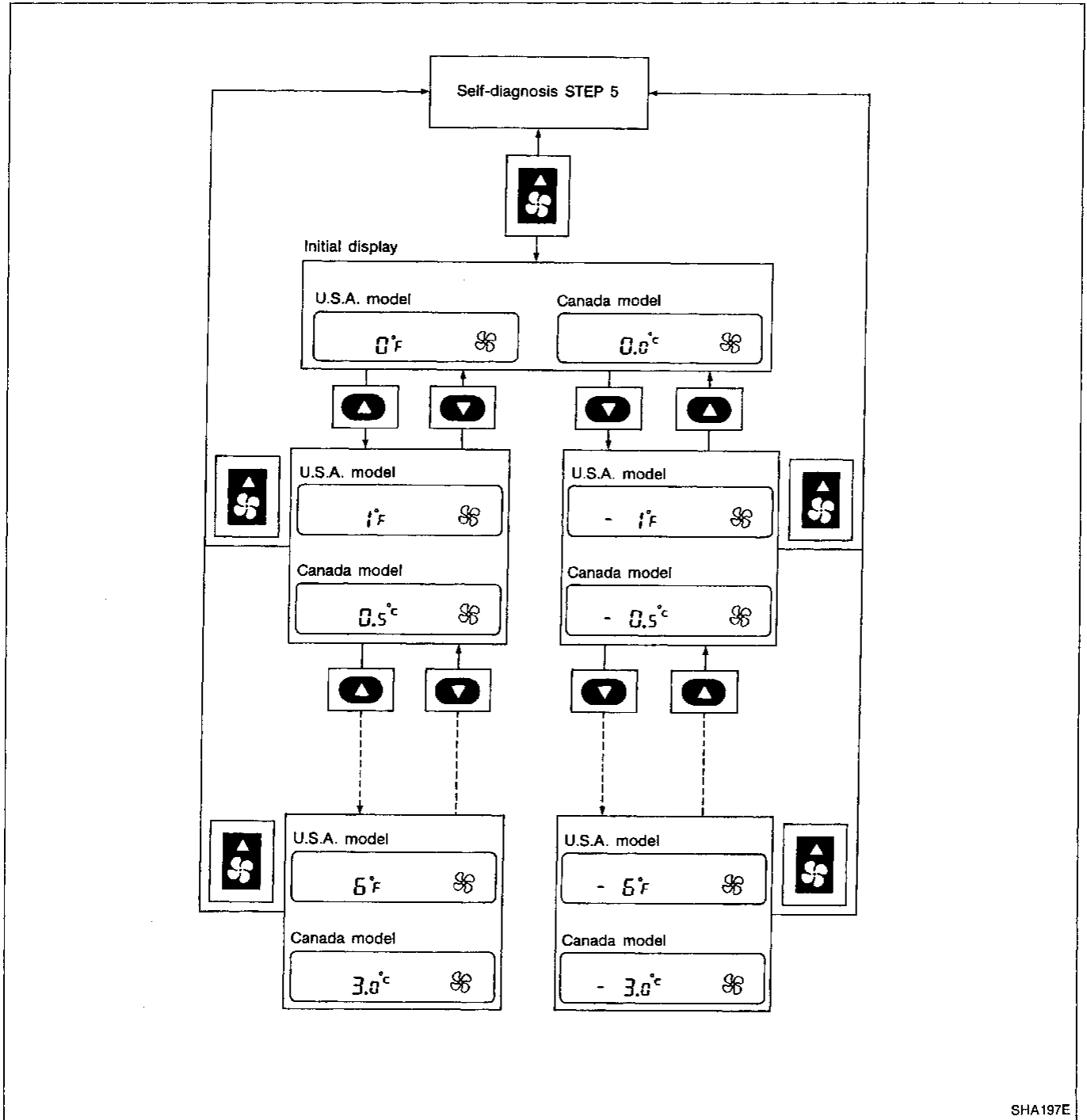

SHA197E

When battery cable is disconnected, trimmer operation is canceled and temperature set becomes that of initial condition, i.e. 0°C (0°F).

TROUBLE DIAGNOSES

Preliminary Check

PRELIMINARY CHECK 1

Air outlet does not change.

- Perform Self-diagnosis STEP 1 before referring to the flow chart.

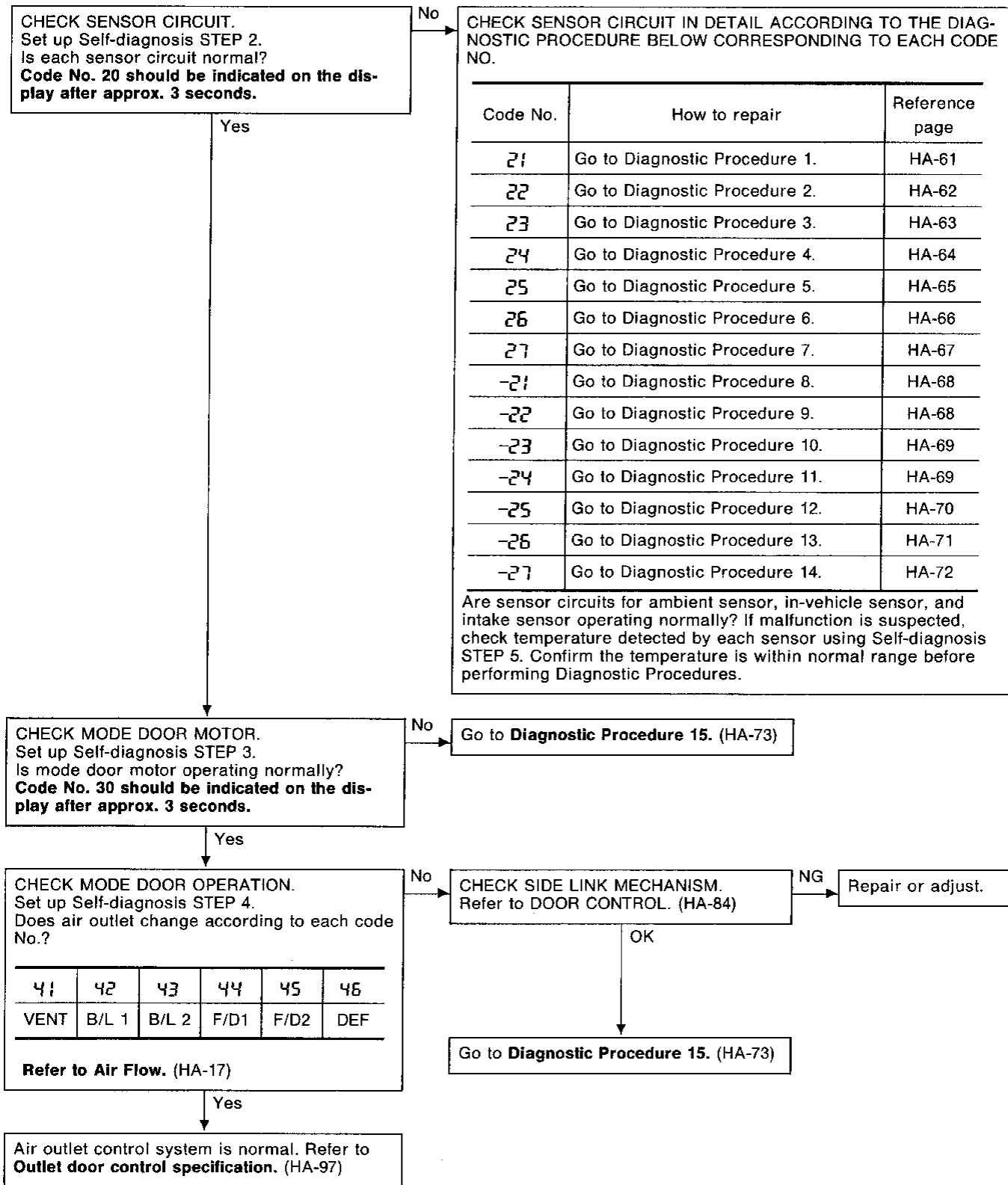

TROUBLE DIAGNOSES

Preliminary Check (Cont'd)

PRELIMINARY CHECK 2

Intake door does not change.

- Perform Self-diagnosis STEP 1 before referring to the following flow chart.

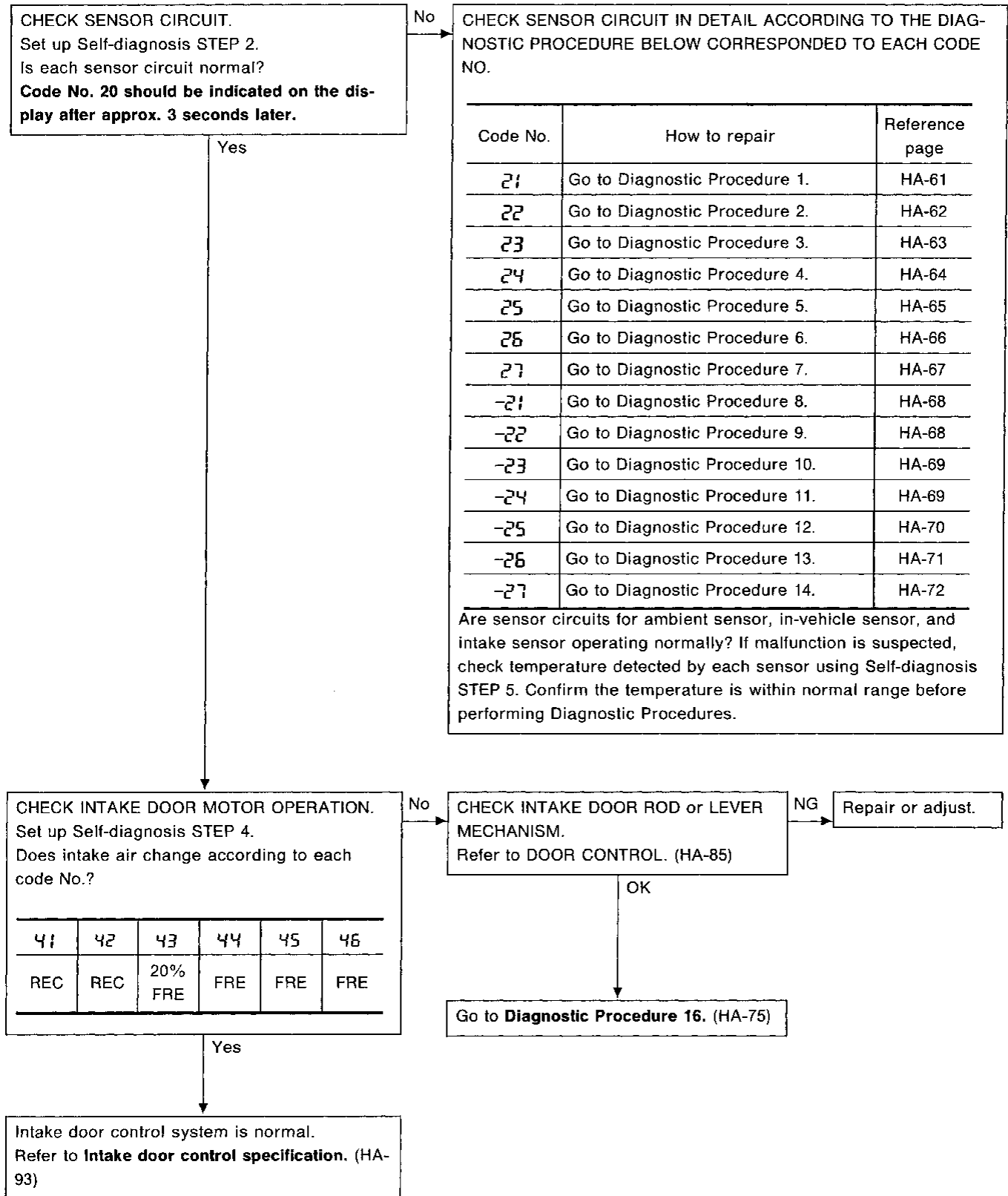

GI
MA
EM
LC
EF & EC
FE
AT
PD
FA
RA
BR
ST
RS
BT
HA
EL
IDX

TROUBLE DIAGNOSES

Preliminary Check (Cont'd)

PRELIMINARY CHECK 3

Insufficient cooling

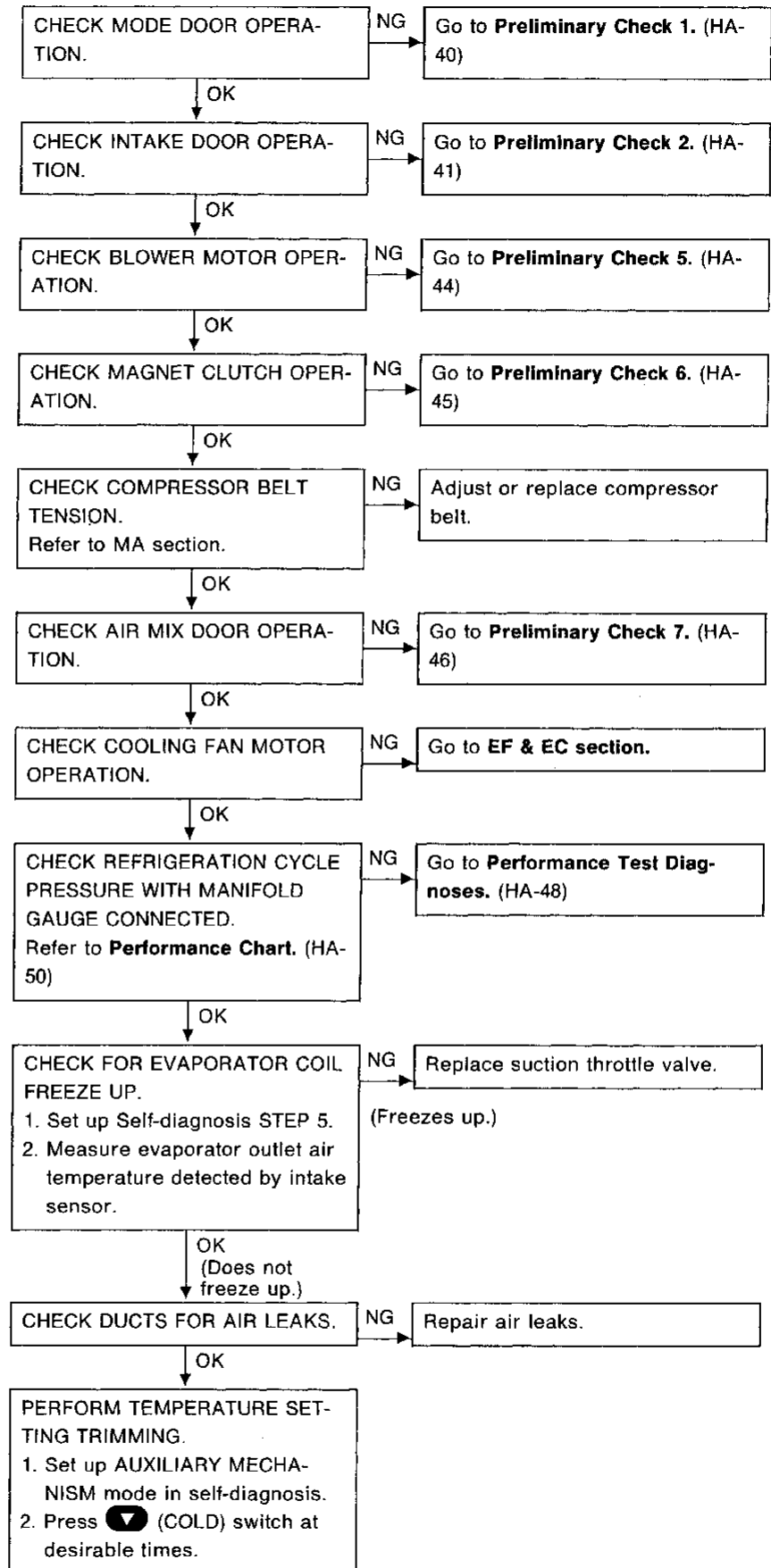

TROUBLE DIAGNOSES

Preliminary Check (Cont'd)

PRELIMINARY CHECK 4

Insufficient heating

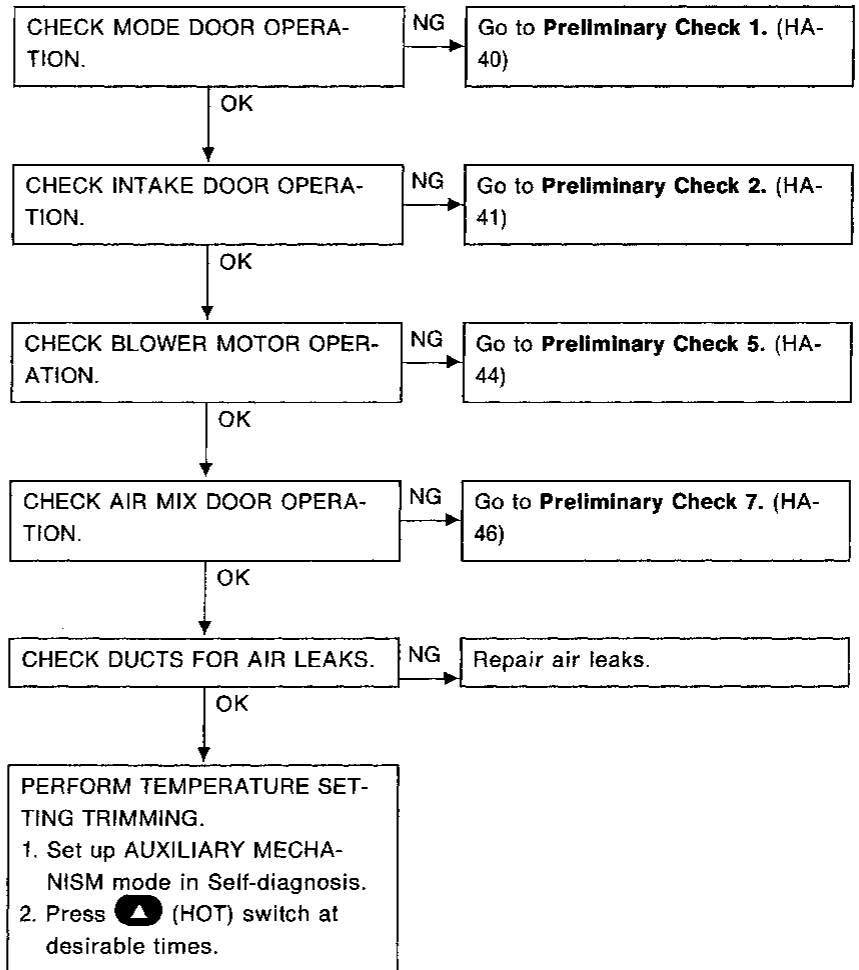

GI

MA

EM

LC

EF &
EC

FE

AT

PD

FA

RA

BR

ST

RS

BT

HA

EL

IDX

TROUBLE DIAGNOSES

Preliminary Check (Cont'd)

PRELIMINARY CHECK 5

Blower motor operation is malfunctioning.

- Perform Self-diagnosis STEP 1 before referring to the following flow chart.

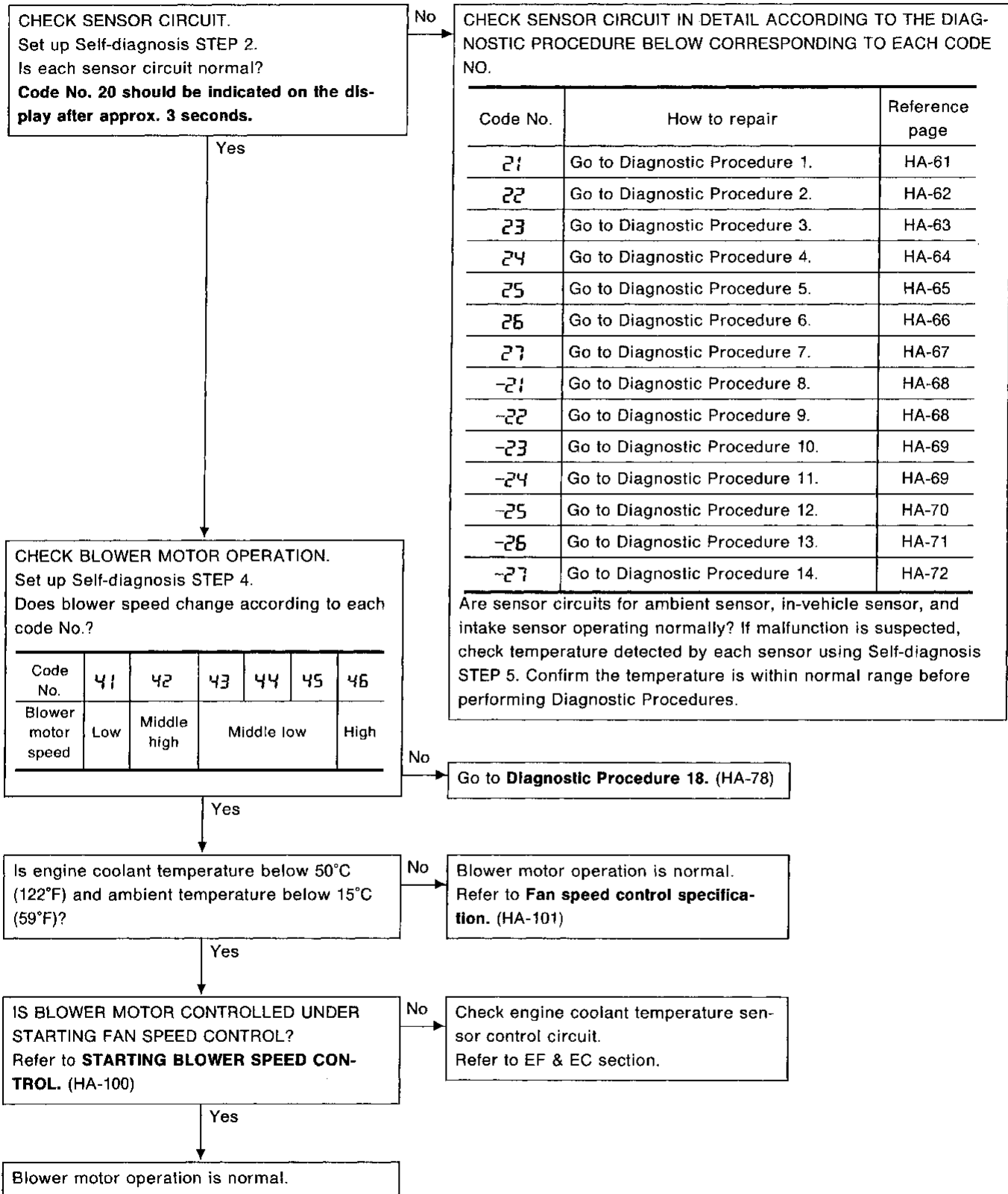

TROUBLE DIAGNOSES

Preliminary Check (Cont'd)

PRELIMINARY CHECK 6

Magnet clutch does not engage.

Perform Self-diagnosis STEP 1 before referring to the following flow chart.

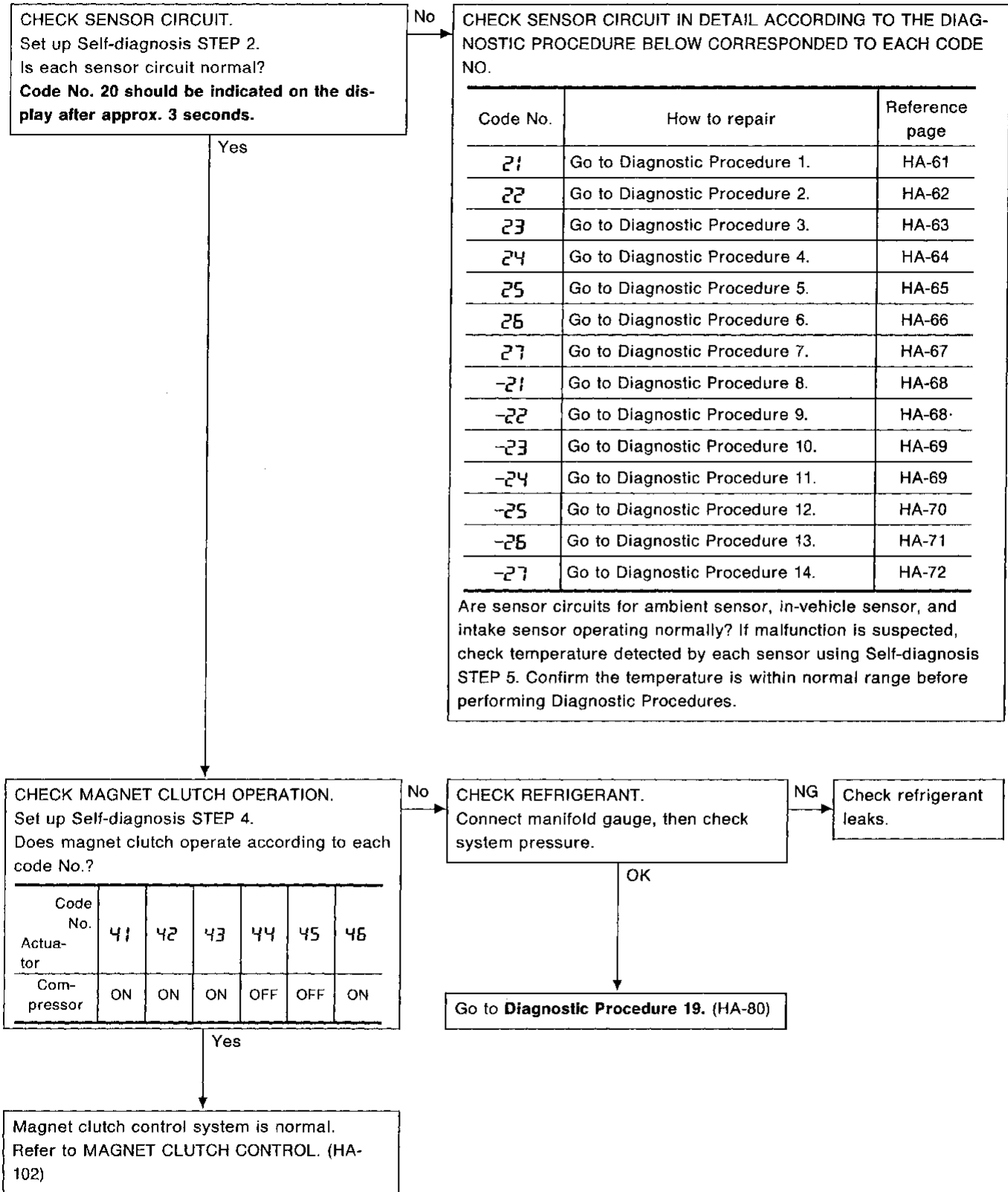

GI
MA
EM
LC
EF & EC
FE
AT
PD
FA
RA
BR
ST
RS
BT
HA
EL
IDX

TROUBLE DIAGNOSES

Preliminary Check (Cont'd)

PRELIMINARY CHECK 7

Discharged air temperature does not change.

Perform Self-diagnosis STEP 1 before referring to the following flow chart.

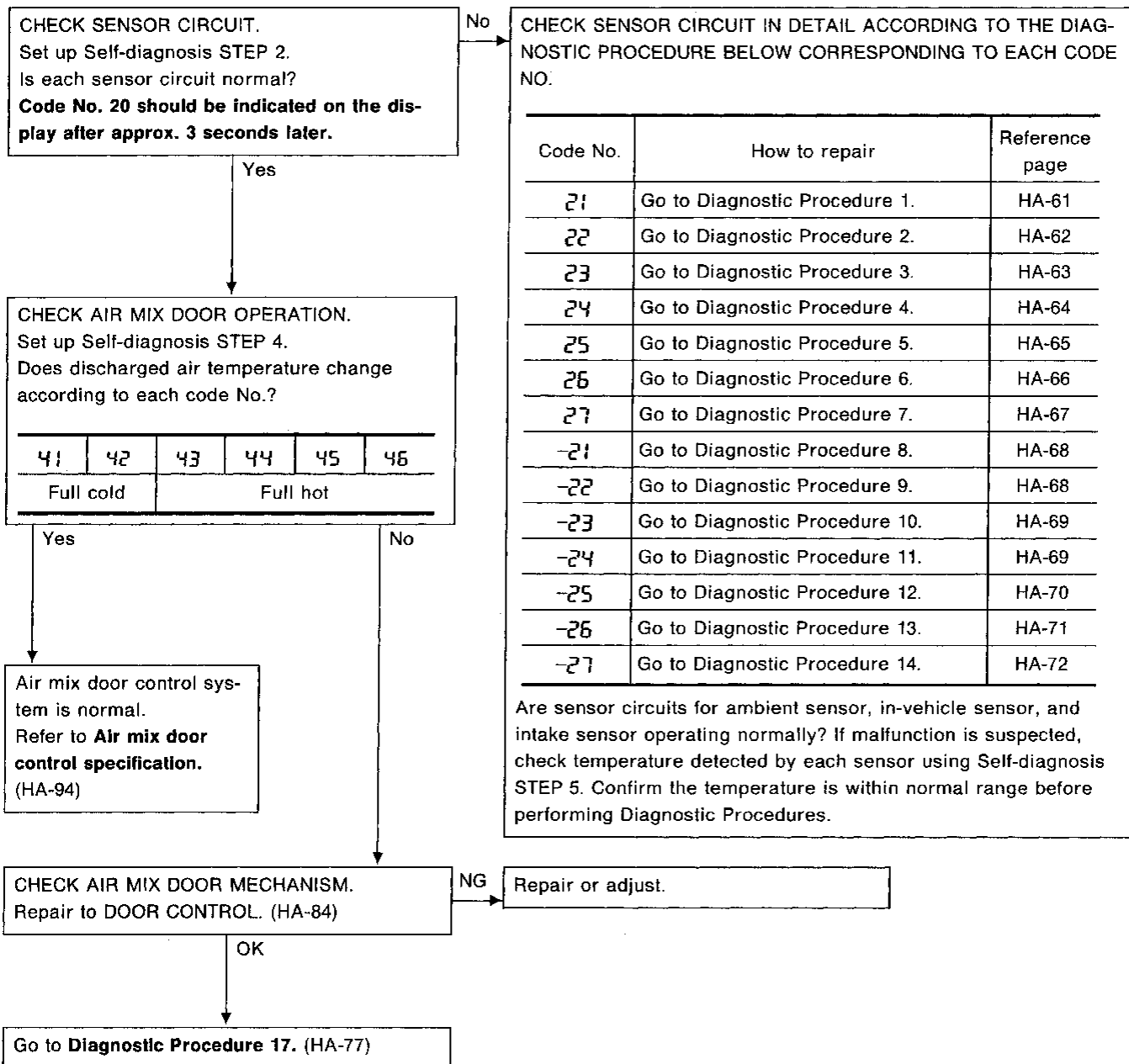

TROUBLE DIAGNOSES

Preliminary Check (Cont'd)

PRELIMINARY CHECK 8

Noise

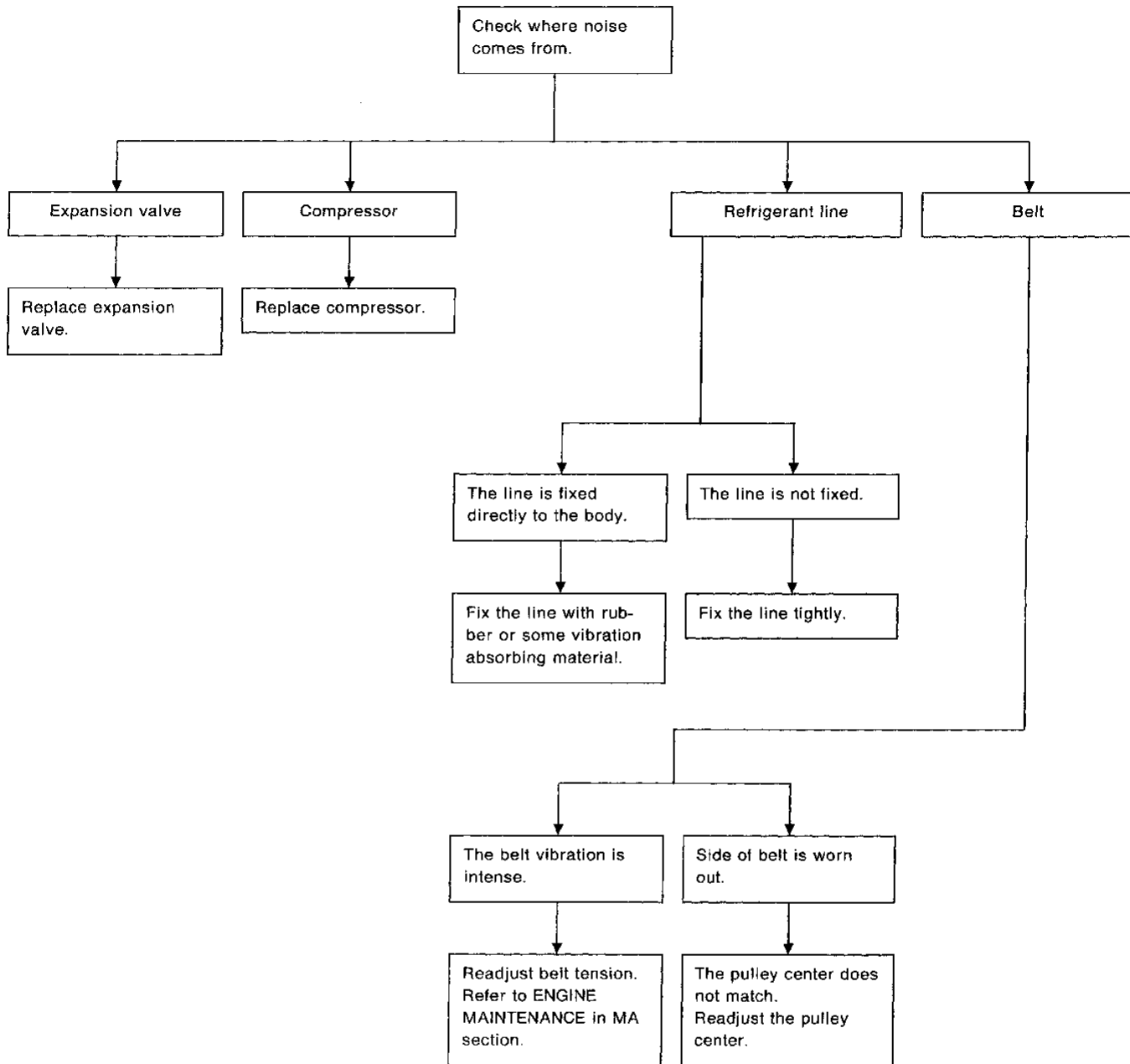

TROUBLE DIAGNOSES

Performance Test Diagnoses INSUFFICIENT COOLING

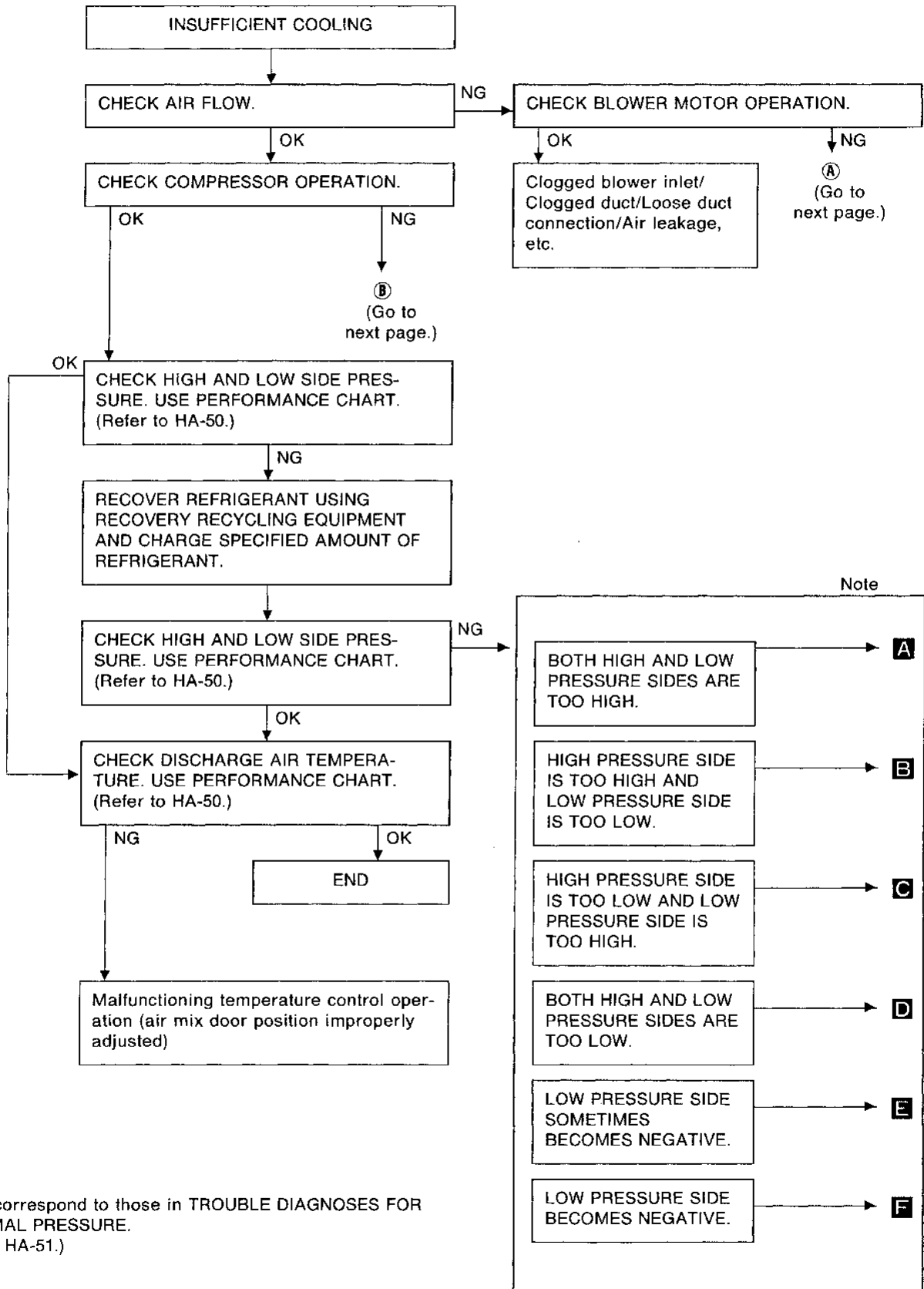

Note: **A-F** correspond to those in TROUBLE DIAGNOSES FOR ABNORMAL PRESSURE. (Refer to HA-51.)

TROUBLE DIAGNOSES

Performance Test Diagnoses (Cont'd)

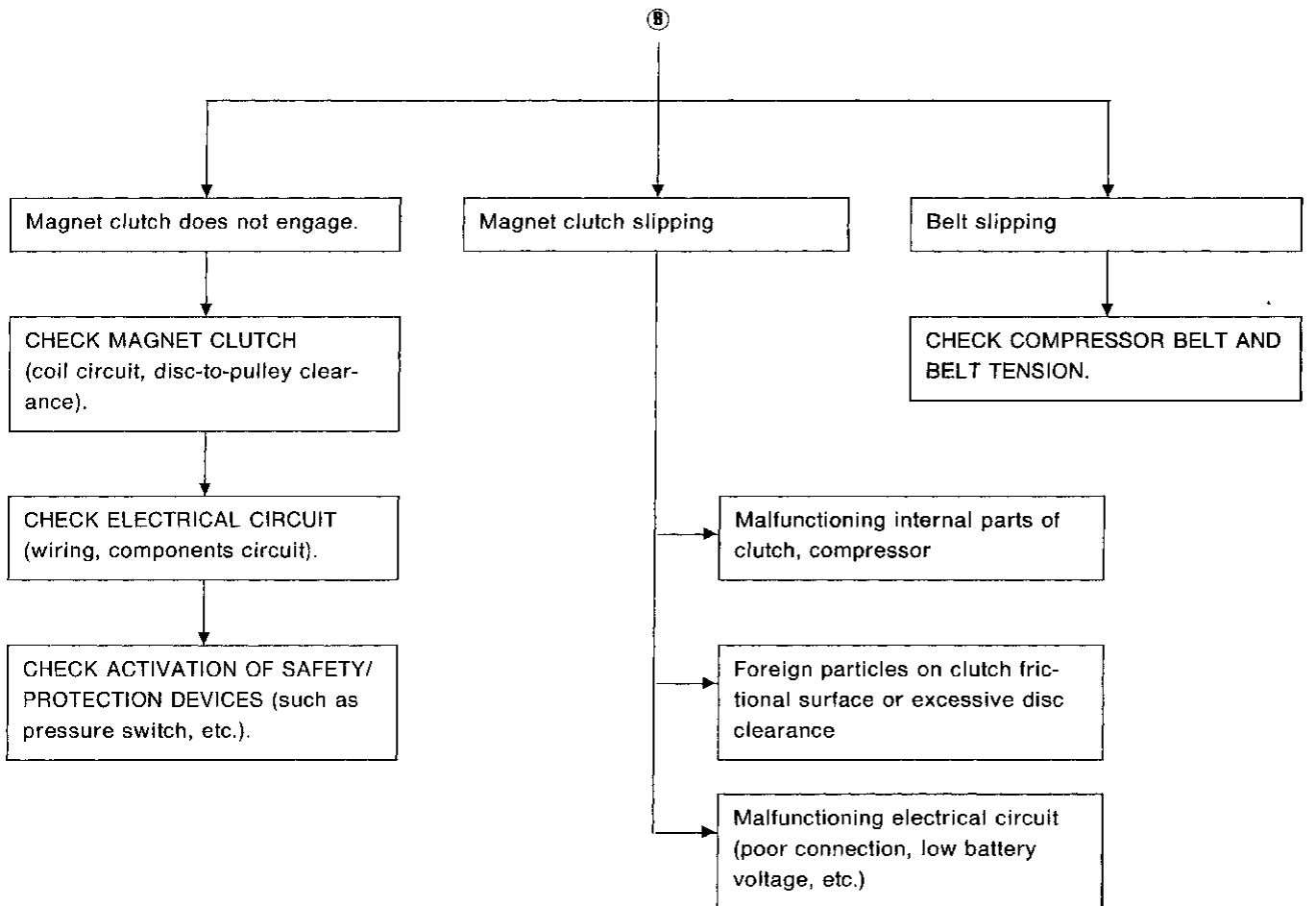
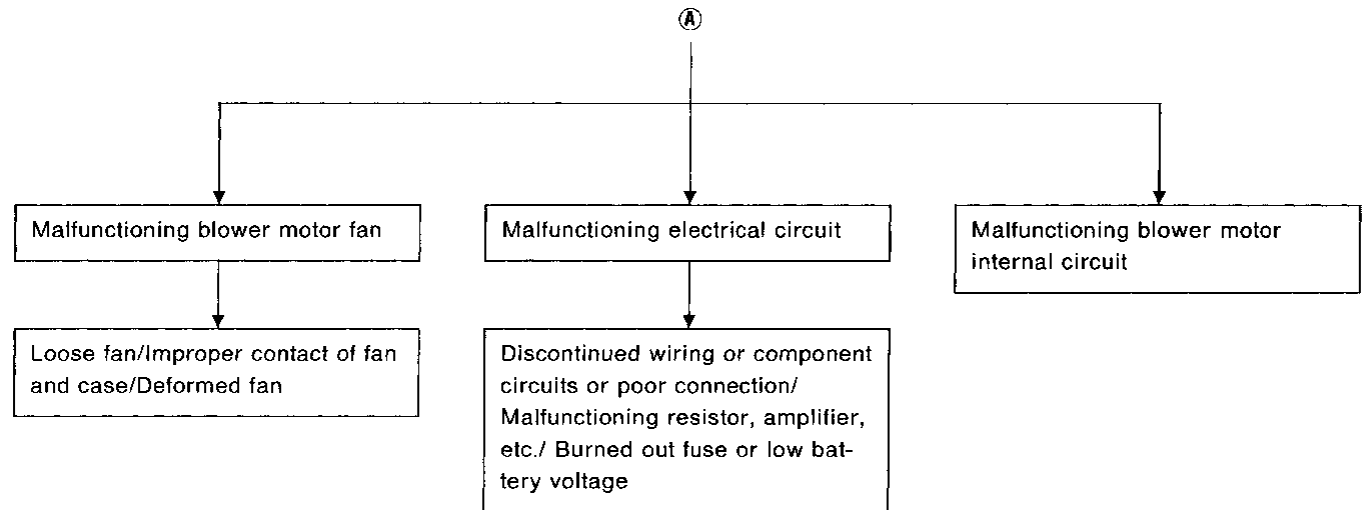

GI
MA
EM
LC
EF & EC
FE
AT
PD
FA
RA
BR
ST
RS
BT
HA
EL
FDX

TROUBLE DIAGNOSES

Performance Chart

TEST CONDITION

Before conducting performance test, disconnect ambient sensor harness connector and make short circuit using jumper cable.

Testing must be performed as follows:

Vehicle location: Indoors or in the shade (in a well-ventilated place)

Doors: Closed

Door window: Open (Front driver side only)

Hood: Open

(AUTO) switch: ON

Temperature switch (PTC): Max. COLD set

Mode switch:  (Ventilation) set

(REC) switch:  (Recirculation) set

(fan) switch: Max. speed set

Engine speed: 1,500 rpm

Time required before starting testing after air conditioner starts operating: More than 10 minutes

TEST READING

Recirculating-to-discharge air temperature table

Inside air (Recirculating air) at blower assembly inlet		Discharge air temperature at center ventilator °C (°F)
Relative humidity %	Air temperature °C (°F)	
50 - 60	25 (77)	9.0 - 11.1 (48 - 52)
	30 (86)	13.1 - 15.2 (56 - 59)
	35 (95)	17.1 - 19.3 (63 - 67)
60 - 70	25 (77)	11.1 - 13.2 (52 - 56)
	30 (86)	15.2 - 17.4 (59 - 63)
	35 (95)	19.3 - 21.5 (67 - 71)

Ambient air temperature-to-operating pressure table

Ambient air		High-pressure (Discharge side) kPa (kg/cm ² , psi)	Low-pressure (Suction side) kPa (kg/cm ² , psi)
Relative humidity %	Air temperature °C (°F)		
50 - 70	25 (77)	1,226 - 1,432 (12.5 - 14.6, 178 - 208)	190.3 - 213.8 (1.94 - 2.18, 27.6 - 31.0)
	30 (86)	1,324 - 1,599 (13.5 - 16.3, 192 - 232)	193.2 - 217.7 (1.97 - 2.22, 28.0 - 31.6)
	35 (95)	1,520 - 1,844 (15.5 - 18.8, 220 - 267)	201.0 - 229.5 (2.05 - 2.34, 29.2 - 33.3)
	40 (104)	1,755 - 2,118 (17.9 - 21.6, 255 - 307)	213.8 - 246.2 (2.18 - 2.51, 31.0 - 35.7)

TROUBLE DIAGNOSES

Trouble Diagnoses for Abnormal Pressure

Whenever system's high and/or low side pressure is abnormal, diagnose using a manifold gauge. The marker above the gauge scale in the following tables indicates the standard (normal) pressure range. Since the standard (normal) pressure, however, differs from vehicle to vehicle, refer to HA-50 ("Ambient air temperature-to-operating pressure table").

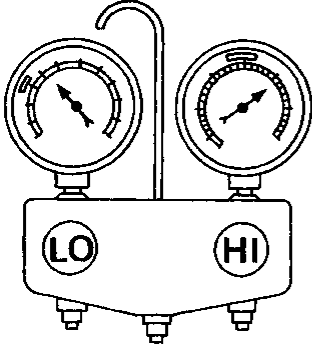
Gauge indication	Refrigerant cycle	Probable cause	Corrective action
<p>Both high and low-pressure sides are too high.</p> <p>A</p>  <p style="text-align: center;">AC359A</p>	<ul style="list-style-type: none"> ● Pressure is reduced soon after water is splashed on condenser. 	<p>Excessive refrigerant charge in refrigeration cycle</p>	<p>Reduce refrigerant until specified pressure is obtained.</p>
	<p>Air suction by cooling fan is insufficient.</p>	<p>Insufficient condenser cooling performance</p> <p style="text-align: center;">↓</p> <p>① Condenser fins are clogged. ② Improper fan rotation of cooling fan</p>	<ul style="list-style-type: none"> ● Clean condenser. ● Check and repair cooling fan as necessary.
	<ul style="list-style-type: none"> ● Low-pressure pipe is not cold. ● When compressor is stopped high-pressure value quickly drops by approximately 196 kPa (2 kg/cm², 28 psi). It then decreases gradually thereafter. 	<p>Poor heat exchange in condenser (After compressor operation stops, high pressure decreases too slowly.)</p> <p style="text-align: center;">↓</p> <p>Air in refrigeration cycle</p>	<p>Evacuate repeatedly and recharge system.</p>
	<p>Engine tends to overheat.</p>	<p>Engine cooling systems malfunction.</p>	<p>Check and repair each engine cooling system.</p>
	<ul style="list-style-type: none"> ● An area of the low-pressure pipe is colder than near the evaporator outlet. ● Plates are sometimes covered with frost. 	<ul style="list-style-type: none"> ● Excessive liquid refrigerant on low-pressure side ● Excessive refrigerant discharge flow ● Expansion valve is open a little compared with the specification. <p style="text-align: center;">↓</p> <p>① Improper thermal valve installation ② Improper expansion valve adjustment</p>	<p>Replace expansion valve.</p>

CI

MA

EM

LC

EF & EC

FE

AT

PD

FA

RA

BR

ST

RS

BT

HA

EL

IDX

TROUBLE DIAGNOSES

Trouble Diagnoses for Abnormal Pressure (Cont'd)

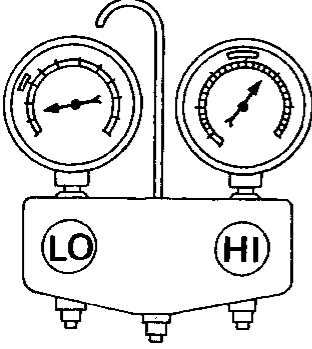
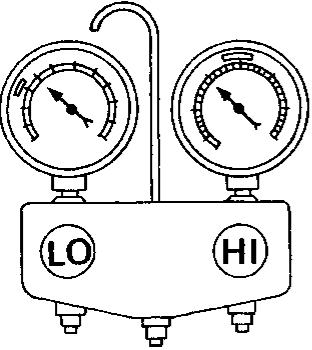
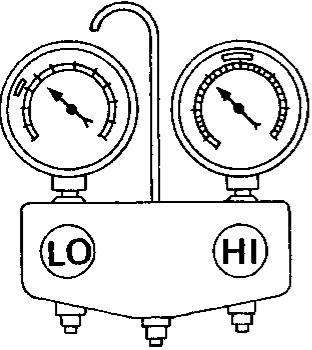
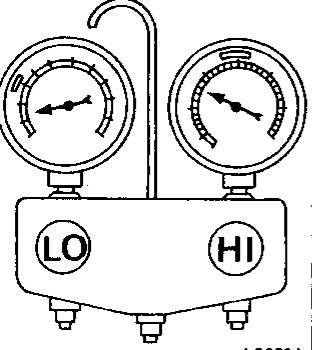
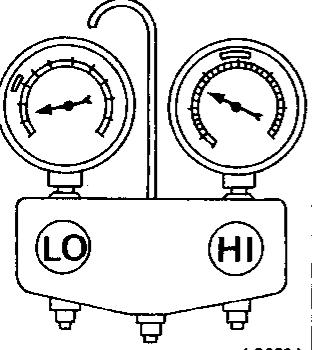
Gauge indication	Refrigerant cycle	Probable cause	Corrective action
<p>High-pressure side is too high and low-pressure side is too low.</p> <p>B</p>  <p style="text-align: center;">AC360A</p>	<p>Upper side of condenser and high-pressure side are hot, however, liquid tank is not so hot.</p>	<p>High-pressure tube or parts located between compressor and condenser are clogged or crushed.</p>	<ul style="list-style-type: none"> ● Check and repair or replace malfunctioning parts. ● Check lubricant for contamination.
<p>High-pressure side is too low and low-pressure side is too high.</p> <p>C</p>  <p style="text-align: center;">AC356A</p>	<p>High and low-pressure sides become equal soon after compressor operation stops.</p>	<p>Compressor pressure operation is improper.</p> <p style="text-align: center;">↓</p> <p>Damaged inside compressor packings</p>	<p>Replace compressor.</p>
<p>High-pressure side is too low and low-pressure side is too high.</p> <p>C</p>  <p style="text-align: center;">AC356A</p>	<p>No temperature difference between high and low-pressure sides</p>	<p>Compressor discharge capacity does not change. (Compressor stroke is set at maximum.)</p>	<p>Replace compressor.</p>
<p>Both high- and low-pressure sides are too low.</p> <p>D</p>  <p style="text-align: center;">AC353A</p>	<ul style="list-style-type: none"> ● There is a big temperature difference between liquid tank outlet and inlet. Outlet temperature is extremely low. ● Liquid tank inlet and expansion valve are frosted. ● Temperature of expansion valve inlet is extremely low as compared with areas near liquid tank. ● Expansion valve inlet may be frosted. ● Temperature difference occurs somewhere in high-pressure side 	<p>Liquid tank inside is clogged a little.</p>	<ul style="list-style-type: none"> ● Replace liquid tank. ● Check lubricant for contamination.
<p>Both high- and low-pressure sides are too low.</p> <p>D</p>  <p style="text-align: center;">AC353A</p>	<ul style="list-style-type: none"> ● There is a big temperature difference between liquid tank outlet and inlet. Outlet temperature is extremely low. ● Liquid tank inlet and expansion valve are frosted. ● Temperature of expansion valve inlet is extremely low as compared with areas near liquid tank. ● Expansion valve inlet may be frosted. ● Temperature difference occurs somewhere in high-pressure side 	<p>High-pressure pipe located between liquid tank and expansion valve is clogged.</p>	<ul style="list-style-type: none"> ● Check and repair malfunctioning parts. ● Check lubricant for contamination.

TROUBLE DIAGNOSES

Trouble Diagnoses for Abnormal Pressure (Cont'd)

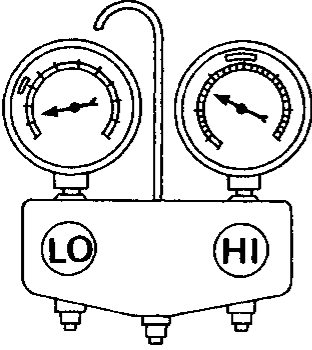
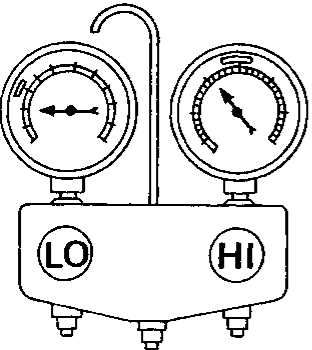
Gauge indication	Refrigerant cycle	Probable cause	Corrective action
<p>Both high- and low-pressure sides are too low.</p> <p>D</p>  <p style="text-align: right;">AC353A</p>	<p>There is a big temperature difference between expansion valve inlet and outlet while the valve itself is frosted.</p>	<p>Expansion valve closes a little compared with the specification.</p> <p style="text-align: center;">↓</p> <p>① Improper expansion valve adjustment ② Malfunctioning thermal valve ③ Outlet and inlet may be clogged.</p>	<ul style="list-style-type: none"> Remove foreign particles by using compressed air. Check lubricant for contamination.
	<p>An area of the low-pressure pipe is colder than near the evaporator outlet.</p>	<p>Low-pressure pipe is clogged or crushed.</p>	<ul style="list-style-type: none"> Check and repair malfunctioning parts. Check lubricant for contamination.
	<p>Air flow volume is not enough or is too low.</p>	<p>Evaporator is frozen.</p> <p style="text-align: center;">↓</p> <p>Compressor discharge capacity does not change. (Compressor stroke is set at maximum length.)</p>	<p>Replace compressor.</p>
<p>Low-pressure side sometimes becomes negative.</p> <p>E</p>  <p style="text-align: right;">AC354A</p>	<ul style="list-style-type: none"> Air conditioning system does not function and does not cyclically cool the compartment air. The system constantly functions for a certain period of time after compressor is stopped and restarted. 	<p>Refrigerant does not discharge cyclically.</p> <p style="text-align: center;">↓</p> <p>Moisture is frozen at expansion valve outlet and inlet.</p> <p style="text-align: center;">↓</p> <p>Water is mixed with refrigerant.</p>	<ul style="list-style-type: none"> Drain water from refrigerant or replace refrigerant. Replace liquid tank.

GI

MA

EM

LC

EF & EC

FE

AT

PD

FA

RA

BR

ST

RS

BT

HA

EL

IDX

TROUBLE DIAGNOSES

Trouble Diagnoses for Abnormal Pressure (Cont'd)

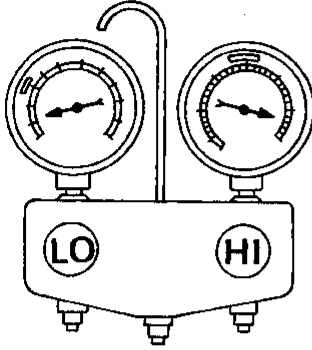
Gauge indication	Refrigerant cycle	Probable cause	Corrective action
<p>Low-pressure side becomes negative.</p> <p>F</p>  <p style="text-align: right;">AC362A</p>	<p>Liquid tank or front/rear side of expansion valve's pipe is frosted or dewed.</p>	<p>High-pressure side is closed and refrigerant does not flow.</p> <p style="text-align: center;">↓</p> <p>Expansion valve or liquid tank is frosted.</p>	<p>Leave the system at rest until no frost is present. Start it again to check whether or not the problem is caused by water or foreign particles. If water is the cause, initially cooling is okay. Then the water freezes, causing a blockage.</p> <ul style="list-style-type: none"> ● If the problem is due to water, drain water from refrigerant or replace refrigerant. ● If due to foreign particles, remove expansion valve and remove the particles with dry and compressed air (not shop air). ● If either of the above methods cannot correct the problem, replace expansion valve. ● Replace liquid tank. ● Check lubricant for contamination.

TROUBLE DIAGNOSES

A/C Component Layout

Engine compartment

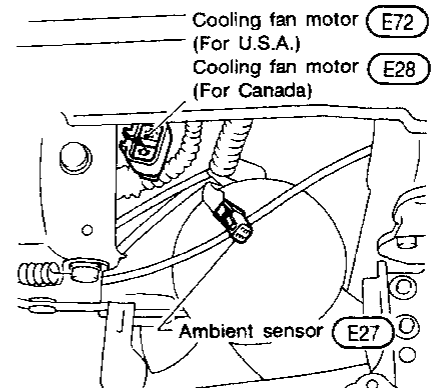
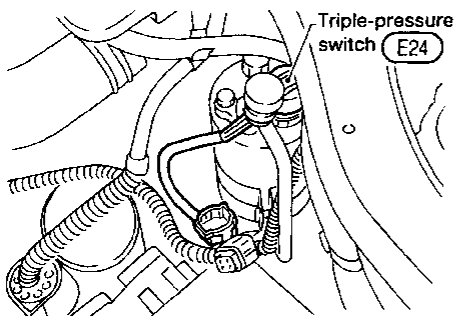
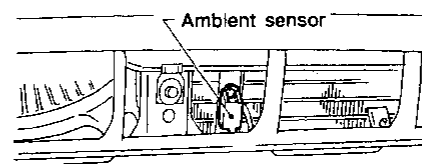
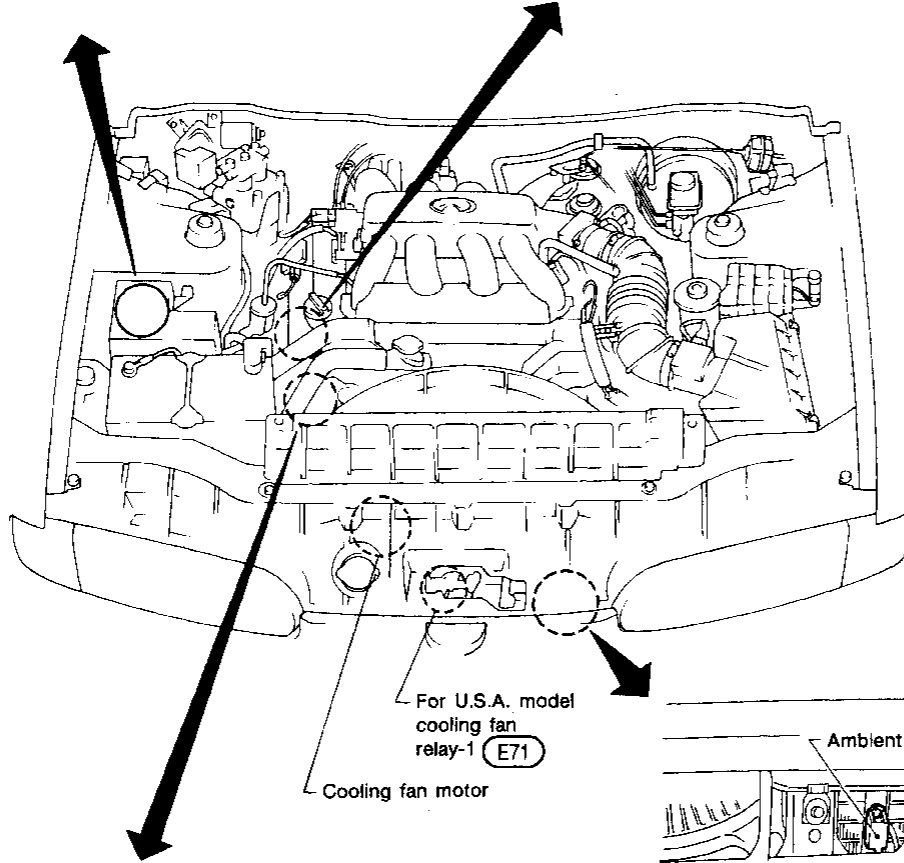
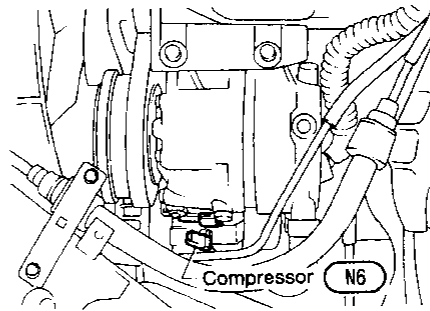
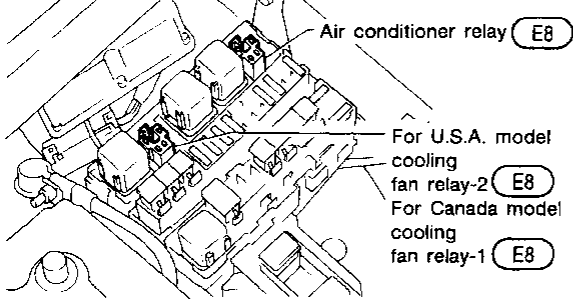

GI
MA
EM
LC
EF & EC
FE
AT
PD
FA
RA
BR
ST
RS
BT
HA
EL
IDX

TROUBLE DIAGNOSES

A/C Component Layout (Cont'd)

Passenger compartment

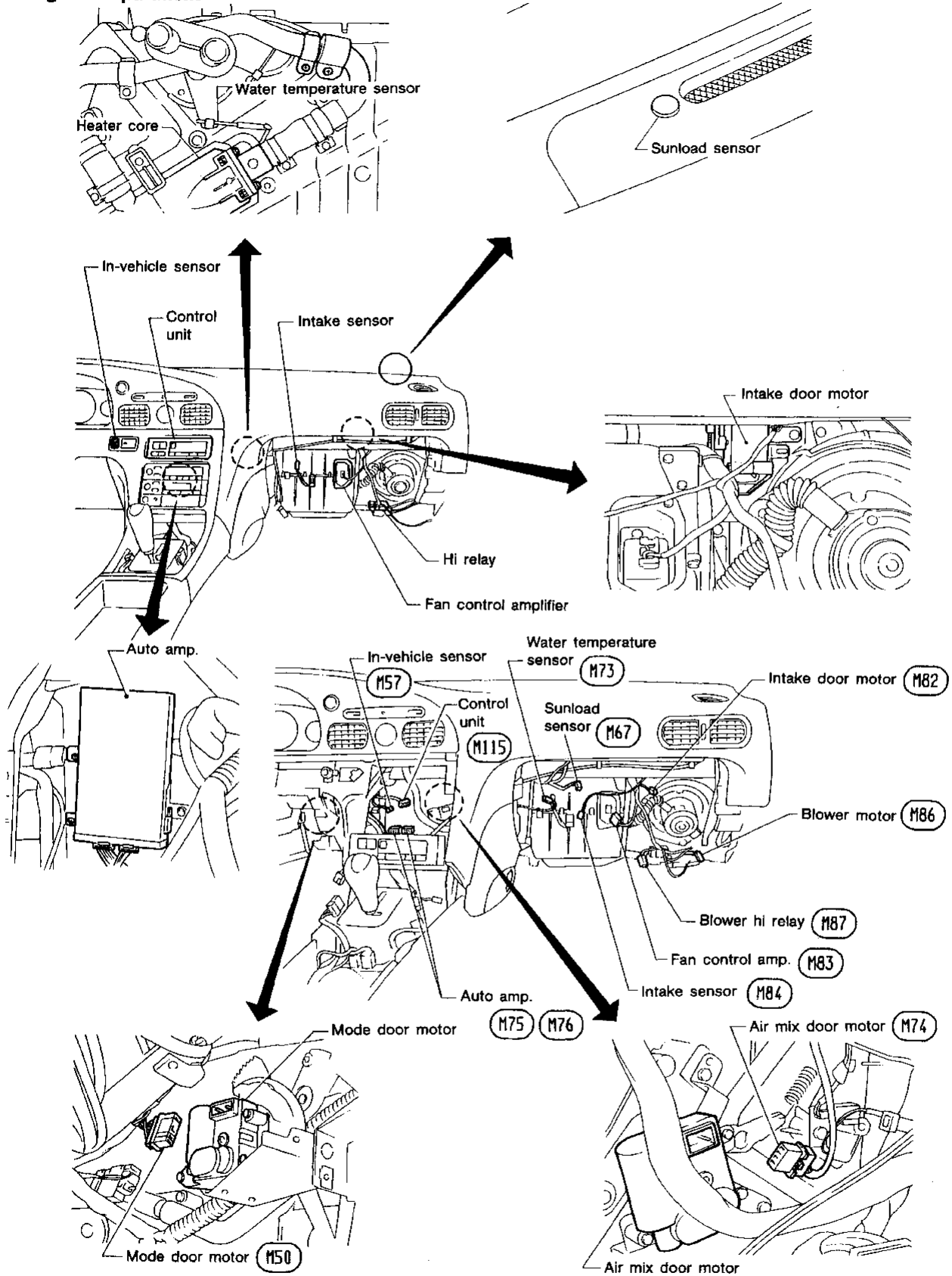

Circuit Diagram for Quick Pinpoint Check

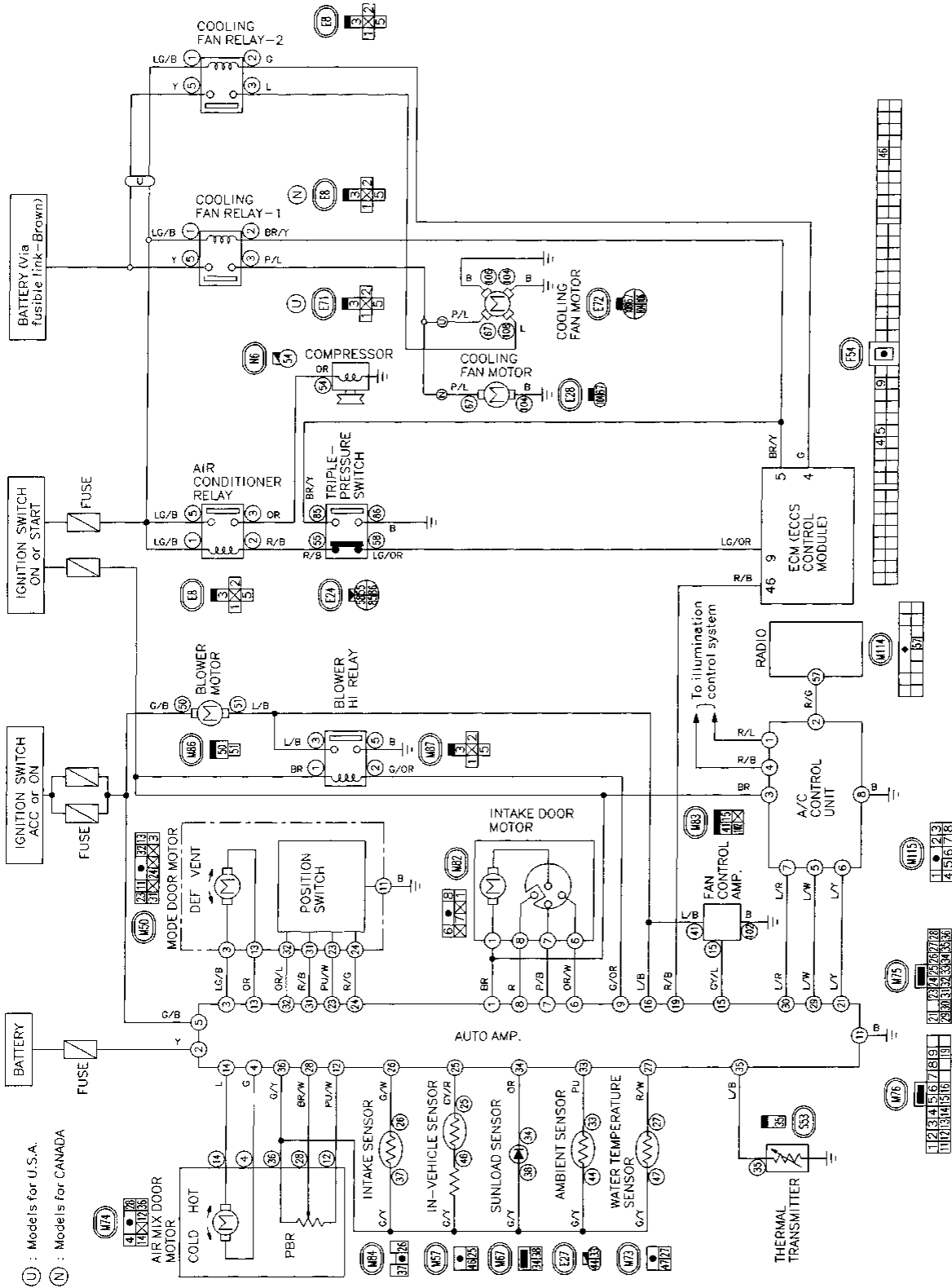

U : Models for U.S.A.
 N : Models for CANADA

- All connectors shown in this illustration are unit side connectors.
- The unit side connectors with a double circle "⊖" are connected to the harness side connectors shown in the "A/C Component Layout". (See page HA-55.)
- The terminal numbers in the connector coincide with the circuit numbers surrounded by a single circle "○".

GI
 MA
 EM
 LC
 EF &
 EC
 FE
 AT
 PD
 FA
 RA
 BR
 ST
 RC
 BT
 HA
 FL
 DX

TROUBLE DIAGNOSES

Wiring Diagram

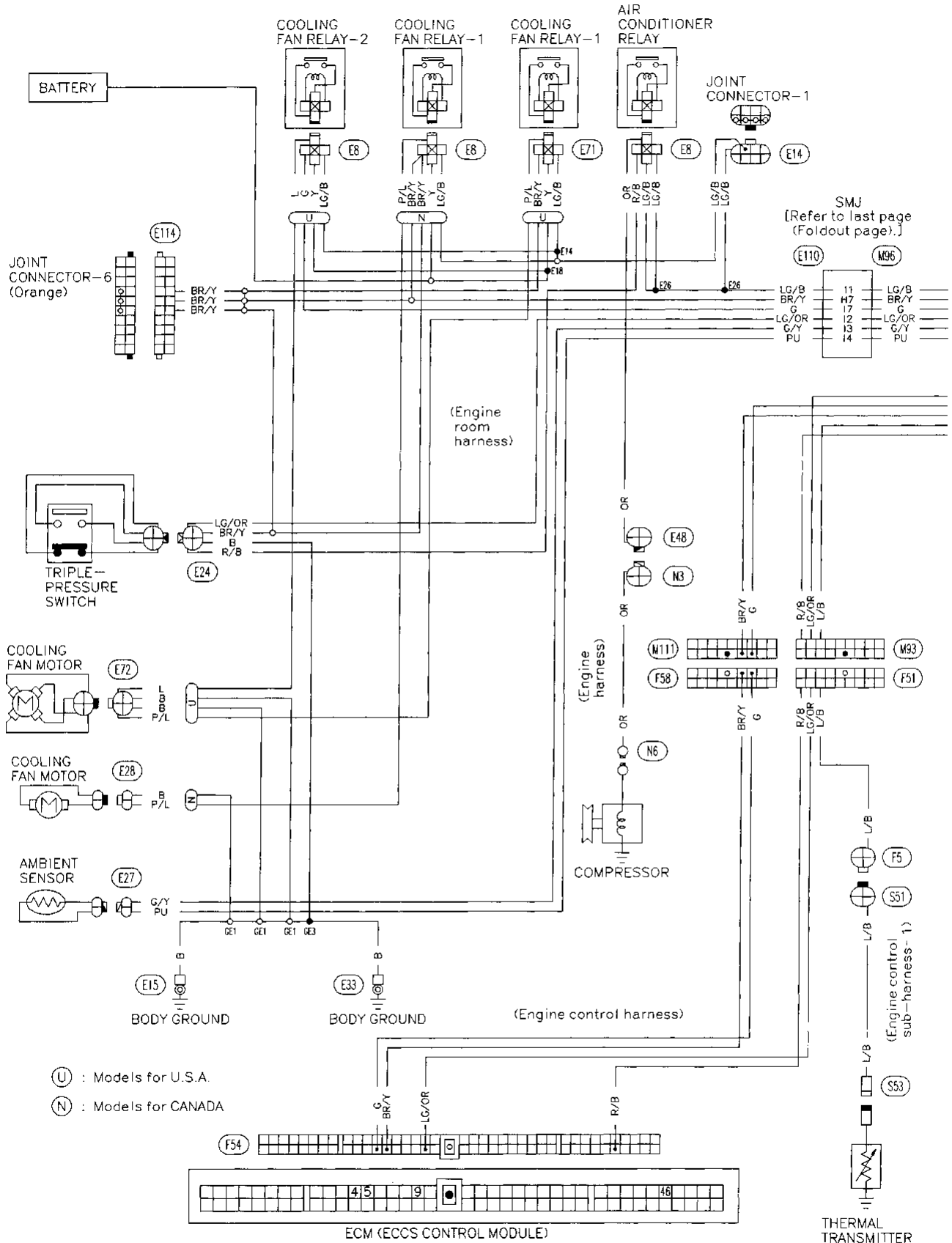

TROUBLE DIAGNOSES

Main Power Supply and Ground Circuit Check POWER SUPPLY CIRCUIT CHECK FOR AUTO A/C SYSTEM

Check power supply circuit for auto air conditioning system.
Refer to "POWER SUPPLY ROUTING" in EL section and Wiring Diagram.

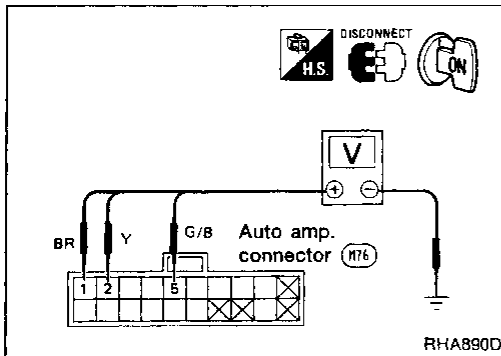

AUTO AMP. CHECK

Check power supply circuit for auto amp. with ignition switch ON.
Measure voltage across terminal Nos. ①, ②, ⑤ and body ground.

Voltmeter terminal		Voltage
⊕	⊖	
②	Body ground	Approx. 12V
⑤		
①		

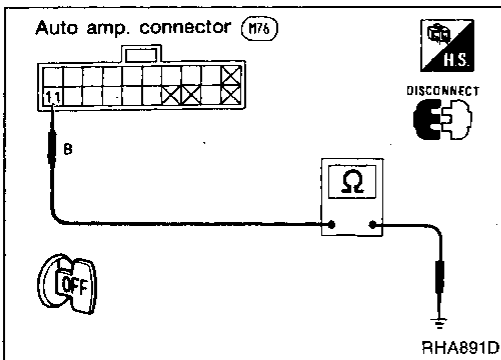

Check body ground circuit for auto amp. with ignition switch OFF.
Check for continuity between terminal No. ⑪ and body ground.

Ohmmeter terminal		Continuity
⊕	⊖	
⑪	Body ground	Yes

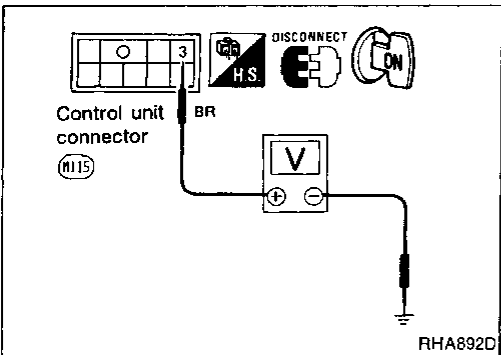

CONTROL UNIT CHECK

Check power supply circuit for control unit with ignition switch ON.
Measure voltage across terminal No. ③ and body ground.

Voltmeter terminal		Voltage
⊕	⊖	
③	Body ground	Approx. 12V

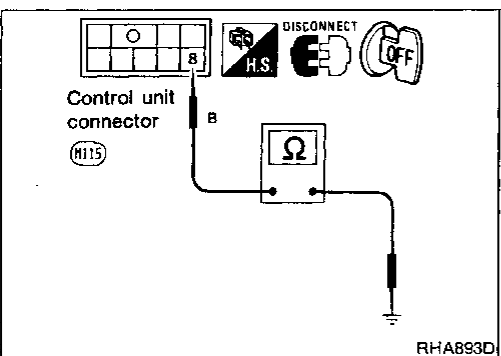

Check body ground circuit for control unit with ignition switch OFF.
Check for continuity between terminal No. ⑧ and body ground.

Ohmmeter terminal		Continuity
⊕	⊖	
⑧	Body ground	Yes

TROUBLE DIAGNOSES

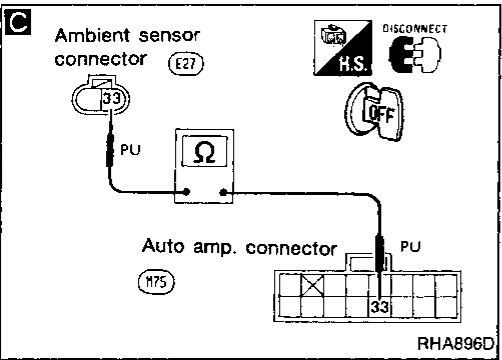
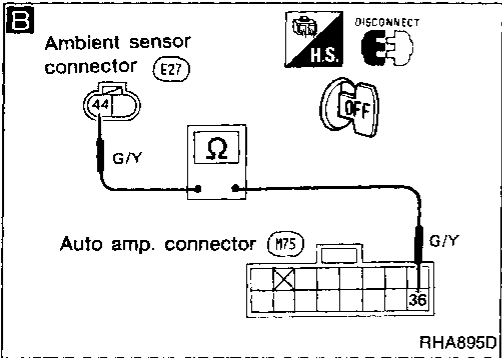
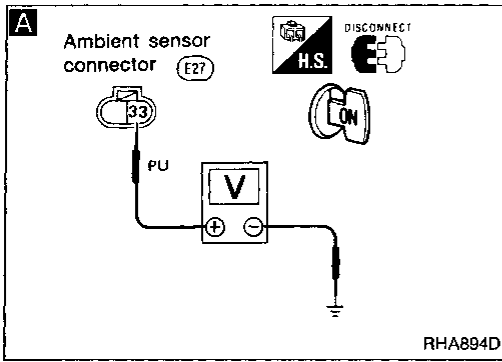

Diagnostic Procedure 1

SYMPTOM: Ambient sensor circuit is open. (21 is indicated on auto amp. as a result of conducting Self-diagnosis STEP 2.)

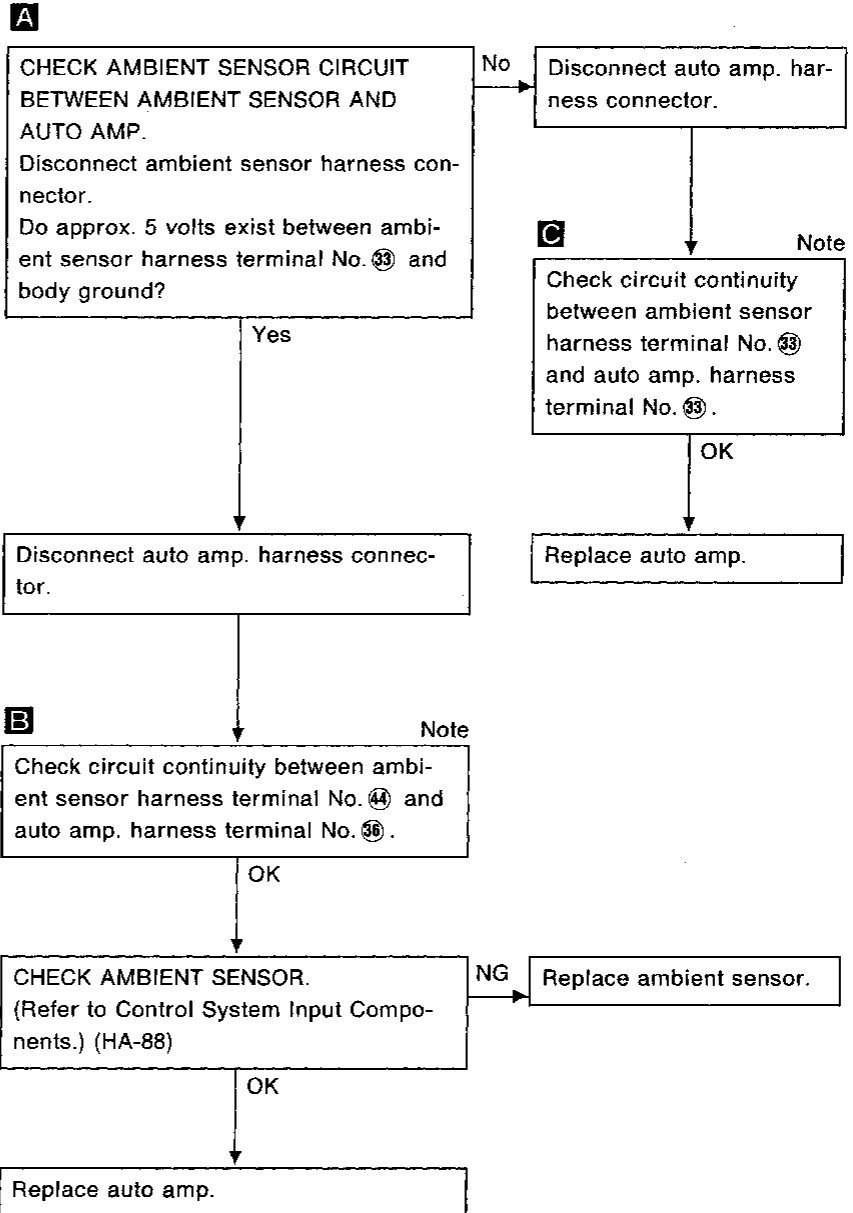

Note:

If the result is NG after checking circuit continuity, repair harness or connector.

GI
MA
EM
LC
EF & EC
FE
AT
PD
FA
RA
BR
ST
RS
BT
HA
EL
IDX

TROUBLE DIAGNOSES

Diagnostic Procedure 2

SYMPTOM: In-vehicle sensor circuit is open. (22 is indicated on auto amp. as a result of conducting Self-diagnosis STEP 2.)

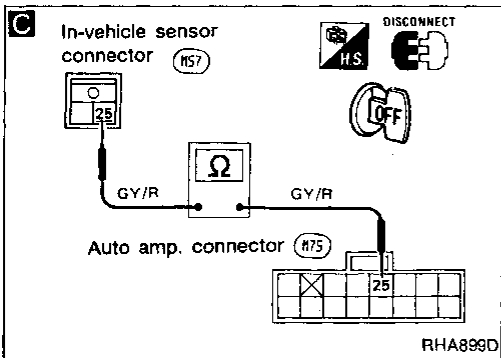
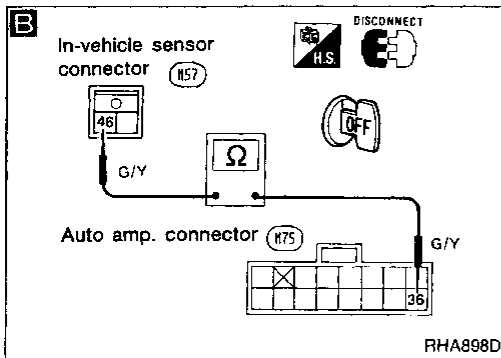
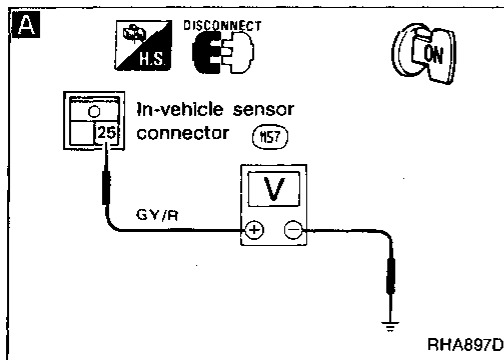

A

CHECK IN-VEHICLE SENSOR CIRCUIT BETWEEN IN-VEHICLE SENSOR AND AUTO AMP.
Disconnect in-vehicle sensor harness connector.
Do approx. 5 volts exist between in-vehicle sensor harness terminal No. 25 and body ground?

No → Disconnect auto amp. harness connector.

C Note

Check circuit continuity between in-vehicle sensor harness terminal No. 25 and auto amp. harness terminal No. 25.

OK → Replace auto amp.

Yes → Disconnect auto amp. harness connector.

B Note

Check circuit continuity between in-vehicle sensor harness terminal No. 46 and auto amp. harness terminal No. 36.

OK →

CHECK IN-VEHICLE SENSOR.
(Refer to Control System Input Components.) (HA-87)

NG → Replace in-vehicle sensor.

OK →

Replace auto amp.

Note:

If the result is NG after checking circuit continuity, repair harness or connector.

TROUBLE DIAGNOSES

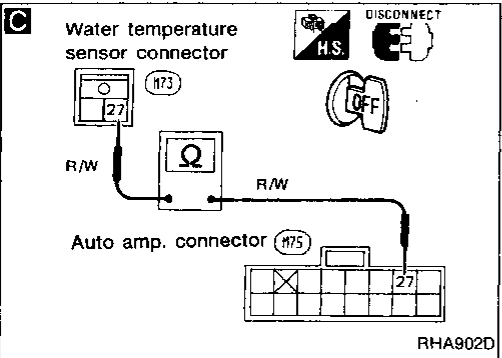
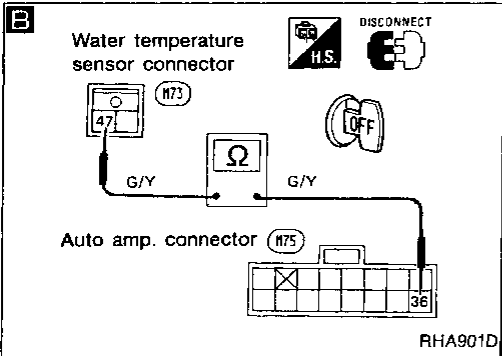
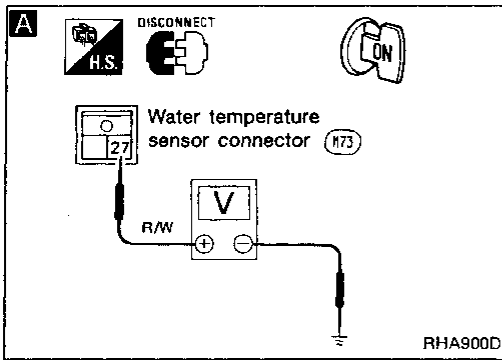

Diagnostic Procedure 3

SYMPTOM: Water temperature sensor circuit is open. (23 is indicated on auto amp. as a result of conducting Self-diagnosis STEP 2.)

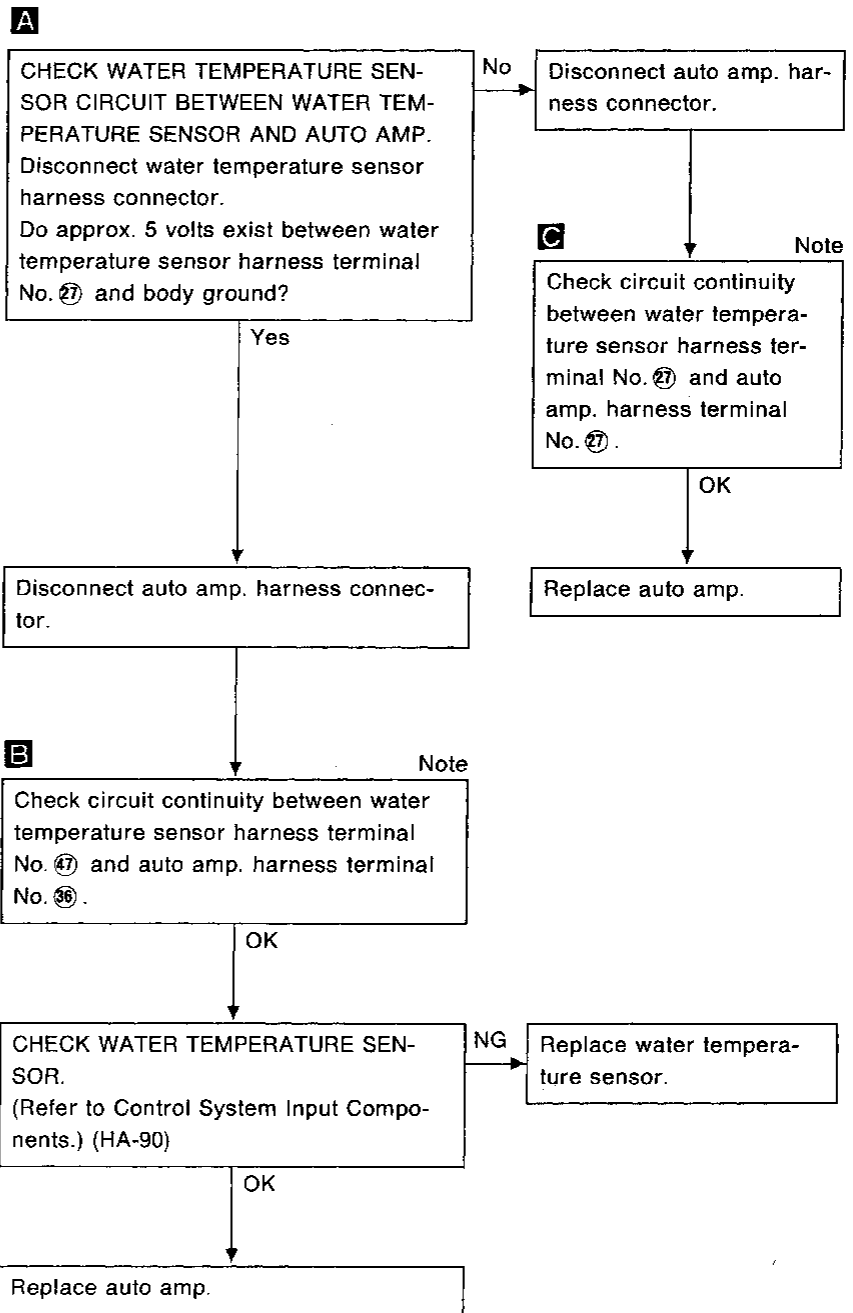

Note:

If the result is NG after checking circuit continuity, repair harness or connector.

GI
MA
EM
LC
EF & EC
FE
AT
PD
FA
RA
BR
ST
RS
BT
HA
EL
IDX

TROUBLE DIAGNOSES

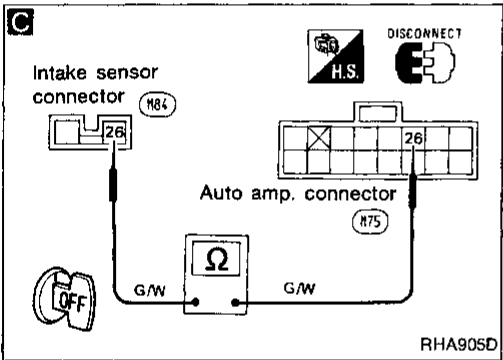
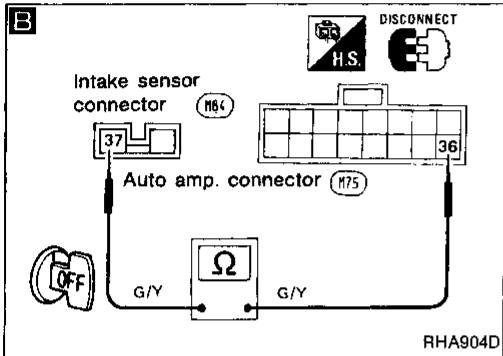
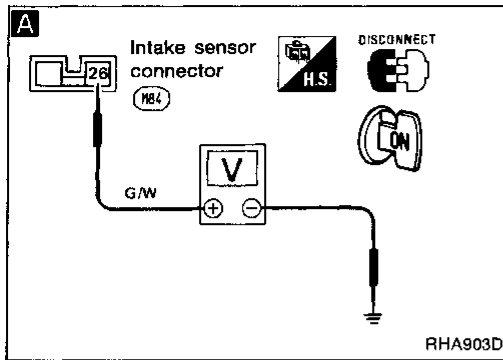

Diagnostic Procedure 4

SYMPTOM: Intake sensor circuit is open. (24 is indicated on auto amp. as a result of conducting Self-diagnosis STEP 2.)

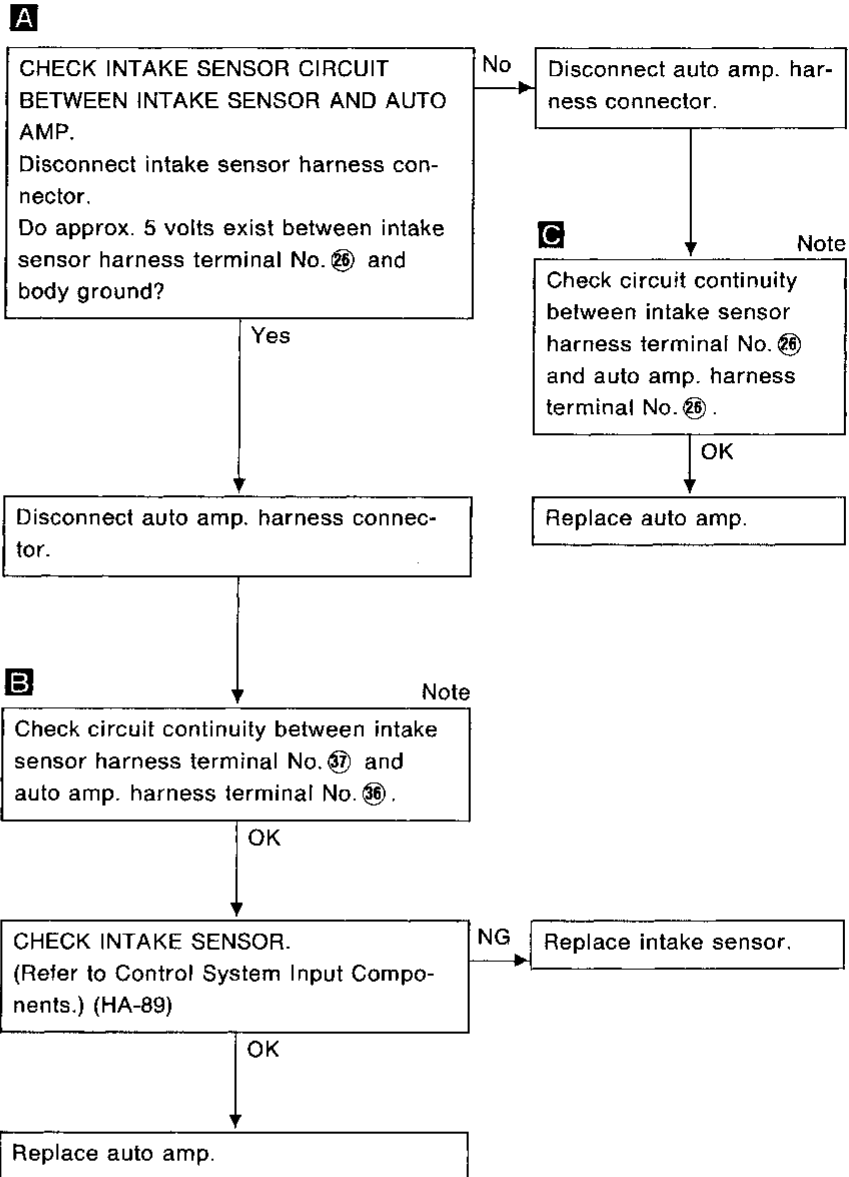

Note:

If the result is NG after checking circuit continuity, repair harness or connector.

TROUBLE DIAGNOSES

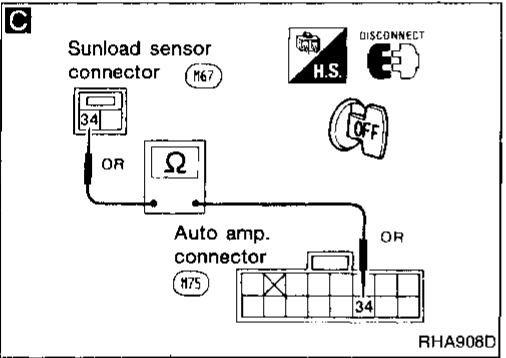
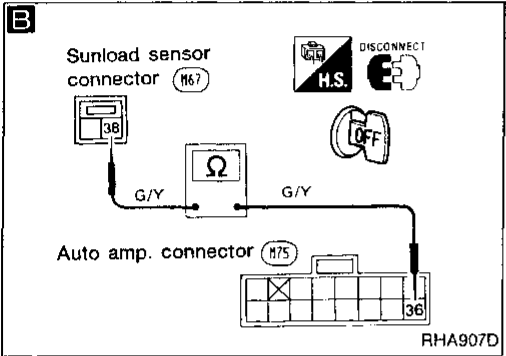
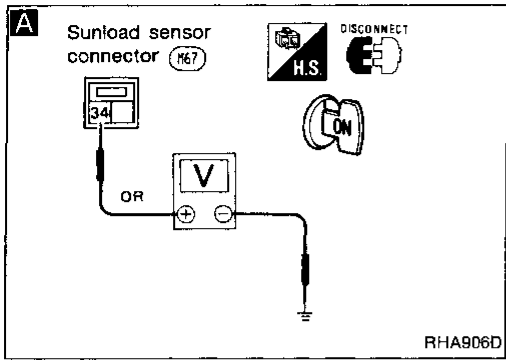

Diagnostic Procedure 5

SYMPTOM: Sunload sensor circuit is open. (25 is indicated on auto amp. as a result of conducting Self-diagnosis STEP 2.)

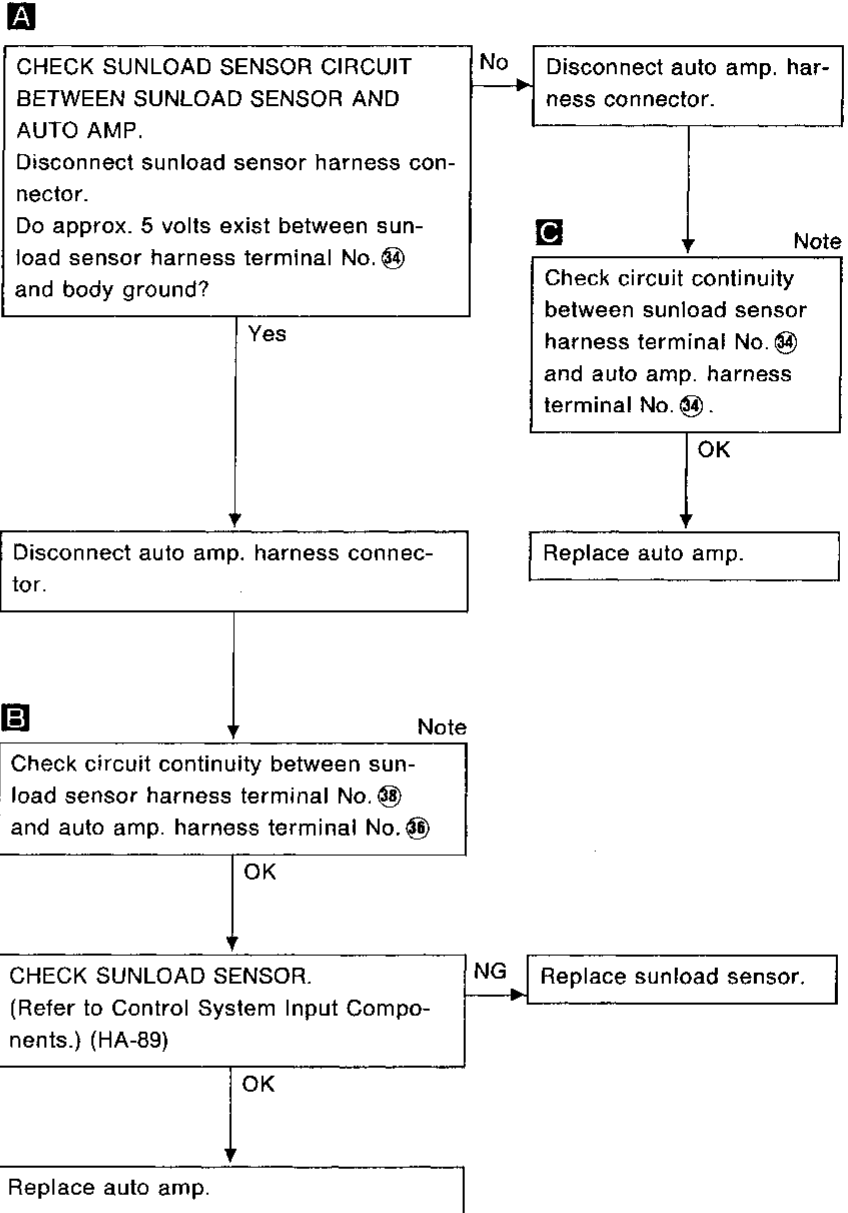

Note:

If the result is NG after checking circuit continuity, repair harness or connector.

GI
MA
EM
LC
EF & EC
FE
AT
PD
FA
RA
BR
ST
RS
BT
HA
EL
IDX

TROUBLE DIAGNOSES

Diagnostic Procedure 6

SYMPTOM: PBR circuit is open. (25 is indicated on auto amp. as a result of conducting Self-diagnosis STEP 2.)

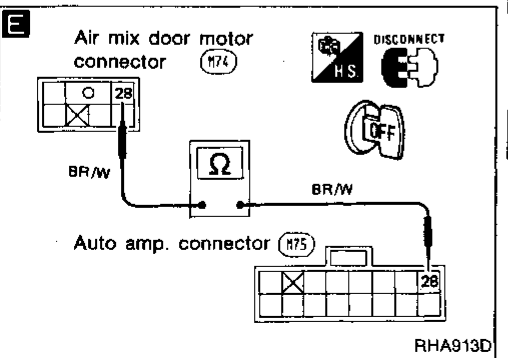
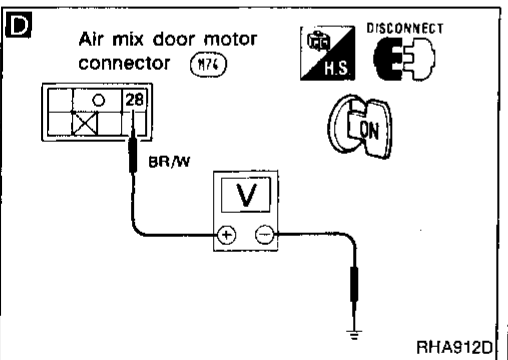
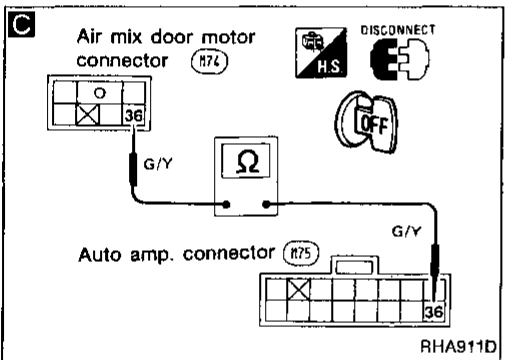
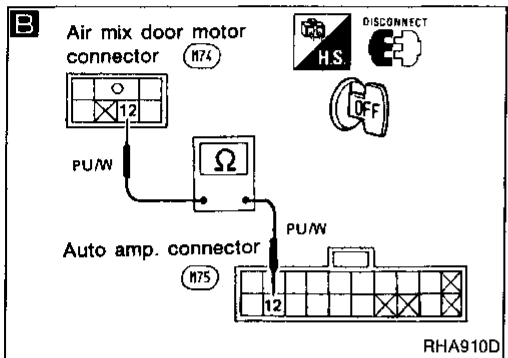
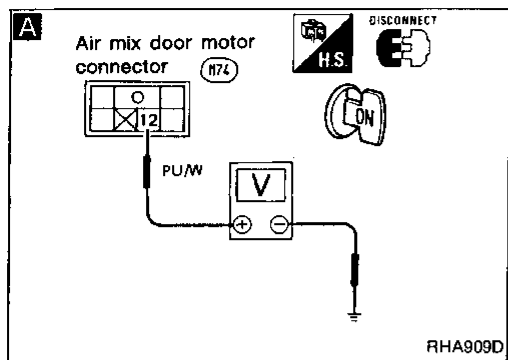

A

CHECK PBR CIRCUIT BETWEEN PBR AND AUTO AMP.
 Disconnect air mix door motor harness connector.
 Do approx. 5 volts exist between air mix door motor harness terminal No. 12 and body ground?

No → Disconnect auto amp. harness connector.

B Note

Check circuit continuity between air mix door motor harness terminal No. 12 and auto amp. harness terminal No. 12.

OK → Replace auto amp.

Yes → Disconnect auto amp. harness connector.

C Note

Check circuit continuity between air mix door motor harness terminal No. 36 and auto amp. harness terminal No. 36.

No → Disconnect auto amp. harness connector.

E Note

Check circuit continuity between air mix door motor harness terminal No. 28 and auto amp. harness terminal No. 28.

OK → Replace auto amp.

OK → **D**

D

CHECK PBR CIRCUIT BETWEEN PBR AND AUTO AMP.
 Reconnect auto amp. harness connector.
 Do approx. 5 volts exist between air mix door motor harness terminal No. 28 and body ground?

NG → Replace air mix door motor (PBR).

Yes → CHECK PBR. (Refer to Control System Output Components.) (HA-95)

OK → Replace auto amp.

Note:
 If the result is NG after checking circuit continuity, repair harness or connector.

TROUBLE DIAGNOSES

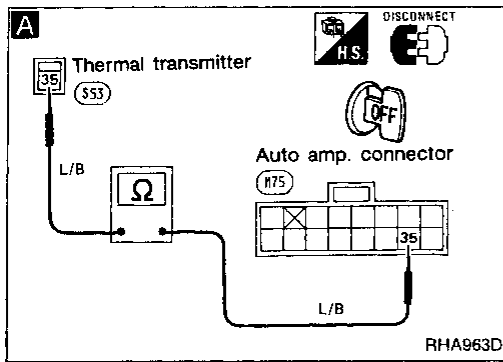

Diagnostic Procedure 7

SYMPTOM: Thermal transmitter circuit is open. (27 is indicated on auto amp. as a result of conducting Self-diagnosis STEP 2.)

A

Note

CHECK THERMAL TRANSMITTER CIRCUIT BETWEEN THERMAL TRANSMITTER AND AUTO AMP.
 Disconnect thermal transmitter harness connector and auto amp. harness connector.
 Check circuit continuity between thermal transmitter harness terminal No. 35 and auto amp. harness terminal No. 35.

↓
OK

CHECK THERMAL TRANSMITTER.
 Refer to EL section.

↓
OK

Replace auto amp.

Note:

If the result is NG after checking circuit continuity, repair harness or connector.

GI

MA

EM

LC

EF &
EC

FE

AT

PD

FA

RA

BR

ST

RS

BT

HA

EL

IDX

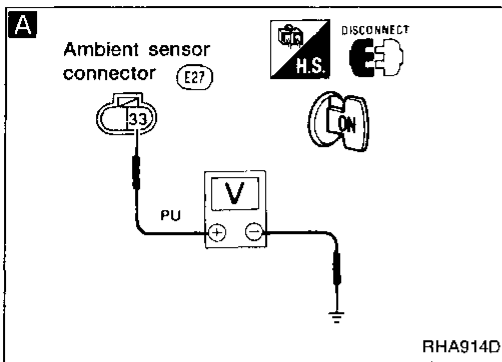

Diagnostic Procedure 8

SYMPTOM: Ambient sensor circuit is shorted. (-21 is indicated on auto amp. as a result of conducting Self-diagnosis STEP 2.)

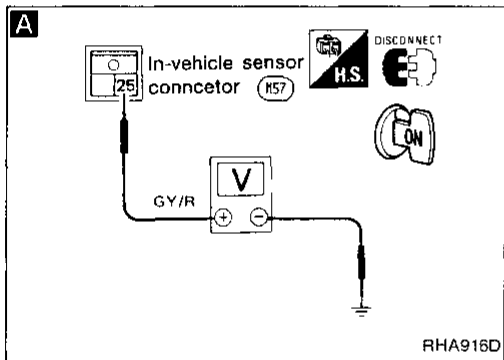
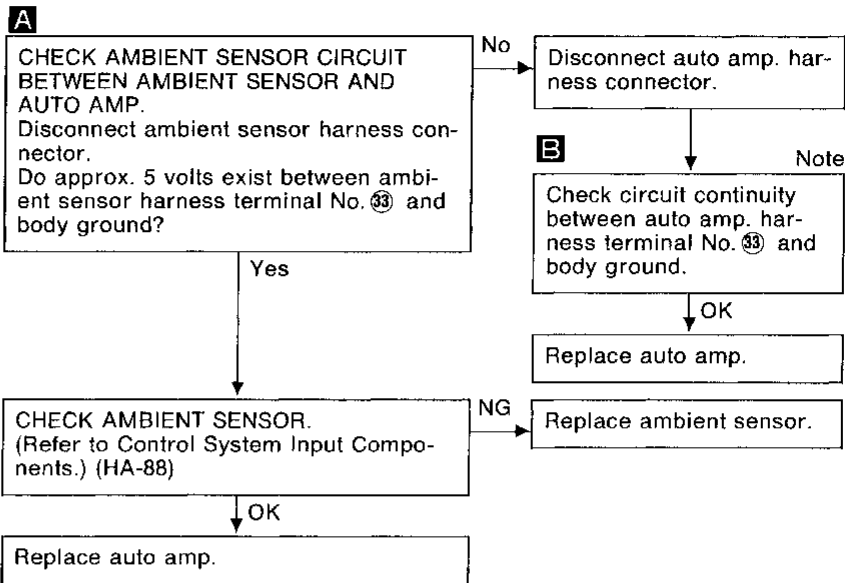
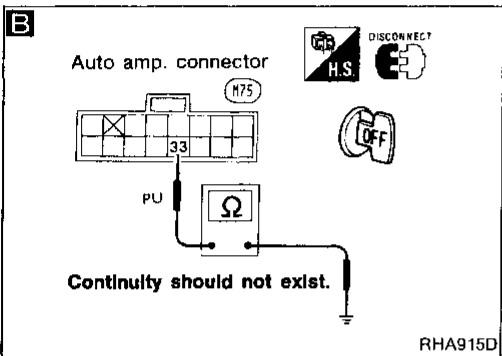

Diagnostic Procedure 9

SYMPTOM: In-vehicle sensor circuit is shorted. (-22 is indicated on auto amp. as a result of conducting Self-diagnosis STEP 2.)

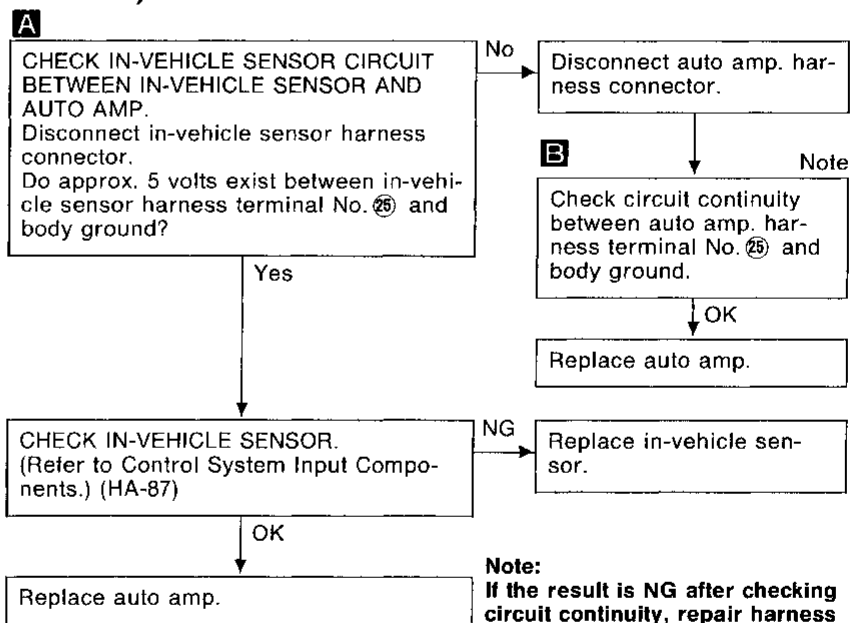
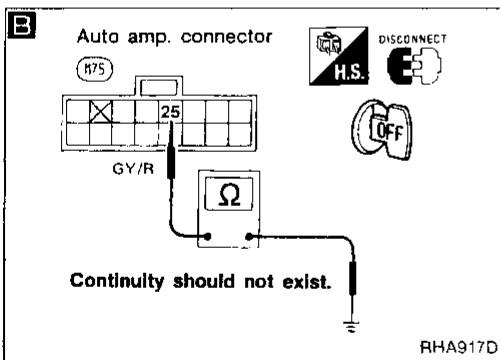

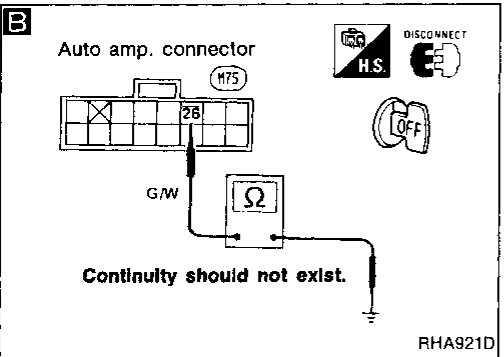
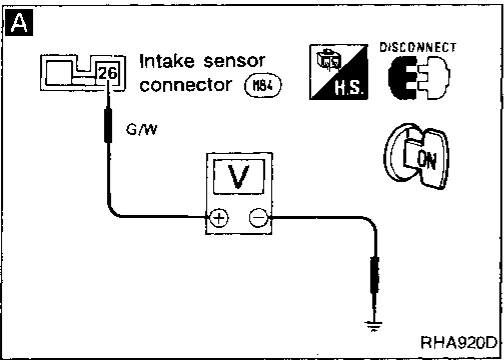
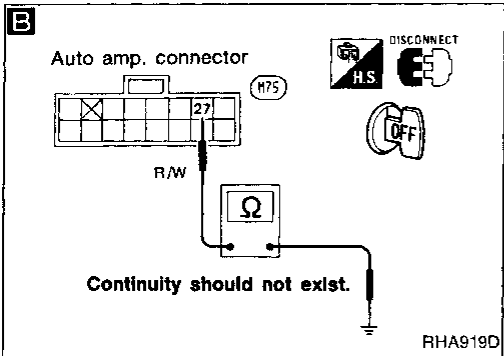
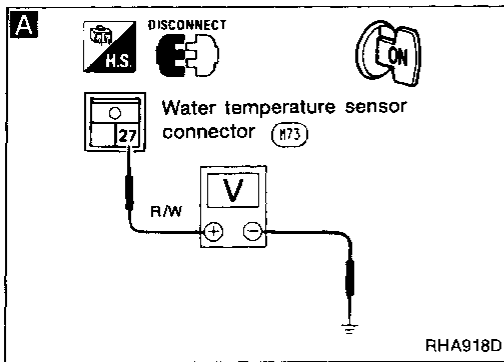

Diagnostic Procedure 10

SYMPTOM: Water temperature sensor circuit is shorted. (-23 is indicated on auto amp. as a result of conducting Self-diagnosis STEP 2.)

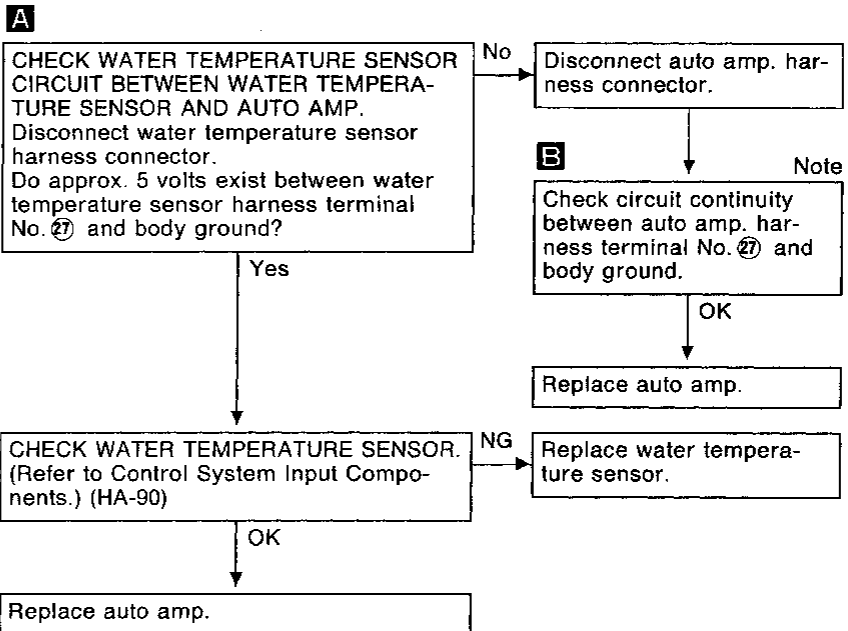

Replace auto amp.

Diagnostic Procedure 11

SYMPTOM: Intake sensor circuit is shorted. (-24 is indicated on auto amp. as a result of conducting Self-diagnosis STEP 2.)

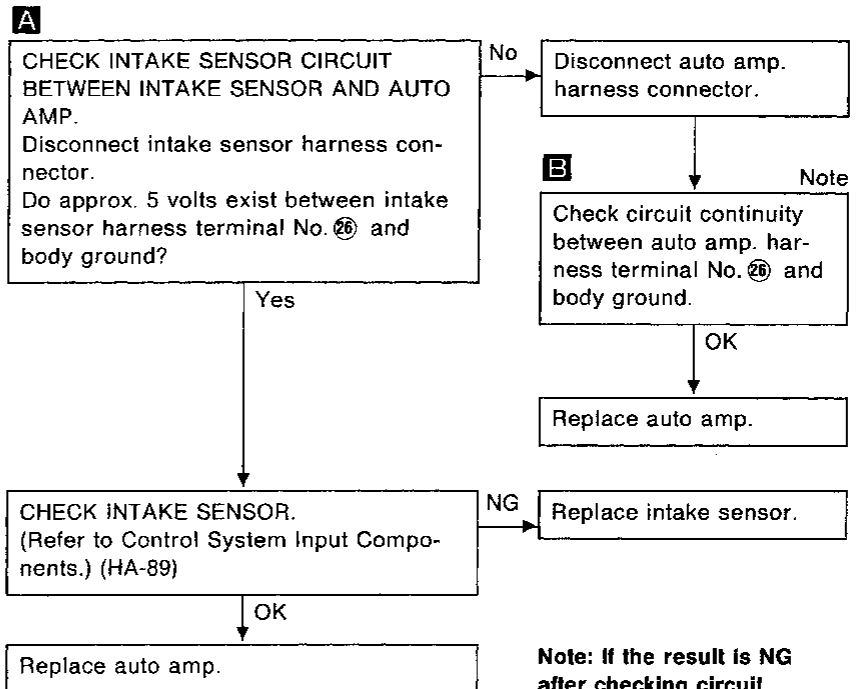

Replace auto amp.

Note: If the result is NG after checking circuit continuity, repair harness or connector short.

TROUBLE DIAGNOSES

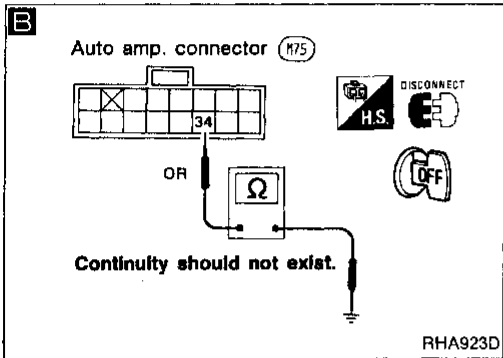
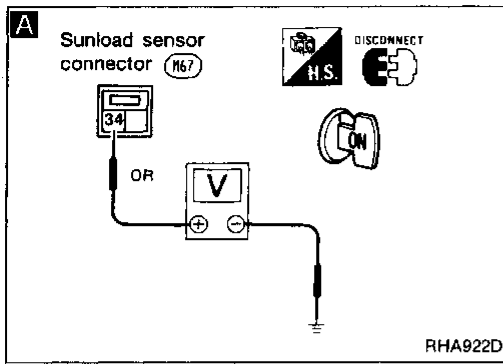

Diagnostic Procedure 12

SYMPTOM: Sunload sensor circuit is shorted. (-25 is indicated on auto amp. as a result of conducting Self-diagnosis STEP 2.)

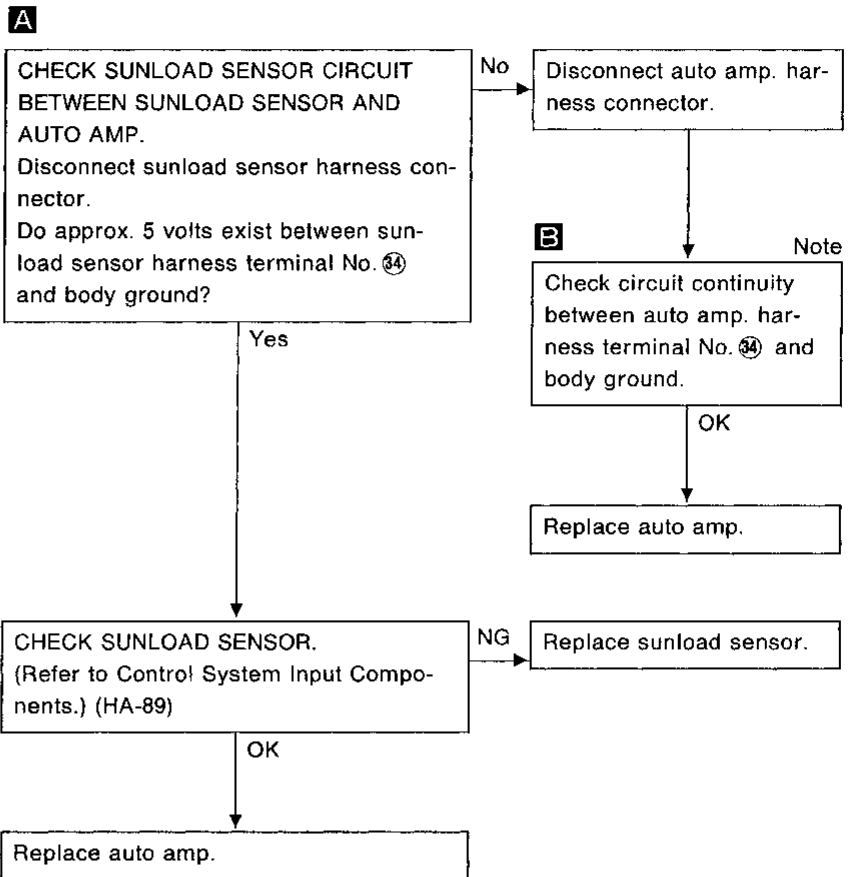

Note:

If the result is NG after checking circuit continuity, repair harness or connector short.

TROUBLE DIAGNOSES

Diagnostic Procedure 13

SYMPTOM: PBR circuit is shorted. (-28 is indicated on auto amp. as a result of conducting Self-diagnosis STEP 2.)

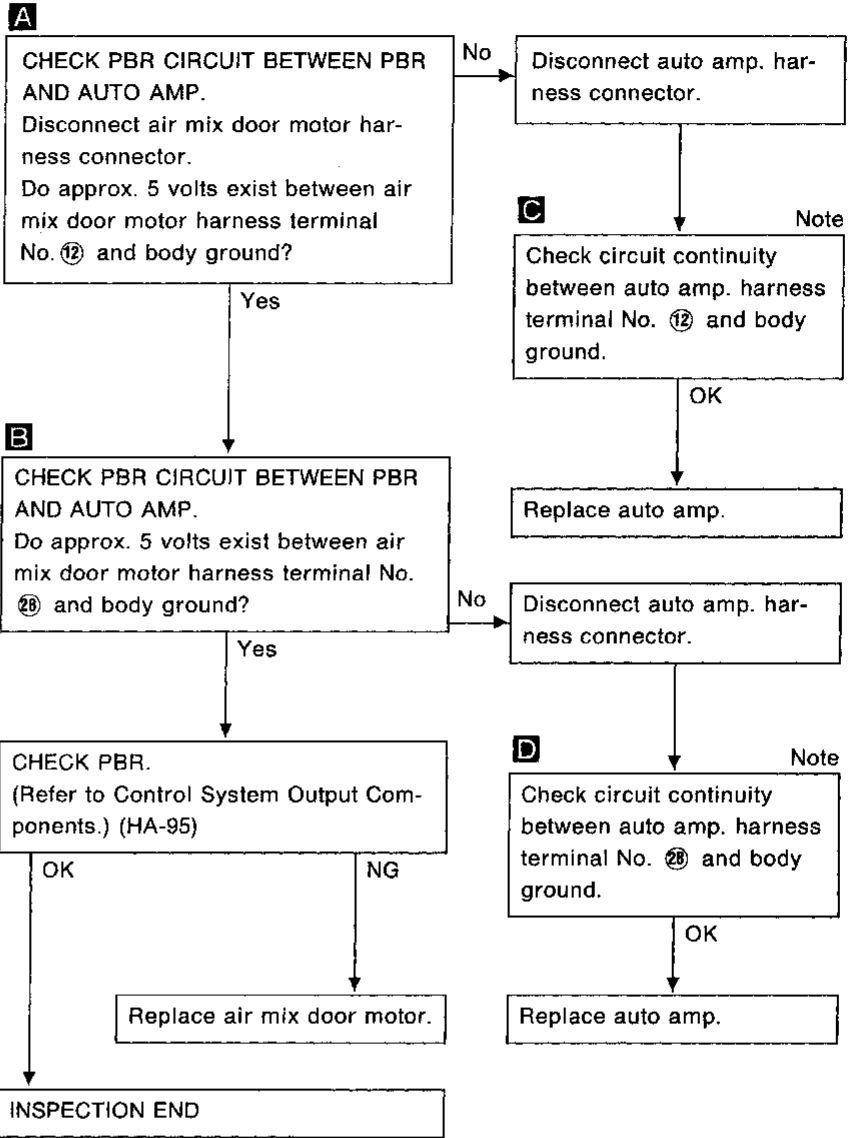
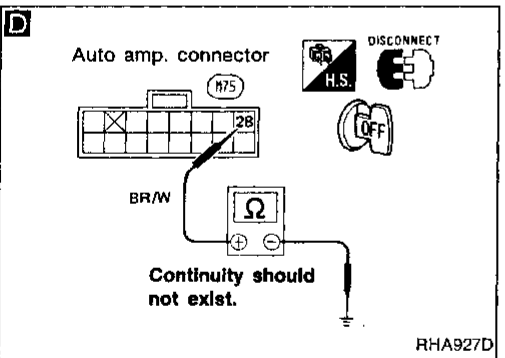
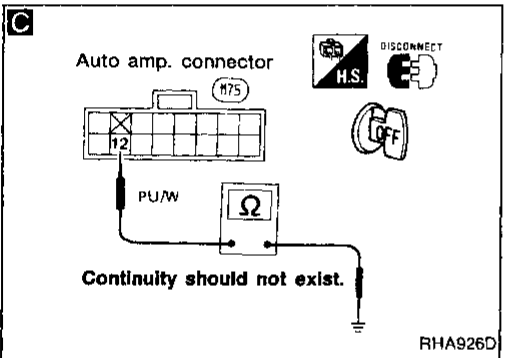
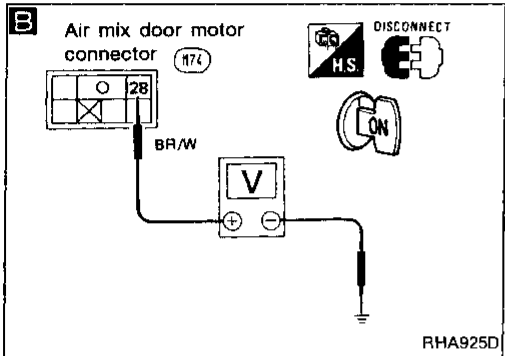
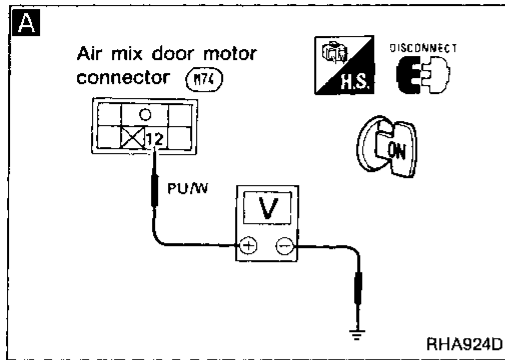

Note:

If the result is NG after checking circuit continuity, repair harness or connector short.

GI
MA
EM
LC
EF & EC
FE
AT
PD
FA
RA
BR
ST
RS
BT
HA
EL
IDX

TROUBLE DIAGNOSES

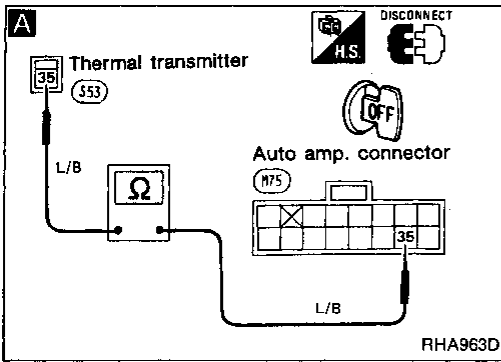

Diagnostic Procedure 14

SYMPTOM: Thermal transmitter circuit is shorted. (-27 is indicated on auto amp. as a result of conducting Self-diagnosis STEP 2.)

A Note

CHECK THERMAL TRANSMITTER CIRCUIT BETWEEN THERMAL TRANSMITTER AND AUTO AMP.
Disconnect thermal transmitter harness connector and auto amp. harness connector.
Check circuit continuity between thermal transmitter harness terminal No. 35 and auto amp. harness terminal No. 35.

OK

CHECK THERMAL TRANSMITTER.
Refer to METER AND GAUGES in EL section.

OK

Replace auto amp.

Note:

If the result is NG after checking circuit continuity, repair harness or connector short.

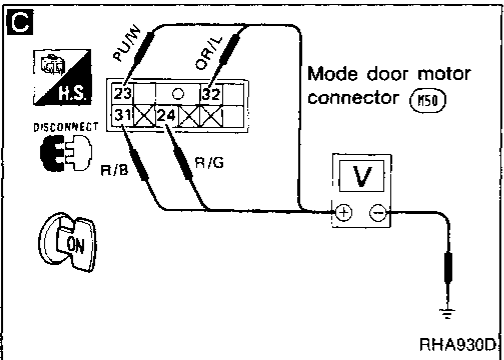
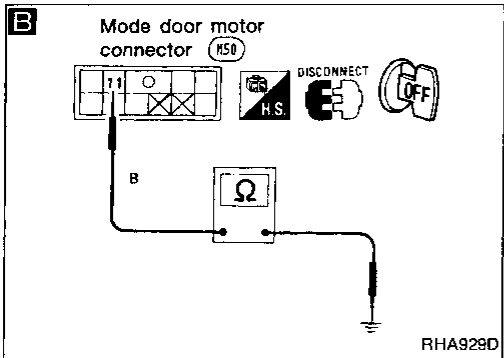
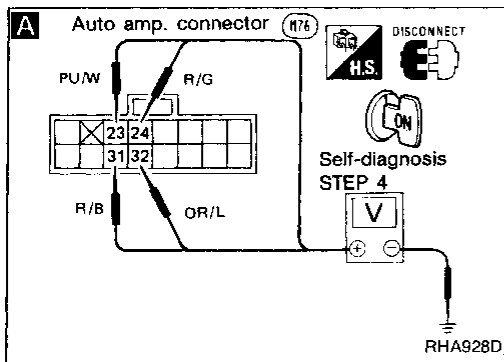

Diagnostic Procedure 15

SYMPTOM: Mode door motor does not operate normally.

- Perform Self-diagnosis STEPS 1 to 4 before referring to the following flow chart.

A
CHECK MODE DOOR MOTOR POSITION SWITCH.

1. Set up code No. 41 in Self-diagnosis STEP 4.
2. Disconnect auto amp. harness connector after turning ignition switch OFF.
3. Check if continuity exists between terminal No. 23 or 24 of auto amp. harness connector and body ground.
4. Using above procedure, check for continuity in any other mode, as indicated in chart.

Code No.	Condition	Terminal No.		Continuity
		⊕	⊖	
41	VENT	23	Body ground	Yes
42 or 43	B/L	24		
44	F/D 1	31		
45	F/D 2	23 or 24 or 32		
46	DEF	23 or 31 or 24		

INSPECTION END

NG → Disconnect mode door motor harness connector.

B Note
CHECK BODY GROUND CIRCUIT FOR MODE DOOR MOTOR.
Does continuity exist between mode door motor harness terminal No. 11 and body ground?

OK → Reconnect auto amp. harness connector.

C
CHECK POWER SUPPLY FOR MODE DOOR MOTOR CONTROL CIRCUIT.
Do approx. 5 volts exist between mode door motor harness terminals and body ground?

Terminal No.		Voltage
⊕	⊖	
23	Body ground	Approx. 5V
24		
31		
32		

Yes → Reconnect mode door motor harness connector.

No → (Go to next page.)

Note:

If the result is NG after checking circuit continuity, repair harness or connector.

TROUBLE DIAGNOSES

Diagnostic Procedure 15 (Cont'd)

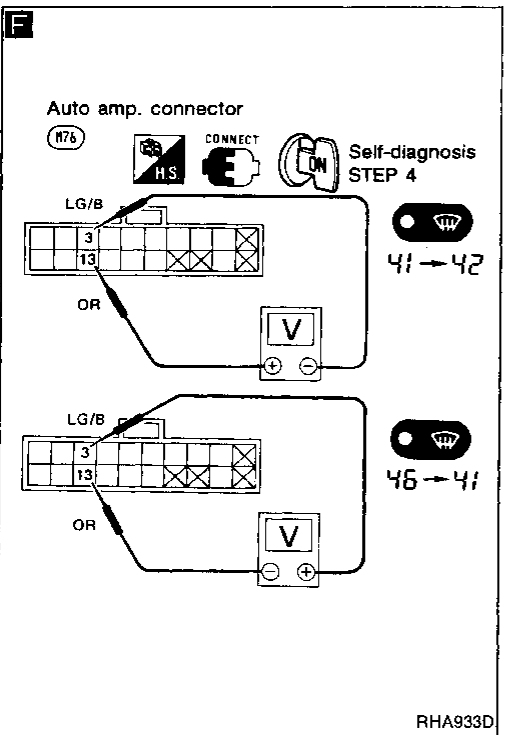
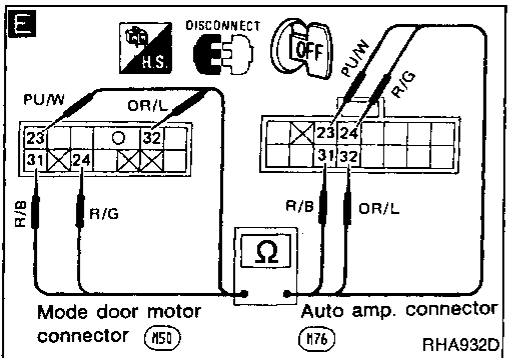
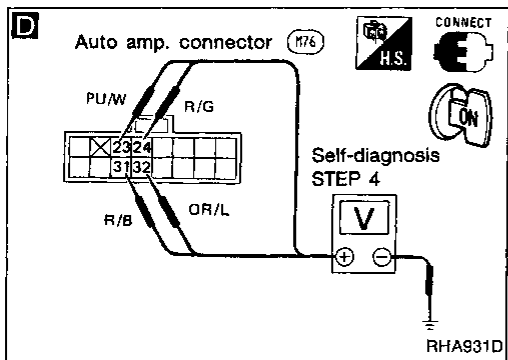

D CHECK MODE DOOR MOTOR POSITION SWITCH.
Set up Self-diagnosis STEP 4.
Measure voltage across auto amp. harness terminals and body ground.

Code No.	Con- dition	Terminal No.				⊖
		⊕	⊕	⊕	⊕	
41	VENT	5V	5V	5V	0V	Body ground
42	B/L1	0V	5V	5V	5V	
43	B/L2	5V	5V	0V	5V	
44	D/F 1	5V	0V	5V	5V	
45	D/F 2	0V	0V	5V	0V	
46	DEF	0V	0V	0V	5V	

0V: Approx. 0V
5V: Approx. 5V

OK →
NG → Replace mode door motor.

E Check circuit continuity between each terminal on auto amp. and on mode door motor.

Terminal No.		Continuity
⊕	⊖	
Auto amp. (23)	Mode door motor (32)	Yes
Auto amp. (31)	Mode door motor (31)	
Auto amp. (24)	Mode door motor (23)	
Auto amp. (32)	Mode door motor (24)	
Auto amp. (32)	Mode door motor (24)	

OK → Replace auto amp.

F CHECK FOR OUTPUT OF AUTO AMP.
Do approx. 10.5 volts exist between auto amp. harness terminals No. 13 and 3 when code No. is switched from "41" to "42" or when code No. is switched from "46" to "41"?

Code No.	Mode door motor operation	Terminal No.		Voltage V
		13	3	
41 → 42	VENT → B/L	⊕	⊖	Approx. 10.5
46 → 41	DEF → VENT	⊖	⊕	
-	Stop	-	-	0

Yes → Replace mode door motor.
No → Replace auto amp.

Note:
If the result is NG after checking circuit continuity, repair harness or connector.

TROUBLE DIAGNOSES

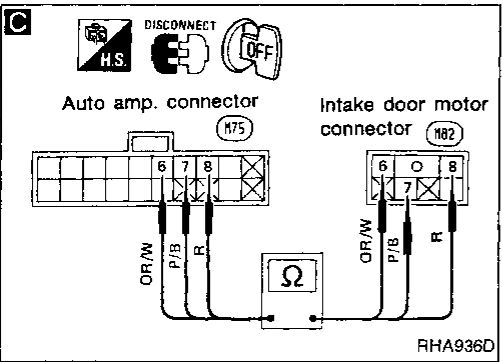
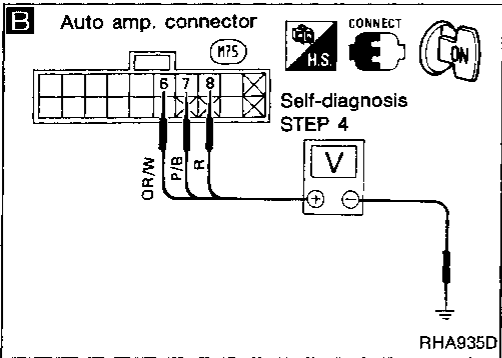
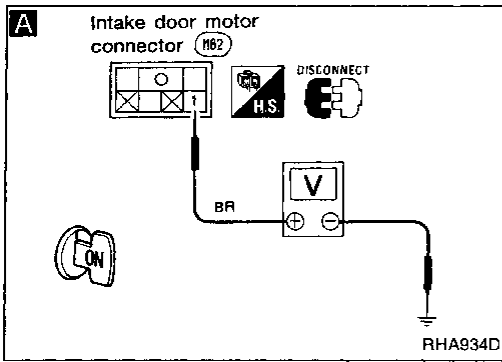

Diagnostic Procedure 16

SYMPTOM: Intake door motor does not operate normally.

- Perform Self-diagnosis STEPS 1, 2 and 4 before referring to the following flow chart.

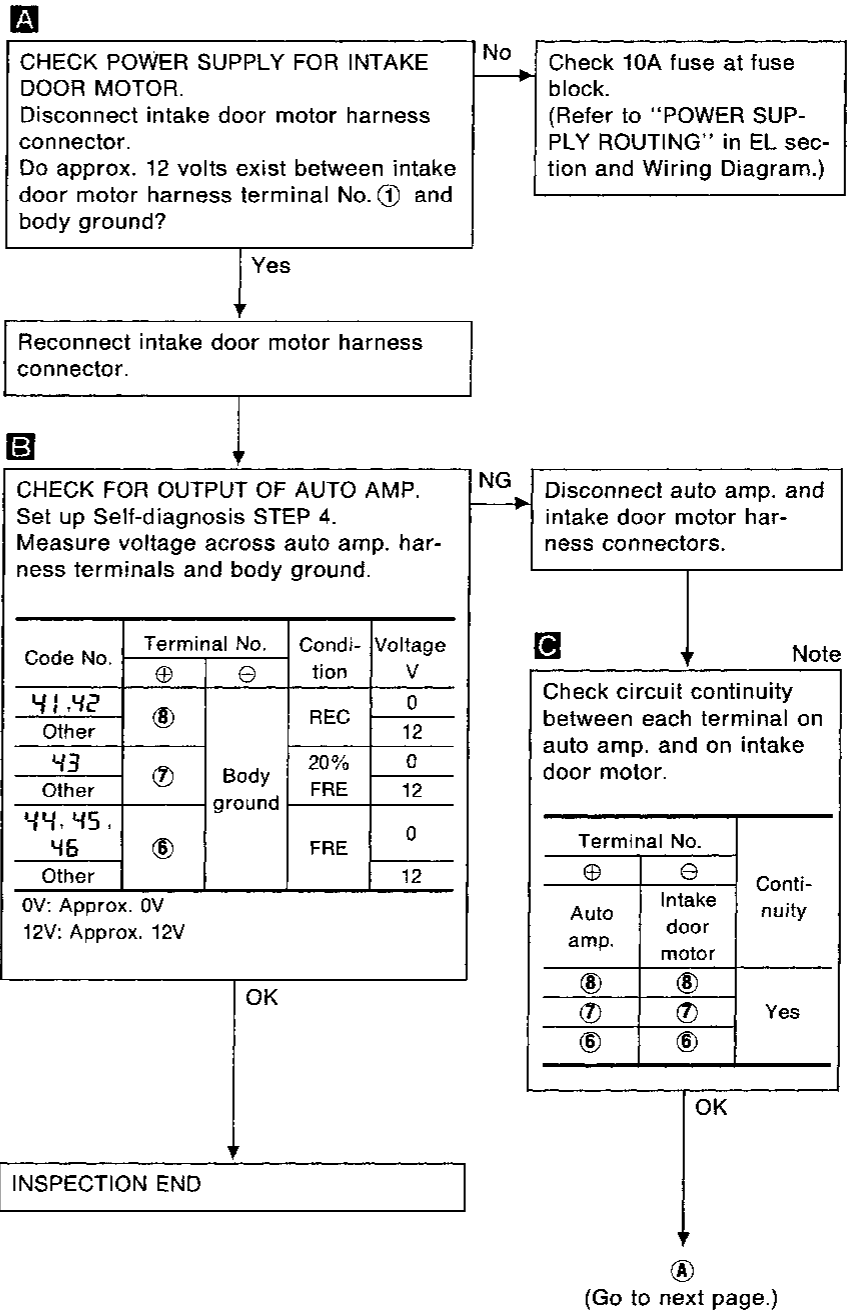

Note:

If the result is NG after checking circuit continuity, repair harness or connector.

TROUBLE DIAGNOSES

Diagnostic Procedure 16 (Cont'd)

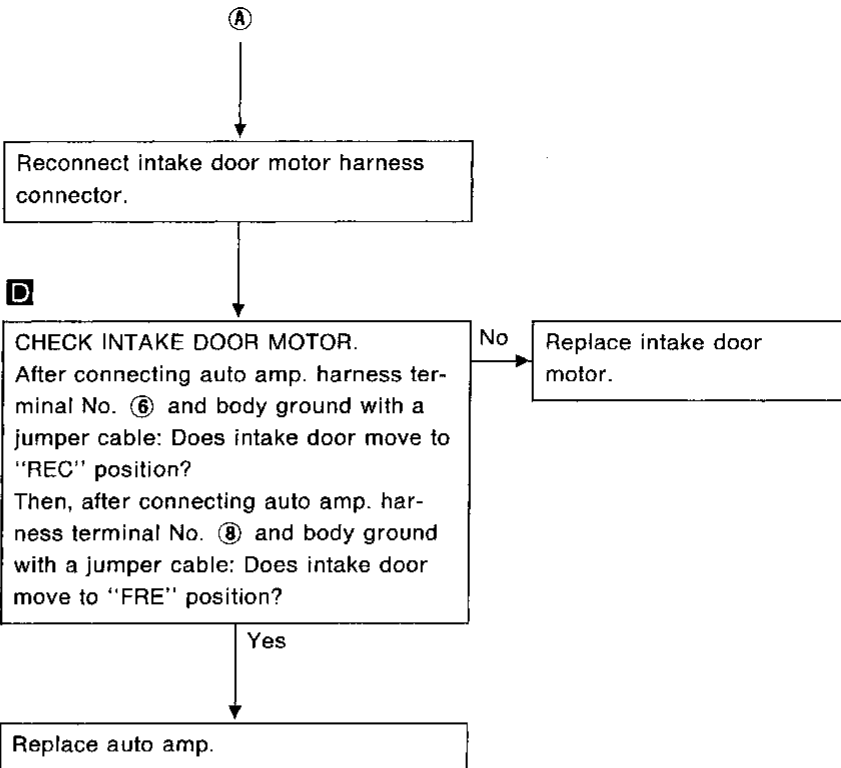
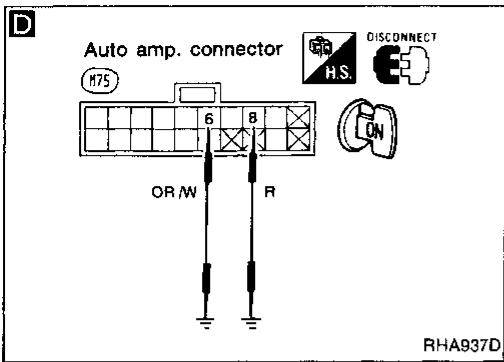

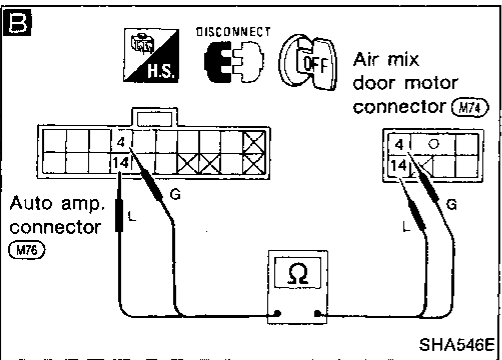
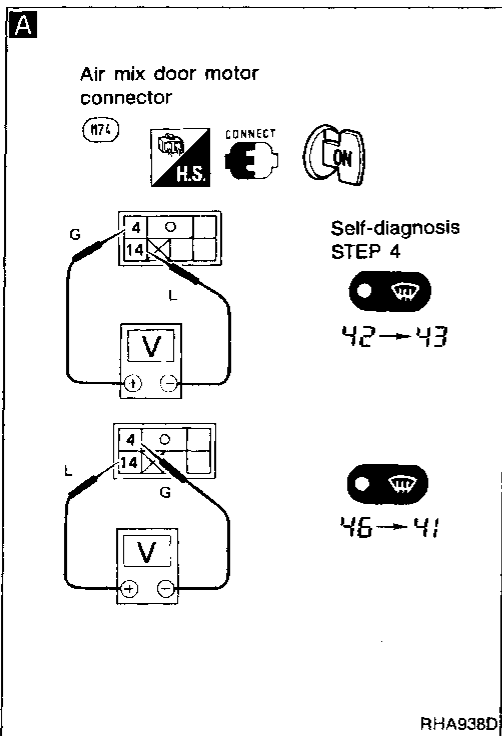

Diagnostic Procedure 17

SYMPTOM: Air mix door motor does not operate normally.

- Perform Self-diagnosis STEPS 1, 2 and 4 before referring to the following flow chart.

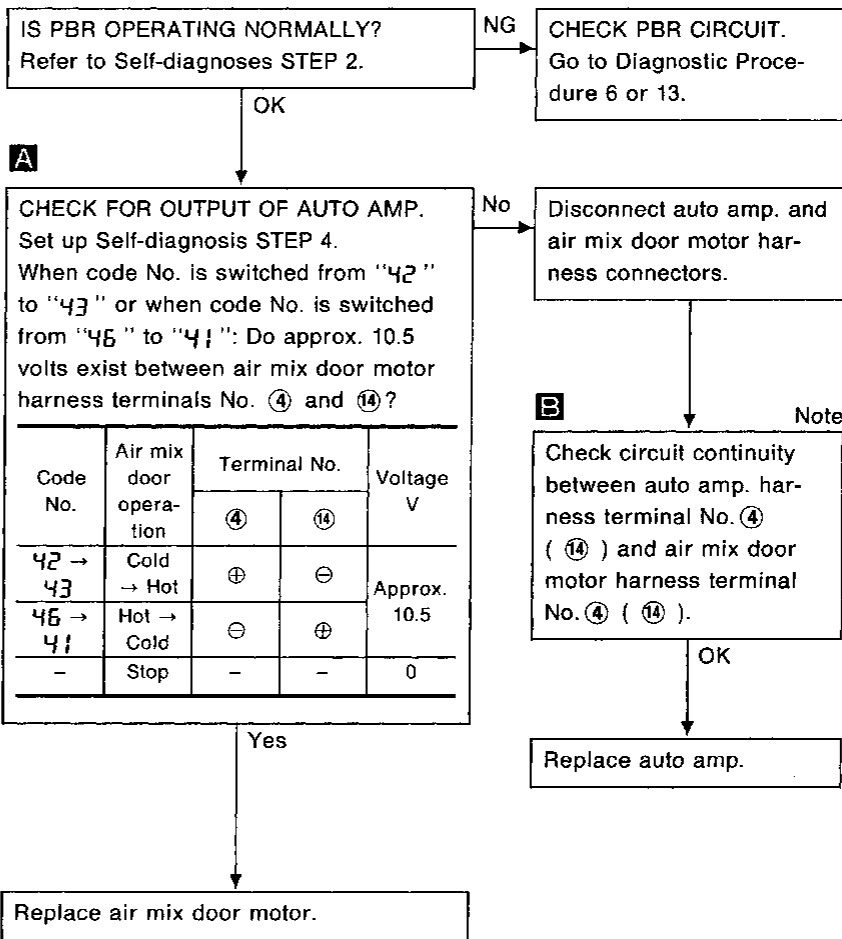

Note:

If the result is NG after checking circuit continuity, repair harness or connector.

CI
MA
EM
LC
EF & EC
FE
AT
PD
FA
RA
BR
ST
RS
BT
HA
EL
IDX

Diagnostic Procedure 18

SYMPTOM: Blower motor operation is malfunctioning under out of Starting Fan Speed Control.

- Perform Preliminary Check 5 before referring to the following flow chart.

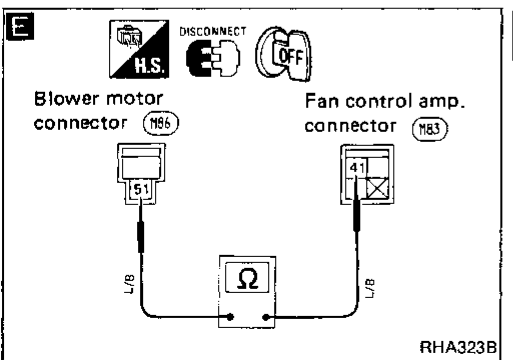
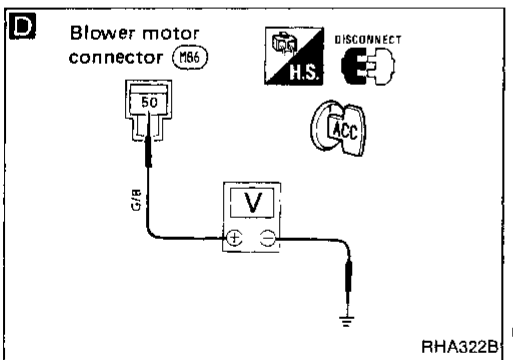
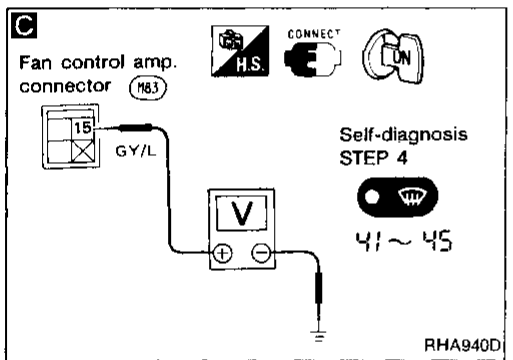
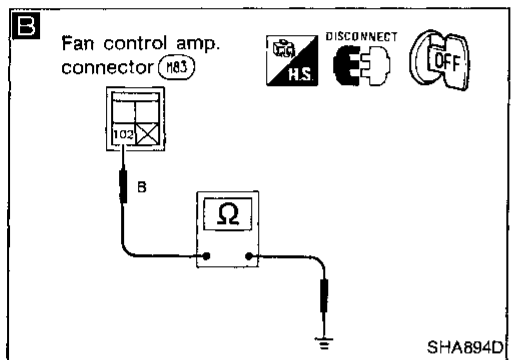
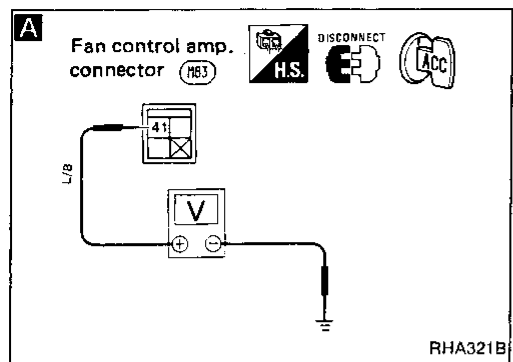

A CHECK POWER SUPPLY FOR FAN CONTROL AMP.
Disconnect fan control amp. harness connector.
Do approx. 12 volts exist between fan control amp. harness terminal No. (41) and body ground?

B Note
CHECK BODY GROUND CIRCUIT FOR FAN CONTROL AMP.
Does continuity exist between fan control amp. harness terminal No. (102) and body ground?

Reconnect fan control amp. harness connector.

C CHECK FOR OUTPUT OF AUTO AMP.
Set up Self-diagnosis STEP 4.
Measure voltage across fan control amp. harness terminal No. (15) and body ground.

Code No.	Terminal No.		Voltage
	⊕	⊖	
41 → 45	(15)	Body ground	Approx. 1 - 3V

Replace fan control amp.

Note:
If the result is NG after checking circuit continuity, repair harness or connector.

D CHECK POWER SUPPLY FOR BLOWER MOTOR.
Disconnect blower motor harness connector.
Do approx. 12 volts exist between blower motor harness terminal No. (50) and body ground?

Note
Check 15A fuses at fuse block.
(Refer to "POWER SUPPLY ROUTING" in EL section and Wiring Diagram.)

E Note
Check circuit continuity between blower motor harness terminal No. (51) and fan control amp. harness terminal No. (41).

CHECK BLOWER MOTOR.
(Refer to Electrical Components Inspection.) (HA-83)

Replace blower motor.

No

Yes

Yes

No

Yes

OK

NG

NG

OK

(A) (Go to next page.)

TROUBLE DIAGNOSES

Diagnostic Procedure 18 (Cont'd)

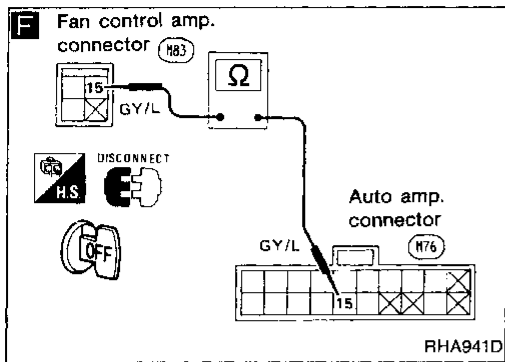

A

Disconnect auto amp. and fan control amp. harness connector.

F **Note**
Does continuity exist between auto amp. harness terminal No. 15 and fan control amp. harness terminal No. 15?

Yes

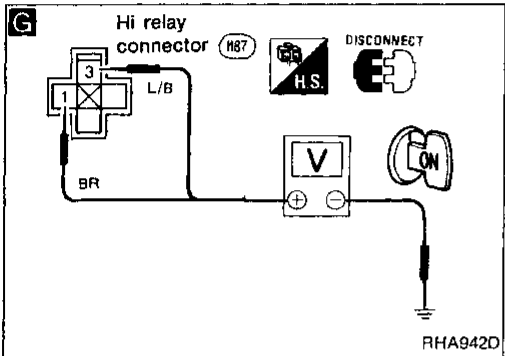

G
CHECK POWER SUPPLY FOR HI RELAY. Do approx. 12 volts exist between Hi relay harness terminals No. ①, ③ and body ground?

No → Check 10A or 15A fuses at fuse block. (Refer to "POWER SUPPLY ROUTING" in EL section and Wiring Diagram.)

Yes

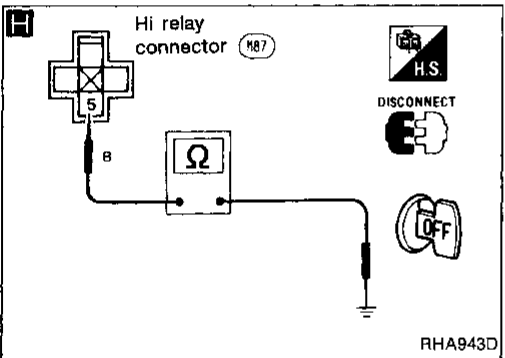

H **Note**
CHECK BODY GROUND CIRCUIT FOR HI RELAY. Does continuity exist between Hi relay harness terminal No. ⑤ and body ground?

Yes

CHECK HI RELAY AFTER DISCONNECTING IT. (Refer to Electrical Components Inspection.) (HA-83)

NG → Replace Hi relay.

OK

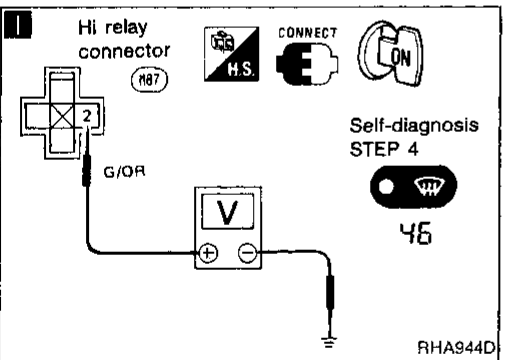

Reconnect Hi relay.

I
CHECK FOR OUTLET OF AUTO AMP. Set up Self-diagnosis STEP 4. Measure voltage across Hi relay harness terminal No. ② and body ground.

Code No.	Terminal No.		Voltage
	⊕	⊖	
46	②	Body ground	Less than approx. 1.5V

NG → Disconnect Hi relay and auto amp. harness connectors.

J **Note**
Does continuity exist between Hi relay harness terminal No. ② and auto amp. harness terminal No. ⑨?

Yes

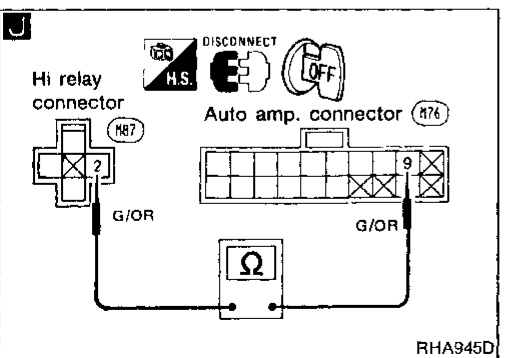

OK → Replace blower motor.

Note:
If the result is NG after checking circuit continuity, repair harness or connector.

GI
MA
EM
LC
EF & EC
FE
AT
PD
FA
RA
BR
ST
RS
BT
HA
EL
IDX

TROUBLE DIAGNOSES

Diagnostic Procedure 19

SYMPTOM: Magnet clutch does not engage after performing Preliminary Check 6.

- Perform Preliminary Check 6 before referring to the flow chart.

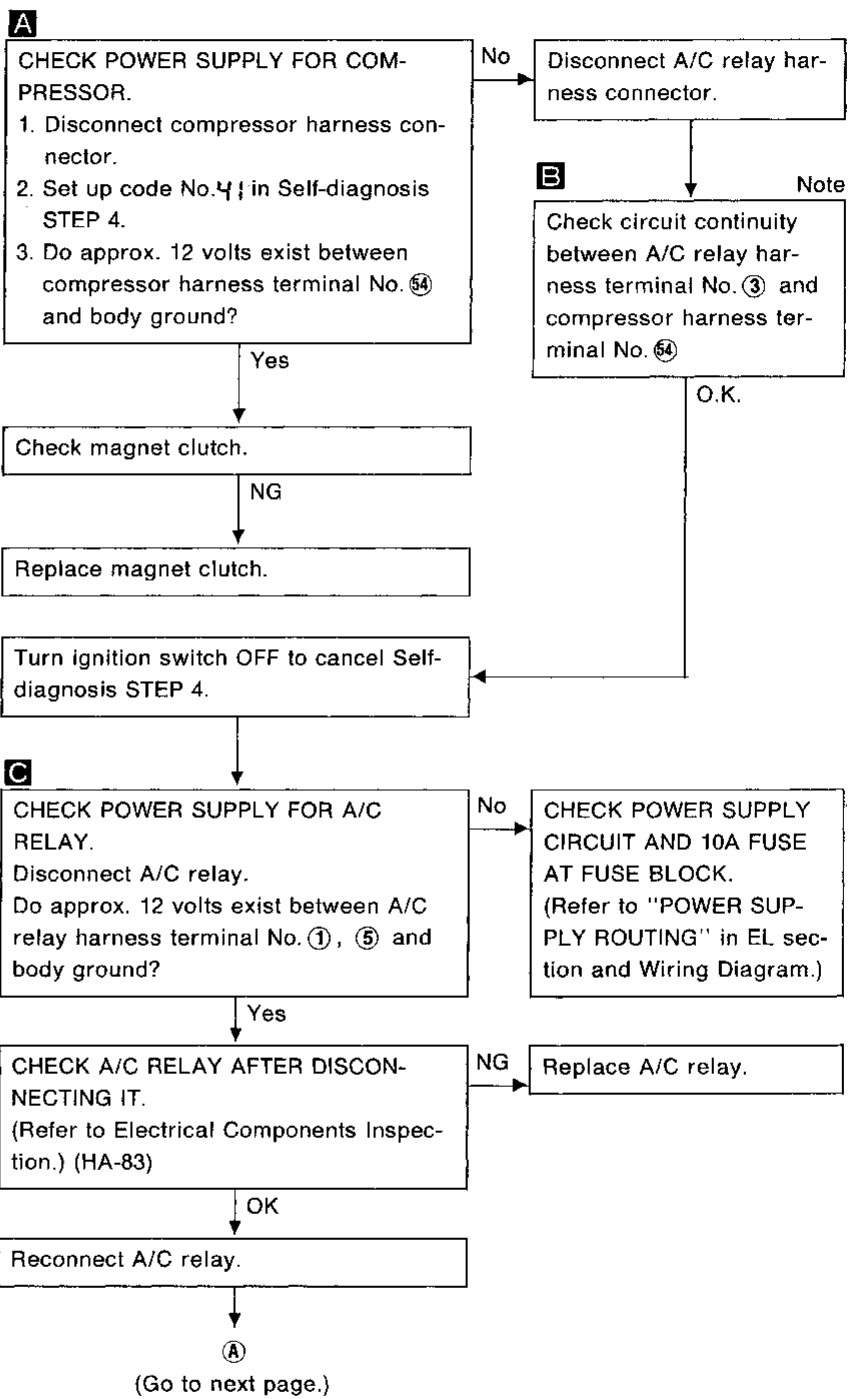
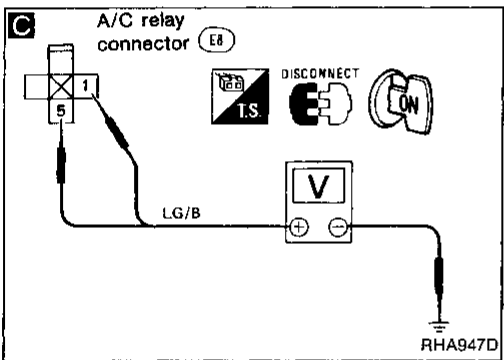
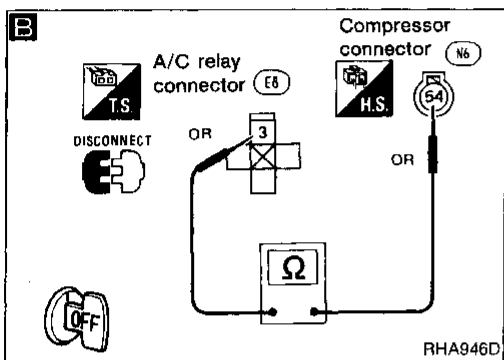
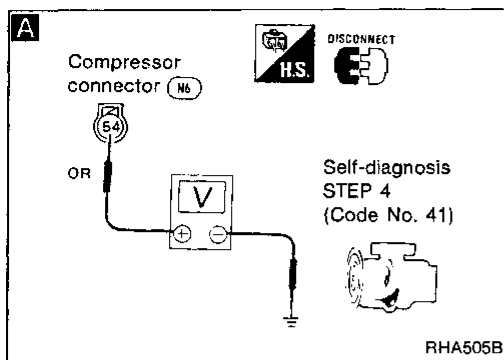

Note:

If the result is NG after checking circuit continuity, repair harness or connector.

TROUBLE DIAGNOSES

Diagnostic Procedure 19 (Cont'd)

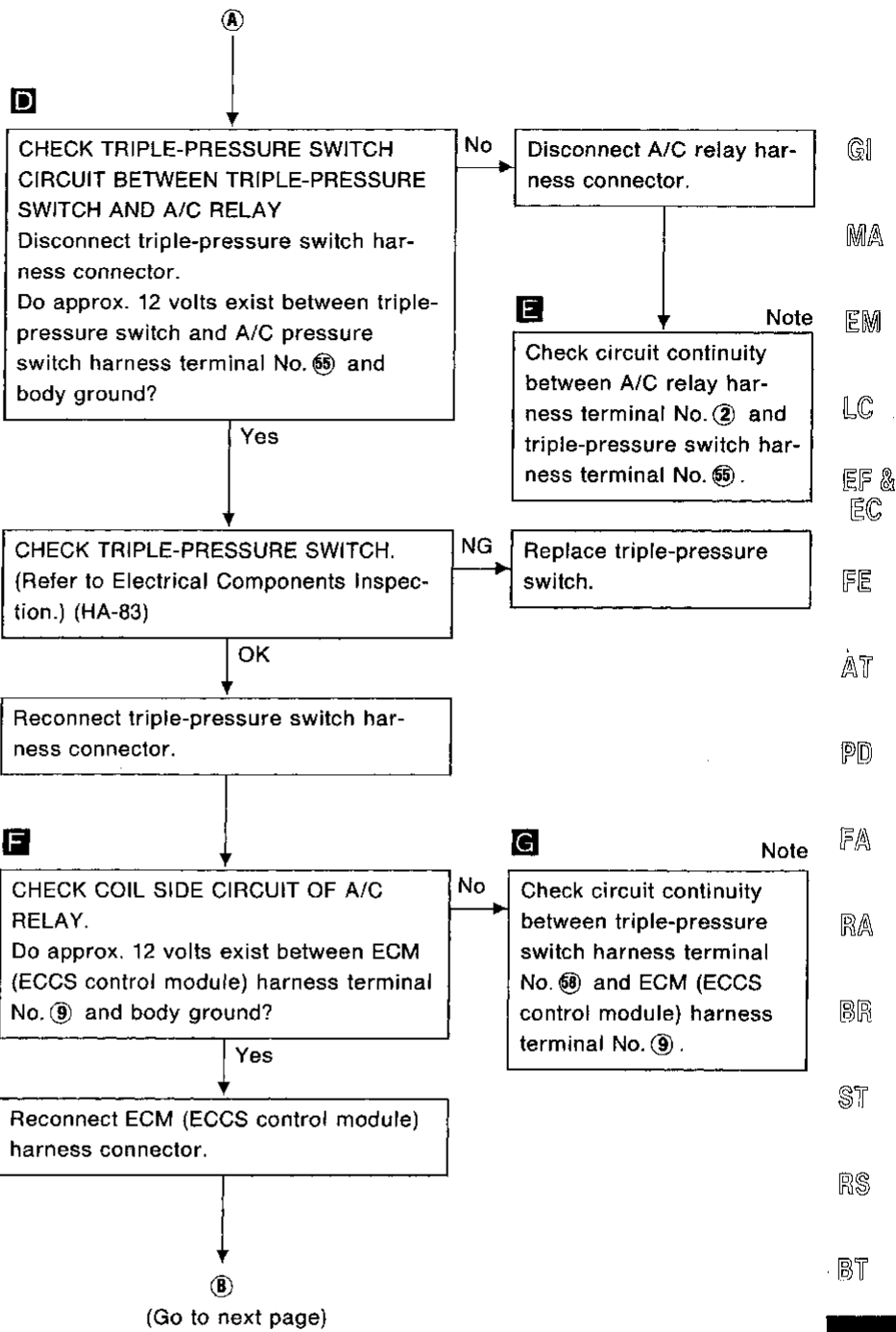
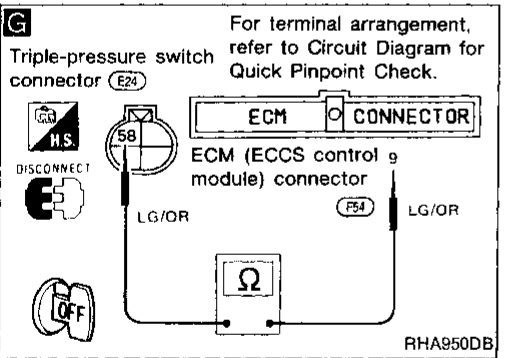
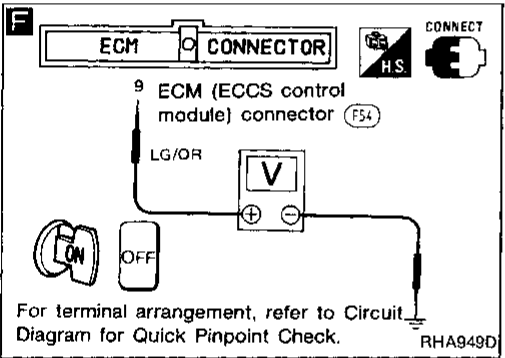
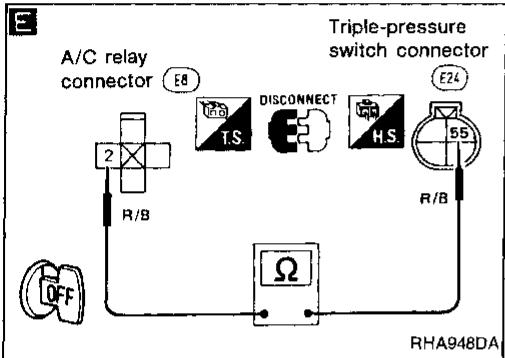
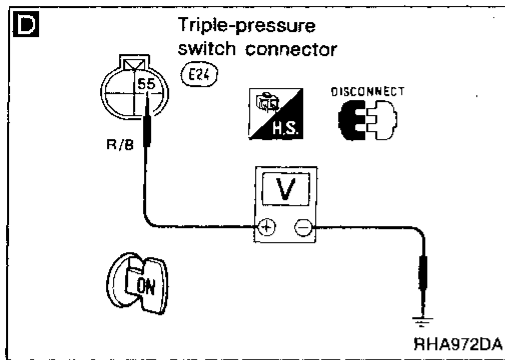

Note:

If the result is NG after checking circuit continuity, repair harness or connector.

GI
MA
EM
LC
EF & EC
FE
AT
PD
FA
RA
BR
ST
RS
BT
HA
EL
IDX

TROUBLE DIAGNOSES

Diagnostic Procedure 19 (Cont'd)

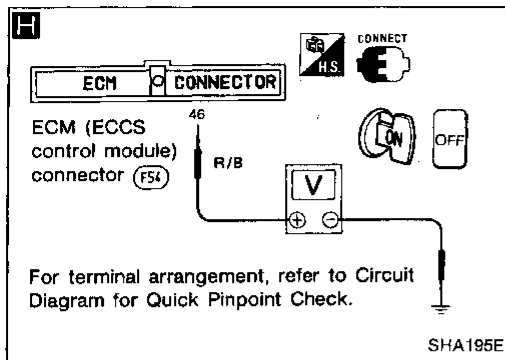

B

H

CHECK COIL SIDE CIRCUIT OF A/C RELAY CONTROLLED BY ECM (ECCS CONTROL MODULE). Do approx. 8 to 9 volts exist between ECM (ECCS control module) harness terminal No. 46 and body ground?

No

CHECK ECM (ECCS CONTROL MODULE). (Refer to EF & EC section.)

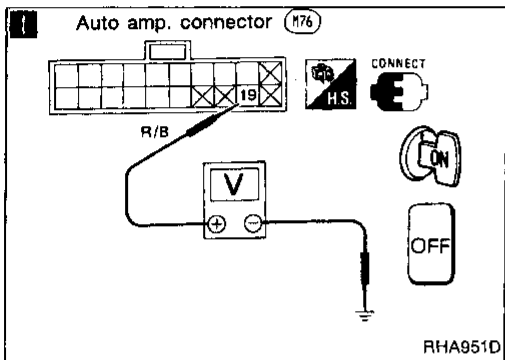

Yes

Disconnect auto amp. harness connector.

I

CHECK AUTO AMP. CIRCUIT BETWEEN ECM (ECCS CONTROL MODULE) AND AUTO AMP. Do approx. 8 to 9 volts exist between auto amp. harness terminal No. 19 and body ground?

No

J Note

Check circuit continuity between auto amp. harness terminal No. 19 and ECM (ECCS control module) harness terminal No. 46.

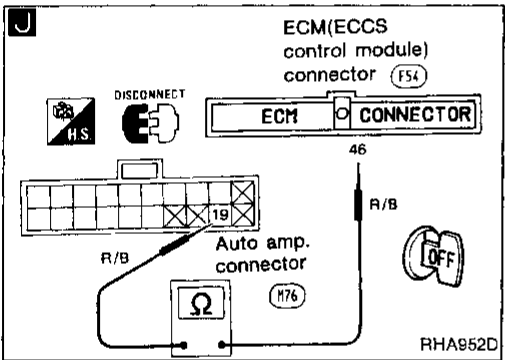

Yes

Replace auto amp.

Note:
If the result is NG after checking circuit continuity, repair harness or connector.

Diagnostic Procedure 20

SYMPTOM: Self-diagnosis cannot be performed.

CHECK MAIN POWER SUPPLY AND GROUND CIRCUIT FOR AUTO AMP. (Refer to page HA-60.)

NG

Repair Main Power Supply and Ground Circuit.

OK

Replace auto amp.

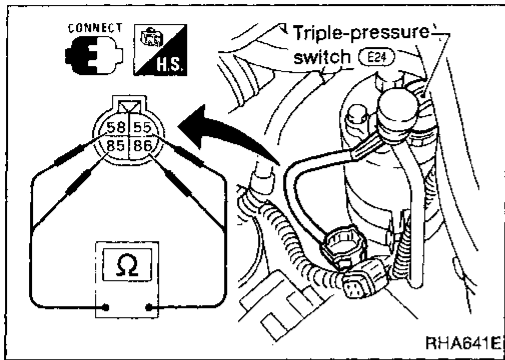

Electrical Components Inspection

TRIPLE-PRESSURE SWITCH

	Terminals	High-pressure side line pressure kPa (kg/cm ² , psi)	Operation	Continuity
Low-pressure side	⑤⑤ - ⑤⑧	Increasing to 177 - 235 (1.8 - 2.2, 26 - 34)	ON	Exist
		Decreasing to 176.5 - 235.4 (1.80 - 2.40, 25.6 - 34.1)	OFF	Does not exist
Medium-pressure side*	⑤⑤ - ⑤⑥	Increasing to 1,422 - 1,520 (14.5 - 15.5, 206 - 220)	ON	Exist
		Decreasing to 1,226 - 1,324 (12.5 - 13.5, 178 - 192)	OFF	Does not exist
High-pressure side	⑤⑤ - ⑤⑧	Increasing to 1,863 - 2,256 (19 - 23, 270 - 327)	ON	Exist
		Decreasing to 2,452 - 2,844 (25 - 29, 356 - 412)	OFF	Does not exist

* For cooling fan motor operation.

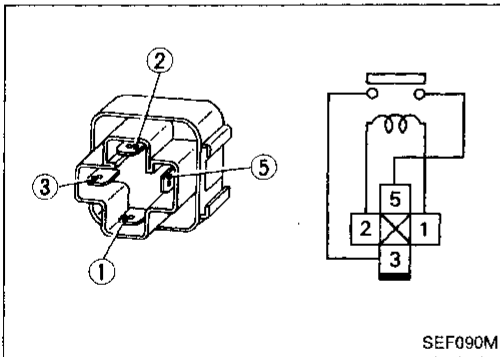

A/C RELAY, CONDENSER FAN RELAYS AND BLOWER HIGH RELAY

Check continuity between terminals ③ and ⑤.

Conditions	Continuity
12V direct current supply between terminals ① and ②.	Yes
No current supply	No

If N.G., replace relay.

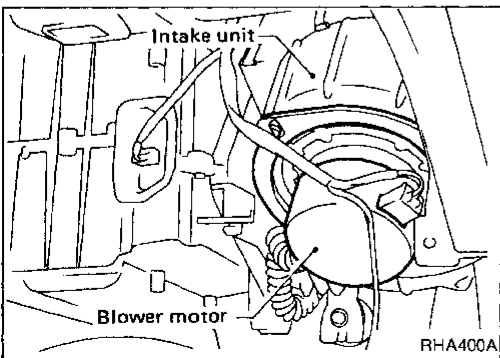

BLOWER MOTOR

Confirm smooth rotation of the blower motor.

- Ensure that there are no foreign particles inside the intake unit.

TROUBLE DIAGNOSES

Control Linkage Adjustment

MODE DOOR

1. Install mode door motor on heater unit and connect it to body harness.
2. Set up code No. 41 in Self-diagnosis STEP 4.
3. Move side link by hand and hold mode door in VENT mode.
4. Attach mode door motor rod to side link rod holder.
5. Check mode door operates properly when changing code No. 41 to 46 by pushing  (DEF) switch.

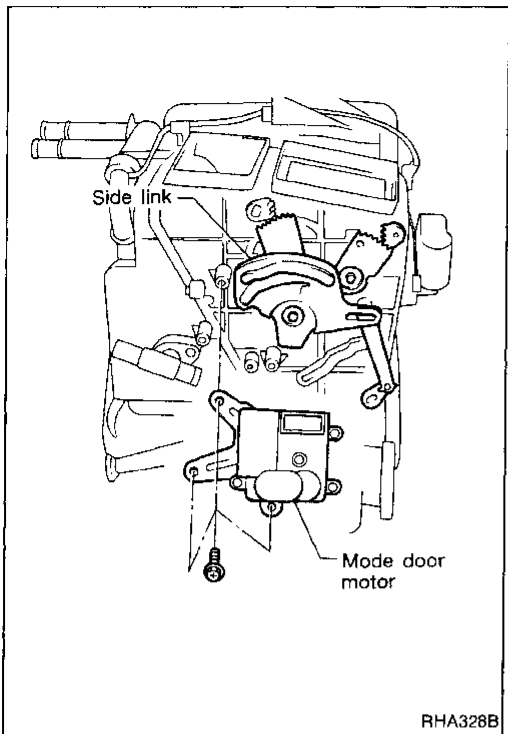

41	42	43	44	45	46
VENT	B/L	B/L	D/F1	D/F2	DEF

AIR MIX DOOR

1. Install air mix door motor on heater unit and connect it to body harness.
2. Set up code No. 41 in Self-diagnosis STEP 4.
3. Move air mix door lever by hand and hold it at full cold position.
4. Attach air mix door lever to rod holder.
5. Check air mix door operates properly when changing code No. 41 to 46 by pushing  (DEF) switch.

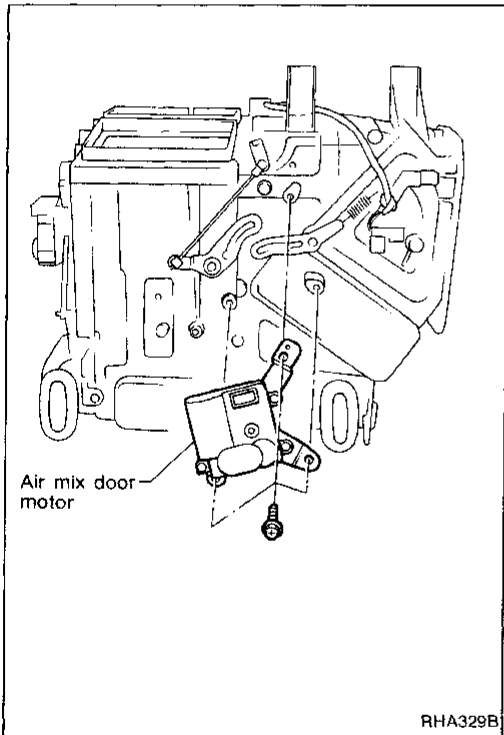

41	42	43	44	45	46
Full Cold			Full Hot		

TROUBLE DIAGNOSES

Control Linkage Adjustment (Cont'd)

INTAKE DOOR

1. Install intake door motor on intake unit and connect it to body harness.
2. Set up code No. 41 in Self-diagnosis STEP 4.
3. Move intake door link by hand and hold it at REC position.
4. Attach intake door lever to rod holder.
5. Check intake door operates properly when changing code No. 41 to 46 by pushing (DEF) switch.

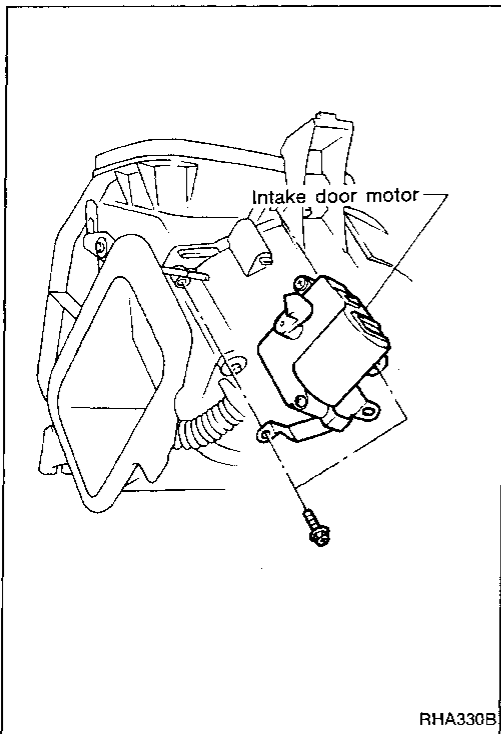

41	42	43	44	45	46
REC		20% FRE	FRE		

GI
MA
EM
LC
EF &
EC
FE
AT
PD
FA
RA
BR
ST
RS
BT
HA
EL
IDX

Overview of Control System

The control system consists of a) input sensors and switches, b) the automatic amplifier (microcomputer), and c) outputs. The relationship of these components is shown in the diagram below:

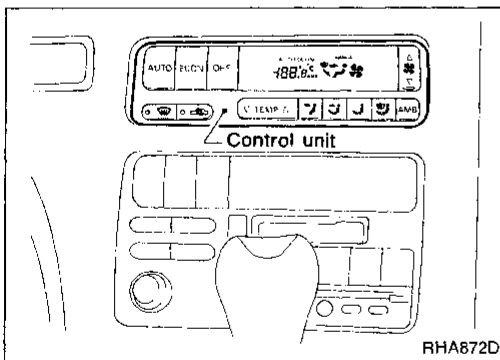
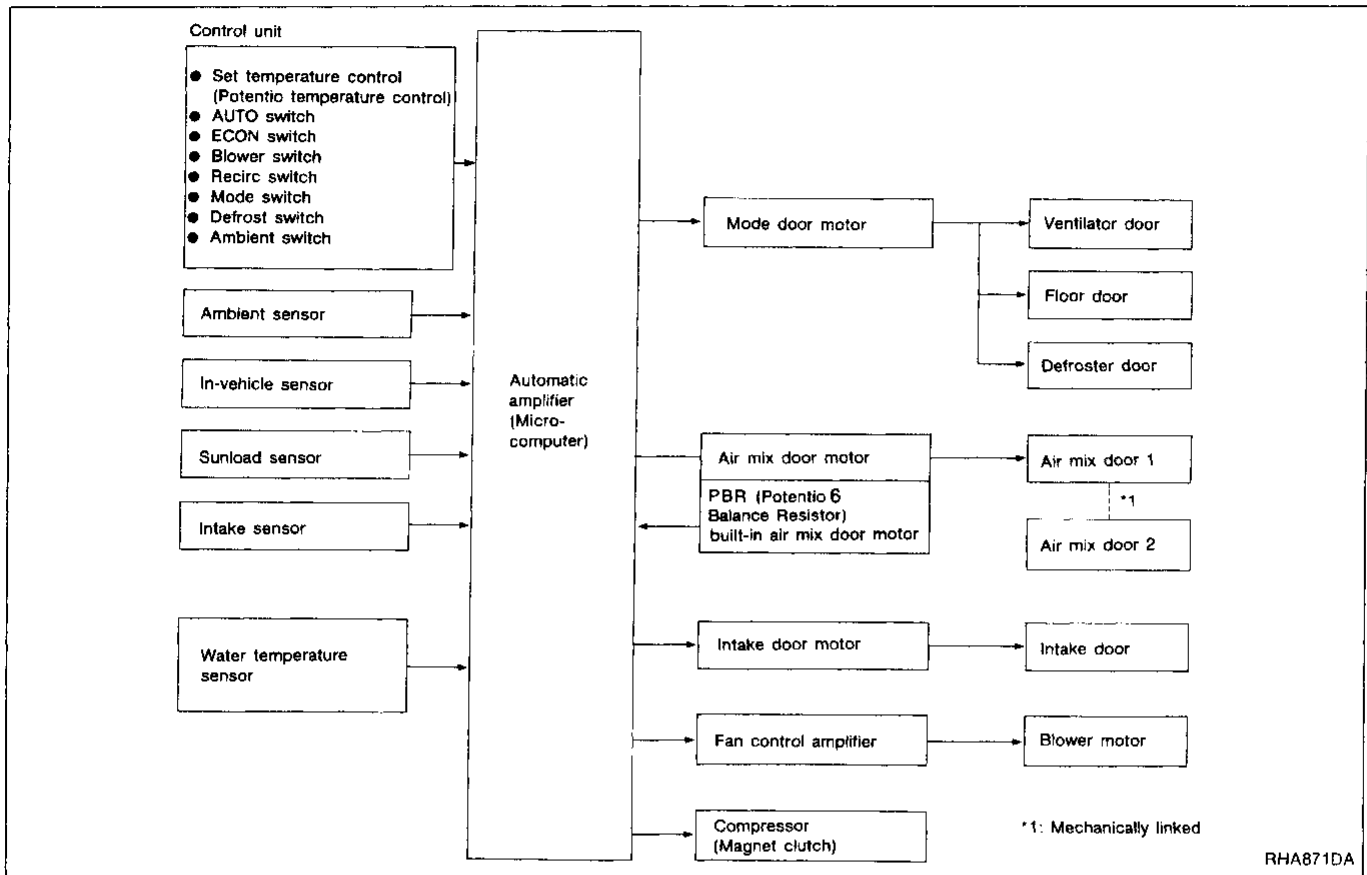

Control System Input Components

CONTROL UNIT

By means of multiplex communication, the control unit signals to the auto amp. the switch position and display mode.

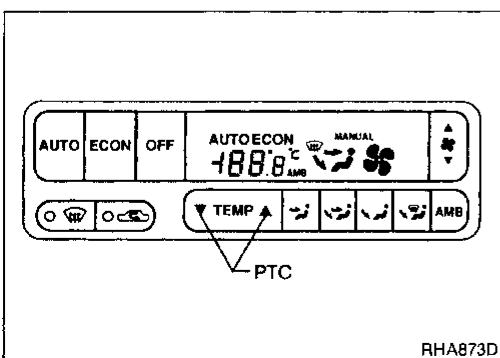

POTENTIO TEMPERATURE CONTROL (PTC)

The PTC is built into the auto amplifier. It can be set at an interval of 0.5°C (1.0°F) in the 18°C (65°F) to 32°C (85°F) temperature range by pushing the temperature switch [▲ (HOT) or ▼ (COLD)].

SYSTEM DESCRIPTION

Control System Input Components (Cont'd)

IN-VEHICLE SENSOR

The in-vehicle sensor is attached to cluster lid C. It converts variations in temperature of compartment air drawn from the aspirator into a resistance value. It is then input into the auto amplifier.

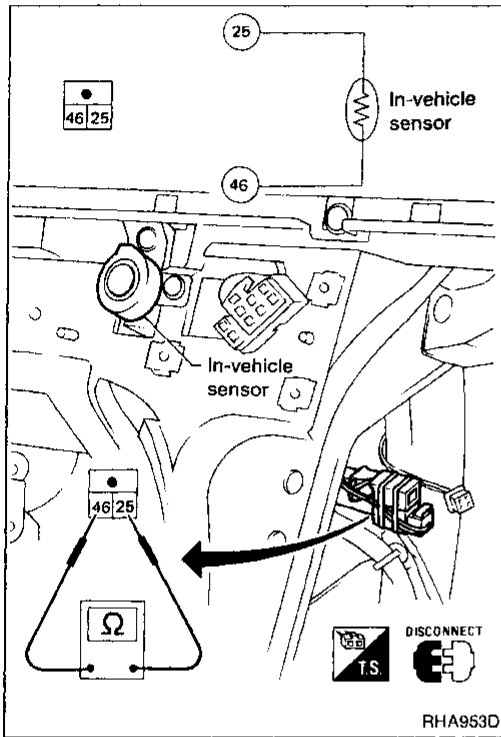
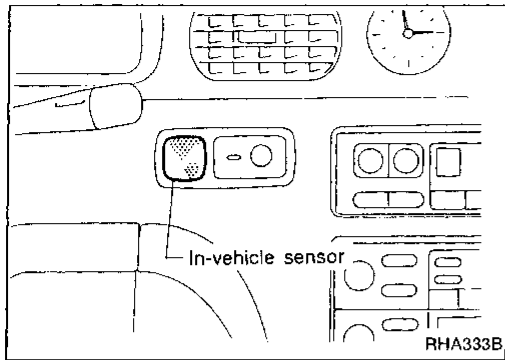

After disconnecting in-vehicle sensor harness connector, measure resistance between terminals 25 and 46 at sensor harness side, using the table below.

Temperature °C (°F)	Resistance kΩ
-35 (-31)	38.57
-30 (-22)	28.84
-25 (-13)	21.83
-20 (-4)	16.72
-15 (5)	12.95
-10 (14)	10.14
-5 (23)	8.02
0 (32)	6.41
5 (41)	5.17
10 (50)	4.21
15 (59)	3.46
20 (68)	2.87
25 (77)	2.41
30 (86)	2.03
35 (95)	1.73
40 (104)	1.49
45 (113)	1.29
50 (122)	1.13
55 (131)	0.99
60 (140)	0.88
65 (149)	0.79

ASPIRATOR

The aspirator is located below the side link of heater unit. It produces vacuum pressure due to air discharged from the heater unit, continuously taking compartment air in the aspirator.

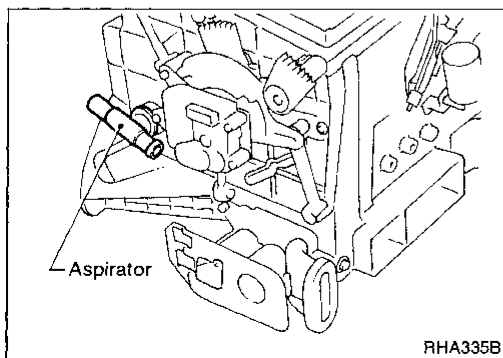

GI
MA
EM
LC
EF & EC
FE
AT
PD
FA
RA
BR
ST
RS
BT
HA

EL
IDX

SYSTEM DESCRIPTION

Control System Input Components (Cont'd)

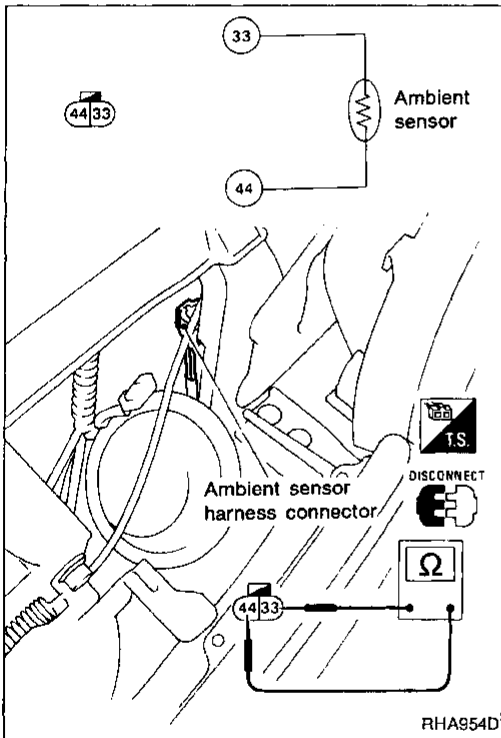
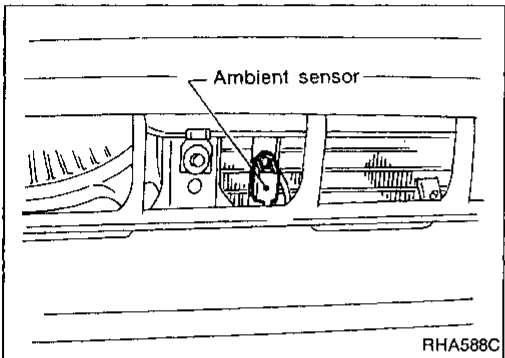
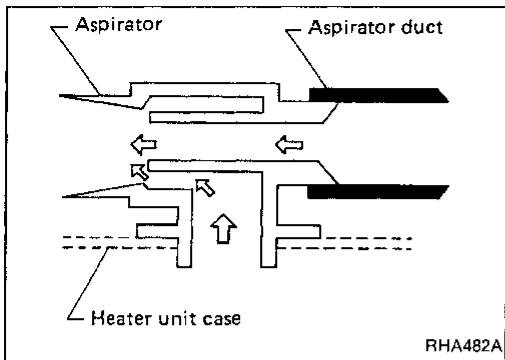

AMBIENT SENSOR

The ambient sensor is attached in front of the driver's side condenser. It detects ambient temperature and converts it into a resistance value which is then input to the auto amplifier. After disconnecting ambient sensor harness connector, measure resistance between terminals ③③ and ④④ at sensor harness side, using the table below.

Temperature °C (°F)	Resistance kΩ
-35 (-31)	38.35
-30 (-22)	28.62
-25 (-13)	21.61
-20 (-4)	16.50
-15 (5)	12.73
-10 (14)	9.92
-5 (23)	7.80
0 (32)	6.19
5 (41)	4.95
10 (50)	3.99
15 (59)	3.24
20 (68)	2.65
25 (77)	2.19
30 (86)	1.81
35 (95)	1.51
40 (104)	1.27
45 (113)	1.07
50 (122)	0.91
55 (131)	0.77
60 (140)	0.66
65 (149)	0.57

SYSTEM DESCRIPTION

Control System Input Components (Cont'd)

SUNLOAD SENSOR

The sunload sensor is located on the right defroster grille. It detects sunload entering through windshield by means of a photo diode. The sensor converts the sunload into a current value which is then input to the auto amplifier.

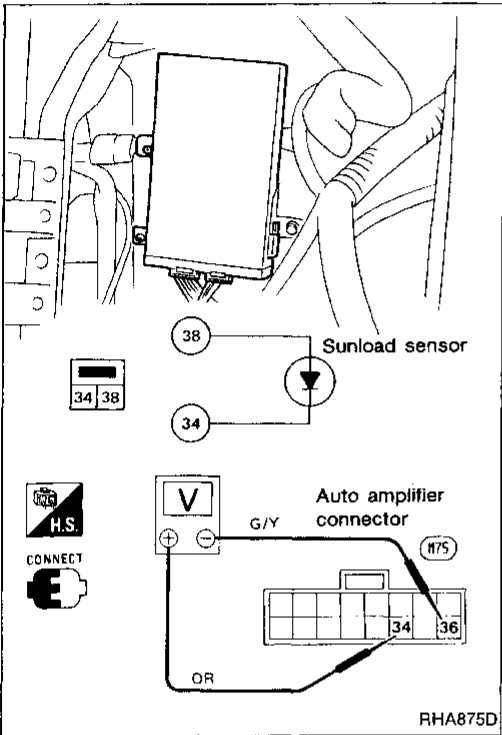
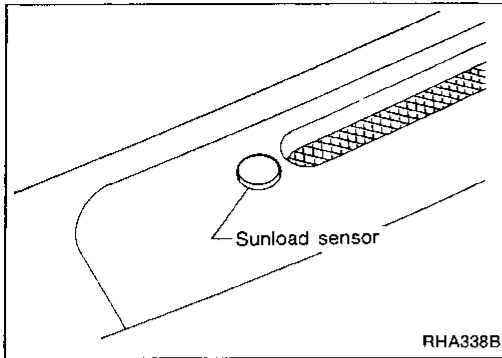

Measure voltage between terminals 34 and 38 at vehicle harness side, using the table below.

Input current mA	Output voltage V
0	5.0
0.1	4.1
0.2	3.1
0.3	2.2
0.4	1.3
0.5	0.4

- When checking sunload sensor, select a place where sun shines directly on it.

INTAKE SENSOR

The intake sensor is located on the cooling unit. It converts temperature of air after it passes through the evaporator into a resistance value. The value is then input to the auto amplifier.

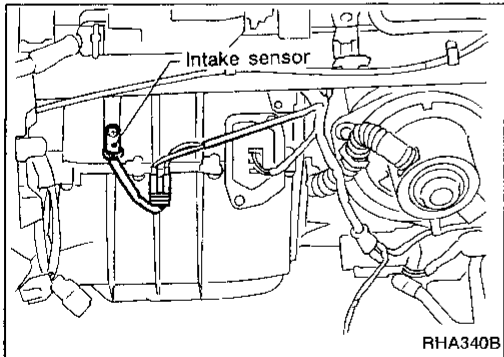

GI

MA

EM

LC

EF &
EC

FE

AT

PD

FA

RA

BR

ST

RS

BT

HA

EL

IDX

SYSTEM DESCRIPTION

Control System Input Components (Cont'd)

After disconnecting intake sensor harness connector, measure resistance between terminals 26 and 37 at sensor harness side, using the table below.

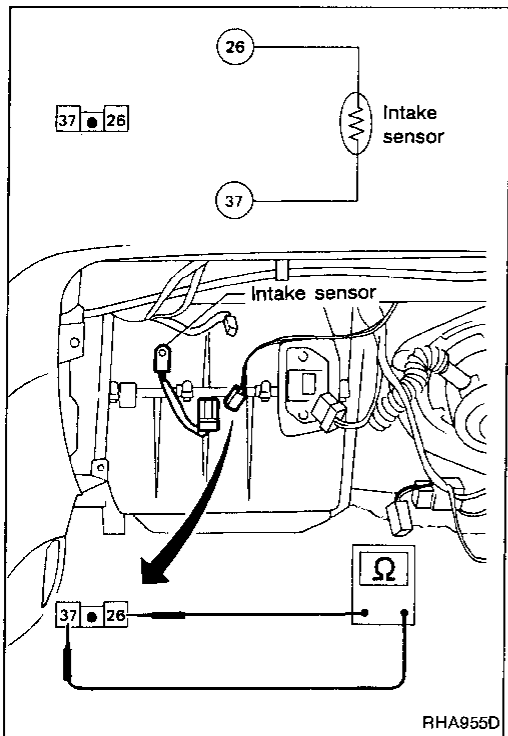

Temperature °C (°F)	Resistance kΩ
-35 (-31)	38.35
-30 (-22)	28.62
-25 (-13)	21.61
-20 (-4)	16.50
-15 (5)	12.73
-10 (14)	9.92
-5 (23)	7.80
0 (32)	6.19
5 (41)	4.95
10 (50)	3.99
15 (59)	3.24
20 (68)	2.65
25 (77)	2.19
30 (86)	1.81
35 (95)	1.51
40 (104)	1.27
45 (113)	1.07
50 (122)	0.91
55 (131)	0.77
60 (140)	0.66
65 (149)	0.57

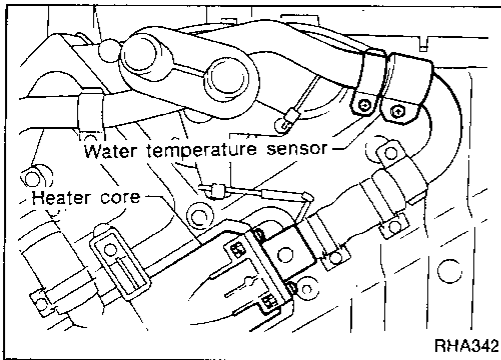

WATER TEMPERATURE SENSOR

The water temperature sensor is attached to the heater unit. It converts the water temperature value at the heater core entrance into a resistance value. It inputs the voltage, that varies according to change in the resistance value, into the auto amp.

SYSTEM DESCRIPTION

Control System Input Components (Cont'd)

After disconnecting water temperature sensor harness connector, measure resistance between terminals 27 and 47 at sensor harness side, using table below.

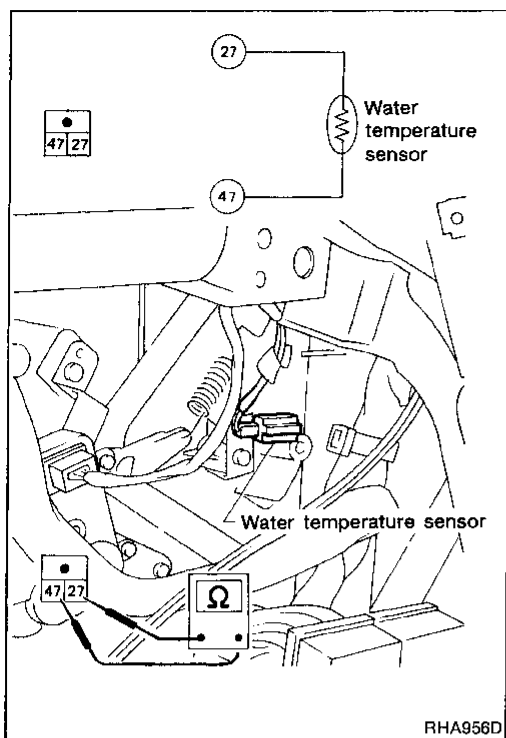

Temperature °C (°F)	Resistance kΩ
0 (32)	3.99
5 (41)	3.17
10 (50)	2.54
15 (59)	2.05
20 (68)	1.67
25 (77)	1.36
30 (86)	1.12
35 (95)	0.93
40 (104)	0.78
45 (113)	0.65
50 (122)	0.55
55 (131)	0.47
60 (140)	0.40
65 (149)	0.34
70 (158)	0.29
75 (167)	0.25
80 (176)	0.22

GI
MA
EM
LC
EF & EC
FE
AT
PD
FA

RA
BR

ST

RS

BT

HA

EL

IDX

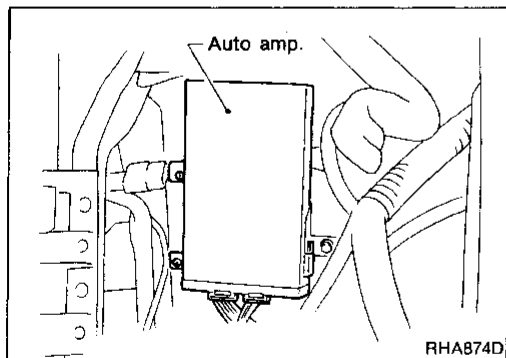

Control System Automatic Amplifier (Auto amp.)

The auto amplifier has a built-in microcomputer which processes information sent from various sensors needed for air conditioner operation. The air mix door motor, mode door motor, intake door motor, blower motor and compressor are then controlled.

The auto amplifier is unitized with control mechanisms. Signals from various switches and Potentio Temperature Control (PTC) are directly entered into auto amplifier.

Self-diagnostic functions are also built into auto amplifier to provide quick check of malfunctions in the auto air conditioner system.

AMBIENT TEMPERATURE INPUT PROCESS

The automatic amplifier includes a "processing circuit" for the ambient sensor input. However, when the temperature detected by the ambient sensor increases quickly, the processing circuit retards the auto amp. function. It only allows the auto amp. to recognize an ambient temperature increase of 0.33°C (0.6°F) per 100 seconds.

As an example, consider stopping for a cup of coffee after high speed driving. Although the actual ambient temperature has not changed, the temperature detected by the ambient sensor will increase. This is because the heat from the engine compartment can radiate to the front grille area, location of the ambient sensor.

SYSTEM DESCRIPTION

Control System Automatic Amplifier (Auto amp.) (Cont'd)

SUNLOAD INPUT PROCESS

The auto amp. also includes a processing circuit which "average" the variations in detected sunload over a period of time. This prevents drastic swings in the ATC system operation due to small or quick variations in detected sunload.

For example, consider driving along a road bordered by an occasional group of large trees. The sunload detected by the sunload sensor will vary whenever the trees obstruct the sunlight. The processing circuit averages the detected sunload over a period of time. As a result, the effect of sunload does not cause any change in the ATC system operation. On the other hand, shortly after entering a long tunnel, the system will recognize the change in sunload, and the system will react accordingly.

Control System Output Components

INTAKE DOOR CONTROL

Components parts

Intake door control system components are:

- 1) Auto amplifier
- 2) Intake door motor
- 3) PBR
- 4) In-vehicle sensor
- 5) Ambient sensor
- 6) Sunload sensor
- 7) Intake sensor
- 8) Control unit (PTC, AUTO, ECON, DEF, REC switches)

System operation

The intake door control determines intake door position based on the ambient temperature and the in-vehicle temperature. When the ECON, DEF, or OFF buttons are pushed, the auto amplifier sets the intake door at the "Fresh" position.

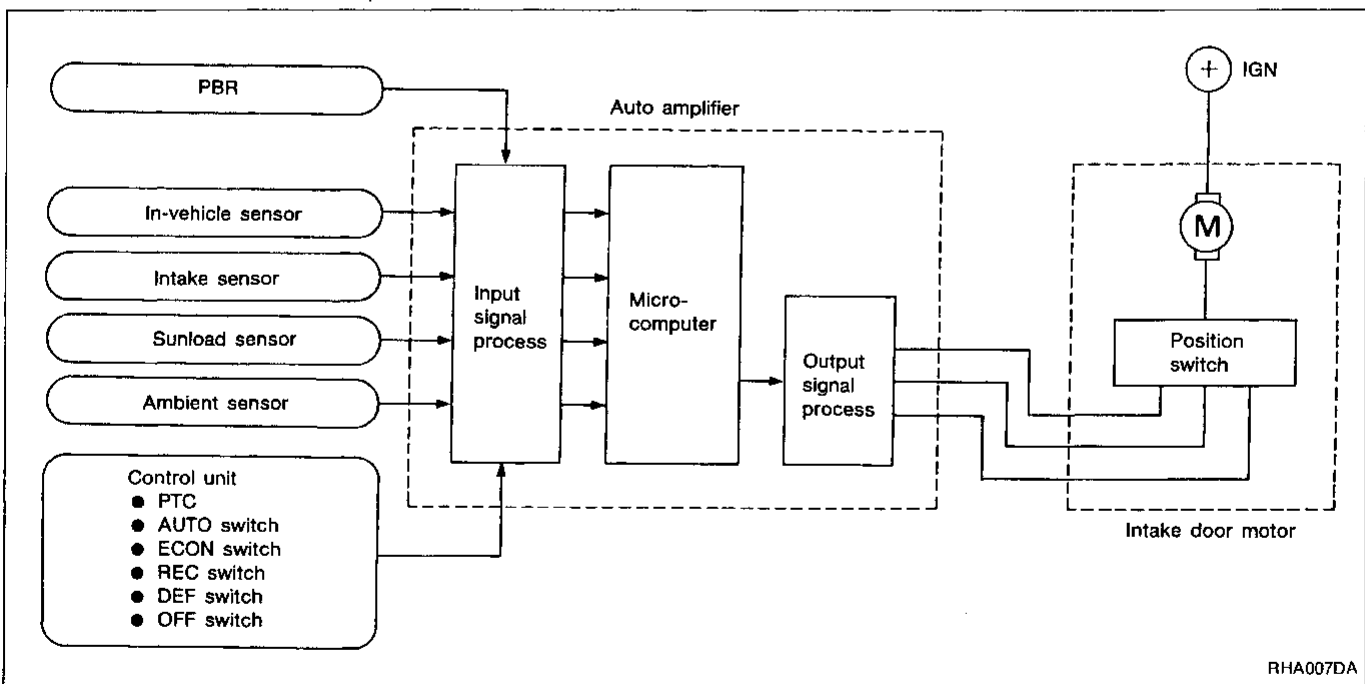

SYSTEM DESCRIPTION

Control System Output Components (Cont'd)

Intake door control specification

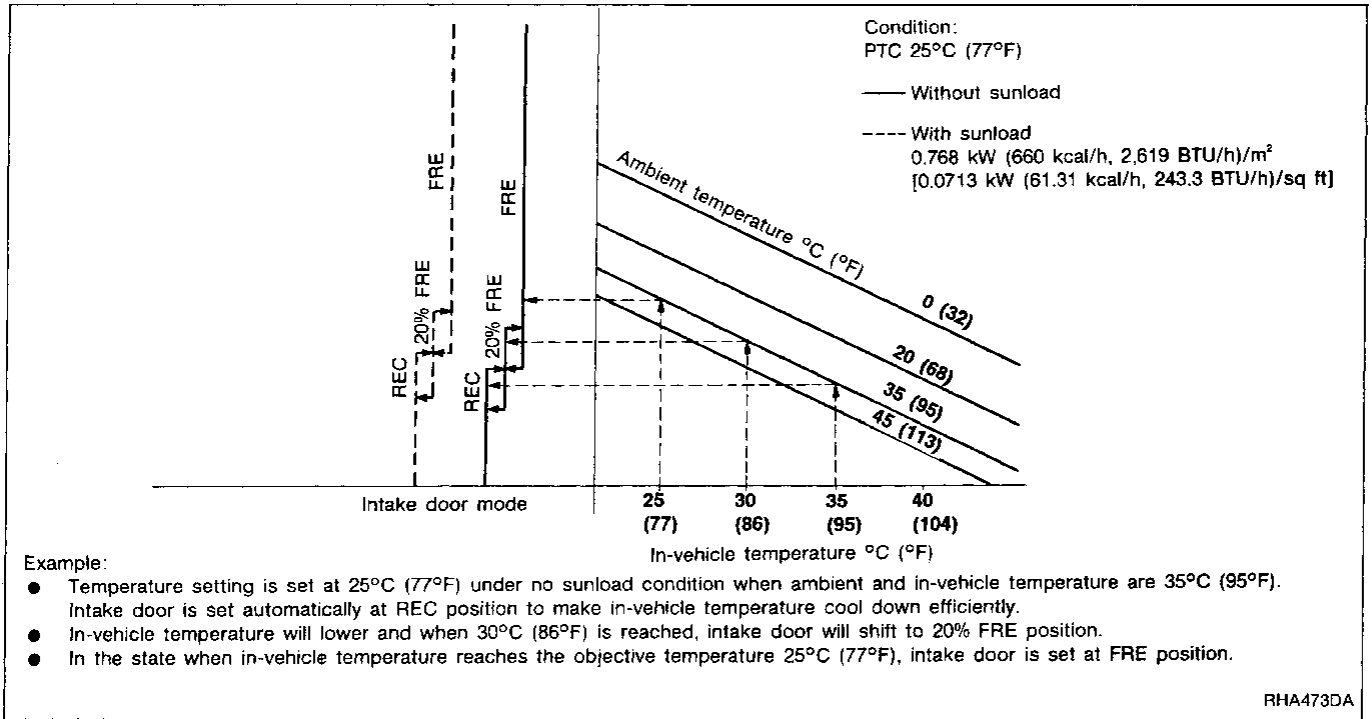

GI
MA
EM
LC
EF &
EC
FE
AT
PD
FA
RA
BR
ST
RS
BT
HA
EL
IOX

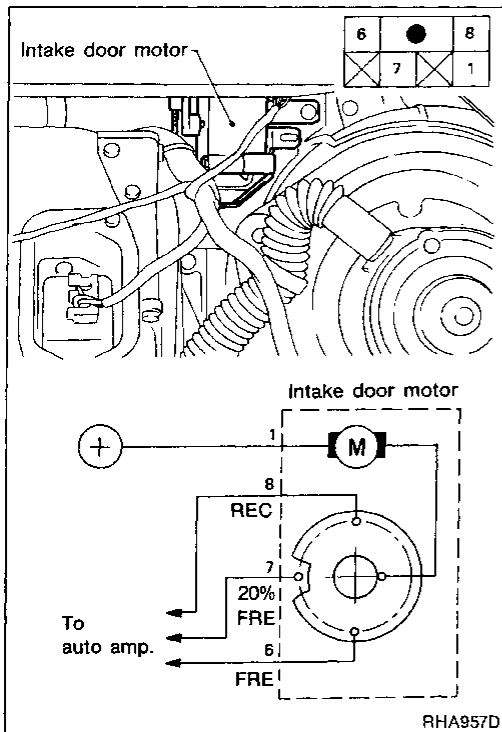

INTAKE DOOR MOTOR

The intake door motor is attached to the intake unit. It rotates so that air is drawn from inlets set by the auto amplifier. Motor rotation is conveyed to a lever which activates the intake door.

Intake door motor operation

Terminal No.			Intake door operation	Direction of lever rotation
① - ⑧ (⊕) (⊖)	① - ⑦ (⊕) (⊖)	① - ⑥ (⊕) (⊖)		
CL	OP	OP	REC	Counter clockwise
OP	CL	OP	20% FRE	
OP	OP	CL	FRE	

OP: Open circuit
CL: Closed circuit

SYSTEM DESCRIPTION

Control System Output Components (Cont'd)

AIR MIX DOOR CONTROL (Automatic temperature control)

Component parts

- Air mix door control system components are:
- | | |
|-----------------------------|-----------------------|
| 1) Auto amplifier | 4) Ambient sensor |
| 2) Air mix door motor (PBR) | 5) Sunload sensor |
| 3) In-vehicle sensor | 6) Intake sensor |
| | 7) Control unit (PTC) |

System operation

Temperature set by Potentio Temperature Control (PTC) is compensated through setting temperature correction circuit to determine target temperature.

Auto amplifier will operate air mix door motor to set air conditioning system in HOT or COLD position, depending upon relationship between conditions (target temperature, sunload, in-vehicle temperature and ambient temperature) and conditions (air mix door position and intake air temperature).

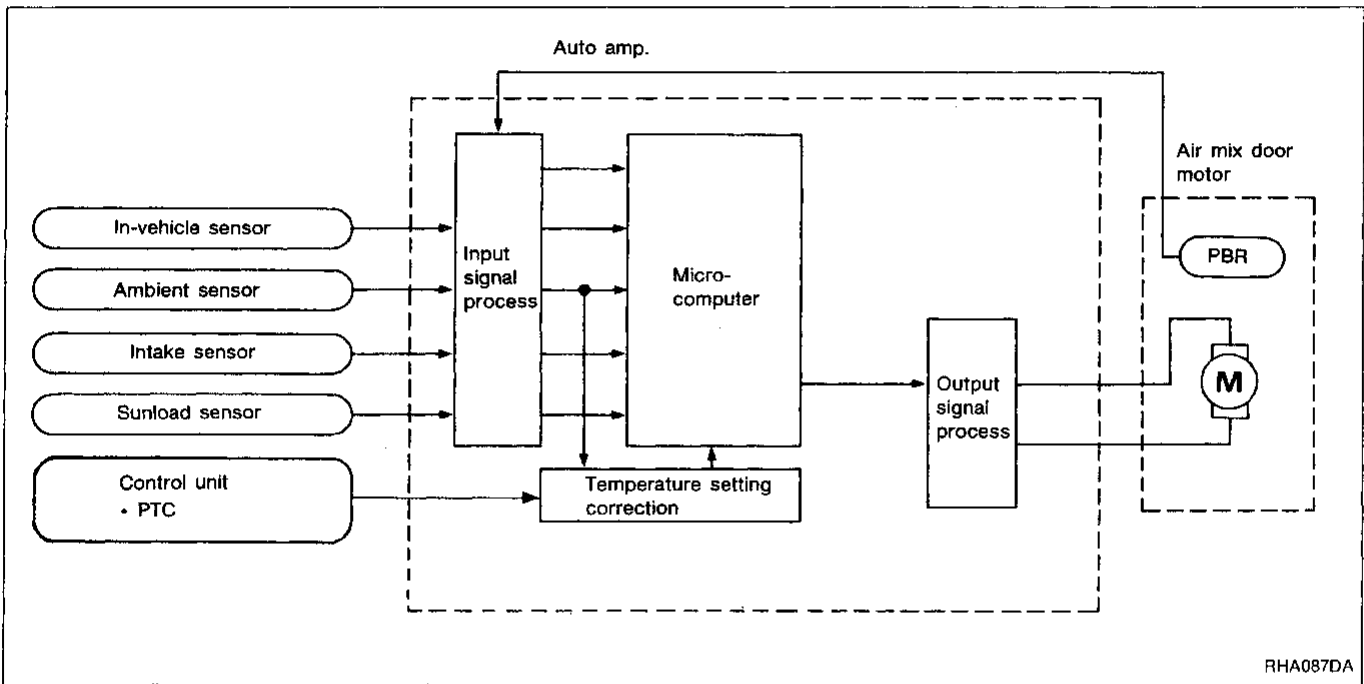

RHA087DA

Air mix door control specification

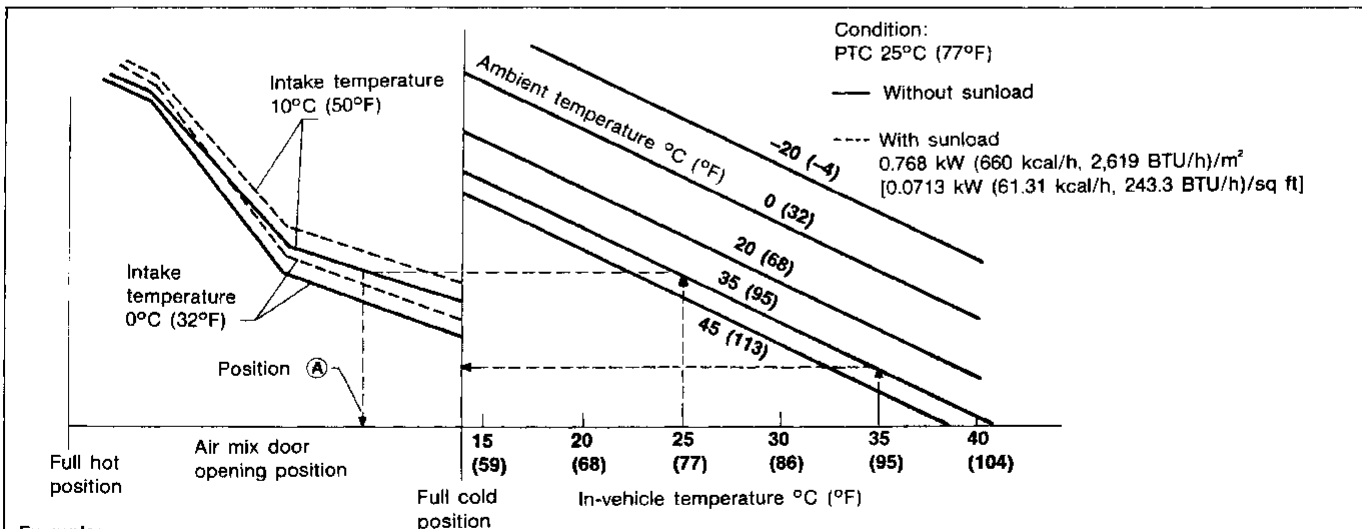

Condition:
PTC 25°C (77°F)

— Without sunload
- - - With sunload
0.768 kW (660 kcal/h, 2,619 BTU/h)/m²
[0.0713 kW (61.31 kcal/h, 243.3 BTU/h)/sq ft]

Example:

- Temperature setting is set at 25°C (77°F) under no sunload condition when ambient and in-vehicle temperature are 35°C (95°F). Air mix door is initially automatically set in full cold position.
- Within some period, in-vehicle temperature will lower towards the target temperature. Then the air mix door position will shift incrementally towards the hot side and finally stay in this position (A) [if intake temperature is 10°C (50°F)]. Air mix door opening position is always fed back to auto amplifier by PBR built-in air mix door motor.

RHA475DA

SYSTEM DESCRIPTION

Control System Output Components (Cont'd)

AIR MIX DOOR MOTOR

The air mix door motor is attached to the heater unit. It rotates so that the air mix door is opened to a position set by the auto amplifier. Motor rotation is then conveyed through a shaft and air mix door position is then fed back to the auto amplifier by PBR built-in air mix door motor.

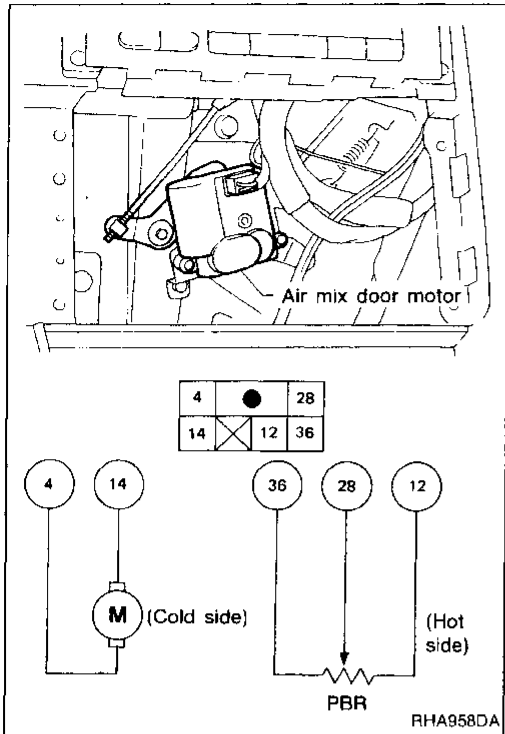

Air mix door motor operation

Terminal No.		Air mix door operation	Direction of lever movement
④	⑭		
⊕	⊖	COLD → HOT	Clockwise (Downward)
-	-	STOP	STOP
⊖	⊕	HOT → COLD	Counterclockwise (Upward)

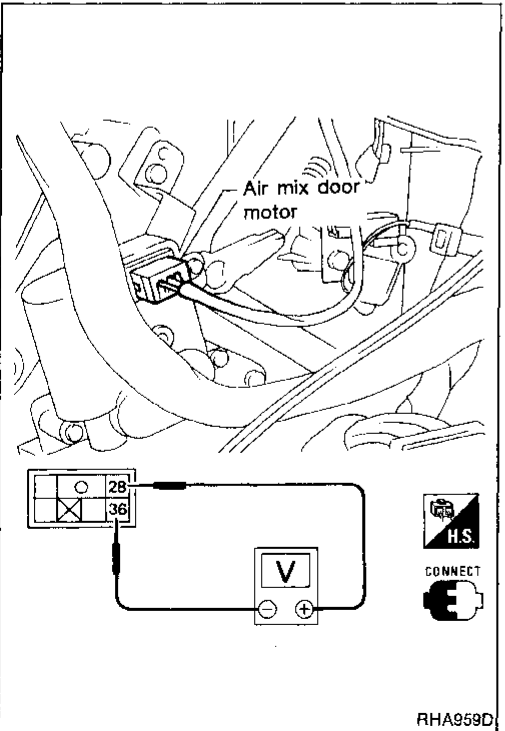
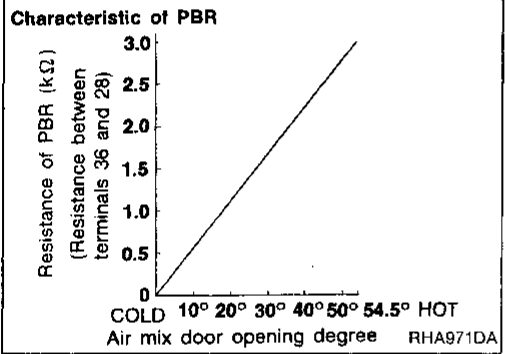

PBR

Measure voltage between terminals ⑭ and ⑮ at vehicle harness side.

SYSTEM DESCRIPTION

Control System Output Components (Cont'd)

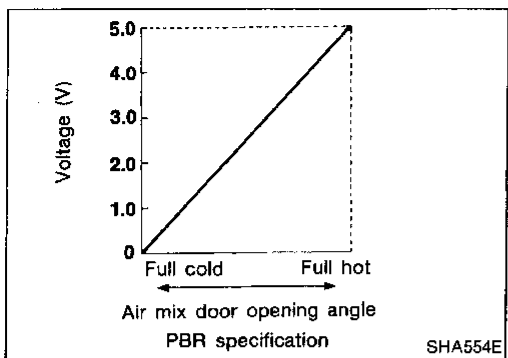

Ignition switch: ON

- Ensure tester pointer deflects smoothly when PTC is moved from 18°C (65°F) to 32°C (85°F) and vice versa.

OUTLET DOOR CONTROL

Component parts

Outlet door control system components are:

- 1) Auto amplifier
- 2) Mode door motor
- 3) PBR
- 4) In-vehicle sensor
- 5) Ambient sensor
- 6) Sunload sensor
- 7) Intake sensor
- 8) Control unit (PTC and AUTO, ECON, MODE, DEF switches)

System operation

The auto amplifier computes the air outlet conditions according to the ambient temperature and the in-vehicle temperature. The computed outlet conditions are then corrected for sunload. By this correction, it is determined through which outlets air will flow into the passenger compartment. When air outlet is automatically determined on FOOT/DEF, the actual outlet will be either F/D1 or F/D2. The selection depends on the target temperature and the ambient temperature.

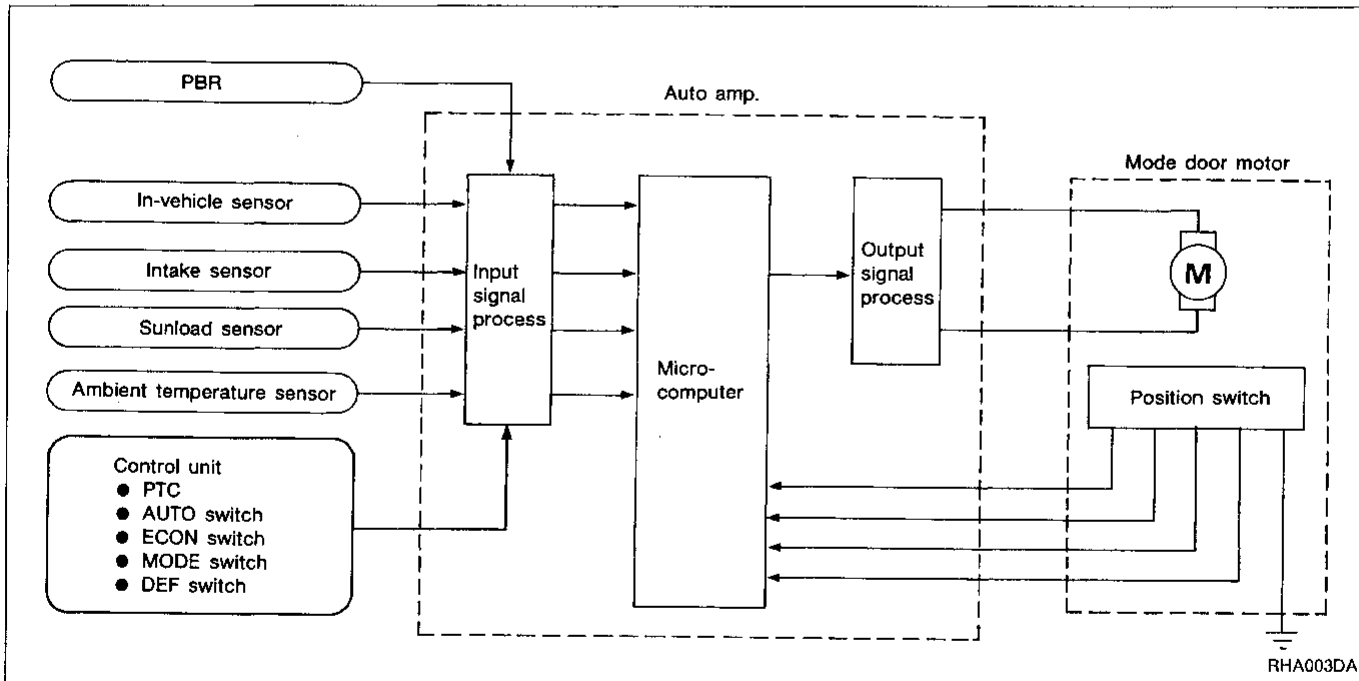

SYSTEM DESCRIPTION

Control System Output Components (Cont'd)

MODE DOOR MOTOR

The mode door motor is attached to the heater unit. It rotates so that air is discharged from outlet set by the auto amplifier. Motor rotation is conveyed to a link which activates the mode door.

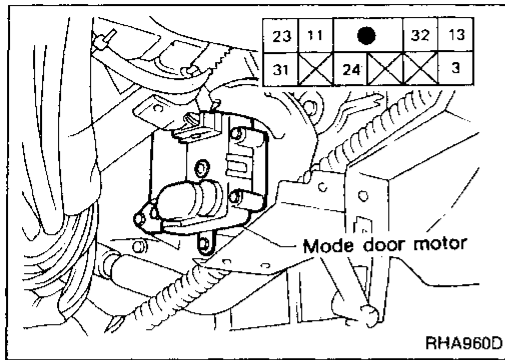

Mode door motor operation

Terminal No.		Mode door operation	Direction of side link rotation
③	⑬		
⊕	⊖	VENT → DEF	Counterclockwise
-	-	STOP	STOP
⊖	⊕	DEF → VENT	Clockwise

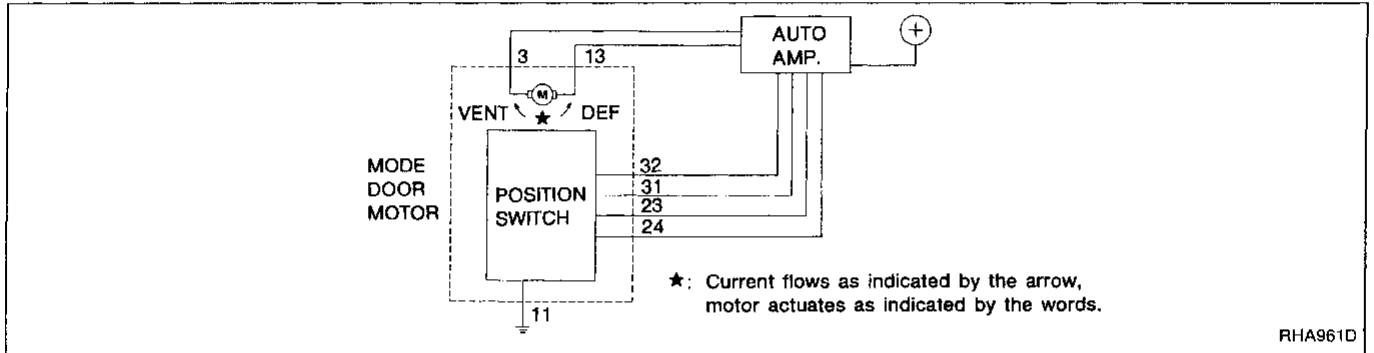

Outlet door control specification

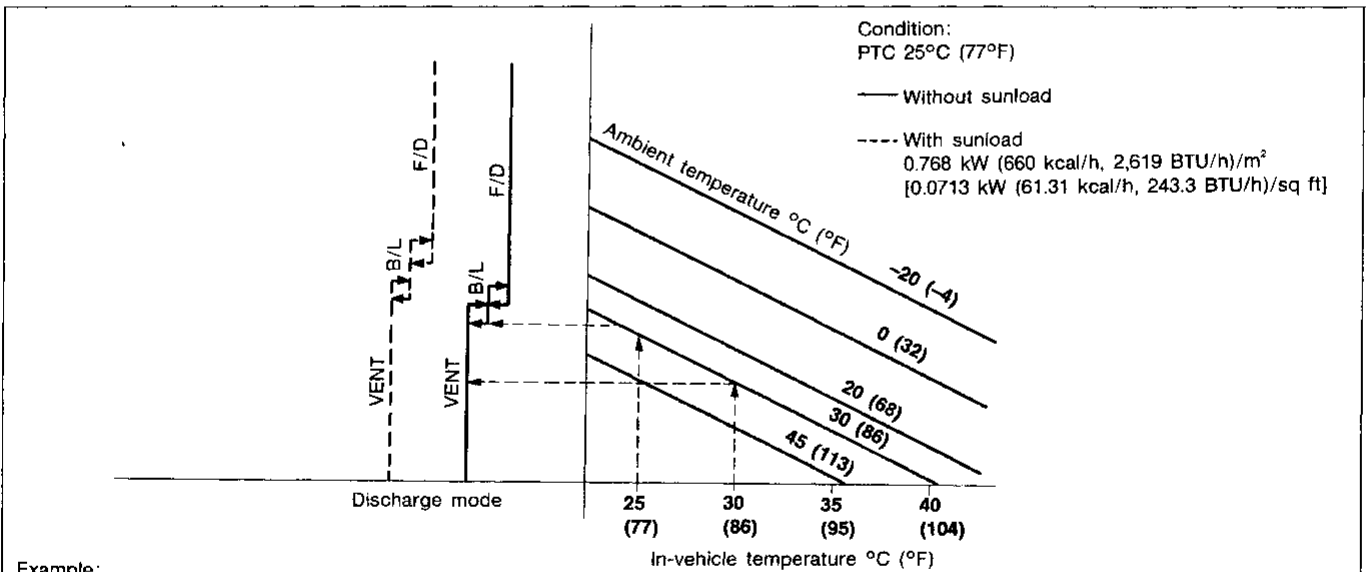

Example:

- Conditions: Temperature set at 25°C (77°F); Without sunload; Ambient and in-vehicle temperature are 30°C (86°F). Control: Mode door is set automatically at VENT position.
- Then in-vehicle temperature will lower. When the target temperature 25°C (77°F) is reached, mode door will shift from VENT position to B/L.

RHA480DA

SYSTEM DESCRIPTION

Control System Output Components (Cont'd)

FOOT/DEF mode specification

- When the air outlet is automatically selected as F/D, when target temperature is high, the air outlet is fixed at F/D 1.
- When the target temperature is low, the air outlet will be either F/D 1 or F/D 2 depending on the ambient temperature.
- When the ambient temperature decreases to -13°C (9°F), air outlet is changed from F/D1 to F/D2.
- When the ambient temperature increases to -8°C (18°F), air outlet is changed from F/D2 to F/D1.

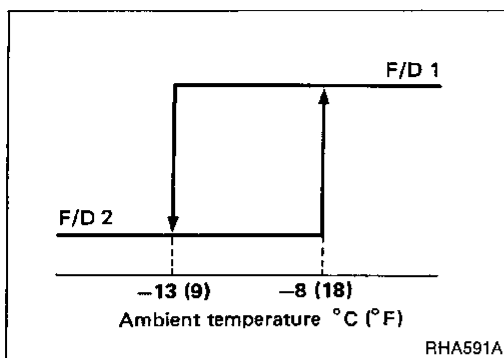

B/L mode specification

- When compressor turn ON, air outlet is changed from B/L2 to B/L1.
- When compressor turns OFF, air outlet is changed from B/L1 to B/L2.

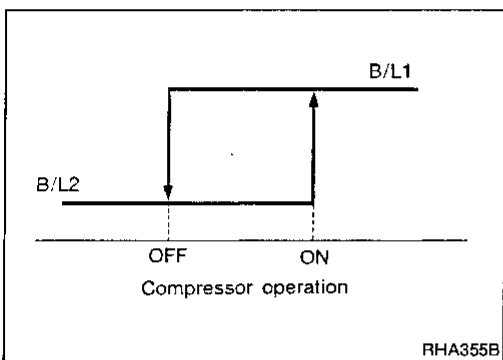

SYSTEM DESCRIPTION

Control System Output Components (Cont'd)

FAN SPEED CONTROL

Component parts

Fan speed control system components are:

- 1) Auto amplifier
- 2) Fan control amplifier
- 3) PBR
- 4) In-vehicle sensor
- 5) Ambient sensor
- 6) Sunload sensor
- 7) Intake sensor
- 8) Hi relay
- 9) Water temperature sensor
- 10) Control unit (PTC, AUTO, ECON, MODE, DEF, FAN, OFF switches)

System operation

For description of system operation, see next page.

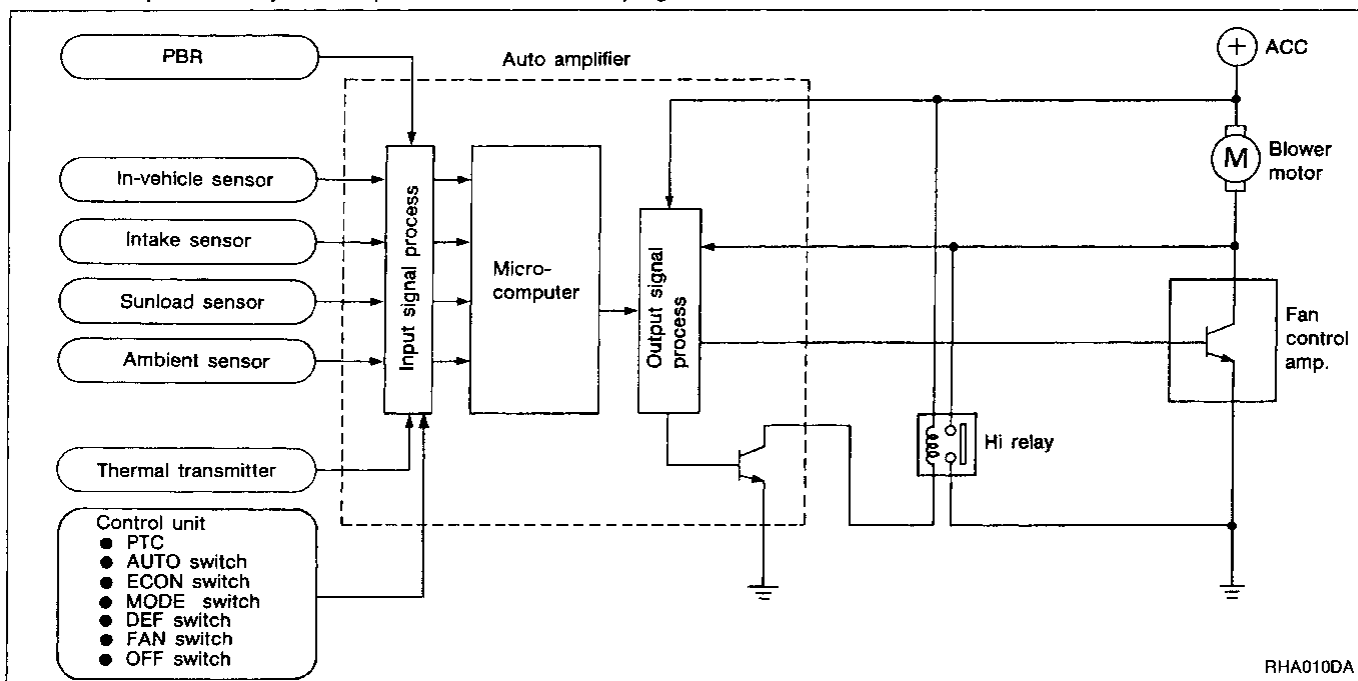

SYSTEM DESCRIPTION

Control System Output Components (Cont'd)

AUTOMATIC MODE

In the automatic mode, the blower motor speed is calculated by the automatic amplifier based on inputs from the PBR, in-vehicle sensor, sunload sensor, and ambient sensor. The blower motor applied voltage ranges from approximately 5 volts (lowest speed) to 12 volts (highest speed).

To control blower speed (in the range of 5 to 10.5V), the automatic amplifier supplies a signal to the fan control amplifier. Based on this signal, the fan control amplifier controls the current flow from the blower motor to ground. If the computed blower voltage (from automatic amplifier) is above 10.5 volts, the high blower relay is activated. The high blower relay provides a direct path to ground (bypassing the fan control amplifier), and the blower motor operates at high speed.

STARTING BLOWER SPEED CONTROL

Start up from "COLD SOAK" condition (Automatic mode)

Take for example a cold start-up with the engine coolant temperature below 32°C (90°F) and the ambient temperature below 15°C (59°F). The blower will not operate for a short period of time (up to 90 seconds). The exact start delay time varies depending on the ambient and engine coolant temperature.

Take another case, of engine coolant temperature between 32°C (90°F) and 35°C (95°F) with ambient temperature below 15°C (59°F). The blower speed will gradually rise to the target speed over a period of 18 minutes or less. (The actual time depends on the target blower speed.) The exact start delay time varies depending on the ambient and engine coolant temperature.

In the most extreme case (very low ambient) the blower starting delay will be 90 seconds as described above. After this delay, the blower will operate at low speed until the engine coolant temperature rises above 32°C (90°F). Then the blower speed will increase to the objective speed.

Start up from normal or "HOT SOAK" condition (Automatic mode)

The blower will begin operation momentarily after the AUTO button is pushed. The blower speed will gradually rise to the objective speed over a time period of 5 seconds or less (actual time depends on the target blower speed).

BLOWER SPEED COMPENSATION

Sunload

When the in-vehicle temperature and the set temperature are very close, the blower will be operating at low speed. The low speed will vary depending on the sunload. During conditions of high sunload, the blower low speed is "normal" low speed (approx. 6V). During low or no sunload conditions, the low speed will drop to "low" low speed (approx. 5V).

Ambient

When the ambient temperature is in the "moderate" range [10 – 15°C (50 - 59°F)], the computed blower voltage will be compensated (reduced) by up to 3.5V (depending on the blower speed). In the "extreme" ambient ranges [below 0°C (32°F) and above 20°C (68°F)] the computed objective blower voltage is not compensated at all. In the ambient temperature ranges between "moderate" and "extreme" [0 - 10°C (32 - 50°F) and 15 - 20°C (59 - 68°F)], the amount of compensation (for a given blower speed) varies depending on the ambient temperature.

SYSTEM DESCRIPTION

Control System Output Components (Cont'd) Fan speed control specification

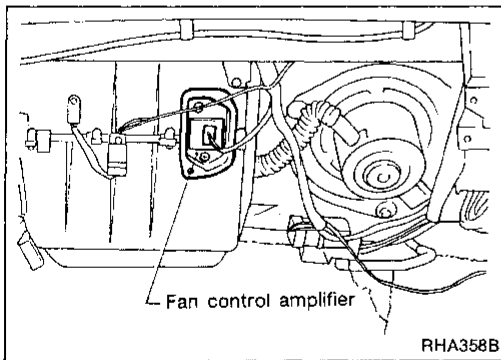
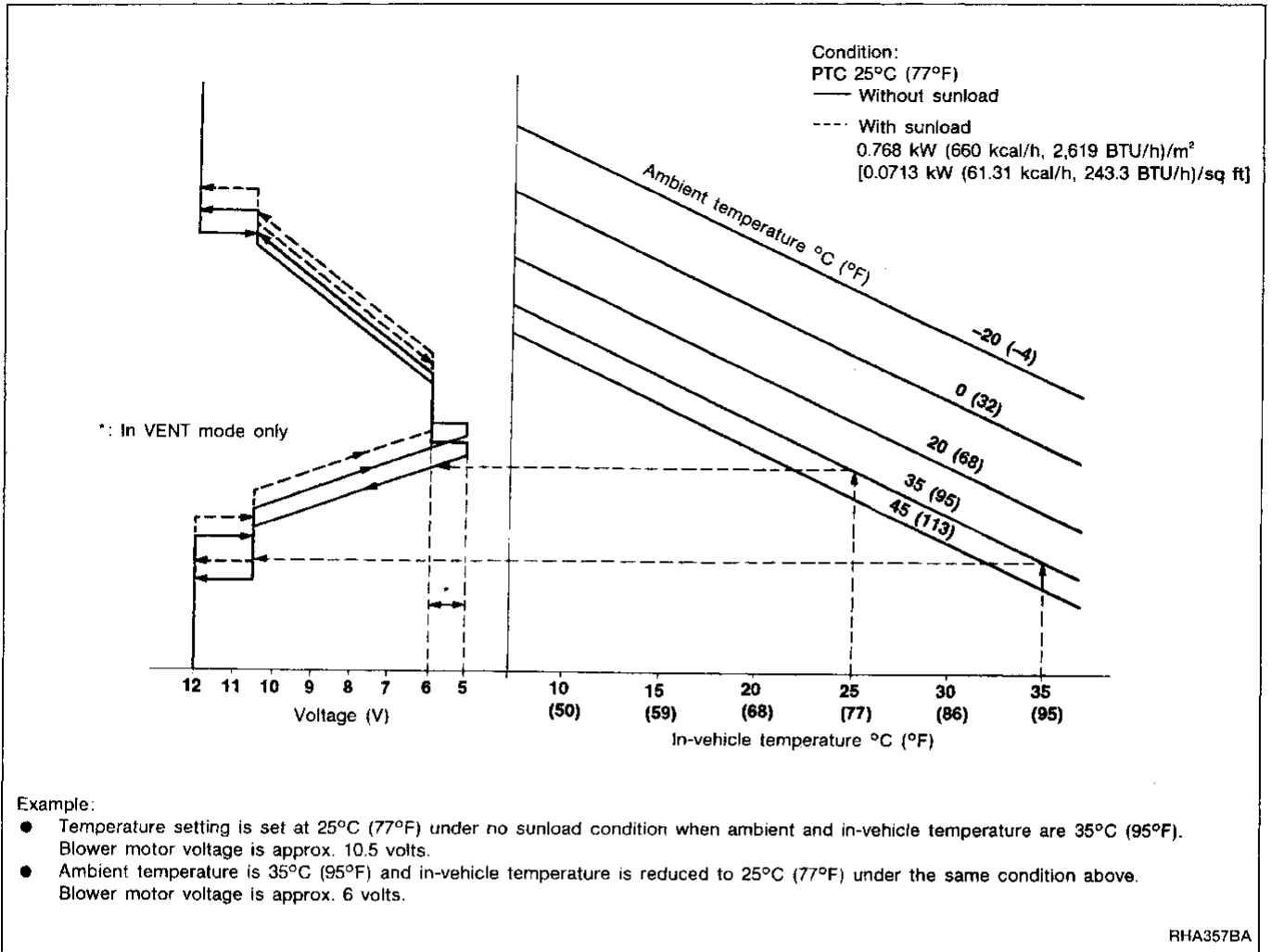

FAN CONTROL AMPLIFIER

The fan control amplifier is located on the cooling unit. It amplifies a 12-step base current flowing from the auto amplifier to change blower speed.

SYSTEM DESCRIPTION

Control System Output Components (Cont'd)

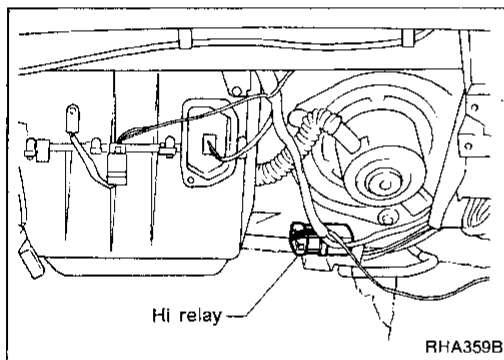
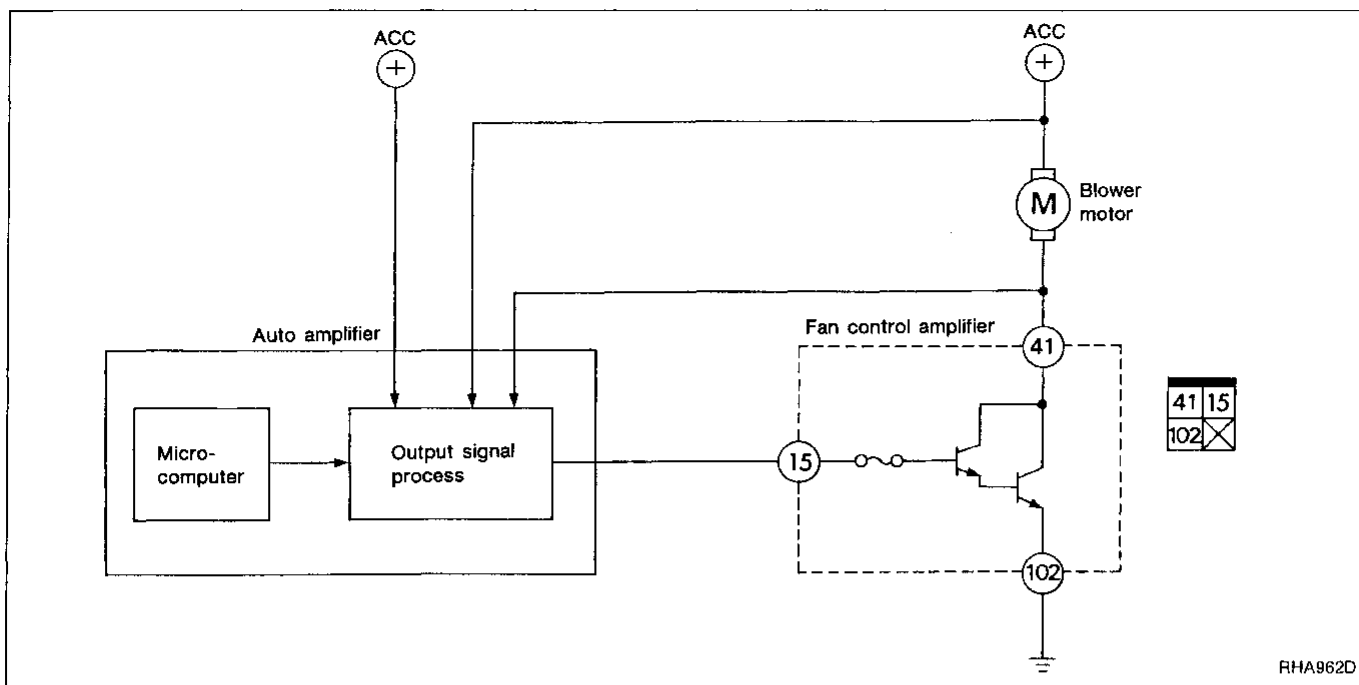

HI RELAY

The Hi relay is located on the intake unit. It receives a signal from the auto amplifier to operate the blower motor at high speed.

MAGNET CLUTCH CONTROL

Auto amplifier controls compressor operation by ambient temperature, intake temperature, and signal from ECM (ECCS control module).

Low temperature protection control

Auto amplifier will turn the compressor "ON" or "OFF" as determined by a signal detected by ambient temperature sensor and intake sensor.

When ambient temperatures are greater than 7°C (45°F), the compressor turns "ON". The compressor turns "OFF" when ambient temperatures are less than -7°C (19°F).

When ambient temperatures are between 7°C (45°F) and -7°C (19°F), the auto amplifier controls ON-OFF operation of compressor. The control is determined by a signal detected by the intake sensor.

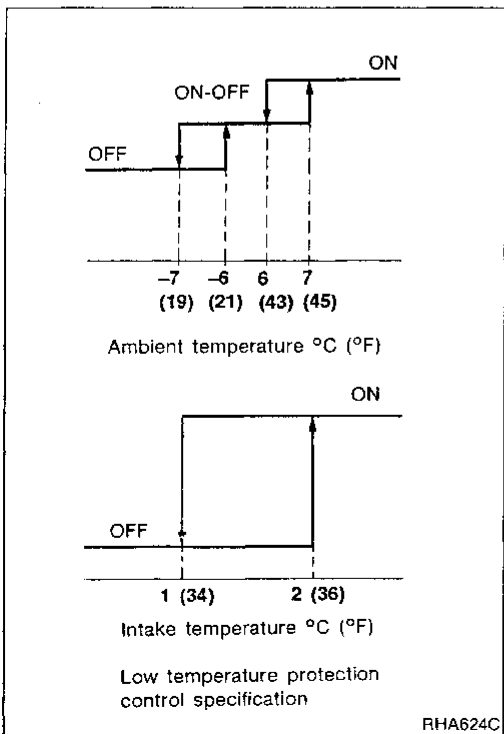

SERVICE PROCEDURES

HFC-134a (R-134a) Service Procedure SETTING OF SERVICE TOOLS AND EQUIPMENT

DISCHARGING REFRIGERANT

WARNING:

Avoid breathing A/C refrigerant and lubrication oil vapor or mist. Exposure may irritate eyes, nose and throat. Remove R-134a from A/C system, using certified service equipment meeting requirements of SAE J2210 (R-134a recycling equipment), or J2209 (R-134a recovery equipment). If accidental system discharge occurs, ventilate work area before resuming work.

Additional health and safety information may be obtained from refrigerant and lubricant manufacturers.

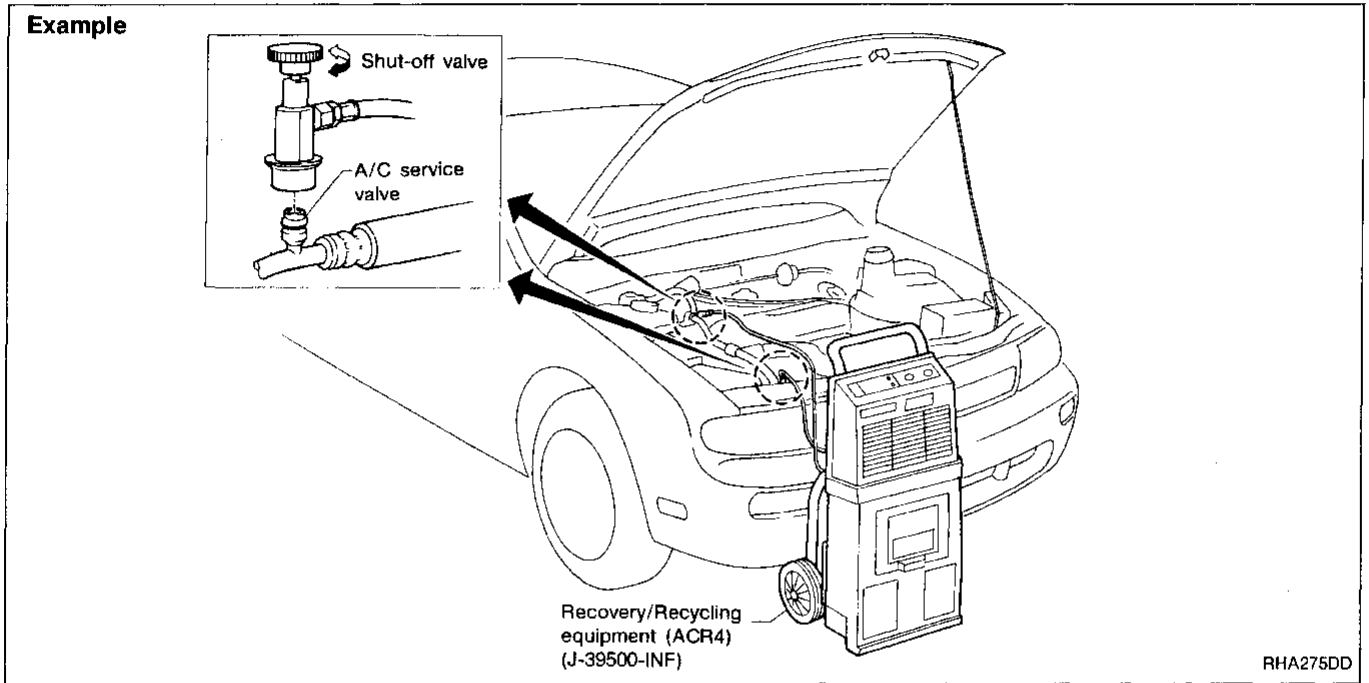

EVACUATING SYSTEM AND CHARGING REFRIGERANT

Example

Preferred (Best) method

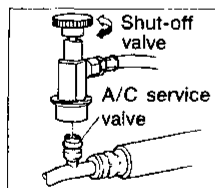

Recovery/Recycling equipment (ACR4) (J-39500-INF)

Alternate method

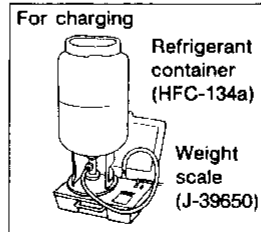
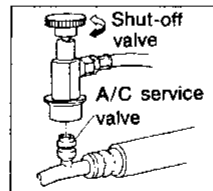

Manifold gauge set (J39183)

For evacuating vacuum pump (J39649)

RHA276DD

SERVICE PROCEDURES

HFC-134a (R-134a) Service Procedure (Cont'd)

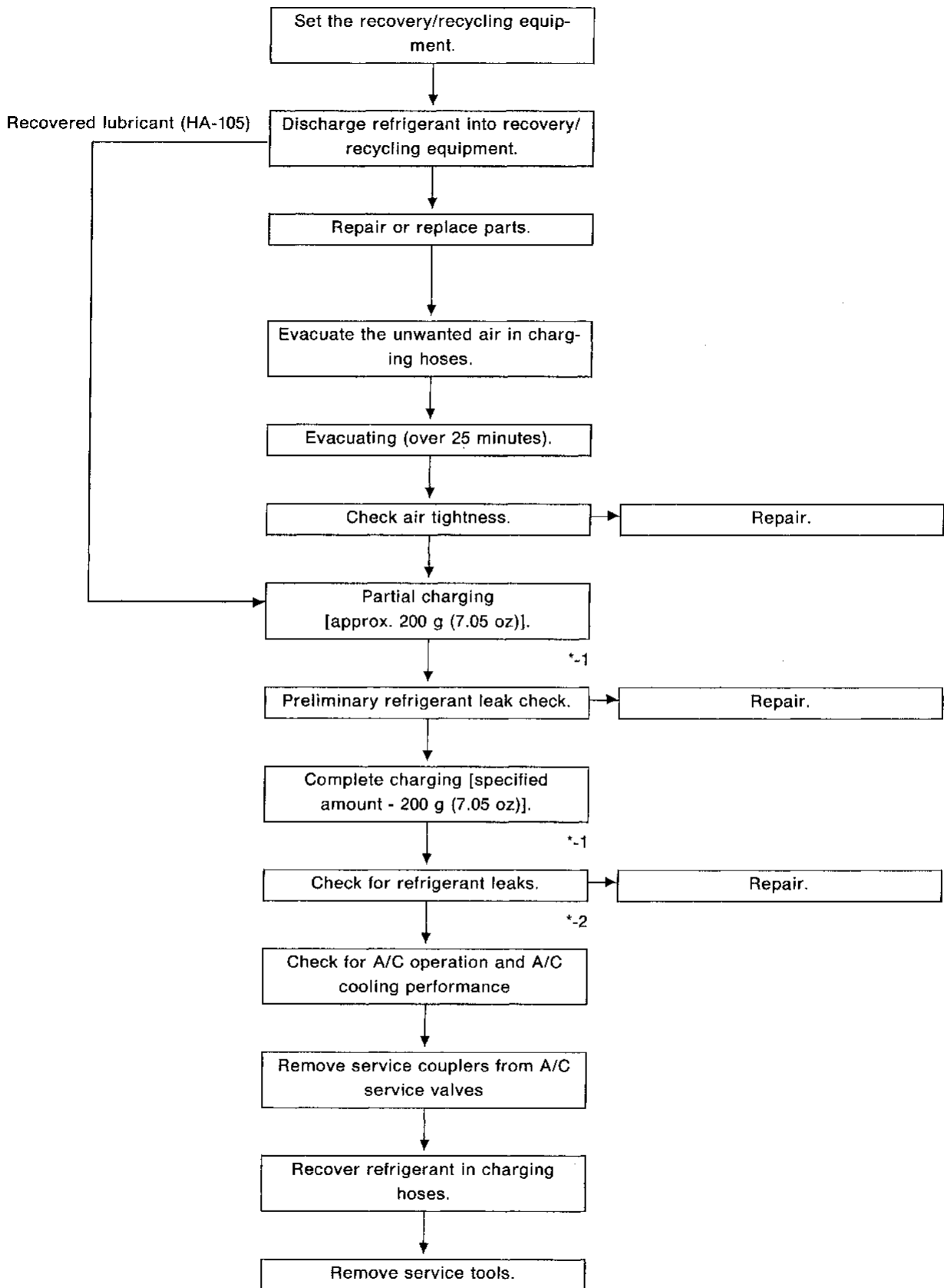

Note: *-1 Before charging refrigerant, ensure engine is off.

*-2 Before checking for leaks, start engine to activate air conditioning system then turn in off. Service valve caps must be attached to valves (to prevent leakage).

Maintenance of Oil Quantity in Compressor

The lubricant used to lubricate the compressor circulates through the system with the refrigerant. Add lubricant to compressor when replacing any component or a large amount of gas leakage has occurred. It is important to maintain the specified amount.

If lubricant quantity is not maintained properly, the following malfunctions may result:

- Lack of lubricant: May lead to a seized compressor
- Excessive lubricant: Inadequate cooling (thermal exchange interference)

LUBRICANT

Name: Nissan A/C System Oil Type S

Part number: KLH00-PAGS0

CHECKING AND ADJUSTING

Adjust the lubricant quantity according to the flowchart shown below.

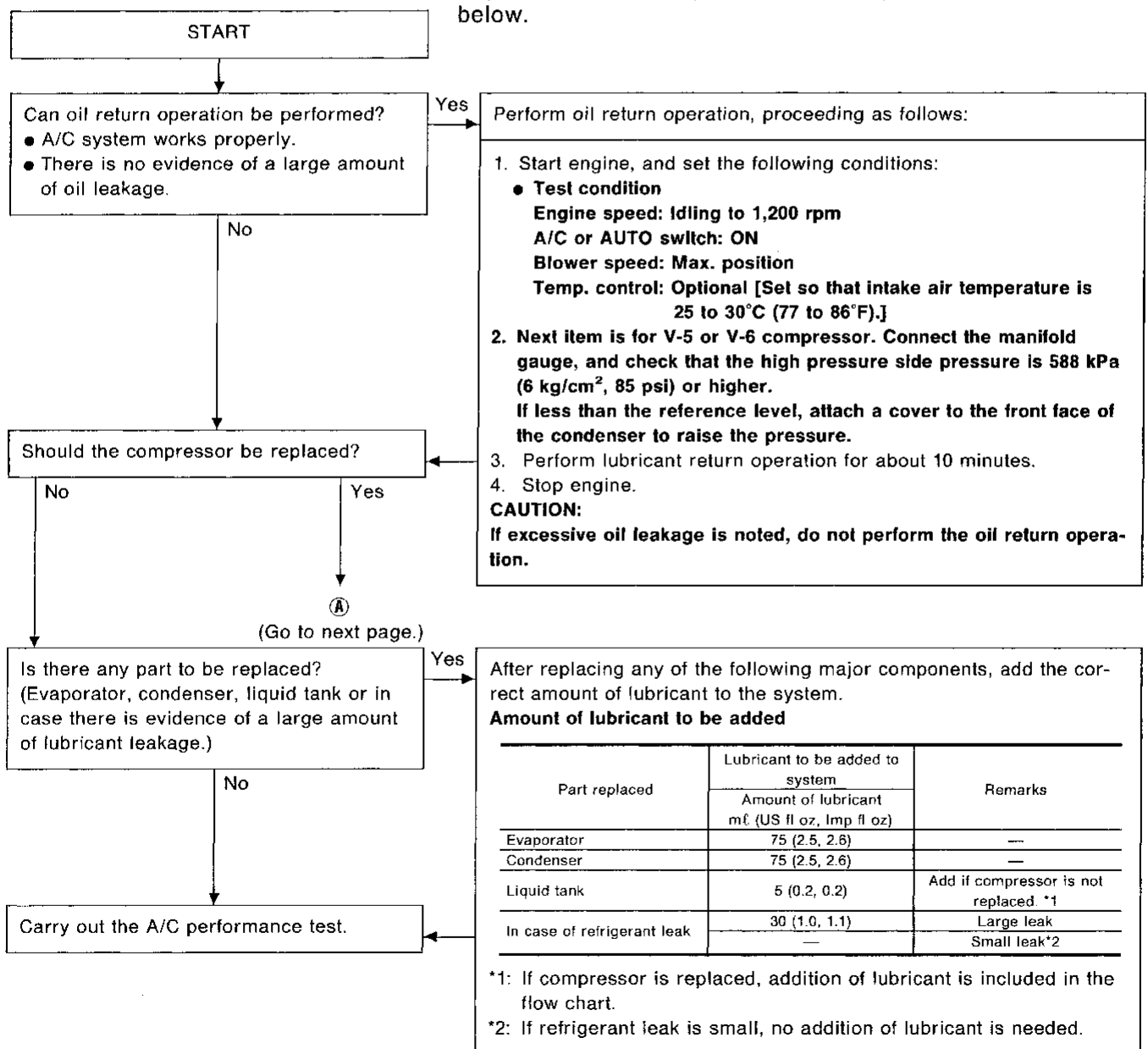

SERVICE PROCEDURES

Maintenance of Oil Quantity in Compressor (Cont'd)

A



1. Discharge refrigerant into the refrigerant recovery/recycling equipment. Measure oil discharged into the recovery/recycling equipment.
2. Remove the drain plug of the "old" (removed) compressor (applicable only to V-5, V-6 or DKS-16H compressor). Drain the oil into a graduated container and record the amount of drained oil.
3. Remove the drain plug and drain the oil from the "new" compressor into a separate, clean container.
4. Measure an amount of new oil equal to amount drained from "old" compressor. Add this oil to "new" compressor through the suction port opening.
5. Measure an amount of new oil equal to the amount recovered during discharging. Add this oil to "new" compressor through the suction port opening.
6. Torque the drain plug.

V-5 or V-6 compressor: 18 - 19 N·m (1.8 - 1.9 kg·m, 13 - 14 ft·lb)

DKS-16H compressor: 14 - 16 N·m (1.4 - 1.6 kg·m, 10 - 12 ft·lb)

7. If the liquid tank also needs to be replaced, add an additional 5 ml (0.2 US fl oz, 0.2 Imp fl oz) of oil at this time.

Do not add this 5 ml (0.2 US fl oz, 0.2 Imp fl oz) of oil if only replacing the compressor.

Oil adjusting procedure for compressor replacement

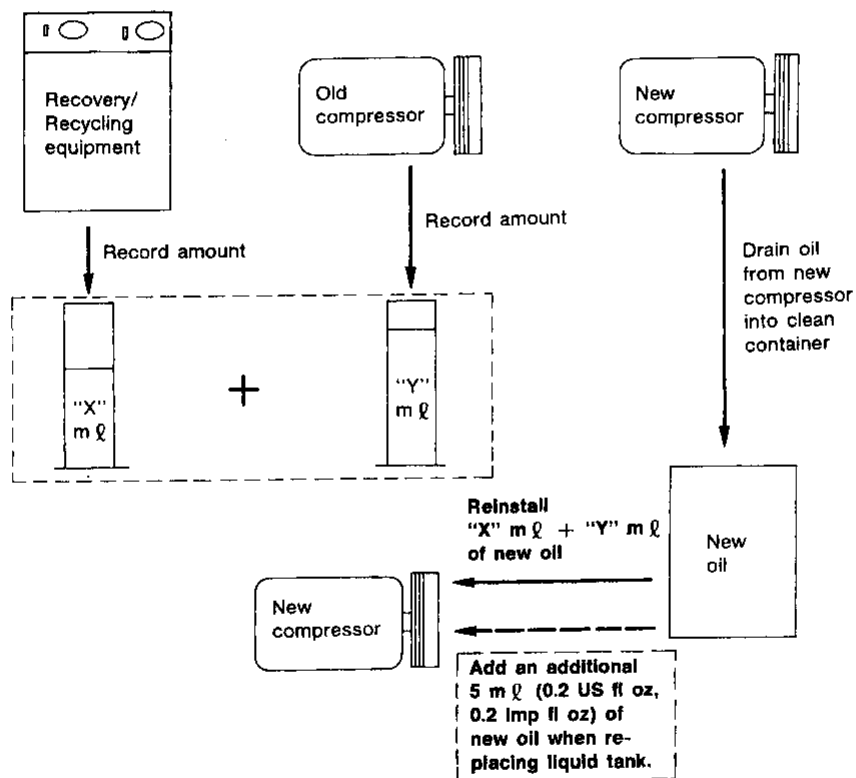

RHA065DB

Refrigerant Lines

- Refer to page HA-5 regarding "Precautions for Refrigerant Connection".

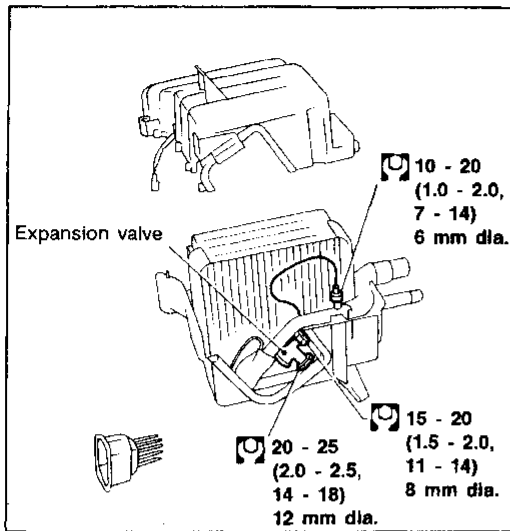

- (Tightening torque)
- (Wrench size)
- (O-ring size)
- A** : 25 - 34 (2.5 - 3.5, 18 - 25)
- B** : 10 - 20 (1.0 - 2.0, 7 - 14)
- C** : 3 - 4 (0.3 - 0.4, 2.2 - 2.9)
- D** : 8 - 11 (0.8 - 1.1, 5.8 - 8.0)
- E** : 10 - 12 (1.0 - 1.2, 7 - 9)
- U** : N·m (kg·m, ft·lb)

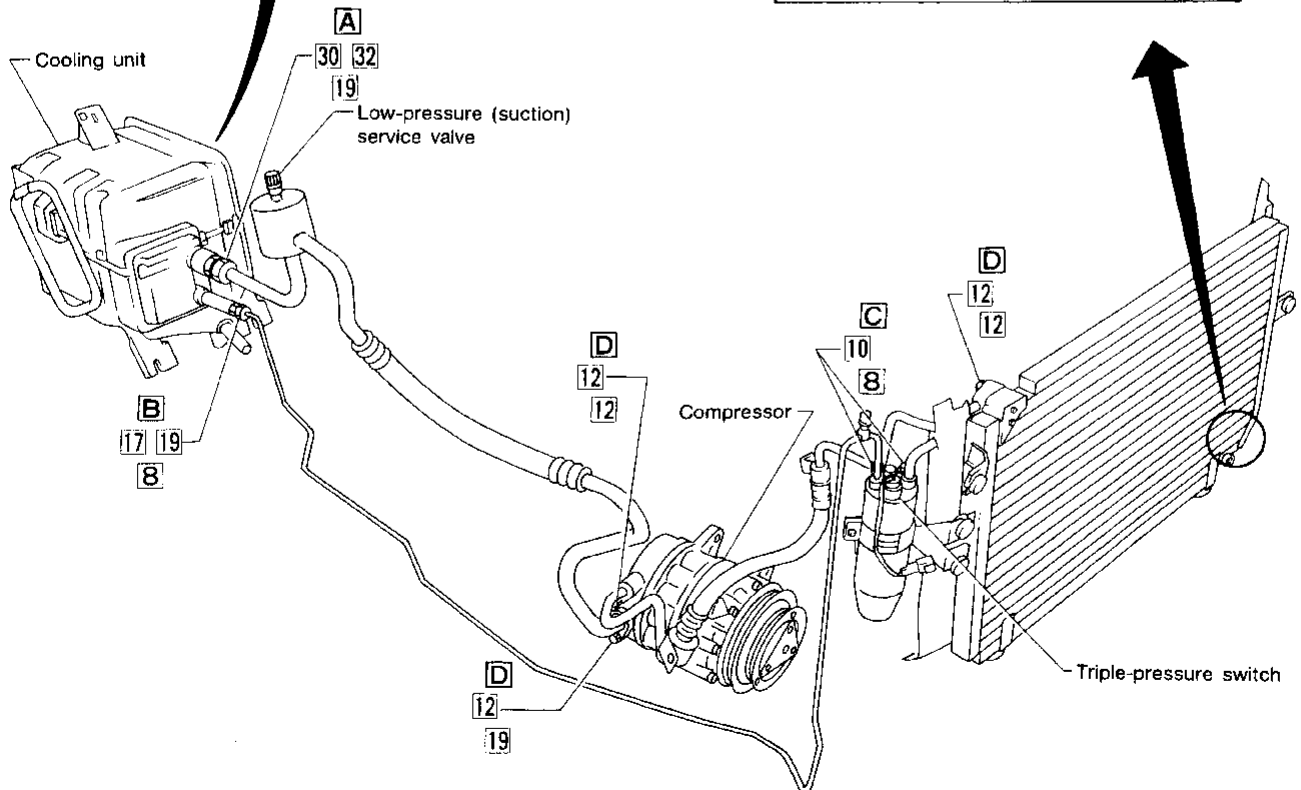
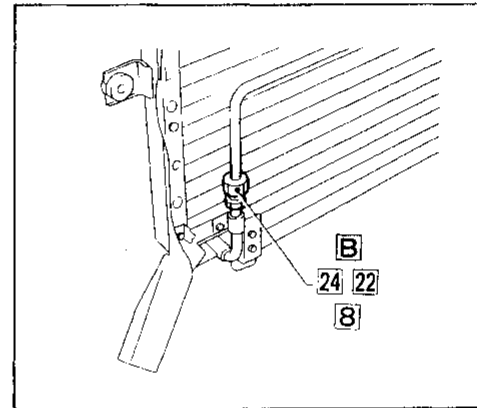

GI

MA

EM

LC

EF &
EC

FE

AT

PD

FA

RA

BR

ST

RS

BT

HA

EL

IDX

Compressor Mounting

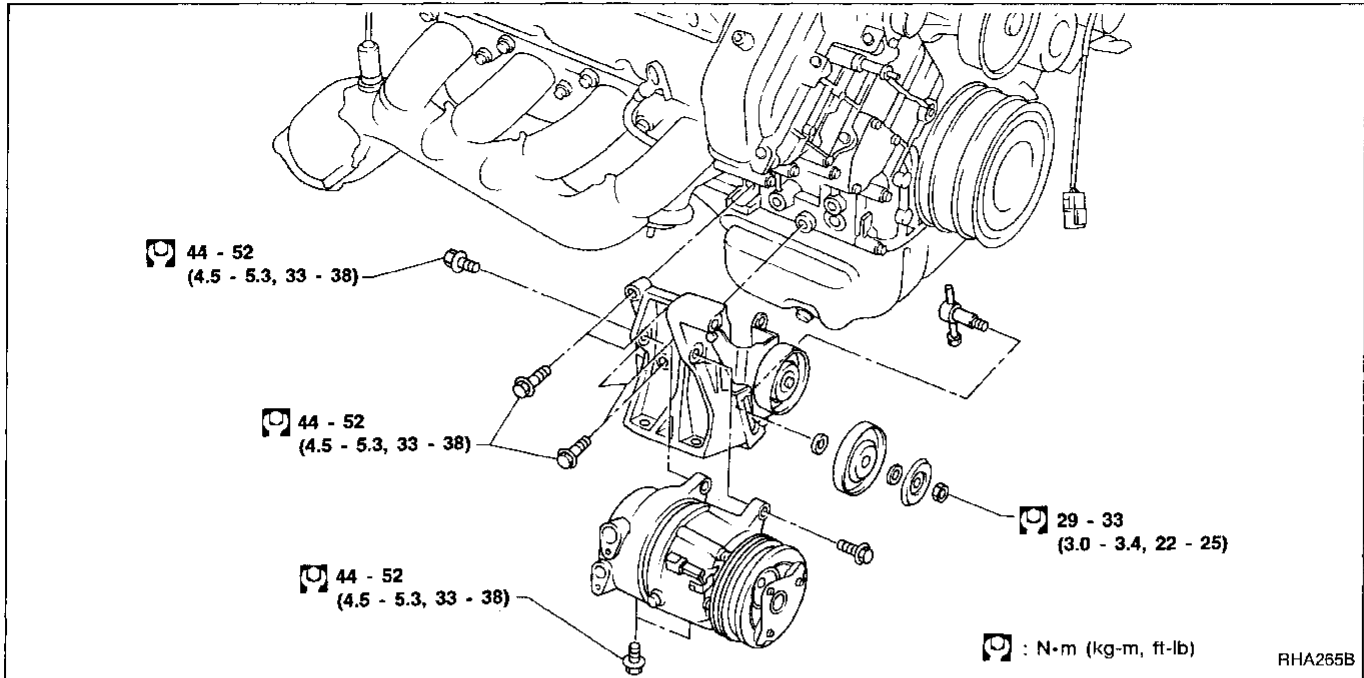

Belt Tension

- Refer to MA section.

Engine Idling Speed (When A/C is ON)

- Refer to EF & EC section.

Compressor — Model V-6 (CALSONIC make)

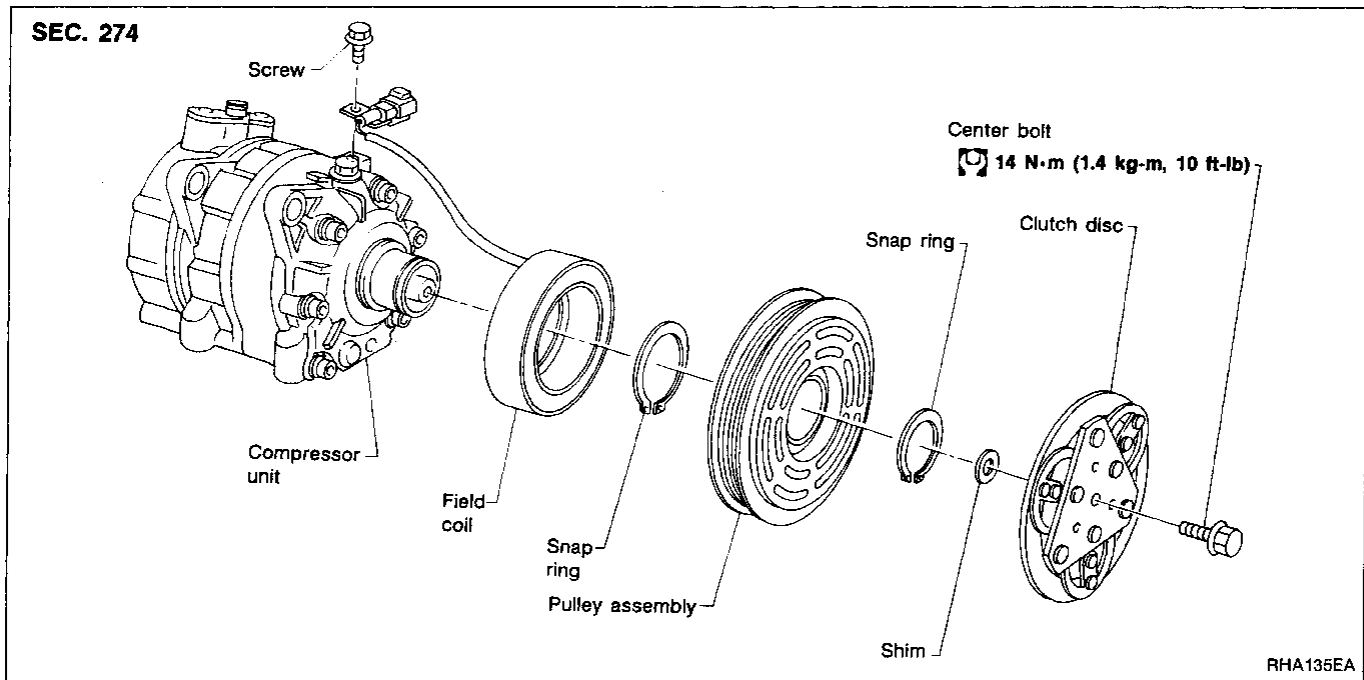

GI
 MA
 EM
 LC
 EF &
 EC
 FE
 AT

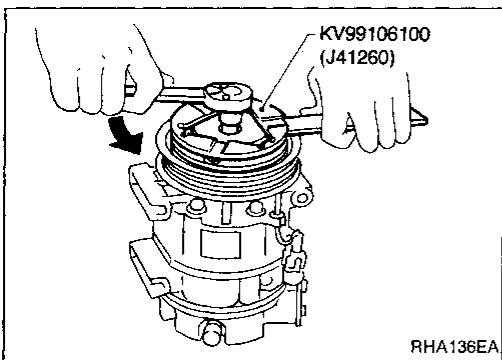

Compressor Clutch

REMOVAL

- When removing center bolt, hold clutch disc with clutch disc wrench.

PD
 FA

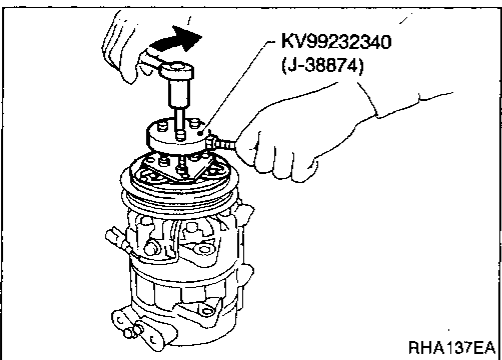

- Remove the clutch disc using the clutch disc puller. Insert the holder's three pins into the holes in the clutch disc. Rotate the holder clockwise to hook it onto the plate. Then, tighten the center bolt to remove the clutch disc. After removing the clutch disc, remove the shims from either the drive shaft or the clutch disc.

RA
 BR
 ST
 RS

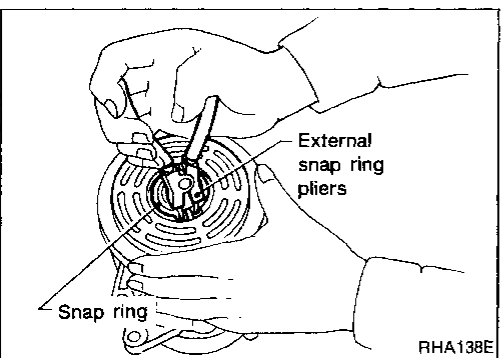

- Remove the snap ring using external snap ring pliers.

BT

HA

EL
 IDX

SERVICE PROCEDURES

Compressor Clutch (Cont'd)

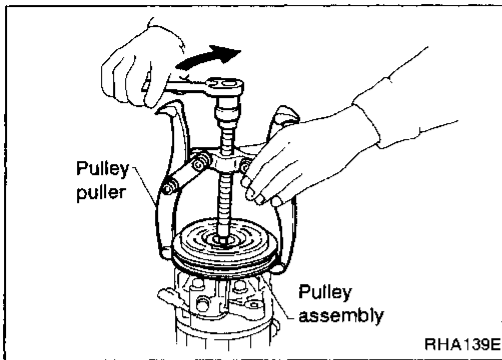

- Pulley removal
Use a commercially available pulley puller. Position the center of it on the end of the drive shaft, and remove the pulley assembly.
To prevent the pulley groove from being deformed, the puller claws should be positioned onto the edge of the pulley assembly.

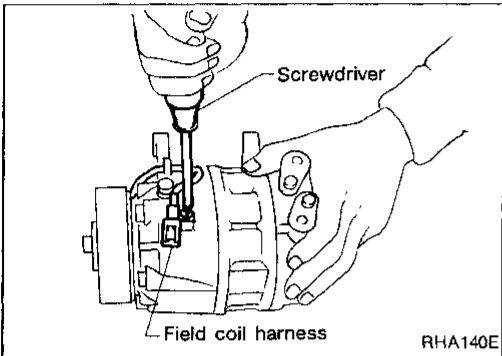

- Remove the field coil harness clip using a screwdriver.

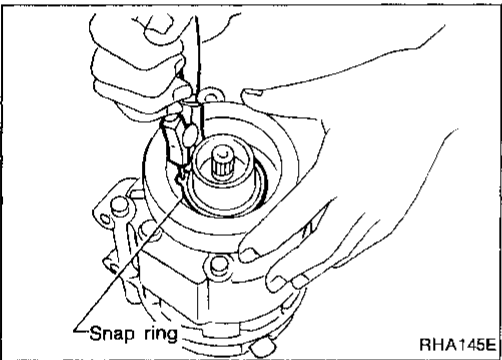

- Remove the snap ring using external snap ring pliers.

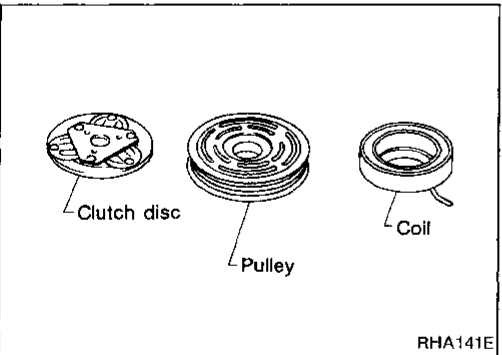

INSPECTION

Clutch disc

If the contact surface shows signs of damage due to excessive heat, replace clutch disc and pulley.

Pulley

Check the appearance of the pulley assembly. If contact surface of pulley shows signs of excessive grooving, replace clutch disc and pulley. The contact surfaces of the pulley assembly should be cleaned with a suitable solvent before reinstallation.

Coil

Check coil for loose connection or cracked insulation.

INSTALLATION

- Install the field coil.
Be sure to align the coil's pin with the hole in the compressor's front head.
- Install the field coil harness clip using a screwdriver.

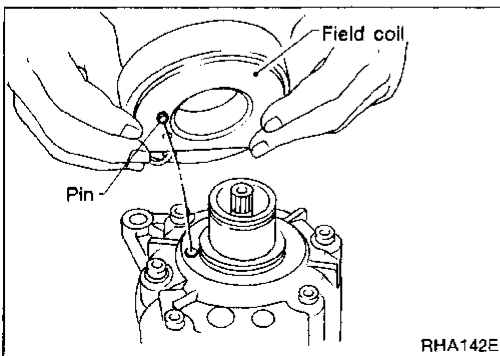

SERVICE PROCEDURES

Compressor Clutch (Cont'd)

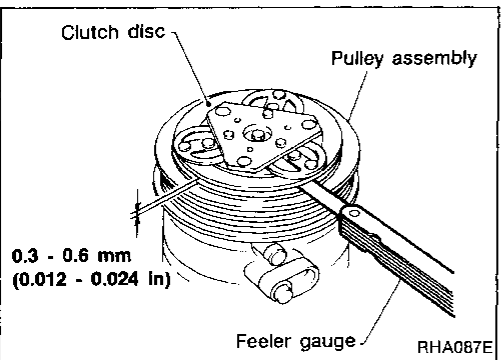
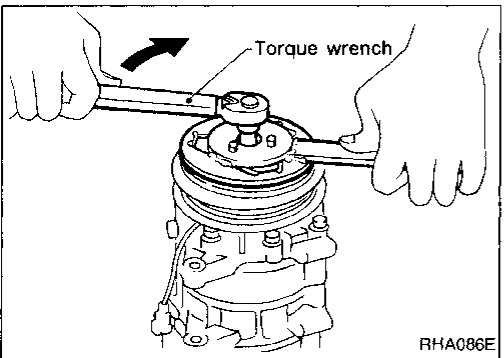
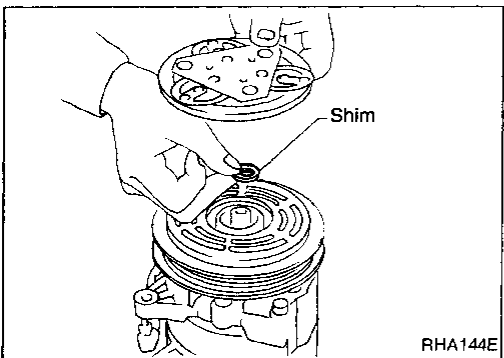
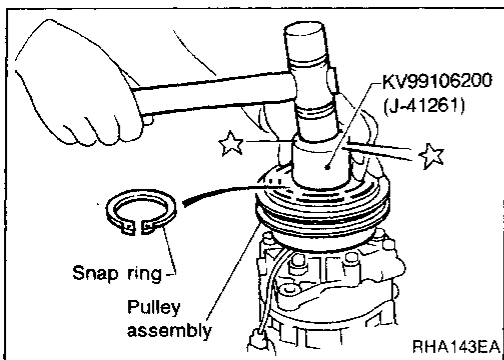

- Install the pulley assembly using the installer and a hand press, and then install the snap ring using snap ring pliers.

- Install the clutch disc on the drive shaft, together with the original shim(s). Press the clutch disc down by hand.

- Using the holder to prevent clutch disc rotation, tighten the bolt to 14 N·m (1.4 kg-m, 10 ft-lb) torque.

After tightening the bolt, check that the pulley rotates smoothly.

- Check clearance around the entire periphery of clutch disc.
Disc-to-pulley clearance:
0.3 - 0.6 mm (0.012 - 0.024 in)
If the specified clearance is not obtained, replace adjusting spacer and readjust.

BREAK-IN OPERATION

When replacing compressor clutch assembly, always conduct the break-in operation. This is done by engaging and disengaging the clutch about thirty times. Break-in operation raises the level of transmitted torque.

GI

MA

EM

LC

EF &
EC

FE

AT

PD

FA

RA

BR

ST

RS

BT

HA

EL

IDX

SERVICE DATA AND SPECIFICATIONS (SDS)

General Specifications

COMPRESSOR

Model	CALSONIC make V-6
Type	V-6 variable displacement
Displacement	cm ³ (cu in)/rev.
Max.	165 (10.07)
Min.	10.5 (0.641)
Cylinder bore x stroke	37 (1.46) mm (in) x [1.6 - 25.6 (0.063 - 1.008)]
Direction of rotation	Clockwise (viewed from drive end)
Drive belt	Poly V

LUBRICATION OIL

Model	CALSONIC make V-6
Name	Nissan A/C System Oil Type S
Part number	KLH00-PAGS0
Capacity	ml (US fl oz, Imp fl oz)
Total in system	200 (6.8, 7.0)
Compressor (Service part) charging amount	200 (6.8, 7.0)

REFRIGERANT

Type	HFC-134a (R-134a)
Capacity	kg (lb) 0.800 ± 0.025 (1.764 ± 0.055)

Inspection and Adjustment

ENGINE IDLING SPEED (When A/C is ON)

- Refer to EF & EC section.

BELT TENSION

- Refer to Checking Drive Belts (MA section).