

# STC

## SECTION

### STEERING CONTROL SYSTEM

A  
B  
C

## CONTENTS

D  
E

### EPS

<b>SYSTEM DESCRIPTION</b> .....	<b>3</b>
Components .....	3
Components (Models with Rear Active Steer) .....	3
Electronically Controlled Power Steering System Function .....	3
Fail-Safe Function .....	4
FAIL-SAFE INPUT/CANCEL CONDITIONS .....	4
<b>TROUBLE DIAGNOSIS</b> .....	<b>5</b>
How to Perform Trouble Diagnosis .....	5
BASIC CONCEPT .....	5
Component Parts Location .....	5
Wiring Diagram — EPS — .....	6
Control Unit Input/Output Signal Standard .....	8
STANDARD BY CIRCUIT TESTER AND OSCILLOSCOPE .....	8
For Fast and Accurate Trouble Diagnosis .....	9
Basic Inspection .....	9
POWER SUPPLY CIRCUIT TERMINAL LOOSENESS AND BATTERY .....	9
Inspection: Power Steering Control Unit Power Supply Circuit and Ground .....	9
Symptom: The Steering Force Does Not Change Smoothly According to the Vehicle Speed .....	10

### RAS

<b>REAR ACTIVE STEER</b> .....	<b>13</b>
Removal and Installation .....	13
COMPONENTS .....	13
REMOVAL .....	13
INSTALLATION .....	13
Disassembly and Assembly .....	14
COMPONENTS .....	14
DISASSEMBLY .....	14
INSPECTION AFTER DISASSEMBLY .....	14
ASSEMBLY .....	14
Neutral Position Adjustment .....	14
<b>SYSTEM DESCRIPTION</b> .....	<b>16</b>
Components .....	16

RAS (Rear Active Steer) Function .....	16
Fail-Safe Function .....	17
<b>TROUBLE DIAGNOSIS</b> .....	<b>18</b>
How to Perform Trouble Diagnosis .....	18
BASIC CONCEPT .....	18
Component Parts Location .....	19
Schematic .....	20
Wiring Diagram — RAS — .....	21
Control Unit Input/Output Signal Standard .....	26
CIRCUIT TESTER REFERENCE VALUE .....	26
STANDARD BY CONSULT-II .....	27
CONSULT-II Function (RAS) .....	28
FUNCTION .....	28
CONSULT-II SETTING PROCEDURE .....	28
SELF-DIAG RESULT MODE .....	28
DATA MONITOR MODE .....	30
ACTIVE TEST MODE .....	30
RAS CONTROL UNIT PART NUMBER .....	30
Diagnosis Procedure with Self-Diagnosis Function (Without CONSULT-II) .....	31
DESCRIPTION .....	31
SELF-DIAGNOSIS PROCEDURE .....	31
SELF-DIAGNOSIS DISPLAY .....	31
SELF-DIAGNOSIS DISPLAY ITEMS .....	31
HOW TO ERASE SELF-DIAGNOSIS .....	31
CAN Communication .....	31
SYSTEM DESCRIPTION .....	31
For Fast and Accurate Trouble Diagnosis .....	32
Basic Inspection .....	32
BASIC INSPECTION 1: POWER SUPPLY CIRCUIT TERMINAL LOOSENESS AND BATTERY..	32
BASIC INSPECTION 2: RAS WARNING LAMP INSPECTION .....	32
BASIC INSPECTION 3: RAS CONTROL UNIT POWER SUPPLY CIRCUIT AND GROUND CIRCUIT INSPECTION .....	32
Trouble Diagnosis Chart .....	33
SELF-DIAGNOSIS .....	33
DIAGNOSIS CHART BY SYMPTOM .....	34
Inspection 1: RAS Control Unit Malfunction .....	35

F  
STC

H  
I

J  
K

L  
M

---

Inspection 2: Motor Power Supply System .....	35	Inspection 10: Stop Lamp Switch Harness .....	44
Inspection 3: RAS Motor Output Malfunction .....	37	Inspection 11: RAS Warning Lamp Harness .....	44
Inspection 4: Vehicle Speed Signal .....	38	Diagnosis Chart by Symptom 1 .....	46
Inspection 5: Steering Angle Signal Malfunction ...	38	Diagnosis Chart by Symptom 2 .....	46
Inspection 6: Rear Main Signal and Rear Sub Signal Malfunction .....	40	Check RAS Static/Dynamic Characteristics .....	48
Inspection 7: VDC Malfunction .....	42	Component Parts Inspection .....	49
Inspection 8: Engine Speed Signal Malfunction ....	43	RAS MOTOR RELAY .....	49
Inspection 9: CAN Communication System Mal- function .....	43	RAS MOTOR .....	49
		REAR WHEEL STEERING ANGLE SENSOR ...	49

## SYSTEM DESCRIPTION

PFP:00000

### Components

NGS000DT

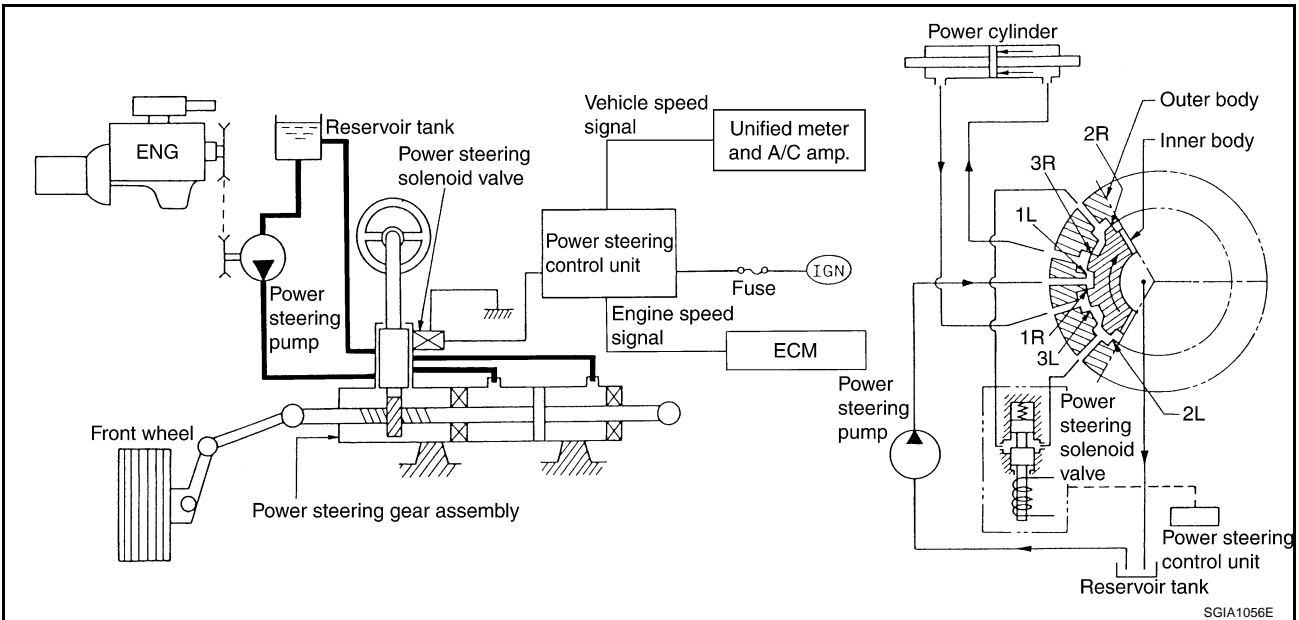

A  
B  
C  
D  
E  
F  
STC

### Components (Models with Rear Active Steer)

NGS000DU

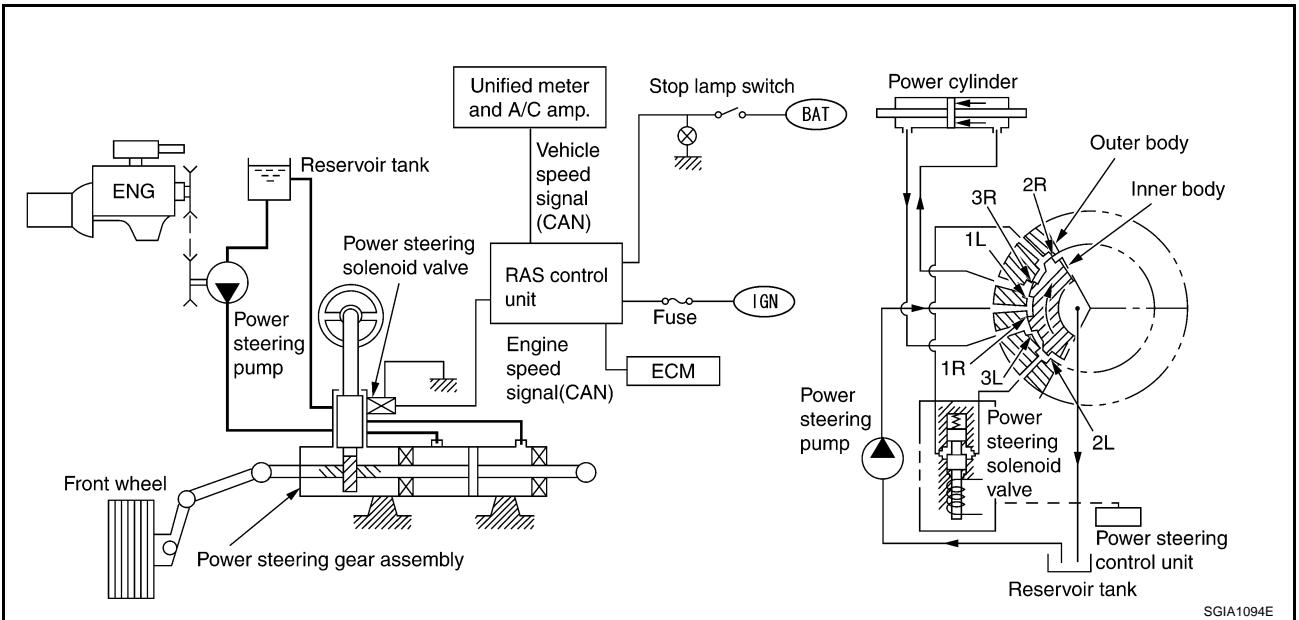

H  
I  
J  
K  
L  
M

### Electronically Controlled Power Steering System Function

NGS000DV

- Vehicle speed sensing electronically controlled power steering (that properly controls the steering force by the vehicle speed) has been adopted. When it is normal, it controls the power steering solenoid valve according to the vehicle speed as shown in the figure and makes the steering force proper.
- For the models with RAS (Rear Active Steer), RAS control unit performs the same control as power steering control unit. For schematic, refer to [STC-20. "Schematic"](#) and trouble diagnosis, refer to [STC-46. "Diagnosis Chart by Symptom 2"](#).

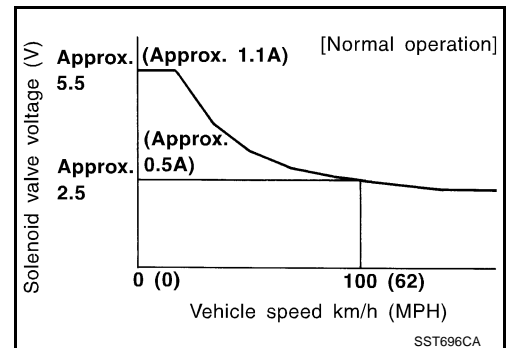

**Fail-Safe Function**

When the fail-safe function operate, it controls power steering solenoid valve by the engine speed as shown in the figure and maintains the steering force.

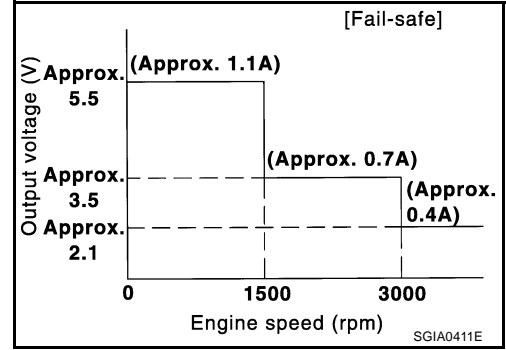

**FAIL-SAFE INPUT/CANCEL CONDITIONS**

Input conditions	Cancel conditions
When vehicle runs at an engine speed of 1,500 rpm or higher and no vehicle speed signal is received for 10 seconds.	<ul style="list-style-type: none"> <li>● A vehicle speed of 2 km/h (1.2 MPH) or more is input.</li> <li>● Turn the ignition switch ON after turning it OFF.</li> </ul>
The continuous vehicle speed signal 30 km/h (19 MPH) or more suddenly drops to less than 2 km/h (1.2 MPH) within 1.4 seconds.	

**CAUTION:**

Fail-safe function is activated when the engine runs at 1,500 rpm or higher for 10 seconds with the vehicle stopped. This is normal and the fail-safe function is automatically deactivated when a vehicle speed signal of 2 km/h (1.2 MPH) or higher is input or the ignition switch is turned OFF.

## TROUBLE DIAGNOSIS

PFP:00004

### How to Perform Trouble Diagnosis BASIC CONCEPT

NGS000DX

- The most important point to perform trouble diagnosis is to understand systems (control and mechanism) in vehicle thoroughly.
- It is also important to clarify customer complaints before inspection.

First of all, reproduce symptom, and understand it fully. Ask customer about his/her complaints carefully. In some cases, they will be necessary to check symptom by driving vehicle with customer.

**CAUTION:**

**Customers are not professionals. Do not assume “maybe customer means...” or “maybe customer mentioned this symptom”.**

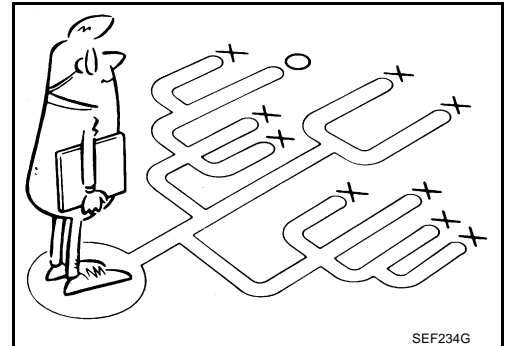

- It is essential to check symptoms right from beginning in order to repair a malfunction completely. For an intermittent malfunction, it is important to reproduce symptom based on interview with customer and past examples. Do not perform inspection on ad hoc basis. Most intermittent malfunctions are caused by poor contacts. In this case, it will be effective to shake suspected harness or connector by hand. When repairs are performed without any symptom check, no one can judge if malfunction has actually been eliminated.

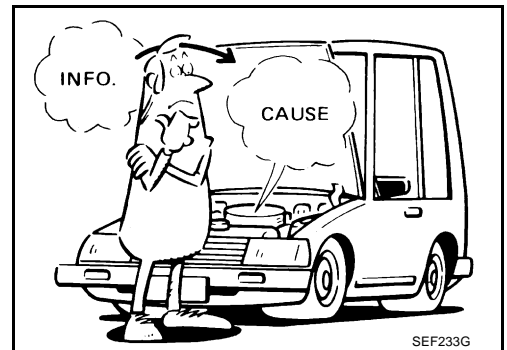

- Always read “GI General Information” to confirm general precautions. Refer to [GI-4, "General Precautions"](#).

### Component Parts Location

NGS000DY

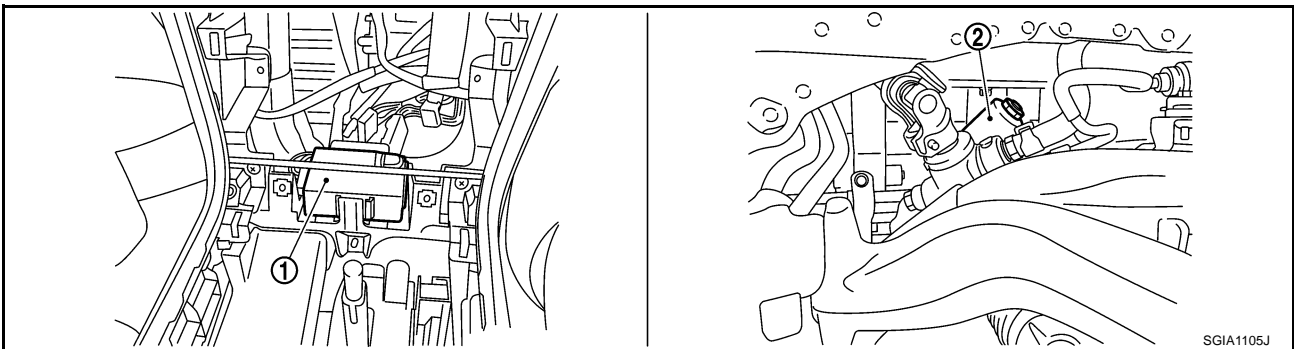

1. Power steering control unit  
(back of center console assembly)

2. Power steering solenoid valve

A  
B  
C  
D  
E  
F  
H  
I  
J  
K  
L  
M

STC

# TROUBLE DIAGNOSIS

[EPS]

NGS000DZ

## Wiring Diagram — EPS —

### STC-EPS-01

▬ : DATA LINE

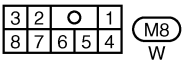
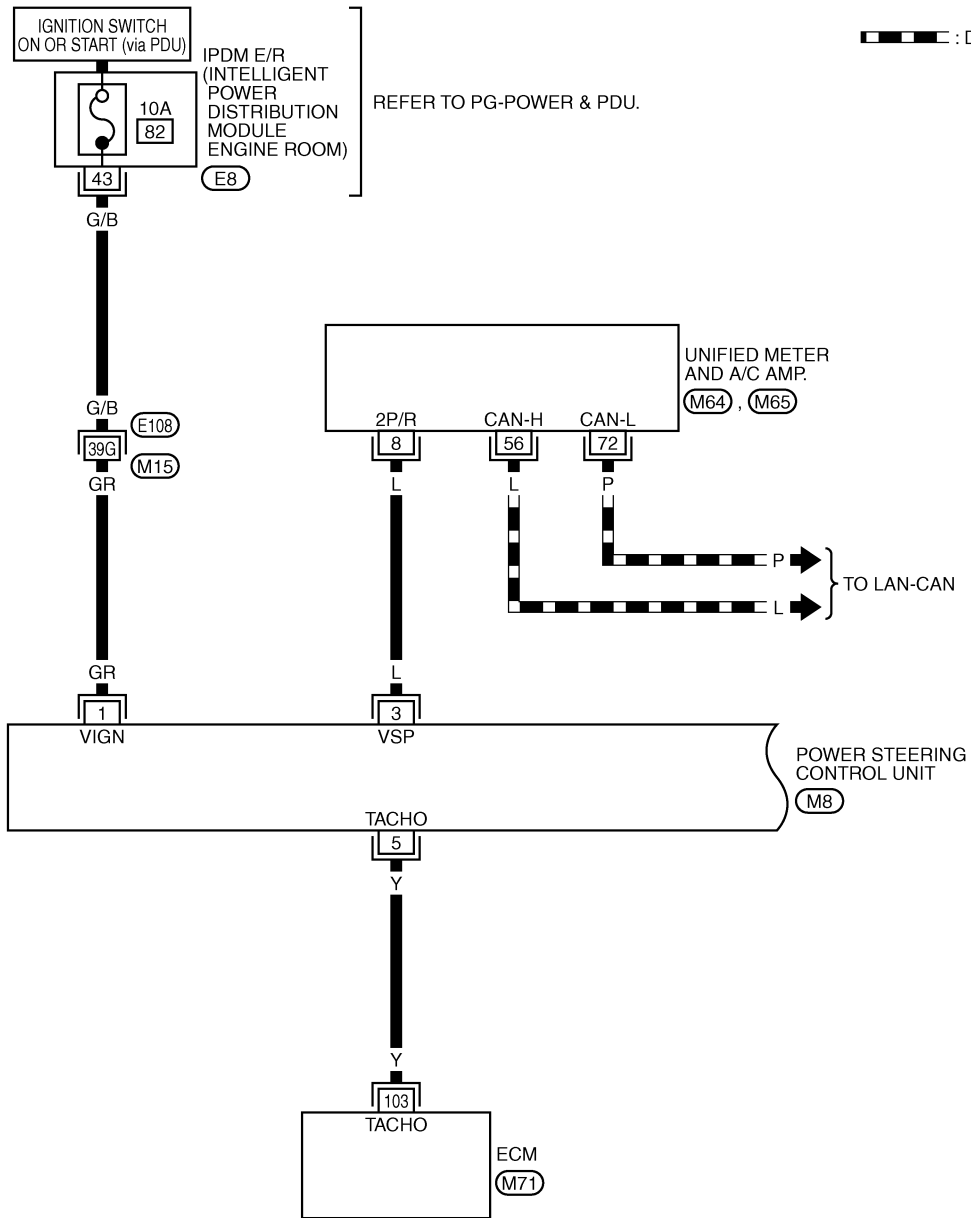

REFER TO THE FOLLOWING.

(E108) -SUPER MULTIPLE JUNCTION (SMJ)

(M71) -ELECTRICAL UNITS

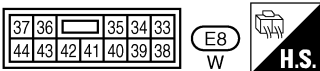
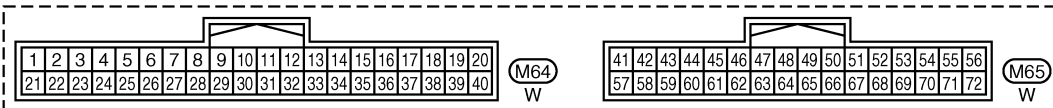

TGWT0023E

# TROUBLE DIAGNOSIS

[EPS]

## STC-EPS-02

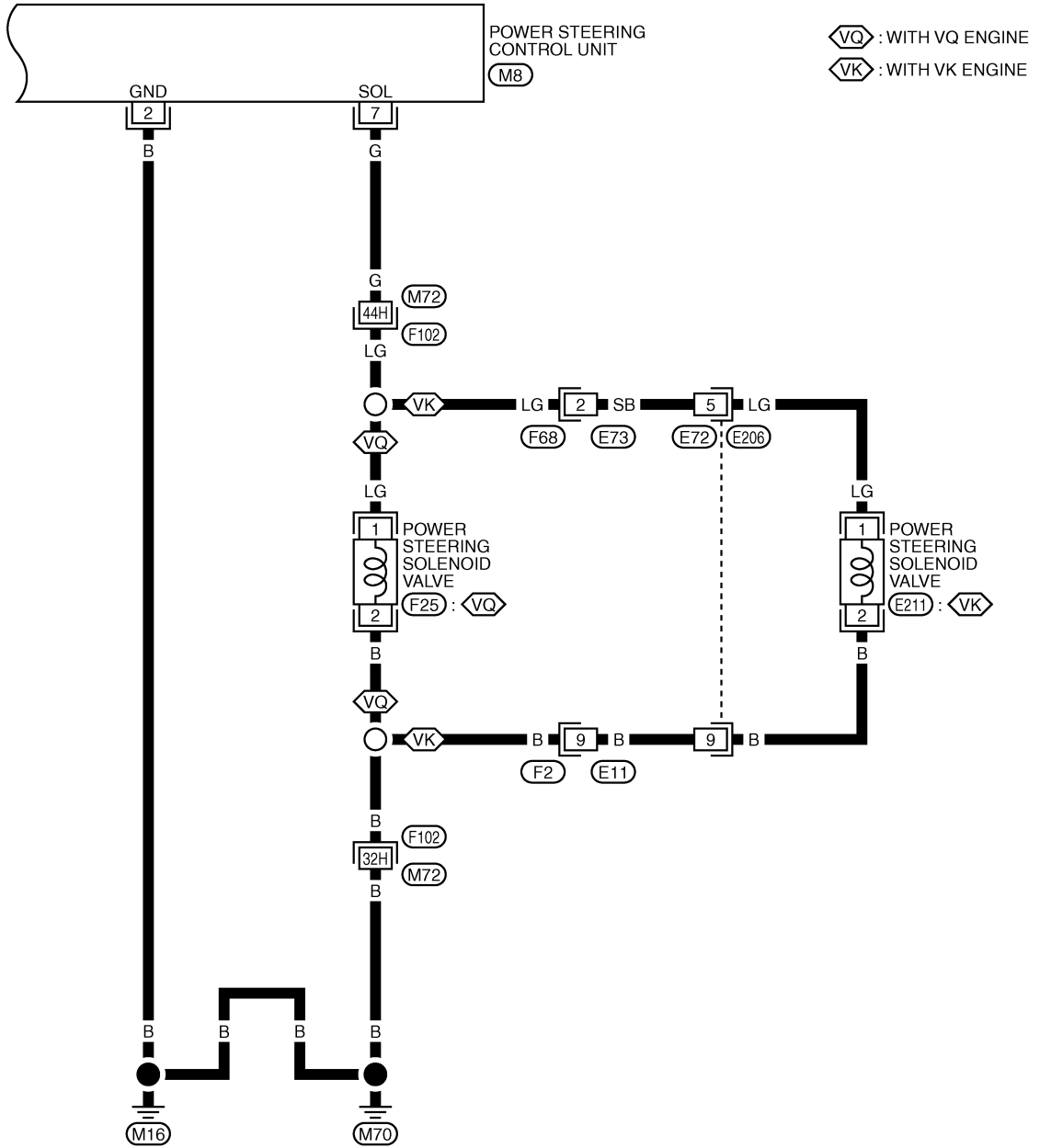

A  
B  
C  
D  
E  
F  
STC  
H  
I  
J  
K  
L  
M

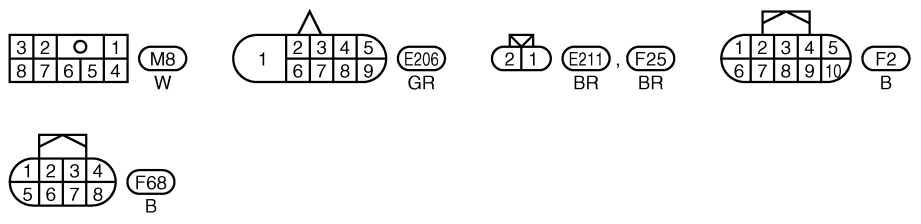

REFER TO THE FOLLOWING.  
**F102** -SUPER MULTIPLE JUNCTION (SMJ)

TGWT0024E

# TROUBLE DIAGNOSIS

[EPS]

## Control Unit Input/Output Signal Standard STANDARD BY CIRCUIT TESTER AND OSCILLOSCOPE

NGS000E0

**CAUTION:**

When checked using a circuit tester for voltage measurement, connector terminals should not be forcefully extended.

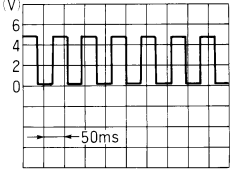
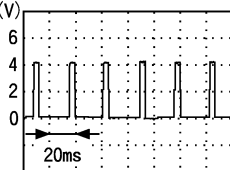
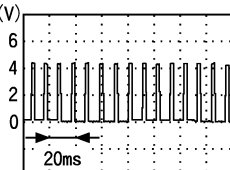
Terminal		Measuring point	Measuring condition		Standard
+	-				
1 (GR)	Ground	IGN	Ignition switch ON.		Battery voltage (Approx. 12 V)
2 (B)		Ground	—		—
3 (L)		Vehicle speed signal (2-pulse)	At 40 km/h (25MPH)		 <p style="text-align: right; font-size: small;">ELF1080D</p>
5 (Y)		Engine speed signal	At idle after warming up		 <p style="text-align: right; font-size: small;">PBIA3654J</p>
			At approx. 2,000 rpm		 <p style="text-align: right; font-size: small;">PBIA3655J</p>
7 (G)		Power steering solenoid valve	Normal (Vehicle speed)	0 km/h (0 MPH)	Approx. 4.4 - 6.6 V
				100 km/h (62 MPH)	Approx. 2.4 - 3.6 V
	In fail-safe mode (Engine speed)		0 - 1,500 rpm	Approx. 4.4 - 6.6 V	
			1,500 - 3,000 rpm	Approx. 3.5 V	
			More than 3,000 rpm	Approx. 2.1 V	



## For Fast and Accurate Trouble Diagnosis

NGS000E1

Check the following items with the vehicle stopped

- Is air pressure and size of tires proper?
- Is the specified part used for the steering wheel?
- Is control unit a genuine part?
- Are there any fluid leakage from steering gear assembly, power steering oil pump, and hydraulic pipes, etc? Refer to [PS-8, "POWER STEERING FLUID"](#) .
- Is the fluid level proper? Refer to [PS-8, "POWER STEERING FLUID"](#) .
- Is the wheel alignment adjusted properly? Refer to [FSU-19, "SERVICE DATA AND SPECIFICATIONS \(SDS\)"](#) (2WD), [FSU-36, "SERVICE DATA AND SPECIFICATIONS \(SDS\)"](#) (AWD).
- Are there any damage or modification to suspension or body resulting in increased weight or altered ground clearance?
- Check each link installation condition of suspension and axle.
- Check each connector connection condition.

Check the following items while driving the vehicle

- Check conditions when the malfunction occurred (5W 1H).
- Is the engine condition normal?

### Basic Inspection

NGS000E2

#### POWER SUPPLY CIRCUIT TERMINAL LOOSENESS AND BATTERY

STC

Check battery terminals for looseness on both positive and negative ones and ground connection. Also make sure that battery voltage does not drop.

### Inspection: Power Steering Control Unit Power Supply Circuit and Ground

NGS000E3

#### 1. CHECK POWER STEERING CONTROL UNIT CONNECTOR

Turn ignition switch OFF, disconnect power steering control unit harness connector, and check terminal for deformation, disconnection, looseness, etc.

OK or NG

OK >> GO TO 2.

NG >> Connector terminal connection is loose, damaged, open, or shorted. Repair or replace the terminal.

#### 2. CHECK POWER STEERING CONTROL UNIT GROUND CIRCUIT

Disconnect power steering control unit harness connector M8, and then check continuity between power steering control unit harness connector M8 and ground.

**Terminal 2 – Ground : Continuity exist.**

OK or NG

OK >> GO TO 3.

NG >> Ground circuit open or shorted. Repair or replace any inoperative parts.

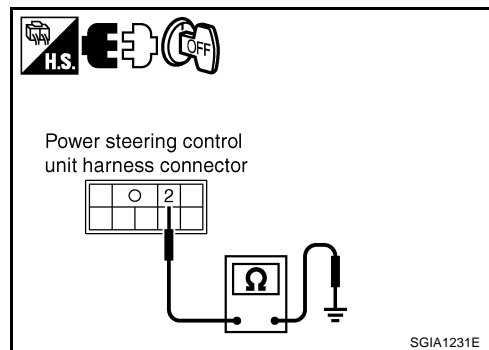

### 3. CHECK POWER STEERING CONTROL UNIT POWER SUPPLY CIRCUIT

Turn ignition switch ON, and then check voltage between power steering control unit harness connector M8 and ground.

**Terminal 1 – ground : Battery voltage (Approx. 12 V)**

OK or NG

- OK >> Power supply and ground circuit are normal.  
 NG >> Power supply circuit open or shorted. Repair or replace any inoperative parts.

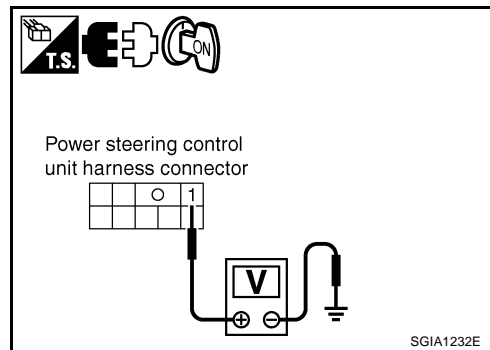

### Symptom: The Steering Force Does Not Change Smoothly According to the Vehicle Speed

NGS000E4

Heavy steering force with the static steering/light steering force during high-speed driving

#### 1. POWER STEERING SOLENOID VALVE SIGNAL INSPECTION 1

1. Start engine.
2. Change the vehicle speed from 0 to 100 km/h (0 to 62 MPH) slowly, and then check voltage between power steering control unit harness connector M8 and ground.

**Terminal 7 – ground : The voltage has changed from approximately 4.4 - 6.6 V to approximately 2.4 - 3.6 V**

OK or NG

- OK >> GO TO 2.  
 NG >> GO TO 7.

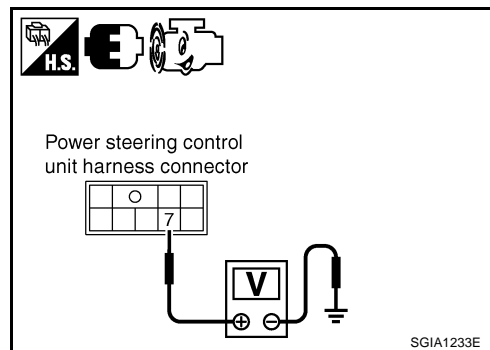

#### 2. POWER STEERING SOLENOID VALVE SIGNAL INSPECTION 2

1. Activate fail-safe function by running the engine speed at 1,500 rpm or higher for 10 seconds with the vehicle stopped.
2. Change the engine speed to the idling, to approximately 1,600 rpm, and to approximately 3,000 rpm slowly, and then check voltage between power steering control unit harness connector M8 and ground.

**Terminal 7 – ground : The voltage has changed from approximately 5.5 V to approximately 2.1 V step-by-step.**

OK or NG

- OK >> GO TO 3.  
 NG >> GO TO 8.

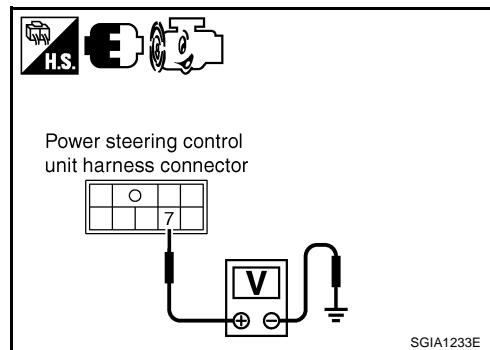

### 3. CHECK POWER STEERING SOLENOID VALVE CONNECTOR

Turn ignition switch OFF, disconnect power steering solenoid valve harness connector, and check terminal for deformation, disconnection, looseness, etc.

OK or NG

- OK >> GO TO 4.  
 NG >> Harness or connector open or shorted. Repair or replace any inoperative parts.

## 4. CHECK POWER STEERING SOLENOID VALVE POWER SUPPLY CIRCUIT

Check continuity between power steering control unit harness connector M8 and power steering solenoid valve harness connector F25 (VQ35DE), E211 (VK45DE).

Power steering control unit	Power steering solenoid valve	Continuity
Terminal 7	Terminal 1	Yes

**OK or NG**

- OK >> GO TO 5.
- NG >> Open or short in harness. Repair or replace any inoperative parts.

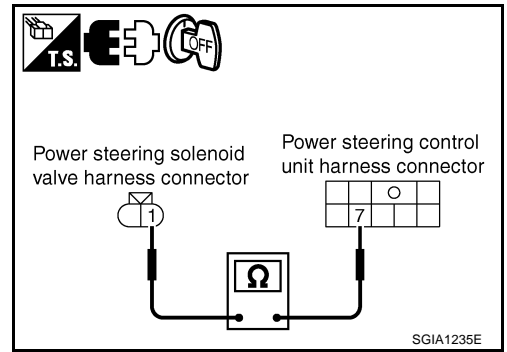

## 5. CHECK POWER STEERING SOLENOID VALVE GROUND CIRCUIT

Check continuity between power steering solenoid valve harness connector F25 (VQ35DE), E211 (VK45DE) and ground.

**Terminal 2 – Ground : Continuity exist.**

**OK or NG**

- OK >> GO TO 6.
- NG >> Open or short in harness. Repair or replace any inoperative parts.

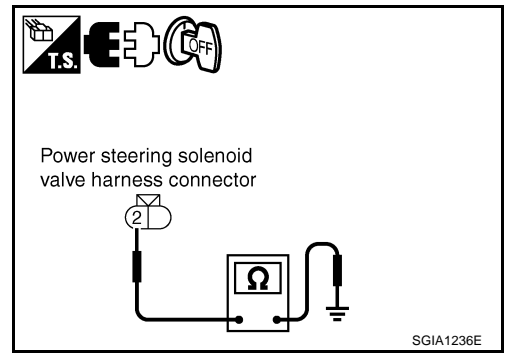

## 6. CHECK POWER STEERING SOLENOID VALVE

Apply voltage power steering solenoid valve connector, and then make sure that the operating sound (clicking sound) is heard.

**Terminal 1 (+) - 2 (-) : Operating sound is heard.**

**OK or NG**

- OK >> Perform steering turning torque inspection. Refer to [PS-10. "CHECKING STEERING WHEEL TURNING FORCE"](#).
- NG >> Power steering solenoid valve is inoperative. Replace.

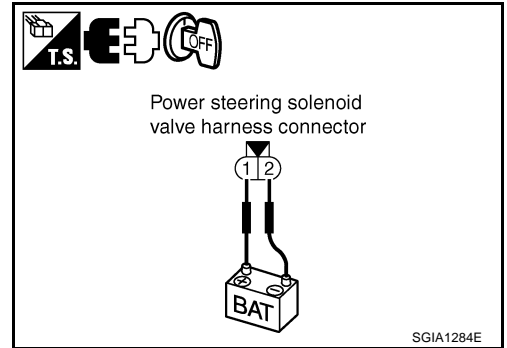

## 7. CHECK VEHICLE SPEED SIGNAL CIRCUIT

Change the vehicle speed, and then check voltage waveform between power steering control unit harness connector M8 and ground.

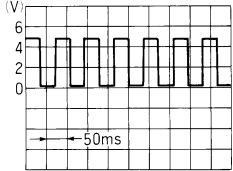
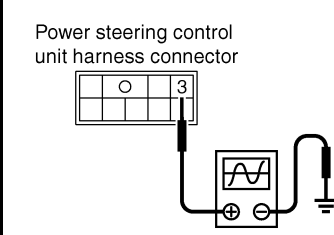
Terminal 3 – Ground	Repeat Approx. 0 V and approx. 5 V  <p style="text-align: right; font-size: small;">ELF1080D</p>	 <p style="text-align: center; font-size: small;">Power steering control unit harness connector</p> <p style="text-align: right; font-size: x-small;">SGIA1237E</p>
---------------------	--	---

**OK or NG**

- OK >> Power steering control unit is inoperative. Replace.
- NG >> Check the following systems and replace if necessary.
  - Harness between unified meter & A/C amp and power steering control unit.
  - Unified meter & A/C amp and vehicle speed signal circuit Refer to [DI-28, "UNIFIED METER AND A/C AMP"](#) .

## 8. CHECK ENGINE SPEED SIGNAL CIRCUIT

Warm up the engine, and then check voltage waveform between power steering control unit harness connector M8 and ground when the engine speed is the idling and at approximately 2,000 rpm.

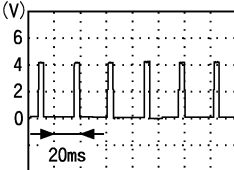
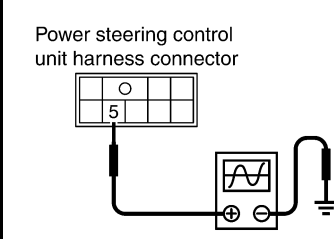
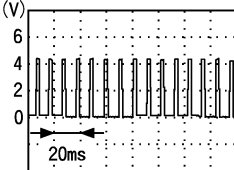
Terminal 5 – Ground	At Idle  <p style="text-align: right; font-size: x-small;">PBIA3654J</p>	 <p style="text-align: center; font-size: small;">Power steering control unit harness connector</p> <p style="text-align: right; font-size: x-small;">SGIA1289E</p>
	Approx. 2,000 rpm  <p style="text-align: right; font-size: x-small;">PBIA3655J</p>	

**OK or NG**

- OK >> Power steering control unit is inoperating. Replace it.
- NG >> Check the following systems and replace if malfunction is detected.
  - Harness between ECM and power steering control unit
  - ECM engine speed signal circuit. Refer to [EC-846, "CONSULT-II Function \(ENGINE\)"](#) .

## REAR ACTIVE STEER

### Removal and Installation COMPONENTS

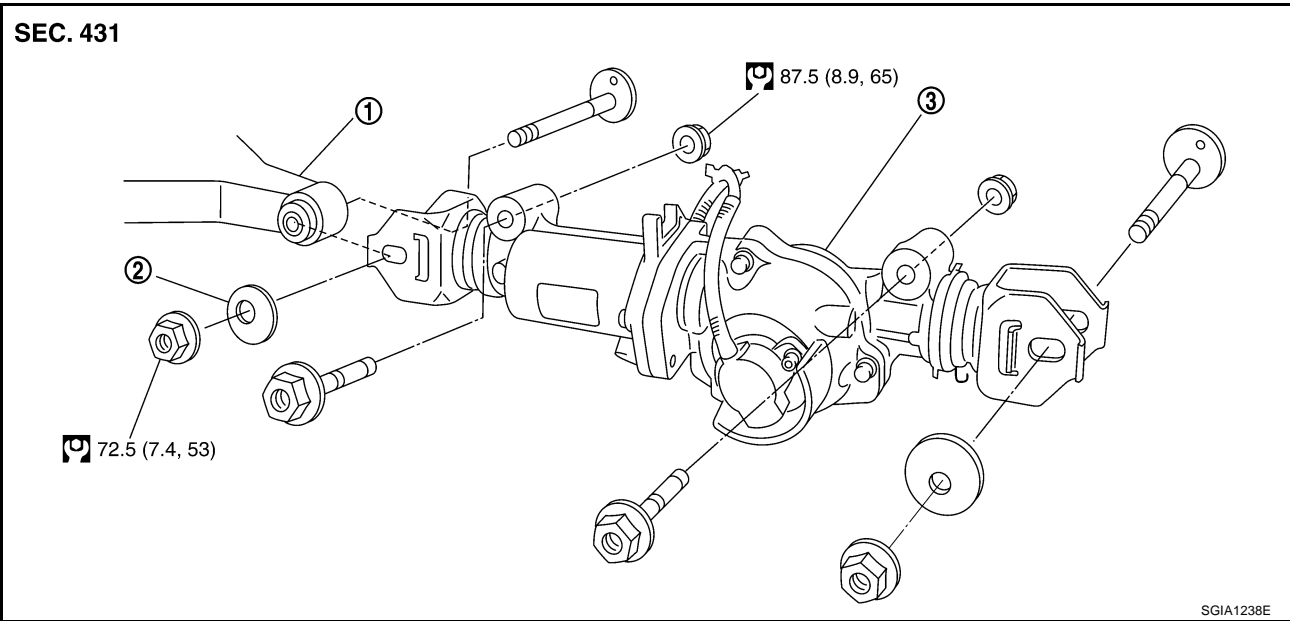

1. Rear lower link
2. Decenter cam
3. RAS actuator assembly

Refer to [GI-11. "Components"](#), for the symbols in the figure.

### REMOVAL

1. Remove coil spring. Refer to [RSU-16. "REAR LOWER LINK & COIL SPRING"](#).
2. Disconnect harness connector from RAS actuator assembly and rear suspension member.
3. Remove fixing bolts and nuts of RAS actuator assembly (1), and then remove RAS actuator assembly (1) from rear suspension member.

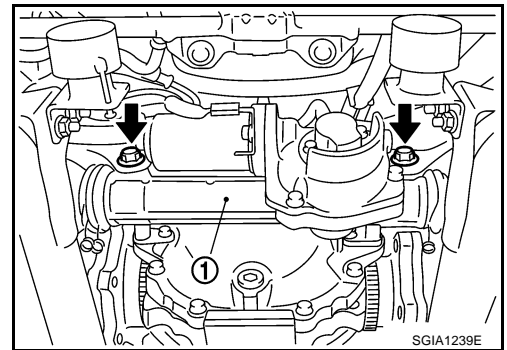

### INSTALLATION

- Installation is the reverse order of removal. For tightening torque, refer to [STC-13. "COMPONENTS"](#).
- When installing RAS actuator assembly to rear suspension member, check the mounting surfaces of RAS actuator assembly and rear suspension member for oil, dirt, sand, or other foreign materials.
- To perform the neutral position adjustment. Refer to [STC-14. "Neutral Position Adjustment"](#).

## Disassembly and Assembly COMPONENTS

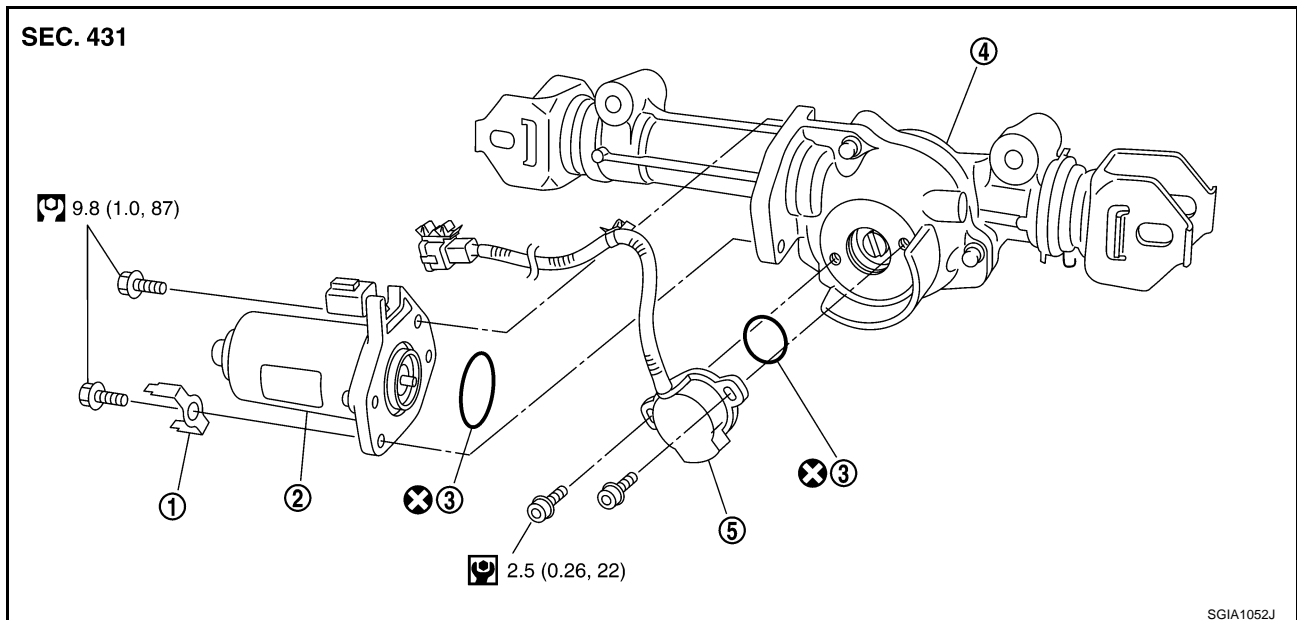

- |                    |                                     |           |
|--------------------|-------------------------------------|-----------|
| 1. Ground terminal | 2. RAS motor assembly               | 3. O-ring |
| 4. RAS actuator    | 5. Rear wheel steering angle sensor |           |

Refer to [GI-11, "Components"](#) , for the symbols in the figure.

### DISASSEMBLY

1. Remove mounting bolts of RAS motor assembly, and then remove RAS motor assembly, ground terminal, O-ring from RAS actuator.
2. Remove mounting bolt of rear wheel steering angle sensor, and then remove rear wheel steering angle sensor, O-ring from RAS actuator.

### INSPECTION AFTER DISASSEMBLY

Check RAS actuator bracket (rear wheel steering angle sensor mounting area) for crush, deformation, cracks, or other damage. Replace the RAS actuator malfunction is detected.

### ASSEMBLY

- Assembly is the reverse order of disassembly. For tightening torque, refer to [STC-14, "COMPONENTS"](#) .
- After assembling RAS actuator assembly (after removing and installing rear wheel angle sensor and RAS motor), perform the neutral position adjustment.

### Neutral Position Adjustment

Adjust neutral position after performing the following procedure.

- Removing and installing or replacing the RAS actuator assembly
- Disassembling the RAS actuator assembly (when removing rear wheel steering angle sensor and RAS motor)

#### CAUTION:

**Perform the neutral position adjustment after installing the RAS actuator assembly to the vehicle. Before that, remove the rear lower link from the RAS actuator.**

1. Disconnect harness connector and remove rear wheel steering angle sensor from the RAS actuator assembly.
2. Disconnect RAS motor harness connector.
3. Turn ignition switch ON.

# REAR ACTIVE STEER

[RAS]

- Supply 6 V voltage by connecting the four 1.5 V batteries in a series. Connect them to the RAS motor connector (motor side), and then operate the motor and adjust the rack in the neutral position (A).

**Full stroke (B) : 6.8 - 7.2 mm (0.268 - 0.283 in)**

**CAUTION:**

**Do not supply 12 V voltage (battery, etc) to the RAS motor.**

**NOTE:**

For right stroke, connect positive probe to the RAS motor connector terminal 1. For left stroke, connect it to the terminal 2.

- Install rear wheel steering angle sensor with O-ring to the RAS actuator assembly. Temporarily tighten the mounting bolts in the specified torque that the sensor can be moved by hand.
- Turn and adjust the rear wheel steering angle sensor so as to make each sensor signal of "DATA MONITOR" mode to the following standard with CONSULT-II.

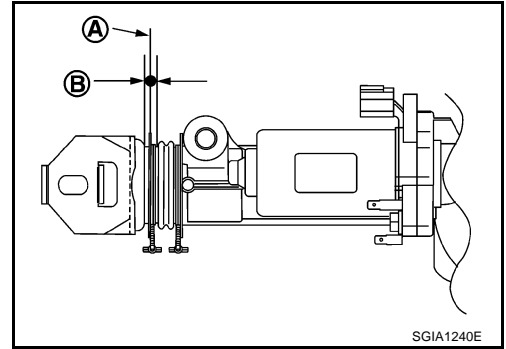

STEERING ANG (°)	L - 0, R - 0, N - 0
RR ST ANG-MAI (V)	Approx. 2.4
RR ST ANG-SUB (V)	Approx. 2.4
RR ST ANG-VOL (V)	Approx. 5.0

**CAUTION:**

**During DATA MONITOR mode, "MONITORING ERROR" is displayed. But there is not malfunction in this procedure.**

- Tighten rear wheel steering angle sensor mounting bolts.
- Perform "ERASE" with CONSULT-II, and then erase the error memory of rear wheel steering angle sensor. Refer to [STC-29, "How to Erase Self-Diagnostic Results"](#) .
- Perform CONSULT-II "SELF-DIAG RESULTS" again, and then make sure that there is no malfunction. Refer to [STC-28, "SELF-DIAG RESULT MODE"](#) .

SYSTEM DESCRIPTION

PFP:00000

Components

NGS000E8

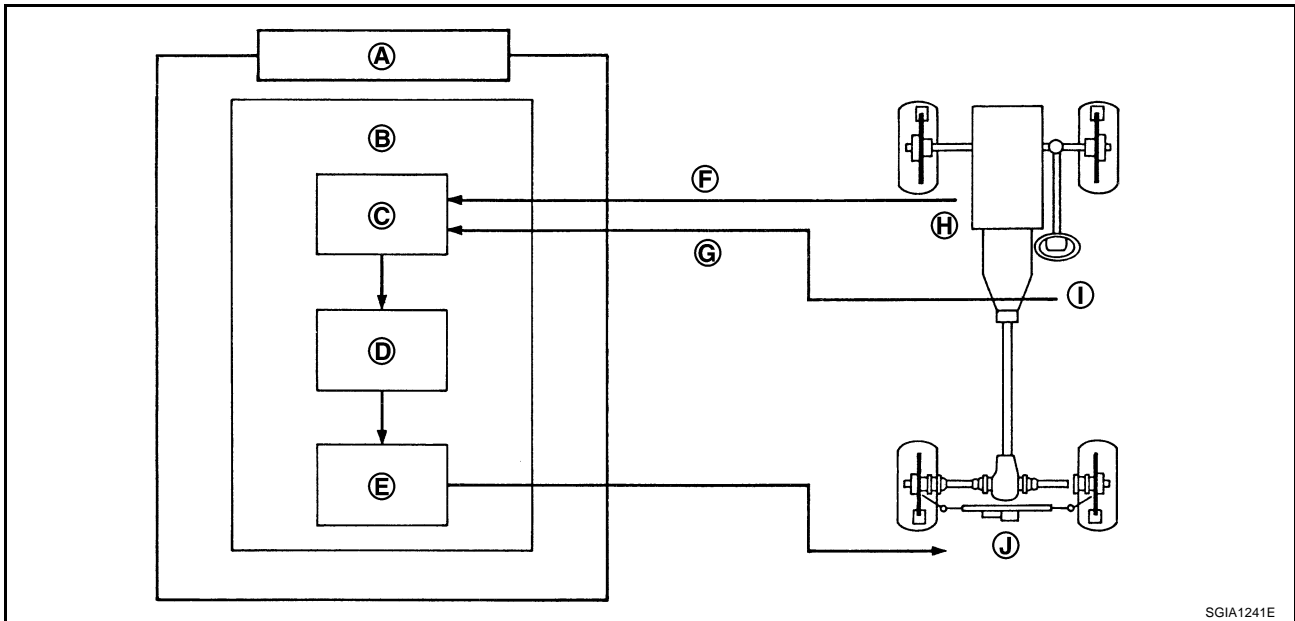

SGIA1241E

- A. RAS control unit
- B. Model following control
- C. Target vehicle dynamics model
- D. Rear wheel steering angle command value operation
- E. Rear wheel steering angle servo
- F. Vehicle speed signal (CAN)
- G. Steering angle signal (CAN)
- H. Vehicle speed sensor
- I. Steering angle sensor
- J. RAS actuator assembly

RAS (Rear Active Steer) Function

NGS000E9

Part name	Function
RAS control unit	<ul style="list-style-type: none"> <li>● Calculate the vehicle speed signal from CAN communication and the signals from steering angle sensor and rear wheel steering angle sensor by a computer, and then control the rear wheel steering angle.</li> <li>● Fail-safe function is activated when the electrical system is malfunctioning. The output signal to the actuator is turned OFF during this mode. At that time, the RAS warning lamp illuminates and indicates the system is malfunctioning.</li> <li>● It performs the communication control function with other control units via CAN communication.</li> <li>● This enables system diagnosis with CONSULT-II.</li> </ul>
RAS actuator	<p>The efficiency of the rear wheel steer improves by locating the electric motor actuator into the lower link of rear suspension.</p>
Steering angle sensor	<ul style="list-style-type: none"> <li>● Measure the steering angle and send it to RAS control unit via CAN communication.</li> <li>● It is shared with the steering angle sensor for VDC.</li> </ul>
Rear wheel steering angle sensor	<ul style="list-style-type: none"> <li>● It sends the rear wheel steering angle status to RAS control unit. The accuracy of rear wheel steer improves by comparing the vehicle speed signal from CAN communication with the rear wheel steering angle target value calculated from the wheel angle sensor signal, and it controls them.</li> <li>● There are 2 types of rear wheel steering angle sensors (main/sub). If one of them is malfunctioning, the other operates the fail-safe mode and stops the control.</li> </ul>
RAS warning lamp	<ul style="list-style-type: none"> <li>● It turns on when the fail-safe function is operated and indicates that a RAS control malfunction has occurred.</li> <li>● It turns on when ignition switch turns on and turns off after the engine is started.</li> <li>● It indicates the suspect system by blinking when performing the self-diagnosis (without CONSULT-II).</li> </ul>



**Fail-Safe Function**

NGS000EA

In the event there is a malfunction with the electrical system, the RAS control is stopped and the fail-safe mode is activated. At that time, it indicates the malfunction by turning the RAS warning lamp ON and stops the rear wheel control.

- A
- B
- C
- D
- E
- F
- STC
- H
- I
- J
- K
- L
- M

## TROUBLE DIAGNOSIS

### How to Perform Trouble Diagnosis BASIC CONCEPT

- The most important point to perform trouble diagnosis is to understand systems (control and mechanism) in vehicle thoroughly.
- It is also important to clarify customer complaints before inspection.  
First of all, reproduce symptom, and understand it fully.  
Ask customer about his/her complaints carefully. In some cases, they will be necessary to check symptom by driving vehicle with customer.

**CAUTION:**

**Customers are not professionals. Do not assume “maybe customer means...” or “maybe customer mentioned this symptom”.**

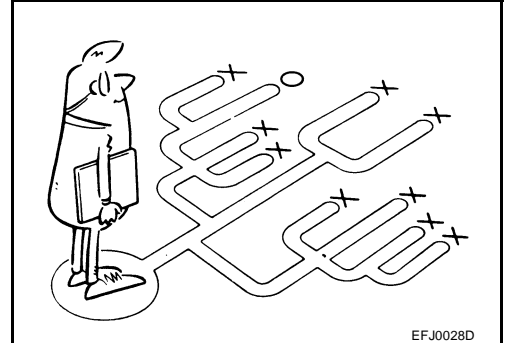

EFJ0028D

- It is essential to check symptoms right from beginning in order to repair a malfunction completely.  
For an intermittent malfunction, it is important to reproduce symptom based on interview with customer and past examples. Do not perform inspection on ad hoc basis. Most intermittent malfunctions are caused by poor contacts. In this case, it will be effective to shake suspected harness or connector by hand. When repairs are performed without any symptom check, no one can judge if malfunction has actually been eliminated.
- After diagnosis, make sure to perform “ERASE MEMORY”. Refer to [STC-29, "How to Erase Self-Diagnostic Results"](#) .
- Always read “GI General Information” to confirm general precautions. Refer to [GI-9, "HOW TO USE THIS MANUAL"](#) .

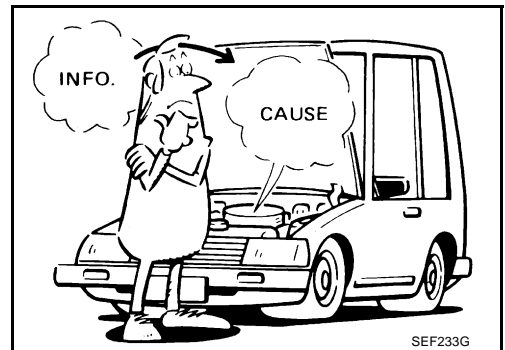

SEF233G

## Component Parts Location

NGS000EC

A  
B  
C  
D  
E  
F

STC

H  
I  
J  
K  
L  
M

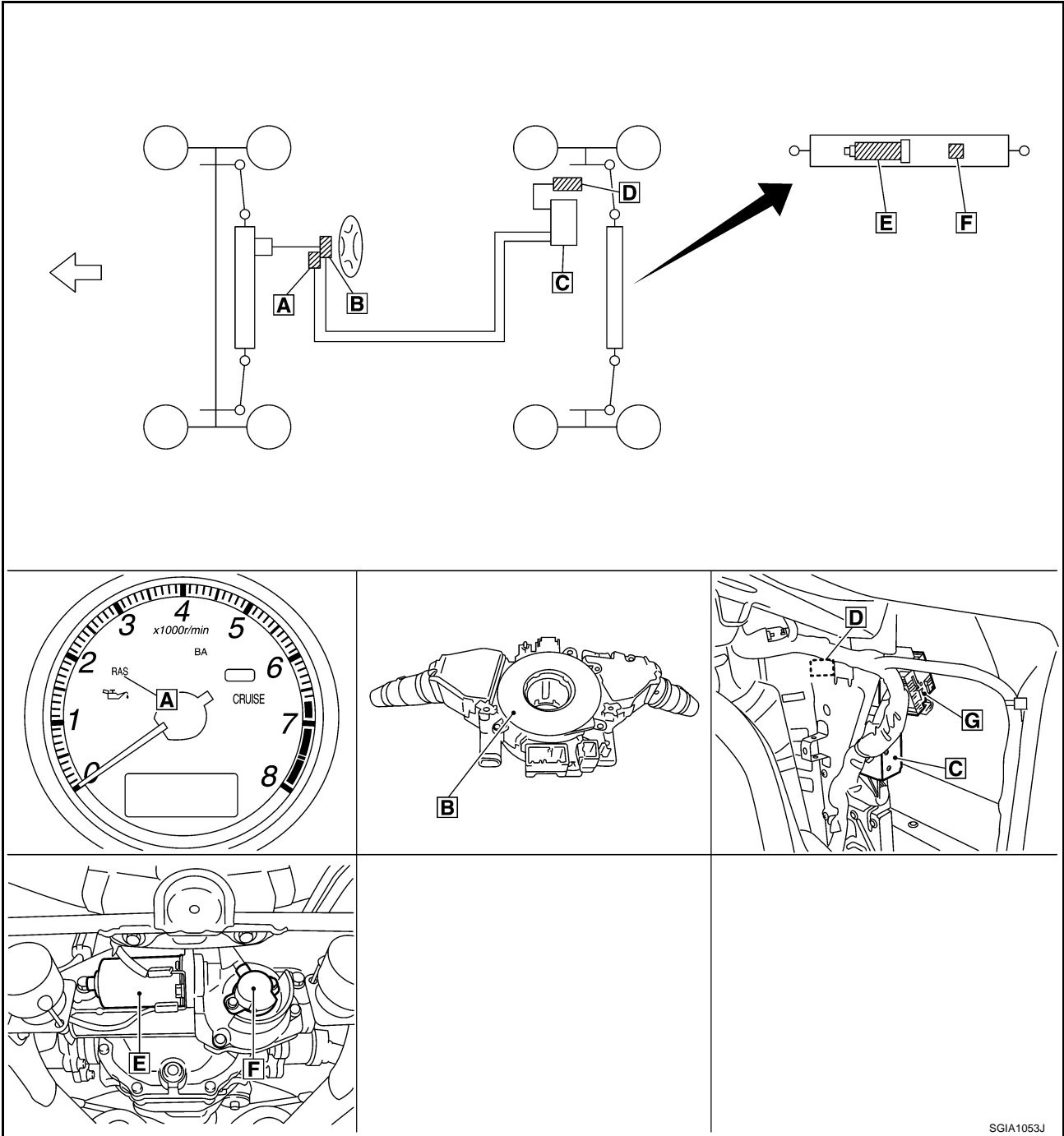

SGIA1053J

A. RAS warning lamp

B. Steering angle sensor

C. RAS control unit

D. RAS motor relay

E. RAS motor

F. Rear wheel steering angle sensor

G. Noise suppressor

## Schematic

NGS000ED

(IC) : With ICC

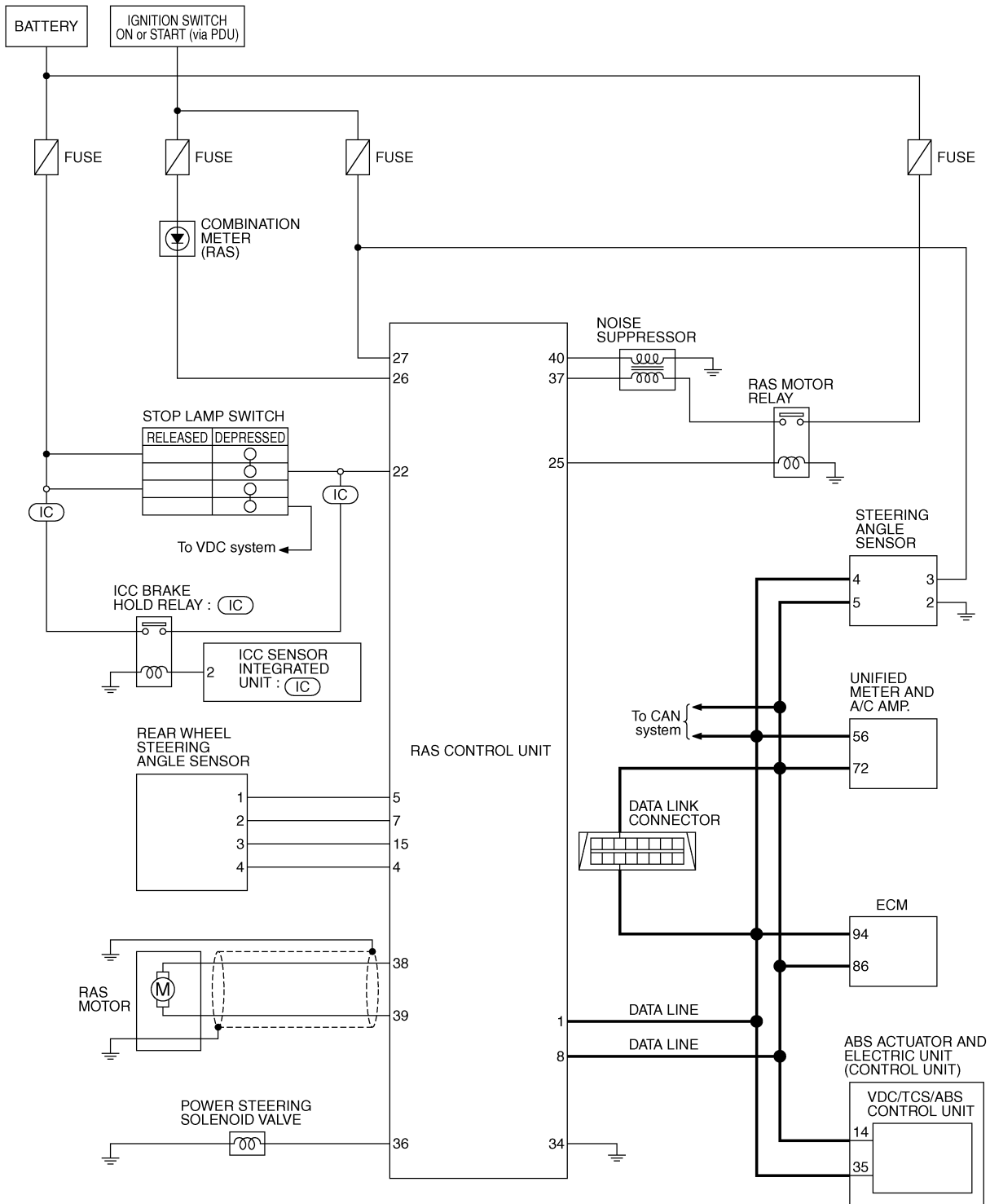

TGWT0025E

Wiring Diagram — RAS —

STC-RAS-01

A  
B  
C  
D  
E  
F  
STC  
H  
I  
J  
K  
L  
M

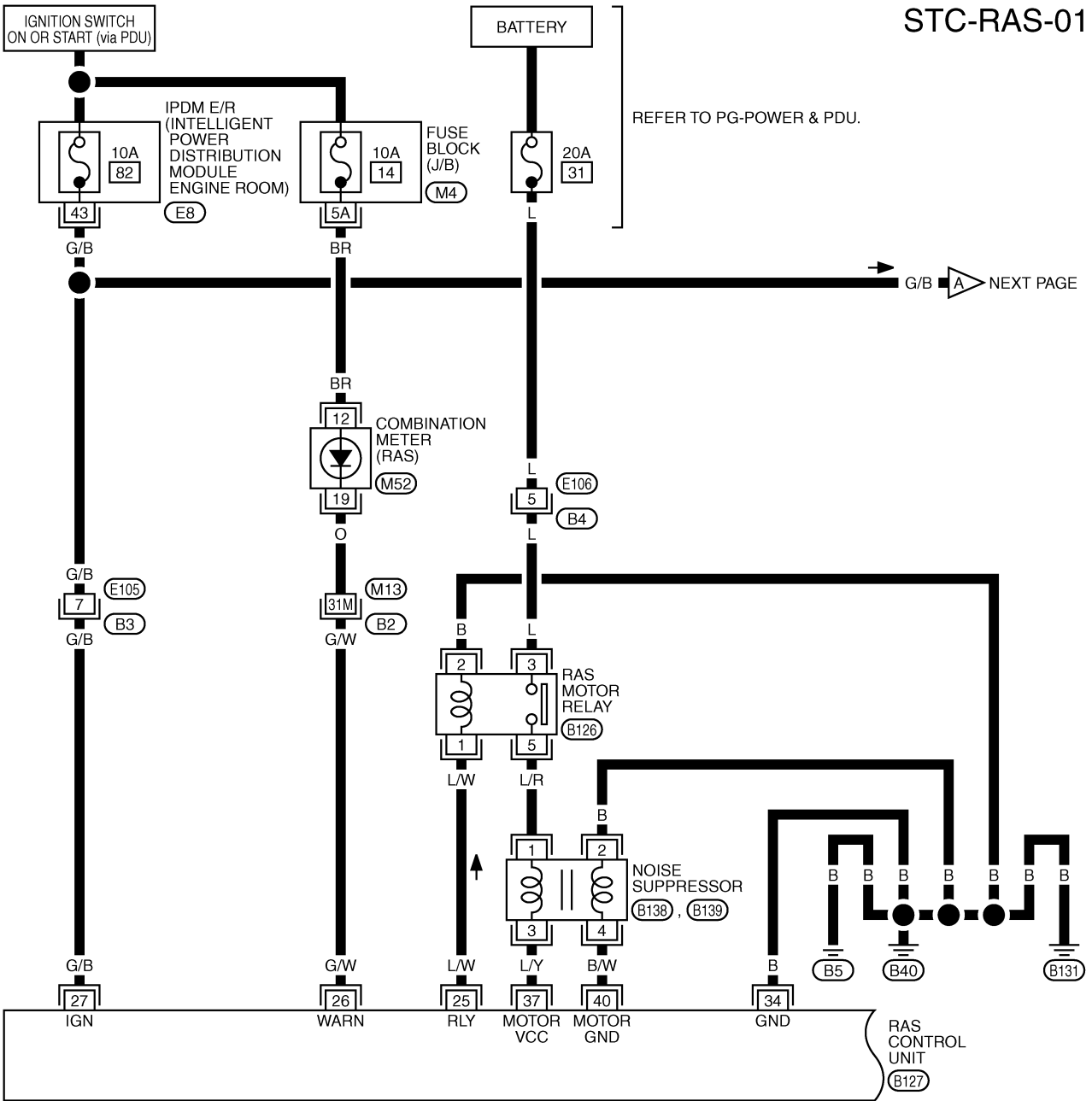

REFER TO PG-POWER & PDU.

G/B NEXT PAGE

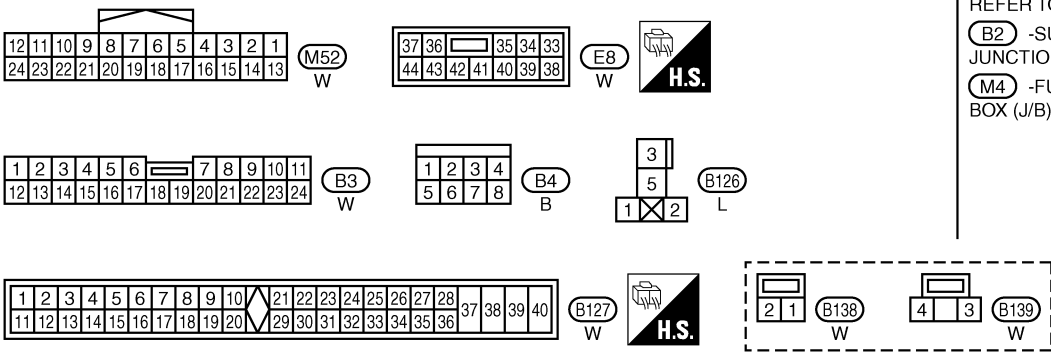

REFER TO THE FOLLOWING.

- (B2) -SUPER MULTIPLE JUNCTION (SMJ)
- (M4) -FUSE BLOCK-JUNCTION BOX (J/B)

# TROUBLE DIAGNOSIS

[RAS]

## STC-RAS-02

▬ : DATA LINE

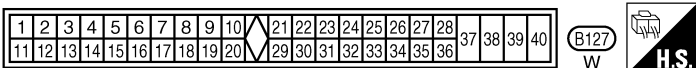
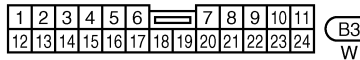
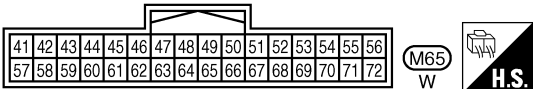
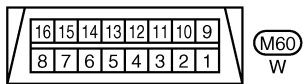
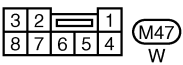
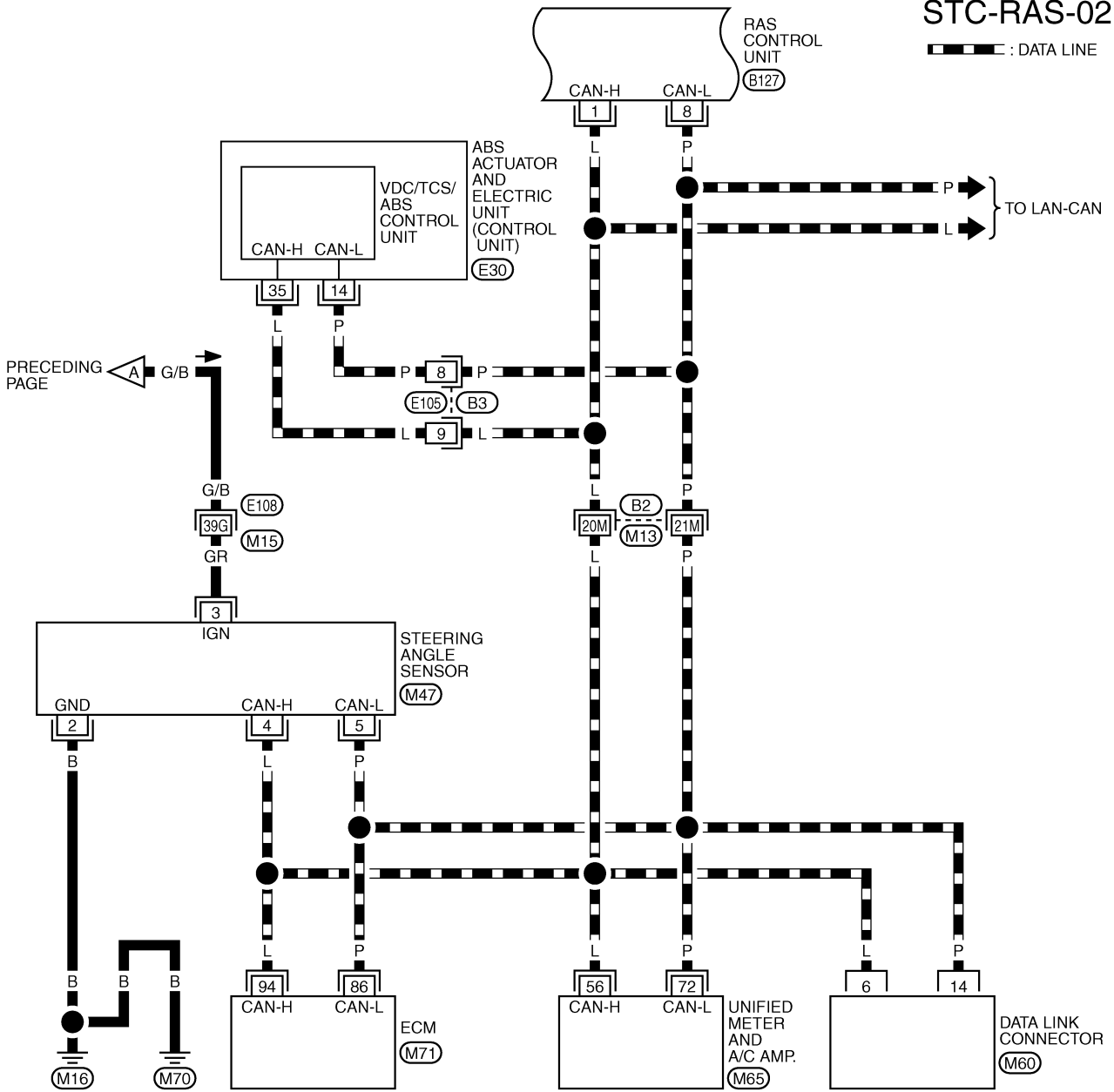

REFER TO THE FOLLOWING.  
 (E108), (B2) -SUPER MULTIPLE JUNCTION (SMJ)  
 (M71), (E30) -ELECTRICAL UNITS

TGWT0027E

# TROUBLE DIAGNOSIS

[RAS]

## STC-RAS-03

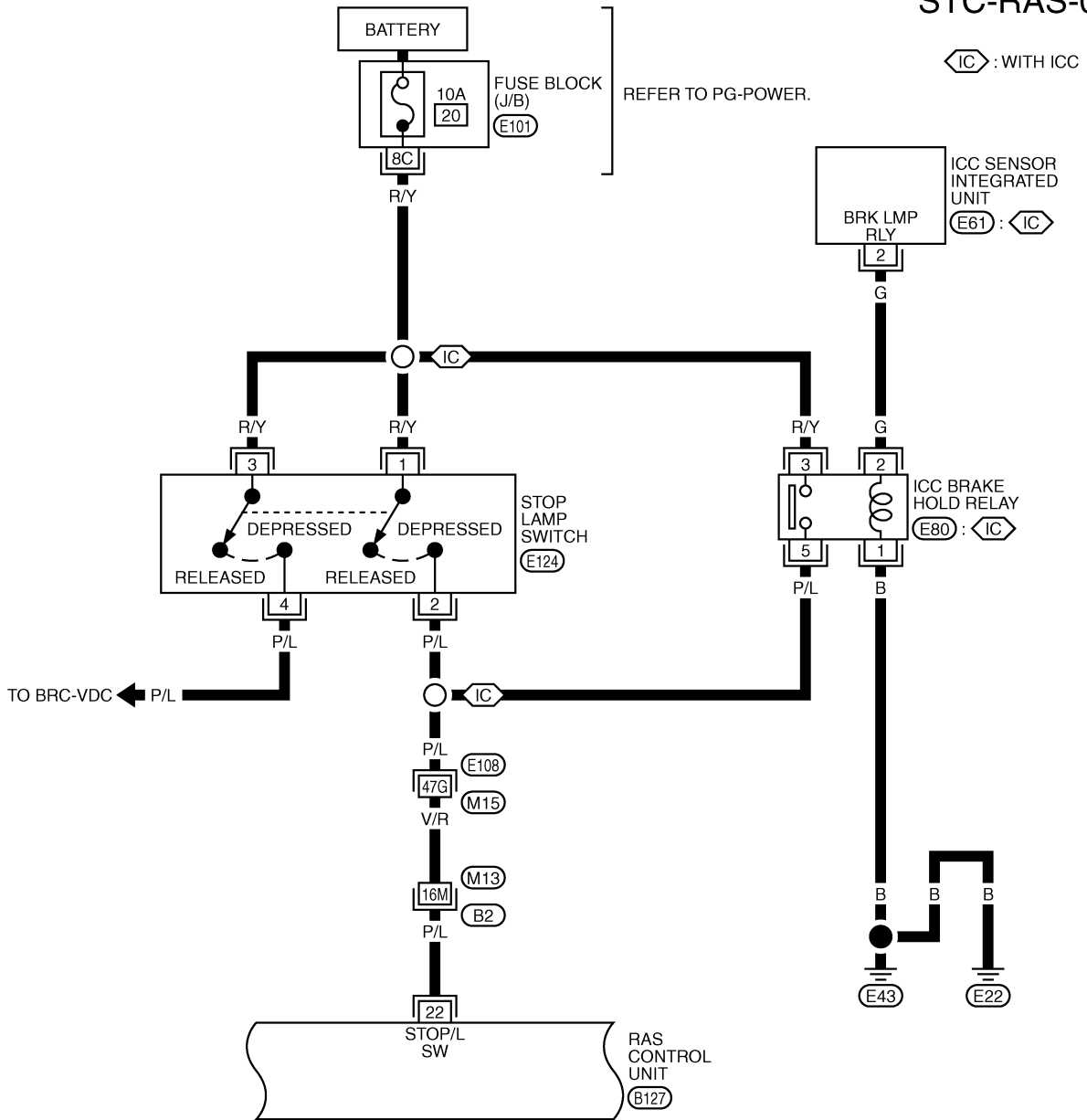

A  
B  
C  
D  
E  
F  
STC  
H  
I  
J  
K  
L  
M

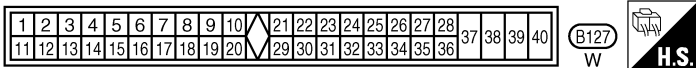
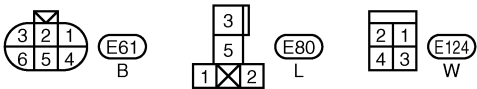

REFER TO THE FOLLOWING.  
 (E108), (B2) -SUPER MULTIPLE JUNCTION (SMJ)  
 (E101) -FUSE BLOCK-JUNCTION BOX (J/B)

TGWT0028E

# TROUBLE DIAGNOSIS

[RAS]

STC-RAS-04

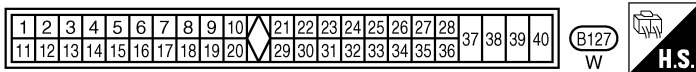
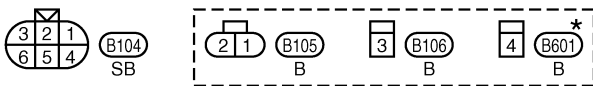
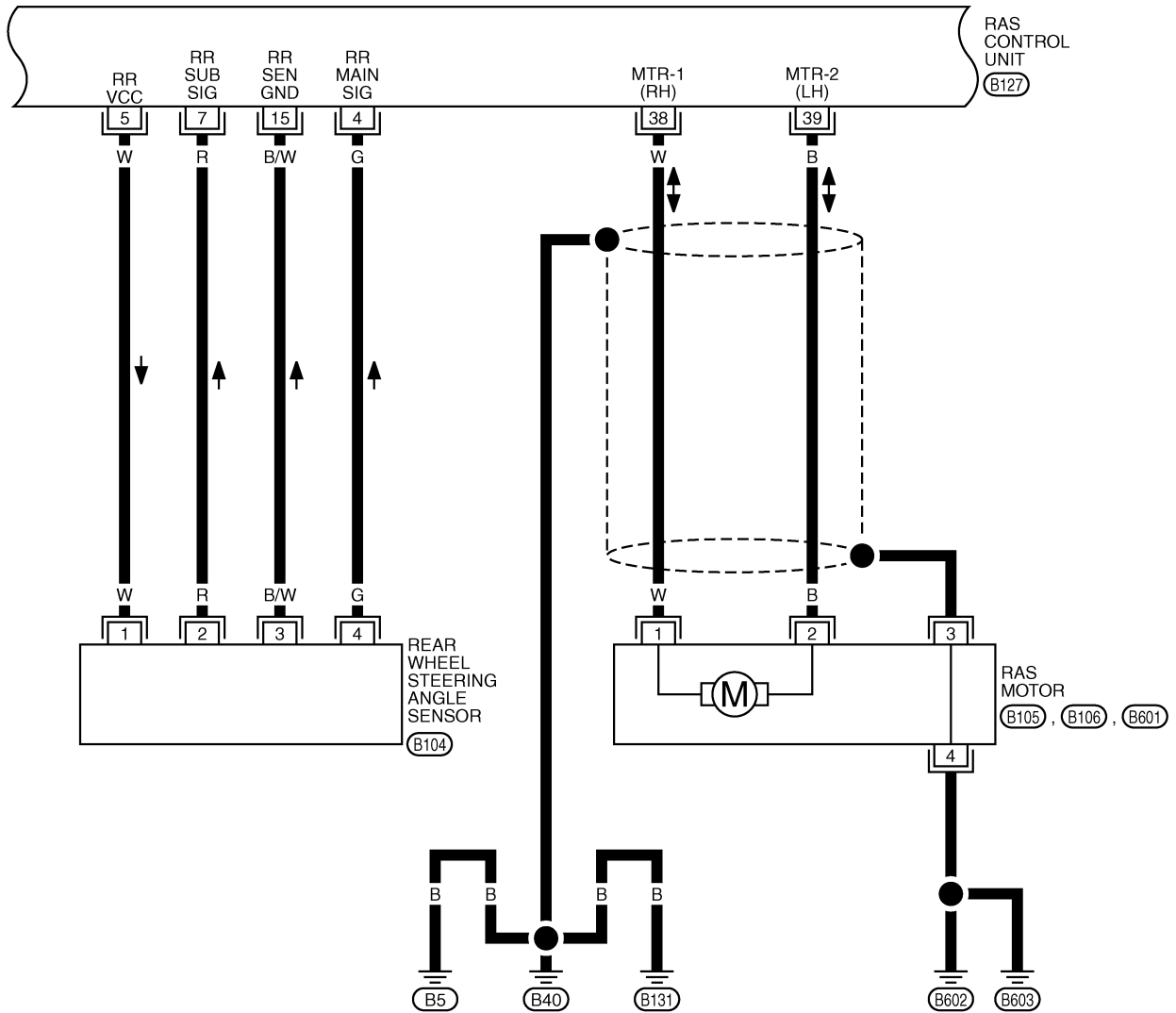

\*: THIS CONNECTOR IS NOT SHOWN IN "HARNESS LAYOUT", PG SECTION.

TGWT0029E



# TROUBLE DIAGNOSIS

[RAS]

## STC-RAS-05

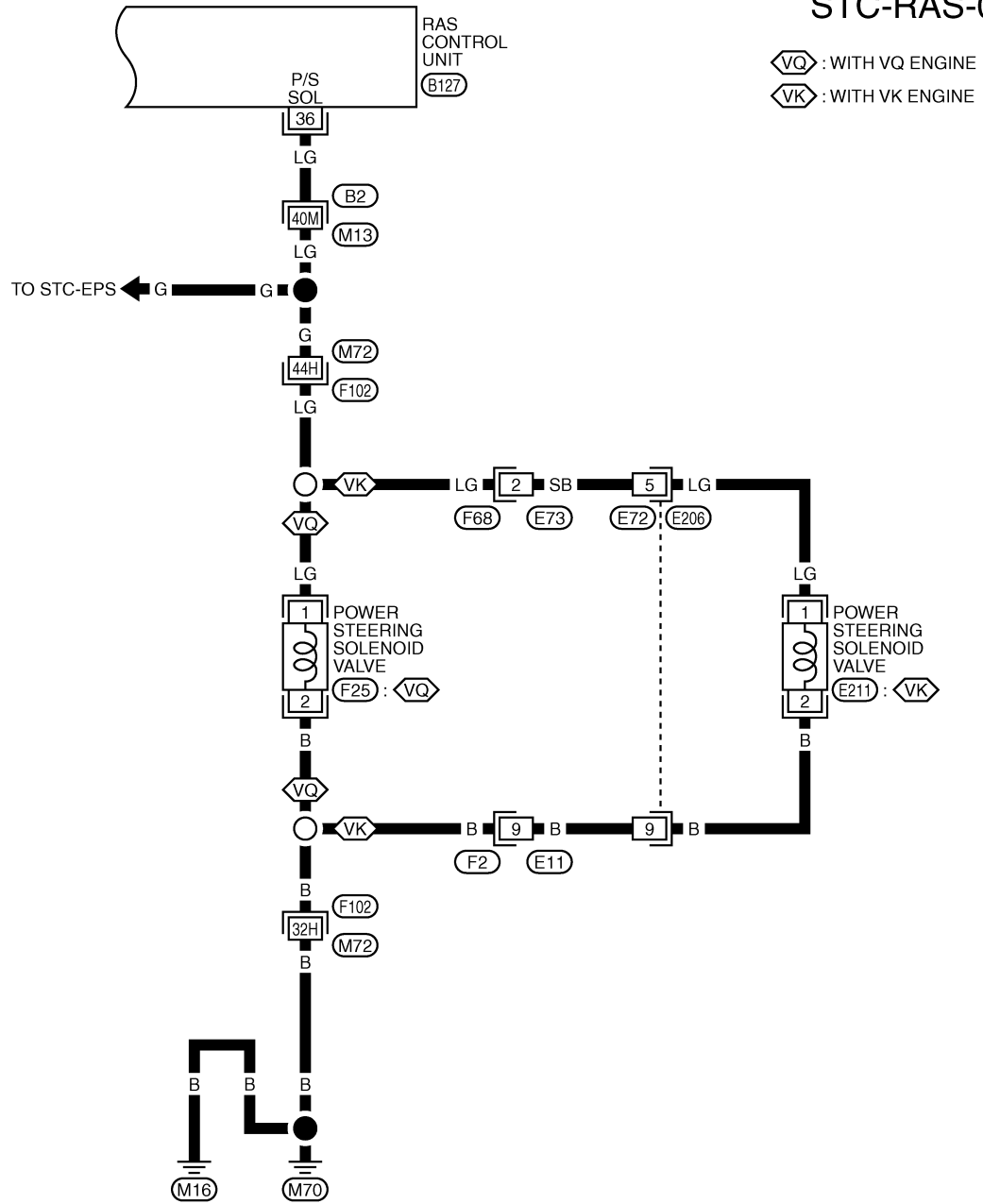

A  
B  
C  
D  
E  
F  
G  
H  
I  
J  
K  
L  
M

STC

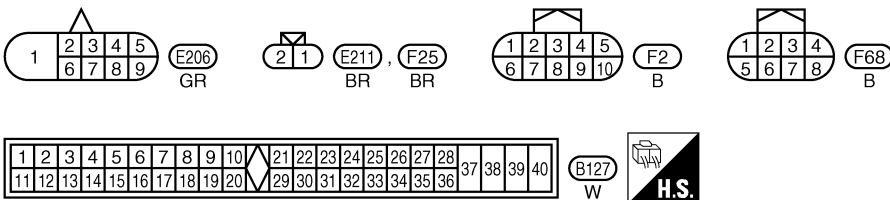

REFER TO THE FOLLOWING.  
 (F102), (B2) -SUPER  
 MULTIPLE JUNCTION (SMJ)

TGWT0030E

# TROUBLE DIAGNOSIS

[RAS]

## Control Unit Input/Output Signal Standard CIRCUIT TESTER REFERENCE VALUE

NGS000EF

**CAUTION:**

When checked using a circuit tester for voltage measurement, connector terminals should not be forcefully extended.

Terminal		Measuring point	Measuring condition		Standard	
+	-					
(wire color)						
1 (L)	—	CAN-H	—			
4 (G)	Ground	RR MAIN SIG	Neutral		Approx. 2.4 V	
5 (W)		RR VCC	Ignition switch ON		Approx. 5 V	
			Ignition switch OFF		Approx. 0 V	
7 (R)	RR SUB SIG	Neutral		Approx. 2.4 V		
8 (P)	—	CAN-L	—			
15 (B/W)	Ground	RR SEN GND	—		Continuity exit	
22 (P/L)		STOP/L SW	Brake pedal depressed		Battery voltage (Approx. 12 V)	
			Brake pedal not depressed		Approx. 0 V	
25 (L/W)		RLY	Ignition switch ON		Battery voltage (Approx. 12 V)	
			Ignition switch OFF		Approx. 0 V	
26 (G/W)		WARN	ON		Approx. 1.4 V or less	
			OFF		Ignition voltage: 2.8 V or more	
27 (G/B)		IGN	Ignition switch ON		Battery voltage (Approx. 12 V)	
			Ignition switch OFF		Approx. 0 V	
34 (B)		GND	—		Continuity exit	
36 (LG)		P/S SOL	Normal (Vehicle speed)	0 km/h (0 MPH)		Approx. 4.4 - 6.6 V
				100 km/h (62 MPH)		Approx. 2.4 - 3.6 V
			In fail-safe mode (Engine speed)	0 - 1,500 rpm		Approx. 4.4 - 6.6 V
				1,500 - 3,000 rpm		Approx. 3.5 V
	3,000 rpm or more			Approx. 2.1 V		
37 (L/Y)	MOTOR VCC	Ignition switch ON		Battery voltage (Approx. 12 V)		
		Ignition switch OFF		Approx. 0 V		
38 (W)	MTR-1 (RH)	—				
39 (B)	MTR-2 (LH)	—				
40 (B/W)	MOTOR GND	—		Continuity exit		

# TROUBLE DIAGNOSIS

[RAS]

## STANDARD BY CONSULT-II

### CAUTION:

The output signal indicates the RAS control unit calculation data. The normal values will be displayed even in the event that the output circuit (harness) is open.

Monitor item	DATA MONITOR		Malfunction inspection checklist
	Condition	Reference values	
VHCL SPEED SE (km/h)	Ignition switch ON or engine running	Almost in accordance with the speedometer display. It is not a malfunction, through it might not be corresponding just after ignition switch is turned ON.	<a href="#">STC-38, "Inspection 4: Vehicle Speed Signal"</a>
STEERING ANG (°)	Turning steering wheel clockwise or counterclockwise.	Displays the angle when the steering wheel turns from the neutral position	<a href="#">STC-38, "Inspection 5: Steering Angle Signal Malfunction"</a>
ENGINE SPEED (rpm)	Engine running	Almost in accordance with tachometer display	<a href="#">STC-43, "Inspection 8: Engine Speed Signal Malfunction"</a>
POWER STR SOL (A)	Accelerate the vehicle from 0 to 100 km/h (0 to 62 MPH)	0 km/h (0 MPH): Approx. 1.10 A 100 km/h (62 MPH): Approx. 0.54 A	<a href="#">STC-46, "Diagnosis Chart by Symptom 2"</a>
RR ST ANG-MAI (V)	Perform the ACTIVE TEST and stroke the actuator (with tires off the ground)	Neutral: Approx. 2.4 V Turn steering wheel to right for full stroke: Approx. 4.4 V Turn steering wheel to left for full stroke: Approx. 0.4 V	<a href="#">STC-40, "Inspection 6: Rear Main Signal and Rear Sub Signal Malfunction"</a>
RR ST ANG- SUB (V)			
RR ST ANG-VOL (V)		Approx. 5 V	<a href="#">STC-40, "Inspection 6: Rear Main Signal and Rear Sub Signal Malfunction"</a>
C/U VOLTAGE (V)	Ignition switch ON or engine running	Battery voltage (Approx. 12 V)	<a href="#">STC-35, "Inspection 1: RAS Control Unit Malfunction"</a>
MOTOR VOLTAGE (V)		Battery voltage (Approx. 12V)	<a href="#">STC-35, "Inspection 2: Motor Power Supply System"</a>
MOTOR CURRENT (A)	Perform the ACTIVE TEST and stroke the actuator.	It is normal when there is the current output at stroke	<a href="#">STC-35, "Inspection 2: Motor Power Supply System"</a>
MTR CRNT OPE (A)	Turning steering wheel clockwise or counterclockwise while ignition switch is ON or running the engine	Neutral (Steering force is zero and straight-ahead position): Approx. 0 A The value is changed according to steering left or right	<a href="#">STC-37, "Inspection 3: RAS Motor Output Malfunction"</a>
STOP LAMP SW	Depressing or releasing brake pedal	Brake pedal depressed: ON	<a href="#">STC-44, "Inspection 10: Stop Lamp Switch Harness"</a>
		Brake pedal not depressed: OFF	
RAS RELAY	Ignition switch ON or engine running	Ignition switch ON: ON	<a href="#">STC-35, "Inspection 2: Motor Power Supply System"</a>
FAIL SAFE		Not activated	Self-diagnosis and suspect system inspection on DATA MONITOR
WARNING LAMP (ON/OFF)		RAS warning lamp ON: ON RAS warning lamp OFF: OFF	Warning lamp circuit inspection

## CONSULT-II Function (RAS) FUNCTION

CONSULT-II can display each self-diagnostic item using the diagnostic test modes shown following.

Mode	Function	Reference
SELF-DIAG RESULTS	Receives self-diagnosis results from RAS control unit and indicates DTCs.	<a href="#">STC-28, "SELF-DIAG RESULT MODE"</a>
DATA MONITOR	Receives input/output signals from RAS control unit and indicates and stores them to facilitate locating cause of malfunctions.	<a href="#">STC-30, "DATA MONITOR MODE"</a>
CAN DIAG SUPPORT MNTR	Monitors transmitting/receiving status of CAN communication.	<a href="#">STC-31, "CAN Communication"</a>
ACTIVE TEST	Sends command to RAS actuator to change output signals and check operation of output system.	<a href="#">STC-30, "ACTIVE TEST MODE"</a>
ECU PART NUMBER	Displays RAS control unit part number.	<a href="#">STC-30, "RAS CONTROL UNIT PART NUMBER"</a>

## CONSULT-II SETTING PROCEDURE

Refer to [GI-39, "CONSULT-II Start Procedure"](#) .

## SELF-DIAG RESULT MODE

### Operation Procedure

1. Perform "CONSULT-II Start Procedure". Refer to [GI-39, "CONSULT-II Start Procedure"](#) .
2. Touch "PRINT" to print out the self-diagnostic results if necessary. Check RAS warning lamp if "NO FAILURE" is displayed.
3. Perform the appropriate inspection from the display item list, and repair or replace the malfunctioning component. Refer to [STC-28, "Display Item List"](#) .

### Display Item List

#### CAUTION:

**When malfunctions are detected in several systems, including the "CAN COMM [U1000]" and "CONTROL\_UNIT (CAN) [U1010]", inspect the CAN communication system.**

DTC code	Diagnostic item	Diagnostic item is detected when...	Check items
C1923	STEERING_ANGLE_SEN [NO_CHANGE] (. a)	While driving at 60 km/h (37 MPH) or more, steering angle does not change for a while.	<a href="#">STC-38</a>
C1924	STEERING_ANGLE_SEN [NO_NEUT_STATE] (. b)	When driving some distance, no neutral signal (ON signal) is input.	<a href="#">STC-38</a>
C1915	RR_ST_ANGLE_SENSOR [MAIN_SIGNAL] (. a)	The main sensor input signal is malfunctioning for some time against the sensor power supply value.	<a href="#">STC-40</a>
C1916	RR_ST_ANGLE_SENSOR [SUB_SIGNAL] (. b)	When the main sensor input signal is 2.4 - 2.6 V, the sub sensor input signal is malfunctioning for some time compared to the sensor power supply value.	<a href="#">STC-40</a>
C1917, C1918	RR_ST_ANGLE_SENSOR [OFFSET_SIG1,2] (. c)	An excessive difference has occurred in the input values of main sensor and sub sensor.	<a href="#">STC-40</a>
C1914	RR_ST_ANGLE_SENSOR [ABNORMAL_VOL] (. d)	Higher or lower value compared to the standard voltage.	<a href="#">STC-40</a>
C1921	MOTOR_OUTPUT	No engine speed is input for a certain time.	<a href="#">STC-43</a>
C1911	MOTOR_VOLTAGE [LOW_VOLTAGE] (. a)	The motor power supply voltage is lower than ignition power supply voltage with RAS motor relay ON.	<a href="#">STC-35</a>

# TROUBLE DIAGNOSIS

[RAS]

DTC code	Diagnostic item	Diagnostic item is detected when...	Check items
C1912	MOTOR_VOLTAGE [BAD_OBSTRCT] (- b)	The motor power supply voltage is inputting for some time with motor power supply OFF by RAS control unit.	<a href="#">STC-35</a>
C1913	MOTOR_OUTPUT [ABNORMAL_SIG] (- a)	When the motor current value is 10A or more, actual output is excessively low and the condition continues for some time.	<a href="#">STC-37</a>
C1902	MOTOR_OUTPUT [REV_CURRENT] (- c)	The current flows in the opposite direction when the motor current is output.	<a href="#">STC-37</a>
C1903	MOTOR_OUTPUT [NO_CURRENT] (- d)	The current flows when the motor current is not output.	<a href="#">STC-37</a>
C1904	MOTOR_OUTPUT [OVERCURRENT] (- e)	The excessive high current flows when the motor current is output.	<a href="#">STC-37</a>
C1910	MOTOR_OUTPUT [MOTOR_LOCK] (- b)	When 17 A or more current flows to the motor, the rear wheel steering angle sensor signal does not change for some time.	<a href="#">STC-37</a>
C1919	VEHICLE_SPEED_SEN [NO_SIGNAL]	No vehicle speed signal is input for some time.	<a href="#">STC-38</a>
C1900	CONTROL_UNIT [ABNORMAL1 - 9]	Control unit malfunction	<a href="#">STC-35</a>
C1901			
C1905			
C1906			
C1907			
C1908			
C1909			
C1922			
C1928			
C1920	STEERING_ANGLE_SEN [NO_SIGNAL]	No steering angle signal is input for some time.	<a href="#">STC-38</a>
C1926	STEERING_ANGLE_SEN	<ul style="list-style-type: none"> <li>An unexpected signal is input.</li> <li>Steering angle sensor outputs the malfunction signal.</li> </ul>	<a href="#">STC-38</a>
C1929	VDC	ABS actuator and electric unit (control unit) outputs the malfunction signal.	<a href="#">STC-42</a>
U1000	CAN COMM CIRCUIT	When a control unit (except for RAS) is not transmitting or receiving CAN communication signal 2 seconds or less.	<a href="#">STC-43</a>
U1010	CONTROL_UNIT [CAN]	When detected error during the initial diagnosis of CAN controller of each control unit.	<a href="#">STC-43</a>

## How to Erase Self-Diagnostic Results

1. Perform applicable inspection of malfunctioning item and then repair or replace.
2. Start engine, and touch "START (NISSAN BASED VHCL)" "RAS/HICAS" "SELF-DIAG RESULTS" and "ERASE" in this order to erase the diagnostic memory.

### CAUTION:

**If memory cannot be erased, repeat step 1, 2.**

3. Perform self-diagnosis again, and make sure that DTC memory is erased.

## DATA MONITOR MODE

### Operation Procedure

1. Perform "CONSULT-II Start Procedure". Refer to [GI-39, "CONSULT-II Start Procedure"](#).
2. Touch "DATA MONITOR".
3. Select from "SELECT MONITOR ITEM", screen of data monitor is displayed.

**NOTE:**

When malfunction is detected, CONSULT-II performs REAL-TIME DIAGNOSIS. Also, any malfunction detected while in this mode will be displayed in real time.

### Display Item List

Item (Display or Unit)	Remarks
VHCL SPEED SE (km/h)	Vehicle speed received via CAN communication is displayed.
STEERING ANG (°)	Steering angle received via CAN communication is displayed.
ENGINE SPEED (rpm)	Engine speed received via CAN communication is displayed.
POWER STR SOL (A)	Power steering solenoid controlling current that RAS control unit outputs is displayed.
RR ST ANG_MAI (V)	Rear wheel steering angle main sensor output voltage is displayed.
RR ST ANG_SUB (V)	Rear wheel angle sub sensor output voltage is displayed.
RR ST ANG_VOL (V)	Voltage supplied from RAS control unit to rear wheel steering angle sensor is displayed.
C/U VOLTAGE (V)	Voltage supplied to RAS control unit is displayed.
MOTOR VOLTAGE (V)	Voltage supplied from RAS control unit to RAS motor is displayed.
MOTOR CURRENT (A)	RAS motor relay controlling current that RAS control unit outputs is displayed.
MOTOR CRNT OPE (A)	Current commanded value to RAS motor is displayed.
RR ANG OPE (°)	Angle commanded value to rear wheel steering angle sensor is displayed.
STOP LAMP SW (ON/OFF)	Condition of stop lamp switch ON/OFF is displayed.
HICAS RELAY (ON/OFF)	RAS motor relay ON/OFF condition is displayed.
FAILSAFE (ON/OFF)	Fail-safe ON/OFF condition is displayed.
WARNING LAMP (ON/OFF)	RAS warning lamp operating condition is displayed.

## ACTIVE TEST MODE

### Operation Procedure

1. Perform "CONSULT-II Start Procedure". Refer to [GI-39, "CONSULT-II Start Procedure"](#).
2. When turning the steering wheel right or left, the rear wheel turns in the same direction. If the steering wheel is not turned, the rear wheel turns left and right 5 times.

STEERING ANG	RR ST ANG_MAI	RR ST ANG_SUB	MOTOR CURRENT
0° (Neutral)	2.4 V	2.4 V	No output (Approx. 0 A)
R 90°	Approx. 4.4 V	Approx. 4.4 V	Output (change)
L 90°	Approx. 0.4 V	Approx. 0.4 V	

## RAS CONTROL UNIT PART NUMBER

1. Perform "CONSULT-II Start Procedure". Refer to [GI-39, "CONSULT-II Start Procedure"](#).
2. The part number described on RAS control unit sticker is displayed.

## Diagnosis Procedure with Self-Diagnosis Function (Without CONSULT-II)

If a malfunction is detected in the system, the RAS warning lamp turns on and indicates the malfunction. At that time, fail-safe activates, and then stops the function.

### SELF-DIAGNOSIS PROCEDURE

1. Start engine.
2. Turn steering wheel left and right at 20° or more and 5 times or more within 10 seconds. And then depress the service brake 5 times or more.
3. RAS warning lamp blinks (displays normal/malfunction).

### SELF-DIAGNOSIS DISPLAY

RAS warning lamp blinks and displays the self-diagnostic results.

- Only DTCs are displayed as the pattern shown in the figure, and then repeat the display.
- If all items are normal, RAS warning lamp blinks at 4 Hz cycle.

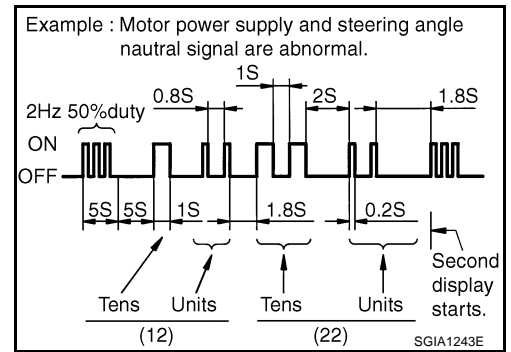

### SELF-DIAGNOSIS DISPLAY ITEMS

DTC (warning lamp blinks)	Diagnosis item	Inspection item
11	RAS control unit	<a href="#">STC-35, "Inspection 1: RAS Control Unit Malfunction"</a>
12	Motor power supply	<a href="#">STC-35, "Inspection 2: Motor Power Supply System"</a>
13	Motor output	<a href="#">STC-37, "Inspection 3: RAS Motor Output Malfunction"</a>
21	Vehicle speed signal	<a href="#">STC-38, "Inspection 4: Vehicle Speed Signal"</a>
22	Steering angle signal	<a href="#">STC-38, "Inspection 5: Steering Angle Signal Malfunction"</a>
24	Rear wheel steering angle (main)	<a href="#">STC-40, "Inspection 6: Rear Main Signal and Rear Sub Signal Malfunction"</a>
25	Rear wheel steering angle (sub)	<a href="#">STC-40, "Inspection 6: Rear Main Signal and Rear Sub Signal Malfunction"</a>
26	VDC	<a href="#">STC-42, "Inspection 7: VDC Malfunction"</a>
33	Engine speed signal	<a href="#">STC-43, "Inspection 8: Engine Speed Signal Malfunction"</a>

### HOW TO ERASE SELF-DIAGNOSIS

If there is the history data for when the fail-safe has activated in the past, erase the memory with CONSULT-II. Refer to [STC-29, "How to Erase Self-Diagnostic Results"](#).

## CAN Communication SYSTEM DESCRIPTION

CAN (Controller Area Network) is a serial communication line for real time application. It is an on-vehicle multiplex communication line with high data communication speed and excellent error detection ability. Many electronic control units are equipped onto a vehicle, and each control unit shares information and links with other control units during operation (not independent). In CAN communication, control units are connected with 2 communication lines (CAN H line, CAN L line) allowing a high rate of information transmission with less wiring. Each control unit transmits/receives data but selectively reads required data only. Refer to [LAN-34, "CAN Communication Unit"](#).

## For Fast and Accurate Trouble Diagnosis

Check the following items with the vehicle stopped

- Is air pressure and size of tires proper?
- Is the specified part used for the steering wheel?
- Is control unit a genuine part?
- Are there any fluid leakage from steering gear assembly, power steering oil pump, and hydraulic pipes, etc? Refer to [PS-8, "POWER STEERING FLUID"](#) .
- Is the fluid level proper? Refer to [PS-8, "POWER STEERING FLUID"](#) .
- Is the wheel alignment is adjusted properly? Refer to [FSU-19, "SERVICE DATA AND SPECIFICATIONS \(SDS\)"](#) (2WD), [FSU-36, "SERVICE DATA AND SPECIFICATIONS \(SDS\)"](#) (AWD).
- Are there any damage or modification to suspension or body resulting in increased weight or altered ground clearance?
- Check each link installation condition of suspension and axle.
- Is the battery voltage proper?
- Check each connector connection condition.

Check the following items while driving the vehicle

- Conditions when the error occurred (5W 1H).
- Is the engine is normal?

### Basic Inspection

#### BASIC INSPECTION 1: POWER SUPPLY CIRCUIT TERMINAL LOOSENESS AND BATTERY

Check battery terminals for looseness on both positive and negative ones and ground connection. Also make sure that battery voltage does not drop.

#### BASIC INSPECTION 2: RAS WARNING LAMP INSPECTION

1. Make sure RAS warning lamp turns on when ignition switch is turned ON.
  - If it does not turn on, refer to [STC-33, "Trouble Diagnosis Chart"](#) .
2. Make sure that RAS warning lamp turns off when the engine is started after ignition switch is turned ON. If it does not turn off, perform self-diagnosis. Refer to [STC-28, "SELF-DIAG RESULT MODE"](#) .
3. Always erase DTC memory after completing self-diagnosis. Refer to [STC-29, "How to Erase Self-Diagnostic Results"](#) .

#### BASIC INSPECTION 3: RAS CONTROL UNIT POWER SUPPLY CIRCUIT AND GROUND CIRCUIT INSPECTION

### 1. CHECK RAS CONTROL UNIT CONNECTOR

Turn ignition switch OFF, disconnect RAS control unit harness connector, and check terminal for deformation, disconnection, looseness, etc.

OK or NG

OK >> GO TO 2.

NG >> Poor connection of connector terminal. Repair or replace the terminal.

### 2. CHECK RAS CONTROL UNIT GROUND CIRCUIT

1. Disconnect RAS control unit harness connector B127, and then check continuity between RAS control unit harness connector B127 and ground.

**Terminal 34 – Ground : Continuity**

OK or NG

OK >> GO TO 3.

NG >> Ground circuit open or shorted. Repair or replace any inoperative parts.

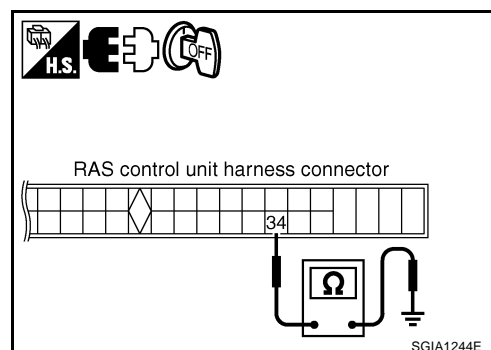



**3. CHECK RAS CONTROL UNIT POWER SUPPLY CIRCUIT**

Turn ignition switch ON, and then check voltage between RAS control unit harness connector B127 and ground.

**Terminal 27 – Ground : Battery voltage (Approx. 12 V)**

OK or NG

- OK >> Power supply and ground circuit are normal.
- NG >> Power supply circuit open or shorted. Repair or replace any inoperative parts.

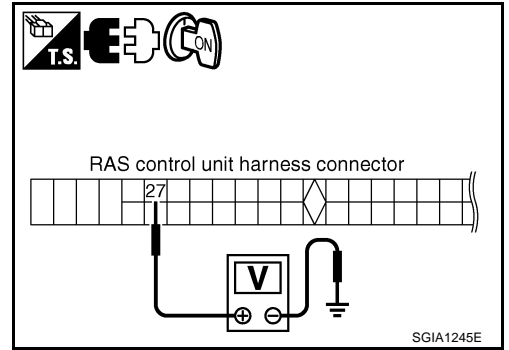

**Trouble Diagnosis Chart  
SELF-DIAGNOSIS**

NGS000EP

Self-diagnosis function		CONSULT-II	Reference
DTC (warning lamp blinks)	Diagnosis item	Diagnosis item	
11	Control unit	CONTROL_UNIT [ABNORMAL 1 - 9]	<a href="#">STC-35</a>
12	Motor power supply	MOTOR_VOLTAGE [LOW_VOLTAGE] (. a)	<a href="#">STC-35</a>
		MOTOR_VOLTAGE [BAD_OBSTRCT] (. b)	
13	Motor output	MOTOR_OUTPUT [ABNORMAL_SIG] (. a)	<a href="#">STC-37</a>
		MOTOR_OUTPUT [REV_CURRENT] (. c)	
		MOTOR_OUTPUT [NO_CURRENT] (. d)	
		MOTOR_OUTPUT [OVERCURRENT] (. e)	
		MOTOR_OUTPUT [MOTOR_LOCK] (. b)	
21	Vehicle speed signal	VEHICLE_SPEED_SEN [NO_SIGNAL]	<a href="#">STC-38</a>
22	Steering angle signal	STEERING_ANGLE_SEN [NO_CHANGE] (. a)	<a href="#">STC-38</a>
		STEERING_ANGLE_SEN [NO_NEUT_STATE] (. b)	
		STEERING_ANGLE_SEN [NO_SIGNAL]	
		STEERING_ANGLE_SEN	
24	Rear wheel steering angle (main)	RR_ST_ANGLE_SENSOR [MAIN_SIGNAL] (. a)	<a href="#">STC-40</a>
		RR_ST_ANGLE_SENSOR [ABNORMAL_VOL] (. d)	
		RR_ST_ANGLE_SENSOR [OFFSET_SIG 1, 2] (. c)	
25	Rear wheel steering angle (sub)	RR_ST_ANGLE_SENSOR [SUB_SIGNAL] (. b)	<a href="#">STC-40</a>
		RR_ST_ANGLE_SENSOR [ABNORMAL_VOL] (. d)	
		RR_ST_ANGLE_SENSOR [OFFSET_SIG 1, 2] (. c)	
26	VDC	VDC	<a href="#">STC-42</a>
27	Engine speed signal	MOTOR_OUTPUT	<a href="#">STC-43</a>
	—	CAN COMM CIRCUIT	<a href="#">STC-43</a>
	—	CONTROL UNIT	

# TROUBLE DIAGNOSIS

[RAS]

## DIAGNOSIS CHART BY SYMPTOM

Symptom	Reference
It is not entering the self-diagnosis mode.	<a href="#">STC-32. "BASIC INSPECTION 3: RAS CONTROL UNIT POWER SUPPLY CIRCUIT AND GROUND CIRCUIT INSPECTION"</a>
	<a href="#">STC-44. "Inspection 10: Stop Lamp Switch Harness"</a>
	<a href="#">STC-44. "Inspection 11: RAS Warning Lamp Harness"</a>
RAS warning lamp does not turn on with ignition switch ON.	<a href="#">STC-32. "BASIC INSPECTION 3: RAS CONTROL UNIT POWER SUPPLY CIRCUIT AND GROUND CIRCUIT INSPECTION"</a>
	<a href="#">STC-44. "Inspection 11: RAS Warning Lamp Harness"</a>
RAS warning lamp turns on with ignition switch ON. It does not turn off even if the engine is started.	<a href="#">STC-32. "Basic Inspection"</a>
	<ul style="list-style-type: none"> <li>● <a href="#">STC-28. "SELF-DIAG RESULT MODE"</a></li> <li>● <a href="#">STC-31. "Diagnosis Procedure with Self-Diagnosis Function (Without CONSULT-II)"</a></li> </ul>
RAS warning lamp may turn on after the engine is started.	<a href="#">STC-28. "SELF-DIAG RESULT MODE"</a>
The steering force does not change smoothly according to the vehicle speed.	<a href="#">STC-46. "Diagnosis Chart by Symptom 2"</a>
Noise	<ul style="list-style-type: none"> <li>● <a href="#">STC-28. "SELF-DIAG RESULT MODE"</a></li> <li>● <a href="#">STC-31. "Diagnosis Procedure with Self-Diagnosis Function (Without CONSULT-II)"</a></li> </ul>
	<a href="#">STC-14. "INSPECTION AFTER DISASSEMBLY"</a>
	<a href="#">STC-46. "Diagnosis Chart by Symptom 1"</a>
Malfunction other than above	<a href="#">STC-46. "Diagnosis Chart by Symptom 1"</a>

**Inspection 1: RAS Control Unit Malfunction**

NGS000EQ

**1. CHECK SELF-DIAGNOSIS RESULTS**

Check self-diagnosis results.

**With CONSULT-II**

Self-diagnostic results

CONTROL\_UNIT [ABNORMAL1 - 9]

**Without CONSULT-II**

DTC (warning lamp blinks)

11

Is above displayed on self-diagnosis display?

- YES >> Replace RAS control unit. Perform self-diagnosis again after replacing.
- NO >> INSPECTION END

**Inspection 2: Motor Power Supply System**

NGS000ER

**1. CHECK RAS CONTROL UNIT CONNECTOR**

1. Turn ignition switch OFF, disconnect RAS control unit harness connector and motor connector, and check terminal for deformation, disconnection, looseness, etc.
2. Reconnect harness connector securely, and perform self-diagnosis.

**With CONSULT-II**

Self-diagnosis results

MOTOR\_VOLTAGE [LOW\_VOLTAGE] (. a)

MOTOR\_VOLTAGE [BAD\_OBSTRCT] (. b)

**Without CONSULT-II**

DTC (warning lamp blinks)

12

Is above displayed on self-diagnosis display?

- YES >> GO TO 2.
- NO >> Connector terminal connection is loose, damaged, open, or shorted. Repair or replace the terminal.

**2. CHECK RAS MOTOR RELAY BATTERY CIRCUIT**

1. Turn ignition switch OFF, and disconnect RAS motor relay harness connector B126.
2. Check voltage between RAS motor relay harness connector B126 and ground.

**Terminal 3 – Ground : Battery voltage (Approx. 12 V)**

OK or NG

- OK >> GO TO 3.
- NG >> RAS motor relay power supply circuit open or shorted. Repair or replace power supply circuit and fuse.

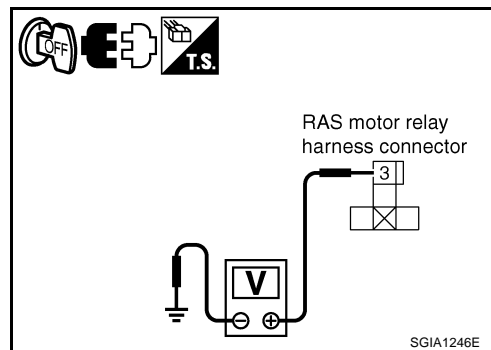

### 3. CHECK RAS MOTOR RELAY HARNESS

1. Disconnect RAS motor relay harness connector B126 and RAS control unit harness connector B127.
2. Check continuity between RAS motor relay harness connector B126 and RAS control unit harness connector B127.

**Terminal 5 – 37 : Continuity exist.**

**Terminal 1 – 25 : Continuity exist.**

3. Check continuity between RAS motor relay harness connector B126 and ground.

**2 – Ground : Continuity exist.**

OK or NG

OK >> GO TO 4.

NG >> RAS motor relay harness open or shorted. Repair or replace applicable malfunctioning harness.

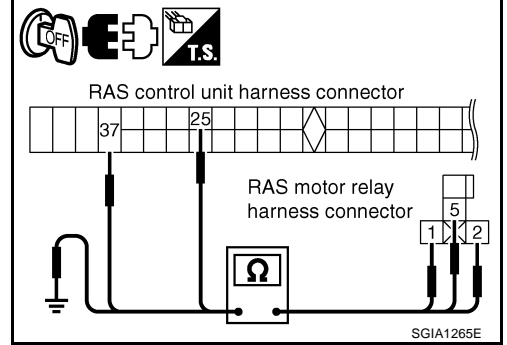

### 4. CHECK RAS MOTOR RELAY RESISTANCE

Check the resistance between RAS motor relay connector.

**Terminal 1 – 2 : Approx. 74 Ω**

OK or NG

OK >> GO TO 5.

NG >> RAS motor relay malfunction (replacement)

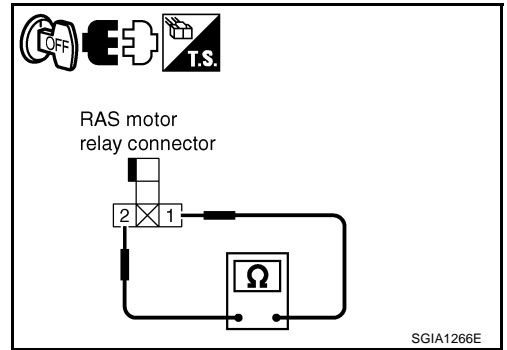

### 5. CHECK RAS CONTROL UNIT OUTPUT SIGNAL

1. Connect RAS control unit harness connector B127 and RAS motor relay harness connector B126.
2. Check voltage between RAS motor relay harness connector B126 and ground.

**1 – Ground**

**Ignition switch ON : Battery voltage (Approx. 12 V)**

**Ignition switch OFF : Approx. 0V**

OK or NG

OK >> Check RAS motor relay separately from other parts. Refer to [STC-49, "RAS MOTOR RELAY"](#).

NG >> RAS control unit malfunction (replacement)

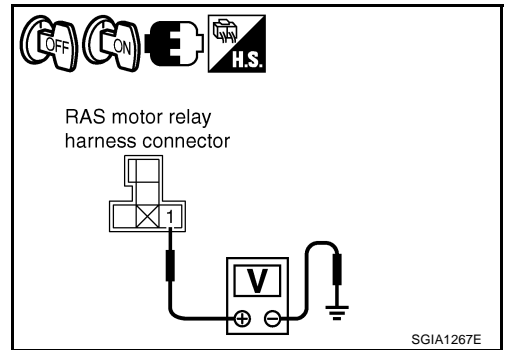

## Inspection 3: RAS Motor Output Malfunction

### 1. CHECK RAS CONTROL UNIT CONNECTOR

1. Turn ignition switch OFF, disconnect RAS control unit harness connector and RAS motor harness connector, and check terminal for deformation, disconnection, looseness, etc.
2. Reconnect harness connector securely, and perform self-diagnosis.

**With CONSULT-II**

Self-diagnosis results
MOTOR_OUTPUT [ABNORMAL_SIG] (. a)
MOTOR_OUTPUT [REV_CURRENT] (. c)
MOTOR_OUTPUT [NO_CURRENT] (. d)
MOTOR_OUTPUT [OVERCURRENT] (. e)
MOTOR_OUTPUT [MOTOR_LOCK] (. b)

**Without CONSULT-II**

DTC (warning lamp blinks)
13

Is above displayed on self-diagnosis display?

YES >> GO TO 2.

NG >> Connector terminal connection is loose, damaged, open, or shorted. Repair or replace the terminal.

### 2. CHECK RAS MOTOR RESISTANCE

1. Turn ignition switch OFF, and disconnect RAS motor harness connector B105.
2. Check the resistance RAS motor connector.

**Terminal 1 – 2 : Approx. 0.6 Ω**

OK or NG

OK >> GO TO 3.

NG >> RAS motor malfunction. Replace RAS motor.

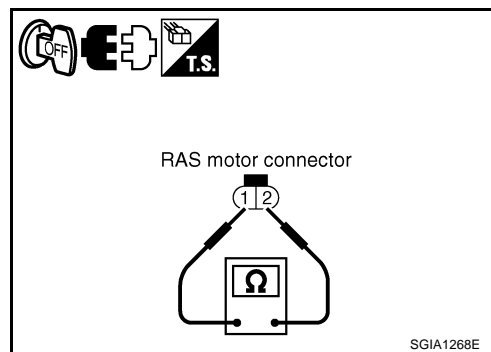

### 3. CHECK RAS MOTOR HARNESS

1. Connect RAS motor harness connector B105.
2. Disconnect RAS control unit harness connector B127.
3. Check continuity RAS control unit harness connector B127.

**Terminal 38 – 39 : Continuity exist.**

OK or NG

OK >> RAS control unit malfunction. Replace RAS control unit.

NG >> Harness between RAS motor and RAS control unit open or shorted. Repair or replace harness.

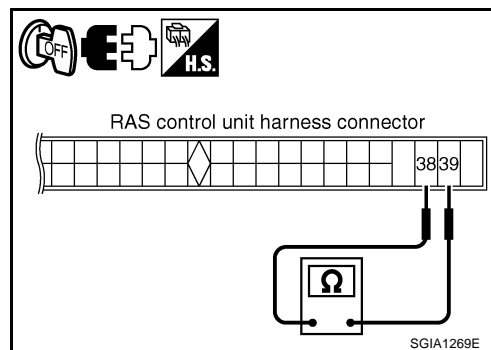

**Inspection 4: Vehicle Speed Signal**

NGS000ET

**1. CHECK SPEEDOMETER**

Start the engine, and then check the combination meter (speed meter) operation.

Does it operate normally?

YES >> GO TO 2.

NO >> Combination meter. Refer to [DI-5, "COMBINATION METERS"](#) .

**2. CHECK RAS CONTROL UNIT CONNECTOR**

1. Turn ignition switch OFF, disconnect RAS control unit harness connector, and check terminal for deformation, disconnection, looseness, etc.
2. Reconnect harness connector securely, and perform self-diagnosis.

**④ With CONSULT-II**

Self-diagnosis results

VEHICLE\_SPEED\_SEN [NO\_SIGNAL]

**⊗ Without CONSULT-II**

DTC (warning lamp blinks)

21

Is above displayed on self-diagnosis display?

YES >> RAS control unit malfunction. Replace RAS control unit.

NO >> Connector terminal connection is loose, damaged, open, or shorted. Repair or replace the terminal.

**Inspection 5: Steering Angle Signal Malfunction**

NGS000EU

**1. CHECK CONNECTOR**

1. Turn ignition switch OFF, disconnect RAS control unit harness connector and steering angle sensor harness connector, and check terminal for deformation, disconnection, looseness, etc.
2. Reconnect harness connector securely, and perform self-diagnosis.

**④ With CONSULT-II**

Self-diagnosis results

STEERING\_ANGLE\_SEN [NO\_CHANGE] (. a)

STEERING\_ANGLE\_SEN [NO\_NEUT\_STATE] (. b)

STEERING\_ANGLE\_SEN [NO\_SIGNAL]

STEERING\_ANGLE\_SEN

**⊗ Without CONSULT-II**

DTC (warning lamp blinks)

22

Is above displayed on self-diagnosis display?

YES >> GO TO 2.

NO >> Connector terminal connection is loose, damaged, open, or shorted. Repair or replace the terminal.

**2. ADJUST NEUTRAL POSITION OF STEERING ANGLE SENSOR**

Adjust the steering angle sensor neutral position, and then perform self-diagnosis again. Refer to [BRC-6, "Adjustment of Steering Angle Sensor Neutral Position"](#) .

Is the result of self-diagnosis normal?

OK >> Inappropriate neutral position adjustment of steering angle sensor.

NG >> GO TO 3.

**3. CHECK STEERING ANGLE SENSOR POWER SUPPLY AND GROUND CIRCUIT**

1. Turn ignition switch OFF, and disconnect steering angle sensor harness connector M47.
2. Check continuity steering angle sensor harness connector M47 and ground.

Steering angle sensor	Ground	Continuity
Terminal 2	—	Yes

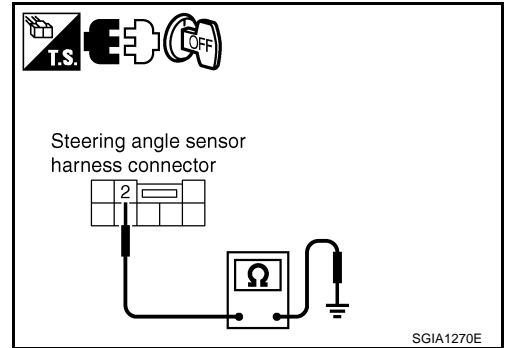

3. Turn ignition switch ON, and then check voltage steering angle sensor harness connector M47 and ground.

Steering angle sensor	Ground	Continuity
Terminal 3	—	Battery voltage (approx. 12V)

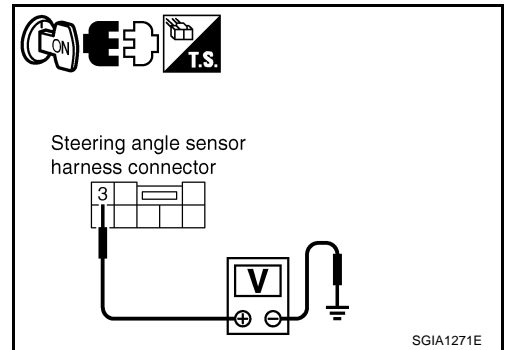

**OK or NG**

- OK >> GO TO 4.
- NG >> Steering angle sensor power supply and ground circuit open or shorted. Repair or replace the applicable malfunctioning circuit.

**4. DATA MONITOR**

1. Connect steering angle sensor harness connector.
2. Select "DATA MONITOR" on "STEERING ANG" mode, and then check the steering angle.

Steering condition	DATA MONITOR
Straight-ahead position	- 3.5 - +3.5°
Turn wheel to the right by 90°	Approx. R 90°
Turn wheel to the left by 90°	Approx. R 90°

**OK or NG**

- OK >> RAS control unit malfunction. Replace RAS control unit.
- NG >> Replace steering angle sensor and adjust neutral position of steering angle sensor. Refer to [BRC-6, "Adjustment of Steering Angle Sensor Neutral Position"](#).

A  
B  
C  
D  
E  
F  
STC  
H  
I  
J  
K  
L  
M

**Inspection 6: Rear Main Signal and Rear Sub Signal Malfunction**

**1. CHECK RAS CONTROL UNIT CONNECTOR**

1. Turn ignition switch OFF, disconnect RAS control unit harness connector and rear wheel steering angle sensor harness connector, and check terminal for deformation, disconnection, looseness, etc.
2. Reconnect harness connector securely, and perform self-diagnosis.

**With CONSULT-II**

Self-diagnosis results
RR_ST_ANGLE_SENSOR [MAIN_SIGNAL] (- a)
RR_ST_ANGLE_SENSOR [SUB_SIGNAL] (- b)
RR_ST_ANGLE_SENSOR [OFFSET_SIG 1, 2] (- c)
RR_ST_ANGLE_SENSOR [ABNORMAL_VOL] (- d)

**Without CONSULT-II**

DTC (warning lamp blinks)
24
25

Is above displayed on self-diagnosis display?

YES >> GO TO 2.

NO >> Connector terminal connection is loose, damaged, open, or shorted. Repair or replace the terminal.

**2. CHECK (1): REAR WHEEL STEERING ANGLE SENSOR POWER SUPPLY AND GROUND CIRCUIT**

1. Turn ignition switch OFF, and disconnect rear wheel steering angle sensor harness connector B104.
2. Check continuity rear wheel steering angle sensor harness connector B104 and ground.

**Terminal 3 – Ground : Continuity exist.**

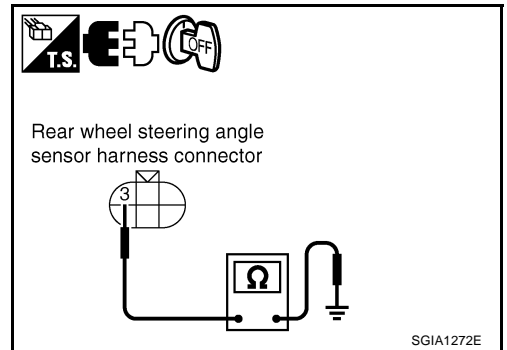

3. Turn ignition switch ON, and then check voltage rear wheel steering angle sensor harness connector B104 and ground.

**Terminal 1 – Ground : Approx. 5 V**

OK or NG

OK >> GO TO 4.

NG >> GO TO 3.

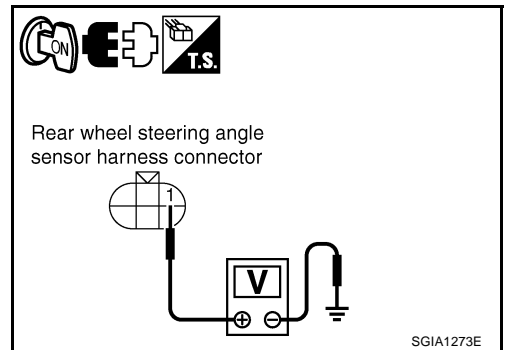



# TROUBLE DIAGNOSIS

[RAS]

## 3. CHECK (2): REAR WHEEL STEERING ANGLE SENSOR POWER SUPPLY AND GROUND CIRCUIT

1. Turn ignition switch OFF, disconnect rear wheel steering angle sensor harness connector B104 and RAS control unit harness connector B127.
2. Check continuity each harness connector of rear wheel steering angle sensor harness connector B 104 and RAS control unit harness connector B127.

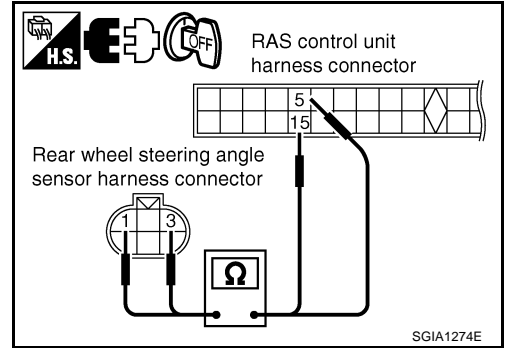

Rear wheel steering angle sensor	RAS control unit	Continuity
Terminal 1	Terminal 5	Yes
Terminal 3	Terminal 15	Yes

### OK or NG

- OK >> RAS control unit malfunction. Replace RAS control unit.  
 NG >> Harness between rear wheel steering angle sensor and RAS control unit open or shorted. Repair or replace harness.

## 4. CHECK REAR WHEEL STEERING ANGLE SENSOR OUTPUT SIGNAL

1. Connect rear wheel steering angle sensor harness connector B104.
2. Check voltage RAS control unit harness connector B127 when starting the engine and turning the steering wheel from neutral position clockwise/counter-clockwise by 180°.

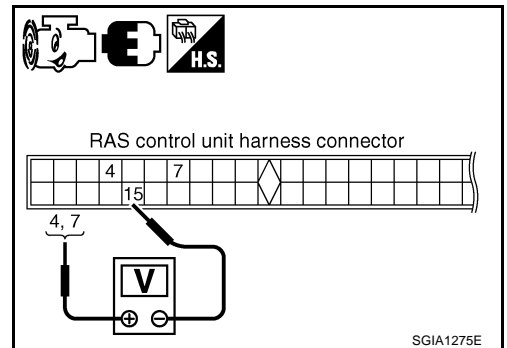

Steering condition	Rear wheel steering angle sensor	
	Rear main output Terminal 4 (+) - 15 (-)	Rear sub output Terminal 7 (+) - 15 (-)
Straight-ahead (neutral position)	Approx. 2.4 V	Approx. 2.4 V
Turn wheel to the right by 180°	Approx. 4.4 V	Approx. 4.4 V
Turn wheel to the left by 180°	Approx. 0.4 V	Approx. 0.4 V

### CAUTION:

There is approximately 1 V or more difference between main output and sub output at straight-ahead position, inspection results are "NG".

### OK or NG

- OK >> RAS control unit malfunction. Replace RAS control unit.  
 NG >> GO TO 5.

## 5. CHECK REAR WHEEL STEERING ANGLE SENSOR OUTPUT SIGNAL CIRCUIT

1. Turn ignition switch OFF, disconnect rear wheel steering angle sensor harness connector B104 and RAS control unit harness connector B127.
2. Check continuity between each harness connector of rear wheel steering angle sensor harness connector B104 and RAS control unit harness connector B127.

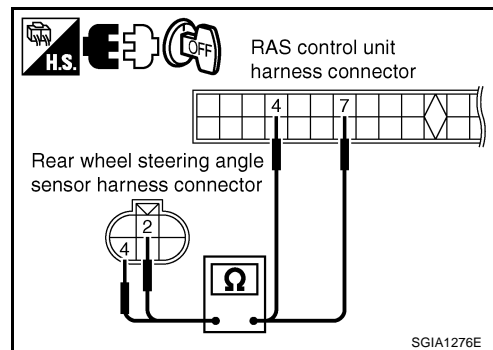

Rear wheel steering angle sensor	RAS C/U	Continuity
Terminal 2	Terminal 7	Yes
Terminal 4	Terminal 4	Yes

### OK or NG

- OK >> Rear wheel steering angle sensor malfunction. Replace rear wheel steering angle sensor.
- NG >> Harness between rear wheel steering angle sensor and RAS control unit open or shorted. Repair or replace harness.

## Inspection 7: VDC Malfunction

NGS000EW

### 1. CHECK RAS CONTROL UNIT CONNECTOR

1. Turn ignition switch OFF, disconnect RAS control unit harness connector and rear wheel steering angle sensor harness connector, and check terminal for deformation, disconnection, looseness, etc.
2. Reconnect harness connector securely, and perform self-diagnosis.

#### With CONSULT-II

Self-diagnosis results
VDC

#### Without CONSULT-II

DTC (warning lamp blinks)
26

Is above displayed on self-diagnosis display?

- YES >> GO TO 2.
- NO >> Connector terminal connection is loose, damaged, open, or shorted. Repair or replace the terminal.

### 2. CHECK SELF-DIAGNOSTIC RESULTS

Perform VDC self-diagnosis. Refer to [BRC-23, "Self-Diagnosis"](#) .

#### OK or NG

- OK >> RAS control unit malfunction. Replace RAS control unit.
- NG >> Repair or replace indicated part. After that, perform RAS self-diagnosis again to make sure that there is no malfunction.

**Inspection 8: Engine Speed Signal Malfunction**

NGS000EX

**1. CHECK SPEEDOMETER**

Start the engine, and then check the combination meter (tachometer) operation.

Does it operate normally?

YES >> GO TO 2.

NO >> Combination meter. Refer to [DI-5, "COMBINATION METERS"](#) [DI-5, "COMBINATION METERS"](#).

**2. CHECK RAS CONTROL UNIT CONNECTOR**

1. Turn ignition switch OFF, disconnect RAS control unit harness connector, and check terminal for deformation, disconnection, looseness, etc.
2. Reconnect harness connector securely, and perform self-diagnosis.

**Ⓟ With CONSULT-II**

Self-diagnostic results
MOTOR_OUTPUT

**ⓧ Without CONSULT-II**

DTC (warning lamp blinks)
27

Is above displayed on self-diagnosis display?

YES >> RAS control unit malfunction. Replace RAS control unit.

NO >> Connector terminal connection is loose, damaged, open, or shorted. Repair or replace the terminal.

**Inspection 9: CAN Communication System Malfunction**

NGS000EY

**1. CHECK RAS CONTROL UNIT CONNECTOR**

1. Turn ignition switch OFF, disconnect RAS control unit harness connector and rear wheel steering angle sensor harness connector, and check terminal for deformation, disconnection, looseness, etc.
2. Reconnect harness connector securely, and perform CONSULT-II self-diagnosis.

Self-diagnostic results
CAN COMM CIRCUIT [U1000]
CONTROL_UNIT [CAN] [U1010]

Is above displayed on self-diagnosis display?

YES >> ● If "CAN COMM [U1000]" is displayed, print out self-diagnosis. And then, GO TO [LAN-7, "Pre-cautions When Using CONSULT-II"](#).

● Replace RAS control unit if "CONTROL\_UNIT [CAN] [U1010]" is displayed.

NO >> Connector terminal connection is loose, damaged, open, or shorted. Repair or replace the terminal.

## Inspection 10: Stop Lamp Switch Harness

NGS000EZ

### 1. CHECK STOP LAMP SWITCH SIGNAL

 With CONSULT-II

Select "STOP LAMP SW" on DATA MONITOR, and then check the stop lamp switch.

Measuring condition	Data monitor
Brake pedal depressed	ON
Brake pedal released	OFF

 Without CONSULT-II

1. Turn ignition switch OFF, disconnect RAS control unit harness connector B127.
2. Operate brake pedal, and then check voltage between RAS control unit harness connector B127 and ground.

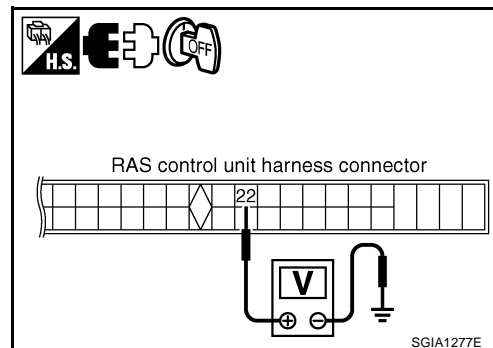

RAS C/U	Ground	Measuring condition	Voltage
Terminal 22	—	Brake pedal depressed	Battery voltage (approx. 12 V)
		Brake pedal released	Approx. 0 V

OK or NG

OK >> Stop lamp switch harness is normal.

NG >> Stop lamp switch harness malfunction. Repair circuit.

## Inspection 11: RAS Warning Lamp Harness

NGS000F0

### 1. CHECK RAS WARNING LAMP SIGNAL

Turn ignition switch ON, and then check voltage between RAS control unit harness connector B127 and ground.

RAS C/U	Ground	Voltage
Terminal 26	—	Warning lamp OFF : Approx. 2.8 V or more
		Warning lamp ON : Approx. 1.4 V or less

OK or NG

OK >> Perform self-diagnosis. Refer to [STC-28, "SELF-DIAG RESULT MODE"](#).

NG >> GO TO 2.

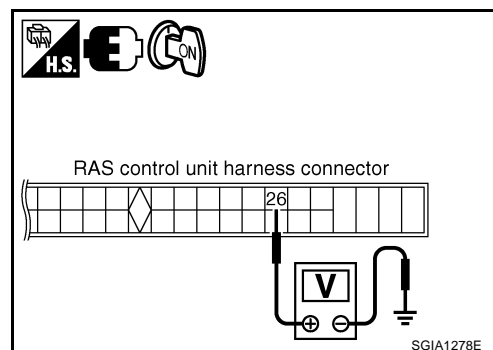

## 2. CHECK RAS WARNING LAMP HARNESS

1. Turn ignition switch OFF, disconnect RAS control unit harness connector B127 and combination meter harness connector M52.
2. Check continuity between RAS control unit harness connector B127 and combination meter harness connector M52.

**Terminal 26 – 19 : Continuity exist.**

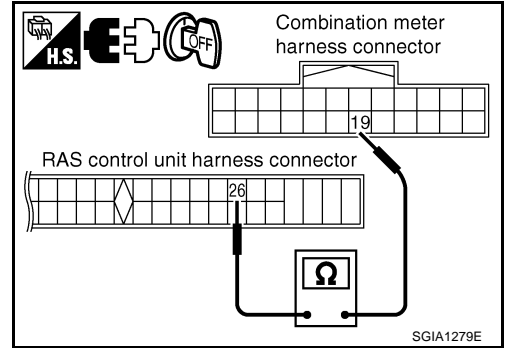

3. Check continuity between RAS control unit harness connector B127 and ground.

**Terminal 26 – Ground : Continuity not exist.**

OK or NG

- OK >> GO TO combination meter power supply circuit.
- NG >> Harness between RAS control unit and combination meter open or shorted. Repair or replace harness.

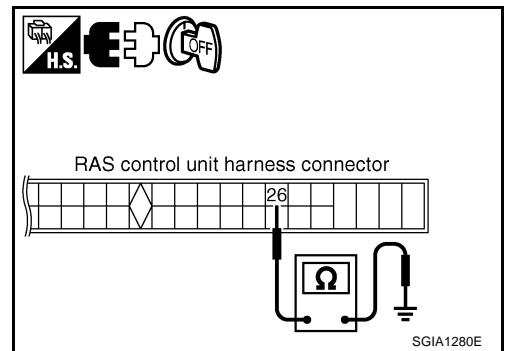

A  
B  
C  
D  
E  
F  
H  
I  
J  
K  
L  
M

STC

## Diagnosis Chart by Symptom 1

### 1. CHECK SELF-DIAGNOSTIC RESULTS

Perform RAS self-diagnosis.

- With CONSULT-II: [STC-28, "SELF-DIAG RESULT MODE"](#)
- Without CONSULT-II: [STC-31, "Diagnosis Procedure with Self-Diagnosis Function \(Without CONSULT-II\)"](#)

Are malfunctioning items displayed in self-diagnosis results?

- YES >> Repair or replace any malfunctioning items.  
 NO >> GO TO 2.

### 2. CHECK RAS STATIC/DYNAMIC CHARACTERISTICS

Check RAS static/dynamic characteristics. Refer to [STC-48, "Check RAS Static/Dynamic Characteristics"](#) .

Is the malfunction corrected?

- YES >> INSPECTION END  
 NO >> Perform the following check, and then check the symptom again.
- Adjust neutral position of steering angle sensor. Refer to [BRC-6, "Adjustment of Steering Angle Sensor Neutral Position"](#) .
  - Steering angle sensor mounting condition. Refer to [BRC-63, "Removal and Installation"](#) .

## Diagnosis Chart by Symptom 2

The steering force does not change smoothly according to the vehicle speed (Heavy steering force with the vehicle stopped/Light handle operation during high-speed driving)

### 1. CHECK (1): POWER STEERING SOLENOID VALVE SIGNAL

1. Start engine.
2. Change the vehicle speed from 0 to 100 km/h (0 to 62 MPH) slowly, and then check voltage RAS control unit harness connector B127.

**Terminal 36 – 34 : The voltage has changed from approximately 4.4 - 6.6 V to approximately 2.4 - 3.6 V.**

OK or NG

- OK >> GO TO 2.  
 NG >> GO TO 7.

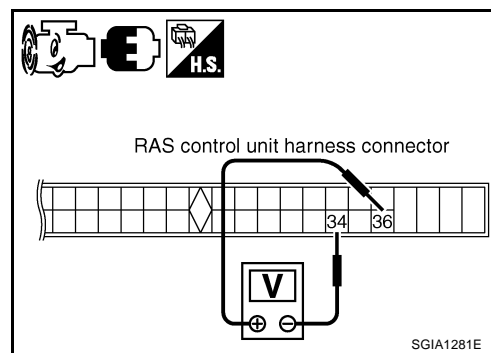

### 2. CHECK (2): POWER STEERING SOLENOID VALVE SIGNAL

1. Activate fail-safe function by running engine speed at 1,500 rpm or higher for 10 seconds with the vehicle stopped.
2. Change the engine speed to the idling speed, approx. 1,600 rpm, and approximately 3,000 rpm slowly, and then check voltage RAS control unit harness connector B127.

**Terminal 36 – 34 : The voltage is changed from approximately 5.5 V to approximately 2.1 V step-by-step.**

OK or NG

- OK >> GO TO 3.  
 NG >> GO TO 7.

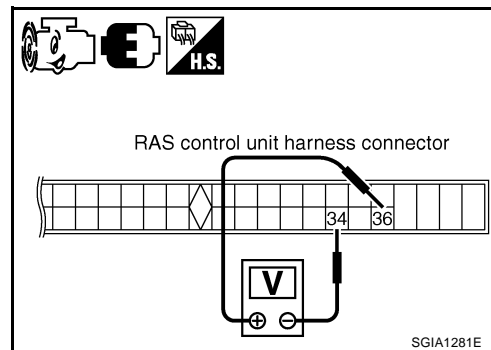

## 3. CHECK POWER STEERING SOLENOID VALVE CONNECTOR

Turn ignition switch OFF, disconnect power steering solenoid valve harness connector, and check terminal for deformation, disconnection, looseness, etc.

OK or NG

OK >> GO TO 4.

NG >> Harness or connector open or shorted. Repair or replace any inoperative parts.

## 4. CHECK POWER STEERING SOLENOID VALVE POWER SUPPLY CIRCUIT

Check continuity between RAS control unit harness connector B127 and power steering solenoid valve harness connector F25 (VQ35DE), E211 (VK45DE).

RAS C/U	Power steering solenoid valve	Continuity
Terminal 36	Terminal 1	Yes

OK or NG

OK >> GO TO 5.

NG >> Open or short in harness. Repair or replace any inoperative parts.

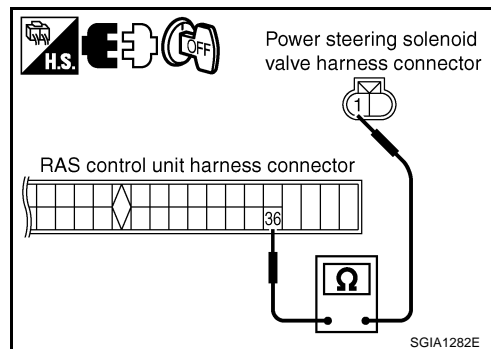

## 5. CHECK POWER STEERING SOLENOID VALVE GROUND CIRCUIT

Check continuity between power steering solenoid valve harness connector F25 (VQ35DE), E211 (VK45DE) and ground.

**Terminal 2 – Ground : Continuity exist.**

OK or NG

OK >> GO TO 6.

NG >> Open or short in harness. Repair or replace any inoperative parts.

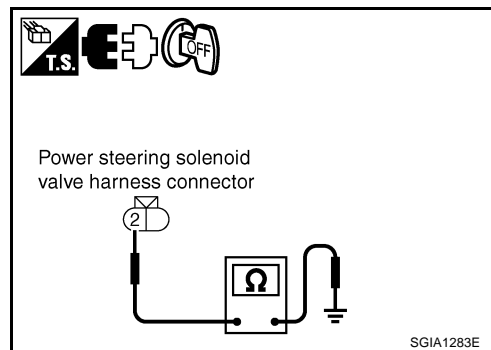

## 6. CHECK POWER STEERING SOLENOID VALVE

Apply voltage power steering solenoid valve connector F25 (VQ35DE), E211 (VK45DE) and then make sure that the operating sound (clicking sound) is heard.

**Terminal 1 (+) - 2 (-) : Operating sound is heard.**

OK or NG

OK >> Perform steering turning torque inspection. Refer to [PS-10. "CHECKING STEERING WHEEL TURNING FORCE"](#).

NG >> Power steering solenoid valve is inoperating. Replace it.

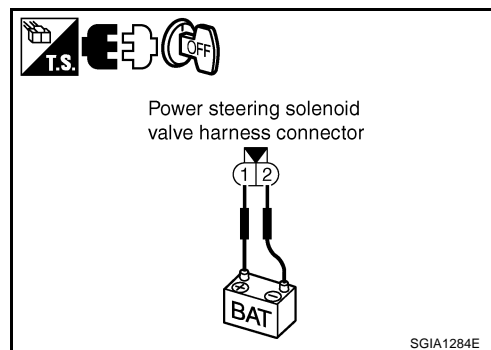

## 7. CHECK SELF-DIAGNOSIS RESULTS

Perform RAS self-diagnosis.

- With CONSULT-II: [STC-28. "SELF-DIAG RESULT MODE"](#)
- Without CONSULT-II: [STC-31. "Diagnosis Procedure with Self-Diagnosis Function \(Without CONSULT-II\)"](#)

Are malfunctioning items displayed in self-diagnosis results?

YES >> Repair or replace any malfunctioning items.

NO >> RAS control unit malfunction. Replace it.

## Check RAS Static/Dynamic Characteristics

### 1. CHECK (1): RAS ACTUATOR STROKE

Perform CONSULT-II "ACTIVE TEST", and then check the actuator stroke when turning the steering wheel clockwise or counterclockwise by 180° or more.

**Neutral position (A)**

**Actuator stroke (B) : 2.8 - 3.0 mm (0.110 - 0.118 in)**

OK or NG

OK >> GO TO 2.

NG >> GO TO 3.

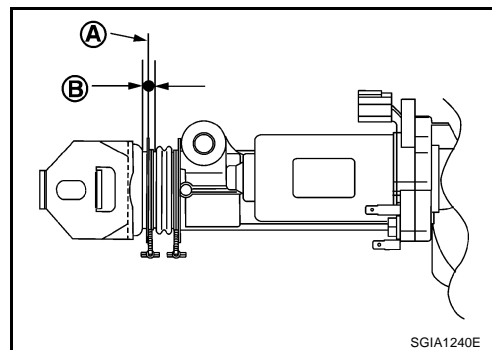

### 2. CHECK (2): RAS ACTUATOR STROKE

Perform CONSULT-II "ACTIVE TEST". When turning the steering wheel in neutral position (A), the rear wheel turns clockwise/counterclockwise periodically. At that time, check actuator stroke (B).

**Actuator stroke (B) : 2.3 - 2.5 mm (0.091 - 0.098 in)**

OK or NG

OK >> RAS static/dynamic characteristics inspection is completed.

NG >> GO TO 3.

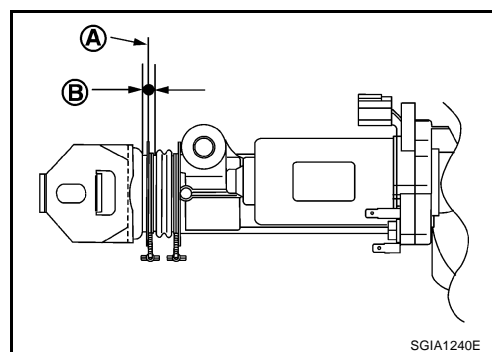

### 3. CHECK RAS MOTOR

Check RAS motor itself separated from other parts. Refer to [STC-49, "RAS MOTOR"](#).

OK or NG

OK >> GO TO 4.

NG >> RAS motor malfunction. Check the stroke again after replacing.

### 4. CHECK REAR WHEEL STEERING ANGLE SENSOR

Check rear wheel steering angle sensor separated from other parts. Refer to [STC-49, "REAR WHEEL STEERING ANGLE SENSOR"](#).

OK or NG

OK >> GO TO 5.

NG >> Rear wheel steering angle sensor malfunction. Check the stroke again after replacing.

### 5. CHECK RAS CONTROL UNIT

Replace RAS control unit. Check the symptom of malfunction again.

Is the malfunction corrected?

YES >> RAS control unit malfunction

NO >> GO TO 6.

### 6. REPLACE RAS ACTUATOR ASSEMBLY

Replace RAS actuator assembly. Check the symptom of malfunction again.

Is the malfunction corrected?

YES >> RAS actuator malfunction

NO >> Check rear suspension components. Refer to [RSU-7, "Components"](#).



## Component Parts Inspection

### RAS MOTOR RELAY

1. Check the resistance between RAS motor relay connector.

**Terminal 1 – 2 : Approx. 74 Ω**

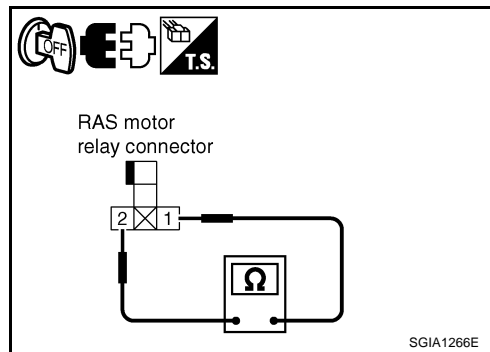

2. When applying or not supplying approximately 12 V between RAS motor relay connector, check continuity RAS motor relay connector.

**Terminal 3 – 5 : When applying 12 V voltage: Continuity exist.**

**: When not applying 12 V voltage: Continuity not exist.**

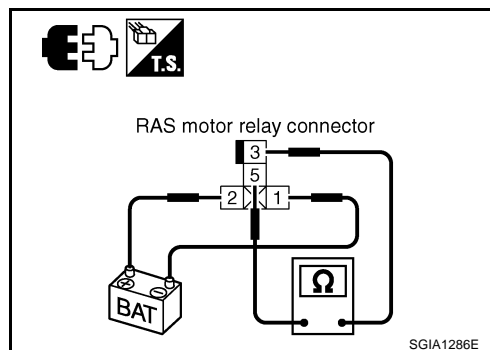

### RAS MOTOR

1. Check the resistance RAS motor connector.

**Terminal 1 – 2 : Approx. 0.6 Ω**

2. Remove RAS motor from RAS actuator, and then turn the motor by 6 V battery.

**If it is normal, it turns.**

**CAUTION:**

**Do not apply 12 V (battery voltage) to the RAS motor terminal because RAS motor might be damaged.**

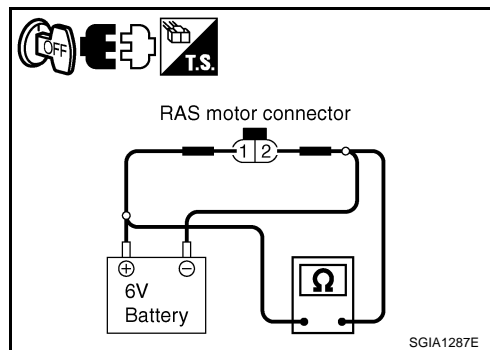

### REAR WHEEL STEERING ANGLE SENSOR

1. Disconnect rear wheel steering angle sensor harness connector B104.
2. Check resistance of rear wheel steering angle sensor side connectors.

Terminal 2 – 3	: Approx. 1 kΩ
Terminal 4 – 3	
Terminal 1 – 3	: Approx. 1.25 kΩ

