

A  
EM  
C  
D  
E  
F  
G  
H  
I  
J  
K  
L  
M

# SECTION **EM**

## ENGINE MECHANICAL

### CONTENTS

<b>VQ35DE</b>	
<b>PRECAUTIONS</b> .....	<b>5</b>
Precautions for Procedures without Cowl Top Cover...	5
Precautions Necessary for Steering Wheel Rotation After Battery Disconnect .....	5
<b>OPERATION PROCEDURE</b> .....	5
Precautions for Drain Engine Coolant and Engine Oil .....	5
Precautions for Disconnecting Fuel Piping .....	5
Precautions for Removal and Disassembly .....	5
Precautions for Inspection, Repair and Replace- ment .....	6
Precautions for Assembly and Installation .....	6
Precautions for Angle Tightening .....	6
Precautions for Liquid Gasket .....	6
<b>REMOVAL OF LIQUID GASKET SEALING</b> .....	6
<b>LIQUID GASKET APPLICATION PROCEDURE</b> ...	7
<b>PREPARATION</b> .....	<b>8</b>
Special Service Tools .....	8
Commercial Service Tools .....	10
<b>NOISE, VIBRATION AND HARSHNESS (NVH)</b>	
<b>TROUBLESHOOTING</b> .....	<b>12</b>
NVH Troubleshooting — Engine Noise .....	12
Use the Chart Below to Help You Find the Cause of the Symptom. ....	13
<b>ENGINE ROOM COVER</b> .....	<b>14</b>
Components .....	14
Removal and Installation .....	14
<b>REMOVAL</b> .....	14
<b>INSTALLATION</b> .....	14
<b>DRIVE BELTS</b> .....	<b>15</b>
Checking Drive Belts .....	15
Tension Adjustment .....	15
<b>ALTERNATOR AND POWER STEERING OIL     PUMP BELT</b> .....	16
<b>A/C COMPRESSOR BELT</b> .....	16
Removal and Installation .....	16
<b>REMOVAL</b> .....	16
<b>INSTALLATION</b> .....	16
<b>AIR CLEANER AND AIR DUCT</b> .....	<b>17</b>
Components .....	17
Removal and Installation .....	17
<b>REMOVAL</b> .....	17
<b>INSTALLATION</b> .....	17
Changing Air Cleaner Filter .....	18
<b>REMOVAL</b> .....	18
<b>INSTALLATION</b> .....	18
<b>INTAKE MANIFOLD COLLECTOR</b> .....	<b>19</b>
Components .....	19
Removal and Installation .....	19
<b>REMOVAL</b> .....	19
<b>INSPECTION AFTER REMOVAL</b> .....	21
<b>INSTALLATION</b> .....	22
<b>INTAKE MANIFOLD</b> .....	<b>24</b>
Components .....	24
Removal and Installation .....	24
<b>REMOVAL</b> .....	24
<b>INSPECTION AFTER REMOVAL</b> .....	25
<b>INSTALLATION</b> .....	25
<b>EXHAUST MANIFOLD</b> .....	<b>26</b>
Components .....	26
Removal and Installation .....	26
<b>REMOVAL</b> .....	26
<b>INSPECTION AFTER REMOVAL</b> .....	27
<b>INSTALLATION</b> .....	27
<b>OIL PAN AND OIL STRAINER</b> .....	<b>29</b>
Components (2WD Models) .....	29
Removal and Installation (2WD Models) .....	29
<b>REMOVAL</b> .....	29
<b>INSPECTION AFTER REMOVAL</b> .....	31
<b>INSTALLATION</b> .....	31
<b>INSPECTION AFTER INSTALLATION</b> .....	34
Components (AWD Models) .....	35
Removal and Installation (AWD Models) .....	36
<b>REMOVAL</b> .....	36
<b>INSPECTION AFTER REMOVAL</b> .....	38
<b>INSTALLATION</b> .....	38
<b>INSPECTION AFTER INSTALLATION</b> .....	41

<b>IGNITION COIL</b> .....	<b>42</b>	Removal and Installation .....	102
Components .....	42	REMOVAL .....	102
Removal and Installation .....	42	INSPECTION AFTER REMOVAL .....	103
REMOVAL .....	42	INSTALLATION .....	104
INSTALLATION .....	42	INSPECTION AFTER INSTALLATION .....	105
<b>SPARK PLUG (PLATINUM-TIPPED TYPE)</b> .....	<b>43</b>	Disassembly and Assembly .....	106
Components .....	43	COMPONENTS .....	106
Removal and Installation .....	43	DISASSEMBLY .....	106
REMOVAL .....	43	ASSEMBLY .....	107
INSPECTION AFTER REMOVAL .....	43	Inspection after Disassembly .....	108
INSTALLATION .....	44	VALVE DIMENSIONS .....	108
<b>FUEL INJECTOR AND FUEL TUBE</b> .....	<b>45</b>	VALVE GUIDE CLEARANCE .....	108
Components .....	45	VALVE GUIDE REPLACEMENT .....	109
Removal and Installation .....	45	VALVE SEAT CONTACT .....	110
REMOVAL .....	45	VALVE SEAT REPLACEMENT .....	110
INSTALLATION .....	47	VALVE SPRING SQUARENESS .....	111
INSPECTION AFTER INSTALLATION .....	50	VALVE SPRING DIMENSIONS AND VALVE SPRING PRESSURE LOAD .....	112
<b>ROCKER COVER</b> .....	<b>51</b>	<b>ENGINE ASSEMBLY</b> .....	<b>113</b>
Components .....	51	Components (2WD Models) .....	113
Removal and Installation .....	51	Removal and Installation (2WD Models) .....	113
REMOVAL .....	51	REMOVAL .....	114
INSTALLATION .....	52	INSTALLATION .....	116
<b>FRONT TIMING CHAIN CASE</b> .....	<b>54</b>	INSPECTION AFTER INSTALLATION .....	117
Removal and Installation .....	54	Components (AWD Models) .....	118
REMOVAL .....	54	Removal and Installation (AWD Models) .....	118
INSTALLATION .....	58	REMOVAL .....	119
INSPECTION AFTER INSTALLATION .....	63	INSTALLATION .....	121
<b>TIMING CHAIN</b> .....	<b>64</b>	INSPECTION AFTER INSTALLATION .....	122
Components .....	64	<b>CYLINDER BLOCK</b> .....	<b>123</b>
Removal and Installation .....	65	Components .....	123
REMOVAL .....	65	Disassembly and Assembly .....	124
INSPECTION AFTER REMOVAL .....	72	DISASSEMBLY .....	124
INSTALLATION .....	72	ASSEMBLY .....	128
INSPECTION AFTER INSTALLATION .....	82	How to Select Piston and Bearing .....	135
<b>CAMSHAFT</b> .....	<b>84</b>	DESCRIPTION .....	135
Components .....	84	HOW TO SELECT PISTON .....	135
Removal and Installation .....	85	HOW TO SELECT CONNECTING ROD BEAR- ING .....	136
REMOVAL .....	85	HOW TO SELECT MAIN BEARING .....	137
INSPECTION AFTER REMOVAL .....	86	Inspection after Disassembly .....	140
INSTALLATION .....	89	CRANKSHAFT END PLAY .....	140
INSPECTION AFTER INSTALLATION .....	92	CONNECTING ROD SIDE CLEARANCE .....	140
Valve Clearance .....	93	PISTON TO PISTON PIN OIL CLEARANCE .....	140
INSPECTION .....	93	PISTON RING SIDE CLEARANCE .....	141
ADJUSTMENT .....	96	PISTON RING END GAP .....	141
<b>OIL SEAL</b> .....	<b>98</b>	CONNECTING ROD BEND AND TORSION .....	142
Removal and Installation of Valve Oil Seal .....	98	CONNECTING ROD BIG END DIAMETER .....	142
REMOVAL .....	98	CONNECTING ROD BUSHING OIL CLEAR- ANCE .....	142
INSTALLATION .....	98	CYLINDER BLOCK DISTORTION .....	143
Removal and Installation of Front Oil Seal .....	99	MAIN BEARING HOUSING INNER DIAMETER .....	144
REMOVAL .....	99	PISTON TO CYLINDER BORE CLEARANCE .....	144
INSTALLATION .....	99	CRANKSHAFT MAIN JOURNAL DIAMETER .....	145
Removal and Installation of Rear Oil Seal .....	99	CRANKSHAFT PIN JOURNAL DIAMETER .....	146
REMOVAL .....	99	CRANKSHAFT OUT-OF-ROUND AND TAPER .....	146
INSTALLATION .....	100	CRANKSHAFT RUNOUT .....	146
<b>CYLINDER HEAD</b> .....	<b>101</b>	CONNECTING ROD BEARING OIL CLEAR-	
On-Vehicle Service .....	101		
CHECKING COMPRESSION PRESSURE .....	101		
Components .....	102		

ANCE .....	146
MAIN BEARING OIL CLEARANCE .....	147
MAIN BEARING CRUSH HEIGHT .....	148
CONNECTING ROD BEARING CRUSH HEIGHT .....	148
MAIN BEARING CAP BOLT OUTER DIAMETER .....	148
CONNECTING ROD BOLT OUTER DIAMETER .....	149
DRIVE PLATE .....	149
OIL JET .....	149
OIL JET RELIEF VALVE .....	149
<b>SERVICE DATA AND SPECIFICATIONS (SDS) ...</b>	<b>150</b>
Standard and Limit .....	150
GENERAL SPECIFICATIONS .....	150
DRIVE BELT .....	151
INTAKE MANIFOLD COLLECTOR, INTAKE MANIFOLD AND EXHAUST MANIFOLD .....	151
SPARK PLUG .....	151
CAMSHAFT AND CAMSHAFT BEARING .....	152
CYLINDER HEAD .....	154
CYLINDER BLOCK .....	157
PISTON, PISTON RING AND PISTON PIN .....	158
CONNECTING ROD .....	159
CRANKSHAFT .....	160
MAIN BEARING .....	161
CONNECTING ROD BEARING .....	162

## VK45DE

<b>PRECAUTIONS .....</b>	<b>163</b>
Precautions for Procedures without Cowl Top Cover .....	163
Precautions Necessary for Steering Wheel Rotation .....	163
After Battery Disconnect .....	163
OPERATION PROCEDURE .....	163
Precautions for Drain Engine Coolant and Engine Oil .....	163
Precautions for Disconnecting Fuel Piping .....	163
Precautions for Removal and Disassembly .....	163
Precautions for Inspection, Repair and Replacement .....	164
Precautions for Assembly and Installation .....	164
Parts Requiring Angle Tightening .....	164
Precautions for Liquid Gasket .....	164
REMOVAL OF LIQUID GASKET SEALING .....	164
LIQUID GASKET APPLICATION PROCEDURE .....	165
<b>PREPARATION .....</b>	<b>166</b>
Special Service Tools .....	166
Commercial Service Tools .....	169
<b>NOISE, VIBRATION AND HARSHNESS (NVH)</b>	
<b>TROUBLESHOOTING .....</b>	<b>171</b>
NVH Troubleshooting — Engine Noise .....	171
Use the Chart Below to Help You Find the Cause of the Symptom. ....	172
<b>ENGINE ROOM COVER .....</b>	<b>173</b>
Components .....	173
Removal and Installation .....	173
REMOVAL .....	173
INSTALLATION .....	173

<b>DRIVE BELTS .....</b>	<b>174</b>
Components .....	174
Checking Drive Belts .....	174
Tension Adjustment .....	174
Removal and Installation .....	174
REMOVAL .....	174
INSTALLATION .....	175
Components .....	176
Drive Belt Auto Tensioner and Idler Pulley .....	176
REMOVAL .....	176
INSTALLATION .....	176
<b>AIR CLEANER AND AIR DUCT .....</b>	<b>177</b>
Components .....	177
Removal and Installation .....	177
REMOVAL .....	177
INSPECTION AFTER REMOVAL .....	178
INSTALLATION .....	178
Changing Air Cleaner Filter .....	178
REMOVAL .....	178
INSTALLATION .....	178
<b>INTAKE MANIFOLD .....</b>	<b>179</b>
Components .....	179
Removal and Installation .....	180
REMOVAL .....	180
INSPECTION AFTER REMOVAL .....	182
INSTALLATION .....	182
INSPECTION AFTER INSTALLATION .....	182
<b>EXHAUST MANIFOLD AND THREE WAY CATALYST .....</b>	<b>183</b>
Components .....	183
Removal and Installation .....	183
REMOVAL .....	183
INSPECTION AFTER REMOVAL .....	185
INSTALLATION .....	185
<b>OIL PAN AND OIL STRAINER .....</b>	<b>187</b>
Components .....	187
Removal and Installation .....	187
REMOVAL .....	187
INSPECTION AFTER REMOVAL .....	188
INSTALLATION .....	188
INSPECTION AFTER INSTALLATION .....	189
<b>IGNITION COIL .....</b>	<b>190</b>
Components .....	190
Removal and Installation .....	190
REMOVAL .....	190
INSTALLATION .....	190
<b>SPARK PLUG (PLATINUM-TIPPED TYPE) .....</b>	<b>191</b>
Components .....	191
Removal and Installation .....	191
REMOVAL .....	191
INSPECTION AFTER REMOVAL .....	191
INSTALLATION .....	192
<b>FUEL INJECTOR AND FUEL TUBE .....</b>	<b>193</b>
Components .....	193
Removal and Installation .....	193
REMOVAL .....	193
INSTALLATION .....	195
INSPECTION AFTER INSTALLATION .....	197

A  
 EM  
 C  
 D  
 E  
 F  
 G  
 H  
 I  
 J  
 K  
 L  
 M

<b>ROCKER COVER</b> .....	<b>199</b>	<b>ENGINE ASSEMBLY</b> .....	<b>244</b>
Components .....	199	Components .....	244
Removal and Installation .....	199	Removal and Installation .....	244
REMOVAL .....	199	REMOVAL .....	245
INSTALLATION .....	201	INSTALLATION .....	247
<b>TIMING CHAIN</b> .....	<b>203</b>	INSPECTION AFTER INSTALLATION .....	247
Components .....	203	<b>CYLINDER BLOCK</b> .....	<b>249</b>
Removal and Installation .....	204	Components .....	249
REMOVAL .....	204	Disassembly and Assembly .....	250
INSPECTION AFTER REMOVAL .....	208	DISASSEMBLY .....	250
INSTALLATION .....	208	ASSEMBLY .....	254
INSPECTION AFTER INSTALLATION .....	214	How to Select Piston and Bearing .....	259
<b>CAMSHAFT</b> .....	<b>215</b>	DESCRIPTION .....	259
Components .....	215	HOW TO SELECT PISTON .....	260
Removal and Installation .....	215	HOW TO SELECT CONNECTING ROD BEAR-	
REMOVAL .....	215	ING .....	261
INSPECTION AFTER REMOVAL .....	216	HOW TO SELECT MAIN BEARING .....	262
INSTALLATION .....	219	Inspection after Disassembly .....	266
INSPECTION AFTER INSTALLATION .....	221	CRANKSHAFT END PLAY .....	266
INSPECTION AFTER INSTALLATION .....	222	CONNECTING ROD SIDE CLEARANCE .....	266
Valve Clearance .....	222	PISTON TO PISTON PIN OIL CLEARANCE .....	266
INSPECTION .....	222	PISTON RING SIDE CLEARANCE .....	267
ADJUSTMENT .....	225	PISTON RING END GAP .....	267
<b>OIL SEAL</b> .....	<b>229</b>	CONNECTING ROD BEND AND TORSION .....	268
Removal and Installation of Valve Oil Seal .....	229	CONNECTING ROD BIG END DIAMETER .....	268
REMOVAL .....	229	CONNECTING ROD BUSHING OIL CLEAR-	
INSTALLATION .....	229	ANCE .....	268
Removal and Installation of Front Oil Seal .....	230	CYLINDER BLOCK DISTORTION .....	269
REMOVAL .....	230	MAIN BEARING HOUSING INNER DIAMETER .....	270
INSTALLATION .....	230	PISTON TO CYLINDER BORE CLEARANCE .....	270
Removal and Installation of Rear Oil Seal .....	231	CRANKSHAFT MAIN JOURNAL DIAMETER .....	271
REMOVAL .....	231	CRANKSHAFT PIN JOURNAL DIAMETER .....	272
INSTALLATION .....	231	CRANKSHAFT OUT-OF-ROUND AND TAPER .....	272
<b>CYLINDER HEAD</b> .....	<b>233</b>	CRANKSHAFT RUNOUT .....	272
On-Vehicle Service .....	233	CONNECTING ROD BEARING OIL CLEAR-	
CHECKING COMPRESSION PRESSURE .....	233	ANCE .....	273
Components .....	234	MAIN BEARING OIL CLEARANCE .....	274
Removal and Installation .....	234	CRUSH HEIGHT OF MAIN BEARING .....	275
REMOVAL .....	234	CRUSH HEIGHT OF CONNECTING ROD	
INSPECTION AFTER REMOVAL .....	235	BEARING .....	275
INSTALLATION .....	235	DRIVE PLATE .....	275
Disassembly and Assembly .....	237	<b>SERVICE DATA AND SPECIFICATIONS (SDS)</b> ...	<b>276</b>
COMPONENTS .....	237	Standard and Limit .....	276
DISASSEMBLY .....	237	GENERAL SPECIFICATIONS .....	276
ASSEMBLY .....	238	DRIVE BELTS .....	276
Inspection after Disassembly .....	239	INTAKE MANIFOLD AND EXHAUST MANI-	
VALVE DIMENSIONS .....	239	FOLD .....	276
VALVE GUIDE CLEARANCE .....	240	SPARK PLUG .....	277
VALVE GUIDE REPLACEMENT .....	240	CAMSHAFT AND CAMSHAFT BEARING .....	277
VALVE SEAT CONTACT .....	242	CYLINDER HEAD .....	279
VALVE SEAT REPLACEMENT .....	242	CYLINDER BLOCK .....	282
VALVE SPRING SQUARENESS .....	243	PISTON, PISTON RING AND PISTON PIN .....	283
VALVE SPRING DIMENSIONS AND VALVE		CONNECTING ROD .....	284
SPRING PRESSURE LOAD .....	243	CRANKSHAFT .....	285
		MAIN BEARING .....	287
		CONNECTING ROD BEARING .....	288



## PRECAUTIONS

PF0:00001

### Precautions for Procedures without Cowl Top Cover

NBS004MF

When performing the procedure after removing cowl top cover, cover the lower end of windshield with urethane, etc.

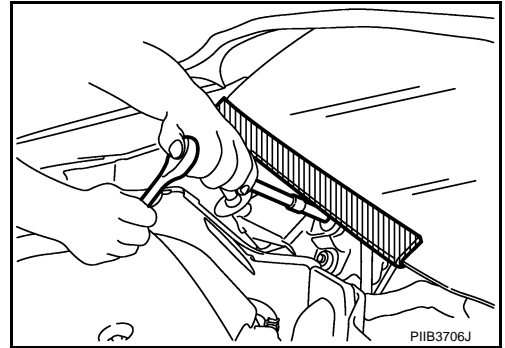

### Precautions Necessary for Steering Wheel Rotation After Battery Disconnect

NBS005RR

#### NOTE:

- This Procedure is applied only to models with Intelligent Key system and NVIS/IVIS (NISSAN/INFINITI VEHICLE IMMOBILIZER SYSTEM - NATS).
- Remove and install all control units after disconnecting both battery cables with the ignition knob in the "LOCK" position.
- Always use CONSULT-II to perform self-diagnosis as a part of each function inspection after finishing work. If DTC is detected, perform trouble diagnosis according to self-diagnostic results.

For models equipped with the Intelligent Key system and NVIS/IVIS, an electrically controlled steering lock mechanism is adopted on the key cylinder.

For this reason, if the battery is disconnected or if the battery is discharged, the steering wheel will lock and steering wheel rotation will become impossible.

If steering wheel rotation is required when battery power is interrupted, follow the procedure below before starting the repair operation.

#### OPERATION PROCEDURE

1. Connect both battery cables.

#### NOTE:

Supply power using jumper cables if battery is discharged.

2. Use the Intelligent Key or mechanical key to turn the ignition switch to the "ACC" position. At this time, the steering lock will be released.
3. Disconnect both battery cables. The steering lock will remain released and the steering wheel can be rotated.
4. Perform the necessary repair operation.
5. When the repair work is completed, return the ignition switch to the "LOCK" position before connecting the battery cables. (At this time, the steering lock mechanism will engage.)
6. Perform a self-diagnosis check of all control units using CONSULT-II.

### Precautions for Drain Engine Coolant and Engine Oil

NBS004MH

Drain engine coolant and engine oil when the engine is cooled.

### Precautions for Disconnecting Fuel Piping

NBS004MI

- Before starting work, make sure no fire or spark producing items are in the work area.
- Release fuel pressure before disconnecting and disassembly.
- After disconnecting pipes, plug openings to stop fuel leakage.

### Precautions for Removal and Disassembly

NBS004MJ

- When instructed to use SST, use specified tools. Always be careful to work safely, avoid forceful or uninstructed operations.
- Exercise maximum care to avoid damage to mating or sliding surfaces.

# PRECAUTIONS

[VQ35DE]

- Dowel pins are used for several parts alignment. When replacing and reassembling parts with dowel pins, make sure that dowel pins are installed in the original position.
- Cover openings of engine system with a tape or equivalent, if necessary, to seal out foreign materials.
- Mark and arrange disassembly parts in an organized way for easy troubleshooting and re-assembly.
- When loosening nuts and bolts, as a basic rule, start with the one furthest outside, then the one diagonally opposite, and so on. If the order of loosening is specified, do exactly as specified. Power tools may be used in the step.

## Precautions for Inspection, Repair and Replacement

NBS004MK

Before repairing or replacing, thoroughly inspect parts. Inspect new replacement parts in the same way, and replace if necessary.

## Precautions for Assembly and Installation

NBS004ML

- Use torque wrench to tighten bolts or nuts to specification.
- When tightening nuts and bolts, as a basic rule, equally tighten in several different steps starting with the ones in center, then ones on inside and outside diagonally in this order. If the order of tightening is specified, do exactly as specified.
- Replace with new gasket, packing, oil seal or O-ring.
- Dowel pins are used for several parts alignment. When replacing and reassembling parts with dowel pins, make sure that dowel pins are installed in the original position.
- Thoroughly wash, clean, and air-blow each part. Carefully check engine oil or engine coolant passages for any restriction and blockage.
- Avoid damaging sliding or mating surfaces. Completely remove foreign materials such as cloth lint or dust. Before assembly, oil sliding surfaces well.
- Release air within route when refilling after draining engine coolant.
- After repairing, start the engine and increase engine speed to check engine coolant, fuel, engine oil, and exhaust gases for leakage.

## Precautions for Angle Tightening

NBS004MM

- Use the angle wrench [SST: KV10112100 (BT8653-A)] for the final tightening of the following engine parts:
  - Cylinder head bolts
  - Main bearing cap bolts
  - Connecting rod cap bolts
  - Crankshaft pulley bolt
- Do not use a torque value for final tightening.
- The torque value for these parts are for a preliminary step.
- Ensure thread and seat surfaces are clean and coated with engine oil.

## Precautions for Liquid Gasket

NBS004MN

### REMOVAL OF LIQUID GASKET SEALING

- After removing mounting nuts and bolts, separate the mating surface using the seal cutter (SST) and remove old liquid gasket sealing.

#### CAUTION:

**Be careful not to damage the mating surfaces.**

- Tap the seal cutter to insert it (1), and then slide it (2) by tapping on the side as shown in the figure.
- In areas where the seal cutter (SST) is difficult to use, use a plastic hammer to lightly tap the parts, to remove it.

#### CAUTION:

**If for some unavoidable reason tool such as a screwdriver is used, be careful not to damage the mating surfaces.**

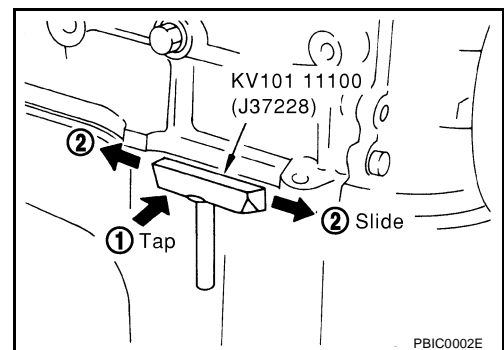

# PRECAUTIONS

[VQ35DE]

## LIQUID GASKET APPLICATION PROCEDURE

1. Using a scraper, remove old liquid gasket adhering to the liquid gasket application surface and the mating surface.
  - Remove liquid gasket completely from the groove of the liquid gasket application surface, mounting bolts, and bolt holes.
2. Wipe the liquid gasket application surface and the mating surface with white gasoline (lighting and heating use) to remove adhering moisture, grease and foreign materials.

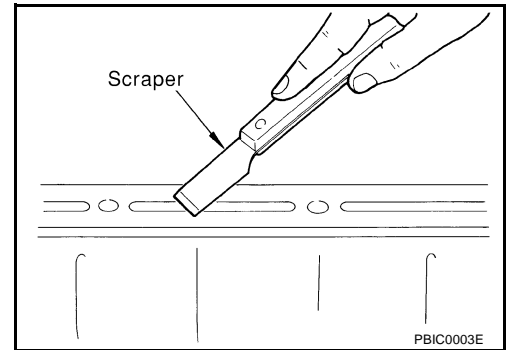

3. Attach liquid gasket tube to the tube presser [SST: WS39930000 ( — )].  
**Use Genuine RTV Silicone Sealant or equivalent. Refer to [GI-48, "RECOMMENDED CHEMICAL PRODUCTS AND SEALANTS"](#).**

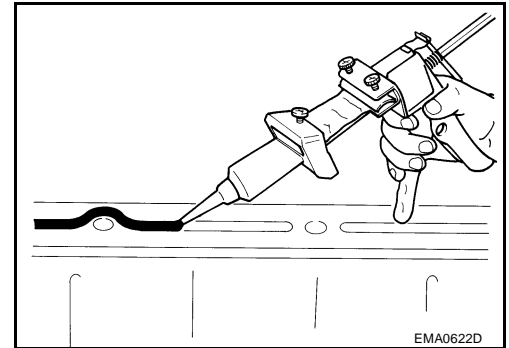

4. Apply liquid gasket without breaks to the specified location with the specified dimensions.
  - If there is a groove for liquid gasket application, apply liquid gasket to the groove.

- As for bolt holes, normally apply liquid gasket inside the holes. Occasionally, it should be applied outside the holes. Make sure to read the text of this manual.
- Within five minutes of liquid gasket application, install the mating component.
- If liquid gasket protrudes, wipe it off immediately.
- Do not retighten mounting bolts or nuts after the installation.
- After 30 minutes or more have passed from the installation, fill engine oil and engine coolant.

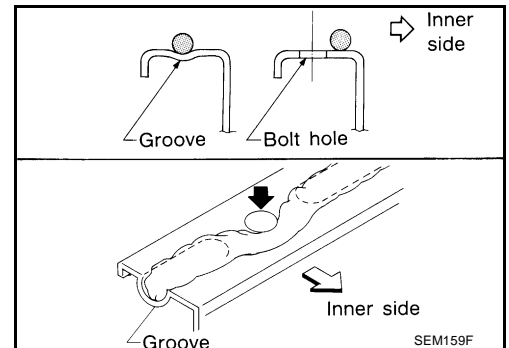

### CAUTION:

**If there are specific instructions in this manual, observe them.**

A  
EM  
C  
D  
E  
F  
G  
H  
I  
J  
K  
L  
M

## PREPARATION

PFP:00002

### Special Service Tools

NBS004MO

The actual shapes of Kent-Moore tools may differ from those of special service tools illustrated here.

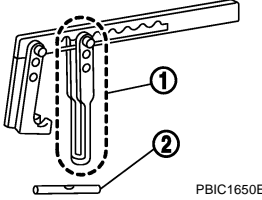
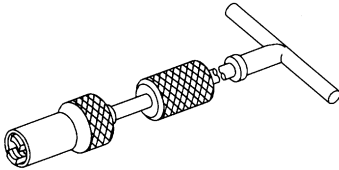
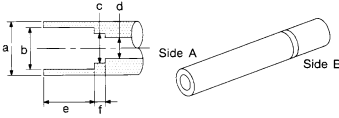
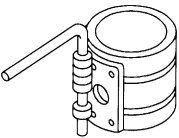
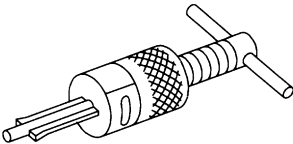
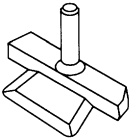
Tool number (Kent-Moore No.) Tool name		Description
KV10116200 (J26336-A) Valve spring compressor 1. KV10115900 (J26336-20) Attachment 2. KV10109220 ( — ) Adapter		Disassembling valve mechanism Part (1) is a component of KV10116200 (J26336-A), but Part (2) is not so.
KV10107902 (J38959) Valve oil seal puller		Replacing valve oil seal
KV10115600 (J-38958) Valve oil seal drift		Installing valve oil seal <b>Use side A.</b> <b>a: 20 (0.79) dia.</b> <b>d: 8 (0.31) dia.</b> <b>b: 13 (0.51) dia.</b> <b>e: 10.7 (0.421)</b> <b>c: 10.3 (0.406) dia.</b> <b>f: 5 (0.20)</b> Unit: mm (in)
EM03470000 (J8037) Piston ring compressor		Installing piston assembly into cylinder bore
ST16610001 (J23907) Pilot bushing puller		Removing pilot converter
KV10111100 (J37228) Seal cutter		Removing oil pan (lower and upper), front and rear timing chain case, etc.

# PREPARATION

[VQ35DE]

Tool number (Kent-Moore No.) Tool name	Description	A
WS39930000 ( — ) Tube presser	Pressing the tube of liquid gasket	EM
KV10112100 (BT8653-A) Angle wrench	Tightening bolts for connecting rod bearing cap, cylinder head, etc. in angle	D
KV10114400 (J38365) Heated oxygen sensor wrench	Loosening or tightening air fuel ratio sensor 1 <b>a: 22 mm (0.87 in)</b>	F
KV10117700 (J44716) Ring gear stopper	Removing and installing crankshaft pulley	I
— (J-45488) Quick connector release	Removing fuel tube quick connectors in engine room	K

EM

C

D

E

F

G

H

I

J

K

L

M

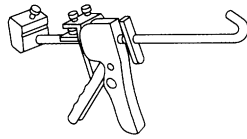

NT052

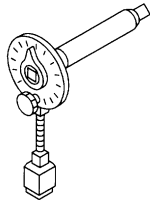

NT014

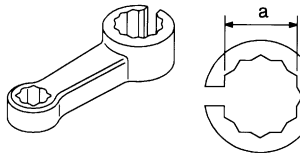

NT636

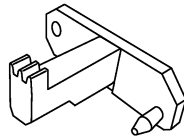

NT822

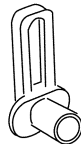

PBIC0198E

# PREPARATION

[VQ35DE]

## Commercial Service Tools

NBS004MP

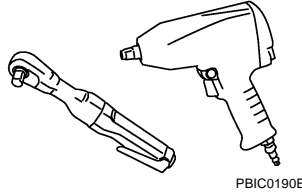
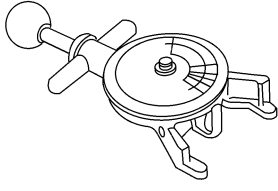
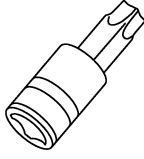
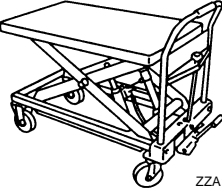
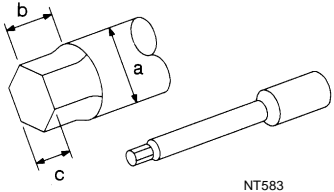
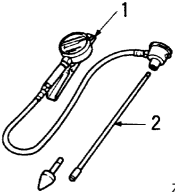
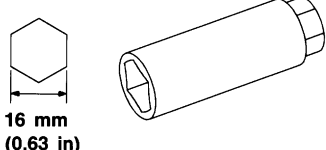
(Kent-Moore No.) Tool name	Description
( — ) Power tool  <p style="text-align: right;">PBIC0190E</p>	Loosening nuts and bolts
(BT3373-F) Belt tension gauge  <p style="text-align: right;">AMA126</p>	Checking drive belt tension
( — ) TORX socket  <p style="text-align: right;">PBIC1113E</p>	Removing and installing drive plate <b>Size: T55</b>
( — ) Manual lift table caddy  <p style="text-align: right;">ZZA1210D</p>	Removing and installing engine
(J24239-01) Cylinder head bolt wrench  <p style="text-align: right;">NT583</p>	Loosening and tightening cylinder head bolt, and used with the angle wrench [SST: KV10112100 (BT8653-A)] <b>a: 13 (0.51) dia.</b> <b>b: 12 (0.47)</b> <b>c: 10 (0.39)</b> Unit: mm (in)
( — ) 1.Compression gauge 2.Adapter  <p style="text-align: right;">ZZA0008D</p>	Checking compression pressure
( — ) Spark plug wrench  <p style="text-align: right;">NT047</p>	Removing and installing spark plug

# PREPARATION

[VQ35DE]

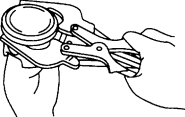
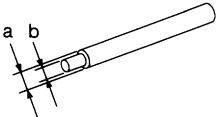
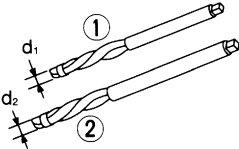
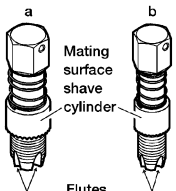
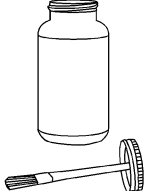
(Kent-Moore No.) Tool name	Description	A
( — ) Valve seat cutter set  NT048	Finishing valve seat dimensions	EM C
( — ) Piston ring expander  NT030	Removing and installing piston ring	D E
( — ) Valve guide drift  NT015	Removing and installing valve guide <b>Intake and Exhaust:</b> <b>a: 9.5 mm (0.374 in) dia.</b> <b>b: 5.5 mm (0.217 in) dia.</b>	F G
( — ) Valve guide reamer  NT016	(1): Reaming valve guide inner hole (2): Reaming hole for oversize valve guide <b>Intake and Exhaust:</b> <b>d1 : 6.0 mm (0.236 in) dia.</b> <b>d2 : 10.2 mm (0.402 in) dia.</b>	H I J
(J-43897-18) (J-43897-12) Oxygen sensor thread cleaner  AEM488	Reconditioning the exhaust system threads before installing a new air fuel ratio sensor and heated oxygen sensor (Use with anti-seize lubricant shown below.) <b>a: J-43897-18 [18 mm (0.71 in) dia.] for zirconia heated oxygen sensor and air fuel ratio sensor</b> <b>b: J-43897-12 [12 mm (0.47 in) dia.] for titania heated oxygen sensor and air fuel ratio sensor</b>	K L
( — ) Anti-seize lubricant (Permatex 133AR or equivalent meeting MIL specification MIL-A-907)  AEM489	Lubricating oxygen sensor thread cleaning tool when reconditioning exhaust system threads	M

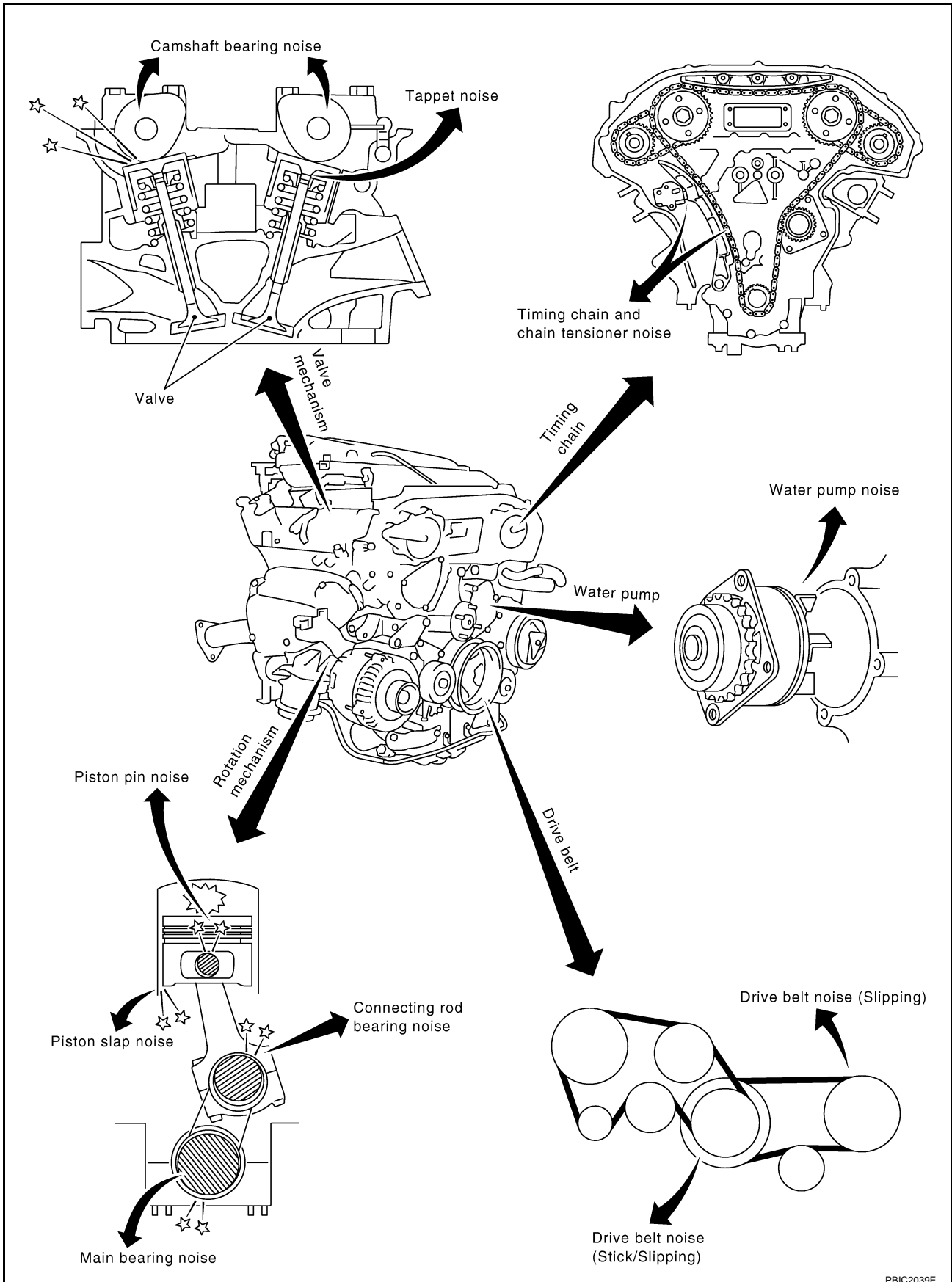



# NOISE, VIBRATION AND HARSHNESS (NVH) TROUBLESHOOTING

[VQ35DE]

NBS004MR

## Use the Chart Below to Help You Find the Cause of the Symptom.

1. Locate the area where noise occurs.
2. Confirm the type of noise.
3. Specify the operating condition of the engine.
4. Check specified noise source.

If necessary, repair or replace these parts.

Location of noise	Type of noise	Operating condition of engine						Source of noise	Check item	Reference page
		Before warm-up	After warm-up	When starting	When idling	When racing	While driving			
Top of engine Rocker cover Cylinder head	Ticking or clicking	C	A	—	A	B	—	Tappet noise	Valve clearance	<a href="#">EM-93</a>
	Rattle	C	A	—	A	B	C	Camshaft bearing noise	Camshaft runout Camshaft journal oil clearance	<a href="#">EM-86</a> <a href="#">EM-86</a>
Crankshaft pulley Cylinder block (Side of engine) Oil pan	Slap or knock	—	A	—	B	B	—	Piston pin noise	Piston to piston pin oil clearance Connecting rod bushing oil clearance	<a href="#">EM-140</a> <a href="#">EM-142</a>
	Slap or rap	A	—	—	B	B	A	Piston slap noise	Piston to cylinder bore clearance Piston ring side clearance Piston ring end gap Connecting rod bend and torsion	<a href="#">EM-144</a> <a href="#">EM-141</a> <a href="#">EM-141</a> <a href="#">EM-142</a>
	Knock	A	B	C	B	B	B	Connecting rod bearing noise	Connecting rod bushing oil clearance Connecting rod bearing oil clearance	<a href="#">EM-142</a> <a href="#">EM-146</a>
	Knock	A	B	—	A	B	C	Main bearing noise	Main bearing oil clearance Crankshaft runout	<a href="#">EM-147</a> <a href="#">EM-146</a>
Front of engine Timing chain case	Tapping or ticking	A	A	—	B	B	B	Timing chain and timing chain tensioner noise	Timing chain cracks and wear Timing chain tensioner operation	<a href="#">EM-72</a> <a href="#">EM-64</a>
Front of engine	Squeaking or fizzing	A	B	—	B	—	C	Drive belts (Sticking or slipping)	Drive belts deflection	<a href="#">EM-15</a>
	Creaking	A	B	A	B	A	B	Drive belts (Slipping)	Idler pulley bearing operation	
	Squall Creak	A	B	—	B	A	B	Water pump noise	Water pump operation	<a href="#">CO-24</a> <a href="#">"WATER PUMP"</a>

A: Closely related B: Related C: Sometimes related —: Not related

## ENGINE ROOM COVER

PFP:14049

## Components

NBS004MS

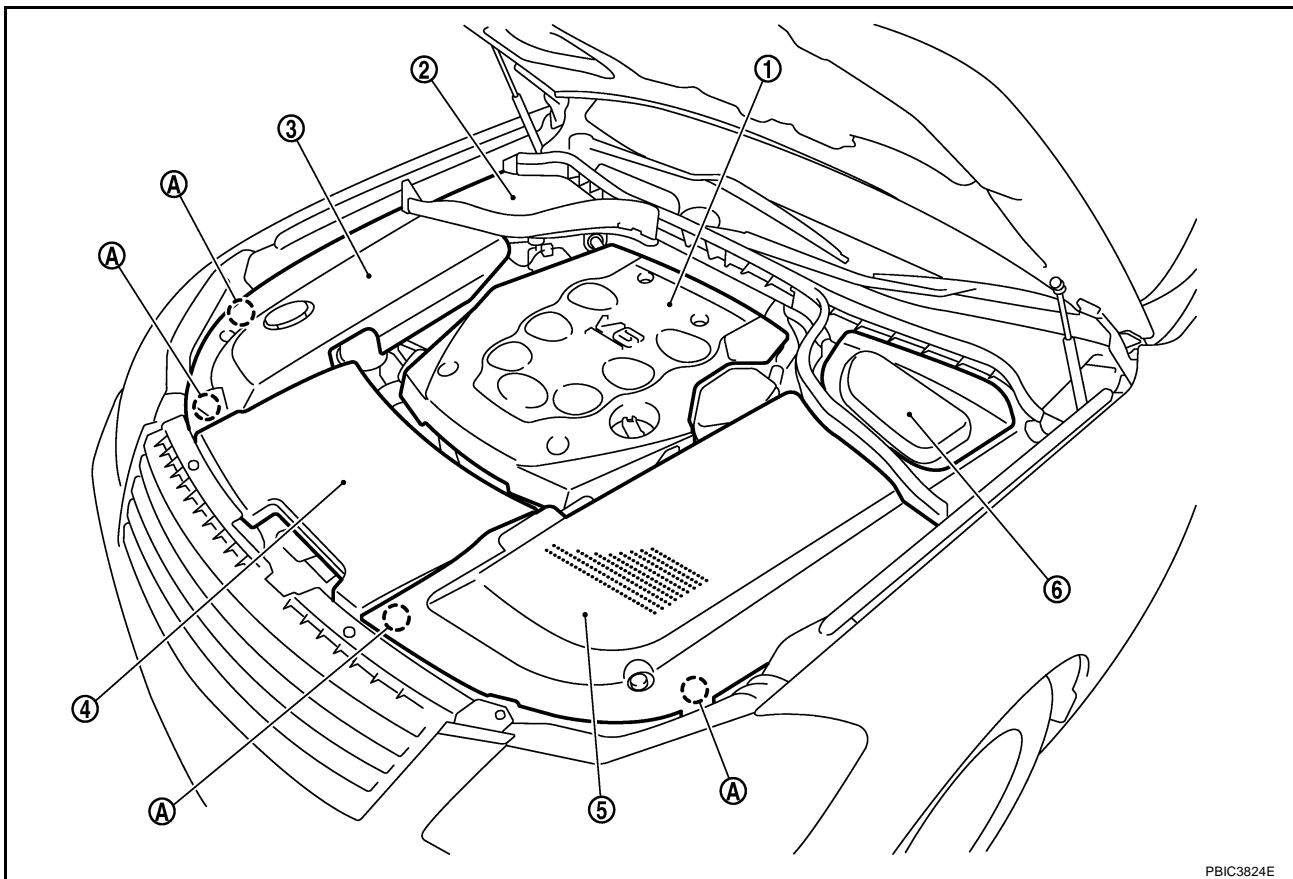

PBIC3824E

- |                                  |                           |                                |
|----------------------------------|---------------------------|--------------------------------|
| 1. Engine cover                  | 2. Battery cover          | 3. Engine room cover (RH)      |
| 4. Air duct (inlet)              | 5. Engine room cover (LH) | 6. Brake master cylinder cover |
| A. Clip (secure at back surface) |                           |                                |

## Removal and Installation

### REMOVAL

NBS004MT

**CAUTION:**

Do not damage or scratch cover when installing or removing.

- Refer to [EM-19, "INTAKE MANIFOLD COLLECTOR"](#) for removal and installation of engine cover.
- Refer to [EM-17, "AIR CLEANER AND AIR DUCT"](#) for removal and installation of air duct (inlet).
- Remove the washer tank cap before removing the engine room cover (RH).
- Remove the engine room covers (RH and LH) by lifting the clipped point using a clip driver.
- Major parts and inspection points under each cover are as follows; (numbered as in figure)

1. Upper side of engine assembly
2. Battery, relay box
3. Power steering fluid reservoir tank, engine coolant reservoir tank, relay box
4. Engine assembly front side, drive belts, cooling fan
5. Mass air flow sensor, air cleaner case
6. Brake master cylinder, brake booster

**INSTALLATION**

Installation is the reverse order of removal.

## DRIVE BELTS

PFP:02117

### Checking Drive Belts

NBS004MU

**WARNING:**

**Be sure to perform when engine is stopped.**

1. Inspect belts for cracks, fraying, wear and oil. If necessary, replace.
2. Inspect drive belt deflection or tension at a point on belt midway between pulleys.
  - Inspection should be done only when engine is cold, or over 30 minutes after engine is stopped.
  - Measure the belt tension with belt tension gauge (Commercial service tool: BT3373-F or equivalent) at points marked ▼ shown in the figure.
  - When measuring the deflection, apply 98 N (10 kg, 22 lb) at the ▼ marked point.
  - Adjust if the belt deflection exceeds the limit or if the belt tension is not within specifications.

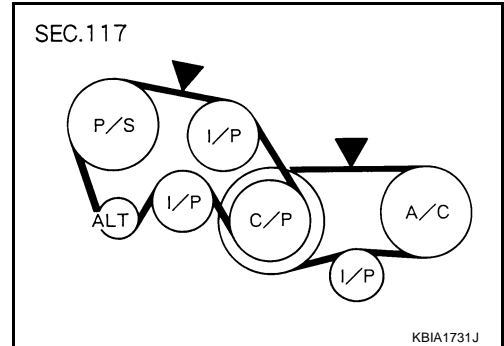

**CAUTION:**

- **When checking the belt deflection or the tension immediately after installation, first adjust it to the specified value. Then, after turning crankshaft two turns or more, re-adjust to the specified value to avoid variation in deflection between pulleys.**
- **Tighten idler pulley lock nut by hand and measure the deflection or the tension without looseness.**

#### Belt Deflection and Tension

Items	Deflection adjustment		Unit: mm (in)	Tension adjustment*		Unit: N (kg, lb)
	Used belt			Used belt		
	Limit	After adjustment	New belt	Limit	After adjustment	New belt
Alternator and power steering oil pump belt	7 (0.28)	4 - 5 (0.16 - 0.20)	3.5 - 4.5 (0.138 - 0.177)	294 (30, 66)	730 - 818 (74.5 - 83.5, 164 - 184)	838 - 926 (85.5 - 94.5, 188 - 208)
A/C compressor belt	12 (0.47)	9 - 10 (0.35 - 0.39)	8 - 9 (0.31 - 0.35)	196 (20, 44)	348 - 436 (35.5 - 44.5, 78 - 98)	470 - 559 (48 - 57, 106 - 126)
Applied pushing force	98 N (10 kg, 22 lb)			—		

\*: If belt tension gauge cannot be installed at check points shown, check drive belt tension at different location on belt.

### Tension Adjustment

NBS004MV

Portion	Belt tightening method for adjustment
Alternator and power steering oil pump belt	Adjusting bolt on idler pulley
A/C compressor belt	Adjusting bolt on idler pulley

**CAUTION:**

- **When belt is replaced with a new one, adjust it to value for “New belt” to accommodate for insufficient adaptability with pulley grooves.**
- **When deflection or tension of belt being used exceeds “Limit”, adjust it to value for “After adjustment”.**
- **When checking belt deflection or tension immediately after installation, first adjust it to the specified value. Then, after turning crankshaft two turns or more, re-adjust to the specified value to avoid variation in deflection between pulleys.**
- **When installing belt, make sure that it is correctly engaged with pulley grooves.**
- **Keep engine oil, working fluid and engine coolant away from belt and pulley grooves.**
- **Do not twist or bend belt excessively.**

## ALTERNATOR AND POWER STEERING OIL PUMP BELT

1. Remove front engine undercover with power tool.
2. Loosen idler pulley lock nut (A) and adjust tension by turning adjusting bolt (B).
  - For the specified belt tension, refer to [EM-15, "Checking Drive Belts"](#).
3. Tighten nut (A).

: 34.8 N-m (3.5 kg-m, 26 ft-lb)

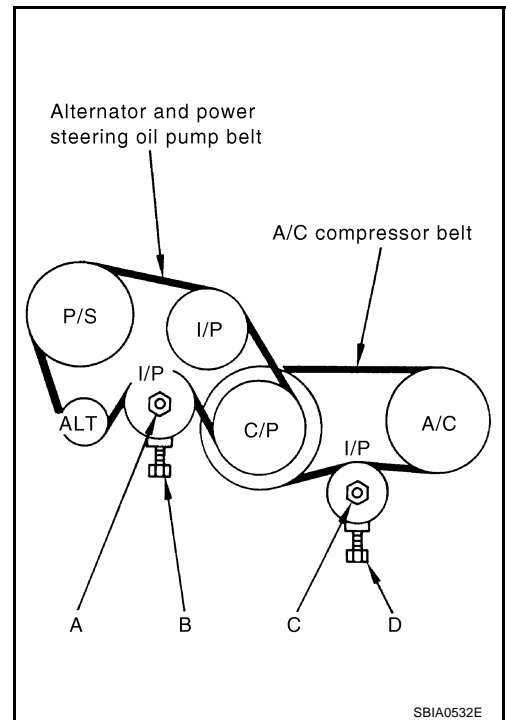

## A/C COMPRESSOR BELT

1. Remove front engine undercover with power tool.
2. Loosen idler pulley lock nut (C) and adjust tension by turning adjusting bolt (D).
  - For the specified belt tension, refer to [EM-15, "Checking Drive Belts"](#).
3. Tighten nut (C).

: 34.8 N-m (3.5 kg-m, 26 ft-lb)

## Removal and Installation

### REMOVAL

1. Remove front engine undercover with power tool.
2. Remove alternator and power steering oil pump belt. Refer to [EM-16, "ALTERNATOR AND POWER STEERING OIL PUMP BELT"](#).
3. Remove A/C compressor belt. Refer to [EM-16, "A/C COMPRESSOR BELT"](#).

### CAUTION:

Grease is applied to idler pulley adjusting bolt. Be careful to keep grease away from belt.

### INSTALLATION

1. Install belts to pulley in reverse order of removal.
  - CAUTION:**
    - Make sure drive belt is correctly engaged with pulley groove.
    - Make sure that for engine oil and engine coolant do not adhere to belt and each pulley grooves.
2. Adjust belt tension. Refer to [EM-15, "Tension Adjustment"](#).
3. Tighten each adjusting bolt and nut to the specified torque.
4. Make sure that tension of each belt is within the standard. Refer to [EM-15, "Checking Drive Belts"](#).

## AIR CLEANER AND AIR DUCT

PFP:16500

### Components

NBS004MX

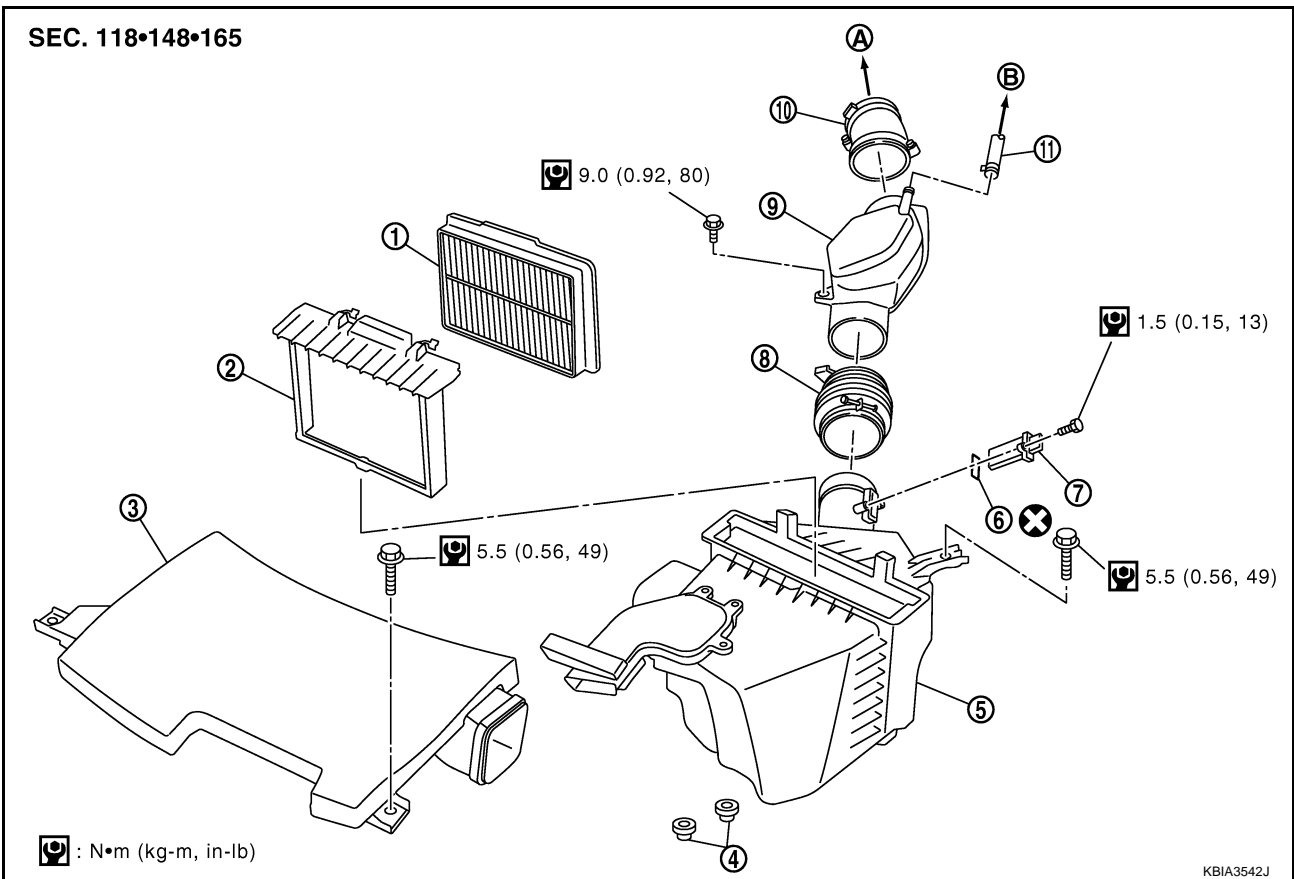

- |  |                                |                     |
|--|--------------------------------|---------------------|
| 1. Air cleaner filter                    | 2. Holder                      | 3. Air duct (inlet) |
| 4. Grommet                               | 5. Air cleaner case            | 6. O-ring           |
| 7. Mass air flow sensor                  | 8. Air hose                    | 9. Air duct         |
| 10. Air hose                             | 11. PCV hose                   |                     |
| A. To electric throttle control actuator | B. To rocker cover (left bank) |                     |

- Refer to [GI-11, "Components"](#) for symbol marks in the figure.

## Removal and Installation

### REMOVAL

1. Remove engine room cover (RH and LH). Refer to [EM-14, "ENGINE ROOM COVER"](#).
2. Remove air duct (inlet).
3. Disconnect mass air flow sensor harness connector.
4. Disconnect PCV hose.
5. Remove air cleaner case/mass air flow sensor assembly and air duct/air hose disconnecting their joints.
  - Add marks as necessary for easier installation.
6. Remove mass air flow sensor from air cleaner case, as necessary.

### CAUTION:

**Handle mass air flow sensor with the following cares.**

- Do not shock it.
- Do not disassemble it.
- Do not touch its sensor.

### INSTALLATION

Note the following, and install in the reverse order of removal.

- Align marks. Attach each joint. Screw clamps firmly.

## Changing Air Cleaner Filter REMOVAL

1. Remove engine room cover (LH). Refer to [EM-14, "ENGINE ROOM COVER"](#) .
2. Unhook clips (1) and remove holder (3) from air cleaner case (2).

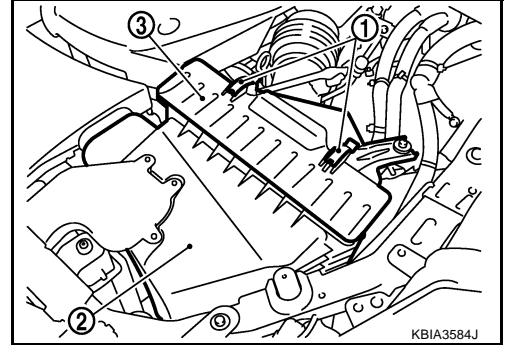

3. Remove air cleaner filter (2) from air cleaner case (1).

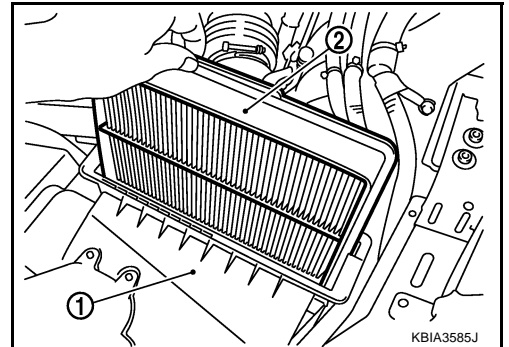

## INSTALLATION

Note the following, and install in the reverse order of removal.

- Install the air cleaner filter by aligning the seal with the notch of air cleaner case.

## INTAKE MANIFOLD COLLECTOR

PFP:14003

### Components

NBS004N0

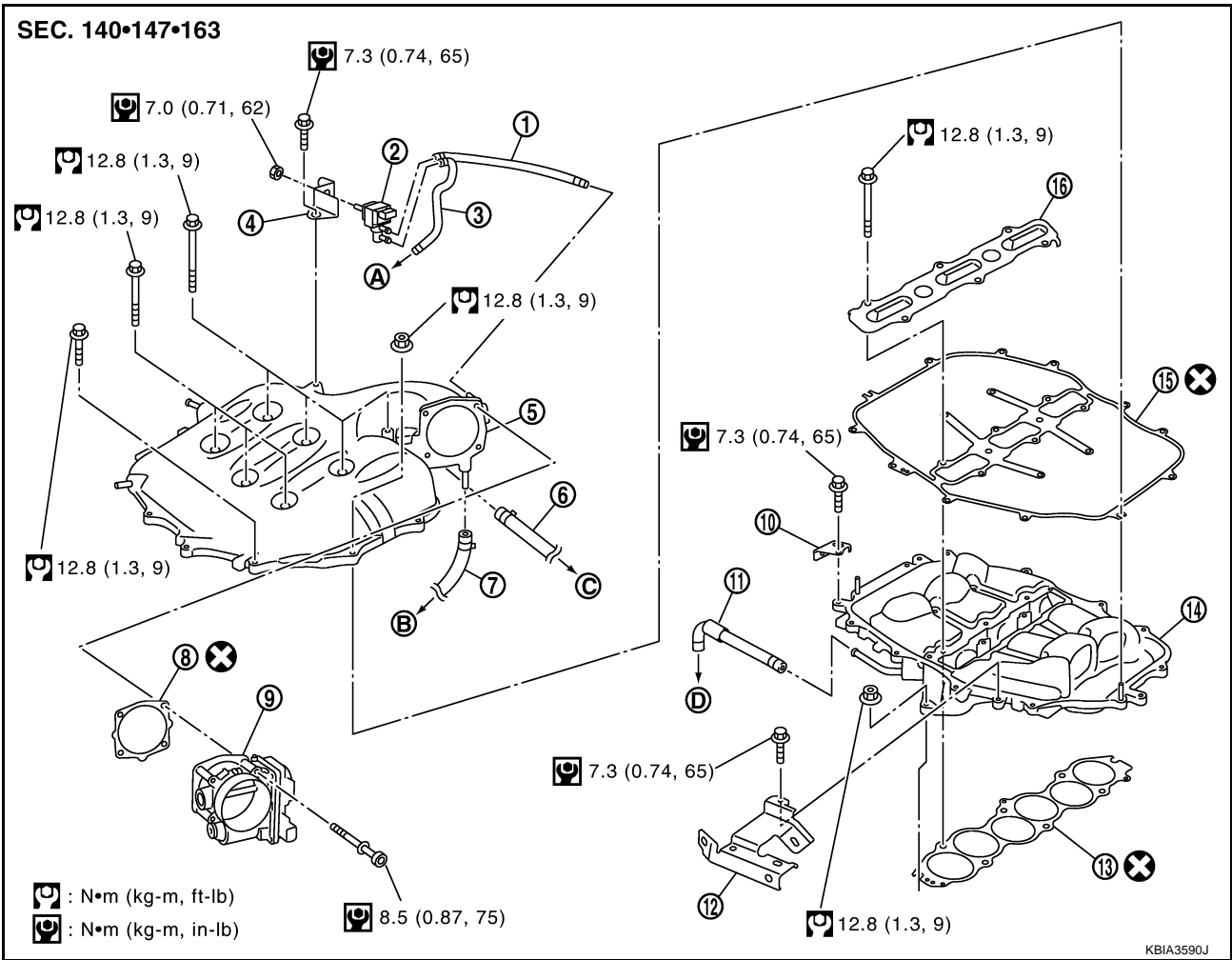

- |                                     |  |                                       |
|-------------------------------------|--|---------------------------------------|
| 1. Vacuum hose                      | 2. EVAP canister purge volume control solenoid valve | 3. Vacuum hose                        |
| 4. Bracket                          | 5. Intake manifold collector (upper)                 | 6. Water hose                         |
| 7. Water hose                       | 8. Gasket  | 9. Electric throttle control actuator |
| 10. Bracket                         | 11. PCV hose   | 12. Bracket                           |
| 13. Gasket                          | 14. Intake manifold collector (lower)                | 15. Gasket                            |
| 16. Intake manifold collector cover |  |                                       |
| A. To vacuum pipe                   | B. To water outlet                                   | C. To heater pipe                     |
| D. To PCV valve                     |  |                                       |

- Refer to [GI-11, "Components"](#) for symbol marks in the figure.

### Removal and Installation

#### REMOVAL

NBS004N1

#### WARNING:

- To avoid the danger of being scalded, never drain engine coolant when the engine is hot.
- Gasket for intake manifold collector (upper) is secured together with mounting bolt for intake manifold collector (lower). Thus, even when only gasket for upper side is replaced, gasket for lower side must be also replaced.

# INTAKE MANIFOLD COLLECTOR

[VQ35DE]

1. Remove engine cover (1) with power tool.

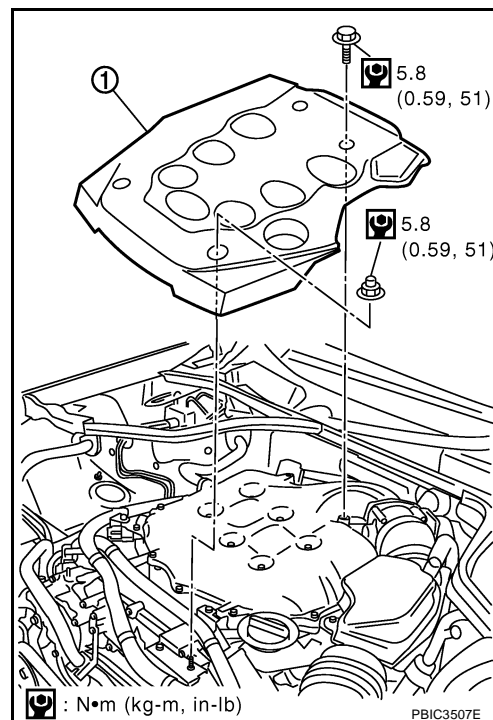

2. Disconnect water hoses from intake manifold collector (upper), attach blind plug to prevent engine coolant leakage.

**CAUTION:**

- Perform this step when the engine is cold.
- Do not spill engine coolant on drive belts.

3. Remove air cleaner case and air duct. Refer to [EM-17, "AIR CLEANER AND AIR DUCT"](#).
4. Remove electric throttle control actuator as follows:
  - a. Disconnect harness connector.
  - b. Loosen mounting bolts in reverse order as shown in the figure.

**CAUTION:**

- Handle carefully to avoid any shock to electric throttle control actuator.
- Do not disassemble.

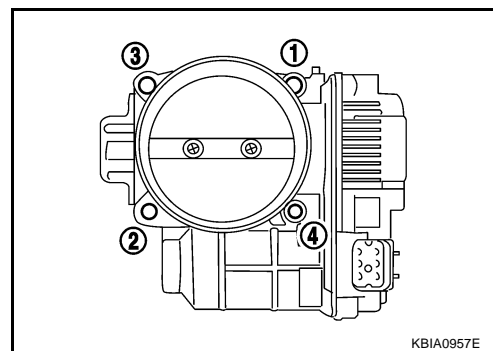

5. Remove fuel sub-tube mounting bolt to disconnect from rear of intake manifold collector (lower). Refer to [EM-45, "FUEL INJECTOR AND FUEL TUBE"](#).
6. Disconnect vacuum hose from intake manifold collector (upper).
7. Remove EVAP canister purge volume control solenoid valve and bracket mounting bolt from intake manifold collector (upper).



# INTAKE MANIFOLD COLLECTOR

[VQ35DE]

8. Loosen mounting bolts in reverse order of illustration to remove intake manifold collector (upper) with power tool.

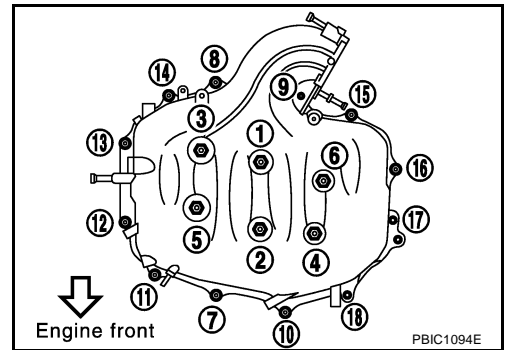

9. Remove PCV hose [between intake manifold collector (lower) and rocker cover (right bank)].
10. Loosen mounting bolts in reverse order as shown in the figure, and remove intake manifold collector cover, gasket, intake manifold collector (lower) and gasket with power tool.

**CAUTION:**

**Cover engine openings to avoid entry of foreign materials.**

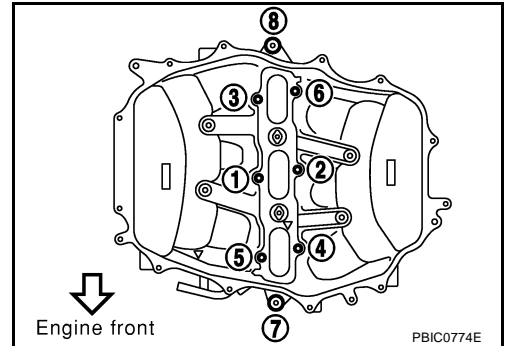

## INSPECTION AFTER REMOVAL

### Surface Distortion

- Check the surface distortion of both the intake manifold collector (upper and lower) mating surfaces with a straightedge and a feeler gauge.  
**Limit : 0.1 mm (0.004 in)**
- If it exceeds the limit, replace intake manifold collector (upper and/or lower).

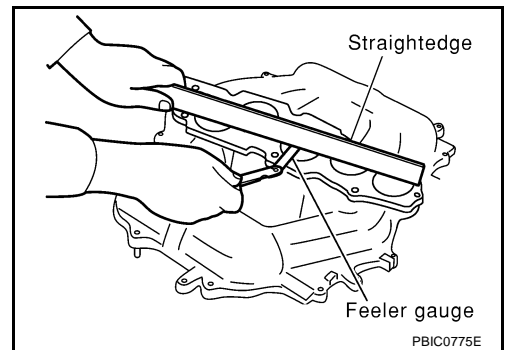

## INSTALLATION

Note the following, and install in the reverse order of removal.

### Part Installation Direction

Referring to front marks, install parts shown in figure.

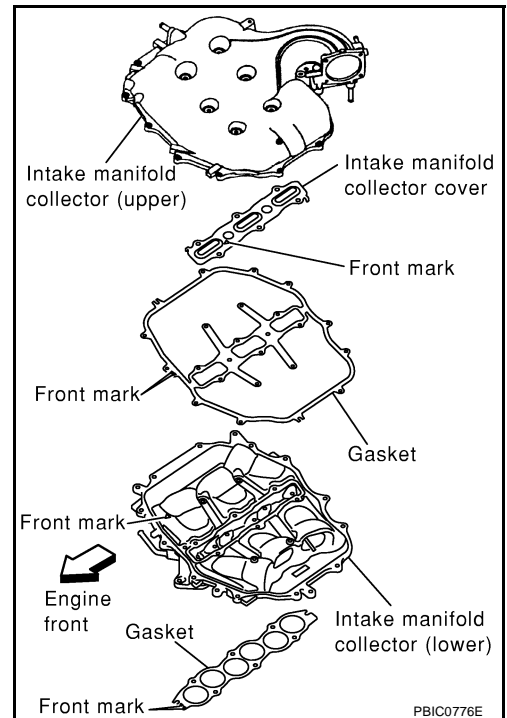

### Intake Manifold Collector (Lower)

Tighten mounting bolts in numerical order as shown in the figure.

#### NOTE:

Tighten mounting bolts to secure gasket (lower), intake manifold collector (lower), gasket (upper), and intake manifold collector cover.

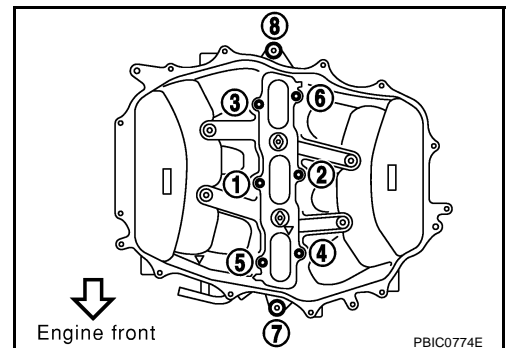

### Intake Manifold Collector (Upper)

- If stud bolts were removed, install them and tighten to the specified torque below.

: 5.9 N·m (0.6 kg-m, 52 in-lb)

- Shank length under bolt head varies with bolt location. Install mounting bolts while referring to numbers shown below and in the figure. (Bolt length does not include pilot portion.)

#### Bolt

**M6 × 25 mm (0.98 in)** : 7, 8, 10, 11, 13, 14, 15, 16, 18

**M6 × 45 mm (1.77 in)** : 2, 4, 5

**M6 × 60 mm (2.36 in)** : 1, 3, 6, 9

**M6 Nut** : 12, 17

- Tighten mounting bolts in numerical order as shown in the figure.

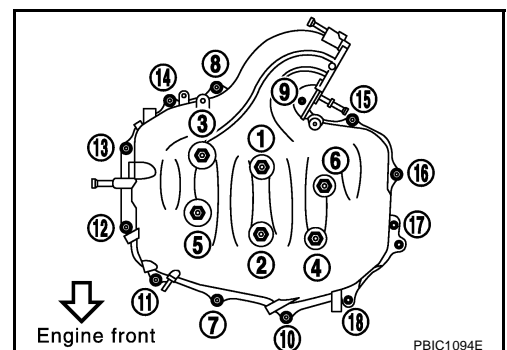

### Water Hose

- Insert hose by 27 to 32 mm (1.06 to 1.26 in) from connector end.

- Clamp hose at location of 3 to 7 mm (0.12 to 0.28 in) from hose end.

## Electric Throttle Control Actuator

- Install gasket with positioning no-protrusion surface upward or downward.
- Tighten in numerical order as shown in the figure.
- Perform the "Throttle Valve Closed Position Learning" when harness connector of electric throttle control actuator is disconnected. Refer to [EC-95, "Throttle Valve Closed Position Learning"](#).
- Perform the "Idle Air Volume Learning" and "Throttle Valve Closed Position Learning" when electric throttle control actuator is replaced. Refer to [EC-96, "Idle Air Volume Learning"](#) and [EC-95, "Throttle Valve Closed Position Learning"](#).

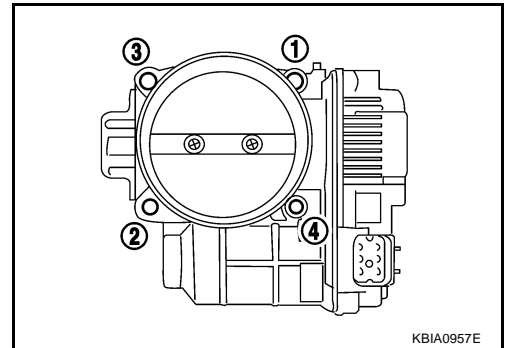

A

EM

C

D

E

F

G

H

I

J

K

L

M

## INTAKE MANIFOLD

PFP:14003

### Components

NBS004N2

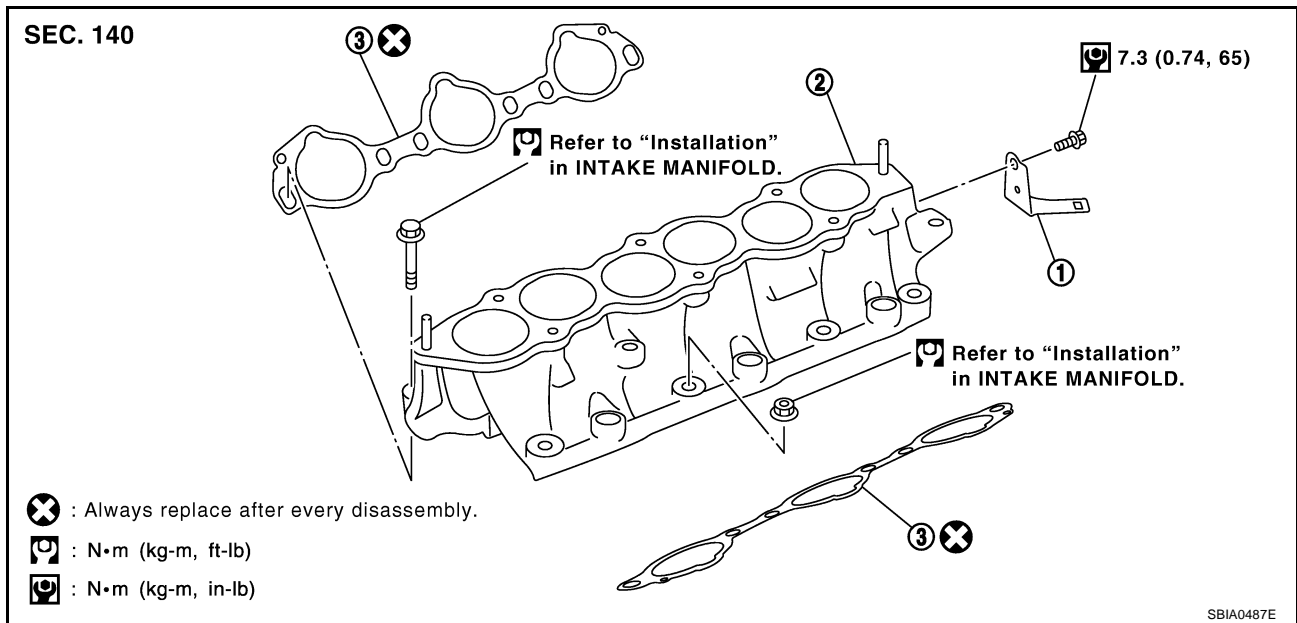

### Removal and Installation

NBS004N3

#### REMOVAL

1. Release fuel pressure. Refer to [EC-98, "FUEL PRESSURE RELEASE"](#).
2. Remove intake manifold collectors (upper and lower). Refer to [EM-19, "INTAKE MANIFOLD COLLECTOR"](#).
3. Remove fuel tube and fuel injector assembly. Refer to [EM-45, "FUEL INJECTOR AND FUEL TUBE"](#).
4. Loosen mounting bolts and nuts in reverse order as shown in the figure to remove intake manifold with power tool.

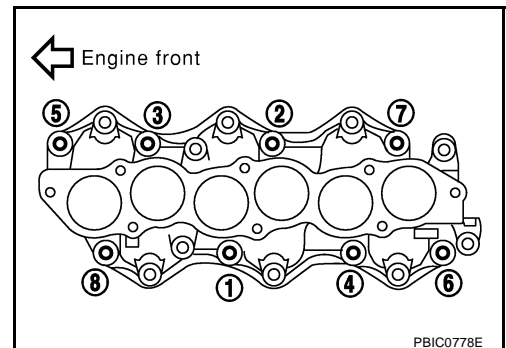

5. Remove gaskets.

**CAUTION:**

**Cover engine openings to avoid entry of foreign materials.**

## INSPECTION AFTER REMOVAL

### Surface Distortion

- Check the surface distortion of the intake manifold mating surface with a straightedge and a feeler gauge.

**Limit : 0.1 mm (0.004 in)**

- If it exceeds the limit, replace intake manifold.

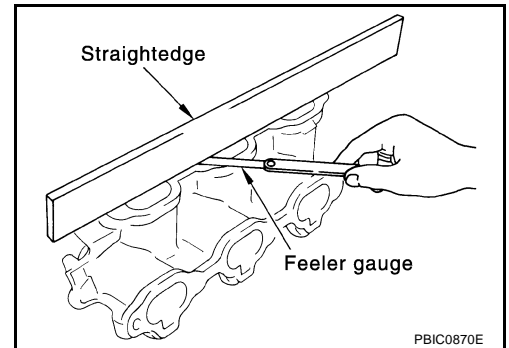

## INSTALLATION

Note the following, and install in the reverse order of removal.

### Intake Manifold

- If stud bolts were removed, install them and tighten to the specified torque below.

: **10.8 N·m (1.1 kg-m, 8 ft-lb)**

- Tighten all mounting bolts and nuts to the specified torque in two or more steps in numerical order shown in the figure.

**1st step:**

: **7.4 N·m (0.75 kg-m, 5 ft-lb)**

**2nd step and after:**

: **29.0 N·m (3.0 kg-m, 21 ft-lb)**

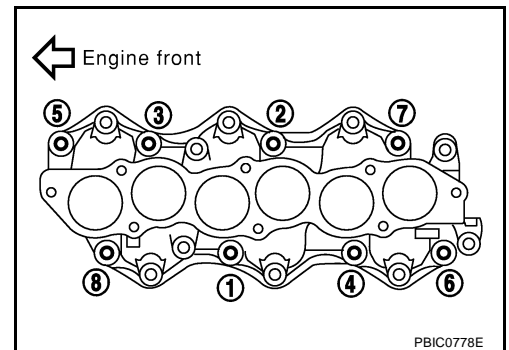

## EXHAUST MANIFOLD

PFP:14004

### Components

NBS004N4

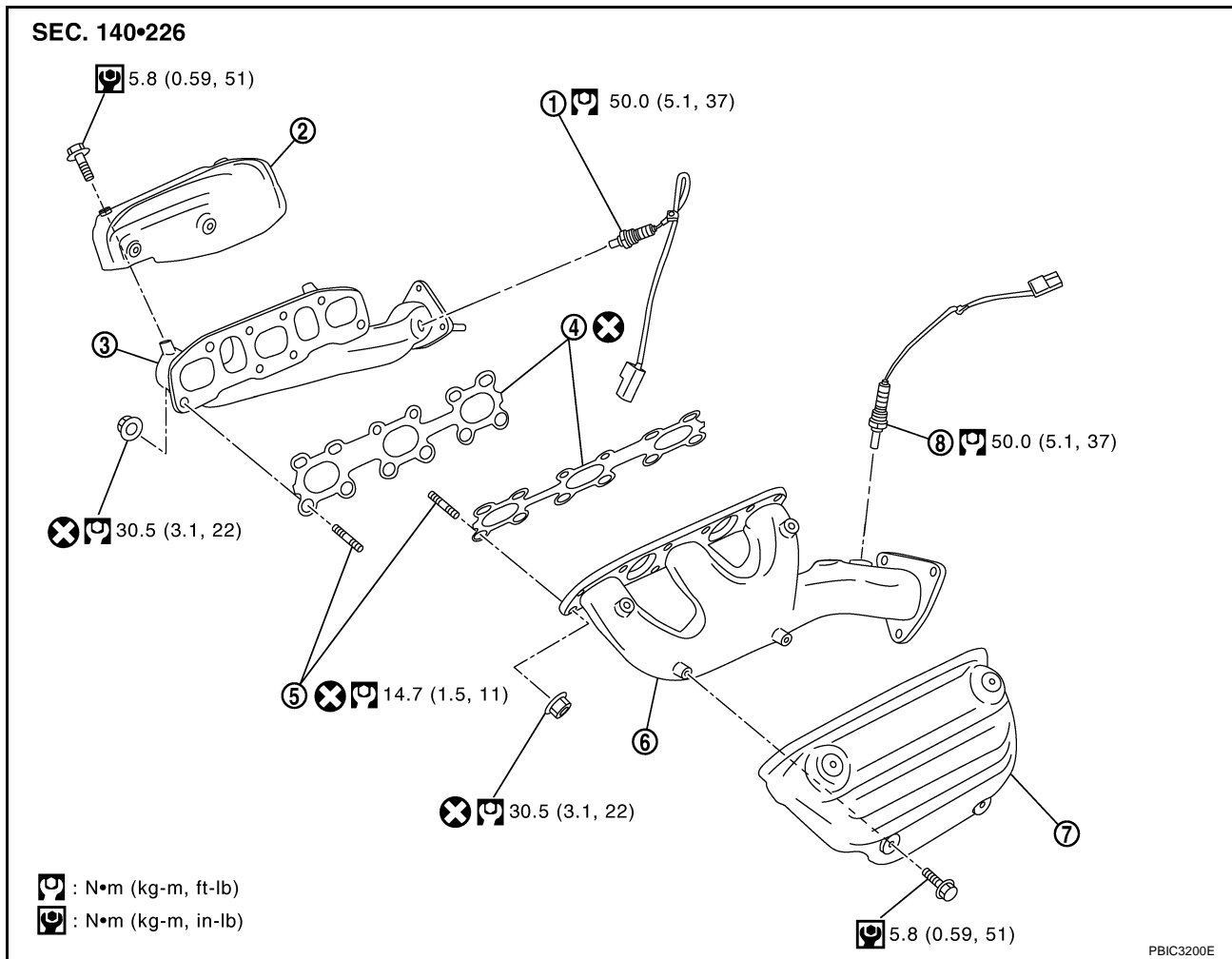

- |                                       |  |                                  |
|---------------------------------------|--|----------------------------------|
| 1. Air fuel ratio sensor 1 (bank 1)   | 2. Exhaust manifold cover (right bank) | 3. Exhaust manifold (right bank) |
| 4. Gasket                             | 5. Stud bolt                           | 6. Exhaust manifold (left bank)  |
| 7. Exhaust manifold cover (left bank) | 8. Air fuel ratio sensor 1 (bank 2)    |                                  |

- Refer to [GI-11, "Components"](#) for symbol marks in the figure.

## Removal and Installation

### REMOVAL

NBS004N5

#### WARNING:

Perform the work when the exhaust and cooling system have completely cooled down.

1. Remove engine room cover (RH and LH). Refer to [EM-14, "ENGINE ROOM COVER"](#).
2. Remove engine cover with power tool. Refer to [EM-19, "INTAKE MANIFOLD COLLECTOR"](#).
3. Remove air cleaner case and air duct. Refer to [EM-17, "AIR CLEANER AND AIR DUCT"](#).
4. Remove front and rear engine undercover with power tool.
5. Remove exhaust front tube and three way catalyts (right and left bank). Refer to [EX-3, "EXHAUST SYSTEM"](#).
6. Disconnect air fuel ratio sensor 1 (bank 1 and bank 2) harness connectors and remove harness clip.

# EXHAUST MANIFOLD

[VQ35DE]

7. Using the heated oxygen sensor wrench (SST), remove air fuel ratio sensor 1 (bank 1 and bank 2).

**CAUTION:**

- Be careful not to damage air fuel ratio sensor 1.
- Discard any air fuel ratio sensor 1 which has been dropped onto a hard surface such as a concrete floor; replace with a new sensor.

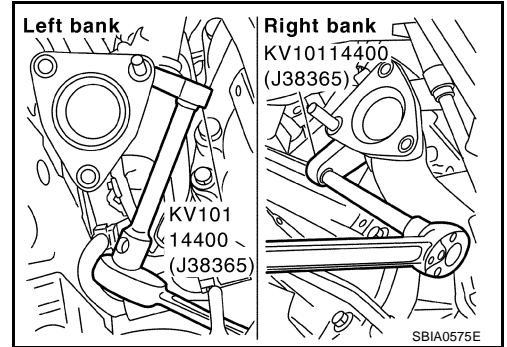

8. Remove exhaust manifold cover (right and left bank).  
9. Loosen mounting nuts in the reverse order as shown in the figure to remove exhaust manifold with power tool.

**NOTE:**

Disregard the numerical order No. 7 and 8 in removal.

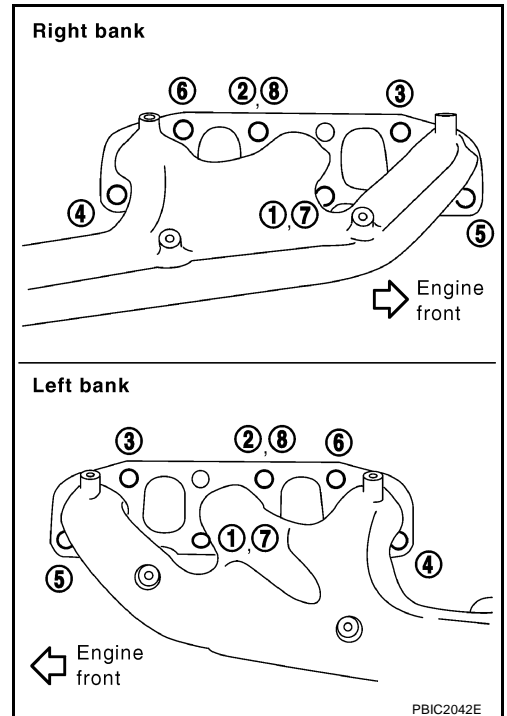

10. Remove gaskets.

**CAUTION:**

Cover engine openings to avoid entry of foreign materials.

## INSPECTION AFTER REMOVAL

### Surface Distortion

- Check the surface distortion of the exhaust manifold mating surface with a straightedge and a feeler gauge.

**Limit : 0.3 mm (0.012 in)**

- If it exceeds the limit, replace exhaust manifold.

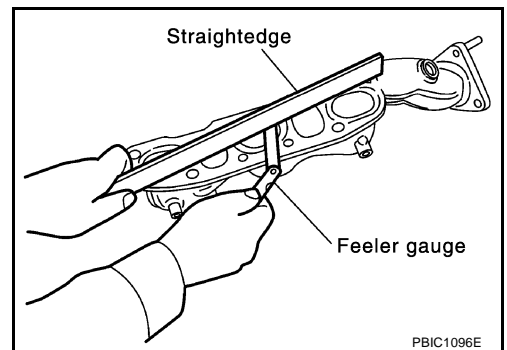

## INSTALLATION

Note the following, and install in the reverse order of removal.

## Exhaust Manifold Gasket

- Install in direction shown below. (Follow same procedure for both banks.)
- Locate thick side of port connecting part on right side from technician's view.
- Locate round press in thick side of port connecting part above center level line of port.

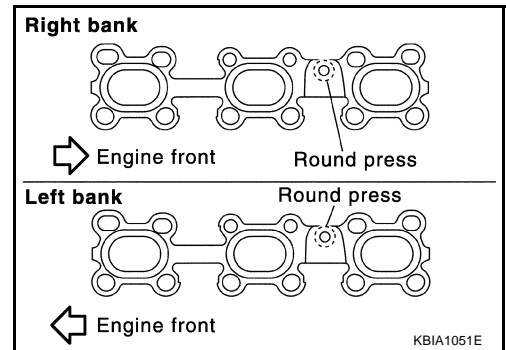

## Exhaust Manifold

- If stud bolts were removed, install them and tighten to the specified torque below.

: 14.7 N·m (1.5 kg·m, 11 ft·lb)

- Install exhaust manifold and tighten mounting bolts in numerical order as shown in the figure.

### NOTE:

Tighten nuts No. 1 and 2 in two steps. The numerical order No. 7 and 8 shows second step.

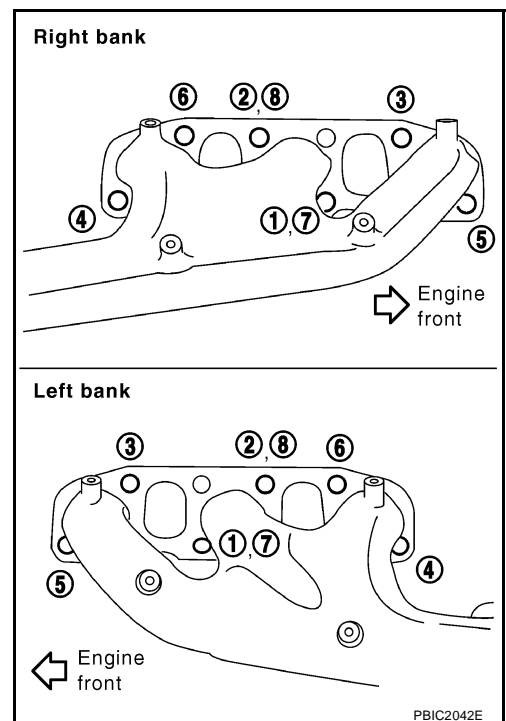

## Air Fuel Ratio Sensor

### CAUTION:

- Before installing a new air fuel ratio sensor, clean exhaust system threads using heated oxygen sensor thread cleaner tool (Commercial Service Tool: J-43897-18 or J-43897-12) and apply anti-seize lubricant.
- Do not over torque air fuel ratio sensor. Doing so may cause damage to air fuel ratio sensor, resulting in the "MIL" coming on.



## OIL PAN AND OIL STRAINER

PFP:11110

### Components (2WD Models)

NBS004N6

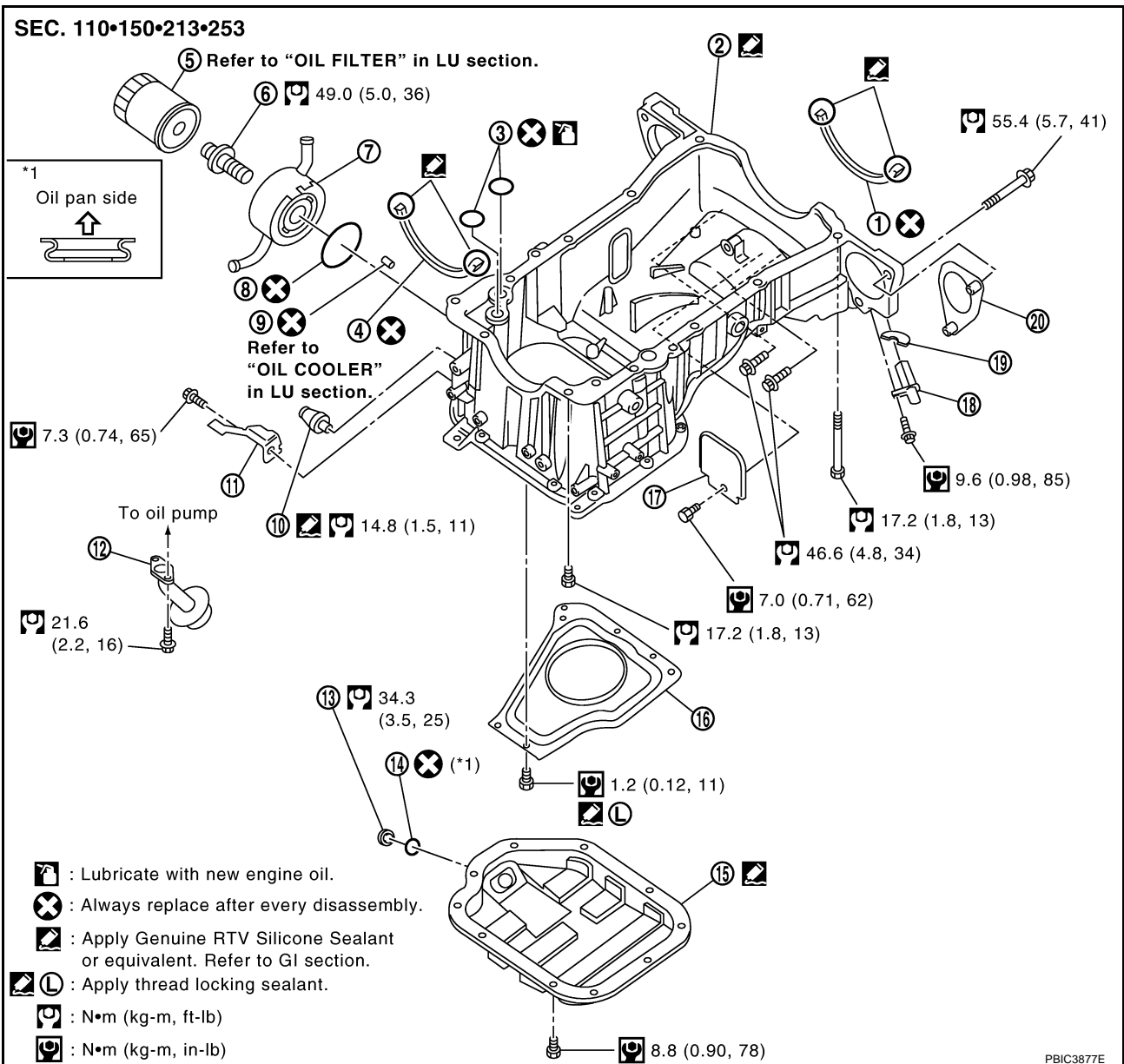

- |                           |                       |                                      |
|---------------------------|-----------------------|--------------------------------------|
| 1. Oil pan gasket (rear)  | 2. Oil pan (upper)    | 3. O-ring                            |
| 4. Oil pan gasket (front) | 5. Oil filter         | 6. Connector bolt                    |
| 7. Oil cooler             | 8. O-ring             | 9. Relief valve                      |
| 10. Oil pressure switch   | 11. Bracket           | 12. Oil strainer                     |
| 13. Drain plug            | 14. Drain plug washer | 15. Oil pan (lower)                  |
| 16. Baffle plate          | 17. Rear plate cover  | 18. Crankshaft position sensor (POS) |
| 19. Seal rubber           | 20. Rear cover plate  |                                      |

## Removal and Installation (2WD Models)

### REMOVAL

#### CAUTION:

To avoid the danger of being scalded, never drain engine oil when the engine is hot.

#### NOTE:

When removing oil pan (lower) only, steps 2 to 6 are not necessary. Perform step 22 after completing step 7.

1. Remove front and rear engine undercover with power tool.
2. Remove front tire.

NBS004N7

3. Remove hood assembly. Refer to [BL-15, "HOOD"](#) .
4. Remove engine room cover (RH and LH). Refer to [EM-14, "ENGINE ROOM COVER"](#) .
5. Remove engine cover with power tool. Refer to [EM-19, "INTAKE MANIFOLD COLLECTOR"](#) .
6. Remove air duct (inlet). Refer to [EM-17, "AIR CLEANER AND AIR DUCT"](#) .
7. Drain engine oil. Refer to [LU-9, "Changing Engine Oil"](#) .

**CAUTION:**

- Perform this step when the engine is cold.
- Do not spill engine oil on drive belts.

8. Drain engine coolant. Refer to [CO-11, "Changing Engine Coolant"](#) .

**CAUTION:**

- Perform this step when the engine is cold.
- Do not spill engine coolant on drive belts.

9. Remove air duct from air cleaner case. Refer to [EM-17, "AIR CLEANER AND AIR DUCT"](#) .
10. Remove stabilizer clamp, and then obtain the space under the oil pan (lower) by lowering the stabilizer. Refer to [FSU-6, "FRONT SUSPENSION ASSEMBLY"](#) .

**NOTE:**

If the oil pan (upper) is removed, this procedure is not necessary.

11. Install engine slinger to sling engine assembly for positioning. Refer to [EM-113, "ENGINE ASSEMBLY"](#) .

**Slinger bolts:**

: 28.0 N·m (2.9 kg-m, 21 ft-lb)

12. Remove front suspension member. Refer to [FSU-6, "FRONT SUSPENSION ASSEMBLY"](#) .
13. Remove drive belts. Refer to [EM-15, "DRIVE BELTS"](#) .
14. Remove alternator stay. Refer to [SC-23, "CHARGING SYSTEM"](#) .
15. Remove starter motor. Refer to [SC-10, "STARTING SYSTEM"](#) .
16. Remove idler pulley and bracket assembly. Refer to [EM-64, "TIMING CHAIN"](#) .
17. Disconnect oil cooler water hoses, and remove oil cooler water pipe mounting bolt. Refer to [LU-14, "OIL COOLER"](#) .
18. Disconnect A/T fluid cooler hoses, and remove A/T fluid cooler tube. Refer to [AT-271, "TRANSMISSION ASSEMBLY"](#) .
19. Remove crankshaft position sensor (POS).

**CAUTION:**

- Handle carefully to avoid dropping and shocks.
- Do not disassemble.
- Do not allow metal powder to adhere to magnetic part at sensor tip.
- Do not place sensors in a location where they are exposed to magnetism.

20. Remove oil filter, as necessary. Refer to [LU-10, "OIL FILTER"](#) .
21. Remove oil cooler, as necessary. Refer to [LU-14, "OIL COOLER"](#) .
22. Remove oil pan (lower) as follows:

- a. Loosen mounting bolts in reverse order as shown in the figure to remove.

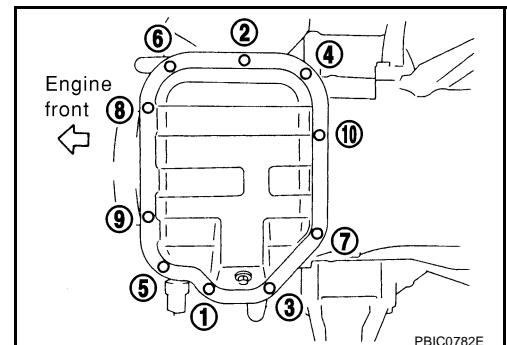

# OIL PAN AND OIL STRAINER

[VQ35DE]

- b. Insert the seal cutter (SST) between oil pan (upper) and oil pan (lower).

**CAUTION:**

- Be careful not to damage the mating surfaces.
- Do not insert a screwdriver, this will damage the mating surfaces.

- c. Slide the seal cutter by tapping on the side of tool with a hammer. Remove oil pan (lower).

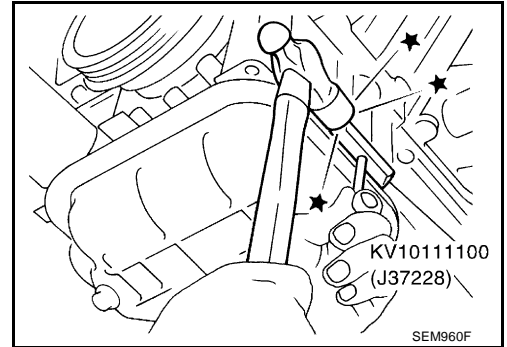

23. Remove baffle plate.

24. Remove oil strainer.

25. Remove transmission joint bolts which pierce oil pan (upper). Refer to [AT-271, "TRANSMISSION ASSEMBLY"](#).

26. Remove rear cover plate.

27. Loosen mounting bolts in the reverse order as shown in the figure with power tool to remove.

- Insert the seal cutter [SST: KV10111100 (J37228)] between oil pan (upper) and cylinder block. Slide seal cutter by tapping on the side of tool with a hammer. Remove oil pan (upper).

**CAUTION:**

- Be careful not to damage the mating surfaces.
- Do not insert a screwdriver, this will damage the mating surfaces.

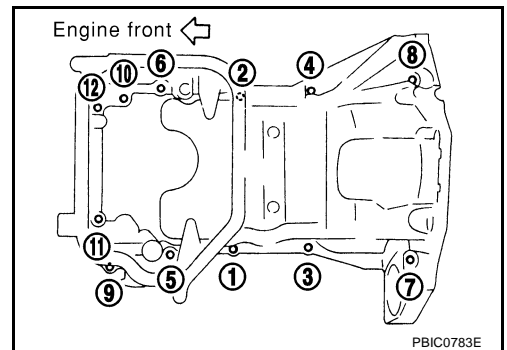

28. Remove O-rings from bottom of cylinder block and oil pump.

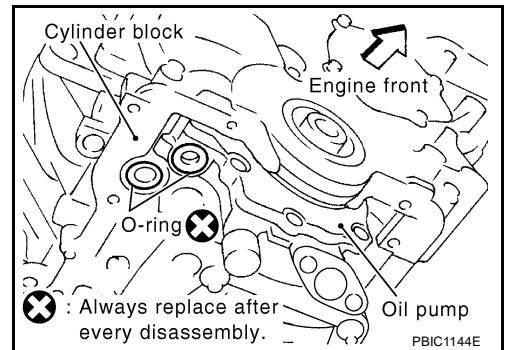

29. Remove oil pan gaskets.

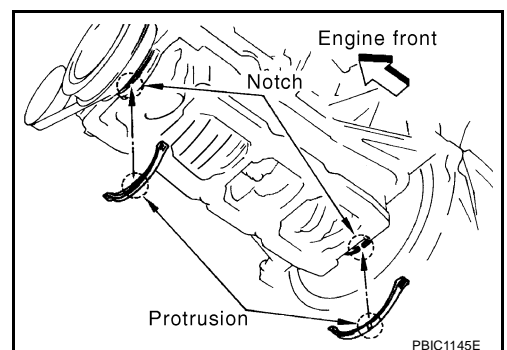

## INSPECTION AFTER REMOVAL

Clean oil strainer if any object attached.

## INSTALLATION

1. Install oil pan (upper) as follows:

# OIL PAN AND OIL STRAINER

[VQ35DE]

- a. Use a scraper to remove old liquid gasket from mating surfaces.

**CAUTION:**

**Do not scratch or damage the mating surfaces when cleaning off old liquid gasket.**

- Also remove old liquid gasket from mating surface of cylinder block.
- Remove old liquid gasket from the bolt holes and threads.

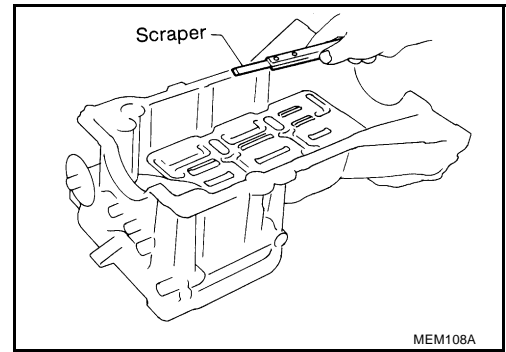

- b. Install new oil pan gaskets.

- Apply liquid gasket to oil pan gaskets as shown in the figure. **Use Genuine RTV Silicone Sealant or equivalent. Refer to GI-48, "RECOMMENDED CHEMICAL PRODUCTS AND SEALANTS".**

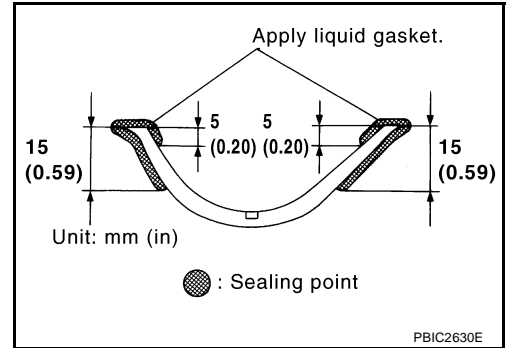

- To install, align protrusion of oil pan gasket with notches of front timing chain case and rear oil seal retainer.
- Install oil pan gasket with smaller arc to front timing chain case side.

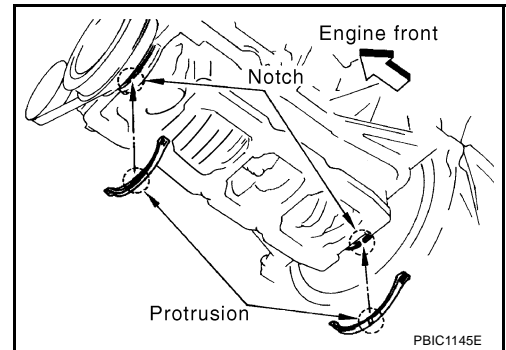

- c. Install new O-rings on the bottom of cylinder block and oil pump.

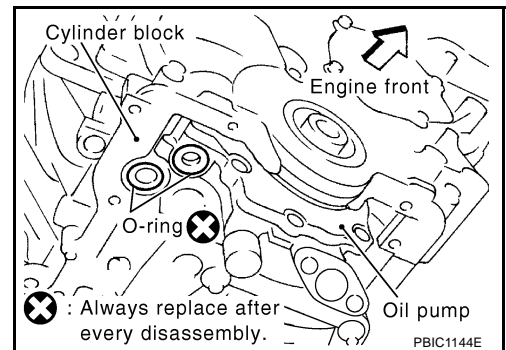

# OIL PAN AND OIL STRAINER

[VQ35DE]

- d. Apply a continuous bead of liquid gasket with the tube presser [SST: WS39930000 ( — )] to the cylinder block mating surface of oil pan (upper) to a limited portion as shown in the figure. Use **Genuine RTV Silicone Sealant or equivalent. Refer to GI-48, "RECOMMENDED CHEMICAL PRODUCTS AND SEALANTS"**.

**CAUTION:**

- For bolt holes with ▲ marks (5 locations), apply liquid gasket outside the holes.
- Apply a bead of 4.5 to 5.5 mm (0.177 to 0.217 in) in diameter to area "A".
- Attaching should be done within 5 minutes after coating.

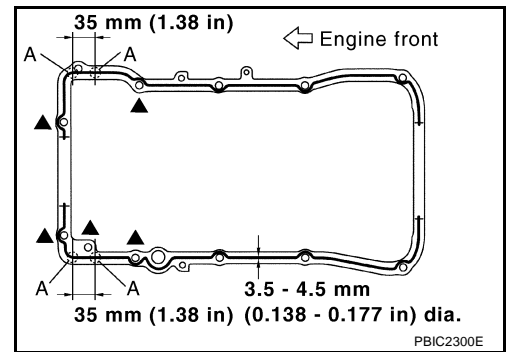

- e. Install oil pan (upper).

**CAUTION:**

**Install avoiding misalignment of both oil pan gaskets and O-rings.**

- Tighten mounting bolts in numerical order as shown in the figure.
- There are two types of mounting bolts. Refer to the following for locating bolts.

- M8 × 100 mm (3.97 in) : 5, 7, 8, 11**
- M8 × 25 mm (0.98 in) : Except the above**

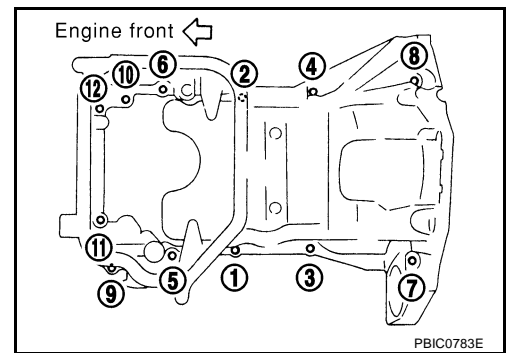

- f. Tighten transmission joint bolts. Refer to [AT-271, "TRANSMISSION ASSEMBLY"](#).

2. Install oil strainer to oil pump.
3. Install baffle plate.

4. Install oil pan (lower) as follows:

- a. Use scraper to remove old liquid gasket from mating surfaces.
- Also remove old liquid gasket from mating surface of oil pan (upper).
  - Remove old liquid gasket from the bolt holes and thread.

**CAUTION:**

**Do not scratch or damage the mating surfaces when cleaning off old liquid gasket.**

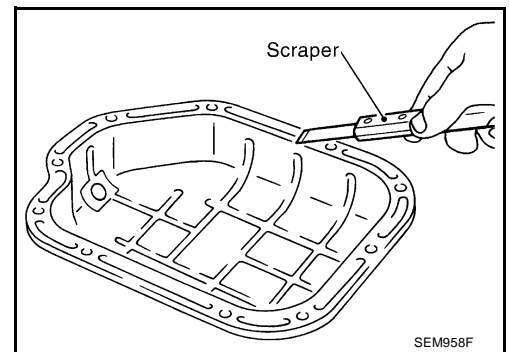

A  
EM  
C  
D  
E  
F  
G  
H  
I  
J  
K  
L  
M

# OIL PAN AND OIL STRAINER

[VQ35DE]

- b. Apply a continuous bead of liquid gasket with the tube presser [SST: WS39930000 ( — )] to the oil pan (lower) as shown in the figure.

**Use Genuine RTV Silicone Sealant or equivalent. Refer to [GI-48, "RECOMMENDED CHEMICAL PRODUCTS AND SEALANTS"](#) .**

**CAUTION:**

**Attaching should be done within 5 minutes after coating.**

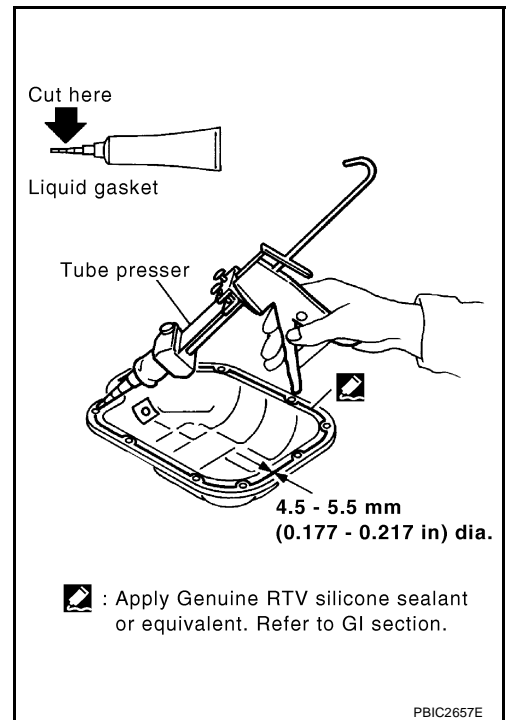

- c. Install oil pan (lower).

- Tighten mounting bolts in numerical order as shown in the figure.

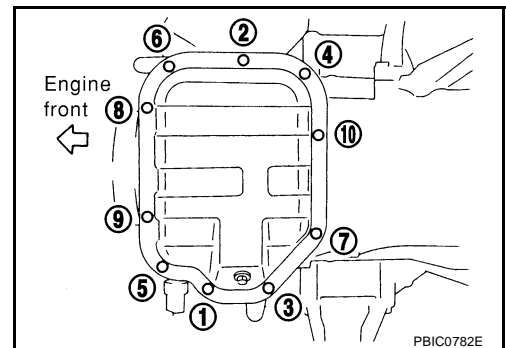

5. Install oil pan drain plug.

- Refer to the figure of components of former page for installation direction of drain plug washer. Refer to [EM-29, "Components \(2WD Models\)"](#) .

6. Install in the reverse order of removal after this step.

**NOTE:**

At least 30 minutes after oil pan is installed, pour engine oil.

## INSPECTION AFTER INSTALLATION

1. Check the engine oil level and adjust engine oil. Refer to [LU-7, "ENGINE OIL"](#) .
2. Start engine, and check there is no leak of engine oil.
3. Stop engine and wait for 10 minutes.
4. Check the engine oil level again. Refer to [LU-7, "ENGINE OIL"](#) .

## Components (AWD Models)

NBS004NB

SEC. 110•150•211•213•221•253

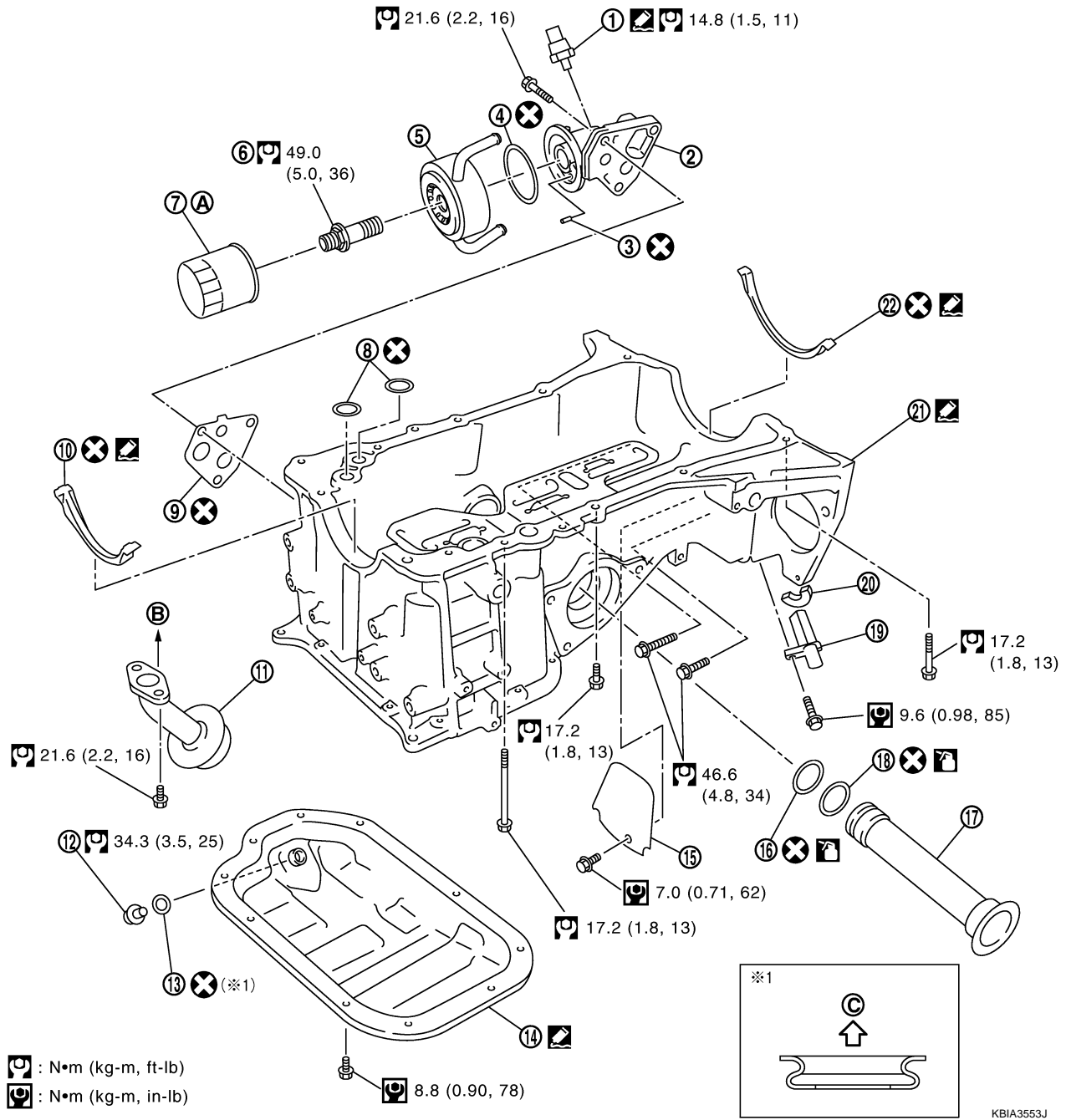

- |                                      |                       |                      |
|--------------------------------------|-----------------------|----------------------|
| 1. Oil pressure switch               | 2. Oil filter bracket | 3. Relief valve      |
| 4. O-ring                            | 5. Oil cooler         | 6. Connector bolt    |
| 7. Oil filter                        | 8. O-ring             | 9. Gasket            |
| 10. Oil pan gasket (front)           | 11. Oil strainer      | 12. Drain plug       |
| 13. Drain plug washer                | 14. Oil pan (lower)   | 15. Rear plate cover |
| 16. O-ring (small)                   | 17. Axle pipe         | 18. O-ring (large)   |
| 19. Crankshaft position sensor (POS) | 20. Seal rubber       | 21. Oil pan (upper)  |
| 22. Oil pan gasket (rear)            |                       |                      |
| A. Refer to <a href="#">LU-10</a>    | B. To oil pump        | C. Oil pan side      |

● Refer to [GI-11, "Components"](#) for symbol marks in the figure.



**Removal and Installation (AWD Models)****REMOVAL****CAUTION:**

To avoid the danger of being scalded, never drain engine oil when the engine is hot.

**NOTE:**

When removing oil pan (lower) only, steps 2 to 6 are not necessary. Perform step 25 after completing step 7.

1. Remove front and rear engine undercover with power tool.
2. Remove front tire.
3. Remove hood assembly. Refer to [BL-15, "HOOD"](#) .
4. Remove engine room cover (RH and LH). Refer to [EM-14, "ENGINE ROOM COVER"](#) .
5. Remove engine cover with power tool. Refer to [EM-19, "INTAKE MANIFOLD COLLECTOR"](#) .
6. Remove air duct (inlet). Refer to [EM-17, "AIR CLEANER AND AIR DUCT"](#) .
7. Drain engine oil. Refer to [LU-9, "Changing Engine Oil"](#) .

**CAUTION:**

- Perform this step when the engine is cold.
- Do not spill engine oil on drive belts.

8. Drain engine coolant. Refer to [CO-11, "Changing Engine Coolant"](#) .

**CAUTION:**

- Perform this step when the engine is cold.
- Do not spill engine coolant on drive belts.

9. Remove air duct from air cleaner case assembly. Refer to [EM-17, "AIR CLEANER AND AIR DUCT"](#) .
10. Remove drive belts. Refer to [EM-15, "DRIVE BELTS"](#) .
11. Remove front drive shaft (RH and LH). Refer to [FAX-8, "FRONT DRIVE SHAFT"](#) .
12. Remove side shaft. Refer to [FFD-13, "FRONT FINAL DRIVE ASSEMBLY"](#) .
13. Install engine slinger to sling engine assembly for positioning. Refer to [EM-113, "ENGINE ASSEMBLY"](#) .

**Slinger bolts:**

: 28.0 N·m (2.9 kg·m, 21 ft·lb)

14. Remove front suspension member. Refer to Refer to [FSU-23, "FRONT SUSPENSION ASSEMBLY"](#) .
15. Remove engine mounting bracket, engine mounting bracket (lower) and insulator. Refer to [EM-113, "ENGINE ASSEMBLY"](#) .
16. Remove front propeller shaft. Refer to [PR-4, "FRONT PROPELLER SHAFT"](#) .
17. Remove oil filter and oil filter bracket. Refer to [LU-12, "OIL FILTER BRACKET \(AWD\)"](#) .
18. Remove alternator stay. Refer to [SC-23, "CHARGING SYSTEM"](#) .
19. Remove idler pulley and bracket. Refer to [EM-15, "DRIVE BELTS"](#) .
20. Disconnect oil cooler water hoses, and remove oil cooler water pipe mounting bolt. Refer to [LU-14, "OIL COOLER"](#) .
21. Disconnect A/T fluid cooler hoses, and remove A/T fluid cooler tube. Refer to [AT-271, "TRANSMISSION ASSEMBLY"](#) .
22. Remove front final drive assembly. Refer to [FFD-13, "FRONT FINAL DRIVE ASSEMBLY"](#) .
23. Remove starter motor. Refer to [SC-10, "STARTING SYSTEM"](#) .
24. Remove crankshaft position sensor (POS).

**CAUTION:**

- Handle carefully to avoid dropping and shocks.
- Do not disassemble.
- Do not allow metal powder to adhere to magnetic part at sensor tip.
- Do not place sensors in a location where they are exposed to magnetism.

25. Remove oil pan (lower) as follows:



# OIL PAN AND OIL STRAINER

[VQ35DE]

- a. Loosen mounting bolts in reverse order as shown in the figure to remove.

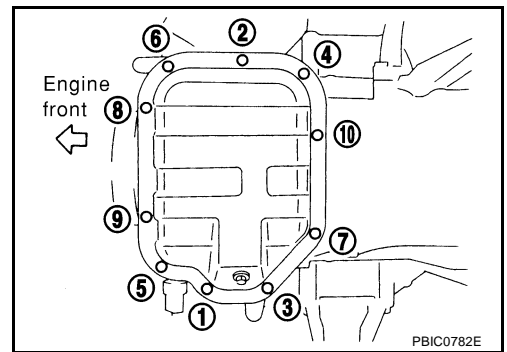

- b. Insert the seal cutter (SST) between oil pan (upper) and oil pan (lower).  
 c. Slide the seal cutter by tapping on the side of tool with a hammer. Remove oil pan (lower).

**CAUTION:**

- Be careful not to damage the mating surface.
- Do not insert flat-bladed screwdriver, this will damage the mating surface.

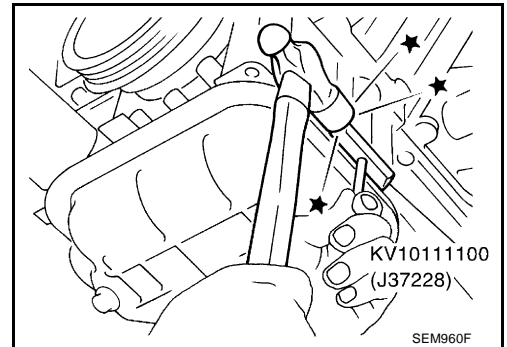

26. Remove oil strainer.

27. Remove transmission joint bolts which pierce oil pan (upper). Refer to [AT-271, "TRANSMISSION ASSEMBLY"](#).

28. Loosen mounting bolts in the reverse order as shown in the figure with power tool to remove.

- Insert the seal cutter [SST: KV10111100 (J37228)] between oil pan (upper) and cylinder block. Slide seal cutter by tapping on the side of tool with a hammer. Remove oil pan (upper).

**CAUTION:**

- Be careful not to damage the mating surfaces.
- Do not insert a screwdriver, this will damage the mating surfaces.

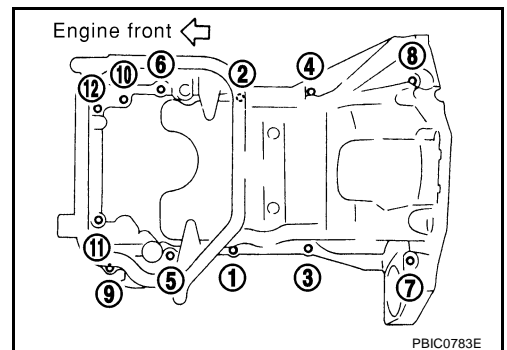

29. Remove O-rings from bottom of cylinder block and oil pump.

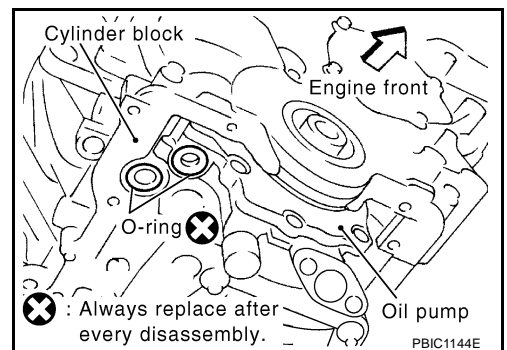

A  
EM  
C  
D  
E  
F  
G  
H  
I  
J  
K  
L  
M

30. Remove oil pan gaskets.

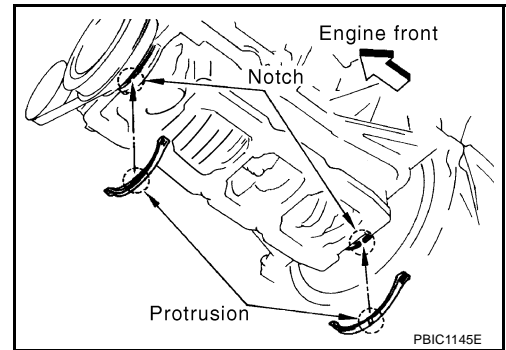

31. Remove axle pipe, as necessary.

- Remove axle pipe from oil pan (upper) using a suitable drift [outer diameter: 37 mm (1.46 in)].

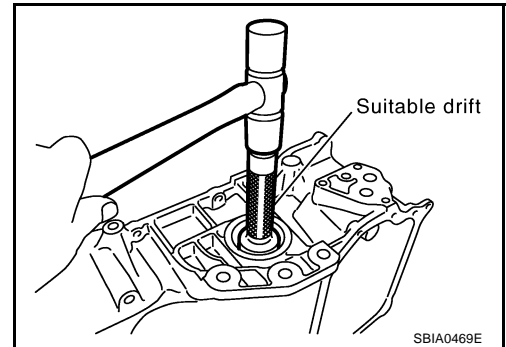

## INSPECTION AFTER REMOVAL

Clean oil strainer if any object attached.

## INSTALLATION

1. Install axle pipe to oil pan (upper), if removed.

- Lubricate O-ring groove of axle pipe, O-ring, and O-ring joint of oil pan with new engine oil.

Unit: mm (in)

Item	O-ring inner diameter
Final drive side (right side)	32 (1.26)
Axle pipe flange side (left side)	34 (1.34)

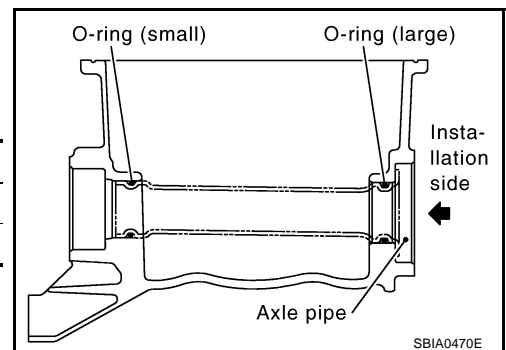

- Install axle pipe to oil pan (upper) from axle pipe flange side (left side) using a suitable drift [outer diameter: 43 to 57 mm (1.69 to 2.24 in)].

**CAUTION:**

Insert it with care to prevent O-ring from sliding.

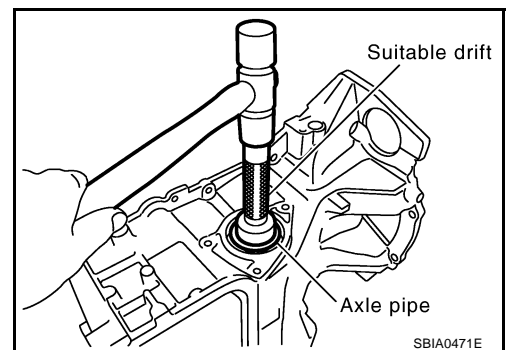

2. Install oil pan (upper) as follows:

# OIL PAN AND OIL STRAINER

[VQ35DE]

- a. Use a scraper to remove old liquid gasket from mating surfaces.

**CAUTION:**

**Do not scratch or damage the mating surfaces when cleaning off old liquid gasket.**

- Also remove old liquid gasket from mating surface of cylinder block.
- Remove old liquid gasket from the bolt holes and threads.

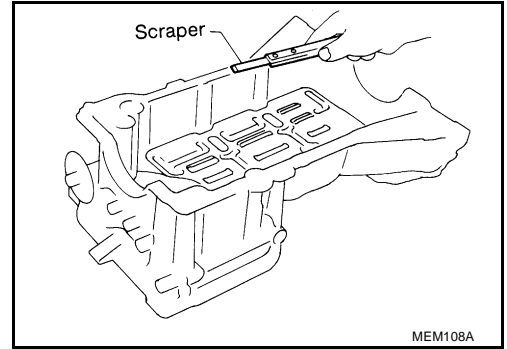

- b. Install new oil pan gaskets.

- Apply liquid gasket to oil pan gaskets as shown in the figure. **Use Genuine RTV Silicone Sealant or equivalent. Refer to [GI-48, "RECOMMENDED CHEMICAL PRODUCTS AND SEALANTS"](#).**

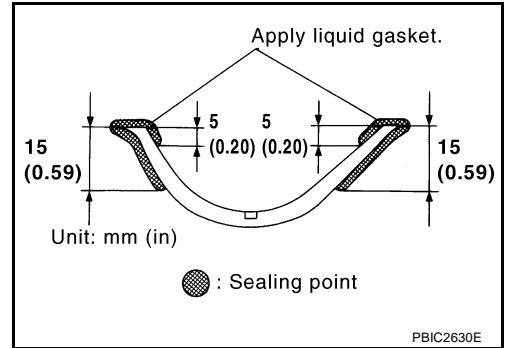

- To install, align protrusion of oil pan gasket with notches of front timing chain case and rear oil seal retainer.
- Install oil pan gasket with smaller arc to front timing chain case side.

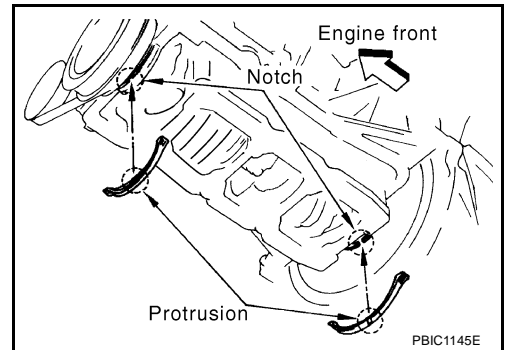

- c. Install new O-rings on the bottom of cylinder block and oil pump.

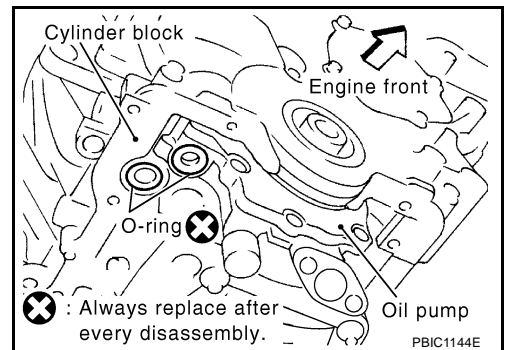

# OIL PAN AND OIL STRAINER

[VQ35DE]

- d. Apply a continuous bead of liquid gasket with the tube presser [SST: WS39930000 ( — )] to the cylinder block mating surface of oil pan (upper) to a limited portion as shown in the figure. Use **Genuine RTV Silicone Sealant or equivalent**. Refer to [GI-48, "RECOMMENDED CHEMICAL PRODUCTS AND SEALANTS"](#).

**CAUTION:**

- For bolt holes with ▲ marks (5 locations), apply liquid gasket outside the holes.
- Apply a bead of 4.5 to 5.5 mm (0.177 to 0.217 in) in diameter to area "A".
- Attaching should be done within 5 minutes after coating.

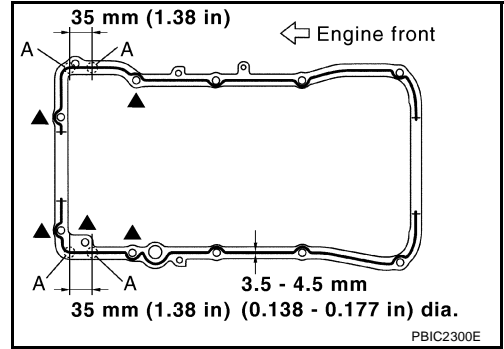

- e. Install oil pan (upper).

**CAUTION:**

Install avoiding misalignment of both oil pan gasket and O-rings.

- Tighten mounting bolts in numerical order as shown in the figure.
- There are two types of mounting bolts. Refer to the following for locating bolts.

<b>M8 × 25 mm (0.98in)</b>	<b>: 1,2,3,4,9</b>
<b>M8 × 50 mm (1.97in)</b>	<b>: 8</b>
<b>M8 × 100 mm (3.97 in)</b>	<b>: 5,6,7,10,11,12</b>

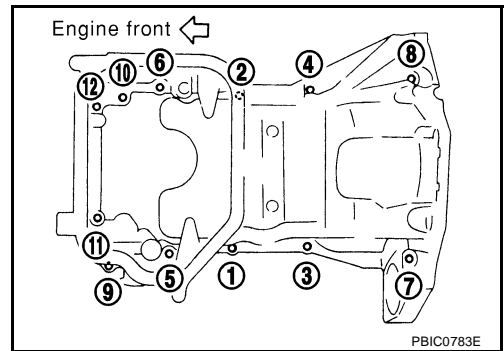

- f. Tighten transmission joint bolts. Refer to [AT-271, "TRANSMISSION ASSEMBLY"](#).

3. Install oil strainer to oil pump.  
4. Install oil pan (lower) as follows:

- a. Use scraper to remove old liquid gasket from mating surfaces.
- Also remove old liquid gasket from mating surface of oil pan (upper).
  - Remove old liquid gasket from the bolt holes and thread.

**CAUTION:**

Do not scratch or damage the mating surfaces when cleaning off old liquid gasket.

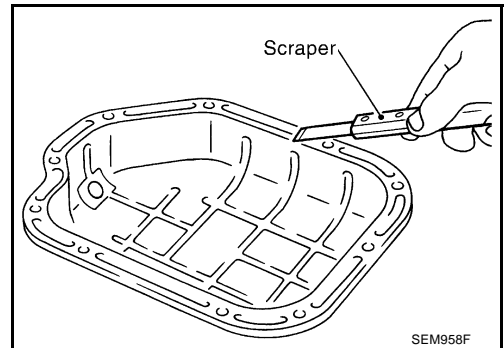

# OIL PAN AND OIL STRAINER

[VQ35DE]

- b. Apply a continuous bead of liquid gasket with the tube presser [SST: WS39930000 ( — )] to the oil pan (lower) as shown in the figure.

**Use Genuine RTV Silicone Sealant or equivalent. Refer to [GI-48, "RECOMMENDED CHEMICAL PRODUCTS AND SEALANTS"](#).**

**CAUTION:**

Attaching should be done within 5 minutes after coating.

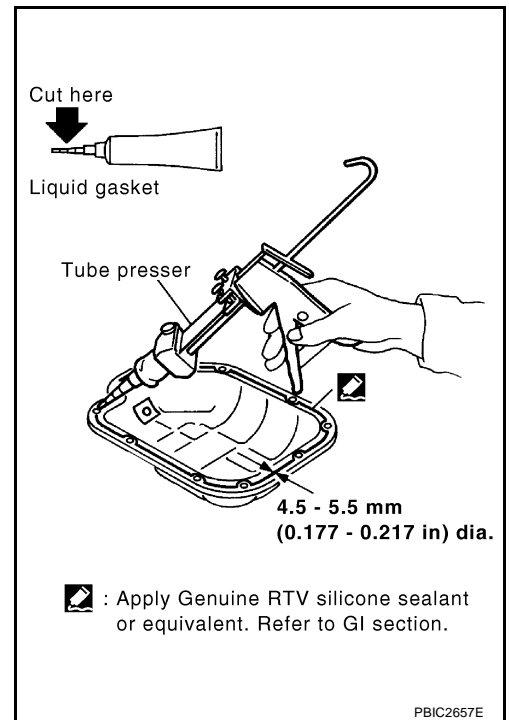

- c. Install oil pan (lower).

- Tighten mounting bolts in numerical order as shown in the figure.

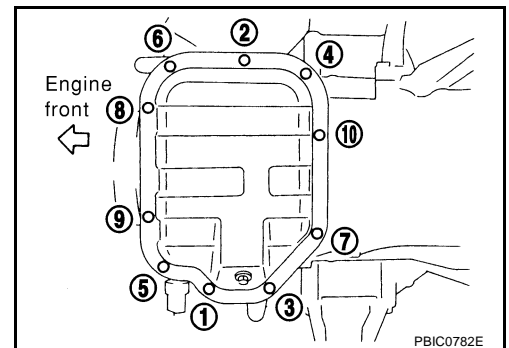

5. Install oil pan drain plug.

- Refer to the figure of components of former page for installation direction of drain plug washer. Refer to [EM-35, "Components \(AWD Models\)"](#).

6. Install in the reverse order of removal after this step.

**NOTE:**

At least 30 minutes after oil pan is installed, pour engine oil.

## INSPECTION AFTER INSTALLATION

1. Check the engine oil level and adjust engine oil. Refer to [LU-7, "ENGINE OIL"](#).
2. Start engine, and check there is no leak of engine oil.
3. Stop engine and wait for 10 minutes.
4. Check the engine oil level again. Refer to [LU-7, "ENGINE OIL"](#).

## IGNITION COIL

PFP:22448

### Components

NBS004NA

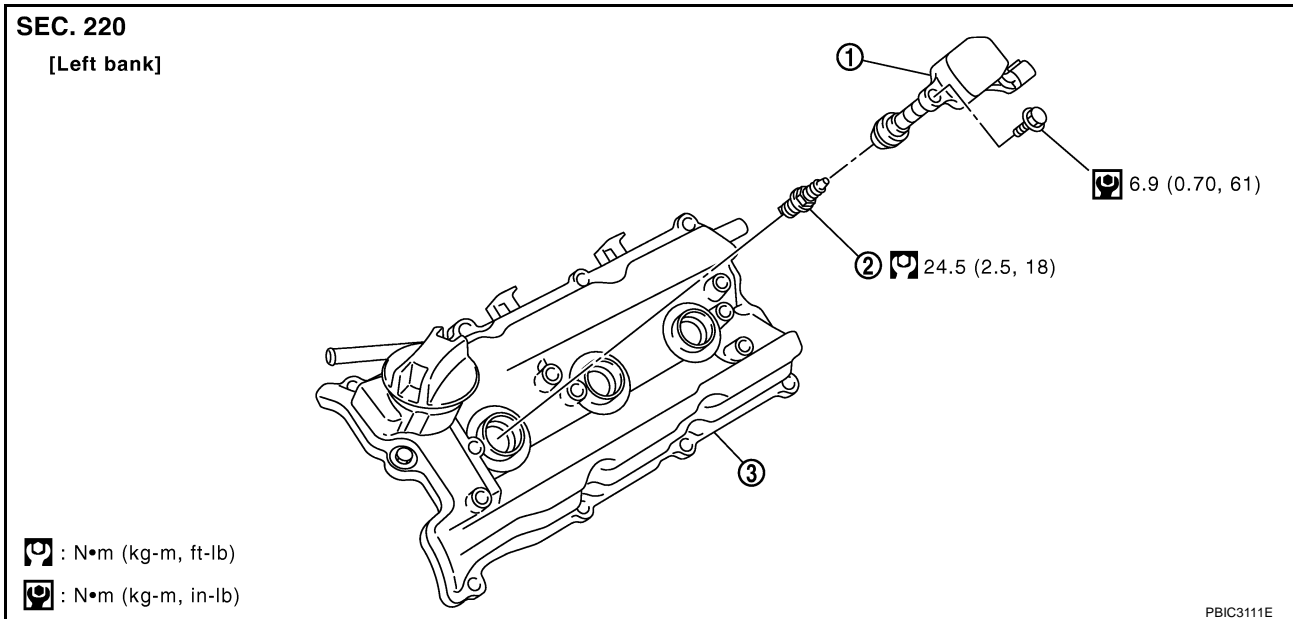

1. Ignition coil

2. Spark plug

3. Rocker cover

## Removal and Installation

NBS004NB

### REMOVAL

1. Remove engine room cover (RH and LH). Refer to [EM-14, "ENGINE ROOM COVER"](#) .
2. Remove engine cover with power tool. Refer to [EM-19, "INTAKE MANIFOLD COLLECTOR"](#) .
3. Remove air duct (inlet) and air duct (at the left bank side, remove ignition coil). Refer to [EM-17, "AIR CLEANER AND AIR DUCT"](#) .
4. Move aside harness, harness bracket, and hoses located above ignition coil.
5. Disconnect harness connector from ignition coil.
6. Remove ignition coil.

### CAUTION:

**Do not shock it.**

### INSTALLATION

Installation is the reverse order of removal.

# SPARK PLUG (PLATINUM-TIPPED TYPE)

[VQ35DE]

## SPARK PLUG (PLATINUM-TIPPED TYPE)

PFP:22401

### Components

NBS004NC

SEC. 220

[Left bank]

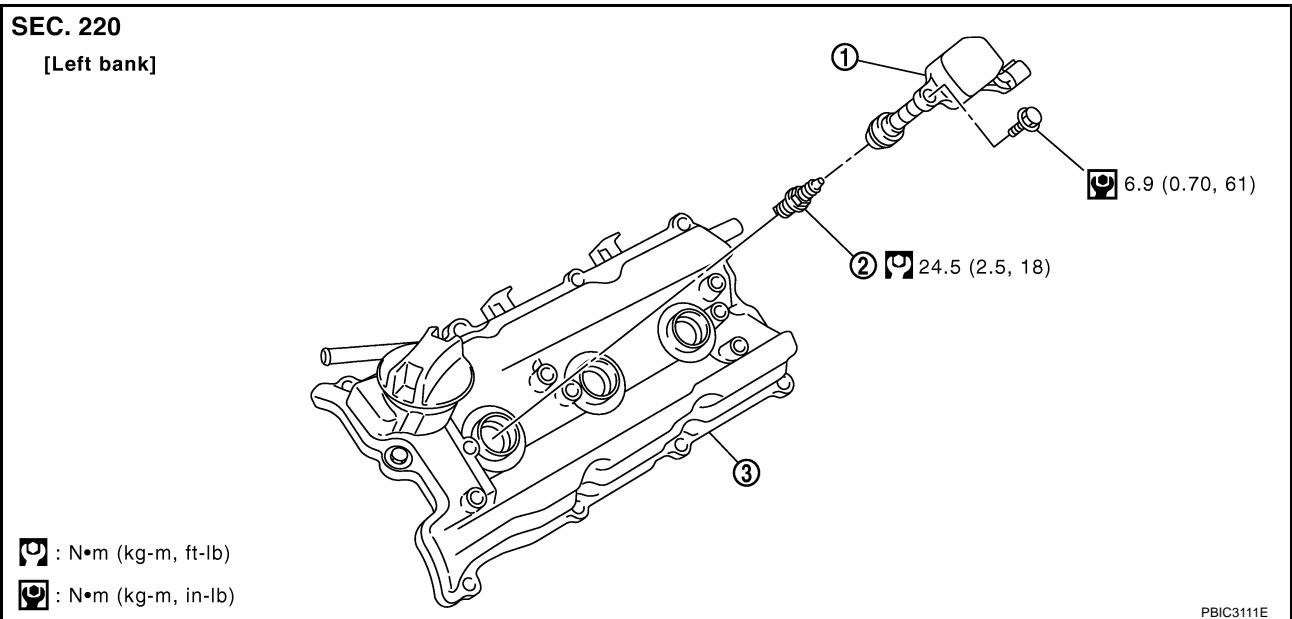

: N·m (kg-m, ft-lb)

: N·m (kg-m, in-lb)

PBIC3111E

1. Ignition coil

2. Spark plug

3. Rocker cover

### Removal and Installation

#### REMOVAL

NBS004ND

1. Remove ignition coil. Refer to [EM-42, "IGNITION COIL"](#).
2. Remove spark plug with a spark plug wrench (commercial service tool).

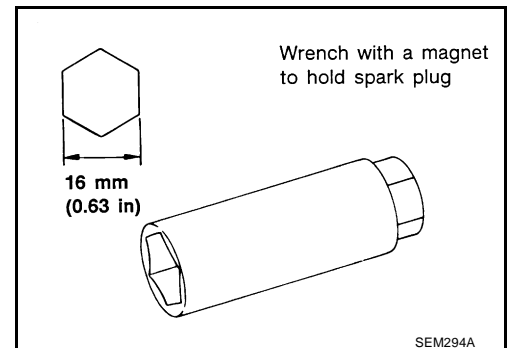

#### INSPECTION AFTER REMOVAL

**Use the standard type spark plug for normal condition.**

The hot type spark plug is suitable when fouling occurs with the standard type spark plug under conditions such as:

- Frequent engine starts
- Low ambient temperatures

The cold type spark plug is suitable when spark knock occurs with the standard type spark plug under conditions such as:

- Extended highway driving
- Frequent high engine revolution

Make	NGK
Standard type	PLFR5A-11
Hot type	PLFR4A-11
Cold type	PLFR6A-11

**Gap (Nominal) : 1.1 mm (0.043 in)**

# SPARK PLUG (PLATINUM-TIPPED TYPE)

[VQ35DE]

## CAUTION:

- Do not drop or shock spark plug.
- Do not use a wire brush for cleaning.
- If plug tip is covered with carbon, spark plug cleaner may be used.

Cleaner air pressure:

Less than 588 kPa (6 kg/cm<sup>2</sup> , 85 psi)

Cleaning time:

Less than 20 seconds

- Checking and adjusting plug gap is not required between change intervals.

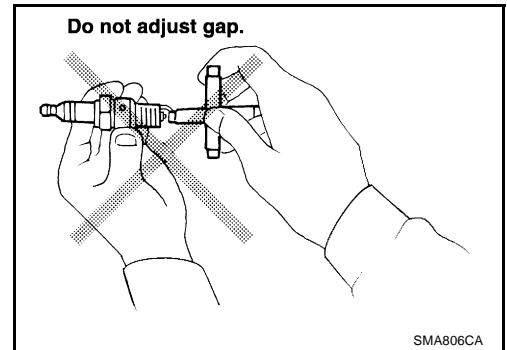
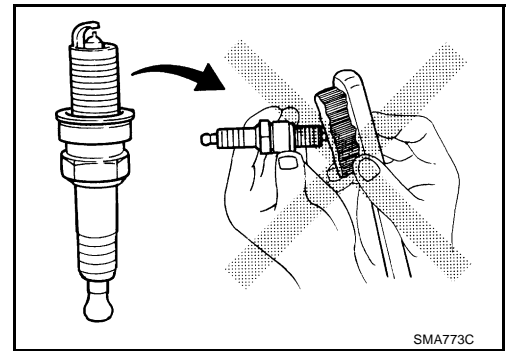

## INSTALLATION

Installation is the reverse order of removal.



## FUEL INJECTOR AND FUEL TUBE

### Components

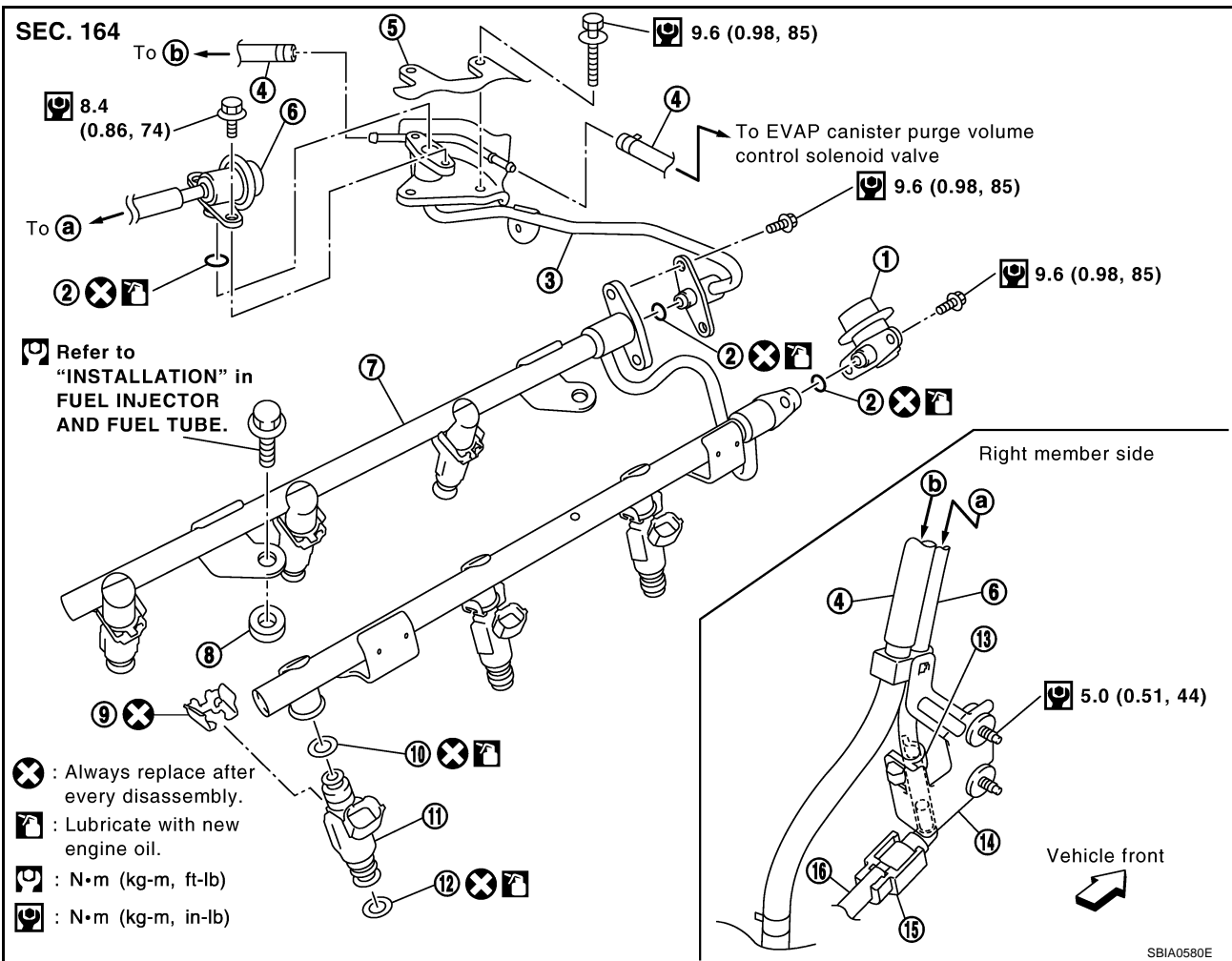

- |                                    |                                      |                                 |
|------------------------------------|--------------------------------------|---------------------------------|
| 1. Fuel damper                     | 2. O-ring                            | 3. Fuel sub-tube                |
| 4. EVAP hose                       | 5. Intake manifold collector (lower) | 6. Fuel feed hose (with damper) |
| 7. Fuel tube                       | 8. Spacer                            | 9. Clip                         |
| 10. O-ring (Black)                 | 11. Fuel injector                    | 12. O-ring (Green)              |
| 13. Hose clamp                     | 14. Bracket                          | 15. Quick connector cap         |
| 16. Centralized under-floor piping |                                      |                                 |

### CAUTION:

Do not remove or disassemble parts unless instructed as shown in the figure.

## Removal and Installation

### REMOVAL

### WARNING:

- Put a "CAUTION: FLAMMABLE" sign in the workshop.
  - Be sure to work in a well ventilated area and furnish workshop with a CO<sub>2</sub> fire extinguisher.
  - Do not smoke while servicing fuel system. Keep open flames and sparks away from the work area.
  - To avoid the danger of being scalded, do not drain engine coolant when the engine is hot.
1. Remove engine room cover (RH and LH). Refer to [EM-14, "ENGINE ROOM COVER"](#).
  2. Remove engine cover with power tool. Refer to [EM-19, "INTAKE MANIFOLD COLLECTOR"](#).
  3. Release fuel pressure. Refer to [EC-98, "FUEL PRESSURE RELEASE"](#).
  4. Drain engine coolant, or when water hoses are disconnected, attach plug to prevent engine coolant leakage. Refer to [CO-11, "Changing Engine Coolant"](#) and [EM-19, "INTAKE MANIFOLD COLLECTOR"](#).

**CAUTION:**

Perform this step when the engine is cold.

5. Remove fuel feed hose (with damper) from fuel sub-tube.

**NOTE:**

There is no fuel return route.

**CAUTION:**

- While hoses are disconnected, plug them to prevent fuel from draining.
- Do not separate damper and hose.

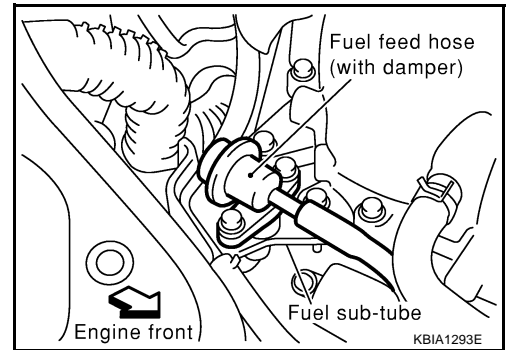

6. When separating fuel feed hose (with damper) and centralized under-floor piping connection, disconnect quick connector as follows:

- a. Remove quick connector cap from quick connector connection on right member side.
- b. Disconnect fuel feed hose (with damper) from bracket hose clamp.

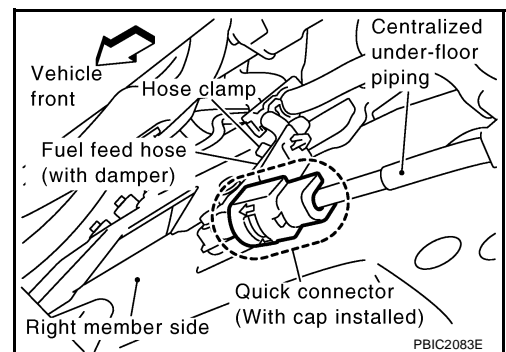

- c. Disconnect quick connector from centralized under-floor piping as follows:

**CAUTION:**

Disconnect quick connector by using quick connector release [SST: — (J-45488)], not by picking out retainer tabs.

- i. With the sleeve side of quick connector release facing quick connector, install quick connector release onto centralized under-floor piping.
- ii. Insert quick connector release into quick connector until sleeve contacts and goes no further. Hold quick connector release on that position.

**CAUTION:**

Inserting quick connector release hard will not disconnect quick connector. Hold quick connector release where it contacts and goes no further.

- iii. Draw and pull out quick connector straight from centralized under-floor piping.

**CAUTION:**

- Pull quick connector holding "A" position as shown in the figure.

- Do not pull with lateral force applied. O-ring inside quick connector may be damaged.

- Prepare container and cloth beforehand as fuel will leak out.

- Avoid fire and sparks.

- Keep parts away from heat source. Especially, be careful when welding is performed around them.

- Do not expose parts to battery electrolyte or other acids.

- Do not bend or twist connection between quick connector and fuel feed hose (with damper) during installation/removal.

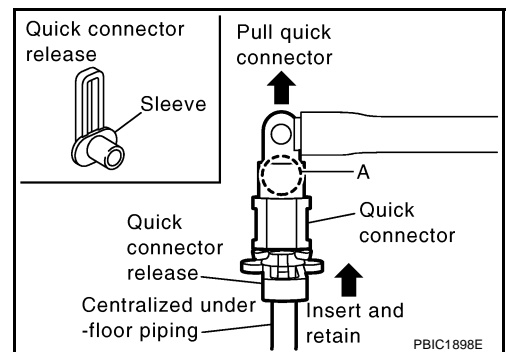

# FUEL INJECTOR AND FUEL TUBE

[VQ35DE]

- To keep clean the connecting portion and to avoid damage and foreign materials, cover them completely with plastic bags or something similar.

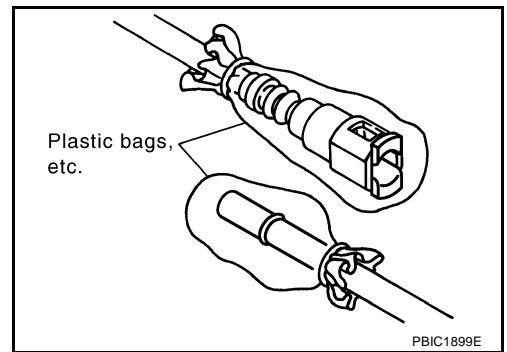

7. Remove intake manifold collectors (upper and lower). Refer to [EM-19, "INTAKE MANIFOLD COLLECTOR"](#).
8. Disconnect harness connector from fuel injector.
9. Loosen mounting bolts in reverse order as shown in the figure, and remove fuel tube and fuel injector assembly.

**CAUTION:**

Do not tilt it, or remaining fuel in pipes may flow out from pipes.

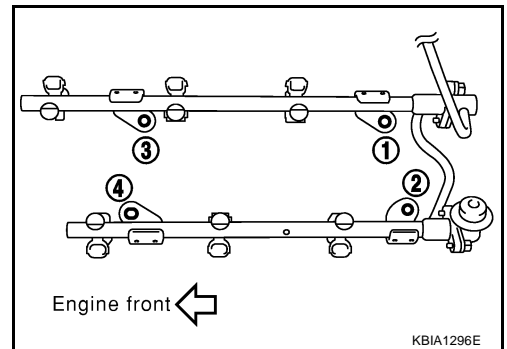

10. Remove spacers on intake manifold.
11. Remove fuel injector from fuel tube as follows:
  - a. Open and remove clip.
  - b. Remove fuel injector from fuel tube by pulling straight.

**CAUTION:**

- Be careful with remaining fuel that may go out from fuel tube.
- Be careful not to damage injector nozzles during removal.
- Do not bump or drop fuel injector.
- Do not disassemble fuel injector.

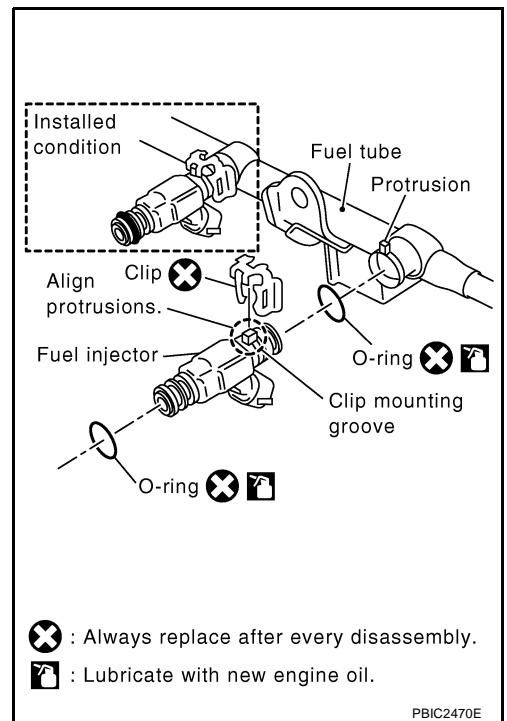

12. Remove fuel sub-tube and fuel damper.

## INSTALLATION

1. Install fuel damper and fuel sub-tube.
  - When handling new O-rings, be careful of the following caution:

**CAUTION:**

    - Handle O-ring with bare hands. Do not wear gloves.

- Lubricate O-ring with new engine oil.
  - Do not clean O-ring with solvent.
  - Make sure that O-ring and its mating part are free of foreign material.
  - When installing O-ring, be careful not to scratch it with tool or fingernails. Also be careful not to twist or stretch O-ring. If O-ring was stretched while it was being attached, do not insert it quickly into fuel tube.
  - Insert new O-ring straight into fuel tube. Do not decenter or twist it.
1. Insert fuel damper and fuel sub-tube straight into fuel tube.
  2. Tighten mounting bolts evenly in turn.
  3. After tightening mounting bolts, make sure that there is no gap between flange and fuel tube.
2. Install new O-rings to fuel injector, paying attention to the following.

**CAUTION:**

- Upper and lower O-ring are different. Be careful not to confuse them.

Fuel tube side : Black

Nozzle side : Green

- Handle O-ring with bare hands. Do not wear gloves.
- Lubricate O-ring with new engine oil.
- Do not clean O-ring with solvent.
- Make sure that O-ring and its mating part are free of foreign material.
- When installing O-ring, be careful not to scratch it with tool or fingernails. Also be careful not to twist or stretch O-ring. If O-ring was stretched while it was being attached, do not insert it quickly into fuel tube.
- Insert O-ring straight into fuel injector. Do not decenter or twist it.

3. Install fuel injector to fuel tube as follows:

- a. Insert clip into clip mounting groove on fuel injector.
  - Insert clip so that protrusion "A" of fuel injector matches cutout "A" of clip.

**CAUTION:**

- Do not reuse clip. Replace it with a new one.
- Be careful to keep clip from interfering with O-ring. If interference occurs, replace O-ring.

- b. Insert fuel injector into fuel tube with clip attached.
  - Insert it while matching it to the axial center.
  - Insert fuel injector so that protrusion "B" of fuel tube matches cutout "B" of clip.
  - Make sure that fuel tube flange is securely fixed in flange fixing groove on clip.
- c. Make sure that installation is complete by checking that fuel injector does not rotate or come off.
  - Make sure that protrusions of fuel injectors are aligned with cutouts of clips after installation.

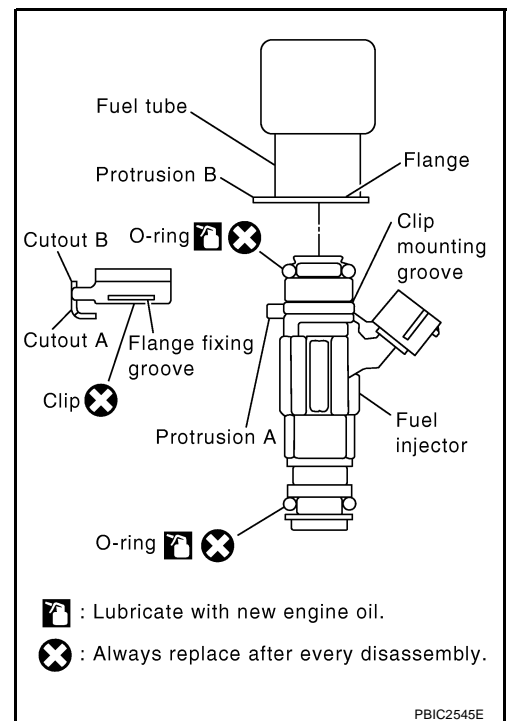

4. Install spacers on intake manifold.
5. Install fuel tube and fuel injector assembly to intake manifold.

**CAUTION:**

Be careful not to let tip of injector nozzle come in contact with other parts.

# FUEL INJECTOR AND FUEL TUBE

[VQ35DE]

- Tighten mounting bolts in two steps in numerical order as shown in the figure.

 **1st step**  
: 10.1 N·m (1.0 kg·m, 7 ft·lb)

 **2nd step**  
: 23.6 N·m (2.4 kg·m, 17 ft·lb)

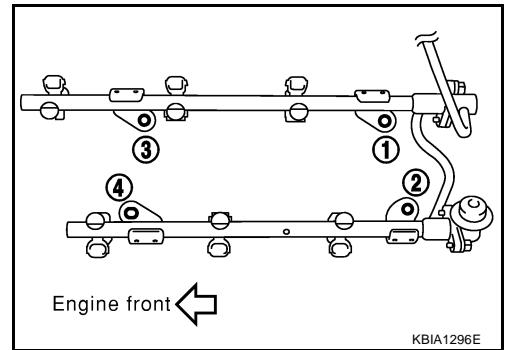

6. Connect injector sub-harness.
7. Install intake manifold collectors (upper and lower). Refer to [EM-19. "INTAKE MANIFOLD COLLECTOR"](#).
8. Install fuel sub-tube on rear end of intake manifold collector (lower).
9. Connect fuel feed hose (with damper).
  - Handling procedure of O-ring is the same as that of fuel damper and fuel sub-tube.
  - Insert fuel damper straight into fuel sub-tube.
  - Tighten mounting bolts evenly in turn.
  - After tightening mounting bolts, make sure that there is no gap between flange and fuel sub-tube.
10. Connect quick connector between fuel feed hose (with damper) and centralized under-floor piping connection as follows:
  - a. Make sure no foreign substances are deposited in and around centralized under-floor piping and quick connector, and no damage on them.
  - b. Thinly apply new engine oil around centralized under-floor piping from tip end to spool end.
  - c. Align center to insert quick connector straightly into centralized under-floor piping.
    - Insert quick connector to centralized under-floor piping until top spool is completely inside quick connector, and 2nd level spool exposes right below quick connector.

**CAUTION:**

- Hold "A" position as shown in the figure when inserting centralized under-floor piping into quick connector.
- Carefully align center to avoid inclined insertion to prevent damage to O-ring inside quick connector.
- Insert until you hear a "click" sound and actually feel the engagement.
- To avoid misidentification of engagement with a similar sound, be sure to perform the next step.

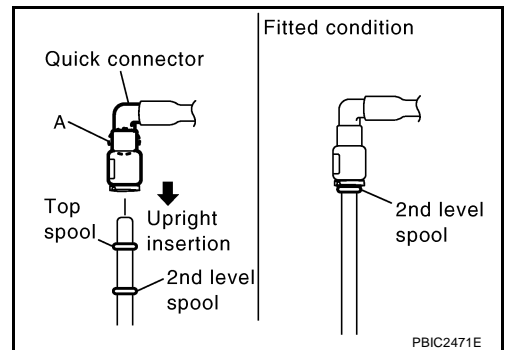

- d. Pull quick connector by hand holding "A" position. Make sure it is completely engaged (connected) so that it does not come out from centralized under-floor piping.
- e. Install quick connector cap to quick connector connection.
  - Install quick connector cap with arrow on surface facing in direction of quick connector (fuel feed hose side).

**CAUTION:**

**If quick connector cap cannot be installed smoothly, quick connector may have not been installed correctly. Check the connection again.**

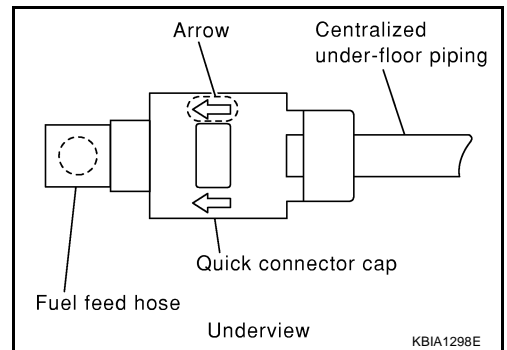

11. Install in the reverse order of removal after this step.

## INSPECTION AFTER INSTALLATION

### Check on Fuel Leakage

1. Turn ignition switch "ON" (with the engine stopped). With fuel pressure applied to fuel piping, make sure there are no fuel leaks at connection points.

**NOTE:**

Use mirrors for checking at points out of clear sight.

2. Start the engine. With engine speed increased, make sure again that there are no fuel leaks at connection points.

**CAUTION:**

**Do not touch the engine immediately after stopped, as the engine becomes extremely hot.**

## ROCKER COVER

PFP:13264

### Components

NBS004NG

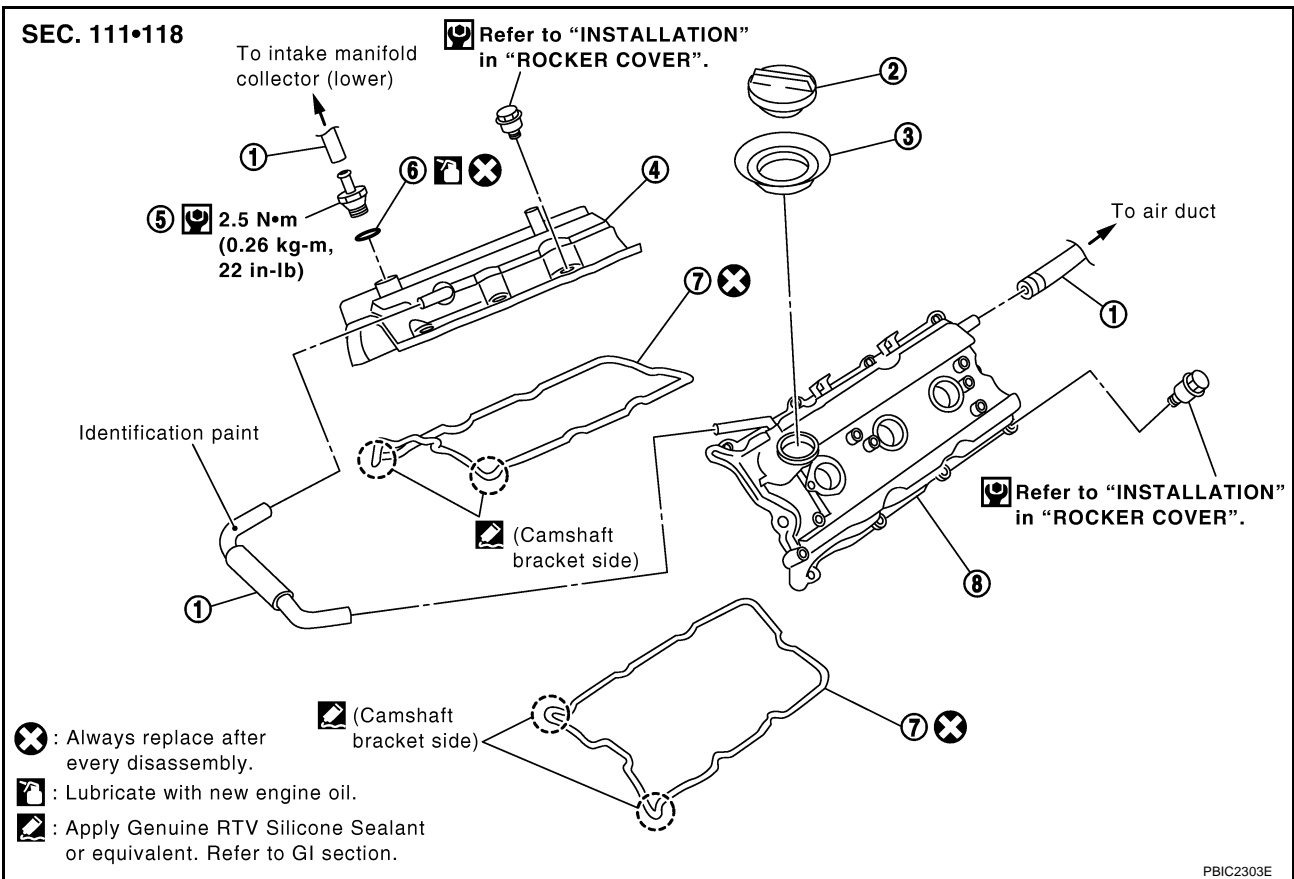

- |                              |                             |                |
|------------------------------|-----------------------------|----------------|
| 1. PCV hose                  | 2. Oil filler cap           | 3. Oil catcher |
| 4. Rocker cover (right bank) | 5. PCV control valve        | 6. O-ring      |
| 7. Rocker cover gasket       | 8. Rocker cover (left bank) |                |

### Removal and Installation

#### REMOVAL

NBS004NH

1. Release the fuel pressure. Refer to [EC-98, "FUEL PRESSURE RELEASE"](#).
2. Remove intake manifold collectors (upper and lower). Refer to [EM-19, "INTAKE MANIFOLD COLLECTOR"](#).
3. Separate engine harness removing their brackets from rocker covers.
4. Remove ignition coil. Refer to [EM-42, "IGNITION COIL"](#).
5. Remove PCV hoses from rocker covers.
6. Remove PCV valve and O-ring from rocker cover (right bank), if necessary.
7. Remove oil filler cap and oil catcher from rocker cover (left bank), if necessary.

# ROCKER COVER

[VQ35DE]

- Loosen mounting bolts with power tool in reverse order as shown in the figure.

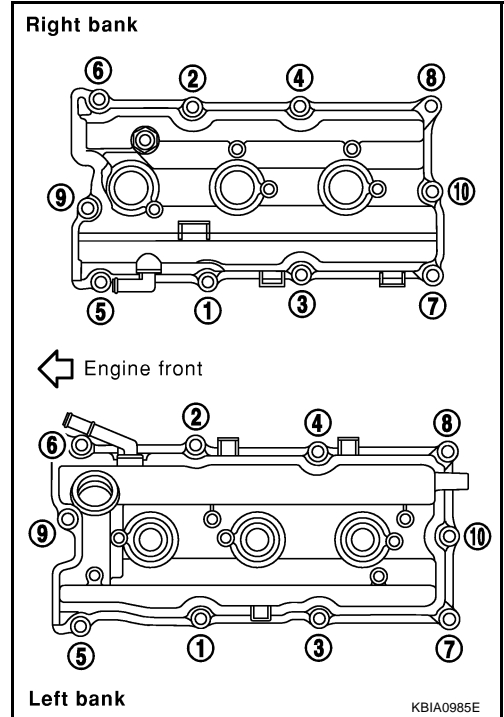

- Remove rocker cover gaskets from rocker covers.
- Use a scraper to remove all traces of liquid gasket from cylinder head and camshaft bracket (No. 1).

**CAUTION:**

**Do not scratch or damage the mating surface when cleaning off old liquid gasket.**

## INSTALLATION

- Apply liquid gasket with the tube presser [SST: WS39930000 ( — )] to joint part among rocker cover, cylinder head and camshaft bracket (No. 1) as follows:

**Use Genuine RTV Silicone Sealant or equivalent. Refer to [GI-48, "RECOMMENDED CHEMICAL PRODUCTS AND SEALANTS"](#).**

**NOTE:**

The figure shows an example of left bank side [zoomed in shows camshaft bracket (No. 1)].

- Refer to the figure "a" to apply liquid gasket to joint part of camshaft bracket (No. 1) and cylinder head.
- Refer to the figure "b" to apply liquid gasket to the figure "a" squarely.

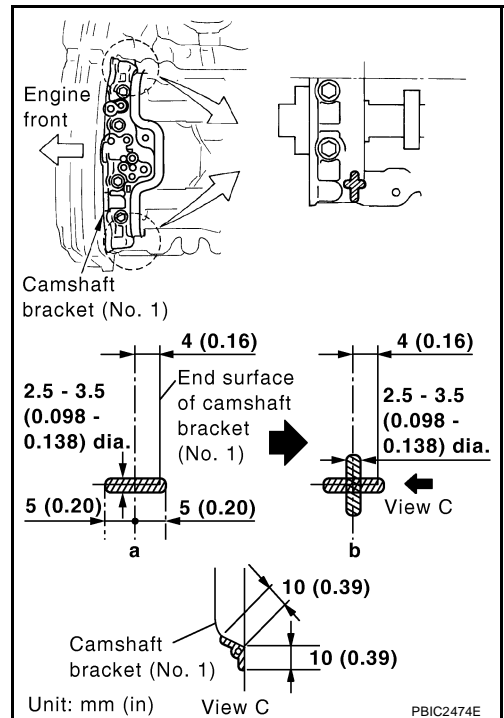

- Install new rocker cover gasket to rocker cover.
- Install rocker cover.
  - Check if rocker cover gasket is not dropped from installation groove of rocker cover.



# ROCKER COVER

[VQ35DE]

4. Tighten bolts in two steps separately in numerical order as shown in the figure.

 **1st step**  
: 1.96 N·m (0.20 kg·m, 17 in·lb)

 **2nd step**  
: 8.33 N·m (0.85 kg·m, 74 in·lb)

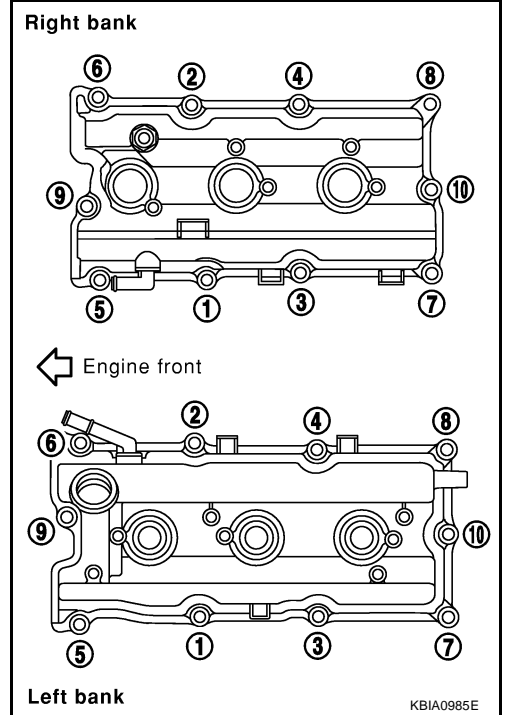

5. Install oil catcher and oil filter cap to rocker cover (left bank), if removed.
6. Install new O-ring and PCV valve to rocker cover (right bank), if removed.
7. Install PCV hose.
- Insert PCV hose by 25 to 30 mm (0.98 to 1.18 in) from connector end.
  - When installing, be careful not to twist or come in contact with other parts.
  - Install PCV hose between right and left rocker covers with its identification paint facing upward (right rocker cover side). Refer to component figure in [EM-51, "Removal and Installation"](#).
8. Install in the reverse order of removal after this step.

## FRONT TIMING CHAIN CASE

PFP:13599

## Removal and Installation

NBS004NI

## NOTE:

- This section describes removal/installation procedure of front timing chain case and timing chain related parts without removing oil pan (upper) on the vehicle.
- When oil pan (upper) needs to be removed or installed, or when rear timing chain case is removed or installed, remove oil pans (upper and lower) first. Then remove front timing chain case, timing chain related parts, and rear timing chain case in this order, and install in reverse order of removal. Refer to [EM-64, "TIMING CHAIN"](#).
- Refer to [EM-64, "TIMING CHAIN"](#) for component parts location.

## REMOVAL

1. Remove engine room cover (RH and LH). Refer to [EM-14, "ENGINE ROOM COVER"](#).
2. Disconnect the battery cable from the negative terminal. Refer to [SC-4, "BATTERY"](#).
3. Remove engine cover with power tool. Refer to [EM-19, "INTAKE MANIFOLD COLLECTOR"](#).
4. Remove air duct (inlet) and air cleaner case assembly. Refer to [EM-17, "AIR CLEANER AND AIR DUCT"](#).
5. Remove front and rear engine undercover with power tool.
6. Release the fuel pressure. Refer to [EC-98, "FUEL PRESSURE RELEASE"](#).
7. Drain engine oil. Refer to [LU-9, "Changing Engine Oil"](#).

**CAUTION:**

- Perform this step when the engine is cold.
  - Do not spill engine oil on drive belts.
8. Drain engine coolant from radiator. Refer to [CO-11, "Changing Engine Coolant"](#).

**CAUTION:**

- Perform this step when the engine is cold.
  - Do not spill engine coolant on drive belts.
9. Remove radiator hose (upper and lower) and A/T fluid cooler hose. Refer to [CO-14, "RADIATOR"](#).
  10. Separate engine harnesses removing their brackets from front timing chain case.
  11. Remove drive belts. Refer to [EM-15, "DRIVE BELTS"](#).
  12. Remove intake manifold collectors (upper and lower). Refer to [EM-19, "INTAKE MANIFOLD COLLECTOR"](#).
  13. Remove power steering oil pump from bracket with piping connected, and temporarily secure it aside. Refer to [PS-29, "POWER STEERING OIL PUMP"](#).
  14. Remove power steering oil pump bracket. Refer to [PS-29, "POWER STEERING OIL PUMP"](#).
  15. Remove alternator. Refer to [SC-23, "CHARGING SYSTEM"](#).
  16. Remove water bypass hose, water hose clamp and idler pulley bracket from front timing chain case.
  17. Remove intake valve timing control covers.
    - Loosen mounting bolts in reverse order as shown in the figure.
    - Use the seal cutter [SST: KV10111100 (J37228)] to cut liquid gasket for removal.

**CAUTION:**

Shaft is internally jointed with camshaft sprocket (INT) center hole. When removing, keep it horizontal until it is completely disconnected.

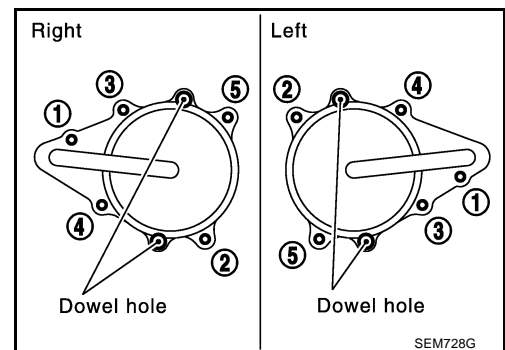

# FRONT TIMING CHAIN CASE

[VQ35DE]

18. Remove collared O-ring from front timing chain case (left and right side).

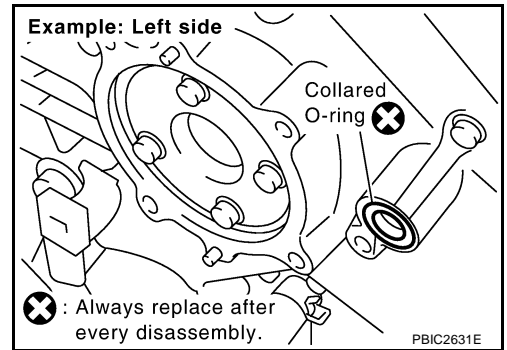

19. Remove rocker covers (right and left banks). Refer to [EM-51, "ROCKER COVER"](#).

**NOTE:**

When only timing chain (primary) is removed, rocker cover does not need to be removed.

20. Obtain No. 1 cylinder at TDC of its compression stroke as follows:

**NOTE:**

When timing chain is not removed/installed, this step is not required.

- a. Rotate crankshaft pulley clockwise to align timing mark (grooved line without color) with timing indicator.

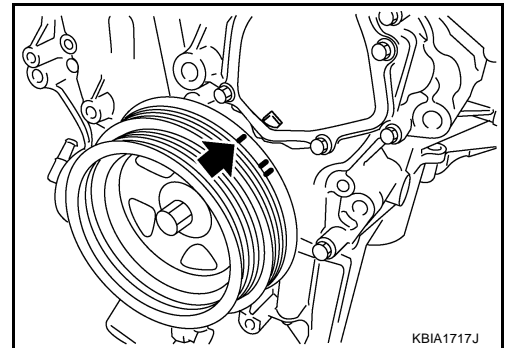

- b. Make sure that intake and exhaust cam noses on No. 1 cylinder (engine front side of right bank) are located as shown in the figure.

- If not, turn crankshaft one revolution (360 degrees) and align as shown in the figure.

**NOTE:**

When only timing chain (primary) is removed, rocker cover does not need to be removed. To make sure that No. 1 cylinder is at its compression TDC, remove front timing chain case first. Then check mating marks on camshaft sprockets. Refer to [EM-72, "INSTALLATION"](#).

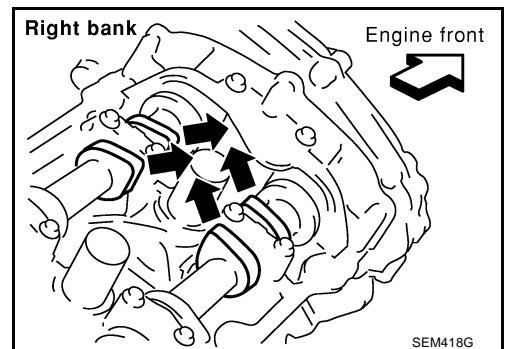

21. Remove crankshaft pulley as follows:

- a. Remove rear cover plate (2WD models) or starter motor (AWD models) and set ring gear stopper (SST) as shown in the figure. Refer to [SC-10, "STARTING SYSTEM"](#).

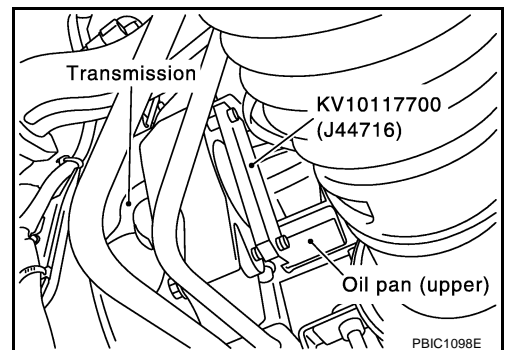

# FRONT TIMING CHAIN CASE

[VQ35DE]

- b. Loosen crankshaft pulley bolt and locate bolt seating surface as 10 mm (0.39 in) from its original position.

**CAUTION:**

**Do not remove crankshaft pulley bolt as it will be used as a supporting point for suitable puller.**

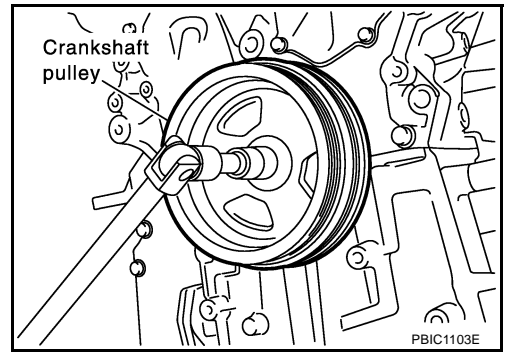

- c. Place suitable puller tab on holes of crankshaft pulley, and pull crankshaft pulley through.

**CAUTION:**

**Do not put suitable puller tab on crankshaft pulley periphery, as this will damage internal damper.**

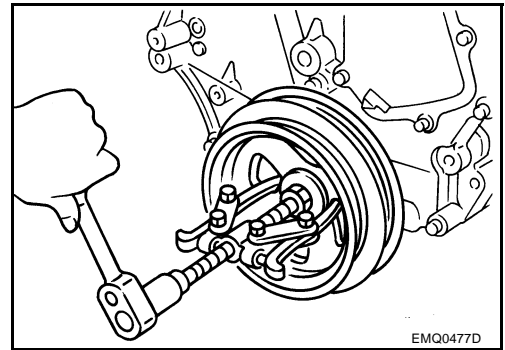

- 22. Remove oil pan (lower). Refer to [EM-29. "OIL PAN AND OIL STRAINER"](#) .
- 23. Loosen two mounting bolts in front of oil pan (upper) with power tool in reverse order shown in figure.

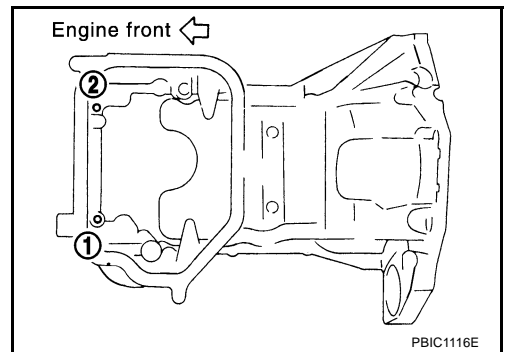

- 24. Remove front timing chain case as follows:
  - a. Loosen mounting bolts with power tool in reverse order as shown in the figure.

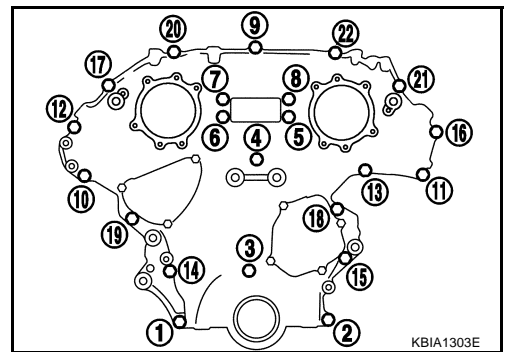

# FRONT TIMING CHAIN CASE

[VQ35DE]

- b. Insert suitable tool into the notch at the top of front timing chain case as shown (1).
- c. Pry off case by moving a tool as shown (2).
  - Use the seal cutter [SST: KV10111100 (J37228)] to cut liquid gasket for removal.

**CAUTION:**

- Do not use a screwdrivers or something similar.
- After removal, handle front timing chain case carefully so it does not tilt, cant, or warp under a load.

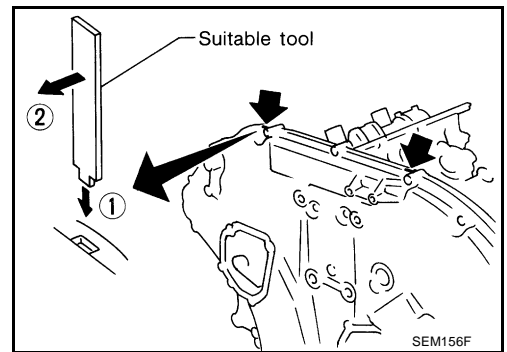

- 25. Remove O-rings from rear timing chain case.

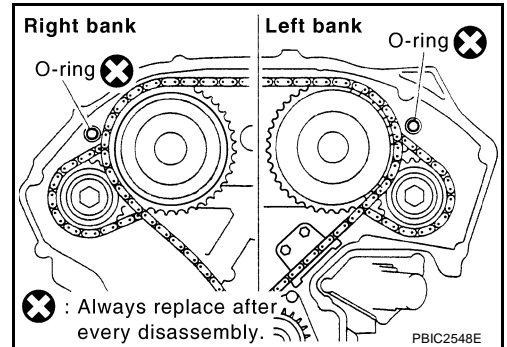

- 26. Remove oil pan gasket (front). Refer to [EM-29, "OIL PAN AND OIL STRAINER"](#) .
- 27. Remove water pump cover and chain tensioner cover from front timing chain case, if necessary.
  - Use the seal cutter [SST: KV10111100 (J37228)] to cut liquid gasket for removal.
- 28. Remove front oil seal from front timing chain case using a suitable tool.
  - Use a screwdriver for removal.

**CAUTION:**

**Exercise care not to damage front timing chain case.**

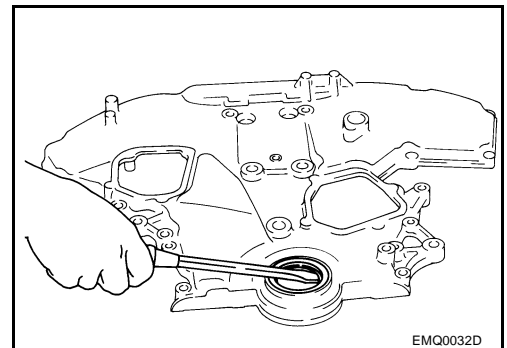

- 29. Remove timing chain and related parts. Refer to [EM-64, "TIMING CHAIN"](#) .
- 30. Use a scraper to remove all traces of old liquid gasket from front and rear timing chain cases and oil pan (upper), and liquid gasket mating surfaces.

**CAUTION:**

**Be careful not to allow gasket fragments to enter oil pan.**

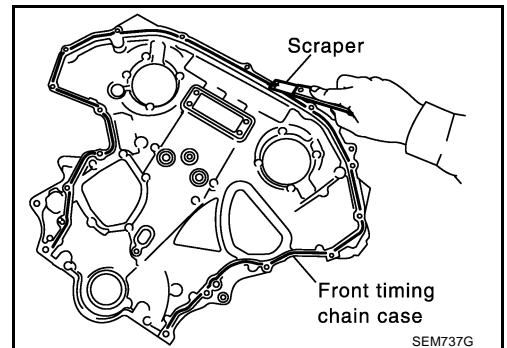

# FRONT TIMING CHAIN CASE

[VQ35DE]

- Remove old liquid gasket from bolt hole and thread.

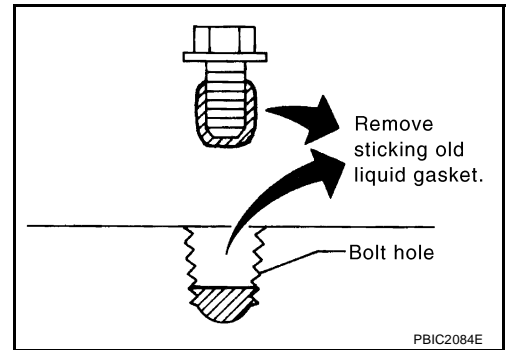

31. Use a scraper to remove all traces of liquid gasket from water pump cover, chain tensioner cover and intake valve timing control covers.

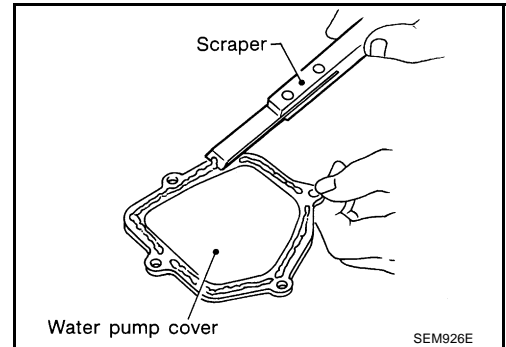

## INSTALLATION

1. Install timing chain and related parts. Refer to [EM-64, "TIMING CHAIN"](#).
2. Hammer dowel pins (right and left bank) into front timing chain case up to a point close to taper in order to shorten protrusion length.

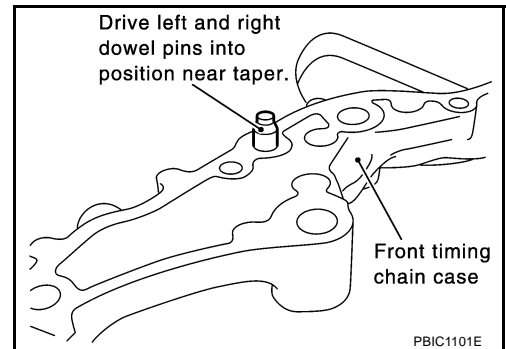

3. Install front oil seal on front timing chain case.
  - Apply new engine oil to the oil seal lip and dust seal lip.
  - Install it so that each seal lip is oriented as shown in the figure.

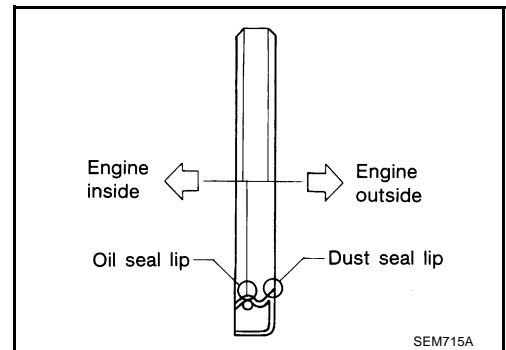

# FRONT TIMING CHAIN CASE

[VQ35DE]

- Using a suitable drift [outer diameter: 60 mm (2.36 in)], press-fit oil seal until it becomes flush with front timing chain case end face.
- Make sure the garter spring is in position and seal lip is not inverted.

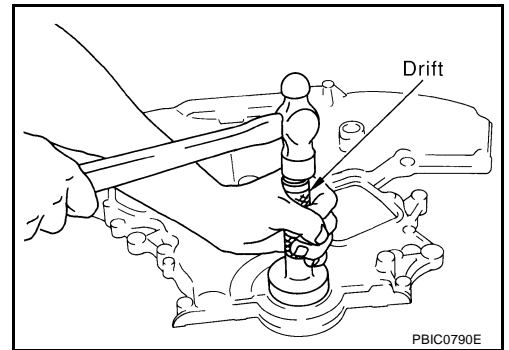

4. Install water pump cover and chain tensioner cover to front timing chain case.

- Apply a continuous bead of liquid gasket with the tube presser [SST: WS39930000 ( — )] to front timing chain case as shown in the figure.  
**Use Genuine RTV Silicone Sealant or equivalent. Refer to [GI-48, "RECOMMENDED CHEMICAL PRODUCTS AND SEALANTS"](#).**

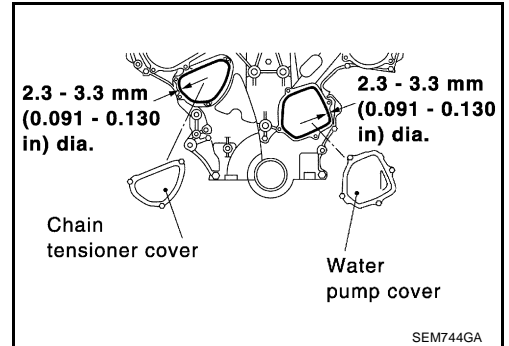

5. Install front timing chain case as follows:

- a. Apply a continuous bead of liquid gasket with the tube presser [SST: WS39930000 ( — )] to front timing chain case back side as shown in the figure.  
**Use Genuine RTV Silicone Sealant or equivalent. Refer to [GI-48, "RECOMMENDED CHEMICAL PRODUCTS AND SEALANTS"](#).**

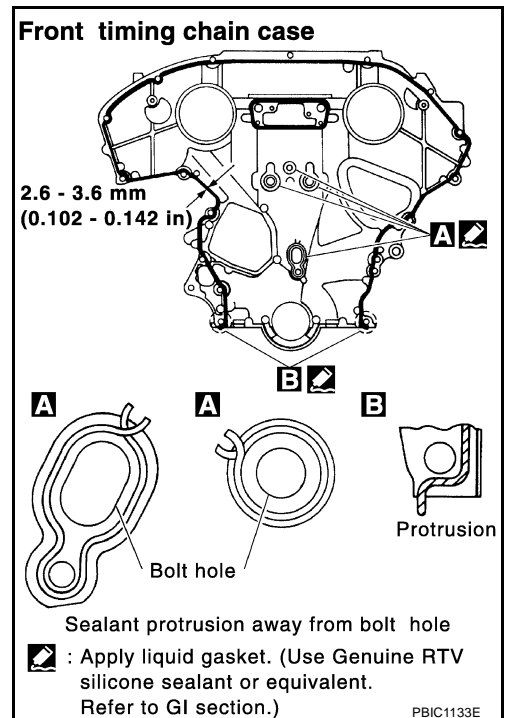

A  
EM  
C  
D  
E  
F  
G  
H  
I  
J  
K  
L  
M



# FRONT TIMING CHAIN CASE

[VQ35DE]

b. Install new oil pan gasket (front).

- Apply liquid gasket to oil pan gasket (front) as shown in the figure.

**Use Genuine RTV Silicone Sealant or equivalent. Refer to [GI-48, "RECOMMENDED CHEMICAL PRODUCTS AND SEALANTS"](#).**

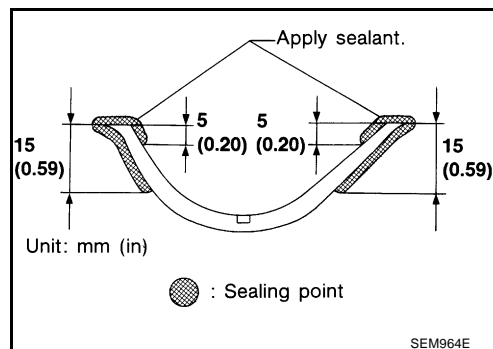

- Align notch of front timing chain case with protrusion of oil pan gasket.

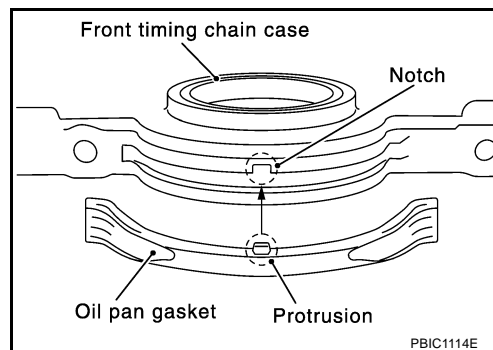

- Apply liquid gasket with the tube presser [SST: WS39930000 ( — )] to top surface of oil pan (upper) as shown in the figure.

**Use Genuine RTV Silicone Sealant or equivalent. Refer to [GI-48, "RECOMMENDED CHEMICAL PRODUCTS AND SEALANTS"](#).**

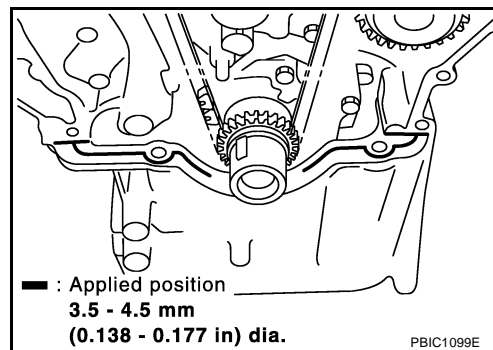

c. Install new O-rings on rear timing chain case.

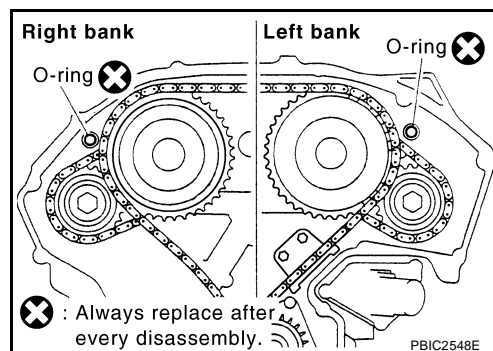

d. Assemble front timing chain case as follows:

- Fit lower end of front timing chain case tightly onto top face of oil pan (upper). From the fitting point, make entire front timing chain case contact rear timing chain case completely.

**CAUTION:**

**Be careful that oil pan gasket is in place.**

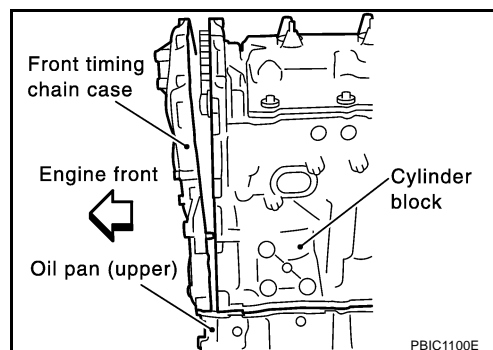



# FRONT TIMING CHAIN CASE

[VQ35DE]

- ii. Since front timing chain case is offset for difference of bolt holes, tighten bolts temporarily with holding front timing chain case from front and top as shown in the figure. For bolt length and positions, refer to the step e.
- iii. Same as the step ii, insert dowel pin with holding front timing chain case from front and top completely.

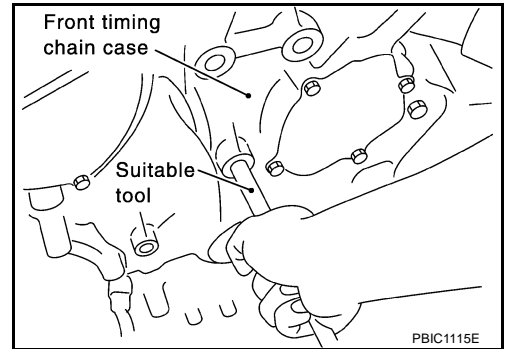

- e. Tighten mounting bolts to the specified torque in numerical order as shown in the figure.
  - There are two type of mounting bolts. Refer to the following for locating bolts.

**M8 bolts : 1, 2**

: **28.4 N-m (2.9 kg-m, 21 ft-lb)**

**M6 bolts : Except the above**

: **12.7 N-m (1.3 kg-m, 9 ft-lb)**

- f. After all bolts tightened, retighten them to the specified torque in numerical order as shown in the figure.
- 6. Install two mounting bolts in front of oil pan (upper) in numerical order as shown in figure.

: **17.2 N-m (1.8 kg-m, 13 ft-lb)**

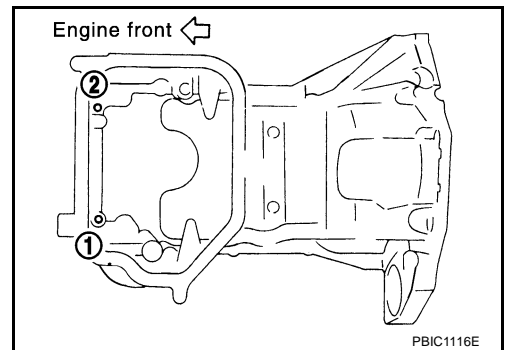
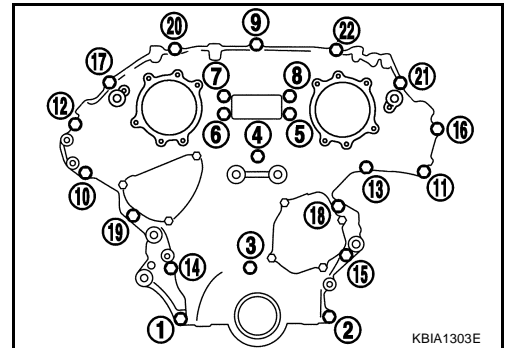

- 7. Install oil pan (lower). Refer to [EM-29, "OIL PAN AND OIL STRAINER"](#) .

- 8. Install intake valve timing control covers as follows:

- a. Install new seal rings in shaft grooves.
- b. Apply a continuous bead of liquid gasket with the tube presser [SST: WS39930000 ( — )] to intake valve timing control covers as shown in the figure.

**Use Genuine RTV Silicone Sealant or equivalent. Refer to [GI-48, "RECOMMENDED CHEMICAL PRODUCTS AND SEALANTS"](#) .**

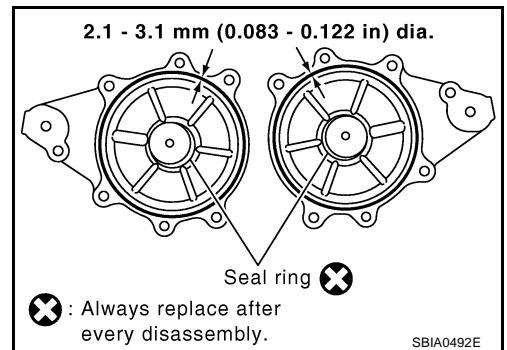

# FRONT TIMING CHAIN CASE

[VQ35DE]

- c. Install new collared O-rings in front timing chain case oil hole (left and right sides).

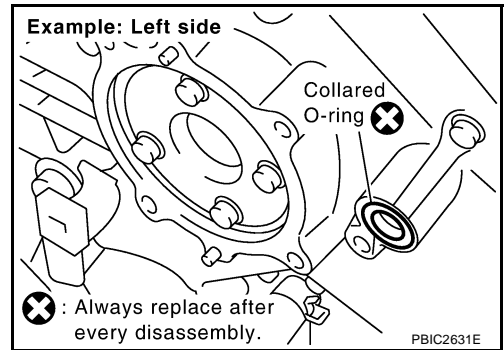

- d. Being careful not to move seal ring from the installation groove, align dowel pins on front timing chain case with the holes to install intake valve timing control covers.
- e. Tighten mounting bolts in numerical order as shown in the figure.

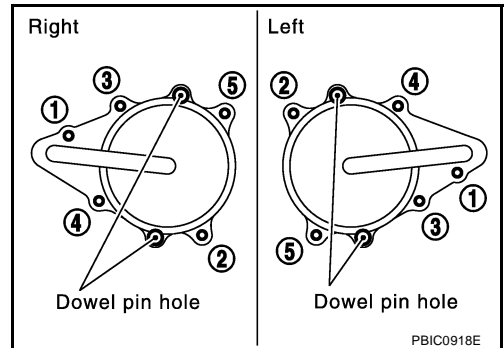

9. Install crankshaft pulley as follows:

- Fix crankshaft using the ring gear stopper [SST: KV10117700 (J44716)].
- Install crankshaft pulley, taking care not to damage front oil seal.
  - When press-fitting crankshaft pulley with plastic hammer, tap on its center portion (not circumference).
- Tighten crankshaft pulley bolt.

: **44.1 N·m (4.5 kg-m, 33 ft-lb)**

- d. Place a matching mark (A) on crank pulley (1) aligning with the matching (B) of crank pulley mounting bolt (2). Tighten the bolts 90 degrees (one marks).

**NOTE:**

- The figure shows crank pulley bolt with four marks.

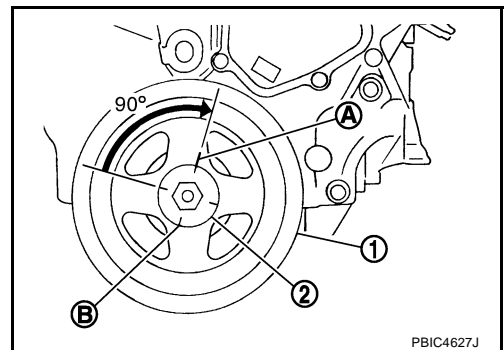

- Use an angle wrench (SST) for a crankshaft pulley bolt with six-marks.

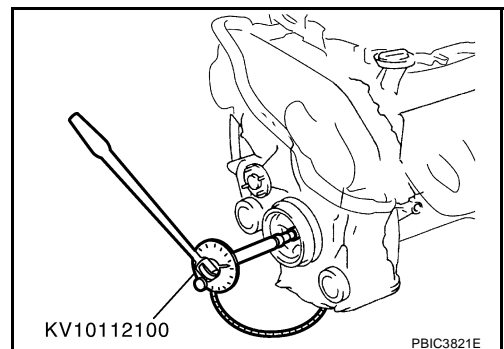

- 10. Rotate crankshaft pulley in normal direction (clockwise when viewed from front) to confirm it turns smoothly.
- 11. For the following operations, perform steps in the reverse order of removal.

**INSPECTION AFTER INSTALLATION**

**Inspection for Leaks**

The following are procedures for checking fluids leak, lubricates leak.

- Before starting engine, check oil/fluid levels including engine coolant and engine oil. If less than required quantity, fill to the specified level. Refer to [MA-12, "RECOMMENDED FLUIDS AND LUBRICANTS"](#) .
- Use procedure below to check for fuel leakage.
  - Turn ignition switch "ON" (with engine stopped). With fuel pressure applied to fuel piping, check for fuel leakage at connection points.
  - Start engine. With engine speed increased, check again for fuel leakage at connection points.
- Run engine to check for unusual noise and vibration.

**NOTE:**

If hydraulic pressure inside chain tensioner drops after removal/installation, slack in guide may generate a pounding noise during and just after the engine start. However, this does not indicate an unusualness. Noise will stop after hydraulic pressure rises.

- Warm up engine thoroughly to make sure there is no leakage of fuel, or any oil/fluids including engine oil and engine coolant.
- Bleed air from lines and hoses of applicable lines, such as in cooling system.
- After cooling down engine, again check oil/fluid levels including engine oil and engine coolant. Refill to the specified level, if necessary.

**Summary of the inspection items:**

Item	Before starting engine	Engine running	After engine stopped
Engine coolant	Level	Leakage	Level
Engine oil	Level	Leakage	Level
Other oils and fluid*	Level	Leakage	Level
Fuel	Leakage	Leakage	Leakage

\* Transmission/transaxle/CVT fluid, power steering fluid, brake fluid, etc.

# TIMING CHAIN

[VQ35DE]

## TIMING CHAIN

PFP:13028

### Components

NBS004NJ

SEC. 120•130•150•210•275

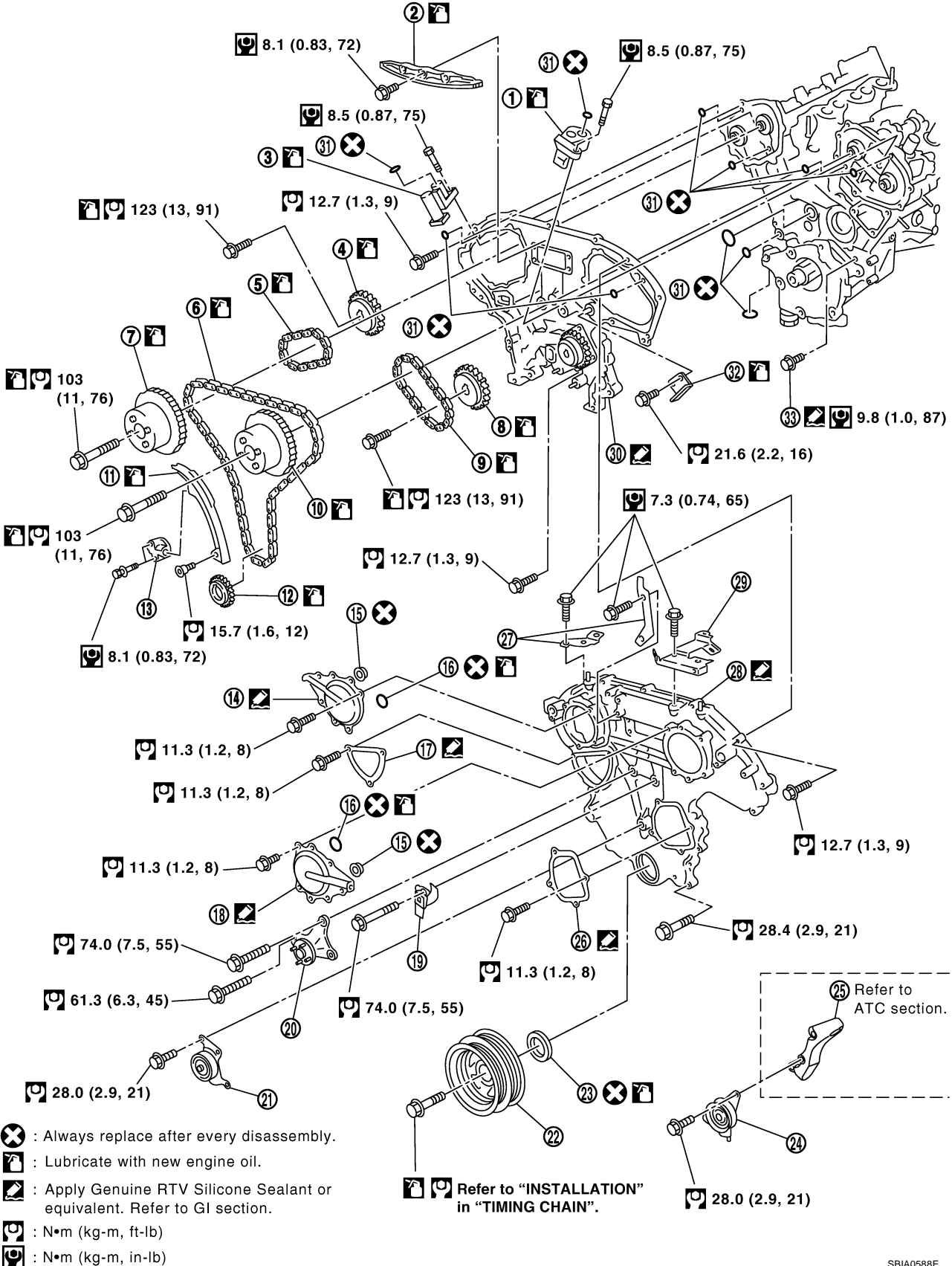

SBI A0588E

- |                                       |                                       |                                       |
|---------------------------------------|---------------------------------------|---------------------------------------|
| 1. Timing chain tensioner (secondary) | 2. Internal chain guide               | 3. Timing chain tensioner (secondary) |
| 4. Camshaft sprocket (EXH)            | 5. Timing chain (secondary)           | 6. Timing chain (primary)             |
| 7. Camshaft sprocket (INT)            | 8. Camshaft sprocket (EXH)            | 9. Timing chain (secondary)           |
| 10. Camshaft sprocket (INT)           | 11. Slack guide                       | 12. Crankshaft sprocket               |
| 13. Timing chain tensioner (primary)  | 14. Intake valve timing control cover | 15. Collared O-ring                   |
| 16. O-ring                            | 17. Chain tensioner cover             | 18. Intake valve timing control cover |
| 19. Water hose clamp                  | 20. Idler pulley bracket              | 21. Idler pulley                      |
| 22. Crankshaft pulley                 | 23. Front oil seal                    | 24. Idler pulley                      |
| 25. A/C compressor bracket            | 26. Water pump cover                  | 27. Bracket                           |
| 28. Front timing chain case           | 29. Bracket                           | 30. Rear timing chain case            |
| 31. O-ring                            | 32. Tension guide                     | 33. Water drain plug (front side)     |

A  
EM  
C  
D  
E  
F  
G  
H  
I  
J  
K  
L  
M

## Removal and Installation

NBS004NK

### NOTE:

- This section describes procedures for removing/installing front timing chain case and timing chain related parts, and rear timing chain case, when oil pan (upper) needs to be removed/installed for engine overhaul, etc.
- To remove/install front timing chain case, timing chain, and its related parts without removing oil pan (upper), refer to [EM-54, "FRONT TIMING CHAIN CASE"](#) .

### REMOVAL

1. Remove engine room cover (RH and LH) Refer to [EM-14, "ENGINE ROOM COVER"](#) .
2. Remove front tire.
3. Disconnect the battery cable from the negative terminal.
4. Remove engine cover with power tool. Refer to [EM-19, "INTAKE MANIFOLD COLLECTOR"](#) .
5. Remove air duct (inlet) and air cleaner case assembly. Refer to [EM-17, "AIR CLEANER AND AIR DUCT"](#) .
6. Remove front and rear engine undercover with power tool.
7. Release the fuel pressure. Refer to [EC-98, "FUEL PRESSURE RELEASE"](#) .
8. Drain engine coolant from radiator. Refer to [CO-11, "Changing Engine Coolant"](#) .

### CAUTION:

- Perform this step when the engine is cold.
- Do not spill engine coolant on drive belts.

9. Remove radiator hose (upper and lower) and A/T fluid cooler hose. Refer to [CO-14, "RADIATOR"](#) .
10. Drain engine oil. Refer to [LU-9, "Changing Engine Oil"](#) .

### CAUTION:

- Perform this step when the engine is cold.
- Do not spill engine oil on drive belts.

11. Separate engine harnesses removing their brackets from front timing chain case.
12. Remove intake manifold collectors (upper and lower). Refer to [EM-19, "INTAKE MANIFOLD COLLECTOR"](#) .
13. Remove radiator cooling fan assembly. Refer to [CO-22, "COOLING FAN"](#) .
14. Remove drive belts. Refer to [EM-15, "DRIVE BELTS"](#) .
15. Remove A/C compressor from bracket with piping connected, and temporarily secure it aside. Refer to [ATC-155, "Removal and Installation of Compressor"](#) .
16. Remove power steering oil pump from bracket with piping connected, and temporarily secure it aside. Refer to [PS-29, "POWER STEERING OIL PUMP"](#) .
17. Remove power steering oil pump bracket. Refer to [PS-29, "POWER STEERING OIL PUMP"](#) .
18. Remove alternator. Refer to [SC-23, "CHARGING SYSTEM"](#) .
19. Remove water bypass hose, water hose clamp and idler pulley bracket from front timing chain case.
20. Remove intake valve timing control covers.

# TIMING CHAIN

[VQ35DE]

- Loosen mounting bolts in reverse order as shown in the figure.
- Use the seal cutter [SST: KV10111100 (J37228)] to cut liquid gasket for removal.

**CAUTION:**

Shaft is internally jointed with camshaft sprocket (INT) center hole. When removing, keep it horizontal until it is completely disconnected.

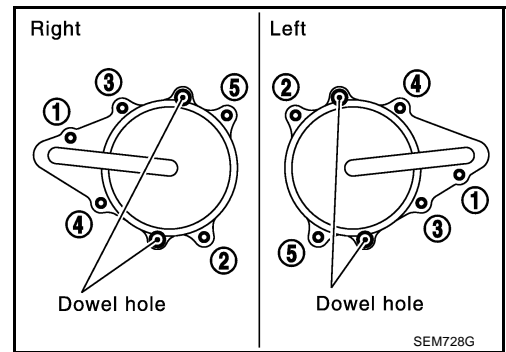

21. Remove collared O-ring from front timing chain case (left and right side).

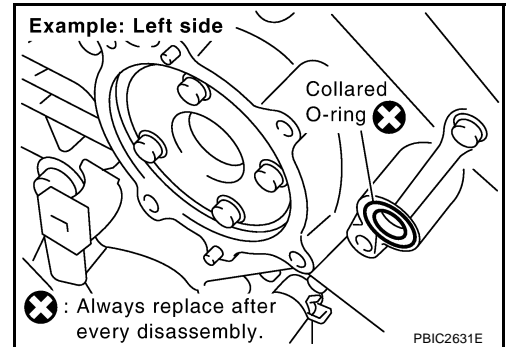

22. Remove rocker covers (right and left bank). Refer to [EM-51, "ROCKER COVER"](#) .
23. Remove oil pans (lower and upper). Refer to [EM-29, "OIL PAN AND OIL STRAINER"](#) .
24. Obtain No. 1 cylinder at TDC of its compression stroke as follows:

- a. Rotate crankshaft pulley clockwise to align timing mark (grooved line without color) with timing indicator.

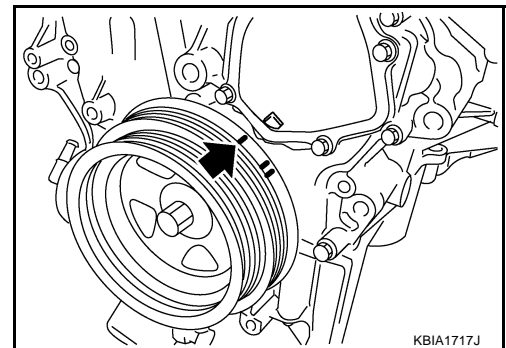

- b. Make sure that intake and exhaust cam noses on No. 1 cylinder (engine front side of right bank) are located as shown in the figure.
- If not, turn crankshaft one revolution (360 degrees) and align as shown in the figure.

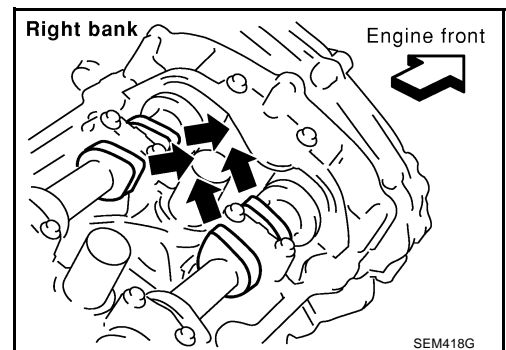

25. Remove crankshaft pulley as follows:

# TIMING CHAIN

[VQ35DE]

- a. Remove rear cover plate (2WD) or starter motor (AWD) and set the ring gear stopper (SST) as shown in the figure. Refer to [SC-10, "STARTING SYSTEM"](#).

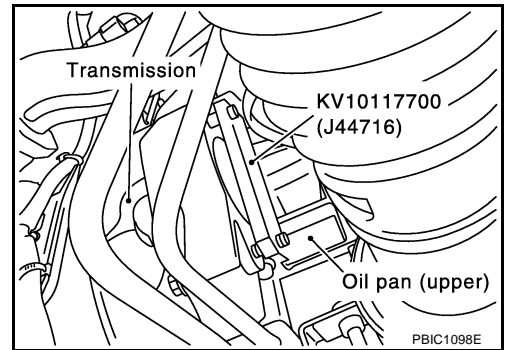

- b. Loosen crankshaft pulley bolt and rotate bolt seating surface at 10 mm (0.39 in) from its original position.

**CAUTION:**

**Do not remove crankshaft pulley bolt as it will be used as a supporting point for suitable puller.**

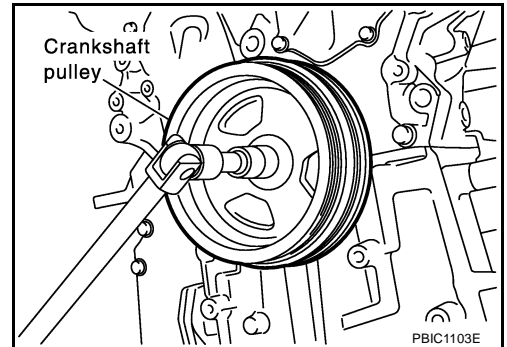

- c. Place suitable puller tab on holes of crankshaft pulley, and pull crankshaft pulley through.

**CAUTION:**

**Do not put suitable puller tab on crankshaft pulley periphery, as this will damage internal damper.**

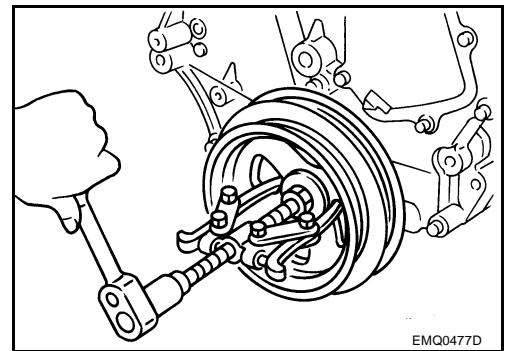

26. Remove front timing chain case as follows:

- a. Loosen mounting bolts in reverse order as shown in the figure.

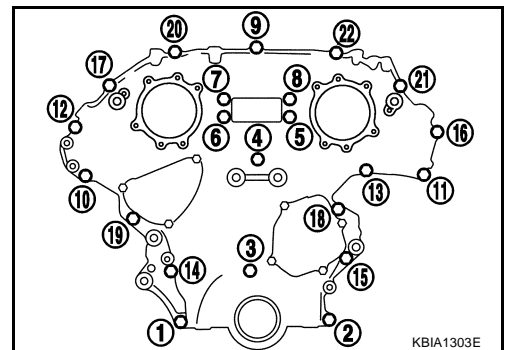

A  
EM  
C  
D  
E  
F  
G  
H  
I  
J  
K  
L  
M



# TIMING CHAIN

[VQ35DE]

- b. Insert a suitable tool into the notch at the top of front timing chain case as shown (1).
- c. Pry off case by moving the tool as shown (2).
  - Use the seal cutter [SST: KV10111100 (J37228)] to cut liquid gasket for removal.

**CAUTION:**

- Do not use a screwdriver or something similar.
- After removal, handle front timing chain case carefully so it does not tilt, cant, or warp under a load.

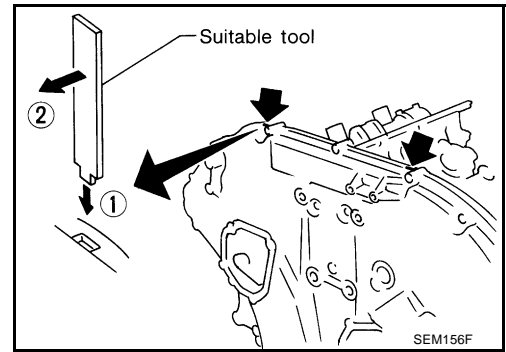

- 27. Remove O-rings from rear timing chain case.

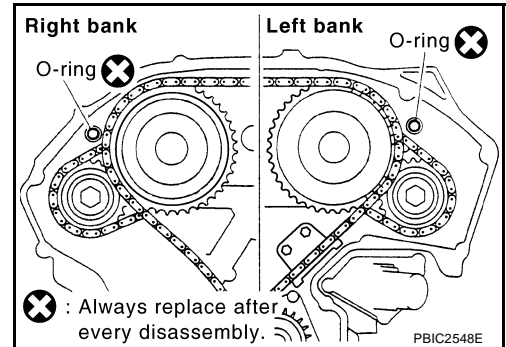

- 28. Remove water pump cover and chain tensioner cover from front timing chain case, if necessary.
  - Use the seal cutter [SST: KV10111100 (J37228)] to cut liquid gasket for removal.

- 29. Remove front oil seal from front timing chain case using a suitable tool.
  - Use a screwdriver for removal.

**CAUTION:**

**Be careful not to damage front timing chain case.**

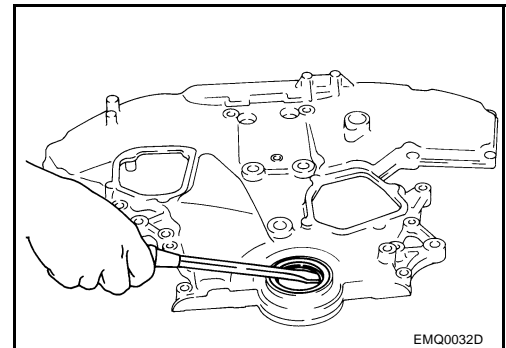

- 30. Remove timing chain tensioner (primary) as follows:

- a. Remove lower mounting bolt.
- b. Loosen upper mounting bolt slowly, and then turn timing chain tensioner (primary) on the mounting bolt so that plunger is fully expanded.

**NOTE:**

Even if plunger is fully expanded, it is not dropped from the body of timing chain tensioner (primary).

- c. Remove upper mounting bolt, and then remove timing chain tensioner (primary).

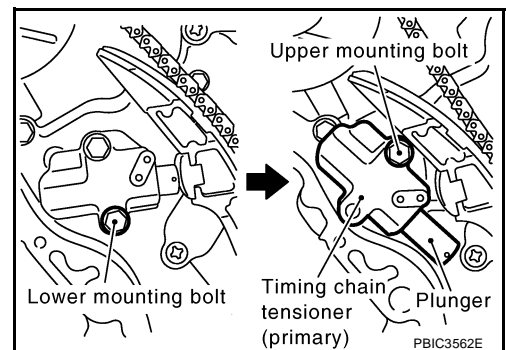



# TIMING CHAIN

[VQ35DE]

31. Remove internal chain guide, tension guide and slack guide.

**NOTE:**

Tension guide can be removed after removing timing chain (primary).

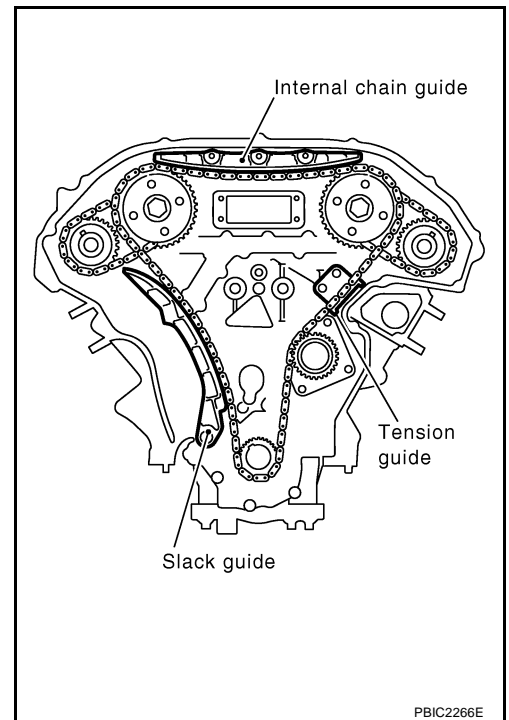

32. Remove timing chain (primary) and crankshaft sprocket.

**CAUTION:**

After removing timing chain (primary), do not turn crankshaft and camshaft separately, or valves will strike the piston heads.

33. Remove timing chain (secondary) and camshaft sprockets as follows:

- a. Attach suitable stopper pin to the right and left timing chain tensioners (secondary).

**NOTE:**

- Use approximately 0.5 mm (0.02 in) dia. hard metal pin as a stopper pin.
- For removal of timing chain tensioner (secondary), refer to [EM-84. "CAMSHAFT"](#) . [Removing camshaft bracket (No. 1) is required.]

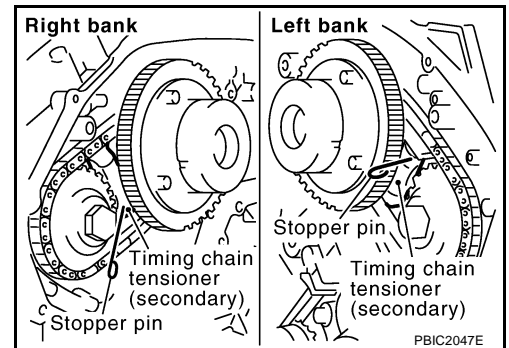

- b. Remove camshaft sprocket (INT and EXH) mounting bolts.

- Secure the hexagonal portion of camshaft using a wrench to loosen mounting bolts.

**CAUTION:**

Do not loosen the mounting bolts with securing anything other than the camshaft hexagonal portion or with tensioning the timing chain.

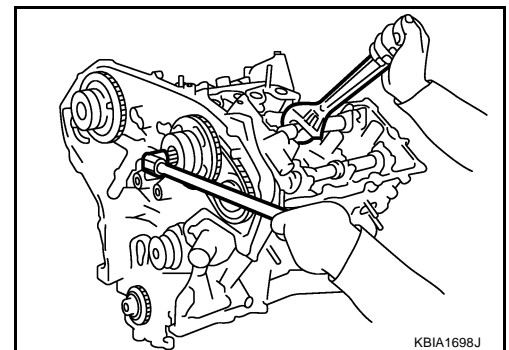

- c. Remove timing chain (secondary) together with camshaft sprockets.

- Turn camshaft slightly to secure slackness of timing chain on timing chain tensioner (secondary) side.

A  
EM  
C  
D  
E  
F  
G  
H  
I  
J  
K  
L  
M

# TIMING CHAIN

[VQ35DE]

- Insert 0.5 mm (0.020 in)-thick metal or resin plate between timing chain and timing chain tensioner plunger (guide). Remove timing chain (secondary) together with camshaft sprockets with timing chain loose from guide groove.

**CAUTION:**

Be careful of plunger coming-off when removing timing chain (secondary). This is because plunger of timing chain tensioner (secondary) moves during operation, leading to coming-off of fixed stopper pin.

**NOTE:**

Camshaft sprocket (INT) is two-for-one structure of primary and secondary sprockets.

- When handling camshaft sprocket (INT), be careful of the following caution:

**CAUTION:**

- Handle carefully to avoid any shock to camshaft sprocket.
- Do not disassemble. (Do not loosen bolts "A" as shown in the figure).

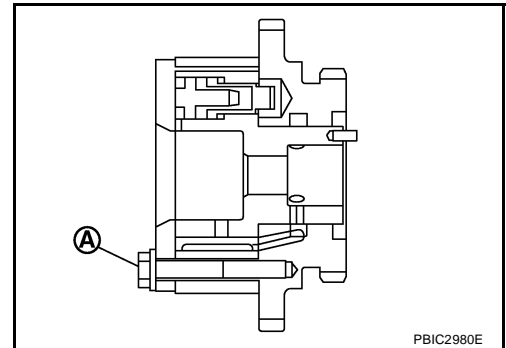
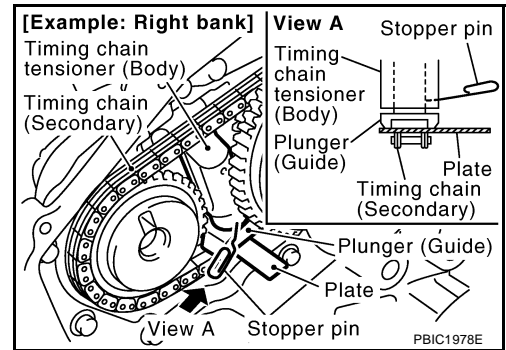

34. Remove rear timing chain case as follows:

- Loosen and remove mounting bolts in reverse order as shown in the figure.
- Cut liquid gasket using the seal cutter [SST: KV10111100 (J37228)] and remove rear timing chain case.

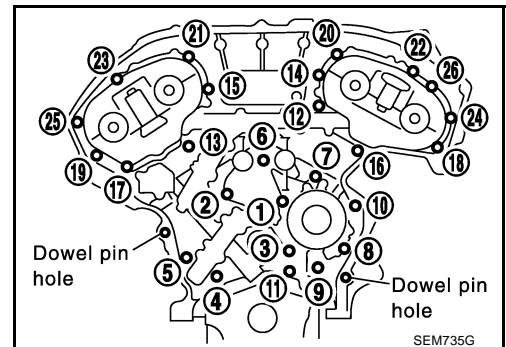

**CAUTION:**

- Do not remove plate metal cover of oil passage.
- After removal, handle rear timing chain case carefully so it does not tilt, cant, or warp under a load.

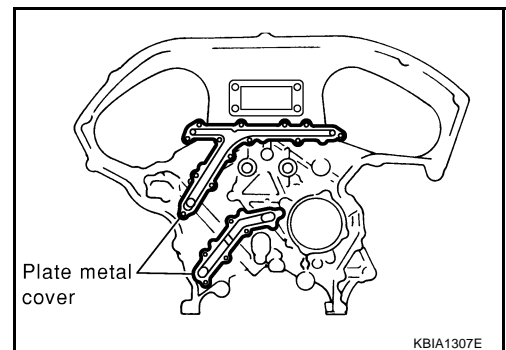

# TIMING CHAIN

[VQ35DE]

35. Remove O-rings from cylinder head.

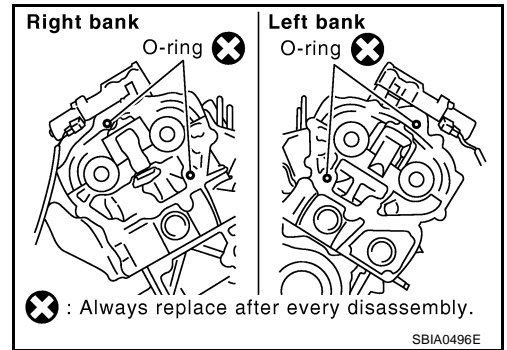

36. Remove O-rings from cylinder block.

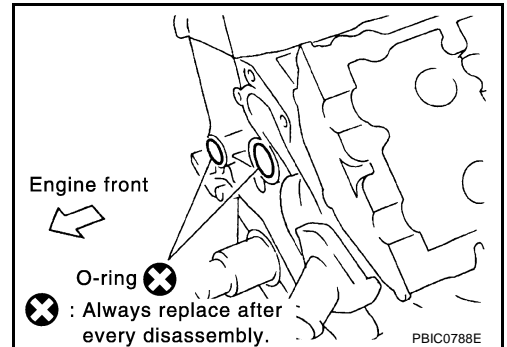

37. Remove timing chain tensioners (secondary) from cylinder head as follows, if necessary.

- Remove camshaft brackets (No. 1). Refer to [EM-85, "REMOVAL"](#).
- Remove timing chain tensioners (secondary) with a stopper pin attached.

38. Use a scraper to remove all traces of liquid gasket from front and rear timing chain cases, and opposite mating surfaces.

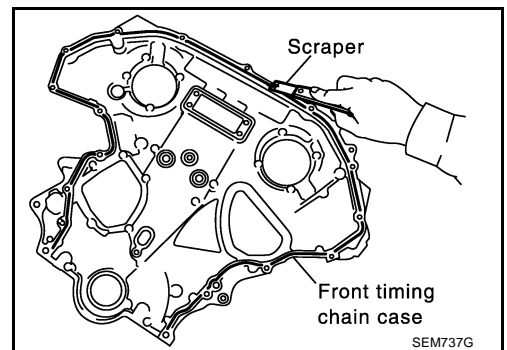

- Remove old liquid gasket from the bolt hole and thread.

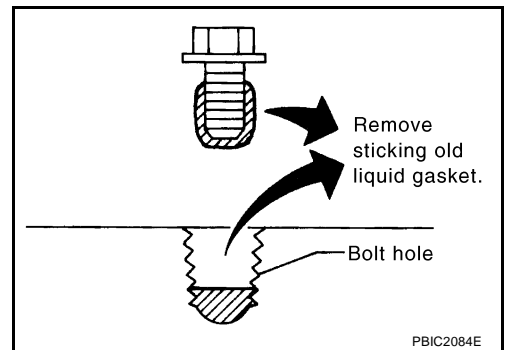

A  
EM  
C  
D  
E  
F  
G  
H  
I  
J  
K  
L  
M

# TIMING CHAIN

[VQ35DE]

39. Use a scraper to remove all traces of liquid gasket from water pump cover, chain tensioner cover and intake valve timing control covers.

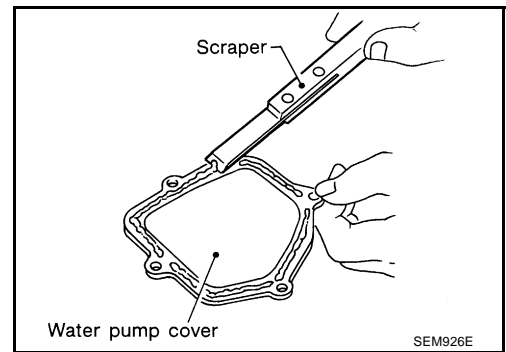

## INSPECTION AFTER REMOVAL

### Timing Chain

Check for cracks and any excessive wear at link plates and roller links of timing chain. Replace timing chain as necessary.

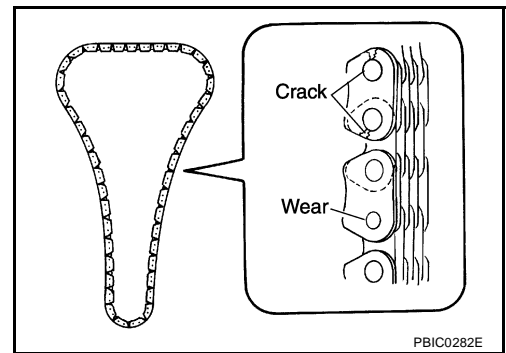

## INSTALLATION

### NOTE:

The below figure shows the relationship between the mating mark on each timing chain and that on the corresponding sprocket, with the components installed.

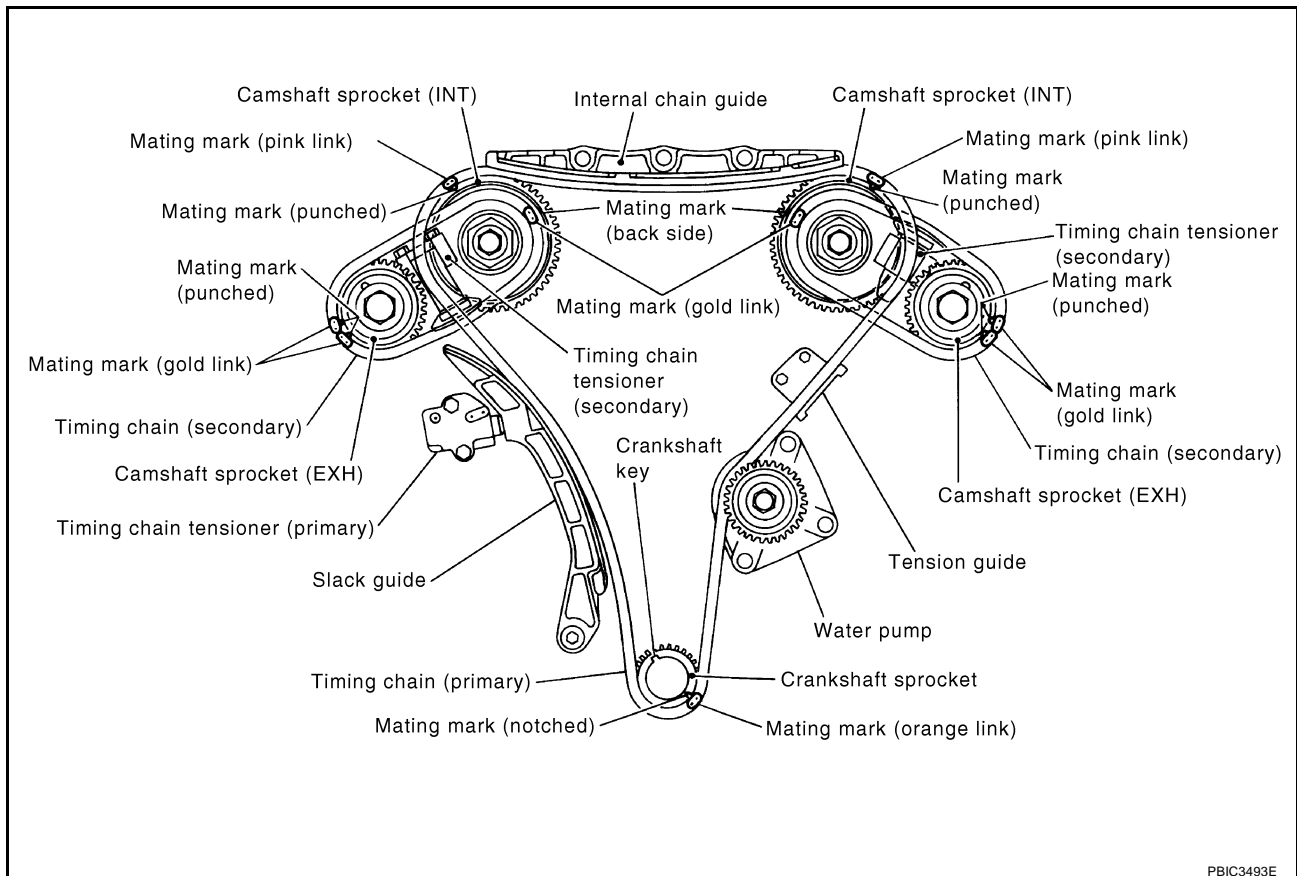

# TIMING CHAIN

[VQ35DE]

1. Install timing chain tensioners (secondary) to cylinder head as follows if removed. Refer to [EM-89, "INSTALLATION"](#).
  - a. Install timing chain tensioners (secondary) with a stopper pin attached and new O-rings.
  - b. Install camshaft brackets (No. 1). Refer to [EM-89, "INSTALLATION"](#).
2. Install rear timing chain case as follows:
  - a. Install new O-rings onto cylinder block.

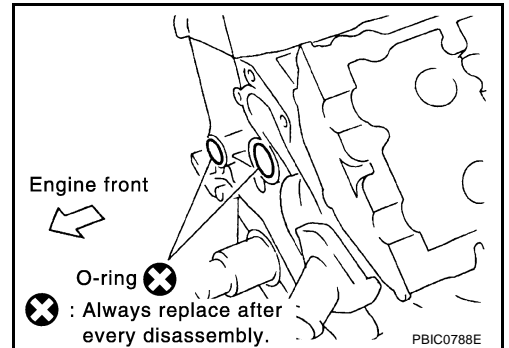

- b. Install new O-rings to cylinder head.

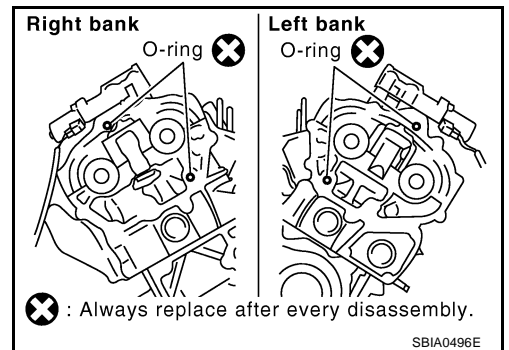

- c. Apply liquid gasket with the tube presser [SST: WS39930000 ( — )] to rear timing chain case back side as shown in the figure.  
**Use Genuine RTV Silicone Sealant or equivalent. Refer to [GI-48, "RECOMMENDED CHEMICAL PRODUCTS AND SEALANTS"](#).**

**CAUTION:**

- For "A" in the figure, completely wipe out liquid gasket extended on a portion touching at engine coolant.

# TIMING CHAIN

[VQ35DE]

- Apply liquid gasket on installation position of water pump and cylinder head very completely.

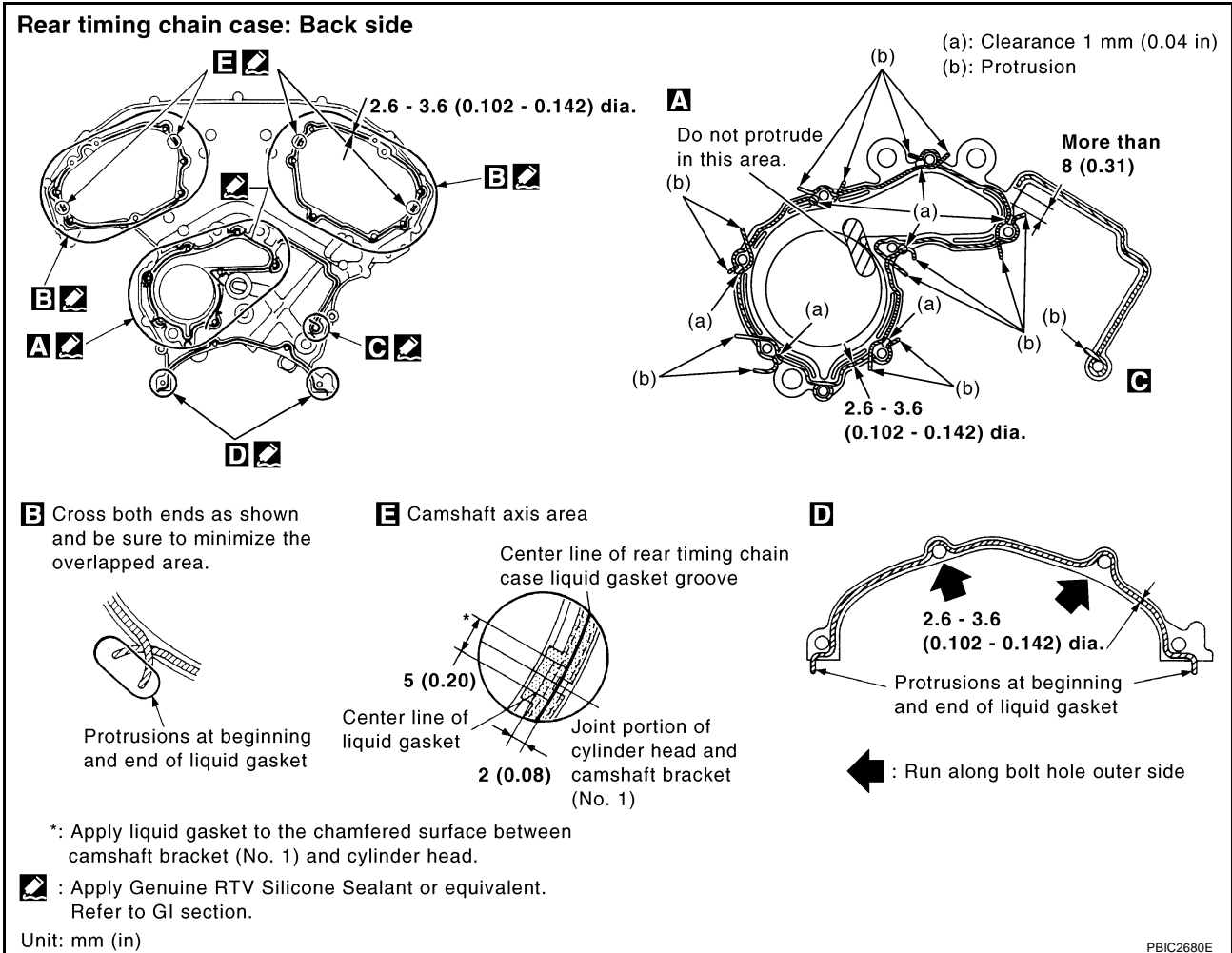

- d. Align rear timing chain case and water pump assembly with dowel pins (right and left bank) on cylinder block and install rear timing chain case.
- Make sure O-rings stay in place during installation to cylinder block and cylinder head.
- e. Tighten mounting bolts in numerical order as shown in the figure.
- There are two type mounting bolts. Refer to the following for locating bolts.

Bolt length:	Bolt position
20 mm (0.79 in)	: 1, 2, 3, 6, 7, 8, 9, 10
16 mm (0.63 in)	: Except the above

☒: 12.7 N·m (1.3 kg·m, 9 ft·lb)

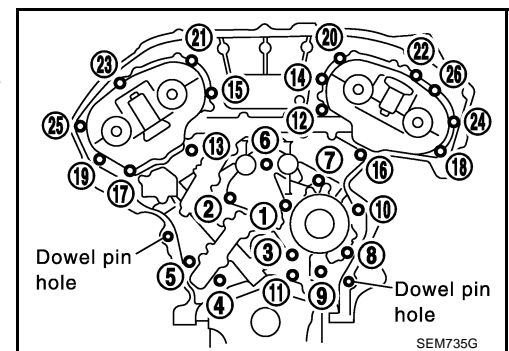

- f. After all bolts are tightened, retighten them to the specified torque in numerical order shown in the figure.
- If liquid gasket protrudes, wipe it off immediately.

# TIMING CHAIN

[VQ35DE]

- g. After installing rear timing chain case, check the surface height difference between the following parts on the oil pan (upper) mounting surface.

## Standard

### Rear timing chain case to cylinder block:

-0.24 to 0.14 mm (-0.0094 to 0.0055 in)

- If not within the standard, repeat the installation procedure.

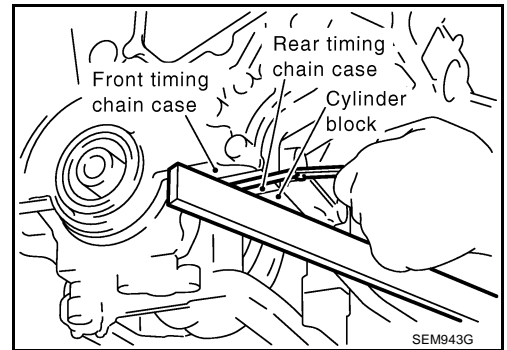

3. Install water pump with new O-rings. Refer to [CO-24, "WATER PUMP"](#) .

4. Make sure that dowel pin hole, dowel pin and crankshaft key are located as shown in the figure. (No. 1 cylinder at compression TDC)

## NOTE:

Though camshaft does not stop at the position as shown in the figure, for the placement of cam nose, it is generally accepted camshaft is placed for the same direction of the figure.

### Camshaft dowel pin hole (intake side)

: At cylinder head upper face side in each bank.

### Camshaft dowel pin (exhaust side)

: At cylinder head upper face side in each bank.

### Crankshaft key

: At cylinder head side of right bank.

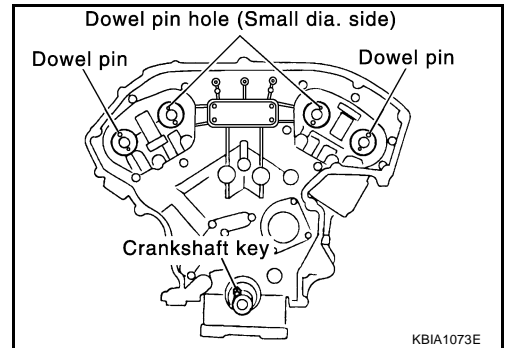

## CAUTION:

Hole on small dia. side must be used for intake side dowel pin hole. Do not misidentify (ignore big dia. side).

5. Install timing chains (secondary) and camshaft sprockets as follows:

## CAUTION:

Mating marks between timing chain and sprockets slip easily. Confirm all mating mark positions repeatedly during the installation process.

- a. Push plunger of timing chain tensioner (secondary) and keep it pressed in with a stopper pin.

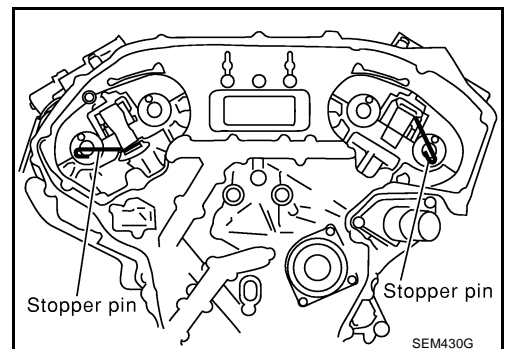

# TIMING CHAIN

[VQ35DE]

b. Install timing chains (secondary) and camshaft sprockets.

- Align the mating marks on timing chain (secondary) (gold link) with the ones on intake and exhaust camshaft sprockets (punched), and install them.

**NOTE:**

- Mating marks for intake camshaft sprocket are on the back side of camshaft sprocket (secondary).
- There are two types of mating marks, circle and oval types. They should be used for the right and left banks, respectively.

**Right bank : Use circle type.**

**Left bank : Use oval type.**

- Align dowel pin and pin hole on camshafts with the groove and dowel pin on sprockets, and install them.
- On the intake side, align pin hole on the small diameter side of the camshaft front end with dowel pin on the back side of camshaft sprocket, and install them.
- On the exhaust side, align dowel pin on camshaft front end with pin groove on camshaft sprocket, and install them.
- In case that positions of each mating mark and each dowel pin are not fit on mating parts, make fine adjustment to the position holding the hexagonal portion on camshaft with wrench or equivalent.
- Mounting bolts for camshaft sprockets must be tightened in the next step. Tightening them by hand is enough to prevent the dislocation of dowel pins.
- It may be difficult to visually check the dislocation of mating marks during and after installation. To make the matching easier, make a mating mark on the top of sprocket teeth and its extended line in advance with paint.

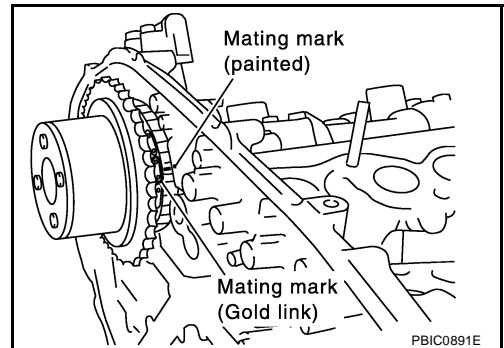
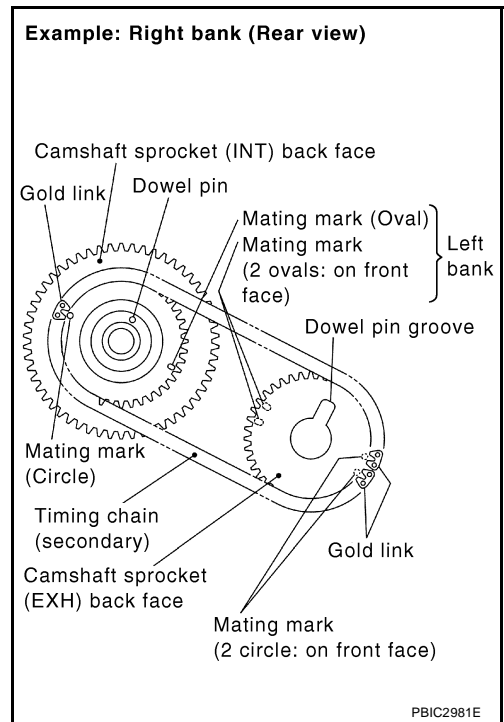

c. After confirming the mating marks are aligned, tighten camshaft sprocket mounting bolts.

- Secure camshaft using a wrench at the hexagonal portion to tighten mounting bolts.

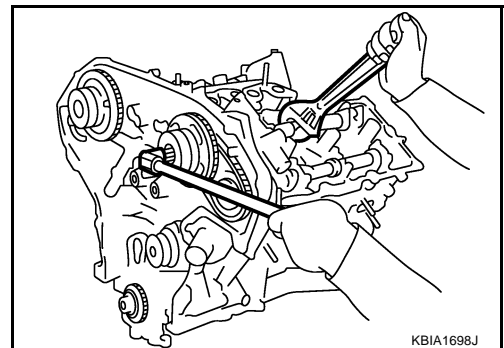



# TIMING CHAIN

[VQ35DE]

d. Pull stopper pins out from timing chain tensioners (secondary).

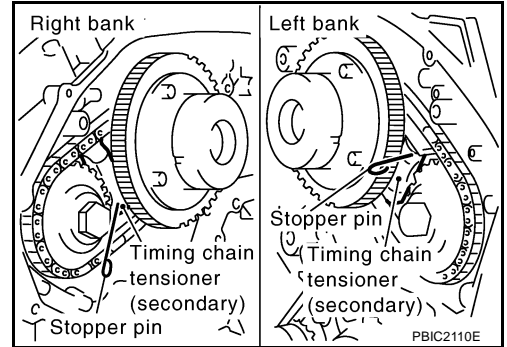

6. Install tension guide.

7. Install timing chain (primary) as follows:

a. Install crankshaft sprocket.

- Make sure the mating marks on crankshaft sprocket face the front of the engine.

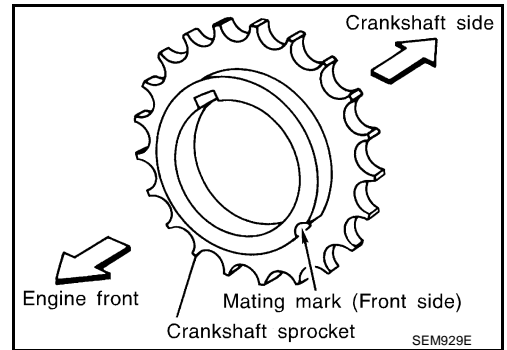

b. Install timing chain (primary).

- Install timing chain (primary) so the mating mark (punched) on camshaft sprocket is aligned with the pink link on timing chain, while the mating mark (notched) on crankshaft sprocket is aligned with the orange one on timing chain, as shown in the figure.
- When it is difficult to align mating marks of timing chain (primary) with each sprocket, gradually turn camshaft using wrench on the hexagonal portion to align it with the mating marks.
- During alignment, be careful to prevent dislocation of mating mark alignments of timing chains (secondary).

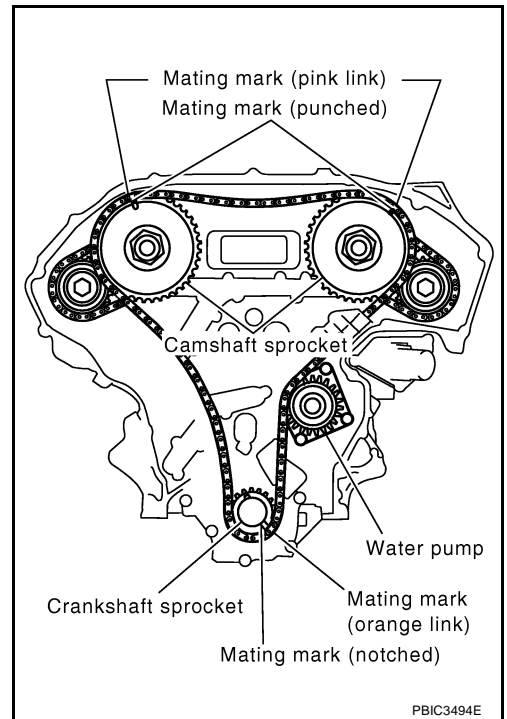

# TIMING CHAIN

[VQ35DE]

8. Install internal chain guide, slack guide and timing chain tensioner (primary).

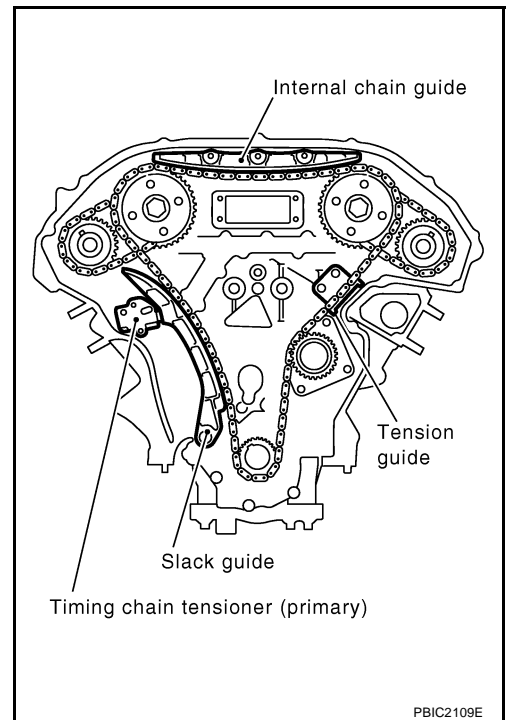

**CAUTION:**

Do not overtighten slack guide mounting bolts. It is normal for a gap to exist under the bolt seats when mounting bolts are tightened to the specification.

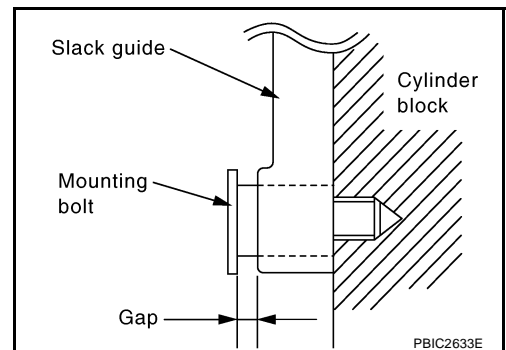

9. Install the timing chain tensioner (primary) with the following procedure:

- a. Pull plunger stopper tab up (or turn lever downward) so as to remove plunger stopper tab from the ratchet of plunger.

**NOTE:**

Plunger stopper tab and lever are synchronized.

- b. Push plunger into the inside of tensioner body.
- c. Hold plunger in the fully compressed position by engaging plunger stopper tab with the tip of ratchet.
- d. To secure lever, insert stopper pin through hole of lever into tensioner body hole.

- The lever parts and the tab are synchronized. Therefore, the plunger will be secured under this condition.

**NOTE:**

Figure shows the example of 1.2 mm (0.047 in) diameter thin screwdriver being used as the stopper pin.

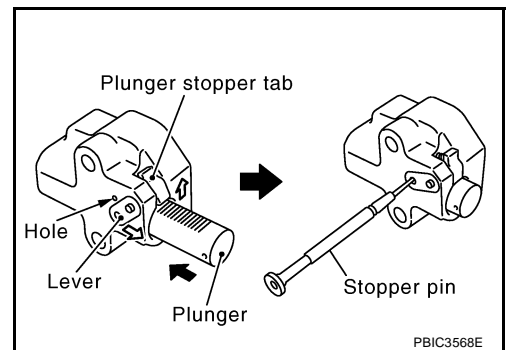

# TIMING CHAIN

[VQ35DE]

- e. Install timing chain tensioner (primary).
  - Remove any dirt and foreign materials completely from the back and the mounting surfaces of timing chain tensioner (primary).
- f. Pull out stopper pin after installing, and then release plunger.

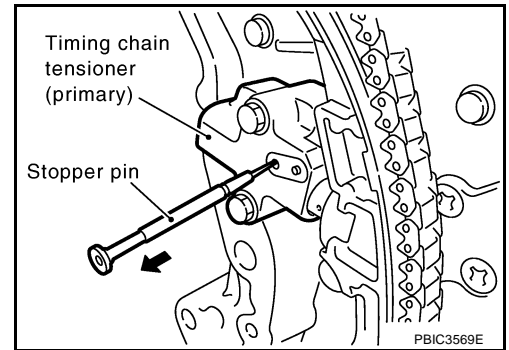

- 10. Make sure again that the mating marks on sprockets and timing chain have not slipped out of alignment.
- 11. Install new O-rings on rear timing chain case.

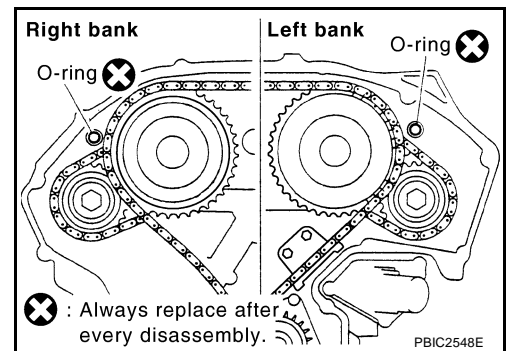

- 12. Install new front oil seal on front timing chain case.
  - Apply new engine oil to both oil seal lip and dust seal lip.
  - Install it so that each seal lip is oriented as shown in the figure.

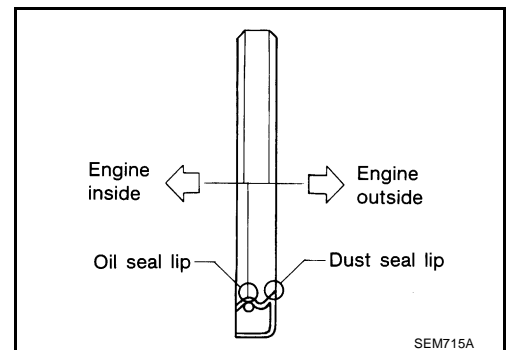

- Using a suitable drift [outer diameter: 60 mm (2.36 in)], press-fit oil seal until it becomes flush with front timing chain case end face.
- Make sure the garter spring is in position and seal lip is not inverted.

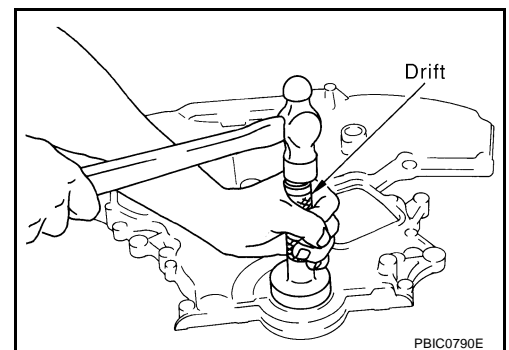

- 13. Install water pump cover and chain tensioner cover to front timing chain case.

# TIMING CHAIN

[VQ35DE]

- Apply a continuous bead of liquid gasket with the tube presser [SST: WS39930000 ( — )] to front timing chain case as shown in the figure.

**Use Genuine RTV Silicone Sealant or equivalent. Refer to [GI-48, "RECOMMENDED CHEMICAL PRODUCTS AND SEALANTS"](#) .**

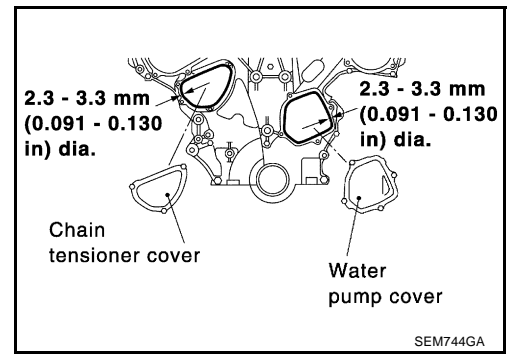

14. Install front timing chain case as follows:

- Apply a continuous bead of liquid gasket with the tube presser [SST: WS39930000 ( — )] to front timing chain case back side as shown in the figure.

**Use Genuine RTV Silicone Sealant or equivalent. Refer to [GI-48, "RECOMMENDED CHEMICAL PRODUCTS AND SEALANTS"](#) .**

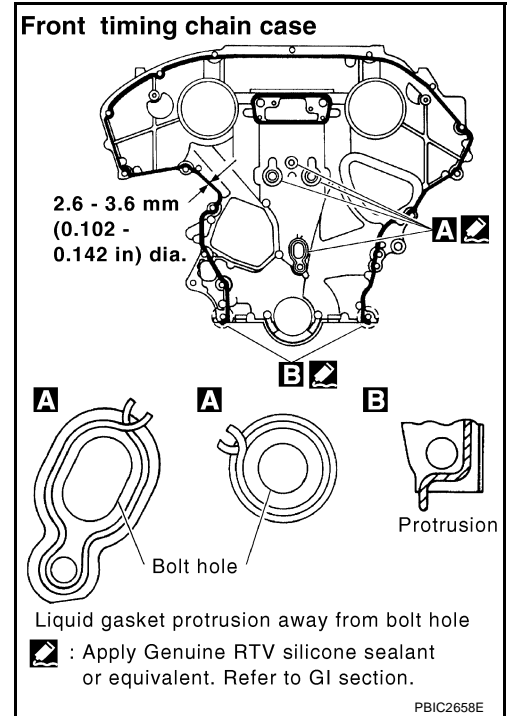

- Install front timing chain case as to fit its dowel pin hole together dowel pin on rear timing chain case.

- Tighten mounting bolts to the specified torque in numerical order as shown in the figure.

- There are two type of mounting bolts. Refer to the following for locating bolts.

**M8 bolts : 1, 2**

☐ : 28.4 N-m (2.9 kg-m, 21 ft-lb)

**M6 bolts : Except the above**

☐ : 12.7 N-m (1.3 kg-m, 9 ft-lb)

- After all bolts are tightened, retighten them to the specified torque in numerical order shown in the figure.

**CAUTION:**

**Be sure to wipe off any excessive liquid gasket leaking on surface mating with oil pan (upper).**

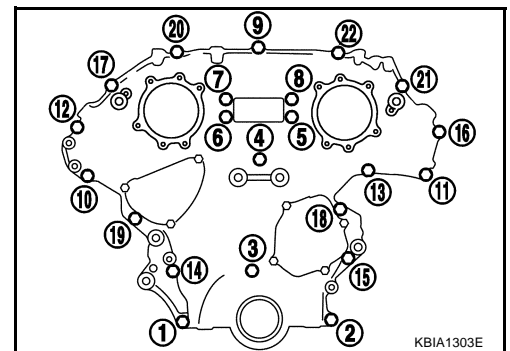

# TIMING CHAIN

[VQ35DE]

- e. After installing front timing chain case, check the surface height difference between the following parts on the oil pan (upper) mounting surface.

**Standard**

**Front timing chain case to rear timing chain case:  
-0.14 to 0.14 mm (-0.005 to 0.0055 in)**

- If not within the standard, repeat the installation procedure.

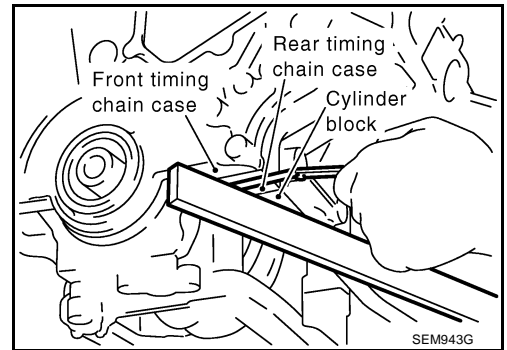

15. Install right and left intake valve timing control covers as follows:

- Install new seal rings in shaft grooves.
- Apply a continuous bead of liquid gasket with the tube presser [SST: WS39930000 ( — )] to intake valve timing control covers as shown in the figure.

**Use Genuine RTV Silicone Sealant or equivalent. Refer to [GI-48. "RECOMMENDED CHEMICAL PRODUCTS AND SEALANTS"](#).**

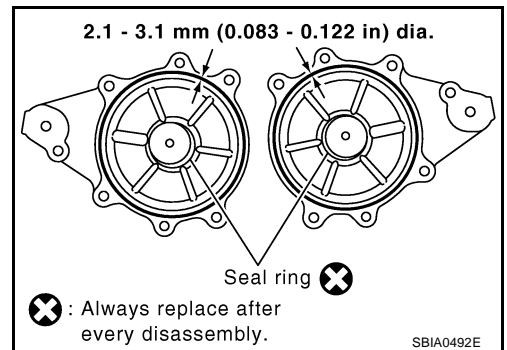

- Install new collared O-rings in front timing chain case oil hole (left and right sides).

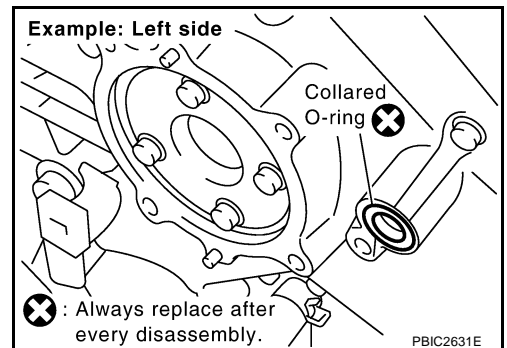

- Being careful not to move seal ring from the installation groove, align dowel pins on front timing chain case with holes to install intake valve timing control covers.

- Tighten mounting bolts in numerical order as shown in the figure.

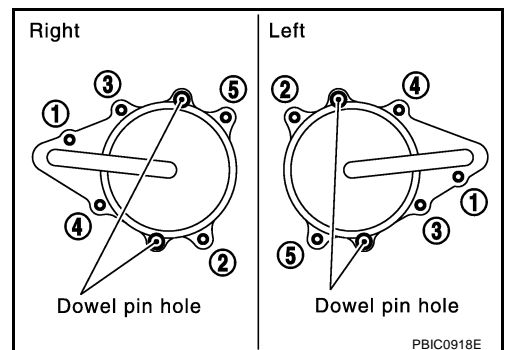

16. Install oil pans (upper and lower). Refer to [EM-29. "OIL PAN AND OIL STRAINER"](#).

17. Install rocker covers (right and left banks). Refer to [EM-51. "ROCKER COVER"](#).

18. Install crankshaft pulley as follows:

- Fix crankshaft using the ring gear stopper [SST: KV10117700 (J44716)].
- Install crankshaft pulley, taking care not to damage front oil seal.
  - When press-fitting crankshaft pulley with plastic hammer, tap on its center portion (not circumference).

A  
EM  
C  
D  
E  
F  
G  
H  
I  
J  
K  
L  
M

- c. Tighten crankshaft pulley bolt.

: 44.1 N-m (4.5 kg-m, 33 ft-lb)

- d. Place a matching mark (A) on crank pulley (1) aligning with the matching (B) of crank pulley mounting bolt (2). Tighten the bolts 90 degrees (one marks).

**NOTE:**

- The figure shows crankshaft pulley bolt with four marks.

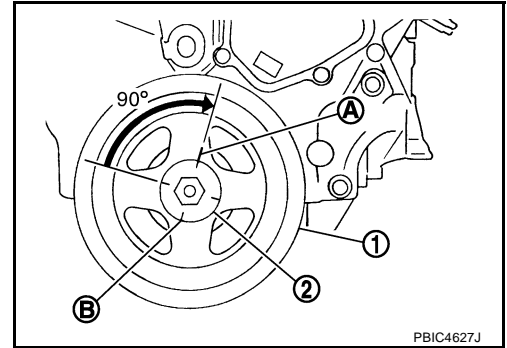

- Use an angle wrench (SST) for a crankshaft pulley bolt with six-marks.

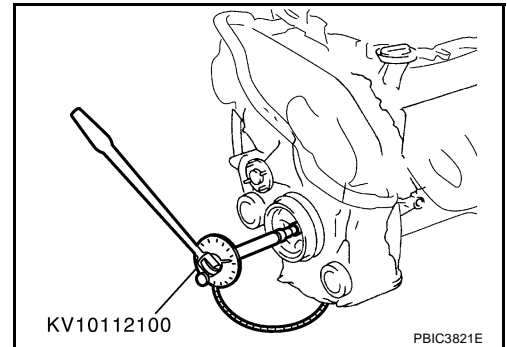

- e. Rotate crankshaft pulley in normal direction (clockwise when viewed from front) to confirm it turns smoothly.
19. For the following operations, perform steps in the reverse order of removal.

## INSPECTION AFTER INSTALLATION

### Inspection for Leaks

The following are procedures for checking fluids leak, lubricates leak.

- Before starting engine, check oil/fluid levels including engine coolant and engine oil. If less than required quantity, fill to the specified level. Refer to [MA-12, "RECOMMENDED FLUIDS AND LUBRICANTS"](#).
- Use procedure below to check for fuel leakage.
  - Turn ignition switch "ON" (with engine stopped). With fuel pressure applied to fuel piping, check for fuel leakage at connection points.
  - Start engine. With engine speed increased, check again for fuel leakage at connection points.
- Run engine to check for unusual noise and vibration.

**NOTE:**

If hydraulic pressure inside chain tensioner drops after removal/installation, slack in guide may generate a pounding noise during and just after the engine start. However, this does not indicate an unusualness. Noise will stop after hydraulic pressure rises.

- Warm up engine thoroughly to make sure there is no leakage of fuel, or any oil/fluids including engine oil and engine coolant.
- Bleed air from lines and hoses of applicable lines, such as in cooling system.
- After cooling down engine, again check oil/fluid levels including engine oil and engine coolant. Refill to the specified level, if necessary.

# TIMING CHAIN

[VQ35DE]

## Summary of the inspection items:

Item	Before starting engine	Engine running	After engine stopped
Engine coolant	Level	Leakage	Level
Engine oil	Level	Leakage	Level
Other oils and fluid*	Level	Leakage	Level
Fuel	Leakage	Leakage	Leakage

\* Transmission/transaxle/CVT fluid, power steering fluid, brake fluid, etc.

A

EM

C

D

E

F

G

H

I

J

K

L

M





## Removal and Installation

### REMOVAL

1. Remove front timing chain case, camshaft sprocket, timing chain and rear timing chain case. Refer to [EM-64, "TIMING CHAIN"](#).
2. Remove camshaft position sensor (PHASE) (bank 1 and bank 2) from cylinder head back side.

**CAUTION:**

- Handle carefully to avoid dropping and shocks.
- Do not disassemble.
- Do not allow metal powder to adhere to magnetic part at sensor tip.
- Do not place sensors in a location where they are exposed to magnetism.

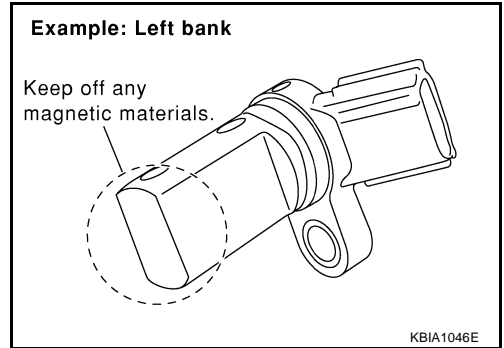

3. Remove intake valve timing control solenoid valves.
  - Discard intake valve timing control solenoid valve gaskets and use new gaskets for installation.

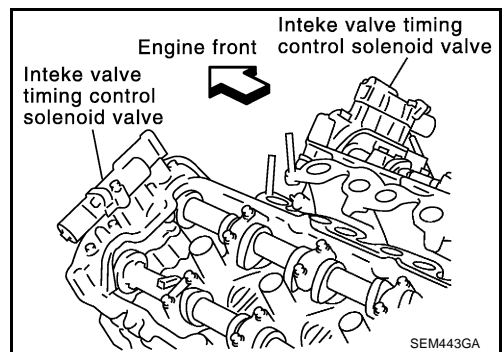

4. Remove camshaft brackets.
  - Mark camshafts, camshaft brackets and bolts so they are placed in the same position and direction for installation.
  - Equally loosen camshaft bracket bolts in several steps in reverse order as shown in the figure.

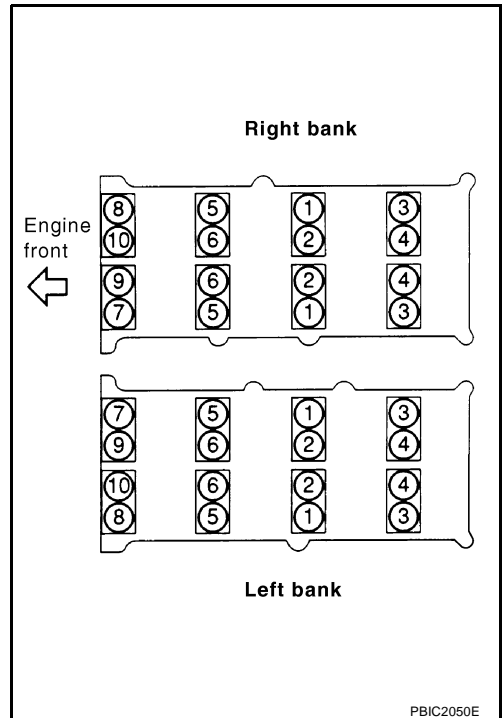

5. Remove camshaft.
6. Remove valve lifter.
  - Identify installation positions, and store them without mixing them up.

A  
EM  
C  
D  
E  
F  
G  
H  
I  
J  
K  
L  
M

# CAMSHAFT

[VQ35DE]

- Remove timing chain tensioner (secondary) from cylinder head.
  - Remove timing chain tensioner (secondary) with its stopper pin attached.

**NOTE:**

Stopper pin should be attached when timing chain (secondary) is removed.

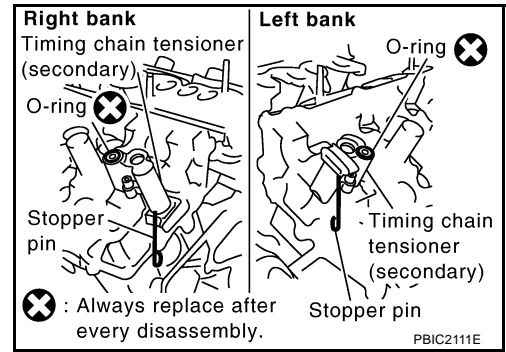

## INSPECTION AFTER REMOVAL

### Camshaft Runout

- Put V-block on precise flat table, and support No. 2 and 4 journals of camshaft.

**CAUTION:**

**Do not support No. 1 journal (on the side of camshaft sprocket) because it has a different diameter from the other three locations.**

- Set a dial indicator vertically to No. 3 journal.
- Turn camshaft to one direction with hands, and measure the camshaft runout on a dial indicator. (Total indicator reading)

**Standard** : Less than 0.02 mm (0.001 in)

**Limit** : 0.05 mm (0.002 in)

- If it exceeds the limit, replace camshaft.

### Camshaft Cam Height

- Measure the camshaft cam height with a micrometer.

**Standard cam height (intake and exhaust)**

**: 44.865 - 45.055 mm (1.7663 - 1.7738 in)**

**Cam wear limit**

**: 0.2 mm (0.0078 in)**

- If wear exceeds the limit, replace camshaft.

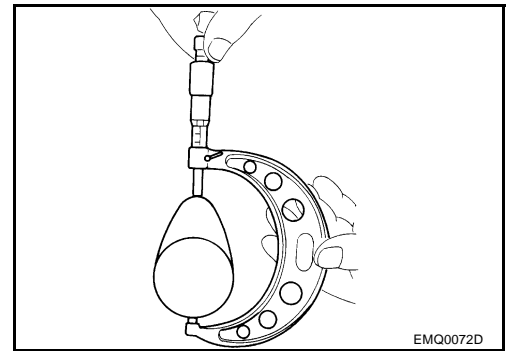
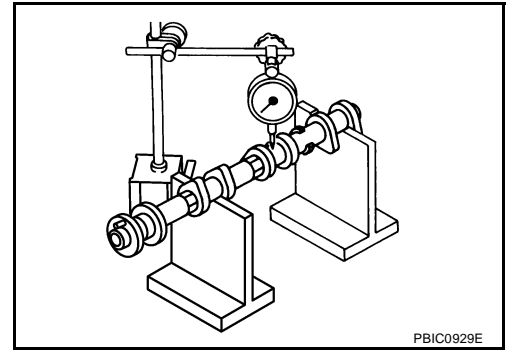

### Camshaft Journal Oil Clearance

#### CAMSHAFT JOURNAL DIAMETER

- Measure the outer diameter of camshaft journal with a micrometer.

**Standard:**

**No. 1** : 25.935 - 25.955 mm (1.0211 - 1.0218 in)

**No. 2, 3, 4** : 23.445 - 23.465 mm (0.9230 - 0.9238 in)

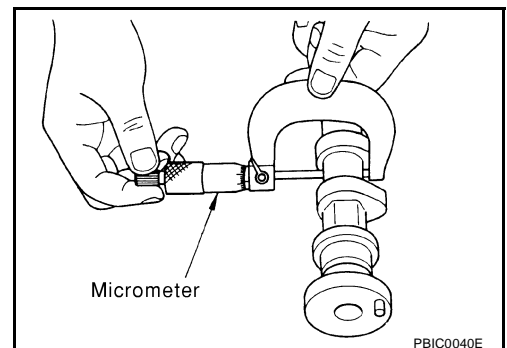

#### CAMSHAFT BRACKET INNER DIAMETER

- Tighten camshaft bracket bolt with the specified torque. Refer to [EM-89, "INSTALLATION"](#) for the tightening procedure.

# CAMSHAFT

[VQ35DE]

- Measure inner diameter "A" of camshaft bracket with a bore gauge.

**Standard:**

**No. 1 : 26.000 - 26.021 mm (1.0236 - 1.0244 in)**

**No. 2, 3, 4 : 23.500 - 23.521 mm (0.9252 - 0.9260 in)**

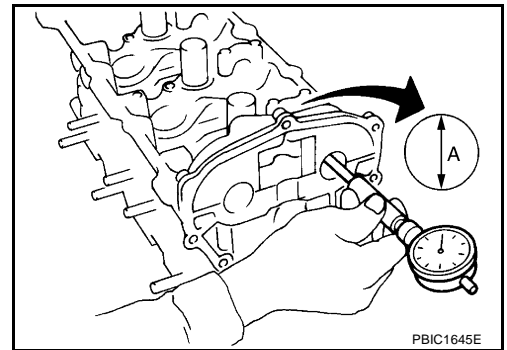

## CAMSHAFT JOURNAL OIL CLEARANCE

- (Oil clearance) = (Camshaft bracket inner diameter) – (Camshaft journal diameter).

**Standard:**

**No. 1 : 0.045 - 0.086 mm (0.0018 - 0.0034 in)**

**No. 2, 3, 4 : 0.035 - 0.076 mm (0.0014 - 0.0030 in)**

**Limit : 0.15 mm (0.0059 in)**

- If the calculated value exceeds the limit, replace either or both camshaft and cylinder head.

**NOTE:**

Camshaft brackets cannot be replaced as single parts, because there are machined together with cylinder head. Replace whole cylinder head assembly.

## Camshaft End Play

- Install a dial indicator in thrust direction on front end of camshaft. Measure the end play of a dial indicator when camshaft is moved forward/backward (in direction to axis).

**Standard : 0.115 - 0.188 mm (0.0045 - 0.0074 in)**

**Limit : 0.24 mm (0.0094 in)**

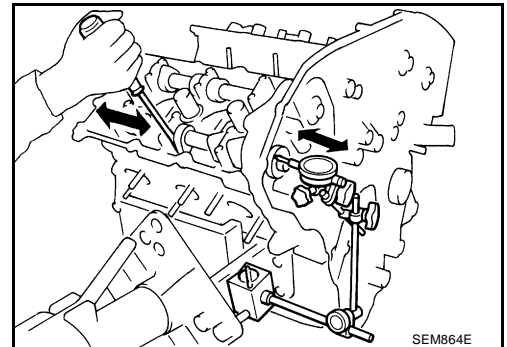

- Measure the following parts if out of the limit.

- Dimension "A" for camshaft No. 1 journal

**Standard : 27.500 - 27.548 mm (1.0827 - 1.0846 in)**

- Dimension "B" for cylinder head No. 1 journal bearing

**Standard : 27.360 - 27.385 mm (1.0772 - 1.0781 in)**

- Refer to the standards above, and then replace camshaft and/or cylinder head.

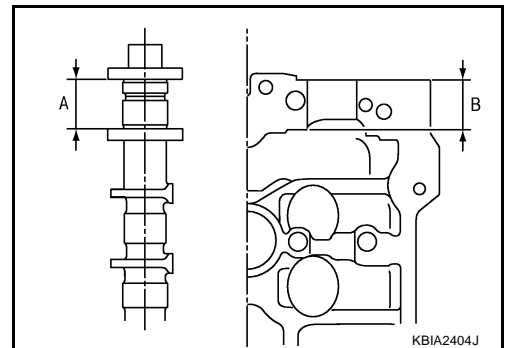

## Camshaft Sprocket Runout

1. Put V-block on precise flat table, and support No. 2 and 4 journals of camshaft.

**CAUTION:**

**Do not support No. 1 journal (on the side of camshaft sprocket) because it has a different diameter from the other three locations.**

# CAMSHAFT

[VQ35DE]

2. Measure the camshaft sprocket runout with a dial indicator.  
(Total indicator reading)

**Limit : 0.15 mm (0.0059 in)**

- If it exceeds the limit, replace camshaft sprocket.

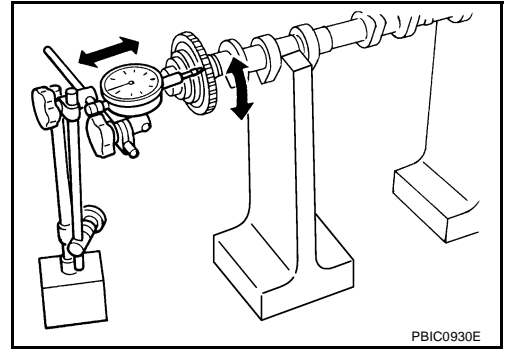

## Valve Lifter

Check if surface of valve lifter has any wear or cracks.

- If anything above is found, replace valve lifter. Refer to [EM-153](#), "[Available Valve Lifter](#)".

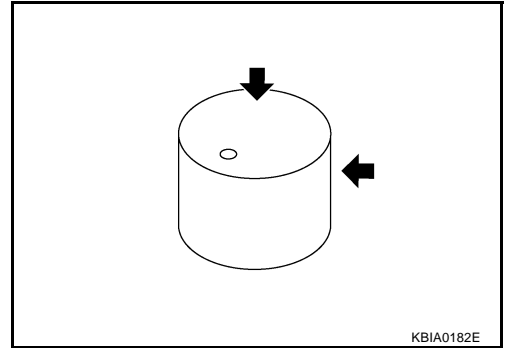

## Valve Lifter Clearance

### VALVE LIFTER OUTER DIAMETER

- Measure the outer diameter at 1/2 height of valve lifter with a micrometer since valve lifter is in barrel shape.

**Standard (Intake and exhaust)**

**: 33.977 - 33.987 mm (1.3377 - 1.3381 in)**

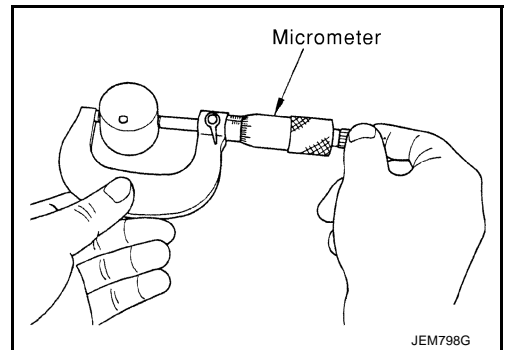

### VALVE LIFTER HOLE DIAMETER

- Measure the inner diameter of valve lifter hole of cylinder head with an inside micrometer.

**Standard (Intake and exhaust)**

**: 34.000 - 34.016 mm (1.3386 - 1.3392 in)**

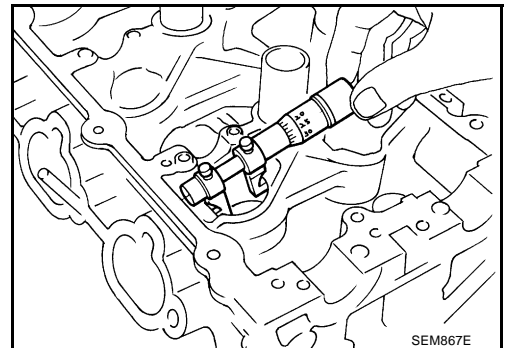

### VALVE LIFTER CLEARANCE

- (Valve lifter clearance) = (Valve lifter hole diameter) – (Valve lifter outer diameter)

**Standard (Intake and exhaust)**

**: 0.013 - 0.039 mm (0.0005 - 0.0015 in)**

- If the calculated value is out of the standard, referring to each standard of valve lifter outer diameter and valve lifter hole diameter, replace either or both valve lifter and cylinder head.

## INSTALLATION

1. Install timing chain tensioners (secondary) on both sides of cylinder head.
  - Install timing chain tensioner with its stopper pin attached.
  - Install timing chain tensioner with sliding part facing downward on right-side cylinder head, and with sliding part facing upward on left-side cylinder head.
  - Install new O-ring as shown in the figure.
  
2. Install valve lifter.
  - Install it in the original position.
3. Install camshafts.
  - Install camshaft with dowel pin attached to its front end face on the exhaust side.

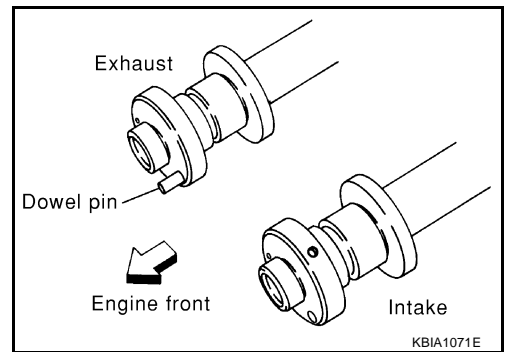
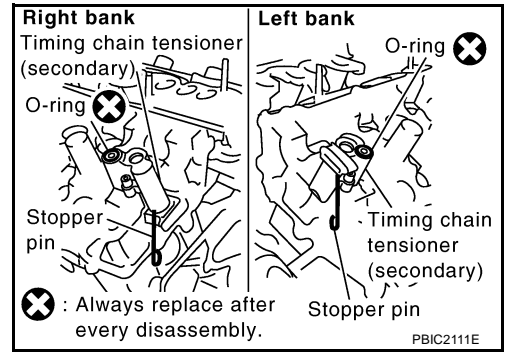

- Follow your identification marks made during removal, or follow the identification marks that are present on new camshafts for proper placement and direction.

Bank	INT/EXH	Dowel pin	Paint marks		Identification mark
			M1	M2	
RH	INT	No	Pink	No	RE
	EXH	Yes	No	Orange	RE
LH	INT	No	Pink	No	LH
	EXH	Yes	No	Orange	LH

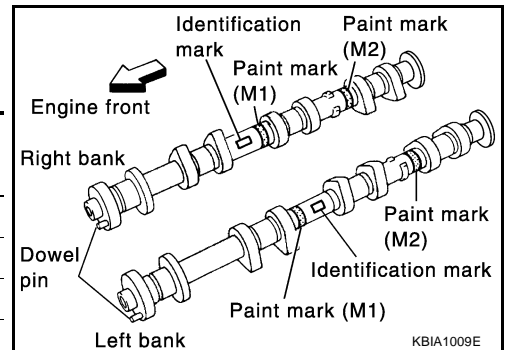

- Install camshaft so that dowel pin hole and dowel pin on front end face are positioned as shown in the figure. (No. 1 cylinder TDC on its compression stroke)

**NOTE:**

- Large and small pin holes are located on front end face of camshaft (INT), at intervals of 180 degrees. Face small dia. side pin hole upward (in cylinder head upper face direction).
- Though camshaft does not stop at the portion as shown in the figure, for the placement of cam nose, it is generally accepted camshaft is placed for the same direction of the figure.

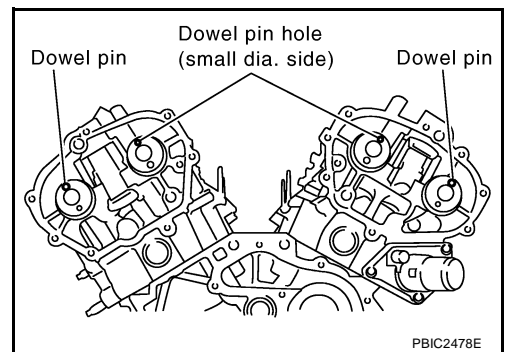

# CAMSHAFT

[VQ35DE]

## 4. Install camshaft brackets.

- Remove foreign material completely from camshaft bracket backside and from cylinder head installation face.
- Install camshaft bracket in original position and direction as shown in figure.

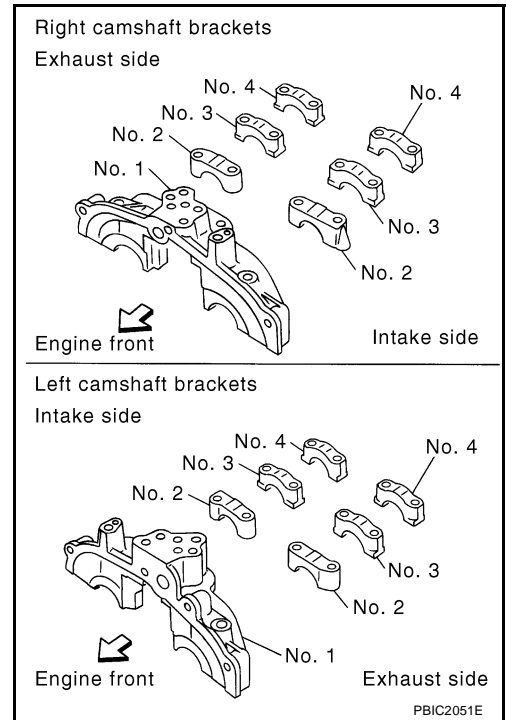

- Install camshaft brackets (No. 2 to 4) aligning the stamp marks as shown in the figure.

**NOTE:**

There are no identification marks indicating left and right for camshaft bracket (No. 1).

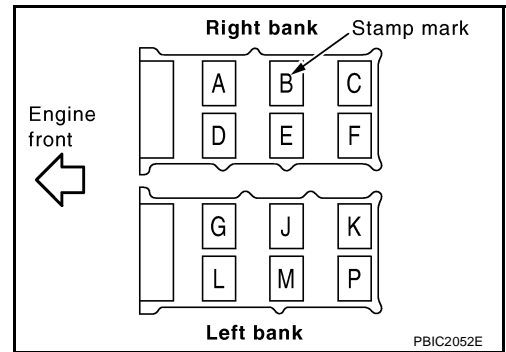

- Apply liquid gasket to mating surface of camshaft bracket (No. 1) as shown on both right and left banks.

**Use Genuine RTV Silicone Sealant or equivalent. Refer to [GI-48, "RECOMMENDED CHEMICAL PRODUCTS AND SEALANTS"](#).**

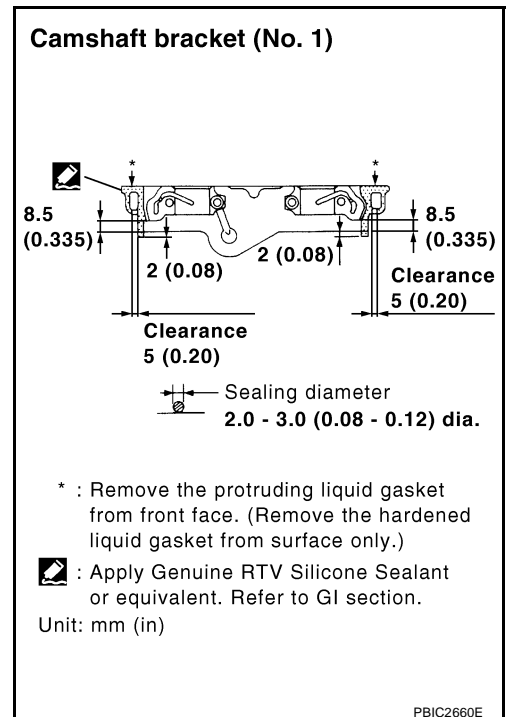

5. Tighten camshaft bracket bolts in the following steps, in numerical order as shown.

a. Tighten No. 7 to 10 in numerical order as shown.

 : 1.96 N·m (0.20 kg-m, 1 ft-lb)

b. Tighten No. 1 to 6 in numerical order as shown.

 : 1.96 N·m (0.20 kg-m, 1 ft-lb)

c. Tighten No. 1 to 10 in numerical order as shown.

 : 5.88 N·m (0.60 kg-m, 4 ft-lb)

d. Tighten No. 1 to 6 in numerical order as shown.

 : 10.4 N·m (1.1 kg-m, 8 ft-lb)

e. Tighten No. 7 to 10 in numerical order as shown.

 : 9.3 N·m (0.95 kg-m, 7 ft-lb)

**CAUTION:**

After tightening mounting bolts of camshaft brackets (No. 1), be sure to wipe off excessive liquid gasket from the parts list below.

- Mating surface of rocker cover
- Mating surface of rear timing chain case

6. Measure difference in levels between front end faces of camshaft bracket (No. 1) and cylinder head.

**Standard** : -0.14 to 0.14 mm (-0.0055 to 0.0055 in)

- Measure two positions (both intake and exhaust side) for a single bank.
- If the measured value is out of the standard, re-install camshaft bracket (No. 1).

7. Inspect and adjust the valve clearance. Refer to [EM-93, "Valve Clearance"](#).

8. Install in the reverse order of removal after this step.

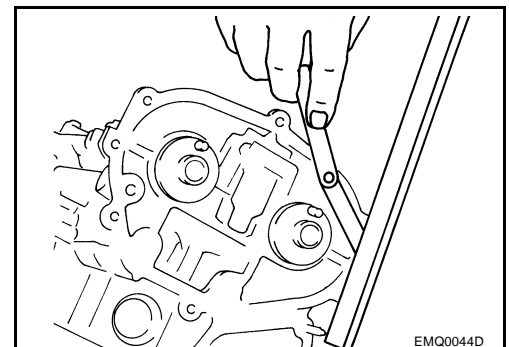
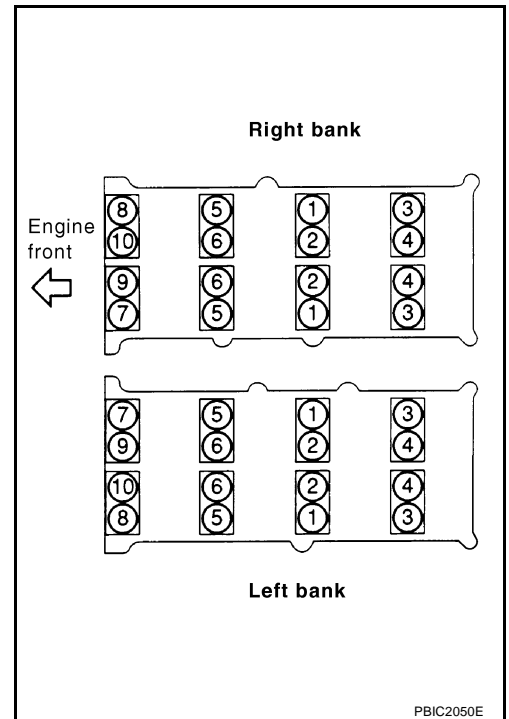

A  
EM  
C  
D  
E  
F  
G  
H  
I  
J  
K  
L  
M

**INSPECTION AFTER INSTALLATION****Inspection of Camshaft Sprocket (INT) Oil Groove****CAUTION:**

- Perform this inspection only when DTC P0011 or P0021 are detected in self-diagnostic results of CONSULT-II and it is directed according to inspection procedure of EC section. Refer to [EC-137, "SELF-DIAG RESULTS MODE"](#) .
- Check when engine ins cold so as to prevent burns from any splashing engine oil.
  1. Check the engine oil level. Refer to [LU-7, "ENGINE OIL"](#) .
  2. Perform the following procedure so as to prevent the engine from being unintentionally started while checking.
    - a. Release fuel pressure. Refer to [EC-98, "FUEL PRESSURE RELEASE"](#) .
    - b. Disconnect ignition coil and injector harness connectors.
  3. Remove intake valve timing control solenoid valve. Refer to [EM-84, "CAMSHAFT"](#) .
  4. Crank the engine, and then make sure that engine oil comes out from camshaft bracket (No. 1) oil hole. End crank after checking.

**WARNING:**

Be careful not to touch rotating parts (drive belts, idler pulley, and crankshaft pulley, etc.).

**CAUTION:**

Engine oil may squirt from intake valve timing control solenoid valve installation hole during cranking. Use a shop cloth to prevent the engine components and the vehicle. Do not allow engine oil to get on rubber components such as drive belt or engine mount insulators. Immediately wipe off any splashed engine oil.

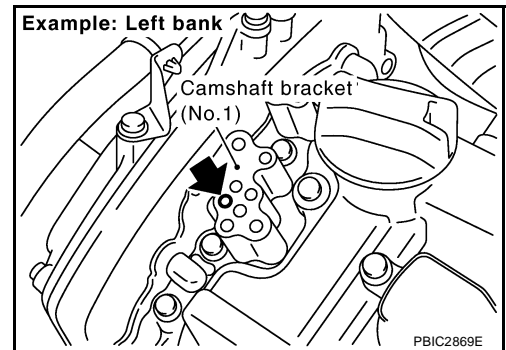

- Clean oil groove between oil strainer and intake valve timing control solenoid valve if engine oil does not come out from camshaft bracket (No. 1) oil hole. Refer to [LU-5, "LUBRICATION SYSTEM"](#) .
- 5. Remove components between intake valve timing control solenoid valve and camshaft sprocket (INT), and then check each oil groove for clogging.
  - Clean oil groove if necessary. Refer to [LU-5, "LUBRICATION SYSTEM"](#) .
- 6. After inspection, install removed parts.

**Inspection for Leaks**

The following are procedures for checking fluids leak, lubricates leak.

- Before starting engine, check oil/fluid levels including engine coolant and engine oil. If less than required quantity, fill to the specified level. Refer to [MA-12, "RECOMMENDED FLUIDS AND LUBRICANTS"](#) .
- Use procedure below to check for fuel leakage.
  - Turn ignition switch "ON" (with engine stopped). With fuel pressure applied to fuel piping, check for fuel leakage at connection points.
  - Start engine. With engine speed increased, check again for fuel leakage at connection points.
- Run engine to check for unusual noise and vibration.

**NOTE:**

If hydraulic pressure inside timing chain tensioner drops after removal/installation, slack in the guide may generate a pounding noise during and just after engine start. However, this is normal. Noise will stop after hydraulic pressure rises.

- Warm up engine thoroughly to make sure there is no leakage of fuel, or any oil/fluids including engine oil and engine coolant.
- Bleed air from lines and hoses of applicable lines, such as in cooling system.
- After cooling down engine, again check oil/fluid levels including engine oil and engine coolant. Refill to the specified level, if necessary.



**Summary of the inspection items:**

Item	Before starting engine	Engine running	After engine stopped
Engine coolant	Level	Leakage	Level
Engine oil	Level	Leakage	Level
Other oils and fluid*	Level	Leakage	Level
Fuel	Leakage	Leakage	Leakage

\* Transmission/transaxle/CVT fluid, power steering fluid, brake fluid, etc.

## Valve Clearance INSPECTION

NBS004NN

Perform inspection as follows after removal, installation or replacement of camshaft or valve-related parts, or if there is unusual engine conditions regarding valve clearance.

In cases of removing/installing or replacing camshaft and valve-related parts, or of unusual engine conditions due to changes in valve clearance (found malfunctions during starting, idling or causing noise), perform inspection as follows:

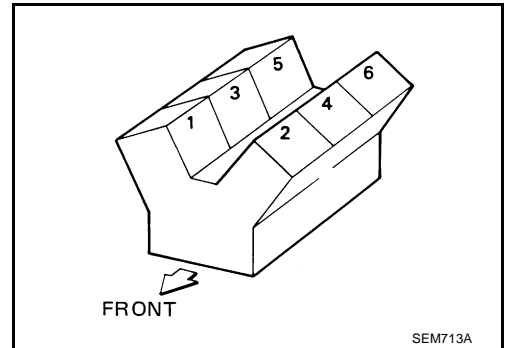

1. Remove rocker covers (right and left bank). Refer to [EM-51, "ROCKER COVER"](#).
2. Measure the valve clearance as follows:
  - a. Set No. 1 cylinder at TDC of its compression stroke.
    - Rotate crankshaft pulley clockwise to align timing mark (grooved line without color) with timing indicator.

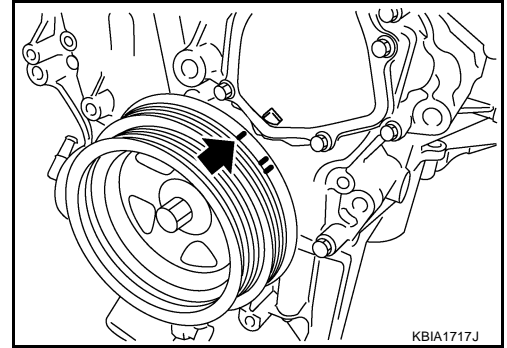

- Make sure that intake and exhaust cam nose on No. 1 cylinder (engine front side of right bank) are located as shown in the figure.
- If not, turn crankshaft one revolution (360 degrees) and align as shown in the figure.

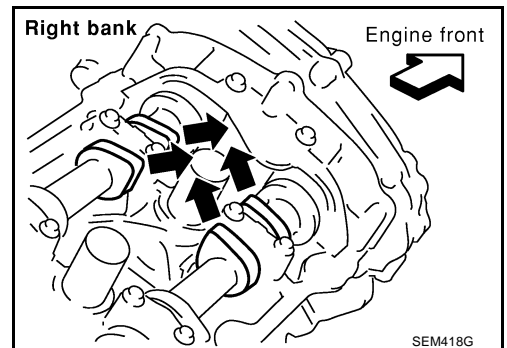

# CAMSHAFT

[VQ35DE]

- b. Use a feeler gauge, measure the clearance between valve lifter and camshaft.

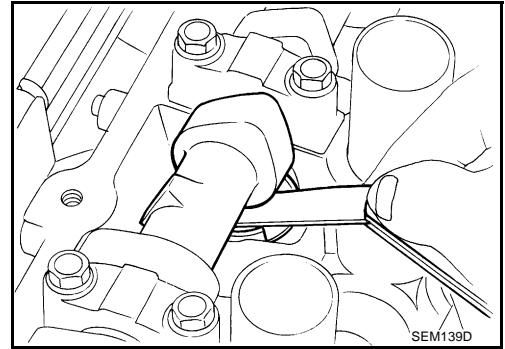

## Valve clearance:

Unit: mm (in)

Items	Cold	Hot * (reference data)
Intake	0.26 - 0.34 (0.010 - 0.013)	0.304 - 0.416 (0.012 - 0.016)
Exhaust	0.29 - 0.37 (0.011 - 0.015)	0.308 - 0.432 (0.012 - 0.016)

\*: Approximately 80°C (176°F)

- By referring to the figure, measure the valve clearances at locations marked "x" as shown in the table below (locations indicated in the figure).
- No. 1 cylinder at compression TDC

Measuring position (right bank)		No. 1 CYL.	No. 3 CYL.	No. 5 CYL.
No. 1 cylinder at compression TDC	EXH		x	
	INT	x		
Measuring position (left bank)		No. 2 CYL.	No. 4 CYL.	No. 6 CYL.
No. 1 cylinder at compression TDC	INT			x
	EXH	x		

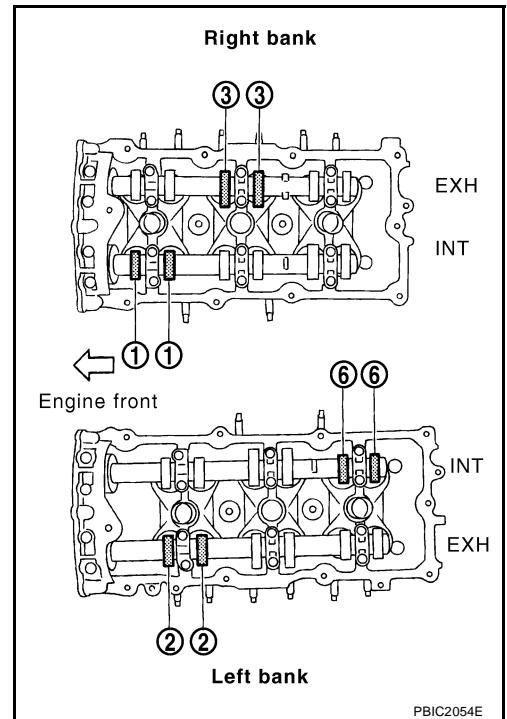

- c. Rotate crankshaft by 240 degrees clockwise (when viewed from engine front) to align No. 3 cylinder at TDC of its compression stroke.

## NOTE:

- To align cylinder No.3 with the compression top dead center, place matching marks (A) on the crank pulley (1) side and on the cylinder block side at a point 240°counterclockwise from the compression top dead center using the hex head of the crank pulley mounting bolt as a guide. (with crankshaft pulley bolt with four marks).

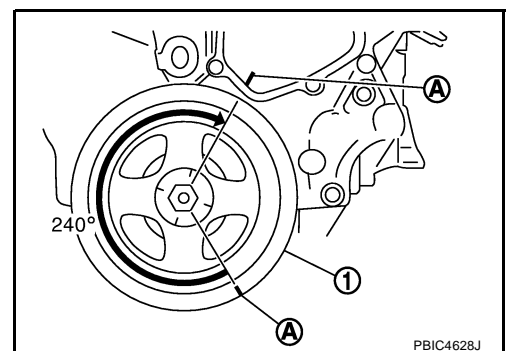

# CAMSHAFT

[VQ35DE]

- Crankshaft pulley mounting bolt flange has a stamped line every 60 degrees. They can be used as a guide to rotation angle. (with crankshaft pulley bolt with six-marks).

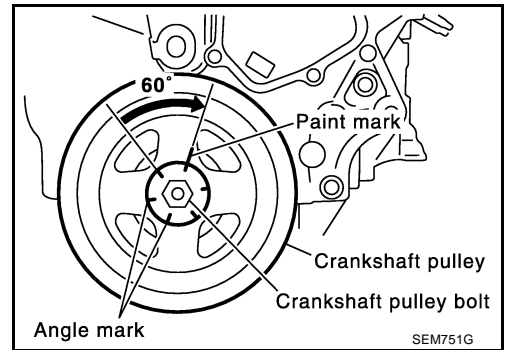

- By referring to the figure, measure the valve clearances at locations marked "x" as shown in the table below (locations indicated in the figure).
- No. 3 cylinder at compression TDC

Measuring position (right bank)		No. 1 CYL.	No. 3 CYL.	No. 5 CYL.
No. 3 cylinder at compression TDC	EXH			x
	INT		x	
Measuring position (left bank)		No. 2 CYL.	No. 4 CYL.	No. 6 CYL.
No. 3 cylinder at compression TDC	INT	x		
	EXH		x	

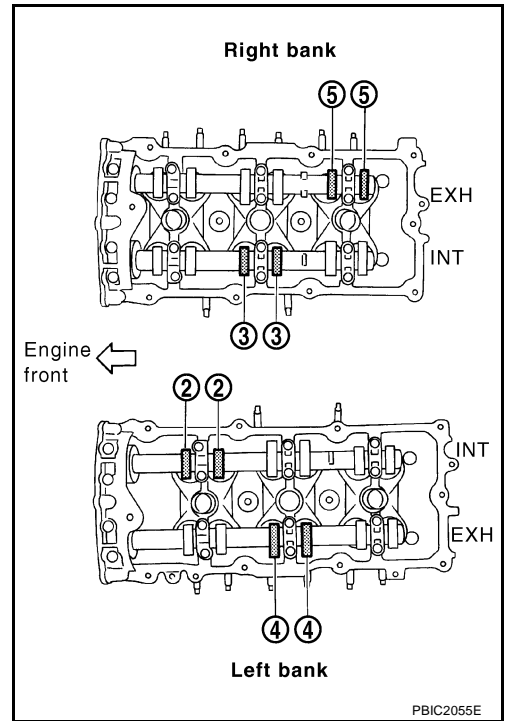

- d. Rotate crankshaft by 240 degrees clockwise (when viewed from engine front) to align No. 5 cylinder at TDC of compression stroke.

**NOTE:**

- To align cylinder No.5 with the compression top dead center, place matching marks (A) on the crank pulley (1) side and on the cylinder block side at a point 240°counterclockwise from the compression top dead center using the hex head of the crank pulley mounting bolt as a guide. (with crankshaft pulley bolt with four marks).

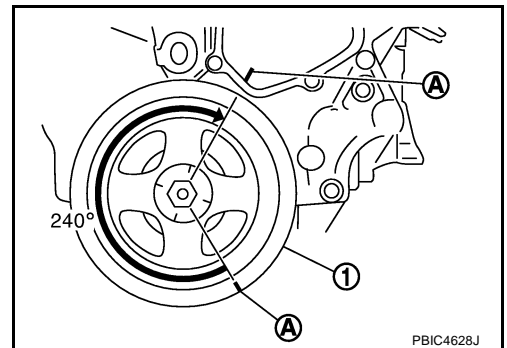

# CAMSHAFT

[VQ35DE]

- Crankshaft pulley mounting bolt flange has a stamped line every 60 degrees. They can be used as a guide to rotation angle. (with crankshaft pulley blot with six-marks).

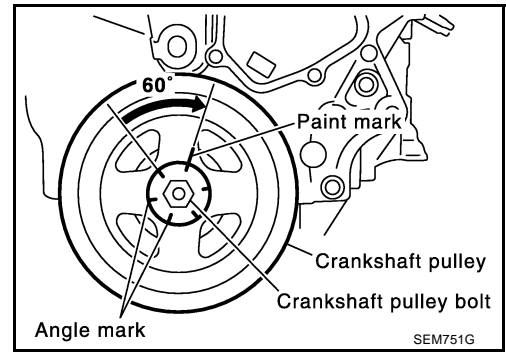

- By referring to the figure, measure the valve clearances at locations marked "x" as shown in the table below (locations indicated in the figure).
- No. 5 cylinder at compression TDC

Measuring position (right bank)		No. 1 CYL.	No. 3 CYL.	No. 5 CYL.
No. 5 cylinder at compression TDC	EXH	x		
	INT			x
Measuring position (left bank)		No. 2 CYL.	No. 4 CYL.	No. 6 CYL.
No. 5 cylinder at compression TDC	INT		x	
	EXH			x

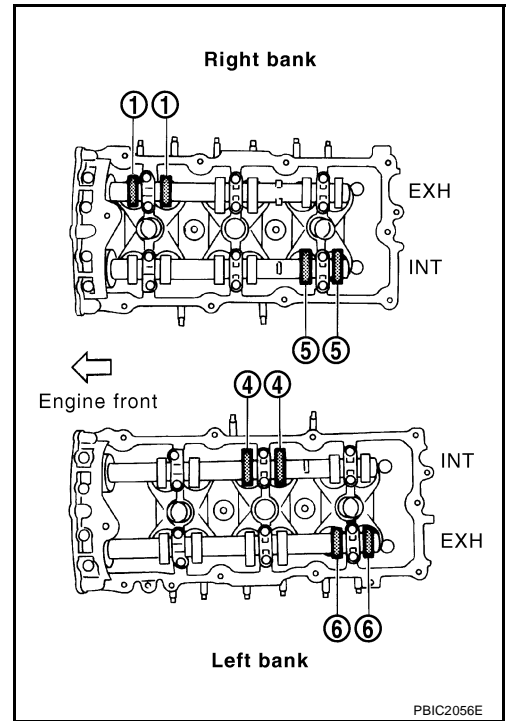

3. Perform adjustment if the measured value is out of the standard. Refer to [EM-96, "ADJUSTMENT"](#).

## ADJUSTMENT

- Perform adjustment depending on selected head thickness of valve lifter.
1. Measure the valve clearance. Refer to [EM-93, "INSPECTION"](#).
  2. Remove camshaft. Refer to [EM-85, "REMOVAL"](#).
  3. Remove valve lifters at the locations that are out of the standard.
  4. Measure the center thickness of the removed valve lifters with a micrometer.

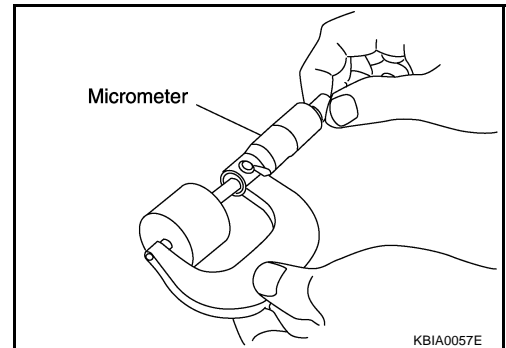

5. Use the equation below to calculate valve lifter thickness for replacement.

**Valve lifter thickness calculation:**  $t = t_1 + (C_1 - C_2)$   
 $t$  = Valve lifter thickness to be replaced

- t<sub>1</sub>** = Removed valve lifter thickness
- C<sub>1</sub>** = Measured valve clearance
- C<sub>2</sub>** = Standard valve clearance:
  - Intake : 0.30 mm (0.012 in)
  - Exhaust : 0.33 mm (0.013 in)

- Thickness of new valve lifter can be identified by stamp marks on the reverse side (inside the cylinder). Stamp mark 788U or 788R indicates 7.88 mm (0.3102 in) in thickness.

**NOTE:**

Two types of stamp marks are used for parallel setting and for manufacturer identification.

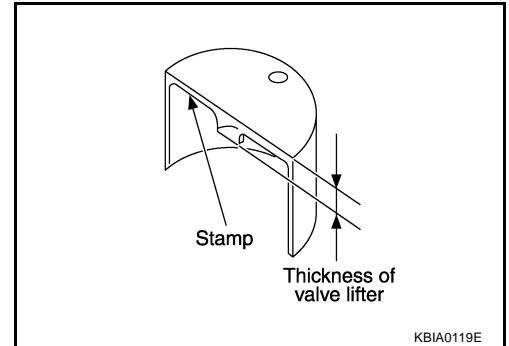

Available thickness of valve lifter: 27 sizes with range 7.88 to 8.40 mm (0.3102 to 0.3307 in) in steps of 0.02 mm (0.0008 in) (when manufactured at factory). Refer to [EM-153, "Available Valve Lifter"](#) .

6. Install selected valve lifter.
7. Install camshaft. Refer to [EM-89, "INSTALLATION"](#) .
8. Manually turn crankshaft pulley a few turns.
9. Make sure that the valve clearances for cold engine are within the specifications by referring to the specified values. Refer to [EM-93, "INSPECTION"](#) .
10. Install all removal parts in the reverse order of removal. Refer to [EM-89, "INSTALLATION"](#) .
11. Warm up the engine, and check for unusual noise and vibration.

## OIL SEAL

PFP:00100

### Removal and Installation of Valve Oil Seal REMOVAL

NBS004NO

1. Remove camshaft relating to valve oil seal to be removed. Refer to [EM-84, "CAMSHAFT"](#) .
2. Remove valve lifters. Refer to [EM-84, "CAMSHAFT"](#) .
3. Turn crankshaft until the cylinder requiring new oil seals is at TDC. This will prevent valve from dropping into cylinder.
4. Remove valve collet.

- Compress valve spring with the valve spring compressor, the attachment, the adapter (SST). Remove valve collet with a magnet hand.

**CAUTION:**

**When working, take care not to damage valve lifter holes.**

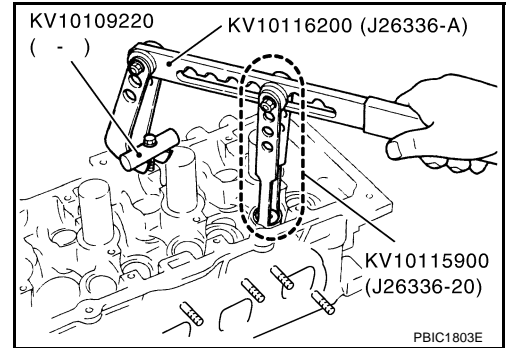

5. Remove valve spring retainer, and valve spring.
6. Remove valve oil seal using the valve oil seal puller (SST).

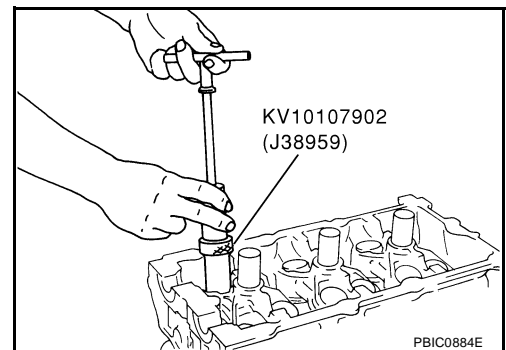

### INSTALLATION

1. Apply new engine oil on new valve oil seal joint and seal lip.
2. Using the valve oil seal drift (SST), press fit valve seal to height "H" shown in figure.

**NOTE:**

Dimension "H": Height measured before valve spring seat installation

**Intake and exhaust : 14.3 - 14.9 mm (0.563 - 0.587 in)**

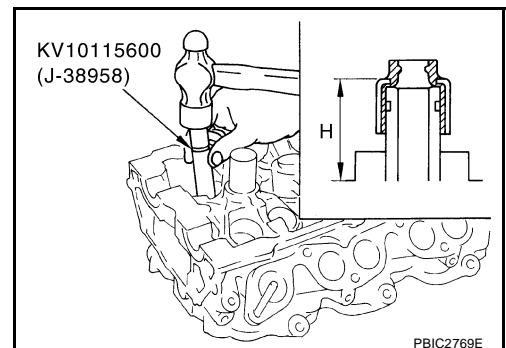

3. Install in the reverse order of removal after this step.

## Removal and Installation of Front Oil Seal

### REMOVAL

- Remove the following parts:
  - Front engine undercover (power tool)
  - Drive belts; Refer to [EM-15, "DRIVE BELTS"](#) .
  - Crankshaft pulley; Refer to [EM-64, "TIMING CHAIN"](#) .
- Remove front oil seal using a suitable tool.

#### CAUTION:

Be careful not to damage front timing chain case and crankshaft.

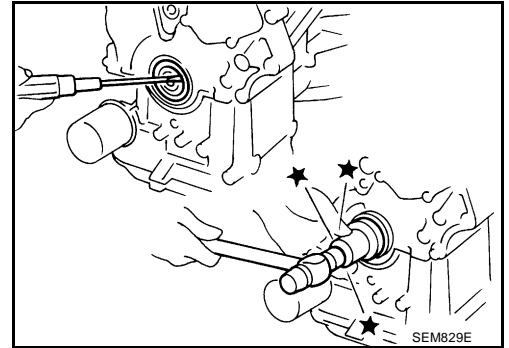

### INSTALLATION

- Apply new engine oil to both oil seal lip and dust seal lip of new front oil seal.
- Install front oil seal.
  - Install front oil seal so that each seal lip is oriented as shown in the figure.

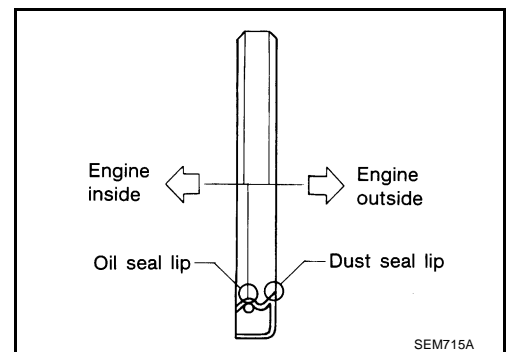

- Using a suitable drift, press-fit until the height of front oil seal is level with the mounting surface.
  - Suitable drift: outer diameter 60 mm (2.36 in), inner diameter 50 mm (1.97 in).
- Make sure the garter spring is in position and seal lips not inverted

#### CAUTION:

- Be careful not to damage front timing chain case and crankshaft.
- Press-fit straight and avoid causing burrs or tilting oil seal.

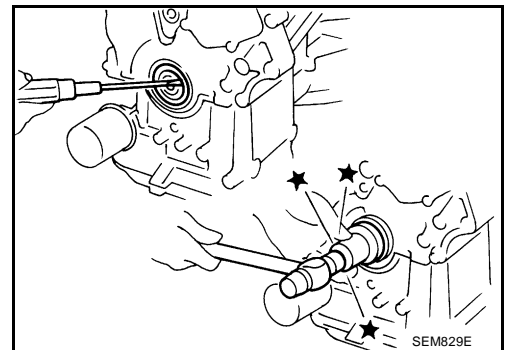

- Install in the reverse order of removal after this step.

## Removal and Installation of Rear Oil Seal

### REMOVAL

- Remove oil pan (upper). Refer to [EM-29, "OIL PAN AND OIL STRAINER"](#) .
- Remove transmission assembly. Refer to [AT-271, "TRANSMISSION ASSEMBLY"](#) .
- Remove drive plate. Refer to [EM-123, "CYLINDER BLOCK"](#) .

# OIL SEAL

[VQ35DE]

4. Use a seal cutter (SST) to cut away liquid gasket and remove rear oil seal retainer.

**CAUTION:**

**Be careful not to damage mounting surface.**

**NOTE:**

Regard both rear oil seal and retainer as an assembly.

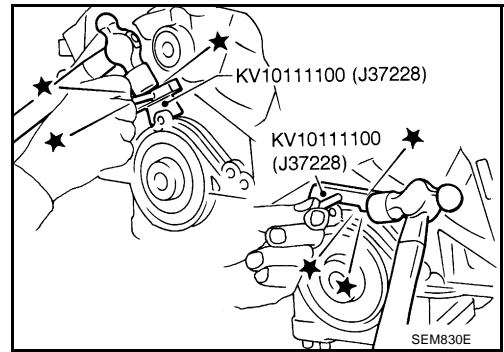

## INSTALLATION

1. Remove old liquid gasket on mating surfaces of cylinder block and oil pan (upper) using a scraper.
2. Apply new engine oil to both oil seal lip and dust seal lip of new rear oil seal retainer.
3. Apply a continuous bead of liquid gasket with the tube presser [SST: WS39930000 ( — )] to rear oil seal retainer as shown in the figure.

**Use Genuine RTV Silicone Sealant or equivalent. Refer to [GI-48, "RECOMMENDED CHEMICAL PRODUCTS AND SEALANTS"](#) .**

- Assembly should be done within 5 minutes after coating.

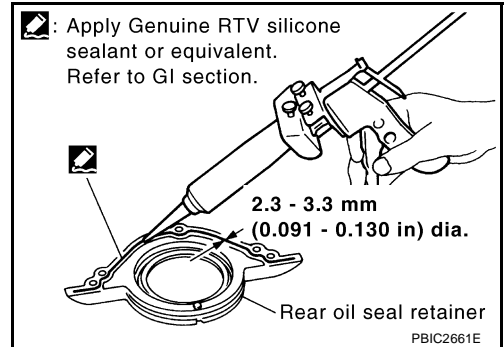

4. Install rear oil seal retainer to cylinder block. Refer to [EM-123, "CYLINDER BLOCK"](#) .
  - Make sure the garter spring is in position and seal lips not inverted.
5. Install in the reverse order of removal after this step.



## CYLINDER HEAD

PFP:11041

### On-Vehicle Service CHECKING COMPRESSION PRESSURE

NBS004NR

1. Warm up engine thoroughly. Then, stop it.
2. Release fuel pressure. Refer to [EC-98, "FUEL PRESSURE RELEASE"](#) .
3. Disconnect fuel pump fuse to avoid fuel injection during measurement.

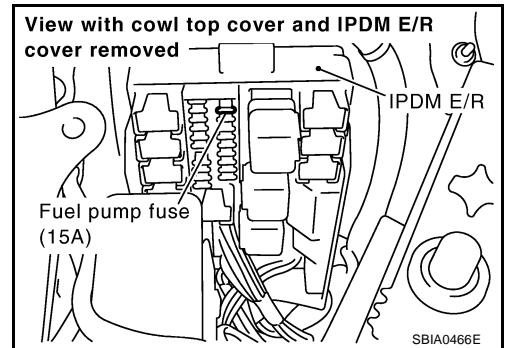

4. Remove engine cover with power tool. Refer to [EM-19, "INTAKE MANIFOLD COLLECTOR"](#) .
5. Remove ignition coil and spark plug from each cylinder. Refer to [EM-42, "IGNITION COIL"](#) and [EM-43, "SPARK PLUG \(PLATINUM-TIPPED TYPE\)"](#) .
6. Connect engine tachometer (not required in use of CONSULT-II).
7. Install compression gauge with an adapter (commercial service tool) onto spark plug hole.

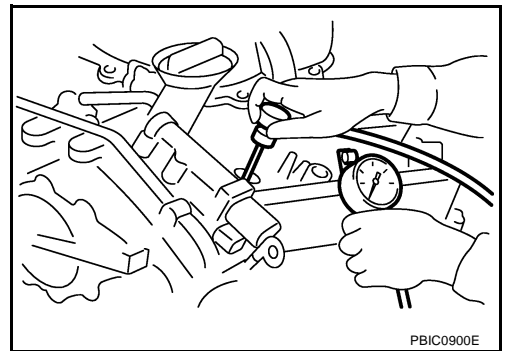

- Use the adapter whose picking up end inserted to spark plug hole is smaller than 20 mm (0.79 in) in diameter. Otherwise, it may be caught by cylinder head during removal.

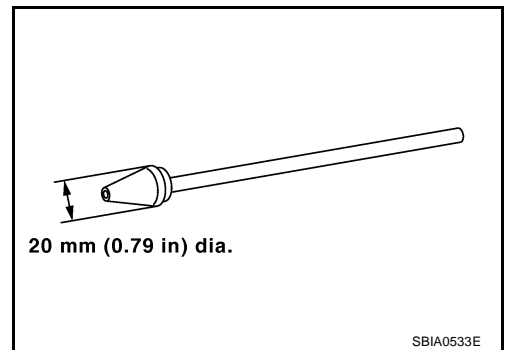

8. With accelerator pedal fully depressed, turn ignition switch to "START" for cranking. When the gauge pointer stabilizes, read the compression pressure and the engine rpm. Perform these steps to check each cylinder.

#### Compression pressure:

Unit: kPa (kg/cm<sup>2</sup>, psi) /rpm

Standard	Minimum	Deference limit between cylinders
1,275 (13.0, 185) / 300	981 (10.0, 142) / 300	98 (1.0, 14) / 300

#### CAUTION:

Always use a fully charged battery to obtain the specified engine speed.

# CYLINDER HEAD

[VQ35DE]

- If the engine speed is out of the specified range, check battery liquid for proper gravity. Check the engine speed again with normal battery gravity.
  - If compression pressure is below minimum value, check valve clearances and parts associated with combustion chamber (valve, valve seat, piston, piston ring, cylinder bore, cylinder head, cylinder head gasket). After the checking, measure compression pressure again.
  - If some cylinder has low compression pressure, pour small amount of engine oil into the spark plug hole of the cylinder to re-check it for compression.
    - If the added engine oil improves the compression, piston rings may be worn out or damaged. Check piston rings and replace if necessary.
    - If the compression pressure remains at low level despite the addition of engine oil, valves may be malfunctioning. Check valves for damage. Replace valve or valve seat accordingly.
  - If two adjacent cylinders have respectively low compression pressure and their compression remains low even after the addition of engine oil, cylinder head gaskets are leaking. In such a case, replace cylinder head gaskets.
9. After inspection is completed, install removed parts.
10. Start the engine, and make sure that the engine runs smoothly.
11. Perform trouble diagnosis. If DTC appears, erase it. Refer to [EC-100, "TROUBLE DIAGNOSIS"](#).

## Components

NBS004NS

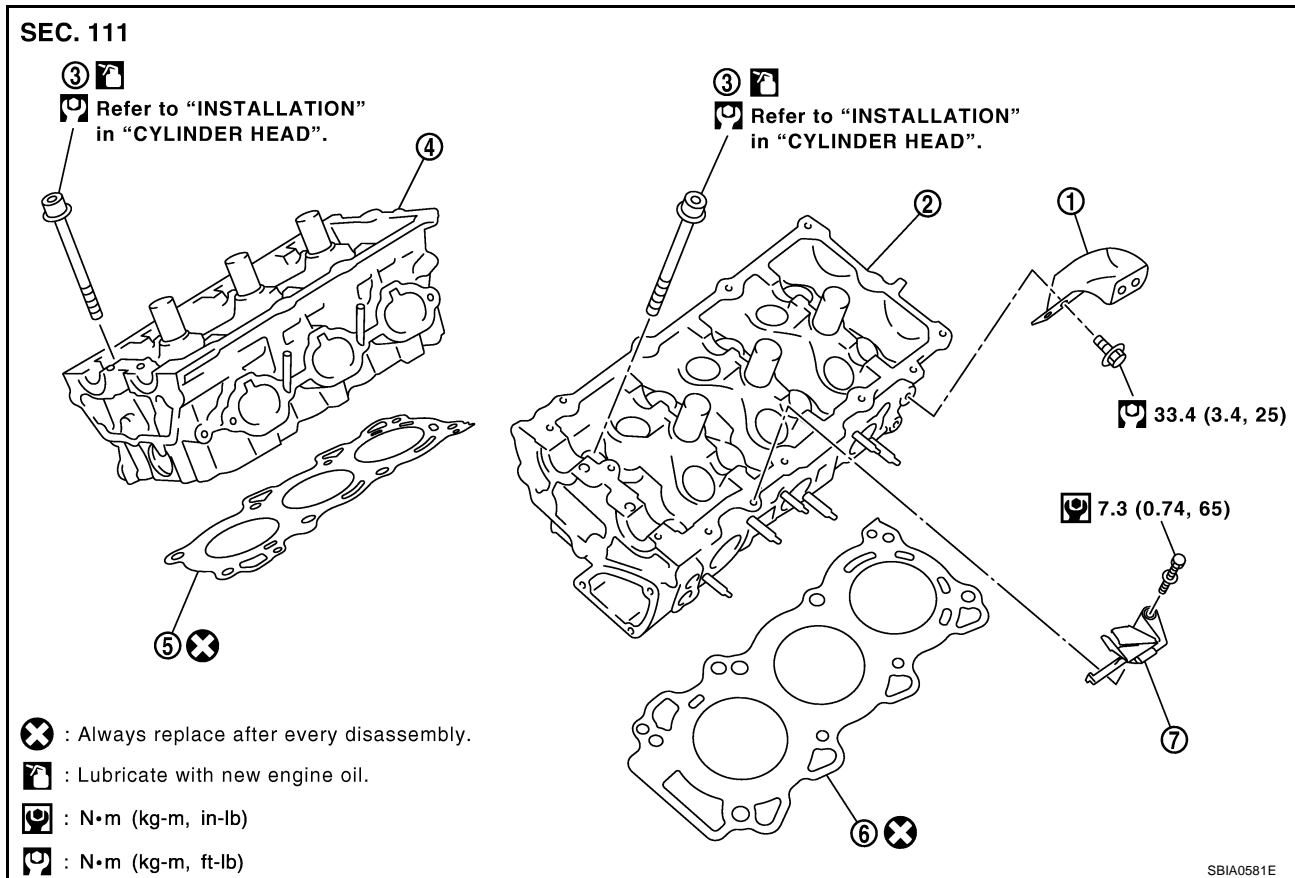

- |                               |                                      |                                     |
|-------------------------------|--------------------------------------|-------------------------------------|
| 1. Engine rear lower slinger  | 2. Cylinder head (left bank)         | 3. Cylinder head bolt               |
| 4. Cylinder head (right bank) | 5. Cylinder head gasket (right bank) | 6. Cylinder head gasket (left bank) |
| 7. Oil level gauge guide      |                                      |                                     |

## Removal and Installation

### REMOVAL

1. Remove camshaft. Refer to [EM-84, "CAMSHAFT"](#).

#### NOTE:

It is also possible to perform the following steps 2 and 3 just before removing camshaft.

NBS004NT

# CYLINDER HEAD

[VQ35DE]

- Temporarily fit front suspension member to support engine. Refer to [FSU-6, "FRONT SUSPENSION ASSEMBLY"](#) (2WD) or [FSU-23, "FRONT SUSPENSION ASSEMBLY"](#) (AWD).

## CAUTION:

Temporary fitting means the status that engine is adequately stable though the hoist is released from hanging.

## NOTE:

At the time of the start of this procedure front suspension member is removed, and cylinder head is hanged by hoist with the engine slinger installed.

- Release the hoist from hanging, then remove the engine slinger.
- Remove the following parts:
  - Fuel tube and fuel injector assembly; Refer to [EM-45, "FUEL INJECTOR AND FUEL TUBE"](#).
  - Intake manifold; Refer to [EM-24, "INTAKE MANIFOLD"](#).
  - Exhaust manifold; Refer to [EM-26, "EXHAUST MANIFOLD"](#).
  - Water inlet and thermostat assembly; Refer to [CO-29, "WATER INLET AND THERMOSTAT ASSEMBLY"](#).
  - Water outlet, water pipe and heater pipe; Refer to [CO-31, "WATER OUTLET AND WATER PIPING"](#).
- Remove cylinder head bolts in reverse order as shown in the figure with cylinder head bolt wrench (commercial service tool) and power tool to remove cylinder heads (right and left banks).

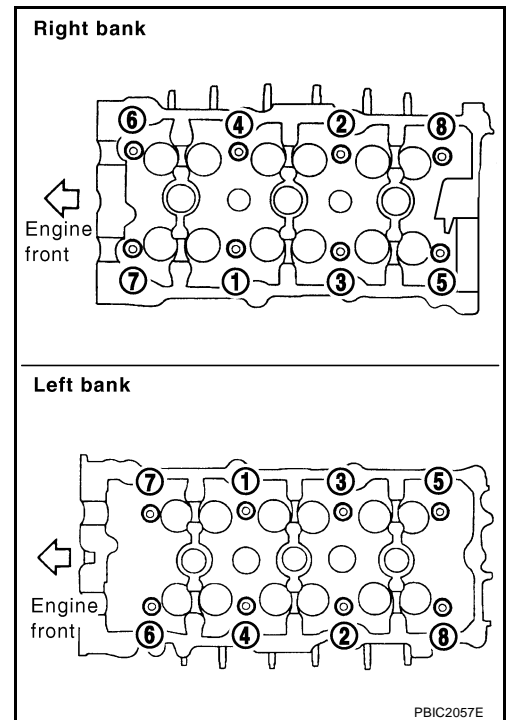

- Remove cylinder head gaskets.

## INSPECTION AFTER REMOVAL

### Cylinder Head Bolts Outer Diameter

- Cylinder head bolts are tightened by plastic zone tightening method. Whenever the size difference between "d1" and "d2" exceeds the limit, replace them with new one.

**Limit ("d1" – "d2") : 0.11 mm (0.0043 in)**

- If reduction of outer diameter appears in a position other than "d2", use it as "d2" point.

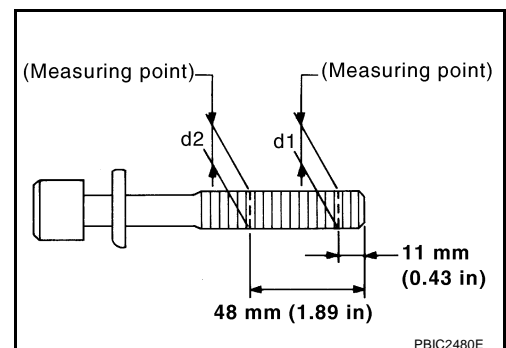

## Cylinder Head Distortion

### NOTE:

When performing this inspection, cylinder block distortion should be also checking. Refer to [EM-143, "CYLINDER BLOCK DISTORTION"](#) .

- Using a scraper, wipe off oil, scale, gasket, sealant and carbon deposits from surface of cylinder head.

### CAUTION:

**Do not allow gasket fragments to enter engine oil or engine coolant passages.**

- At each of several locations on bottom surface of cylinder head, measure the distortion in six directions.

**Limit : 0.1 mm (0.004 in)**

- If it exceeds the limit, replace cylinder head.

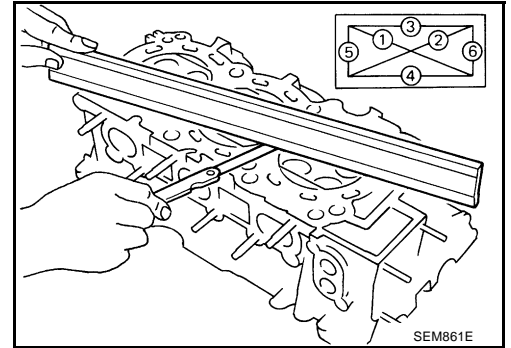

## INSTALLATION

- Install new cylinder head gaskets.
- Turn crankshaft until No. 1 piston is set at TDC.
  - Crankshaft key should line up with the right bank cylinder center line as shown in the figure.

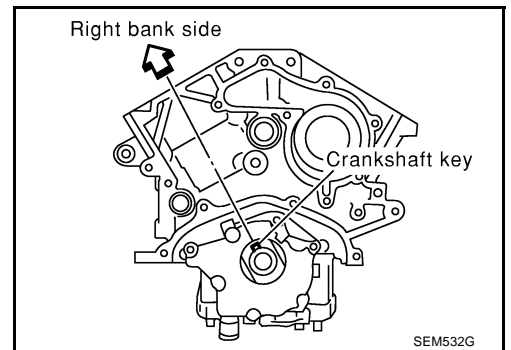

- Install cylinder head follow the steps below to tighten cylinder head bolts in numerical order as shown in the figure with cylinder head bolts wrench (commercial service tool).

### CAUTION:

**If cylinder head bolts re-used, check their outer diameters before installation. Refer to [EM-103, "Cylinder Head Bolts Outer Diameter"](#) .**

- Apply new engine oil to threads and seat surfaces of cylinder head bolts.
- Tighten all cylinder head bolts.

: **98.1 N·m (10 kg·m, 72 ft·lb)**

- Completely loosen all cylinder head bolts.

: **0 N·m (0 kg·m, 0 ft·lb)**

### CAUTION:

**In step "c", loosen bolts in reverse order of that indicated in the figure.**

- Tighten all cylinder head bolts.

: **39.2 N·m (4.0 kg·m, 29 ft·lb)**

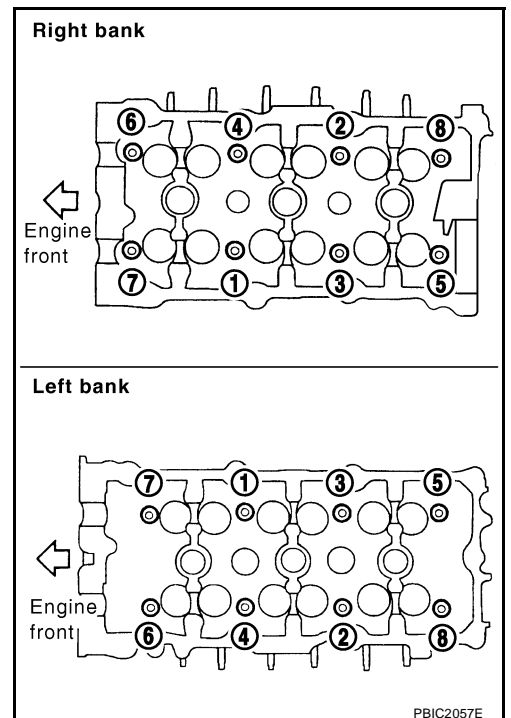

# CYLINDER HEAD

[VQ35DE]

- e. Turn all cylinder head bolts 90 degrees clockwise (angle tightening).
- CAUTION:**  
**Check the tightening angle by using the angle wrench (SST). Avoid judgment by visual inspection without SST.**
- Check tightening angle indicated on the angle wrench indicator plate.
- f. Turn all cylinder head bolts 90 degrees clockwise again (angle tightening).

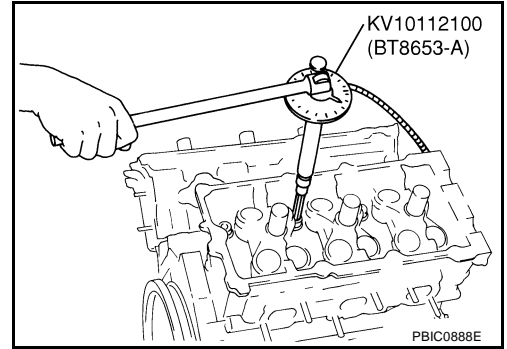

4. After installing cylinder head, measure distance between front end faces of cylinder block and cylinder head (left and right banks).
- Standard : 14.1 - 14.9 mm (0.555 - 0.587 in)**
- If measured value is out of the standard, re-install cylinder head.

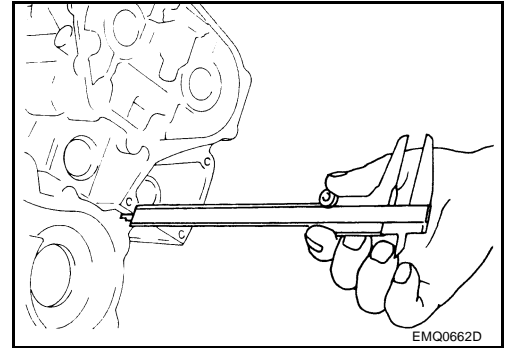

5. Install in the reverse order of removal after this step.

## INSPECTION AFTER INSTALLATION

### Inspection for Leaks

The following are procedures for checking fluids leak, lubricates leak and exhaust gases leak.

- Before starting engine, check oil/fluid levels including engine coolant and engine oil. If less than required quantity, fill to the specified level. Refer to [MA-12, "RECOMMENDED FLUIDS AND LUBRICANTS"](#).
- Use procedure below to check for fuel leakage.
  - Turn ignition switch "ON" (with engine stopped). With fuel pressure applied to fuel piping, check for fuel leakage at connection points.
  - Start engine. With engine speed increased, check again for fuel leakage at connection points.
- Run engine to check for unusual noise and vibration.
- Warm up engine thoroughly to make sure there is no leakage of fuel, exhaust gases, or any oil/fluids including engine oil and engine coolant.
- Bleed air from lines and hoses of applicable lines, such as in cooling system.
- After cooling down engine, again check oil/fluid levels including engine oil and engine coolant. Refill to the specified level, if necessary.

### Summary of the inspection items:

Item	Before starting engine	Engine running	After engine stopped
Engine coolant	Level	Leakage	Level
Engine oil	Level	Leakage	Level
Other oils and fluid*	Level	Leakage	Level
Fuel	Leakage	Leakage	Leakage
Exhaust gases	—	Leakage	—

\* Transmission/transaxle/CVT fluid, power steering fluid, brake fluid, etc.

## Disassembly and Assembly COMPONENTS

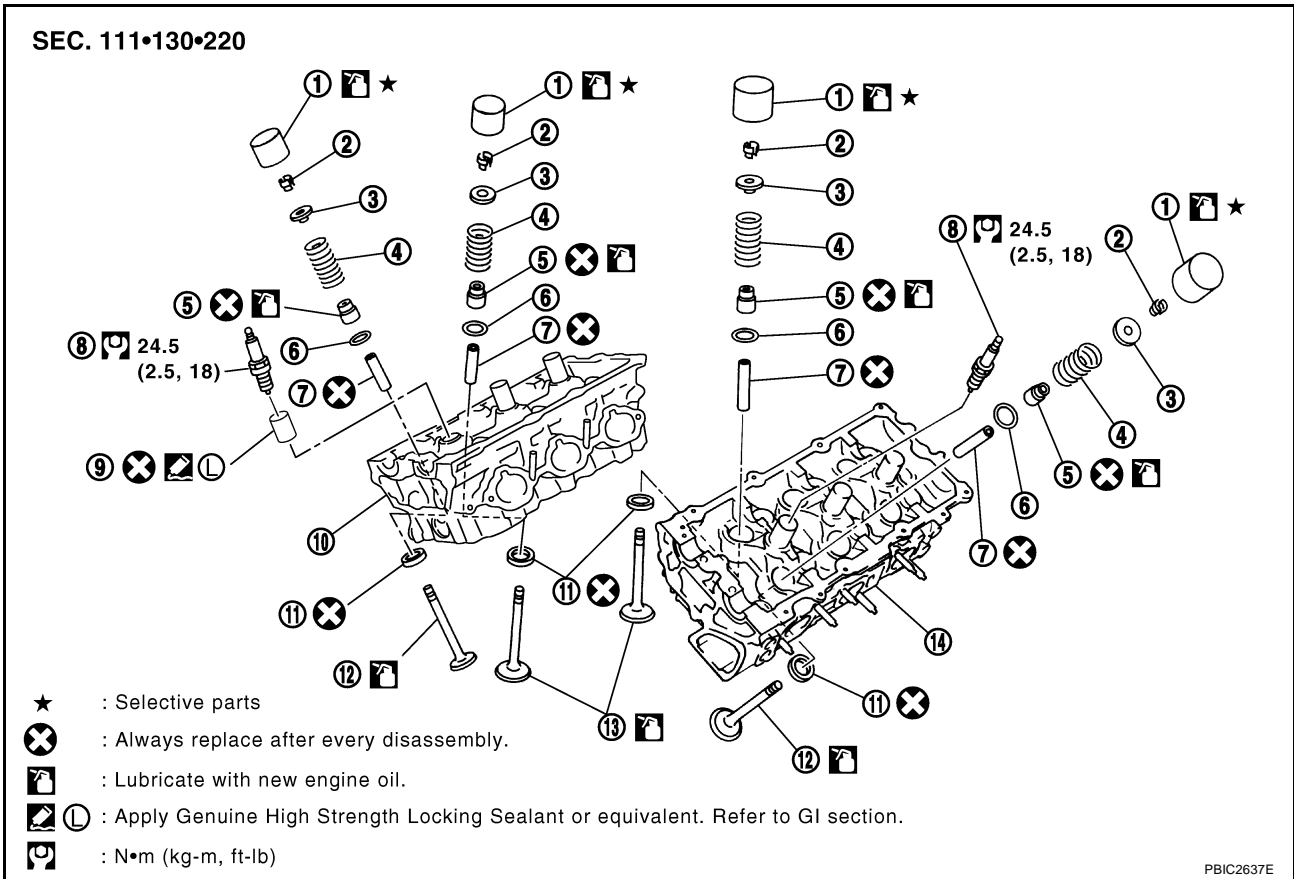

PBIC2637E

- |                                |                               |                          |
|--------------------------------|-------------------------------|--------------------------|
| 1. Valve lifter                | 2. Valve collet               | 3. Valve spring retainer |
| 4. Valve spring                | 5. Valve oil seal             | 6. Valve spring seat     |
| 7. Valve guide                 | 8. Spark plug                 | 9. Spark plug tube       |
| 10. Cylinder head (right bank) | 11. Valve seat                | 12. Valve (EXH)          |
| 13. Valve (INT)                | 14. Cylinder head (left bank) |                          |

### DISASSEMBLY

- Remove spark plug with spark plug wrench (commercial service tool).
- Remove valve lifter.
  - Identify installation positions, and store them without mixing them up.
- Remove valve collet.
  - Compress valve spring with the valve spring compressor, the attachment and the adapter (SST). Remove valve collet with a magnet hand.

**CAUTION:**

When working, take care not to damage valve lifter holes.

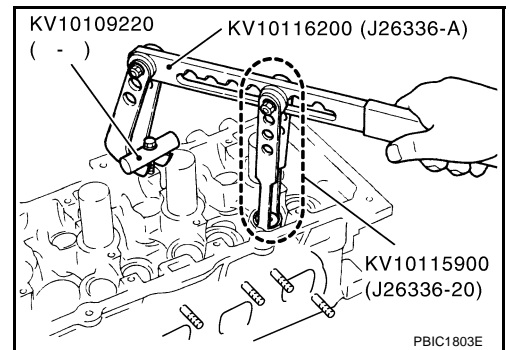

- Remove valve spring retainer, valve spring and valve spring seat.
- Push valve stem to combustion chamber side, and remove valve.
  - Identify installation positions, and store them without mixing them up.

# CYLINDER HEAD

[VQ35DE]

6. Remove valve oil seal using the valve oil seal puller (SST).

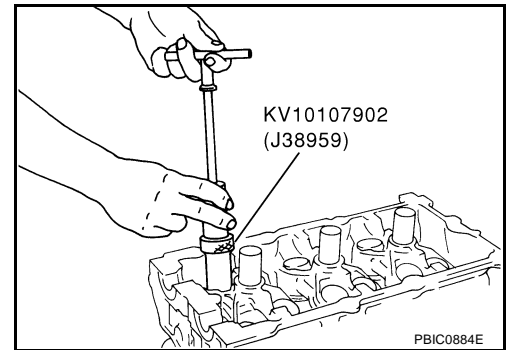

7. If valve seat must be replaced, refer to [EM-110, "VALVE SEAT REPLACEMENT"](#) .  
8. If valve guide must be replaced, refer to [EM-109, "VALVE GUIDE REPLACEMENT"](#) .  
9. Remove spark plug tube, as necessary.

- Using a pliers, pull spark plug tube out of cylinder head.

**CAUTION:**

- Take care not to damage cylinder head.
- Once removed, spark plug tube will be deformed and cannot be reused. Do not remove it unless absolutely necessary.

## ASSEMBLY

1. When valve guide is removed, install it. Refer to [EM-109, "VALVE GUIDE REPLACEMENT"](#) .  
2. When valve seat is removed, install it. Refer to [EM-110, "VALVE SEAT REPLACEMENT"](#) .  
3. Install new valve oil seals as follows:  
a. Apply new engine oil on valve oil seal joint and seal lip.  
b. Install with the valve oil seal drift (SST) to match dimension in the figure.

**Height "H" (Without valve spring seat installed)**

**Intake and exhaust : 14.3 - 14.9 mm (0.563 - 0.587 in)**

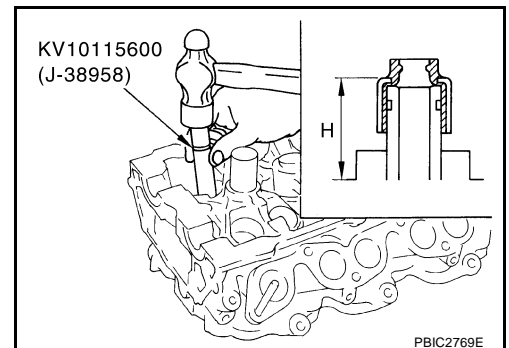

4. Install valve spring seat.  
5. Install valve.  
● Larger diameter valves are for intake side.

**NOTE:**

Larger diameter valves are for intake side.

6. Install valve spring (uneven pitch type).  
● Install narrow pitch end (paint mark) to cylinder head side (valve spring seat side).

**Paint mark collar**

**: Blue**

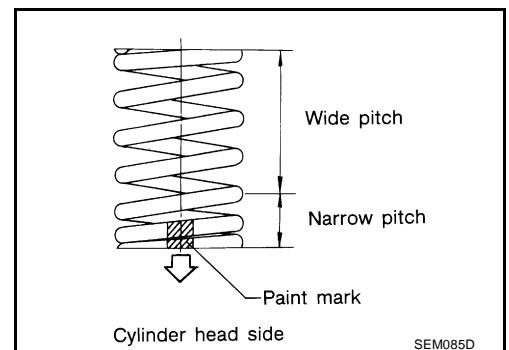

7. Install valve spring retainer.



# CYLINDER HEAD

[VQ35DE]

## 8. Install valve collet.

- Compress valve spring with the valve spring compressor, the attachment and the adapter (SST). Install valve collet with a magnet hand.

### CAUTION:

**When working, take care not to damage valve lifter holes.**

- Tap valve stem edge lightly with plastic hammer after installation to check its installed condition.

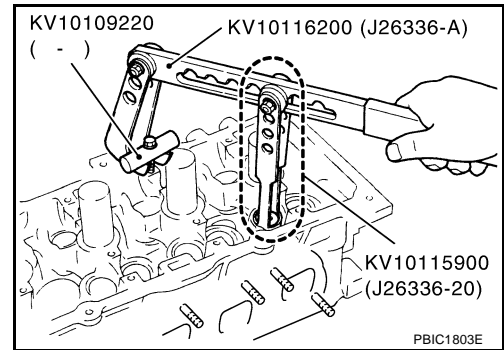

## 9. Install valve lifter.

- Install it in the original position.

## 10. Install spark plug tube.

- Press-fit spark plug tube as follows:

a. Remove old locking sealant adhering to cylinder head mounting hole.

b. Apply sealant to area within approximately 12 mm (0.47 in) from edge of spark plug tube press-fit side.

**Use Genuine High Strength Locking Sealant or equivalent. Refer to [GI-48](#), "RECOMMENDED CHEMICAL PRODUCTS AND SEALANTS".**

c. Using drift, press-fit spark plug tube so that its height "H" is as specified in the figure.

**Standard press-fit height "H":**

**: 38.1 - 39.1 mm (1.500 - 1.539 in)**

### CAUTION:

- **When press-fitting, take care not to deform spark plug tube.**
- **After press-fitting, wipe off liquid gasket protruding onto cylinder-head upper face.**

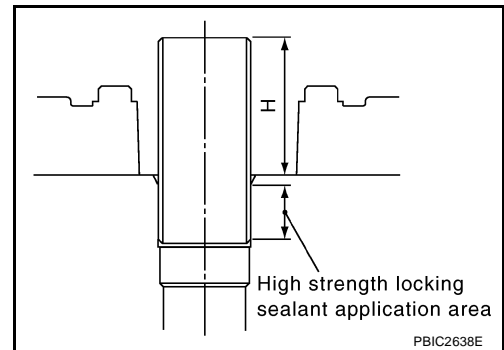

11. Install spark plug with spark plug wrench (commercial service tool).

## Inspection after Disassembly VALVE DIMENSIONS

NBS004NV

- Check the dimensions of each valve. For the dimensions, refer to [EM-154](#), "Valve Dimensions".
- If dimensions are out of the standard, replace valve and check valve seat contact. Refer to [EM-110](#), "VALVE SEAT CONTACT".

## VALVE GUIDE CLEARANCE

### Valve Stem Diameter

Measure the diameter of valve stem with micrometer.

#### Standard

**Intake : 5.965 - 5.980 mm (0.2348 - 0.2354 in)**

**Exhaust : 5.955 - 5.970 mm (0.2344 - 0.2350 in)**

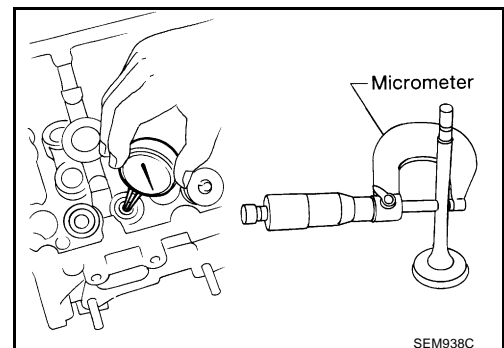

### Valve Guide Inner Diameter

Measure the inner diameter of valve guide with bore gauge.



## Standard

Intake and Exhaust : 6.000 - 6.018 mm (0.2362 - 0.2369 in)

## Valve Guide Clearance

(Valve guide clearance) = (Valve guide inner diameter) – (Valve stem diameter)

### Valve guide clearance:

#### Standard

Intake : 0.020 - 0.053 mm (0.0008 - 0.0021 in)

Exhaust : 0.030 - 0.063 mm (0.0012 - 0.0025 in)

#### Limit

Intake : 0.08 mm (0.003 in)

Exhaust : 0.10 mm (0.004 in)

- If the calculated value exceeds the limit, replace valve and/or valve guide. When valve guide must be replaced, refer to [EM-109, "VALVE GUIDE REPLACEMENT"](#).

## VALVE GUIDE REPLACEMENT

When valve guide is removed, replace with oversized [0.2 mm (0.008 in)] valve guide.

1. To remove valve guide, heat cylinder head to 110 to 130°C (230 to 266°F) by soaking in heated oil.

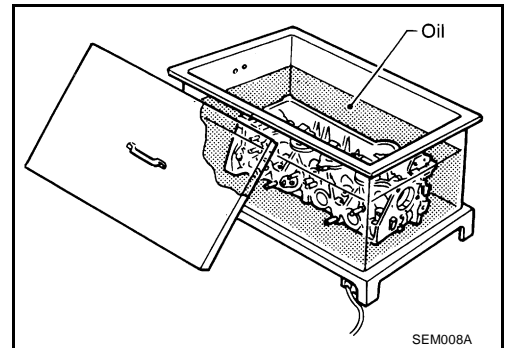

2. Drive out valve guide with a press [under a 20 kN (2 ton, 2.2 US ton, 2.0 Imp ton) pressure] or a hammer and the valve guide drift (commercial service tool).

### **WARNING:**

**Cylinder head contains heat. When working, wear protective equipment to avoid getting burned.**

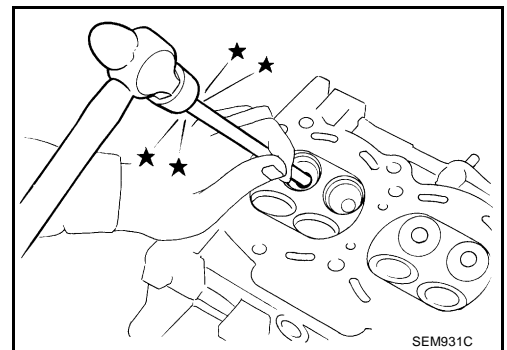

3. Using the valve guide reamer (commercial service tool), ream cylinder head valve guide hole.

### Valve guide hole diameter (for service parts):

Intake and exhaust

: 10.175 - 10.196 mm (0.4006 - 0.4014 in)

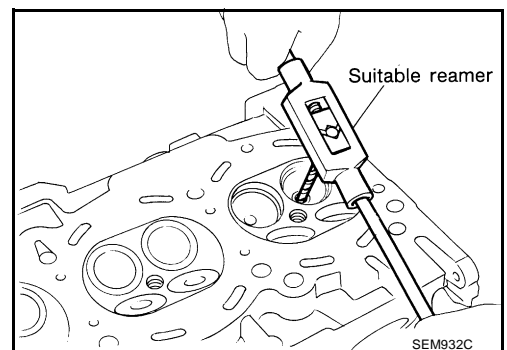

# CYLINDER HEAD

[VQ35DE]

- Heat cylinder head to 110 to 130°C (230 to 266°F) by soaking in heated oil.

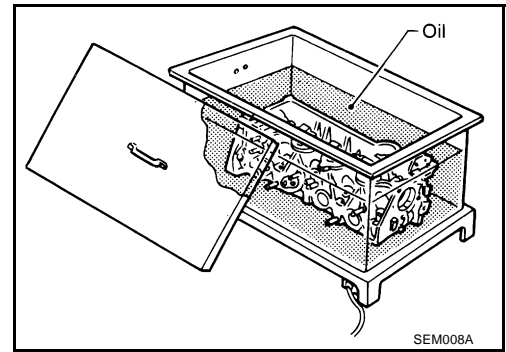

- Using the valve guide drift (commercial service tool), press valve guide from camshaft side to the dimensions as in the figure.

**Projection "L"**

**Intake and exhaust**

**: 12.6 - 12.8 mm (0.496 - 0.504 in)**

**WARNING:**

**Cylinder head contains heat. When working, wear protective equipment to avoid getting burned.**

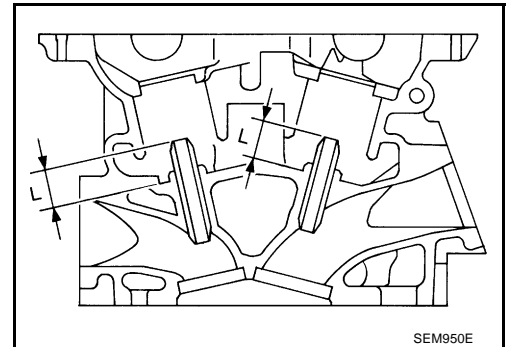

- Using the valve guide reamer (commercial service tool), apply reamer finish to valve guide.

**Standard:**

**Intake and exhaust**

**: 6.000 - 6.018 mm (0.2362 - 0.2369 in)**

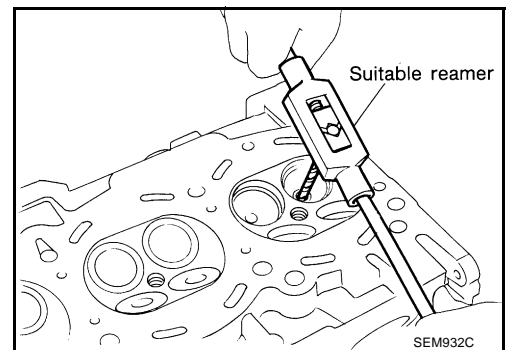

## VALVE SEAT CONTACT

- After confirming that the dimensions of valve guides and valves are within the specifications, perform this procedure.
- Apply prussian blue (or white lead) onto contacting surface of valve seat to check the condition of the valve contact on the surface.
- Check if the contact area band is continuous all around the circumference.
- If not, grind to adjust valve fitting and check again. If the contacting surface still has "NG" conditions even after the re-check, replace valve seat. Refer to [EM-110, "VALVE SEAT REPLACEMENT"](#).

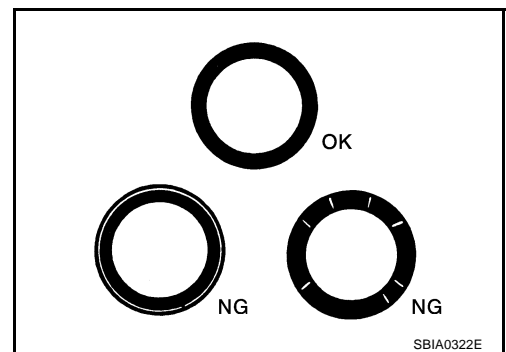

## VALVE SEAT REPLACEMENT

When valve seat is removed, replace with oversized [0.5 mm (0.020 in)] valve seat.

- Bore out old seat until it collapses. Boring should not continue beyond the bottom face of the seat recess in cylinder head. Set the machine depth stop to ensure this. Refer to [EM-156, "Valve Seat"](#).

**CAUTION:**

**Prevent to scratch cylinder head by excessive boring.**

# CYLINDER HEAD

[VQ35DE]

2. Ream cylinder head recess diameter for service valve seat.

**Enlarge [0.5 mm (0.020 in)]**

**Intake : 38.500 - 38.516 mm (1.5157 - 1.5164 in)**

**Exhaust : 32.700 - 32.716 mm (1.2874 - 1.2880 in)**

- Be sure to ream in circles concentric to valve guide center. This will enable valve to fit correctly.

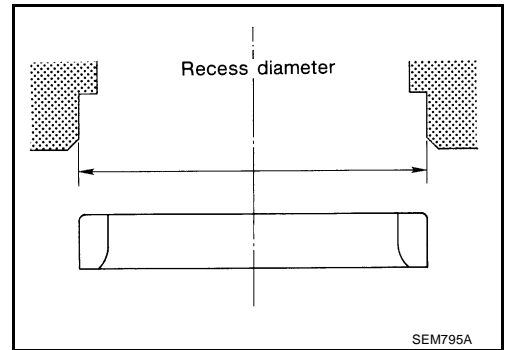

3. Heat cylinder head to 110 to 130°C (230 to 266°F) by soaking in heated oil.

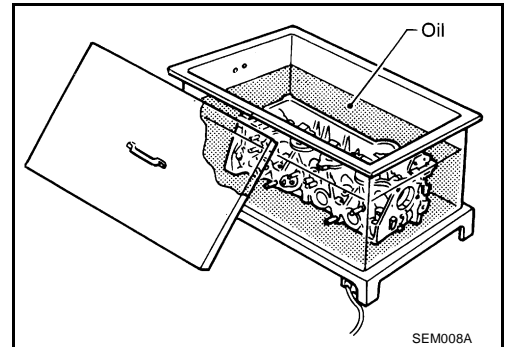

4. Provide valve seats cooled well with dry ice. Force fit valve seat into cylinder head.

**WARNING:**

**Cylinder head contains heat. When working, wear protective equipment to avoid getting burned.**

**CAUTION:**

**Avoid directly touching cold valve seats.**

5. Using the valve seat cutter set (commercial service tool) or valve seat grinder, finish seat to the specified dimensions. Refer to [EM-156, "Valve Seat"](#).

**CAUTION:**

**When using the valve seat cutter, firmly grip cutter handle with both hands. Then, press on the contacting surface all around the circumference to cut in a single drive. Improper pressure on with cutter or cutting many different times may result in stage valve seat.**

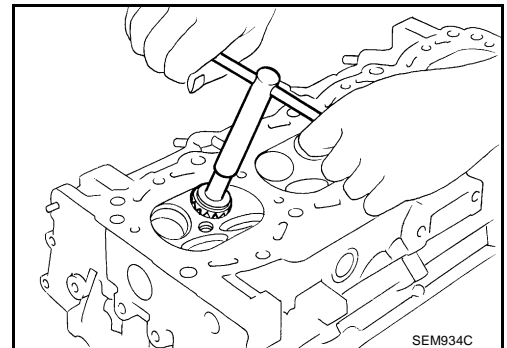

6. Using compound, grind to adjust valve fitting.

7. Check again for normal contact. Refer to [EM-110, "VALVE SEAT CONTACT"](#).

## VALVE SPRING SQUARENESS

- Set a try square along the side of valve spring and rotate spring. Measure the maximum clearance between the top of spring and try square.

**Limit : 2.1 mm (0.083 in)**

- If it exceeds the limit, replace valve spring.

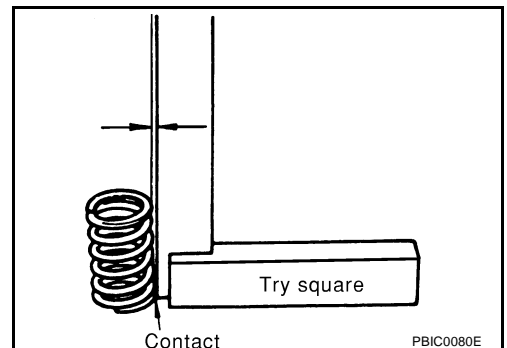

## VALVE SPRING DIMENSIONS AND VALVE SPRING PRESSURE LOAD

- Check the valve spring pressure at specified spring height.

**Standard:**

**Intake and exhaust**

**Free height**

: 47.07 mm (1.8531 in)

**Installation height**

: 37.0 mm (1.457 in)

**Installation load**

: 166 - 188 N (16.9 - 19.2 kg, 37 - 42 lb)

**Height during valve open**

: 27.2 mm (1.0709 in)

**Load with valve open**

: 373 - 421 N (38.0 - 42.9 kg, 84 - 95 lb)

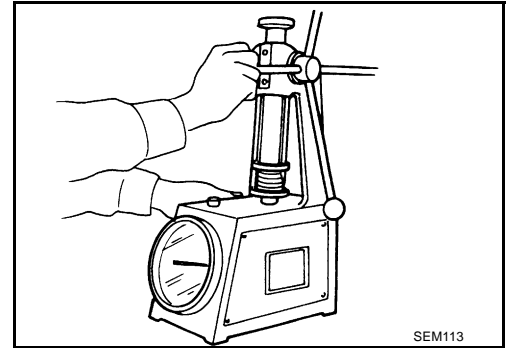

- If the installation load or load with valve open is out of the standard, replace valve spring.

## ENGINE ASSEMBLY

PFP:10001

### Components (2WD Models)

NBS004NW

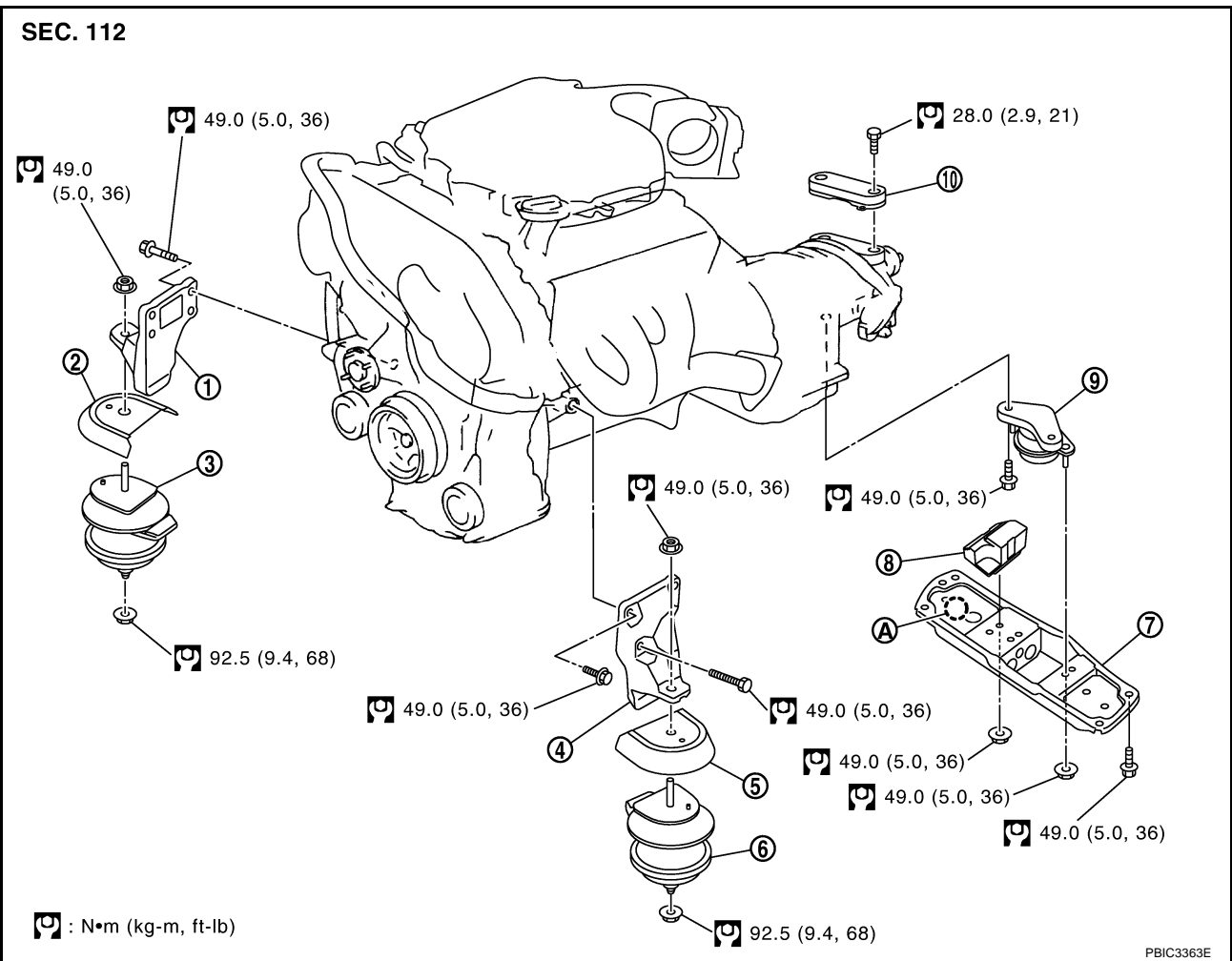

- |                                 |                        |                                     |
|---------------------------------|------------------------|-------------------------------------|
| 1. Engine mounting bracket (RH) | 2. Heat insulator (RH) | 3. Engine mounting insulator (RH)   |
| 4. Engine mounting bracket (LH) | 5. Heat insulator (LH) | 6. Engine mounting insulator (LH)   |
| 7. Rear engine mounting member  | 8. Dynamic damper      | 9. Engine mounting insulator (rear) |
| 10. Dynamic damper              |                        |                                     |
| A. Front mark                   |                        |                                     |

### Removal and Installation (2WD Models)

NBS004NX

**WARNING:**

- Situate the vehicle on a flat and solid surface.
- Place chocks at front and back of rear wheels.
- For engines not equipped with engine slingers, attach proper slingers and bolts described in PARTS CATALOG.

**CAUTION:**

- Always be careful to work safely, avoid forceful or un instructed operations.
- Do not start working until exhaust system and engine coolant are cool enough.
- If items or work required are not covered by the engine section, refer to the applicable sections.
- Always use the support point specified for lifting.
- Use either 2-pole lift type or separate type lift as best you can. If board-on type is used for unavoidable reasons, support at rear axle jacking point with transmission jack or similar tool before starting work, in preparation for the backward shift of center of gravity.
- For supporting points for lifting and jacking point at rear axle, refer to [GI-42, "Garage Jack and Safety Stand and 2-Pole Lift"](#).

## REMOVAL

### Outline

At first, remove the engine and the transmission assembly with front suspension member from vehicle downward. Then separate the engine from transmission.

### Preparation

1. Release fuel pressure. Refer to [EC-98, "FUEL PRESSURE RELEASE"](#) .
2. Drain engine coolant from radiator. Refer to [CO-11, "Changing Engine Coolant"](#) .  
**CAUTION:**
  - Perform this step when engine is cold.
  - Do not spill engine coolant on drive belts.
3. Disconnect both battery cables. Refer to [SC-4, "BATTERY"](#) .
4. Remove the following parts:
  - Engine room cover (RH and LH); Refer to [EM-14, "ENGINE ROOM COVER"](#) .
  - Engine cover; Refer to [EM-19, "INTAKE MANIFOLD COLLECTOR"](#) .
  - Front road wheel and tires (power tool)
  - Front and rear engine undercover (power tool)
  - Cowl top cover (RH); Refer to [EI-18, "COWL TOP"](#) .
  - Air duct and air cleaner case assembly; [EM-17, "AIR CLEANER AND AIR DUCT"](#) .
5. Discharge refrigerant from A/C circuit. Refer to [ATC-151, "REFRIGERANT LINES"](#) .
6. Remove radiator hoses (upper and lower). Refer to [CO-14, "RADIATOR"](#) .

### Engine Room LH

1. Disconnect heater hose from vehicle-side, and fit a plug onto hose end to prevent engine coolant leak.
2. Disconnect wire bonding (between vehicle to left bank cylinder head).
3. Disconnect A/C piping from A/C compressor, and temporarily fasten it on vehicle with a rope. Refer to [ATC-151, "REFRIGERANT LINES"](#) .
4. Disconnect brake booster vacuum hose.

### Engine Room RH

1. Disconnect battery positive cable at vehicle side and temporarily fasten it on engine.
2. Disconnect grounding cable.
3. Disconnect fuel feed hose (with damper) and EVAP hose. Refer to [EM-45, "FUEL INJECTOR AND FUEL TUBE"](#) .

**CAUTION:**

**Fit plugs onto disconnected hoses to prevent fuel leak.**

4. Remove reservoir tank of power steering oil pump and piping from vehicle, and temporarily secure them on engine. Refer to [PS-29, "POWER STEERING OIL PUMP"](#) .

**CAUTION:**

**When temporarily securing, keep the reservoir tank upright to avoid a fluid leak.**

### Vehicle inside

Follow procedure below to disconnect engine room harness connectors at passenger room side, and temporarily secure them on engine.

1. Remove passenger-side kicking plate, dash side finisher, and glove box. Refer to [EI-37, "BODY SIDE TRIM"](#) and [IP-10, "INSTRUMENT PANEL ASSEMBLY"](#) .
2. Disconnect engine room harness connectors at unit sides TCM, ECM and other.
3. Disengage intermediate fixing point. Pull out engine room harnesses to engine room side, and temporarily secure them on engine.

**CAUTION:**

- When pulling out harnesses, take care not to damage harnesses and connectors.
- After temporarily securing, cover connectors with vinyl or similar material to protect against foreign material adhesion.

## Vehicle Underbody

1. Remove A/T fluid cooler hoses and power steering oil pump oil cooler hoses.
  - Install plug to avoid leakage of A/T fluid and power steering fluid.
2. Disconnect heated oxygen sensor 2 harness.
3. Remove three way catalyst and exhaust front tube. Refer to [EX-3, "EXHAUST SYSTEM"](#) .
4. Disconnect steering lower joint at power steering gear assembly side, and release steering lower shaft. Refer to [PS-13, "STEERING COLUMN"](#) .
5. Remove rear propeller shaft. Refer to [PR-6, "REAR PROPELLER SHAFT"](#) .
6. Disengage A/T control rod at control device assembly side. Then, temporarily secure it on the transmission assembly, so that it does not sag. Refer to [AT-222, "SHIFT CONTROL SYSTEM"](#) .
7. Remove rear plate cover from oil pan (upper). Then remove bolts fixing drive plate to torque converter. Refer to [EM-29, "OIL PAN AND OIL STRAINER"](#) and [AT-271, "TRANSMISSION ASSEMBLY"](#) .
8. Remove transmission joint bolts which pierce at oil pan (upper) lower rear side. Refer to [AT-271, "TRANSMISSION ASSEMBLY"](#) .
9. Remove front stabilizer at transverse link side. Refer to [FSU-18, "STABILIZER BAR"](#) .
10. Remove lower ends of left and right strut from transverse link. Refer to [FSU-6, "FRONT SUSPENSION ASSEMBLY"](#) .
11. Separate steering outer sockets from steering knuckle. Refer to [PS-18, "POWER STEERING GEAR"](#) .
12. Remove transverse links mounting bolts at knuckle side. Refer to [FSU-14, "TRANSVERSE LINK"](#) .

## Removal Work

1. Use a manual lift table caddy (commercial service tool) or equivalently rigid tool such as a transmission jack. Securely support bottom of suspension member and the transmission assembly.

### CAUTION:

Put a piece of wood or something similar as the supporting surface, secure a completely stable condition.

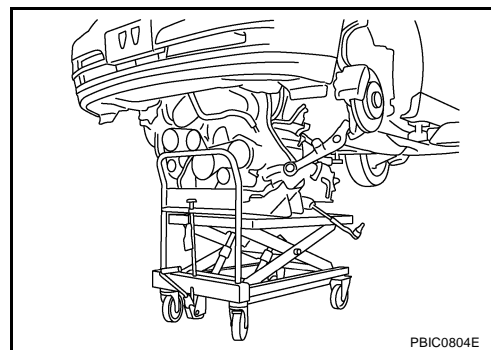

2. Remove rear engine mounting member bolts.
3. Remove front suspension member mounting bolts and nuts. Refer to [FSU-6, "FRONT SUSPENSION ASSEMBLY"](#) .
4. Carefully lower jack, or raise lift to remove the engine, the transmission assembly and front suspension member. When performing work, observe the following caution:

### CAUTION:

- Confirm there is no interference with the vehicle.
- Make sure that all connection points have been disconnected.
- Keep in mind the center of vehicle gravity changes. If necessary, use jack(s) to support the vehicle at rear jacking point(s) to prevent it from falling off the lift.

## Separation Work

1. Install engine slingers into front of cylinder head (right bank) and rear of cylinder head (left bank).

### Slinger bolts:

: 28.0 N·m (2.9 kg-m, 21 ft-lb)

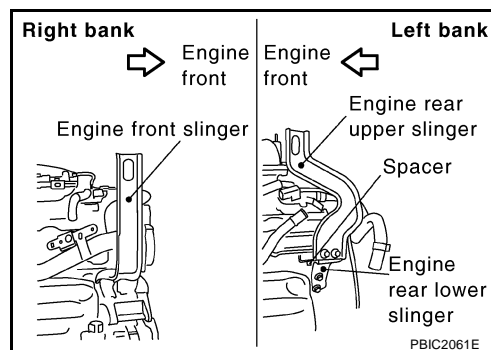



- To protect rocker cover against damage caused by tilting of engine slinger, insert spacer between cylinder head and engine rear lower slinger, in direction shown in the figure.

**NOTE:**

Spacer is a component part of engine rear upper slinger assembly.

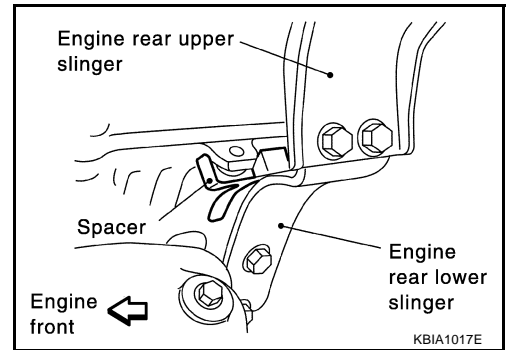

2. Remove power steering oil pump from engine side. Refer to [PS-29, "POWER STEERING OIL PUMP"](#) .
3. Remove engine mounting insulators (RH and LH) under side nuts with power tool.
4. Lift with hoist and separate the engine and the transmission assembly from front suspension member.

**CAUTION:**

- Before and during this lifting, always make sure that any harnesses are left connected.
- Avoid damage to and oil/grease smearing or spills onto engine mounting insulator.

5. Remove alternator. Refer to [SC-23, "CHARGING SYSTEM"](#) .
6. Remove starter motor. Refer to [SC-10, "STARTING SYSTEM"](#) .
7. Separate the engine from the transmission assembly. Refer to [AT-271, "TRANSMISSION ASSEMBLY"](#) .
8. Remove each engine mounting insulator and each engine mounting bracket from the engine with power tool.

## INSTALLATION

Note the following, and install in the reverse order of removal.

- Do not allow engine mounting insulator to be damage and careful no oil gets on it.
- For a location with a positioning pin, insert it securely into hole of mating part.
- For a part with a specified installation orientation, refer to component figure in [EM-29, "Components \(2WD Models\)"](#) .
- When installing engine mounting bracket (RH and LH) on cylinder block, tighten two upper bolts (shown as "A" in the figure) first. Then tighten two lower bolts (shown as "B" in the figure).

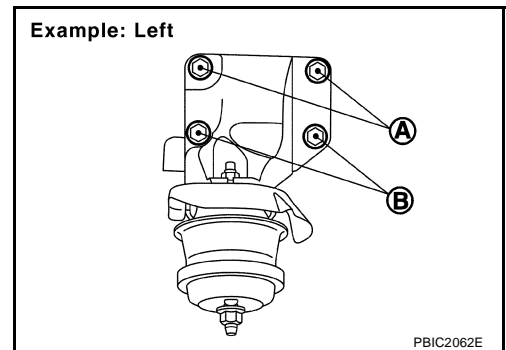

- Make sure all engine mounting insulators are seated properly, then tighten mounting nuts.
- Tighten rear engine mounting member bolts in numerical order as shown in the figure.

↔ Vehicle front

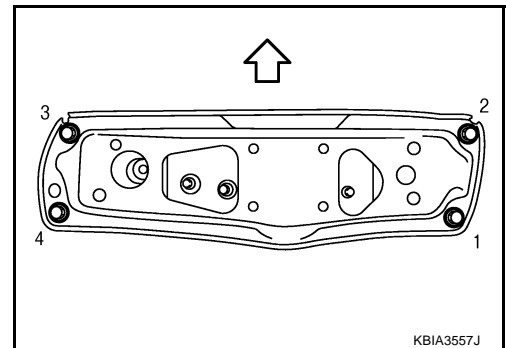



## INSPECTION AFTER INSTALLATION

### Inspection for Leaks

The following are procedures for checking fluids leak, lubricates leak and exhaust gases leak.

- Before starting engine, check oil/fluid levels including engine coolant and engine oil. If less than required quantity, fill to the specified level. Refer to [MA-12, "RECOMMENDED FLUIDS AND LUBRICANTS"](#) .
- Use procedure below to check for fuel leakage.
  - Turn ignition switch “ON” (with engine stopped). With fuel pressure applied to fuel piping, check for fuel leakage at connection points.
  - Start engine. With engine speed increased, check again for fuel leakage at connection points.
- Run engine to check for unusual noise and vibration.
- Warm up engine thoroughly to make sure there is no leakage of fuel, exhaust gases, or any oil/fluids including engine oil and engine coolant.
- Bleed air from lines and hoses of applicable lines, such as in cooling system.
- After cooling down engine, again check oil/fluid levels including engine oil and engine coolant. Refill to the specified level, if necessary.

#### Summary of the inspection items:

Item	Before starting engine	Engine running	After engine stopped
Engine coolant	Level	Leakage	Level
Engine oil	Level	Leakage	Level
Other oils and fluid*	Level	Leakage	Level
Fuel	Leakage	Leakage	Leakage
Exhaust gases	—	Leakage	—

\* Transmission/transaxle/CVT fluid, power steering fluid, brake fluid, etc.

### Components (AWD Models)

NBS004NY

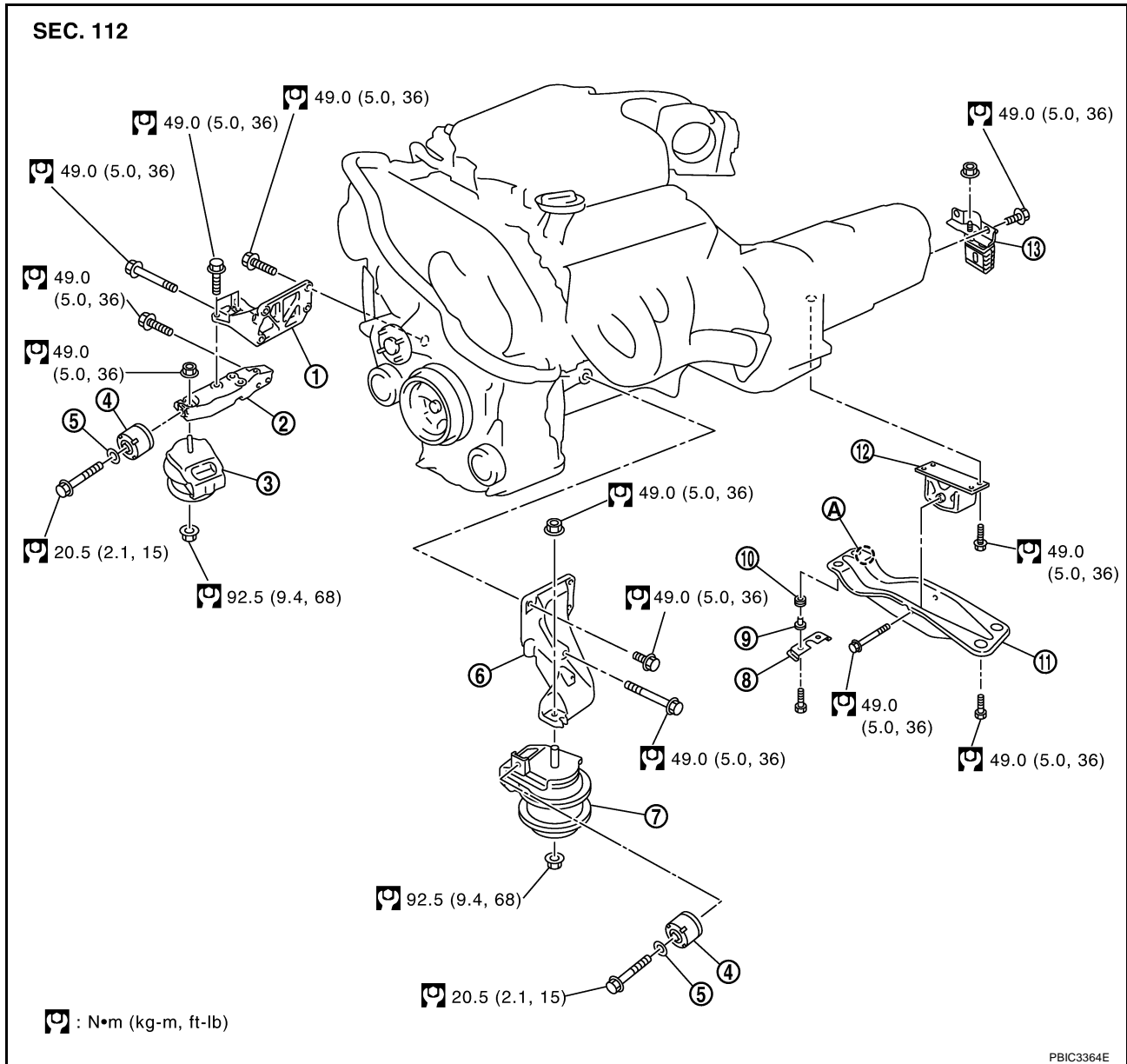

- |                                   |   |                                      |
|-----------------------------------|---|--------------------------------------|
| 1. Engine mounting bracket (RH)   | 2. Engine mounting bracket (RH) (Lower) | 3. Engine mounting insulator (RH)    |
| 4. Dynamic damper                 | 5. Washer                               | 6. Engine mounting bracket (LH)      |
| 7. Engine mounting insulator (LH) | 8. Heat insulator                       | 9. Coller                            |
| 10. Rubber bushing                | 11. Rear engine mounting member         | 12. Engine mounting insulator (rear) |
| 13. Dynamic damper                |   |                                      |
| A. Front mark                     |   |                                      |

### Removal and Installation (AWD Models)

NBS004NZ

#### WARNING:

- Situate the vehicle on a flat and solid surface.
- Place chocks at front and back of rear wheels.
- For engines not equipped with engine slingers, attach proper slingers and bolts described in PARTS CATALOG.

#### CAUTION:

- Always be careful to work safely, avoid forceful or uninstructed operations.
- Do not start working until exhaust system and engine coolant are cool enough.

- If items or work required are not covered by the engine section, refer to the applicable sections.
- Always use the support point specified for lifting.
- Use either 2-pole lift type or separate type lift as best you can. If board-on type is used for unavoidable reasons, support at rear axle jacking point with transmission jack or similar tool before starting work, in preparation for the backward shift of center of gravity.
- For supporting points for lifting and jacking point at rear axle, refer to [GI-42, "Garage Jack and Safety Stand and 2-Pole Lift"](#).

## REMOVAL

### Outline

At first, remove the engine, the transmission assembly, the transfer assembly and the front final drive assembly with front suspension member from vehicle downward. Then separate the engine, the transmission assembly, the transfer and the front final drive assembly.

### Preparation

1. Release fuel pressure. Refer to [EC-98, "FUEL PRESSURE RELEASE"](#).
2. Drain engine coolant from radiator. Refer to [CO-11, "Changing Engine Coolant"](#).
 

**CAUTION:**

  - Perform this step when engine is cold.
  - Do not spill engine coolant on drive belts.
3. Disconnect both battery terminals. Refer to [SC-4, "BATTERY"](#).
4. Remove the following parts:
  - Engine room cover (RH and LH); Refer to [EM-14, "ENGINE ROOM COVER"](#).
  - Engine cover; Refer to [EM-19, "INTAKE MANIFOLD COLLECTOR"](#).
  - Front road wheel and tires (power tool)
  - Front and rear engine undercover (power tool)
  - Front cross bar; Refer to [FSU-23, "FRONT SUSPENSION ASSEMBLY"](#).
  - Cowl top cover (RH); Refer to [EI-18, "COWL TOP"](#).
  - Air duct and air cleaner case assembly; [EM-17, "AIR CLEANER AND AIR DUCT"](#).
5. Discharge refrigerant from A/C circuit. Refer to [ATC-151, "REFRIGERANT LINES"](#).
6. Remove radiator hoses (upper and lower). Refer to [CO-14, "RADIATOR"](#).

### Engine Room LH

1. Disconnect heater hose from vehicle-side, and fit a plug onto hose end to prevent engine coolant leak.
2. Disconnect wire bonding (between vehicle to left bank cylinder head).
3. Disconnect A/C piping from A/C compressor, and temporarily fasten it on vehicle with a rope. Refer to [ATC-151, "REFRIGERANT LINES"](#).
4. Disconnect brake booster vacuum hose.

### Engine Room RH

1. Disconnect battery positive cable vehicle side and temporarily fasten it on engine.
2. Disconnect grounding cables.
3. Disconnect fuel feed hose (with damper) and EVAP hose. Refer to [EM-45, "FUEL INJECTOR AND FUEL TUBE"](#).

**CAUTION:**

**Fit plugs onto disconnected hoses to prevent fuel leak.**

4. Remove reservoir tank of power steering oil pump and piping from vehicle, and temporarily secure them on engine. Refer to [PS-29, "POWER STEERING OIL PUMP"](#).

**CAUTION:**

**When temporarily securing, keep the reservoir tank upright to avoid a fluid leak.**

### Vehicle inSide

Follow procedure below to disconnect engine room harness connectors at passenger room side, and temporarily secure them on engine.

1. Remove passenger-side kicking plate, dash side finisher, and glove box. Refer to [EI-37, "BODY SIDE TRIM"](#) and [IP-10, "INSTRUMENT PANEL ASSEMBLY"](#).
2. Disconnect engine room harness connectors at unit sides TCM, ECM and other.
3. Disengage intermediate fixing point. Pull out engine room harnesses to engine room side, and temporarily secure them on engine.

**CAUTION:**

- When pulling out harnesses, take care not to damage harnesses and connectors.
- After temporarily securing, cover connectors with vinyl or similar material to protect against foreign material adhesion.

## Vehicle Underbody

1. Remove A/T fluid cooler hoses and power steering oil pump oil cooler hoses.
  - Install plug to avoid leakage of A/T fluid and power steering fluid.
2. Disconnect heated oxygen sensor 2 harness. Refer to [EX-3, "EXHAUST SYSTEM"](#).
3. Remove three way catalyst and exhaust front tube. Refer to [EX-3, "EXHAUST SYSTEM"](#).
4. Disconnect steering lower joint at power steering gear assembly side, and release steering lower shaft. Refer to [PS-13, "STEERING COLUMN"](#).
5. Remove rear propeller shaft. Refer to [PR-6, "REAR PROPELLER SHAFT"](#).
6. Remove front drive shaft (both side). Refer to [FAX-8, "FRONT DRIVE SHAFT"](#).
7. Disconnect harness connector from transmission assembly and transfer assembly.
8. Disengage A/T control rod at control device assembly side. Then, temporarily secure it on the transmission assembly, so that it does not sag. Refer to [AT-222, "SHIFT CONTROL SYSTEM"](#).
9. Remove rear plate cover from oil pan (upper). Then remove bolts fixing drive plate to torque converter. Refer to [EM-29, "OIL PAN AND OIL STRAINER"](#) and [AT-271, "TRANSMISSION ASSEMBLY"](#).
10. Remove bolts fixing the transmission assembly to lower rear side of oil pan (upper). Refer to [AT-271, "TRANSMISSION ASSEMBLY"](#).
11. Remove front stabilizer at transverse link side. Refer to [FSU-18, "STABILIZER BAR"](#).
12. Remove lower ends of left and right strut from transverse link. Refer to [FSU-23, "FRONT SUSPENSION ASSEMBLY"](#).
13. Separate steering outer sockets from steering knuckle. Refer to [PS-18, "POWER STEERING GEAR"](#).
14. Remove transverse links mounting bolts at knuckle side. Refer to [FSU-31, "TRANSVERSE LINK"](#).

## Removal Work

1. Use a manual lift table caddy (commercial service tool) or equivalently rigid tool such as a transmission jack. Securely support bottom of suspension member and transmission.

**CAUTION:**

**Put a piece of wood or something similar as the supporting surface, secure a completely stable condition.**

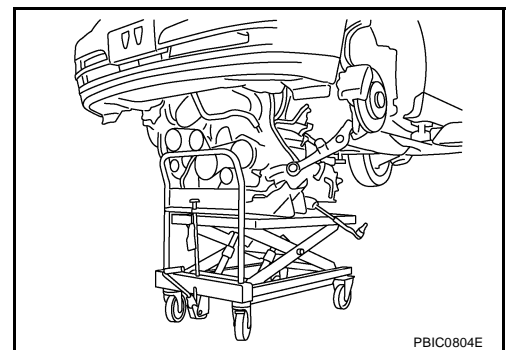

2. Remove rear engine mounting member bolts.
3. Remove front suspension member mounting bolts and nuts. Refer to [FSU-23, "FRONT SUSPENSION ASSEMBLY"](#).
4. Carefully lower jack, or raise lift to remove the engine, transmission assembly, transfer, front final drive assembly and front suspension member. When performing work, observe the following caution:

**CAUTION:**

- Confirm there is no interference with the vehicle.
- Make sure that all connection points have been disconnected.
- Keep in mind the center of the vehicle gravity changes. If necessary, use jack(s) to support the vehicle at rear jacking point(s) to prevent it from falling off the lift.

## Separation Work

1. Install engine slingers into front of cylinder head (right bank) and rear of cylinder head (left bank).

### Slinger bolts:

: 28.0 N-m (2.9 kg-m, 21 ft-lb)

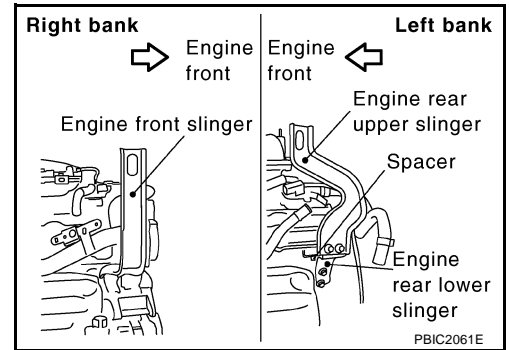

- To protect rocker cover against damage caused by tilting of engine slinger, insert spacer between cylinder head and engine rear lower slinger, in direction shown in the figure.

### NOTE:

Spacer is a component part of engine rear upper slinger assembly.

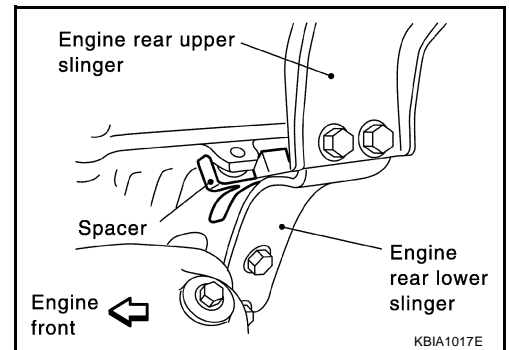

2. Remove power steering oil pump from engine side. Refer to [PS-29, "POWER STEERING OIL PUMP"](#) .
3. Remove engine mounting insulators (RH and LH) under side nuts with power tool.
4. Lift with hoist and separate the engine, the transmission assembly, the transfer assembly and the front final drive assembly from front suspension member.

### CAUTION:

- Before and during this lifting, always check if any harnesses are left connected.
- Avoid damage to and oil/grease smearing or spills onto engine mounting insulator.

5. Remove alternator. Refer to [SC-23, "CHARGING SYSTEM"](#) .
6. Remove starter motor. Refer to [SC-10, "STARTING SYSTEM"](#) .
7. Remove front propeller shaft from the front final drive assembly side. Refer to [PR-4, "FRONT PROPELLER SHAFT"](#) .
8. Separate the engine from the transmission assembly. Refer to [AT-271, "TRANSMISSION ASSEMBLY"](#) .
9. Remove the front final drive assembly from oil pan (upper). Refer to [FFD-13, "FRONT FINAL DRIVE ASSEMBLY"](#) .
10. Remove each engine mounting insulator and each engine mounting bracket from the engine with power tool.

## INSTALLATION

Note the following, and install in the reverse order of removal.

- Do not allow engine mounting insulator to be damage and careful no engine oil gets on it.
- For a location with a positioning pin, insert it securely into hole of mating part.
- For a part with a specified installation orientation, refer to component figure in [EM-35, "Components \(AWD Models\)"](#) .

- When installing engine mounting bracket (RH and LH) on cylinder block, tighten two upper bolts (shown as “A” in the figure) first. Then tighten two lower bolts (shown as “B” in the figure).
- Install engine mounting bracket (RH) (lower) as follows:
  - Temporarily tighten mounting bolts (shown as “C”, “D” and “E” in the figure).
  - Tighten mounting bolts to the specified torque with following mounting surfaces touched.
- Engine mounting bracket (RH) to engine mounting bracket (RH) (lower) (shown as “C” and “D” in figure).
- Front final drive to engine mounting bracket (RH) (lower) (shown as “E” in figure).
- Make sure all engine mounting insulators are seated properly, then tighten mounting nuts.

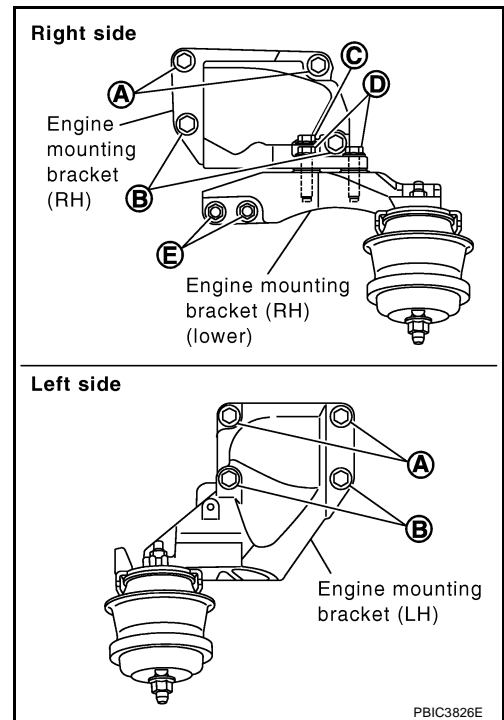

## INSPECTION AFTER INSTALLATION

### Inspection for Leaks

The following are procedures for checking fluids leak, lubricates leak and exhaust gases leak.

- Before starting engine, check oil/fluid levels including engine coolant and engine oil. If less than required quantity, fill to the specified level. Refer to [MA-12, "RECOMMENDED FLUIDS AND LUBRICANTS"](#) .
- Use procedure below to check for fuel leakage.
  - Turn ignition switch “ON” (with engine stopped). With fuel pressure applied to fuel piping, check for fuel leakage at connection points.
  - Start engine. With engine speed increased, check again for fuel leakage at connection points.
- Run engine to check for unusual noise and vibration.
- Warm up engine thoroughly to make sure there is no leakage of fuel, exhaust gases, or any oil/fluids including engine oil and engine coolant.
- Bleed air from lines and hoses of applicable lines, such as in cooling system.
- After cooling down engine, again check oil/fluid levels including engine oil and engine coolant. Refill to the specified level, if necessary.

### Summary of the inspection items:

Item	Before starting engine	Engine running	After engine stopped
Engine coolant	Level	Leakage	Level
Engine oil	Level	Leakage	Level
Other oils and fluid*	Level	Leakage	Level
Fuel	Leakage	Leakage	Leakage
Exhaust gases	—	Leakage	—

\* Transmission/transaxle/CVT fluid, power steering fluid, brake fluid, etc.

# CYLINDER BLOCK

[VQ35DE]

## CYLINDER BLOCK

PF11010

### Components

NBS00400

A  
C  
D  
E  
F  
G  
H  
I  
J  
K  
L  
M

EM

SEC. 110•120•226

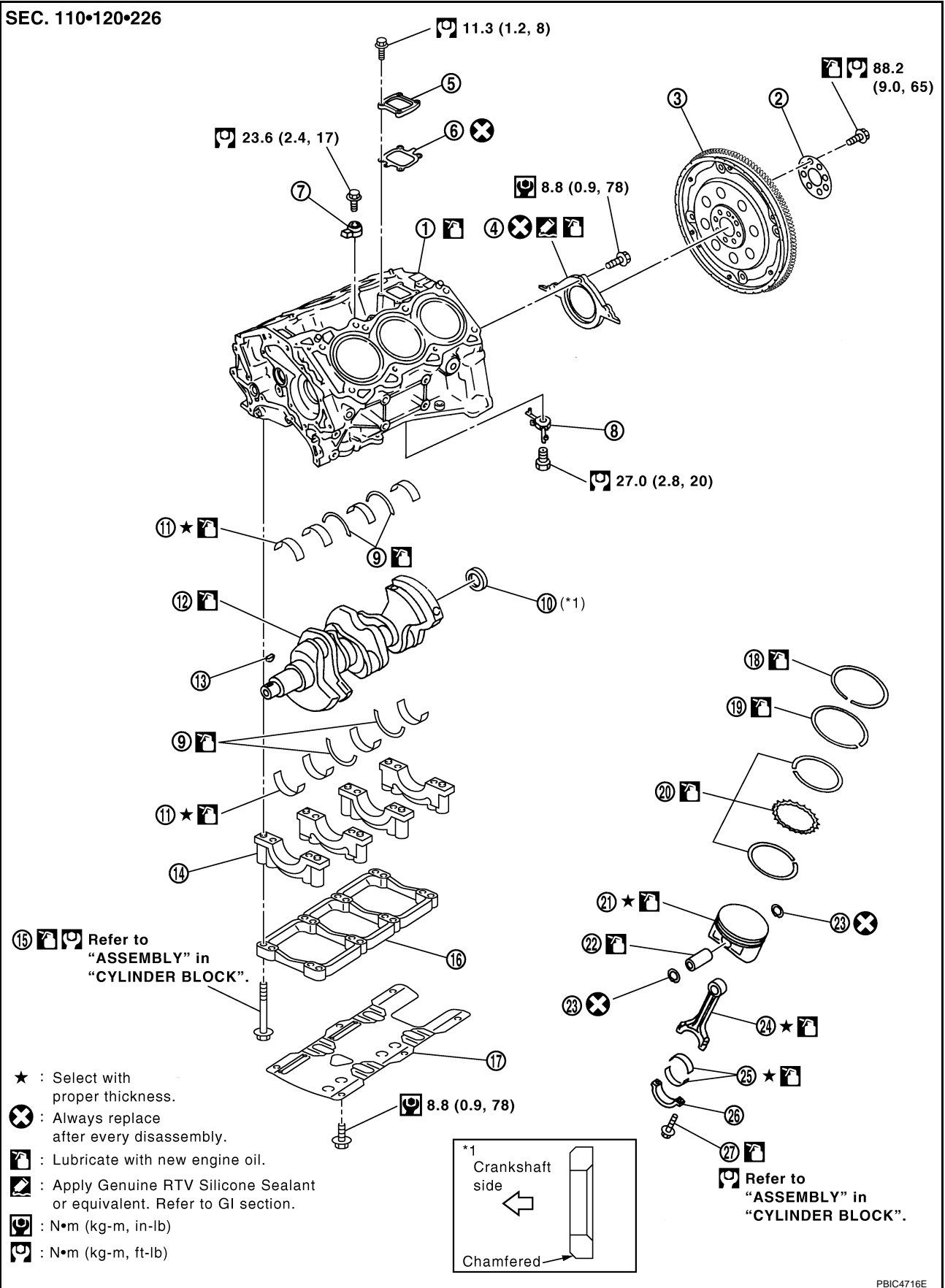

15 Refer to "ASSEMBLY" in "CYLINDER BLOCK".

★ : Select with proper thickness.

⊗ : Always replace after every disassembly.

☞ : Lubricate with new engine oil.

▣ : Apply Genuine RTV Silicone Sealant or equivalent. Refer to GI section.

⊕ : N•m (kg-m, in-lb)

⊖ : N•m (kg-m, ft-lb)

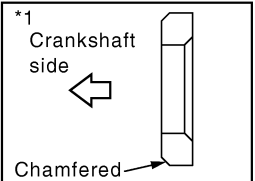

Refer to "ASSEMBLY" in "CYLINDER BLOCK".

PBIC4716E

# CYLINDER BLOCK

[VQ35DE]

- |                            |                                |                           |
|----------------------------|--------------------------------|---------------------------|
| 1. Cylinder block          | 2. Reinforcement plate         | 3. Drive plate            |
| 4. Rear oil seal retainer  | 5. Cover                       | 6. Gasket                 |
| 7. Knock sensor            | 8. Oil jet                     | 9. Thrust bearing         |
| 10. Pilot converter        | 11. Main bearing               | 12. Crankshaft            |
| 13. Crankshaft key         | 14. Main bearing cap           | 15. Main bearing cap bolt |
| 16. Main bearing beam      | 17. Baffle plate (2WD models)  | 18. Top ring              |
| 19. Second ring            | 20. Oil ring                   | 21. Piston                |
| 22. Piston pin             | 23. Snap ring                  | 24. Connecting rod        |
| 25. Connecting rod bearing | 26. Connecting rod bearing cap | 27. Connecting rod bolt   |

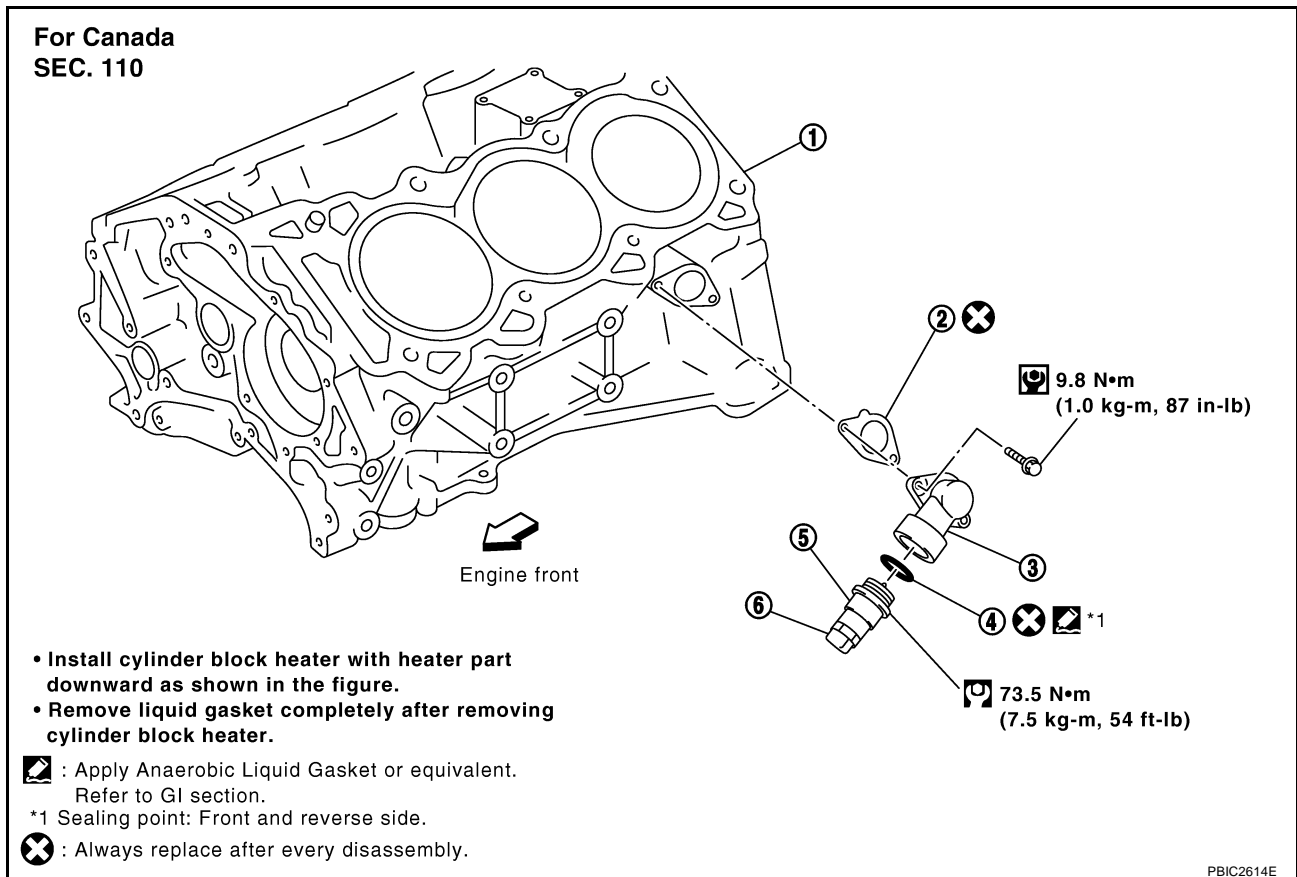

- |                   |                          |                            |
|-------------------|--------------------------|----------------------------|
| 1. Cylinder block | 2. Gasket                | 3. Water connector         |
| 4. Gasket         | 5. Cylinder block heater | 6. Connector protector cap |

## Disassembly and Assembly DISASSEMBLY

NBS00401

### NOTE:

Explained here is how to disassemble with engine stand supporting transmission surface. When using different type of engine stand, note with difference in steps and etc.

1. Remove the engine assembly from the vehicle. Refer to [EM-29, "Removal and Installation \(2WD Models\)"](#) or [EM-36, "Removal and Installation \(AWD Models\)"](#).
2. Remove the parts that may restrict installation of engine to widely use engine stand.

### NOTE:

The procedure is described assuming that you use a widely use engine stand holding the surface, to which transmission is installed.

- Remove drive plate with power tool. Fix crankshaft with a ring gear stopper [SST: KV1011770 (J44716)], and remove mounting bolts.
- Loosen mounting bolts in diagonal order.



**CAUTION:**

- Do not disassemble drive plate.
- Never place drive plate with signal plate facing down.
- When handling signal plate, take care not to damage or scratch it.
- Handle signal plate in a manner that prevents it from becoming magnetized.

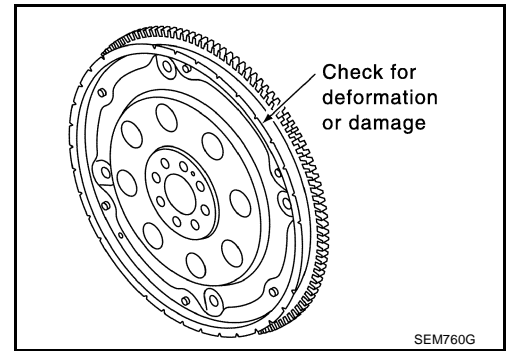

3. Lift the engine with hoist to install it onto the widely use engine stand.

**CAUTION:**

**Use an engine stand that has a load capacity [220 kg (441 lb) or more] large enough for supporting the engine weight.**

- If the load capacity of the stand is not adequate, remove the following parts beforehand to reduce the potential risk of overturning the stand.
  - Remove intake manifold collector. Refer to [EM-19, "INTAKE MANIFOLD COLLECTOR"](#) .
  - Remove intake manifold. Refer to [EM-24, "INTAKE MANIFOLD"](#) .
  - Remove fuel injector and fuel tube assembly. Refer to [EM-45, "FUEL INJECTOR AND FUEL TUBE"](#) .
  - Remove ignition coil. Refer to [EM-42, "IGNITION COIL"](#) .
  - Remove rocker cover. Refer to [EM-51, "ROCKER COVER"](#) .
  - Remove exhaust manifold. Refer to [EM-26, "EXHAUST MANIFOLD"](#) .
  - Other removable brackets.

**NOTE:**

The figure shows an example of widely use engine stand that can hold mating surface of transmission with drive plate removed.

**CAUTION:**

**Before removing the hanging chains, make sure the engine stand is stable and there is no risk of overturning.**

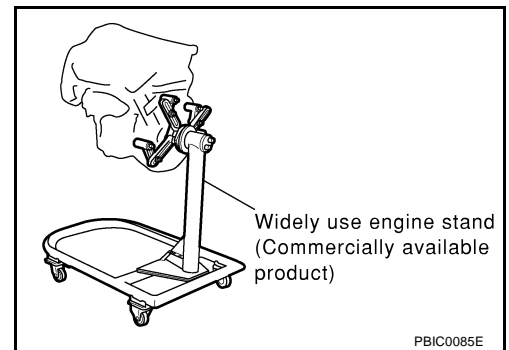

4. Drain engine oil. Refer to [LU-9, "Changing Engine Oil"](#) .

# CYLINDER BLOCK

[VQ35DE]

5. Drain engine coolant by removing water drain plugs from cylinder block both sides at "B" and "C" and cylinder block front side at "A" as shown in the figure.

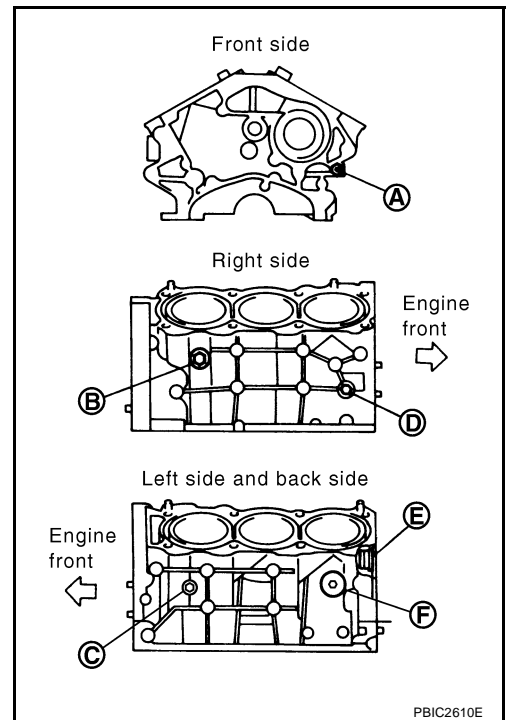

6. Remove the following parts:
- Oil pans (lower and upper); Refer to [EM-29, "OIL PAN AND OIL STRAINER"](#) .
  - Front and rear timing chain case; Refer to [EM-64, "TIMING CHAIN"](#) .
  - Cylinder head; Refer to [EM-101, "CYLINDER HEAD"](#) .
7. Remove knock sensor.
- CAUTION:**  
**Carefully handle sensor avoiding shocks.**
8. Remove pilot converter using the pilot bushing puller (SST) as necessary.

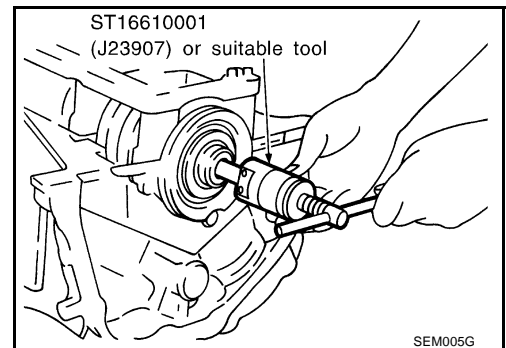

9. Remove rear oil seal retainer.
- Remove by inserting a screwdriver between main bearing cap and rear oil seal retainer.
- CAUTION:**  
**If rear oil seal retainer is removed, replace it with new one.**
- NOTE:**  
Regard both rear oil seal and retainer as an assembly.
10. Remove baffle plate from main bearing beam (2WD models).
11. Remove piston and connecting rod assembly with the following procedure:
- Before removing piston and connecting rod assembly, check the connecting rod side clearance. Refer to [EM-140, "CONNECTING ROD SIDE CLEARANCE"](#) .
- CAUTION:**  
**Be careful not to drop connecting rod bearing, and to scratch the surface.**
- a. Position crankshaft pin corresponding to connecting rod to be removed onto the bottom dead center.

- b. Remove connecting rod bearing cap.
- c. Using a hammer handle or similar tool, push piston and connecting rod assembly out to the cylinder head side.

**CAUTION:**

Be careful not to damage the cylinder wall and crankshaft pin, resulting from an interference of the connecting rod big end.

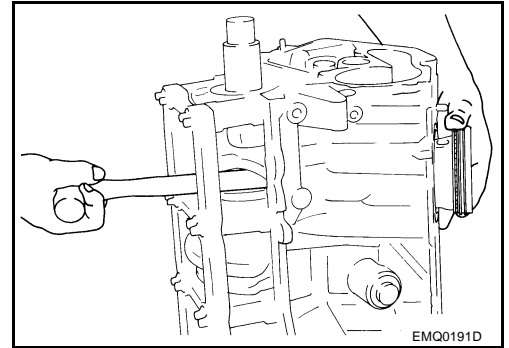

12. Remove connecting rod bearings from connecting rod and connecting rod bearing cap.

**CAUTION:**

- Be careful not to drop connecting rod bearing, and to scratch the surface.
- Identify installation positions, and store them without mixing them up.

13. Remove piston rings from piston.

- Before removing piston rings, check the piston ring side clearance. Refer to [EM-141, "PISTON RING SIDE CLEARANCE"](#).
- Use a piston ring expander (commercial service tool).

**CAUTION:**

- When removing piston rings, be careful not to damage piston.
- Be careful not to damage piston rings by expanding them excessively.

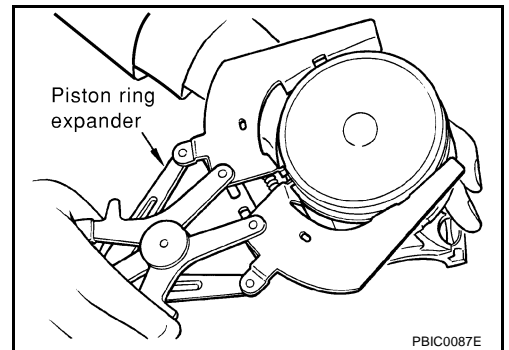

14. Remove piston from connecting rod as follows:

- a. Using a snap ring pliers, remove snap rings.

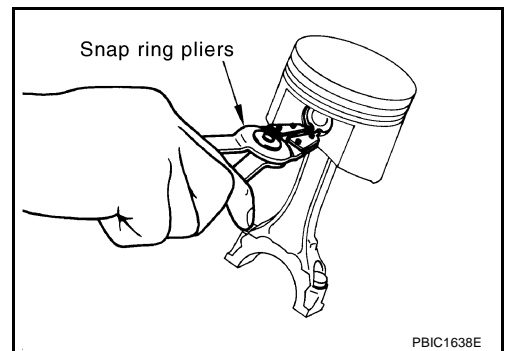

- b. Heat piston to 60 to 70°C (140 to 158°F) with an industrial use drier or equivalent.

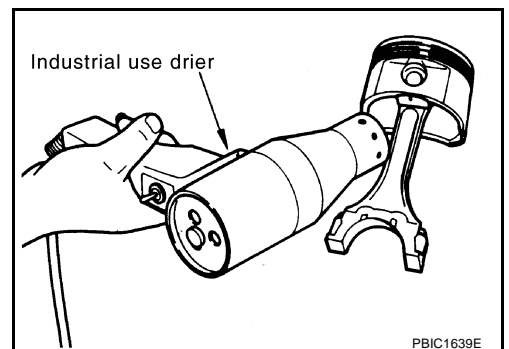

A  
EM  
C  
D  
E  
F  
G  
H  
I  
J  
K  
L  
M

# CYLINDER BLOCK

[VQ35DE]

- c. Push out piston pin with stick of outer diameter approximately 20 mm (0.79 in).

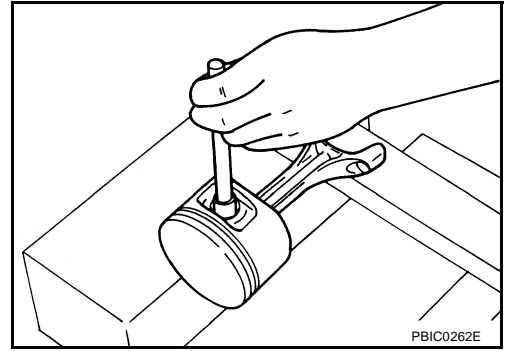

15. Remove main bearing cap bolts.

**NOTE:**

Use TORX socket (size E14).

- Before loosening main bearing cap bolts, measure the crankshaft end play. Refer to [EM-140, "CRANK-SHAFT END PLAY"](#).
- Loosen main bearing cap bolts in the reverse order shown in the figure in several different steps.

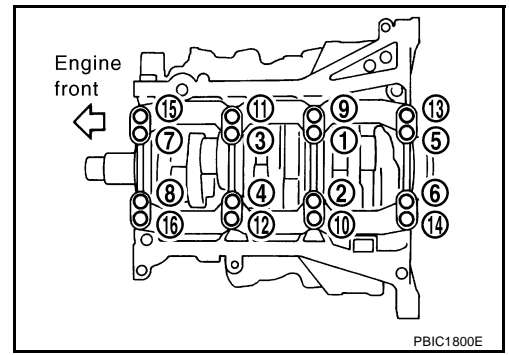

16. Remove main bearing beam.  
17. Remove main bearing caps.

**CAUTION:**

**Be careful not to drop main bearing, and to scratch the surface.**

- Using main bearing cap bolts, remove main bearing cap while shaking it back-and-forth.

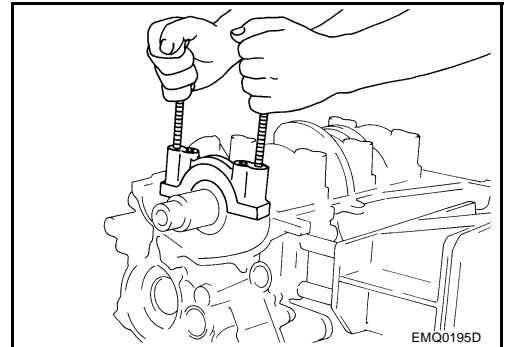

18. Remove crankshaft.  
19. Remove main bearings and thrust bearings from cylinder block and main bearing caps.

**CAUTION:**

- **Be careful not to drop main bearing, and to scratch the surface.**
- **Identify installation positions, and store them without mixing them up.**

20. Remove oil jet.

## ASSEMBLY

1. Fully air-blow engine coolant and engine oil passages in cylinder block, cylinder bore and crankcase to remove any foreign material.

**CAUTION:**

**Use a goggles to protect your eye.**

# CYLINDER BLOCK

[VQ35DE]

2. Install each plug to cylinder block as shown in the figure.

- Apply sealant to the thread of water drain plugs "A", "B" and "C".

**Use Genuine RTV Silicone Sealant or equivalent. Refer to [GI-48, "RECOMMENDED CHEMICAL PRODUCTS AND SEALANTS"](#) .**

- Apply sealant to the thread of plugs "D" and "E".

**Use Genuine High Strength Thread Locking Sealant or equivalent. Refer to [GI-48, "RECOMMENDED CHEMICAL PRODUCTS AND SEALANTS"](#) .**

- Apply sealant to the thread of plug "F".

**Use Anaerobic Liquid Gasket or equivalent. Refer to [GI-48, "RECOMMENDED CHEMICAL PRODUCTS AND SEALANTS"](#) .**

**NOTE:**

For Canada, "F" in the figure is not plug but block heater. Refer to [EM-123, "Components"](#) .

- Replace washers with new one.

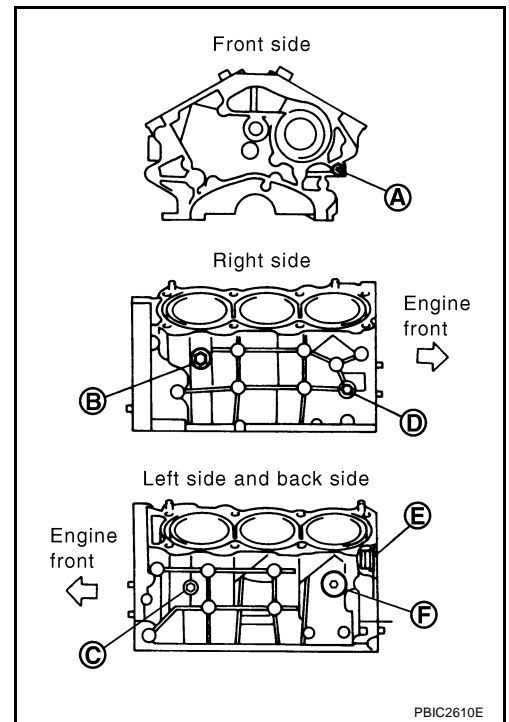

- Tighten each plug as specified below.

Part	Washer	Tightening torque
A	No	9.8 N·m (1.0 kg-m, 87 in-lb)
B	No	19.6 N·m (2.0 kg-m, 14 ft-lb)
C	No	19.6 N·m (2.0 kg-m, 14 ft-lb)
D	Yes	12.3 N·m (1.3 kg-m, 9 ft-lb)
E	Yes	62 N·m (6.3 kg-m, 46 ft-lb)
F	Yes	62 N·m (6.3 kg-m, 46 ft-lb)

3. Install oil jet.

- Insert oil jet dowel pin into cylinder block dowel pin hole, and tighten mounting bolts.

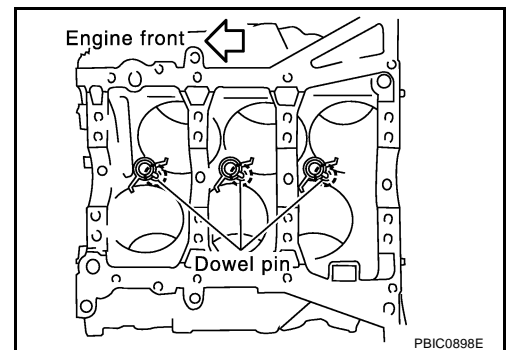

4. Install main bearings and thrust bearings as follows:

**CAUTION:**

**Be careful not to drop main bearing, and to scratch the surface.**

- Remove dust, dirt, and engine oil on bearing mating surfaces of cylinder block and main bearing caps.

# CYLINDER BLOCK

[VQ35DE]

- b. Install thrust bearings to the both sides of the No. 3 journal housing on cylinder block and main bearing cap.
- Install thrust bearings with the oil groove facing crankshaft arm (outside).
  - Install thrust bearing with a protrusion on one end on cylinder block, and thrust bearing with a protrusion at center on main bearing cap. Align each protrusion with mating notch.

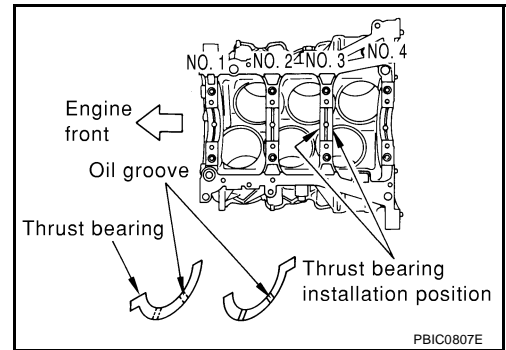

- c. Install main bearings paying attention to the direction.
- Main bearing with oil hole and groove goes on cylinder block. The one without them goes on main bearing cap.
  - Before installing main bearings, apply engine oil to the bearing surface (inside). Do not apply engine oil to the back surface, but thoroughly clean it.
  - When installing, align main bearing stopper protrusion to cut-out of cylinder block and main bearing caps.
  - Ensure the oil holes on cylinder block and those on the corresponding bearing are aligned.

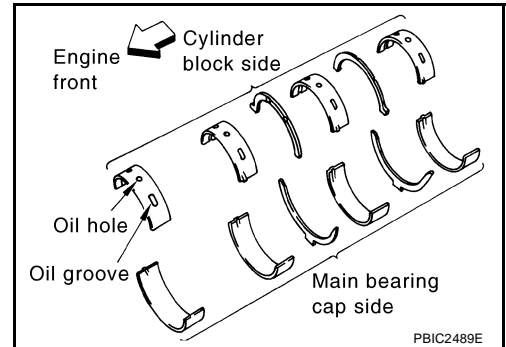

5. Install crankshaft to cylinder block.
- While turning crankshaft by hand, check that it turns smoothly.
6. Install main bearing cap.
- Main bearing caps are identified by identification mark cast on them. For installation, face front mark to front side.

**NOTE:**

Main bearing cap cannot be replaced as a single part, because it is machined together with cylinder block.

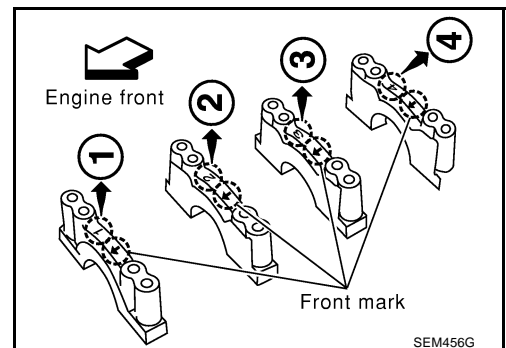

7. Install main bearing beam.
- Install main bearing beam with front mark facing downward (oil pan side) and front mark facing front of the engine.

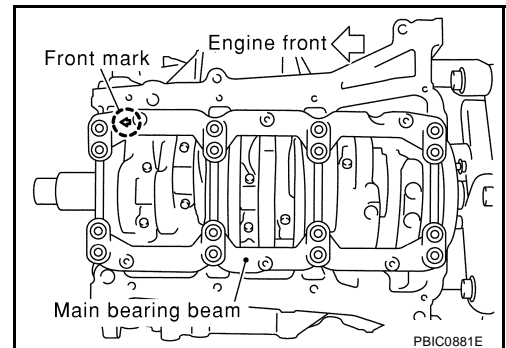

# CYLINDER BLOCK

[VQ35DE]

8. Install main bearing cap bolts in numerical order as shown in the figure as follows:
  - a. Inspect the outer diameter of main bearing cap bolt. Refer to [EM-148, "MAIN BEARING CAP BOLT OUTER DIAMETER"](#).
  - b. Apply new engine oil to threads and seat surfaces of main bearing cap bolts.
  - c. Tighten main bearing cap bolts in several different steps.

: 35.3 N·m (3.6 kg-m, 26 ft-lb)

- d. Turn all main bearing cap bolts 90 degrees clockwise (Angle tightening).

**CAUTION:**

Use the angle wrench [SST: KV10112100 (BT8653-A)] to check tightening angle. Do not make judgment by visual inspection.

- After installing main bearing cap bolts, make sure that crankshaft can be rotated smoothly by hand.
- Check the crankshaft end play. Refer to [EM-140, "CRANK-SHAFT END PLAY"](#).

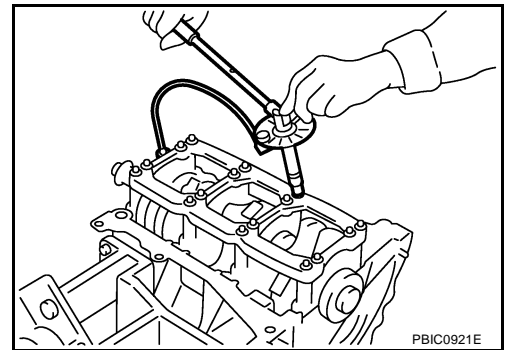
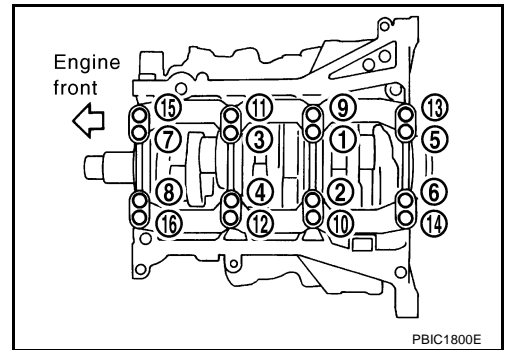

9. Install piston to connecting rod as follows:

- a. Using a snap ring pliers, install new snap ring to the groove of piston rear side.

- Insert it fully into groove to install.

- b. Install piston to connecting rod.

- Using an industrial use drier or similar tool, heat piston until piston pin can be pushed in by hand without excess force [approx. 60 to 70°C (140 to 158°F)]. From the front to the rear, insert piston pin into piston and connecting rod.
- Assemble so that the front mark on the piston head and the cylinder number on connecting rod are positioned as shown in the figure.

- c. Install new snap ring to the groove of the piston front side.

- Insert it fully into groove to install.

- After installing, make sure that connecting rod moves smoothly.

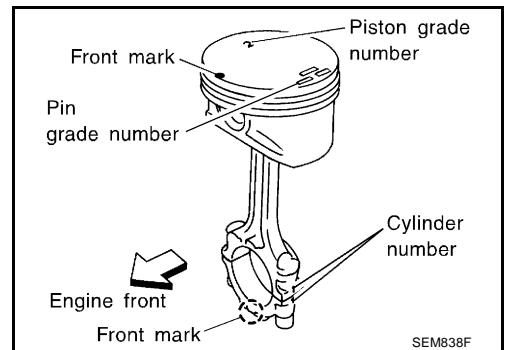

10. Using a piston ring expander (commercial service tool), install piston rings.

**CAUTION:**

- When installing piston rings, be careful not to damage piston.
- Be careful not to damage piston rings by expending them excessively.

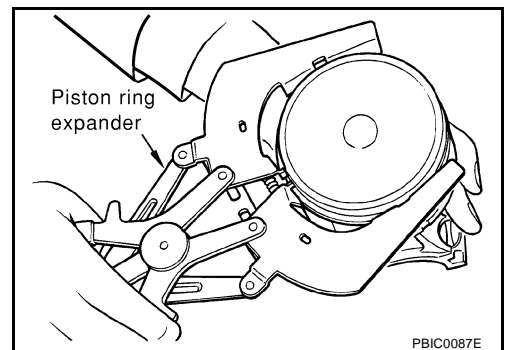

A  
EM  
C  
D  
E  
F  
G  
H  
I  
J  
K  
L  
M

# CYLINDER BLOCK

[VQ35DE]

- If there is stamped mark on ring, mount it with marked side up.

**NOTE:**

If there is no stamp on ring, no specific orientation is required for installation.

**Stamped mark:**

**Top ring** : —

**Second ring** : “R”

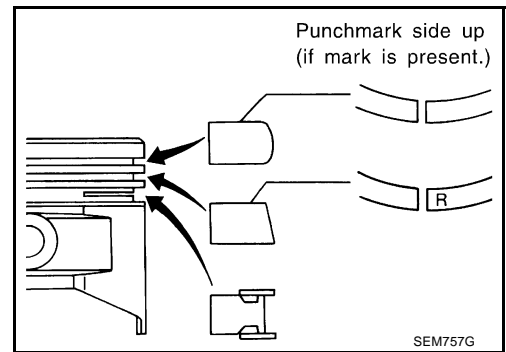

- Position each ring with the gap as shown in the figure referring to the piston front mark.

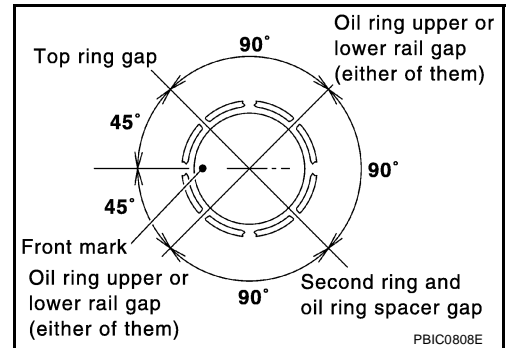

- Check the piston ring side clearance. Refer to [EM-141, "PISTON RING SIDE CLEARANCE"](#).

11. Install connecting rod bearings to connecting rod and connecting rod bearing cap.

**CAUTION:**

**Be careful not to drop connecting rod bearing, and to scratch the surface.**

- Before installing connecting rod bearings, apply engine oil to the bearing surface (inside). Do not apply engine oil to the back surface, but thoroughly clean it.
- When installing, align connecting rod bearing stopper protrusion with cutout of connecting rods and connecting rod bearing caps to install.
- Ensure the oil hole on connecting rod and that on the corresponding bearing are aligned.

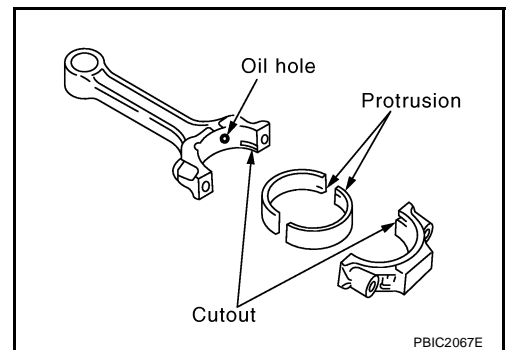

12. Install piston and connecting rod assembly to crankshaft.

- Position crankshaft pin corresponding to connecting rod to be installed onto the bottom dead center.
- Apply engine oil sufficiently to the cylinder bore, piston and crankshaft pin journal.
- Match the cylinder position with the cylinder number on connecting rod to install.
- Be sure that front mark on piston crown is facing front of engine.
- Using a piston ring compressor (SST) or suitable tool, install piston with the front mark on the piston crown facing the front of the engine.

**CAUTION:**

**Be careful not to damage the cylinder wall and crankshaft pin, resulting from an interference of the connecting rod big end.**

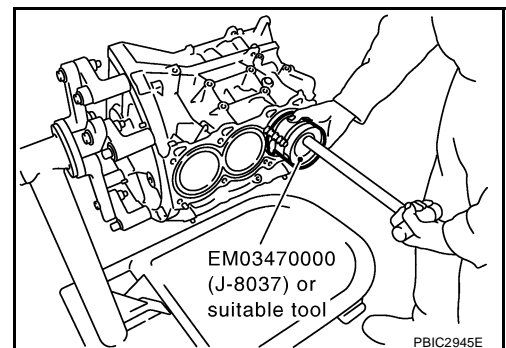



### 13. Install connecting rod bearing cap.

- Match the stamped cylinder number marks on connecting rod with those on connecting rod bearing cap to install.
- Be sure that front mark on connecting rod bearing cap is facing front of the engine.

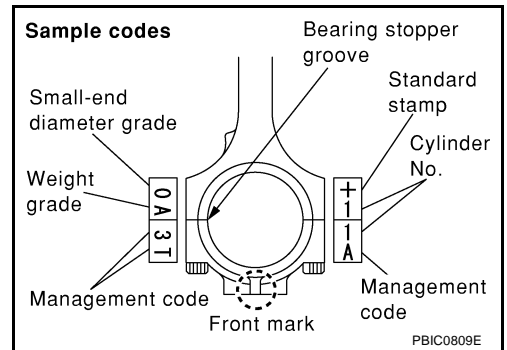

### 14. Tighten connecting rod bolt as follows:

- Inspect the outer diameter of connecting rod bolt. Refer to [EM-149, "CONNECTING ROD BOLT OUTER DIAMETER"](#).
- Apply engine oil to the threads and seats of connecting rod bolts.
- Tighten connecting rod bolts.

: 19.6 N·m (2.0 kg·m, 14 ft·lb)

- Then tighten all connecting rod bolts 90 degrees clockwise (Angle tightening).

#### CAUTION:

**Always use the angle wrench [SST: KV10112100 (BT8653-A)]. Avoid tightening based on visual check alone.**

- After tightening connecting rod bolts, make sure that crankshaft rotates smoothly.
- Check the connecting rod side clearance. Refer to [EM-140, "CONNECTING ROD SIDE CLEARANCE"](#).

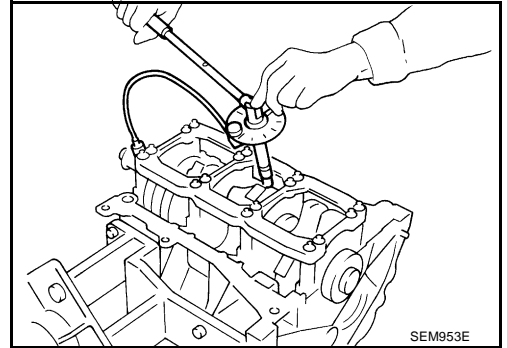

### 15. Install baffle plate to main bearing beam (2WD models).

### 16. Install new rear oil seal retainer to cylinder block.

- Apply new engine oil to both oil seal lip and dust seal lip.
- Apply a continuous bead of liquid gasket with the tube presser [SST: WS39930000 ( — )] to rear oil seal retainer as shown in the figure.

**Use Genuine RTV Silicone Sealant or equivalent. Refer to [GI-48, "RECOMMENDED CHEMICAL PRODUCTS AND SEALANTS"](#).**

#### CAUTION:

- Replace with a new parts.
- Attaching should be done within 5 minutes after coating.
- Make sure the garter spring is in position and seal lips not inverted.

#### NOTE:

Regard both rear oil seal and retainer as an assembly.

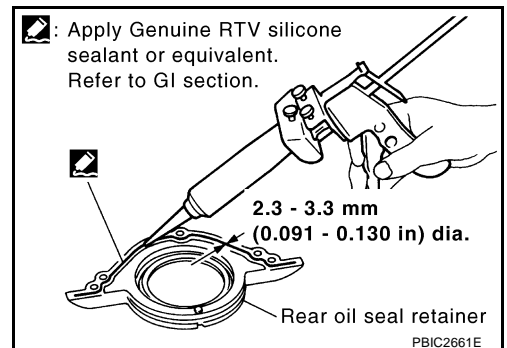

17. Install pilot converter.

- With a drift [outer diameter: approx. 33 mm (1.30 in)], press-fit as far as it will go.

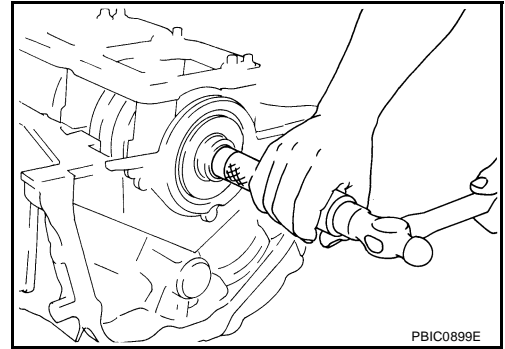

- Press-fit pilot converter with its chamfer facing crankshaft as shown in the figure.

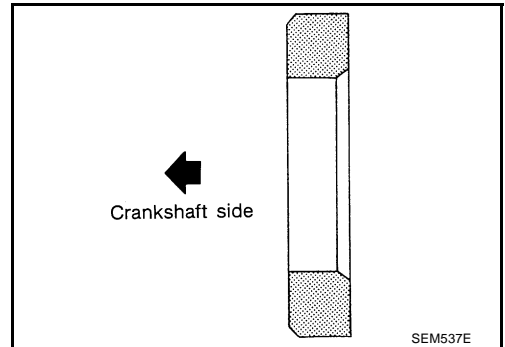

18. Install knock sensor.

- Install knock sensor so that connector faces front of the engine.
- After installing knock sensor, connect harness connector, and lay it out to rear of the engine.

**CAUTION:**

- Do not tighten mounting bolts while holding connector.
- If any impact by dropping is applied to knock sensor, replace it with new one.

**NOTE:**

- Make sure that there is no foreign material on the cylinder block mating surface and the back surface of knock sensor.
- Make sure that knock sensor does not interfere with other parts.

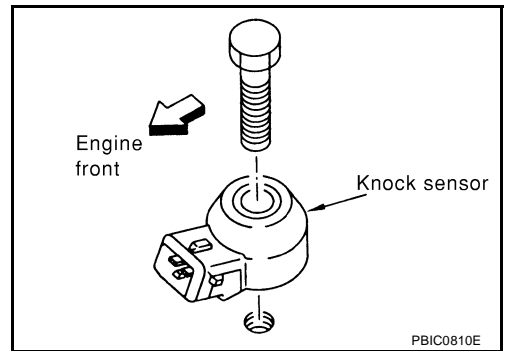

19. Note the following, assemble in the reverse order of disassembly after this step.

**Drive plate**

- When installing drive plate to crankshaft, be sure to correctly align crankshaft side dowel pin and drive plate side dowel pin hole.

**CAUTION:**

**If these are not aligned correctly, engine runs roughly and "MIL" turns on.**

- Install drive plate and reinforcement plate as shown in the figure.
- Holding ring gear with the ring gear stopper [SST: KV10117700 (J44716)].
- Tighten the mounting bolts crosswise over several times.

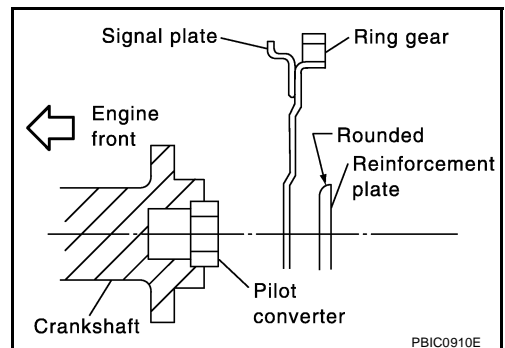

## How to Select Piston and Bearing

### DESCRIPTION

Selection points	Selection parts	Selection items	Selection methods
Between cylinder block and crankshaft	Main bearing	Main bearing grade (bearing thickness)	Determined by match of cylinder block bearing housing grade (inner diameter of housing) and crankshaft journal grade (outer diameter of journal)
Between crankshaft and connecting rod	Connecting rod bearing	Connecting rod bearing grade (bearing thickness)	Combining service grades for connecting rod big end diameter and crankshaft pin outer diameter determine connecting rod bearing selection.
Between cylinder block and piston	Piston and piston pin assembly (Piston is available together with piston pin as assembly.)	Piston grade (piston skirt diameter)	Piston grade = cylinder bore grade (inner diameter of bore)
Between piston and connecting rod*	—	—	—

\*: For the service parts, the grade for fitting cannot be selected between piston pin and connecting rod. (Only "0" grade is available.) The information at the shipment from the plant is described as a reference.

- The identification grade stamped on each part is the grade for the dimension measured in new condition. This grade cannot apply to reused parts.
- For reused or repaired parts, measure the dimension accurately. Determine the grade by comparing the measurement with the values of each selection table.
- For details of the measurement method of each part, the reuse standards and the selection method of the selective fitting parts, refer to the text.

### HOW TO SELECT PISTON

#### When New Cylinder Block is Used

Check the cylinder bore grade ("1", "2" or "3") on rear side of cylinder block, and select piston of the same grade.

#### NOTE:

Piston is available with piston pin as a set for the service part. (Only "0" grade piston pin is available.)

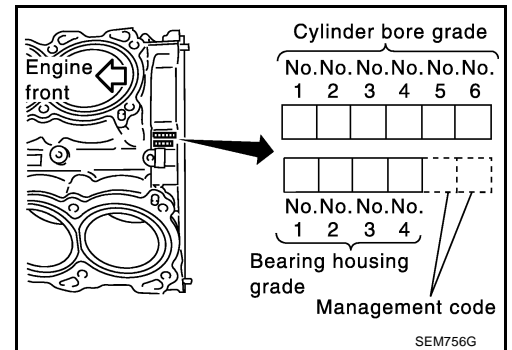

#### When Cylinder Block is Reused

1. Measure the cylinder bore inner diameter. Refer to [EM-144, "Cylinder Bore inner Diameter"](#).
2. Determine the bore grade by comparing the measurement with the values under the cylinder bore inner diameter of the "Piston Selection Table".

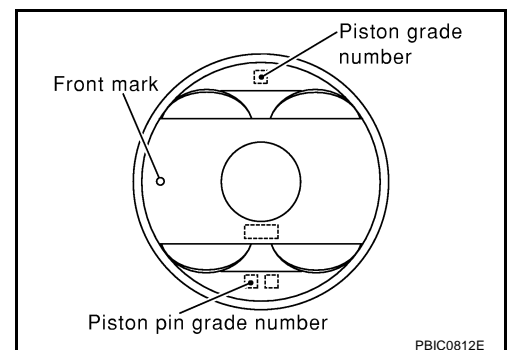

3. Select piston of the same grade.

# CYLINDER BLOCK

[VQ35DE]

## Piston Selection Table

Unit: mm (in)

Grade	1	2 (or no mark)	3
Cylinder bore inner diameter	95.500 - 95.510 (3.7598 - 3.7602)	95.510 - 95.520 (3.7602 - 3.7606)	95.520 - 95.530 (3.7606 - 3.7610)
Piston skirt diameter	95.480 - 95.490 (3.7590 - 3.7594)	95.490 - 95.500 (3.7594 - 3.7598)	95.500 - 95.510 (3.7598 - 3.7602)

### NOTE:

- Piston is available together with piston pin as assembly.
- Piston pin (piston pin hole) grade is provided only for the parts installed at the plant. For service parts, no piston pin grades can be selected. (Only "0" grade is available.)
- No second grade mark is available on piston.

## HOW TO SELECT CONNECTING ROD BEARING

### When New Connecting Rod and Crankshaft are Used

Check pin diameter grade ("0", "1" or "2") on front of crankshaft, and select connecting rod bearing of the same grade.

### NOTE:

There is no grading for connecting rod big end diameter.

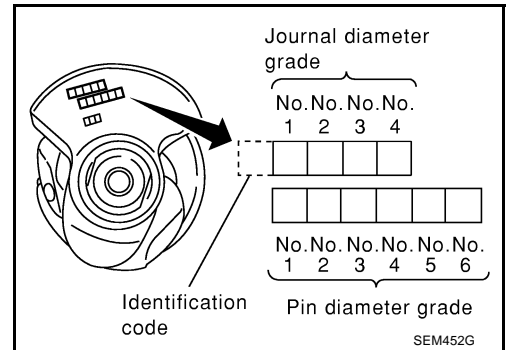

### When Crankshaft and Connecting Rod are Reused

1. Measure the connecting rod big end diameter. Refer to [EM-142, "CONNECTING ROD BIG END DIAMETER"](#).
2. Make sure that the connecting rod big end diameter is within the standard value.
3. Measure the crankshaft pin journal diameter. Refer to [EM-146, "CRANKSHAFT PIN JOURNAL DIAMETER"](#).
4. Determine the grade of crankshaft pin diameter grade by corresponding to the measured dimension in "Crankshaft pin journal diameter" column of "Connecting Rod Bearing Selection Table".
5. Select connecting rod bearing of the same grade.

## Connecting Rod Bearing Selection Table

Unit: mm (in)

Connecting rod big end diameter	55.000 - 55.013 (2.1654 - 2.1659)
---------------------------------	-----------------------------------

Unit: mm (in)

Crankshaft		Connecting rod bearing		
Crankshaft pin journal diameter	Grade (Mark)	Dimension (Bearing thickness range)	Bearing grade No.	Color
51.968 - 51.974 (2.0460 - 2.0462)	0	1.500 - 1.503 (0.0591 - 0.0592)	STD 0	Black
51.962 - 51.968 (2.0457 - 2.0460)	1	1.503 - 1.506 (0.0592 - 0.0593)	STD 1	Brown
51.956 - 51.962 (2.0455 - 2.0457)	2	1.506 - 1.509 (0.0593 - 0.0594)	STD 2	Green

## Undersize Bearings Usage Guide

- When the specified connecting rod bearing oil clearance is not obtained with standard size connecting rod bearings, use undersize (US) bearings.
- When using undersize (US) bearing, measure the connecting rod bearing inner diameter with bearing installed, and grind crankshaft pin so that the connecting rod bearing oil clearance satisfies the standard.

# CYLINDER BLOCK

[VQ35DE]

**CAUTION:**

In grinding crankshaft pin to use undersize bearings, keep the fillet R [1.5 - 1.7 mm (0.059 - 0.067 in)].

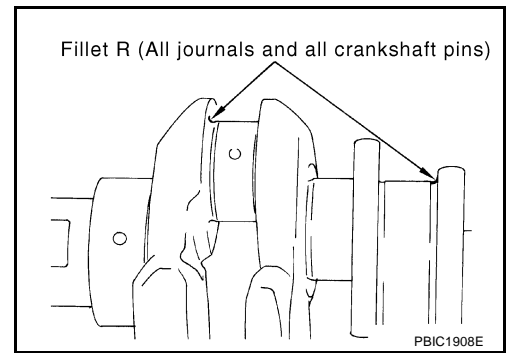

A  
EM  
C  
D  
E  
F  
G  
H  
I  
J  
K  
L  
M

**Bearing undersize table**

Unit: mm (in)

Size	Thickness
US 0.25 (0.0098)	1.626 - 1.634 (0.0640 - 0.0643)

**HOW TO SELECT MAIN BEARING**

**When New Cylinder Block and Crankshaft are Used**

1. "Main Bearing Selection Table" rows correspond to bearing housing grade on rear left side of cylinder block.

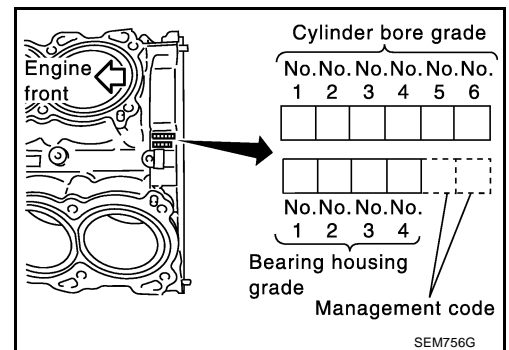

2. "Main Bearing Selection Table" columns correspond to journal diameter grade on front side of crankshaft.

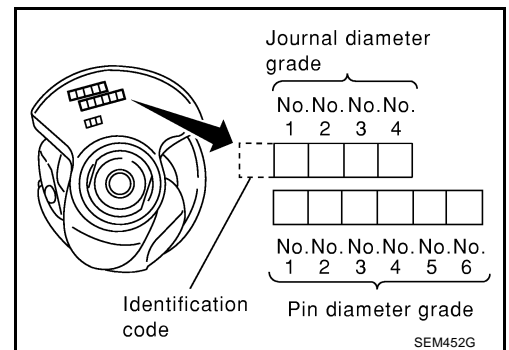

3. Select main bearing grade at the point where selected row and column meet in "Main Bearing Selection Table".

**When Cylinder Block and Crankshaft are Reused**

1. Measure cylinder block main bearing housing inner diameter and crankshaft main journal diameter. Refer to [EM-144, "MAIN BEARING HOUSING INNER DIAMETER"](#) and [EM-145, "CRANKSHAFT MAIN JOURNAL DIAMETER"](#).
2. Correspond the measured dimension in "Cylinder block main bearing housing inner diameter" row of "Main Bearing Selection Table".
3. Correspond the measured dimension in "Crankshaft main journal diameter" column of "Main Bearing Selection Table".
4. Select main bearing grade at the point where selected row and column meet in following selection table.

# CYLINDER BLOCK

[VQ35DE]

**Main Bearing Selection Table**

Cylinder block main bearing housing inner diameter Unit: mm (in)  Crankshaft main journal diameter Unit: mm (in)		Hole diameter																								
		Mark																								
Axle diameter		A	B	C	D	E	F	G	H	J	K	L	M	N	P	R	S	T	U	V	W	X	Y	4	7	
Mark		63.993 - 63.994 (2.5194 - 2.5194)	63.994 - 63.995 (2.5194 - 2.5195)	63.995 - 63.996 (2.5195 - 2.5195)	63.996 - 63.997 (2.5195 - 2.5196)	63.997 - 63.998 (2.5196 - 2.5196)	63.998 - 63.999 (2.5196 - 2.5196)	63.999 - 64.000 (2.5196 - 2.5197)	64.000 - 64.001 (2.5197 - 2.5197)	64.001 - 64.002 (2.5197 - 2.5198)	64.002 - 64.003 (2.5198 - 2.5198)	64.003 - 64.004 (2.5198 - 2.5198)	64.004 - 64.005 (2.5198 - 2.5199)	64.005 - 64.006 (2.5199 - 2.5199)	64.006 - 64.007 (2.5199 - 2.5200)	64.007 - 64.008 (2.5200 - 2.5200)	64.008 - 64.009 (2.5200 - 2.5200)	64.009 - 64.010 (2.5200 - 2.5201)	64.010 - 64.011 (2.5201 - 2.5201)	64.011 - 64.012 (2.5201 - 2.5202)	64.012 - 64.013 (2.5202 - 2.5202)	64.013 - 64.014 (2.5202 - 2.5202)	64.014 - 64.015 (2.5202 - 2.5203)	64.015 - 64.016 (2.5203 - 2.5203)	64.016 - 64.017 (2.5203 - 2.5203)	
A	59.975 - 59.974 (2.3612 - 2.3612)	0	0	0	0	01	01	01	1	1	1	12	12	12	2	2	2	23	23	23	3	3	3	34	34	34
B	59.974 - 59.973 (2.3612 - 2.3611)	0	0	01	01	01	1	1	1	1	12	12	12	2	2	2	23	23	23	3	3	3	34	34	34	4
C	59.973 - 59.972 (2.3611 - 2.3611)	0	01	01	01	1	1	1	1	12	12	12	2	2	2	23	23	23	3	3	3	34	34	34	4	4
D	59.972 - 59.971 (2.3611 - 2.3611)	01	01	01	1	1	1	1	12	12	12	2	2	2	23	23	23	3	3	3	34	34	34	4	4	4
E	59.971 - 59.970 (2.3611 - 2.3610)	01	01	1	1	1	1	12	12	12	2	2	2	23	23	23	3	3	3	34	34	34	4	4	4	45
F	59.970 - 59.969 (2.3610 - 2.3610)	01	1	1	1	1	12	12	12	2	2	2	23	23	23	3	3	3	34	34	34	4	4	4	45	45
G	59.969 - 59.968 (2.3610 - 2.3609)	1	1	1	12	12	12	2	2	2	23	23	23	3	3	3	34	34	34	4	4	4	45	45	45	45
H	59.968 - 59.967 (2.3609 - 2.3609)	1	1	12	12	12	2	2	2	23	23	23	3	3	3	34	34	34	4	4	4	45	45	45	45	5
J	59.967 - 59.966 (2.3609 - 2.3609)	1	12	12	12	2	2	2	23	23	23	3	3	3	34	34	34	4	4	4	45	45	45	45	5	5
K	59.966 - 59.965 (2.3909 - 2.3608)	12	12	12	2	2	2	23	23	23	3	3	3	34	34	34	4	4	4	45	45	45	45	5	5	5
L	59.965 - 59.964 (2.3608 - 2.3608)	12	12	2	2	2	23	23	23	3	3	3	34	34	34	4	4	4	45	45	45	45	5	5	5	56
M	59.964 - 59.963 (2.3608 - 2.3607)	12	2	2	2	23	23	23	3	3	3	34	34	34	4	4	4	45	45	45	45	5	5	5	56	56
N	59.963 - 59.962 (2.3607 - 2.3607)	2	2	2	23	23	23	3	3	3	34	34	34	4	4	4	45	45	45	45	5	5	5	56	56	56
P	59.962 - 59.961 (2.3607 - 2.3607)	2	2	23	23	23	3	3	3	34	34	34	4	4	4	45	45	45	45	5	5	5	56	56	56	6
R	59.961 - 59.960 (2.3607 - 2.3606)	2	23	23	23	3	3	3	34	34	34	4	4	4	45	45	45	45	5	5	5	56	56	56	6	6
S	59.960 - 59.959 (2.3606 - 2.3606)	23	23	23	3	3	3	34	34	34	4	4	4	45	45	45	45	5	5	5	56	56	56	6	6	6
T	59.959 - 59.958 (2.3606 - 2.3605)	23	23	3	3	3	34	34	34	4	4	4	45	45	45	45	5	5	5	56	56	56	6	6	6	67
U	59.958 - 59.957 (2.3605 - 2.3605)	23	3	3	3	34	34	34	4	4	4	45	45	45	45	5	5	5	56	56	56	6	6	6	67	67
V	59.957 - 59.956 (2.3605 - 2.3605)	3	3	3	34	34	34	4	4	4	45	45	45	45	5	5	5	56	56	56	6	6	6	67	67	67
W	59.956 - 59.955 (2.3605 - 2.3604)	3	3	34	34	34	4	4	4	45	45	45	45	5	5	5	56	56	56	6	6	6	67	67	67	7
X	59.955 - 59.954 (2.3604 - 2.3604)	3	34	34	34	4	4	4	45	45	45	45	5	5	5	56	56	56	6	6	6	67	67	67	7	7
Y	59.954 - 59.953 (2.3604 - 2.3603)	34	34	34	4	4	4	45	45	45	45	5	5	5	56	56	56	6	6	6	67	67	67	7	7	7
4	59.953 - 59.952 (2.3603 - 2.3603)	34	34	4	4	4	45	45	45	45	5	5	5	56	56	56	6	6	6	67	67	67	7	7	7	7
7	59.952 - 59.951 (2.3603 - 2.3603)	34	4	4	4	45	45	45	45	5	5	5	56	56	56	6	6	6	67	67	67	7	7	7	7	7

PBIC1981E

# CYLINDER BLOCK

[VQ35DE]

**Main Bearing Grade Table (All Journals)**

Grade number	Thickness Unit: mm (in)	Width Unit: mm (in)	Identification color	Remarks	
0	2.000 - 2.003 (0.0787 - 0.0789)	19.9 - 20.1 (0.783 - 0.791)	Black	Grade and color are the same for upper and lower bearings.	
1	2.003 - 2.006 (0.0789 - 0.0790)		Brown		
2	2.006 - 2.009 (0.0790 - 0.0791)		Green		
3	2.009 - 2.012 (0.0791 - 0.0792)		Yellow		
4	2.012 - 2.015 (0.0792 - 0.0793)		Blue		
5	2.015 - 2.018 (0.0793 - 0.0794)		Pink		
6	2.018 - 2.021 (0.0794 - 0.0796)		Purple		
7	2.021 - 2.024 (0.0796 - 0.0797)		White	Grade and color are different for upper and lower bearings.	
01	UPR		2.003 - 2.006 (0.0789 - 0.0790)		Brown
	LWR		2.000 - 2.003 (0.0787 - 0.0789)		Black
12	UPR		2.006 - 2.009 (0.0790 - 0.0791)		Green
	LWR		2.003 - 2.006 (0.0789 - 0.0790)		Brown
23	UPR		2.009 - 2.012 (0.0791 - 0.0792)		Yellow
	LWR		2.006 - 2.009 (0.0790 - 0.0791)		Green
34	UPR	2.012 - 2.015 (0.0792 - 0.0793)	Blue		
	LWR	2.009 - 2.012 (0.0791 - 0.0792)	Yellow		
45	UPR	2.015 - 2.018 (0.0793 - 0.0794)	Pink		
	LWR	2.012 - 2.015 (0.0792 - 0.0793)	Blue		
56	UPR	2.018 - 2.021 (0.0794 - 0.0796)	Purple		
	LWR	2.015 - 2.018 (0.0793 - 0.0794)	Pink		
67	UPR	2.021 - 2.024 (0.0796 - 0.0797)	White		
	LWR	2.018 - 2.021 (0.0794 - 0.0796)	Purple		

**Undersize Bearing Usage Guide**

- When the specified main bearing oil clearance is not obtained with standard size main bearings, use underside (US) bearing.
- When using undersize (US) bearing, measure the main bearing inner diameter with bearing installed, and grind main journal so that the main bearing oil clearance satisfies the standard.

**CAUTION:**

**In grinding crankshaft main journal to use undersize bearings, keep the fillet R [1.5 - 1.7 mm (0.059 - 0.067 in)].**

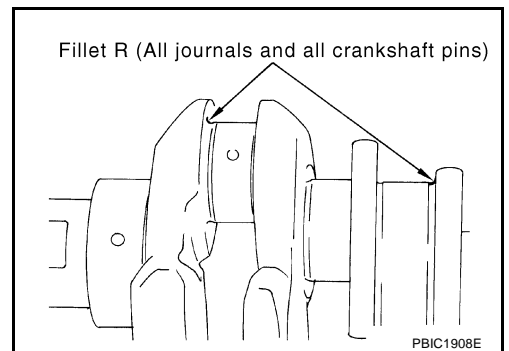

**Bearing undersize table**

Unit: mm (in)

Size	Thickness
US 0.25 (0.0098)	2.132 - 2.140 (0.0839 - 0.0843)

## Inspection after Disassembly CRANKSHAFT END PLAY

- Measure the clearance between thrust bearings and crankshaft arm when crankshaft is moved fully forward or backward with a dial indicator.

**Standard : 0.10 - 0.25 mm (0.0039 - 0.0098 in)**

**Limit : 0.30 mm (0.012 in)**

- If the measured value exceeds the limit, replace thrust bearings, and measure again. If it still exceeds the limit, replace crankshaft also.

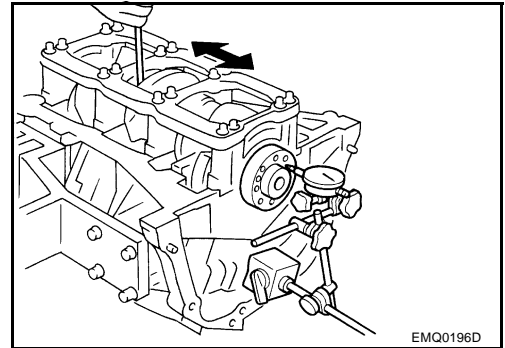

## CONNECTING ROD SIDE CLEARANCE

- Measure the side clearance between connecting rod and crankshaft arm with a feeler gauge.

**Standard : 0.20 - 0.35 mm (0.0079 - 0.0138 in)**

**Limit : 0.40 mm (0.016 in)**

- If the measured value exceeds the limit, replace connecting rod, and measure again. If it still exceeds the limit, replace crankshaft also.

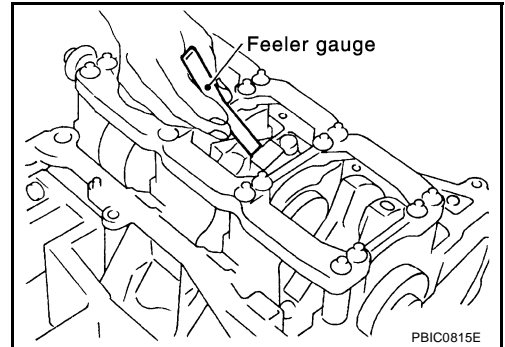

## PISTON TO PISTON PIN OIL CLEARANCE

### Piston Pin Hole Diameter

Measure the inner diameter of piston pin hole with an inside micrometer.

**Standard : 21.993 - 22.005 mm (0.8659 - 0.8663 in)**

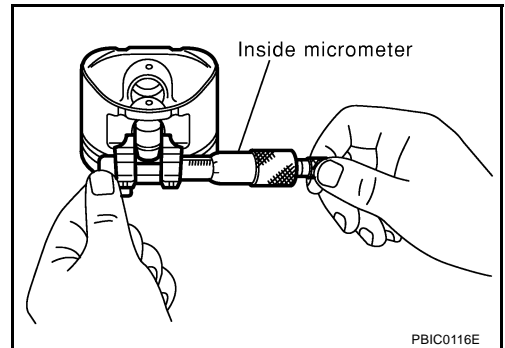

### Piston Pin Outer Diameter

Measure the outer diameter of piston pin with a micrometer.

**Standard : 21.989 - 22.001 mm (0.8657 - 0.8662 in)**

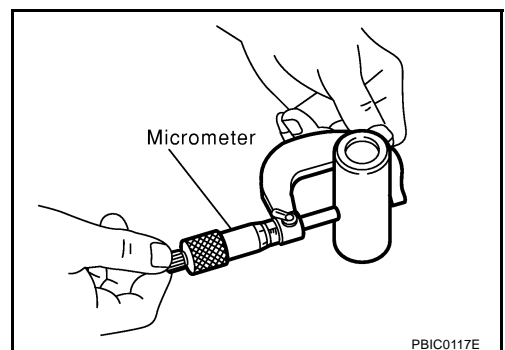

### Piston to Piston Pin Oil Clearance

(Piston to piston pin oil clearance) = (Piston pin hole diameter) – (Piston pin outer diameter)

**Standard : 0.002 - 0.006 mm (0.0001 - 0.0002 in)**

- If the calculated value is out of the standard, replace piston and piston pin assembly.



- When replacing piston and piston pin assembly, refer to [EM-135, "HOW TO SELECT PISTON"](#).

**NOTE:**

- Piston is available together with piston pin as assembly.
- Piston pin (piston pin hole) grade is provided only for the parts installed at the plant. For service parts, no piston pin grades can be selected. (Only "0" grade is available.)

**PISTON RING SIDE CLEARANCE**

- Measure the side clearance of piston ring and piston ring groove with a feeler gauge.

**Standard:**

- Top ring** : 0.045 - 0.080 mm (0.0018 - 0.0031 in)
- 2nd ring** : 0.030 - 0.070 mm (0.0012 - 0.0028 in)
- Oil ring** : 0.065 - 0.135 mm (0.0026 - 0.0053 in)

**Limit:**

- Top ring** : 0.11 mm (0.0043 in)
- 2nd ring** : 0.10 mm (0.004 in)

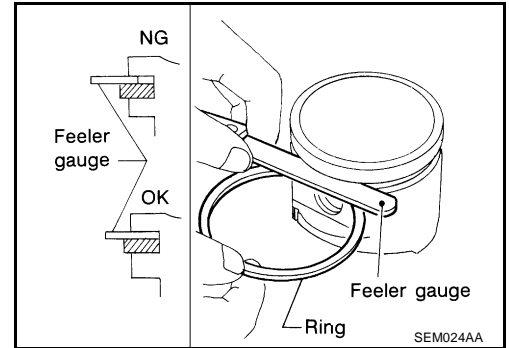

- If the measured value exceeds the limit, replace piston ring, and measure again. If it still exceeds the limit, replace piston also.

**PISTON RING END GAP**

- Make sure that the cylinder bore inner diameter is within the specification. Refer to [EM-144, "Cylinder Bore inner Diameter"](#).
- Lubricate with new engine oil to piston and piston ring, and then insert piston ring until middle of cylinder with piston, and measure the piston ring end gap with a feeler gauge.

**Standard:**

- Top ring** : 0.23 - 0.33 mm (0.0091 - 0.0130 in)
- 2nd ring** : 0.33 - 0.48 mm (0.0130 - 0.0189 in)
- Oil ring** : 0.20 - 0.50 mm (0.0079 - 0.0197 in)

**Limit:**

- Top ring** : 0.54 mm (0.0213 in)
- 2nd ring** : 0.80 mm (0.0315 in)
- Oil ring** : 0.95 mm (0.0374 in)

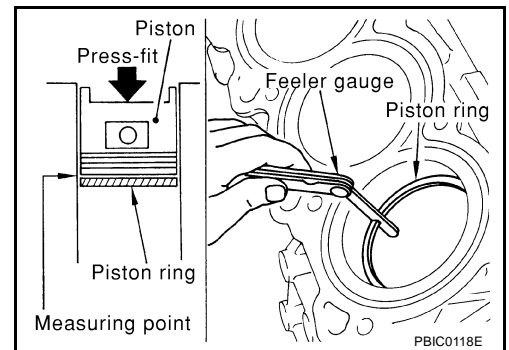

- If the measured value exceeds the limit, replace piston ring, and measure again. If it still exceeds the limit, re-bore cylinder and use oversize piston and piston rings.

## CONNECTING ROD BEND AND TORSION

- Check with a connecting rod aligner.

### Bend:

Limit : 0.15 mm (0.0059 in) per 100 mm (3.94 in) length

### Torsion:

Limit : 0.30 mm (0.012 in) per 100 mm (3.94 in) length

- If it exceeds the limit, replace connecting rod assembly.

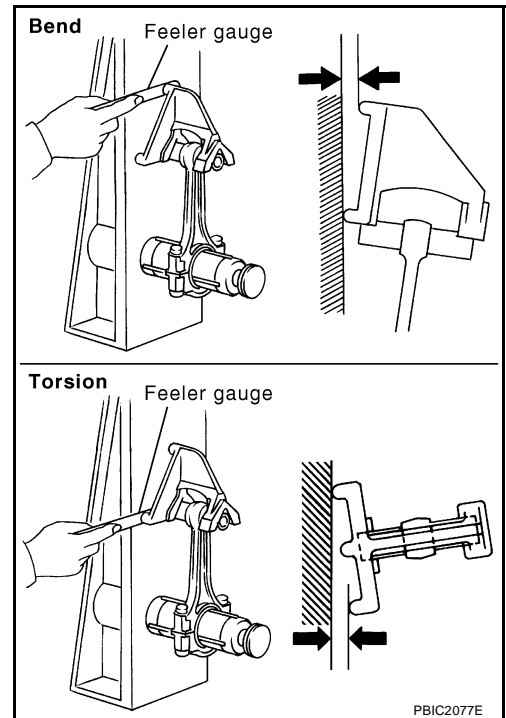

## CONNECTING ROD BIG END DIAMETER

- Install connecting rod bearing cap without installing connecting rod bearing, and tightening connecting rod bolts to the specified torque. Refer to [EM-128, "ASSEMBLY"](#) for the tightening procedure.
- Measure the inner diameter of connecting rod big end with an inside micrometer.

Standard : 55.000 - 55.013 mm (2.1654 - 2.1659 in)

- If out of the standard, replace connecting rod assembly.

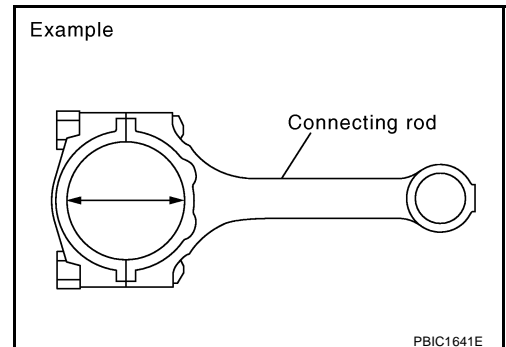

## CONNECTING ROD BUSHING OIL CLEARANCE

### Connecting Rod Bushing Inner Diameter

Measure the inner diameter of connecting rod bushing with an inside micrometer.

Standard : 22.000 - 22.012 mm (0.8661 - 0.8666 in)

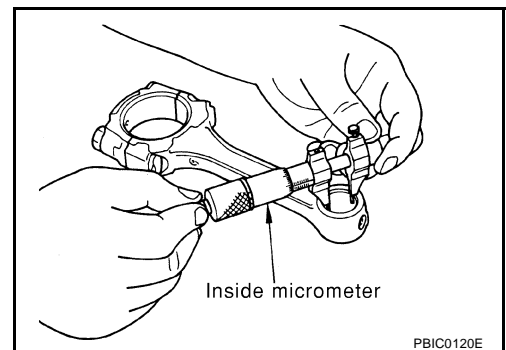

## Piston Pin Outer Diameter

Measure the outer diameter of piston pin with a micrometer.

**Standard : 21.989 - 22.001 mm (0.8657 - 0.8662 in)**

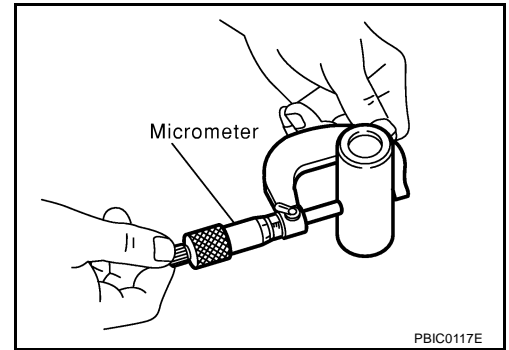

## Connecting Rod Bushing Oil Clearance

(Connecting rod bushing oil clearance) = (Connecting rod bushing inner diameter) – (Piston pin outer diameter)

**Standard : 0.005 - 0.017 mm (0.0002 - 0.0007 in)**

**Limit : 0.030 mm (0.0012 in)**

- If the calculated value exceeds the limit, replace connecting rod assembly and/or piston and piston pin assembly.
- If replacing piston and piston pin assembly, refer to [EM-135, "HOW TO SELECT PISTON"](#).
- If replacing connecting rod assembly, refer to [EM-146, "CONNECTING ROD BEARING OIL CLEARANCE"](#) to select the connecting rod bearing.

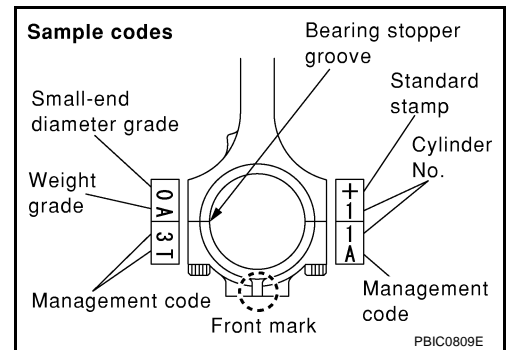

## Factory installed parts grading:

- Service parts apply only to grade "0".

Grade	Unit: mm (in)	
	0	1
Connecting rod bushing inner diameter *	22.000 - 22.006 (0.8661 - 0.8664)	22.006 - 22.012 (0.8664 - 0.8666)
Piston pin hole diameter	21.993 - 21.999 (0.8659 - 0.8661)	21.999 - 22.005 (0.8661 - 0.8663)
Piston pin outer diameter	21.989 - 21.995 (0.8657 - 0.8659)	21.995 - 22.001 (0.8659 - 0.8662)

\*: After installing in connecting rod

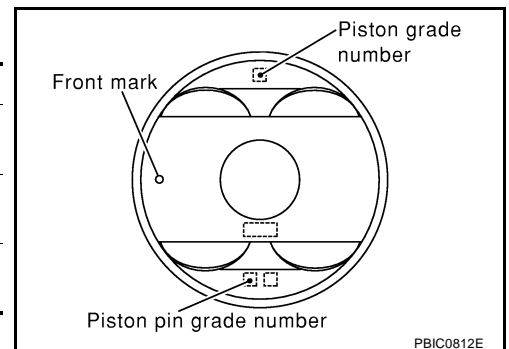

## CYLINDER BLOCK DISTORTION

- Using a scraper, remove gasket on the cylinder block surface, and also remove engine oil, scale, carbon, or other contamination.

**CAUTION:**

**Be careful not to allow gasket flakes to enter engine oil or engine coolant passages.**

# CYLINDER BLOCK

[VQ35DE]

- Measure the distortion on the cylinder block upper face at some different points in six directions with a straightedge and a feeler gauge.

**Limit : 0.1 mm (0.004 in)**

- If it exceeds the limit, replace cylinder block.

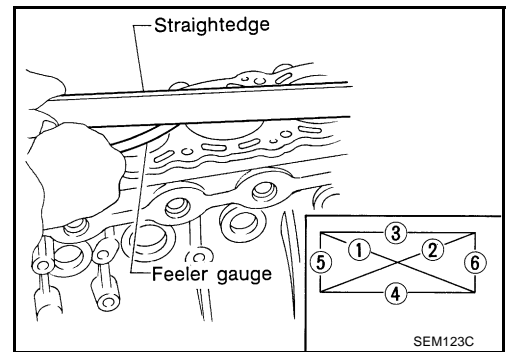

## MAIN BEARING HOUSING INNER DIAMETER

- Install main bearing caps and main bearing beam without installing main bearings, and tighten main bearing cap bolts to the specified torque. Refer to [EM-128, "ASSEMBLY"](#) for the tightening procedure.
- Measure the inner diameter of main bearing housing with a bore gauge.

**Standard : 63.993 - 64.017 mm (2.5194 - 2.5203 in)**

- If out of the standard, replace cylinder block and main bearing caps as assembly.

### NOTE:

Cylinder block cannot be replaced as a single part, because it is machined together with main bearing caps.

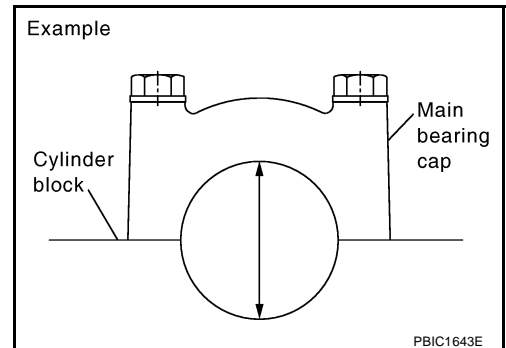

## PISTON TO CYLINDER BORE CLEARANCE

### Cylinder Bore inner Diameter

- Using a bore gauge, measure cylinder bore for wear, out-of-round and taper at six different points on each cylinder. ("X" and "Y" directions at "A", "B" and "C") ("X" is in longitudinal direction of engine)

### Standard inner diameter:

**95.500 - 95.530 mm (3.7598 - 3.7610 in)**

### Wear limit:

**0.20 mm (0.008 in)**

### Out-of-round (Difference between "X" and "Y"):

**Limit: 0.015 mm (0.0006 in)**

### Taper (Difference between "A" and "C"):

**Limit: 0.010 mm (0.0004 in)**

- If the measured value exceeds the limit, or if there are scratches and/or seizure on the cylinder inner wall, hone or re-bore the inner wall.
- Oversize piston is provided. When using oversize piston, re-bore cylinder so that the clearance of the piston-to-cylinder bore satisfies the standard.

### CAUTION:

When using oversize piston, use oversize pistons for all cylinders with oversize piston rings.

**Oversize (OS) : 0.2 mm (0.008 in)**

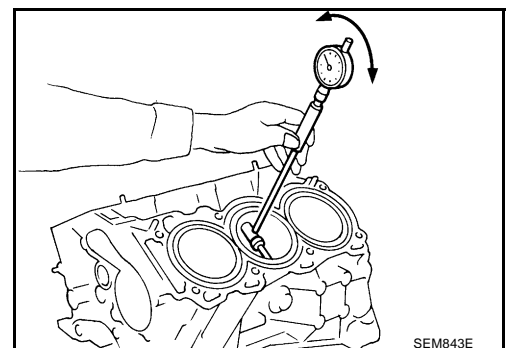
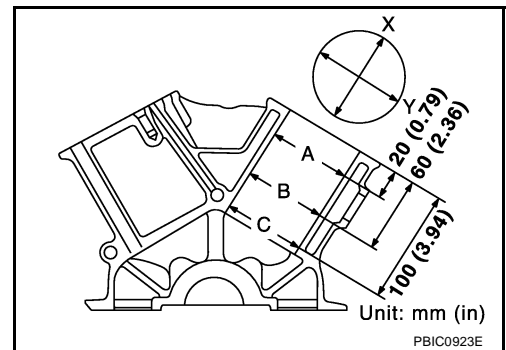

## Piston Skirt Diameter

Measure the outer diameter of piston skirt with a micrometer.

### Measure point

: Distance from the top 41.0 mm (1.614 in)

### Standard

: 95.480 - 95.510 mm (3.7590 - 3.7602 in)

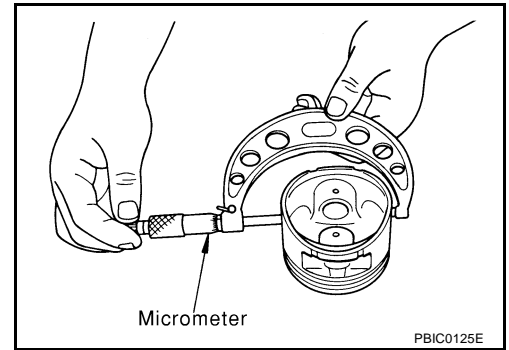

## Piston-to-Cylinder Bore Clearance

Calculate by piston skirt diameter and cylinder bore inner diameter (direction "Y", position "B").  
(Clearance) = (Cylinder bore inner diameter) – (Piston skirt diameter).

**Standard** : 0.010 - 0.030 mm (0.0004 - 0.0012 in)

**Limit** : 0.08 mm (0.0031 in)

- If the calculated value exceeds the limit, replace piston and piston pin assembly. Refer to [EM-135, "HOW TO SELECT PISTON"](#).

## Re-boring Cylinder Bore

1. Cylinder bore size is determined by adding piston to cylinder bore clearance to piston skirt diameter.

**Re-bored size calculation:  $D = A + B - C$**

where,

**D: Bored diameter**

**A: Piston skirt diameter as measured**

**B: Piston to cylinder bore clearance (standard value)**

**C: Honing allowance 0.02 mm (0.0008 in)**

2. Install main bearing caps and main bearing beam, and tighten to the specified torque. Otherwise, cylinder bores may be distorted in final assembly.

3. Cut cylinder bores.

### NOTE:

- When any cylinder needs boring, all other cylinders must also be bored.
- Do not cut too much out of cylinder bore at a time. Cut only 0.05 mm (0.0020 in) or so in diameter at a time.

4. Hone cylinders to obtain the specified piston to cylinder bore clearance.

5. Measure finished cylinder bore for the out-of-round and taper.

### NOTE:

Measurement should be done after cylinder bore cools down.

## CRANKSHAFT MAIN JOURNAL DIAMETER

- Measure the outer diameter of crankshaft main journals with a micrometer.

**Standard** : 59.951 - 59.975 mm (2.3603 - 2.3612 in) dia.

- If out of the standard, measure the main bearing oil clearance. Then use undersize bearing. Refer to [EM-147, "MAIN BEARING OIL CLEARANCE"](#).

## CRANKSHAFT PIN JOURNAL DIAMETER

- Measure the outer diameter of crankshaft pin journal with a micrometer.

**Standard : 51.956 - 51.974 mm (2.0455 - 2.0462 in) dia.**

- If out of the standard, measure the connecting rod bearing oil clearance. Then use undersize bearing. Refer to [EM-146, "CONNECTING ROD BEARING OIL CLEARANCE"](#).

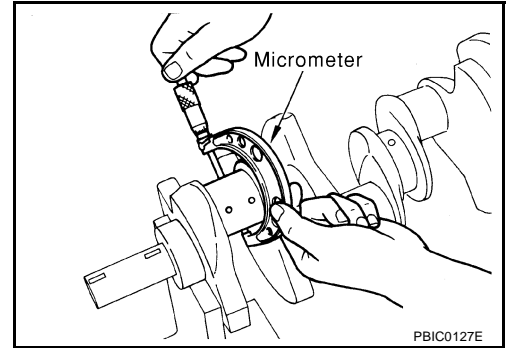

## CRANKSHAFT OUT-OF-ROUND AND TAPER

- Measure the dimensions at four different points as shown in the figure on each main journal and pin journal with a micrometer.
- Out-of-round is indicated by the difference in the dimensions between "X" and "Y" at "A" and "B".
- Taper is indicated by the difference in the dimensions between "A" and "B" at "X" and "Y".

**Limit:**

**Out-of-round (Difference between "X" and "Y")  
: 0.002 mm (0.0001 in)**

**Taper (Difference between "A" and "B")  
: 0.002 mm (0.0001 in)**

- If the measured value exceeds the limit, correct or replace crankshaft.
- If corrected, measure the bearing oil clearance of the corrected main journal and/or pin journal. Then select the main bearing and/or connecting rod bearing. Refer to [EM-147, "MAIN BEARING OIL CLEARANCE"](#) and/or [EM-146, "CONNECTING ROD BEARING OIL CLEARANCE"](#).

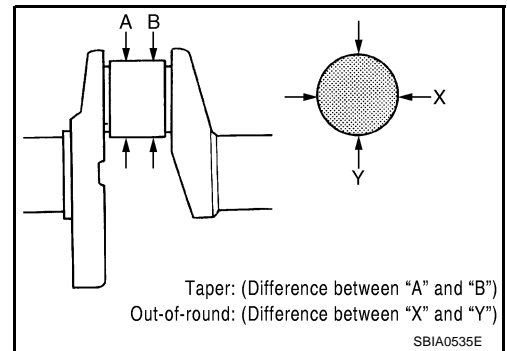

## CRANKSHAFT RUNOUT

- Place V-block on precise flat table, and support the journals on the both end of crankshaft.
- Place a dial indicator straight up on the No. 3 journal.
- While rotating crankshaft, read the movement of the pointer on a dial indicator. (Total indicator reading)

**Standard : Less than 0.05 mm (0.002 in)**

**Limit : 0.10 mm (0.004 in)**

- If it exceeds the limit, replace crankshaft.

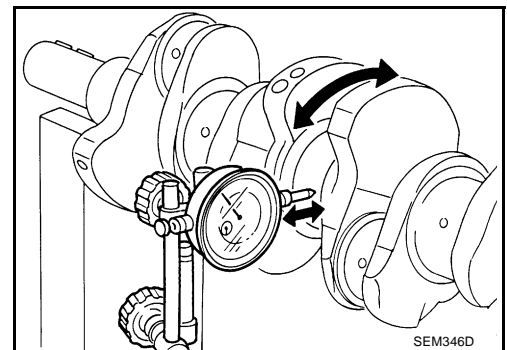

## CONNECTING ROD BEARING OIL CLEARANCE

### Method by Calculation

- Install connecting rod bearings to connecting rod and connecting rod cap, and tighten connecting rod bolts to the specified torque. Refer to [EM-128, "ASSEMBLY"](#) for the tightening procedure.
- Measure the inner diameter of connecting rod bearing with an inside micrometer.

(Oil clearance) = (Connecting rod bearing inner diameter) – (Crankshaft pin journal diameter)

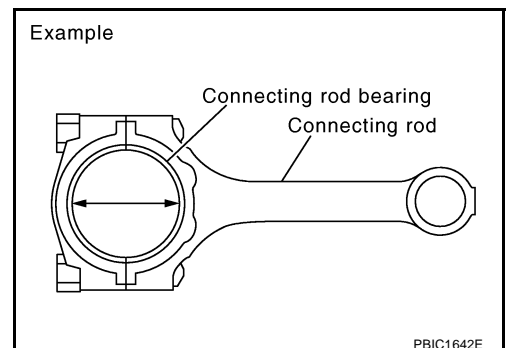

**Standard** : 0.034 - 0.059 mm (0.0013 - 0.0023 in)  
(actual clearance)

**Limit** : 0.070 mm (0.0028 in)

- If the calculated value exceeds the limit, select proper connecting rod bearing according to connecting rod big end diameter and crankshaft pin journal diameter to obtain the specified bearing oil clearance. Refer to [EM-136, "HOW TO SELECT CONNECTING ROD BEARING"](#).

## Method of Using Plastigage

- Remove oil and dust on crankshaft pin journal and the surfaces of each bearing completely.
- Cut a plastigage slightly shorter than the bearing width, and place it in crankshaft axial direction, avoiding oil holes.
- Install connecting rod bearings to connecting rod and connecting rod bearing cap, and tighten connecting rod bolts to the specified torque. Refer to [EM-128, "ASSEMBLY"](#) for the tightening procedure.

**CAUTION:**

**Do not rotate crankshaft.**

- Remove connecting rod bearing cap and bearings, and using the scale on the plastigage bag, measure the plastigage width.

**NOTE:**

The procedure when the measured value exceeds the limit is same as that described in the "Method by Calculation".

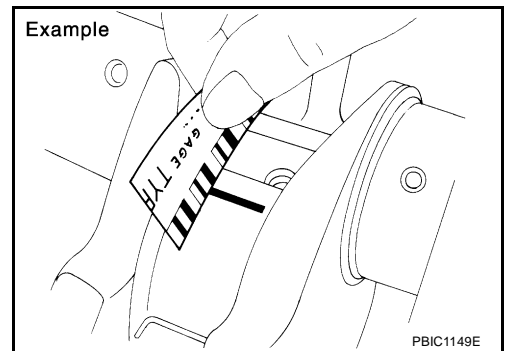

## MAIN BEARING OIL CLEARANCE

### Method by Calculation

- Install main bearings to cylinder block and main bearing caps, and tighten main bearing cap bolts with main bearing beam to the specified torque. Refer to [EM-128, "ASSEMBLY"](#) for the tightening procedure.

- Measure the inner diameter of main bearing with a bore gauge.  
(Oil clearance) = (Main bearing inner diameter) – (Crankshaft main journal diameter)

**Standard** : 0.035 - 0.045 mm (0.0014 - 0.0018 in)  
(actual clearance)

**Limit** : 0.065 mm (0.0026 in)

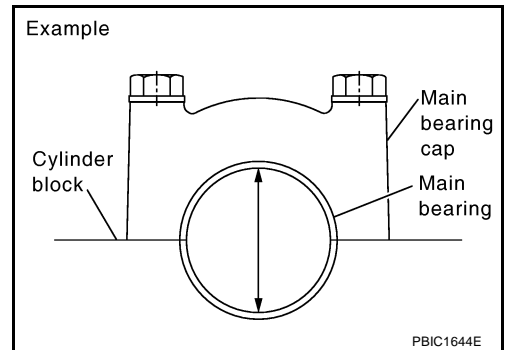

- If the calculated value exceeds the limit, select proper main bearing according to main bearing inner diameter and crankshaft main journal diameter to obtain the specified bearing oil clearance. Refer to [EM-137, "HOW TO SELECT MAIN BEARING"](#).

## Method of Using Plastigage

- Remove engine oil and dust on crankshaft journal and the surfaces of each bearing completely.
- Cut a plastigage slightly shorter than the bearing width, and place it in crankshaft axial direction, avoiding oil holes.
- Install main bearing to cylinder block and main bearing cap, and tighten main bearing bolts with main bearing beam to the specified torque. Refer to [EM-128, "ASSEMBLY"](#) for the tightening procedure.

**CAUTION:**

**Never rotate crankshaft.**



# CYLINDER BLOCK

[VQ35DE]

- Remove main bearing caps and bearings, and using the scale on the plastigage bag, measure the plastigage width.

**NOTE:**

The procedure when the measured value exceeds the limit is same as that described in the "Method by Calculation".

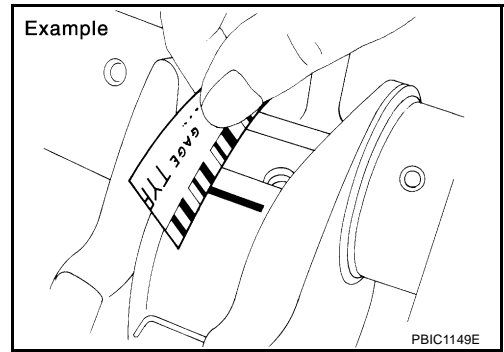

## MAIN BEARING CRUSH HEIGHT

- When main bearing cap is removed after being tightened to the specified torque with main bearings installed, the tip end of bearing must protrude. Refer to [EM-128, "ASSEMBLY"](#) for the tightening procedure.

**Standard** : There must be crush height.

- If the standard is not met, replace main bearings.

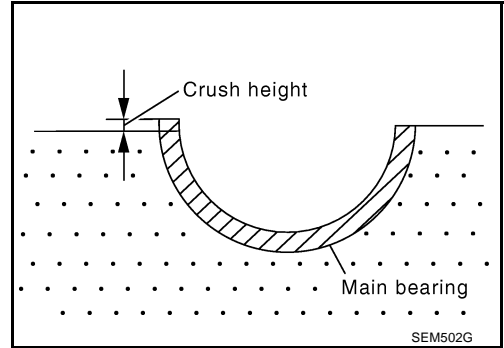

## CONNECTING ROD BEARING CRUSH HEIGHT

- When connecting rod bearing cap is removed after being tightened to the specified torque with connecting rod bearings installed, the tip end of bearing must protrude. Refer to [EM-128, "ASSEMBLY"](#) for the tightening procedure.

**Standard** : There must be crush height.

- If the standard is not met, replace connecting rod bearings.

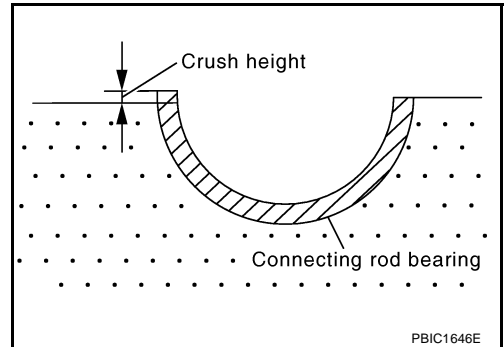

## MAIN BEARING CAP BOLT OUTER DIAMETER

- Measure the outer diameters ("d1", "d2") at two positions as shown in the figure.
- If reduction appears in "A" range, regard it as "d2".

**Limit ("d1" - "d2")** : 0.11 mm (0.0043 in)

- If it exceeds the limit (large difference in dimensions), replace main bearing cap bolt with new one.

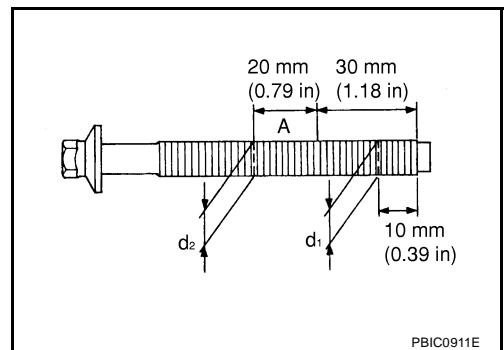



## CONNECTING ROD BOLT OUTER DIAMETER

- Measure the outer diameter "d" at position shown in the figure.
- If the reduction appears in a position other than "d", regard it as "d".

**Standard : 7.90 - 8.00 mm (0.3110 - 0.3150 in)**

**Limit : 7.75 mm (0.3051 in)**

- When "d" exceeds the limit (when it becomes thinner), replace connecting rod bolt with new one.

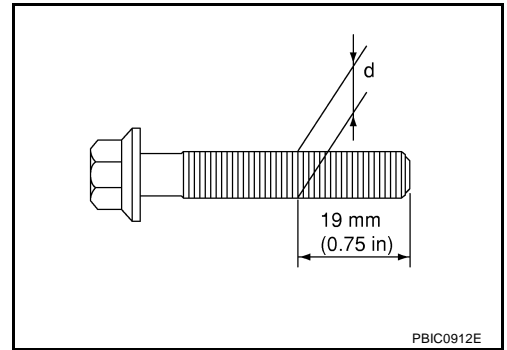

## DRIVE PLATE

- Check drive plate and signal plate for deformation or damage.

**CAUTION:**

- **Do not disassemble drive plate.**
- **Do not place drive plate with signal plate facing down.**
- **When handling signal plate, take care not to damage or scratch it.**
- **Handle signal plate in a manner that prevents it from becoming magnetized.**
- If anything is found, replace drive plate.

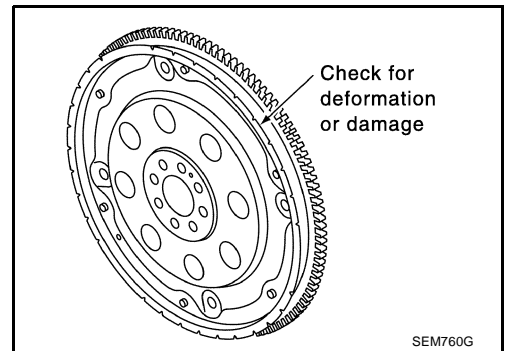

## OIL JET

- Check nozzle for deformation and damage.
- Blow compressed air from nozzle, and check for clogs.
- If it is not satisfied, clean or replace oil jet.

## OIL JET RELIEF VALVE

- Using a clean plastic stick, press check valve in oil jet relief valve. Make sure that valve moves smoothly with proper reaction force.
- If it is not satisfied, replace oil jet relief valve.

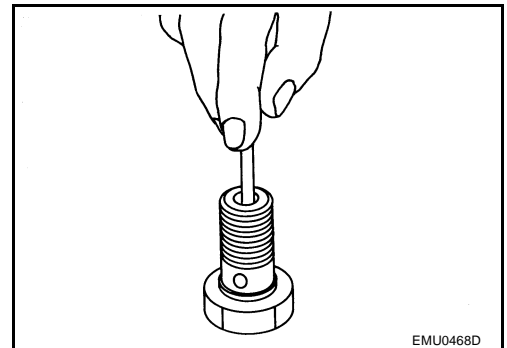

A  
EM  
C  
D  
E  
F  
G  
H  
I  
J  
K  
L  
M

# SERVICE DATA AND SPECIFICATIONS (SDS)

[VQ35DE]

## SERVICE DATA AND SPECIFICATIONS (SDS)

PFP:00100

### Standard and Limit GENERAL SPECIFICATIONS

NBS00404

Cylinder arrangement		V-6
Displacement cm <sup>3</sup> (cu in)		3,498 (213.45)
Bore and stroke mm (in)		95.5 x 81.4 (3.76 x 3.205)
Valve arrangement		DOHC
Firing order		1-2-3-4-5-6
Number of piston rings	Compression	2
	Oil	1
Number of main bearings		4
Compression ratio		10.3
Compression pressure kPa (kg/cm <sup>2</sup> , psi)/300 rpm	Standard	1,275 (13.0, 185)
	Minimum	981 (10.0, 142)
	Differential limit between cylinders	98 (1.0, 14)

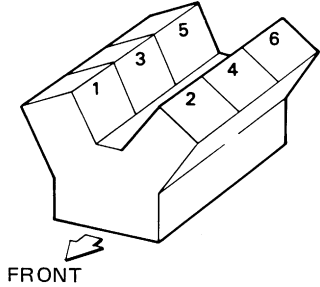
Cylinder number	 <p style="text-align: right; margin-top: 10px;">SEM713A</p>
-----------------	---

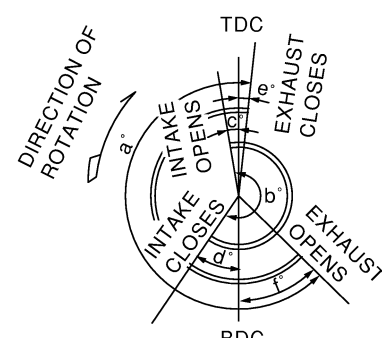
Valve timing (Intake valve timing control - "OFF")	 <p style="text-align: right; margin-top: 10px;">PBIC0187E</p>
---	--

Unit: degree

a	b	c	d	e	f
240	238	-6	64	8	52

# SERVICE DATA AND SPECIFICATIONS (SDS)

[VQ35DE]

## DRIVE BELT

	Deflection adjustment		Unit: mm (in)	Tension adjustment*		Unit: N (kg, lb)
	Used belt		New belt	Used belt		New belt
	Limit	After adjustment		Limit	After adjustment	
Alternator and power steering oil pump belt	7 (0.28)	4 - 5 (0.16 - 0.20)	3.5 - 4.5 (0.138 - 0.177)	294 (30, 66)	730 - 818 (74.5 - 83.5, 164 - 184)	838 - 926 (85.5 - 94.5, 188 - 208)
A/C compressor belt	12 (0.47)	9 - 10 (0.35 - 0.39)	8 - 9 (0.31 - 0.35)	196 (20, 44)	348 - 436 (35.5 - 44.5, 78 - 98)	470 - 559 (48 - 57, 106 - 126)
Applied pushing force	98 N (10 kg, 22 lb)			—		

SEC.117

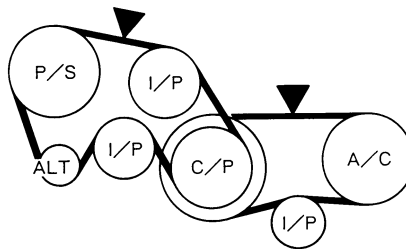

KBIA1731J

\*: If belt tension gauge cannot be installed at check points shown, check drive belt tension at different location on the belt.

## INTAKE MANIFOLD COLLECTOR, INTAKE MANIFOLD AND EXHAUST MANIFOLD

Unit: mm (in)

Items	Limit	
Surface distortion	Intake manifold collector (upper)	0.1 (0.004)
	Intake manifold collector (lower)	0.1 (0.004)
	Intake manifold	0.1 (0.004)
	Exhaust manifold	0.3 (0.012)

## SPARK PLUG

Unit: mm (in)

Make	NGK
Standard type	PLFR5A-11
Hot type	PLFR4A-11
Cold type	PLFR6A-11
Gap (Nominal)	1.1 (0.043)

# SERVICE DATA AND SPECIFICATIONS (SDS)

**[VQ35DE]**

## CAMSHAFT AND CAMSHAFT BEARING

Unit: mm (in)

Items		Standard	Limit
Camshaft journal oil clearance	No. 1	0.045 - 0.086 (0.0018 - 0.0034)	0.15 (0.0059)
	No. 2, 3, 4	0.035 - 0.076 (0.0014 - 0.0030)	
Camshaft bracket inner diameter	No. 1	26.000 - 26.021 (1.0236 - 1.0244)	—
	No. 2, 3, 4	23.500 - 23.521 (0.9252 - 0.9260)	—
Camshaft journal diameter	No. 1	25.935 - 25.955 (1.0211 - 1.0218)	—
	No. 2, 3, 4	23.445 - 23.465 (0.9230 - 0.9238)	—
Camshaft end play		0.115 - 0.188 (0.0045 - 0.0074)	0.24 (0.0094)
Camshaft cam height "A"	Intake and exhaust	44.865 - 45.055 (1.7663 - 1.7738)	0.2 (0.008)* <sup>1</sup>
Camshaft runout [TIR* <sup>2</sup> ]		Less than 0.02 (0.001)	0.05 (0.002)
Camshaft sprocket runout [TIR* <sup>2</sup> ]		—	0.15 (0.0059)

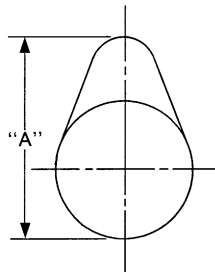

SEM671

\*<sup>1</sup> : Cam wear limit

\*<sup>2</sup> : Total indicator reading

## Valve Lifter

Unit: mm (in)

Items	Standard
Valve lifter outer diameter	33.977 - 33.987 (1.3377 - 1.3381)
Valve lifter hole diameter	34.000 - 34.016 (1.3386 - 1.3392)
Valve lifter clearance	0.013 - 0.039 (0.0005 - 0.0015)

## Valve Clearance

Unit: mm (in)

Items	Cold	Hot* (reference data)
Intake	0.26 - 0.34 (0.010 - 0.013)	0.304 - 0.416 (0.012 - 0.016)
Exhaust	0.29 - 0.37 (0.011 - 0.015)	0.308 - 0.432 (0.012 - 0.017)

\*: Approximately 80°C (176°F)

# SERVICE DATA AND SPECIFICATIONS (SDS)

[VQ35DE]

## Available Valve Lifter

Unit: mm (in)

Identification (stamped) mark	Thickness
788U or 788R	7.88 (0.3102)
790U or 790R	7.90 (0.3110)
792U or 792R	7.92 (0.3118)
794U or 794R	7.94 (0.3126)
796U or 796R	7.96 (0.3134)
798U or 798R	7.98 (0.3142)
800U or 800R	8.00 (0.3150)
802U or 802R	8.02 (0.3157)
804U or 804R	8.04 (0.3165)
806U or 806R	8.06 (0.3173)
808U or 808R	8.08 (0.3181)
810U or 810R	8.10 (0.3189)
812U or 812R	8.12 (0.3197)
814U or 814R	8.14 (0.3205)
816U or 816R	8.16 (0.3213)
818U or 818R	8.18 (0.3220)
820U or 820R	8.20 (0.3228)
822U or 822R	8.22 (0.3236)
824U or 824R	8.24 (0.3244)
826U or 826R	8.26 (0.3252)
828U or 828R	8.28 (0.3260)
830U or 830R	8.30 (0.3268)
832U or 832R	8.32 (0.3276)
834U or 834R	8.34 (0.3283)
836U or 836R	8.36 (0.3291)
838U or 838R	8.38 (0.3299)
840U or 840R	8.40 (0.3307)

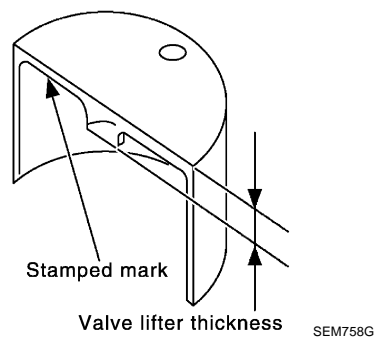

# SERVICE DATA AND SPECIFICATIONS (SDS)

[VQ35DE]

## CYLINDER HEAD

Unit: mm (in)

Items	Standard	Limit
Head surface distortion	Less than 0.03 (0.0012)	0.1 (0.004)
Normal cylinder head height "H"	126.3 - 126.5 (4.972 - 4.980)	—

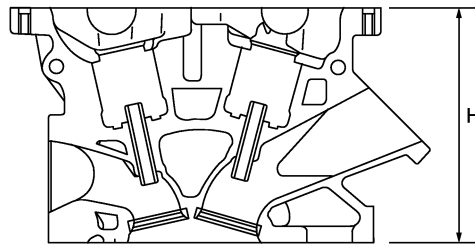

PBIC0924E

## Valve Dimensions

Unit: mm (in)

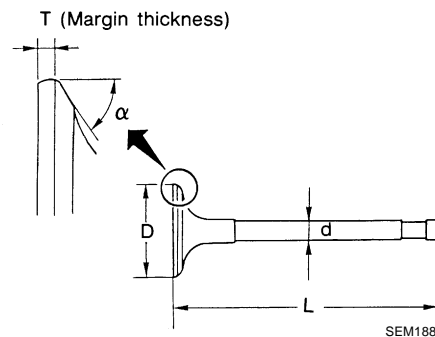

Valve head diameter "D"	Intake	37.0 - 37.3 (1.457 - 1.469)
	Exhaust	31.2 - 31.5 (1.228 - 1.240)
Valve length "L"	Intake	96.46 (3.798)
	Exhaust	93.99 (3.700)
Valve stem diameter "d"	Intake	5.965 - 5.980 (0.2348 - 0.2354)
	Exhaust	5.955 - 5.970 (0.2344 - 0.2350)
Valve seat angle " $\alpha$ "	Intake	45°15' - 45°45'
	Exhaust	
Valve margin "T"	Intake	1.1 (0.043)
	Exhaust	1.3 (0.051)
Valve margin "T" limit		0.5 (0.020)
Valve stem end surface grinding limit		0.2 (0.008)

# SERVICE DATA AND SPECIFICATIONS (SDS)

[VQ35DE]

## Valve Guide

Unit: mm (in)

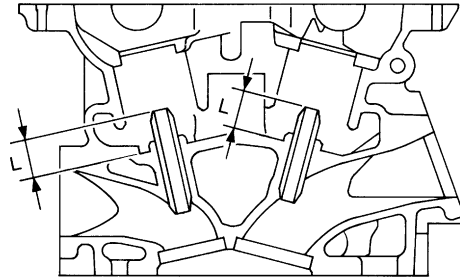

SEM950E

Items		Standard	Oversize (Service) [0.2 (0.008)]
Valve guide	Outer diameter	10.023 - 10.034 (0.3946 - 0.3950)	10.223 - 10.234 (0.4025 - 0.4029)
	Inner diameter (Finished size)	6.000 - 6.018 (0.2362 - 0.2369)	
Cylinder head valve guide hole diameter		9.975 - 9.996 (0.3927 - 0.3935)	10.175 - 10.196 (0.4006 - 0.4014)
Interference fit of valve guide		0.027 - 0.059 (0.0011 - 0.0023)	
Items		Standard	Limit
Valve guide clearance	Intake	0.020 - 0.053 (0.0008 - 0.0021)	0.08 (0.003)
	Exhaust	0.030 - 0.063 (0.0012 - 0.0025)	0.09 (0.004)
Projection length "L"		12.6 - 12.8 (0.496 - 0.504)	

Valve Seat

Unit: mm (in)

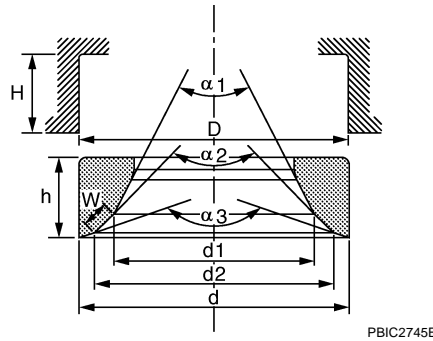

Items		Standard	Oversize (Service) [0.5 (0.02)]
Cylinder head seat recess diameter "D"	Intake	38.000 - 38.016 (1.4961 - 1.4967)	38.500 - 38.516 (1.5157 - 1.5164)
	Exhaust	32.200 - 32.216 (1.2677 - 1.2683)	32.700 - 32.716 (1.2874 - 1.2880)
Valve seat outer diameter "d"	Intake	38.097 - 38.113 (1.4999 - 1.5005)	38.597 - 38.613 (1.5196 - 1.5202)
	Exhaust	32.280 - 32.296 (1.2709 - 1.2715)	32.780 - 32.796 (1.2905 - 1.2912)
Valve seat interference fit	Intake	0.081 - 0.113 (0.0032 - 0.0044)	
	Exhaust	0.064 - 0.096 (0.0025 - 0.0038)	
Diameter "d1"*1	Intake	35 (1.38)	
	Exhaust	28.7 (1.130)	
Diameter "d2"*2	Intake	36.6 - 36.8 (1.441 - 1.449)	
	Exhaust	30.6 - 30.8 (1.205 - 1.213)	
Angle "alpha1"	Intake	60°	
	Exhaust	60°	
Angle "alpha2"	Intake	88°45' - 90°15'	
	Exhaust	88°45' - 90°15'	
Angle "alpha3"	Intake	120°	
	Exhaust	120°	
Contacting width "W"*3	Intake	1.09 - 1.31 (0.043 - 0.052)	
	Exhaust	1.29 - 1.51 (0.051 - 0.059)	
Height "h"	Intake	5.9 - 6.0 (0.232 - 0.236)	5.05 - 5.15 (0.1988 - 0.2028)
	Exhaust	5.9 - 6.0 (0.232 - 0.236)	4.95 - 5.05 (0.1949 - 0.1988)
Depth "H"		6.0 (0.236)	

\*1 : Diameter made by intersection point of conic angles "alpha1" and "alpha2"

\*2 : Diameter made by intersection point of conic angles "alpha2" and "alpha3"

\*3 : Machining data

Valve Spring

Free height	mm (in)	47.07 (1.8531)
Pressure	N (kg, lb) at height mm (in)	166 - 188 (16.9 - 19.2, 37 - 42) at 37.00 (1.4567)
		373 - 421 (38.0 - 42.9, 84 - 95) at 27.20 (1.0709)
Out-of-square	mm (in)	Limit 2.1 (0.083)



# SERVICE DATA AND SPECIFICATIONS (SDS)

[VQ35DE]

## CYLINDER BLOCK

Unit: mm (in)

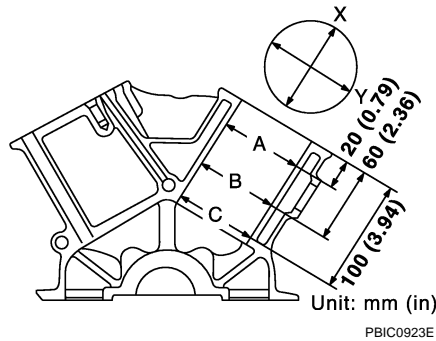

Surface flatness		Standard		Less than 0.03 (0.0012)
		Limit		0.1 (0.004)
Main bearing housing inner diameter		Standard		63.993 - 64.017 (2.5194 - 2.5203)
Cylinder bore	Inner diameter	Standard	Grade No. 1	95.500 - 95.510 (3.7598 - 3.7602)
			Grade No. 2	95.510 - 95.520 (3.7602 - 3.7606)
			Grade No. 3	95.520 - 95.530 (3.7606 - 3.7610)
		Wear limit		0.2 (0.008)
Out-of-round (Difference between "X" and "Y")		Limit		0.015 (0.0006)
Taper (Difference between "A" and "C")				0.010 (0.0004)
Main bearing housing inner diameter grade (Without bearing)		Grade No. A		63.993 - 63.994 (2.5194 - 2.5194)
		Grade No. B		63.994 - 63.995 (2.5194 - 2.5195)
		Grade No. C		63.995 - 63.996 (2.5195 - 2.5195)
		Grade No. D		63.996 - 63.997 (2.5195 - 2.5196)
		Grade No. E		63.997 - 63.998 (2.5196 - 2.5196)
		Grade No. F		63.998 - 63.999 (2.5196 - 2.5196)
		Grade No. G		63.999 - 64.000 (2.5196 - 2.5197)
		Grade No. H		64.000 - 64.001 (2.5197 - 2.5197)
		Grade No. J		64.001 - 64.002 (2.5197 - 2.5198)
		Grade No. K		64.002 - 64.003 (2.5198 - 2.5198)
		Grade No. L		64.003 - 64.004 (2.5198 - 2.5198)
		Grade No. M		64.004 - 64.005 (2.5198 - 2.5199)
		Grade No. N		64.005 - 64.006 (2.5199 - 2.5199)
		Grade No. P		64.006 - 64.007 (2.5199 - 2.5200)
		Grade No. R		64.007 - 64.008 (2.5200 - 2.5200)
		Grade No. S		64.008 - 64.009 (2.5200 - 2.5200)
		Grade No. T		64.009 - 64.010 (2.5200 - 2.5201)
Grade No. U		64.010 - 64.011 (2.5201 - 2.5201)		
Grade No. V		64.011 - 64.012 (2.5201 - 2.5202)		
Grade No. W		64.012 - 64.013 (2.5202 - 2.5202)		
Grade No. X		64.013 - 64.014 (2.5202 - 2.5202)		
Grade No. Y		64.014 - 64.015 (2.5202 - 2.5203)		
Grade No. 4		64.015 - 64.016 (2.5203 - 2.5203)		
Grade No. 7		64.016 - 64.017 (2.5203 - 2.5203)		
Difference in inner diameter between cylinders		Standard		Less than 0.03 (0.0012)

# SERVICE DATA AND SPECIFICATIONS (SDS)

[VQ35DE]

## PISTON, PISTON RING AND PISTON PIN

### Available Piston

Unit: mm (in)

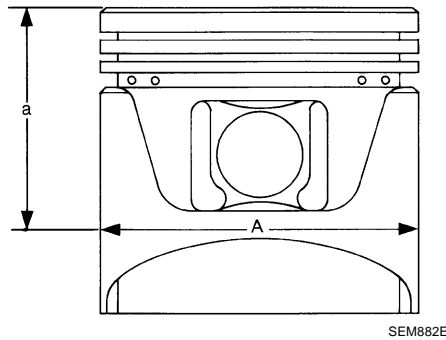

SEM882E

Items		Standard	Oversize [0.2 (0.008)]
Piston skirt diameter "A"	Grade No. 1	95.480 - 95.490 (3.7590 - 3.7594)	—
	Grade No. 2	95.490 - 95.500 (3.7594 - 3.7598)	—
	Grade No. 3	95.500 - 95.510 (3.7598 - 3.7602)	—
	Service	—	95.680 - 95.710 (3.7669 - 3.7681)
Items		Standard	Limit
"a" dimension		41.0 (1.614)	—
Piston pin hole diameter	Grade No. 0	21.993 - 21.999 (0.8659 - 0.8661)	—
	Grade No. 1	21.999 - 22.005 (0.8661 - 0.8663)	—
Piston to cylinder bore clearance		0.010 - 0.030 (0.0004 - 0.0012)	0.08 (0.0031)

### Piston Ring

Unit: mm (in)

Items		Standard	Limit
Side clearance	Top	0.045 - 0.080 (0.0018 - 0.0031)	0.11 (0.0043)
	2nd	0.030 - 0.070 (0.0012 - 0.0028)	0.10 (0.004)
	Oil ring	0.065 - 0.135 (0.0026 - 0.0053)	—
End gap	Top	0.23 - 0.33 (0.0091 - 0.0130)	0.54 (0.0213)
	2nd	0.33 - 0.48 (0.0130 - 0.0189)	0.80 (0.0315)
	Oil (rail ring)	0.20 - 0.50 (0.0079 - 0.0197)	0.95 (0.0374)

### Piston Pin

Unit: mm (in)

Items		Standard	Limit
Piston pin outer diameter	Grade No. 0	21.989 - 21.995 (0.8657 - 0.8659)	—
	Grade No. 1	21.995 - 22.001 (0.8659 - 0.8662)	—
Piston to piston pin oil clearance		0.002 - 0.006 (0.0001 - 0.0002)	—
Connecting rod bushing oil clearance		0.005 - 0.017 (0.0002 - 0.0007)	0.030 (0.0012)

# SERVICE DATA AND SPECIFICATIONS (SDS)

[VQ35DE]

## CONNECTING ROD

Unit: mm (in)

Items		Standard	Limit
Center distance		144.15 - 144.25 (5.6752 - 5.6791)	—
Bend [per 100 (3.94)]		—	0.15 (0.0059)
Torsion [per 100 (3.94)]		—	0.30 (0.012)
Connecting rod bushing inner diameter*	Grade No. 0	22.000 - 22.006 (0.8661 - 0.8664)	—
	Grade No. 1	22.006 - 22.012 (0.8664 - 0.8666)	—
Connecting rod big end diameter (Without bearing)		55.000 - 55.013 (2.1654 - 2.1659)	—
Side clearance		0.20 - 0.35 (0.0079 - 0.0138)	0.40 (0.016)

\*: After installing in connecting rod

A  
EM  
C  
D  
E  
F  
G  
H  
I  
J  
K  
L  
M

# SERVICE DATA AND SPECIFICATIONS (SDS)

[VQ35DE]

## CRANKSHAFT

Unit: mm (in)

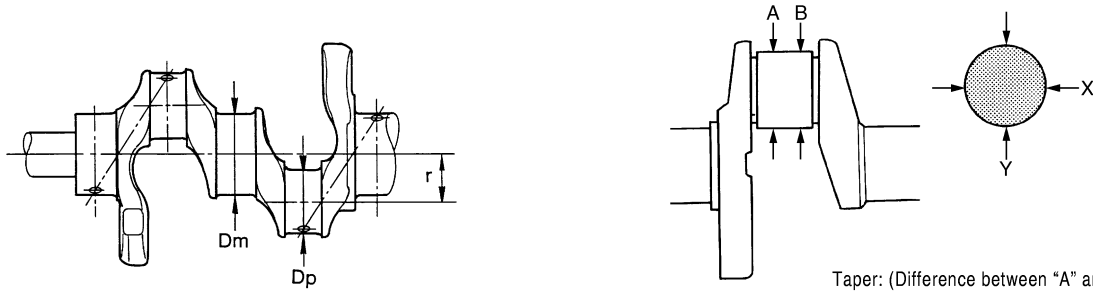

SEM645

Taper: (Difference between "A" and "B")  
Out-of-round: (Difference between "X" and "Y")

SBIA0535E

Main journal diameter. "Dm" grade	Standard	Grade No. A	59.974 - 59.975 (2.3612 - 2.3612)
		Grade No. B	59.973 - 59.974 (2.3611 - 2.3612)
		Grade No. C	59.972 - 59.973 (2.3611 - 2.3611)
		Grade No. D	59.971 - 59.972 (2.3611 - 2.3611)
		Grade No. E	59.970 - 59.971 (2.3610 - 2.3611)
		Grade No. F	59.969 - 59.970 (2.3610 - 2.3610)
		Grade No. G	59.968 - 59.969 (2.3609 - 2.3610)
		Grade No. H	59.967 - 59.968 (2.3609 - 2.3609)
		Grade No. J	59.966 - 59.967 (2.3609 - 2.3609)
		Grade No. K	59.965 - 59.966 (2.3608 - 2.3609)
		Grade No. L	59.964 - 59.965 (2.3608 - 2.3608)
		Grade No. M	59.963 - 59.964 (2.3607 - 2.3608)
		Grade No. N	59.962 - 59.963 (2.3607 - 2.3607)
		Grade No. P	59.961 - 59.962 (2.3607 - 2.3607)
		Grade No. R	59.960 - 59.961 (2.3606 - 2.3607)
		Grade No. S	59.959 - 59.960 (2.3606 - 2.3606)
Grade No. T	59.958 - 59.959 (2.3605 - 2.3606)		
Grade No. U	59.957 - 59.958 (2.3605 - 2.3605)		
Grade No. V	59.956 - 59.957 (2.3605 - 2.3605)		
Grade No. W	59.955 - 59.956 (2.3604 - 2.3605)		
Grade No. X	59.954 - 59.955 (2.3604 - 2.3604)		
Grade No. Y	59.953 - 59.954 (2.3603 - 2.3604)		
Grade No. 4	59.952 - 59.953 (2.3603 - 2.3603)		
Grade No. 7	59.951 - 59.952 (2.3603 - 2.3603)		
Pin journal diameter. "Dp"	Standard	Grade No. 0	51.968 - 51.974 (2.0460 - 2.0462)
		Grade No. 1	51.962 - 51.968 (2.0457 - 2.0460)
		Grade No. 2	51.956 - 51.962 (2.0455 - 2.0457)
Center distance "r"			40.66 - 40.74 (1.6008 - 1.6039)
Taper (Difference between "A" and "B")	Limit		0.002 (0.0001)
Out-of-round (Difference between "X" and "Y")			0.002 (0.0001)
Crankshaft runout [TIR*]	Standard		Less than 0.05 (0.002)
	Limit		0.10 (0.004)
Crankshaft end play	Standard		0.10 - 0.25 (0.0039 - 0.0098)
	Limit		0.30 (0.012)

\*: Total indicator reading

# SERVICE DATA AND SPECIFICATIONS (SDS)

[VQ35DE]

## MAIN BEARING

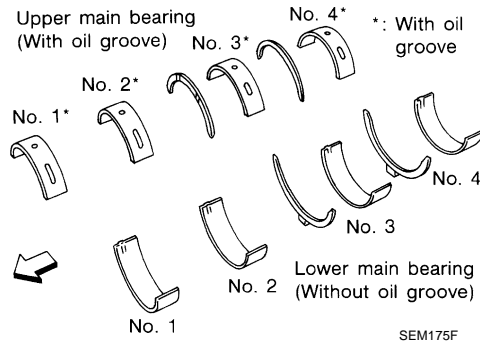

Grade number	UPR/LWR	Thickness mm (in)	Width mm (in)	Identification color	Remarks
0	—	2.000 - 2.003 (0.0787 - 0.0789)	19.9 - 20.1 (0.783 - 0.791)	Black	Grade is the same for upper and lower bearings.
1	—	2.003 - 2.006 (0.0789 - 0.0790)		Brown	
2	—	2.006 - 2.009 (0.0790 - 0.0791)		Green	
3	—	2.009 - 2.012 (0.0791 - 0.0792)		Yellow	
4	—	2.012 - 2.015 (0.0792 - 0.0793)		Blue	
5	—	2.015 - 2.018 (0.0793 - 0.0794)		Pink	
6	—	2.018 - 2.021 (0.0794 - 0.0796)		Purple	
7	—	2.021 - 2.024 (0.0796 - 0.0797)		White	Grade and color are different for upper and lower bearings.
01	UPR	2.003 - 2.006 (0.0789 - 0.0790)		Brown	
	LWR	2.000 - 2.003 (0.0787 - 0.0789)		Black	
12	UPR	2.006 - 2.009 (0.0790 - 0.0791)		Green	
	LWR	2.003 - 2.006 (0.0789 - 0.0790)		Brown	
23	UPR	2.009 - 2.012 (0.0791 - 0.0792)		Yellow	
	LWR	2.006 - 2.009 (0.0790 - 0.0791)		Green	
34	UPR	2.012 - 2.015 (0.0792 - 0.0793)	Blue		
	LWR	2.009 - 2.012 (0.0791 - 0.0792)	Yellow		
45	UPR	2.015 - 2.018 (0.0793 - 0.0794)	Pink		
	LWR	2.012 - 2.015 (0.0792 - 0.0793)	Blue		
56	UPR	2.018 - 2.021 (0.0794 - 0.0796)	Purple		
	LWR	2.015 - 2.018 (0.0793 - 0.0794)	Pink		
67	UPR	2.021 - 2.024 (0.0796 - 0.0797)	White		
	LWR	2.018 - 2.021 (0.0794 - 0.0796)	Purple		

### Undersize

Unit: mm (in)

Items	Thickness	Main journal diameter
0.25 (0.0098)	2.132 - 2.140 (0.0839 - 0.0843)	Grind so that bearing clearance is the specified value.

### Main Bearing Oil Clearance

Unit: mm (in)

Items	Standard	Limit
Main bearing oil clearance	0.035 - 0.045 (0.0014 - 0.0018)*	0.065 (0.0026)

\*: Actual clearance

# SERVICE DATA AND SPECIFICATIONS (SDS)

[VQ35DE]

## CONNECTING ROD BEARING

Grade number	Thickness mm (in)	Identification color (mark)
0	1.500 - 1.503 (0.0591 - 0.0592)	Black
1	1.503 - 1.506 (0.0592 - 0.0593)	Brown
2	1.506 - 1.509 (0.0593 - 0.0594)	Green

## Undersize

Unit: mm (in)

Items	Thickness	Crank pin journal diameter
0.25 (0.0098)	1.626 - 1.634 (0.0640 - 0.0643)	Grind so that bearing clearance is the specified value.

## Connecting Rod Bearing Oil Clearance

Unit: mm (in)

Items	Standard	Limit
Connecting rod bearing oil clearance	0.034 - 0.059 (0.0013 - 0.0023)*	0.070 (0.0028)

\*: Actual clearance

## PRECAUTIONS

PFP:00001

### Precautions for Procedures without Cowl Top Cover

NBS00405

When performing the procedure after removing cowl top cover, cover the lower end of windshield with urethane, etc.

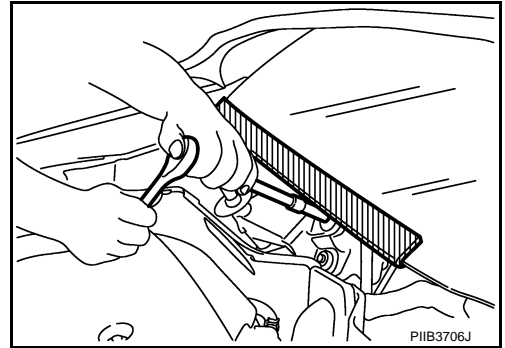

### Precautions Necessary for Steering Wheel Rotation After Battery Disconnect

NBS005RS

#### NOTE:

- This Procedure is applied only to models with Intelligent Key system and NVIS/IVIS (NISSAN/INFINITI VEHICLE IMMOBILIZER SYSTEM - NATS).
- Remove and install all control units after disconnecting both battery cables with the ignition knob in the "LOCK" position.
- Always use CONSULT-II to perform self-diagnosis as a part of each function inspection after finishing work. If DTC is detected, perform trouble diagnosis according to self-diagnostic results.

For models equipped with the Intelligent Key system and NVIS/IVIS, an electrically controlled steering lock mechanism is adopted on the key cylinder.

For this reason, if the battery is disconnected or if the battery is discharged, the steering wheel will lock and steering wheel rotation will become impossible.

If steering wheel rotation is required when battery power is interrupted, follow the procedure below before starting the repair operation.

#### OPERATION PROCEDURE

1. Connect both battery cables.

#### NOTE:

Supply power using jumper cables if battery is discharged.

2. Use the Intelligent Key or mechanical key to turn the ignition switch to the "ACC" position. At this time, the steering lock will be released.
3. Disconnect both battery cables. The steering lock will remain released and the steering wheel can be rotated.
4. Perform the necessary repair operation.
5. When the repair work is completed, return the ignition switch to the "LOCK" position before connecting the battery cables. (At this time, the steering lock mechanism will engage.)
6. Perform a self-diagnosis check of all control units using CONSULT-II.

### Precautions for Drain Engine Coolant and Engine Oil

NBS00407

Drain engine coolant and engine oil when engine is cooled.

### Precautions for Disconnecting Fuel Piping

NBS00408

- Before starting work, make sure no fire or spark producing items are in the work area.
- Release fuel pressure before disconnecting and disassembly.
- After disconnecting pipes, plug openings to stop fuel leakage.

### Precautions for Removal and Disassembly

NBS00409

- When instructed to use SST, use specified tools. Always be careful to work safely, avoid forceful or uninstructed operations.
- Exercise maximum care to avoid damage to mating or sliding surfaces.
- Cover openings of engine system with tape or the equivalent, if necessary, to seal out foreign materials.

# PRECAUTIONS

[VK45DE]

- Mark and arrange disassembly parts in an organized way for easy troubleshooting and assembly.
- When loosening nuts and bolts, as a basic rule, start with the one furthest outside, then the one diagonally opposite, and so on. If the order of loosening is specified, do exactly as specified. Power tools may be used where noted in the step.

## Precautions for Inspection, Repair and Replacement

NBS0040A

Before repairing or replacing, thoroughly inspect parts. Inspect new replacement parts in the same way, and replace if necessary.

## Precautions for Assembly and Installation

NBS0040B

- Use torque wrench to tighten bolts or nuts to specification.
- When tightening nuts and bolts, as a basic rule, equally tighten in several different steps starting with the ones in center, then ones on inside and outside diagonally in this order. If the order of tightening is specified, do exactly as specified.
- Replace with new gasket, packing, oil seal or O-ring.
- Thoroughly wash, clean, and air-blow each part. Carefully check engine oil or engine coolant passages for any restriction and blockage.
- Guide pins are used for several parts alignment. When replacing and reassembling parts with guide pins, make sure that guide pins are installed in the original position.
- Avoid damaging sliding or mating surfaces. Completely remove foreign materials such as cloth lint or dust. Before assembly, oil sliding surfaces well.
- Release air within route when refilling after draining engine coolant.
- After repairing, start engine and increase engine speed to check engine coolant, fuel, engine oil, and exhaust gases for leakage.

## Parts Requiring Angle Tightening

NBS0040C

- Use angle wrench [SST: KV10112100 (BT8653-A)] for the final tightening of the following engine parts:
  - Cylinder head bolts
  - Main bearing cap bolts
  - Connecting rod cap nuts
  - Crankshaft pulley bolt (No angle wrench is required as the bolt flange is provided with notches for angle tightening)
- Do not use a torque value for final tightening.
- The torque value for these parts are for a preliminary step.
- Ensure thread and seat surfaces are clean and coated with engine oil.

## Precautions for Liquid Gasket

NBS0040D

### REMOVAL OF LIQUID GASKET SEALING

- After removing mounting nuts and bolts, separate the mating surface using seal cutter (SST) and remove old liquid gasket sealing.

#### **CAUTION:**

**Be careful not to damage the mating surfaces.**

- Tap seal cutter to insert it (1), and then slide it (2) by tapping on the side as shown in the figure.
- In areas where seal cutter (SST) is difficult to use, use plastic hammer to lightly tap the parts, to remove it.

#### **CAUTION:**

**If for some unavoidable reason tool such as screwdriver is used, be careful not to damage the mating surfaces.**

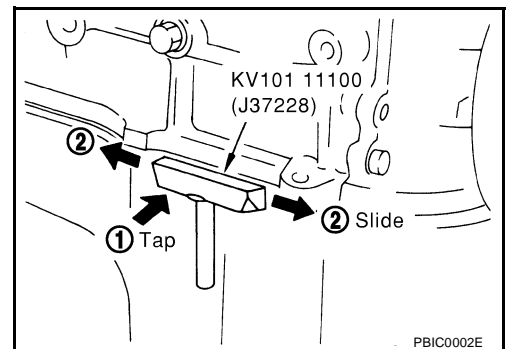



# PRECAUTIONS

[VK45DE]

## LIQUID GASKET APPLICATION PROCEDURE

1. Using scraper, remove old liquid gasket adhering to the liquid gasket application surface and the mating surface.
  - Remove liquid gasket completely from the groove of the liquid gasket application surface, mounting bolts, and bolt holes.
2. Wipe the liquid gasket application surface and the mating surface with white gasoline (lighting and heating use) to remove adhering moisture, grease and foreign materials.

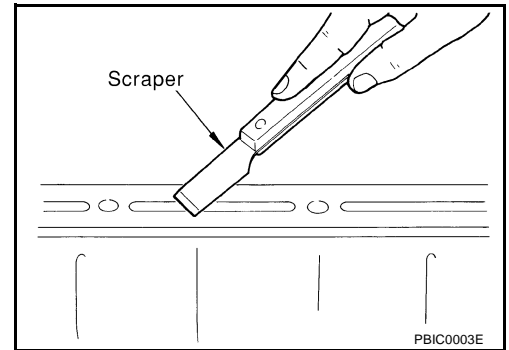

3. Attach liquid gasket tube to tube presser [SST: WS39930000 ( — )].  
**Use Genuine RTV Silicone Sealant or equivalent. Refer to [GI-48, "RECOMMENDED CHEMICAL PRODUCTS AND SEALANTS"](#).**

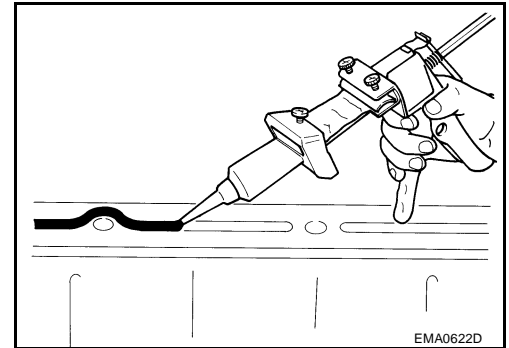

4. Apply liquid gasket without breaks to the specified location with the specified dimensions.
  - If there is a groove for the liquid gasket application, apply liquid gasket to the groove.
  - As for the bolt holes, normally apply liquid gasket inside the holes. Occasionally, it should be applied outside the holes. Make sure to read the text of this manual.
  - Within five minutes of liquid gasket application, install the mating component.
  - If liquid gasket protrudes, wipe it off immediately.
  - Do not retighten mounting bolts and nuts after the installation.
  - Wait 30 minutes or more after installation before refilling engine with engine oil and engine coolant.

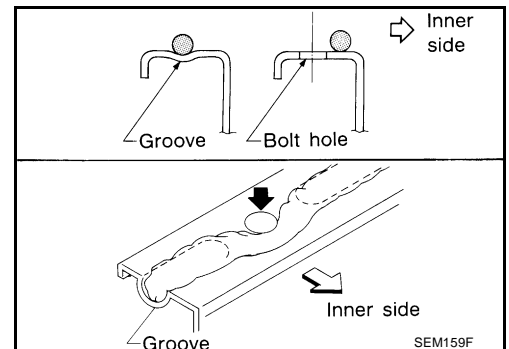

### CAUTION:

**If there are specific instructions in this manual, observe them.**

A  
EM  
C  
D  
E  
F  
G  
H  
I  
J  
K  
L  
M



## PREPARATION

PFP:00002

### Special Service Tools

NBS0040E

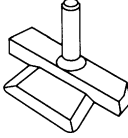
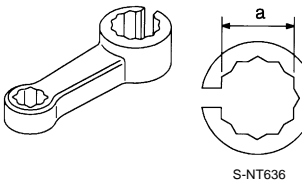
The actual shapes of Kent-Moore tools may differ from those of special service tools illustrated here.

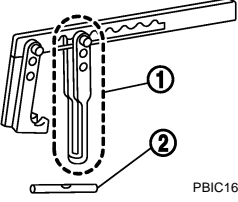
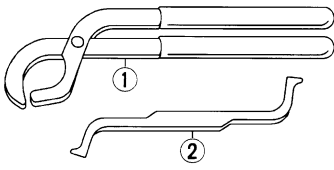
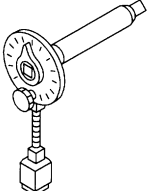
Tool number (Kent-Moore No.) Tool name		Description
KV10111100 (J-37228) Seal cutter	 <p style="text-align: center;">S-NT046</p>	Removing steel oil pan and front cover
KV10114400 (J-38365) Heated oxygen sensor wrench	 <p style="text-align: center;">S-NT636</p>	Loosening or tightening heated oxygen sensors <b>a: 22 mm (0.87 in)</b>
EG15050500 (J-45402) Compression gauge adapter	 <p style="text-align: center;">ZZA1225D</p>	Inspecting of compression pressure
KV10116200 (J-26336-A) Valve spring compressor 1. KV10115900 (J-26336-20) Attachment 2. KV10109220 ( — ) Adapter	 <p style="text-align: center;">PBIC1650E</p>	Disassembling valve mechanism Part (1) is a component of KV10116200 (J26336-A), but part (2) is not so.
KV101151S0 (J-38972) Lifter stopper set 1. KV10115110 (J-38972-1) Camshaft pliers 2. KV10115120 (J-38972-2) Lifter stopper	 <p style="text-align: center;">S-NT041</p>	Changing valve lifter shims
KV10112100 (BT8653-A) Angle wrench	 <p style="text-align: center;">S-NT014</p>	Tightening bolts for bearing cap, cylinder head, etc.

# PREPARATION

[VK45DE]

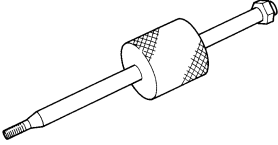
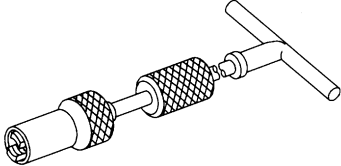
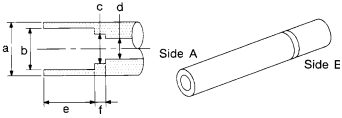
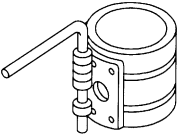
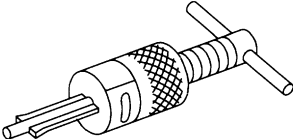
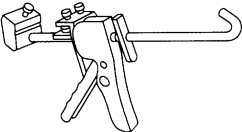
Tool number (Kent-Moore No.) Tool name	Description	
KV10114700 (J-38139) Main bearing cap remover   ZZA0023D	Removing crankshaft main bearing cap	A EM C
KV10107902 (J-38959) Valve oil seal puller   S-NT011	Removing valve oil seal	D E F
KV10115600 (J-38958) Valve oil seal drift   S-NT603	Installing valve oil seal <b>Use side A.</b> <b>a: 20 (0.79) dia.</b> <b>d: 8 (0.31) dia.</b> <b>b: 13 (0.51) dia.</b> <b>e: 10.7 (0.421)</b> <b>c: 10.3 (0.406) dia.</b> <b>f: 5 (0.20)</b> Unit: mm (in)	G H
EM03470000 (J-8037) Piston ring compressor   S-NT044	Installing piston assembly into cylinder bore	I J
ST16610001 (J-23907) Pilot bushing puller   S-NT045	Removing crankshaft pilot converter	K L
WS39930000 ( — ) Tube presser   S-NT052	Pressing the tube of liquid gasket	M

# PREPARATION

[VK45DE]

Tool number (Kent-Moore No.) Tool name	Description
— (J-45476) Ring gear stopper	Removing and installing crankshaft pulley
— (J-45488) Quick connector release	Removing fuel tube quick connectors in engine room

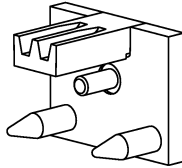

PBIC1655E



PBIC0198E

# PREPARATION

[VK45DE]

## Commercial Service Tools

NBS004OF

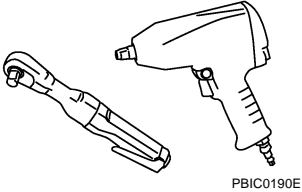
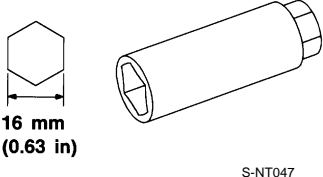
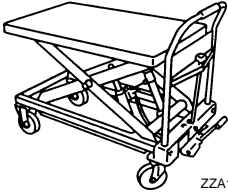
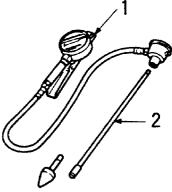
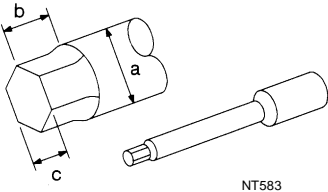
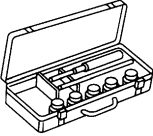
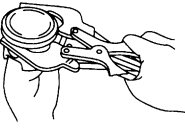
(Kent-Moore No.) Tool name	Description
( — ) Power tool  	Loosening nuts and bolts  EM
( — ) Spark plug wrench  	Removing and installing spark plug  C D E
( — ) Manual lift table caddy  	Removing and installing engine  F G H
( — ) 1.Compression gauge 2.Adapter  	Checking compression pressure  I J
(J-24239-01) Cylinder head bolt wrench  	Loosening and tightening cylinder head bolt, and use with angle wrench [SST: KV10112100 (BT-8653-A)] <b>a: 13 (0.51) dia.</b> <b>b: 12 (0.47)</b> <b>c: 10 (0.39)</b> Unit: mm (in)  K L
( — ) Valve seat cutter set  	Finishing valve seat dimensions  M
( — ) Piston ring expander  	Removing and installing piston ring

# PREPARATION

[VK45DE]

(Kent-Moore No.) Tool name	Description
( — ) Valve guide drift <div data-bbox="651 293 869 414" data-label="Image"> </div> <div data-bbox="837 436 893 457" data-label="Text"> <p>S-NT015</p> </div>	Removing and installing valve guide <b>Intake and Exhaust:</b> <b>a: 9.5 mm (0.374 in) dia.</b> <b>b: 5.5 mm (0.217 in) dia.</b>
( — ) Valve guide reamer <div data-bbox="638 510 877 670" data-label="Image"> </div> <div data-bbox="837 670 893 691" data-label="Text"> <p>S-NT016</p> </div>	(1): Reaming valve guide inner hole (2): Reaming hole for oversize valve guide <b>Intake and Exhaust:</b> <b>d1 : 6.0 mm (0.236 in) dia.</b> <b>d2 : 10.2 mm (0.402 in) dia.</b>
(J-43897-18) (J-43897-12) Oxygen sensor thread cleaner <div data-bbox="654 755 829 946" data-label="Image"> </div> <div data-bbox="837 946 893 968" data-label="Text"> <p>AEM488</p> </div>	Reconditioning the exhaust system threads before installing a new heated oxygen sensor (Use with anti-seize lubricant shown below.) <b>a: J-43897-18 (18 mm dia.) for zirconia heated oxygen sensor and air fuel ratio sensor</b> <b>b: J-43897-12 (12 mm dia.) for titania heated oxygen sensor and air fuel ratio sensor</b>
( — ) Anti-seize lubricant (Permatex 133AR or equivalent meeting MIL specification MIL-A-907) <div data-bbox="686 1021 829 1223" data-label="Image"> </div> <div data-bbox="837 1202 893 1223" data-label="Text"> <p>AEM489</p> </div>	Lubricating oxygen sensor thread cleaning tool when reconditioning exhaust system threads

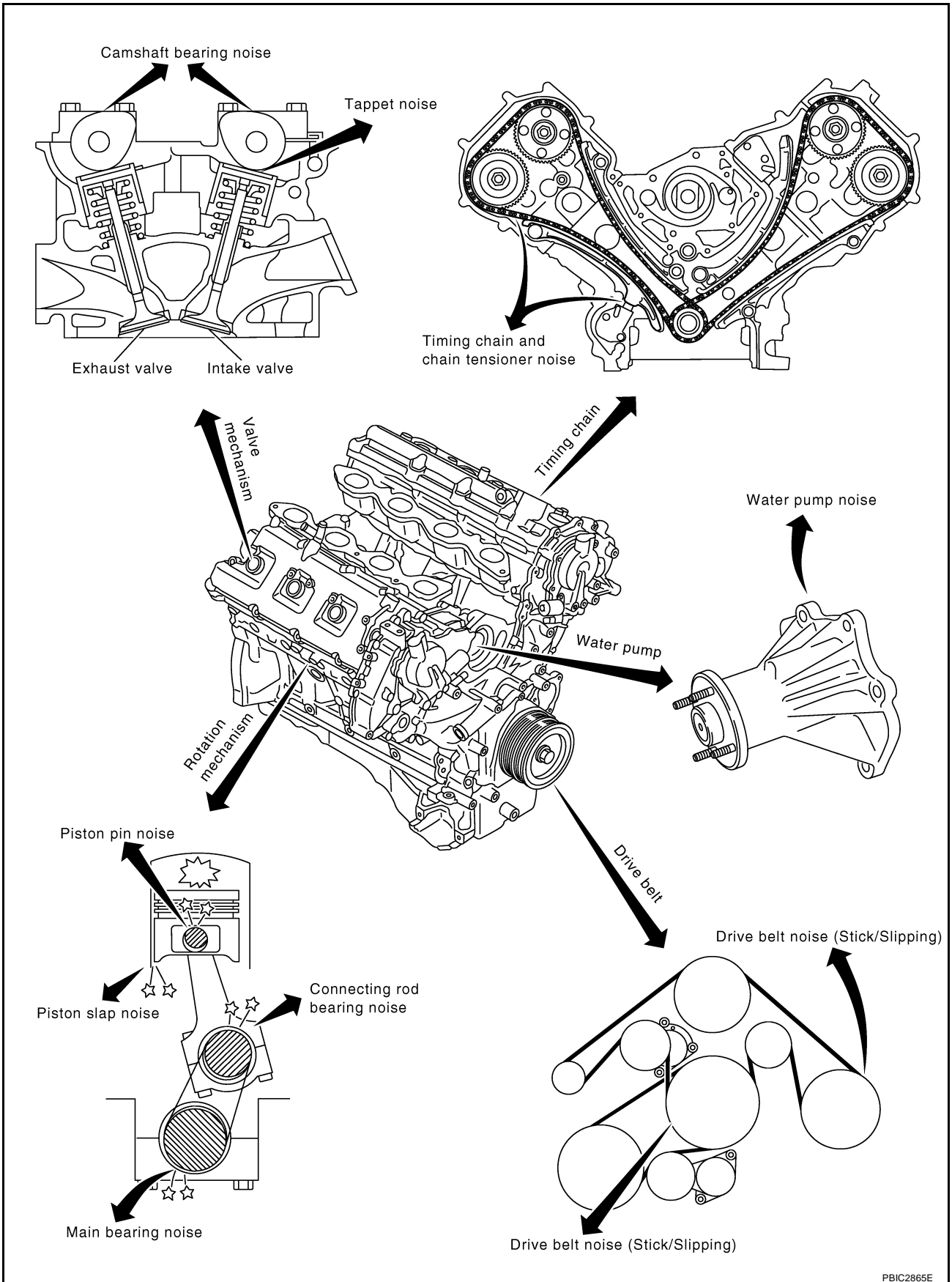

# NOISE, VIBRATION AND HARSHNESS (NVH) TROUBLESHOOTING

[VK45DE]

## Use the Chart Below to Help You Find the Cause of the Symptom.

NBS004OH

1. Locate the area where noise occurs.
2. Confirm the type of noise.
3. Specify the operating condition of engine.
4. Check specified noise source.

If necessary, repair or replace these parts.

Location of noise	Type of noise	Operating condition of engine						Source of noise	Check item	Reference page
		Before warm-up	After warm-up	When starting	When idling	When racing	While driving			
Top of engine Rocker cover Cylinder head	Ticking or clicking	C	A	—	A	B	—	Tappet noise	Valve clearance	<a href="#">EM-222</a>
	Rattle	C	A	—	A	B	C	Camshaft bearing noise	Camshaft journal oil clearance Camshaft runout	<a href="#">EM-217</a> <a href="#">EM-216</a>
Crankshaft pulley Cylinder block (Side of engine) Oil pan	Slap or knock	—	A	—	B	B	—	Piston pin noise	Piston to piston pin oil clearance Connecting rod bushing oil clearance	<a href="#">EM-266</a> <a href="#">EM-268</a>
	Slap or rap	A	—	—	B	B	A	Piston slap noise	Piston to cylinder bore clearance Piston ring side clearance Piston ring end gap Connecting rod bend and torsion	<a href="#">EM-270</a> <a href="#">EM-267</a> <a href="#">EM-267</a> <a href="#">EM-268</a>
	Knock	A	B	C	B	B	B	Connecting rod bearing noise	Connecting rod bushing oil clearance Connecting rod bearing oil clearance	<a href="#">EM-268</a> <a href="#">EM-273</a>
	Knock	A	B	—	A	B	C	Main bearing noise	Main bearing oil clearance Crankshaft runout	<a href="#">EM-274</a> <a href="#">EM-272</a>
Front of engine front cover	Tapping or ticking	A	A	—	B	B	B	Timing chain and chain tensioner noise	Timing chain cracks and wear Timing chain tensioner operation	<a href="#">EM-208</a> <a href="#">EM-203</a>
Front of engine	Squeaking or fizzing	A	B	—	B	—	C	Drive belts (Sticking or slipping)	Drive belts deflection	<a href="#">EM-174</a>
	Creaking	A	B	A	B	A	B	Drive belts (Slipping)	Idler pulley bearing operation	
	Squall Creak	A	B	—	B	A	B	Water pump noise	Water pump operation	<a href="#">CO-53</a> <a href="#">"WATER PUMP"</a>

A: Closely related B: Related C: Sometimes related —: Not related



## ENGINE ROOM COVER

PFP:14049

### Components

NBS0040I

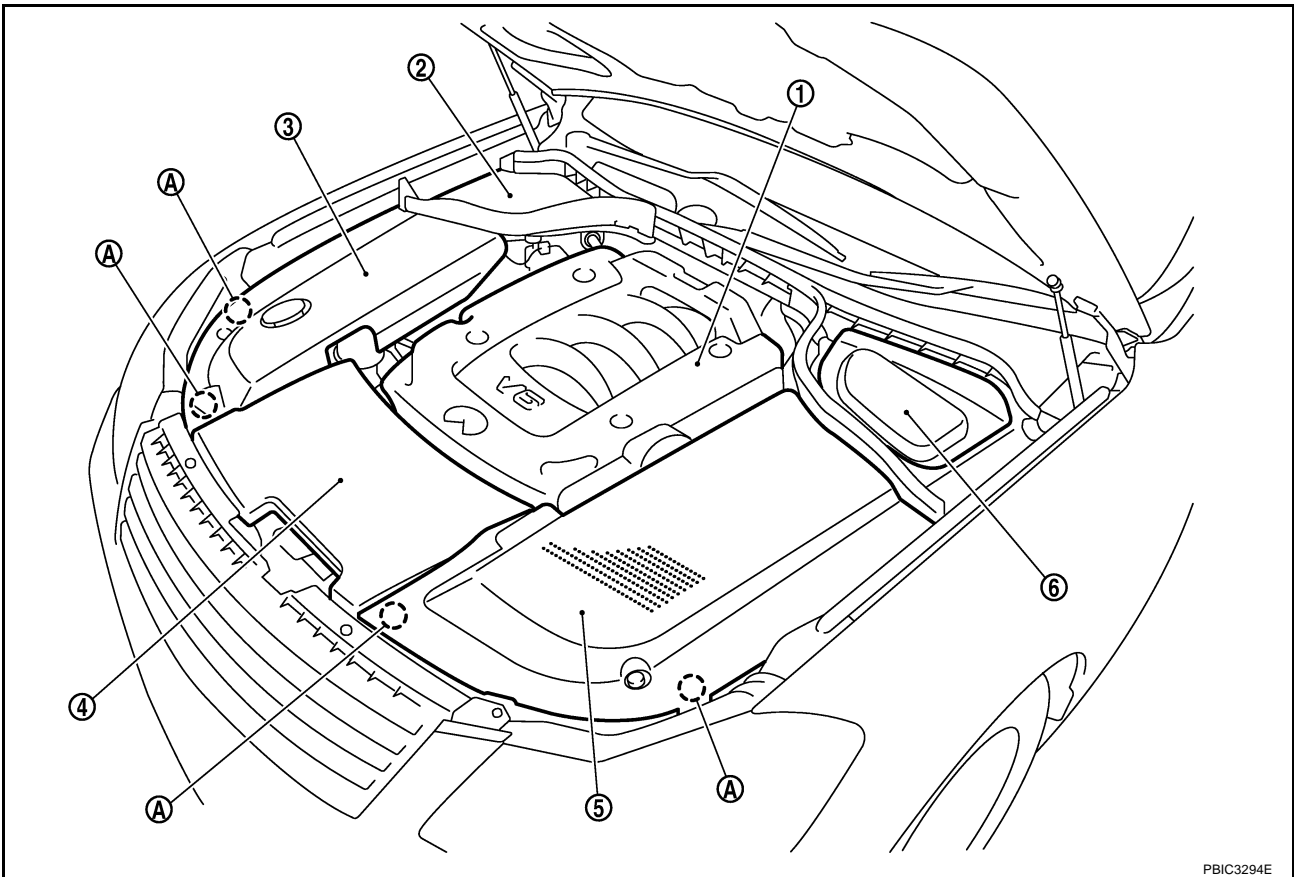

- |                                  |                           |                                |
|----------------------------------|---------------------------|--------------------------------|
| 1. Engine cover                  | 2. Battery cover          | 3. Engine room cover (RH)      |
| 4. Air duct (inlet)              | 5. Engine room cover (LH) | 6. Brake master cylinder cover |
| A. Clip (secure at back surface) |                           |                                |

### Removal and Installation

#### REMOVAL

NBS0040J

#### CAUTION:

Do not damage or scratch cover when installing or removing.

- Refer to [EM-179, "INTAKE MANIFOLD"](#) for removal and installation of engine cover.
- Refer to [EM-177, "AIR CLEANER AND AIR DUCT"](#) for removal and installation of air duct (inlet).
- Remove the washer tank cap before removing the engine room cover (RH).
- Remove the engine room covers (RH and LH) by lifting the clipped point using a clip driver.
- Major parts and inspection points under each cover are as follows; (numbered as in the figure)

1. Upper side of engine assembly
2. Battery, relay box
3. Power steering fluid reservoir tank, engine coolant reservoir tank, relay box
4. Engine assembly front side, drive belts, cooling fan
5. Mass air flow sensor, air cleaner case
6. Brake master cylinder, brake booster

#### INSTALLATION

Installation is the reverse order of removal.

## DRIVE BELTS

PFP:02117

### Components

NBS0040K

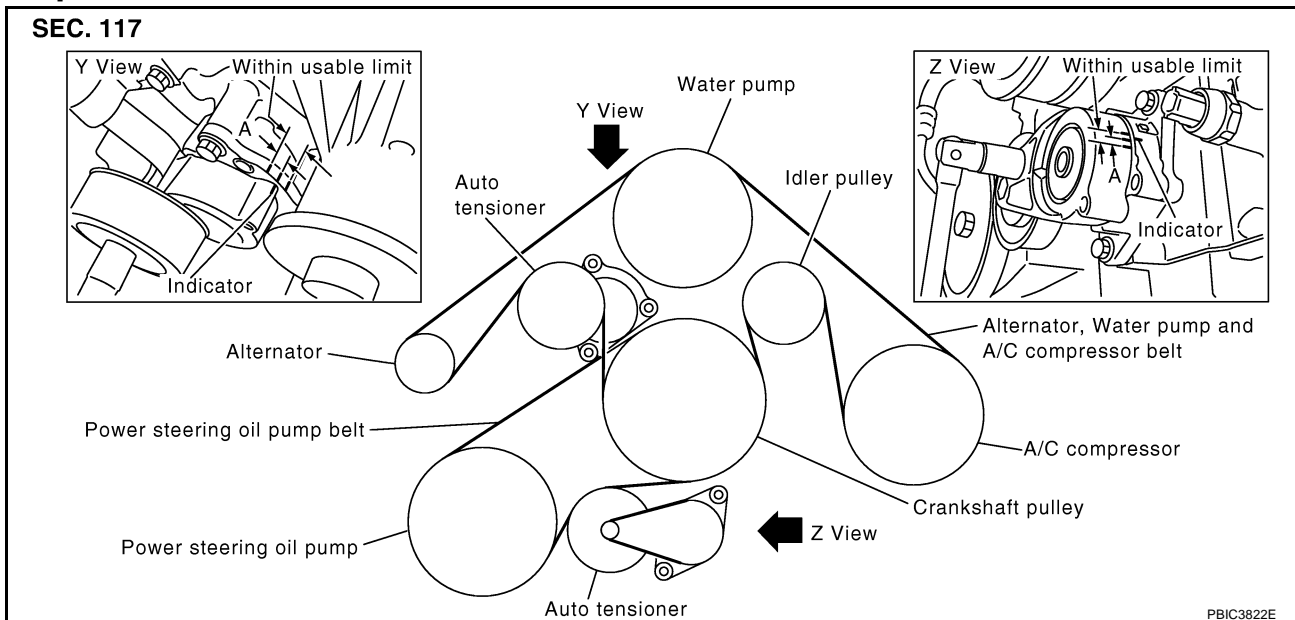

### Checking Drive Belts

NBS0040L

**WARNING:**

Be sure to perform when engine is stopped.

- Remove air duct (inlet) when inspecting drive belt for alternator, water pump and A/C compressor.
- Remove front engine undercover with power tool when inspecting power steering oil pump belt.
- Make sure that indicator (single line notch) of each auto tensioner is within the allowable working range (between three line notches).

**NOTE:**

- Check auto tensioner indication when engine is cold.
- When new drive belt is installed, the range should be "A".
- The indicator notch is located on the moving side of auto tensioner for alternator, water pump and A/C compressor belt, while it is found on the fixed side for power steering oil pump belt.
- Visually check entire belt for wear, damage or cracks.
- If the indicator is out of allowable working range or belt is damaged, replace belt.

### Tension Adjustment

NBS0040M

Belt tensioning is not necessary, as it is automatically adjusted by auto tensioner.

### Removal and Installation

NBS0040N

#### REMOVAL

#### Alternator, Water Pump and A/C Compressor Belt

1. Remove air duct (inlet). Refer to [EM-177, "AIR CLEANER AND AIR DUCT"](#).
2. With box wrench, and while securely holding the hexagonal part in pulley center of auto tensioner, move wrench handle in the direction of arrow (loosening direction of tensioner).

**CAUTION:**

- Avoid placing hand in a location where pinching may occur if the holding tool accidentally comes off.
- Do not loosen the hexagonal part in center of drive belt auto tensioner pulley (Do not turn it clockwise). If turned clockwise, the complete drive belt auto tensioner must be replaced as a unit, including the pulley.

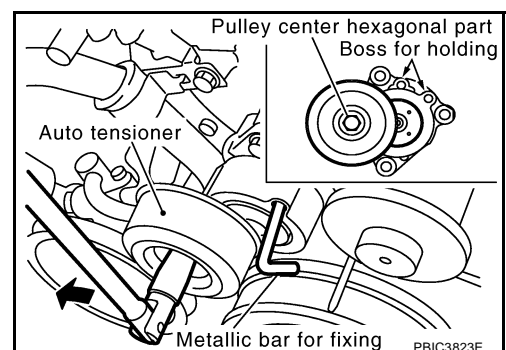

3. Under the above condition, insert a metallic bar of approximately 6 mm (0.24 in) in diameter (hexagonal bar wrench shown as example in the figure) through the holding boss to lock auto tensioner pulley arm.
  - Leave auto tensioner pulley arm locked until belt is installed again.
4. Remove alternator, water pump and A/C compressor belt.

### Power Steering Oil Pump Belt

1. Remove air duct (inlet). Refer to [EM-177, "AIR CLEANER AND AIR DUCT"](#) .
2. Remove front engine undercover with power tool.
3. Remove alternator, water pump and A/C compressor belt. Refer to [EM-174, "Alternator, Water Pump and A/C Compressor Belt"](#) .
4. While securely holding the hexagonal protrusion part of auto tensioner pulley with box wrench, move wrench handle in the direction of arrow (loosening direction of tensioner).

#### CAUTION:

**Avoid placing hand in a location where pinching may occur if holding tool accidentally comes off.**

5. Under the above condition, insert a metallic bar of approximately 6 mm (0.24 in) in diameter (hexagonal bar wrench shown as example in the figure) through the holding boss to lock auto tensioner pulley arm.
  - Leave auto tensioner pulley arm locked until belt is installed again.
6. Remove power steering oil pump belt.

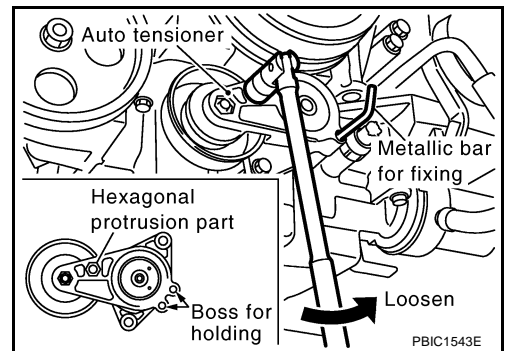

### INSTALLATION

Note the following, and install in the reverse order of removal.

#### CAUTION:

- **Make sure belt is securely installed around all pulleys.**
- **Make sure belt is correctly engaged with the pulley groove.**
- **Check for engine oil and engine coolant are not adhered belt and pulley groove.**
- **Make sure that belt tension is within the allowable working range, using indicator notch on auto tensioner. Refer to [EM-174, "Checking Drive Belts"](#) .**

## Components

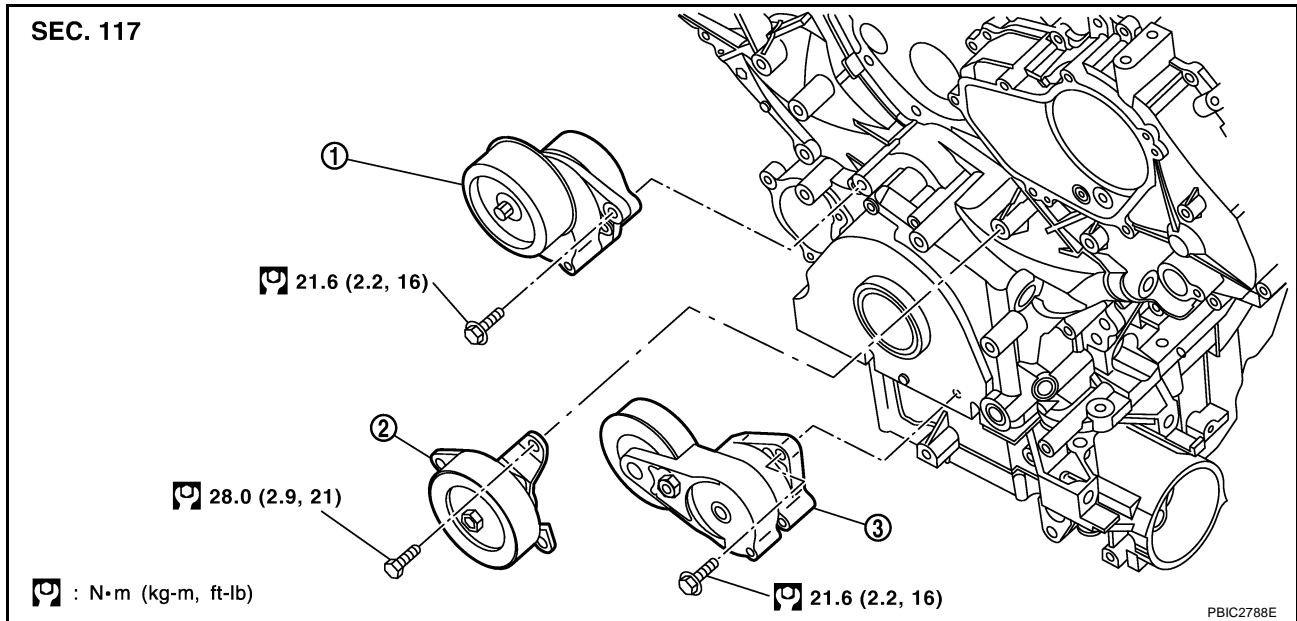

1. Auto tensioner (Used for alternator, water pump and A/C compressor)
2. Idler pulley
3. Auto tensioner (Used for power steering oil pump belt)

### CAUTION:

The complete drive belt auto tensioner must be replaced as a unit, including the pulley.

## Drive Belt Auto Tensioner and Idler Pulley REMOVAL

1. Remove air duct (inlet). Refer to [EM-177, "AIR CLEANER AND AIR DUCT"](#) .
2. Remove front engine undercover with power tool.
3. Remove drive belts. Refer to [EM-174, "Removal and Installation"](#) .
  - Keep auto tensioner pulley arm locked after belt is removed.
4. Remove auto tensioner and idler pulley with power tool.
  - Keep auto tensioner pulley arm locked to install or remove auto tensioner.

### CAUTION:

Do not loosen the hexagonal part in center of drive belt auto tensioner pulley (Do not turn it clockwise). If turned clockwise, the complete drive belt auto tensioner must be replaced as a unit, including the pulley.

## INSTALLATION

Installation is the reverse order of removal.

### CAUTION:

Do not swap the pulley between new and old drive belt auto tensioner.

AIR CLEANER AND AIR DUCT

PF16500

Components

NBS0040Q

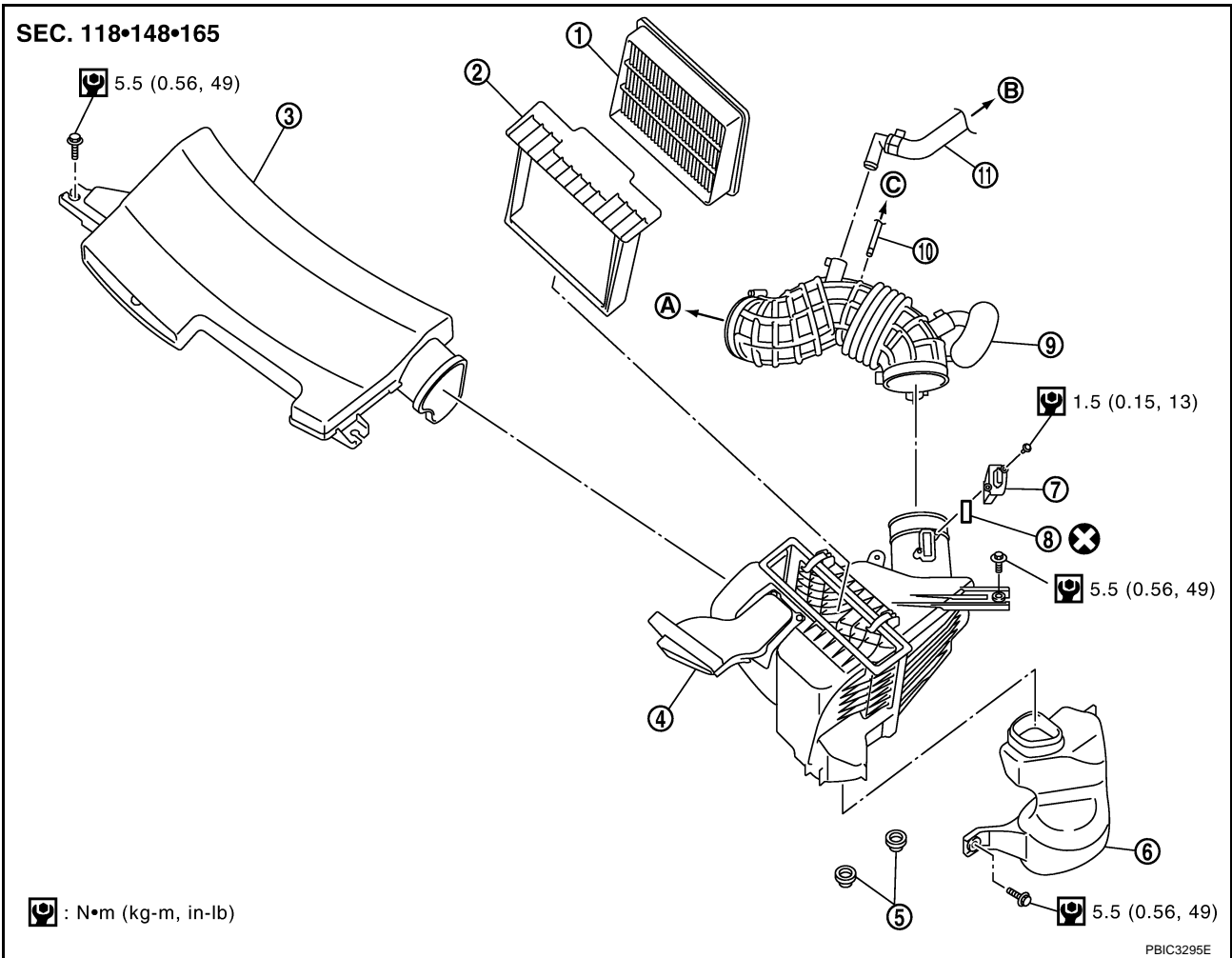

- |  |                                |                                    |
|--|--------------------------------|------------------------------------|
| 1. Air cleaner filter                    | 2. Holder                      | 3. Air duct (inlet)                |
| 4. Air cleaner case                      | 5. Mounting rubber             | 6. Resonator                       |
| 7. Mass air flow sensor                  | 8. O-ring                      | 9. Air duct and resonator assembly |
| 10. Vacuum hose                          | 11. PCV hose                   |                                    |
| A. To electric throttle control actuator | B. To rocker cover (left bank) | C. To VIAS control solenoid valve  |

● Refer to [GI-11, "Components"](#) for symbol marks in the figure.

**Removal and Installation**

**REMOVAL**

- Remove engine room cover (RH and LH). Refer to [EM-173, "ENGINE ROOM COVER"](#).
- Disconnect harness connector from mass air flow sensor.
- Disconnect vacuum hose and PCV hose.
- Remove air duct (inlet), air cleaner case and mass air flow sensor assembly, air duct and resonator assembly disconnecting their joints.
  - Add marks as necessary for easier installation.
- Remove mass air flow sensor from air cleaner case, as necessary.

**CAUTION:**

**Handle mass air flow sensor with following cares.**

- Do not shock it.
- Do not disassemble it.
- Do not touch its sensor.

6. Remove resonator in fender lifting front fender protector (LH). Refer to [EI-20, "FENDER PROTECTOR"](#).

## INSPECTION AFTER REMOVAL

Inspect air duct and resonator assembly for crack or tear.

- If anything found, replace air duct and resonator assembly.

## INSTALLATION

Note the following, and install in the reverse order of removal.

- Align marks. Attach each joint. Screw clamps firmly.

## Changing Air Cleaner Filter

### REMOVAL

1. Remove engine room cover (LH). Refer to [EM-173, "ENGINE ROOM COVER"](#).
2. Unhook clips (1) and remove holder (3) from air cleaner case (2).

NBS0040S

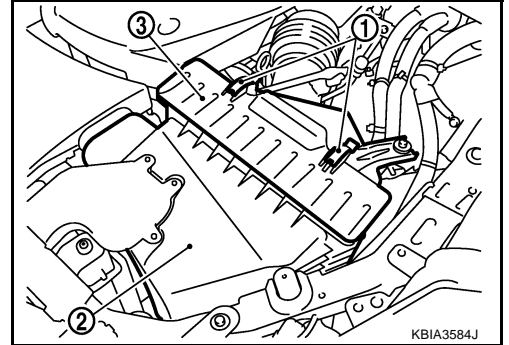

3. Remove air cleaner filter (2) from air cleaner case (1).

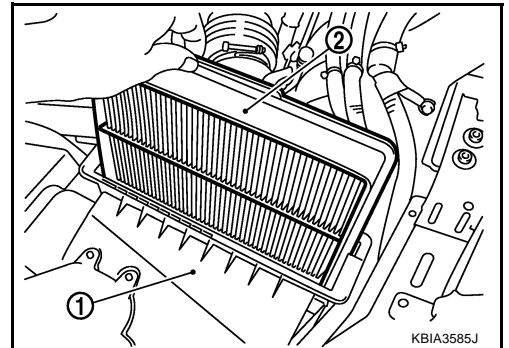

## INSTALLATION

Note the following, and install in the reverse order of removal.

- Install the air cleaner filter by aligning the seal with the notch of air cleaner case.

# INTAKE MANIFOLD

[VK45DE]

## INTAKE MANIFOLD

PF14003

### Components

NBS0040T

A

EM

C

D

E

F

G

H

I

J

K

L

M

SEC. 118•140•163•211•223

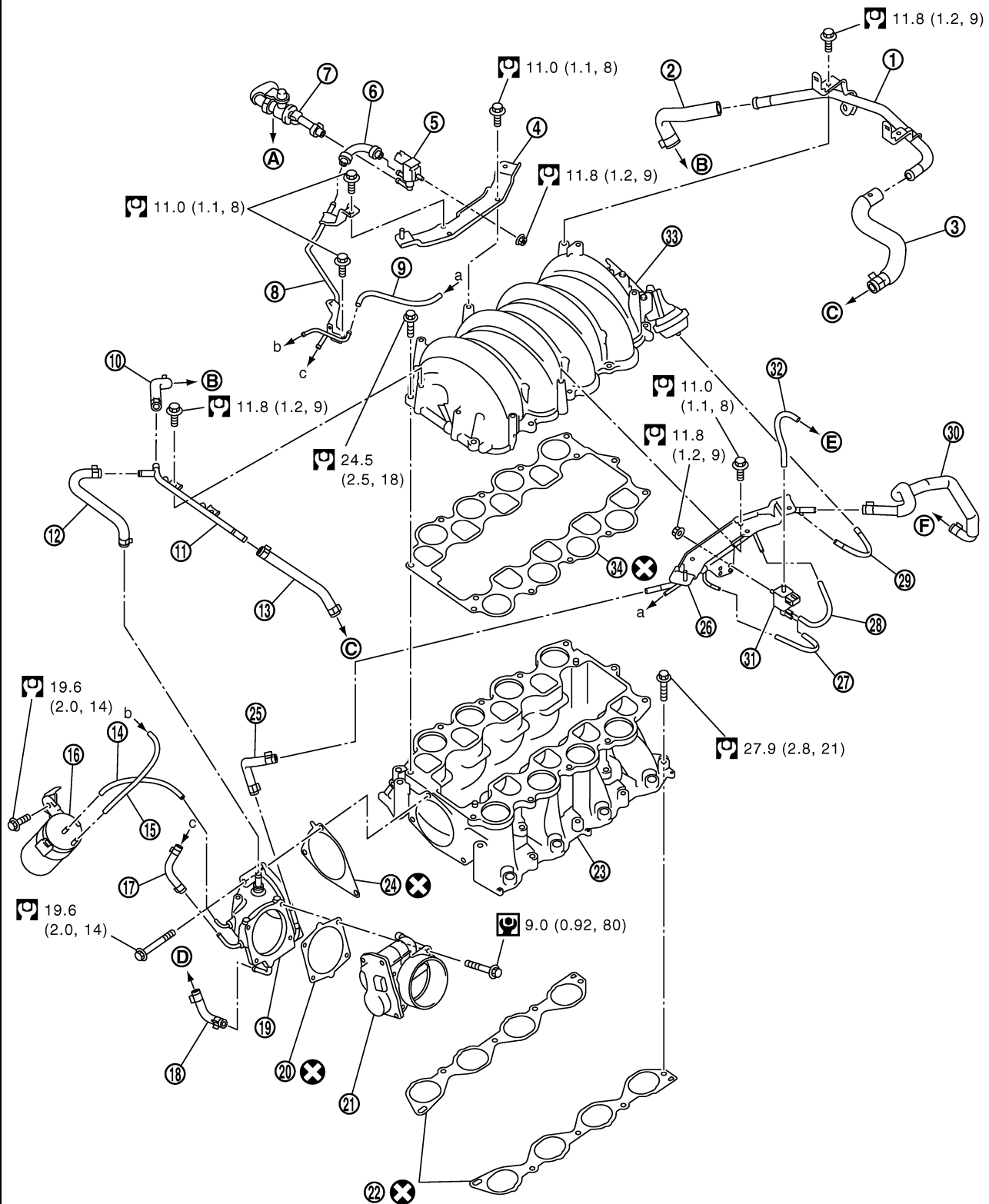

: N•m (kg-m, in-lb)  
 : N•m (kg-m, ft-lb)

PBIC3296E

# INTAKE MANIFOLD

[VK45DE]

- |                                 |   |  |
|---------------------------------|---|--|
| 1. PCV tube                     | 2. PCV hose                                   | 3. PCV hose                            |
| 4. Engine cover bracket (RH)    | 5. EVAP canister purge control solenoid valve | 6. EVAP hose                           |
| 7. EVAP service port            | 8. EVAP tube                                  | 9. Vacuum hose                         |
| 10. PCV hose                    | 11. PCV tube                                  | 12. PCV hose                           |
| 13. PCV hose                    | 14. Vacuum hose                               | 15. Vacuum hose                        |
| 16. Vacuum tank                 | 17. EVAP hose                                 | 18. Water hose                         |
| 19. Intake manifold adapter     | 20. Gasket                                    | 21. Electric throttle control actuator |
| 22. Gasket                      | 23. Intake manifold (lower)                   | 24. Gasket                             |
| 25. Water hose                  | 26. Engine cover bracket (LH)                 | 27. Vacuum hose                        |
| 28. Vacuum hose                 | 29. Vacuum hose                               | 30. Water hose                         |
| 31. VIAS control solenoid valve | 32. Vacuum hose                               | 33. Intake manifold (upper)            |
| 34. Gasket                      |   |  |
- A. To centralized under-floor piping    B. To rocker cover (right bank)    C. To rocker cover (left bank)  
D. To thermostat housing    E. To air duct and resonator assembly    F. To heater pipe

- Refer to [GI-11, "Components"](#) for symbol marks in the figure.

## Removal and Installation

### REMOVAL

NBS0040U

#### WARNING:

To avoid the danger of being scalded, never drain the engine coolant when the engine is hot.

1. Remove engine room cover (RH and LH). Refer to [EM-173, "ENGINE ROOM COVER"](#).
2. Remove engine cover with power tool.

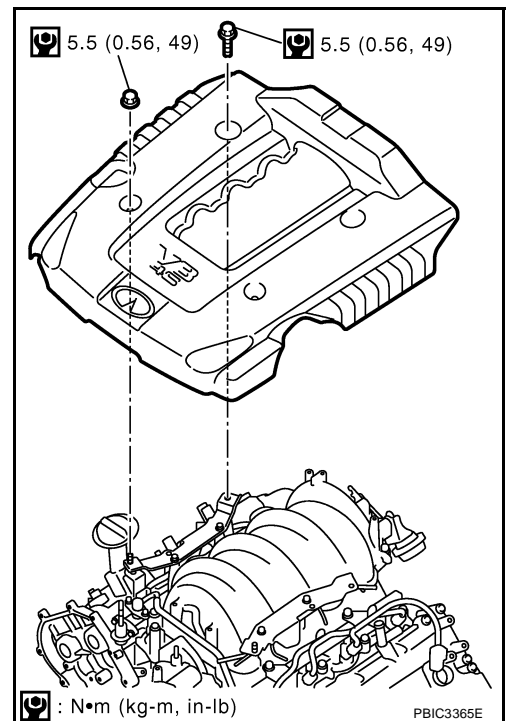

3. Release fuel pressure. Refer to [EC-809, "FUEL PRESSURE RELEASE"](#).
4. Remove air duct (inlet), air cleaner case and air duct and resonator assembly. Refer to [EM-177, "AIR CLEANER AND AIR DUCT"](#).
5. Drain engine coolant from radiator. Refer to [CO-40, "DRAINING ENGINE COOLANT"](#).

#### CAUTION:

- Perform this step when the engine is cold.
- Do not spill engine coolant on drive belts.



# INTAKE MANIFOLD

[VK45DE]

6. Disconnect fuel feed hose quick connector on engine side. Refer to [EM-193, "FUEL INJECTOR AND FUEL TUBE"](#).

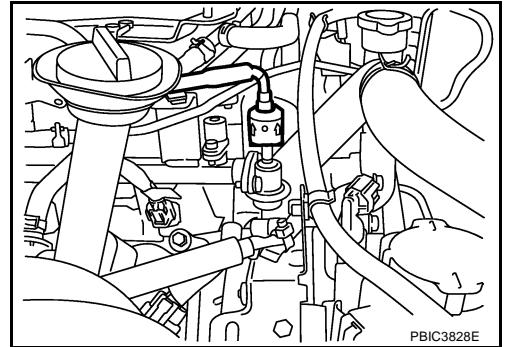

7. Remove fuel damper and fuel hose assembly. Refer to [EM-193, "FUEL INJECTOR AND FUEL TUBE"](#).

**CAUTION:**

- While hoses are disconnected, plug them to prevent fuel from draining.
- Do not separate fuel damper and fuel hose.

8. Remove or disconnect harnesses, engine cover bracket (RH and LH), vacuum hose, EVAP tube and hose and PCV hose and tube from intake manifold (upper).

9. Loosen mounting bolts in reverse order as shown in the figure to remove intake manifold (upper) with power tool.

⇐ : Engine front

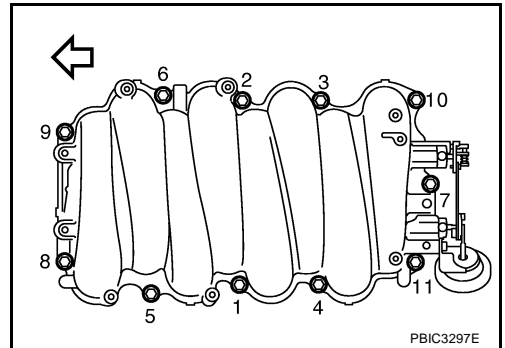

10. Remove electric throttle control actuator as follows:

- Disconnect harness connector.
- Loosen mounting bolts diagonally.

**CAUTION:**

- Handle carefully to avoid any shock to electric throttle control actuator.
- Do not disassemble.

11. Remove fuel injector and fuel tube assembly. Refer to [EM-193, "FUEL INJECTOR AND FUEL TUBE"](#).

12. Disconnect water hoses from intake manifold adaptor.

13. Loosen mounting bolts in reverse order as shown in the figure to remove intake manifold (lower) with power tool.

⇐ : Engine front

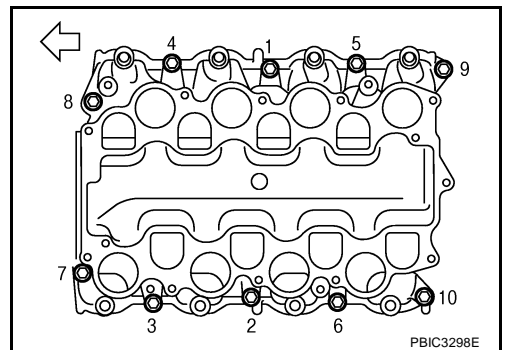

14. Remove intake manifold adaptor from intake manifold (lower).

15. Remove vacuum tank.

16. Remove intake manifold gaskets.

**CAUTION:**

**Cover engine openings to avoid entry of foreign materials.**

## INSPECTION AFTER REMOVAL

### Surface Distortion

- Check the surface distortion of both the intake manifold (upper and lower) mating surfaces with straightedge and feeler gauge.

**Limit : 0.1 mm (0.004 in)**

- If it exceeds the limit, replace intake manifolds (lower and/or upper).

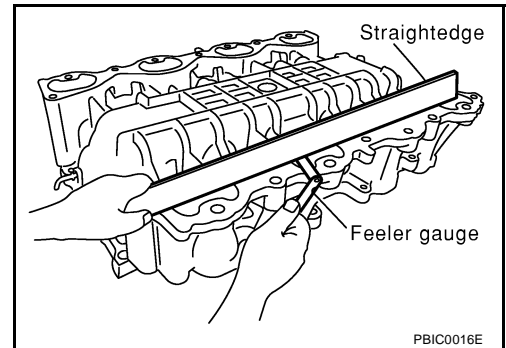

## INSTALLATION

Note the following, and install in the reverse order of removal.

### Intake Manifold (Lower)

Tighten in numerical order as shown in the figure.

↩ : Engine front

- There are two types of mounting bolts. Refer to the following for locating bolts.

**M8 × 90 mm (3.54 in) : 7, 8**

**M8 × 35 mm (1.38 in) Except the above**

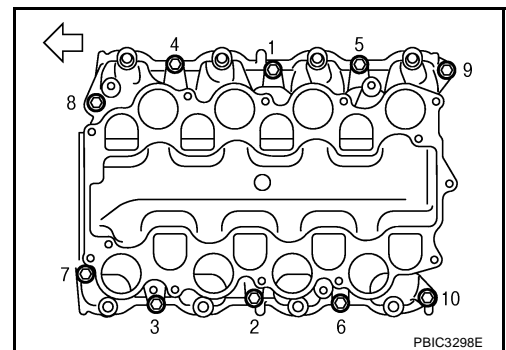

### Intake Manifold (Upper)

Tighten in numerical order as shown in the figure.

↩ : Engine front

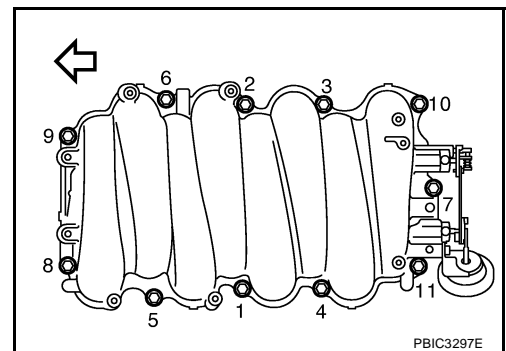

## Electric Throttle Control Actuator

- Install gasket with its directional protrusion set up/downward.
- Tighten mounting bolts of electric throttle control actuator equally and diagonally in several steps.
- After installation perform procedure in [EM-182, "INSPECTION AFTER INSTALLATION"](#) .

## Water Hose

Insert hose by 27 to 32 mm (1.06 to 1.26 in) from connector end.

## Vacuum Hose

Refer to [EC-833, "Vacuum Hose Drawing"](#) .

## INSPECTION AFTER INSTALLATION

- Perform the "Throttle Valve Closed Position Learning" when harness connector of electric throttle control actuator is disconnected. Refer to [EC-806, "Throttle Valve Closed Position Learning"](#) .
- Perform the "Idle Air Volume Learning" and "Throttle Valve Closed Position Learning" when electric throttle control actuator is replaced. Refer to [EC-807, "Idle Air Volume Learning"](#) .

## EXHAUST MANIFOLD AND THREE WAY CATALYST

PF14004

### Components

NBS0040V

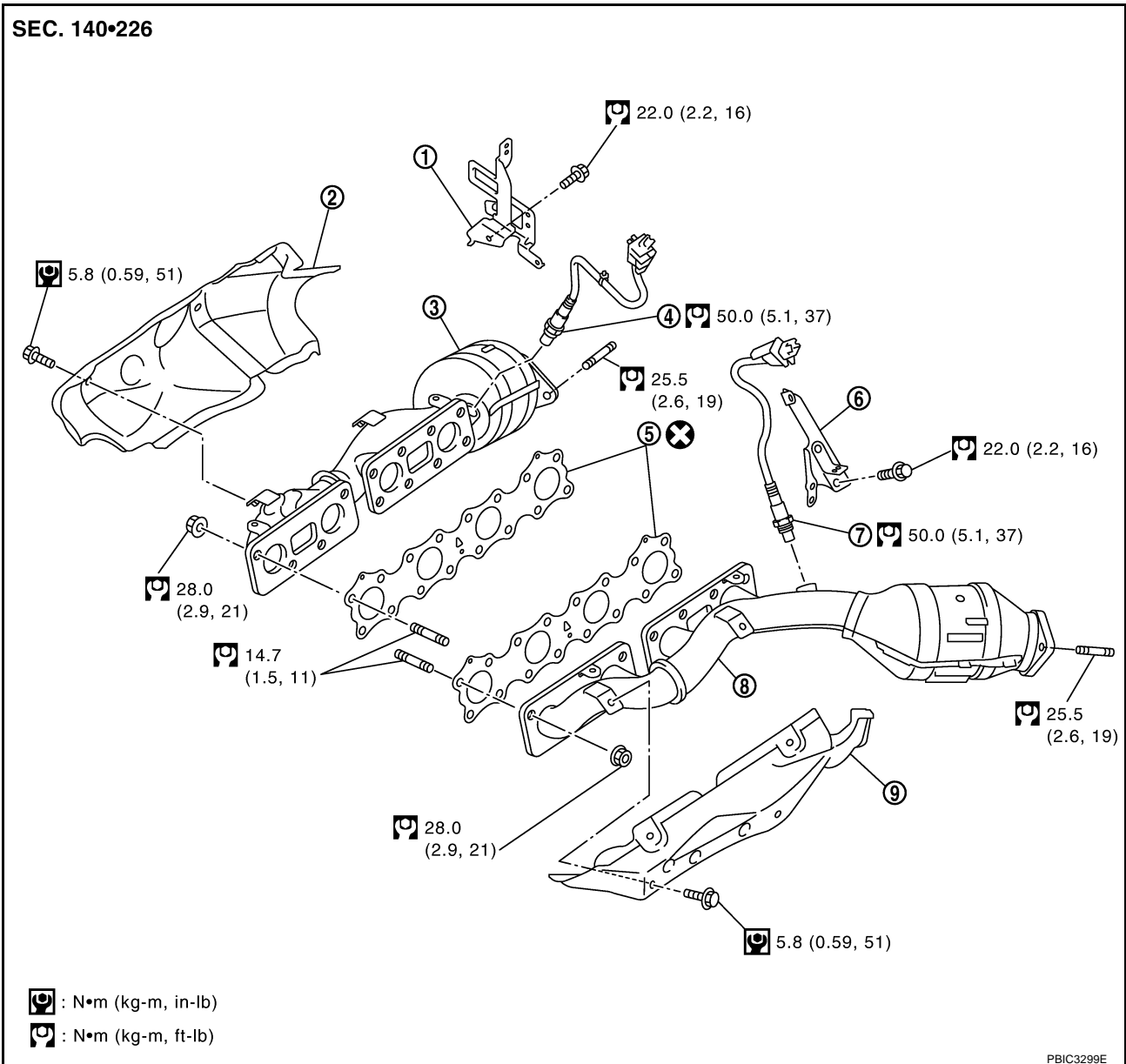

- |                                     |  |   |
|-------------------------------------|--|---|
| 1. Harness bracket                  | 2. Exhaust manifold cover (right bank)                 | 3. Exhaust manifold and three way catalyst (right bank) |
| 4. Air fuel ratio sensor 1 (bank 2) | 5. Gasket  | 6. Harness bracket                                      |
| 7. Air fuel ratio sensor 1 (bank 1) | 8. Exhaust manifold and three way catalyst (left bank) | 9. Exhaust manifold cover (left bank)                   |

- Refer to [GI-11, "Components"](#) for symbol marks in the figure.

### Removal and Installation

#### REMOVAL

NBS0040W

#### WARNING:

Perform the work when the exhaust and cooling system have completely cooled down.

- Remove engine room cover (RH and LH). Refer to [EM-173, "ENGINE ROOM COVER"](#).
- Remove engine cover with power tool. Refer to [EM-179, "INTAKE MANIFOLD"](#).
- Remove air duct (inlet), air cleaner case and air duct and resonator assembly. Refer to [EM-177, "AIR CLEANER AND AIR DUCT"](#).
- Remove front and rear engine undercovers with power tool.

# EXHAUST MANIFOLD AND THREE WAY CATALYST

[VK45DE]

5. Drain engine coolant from radiator. Refer to [CO-40, "Changing Engine Coolant"](#) .

**CAUTION:**

- Perform this step when engine is cold.
- Do not spill engine coolant on drive belts.

6. Remove radiator. Refer to [CO-43, "RADIATOR"](#) .
7. Remove drive belts. Refer to [EM-174, "DRIVE BELTS"](#) .
8. Remove exhaust front tube with power tool. Refer to [EX-3, "EXHAUST SYSTEM"](#) .
9. Remove air fuel ratio sensor 1 as follows:
- a. Disconnect harness connector of each air fuel ratio sensor 1.
  - b. Remove air fuel ratio sensor 1 on both bank with heated oxygen sensor wrench (SST).

**CAUTION:**

- Be careful not to damage air fuel ratio sensor 1.
- Discard any air fuel ratio sensor 1 which has been dropped onto a hard surface such as a concrete floor; replace with a new one.

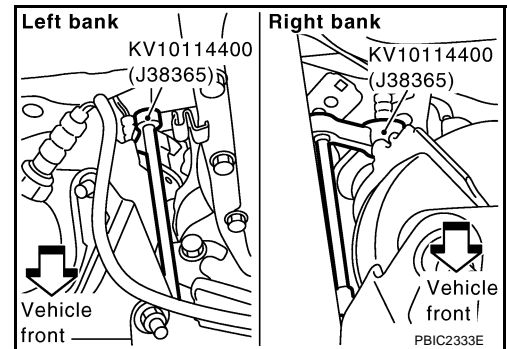

10. Remove exhaust manifold and three way catalyst (left bank) as follows:
- a. Disconnect A/C piping from A/C compressor, then remove A/C compressor with power tool. Refer to [ATC-151, "REFRIGERANT LINES"](#) .
  - b. Remove steering lower joint to enable steering shaft to move freely. Refer to [PS-13, "STEERING COLUMN"](#) .
  - c. Remove starter motor. Refer to [SC-10, "STARTING SYSTEM"](#) .
  - d. Remove nuts on bottom of engine mounting insulator (LH), and lift up left side of engine approximately 3 cm (1.18 in) with transmission jack. Refer to [EM-244, "ENGINE ASSEMBLY"](#) .
  - e. Remove exhaust manifold cover (left bank).
  - f. Loosen nuts in the reverse order of figure to remove exhaust manifold and three way catalyst (left bank) with power tool.

- A : Left bank  
 B : Right bank  
 ⇐ : Engine front

**NOTE:**

Disregard No. 9 to No. 12 when loosening.

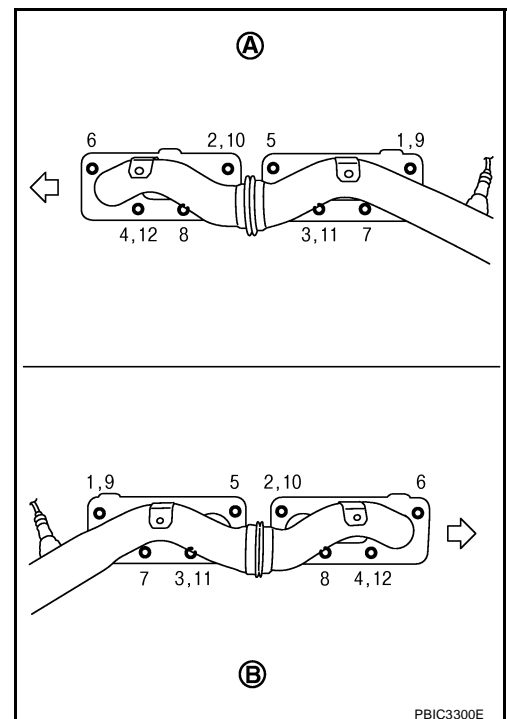

11. Remove exhaust manifold and three way catalyst (right bank) as follows:

- a. Remove alternator and bracket. Refer to [SC-23, "CHARGING SYSTEM"](#) .

# EXHAUST MANIFOLD AND THREE WAY CATALYST

[VK45DE]

- b. Remove nuts on bottom of engine mounting insulator (RH), and lift up right side of engine approximately 3 cm (1.18 in) with transmission jack. Refer to [EM-244, "ENGINE ASSEMBLY"](#).
- c. Remove exhaust manifold cover (right bank).
- d. Loosen nuts in the reverse order of figure to remove exhaust manifold and three way catalyst (right bank) with power tool.

- A : Left bank
- B : Right bank
- ← : Engine front

**NOTE:**

Disregard No. 9 to No. 12 when loosening.

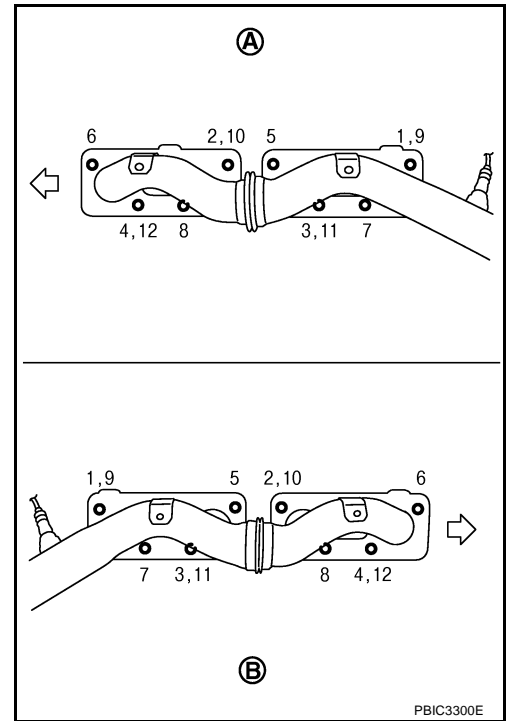

- 12. Remove exhaust manifold gaskets.

**CAUTION:**

Cover engine openings to avoid entry of foreign materials.

## INSPECTION AFTER REMOVAL

### Surface Distortion

- Check the surface distortion of the each exhaust manifold flange mating surface with straightedge and feeler gauge.

**Limit : 0.3 mm (0.012 in)**

- If it exceeds the limit, replace exhaust manifold and three way catalyst.

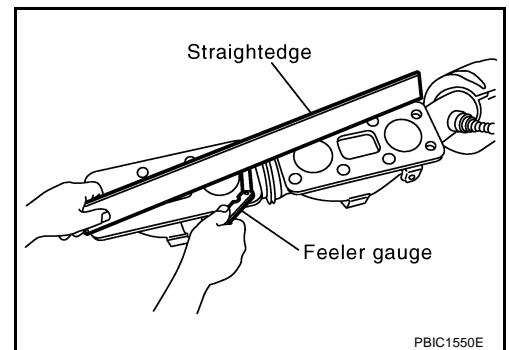

## INSTALLATION

Note the following, and install in the reverse order of removal.

## Exhaust Manifold Gasket

Install exhaust manifold gasket with its directional protrusion set upward.

A : Protrusion for confirming installation

↖ : Above

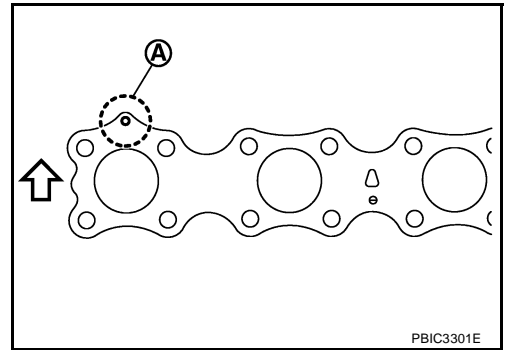

## Exhaust Manifold

- Install exhaust manifold and tighten mounting nuts in numerical order as shown in the figure.

A : Left bank

B : Right bank

↖ : Engine front

### NOTE:

Tighten mounting nuts No. 1 to 4 in two steps. The numerical order No. 9 to 12 shown second steps.

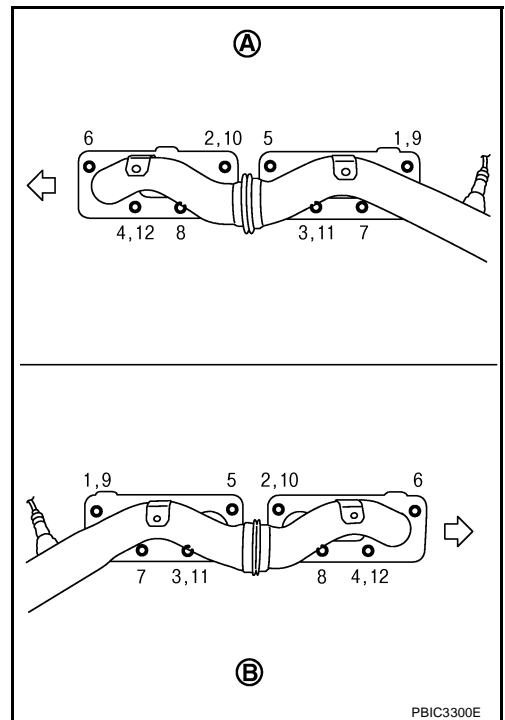

## Air Fuel Ratio Sensor

### CAUTION:

- Before installing a new air fuel ratio sensor 1, clean exhaust system threads using oxygen sensor thread cleaner (commercial service tool: J-43897-18 or J-43897-12), and apply anti-seize lubricant (commercial service tool).
- Do not over torque air fuel ratio sensor. Doing so may cause damage to the air fuel ratio sensor 1, resulting in "MIL" coming on.

## OIL PAN AND OIL STRAINER

PFP:11110

### Components

NBS0040X

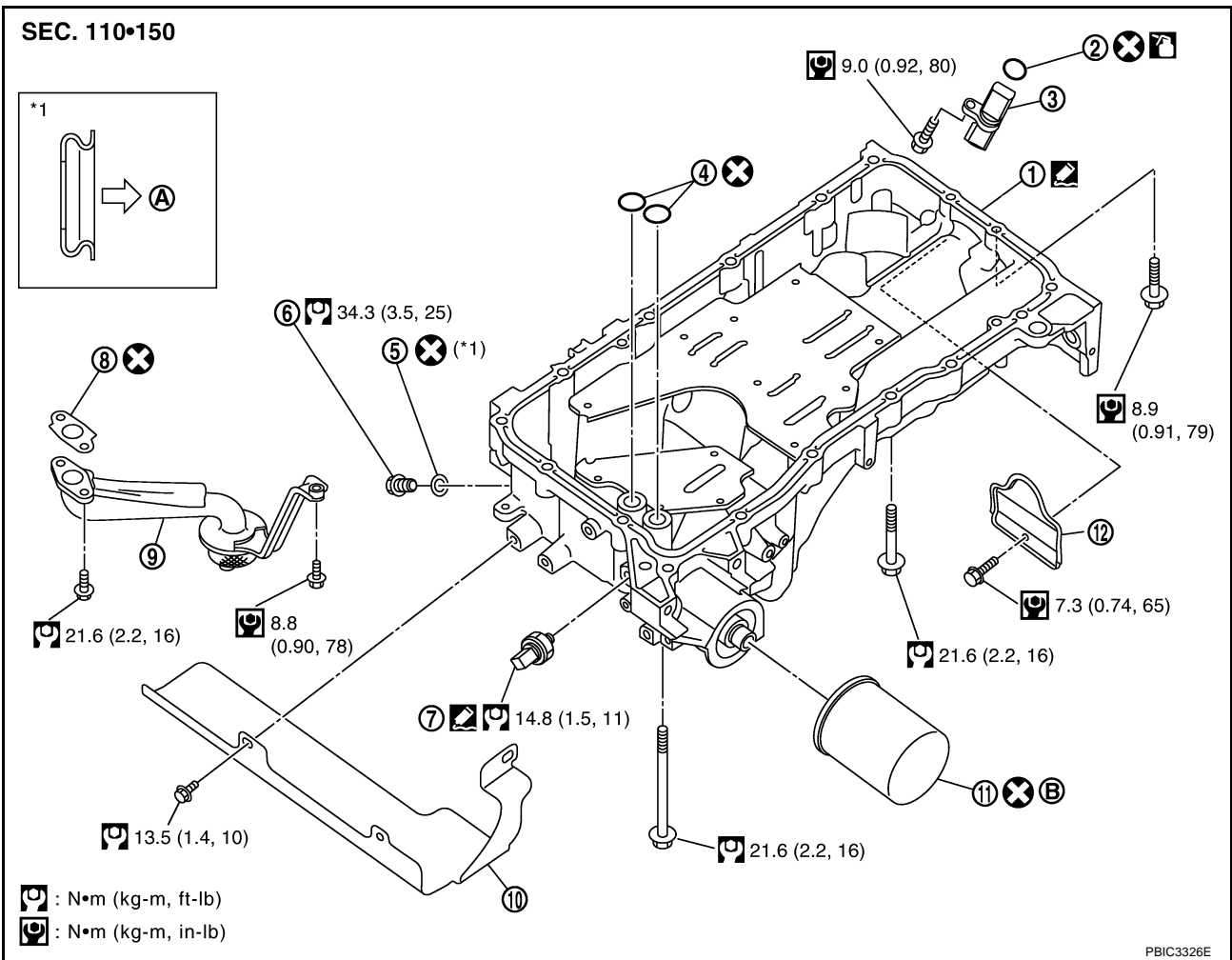

- |                        |                                   |                                     |
|------------------------|-----------------------------------|-------------------------------------|
| 1. Oil pan             | 2. O-ring                         | 3. Crankshaft position sensor (POS) |
| 4. O-ring              | 5. Drain plug washer              | 6. Drain plug                       |
| 7. Oil pressure switch | 8. Gasket                         | 9. Oil strainer                     |
| 10. Harness bracket    | 11. Oil filter                    | 12. Rear plate cover                |
| A. Oil pan side        | B. Refer to <a href="#">LU-29</a> |                                     |

- Refer to [GI-11, "Components"](#) for symbol marks in the figure.

## Removal and Installation

### REMOVAL

#### WARNING:

To avoid the danger of being scalded, do not drain engine oil when engine is hot.

1. Remove front and rear engine undercovers with power tool.
2. Drain engine oil. Refer to [LU-28, "Changing Engine Oil"](#).

#### CAUTION:

- Perform this step when engine is cold.
  - Do not spill engine oil on drive belts.
3. Remove engine assembly from vehicle. Refer to [EM-244, "ENGINE ASSEMBLY"](#).

NBS0040Y

# OIL PAN AND OIL STRAINER

[VK45DE]

4. Install engine slingers into front of cylinder head (left bank) and rear of cylinder head (right bank).

**Slinger bolts:**

:33.4 N·m (3.4 kg·m, 25 ft·lb)

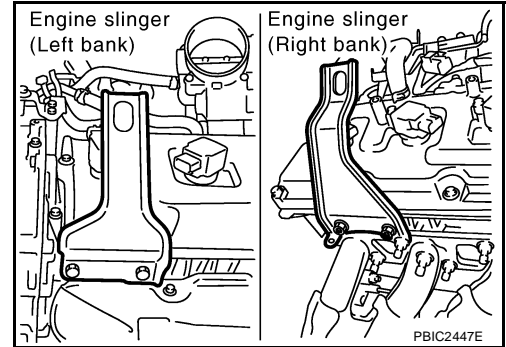

5. Remove engine mounting insulators (RH and LH) under side nut with power tool.  
6. Lift with hoist and separate engine and transmission assembly from front suspension member.

**CAUTION:**

**Avoid damage to and oil/grease smearing or spills onto engine mounting insulator.**

7. Remove harness bracket from oil pan.  
8. Remove oil filter. Refer to [LU-29, "OIL FILTER"](#).  
9. Remove oil pan as the follows:  
a. Remove rear plate cover.  
b. Remove transmission joint bolts which pierce oil pan. Refer to [AT-271, "TRANSMISSION ASSEMBLY"](#).  
c. Loosen mounting bolts with power tool in reverse order as shown in the figure.

**NOTE:**

Disregard the numerical order No. 11 and 17 in removal.

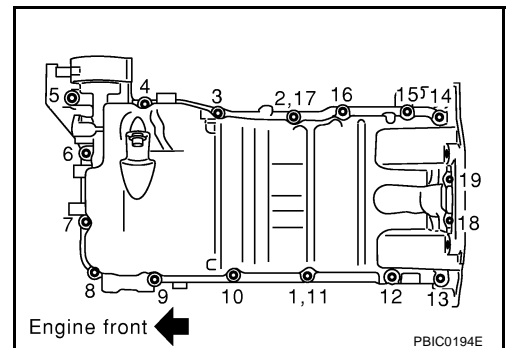

- d. Insert seal cutter (SST) between oil pan and cylinder block. Slide seal cutter by tapping on the side of seal cutter with hammer. Remove oil pan.

**CAUTION:**

- Be careful not to damage the mating surfaces.
- Do not insert screwdriver, this will damage the mating surface.

- e. Remove O-rings from bottom of oil pump and front cover.

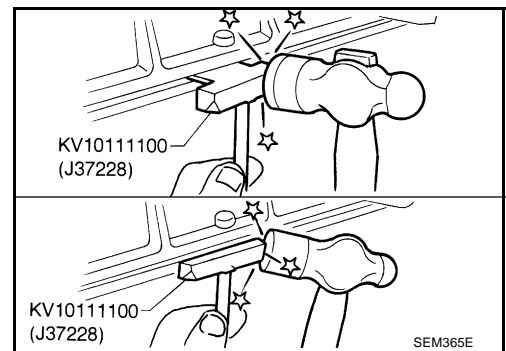

10. Remove oil pressure switch, as necessary. Refer to [LU-26, "OIL PRESSURE CHECK"](#).  
11. Remove oil strainer.

## INSPECTION AFTER REMOVAL

Clean oil strainer if any object attached.

## INSTALLATION

1. Install oil strainer.  
2. Install oil pan as follows:  
a. Use scraper to remove old liquid gasket from mating surfaces.
  - Also remove the old liquid gasket from mating surface of cylinder block.
  - Remove old liquid gasket from the bolt holes and threads.



**CAUTION:**

Do not scratch or damage the mating surfaces when cleaning off old liquid gasket.

- b. Install new O-rings to oil pump and front cover side.
- c. Apply a continuous bead of liquid gasket with tube presser [SST: WS39930000 ( — )] to the cylinder block mating surfaces of oil pan to a limited portion as shown in the figure.

Use Genuine RTV Silicone Sealant or equivalent. Refer to [GI-48, "RECOMMENDED CHEMICAL PRODUCTS AND SEALANTS"](#).

**CAUTION:**

Attaching should be done within 5 minutes after coating.

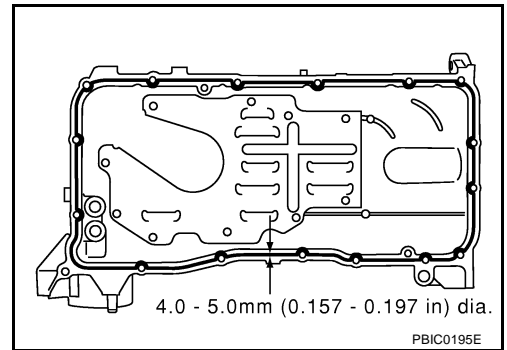

- d. Install oil pan.

**CAUTION:**

Install avoiding misalignment of O-rings.

- Tighten mounting bolts in numerical order as shown in the figure.

**NOTE:**

Tighten mounting bolts No. 1 and 2 in two steps. The numerical order No. 11 and 17 shown second steps.

- There are three types of mounting bolts. Refer to the following for locating bolts.

**M6 × 30 mm. (1.18 in) : 18, 19**

**M8 × 100 mm (3.94 in) : 5, 9**

**M8 × 45 mm (1.77 in) : Except the above**

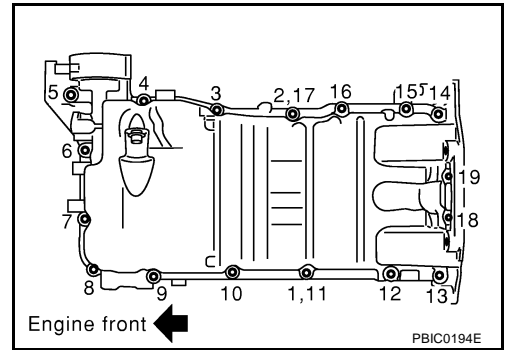

- e. Tighten transmission joint bolts. Refer to [AT-271, "TRANSMISSION ASSEMBLY"](#).

- f. Install rear plate cover.

- 3. Install oil pan drain plug with new drain plug washer.

- Refer to the figure of components of former page for installation direction of drain plug washer. Refer to [EM-187, "Removal and Installation"](#).

- 4. Install in the reverse order of removal after this step.

**NOTE:**

At least 30 minutes after oil pan is installed, pour engine oil.

**INSPECTION AFTER INSTALLATION**

- 1. Check engine oil level and adjust engine oil. Refer to [LU-26, "ENGINE OIL"](#).
- 2. Start engine, and check there is no leak of engine oil.
- 3. Stop engine and wait for 15 minutes.
- 4. Check engine oil level again. Refer to [LU-26, "ENGINE OIL"](#).

## IGNITION COIL

PFP:22448

### Components

NBS0040Z

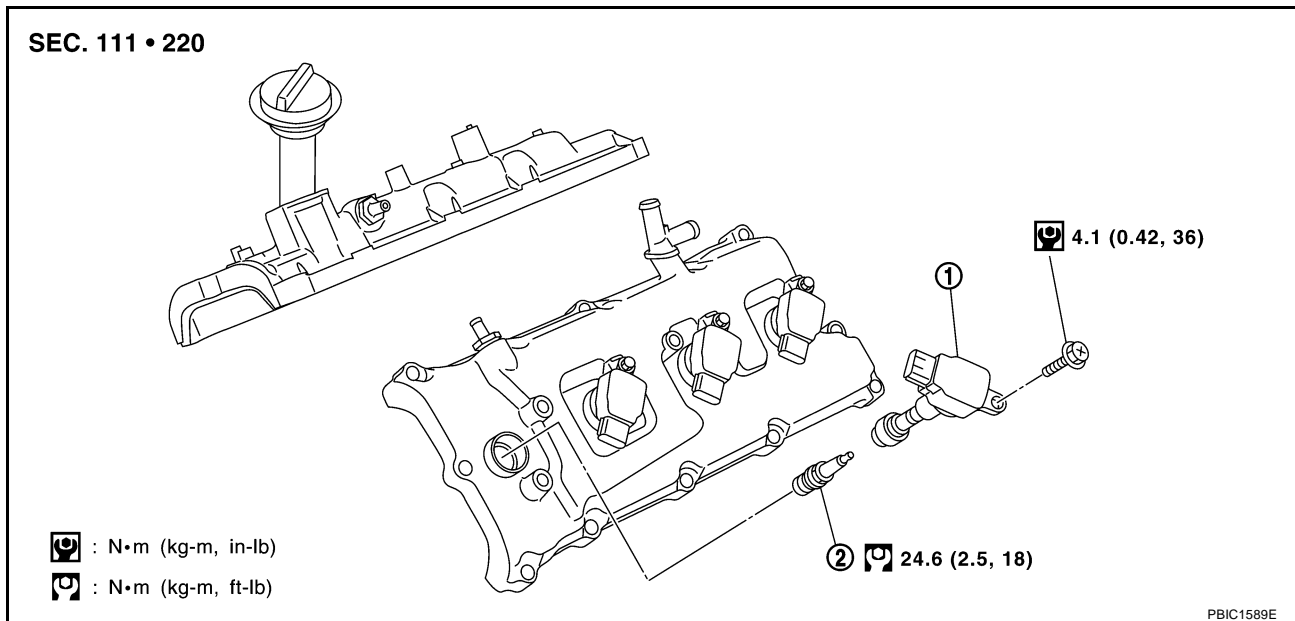

1. Ignition coil

2. Spark plug

## Removal and Installation

NBS004P0

### REMOVAL

1. Remove engine room cover (RH and LH). Refer to [EM-173, "ENGINE ROOM COVER"](#) .
2. Remove engine cover with power tool. Refer to [EM-179, "INTAKE MANIFOLD"](#) .
3. Remove air duct (inlet), air cleaner case and air duct and resonator assembly. Refer to [EM-177, "AIR CLEANER AND AIR DUCT"](#) .
4. Disconnect harness connector from ignition coil.
5. Remove ignition coil.

### CAUTION:

**Do not shock it.**

### INSTALLATION

Installation is the reverse order of removal.

# SPARK PLUG (PLATINUM-TIPPED TYPE)

[VK45DE]

## SPARK PLUG (PLATINUM-TIPPED TYPE)

PFP:22401

### Components

NBS004P1

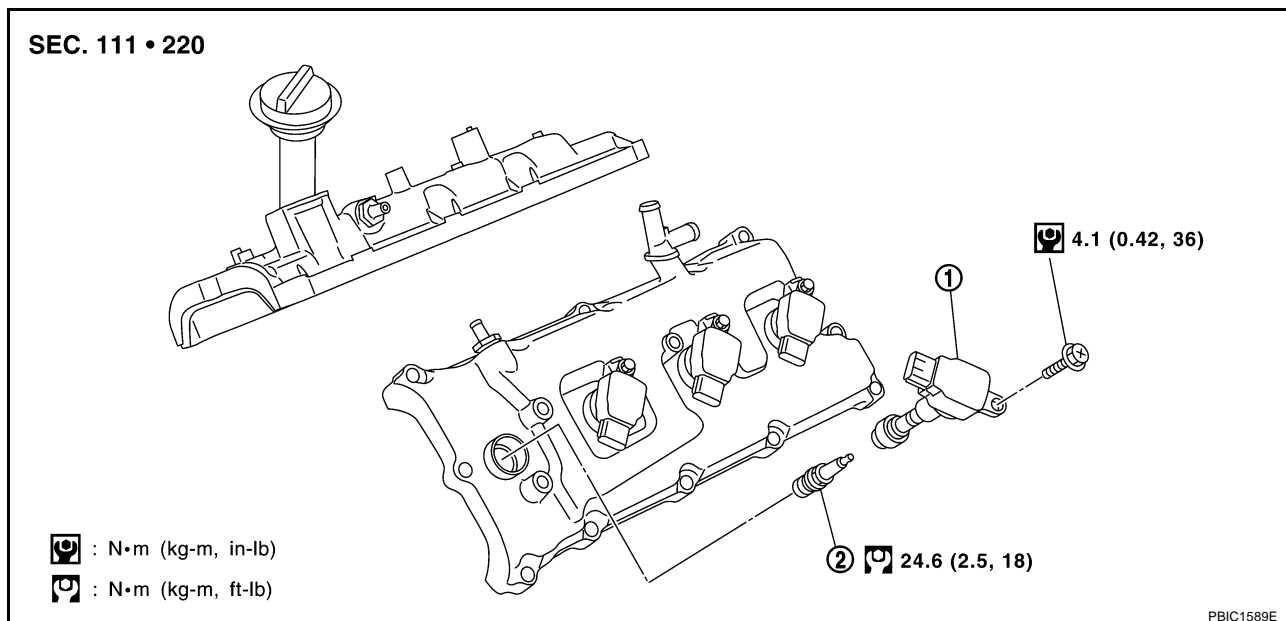

1. Ignition coil

2. Spark plug

### Removal and Installation

#### REMOVAL

1. Remove ignition coil. Refer to [EM-190, "IGNITION COIL"](#).
2. Remove spark plug with spark plug wrench (commercial service tool).

#### CAUTION:

Do not drop or shock it.

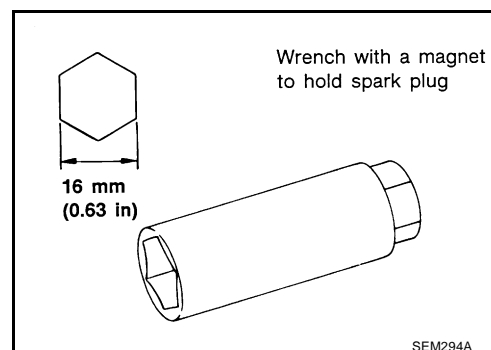

#### INSPECTION AFTER REMOVAL

Use standard type spark plug for normal condition.

Hot type spark plug is suitable when fouling occurs with standard type spark plug under conditions such as:

- Frequent engine starts
- Low ambient temperatures

Cold type spark plug is suitable when spark plug knock occurs with standard type spark plug under conditions such as:

- Extended highway driving
- Frequent high engine revolution

Make	NGK
Standard type	PLFR5A-11
Hot type	PLFR4A-11
Cold type	PLFR6A-11

Gap (Nominal) : 1.1 mm (0.043 in)

# SPARK PLUG (PLATINUM-TIPPED TYPE)

[VK45DE]

## CAUTION:

- Do not drop or shock spark plug.
- Do not use wire brush for cleaning.
- If plug tip is covered with carbon, spark plug cleaner may be used.

Cleaner air pressure:

Less than 588 kPa (6 kg/cm<sup>2</sup> , 85 psi)

Cleaning time:

Less than 20 seconds

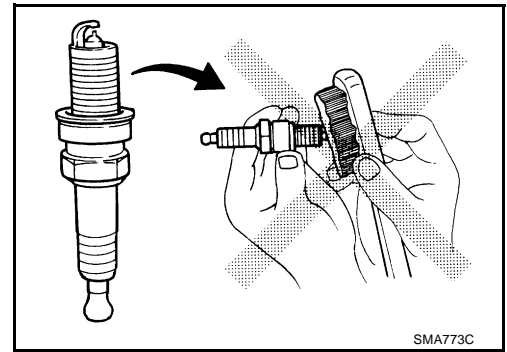

- Checking and adjusting plug gap is not required between change intervals.

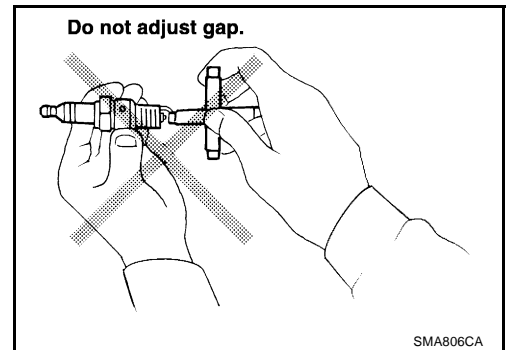

## INSTALLATION

Installation is the reverse order of removal.

## FUEL INJECTOR AND FUEL TUBE

PFP:16600

### Components

NBS004P3

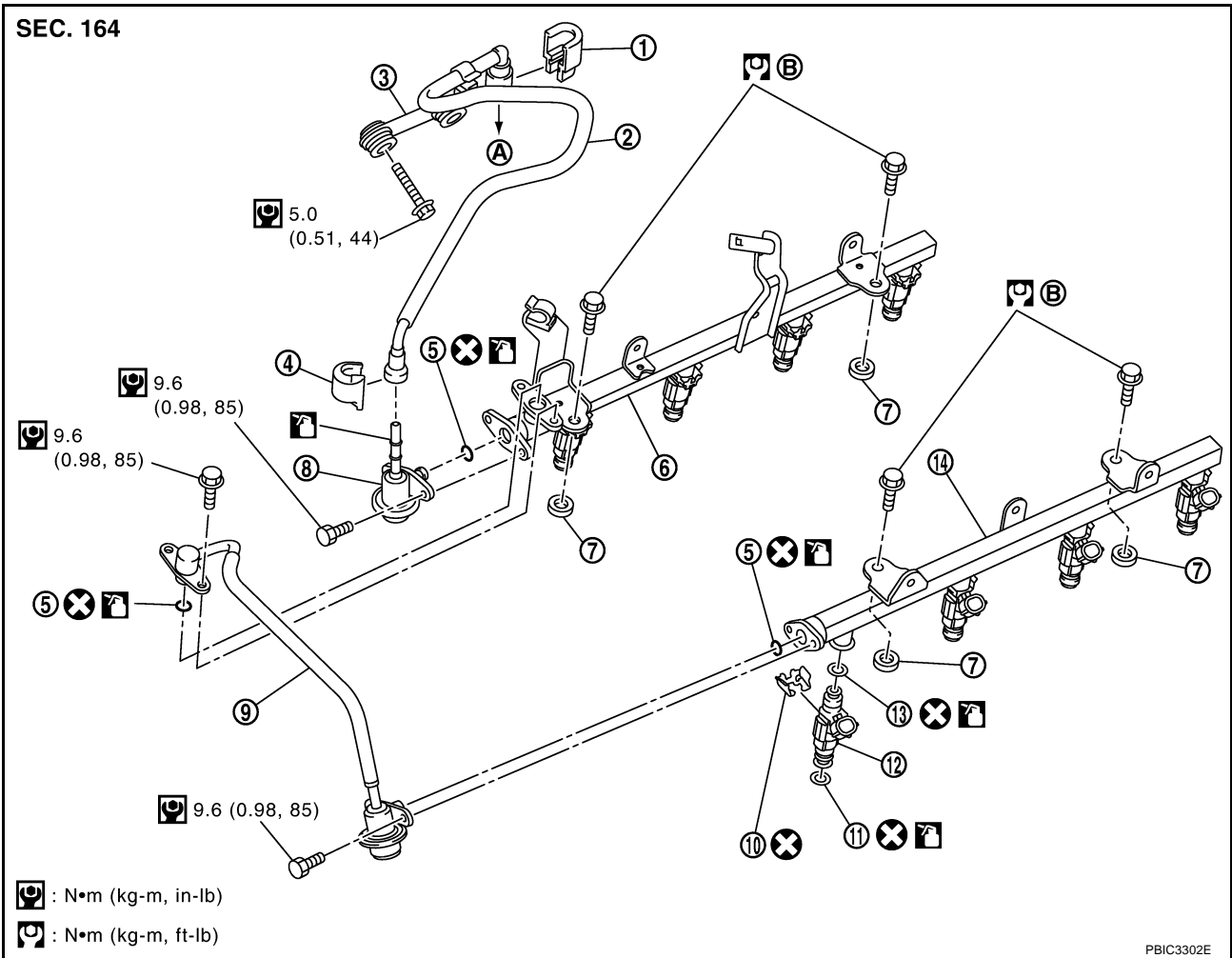

- |                        |                     |                                       |
|------------------------|---------------------|---------------------------------------|
| 1. Quick connector cap | 2. Fuel feed hose   | 3. Fuel feed hose bracket             |
| 4. Quick connector cap | 5. O-ring           | 6. Fuel tube (RH)                     |
| 7. Spacer              | 8. Fuel feed damper | 9. Fuel damper and fuel hose assembly |
| 10. Clip               | 11. O-ring (Green)  | 12. Fuel injector                     |
| 13. O-ring (Black)     | 14. Fuel tube (LH)  |                                       |
- A. To centralized under-floor piping      B. Refer to [EM-193](#)

#### CAUTION:

Do not remove or disassemble parts unless instructed as shown in the figure.

- Refer to [GI-11, "Components"](#) for symbol marks in the figure.

### Removal and Installation

#### REMOVAL

#### WARNING:

- Put a "CAUTION: FLAMMABLE" sign in the workshop.
  - Be sure to work in a well ventilated area and furnish workshop with a CO<sub>2</sub> fire extinguisher.
  - Do not smoke while servicing fuel system. Keep open flames and sparks away from the work area.
  - To avoid the danger of being scalded, do not drain engine coolant when engine is hot.
1. Remove engine room cover (RH and LH). Refer to [EM-173, "ENGINE ROOM COVER"](#).
  2. Remove engine cover with power tool. Refer to [EM-179, "INTAKE MANIFOLD"](#).
  3. Release fuel pressure. Refer to [EC-809, "FUEL PRESSURE RELEASE"](#).

NBS004P4

# FUEL INJECTOR AND FUEL TUBE

[VK45DE]

4. Disconnect fuel feed hose on engine side as follows: (Perform same procedure for the side of centralized under-floor piping as well.)

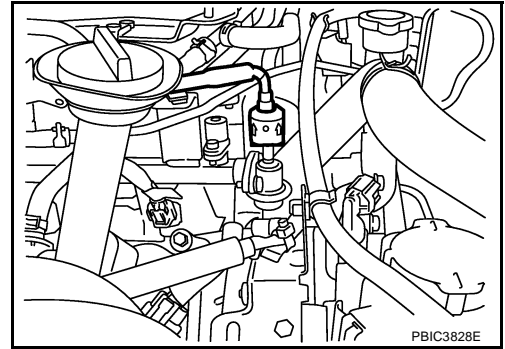

- a. Remove quick connector cap from quick connector connection.

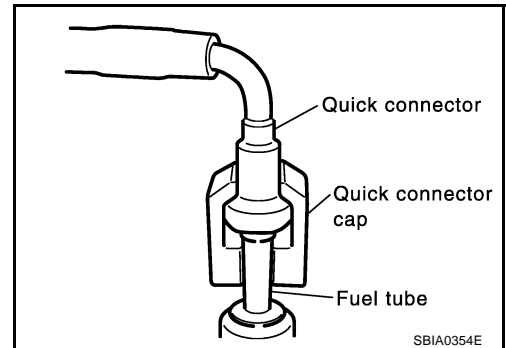

- b. Disconnect quick connector from fuel feed damper as follows:

**CAUTION:**

**Disconnect quick connector by using quick connector release [SST: J-45488], not by picking out retainer tabs (centralized under-floor piping side).**

- i. With the sleeve side of quick connector release facing to quick connector, install quick connector release onto fuel tube.
- ii. Insert quick connector release into quick connector until sleeve contacts and goes no further. Hold quick connector release on that position.

**CAUTION:**

**Inserting quick connector release hard will not disconnect quick connector. Hold quick connector release where it contacts and goes no further.**

- iii. Draw and pull out quick connector straight from fuel feed damper.

**CAUTION:**

● Pull quick connector holding "A" position as shown in the figure.

- Do not pull with lateral force applied. O-ring inside quick connector may be damaged.
- Prepare container and cloth beforehand as fuel will leak out.
- Avoid fire and sparks.
- Keep parts away from heat source. Especially, be careful when welding is performed around them.
- Do not expose parts to battery electrolyte or other acids.
- Do not bend or twist connection between quick connector and fuel feed hose during installation/removal.

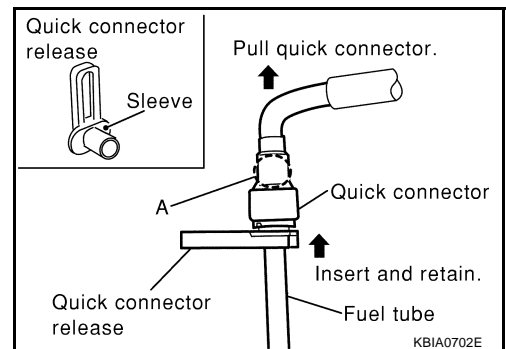

# FUEL INJECTOR AND FUEL TUBE

[VK45DE]

- To keep clean the connecting portion and to avoid damage and foreign materials, cover them completely with plastic bags or something similar.

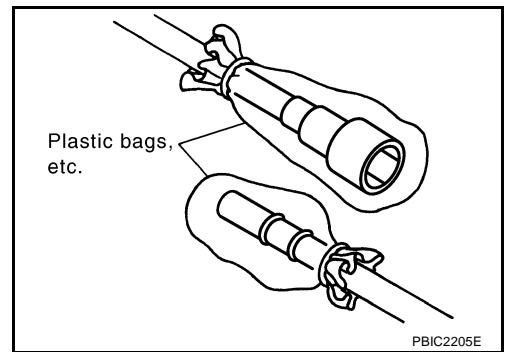

5. Disconnect fuel damper and fuel hose assembly from fuel tubes (RH and LH).

**CAUTION:**

- While hoses are disconnected, plug them to prevent fuel from draining.
- Do not separate fuel damper and fuel hose.

6. Disconnect harness connector from fuel injector.

7. Loosen mounting bolts in reverse order as shown in the figure, and remove fuel tube and fuel injector assembly.

- A. : Right bank  
B. : Left bank  
← : Engine front

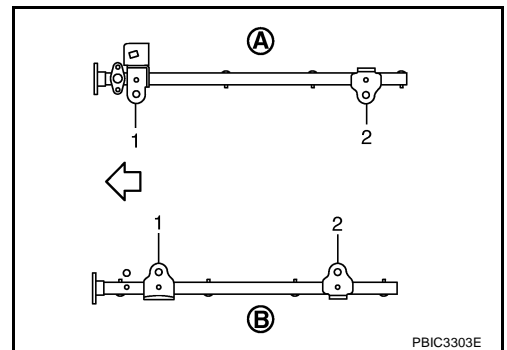

**CAUTION:**

Do not tilt it, or remaining fuel in pipes may flow out from pipes.

8. Remove spacers on intake manifold (lower).  
9. Remove fuel injector from fuel tube as follows:  
a. Open and remove clip.  
b. Remove fuel injector from fuel tube by pulling straight.

**CAUTION:**

- Be careful with remaining fuel that may go out from fuel tube.
- Be careful not to damage injector nozzles during removal.
- Do not bump or drop fuel injector.
- Do not disassemble fuel injector.

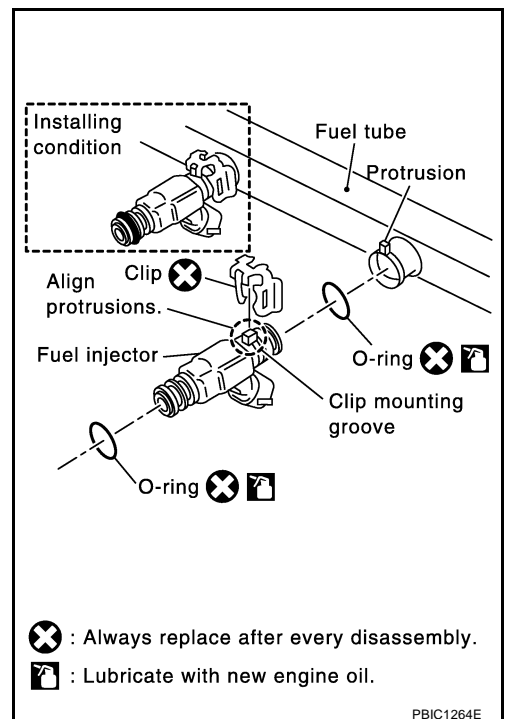

10. Remove fuel feed damper.

## INSTALLATION

1. Install fuel feed damper.
- When handling new O-rings, be careful of the following caution.

**CAUTION:**

- Handle O-ring with bare hands. Do not wear gloves.
  - Lubricate O-ring with new engine oil.
  - Do not clean O-ring with solvent.
  - Make sure that O-ring and its mating part are free of foreign material.
  - When installing O-ring, be careful not to scratch it with tool or fingernails. Also be careful not to twist or stretch O-ring. If O-ring was stretched while it was being attached, do not insert it quickly into fuel tube.
  - Insert new O-ring straight into fuel tube. Do not decenter or twist it.
  - Insert fuel feed damper straight into fuel tube (RH).
  - Tighten mounting bolts evenly in turn.
  - After tightening mounting bolts, make sure that there is no gap between flange and fuel tube (RH).
2. Install new O-rings to fuel injector paying attention to the following caution.

**CAUTION:**

- Upper and lower O-ring are different. Be careful not to confuse them.

Fuel tube side : Black

Nozzle side : Green

- Handle O-ring with bare hands. Never wear gloves.
- Lubricate O-ring with new engine oil.
- Do not clean O-ring with solvent.
- Make sure that O-ring and its mating part are free of foreign material.
- When installing O-ring, be careful not to scratch it with tool or fingernails. Also be careful not to twist or stretch O-ring. If O-ring was stretched while it was being attached, do not insert it quickly into fuel tube.
- Insert O-ring straight into fuel injector. Do not decenter or twist it.

3. Install fuel injector to fuel tube as follows:

- a. Insert clip into clip mounting groove on fuel injector.
- Insert clip so that "protrusion A" of fuel injector matches "cutout A" of clip.

**CAUTION:**

- Do not reuse clip. Replace it with a new one.
- Be careful to keep clip from interfering with O-ring. If interference occurs, replace O-ring.

- b. Insert fuel injector into fuel tube with clip attached.
- Insert it while matching it to the axial center.
  - Insert fuel injector so that "protrusion B" of fuel tube matches "cutout B" of clip.
  - Make sure that fuel tube flange is securely fixed in flange fixing groove on clip.
- c. Make sure that installation is complete by checking that fuel injector does not rotate or come off.
- Make sure that protrusions of fuel injectors are aligned with cutouts of clips after installation.

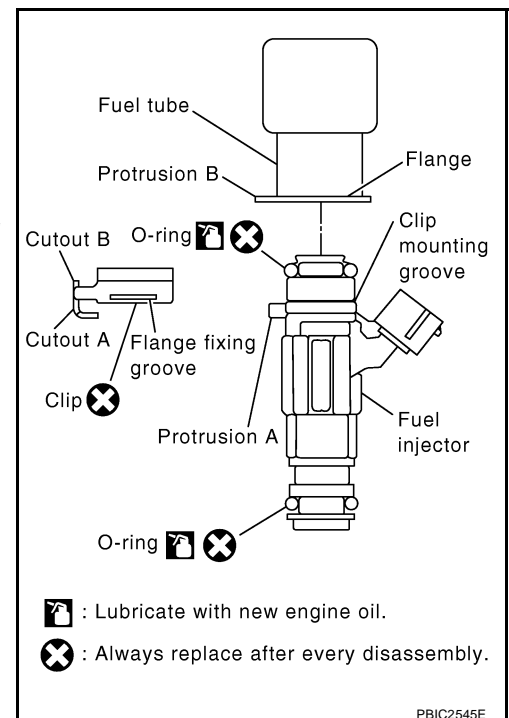

4. Install spacers on intake manifold (lower).
5. Install fuel tube and fuel injector assembly to intake manifold (lower).

**CAUTION:**

Be careful not to let tip of injector nozzle come in contact with other parts.





# FUEL INJECTOR AND FUEL TUBE

[VK45DE]

- Tighten mounting bolts in two steps in numerical order as shown in the figure.

- A : Right bank
- B : Left bank
- ↶ : Engine front

-  **1st step** : 10.1 N·m (1.0 kg·m, 7 ft·lb)
-  **2nd step** : 23.5 N·m (2.4 kg·m, 17 ft·lb)

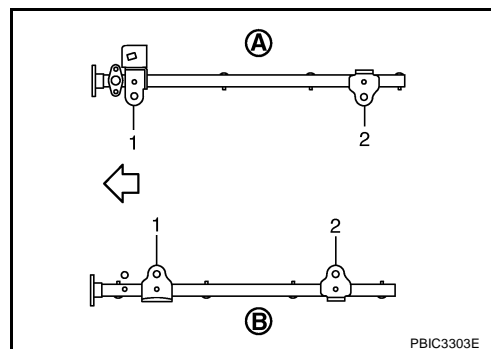

6. Connect fuel feed hose on engine side as follows: (Unless otherwise indicated, the installation to the engine side and centralized under-floor piping side is exactly alike.)
  - a. Make sure no foreign substances are deposited in and around fuel tube and quick connector, and no damage on them.
  - b. Thinly apply new engine oil around fuel tube from tip end to spool end.
  - c. Align center to insert quick connector straightly into fuel tube.
 

Engine side:

- Insert fuel tube into quick connector until top spool is completely inside quick connector, and 2nd level spool exposes right below quick connector.

**CAUTION:**

- Hold “A” position as shown in the figure when inserting fuel tube into quick connector.
- Carefully align center to avoid inclined insertion to prevent damage to O-ring inside quick connector.
- Insert until you hear a “click” sound and actually feel the engagement.
- To avoid misidentification of engagement with a similar sound, be sure to perform the next step.

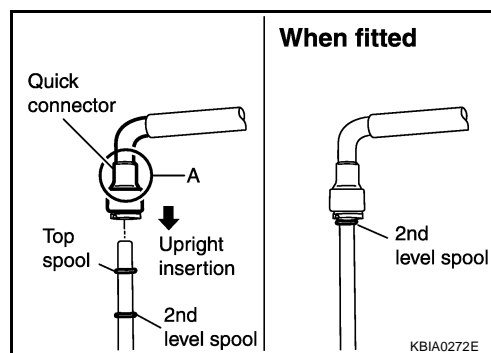

Centralized under-floor piping side:

- Visually confirm that the two retainer tabs are connected to the connector.

**CAUTION:**

- Carefully align center to avoid inclined insertion to prevent damage to O-ring inside quick connector.
- Insert until you hear a “click” sound and actually feel the engagement.
- To avoid misidentification of engagement with a similar sound, be sure to perform the next step.

- d. Pull quick connector by hand holding position. Make sure it is completely engaged (connected) so that it does not come out from fuel tube.
- e. Install quick connector cap on quick connector connection.

**CAUTION:**

If cap cannot be installed smoothly, quick connector may have not been installed correctly. Check connection again.

- f. Install fuel feed hose to hose clamps.

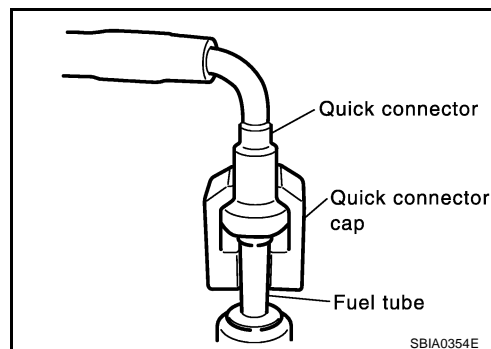

7. Install in the reverse order of removal after this step.

## INSPECTION AFTER INSTALLATION

### Check on Fuel Leakage

1. Turn ignition switch “ON” (with engine stopped). With fuel pressure applied to fuel piping, check for fuel leakage at connection points.

**NOTE:**

Use mirrors for checking at points out of clear sight.

2. Start engine. With engine speed increased, check again for fuel leakage at connection points.

**CAUTION:**

**Do not touch engine immediately after stopped, as engine becomes extremely hot.**

## ROCKER COVER

PF13264

### Components

NBS004P5

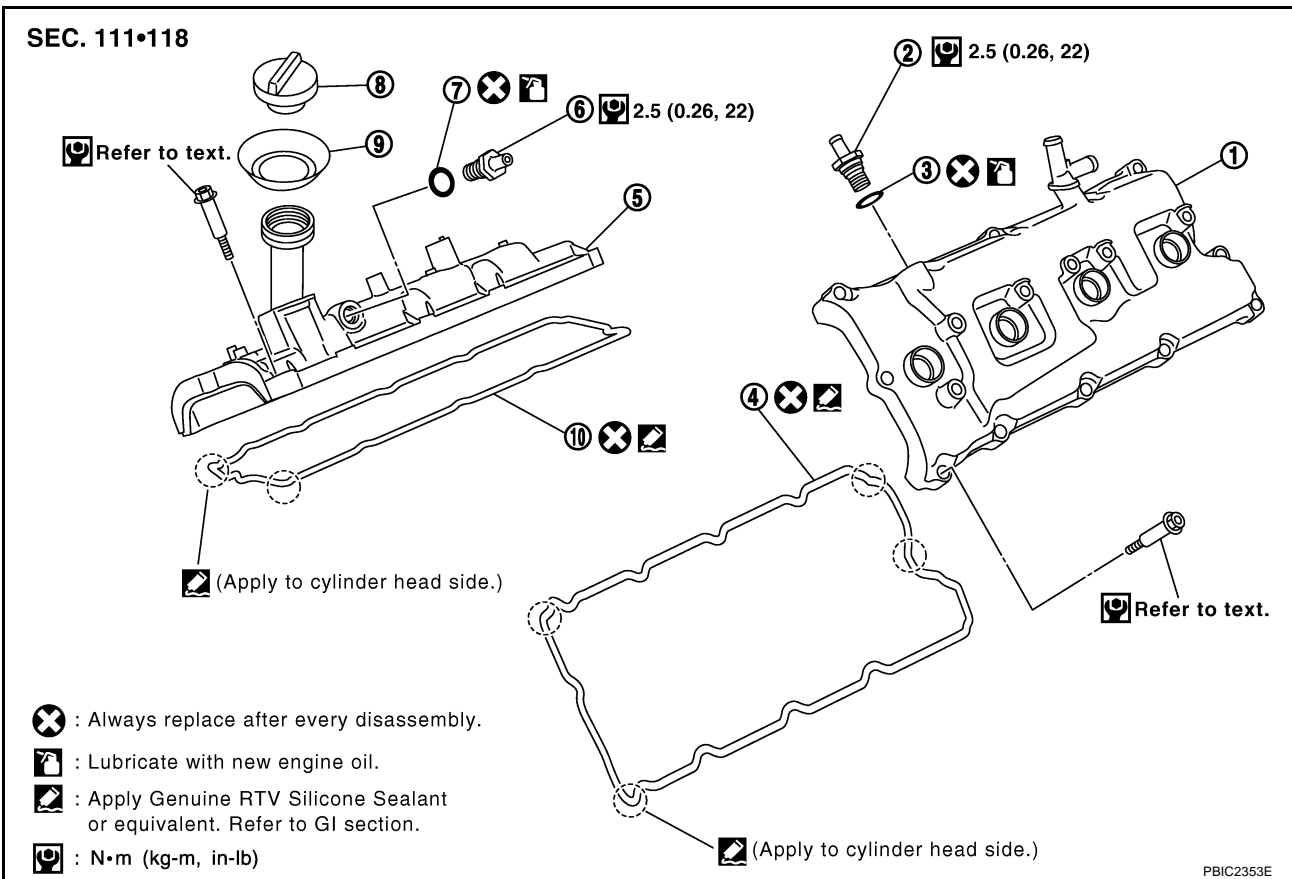

- |                                      |                              |                |
|--------------------------------------|------------------------------|----------------|
| 1. Rocker cover (left bank)          | 2. PCV valve                 | 3. O-ring      |
| 4. Rocker cover gasket (left bank)   | 5. Rocker cover (right bank) | 6. PCV valve   |
| 7. O-ring                            | 8. Oil filler cap            | 9. Oil catcher |
| 10. Rocker cover gasket (right bank) |                              |                |

## Removal and Installation

### REMOVAL

NBS004P6

1. Remove engine room cover (RH and LH). Refer to [EM-173, "ENGINE ROOM COVER"](#).
2. Remove engine cover with power tool. Refer to [EM-179, "INTAKE MANIFOLD"](#).
3. Refer to the following for incidental works related to left bank.
  - a. Remove air duct (inlet), air cleaner case and air duct and resonator assembly. Refer to [EM-177, "AIR CLEANER AND AIR DUCT"](#).
  - b. Move harness on upper rocker cover and its peripheral aside.
  - c. Remove harness bracket from camshaft bracket (No. 6). Refer to [EM-215, "CAMSHAFT"](#).
  - d. Remove ignition coil. Refer to [EM-190, "IGNITION COIL"](#).
  - e. Remove PCV hose from PCV valve.
4. Refer to the following for incidental works related to right bank.
  - a. Move harness on upper rocker cover and its peripheral aside.
  - b. Remove ignition coil. Refer to [EM-190, "IGNITION COIL"](#).
  - c. Remove PCV hose from PCV valve.
5. Remove PCV valves and O-rings from rocker covers (right and left bank), if necessary.
6. Remove oil filler cap and oil catcher from rocker cover (right bank), if necessary.
7. Remove rocker cover (right bank) as follows:
  - a. Remove battery cover. Refer to [EM-173, "ENGINE ROOM COVER"](#).

# ROCKER COVER

[VK45DE]

- b. Remove battery and battery tray. Refer to [SC-4, "BATTERY"](#).
- c. Remove grommet (2) from cowl top panel hole (RH).

- 1 : Relay box
- ⇐ : Engine front

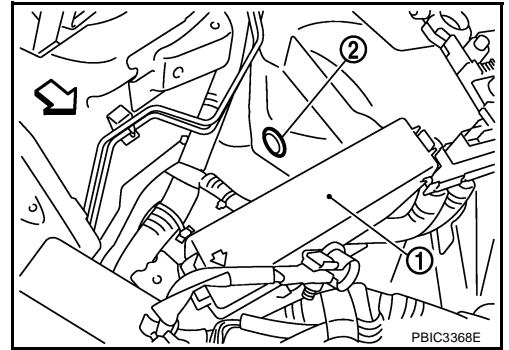

- d. Loosen mounting bolts in reverse order as that shown in the figure.

**CAUTION:**

Do not hold oil filler neck (right bank) so as not to damage it.

**NOTE:**

Loosen No. 10 bolt of right bank from cowl top panel hole using tool.

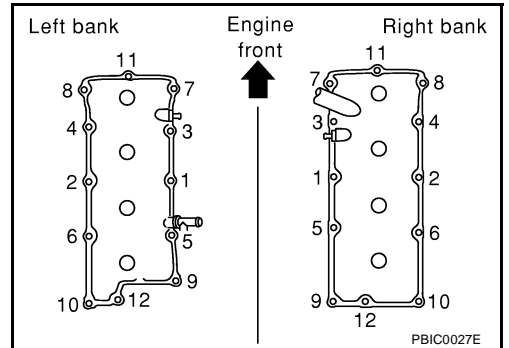

- 8. Remove rocker cover (left bank) as follows:

- a. Remove brake master cylinder cover. Refer to [EM-173, "ENGINE ROOM COVER"](#).
- b. Remove two grommets (1) from cowl top panel hole (LH).

- 2 : Brake master cylinder
- ⇐ : Engine front

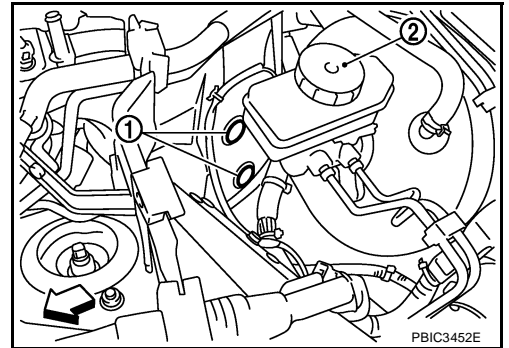

- c. Loosen mounting bolts in reverse order as that shown in the figure.

**NOTE:**

Loosen No. 10 and 12 bolts of the left bank from cowl top panel hole using tool.

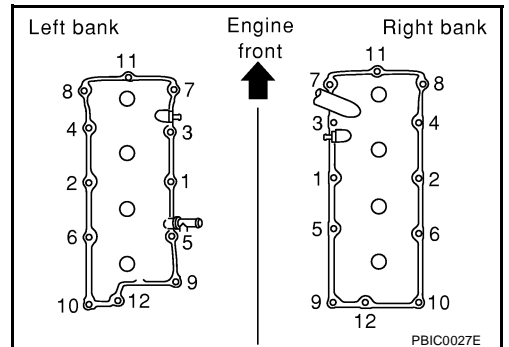

- Refer to the following procedure for removal of mounting bolts No. 10 and 12. (For ICC models)

**CAUTION:**

Do not bend or damage brake piping by tools.

# ROCKER COVER

[VK45DE]

- No. 10 bolt. See the figure and remove them using a 300 mm expansion bar.

A : Cowl top panel hole

↶ : Engine front

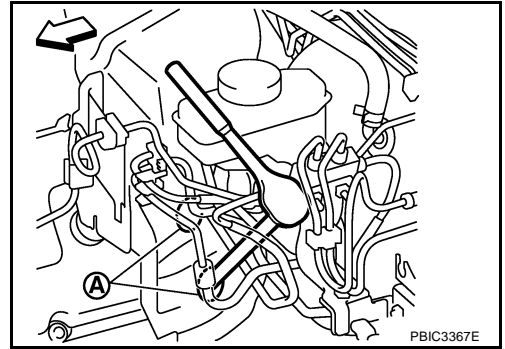

- No. 12 bolt. See the figure and remove them using a 300 mm expansion bar.

A : Cowl top panel hole

↶ : Engine front

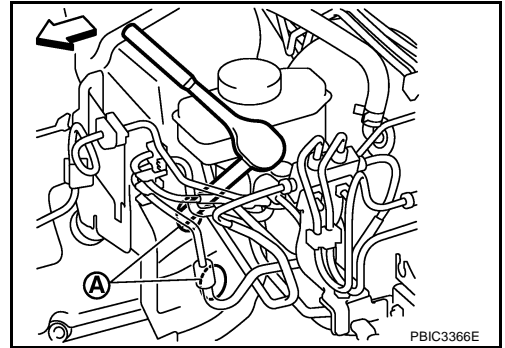

**NOTE:**

Slide the brake piping forward to obtain working space.

- Remove rocker cover gaskets from rocker covers.
- Use scraper to remove all traces of liquid gasket from cylinder head and camshaft bracket (No. 1 and 6).

**CAUTION:**

Do not scratch or damage the mating surface when cleaning off oil liquid gasket.

**INSTALLATION**

- Apply liquid gasket with tube presser [SST: WS39930000 ( — )] to joint among rocker cover, cylinder head and camshaft bracket (No. 1 and 6) as follows:

**Use Genuine RTV Silicone Sealant or equivalent. Refer to [GI-48, "RECOMMENDED CHEMICAL PRODUCTS AND SEALANTS"](#).**

**NOTE:**

The figure shows an example of left bank side [zoomed in shows camshaft bracket (No. 1)]. Apply only to camshaft bracket (No. 1) for right bank side.

- Refer to the figure "a" to apply liquid gasket to joint part of camshaft bracket (both No. 1 and 6) and cylinder head.
- Refer to the figure "b" to apply liquid gasket to the figure "a" squarely.

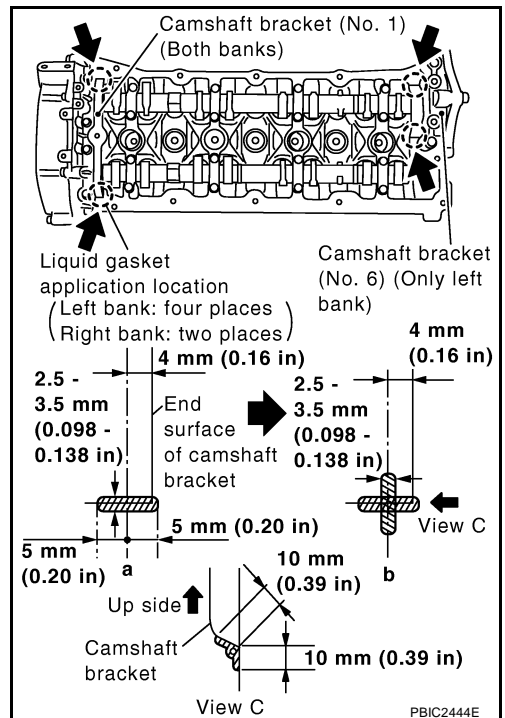

- Install new rocker cover gaskets to rocker covers.
- Install rocker cover.
  - Check if rocker cover gasket is not dropped from installation groove of rocker cover.

# ROCKER COVER

[VK45DE]

4. Tighten mounting bolts in two steps separately in numerical order as shown in the figure.

**CAUTION:**

- Do not hold oil filler neck (right bank) so as not to damage it.
- Do not bend or damage brake piping by tools. (ICC models)

**NOTE:**

Tighten No. 10 bolt of the right bank and No. 10 and 12 bolts of the left bank from cowl top panel hole with using tool.

 **1st step** : 2.0 N·m (0.2 kg·m, 18 in·lb)

 **2nd step** : 8.3 N·m (0.85 kg·m, 73 in·lb)

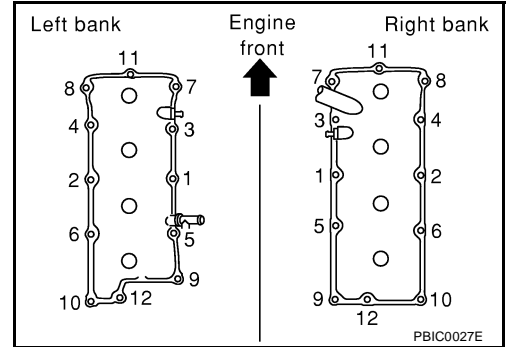

5. Install oil filler cap and oil catcher to rocker cover (right bank), if removed.
6. Install new O-rings and PCV valves to rocker covers (right and left bank), if removed.
7. Install in the reverse order of removal.

# TIMING CHAIN

[VK45DE]

## TIMING CHAIN

PF13028

### Components

NBS004P7

A  
EM  
C  
D  
E  
F  
G  
H  
I  
J  
K  
L  
M

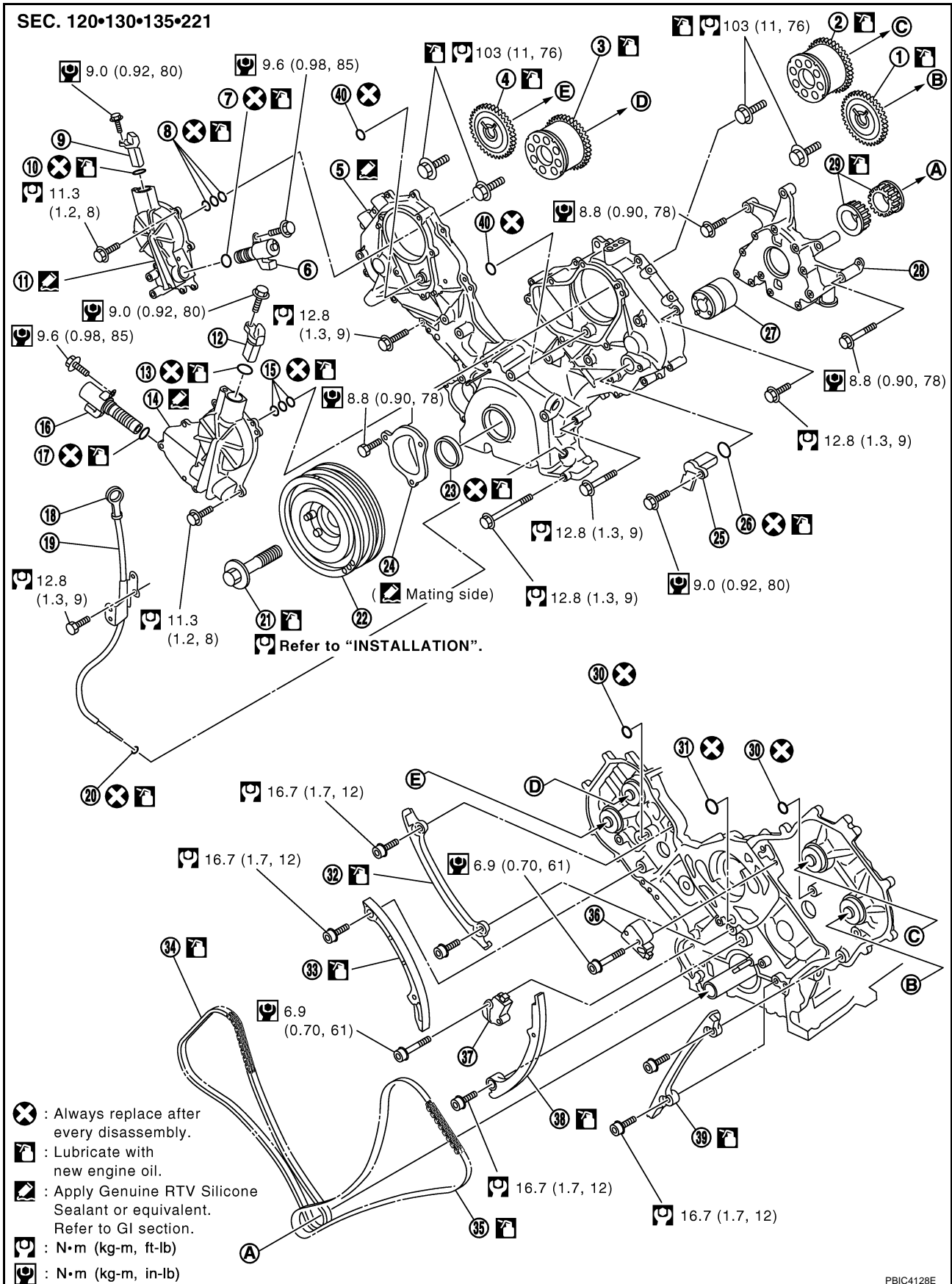

# TIMING CHAIN

[VK45DE]

- |  |  |   |
|--|--|---|
| 1. Camshaft sprocket (EXH)                                 | 2. Camshaft sprocket (INT)                         | 3. Camshaft sprocket (INT)                                  |
| 4. Camshaft sprocket (EXH)                                 | 5. Front cover                                     | 6. Intake valve timing control solenoid valve (right bank)  |
| 7. O-ring  | 8. Seal ring                                       | 9. Intake valve timing control position sensor (right bank) |
| 10. O-ring   | 11. Intake valve timing control cover (right bank) | 12. Intake valve timing control position sensor (left bank) |
| 13. O-ring   | 14. Intake valve timing control cover (left bank)  | 15. Seal ring   |
| 16. Intake valve timing control solenoid valve (left bank) | 17. O-ring   | 18. Oil level gauge   |
| 19. Oil level gauge guide                                  | 20. O-ring   | 21. Crankshaft pulley bolt                                  |
| 22. Crankshaft pulley                                      | 23. Front oil seal                                 | 24. Chain tensioner cover                                   |
| 25. Camshaft position sensor (PHASE)                       | 26. O-ring   | 27. Oil pump drive spacer                                   |
| 28. Oil pump assembly                                      | 29. Crankshaft sprocket                            | 30. O-ring  |
| 31. O-ring   | 32. Timing chain tension guide (right bank)        | 33. Timing chain slack guide (right bank)                   |
| 34. Timing chain (right bank)                              | 35. Timing chain (left bank)                       | 36. Chain tensioner (left bank)                             |
| 37. Chain tensioner (right bank)                           | 38. Timing chain slack guide (left bank)           | 39. Timing chain tension guide (left bank)                  |
| 40. O-ring   |  |   |

## Removal and Installation

### REMOVAL

NBS004P8

1. Remove engine assembly from vehicle. Refer to [EM-244, "ENGINE ASSEMBLY"](#) .
2. Remove the following components and related parts:
  - Drive belt auto tensioner and idler pulley; Refer to [EM-176, "Drive Belt Auto Tensioner and Idler Pulley"](#) .
  - Thermostat housing and hoses; Refer to [CO-55, "THERMOSTAT AND WATER CONTROL VALVE"](#) .
  - Ignition coil; Refer to [EM-190, "IGNITION COIL"](#) .
  - Rocker cover; Refer to [EM-199, "ROCKER COVER"](#) .
3. If necessary, remove intake valve timing control position sensor (right and left bank) and camshaft position sensor (PHASE) from intake valve timing control cover and front cover.

#### CAUTION:

- Handle carefully to avoid dropping and shocks.
- Do not disassemble.

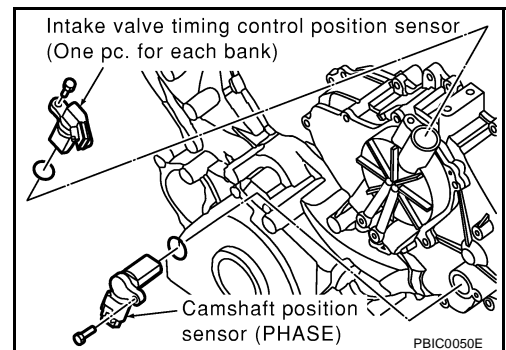

4. If necessary, remove intake valve timing control solenoid valve from intake valve timing control cover.

#### CAUTION:

- Handle components and parts carefully to avoid dropping and shocks.
- Do not disassemble.
- Do not allow metal powder to adhere to magnetic part at sensor tip.
- Do not place sensors in a location where they are exposed to magnetism.



# TIMING CHAIN

[VK45DE]

5. Remove intake valve timing control cover as follows:
  - a. Loosen and remove mounting bolts in the reverse order as shown in the figure.
  - b. Use seal cutter [SST: KV10111100 (J37228)] to cut liquid gasket for removal.

**CAUTION:**

- Exercise care not to damage mating surfaces.
- Pull out cover keeping levelness without an angle, as inner part of cover is engaged with the center of camshaft sprocket (INT).

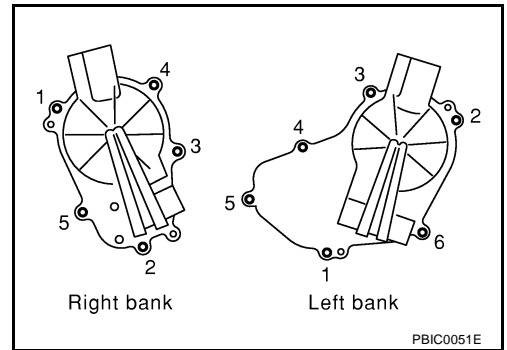

6. Remove O-rings from front cover.

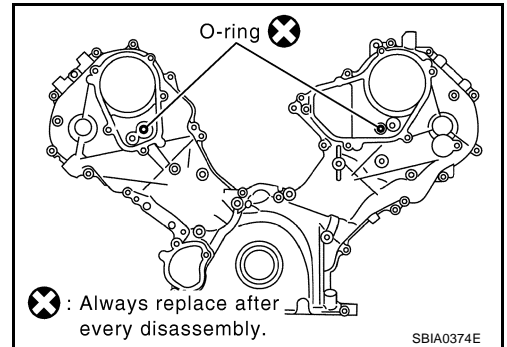

7. Obtain No. 1 cylinder at TDC of its compression stroke as follows:

- a. Rotate crankshaft pulley clockwise to align the TDC identification notch (without paint mark) with timing indicator on front cover.

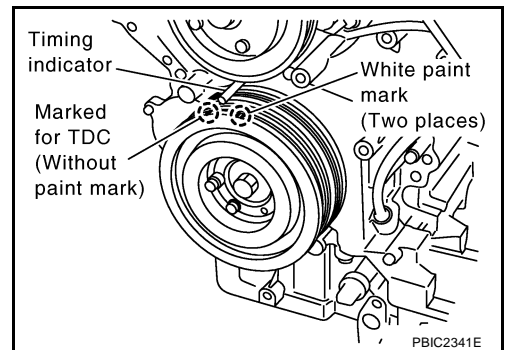

- b. Make sure that both intake and exhaust cam noses of No. 1 cylinder (engine front side of left bank) are located as shown in the figure.

- If not, turn crankshaft one revolution (360 degrees) and align as shown in the figure.

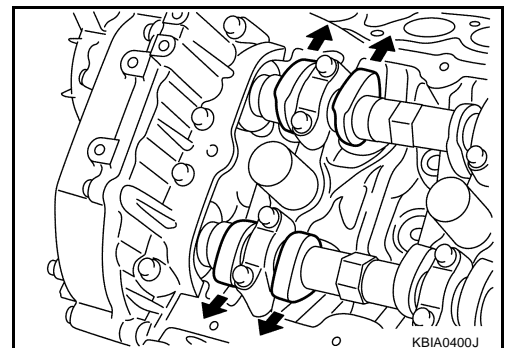

8. Remove crankshaft pulley as follows:

# TIMING CHAIN

[VK45DE]

- a. Remove rear plate cover, and set ring gear stopper (SST).
- b. Loosen crankshaft pulley bolt, and then pull crankshaft pulley with both hands to remove it.

**CAUTION:**

- Do not remove crankshaft pulley bolt. Keep loosened crankshaft pulley bolt in place to protect removed crankshaft pulley from dropping.
- Do not remove balance weight (inner hexagon bolt) at the front of crankshaft pulley.

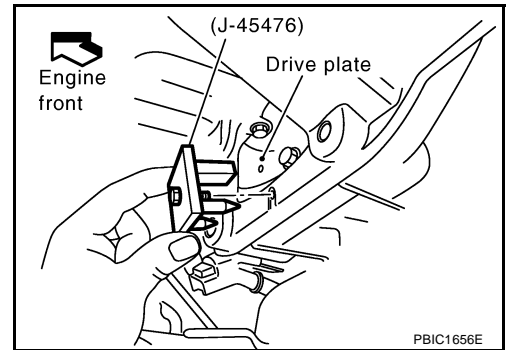

9. Remove oil pan and oil strainer. Refer to [EM-187, "OIL PAN AND OIL STRAINER"](#).
10. Remove front cover as follows:

- a. Loosen mounting bolts in reverse order as shown in the figure.
- b. Use seal cutter [SST: KV10111100 (J37228)] to cut liquid gasket for removal.

**CAUTION:**

- Exercise care not to damage mating surfaces.
- After removal, handle front cover carefully so it does not tilt, cant, or warp under a load.

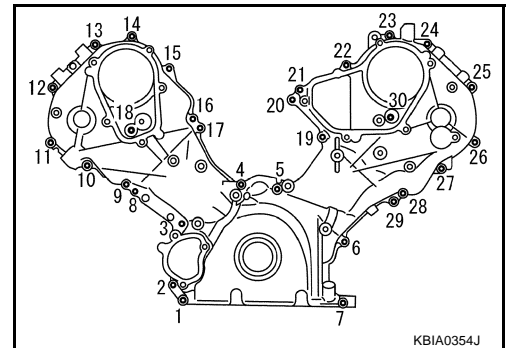

11. Remove front oil seal from front cover using suitable tool.
  - Use screwdriver for removal.

**CAUTION:**

**Be careful not to damage front cover.**

12. Remove O-rings from cylinder heads (right and left bank) and cylinder block.

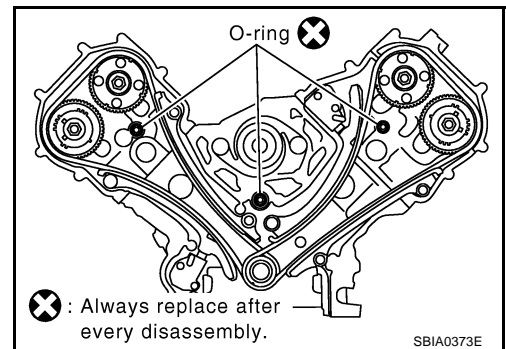

13. Remove chain tensioner cover from front cover.
  - Use seal cutter [SST: KV10111100 (J37228)] to cut liquid gasket for remove.

14. Remove oil pump drive spacer.
  - Set bolts in the two bolt holes [M6 × pitch 1.0 mm (0.04 in)] on front surface. Using suitable puller, pull oil pump drive spacer off from crankshaft.

**NOTE:**

The dimension between the centers of the two bolt holes is 33 mm (1.30 in).  
In the figure, a commercial steering puller is used.

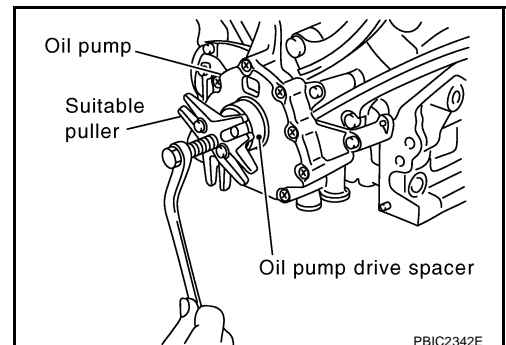

15. Remove oil pump. Refer to [LU-30, "OIL PUMP"](#).
16. Remove chain tensioner (left bank) as follows:

# TIMING CHAIN

[VK45DE]

## NOTE:

To remove timing chain and related parts, start with those on left bank. The procedure for removing parts on right bank is omitted because it is the same as that for left bank.

- a. Press tab in the direction of arrow (or turn lever in the direction of arrow) to unlock the locking with the groove that stops tensioner plunger from returning.
  - Lightly press tensioner plunger to release the tension of spring for this operation.
- b. Push in tensioner plunger to align the hole on lever and that on pump main body.
  - Pushing in tensioner too far does not allow the holes to align. Therefore, push in plunger to the degree at which the start of stopper groove and tab engages.

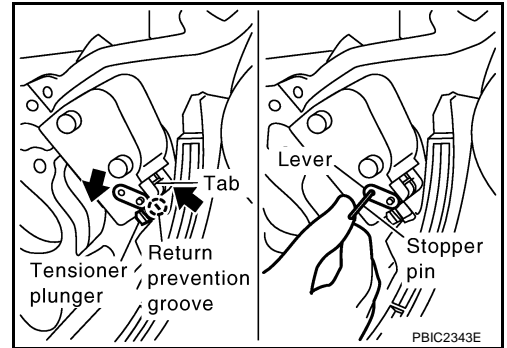

- c. Insert stopper pin [hard wire with approx. 0.5 mm (0.020 in) diameter or similar tool] to fix plunger. With plunger fixed, remove chain tensioner.
17. Remove chain tension guide and timing chain slack guide.
18. Remove timing chain and crankshaft sprocket.

## CAUTION:

**After removing timing chain, do not turn crankshaft and camshaft separately, or valves will strike the piston head.**

19. With hexagonal part of camshaft locked with wrench, loosen mounting bolts securing camshaft sprocket to remove camshaft sprocket.

## CAUTION:

**Do not loosen mounting bolts with securing anything other than the camshaft hexagonal portion or with tensioning the timing chain.**

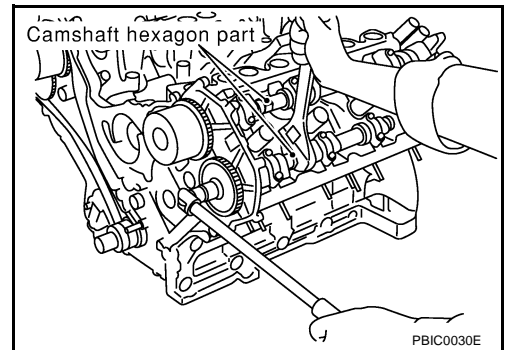

20. Perform same procedure as for left bank, remove timing chain and related parts on right side.
21. Use scraper to remove all traces of old liquid gasket from front cover and opposite mating surfaces.
  - Remove oil liquid gasket from bolt hole and thread.

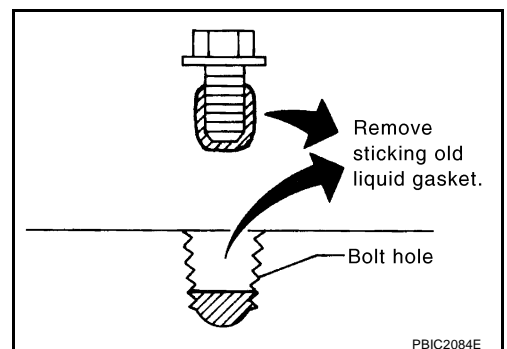

22. Use scraper to remove all trace of liquid gasket from chain tensioner cover and intake valve timing control covers.

## INSPECTION AFTER REMOVAL

### Timing Chain

Check for cracks and any excessive wear at link plates and roller links of timing chain. Replace timing chain as necessary.

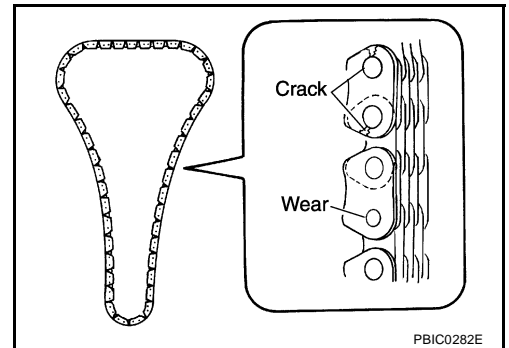

## INSTALLATION

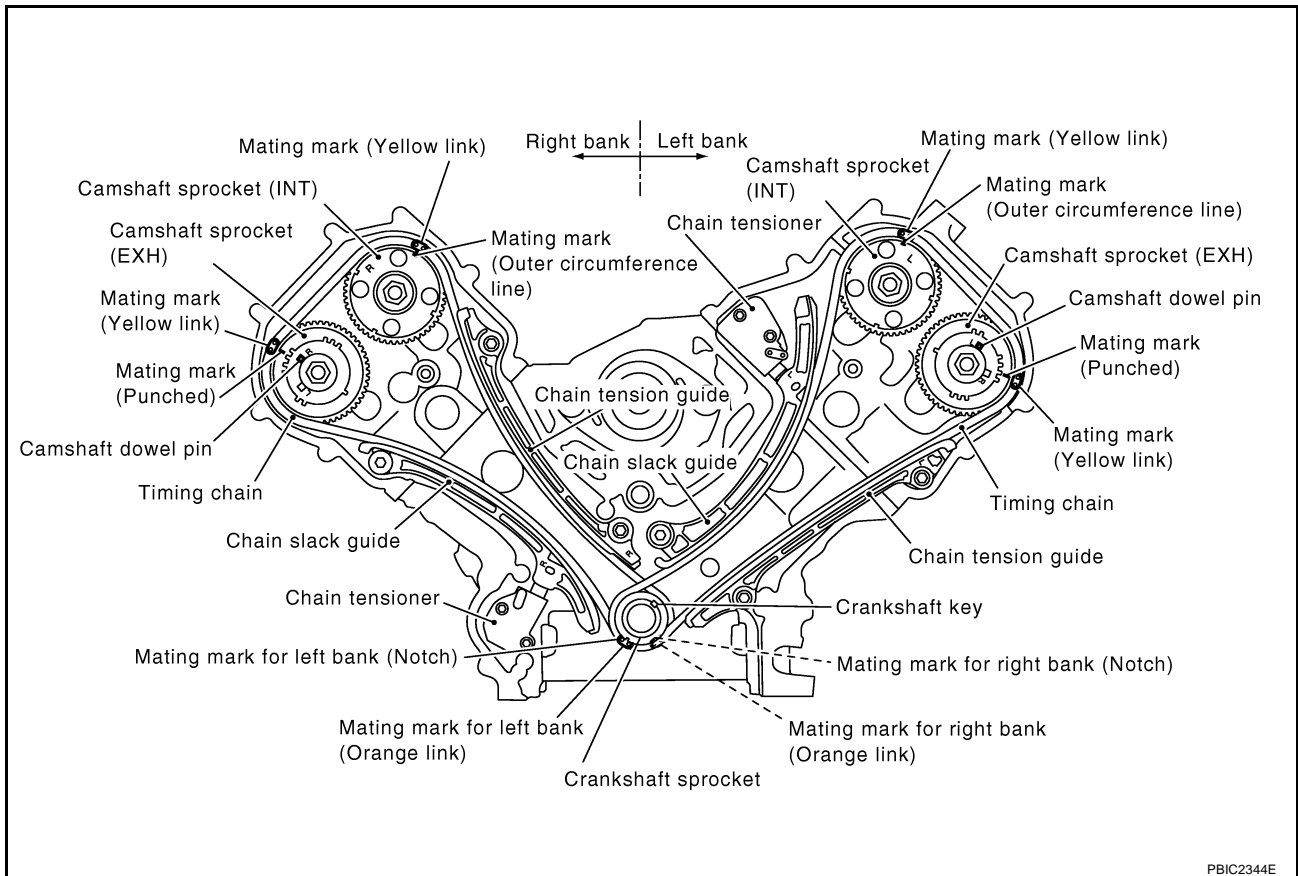

### NOTE:

- The above figure shows the relationship between the mating mark on each timing chain and that on the corresponding sprocket, with the components installed.
- Parts with an identification mark (R or L) should be installed on the corresponding bank according to the mark.

Parts with an identification mark:

- Camshaft sprocket (INT)
- Dowel pin groove of camshaft sprocket (EXH) (camshaft sprocket is same part both banks)
- Chain tension guide
- Chain slack guide
- To install timing chain and related parts, start with those on right bank. The procedure for installing parts on left bank is omitted because it is the same as that for installation on right bank.

# TIMING CHAIN

[VK45DE]

1. Make sure that crankshaft key and dowel pin of each camshaft are located as shown in the figure. (No. 1 cylinder at compression TDC)

**NOTE:**

Though camshaft does not stop at the position as shown in the figure, for the placement of cam nose, it is generally accepted camshaft is placed for the same direction of the figure.

**Camshaft dowel pin**

: At cylinder head upper face side in each bank

**Crankshaft key**

: At cylinder head side of left bank

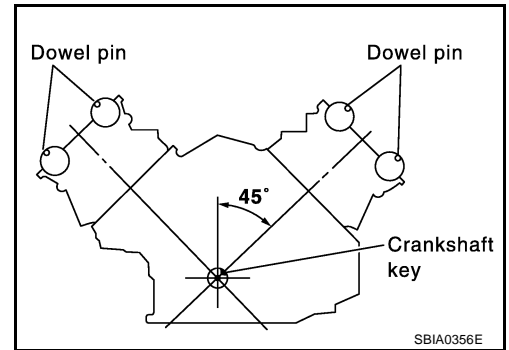

2. Install camshaft sprockets.
  - Install onto correct side by checking with identification mark on surface.
  - Install camshaft sprocket (EXH) by selectively using the groove of dowel pin according to the bank. (Common part used for both banks.)
  - Lock the hexagonal part of camshaft in the same procedure as for removal, and tighten mounting bolts.

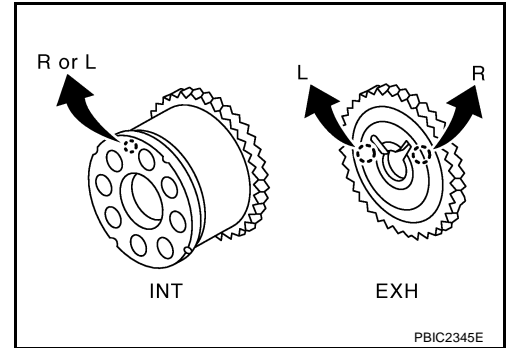

3. Install crankshaft sprockets for both banks.
  - Install each crankshaft sprocket so that its flange side (the larger diameter side without teeth) faces in the direction shown in the figure.

**NOTE:**

The same parts are used but facing directions are different.

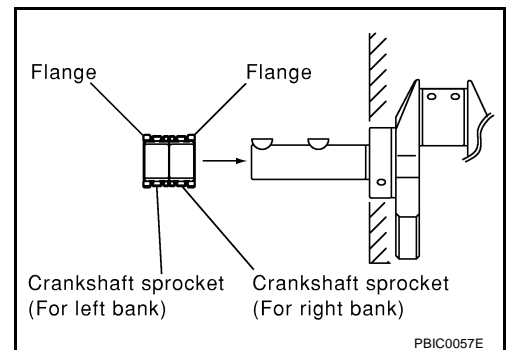

A  
EM  
C  
D  
E  
F  
G  
H  
I  
J  
K  
L  
M

## 4. Install timing chains and related parts.

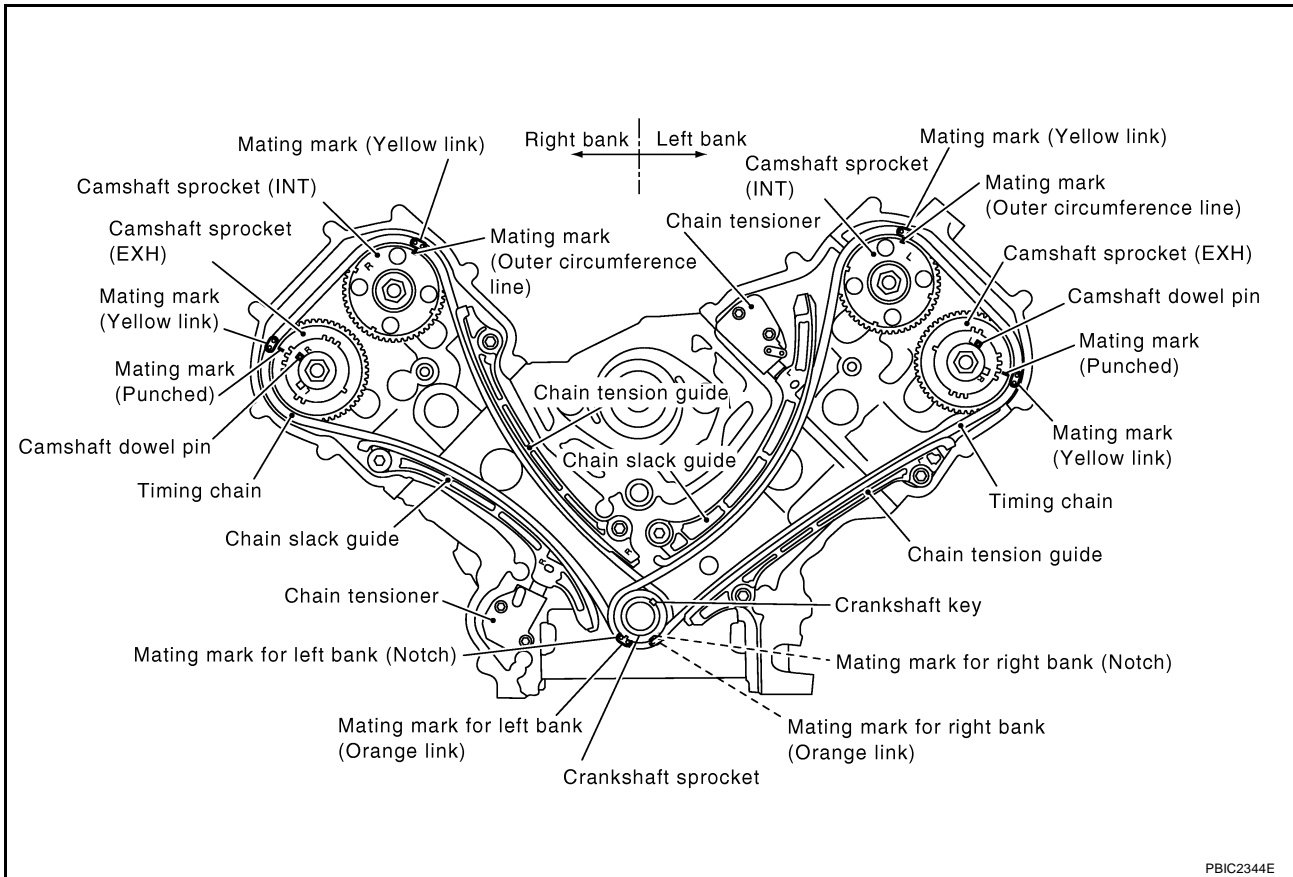

- Align the mating mark on each sprocket and timing chain for installation.

**NOTE:**

Before installing chain tensioner, it is possible to change the position of mating mark on timing chain for that on each sprocket for alignment.

**CAUTION:**

**For the above reason, after the mating marks are aligned, keep them aligned by holding them with a hand.**

- Install slack guides and tension guides onto correct side by checking with identification mark on surface.
- Install chain tensioner with plunger fixed as described in its removal.

**CAUTION:**

- **Before and after the installation of chain tensioner, make sure that the mating mark on timing chain is not out of alignment.**
- **After installing chain tensioner, remove stopper pin to release tensioner. Make sure tensioner is released.**
- **To avoid chain-link skipping of timing chain, do not move crankshaft or camshafts until front cover is installed.**

5. Perform the same procedure as for right bank, install timing chain and related parts on left side.

6. Install oil pump. Refer to [LU-30, "OIL PUMP"](#) .

# TIMING CHAIN

[VK45DE]

7. Install oil pump drive spacer as follows:

- a. Insert oil pump drive spacer according to the directions of crankshaft key and the two flat surfaces of oil pump inner rotor.
  - If the positional relationship does not allow the insertion, rotate oil pump inner rotor with a finger to allow spacer.
- b. After confirming that the position of each part is in correct condition to allow for spacer, force fit spacer by lightly tapping with plastic hammer until it contacts and does not go further.

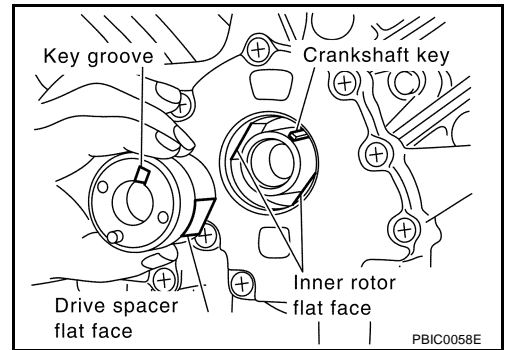

8. Install front oil seal on front cover.

- Apply new engine oil to both oil seal lip and dust seal lip.
- Install it so that each seal lip is oriented as shown in the figure.

**CAUTION:**

**Be careful not to scratch or make burrs on circumference of oil seal.**

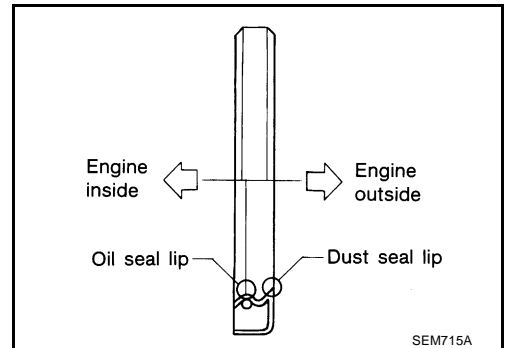

- Using front oil seal drift (commercial service tool), press fit until the height of front oil seal is level with the mounting surface.

**Front oil seal drift**

**Outer diameter : 56 mm (2.20 in)**

**Inner diameter : 49 mm (1.93 in)**

- Make sure the garter spring is in position and seal lips not inverted.

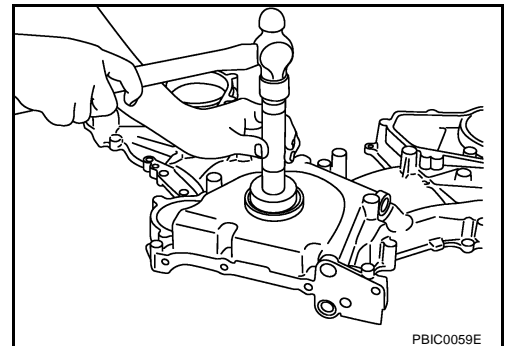

9. Install chain tensioner cover to front cover.

- Apply a continuous bead of liquid gasket with tube presser [SST: WS39930000 ( — )] to front cover as shown in the figure.

**Use Genuine RTV Silicone Sealant or equivalent. Refer to [GI-48, "RECOMMENDED CHEMICAL PRODUCTS AND SEALANTS"](#).**

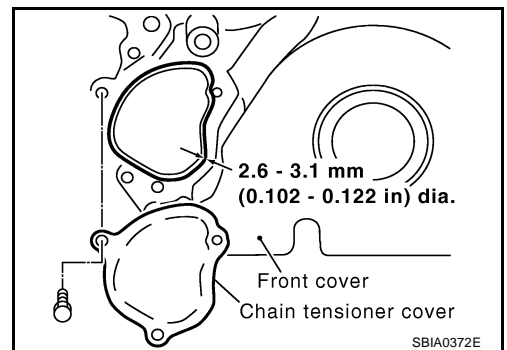

10. Install front cover as follows:



# TIMING CHAIN

[VK45DE]

- a. Install new O-rings onto cylinder heads (right and left bank) and cylinder block.

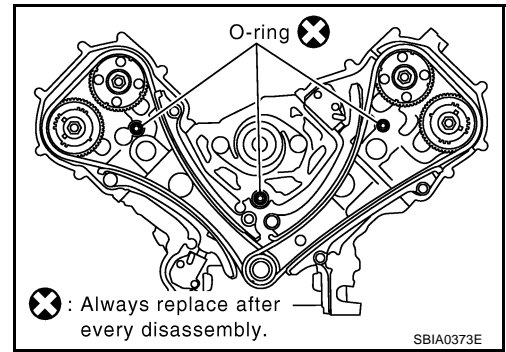

- b. Apply a continuous bead of liquid gasket with tube presser [SST: WS39930000 ( — )] to front cover as shown in the figure.

**Use Genuine RTV Silicone Sealant or equivalent. Refer to [GI-48, "RECOMMENDED CHEMICAL PRODUCTS AND SEALANTS"](#).**

- c. Make sure again that the mating marks on timing chain and that on each sprocket are aligned. Then, install front cover.

**CAUTION:**

**Be careful to avoid interference with the front end of oil pump drive spacer. Such interference may damage front oil seal.**

- d. Tighten mounting bolts in numerical order as shown in the figure.

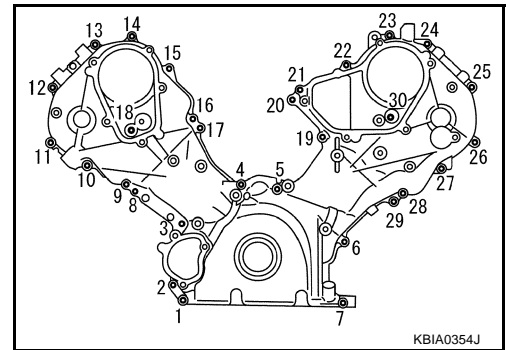
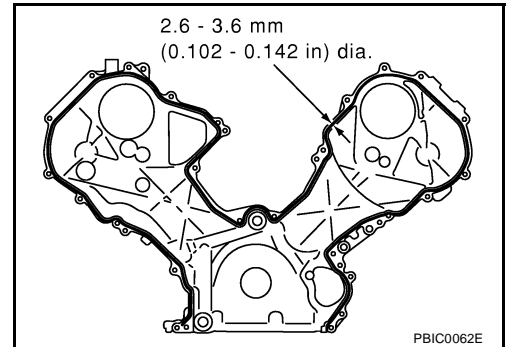

- There are four type mounting bolts.

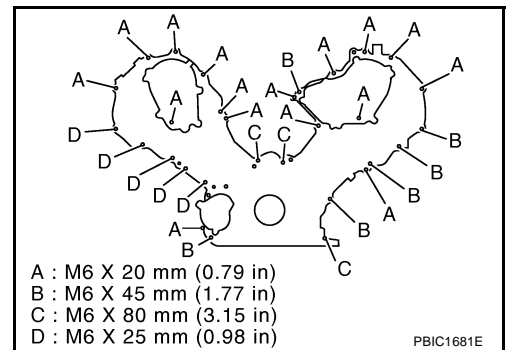

- e. After all mounting bolts are tightened, retighten them in numerical order as shown in the figure.

**CAUTION:**

**Be sure to wipe off any excessive liquid gasket leaking onto surface mating with oil pan.**

11. Install intake valve timing control cover as follows:

- a. At the back of intake valve timing control cover, install new seal rings (three for each bank) to the area to be inserted into camshaft sprocket (INT).

**CAUTION:**

**Do not spread seal ring excessively to avoid breaks and deformation.**



# TIMING CHAIN

[VK45DE]

- b. Install new O-rings on front cover.

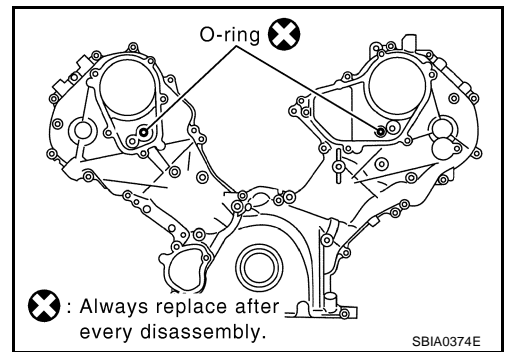

- c. Apply a continuous bead of liquid gasket with tube presser [SST: WS3930000 ( — )] to intake valve timing control covers as shown in the figure.

**Use Genuine RTV Silicone Sealant or equivalent. Refer to [GI-48, "RECOMMENDED CHEMICAL PRODUCTS AND SEALANTS"](#).**

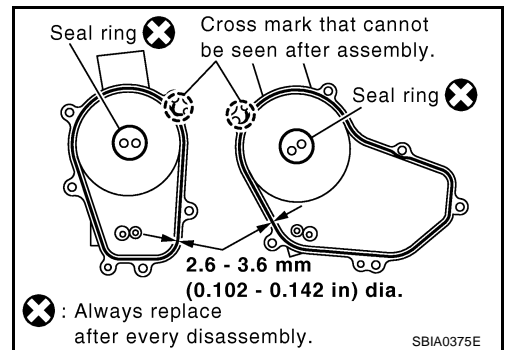

- d. Tighten mounting bolts in numerical order as shown in the figure.

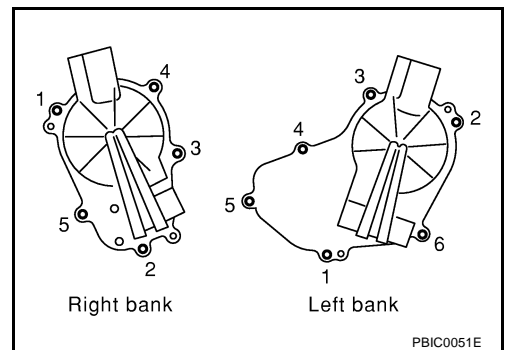

12. Install intake valve timing control position sensor, intake valve timing control solenoid valve and camshaft position sensor (PHASE) to intake valve timing control cover and front cover if removed.

- Be sure to tighten mounting bolts with flanges completely seated.

13. Install oil pan and oil strainer. Refer to [EM-187, "OIL PAN AND OIL STRAINER"](#).

14. Install crankshaft pulley as follows:

- Fix crankshaft with ring gear stopper [SST: J-45476].
- Install crankshaft pulley, taking care not to damage front oil seal.
  - Install according to dowel pin of oil pump drive spacer.
  - Lightly tapping its center with plastic hammer, insert pulley.

**CAUTION:**

**Do not tap pulley on the side surface where belt is installed (outer circumference).**

- Apply engine oil onto threaded parts of crankshaft pulley bolt and seating area.

- Tighten crankshaft pulley bolt.

: 93.1 N·m (9.5 kg·m, 69 ft·lb)

- Put a paint mark on crankshaft pulley aligning with angle mark on crankshaft pulley bolt.

A  
EM  
C  
D  
E  
F  
G  
H  
I  
J  
K  
L  
M

# TIMING CHAIN

[VK45DE]

- f. Further tighten by 90 degrees. (Angle tightening)
- Check the tightening angle by referencing to the notches. The angle between two notches is 90 degrees.

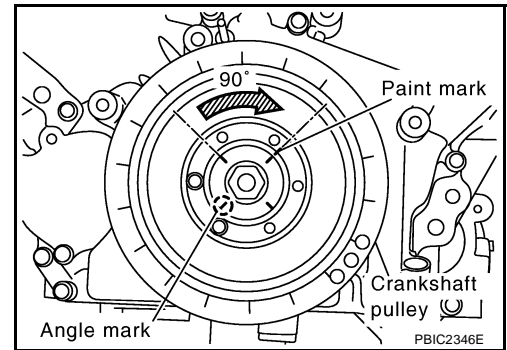

15. Rotate crankshaft pulley in normal direction (clockwise when viewed from engine front) to confirm it turns smoothly.
16. Install in the reverse order of removal after this step.

## INSPECTION AFTER INSTALLATION

### Inspection for Leaks

The following are procedures for checking fluids leak, lubricates leak and exhaust gases leak.

- Before starting engine, check oil/fluid levels including engine coolant and engine oil. If less than required quantity, fill to the specified level. Refer to [MA-12, "RECOMMENDED FLUIDS AND LUBRICANTS"](#).
- Use procedure below to check for fuel leakage.
  - Turn ignition switch "ON" (with engine stopped). With fuel pressure applied to fuel piping, check for fuel leakage at connection points.
  - Start engine. With engine speed increased, check again for fuel leakage at connection points.
- Run engine to check for unusual noise and vibration.

#### NOTE:

If hydraulic pressure inside timing chain tensioner drops after removal/installation, slack in guide may generate a pounding noise during and just after engine start. However, this does not indicate an unusualness. Noise will stop after hydraulic pressure rises.

- Warm up engine thoroughly to make sure there is no leakage of fuel, exhaust gases, or any oil/fluids including engine oil and engine coolant.
- Bleed air from lines and hoses of applicable lines, such as in cooling system.
- After cooling down engine, again check oil/fluid levels including engine oil and engine coolant. Refill to the specified level, if necessary.

#### Summary of the inspection items:

Item	Before starting engine	Engine running	After engine stopped
Engine coolant	Level	Leakage	Level
Engine oil	Level	Leakage	Level
Other oils and fluid*	Level	Leakage	Level
Fuel	Leakage	Leakage	Leakage
Exhaust gases	—	Leakage	—

\* Transmission/transaxle/CVT fluid, power steering fluid, brake fluid, etc.

## CAMSHAFT Components

PFP:13001

NBS004P9

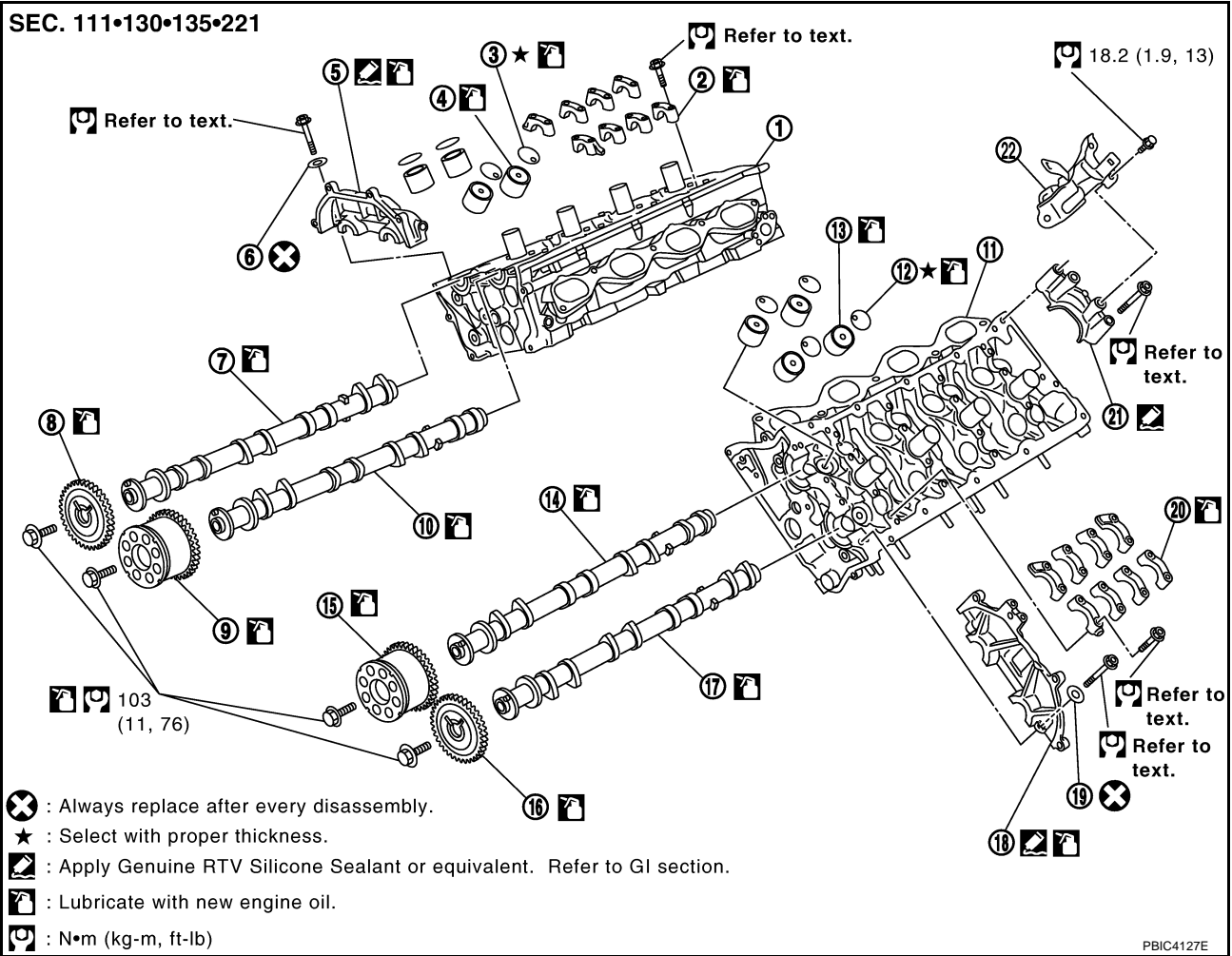

- |                               |                                   |                              |
|-------------------------------|-----------------------------------|------------------------------|
| 1. Cylinder head (right bank) | 2. Camshaft bracket (No. 2 to 5)  | 3. Adjusting shim            |
| 4. Valve lifter               | 5. Camshaft bracket (No. 1)       | 6. Seal washer               |
| 7. Camshaft (EXH)             | 8. Camshaft sprocket (EXH)        | 9. Camshaft sprocket (INT)   |
| 10. Camshaft (INT)            | 11. Cylinder head (left bank)     | 12. Adjusting shim           |
| 13. Valve lifter              | 14. Camshaft (INT)                | 15. Camshaft sprocket (INT)  |
| 16. Camshaft sprocket (EXH)   | 17. Camshaft (EXH)                | 18. Camshaft bracket (No. 1) |
| 19. Seal washer               | 20. Camshaft bracket (No. 2 to 5) | 21. Camshaft bracket (No. 6) |
| 22. Harness bracket           |                                   |                              |

## Removal and Installation

### REMOVAL

NBS004PA

1. Remove engine assembly from vehicle. Refer to [EM-244, "ENGINE ASSEMBLY"](#) .
2. Remove timing chain. Refer to [EM-203, "TIMING CHAIN"](#) .

# CAMSHAFT

[VK45DE]

3. With hexagonal part of camshaft locked with wrench, loosen bolts securing camshaft sprocket to remove camshaft sprocket.

**CAUTION:**

- Do not loosen mounting bolts with securing anything other than the camshaft hexagonal portion or with tensioning the timing chain.
- After removing timing chain, do not turn crankshaft and camshaft separately, or valves will strike the piston head.

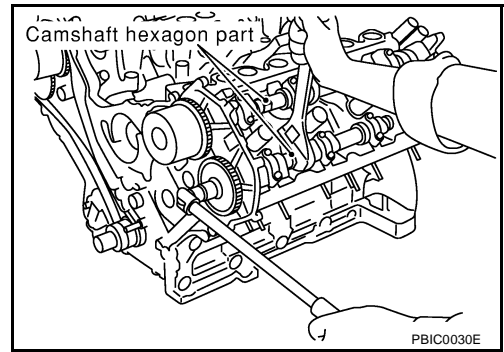

4. Remove intake and exhaust camshaft brackets.

- Mark camshafts, camshaft brackets and bolts so placed in the same position and direction for installation.
- Equally loosen camshaft brackets and bolts in several steps in reverse order as shown in the figure.
- Lightly tapping with plastic hammer, remove camshaft bracket (No. 1) and camshaft bracket (No. 6).

**NOTE:**

The bottom surface of each bracket will be stuck to cylinder head because of liquid gasket.

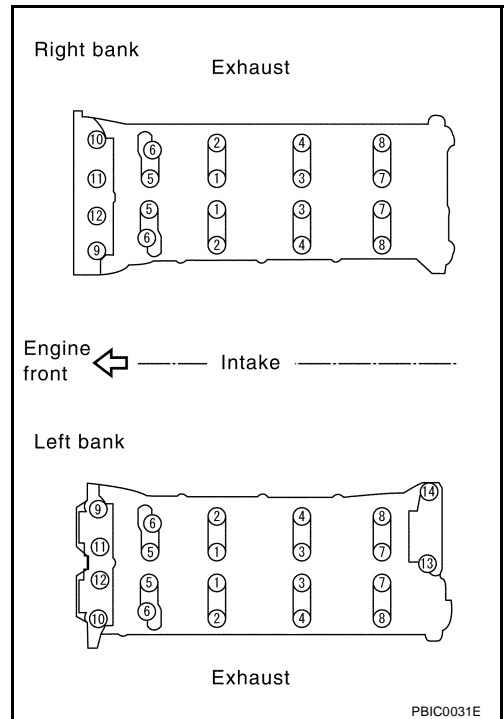

5. Remove camshaft.
6. Remove adjusting shim and valve lifter if necessary.
  - Identify installation positions, and store them without mixing them up.

## INSPECTION AFTER REMOVAL

### Camshaft Runout

1. Put V-block on precise flat table, and support No. 2 and 5 journal of camshaft.

**CAUTION:**

Do not support journal No. 1 (on the side of camshaft sprocket) because it has a different diameter from the other four locations.

2. Set dial indicator vertically to No. 3 journal.
3. Turn camshaft to one direction with hands, and measure the camshaft runout on dial indicator (total indicator reading).

**Standard:**

**0.02 mm (0.001 in)**

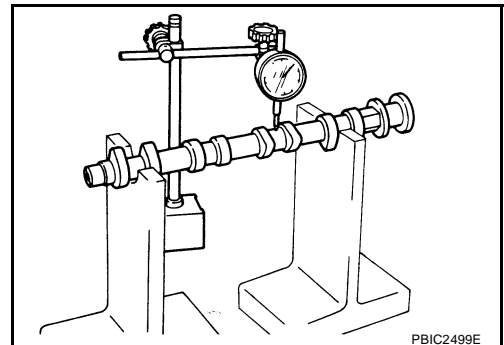

**Limit:**

**0.05 mm (0.002 in)**

- If it exceeds the limit, replace camshaft.

## Camshaft Cam Height

- Measure the camshaft cam height with micrometer.

**Standard cam height**

**Intake : 44.865 - 45.055 mm (1.7663 - 1.7738 in)**

**Exhaust : 43.925 - 44.115 mm (1.7293 - 1.7368 in)**

**Cam wear limit**

**: 0.2 mm (0.008 in)**

- If wear exceeds the limit, replace camshaft.

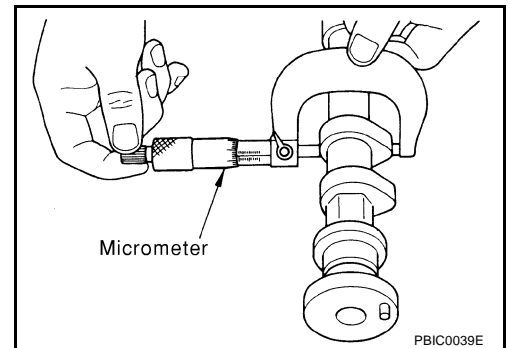

## Camshaft Journal Oil Clearance

### CAMSHAFT JOURNAL DIAMETER

- Measure the outer diameter of camshaft journal with micrometer.

**Standard:**

**No. 1 : 25.938 - 25.955 mm (1.0212 - 1.0218 in)**

**No. 2, 3, 4, 5 : 25.953 - 25.970 mm (1.0218 - 1.0224 in)**

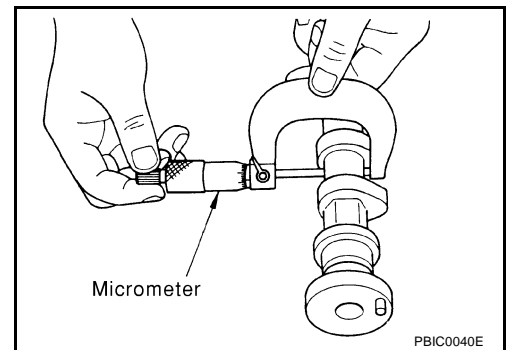

### CAMSHAFT BRACKET INNER DIAMETER

- Tighten camshaft bracket bolt with the specified torque. Refer to [EM-219, "INSTALLATION"](#) for the tightening procedure.
- Measure the inner diameter "A" of camshaft bracket with bore gauge.

**Standard:**

**26.000 - 26.021 mm (1.0236 - 1.0244 in)**

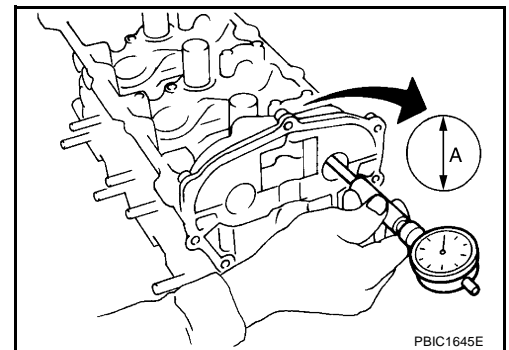

### CAMSHAFT JOURNAL OIL CLEARANCE

- (Oil clearance) = (Camshaft bracket inner diameter) – (Camshaft journal diameter).

**Standard:**

**No. 1 : 0.045 - 0.083 mm (0.0018 - 0.0033 in)**

**No. 2, 3, 4, 5 : 0.030 - 0.068 mm (0.0012 - 0.0027 in)**

- If the calculated value out of the standard, replace either or both camshaft and cylinder head.

**NOTE:**

Camshaft bracket cannot be replaced as a single part, because it is machined together with cylinder head. Replace whole cylinder head assembly.

A  
EM  
C  
D  
E  
F  
G  
H  
I  
J  
K  
L  
M

## Camshaft End Play

- Install dial indicator in thrust direction on front end of camshaft. Measure the end play of dial indicator when camshaft is moved forward/backward (in direction to axis).

**Standard:**

**0.115 - 0.188 mm (0.0045 - 0.0074 in)**

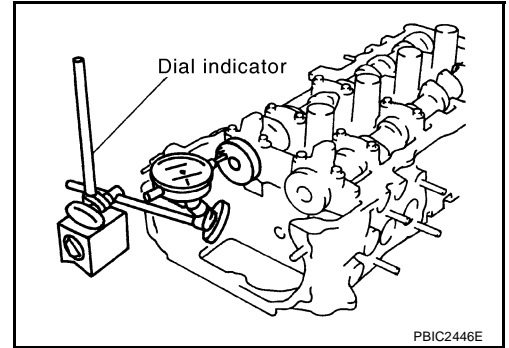

- Measure the following parts if out of the standard.
  - Dimension "A" for camshaft No. 1 journal

**Standard : 30.500 - 30.548 mm (1.2008 - 1.2027 in)**

- Dimension "B" for cylinder head No. 1 journal bearing

**Standard : 30.360 - 30.385 mm (1.1953 - 1.1963 in)**

- Refer to the standards above, and then replace camshaft and/or cylinder head.

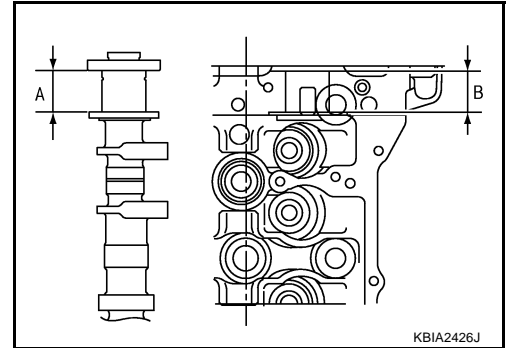

## Camshaft Sprocket Runout

1. Put V-block on precise flat table, and support No. 2 and 5 journal of camshaft.

**CAUTION:**

**Do not support journal No. 1 (on the side of camshaft sprocket) because it has a different diameter from the other four locations.**

2. Measure the camshaft sprocket runout with dial indicator. (Total indicator reading)

**Limit : 0.15 mm (0.0059 in)**

- If it exceeds the limit, replace camshaft sprocket.

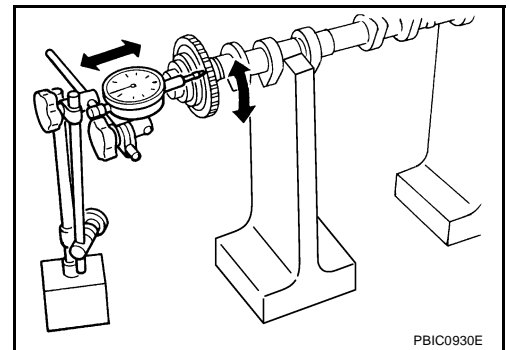

## Valve Lifter and Adjusting Shim

Check if surface of valve lifter and adjusting shim has any wear or cracks.

- If anything above is found, replace valve lifter.
- When replacing adjusting shim, refer to [EM-225, "ADJUSTMENT"](#).

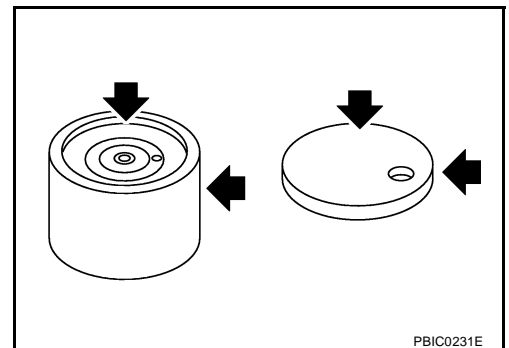

## Valve Lifter Clearance

### VALVE LIFTER OUTER DIAMETER

- Measure the outer diameter of valve lifter with micrometer.  
Standard : 33.965 - 33.975 mm (1.3372 - 1.3376 in)

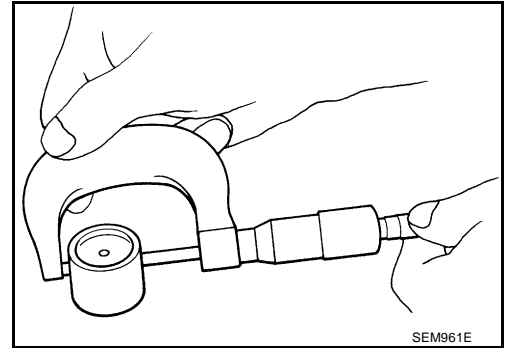

### VALVE LIFTER HOLE DIAMETER

- Measure the inner diameter of valve lifter hole of cylinder head with inside micrometer.  
Standard : 34.000 - 34.016 mm (1.3386 - 1.3392 in)

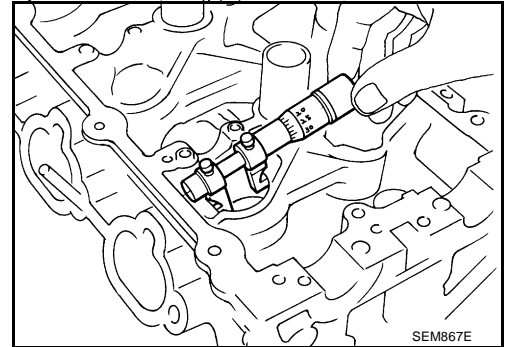

### VALVE LIFTER CLEARANCE

- (Valve lifter clearance) = (Valve lifter hole diameter) – (Valve lifter outer diameter)  
Standard : 0.025 - 0.051 mm (0.0010 - 0.0020 in)
- If the calculated value is out of the standard, referring to each standard of valve lifter outer diameter and valve lifter hole diameter, replace either or both valve lifter and cylinder head.

## INSTALLATION

1. Install valve lifters and adjusting shims if removed.
  - Install it in the original position.
2. Install camshafts.
  - Follow your identification marks made during removal, or follow the identification marks that are present on new camshafts for proper placement and direction.

Bank	INT/EXH	Identification rib	Paint marks		Identification mark
			M1	M2	
RH	INT	Yes	White	No	RH
	EXH	Yes	No	White	RH
LH	INT	No	White	No	LH
	EXH	No	No	White	LH

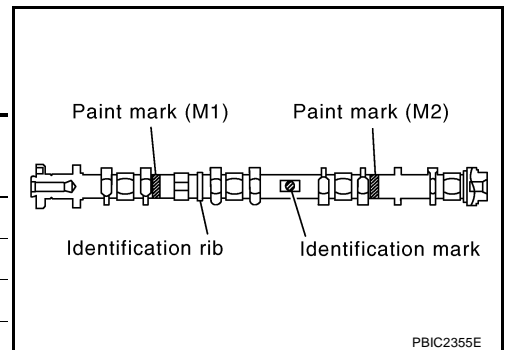



# CAMSHAFT

[VK45DE]

- Install camshaft so that dowel pin on front end face are positioned as shown in the figure. (No. 1 cylinder TDC on its compression stroke)

**NOTE:**

Though camshaft does not stop at the position as shown in the figure, for the placement of cam nose, it is generally accepted camshaft is placed for the same direction of the figure.

**Camshaft dowel pin**

: At cylinder head upper face side in each bank

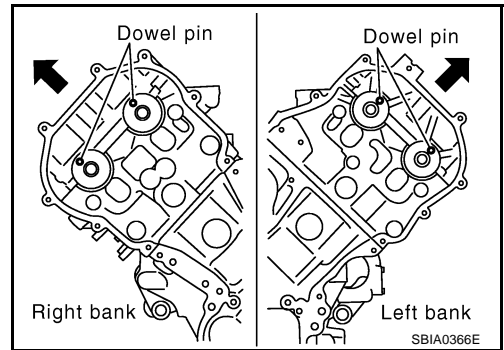

3. Install camshaft brackets.

- Remove foreign material completely from camshaft bracket backside and from cylinder head installation face.
- Install by referring to installation location mark on upper surface and front mark.
- Install so that installation location mark can be correctly read when viewed from the side of left exhaust bank.

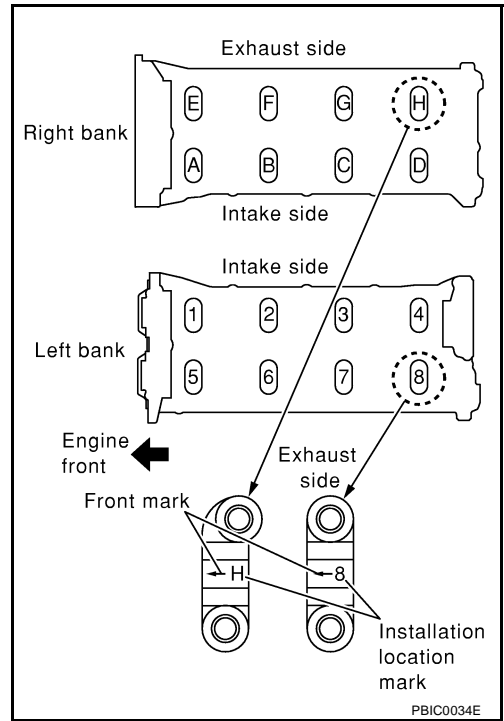

- Apply liquid gasket to mating surface of camshaft bracket (No. 1) as shown in the figure.

Use Genuine RTV Silicone Sealant or equivalent. Refer to [GI-48, "RECOMMENDED CHEMICAL PRODUCTS AND SEALANTS"](#).

**CAUTION:**

- After installation, be sure to wipe off any excessive liquid gasket leaking from part "A" and "B" (both on right and left sides).
- Remove completely any excess of liquid gasket inside bracket.

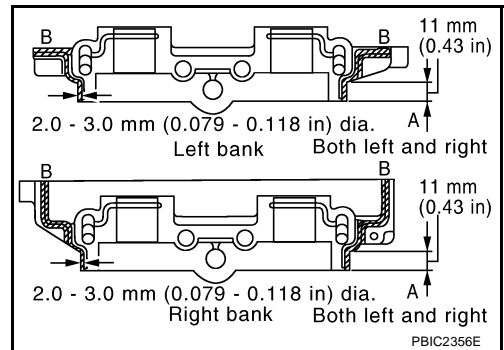

- Apply liquid gasket to mating surface of camshaft bracket (No. 6) on left bank intake as shown in the figure.

Use Genuine RTV Silicone Sealant or equivalent. Refer to [GI-48, "RECOMMENDED CHEMICAL PRODUCTS AND SEALANTS"](#).

**CAUTION:**

- After installation, be sure to wipe off any excessive liquid gasket leaking from part "A" and "B" (both on right and left sides).
- Remove completely any excess of liquid gasket inside bracket.

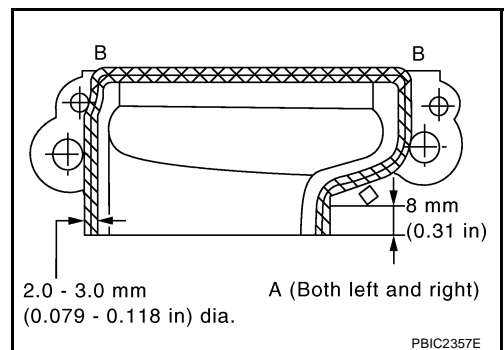



# CAMSHAFT

[VK45DE]

4. Tighten camshaft bracket bolts in the following steps, in numerical order as shown in the figure.
- a. Tighten No. 9 to 12 in numerical order as shown.

 : 1.96 N-m (0.2 kg-m, 1 ft-lb)

- b. Tighten No. 1 to 8 in numerical order as shown.

 : 1.96 N-m (0.2 kg-m, 1 ft-lb)

- c. Tighten No. 13 to 14 in numerical order as shown. (Left bank only)

 : 1.96 N-m (0.2 kg-m, 1 ft-lb)

- d. Tighten all bolts in numerical order as shown.

 : 5.88 N-m (0.6 kg-m, 4 ft-lb)

- e. Tighten No. 1 to 12 in numerical order as shown.

 : 10.41 N-m (1.1 kg-m, 8 ft-lb)

- f. Tighten No. 13 to 14 in numerical order as shown. (Left bank only)

 : 31.35 N-m (3.2 kg-m, 23 ft-lb)

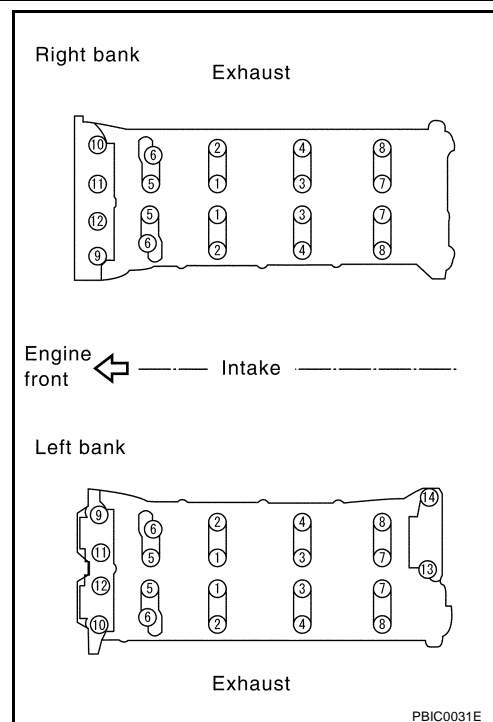

## CAUTION:

After tightening mounting bolts of camshaft brackets, be sure to wipe off excessive liquid gasket from the parts listed below.

- Mating surface of rocker cover
- Mating surface of front cover

5. Install camshaft sprockets.

- Install by checking with identification mark on surface.
- Install camshaft sprocket (EXH) by selectively using the groove of dowel pin according to the bank. (Common part used for both banks.)
- Lock the hexagonal part of camshaft in the same way as for removal, and tighten mounting bolts.

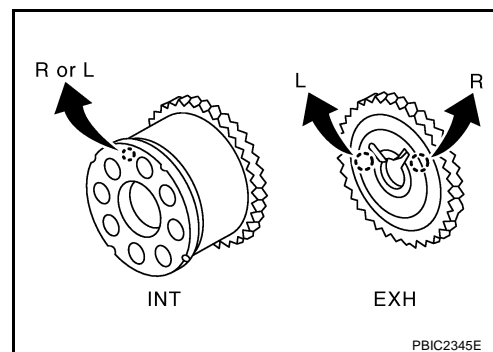

6. Check and adjust the valve clearance. Refer to [EM-222, "Valve Clearance"](#).
7. Install in the reverse order of removal after this step.

## INSPECTION AFTER INSTALLATION

### Inspection of Camshaft Sprocket (INT) Oil Groove

#### CAUTION:

- Perform this inspection only when DTC P0011 and/or P0021 are detected in self-diagnostic results of CONSULT-II and it is directed according to inspection procedure of EC section. Refer to [EC-850, "SELF-DIAG RESULTS MODE"](#).
  - Check when the engine is cold so as to prevent burns from any splashing engine oil.
1. Check the engine oil level. Refer to [LU-26, "ENGINE OIL"](#).
  2. Perform the following procedure so as to prevent the engine from being unintentionally started while checking.
    - a. Release fuel pressure. Refer to [EC-809, "FUEL PRESSURE RELEASE"](#).
    - b. Disconnect ignition coil and injector harness connectors.
  3. Remove intake valve timing control solenoid valve. Refer to [EM-203, "TIMING CHAIN"](#).

4. Crank the engine, and then make sure that engine oil comes out from intake valve timing control cover oil hole. End crank after checking.

**WARNING:**

**Be careful not to touch rotating parts (drive belt, idler pulley, and crankshaft pulley, etc.).**

**CAUTION:**

**Engine oil may squirt from intake valve timing control solenoid valve installation hole during cranking. Use a shop cloth to prevent the engine components and the vehicle. Do not allow engine oil to get on rubber components such as drive belt or engine mount insulators. Immediately wipe off any splashed engine oil.**

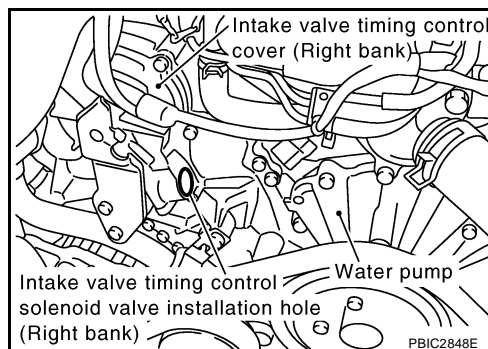

- Clean oil groove between oil strainer and intake valve timing control solenoid valve if engine oil does not come out from intake valve timing control cover oil hole. Refer to [LU-24, "LUBRICATION SYSTEM"](#) .
5. Remove components between intake valve timing control solenoid valve and camshaft sprocket (INT), and then check each oil groove for clogging.
    - Clean oil groove if necessary. Refer to [LU-24, "LUBRICATION SYSTEM"](#) .
  6. After inspection, install removed parts.

## INSPECTION AFTER INSTALLATION

### Inspection for Leaks

The following are procedures for checking fluids leak, lubricates leak and exhaust gases leak.

- Before starting engine, check oil/fluid levels including engine coolant and engine oil. If less than required quantity, fill to the specified level. Refer to [MA-12, "RECOMMENDED FLUIDS AND LUBRICANTS"](#) .
- Use procedure below to check for fuel leakage.
  - Turn ignition switch "ON" (with engine stopped). With fuel pressure applied to fuel piping, check for fuel leakage at connection points.
  - Start engine. With engine speed increased, check again for fuel leakage at connection points.
- Run engine to check for unusual noise and vibration.

**NOTE:**

If hydraulic pressure inside timing chain tensioner drops after removal/installation, slack in guide may generate a pounding noise during and just after engine start. However, this does not indicate an unusualness. Noise will stop after hydraulic pressure rises.

- Warm up engine thoroughly to make sure there is no leakage of fuel, exhaust gases, or any oil/fluids including engine oil and engine coolant.
- Bleed air from lines and hoses of applicable lines, such as in cooling system.
- After cooling down engine, again check oil/fluid levels including engine oil and engine coolant. Refill to the specified level, if necessary.

**Summary of the inspection items:**

Item	Before starting engine	Engine running	After engine stopped
Engine coolant	Level	Leakage	Level
Engine oil	Level	Leakage	Level
Other oils and fluid*	Level	Leakage	Level
Fuel	Leakage	Leakage	Leakage
Exhaust gases	—	Leakage	—

\* Transmission/transaxle/CVT fluid, power steering fluid, brake fluid, etc.

## Valve Clearance INSPECTION

NBS004PB

In cases of removing/installing or replacing camshaft and valve-related parts, or of unusual engine conditions due to changes in valve clearance (found malfunctions during starting, idling or causing noise), perform inspection as follows:

1. Remove rocker covers (right and left bank). Refer to [EM-199, "ROCKER COVER"](#) .

# CAMSHAFT

[VK45DE]

2. Measure the valve clearance as follows:
  - a. Set No. 1 cylinder at TDC of its compression stroke.
    - Rotate crankshaft pulley in clockwise to align TDC identification notch (without paint mark) with timing indicator on front cover.

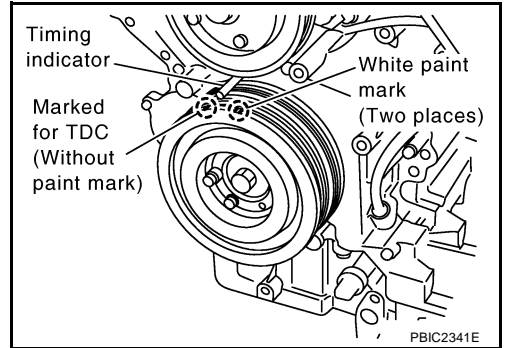

- Make sure that both intake and exhaust cam noses of No. 1 cylinder (engine front side of left bank) are located as shown in the figure.
- If not, turn crankshaft one revolution (360 degrees) and align as shown in the figure.

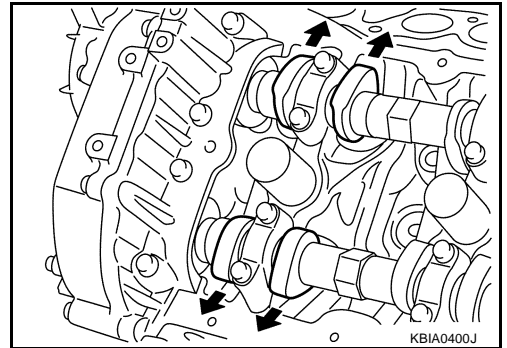

- b. Use feeler gauge, measure the clearance between valve lifter and camshaft.

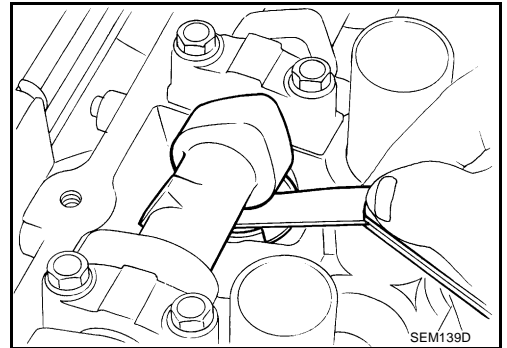

## Valve clearance:

Unit: mm (in)

	Cold	Hot * (reference data)
Intake	0.26 - 0.34 (0.010 - 0.013)	0.304 - 0.416 (0.012 - 0.016)
Exhaust	0.29 - 0.37 (0.011 - 0.015)	0.308 - 0.432 (0.012 - 0.017)

\*:Approximately 80°C (176°F)

# CAMSHAFT

[VK45DE]

- By referring to the figure, measure the valve clearances at locations marked "x" as shown in the table below (locations indicated with black arrow in figure).

**NOTE:**

Firing order 1-8-7-3-6-5-4-2

- No.1 cylinder at compression TDC

Measuring position (right bank)		No. 2 CYL.	No. 4 CYL.	No. 6 CYL.	No. 8 CYL.
No. 1 cylinder at compression TDC	EXH				x
	INT	x	x		
Measuring position (left bank)		No. 1 CYL.	No. 3 CYL.	No. 5 CYL.	No. 7 CYL.
No. 1 cylinder at compression TDC	INT	x		x	
	EXH	x			x

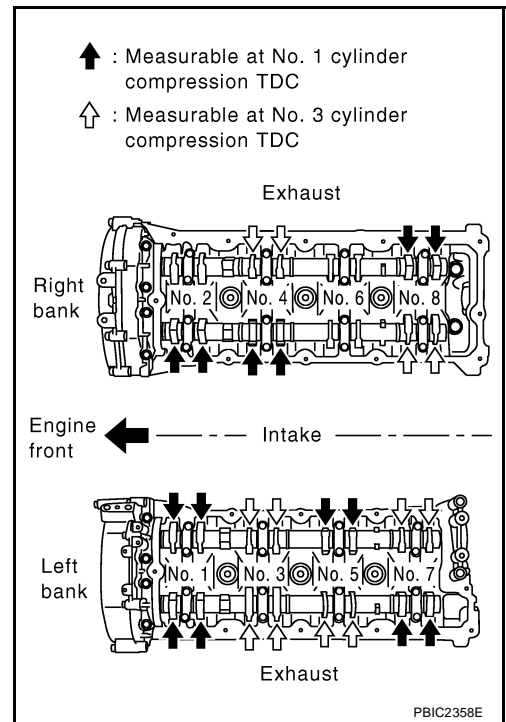

- c. Rotate crankshaft pulley clockwise (when view from engine front) by 270 degrees from the position of No. 1 cylinder compression TDC to align No. 3 cylinder at TDC of its compression stroke.

**NOTE:**

Crankshaft pulley mounting bolt flange has a angle mark every 90 degrees. They can be used as a guide to rotation angle.

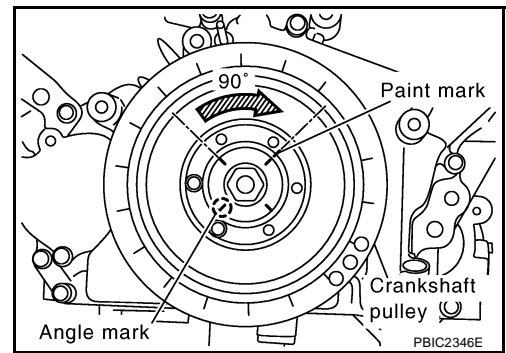

- By referring to the figure, measure the valve clearances at locations marked "x" as shown in the table below (locations indicated with white arrow in figure)

- No. 3 cylinder at compression TDC

Measuring position (right bank)		No. 2 CYL.	No. 4 CYL.	No. 6 CYL.	No. 8 CYL.
No. 3 cylinder at compression TDC	EXH		x		
	INT				x
Measuring position (left bank)		No. 1 CYL.	No. 3 CYL.	No. 5 CYL.	No. 7 CYL.
No. 3 cylinder at compression TDC	INT		x		x
	EXH		x	x	

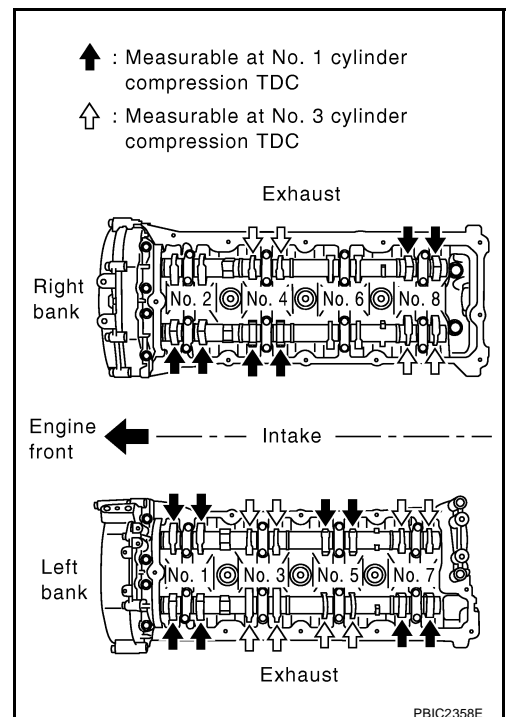

# CAMSHAFT

[VK45DE]

- d. Rotate crankshaft pulley clockwise (when view from engine front) by 90 degrees from the position of No. 3 cylinder compression TDC to align No. 6 cylinder at TDC of its compression stroke.

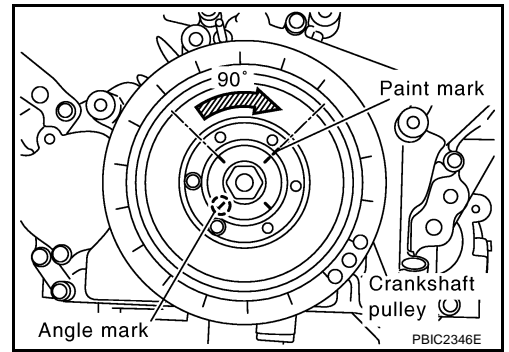

- By referring to the figure, measure the valve clearances at locations marked "x" as shown in the table below.
- No. 6 cylinder at compression TDC

Measuring position (right bank)		No. 2 CYL.	No. 4 CYL.	No. 6 CYL.	No. 8 CYL.
No. 6 cylinder at compression TDC	EXH	x		x	
	INT			x	

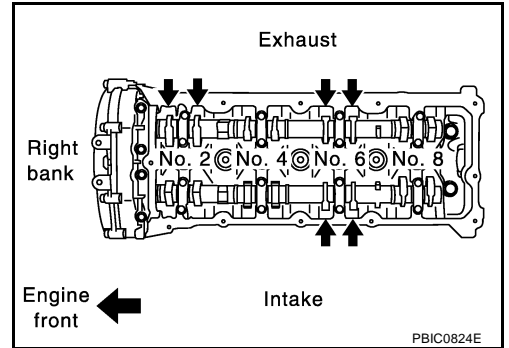

3. Perform adjustment if the measured value is out of the standard. Refer to [EM-225, "ADJUSTMENT"](#).

## ADJUSTMENT

### NOTE:

Adjust valve clearance while engine is cold.

1. Thoroughly wipe off engine oil around adjusting shim using rag.
2. Rotate crankshaft to position cam nose on camshaft of valve that must be adjusted upward.
3. Using small screwdriver, turn the round hole of adjusting shim in the direction of the arrow.

### CAUTION:

Perform the above procedure so as not to contact camshaft with adjusting shim.

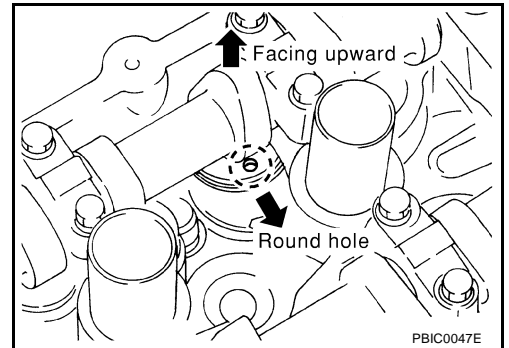

4. Install lifter stopper [SST: 10115120 (J38972-2)] as follows:
  - a. Except exhaust side of No. 7 and 8 cylinder;
    - i. Place camshaft pliers (SST) around camshaft as shown in the figure.
    - ii. Rotate camshaft pliers so that valve lifter is pushed down.

### CAUTION:

Be careful not to damage cam surface, valve lifter and cylinder head with camshaft pliers.

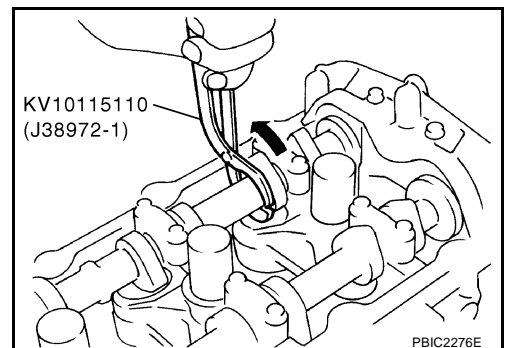

# CAMSHAFT

[VK45DE]

- iii. Place lifter stopper between camshaft and the edge of valve lifter to retain valve lifter.

**CAUTION:**

- Lifter stopper must be placed as close to camshaft bracket as possible.
- Be careful not to damage cam surface, valve lifter and cylinder head with lifter stopper.

- iv. Remove camshaft pliers.

**CAUTION:**

Camshaft pliers should be removed by rotating it slowly because lifter stopper hits and damages journal portion by rotating camshaft pliers quickly.

- b. Exhaust side of No. 7 and 8 cylinder;

**NOTE:**

Exhaust side of No. 7 and 8 cylinder does not have space for installing camshaft pliers [SST: KV10115110 (J38972-1)]. therefore, install lifter stopper [SST: KV10115120 (J38972-2)] according to the following instructions.

- i. Rotate crankshaft to press cam nose to the adjusting part of valve lifter.  
ii. Place lifter stopper between camshaft and the edge of valve lifter to retain valve lifter.

**CAUTION:**

- Lifter stopper must be placed as close to camshaft bracket as possible.
- Be careful not to damage cam surface, valve lifter and cylinder head with lifter stopper.

- iii. Rotate crankshaft slowly 180 degrees clockwise.

**CAUTION:**

Rotating crankshaft slowly because lifter stopper hits and damages journal portion by rotating crankshaft quickly.

5. Blow air into the round hole to separate adjusting shim from valve lifter.

**CAUTION:**

When blowing, use goggles to protect your eye.

6. Remove adjusting shim with magnetic hand.

7. Use the equation below to calculate adjusting shim thickness for replacement.

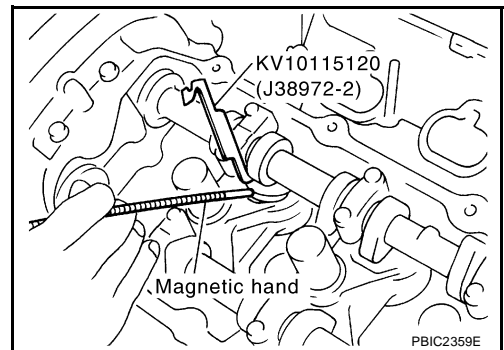
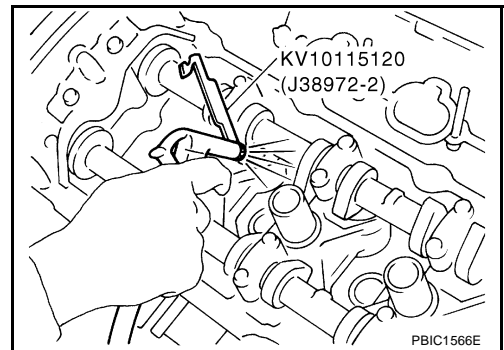
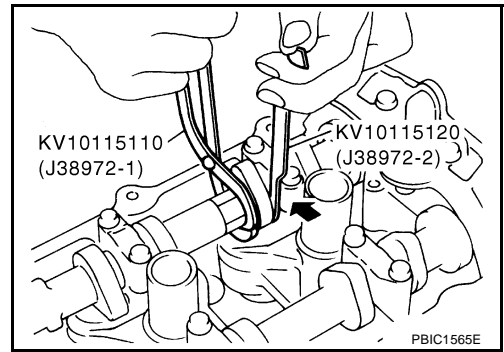

- Using micrometer determine thickness of removed shim with measured at center.

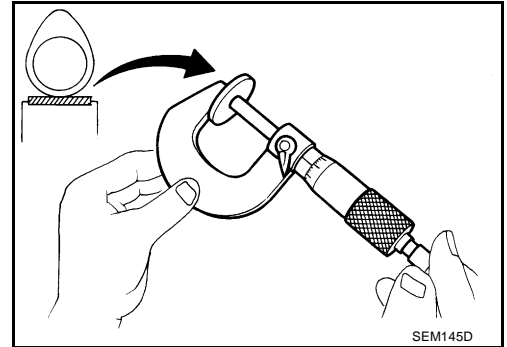

- Calculate thickness of new adjusting shim so valve clearance comes within specified values.

**Valve lifter thickness calculation:**  $t = t_1 + (C_1 - C_2)$

**t** = Valve lifter thickness to be replaced

**t<sub>1</sub>** = Removed valve lifter thickness

**C<sub>1</sub>** = Measured valve clearance

**C<sub>2</sub>** = Standard valve clearance:

Intake : 0.30 mm (0.012 in)

Exhaust : 0.33 mm (0.013 in)

Shims are available in 64 sizes from 2.32 mm (0.0913 in) to 2.95 mm (0.1161 in) in steps of 0.01 mm (0.0004 in). Refer to [EM-278, "Available Adjusting Shims"](#).

- Thickness of new adjusting shim can be identified by stamp marks on the reverse side (inside the cylinder).

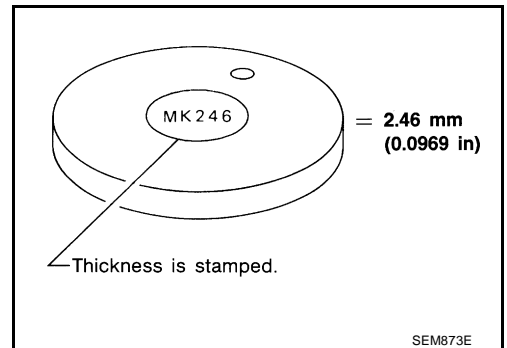

8. Install new adjusting shim using suitable tool.

- Install with the surface on which the thickness is stamped facing down.

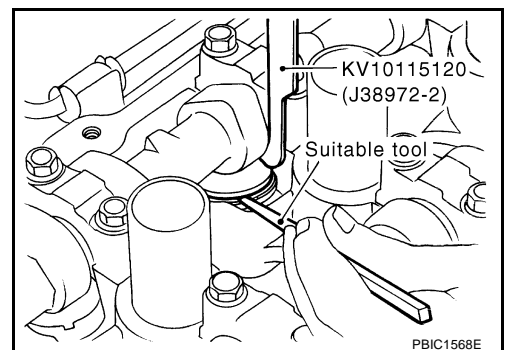

9. Remove lifter stopper as follows:

- a. Except exhaust side of No. 7 and 8 cylinder;

A  
EM  
C  
D  
E  
F  
G  
H  
I  
J  
K  
L  
M

# CAMSHAFT

[VK45DE]

- i. Perform same procedure for removal, place camshaft pliers (SST).
- ii. Remove lifter stopper (SST).
- iii. Remove camshaft pliers.

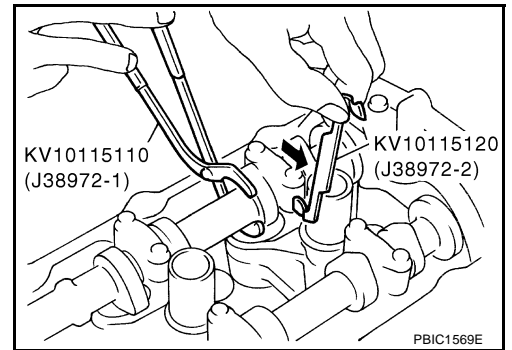

- b. Exhaust side of No. 7 and 8 cylinder.
  - Rotate crankshaft slowly 180 degrees clockwise. then remove lifter stopper.
10. Manually turn crankshaft pulley a few turns.
11. Make sure that the valve clearance is within the standard. Refer to [EM-222, "INSPECTION"](#).
12. Install all removed parts in the reverse order of removal. Refer to [EM-219, "INSTALLATION"](#).
13. Warm up the engine, and check for unusual noise and vibration.



## OIL SEAL

## Removal and Installation of Valve Oil Seal

## REMOVAL

1. Remove engine assembly from vehicle. Refer to [EM-244, "ENGINE ASSEMBLY"](#) .
2. Remove camshaft relating to valve oil seal to be removed. Refer to [EM-215, "CAMSHAFT"](#) .
3. Remove adjusting shims and valve lifters. Refer to [EM-215, "CAMSHAFT"](#) .
  - Identify installation positions, and store them without mixing them up.
4. Turn crankshaft until the cylinder requiring new oil seals is at TDC. This will prevent valve from dropping into cylinder.
5. Remove valve collet.
  - Compress valve spring with valve spring compressor, attachment and adapter (SST). Remove valve collet with magnetic hand.

**CAUTION:**

When working, take care not to damage valve lifter holes.

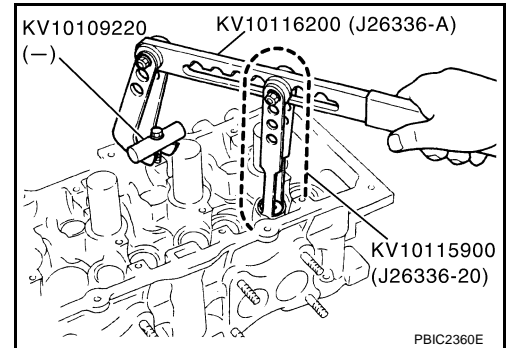

6. Remove valve spring retainer and valve spring (with valve spring seat).

**CAUTION:**

Do not remove valve spring seat from valve spring.

7. Remove valve oil seal using valve oil seal puller (SST).

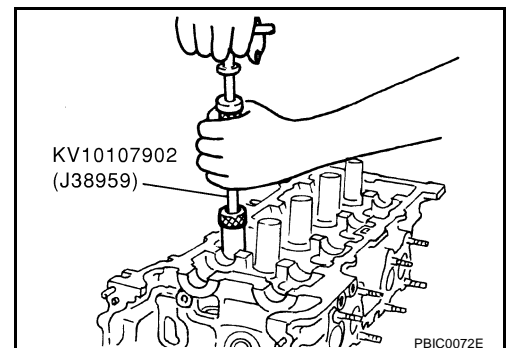

## INSTALLATION

1. Apply new engine oil on new valve oil seal joint and seal lip.
2. Install valve oil seal.
  - Install with valve oil seal drift (SST) to match dimension in the figure.

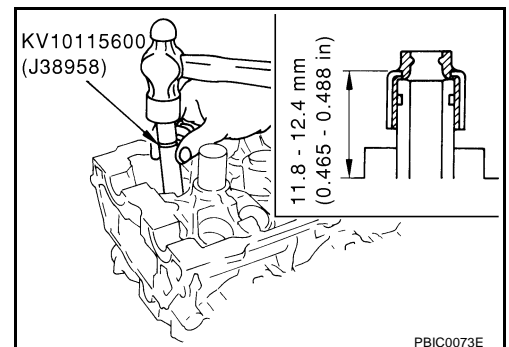

3. Install in the reverse order of removal.

## Removal and Installation of Front Oil Seal

### REMOVAL

1. Remove the following parts:
  - Front engine undercover (power tool)
  - Radiator; Refer to [CO-43, "RADIATOR"](#) .
  - Drive belt; Refer to [EM-174, "DRIVE BELTS"](#) .
  - Rear plate cover; Refer to [EM-187, "OIL PAN AND OIL STRAINER"](#) .
2. Remove crankshaft pulley as follows:
  - a. Set ring gear stopper (SST).

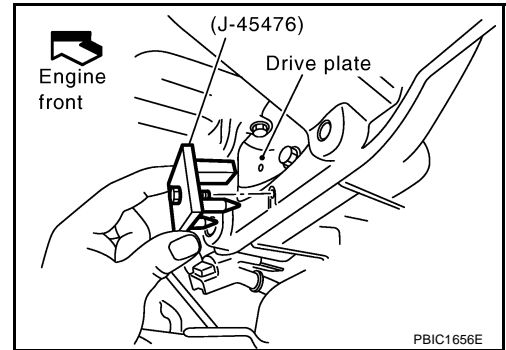

- b. Loosen crankshaft pulley bolt, and then pull crankshaft pulley with both hands to remove it.

#### CAUTION:

- Do not remove crankshaft pulley bolt. Keep loosened crankshaft pulley bolt in place to protect removed crankshaft pulley from dropping.
- Do not remove balance weight (inner hexagon bolt) at the front of crankshaft pulley.

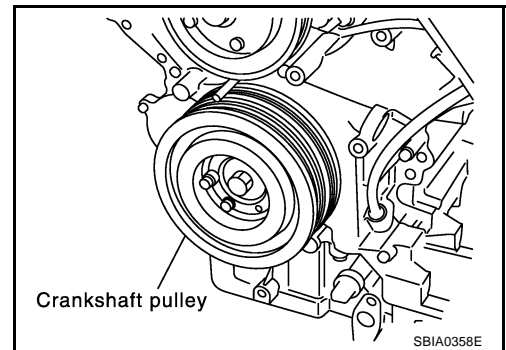

3. Remove front oil seal using suitable tool.

#### CAUTION:

Be careful not to damage front cover and oil pump drive spacer.

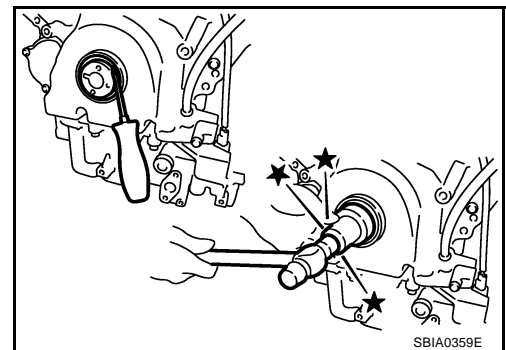

### INSTALLATION

1. Apply new engine oil to both oil seal lip and dust seal lip of new front oil seal.
2. Install front oil seal.

# OIL SEAL

[VK45DE]

- Install front oil seal so that each seal lip is oriented as shown in the figure.

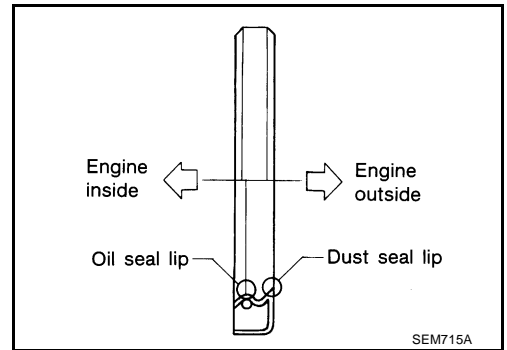

- Using front oil seal drift, press fit until the height of front oil seal is level with the mounting surface.

### Front oil seal drift

**Outer diameter : 56 mm (2.20 in)**

**Inner diameter : 49 mm (1.93 in)**

- Make sure the garter spring is in position and seal lips not inverted.

### CAUTION:

- Be careful not to damage front cover and oil pump drive spacer.
- Press fit straight and avoid causing burrs or tilting oil seal.

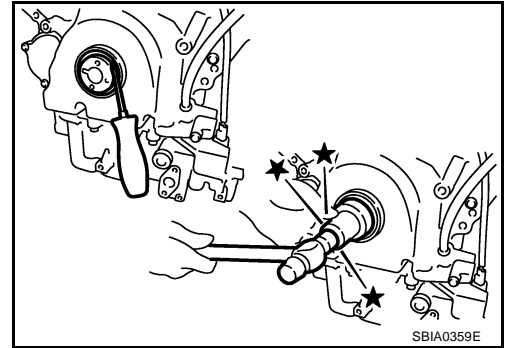

3. Install in the reverse order of removal.

## Removal and Installation of Rear Oil Seal

### REMOVAL

1. Remove transmission assembly. Refer to [AT-271, "TRANSMISSION ASSEMBLY"](#) .
  - a. Remove drive plate. Refer to [EM-249, "CYLINDER BLOCK"](#) .
  - b. Remove rear plate. Refer to [EM-249, "CYLINDER BLOCK"](#) .
2. Remove rear oil seal using suitable tool.

### CAUTION:

**Be careful not to damage crankshaft and oil seal retainer surface.**

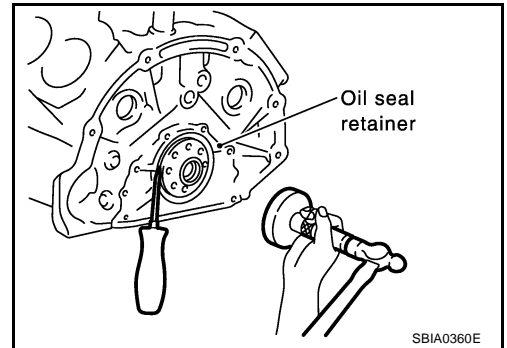

### INSTALLATION

1. Apply new engine oil to both oil seal lip and dust seal lip of new rear oil seal.
2. Install rear oil seal.
  - Install rear oil seal so that each seal lip is oriented as shown in the figure.

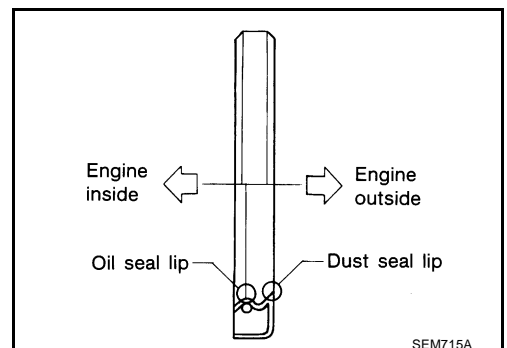

# OIL SEAL

[VK45DE]

- Using rear oil seal drift (commercial service tool), press fit until the height of front oil seal is level with the mounting surface.

## Rear oil seal drift

Outer diameter : 102 mm (4.02 in)

Inner diameter : 86 mm (3.39 in)

- Make sure the garter spring is in position and seal lips not inverted.

## CAUTION:

- Be careful not to damage crankshaft and rear oil seal retainer.
- Press fit straight and avoid causing burrs or tilting oil seal.

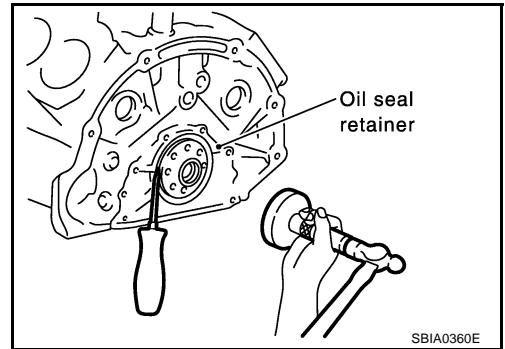

3. Install in the reverse order of removal.

## CYLINDER HEAD

PF1:11041

### On-Vehicle Service

NBS004PF

### CHECKING COMPRESSION PRESSURE

1. Warm up engine thoroughly. Then, stop it.
2. Release fuel pressure. Refer to [EC-809, "FUEL PRESSURE RELEASE"](#).
- a. Remove fuel pump fuse to avoid fuel injection during measurement.

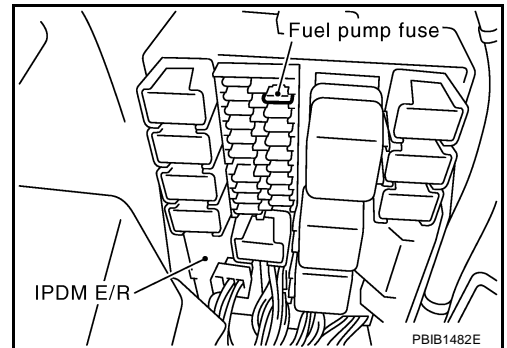

3. Remove engine cover with power tool. Refer to [EM-173, "ENGINE ROOM COVER"](#).
4. Remove ignition coil and spark plug from each cylinder. Refer to [EM-190, "IGNITION COIL"](#) and [EM-191, "SPARK PLUG \(PLATINUM-TIPPED TYPE\)"](#).
5. Connect engine tachometer (not required in use of CONSULT-II).
6. Install compression gauge with adapter (SST or commercial service tool) onto spark plug hole.
  - Use compression gauge adapter (SST) which is required on No. 7 and 8 cylinders.

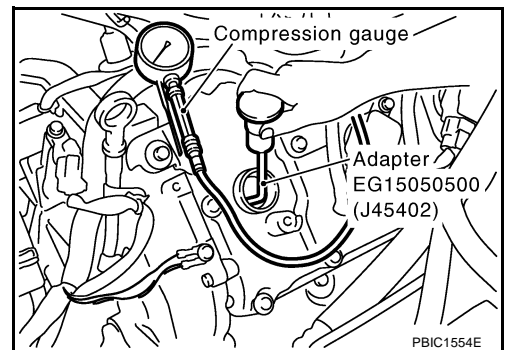

- Use compression gauge adapter (if no SST is used) whose picking up end inserted to spark plug hole is smaller than 20 mm (0.79 in) in diameter. Otherwise, it may be caught by cylinder head during removal.

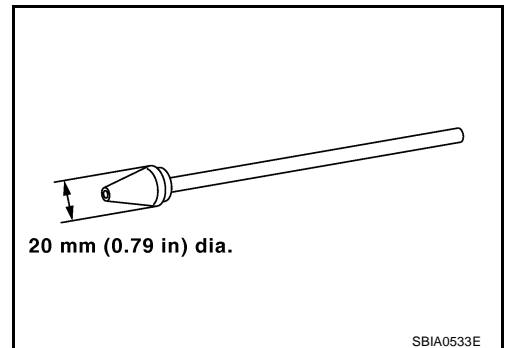

7. With accelerator pedal fully depressed, turn ignition switch to "START" for cranking. When the gauge pointer stabilizes, read the compression pressure and engine rpm. Perform these steps to check each cylinder.

### Compression pressure:

Unit: kPa (kg/cm<sup>2</sup>, psi) /rpm

Standard	Minimum	Differential limit between cylinders
1,320 (13.5, 191) / 300	1,130 (11.5, 164) / 300	98 (1.0, 14) / 300

### CAUTION:

Always use a fully charged battery to obtain the specified engine speed.

# CYLINDER HEAD

[VK45DE]

- If the engine speed is out of specified range, check battery liquid for proper gravity. Check engine speed again with normal battery gravity.
  - If compression pressure is below minimum value, check valve clearances and parts associated with combustion chamber (valve, valve seat, piston, piston ring, cylinder bore, cylinder head, cylinder head gasket). After the checking, measure compression pressure again.
  - If some cylinders have low compression pressure, pour small amount of engine oil into the spark plug hole of the cylinder to re-check it for compression.
    - If the added engine oil improves the compression, piston rings may be worn out or damaged. Check the piston rings and replace if necessary.
    - If the compression pressure remains at low level despite the addition of engine oil, valves may be malfunctioning. Check valves for damage. Replace valve or valve seat accordingly.
  - If two adjacent cylinders have respectively low compression pressure and their compression remains low even after the addition of engine oil, cylinder head gaskets are leaking. In such a case, replace cylinder head gaskets.
8. After inspection is completed, install removed parts in the reverse order of removal.
9. Start engine, and make sure that engine runs smoothly.
10. Perform trouble diagnosis. If DTC appears, erase it. Refer to [EC-811, "TROUBLE DIAGNOSIS"](#) .

## Components

NBS004PG

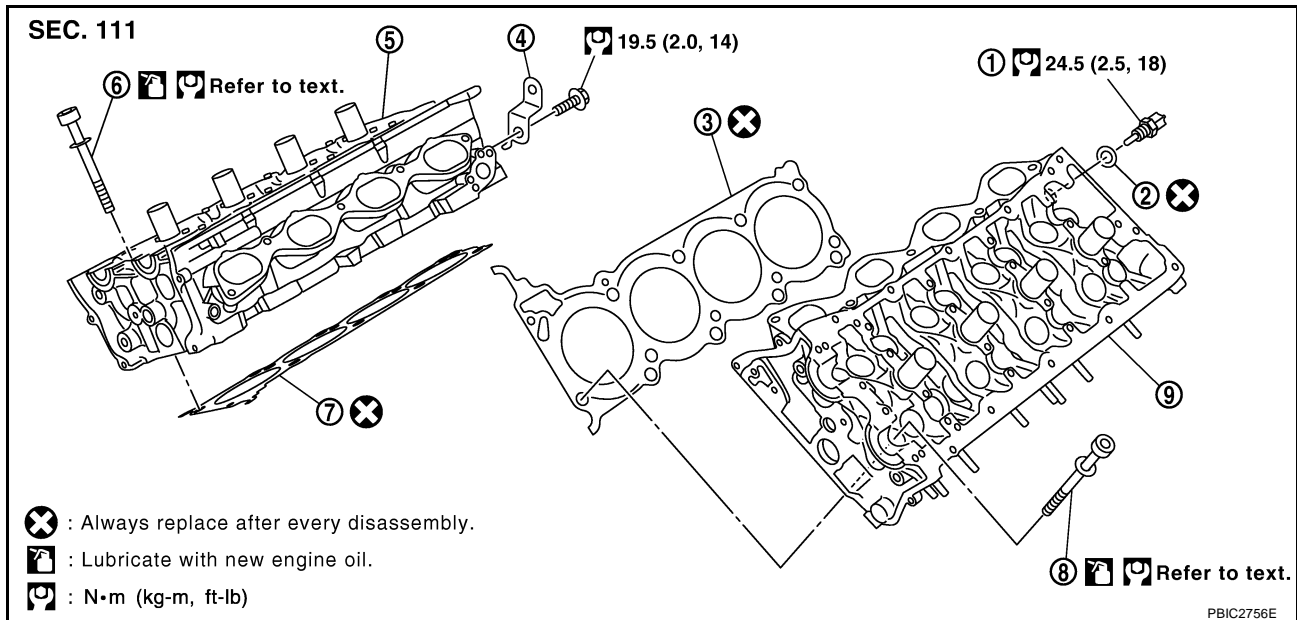

- |                                      |                               |                                     |
|--------------------------------------|-------------------------------|-------------------------------------|
| 1. Engine coolant temperature sensor | 2. Washer                     | 3. Cylinder head gasket (left bank) |
| 4. Harness bracket                   | 5. Cylinder head (right bank) | 6. Cylinder head bolt               |
| 7. Cylinder head gasket (right bank) | 8. Cylinder head bolt         | 9. Cylinder head (left bank)        |

## Removal and Installation

### REMOVAL

NBS004PH

1. Remove engine assembly from vehicle. Refer to [EM-244, "ENGINE ASSEMBLY"](#) .
2. Remove exhaust manifold. Refer to [EM-183, "EXHAUST MANIFOLD AND THREE WAY CATALYST"](#) .
3. Remove camshaft. Refer to [EM-215, "CAMSHAFT"](#) .

# CYLINDER HEAD

[VK45DE]

- Remove cylinder head bolts in reverse order as shown in the figure with cylinder head bolt wrench (commercial service tool) to remove cylinder heads (right and left banks).

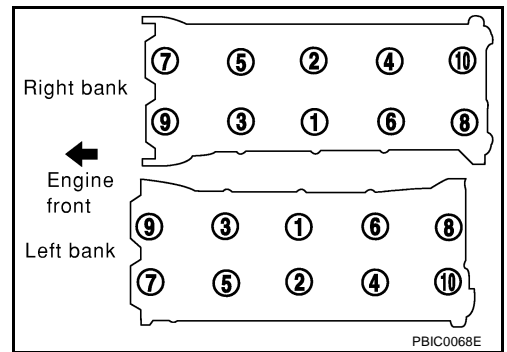

- Remove cylinder head gaskets.

## INSPECTION AFTER REMOVAL

### Cylinder Head Bolts Outer Diameter

- Cylinder head bolts are tightened by plastic zone tightening method. Whenever the size difference between "d1" and "d2" exceeds the limit, replace them with new one.

**Limit ("d1" – "d2") : 0.18 mm (0.0071 in)**

- If reduction of outer diameter appears in a position other than "d2", use it as "d2" point.

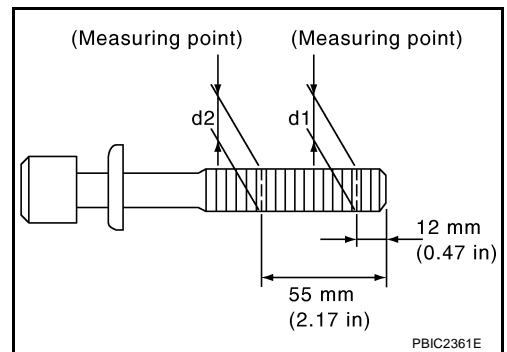

### Cylinder Head Distortion

#### NOTE:

When performing this inspection, cylinder block distortion should be also checking. Refer to [EM-269, "CYLINDER BLOCK DISTORTION"](#).

- Using scraper, wipe off oil, scale, gasket, sealant and carbon deposits from surface of cylinder head.

#### CAUTION:

**Do not allow gasket fragments to enter engine oil or engine coolant passages.**

- At each of several locations on bottom surface of cylinder head, measure the distortion in six directions.

**Limit : 0.1 mm (0.004 in)**

- If it exceeds the limit, replace cylinder head.

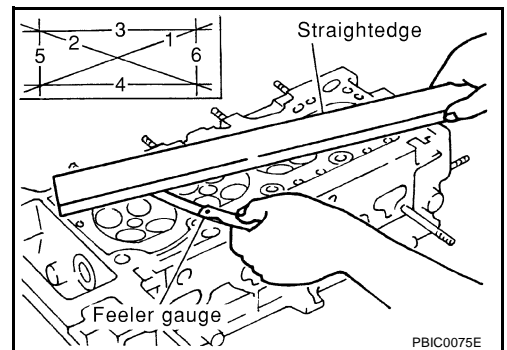

## INSTALLATION

- Install new cylinder head gasket.
- Turn crankshaft until No. 1 piston is set at TDC.

# CYLINDER HEAD

[VK45DE]

- Crankshaft key should line up with the left bank cylinder center line as shown in the figure.

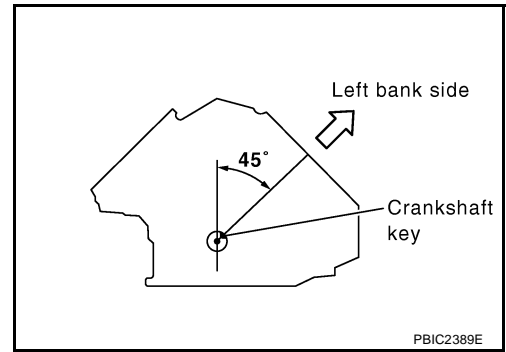

3. Install cylinder head follow the steps below to tighten cylinder head bolts in numerical order as shown in the figure with cylinder head bolt wrench (commercial service tool).

**CAUTION:**

**If cylinder head bolts are re-used, check their outer diameters before installation. Refer to [EM-235, "Cylinder Head Bolts Outer Diameter"](#).**

- a. Apply new engine oil to threads and seating surface of cylinder head bolts.
- b. Tighten all cylinder head bolts.

 : 98.1 N·m (10 kg·m, 72 ft·lb)

- c. Completely loosen all cylinder head bolts.

 : 0 N·m (0 kg·m, 0 ft·lb)

**CAUTION:**

**In step "c", loosen cylinder head bolts in reverse order of that indicated in the figure.**

- d. Tighten all cylinder head bolts.

 : 44 N·m (4.5 kg·m, 33 ft·lb)

- e. Turn all cylinder head bolts 60 degrees clockwise. (Angle tightening)

**CAUTION:**

**Check the tightening angle by using angle wrench (SST). Avoid judgment by visual inspection without SST.**

- Check tightening angle indicated on angle wrench indicator plate.
- f. Turn all cylinder head bolts 60 degrees clockwise again. (Angle tightening)

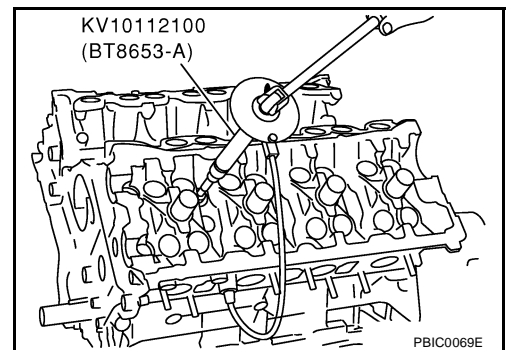
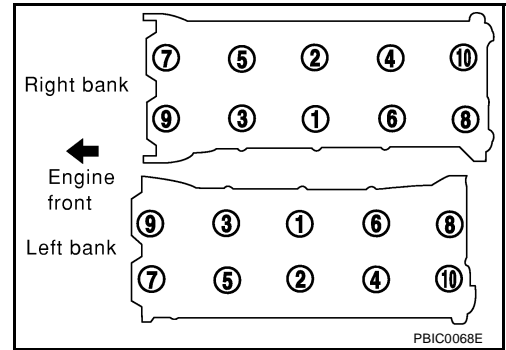

4. Install in the reverse order of removal.



## Disassembly and Assembly COMPONENTS

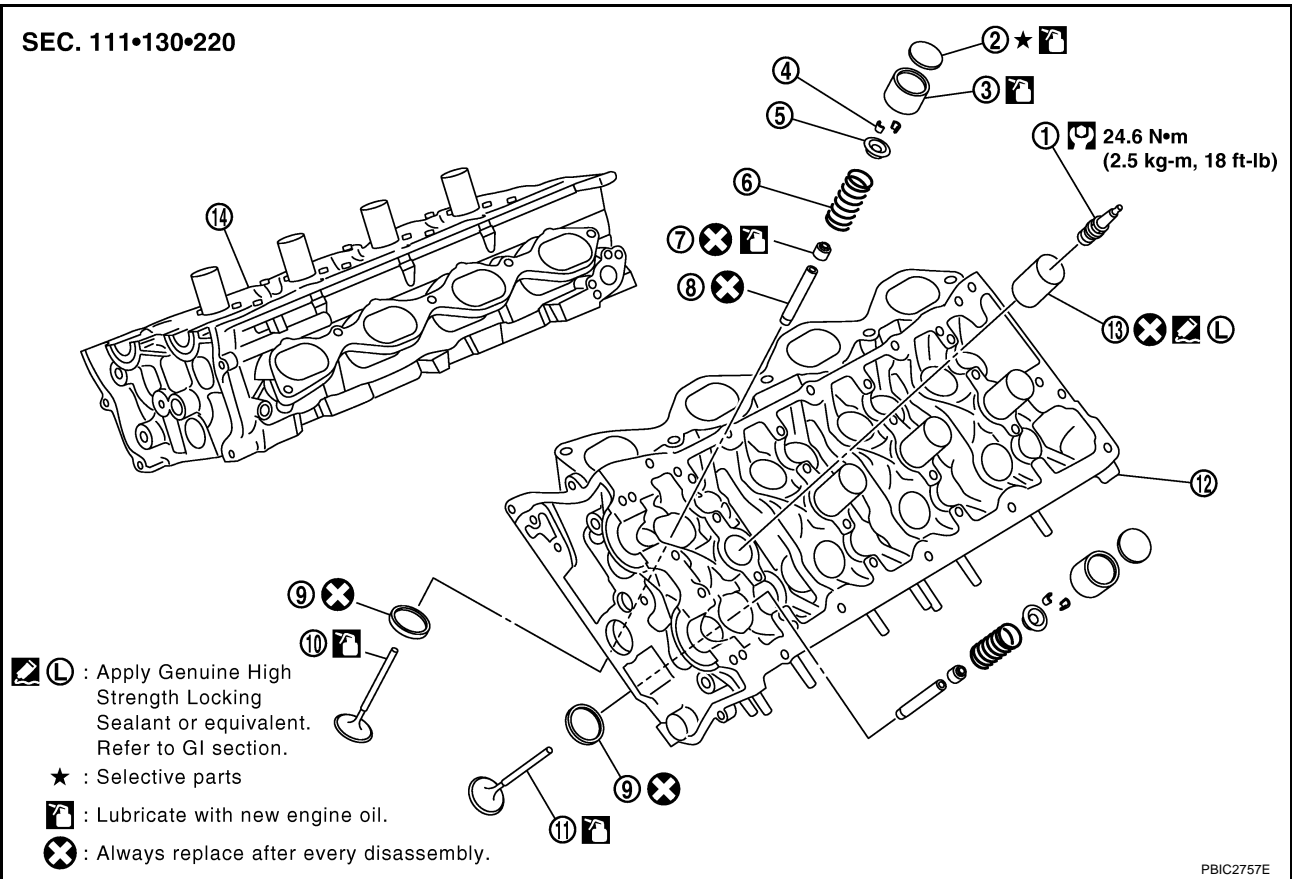

- |                     |                                |  |
|---------------------|--------------------------------|--|
| 1. Spark plug       | 2. Adjusting shim              | 3. Valve lifter                          |
| 4. Valve collet     | 5. Valve spring retainer       | 6. Valve spring (with valve spring seat) |
| 7. Valve oil seal   | 8. Valve guide                 | 9. Valve seat                            |
| 10. Valve (INT)     | 11. Valve (EXH)                | 12. Cylinder head (left bank)            |
| 13. Spark plug tube | 14. Cylinder head (right bank) |  |

### DISASSEMBLY

- Remove spark plug with spark plug wrench (commercial service tool).
- Remove adjusting shim and valve lifter.
  - Identify installation positions, and store them without mixing them up.
- Remove valve collet.
  - Compress valve spring with valve spring compressor, attachment and adapter (SST). Remove valve collet with magnetic hand.

**CAUTION:**

When working, take care not to damage valve lifter holes.

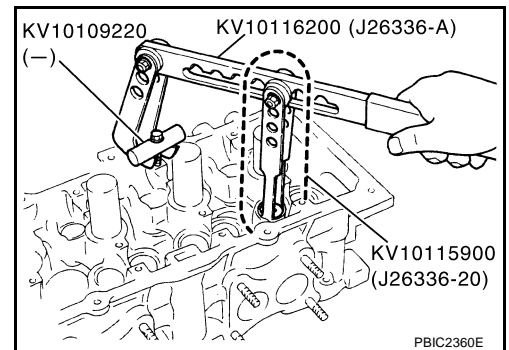

- Remove valve spring retainer and valve spring (with valve spring seat).
 

**CAUTION:**  
Do not remove valve spring seat from valve spring.
- Push valve stem to combustion chamber side, and remove valve.

# CYLINDER HEAD

[VK45DE]

- Identify installation positions, and store them without mixing them up.
6. Remove valve oil seal with valve oil seal puller (SST).

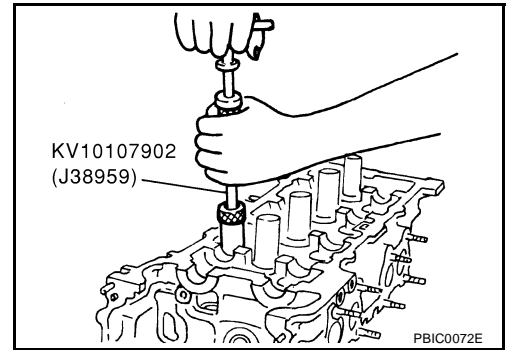

7. If valve seat must be replaced, refer to [EM-242, "VALVE SEAT REPLACEMENT"](#).
8. If valve guide must be replaced, refer to [EM-240, "VALVE GUIDE REPLACEMENT"](#).
9. Remove spark plug tube, as necessary.
  - Using pair of pliers, pull spark plug tube out of cylinder head.

### CAUTION:

- Take care not to damage cylinder head.
- Once removed, spark plug tube will be deformed and cannot be reused. Do not remove it unless absolutely necessary.

### ASSEMBLY

1. When valve guide is removed, install it. Refer to [EM-240, "VALVE GUIDE REPLACEMENT"](#).
2. When valve seat is removed, install it. Refer to [EM-242, "VALVE SEAT REPLACEMENT"](#).
3. Install new valve oil seal as follows:
  - a. Apply new engine oil on valve oil seal joint and seal lip.
  - b. Install with valve oil seal drift (SST) to match dimension in the figure.

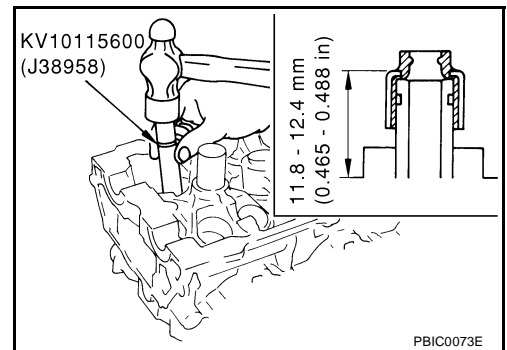

4. Install valve.
    - Install in the original position.
- NOTE:**  
Larger diameter valves are for intake side.
5. Install valve spring (with valve spring seat).
    - Install smaller pitch (valve spring seat side) to cylinder head side.

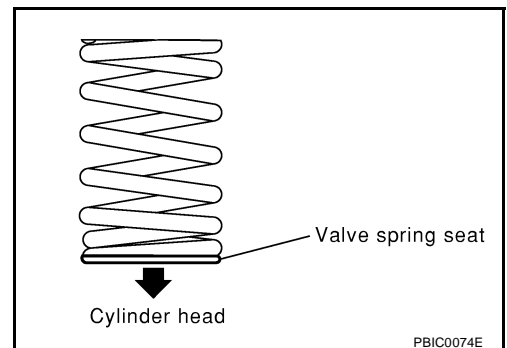

6. Install valve spring retainer.

7. Install valve collet.

- Compress valve spring with valve spring compressor, attachment and adapter (SST). Install valve collet with magnetic hand.

**CAUTION:**

**When working, take care not to damage valve lifter holes.**

- Tap stem edge lightly with plastic hammer after installation to check its installed condition.

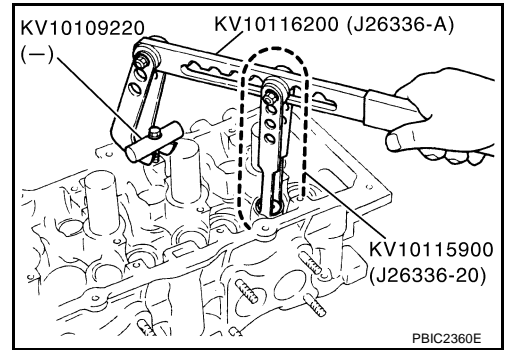

8. Install valve lifter and adjusting shim.

- Install it in the original position.

9. Install spark plug tube.

- Press-fit spark plug tube as follows:

- Remove old liquid gasket adhering to cylinder-head mounting hole.
- Apply sealant to area within approximately 12 mm (0.47 in) from edge of spark plug tube press-fit side. **Use Genuine High Strength Locking Sealant or equivalent. Refer to [GI-48, "RECOMMENDED CHEMICAL PRODUCTS AND SEALANTS"](#).**
- Using drift, press-fit spark plug tube so that its height "H" is as specified in the figure.

**Standard press-fit height "H" :**  
**: 38.4 - 39.4 mm (1.512 - 1.551 in)**

**CAUTION:**

- When press-fitting, take care not to deform spark plug tube.
- After press-fitting, wipe off liquid gasket protruding onto cylinder head upper face.

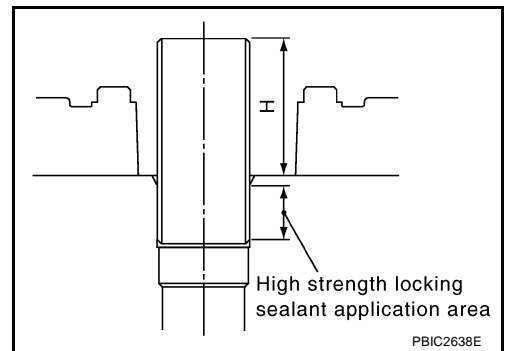

10. Install spark plug with spark plug wrench (commercial service tool).

**Inspection after Disassembly**  
**VALVE DIMENSIONS**

NBS004PJ

- Check the dimensions of each valve. For the dimensions, refer to [EM-280, "Valve Dimensions"](#).
- If the dimensions are out of the standard, replace valve and check the valve seat contact. Refer to [EM-242, "VALVE SEAT CONTACT"](#).

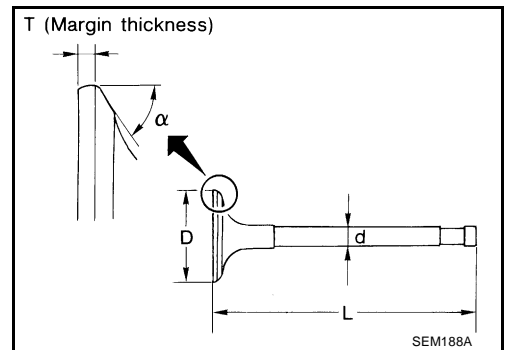

## VALVE GUIDE CLEARANCE

### Valve Stem Diameter

Measure the diameter of valve stem with micrometer.

#### Standard

**Intake** : 5.972 - 5.980 mm (0.2351 - 0.2354 in)

**Exhaust** : 5.962 - 5.970 mm (0.2347 - 0.2350 in)

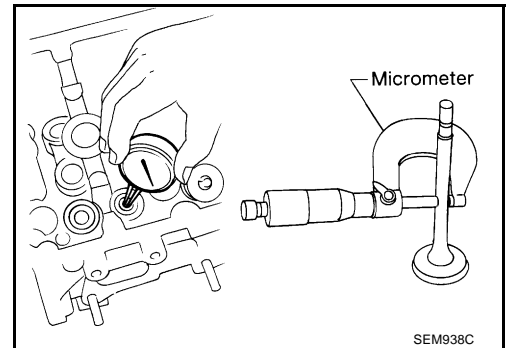

### Valve Guide Inner Diameter

Measure the inner diameter of valve guide with bore gauge.

#### Standard

**Intake and Exhaust** : 6.000 - 6.018 mm (0.2362 - 0.2369 in)

### Valve Guide Clearance

(Valve guide clearance) = (Valve guide inner diameter) – (Valve stem diameter).

#### Valve guide clearance:

##### Standard

**Intake** : 0.020 - 0.046 mm (0.0008 - 0.0018 in)

**Exhaust** : 0.030 - 0.056 mm (0.0012 - 0.0022 in)

##### Limit

**Intake** : 0.08 mm (0.003 in)

**Exhaust** : 0.1 mm (0.004 in)

- If the calculated value exceeds the limit, replace valve and/or valve guide. When valve guide must be replaced, refer to [EM-240, "VALVE GUIDE REPLACEMENT"](#).

## VALVE GUIDE REPLACEMENT

When valve guide is removed, replace with oversized [0.2 mm (0.008 in)] valve guide.

1. To remove valve guide, heat cylinder head to 110 to 130°C (230 to 266°F) by soaking in heated oil.

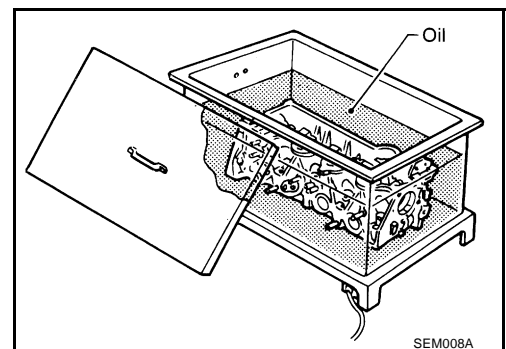

2. Drive out valve guide with a press [under a 20 kN (2 ton, 2.2 US ton, 2.0 Imp ton) pressure] or hammer and valve guide drift (commercial service tool).

#### **WARNING:**

**Cylinder head contains heat. When working, wear protective equipment to avoid getting burned.**

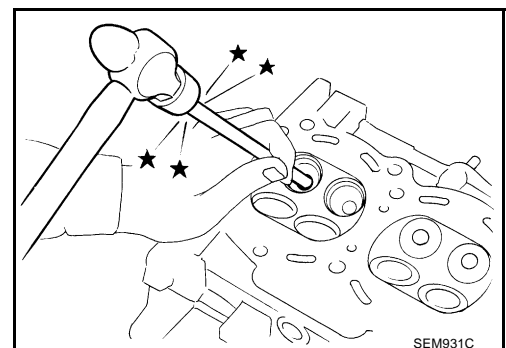

# CYLINDER HEAD

[VK45DE]

3. Using valve guide reamer (commercial service tool), ream cylinder head valve guide hole.

**Valve guide hole diameter (for service parts):**

**Intake and exhaust**

**: 10.175 - 10.196 mm (0.4006 - 0.4014 in)**

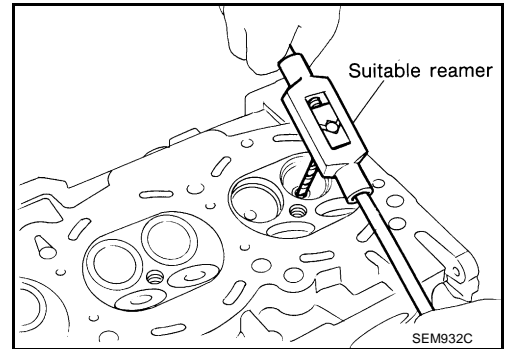

4. Heat cylinder head to 110 to 130°C (230 to 266°F) by soaking in heated oil.

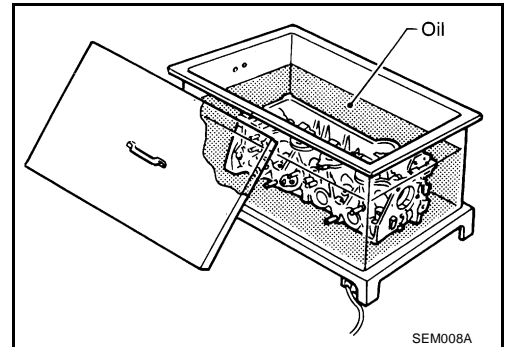

5. Using valve guide drift (commercial service tool), press valve guide from camshaft side to the dimensions as in the figure.

**WARNING:**

**Cylinder head contains heat. When working, wear protective equipment to avoid getting burned.**

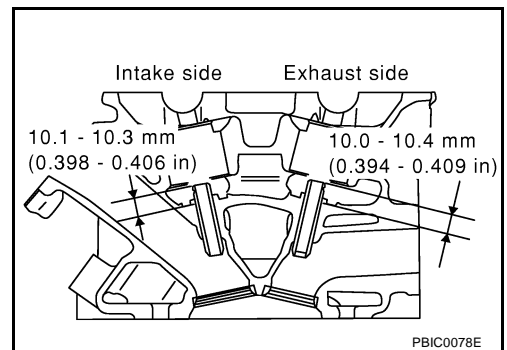

6. Using valve guide reamer (commercial service tool), apply reamer finish to valve guide.

**Standard:**

**Intake and exhaust**

**: 6.000 - 6.018 mm (0.2362 - 0.2369 in)**

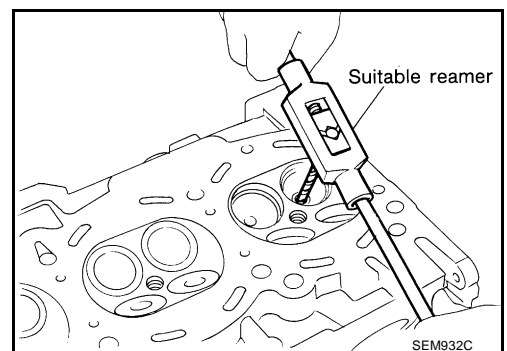

A  
EM  
C  
D  
E  
F  
G  
H  
I  
J  
K  
L  
M

## VALVE SEAT CONTACT

- After confirming that the dimensions of valve guides and valves are within the specifications, perform this procedure.
- Apply prussian blue (or white lead) onto contacting surface of valve seat to check the condition of the valve contact on the surface.
- Check if the contact area band is continuous all around the circumference.
- If not, grind to adjust valve fitting and check again. If the contacting surface still has "NG" conditions even after the re-check, replace valve seat. Refer to [EM-242, "VALVE SEAT REPLACEMENT"](#).

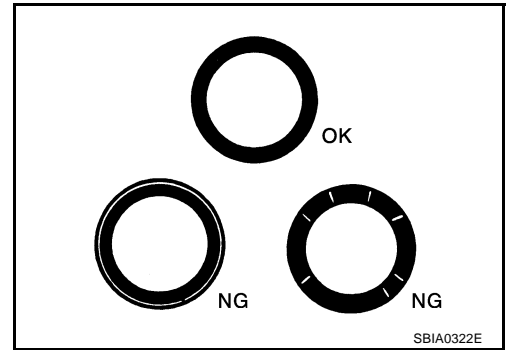

## VALVE SEAT REPLACEMENT

When valve seat is removed, replace with oversized [0.5 mm (0.020 in)] valve seat.

1. Bore out old seat until it collapses. Boring should not continue beyond the bottom face of the seat recess in cylinder head. Set the machine depth stop to ensure this. Refer to [EM-281, "Valve Seat"](#).

**CAUTION:**

**Prevent to scratch cylinder head by excessive boring.**

2. Ream cylinder head recess diameter for service valve seat.

**Oversize [0.5 mm (0.020 in)]**

**Intake : 37.500 - 37.516 mm (1.4764 - 1.4770 in)**

**Exhaust : 32.700 - 32.716 mm (1.2874 - 1.2880 in)**

- Be sure to ream in circles concentric to valve guide center. This will enable valve to fit correctly.

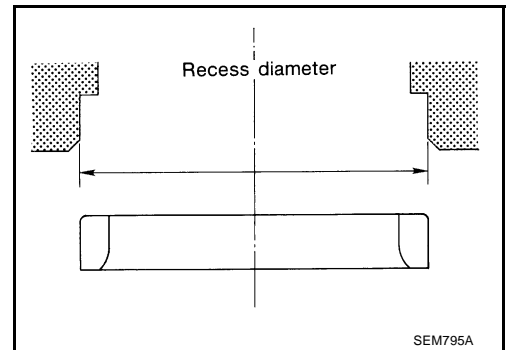

3. Heat cylinder head to 110 to 130°C (230 to 266°F) by soaking in heated oil.

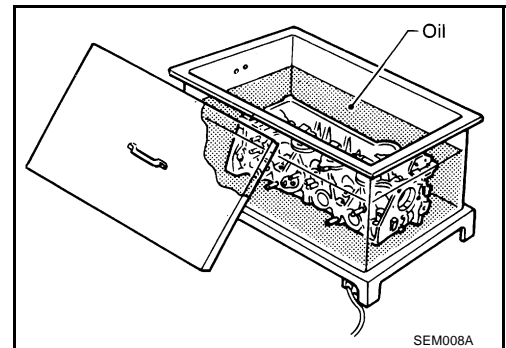

4. Provide valve seats cooled well with dry ice. Force fit valve seat into cylinder head.

**WARNING:**

**Cylinder head contains heat. When working, wear protective equipment to avoid getting burned.**

**CAUTION:**

**Avoid directly touching cold valve seats.**

# CYLINDER HEAD

[VK45DE]

- Using valve seat cutter set (commercial service tool) or valve seat grinder, finish seat to the specified dimensions. Refer to [EM-281, "Valve Seat"](#).

**CAUTION:**

When using valve seat cutter, firmly grip cutter handle with both hands. Then, press on the contacting surface all around the circumference to cut in a single drive. Improper pressure on with cutter or cutting many different times may result in stage valve seat.

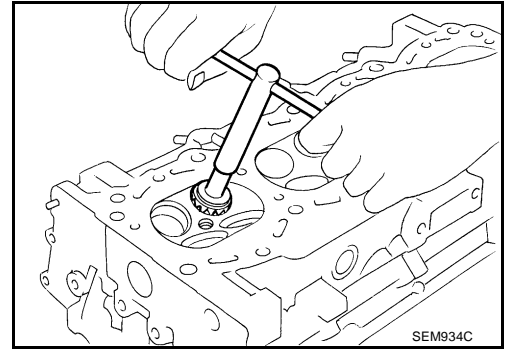

- Using compound, grind to adjust valve fitting.
- Check again for normal contact. Refer to [EM-242, "VALVE SEAT CONTACT"](#).

## VALVE SPRING SQUARENESS

- Set try square along the side of valve spring and rotate spring. Measure the maximum clearance between the top face of spring and try square.

**Limit : 2.0 mm (0.079 in)**

- If it exceeds the limit, replace valve spring.

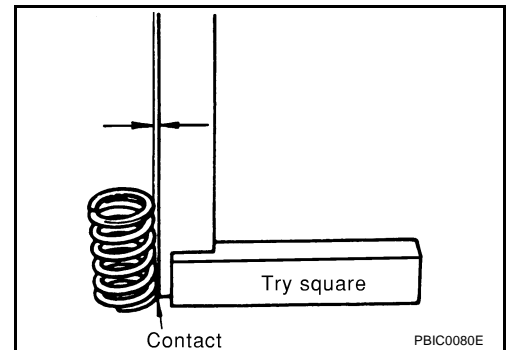

## VALVE SPRING DIMENSIONS AND VALVE SPRING PRESSURE LOAD

- Check valve spring pressure at the specified spring height.

**Standard:**

**Intake and exhaust**

**Free height**

: 46.35 - 46.85 mm (1.8247 - 1.8444 in)

**Installation height**

: 33.8 mm (1.331 in)

**Installation load**

: 165 - 189 N (16.8 - 19.3 kg, 37 - 42 lb)

**Height during valve open**

: 24.4 mm (0.961 in)

**Load with valve open**

: 290 - 330 N (29.6 - 33.7 kg, 65 - 74 lb)

- If the installation load or load with valve open is out of the standard, replace valve spring.

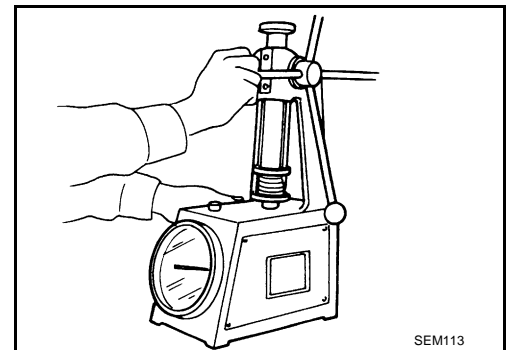

## ENGINE ASSEMBLY

PFP:10001

### Components

NBS004PK

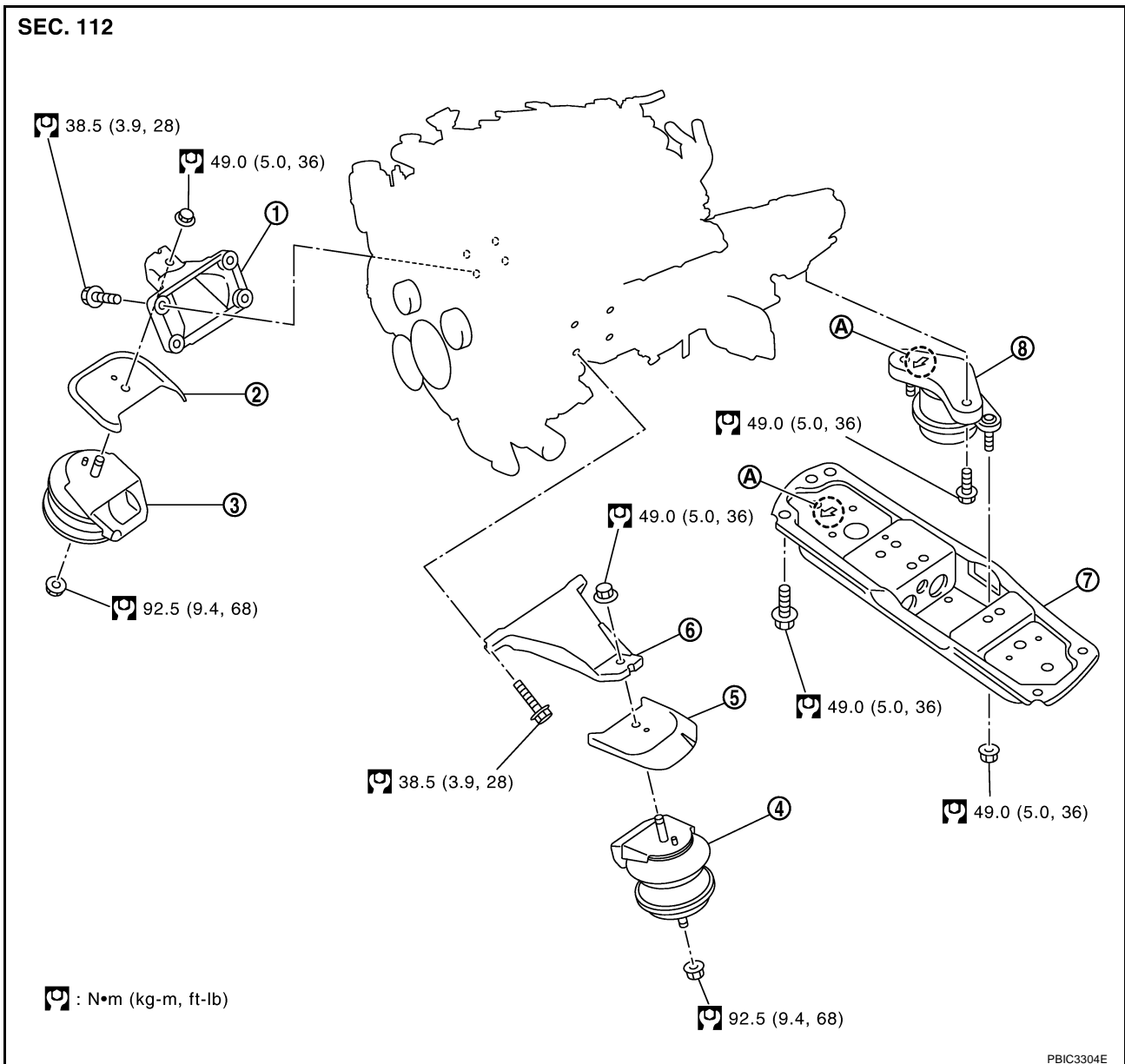

- |                                   |                                     |                                   |
|-----------------------------------|-------------------------------------|-----------------------------------|
| 1. Engine mounting bracket (RH)   | 2. Heat insulator                   | 3. Engine mounting insulator (RH) |
| 4. Engine mounting insulator (LH) | 5. Heat insulator                   | 6. Engine mounting bracket (LH)   |
| 7. Rear engine mounting member    | 8. Engine mounting insulator (rear) |                                   |
| A. Front mark                     |                                     |                                   |

### Removal and Installation

NBS004PL

#### WARNING:

- Situate vehicle on a flat and solid surface.
- Place chocks at front and back of rear wheels.
- For engines not equipped with engine slingers, attach proper slingers and bolts described in PARTS CATALOG.

#### CAUTION:

- Always be careful to work safely, avoid forceful or uninstructed operations.
- Do not start working until exhaust system and engine coolant are cool enough.
- If items or work required are not covered by the engine section, refer to the applicable sections.



- Always use the support point specified for lifting.
- Use either 2-pole lift type or separate type lift as best you can. If board-on type is used for unavoidable reasons, support at the rear axle jacking point with transmission jack or similar tool before starting work, in preparation for the backward shift of center of gravity.
- For supporting points for lifting and jacking point at rear axle, refer to [GI-42, "Garage Jack and Safety Stand and 2-Pole Lift"](#) .

## REMOVAL

### Outline

At first, remove engine, transmission assembly with front suspension member from vehicle downward. Then separate engine from transmission.

### Preparation

1. Release fuel pressure. Refer to [EC-809, "FUEL PRESSURE RELEASE"](#) .
2. Drain engine coolant from radiator. Refer to [CO-40, "Changing Engine Coolant"](#) .

#### CAUTION:

- Perform this step when engine is cold.
  - Do not spill engine coolant on drive belts.
3. Disconnect both battery cables. Refer to [SC-4, "BATTERY"](#) .
  4. Remove crankshaft position sensor (POS) from transmission.
- #### CAUTION:
- Handle carefully to avoid dropping and shocks.
  - Do not disassemble.
  - Do not allow metal powder to adhere to magnetic part at sensor tip.
  - Do not place sensors in a location where they are exposed to magnetism.

5. Remove the following parts:
  - Front and rear engine undercover (power tool)
  - Air duct (inlet), air duct and air cleaner case assembly; Refer to [EM-177, "AIR CLEANER AND AIR DUCT"](#) .
  - Front road wheels and tires (power tool)

### Engine Room LH

1. Disconnect heater hoses, and install plugs to avoid leakage of engine coolant.
2. Disconnect wire bonding from exhaust manifold cover to vehicle.
3. Disconnect vacuum hose between vehicle and engine and set it aside.
4. Discharge refrigerant from A/C circuit. Refer to [ATC-151, "REFRIGERANT LINES"](#) .
5. Remove A/C piping from A/C compressor, and temporarily fasten it on vehicle with a rope. Refer to [ATC-151, "REFRIGERANT LINES"](#) .

### Engine Room RH

1. Disconnect fuel feed hose and EVAP hose. Refer to [EM-193, "FUEL INJECTOR AND FUEL TUBE"](#) .

#### CAUTION:

**Fit plugs onto disconnected hose to prevent fuel leak.**

2. Disconnect ground cable (between vehicle and right bank cylinder head).
3. Disconnect vacuum hose between vehicle and engine and set it aside.
4. Disconnect reservoir tank of power steering oil pump from engine, and move it aside for easier work.

#### CAUTION:

**When temporarily securing, keep reservoir tank upright to avoid a fluid leak.**

### Vehicle inside

Follow procedure below to disconnect engine room harness connectors at passenger room side, and temporarily secure them on engine.

1. Remove passenger-side kicking plate, dash side finisher, and glove box. Refer to [EI-37, "BODY SIDE TRIM"](#) and [IP-10, "INSTRUMENT PANEL ASSEMBLY"](#) .
2. Disconnect engine room harness connectors at unit sides TCM, ECM and other.

- Disengage intermediate fixing point. Pull out engine room harnesses to engine room side, and temporarily secure them on engine.

**CAUTION:**

- When pulling out harnesses, take care not to damage harnesses and connectors.
- After temporarily securing, cover connectors with vinyl or similar material to protect against foreign material adhesion.

## Vehicle Underbody

- Remove A/T fluid cooler hoses and power steering oil pump oil cooler hoses.
  - Install plug to avoid leakage of A/T fluid and power steering fluid.
- Disconnect heated oxygen sensor 2 harness. Refer to [EX-3, "EXHAUST SYSTEM"](#) .
- Remove exhaust front tube with power tool. Refer to [EX-3, "EXHAUST SYSTEM"](#) .
- Disconnect steering lower joint at power steering gear assembly side, and release steering lower shaft. Refer to [PS-13, "STEERING COLUMN"](#) .
- Separate steering outer sockets from steering knuckle. Refer to [PS-18, "POWER STEERING GEAR"](#) .
- Remove A/T control rod at control device assembly side. Then temporarily secure it on transmission, so that it does not sag. Refer to [AT-222, "SHIFT CONTROL SYSTEM"](#) .
- Remove rear plate cover from oil pan. Then remove bolts fixing drive plate to torque converter. Refer to [EM-187, "OIL PAN AND OIL STRAINER"](#) and [AT-271, "TRANSMISSION ASSEMBLY"](#) .
- Remove transmission joint bolts which pierce at oil pan lower rear side. Refer to [AT-271, "TRANSMISSION ASSEMBLY"](#) .
- Remove lower ends of left and right strut from transverse link. Refer to [FSU-6, "FRONT SUSPENSION ASSEMBLY"](#) .
- Remove transverse link mounting bolts at knuckle side. Refer to [FSU-14, "TRANSVERSE LINK"](#) .
- Remove front stabilizer at transverse link side. Refer to [FSU-6, "FRONT SUSPENSION ASSEMBLY"](#) .
- Remove rear propeller shaft. Refer to [PR-6, "REAR PROPELLER SHAFT"](#) .

## Removal Work

- Use manual lift table caddy (commercial service tool) or equivalently rigid tool such as transmission jack. Securely support bottom of suspension member and transmission assembly.

**CAUTION:**

Put a piece of wood or something similar as the supporting surface, secure a completely stable condition.

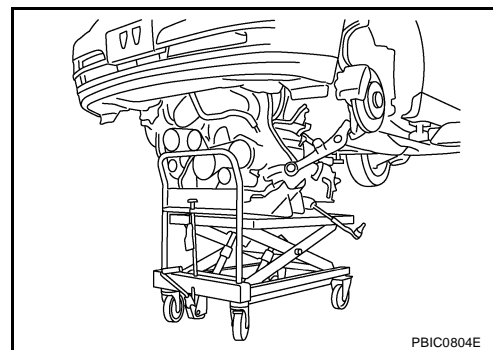

- Remove engine rear member mounting bolts.
- Remove front suspension member mounting nuts and bolts with power tool. Refer to [FSU-6, "FRONT SUSPENSION ASSEMBLY"](#) .
- Carefully lower jack, or raise lift to remove engine, transmission and front suspension member assembly. When performing work, observe the following caution:

**CAUTION:**

- Confirm there is no interference with vehicle.
- Make sure that all connection points have been disconnected.
- Keep in mind the center of vehicle gravity changes. If necessary, use jack(s) to support vehicle at rear jacking point(s) to prevent it from falling off the lift.

## Separation Work

1. Install engine slingers into front of cylinder head (left bank) and rear of cylinder head (right bank).

### Slinger bolts:

: 33.4 N-m (3.4 kg-m, 25 ft-lb)

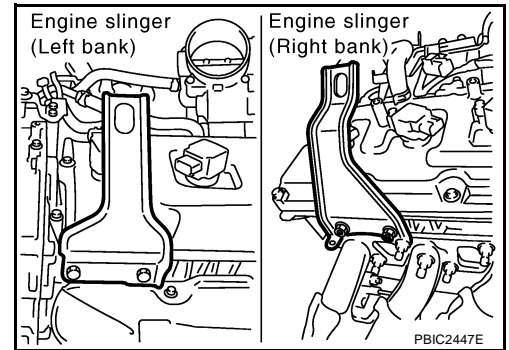

2. Remove engine mounting insulators (RH and LH) under side nut with power tool.
3. Lift with hoist and separate engine and transmission assembly from front suspension member.
 

**CAUTION:**  
Avoid damage to and oil/grease smearing or spills onto engine mounting insulator.
4. Remove alternator. Refer to [SC-23, "CHARGING SYSTEM"](#) .
5. Remove starter motor. Refer to [SC-10, "STARTING SYSTEM"](#) .
6. Separate engine from transmission assembly. Refer to [AT-271, "TRANSMISSION ASSEMBLY"](#) .
7. Remove engine mounting insulators (RH and LH) and brackets (RH and LH) from engine with power tool.
8. Remove rear engine mounting member and engine mounting insulator (rear) from transmission.

## INSTALLATION

Note the following, and install in the reverse order of removal.

- Do not allow engine mounting insulator to be damage and careful no engine oil gets on it.
- For a location with a positioning pin, insert it securely into hole of mating part.
- For a part with a specified installation orientation, refer to component figure in [EM-244, "Components"](#) .
- When installing engine mounting brackets (RH and LH) on cylinder block, tighten two upper bolts (shown as "A" in the figure) first. Then tighten two lower bolts (shown as "B" in the figure).

### NOTE:

Figure shows LH bank.

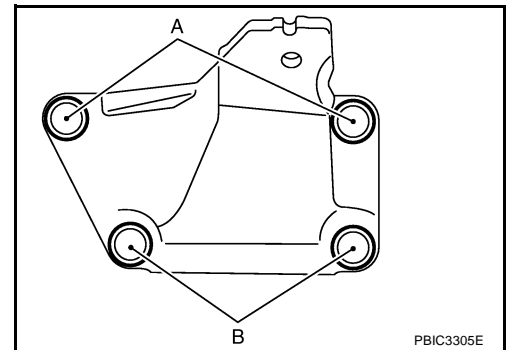

## INSPECTION AFTER INSTALLATION

### Inspection for Leaks

The following are procedure for checking fluids leak, lubricates leak and exhaust gases leak.

- Before starting engine, check oil/fluid levels including engine coolant and engine oil. If less than required quantity, fill to the specified level. Refer to [MA-12, "RECOMMENDED FLUIDS AND LUBRICANTS"](#) .
- Use procedure below to check for fuel leakage.
  - Turn ignition switch "ON" (with engine stopped). With fuel pressure applied to fuel piping, check for fuel leakage at connection points.
  - Start engine. With engine speed increased, check again for fuel leakage at connection points.
- Run engine to check for unusual noise and vibration.
- Warm up engine thoroughly to make sure there is no leakage of fuel, exhaust gases, or any oil/fluids including engine oil and engine coolant.
- Bleed air from lines and hoses of applicable lines, such as in cooling system.
- After cooling down engine, again check oil/fluid levels including engine oil and engine coolant. Refill to the specified level, if necessary.

# ENGINE ASSEMBLY

[VK45DE]

## Summary of the inspection items:

Item	Before starting engine	Engine running	After engine stopped
Engine coolant	Level	Leakage	Level
Engine oil	Level	Leakage	Level
Other oils and fluid*	Level	Leakage	Level
Fuel	Leakage	Leakage	Leakage
Exhaust gases	—	Leakage	—

\* Transmission/transaxle/CVT fluid, power steering fluid, brake fluid, etc.

# CYLINDER BLOCK

[VK45DE]

## CYLINDER BLOCK

PF1:11010

### Components

NBS004PM

SEC. 110•120•226

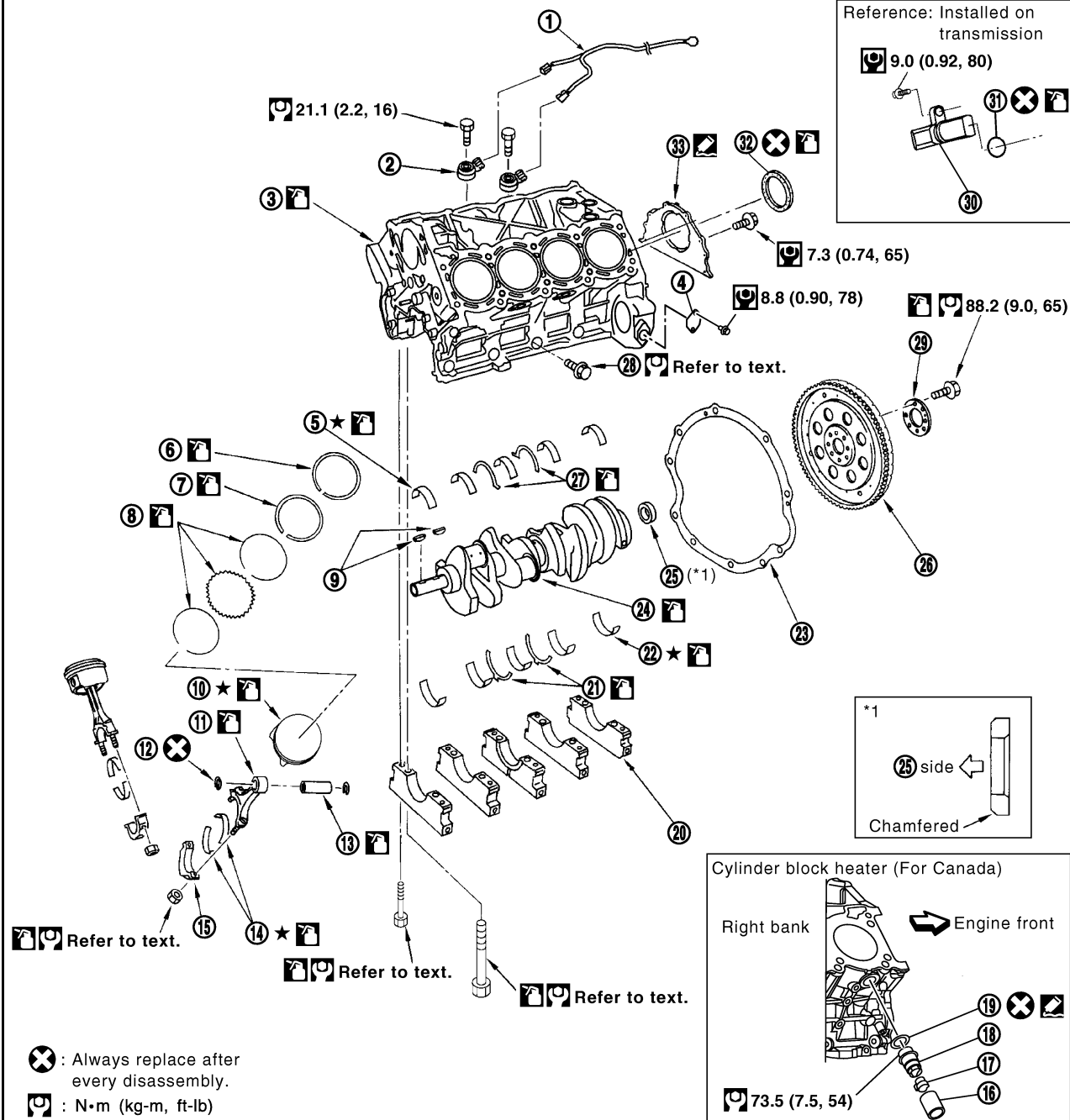

PBIC2366E

- |                             |                    |                   |
|-----------------------------|--------------------|-------------------|
| 1. Knock sensor sub harness | 2. Knock sensor    | 3. Cylinder block |
| 4. Cover                    | 5. Main bearing    | 6. Top ring       |
| 7. Second ring              | 8. Oil ring        | 9. Crankshaft key |
| 10. Piston                  | 11. Connecting rod | 12. Snap ring     |

- |                            |                            |                                      |
|----------------------------|----------------------------|--------------------------------------|
| 13. Piston pin             | 14. Connecting rod bearing | 15. Connecting rod bearing cap       |
| 16. Block heater protector | 17. Connector cap          | 18. Cylinder block heater            |
| 19. Gasket                 | 20. Main bearing cap       | 21. Thrust bearing                   |
| 22. Main bearing           | 23. Rear plate             | 24. Crankshaft                       |
| 25. Pilot convertor        | 26. Drive plate            | 27. Thrust bearing                   |
| 28. Side bolt              | 29. Reinforcement plate    | 30. Crankshaft position sensor (POS) |
| 31. O-ring                 | 32. Rear oil seal          | 33. Rear oil seal retainer           |

## Disassembly and Assembly DISASSEMBLY

NBS004PN

### NOTE:

Explained here is how to disassemble with engine stand supporting transmission surface. When using different type of engine stand, note with difference in steps and etc.

1. Remove engine assembly from vehicle, and separate front suspension member, transmission from engine. Refer to [EM-244, "ENGINE ASSEMBLY"](#).
2. Remove the parts that may restrict installation of engine to widely use engine stand.

### NOTE:

The procedure is described assuming that you use widely use engine holding the surface, to which transmission is installed.

- a. Remove drive plate.
  - Holding ring gear with ring gear stopper (SST).
  - Loosen mounting bolts diagonally order.

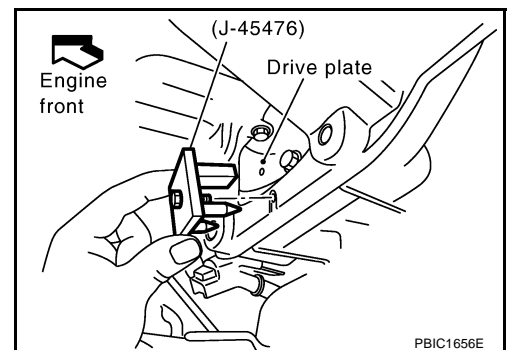

### CAUTION:

- Do not disassemble drive plate.
- Do not place drive plate with signal plate facing down.
- When handling signal plate, take care not to damage or scratch it.
- Handle signal plate in a manner that prevents it from becoming magnetized.

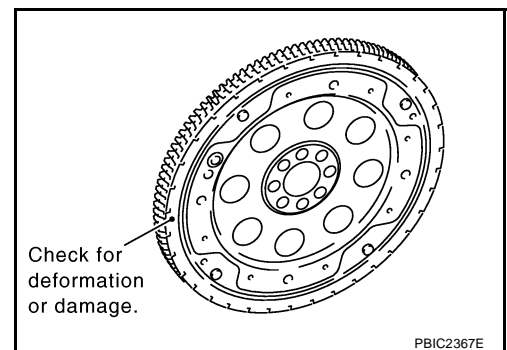

- b. Remove rear plate.
3. Lift engine with hoist to install it onto widely use engine stand.

### CAUTION:

Use engine stand that has a load capacity [approximately 240kg (529 lb) or more] large enough for supporting the engine weight.

- If the load capacity of stand is not adequate, remove the following parts beforehand to reduce the potential risk of overturning stand.
  - Intake manifolds (upper and lower); Refer to [EM-179, "INTAKE MANIFOLD"](#).
  - Exhaust manifold and three way catalyst; Refer to [EM-183, "EXHAUST MANIFOLD AND THREE WAY CATALYST"](#).

- Fuel tube and fuel injector assembly; Refer to [EM-193, "FUEL INJECTOR AND FUEL TUBE"](#) .
- Ignition coil; Refer to [EM-190, "IGNITION COIL"](#) .
- Rocker cover; Refer to [EM-199, "ROCKER COVER"](#) .
- Other removable brackets

**NOTE:**

The figure shows an example of widely use engine stand that can hold mating surface of transmission with drive plate and rear plate removed.

**CAUTION:**

**Before removing the hanging chains, make sure the engine stand is stable and there is no risk of overturning.**

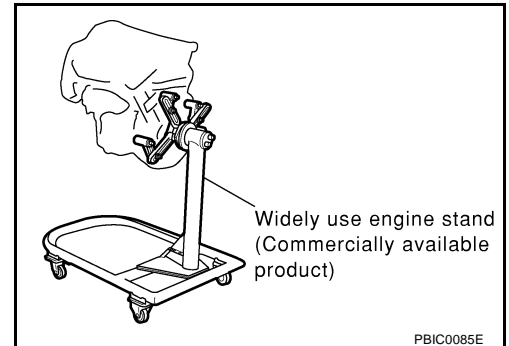

4. Drain engine oil. Refer to [LU-28, "Changing Engine Oil"](#) .
5. Drain engine coolant from inside engine by removing water drain plugs "B" as shown in the figure.

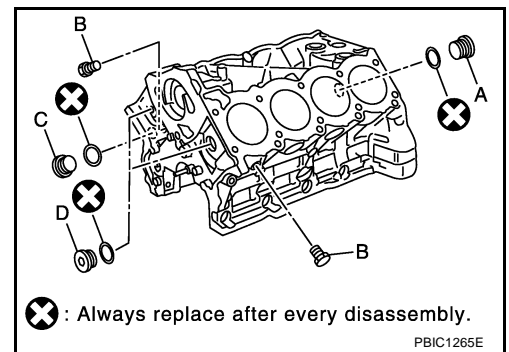

6. Remove oil pan and oil strainer; Refer to [EM-187, "OIL PAN AND OIL STRAINER"](#) .
7. Remove crankshaft pulley as follows:
  - a. Lock crankshaft with a hammer handle or similar tool to loosen crankshaft bolt.
  - b. Pull crankshaft pulley with both hands to remove it.

**CAUTION:**

- Do not remove crankshaft pulley bolt. Keep loosened crankshaft pulley bolt in place to protect removed crankshaft pulley from dropping.
- Do not remove balance weight (inner hexagon bolt) at the front of crankshaft pulley.

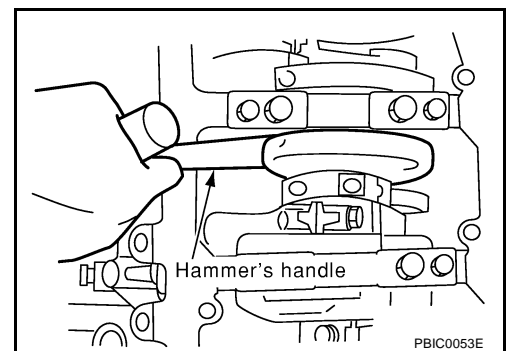

8. Remove the following parts and related parts (The parts listed in step 3 are not included here.)
  - Front cover and timing chain; Refer to [EM-203, "TIMING CHAIN"](#) .
  - Camshaft; Refer to [EM-215, "CAMSHAFT"](#) .
  - Cylinder head; Refer to [EM-233, "CYLINDER HEAD"](#) .
9. Remove knock sensor.
 

**CAUTION:**  
**Carefully handle sensor, avoiding shocks.**
10. Remove piston and connecting rod assembly as follows:
  - Before removing piston and connecting rod assembly, check the connecting rod side clearance. Refer to [EM-266, "CONNECTING ROD SIDE CLEARANCE"](#) .
  - a. Position crankshaft pin corresponding to connecting rod to be removed onto the bottom dead center.
  - b. Remove connecting rod bearing cap.

# CYLINDER BLOCK

[VK45DE]

- c. Using hammer handle or similar tool, push piston and connecting rod assembly out to the cylinder head side.

**CAUTION:**

**Be careful not to damage the cylinder wall and crankshaft pin, resulting from an interference of the connecting rod big end.**

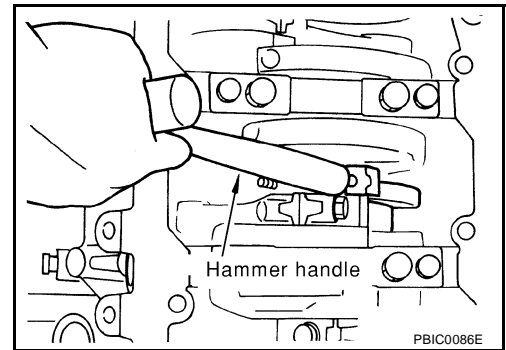

11. Remove connecting rod bearings from connecting rod and connecting rod bearing cap.

**CAUTION:**

**Identify installation positions, and store them without mixing them up.**

12. Remove piston rings from piston.

- Before removing the piston rings, check the piston ring side clearance. Refer to [EM-267, "PISTON RING SIDE CLEARANCE"](#).

- Use piston ring expander (commercial service tool).

**CAUTION:**

- **When removing piston rings, be careful not to damage piston.**
- **Be careful not to damage piston rings by expanding them excessively.**

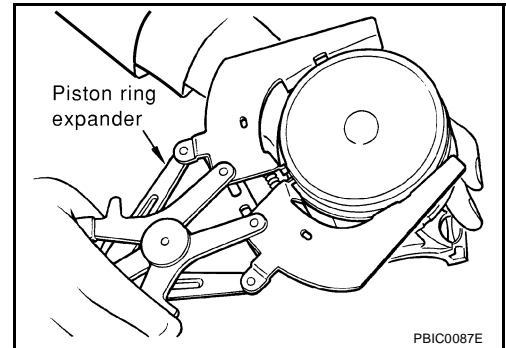

13. Remove piston from connecting rod as follows:

- a. Using snap ring pliers, remove the snap rings.

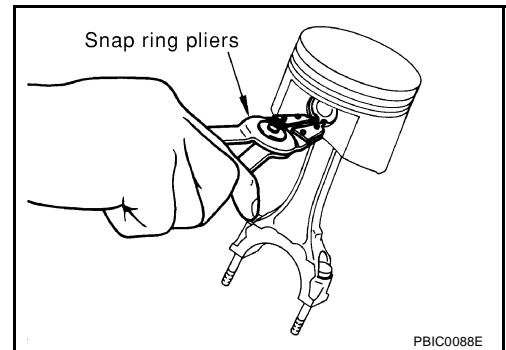

- b. Heat piston to 60 to 70°C (140 to 158°F) with industrial use drier or equivalent.

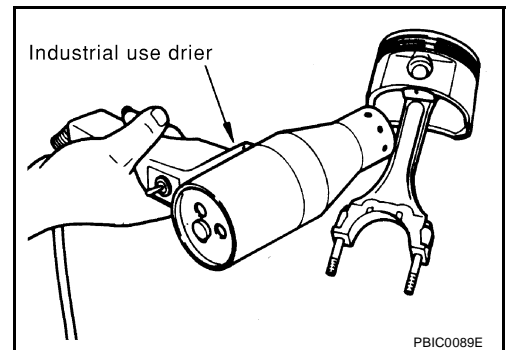



# CYLINDER BLOCK

[VK45DE]

- c. Push out piston pin with stick of outer diameter approximately 20 mm (0.8 in).

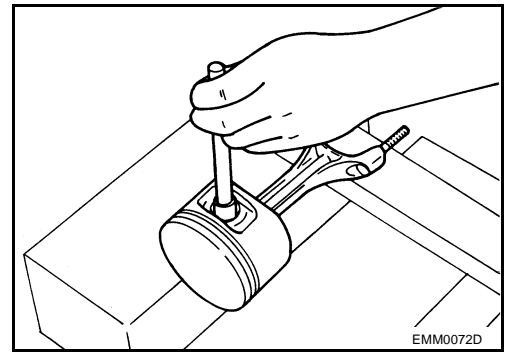

14. Remove rear oil seal retainer from cylinder block.
- Insert screwdriver or similar tool between rear end of crankshaft counter weight and rear oil seal retainer, and separate liquid gasket to remove.

**CAUTION:**

**Be careful not to damage the mating surfaces.**

15. Using screwdriver or similar tool, and lever off rear oil seal from rear oil seal retainer.
16. Remove main bearing cap as follows:
- Before loosening main bearing cap bolts, measure the crankshaft end play. Refer to [EM-266, "CRANK-SHAFT END PLAY"](#).
  - Loosen main bearing cap bolts in several different steps.

- a. Remove cover attached to the rear left side of cylinder block (next to the starter motor housing).

**NOTE:**

Bolts (No. 27 shown in the figure) are installed on the inside of cover.

- b. Loosen side bolts (M10) starting from 30 to 21 to remove.
- c. Loosen main bearing cap sub bolts (M9) starting from 20 to 11 to remove.
- d. Loosen main bearing cap bolts (M12) starting from 10 to 1 to remove.
- e. Using main bearing cap remover (SST), remove main bearing cap.

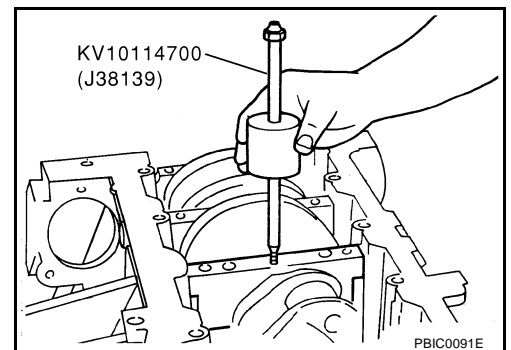
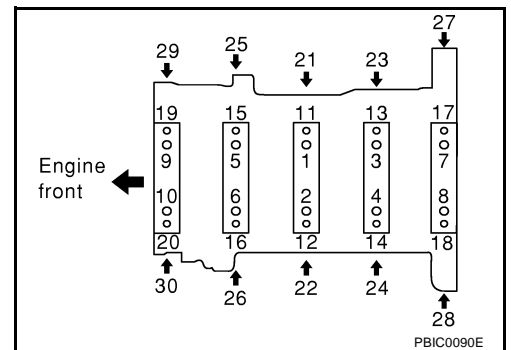

17. Remove crankshaft.
18. Remove main bearings and thrust bearings from cylinder block and main bearing caps.

**CAUTION:**

**Identify installation positions, and store them without mixing them up.**

A  
EM  
C  
D  
E  
F  
G  
H  
I  
J  
K  
L  
M

# CYLINDER BLOCK

[VK45DE]

19. If pilot converter must be removed, remove it from the rear end of the crankshaft using pilot bushing puller (SST).

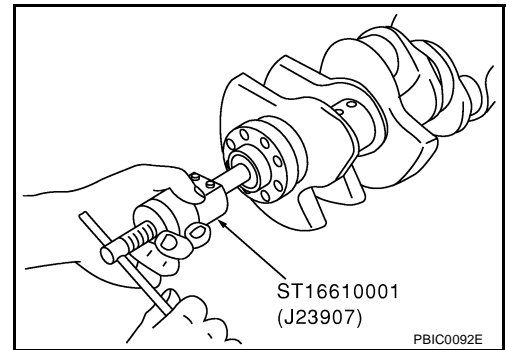

## ASSEMBLY

1. Fully air-blow engine coolant and engine oil passages in cylinder block, cylinder bore and crankcase to remove any foreign material.

### CAUTION:

**Use a goggles to protect your eye.**

2. Install each plug to the cylinder block. (Only screwed-type plugs are shown in the figure.)

- Apply sealant to the thread of each plug "A" and "D".  
**Use Genuine High Strength Locking Sealant or equivalent. Refer to GI-48, "RECOMMENDED CHEMICAL PRODUCTS AND SEALANTS".**
- Apply sealant to the thread of each plug "B" and "C".  
**Use Anaerobic Liquid Gasket or equivalent. Refer to GI-48, "RECOMMENDED CHEMICAL PRODUCTS AND SEALANTS".**
- Replace copper washers with new ones.
- Tighten each plug as specified below.

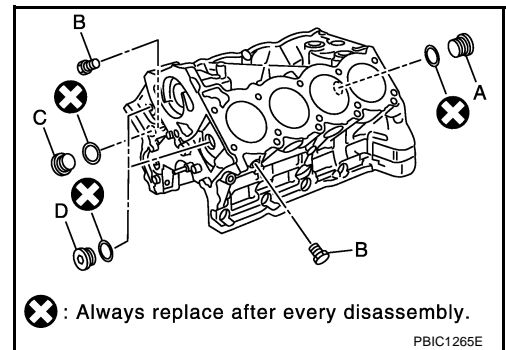

Part	Washer	Tightening torque
A	Yes	53.9 N·m (5.5 kg-m, 40 ft-lb)
B	No	19.6 N·m (2.0 kg-m, 15 ft-lb)
C	Yes	62.7 N·m (6.4 kg-m, 46 ft-lb)
D	Yes	62.7 N·m (6.4 kg-m, 46 ft-lb)

3. Install main bearings and thrust bearings as follows:

- a. Remove dust, dirt and oil on the bearing mating surfaces of cylinder block and main bearing caps.

- b. Install thrust bearings to the both sides of the No. 3 journal housing on cylinder block and main bearing cap.

- Install thrust bearings with the oil groove facing the crankshaft arm (outside).
- Install thrust bearing with a protrusion on one end on cylinder block, and thrust bearing with a protrusion at center on main bearing cap. Align each protrusion with mating notch.

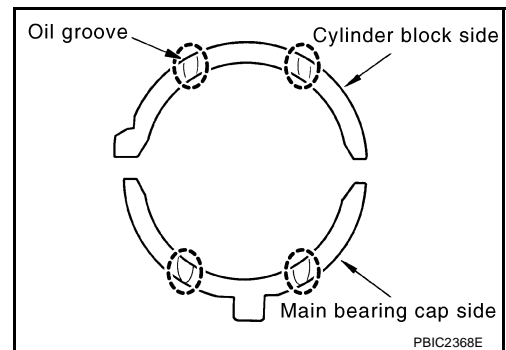

# CYLINDER BLOCK

[VK45DE]

- c. Install main bearings paying attention to the direction.
- Main bearing with oil hole and groove goes on cylinder block. The one without them goes on main bearing cap.
  - Before installing main bearings, apply engine oil to the bearing surface (inside). Do not apply engine oil to the back surface, but thoroughly clean it.
  - When installing, align main bearing stopper protrusion to cut-out of cylinder block and main bearing caps.
  - Ensure the oil holes on cylinder block and those on the corresponding bearing are aligned.

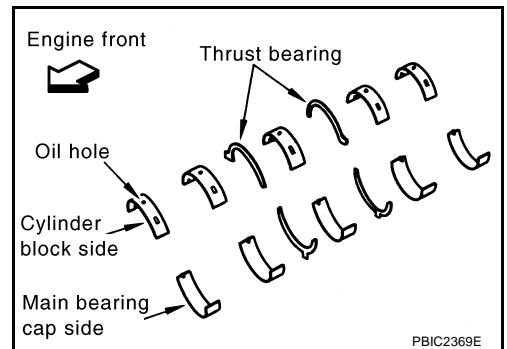

4. Install pilot converter to crankshaft, if removed.
- With drift [outer diameter: approx. 35 mm (1.38 in)], press-fit as far as it will go.

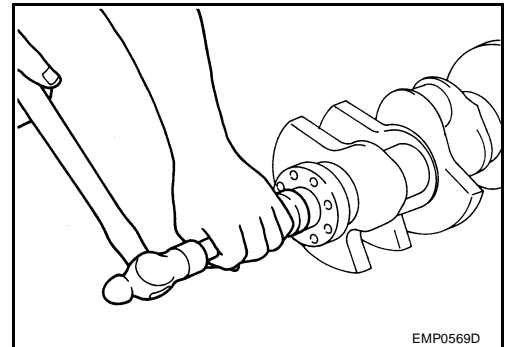

- Press-fit pilot converter with its chamfering side facing crankshaft as shown in the figure.
- It is possible to remove pilot converter without hoisting engine with engine stand.

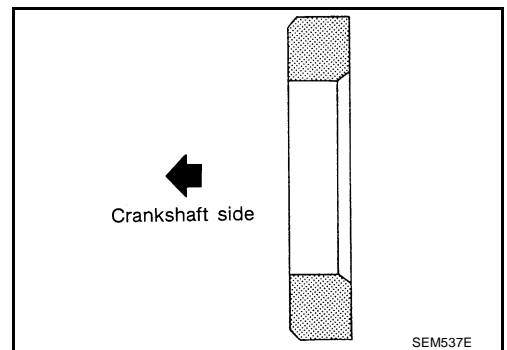

5. Install crankshaft to cylinder block.
- While turning crankshaft by hand, make sure it turns smoothly.
6. Install main bearing caps.
- Align the identification number to the journal position to install.
  - Install the upper side of the identification number facing the front of engine. (The number shall be read correctly from the rear of engine.)
  - Using plastic hammer or similar tool, tap them lightly to seat them on the installation position.

**NOTE:**

Main bearing cap cannot be replaced as a single parts, because it is machined together with cylinder block.

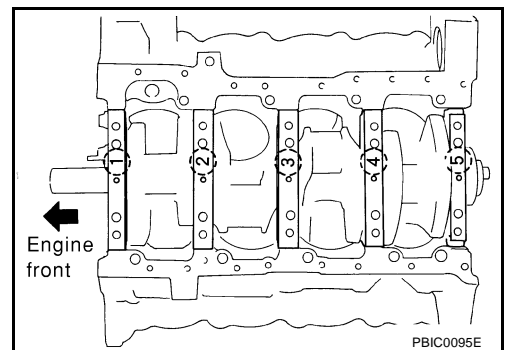

A  
EM  
C  
D  
E  
F  
G  
H  
I  
J  
K  
L  
M

# CYLINDER BLOCK

[VK45DE]

7. Install each main bearing cap bolt as follows:

- Apply new engine oil to threads and seating surface of main bearing cap bolts, and tighten all bolts temporarily.
- Tighten main bearing cap bolt (M12) in order of 1 to 10.

: **39.2 N·m (4.0 kg-m, 29 ft-lb)**

- Tighten main bearing cap sub bolt (M9) in order of 11 to 20.

: **29.4 N·m (3.0 kg-m, 22 ft-lb)**

- Tighten main bearing cap bolt (M12) to 40 degrees clockwise in order of 1 to 10. (Angle tightening)

**CAUTION:**

**Use angle wrench (SST) to check tightening angle in step "d" and "e". Do not make judgment by visual inspection.**

- Tighten main bearing cap sub bolt (M9) to 30 degrees clockwise in order of 11 to 20. (Angle tightening)

- Tighten side bolt (M10) in order of 21 to 30.

: **49 N·m (5.0 kg-m, 36 ft-lb)**

- After installing main bearing cap bolts, make sure that crankshaft can be rotated smoothly.
- Check the crankshaft end play. Refer to [EM-266, "CRANKSHAFT END PLAY"](#).

- Install cover of cylinder block rear left side (next to the starter motor housing).

- Install new rear oil seal on rear oil seal retainer.

- Install new rear oil seal so that each seal lip is oriented as shown in the figure.

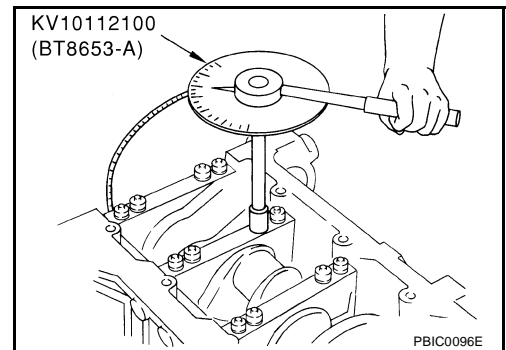
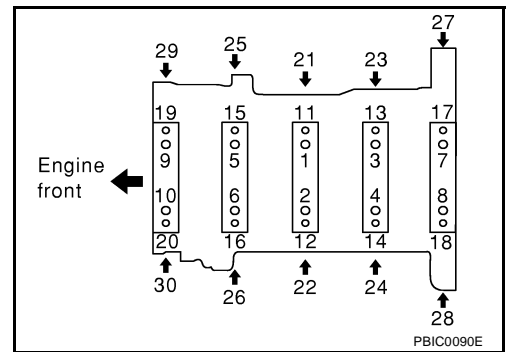

- Install rear oil seal to rear oil seal retainer with rear oil seal drift (commercial service tool).

**Rear oil seal drift**

**Outer diameter : 102 mm (4.02 in)**

**Inner diameter : 86 mm (3.39 in)**

- Tap until flattened with front edge of rear oil seal retainer. Do not damage or scratch outer circumference of oil seal.
- Make sure the garter spring is in position and seal lips not inverted.

- Install rear oil seal retainer.

- Apply new engine oil to both oil seal lip and dust seal lip.

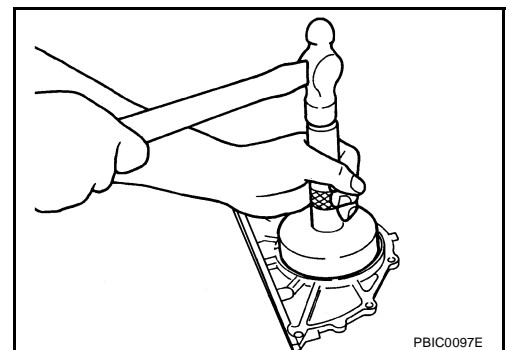
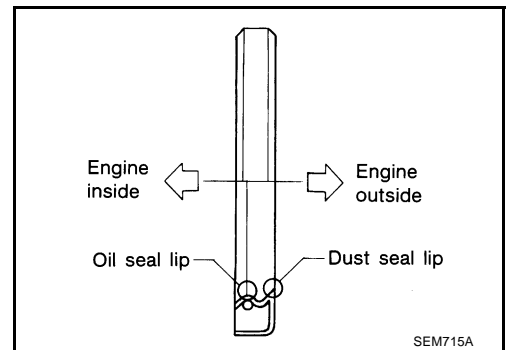

# CYLINDER BLOCK

[VK45DE]

- Apply a continuous bead of liquid gasket with tube presser [SST: WS39930000 ( — )] to rear oil seal retainer as shown in the figure.

**Use Genuine RTV Silicone Sealant or equivalent. Refer to [GI-48, "RECOMMENDED CHEMICAL PRODUCTS AND SEALANTS"](#).**

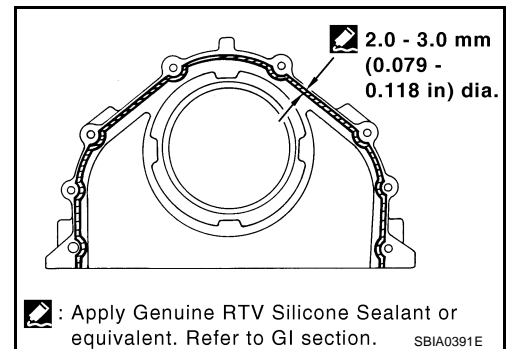

10. Install piston to connecting rod.

a. Using snap ring pliers, install new snap ring to the groove of the piston rear side.

- Insert it fully into groove to install.

b. Install piston to connecting rod.

- Using industrial use drier or similar tool, heat piston until piston pin can be pushed in by hand without excess force [approx. 60 to 70°C (140 to 158°F)]. From the front to the rear, insert piston pin into piston and connecting rod.
- Assemble so that the front mark on the piston head and the oil holes and the cylinder No. on connecting rod are positioned as shown in the figure.

c. Using snap ring pliers, install new snap rings to the groove of the piston front side.

- Insert it fully into groove to install.
- After installing, make sure that connecting rod moves smoothly.

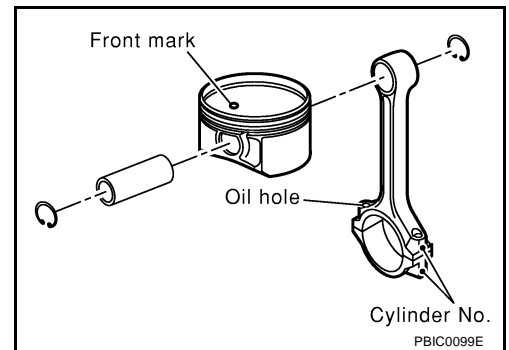

11. Using piston ring expander (commercial service tool), install piston rings.

**CAUTION:**

- **When installing piston rings, be careful not to damage piston.**
- **Be careful not to damage piston rings by expending them excessively.**

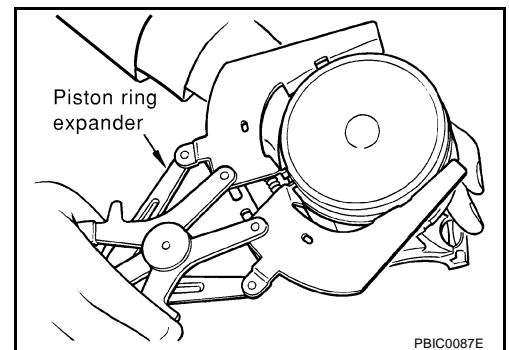

- Position each ring with the gap as shown in the figure, referring to the piston front mark.
- Install top ring and second ring with the stamped surface facing upward.

**Stamped mark**

**Top ring : R**  
**Second ring : 2R**

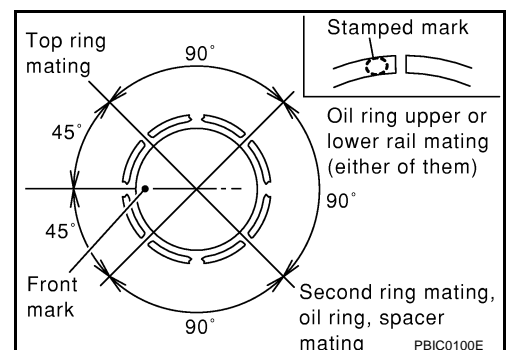

12. Install connecting rod bearings to connecting rod and connecting rod bearing cap.

- Before installing connecting rod bearings, apply engine oil to the bearing surface (inside). Do not apply engine oil to the back surface, but thoroughly clean it.

A  
EM  
C  
D  
E  
F  
G  
H  
I  
J  
K  
L  
M

# CYLINDER BLOCK

[VK45DE]

- When installing, align the connecting rod bearing stopper protrusion with the cutout of connecting rod and connecting rod bearing cap to install.
- Ensure the oil holes on connecting rod and that on the corresponding bearing are aligned.

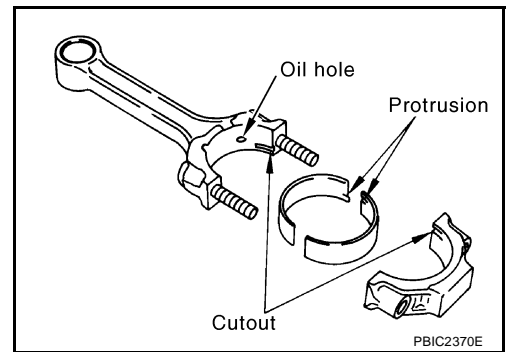

## 13. Install piston and connecting rod assembly to crankshaft.

- Position the crankshaft pin corresponding to connecting rod to be installed onto the bottom dead center.
- Apply engine oil sufficiently to the cylinder bore, piston and crankshaft pin journal.
- Match the cylinder position with the cylinder No. on connecting rod to install.
- Be sure that front mark on piston head is facing front of engine.
- Using piston ring compressor [SST: EM03470000 (J8037)], install piston with the front mark on the piston head facing the front of engine.

### CAUTION:

**Be careful not to damage cylinder wall and crankshaft pin, resulting from an interference of the connecting rod big end.**

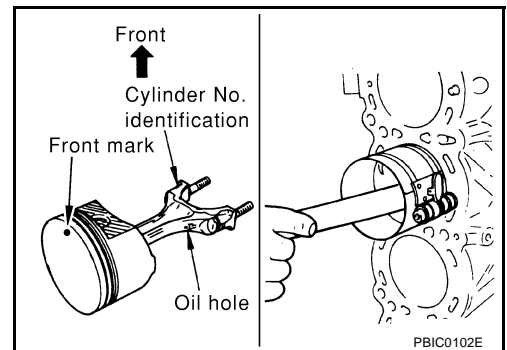

## 14. Install connecting rod bearing cap.

- Match the stamped cylinder number marks on connecting rod with those on cap to install.

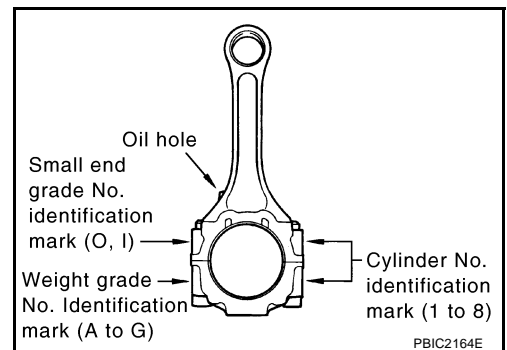

## 15. Tighten connecting rod nuts as follows:

- Apply new engine oil to the threads and seats of connecting rod bolts and nuts.
- Tighten connecting rod nuts.

: 14.7 N·m (1.5 kg·m, 11 ft·lb)

- Then tighten all connecting rod nuts 60 degrees clockwise. (Angle tightening)

### CAUTION:

**Use angle wrench (SST) to check tightening angle. Do not make judgment by visual inspection.**

- After tightening connecting rod nuts, make sure that crankshaft rotates smoothly.
- Check the connecting rod side clearance. Refer to [EM-266](#). "[CONNECTING ROD SIDE CLEARANCE](#)".

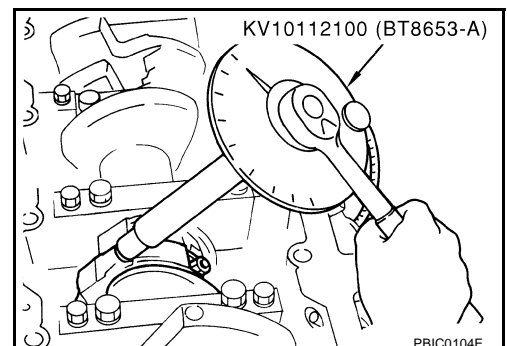

# CYLINDER BLOCK

[VK45DE]

## 16. Install knock sensor.

- Install it with its connector facing the rear of engine.
- Install the sub-harness with its shorter branch line to the right bank.

### CAUTION:

- Do not tighten mounting bolts while holding connector.
- If any impact by dropping is applied to knock sensor, replace it with new one.

### NOTE:

- Make sure that there is no foreign material on the cylinder block mating surface and the back surface of knock sensor.
- Make sure that knock sensor does not interfere with other parts.

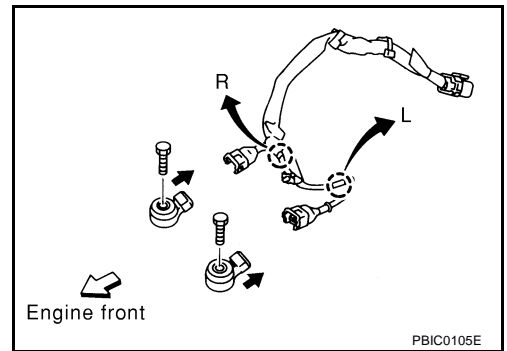

## 17. Note the following, and assemble in the reverse order of disassembly after this step.

### Drive plate

- When installing drive plate to crankshaft, be sure to correctly align crankshaft side guide pin and drive plate side guide pin hole.

### CAUTION:

If these are not aligned correctly, engine runs roughly and "MIL" turns on.

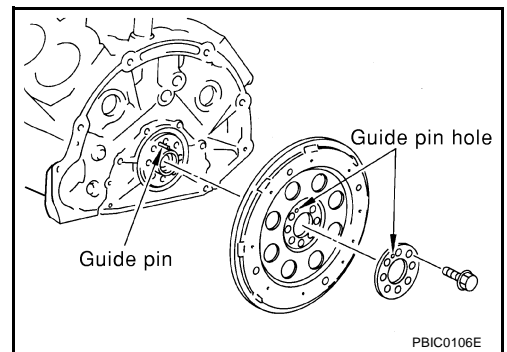

- Install drive plate, reinforcement plate and pilot converter (if not installed in step 4) as shown in the figure.
- Face chamfered or rounded edge side to crankshaft.
- Holding ring gear with ring gear stopper [SST: J-45476].
- Tighten mounting bolts crosswise over several times.
- When install pilot converter, using drift [outer diameter: approx. 35 mm (1.38 in)]. Press-fit as far as it will go.

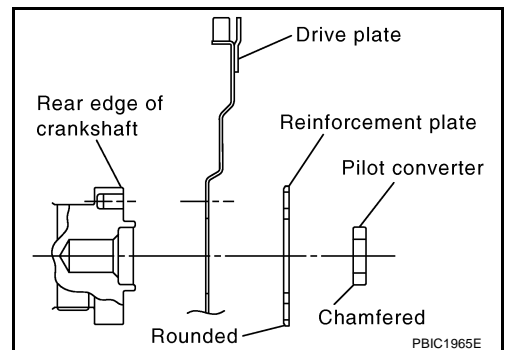

## How to Select Piston and Bearing

NBS004PO

Selection points	Selection parts	Selection items	Selection methods
Between cylinder block and crankshaft	Main bearing	Main bearing grade (bearing thickness)	Determined by match of cylinder block bearing housing grade (inner diameter of housing) and crankshaft journal grade (outer diameter of journal)
Between crankshaft and connecting rod	Connecting rod bearing	Connecting rod bearing grade (bearing thickness)	Combining service grades for connecting rod big end diameter and crankshaft pin outer diameter determine connecting rod bearing selection.
Between cylinder block and piston	Piston and piston pin assembly (Piston is available together with piston pin as assembly.)	Piston grade (piston skirt diameter)	Piston grade = cylinder bore grade (inner diameter of bore)
Between piston and connecting rod*	—	—	—

# CYLINDER BLOCK

[VK45DE]

\*: For the service parts, the grade for fitting cannot be selected between piston pin and connecting rod. (Only "0" grade is available.) The information at the shipment from the plant is described as a reference.

- The identification grade stamped on each part is the grade for the dimension measured in new condition. This grade cannot apply to reused parts.
- For reused or repaired parts, measure the dimension accurately. Determine the grade by comparing the measurement with the values of each selection table.
- For details of the measurement method of each part, the reuse standards, and the selection method of the selective fitting parts, refer to the text.

## HOW TO SELECT PISTON

### When New Cylinder Block is Used

Check the cylinder bore grade ("1", "2" or "3") on the rear upper side between cylinder block banks, and select piston of the same grade.

#### NOTE:

Piston is available with piston pin as a set for the service part. (Only "0" grade piston pin is available.)

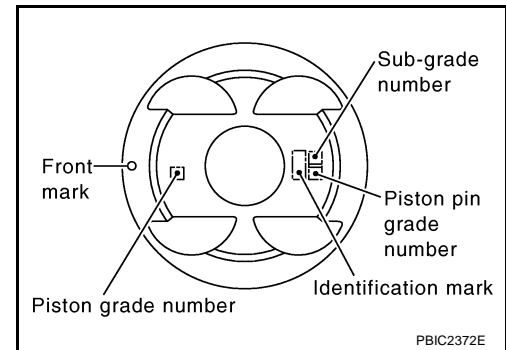
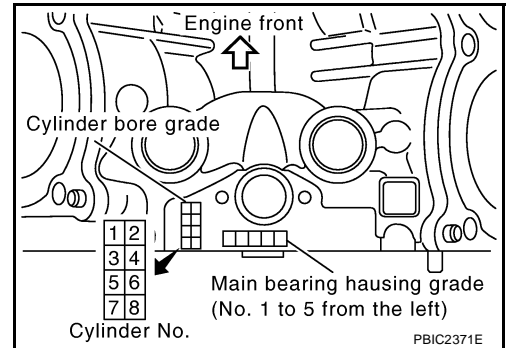

### When Cylinder Block is Reused

1. Measure the cylinder bore inner diameter. Refer to [EM-270, "Cylinder Bore Inner Diameter"](#).
2. Determine the bore grade by comparing the measurement with the values the "Cylinder bore inner diameter" of the "Piston Selection Table". Select piston of the same grade.

### Piston Selection Table

Unit: mm (in)

Grade	1	2 (or no mark)	3
Cylinder bore inner diameter	93.000 - 93.010 (3.6614 - 3.6618)	93.010 - 93.020 (3.6618 - 3.6622)	93.020 - 93.030 (3.6622 - 3.6626)
Piston skirt diameter	92.980 - 92.990 (3.6606 - 3.6610)	92.990 - 93.000 (3.6610 - 3.6614)	93.000 - 93.010 (3.6614 - 3.6618)

#### NOTE:

- Piston is available together with piston pin as assembly.
- Piston pin (piston pin hole) grade is provided only for the parts installed at the plant. For service parts, no piston pin grades can be selected. (Only "0" grade is available.)
- No second grade mark is available on piston.



## HOW TO SELECT CONNECTING ROD BEARING

### When New Connecting Rod and Crankshaft are Used

Check pin diameter grade ("0", "1" or "2") on front of crankshaft, and select connecting rod bearing of the same grade.

**NOTE:**

There is no grading for connecting rod big end diameter.

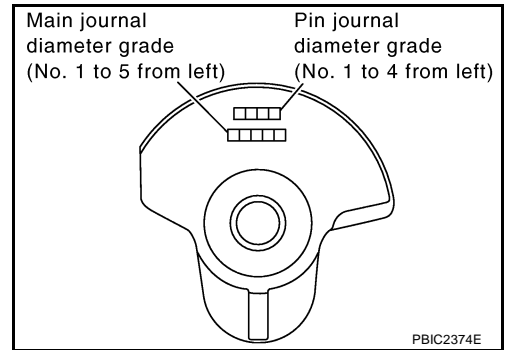

### When Crankshaft and Connecting Rod are Reused

1. Measure the connecting rod big end diameter. Refer to [EM-268, "CONNECTING ROD BIG END DIAMETER"](#).
2. Make sure that the connecting rod big end diameter is within the standard value.
3. Measure the crankshaft pin journal diameter. Refer to [EM-272, "CRANKSHAFT PIN JOURNAL DIAMETER"](#).
4. Determine the grade of crankshaft pin diameter grade by corresponding to the measured dimension in "Crankshaft pin journal diameter" column of "Connecting Rod Bearing Selection Table".
5. Select connecting rod bearing of the same grade.

### Connecting Rod Bearing Selection Table

Unit: mm (in)

Connecting rod big end diameter	55.000 - 55.013 (2.1654 - 2.1659)
---------------------------------	-----------------------------------

Unit: mm (in)

Crankshaft		Connecting rod bearing		
Crankshaft pin journal diameter	Grade (Mark)	Dimension (Bearing thickness range)	Bearing grade No.	Color
51.968 - 51.974 (2.0460 - 2.0462)	0	1.500 - 1.503 (0.0591 - 0.0592)	STD 0	No color
51.962 - 51.968 (2.0457 - 2.0460)	1	1.503 - 1.506 (0.0592 - 0.0593)	STD 1	Brown
51.956 - 51.962 (2.0455 - 2.0457)	2	1.506 - 1.509 (0.0593 - 0.0594)	STD 2	Green

### Under Size Bearings Usage Guide

- When the specified connecting rod bearing oil clearance is not obtained with standard size connecting rod bearings, use undersize (US) bearings.
- When using undersize (US) bearing, measure the connecting rod bearing inner diameter with bearing installed, and grind crankshaft pin so that the connecting rod bearing oil clearance satisfies the standard.

**CAUTION:**

In grinding crankshaft pin to use undersize bearings, keep the fillet R [1.5 mm (0.059 in)].

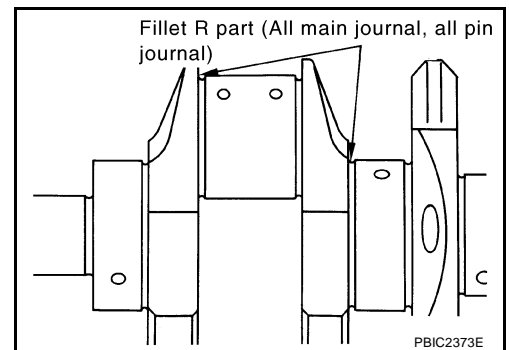

### Bearing undersize table

Unit: mm (in)

Size	Thickness
US 0.25 (0.0098)	1.626 - 1.634 (0.0640 - 0.0643)

## HOW TO SELECT MAIN BEARING

### When New Cylinder Block and Crankshaft are Used

1. "Main Bearing Selection Table" rows correspond to main bearing housing grade on rear upper side between cylinder block banks.

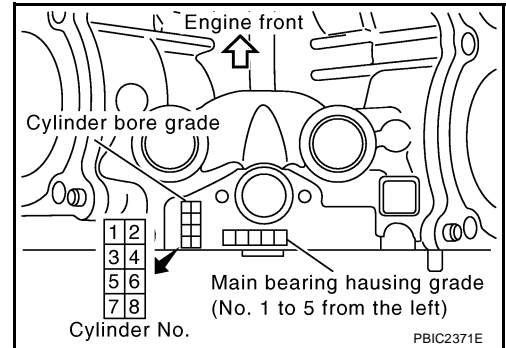

2. "Main Bearing Selection Table" columns correspond to main journal diameter grade on front side of crankshaft.

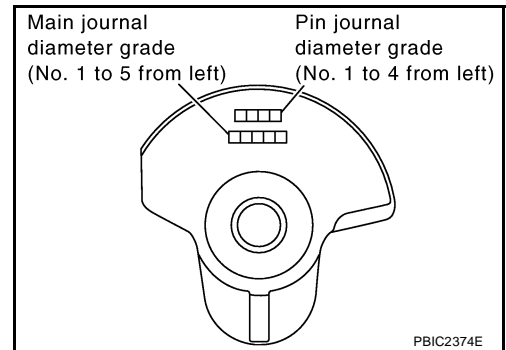

3. Select main bearing grade at the point where selected row and column meet in "Main Bearing Selection Table".

**CAUTION:**

- Initial clearance for No. 1, 5 journal and No. 2, 3, 4 journal is different. Use two different selection table for each part.
- No. 1, 5 journal and No. 2, 3, 4 journal have the same signs but different measures. Do not confuse.

4. Apply sign at crossing in above step 3 to "Main Bearing Grade Table".

**NOTE:**

- "Main Bearing Grade Table" applies to all journals.
- Service parts is available as a set of both upper and lower.

### When Cylinder Block and Crankshaft are Reused

1. Measure the cylinder block main bearing housing inner diameter and the crankshaft main journal diameter. Refer to [EM-270, "MAIN BEARING HOUSING INNER DIAMETER"](#) and [EM-271, "CRANKSHAFT MAIN JOURNAL DIAMETER"](#).
2. Correspond the measured dimension in "Cylinder block main bearing housing inner diameter" row of "Main Bearing Selection Table".
3. Correspond the measured dimension in "Crankshaft main journal diameter" column of "Main Bearing Selection Table".
4. Follow step 3 and later in "When New Cylinder Block and Crankshaft are Used".

# CYLINDER BLOCK

[VK45DE]

**Main Bearing Selection Table (No. 1 and 5 Journal)**

I.D. mark	Cylinder block main bearing housing inner diameter	Crankshaft main journal diameter	I.D. mark		Hole diameter Unit: mm (in)																							
			A	B	C	D	E	F	G	H	J	K	L	M	N	P	R	S	T	U	V	W	X	Y	1	2		
G	63.964 - 63.963 (2.5183 - 2.5182)	68.944 - 68.945 (2.7143 - 2.7144)	1	1	12	12	12	2	2	2	23	23	23	3	3	3	34	34	34	4	4	4	45	45	45	5	5	5
H	63.963 - 63.962 (2.5182 - 2.5182)	68.945 - 68.946 (2.7144 - 2.7144)	1	12	12	12	2	2	2	23	23	23	3	3	3	34	34	34	4	4	4	45	45	45	5	5	5	
J	63.962 - 63.961 (2.5182 - 2.5181)	68.946 - 68.947 (2.7144 - 2.7144)	12	12	12	2	2	2	23	23	23	3	3	3	34	34	34	4	4	4	45	45	45	5	5	5	5	
K	63.961 - 63.960 (2.5181 - 2.5181)	68.947 - 68.948 (2.7144 - 2.7145)	12	12	2	2	2	23	23	23	3	3	3	34	34	34	4	4	4	45	45	45	5	5	5	5	56	
L	63.960 - 63.959 (2.5181 - 2.5181)	68.948 - 68.949 (2.7145 - 2.7145)	12	2	2	2	23	23	23	3	3	3	34	34	34	4	4	4	45	45	45	5	5	5	5	56	56	
M	63.959 - 63.958 (2.5181 - 2.5180)	68.949 - 68.950 (2.7145 - 2.7146)	2	2	2	23	23	23	3	3	3	34	34	34	4	4	4	45	45	45	5	5	5	5	56	56	56	
N	63.958 - 63.957 (2.5180 - 2.5180)	68.950 - 68.951 (2.7146 - 2.7146)	2	2	23	23	23	3	3	3	34	34	34	4	4	4	45	45	45	5	5	5	5	56	56	56	6	
P	63.957 - 63.956 (2.5180 - 2.5179)	68.951 - 68.952 (2.7146 - 2.7146)	2	23	23	23	3	3	3	34	34	34	4	4	4	45	45	45	5	5	5	5	56	56	56	6	6	
R	63.956 - 63.955 (2.5179 - 2.5179)	68.952 - 68.953 (2.7146 - 2.7147)	23	23	23	3	3	3	34	34	34	4	4	4	45	45	45	5	5	5	5	56	56	56	6	6	6	
S	63.955 - 63.954 (2.5179 - 2.5179)	68.953 - 68.954 (2.7147 - 2.7147)	23	23	3	3	3	34	34	34	4	4	4	45	45	45	5	5	5	5	56	56	56	6	6	6	67	
T	63.954 - 63.953 (2.5179 - 2.5178)	68.954 - 68.955 (2.7147 - 2.7148)	23	3	3	3	34	34	34	4	4	4	45	45	45	5	5	5	5	56	56	56	6	6	6	67	67	
U	63.953 - 63.952 (2.5178 - 2.5178)	68.955 - 68.956 (2.7148 - 2.7148)	3	3	3	34	34	34	4	4	4	45	45	45	5	5	5	5	56	56	56	6	6	6	67	67	67	
V	63.952 - 63.951 (2.5178 - 2.5178)	68.956 - 68.957 (2.7148 - 2.7148)	3	3	34	34	34	4	4	4	45	45	45	5	5	5	56	56	56	6	6	6	6	67	67	67	7	
W	63.951 - 63.950 (2.5178 - 2.5177)	68.957 - 68.958 (2.7148 - 2.7149)	3	34	34	34	4	4	4	45	45	45	5	5	5	56	56	56	6	6	6	6	67	67	67	7	7	
X	63.950 - 63.949 (2.5177 - 2.5177)	68.958 - 68.959 (2.7149 - 2.7149)	34	34	34	4	4	4	45	45	45	5	5	5	56	56	56	6	6	6	6	67	67	67	7	7	7	
Y	63.949 - 63.948 (2.5177 - 2.5176)	68.959 - 68.960 (2.7149 - 2.7150)	34	34	4	4	4	45	45	45	5	5	5	56	56	56	6	6	6	6	67	67	67	7	7	7	78	
1	63.948 - 63.947 (2.5176 - 2.5176)	68.960 - 68.961 (2.7150 - 2.7150)	34	4	4	4	45	45	45	5	5	5	56	56	56	6	6	6	6	67	67	67	7	7	7	78	78	
2	63.947 - 63.946 (2.5176 - 2.5176)	68.961 - 68.962 (2.7150 - 2.7150)	4	4	4	45	45	45	5	5	5	56	56	56	6	6	6	6	67	67	67	7	7	7	78	78	78	
3	63.946 - 63.945 (2.5176 - 2.5175)	68.962 - 68.963 (2.7150 - 2.7151)	4	4	45	45	45	5	5	5	56	56	56	6	6	6	67	67	67	7	7	7	7	78	78	78	8	
4	63.945 - 63.944 (2.5175 - 2.5175)	68.963 - 68.964 (2.7151 - 2.7151)	4	45	45	45	5	5	5	56	56	56	6	6	6	67	67	67	7	7	7	7	78	78	78	8	8	
5	63.944 - 63.943 (2.5175 - 2.5174)	68.964 - 68.965 (2.7151 - 2.7152)	45	45	45	5	5	5	56	56	56	6	6	6	67	67	67	7	7	7	7	78	78	78	8	8	8	
6	63.943 - 63.942 (2.5174 - 2.5174)	68.965 - 68.966 (2.7152 - 2.7152)	45	45	5	5	5	56	56	56	6	6	6	67	67	67	7	7	7	7	78	78	78	8	8	8	8	
7	63.942 - 63.941 (2.5174 - 2.5174)	68.966 - 68.967 (2.7152 - 2.7152)	45	5	5	5	56	56	56	6	6	6	67	67	67	7	7	7	7	78	78	78	8	8	8	8	8	
9	63.941 - 63.940 (2.5174 - 2.5173)	68.967 - 68.968 (2.7152 - 2.7153)	5	5	5	56	56	56	6	6	6	67	67	67	7	7	7	7	78	78	78	8	8	8	8	8	8	

PBIC2375E

# CYLINDER BLOCK

[VK45DE]

**Main Bearing Selection Table (No. 2, 3 and 4 Journal)**

I.D. mark	Axle diameter Unit: mm (in)	Cylinder block main bearing housing inner diameter		Crankshaft main journal diameter		I.D. mark																							
		A	B	Hole diameter Unit: mm (in)	A	B	C	D	E	F	G	H	J	K	L	M	N	P	R	S	T	U	V	W	X	Y	1	2	
A	63.964 - 63.963 (2.5183 - 2.5182)	0	0	68.944 - 68.945 (2.7143 - 2.7144)	01	01	01	01	01	1	1	1	12	12	12	2	2	2	23	23	23	3	3	3	34	34	34	4	4
B	63.963 - 63.962 (2.5182 - 2.5182)	0	01	68.945 - 68.946 (2.7144 - 2.7144)	01	01	01	01	1	1	1	12	12	12	2	2	2	23	23	23	3	3	3	34	34	34	4	4	
C	63.962 - 63.961 (2.5182 - 2.5181)	01	01	68.946 - 68.947 (2.7144 - 2.7144)	01	01	1	1	1	1	12	12	12	2	2	2	23	23	23	3	3	3	34	34	34	4	4		
D	63.961 - 63.960 (2.5181 - 2.5181)	01	01	68.947 - 68.948 (2.7144 - 2.7145)	01	01	1	1	1	12	12	12	2	2	2	23	23	23	3	3	3	34	34	34	4	4	4	4	
E	63.960 - 63.959 (2.5181 - 2.5181)	01	1	68.948 - 68.949 (2.7145 - 2.7145)	01	1	1	1	12	12	12	2	2	2	2	23	23	23	3	3	3	34	34	34	4	4	4	4	
F	63.959 - 63.958 (2.5181 - 2.5180)	1	1	68.949 - 68.950 (2.7145 - 2.7146)	1	1	1	12	12	12	2	2	2	2	23	23	23	3	3	3	34	34	34	4	4	4	4	4	
G	63.958 - 63.957 (2.5180 - 2.5180)	1	1	68.950 - 68.951 (2.7146 - 2.7146)	1	1	12	12	12	2	2	2	23	23	23	3	3	3	34	34	34	4	4	4	4	4	4	4	
H	63.957 - 63.956 (2.5180 - 2.5179)	1	12	68.951 - 68.952 (2.7146 - 2.7146)	1	12	12	12	2	2	2	2	23	23	23	3	3	3	34	34	34	4	4	4	4	4	4	4	
J	63.956 - 63.955 (2.5179 - 2.5179)	12	12	68.952 - 68.953 (2.7146 - 2.7147)	12	12	2	2	2	2	23	23	23	3	3	3	34	34	34	4	4	4	4	4	4	4	4	4	
K	63.955 - 63.954 (2.5179 - 2.5179)	12	12	68.953 - 68.954 (2.7147 - 2.7147)	12	12	2	2	2	23	23	23	3	3	3	34	34	34	4	4	4	4	4	4	4	4	4	4	
L	63.954 - 63.953 (2.5179 - 2.5178)	12	2	68.954 - 68.955 (2.7147 - 2.7148)	12	2	2	2	23	23	23	3	3	3	34	34	34	4	4	4	4	4	4	4	4	4	4	4	
M	63.953 - 63.952 (2.5178 - 2.5178)	2	2	68.955 - 68.956 (2.7148 - 2.7148)	2	2	2	23	23	23	3	3	3	34	34	34	4	4	4	4	4	4	4	4	4	4	4	4	
N	63.952 - 63.951 (2.5178 - 2.5178)	2	2	68.956 - 68.957 (2.7148 - 2.7148)	2	2	23	23	23	3	3	3	34	34	34	4	4	4	4	4	4	4	4	4	4	4	4	4	
P	63.951 - 63.950 (2.5178 - 2.5177)	2	23	68.957 - 68.958 (2.7148 - 2.7149)	2	23	23	23	3	3	3	3	34	34	34	4	4	4	4	4	4	4	4	4	4	4	4	4	
R	63.950 - 63.949 (2.5177 - 2.5177)	23	23	68.958 - 68.959 (2.7149 - 2.7149)	23	23	3	3	3	3	34	34	34	4	4	4	4	4	4	4	4	4	4	4	4	4	4	4	
S	63.949 - 63.948 (2.5177 - 2.5176)	23	23	68.959 - 68.960 (2.7149 - 2.7150)	23	23	3	3	3	34	34	34	4	4	4	4	4	4	4	4	4	4	4	4	4	4	4	4	
T	63.948 - 63.947 (2.5176 - 2.5176)	23	3	68.960 - 68.961 (2.7150 - 2.7150)	23	3	3	3	34	34	34	4	4	4	4	4	4	4	4	4	4	4	4	4	4	4	4	4	
U	63.947 - 63.946 (2.5176 - 2.5176)	3	3	68.961 - 68.962 (2.7150 - 2.7150)	3	3	3	34	34	34	4	4	4	4	4	4	4	4	4	4	4	4	4	4	4	4	4	4	
V	63.946 - 63.945 (2.5176 - 2.5175)	3	3	68.962 - 68.963 (2.7150 - 2.7151)	3	3	34	34	34	4	4	4	4	4	4	4	4	4	4	4	4	4	4	4	4	4	4	4	
W	63.945 - 63.944 (2.5175 - 2.5175)	3	34	68.963 - 68.964 (2.7151 - 2.7151)	3	34	34	34	4	4	4	4	4	4	4	4	4	4	4	4	4	4	4	4	4	4	4	4	
X	63.944 - 63.943 (2.5175 - 2.5174)	34	34	68.964 - 68.965 (2.7151 - 2.7152)	34	34	4	4	4	4	4	4	4	4	4	4	4	4	4	4	4	4	4	4	4	4	4	4	
Y	63.943 - 63.942 (2.5174 - 2.5174)	34	34	68.965 - 68.966 (2.7152 - 2.7152)	34	34	4	4	4	4	4	4	4	4	4	4	4	4	4	4	4	4	4	4	4	4	4	4	
1	63.942 - 63.941 (2.5174 - 2.5174)	34	4	68.966 - 68.967 (2.7152 - 2.7152)	34	4	4	4	4	4	4	4	4	4	4	4	4	4	4	4	4	4	4	4	4	4	4	4	
2	63.941 - 63.940 (2.5174 - 2.5173)	4	4	68.967 - 68.968 (2.7152 - 2.7153)	4	4	4	4	4	4	4	4	4	4	4	4	4	4	4	4	4	4	4	4	4	4	4	4	

PBIC2376E

# CYLINDER BLOCK

[VK45DE]

## Main Bearing Grade Table (All Journals)

Unit: mm (in)

Grade number	Thickness	Identification color	Remarks
0	2.483 - 2.486 (0.0978 - 0.0979)	Black	Grade and color are the same for upper and lower bearings.
1	2.486 - 2.489 (0.0979 - 0.0980)	Brown	
2	2.489 - 2.492 (0.0980 - 0.0981)	Green	
3	2.492 - 2.495 (0.0981 - 0.0982)	Yellow	
4	2.495 - 2.498 (0.0982 - 0.0983)	Blue	
5	2.498 - 2.501 (0.0983 - 0.0985)	Pink	
6	2.501 - 2.504 (0.0985 - 0.0986)	Purple	
7	2.504 - 2.507 (0.0986 - 0.0987)	White	
8	2.507 - 2.510 (0.0987 - 0.0988)	Red	
01	UPR	2.483 - 2.486 (0.0978 - 0.0979)	Grade and color are different for upper and lower bearings.
	LWR	2.486 - 2.489 (0.0979 - 0.0980)	
12	UPR	2.486 - 2.489 (0.0979 - 0.0980)	
	LWR	2.489 - 2.492 (0.0980 - 0.0981)	
23	UPR	2.489 - 2.492 (0.0980 - 0.0981)	
	LWR	2.492 - 2.495 (0.0981 - 0.0982)	
34	UPR	2.492 - 2.495 (0.0981 - 0.0982)	
	LWR	2.495 - 2.498 (0.0982 - 0.0983)	
45	UPR	2.495 - 2.498 (0.0982 - 0.0983)	
	LWR	2.498 - 2.501 (0.0983 - 0.0985)	
56	UPR	2.498 - 2.501 (0.0983 - 0.0985)	
	LWR	2.501 - 2.504 (0.0985 - 0.0986)	
67	UPR	2.501 - 2.504 (0.0985 - 0.0986)	
	LWR	2.504 - 2.507 (0.0986 - 0.0987)	
78	UPR	2.504 - 2.507 (0.0986 - 0.0987)	
	LWR	2.507 - 2.510 (0.0987 - 0.0988)	

### Use Undersize Bearing Usage Guide

- When the specified main bearing oil clearance is not obtained with standard size main bearings, use underside (US) bearing.
- When using undersize (US) bearing, measure the main bearing inner diameter with bearing installed, and grind main journal so that the main bearing oil clearance satisfies the standard.

**CAUTION:**

**In grinding crankshaft main journal to use undersize bearings, keep the fillet R [1.5 mm (0.059 in)].**

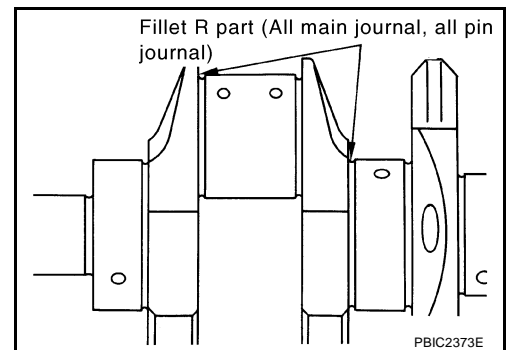

### Bearing undersize table

Unit: mm (in)

Size	Thickness
US 0.25 (0.0098)	2.618 - 2.626 (0.1031 - 0.1034)

## Inspection after Disassembly CRANKSHAFT END PLAY

- Measure the clearance between thrust bearings and crankshaft arm when crankshaft is moved fully forward or backward with dial indicator.

**Standard** : 0.10 - 0.25 mm (0.0039 - 0.0098 in)

**Limit** : 0.30 mm (0.012 in)

- If the measured value exceeds the limit, replace thrust bearings, and measure again. If it still exceeds the limit, replace crankshaft also.

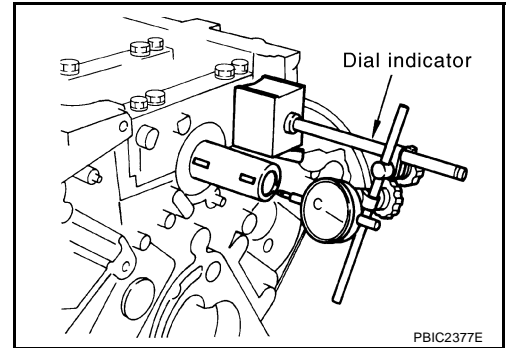

## CONNECTING ROD SIDE CLEARANCE

- Measure the side clearance between connecting rod and crankshaft arm with feeler gauge.

**Standard** : 0.20 - 0.35 mm (0.0079 - 0.0138 in)

**Limit** : 0.40 mm (0.016 in)

- If the measured value exceeds the limit, replace connecting rod, and measure again. If it still exceeds the limit, replace crankshaft also.

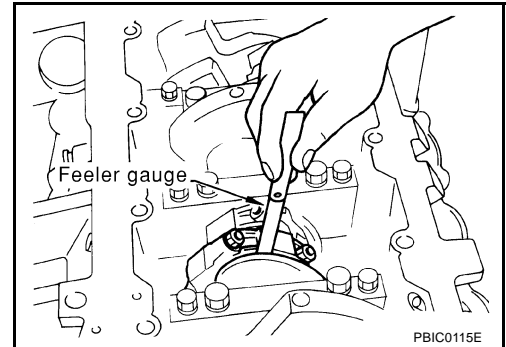

## PISTON TO PISTON PIN OIL CLEARANCE

### Piston Pin Hole Diameter

Measure the inner diameter of piston pin hole with inside micrometer.

**Standard** : 21.993 - 22.005 mm (0.8659 - 0.8663 in)

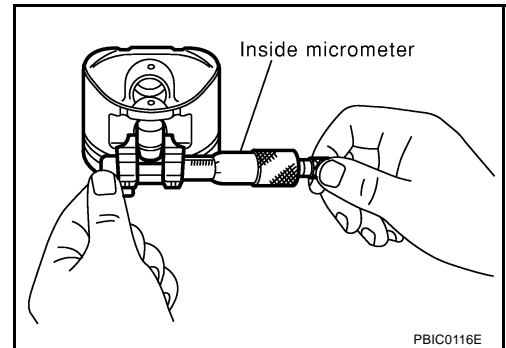

### Piston Pin Outer Diameter

Measure the outer diameter of piston pin with micrometer.

**Standard** : 21.989 - 22.001 mm (0.8657 - 0.8662 in)

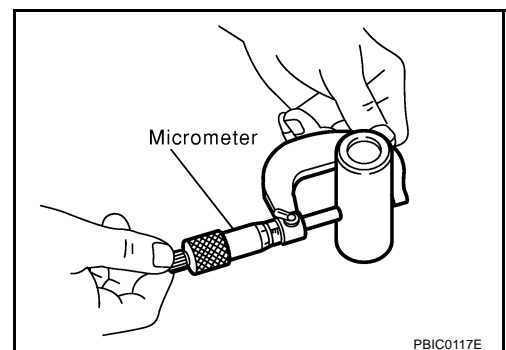

### Piston to Piston Pin Oil Clearance

(Piston to piston pin oil clearance) = (Piston pin hole diameter) – (Piston pin outer diameter)

**Standard** : 0.002 - 0.006 mm (0.0001 - 0.0002 in)

- If the calculated value is out of the standard, replace piston and piston pin assembly.

- When replacing piston and piston pin assembly, refer to [EM-260, "HOW TO SELECT PISTON"](#).

**NOTE:**

- Piston is available together with piston pin as assembly.
- Piston pin (piston pin hole) grade is provided only for the parts installed at the plant. For service parts, no piston pin grades can be selected. (Only "0" grade is available.)

**PISTON RING SIDE CLEARANCE**

- Measure the side clearance of piston ring and piston ring groove with feeler gauge.

**Standard:**

**Top ring** : 0.045 - 0.080 mm (0.0018 - 0.0031 in)

**2nd ring** : 0.030 - 0.070 mm (0.0012 - 0.0028 in)

**Oil ring** : 0.065 - 0.135 mm (0.0026 - 0.0053 in)

**Limit:**

**Top ring** : 0.11 mm (0.0043 in)

**2nd ring** : 0.10 mm (0.004 in)

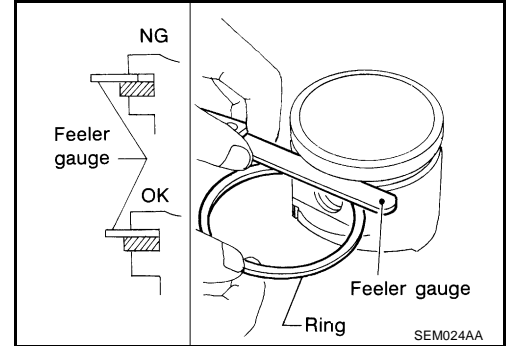

- If the measured value exceeds the limit, replace piston ring, and measure again. If it still exceeds the limit, replace piston also.

**PISTON RING END GAP**

- Make sure that the cylinder bore inner diameter is within the specification. Refer to [EM-270, "Cylinder Bore Inner Diameter"](#).
- Lubricate with new engine oil to piston and piston ring, and then insert piston ring until middle of cylinder with piston, and measure the piston ring end gap with feeler gauge.

**Standard:**

**Top ring** : 0.22 - 0.32 mm (0.0087 - 0.0126 in)

**2nd ring** : 0.22 - 0.32 mm (0.0087 - 0.0126 in)

**Oil ring** : 0.20 - 0.50 mm (0.008 - 0.020 in)

**Limit:**

**Top ring** : 0.56 mm (0.0220 in)

**2nd ring** : 0.56 mm (0.0220 in)

**Oil ring** : 0.96 mm (0.0378 in)

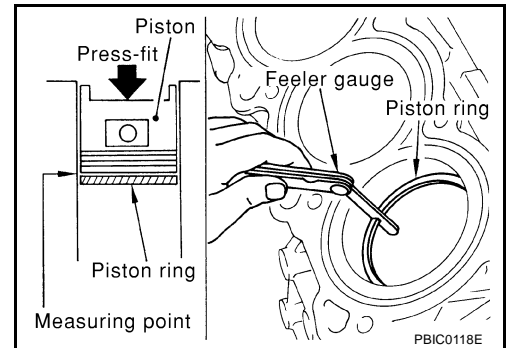

- If the measured value exceeds the limit, replace piston ring, and measure again. If it still exceeds the limit, re-bore cylinder and use oversize piston and piston rings.

## CONNECTING ROD BEND AND TORSION

- Check with connecting rod aligner.

### Bend:

Limit : 0.15 mm (0.0059 in) per 100 mm (3.94 in) length

### Torsion:

Limit : 0.30 mm (0.012 in) per 100 mm (3.94 in) length

- If it exceeds the limit, replace connecting rod assembly.

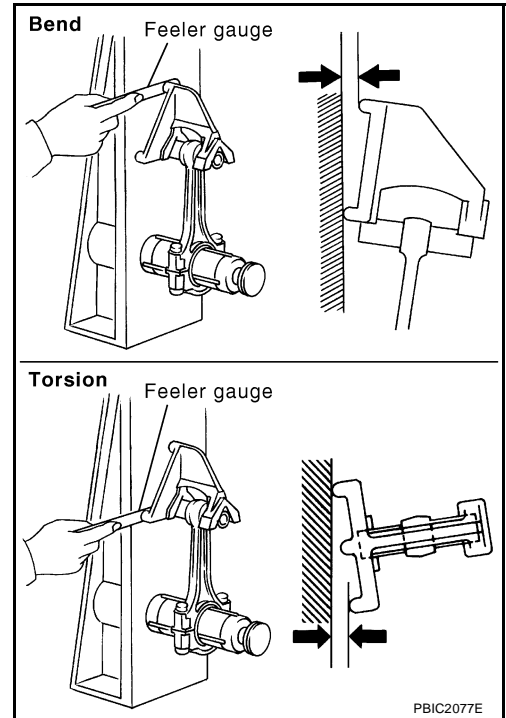

## CONNECTING ROD BIG END DIAMETER

- Install connecting rod bearing cap without installing connecting rod bearing, and tightening connecting rod bolts to the specified torque. Refer to [EM-254, "ASSEMBLY"](#) for the tightening procedure.
- Measure the inner diameter of connecting rod big end with inside micrometer.

Standard : 55.000 - 55.013 mm (2.1654 - 2.1659 in)

- If out of the standard, replace connecting rod assembly.

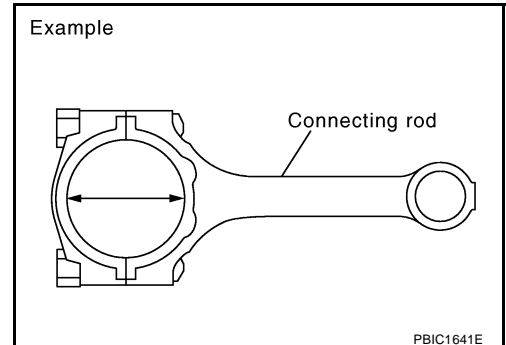

## CONNECTING ROD BUSHING OIL CLEARANCE

### Connecting Rod Bushing Inner Diameter

Measure the inner diameter of connecting rod bushing with inside micrometer.

Standard : 22.000 - 22.012 mm (0.8661 - 0.8666 in)

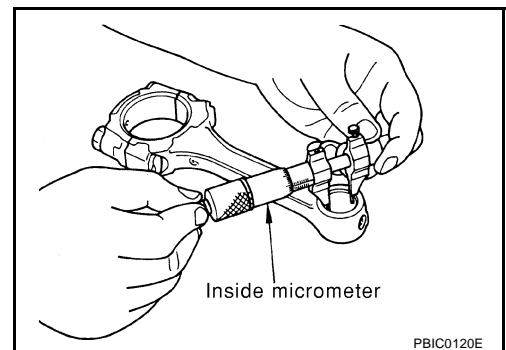



## Piston Pin Outer Diameter

Measure the outer diameter of piston pin with micrometer.

**Standard : 21.989 - 22.001 mm (0.8657 - 0.8662 in)**

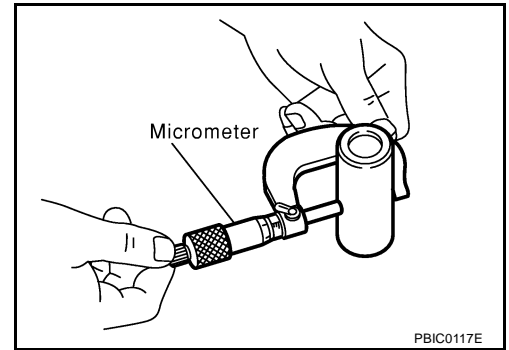

## Connecting Rod Bushing Oil Clearance

(Connecting rod bushing oil clearance) = (Connecting rod bushing inner diameter) – (Piston pin outer diameter)

**Standard : 0.005 - 0.017 mm (0.0002 - 0.0007 in)**

**Limit : 0.030 mm (0.0012 in)**

- If the calculated value exceeds the limit, replace connecting rod assembly and/or piston and piston pin assembly.
- If replacing piston and piston pin assembly, refer to [EM-260, "HOW TO SELECT PISTON"](#) .
- If replacing connecting rod assembly, refer to [EM-273, "CONNECTING ROD BEARING OIL CLEARANCE"](#) to select the connecting rod bearing.

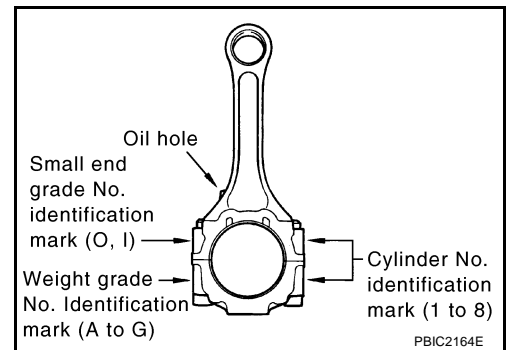

## Factory installed parts grading:

- Service parts apply only to grade "0".

Grade	Unit: mm (in)	
	0	1
Connecting rod bushing inner diameter *	22.000 - 22.006 (0.8661 - 0.8664)	22.006 - 22.012 (0.8664 - 0.8666)
Piston pin hole diameter	21.993 - 21.999 (0.8659 - 0.8661)	21.999 - 22.005 (0.8661 - 0.8663)
Piston pin outer diameter	21.989 - 21.995 (0.8657 - 0.8659)	21.995 - 22.001 (0.8659 - 0.8662)

\*: After installing in connecting rod

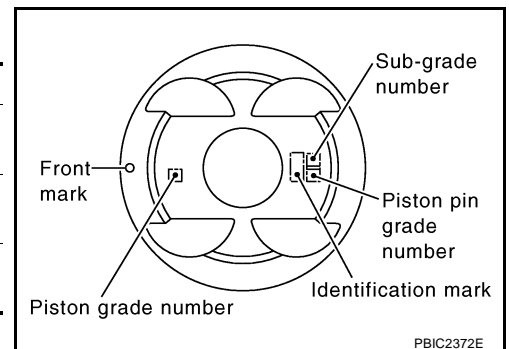

## CYLINDER BLOCK DISTORTION

- Using scraper, remove gasket on the cylinder block surface, and also remove engine oil, scale, carbon, or other contamination.

### CAUTION:

**Be careful not to allow gasket flakes to enter engine oil or engine coolant passages.**

# CYLINDER BLOCK

[VK45DE]

- Measure the distortion on the cylinder block upper face at some different points in six directions with straightedge and feeler gauge.

**Limit : 0.1 mm (0.004 in)**

- If it exceeds the limit, replace cylinder block.

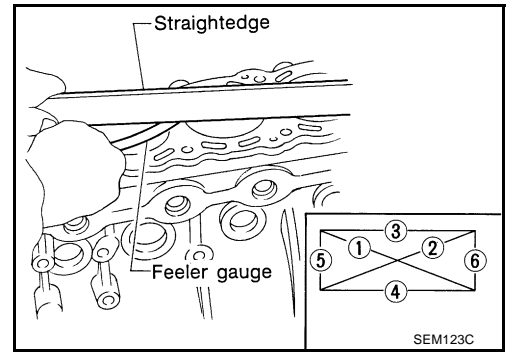

## MAIN BEARING HOUSING INNER DIAMETER

- Install main bearing caps and main bearing without installing main bearings, and tighten main bearing cap bolts to the specified torque. Refer to [EM-254, "ASSEMBLY"](#) for the tightening procedure.
- Measure the inner diameter of main bearing housing with bore gauge.

**Standard : 68.944 - 68.968 mm (2.7143 - 2.7153 in)**

- If out of the standard, replace cylinder block and main bearing caps as assembly.

### NOTE:

Cylinder block cannot be replaced as a single part, because it is machined together with main bearing caps.

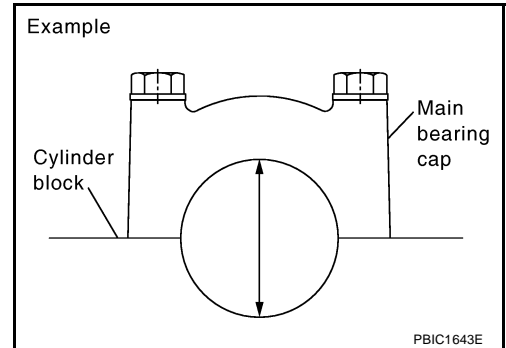

## PISTON TO CYLINDER BORE CLEARANCE

### Cylinder Bore Inner Diameter

- Using bore gauge, measure cylinder bore for wear, out-of-round and taper at six different points on each cylinder. ("X" and "Y" directions at "A", "B" and "C") ("X" is in longitudinal direction of engine)

**Standard inner diameter:**

**93.000 - 93.030 mm (3.6614 - 3.6626 in)**

**Wear limit:**

**0.2 mm (0.008 in)**

**Out-of-round (Difference between "X" and "Y"):**

**0.015 mm (0.0006 in)**

**Taper limit (Difference between "A" and "C"):**

**0.01 mm (0.0004 in)**

- If the measured value exceeds the limit, or if there are scratches and/or seizure on the cylinder inner wall, hone or re-bore the inner wall.
- Oversize piston is provided. When using oversize piston, re-bore cylinder so that the clearance of the piston-to-cylinder bore satisfies the standard.

### CAUTION:

**When using oversize piston, use oversize pistons for all cylinders with oversize piston rings.**

**Oversize (OS) : 0.2 mm (0.008 in)**

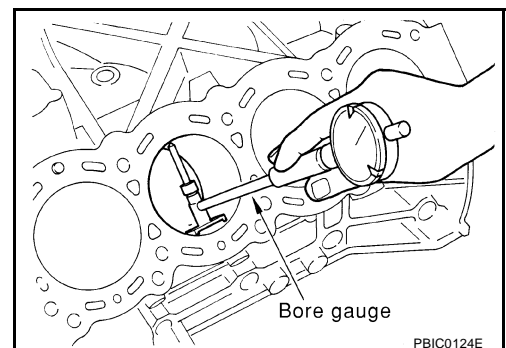
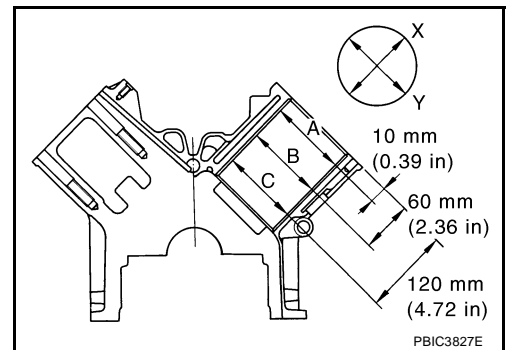

## Piston Skirt Diameter

- Measure the outer diameter of piston skirt with micrometer.

**Standard**

**: 92.980 - 93.010 mm (3.6606 - 3.6618 in)**

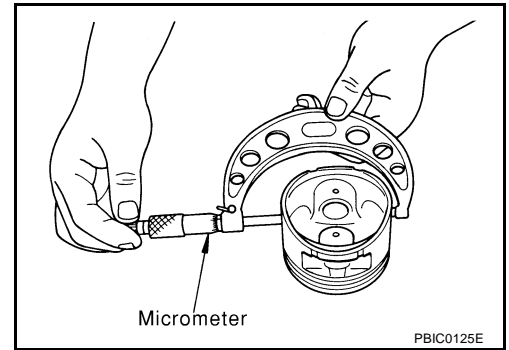

- Measure point "H" (Distance from the top): 42 mm (1.65 in)

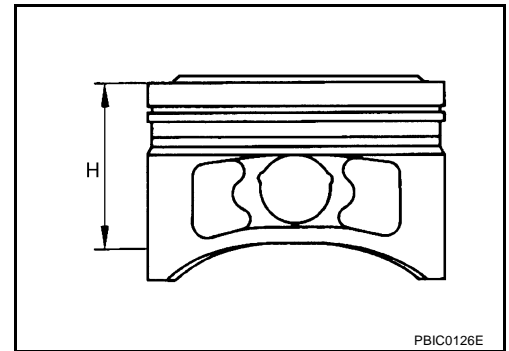

## Piston to Cylinder Bore Clearance

Calculate by piston skirt diameter and cylinder bore inner diameter (direction "Y", position "B").  
 (Clearance) = (Cylinder bore inner diameter) – (Piston skirt diameter).

**Standard : 0.010 - 0.030 mm (0.0004 - 0.0012 in)**

**Limit : 0.08 mm (0.0031 in)**

- If the calculated value exceeds the limit, replace piston and piston pin assembly. Refer to [EM-260, "HOW TO SELECT PISTON"](#).

## Re-boring Cylinder Bore

1. Cylinder bore size is determined by adding piston to cylinder bore clearance to piston skirt diameter.

**Re-bored size calculation:  $D = A + B - C$**

**where,**

**D: Bored diameter**

**A: Piston skirt diameter as measured**

**B: Piston to cylinder bore clearance (standard value)**

**C: Honing allowance 0.02 mm (0.0008 in)**

2. Install main bearing caps and main bearing, and tighten to the specified torque. Otherwise, cylinder bores may be distorted in final assembly.
3. Cut cylinder bores.

**NOTE:**

- When any cylinder needs boring, all other cylinders must also be bored.
- Do not cut too much out of cylinder bore at a time. Cut only 0.05 mm (0.0020 in) or so in diameter at a time.

4. Hone cylinders to obtain the specified piston to cylinder bore clearance.
5. Measure finished cylinder bore for the out-of-round and taper.

**NOTE:**

Measurement should be done after cylinder bore cools down.

## CRANKSHAFT MAIN JOURNAL DIAMETER

- Measure the outer diameter of crankshaft main journals with micrometer.

**Standard** : 63.940 - 63.964 mm (2.5173 - 2.5183 in) dia.

- If out of the standard, measure the main bearing oil clearance. Then use undersize bearing. Refer to [EM-274, "MAIN BEARING OIL CLEARANCE"](#) .

## CRANKSHAFT PIN JOURNAL DIAMETER

- Measure the outer diameter of crankshaft pin journal with micrometer.

**Standard** : 51.956 - 51.974 mm (2.0455 - 2.0462 in) dia.

- If out of the standard, measure the connecting rod bearing oil clearance. Then use undersize bearing. Refer to [EM-273, "CONNECTING ROD BEARING OIL CLEARANCE"](#) .

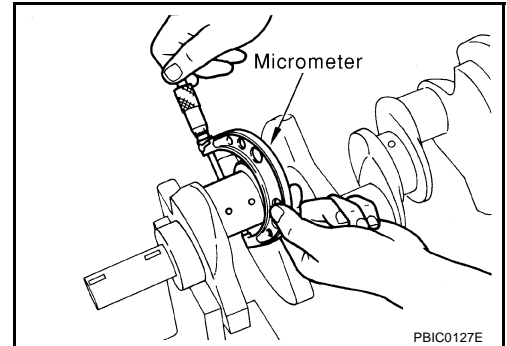

## CRANKSHAFT OUT-OF-ROUND AND TAPER

- Measure the dimensions at four different points as shown in the figure on each main journal and pin journal with micrometer.
- Out-of-round is indicated by the difference in the dimensions between "X" and "Y" at "A" and "B".
- Taper is indicated by the difference in the dimensions between "A" and "B" at "X" and "Y".

**Limit:**

**Out-of-round (Difference between "X" and "Y")**  
: 0.015 mm (0.0006 in)

**Taper (Difference between "A" and "B")**  
: 0.010 mm (0.0004 in)

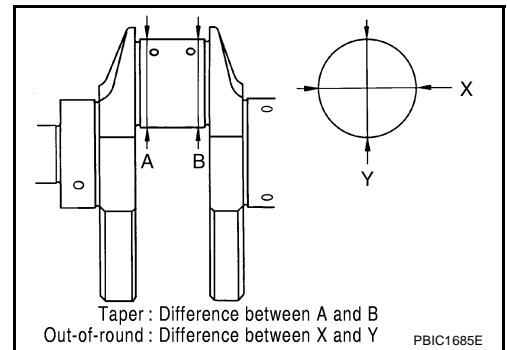

- If the measured value exceeds the limit, correct or replace crankshaft.
- If corrected, measure the bearing oil clearance of the corrected main journal and/or pin journal. Then select the main bearing and/or connecting rod bearing. Refer to [EM-274, "MAIN BEARING OIL CLEARANCE"](#) and/or [EM-273, "CONNECTING ROD BEARING OIL CLEARANCE"](#) .

## CRANKSHAFT RUNOUT

- Place V-block on precise flat table, and support the journals on the both end of crankshaft.
- Place dial indicator straight up on the No. 3 journal.
- While rotating crankshaft, read the movement of the pointer on dial indicator (total indicator reading).

**Standard** : Less than 0.05 mm (0.002 in)

**Limit** : 0.10 mm (0.004 in)

- If it exceeds the limit, replace crankshaft.

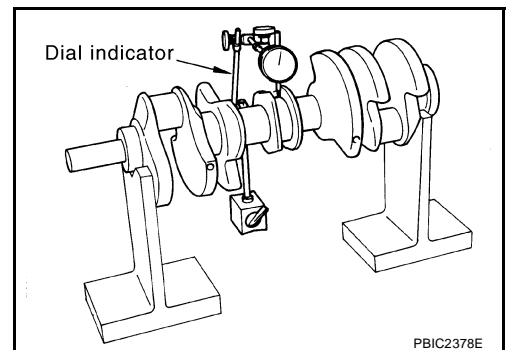

## CONNECTING ROD BEARING OIL CLEARANCE

### Method by Calculation

- Install connecting rod bearings to connecting rod and cap, and tighten connecting rod bolts to the specified torque. Refer to [EM-254, "ASSEMBLY"](#) for the tightening procedure.
- Measure the inner diameter of connecting rod bearing with inside micrometer.

(Bearing oil clearance) = (Connecting rod bearing inner diameter) – (Crankshaft pin journal diameter)

**Standard : 0.020 - 0.045 mm (0.0008 - 0.0018 in)**  
(actual clearance)

**Limit : 0.055 mm (0.0022 in)**

- If the calculated value exceeds the limit, select proper connecting rod bearing according to connecting rod big end diameter and crankshaft pin journal diameter to obtain the specified bearing oil clearance. Refer to [EM-261, "HOW TO SELECT CONNECTING ROD BEARING"](#).

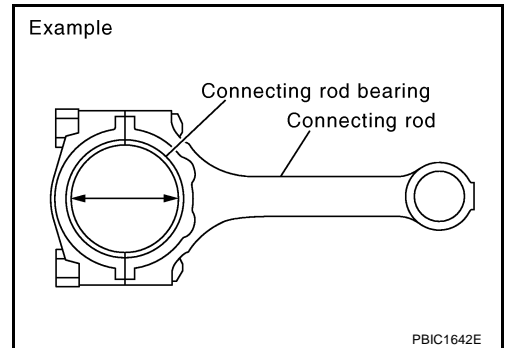

### Method of Using Plastigage

- Remove oil and dust on crankshaft pin journal and the surfaces of each bearing completely.
- Cut plastigage slightly shorter than the bearing width, and place it in crankshaft axial direction, avoiding oil holes.
- Install connecting rod bearings to connecting rod and cap, and tighten connecting rod bolts to the specified torque. Refer to [EM-254, "ASSEMBLY"](#) for the tightening procedure.

**CAUTION:**

**Do not rotate crankshaft.**

- Remove connecting rod bearing cap and bearing, and using scale on plastigage bag, measure the plastigage width.

**NOTE:**

The procedure when the measured value exceeds the limit is same as that described in the "Method by Calculation".

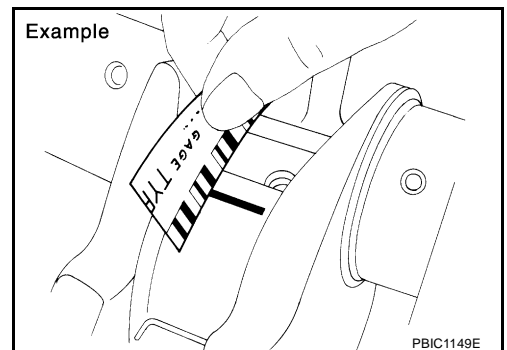

A  
EM  
C  
D  
E  
F  
G  
H  
I  
J  
K  
L  
M

## MAIN BEARING OIL CLEARANCE

### Method by Calculation

- Install main bearings to cylinder block and main bearing caps, and tighten main bearing cap bolts with main bearing to the specified torque. Refer to [EM-254, "ASSEMBLY"](#) for the tightening procedure.
- Measure the inner diameter of main bearing with bore gauge.

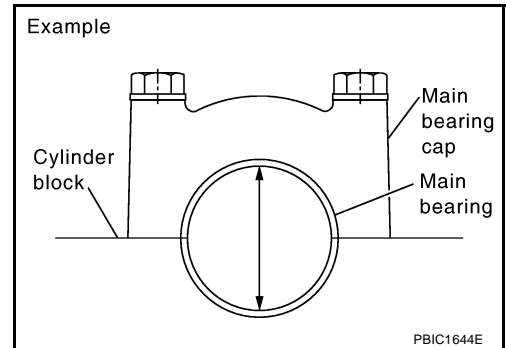

(Bearing clearance) = (Main bearing inner diameter) – (Crankshaft main journal diameter)

#### Standard

No. 1 and 5 journal : 0.001 - 0.011 mm (0.00004 - 0.0004 in)

No. 2, 3 and 4 journal : 0.007 - 0.017 mm (0.0003 - 0.0007 in)

#### Limit

No. 1 and 5 journal : 0.021 mm (0.0008 in)

No. 2, 3 and 4 journal : 0.027 mm (0.0011 in)

- If the calculated value exceeds the limit, select proper main bearing according to main bearing inner diameter and crankshaft main journal diameter to obtain the specified bearing oil clearance. Refer to [EM-262, "HOW TO SELECT MAIN BEARING"](#).

### Method of Using Plastigage

- Remove oil and dust on crankshaft main journal and the surfaces of each bearing completely.
- Cut plastigage slightly shorter than the bearing width, and place it in crankshaft axial direction, avoiding oil holes.
- Install main bearings to cylinder block and main bearing caps, and tighten main bearing bolts with main bearing to the specified torque. Refer to [EM-254, "ASSEMBLY"](#) for the tightening procedure.

#### CAUTION:

**Do not rotate crankshaft.**

- Remove main bearing caps and bearings, and using scale on plastigage bag, measure the plastigage width.

#### NOTE:

The procedure when the measured value exceeds the limit is same as that described in the "Method by Calculation".

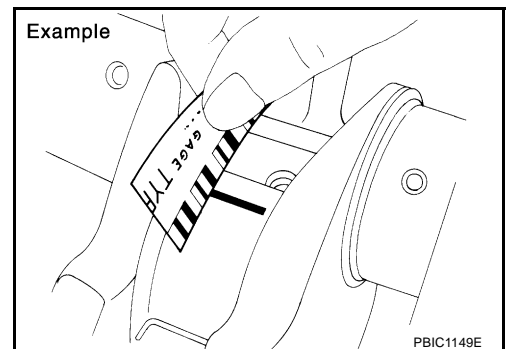

## CRUSH HEIGHT OF MAIN BEARING

- When main bearing cap is removed after being tightened to the specified torque with main bearings installed, the tip end of bearing must protrude. Refer to [EM-254, "ASSEMBLY"](#) for the tightening procedure.

**Standard** : There must be crush height.

- If the standard is not met, replace main bearings.

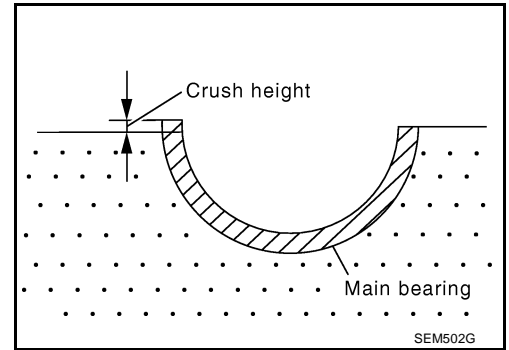

## CRUSH HEIGHT OF CONNECTING ROD BEARING

- When connecting rod bearing cap is removed after being tightened to the specified torque with connecting rod bearings installed, the tip end of bearing must protrude. Refer to [EM-254, "ASSEMBLY"](#) for the tightening procedure.

**Standard** : There must be crush height.

- If the standard is not met, replace connecting rod bearings.

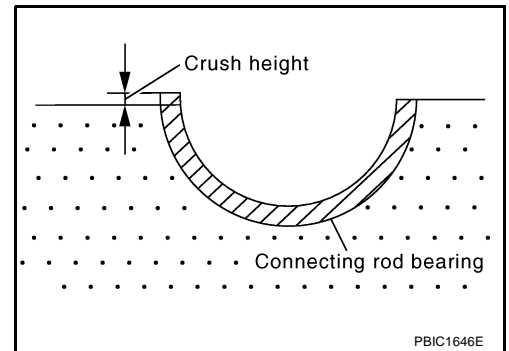

## DRIVE PLATE

- Check drive plate and signal plate for deformation or cracks.

**CAUTION:**

- Do not disassemble drive plate.
- Do not place drive plate with signal plate facing down.
- When handling signal plate, take care not to damage or scratch it.
- Handle signal plate in a manner that prevents it from becoming magnetized.
- If anything is found, replace drive plate.

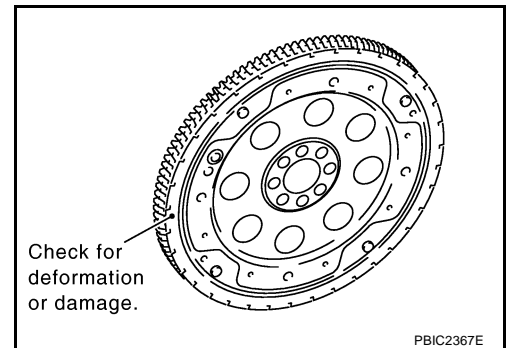

A  
EM  
C  
D  
E  
F  
G  
H  
I  
J  
K  
L  
M

# SERVICE DATA AND SPECIFICATIONS (SDS)

[VK45DE]

## SERVICE DATA AND SPECIFICATIONS (SDS)

PFP:00030

### Standard and Limit GENERAL SPECIFICATIONS

NBS004PQ

Cylinder arrangement		V-8
Displacement cm <sup>3</sup> (cu in)		4,494 (274.22)
Bore and stroke mm (in)		93 x 82.7 (3.66 x 3.256)
Valve arrangement		DOHC
Firing order		1-8-7-3-6-5-4-2
Number of piston rings	Compression	2
	Oil	1
Number of main bearings		5
Compression ratio		10.5
Compression pressure kPa (kg/cm <sup>2</sup> , psi)/300 rpm	Standard	1,320 (13.5, 191)
	Minimum	1,130 (11.5, 164)
	Differential limit between cylinders	98 (1.0, 14)

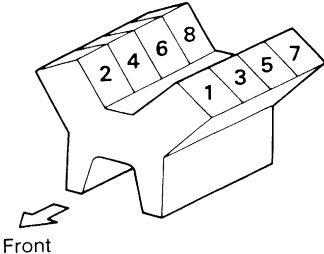
Cylinder number	 <p style="text-align: center;">SEM957C</p>
-----------------	--

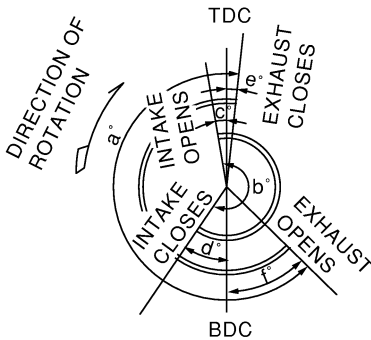
Valve timing	 <p style="text-align: center;">PBIC0187E</p>
--------------	---

Unit: degree					
a	b	c	d	e	f
228	240	-2	62	4	44

### DRIVE BELTS

Tension of drive belts	Auto adjustment by auto tensioner
------------------------	-----------------------------------

### INTAKE MANIFOLD AND EXHAUST MANIFOLD

Unit: mm (in)

Items		Limit
Surface distortion	Intake manifold (upper)	0.1 (0.004)
	Intake manifold (lower)	0.1 (0.004)
	Exhaust manifold	0.3 (0.012)



# SERVICE DATA AND SPECIFICATIONS (SDS)

[VK45DE]

## SPARK PLUG

Unit: mm (in)

Make	NGK
Standard type	PLFR5A-11
Hot type	PLFR4A-11
Cold type	PLFR6A-11
Gap (Nominal)	1.1 (0.043)

## CAMSHAFT AND CAMSHAFT BEARING

Unit: mm (in)

Items		Standard	Limit
Camshaft journal clearance	No. 1	0.045 - 0.083 (0.0018 - 0.0033)	—
	No. 2, 3, 4, 5	0.030 - 0.068 (0.0012 - 0.0027)	—
Camshaft journal diameter	No. 1	25.938 - 25.955 (1.0212 - 1.0218)	—
	No. 2, 3, 4, 5	25.953 - 25.970 (1.0218 - 1.0224)	—
Camshaft bracket inner diameter		26.000 - 26.021 (1.0236 - 1.0244)	—
Camshaft end play		0.115 - 0.188 (0.0045 - 0.0074)	—
Cam height "A"	Intake	44.865 - 45.055 (1.7663 - 1.7738)	0.2 (0.008)
	Exhaust	43.925 - 44.115 (1.7293 - 1.7368)	0.2 (0.008)
Camshaft runout [TIR*]		0.02 (0.001)	0.05 (0.002)
Camshaft sprocket runout [TIR*]		—	0.15 (0.059)

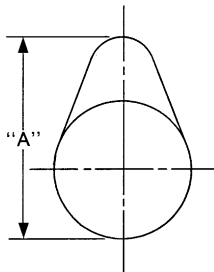

SEM671

\*: Total indicator reading

## Valve Lifter

Unit: mm (in)

Items	Standard
Valve lifter outer diameter	33.965 - 33.975 (1.3372 - 1.3776)
Valve lifter hole diameter	34.000 - 34.016 (1.3386 - 1.3392)
Valve lifter clearance	0.025 - 0.051 (0.0010 - 0.0020)

## Valve Clearance

Unit: mm (in)

Items	Cold	Hot* (reference data)
Intake	0.26 - 0.34 (0.010 - 0.013)	0.304 - 0.416 (0.012 - 0.016)
Exhaust	0.29 - 0.37 (0.011 - 0.015)	0.308 - 0.432 (0.012 - 0.017)

\*: Approximately 80°C (176°F)

# SERVICE DATA AND SPECIFICATIONS (SDS)

[VK45DE]

## Available Adjusting Shims

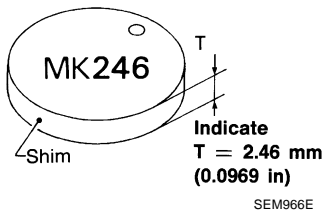
Thickness "T" mm (in)	Identification (stamped) mark
	
2.32 (0.0913)	232
2.33 (0.0917)	233
2.34 (0.0921)	234
2.35 (0.0925)	235
2.36 (0.0929)	236
2.37 (0.0933)	237
2.38 (0.0937)	238
2.39 (0.0941)	239
2.40 (0.0945)	240
2.41 (0.0949)	241
2.42 (0.0953)	242
2.43 (0.0957)	243
2.44 (0.0961)	244
2.45 (0.0965)	245
2.46 (0.0969)	246
2.47 (0.0972)	247
2.48 (0.0976)	248
2.49 (0.0980)	249
2.50 (0.0984)	250
2.51 (0.0988)	251
2.52 (0.0992)	252
2.53 (0.0996)	253
2.54 (0.1000)	254
2.55 (0.1004)	255
2.56 (0.1008)	256
2.57 (0.1012)	257
2.58 (0.1016)	258
2.59 (0.1020)	259
2.60 (0.1024)	260
2.61 (0.1028)	261
2.62 (0.1031)	262
2.63 (0.1035)	263
2.64 (0.1039)	264
2.65 (0.1043)	265
2.66 (0.1047)	266
2.67 (0.1051)	267
2.68 (0.1055)	268
2.69 (0.1059)	269

# SERVICE DATA AND SPECIFICATIONS (SDS)

[VK45DE]

Thickness "T" mm (in)	Identification (stamped) mark
2.70 (0.1063)	270
2.71 (0.1067)	271
2.72 (0.1071)	272
2.73 (0.1075)	273
2.74 (0.1079)	274
2.75 (0.1083)	275
2.76 (0.1087)	276
2.77 (0.1091)	277
2.78 (0.1094)	278
2.79 (0.1098)	279
2.80 (0.1102)	280
2.81 (0.1106)	281
2.82 (0.1110)	282
2.83 (0.1114)	283
2.84 (0.1118)	284
2.85 (0.1122)	285
2.86 (0.1126)	286
2.87 (0.1130)	287
2.88 (0.1134)	288
2.89 (0.1138)	289
2.90 (0.1142)	290
2.91 (0.1146)	291
2.92 (0.1150)	292
2.93 (0.1154)	293
2.94 (0.1157)	294
2.95 (0.1161)	295

A  
EM  
C  
D  
E  
F  
G  
H  
I  
J  
K

## CYLINDER HEAD

Unit: mm (in)

Items	Standard	Limit
Surface distortion	Less than 0.03 (0.0012)	0.1 (0.004)

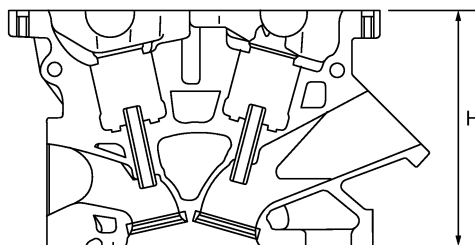

Nominal cylinder head height:  
H = 126.4 mm (4.98 in)

PBIC0183E

L  
M

# SERVICE DATA AND SPECIFICATIONS (SDS)

[VK45DE]

## Valve Dimensions

Unit: mm (in)

Items		Standard
Valve head diameter "D"	Intake	36.0 - 36.3 (1.417 - 1.429)
	Exhaust	31.2 - 31.5 (1.228 - 1.240)
Valve length "L"	Intake	96.57 (3.8020)
	Exhaust	94.50 (3.720)
Valve stem diameter "d"	Intake	5.972 - 5.980 (0.2351 - 0.2354)
	Exhaust	5.962 - 5.970 (0.2347 - 0.2350)
Valve seat angle "α"	Intake	45°15' - 45°45'
	Exhaust	
Valve margin "T"	Intake	1.15 - 1.45 (0.0453 - 0.0571)
	Exhaust	1.85 - 2.15 (0.0728 - 0.0846)

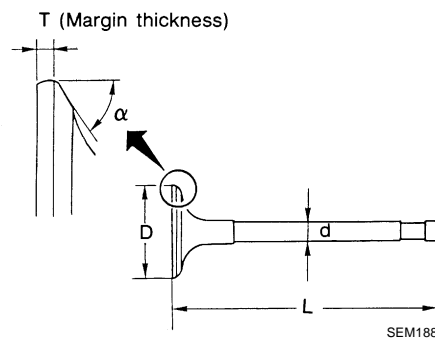

## Valve Guide

Unit: mm (in)

Items		Standard	Oversize (Service) [0.2 (0.008)]
Valve guide	Outer diameter	10.023 - 10.034 (0.3946 - 0.3950)	10.223 - 10.234 (0.4025 - 0.4029)
	Inner diameter (Finished size)	6.000 - 6.018 (0.2362 - 0.2369)	
Cylinder head valve guide hole diameter		9.975 - 9.996 (0.3927 - 0.3935)	10.175 - 10.196 (0.4006 - 0.4014)
Interference fit of valve guide		0.027 - 0.059 (0.0011 - 0.0023)	
Items		Standard	Limit
Valve guide clearance	Intake	0.020 - 0.046 (0.0008 - 0.0018)	0.08 (0.003)
	Exhaust	0.030 - 0.056 (0.0012 - 0.0022)	0.1 (0.004)
Projection length "L"	Intake	10.1 - 10.3 (0.398 - 0.406)	—
	Exhaust	10.0 - 10.4 (0.394 - 0.409)	—

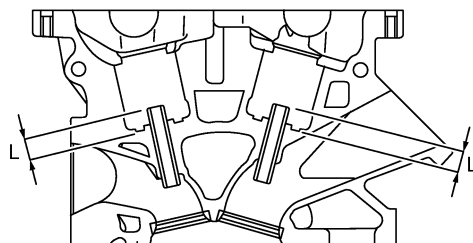

PBIC0184E

# SERVICE DATA AND SPECIFICATIONS (SDS)

[VK45DE]

## Valve Seat

Unit: mm (in)

\* : Machining data

\*1 : 44°45'±22'

Contacting width (W)  
; 1.0 - 1.4 (0.040 - 0.055)

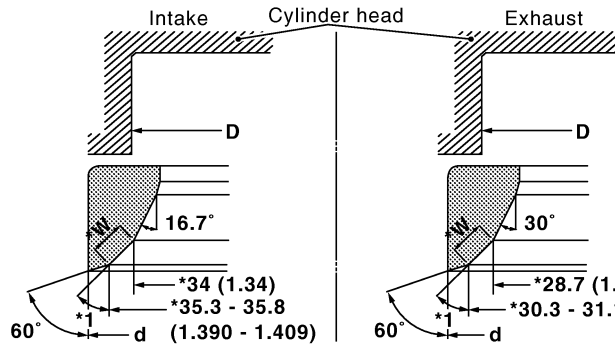

Contacting width (W)  
; 1.2 - 1.6 (0.047 - 0.063)

PBIC2379E

Items		Standard	Service
Cylinder head seat recess diameter "D"	Intake	37.000 - 37.016 (1.4567 - 1.4573)	37.500 - 37.516 (1.4764 - 1.4770)
	Exhaust	32.200 - 32.216 (1.2677 - 1.2683)	32.700 - 32.716 (1.2874 - 1.2880)
Valve seat interference fit	Intake	0.081 - 0.113 (0.0032 - 0.0044)	
	Exhaust	0.064 - 0.096 (0.0025 - 0.0038)	
Valve seat outer diameter "d"	Intake	37.097 - 37.113 (1.4605 - 1.4611)	37.597 - 37.613 (1.4802 - 1.4808)
	Exhaust	32.280 - 32.296 (1.2709 - 1.2715)	32.780 - 32.796 (1.2905 - 1.2912)

## Valve Spring

Free height	mm (in)	46.35 - 46.85 (1.8247 - 1.8444)
Pressure	N (kg, lb) at height mm (in)	165 - 189 (16.8 - 19.3, 37 - 42) at 33.8 (1.331)
		290 - 330 (29.6 - 33.7, 65 - 74) at 24.4 (0.961)
Out-of-square	mm (in)	Limit 2.0 (0.079)

# SERVICE DATA AND SPECIFICATIONS (SDS)

[VK45DE]

## CYLINDER BLOCK

Unit: mm (in)

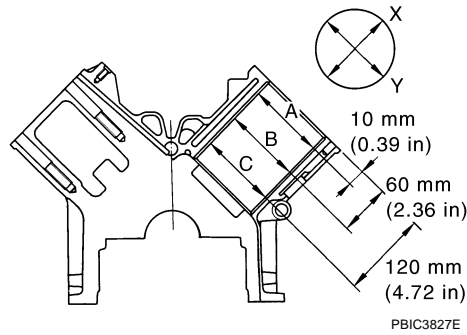

Surface distortion	Standard		Less than 0.03 (0.0012)
	Limit		0.1 (0.004)
Main bearing housing inner diameter	Standard		68.944 - 68.968 (2.7143 - 2.7153)
Cylinder bore inner diameter	Standard	Grade No. 1	93.000 - 93.010 (3.6614 - 3.6618)
		Grade No. 2	93.010 - 93.020 (3.6618 - 3.6622)
		Grade No. 3	93.020 - 93.030 (3.6622 - 3.6626)
	Wear limit		0.2 (0.008)
Out-of-round (Difference between "X" and "Y")	Limit		0.015 (0.0006)
Taper (Difference between "A" and "C")			0.01 (0.0004)
Main bearing housing inner diameter (Without bearing)	Grade No. A		68.944 - 68.945 (2.7143 - 2.7144)
	Grade No. B		68.945 - 68.946 (2.7144 - 2.7144)
	Grade No. C		68.946 - 68.947 (2.7144 - 2.7144)
	Grade No. D		68.947 - 68.948 (2.7144 - 2.7145)
	Grade No. E		68.948 - 68.949 (2.7145 - 2.7145)
	Grade No. F		68.949 - 68.950 (2.7145 - 2.7146)
	Grade No. G		68.950 - 68.951 (2.7146 - 2.7146)
	Grade No. H		68.951 - 68.952 (2.7146 - 2.7146)
	Grade No. J		68.952 - 68.953 (2.7146 - 2.7147)
	Grade No. K		68.953 - 68.954 (2.7147 - 2.7147)
	Grade No. L		68.954 - 68.955 (2.7147 - 2.7148)
	Grade No. M		68.955 - 68.956 (2.7148 - 2.7148)
	Grade No. N		68.956 - 68.957 (2.7148 - 2.7148)
	Grade No. P		68.957 - 68.958 (2.7148 - 2.7149)
	Grade No. R		68.958 - 68.959 (2.7149 - 2.7149)
	Grade No. S		68.959 - 68.960 (2.7149 - 2.7150)
	Grade No. T		68.960 - 68.961 (2.7150 - 2.7150)
	Grade No. U		68.961 - 68.962 (2.7150 - 2.7150)
	Grade No. V		68.962 - 68.963 (2.7150 - 2.7151)
	Grade No. W		68.963 - 68.964 (2.7151 - 2.7151)
Grade No. X		68.964 - 68.965 (2.7151 - 2.7152)	
Grade No. Y		68.965 - 68.966 (2.7152 - 2.7152)	
Grade No. 1		68.966 - 68.967 (2.7152 - 2.7152)	
Grade No. 2		68.967 - 68.968 (2.7152 - 2.7153)	
Difference in inner diameter between cylinders	Standard		Less than 0.03 (0.0012)

# SERVICE DATA AND SPECIFICATIONS (SDS)

[VK45DE]

## PISTON, PISTON RING AND PISTON PIN

### Available Piston

Unit: mm (in)

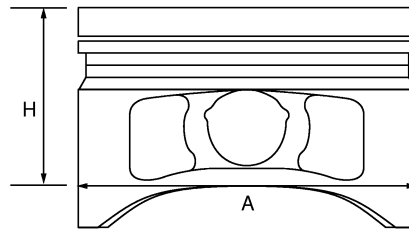

PBIC0188E

Items		Standard	Oversize [0.2 (0.008)]
Piston skirt diameter "A"	Grade No. 1	92.980 - 92.990 (3.6606 - 3.6610)	—
	Grade No. 2	92.990 - 93.000 (3.6610 - 3.6614)	—
	Grade No. 3	93.000 - 93.010 (3.6614 - 3.6618)	—
	Service	—	93.180 - 93.210 (3.6685 - 3.6697)
"H" dimension		42 (1.65)	
Piston pin hole diameter	Grade No. 0	21.993 - 21.999 (0.8659 - 0.8661)	
	Grade No. 1	21.999 - 22.005 (0.8661 - 0.8663)	
Piston to cylinder bore clearance	Standard	0.010 - 0.030 (0.0004 - 0.0012)	
	Limit	0.08 (0.0031)	

### Piston Ring

Unit: mm (in)

		Standard	Limit
Side clearance	Top	0.045 - 0.080 (0.0018 - 0.0031)	0.11 (0.0043)
	2nd	0.030 - 0.070 (0.0012 - 0.0028)	0.1 (0.004)
	Oil ring	0.065 - 0.135 (0.0026 - 0.0053)	—
End gap	Top	0.22 - 0.32 (0.0087 - 0.0126)	0.56 (0.0220)
	2nd	0.22 - 0.32 (0.0087 - 0.0126)	0.56 (0.0220)
	Oil (rail ring)	0.20 - 0.50 (0.0079 - 0.0197)	0.96 (0.0378)

### Piston Pin

Unit: mm (in)

Items		Standard	Limit
Piston pin outer diameter	Grade No. 0	21.989 - 21.995 (0.8657 - 0.8659)	—
	Grade No. 1	21.995 - 22.001 (0.8659 - 0.8662)	—
Piston to piston pin oil clearance		0.002 - 0.006 (0.0001 - 0.0002)	—
Connecting rod bushing oil clearance		0.005 - 0.017 (0.0002 - 0.0007)	0.030 (0.0012)

# SERVICE DATA AND SPECIFICATIONS (SDS)

[VK45DE]

## CONNECTING ROD

Unit: mm (in)

Items		Standard	Limit
Center distance		146.95 - 147.05 (5.79 - 5.79)	—
Bend [per 100 (3.94)]		—	0.15 (0.0059)
Torsion [per 100 (3.94)]		—	0.30 (0.012)
Connecting rod bushing inner diameter*	Grade No. 0	22.000 - 22.006 (0.8661 - 0.8664)	—
	Grade No. 1	22.006 - 22.012 (0.8664 - 0.8666)	—
Connecting rod big end diameter (without bearing)		55.000 - 55.013 (2.1654 - 2.1659)	—
Side clearance		0.20 - 0.35 (0.008 - 0.0138)	0.40 (0.016)

\*: After installing in connecting rod



# SERVICE DATA AND SPECIFICATIONS (SDS)

[VK45DE]

## CRANKSHAFT

Unit: mm (in)

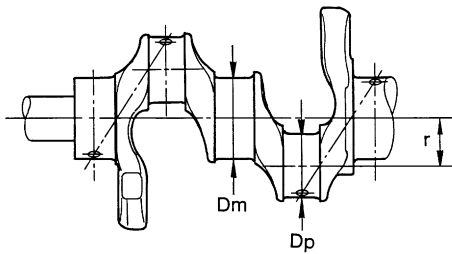

SEM645

Out-of-round : Difference between X and Y.  
Taper : Difference between A and B.

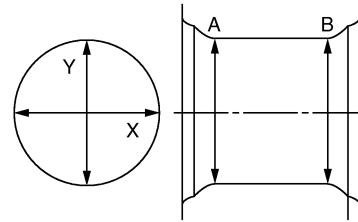

PBIC1686E

Main journal diameter "Dm" (No. 1 and 5 journal)	Standard	Grade No. G	63.963 - 63.964 (2.5182 - 2.5183)
		Grade No. H	63.962 - 63.963 (2.5182 - 2.5182)
		Grade No. J	63.961 - 63.962 (2.5181 - 2.5182)
		Grade No. K	63.960 - 63.961 (2.5181 - 2.5181)
		Grade No. L	63.959 - 63.960 (2.5181 - 2.5181)
		Grade No. M	63.958 - 63.959 (2.5180 - 2.5181)
		Grade No. N	63.957 - 63.958 (2.5180 - 2.5180)
		Grade No. P	63.956 - 63.957 (2.5179 - 2.5180)
		Grade No. R	63.955 - 63.956 (2.5179 - 2.5179)
		Grade No. S	63.954 - 63.955 (2.5179 - 2.5179)
		Grade No. T	63.953 - 63.954 (2.5178 - 2.5179)
		Grade No. U	63.952 - 63.953 (2.5178 - 2.5178)
		Grade No. V	63.951 - 63.952 (2.5178 - 2.5178)
		Grade No. W	63.950 - 63.951 (2.5177 - 2.5178)
		Grade No. X	63.949 - 63.950 (2.5177 - 2.5177)
		Grade No. Y	63.948 - 63.949 (2.5176 - 2.5177)
		Grade No. 1	63.947 - 63.948 (2.5176 - 2.5176)
		Grade No. 2	63.946 - 63.947 (2.5176 - 2.5176)
		Grade No. 3	63.945 - 63.946 (2.5175 - 2.5176)
Main journal diameter "Dm" (No. 2, 3 and 4 journal)	Standard	Grade No. A	63.963 - 63.964 (2.5182 - 2.5183)
		Grade No. B	63.962 - 63.963 (2.5182 - 2.5182)
		Grade No. C	63.961 - 63.962 (2.5181 - 2.5182)
		Grade No. D	63.960 - 63.961 (2.5181 - 2.5181)
		Grade No. E	63.959 - 63.960 (2.5181 - 2.5181)
		Grade No. F	63.958 - 63.959 (2.5180 - 2.5181)
		Grade No. G	63.957 - 63.958 (2.5180 - 2.5180)
		Grade No. H	63.956 - 63.957 (2.5179 - 2.5180)
		Grade No. J	63.955 - 63.956 (2.5179 - 2.5179)
		Grade No. K	63.954 - 63.955 (2.5179 - 2.5179)
		Grade No. L	63.953 - 63.954 (2.5178 - 2.5179)
		Grade No. M	63.952 - 63.953 (2.5178 - 2.5178)
		Grade No. N	63.951 - 63.952 (2.5178 - 2.5178)
		Grade No. P	63.950 - 63.951 (2.5177 - 2.5178)
		Grade No. R	63.949 - 63.950 (2.5177 - 2.5177)
		Grade No. S	63.948 - 63.949 (2.5176 - 2.5177)
		Grade No. T	63.947 - 63.948 (2.5176 - 2.5176)
		Grade No. U	63.946 - 63.947 (2.5176 - 2.5176)
		Grade No. V	63.945 - 63.946 (2.5175 - 2.5176)
Grade No. W	63.944 - 63.945 (2.5175 - 2.5175)		
Grade No. X	63.943 - 63.944 (2.5174 - 2.5175)		
Grade No. Y	63.942 - 63.943 (2.5174 - 2.5174)		
Grade No. 1	63.941 - 63.942 (2.5174 - 2.5174)		
Grade No. 2	63.940 - 63.941 (2.5173 - 2.5174)		

# SERVICE DATA AND SPECIFICATIONS (SDS)

[VK45DE]

Pin journal diameter "Dp"	Grade No. 0	51.968 - 51.974 (2.0460 - 2.0462)
	Grade No. 1	51.962 - 51.968 (2.0457 - 2.0460)
	Grade No. 2	51.956 - 51.962 (2.0455 - 2.0457)
Center distance "r"		41.31 - 41.39 (1.6264 - 1.6295)
Out-of-round (Difference between "X" and "Y")	Limit	0.015 (0.0006)
Taper (Difference between "A" and "B")	Limit	0.010 (0.0004)
Runout [TIR*]	Standard	Less than 0.05 (0.002)
	Limit	0.10 (0.004)
Crankshaft end play	Standard	0.10 - 0.25 (0.0039 - 0.0098)
	Limit	0.30 (0.012)

\*: Total indicator reading

# SERVICE DATA AND SPECIFICATIONS (SDS)

[VK45DE]

## MAIN BEARING

Unit: mm (in)

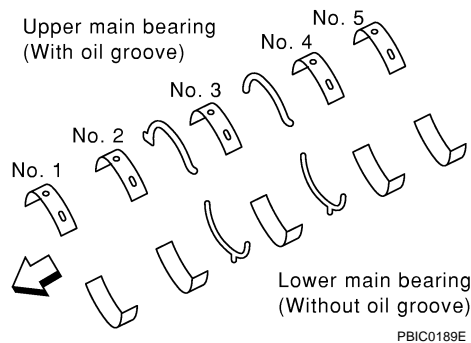

Grade number		Thickness	Identification color	Remarks
0		2.483 - 2.486 (0.0978 - 0.0979)	Black	Grade and color are the same for upper and lower bearings.
1		2.486 - 2.489 (0.0979 - 0.0980)	Brown	
2		2.489 - 2.492 (0.0980 - 0.0981)	Green	
3		2.492 - 2.495 (0.0981 - 0.0982)	Yellow	
4		2.495 - 2.498 (0.0982 - 0.0983)	Blue	
5		2.498 - 2.501 (0.0983 - 0.0985)	Pink	
6		2.501 - 2.504 (0.0985 - 0.0986)	Purple	
7		2.504 - 2.507 (0.0986 - 0.0987)	White	
8		2.507 - 2.510 (0.0987 - 0.0988)	Red	
01	UPR	2.483 - 2.486 (0.0978 - 0.0979)	Black	Grade and color are different for upper and lower bearings.
	LWR	2.486 - 2.489 (0.0979 - 0.0980)	Brown	
12	UPR	2.486 - 2.489 (0.0979 - 0.0980)	Brown	
	LWR	2.489 - 2.492 (0.0980 - 0.0981)	Green	
23	UPR	2.489 - 2.492 (0.0980 - 0.0981)	Green	
	LWR	2.492 - 2.495 (0.0981 - 0.0982)	Yellow	
34	UPR	2.492 - 2.495 (0.0981 - 0.0982)	Yellow	
	LWR	2.495 - 2.498 (0.0982 - 0.0983)	Blue	
45	UPR	2.495 - 2.498 (0.0982 - 0.0983)	Blue	
	LWR	2.498 - 2.501 (0.0983 - 0.0985)	Pink	
56	UPR	2.498 - 2.501 (0.0983 - 0.0985)	Pink	
	LWR	2.501 - 2.504 (0.0985 - 0.0986)	Purple	
67	UPR	2.501 - 2.504 (0.0985 - 0.0986)	Purple	
	LWR	2.504 - 2.507 (0.0986 - 0.0987)	White	
78	UPR	2.504 - 2.507 (0.0986 - 0.0987)	White	
	LWR	2.507 - 2.510 (0.0987 - 0.0988)	Red	

## Undersize

Unit: mm (in)

Undersize	Thickness	Main journal diameter
0.25 (0.0098)	2.618 - 2.626 (0.1031 - 0.1034)	Grind so that bearing clearance is the specified value.

# SERVICE DATA AND SPECIFICATIONS (SDS)

[VK45DE]

## Main Bearing Oil Clearance

Unit: mm (in)

Main bearing oil clearance	Standard	No.1 and 5	0.001 - 0.011 (0.00004 - 0.0004)
		No.2, 3 and 4	0.007 - 0.017 (0.0003 - 0.0007)
	Limit	No.1 and 5	0.021 (0.0008)
		No.2, 3 and 4	0.027 (0.0011)

## CONNECTING ROD BEARING

Unit: mm (in)

Grade number	Thickness	Identification color (mark)
0	1.500 - 1.503 (0.0591 - 0.0592)	No color
1	1.503 - 1.506 (0.0592 - 0.0593)	Brown
2	1.506 - 1.509 (0.0593 - 0.0594)	Green

## Undersize

Unit: mm (in)

Undersize	Thickness	Pin journal diameter
0.25 (0.0098)	1.626 - 1.634 (0.0640 - 0.0643)	Grind so that bearing clearance is the specified value.

## Connecting Rod Bearing Oil Clearance

Unit: mm (in)

Connecting rod bearing oil clearance	Standard	0.020 - 0.045 (0.0008 - 0.0018)
	Limit	0.055 (0.0022)