

SECTION **BF**

GI

MA

EM

LC

EF &

EC

FE

AT

PD

FA

RA

BR

ST

BF

HA

EL

IDX

CONTENTS

GENERAL SERVICING	2	Wiring Diagram	60
Precautions.....	2	WINDSHIELD AND WINDOWS	61
Supplemental Restraint System "AIR BAG" and "SEAT BELT PRE-TENSIONER"	2	Windshield and Rear Window	61
Circuit Breaker Inspection.....	2	MIRROR	62
Clip and Fastener	3	Door Mirror	62
BODY END	5	REAR AIR SPOILER	64
Body Front End	5	BODY ALIGNMENT	65
Body Rear End and Opener	7	Engine Compartment	65
DOOR	10	Underbody	67
Front Door	10	SUPPLEMENTAL RESTRAINT SYSTEM (SRS)	69
Rear Door.....	11	Precautions for SRS "Air Bag" and "Seat Belt Pre-tensioner" Service.....	69
DOOR — Power Window	12	Special Service Tools	69
Power Window	12	Commercial Service Tools	69
DOOR — Trouble Diagnoses for Power Window	14	Description	70
Contents.....	14	Caution Labels and SRS Component Parts Location	71
DOOR — Power Door Lock	22	Maintenance Items.....	74
Power Door Lock.....	22	Removal and Installation — Diagnosis (Control) Unit, Sensors and Seat Belt Pre-tensioner.....	75
MULTI-REMOTE CONTROL SYSTEM	28	Removal — Air Bag Module and Spiral Cable	76
Wiring Diagram	28	Removal — Front Passenger Air Bag Module.....	77
Circuit Diagram for Quick Pinpoint Check.....	30	Installation — Air Bag Module and Spiral Cable	78
Trouble Diagnoses Preliminary Inspection	31	Installation — Front Passenger Air Bag Module.....	80
Trouble Diagnoses.....	32	Scrapping Air Bag and Seat Belt Pre-tensioners.....	80
Replacing Remote Controller or Control Unit	38	TROUBLE DIAGNOSES — Supplemental Restraint System (SRS)	83
INSTRUMENT PANEL	39	Contents.....	83
INTERIOR AND EXTERIOR	41		
Interior	41		
Exterior	47		
SEAT	52		
Front Seat.....	52		
Rear Seat	58		
SUN ROOF	59		

When you read wiring diagrams:

- Read GI section, "HOW TO READ WIRING DIAGRAMS".
- See EL section, "POWER SUPPLY ROUTING" for power distribution circuit.

When you perform trouble diagnoses, read GI section, "HOW TO FOLLOW FLOW CHART IN TROUBLE DIAGNOSES".

Precautions

- When removing or installing various parts, place a cloth or padding onto the vehicle body to prevent scratches.
- Handle trim, molding, instruments, grille, etc. carefully during removing or installation. Be careful not to soil or damage them.
- Apply sealing compound where necessary when installing parts.
- When applying sealing compound, be careful that the sealing compound does not protrude from parts.
- When replacing any metal parts (for example body outer panel, members, etc.), be sure to take rust prevention measures.

Supplemental Restraint System "AIR BAG" and "SEAT BELT PRE-TENSIONER"

The Supplemental Restraint System "Air Bag" and "Seat Belt Pre-tensioner" help to reduce the risk or severity of injury to the driver and front passenger in a frontal collision. The Supplemental Restraint System consists of air bags (located in the center of the steering wheel and on the instrument panel on the passenger side), seat belt pre-tensioners sensors, a diagnosis unit, warning lamp, wiring harness and spiral cable. Information necessary to service the system safely is included in the **BF section** of this Service Manual.

WARNING:

- To avoid rendering the SRS inoperative, which could lead to personal injury or death in the event of a severe frontal collision, all maintenance must be performed by an authorized INFINITI dealer.
- Improper maintenance, including incorrect removal and installation of the SRS, can lead to personal injury caused by unintentional activation of the system.
- All SRS air bag electrical wiring harnesses and connectors are covered with yellow outer insulation. Do not use electrical test equipment on any circuit related to the SRS SYSTEM.

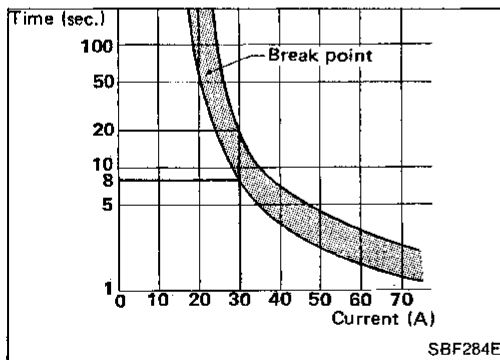

Circuit Breaker Inspection

For example, when current is 30A, the circuit is broken within 8 to 20 seconds.







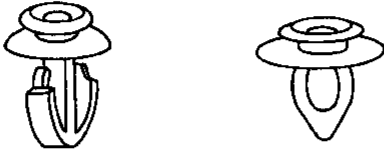

Circuit breakers are used in the following systems.

- Power window & power door lock
- Power seat
- Power sun roof

GENERAL SERVICING

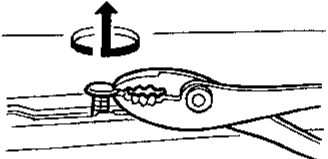
Clip and Fastener

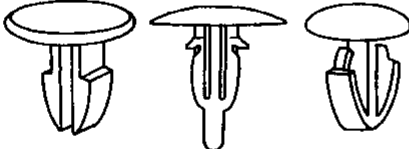
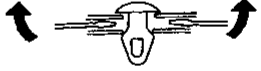
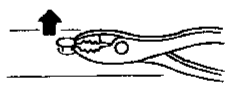
- Clips and fasteners in BF section correspond to the following numbers and symbols.
- Replace any clips and/or fasteners which are damaged during removal or installation.

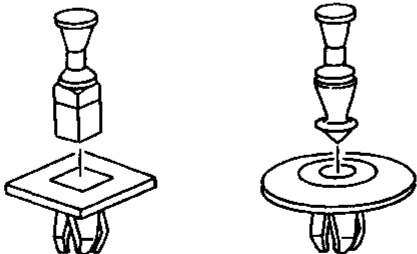
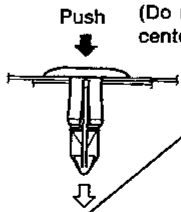
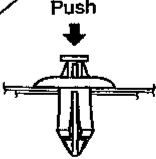
Symbol No.	Shapes	Removal & Installation
		<p>Removal: Remove by bending up with flat-bladed screwdrivers.</p> 
		 <p>Removal: Pull up by rotating.</p> <p style="text-align: right;">MBF176B</p>
		<p>Removal: Remove with a flat-bladed screwdriver or pliers.</p>  
		<p>Push center pin to catching position. (Do not remove center pin by hitting it.)</p>   <p>Installation:</p>

GI

MA

EM

LC

EF &
EC

FE

AT

PD

FA

RA

BR

ST

BF











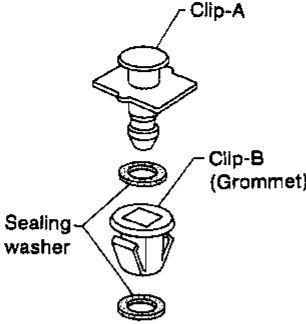
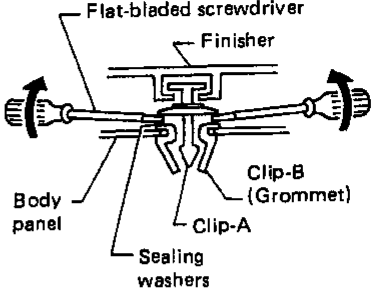

HA

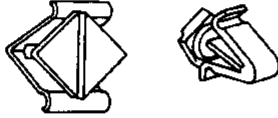
EL

IDX

GENERAL SERVICING

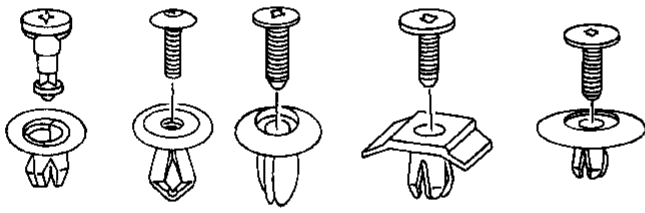
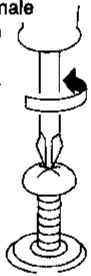
Clip and Fastener (Cont'd)

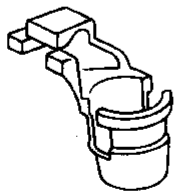
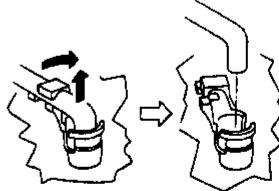
Symbol No.	Shapes	Removal & Installation
 		<p>Removal:</p> 
 		<p>Removal:</p>  <p>Rotate 45° to remove.</p> <p>Installation:</p>  <p>Removal:</p> 
 	 <p style="text-align: right;">SBF078B</p>	<p>Removal:</p> <ol style="list-style-type: none"> Screw out with a Phillips screwdriver. Remove female portion with flat-bladed screwdriver.  <p style="text-align: right;">SBF992G</p>
 		<p>Removal:</p> <p>Holder portion of clip must be spread out to remove rod.</p> 

Body Front End

- Hood adjustment: Adjust at hinge portion.
- Hood lock adjustment: After adjusting, check hood lock control operation. Apply a coat of grease to hood locks engaging mechanism.
- Hood opener: Do not attempt to bend cable forcibly. Doing so increases effort required to unlock hood.

WARNING:

- Be careful not to scratch hood stay when installing hood. A scratched stay may cause gas leakage.
- The contents of the hood stay are under pressure. Do not take apart, puncture, apply heat or allow fire near it.

CAUTION:

Do not touch reinforcement with bare hands. Wear leather working gloves, since reinforcement surface is covered with fiberglass.

REMOVAL — Front bumper assembly

- ① Remove four bolts securing bumper fascia to engine undercover.
- ② Remove three clips (CS101) securing air guide to radiator grille. Turn four clips (CG101) 45° counter-clockwise using a standard screwdriver from the front of radiator grille, then remove radiator grille.
- ③ Remove two screws and twelve clips (CS101), then remove radiator core support seal rubber and air guide.
- ④ Remove six screws securing left and right sides of front fender protector.
- ⑤ Remove the screw and two bolts securing each side of front bumper.
- ⑥ Remove the screw securing each side of front combination lamp assembly, then remove the assembly.
- ⑦ Remove two bolts securing each side of front fender bracket.
- ⑧ Remove four bolts securing each side of front bumper center bracket.
- ⑨ Remove front bumper assembly.
- ⑩ Remove bumper stay retainer from stay bolt.
- ⑪ Remove two bumper stay bolts (one on each side).
- ⑫ Remove energy absorber.
- ⑬ Remove bumper reinforcement assembly.

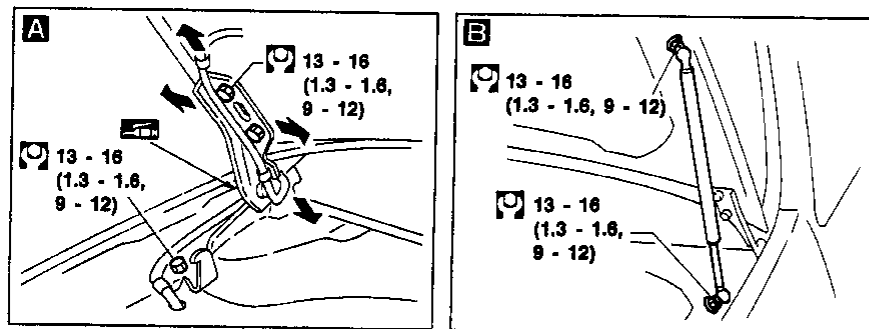

GI

MA

EM

LC

EF &

EC

FE

AT

PD

FA

RA

BR

ST

BF

HA

EL

IDX

BODY END

Body Front End (Cont'd)

Hood lock adjustment

- Adjust hood so that hood primary lock meshes at a position 1 to 1.5 mm (0.039 to 0.059 in) lower than fender.
- After hood lock adjustment, adjust bumper rubber.
- When securing hood lock, ensure it does not tilt. Striker must be positioned at the center of hood primary lock.
- After adjustment, ensure that hood primary and secondary lock operate properly.

Hood lock secondary latch hooking length

More than 5.0 mm (0.197 in)

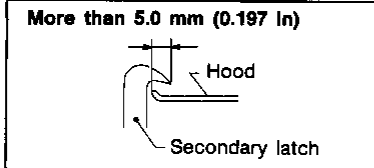

Bumper rubber adjustment

- Adjust so that hood is aligned with fender. At that time deflection is approx. 2 mm (0.08 in).

[Bumper rubber free height is approx. 13 mm (0.51 in)]

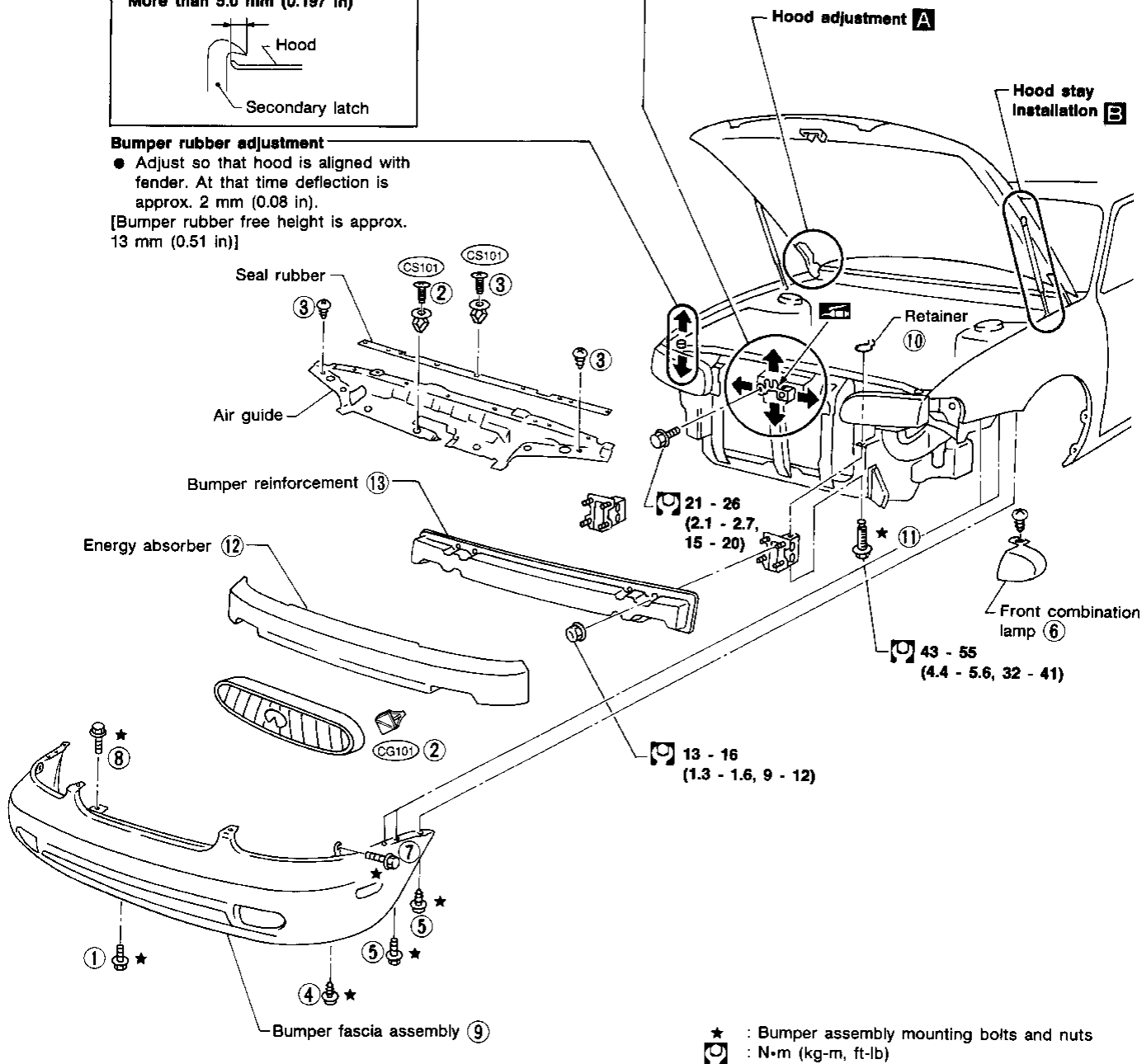

★ : Bumper assembly mounting bolts and nuts
 ☐ : N·m (kg·m, ft·lb)

Body Rear End and Opener

- Trunk lid adjustment: Adjust at hinge-trunk lid portion for proper trunk lid fit.
- Trunk lid lock system adjustment: Adjust striker so that it is in the center of the lock. After adjustment, check trunk lid lock operation.
- Opener cable: Do not attempt to bend cable using excessive force.
- After installation, make sure that trunk lid and fuel filler lid open smoothly.

GI

MA

EM

LC

EF &
EC

FE

AT

PD

FA

RA

BR

ST

BF

HA

EL

IDX

CAUTION:

Do not touch reinforcement with bare hands. Wear leather working gloves, since reinforcement surface is covered with fiberglass.

REMOVAL — Rear bumper assembly

- 1 Remove license plate.
- 2 Remove bolts from lower side of rear bumper.
- 3 Remove clips (C203) securing rear fender protectors.
- 4 Remove screws from lower side of each side bumper.
- 5 Remove screws securing wheelarch to each bumper side.
- 6 Remove trunk trim. Refer to "LUGGAGE COMPARTMENT TRIM" in "Interior" for details.
- 7 Working inside trunk, remove power antenna motor.
- 8 Working inside trunk, remove bolts securing each bumper side to fender.
- 9 Also remove nuts from center of trunk compartment.
- 10 Pull bumper fascia out. Disconnect rear side marker lamps and back-up lamp harness connectors.
- 11 Remove bumper stays. Working inside trunk, remove left and right plugs from floor, then remove bolts.

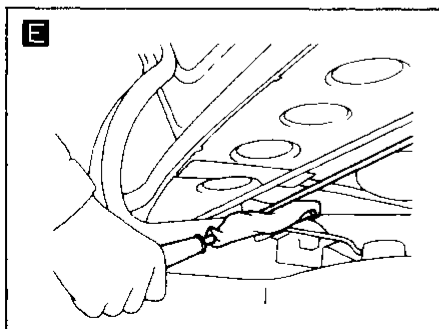
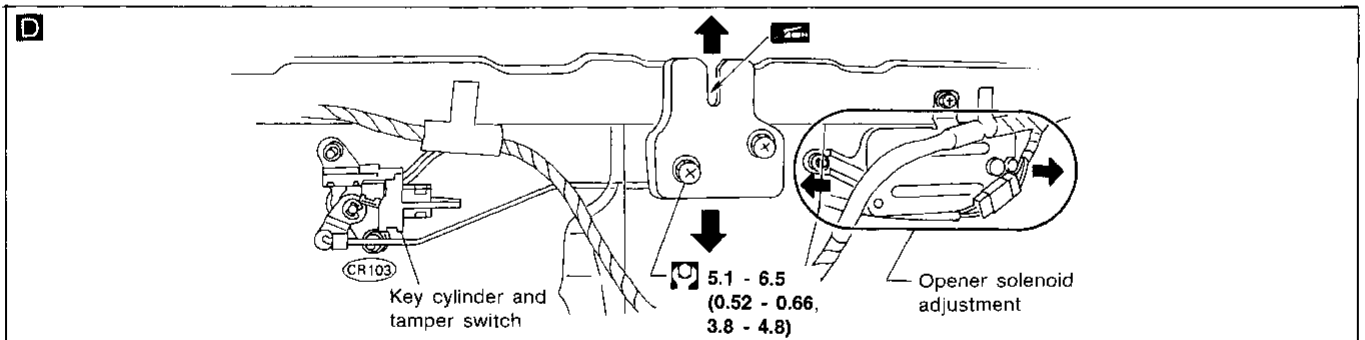
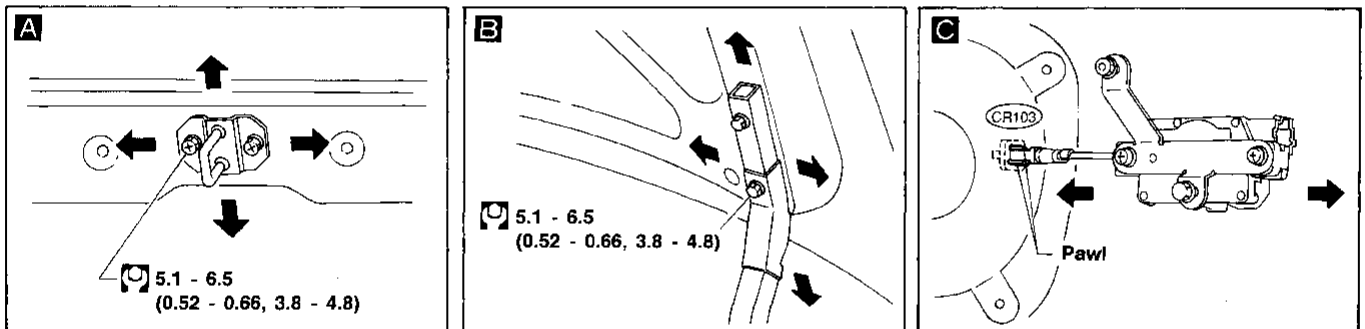

BODY END

Body Rear End and Opener (Cont'd)

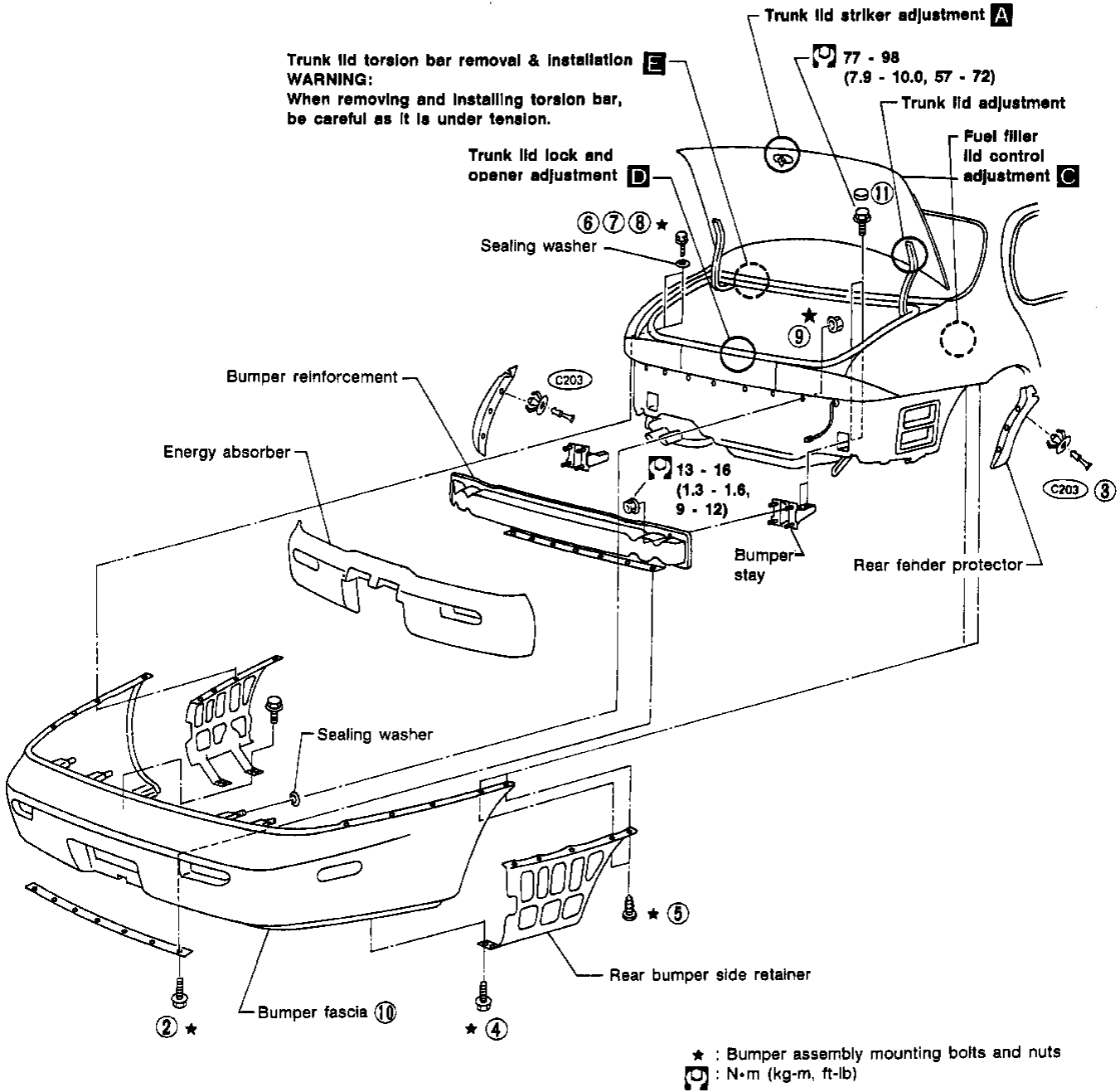

BODY END

Body Rear End and Opener (Cont'd)

TRUNK LID AND FUEL FILLER LID OPENER/WIRING DIAGRAM

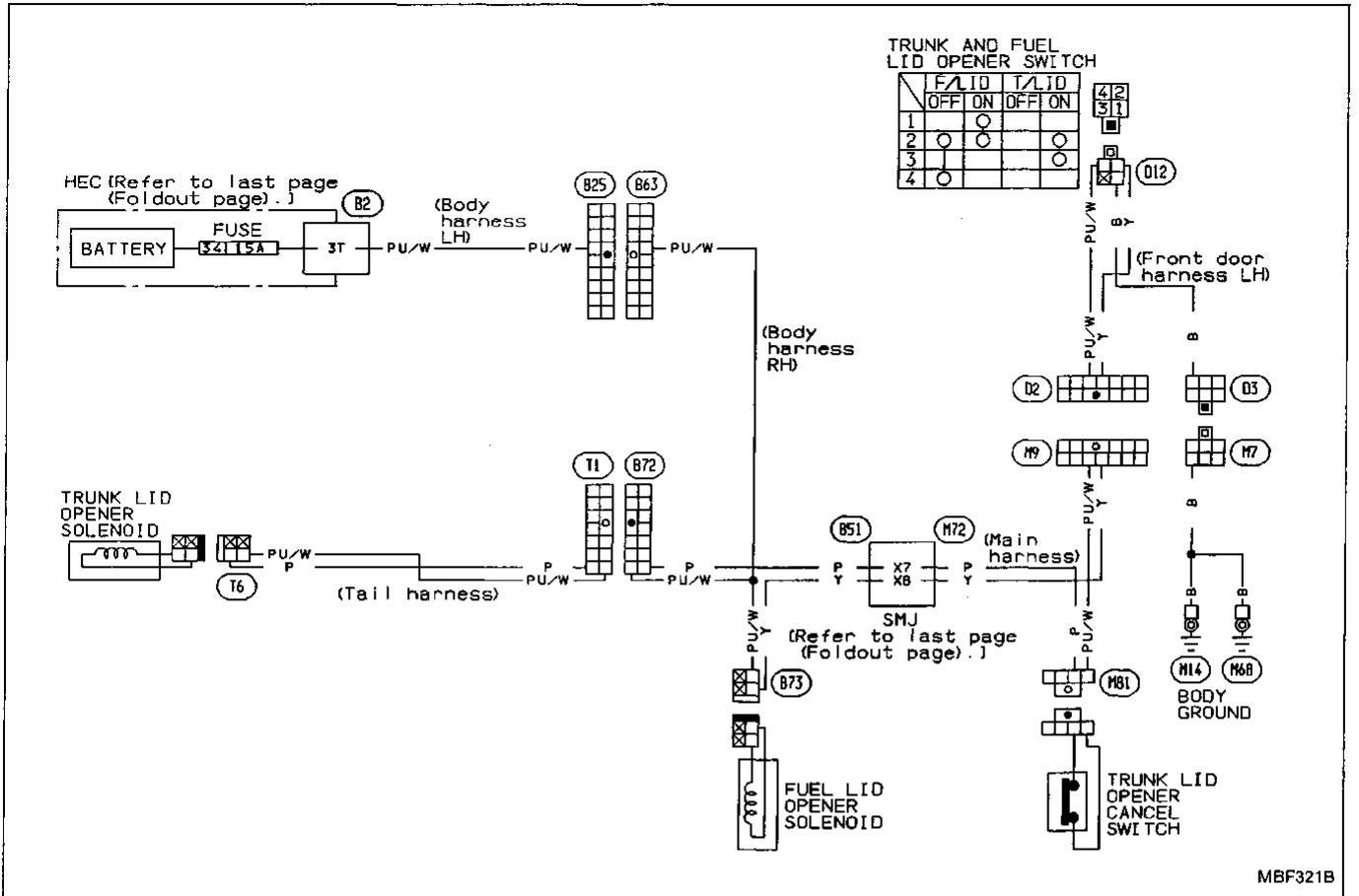

GI
MA
EM
LC
EF & EC
FE
AT
PD
FA
RA
BR
ST
BF
HA
EL
IDX

DOOR

Front Door

- For removal of door trim, refer to "INTERIOR AND EXTERIOR" (BF-45).
- After adjusting door or door lock, check door lock operation.

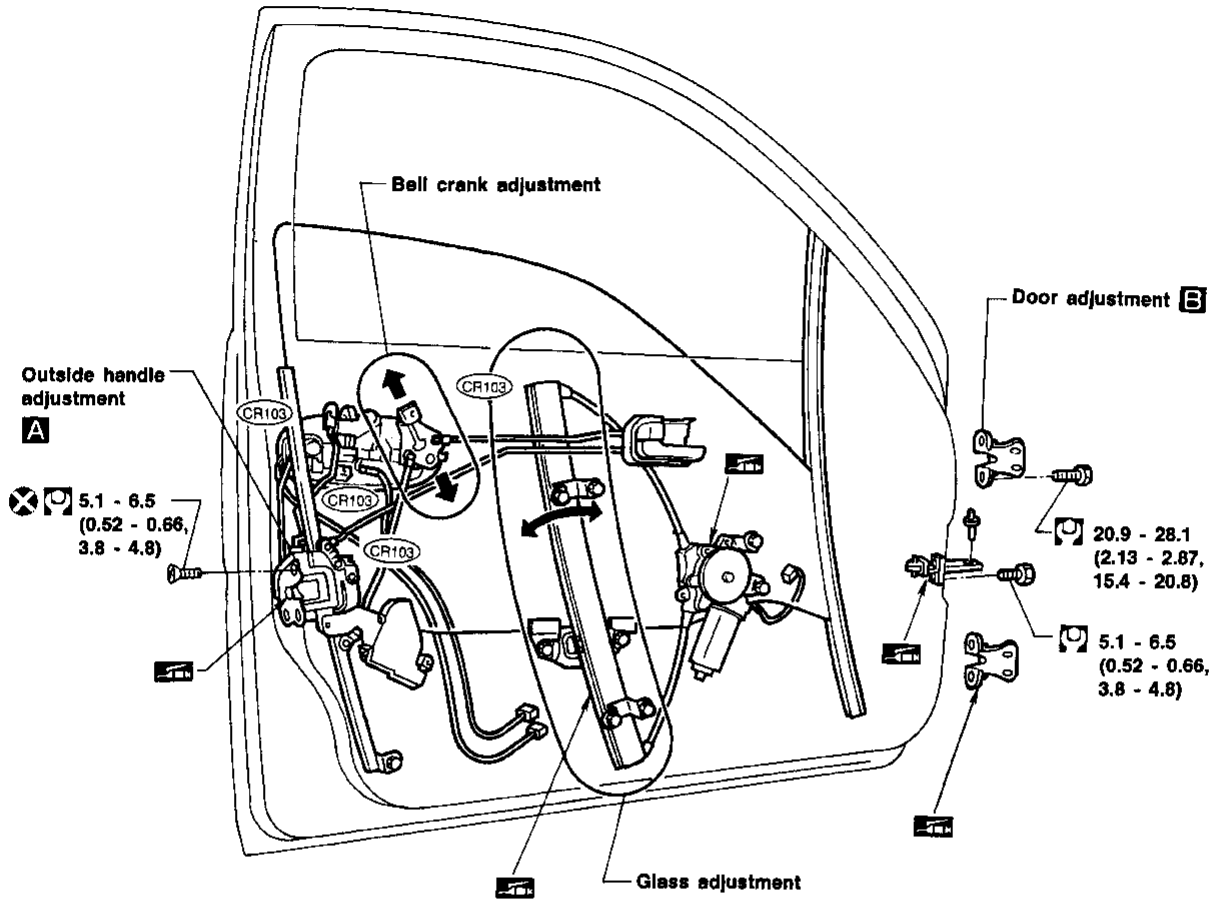

: N·m (kg-m, ft-lb)

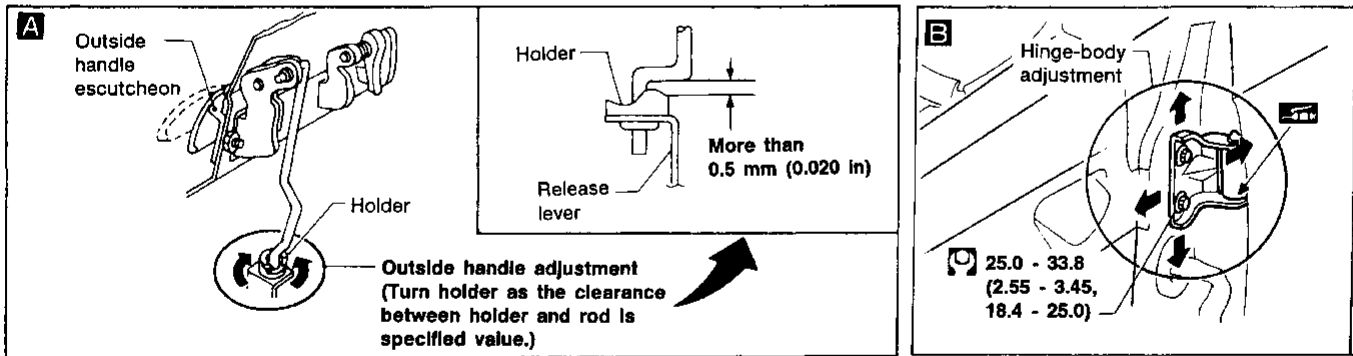

Striker adjustment

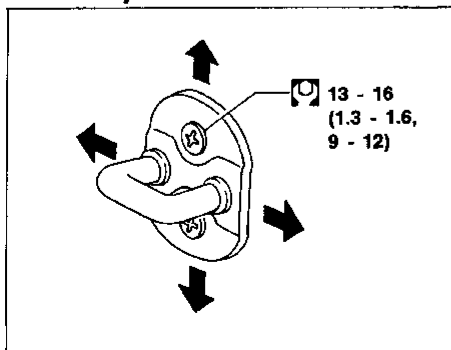

MBF639AA

DOOR

Rear Door

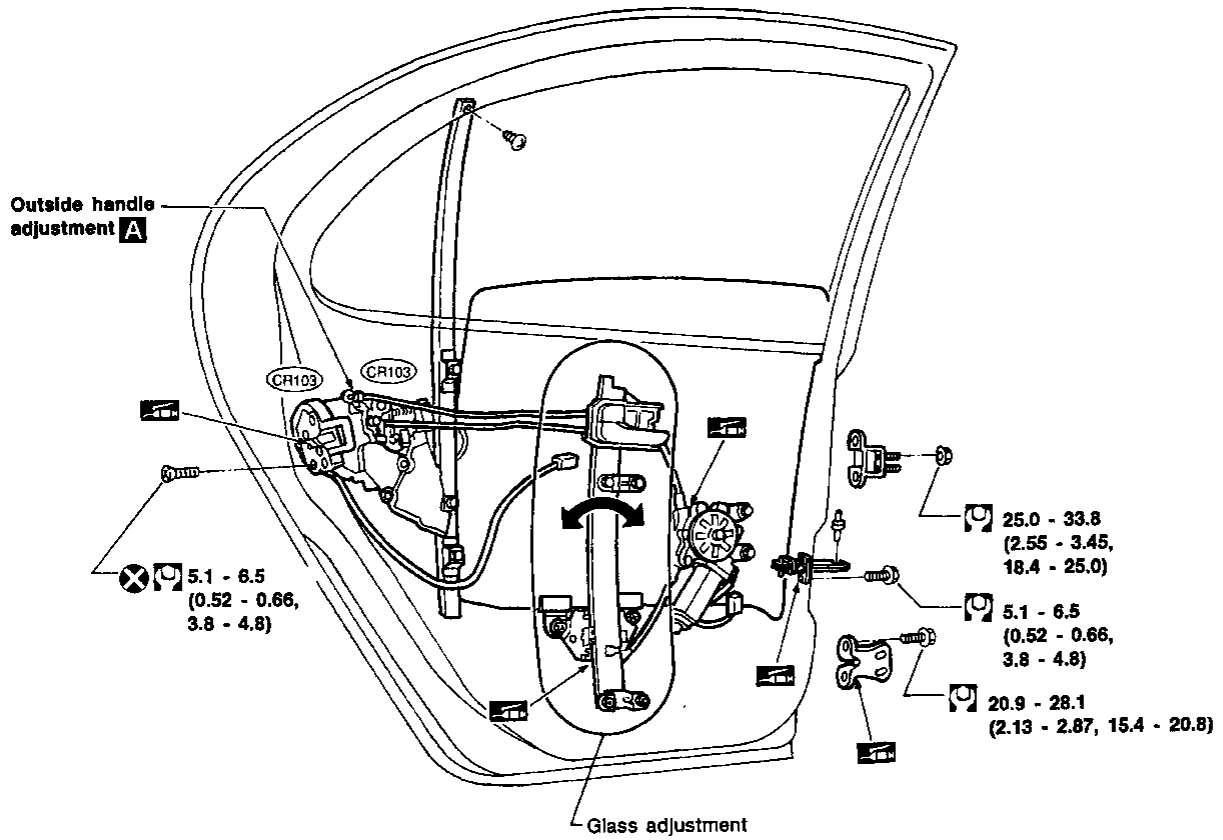

: N·m (kg·m, ft·lb)

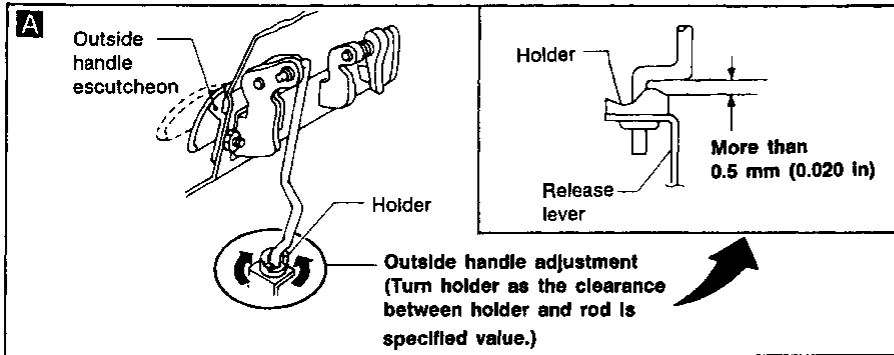

Striker adjustment

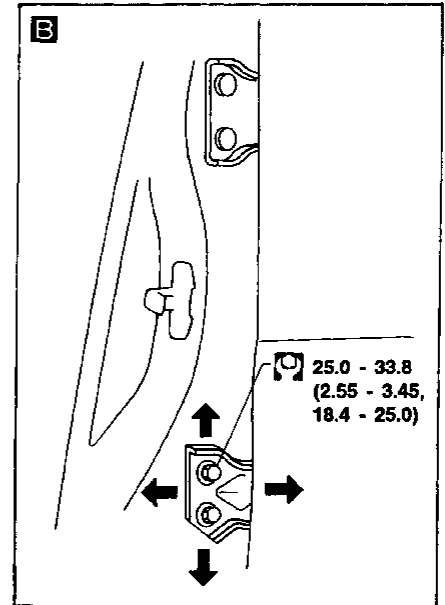
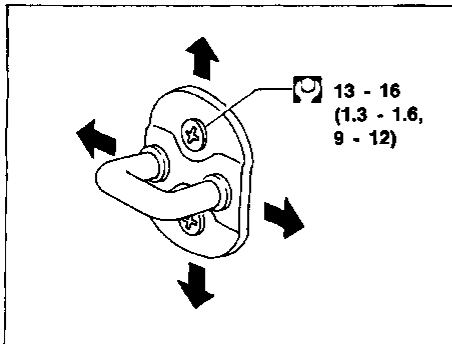

CI
MA
EM
LC
EF & EC
FE
AT
PD
FA
RA
BR
ST
BF
HA
EL
IDX

DOOR — Power Window

Power Window

WIRING DIAGRAM

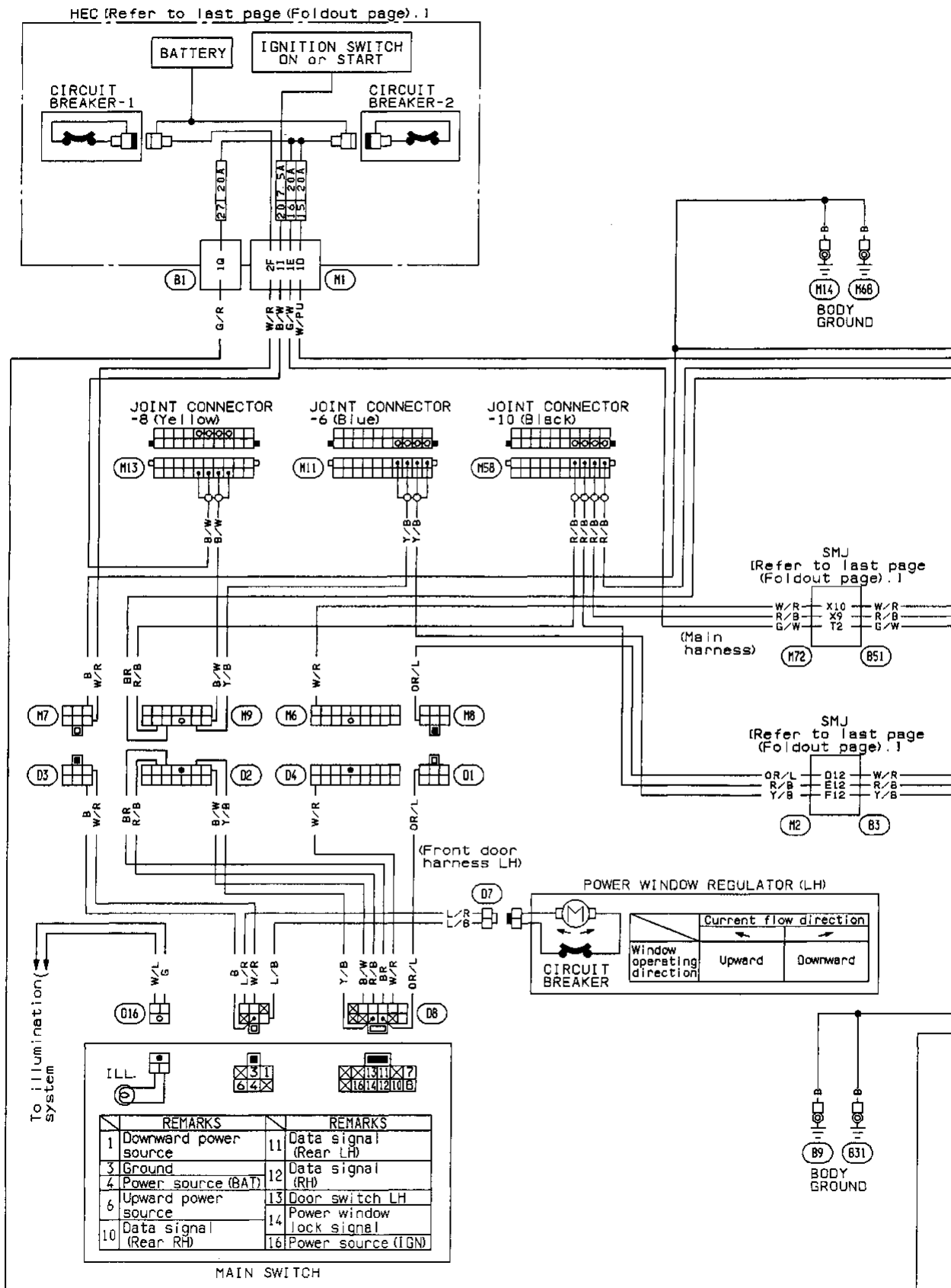

DOOR — Power Window

Power Window (Cont'd)

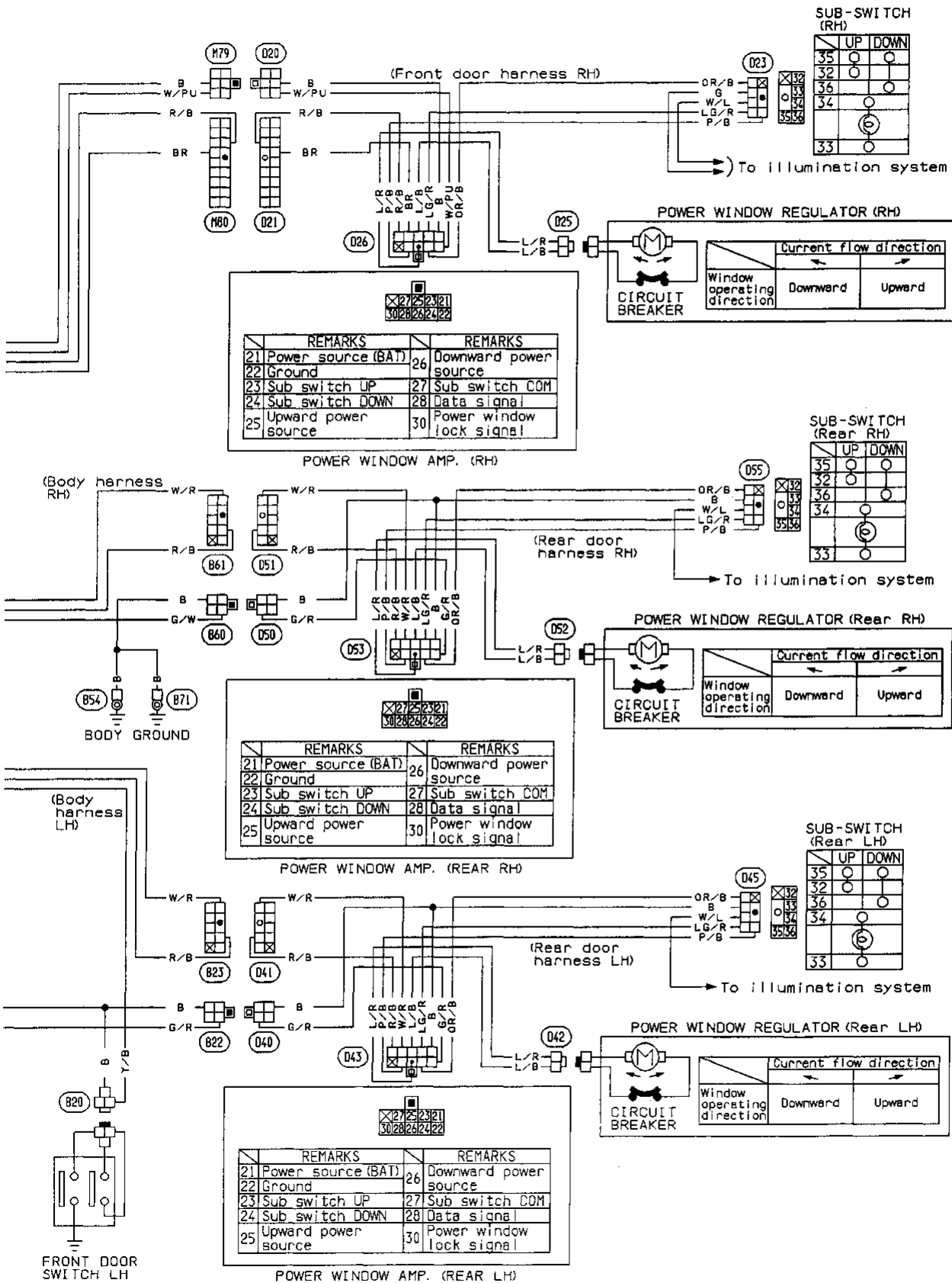

GI
MA
EM
LC
EF & EC
FE
AT
PD
FA
RA
BR
ST
BF
HA
EL
IDX

DOOR — Trouble Diagnoses for Power Window

Contents

Symptom Chart	BF-14
Main Power Supply and Ground Circuit Check	BF-15
Circuit Diagram for Quick Pinpoint Check	BF-16
Diagnostic Procedure 1	
(Check driver's window motor circuit.)	BF-17
Diagnostic Procedure 2	
(Check passenger power window circuit.)	BF-18
Diagnostic Procedure 3	
(Check power window lock signal circuit.)	BF-19
Diagnostic Procedure 4	
(Check data line signal circuit.)	BF-20
Electrical Components Inspection	BF-21

Since left and right component parts are basically the same, harness layout and methods for electrical components inspection are shown for one side only. Although methods for checking component parts on both sides are described in the flow chart, making it easier to troubleshoot, apply checking procedures to either side that have malfunction during trouble diagnoses.

Symptom Chart

Procedure	Main Power Supply and Ground Circuit Check			Diagnostic Procedure				Electrical Components Inspection	
	BF-15	BF-15	BF-15	BF-17	BF-18	BF-19	BF-20	BF-21	BF-21
Reference Page									
SYMPTOM	Procedure 1	Procedure 2	Procedure 3	Procedure 1	Procedure 2	Procedure 3	Procedure 4	Power window motor(s)	Power window sub-switch(es)
All power windows cannot be operated.	<input type="checkbox"/>		<input type="checkbox"/>	<input type="checkbox"/>	<input type="checkbox"/>	<input type="checkbox"/>	<input type="checkbox"/>	<input type="checkbox"/>	<input type="checkbox"/>
Passenger power windows cannot be operated.		<input type="checkbox"/>			<input type="checkbox"/>	<input type="checkbox"/>	<input type="checkbox"/>	<input type="checkbox"/>	<input type="checkbox"/>
Driver's power window cannot be operated but other windows can be operated.				<input type="checkbox"/>				<input type="checkbox"/>	
Passenger power windows cannot be operated by main switch but can be operated by passenger's switches.							<input type="checkbox"/>		

DOOR — Trouble Diagnoses for Power Window

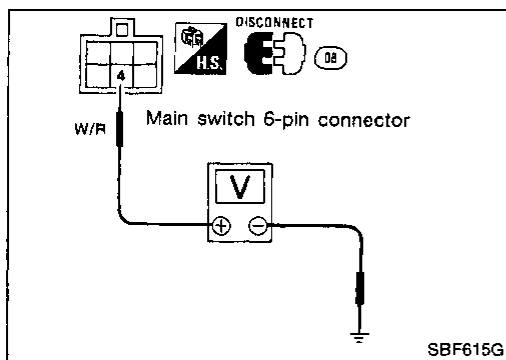

Main Power Supply and Ground Circuit Check PROCEDURE 1

Main power supply

Terminals	Battery voltage existence	
④ - Ground	Yes	GI

MA

EM

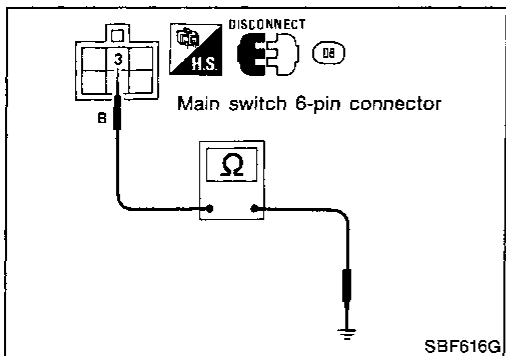

Ground circuit

Terminals	Continuity	
③ - Ground	Yes	LC

EF &
EC

FE

AT

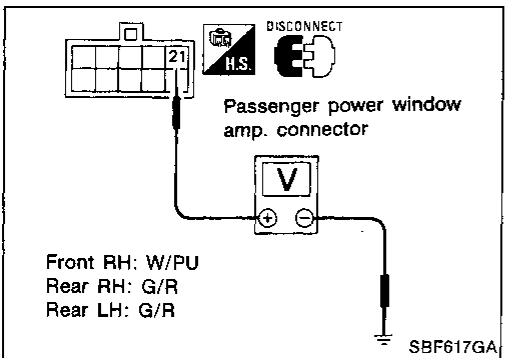

PROCEDURE 2

Power supply for power window amp. (front and rear passengers)

Terminals	Battery voltage existence	
⑳ - Ground	Yes	FA

RA

BR

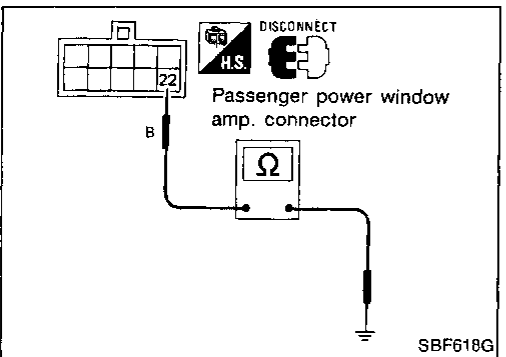

Ground circuit for power window amp. (front and rear passengers)

Terminals	Continuity	
㉒ - Ground	Yes	BF

ST

HA

EL

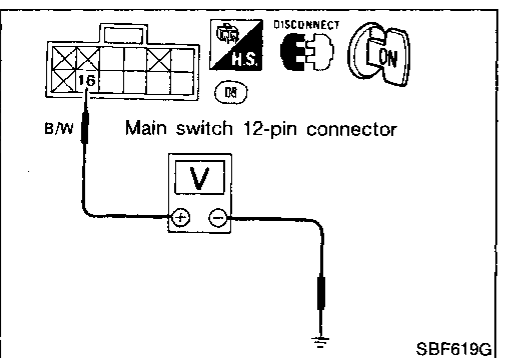

PROCEDURE 3

Power supply for ignition signal

Terminals	Ignition switch	Battery voltage existence	
⑯ - Ground	ON	Yes	IDX

Circuit Diagram for Quick Pinpoint Check

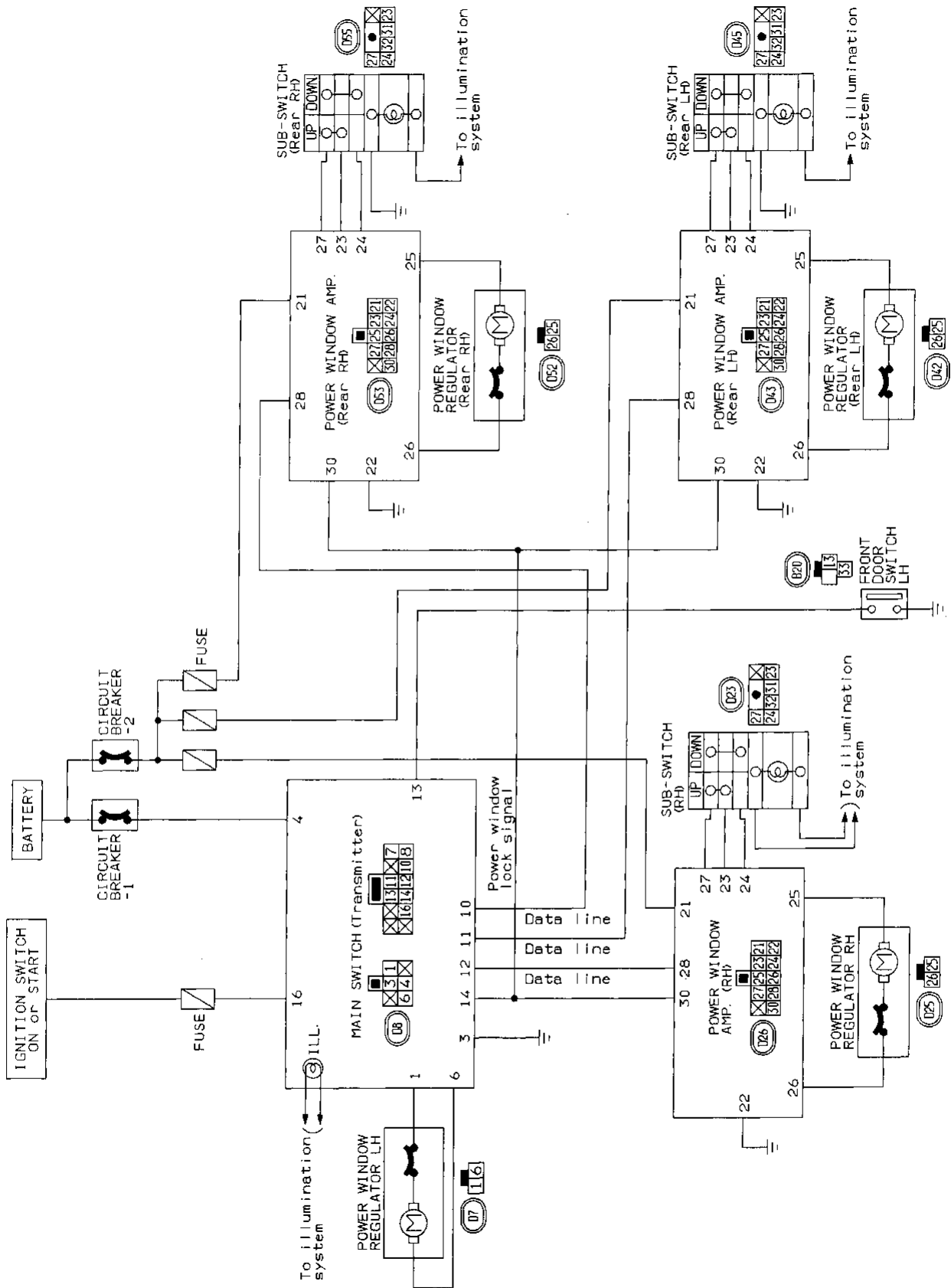

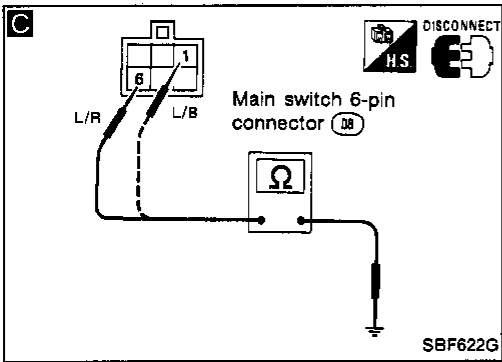
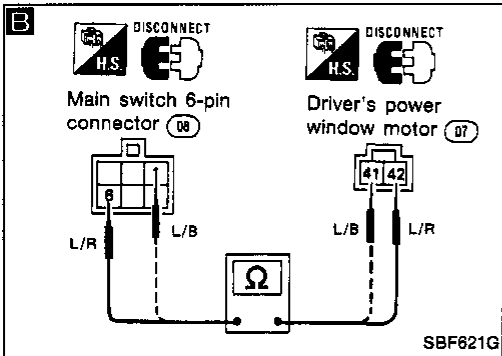
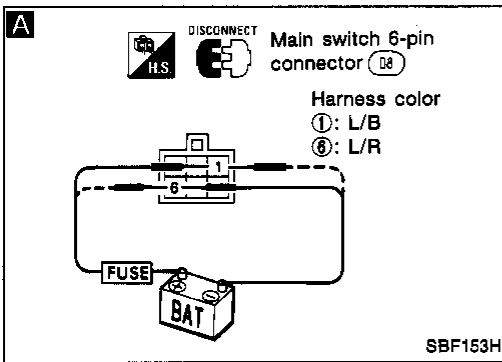

Diagnostic Procedure 1

SYMPTOM:

Driver's power window cannot be operated but other power windows can be operated.

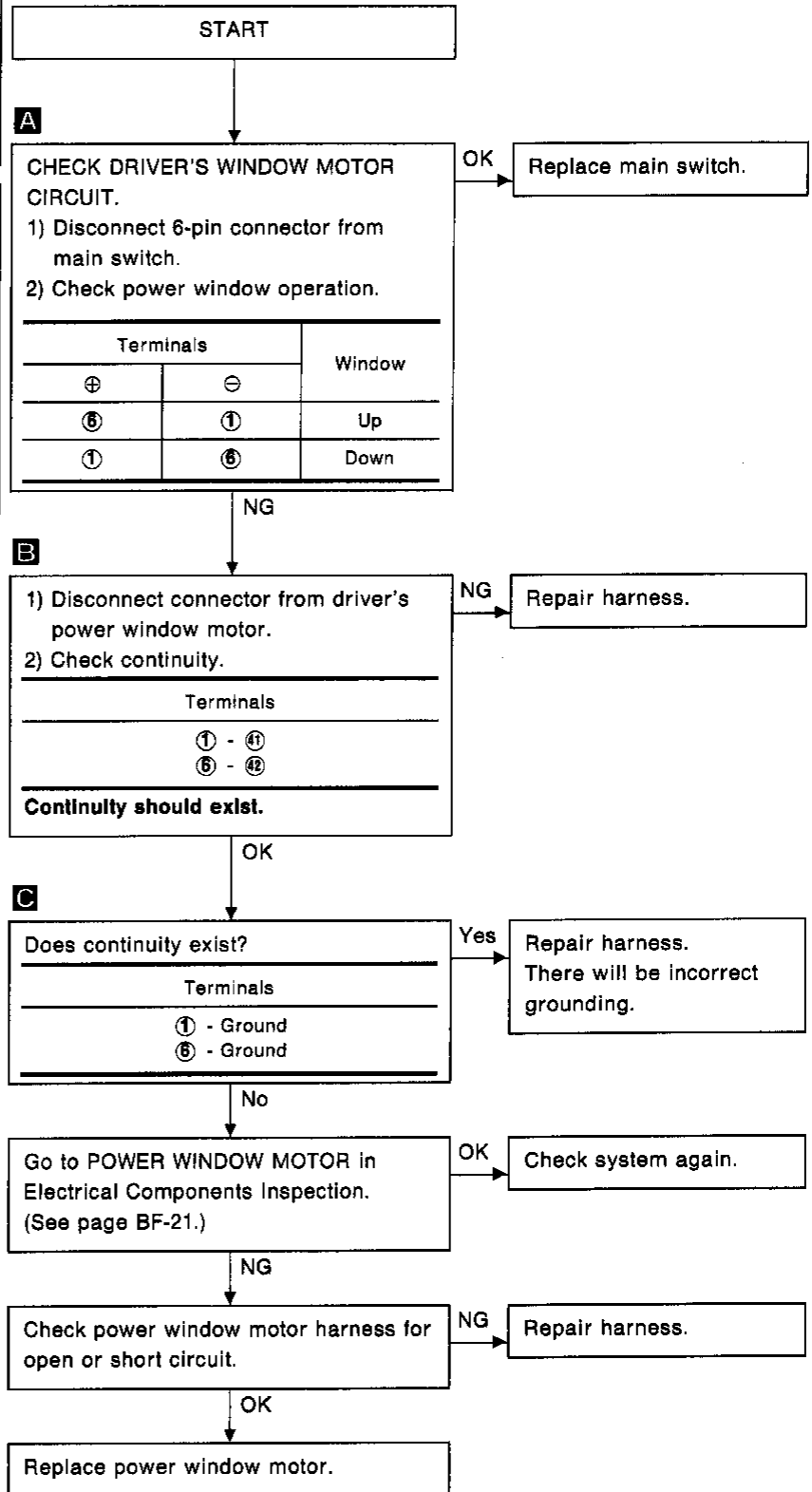

GI
 MA
 EM
 LC
 EF & EC
 FE
 AT
 PD
 FA
 RA
 BR
 ST
 BF
 HA
 EL
 DX

Diagnostic Procedure 2

SYMPTOM:

Passenger power windows cannot be operated.

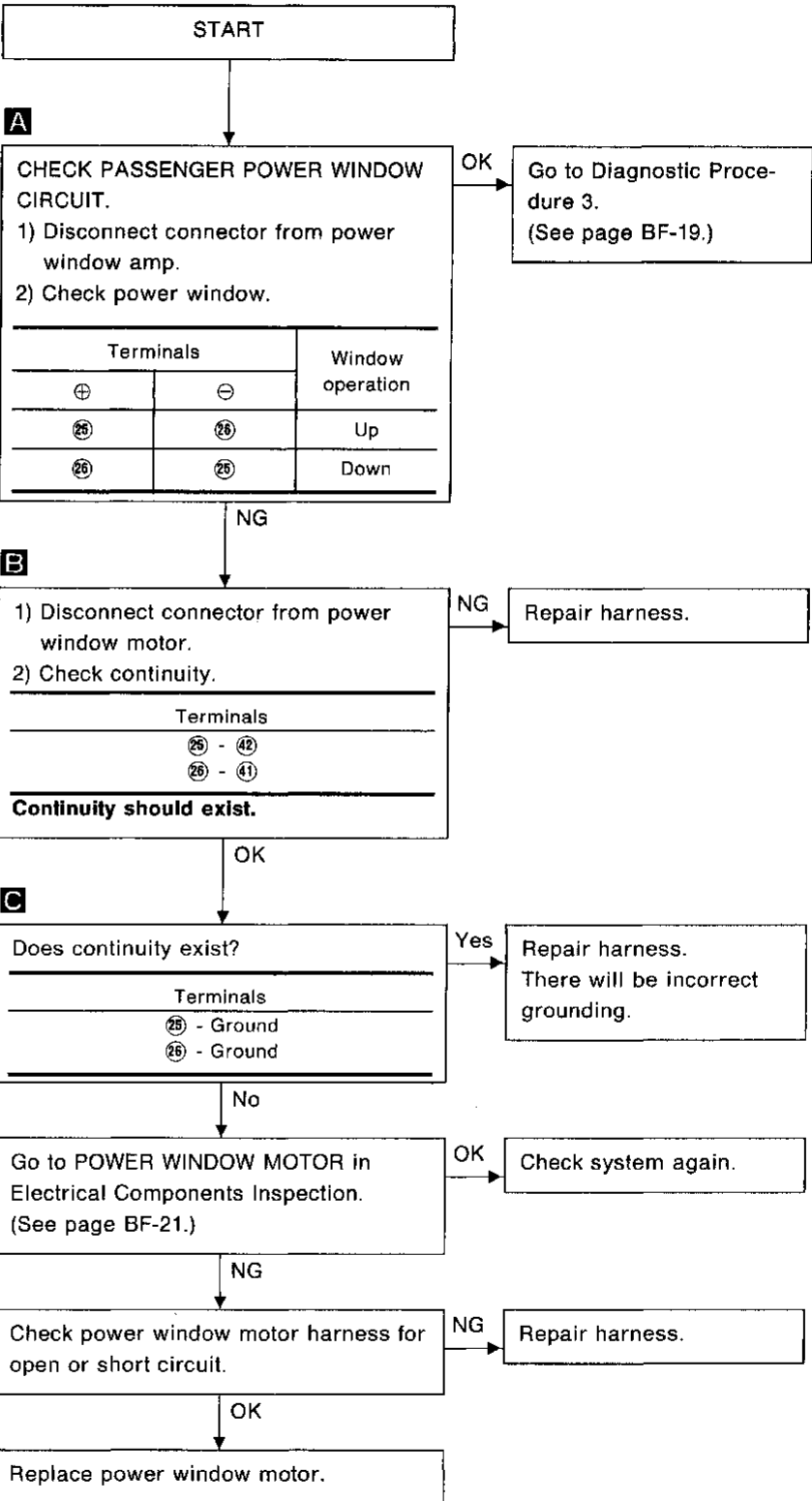
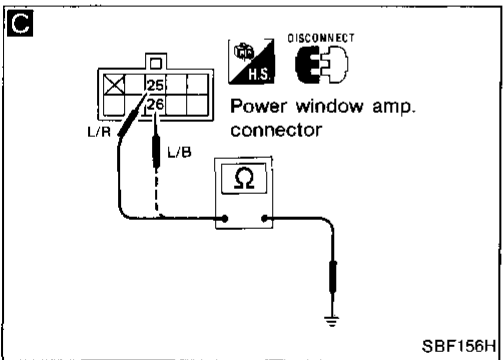
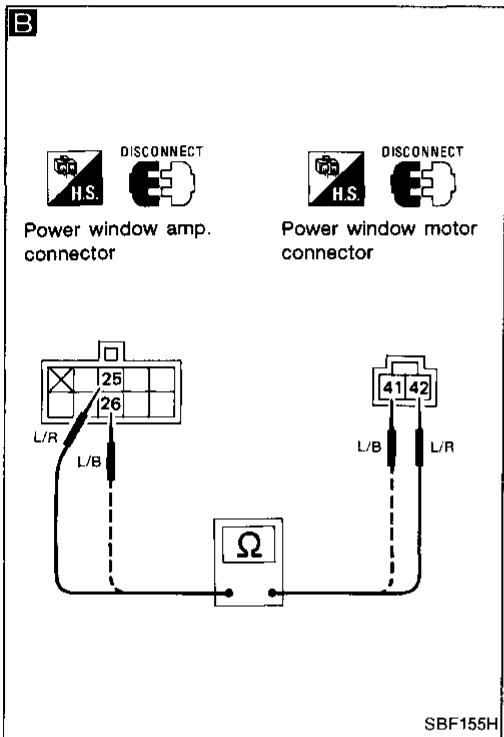
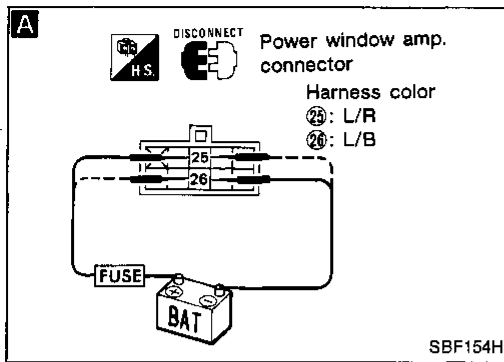

DOOR — Trouble Diagnoses for Power Window

Diagnostic Procedure 3

SYMPTOM:

Passenger power windows cannot be operated but driver's power window can be operated.

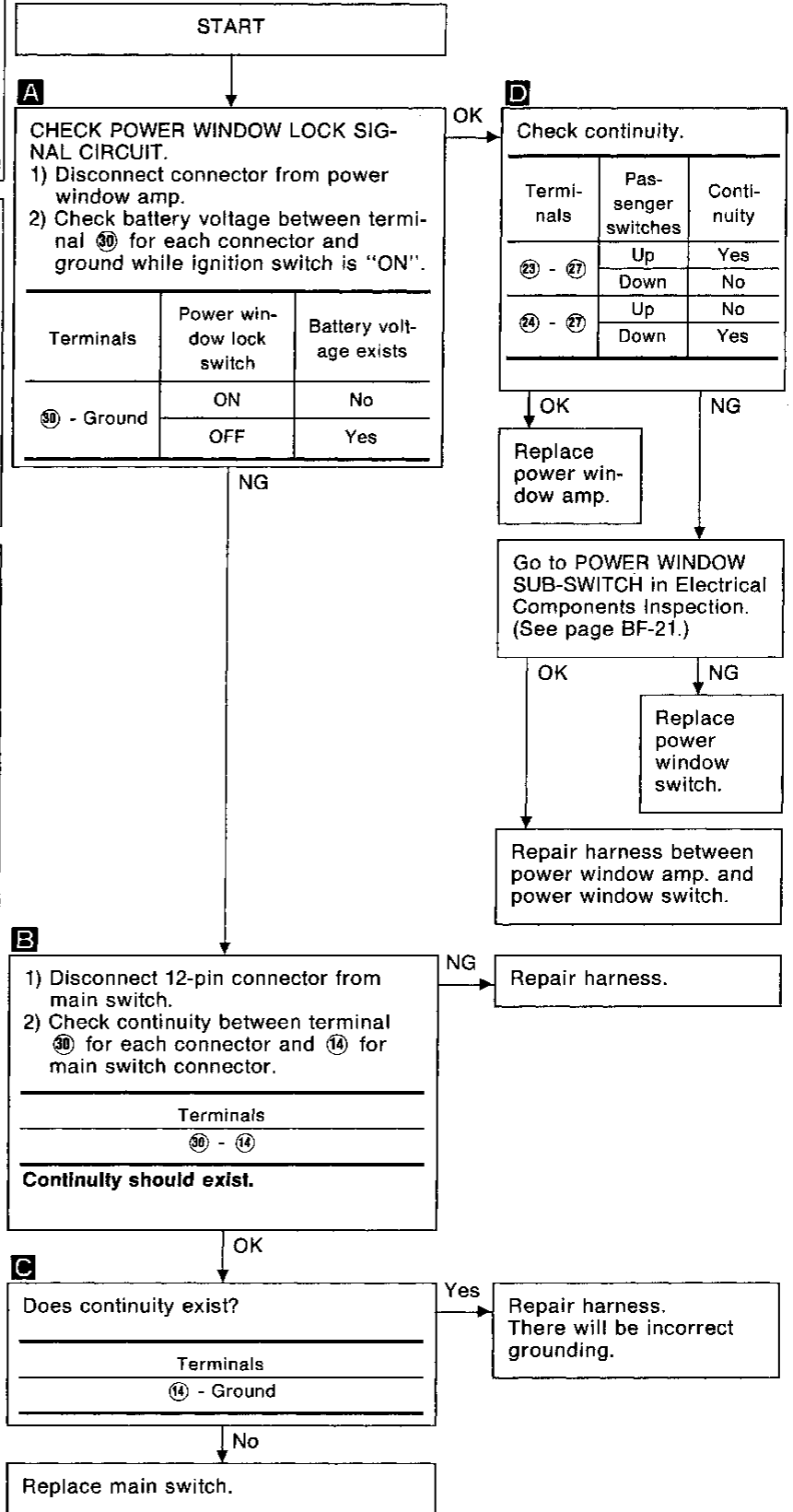
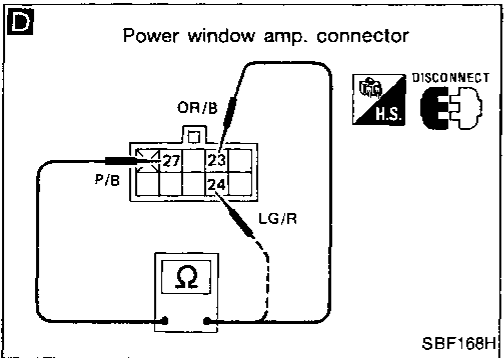
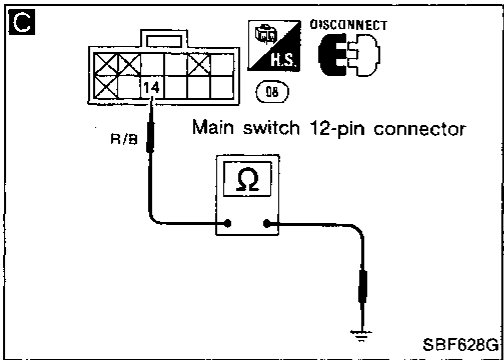
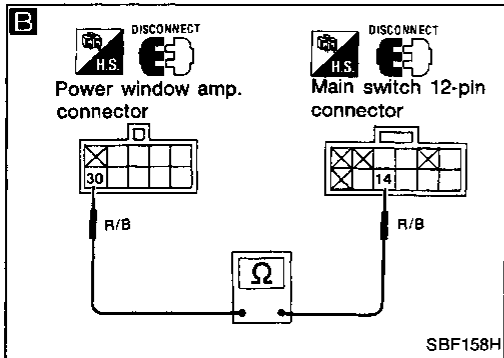
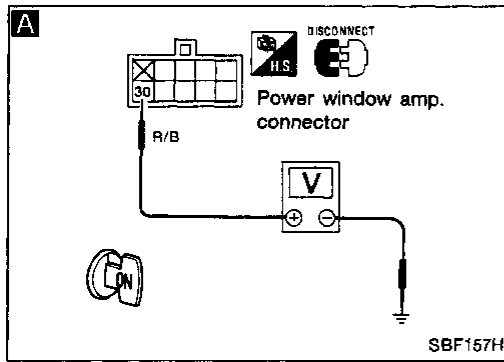

GI
MA
EM
LC
EF & EC
FE
AT
PD
FA
RA
BR
ST
BF
HA
EL
FDX

DOOR — Trouble Diagnoses for Power Window

Diagnostic Procedure 4

SYMPTOM:

Passenger power windows cannot be operated by main switch but can be operated by passenger's switches.

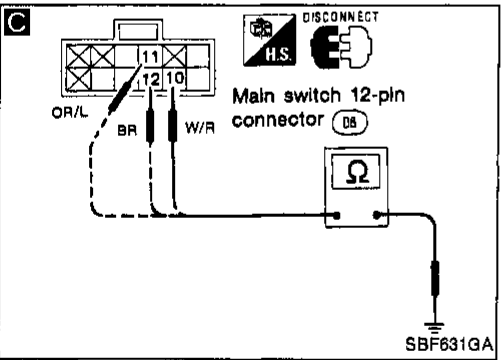
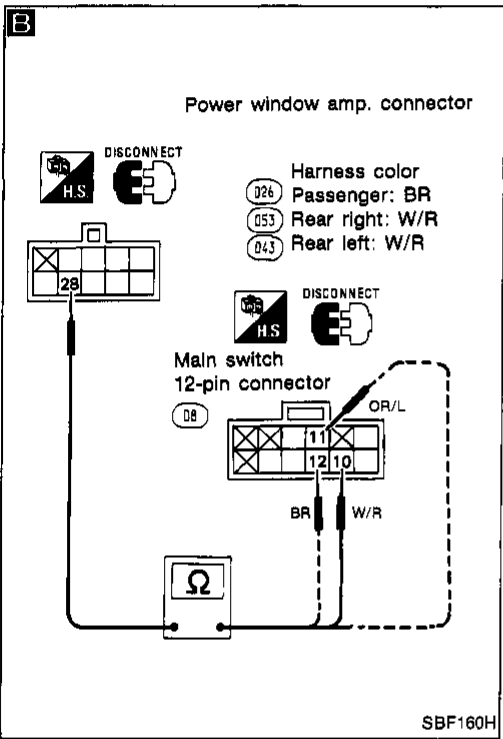
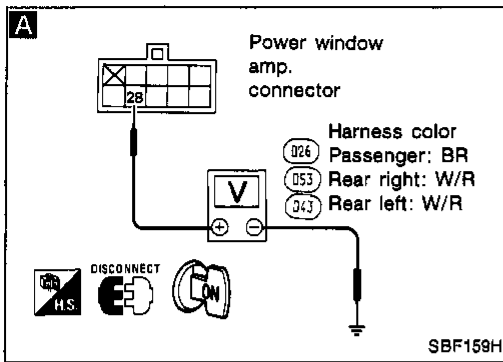

START

A

CHECK DATA LINE SIGNAL CIRCUIT.

- 1) Disconnect connectors from power window amp.
- 2) Check voltage while power window lock switch is "OFF".

Terminals	Main switch operation	Voltage
28 - Ground	Up	Above 12V
	Down	Approx. 4V
	No operation	Approx. 0V

OK → Replace switch.

NG

B

- 1) Disconnect 12-pin connector from main switch.
- 2) Check continuity.

	Terminals
Passenger	12 - 28
Rear left	11 - 28
Rear right	10 - 28

Continuity should exist.

NG → Repair harness.

OK

C

Does continuity exist?

	Terminals
Passenger	12 - Ground
Rear left	11 - Ground
Rear right	10 - Ground

Yes → Repair harness. There will be incorrect grounding.

No → Replace main switch.

DOOR — Trouble Diagnoses for Power Window

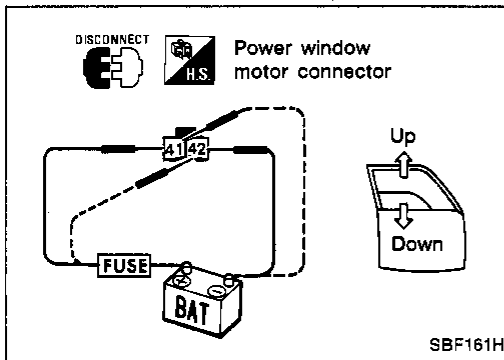

Electrical Components Inspection

POWER WINDOW MOTOR

Terminals		Operation
⊕	⊖	
41	42	Downward
42	41	Upward

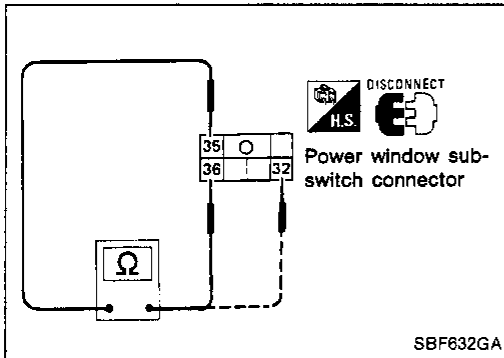

POWER WINDOW SUB-SWITCH

Terminals	Condition	Continuity
32 - 35	UP	Yes
	Down	No
36 - 36	UP	No
	Down	Yes

GI
MA
EM
LC
EF & EC
FE
AT
PD
FA
RA
BR
ST
BF
HA
EL
IDX

DOOR — Power Door Lock

Power Door Lock

WIRING DIAGRAM

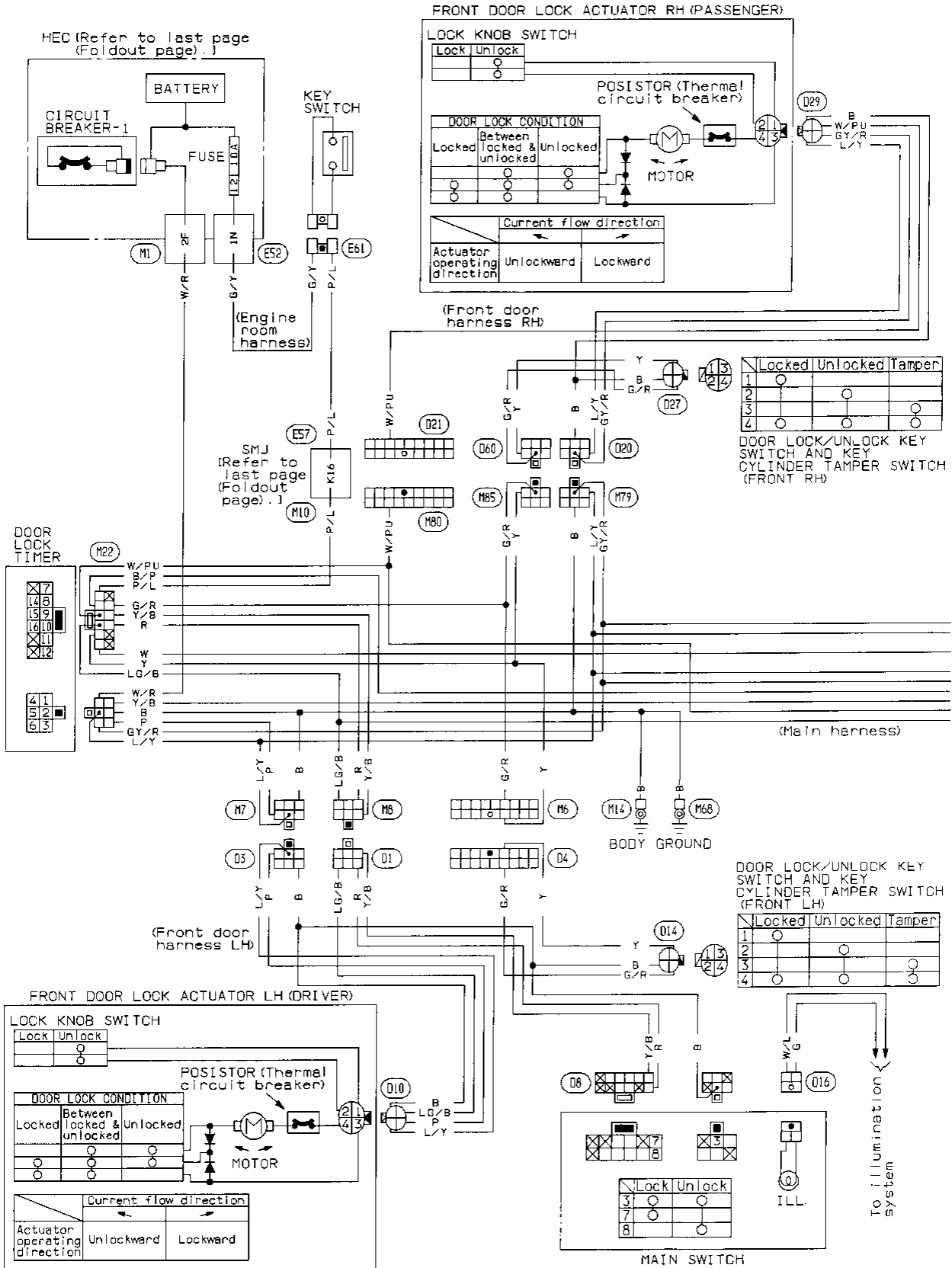

DOOR — Power Door Lock

Power Door Lock (Cont'd)

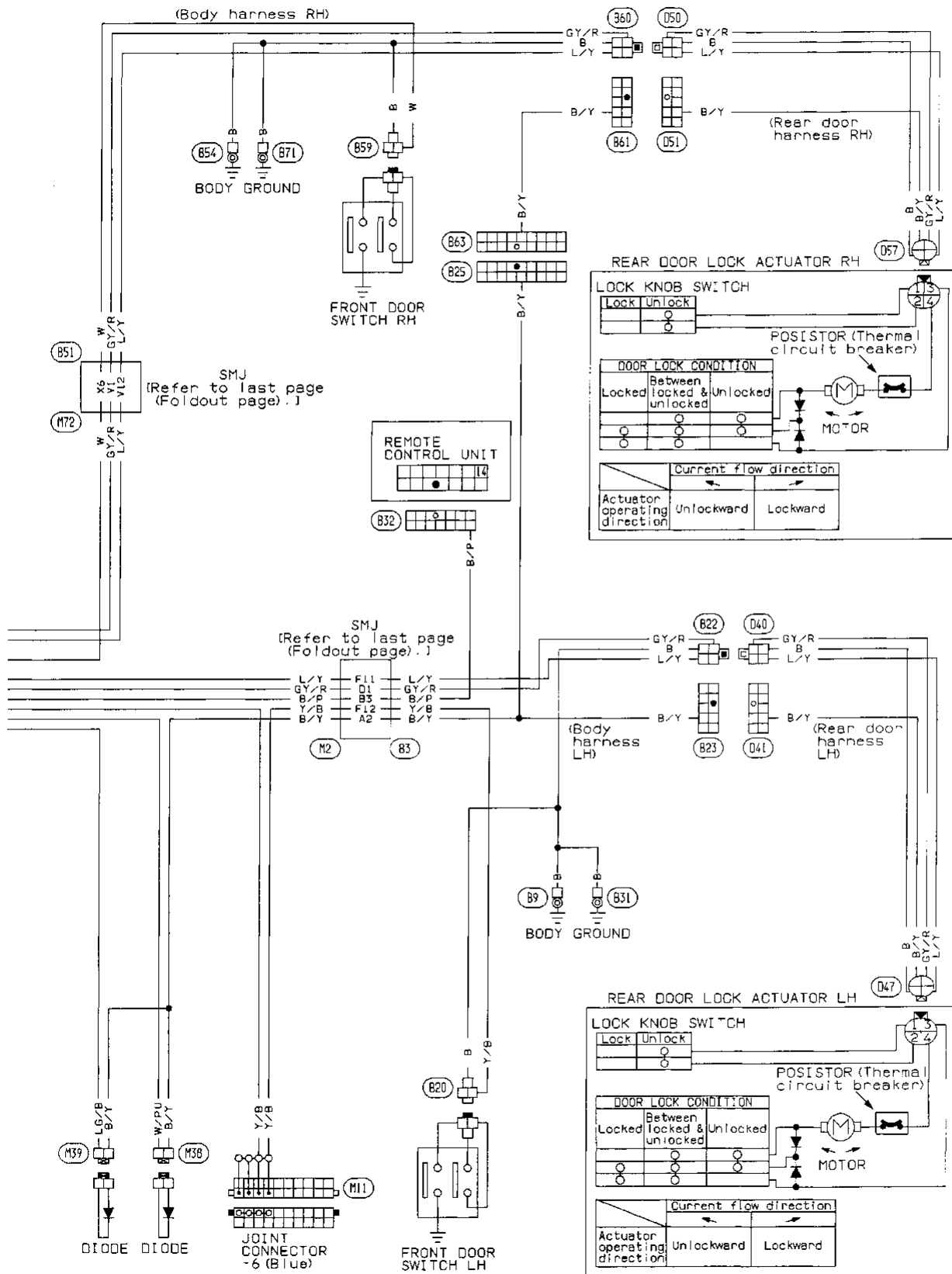

GI
 MA
 EM
 LC
 EF &
 EC
 FE
 AT
 PD
 FA
 RA
 BR
 ST
BF
 HA
 EL
 IDX

DOOR — Power Door Lock

Power Door Lock (Cont'd)

DOOR LOCK TIMER INSPECTION

● Carry out the following inspections:

(1) Check power source and ground.

(2) Check input signals.

If the input signal is NG, go to ELECTRICAL COMPONENTS INSPECTION.

(3) Check output signals.

If the input signal is OK, and the output signal is NG, replace the door lock timer.

If the input signal and output signal are OK, check door lock actuator in ELECTRICAL COMPONENTS INSPECTION.

Lock & unlock operation by lock knob or main switch

(The voltages are approximate values.)

	Connections		Operations			
			Lock knob switch LH	Lock knob switch RH	Main switch	
			Unlock → Lock	Unlock → Lock	N → Unlock	N → Lock
1	Power source		12V	12V	12V	12V
5	Ground		Ground	Ground	Ground	Ground
7	Input signals	Key switch	Either key switch or door switches are off. (Key is not in the ignition or all doors are closed.)			
4		Door switch LH				
12		Door switch RH				
10		Lock knob switch LH	ON (Ground) → OFF (Open)	—	—	—
9		Lock knob switch RH	—	ON (Ground) → OFF (Open)	—	—
14		Door lock key switch	—	—	—	—
16		Lock & unlock switch (lock)	—	—	—	OFF (Open) → ON (Ground)
15		Lock & unlock switch (unlock)	—	—	OFF (Open) → ON (Ground)	—
2	Output signals	Door lock actuator (Lock power source)	0V → 12V → 0V (Approx. 1.0 sec.)	0V → 12V → 0V (Approx. 1.0 sec.)	0V	0V → 12V → 0V (Approx. 1.0 sec.)
3		Door lock actuator (Unlock power source)	0V	0V	0V → 12V → 0V (Approx. 1.0 sec.)	0V

DOOR — Power Door Lock

Power Door Lock (Cont'd)

Unlock operation by door lock key switch

(The voltages are approximate values.)

	Connections		Operations		
			Door lock key switch LH		
			N → Unlock → N → Unlock	Unlock → Lock	
1	Lock source	12V	12V	12V	GI
5	Ground	Ground	Ground	Ground	MA
7	Key switch	Either key switch or door switches are off. (Key is not in the ignition or all doors are closed.)			EM
4	Door switch LH				
12	Door switch RH				
10	Lock knob switch LH	—	—	ON (Ground) → OFF (Open)	LC
9	Lock knob switch RH	—	—	—	EF & EC
14	Door lock key switch	OFF (Open) → ON (Ground) → OFF (Open) → ON (Ground) → OFF (Open)		OFF (Open)	FE
16	Lock & unlock switch (lock)	—	—	—	AT
15	Lock & unlock switch (unlock)	—	—	—	PD
2	Door lock actuator (Lock power source)	0V	0V	0V → 12V → 0V (Approx. 1.0 sec.)	FA
3	Door lock actuator (Unlock power source)	0V	0V → 12V → 0V (Approx. 1.0 sec.)	0V	RA

- The second unlock signal of door lock key switch is counted when it is within approximately 4 seconds of the first signal.
- Lock operation by key is mechanically transmitted to the lock knob switch.
- Operation of door lock key switch RH is the same as LH.

GI

MA

EM

LC

EF & EC

FE

AT

PD

FA

RA

BR

ST

BF

HA

EL

IDX

DOOR — Power Door Lock

Power Door Lock (Cont'd)

Key reminder operation

(The voltages are approximate values.)

	Connections	Operations					
		Lock knob switch LH			Main switch		
		Unlock	→ Lock	→ Automatically unlocked	N	→ Lock	→ Automatically unlocked
1	Power source	12V			12V		
5	Ground	0V			0V		
7	Key switch	ON (12V) — Key is in the ignition.					
4	Door switch LH	ON (Ground) — Either door is open.					
12	Door switch RH						
10	Lock knob switch LH	ON (Ground)	→ OFF (Open)	→ ON (Ground)	—		
9	Input signal Lock knob switch RH	—			—		
14	Door lock key switch	—			—		
16	Lock & unlock switch lock	—			OFF (Open)	→ ON (Ground)	→ OFF (Open)
15	Lock & unlock switch unlock	—			—		
2	Output signal Door lock actuator (Lock power source)	0V	→ 12V	→ 0V	0V	→ 12V	→ 0V
		(Approx. 0.3 sec.)			(Approx. 0.3 sec.)		
3	Door lock actuator (Unlock power source)	0V	→ 12V	→ 0V	0V	→ 12V	→ 0V
		(Approx. 1.4 sec.)			(Approx. 1.4 sec.)		

● Operation of lock knob switch RH is the same as LH.

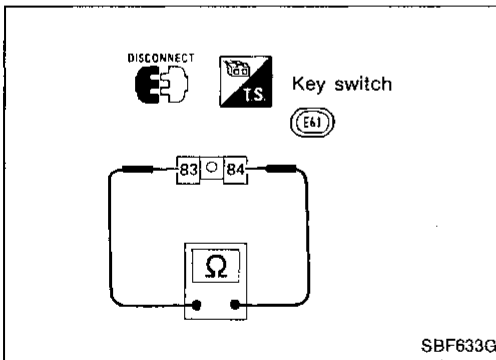

ELECTRICAL COMPONENTS INSPECTION

Key switch

Terminals	Condition	Continuity
83 - 84	Key is in the ignition.	Yes
	Key is not in the ignition.	No

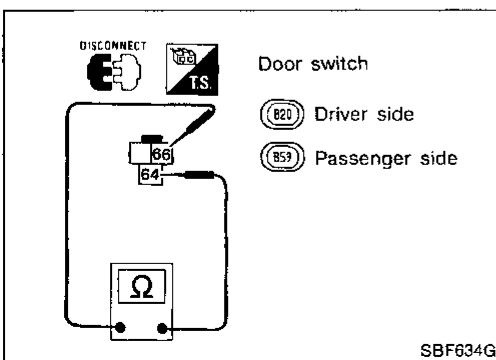

Door switch

Terminals	Condition	Continuity
85 - 86	Door is closed.	No
	Door is open.	Yes

DOOR — Power Door Lock

Power Door Lock (Cont'd)

Lock knob switch

Terminals	Condition	Continuity
① - ②	Lock	No
	Unlock	Yes

GI

MA

EM

LC

EF &
EC

FE

AT

PD

FA

RA

BR

ST

BF

HA

EL

IDX

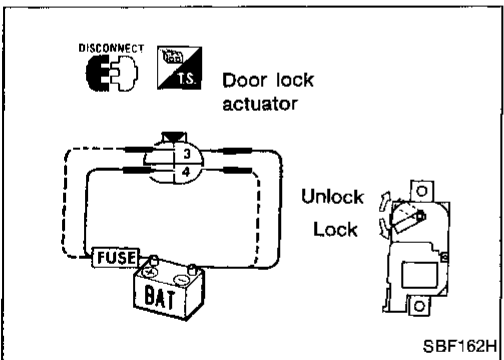
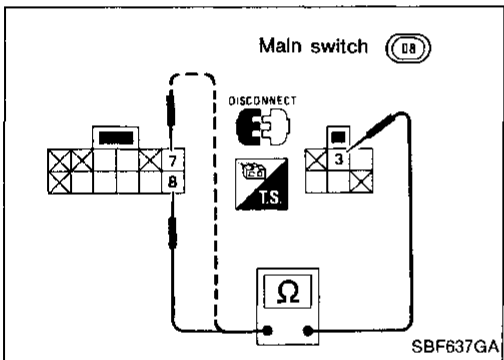
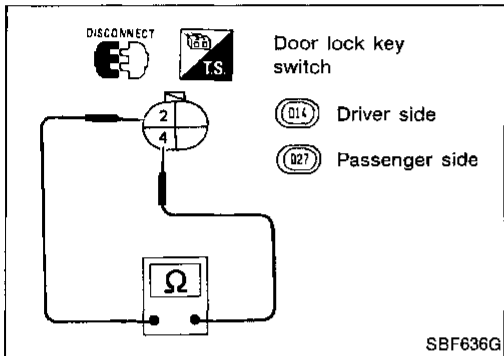
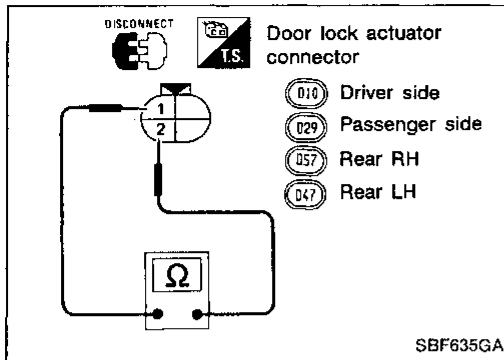

Door unlock key switch

Terminals	Operation	Continuity
② - ④	Key is turned toward unlock	Yes
	Except above	No

Lock and unlock switch

Terminals	Operation	Continuity
③ - ⑦	Lock	Yes
	Neutral and unlock	No
③ - ⑧	Unlock	Yes
	Neutral and unlock	No

Door lock actuator

Terminals		Operation
⊕	⊖	
③	④	Lock
④	③	Unlock

MULTI-REMOTE CONTROL SYSTEM

Wiring Diagram

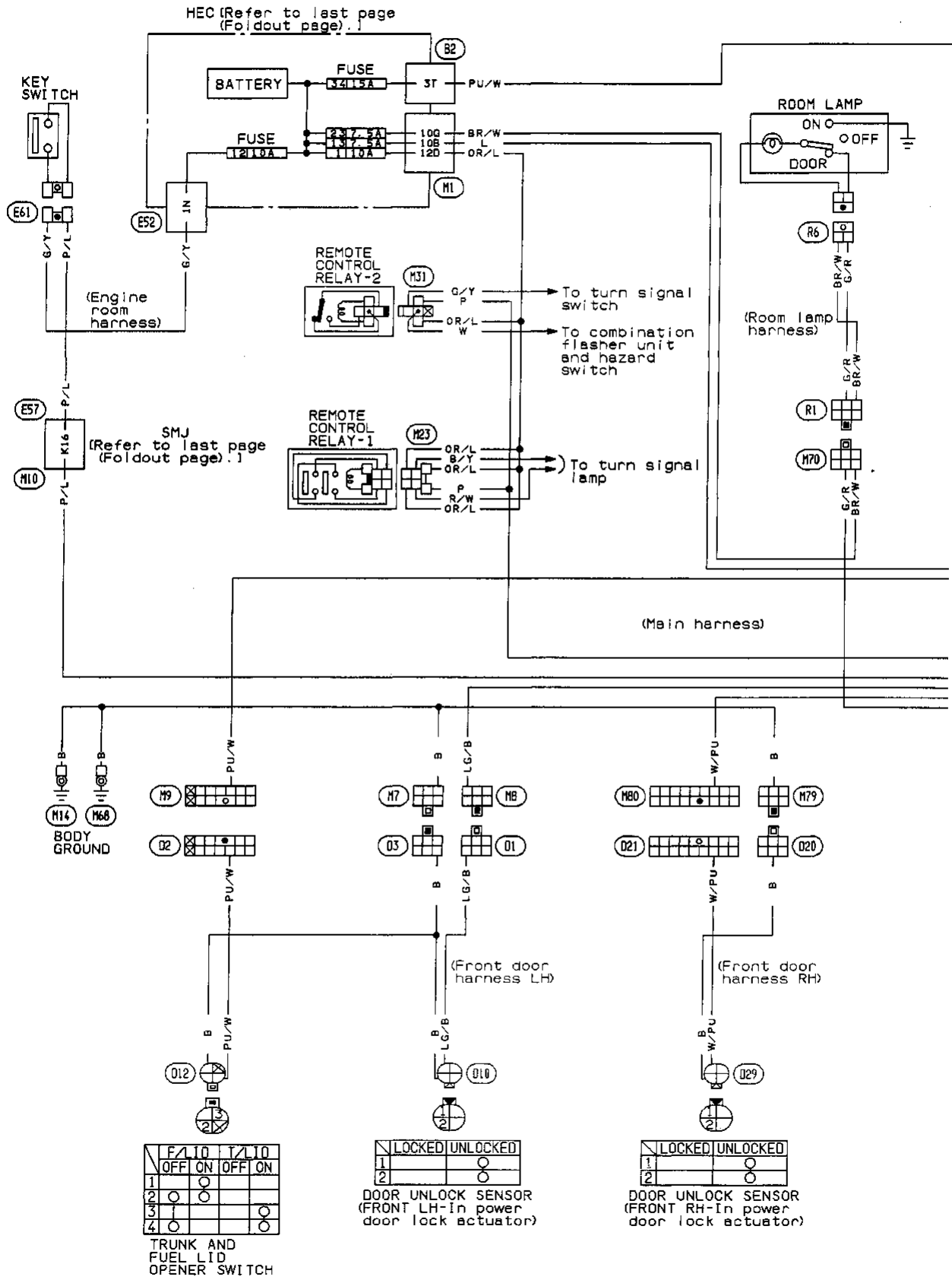

MULTI-REMOTE CONTROL SYSTEM

Wiring Diagram (Cont'd)

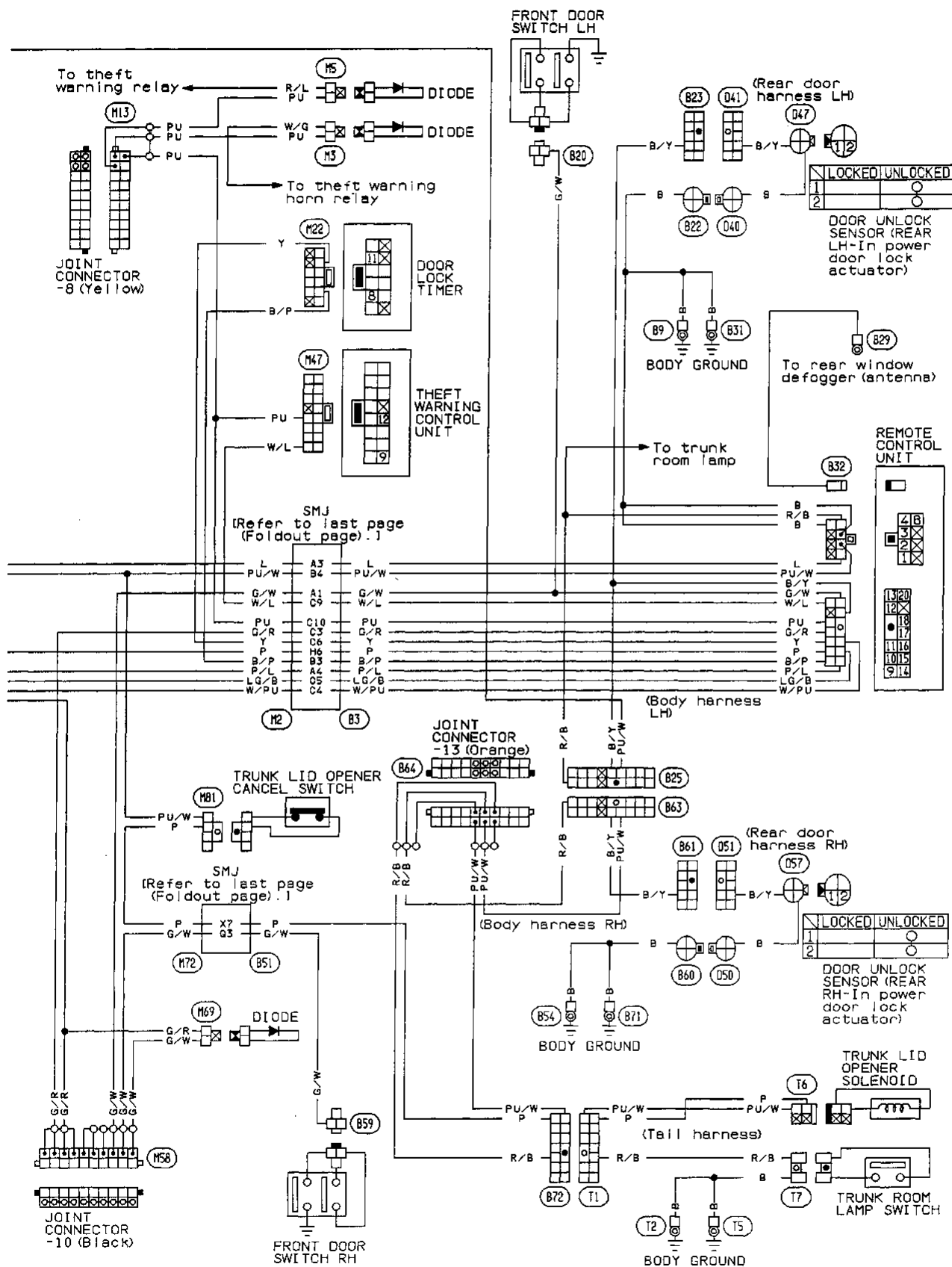

GI
MA
EM
LC
EF & EC
FE
AT
PD
FA
RA
BR
ST
BF
HA
EL
IDX

MULTI-REMOTE CONTROL SYSTEM

Circuit Diagram for Quick Pinpoint Check

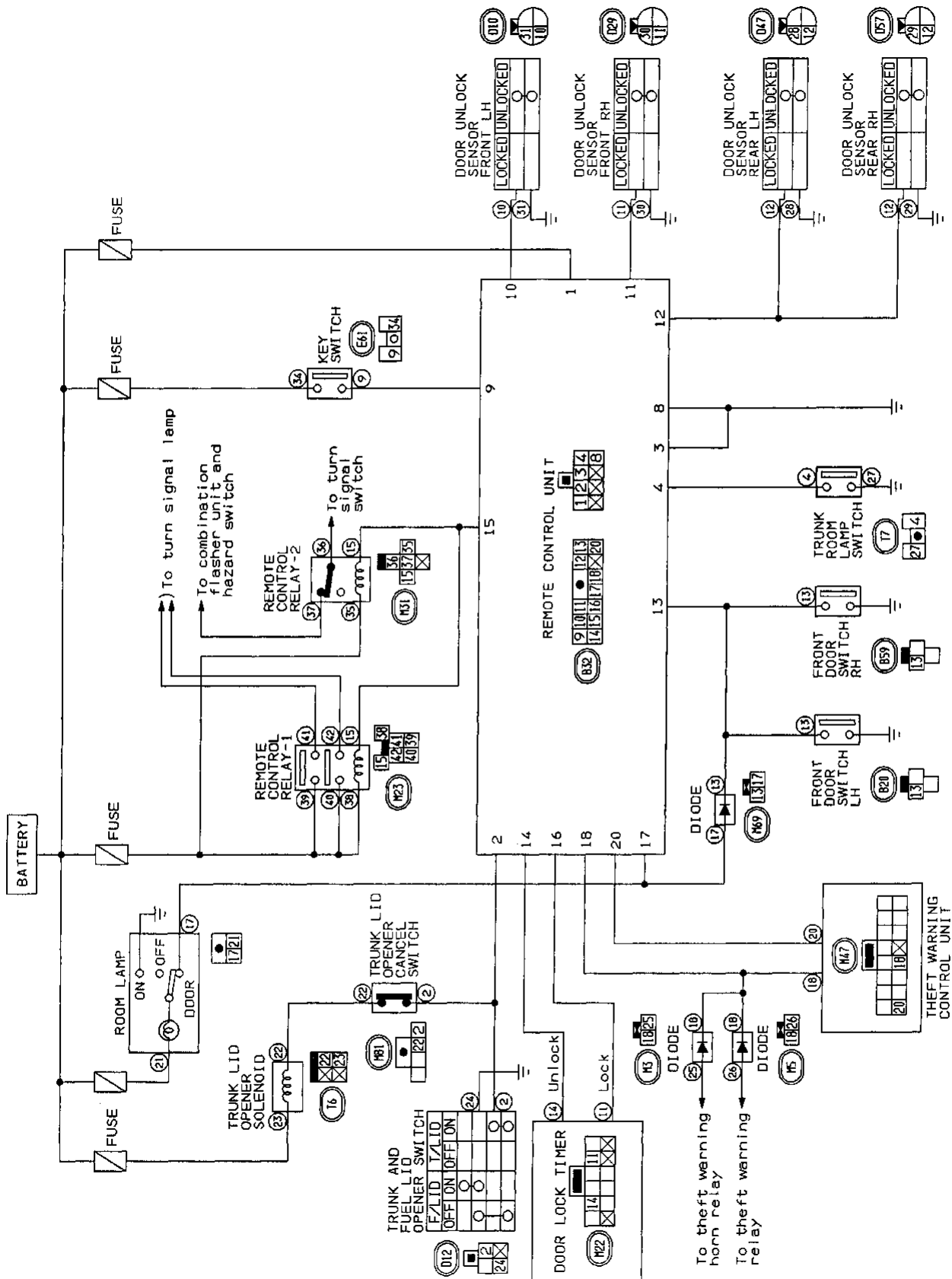

Trouble Diagnoses Preliminary Inspection

PRELIMINARY INSPECTION PROCEDURE 1

All functions of remote control system function.

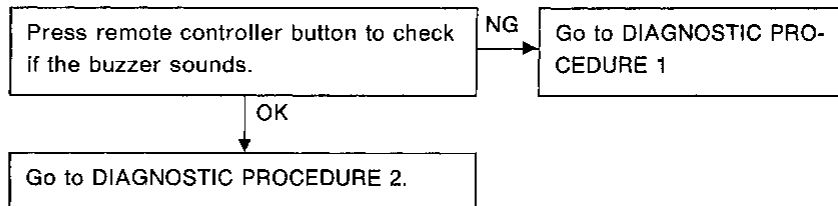

GI
MA

PRELIMINARY INSPECTION PROCEDURE 2

Door lock and unlock does not function.

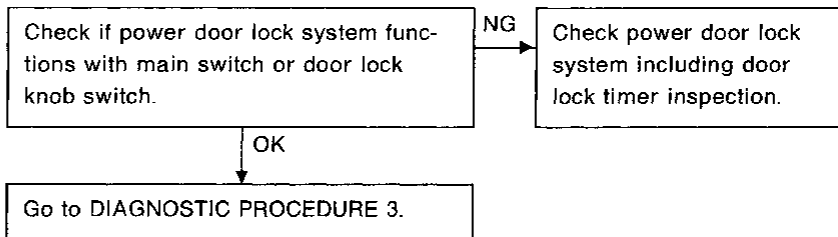

EM
LC
EF & EC
FE

PRELIMINARY INSPECTION PROCEDURE 3

Trunk opener function does not function.

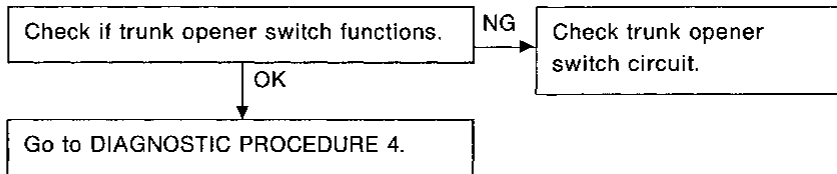

AT
PD
FA
RA

PRELIMINARY INSPECTION PROCEDURE 4

Interior light does not function.

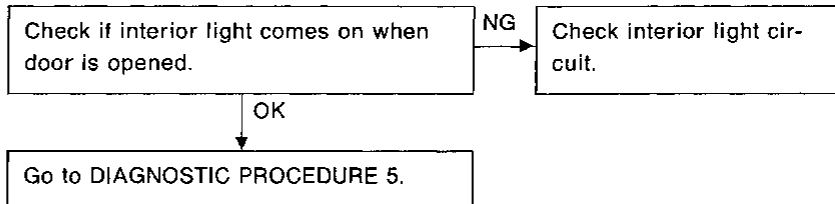

BR
ST

BF

PRELIMINARY INSPECTION PROCEDURE 5

Panic alarm does not function.

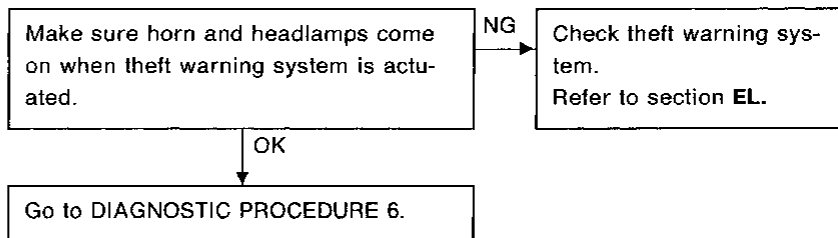

HA
EL
IDX

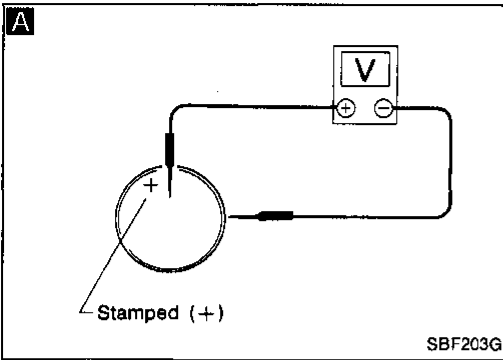

Trouble Diagnoses

DIAGNOSTIC PROCEDURE 1

Remote controller buzzer does not sound when the button is pressed.

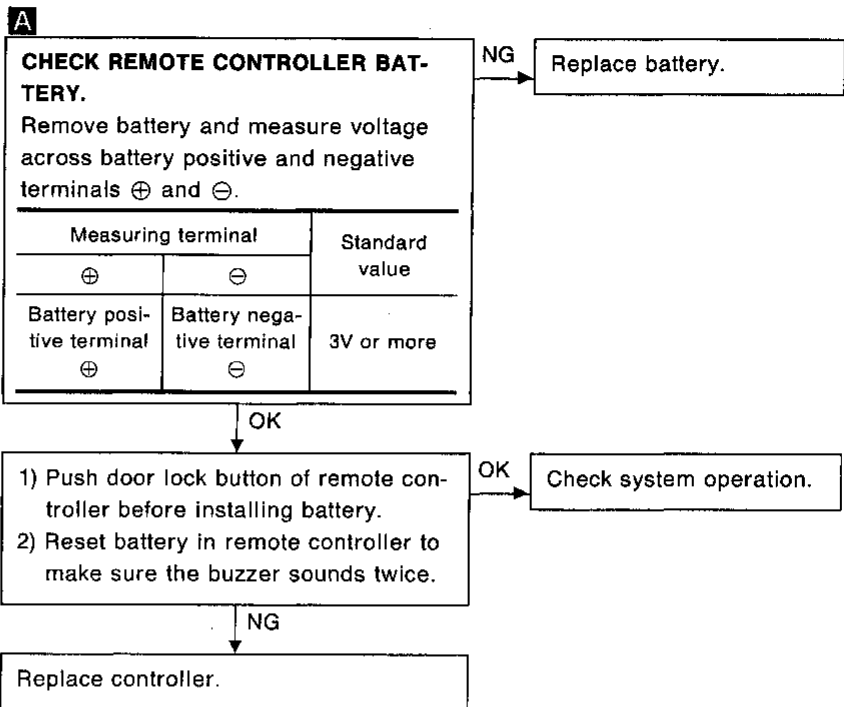

Note:

Remote controller does not function if battery is not set correctly.

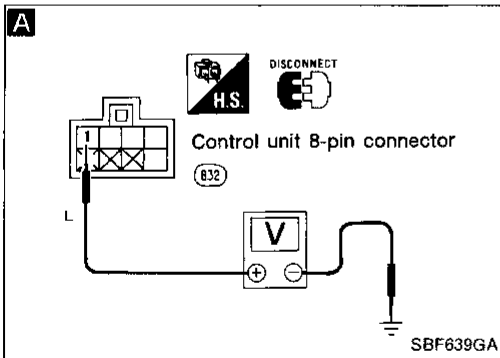

DIAGNOSTIC PROCEDURE 2

All remote controls do not function even if remote controller buzzer does sound.

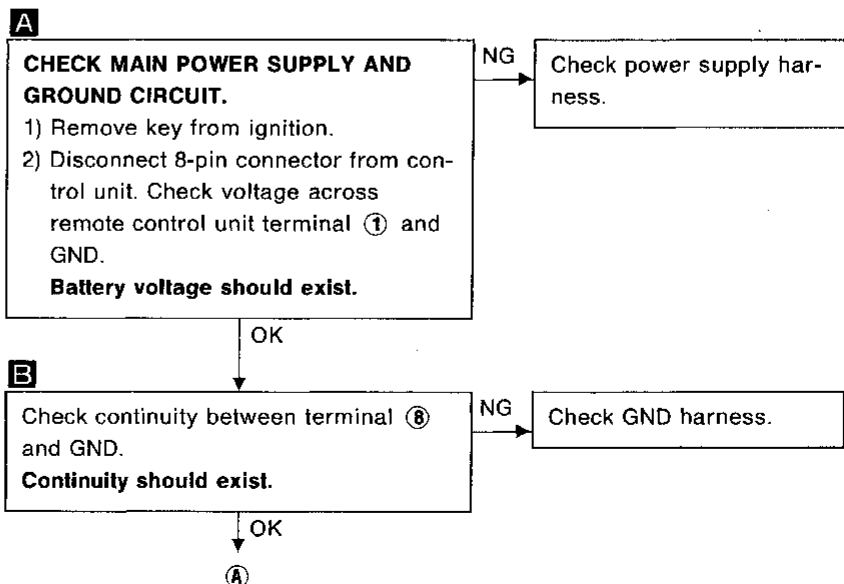
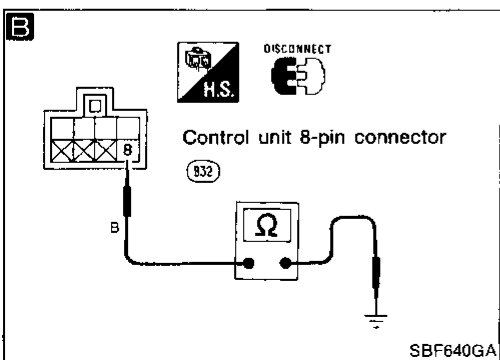

MULTI-REMOTE CONTROL SYSTEM

Trouble Diagnoses (Cont'd)

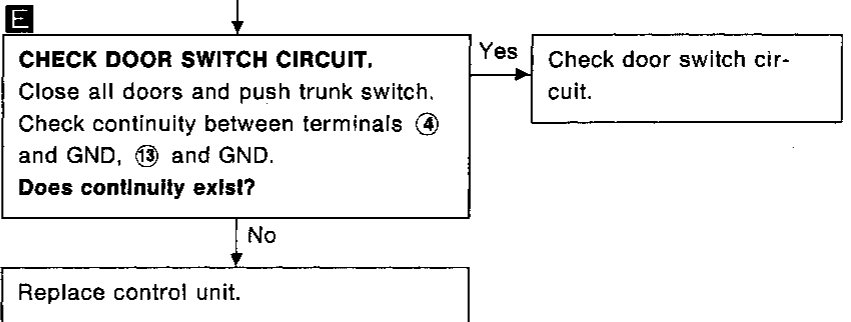
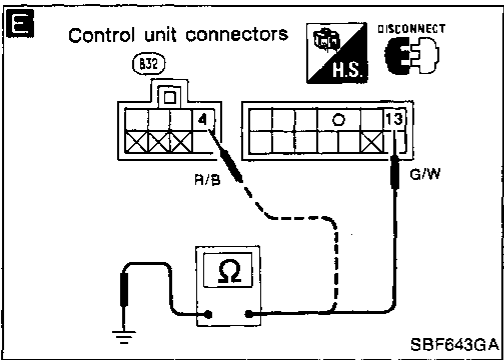
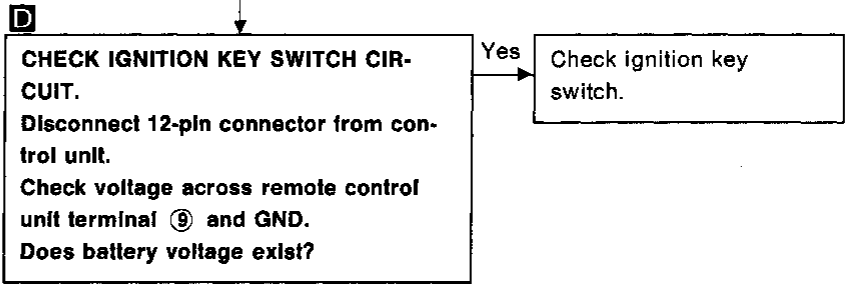
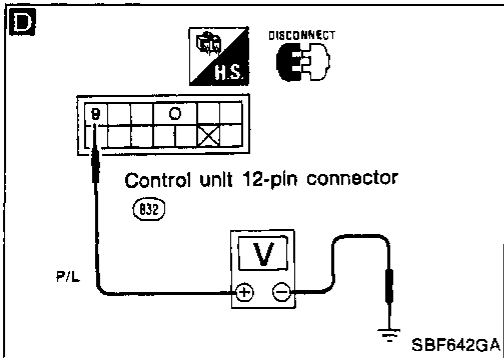
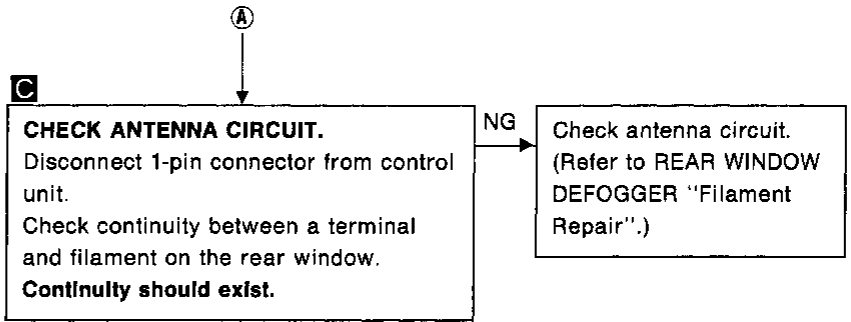
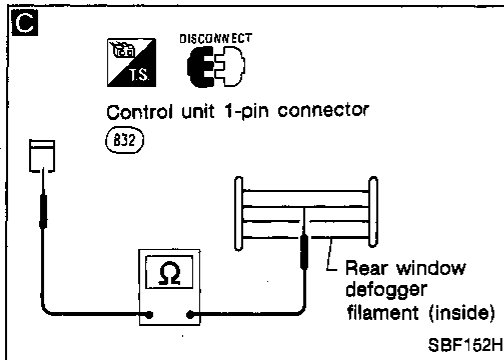

GI

MA

EM

LC

EF & EC

FE

AT

PD

FA

RA

BR

ST

BF

HA

EL

IDX

MULTI-REMOTE CONTROL SYSTEM

Trouble Diagnoses (Cont'd)

DIAGNOSTIC PROCEDURE 3

Door lock and unlock remote control do not function. Everything else does not function.

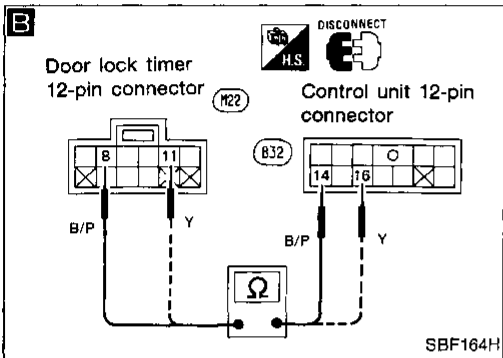
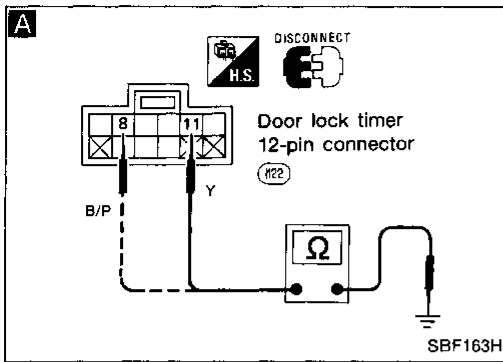

A

CHECK DOOR LOCK AND UNLOCK SIGNAL FOR DOOR LOCK TIMER.

- 1) Remove key from ignition.
- 2) Close all doors and trunk.
- 3) Remove door lock timer 12-pin connector.

Push remote controller buttons and check continuity between terminals ⑪ and GND, ⑧ and GND.

Terminals	Operation	Continuity
⑪ - GND	Lock	Yes
	Unlock	No
⑧ - GND	Unlock	Yes
	Lock	No

OK → Check power door lock system.

NG

Does continuity exist continually?

Yes → Repair harness. (There might be incorrect grounding.)

No

B

Remove remote control unit 12-pin connector.

Check continuity between remote control unit terminals and door lock timer.

Terminals	
Remote control	Door lock timer
⑭	⑧
⑯	⑪

Continuity should exist.

OK → Replace remote control unit.

NG → Repair harness.

MULTI-REMOTE CONTROL SYSTEM

Trouble Diagnoses (Cont'd)

DIAGNOSTIC PROCEDURE 4

Trunk open remote control does not function. Everything else does function.

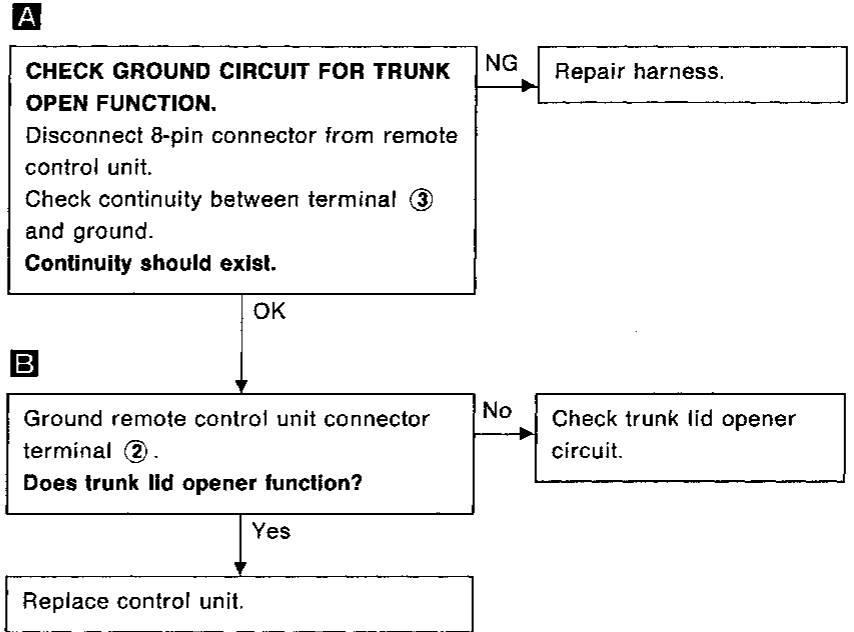
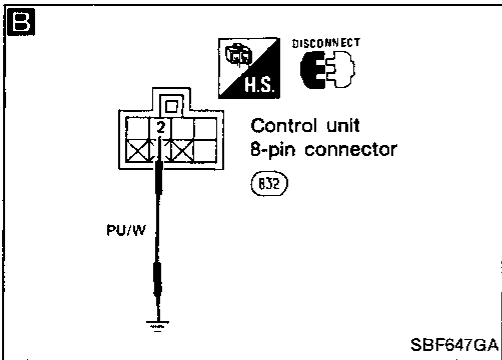
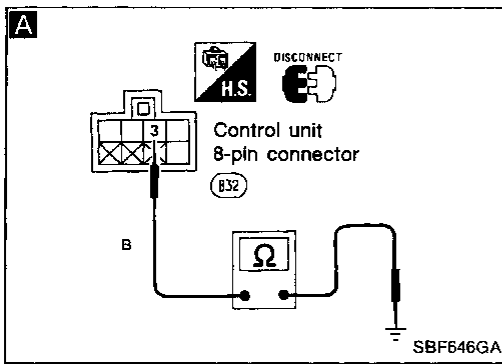

GI
MA
EM
LC
EF & EC
FE
AT
PD
FA
RA
BR
ST
BF
HA
EL
IDX

DIAGNOSTIC PROCEDURE 5

Interior light does not function. Everything else does function.

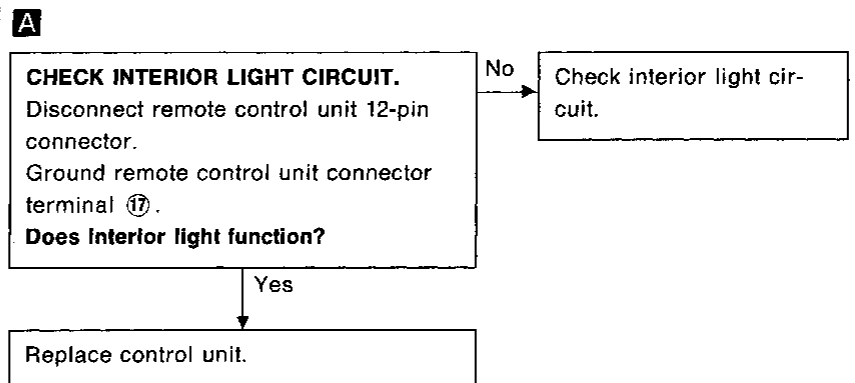
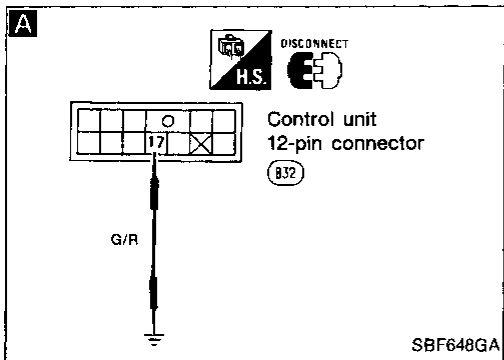

MULTI-REMOTE CONTROL SYSTEM

Trouble Diagnoses (Cont'd)

DIAGNOSTIC PROCEDURE 6

Panic alarm function does not function. Everything else does function.

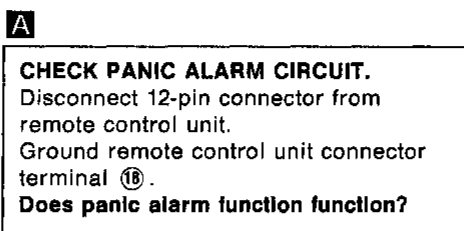
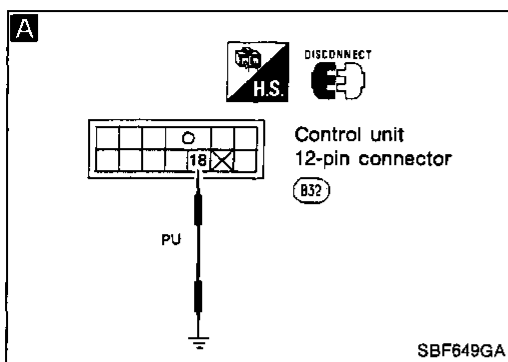

Yes → Replace control unit.

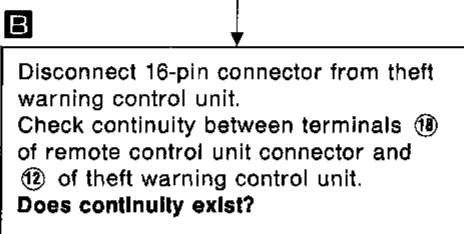
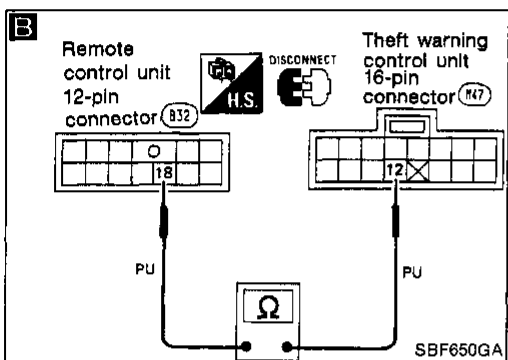

Yes → Check theft warning system. Refer to section EL.

No → Repair harness.

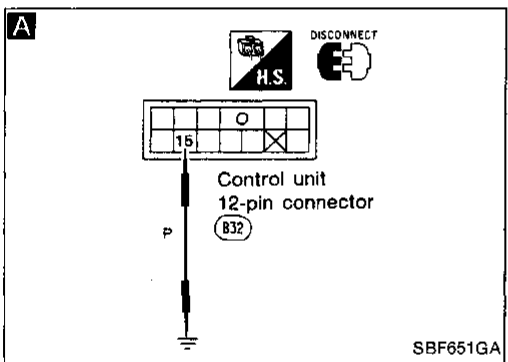

DIAGNOSTIC PROCEDURE 7

Hazard indicator flashing does not function. Everything else does function.

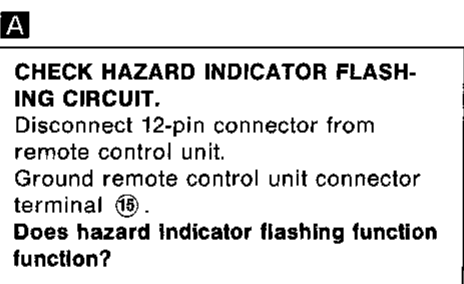

Yes → Replace control unit.

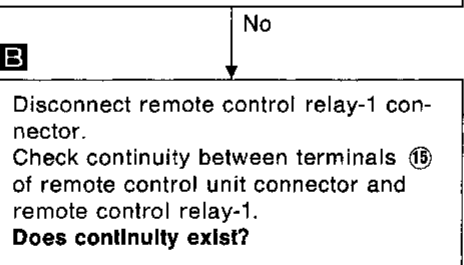
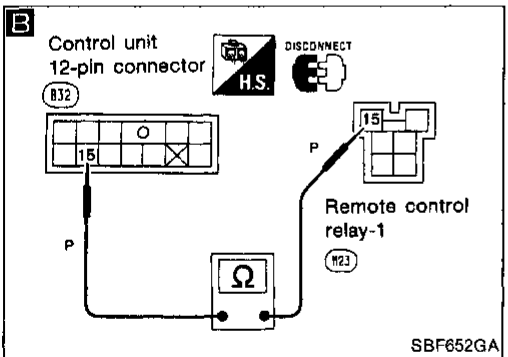

Yes → Check remote control relay-1 and harness.

No → Repair harness.

MULTI-REMOTE CONTROL SYSTEM

Trouble Diagnoses (Cont'd)

DIAGNOSTIC PROCEDURE 8

Theft warning is actuated when door is unlocked or trunk lid is opened with remote control.

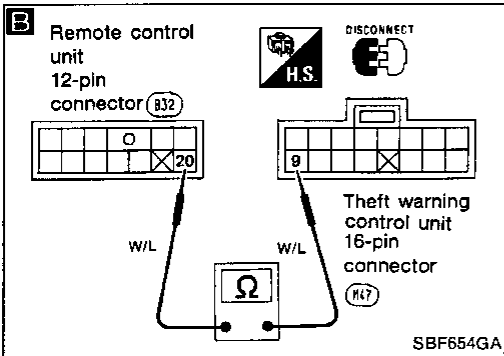
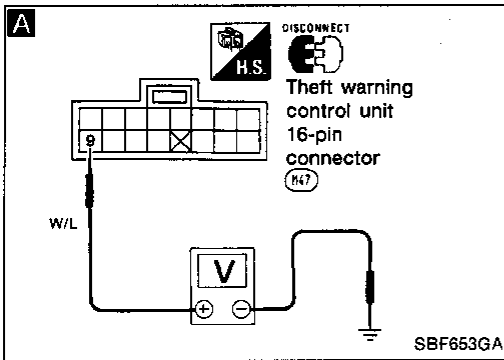

A

CHECK THEFT WARNING CANCEL SIGNAL CIRCUIT.

- 1) Disconnect theft warning control unit 16-pin connector.
- 2) Remove key from ignition.
- 3) Close all doors and trunk lid.

Check voltage between terminal ⑨ and GND when door unlock remote control function is operated.

Terminal	Operation	Voltage
⑨ - GND	Door is unlocked	12V → 0V → 12V

Does voltmeter gauge move when door is unlocked?

Yes → Check theft warning system. Refer to section EL.

No ↓

B

Disconnect 12-pin connector from remote control unit. Check continuity between terminals ⑳ of remote control unit and ⑨ of theft warning control unit. **Does continuity exist?**

Yes → Replace remote control unit.

No ↓

Repair harness.

GI

MA

EM

LC

EF & EC

FE

AT

PD

FA

RA

BR

ST

BF

HA

EL

IDX

Replacing Remote Controller or Control Unit

If the remote controller or the control unit needs to be replaced or if an additional remote controller needs to be set, enter the Identity (ID) code manually.

ID Code Entry Procedure

To enter the ID code, follow this procedure.

“Setting mode”.

Three steps must be followed to establish the “setting mode”.

- (1) Open the trunk.
- (2) Close and lock all doors.
- (3) Insert and remove the key from the ignition more than six times within 10 seconds.

- **At this time, the original ID codes are eliminated.**

ID code entry:

- (4) Unlock and lock the driver's door inside lock lever once.
- (5) Push lock button on the new remote controller once (for example, if door is locked using the remote controller during this ID code entry enable state, a new ID code can be entered).

- **At this time, the new ID code is entered.**

- (6) If you need to enter additional remote controllers (including the original) repeat the step (4) and (5) for each additional controller.
- (7) This ID code entry enable state and setting mode remain until any one of the doors is opened.

Note

- **If the same ID code that existing in the memory is input, the entry is canceled, and no ID code will be entered.**
- **Entry of maximum four ID codes is allowed and any attempt to enter more will be ignored.**
- **Any ID codes entered after termination of the “setting” mode will not be accepted. Additionally remote control signals will be inhibited when an ID code has not been entered during the “setting” mode.**

INSTRUMENT PANEL

CAUTION:

- Disconnect ground terminal from battery in advance.
- Disconnect air bag system line in advance.
- Never force the air bag lid open or tamper with it as this may adversely affect air bag performance.
- Be careful not to scratch pad and other parts.

REMOVAL — Instrument panel assembly

- ① Remove steering wheel. Disengage air bag system in advance.
- ② Remove steering column cover.
- ③ Remove lower instrument panel on driver's side.
- ④ Remove cluster lid D.
- ⑤ Remove cluster lid A.
- ⑥ Remove combination meter.
- ⑦ Remove lower instrument cover on passenger side.
- ⑧ Remove glove box assembly.
- ⑨ Remove A/T finisher.
- ⑩ Remove cluster lid C.
- ⑪ Remove A/C control and radio.
- ⑫ Remove center ventilator.
- ⑬ Remove console mask.
- ⑭ Remove cup holder.
- ⑮ Remove console pocket.
- ⑯ Remove lower instrument center panel.
- ⑰ Remove defroster grille.
- ⑱ Remove front pillar garnish. Refer to "SIDE AND FLOOR TRIM" in "Interior" for details.
- ⑲ Remove instrument panel and pads.

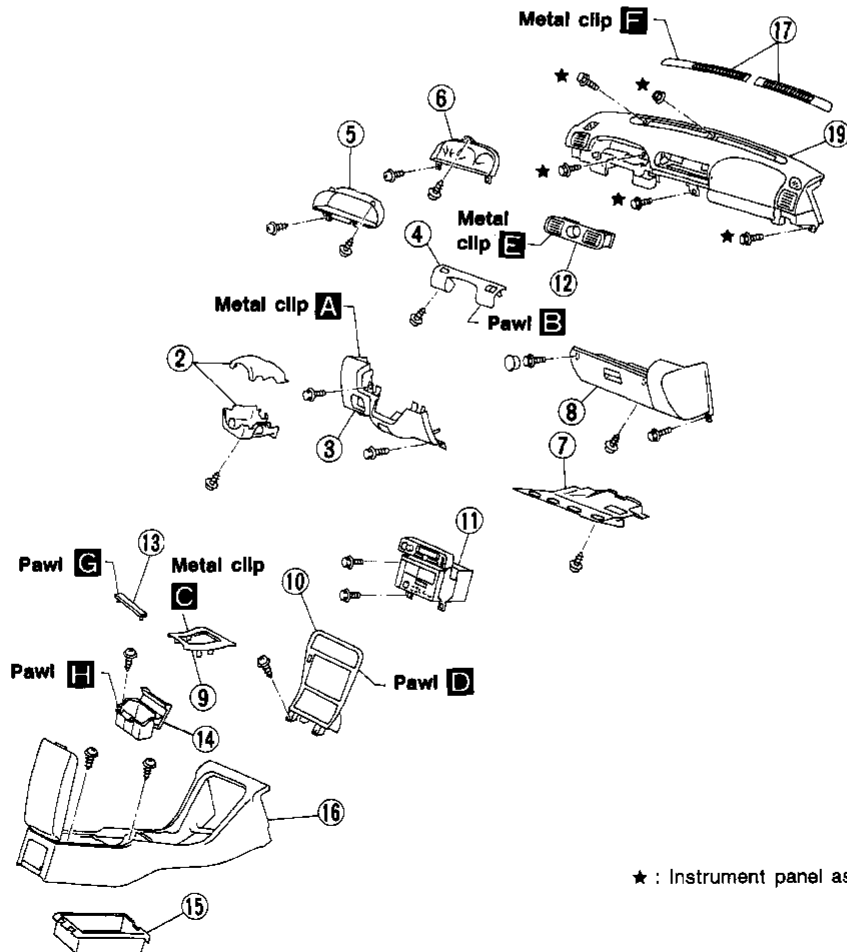

★ : Instrument panel assembly mounting bolts

GI
MA
EM
LC
EF &
EC
FE
AT
PD
FA
RA
BR
ST
BF
HA
EL
IDX

INSTRUMENT PANEL

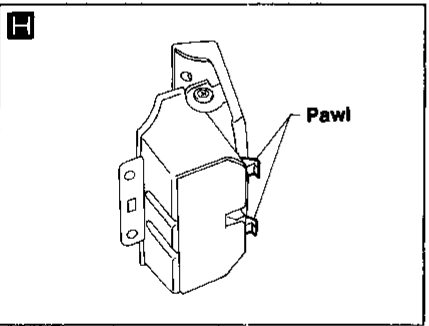
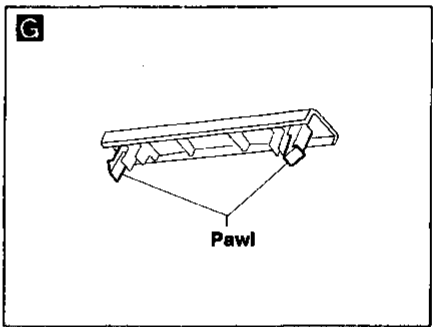
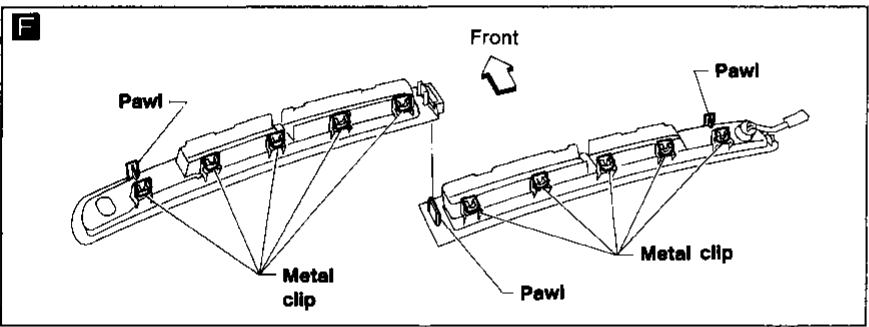
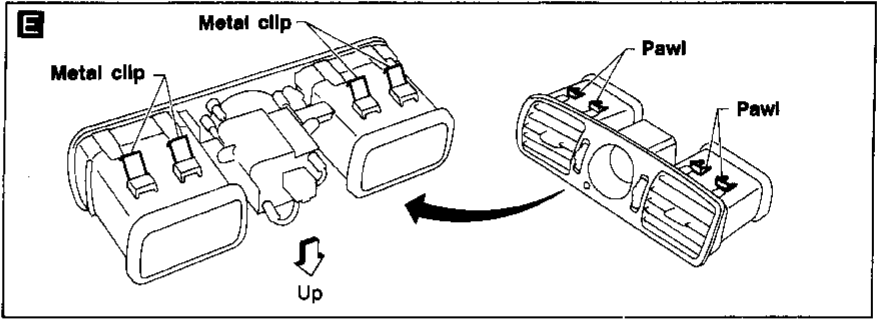
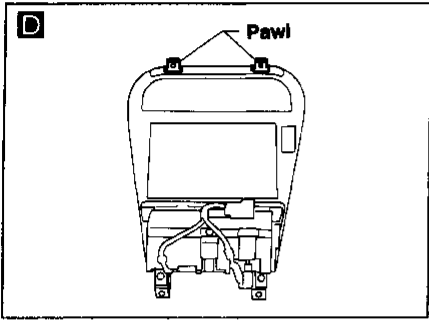
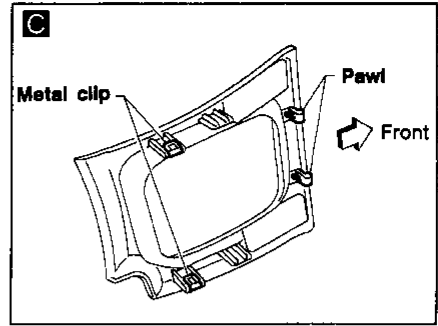
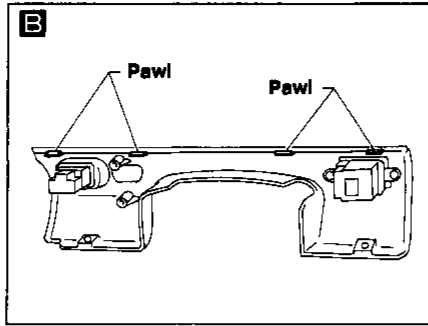
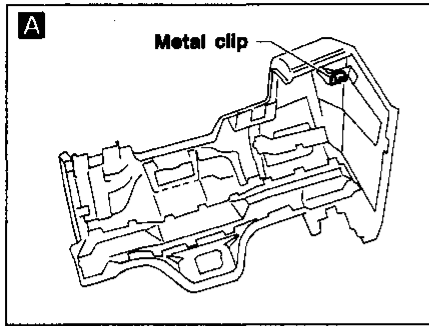

Interior

SIDE AND FLOOR TRIM — Passenger room

CAUTION:

- Be sure to remove front, center and rear pillar garnishes by pulling them straight out. Use a long flat-bladed screwdriver when removing metal clips from rear pillar garnish **A**.
- Wrap the tip of flat-bladed screwdriver with a cloth when removing metal clips from garnishes.

Removal — Body side trim

- ① Remove front and rear seats. For details, refer to "Front Seat" and "Rear Seat" in "SEAT".
- ② Remove front and rear kick plates.
- ③ Remove dash side lower finishers.
- ④ Remove front and rear body side welts.
- ⑤ Remove front pillar garnishes.
- ⑥ Remove center pillar lower garnishes.
- ⑦ Remove center pillar upper garnishes.
- ⑧ Remove high-mounted stop lamp.
- ⑨ Remove rear parcel shelf finisher.
- ⑩ Remove rear pillar garnishes.

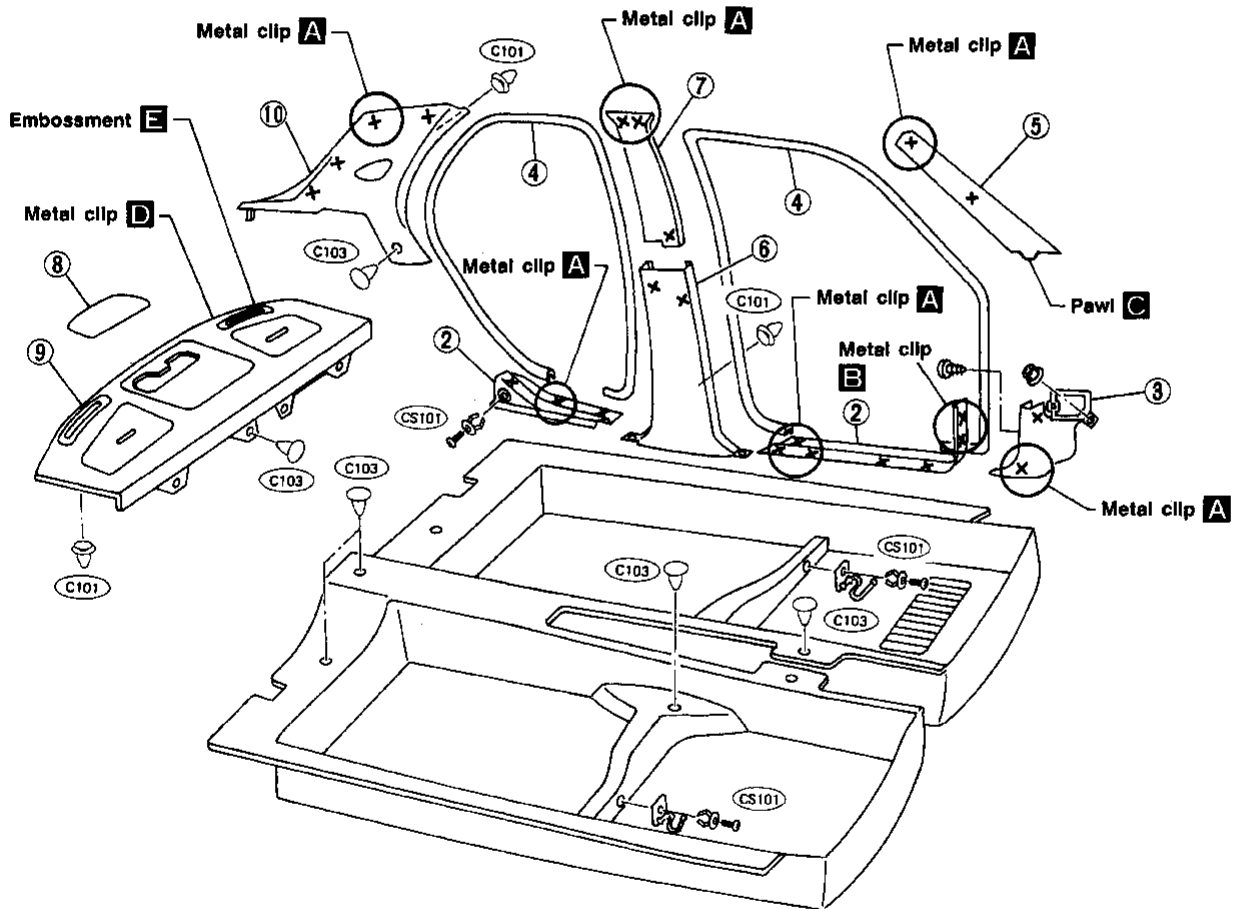

CI
 MA
 EM
 LC
 EF &
 EC
 FE
 AT
 PD
 FA
 RA
 BR
 ST
BF
 HA
 EL
 IDX

INTERIOR AND EXTERIOR

Interior (Cont'd)

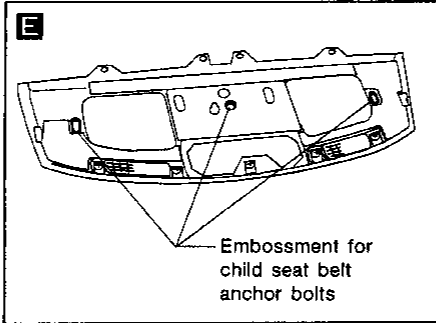
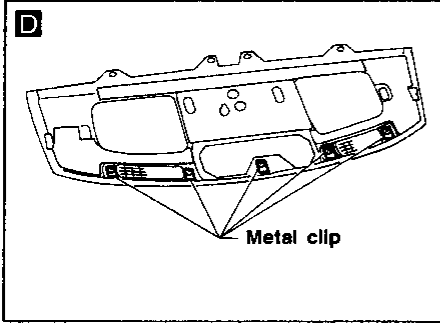
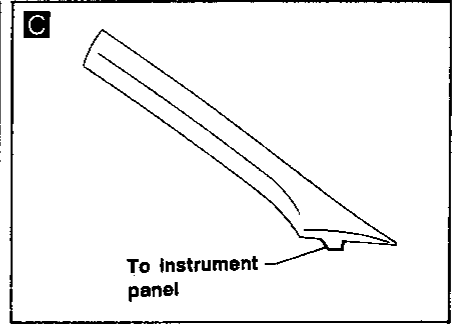
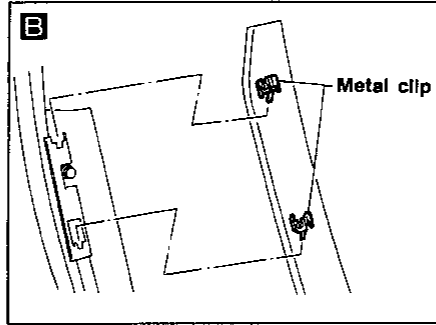
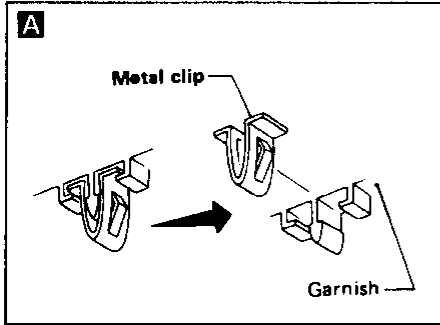

ROOF TRIM

CAUTION:

- Front garnish is heavy. Always support each side of sun visor firmly when removing or installing front garnish.
- Remove metal clip from rear of front garnish by pulling it toward rear of vehicle.
- Headlining metal clip removal
 - 1) Remove retainer from sun roof side.
 - 2) Remove rear metal clip by pulling it straight down.
 - 3) Remove metal clip from rear of sun roof by pulling it toward front of vehicle.

Removal — Headlining

- ① Remove body side trim. Refer to "Removal — Body side trim" for details.
- ② Remove sun roof switch assembly.
- ③ Remove rearview mirror assembly.
- ④ Remove room lamp assembly.
- ⑤ Remove sun visors.
- ⑥ Remove assist grips.
- ⑦ Remove velcro retainers from sun roof opening.

Velcro

- ① Detach roof panel-side velcro pieces from headlinings using screwdriver.
- ② Secure detached velcro pieces to roof panel with retainers paying attention to installation direction.

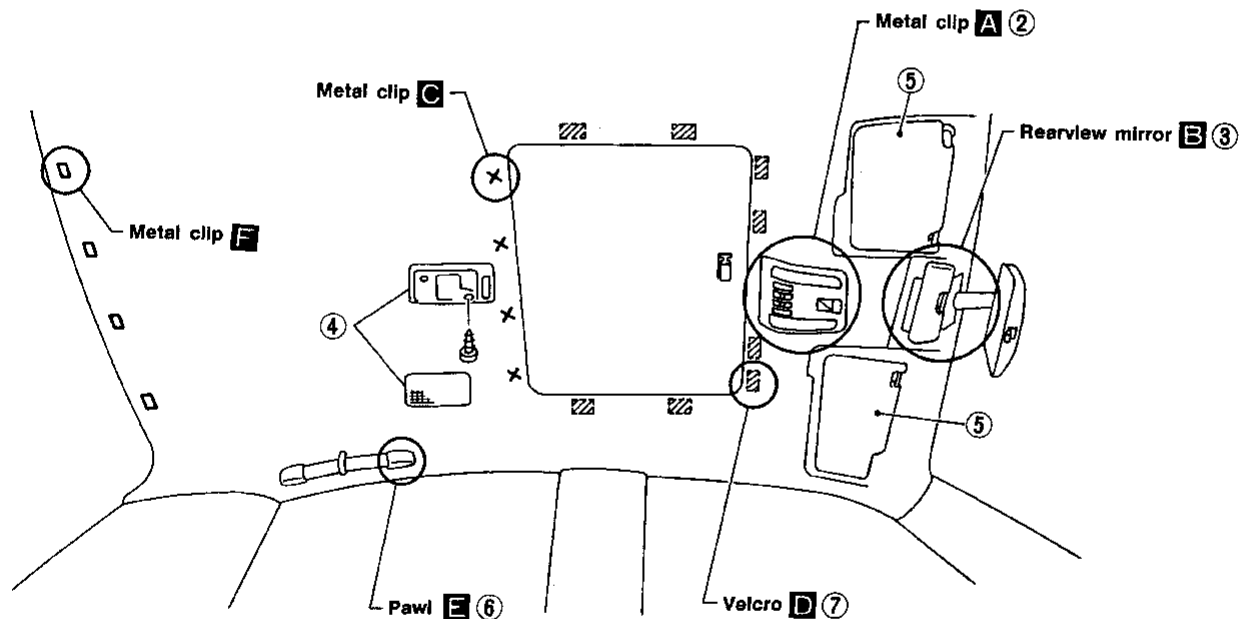

INTERIOR AND EXTERIOR

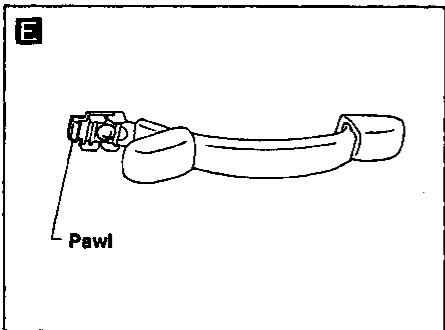
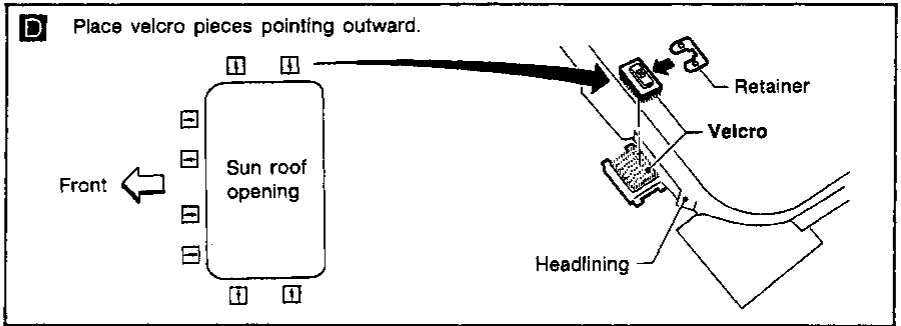
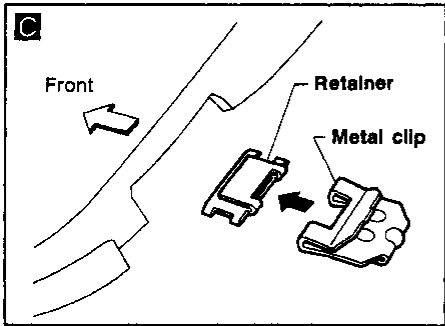
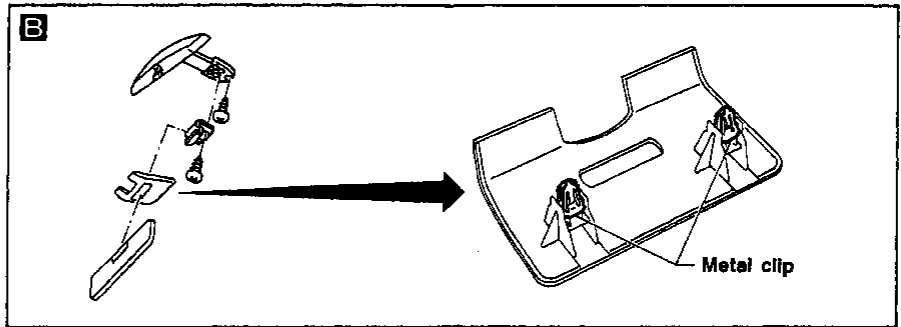
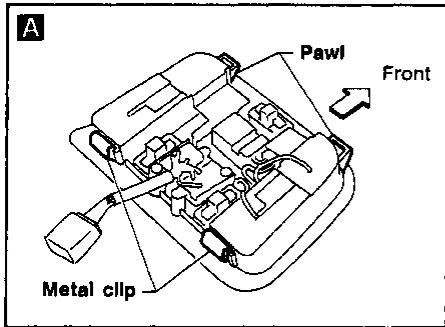

DOOR TRIM

Removal — Door trim

- ① Remove inside handle escutcheon.
- ② Remove door mirror switch.
- ③ Remove front and rear power window switches.
- ④ Remove eight screws.
- ⑤ Remove clips (C101) securing door finisher.
- ⑥ Lift out door finisher.

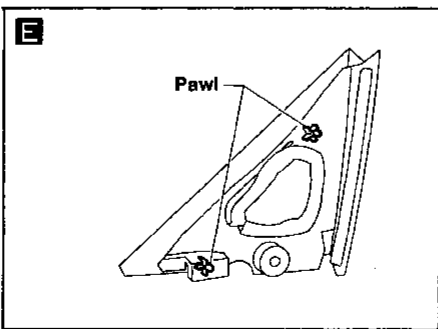
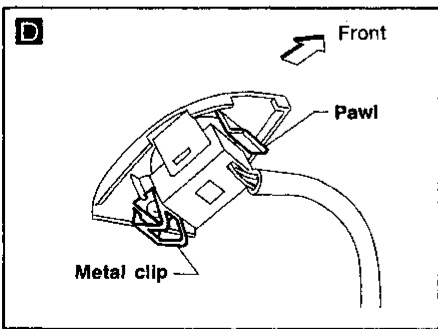
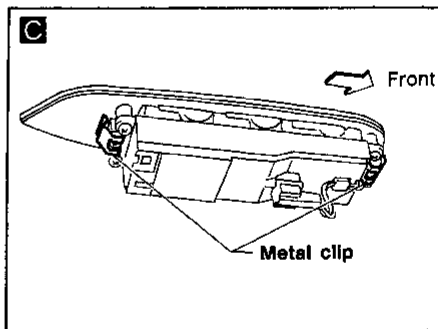
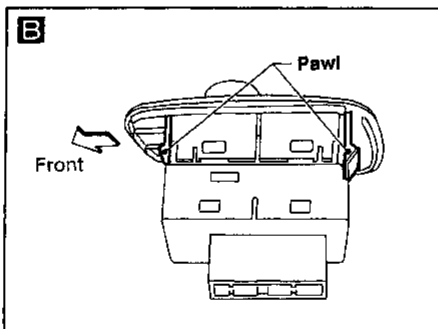
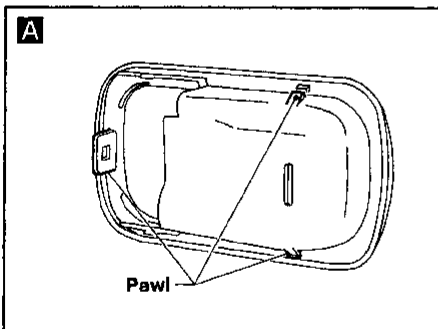
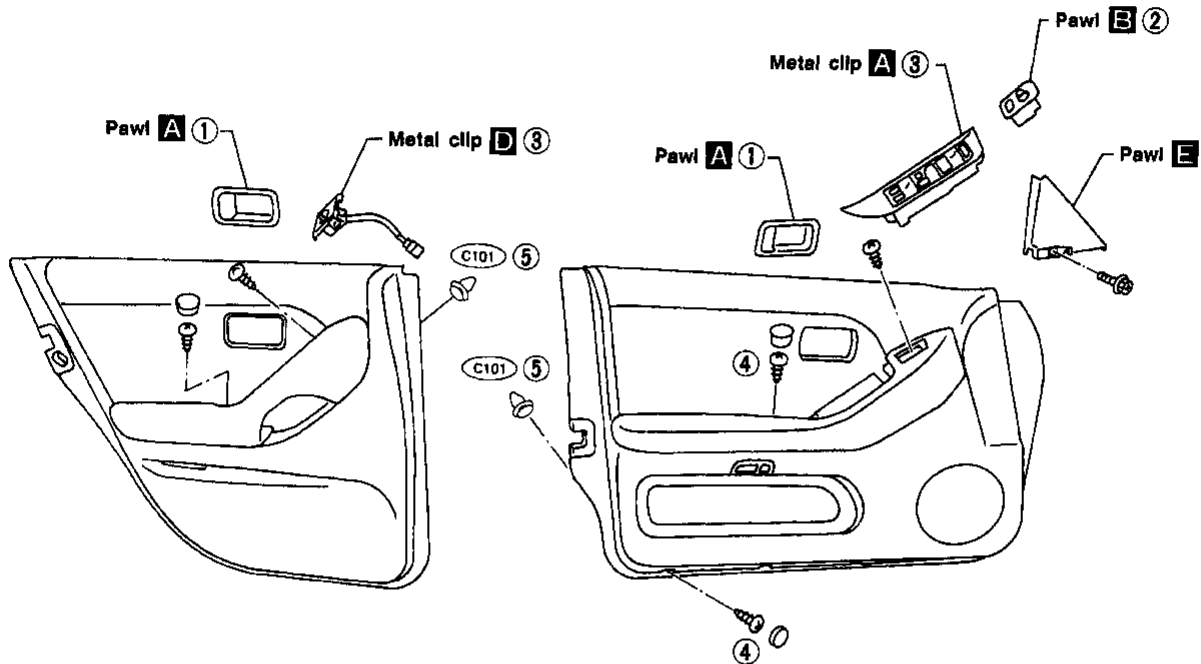

GI

MA

EM

LC

EF &
EC

FE

AT

PD

FA

RA

BR

ST

BF

HA

EL

IDX

INTERIOR AND EXTERIOR

LUGGAGE COMPARTMENT TRIM — Trunk space

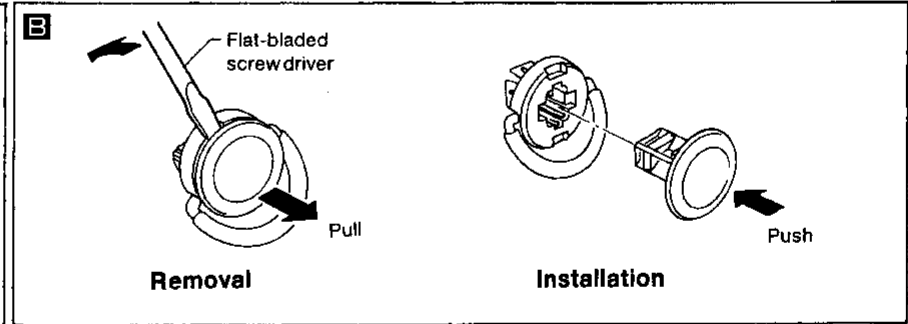
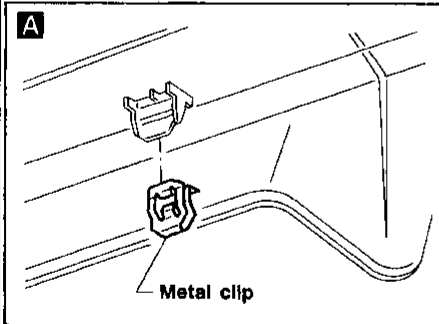
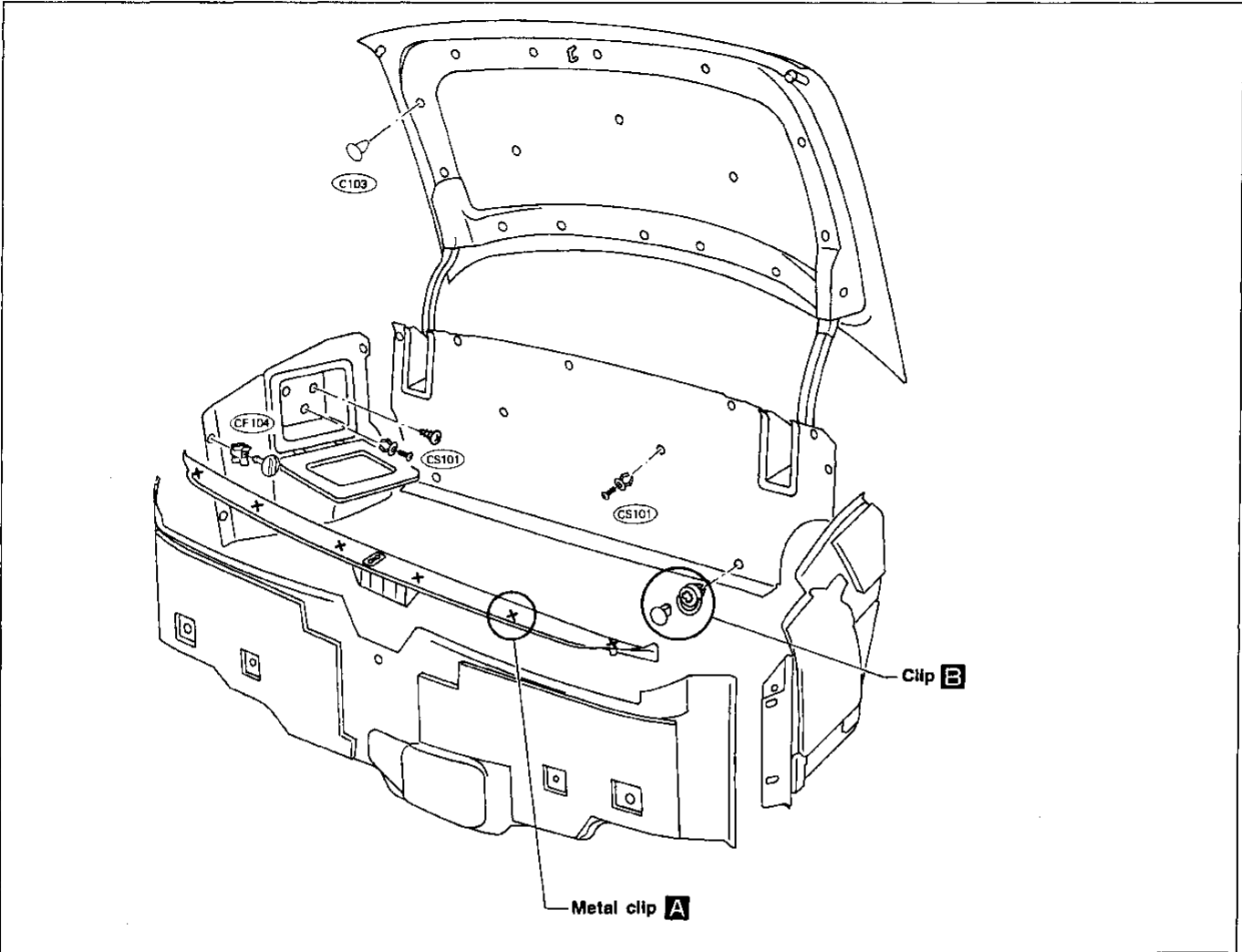

MBF645A

INTERIOR AND EXTERIOR

Exterior

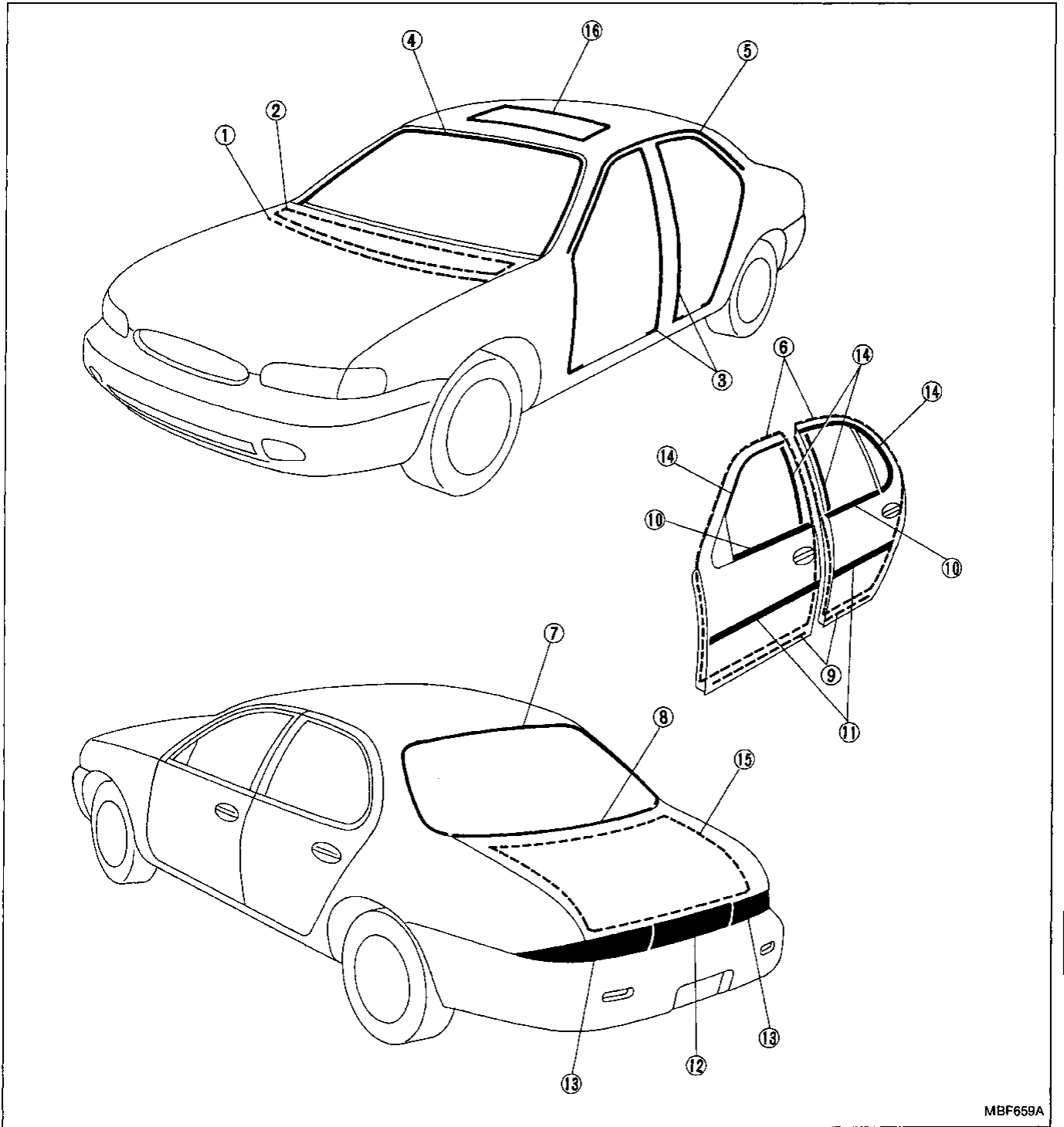

GI

MA

EM

LC

EF &
EC

FE

AT

PD

FA

RA

BR

ST

BF

HA

EL

IDX

INTERIOR AND EXTERIOR

Exterior (Cont'd)

① ② Cowl top seal and cowl top grille

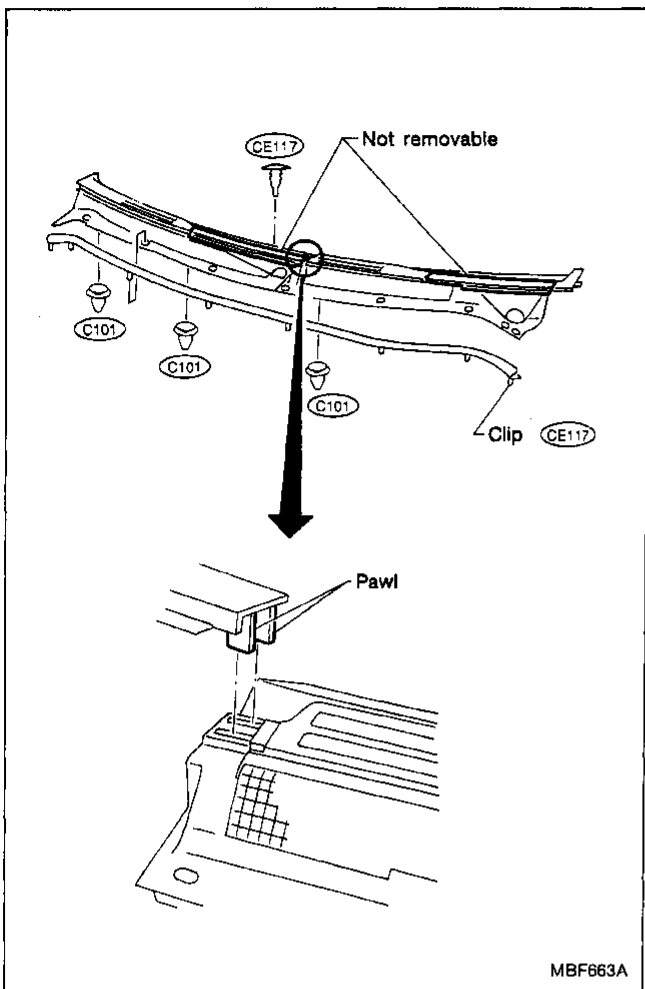

③ Body side welt

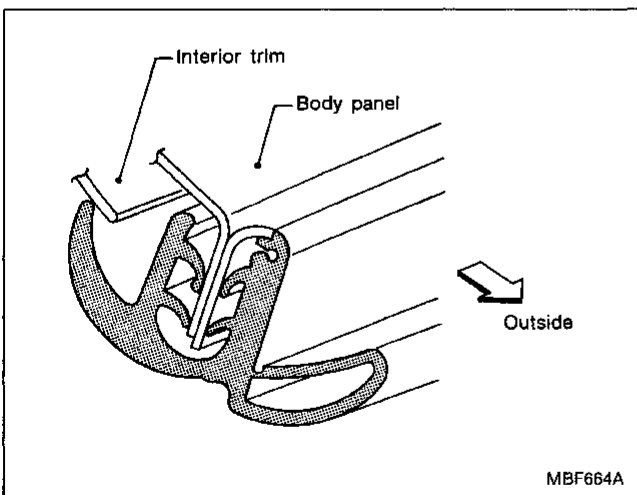

④ Windshield upper molding and side molding

Method 1

Cut off top portion of molding and clean glass and panel surfaces.

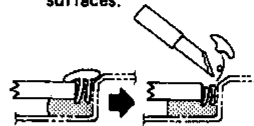

Apply sealant to top portion of molding.



Cut off lower portion of new molding.

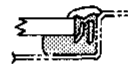

Finish well to give it a good appearance.

Method 2

1. Cut off sealant at glass end.
2. Clean the side on which panel was mounted.
3. Set molding fastener and apply sealant to body panel, and apply primer to molding and body.

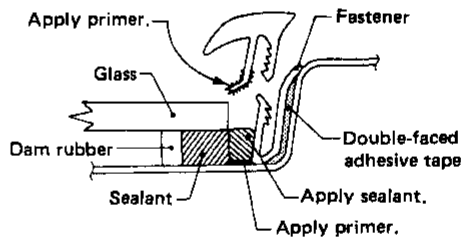

4. Install molding by aligning the molding mark located on center with vehicle center. Be sure to install tightly so that there is no gap around the corner.

SBF161E

INTERIOR AND EXTERIOR

Exterior (Cont'd)

⑤ Drip molding

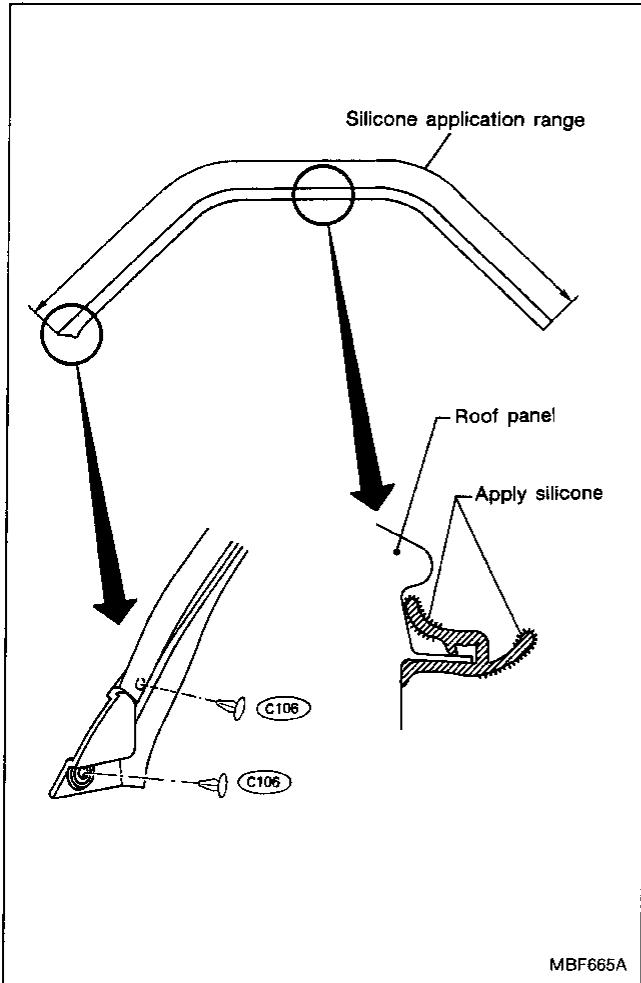

⑥ Door weatherstrip

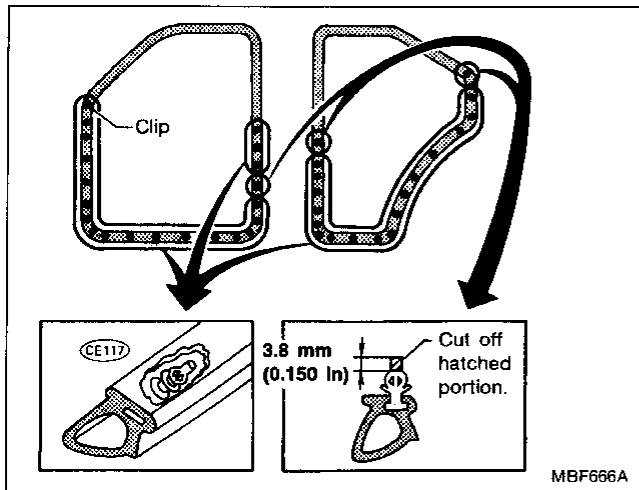

⑦ Rear window upper molding and side molding

Basically the same as windshield upper molding and side molding.

Refer to ④ Windshield upper molding and side molding.

⑧ Rear window lower molding

Mounted with screws.

⑨ Door parting seal

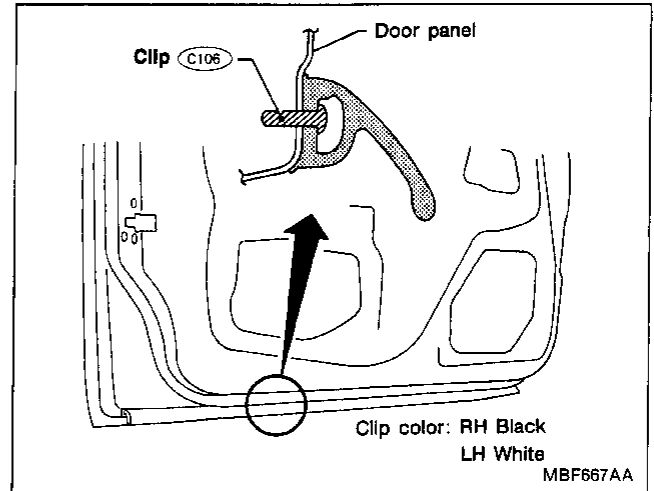

⑩ Door outside molding

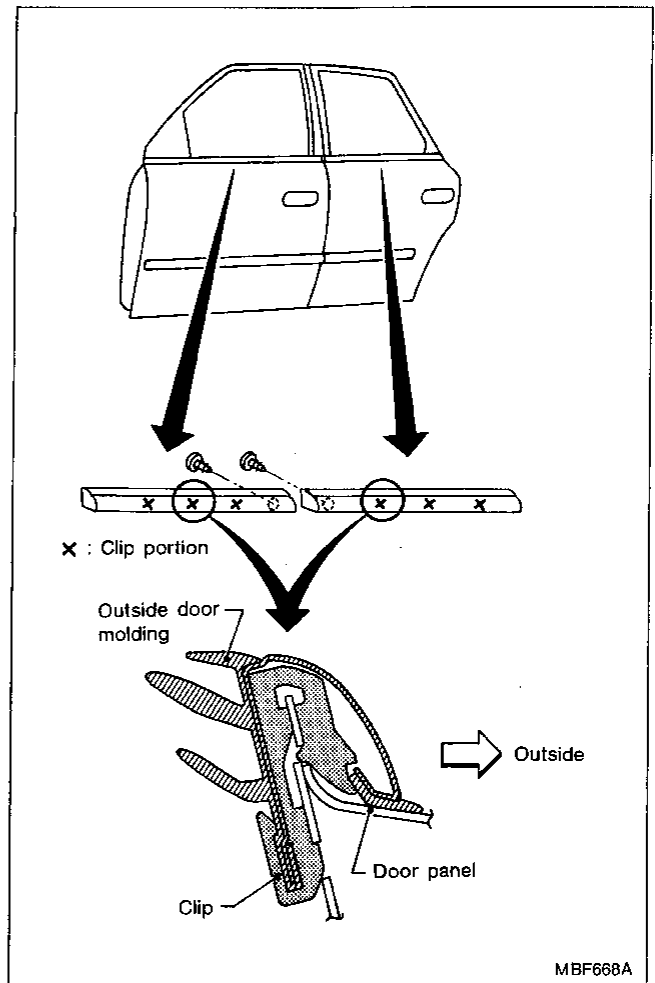

GI

MA

EM

LC

EF &
EC

FE

AT

PD

FA

RA

BR

ST

BF

HA

EL

IDX

INTERIOR AND EXTERIOR

Exterior (Cont'd)

⑪ Side guard molding

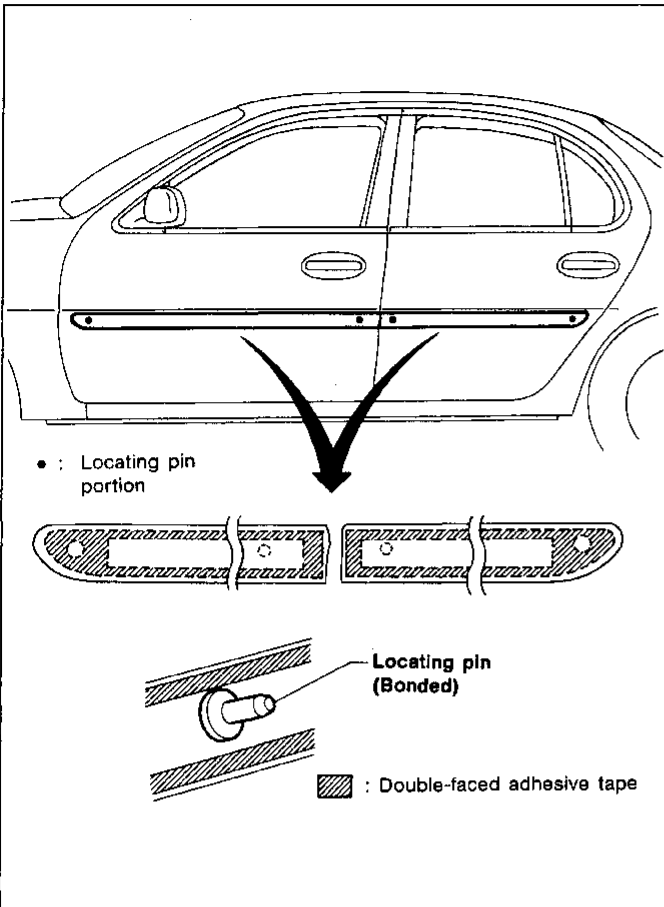

- **Removal:**
 1. Heat molding portion to 30 to 40°C (86 to 104°F) with a heat gun.

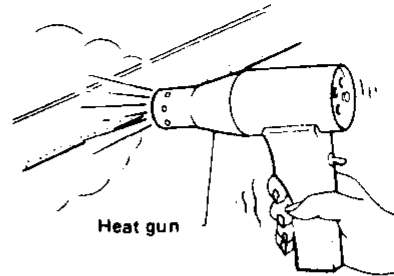

SBF455A

2. Raise end of molding and, while cutting off bonding agent, detach molding.

- **Installation:**
 1. Remove all traces of bonding agent from body panel. Then clean contact face of body.
 2. Heat body panel and molding to 30 to 40°C (86 to 104°F) with a heat gun. Then install molding.

MBF669A

⑫ Rear garnish

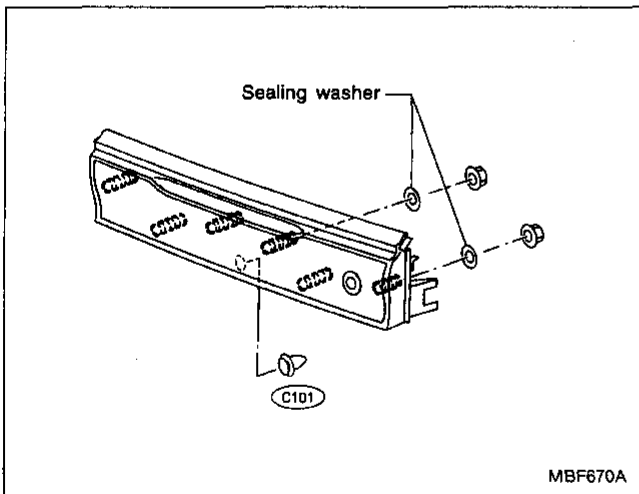

MBF670A

⑬ Rear combination lamp

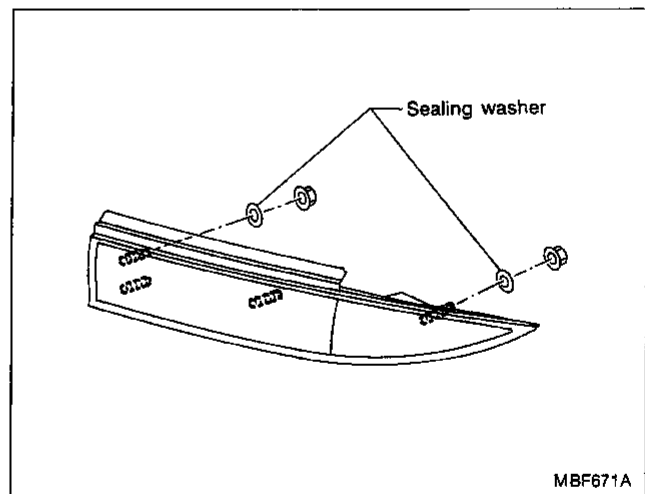

MBF671A

INTERIOR AND EXTERIOR

Exterior (Cont'd)

14 Front and rear door sash molding

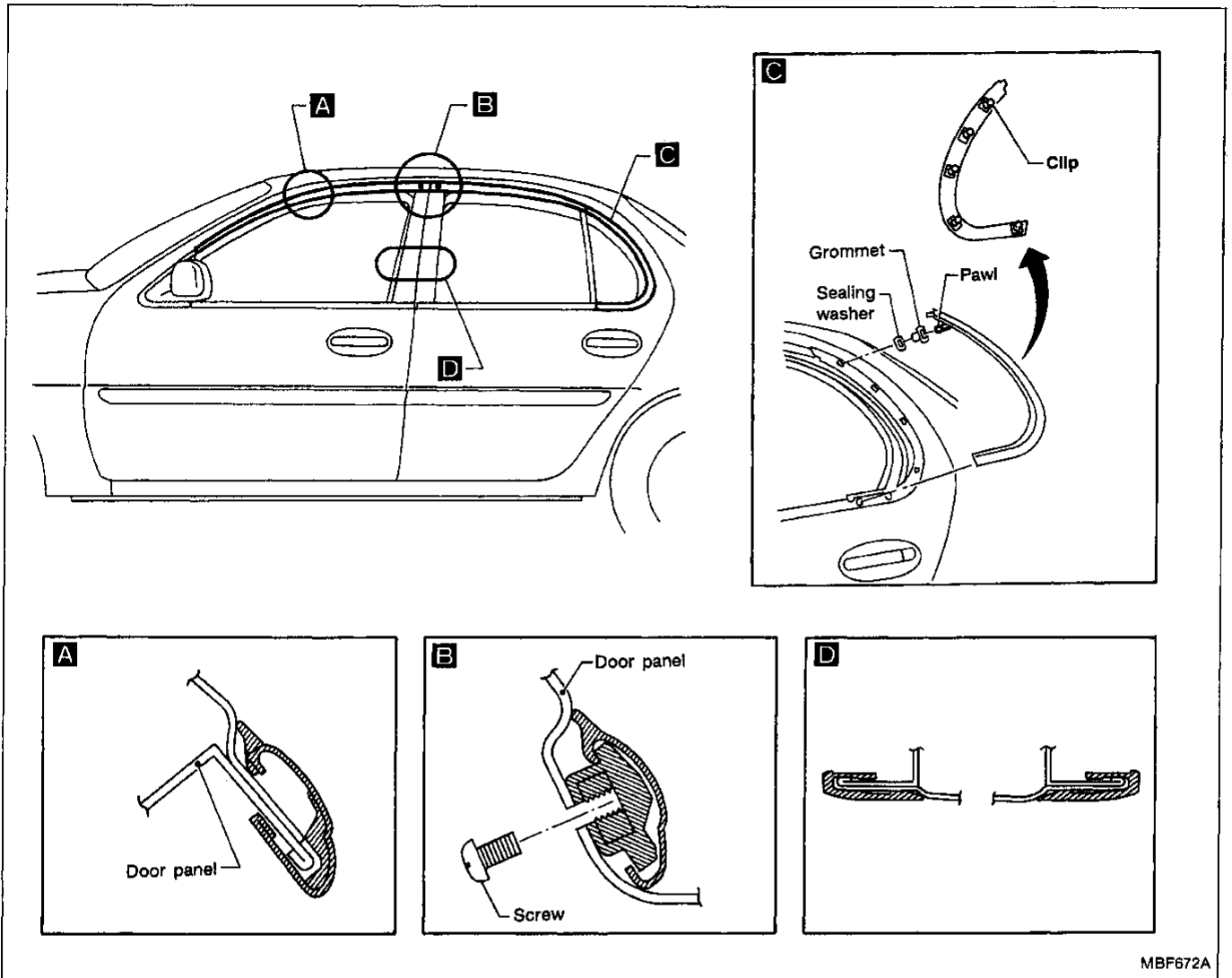

GI
MA
EM
LC
EF &
EC
FE
AT
PD
FA
RA
BR
ST

15 Trunk lid weatherstrip

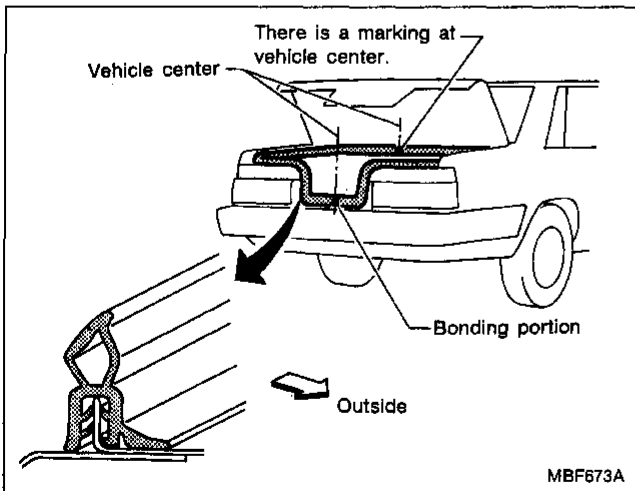

16 Sun roof weatherstrip

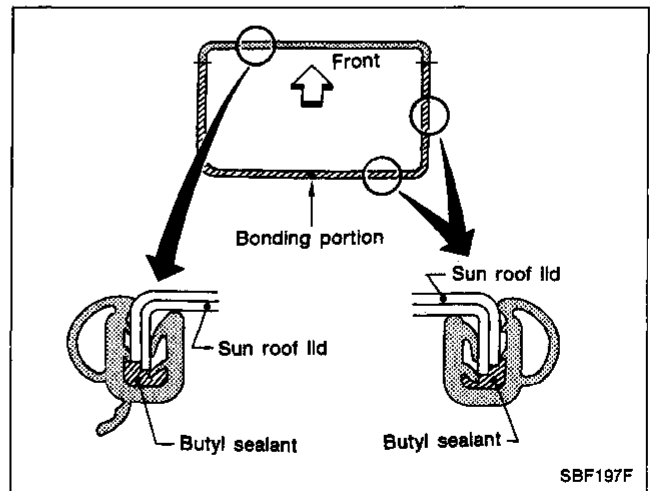

BF
HA
EL
IDX

SEAT

- When removing or installing the seat trim, carefully handle it to keep dirt out and avoid damage.

Front Seat

POWER SEAT

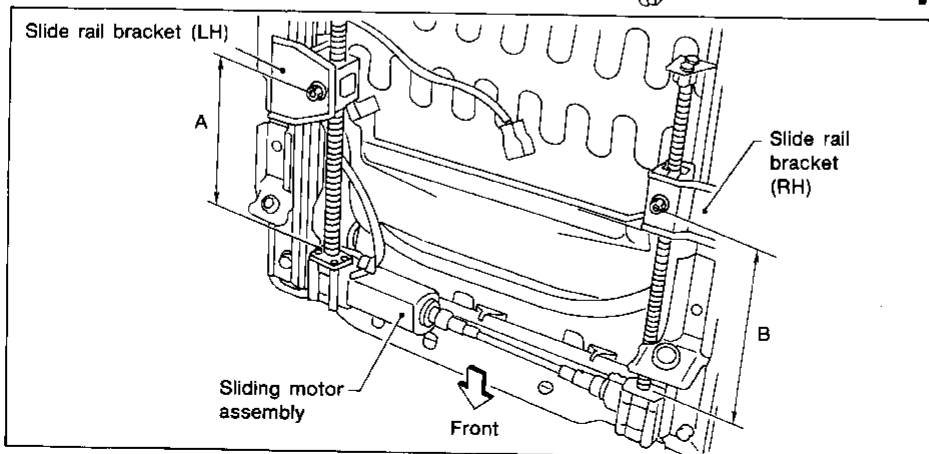
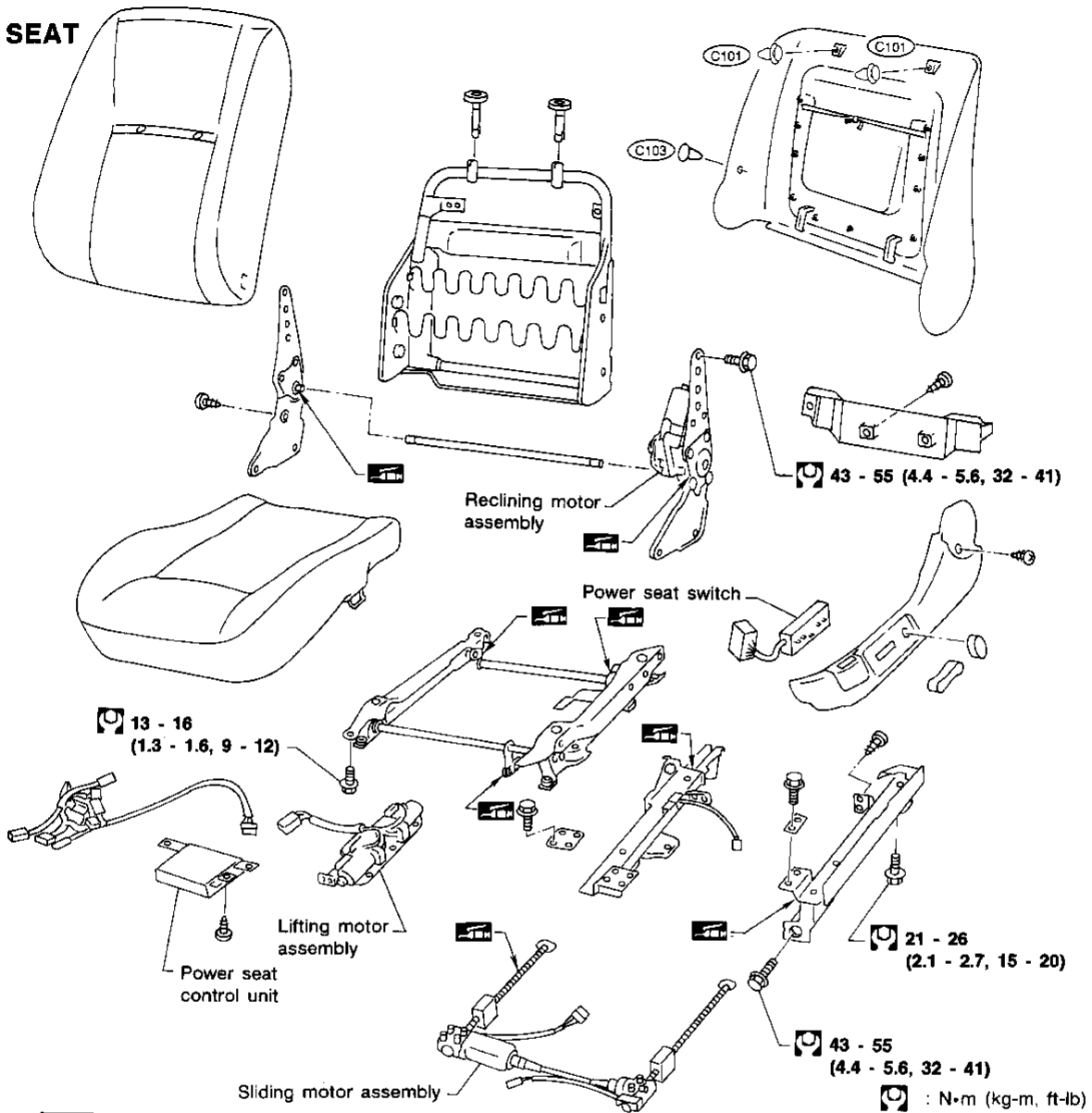

Sliding motor installation
 When installing sliding motor, an equal distance should be placed between left/right slide rail brackets and sliding motor.

SEAT

Front Seat (Cont'd)

MANUAL SEAT

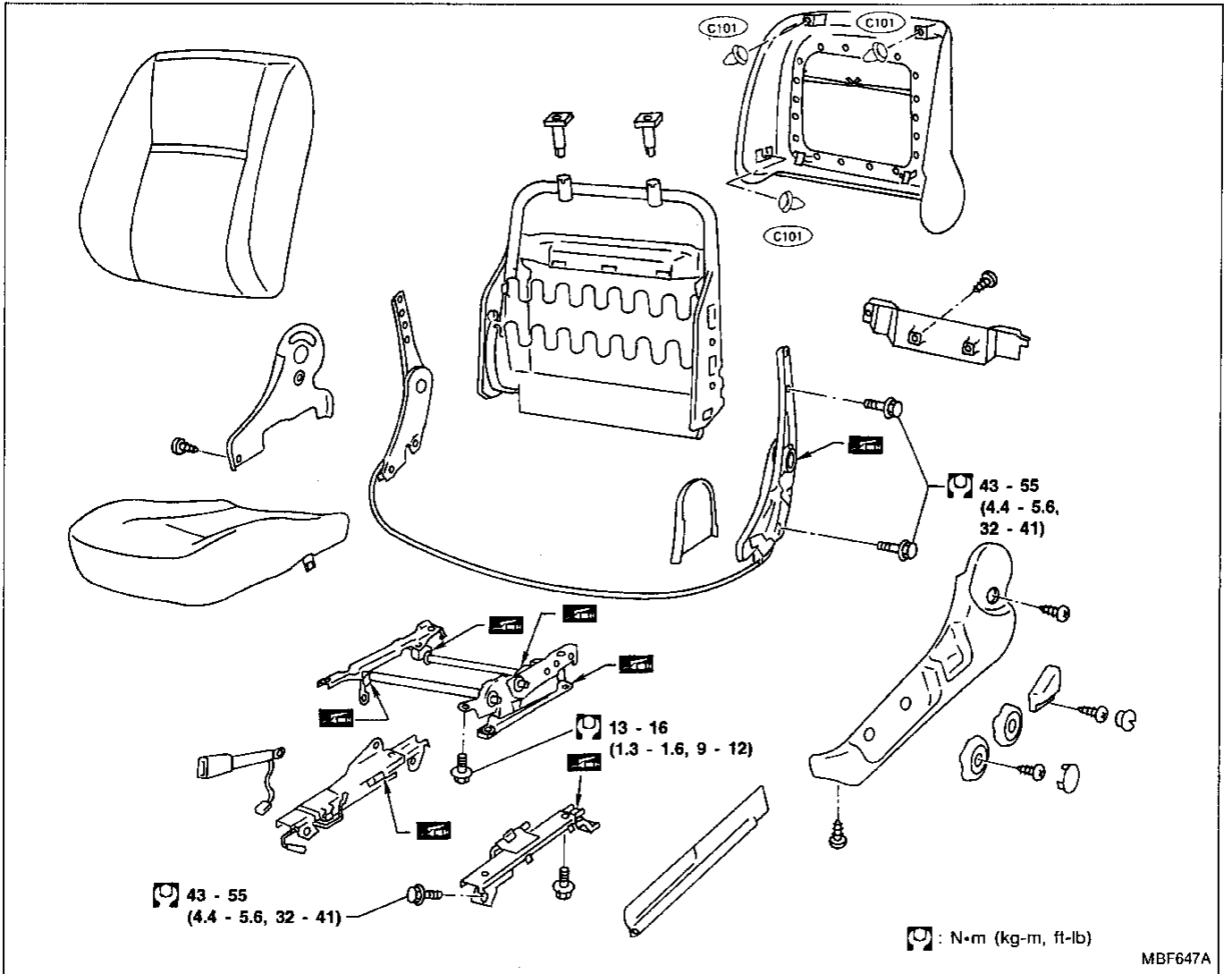

Seat rail cover

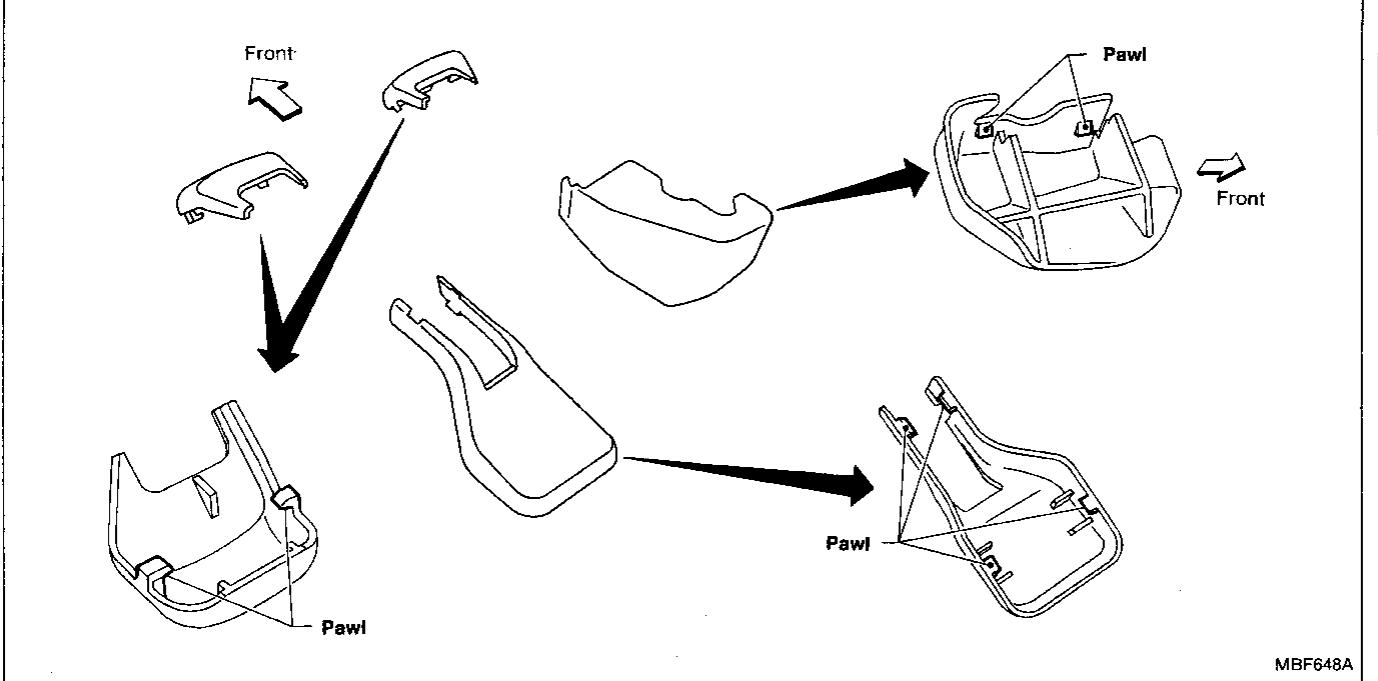

SEAT

Front Seat (Cont'd)

POWER SEAT/WIRING DIAGRAM

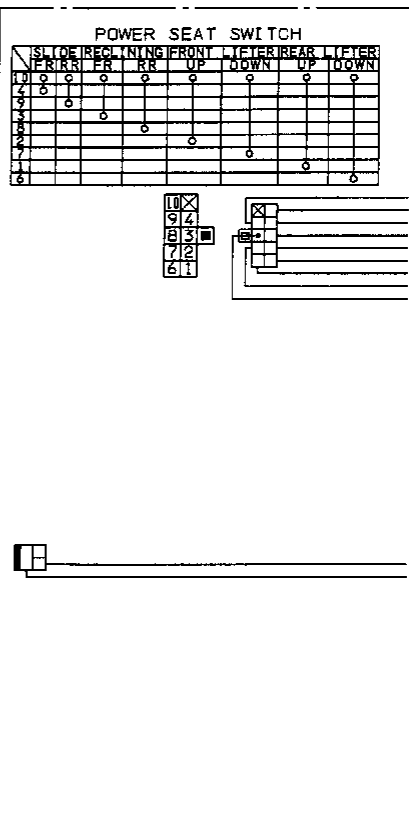
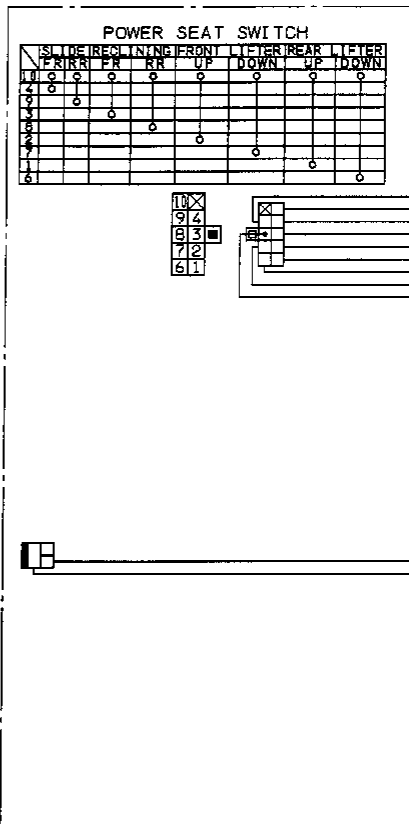
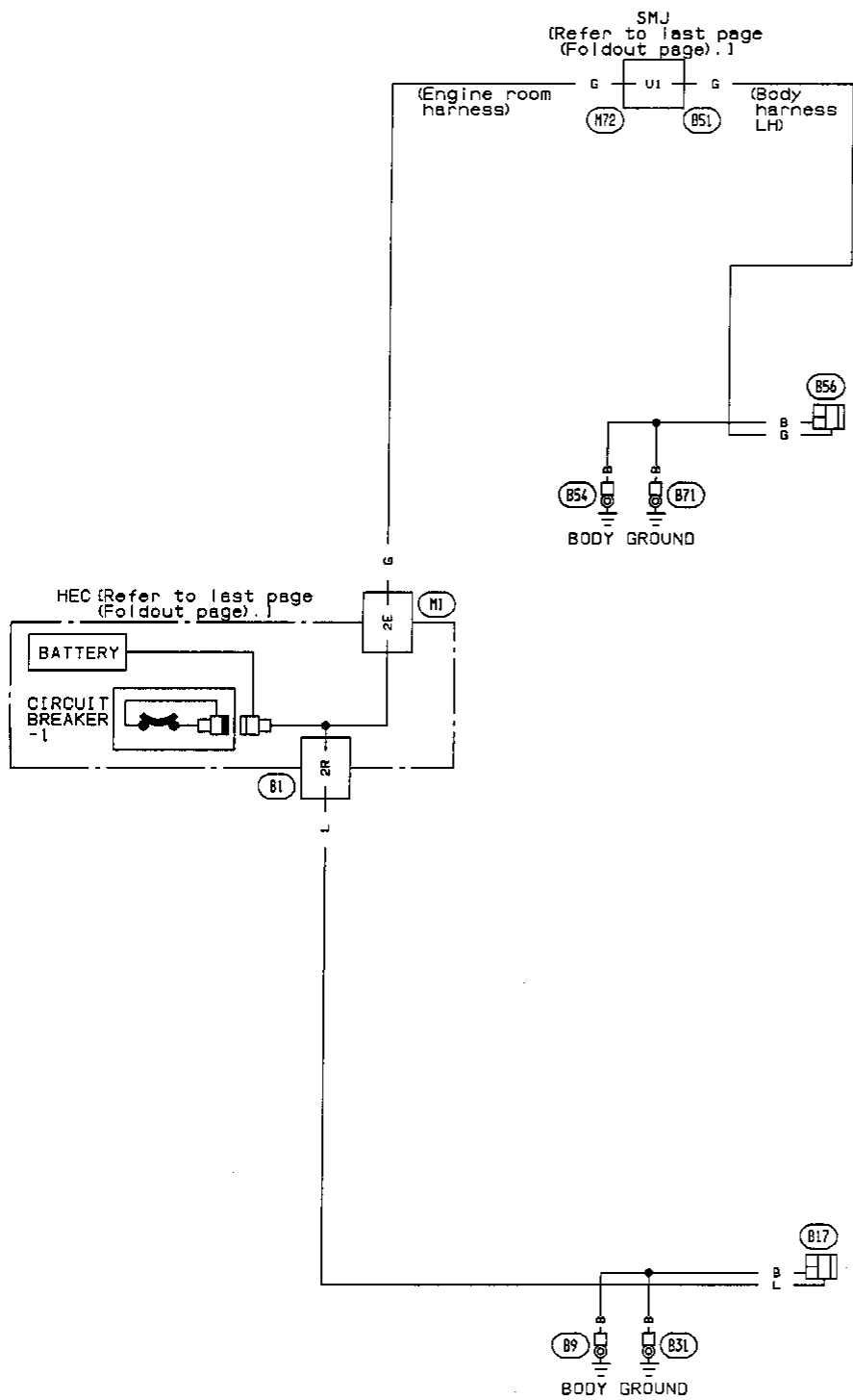

SEAT

Front Seat (Cont'd)

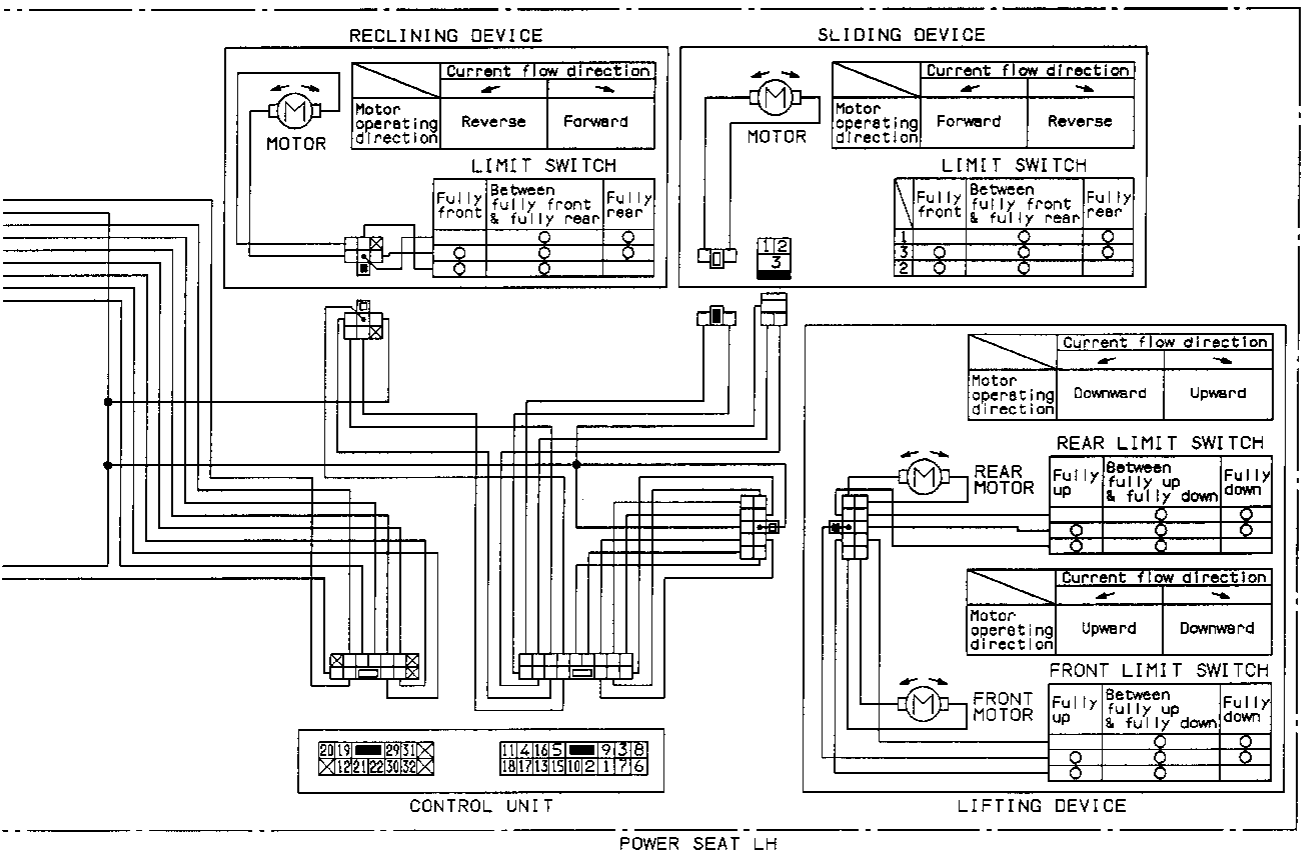
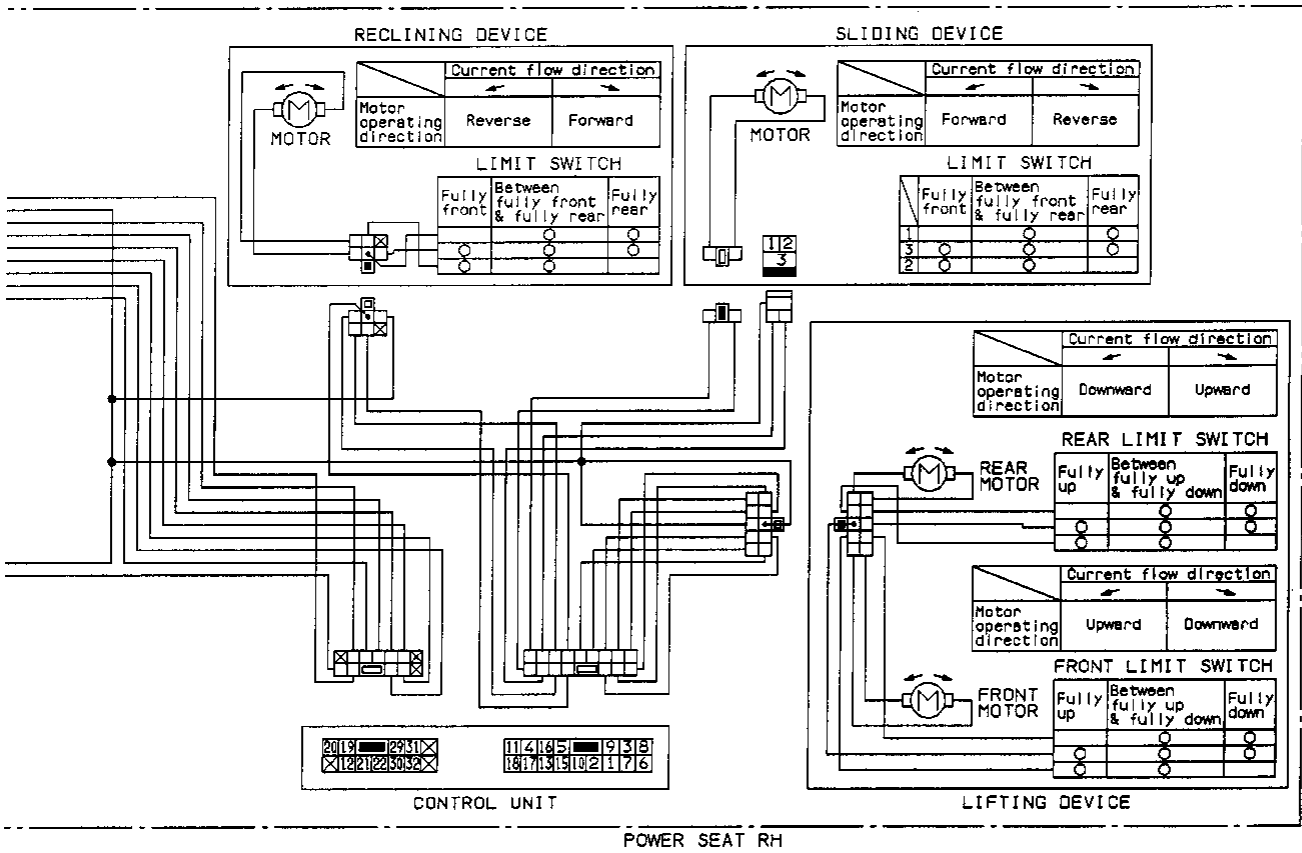

GI
MA
EM
LC
EF & EC
FE
AT
PD
FA
RA
BR
ST
BF
HA
EL
DX

SEAT

Front Seat (Cont'd)

HEATED SEAT

- When handling seat, be extremely careful not to scratch heating unit.
- To replace heating unit, seat trim and pad should be separated.
- Do not use any organic solvent, such as thinner, benzene, alcohol, gasoline, etc. to clean trims.

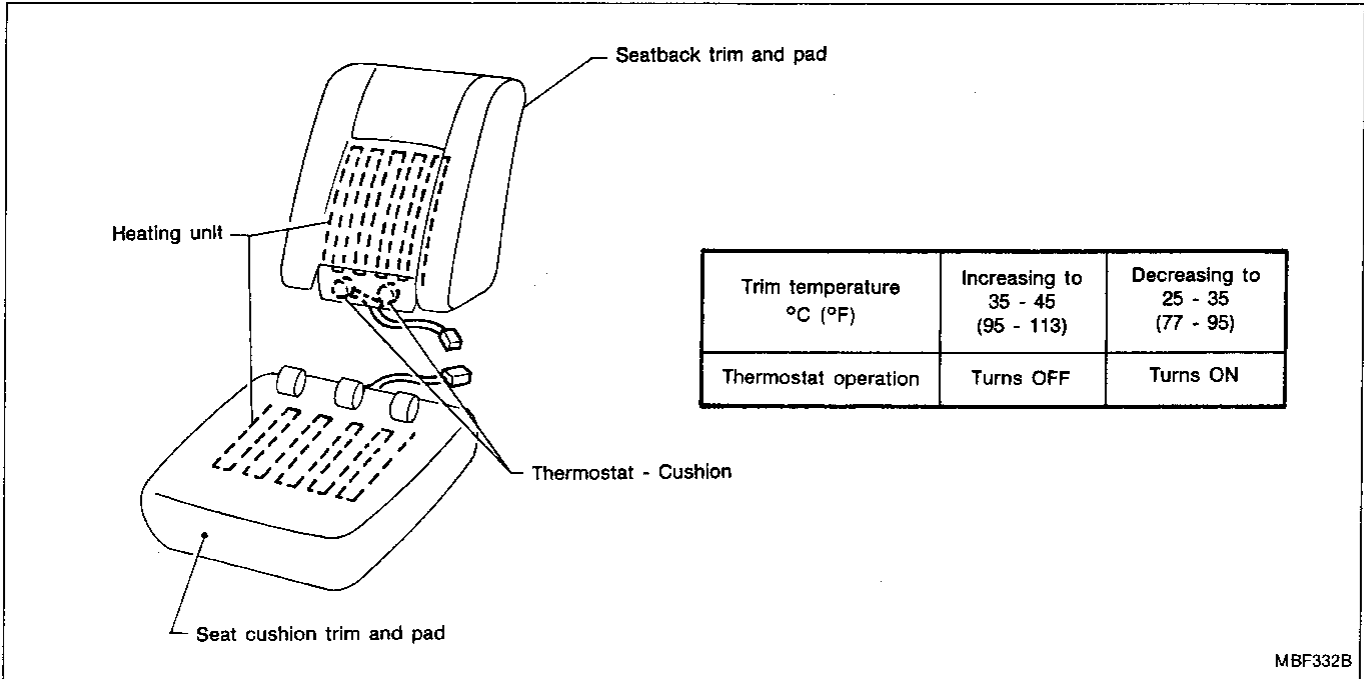

SEAT
Front Seat (Cont'd)

HEATED SEAT/WARNING DIAGRAM

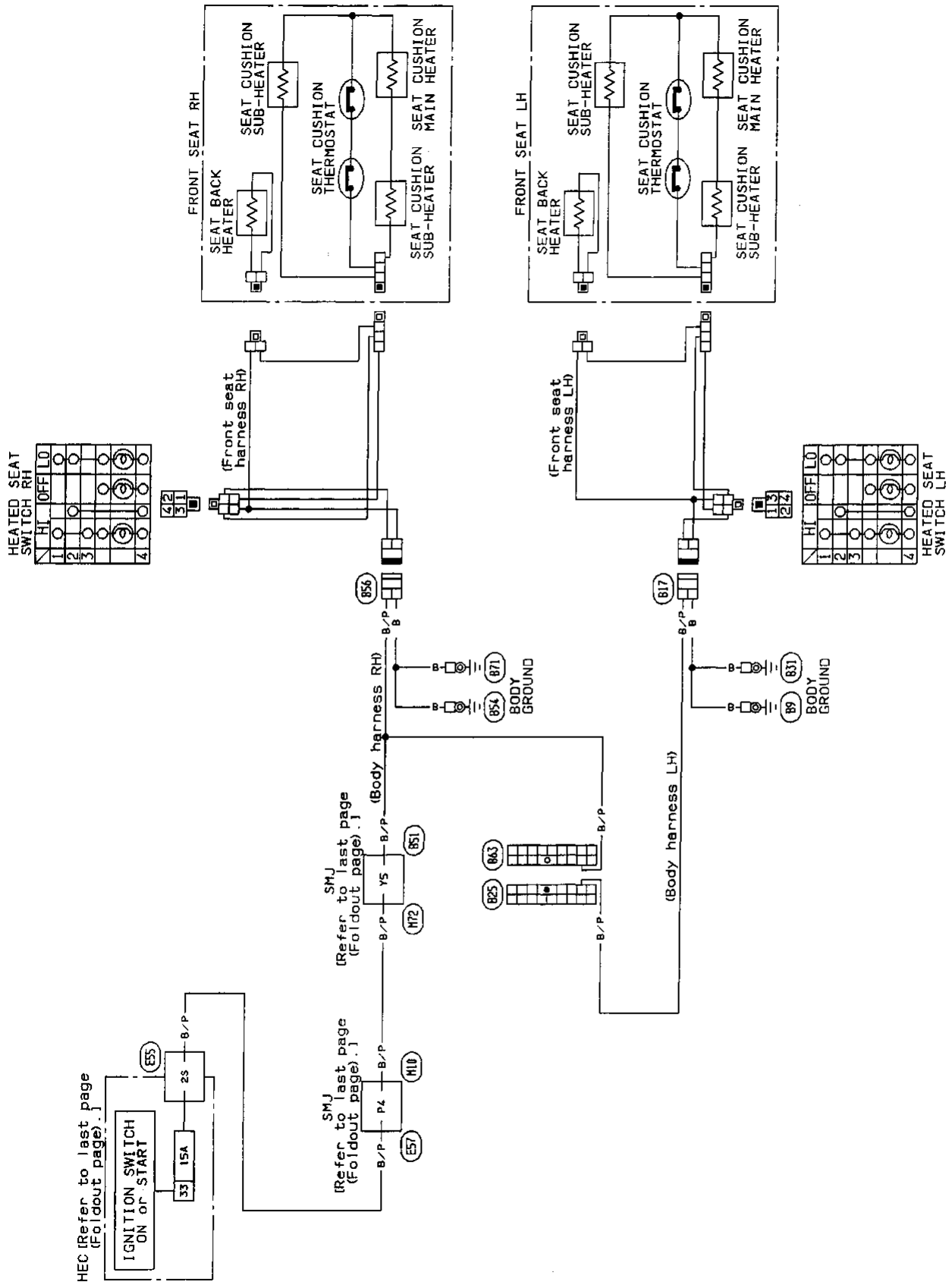

GI
MA
EM
LC
EF &
EC
FE
AT
PD
FA
RA
BR
ST
BF
HA
EL
IDX

SEAT

Rear Seat

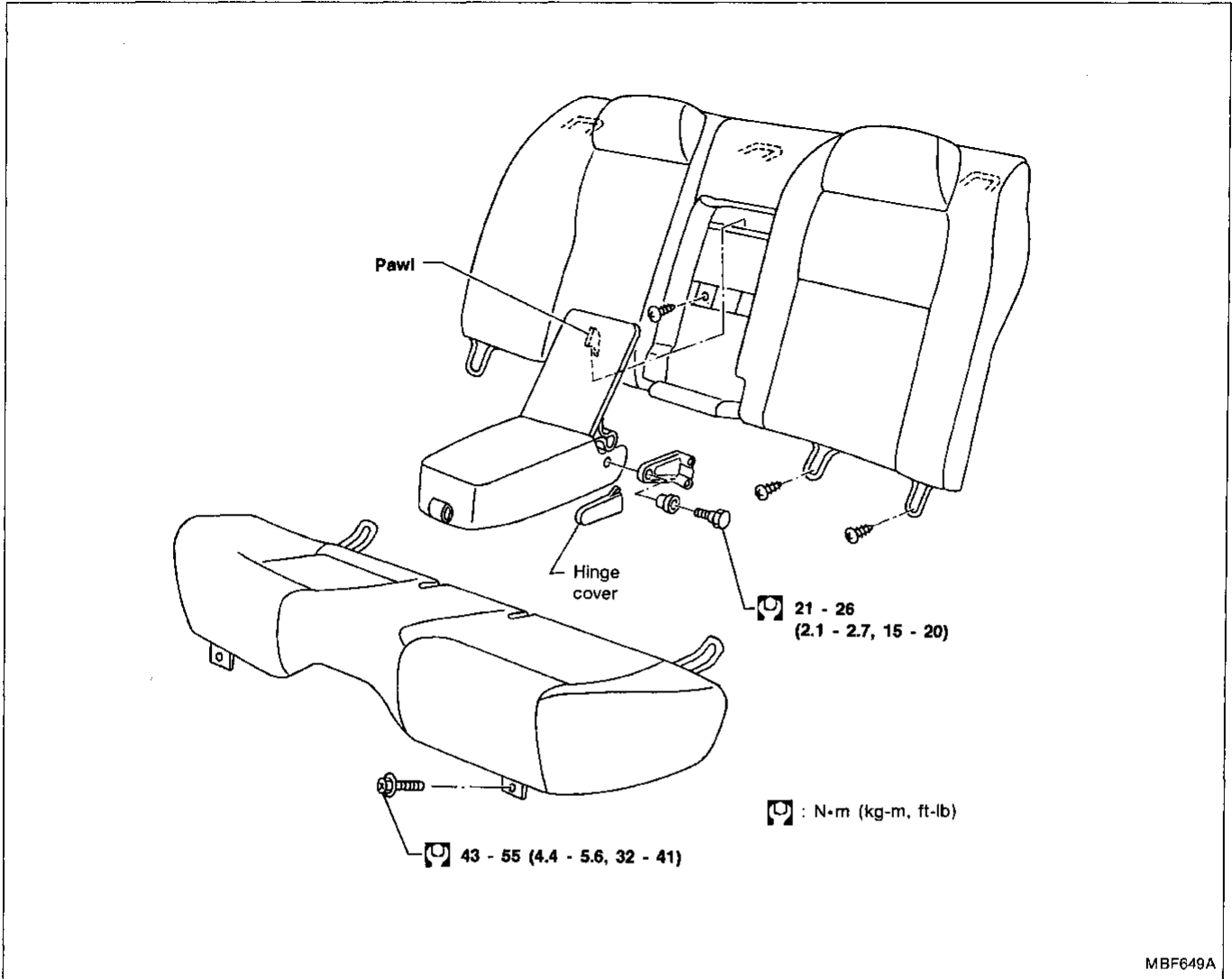

MBF649A

SUN ROOF

GI
MA
EM
LC
EF &
EC
FE
AT
PD
FA
RA
BR
ST
BF
HA
EL
IDX

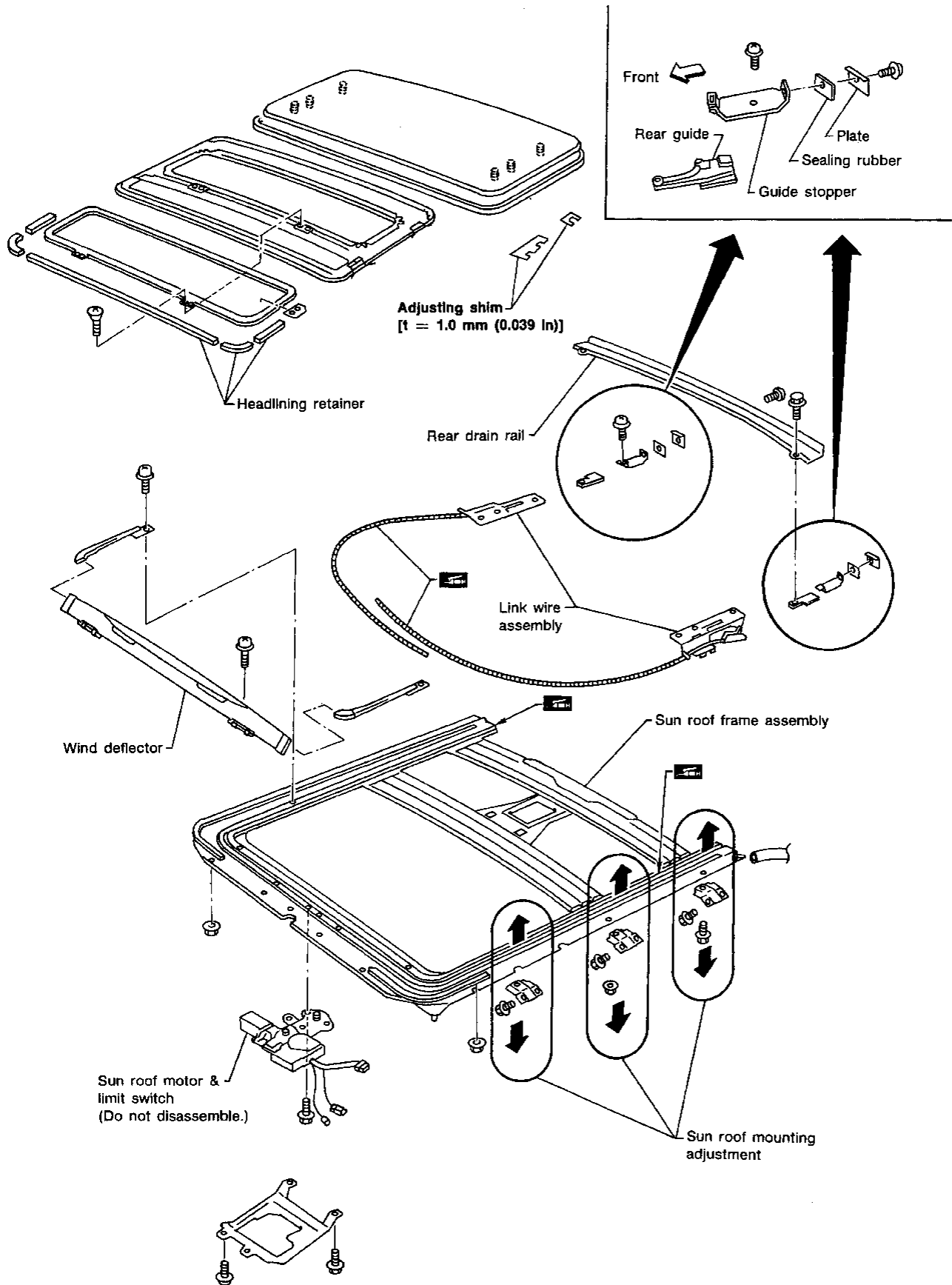

SUN ROOF

Wiring Diagram

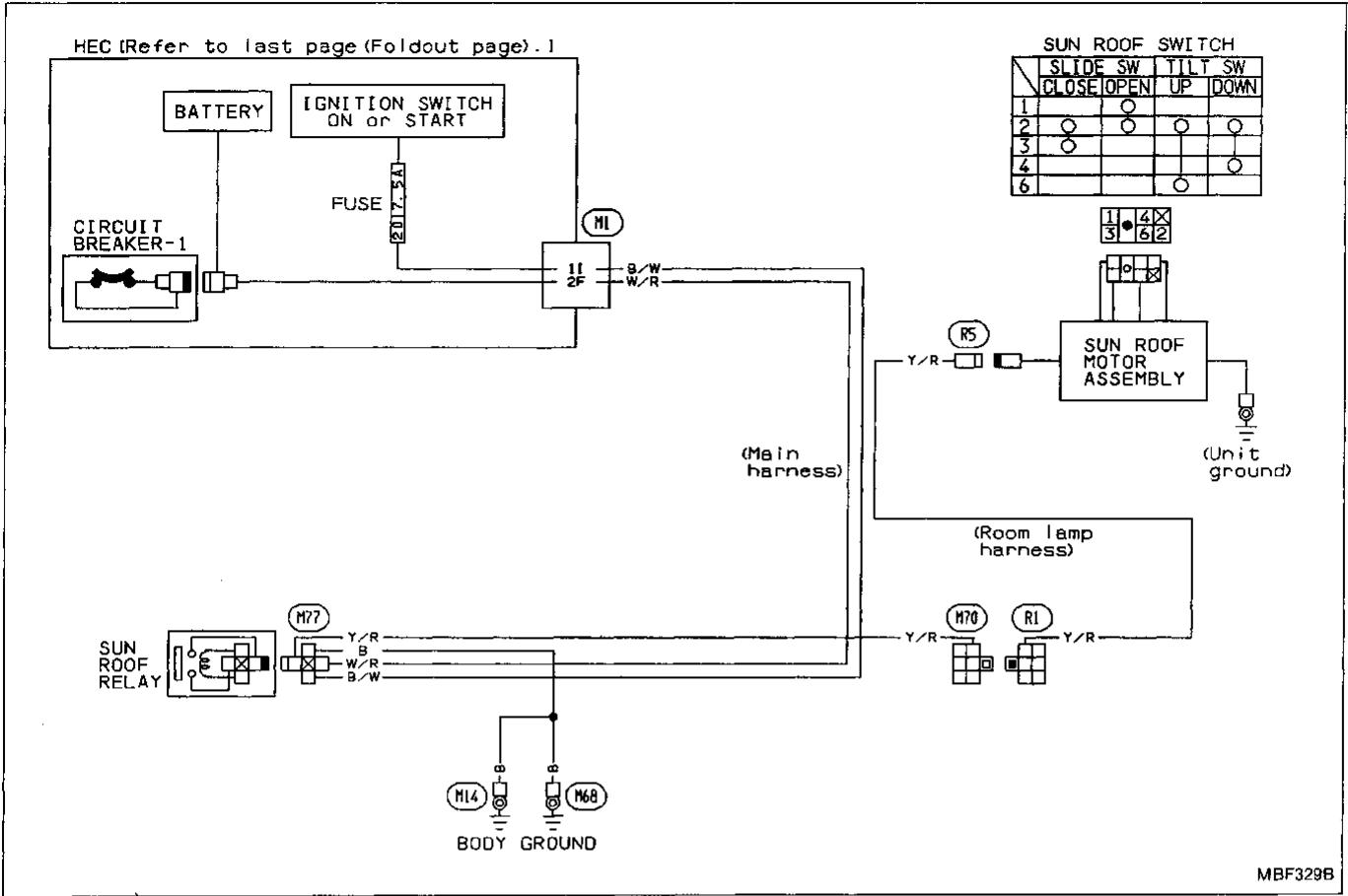

WINDSHIELD AND WINDOWS

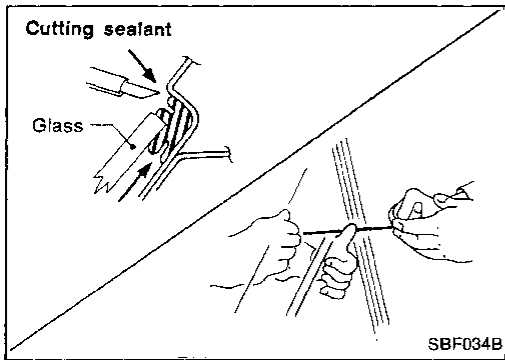

REMOVAL

After removing moldings, remove glass.

CAUTION:

Be careful not to scratch glass when removing.

INSTALLATION

- Use genuine Nissan Sealant kit or equivalent. Follow instructions furnished with it.
- After installing the glass, the vehicle should remain stationary until the sealant hardens.

WARNING :

Keep heat and open flames away as primers are flammable.

CAUTION:

Advise the user of the fact that vehicle should not be driven on rough roads or surfaces until sealant has properly vulcanized.

- Do not use sealant which is past its usable term.
- Do not leave cartridge unattended with its cap open.
- Keep primers and sealant in a cool, dry place. Ideally, they should be stored in a refrigerator.
- Molding must be installed securely so that it is in position and leaves no gap.

Windshield and Rear Window

<p>Body side</p> <p>Install spacer to panel. Windshield 447.2 (17.61)</p> <p>Locating panel 450 (17.72)</p>	<p>Glass side</p> <p>Install dam rubber. Windshield Rear window</p> <p>Vehicle center 8 (0.31) 8 (0.31) 8 (0.31) 8 (0.31) Joint portion Joint portion Dam rubber Glass Double-faced adhesive tape</p>
<p>Install molding fastener. When installing it, heat body panel and fastener to approx. 30 to 40°C (86 to 104°F). Upper & side molding fasteners</p>	<p>Apply sealant evenly. Windshield and rear window</p> <p>7 - 8 (0.28 - 0.31) 12 - 15 (0.47 - 0.59) Dam rubber Glass</p> <p>Unit: mm (in)</p> <p>MBF344B</p>

REPAIRING WATER LEAKS FOR WINDSHIELD

Leaks can be repaired without removing and reinstalling glass.

If water is leaking between caulking material and body or between glass and caulking material, determine the extent of the leak by applying water while pushing glass outward.

To stop the leak, apply primer and then sealant to the leak point.

MIRROR

Door Mirror

CAUTION:

Be careful not to scratch door rearview mirror body.

REMOVAL — Door mirror

1. Remove door trim. Refer to "Removal — Door trim" in "Interior" for details.
2. Remove inner cover front corner of door.
3. Disconnect door mirror harness connector.
4. Remove harness clips.
5. Remove three bolts securing door mirror.

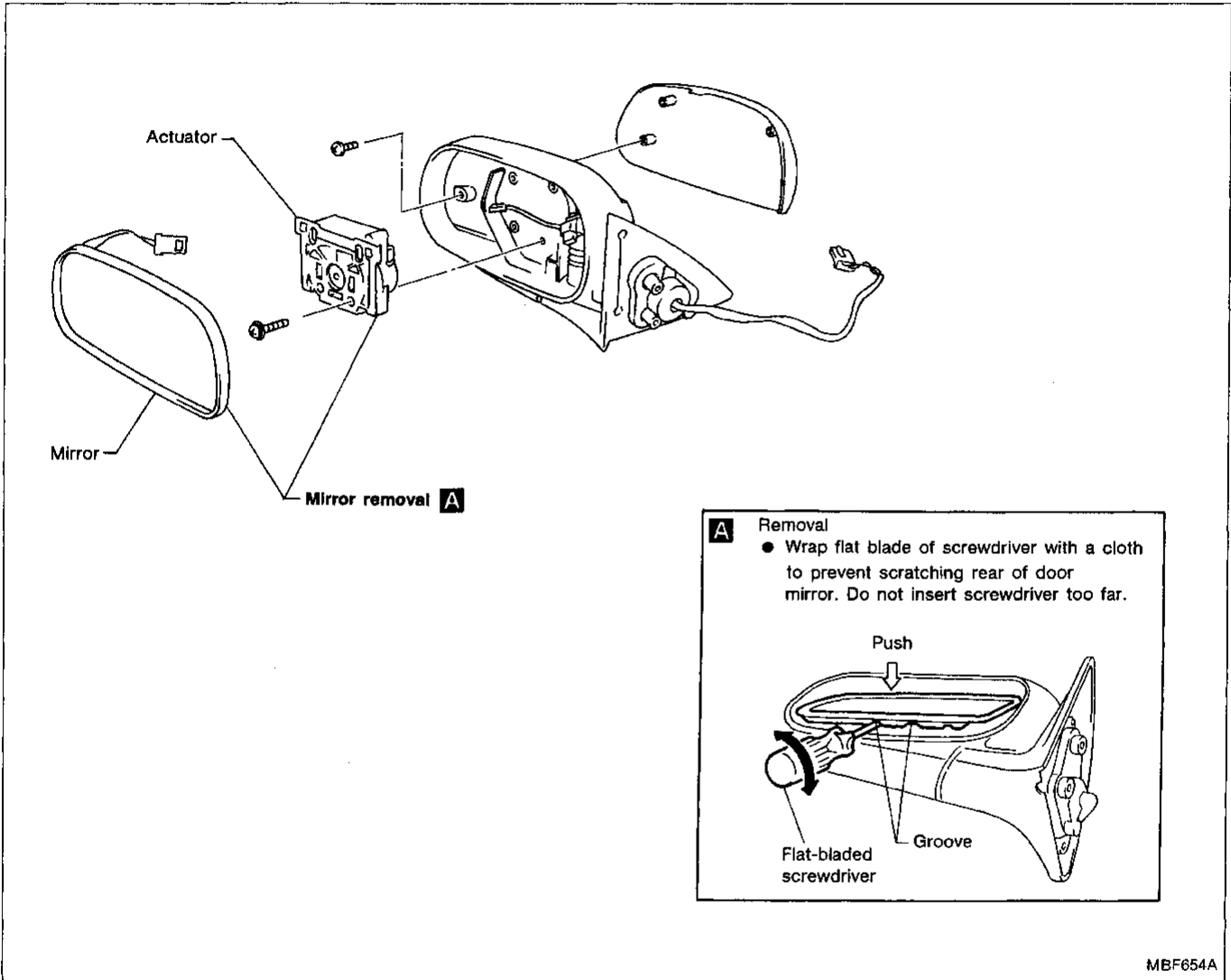

MIRROR

Door Mirror (Cont'd)

WIRING DIAGRAM

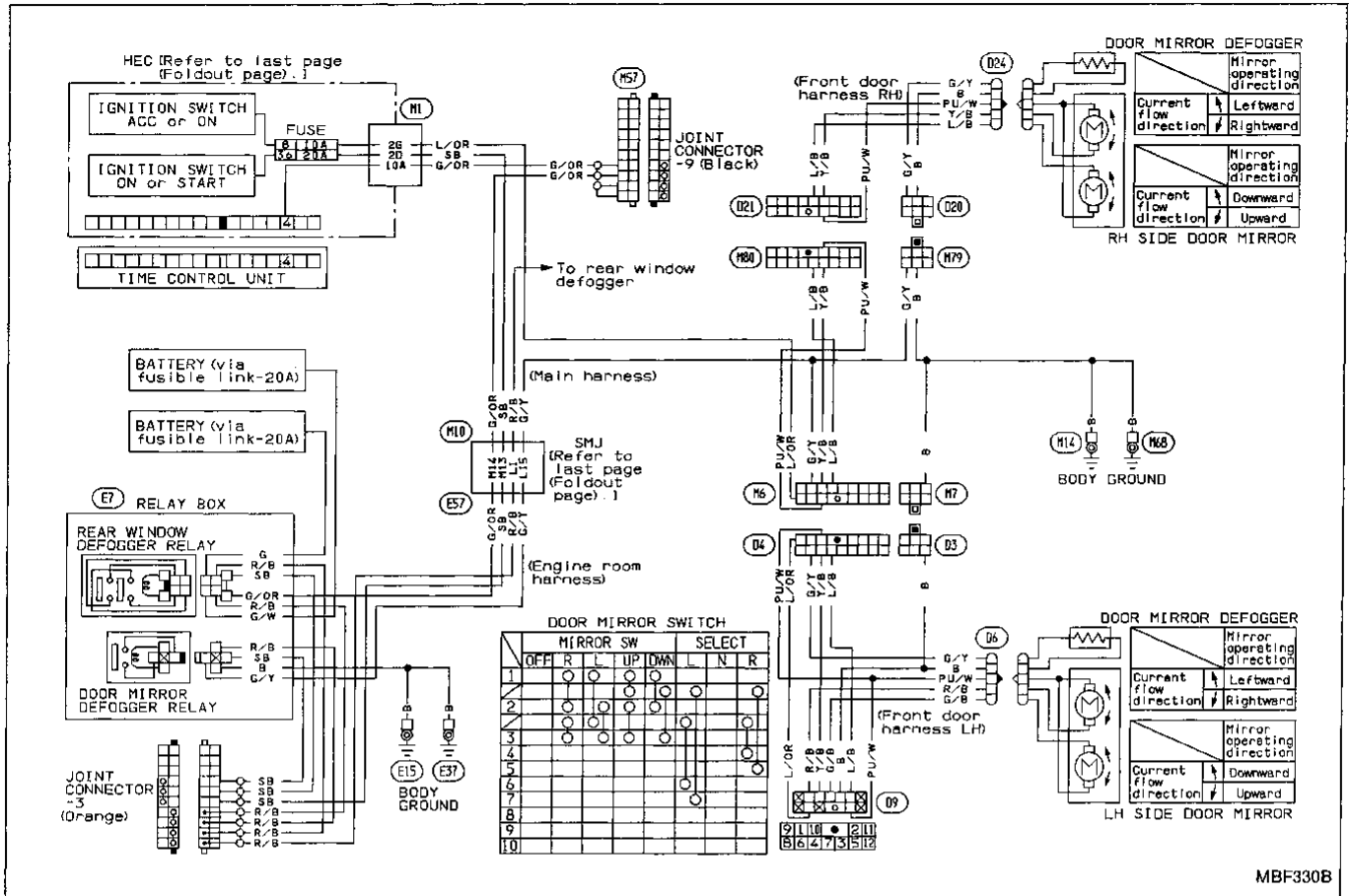

GI
MA
EM
LC
EF & EC
FE
AT
PD
FA
RA
BR
ST
BF
HA
EL
IDX

REAR AIR SPOILER

- When installing, make sure that there are not gaps or waves at ends of air spoiler.
- Before installing spoiler, clean and remove oil from surface where spoiler will be mounted.

REAR AIR SPOILER

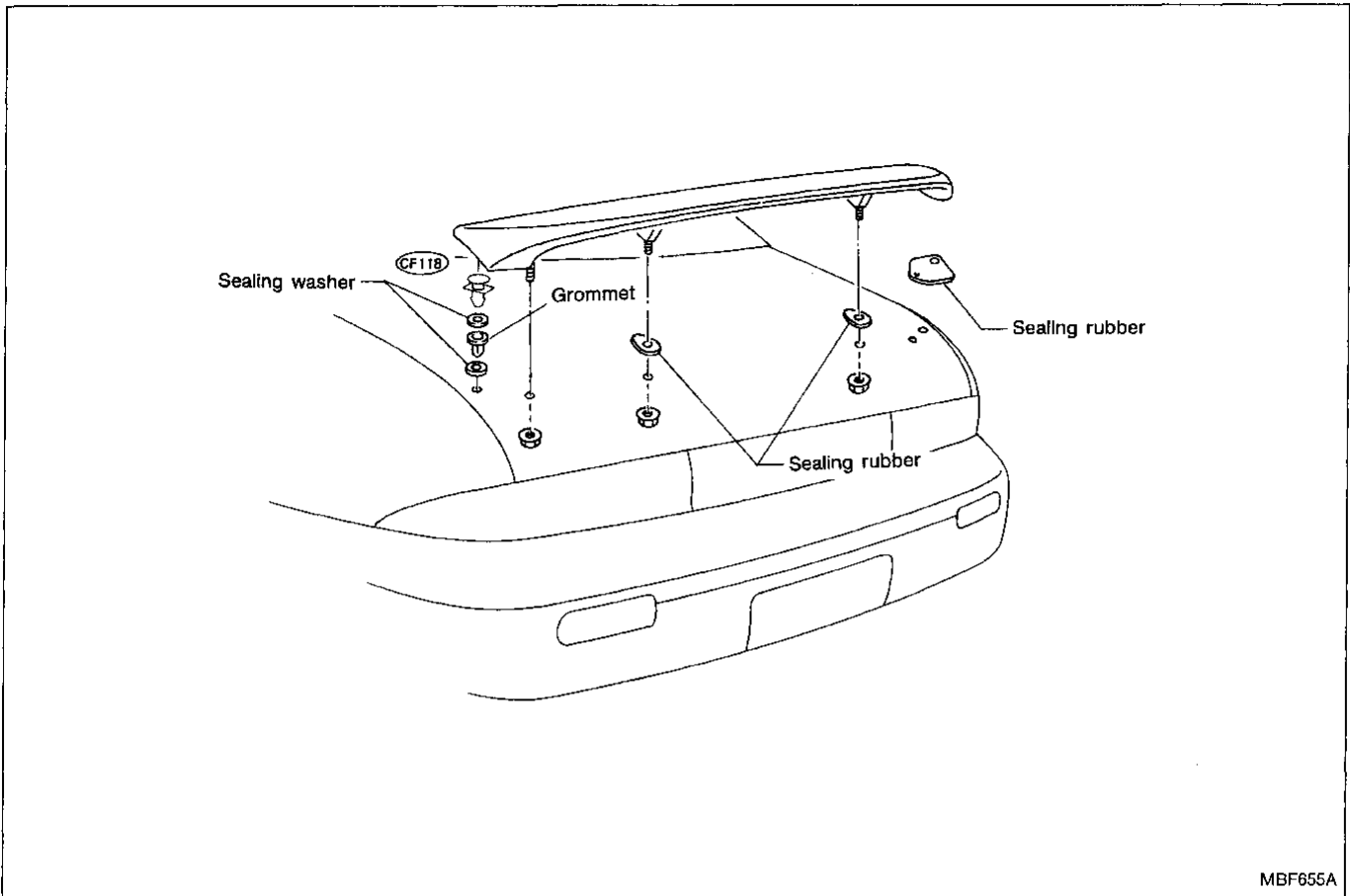

BODY ALIGNMENT

- All dimensions indicated in figures are actual ones.
- When a tram tracking gauge is used, adjust both pointers to equal length and check the pointers and gauge itself to make sure there is no free play.
- When a measuring tape is used, check to be sure there is no elongation, twisting or bending.
- Measurements should be taken at the center of the mounting holes.
- An asterisk (*) following the value at the measuring point indicates that the measuring point on the other side is symmetrically the same value.
- The coordinates of the measurement points are the distances measured from the standard line of "X", "Y" and "Z".

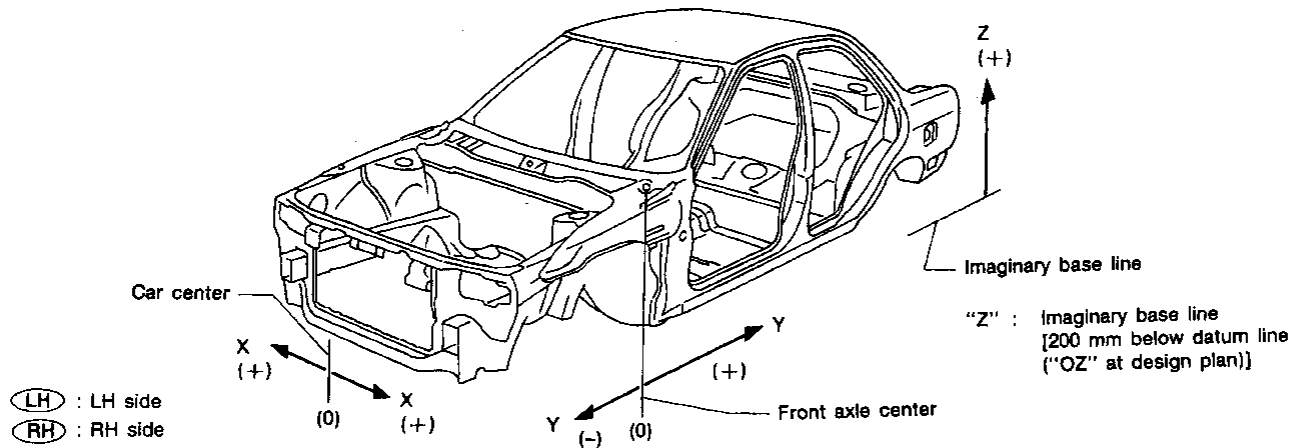

SBF874G

Engine Compartment

MEASUREMENT

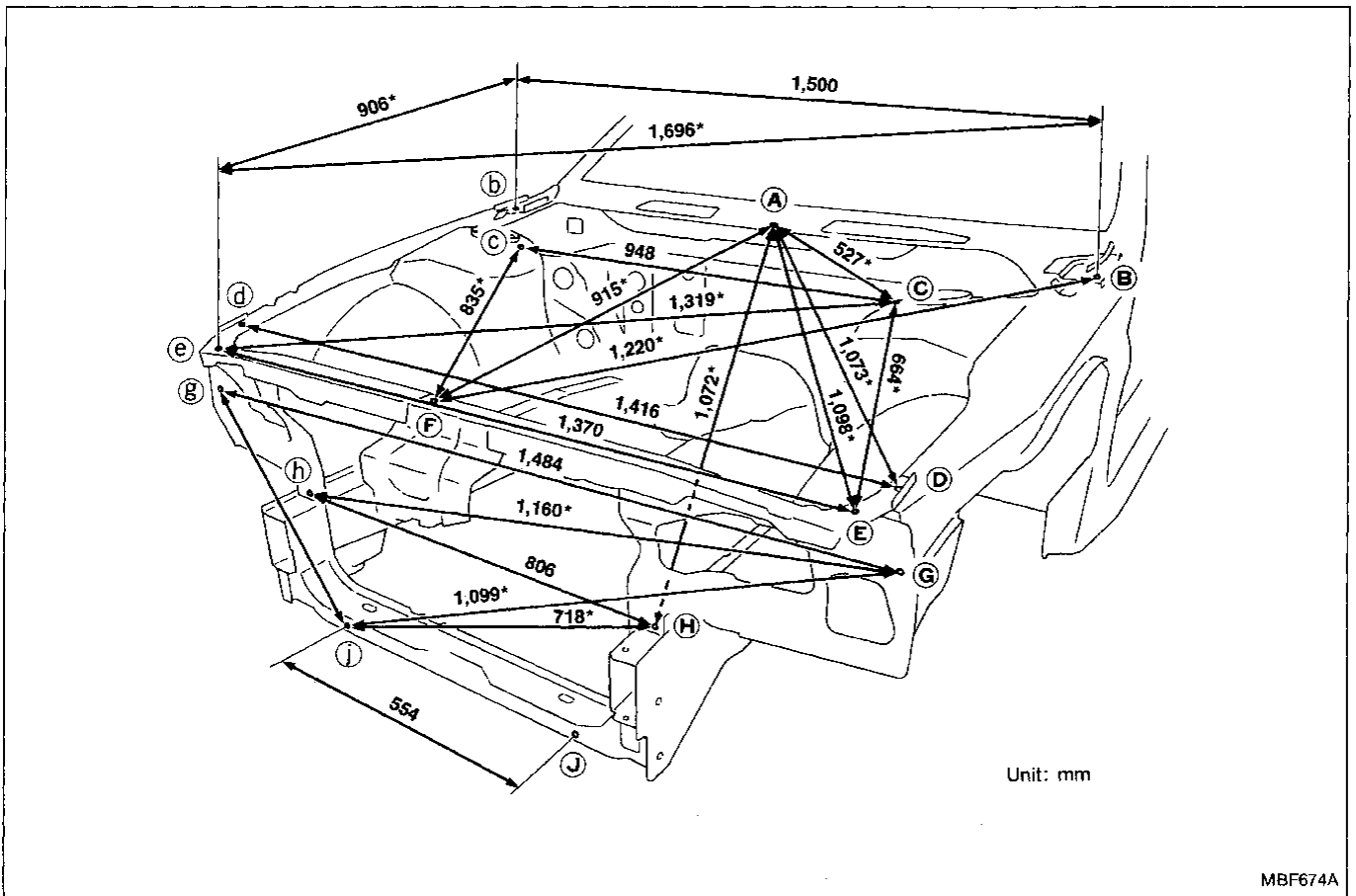

MBF674A

BODY ALIGNMENT

Engine Compartment (Cont'd)

Unit: mm

MEASUREMENT POINTS

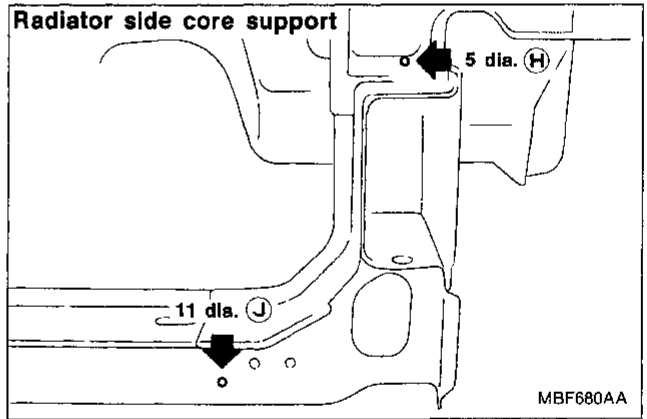
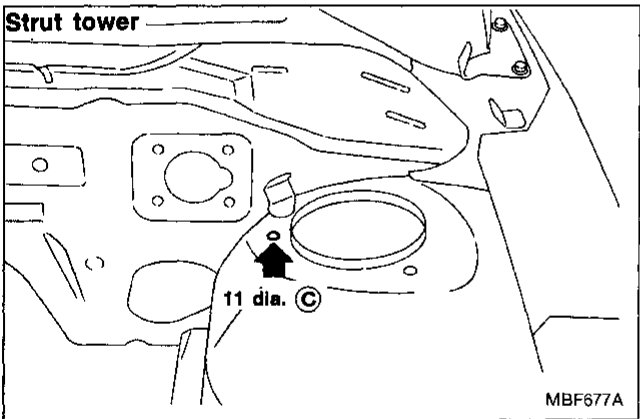
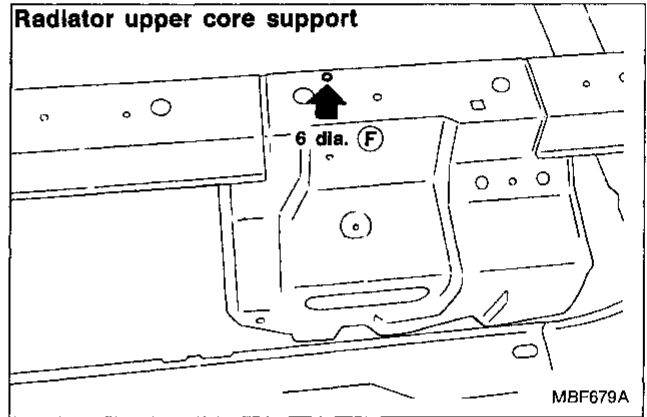
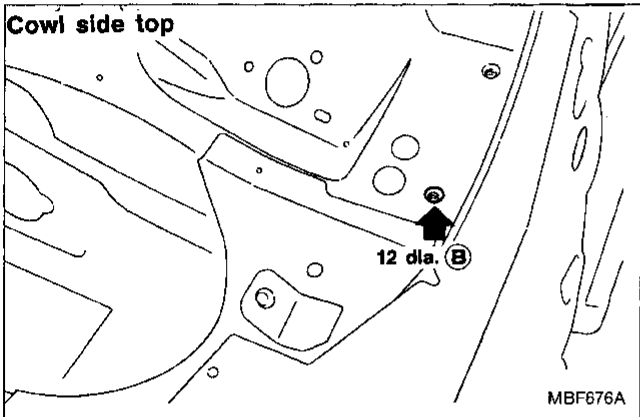
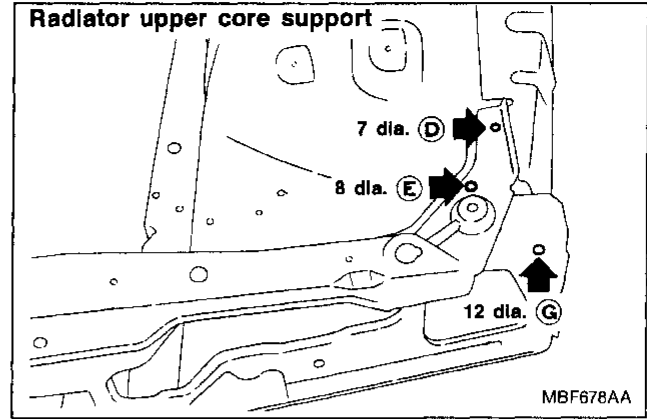
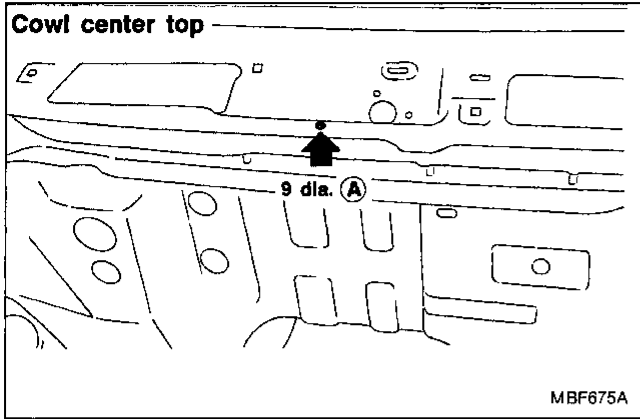

BODY ALIGNMENT

Underbody

MEASUREMENT

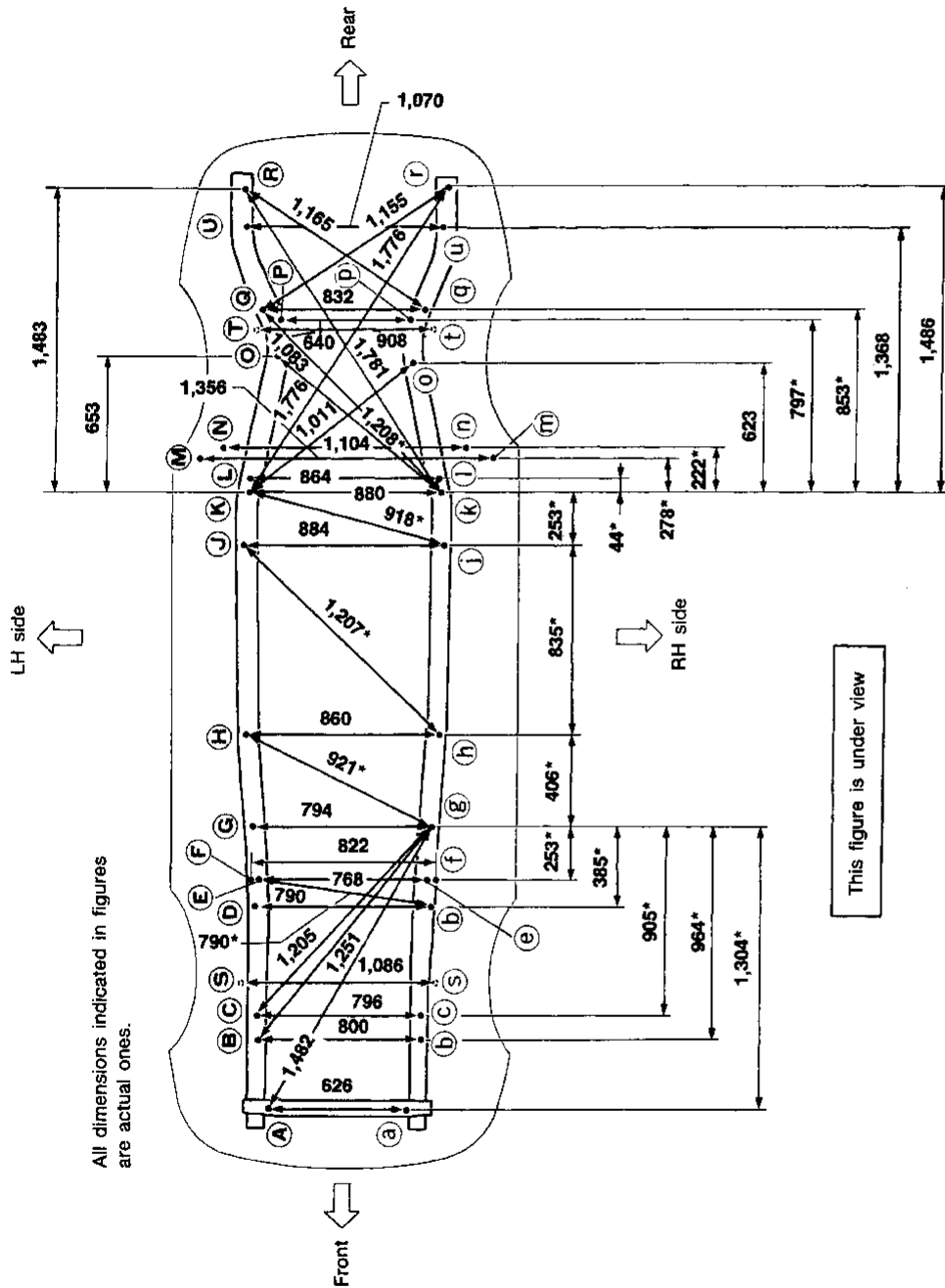

This figure is under view

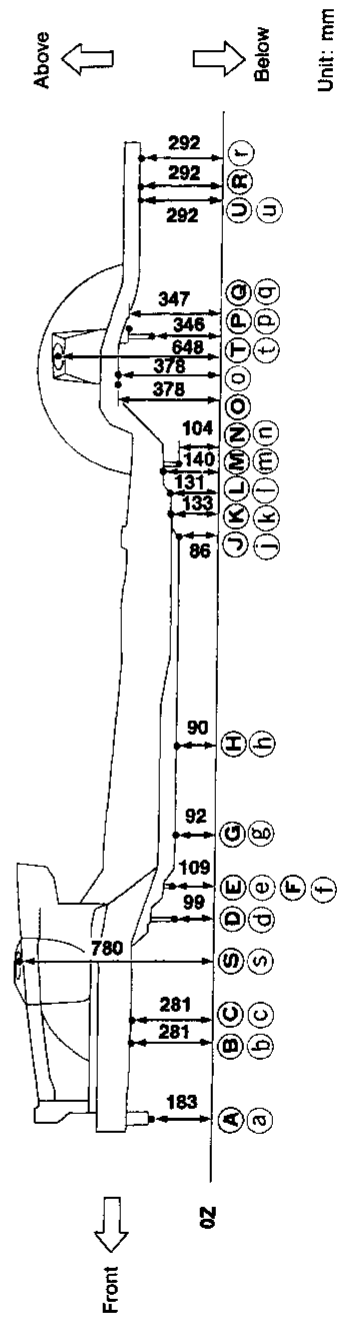

- GI
- MA
- EM
- LC
- EF & EC
- FE
- AT
- PD
- FA
- RA
- BR
- ST
- BF**
- HA
- EL
- IDX

BODY ALIGNMENT

Underbody (Cont'd)

MEASUREMENT POINTS

Coordinates:

(A)	(a)	(C)	(c)	(E)	(e)	(G)	(g)	(J)	(j)	(L)	(l)	(N)	(n)	(O)	(o)	(Q)	(q)	(U)	(u)
X: 313	X: 400	X: 398	X: 230	X: 364	X: 403	X: 397	X: 357	X: 442	X: 1,895	X: 432	X: 432	X: 552	X: 552	X: 361	X: 416	X: 416	X: 538	X: 538	X: 535
Y: -643	Y: -290	Y: 403	Y: -230	Y: 403	Y: 403	Y: 655	Y: 92	Y: 1,895	Y: 1,895	Y: 2,188	Y: 2,188	Y: 2,335	Y: 2,335	Y: 2,712	Y: 2,970	Y: 2,970	Y: 3,619	Y: 3,619	Y: 3,615
Z: 183	Z: 281	Z: 109	Z: 281	Z: 109	Z: 109	Z: 92	Z: 90	Z: 96	Z: 96	Z: 131	Z: 131	Z: 104	Z: 104	Z: 178	Z: 347	Z: 347	Z: 292	Z: 292	Z: 292

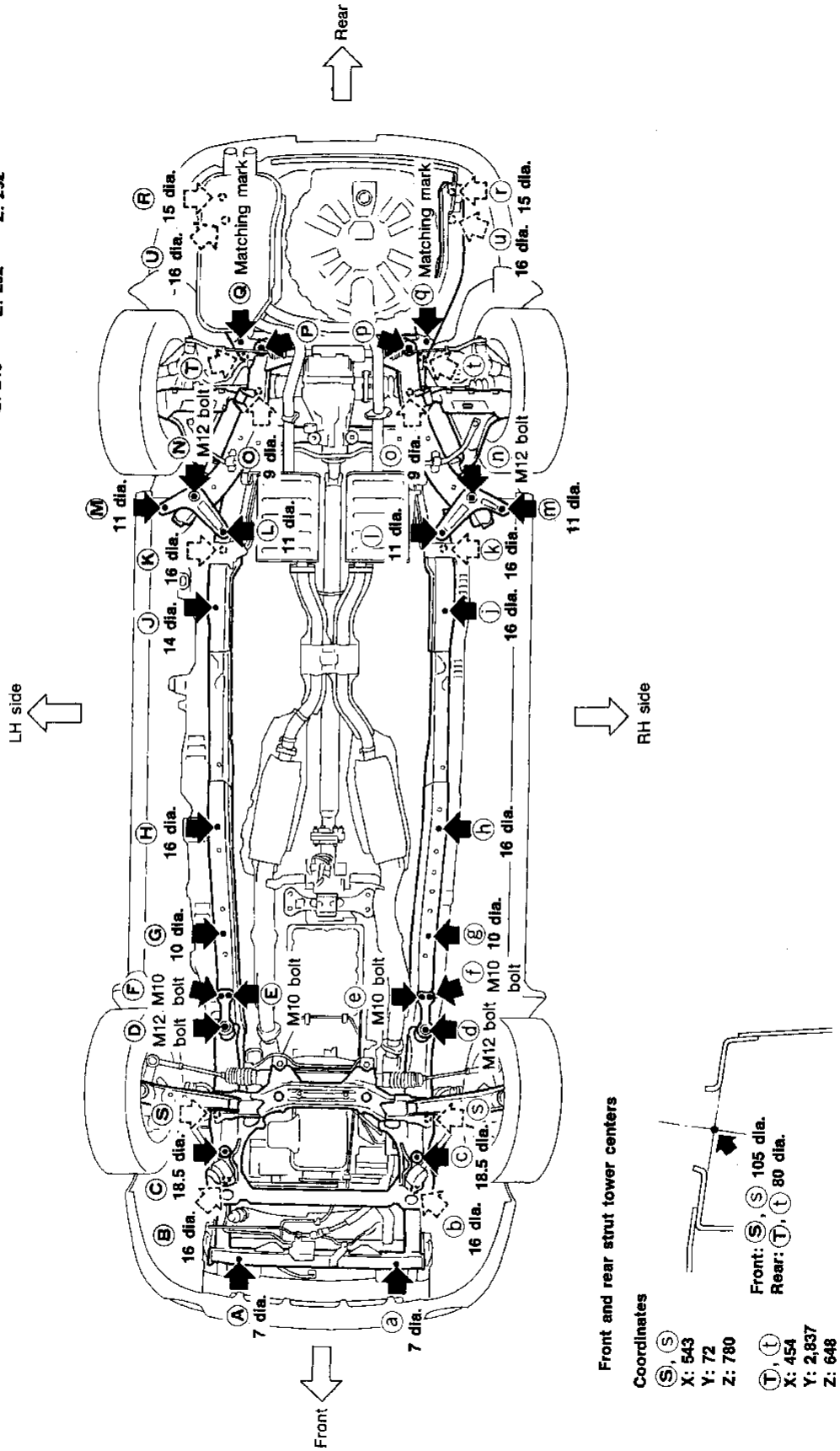

Unit: mm

SUPPLEMENTAL RESTRAINT SYSTEM (SRS)

Precautions for SRS "Air Bag" and "Seat Belt Pre-tensioner" Service

- Do not use a circuit tester to check SRS circuits.
- Before servicing the SRS, turn ignition switch "OFF", disconnect battery ground cable and wait for at least 10 minutes.
For approximately ten minutes after the cables are removed, it is still possible for the air bag to inflate. Therefore, do not work on any air bag system connectors or wires until at least ten minutes have passed.
- SRS sensors must always be installed with their arrow marks " ← " facing the front of the vehicle for proper operation. Also check sensors for cracks, deformities or rust before installation and replace as required.
- The spiral cable must be aligned with the neutral position since its rotations are limited. Do not attempt to turn steering wheel or column after removal of steering gear.
- Handle air bag module carefully. Always place it with the pad side facing upward.
- After removing any SRS parts, discard old bolts and replace with new ones. Conduct self-diagnosis to check entire SRS for proper function.
- If front of vehicle is damaged in a collision, always check the crash zone sensor and the wiring harness.
- After air bag inflates, the front instrument panel assembly should be replaced.

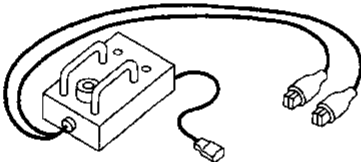
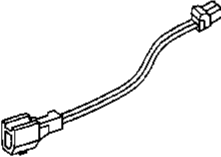

GI
 MA
 EM
 LC
 EF &
 EC
 FE

Special Service Tools

Tool number (Kent-Moore No.) Tool name	Description	
KV99106400 (J38381) Deployment tool		Disposing of air bag module
KV991065S0 (J38381-30) Deployment tool adapters		

AT
 PD
 FA
 RA
 BR
 ST

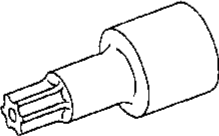
Commercial Service Tools

Tool name	Description	
Special torx bit		Use for special bolts (tamper resistant screw)
Spiral cable stopper		Avoiding unexpected spiral cable rotation

BF
 HA
 EL
 IDX

- When laying aside a single pre-tensioner (belt assembly), make sure cylinder tip does not point towards a person. Always place pre-tensioner in a box if possible. (If pre-tensioner should go off accidentally, rubber cap will jump out of cylinder tip, blowing out high-temperature gas.)

SUPPLEMENTAL RESTRAINT SYSTEM (SRS)

Description

The air bag deploys when any of the two sensors (front crash zone sensor or tunnel sensor) and the safing sensor simultaneously activate while the ignition switch is "ON".

Ignition	Front crash zone sensor	Tunnel sensor	Safing sensor	Air bag signal
ON	ON		ON	ON
ON		ON	ON	ON

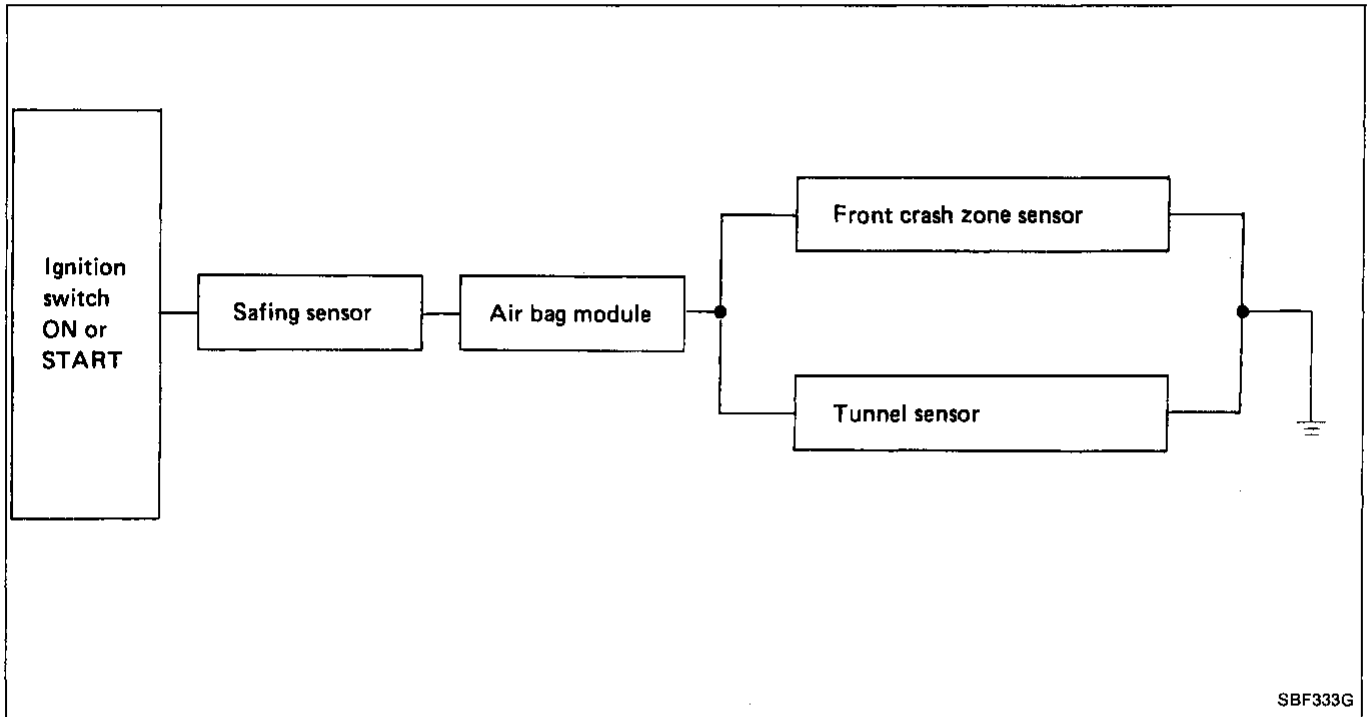

Self-diagnosis

The diagnosis unit (control unit) diagnoses the SRS circuit. When the ignition key is in the "ON" or "START" position, the "AIR BAG" warning lamp will illuminate for about 7 seconds and then turn off. This means that the system is operational.

SUPPLEMENTAL RESTRAINT SYSTEM (SRS)

Caution Labels and SRS Component Parts Location

The CAUTION LABELS are important when servicing SRS system in the field. If they are dirty or damaged, replace them with new ones.

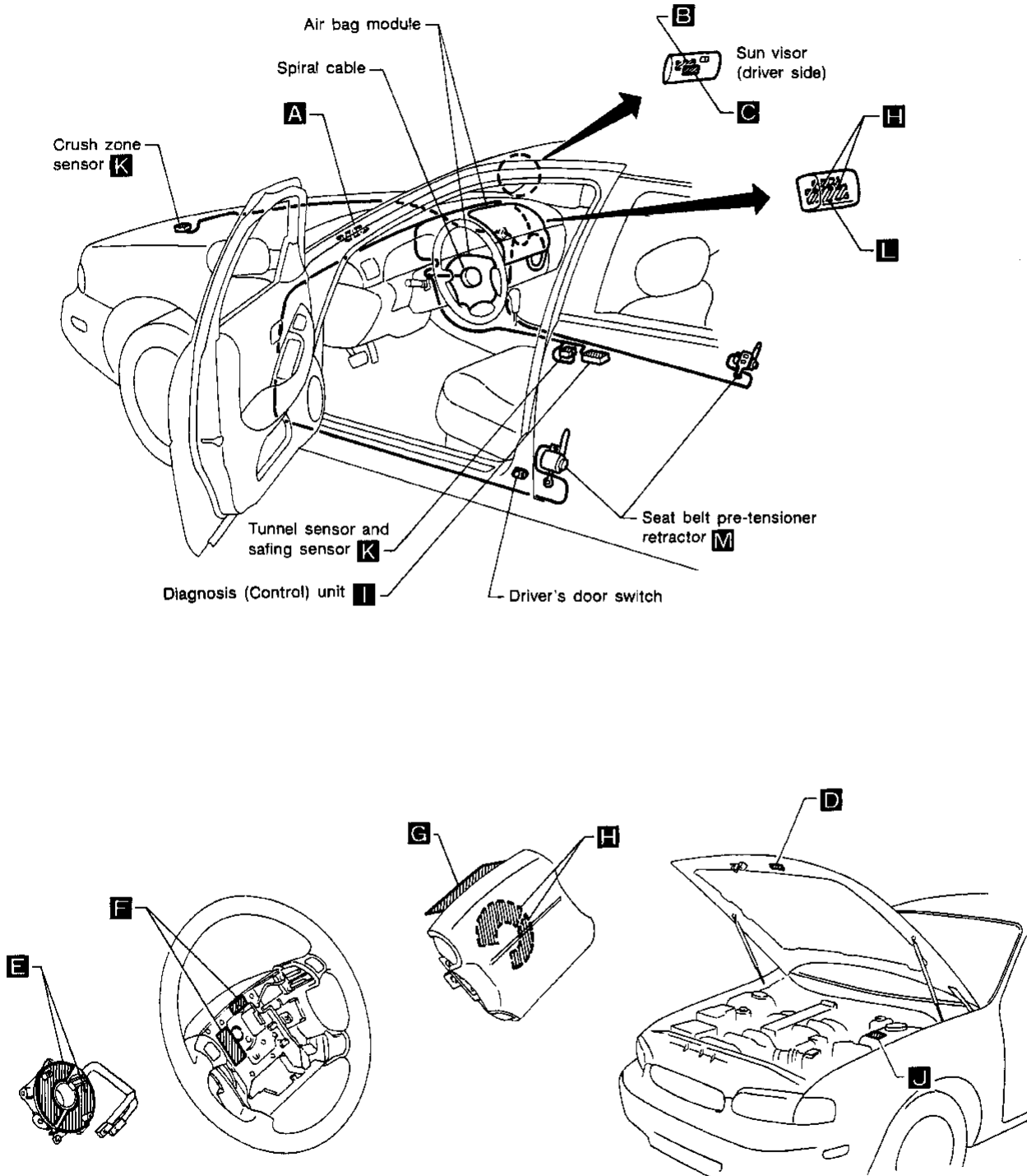

GI
MA
EM
LC
EF &
EC
FE
AT
PD
FA
RA
BR
ST
BF
HA
EL
IDX

SUPPLEMENTAL RESTRAINT SYSTEM (SRS)

Caution Labels and SRS Component Parts Location (Cont'd)

A

DRIVER-AIRBAG

B

INFORMATION SRS AIRBAG

- THIS CAR IS EQUIPPED WITH A DRIVER AIR BAG AS A SUPPLEMENTAL RESTRAINT SYSTEM (S.R.S.) TO HELP PROTECT FRONT OCCUPANTS IN A FRONTAL COLLISION.
- ALWAYS USE SEAT BELTS & CHILD SEAT.
- THE SYSTEM MUST BE INSPECTED 10 YEARS AFTER DATE OF MANUFACTURE, AS NOTED ON THE CERTIFICATION LABEL LOCATED ON THE LEFT FRONT DOOR.
- IF ANY OF THE FOLLOWING CONDITIONS OCCUR, THE SYSTEM MUST BE SERVICED: THE "AIR BAG" LAMP DOES NOT GO ON. FLASHES INTERMITTENTLY OR REMAINS ON.
- SEE YOUR OWNER'S MANUAL FOR DETAILS ABOUT THE FUNCTIONING, SERVICE, AND DISPOSAL PROCEDURES FOR THE SYSTEM.

C

NOTICE SRS AIRBAG

- THIS CAR IS EQUIPPED WITH AIR BAGS TO SUPPLEMENT THE SEAT BELTS.
- ALWAYS USE SEAT BELTS & CHILD SEAT.
- READ THE INFORMATION ON THE REVERSE SIDE.

D

WARNING SRS AIRBAG

- THIS CAR IS EQUIPPED WITH AIR BAGS AS A SUPPLEMENTAL RESTRAINT SYSTEM (S.R.S.)
- ALL S.R.S. ELECTRICAL WIRING AND CONNECTORS ARE COLORED YELLOW.
- DO NOT USE ELECTRICAL TEST EQUIPMENT ON THESE CIRCUITS.
- TAMPERING WITH OR DISCONNECTING THE S.R.S. WIRING AND CONNECTORS COULD RESULT IN ACCIDENTAL DEPLOYMENT OF THE AIR BAGS OR MAKE THE SYSTEM INOPERATIVE, WHICH MAY RESULT IN SERIOUS INJURY.

E

CAUTION SRS AIRBAG

- BEFORE ASSEMBLY;
 - LINE UP THE FRONT WHEELS STRAIGHT AHEAD.
 - ALIGN THE ARROW WITH THE YELLOW MARK ON THE SIDE GEAR.
 - READ SERVICE MANUAL.
- NO SERVICEABLE PARTS INSIDE.
- DO NOT DISASSEMBLE OR TAMPER.

F

WARNING SRS AIRBAG

- BEFORE MOUNTING STEERING WHEEL;
- MAKE SURE THAT THE FRONT WHEELS ARE IN STRAIGHT-AHEAD POSITION.
 - ALIGN THE ARROW WITH THE YELLOW MARK ON THE SIDE GEAR. (SPIRAL CABLE)
 - READ SERVICE MANUAL.

G

WARNING SRS AIRBAG

- THIS AIRBAG MODULE CANNOT BE REPAIRED.
- USE DIAGNOSTIC INSTRUCTIONS TO DETERMINE IF THE UNIT IS OPERATIONAL.
- IF NOT OPERATIONAL, REPLACE AND DISPOSE OF THE ENTIRE UNIT AS DIRECTED IN THE INSTRUCTIONS.
- UNDER NO CIRCUMSTANCES SHOULD A DIAGNOSIS BE PERFORMED USING ELECTRICALLY POWERED TEST EQUIPMENT OR PROBING DEVICES.
- TAMPERING OR MISHANDLING CAN RESULT IN PERSONAL INJURY.
- STORE THE REMOVED AIRBAG MODULE WITH THE PAD SURFACE UP.
- FOR SPECIAL HANDLING OR STORAGE REFER TO SERVICE MANUAL.

SUPPLEMENTAL RESTRAINT SYSTEM (SRS)

Caution Labels and SRS Component Parts Location (Cont'd)

H

DANGER POISON

- KEEP OUT OF THE REACH OF CHILDREN.
- CONTAINS SODIUM AZIDE AND POTASSIUM NITRATE.
- CONTENTS ARE POISONOUS AND EXTREMELY FLAMMABLE.
- CONTACT WITH ACID, WATER OR HEAVY METALS MAY PRODUCE HARMFUL AND IRRITATING GASES OR EXPLOSIVE COMPOUNDS.
- DO NOT DISMANTLE, INCINERATE, OR BRING INTO CONTACT WITH ELECTRICITY OR STORE AT TEMPERATURES EXCEEDING 200°F.
- FIRST AID: IF CONTENTS ARE SWALLOWED, INDUCE VOMITING;
 - FOR EYE CONTACT, FLUSH EYES WITH WATER FOR 15 MINUTES
 - IF GASES FROM ACID OR WATER CONTACT ARE INHALED, SEEK FRESH AIR
 - IN EVERY CASE, GET PROMPT MEDICAL ATTENTION
- FOR ADDITIONAL INFORMATION, SEE MATERIAL SAFETY DATA SHEET (MSDS) FOR THIS PRODUCT.

I

CAUTION SRS AIRBAG

- NO SERVICEABLE PARTS INSIDE.
- DO NOT DISASSEMBLE OR TAMPER.
- DO NOT DROP; KEEP DRY.
- WHILE REMOVED, STORE IN A CLEAN AND DRY AREA.
- IF WET CONDITION OCCURS, THIS UNIT MUST BE SERVICED.

J

CAUTION SRS AIRBAG

- TO AVOID DAMAGING THE S.R.S. SPIRAL CABLE, REMOVE THE STEERING WHEEL BEFORE REMOVING THE STEERING LOWER JOINT.

K

WARNING

SRS AIRBAG

- DO NOT DISASSEMBLE OR TAMPER.
- DISMANTLING AND INSTALLATION SHOULD ONLY BE PERFORMED BY TRAINED PERSONNEL.

L

WARNING

SRS AIRBAG

- THIS AIR BAG MODULE CANNOT BE REPAIRED.
- USE DIAGNOSTIC INSTRUCTIONS TO DETERMINE IF THE UNIT IS OPERATIONAL.
- IF NOT OPERATIONAL, REPLACE AND DISPOSE OF THE ENTIRE UNIT AS DIRECTED IN THE INSTRUCTIONS.
- UNDER NO CIRCUMSTANCES SHOULD A DIAGNOSIS BE PERFORMED USING ELECTRICALLY POWERED TEST EQUIPMENT OR PROBING DEVICES.
- TAMPERING OR MISHANDLING CAN RESULT IN PERSONAL INJURY.
- STORE THE REMOVED AIR BAG MODULE WITH THE BAG—COVER SURFACE UP.
- FOR SPECIAL HANDLING OR STORAGE REFER TO SERVICE MANUAL.

M

DANGER

- DO NOT REMOVE, IMPACT OR DISASSEMBLE.

GI

MA

EM

LC

EF &
EC

FE

AT

PD

FA

RA

BR

ST

BF

HA

EL

IDX

SUPPLEMENTAL RESTRAINT SYSTEM (SRS)

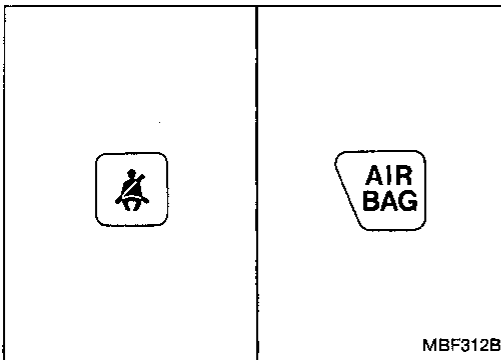

Maintenance Items

1. Check "AIR BAG" and "Seat belt" warning lamp
When the ignition key is in the "ON" or "START" position, the "AIR BAG" and "Seat belt" (when fastening seat belt) warning lamp will illuminate for about 7 seconds and then turn off. This means that the system is operational.
When a warning lamp flashes, check and correct cause of the problem.
2. Visually check SRS components
 - (1) Sensors
 - Check sensors to ensure the arrow marks face the front of the vehicle.
 - Check body and sensor brackets for deformities or rust.
 - Check sensor case for dents, cracks, deformities or rust.
 - Check sensor harness for binds, connector for damage, and terminals for deformities.
 - (2) Diagnosis (Control) unit — Airbag
 - Check case and bracket for dents, cracks or deformities.
 - Check connectors for damage, and terminals for deformities.
 - (3) Main harness and instrument harness
 - Check connectors for poor connections.
 - Check harnesses for binds, connectors for damage, and terminals deformities.
 - (4) Spiral cable
 - Visually check lock (engagement) pins and combination switch for damage.
 - Check connectors, flat cable and protective tape for damage.
 - Check steering wheel for noise, binds or difficult operation.
 - (5) Steering wheel
 - Check harness (built into steering wheel) and connectors for damage, and terminals for deformities.
 - Install air bag module to check fit or alignment with steering wheel.
 - Check steering wheel for excessive free play.
 - (6) Air bag module
 - Remove air bag module from steering wheel.
Check harness cover and connectors for damage, terminals for deformities, and harness for binds.
 - Install air bag module to steering wheel to check fit or alignment with the wheel.

CAUTION:

Replace previously used screws with new ones.

Removal and Installation — Diagnosis (Control) Unit, Sensors and Seat Belt Pre-tensioner

CAUTION:

- Before servicing SRS, turn the ignition switch off, disconnect battery ground cable and wait for at least 10 minutes.
- Do not attempt to disassemble seat belt pre-tensioner.
- Do not drop or impact seat belt pre-tensioner. If any portion is damaged, replace the seat belt pre-tensioner.
- Do not expose seat belt pre-tensioner to temperatures exceeding 80°C (176°F).
- Whenever seat belts (equipped with pre-tensioner) are moved, ensure that cylinder faces down. Do not hold cylinder.
- The special bolts are coated with bonding agent. Discard old ones after removal; replace with new ones.
- Check all sensors for proper installation.
- Check all sensors to ensure they are free of deformities, dents, cracks or rust. If they show any visible signs of damage, replace them with new ones.
- Check sensor brackets to ensure they are free of deformities or rust.

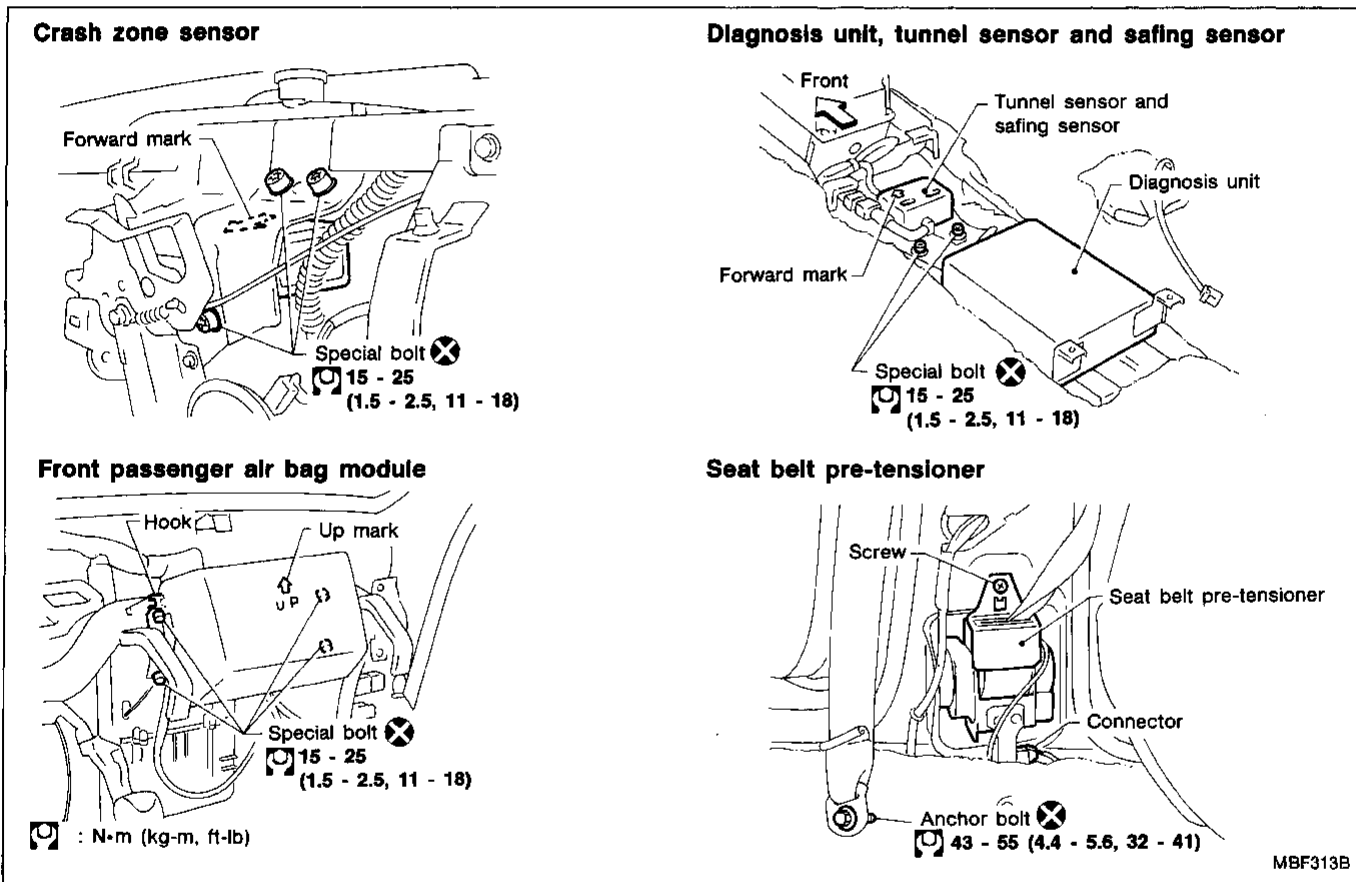

GI
 MA
 EM
 LC
 EF & EC
 FE
 AT
 PD
 FA
 RA
 BR
 ST
 BF
 HA
 EL
 IDX

Removal — Air Bag Module and Spiral Cable

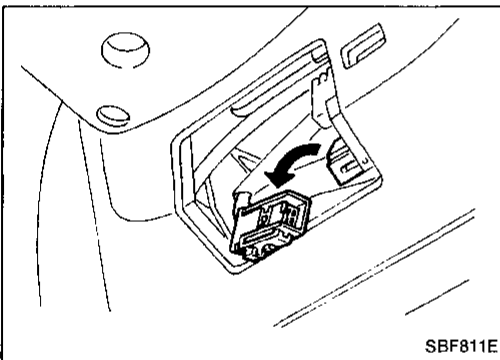
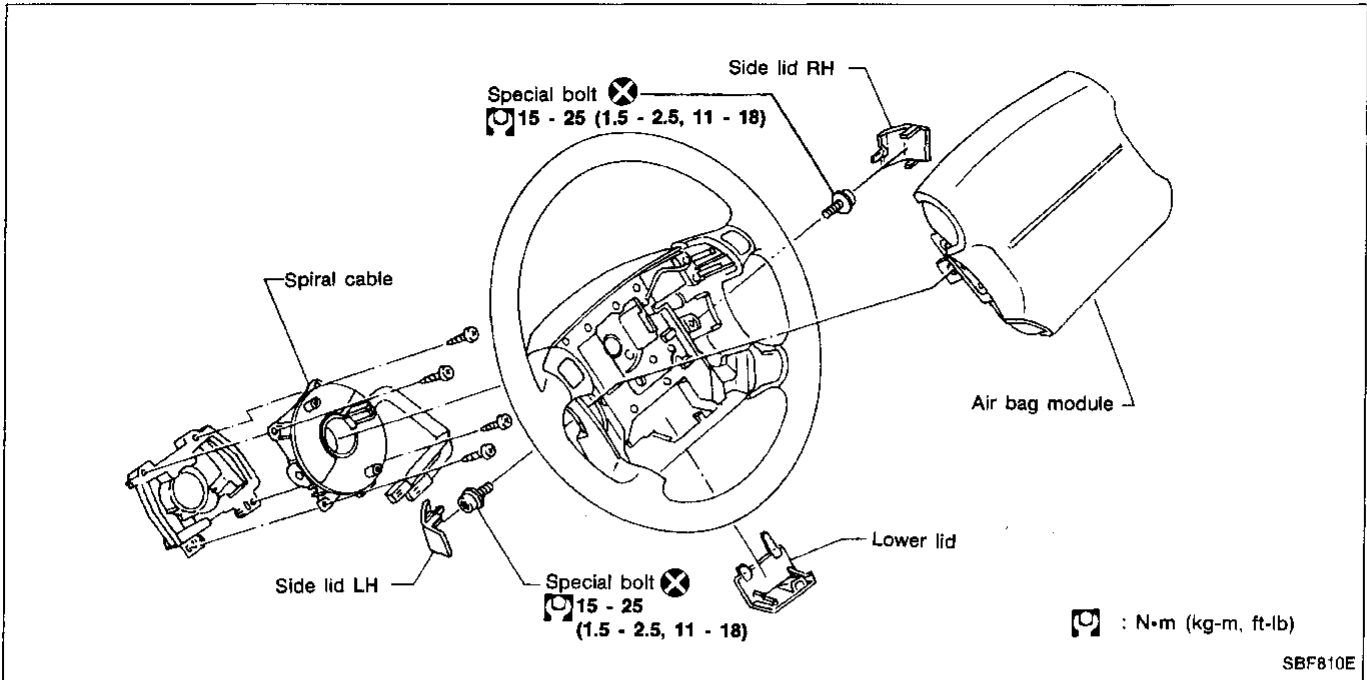

CAUTION:

Before servicing SRS, turn the ignition switch off, disconnect battery ground cable and wait for at least 10 minutes.

1. Remove lower lid from steering wheel, and disconnect air bag module connector.

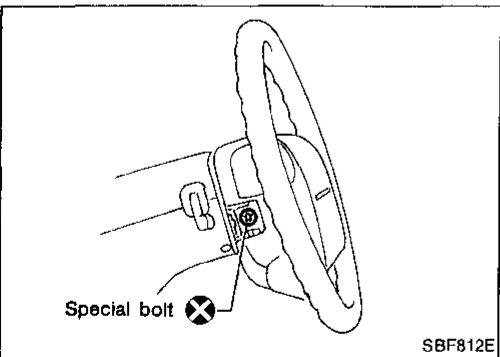

2. Remove side lid. Using the T50H torx bit, remove left and right special bolts. Air bag module can then be removed.

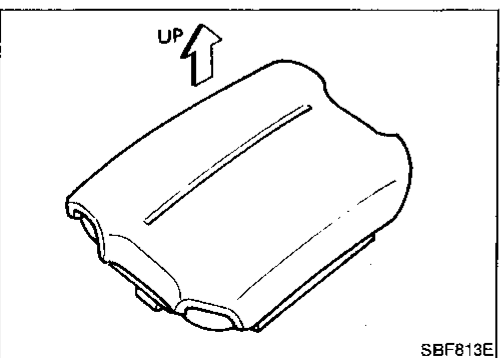

CAUTION:

- Always place air bag module with pad side facing upward.
- Do not attempt to disassemble air bag module.
- The special bolts are coated with bonding agent. Discard old ones after removal; replace with new ones.

SUPPLEMENTAL RESTRAINT SYSTEM (SRS)

Removal — Air Bag Module and Spiral Cable (Cont'd)

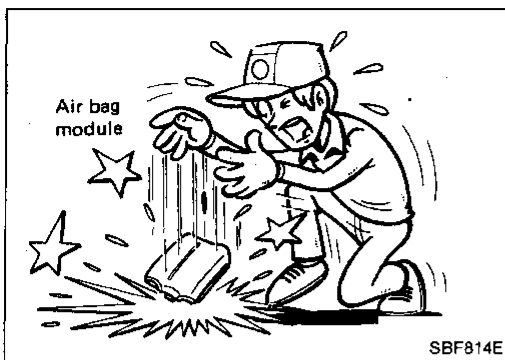

- Do not drop or impact air bag module. If any portion is deformed or cracked, replace the module.
- Do not expose the air bag module to temperatures exceeding 100°C (212°F).
- Do not allow oil, grease or water to come in contact with the air bag module.

GI

MA

EM

LC

EF &
EC

FE

AT

PD

FA

RA

BR

ST

BF

HA

EL

IDX

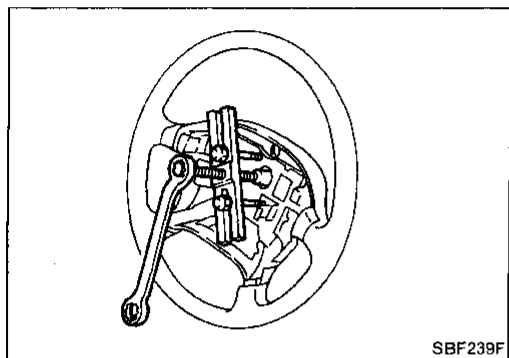

3. Set steering wheel in the neutral position.
4. Disconnect horn connector and remove nuts.
5. Using steering wheel puller, remove steering wheel. Be careful not to over-tighten puller bolt on steering wheel.

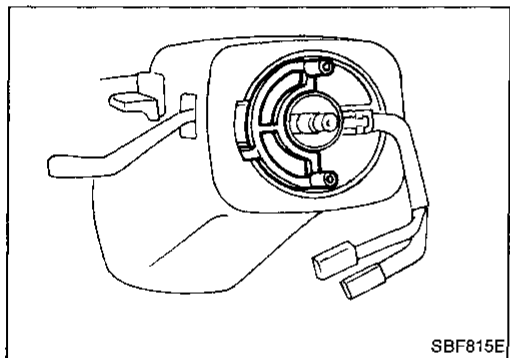

6. Attach spiral cable to stopper.
7. Remove steering column cover.
8. Disconnect connector and remove the four screws. The spiral cable can then be removed.

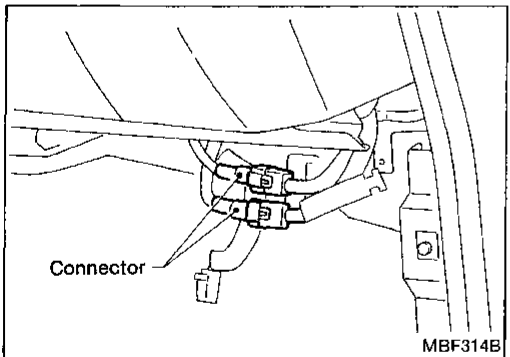

Removal — Front Passenger Air Bag Module

CAUTION:

Before servicing SRS, turn the ignition switch off, disconnect battery ground cable and wait for at least 10 minutes.

1. Remove lower instrument cover on passenger side.
2. Remove connector bracket from air bag module and disconnect inflator connector from body harness air bag connector.

SUPPLEMENTAL RESTRAINT SYSTEM (SRS)

Removal — Front Passenger Air Bag Module (Cont'd)

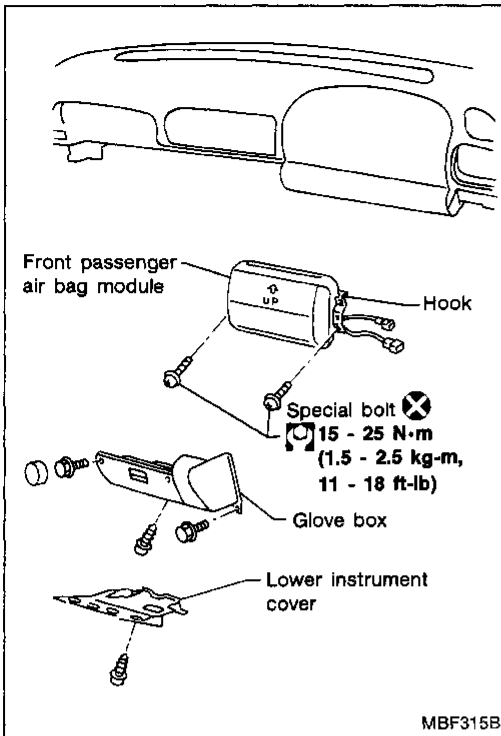

3. Remove glove box assembly.
 4. Remove the special bolt from left and right sides of front passenger air bag module and remove the air bag module.
- Air bag module is heavy and should be supported using both hands during removal.

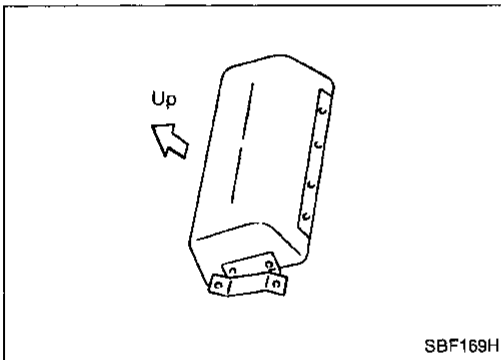

CAUTION:

- Always place air bag module with pad side facing upward.
- Do not attempt to disassemble air bag module.
- The special bolts are coated with bonding agent. Discard old ones after removal; replace with new ones.

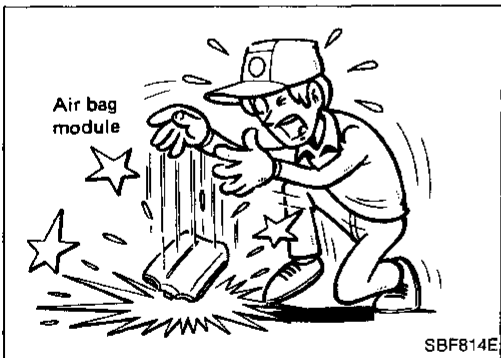

- Do not drop or impact air bag module. If any portion is deformed or cracked, replace the module.
- Do not expose the air bag module to temperatures exceeding 100°C (212°F).
- Do not allow oil, grease or water to come in contact with the air bag module.

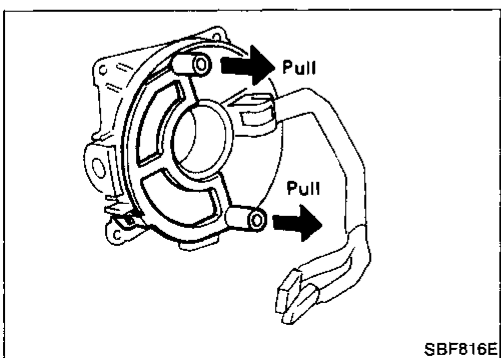

Installation — Air Bag Module and Spiral Cable

1. Connect spiral cable connector and tighten with screws. Install steering column cover.
2. Remove stopper by pulling two pin guides.

SUPPLEMENTAL RESTRAINT SYSTEM (SRS)

Installation — Air Bag Module and Spiral Cable (Cont'd)

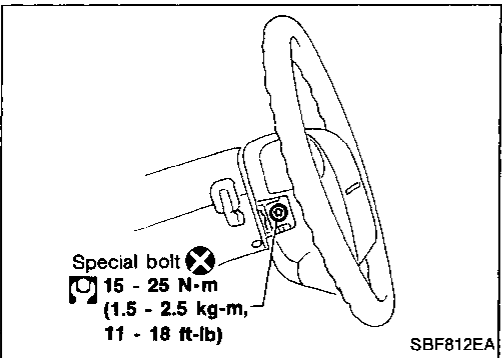
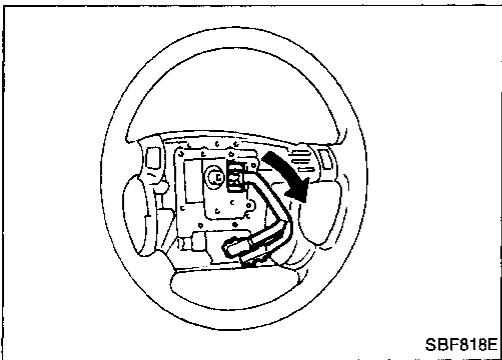
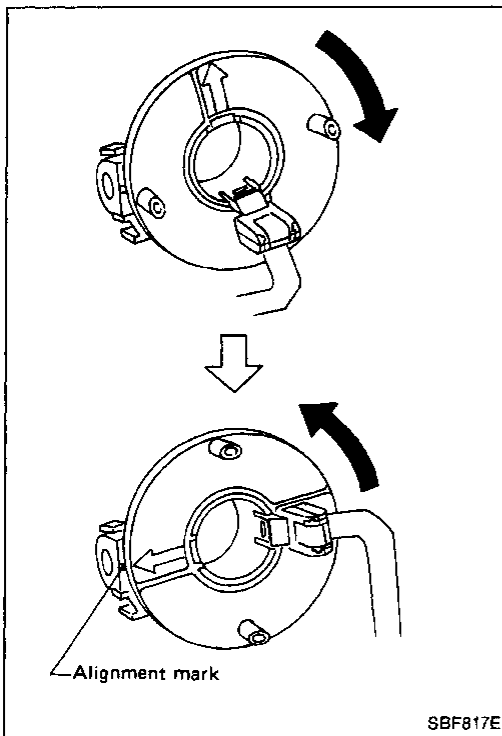

- Alignment of spiral cable with neutral position
If stopper is not used, align spiral cable with neutral position as follows:

Turn spiral cable clockwise until it catches stopper. Then, back spiral cable off approximately two turns until yellow alignment mark appears on left gear. Align arrow mark "←" of spiral cable with this yellow mark.

3. Install steering wheel setting spiral cable pin guides, and pull spiral cable through.

4. Connect horn connector and engage spiral cable with pawls in steering wheel.

5. Tighten nuts.

6. Position air bag module and tighten with new special bolts.

7. Connect air bag module connector.

8. Install all lids.

9. Conduct self-diagnosis to ensure entire SRS operates properly. (Use CONSULT or warning lamp check.)

SUPPLEMENTAL RESTRAINT SYSTEM (SRS)

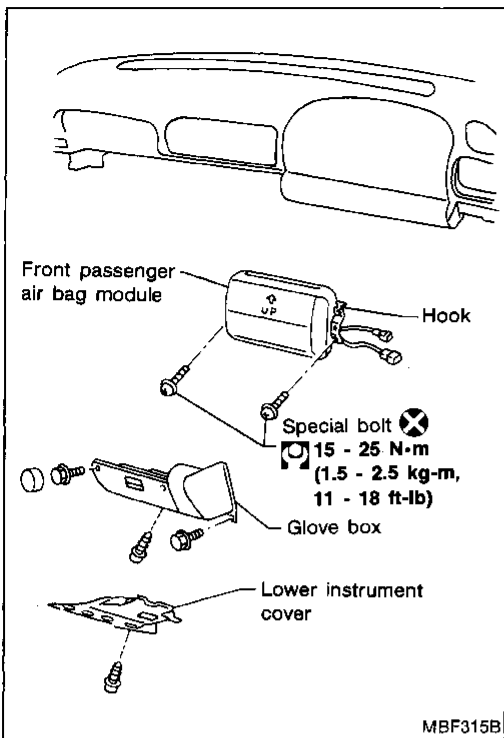

Installation — Front Passenger Air Bag Module

1. Install front passenger air bag module.
 - Ensure harness is not caught between rear of air bag module and steering member.
2. Install glove box assembly.

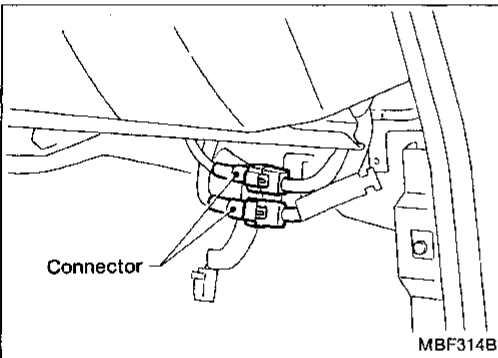

3. Connect air bag module connector to body harness connector.
4. Install air bag module connector on connector bracket.
5. Install connector bracket on air bag module, then install lower instrument cover on passenger side.

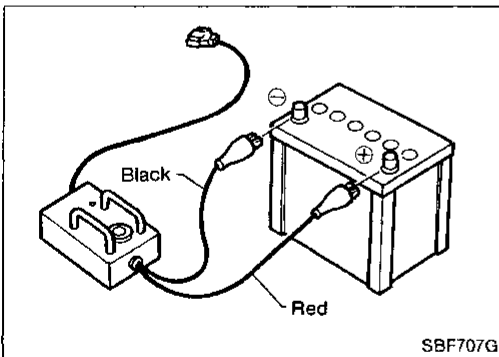

Scrapping Air Bag and Seat Belt Pre-tensioners

Before scrapping air bag modules, seat belt pre-tensioners or a vehicle equipped with an SRS system, be sure to deactivate the units or the system.

CONNECTING TO BATTERY

- Place the vehicle outdoors in such a way that it is surrounded on all sides by at least 6 m (20 ft) of open space.
- Use a voltmeter to make sure the vehicle battery is fully charged.

CAUTION:

The battery must show voltage of 9.6V or more.

Remove the battery from the vehicle and place it on dry wood blocks approximately 5 m (16 ft) away from the vehicle.

- Wait 10 to 12 minutes after the vehicle battery is disconnected before proceeding.
- Connect deployment tool to the battery.

CAUTION:

Make sure the polarity is correct. The right side lamp in the tool, marked "deployment tool power", should glow with a green light. If the right side lamp glows red, reverse the connections to the battery.

SUPPLEMENTAL RESTRAINT SYSTEM (SRS)

Scrapping Air Bag and Seat Belt Pre-tensioners (Cont'd)

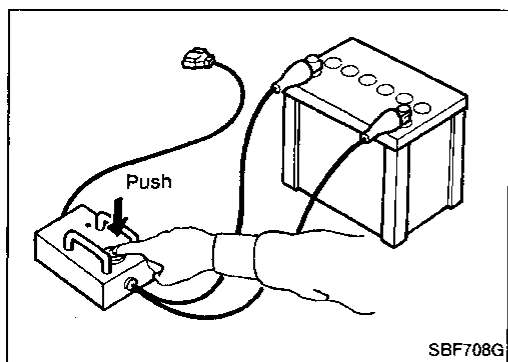

DEPLOYMENT TOOL CHECK

Press the deployment tool switch to the "ON" position. The left side lamp in the tool, marked "air bag connector voltage" should illuminate. If it does not illuminate, replace the tool.

AIR BAG DEPLOYMENT TOOL LAMP ILLUMINATION CHART (Battery connected)

Switch operation	Left side lamp, green* "AIR BAG CONNECTOR VOLTAGE"	Right side lamp, green* "DEPLOYMENT TOOL POWER"
OFF	OFF	ON
ON	ON	ON

*: If this lamp glows red, the tool is connected to the battery incorrectly. Reverse the connections and make sure the lamp glows green.

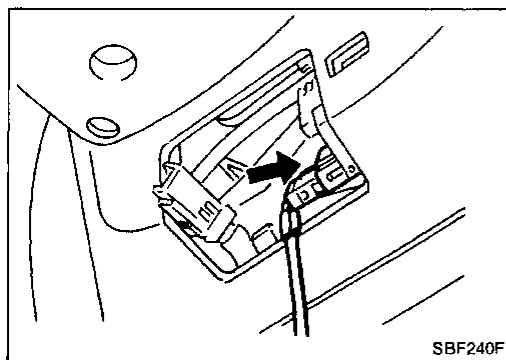

CONNECTING TO AIR BAG AND SEAT BELT PRE-TENSIONER

- Disconnect the prepared battery cable.
- Also disconnect the vehicle battery ground cable and wait 10 minutes.
- Disconnect air bag module and seat belt pre-tensioner connector.
- Connect deployment tool connector to air bag module or seat belt pre-tensioner.
For front passenger air bag and seat belt pre-tensioners, attach the adapters to the tool connector.

CAUTION:

Make sure the deployment tool is disconnected from the battery before you make this connection.

- Reconnect the battery cable to the prepared battery.
- The lamp on the right side of the tool, marked "deployment tool power", should glow green, not red.

GI

MA

EM

LC

EF &
EC

FE

AT

PD

FA

RA

BR

ST

BF

HA

EL

IDX

SUPPLEMENTAL RESTRAINT SYSTEM (SRS)

Scrapping Air Bag and Seat Belt Pre-tensioners (Cont'd)

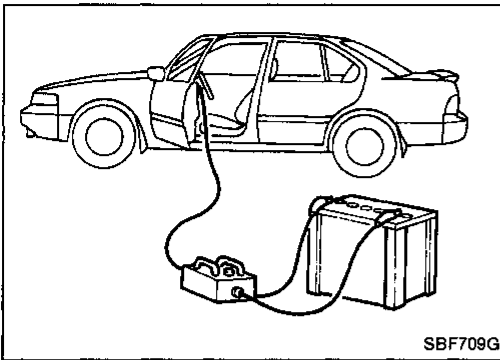

DEPLOYMENT

Press the button on the deployment tool. The left side lamp on the tool, marked "air bag connector voltage", will illuminate and the air bag will deploy.

DISPOSAL

- Remove steering wheel side lids. Use the special "torx" bit to remove the air bag module from the steering wheel. Place it into a sealed vinyl bag for disposal.

CAUTION:

- When deploying air bag, ensure vehicle is empty.
- No poisonous gas is produced upon air bag deployment. However, be careful not to inhale gas since it irritates throat and can cause choking.
- Due to heat, leave air bag module unattended for more than 30 minutes and leave seat belt pre-tensioner unattended for more than 10 minutes after deployment.
- Do not attempt to disassemble air bag module and seat belt pre-tensioner.
- Air bag module and seat belt pre-tensioner can not be re-used.
- Never apply water to a deployed air bag module.
- Be sure to wear gloves when handling a deployed air bag module.

Contents

Schematic	BF-83	
Wiring Diagram	BF-84	
Self-diagnosis	BF-85	
USING CONSULT	BF-85	GI
USING THE WARNING LAMP	BF-88	
Diagnostic Procedure 1	BF-91	
SYMPTOM: Warning lamp flashes.		MA
Diagnostic Procedure 2	BF-91	
SYMPTOM: Warning lamp does not come on.		EM
Diagnostic Procedure 3	BF-92	
SYMPTOM: Warning lamp does not go off.		LC
Collision Diagnosis	BF-93	

Schematic

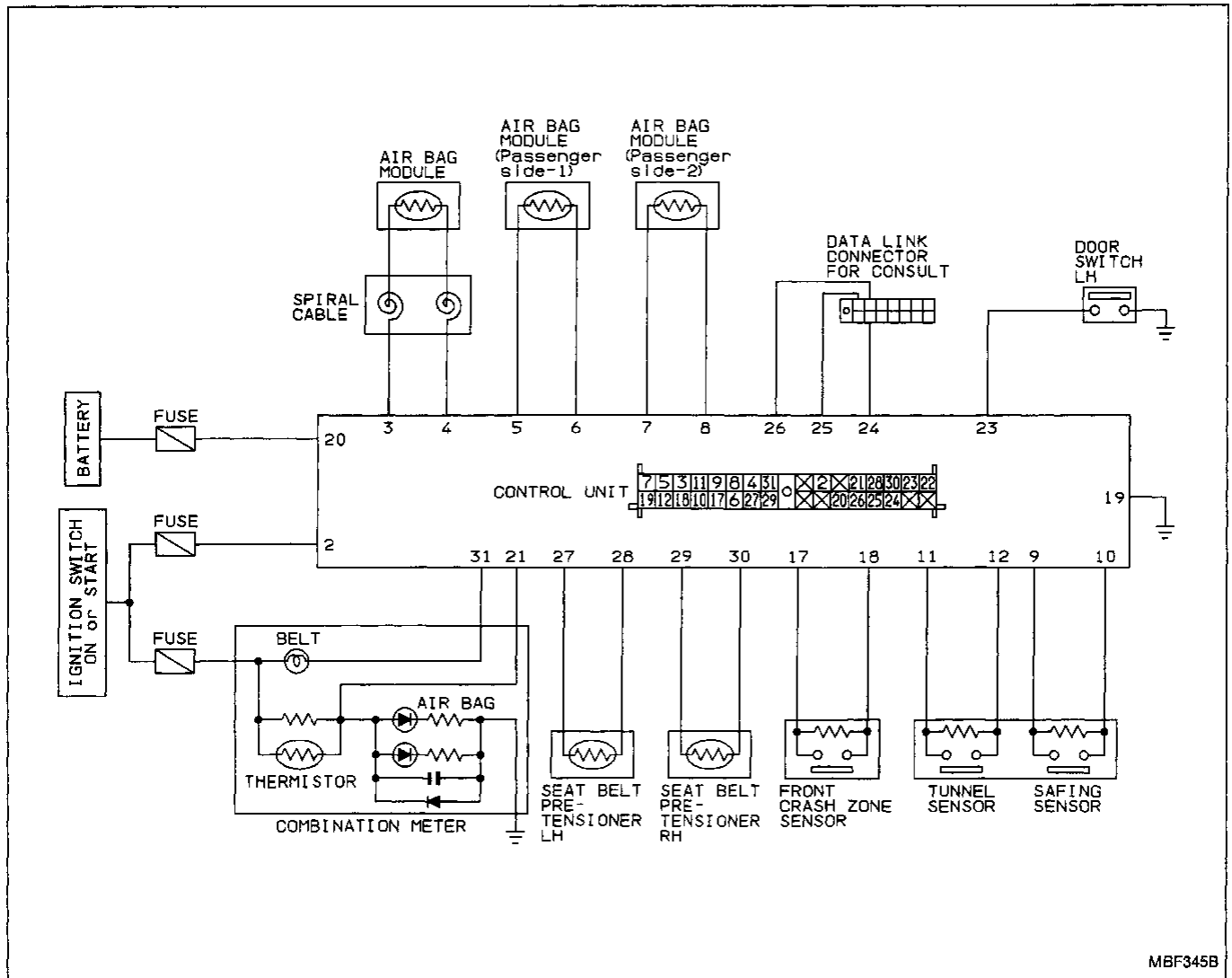

Wiring Diagram

CAUTION:

- Do not use a circuit tester to check SRS "Air Bag" harness connectors. The wiring harness and connectors have yellow outer insulation for easy identification.
- Do not attempt to repair, splice or modify the SRS "Air Bag" wiring harness. If the harness is damaged, replace it with a new one.
- Keep ground portion clean.

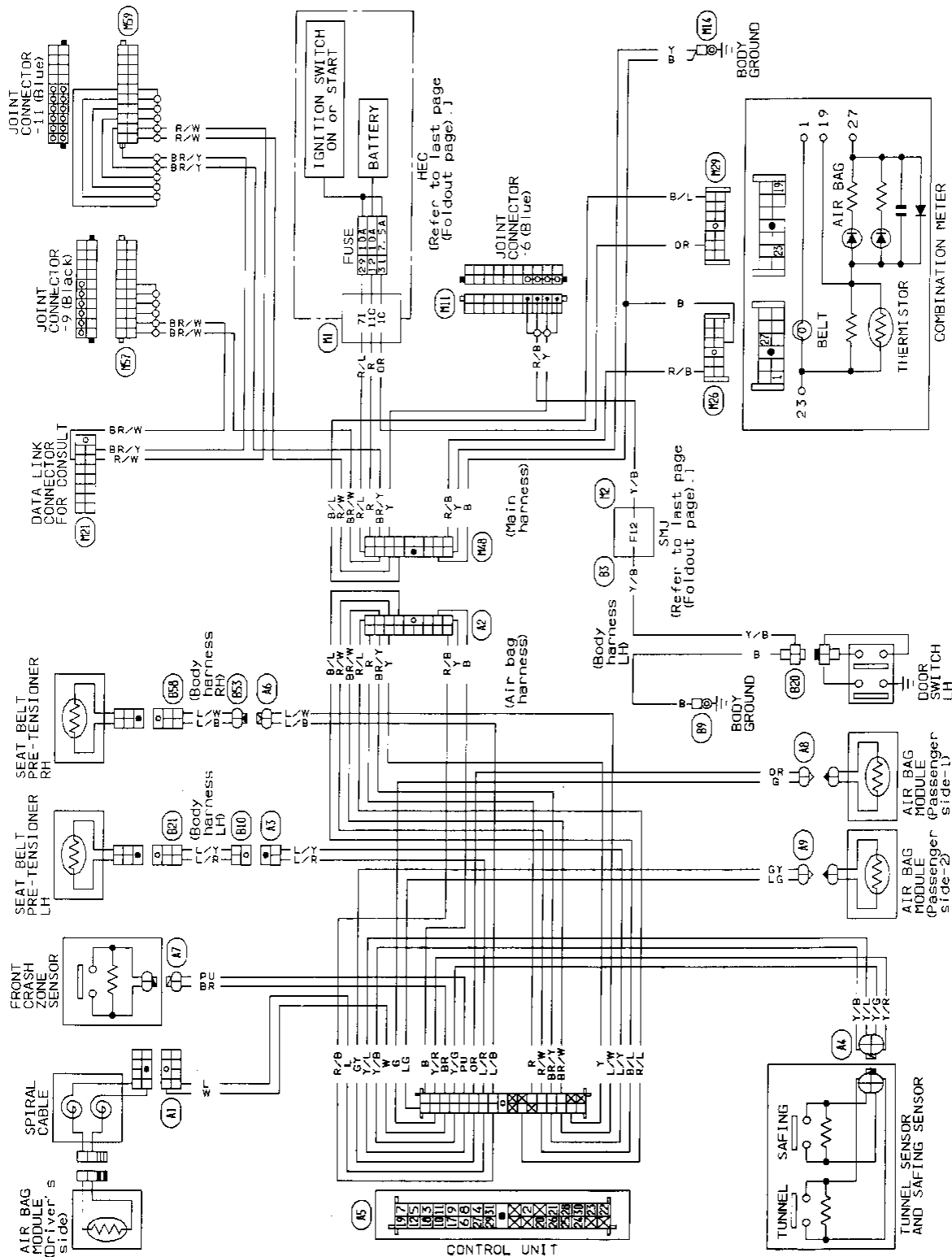

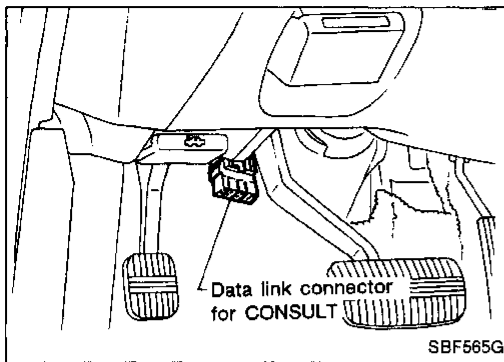

Self-diagnosis

USING CONSULT

The self-diagnosis results can be read by CONSULT, as follows:

1. Connect "CONSULT" to data link connector for CONSULT. (Data link connector for CONSULT is located in left dash side panel.)

GI

2. Turn ignition switch to "ON". (When CONSULT is connected, the "AIR BAG" warning lamp will be turned to present diagnosis mode.)

MA

EM

3. Touch "START" to operate "CONSULT".

LC

4. Touch "AIR BAG" to choose air bag system.

EF &

EC

5. Touch "SELF DIAG RESULTS" to read self-diagnosis results.

FE

6. Problem codes are displayed on "SELF DIAG RESULT 1" (first page — present mode). The problem code last indicated is displayed on "SELF DIAG RESULT 2" (second page — initial mode).

AT

7. When "PRINT" is pressed, information displayed on "SELF DIAG RESULTS 1 and 2" is printed out.

PD

8. After repairing malfunctioning parts, press "ERASE" to clear self-diagnosis results.

FA

- After repairing malfunctioning parts, attempt to clear self-diagnosis results from memory.

RA

- If malfunctioning parts are not completely repaired, self-diagnosis results remain stored in memory.

BR

9. Push Back Key of CONSULT until SELECT SYSTEM mode appears to make "SELF-DIAGNOSIS" user mode.

ST

10. Push the power off switch.

BF

11. Turn off ignition switch.

HA

EL

IDX

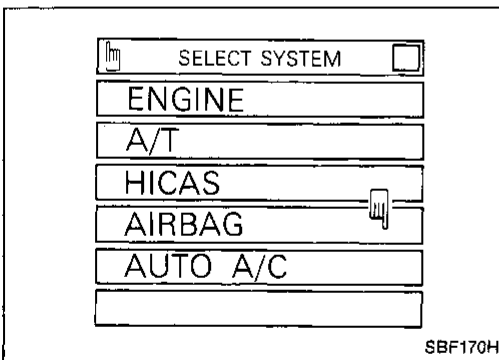

TROUBLE DIAGNOSES — Supplemental Restraint System (SRS)

Self-diagnosis (Cont'd)

Self-diagnosis results

Diagnostic item	Explanation	Repair order * Recheck SRS at each replacement.
NO SELF DIAGNOSTIC FAILURE INDICATED.	Normal. The SRS system is in good order.	—
SAFING SENSOR [OPEN/UPR-VB-SHORT]	The circuit for the safing sensor is open or the wire from the diagnosis (control) unit (terminal No. 9) to the safing sensor is shorted to some power supply circuit.	<ol style="list-style-type: none"> 1. Visually check the wiring harness connections. 2. Replace the safing sensor. (safing sensor and tunnel sensor unit) 3. Replace the diagnosis (control) unit. 4. Replace the main harness.
SAFING SENSOR [SHORT/UPR-GND-SHORT]	Both the wires for the safing sensor are shorted or the wire from the diagnosis (control) unit (terminal No. 9) to the safing sensor is shorted to ground.	<ol style="list-style-type: none"> 3. Replace the diagnosis (control) unit. 4. Replace the main harness.
AIRBAG MODULE [OPEN]	The circuit for driver's air bag module is open. (including the spiral cable)	<ol style="list-style-type: none"> 1. Visually check the wiring harness connections. 2. Replace the spiral cable. 3. Replace driver's air bag module. (Before disposing of it, it must be deployed.) 4. Replace the diagnosis (control) unit. 5. Replace the main harness.
AIRBAG MODULE [VB-SHORT]	The circuit for driver's air bag module is shorted to some power supply circuit. (including the spiral cable)	<ol style="list-style-type: none"> 3. Replace driver's air bag module. (Before disposing of it, it must be deployed.) 4. Replace the diagnosis (control) unit. 5. Replace the main harness.
AIRBAG MODULE [GND-SHORT]	The circuit for driver's air bag module is shorted to ground. (including the spiral cable)	<ol style="list-style-type: none"> 4. Replace the diagnosis (control) unit. 5. Replace the main harness.
AIRBAG MODULE [SHORT]	The circuits for driver's air bag module are shorted to each other.	
ASSIST A/B MODULE 1 [OPEN]	The circuit for front passenger air bag module 1 is open.	<ol style="list-style-type: none"> 1. Visually check the wiring harness connections. 2. Replace front passenger air bag module. (Before disposing of it, it must be deployed.) 3. Replace the diagnosis (control) unit. 4. Replace the main harness.
ASSIST A/B MODULE 1 [VB-SHORT]	The circuit for front passenger air bag module 1 is shorted to some power supply circuit.	<ol style="list-style-type: none"> 2. Replace front passenger air bag module. (Before disposing of it, it must be deployed.) 3. Replace the diagnosis (control) unit. 4. Replace the main harness.
ASSIST A/B MODULE 1 [GND-SHORT]	The circuit for front passenger air bag module 1 is shorted to ground.	<ol style="list-style-type: none"> 3. Replace the diagnosis (control) unit. 4. Replace the main harness.
ASSIST A/B MODULE 1 [SHORT]	The circuits for front passenger air bag module 1 are shorted to each other.	
ASSIST A/B MODULE 2 [OPEN]	The circuit for front passenger air bag module 2 is open.	<ol style="list-style-type: none"> 1. Visually check the wiring harness connections. 2. Replace front passenger air bag module. (Before disposing of it, it must be deployed.) 3. Replace the diagnosis (control) unit. 4. Replace the main harness.
ASSIST A/B MODULE 2 [VB-SHORT]	The circuit for front passenger air bag module 2 is shorted to some power supply circuit.	<ol style="list-style-type: none"> 2. Replace front passenger air bag module. (Before disposing of it, it must be deployed.) 3. Replace the diagnosis (control) unit. 4. Replace the main harness.
ASSIST A/B MODULE 2 [GND-SHORT]	The circuit for front passenger air bag module 2 is shorted to ground.	<ol style="list-style-type: none"> 3. Replace the diagnosis (control) unit. 4. Replace the main harness.
ASSIST A/B MODULE 2 [SHORT]	The circuits for front passenger air bag module 2 are shorted to each other.	

TROUBLE DIAGNOSES — Supplemental Restraint System (SRS)

Self-diagnosis (Cont'd)

Diagnostic item	Explanation	Repair order * Recheck SRS at each replacement.	
TUNNEL SENSOR [OPEN/UPR-VB-SHORT]	The circuit for the tunnel sensor is open or the wire from the diagnosis (control) unit (terminal No. 11) to the tunnel sensor is shorted to some power supply circuit.	1. Visually check the wiring harness connections. 2. Replace the tunnel sensor. (safing sensor and tunnel sensor unit) 3. Replace the diagnosis (control) unit. 4. Replace the main harness.	GI
TUNNEL SENSOR [SHORT/UPR-GND-SHORT]	Both the wires for the tunnel sensor are shorted or the wire from the diagnosis (control) unit (terminal No. 11) to the tunnel sensor is shorted to ground.		MA
CRASH ZONE SEN-CTR [OPEN/UPR-VB-SHORT]	The circuit for the crash zone sensor is open or the wire from the diagnosis (control) unit (terminal No. 17) to the crash zone sensor is shorted to some power supply circuit.	1. Visually check the wiring harness connections. 2. Replace the crash zone sensor. 3. Replace the diagnosis (control) unit. 4. Replace the main harness.	EM
CRASH ZONE SEN-CTR [SHORT/UPR-GND-SHORT]	Both the wires for the crash zone sensor are shorted or the wire from the diagnosis (control) unit (terminal No. 17) to the crash zone sensor is shorted to ground.		LC EF & EC
DRIVE PRE-TENSION [OPEN/VB-SHORT]	The circuit for the driver's pre-tensioner is open or shorted to some power supply circuit.	1. Visually check the wiring harness connections. 2. Replace the driver's seat belt. (Before disposing, it must be deactivated.) 3. Replace the diagnosis (control) unit. 4. Replace the main harness.	FE
DRIVE PRE-TENSION [GND-SHORT]	The circuit for the driver's pre-tensioner is shorted to ground.		AT
ASSIST PRE-TENSION [OPEN/VB-SHORT]	The circuit for the front passenger pre-tensioner is open or shorted to some power supply circuit.	1. Visually check the wiring harness connections. 2. Replace the front passenger seat belt. (Before disposing, it must be deactivated.) 3. Replace the diagnosis (control) unit. 4. Replace the main harness.	PD
ASSIST PRE-TENSION [GND-SHORT]	The circuit for the front passenger pre-tensioner is shorted to ground.		FA
CONTROL UNIT	The diagnosis unit (control unit) is out of order.	1. Visually check the wiring harness connections. 2. Replace the diagnosis (control) unit. 3. Replace the main harness.	RA BR
INDEFINITE FAILURES [AIR BAG]	A problem which cannot be specified occurs because more than two parts except seat belt pre-tensioners are out of order.	1. See the SELF-DIAGNOSIS RESULT 2 failure parts group [Initial], then repair as necessary. 2. Visually check the wiring harness connections. 3. Replace the diagnosis (control) unit. 4. Replace all sensors, spiral cable and air bag modules and seat belts. 5. Replace the main harness.	ST BF HA
INDEFINITE FAILURES [PRE-TENSIONER]	Driver's and front passenger seat belt pre-tensioners are out of order.	1. Visually check the wiring harness connections. 2. Replace the driver's and front passenger seat belts. (Before disposing, they must be deactivated.) 3. Replace the diagnosis (control) unit. 4. Replace the main harness.	EL IDX

Self-diagnosis (Cont'd)

USING THE WARNING LAMP

Self-diagnosis results can be also read by using the "AIR BAG" warning lamp for SRS system except seat belt pre-tensioner. When "Seat belt" warning lamp flashes (when fastening seat belt), check seat belt pre-tensioner system.

The "Air bag" warning lamp operates as shown below:

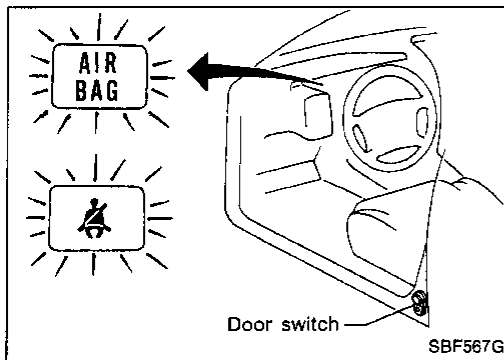

How to alternate self-diagnosis

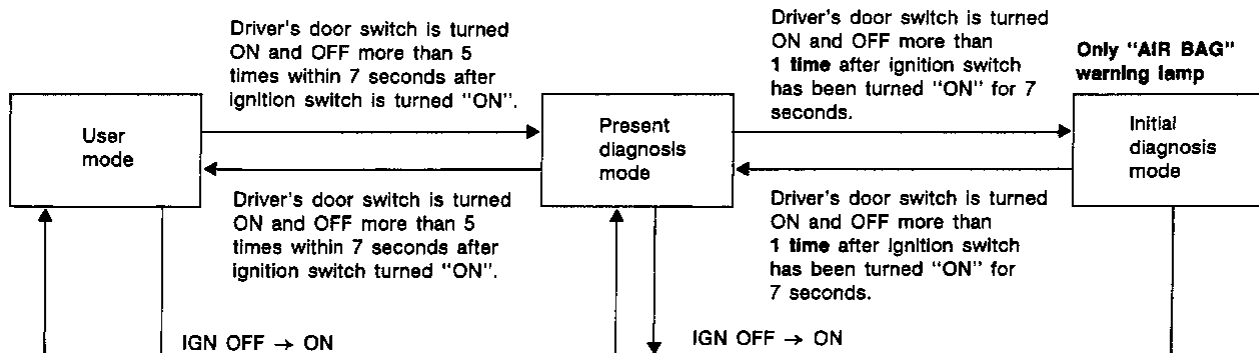

Problem codes are displayed in present diagnosis mode (self-diagnosis result 1). The problem code last indicated is displayed in initial diagnosis mode (self-diagnosis result 2).

After the malfunctioning parts have been repaired and the system is returned to the user mode, the present diagnosis mode information, displayed as self-diagnosis results, is automatically cleared from memory.

- After repairing malfunctioning part, attempt to clear self-diagnosis results from memory.
- If a malfunctioning part is not completely repaired, information stored in memory will not be cleared.

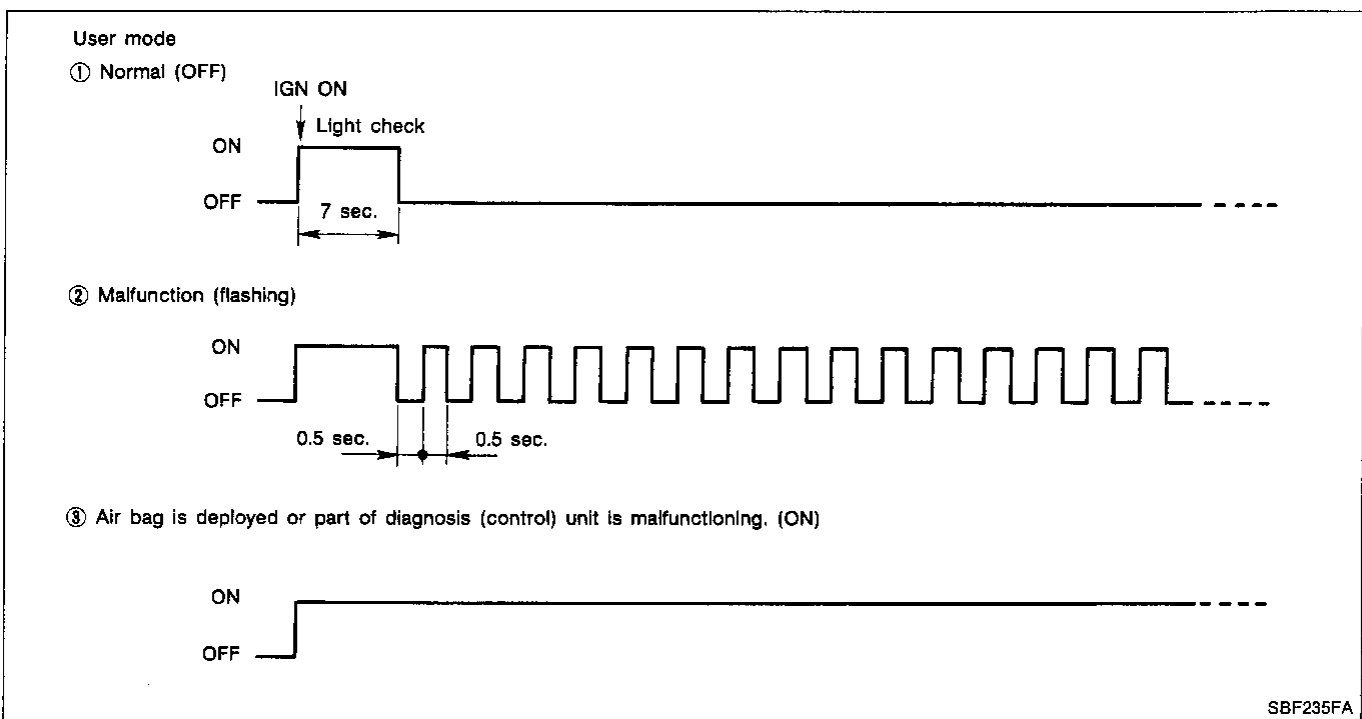

TROUBLE DIAGNOSES — Supplemental Restraint System (SRS)

Self-diagnosis (Cont'd)

Present diagnosis mode (self-diagnosis result 1)

(b) Start signal; Start signal identifies display modes.

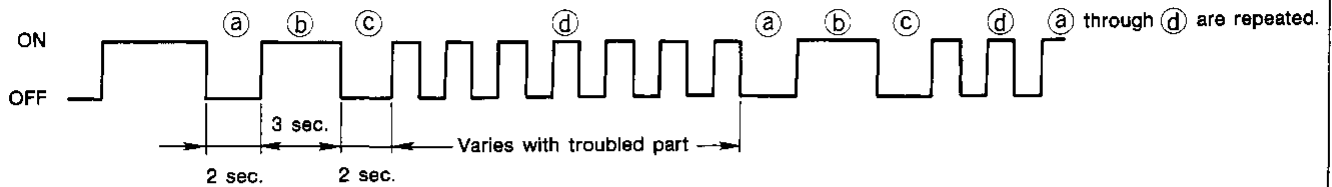

No trouble (or intermittent trouble/repair completion)

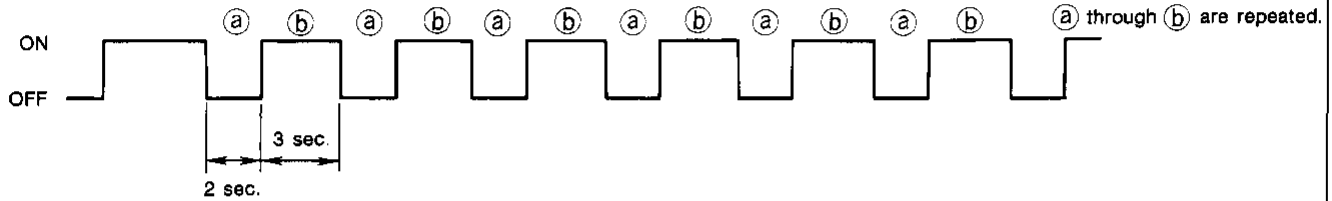

SBF236FA

Initial diagnosis mode (self-diagnosis result 2)

(b) Start signal; Start signal identifies display modes.

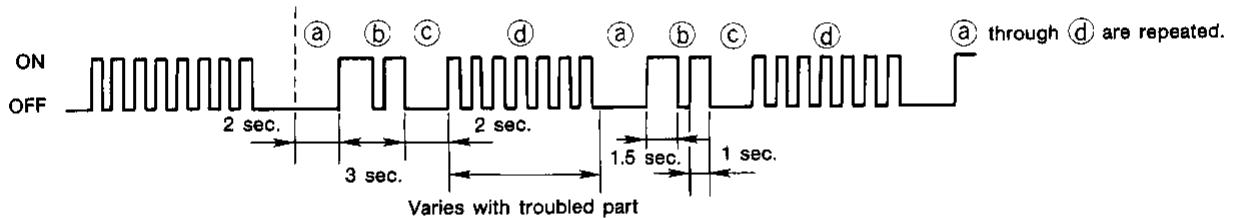

No trouble

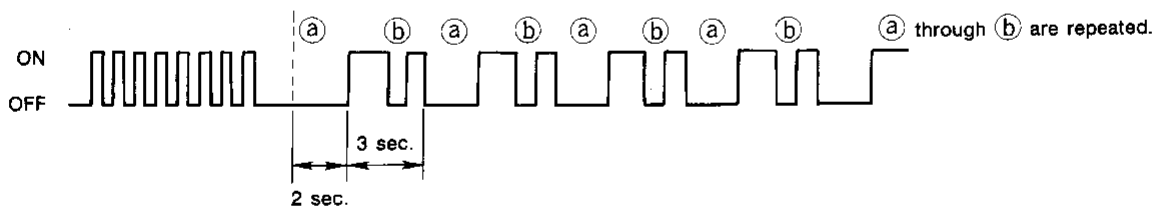

SBF237FA

Self-diagnosis results in present- and initial-diagnosis modes can be identified by number of flashes (d). Refer to Table on next page for troubled parts.

TROUBLE DIAGNOSES — Supplemental Restraint System (SRS)

Self-diagnosis (Cont'd)

Warning lamp flashing times and repair

Warning lamp	Flash code ① (# of flashes)	Explanation	Repair order * Recheck SRS at each replacement.
"AIR BAG" warning lamp	0	Normal. The SRS "Air Bag" is in good order.	—
	1	The circuit for the safing sensor is out of order.	<ol style="list-style-type: none"> 1. Visually check the wiring harness connections. 2. Replace the safing sensor. (safing sensor and tunnel sensor unit) 3. Replace the diagnosis (control) unit. 4. Replace the main harness.
	2	The circuit for the driver's air bag module is out of order.	<ol style="list-style-type: none"> 1. Visually check the wiring harness connections. 2. Replace the spiral cable. 3. Replace the driver's air bag module. (Before disposing of it, it must be deployed.) 4. Replace the diagnosis (control) unit. 5. Replace the main harness.
	3	The circuit for the tunnel sensor is out of order.	<ol style="list-style-type: none"> 1. Visually check the wiring harness connections. 2. Replace the tunnel sensor. (safing sensor and tunnel sensor unit) 3. Replace the diagnosis (control) unit. 4. Replace the main harness.
	6	The circuit for the center crash zone sensor is out of order.	<ol style="list-style-type: none"> 1. Visually check the wiring harness connections. 2. Replace the center crash zone sensor. 3. Replace the diagnosis (control) unit. 4. Replace the main harness.
	7	The diagnosis unit (control unit) is out of order.	<ol style="list-style-type: none"> 1. Visually check the wiring harness connections. 2. Replace the diagnosis (control) unit. 3. Replace the main harness.
	8	The circuit for the front passenger air bag module is out of order.	<ol style="list-style-type: none"> 1. Visually check the wiring harness connections. 2. Replace the front passenger air bag module. (Before disposing of it, it must be deployed.) 3. Replace the diagnosis (control) unit. 4. Replace the main harness.
	9	More than two parts groups are out of order.	<ol style="list-style-type: none"> 1. Visually check the wiring harness connections. 2. Replace the diagnosis (control) unit. 3. Replace all sensors, spiral cable and air bag module. 4. Replace the main harness.

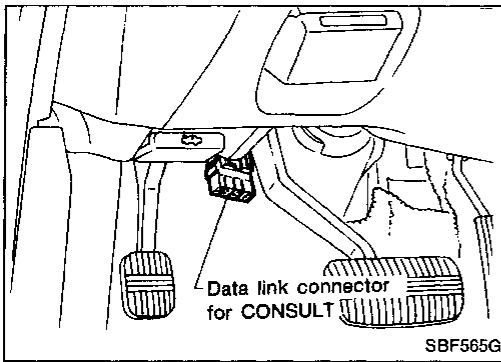

Diagnostic Procedure 1

SYMPTOM: Warning lamp flashes.

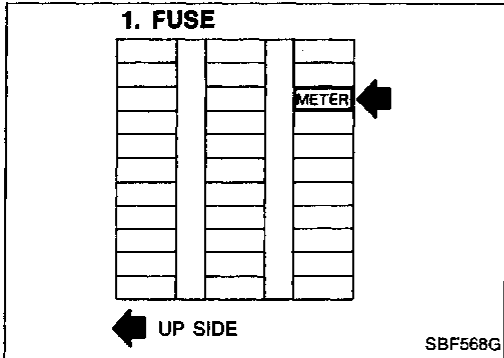
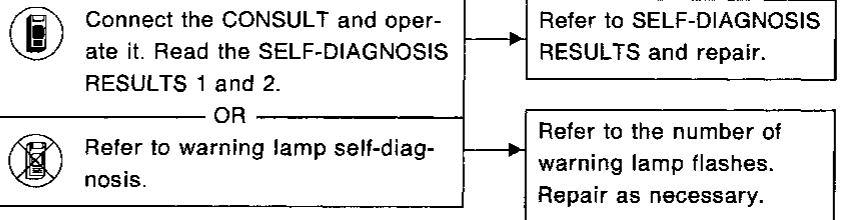

Diagnostic Procedure 2

SYMPTOM: Warning lamp does not come on.

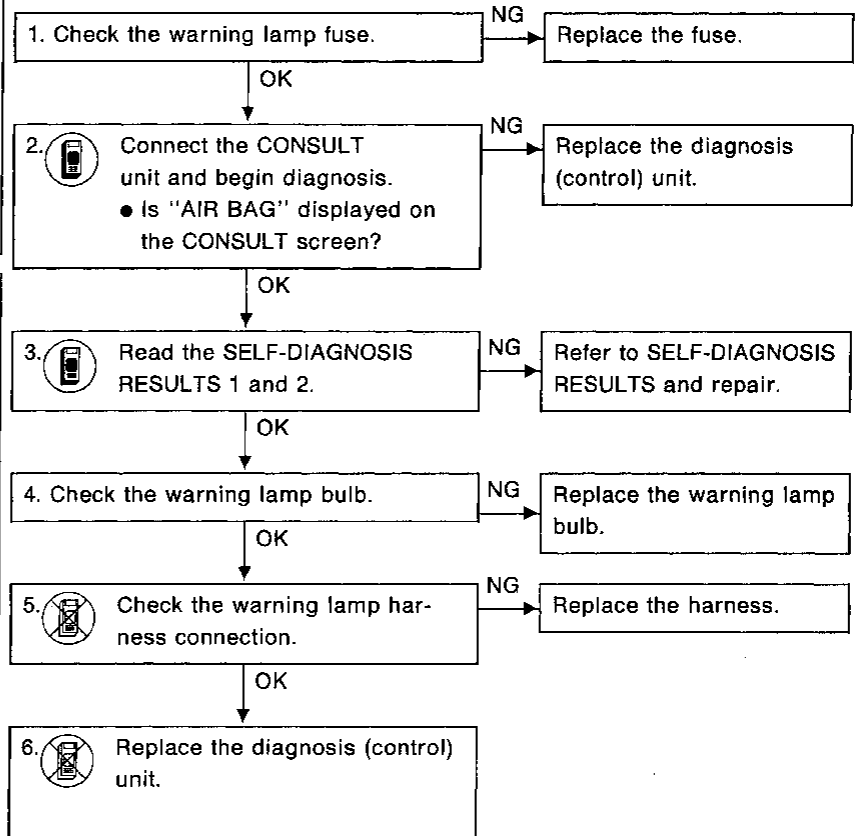
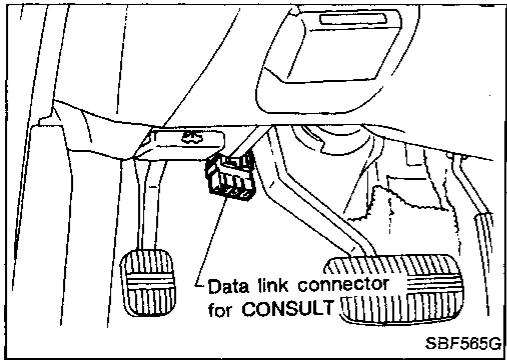

GI

MA

EM

LC

EF & EC

FE

AT

PD

FA

RA

BR

ST

BF

HA

EL

IDX

Diagnostic Procedure 3

SYMPTOM: Warning lamp does not go off.

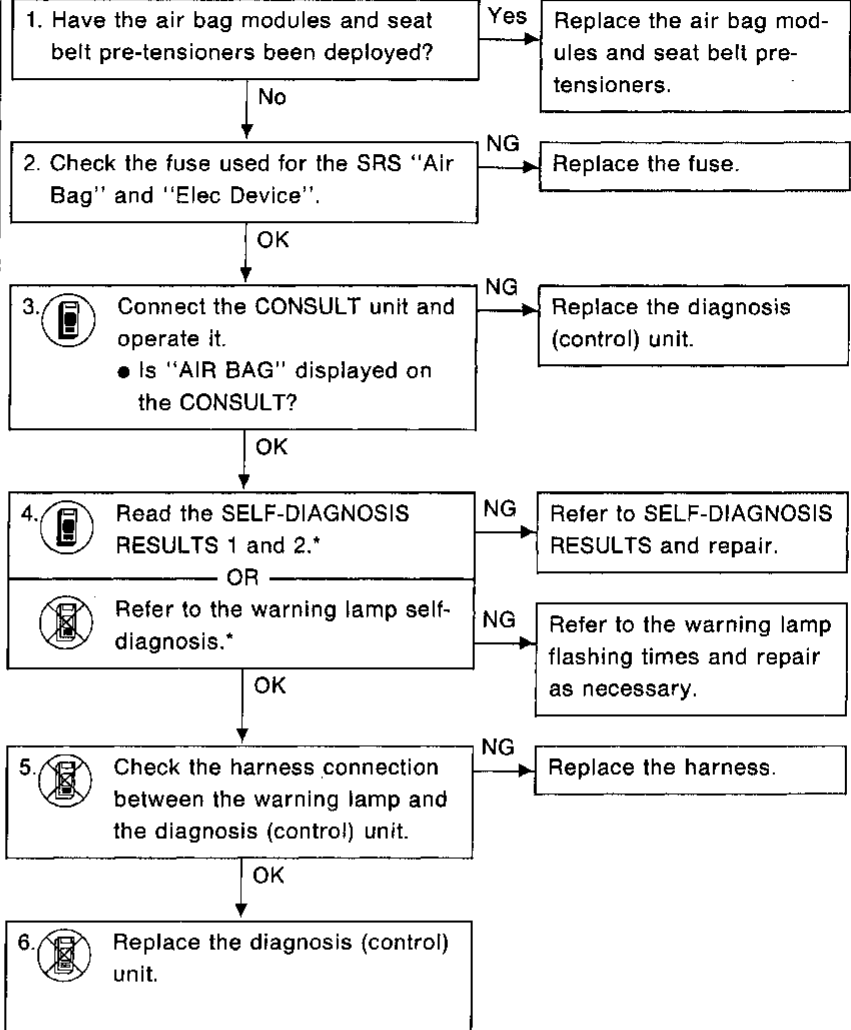
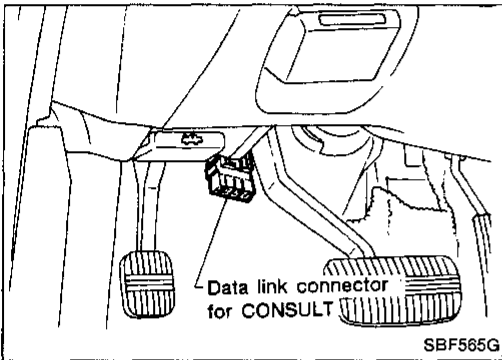
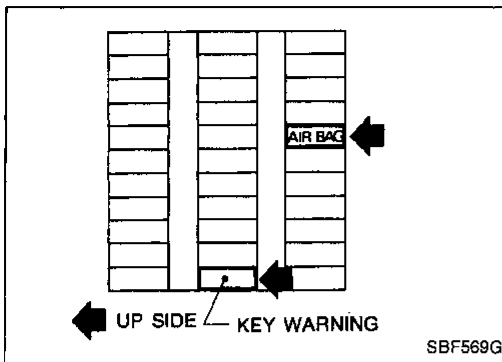

* Recheck SRS after each replacement.

Collision Diagnosis

To repair the SRS "AIR BAG", perform the following steps.

When air bag deployed In a collision:

- ① Replace the diagnosis (control) unit.
- ② Remove the air bag module.
- ③ Check the SRS components using the table shown below:
 - If the SRS components are showing any visible damage such as dents, cracks, or deformation, replace them with new ones.
- ④ Conduct self-diagnosis using CONSULT or "AIR BAG" warning lamp to ensure entire SRS operates properly except open circuits of air bag module and seat belt pre-tensioners.
- ⑤ Install new air bag module and seat belt pre-tensioners.
- ⑥ Conduct self-diagnosis again.

When air bag did not deploy in a collision:

- ① Check the SRS components using the table shown below:
 - If the SRS components are showing any visible damage such as dents, cracks, or deformation, replace them with new ones.
- ② Conduct self-diagnosis using CONSULT or "AIR BAG" warning lamp to ensure entire SRS operates properly.

SRS inspection

Part	Air bag deployed	Air bag did NOT deploy
Air bag module (driver and passenger side)	REPLACE Install with new bolts.	1. Remove air bag module. Check harness cover and connectors for damage, terminals for deformities, and harness for binding. 2. Install air bag module into the steering wheel to check fit and alignment with the wheel. 3. No damage found, reinstall with new bolts. 4. If damaged—REPLACE. Air bag must be deployed before discarding.
Instrument panel	REPLACE Install with new bolts.	1. Check instrument panel for bending, deformities, or cracks. 2. If no damage is found, reinstall with new bolts. 3. If damaged—REPLACE.
Seat belt pre-tensioner assembly	REPLACE Install with new bolts.	1. Remove seat belt pre-tensioners. Check harness cover and connectors for damage, terminals for deformities, and harness for binding. 2. Check belts for damage and anchors for loose mounting. 3. Check retractor for smooth operation. 4. If no damage is found, reinstall with new bolts. 5. If damaged—REPLACE.
Diagnosis (control) unit	REPLACE Install with new bolts.	1. Check case and bracket for dents, cracks or deformities. 2. Check connectors for damage, and terminals for deformities. 3. If no damage is found, reinstall with new bolts. 4. If damaged—REPLACE.
Sensors		1. Check body and sensor brackets for deformities or rust. 2. Check sensor case for dents, cracks, scratches, deformities or rust. 3. Check sensor harness, connector, and terminals for binding, damage, or deformities. 4. If no damage is found, reinstall with new bolts. 5. If damaged—REPLACE.
Steering wheel		1. Check harness (built into steering wheel) and connectors for damage, and terminals for deformities. 2. Install air bag module to check fit or alignment with steering wheel. 3. Check steering wheel for excessive free play. 4. If no damage is found, reinstall with new bolts. 5. If damaged—REPLACE.

TROUBLE DIAGNOSES — Supplemental Restraint System (SRS)

Collision Diagnosis (Cont'd)

Part	Air bag deployed	Air bag did NOT deploy
Spiral cable		<ol style="list-style-type: none">1. Visually check lock (engagement) pins and combination switch for damage.2. Check connectors, flat cable and protective tape for damage.3. Check steering wheel for noise, binding or heavy operation.4. If no damage is found, reinstall with new bolts.5. If damaged—REPLACE.
Harness and Connectors		<ol style="list-style-type: none">1. Check connectors for poor connection, damage, and terminals for deformities.2. Check harness for binding, chafing, cuts, or deformities.3. If no damage is found, reinstall4. Damaged—REPLACE damaged section of harness. Do not attempt to repair, splice or modify any SRS harness.