

VTL
SECTION
VENTILATION SYSTEM

A
B
C

CONTENTS

<p>FUNCTION DIAGNOSIS 3</p> <p>SWITCHES AND THEIR CONTROL FUNCTION 3</p> <p>WITHOUT LEFT AND RIGHT VENTILATION TEMPERATURE SEPARATELY CONTROL SYSTEM.....3</p> <p style="padding-left: 20px;">WITHOUT LEFT AND RIGHT VENTILATION TEMPERATURE SEPARATELY CONTROL SYSTEM : System Description3</p> <p>WITH LEFT AND RIGHT VENTILATION TEMPERATURE SEPARATELY CONTROL SYSTEM3</p> <p style="padding-left: 20px;">WITH LEFT AND RIGHT VENTILATION TEMPERATURE SEPARATELY CONTROL SYSTEM : System Description3</p> <p>AIR DISTRIBUTION 5</p> <p style="padding-left: 20px;">System Description5</p> <p>PRECAUTION 6</p> <p>PRECAUTIONS 6</p> <p style="padding-left: 20px;">Precaution for Supplemental Restraint System (SRS) "AIR BAG" and "SEAT BELT PRE-TENSIONER"6</p> <p style="padding-left: 20px;">Precaution Necessary for Steering Wheel Rotation after Battery Disconnect6</p> <p style="padding-left: 20px;">Precaution for Procedure without Cowl Top Cover.....6</p> <p style="padding-left: 20px;">Precautions For Xenon Headlamp Service7</p> <p style="padding-left: 20px;">Working with HFC-134a (R-134a)7</p> <p style="padding-left: 20px;">General Refrigerant Precaution8</p> <p style="padding-left: 20px;">Refrigerant Connection8</p> <p style="padding-left: 20px;">Service Equipment12</p> <p>COMPRESSOR15</p> <p style="padding-left: 20px;">General Precautions15</p> <p>FLUORESCENT LEAK DETECTOR16</p> <p style="padding-left: 20px;">General Precautions16</p> <p>PREPARATION17</p>	<p>PREPARATION17</p> <p style="padding-left: 20px;">Special Service Tool17</p> <p style="padding-left: 20px;">Commercial Service Tool19</p> <p style="padding-left: 20px;">Sealant or/and Lubricant20</p> <p>ON-VEHICLE MAINTENANCE21</p> <p>IN-CABIN MICROFILTER21</p> <p style="padding-left: 20px;">Exploded View21</p> <p style="padding-left: 20px;">Removal and Installation21</p> <p style="padding-left: 20px;">Replacement21</p> <p>ON-VEHICLE REPAIR23</p> <p>PRESET SWITCH23</p> <p style="padding-left: 20px;">Exploded View23</p> <p style="padding-left: 20px;">Removal and Installation23</p> <p>AUTO AMP.24</p> <p style="padding-left: 20px;">Exploded View24</p> <p style="padding-left: 20px;">Removal and Installation24</p> <p>AMBIENT SENSOR25</p> <p style="padding-left: 20px;">Exploded View25</p> <p style="padding-left: 20px;">Removal and Installation25</p> <p>IN-VEHICLE SENSOR26</p> <p style="padding-left: 20px;">Exploded View26</p> <p style="padding-left: 20px;">Removal and Installation26</p> <p>SUNLOAD SENSOR27</p> <p style="padding-left: 20px;">Exploded View27</p> <p style="padding-left: 20px;">Removal and Installation27</p> <p>INTAKE SENSOR28</p> <p style="padding-left: 20px;">Exploded View28</p> <p style="padding-left: 20px;">Removal and Installation29</p> <p>BLOWER UNIT30</p> <p style="padding-left: 20px;">Exploded View30</p> <p style="padding-left: 20px;">Removal and Installation30</p> <p>BLOWER MOTOR32</p>
--	--

D
E
F
G
H
VTL

J
K
L
M
N
O
P

Exploded View	32	FRONT DEFROSTER NOZZLE, SIDE DEFROSTER NOZZLES AND VENTILATOR DUCT : Removal and Installation	46
Removal and Installation	32		
INTAKE DOOR MOTOR	33	SIDE DEFROSTER DUCTS	47
Exploded View	33	SIDE DEFROSTER DUCTS : Exploded View	47
Removal and Installation	33	SIDE DEFROSTER DUCTS : Removal and Installation	48
HEATER & COOLING UNIT ASSEMBLY	34	REAR VENTILATOR GRILLE	48
Exploded View	34	REAR VENTILATOR GRILLE : Exploded View	48
Removal and Installation	35	REAR VENTILATOR GRILLE : Removal and Installation	48
MODE DOOR MOTOR	38	REAR VENTILATOR DUCT 2	48
Exploded View	38	REAR VENTILATOR DUCT 2 : Exploded View	48
Removal and Installation	39	REAR VENTILATOR DUCT 2 : Removal and Installation	49
AIR MIX DOOR MOTOR	40	FOOT GRILLES	49
Exploded View	40	FOOT GRILLES : Exploded View	49
Removal and Installation	41	FOOT GRILLES : Removal and Installation	50
HEATER CORE	42	FOOT DUCTS	50
Exploded View	42	FOOT DUCTS : Exploded View	50
Removal and Installation	43	FOOT DUCTS : Removal and Installation	52
DUCTS AND GRILLES	44	REAR FLOOR DUCT 1 (WITHOUT REAR VENTILATOR)	52
CENTER VENTILATOR GRILLES	44	REAR FLOOR DUCT 1 (WITHOUT REAR VENTILATOR) : Exploded View	52
CENTER VENTILATOR GRILLES : Exploded View	44	REAR FLOOR DUCT 1 (WITHOUT REAR VENTILATOR) : Removal and Installation	53
CENTER VENTILATOR GRILLES : Removal and Installation	44	REAR FLOOR DUCT 1 & REAR VENTILATOR DUCT 1(WITH REAR VENTILATOR)	53
SIDE VENTILATOR GRILLES	44	REAR FLOOR DUCT 1 & REAR VENTILATOR DUCT 1(WITH REAR VENTILATOR) : Exploded View	53
SIDE VENTILATOR GRILLES : Exploded View	44	REAR FLOOR DUCT 1 & REAR VENTILATOR DUCT 1(WITH REAR VENTILATOR) : Removal and Installation	54
SIDE VENTILATOR GRILLES : Removal and Installation	45		
FRONT DEFROSTER NOZZLE, SIDE DEFROSTER NOZZLES AND VENTILATOR DUCT	45		
FRONT DEFROSTER NOZZLE, SIDE DEFROSTER NOZZLES AND VENTILATOR DUCT : Exploded View	45		

SWITCHES AND THEIR CONTROL FUNCTION

< FUNCTION DIAGNOSIS >

FUNCTION DIAGNOSIS

SWITCHES AND THEIR CONTROL FUNCTION

WITHOUT LEFT AND RIGHT VENTILATION TEMPERATURE SEPARATELY CONTROL SYSTEM

WITHOUT LEFT AND RIGHT VENTILATION TEMPERATURE SEPARATELY CONTROL SYSTEM : System Description

INFOID:000000000959769

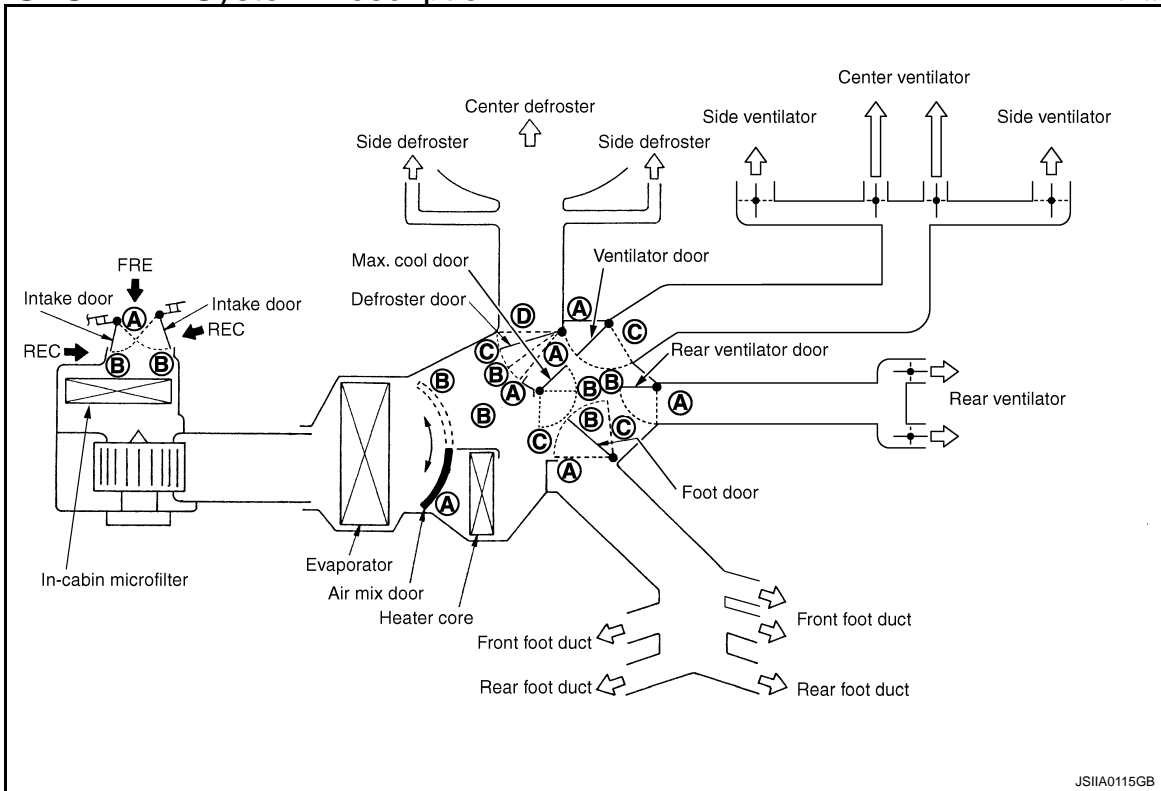

JSIIA0115GB

Position or switch	MODE SW				DEF SW		AUTO SW	Intake SW		Temperature control dial			OFF SW
	VENT	B/L	FOOT	D/F	ON	OFF	AUTO	FRE	REC	18°C (60°F) ↔ 32°C (90°F)			OFF
Door													OFF
Ventilator door	(A)	(B)	(C)	(C)	(C)		AUTO	—	—				AUTO
Max. cool door	(A)	(B)	(B)	(B)	(C)			—	—				
Defroster door	(D)	(D)	(C)	(B)	(A)			—	—				
Foot door	(A)	(B)	(C)	(C)	(C)			—	—				
Rear ventilator door	(B)	(B)	(B)	(B)	(A)			—	—				
Intake door	—				(B)	(B)		(B)*	(A)*				
Air mix door	—				—		AUTO	—	—	(A)	AUTO	(B)	—

*:Inlet status is displayed by LED when activating automatic control.

JSIIA0079GB

WITH LEFT AND RIGHT VENTILATION TEMPERATURE SEPARATELY CONTROL SYSTEM

WITH LEFT AND RIGHT VENTILATION TEMPERATURE SEPARATELY CONTROL

SWITCHES AND THEIR CONTROL FUNCTION

< FUNCTION DIAGNOSIS >

SYSTEM : System Description

INFOID:00000000959770

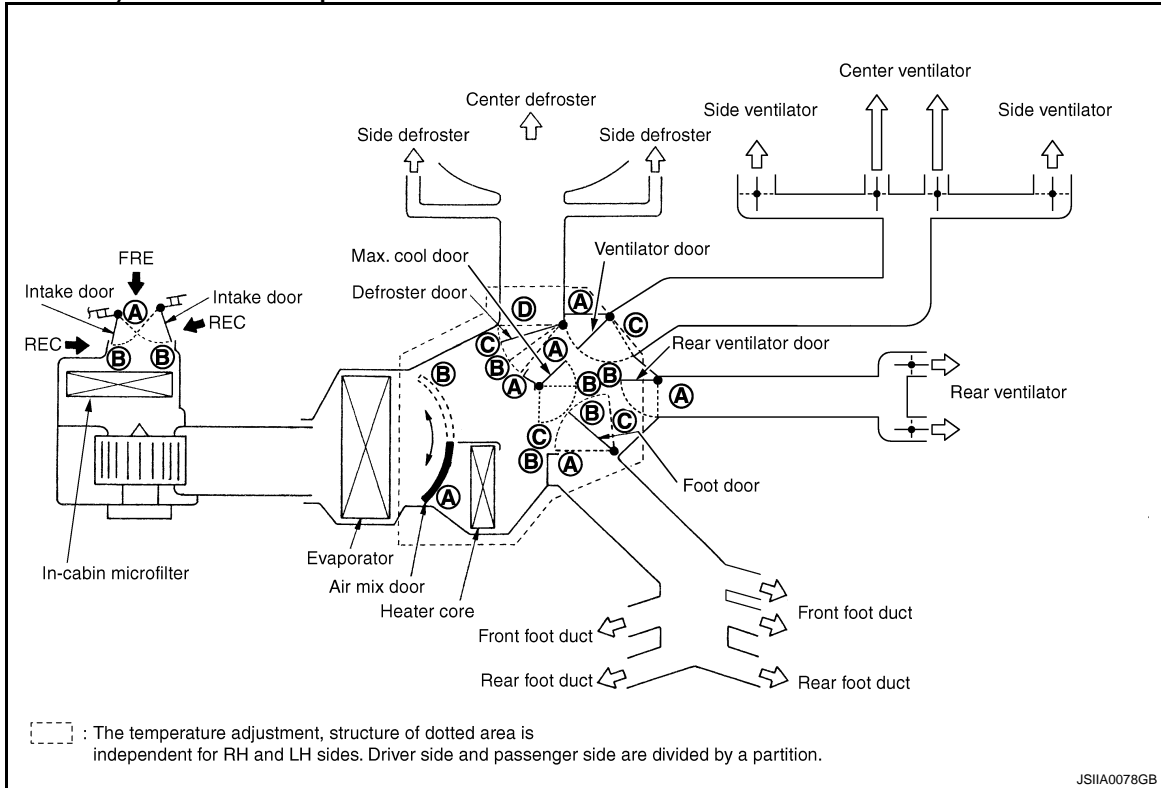

JSIIA0078GB

Position or switch	DUAL SW	MODE SW				DEF SW		AUTO SW	Intake SW		Temperature control dial(Driver side)		Temperature control dial(Passenger side)		OFF SW
		VENT	B/L	FOOT	D/F	ON	OFF		FRE	REC					OFF
Door		MODE													OFF
											18°C (60°F) ↔ 32°C (90°F)	18°C (60°F) ↔ 32°C (90°F)			
Ventilator door	—	(A)	(B)	(C)	(C)	(C)	—	AUTO	—	—	—	—	—	AUTO	
Max.cool door	—	(A)	(B)	(B)	(B)	(C)	—		—	—	—	—	—		
Defroster door	—	(D)	(D)	(C)	(B)	(A)	—		—	—	—	—	—		
Foot door	—	(A)	(B)	(C)	(C)	(C)	—		—	—	—	—	—		
Rear ventilator door	—	(B)	(B)	(B)	(B)	(A)	—		—	—	—	—	—		
Intake door	—	—			(B)	(B)	—	—	(B)*	(A)*	—	—	—	—	
Air mix door (Driver side)	—	—				—	—	—	—	—	(A) AUTO	(B)	—	—	
Air mix door (Passenger side)	ON	—				—	—	—	—	—	—	(A) AUTO	(B)	—	
	OFF	—				—	—	—	—	—	—	(A) AUTO	(B)	—	

*: Inlet status is displayed by LED when activating automatic control.

JSIIA0080GB

AIR DISTRIBUTION

< FUNCTION DIAGNOSIS >

AIR DISTRIBUTION

System Description

INFOID:000000000959771

Without rear ventilation

Discharge air flow					
Mode position indication	Condition	Air outlet/distribution			
		VENT	FOOT		DEF
			Front	Rear	
	DUAL SW: OFF	100%	—	—	—
		53%	29%	18%	—
		11%	39%	24%	26%
		9%	33%	21%	37%
		16%	—	—	84%

JSIIA0111GB

With rear ventilation

Discharge air flow						
Mode position indication	Condition	Air outlet/distribution				
		VENT		FOOT		DEF
		Front	Rear	Front	Rear	
	DUAL SW: OFF Rear ventilator door: OPEN	88%	12%	—	—	—
		49%	10%	25%	16%	—
		10%	12%	33%	22%	23%
		9%	11%	29%	18%	33%
		15%	—	—	—	85%

JSIIA0060GB

A
B
C
D
E
F
G
H
I
J
K
L
M
N
O
P

VTL

PRECAUTIONS

< PRECAUTION >

PRECAUTION

PRECAUTIONS

Precaution for Supplemental Restraint System (SRS) "AIR BAG" and "SEAT BELT PRE-TENSIONER"

INFOID:000000000959772

The Supplemental Restraint System such as "AIR BAG" and "SEAT BELT PRE-TENSIONER", used along with a front seat belt, helps to reduce the risk or severity of injury to the driver and front passenger for certain types of collision. This system includes seat belt switch inputs and dual stage front air bag modules. The SRS system uses the seat belt switches to determine the front air bag deployment, and may only deploy one front air bag, depending on the severity of a collision and whether the front occupants are belted or unbelted. Information necessary to service the system safely is included in the SRS and SB section of this Service Manual.

WARNING:

- To avoid rendering the SRS inoperative, which could increase the risk of personal injury or death in the event of a collision which would result in air bag inflation, all maintenance must be performed by an authorized NISSAN/INFINITI dealer.
- Improper maintenance, including incorrect removal and installation of the SRS, can lead to personal injury caused by unintentional activation of the system. For removal of Spiral Cable and Air Bag Module, see the SRS section.
- Do not use electrical test equipment on any circuit related to the SRS unless instructed to in this Service Manual. SRS wiring harnesses can be identified by yellow and/or orange harnesses or harness connectors.

Precaution Necessary for Steering Wheel Rotation after Battery Disconnect

INFOID:000000000959773

NOTE:

- Before removing and installing any control units, first turn the push-button ignition switch to the LOCK position, then disconnect both battery cables.
- After finishing work, confirm that all control unit connectors are connected properly, then re-connect both battery cables.
- Always use CONSULT-III to perform self-diagnosis as a part of each function inspection after finishing work. If a DTC is detected, perform trouble diagnosis according to self-diagnosis results.

This vehicle is equipped with a push-button ignition switch and a steering lock unit.

If the battery is disconnected or discharged, the steering wheel will lock and cannot be turned.

If turning the steering wheel is required with the battery disconnected or discharged, follow the procedure below before starting the repair operation.

OPERATION PROCEDURE

1. Connect both battery cables.

NOTE:

Supply power using jumper cables if battery is discharged.

2. Carry the Intelligent Key or insert it to the key slot and turn the push-button ignition switch to ACC position. (At this time, the steering lock will be released.)
3. Disconnect both battery cables. The steering lock will remain released with both battery cables disconnected and the steering wheel can be turned.
4. Perform the necessary repair operation.
5. When the repair work is completed, re-connect both battery cables. With the brake pedal released, turn the push-button ignition switch from ACC position to ON position, then to LOCK position. (The steering wheel will lock when the push-button ignition switch is turned to LOCK position.)
6. Perform self-diagnosis check of all control units using CONSULT-III.

Precaution for Procedure without Cowl Top Cover

INFOID:000000000959774

PRECAUTIONS

< PRECAUTION >

When performing the procedure after removing cowl top cover, cover the lower end of windshield with urethane, etc.

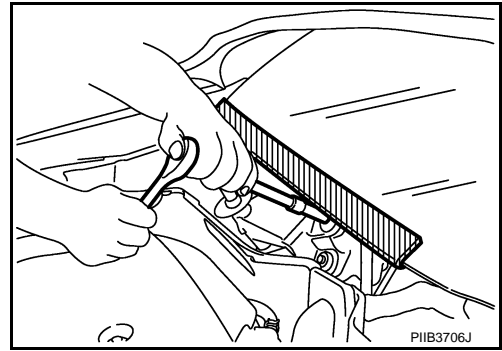

Precautions For Xenon Headlamp Service

INFOID:000000000959775

WARNING:

Comply with the following warnings to prevent any serious accident.

- Disconnect the battery cable (negative terminal) or the power supply fuse before installing, removing, or touching the xenon headlamp (bulb included). The xenon headlamp contains high-voltage generated parts.
- Never work with wet hands.
- Check the xenon headlamp ON-OFF status after assembling it to the vehicle. Never turn the xenon headlamp ON in other conditions. Connect the power supply to the vehicle-side connector. (Turning it ON outside the lamp case may cause fire or visual impairments.)
- Never touch the bulb glass immediately after turning it OFF. It is extremely hot.

CAUTION:

Comply with the following cautions to prevent any error and malfunction.

- Install the xenon bulb securely. (Insufficient bulb socket installation may melt the bulb, the connector, the housing, etc. by high-voltage leakage or corona discharge.)
- Never perform HID circuit inspection with a tester.
- Never touch the xenon bulb glass with hands. Never put oil and grease on it.
- Dispose of the used xenon bulb after packing it in thick vinyl without breaking it.
- Never wipe out dirt and contamination with organic solvent (thinner, gasoline, etc.).

Working with HFC-134a (R-134a)

INFOID:000000000959776

CAUTION:

- CFC-12 (R-12) refrigerant and HFC-134a (R-134a) refrigerant are not compatible. If the refrigerants are mixed and compressor malfunction is likely to occur, refer to "CONTAMINATED REFRIGERANT" below. To determine the purity of HFC-134a (R-134a) in the vehicle and recovery tank, use Refrigerant Recovery/Recycling Recharging equipment and Refrigerant Identifier.
- Use only specified lubricant for the HFC-134a (R-134a) A/C system and HFC-134a (R-134a) components. If lubricant other than that specified is used, compressor malfunction is likely to occur.
- The specified HFC-134a (R-134a) lubricant rapidly absorbs moisture from the atmosphere. The following handling precautions must be observed:
 - When removing refrigerant components from a vehicle, immediately cap (seal) the component to minimize the entry of moisture from the atmosphere.
 - When installing refrigerant components to a vehicle, never remove the caps (unseal) until just before connecting the components. Connect all refrigerant loop components as quickly as possible to minimize the entry of moisture into system.
 - Only use the specified lubricant from a sealed container. Immediately reseal containers of lubricant. Without proper sealing, lubricant will become moisture saturated and should not be used.
 - Never allow lubricant (Nissan A/C System Oil Type S) to come in contact with styrene foam parts. Damage may result.

CONTAMINATED REFRIGERANT

If a refrigerant other than pure HFC-134a (R-134a) is identified in a vehicle, take appropriate steps shown below:

- Explain to the customer that environmental regulations prohibit the release of contaminated refrigerant into the atmosphere.
- Explain that recovery of the contaminated refrigerant could damage service equipment and refrigerant supply.

A
B
C
D
E
F
G
H
VTL
J
K
L
M
N
O
P

PRECAUTIONS

< PRECAUTION >

- Suggest the customer return the vehicle to the location of previous service where the contamination may have occurred.
- In case of repairing, recover the refrigerant using only **dedicated equipment and containers. Never recover contaminated refrigerant into the existing service equipment.** If the facility does not have dedicated recovery equipment, contact a local refrigerant product retailer for available service. This refrigerant must be disposed of in accordance with all federal and local regulations. In addition, replacement of all refrigerant system components on the vehicle is recommended.
- If the vehicle is within the warranty period, the air conditioner warranty is void. Please contact Nissan Customer Affairs for further assistance.

General Refrigerant Precaution

INFOID:000000000959777

WARNING:

- **Avoid breathing A/C refrigerant and lubricant vapor or mist. Exposure may irritate eyes, nose and throat. Remove HFC-134a (R-134a) from the A/C system, using certified service equipment meeting requirements of SAE J-2210 [HFC-134a (R-134a) recycling equipment], or J-2209 [HFC-134a (R-134a) recovery equipment]. If accidental system discharge occurs, ventilate work area before resuming service. Additional health and safety information may be obtained from refrigerant and lubricant manufacturers.**
- **Never release refrigerant into the air. Use approved recovery/recycling equipment to capture the refrigerant every time an air conditioning system is discharged.**
- **Always wear eye and hand protection (goggles and gloves) when working with any refrigerant or air conditioning system.**
- **Never store or heat refrigerant containers above 52°C (126°F).**
- **Never heat a refrigerant container with an open flame; if container warming is required, place the bottom of the container in a warm pail of water.**
- **Never intentionally drop, puncture, or incinerate refrigerant containers.**
- **Keep refrigerant away from open flames: poisonous gas will be produced if refrigerant burns.**
- **Refrigerant will displace oxygen, therefore be certain to work in well ventilated areas to prevent suffocation.**
- **Never pressure test or leak test HFC-134a (R-134a) service equipment and/or vehicle air conditioning systems with compressed air during repair. Some mixtures of air and HFC-134a (R-134a) have been shown to be combustible at elevated pressures. These mixtures, if ignited, may cause injury or property damage. Additional health and safety information may be obtained from refrigerant manufacturers.**

Refrigerant Connection

INFOID:000000000959778

A new type refrigerant connection has been introduced to all refrigerant lines except the following location.

- Expansion valve to evaporator
- Refrigerant pressure sensor to liquid tank

ABOUT ONE-TOUCH JOINT

Description

- One-touch joints are pipe joints which do not require tools during piping connection.
- Unlike conventional connection methods using union nuts and flanges, controlling tightening torque at connection point is not necessary.
- When removing a pipe joint, use a disconnecter.

PRECAUTIONS

< PRECAUTION >

COMPONENT PARTS

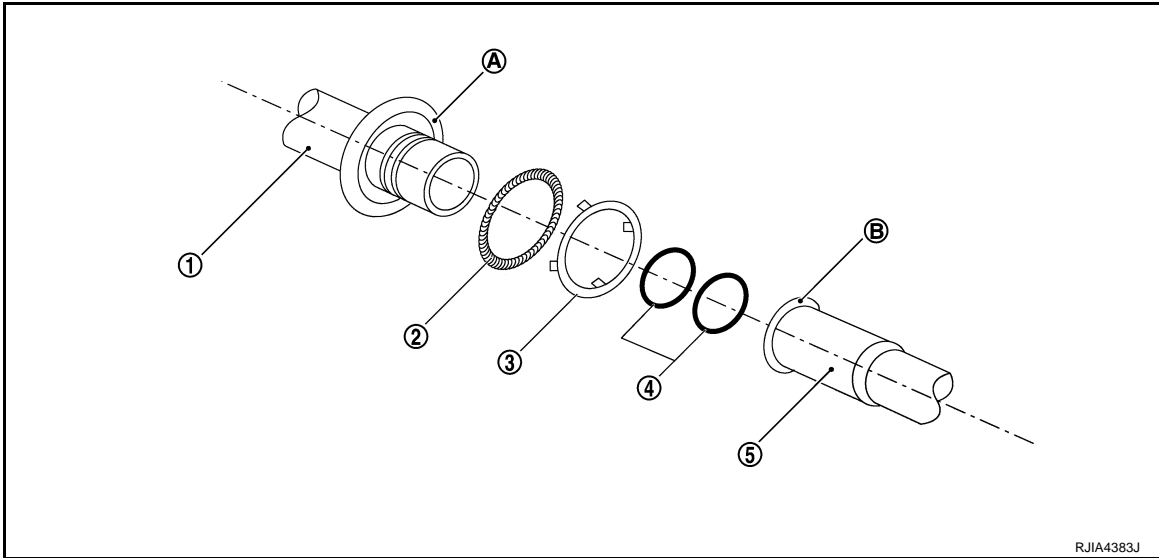

FUNCTIONS OF COMPONENT PARTS

1	Pipe (Male-side)	<ul style="list-style-type: none"> Retains O-rings (4). Retains garter spring (2) in cage (A).
2	Garter spring	Anchors female-side piping (5).
3	Indicator ring	When connection is made properly, this is ejected from male-side piping (1). (This part is no longer necessary after connection.)
4	O-ring	Seals connection point. (Not reusable)
5	Pipe (Female-side)	<ul style="list-style-type: none"> Seals connection by compressing O-rings (4). Anchors piping connection using flare (B) and garter spring (2).

NOTE:

- Garter spring (2) cannot be removed from cage (A) of male-side piping.
- Indicator ring (3) remains near piping connection point, however, this is not a malfunction. (This is to check piping connection during factory assembly.)

REMOVAL

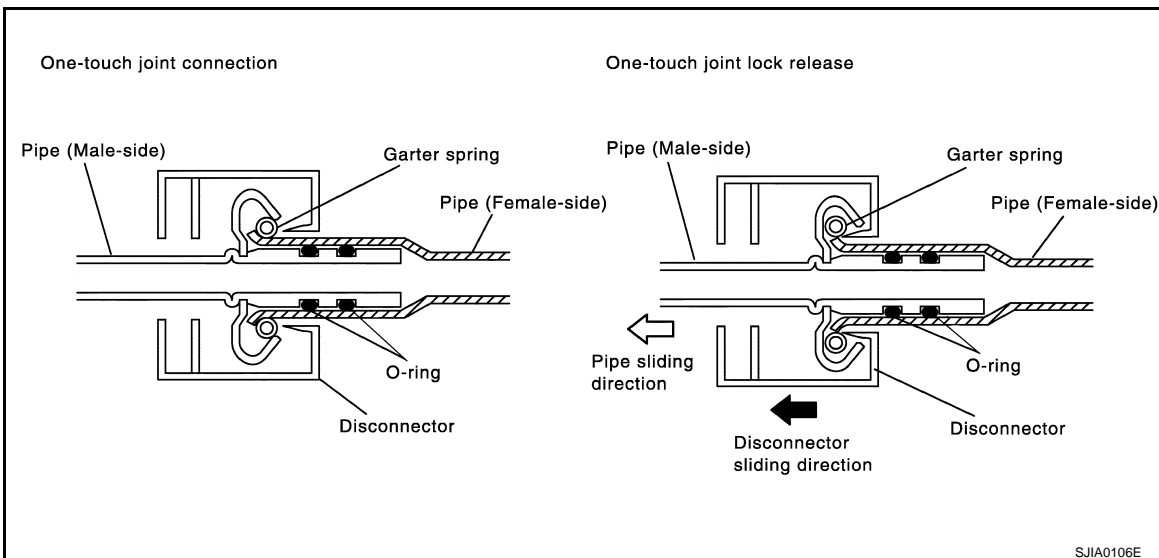

- Clean piping connection point, and set a disconnector.
- Slide disconnector in axial direction of piping, and stretch garter spring with tapered point of disconnector.
- Slide disconnector farther so that inside diameter of garter spring becomes larger than outside diameter of female-side piping flare. Then male-side piping can be disconnected.

PRECAUTIONS

< PRECAUTION >

INSTALLATION

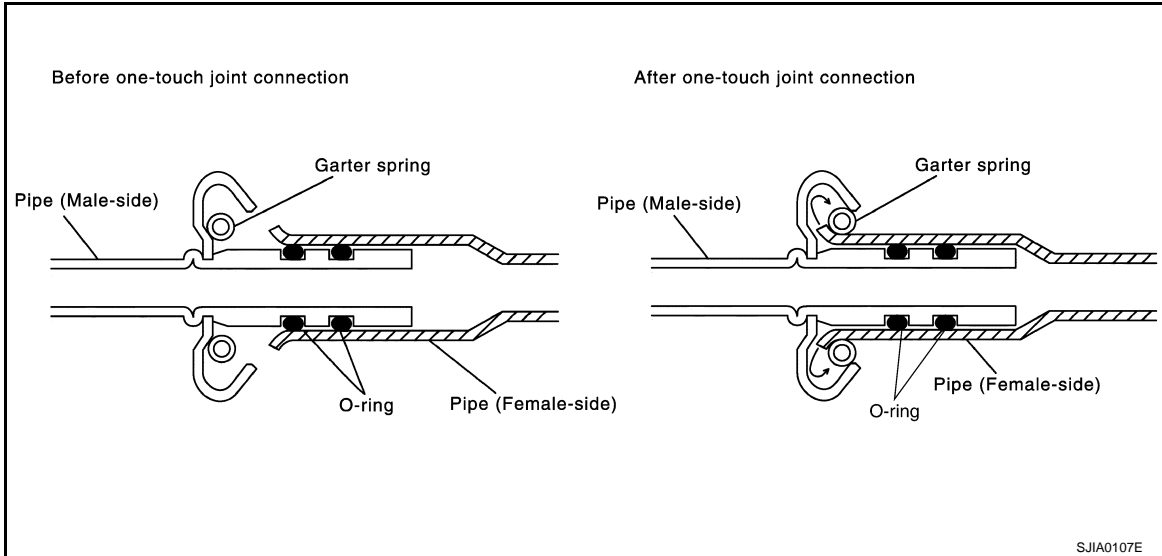

1. Clean piping connection points, and insert male-side piping into female-side piping.
2. Push inserted male-side piping harder so that female-side piping flare stretches garter spring.
3. If inside diameter of garter spring becomes larger than outside diameter of female-side piping flare, garter spring seats on flare. Then, it fits in between male-side piping cage and female-side piping flare to anchor piping connection point.

NOTE:

When garter spring seats on flare, and fits in between male-side piping cage and female-side piping flare, it clicks.

CAUTION:

- Female-side piping connection point is thin and easy to deform. Slowly insert the male-side piping straight in axial direction.
- Insert piping securely until a click is heard.
- After piping connection is completed, pull male-side piping by hand to make sure that connection does not come loose.

NOTE:

One-touch joint connection is used in points below.

- Low-pressure flexible hose to low-pressure pipe 2 (O-ring size: 16)
- Low-pressure pipe 1 to low-pressure pipe 2 (O-ring size: 16)
- High-pressure flexible hose to condenser pipe assembly (O-ring size: 12)
- High-pressure pipe 1 to high-pressure pipe 2 (O-ring size: 8)
- High-pressure pipe 1 to condenser pipe assembly (O-ring size: 8)

O-RING AND REFRIGERANT CONNECTION

PRECAUTIONS

< PRECAUTION >

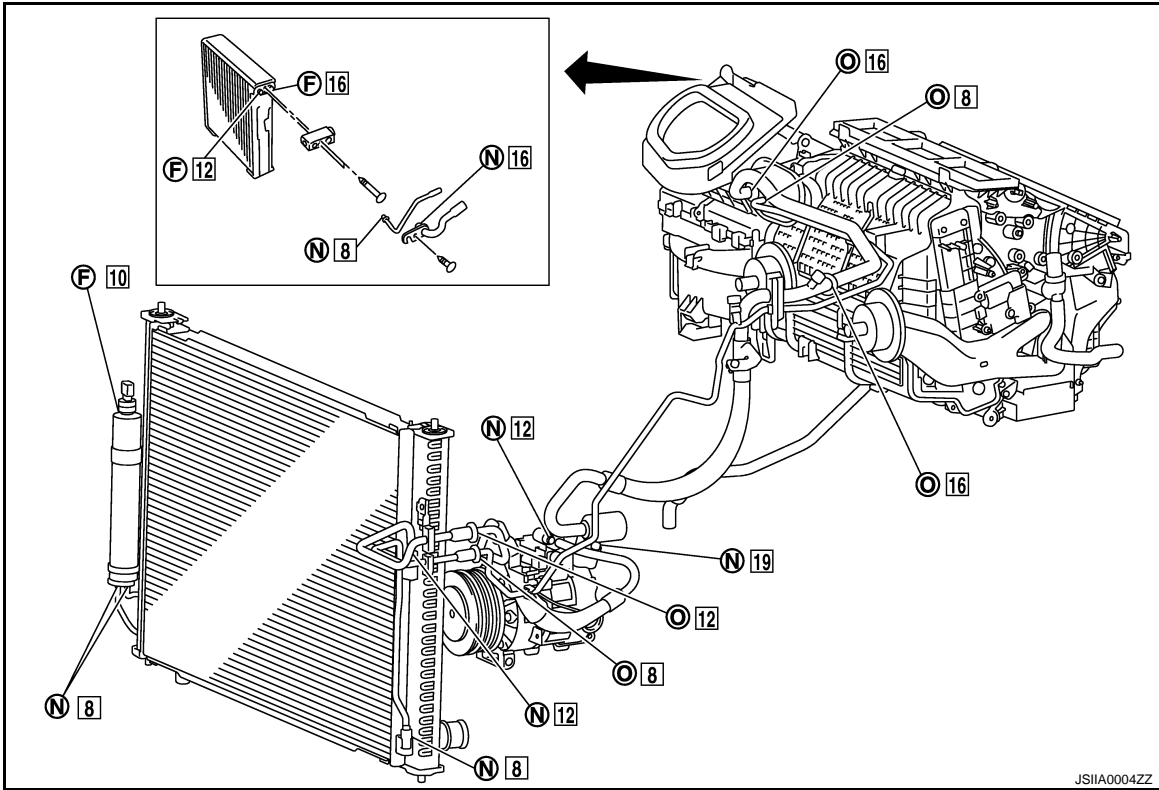

F. Former type refrigerant connection N. New type refrigerant connection O. One-touch joint

□: O-ring size

CAUTION:

The new and former refrigerant connections use different O-ring configurations. Never confuse O-rings since they are not interchangeable. If a wrong O-ring is installed, refrigerant may leak at the connection.

O-Ring Part Numbers and Specifications

Connection type	Piping connection point	Part number	QTY	O-ring size	
New	Low-pressure flexible hose to low-pressure pipe 2 (One-touch joint)	92473 N8221	2	16	
	High-pressure pipe 1 to high-pressure pipe 2 (One-touch joint)	92471 N8221	2	8	
	Condenser pipe assembly to high-pressure flexible hose (One-touch joint)	92472 N8221	2	12	
	Condenser pipe assembly to high-pressure pipe 1 (One-touch joint)	92471 N8221	2	8	
	Radiator & condenser assembly to condenser pipe assembly	Inlet	92472 N8210	1	12
		Outlet	92471 N8210	1	8
	Low-pressure pipe 1 to low-pressure pipe 2	92473 N8210	1	16	
	Low-pressure pipe 1 to expansion valve	92473 N8210	1	16	
	High-pressure pipe 2 to expansion valve	92471 N8210	1	8	
	Compressor to low-pressure flexible hose	92474 N8210	1	19	
	Compressor to high-pressure flexible hose	92472 N8210	1	12	
	Liquid tank to radiator & condenser assembly	Inlet	92471 N8210	1	8
Outlet		1			

A
B
C
D
E
F
G
H

VTL

J
K
L
M
N
O
P

PRECAUTIONS

< PRECAUTION >

Connection type	Piping connection point		Part number	QTY	O-ring size
Former	Refrigerant pressure sensor to liquid tank		J2476 89956	1	10
	Expansion valve to evaporator	Inlet	92475 71L00	1	12
		Outlet	92475 72L00	1	16

WARNING:

Make sure all refrigerant is discharged into the recycling equipment and the pressure in the system is less than atmospheric pressure. Then gradually loosen the discharge side hose fitting and remove it.

CAUTION:

When replacing or cleaning refrigerant cycle components, observe the following.

- When the compressor is removed, store it in the same way as it is when mounted on the car. Failure to do so will cause lubricant to enter the low-pressure chamber.
- When connecting tubes, always use a torque wrench and a back-up wrench.
- After disconnecting tubes, immediately plug all openings to prevent entry of dust and moisture.
- When installing an air conditioner in the vehicle, connect the pipes at the final stage of the operation. Never remove the seal caps of pipes and other components until just before required for connection.
- Allow components stored in cool areas to warm to working area temperature before removing seal caps. This prevents condensation from forming inside A/C components.
- Thoroughly remove moisture from the refrigeration system before charging the refrigerant.
- Always replace used O-rings.
- When connecting tube, apply lubricant to circle of the O-rings shown in illustration. Be careful not to apply lubricant to threaded portion.

Name : Nissan A/C System Oil
Type S

- O-ring must be closely attached to the groove portion of tube.
- When replacing the O-ring, be careful not to damage O-ring and tube.
- Connect tube until a click can be heard, then tighten the nut or bolt by hand. Make sure that the O-ring is installed to tube correctly.
- After connecting line, perform leak test and make sure that there is no leakage from connections. When the refrigerant leaking point is found, disconnect that line and replace the O-ring. Then tighten connections of seal seat to the specified torque.

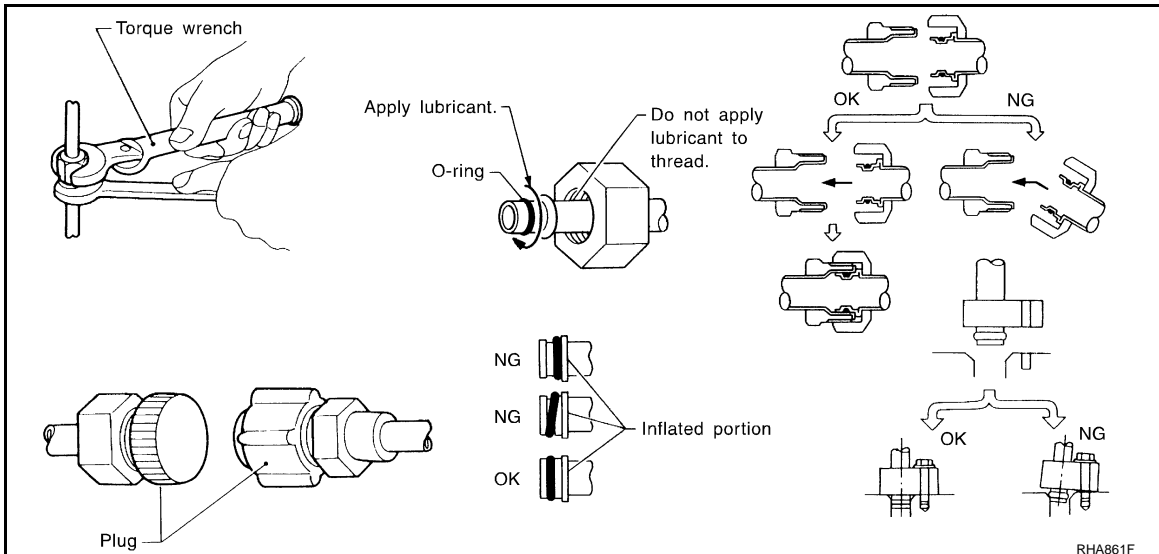

Service Equipment

INFOID:000000000959779

RECOVERY/RECYCLING EQUIPMENT

Be certain to follow the manufacturer's instructions for machine operation and machine maintenance. Never introduce any refrigerant other than that specified into the machine.

ELECTRICAL LEAK DETECTOR

Be certain to follow the manufacturer's instructions for tester operation and tester maintenance.

PRECAUTIONS

< PRECAUTION >

VACUUM PUMP

The lubricant contained inside the vacuum pump is not compatible with the specified lubricant for HFC-134a (R-134a) A/C systems. The vent side of the vacuum pump is exposed to atmospheric pressure. So the vacuum pump lubricant may migrate out of the pump into the service hose. This is possible when the pump is switched off after evacuation (vacuuming) and hose is connected to it.

To prevent this migration, use a manual valve placed near the hose-to-pump connection, as follows.

- Usually vacuum pumps have a manual isolator valve as part of the pump. Close this valve to isolate the service hose from the pump.
- For pumps without an isolator, use a hose equipped with a manual shut-off valve near the pump end. Close the valve to isolate the hose from the pump.
- If the hose has an automatic shut-off valve, disconnect the hose from the pump. As long as the hose is connected, the valve is open and lubricating oil may migrate.

Some one-way valves open when vacuum is applied and close under no vacuum condition. Such valves may restrict the pump's ability to pull a deep vacuum and are not recommended.

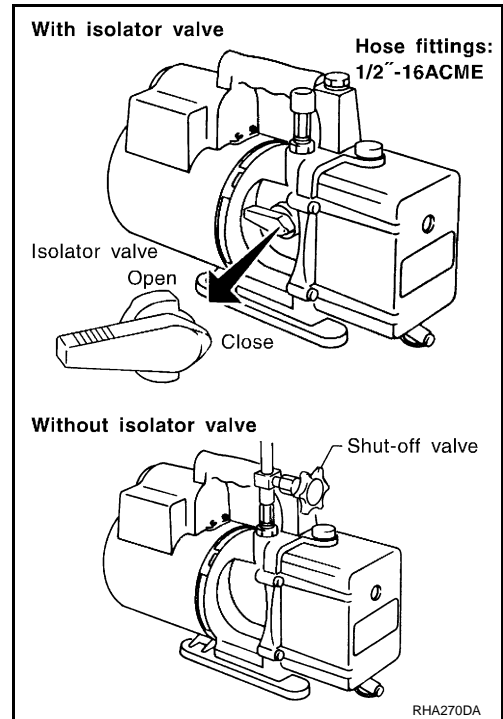

MANIFOLD GAUGE SET

Be certain that the gauge face indicates HFC-134a or R-134a. Be sure the gauge set has 1/2"-16 ACME threaded connections for service hoses. Confirm the set has been used only with refrigerant HFC-134a (R-134a) and specified lubricants.

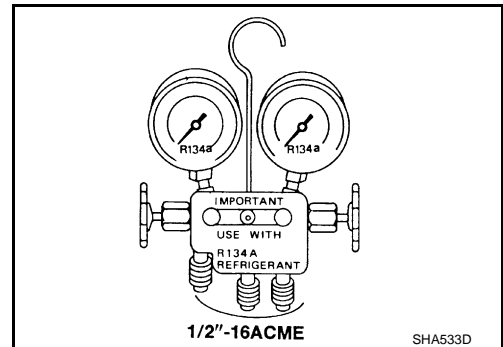

SERVICE HOSES

Be certain that the service hoses display the markings described (colored hose with black stripe). All hoses must include positive shut-off devices (either manual or automatic) near the end of the hoses opposite to the manifold gauge.

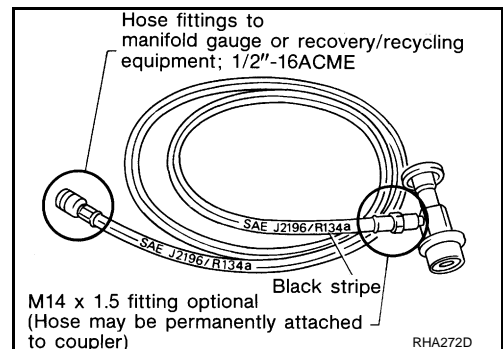

SERVICE COUPLERS

A
B
C
D
E
F
G
H
VTL
J
K
L
M
N
O
P

PRECAUTIONS

< PRECAUTION >

Never attempt to connect HFC-134a (R-134a) service couplers to a CFC-12 (R-12) A/C system. The HFC-134a (R-134a) couplers will not properly connect to the CFC-12 (R-12) system. However, if an improper connection is attempted, discharging and contamination may occur.

Shut-off valve rotation	A/C service valve
Clockwise	Open
Counterclockwise	Close

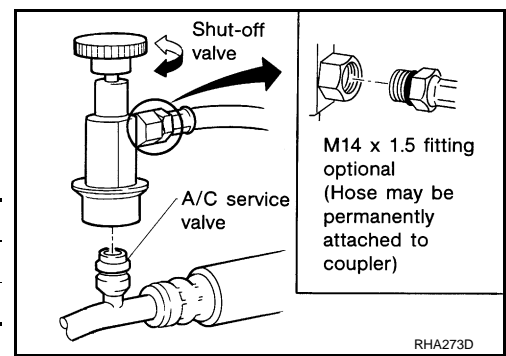

REFRIGERANT WEIGHT SCALE

Verify that no refrigerant other than HFC-134a (R-134a) and specified lubricants have been used with the scale. If the scale controls refrigerant flow electronically, the hose fitting must be 1/2"-16 ACME.

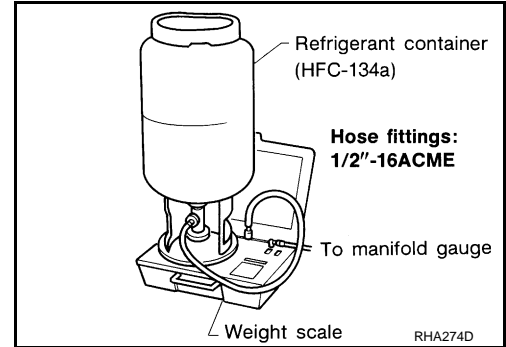

CHARGING CYLINDER

Using a charging cylinder is not recommended. Refrigerant may be vented into air from cylinder's top valve when filling the cylinder with refrigerant. Also, the accuracy of the cylinder is generally less than that of an electronic scale or of quality recycle/recharge equipment.

COMPRESSOR

< PRECAUTION >

COMPRESSOR

General Precautions

INFOID:000000000959780

CAUTION:

- Plug all openings to prevent moisture and foreign matter from entering.
- When the compressor is removed, store it in the same way as it is when mounted on the car.
- When replacing or repairing compressor, follow "Maintenance of Lubricant Quantity in Compressor" exactly. Refer to [HA-30, "Adjustment"](#).
- Keep friction surfaces between clutch and pulley clean. If the surface is contaminated with lubricant, wipe it off by using a clean waste cloth moistened with thinner.
- After compressor service operation, turn the compressor shaft by hand more than five turns in both directions. This will equally distribute lubricant inside the compressor. After the compressor is installed, let the engine idle and operate the compressor for one hour.
- After replacing the compressor magnet clutch, apply voltage to the new one and check for normal operation.

A
B
C
D
E
F
G
H
VTL
J
K
L
M
N
O
P

FLUORESCENT LEAK DETECTOR

< PRECAUTION >

FLUORESCENT LEAK DETECTOR

General Precautions

INFOID:000000000959781

CAUTION:

- The A/C system contains a fluorescent leak detection dye used for locating refrigerant leaks. An ultraviolet (UV) lamp is required to illuminate the dye when inspecting for leaks.
- Always wear fluorescence enhancing UV safety goggles to protect your eyes and enhance the visibility of the fluorescent dye.
- The fluorescent dye leak detector is not a replacement for an electrical leak detector (SST: J-41995). The fluorescent dye leak detector should be used in conjunction with an electrical leak detector (SST: J-41995) to pin-point refrigerant leaks.
- For the purpose of safety and customer's satisfaction, read and follow all manufacturer's operating instructions and precautions prior to performing the work.
- A compressor shaft seal should not necessarily be repaired because of dye seepage. The compressor shaft seal should only be repaired after confirming the leak with an electrical leak detector (SST: J-41995).
- Always remove any remaining dye from the leak area after repairs are completed to avoid a misdiagnosis during a future service.
- Never allow dye to come into contact with painted body panels or interior components. If dye is spilled, clean immediately with the approved dye cleaner. Fluorescent dye left on a surface for an extended period of time cannot be removed.
- Never spray the fluorescent dye cleaning agent on hot surfaces (engine exhaust manifold, etc.).
- Never use more than one refrigerant dye bottle (1/4 ounce /7.4 cc) per A/C system.
- Leak detection dyes for HFC-134a (R-134a) and CFC-12 (R-12) A/C systems are different. Never use HFC-134a (R-134a) leak detection dye in CFC-12 (R-12) A/C system, or CFC-12 (R-12) leak detection dye in HFC-134a (R-134a) A/C system, or A/C system damage may result.
- The fluorescent properties of the dye will remain for three years or a little over unless a compressor malfunction occurs.

IDENTIFICATION

NOTE:

Vehicles with factory installed fluorescent dye have a green label.

Vehicles without factory installed fluorescent dye have a blue label.

IDENTIFICATION LABEL FOR VEHICLE

Vehicles with factory installed fluorescent dye have the identification label on the front side of hood.

PREPARATION

< PREPARATION >

PREPARATION

PREPARATION

Special Service Tool

INFOID:000000000959782

The actual shapes of Kent-Moore tools may differ from those of special service tools illustrated here.



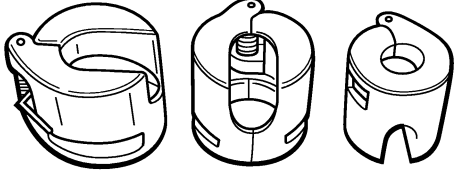
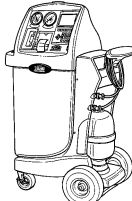
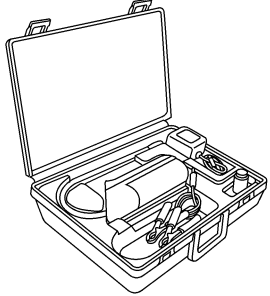

HFC-134a (R-134a) Service Tool and Equipment

- Never mix HFC-134a (R-134a) refrigerant and/or its specified lubricant with CFC-12 (R-12) refrigerant and/or its lubricant.
- Separate and non-interchangeable service equipment must be used for handling each type of refrigerant/lubricant.
- Refrigerant container fittings, service hose fittings and service equipment fittings (equipment which handles refrigerant and/or lubricant) are different between CFC-12 (R-12) and HFC-134a (R-134a). This is to avoid mixed use of the refrigerants/lubricant.
- Never use adapters that convert one size fitting to another: refrigerant/lubricant contamination occurs and compressor malfunction may result.

Tool number (Kent-Moore No.) Tool name	Description
<p>9253089908 (for high-pressure pipe 1) (-) 9253089912 (for high-pressure flexible hose) (-) 9253089916 (for low-pressure pipe 2 and low-pressure flexible hose) (-) Disconnecter tool set (J-45815)</p> <div style="display: flex; justify-content: center; align-items: center;">  </div> <p style="text-align: center;"> 9253089916 (16 mm) 9253089912 (12 mm) 9253089908 (8 mm) </p> <p style="text-align: center;">Disconnecter tool set : J-45815</p> <p style="text-align: right; font-size: small;">SJIA1274E</p>	<p>Disconnect one-touch joint connection</p>
<p>(ACR2005-NI) ACR5 A/C Service Center</p> <div style="text-align: center;">  <p style="font-size: x-small;">WJIA0293E</p> </div>	<p>Function: Refrigerant recovery, recycling and recharging</p>
<p>(J-41995) Electrical leak detector</p> <div style="text-align: center;">  <p style="font-size: x-small;">AHA281A</p> </div>	<p>Power supply: DC 12 V (Battery terminal)</p>

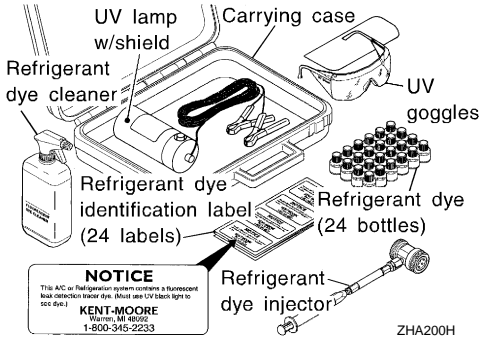
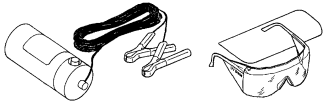
PREPARATION

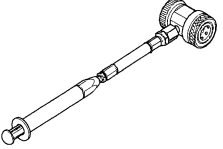
< PREPARATION >

Tool number (Kent-Moore No.) Tool name	Description
<p>(J-43926) Refrigerant dye leak detection kit Kit includes: (J-42220) UV lamp and UV safety goggles (J-41459) HFC-134a (R-134a) dye injector Use with J-41447, 1/4 ounce bottle (J-41447) HFC-134a (R-134a) fluorescent leak detection dye (Box of 24, 1/4 ounce bottles) (J-43872) Refrigerant dye cleaner</p>	 <p style="text-align: right;">Power supply: DC 12 V (Battery terminal)</p>
<p>(J-42220) UV lamp and UV safety goggles</p>	 <p style="text-align: right;">Power supply: DC 12 V (Battery terminal) For checking refrigerant leak when fluorescent dye is installed in A/C system Includes: UV lamp and UV safety goggles</p>
<p>(J-41447) HFC-134a (R-134a) fluorescent leak detection dye (Box of 24, 1/4 ounce bottles)</p>	 <p style="text-align: right;">Application: For HFC-134a (R-134a) PAG oil Container: 1/4 ounce (7.4 cc) bottle (Includes self-adhesive dye identification labels for affixing to vehicle after charging system with dye.)</p>
<p>(J-41459) HFC-134a (R-134a) dye injector Use with J-41447, 1/4 ounce bottle</p>	 <p style="text-align: right;">For injecting 1/4 ounce of fluorescent leak detection dye into A/C system</p>
<p>(J-43872) Refrigerant dye cleaner</p>	 <p style="text-align: right;">For cleaning dye spills</p>

PREPARATION

< PREPARATION >

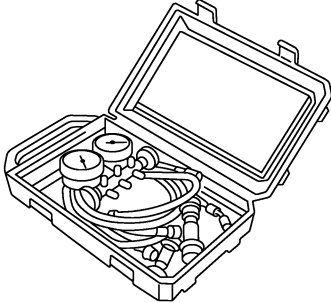
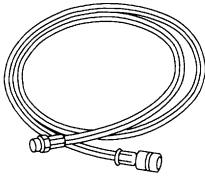
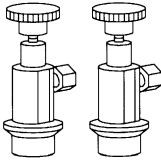
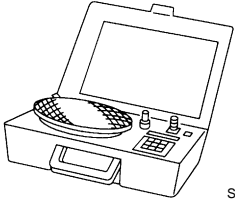
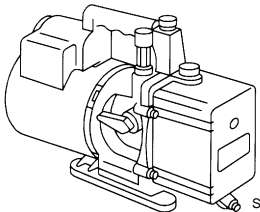
Tool number (Kent-Moore No.) Tool name	Description	A
<p>(J-39183) Manifold gauge set (with hoses and couplers)</p>  <p style="text-align: right; font-size: small;">RJIA0196E</p>	<p>Identification:</p> <ul style="list-style-type: none"> The gauge face indicates HFC-134a (R-134a). <p>Fitting size: Thread size</p> <ul style="list-style-type: none"> 1/2"-16 ACME 	B C D
<p>Service hoses</p> <ul style="list-style-type: none"> High-pressure side hose (J-39501-72) Low-pressure side hose (J-39502-72) Utility hose (J-39476-72)  <p style="text-align: right; font-size: small;">S-NT201</p>	<p>Hose color:</p> <ul style="list-style-type: none"> Low-pressure side hose: Blue with black stripe High-pressure side hose: Red with black stripe Utility hose: Yellow with black stripe or green with black stripe <p>Hose fitting to gauge:</p> <ul style="list-style-type: none"> 1/2"-16 ACME 	E F G
<p>Service couplers</p> <ul style="list-style-type: none"> High-pressure side coupler (J-39500-20) Low-pressure side coupler (J-39500-24)  <p style="text-align: right; font-size: small;">S-NT202</p>	<p>Hose fitting to service hose: M14 x 1.5 fitting is optional or permanently attached.</p>	H VTL
<p>(J-39650) Refrigerant weight scale</p>  <p style="text-align: right; font-size: small;">S-NT200</p>	<p>For measuring of refrigerant</p> <p>Fitting size: Thread size</p> <p>1/2"-16 ACME</p>	J K L
<p>(J-39649) Vacuum pump (Including the isolator valve)</p>  <p style="text-align: right; font-size: small;">S-NT203</p>	<p>Capacity:</p> <ul style="list-style-type: none"> Air displacement: 4 CFM Micron rating: 20 microns Oil capacity: 482 g (17 oz.) <p>Fitting size: Thread size</p> <ul style="list-style-type: none"> 1/2"-16 ACME 	M N

Commercial Service Tool

INFOID:000000000959783

A
B
C
D
E
F
G
H
J
K
L
M
N
O
P

PREPARATION

< PREPARATION >

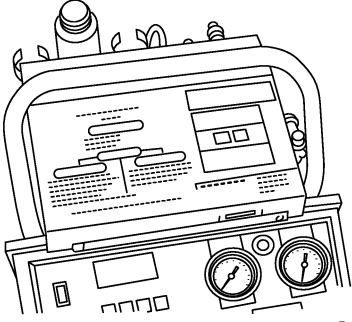
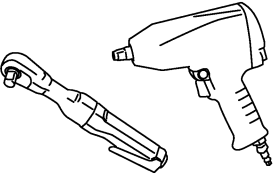

Tool name	Description
Refrigerant identifier equipment  <p style="text-align: right; font-size: small;">RJIA0197E</p>	Checking for refrigerant purity and system contamination
Power tool  <p style="text-align: right; font-size: small;">PBIC0190E</p>	For loosening bolts and nuts

Sealant or/and Lubricant

INFOID:000000000959784

HFC-134a (R-134a) Service Tool and Equipment

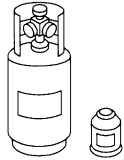
- Never mix HFC-134a (R-134a) refrigerant and/or its specified lubricant with CFC-12 (R-12) refrigerant and/or its lubricant.
- Separate and non-interchangeable service equipment must be used for handling each type of refrigerant/lubricant.
- Refrigerant container fittings, service hose fittings and service equipment fittings (equipment which handles refrigerant and/or lubricant) are different between CFC-12 (R-12) and HFC-134a (R-134a). This is to avoid mixed use of the refrigerants/lubricant.
- Never use adapters that convert one size fitting to another: refrigerant/lubricant contamination occurs and compressor malfunction may result.

Tool name	Description
HFC-134a (R-134a) refrigerant  <p style="text-align: right; font-size: x-small;">S-NT196</p>	Container color: Light blue Container marking: HFC-134a (R-134a) Fitting size: Thread size • Large container 1/2" -16 ACME
Nissan A/C System Oil Type S (DH-PS)  <p style="text-align: right; font-size: x-small;">S-NT197</p>	Type: Polyalkylene glycol oil (PAG), type S (DH-PS) Application: HFC-134a (R-134a) swash plate compressors (Nissan only) Capacity: 40 mℓ (1.4 US fl oz., 1.4 Imp fl oz.)

IN-CABIN MICROFILTER

< ON-VEHICLE MAINTENANCE >

ON-VEHICLE MAINTENANCE

IN-CABIN MICROFILTER

Exploded View

INFOID:000000000959785

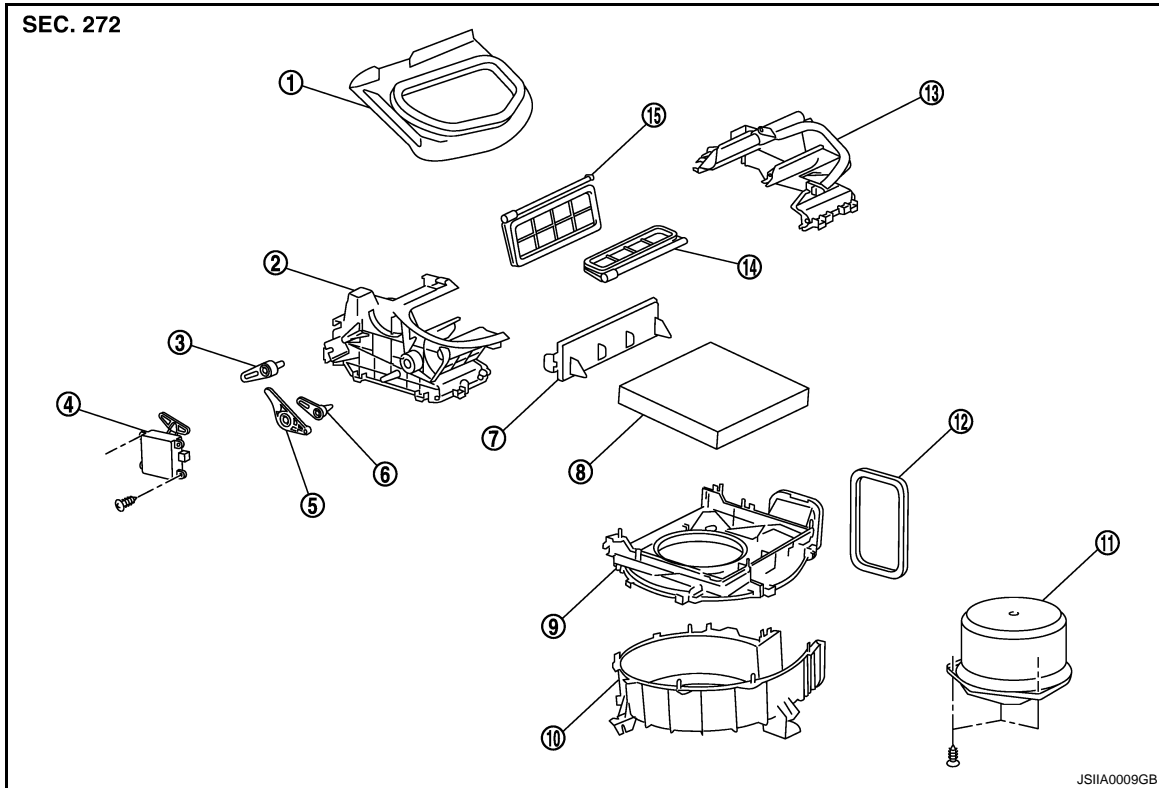

- | | | |
|-----------------------|---------------------------|------------------------|
| 1. Adapter | 2. Intake box (right) | 3. Intake door lever 2 |
| 4. Intake door motor | 5. Intake door link | 6. Intake door lever 1 |
| 7. Filter cover | 8. In-cabin microfilter | 9. Intake upper case |
| 10. Intake lower case | 11. Blower motor assembly | 12. Seal |
| 13. Intake box (left) | 14. Intake door 1 | 15. Intake door 2 |

Removal and Installation

INFOID:000000000959786

REMOVAL

1. Remove instrument assist lower panel. Refer to [IP-12. "Removal and Installation"](#).
2. Remove filter cover (1), and then remove in-cabin microfilter (2).

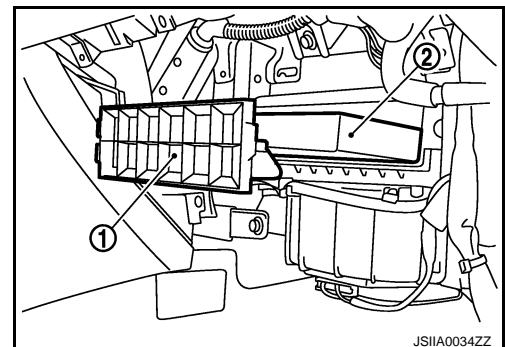

INSTALLATION

Installation is basically the reverse order of removal.

Replacement

INFOID:000000000959787

A
B
C
D
E
F
G
H
J
K
L
M
N
O
P

VTL

IN-CABIN MICROFILTER

< ON-VEHICLE MAINTENANCE >

Replace in-cabin microfilter.

Refer to [MA-6, "Schedule 1"](#) and [MA-8, "Schedule 2"](#).

When replacing filter, affix a caution label inside the glove box.

PRESET SWITCH

< ON-VEHICLE REPAIR >

ON-VEHICLE REPAIR

PRESET SWITCH

Exploded View

INFOID:000000000959788

REMOVAL

Refer to [IP-11. "Exploded View"](#).

DISASSEMBLY

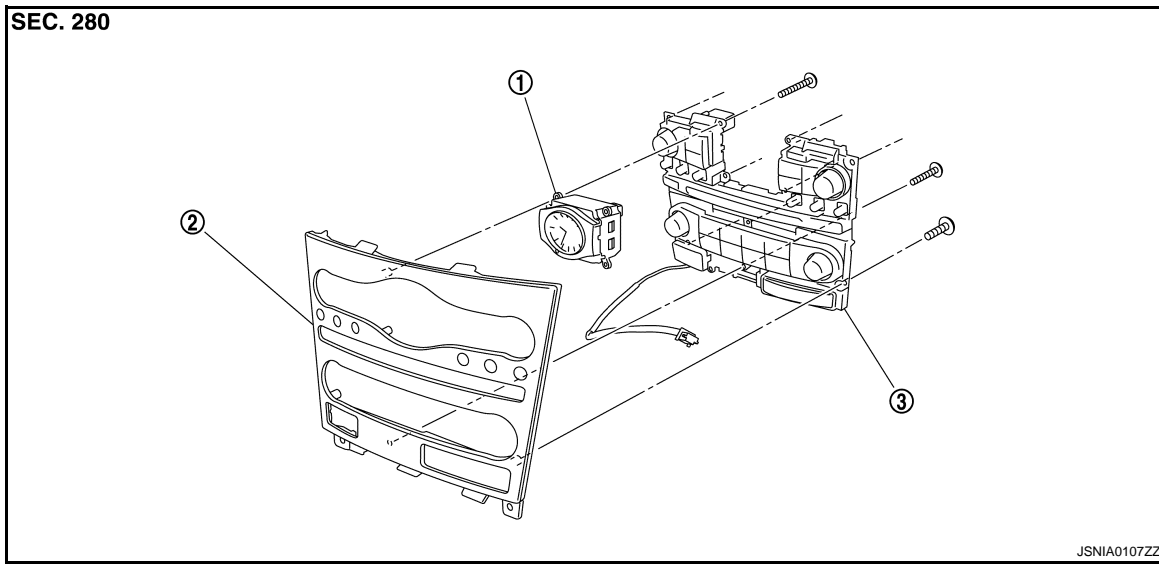

1. Clock

2. Cluster lid C

3. Preset switch

Removal and Installation

INFOID:000000000959789

REMOVAL

Refer to [AV-120. "Removal and Installation"](#) (BASE AUDIO WITHOUT NAVIGATION), [AV-305. "Removal and Installation"](#) (BOSE AUDIO WITHOUT NAVIGATION), [AV-542. "Removal and Installation"](#) (BOSE AUDIO WITH NAVIGATION).

INSTALLATION

Installation is basically the reverse order of removal.

AUTO AMP.

< ON-VEHICLE REPAIR >

AUTO AMP.

Exploded View

INFOID:000000000959790

REMOVAL

Refer to [IP-11, "Exploded View"](#).

DISASSEMBLY

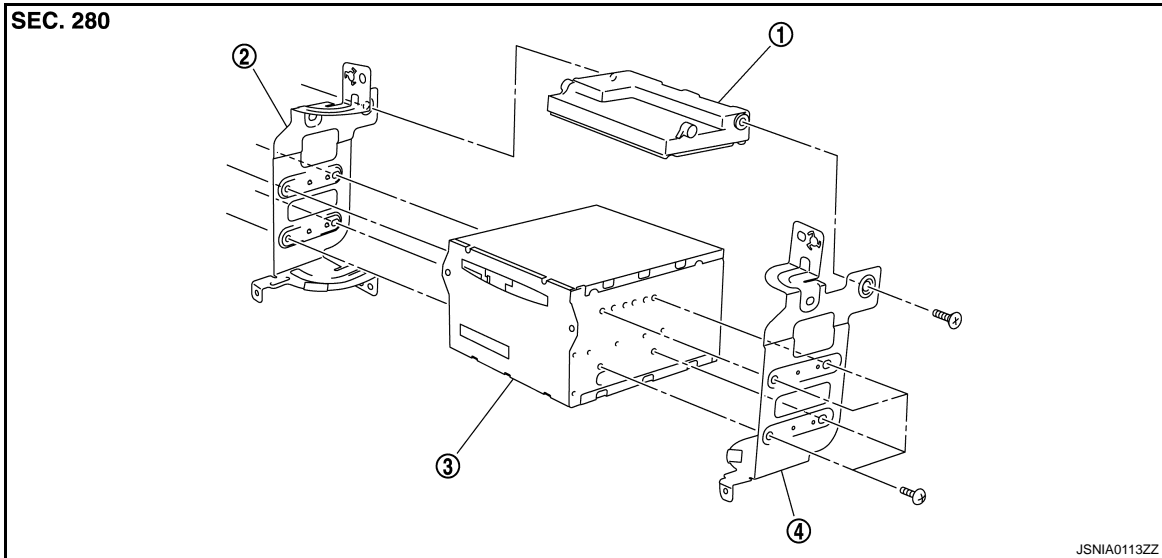

1. Unified meter and A/C amp.
2. Bracket LH
3. AV control unit
4. Bracket RH

Removal and Installation

INFOID:000000000959791

REMOVAL

1. Remove AV control unit. Refer to [AV-111, "Removal and Installation"](#) (BASE AUDIO WITHOUT NAVIGATION), [AV-292, "Removal and Installation"](#) (BOSE AUDIO WITHOUT NAVIGATION) or [AV-530, "Removal and Installation"](#) (BOSE AUDIO WITH NAVIGATION).
2. Remove mounting screws (A), and then remove unified meter and A/C amp. (1).

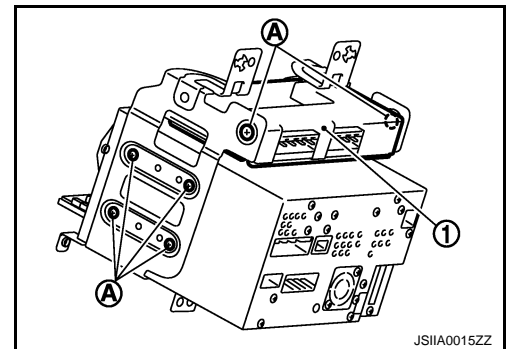

INSTALLATION

Installation is basically the reverse order of removal.

AMBIENT SENSOR

< ON-VEHICLE REPAIR >

AMBIENT SENSOR

Exploded View

1. Ambient sensor

INFOID:000000000959792

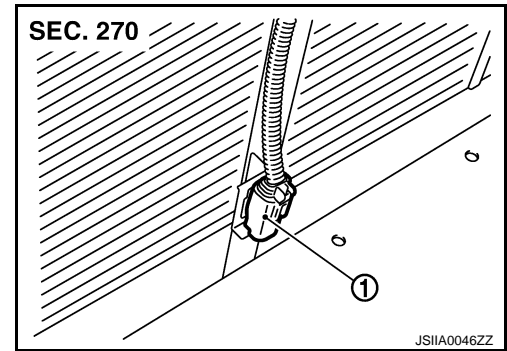

Removal and Installation

INFOID:000000000959793

REMOVAL

1. Remove front grille. Refer to [EXT-16, "Removal and Installation"](#).
2. Disconnect ambient sensor connector (A), and then remove ambient sensor (1).

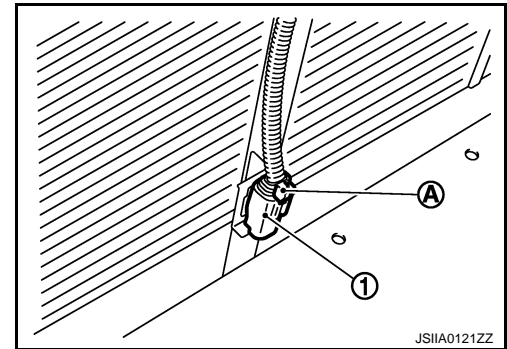

INSTALLATION

Installation is basically the reverse order of removal.

A
B
C
D
E
F
G
H
VTL
J
K
L
M
N
O
P

IN-VEHICLE SENSOR

< ON-VEHICLE REPAIR >

IN-VEHICLE SENSOR

Exploded View

INFOID:000000000959794

1. In-vehicle sensor
2. instrument driver lower panel

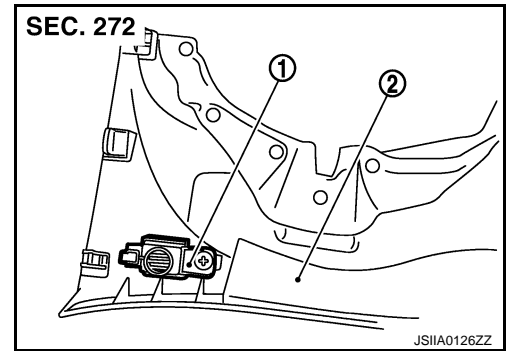

Removal and Installation

INFOID:000000000959795

REMOVAL

1. Remove instrument driver lower panel. Refer to [IP-12, "Removal and Installation"](#).
2. Remove mounting screw (A), and then remove in-vehicle sensor (1).

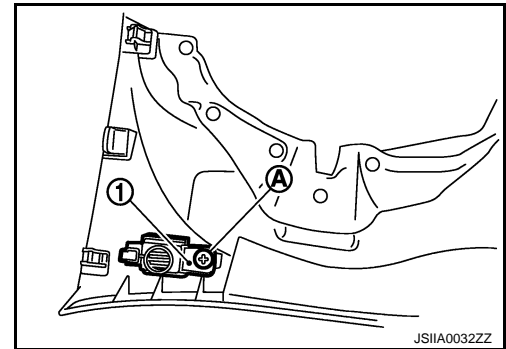

INSTALLATION

Installation is basically the reverse order of removal.

SUNLOAD SENSOR

< ON-VEHICLE REPAIR >

SUNLOAD SENSOR

Exploded View

INFOID:000000000959796

1. Sunload sensor

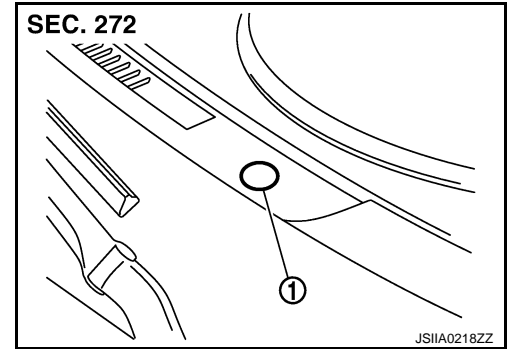

Removal and Installation

INFOID:000000000959797

REMOVAL

1. Remove front defroster grille (left). Refer to [IP-12, "Removal and Installation"](#).
2. Disconnect sunload sensor connector, and then remove sunload sensor (1).

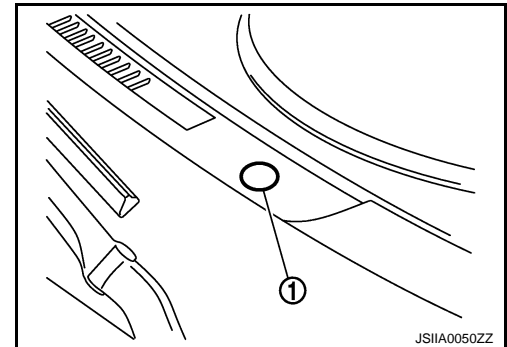

INSTALLATION

Installation is basically the reverse order of removal.

A
B
C
D
E
F
G
H
VTL
J
K
L
M
N
O
P

INTAKE SENSOR

< ON-VEHICLE REPAIR >

INTAKE SENSOR

Exploded View

INFOID:00000000959798

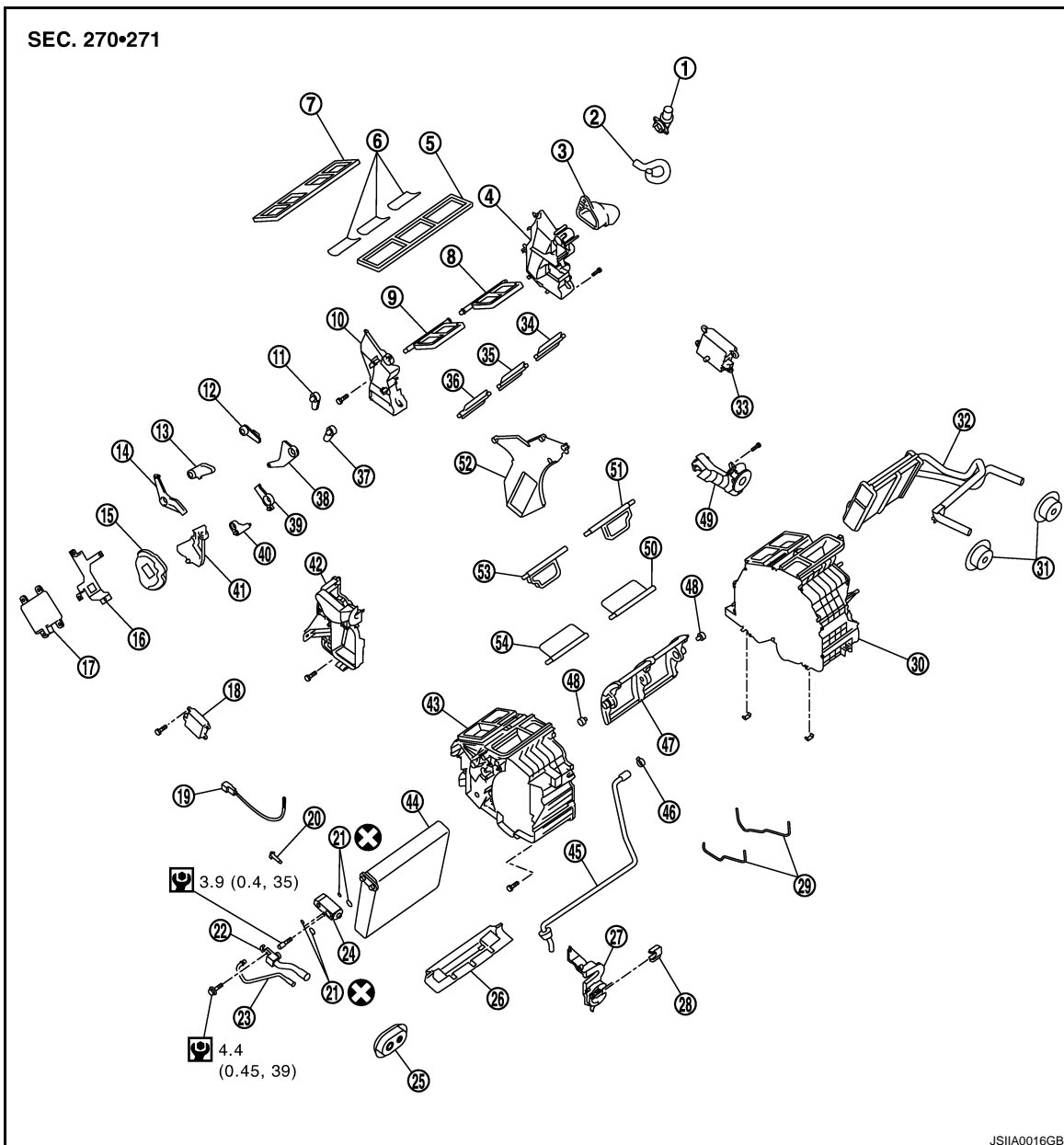

- | | | |
|-----------------------------|---------------------------|---|
| 1. Aspirator | 2. Aspirator hose | 3. Front heater duct |
| 4. Foot duct (left) | 5. Defroster seal | 6. Packing |
| 7. Ventilator seal | 8. Ventilator door (left) | 9. Ventilator door (right) |
| 10. Foot duct (right) | 11. Defroster door lever | 12. Foot door lever |
| 13. Ventilator door lever | 14. Ventilator door link | 15. Main link |
| 16. Mode door motor bracket | 17. Mode door motor | 18. Air mix door motor (passenger side) |
| 19. Intake sensor | 20. Intake sensor bracket | 21. O-ring |
| 22. Low-pressure pipe 1 | 23. High-pressure pipe 2 | 24. Expansion valve |
| 25. Cooler pipe grommet | 26. Insulator | 27. Evaporator cover adapter |
| 28. Heater pipe bracket | 29. Case packing | 30. Heater & cooling unit case (left) |
| 31. Heater pipe grommet | 32. Heater core | 33. Air mix door motor (driver side)* |
| 34. Foot door (left) | 35. Rear ventilator door | 36. Foot door (right) |

INTAKE SENSOR

< ON-VEHICLE REPAIR >

- | | | |
|--|-------------------------------|----------------------------|
| 37. Max. cool door lever | 38. Foot door link | 39. Defroster door link |
| 40. Max. cool door link | 41. Main link sub | 42. Evaporator cover |
| 43. Heater & cooling unit case (right) | 44. Evaporator | 45. Drain hose |
| 46. Clamp | 47. Air mix door (Slide door) | 48. Air mix door adapter |
| 49. Heater pipe cover | 50. Max. cool door (left) | 51. Defroster door (left) |
| 52. Center case | 53. Defroster door (right) | 54. Max. cool door (right) |

*With left and right ventilation temperature separately system.

Refer to [GI-4. "Components"](#) for symbols in the figure.

Removal and Installation

INFOID:000000000959799

REMOVAL

1. Remove low-pressure pipe 1 and high-pressure pipe 2. Refer to [HA-51. "Removal and Installation"](#).

CAUTION:

Cap or wrap the joint of low-pressure pipe 1, 2 and high-pressure pipe 1, 2 with suitable material such as vinyl tape to avoid the entry of air.

2. Slide evaporator (1) to passenger side, and then remove intake sensor (2).

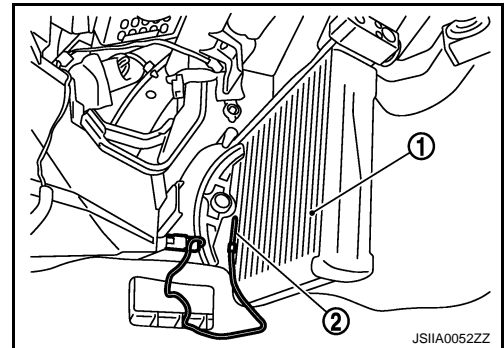

INSTALLATION

Installation is basically the reverse order of removal.

CAUTION:

- Replace O-rings of low-pressure pipe 1, 2 and high-pressure pipe 1, 2 with new ones, and then apply compressor oil to it when installing it.
- Mark the mounting position of intake sensor bracket prior to removal so that the reinstalled sensor can be located in the same position.
- Female-side piping connection is thin and easy to deform. Slowly insert the male-side piping straight in axial direction.
- Insert piping securely until a click is heard.
- After piping connection is completed, pull male-side piping by hand to make sure that connection does not come loose.
- When recharging refrigerant, check for leaks.

BLOWER UNIT

< ON-VEHICLE REPAIR >

BLOWER UNIT

Exploded View

INFOID:000000000959800

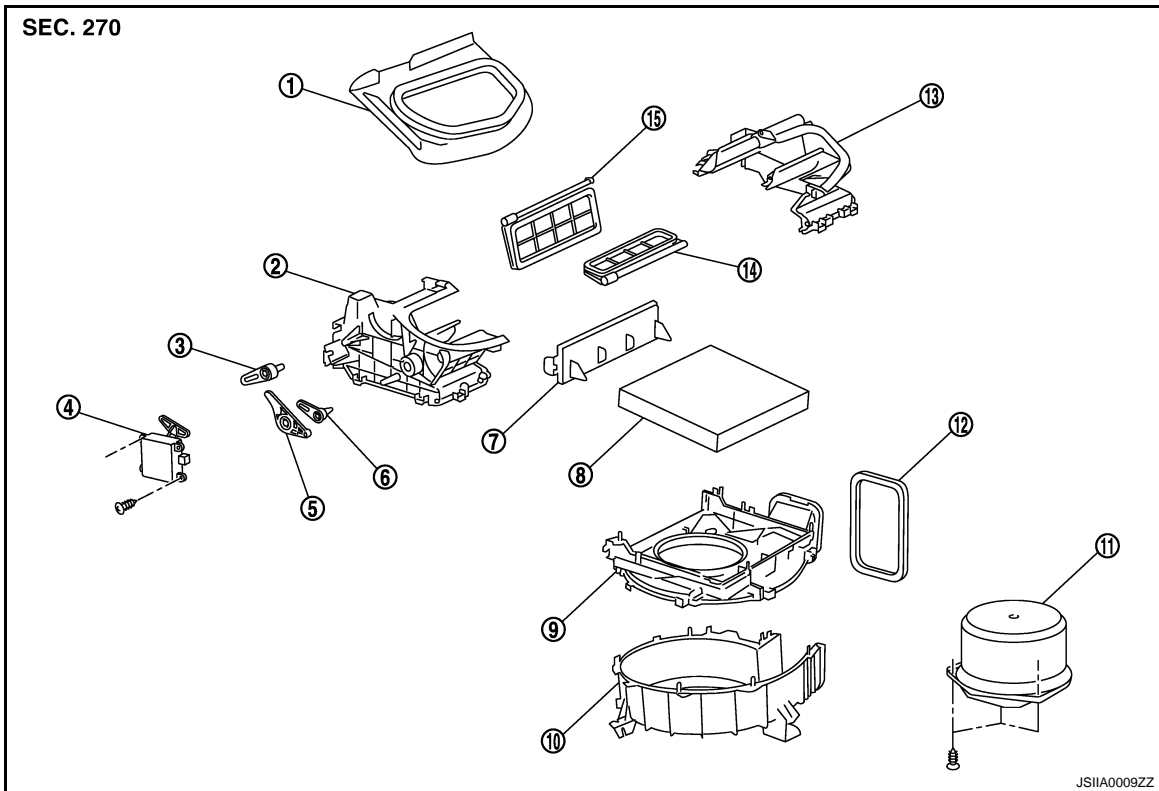

- | | | |
|-----------------------|---------------------------|------------------------|
| 1. Adapter | 2. Intake box (right) | 3. Intake door lever 2 |
| 4. Intake door motor | 5. Intake door link | 6. Intake door lever 1 |
| 7. Filter cover | 8. In-cabin microfilter | 9. Intake upper case |
| 10. Intake lower case | 11. Blower motor assembly | 12. Seal |
| 13. Intake box (left) | 14. Intake door 1 | 15. Intake door 2 |

Removal and Installation

INFOID:000000000959801

REMOVAL

1. Remove instrument lower panel. Refer to [IP-12. "Removal and Installation"](#).
2. Disconnect ECM (1) connectors.
3. Disconnect AWD control unit (2) connector (AWD).
4. Remove mounting nuts (A), and then remove ECM with bracket attached.
5. Remove power steering C/U. Refer to [STC-24. "Removal and Installation"](#).
6. Disconnect intake door motor (3) connector and blower fan motor (4) connector.
7. Remove mounting bolt (B) and screw (C), from blower unit (5).
8. Remove blower unit.

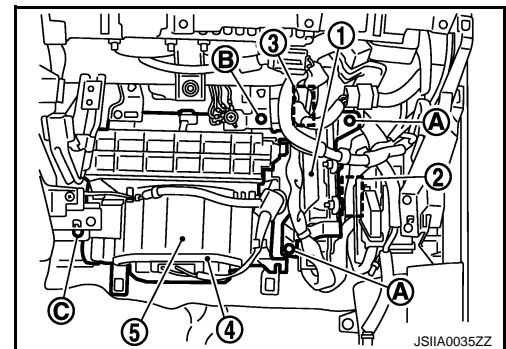

CAUTION:

Move blower unit rightward, and remove locating pin (1 part) and joint. Then remove blower unit downward.

INSTALLATION

Installation is basically the reverse order of removal.

BLOWER UNIT

< ON-VEHICLE REPAIR >

←: Vehicle front

CAUTION:
Make sure locating pin (A) and joint (B) are securely inserted.

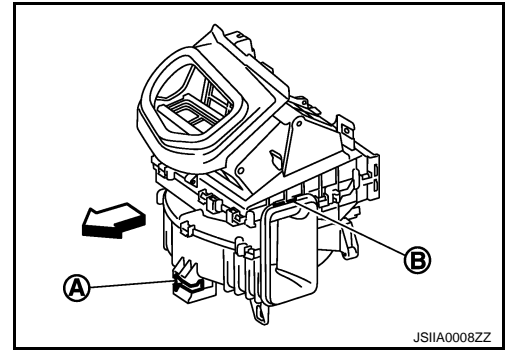

A
B
C
D
E
F
G
H
VTL
J
K
L
M
N
O
P

BLOWER MOTOR

< ON-VEHICLE REPAIR >

BLOWER MOTOR

Exploded View

INFOID:000000000959802

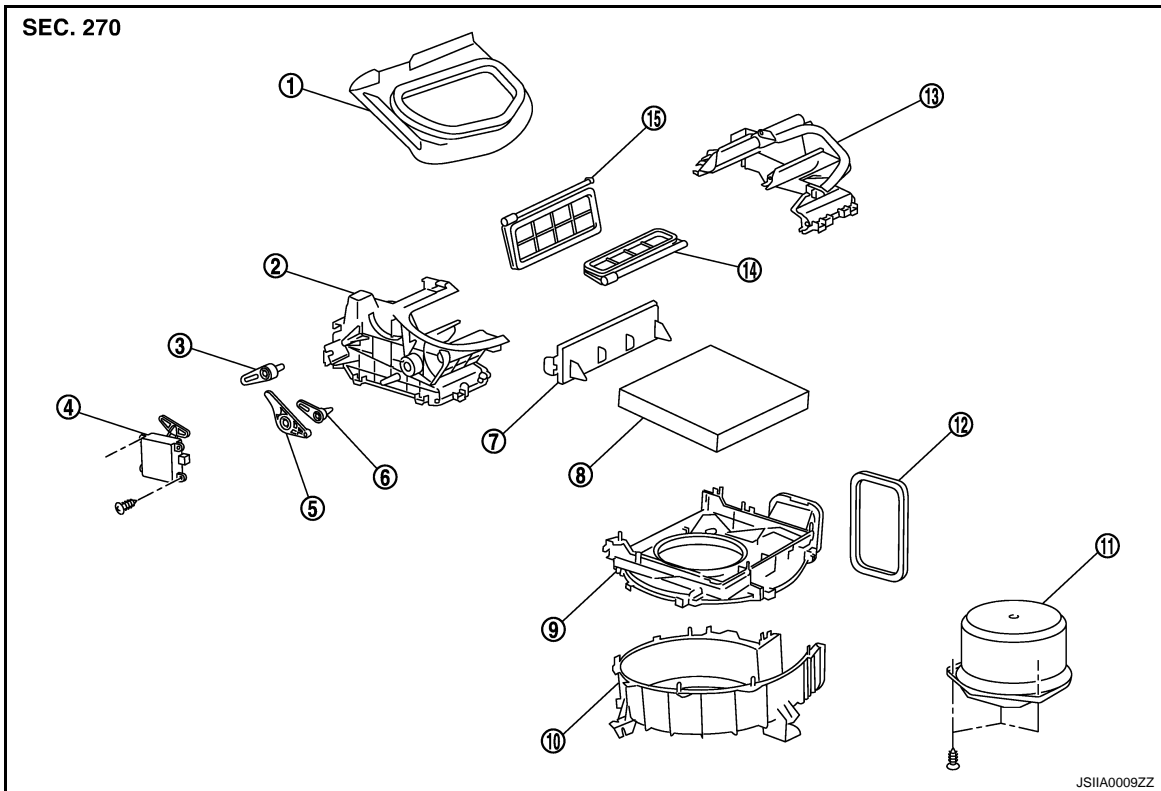

- | | | |
|-----------------------|---------------------------|------------------------|
| 1. Adapter | 2. Intake box (right) | 3. Intake door lever 2 |
| 4. Intake door motor | 5. Intake door link | 6. Intake door lever 1 |
| 7. Filter cover | 8. In-cabin microfilter | 9. Intake upper case |
| 10. Intake lower case | 11. Blower motor assembly | 12. Seal |
| 13. Intake box (left) | 14. Intake door 1 | 15. Intake door 2 |

Removal and Installation

INFOID:000000000959803

REMOVAL

1. Remove instrument lower cover. Refer to [IP-12. "Removal and Installation"](#).
2. Disconnect blower motor connector (A).
3. Remove mounting screws (B), and then remove blower motor assembly (1).

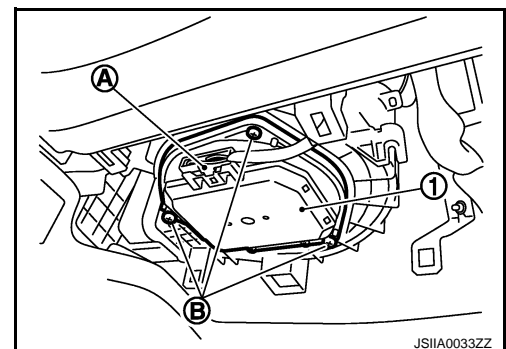

INSTALLATION

Installation is basically the reverse order of removal.

INTAKE DOOR MOTOR

< ON-VEHICLE REPAIR >

INTAKE DOOR MOTOR

Exploded View

INFOID:000000000959804

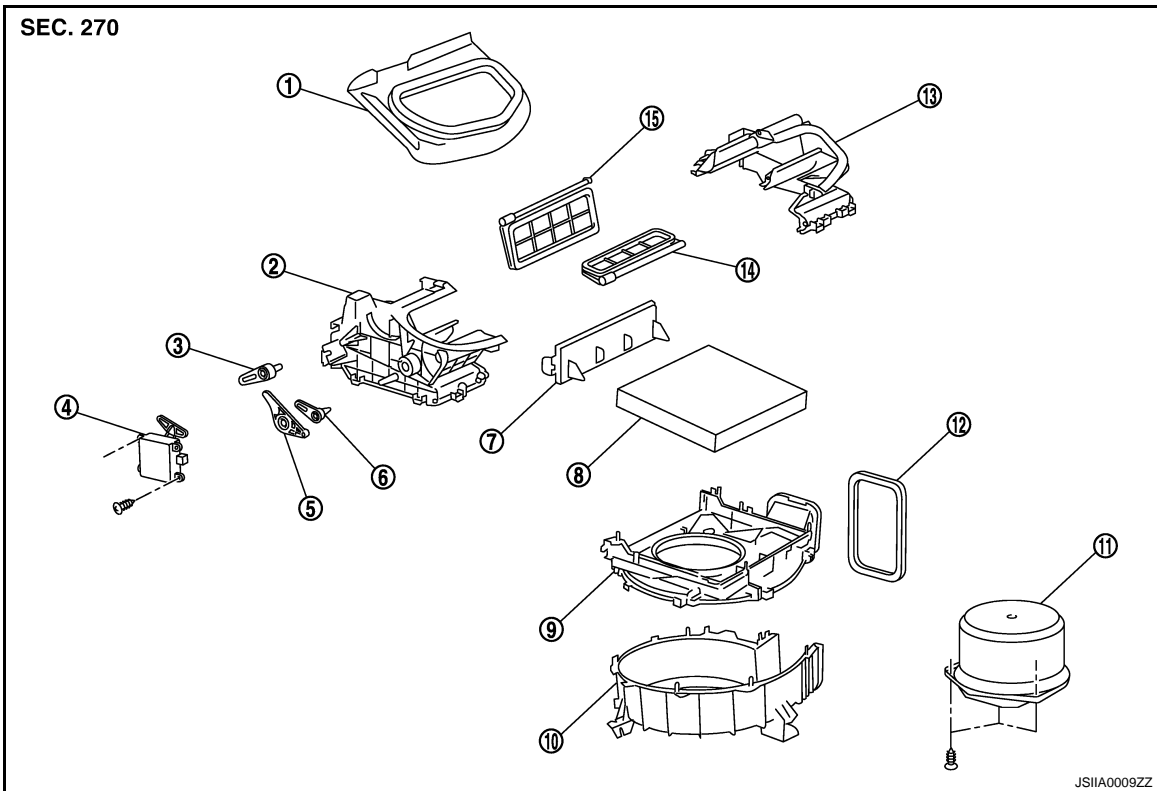

- | | | |
|-----------------------|---------------------------|------------------------|
| 1. Adapter | 2. Intake box (right) | 3. Intake door lever 2 |
| 4. Intake door motor | 5. Intake door link | 6. Intake door lever 1 |
| 7. Filter cover | 8. In-cabin microfilter | 9. Intake upper case |
| 10. Intake lower case | 11. Blower motor assembly | 12. Seal |
| 13. Intake box (left) | 14. Intake door 1 | 15. Intake door 2 |

Removal and Installation

INFOID:000000000959805

REMOVAL

1. Remove ECM and power steering control unit with bracket attached. Refer to [VTL-30. "Removal and Installation"](#).
2. Remove mounting screws (A), and then remove intake door motor (1) from blower unit.

←: Vehicle front

3. Disconnect intake door motor connector (B).

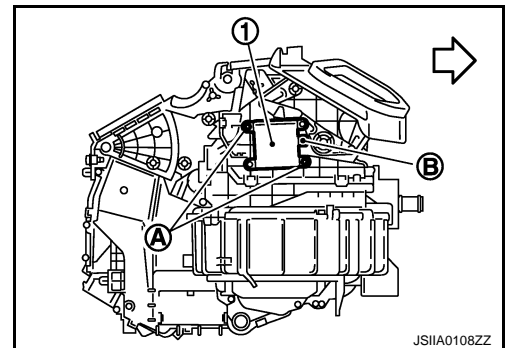

INSTALLATION

Installation is basically the reverse order of removal.

HEATER & COOLING UNIT ASSEMBLY

< ON-VEHICLE REPAIR >

HEATER & COOLING UNIT ASSEMBLY

Exploded View

INFOID:00000000959806

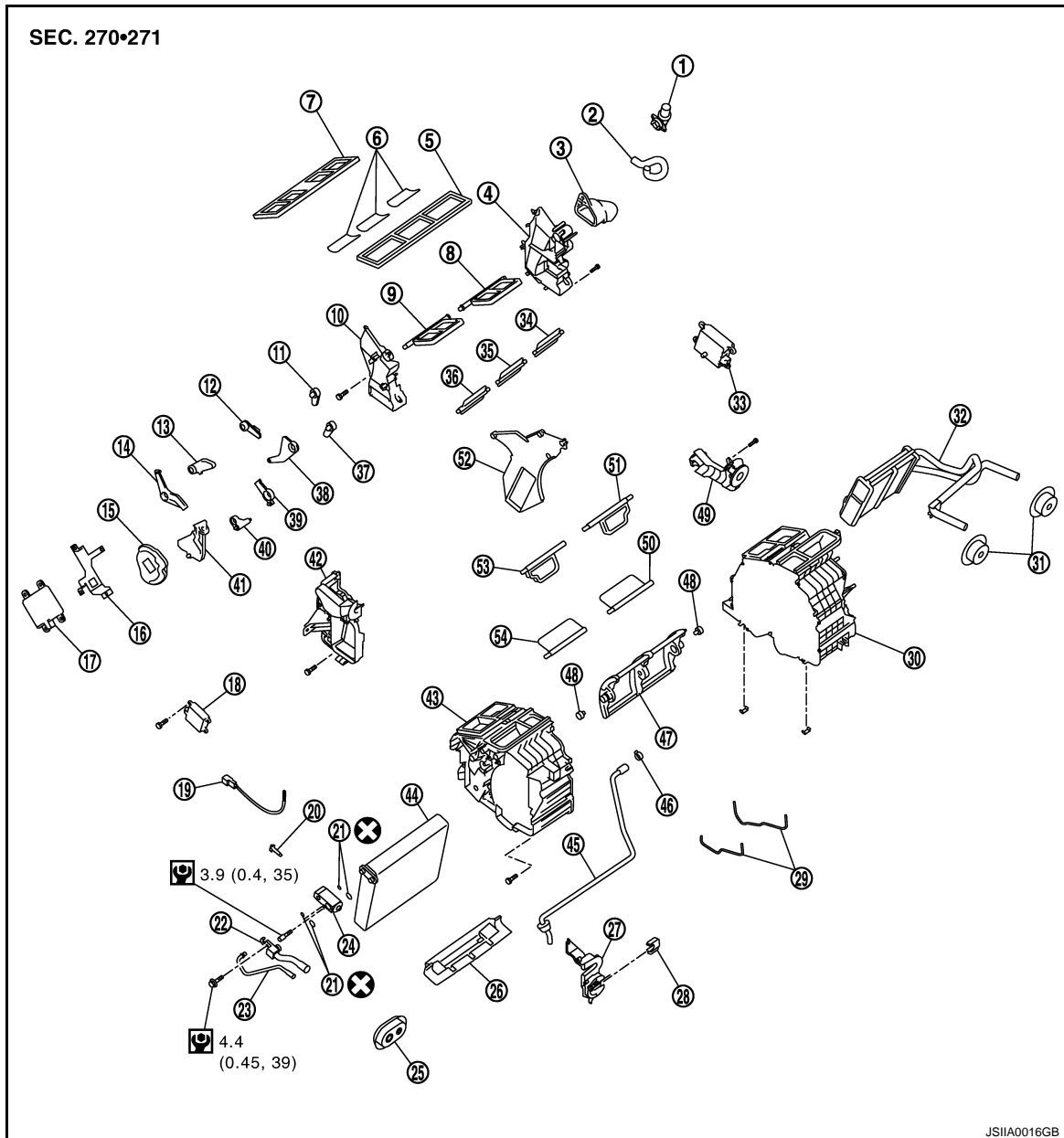

- | | | |
|-----------------------------|---------------------------|---|
| 1. Aspirator | 2. Aspirator hose | 3. Front heater duct |
| 4. Foot duct (left) | 5. Defroster seal | 6. Packing |
| 7. Ventilator seal | 8. Ventilator door (left) | 9. Ventilator door (right) |
| 10. Foot duct (right) | 11. Defroster door lever | 12. Foot door lever |
| 13. Ventilator door lever | 14. Ventilator door link | 15. Main link |
| 16. Mode door motor bracket | 17. Mode door motor | 18. Air mix door motor (passenger side) |
| 19. Intake sensor | 20. Intake sensor bracket | 21. O-ring |
| 22. Low-pressure pipe 1 | 23. High-pressure pipe 2 | 24. Expansion valve |
| 25. Cooler pipe grommet | 26. Insulator | 27. Evaporator cover adapter |
| 28. Heater pipe bracket | 29. Case packing | 30. Heater & cooling unit case (left) |
| 31. Heater pipe grommet | 32. Heater core | 33. Air mix door motor (driver side)* |
| 34. Foot door (left) | 35. Rear ventilator door | 36. Foot door (right) |

HEATER & COOLING UNIT ASSEMBLY

< ON-VEHICLE REPAIR >

- | | | |
|--|-------------------------------|----------------------------|
| 37. Max. cool door lever | 38. Foot door link | 39. Defroster door link |
| 40. Max. cool door link | 41. Main link sub | 42. Evaporator cover |
| 43. Heater & cooling unit case (right) | 44. Evaporator | 45. Drain hose |
| 46. Clamp | 47. Air mix door (Slide door) | 48. Air mix door adapter |
| 49. Heater pipe cover | 50. Max. cool door (left) | 51. Defroster door (left) |
| 52. Center case | 53. Defroster door (right) | 54. Max. cool door (right) |

*With left and right ventilation temperature separately system.

Refer to [GI-4, "Components"](#) for symbols in the figure.

Removal and Installation

INFOID:000000000959807

REMOVAL

1. Use a refrigerant collecting equipment (for HFC-134a) to discharge the refrigerant.
2. Drain engine coolant from cooling system. Refer to [CO-8, "Draining"](#).
3. Remove cowl top cover. Refer to [EXT-18, "Removal and Installation"](#).

4. Disconnect one-touch joint between low-pressure pipe 1 (1) and low-pressure pipe 2 (2) with disconnecter (SST: 9253089916) (A).

CAUTION:

Cap or wrap the joint of low-pressure pipe 1 and low-pressure pipe 2 with suitable material such as vinyl tape to avoid the entry of air.

5. Disconnect one-touch joint between high-pressure pipe 1 (3) and high-pressure pipe 2 (4) with disconnecter (SST: 9253089908).

CAUTION:

Cap or wrap the joint of high-pressure pipe 1 and high-pressure pipe 2 with suitable material such as vinyl tape to avoid the entry of air.

6. Remove clamp (A), and then disconnect heater hoses (1).

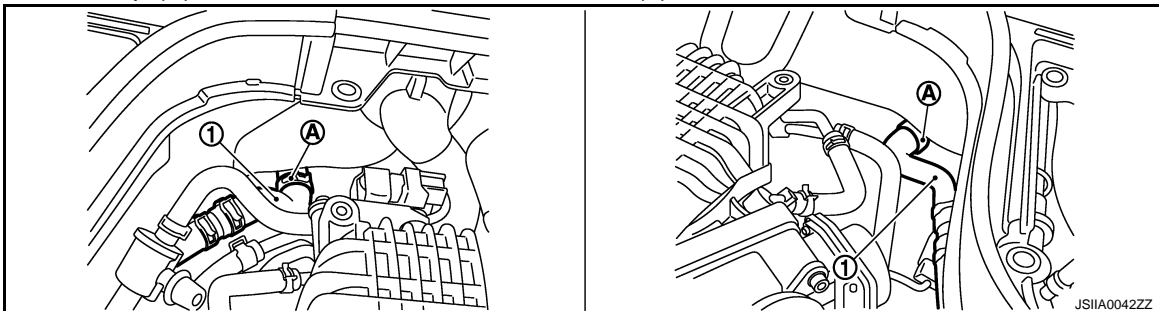
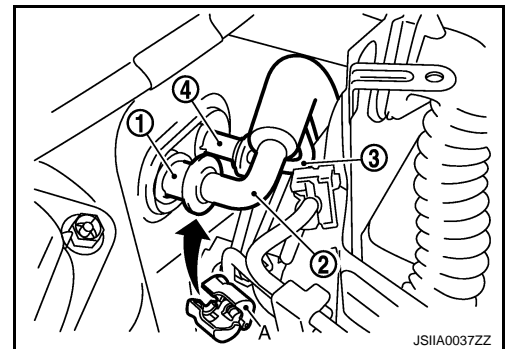

7. Remove instrument panel & pad. Refer to [IP-12, "Removal and Installation"](#).
8. Remove blower unit. Refer to [VTL-30, "Removal and Installation"](#).
9. Remove clips of vehicle harness from steering member.
10. Remove mounting nuts (A), and then remove instrument stays (1).

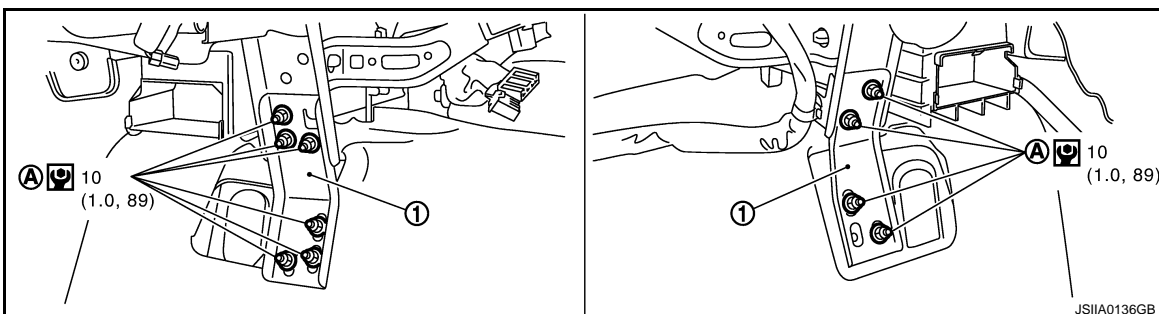

Refer to [GI-4, "Components"](#) for symbols in the figure.

A
B
C
D
E
F
G
H
VTL
J
K
L
M
N
O
P

HEATER & COOLING UNIT ASSEMBLY

< ON-VEHICLE REPAIR >

11. Remove clamp (A), and then remove drain hose (1).

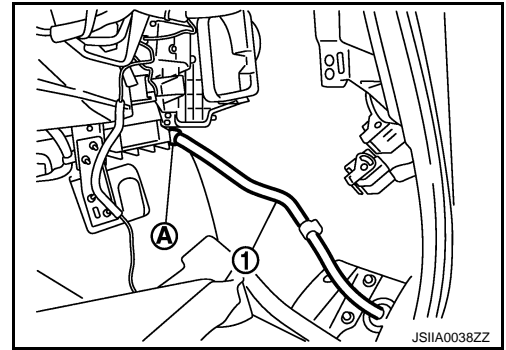

12. Remove mounting bolts (A) from heater & cooling unit assembly (1).

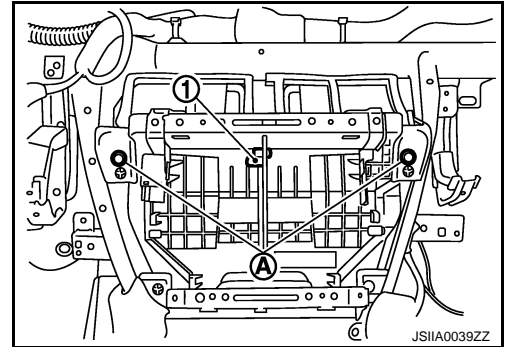

13. Remove front defroster nozzle, side defroster nozzles and ventilator duct. Refer to [VTL-46, "FRONT DEFROSTER NOZZLE, SIDE DEFROSTER NOZZLES AND VENTILATOR DUCT : Removal and Installation"](#).

14. Remove steering column mounting bolts (A) and nuts (B). Refer to [IP-12, "Removal and Installation"](#).

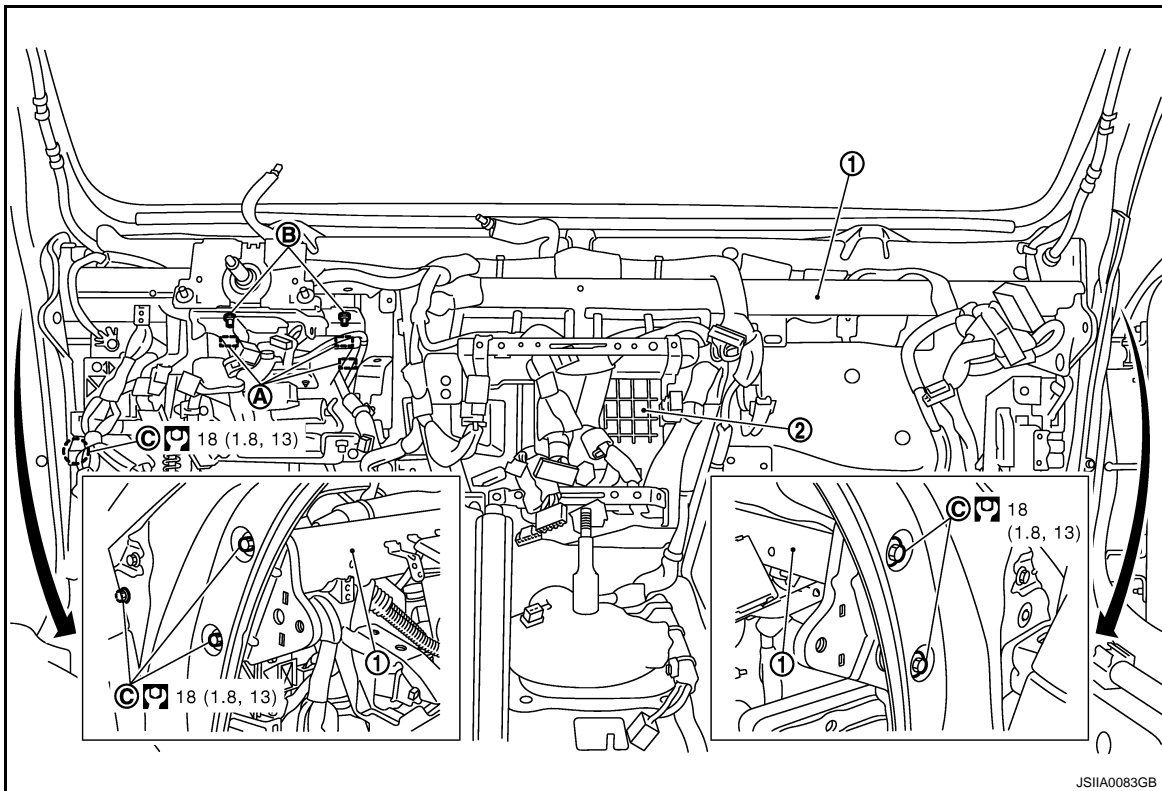

Refer to [GI-4, "Components"](#) for symbols in the figure.

15. Remove steering member mounting bolts (C).

16. Remove steering member (1), and then remove heater & cooling unit (2).

HEATER & COOLING UNIT ASSEMBLY

< ON-VEHICLE REPAIR >

INSTALLATION

Installation is basically the reverse order of removal.

CAUTION:

- Replace O-rings of low-pressure pipe 1, 2 and high-pressure pipe 1, 2 with new ones, and then apply compressor oil to it when installing it.
- Female-side piping connection is thin and easy to deform. Slowly insert the male-side piping straight in axial direction.
- Insert piping securely until a clicks is heard.
- After piping connection is completed, pull male-side piping by hand to make sure that connection does not come loose.
- When recharging refrigerant, check for leaks.

NOTE:

- Perform 4WAS front actuator adjustment (WITH 4WAS). Refer to [STC-27. "4WAS FRONT ACTUATOR NEUTRAL POSITION ADJUSTMENT : Description"](#).
- When filling radiator with engine coolant, refer to [CO-9. "Refilling"](#).
- Recharge the refrigerant.

Heater & cooling unit (1)
assembly mounting bolt
(A)



: 6.9 N·m (0.7 kg·m, 61 in·lb)

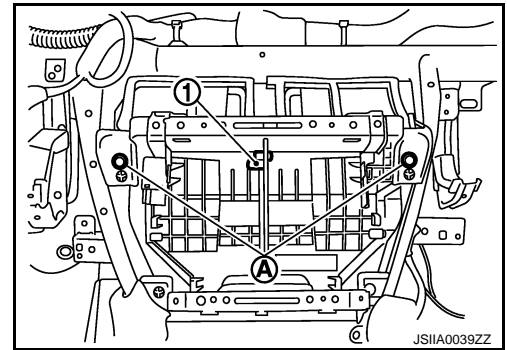

A
B
C
D
E
F
G
H
J
K
L
M
N
O
P

VTL

MODE DOOR MOTOR

< ON-VEHICLE REPAIR >

MODE DOOR MOTOR

Exploded View

INFOID:00000000959808

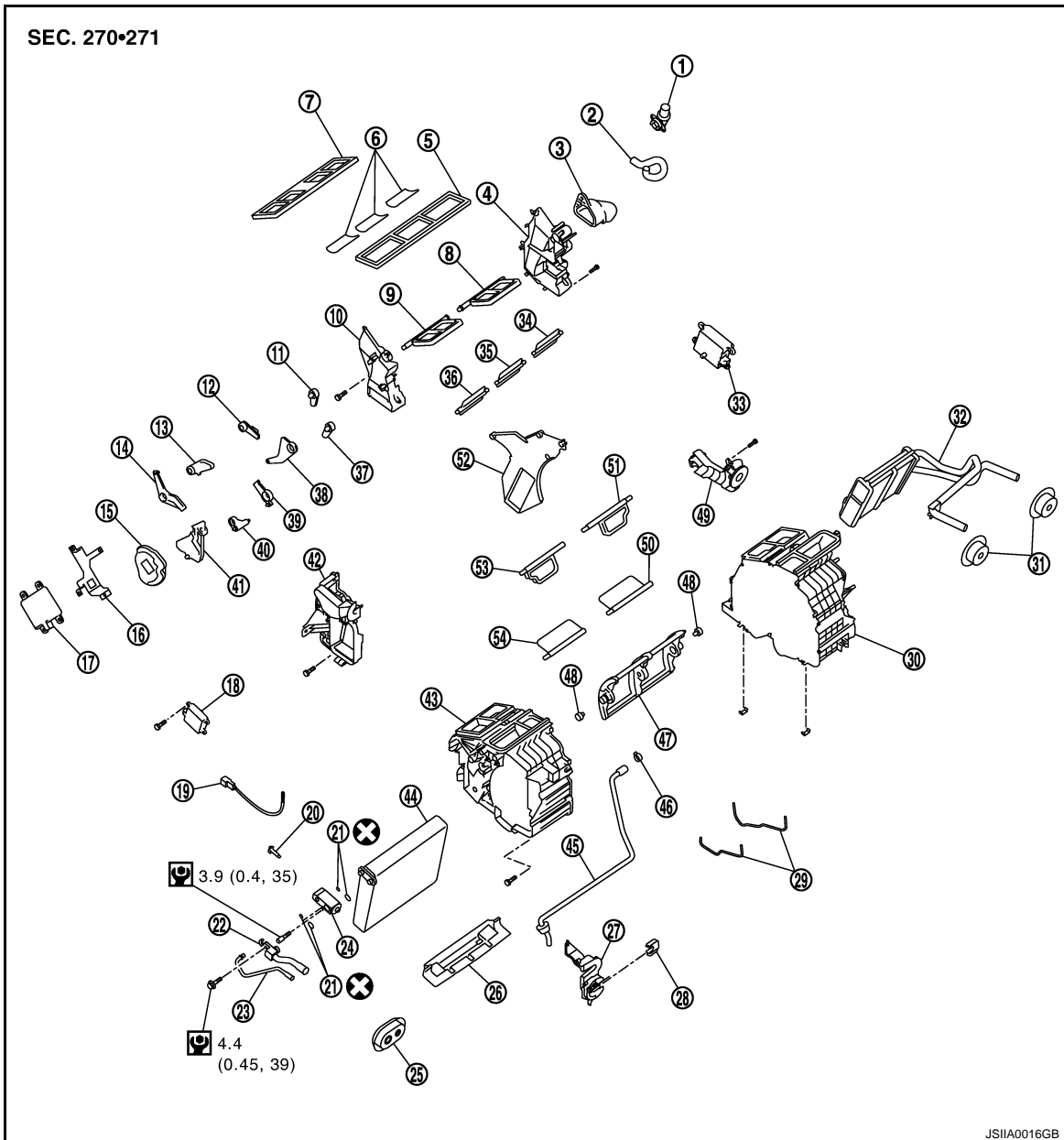

- | | | |
|-----------------------------|---------------------------|---|
| 1. Aspirator | 2. Aspirator hose | 3. Front heater duct |
| 4. Foot duct (left) | 5. Defroster seal | 6. Packing |
| 7. Ventilator seal | 8. Ventilator door (left) | 9. Ventilator door (right) |
| 10. Foot duct (right) | 11. Defroster door lever | 12. Foot door lever |
| 13. Ventilator door lever | 14. Ventilator door link | 15. Main link |
| 16. Mode door motor bracket | 17. Mode door motor | 18. Air mix door motor (passenger side) |
| 19. Intake sensor | 20. Intake sensor bracket | 21. O-ring |
| 22. Low-pressure pipe 1 | 23. High-pressure pipe 2 | 24. Expansion valve |
| 25. Cooler pipe grommet | 26. Insulator | 27. Evaporator cover adapter |
| 28. Heater pipe bracket | 29. Case packing | 30. Heater & cooling unit case (left) |
| 31. Heater pipe grommet | 32. Heater core | 33. Air mix door motor (driver side)* |
| 34. Foot door (left) | 35. Rear ventilator door | 36. Foot door (right) |

MODE DOOR MOTOR

< ON-VEHICLE REPAIR >

- | | | |
|--|-------------------------------|----------------------------|
| 37. Max. cool door lever | 38. Foot door link | 39. Defroster door link |
| 40. Max. cool door link | 41. Main link sub | 42. Evaporator cover |
| 43. Heater & cooling unit case (right) | 44. Evaporator | 45. Drain hose |
| 46. Clamp | 47. Air mix door (Slide door) | 48. Air mix door adapter |
| 49. Heater pipe cover | 50. Max. cool door (left) | 51. Defroster door (left) |
| 52. Center case | 53. Defroster door (right) | 54. Max. cool door (right) |

*With left and right ventilation temperature separately system.

Refer to [GI-4. "Components"](#) for symbols in the figure.

Removal and Installation

INFOID:000000000959809

REMOVAL

1. Remove blower unit. Refer to [VTL-30. "Removal and Installation"](#).
2. Remove mounting screws (A), and then remove mode door motor (1).
3. Disconnect mode door motor connector (B).

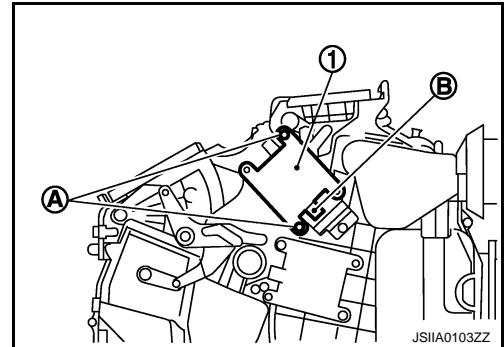

INSTALLATION

installation is basically the reverse order of removal.

A
B
C
D
E
F
G
H
J
K
L
M
N
O
P

VTL

AIR MIX DOOR MOTOR

< ON-VEHICLE REPAIR >

AIR MIX DOOR MOTOR

Exploded View

INFOID:00000000959810

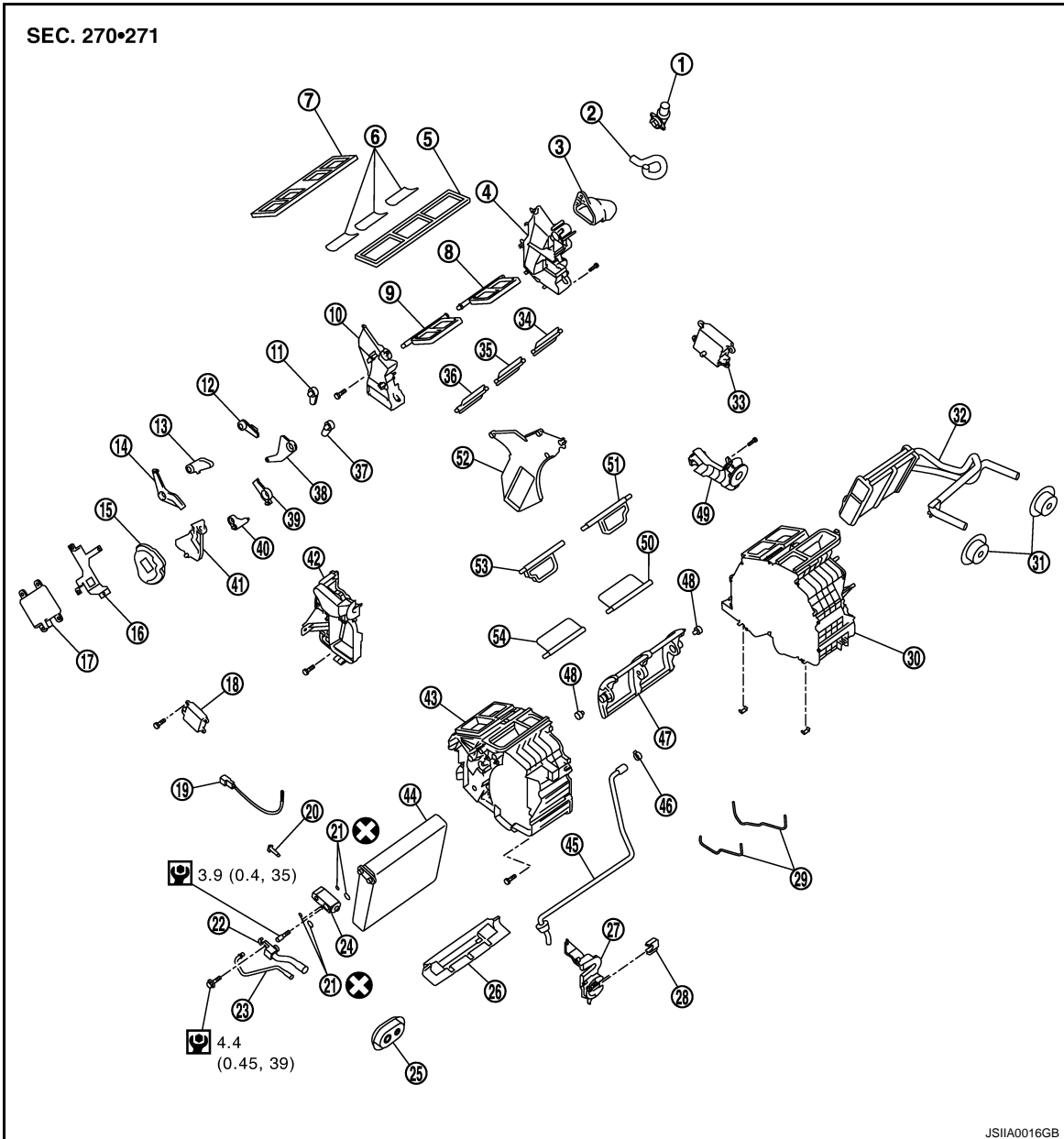

- | | | |
|-----------------------------|---------------------------|---|
| 1. Aspirator | 2. Aspirator hose | 3. Front heater duct |
| 4. Foot duct (left) | 5. Defroster seal | 6. Packing |
| 7. Ventilator seal | 8. Ventilator door (left) | 9. Ventilator door (right) |
| 10. Foot duct (right) | 11. Defroster door lever | 12. Foot door lever |
| 13. Ventilator door lever | 14. Ventilator door link | 15. Main link |
| 16. Mode door motor bracket | 17. Mode door motor | 18. Air mix door motor (passenger side) |
| 19. Intake sensor | 20. Intake sensor bracket | 21. O-ring |
| 22. Low-pressure pipe 1 | 23. High-pressure pipe 2 | 24. Expansion valve |
| 25. Cooler pipe grommet | 26. Insulator | 27. Evaporator cover adapter |
| 28. Heater pipe bracket | 29. Case packing | 30. Heater & cooling unit case (left) |
| 31. Heater pipe grommet | 32. Heater core | 33. Air mix door motor (driver side)* |
| 34. Foot door (left) | 35. Rear ventilator door | 36. Foot door (right) |

AIR MIX DOOR MOTOR

< ON-VEHICLE REPAIR >

- | | | |
|--|-------------------------------|----------------------------|
| 37. Max. cool door lever | 38. Foot door link | 39. Defroster door link |
| 40. Max. cool door link | 41. Main link sub | 42. Evaporator cover |
| 43. Heater & cooling unit case (right) | 44. Evaporator | 45. Drain hose |
| 46. Clamp | 47. Air mix door (Slide door) | 48. Air mix door adapter |
| 49. Heater pipe cover | 50. Max. cool door (left) | 51. Defroster door (left) |
| 52. Center case | 53. Defroster door (right) | 54. Max. cool door (right) |

*With left and right ventilation temperature separately system.

Refer to [GI-4. "Components"](#) for symbols in the figure.

Removal and Installation

INFOID:000000000959811

REMOVAL

Driver Side (With left and right ventilation temperature separately system)

1. Set the temperature (driver side) at 18°C (60°F), and then disconnect the battery from the negative terminal.
2. Remove instrument driver lower panel. Refer to [IP-12. "Removal and Installation"](#).
3. Remove accelerator pedal bracket and lever assembly. Refer to [ACC-3. "Removal and Installation"](#).
4. Remove automatic drive positioner control unit. Refer to [ADP-218. "Removal and Installation"](#).
5. Remove mounting screws (A), and then remove air mix door motor (1).

←: Vehicle front

6. Disconnect air mix door motor connector (B).

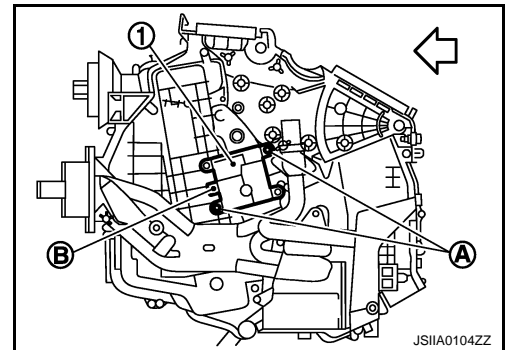

Passenger Side

1. Set the temperature (passenger side) at 18°C (60°F), and then disconnect the battery from the negative terminal.
2. Remove blower unit. Refer to [VTL-30. "Removal and Installation"](#).
3. Remove mounting screws (A), and then remove air mix door motor (1).

←: Vehicle front

4. Disconnect air mix door motor connector (B).

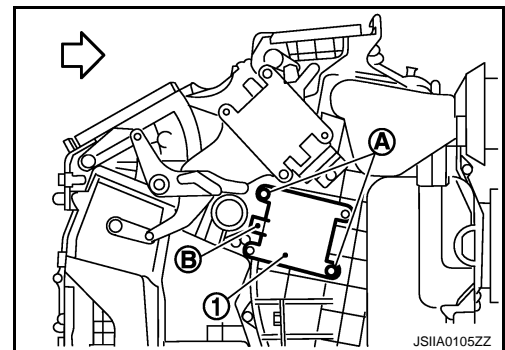

INSTALLATION

Installation is basically the reverse order of removal.

A
B
C
D
E
F
G
H
VTL
J
K
L
M
N
O
P

HEATER CORE

< ON-VEHICLE REPAIR >

HEATER CORE

Exploded View

INFOID:00000000959812

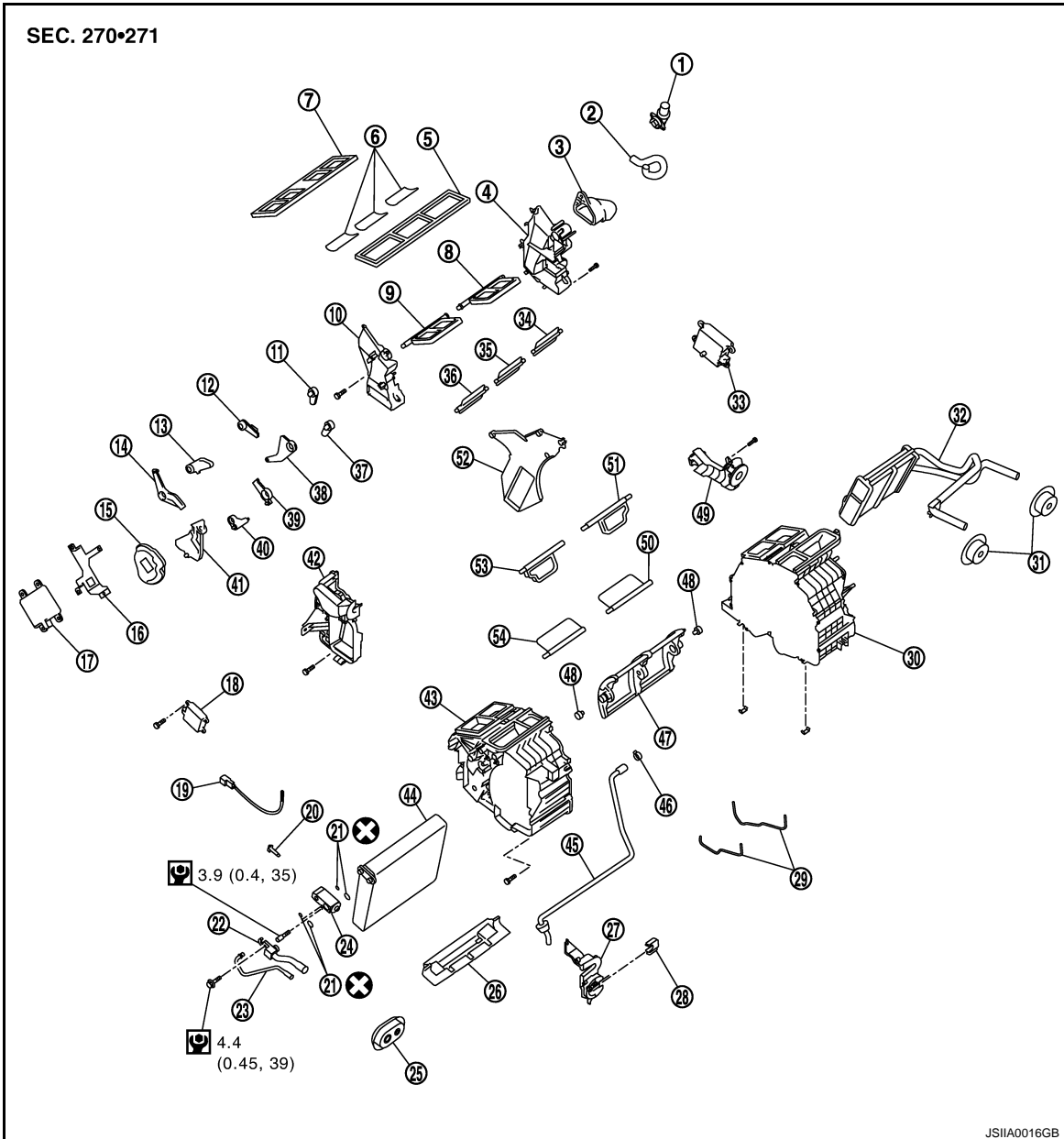

- | | | |
|-----------------------------|---------------------------|---|
| 1. Aspirator | 2. Aspirator hose | 3. Front heater duct |
| 4. Foot duct (left) | 5. Defroster seal | 6. Packing |
| 7. Ventilator seal | 8. Ventilator door (left) | 9. Ventilator door (right) |
| 10. Foot duct (right) | 11. Defroster door lever | 12. Foot door lever |
| 13. Ventilator door lever | 14. Ventilator door link | 15. Main link |
| 16. Mode door motor bracket | 17. Mode door motor | 18. Air mix door motor (passenger side) |
| 19. Intake sensor | 20. Intake sensor bracket | 21. O-ring |
| 22. Low-pressure pipe 1 | 23. High-pressure pipe 2 | 24. Expansion valve |
| 25. Cooler pipe grommet | 26. Insulator | 27. Evaporator cover adapter |
| 28. Heater pipe bracket | 29. Case packing | 30. Heater & cooling unit case (left) |
| 31. Heater pipe grommet | 32. Heater core | 33. Air mix door motor (driver side)* |
| 34. Foot door (left) | 35. Rear ventilator door | 36. Foot door (right) |

HEATER CORE

< ON-VEHICLE REPAIR >

- | | | |
|--|-------------------------------|----------------------------|
| 37. Max. cool door lever | 38. Foot door link | 39. Defroster door link |
| 40. Max. cool door link | 41. Main link sub | 42. Evaporator cover |
| 43. Heater & cooling unit case (right) | 44. Evaporator | 45. Drain hose |
| 46. Clamp | 47. Air mix door (Slide door) | 48. Air mix door adapter |
| 49. Heater pipe cover | 50. Max. cool door (left) | 51. Defroster door (left) |
| 52. Center case | 53. Defroster door (right) | 54. Max. cool door (right) |

*With left and right ventilation temperature separately system.

Refer to [GI-4. "Components"](#) for symbols in the figure.

Removal and Installation

INFOID:000000000959813

REMOVAL

1. Remove heater & cooling unit assembly. Refer to [VTL-35. "Removal and Installation"](#).
2. Remove mounting screws (A), and then remove heater pipe cover (1).
3. Remove mounting screws (B), and then remove foot duct (left) (2).
4. Slide heater core (3) to leftward (shown in the figure).

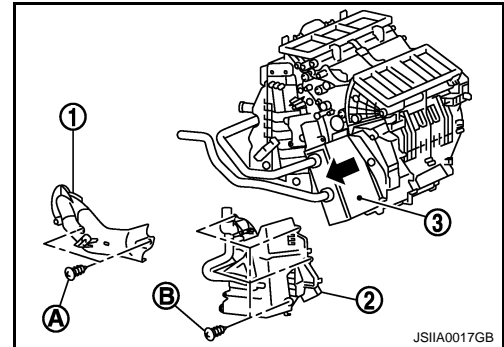

INSTALLATION

Installation is basically the reverse order of removal.

A
B
C
D
E
F
G
H
J
K
L
M
N
O
P

VTL

DUCTS AND GRILLES

< ON-VEHICLE REPAIR >

DUCTS AND GRILLES

CENTER VENTILATOR GRILLES

CENTER VENTILATOR GRILLES : Exploded View

INFOID:000000000959814

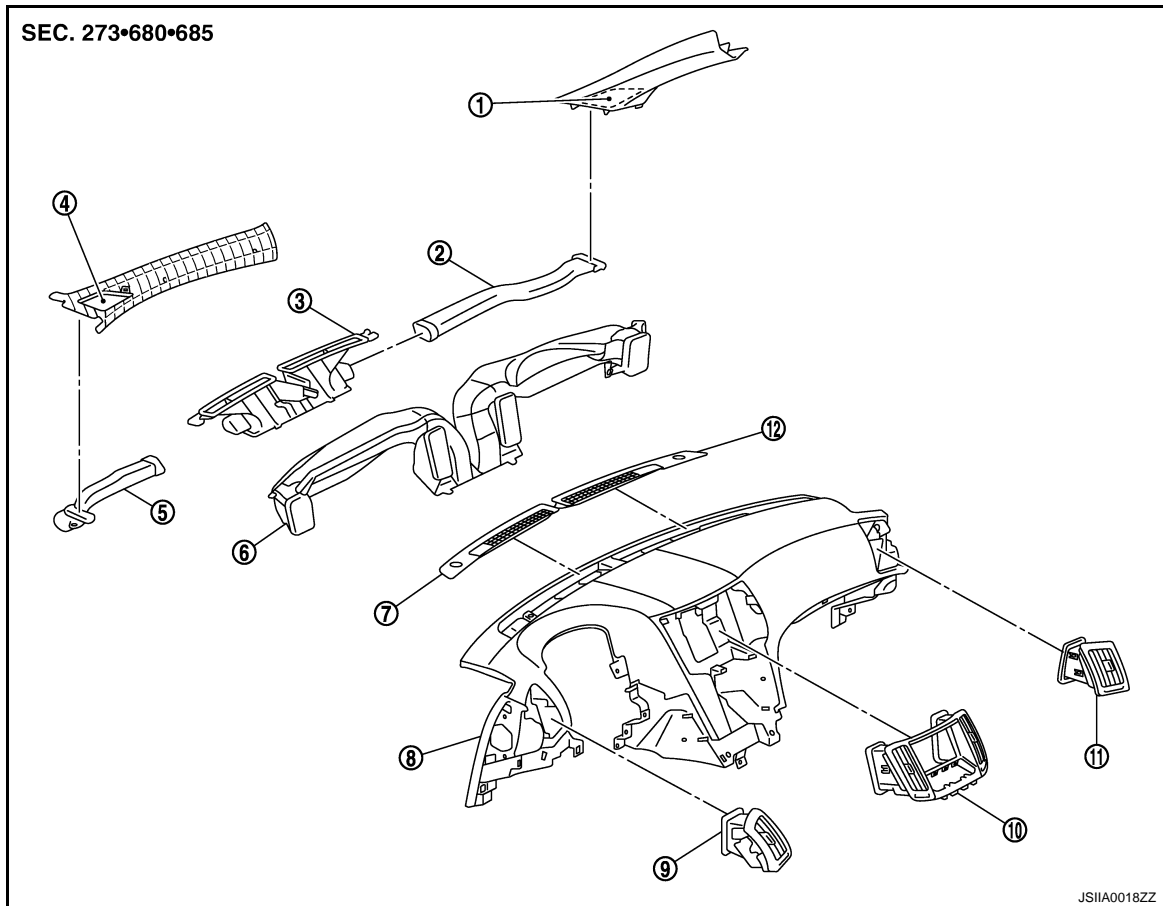

- | | | |
|---|------------------------------------|------------------------------------|
| 1. Side defroster duct (front pillar garnish) (right) | 2. Side defroster nozzle (right) | 3. Defroster nozzle |
| 4. Side defroster duct (front pillar garnish) (left) | 5. Side defroster nozzle (left) | 6. Ventilator duct |
| 7. Front defroster grille (left) | 8. Instrument panel & pad | 9. Side ventilator grille (left) |
| 10. Center ventilator grille (cluster lid D) | 11. Side ventilator grille (right) | 12. Front defroster grille (right) |

CENTER VENTILATOR GRILLES : Removal and Installation

INFOID:000000000959815

REMOVAL

Remove cluster lid D. Refer to [IP-12, "Removal and Installation"](#).

INSTALLATION

Installation is basically the reverse order of removal.

SIDE VENTILATOR GRILLES

SIDE VENTILATOR GRILLES : Exploded View

INFOID:000000000959816

DUCTS AND GRILLES

< ON-VEHICLE REPAIR >

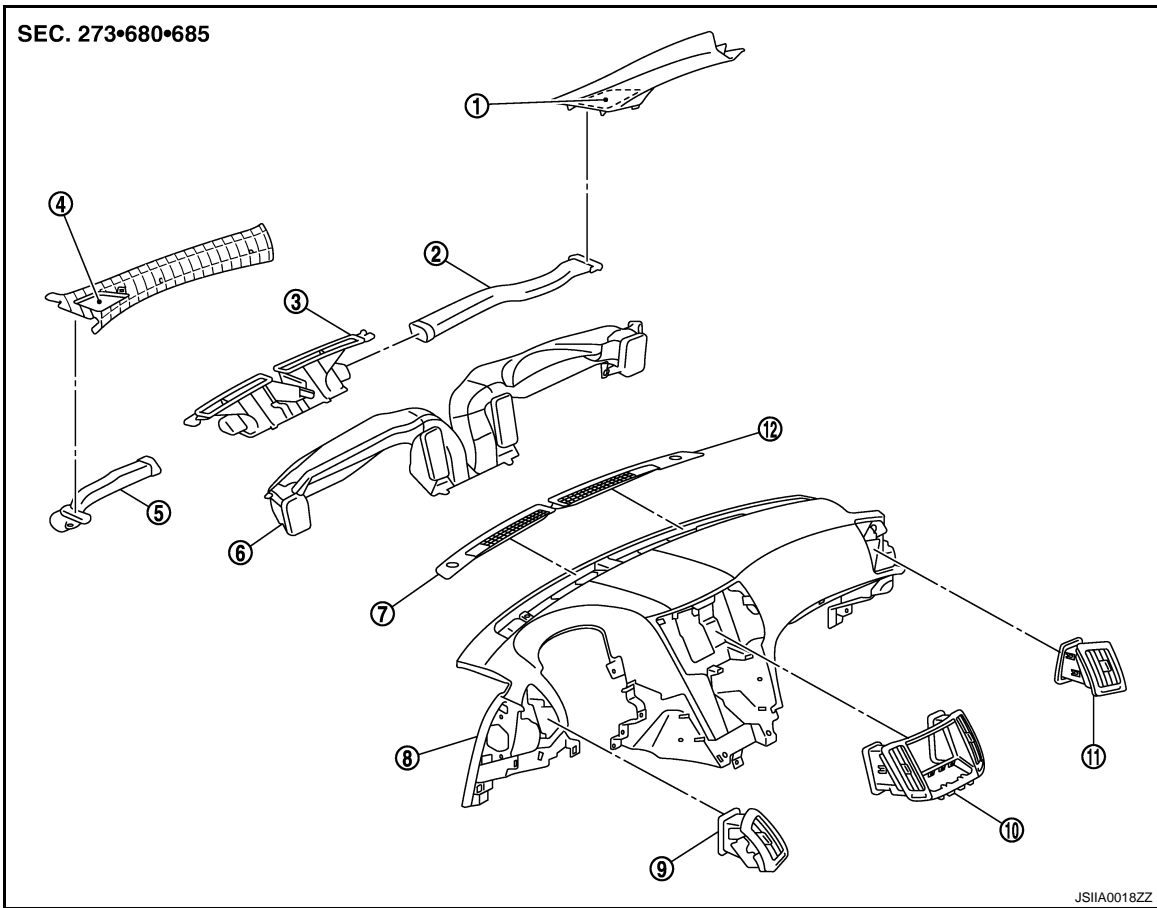

- | | | |
|---|------------------------------------|------------------------------------|
| 1. Side defroster duct (front pillar garnish) (right) | 2. Side defroster nozzle (right) | 3. Defroster nozzle |
| 4. Side defroster duct (front pillar garnish) (left) | 5. Side defroster nozzle (left) | 6. Ventilator duct |
| 7. Front defroster grille (left) | 8. Instrument panel & pad | 9. Side ventilator grille (left) |
| 10. Center ventilator grille (cluster lid D) | 11. Side ventilator grille (right) | 12. Front defroster grille (right) |

SIDE VENTILATOR GRILLES : Removal and Installation

INFOID:000000000959817

REMOVAL

Remove side ventilator assembly. Refer to [IP-12. "Removal and Installation"](#).

INSTALLATION

Installation is basically the reverse order of removal.

FRONT DEFROSTER NOZZLE, SIDE DEFROSTER NOZZLES AND VENTILATOR DUCT

FRONT DEFROSTER NOZZLE, SIDE DEFROSTER NOZZLES AND VENTILATOR DUCT : Exploded View

INFOID:000000000959818

A
B
C
D
E
F
G
H

VTL

J

K

L

M

N

O

P

DUCTS AND GRILLES

< ON-VEHICLE REPAIR >

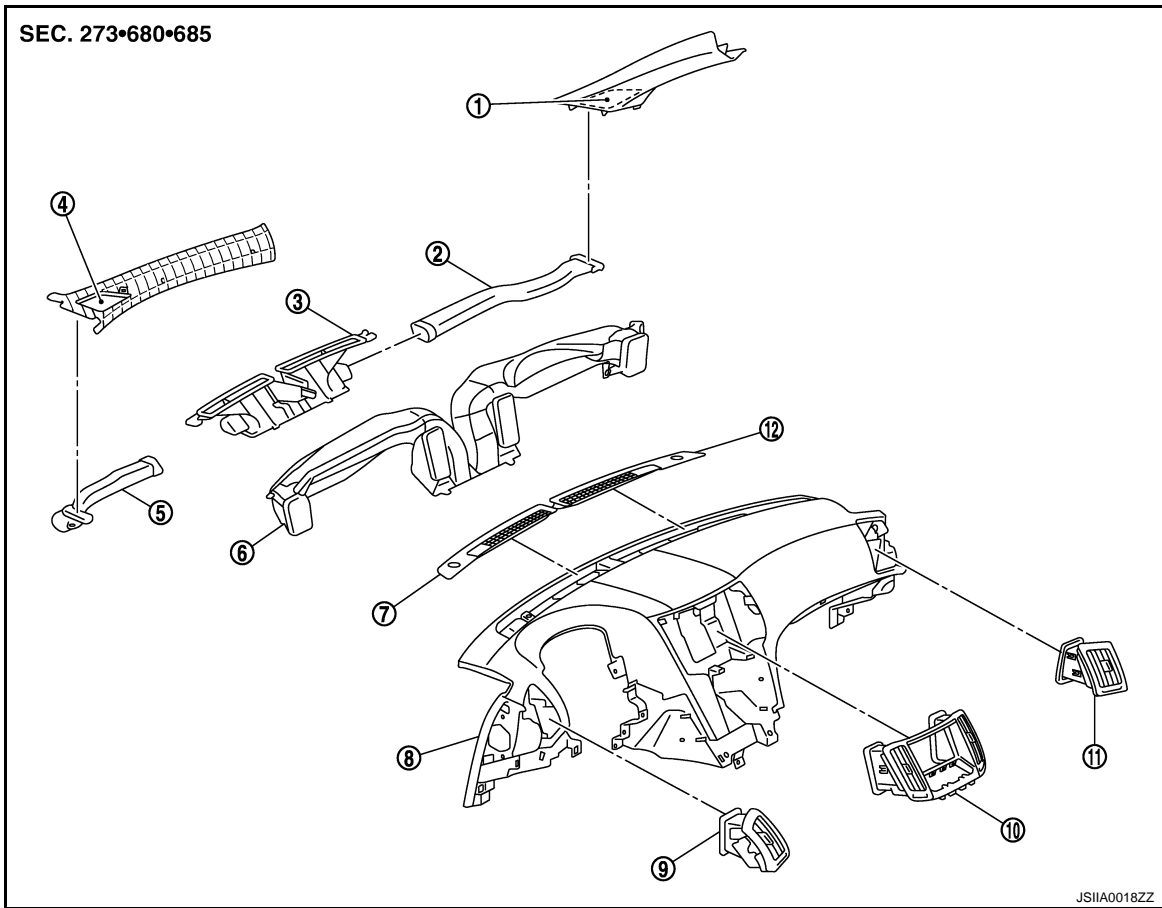

- | | | |
|---|------------------------------------|------------------------------------|
| 1. Side defroster duct (front pillar garnish) (right) | 2. Side defroster nozzle (right) | 3. Defroster nozzle |
| 4. Side defroster duct (front pillar garnish) (left) | 5. Side defroster nozzle (left) | 6. Ventilator duct |
| 7. Front defroster grille (left) | 8. Instrument panel & pad | 9. Side ventilator grille (left) |
| 10. Center ventilator grille (cluster lid D) | 11. Side ventilator grille (right) | 12. Front defroster grille (right) |

FRONT DEFROSTER NOZZLE, SIDE DEFROSTER NOZZLES AND VENTILATOR DUCT : Removal and Installation

INFOID:000000000959819

REMOVAL

1. Remove instrument panel & pad. Refer to [IP-12, "Removal and Installation"](#).

DUCTS AND GRILLES

< ON-VEHICLE REPAIR >

2. Remove mounting screw (A).

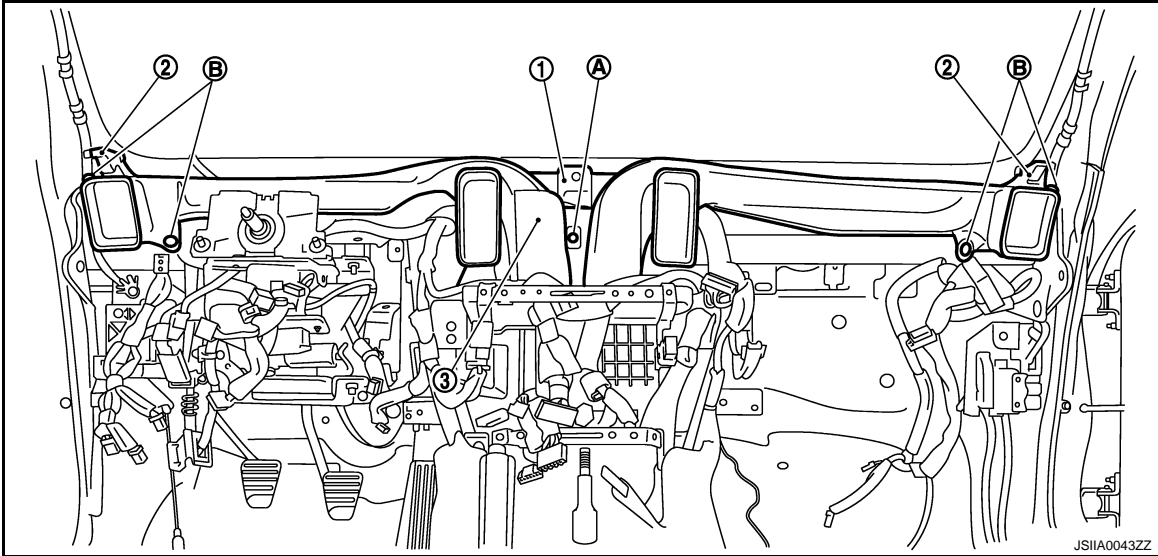

3. Remove clips (B), and then remove defroster nozzle (1), side defroster nozzle (2) and ventilator duct (3).

INSTALLATION

Installation is basically the reverse order of removal.

SIDE DEFROSTER DUCTS

SIDE DEFROSTER DUCTS : Exploded View

INFOID:000000000959820

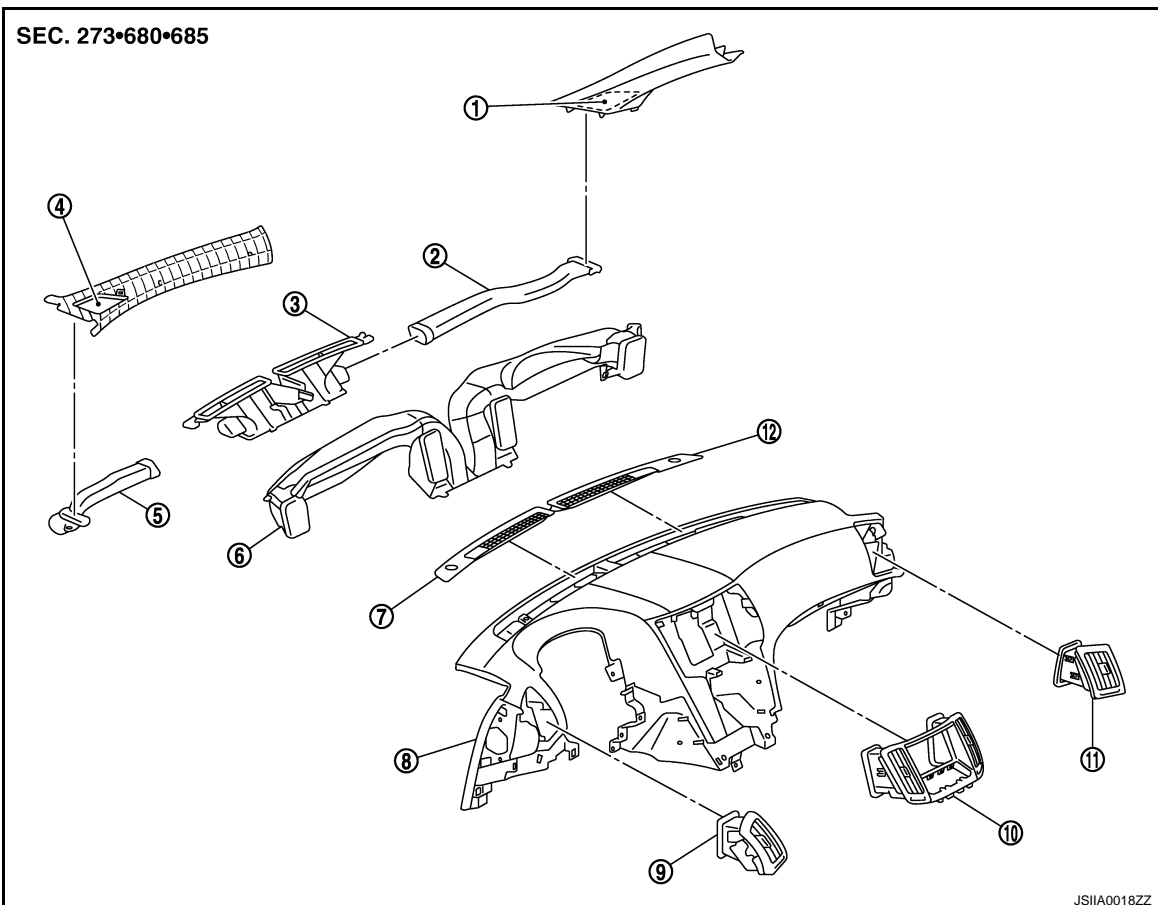

DUCTS AND GRILLES

< ON-VEHICLE REPAIR >

- | | | |
|---|------------------------------------|------------------------------------|
| 1. Side defroster duct (front pillar garnish) (right) | 2. Side defroster nozzle (right) | 3. Defroster nozzle |
| 4. Side defroster duct (front pillar garnish) (left) | 5. Side defroster nozzle (left) | 6. Ventilator duct |
| 7. Front defroster grille (left) | 8. Instrument panel & pad | 9. Side ventilator grille (left) |
| 10. Center ventilator grille (cluster lid D) | 11. Side ventilator grille (right) | 12. Front defroster grille (right) |

SIDE DEFROSTER DUCTS : Removal and Installation

INFOID:000000000959821

REMOVAL

Remove front pillar garnishes Refer to [INT-13, "Removal and Installation"](#).

INSTALLATION

Installation is basically the reverse order of removal.

REAR VENTILATOR GRILLE

REAR VENTILATOR GRILLE : Exploded View

INFOID:000000000959822

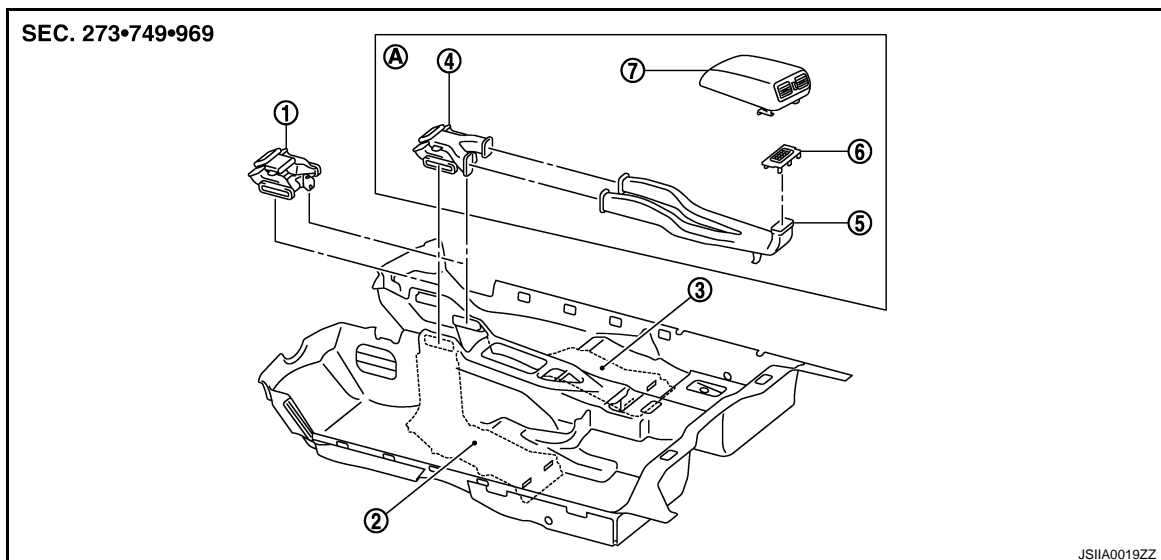

- | | | |
|--|-----------------------------|------------------------------|
| 1. Rear floor duct 1 (without rear ventilator) | 2. Rear floor duct 2 (left) | 3. Rear floor duct 2 (right) |
| 4. Rear floor duct 1 & rear ventilator duct 1 | 5. Rear ventilator duct 2 | 6. Console mask |
| 7. Rear ventilator grille (Console lid assembly) | | |
| A. With rear ventilator | | |

REAR VENTILATOR GRILLE : Removal and Installation

INFOID:000000000959823

REMOVAL

Remove console lid assembly. Refer to [IP-26, "Disassembly and Assembly"](#).

INSTALLATION

Installation is basically the reverse order of removal.

REAR VENTILATOR DUCT 2

REAR VENTILATOR DUCT 2 : Exploded View

INFOID:000000000959824

DUCTS AND GRILLES

< ON-VEHICLE REPAIR >

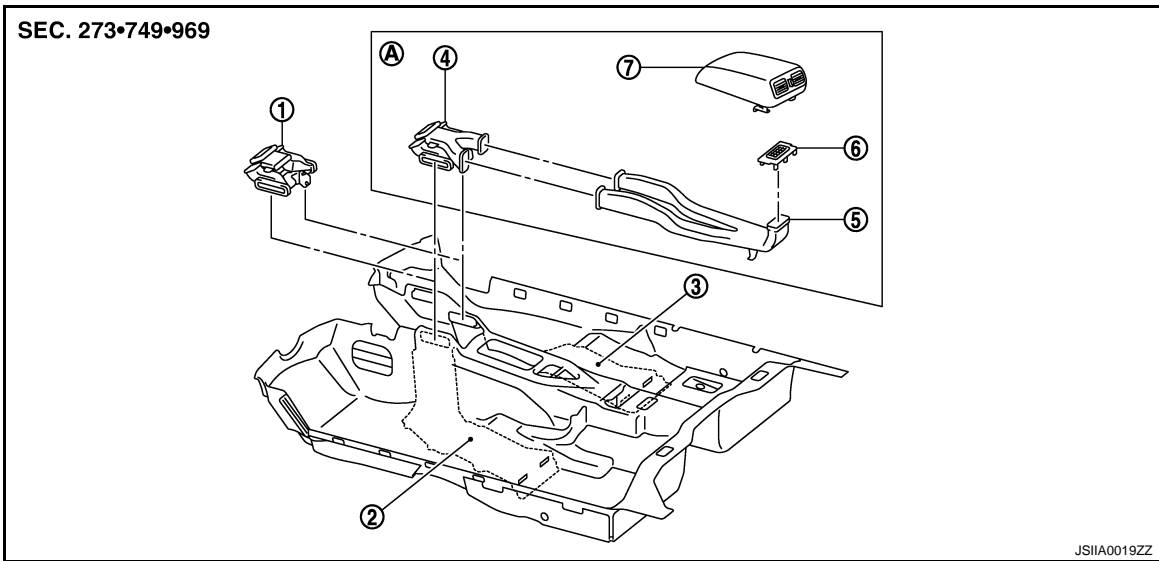

- | | | |
|--|-----------------------------|------------------------------|
| 1. Rear floor duct 1 (without rear ventilator) | 2. Rear floor duct 2 (left) | 3. Rear floor duct 2 (right) |
| 4. Rear floor duct 1 & rear ventilator duct 1 | 5. Rear ventilator duct 2 | 6. Console mask |
| 7. Rear ventilator grille (Console lid assembly) | | |
| A. With rear ventilator | | |

REAR VENTILATOR DUCT 2 : Removal and Installation

INFOID:000000000959825

VTL

REMOVAL

1. Remove center console. Refer to [IP-12. "Removal and Installation"](#).
2. Remove mounting screws (A), and then remove rear ventilator duct 2 (1).

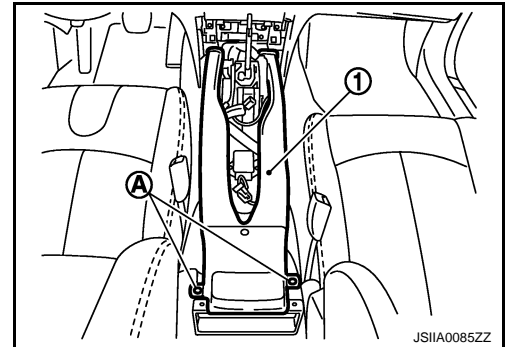

INSTALLATION

Installation is basically the reverse order of removal.

FOOT GRILLES

FOOT GRILLES : Exploded View

INFOID:000000000959826

DUCTS AND GRILLES

< ON-VEHICLE REPAIR >

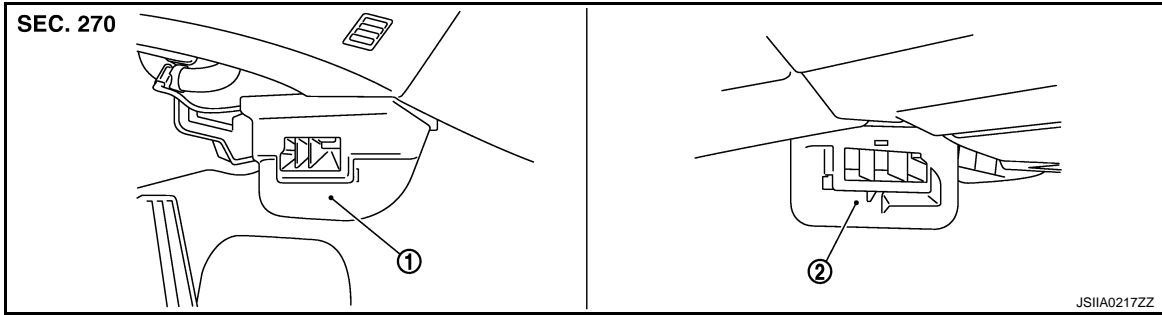

1. Foot grille (left)

2. Foot grille (right)

FOOT GRILLES : Removal and Installation

INFOID:000000000959827

REMOVAL

1. Remove mounting clips (A), and then remove foot grille (left) (1).

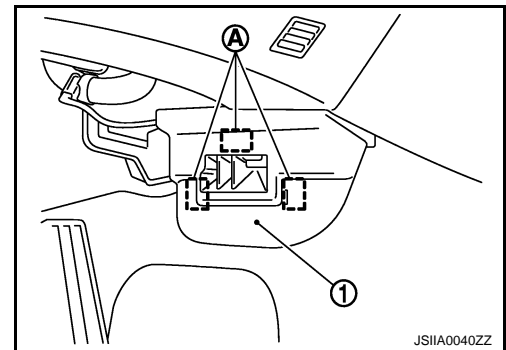

2. Remove mounting clips (A), and then remove foot grille (right) (1).

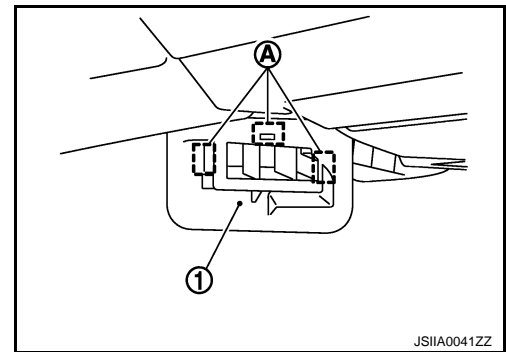

INSTALLATION

Installation is basically the reverse order of removal.

FOOT DUCTS

FOOT DUCTS : Exploded View

INFOID:000000000959828

DUCTS AND GRILLES

< ON-VEHICLE REPAIR >

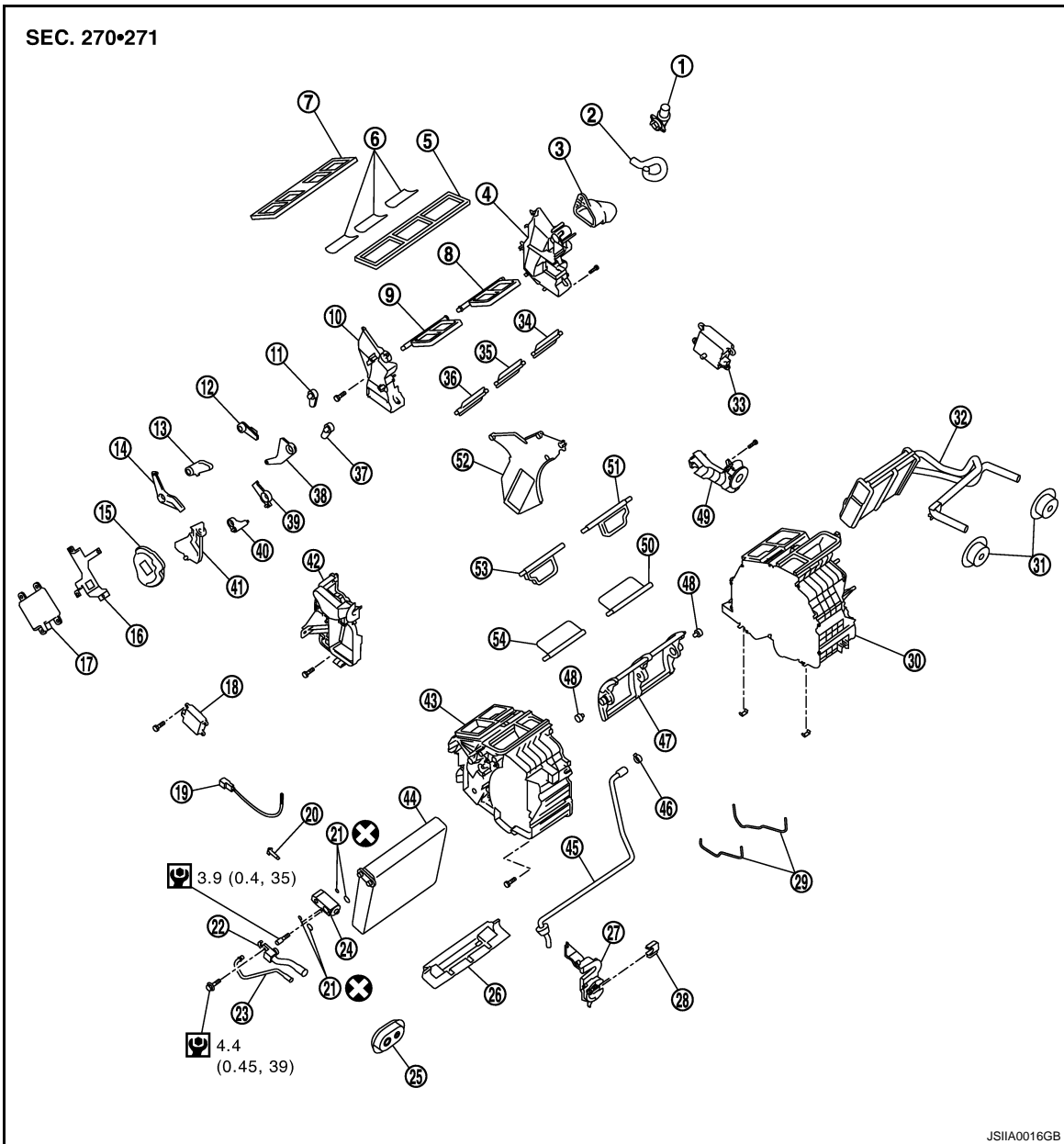

- | | | |
|--|-------------------------------|---|
| 1. Aspirator | 2. Aspirator hose | 3. Front heater duct |
| 4. Foot duct (left) | 5. Defroster seal | 6. Packing |
| 7. Ventilator seal | 8. Ventilator door (left) | 9. Ventilator door (right) |
| 10. Foot duct (right) | 11. Defroster door lever | 12. Foot door lever |
| 13. Ventilator door lever | 14. Ventilator door link | 15. Main link |
| 16. Mode door motor bracket | 17. Mode door motor | 18. Air mix door motor (passenger side) |
| 19. Intake sensor | 20. Intake sensor bracket | 21. O-ring |
| 22. Low-pressure pipe 1 | 23. High-pressure pipe 2 | 24. Expansion valve |
| 25. Cooler pipe grommet | 26. Insulator | 27. Evaporator cover adapter |
| 28. Heater pipe bracket | 29. Case packing | 30. Heater & cooling unit case (left) |
| 31. Heater pipe grommet | 32. Heater core | 33. Air mix door motor (driver side)* |
| 34. Foot door (left) | 35. Rear ventilator door | 36. Foot door (right) |
| 37. Max. cool door lever | 38. Foot door link | 39. Defroster door link |
| 40. Max. cool door link | 41. Main link sub | 42. Evaporator cover |
| 43. Heater & cooling unit case (right) | 44. Evaporator | 45. Drain hose |
| 46. Clamp | 47. Air mix door (Slide door) | 48. Air mix door adapter |

A
B
C
D
E
F
G
H
VTL
J
K
L

M
N
O
P

DUCTS AND GRILLES

< ON-VEHICLE REPAIR >

- | | | |
|-----------------------|----------------------------|----------------------------|
| 49. Heater pipe cover | 50. Max. cool door (left) | 51. Defroster door (left) |
| 52. Center case | 53. Defroster door (right) | 54. Max. cool door (right) |

*With left and right ventilation temperature separately system.

Refer to [GI-4, "Components"](#) for symbols in the figure.

FOOT DUCTS : Removal and Installation

INFOID:000000000959829

REMOVAL

1. Remove heater & cooling unit assembly. Refer to [VTL-35, "Removal and Installation"](#).
2. Remove mounting screws (A), and then remove heater pipe cover (1).
3. Remove mounting screws (B), and then remove foot duct (left) (2).

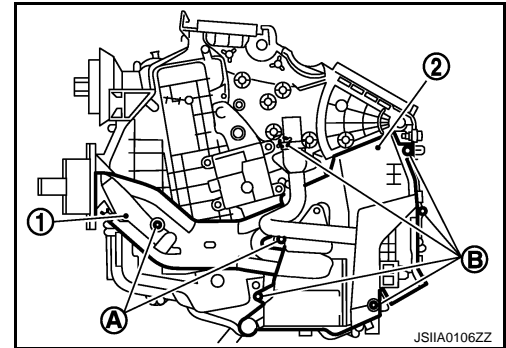

4. Remove air mix door motor (passenger side). Refer to [VTL-41, "Removal and Installation"](#).
5. Remove mode door motor. Refer to [VTL-39, "Removal and Installation"](#).
6. Remove mounting screws (A), and then remove evaporator cover (1).
7. Remove mounting screws (B), and then remove foot duct (right) (2).

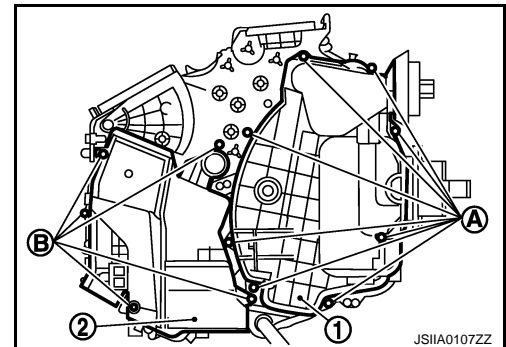

INSTALLATION

Installation is basically the reverse order of removal.

REAR FLOOR DUCT 1 (WITHOUT REAR VENTILATOR)

REAR FLOOR DUCT 1 (WITHOUT REAR VENTILATOR) : Exploded View INFOID:000000000959830

DUCTS AND GRILLES

< ON-VEHICLE REPAIR >

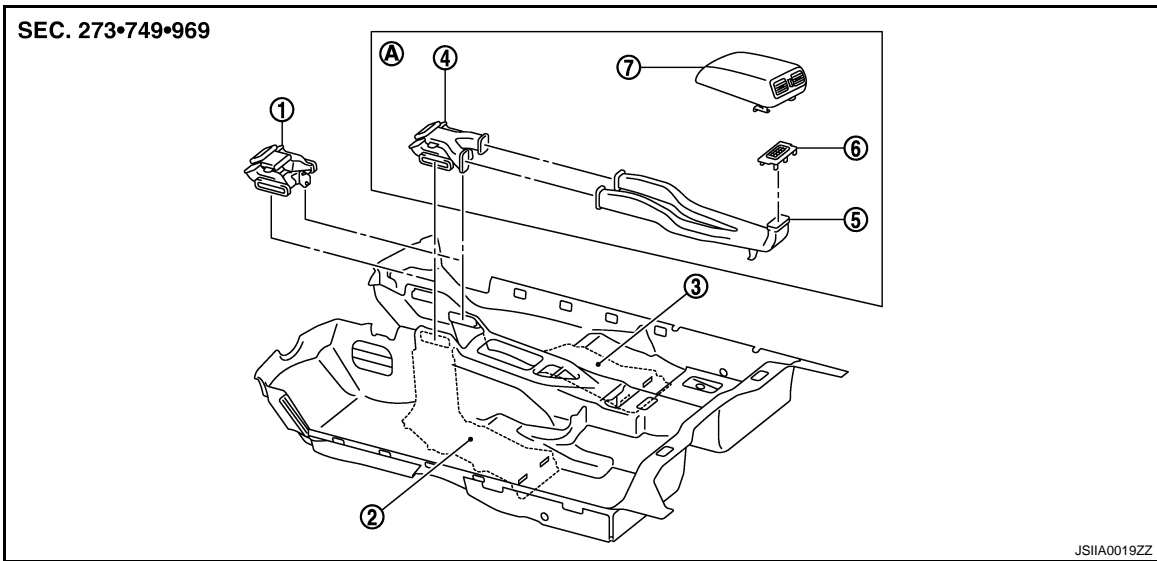

- | | | |
|--|-----------------------------|------------------------------|
| 1. Rear floor duct 1 (without rear ventilator) | 2. Rear floor duct 2 (left) | 3. Rear floor duct 2 (right) |
| 4. Rear floor duct 1 & rear ventilator duct 1 | 5. Rear ventilator duct 2 | 6. Console mask |
| 7. Rear ventilator grille (Console lid assembly) | | |
| A. With rear ventilator | | |

REAR FLOOR DUCT 1 (WITHOUT REAR VENTILATOR) : Removal and Installation

INFOID:000000000959831

VTL

REMOVAL

1. Remove center console. Refer to [IP-12. "Removal and Installation"](#).
2. Remove Instrument side panel (RH). Refer to [IP-12. "Removal and Installation"](#).
3. Remove AV control unit. Refer to [AV-111. "Removal and Installation"](#) (BASE AUDIO WITHOUT NAVIGATION), [AV-292. "Removal and Installation"](#) (BOSE AUDIO WITHOUT NAVIGATION), [AV-530. "Removal and Installation"](#) (BOSE AUDIO WITH NAVIGATION).
4. Remove mounting clip (A).
5. Remove mounting clip (B), and then peel back floor carpet to a point where rear floor duct 1 is visible.
6. Remove rear floor duct 1 to rightward.

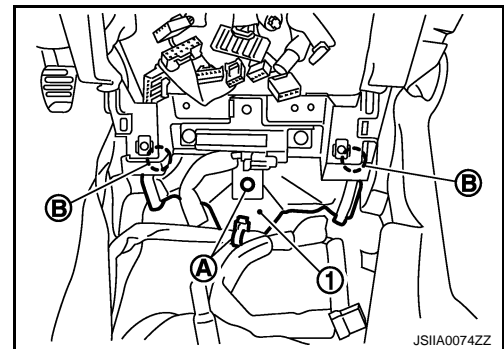

INSTALLATION

Installation is basically the reverse order of removal.

REAR FLOOR DUCT 1 & REAR VENTILATOR DUCT 1(WITH REAR VENTILATOR)

REAR FLOOR DUCT 1 & REAR VENTILATOR DUCT 1(WITH REAR VENTILATOR) : Exploded View

INFOID:000000000959832

DUCTS AND GRILLES

< ON-VEHICLE REPAIR >

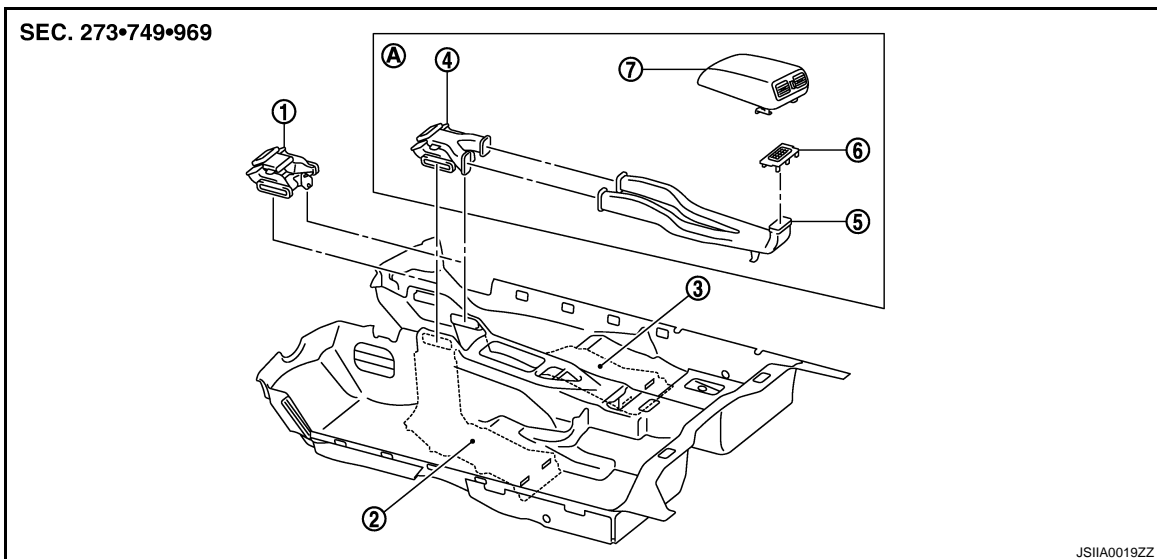

1. Rear floor duct 1 (without rear ventilator)
2. Rear floor duct 2 (left)
3. Rear floor duct 2 (right)
4. Rear floor duct 1 & rear ventilator duct 1
5. Rear ventilator duct 2
6. Console mask
7. Rear ventilator grille (Console lid assembly)
- A. With rear ventilator

REAR FLOOR DUCT 1 & REAR VENTILATOR DUCT 1(WITH REAR VENTILATOR) : Removal and Installation

INFOID:000000000959833

REMOVAL

1. Remove instrument panel & pad. Refer to [JP-12, "Removal and Installation"](#).
2. Remove mounting clip (A), and then remove rear floor duct 1 (1).

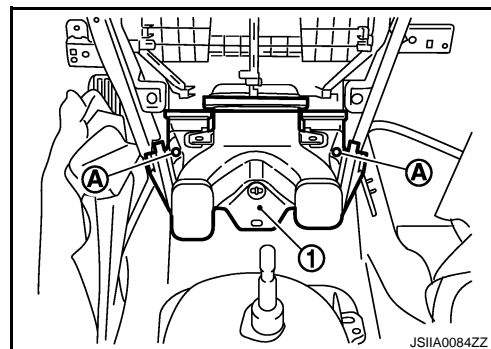

INSTALLATION

Installation is basically the reverse order of removal.