

A
B

SECTION HAC

HEATER & AIR CONDITIONING CONTROL SYSTEM C

CONTENTS D

AUTOMATIC AIR CONDITIONER		E
BASIC INSPECTION	WITH LEFT AND RIGHT VENTILATION TEMPERATURE SEPARATELY CONTROL SYSTEM : Description	F
4	18	G
DIAGNOSIS AND REPAIR WORKFLOW	WITH LEFT AND RIGHT VENTILATION TEMPERATURE SEPARATELY CONTROL SYSTEM : Fail-Safe	H
4	19	HAC
Work Flow	WITH LEFT AND RIGHT VENTILATION TEMPERATURE SEPARATELY CONTROL SYSTEM : Component Part Location	J
4	19	K
INSPECTION AND ADJUSTMENT	WITH LEFT AND RIGHT VENTILATION TEMPERATURE SEPARATELY CONTROL SYSTEM : Component's role	L
5	21	M
WITHOUT LEFT AND RIGHT VENTILATION TEMPERATURE SEPARATELY CONTROL SYSTEM	AUTOMATIC AIR CONDITIONER SYSTEM	N
5	23	O
WITHOUT LEFT AND RIGHT VENTILATION TEMPERATURE SEPARATELY CONTROL SYSTEM : Description & Inspection	WITHOUT LEFT AND RIGHT VENTILATION TEMPERATURE SEPARATELY CONTROL SYSTEM	P
5	23	
WITH LEFT AND RIGHT VENTILATION TEMPERATURE SEPARATELY CONTROL SYSTEM	WITHOUT LEFT AND RIGHT VENTILATION TEMPERATURE SEPARATELY CONTROL SYSTEM : System Diagram	
9	23	
WITH LEFT AND RIGHT VENTILATION TEMPERATURE SEPARATELY CONTROL SYSTEM : Description & Inspection	WITHOUT LEFT AND RIGHT VENTILATION TEMPERATURE SEPARATELY CONTROL SYSTEM : System Description	
9	23	
FUNCTION DIAGNOSIS	WITHOUT LEFT AND RIGHT VENTILATION TEMPERATURE SEPARATELY CONTROL SYSTEM : Component Part Location	
14	29	
COMPRESSOR CONTROL FUNCTION	WITHOUT LEFT AND RIGHT VENTILATION TEMPERATURE SEPARATELY CONTROL SYSTEM : Component Description	
14	31	
WITHOUT LEFT AND RIGHT VENTILATION TEMPERATURE SEPARATELY CONTROL SYSTEM	WITH LEFT AND RIGHT VENTILATION TEMPERATURE SEPARATELY CONTROL SYSTEM	
14	32	
WITHOUT LEFT AND RIGHT VENTILATION TEMPERATURE SEPARATELY CONTROL SYSTEM : Description	WITH LEFT AND RIGHT VENTILATION TEMPERATURE SEPARATELY CONTROL SYSTEM : System Diagram	
14	32	
WITHOUT LEFT AND RIGHT VENTILATION TEMPERATURE SEPARATELY CONTROL SYSTEM : Fail-Safe	WITH LEFT AND RIGHT VENTILATION TEMPERATURE SEPARATELY CONTROL SYSTEM : System Description	
14	32	
WITHOUT LEFT AND RIGHT VENTILATION TEMPERATURE SEPARATELY CONTROL SYSTEM : Component Part Location	WITH LEFT AND RIGHT VENTILATION TEMPERATURE SEPARATELY CONTROL SYSTEM : Component Part Location	
15	39	
WITHOUT LEFT AND RIGHT VENTILATION TEMPERATURE SEPARATELY CONTROL SYSTEM : Component's role		
17		
WITH LEFT AND RIGHT VENTILATION TEMPERATURE SEPARATELY CONTROL SYSTEM		
18		

WITH LEFT AND RIGHT VENTILATION TEMPERATURE SEPARATELY CONTROL SYSTEM : Component Description	41	MAGNET CLUTCH CONTROL SYSTEM	68
CAN COMMUNICATION SYSTEM	43	Description	68
System Description	43	COMPONENT DIAGNOSIS	69
DIAGNOSIS SYSTEM (AUTO AMP.)	44	MODE DOOR MOTOR	69
WITHOUT LEFT AND RIGHT VENTILATION TEMPERATURE SEPARATELY CONTROL SYSTEM ...	44	Description	69
WITHOUT LEFT AND RIGHT VENTILATION TEMPERATURE SEPARATELY CONTROL SYSTEM : Diagnosis Description	44	Component Function Check	69
WITHOUT LEFT AND RIGHT VENTILATION TEMPERATURE SEPARATELY CONTROL SYSTEM : CONSULT-III Function	49	Diagnosis Procedure	69
WITH LEFT AND RIGHT VENTILATION TEMPERATURE SEPARATELY CONTROL SYSTEM	50	AIR MIX DOOR MOTOR	72
WITH LEFT AND RIGHT VENTILATION TEMPERATURE SEPARATELY CONTROL SYSTEM : Diagnosis Description	50	WITHOUT LEFT AND RIGHT VENTILATION TEMPERATURE SEPARATELY CONTROL SYSTEM ...	72
WITH LEFT AND RIGHT VENTILATION TEMPERATURE SEPARATELY CONTROL SYSTEM : CONSULT-III Function	55	WITHOUT LEFT AND RIGHT VENTILATION TEMPERATURE SEPARATELY CONTROL SYSTEM : Description	72
MODE DOOR CONTROL SYSTEM	57	WITHOUT LEFT AND RIGHT VENTILATION TEMPERATURE SEPARATELY CONTROL SYSTEM : Component Function Check	72
Description	57	WITHOUT LEFT AND RIGHT VENTILATION TEMPERATURE SEPARATELY CONTROL SYSTEM : Diagnosis Procedure	72
AIR MIX DOOR CONTROL SYSTEM	59	WITH LEFT AND RIGHT VENTILATION TEMPERATURE SEPARATELY CONTROL SYSTEM	74
WITHOUT LEFT AND RIGHT VENTILATION TEMPERATURE SEPARATELY CONTROL SYSTEM ...	59	WITH LEFT AND RIGHT VENTILATION TEMPERATURE SEPARATELY CONTROL SYSTEM : Description	74
WITHOUT LEFT AND RIGHT VENTILATION TEMPERATURE SEPARATELY CONTROL SYSTEM : Description	59	WITH LEFT AND RIGHT VENTILATION TEMPERATURE SEPARATELY CONTROL SYSTEM : Component Function Check	75
WITH LEFT AND RIGHT VENTILATION TEMPERATURE SEPARATELY CONTROL SYSTEM	60	WITH LEFT AND RIGHT VENTILATION TEMPERATURE SEPARATELY CONTROL SYSTEM : Diagnosis Procedure	75
WITH LEFT AND RIGHT VENTILATION TEMPERATURE SEPARATELY CONTROL SYSTEM : Description	60	INTAKE DOOR MOTOR	80
INTAKE DOOR CONTROL SYSTEM	62	Description	80
Description	62	Component Function Check	80
BLOWER MOTOR CONTROL SYSTEM	64	Diagnosis Procedure	80
WITHOUT LEFT AND RIGHT VENTILATION TEMPERATURE SEPARATELY CONTROL SYSTEM ...	64	BLOWER MOTOR	83
WITHOUT LEFT AND RIGHT VENTILATION TEMPERATURE SEPARATELY CONTROL SYSTEM : Description	64	WITHOUT LEFT AND RIGHT VENTILATION TEMPERATURE SEPARATELY CONTROL SYSTEM ...	83
WITH LEFT AND RIGHT VENTILATION TEMPERATURE SEPARATELY CONTROL SYSTEM	65	WITHOUT LEFT AND RIGHT VENTILATION TEMPERATURE SEPARATELY CONTROL SYSTEM : Description	83
WITH LEFT AND RIGHT VENTILATION TEMPERATURE SEPARATELY CONTROL SYSTEM : Description	65	WITHOUT LEFT AND RIGHT VENTILATION TEMPERATURE SEPARATELY CONTROL SYSTEM : Component Function Check	83
		WITHOUT LEFT AND RIGHT VENTILATION TEMPERATURE SEPARATELY CONTROL SYSTEM : Diagnosis Procedure	83
		WITHOUT LEFT AND RIGHT VENTILATION TEMPERATURE SEPARATELY CONTROL SYSTEM : Component Inspection	86
		WITH LEFT AND RIGHT VENTILATION TEMPERATURE SEPARATELY CONTROL SYSTEM	86

WITH LEFT AND RIGHT VENTILATION TEMPERATURE SEPARATELY CONTROL SYSTEM : Description	86	AUTO AMP.	107	
WITH LEFT AND RIGHT VENTILATION TEMPERATURE SEPARATELY CONTROL SYSTEM : Component Function Check	86	Reference Value	107	A
WITH LEFT AND RIGHT VENTILATION TEMPERATURE SEPARATELY CONTROL SYSTEM : Diagnosis Procedure	86	Wiring Diagram — AIR CONDITIONER CONTROL SYSTEM —	109	
WITH LEFT AND RIGHT VENTILATION TEMPERATURE SEPARATELY CONTROL SYSTEM : Component Inspection	89	Fail-Safe	115	B
MAGNET CLUTCH	90	SYMPTOM DIAGNOSIS	117	
Description	90	AIR CONDITIONER CONTROL	117	C
Component Function Check	90	Diagnosis Chart By Symptom	117	
Diagnosis Procedure	90	INSUFFICIENT COOLING	119	D
Component Inspection	92	Description	119	
AMBIENT SENSOR	93	Inspection procedure	119	
Description	93	INSUFFICIENT HEATING	122	E
Component Function Check	93	Description	122	
Diagnosis Procedure	93	Inspection procedure	122	
Component Inspection	94	NOISE	124	F
IN-VEHICLE SENSOR	96	Description	124	
Description	96	Inspection procedure	124	G
Component Function Check	96	SELF-DIAGNOSIS CANNOT BE PERFORMED	126	
Diagnosis Procedure	97	Description	126	H
Component Inspection	98	Inspection procedure	126	
SUNLOAD SENSOR	99	MEMORY FUNCTION DOES NOT OPERATE.	127	HAC
Description	99	Description	127	
Component Function Check	99	Inspection procedure	127	
Diagnosis Procedure	99	PRECAUTION	128	J
Component Inspection	100	PRECAUTIONS	128	
INTAKE SENSOR	102	Precaution for Supplemental Restraint System (SRS) "AIR BAG" and "SEAT BELT PRE-TENSIONER"	128	K
Description	102	Precaution Necessary for Steering Wheel Rotation after Battery Disconnect	128	
Component Function Check	102	Precaution for Procedure without Cowl Top Cover	128	L
Diagnosis Procedure	102	Precautions For Xenon Headlamp Service	129	
Component Inspection	103	Working with HFC-134a (R-134a)	129	M
POWER SUPPLY AND GROUND CIRCUIT FOR AUTO AMP.	105	General Refrigerant Precaution	130	
Description	105	Refrigerant Connection	130	N
Component Function Check	105	Service Equipment	134	
Diagnosis Procedure	106	COMPRESSOR	137	
ECU DIAGNOSIS	107	General Precautions	137	O
		FLUORESCENT LEAK DETECTOR	138	
		General Precautions	138	P

BASIC INSPECTION

DIAGNOSIS AND REPAIR WORKFLOW

Work Flow

INFOID:000000000959897

DETAILED FLOW

1. LISTEN TO CUSTOMER COMPLAINT

Listen to customer complaint. (Get detailed information about the conditions and environment when the symptom occurs.)

>> GO TO 2.

2. VERIFY THE SYMPTOM WITH OPERATIONAL CHECK

Verify the symptom with operational check. Refer to [HAC-5. "WITHOUT LEFT AND RIGHT VENTILATION TEMPERATURE SEPARATELY CONTROL SYSTEM : Description & Inspection"](#) (Without left and right ventilation temperature separately control system) or [HAC-9. "WITH LEFT AND RIGHT VENTILATION TEMPERATURE SEPARATELY CONTROL SYSTEM : Description & Inspection"](#) (With left and right ventilation temperature separately control system).

>> GO TO 3.

3. GO TO APPROPRIATE TROUBLE DIAGNOSIS

Go to appropriate trouble diagnosis (Refer to [HAC-117. "Diagnosis Chart By Symptom"](#) below).

>> GO TO 4.

4. REPAIR OR REPLACE

Repair or replace the specific parts

>> GO TO 5.

5. FINAL CHECK

Final check.

Is the inspection result normal?

YES >> CHECK OUT
NO >> GO TO 3.

INSPECTION AND ADJUSTMENT

< BASIC INSPECTION >

[AUTOMATIC AIR CONDITIONER]

INSPECTION AND ADJUSTMENT

WITHOUT LEFT AND RIGHT VENTILATION TEMPERATURE SEPARATELY CONTROL SYSTEM

WITHOUT LEFT AND RIGHT VENTILATION TEMPERATURE SEPARATELY CONTROL SYSTEM : Description & Inspection

INFOID:000000000959898

DESCRIPTION

The purpose of the operational check is to check if the individual system operates properly.

Conditions : Engine running at normal operating temperature

INSPECTION PROCEDURE

Memory Function

1. Turn temperature control dial clockwise until 32°C (90°F) is displayed.
2. Press OFF switch.
3. Turn ignition switch OFF.
4. Turn ignition switch ON.
5. Press AUTO switch.
6. Confirm that the set temperature remains at previous temperature.
7. Press OFF switch.

If NG, go to trouble diagnosis procedure for [HAC-127, "Inspection procedure"](#).

If OK, continue the check.

Blower

1. Turn fan control dial clockwise. Blower should operate on low speed. The fan symbol should have one blade lit.
2. Turn fan control dial clockwise again, and continue checking blower speed and fan symbol until all speeds are checked.
3. Leave blower on max. speed.

If NG, go to trouble diagnosis procedure for [HAC-83, "WITHOUT LEFT AND RIGHT VENTILATION TEMPERATURE SEPARATELY CONTROL SYSTEM : Diagnosis Procedure"](#).

If OK, continue the check.

Discharge Air

1. Press MODE switches and DEF switch.
2. Each position indicator should change shape.
3. Confirm that discharge air comes out according to the air distribution table. Refer to [HAC-23, "WITHOUT LEFT AND RIGHT VENTILATION TEMPERATURE SEPARATELY CONTROL SYSTEM : System Description"](#).

If NG, go to trouble diagnosis procedure for [HAC-69, "Diagnosis Procedure"](#).

If OK, continue the check.

NOTE:

Confirm that the compressor clutch is engaged (sound or visual inspection) and intake door position is at FRE when the D/F or DEF is selected.

Intake Air

1. Press intake switch. Recirculation indicator should illuminate.
2. Press intake switch again. Fresh indicator should illuminate.
3. Listen for intake door position change. (Slight change of blower sound can be heard.)

If NG, go to trouble diagnosis procedure for [HAC-80, "Diagnosis Procedure"](#).

If OK, continue the check.

NOTE:

Confirm that the compressor clutch is engaged (sound or visual inspection) and intake door position is at FRE when the D/F or DEF is selected.

A

B

C

D

E

F

G

H

HAC

J

K

L

M

N

O

P

INSPECTION AND ADJUSTMENT

[AUTOMATIC AIR CONDITIONER]

< BASIC INSPECTION >

Temperature Decrease

1. Turn temperature control dial counterclockwise until 18°C (60°F) is displayed.
2. Check for cold air at discharge air outlets.

If NG, go to trouble diagnosis procedure for [HAC-119. "Inspection procedure"](#).

If OK, continue the check.

Temperature Increase

1. Turn temperature control dial clockwise until 32°C (90°F) is displayed.
2. Check for hot air at discharge air outlets.

If NG, go to trouble diagnosis procedure for [HAC-122. "Inspection procedure"](#).

If OK, continue the check.

A/C Switch

1. Press AUTO switch and A/C switch.
2. A/C switch indicator will turn ON.
 - Confirm that the compressor clutch engages (sound or visual inspection).

Auto Mode

1. Press AUTO switch and A/C switch.
2. Display should indicate AUTO.
 - Confirm that discharge air and blower speed will depend on ambient, in-vehicle, and set temperatures.

If NG, go to trouble diagnosis procedure for [HAC-106. "Diagnosis Procedure"](#), then if necessary, trouble diagnosis procedure for [HAC-90. "Diagnosis Procedure"](#).

If all operational checks are OK (symptom cannot be duplicated), go to Incident Simulation Tests in [GI-35. "Work Flow"](#) and perform tests as outlined to simulate driving conditions environment. If symptom appears, refer to [HAC-117. "Diagnosis Chart By Symptom"](#) and perform applicable trouble diagnosis procedures.

AUXILIARY MECHANISM

Temperature Setting Trimmer

The trimmer compensates for differences in range of $\pm 3^{\circ}\text{C}$ ($\pm 6^{\circ}\text{F}$) between temperature setting (displayed digitally) and temperature felt by customer.

Operating procedures for this trimmer are as follows:

1. Begin self-diagnosis STEP-5 mode. Refer to [HAC-44. "WITHOUT LEFT AND RIGHT VENTILATION TEMPERATURE SEPARATELY CONTROL SYSTEM : Diagnosis Description"](#).
2. Turn fan control dial clockwise to set system in auxiliary mode.
3. Display shows "61" in auxiliary mechanism. It takes approximately 3 seconds to enable setting operation.
4. Turn temperature control dial as desired. Temperature will change at a rate of 0.5°C (1.0°F) each time a dial is turned.

CAUTION:

- A decimal point is not indicated on the display.

INSPECTION AND ADJUSTMENT

< BASIC INSPECTION >

[AUTOMATIC AIR CONDITIONER]

- Negative value is not displayed on the display.

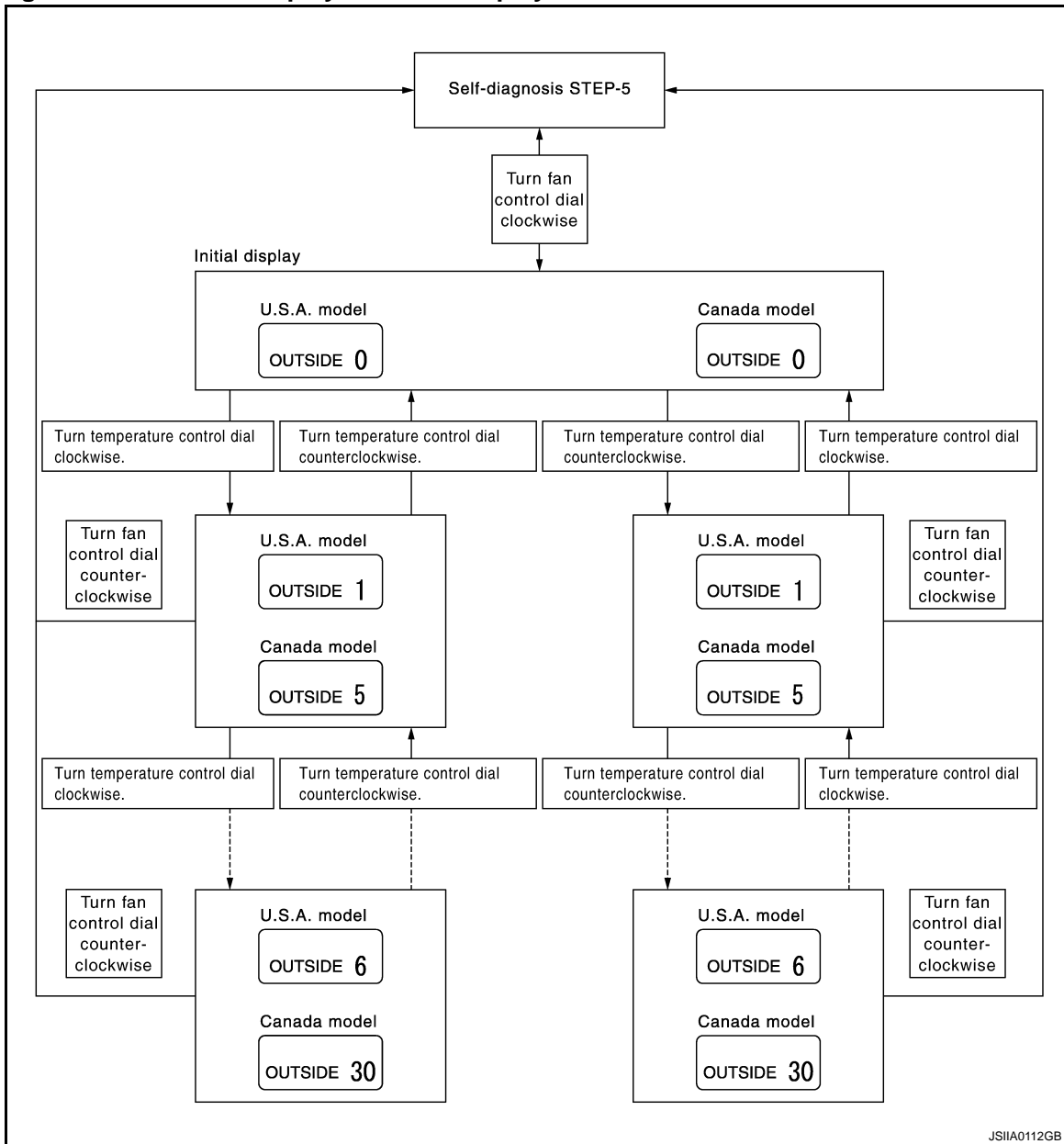

When battery cable is disconnected or battery voltage is below 10 V, trimmer operation is canceled. Temperature set becomes that of initial condition, i.e. 0°C (0°F).

Foot Position Setting Trimmer

Wind distribution ratio in FOOT mode can be set.

Operating procedures for this trimmer are as follows:

1. Begin self-diagnosis STEP-5 mode. Refer to [HAC-44, "WITHOUT LEFT AND RIGHT VENTILATION TEMPERATURE SEPARATELY CONTROL SYSTEM : Diagnosis Description"](#).
2. Turn fan control dial clockwise to set system in auxiliary mode.
3. Press each mode switch as desired.

INSPECTION AND ADJUSTMENT

< BASIC INSPECTION >

[AUTOMATIC AIR CONDITIONER]

Without rear ventilation

Display	Discharge air flow							
	Automatically controls the mode door				Manually controls the mode door			
	VENT	FOOT		DEF	VENT	FOOT		DEF
		Front	Rear			Front	Rear	
	11%	39%	24%	26%	15%	53%	32%	—
	11%	39%	24%	26%	11%	39%	24%	26%
	15%	53%	32%	—	11%	39%	24%	26%
	15%	53%	32%	—	15%	53%	32%	—

JSIIA0110GB

With rear ventilation

Display	Discharge air flow									
	Automatically controls the mode door					Manually controls the mode door				
	VENT		FOOT		DEF	VENT		FOOT		DEF
	Front	Rear	Front	Rear		Front	Rear	Front	Rear	
	10%	12%	33%	22%	23%	13%	16%	43%	28%	—
	10%	12%	33%	22%	23%	10%	12%	33%	22%	23%
	13%	16%	43%	28%	—	10%	12%	33%	22%	23%
	13%	16%	43%	28%	—	13%	16%	43%	28%	—

JSIIA0061GB

When battery cable is disconnected or battery voltage is below 10 V, trimmer operation is canceled. Wind distribution ratio set becomes that of initial condition.

Inlet Port Memory Function

When ignition switch is turned from OFF to ON, inlet port can be set to AUTO or manual.

Operating procedures for this trimmer are as follows:

1. Begin self-diagnosis STEP-5 mode. Refer to [HAC-44. "WITHOUT LEFT AND RIGHT VENTILATION TEMPERATURE SEPARATELY CONTROL SYSTEM : Diagnosis Description"](#).
2. Turn fan control dial clockwise to set system in auxiliary mode.
3. Press intake switch as desired.

LED status of FRE position	LED status of REC position	Setting status		Setting changeover method
		FRE	REC	
OFF	ON	AUTO control (Initial setting)	Manual REC status is memorized. (Initial setting)	INTAKE SW: ON
ON	ON	Manual FRE status is memorized.	Manual REC status is memorized.	
ON	OFF	Manual FRE status is memorized.	AUTO control	
OFF	OFF	AUTO control	AUTO control	

INSPECTION AND ADJUSTMENT

< BASIC INSPECTION >

[AUTOMATIC AIR CONDITIONER]

When battery cable is disconnected or battery voltage is below 10 V, memory function is canceled. Memory function set becomes that of initial condition.

WITH LEFT AND RIGHT VENTILATION TEMPERATURE SEPARATELY CONTROL SYSTEM

WITH LEFT AND RIGHT VENTILATION TEMPERATURE SEPARATELY CONTROL SYSTEM : Description & Inspection

INFOID:000000000959899

DESCRIPTION

The purpose of the operational check is to check if the individual system operates properly.

Conditions : Engine running at normal operating temperature

INSPECTION PROCEDURE

Memory Function

1. Turn temperature control dial (driver side) clockwise until 32°C (90°F) is displayed.
2. Press OFF switch.
3. Turn ignition switch OFF.
4. Turn ignition switch ON.
5. Press AUTO switch.
6. Confirm that the set temperature remains at previous temperature.
7. Press OFF switch.

If NG, go to trouble diagnosis procedure for [HAC-127. "Inspection procedure"](#).

If OK, continue the check.

Blower

1. Press fan (UP:+) switch. Blower should operate on low speed. The fan symbol should have one blade lit.
2. Press fan (UP:+) switch again, and continue checking blower speed and fan symbol until all speeds are checked.
3. Leave blower on max. speed.

If NG, go to trouble diagnosis procedure for [HAC-86. "WITH LEFT AND RIGHT VENTILATION TEMPERATURE SEPARATELY CONTROL SYSTEM : Diagnosis Procedure"](#).

If OK, continue the check.

Discharge Air

1. Press MODE switch and DEF switch.
2. Each position indicator should change shape.
3. Confirm that discharge air comes out according to the air distribution table. Refer to [HAC-32. "WITH LEFT AND RIGHT VENTILATION TEMPERATURE SEPARATELY CONTROL SYSTEM : System Description"](#).

If NG, go to trouble diagnosis procedure for [HAC-69. "Diagnosis Procedure"](#).

If OK, continue the check.

NOTE:

Confirm that the compressor clutch is engaged (sound or visual inspection) and intake door position is at FRE when the D/F or DEF is selected.

Intake Air

1. Press intake switch. Recirculation indicator should illuminate.
2. Press intake switch again. Fresh indicator should illuminate.
3. Listen for intake door position change. (Slight change of blower sound can be heard.)

If NG, go to trouble diagnosis procedure for [HAC-80. "Diagnosis Procedure"](#).

If OK, continue the check.

NOTE:

Confirm that the compressor clutch is engaged (sound or visual inspection) and intake door position is at FRE when the D/F or DEF is selected.

Temperature Decrease

A

B

C

D

E

F

G

H

HAC

J

K

L

M

N

O

P

INSPECTION AND ADJUSTMENT

[AUTOMATIC AIR CONDITIONER]

< BASIC INSPECTION >

1. Turn temperature control dial (driver side) counterclockwise until 18°C (60°F) is displayed.
2. Check for cold air at discharge air outlets.

If NG, go to trouble diagnosis procedure for [HAC-119. "Inspection procedure"](#).

If OK, continue the check.

Temperature Increase

1. Turn temperature control dial (driver side) clockwise until 32°C (90°F) is displayed.
2. Check for hot air at discharge air outlets.

If NG, go to trouble diagnosis procedure for [HAC-122. "Inspection procedure"](#).

If OK, continue the check.

A/C Switch

1. Press AUTO switch and A/C switch.
2. A/C switch indicator will turn ON.
 - Confirm that the compressor clutch engages (sound or visual inspection).

Auto Mode

1. Press AUTO switch and A/C switch.
2. Display should indicate AUTO.
 - Confirm that discharge air and blower speed will depend on ambient, in-vehicle, and set temperatures.

If NG, go to trouble diagnosis procedure for [HAC-106. "Diagnosis Procedure"](#), then if necessary, trouble diagnosis procedure for [HAC-90. "Diagnosis Procedure"](#).

If all operational checks are OK (symptom cannot be duplicated), go to Incident Simulation Tests in [GI-35. "Work Flow"](#) and perform tests as outlined to simulate driving conditions environment. If symptom appears, refer to [HAC-117. "Diagnosis Chart By Symptom"](#) and perform applicable trouble diagnosis procedures.

AUXILIARY MECHANISM

Temperature Setting Trimmer

The trimmer compensates for differences in range of $\pm 3^{\circ}\text{C}$ ($\pm 6^{\circ}\text{F}$) between temperature setting (displayed digitally) and temperature felt by customer.

Operating procedures for this trimmer are as follows:

1. Begin self-diagnosis STEP-5 mode. Refer to [HAC-50. "WITH LEFT AND RIGHT VENTILATION TEMPERATURE SEPARATELY CONTROL SYSTEM : Diagnosis Description"](#).
2. Press fan (UP: +) switch to set system in auxiliary mode.
3. Display shows "61" in auxiliary mechanism. It takes approximately 3 seconds to enable setting operation.
4. Turn temperature control dial (driver side) as desired. Temperature will change at a rate of 0.5°C (1.0°F) each time a dial is turned.

CAUTION:

- A decimal point is not indicated on the display.

INSPECTION AND ADJUSTMENT

< BASIC INSPECTION >

[AUTOMATIC AIR CONDITIONER]

- Negative value is not displayed on the display.

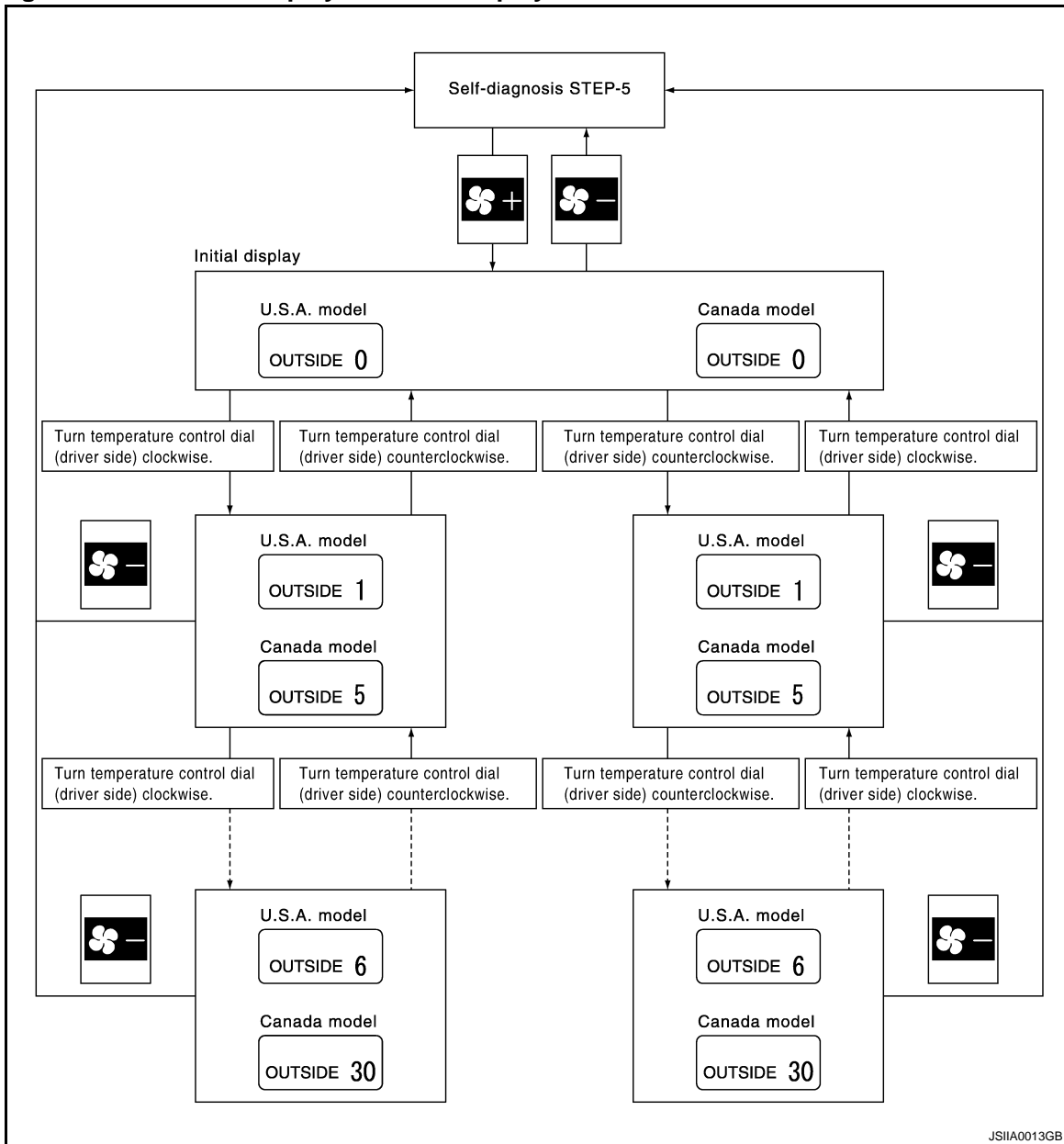

When battery cable is disconnected or battery voltage is below 10 V, trimmer operation is canceled. Temperature set becomes that of initial condition, i.e. 0°C (0°F).

Foot Position Setting Trimmer

Wind distribution ratio in FOOT mode can be set.

Operating procedures for this trimmer are as follows:





1. Begin self-diagnosis STEP-5 mode. Refer to [HAC-50, "WITH LEFT AND RIGHT VENTILATION TEMPERATURE SEPARATELY CONTROL SYSTEM : Diagnosis Description"](#).
2. Press fan (UP:+) switch to set system in auxiliary mode.
3. Press mode switch as desired.

INSPECTION AND ADJUSTMENT

< BASIC INSPECTION >

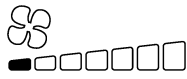

[AUTOMATIC AIR CONDITIONER]

Without rear ventilation

Display	Discharge air flow							
	Automatically controls the mode door				Manually controls the mode door			
	VENT	FOOT		DEF	VENT	FOOT		DEF
		Front	Rear			Front	Rear	
	11%	39%	24%	26%	15%	53%	32%	—
	11%	39%	24%	26%	11%	39%	24%	26%
	15%	53%	32%	—	11%	39%	24%	26%
	15%	53%	32%	—	15%	53%	32%	—

JSIIA0110GB

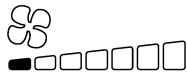
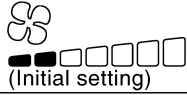
With rear ventilation

Display	Discharge air flow									
	Automatically controls the mode door					Manually controls the mode door				
	VENT		FOOT		DEF	VENT		FOOT		DEF
	Front	Rear	Front	Rear		Front	Rear	Front	Rear	
	10%	12%	33%	22%	23%	13%	16%	43%	28%	—
	10%	12%	33%	22%	23%	10%	12%	33%	22%	23%
	13%	16%	43%	28%	—	10%	12%	33%	22%	23%
	13%	16%	43%	28%	—	13%	16%	43%	28%	—

JSIIA0061GB

When battery cable is disconnected or battery voltage is below 10 V, trimmer operation is canceled. Wind distribution ratio set becomes that of initial condition.

Inlet Port Memory Function

When ignition switch is turned from OFF to ON, inlet port can be set to AUTO or manual.

Operating procedures for this trimmer are as follows:

1. Begin self-diagnosis STEP-5 mode. Refer to [HAC-50. "WITH LEFT AND RIGHT VENTILATION TEMPERATURE SEPARATELY CONTROL SYSTEM : Diagnosis Description"](#).
2. Press fan (UP:+) switch to set system in auxiliary mode.
3. Press intake switch as desired.

LED status of FRE position	LED status of REC position	Setting status		Setting changeover method
		FRE	REC	
OFF	ON	AUTO control (Initial setting)	Manual REC status is memorized. (Initial setting)	INTAKE SW: ON
ON	ON	Manual FRE status is memorized.	Manual REC status is memorized.	
ON	OFF	Manual FRE status is memorized.	AUTO control	
OFF	OFF	AUTO control	AUTO control	

INSPECTION AND ADJUSTMENT

< BASIC INSPECTION >

[AUTOMATIC AIR CONDITIONER]

When battery cable is disconnected or battery voltage is below 10 V, memory function is canceled. Memory function set becomes that of initial condition.

A

B

C

D

E

F

G

H

HAC

J

K

L

M

N

O

P

COMPRESSOR CONTROL FUNCTION

< FUNCTION DIAGNOSIS >

[AUTOMATIC AIR CONDITIONER]

FUNCTION DIAGNOSIS

COMPRESSOR CONTROL FUNCTION

WITHOUT LEFT AND RIGHT VENTILATION TEMPERATURE SEPARATELY CONTROL SYSTEM

WITHOUT LEFT AND RIGHT VENTILATION TEMPERATURE SEPARATELY CONTROL SYSTEM : Description

INFOID:000000000959900

PRINCIPLE OF OPERATION

Compressor is not activated.

Functional circuit diagram

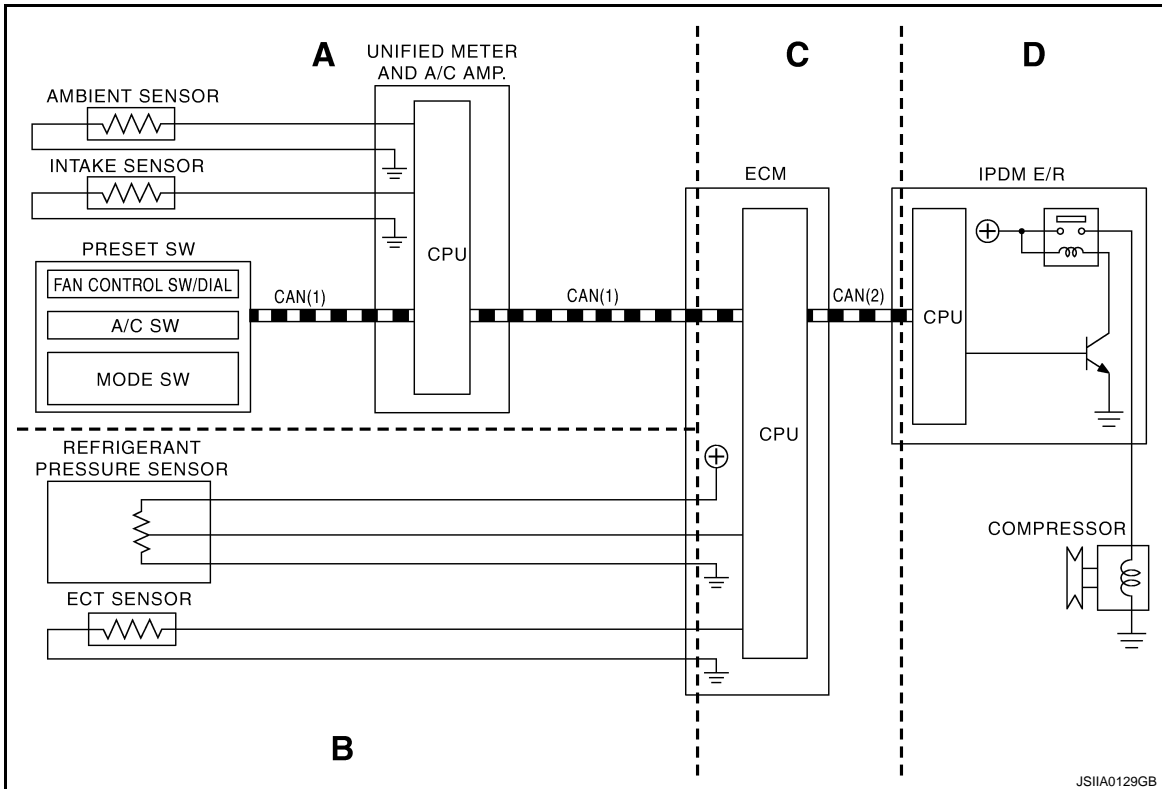

JSIIA0129GB

CAN(1) : A/C signal

CAN(2) : Compressor request signal

Functional initial inspection chart

Location		A	B	C	D
CONSULT-III	ECM DATA MONITOR		Yes	Yes	
	IPDM E/R DATA MONITOR			Yes	
AUTO ACTIVE TEST					Yes
Self-diagnosis function (except CAN diagnosis)		Yes			

WITHOUT LEFT AND RIGHT VENTILATION TEMPERATURE SEPARATELY CONTROL SYSTEM : Fail-Safe

INFOID:000000000959901

FAIL-SAFE FUNCTION

- If a communication error exists between the unified meter and A/C amp., and the AV control unit and preset switch for 30 seconds or longer, air conditioner is controlled under the following conditions:

COMPRESSOR CONTROL FUNCTION

< FUNCTION DIAGNOSIS >

[AUTOMATIC AIR CONDITIONER]

Compressor : ON
Air outlet : AUTO
Air inlet : FRE (Fresh)
Blower fan speed : AUTO
Set temperature : Setting before communication error occurs
Display : OFF

A

B

C

WITHOUT LEFT AND RIGHT VENTILATION TEMPERATURE SEPARATELY CONTROL SYSTEM : Component Part Location

INFOID:000000000959902

D

ENGINE COMPARTMENT

E

F

G

H

HAC

J

K

L

M

N

O

P

COMPRESSOR CONTROL FUNCTION

< FUNCTION DIAGNOSIS >

[AUTOMATIC AIR CONDITIONER]

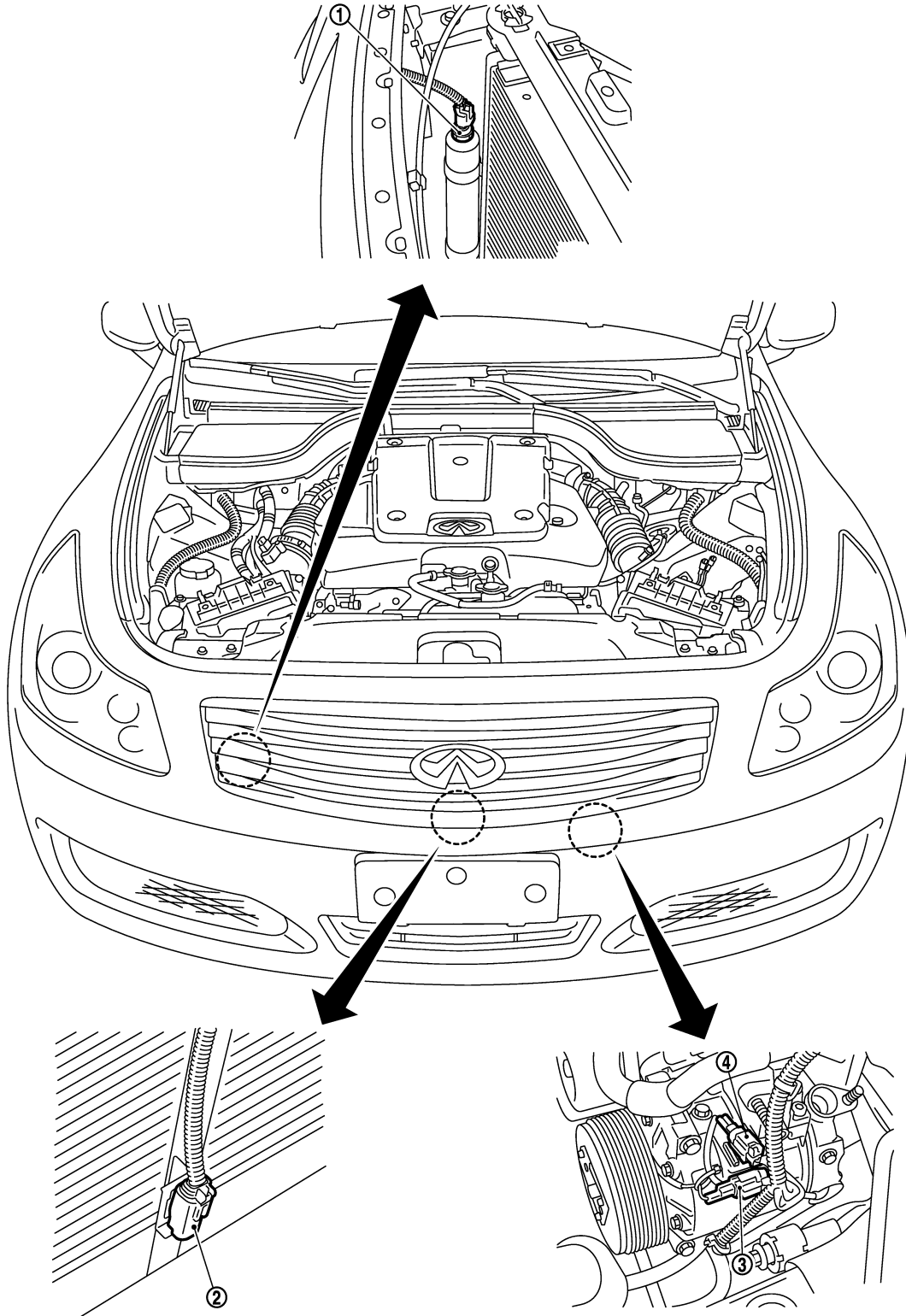

JSIAA0081ZZ

- 1. Refrigerant pressure sensor
- 4. Compressor (ECV)

- 2. Ambient sensor

- 3. Compressor (magnet clutch)

PASSENGER COMPARTMENT

COMPRESSOR CONTROL FUNCTION

< FUNCTION DIAGNOSIS >

[AUTOMATIC AIR CONDITIONER]

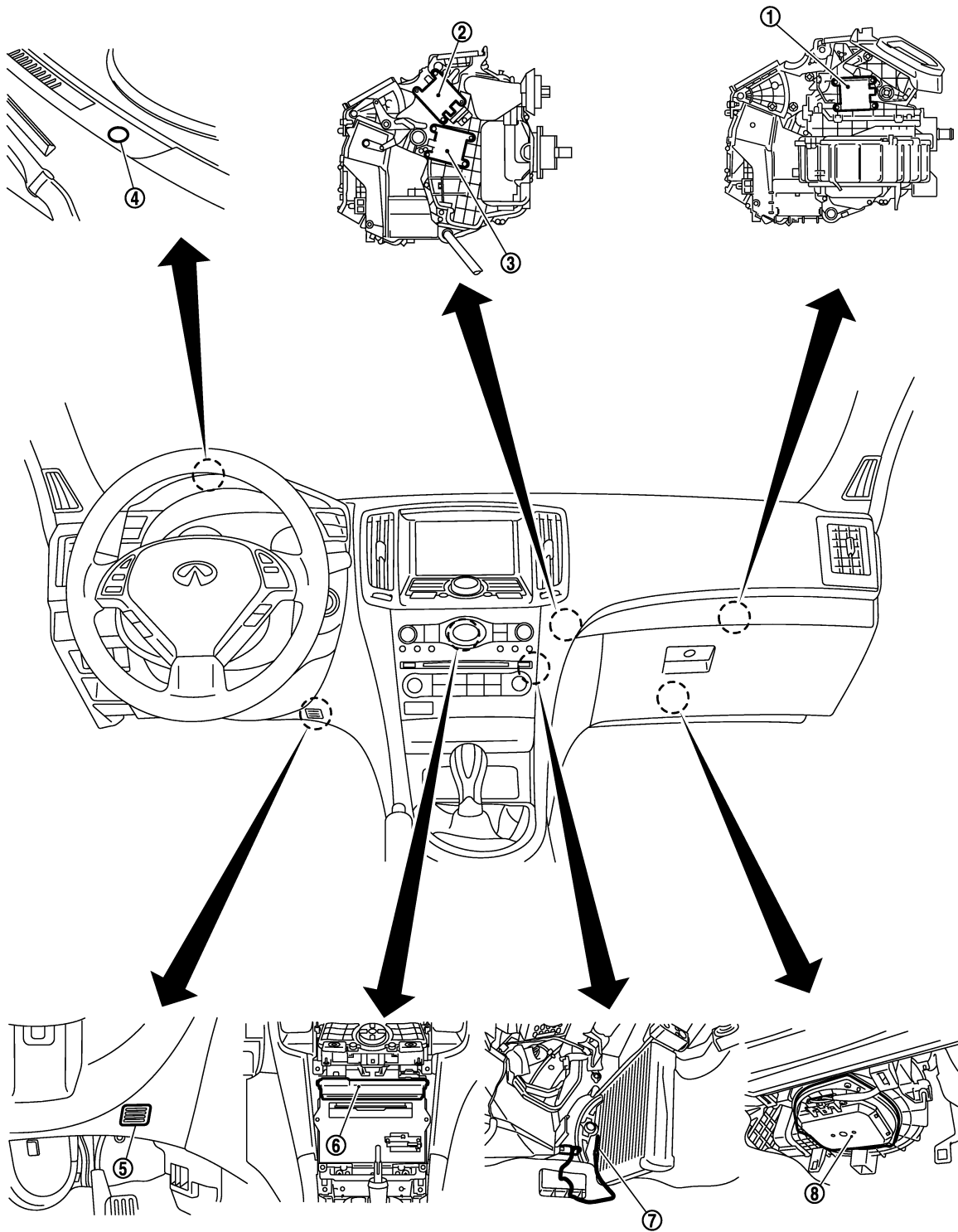

A
B
C
D
E
F
G
H
HAC
J
K
L
M
N
O
P

- | | | |
|----------------------|----------------------|-------------------------------|
| 1. Intake door motor | 2. Mode door motor | 3. Air mix door motor |
| 4. Sunload sensor | 5. In-vehicle sensor | 6. Unified meter and A/C amp. |
| 7. Intake sensor | 8. Blower motor | |

JSIIA0122ZZ

WITHOUT LEFT AND RIGHT VENTILATION TEMPERATURE SEPARATELY CONTROL SYSTEM : Component's role

INFOID:000000000959903

COMPRESSOR CONTROL FUNCTION

< FUNCTION DIAGNOSIS >

[AUTOMATIC AIR CONDITIONER]

Component	Reference
Air mix door motor	HAC-72. "WITHOUT LEFT AND RIGHT VENTILATION TEMPERATURE SEPARATELY CONTROL SYSTEM : Description"
Ambient sensor	HAC-93. "Description"
Blower motor	HAC-83. "WITHOUT LEFT AND RIGHT VENTILATION TEMPERATURE SEPARATELY CONTROL SYSTEM : Description"
Compressor	HAC-90. "Description"
intake door motor	HAC-80. "Description"
intake sensor	HAC-102. "Description"
In-vehicle sensor	HAC-96. "Description"
Mode door motor	HAC-69. "Description"
Refrigerant pressure sensor	HAC-92. "Component Inspection"
Sunload sensor	HAC-99. "Description"
Unified meter and A/C amp.	HAC-105. "Description"

WITH LEFT AND RIGHT VENTILATION TEMPERATURE SEPARATELY CONTROL SYSTEM

WITH LEFT AND RIGHT VENTILATION TEMPERATURE SEPARATELY CONTROL SYSTEM : Description

INFOID:000000000959904

PRINCIPLE OF OPERATION

Compressor is not activated.

Functional circuit diagram

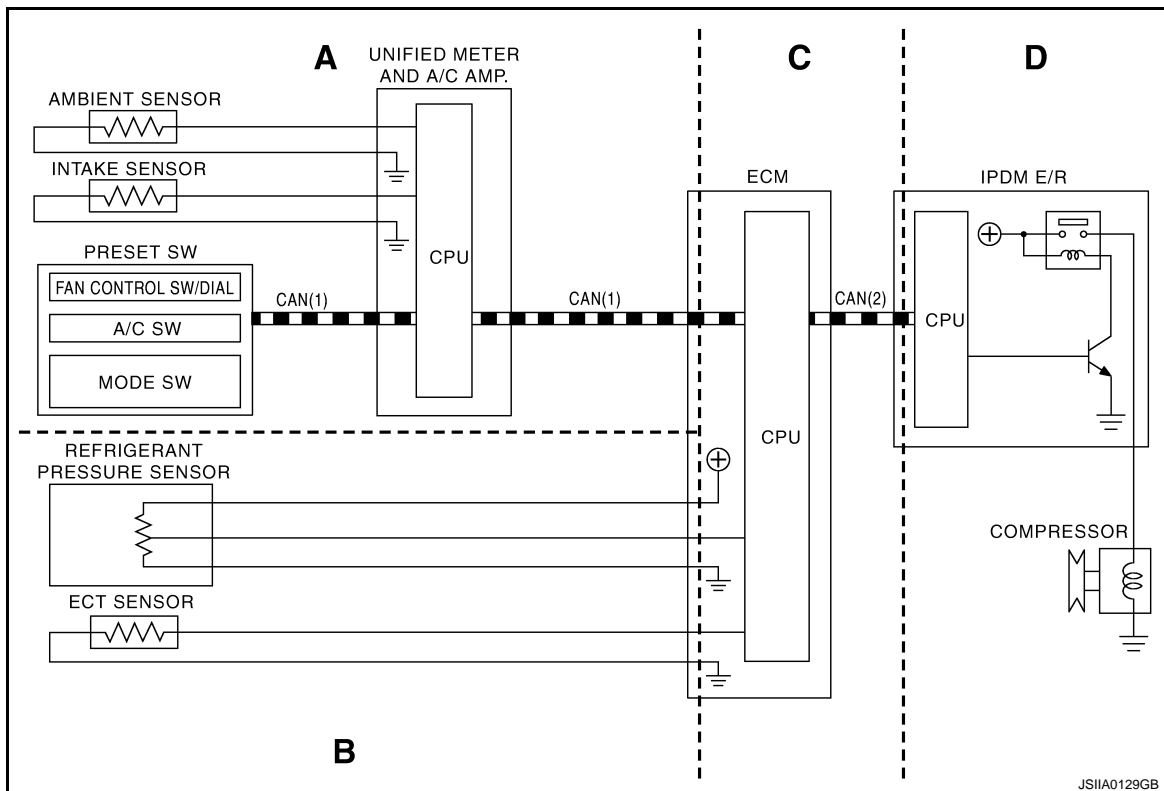

CAN(1) : A/C signal

CAN(2) : Compressor request signal

Functional initial inspection chart

COMPRESSOR CONTROL FUNCTION

< FUNCTION DIAGNOSIS >

[AUTOMATIC AIR CONDITIONER]

Location		A	B	C	D
CONSULT-III	ECM DATA MONITOR		Yes	Yes	
	IPDM E/R DATA MONITOR			Yes	
AUTO ACTIVE TEST					Yes
Self-diagnosis function (except CAN diagnosis)		Yes			

A

B

WITH LEFT AND RIGHT VENTILATION TEMPERATURE SEPARATELY CONTROL SYSTEM : Fail-Safe

INFOID:000000000959905

FAIL-SAFE FUNCTION

- If a communication error exists between the unified meter and A/C amp., and the AV control unit and preset switch for 30 seconds or longer, air conditioner is controlled under the following conditions:

Compressor	: ON
Air outlet	: AUTO
Air inlet	: FRE (Fresh)
Blower fan speed	: AUTO
Set temperature	: Setting before communication error occurs
Display	: OFF

D

E

F

G

WITH LEFT AND RIGHT VENTILATION TEMPERATURE SEPARATELY CONTROL SYSTEM : Component Part Location

INFOID:000000000959906

ENGINE COMPARTMENT

H

HAC

J

K

L

M

N

O

P

COMPRESSOR CONTROL FUNCTION

< FUNCTION DIAGNOSIS >

[AUTOMATIC AIR CONDITIONER]

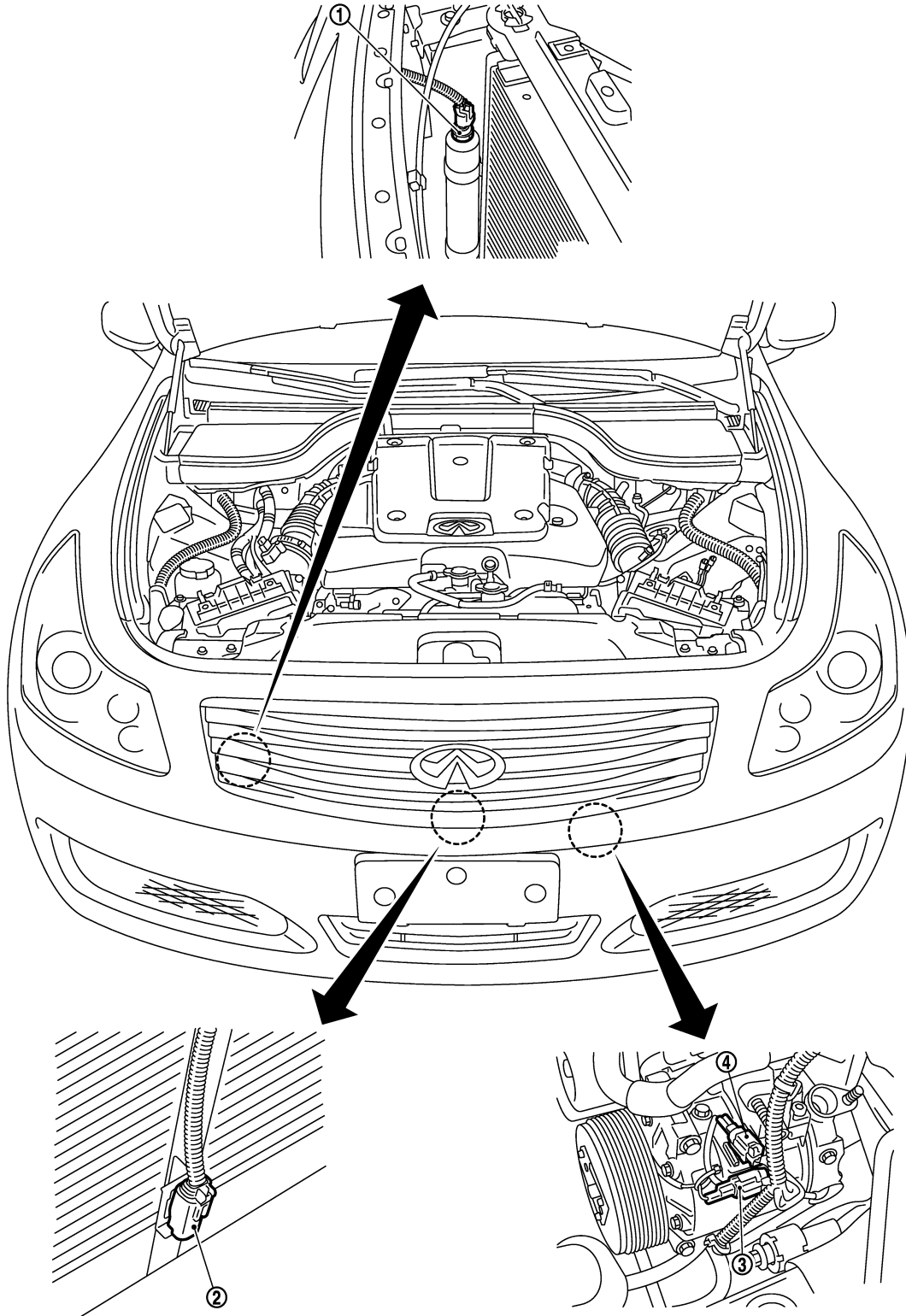

JSIAA0081ZZ

- 1. Refrigerant pressure sensor
- 4. Compressor (ECV)

- 2. Ambient sensor

- 3. Compressor (magnet clutch)

PASSENGER COMPARTMENT

COMPRESSOR CONTROL FUNCTION

< FUNCTION DIAGNOSIS >

[AUTOMATIC AIR CONDITIONER]

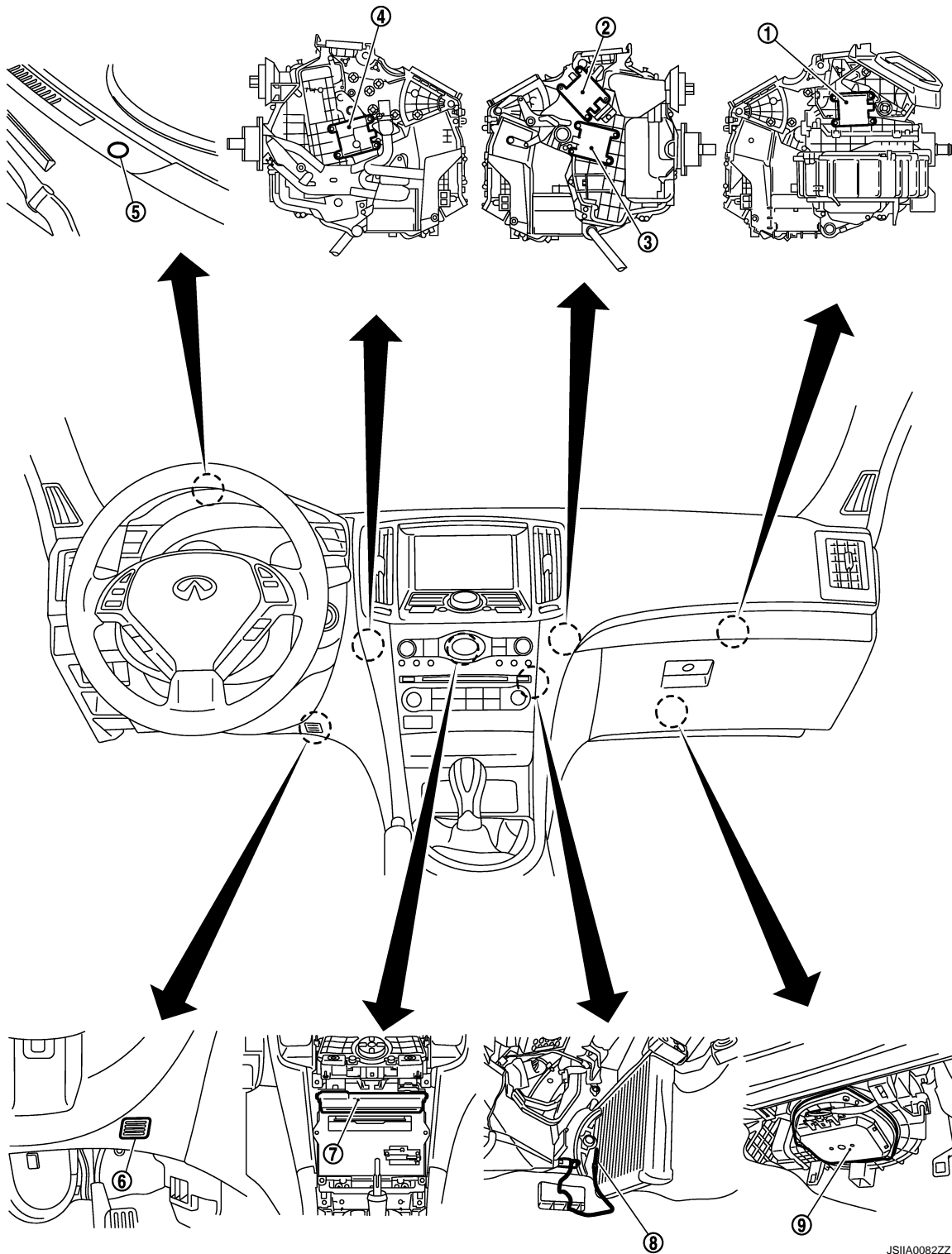

A
B
C
D
E
F
G
H
HAC
J
K
L
M
N
O
P

- | | | |
|-------------------------------------|--------------------|--|
| 1. Intake door motor | 2. Mode door motor | 3. Air mix door motor (passenger side) |
| 4. Air mix door motor (driver side) | 5. Sunload sensor | 6. In-vehicle sensor |
| 7. Unified meter and A/C amp. | 8. Intake sensor | 9. Blower motor |

JSIIA0082ZZ

WITH LEFT AND RIGHT VENTILATION TEMPERATURE SEPARATELY CONTROL SYSTEM : Component's role

INFOID:000000000959907

COMPRESSOR CONTROL FUNCTION

< FUNCTION DIAGNOSIS >

[AUTOMATIC AIR CONDITIONER]

Component	Reference
Air mix door motor	HAC-74. "WITH LEFT AND RIGHT VENTILATION TEMPERATURE SEPARATELY CONTROL SYSTEM : Description"
Ambient sensor	HAC-93. "Description"
Blower motor	HAC-86. "WITH LEFT AND RIGHT VENTILATION TEMPERATURE SEPARATELY CONTROL SYSTEM : Description"
Compressor	HAC-90. "Description"
intake door motor	HAC-80. "Description"
intake sensor	HAC-102. "Description"
In-vehicle sensor	HAC-96. "Description"
Mode door motor	HAC-69. "Description"
Refrigerant pressure sensor	HAC-92. "Component Inspection"
Sunload sensor	HAC-99. "Description"
Unified meter and A/C amp.	HAC-105. "Description"

AUTOMATIC AIR CONDITIONER SYSTEM

< FUNCTION DIAGNOSIS >

[AUTOMATIC AIR CONDITIONER]

AUTOMATIC AIR CONDITIONER SYSTEM

WITHOUT LEFT AND RIGHT VENTILATION TEMPERATURE SEPARATELY CONTROL SYSTEM

WITHOUT LEFT AND RIGHT VENTILATION TEMPERATURE SEPARATELY CONTROL SYSTEM : System Diagram

INFOID:000000000959908

CONTROL SYSTEM

The control system consists of input sensors, switches, unified meter and A/C amp. (microcomputer) and outputs. The relationship of these components is shown in the figure below:

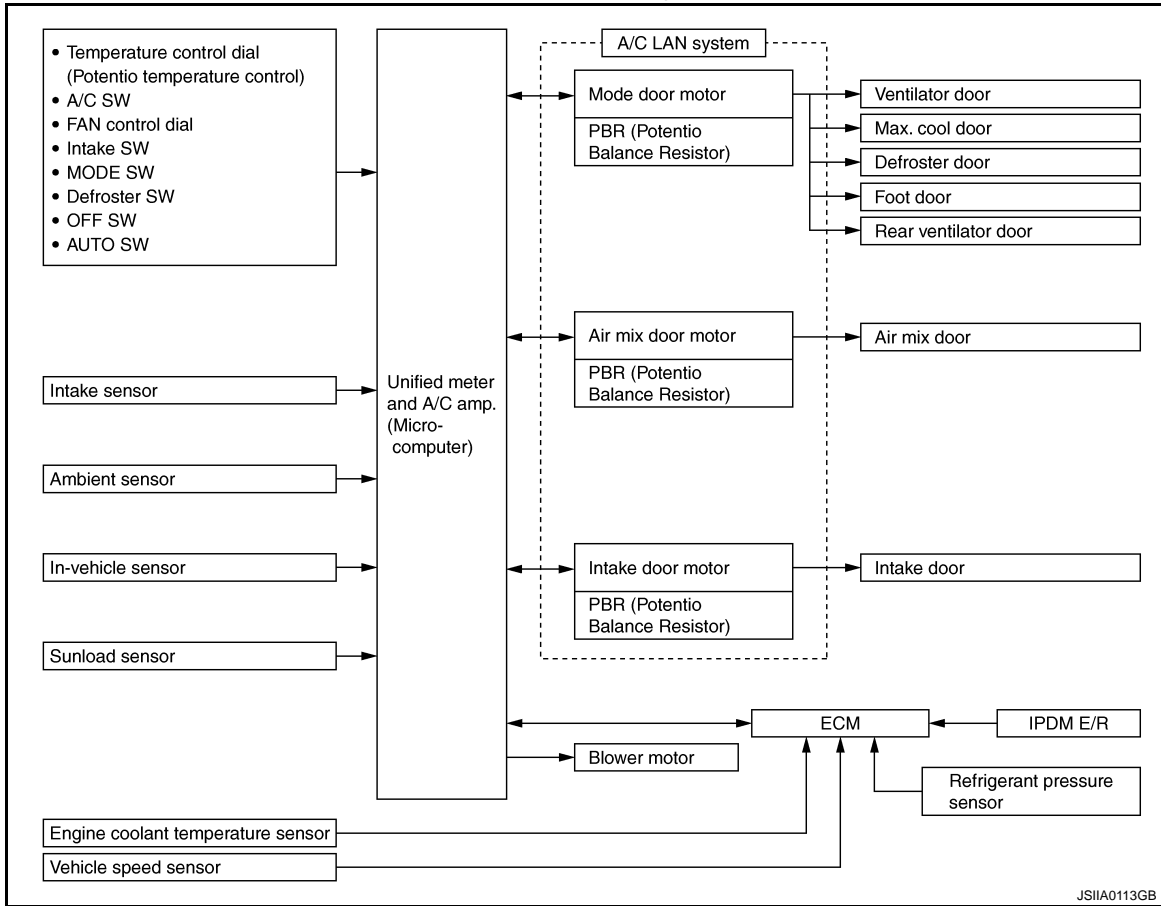

WITHOUT LEFT AND RIGHT VENTILATION TEMPERATURE SEPARATELY CONTROL SYSTEM : System Description

INFOID:000000000959909

CONTROL OPERATION

Display Screen

The operation status of the system is displayed on the screen.

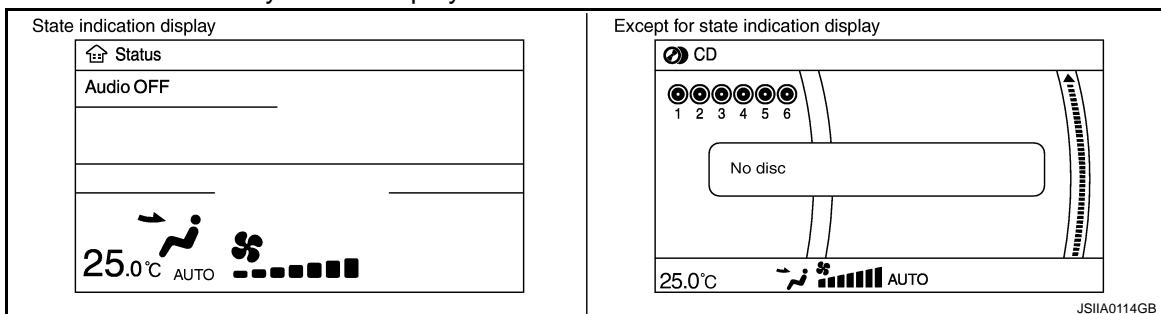

AUTOMATIC AIR CONDITIONER SYSTEM

< FUNCTION DIAGNOSIS >

[AUTOMATIC AIR CONDITIONER]

Preset Switch

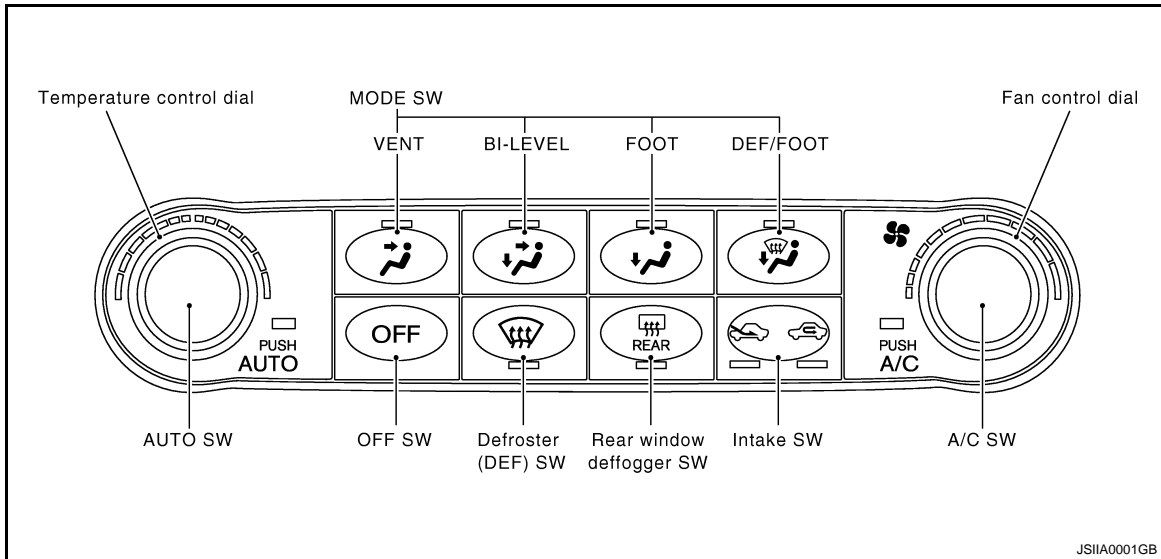

MODE Switch

The air discharge outlets is controlled with these switches.

Temperature Control Dial (Potentio Temperature Control)

The set temperature is increased or decreased with this dial.

AUTO Switch

- The compressor, intake doors, air mix doors, mode doors and blower speed are automatically controlled so that the in-vehicle temperature will reach, and be maintained at the set temperature selected by the operator.
- When pressing AUTO switch, air inlet, air outlet, fan speed, and discharge air temperature are automatically controlled.

Defroster (DEF) Switch

Mode doors are set to the defrost position with this switch. Also, intake doors are set to the outside air position, and compressor turns ON.

A/C Switch

Compressor is ON or OFF with this switch.

(Pressing the A/C switch when the A/C switch is ON will turn OFF the A/C switch and compressor.)

FAN Control Dial

The blower speed is manually controlled with this dial. Seven speeds are available for manual control (as shown on the display screen).

OFF Switch

Compressor and blower are OFF, intake doors and the mode doors are automatically controlled.

Rear Window Defogger Switch

When illumination is ON, rear window is defogged.

Intake Switch

- When intake switch is ON, FRE LED turns ON, and air inlet is fixed to FRE.
- When press intake switch again, REC LED turns ON, and air inlet is fixed to REC.
- When intake switch is pressed for approximately 1.5 seconds or longer, FRE and REC LEDs blink twice. Then, automatic control mode is entered. Inlet status is displayed by LED even during automatic controlled.
- When FRE LED is turned ON, shifting mode position to D/F or DEF, or when compressor is turned from ON to OFF, intake switch is automatically turned OFF (fixed to FRE mode). REC mode can be re-entered by pressing intake switch again, and then compressor is turned ON. (Except D/F or DEF position)

AUTOMATIC AIR CONDITIONER SYSTEM

< FUNCTION DIAGNOSIS >

[AUTOMATIC AIR CONDITIONER]

DISCHARGE AIR FLOW

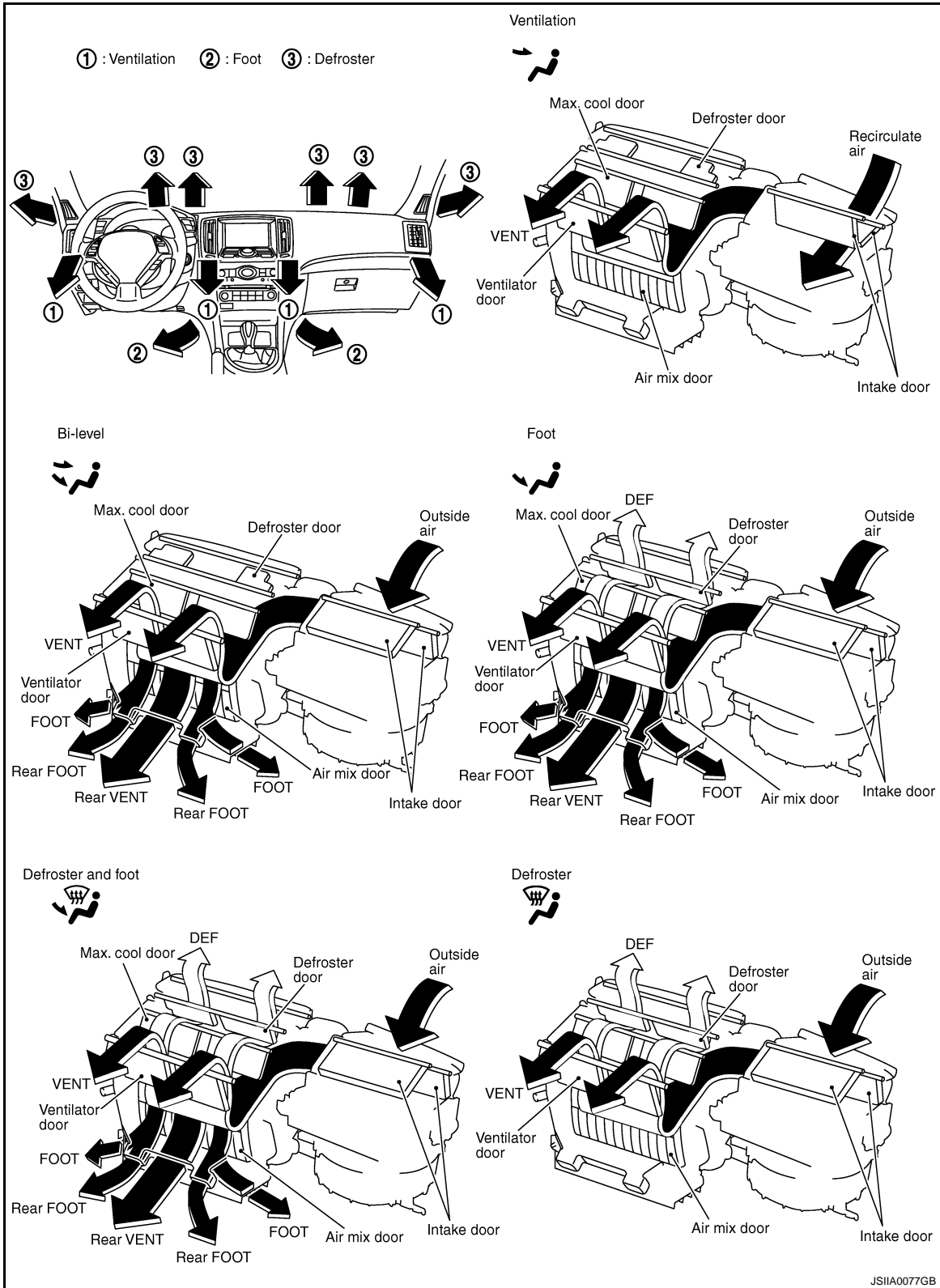

A
B
C
D
E
F
G
H
I
J
K
L
M
N
O
P

HAC

AUTOMATIC AIR CONDITIONER SYSTEM

< FUNCTION DIAGNOSIS >

[AUTOMATIC AIR CONDITIONER]

SWITCHES AND THEIR CONTROL FUNCTION

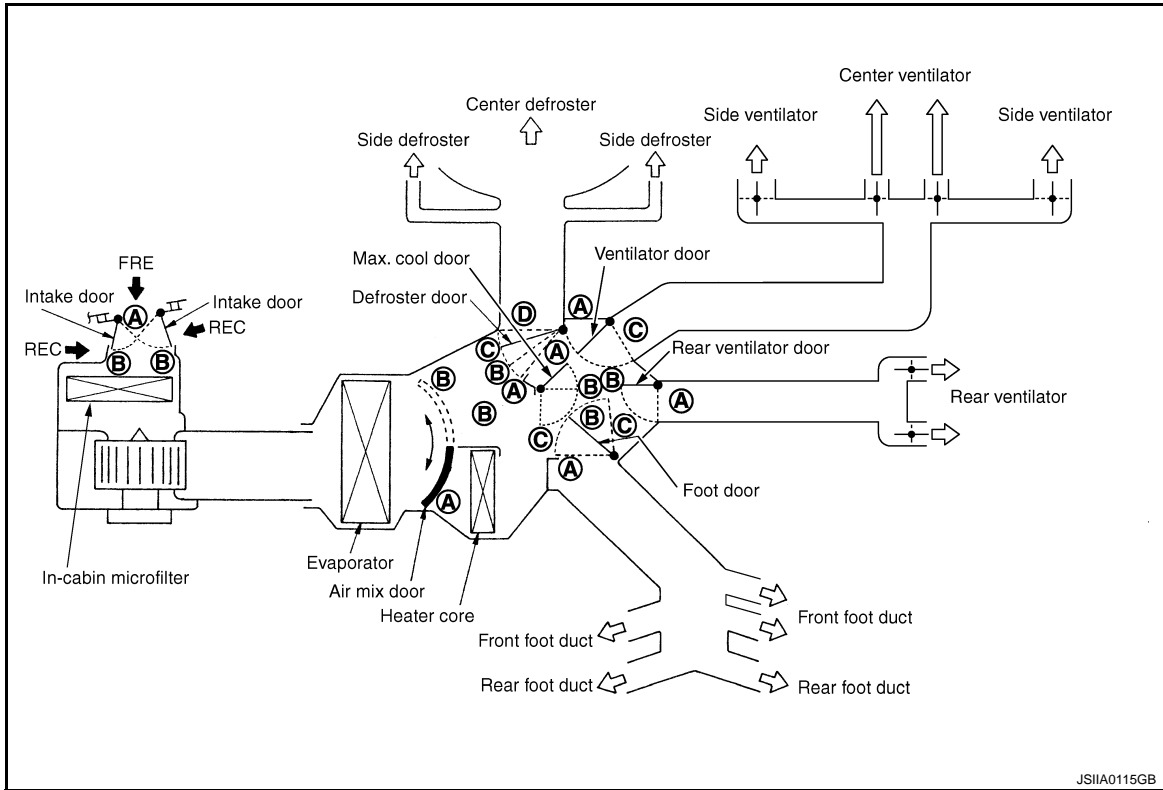

JSIA0115GB

Position or switch	MODE SW				DEF SW		AUTO SW	Intake SW		Temperature control dial			OFF SW
	VENT	B/L	FOOT	D/F	ON	OFF		FRE	REC				OFF
										18°C (60°F)	↔	32°C (90°F)	OFF
Ventilator door	(A)	(B)	(C)	(C)	(C)		AUTO	—	—	—			AUTO
Max. cool door	(A)	(B)	(B)	(B)	(C)			—	—	—			
Defroster door	(D)	(D)	(C)	(B)	(A)			—	—	—			
Foot door	(A)	(B)	(C)	(C)	(C)			—	—	—			
Rear ventilator door	(B)	(B)	(B)	(B)	(A)			—	—	—			
Intake door	—			(B)	(B)			(B)*	(A)*	—			
Air mix door	—				—		AUTO	—	(A) AUTO (B)			—	

*: Inlet status is displayed by LED when activating automatic control.

JSIA0079GB

AIR CONDITIONER LAN CONTROL SYSTEM

The LAN (Local Area Network) system consists of unified meter and A/C amp., mode door motor, air mix door motor and intake door motor.

A configuration of these components is shown in the figure below.

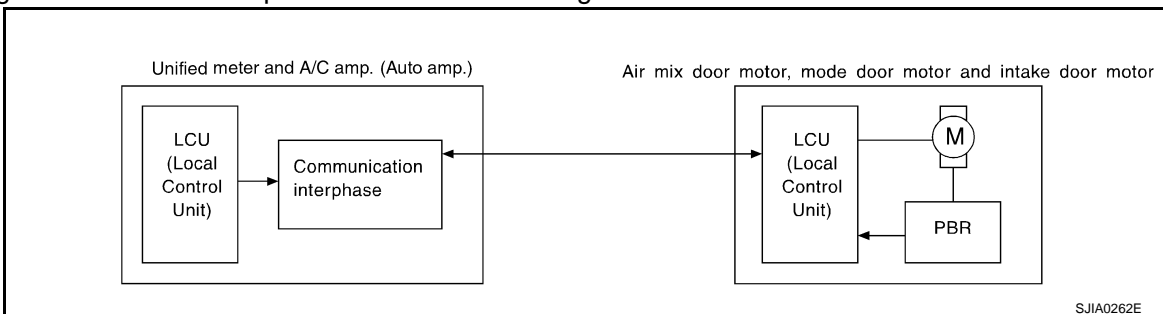

SJIA0262E

AUTOMATIC AIR CONDITIONER SYSTEM

[AUTOMATIC AIR CONDITIONER]

< FUNCTION DIAGNOSIS >

SYSTEM CONSTRUCTION

A small network is constructed between the unified meter and A/C amp., mode door motor, air mix door motor and intake door motor. The unified meter and A/C amp. and motors are connected by data transmission lines and motor power supply lines. The LAN network is built through the ground circuits of each door motor. Addresses, motor opening angle signals, motor stop signals and error checking messages are all transmitted through the data transmission lines connecting the unified meter and A/C amp. and each door motor. The following functions are contained in LCU's built into the mode door motor, the air mix door motor and the intake door motor.

- Address
- Motor opening angle signals
- Data transmission
- Motor stop and drive decision
- Opening angle sensor (PBR function)
- Comparison
- Decision (Unified meter and A/C amp. indicated value and motor opening angle comparison)

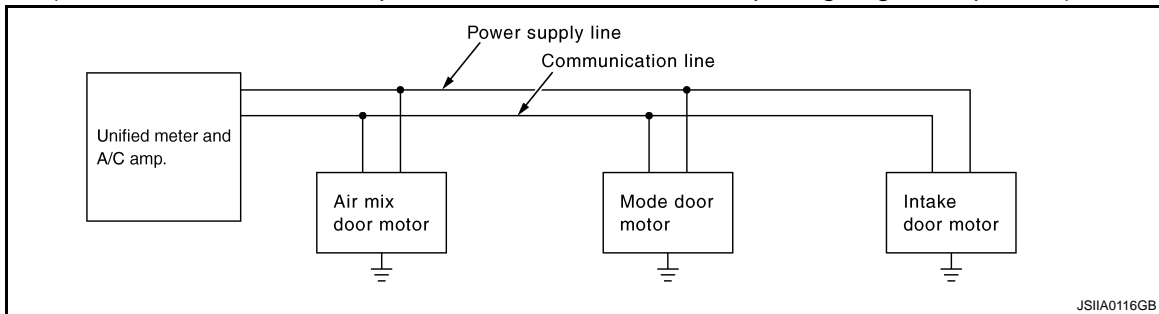

Operation

The unified meter and A/C amp. receives data from each of the sensors. The unified meter and A/C amp. sends mode door, air mix door and intake door opening angle data to the mode door motor LCU, air mix door motor LCU and intake door motor LCU.

The mode door motor, air mix door motor and intake door motor read their respective signals according to the address signal. Opening angle indication signals received from the unified meter and A/C amp. and each of the motor position sensors is compared by the LCU's in each door motor with the existing decision and opening angles. Subsequently, HOT/COLD, DEF/VENT and FRE/REC operation is selected. The new selection data is returned to the unified meter and A/C amp.

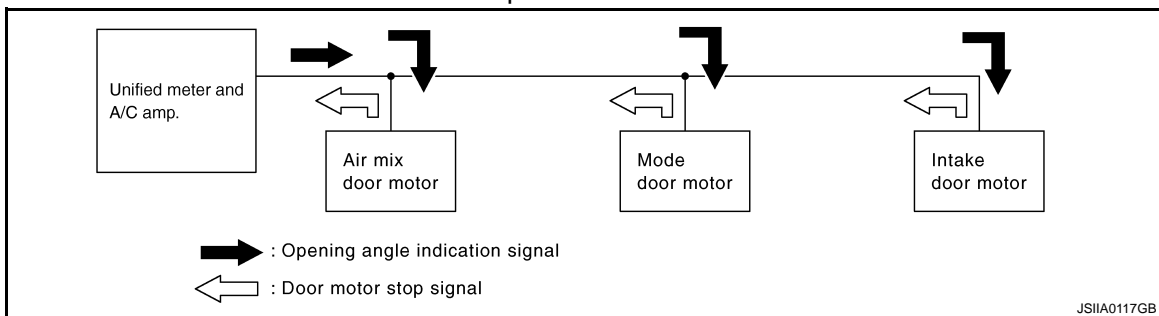

Transmission Data and Transmission Order

Unified meter and A/C amp. data is transmitted consecutively to each of the doors motor following the form shown in the figure below.

START:

- Initial compulsory signal is sent to each of the door motors.

ADDRESS:

- Data sent from the unified meter and A/C amp. are selected according to data-based decisions made by the mode door motor, air mix door motors and intake door motor.
- If the addresses are identical, the opening angle data and error check signals are received by the door motor LCU's. The LCU's then make the appropriate error decision. If the opening angle data have no error, door control begins.
- If an error exists, the received data are rejected and corrected data received. Finally, door control is based upon the corrected opening angle data.

AUTOMATIC AIR CONDITIONER SYSTEM

[AUTOMATIC AIR CONDITIONER]

< FUNCTION DIAGNOSIS >

OPENING ANGLE:

- Data that shows the indicated door opening angle of each door motor.

ERROR CHECK:

- In this procedure, transmitted and received data is checked for errors. Error data are then compiled. The error check prevents corrupted data from being used by the mode door motor, the air mix door motor and the intake door motor. Error data can be related to the following symptoms.
 - Malfunction of electrical frequency
 - Poor electrical connections
 - Signal leakage from transmission lines
 - Signal level fluctuation

STOP SIGNAL:

- At the end of each transmission, a stop operation, in-operation, or internal malfunction message is delivered to the unified meter and A/C amp. This completes one data transmission and control cycle.

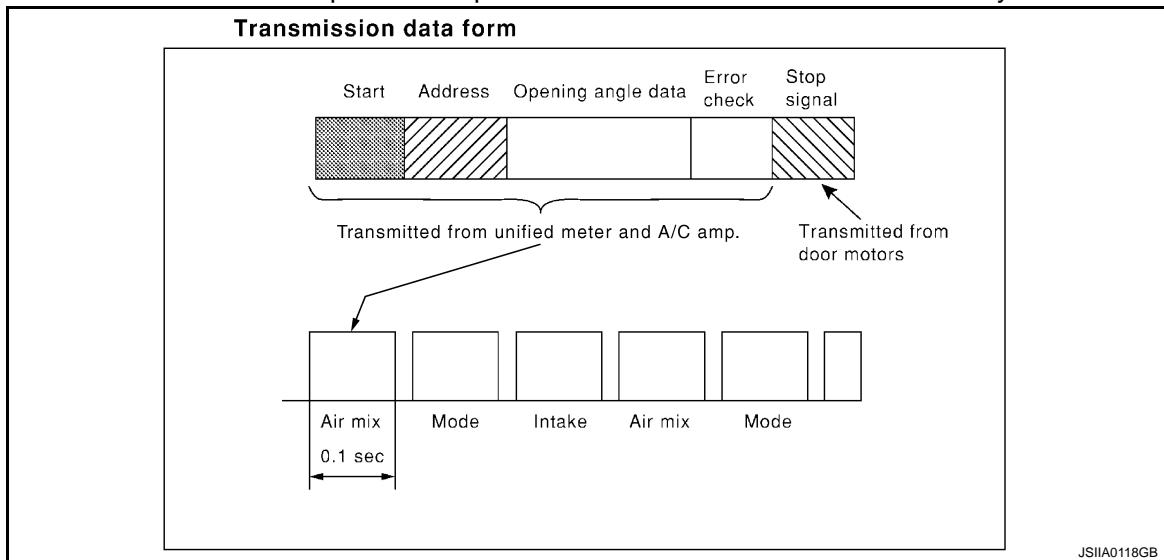

AIR MIX DOOR CONTROL (AUTOMATIC TEMPERATURE CONTROL)

The air mix door is automatically controlled so that in-vehicle temperature is maintained at a predetermined value by the temperature setting, ambient temperature, in-vehicle temperature and amount of sunload.

FAN SPEED CONTROL

Blower speed is automatically controlled by the temperature setting, ambient temperature, in-vehicle temperature, intake temperature, amount of sunload and air mix door position.

With pressing AUTO switch, the blower motor starts to gradually increase air flow volume.

When engine coolant temperature is low, the blower motor operation is delayed to prevent cool air from flowing.

INTAKE DOOR CONTROL

The intake doors are automatically controlled by the temperature setting, ambient temperature, in-vehicle temperature, intake temperature, amount of sunload and ON/OFF operation of the compressor.

MODE DOOR CONTROL

The mode door is automatically controlled by the temperature setting, ambient temperature, in-vehicle temperature, intake temperature and amount of sunload.

AUTOMATIC AIR CONDITIONER SYSTEM

< FUNCTION DIAGNOSIS >

[AUTOMATIC AIR CONDITIONER]

MAGNET CLUTCH CONTROL

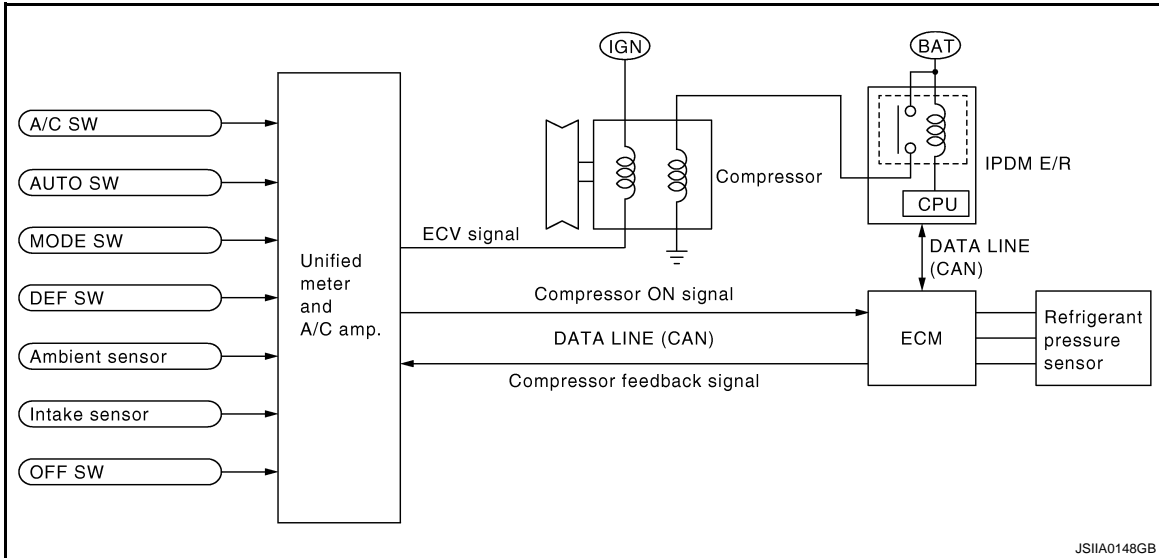

When A/C switch, AUTO switch, DEF switch or D/F switch is pressed, unified meter and A/C amp. transmits compressor ON signal to ECM, via CAN communication.

ECM judges whether compressor can be turned ON, based on each sensor status (refrigerant-pressure sensor signal, throttle angle, etc.). If it judges compressor can be turned ON, it sends compressor ON signal to IPDM E/R, via CAN communication.

Upon receipt of compressor ON signal from ECM, IPDM E/R turns air conditioner relay ON to operate compressor.

When sending compressor ON signal to IPDM E/R via CAN communication line, ECM simultaneously sends compressor feedback signal to ECM via CAN communication line.

ECM sends compressor feedback signal to unified meter and A/C amp., then, uses input compressor feedback signal to control air inlet.

WITHOUT LEFT AND RIGHT VENTILATION TEMPERATURE SEPARATELY CONTROL SYSTEM : Component Part Location

INFOID:000000000959910

ENGINE COMPARTMENT

A
B
C
D
E
F
G
H
HAC
J
K
L
M
N
O
P

AUTOMATIC AIR CONDITIONER SYSTEM

< FUNCTION DIAGNOSIS >

[AUTOMATIC AIR CONDITIONER]

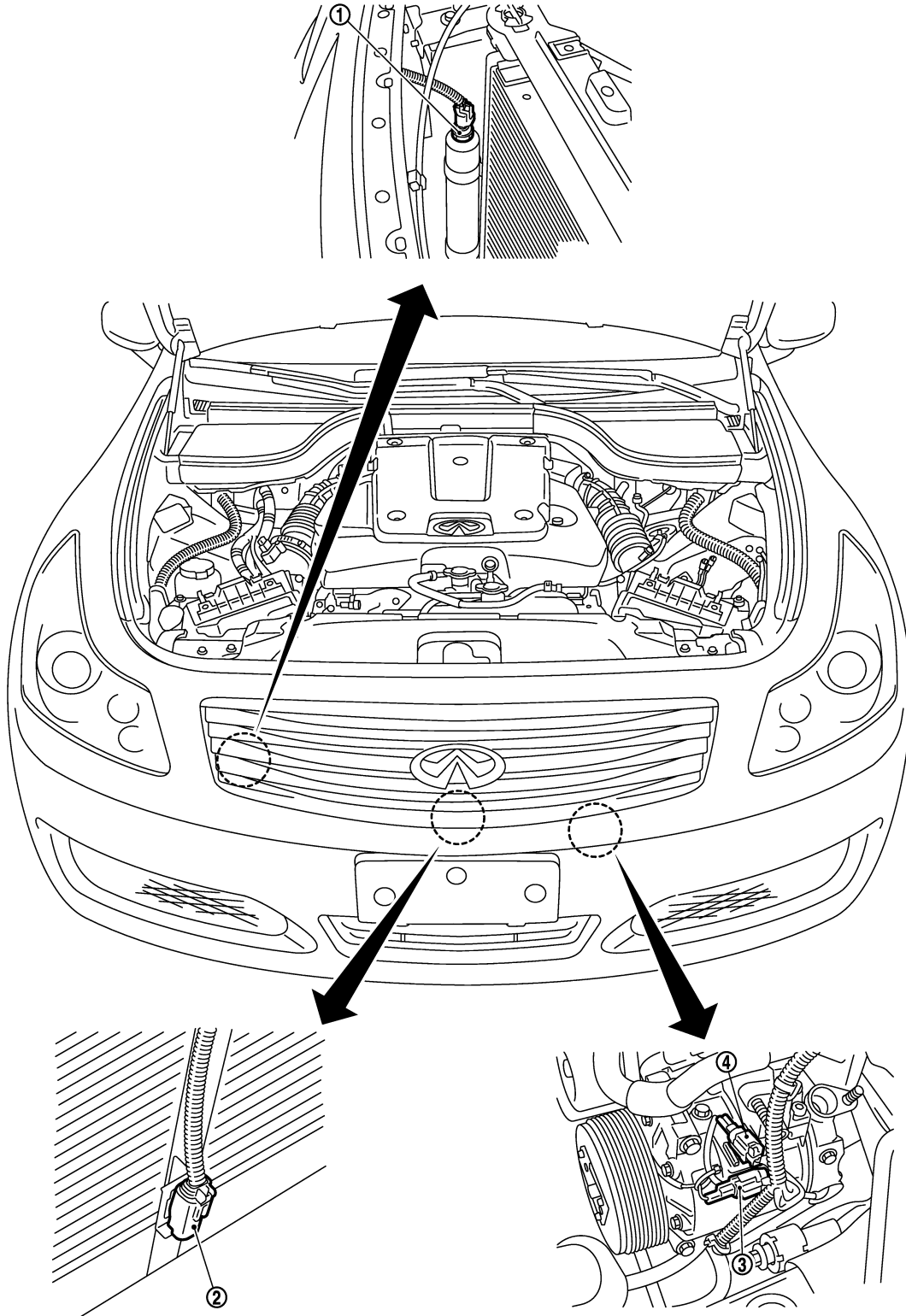

JSIAA0081ZZ

1. Refrigerant pressure sensor

2. Ambient sensor

3. Compressor (magnet clutch)

4. Compressor (ECV)

PASSENGER COMPARTMENT

AUTOMATIC AIR CONDITIONER SYSTEM

< FUNCTION DIAGNOSIS >

[AUTOMATIC AIR CONDITIONER]

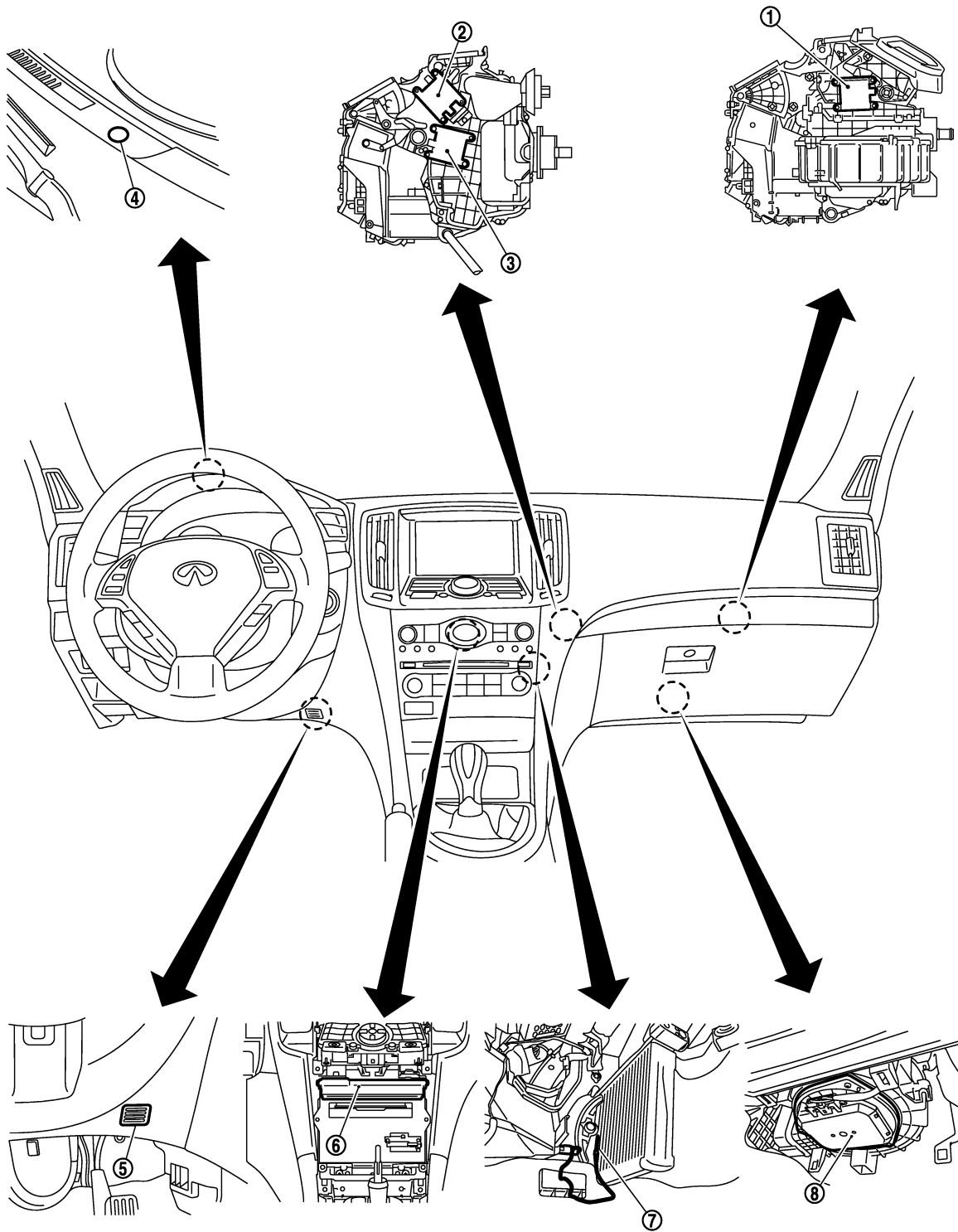

A
B
C
D
E
F
G
H
HAC
J
K
L
M
N
O
P

- | | | |
|----------------------|----------------------|-------------------------------|
| 1. Intake door motor | 2. Mode door motor | 3. Air mix door motor |
| 4. Sunload sensor | 5. In-vehicle sensor | 6. Unified meter and A/C amp. |
| 7. Intake sensor | 8. Blower motor | |

JSIIA0122ZZ

WITHOUT LEFT AND RIGHT VENTILATION TEMPERATURE SEPARATELY CONTROL SYSTEM : Component Description

INFOID:00000000095911

AUTOMATIC AIR CONDITIONER SYSTEM

< FUNCTION DIAGNOSIS >

[AUTOMATIC AIR CONDITIONER]

Component	Reference
Air mix door motor	HAC-72. "WITHOUT LEFT AND RIGHT VENTILATION TEMPERATURE SEPARATELY CONTROL SYSTEM : Description"
Ambient sensor	HAC-93. "Description"
Blower motor	HAC-83. "WITHOUT LEFT AND RIGHT VENTILATION TEMPERATURE SEPARATELY CONTROL SYSTEM : Description"
Compressor	HAC-90. "Description"
intake door motor	HAC-80. "Description"
intake sensor	HAC-102. "Description"
In-vehicle sensor	HAC-96. "Description"
Mode door motor	HAC-69. "Description"
Refrigerant pressure sensor	HAC-92. "Component Inspection"
Sunload sensor	HAC-99. "Description"
Unified meter and A/C amp.	HAC-105. "Description"

WITH LEFT AND RIGHT VENTILATION TEMPERATURE SEPARATELY CONTROL SYSTEM

WITH LEFT AND RIGHT VENTILATION TEMPERATURE SEPARATELY CONTROL SYSTEM : System Diagram

INFOID:000000000959912

CONTROL SYSTEM

The control system consists of input sensors, switches, unified meter and A/C amp. (microcomputer) and outputs. The relationship of these components is shown in the figure below:

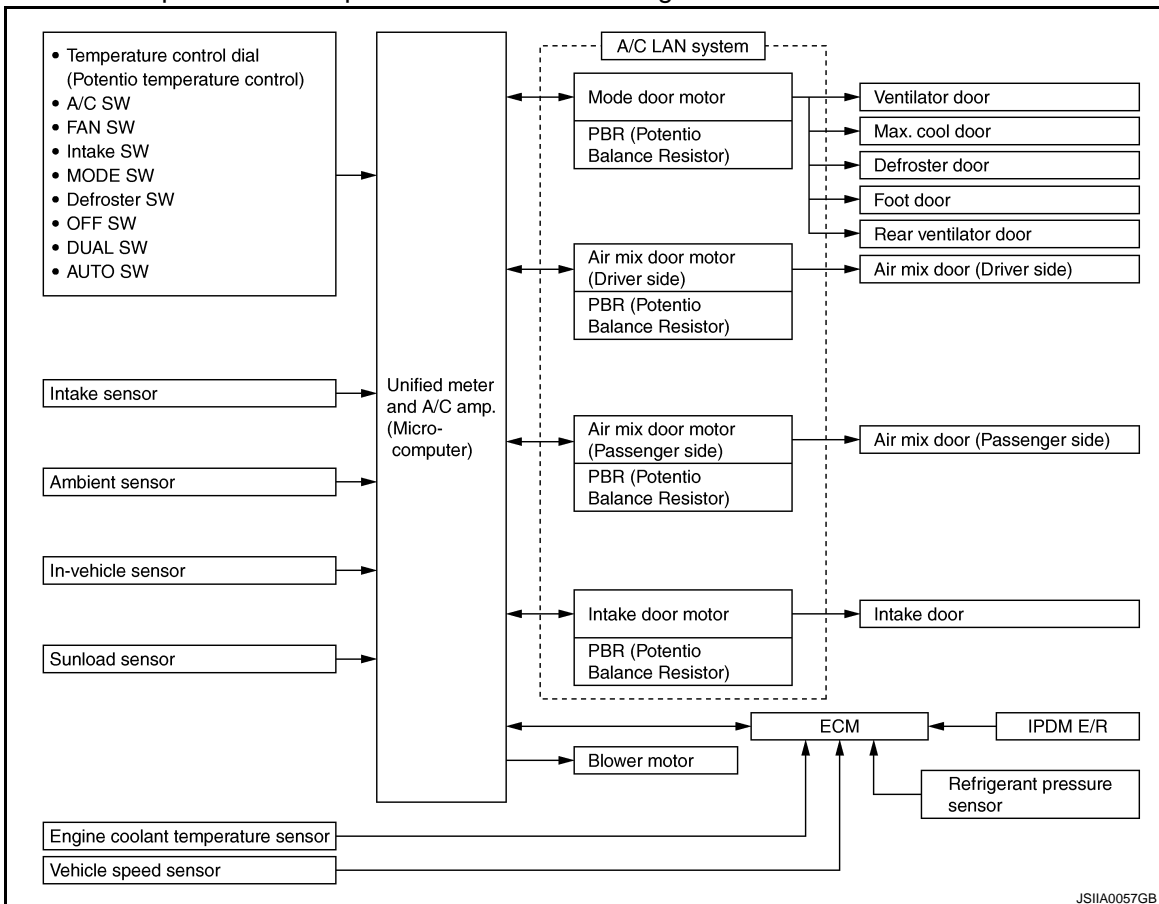

JSIIA0057GB

WITH LEFT AND RIGHT VENTILATION TEMPERATURE SEPARATELY CONTROL

AUTOMATIC AIR CONDITIONER SYSTEM

< FUNCTION DIAGNOSIS >

[AUTOMATIC AIR CONDITIONER]

SYSTEM : System Description

INFOID:00000000959913

CONTROL OPERATION

Display Screen

The operation status of the system is displayed on the screen.

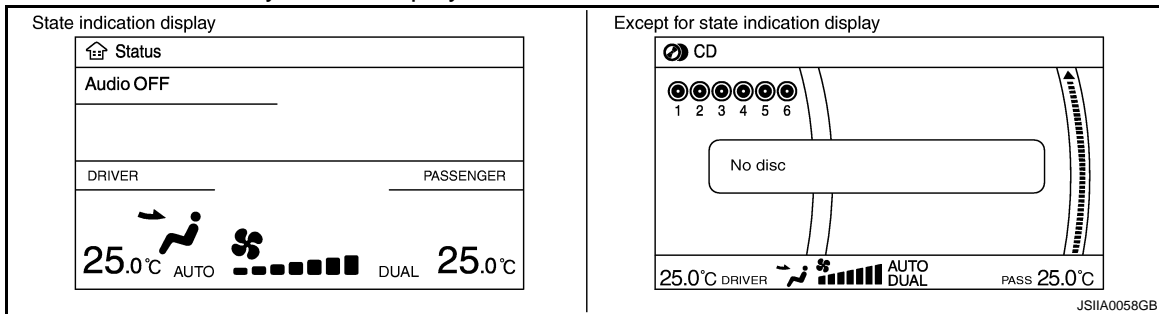

Preset Switch

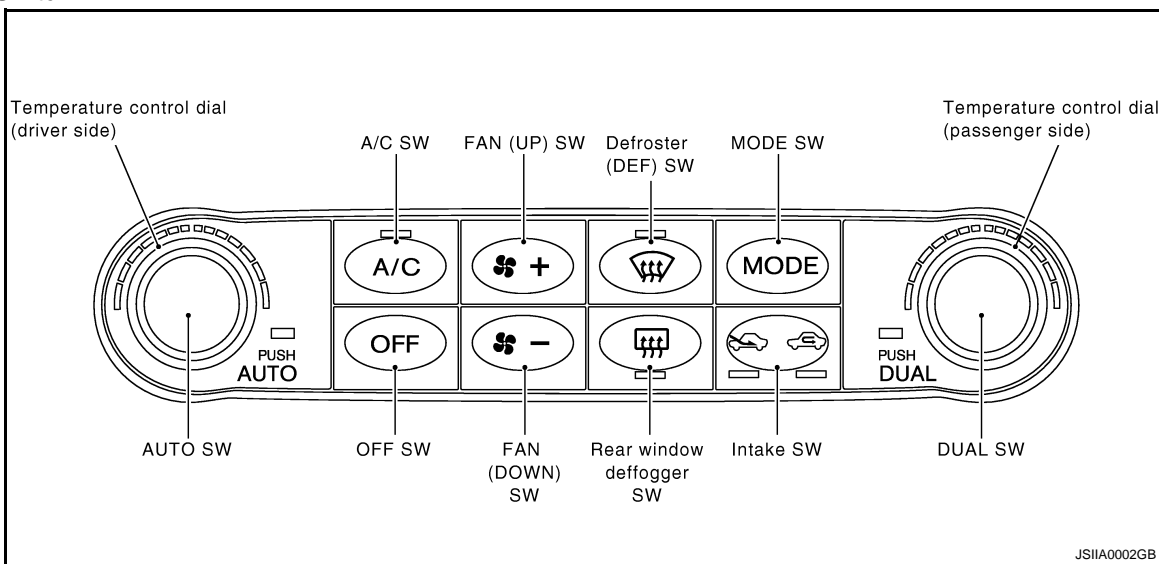

MODE Switch

The air discharge outlets is controlled with this switch.

Temperature Control Dial (Potentio Temperature Control) (Driver Side)

The set temperature is increased or decreased with this dial.

Temperature Control Dial (Potentio Temperature Control) (Passenger Side)

- The set temperature is increased or decreased with this dial.
- When the temperature control dial is turned, the DUAL switch indicator will automatically illuminate.

AUTO Switch

- The compressor, intake doors, air mix doors, mode doors and blower speed are automatically controlled so that the in-vehicle temperature will reach, and be maintained at the set temperature selected by the operator.
- When pressing AUTO switch, air inlet, air outlet, fan speed, and discharge air temperature are automatically controlled.

Defroster (DEF) Switch

Mode doors are set to the defrost position with this switch. Also, intake doors are set to the outside air position, and compressor turns ON.

A/C Switch

Compressor is ON or OFF with this switch.

(Pressing the A/C switch when the A/C switch is ON will turn OFF the A/C switch and compressor.)

FAN Switches

The blower speed is manually controlled with this switch. Seven speeds are available for manual control (as shown on the display screen).

A
B
C
D
E
F
G
H
J
K
L
M
N
O
P

HAC

AUTOMATIC AIR CONDITIONER SYSTEM

< FUNCTION DIAGNOSIS >

[AUTOMATIC AIR CONDITIONER]

OFF Switch

Compressor and blower are OFF, intake doors and the mode doors are automatically controlled.

Rear Window Defogger Switch

When illumination is ON, rear window is defogged.

Intake Switch

- When intake switch is ON, FRE LED turns ON, and air inlet is fixed to FRE.
- When press intake switch again, REC LED turns ON, and air inlet is fixed to REC.
- When intake switch is pressed for approximately 1.5 seconds or longer, FRE and REC LEDs blink twice. Then, automatic control mode is entered. Inlet status is displayed by LED even during automatic controlled.
- When FRE LED is turned ON, shifting mode position to D/F or DEF, or when compressor is turned from ON to OFF, intake switch is automatically turned OFF (fixed to FRE mode). REC mode can be re-entered by pressing intake switch again, and then compressor is turned ON. (Except D/F or DEF position)

DUAL Switch

- When the DUAL switch indicator is illuminated, the driver side and passenger side, temperature can each be set independently.
- When the DUAL switch indicator is not illuminated, the driver side outlet and setting temperature is applied to both sides.

AUTOMATIC AIR CONDITIONER SYSTEM

< FUNCTION DIAGNOSIS >

[AUTOMATIC AIR CONDITIONER]

DISCHARGE AIR FLOW

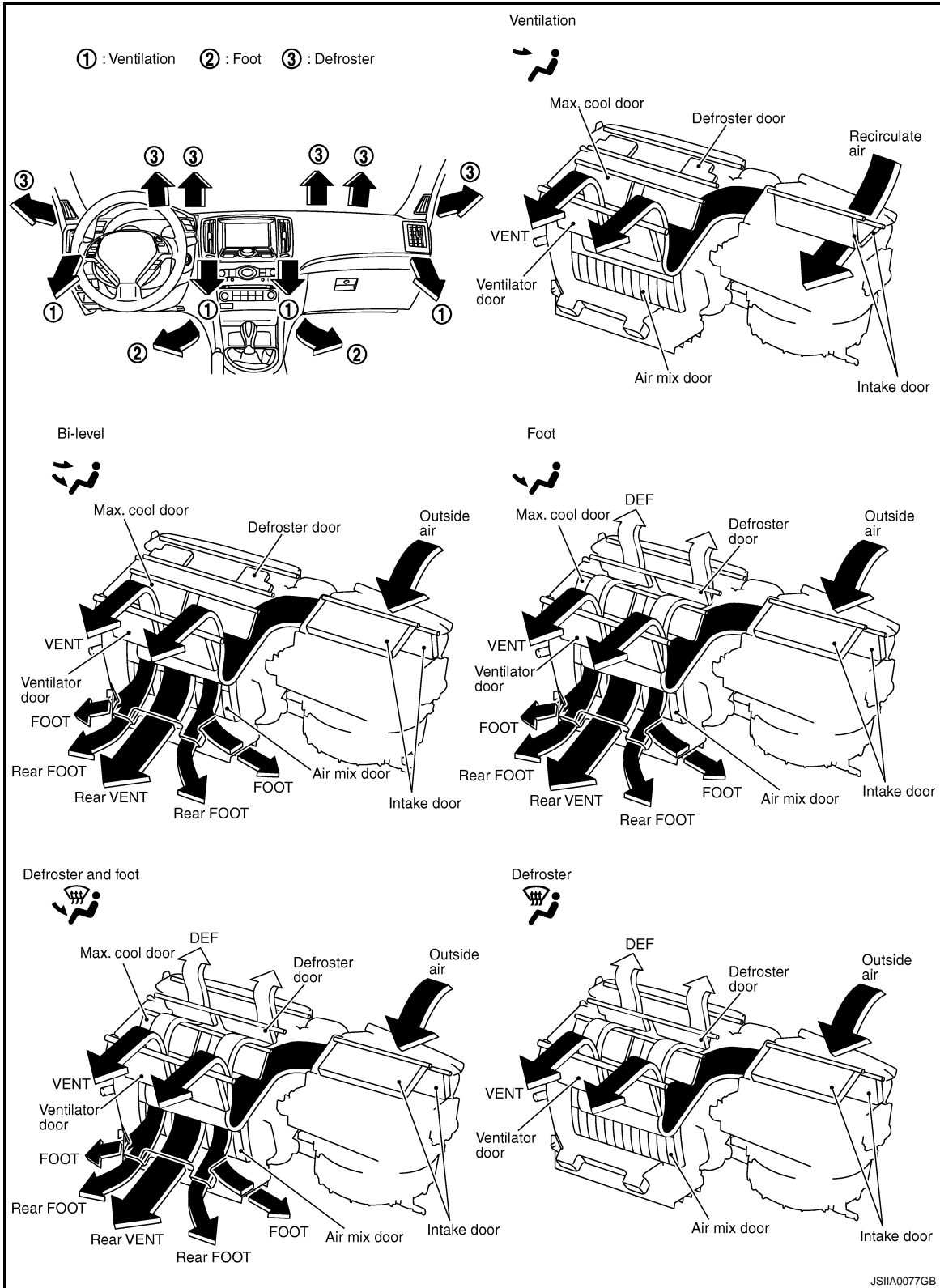

A
B
C
D
E
F
G
H
HAC
J
K
L
M
N
O
P

AUTOMATIC AIR CONDITIONER SYSTEM

< FUNCTION DIAGNOSIS >

[AUTOMATIC AIR CONDITIONER]

SWITCHES AND THEIR CONTROL FUNCTION

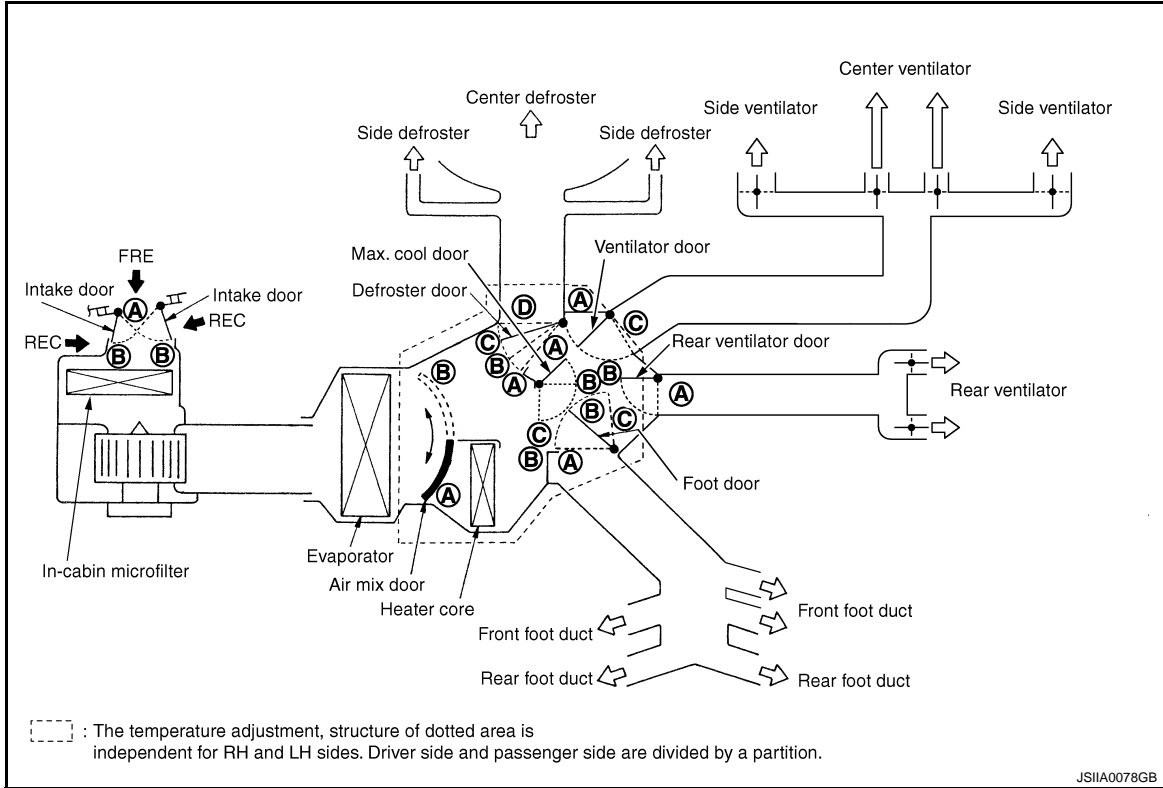

Position or switch	DUAL SW	MODE SW				DEF SW		AUTO SW	Intake SW		Temperature control dial (Driver side)		Temperature control dial (Passenger side)		OFF SW			
		VENT	B/L	FOOT	D/F	ON	OFF		FRE	REC					OFF			
Door		MODE													OFF			
Ventilator door	—	(A)	(B)	(C)	(C)	(C)	—	AUTO	—	—	18°C (60°F)	↔	32°C (90°F)	18°C (60°F)	↔	32°C (90°F)	AUTO	
Max. cool door	—	(A)	(B)	(B)	(B)	(C)	—	AUTO	—	—	—	—	—	—	—	—	AUTO	
Defroster door	—	(D)	(D)	(C)	(B)	(A)	—	AUTO	—	—	—	—	—	—	—	—	AUTO	
Foot door	—	(A)	(B)	(C)	(C)	(C)	—	AUTO	—	—	—	—	—	—	—	—	AUTO	
Rear ventilator door	—	(B)	(B)	(B)	(B)	(A)	—	AUTO	—	—	—	—	—	—	—	—	AUTO	
Intake door	—	—				(B)	(B)	—	(B)*	(A)*	—	—	—	—	—	—	—	AUTO
Air mix door (Driver side)	—	—				—	—	—	—	—	(A)	AUTO	(B)	—	—	—	—	AUTO
Air mix door (Passenger side)	ON	—				—	—	—	—	—	—	(A)	AUTO	(B)	—	—	—	AUTO
Air mix door (Passenger side)	OFF	—				—	—	—	—	—	—	(A)	AUTO	(B)	—	—	—	AUTO

*: Inlet status is displayed by LED when activating automatic control.

JSIIA0080GB

AIR CONDITIONER LAN CONTROL SYSTEM

The LAN (Local Area Network) system consists of unified meter and A/C amp., mode door motor, air mix door motors and intake door motor.

AUTOMATIC AIR CONDITIONER SYSTEM

[AUTOMATIC AIR CONDITIONER]

< FUNCTION DIAGNOSIS >

A configuration of these components is shown in the figure below.

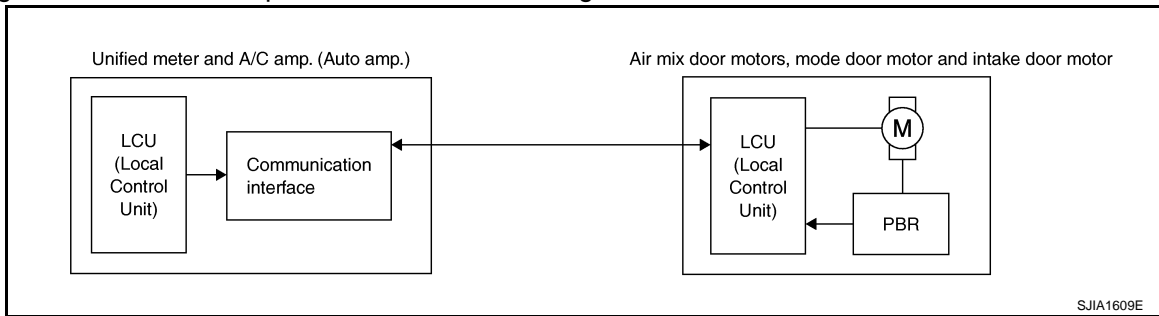

SYSTEM CONSTRUCTION

A small network is constructed between the unified meter and A/C amp., mode door motor, air mix door motors and intake door motor. The unified meter and A/C amp. and motors are connected by data transmission lines and motor power supply lines. The LAN network is built through the ground circuits of each door motor.

Addresses, motor opening angle signals, motor stop signals and error checking messages are all transmitted through the data transmission lines connecting the unified meter and A/C amp. and each door motor.

The following functions are contained in LCUs built into the mode door motor, the air mix door motors and the intake door motor.

- Address
- Motor opening angle signals
- Data transmission
- Motor stop and drive decision
- Opening angle sensor (PBR function)
- Comparison
- Decision (Unified meter and A/C amp. indicated value and motor opening angle comparison)

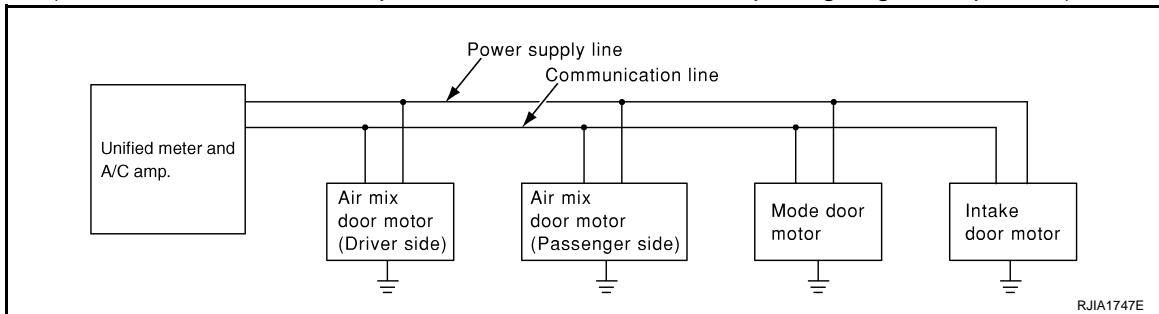

Operation

The unified meter and A/C amp. receives data from each of the sensors. The unified meter and A/C amp. sends mode door, air mix door and intake door opening angle data to the mode door motor LCU, air mix door motor LCUs and intake door motor LCU.

The mode door motor, air mix door motors and intake door motor read their respective signals according to the address signal. Opening angle indication signals received from the unified meter and A/C amp. and each of the motor position sensors is compared by the LCUs in each door motor with the existing decision and opening angles. Subsequently, HOT/COLD, DEF/VENT and FRE/REC operation is selected. The new selection data is returned to the unified meter and A/C amp.

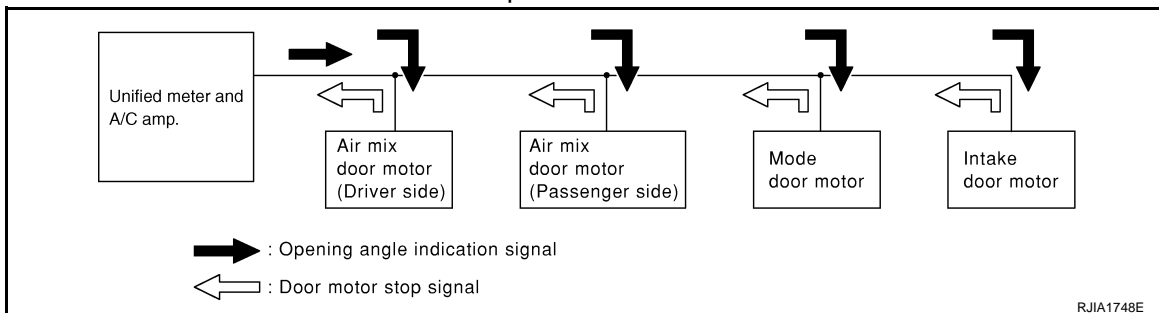

Transmission Data and Transmission Order

Unified meter and A/C amp. data is transmitted consecutively to each of the doors motor following the form shown in the figure below.

A
B
C
D
E
F
G
H
J
K
L
M
N
O
P

HAC

AUTOMATIC AIR CONDITIONER SYSTEM

< FUNCTION DIAGNOSIS >

[AUTOMATIC AIR CONDITIONER]

START:

- Initial compulsory signal is sent to each of the door motors.

ADDRESS:

- Data sent from the unified meter and A/C amp. are selected according to data-based decisions made by the mode door motor, air mix door motors and intake door motor.
- If the addresses are identical, the opening angle data and error check signals are received by the door motor LCUs. The LCUs then make the appropriate error decision. If the opening angle data have no error, door control begins.
- If an error exists, the received data are rejected and corrected data received. Finally, door control is based upon the corrected opening angle data.

OPENING ANGLE:

- Data that shows the indicated door opening angle of each door motor.

ERROR CHECK:

- In this procedure, transmitted and received data is checked for errors. Error data are then compiled. The error check prevents corrupted data from being used by the mode door motor, the air mix door motors and the intake door motor. Error data can be related to the following symptoms.
 - Malfunction of electrical frequency
 - Poor electrical connections
 - Signal leakage from transmission lines
 - Signal level fluctuation

STOP SIGNAL:

- At the end of each transmission, a stop operation, in-operation, or internal malfunction message is delivered to the unified meter and A/C amp. This completes one data transmission and control cycle.

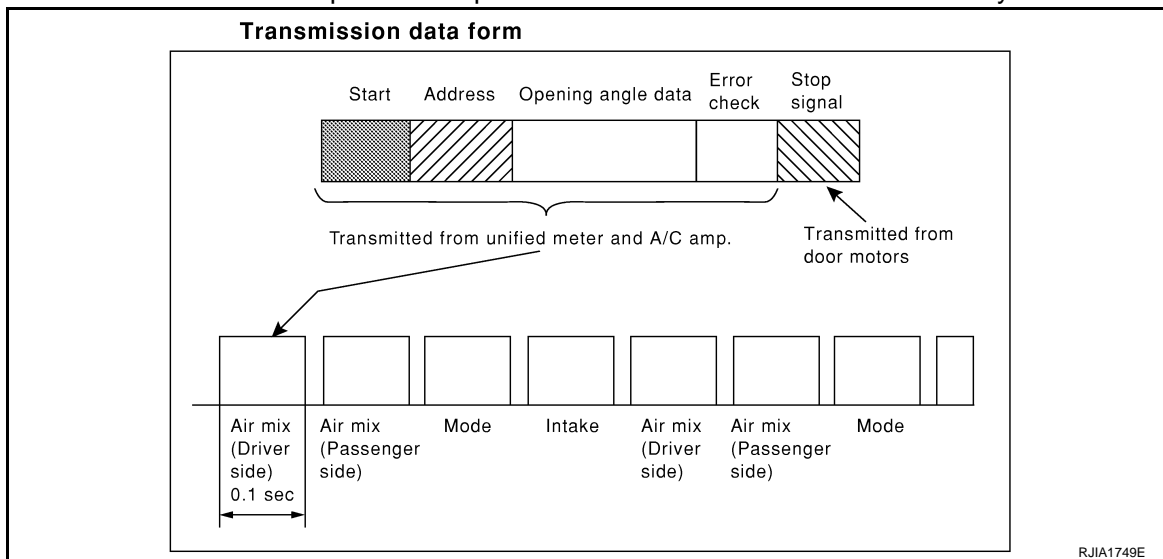

AIR MIX DOOR CONTROL (AUTOMATIC TEMPERATURE CONTROL)

The air mix doors are automatically controlled so that in-vehicle temperature is maintained at a predetermined value by the temperature setting, ambient temperature, in-vehicle temperature and amount of sunload.

FAN SPEED CONTROL

Blower speed is automatically controlled by the temperature setting, ambient temperature, in-vehicle temperature, intake temperature, amount of sunload and air mix door position.

With pressing AUTO switch, the blower motor starts to gradually increase air flow volume.

When engine coolant temperature is low, the blower motor operation is delayed to prevent cool air from flowing.

INTAKE DOOR CONTROL

The intake doors are automatically controlled by the temperature setting, ambient temperature, in-vehicle temperature, intake temperature, amount of sunload and ON/OFF operation of the compressor.

MODE DOOR CONTROL

The mode door is automatically controlled by the temperature setting, ambient temperature, in-vehicle temperature, intake temperature and amount of sunload.

AUTOMATIC AIR CONDITIONER SYSTEM

< FUNCTION DIAGNOSIS >

[AUTOMATIC AIR CONDITIONER]

MAGNET CLUTCH CONTROL

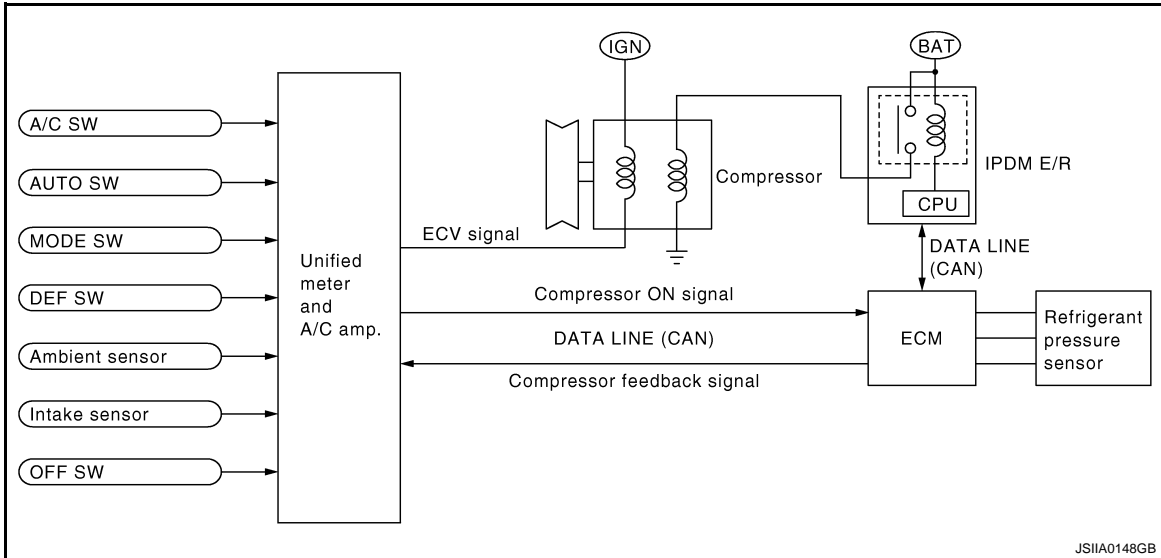

When A/C switch, AUTO switch, DEF switch is pressed or when shifting mode position D/F, unified meter and A/C amp. transmits compressor ON signal to ECM, via CAN communication.

ECM judges whether compressor can be turned ON, based on each sensor status (refrigerant-pressure sensor signal, throttle angle, etc.). If it judges compressor can be turned ON, it sends compressor ON signal to IPDM E/R, via CAN communication.

Upon receipt of compressor ON signal from ECM, IPDM E/R turns air conditioner relay ON to operate compressor.

When sending compressor ON signal to IPDM E/R via CAN communication line, ECM simultaneously sends compressor feedback signal to ECM via CAN communication line.

ECM sends compressor feedback signal to unified meter and A/C amp., then, uses input compressor feedback signal to control air inlet.

WITH LEFT AND RIGHT VENTILATION TEMPERATURE SEPARATELY CONTROL SYSTEM : Component Part Location

INFOID:000000000959914

ENGINE COMPARTMENT

AUTOMATIC AIR CONDITIONER SYSTEM

< FUNCTION DIAGNOSIS >

[AUTOMATIC AIR CONDITIONER]

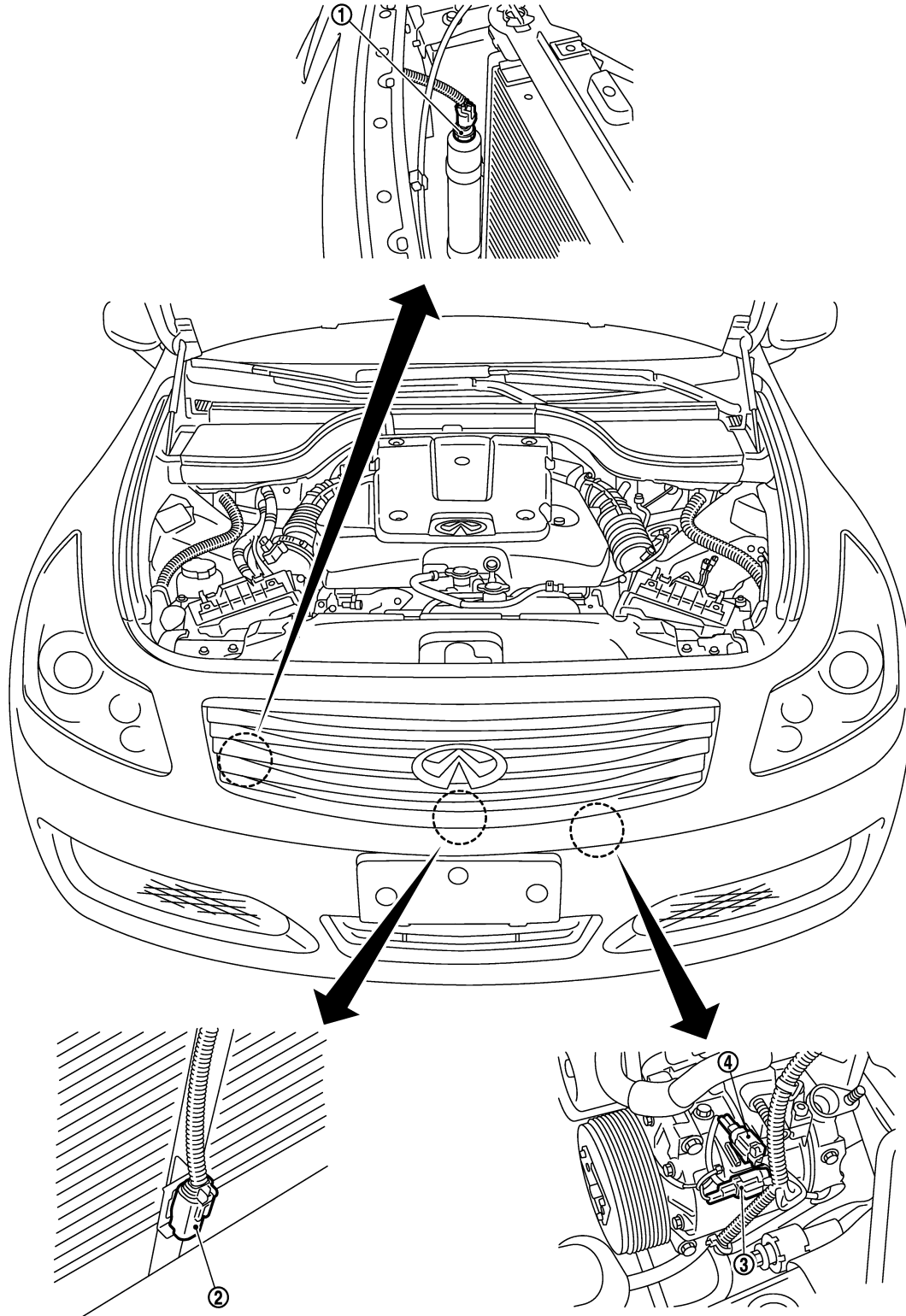

JSIAA0081ZZ

- 1. Refrigerant pressure sensor
- 4. Compressor (ECV)

- 2. Ambient sensor

- 3. Compressor (magnet clutch)

PASSENGER COMPARTMENT

AUTOMATIC AIR CONDITIONER SYSTEM

< FUNCTION DIAGNOSIS >

[AUTOMATIC AIR CONDITIONER]

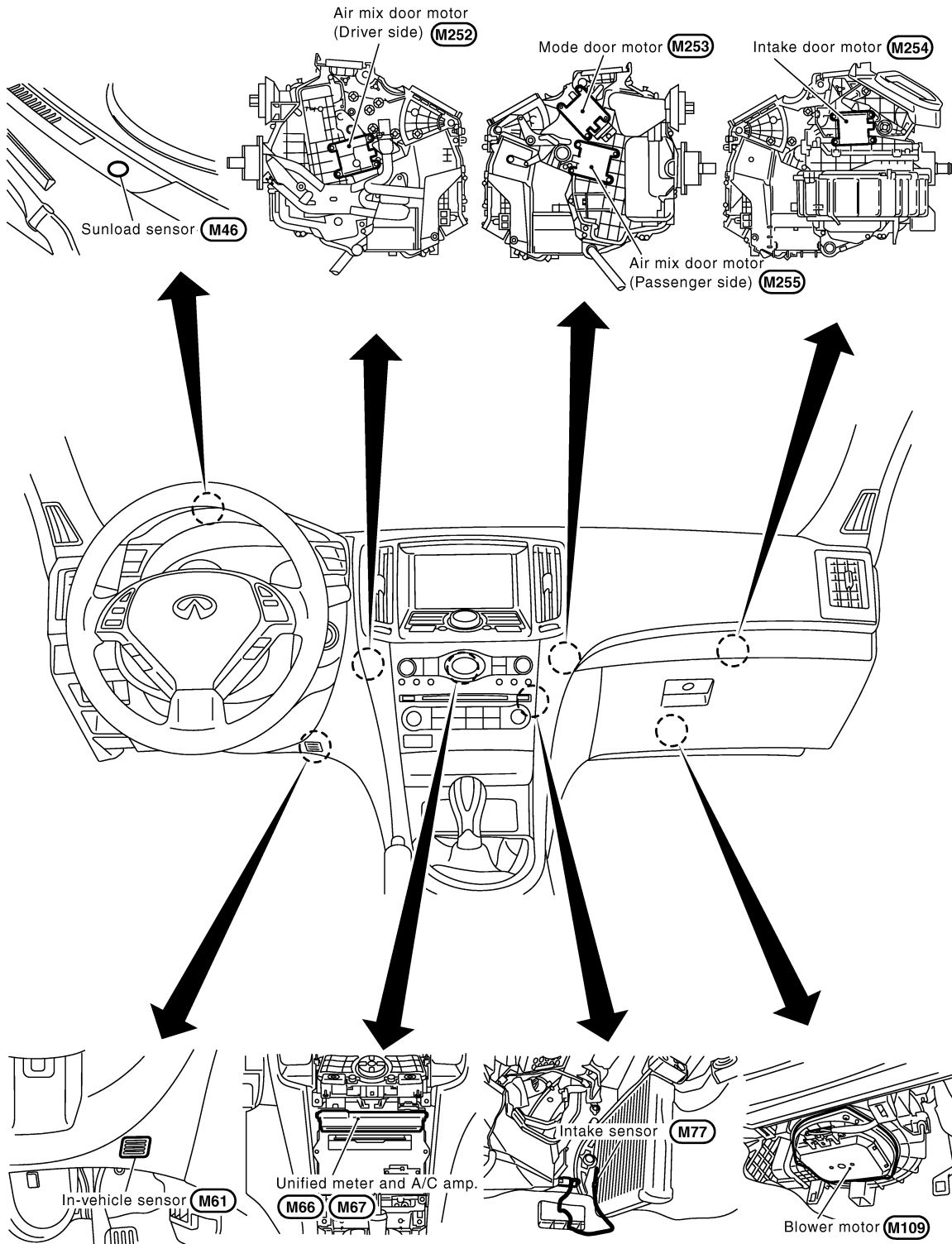

JSIIA0082GB

- | | | |
|-------------------------------------|--------------------|--|
| 1. Intake door motor | 2. Mode door motor | 3. Air mix door motor (passenger side) |
| 4. Air mix door motor (driver side) | 5. Sunload sensor | 6. In-vehicle sensor |
| 7. Unified meter and A/C amp. | 8. Intake sensor | 9. Blower motor |

WITH LEFT AND RIGHT VENTILATION TEMPERATURE SEPARATELY CONTROL SYSTEM : Component Description

INFOID:000000000959915

A
B
C
D
E
F
G
H
HAC
J
K
L
M
N
O
P

AUTOMATIC AIR CONDITIONER SYSTEM

< FUNCTION DIAGNOSIS >

[AUTOMATIC AIR CONDITIONER]

Component	Reference
Air mix door motor	HAC-74. "WITH LEFT AND RIGHT VENTILATION TEMPERATURE SEPARATELY CONTROL SYSTEM : Description"
Ambient sensor	HAC-93. "Description"
Blower motor	HAC-86. "WITH LEFT AND RIGHT VENTILATION TEMPERATURE SEPARATELY CONTROL SYSTEM : Description"
Compressor	HAC-90. "Description"
intake door motor	HAC-80. "Description"
intake sensor	HAC-102. "Description"
In-vehicle sensor	HAC-96. "Description"
Mode door motor	HAC-69. "Description"
Refrigerant pressure sensor	HAC-92. "Component Inspection"
Sunload sensor	HAC-99. "Description"
Unified meter and A/C amp.	HAC-105. "Description"

CAN COMMUNICATION SYSTEM

System Description

INFOID:000000000959916

CAN (Controller Area Network) is a serial communication line for real time application. It is an on-vehicle multiplex communication line with high data communication speed and excellent error detection ability. Many electronic control units are equipped onto a vehicle, and each control unit shares information and links with other control units during operation (not independent). In CAN communication, control units are connected with 2 communication lines (CAN-H line, CAN-L line) allowing a high rate of information transmission with less wiring. Each control unit transmits/receives data but selectively reads required data only. For details, refer to [LAN-27, "CAN System Specification Chart"](#).

A
B
C
D
E
F
G
H
J
K
L
M
N
O
P

HAC

DIAGNOSIS SYSTEM (AUTO AMP.)

< FUNCTION DIAGNOSIS >

[AUTOMATIC AIR CONDITIONER]

DIAGNOSIS SYSTEM (AUTO AMP.)

WITHOUT LEFT AND RIGHT VENTILATION TEMPERATURE SEPARATELY CONTROL SYSTEM

WITHOUT LEFT AND RIGHT VENTILATION TEMPERATURE SEPARATELY CONTROL SYSTEM : Diagnosis Description

INFOID:000000000959917

SELF-DIAGNOSIS SYSTEM

The self-diagnosis system is built into the unified meter and A/C amp. to quickly locate the cause of malfunctions.

SELF-DIAGNOSIS FUNCTION

The self-diagnosis system diagnoses sensors, door motors, blower motor, etc. by system line. Refer to applicable sections (items) for details. Shifting from normal control to the self-diagnosis system is accomplished by starting the engine (turning the ignition switch ON) and pressing OFF switch for at least 5 seconds. The OFF switch must be pressed within 10 seconds after starting the engine (ignition switch is turned ON). This system will be canceled by either pressing AUTO switch or turning the ignition switch OFF. Shifting from one step is accomplished by means of turning temperature control dial, as required.

DIAGNOSIS SYSTEM (AUTO AMP.)

[AUTOMATIC AIR CONDITIONER]

< FUNCTION DIAGNOSIS >

Shifting from STEP-5 to AUXILIARY MECHANISM is accomplished by means of turning fan control dial clockwise.

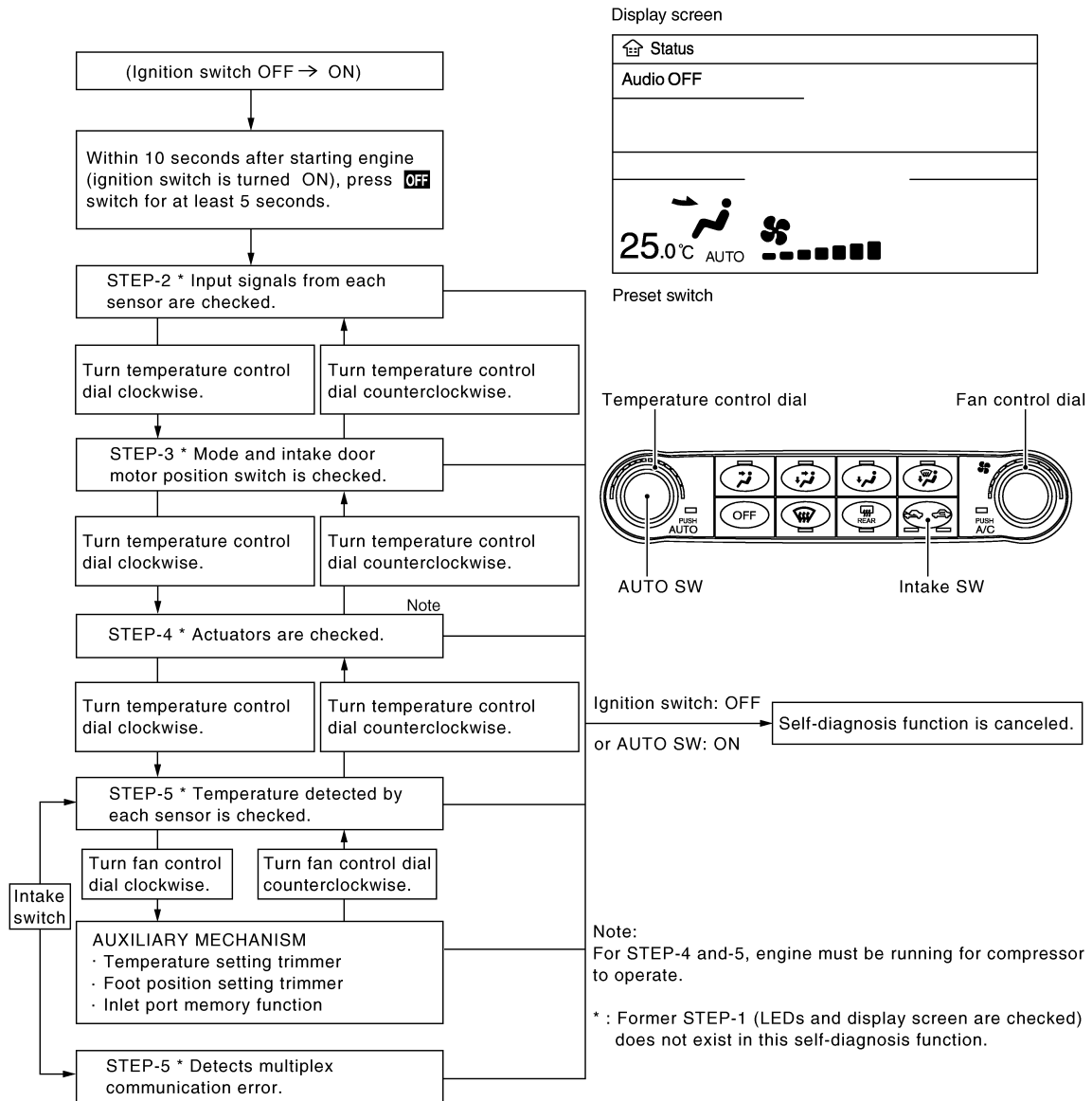

JSIIA0119GB

CONFORMATION METHOD

1. SET IN SELF-DIAGNOSIS MODE

1. Turn ignition switch ON.
2. Set in self-diagnosis mode as follows. Within 10 seconds after starting engine (ignition switch is turned ON.), press OFF switch for at least 5 seconds.

NOTE:

- If battery voltage drops below 12 V during diagnosis STEP-3, door motor speed becomes slower and as a result, the system may generate an error even when operation is normal. To avoid this, start engine before performing this diagnosis.
- Former STEP-1 (LEDs and display screen are checked) does not exist in this self-diagnosis function.
- OFF switch may not be recognized according to the timing of pressing it. Operate OFF switch after turning the intake switch LEDs (REC/FRE) ON.

>> GO TO 2.

2. STEP-2: SENSOR AND DOOR MOTOR CIRCUITS ARE CHECKED FOR OPEN OR SHORT CIRCUIT

DIAGNOSIS SYSTEM (AUTO AMP.)

< FUNCTION DIAGNOSIS >

[AUTOMATIC AIR CONDITIONER]

Does code No. 20 appear on the display?

- YES >> GO TO 3.
- NO >> GO TO 11.

Display (when all sensors are in good order)

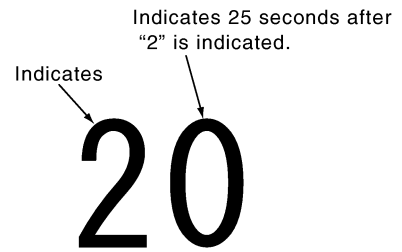

SJIA1778E

3.STEP-3: MODE DOOR AND INTAKE DOOR POSITIONS ARE CHECKED

Turn temperature control dial clockwise.

Does code No. 30 appear on the display?

- YES >> GO TO 4.
- NO >> GO TO 12.

Display (when all doors are in good order)

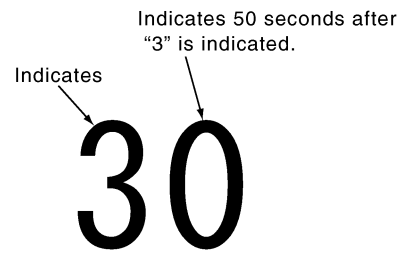

SJIA1779E

4.STEP-4: OPERATION OF EACH DOOR MOTOR IS CHECKED

1. Turn temperature control dial clockwise.
2. Press  (DEF) switch. Code No. of each door motor test is indicated on the display.

>> GO TO 5.

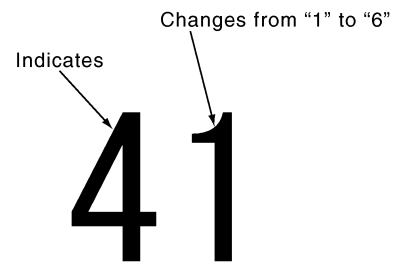





SJIA1780E

5.CHECK ACTUATORS

Refer to the following chart and check discharge air flow, air temperature, blower motor duty ratio and compressor operation.

Without rear ventilation

Discharge air flow				
Mode position indication	Air outlet/distribution			
	VENT	FOOT		DEF
		Front	Rear	
	100%	—	—	—
	53%	29%	18%	—
	11%	39%	24%	26%
	9%	33%	21%	37%
	16%	—	—	84%

JSIIA0242GB

DIAGNOSIS SYSTEM (AUTO AMP.)

< FUNCTION DIAGNOSIS >

[AUTOMATIC AIR CONDITIONER]

With rear ventilation

Discharge air flow						
Mode position indication	Condition	Air outlet/distribution				
		VENT		FOOT		DEF
		Front	Rear	Front	Rear	
	Rear ventilator door: OPEN	88%	12%	—	—	—
		49%	10%	25%	16%	—
		10%	12%	33%	22%	23%
		9%	11%	29%	18%	33%
		15%	—	—	—	85%

JSIIA0243GB

Code No.	41	42	43	44	45	46
Mode door position	VENT	B/L 1	B/L 2	FOOT	D/F	DEF
Intake door position	REC	REC	20% FRE	FRE	FRE	FRE
Air mix door position	FULL COOL	FULL COOL	FULL HOT	FULL HOT	FULL HOT	FULL HOT
Blower motor duty ratio	37%	91%	65%	65%	65%	91%
Compressor	ON	ON	OFF	OFF	ON	ON
Electronic control valve (ECV) duty ratio	100%	100%	0%	0%	50%	100%

Checks must be made visually, by listening the sound, or by touching air outlets with hand, etc. for improper operation.

Is the inspection result normal?

YES >> GO TO 6.

NO-1 >> Air outlet does not change. Go to Mode Door Motor Circuit. Refer to [HAC-69, "Diagnosis Procedure"](#).

NO-2 >> Intake door does not change. Go to Intake Door Motor Circuit. Refer to [HAC-80, "Diagnosis Procedure"](#).

NO-3 >> Discharge air temperature does not change. Go to Air Mix Door Motor Circuit. Refer to [HAC-72, "WITHOUT LEFT AND RIGHT VENTILATION TEMPERATURE SEPARATELY CONTROL SYSTEM : Diagnosis Procedure"](#).

NO-4 >> Blower motor operation is malfunctioning. Go to Blower Motor Circuit. Refer to [HAC-83, "WITHOUT LEFT AND RIGHT VENTILATION TEMPERATURE SEPARATELY CONTROL SYSTEM : Diagnosis Procedure"](#).

NO-5 >> Magnet clutch does not engage. Go to Magnet Clutch Circuit. Refer to [HAC-90, "Diagnosis Procedure"](#).

6. STEP-5: TEMPERATURE OF EACH SENSOR IS CHECKED

1. Turn temperature control dial clockwise.
2. Code No. 51 appears on the display.

>> GO TO 7.

7. CHECK AMBIENT SENSOR

DIAGNOSIS SYSTEM (AUTO AMP.)

[AUTOMATIC AIR CONDITIONER]

< FUNCTION DIAGNOSIS >

Press  (DEF) switch one time. Temperature detected by ambient sensor is indicated on the display.

NOTE:

If the temperature indicated on the display greatly differs from the actual temperature, check sensor circuit first, and then check sensor.

Is the inspection result normal?

YES >> GO TO 8.

NO >> Go to Ambient Sensor Circuit. Refer to [HAC-93. "Diagnosis Procedure"](#).

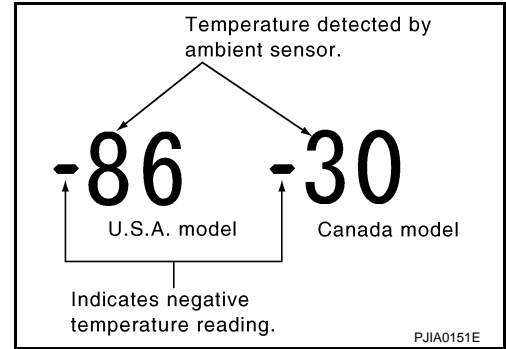

8.CHECK IN-VEHICLE SENSOR

Press  (DEF) switch for the second time. Temperature detected by in-vehicle sensor is indicated on the display.

NOTE:

If the temperature indicated on the display greatly differs from the actual temperature, check sensor circuit first, and then check sensor.

Is the inspection result normal?

YES >> GO TO 9.

NO >> Go to In-vehicle Sensor Circuit. Refer to [HAC-97. "Diagnosis Procedure"](#).

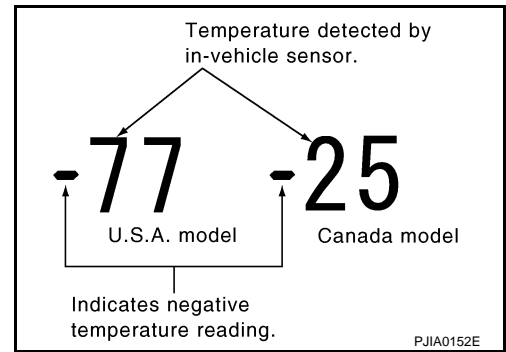

9.CHECK INTAKE SENSOR

Press  (DEF) switch for the third time. Temperature detected by intake sensor is indicated on the display.

NOTE:

If the temperature indicated on the display greatly differs from the actual temperature, check sensor circuit first, and then check sensor.

Is the inspection result normal?

YES >> GO TO 10.

NO >> Go to Intake Sensor Circuit. Refer to [HAC-102. "Diagnosis Procedure"](#).

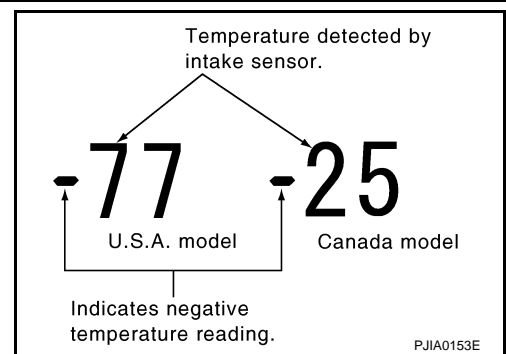

10.CHECK CAN COMMUNICATION ERROR

1. Press intake switch.
2. CAN communication error between each unit that uses the unified meter and A/C amp. can be detected as self-diagnosis results. (If plural errors occur, the display of each error will blink twice for 0.5 second intervals.)

Is the inspection result normal?

YES >> INSPECTION END

NO >> Go to CAN communication. Refer to [MWI-40. "Diagnosis Procedure"](#).

- Unified meter and A/C amp. - AV control unit

Display	CAN communication error
52	In good order
52 ■■■■■■	AV C/U ⇨ Unified meter and A/C amp.
52 ■■■■■■	Unified meter and A/C amp. ⇨ All unit

JSIIA0138GB

11.CHECK MALFUNCTIONING SENSOR AND DOOR MOTOR

Refer to the following chart for malfunctioning code No.

(If two or more sensors and door motor malfunction, corresponding code Nos. indicates 1 second each.)

Code No.	Malfunctioning sensor and door motor (Including circuits)	Reference page
21 / -21	Ambient sensor	HAC-93. "Diagnosis Procedure"
22 / -22	In-vehicle sensor	HAC-97. "Diagnosis Procedure"

DIAGNOSIS SYSTEM (AUTO AMP.)

[AUTOMATIC AIR CONDITIONER]

< FUNCTION DIAGNOSIS >

Code No.	Malfunctioning sensor and door motor (Including circuits)	Reference page
24 / -24	Intake sensor	HAC-102, "Diagnosis Procedure"
25 / -25	Sunload sensor *	HAC-99, "Diagnosis Procedure"
26 / -26	Air mix door motor PBR	HAC-72, "WITHOUT LEFT AND RIGHT VENTILATION TEMPERATURE SEPARATELY CONTROL SYSTEM : Diagnosis Procedure"

*: Perform self-diagnosis STEP-2 under sunshine.

When performing indoors, aim a light (more than 60 W) at sunload sensor, otherwise code No. 25 will indicate despite that sunload sensor is functioning properly.

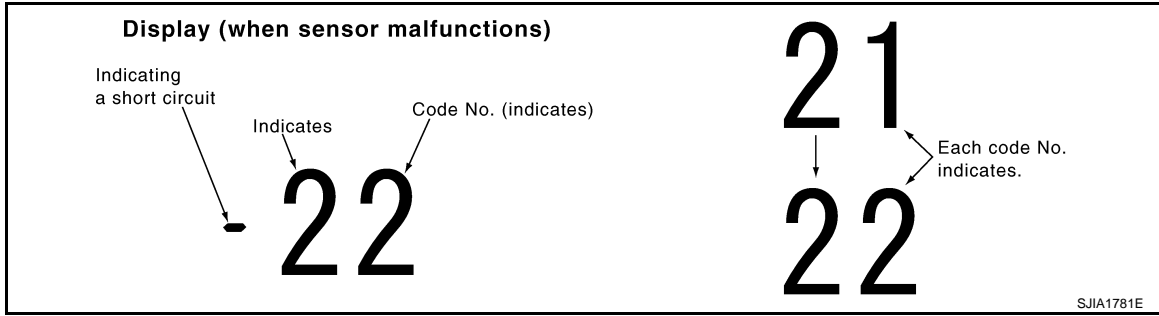

>> INSPECTION END

12.CHECK MALFUNCTIONING DOOR MOTOR POSITION SWITCH

Mode and/or intake door motor PBR(s) is/are malfunctioning.

Code No. *1 *2	Mode or intake door position	Reference page
31	VENT	HAC-69, "Diagnosis Procedure"
32	DEF	
37	FRE	HAC-80, "Diagnosis Procedure"
38	20% FRE	
39	REC	

(If two or more mode or intake door motors malfunction, corresponding code Nos. indicates 1 second each.)

*1: If mode door motor harness connector is disconnected, the following display pattern will appear.

31→32→Return to 31

*2: If intake door motor harness connector is disconnected, the following display pattern will appear.

37→38→39→Return to 37

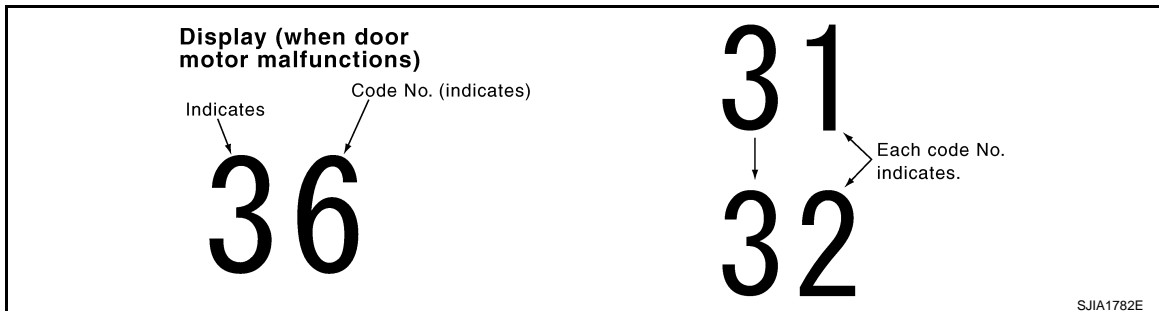

>> INSPECTION END

WITHOUT LEFT AND RIGHT VENTILATION TEMPERATURE SEPARATELY CONTROL SYSTEM : CONSULT-III Function

INFOID:000000000959918

CONSULT-III APPLICATION ITEMS

CONSULT-III can display each diagnosis item using the diagnosis test modes shown following.

DIAGNOSIS SYSTEM (AUTO AMP.)

< FUNCTION DIAGNOSIS >

[AUTOMATIC AIR CONDITIONER]

System part	Check item, diagnosis mode	Description
ECM	Data monitor	Displays ECM input data in real time.

DATA MONITOR

Display Item List

Monitor Item	Condition	Value/Status	
IGN ON SW	Ignition switch OFF → ON	OFF → ON	
FAN ON SIG	Ignition switch ON	Blower fan motor switch ON	ON
		Blower fan motor switch OFF	OFF
AIR COND SW	Ignition switch ON	Compressor ON	ON
		Compressor OFF	OFF
REFRIGERANT PRESSURE SENSOR	<ul style="list-style-type: none">• Engine is running• Warm-up condition• Both A/C switch and blower fan motor switch: ON (Compressor operates)	1.0 - 4.0 V	

WITH LEFT AND RIGHT VENTILATION TEMPERATURE SEPARATELY CONTROL SYSTEM

WITH LEFT AND RIGHT VENTILATION TEMPERATURE SEPARATELY CONTROL SYSTEM : Diagnosis Description

INFOID:000000000959919

SELF-DIAGNOSIS SYSTEM

The self-diagnosis system is built into the unified meter and A/C amp. to quickly locate the cause of malfunctions.

SELF-DIAGNOSIS FUNCTION

The self-diagnosis system diagnoses sensors, door motors, blower motor, etc. by system line. Refer to applicable sections (items) for details. Shifting from normal control to the self-diagnosis system is accomplished by starting the engine (turning the ignition switch ON) and pressing OFF switch for at least 5 seconds. The OFF switch must be pressed within 10 seconds after starting the engine (ignition switch is turned ON). This system will be canceled by either pressing AUTO switch or turning the ignition switch OFF. Shifting from one step is accomplished by means of turning temperature control dial (driver side), as required.

DIAGNOSIS SYSTEM (AUTO AMP.)

[AUTOMATIC AIR CONDITIONER]

< FUNCTION DIAGNOSIS >

Shifting from STEP-5 to AUXILIARY MECHANISM is accomplished by means of pressing fan (UP:+) switch.

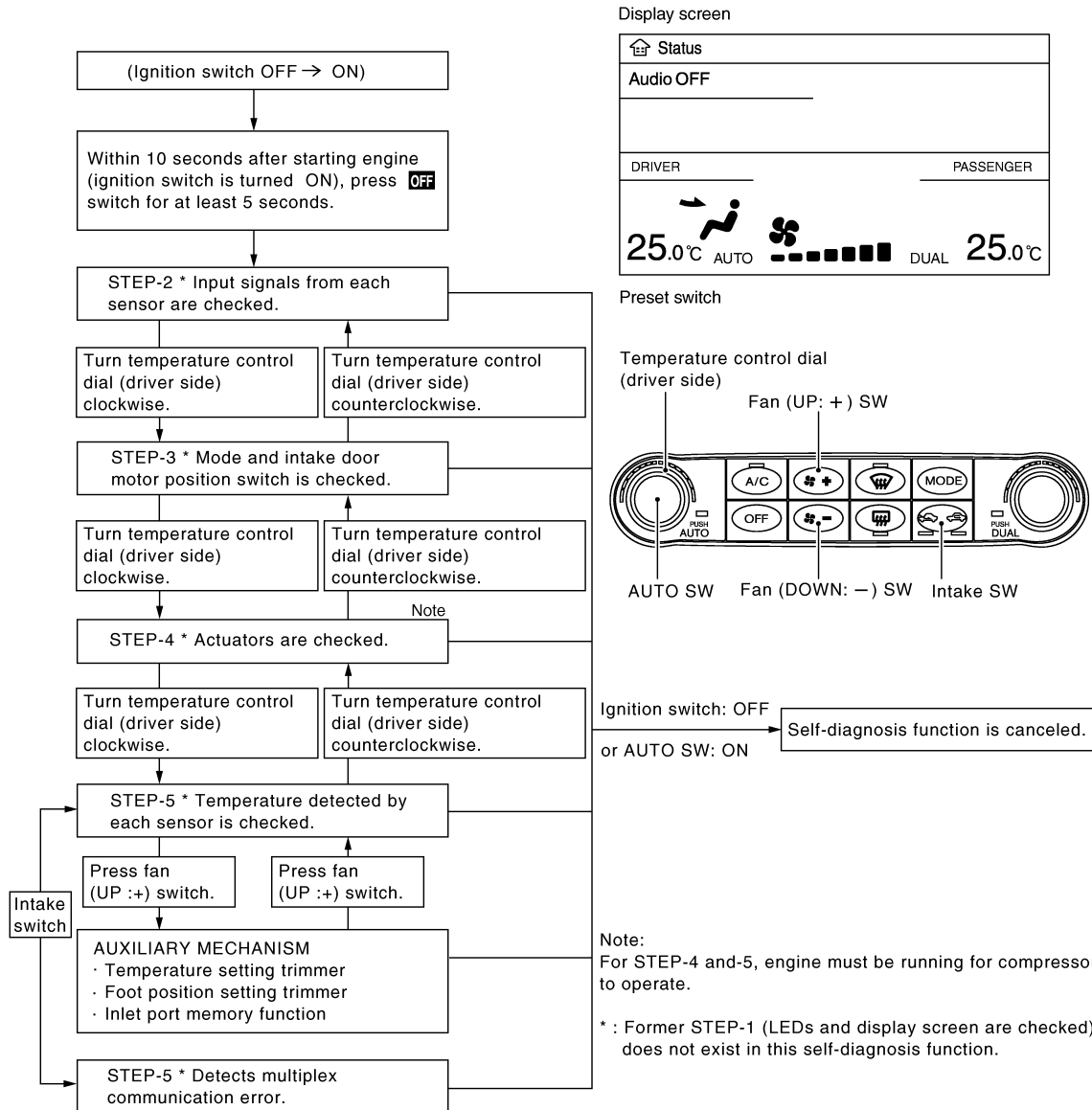

JSIIA0059GB

CONFORMATION METHOD

1.SET IN SELF-DIAGNOSIS MODE

1. Turn ignition switch ON.
2. Set in self-diagnosis mode as follows. Within 10 seconds after starting engine (ignition switch is turned ON.), press OFF switch for at least 5 seconds.

NOTE:

- If battery voltage drops below 12 V during diagnosis STEP-3, door motor speed becomes slower and as a result, the system may generate an error even when operation is normal. To avoid this, start engine before performing this diagnosis.
- Former STEP-1 (LEDs and display screen are checked) does not exist in this self-diagnosis function.
- OFF switch may not be recognized according to the timing of pressing it. Operate OFF switch after turning the intake switch LEDs (REC/FRE) ON.

>> GO TO 2.

2.STEP-2: SENSOR AND DOOR MOTOR CIRCUITS ARE CHECKED FOR OPEN OR SHORT CIRCUIT

DIAGNOSIS SYSTEM (AUTO AMP.)

< FUNCTION DIAGNOSIS >

[AUTOMATIC AIR CONDITIONER]

Does code No. 20 appear on the display?

- YES >> GO TO 3.
- NO >> GO TO 11.

Display (when all sensors are in good order)

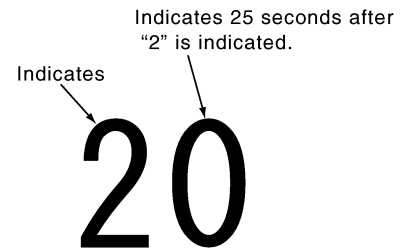

SJIA1778E

3.STEP-3: MODE DOOR AND INTAKE DOOR POSITIONS ARE CHECKED

Turn temperature control dial (driver side) clockwise.

Does code No. 30 appear on the display?

- YES >> GO TO 4.
- NO >> GO TO 12.

Display (when all doors are in good order)

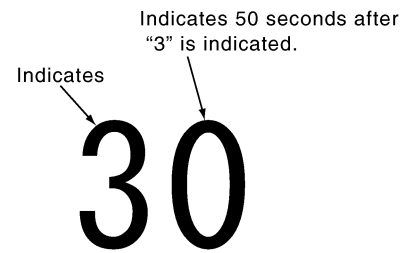

SJIA1779E

4.STEP-4: OPERATION OF EACH DOOR MOTOR IS CHECKED

1. Turn temperature control dial (driver side) clockwise.
2. Press  (DEF) switch. Code No. of each door motor test is indicated on the display.

>> GO TO 5.







SJIA1780E

5.CHECK ACTUATORS

Refer to the following chart and check discharge air flow, air temperature, blower motor duty ratio and compressor operation.

Without rear ventilation

Discharge air flow					
Mode position indication	Condition	Air outlet/distribution			
		VENT	FOOT		DEF
			Front	Rear	
	DUAL SW: OFF	100%	—	—	—
		53%	29%	18%	—
		11%	39%	24%	26%
		9%	33%	21%	37%
		16%	—	—	84%

JSIIA0111GB

DIAGNOSIS SYSTEM (AUTO AMP.)

[AUTOMATIC AIR CONDITIONER]

< FUNCTION DIAGNOSIS >

With rear ventilation

Discharge air flow						
Mode position indication	Condition	Air outlet/distribution				
		VENT		FOOT		DEF
		Front	Rear	Front	Rear	
	DUAL SW: OFF Rear ventilator door: OPEN	88%	12%	—	—	—
		49%	10%	25%	16%	—
		10%	12%	33%	22%	23%
		9%	11%	29%	18%	33%
		15%	—	—	—	85%

JSIIA0060GB

Code No.	41	42	43	44	45	46
Mode door position	VENT	B/L 1	B/L 2	FOOT	D/F	DEF
Intake door position	REC	REC	20% FRE	FRE	FRE	FRE
Air mix door position	FULL COOL	FULL COOL	FULL HOT	FULL HOT	FULL HOT	FULL HOT
Blower motor duty ratio	37%	91%	65%	65%	65%	91%
Compressor	ON	ON	OFF	OFF	ON	ON
Electronic control valve (ECV) duty ratio	100%	100%	0%	0%	50%	100%

Checks must be made visually, by listening the sound, or by touching air outlets with hand, etc. for improper operation.

Is this inspection result normal?

YES >> GO TO 6.

NO-1 >> Air outlet does not change. Go to Mode Door Motor Circuit. Refer to [HAC-69, "Diagnosis Procedure"](#).

NO-2 >> Intake door does not change. Go to Intake Door Motor Circuit. Refer to [HAC-80, "Diagnosis Procedure"](#).

NO-3 >> Discharge air temperature does not change. Go to Air Mix Door Motor Circuit. Refer to [HAC-75, "WITH LEFT AND RIGHT VENTILATION TEMPERATURE SEPARATELY CONTROL SYSTEM : Diagnosis Procedure"](#).

NO-4 >> Blower motor operation is malfunctioning. Go to Blower Motor Circuit. Refer to [HAC-86, "WITH LEFT AND RIGHT VENTILATION TEMPERATURE SEPARATELY CONTROL SYSTEM : Diagnosis Procedure"](#).

NO-5 >> Magnet clutch does not engage. Go to Magnet Clutch Circuit. Refer to [HAC-90, "Diagnosis Procedure"](#).

6. STEP-5: TEMPERATURE OF EACH SENSOR IS CHECKED

1. Turn temperature control dial (driver side) clockwise.
2. Code No. 51 appears on the display.

>> GO TO 7.

7. CHECK AMBIENT SENSOR

DIAGNOSIS SYSTEM (AUTO AMP.)

[AUTOMATIC AIR CONDITIONER]

< FUNCTION DIAGNOSIS >

Press  (DEF) switch one time. Temperature detected by ambient sensor is indicated on the display.

NOTE:

If the temperature indicated on the display greatly differs from the actual temperature, check sensor circuit first, and then check sensor.

Is this inspection result normal?

YES >> GO TO 8.

NO >> Go to Ambient Sensor Circuit. Refer to [HAC-93. "Diagnosis Procedure"](#).

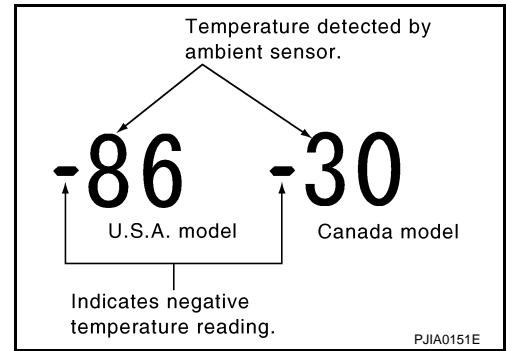

8.CHECK IN-VEHICLE SENSOR

Press  (DEF) switch for the second time. Temperature detected by in-vehicle sensor is indicated on the display.

NOTE:

If the temperature indicated on the display greatly differs from the actual temperature, check sensor circuit first, and then check sensor.

Is this inspection result normal?

YES >> GO TO 9.

NO >> Go to In-vehicle Sensor Circuit. Refer to [HAC-97. "Diagnosis Procedure"](#).

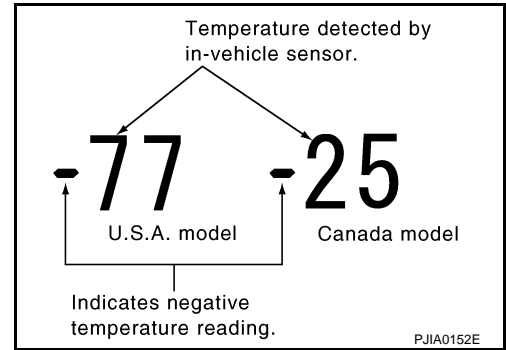

9.CHECK INTAKE SENSOR

Press  (DEF) switch for the third time. Temperature detected by intake sensor is indicated on the display.

NOTE:

If the temperature indicated on the display greatly differs from the actual temperature, check sensor circuit first, and then check sensor.

Is this inspection result normal?

YES >> GO TO 10.

NO >> Go to Intake Sensor Circuit. Refer to [HAC-102. "Diagnosis Procedure"](#).

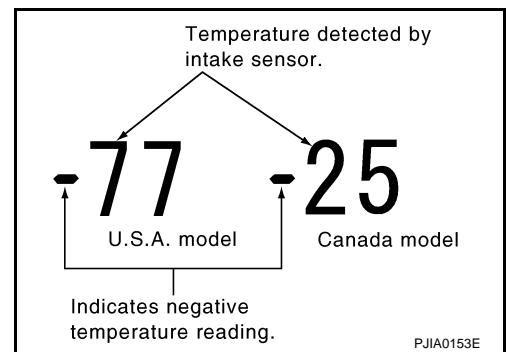

10.CHECK CAN COMMUNICATION ERROR

1. Press intake switch.
2. CAN communication error between each unit that uses the unified meter and A/C amp. can be detected as self-diagnosis results. (If plural errors occur, the display of each error will blink twice for 0.5 second intervals.)

Is the inspection result normal?

YES >> INSPECTION END

NO >> Go to CAN communication. Refer to [MWI-40. "Diagnosis Procedure"](#).

- Unified meter and A/C amp. - AV control unit

Display	CAN communication error
52	In good order
52 ■■■■■■	AV C/U ⇨ Unified meter and A/C amp.
52 ■■■■■■	Unified meter and A/C amp. ⇨ All unit

JSIIA0138GB

11.CHECK MALFUNCTIONING SENSOR AND DOOR MOTOR

Refer to the following chart for malfunctioning code No.

(If two or more sensors and door motors malfunction, corresponding code Nos. indicates 1 second each.)

(If two door motors malfunction, corresponding code Nos. indicates 0.5 second each.)

DIAGNOSIS SYSTEM (AUTO AMP.)

< FUNCTION DIAGNOSIS >

[AUTOMATIC AIR CONDITIONER]

Code No.	Malfunctioning sensor and door motor (Including circuits)	Reference page
21 / -21	Ambient sensor	HAC-93. "Diagnosis Procedure"
22 / -22	In-vehicle sensor	HAC-97. "Diagnosis Procedure"
24 / -24	Intake sensor	HAC-102. "Diagnosis Procedure"
25 / -25	Sunload sensor *	HAC-99. "Diagnosis Procedure"
26 / -26	Air mix door motor PBR (Driver side)	HAC-75. "WITH LEFT AND RIGHT VENTILATION TEMPERATURE SEPARATELY CONTROL SYSTEM : Diagnosis Procedure"
27 / -27	Air mix door motor PBR (Passenger side)	

*: Perform self-diagnosis STEP-2 under sunshine.

When performing indoors, aim a light (more than 60 W) at sunload sensor, otherwise code No. 25 will indicate despite that sunload sensor is functioning properly.

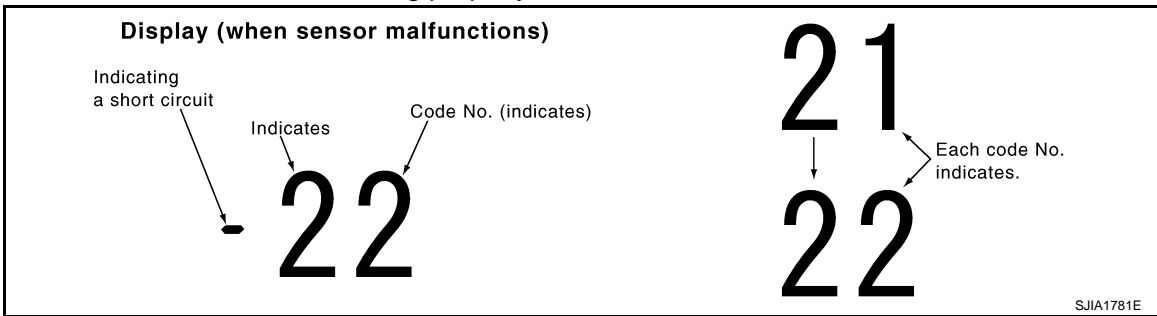

>> INSPECTION END

12.CHECK MALFUNCTIONING DOOR MOTOR POSITION SWITCH

Mode and/or intake door motor PBR(s) is/are malfunctioning.

Code No. *1 *2	Mode or intake door position	Reference page
31	VENT	HAC-69. "Diagnosis Procedure"
32	DEF	
37	FRE	
38	20% FRE	HAC-80. "Diagnosis Procedure"
39	REC	

(If two or more mode or intake door motors malfunction, corresponding code Nos. indicates 1 second each.)

*1: If mode door motor harness connector is disconnected, the following display pattern will appear.

31→32→Return to 31

*2: If intake door motor harness connector is disconnected, the following display pattern will appear.

37→38→39→Return to 37

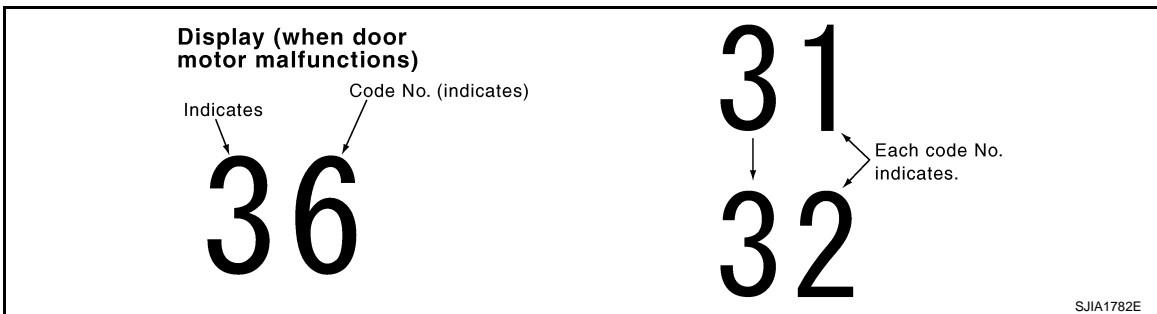

>> INSPECTION END

WITH LEFT AND RIGHT VENTILATION TEMPERATURE SEPARATELY CONTROL SYSTEM : CONSULT-III Function

INFOID:000000000959920

DIAGNOSIS SYSTEM (AUTO AMP.)

[AUTOMATIC AIR CONDITIONER]

< FUNCTION DIAGNOSIS >

CONSULT-III APPLICATION ITEMS

CONSULT-III can display each diagnosis item using the diagnosis test modes shown following.

System part	Check item, diagnosis mode	Description
ECM	Data monitor	Displays ECM input data in real time.

DATA MONITOR

Display Item List

Monitor Item	Condition		Value/Status
IGN ON SW	Ignition switch OFF → ON		OFF → ON
FAN ON SIG	Ignition switch ON	Blower fan motor switch ON	ON
		Blower fan motor switch OFF	OFF
AIR COND SW	Ignition switch ON	Compressor ON	ON
		Compressor OFF	OFF
REFRIGERANT PRESSURE SENSOR	<ul style="list-style-type: none">• Engine is running• Warm-up condition• Both A/C switch and blower fan motor switch: ON (Compressor operates)		1.0 - 4.0 V

MODE DOOR CONTROL SYSTEM

< FUNCTION DIAGNOSIS >

[AUTOMATIC AIR CONDITIONER]

MODE DOOR CONTROL SYSTEM

Description

INFOID:000000000959921

SYSTEM DESCRIPTION

Component Parts

Mode door control system components are:

- Unified meter and A/C amp.
- Mode door motor (LCU)
- A/C LAN system (PBR built-in mode door motor, air mix door motor and intake door motor)
- In-vehicle sensor
- Ambient sensor
- Sunload sensor
- Intake sensor

System Operation

- The unified meter and A/C amp. receives data from each of the sensors.
- The unified meter and A/C amp. sends air mix door, mode door and intake door opening angle data to the air mix door motor LCU(s), mode door motor LCU and intake door motor LCU.
- The air mix door motor(s), mode door motor and intake door motor read their respective signals according to the address signal. Opening angle indication signals received from the unified meter and A/C amp. and each of the motor position sensors are compared by the LCUs in each door motor with the existing decision and opening angles.
- Subsequently, HOT/COLD, DEF/VENT and FRE/REC operation is selected. The new selection data are returned to the unified meter and A/C amp.

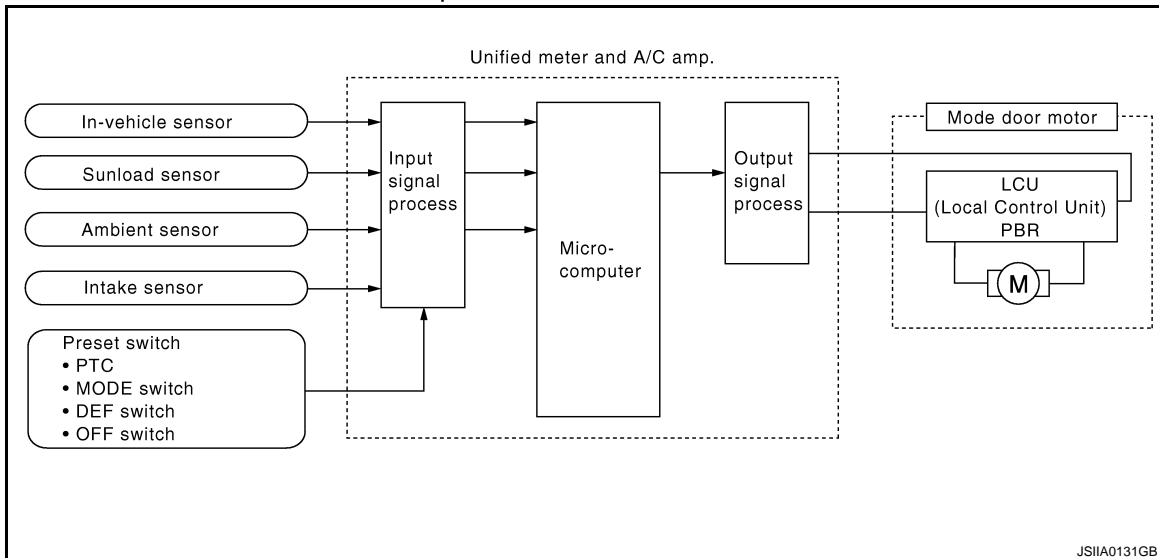

A
B
C
D
E
F
G
H
HAC
J
K
L
M
N
O
P

MODE DOOR CONTROL SYSTEM

[AUTOMATIC AIR CONDITIONER]

< FUNCTION DIAGNOSIS >

LAN System Circuit

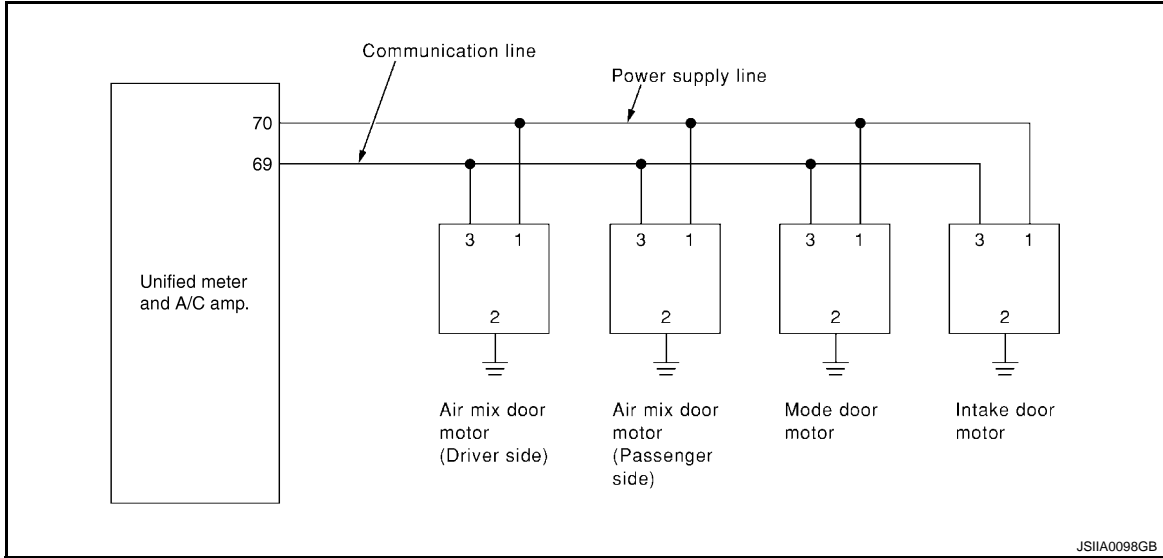

Mode Door Control Specification

Mode position can be selected manually by pressing MODE switch or DEF switch of the preset switch. This enables to fix a mode position. Automatic control by unified meter and A/C amp. Pressing AUTO switch allows automatic control by unified meter and A/C amp. During the automatic control of mode position, a mode door position (VENT, B/L, FOOT, or D/F) is selected based on a target air mix door opening angle and sunload depending on a temperature calculated by unified meter and A/C amp. In addition, D/F is selected to prevent windshield fogging only when ambient temperature is extremely low with mode position FOOT.

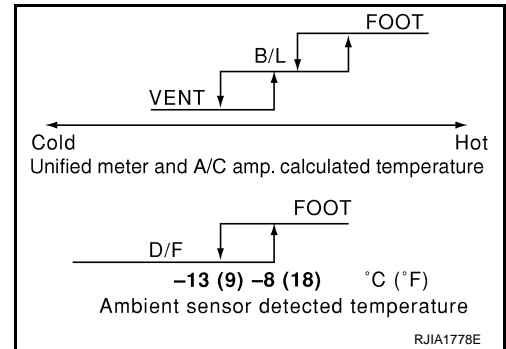

AIR MIX DOOR CONTROL SYSTEM

< FUNCTION DIAGNOSIS >

[AUTOMATIC AIR CONDITIONER]

AIR MIX DOOR CONTROL SYSTEM

WITHOUT LEFT AND RIGHT VENTILATION TEMPERATURE SEPARATELY CONTROL SYSTEM

WITHOUT LEFT AND RIGHT VENTILATION TEMPERATURE SEPARATELY CONTROL SYSTEM : Description

INFOID:000000000959922

SYSTEM DESCRIPTION

Component Parts

Air mix door control system components are:

- Unified meter and A/C amp.
- Air mix door motor (LCU)
- A/C LAN system (PBR built-in mode door motor, air mix door motor and intake door motor)
- In-vehicle sensor
- Ambient sensor
- Sunload sensor
- Intake sensor

System Operation

The unified meter and A/C amp. receives data from each of the sensors. The unified meter and A/C amp. sends air mix doors, mode door and intake door opening angle data to the air mix door motor LCUs, mode door motor LCU and intake door motor LCU.

The air mix door motors, mode door motor and intake door motor read their respective signals according to the address signal. Opening angle indication signals received from the unified meter and A/C amp. and each of the motor position sensors are compared by the LCUs in each door motor with the existing decision and opening angles. Subsequently, HOT/COLD, DEF/VENT and FRE/REC operation is selected. The new selection data are returned to the unified meter and A/C amp.

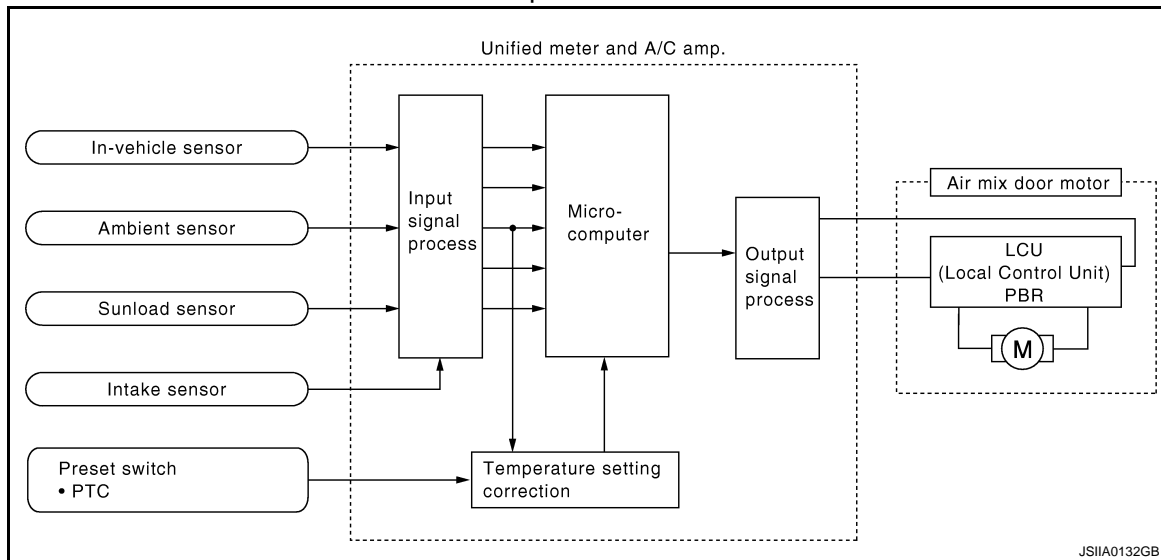

AIR MIX DOOR CONTROL SYSTEM

< FUNCTION DIAGNOSIS >

[AUTOMATIC AIR CONDITIONER]

LAN System Circuit

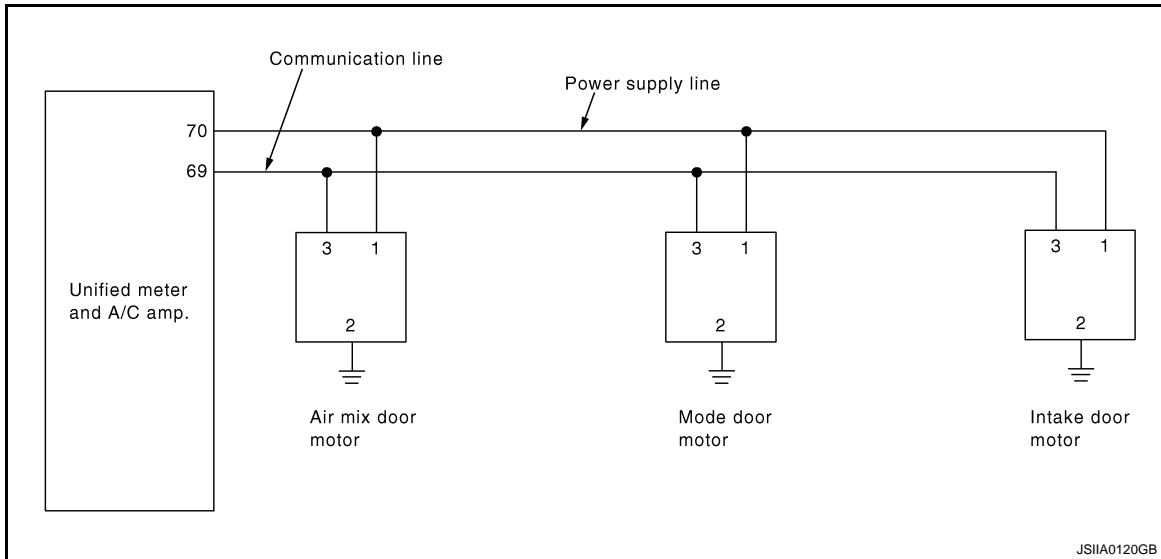

Air Mix Door Control Specification

When ignition switch is ON, unified meter and A/C amp. continuously and automatically controls temperatures regardless of air conditioner operational condition. When setting a target temperature with temperature control dial, unified meter and A/C amp. corrects the set temperature and decides a target air mix door opening angle. Unified meter and A/C amp. controls air mix door according to the target air mix door opening angle and current air mix door opening angle in order to keep an optimum air mix door opening angle. When a temperature is set at 18.0°C (60°F), air mix door is fixed at full cold, and when a temperature is set at 32.0°C (90°F), it is set at full hot.

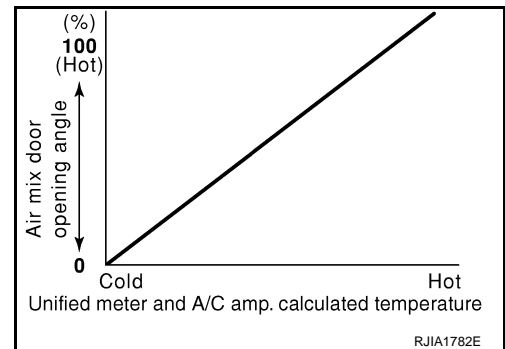

WITH LEFT AND RIGHT VENTILATION TEMPERATURE SEPARATELY CONTROL SYSTEM

WITH LEFT AND RIGHT VENTILATION TEMPERATURE SEPARATELY CONTROL SYSTEM : Description

INFOID:000000000959923

SYSTEM DESCRIPTION

Component Parts

Air mix door control system components are:

- Unified meter and A/C amp.
- Air mix door motor (LCU)
- A/C LAN system (PBR built-in mode door motor, air mix door motor and intake door motor)
- In-vehicle sensor
- Ambient sensor
- Sunload sensor
- Intake sensor

System Operation

The unified meter and A/C amp. receives data from each of the sensors. The unified meter and A/C amp. sends air mix doors, mode door and intake door opening angle data to the air mix door motor LCUs, mode door motor LCU and intake door motor LCU.

The air mix door motors, mode door motor and intake door motor read their respective signals according to the address signal. Opening angle indication signals received from the unified meter and A/C amp. and each of the motor position sensors are compared by the LCUs in each door motor with the existing decision and open-

AIR MIX DOOR CONTROL SYSTEM

[AUTOMATIC AIR CONDITIONER]

< FUNCTION DIAGNOSIS >

ing angles. Subsequently, HOT/COLD, DEF/VENT and FRE/REC operation is selected. The new selection data are returned to the unified meter and A/C amp.

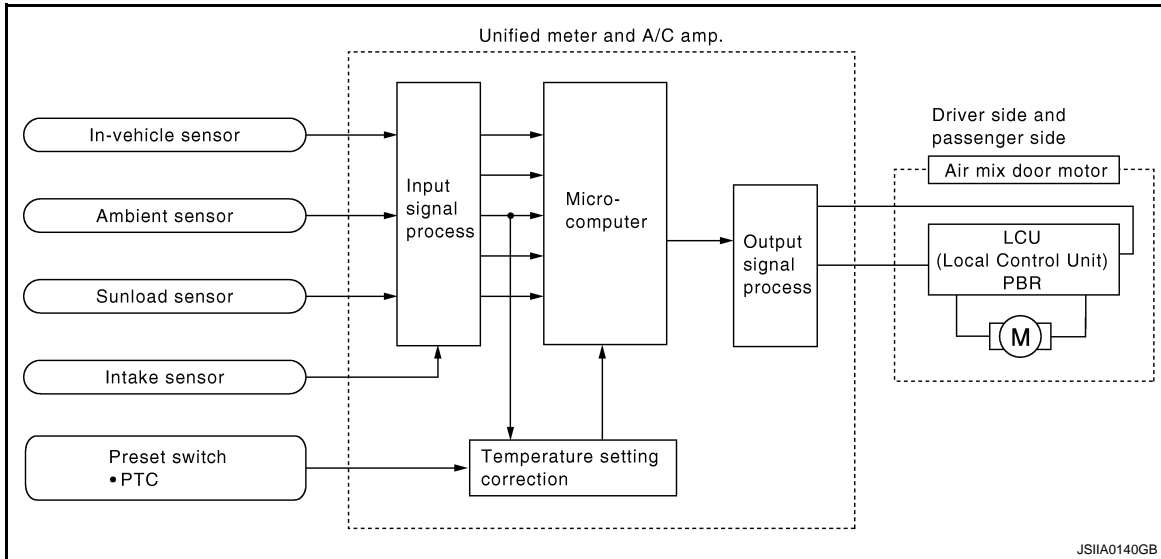

LAN System Circuit

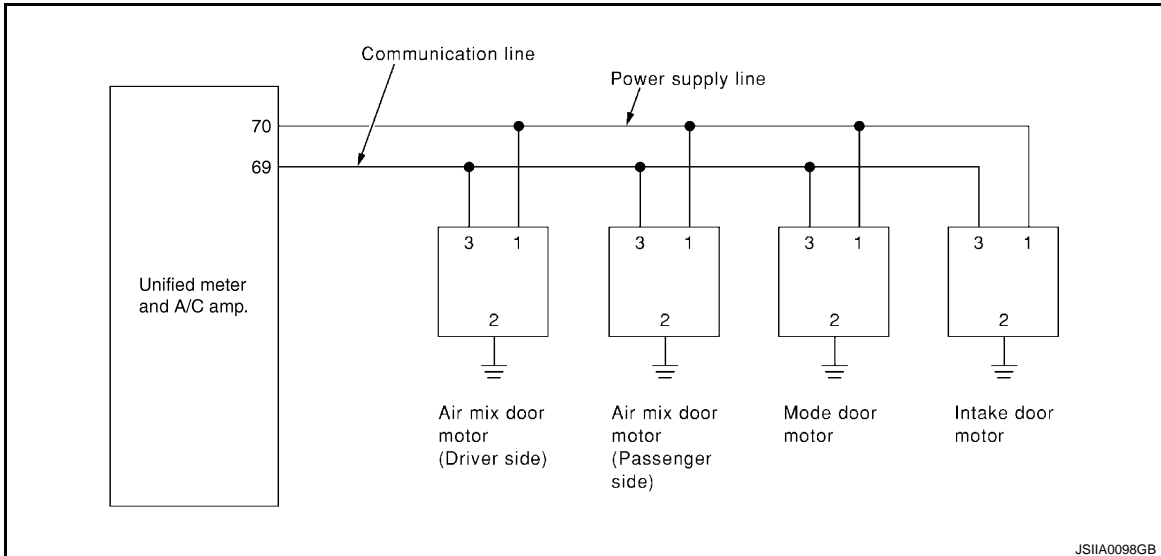

Air Mix Door Control Specification

When ignition switch is ON, unified meter and A/C amp. continuously and automatically controls temperatures regardless of air conditioner operational condition. When setting a target temperature with temperature control dial, unified meter and A/C amp. corrects the set temperature and decides a target air mix door opening angle. Unified meter and A/C amp. controls air mix door according to the target air mix door opening angle and current air mix door opening angle in order to keep an optimum air mix door opening angle. When a temperature is set at 18.0°C (60°F), air mix door is fixed at full cold, and when a temperature is set at 32.0°C (90°F), it is set at full hot.

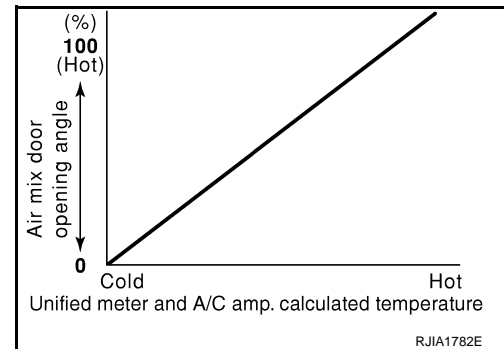

INTAKE DOOR CONTROL SYSTEM

< FUNCTION DIAGNOSIS >

[AUTOMATIC AIR CONDITIONER]

INTAKE DOOR CONTROL SYSTEM

Description

INFOID:000000000959924

SYSTEM DESCRIPTION

Component Parts

Intake door control system components are:

- Unified meter and A/C amp.
- Intake door motor (LCU)
- A/C LAN system (PBR built-in mode door motor, air mix door motor and intake door motor)
- In-vehicle sensor
- Ambient sensor
- Sunload sensor
- Intake sensor

System Operation

The intake door control determines intake door position based on the ambient temperature, the intake air temperature and the in-vehicle temperature. When shifting mode position D/F, when the DEF or OFF switches are pressed, or when A/C switch is OFF, the unified meter and A/C amp. sets the intake door at the FRE position.

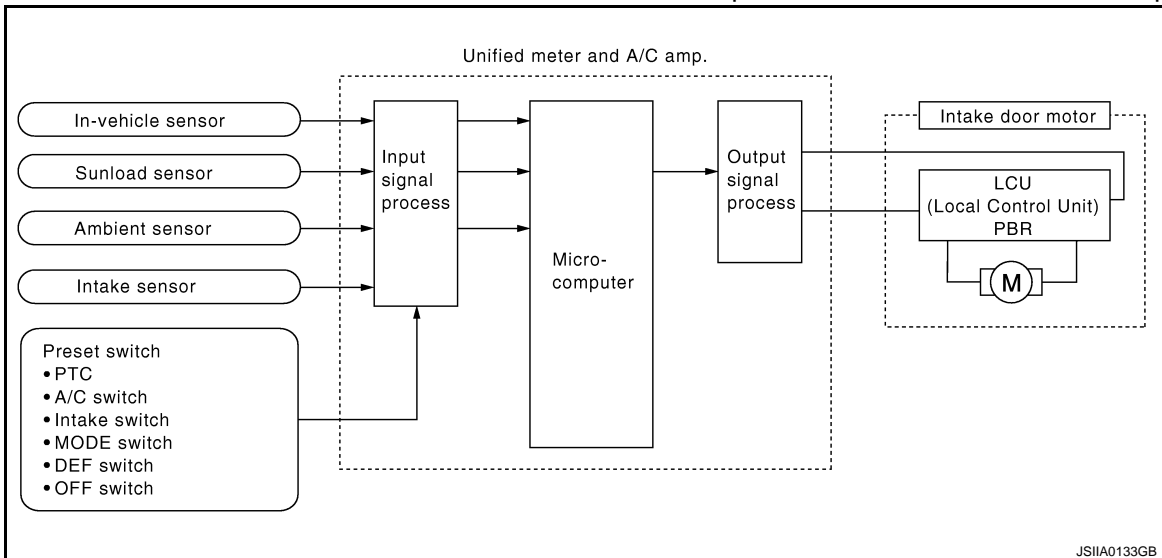

LAN System Circuit

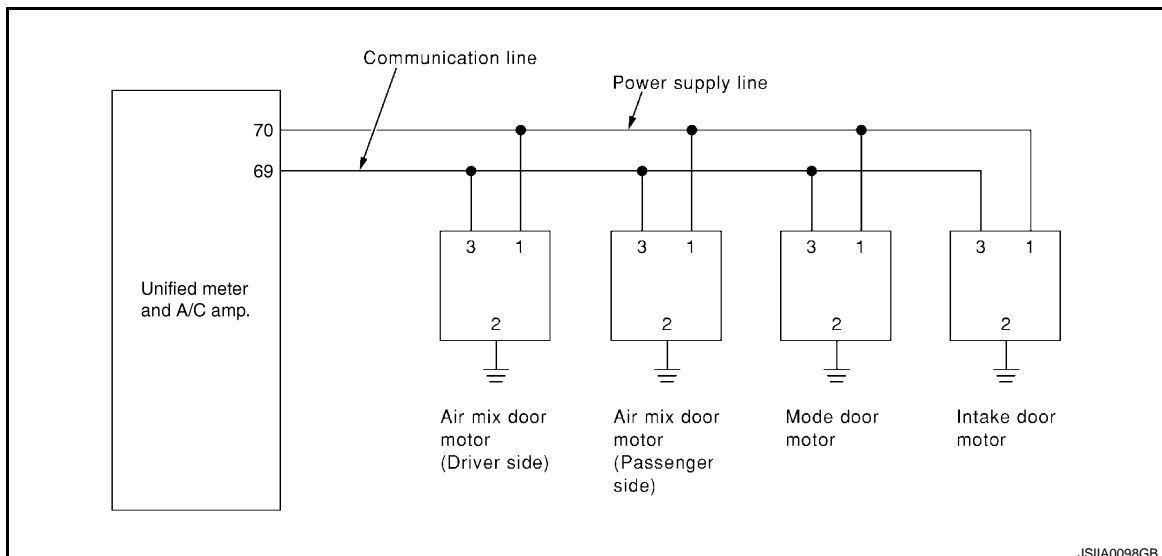

Intake Door Control Specification

INTAKE DOOR CONTROL SYSTEM

[AUTOMATIC AIR CONDITIONER]

< FUNCTION DIAGNOSIS >

Intake door position is basically fixed at FRE when FRE indicator lamps of DEF switch and intake switch turn ON, and fixed at REC when REC indicator lamp of intake switch turns ON.

Intake door automatic control selects FRE, 20 - 80%FRE, or REC depending on a target air mix door opening angle, based on in-vehicle temperature, ambient temperature, and sunload.

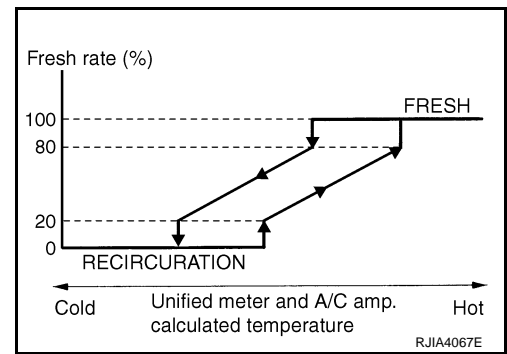

A

B

C

D

E

F

G

H

HAC

J

K

L

M

N

O

P

BLOWER MOTOR CONTROL SYSTEM

< FUNCTION DIAGNOSIS >

[AUTOMATIC AIR CONDITIONER]

BLOWER MOTOR CONTROL SYSTEM

WITHOUT LEFT AND RIGHT VENTILATION TEMPERATURE SEPARATELY CONTROL SYSTEM

WITHOUT LEFT AND RIGHT VENTILATION TEMPERATURE SEPARATELY CONTROL SYSTEM : Description

INFOID:000000000959925

SYSTEM DESCRIPTION

Component Parts

Fan speed control system components are:

- Unified meter and A/C amp.
- A/C LAN system (PBR built-in mode door motor, air mix door motor and intake door motor)
- In-vehicle sensor
- Ambient sensor
- Sunload sensor
- Intake sensor

System Operation

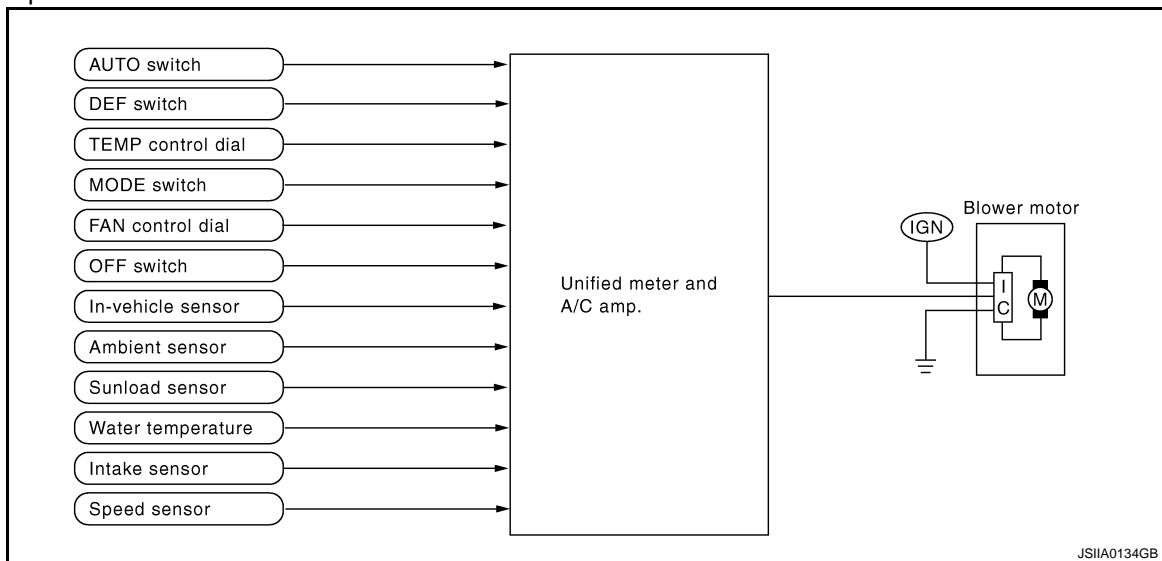

Blower motor circuit

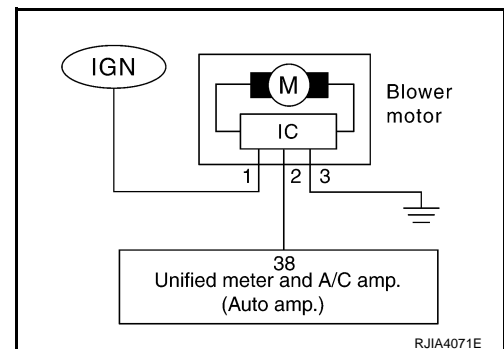

Automatic Mode

In the automatic mode, the blower motor speed is calculated by the unified meter and A/C amp. based on the input from the PBR, in-vehicle sensor, sunload sensor, intake sensor and ambient sensor.

When the air flow is increased, the duty ratio of the blower fan motor's drive signal is changed at 8%/sec. to prevent a sudden increase in air flow.

In addition to manual air flow control and the usual automatic air flow control, starting air flow control, low water temperature starting control and high passenger compartment temperature starting control are available.

BLOWER MOTOR CONTROL SYSTEM

[AUTOMATIC AIR CONDITIONER]

< FUNCTION DIAGNOSIS >

Starting Fan Speed Control

Start up from COLD SOAK Condition (Automatic mode)

In a cold start up condition where the engine coolant temperature is below 56°C (133°F), the blower will not operate for a short period of time (up to 150 seconds). The exact start delay time varies depending on the ambient and engine coolant temperature.

In the most extreme case (very low ambient) the blower starting delay will be 150 seconds as described above. After this delay, the blower will operate at low speed until the engine coolant temperature rises above 56°C (133°F), and then the blower speed will increase to the objective speed.

Start up from usual or HOT SOAK Condition (Automatic mode)

The blower will begin operation momentarily after the AUTO switch is pressed. The blower speed will gradually rise to the objective speed over a time period of 3 seconds or less (actual time depends on the objective blower speed).

Blower Speed Compensation

Sunload

When the in-vehicle temperature and the set temperature are very close, the blower will be operating at low speed. The low speed will vary depending on the sunload. During conditions of low or no sunload, the blower speed is at duty ratio 25%. During high sunload conditions, the unified meter and A/C amp. raise the blower speed (duty ratio 49%).

Fan Speed Control Specification

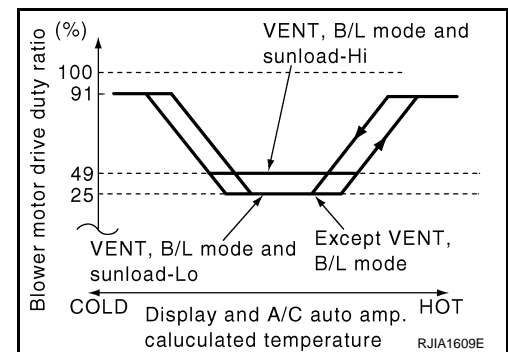

WITH LEFT AND RIGHT VENTILATION TEMPERATURE SEPARATELY CONTROL SYSTEM

WITH LEFT AND RIGHT VENTILATION TEMPERATURE SEPARATELY CONTROL SYSTEM : Description

INFOID:00000000095926

SYSTEM DESCRIPTION

Component Parts

Fan speed control system components are:

- Unified meter and A/C amp.
- A/C LAN system (PBR built-in mode door motor, air mix door motor and intake door motor)
- In-vehicle sensor
- Ambient sensor
- Sunload sensor
- Intake sensor

BLOWER MOTOR CONTROL SYSTEM

< FUNCTION DIAGNOSIS >

[AUTOMATIC AIR CONDITIONER]

System Operation

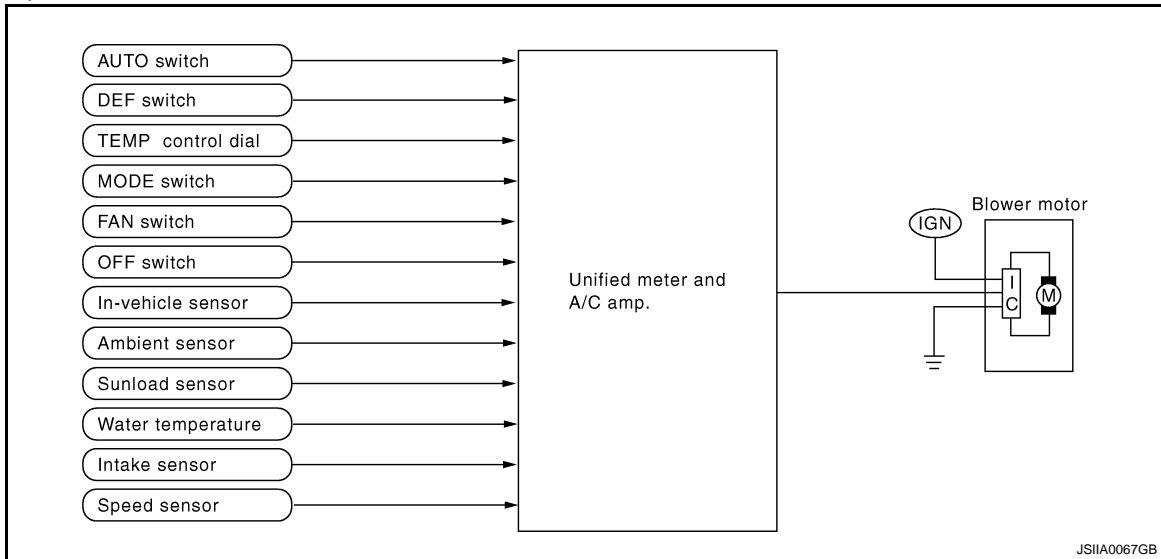

Blower motor circuit

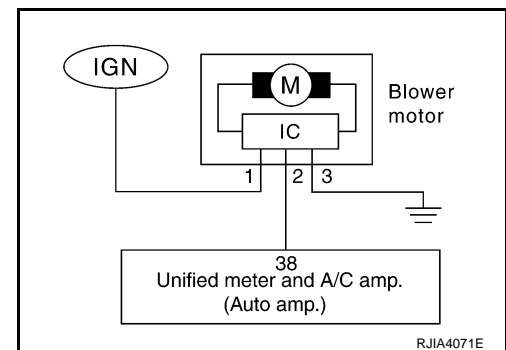

Automatic Mode

In the automatic mode, the blower motor speed is calculated by the unified meter and A/C amp. based on the input from the PBR, in-vehicle sensor, sunload sensor, intake sensor and ambient sensor.

When the air flow is increased, the duty ratio of the blower fan motor's drive signal is changed at 8%/sec. to prevent a sudden increase in air flow.

In addition to manual air flow control and the usual automatic air flow control, starting air flow control, low water temperature starting control and high passenger compartment temperature starting control are available.

Starting Fan Speed Control

Start up from COLD SOAK Condition (Automatic mode)

In a cold start up condition where the engine coolant temperature is below 56°C (133°F), the blower will not operate for a short period of time (up to 150 seconds). The exact start delay time varies depending on the ambient and engine coolant temperature.

In the most extreme case (very low ambient) the blower starting delay will be 150 seconds as described above. After this delay, the blower will operate at low speed until the engine coolant temperature rises above 56°C (133°F), and then the blower speed will increase to the objective speed.

Start up from usual or HOT SOAK Condition (Automatic mode)

The blower will begin operation momentarily after the AUTO switch is pressed. The blower speed will gradually rise to the objective speed over a time period of 3 seconds or less (actual time depends on the objective blower speed).

Blower Speed Compensation

Sunload

When the in-vehicle temperature and the set temperature are very close, the blower will be operating at low speed. The low speed will vary depending on the sunload. During conditions of low or no sunload, the blower speed is at duty ratio 25%. During high sunload conditions, the unified meter and A/C amp. raise the blower speed (duty ratio 49%).

BLOWER MOTOR CONTROL SYSTEM

[AUTOMATIC AIR CONDITIONER]

< FUNCTION DIAGNOSIS >

Fan Speed Control Specification

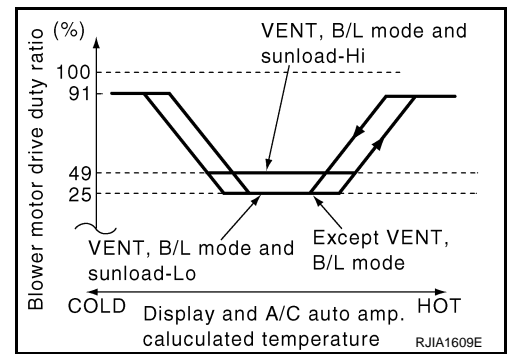

A

B

C

D

E

F

G

H

HAC

J

K

L

M

N

O

P

MAGNET CLUTCH CONTROL SYSTEM

< FUNCTION DIAGNOSIS >

[AUTOMATIC AIR CONDITIONER]

MAGNET CLUTCH CONTROL SYSTEM

Description

INFOID:000000000959927

SYSTEM DESCRIPTION

Unified meter and A/C amp. controls compressor operation by ambient temperature, intake air temperature and signal from ECM.

Magnet Clutch Circuit

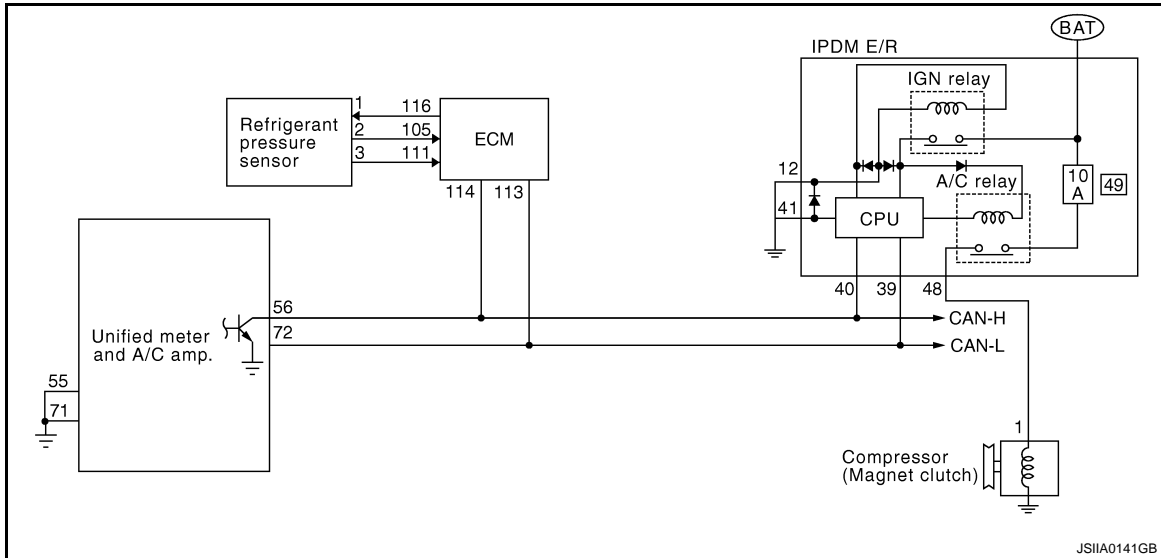

Low Temperature Protection Control

Unified meter and A/C amp. will turn compressor ON or OFF as determined by a signal detected by ambient sensor and intake sensor.

When ambient temperature is higher than -2°C (28°F), the compressor turns ON. The compressor turns OFF when ambient temperature is lower than -5°C (23°F).

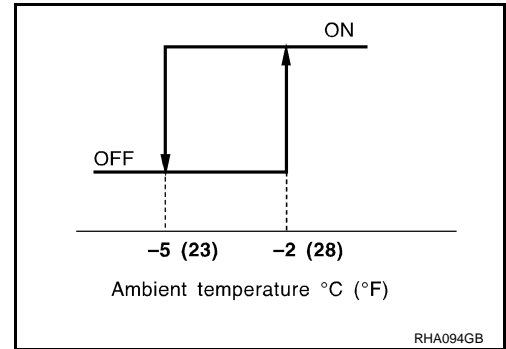

When intake air temperature is higher than 1°C (34°F), the compressor turns ON. The compressor turns OFF when intake air temperature is lower than -5°C (23°F).

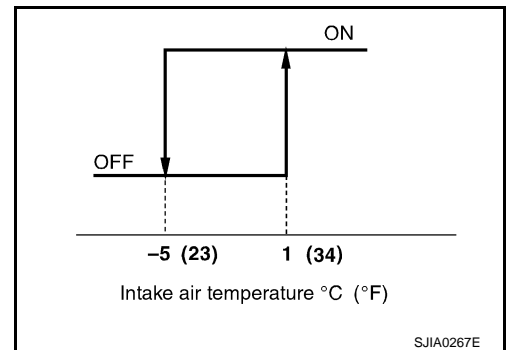

COMPONENT DIAGNOSIS

MODE DOOR MOTOR

Description

INFOID:000000000959928

COMPONENT DESCRIPTION

Mode Door Motor

The mode door motor (1) are attached to the heater & cooling unit assembly. It rotates so that air is discharged from the outlet set by the unified meter and A/C amp. Motor rotation is conveyed to a link which activates the mode door.

← Vehicle front

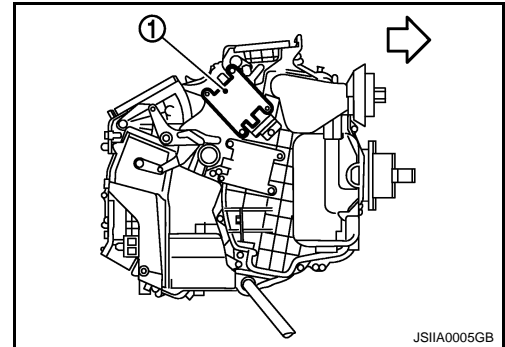

Component Function Check

INFOID:000000000959929

1. CONFIRM SYMPTOM BY PERFORMING THE FOLLOWING OPERATIONAL CHECK

1. Press MODE switch(es) and DEF switch.
2. Each position indicator should change shape.
3. Confirm that discharge air comes out according to the air distribution table at below. Refer to [HAC-23. "WITHOUT LEFT AND RIGHT VENTILATION TEMPERATURE SEPARATELY CONTROL SYSTEM : System Description"](#) (Without left and right ventilation temperature separately control system) or [HAC-32. "WITH LEFT AND RIGHT VENTILATION TEMPERATURE SEPARATELY CONTROL SYSTEM : System Description"](#) (With left and right ventilation temperature separately control system).

NOTE:

Confirm that the compressor clutch is engaged (Sound or visual inspection) and intake door position is at FRE when DEF or D/F is selected.

Is the inspection result normal?

YES >> END.

NO >> Go to diagnosis procedure. Refer to [HAC-69. "Diagnosis Procedure"](#).

Diagnosis Procedure

INFOID:000000000959930

1. PERFORM SELF-DIAGNOSIS STEP-2

Perform self-diagnosis STEP-2. Refer to [HAC-44. "WITHOUT LEFT AND RIGHT VENTILATION TEMPERATURE SEPARATELY CONTROL SYSTEM : Diagnosis Description"](#) (Without left and right ventilation temperature separately control system) or [HAC-50. "WITH LEFT AND RIGHT VENTILATION TEMPERATURE SEPARATELY CONTROL SYSTEM : Diagnosis Description"](#) (With left and right ventilation temperature separately control system), see No. 1 to 2.

Does code No. 20 appear on the display?

YES >> GO TO 2.

NO >> Go to appropriate malfunctioning sensor circuit. Refer to [HAC-44. "WITHOUT LEFT AND RIGHT VENTILATION TEMPERATURE SEPARATELY CONTROL SYSTEM : Diagnosis Description"](#) (Without left and right ventilation temperature separately control system) or [HAC-50. "WITH LEFT AND RIGHT VENTILATION TEMPERATURE SEPARATELY CONTROL SYSTEM : Diagnosis Description"](#) (With left and right ventilation temperature separately control system), see No. 11.

2. PERFORM SELF-DIAGNOSIS STEP-3

Perform self-diagnosis STEP-3. Refer to [HAC-44. "WITHOUT LEFT AND RIGHT VENTILATION TEMPERATURE SEPARATELY CONTROL SYSTEM : Diagnosis Description"](#) (Without left and right ventilation temperature separately control system) or [HAC-50. "WITH LEFT AND RIGHT VENTILATION TEMPERATURE SEPARATELY CONTROL SYSTEM : Diagnosis Description"](#) (With left and right ventilation temperature separately control system).

A
B
C
D
E
F
G
H
I
J
K
L
M
N
O
P

HAC

MODE DOOR MOTOR

[AUTOMATIC AIR CONDITIONER]

< COMPONENT DIAGNOSIS >

SEPARATELY CONTROL SYSTEM : Diagnosis Description" (With left and right ventilation temperature separately control system), see No. 1 to 3.

Does code No. 30 appear on the display?

YES >> GO TO 8.

NO-1 >> Code No. 31 or 32 appear on the display: GO TO 3.

NO-2 >> Code No. 37, 38 or 39 appear on the display: Go to Intake Door Motor Circuit. Refer to [HAC-80, "Diagnosis Procedure"](#).

3.CHECK POWER SUPPLY FOR UNIFIED METER AND A/C AMP.

1. Turn ignition switch ON.
2. Check voltage between unified meter and A/C amp. harness connector M67 terminal 70 and ground.

(+)		(-)	Voltage
Unified meter and A/C amp.		—	
Connector	Terminal		
M67	70	Ground	Battery voltage

Is the inspection result normal?

YES >> GO TO 4.

NO >> Replace unified meter and A/C amp.

4.CHECK SIGNAL FOR UNIFIED METER AND A/C AMP.

Confirm A/C LAN signal between unified meter and A/C amp. harness connector M67 terminal 69 and ground using an oscilloscope.

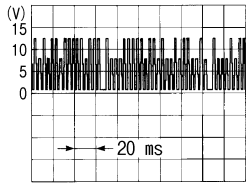
(+)		(-)	Voltage
Unified meter and A/C amp.		—	
Connector	Terminal		
M67	69	Ground	

Is the inspection result normal?

YES >> GO TO 5.

NO >> Replace unified meter and A/C amp.

5.CHECK POWER SUPPLY FOR MODE DOOR MOTOR

Check voltage between mode door motor harness connector M253 terminal 1 and ground.

(+)		(-)	Voltage
Mode door motor		—	
Connector	Terminal		
M253	1	Ground	Battery voltage

Is the inspection result normal?

YES >> GO TO 6.

NO >> Repair harness or connector.

6.CHECK SIGNAL FOR MODE DOOR MOTOR

Confirm A/C LAN signal between mode door motor harness connector M253 terminal 3 and ground using an oscilloscope.

MODE DOOR MOTOR

< COMPONENT DIAGNOSIS >

[AUTOMATIC AIR CONDITIONER]

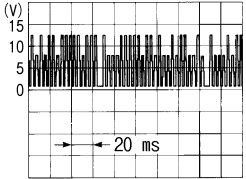
(+)		(-)	Voltage
Mode door motor		—	
Connector	Terminal		
M253	3	Ground	 <p style="text-align: right;">SJIA1453J</p>

Is the inspection result normal?

YES >> GO TO 7.

NO >> Repair harness or connector.

7. CHECK MODE DOOR MOTOR GROUND CIRCUIT

1. Turn ignition switch OFF.
2. Disconnect mode door motor connector.
3. Check continuity between mode door motor harness connector M253 terminal 2 and ground.

(+)		(-)	Continuity
Mode door motor		—	
Connector	Terminal		
M253	2	Ground	Continuity should exist

Is the inspection result normal?

YES >> Replace mode door motor.

NO >> Repair harness or connector.

8. PERFORM SELF-DIAGNOSIS STEP-4

Perform self-diagnosis STEP-4. Refer to [HAC-44, "WITHOUT LEFT AND RIGHT VENTILATION TEMPERATURE SEPARATELY CONTROL SYSTEM : Diagnosis Description"](#) (Without left and right ventilation temperature separately control system) [HAC-50, "WITH LEFT AND RIGHT VENTILATION TEMPERATURE SEPARATELY CONTROL SYSTEM : Diagnosis Description"](#) (With left and right ventilation temperature separately control system), see No. 1 to 5.

Is it operated normally?

YES >> END.

NO >> GO TO 9.

9. CHECK MODE DOOR CONTROL LINKAGE

Check mode door control linkage.

Is it installed normally?

YES >> Refer to [VTL-38, "Exploded View"](#).

NO >> Repair or adjust control linkage.

AIR MIX DOOR MOTOR

< COMPONENT DIAGNOSIS >

[AUTOMATIC AIR CONDITIONER]

AIR MIX DOOR MOTOR

WITHOUT LEFT AND RIGHT VENTILATION TEMPERATURE SEPARATELY CONTROL SYSTEM

WITHOUT LEFT AND RIGHT VENTILATION TEMPERATURE SEPARATELY CONTROL SYSTEM : Description

INFOID:000000000959931

COMPONENT DESCRIPTION

Air Mix Door Motor

The air mix door motor (1) is attached to the heater & cooling unit assembly. It rotates so that the air mix door is opened or closed to a position set by the unified meter and A/C amp. Motor rotation is then conveyed through a shaft and the air mix door position feedback is then sent to the unified meter and A/C amp. by PBR built-in air mix door motor.

←: Vehicle front

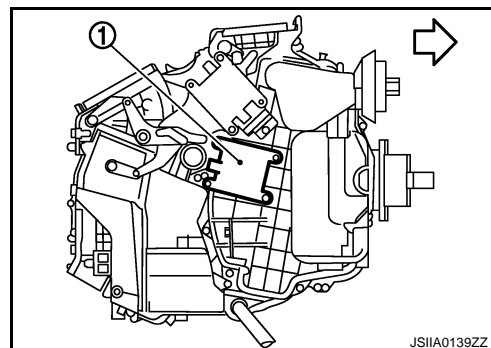

WITHOUT LEFT AND RIGHT VENTILATION TEMPERATURE SEPARATELY CONTROL SYSTEM : Component Function Check

INFOID:000000000959932

1.CONFIRM SYMPTOM BY PERFORMING THE FOLLOWING OPERATIONAL CHECK

1. Turn temperature control dial clockwise until 32°C (90°F) is displayed.
2. Check for hot air at discharge air outlets.
3. Turn temperature control dial counterclockwise until 18°C (60°F) is displayed.
4. Check for cold air at discharge air outlets.

Is the inspection result normal?

YES >> END.

NO >> Go to diagnosis procedure. Refer to [HAC-72. "WITHOUT LEFT AND RIGHT VENTILATION TEMPERATURE SEPARATELY CONTROL SYSTEM : Diagnosis Procedure"](#).

WITHOUT LEFT AND RIGHT VENTILATION TEMPERATURE SEPARATELY CONTROL SYSTEM : Diagnosis Procedure

INFOID:000000000959933

1.PERFORM SELF-DIAGNOSIS STEP-2

Perform self-diagnosis STEP-2. Refer to [HAC-44. "WITHOUT LEFT AND RIGHT VENTILATION TEMPERATURE SEPARATELY CONTROL SYSTEM : Diagnosis Description"](#), see No. 1 to 2.

Does code No. 20 appear on the display.

YES >> GO TO 2.

NO >> Go to appropriate malfunctioning sensor circuit. Refer to [HAC-44. "WITHOUT LEFT AND RIGHT VENTILATION TEMPERATURE SEPARATELY CONTROL SYSTEM : Diagnosis Description"](#), see No. 11.

2.PERFORM SELF-DIAGNOSIS STEP-4

Perform self-diagnosis STEP-4. Refer to [HAC-44. "WITHOUT LEFT AND RIGHT VENTILATION TEMPERATURE SEPARATELY CONTROL SYSTEM : Diagnosis Description"](#), see No. 1 to 5.

Is it operated normally?

YES >> END.

NO >> GO TO 3.

3.CHECK AIR MIX DOOR MOTOR

Check air mix door motor. Refer to [VTL-40. "Exploded View"](#).

AIR MIX DOOR MOTOR

< COMPONENT DIAGNOSIS >

[AUTOMATIC AIR CONDITIONER]

Is it installed normally?

- YES >> GO TO 4.
 NO >> Replace air mix door motor.

4. CHECK POWER SUPPLY FOR UNIFIED METER AND A/C AMP.

1. Turn ignition switch ON.
2. Check voltage between unified meter and A/C amp. harness connector M67 terminal 70 and ground.

(+)		(-)	Voltage
Unified meter and A/C amp.		—	
Connector	Terminal		
M67	70	Ground	Battery voltage

Is the inspection result normal?

- YES >> GO TO 5.
 NO >> Replace unified meter and A/C amp.

5. CHECK SIGNAL FOR UNIFIED METER AND A/C AMP.

Confirm A/C LAN signal between unified meter and A/C amp. harness connector M67 terminal 69 and ground using an oscilloscope.

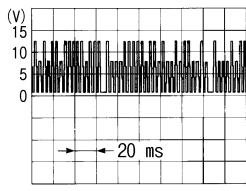
(+)		(-)	Voltage
Unified meter and A/C amp.		—	
Connector	Terminal		
M67	69	Ground	

Is the inspection result normal?

- YES >> GO TO 6.
 NO >> Replace unified meter and A/C amp.

6. CHECK POWER SUPPLY FOR AIR MIX DOOR MOTOR

Check voltage between air mix door motor harness connector M255 terminal 1 and ground.

(+)		(-)	Voltage
Air mix door motor		—	
Connector	Terminal		
M255	1	Ground	Battery voltage

Is the inspection result normal?

- YES >> GO TO 7.
 NO >> Repair harness or connector.

7. CHECK SIGNAL FOR AIR MIX DOOR MOTOR

Confirm A/C LAN signal between air mix door motor harness connector M255 terminal 3 and ground using an oscilloscope.

AIR MIX DOOR MOTOR

< COMPONENT DIAGNOSIS >

[AUTOMATIC AIR CONDITIONER]

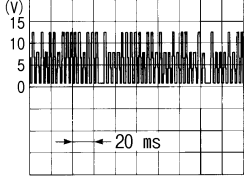
(+)		(-)	Voltage
Air mix door motor		—	
Connector	Terminal		
M255	3	Ground	 <p style="text-align: right; font-size: small;">SJIA1453J</p>

Is the inspection result normal?

YES >> GO TO 8.

NO >> Repair harness or connector.

8. CHECK AIR MIX DOOR MOTOR GROUND CIRCUIT

1. Turn ignition switch OFF.
2. Disconnect air mix door motor connector.
3. Check continuity between air mix door motor harness connector M255 terminal 2 and ground.

(+)		(-)	Continuity
Air mix door motor		—	
Connector	Terminal		
M255	2	Ground	Continuity should exist

Is the inspection result normal?

YES >> Replace air mix door motor.

NO >> Repair harness or connector.

WITH LEFT AND RIGHT VENTILATION TEMPERATURE SEPARATELY CONTROL SYSTEM

WITH LEFT AND RIGHT VENTILATION TEMPERATURE SEPARATELY CONTROL SYSTEM : Description

INFOID:000000000959934

COMPONENT DESCRIPTION

Air Mix Door Motor

AIR MIX DOOR MOTOR

< COMPONENT DIAGNOSIS >

[AUTOMATIC AIR CONDITIONER]

The air mix door motors (1) are attached to the heater & cooling unit assembly. It rotates so that the air mix door is opened or closed to a position set by the unified meter and A/C amp. Motor rotation is then conveyed through a shaft and the air mix door position feedback is then sent to the unified meter and A/C amp. by PBR built-in air mix door motor.

←: Vehicle front

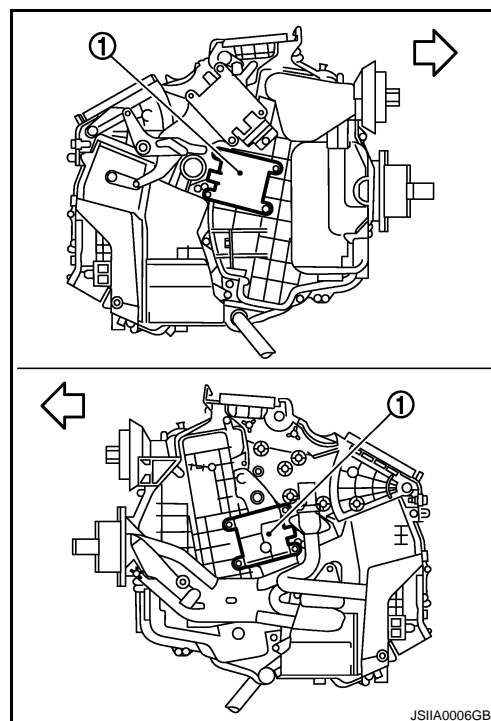

WITH LEFT AND RIGHT VENTILATION TEMPERATURE SEPARATELY CONTROL SYSTEM : Component Function Check

INFOID:000000000959935

1.CONFIRM SYMPTOM BY PERFORMING THE FOLLOWING OPERATIONAL CHECK

1. Turn temperature control dial (driver side) clockwise until 32°C (90°F) is displayed.
2. Check for hot air at discharge air outlets.
3. Turn temperature control dial (driver side) counterclockwise until 18°C (60°F) is displayed.
4. Check for cold air at discharge air outlets.

Is the inspection result normal?

YES >> END.

NO >> Go to diagnosis procedure. Refer to [HAC-75. "WITH LEFT AND RIGHT VENTILATION TEMPERATURE SEPARATELY CONTROL SYSTEM : Diagnosis Procedure"](#).

WITH LEFT AND RIGHT VENTILATION TEMPERATURE SEPARATELY CONTROL SYSTEM : Diagnosis Procedure

INFOID:000000000959936

1.PERFORM SELF-DIAGNOSIS STEP-2

Perform self-diagnosis STEP-2. Refer to [HAC-50. "WITH LEFT AND RIGHT VENTILATION TEMPERATURE SEPARATELY CONTROL SYSTEM : Diagnosis Description"](#), see No. 1 to 2.

Does code No. 20 appear on the display?

YES >> GO TO 2.

NO >> Go to appropriate malfunctioning sensor circuit. Refer to [HAC-50. "WITH LEFT AND RIGHT VENTILATION TEMPERATURE SEPARATELY CONTROL SYSTEM : Diagnosis Description"](#), see No. 11.

2.PERFORM SELF-DIAGNOSIS STEP-4

Perform self-diagnosis STEP-4. Refer to [HAC-50. "WITH LEFT AND RIGHT VENTILATION TEMPERATURE SEPARATELY CONTROL SYSTEM : Diagnosis Description"](#), see No.1 to 5.

Is it operated normally?

YES >> END.

NO-1 >> Malfunction is detected on driver seat side. GO TO 3.

NO-2 >> Malfunction is detected on passenger seat side. GO TO 9

3.CHECK AIR MIX DOOR MOTOR (DRIVER SIDE)

A
B
C
D
E
F
G
H

HAC

J

K

L

M

N

O

P

AIR MIX DOOR MOTOR

< COMPONENT DIAGNOSIS >

[AUTOMATIC AIR CONDITIONER]

Check air mix door motor (driver side). Refer to [VTL-40, "Exploded View"](#).

Is it installed normally?

- YES >> GO TO 4.
- NO >> Replace air mix door motor (driver side).

4. CHECK POWER SUPPLY FOR UNIFIED METER AND A/C AMP.

1. Turn ignition switch ON.
2. Check voltage between unified meter and A/C amp. harness connector M67 terminal 70 and ground.

(+)		(-)	Voltage
Unified meter and A/C amp.		—	
Connector	Terminal	Ground	Battery voltage
M67	70		

Is the inspection result normal?

- YES >> GO TO 5.
- NO >> Replace unified meter and A/C amp.

5. CHECK SIGNAL FOR UNIFIED METER AND A/C AMP.

Confirm A/C LAN signal between unified meter and A/C amp. harness connector M67 terminal 69 and ground using an oscilloscope.

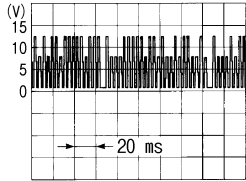
(+)		(-)	Voltage
Unified meter and A/C amp.		—	
Connector	Terminal	Ground	
M67	69		

SJIA1453J

Is the inspection result normal?

- YES >> GO TO 6.
- NO >> Replace unified meter and A/C amp.

6. CHECK POWER SUPPLY FOR AIR MIX DOOR MOTOR (DRIVER SIDE)

Check voltage between air mix door motor (driver side) harness connector M252 terminal 1 and ground.

(+)		(-)	Voltage
Air mix door motor (driver side)		—	
Connector	Terminal	Ground	Battery voltage
M252	1		

Is the inspection result normal?

- YES >> GO TO 7.
- NO >> Repair harness or connector.

7. CHECK SIGNAL FOR AIR MIX DOOR MOTOR (DRIVER SIDE)

Confirm A/C LAN signal between air mix door motor (driver side) harness connector M252 terminal 3 and ground using an oscilloscope.

AIR MIX DOOR MOTOR

< COMPONENT DIAGNOSIS >

[AUTOMATIC AIR CONDITIONER]

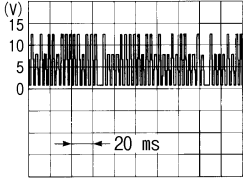
(+)		(-)	Voltage
Air mix door motor (driver side)		—	
Connector	Terminal		
M252	3	Ground	 <p style="text-align: right; font-size: small;">SJIA1453J</p>

Is the inspection result normal?

YES >> GO TO 8.

NO >> Repair harness or connector.

8. CHECK AIR MIX DOOR MOTOR (DRIVER SIDE) GROUND CIRCUIT

1. Turn ignition switch OFF.
2. Disconnect air mix door motor (driver side) connector.
3. Check continuity between air mix door motor (driver side) harness connector M252 terminal 2 and ground.

(+)		(-)	Continuity
Air mix door motor (driver side)		—	
Connector	Terminal		
M252	2	Ground	Continuity should exist

Is the inspection result normal?

YES >> Replace air mix door motor (driver side).

NO >> Repair harness or connector.

9. CHECK AIR MIX DOOR MOTOR (PASSENGER SIDE)

Check air mix door motor (passenger side). Refer to [VTL-40, "Exploded View"](#).

Is it installed normally?

YES >> GO TO 10.

NO >> Replace air mix door motor (passenger side).

10. CHECK POWER SUPPLY FOR UNIFIED METER AND A/C AMP.

1. Turn ignition switch ON.
2. Check voltage between unified meter and A/C amp. harness connector M67 terminal 70 and ground.

(+)		(-)	Voltage
Unified meter and A/C amp.		—	
Connector	Terminal		
M67	70	Ground	Battery voltage

Is the inspection result normal?

YES >> GO TO 11.

NO >> Replace unified meter and A/C amp.

11. CHECK SIGNAL FOR UNIFIED METER AND A/C AMP.

Confirm A/C LAN signal between unified meter and A/C amp. harness connector M67 terminal 69 and ground using an oscilloscope.

AIR MIX DOOR MOTOR

< COMPONENT DIAGNOSIS >

[AUTOMATIC AIR CONDITIONER]

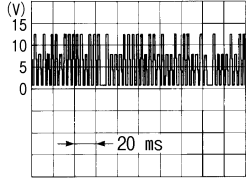
(+)		(-)	Voltage
Unified meter and A/C amp.		—	
Connector	Terminal		
M67	69	Ground	 <p style="text-align: right; font-size: small;">SJIA1453J</p>

Is the inspection result normal?

YES >> GO TO 12.

NO >> Replace unified meter and A/C amp.

12. CHECK POWER SUPPLY FOR AIR MIX DOOR MOTOR (PASSENGER SIDE)

Check voltage between air mix door motor (passenger side) harness connector M255 terminal 1 and ground.

(+)		(-)	Voltage
Air mix door motor (passenger side)		—	
Connector	Terminal		
M255	1	Ground	Battery voltage

Is the inspection result normal?

YES >> GO TO 13.

NO >> Repair harness or connector.

13. CHECK SIGNAL FOR AIR MIX DOOR MOTOR (PASSENGER SIDE)

Confirm A/C LAN signal between air mix door motor (passenger side) harness connector M255 terminal 3 and ground using an oscilloscope.

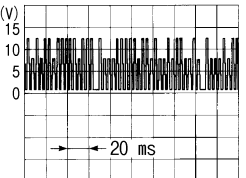
(+)		(-)	Voltage
Air mix door motor (passenger side)		—	
Connector	Terminal		
M255	3	Ground	 <p style="text-align: right; font-size: small;">SJIA1453J</p>

Is the inspection result normal?

YES >> GO TO 14.

NO >> Repair harness or connector.

14. CHECK AIR MIX DOOR MOTOR (PASSENGER SIDE) GROUND CIRCUIT

1. Turn ignition switch OFF.
2. Disconnect air mix door motor (passenger side) connector.
3. Check continuity between air mix door motor (passenger side) harness connector M255 terminal 2 and ground.

AIR MIX DOOR MOTOR

< COMPONENT DIAGNOSIS >

[AUTOMATIC AIR CONDITIONER]

(+)		(-)	Continuity
Air mix door motor (passenger side)		—	
Connector	Terminal		
M255	2	Ground	Continuity should exist

Is the inspection result normal?

YES >> Replace air mix door motor (passenger side).

NO >> Repair harness or connector.

A
B
C
D
E
F
G
H
J
K
L
M
N
O
P

HAC

INTAKE DOOR MOTOR

< COMPONENT DIAGNOSIS >

[AUTOMATIC AIR CONDITIONER]

INTAKE DOOR MOTOR

Description

INFOID:000000000959937

COMPONENT DESCRIPTION

Intake Door Motor

The intake door motor (1) is attached to the blower unit. It rotates so that air is drawn from inlets set by the unified meter and A/C amp. Motor rotation is conveyed to a lever which activates the intake door.

←: Vehicle front

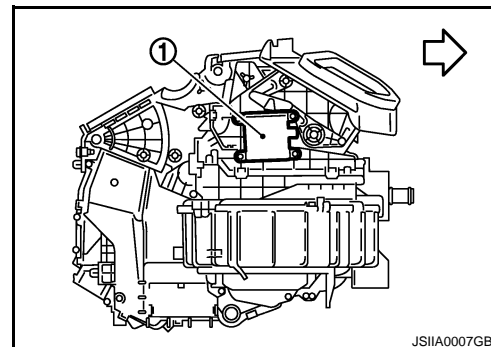

Component Function Check

INFOID:000000000959938

1. CONFIRM SYMPTOM BY PERFORMING THE FOLLOWING OPERATIONAL CHECK

1. Press intake switch.
2. REC indicator should illuminate.
3. Listen for intake door position change (Slight change of blower sound can be heard.).
4. Press intake switch again.
5. FRE indicator should illuminate.

Is the inspection result normal?

YES >> END.

NO >> Go to diagnosis procedure. Refer to [HAC-80, "Diagnosis Procedure"](#).

Diagnosis Procedure

INFOID:000000000959939

1. PERFORM SELF-DIAGNOSIS STEP-2

Perform self-diagnosis STEP-2. Refer to [HAC-44, "WITHOUT LEFT AND RIGHT VENTILATION TEMPERATURE SEPARATELY CONTROL SYSTEM : Diagnosis Description"](#) (Without left and right ventilation temperature separately control system) or [HAC-50, "WITH LEFT AND RIGHT VENTILATION TEMPERATURE SEPARATELY CONTROL SYSTEM : Diagnosis Description"](#) (With left and right ventilation temperature separately control system), see No. 1 to 2.

Does code No. 20 appear on the display?

YES >> GO TO 2.

NO >> Go to appropriate malfunctioning sensor circuit. Refer to [HAC-44, "WITHOUT LEFT AND RIGHT VENTILATION TEMPERATURE SEPARATELY CONTROL SYSTEM : Diagnosis Description"](#) (Without left and right ventilation temperature separately control system) or [HAC-50, "WITH LEFT AND RIGHT VENTILATION TEMPERATURE SEPARATELY CONTROL SYSTEM : Diagnosis Description"](#) (With left and right ventilation temperature separately control system), see No. 11.

2. PERFORM SELF-DIAGNOSIS STEP-4

Perform self-diagnosis STEP-4. Refer to [HAC-44, "WITHOUT LEFT AND RIGHT VENTILATION TEMPERATURE SEPARATELY CONTROL SYSTEM : Diagnosis Description"](#) (Without left and right ventilation temperature separately control system) or [HAC-50, "WITH LEFT AND RIGHT VENTILATION TEMPERATURE SEPARATELY CONTROL SYSTEM : Diagnosis Description"](#) (With left and right ventilation temperature separately control system), see No. 1 to 5.

Is it operated normally?

YES >> END.

NO >> GO TO 3.

3. CHECK INTAKE DOOR CONTROL LINKAGE

INTAKE DOOR MOTOR

[AUTOMATIC AIR CONDITIONER]

< COMPONENT DIAGNOSIS >

Check intake door control linkage.

Is it installed normally?

YES >> GO TO 4.

NO >> Repair or adjust control linkage.

4. CHECK POWER SUPPLY FOR UNIFIED METER AND A/C AMP.

1. Turn ignition switch ON.

2. Check voltage between unified meter and A/C amp. harness connector M67 terminal 70 and ground.

(+)		(-)	Voltage
Unified meter and A/C amp.		—	
Connector	Terminal		
M67	70	Ground	Battery voltage

Is the inspection result normal?

YES >> GO TO 5.

NO >> Replace unified meter and A/C amp.

5. CHECK SIGNAL FOR UNIFIED METER AND A/C AMP.

Confirm A/C LAN signal between unified meter and A/C amp. harness connector M67 terminal 69 and ground using an oscilloscope.

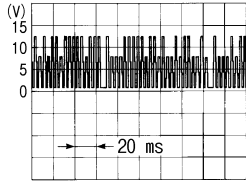
(+)		(-)	Voltage
Unified meter and A/C amp.		—	
Connector	Terminal		
M67	69	Ground	

Is the inspection result normal?

YES >> GO TO 6.

NO >> Replace unified meter and A/C amp.

6. CHECK POWER SUPPLY FOR INTAKE DOOR MOTOR

Check voltage between intake door motor harness connector M254 terminal 1 and ground.

(+)		(-)	Voltage
Intake door motor		—	
Connector	Terminal		
M254	1	Ground	Battery voltage

Is the inspection result normal?

YES >> GO TO 7.

NO >> Repair harness or connector.

7. CHECK SIGNAL FOR INTAKE DOOR MOTOR

Confirm A/C LAN signal between intake door motor harness connector M254 terminal 3 and ground using an oscilloscope.

INTAKE DOOR MOTOR

< COMPONENT DIAGNOSIS >

[AUTOMATIC AIR CONDITIONER]

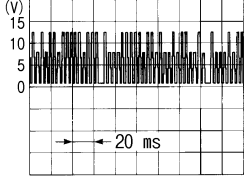
(+)		(-)	Voltage
Intake door motor		—	
Connector	Terminal		
M254	3	Ground	

SJIA1453J

Is the inspection result normal?

YES >> GO TO 8.

NO >> Repair harness or connector.

8. CHECK INTAKE DOOR MOTOR GROUND CIRCUIT

1. Turn ignition switch OFF.
2. Disconnect intake door motor connector.
3. Check continuity between intake door motor harness connector M254 terminal 2 and ground.

(+)		(-)	Continuity
Intake door motor		—	
Connector	Terminal		
M254	2	Ground	Continuity should exist

Is the inspection result normal?

YES >> Replace intake door motor.

NO >> Repair harness or connector.

BLOWER MOTOR

< COMPONENT DIAGNOSIS >

[AUTOMATIC AIR CONDITIONER]

BLOWER MOTOR

WITHOUT LEFT AND RIGHT VENTILATION TEMPERATURE SEPARATELY CONTROL SYSTEM

WITHOUT LEFT AND RIGHT VENTILATION TEMPERATURE SEPARATELY CONTROL SYSTEM : Description

INFOID:000000000959940

COMPONENT DESCRIPTION

Brush-less Motor

The blower motor utilizes a brush-less motor with a rotating magnet. Quietness is improved over previous motors where the brush was the point of contact and the coil rotated.

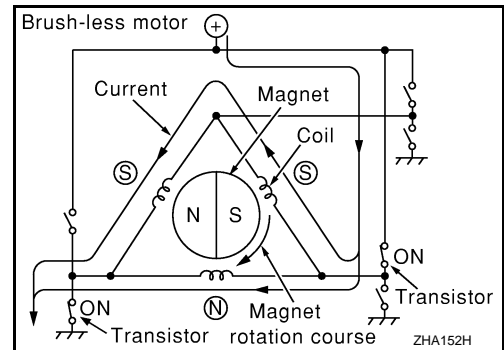

WITHOUT LEFT AND RIGHT VENTILATION TEMPERATURE SEPARATELY CONTROL SYSTEM : Component Function Check

INFOID:000000000959941

1. CONFIRM SYMPTOM BY PERFORMING THE FOLLOWING OPERATIONAL CHECK

1. Turn fan control dial clockwise. Blower should operate on low speed.
2. Turn fan control dial clockwise, and continue checking blower speed and fan symbol until all speeds checked.

Is the inspection result normal?

YES >> END.

NO >> Go to diagnosis procedure. Refer to [HAC-83. "WITHOUT LEFT AND RIGHT VENTILATION TEMPERATURE SEPARATELY CONTROL SYSTEM : Diagnosis Procedure"](#)

WITHOUT LEFT AND RIGHT VENTILATION TEMPERATURE SEPARATELY CONTROL SYSTEM : Diagnosis Procedure

INFOID:000000000959942

1. PERFORM SELF-DIAGNOSIS STEP-2

Perform self-diagnosis STEP-2. Refer to [HAC-44. "WITHOUT LEFT AND RIGHT VENTILATION TEMPERATURE SEPARATELY CONTROL SYSTEM : Diagnosis Description"](#), see No. 1 to 2.

Is there any malfunction displayed?

YES >> Go to appropriate malfunctioning sensor circuit. Refer to [HAC-44. "WITHOUT LEFT AND RIGHT VENTILATION TEMPERATURE SEPARATELY CONTROL SYSTEM : Diagnosis Description"](#), see to No. 11.

NO >> GO TO 2.

2. PERFORM SELF-DIAGNOSIS STEP-4

Perform self-diagnosis STEP-4. Refer to [HAC-44. "WITHOUT LEFT AND RIGHT VENTILATION TEMPERATURE SEPARATELY CONTROL SYSTEM : Diagnosis Description"](#), see No. 1 to 5.

Code No.	41	42	43	44	45	46
Blower motor duty ratio	37%	91%		65%		91%

Does blower motor speed change according to each code No.?

YES >> GO TO 3.

NO >> GO TO 5.

BLOWER MOTOR

< COMPONENT DIAGNOSIS >

[AUTOMATIC AIR CONDITIONER]

3. CHECK ENGINE COOLANT TEMPERATURE

Check engine coolant temperature.

Is engine coolant temperature below 56°C (133°F)?

YES >> GO TO 4.

NO >> Blower motor operation is normal.

4. CHECK BLOWER MOTOR OPERATING

Check blower motor operating.

Is blower motor operation under starting blower speed control?

YES >> END.

NO >> GO TO 5.

5. CHECK POWER SUPPLY FOR BLOWER MOTOR

1. Disconnect blower motor connector.
2. Turn ignition switch ON.
3. Check voltage between blower motor harness connector M109 terminal 1 and ground.

(+)		(-)		Voltage
Blower motor		—		
Connector	Terminal			
M109	1	Ground		Battery voltage

Is the inspection result normal?

OK >> GO TO 6.

NG >> GO TO 9.

6. CHECK BLOWER MOTOR GROUND CIRCUIT

1. Turn ignition switch OFF.
2. Check continuity between blower motor harness connector M109 terminal 3 and ground.

(+)		(-)		Continuity
blower motor		—		
Connector	Terminal			
M109	3	Ground		Continuity should exist

Is the inspection result normal?

YES >> GO TO 7.

NO >> Repair harness or connector.

7. CHECK CIRCUIT CONTINUITY BETWEEN BLOWER MOTOR AND UNIFIED METER AND A/C AMP.

1. Disconnect unified meter and A/C amp. connector.
2. Check continuity between blower motor harness connector M109 terminal 2 and unified meter and A/C amp. harness connector M66 terminal 38.

(+)		(-)		Continuity
blower motor		Unified meter and A/C amp.		
Connector	Terminal	Connector	Terminal	
M109	2	M66	38	Continuity should exist

Is the inspection result normal?

YES >> GO TO 8.

NO >> Repair harness or connector.

8. CHECK UNIFIED METER AND A/C AMP. OUTPUT SIGNAL



1. Reconnect blower motor connector and unified meter and A/C amp. connector.
2. Turn ignition switch ON.

BLOWER MOTOR

[AUTOMATIC AIR CONDITIONER]

< COMPONENT DIAGNOSIS >

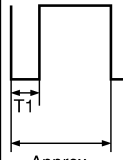
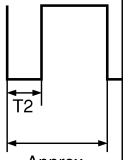
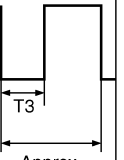
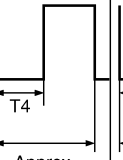
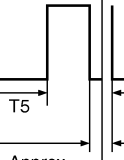
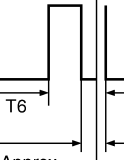
- Set MODE switch to VENT position.
- Change fan speed from Lo to Hi, and check duty ratios between blower motor harness connector M109 terminal 2 and ground by using an oscilloscope. Normal terminal 2 drive signal duty ratios are shown in the table below.

Blower fan speed (Manual) Vent mode	1st	2nd	3rd	4th	5th	6th	7th
Blower motor connector M109 terminal No. 2 (Oscilloscope)							
Duty ratio	Approx. 25%	Approx. 33%	Approx. 41%	Approx. 51%	Approx. 61%	Approx. 71%	Approx. 83%

NOTE: Duty ratio = $\frac{T_x}{\text{Approx. } 1.6 \text{ ms}} \times 100 (\%)$

JSIIA0068GB

Is the inspection result normal?

- YES >> Replace blower motor after confirming the fan air flow does not change.
 NO >> Replace unified meter and A/C amp.

9. CHECK POWER VOLTAGE OF BLOWER FAN MOTOR

- Turn ignition switch OFF.
- Remove blower fan motor relay. Refer to [PG-93. "Fuse, Connector and Terminal Arrangement"](#).
- Turn ignition switch ON.
- Check the voltage between blower fan motor relay fuse block terminals 1, 3 and body ground. Refer to [PG-91. "Description"](#) for relay terminal assignment.

(+)	(-)	Voltage
Blower fan motor relay	—	
Fuse block terminal		
1	Ground	Battery voltage
3		

Is the inspection result normal?

- YES >> GO TO 11.
 NO >> GO TO 10.

10. CHECK IGNITION SWITCH

Check ignition switch.

Is the inspection result normal?

- YES >> Repair harness or connector.
 NG >> Replace ignition switch.

11. CHECK BLOWER FAN MOTOR RELAY

- Turn ignition switch OFF.
- Install blower fan motor relay. Refer to [PG-93. "Fuse, Connector and Terminal Arrangement"](#).
- Check operation sound of the blower fan motor relay after switching ignition switch ON.

Is the inspection result normal?

- YES >> GO TO 12.
 NO >> Replace blower fan motor relay.

12. CHECK FUSE

BLOWER MOTOR

[AUTOMATIC AIR CONDITIONER]

< COMPONENT DIAGNOSIS >

Check fuse 15A [Nos 21 and 22, located in the fuse block (J/B). Refer to [PG-93. "Fuse, Connector and Terminal Arrangement"](#).

Is the inspection result normal?

- YES >> Repair harness or connector.
- NG >> Replace fuse.

WITHOUT LEFT AND RIGHT VENTILATION TEMPERATURE SEPARATELY CONTROL SYSTEM : Component Inspection

INFOID:000000000959943

Confirm smooth rotation of the blower motor (1).

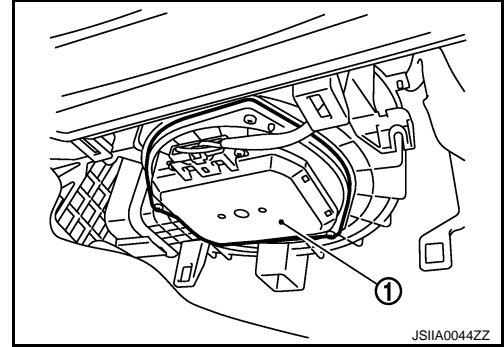

WITH LEFT AND RIGHT VENTILATION TEMPERATURE SEPARATELY CONTROL SYSTEM

WITH LEFT AND RIGHT VENTILATION TEMPERATURE SEPARATELY CONTROL SYSTEM : Description

INFOID:000000000959944

COMPONENT DESCRIPTION

Brush-less Motor

The blower motor utilizes a brush-less motor with a rotating magnet. Quietness is improved over previous motors where the brush was the point of contact and the coil rotated.

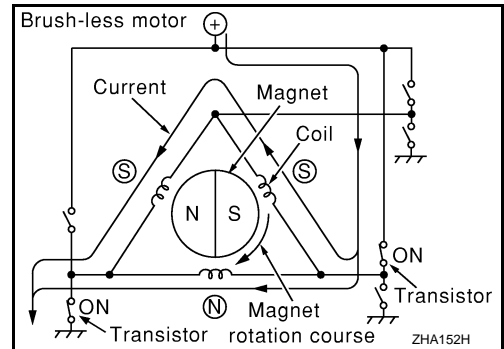

WITH LEFT AND RIGHT VENTILATION TEMPERATURE SEPARATELY CONTROL SYSTEM : Component Function Check

INFOID:000000000959945

1. CONFIRM SYMPTOM BY PERFORMING THE FOLLOWING OPERATIONAL CHECK

1. Press fan (UP: +) switch. Blower should operate on low speed.
2. Press fan (UP: +) switch, and continue checking blower speed and fan symbol until all speeds checked.

Is the inspection result normal?

- YES >> END.
- NO >> Go to diagnosis procedure. Refer to [HAC-86. "WITH LEFT AND RIGHT VENTILATION TEMPERATURE SEPARATELY CONTROL SYSTEM : Diagnosis Procedure"](#).

WITH LEFT AND RIGHT VENTILATION TEMPERATURE SEPARATELY CONTROL SYSTEM : Diagnosis Procedure

INFOID:000000000959946

1. PERFORM SELF-DIAGNOSIS STEP-2

BLOWER MOTOR

[AUTOMATIC AIR CONDITIONER]

< COMPONENT DIAGNOSIS >

Perform self-diagnosis STEP-2. Refer to [HAC-50. "WITH LEFT AND RIGHT VENTILATION TEMPERATURE SEPARATELY CONTROL SYSTEM : Diagnosis Description"](#), see No. 1 to 2.

Is there any malfunction displayed?

YES >> Go to appropriate malfunctioning sensor circuit. Refer to [HAC-50. "WITH LEFT AND RIGHT VENTILATION TEMPERATURE SEPARATELY CONTROL SYSTEM : Diagnosis Description"](#), see to No. 11.

NO >> GO TO 2.

2.PERFORM SELF-DIAGNOSIS STEP-4

Perform self-diagnosis STEP-4. Refer to [HAC-50. "WITH LEFT AND RIGHT VENTILATION TEMPERATURE SEPARATELY CONTROL SYSTEM : Diagnosis Description"](#), see No. 1 to 5.

Code No.	41	42	43	44	45	46
Blower motor duty ratio	37%	91%		65%		91%

Does blower motor speed change according to each code No.?

YES >> GO TO 3.

NO >> GO TO 5.

3.CHECK ENGINE COOLANT TEMPERATURE

Check engine coolant temperature.

Is engine coolant temperature below 56°C (133°F)?

YES >> GO TO 4.

NO >> Blower motor operation is normal.

4.CHECK BLOWER MOTOR OPERATING

Check blower motor operating.

Is blower motor operation under starting blower speed control?

YES >> END.

NO >> GO TO 5.

5.CHECK POWER SUPPLY FOR BLOWER MOTOR

1. Disconnect blower motor connector.
2. Turn ignition switch ON.
3. Check voltage between blower motor harness connector M109 terminal 1 and ground.

(+)		(-)	Voltage
Blower motor		—	
Connector	Terminal		
M109	1	Ground	Battery voltage

Is the inspection result normal?

YES >> GO TO 6.

NO >> GO TO 9.

6.CHECK BLOWER MOTOR GROUND CIRCUIT

1. Turn ignition switch OFF.
2. Check continuity between blower motor harness connector M109 terminal 3 and ground.

(+)		(-)	Continuity
blower motor		—	
Connector	Terminal		
M109	3	Ground	Continuity should exist

Is the inspection result normal?

YES >> GO TO 7.

NO >> Repair harness or connector.

BLOWER MOTOR

< COMPONENT DIAGNOSIS >

[AUTOMATIC AIR CONDITIONER]

7. CHECK CIRCUIT CONTINUITY BETWEEN BLOWER MOTOR AND UNIFIED METER AND A/C AMP.

1. Disconnect unified meter and A/C amp. connector.
2. Check continuity between blower motor harness connector M109 terminal 2 and unified meter and A/C amp. harness connector M66 terminal 38.

(+)		(-)		Continuity
blower motor		Unified meter and A/C amp.		
Connector	Terminal	Connector	Terminal	
M109	2	M66	38	Continuity should exist

Is the inspection result normal?

YES >> GO TO 8.

NO >> Repair harness or connector.

8. CHECK UNIFIED METER AND A/C AMP. OUTPUT SIGNAL

1. Reconnect blower motor connector and unified meter and A/C amp. connector.
2. Turn ignition switch ON.
3. Set MODE switch to VENT position.
4. Change fan speed from Lo to Hi, and check duty ratios between blower motor harness connector M109 terminal 2 and ground by using an oscilloscope. Normal terminal 2 drive signal duty ratios are shown in the table below.

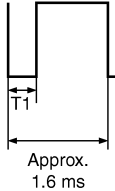
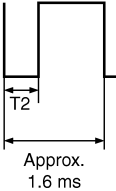
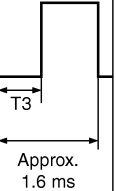
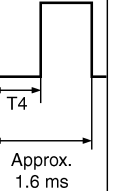
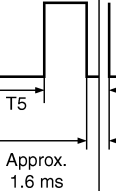
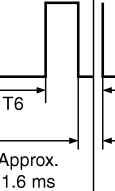
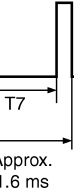
Blower fan speed (Manual) Vent mode	1st	2nd	3rd	4th	5th	6th	7th
Blower motor connector M109 terminal No. 2 (Oscilloscope)							
Duty ratio	Approx. 25%	Approx. 33%	Approx. 41%	Approx. 51%	Approx. 61%	Approx. 71%	Approx. 83%

$$\text{NOTE: Duty ratio} = \frac{T_x}{\text{Approx. } 1.6 \text{ ms}} \times 100 (\%)$$

JS1IA0068GB

Is the inspection result normal?

YES >> Replace blower motor after confirming the fan air flow does not change.

NO >> Replace unified meter and A/C amp.

9. CHECK POWER VOLTAGE OF BLOWER FAN MOTOR

1. Turn ignition switch OFF.
2. Remove blower fan motor relay. Refer to [PG-93, "Fuse, Connector and Terminal Arrangement"](#).
3. Turn ignition switch ON.
4. Check the voltage between blower fan motor relay fuse block terminals 1, 3 and body ground. Refer to [PG-91, "Description"](#) for relay terminal assignment.

(+)		(-)		Voltage
Blower fan motor relay		—		
Fuse block terminal				Battery voltage
1		Ground		
3				

Is the inspection result normal?

BLOWER MOTOR

[AUTOMATIC AIR CONDITIONER]

< COMPONENT DIAGNOSIS >

- YES >> GO TO 11.
- NO >> GO TO 10.

10.CHECK IGNITION SWITCH

Check ignition switch.

Is the inspection result normal?

- YES >> Repair harness or connector.
- NG >> Replace ignition switch.

11.CHECK BLOWER FAN MOTOR RELAY

1. Turn ignition switch OFF.
2. Install blower fan motor relay. Refer to [PG-93, "Fuse, Connector and Terminal Arrangement"](#).
3. Check operation sound of the blower fan motor relay after switching ignition switch ON.

Is the inspection result normal?

- YES >> GO TO 12.
- NO >> Replace blower fan motor relay.

12.CHECK FUSE

Check fuse 15A [Nos 21 and 22, located in the fuse block (J/B)]. Refer to [PG-93, "Fuse, Connector and Terminal Arrangement"](#).

Is the inspection result normal?

- YES >> Repair harness or connector.
- NG >> Replace fuse.

WITH LEFT AND RIGHT VENTILATION TEMPERATURE SEPARATELY CONTROL SYSTEM : Component Inspection

INFOID:000000000959947

Confirm smooth rotation of the blower motor (1).

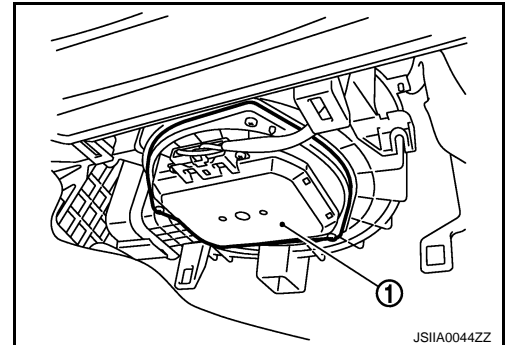

A
B
C
D
E
F
G
H
J
K
L
M
N
O
P

HAC

MAGNET CLUTCH

Description

INFOID:000000000959948

Magnet clutch drives a compressor, by a signal of IPDM/ER.

Component Function Check

INFOID:000000000959949

1. CONFIRM SYMPTOM BY PERFORMING THE FOLLOWING OPERATIONAL CHECK

1. Press AUTO switch and A/C switch.
2. Display should indicate AUTO. Confirm that the magnet clutch engages (sound or visual inspection). (Discharge air and blower speed will depend on ambient, in-vehicle and set temperatures.)

Does the magnet clutch operate?

YES >> END.

NO >> Go to Diagnosis Procedure. Refer to [HAC-90. "Diagnosis Procedure"](#).

Diagnosis Procedure

INFOID:000000000959950

1. PERFORM SELF-DIAGNOSIS STEP-2

Perform self-diagnosis STEP-2. Refer to [HAC-44. "WITHOUT LEFT AND RIGHT VENTILATION TEMPERATURE SEPARATELY CONTROL SYSTEM : Diagnosis Description"](#) (Without left and right ventilation temperature separately control system) or [HAC-50. "WITH LEFT AND RIGHT VENTILATION TEMPERATURE SEPARATELY CONTROL SYSTEM : Diagnosis Description"](#) (With left and right ventilation temperature separately control system), see No. 1 to 2.

Is there any malfunction displayed?

YES >> Go to appropriate malfunctioning sensor circuit. Refer to [HAC-44. "WITHOUT LEFT AND RIGHT VENTILATION TEMPERATURE SEPARATELY CONTROL SYSTEM : Diagnosis Description"](#) (Without left and right ventilation temperature separately control system) or [HAC-50. "WITH LEFT AND RIGHT VENTILATION TEMPERATURE SEPARATELY CONTROL SYSTEM : Diagnosis Description"](#) (With left and right ventilation temperature separately control system), see to No. 11.

NO >> GO TO 2.

2. PERFORM SELF-DIAGNOSIS STEP-4

Perform self-diagnosis STEP-4. Refer to [HAC-44. "WITHOUT LEFT AND RIGHT VENTILATION TEMPERATURE SEPARATELY CONTROL SYSTEM : Diagnosis Description"](#) (Without left and right ventilation temperature separately control system) or [HAC-50. "WITH LEFT AND RIGHT VENTILATION TEMPERATURE SEPARATELY CONTROL SYSTEM : Diagnosis Description"](#) (With left and right ventilation temperature separately control system), see No. 1 to 5.

Is it operated normally?

YES >> END.

NO >> GO TO 3.

3. PERFORM AUTO ACTIVE TEST

Refer to [PCS-10. "Diagnosis Description"](#).

Does the magnet clutch operate?

YES >> • WITH CONSULT-III: GO TO 6.

• WITHOUT CONSULT-III: GO TO 7.

NO >> Check 10A fuse (No. 49, located in IPDM E/R), and GO TO 4.

4. CHECK CIRCUIT CONTINUITY BETWEEN IPDM E/R AND COMPRESSOR

1. Turn ignition switch OFF.
2. Disconnect IPDM E/R connector and compressor connector.
3. Check continuity between IPDM E/R harness connector E7 terminal 48 and compressor harness connector F44 terminal 1.

MAGNET CLUTCH

< COMPONENT DIAGNOSIS >

[AUTOMATIC AIR CONDITIONER]

(+)		(-)		Continuity
IPDM E/R		Compressor		
Connector	Terminal	Connector	Terminal	
E7	48	F44	1	Continuity should exist

Is the inspection result normal?

- YES >> GO TO 5.
 NO >> Repair harness or connector.

5.CHECK MAGNET CLUTCH CIRCUIT

Check for operation sound when applying battery voltage direct current to terminal.

Is the inspection result normal?

- YES >> 1. Replace IPDM E/R.
 2. Refer to self-diagnosis procedure [HAC-44, "WITHOUT LEFT AND RIGHT VENTILATION TEMPERATURE SEPARATELY CONTROL SYSTEM : Diagnosis Description"](#) (Without left and right ventilation temperature separately control system) or [HAC-50, "WITH LEFT AND RIGHT VENTILATION TEMPERATURE SEPARATELY CONTROL SYSTEM : Diagnosis Description"](#) (With left and right ventilation temperature separately control system) and perform self-diagnosis STEP-4. Confirm that magnet clutch operation normal.
- NO >> 1. Replace compressor.
 2. Refer to self-diagnosis procedure [HAC-44, "WITHOUT LEFT AND RIGHT VENTILATION TEMPERATURE SEPARATELY CONTROL SYSTEM : Diagnosis Description"](#) (Without left and right ventilation temperature separately control system) or [HAC-50, "WITH LEFT AND RIGHT VENTILATION TEMPERATURE SEPARATELY CONTROL SYSTEM : Diagnosis Description"](#) (With left and right ventilation temperature separately control system) and perform self-diagnosis STEP-4. Confirm that magnet clutch operation normal.

6.CHECK BCM INPUT (COMPRESSOR ON) SIGNAL

Check compressor ON/OFF signal. Refer to [HAC-49, "WITHOUT LEFT AND RIGHT VENTILATION TEMPERATURE SEPARATELY CONTROL SYSTEM : CONSULT-III Function"](#).

A/C SW ON : AIR COND SIG ON
A/C SW OFF : AIR COND SIG OFF

Is the inspection result normal?

- YES >> GO TO 9.
 NO >> GO TO 7.

7.CHECK REFRIGERANT PRESSURE SENSOR

WITH CONSULT-III

- Start the engine.
- Check voltage of refrigerant pressure sensor. Refer to [EC-484, "Reference Value"](#).

WITHOUT CONSULT-III

- Start the engine.
- Check voltage between ECM harness connector M107 terminal 105 and ground.

(+)		(-)		Condition	Voltage
ECM		—			
connector	Terminal				
M107	105	Ground		A/C switch: ON (Blower motor operates.)	Approx. 1.0 - 4.0 V

Is the inspection result normal?

- YES >> • WITH CONSULT-III: GO TO 8.
 • WITHOUT CONSULT-III: Repair harness or connector.
 NO >> Refer to [EC-479, "Diagnosis Procedure"](#).

MAGNET CLUTCH

[AUTOMATIC AIR CONDITIONER]

< COMPONENT DIAGNOSIS >

8. CHECK ECM INPUT (FAN ON) SIGNAL

Check FAN ON/OFF signal. Refer to [HAC-49, "WITHOUT LEFT AND RIGHT VENTILATION TEMPERATURE SEPARATELY CONTROL SYSTEM : CONSULT-III Function"](#).

FAN SW ON : HEATER FAN SW ON
FAN SW OFF : HEATER FAN SW OFF

Is the inspection result normal?

- YES >> GO TO 9.
- NO >> Repair harness or connector.

9. CHECK CAN COMMUNICATION

Check CAN communication. Refer to [BCS-43, "Reference Value"](#).

- ECM – IPDM E/R
- ECM – Unified meter and A/C amp.

Is the inspection result normal?

- YES >> Replace ECM.
- NO >> Repair or replace malfunctioning part(s).

Component Inspection

INFOID:000000000959951

Refrigerant Pressure Sensor

The refrigerant pressure sensor (1) is attached to the liquid tank. Make sure that the A/C refrigerant pressure and the sensor output voltage are within the specified range as shown in the A/C operating condition figure. Refer to [EC-479, "Description"](#).

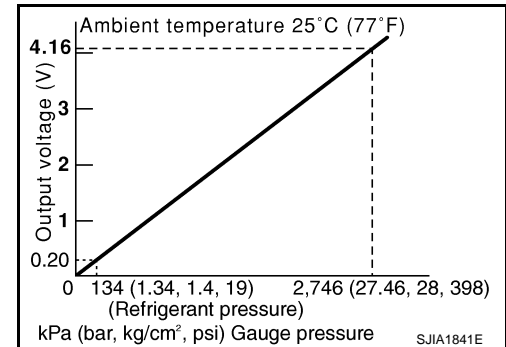
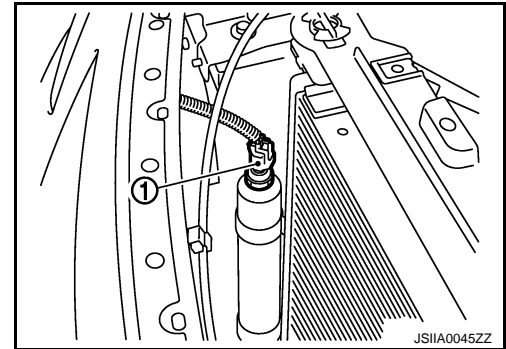

AMBIENT SENSOR

< COMPONENT DIAGNOSIS >

[AUTOMATIC AIR CONDITIONER]

AMBIENT SENSOR

Description

INFOID:000000000959952

COMPONENT DESCRIPTION

Ambient Sensor

The ambient sensor (1) is attached on the radiator core support (left side). It detects ambient temperature and converts it into a resistance value which is then input into the unified meter and A/C amp.

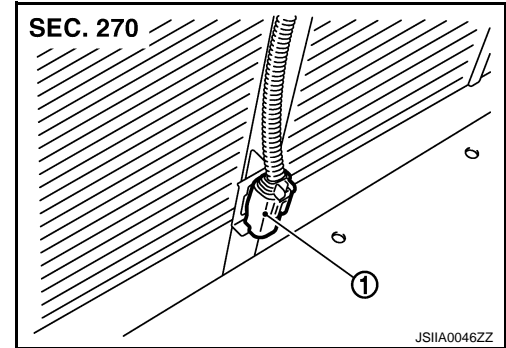

Ambient Sensor Circuit

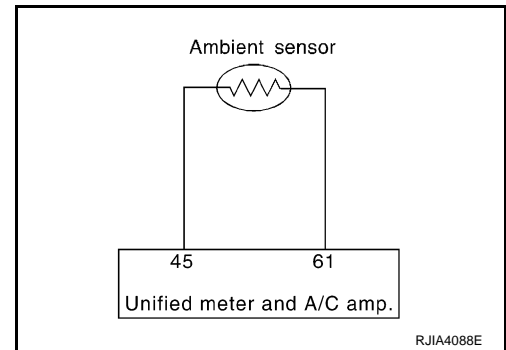

AMBIENT TEMPERATURE INPUT PROCESS

The unified meter and A/C amp. includes a processing circuit for the ambient sensor input. However, when the temperature detected by the ambient sensor increases quickly, the processing circuit retards the unified meter and A/C amp. function. It only allows the unified meter and A/C amp. to recognize an ambient temperature increase of 0.33°C (0.6°F) per 100 seconds.

As an example, consider stopping for a few minutes after high speed driving. Although the actual ambient temperature has not changed, the temperature detected by the ambient sensor will increase. This is because the heat from the engine compartment can radiate to the front bumper area, location of the ambient sensor.

Component Function Check

INFOID:000000000959953

1.PERFORM SELF-DIAGNOSIS STEP-2

Perform self-diagnosis STEP-2. Refer to [HAC-44. "WITHOUT LEFT AND RIGHT VENTILATION TEMPERATURE SEPARATELY CONTROL SYSTEM : Diagnosis Description"](#) (Without left and right ventilation temperature separately control system) or [HAC-50. "WITH LEFT AND RIGHT VENTILATION TEMPERATURE SEPARATELY CONTROL SYSTEM : Diagnosis Description"](#) (With left and right ventilation temperature separately control system), see No. 1 to 2.

21 or -21 is displayed.

- YES >> Go to Diagnosis Procedure. Refer to [HAC-93. "Diagnosis Procedure"](#).
- NO >> END.

Diagnosis Procedure

INFOID:000000000959954

1.CHECK VOLTAGE BETWEEN AMBIENT SENSOR AND GROUND

1. Disconnect ambient sensor connector.
2. Turn ignition switch ON.
3. Check voltage between ambient sensor harness connector E76 terminal 1 and ground.

AMBIENT SENSOR

< COMPONENT DIAGNOSIS >

[AUTOMATIC AIR CONDITIONER]

(+)		(-)		Voltage
Ambient sensor		—		
Connector	Terminal	Connector	Terminal	
E76	1	Ground		Approx. 5 V

Is the inspection result normal?

- YES >> GO TO 2.
- NO >> GO TO 4.

2. CHECK CIRCUIT CONTINUITY BETWEEN AMBIENT SENSOR AND UNIFIED METER AND A/C AMP.

1. Turn ignition switch OFF.
2. Disconnect unified meter and A/C amp. connector.
3. Check continuity between ambient sensor harness connector E76 terminal 2 and unified meter and A/C amp. harness connector M67 terminal 61.

(+)		(-)		Continuity
ambient sensor		Unified meter and A/C amp.		
Connector	Terminal	Connector	Terminal	
E76	2	M67	61	Continuity should exist

Is the inspection result normal?

- YES >> GO TO 3.
- NO >> Repair harness or connector.

3. CHECK AMBIENT SENSOR

Refer to [HAC-94, "Component Inspection"](#).

Is the inspection result normal?

- YES >> Replace unified meter and A/C amp.
- NO >> Replace ambient sensor.

4. CHECK CIRCUIT CONTINUITY BETWEEN AMBIENT SENSOR AND UNIFIED METER AND A/C AMP.

1. Turn ignition switch OFF.
2. Disconnect unified meter and A/C amp. connector.
3. Check continuity between ambient sensor harness connector E76 terminal 1 and unified meter and A/C amp. harness connector M67 terminal 45.

(+)		(-)		Continuity
Ambient sensor		Unified meter and A/C amp.		
Connector	Terminal	Connector	Terminal	
E76	1	M67	45	Continuity should exist

4. Check continuity between ambient sensor harness connector E76 terminal 1 and ground.

(+)		(-)		Continuity
Ambient sensor		—		
Connector	Terminal	Connector	Terminal	
E76	1	Ground		Continuity should not exist

Is the inspection result normal?

- YES >> Replace unified meter and A/C amp.
- NO >> Repair harness or connector.

Component Inspection

INFOID:000000000959955

AMBIENT SENSOR

< COMPONENT DIAGNOSIS >

[AUTOMATIC AIR CONDITIONER]

After disconnecting ambient sensor (1) connector E76, measure resistance between terminals 1 and 2 at sensor side. Refer to table below.

Temperature °C (°F)	Resistance kΩ
-15 (5)	12.73
-10 (14)	9.92
-5 (23)	7.80
0 (32)	6.19
5 (41)	4.95
10 (50)	3.99
15 (59)	3.24
20 (68)	2.65
25 (77)	2.19
30 (86)	1.81
35 (95)	1.51
40 (104)	1.27
45 (113)	1.07

If NG, replace ambient sensor.

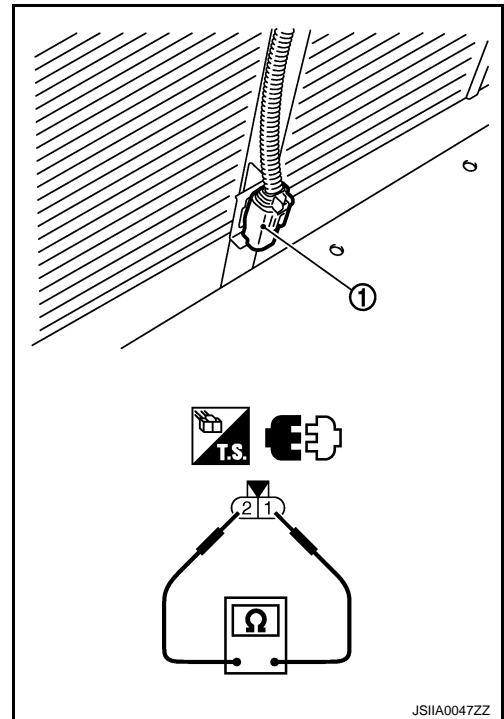

A
B
C
D
E
F
G
H
J
K
L
M
N
O
P

HAC

IN-VEHICLE SENSOR

< COMPONENT DIAGNOSIS >

[AUTOMATIC AIR CONDITIONER]

IN-VEHICLE SENSOR

Description

INFOID:000000000959956

In-vehicle Sensor

The in-vehicle sensor (1) is located on instrument driver lower panel. It converts variations in temperature of compartment air drawn from the aspirator into a resistance value. It is then input into the unified meter and A/C amp.

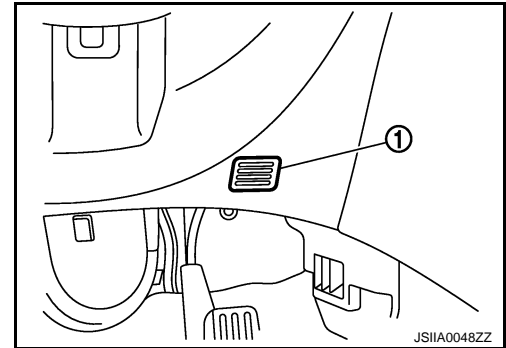

In-vehicle Sensor Circuit

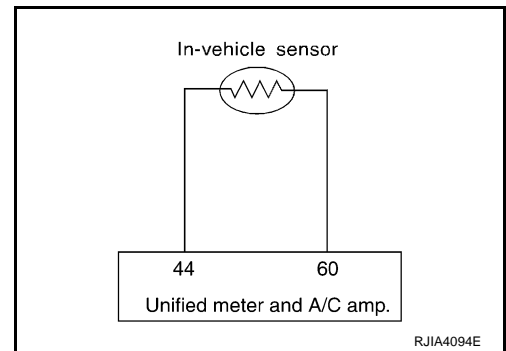

Aspirator

The aspirator (1) is located on driver's side of heater & cooling unit assembly. It produces vacuum pressure due to air discharged from the heater & cooling unit assembly, continuously taking compartment air in the aspirator.

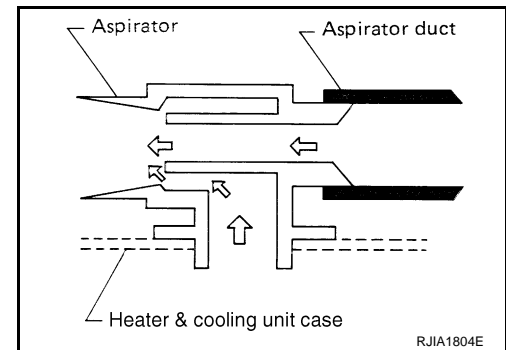
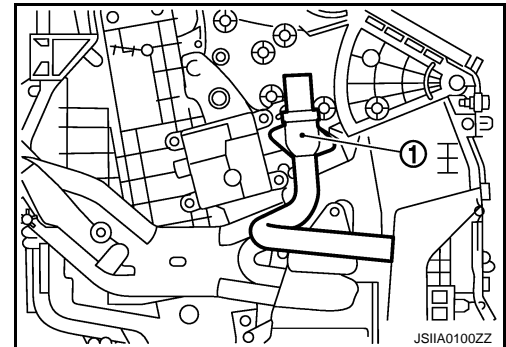

Component Function Check

INFOID:000000000959957

1. PERFORM SELF-DIAGNOSIS STEP-2

IN-VEHICLE SENSOR

[AUTOMATIC AIR CONDITIONER]

< COMPONENT DIAGNOSIS >

Perform self-diagnosis STEP-2. Refer to [HAC-44. "WITHOUT LEFT AND RIGHT VENTILATION TEMPERATURE SEPARATELY CONTROL SYSTEM : Diagnosis Description"](#) (Without left and right ventilation temperature separately control system) or [HAC-50. "WITH LEFT AND RIGHT VENTILATION TEMPERATURE SEPARATELY CONTROL SYSTEM : Diagnosis Description"](#) (With left and right ventilation temperature separately control system), see No. 1 to 2.

22 or -22 is displayed.

- YES >> Go to Diagnosis Procedure. Refer to [HAC-97. "Diagnosis Procedure"](#).
NO >> END.

Diagnosis Procedure

INFOID:000000000959958

1. CHECK VOLTAGE BETWEEN IN-VEHICLE SENSOR AND GROUND

1. Disconnect in-vehicle sensor connector.
2. Turn ignition switch ON.
3. Check voltage between in-vehicle sensor harness connector M61 terminal 1 and ground.

(+)		(-)		Voltage
In-vehicle sensor		—		
Connector	Terminal			
M61	1	Ground		Approx. 5 V

Is the inspection result normal?

- YES >> GO TO 2.
NO >> GO TO 4.

2. CHECK CIRCUIT CONTINUITY BETWEEN IN-VEHICLE SENSOR AND UNIFIED METER AND A/C AMP.

1. Turn ignition switch OFF.
2. Disconnect unified meter and A/C amp. connector.
3. Check continuity between in-vehicle sensor harness connector M61 terminal 2 and unified meter and A/C amp. harness connector M67 terminal 60.

(+)		(-)		Continuity
In-vehicle sensor		Unified meter and A/C amp.		
Connector	Terminal	Connector	Terminal	
M61	2	M67	60	Continuity should exist

Is the inspection result normal?

- YES >> GO TO 3.
NO >> Repair harness or connector.

3. CHECK IN-VEHICLE SENSOR

Refer to [HAC-98. "Component Inspection"](#).

Is the inspection result normal?

- YES >> Replace unified meter and A/C amp.
NO >> Replace in-vehicle sensor.

4. CHECK CIRCUIT CONTINUITY BETWEEN IN-VEHICLE SENSOR AND UNIFIED METER AND A/C AMP.

1. Turn ignition switch OFF.
2. Disconnect unified meter and A/C amp. connector.
3. Check continuity between in-vehicle sensor harness connector M61 terminal 1 and unified meter and A/C amp. harness connector M67 terminal 44.

(+)		(-)		Continuity
In-vehicle sensor		Unified meter and A/C amp.		
Connector	Terminal	Connector	Terminal	
M61	1	M67	44	Continuity should exist

IN-VEHICLE SENSOR

[AUTOMATIC AIR CONDITIONER]

< COMPONENT DIAGNOSIS >

4. Check continuity between in-vehicle sensor harness connector M61 terminal 1 and ground.

(+)		(-)	Continuity
In-vehicle sensor		—	
Connector	Terminal		
M61	1	Ground	Continuity should not exist

Is the inspection result normal?

- YES >> Replace unified meter and A/C amp.
- NO >> Repair harness or connector.

Component Inspection

INFOID:000000000959959

After disconnecting in-vehicle sensor (1) connector M61, measure resistance between terminals 1 and 2 at sensor side. Refer to table below.

Temperature °C (°F)	Resistance kΩ
-15 (5)	12.73
-10 (14)	9.92
-5 (23)	7.80
0 (32)	6.19
5 (41)	4.95
10 (50)	3.99
15 (59)	3.24
20 (68)	2.65
25 (77)	2.19
30 (86)	1.81
35 (95)	1.51
40 (104)	1.27
45 (113)	1.07

If NG, replace in-vehicle sensor.

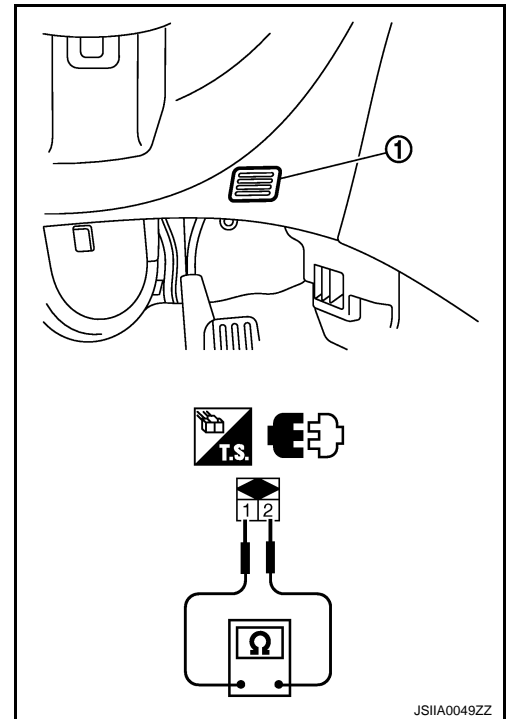

JSIIA0049ZZ

SUNLOAD SENSOR

< COMPONENT DIAGNOSIS >

[AUTOMATIC AIR CONDITIONER]

SUNLOAD SENSOR

Description

INFOID:000000000959960

COMPONENT DESCRIPTION

Sunload Sensor

The sunload sensor (1) is located on the driver's side front defroster grille. It detects sunload entering through windshield by means of a photo diode. The sensor converts the sunload into a current value which is then input into the unified meter and A/C amp.

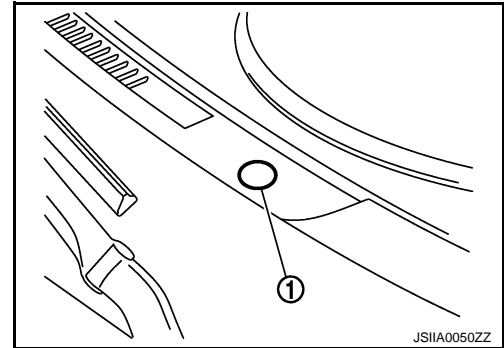

Sunload Sensor Circuit

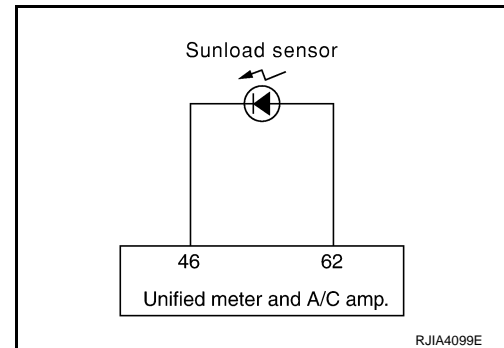

SUNLOAD INPUT PROCESS

The unified meter and A/C amp. also includes a processing circuit which averages the variations in detected sunload over a period of time. This prevents drastic swings in the ATC system operation due to small or quick variations in detected sunload.

For example, consider driving along a road bordered by an occasional group of large trees. The sunload detected by the sunload sensor will vary whenever the trees obstruct the sunlight. The processing circuit averages the detected sunload over a period of time, so that the (insignificant) effect of the trees momentarily obstructing the sunlight does not cause any change in the ATC system operation. On the other hand, shortly after entering a long tunnel, the system will recognize the change in sunload, and the system will react accordingly.

Component Function Check

INFOID:000000000959961

1.PERFORM SELF-DIAGNOSIS STEP-2

Perform self-diagnosis STEP-2. Refer to [HAC-44, "WITHOUT LEFT AND RIGHT VENTILATION TEMPERATURE SEPARATELY CONTROL SYSTEM : Diagnosis Description"](#) (Without left and right ventilation temperature separately control system) or [HAC-50, "WITH LEFT AND RIGHT VENTILATION TEMPERATURE SEPARATELY CONTROL SYSTEM : Diagnosis Description"](#) (With left and right ventilation temperature separately control system), see No. 1 to 2.

25 or -25 is displayed.

- YES >> Go to Diagnosis Procedure. Refer to [HAC-99, "Diagnosis Procedure"](#).
- NO >> END.

Diagnosis Procedure

INFOID:000000000959962

1.CHECK VOLTAGE BETWEEN SUNLOAD SENSOR AND GROUND

1. Disconnect sunload sensor connector.
2. Turn ignition switch ON.

A
B
C
D
E
F
G
H
HAC
J
K
L
M
N
O
P

SUNLOAD SENSOR

[AUTOMATIC AIR CONDITIONER]

< COMPONENT DIAGNOSIS >

3. Check voltage between sunload sensor harness connector M46 terminal 1 and ground.

(+)		(-)		Voltage
Sunload sensor		—		
Connector	Terminal	Connector	Terminal	
M46	1	Ground		Approx. 5 V

Is the inspection result normal?

YES >> GO TO 2.

NO >> GO TO 4.

2.CHECK CIRCUIT CONTINUITY BETWEEN SUNLOAD SENSOR AND UNIFIED METER AND A/C AMP.

1. Turn ignition switch OFF.
2. Disconnect unified meter and A/C amp. connector.
3. Check continuity between sunload sensor harness connector M46 terminal 2 and unified meter and A/C amp. harness connector M67 terminal 62.

(+)		(-)		Continuity
Sunload sensor		Unified meter and A/C amp.		
Connector	Terminal	Connector	Terminal	
M46	2	M67	62	Continuity should exist

Is the inspection result normal?

YES >> GO TO 3.

NO >> Repair harness or connector.

3.CHECK SUNLOAD SENSOR

1. Reconnect sunload sensor connector and unified meter and A/C amp. connector.
2. Refer to [HAC-100, "Component Inspection"](#).

Is the inspection result normal?

YES >> Replace unified meter and A/C amp.

NO >> Replace sunload sensor.

4.CHECK CIRCUIT CONTINUITY BETWEEN SUNLOAD SENSOR AND UNIFIED METER AND A/C AMP.

1. Turn ignition switch OFF.
2. Disconnect unified meter and A/C amp. connector.
3. Check continuity between sunload sensor harness connector M46 terminal 1 and unified meter and A/C amp. harness connector M67 terminal 46.

(+)		(-)		Continuity
Sunload sensor		Unified meter and A/C amp.		
Connector	Terminal	Connector	Terminal	
M46	1	M67	46	Continuity should exist

4. Check continuity between sunload sensor harness connector M46 terminal 1 and ground.

(+)		(-)		Continuity
Sunload sensor		—		
Connector	Terminal	Connector	Terminal	
M46	1	Ground		Continuity should not exist

Is the inspection result normal?

YES >> Replace unified meter and A/C amp.

NO >> Repair harness or connector.

Component Inspection

INFOID:000000000959963

SUNLOAD SENSOR

[AUTOMATIC AIR CONDITIONER]

< COMPONENT DIAGNOSIS >

Measure voltage between unified meter and A/C amp. harness connector (2) M67 terminal 46 and ground.

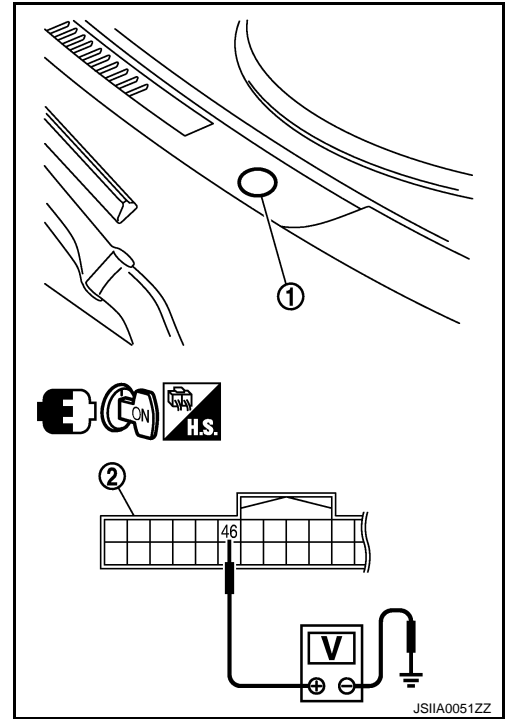

- When checking sunload sensor, select a place where sunshine directly on it.

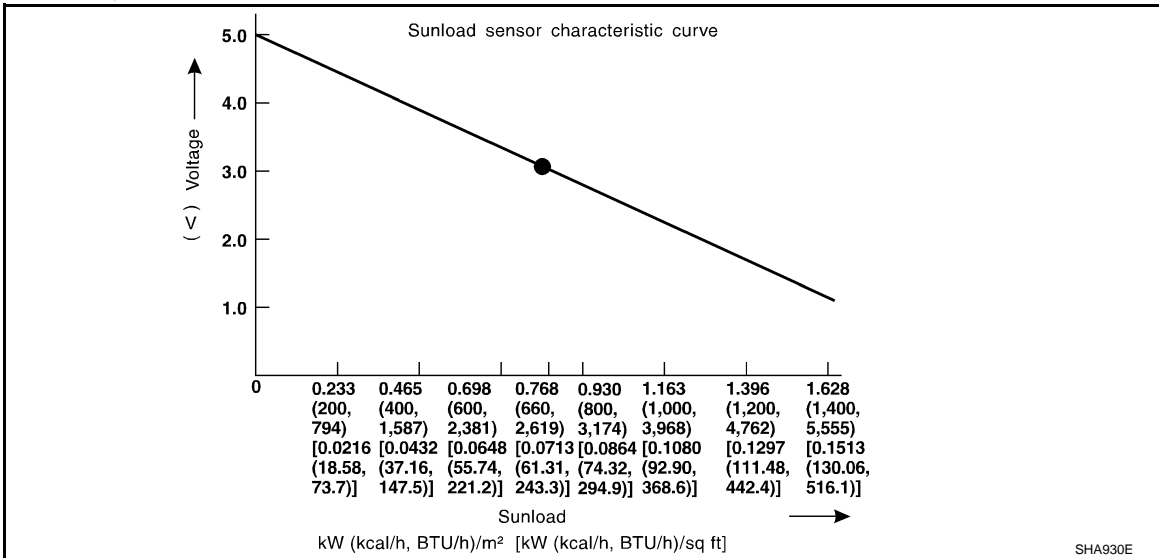

If NG, replace sunload sensor (1).

INTAKE SENSOR

< COMPONENT DIAGNOSIS >

[AUTOMATIC AIR CONDITIONER]

INTAKE SENSOR

Description

INFOID:000000000959964

Intake Sensor

The intake sensor (1) is located on the heater & cooling unit assembly. It converts temperature of air after it passes through the evaporator (2) into a resistance value which is then input to the unified meter and A/C amp.

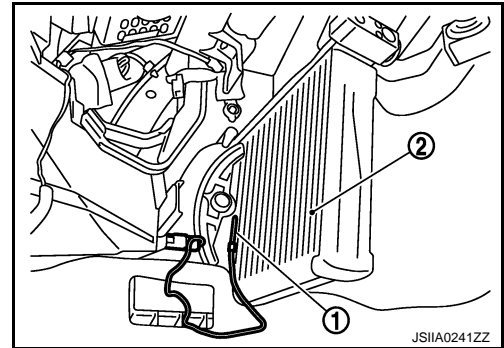

Intake Sensor Circuit

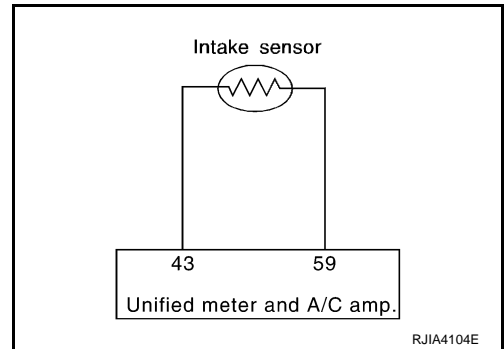

Component Function Check

INFOID:000000000959965

1.PERFORM SELF-DIAGNOSIS STEP-2

Perform self-diagnosis STEP-2. Refer to [HAC-44, "WITHOUT LEFT AND RIGHT VENTILATION TEMPERATURE SEPARATELY CONTROL SYSTEM : Diagnosis Description"](#) (Without left and right ventilation temperature separately control system) or [HAC-50, "WITH LEFT AND RIGHT VENTILATION TEMPERATURE SEPARATELY CONTROL SYSTEM : Diagnosis Description"](#) (With left and right ventilation temperature separately control system), see No. 1 to 2.

24 or -24 is displayed.

- YES >> Go to Diagnosis Procedure. Refer to [HAC-102, "Diagnosis Procedure"](#).
- NO >> END.

Diagnosis Procedure

INFOID:000000000959966

1.CHECK VOLTAGE BETWEEN INTAKE SENSOR AND GROUND

1. Disconnect intake sensor connector.
2. Turn ignition switch ON.
3. Check voltage between intake sensor harness connector M77 terminal 1 and ground.

(+)		(-)	Voltage
Intake sensor		—	
Connector	Terminal	Ground	Approx. 5 V
M77	1		

Is the inspection result normal?

- YES >> GO TO 2.
- NO >> GO TO 4.

INTAKE SENSOR

< COMPONENT DIAGNOSIS >

[AUTOMATIC AIR CONDITIONER]

2. CHECK CIRCUIT CONTINUITY BETWEEN INTAKE SENSOR AND UNIFIED METER AND A/C AMP.

1. Turn ignition switch OFF.
2. Disconnect unified meter and A/C amp. connector.
3. Check continuity between intake sensor harness connector M77 terminal 2 and unified meter and A/C amp. harness connector M67 terminal 59.

(+)		(-)		Continuity
Intake sensor		Unified meter and A/C amp.		
Connector	Terminal	Connector	Terminal	
M77	2	M67	59	Continuity should exist

Is the inspection result normal?

YES >> GO TO 3.

NO >> Repair harness or connector.

3. CHECK INTAKE SENSOR

Refer to [HAC-103, "Component Inspection"](#).

Is the inspection result normal?

YES >> Replace unified meter and A/C amp.

NO >> Replace intake sensor.

4. CHECK CIRCUIT CONTINUITY BETWEEN INTAKE SENSOR AND UNIFIED METER AND A/C AMP.

1. Turn ignition switch OFF.
2. Disconnect unified meter and A/C amp. connector.
3. Check continuity between intake sensor harness connector M77 terminal 1 and unified meter and A/C amp. harness connector M67 terminal 43.

(+)		(-)		Continuity
Intake sensor		Unified meter and A/C amp.		
Connector	Terminal	Connector	Terminal	
M77	1	M67	43	Continuity should exist

4. Check continuity between intake sensor harness connector M77 terminal 1 and ground.

(+)		(-)		Continuity
Intake sensor		—		
Connector	Terminal			
M77	1	Ground		Continuity should not exist

Is the inspection result normal?

YES >> Replace unified meter and A/C amp.

NO >> Repair harness or connector.

Component Inspection

INFOID:000000000959967

A
B
C
D
E
F
G
H
J
K
L
M
N
O
P

HAC

INTAKE SENSOR

[AUTOMATIC AIR CONDITIONER]

< COMPONENT DIAGNOSIS >

After disconnecting intake sensor (1) connector M77, measure resistance between terminals 1 and 2 at sensor side. Refer to table below.

Temperature °C (°F)	Resistance kΩ
-15 (5)	12.34
-10 (14)	9.62
-5 (23)	7.56
0 (32)	6.00
5 (41)	4.80
10 (50)	3.87
15 (59)	3.15
20 (68)	2.57
25 (77)	2.12
30 (86)	1.76
35 (95)	1.47
40 (104)	1.23
45 (113)	1.04

If NG, replace intake sensor.

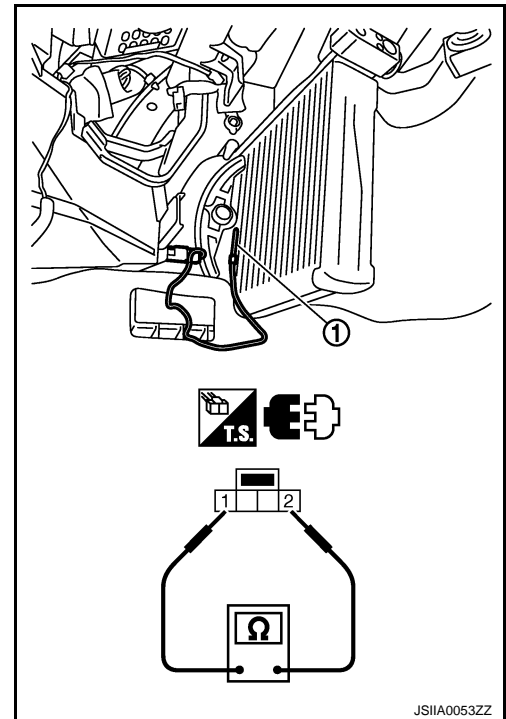

POWER SUPPLY AND GROUND CIRCUIT FOR AUTO AMP.

< COMPONENT DIAGNOSIS >

[AUTOMATIC AIR CONDITIONER]

POWER SUPPLY AND GROUND CIRCUIT FOR AUTO AMP.

Description

INFOID:000000000959968

COMPONENT DESCRIPTION

Unified Meter and A/C Amp. (Automatic Amplifier)

The unified meter and A/C amp. (1) has a built-in microcomputer which processes information sent from various sensors needed for air conditioner operation. The air mix door motor(s), mode door motor, intake door motor, blower motor and compressor are then controlled.

When the various switches and temperature control dial are operated, data is input to the unified meter and A/C amp. from the AV control unit using CAN communication.

Self-diagnosis functions are also built into unified meter and A/C amp. to provide quick check of malfunctions in the auto air conditioner system.

Power Supply and Ground Circuit for Unified Meter and A/C Amp.

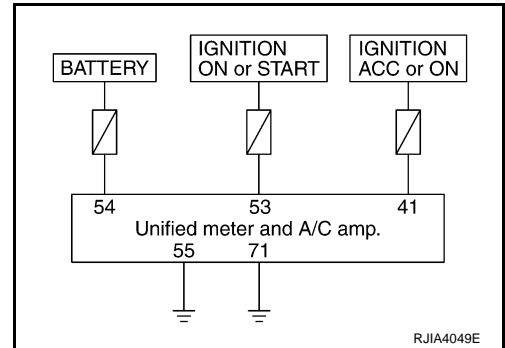
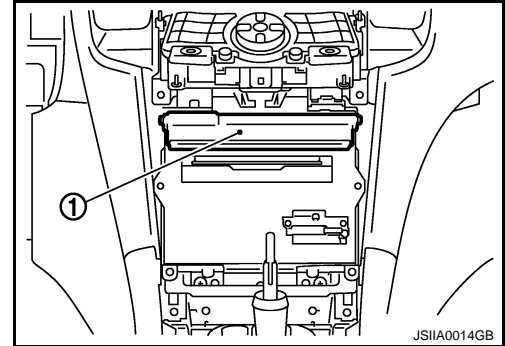

Potential Temperature Control (PTC)

The PTC (1) is built into the preset switch. It can be set at an interval of 0.5°C (1.0°F) in the 18°C (60°F) to 32°C (90°F) temperature range by turning temperature control dial. The set temperature is displayed.

Without left and right ventilation temperature separately system

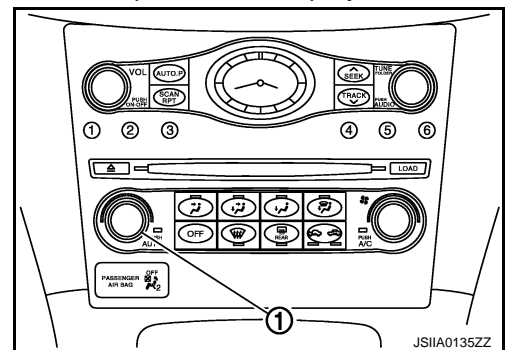

With left and right ventilation temperature separately system

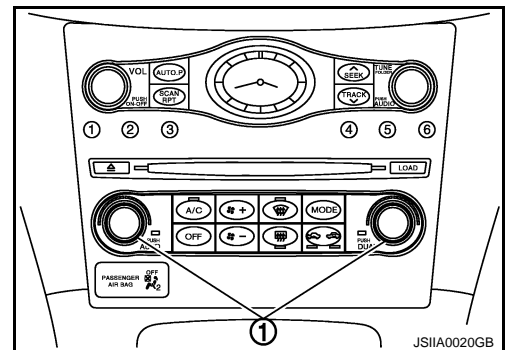

Component Function Check

INFOID:000000000959969

POWER SUPPLY AND GROUND CIRCUIT FOR AUTO AMP.

< COMPONENT DIAGNOSIS >

[AUTOMATIC AIR CONDITIONER]

1. CONFIRM SYMPTOM BY PERFORMING THE FOLLOWING OPERATIONAL CHECK

1. Press AUTO switch and A/C switch.
2. Display should indicate AUTO. Confirm that the compressor clutch engages (sound or visual inspection). (Discharge air and blower speed will depend on ambient, in-vehicle and set temperatures.)

Does magnet clutch engaged?

YES >> END.

NO >> Go to Diagnosis Procedure. Refer to [HAC-106. "Diagnosis Procedure"](#).

Diagnosis Procedure

INFOID:000000000959970

1. CHECK POWER SUPPLY CIRCUIT FOR UNIFIED METER AND A/C AMP.

1. Disconnect unified meter and A/C amp. connector.
2. Check voltage between unified meter and A/C amp. harness connector M67 terminals 41, 53 and 54 and ground.

(+)		(-)	Ignition switch position		
Unified meter and A/C amp.		—	OFF	ACC	ON
Connector	Terminal				
M67	41	Ground	Approx. 0 V	Battery voltage	Battery voltage
	53		Approx. 0 V	Approx. 0 V	Battery voltage
	54		Battery voltage	Battery voltage	Battery voltage

Is the inspection result normal?

YES >> GO TO 3.

NO >> GO TO 2.

2. CHECK FUSE

Check 10A fuses [Nos. 3, 6 and 19, located in the fuse block (J/B)]. Refer to [PG-93. "Fuse, Connector and Terminal Arrangement"](#).

Is the inspection result normal?

YES >> Check harness for open circuit. Repair or replace if necessary.

NO >> Check harness for short circuit and replace fuse.

3. CHECK GROUND CIRCUIT FOR UNIFIED METER AND A/C AMP.

1. Turn ignition switch OFF.
2. Check continuity between unified meter and A/C amp. harness connector M67 terminal 55, 71 and ground.

(+)		(-)	
Unified meter and A/C amp.		—	Continuity
Connector	Terminal		
M67	55	Ground	Continuity should exist
	71		

Is the inspection result normal?

YES >> GO TO 4.

NO >> Repair harness or connector.

4. CHECK PRESET SWITCH

Check preset switch. Refer to [AV-105. "Symptom Table"](#) (BASE AUDIO WITHOUT NAVIGATION), [AV-285. "Symptom Table"](#) (BOSE AUDIO WITHOUT NAVIGATION) or [AV-514. "Symptom Table"](#) (BOSE AUDIO WITH NAVIGATION).

Is the inspection result normal?

YES >> Replace unified meter and A/C amp.

NO >> Repair or replace malfunctioning part(s).

AUTO AMP.

< ECU DIAGNOSIS >

[AUTOMATIC AIR CONDITIONER]

ECU DIAGNOSIS

AUTO AMP.

Reference Value

INFOID:000000000959971

VALUES ON THE DIAGNOSIS TOOL

Display Item List

Monitor Item	Condition		Value/Status
IGN ON SW	Ignition switch OFF → ON		OFF → ON
FAN ON SIG	Ignition switch ON	Blower fan motor switch ON	ON
		Blower fan motor switch OFF	OFF
AIR COND SW	Ignition switch ON	Compressor ON	ON
		Compressor OFF	OFF
REFRIGERANT PRESSURE SENSOR	<ul style="list-style-type: none"> Engine is running Warm-up condition Both A/C switch and blower fan motor switch: ON (Compressor operates) 		1.0 - 4.0 V

TERMINAL LAYOUT

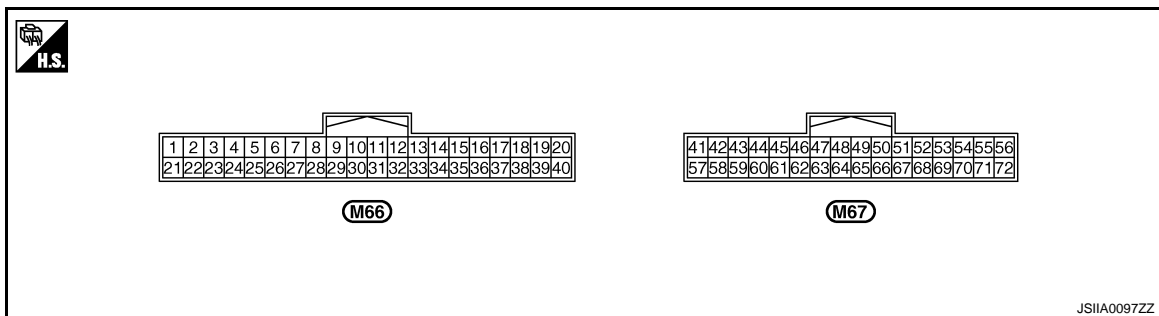

PHYSICAL VALUES

Terminal No. (Wire color)		Description		Condition	Value (Approx.)
+	-	Signal name	Input/ Output		
38 (L)	Ground	Blower motor control signal	Output	<ul style="list-style-type: none"> Ignition switch ON Blower speed: 1st speed (manual) 	<p>JSIIA0096ZZ</p>
41 (V)	Ground	Power supply from ACC	—	Ignition switch ACC	Battery voltage
43 (R)	Ground	Intake sensor	Input	—	—
44 (LG)	Ground	In-vehicle sensor	Input	—	—
45 (P)	Ground	Ambient sensor	Input	—	—
46 (O)	Ground	Sunload sensor	Input	—	—

AUTO AMP.

< ECU DIAGNOSIS >

[AUTOMATIC AIR CONDITIONER]

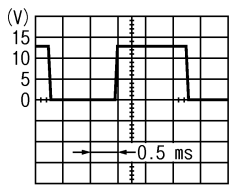
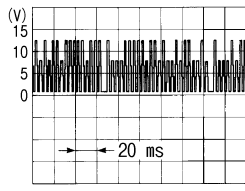
Terminal No. (Wire color)		Description		Condition	Value (Approx.)
+	-	Signal name	Input/ Output		
53 (G)	Ground	Power supply from IGN	—	Ignition switch ON	Battery voltage
54 (Y)	Ground	Power supply from BATT	—	Ignition switch OFF	Battery voltage
55 (B)	Ground	Ground	—	Ignition switch ON	0 V
56 (L)	Ground	CAN-H	—	—	—
59 (GR)	Ground	Intake sensor ground	—	—	0 V
60 (L)	Ground	In-vehicle sensor ground	—	Ignition switch ON	0 V
61 (BR)	Ground	Ambient sensor ground	—	Ignition switch ON	0 V
62 (SB)	Ground	Sunload sensor ground	—	Ignition switch ON	0 V
65 (O)	Ground	ECV (Electrical Control Valve) signal	Output	<ul style="list-style-type: none"> Ignition switch ON Self-diagnosis. STEP-4 (Code No. 45) 	 <p style="text-align: right; font-size: small;">SJIA1607E</p>
69 (L)	Ground	A/C LAN signal	—	Ignition switch ON	 <p style="text-align: right; font-size: small;">SJIA1453J</p>
70 (R)	Ground	Power supply for each door motor	Output	Ignition switch ON	Battery voltage
71 (B)	Ground	Ground	—	Ignition switch ON	0 V
72 (P)	Ground	CAN-L	—	—	—

Wiring Diagram — AIR CONDITIONER CONTROL SYSTEM —

INFOID:00000000959972

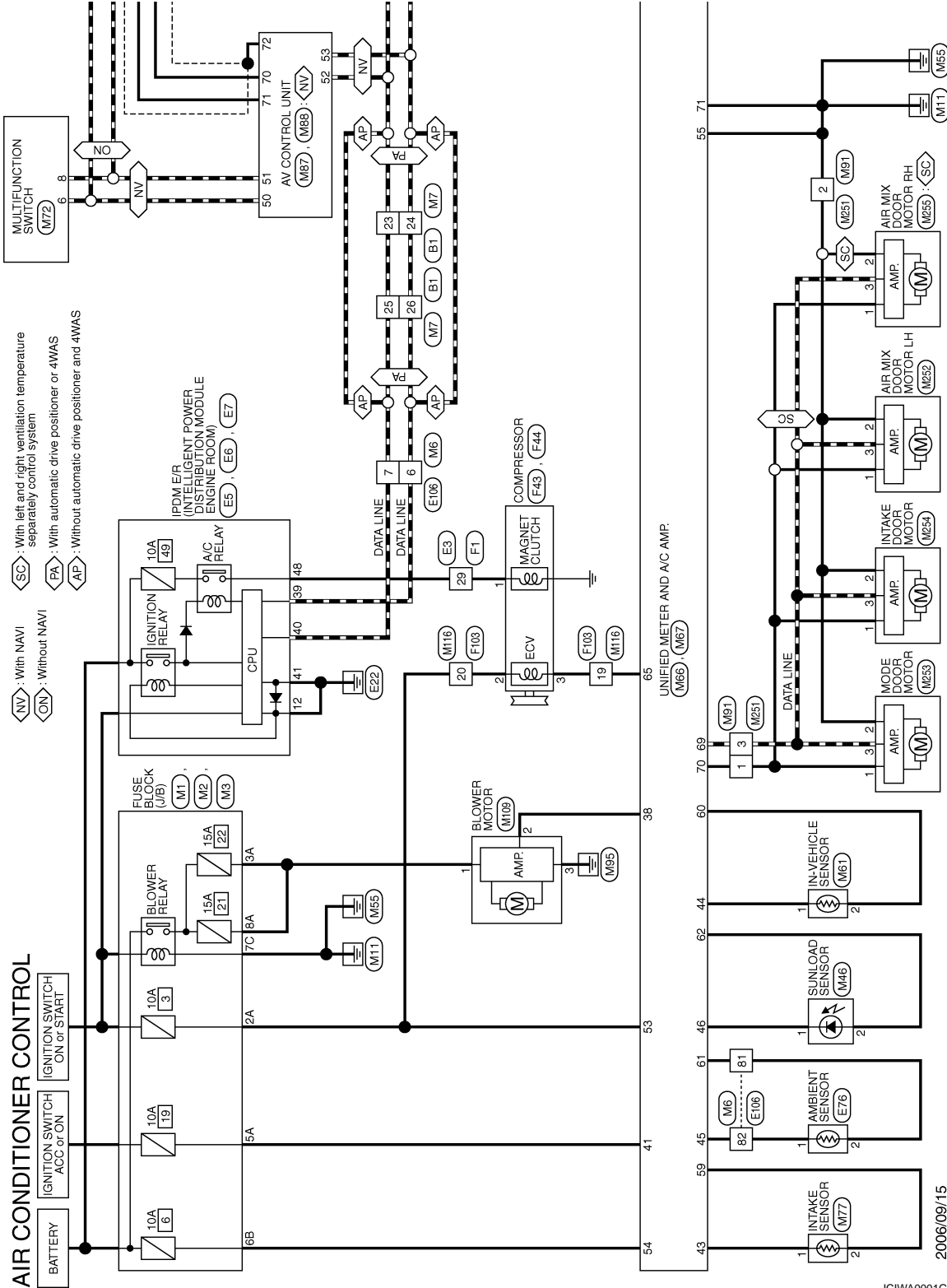

2006/09/15



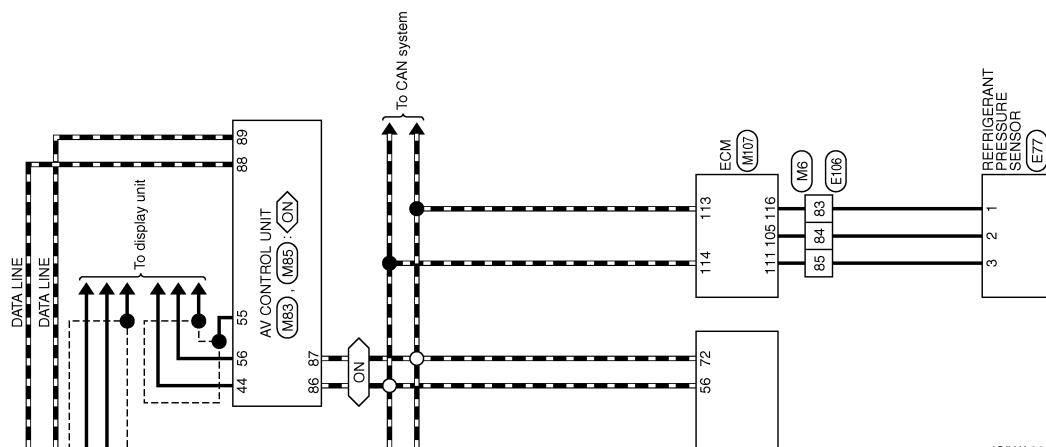

JCIWA0001GB

A B C D E F G H HAC I J K L M N O P



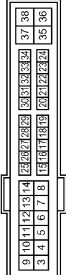

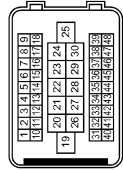

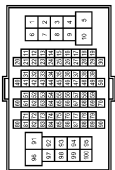
JCIWA0002GB

AIR CONDITIONER CONTROL

Connector No. E1	IPDM E/R (INTELLIGENT POWER DISTRIBUTION MODULE ENGINE ROOM)	TH88FW-NH		Terminal No.	Color of Wire	Signal Name
39	P	-		40	L	-
40	L	-		41	B/W	-
41	B/W	-				
Connector No. E5	IPDM E/R (INTELLIGENT POWER DISTRIBUTION MODULE ENGINE ROOM)	TH20FW-CS12-M4-1V		Terminal No.	Color of Wire	Signal Name
12	B/W	-				
Connector No. E7	REFRIGERANT PRESSURE SENSOR	RK039FB		Terminal No.	Color of Wire	Signal Name
1	W	-		2	L	-
2	L	-		3	SB	-
3	SB	-				
Connector No. E3	WIRE TO WIRE	SA438MB-RS10-SJZZ		Terminal No.	Color of Wire	Signal Name
29	L	-				
Connector No. E7	AMBIENT SENSOR	RS02FB		Terminal No.	Color of Wire	Signal Name
1	G	-		2	P	-
2	P	-				
Connector No. E7	IPDM E/R (INTELLIGENT POWER DISTRIBUTION MODULE ENGINE ROOM)	TH20FW-CS12-M4		Terminal No.	Color of Wire	Signal Name
48	L	-				
Connector No. E106	WIRE TO WIRE	TH80FW-CS16-TM4		Terminal No.	Color of Wire	Signal Name
6	P	-				
7	L	-				
8	L	-				
9	P	-				
10	G	-				
11	W	-				
12	L	-				
13	L	-				
14	L	-				
15	L	-				
16	L	-				
17	L	-				
18	L	-				
19	L	-				
20	L	-				
21	L	-				
22	L	-				
23	L	-				
24	L	-				
25	L	-				
26	L	-				
27	L	-				
28	L	-				
29	L	-				
30	L	-				
31	L	-				
32	L	-				
33	L	-				
34	L	-				
35	L	-				
36	L	-				
37	L	-				
38	L	-				
39	L	-				
40	L	-				
41	L	-				
42	L	-				
43	L	-				
44	L	-				
45	L	-				
46	L	-				
47	L	-				
48	L	-				
49	L	-				
50	L	-				
51	L	-				
52	L	-				
53	L	-				
54	L	-				
55	L	-				
56	L	-				
57	L	-				
58	L	-				
59	L	-				
60	L	-				
61	L	-				
62	L	-				
63	L	-				
64	L	-				
65	L	-				
66	L	-				
67	L	-				
68	L	-				
69	L	-				
70	L	-				
71	L	-				
72	L	-				
73	L	-				
74	L	-				
75	L	-				
76	L	-				
77	L	-				
78	L	-				
79	L	-				
80	L	-				

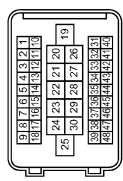
A
B
C
D
E
F
G
H
HAC
J
K
L
M
N
O
P

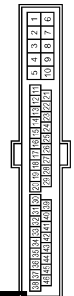
AIR CONDITIONER CONTROL

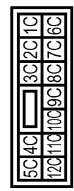
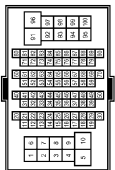
<table border="1" style="width: 100%; border-collapse: collapse;"> <tr><td>Connector No.</td><td>F1</td></tr> <tr><td>Connector Name</td><td>WIRE TO WIRE</td></tr> <tr><td>Connector Type</td><td>SAA36FE-RS1D-SUZZ</td></tr> </table> 	Connector No.	F1	Connector Name	WIRE TO WIRE	Connector Type	SAA36FE-RS1D-SUZZ	<table border="1" style="width: 100%; border-collapse: collapse;"> <tr><td>Terminal No.</td><td>Color of Wire</td><td>Signal Name</td></tr> <tr><td>29</td><td>L</td><td>-</td></tr> </table>	Terminal No.	Color of Wire	Signal Name	29	L	-	<table border="1" style="width: 100%; border-collapse: collapse;"> <tr><td>Connector No.</td><td>F43</td></tr> <tr><td>Connector Name</td><td>COMPRESSOR</td></tr> <tr><td>Connector Type</td><td>RS01FB</td></tr> </table> 	Connector No.	F43	Connector Name	COMPRESSOR	Connector Type	RS01FB	<table border="1" style="width: 100%; border-collapse: collapse;"> <tr><td>Terminal No.</td><td>Color of Wire</td><td>Signal Name</td></tr> <tr><td>1</td><td>L</td><td>-</td></tr> </table>	Terminal No.	Color of Wire	Signal Name	1	L	-																		
Connector No.	F1																																												
Connector Name	WIRE TO WIRE																																												
Connector Type	SAA36FE-RS1D-SUZZ																																												
Terminal No.	Color of Wire	Signal Name																																											
29	L	-																																											
Connector No.	F43																																												
Connector Name	COMPRESSOR																																												
Connector Type	RS01FB																																												
Terminal No.	Color of Wire	Signal Name																																											
1	L	-																																											
<table border="1" style="width: 100%; border-collapse: collapse;"> <tr><td>Connector No.</td><td>F44</td></tr> <tr><td>Connector Name</td><td>COMPRESSOR</td></tr> <tr><td>Connector Type</td><td>RK02FGY</td></tr> </table> 	Connector No.	F44	Connector Name	COMPRESSOR	Connector Type	RK02FGY	<table border="1" style="width: 100%; border-collapse: collapse;"> <tr><td>Terminal No.</td><td>Color of Wire</td><td>Signal Name</td></tr> <tr><td>2</td><td>Y</td><td>-</td></tr> <tr><td>3</td><td>O</td><td>-</td></tr> </table>	Terminal No.	Color of Wire	Signal Name	2	Y	-	3	O	-	<table border="1" style="width: 100%; border-collapse: collapse;"> <tr><td>Connector No.</td><td>F103</td></tr> <tr><td>Connector Name</td><td>WIRE TO WIRE</td></tr> <tr><td>Connector Type</td><td>TK36FW-NS10</td></tr> </table> 	Connector No.	F103	Connector Name	WIRE TO WIRE	Connector Type	TK36FW-NS10	<table border="1" style="width: 100%; border-collapse: collapse;"> <tr><td>Terminal No.</td><td>Color of Wire</td><td>Signal Name</td></tr> <tr><td>19</td><td>O</td><td>-</td></tr> <tr><td>20</td><td>Y</td><td>-</td></tr> </table>	Terminal No.	Color of Wire	Signal Name	19	O	-	20	Y	-												
Connector No.	F44																																												
Connector Name	COMPRESSOR																																												
Connector Type	RK02FGY																																												
Terminal No.	Color of Wire	Signal Name																																											
2	Y	-																																											
3	O	-																																											
Connector No.	F103																																												
Connector Name	WIRE TO WIRE																																												
Connector Type	TK36FW-NS10																																												
Terminal No.	Color of Wire	Signal Name																																											
19	O	-																																											
20	Y	-																																											
<table border="1" style="width: 100%; border-collapse: collapse;"> <tr><td>Connector No.</td><td>M1</td></tr> <tr><td>Connector Name</td><td>FUSE BLOCK (J/B)</td></tr> <tr><td>Connector Type</td><td>NS06FW-M2</td></tr> </table> 	Connector No.	M1	Connector Name	FUSE BLOCK (J/B)	Connector Type	NS06FW-M2	<table border="1" style="width: 100%; border-collapse: collapse;"> <tr><td>Terminal No.</td><td>Color of Wire</td><td>Signal Name</td></tr> <tr><td>2A</td><td>G</td><td>-</td></tr> <tr><td>3A</td><td>L</td><td>-</td></tr> <tr><td>5A</td><td>Y</td><td>-</td></tr> <tr><td>8A</td><td>L</td><td>-</td></tr> </table>	Terminal No.	Color of Wire	Signal Name	2A	G	-	3A	L	-	5A	Y	-	8A	L	-	<table border="1" style="width: 100%; border-collapse: collapse;"> <tr><td>Connector No.</td><td>M2</td></tr> <tr><td>Connector Name</td><td>FUSE BLOCK (J/B)</td></tr> <tr><td>Connector Type</td><td>NS10FW-CS</td></tr> </table> 	Connector No.	M2	Connector Name	FUSE BLOCK (J/B)	Connector Type	NS10FW-CS	<table border="1" style="width: 100%; border-collapse: collapse;"> <tr><td>Terminal No.</td><td>Color of Wire</td><td>Signal Name</td></tr> <tr><td>6B</td><td>Y</td><td>-</td></tr> </table>	Terminal No.	Color of Wire	Signal Name	6B	Y	-									
Connector No.	M1																																												
Connector Name	FUSE BLOCK (J/B)																																												
Connector Type	NS06FW-M2																																												
Terminal No.	Color of Wire	Signal Name																																											
2A	G	-																																											
3A	L	-																																											
5A	Y	-																																											
8A	L	-																																											
Connector No.	M2																																												
Connector Name	FUSE BLOCK (J/B)																																												
Connector Type	NS10FW-CS																																												
Terminal No.	Color of Wire	Signal Name																																											
6B	Y	-																																											
<table border="1" style="width: 100%; border-collapse: collapse;"> <tr><td>Connector No.</td><td>M3</td></tr> <tr><td>Connector Name</td><td>FUSE BLOCK (J/B)</td></tr> <tr><td>Connector Type</td><td>NS12FW-CS</td></tr> </table> 	Connector No.	M3	Connector Name	FUSE BLOCK (J/B)	Connector Type	NS12FW-CS	<table border="1" style="width: 100%; border-collapse: collapse;"> <tr><td>Terminal No.</td><td>Color of Wire</td><td>Signal Name</td></tr> <tr><td>7C</td><td>B</td><td>-</td></tr> </table>	Terminal No.	Color of Wire	Signal Name	7C	B	-	<table border="1" style="width: 100%; border-collapse: collapse;"> <tr><td>Connector No.</td><td>M6</td></tr> <tr><td>Connector Name</td><td>WIRE TO WIRE</td></tr> <tr><td>Connector Type</td><td>TH00MW-GS16-TM4</td></tr> </table> 	Connector No.	M6	Connector Name	WIRE TO WIRE	Connector Type	TH00MW-GS16-TM4	<table border="1" style="width: 100%; border-collapse: collapse;"> <tr><td>Terminal No.</td><td>Color of Wire</td><td>Signal Name</td></tr> <tr><td>6</td><td>P</td><td>-</td></tr> <tr><td>7</td><td>L</td><td>-</td></tr> <tr><td>81</td><td>BR</td><td>-</td></tr> <tr><td>82</td><td>P</td><td>-</td></tr> <tr><td>83</td><td>W</td><td>-</td></tr> <tr><td>84</td><td>L</td><td>-</td></tr> <tr><td>85</td><td>O</td><td>-</td></tr> </table>	Terminal No.	Color of Wire	Signal Name	6	P	-	7	L	-	81	BR	-	82	P	-	83	W	-	84	L	-	85	O	-
Connector No.	M3																																												
Connector Name	FUSE BLOCK (J/B)																																												
Connector Type	NS12FW-CS																																												
Terminal No.	Color of Wire	Signal Name																																											
7C	B	-																																											
Connector No.	M6																																												
Connector Name	WIRE TO WIRE																																												
Connector Type	TH00MW-GS16-TM4																																												
Terminal No.	Color of Wire	Signal Name																																											
6	P	-																																											
7	L	-																																											
81	BR	-																																											
82	P	-																																											
83	W	-																																											
84	L	-																																											
85	O	-																																											

AIR CONDITIONER CONTROL

Connector No.	M7
Connector Name	WIRE TO WIRE
Connector Type	THROW-CSI6-TM4

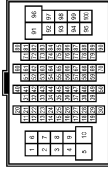

Terminal No.	Color of Wire	Signal Name
23	L	-
24	P	-
25	L	-
26	P	-

Connector No.	M45
Connector Name	SUNLOAD SENSOR
Connector Type	K02FB



Terminal No.	Color of Wire	Signal Name
1	O	-
2	SB	-

Connector No.	M61
Connector Name	IN-VEHICLE SENSOR
Connector Type	A02FW



Terminal No.	Color of Wire	Signal Name
1	LG	-
2	L	-

Connector No.	M66
Connector Name	UNIFIED METER AND A/C AMP.
Connector Type	TH40FW-NH



Terminal No.	Color of Wire	Signal Name
38	L	FAN PWM OUT

Connector No.	M67
Connector Name	UNIFIED METER AND A/C AMP.
Connector Type	TH22FW-NH



Terminal No.	Color of Wire	Signal Name
41	V	ACC
43	R	INTAKE SENS
44	LG	INCAR SENS
45	P	INCAR SENS
46	O	AMP SENS
53	G	SUN SENS
54	Y	IGN
55	B	BAT
56	L	GND
59	GR	CAN-H
60	L	INTAKE SENS GND
	L	INCAR SENS GND

61	BR	AMB SENS GND
62	SB	SUN SENS GND
65	O	COMP EGV
69	L	LAN SIG
70	R	VACTR
71	B	GND
72	P	CAN-L

Connector No.	M72
Connector Name	MULTIFUNCTION SWITCH
Connector Type	TH18FW-NH

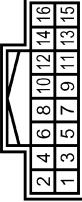

Terminal No.	Color of Wire	Signal Name
6	LG	AV COMM (H)
8	V	AV COMM (L)

Connector No.	M77
Connector Name	INTAKE SENSOR
Connector Type	TK04FW



Terminal No.	Color of Wire	Signal Name
1	R	-
2	GR	-

JCIWA0005GB

AIR CONDITIONER CONTROL

Connector No.	M83
Connector Name	AV CONTROL UNIT
Connector Type	TH24FW-NH

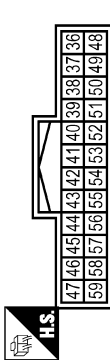

Terminal No.	Color of Wire	Signal Name
44	BR	COMM (DISP->CONT)
55	SHIELD	SHIELD
56	Y	COMM (CONT->DISP)

Connector No.	M85
Connector Name	AV CONTROL UNIT
Connector Type	TH32FW-NH

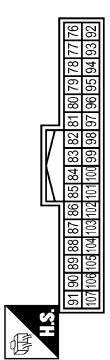

Terminal No.	Color of Wire	Signal Name
86	L	CAN-H
87	P	CAN-L
88	G	AV COMM (H) [With BOSE system]
88	LG	AV COMM (H) [Without BOSE system]
89	R	AV COMM (L) [With BOSE system]
89	V	AV COMM (L) [Without BOSE system]

Connector No.	M87
Connector Name	AV CONTROL UNIT
Connector Type	TH40FW-NH

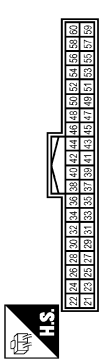

Terminal No.	Color of Wire	Signal Name
50	V	AV COMM (H)
51	LG	AV COMM (L)
52	L	CAN-H
53	P	CAN-L

Connector No.	M88
Connector Name	AV CONTROL UNIT
Connector Type	TH12FW-NH

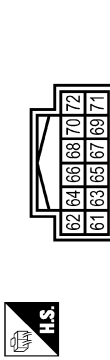

Terminal No.	Color of Wire	Signal Name
70	BR	COMM (CONT->DISP)
71	Y	COMM (DISP->CONT)
72	SHIELD	SHIELD

Connector No.	M91
Connector Name	WIRE TO WIRE
Connector Type	AG3MW-P

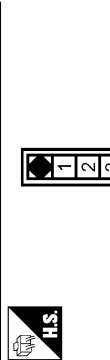

Terminal No.	Color of Wire	Signal Name
1	R	-
2	B	-
3	L	-

Connector No.	M107
Connector Name	ECM
Connector Type	MAA24GY-MEAB-LH-Z

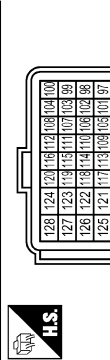

Terminal No.	Color of Wire	Signal Name
105	L	PDPRES
111	O	AVCC2-PDPRES
113	P	WHECAN LI
114	L	WHECAN LH
116	W	GND A-PDPRES

Connector No.	M109
Connector Name	BLOWER MOTOR
Connector Type	NS36FW-H3

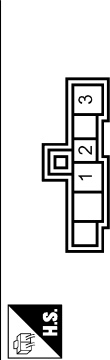

Terminal No.	Color of Wire	Signal Name
1	L	-
2	L	-
3	B	-

Connector No.	M116
Connector Name	WIRE TO WIRE
Connector Type	TK36MW-HS10

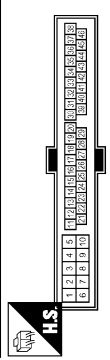

Terminal No.	Color of Wire	Signal Name
19	O	-
20	Y	-

A
B
C
D
E
F
G
H
HAC
J
K
L
M
N
O
P

AIR CONDITIONER CONTROL

Connector No.	M251
Connector Name	WIRE TO WIRE
Connector Type	AG3FW

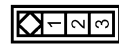

Terminal No.	Color of Wire	Signal Name
1	L	-
2	B	-
3	L	-

Connector No.	M252
Connector Name	AIR MIX DOOR MOTOR LH
Connector Type	AG3FW



Terminal No.	Color of Wire	Signal Name
1	L	-
2	B	-
3	L	-

Connector No.	M253
Connector Name	MODE DOOR MOTOR
Connector Type	AG3FW

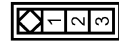

Terminal No.	Color of Wire	Signal Name
1	L	-
2	B	-
3	L	-

Connector No.	M254
Connector Name	INTAKE DOOR MOTOR
Connector Type	AG3FW

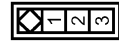

Terminal No.	Color of Wire	Signal Name
1	L	-
2	B	-
3	L	-

Connector No.	M255
Connector Name	AIR MIX DOOR MOTOR RH
Connector Type	AG3FW

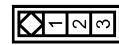

Terminal No.	Color of Wire	Signal Name
1	L	-
2	B	-
3	L	-

Fail-Safe

FAIL-SAFE FUNCTION

- If a communication error exists between the unified meter and A/C amp., and the AV control unit and preset switch for 30 seconds or longer, air conditioner is controlled under the following conditions:

JCIWA0007GB

INFOID:000000000959973

AUTO AMP.

< ECU DIAGNOSIS >

[AUTOMATIC AIR CONDITIONER]

Compressor	: ON
Air outlet	: AUTO
Air inlet	: FRE (Fresh)
Blower fan speed	: AUTO
Set temperature	: Setting before communication error occurs
Display	: OFF

AIR CONDITIONER CONTROL

[AUTOMATIC AIR CONDITIONER]

< SYMPTOM DIAGNOSIS >

SYMPTOM DIAGNOSIS

AIR CONDITIONER CONTROL

Diagnosis Chart By Symptom

INFOID:000000000959974

Symptom	Reference page	
A/C system does not come on.	Go to Trouble Diagnosis Procedure for A/C System.	HAC-106. "Diagnosis Procedure"
A/C system cannot be controlled.	Go to Preset Switch System.	AV-105. "Symptom Table" (BASE AUDIO WITHOUT NAVIGATION), AV-285. "Symptom Table" (BOSE AUDIO WITHOUT NAVIGATION) or AV-514. "Symptom Table" (BOSE AUDIO WITH NAVIGATION)
Air outlet does not change.	Go to Trouble Diagnosis Procedure for Mode Door Motor. (LAN)	HAC-69. "Diagnosis Procedure"
Mode door motor does not operate normally.		
Discharge air temperature does not change.	Go to Trouble Diagnosis Procedure for Air Mix Door Motor. (LAN)	HAC-72. "WITHOUT LEFT AND RIGHT VENTILATION TEMPERATURE SEPARATELY CONTROL SYSTEM : Diagnosis Procedure" (Without left and right ventilation temperature separately control system) or HAC-75. "WITH LEFT AND RIGHT VENTILATION TEMPERATURE SEPARATELY CONTROL SYSTEM : Diagnosis Procedure" (With left and right ventilation temperature separately control system)
Air mix door motor does not operate normally.		
Intake door does not change.	Go to Trouble Diagnosis Procedure for Intake Door Motor. (LAN)	HAC-80. "Diagnosis Procedure"
Intake door motor does not operate normally.		
Blower motor operation is malfunctioning.	Go to Trouble Diagnosis Procedure for Blower Motor.	HAC-83. "WITHOUT LEFT AND RIGHT VENTILATION TEMPERATURE SEPARATELY CONTROL SYSTEM : Diagnosis Procedure" (Without left and right ventilation temperature separately control system) or HAC-86. "WITH LEFT AND RIGHT VENTILATION TEMPERATURE SEPARATELY CONTROL SYSTEM : Diagnosis Procedure" (With left and right ventilation temperature separately control system)
Magnet clutch does not engage.	Go to Trouble Diagnosis Procedure for Magnet Clutch.	HAC-90. "Diagnosis Procedure"
Insufficient cooling	Go to Trouble Diagnosis Procedure for Insufficient Cooling.	HAC-119. "Inspection procedure"
Insufficient heating	Go to Trouble Diagnosis Procedure for Insufficient Heating.	HAC-122. "Inspection procedure"
Noise	Go to Trouble Diagnosis Procedure for Noise.	HAC-124. "Inspection procedure"

A

B

C

D

E

F

G

H

HAC

J

K

L

M

N

O

P

AIR CONDITIONER CONTROL

[AUTOMATIC AIR CONDITIONER]

< SYMPTOM DIAGNOSIS >

Symptom	Reference page	
Self-diagnosis cannot be performed.	Go to Trouble Diagnosis Procedure for Self-diagnosis.	HAC-126. "Inspection procedure"
Memory function does not operate.	Go to Trouble Diagnosis Procedure for Memory Function.	HAC-127. "Inspection procedure"

INSUFFICIENT COOLING

< SYMPTOM DIAGNOSIS >

[AUTOMATIC AIR CONDITIONER]

INSUFFICIENT COOLING

Description

INFOID:000000000959975

Symptom

- Insufficient cooling
- No cold air comes out. (Air flow volume is normal.)

Inspection procedure

INFOID:000000000959976

1. CHECK WITH A GAUGE OF REFRIGERANT RECOVERY/RECYCLING RECHARGING EQUIPMENT

Connect the refrigerant recovery/recycling recharging equipment to the vehicle and perform the pressure inspection with the gauge.

Is there refrigerant?

YES >> GO TO 2.

NO-1 >> Check for refrigerant leakages with the refrigerant leakage detecting fluorescent leak detector. Refer to [HA-36, "Inspection"](#).

NO-2 >> GO TO 2 after repairing or replacing the parts according to the inspection results.

2. CHECK CHARGED REFRIGERANT AMOUNT

1. Connect refrigerant recovery/recycling recharging equipment to the vehicle and discharge the refrigerant.
2. Recharge with the proper amount of refrigerant and perform the inspection with the refrigerant leakage detecting fluorescent leak detector. Refer to [HA-36, "Inspection"](#).

Is the inspection result normal?

YES >> GO TO 3.

NO >> Refill the refrigerant and repair or replace the parts according to the inspection results.

3. CHECK REFRIGERANT CYCLE PRESSURE

Connect refrigerant recovery/recycling recharging equipment to the vehicle and perform the performance test. Refer to [HA-33, "Performance Chart"](#).

Is the inspection result normal?

YES >> GO TO 4.

NO >> Perform the diagnosis with the gauge pressure. Refer to [HA-11, "SYMPTOM DIAGNOSIS PROCEDURE : Trouble Diagnosis For Unusual Pressure"](#).

4. CHECK SETTING OF TEMPERATURE SETTING TRIMMER

Check the setting of temperature setting trimmer. Refer to [HAC-5, "WITHOUT LEFT AND RIGHT VENTILATION TEMPERATURE SEPARATELY CONTROL SYSTEM : Description & Inspection"](#) (Without left and right ventilation temperature separately control system) or [HAC-9, "WITH LEFT AND RIGHT VENTILATION TEMPERATURE SEPARATELY CONTROL SYSTEM : Description & Inspection"](#) (With left and right ventilation temperature separately control system).

1. Check that the temperature setting trimmer is set to "+ direction".

NOTE:

The control temperature can be set with the setting of temperature setting trimmer.

2. Set temperature control dial to "0".

Are the symptoms solved?

YES >> Perform the setting separately if necessary. END.

NO >> GO TO 5.

5. PERFORM SELF-DIAGNOSIS STEP-2

Perform self-diagnosis STEP-2. Refer to [HAC-44, "WITHOUT LEFT AND RIGHT VENTILATION TEMPERATURE SEPARATELY CONTROL SYSTEM : Diagnosis Description"](#) (Without left and right ventilation temperature separately control system) or [HAC-50, "WITH LEFT AND RIGHT VENTILATION TEMPERATURE SEPARATELY CONTROL SYSTEM : Diagnosis Description"](#) (With left and right ventilation temperature separately control system), see No. 1 to 2.

Does code No. 20 appear on the display?

YES >> GO TO 6.

A

B

C

D

E

F

G

H

HAC

J

K

L

M

N

O

P

INSUFFICIENT COOLING

[AUTOMATIC AIR CONDITIONER]

< SYMPTOM DIAGNOSIS >

NO >> Go to appropriate malfunctioning sensor circuit. Refer to [HAC-44, "WITHOUT LEFT AND RIGHT VENTILATION TEMPERATURE SEPARATELY CONTROL SYSTEM : Diagnosis Description"](#) (Without left and right ventilation temperature separately control system) or [HAC-50, "WITH LEFT AND RIGHT VENTILATION TEMPERATURE SEPARATELY CONTROL SYSTEM : Diagnosis Description"](#) (With left and right ventilation temperature separately control system), see No. 11.

6.PERFORM SELF-DIAGNOSIS STEP-4

Perform self-diagnosis STEP-4. Refer to [HAC-44, "WITHOUT LEFT AND RIGHT VENTILATION TEMPERATURE SEPARATELY CONTROL SYSTEM : Diagnosis Description"](#) (Without left and right ventilation temperature separately control system) or [HAC-50, "WITH LEFT AND RIGHT VENTILATION TEMPERATURE SEPARATELY CONTROL SYSTEM : Diagnosis Description"](#) (With left and right ventilation temperature separately control system), see No.1 to 5.

Is it operated normally?

YES >> GO TO 7.

NO >> Perform the diagnosis applicable to each output device.

7.PERFORM SELF-DIAGNOSIS STEP-5

Perform self-diagnosis STEP-5. Refer to [HAC-44, "WITHOUT LEFT AND RIGHT VENTILATION TEMPERATURE SEPARATELY CONTROL SYSTEM : Diagnosis Description"](#) (Without left and right ventilation temperature separately control system) or [HAC-50, "WITH LEFT AND RIGHT VENTILATION TEMPERATURE SEPARATELY CONTROL SYSTEM : Diagnosis Description"](#) (With left and right ventilation temperature separately control system), see No.1 to 10.

Is the inspection result normal?

YES >> GO TO 8.

NO >> Go to appropriate malfunctioning sensor circuit. Refer to [HAC-44, "WITHOUT LEFT AND RIGHT VENTILATION TEMPERATURE SEPARATELY CONTROL SYSTEM : Diagnosis Description"](#) (Without left and right ventilation temperature separately control system) or [HAC-50, "WITH LEFT AND RIGHT VENTILATION TEMPERATURE SEPARATELY CONTROL SYSTEM : Diagnosis Description"](#) (With left and right ventilation temperature separately control system).

8.CHECK A/C COMPRESSOR BELT

Check the A/C compressor belt. Refer to [EM-12, "Checking"](#).

Is the inspection result normal?

YES >> GO TO 9.

NO >> Adjust or replace the A/C compressor belt.

9.CHECK AIR LEAKAGE FROM DUCT

Check duct and nozzle, etc. of A/C system for air leakage.

Is the inspection result normal?

YES >> GO TO 10.

NO >> Repair or replace parts according to the inspection results.

10.CHECK POWER SUPPLY FOR ECV (ELECTRIC CONTROL VALVE)

1. Disconnect compressor (ECV) connector.
2. Turn ignition switch ON.
3. Check voltage between compressor (ECV) harness connector F43 terminal 2 and ground.

(+)		(-)	Voltage
Compressor (ECV)		—	
Connector	Terminal		
F43	2	Ground	Battery voltage

Is the inspection result normal?

YES >> GO TO 12.

NO >> GO TO 11.

11.CHECK FUSE

INSUFFICIENT COOLING

[AUTOMATIC AIR CONDITIONER]

< SYMPTOM DIAGNOSIS >

Check power supply circuit and 10A fuse [No. 3, located in the fuse block (J/B)]. Refer to [PG-93. "Fuse, Connector and Terminal Arrangement"](#).

Is the inspection result normal?

- YES >> Check harness for open circuit. Repair or replace if necessary.
- NO >> Replace fuse and check harness for short circuit. Repair or replace if necessary.

12. CHECK ECV CONTROL SIGNAL

1. Turn ignition switch OFF.
2. Reconnect compressor (ECV) connector.
3. Perform self-diagnosis. Refer to [HAC-44. "WITHOUT LEFT AND RIGHT VENTILATION TEMPERATURE SEPARATELY CONTROL SYSTEM : Diagnosis Description"](#) (Without left and right ventilation temperature separately control system) or [HAC-50. "WITH LEFT AND RIGHT VENTILATION TEMPERATURE SEPARATELY CONTROL SYSTEM : Diagnosis Description"](#) (With left and right ventilation temperature separately control system).
4. Set in self-diagnosis STEP-4 (Code No. 45).
5. Confirm ECV control signal between unified meter and A/C amp harness connector M67 terminal 65 and ground using an oscilloscope.

Is the inspection result normal?

- YES >> Replace compressor.
- NO >> GO TO 13.

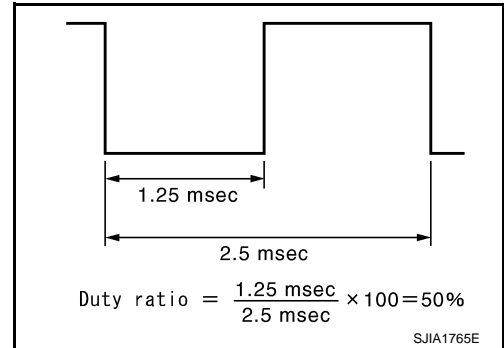

13. CHECK CIRCUIT CONTINUITY BETWEEN ECV AND UNIFIED METER AND A/C AMP.

1. Turn ignition switch OFF.
2. Disconnect compressor (ECV) connector and unified meter and A/C amp. connector.
3. Check continuity between compressor (ECV) harness connector F43 terminals 3 and unified meter and A/C amp harness connector M67 terminal 65.

(+)		(-)		Continuity
Compressor (ECV)		Unified meter and A/C amp.		
Connector	Terminal	Connector	Terminal	
F43	3	M67	65	Continuity should exist

Is the inspection result normal?

- YES >> GO TO 14.
- NO >> Repair the harnesses or connectors.

14. CHECK ECV

Check continuity between compressor (ECV) connector F43 terminals 2 and 3.

(+)		(-)		Continuity
Mode door motor		Mode door motor		
Connector	Terminal	Connector	Terminal	
M253	2	F43	3	Continuity should exist

Is the inspection result normal?

- YES >> Replace the unified meter and A/C amp.
- NO >> Replace the compressor.

INSUFFICIENT HEATING

< SYMPTOM DIAGNOSIS >

[AUTOMATIC AIR CONDITIONER]

INSUFFICIENT HEATING

Description

INFOID:00000000095977

Symptom

- Insufficient heating
- No warm air comes out. (Air flow volume is normal.)

Inspection procedure

INFOID:00000000095978

1.CHECK COOLING SYSTEM

1. Check engine coolant level and check for leakage. Refer to [CO-8, "Inspection"](#).
2. Check radiator cap. Refer to [CO-12, "RADIATOR CAP : Inspection"](#).
3. Check water flow sounds of engine coolant. Refer to [CO-9, "Refilling"](#).

Is the inspection result normal?

- YES >> GO TO 2.
NO >> Refill the engine coolant and repair or replace the parts according to the inspection results.

2.CHECK SETTING OF TEMPERATURE SETTING TRIMMER

1. Check the setting of temperature setting trimmer. Refer to [HAC-5, "WITHOUT LEFT AND RIGHT VENTILATION TEMPERATURE SEPARATELY CONTROL SYSTEM : Description & Inspection"](#) (Without left and right ventilation temperature separately control system) or [HAC-9, "WITH LEFT AND RIGHT VENTILATION TEMPERATURE SEPARATELY CONTROL SYSTEM : Description & Inspection"](#) (With left and right ventilation temperature separately control system).
2. Check that the temperature setting trimmer is set to "– direction".

NOTE:

The control temperature can be set with the setting of temperature setting trimmer.

3. Set temperature control dial to "0".

Are the symptoms solved?

- YES >> Perform the setting separately if necessary. END.
NO >> GO TO 3.

3.CHECK OPERATION

1. Turn temperature dial (driver side) and raise temperature setting to 32°C (90°F) after warming up the engine.
2. Check that warm air blows from outlets.

Is the inspection result normal?

- YES >> END.
NO >> GO TO 4.

4.PERFORM SELF-DIAGNOSIS STEP-2

Perform self-diagnosis STEP-2. Refer to [HAC-44, "WITHOUT LEFT AND RIGHT VENTILATION TEMPERATURE SEPARATELY CONTROL SYSTEM : Diagnosis Description"](#) (Without left and right ventilation temperature separately control system) or [HAC-50, "WITH LEFT AND RIGHT VENTILATION TEMPERATURE SEPARATELY CONTROL SYSTEM : Diagnosis Description"](#) (With left and right ventilation temperature separately control system), see No. 1 to 2.

Does code No. 20 appear on the display?

- YES >> GO TO 5.
NO >> Go to appropriate malfunctioning sensor circuit. Refer to [HAC-44, "WITHOUT LEFT AND RIGHT VENTILATION TEMPERATURE SEPARATELY CONTROL SYSTEM : Diagnosis Description"](#) (Without left and right ventilation temperature separately control system) or [HAC-50, "WITH LEFT AND RIGHT VENTILATION TEMPERATURE SEPARATELY CONTROL SYSTEM : Diagnosis Description"](#) (With left and right ventilation temperature separately control system), see No. 11.

5.PERFORM SELF-DIAGNOSIS STEP-4

Perform self-diagnosis STEP-4. Refer to [HAC-44, "WITHOUT LEFT AND RIGHT VENTILATION TEMPERATURE SEPARATELY CONTROL SYSTEM : Diagnosis Description"](#) (Without left and right ventilation temperature separately control system) or [HAC-50, "WITH LEFT AND RIGHT VENTILATION TEMPERATURE](#)

INSUFFICIENT HEATING

[AUTOMATIC AIR CONDITIONER]

< SYMPTOM DIAGNOSIS >

[SEPARATELY CONTROL SYSTEM : Diagnosis Description](#) (With left and right ventilation temperature separately control system), see No. 1 to 5.

Is it installed normally?

YES >> GO TO 6.

NO >> Perform the diagnosis applicable to each output device.

6.PERFORM SELF-DIAGNOSIS STEP-5

Perform self-diagnosis STEP-5. Refer to [HAC-44. "WITHOUT LEFT AND RIGHT VENTILATION TEMPERATURE SEPARATELY CONTROL SYSTEM : Diagnosis Description](#) (Without left and right ventilation temperature separately control system) or [HAC-50. "WITH LEFT AND RIGHT VENTILATION TEMPERATURE SEPARATELY CONTROL SYSTEM : Diagnosis Description](#) (With left and right ventilation temperature separately control system).

Is the inspection result normal?

YES >> GO TO 7.

NO >> Go to appropriate malfunctioning sensor circuit. Refer to [HAC-44. "WITHOUT LEFT AND RIGHT VENTILATION TEMPERATURE SEPARATELY CONTROL SYSTEM : Diagnosis Description](#) (Without left and right ventilation temperature separately control system) or [HAC-50. "WITH LEFT AND RIGHT VENTILATION TEMPERATURE SEPARATELY CONTROL SYSTEM : Diagnosis Description](#) (With left and right ventilation temperature separately control system).

7.CHECK AIR LEAKAGE FROM DUCT

Check duct and nozzle, etc. of A/C system for air leakage.

Is the inspection result normal?

YES >> GO TO 8.

NO >> Repair or replace parts according to the inspection results.

8.CHECK HEATER HOSE INSTALLATION CONDITION

Check the heater hose installation condition visually (for twist, crush, etc.).

Is the inspection result normal?

YES >> GO TO 9.

NO >> Repair or replace parts according to the inspection results.

9.CHECK TEMPERATURE OF HEATER HOSE

1. Check the temperature of inlet hose and outlet hose of heater core.
2. Check that the inlet side of heater core is hot and the outlet side is slightly lower than/almost equal to the inlet side.

CAUTION:

The temperature inspection should be performed in a short time because the engine coolant temperature is too hot.

Is the inspection result normal?

YES >> GO TO 10.

NO >> Replace the heater core after performing the procedures after the cooling system inspection again. GO TO 1.

10.REPLACE HEATER CORE

Replace the heater core. Refer to heater core. Refer to [VTL-43. "Removal and Installation"](#).

Are the symptoms solved?

YES >> END

NO >> Perform the procedures after the cooling system inspection again. GO TO 1.

A
B
C
D
E
F
G
H
J
K
L
M
N
O
P

HAC

NOISE**Description**

INFOID:000000000959979

Symptom

- Noise
- Noise is heard when the A/C system operates.

Inspection procedure

INFOID:000000000959980

1.CHECK OPERATION

1. Operate the A/C system and check the operation. Refer to [HAC-5. "WITHOUT LEFT AND RIGHT VENTILATION TEMPERATURE SEPARATELY CONTROL SYSTEM : Description & Inspection"](#) (Without left and right ventilation temperature separately control system) or [HAC-9. "WITH LEFT AND RIGHT VENTILATION TEMPERATURE SEPARATELY CONTROL SYSTEM : Description & Inspection"](#) (With left and right ventilation temperature separately control system).
2. Check the parts where noise is occurring.

Can the parts where noise is occurring be checked?

- YES-1 >> Noise from blower fan motor: GO TO 2.
 YES-2 >> Noise from compressor: GO TO 3.
 YES-3 >> Noise from expansion valve: GO TO 4.
 YES-4 >> Noise from A/C piping (pipe, flexible hose): GO TO 6.
 YES-5 >> Noise from A/C compressor belt: GO TO 7.
 NO >> END

2.CHECK BLOWER FAN MOTOR

1. Remove blower fan motor.
2. Remove in-cabin microfilter.
3. Remove foreign materials that are in the blower unit.
4. Check the noise from blower fan motor again.

Is the inspection result normal?

- YES >> END.
 NO >> Replace blower fan motor.

3.REPLACE COMPRESSOR

1. Correct the refrigerant with refrigerant recover/recycling recharging equipment.
2. Recharge with the proper amount of the collected refrigerant after recycling or new refrigerant.
3. Check for the noise from compressor again.

Is the inspection result normal?

- YES >> END.
 NO >> Replace compressor.

4.CHECK WITH GAUGE PRESSURE

Perform the diagnosis with the gauge pressure. Refer to [HA-11. "SYMPTOM DIAGNOSIS PROCEDURE : Trouble Diagnosis For Unusual Pressure"](#).

Is the inspection result normal?

- YES >> GO TO 5.
 NO >> Repair or replace malfunctioning part(s).

5.REPLACE EXPANSION VALVE

1. Correct the refrigerant with refrigerant recover/recycling recharging equipment.
2. Recharge with the proper amount of the collected refrigerant after recycling or new refrigerant.
3. Check for the noise from expansion valve again.

Are the symptoms solved?

- YES >> END.
 NO >> Replace expansion valve.

6.CHECK A/C PIPING (PIPE, FLEXIBLE HOSE)

NOISE

< SYMPTOM DIAGNOSIS >

[AUTOMATIC AIR CONDITIONER]

1. Check A/C piping (pipe, flexible hose) (for deformation and damage, etc.).
2. Check the installation condition of clips and brackets, etc. of A/C piping (pipe, flexible hose).

Is the inspection result normal?

YES >> Fix the line with rubber or come vibration absorbing material.

NO >> Repair or replace parts according to the inspection results.

7.CHECK A/C COMPRESSOR BELT

Check tension of the A/C compressor belt. Refer to [EM-12. "Checking"](#).

Is the inspection result normal?

YES >> Check the noise from compressor: GO TO 3.

NO >> Adjust or replace the A/C compressor belt according to the inspection results.

A
B
C
D
E
F
G
H
J
K
L
M
N
O
P

HAC

SELF-DIAGNOSIS CANNOT BE PERFORMED

< SYMPTOM DIAGNOSIS >

[AUTOMATIC AIR CONDITIONER]

SELF-DIAGNOSIS CANNOT BE PERFORMED

Description

INFOID:000000000959981

Symptom: Self-diagnosis function does not operate normally.

Inspection procedure

INFOID:000000000959982

1. CHECK SELF-DIAGNOSIS FUNCTION

1. Turn ignition switch ON.
2. Set in self-diagnosis mode as follows. Within 10 seconds after starting engine (ignition switch is turned ON.), press OFF switch for at least 5 seconds.

NOTE:

- If battery voltage drops below 12 V during diagnosis STEP-3, door motor speed becomes slower and as a result, the system may generate an error even when operation is normal. To avoid this, start engine before performing this diagnosis.
- Former STEP-1 (LEDs and display screen are checked) does not exist in this self-diagnosis function.
- OFF switch may not be recognized according to the timing of pressing it. Operate OFF switch after turning the intake switch LEDs (REC/FRE) ON.

Does self-diagnosis function operate?

- YES >> END.
NO >> GO TO 2.

2. CHECK POWER SUPPLY AND GROUND CIRCUIT OF UNIFIED METER AND A/C AMP

Check power supply and ground circuit of unified meter and A/C amp. Refer to [HAC-106. "Diagnosis Procedure"](#).

Is the inspection result normal?

- YES >> Replace unified meter and A/C amp.
NO >> Repair or replace malfunctioning part(s).

MEMORY FUNCTION DOES NOT OPERATE

< SYMPTOM DIAGNOSIS >

[AUTOMATIC AIR CONDITIONER]

MEMORY FUNCTION DOES NOT OPERATE

Description

INFOID:000000000959983

Symptom

- Memory function does not operate normally.
- The setting is not maintained. (It returns to the initial condition.)

Inspection procedure

INFOID:000000000959984

1.CHECK OPERATION

1. Set temperature control dial to 32°C (90°F).
2. Press OFF switch.
3. Turn ignition switch OFF.
4. Turn ignition switch ON.
5. Press AUTO switch.
6. Check that the set temperature is maintained.

Is the inspection result normal?

- YES >> END.
NO >> GO TO 2.

2.CHECK POWER SUPPLY AND GROUND CIRCUIT OF UNIFIED METER AND A/C AMP

Check power supply and ground circuit of unified meter and A/C amp. Refer to [HAC-106, "Diagnosis Procedure"](#).

Is the inspection result normal?

- YES >> Replace unified meter and A/C amp.
NO >> Repair or replace malfunctioning part(s).

A
B
C
D
E
F
G
H
J
K
L
M
N
O
P

HAC

PRECAUTION**PRECAUTIONS****Precaution for Supplemental Restraint System (SRS) "AIR BAG" and "SEAT BELT PRE-TENSIONER"**

INFOID:000000000959985

The Supplemental Restraint System such as "AIR BAG" and "SEAT BELT PRE-TENSIONER", used along with a front seat belt, helps to reduce the risk or severity of injury to the driver and front passenger for certain types of collision. This system includes seat belt switch inputs and dual stage front air bag modules. The SRS system uses the seat belt switches to determine the front air bag deployment, and may only deploy one front air bag, depending on the severity of a collision and whether the front occupants are belted or unbelted. Information necessary to service the system safely is included in the SRS and SB section of this Service Manual.

WARNING:

- To avoid rendering the SRS inoperative, which could increase the risk of personal injury or death in the event of a collision which would result in air bag inflation, all maintenance must be performed by an authorized NISSAN/INFINITI dealer.
- Improper maintenance, including incorrect removal and installation of the SRS, can lead to personal injury caused by unintentional activation of the system. For removal of Spiral Cable and Air Bag Module, see the SRS section.
- Do not use electrical test equipment on any circuit related to the SRS unless instructed to in this Service Manual. SRS wiring harnesses can be identified by yellow and/or orange harnesses or harness connectors.

Precaution Necessary for Steering Wheel Rotation after Battery Disconnect

INFOID:000000000959986

NOTE:

- Before removing and installing any control units, first turn the push-button ignition switch to the LOCK position, then disconnect both battery cables.
- After finishing work, confirm that all control unit connectors are connected properly, then re-connect both battery cables.
- Always use CONSULT-III to perform self-diagnosis as a part of each function inspection after finishing work. If a DTC is detected, perform trouble diagnosis according to self-diagnosis results.

This vehicle is equipped with a push-button ignition switch and a steering lock unit.

If the battery is disconnected or discharged, the steering wheel will lock and cannot be turned.

If turning the steering wheel is required with the battery disconnected or discharged, follow the procedure below before starting the repair operation.

OPERATION PROCEDURE

1. Connect both battery cables.

NOTE:

Supply power using jumper cables if battery is discharged.

2. Carry the Intelligent Key or insert it to the key slot and turn the push-button ignition switch to ACC position. (At this time, the steering lock will be released.)
3. Disconnect both battery cables. The steering lock will remain released with both battery cables disconnected and the steering wheel can be turned.
4. Perform the necessary repair operation.
5. When the repair work is completed, re-connect both battery cables. With the brake pedal released, turn the push-button ignition switch from ACC position to ON position, then to LOCK position. (The steering wheel will lock when the push-button ignition switch is turned to LOCK position.)
6. Perform self-diagnosis check of all control units using CONSULT-III.

Precaution for Procedure without Cowl Top Cover

INFOID:000000000959987

PRECAUTIONS

< PRECAUTION >

[AUTOMATIC AIR CONDITIONER]

When performing the procedure after removing cowl top cover, cover the lower end of windshield with urethane, etc.

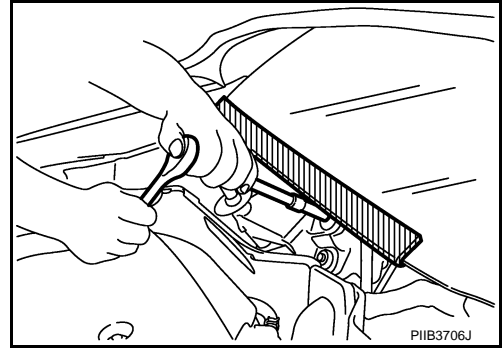

Precautions For Xenon Headlamp Service

INFOID:000000000959988

WARNING:

Comply with the following warnings to prevent any serious accident.

- Disconnect the battery cable (negative terminal) or the power supply fuse before installing, removing, or touching the xenon headlamp (bulb included). The xenon headlamp contains high-voltage generated parts.
- Never work with wet hands.
- Check the xenon headlamp ON-OFF status after assembling it to the vehicle. Never turn the xenon headlamp ON in other conditions. Connect the power supply to the vehicle-side connector. (Turning it ON outside the lamp case may cause fire or visual impairments.)
- Never touch the bulb glass immediately after turning it OFF. It is extremely hot.

CAUTION:

Comply with the following cautions to prevent any error and malfunction.

- Install the xenon bulb securely. (Insufficient bulb socket installation may melt the bulb, the connector, the housing, etc. by high-voltage leakage or corona discharge.)
- Never perform HID circuit inspection with a tester.
- Never touch the xenon bulb glass with hands. Never put oil and grease on it.
- Dispose of the used xenon bulb after packing it in thick vinyl without breaking it.
- Never wipe out dirt and contamination with organic solvent (thinner, gasoline, etc.).

Working with HFC-134a (R-134a)

INFOID:000000000959989

CAUTION:

- CFC-12 (R-12) refrigerant and HFC-134a (R-134a) refrigerant are not compatible. If the refrigerants are mixed and compressor malfunction is likely to occur, refer to "CONTAMINATED REFRIGERANT" below. To determine the purity of HFC-134a (R-134a) in the vehicle and recovery tank, use Refrigerant Recovery/Recycling Recharging equipment and Refrigerant Identifier.
- Use only specified lubricant for the HFC-134a (R-134a) A/C system and HFC-134a (R-134a) components. If lubricant other than that specified is used, compressor malfunction is likely to occur.
- The specified HFC-134a (R-134a) lubricant rapidly absorbs moisture from the atmosphere. The following handling precautions must be observed:
 - When removing refrigerant components from a vehicle, immediately cap (seal) the component to minimize the entry of moisture from the atmosphere.
 - When installing refrigerant components to a vehicle, never remove the caps (unseal) until just before connecting the components. Connect all refrigerant loop components as quickly as possible to minimize the entry of moisture into system.
 - Only use the specified lubricant from a sealed container. Immediately reseal containers of lubricant. Without proper sealing, lubricant will become moisture saturated and should not be used.
 - Never allow lubricant (Nissan A/C System Oil Type S) to come in contact with styrene foam parts. Damage may result.

CONTAMINATED REFRIGERANT

If a refrigerant other than pure HFC-134a (R-134a) is identified in a vehicle, take appropriate steps shown below:

- Explain to the customer that environmental regulations prohibit the release of contaminated refrigerant into the atmosphere.
- Explain that recovery of the contaminated refrigerant could damage service equipment and refrigerant supply.

A
B
C
D
E
F
G
H
HAC
J
K
L
M
N
O
P

PRECAUTIONS

< PRECAUTION >

[AUTOMATIC AIR CONDITIONER]

- Suggest the customer return the vehicle to the location of previous service where the contamination may have occurred.
- In case of repairing, recover the refrigerant using only **dedicated equipment and containers. Never recover contaminated refrigerant into the existing service equipment.** If the facility does not have dedicated recovery equipment, contact a local refrigerant product retailer for available service. This refrigerant must be disposed of in accordance with all federal and local regulations. In addition, replacement of all refrigerant system components on the vehicle is recommended.
- If the vehicle is within the warranty period, the air conditioner warranty is void. Please contact Nissan Customer Affairs for further assistance.

General Refrigerant Precaution

INFOID:000000000959990

WARNING:

- **Avoid breathing A/C refrigerant and lubricant vapor or mist. Exposure may irritate eyes, nose and throat. Remove HFC-134a (R-134a) from the A/C system, using certified service equipment meeting requirements of SAE J-2210 [HFC-134a (R-134a) recycling equipment], or J-2209 [HFC-134a (R-134a) recovery equipment]. If accidental system discharge occurs, ventilate work area before resuming service. Additional health and safety information may be obtained from refrigerant and lubricant manufacturers.**
- **Never release refrigerant into the air. Use approved recovery/recycling equipment to capture the refrigerant every time an air conditioning system is discharged.**
- **Always wear eye and hand protection (goggles and gloves) when working with any refrigerant or air conditioning system.**
- **Never store or heat refrigerant containers above 52°C (126°F).**
- **Never heat a refrigerant container with an open flame; if container warming is required, place the bottom of the container in a warm pail of water.**
- **Never intentionally drop, puncture, or incinerate refrigerant containers.**
- **Keep refrigerant away from open flames: poisonous gas will be produced if refrigerant burns.**
- **Refrigerant will displace oxygen, therefore be certain to work in well ventilated areas to prevent suffocation.**
- **Never pressure test or leak test HFC-134a (R-134a) service equipment and/or vehicle air conditioning systems with compressed air during repair. Some mixtures of air and HFC-134a (R-134a) have been shown to be combustible at elevated pressures. These mixtures, if ignited, may cause injury or property damage. Additional health and safety information may be obtained from refrigerant manufacturers.**

Refrigerant Connection

INFOID:000000000959991

A new type refrigerant connection has been introduced to all refrigerant lines except the following location.

- Expansion valve to evaporator
- Refrigerant pressure sensor to liquid tank

ABOUT ONE-TOUCH JOINT

Description

- One-touch joints are pipe joints which do not require tools during piping connection.
- Unlike conventional connection methods using union nuts and flanges, controlling tightening torque at connection point is not necessary.
- When removing a pipe joint, use a disconnecter.

PRECAUTIONS

[AUTOMATIC AIR CONDITIONER]

< PRECAUTION >

COMPONENT PARTS

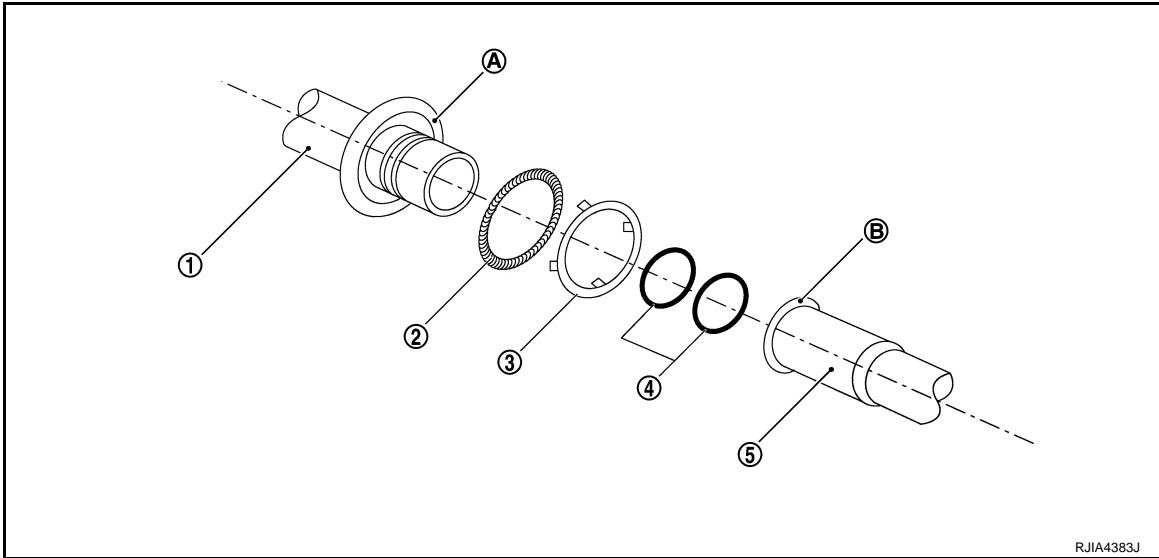

FUNCTIONS OF COMPONENT PARTS

1	Pipe (Male-side)	<ul style="list-style-type: none"> Retains O-rings (4). Retains garter spring (2) in cage (A).
2	Garter spring	Anchors female-side piping (5).
3	Indicator ring	When connection is made properly, this is ejected from male-side piping (1). (This part is no longer necessary after connection.)
4	O-ring	Seals connection point. (Not reusable)
5	Pipe (Female-side)	<ul style="list-style-type: none"> Seals connection by compressing O-rings (4). Anchors piping connection using flare (B) and garter spring (2).

NOTE:

- Garter spring (2) cannot be removed from cage (A) of male-side piping.
- Indicator ring (3) remains near piping connection point, however, this is not a malfunction. (This is to check piping connection during factory assembly.)

REMOVAL

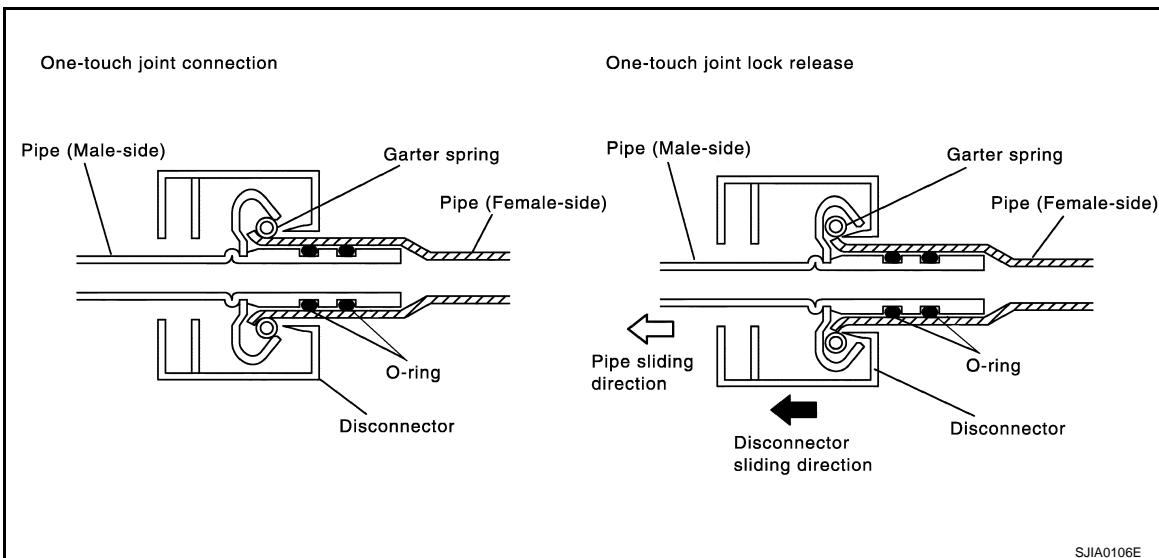

- Clean piping connection point, and set a disconnector.
- Slide disconnector in axial direction of piping, and stretch garter spring with tapered point of disconnector.
- Slide disconnector farther so that inside diameter of garter spring becomes larger than outside diameter of female-side piping flare. Then male-side piping can be disconnected.

PRECAUTIONS

< PRECAUTION >

[AUTOMATIC AIR CONDITIONER]

INSTALLATION

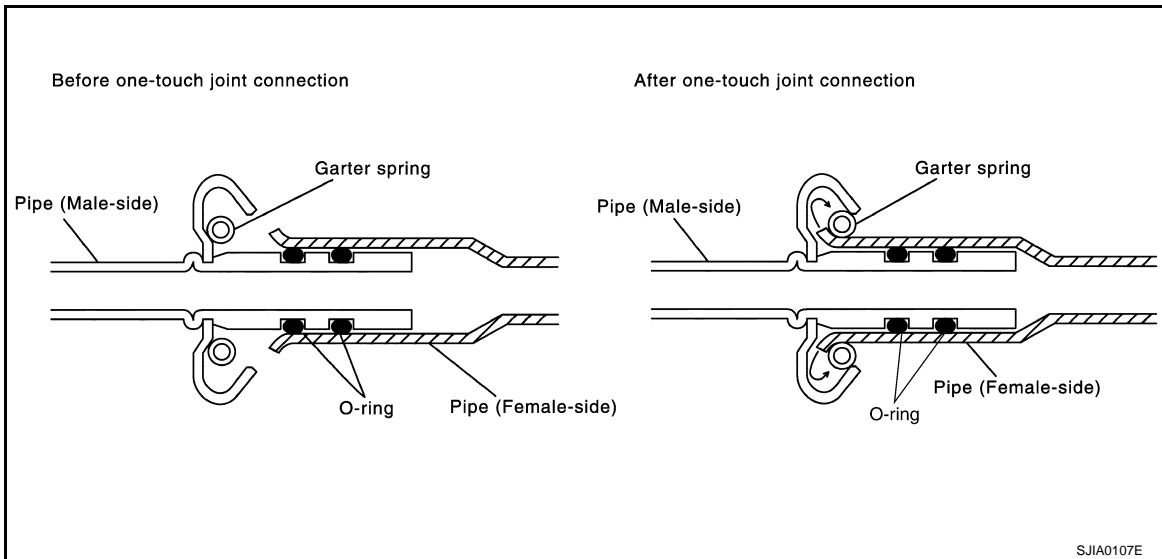

1. Clean piping connection points, and insert male-side piping into female-side piping.
2. Push inserted male-side piping harder so that female-side piping flare stretches garter spring.
3. If inside diameter of garter spring becomes larger than outside diameter of female-side piping flare, garter spring seats on flare. Then, it fits in between male-side piping cage and female-side piping flare to anchor piping connection point.

NOTE:

When garter spring seats on flare, and fits in between male-side piping cage and female-side piping flare, it clicks.

CAUTION:

- Female-side piping connection point is thin and easy to deform. Slowly insert the male-side piping straight in axial direction.
- Insert piping securely until a click is heard.
- After piping connection is completed, pull male-side piping by hand to make sure that connection does not come loose.

NOTE:

One-touch joint connection is used in points below.

- Low-pressure flexible hose to low-pressure pipe 2 (O-ring size: 16)
- Low-pressure pipe 1 to low-pressure pipe 2 (O-ring size: 16)
- High-pressure flexible hose to condenser pipe assembly (O-ring size: 12)
- High-pressure pipe 1 to high-pressure pipe 2 (O-ring size: 8)
- High-pressure pipe 1 to condenser pipe assembly (O-ring size: 8)

O-RING AND REFRIGERANT CONNECTION

PRECAUTIONS

< PRECAUTION >

[AUTOMATIC AIR CONDITIONER]

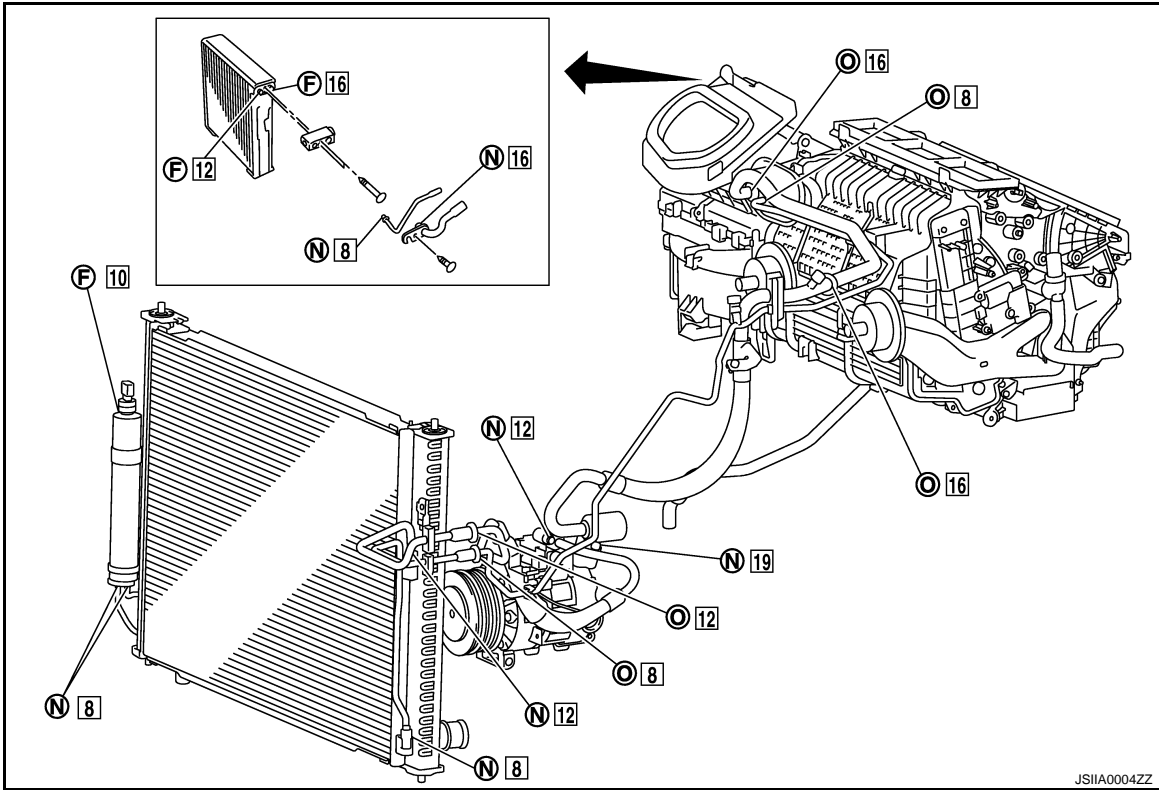

F. Former type refrigerant connection N. New type refrigerant connection O. One-touch joint

□: O-ring size

CAUTION:

The new and former refrigerant connections use different O-ring configurations. Never confuse O-rings since they are not interchangeable. If a wrong O-ring is installed, refrigerant may leak at the connection.

O-Ring Part Numbers and Specifications

Connection type	Piping connection point	Part number	QTY	O-ring size	
New	Low-pressure flexible hose to low-pressure pipe 2 (One-touch joint)	92473 N8221	2	16	
	High-pressure pipe 1 to high-pressure pipe 2 (One-touch joint)	92471 N8221	2	8	
	Condenser pipe assembly to high-pressure flexible hose (One-touch joint)	92472 N8221	2	12	
	Condenser pipe assembly to high-pressure pipe 1 (One-touch joint)	92471 N8221	2	8	
	Radiator & condenser assembly to condenser pipe assembly	Inlet	92472 N8210	1	12
		Outlet	92471 N8210	1	8
	Low-pressure pipe 1 to low-pressure pipe 2	92473 N8210	1	16	
	Low-pressure pipe 1 to expansion valve	92473 N8210	1	16	
	High-pressure pipe 2 to expansion valve	92471 N8210	1	8	
	Compressor to low-pressure flexible hose	92474 N8210	1	19	
	Compressor to high-pressure flexible hose	92472 N8210	1	12	
	Liquid tank to radiator & condenser assembly	Inlet	92471 N8210	1	8
Outlet		1			

A
B
C
D
E
F
G
H

HAC

J
K
L
M
N
O
P

PRECAUTIONS

< PRECAUTION >

[AUTOMATIC AIR CONDITIONER]

Connection type	Piping connection point		Part number	QTY	O-ring size
Former	Refrigerant pressure sensor to liquid tank		J2476 89956	1	10
	Expansion valve to evaporator	Inlet	92475 71L00	1	12
		Outlet	92475 72L00	1	16

WARNING:

Make sure all refrigerant is discharged into the recycling equipment and the pressure in the system is less than atmospheric pressure. Then gradually loosen the discharge side hose fitting and remove it.

CAUTION:

When replacing or cleaning refrigerant cycle components, observe the following.

- When the compressor is removed, store it in the same way as it is when mounted on the car. Failure to do so will cause lubricant to enter the low-pressure chamber.
- When connecting tubes, always use a torque wrench and a back-up wrench.
- After disconnecting tubes, immediately plug all openings to prevent entry of dust and moisture.
- When installing an air conditioner in the vehicle, connect the pipes at the final stage of the operation. Never remove the seal caps of pipes and other components until just before required for connection.
- Allow components stored in cool areas to warm to working area temperature before removing seal caps. This prevents condensation from forming inside A/C components.
- Thoroughly remove moisture from the refrigeration system before charging the refrigerant.
- Always replace used O-rings.
- When connecting tube, apply lubricant to circle of the O-rings shown in illustration. Be careful not to apply lubricant to threaded portion.

Name : Nissan A/C System Oil
Type S

- O-ring must be closely attached to the groove portion of tube.
- When replacing the O-ring, be careful not to damage O-ring and tube.
- Connect tube until a click can be heard, then tighten the nut or bolt by hand. Make sure that the O-ring is installed to tube correctly.
- After connecting line, perform leak test and make sure that there is no leakage from connections. When the refrigerant leaking point is found, disconnect that line and replace the O-ring. Then tighten connections of seal seat to the specified torque.

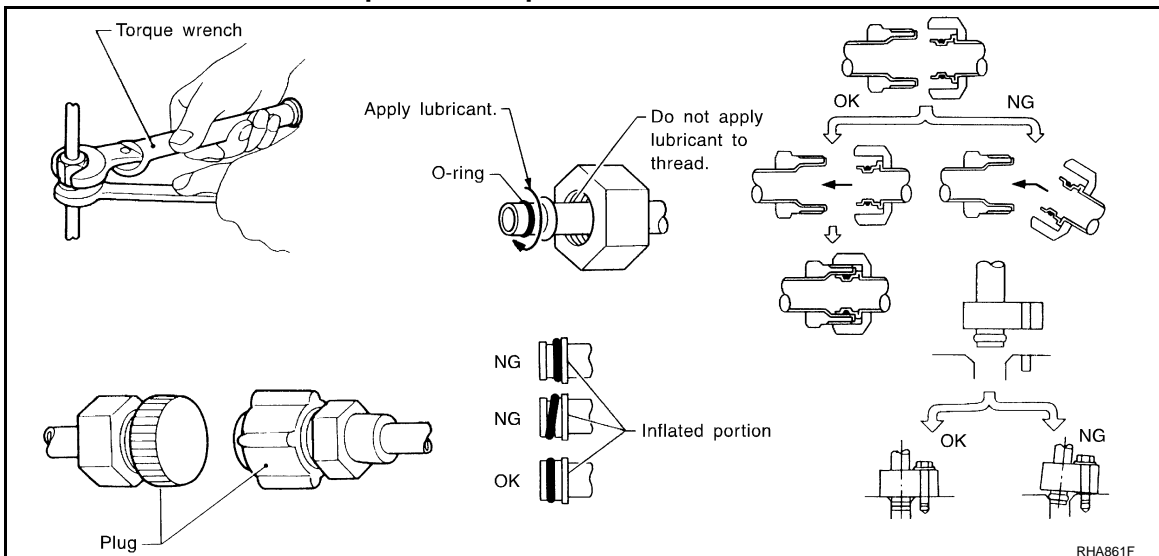

Service Equipment

INFOID:00000000095992

RECOVERY/RECYCLING EQUIPMENT

Be certain to follow the manufacturer's instructions for machine operation and machine maintenance. Never introduce any refrigerant other than that specified into the machine.

ELECTRICAL LEAK DETECTOR

Be certain to follow the manufacturer's instructions for tester operation and tester maintenance.

PRECAUTIONS

[AUTOMATIC AIR CONDITIONER]

< PRECAUTION >

VACUUM PUMP

The lubricant contained inside the vacuum pump is not compatible with the specified lubricant for HFC-134a (R-134a) A/C systems. The vent side of the vacuum pump is exposed to atmospheric pressure. So the vacuum pump lubricant may migrate out of the pump into the service hose. This is possible when the pump is switched off after evacuation (vacuuming) and hose is connected to it.

To prevent this migration, use a manual valve placed near the hose-to-pump connection, as follows.

- Usually vacuum pumps have a manual isolator valve as part of the pump. Close this valve to isolate the service hose from the pump.
- For pumps without an isolator, use a hose equipped with a manual shut-off valve near the pump end. Close the valve to isolate the hose from the pump.
- If the hose has an automatic shut-off valve, disconnect the hose from the pump. As long as the hose is connected, the valve is open and lubricating oil may migrate.

Some one-way valves open when vacuum is applied and close under no vacuum condition. Such valves may restrict the pump's ability to pull a deep vacuum and are not recommended.

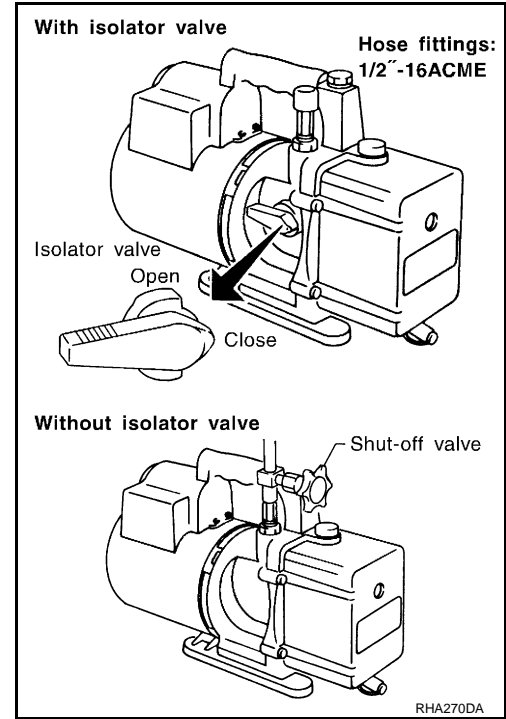

MANIFOLD GAUGE SET

Be certain that the gauge face indicates HFC-134a or R-134a. Be sure the gauge set has 1/2"-16 ACME threaded connections for service hoses. Confirm the set has been used only with refrigerant HFC-134a (R-134a) and specified lubricants.

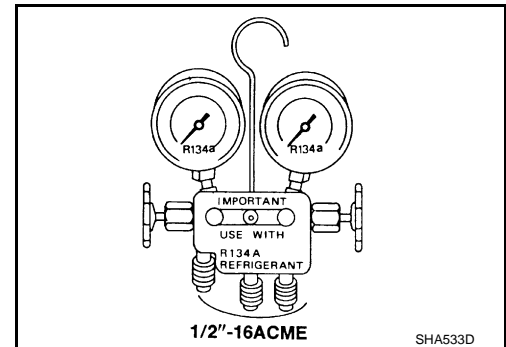

SERVICE HOSES

Be certain that the service hoses display the markings described (colored hose with black stripe). All hoses must include positive shut-off devices (either manual or automatic) near the end of the hoses opposite to the manifold gauge.

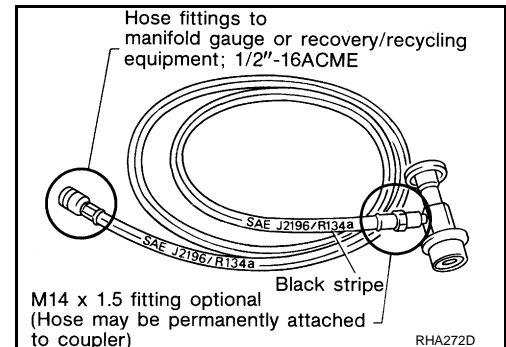

SERVICE COUPLERS

A
B
C
D
E
F
G
H
HAC
J
K
L
M
N
O
P

PRECAUTIONS

< PRECAUTION >

Never attempt to connect HFC-134a (R-134a) service couplers to a CFC-12 (R-12) A/C system. The HFC-134a (R-134a) couplers will not properly connect to the CFC-12 (R-12) system. However, if an improper connection is attempted, discharging and contamination may occur.

Shut-off valve rotation	A/C service valve
Clockwise	Open
Counterclockwise	Close

[AUTOMATIC AIR CONDITIONER]

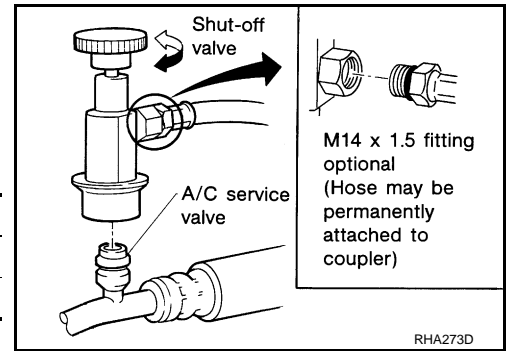

REFRIGERANT WEIGHT SCALE

Verify that no refrigerant other than HFC-134a (R-134a) and specified lubricants have been used with the scale. If the scale controls refrigerant flow electronically, the hose fitting must be 1/2"-16 ACME.

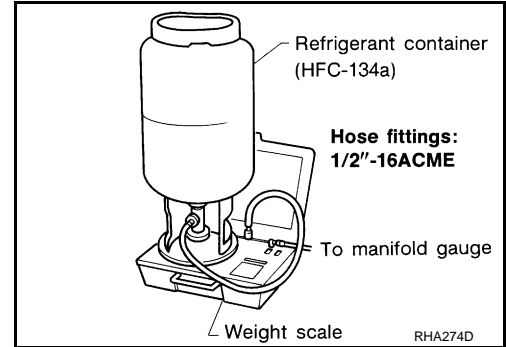

CHARGING CYLINDER

Using a charging cylinder is not recommended. Refrigerant may be vented into air from cylinder's top valve when filling the cylinder with refrigerant. Also, the accuracy of the cylinder is generally less than that of an electronic scale or of quality recycle/recharge equipment.

COMPRESSOR

General Precautions

INFOID:000000000959993

CAUTION:

- Plug all openings to prevent moisture and foreign matter from entering.
- When the compressor is removed, store it in the same way as it is when mounted on the car.
- When replacing or repairing compressor, follow “Maintenance of Lubricant Quantity in Compressor” exactly. Refer to [HA-30, "Adjustment"](#).
- Keep friction surfaces between clutch and pulley clean. If the surface is contaminated with lubricant, wipe it off by using a clean waste cloth moistened with thinner.
- After compressor service operation, turn the compressor shaft by hand more than five turns in both directions. This will equally distribute lubricant inside the compressor. After the compressor is installed, let the engine idle and operate the compressor for one hour.
- After replacing the compressor magnet clutch, apply voltage to the new one and check for normal operation.

A
B
C
D
E
F
G
H
J
K
L
M
N
O
P

HAC

FLUORESCENT LEAK DETECTOR

< PRECAUTION >

[AUTOMATIC AIR CONDITIONER]

FLUORESCENT LEAK DETECTOR

General Precautions

INFOID:000000000959994

CAUTION:

- The A/C system contains a fluorescent leak detection dye used for locating refrigerant leaks. An ultraviolet (UV) lamp is required to illuminate the dye when inspecting for leaks.
- Always wear fluorescence enhancing UV safety goggles to protect your eyes and enhance the visibility of the fluorescent dye.
- The fluorescent dye leak detector is not a replacement for an electrical leak detector (SST: J-41995). The fluorescent dye leak detector should be used in conjunction with an electrical leak detector (SST: J-41995) to pin-point refrigerant leaks.
- For the purpose of safety and customer's satisfaction, read and follow all manufacturer's operating instructions and precautions prior to performing the work.
- A compressor shaft seal should not necessarily be repaired because of dye seepage. The compressor shaft seal should only be repaired after confirming the leak with an electrical leak detector (SST: J-41995).
- Always remove any remaining dye from the leak area after repairs are completed to avoid a misdiagnosis during a future service.
- Never allow dye to come into contact with painted body panels or interior components. If dye is spilled, clean immediately with the approved dye cleaner. Fluorescent dye left on a surface for an extended period of time cannot be removed.
- Never spray the fluorescent dye cleaning agent on hot surfaces (engine exhaust manifold, etc.).
- Never use more than one refrigerant dye bottle (1/4 ounce /7.4 cc) per A/C system.
- Leak detection dyes for HFC-134a (R-134a) and CFC-12 (R-12) A/C systems are different. Never use HFC-134a (R-134a) leak detection dye in CFC-12 (R-12) A/C system, or CFC-12 (R-12) leak detection dye in HFC-134a (R-134a) A/C system, or A/C system damage may result.
- The fluorescent properties of the dye will remain for three years or a little over unless a compressor malfunction occurs.

IDENTIFICATION

NOTE:

Vehicles with factory installed fluorescent dye have a green label.

Vehicles without factory installed fluorescent dye have a blue label.

IDENTIFICATION LABEL FOR VEHICLE

Vehicles with factory installed fluorescent dye have the identification label on the front side of hood.