

SECTION **EXT**  
EXTERIOR

A  
B  
C  
D  
E  
F  
G  
H  
I  
J  
EXT  
L  
M  
N  
O  
P

CONTENTS

<b>SYMPTOM DIAGNOSIS</b> .....	2	Exploded View .....	18
<b>SQUEAK AND RATTLE TROUBLE DIAG- NOSES</b> .....	2	Removal and Installation .....	18
Work Flow .....	2	<b>FENDER PROTECTOR</b> .....	21
Inspection Procedure .....	4	Exploded View .....	21
Diagnostic Worksheet .....	6	Removal and Installation .....	22
<b>PRECAUTION</b> .....	8	<b>CENTER MUD GUARD</b> .....	24
<b>PRECAUTIONS</b> .....	8	Exploded View .....	24
Precaution for Supplemental Restraint System (SRS) "AIR BAG" and "SEAT BELT PRE-TEN- SIONER" .....	8	Removal and Installation .....	24
Precaution for Procedure without Cowl Top Cover.....	8	<b>FLOOR SIDE FAIRING</b> .....	26
Precaution for Work .....	8	Exploded View .....	26
<b>PREPARATION</b> .....	9	Removal and Installation .....	26
<b>PREPARATION</b> .....	9	<b>ROOF SIDE MOLDING</b> .....	28
Special Service Tools .....	9	Exploded View .....	28
Commercial Service Tools .....	9	Removal and Installation .....	28
<b>ON-VEHICLE REPAIR</b> .....	10	<b>DOOR SASH MOLDING</b> .....	30
<b>FRONT BUMPER</b> .....	10	Exploded View .....	30
Exploded View .....	10	Removal and Installation .....	30
Removal and Installation .....	11	<b>DOOR OUTSIDE MOLDING</b> .....	32
<b>REAR BUMPER</b> .....	13	Exploded View .....	32
Exploded View .....	13	Removal and Installation .....	32
Removal and Installation .....	14	<b>DOOR PARTING SEAL</b> .....	34
<b>FRONT GRILLE</b> .....	16	Exploded View .....	34
Exploded View .....	16	Removal and Installation .....	34
Removal and Installation .....	16	<b>TRUNK LID FINISHER</b> .....	35
<b>COWL TOP</b> .....	18	Exploded View .....	35
		Removal and Installation .....	35
		<b>REAR SPOILER</b> .....	37
		Exploded View .....	37
		Removal and Installation .....	37

# SQUEAK AND RATTLE TROUBLE DIAGNOSES

< SYMPTOM DIAGNOSIS >

## SYMPTOM DIAGNOSIS

### SQUEAK AND RATTLE TROUBLE DIAGNOSES

#### Work Flow

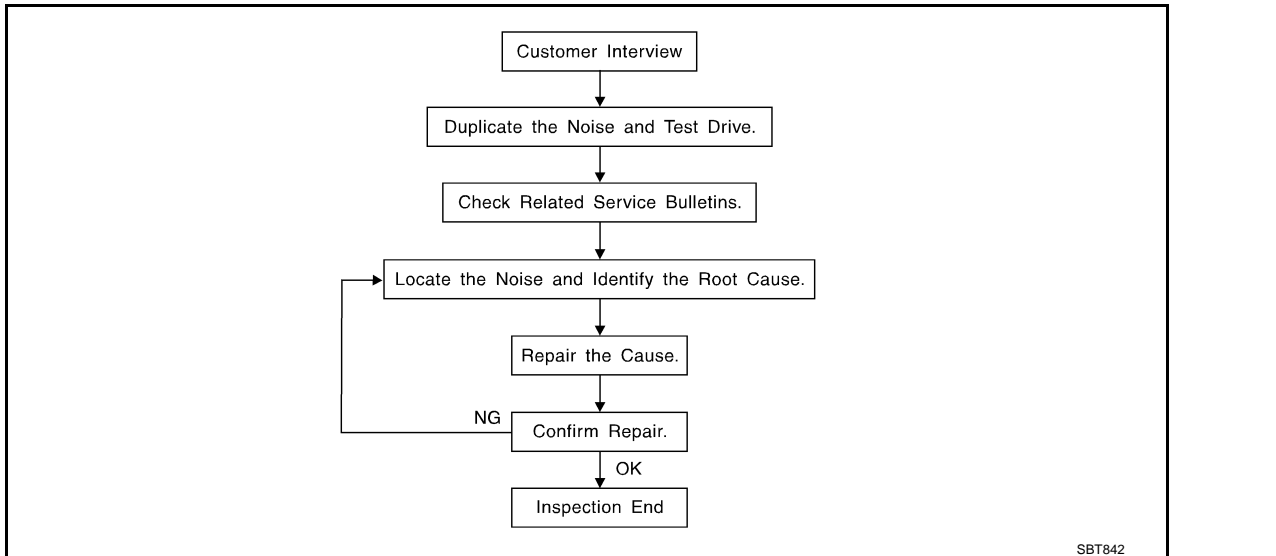

#### CUSTOMER INTERVIEW

Interview the customer if possible, to determine the conditions that exist when the noise occurs. Use the Diagnostic Worksheet during the interview to document the facts and conditions when the noise occurs and any of customer's comments; refer to [EXT-6. "Diagnostic Worksheet"](#). This information is necessary to duplicate the conditions that exist when the noise occurs.

- The customer may not be able to provide a detailed description or the location of the noise. Attempt to obtain all the facts and conditions that exist when the noise occurs (or does not occur).
- If there is more than one noise in the vehicle, perform a diagnosis and repair the noise that the customer is concerned about. This can be accomplished by performing a cruise test on the vehicle with the customer.
- After identifying the type of noise, isolate the noise in terms of its characteristics. The noise characteristics are provided so the customer, service adviser and technician are all speaking the same language when defining the noise.
- Squeak —(Like tennis shoes on a clean floor)  
Squeak characteristics include the light contact/fast movement/brought on by road conditions/hard surfaces=higher pitch noise/softer surfaces=lower pitch noises/edge to surface=chirping
- Creak—(Like walking on an old wooden floor)  
Creak characteristics include firm contact/slow movement/twisting with a rotational movement/pitch dependent on materials/often brought on by activity.
- Rattle—(Like shaking a baby rattle)  
Rattle characteristics include the fast repeated contact/vibration or similar movement/loose parts/missing clip or fastener/incorrect clearance.
- Knock —(Like a knock on a door)  
Knock characteristics include hollow sounding/sometimes repeating/often brought on by driver action.
- Tick—(Like a clock second hand)  
Tick characteristics include gentle contacting of light materials/loose components/can be caused by driver action or road conditions.
- Thump—(Heavy, muffled knock noise)  
Thump characteristics include softer knock/dead sound often brought on by activity.
- Buzz—(Like a bumblebee)  
Buzz characteristics include high frequency rattle/firm contact.
- Often the degree of acceptable noise level will vary depending up on the person. A noise that you may judge as acceptable may be very irritating to the customer.
- Weather conditions, especially humidity and temperature, may have a great effect on noise level.

#### DUPLICATE THE NOISE AND TEST DRIVE

# SQUEAK AND RATTLE TROUBLE DIAGNOSES

## < SYMPTOM DIAGNOSIS >

If possible, drive the vehicle with the customer until the noise is duplicated. Note any additional information on the Diagnostic Worksheet regarding the conditions or location of the noise. This information can be used to duplicate the same conditions when you confirm the repair.

If the noise can be duplicated easily during the test drive, to help identify the source of the noise, try to duplicate the noise with the vehicle stopped by doing one or all of the following:

- 1) Close a door.
  - 2) Tap or push/pull around the area where the noise appears to be coming from.
  - 3) Rev the engine.
  - 4) Use a floor jack to recreate vehicle "twist".
  - 5) At idle, apply engine load (electrical load, half-clutch on M/T models, drive position on A/T models).
  - 6) Raise the vehicle on a hoist and hit a tire with a rubber hammer.
- Drive the vehicle and attempt to duplicate the conditions the customer states exist when the noise occurs.
  - If it is difficult to duplicate the noise, drive the vehicle slowly on an undulating or rough road to stress the vehicle body.

## CHECK RELATED SERVICE BULLETINS

After verifying the customer concern or symptom, check ASIST for Technical Service Bulletins (TSBs) related to that concern or symptom.

If a TSB relates to the symptom, follow the procedure to repair the noise.

## LOCATE THE NOISE AND IDENTIFY THE ROOT CAUSE

1. Narrow down the noise to a general area. To help pinpoint the source of the noise, use a listening tool (Chassis Ear: J-39570, Engine Ear and mechanics stethoscope).
2. Narrow down the noise to a more specific area and identify the cause of the noise by:
  - removing the components in the area that you suspect the noise is coming from.  
Do not use too much force when removing clips and fasteners, otherwise clips and fastener can be broken or lost during the repair, resulting in the creation of new noise.
  - tapping or pushing/pulling the component that you suspect is causing the noise.  
Do not tap or push/pull the component with excessive force, otherwise the noise will be eliminated only temporarily.
  - feeling for a vibration with your hand by touching the component(s) that you suspect is (are) causing the noise.
  - placing a piece of paper between components that you suspect are causing the noise.
  - looking for loose components and contact marks.  
Refer to [EXT-4. "Inspection Procedure"](#).

## REPAIR THE CAUSE

- If the cause is a loose component, tighten the component securely.
- If the cause is insufficient clearance between components:
  - separate components by repositioning or loosening and retightening the component, if possible.
  - insulate components with a suitable insulator such as urethane pads, foam blocks, felt cloth tape or urethane tape. A Nissan Squeak and Rattle Kit (J-43980) is available through your authorized Nissan Parts Department.

### **CAUTION:**

**Do not use excessive force as many components are constructed of plastic and may be damaged.**

### **NOTE:**

Always check with the Parts Department for the latest parts information.

The following materials are contained in the Nissan Squeak and Rattle Kit (J-43980). Each item can be ordered separately as needed.

URETHANE PADS [1.5 mm (0.059 in) thick]

Insulates connectors, harness, etc.

76268-9E005: 100 × 135 mm (3.94 × 5.31 in)/76884-71L01: 60 × 85 mm (2.36 × 3.35 in)/76884-71L02: 15 × 25 mm (0.59 × 0.98 in)

INSULATOR (Foam blocks)

Insulates components from contact. Can be used to fill space behind a panel.

73982-9E000: 45 mm (1.77 in) thick, 50 × 50 mm (1.97 × 1.97 in)/73982-

50Y00: 10 mm (0.39 in) thick, 50 × 50 mm (1.97 × 1.97 in)

INSULATOR (Light foam block)

80845-71L00: 30 mm (1.18 in) thick, 30 × 50 mm (1.18 × 1.97in)

FELT CLOTHTAPE

Used to insulate where movement does not occur. Ideal for instrument panel applications.

# SQUEAK AND RATTLE TROUBLE DIAGNOSES

## < SYMPTOM DIAGNOSIS >

---

68370-4B000: 15 × 25 mm (0.59 × 0.98 in) pad/68239-13E00: 5 mm (0.20 in) wide tape roll

The following materials, not found in the kit, can also be used to repair squeaks and rattles.

### UHMW (TEFLON) TAPE

Insulates where slight movement is present. Ideal for instrument panel applications.

### SILICONE GREASE

Used in place of UHMW tape that will be visible or not fit. Will only last a few months.

### SILICONE SPRAY

Use when grease cannot be applied.

### DUCT TAPE

Use to eliminate movement.

## CONFIRM THE REPAIR

Confirm that the cause of a noise is repaired by test driving the vehicle. Operate the vehicle under the same conditions as when the noise originally occurred. Refer to the notes on the Diagnostic Worksheet.

## Inspection Procedure

INFOID:000000000961787

Refer to Table of Contents for specific component removal and installation information.

## INSTRUMENT PANEL

Most incidents are caused by contact and movement between:

1. The cluster lid A and instrument panel
2. Acrylic lens and combination meter housing
3. Instrument panel to front pillar garnish
4. Instrument panel to windshield
5. Instrument panel mounting pins
6. Wiring harnesses behind the combination meter
7. A/C defroster duct and duct joint

These incidents can usually be located by tapping or moving the components to duplicate the noise or by pressing on the components while driving to stop the noise. Most of these incidents can be repaired by applying felt cloth tape or silicon spray (in hard to reach areas). Urethane pads can be used to insulate wiring harness.

### **CAUTION:**

**Do not use silicone spray to isolate a squeak or rattle. If you saturate the area with silicone, you will not be able to recheck the repair.**

## CENTER CONSOLE

Components to pay attention to include:

1. Shifter assembly cover to finisher
2. A/C control unit and cluster lid C
3. Wiring harnesses behind audio and A/C control unit

The instrument panel repair and isolation procedures also apply to the center console.

## DOORS

Pay attention to the:

1. Finisher and inner panel making a slapping noise
2. Inside handle escutcheon to door finisher
3. Wiring harnesses tapping
4. Door striker out of alignment causing a popping noise on starts and stops

Tapping or moving the components or pressing on them while driving to duplicate the conditions can isolate many of these incidents. You can usually insulate the areas with felt cloth tape or insulator foam blocks from the Nissan Squeak and Rattle Kit (J-43980) to repair the noise.

## TRUNK

Trunk noises are often caused by a loose jack or loose items put into the trunk by the owner.

In addition look for:

1. Trunk lid dumpers out of adjustment
2. Trunk lid striker out of adjustment

# SQUEAK AND RATTLE TROUBLE DIAGNOSES

## < SYMPTOM DIAGNOSIS >

---

3. The trunk lid torsion bars knocking together

4. A loose license plate or bracket

Most of these incidents can be repaired by adjusting, securing or insulating the item(s) or component(s) causing the noise.

### SUNROOF/HEADLINING

Noises in the sunroof/headlining area can often be traced to one of the following:

1. Sunroof lid, rail, linkage or seals making a rattle or light knocking noise

2. Sunvisor shaft shaking in the holder

3. Front or rear windshield touching headlining and squeaking

Again, pressing on the components to stop the noise while duplicating the conditions can isolate most of these incidents. Repairs usually consist of insulating with felt cloth tape.

### SEATS

When isolating seat noise it's important to note the position the seat is in and the load placed on the seat when the noise is present. These conditions should be duplicated when verifying and isolating the cause of the noise.

Cause of seat noise include:

1. Headrest rods and holder

2. A squeak between the seat pad cushion and frame

3. The rear seatback lock and bracket

These noises can be isolated by moving or pressing on the suspected components while duplicating the conditions under which the noise occurs. Most of these incidents can be repaired by repositioning the component or applying urethane tape to the contact area.

### UNDERHOOD

Some interior noise may be caused by components under the hood or on the engine wall. The noise is then transmitted into the passenger compartment.

Causes of transmitted underhood noise include:

1. Any component mounted to the engine wall

2. Components that pass through the engine wall

3. Engine wall mounts and connectors

4. Loose radiator mounting pins

5. Hood bumpers out of adjustment

6. Hood striker out of adjustment

These noises can be difficult to isolate since they cannot be reached from the interior of the vehicle. The best method is to secure, move or insulate one component at a time and test drive the vehicle. Also, engine RPM or load can be changed to isolate the noise. Repairs can usually be made by moving, adjusting, securing, or insulating the component causing the noise.

A

B

C

D

E

F

G

H

I

J

EXT

L

M

N

O

P

# SQUEAK AND RATTLE TROUBLE DIAGNOSES

< SYMPTOM DIAGNOSIS >

## Diagnostic Worksheet

INFOID:000000000961788



### SQUEAK & RATTLE DIAGNOSTIC WORKSHEET

Dear Infiniti Customer:

We are concerned about your satisfaction with your Infiniti vehicle. Repairing a squeak or rattle sometimes can be very difficult. To help us fix your Infiniti right the first time, please take a moment to note the area of the vehicle where the squeak or rattle occurs and under what conditions. You may be asked to take a test drive with a service consultant or technician to ensure we confirm the noise you are hearing.

#### I. WHERE DOES THE NOISE COME FROM? (circle the area of the vehicle)

The illustrations are for reference only, and may not reflect the actual configuration of your vehicle.

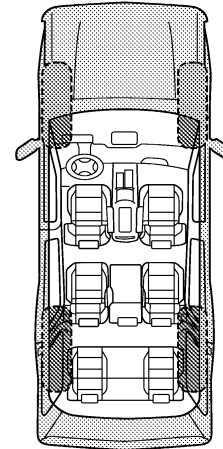
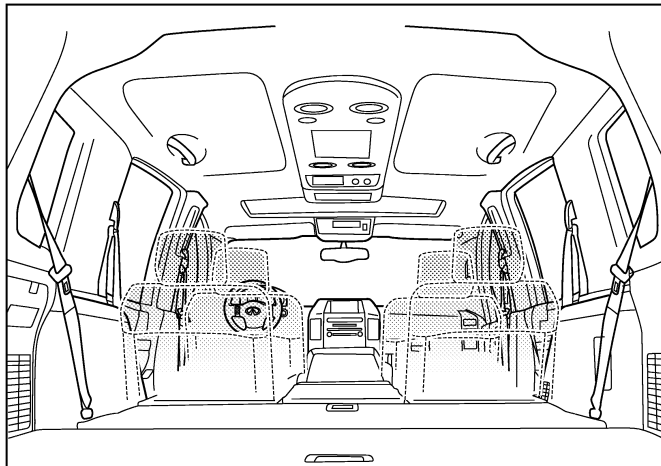
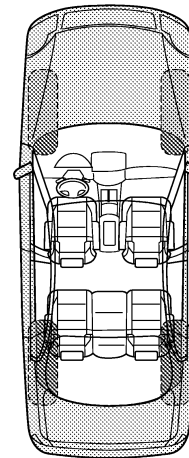
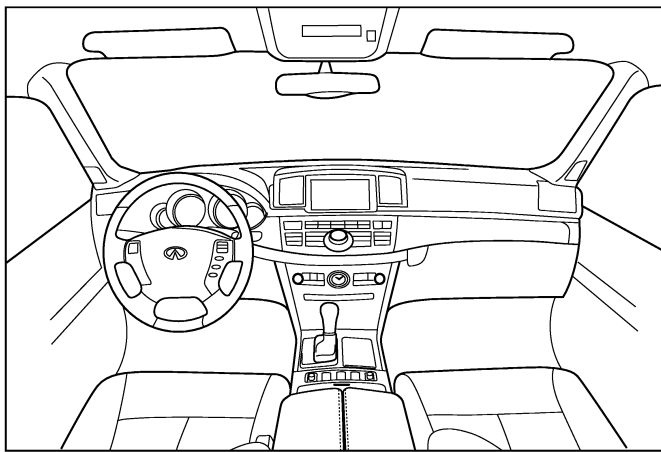

Continue to page 2 of the worksheet and briefly describe the location of the noise or rattle. In addition, please indicate the conditions which are present when the noise occurs.

PIIB8741E

# SQUEAK AND RATTLE TROUBLE DIAGNOSES

< SYMPTOM DIAGNOSIS >

## SQUEAK & RATTLE DIAGNOSTIC WORKSHEET - page 2

Briefly describe the location where the noise occurs:

---

---

### II. WHEN DOES IT OCCUR? (please check the boxes that apply)

- |   |  |
|---|--|
| <input type="checkbox"/> anytime                      | <input type="checkbox"/> after sitting out in the rain |
| <input type="checkbox"/> 1st time in the morning      | <input type="checkbox"/> when it is raining or wet     |
| <input type="checkbox"/> only when it is cold outside | <input type="checkbox"/> dry or dusty conditions       |
| <input type="checkbox"/> only when it is hot outside  | <input type="checkbox"/> other:                        |

### III. WHEN DRIVING:

- through driveways
- over rough roads
- over speed bumps
- only about \_\_\_\_ mph
- on acceleration
- coming to a stop
- on turns: left, right or either (circle)
- with passengers or cargo
- other: \_\_\_\_\_
- after driving \_\_\_\_ miles or \_\_\_\_ minutes

### IV. WHAT TYPE OF NOISE

- squeak (like tennis shoes on a clean floor)
- creak (like walking on an old wooden floor)
- rattle (like shaking a baby rattle)
- knock (like a knock at the door)
- tick (like a clock second hand)
- thump (heavy, muffled knock noise)
- buzz (like a bumble bee)

### TO BE COMPLETED BY DEALERSHIP PERSONNEL

#### Test Drive Notes:

---

---

---

	YES	NO	Initials of person performing
Vehicle test driven with customer	<input type="checkbox"/>	<input type="checkbox"/>	_____
- Noise verified on test drive	<input type="checkbox"/>	<input type="checkbox"/>	_____
- Noise source located and repaired	<input type="checkbox"/>	<input type="checkbox"/>	_____
- Follow up test drive performed to confirm repair	<input type="checkbox"/>	<input type="checkbox"/>	_____

VIN: \_\_\_\_\_ Customer Name: \_\_\_\_\_  
W.O.# \_\_\_\_\_ Date: \_\_\_\_\_

This form must be attached to Work Order

PIIB8742E

A  
B  
C  
D  
E  
F  
G  
H  
I  
J  
L  
M  
N  
O  
P

EXT

# PRECAUTIONS

< PRECAUTION >

## PRECAUTION

### PRECAUTIONS

#### Precaution for Supplemental Restraint System (SRS) "AIR BAG" and "SEAT BELT PRE-TENSIONER"

INFOID:000000000961789

The Supplemental Restraint System such as "AIR BAG" and "SEAT BELT PRE-TENSIONER", used along with a front seat belt, helps to reduce the risk or severity of injury to the driver and front passenger for certain types of collision. This system includes seat belt switch inputs and dual stage front air bag modules. The SRS system uses the seat belt switches to determine the front air bag deployment, and may only deploy one front air bag, depending on the severity of a collision and whether the front occupants are belted or unbelted. Information necessary to service the system safely is included in the SRS and SB section of this Service Manual.

#### **WARNING:**

- To avoid rendering the SRS inoperative, which could increase the risk of personal injury or death in the event of a collision which would result in air bag inflation, all maintenance must be performed by an authorized NISSAN/INFINITI dealer.
- Improper maintenance, including incorrect removal and installation of the SRS, can lead to personal injury caused by unintentional activation of the system. For removal of Spiral Cable and Air Bag Module, see the SRS section.
- Do not use electrical test equipment on any circuit related to the SRS unless instructed to in this Service Manual. SRS wiring harnesses can be identified by yellow and/or orange harnesses or harness connectors.

#### Precaution for Procedure without Cowl Top Cover

INFOID:000000000961790

When performing the procedure after removing cowl top cover, cover the lower end of windshield with urethane, etc.

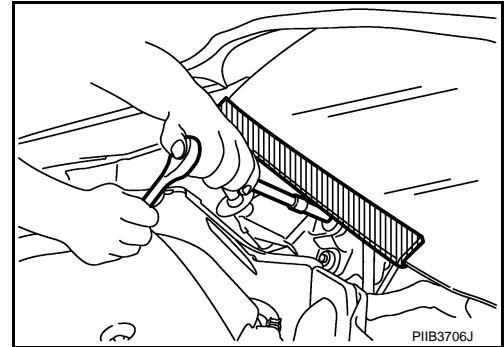

#### Precaution for Work

INFOID:000000000961791

- After removing and installing the opening/closing parts, be sure to carry out fitting adjustments to check their operation.
- Check the lubrication level, damage, and wear of each part. If necessary, grease or replace it.



# PREPARATION

< PREPARATION >

## PREPARATION

### PREPARATION

#### Special Service Tools

INFOID:000000000961792

The actual shapes of Kent-Moore tools may differ from those of special service tools illustrated here.

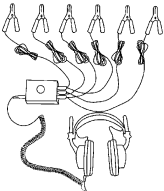
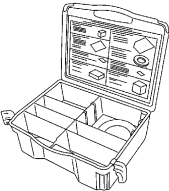
Tool number (Kent-Moore No.) Tool name	Description
(J-39570) Chassis ear   SIIA0993E	Location the noise
(J-43980) NISSAN Squeak and Rattle Kit   SIIA0994E	Repairing the cause of noise

#### Commercial Service Tools

INFOID:000000000961793

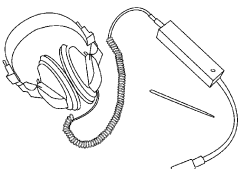
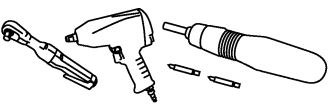
Tool name	Description
Engine ear   SIIA0995E	Locating the noise
Power tool   PIIB1407E	

A  
B  
C  
D  
E  
F  
G  
H  
I  
J  
L  
M  
N  
O  
P

EXT

# FRONT BUMPER

< ON-VEHICLE REPAIR >

## ON-VEHICLE REPAIR

### FRONT BUMPER

Exploded View

INFOID:000000000961794

SEC. 620

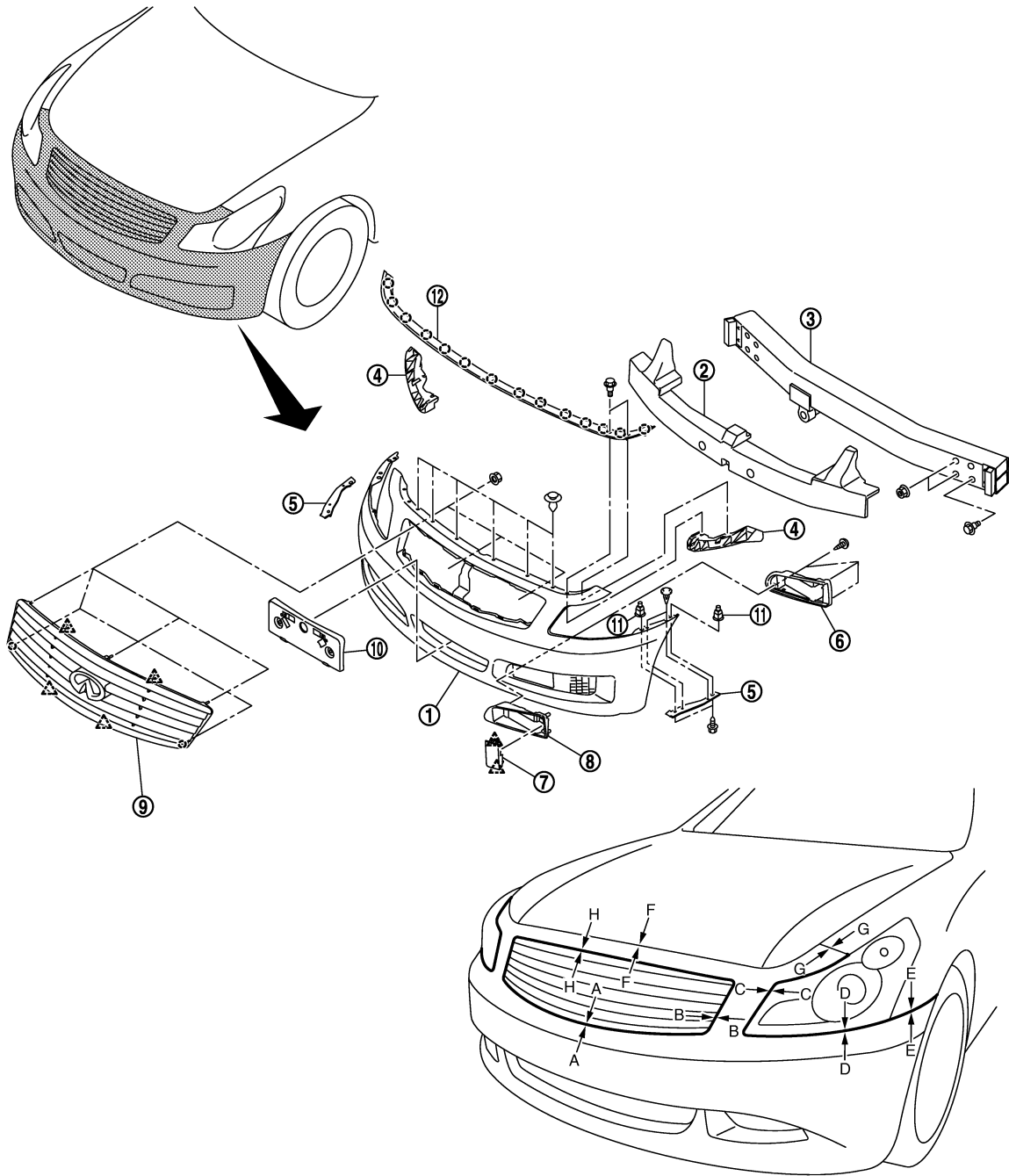

JMKIA0074GB

- |                           |                        |                                |
|---------------------------|------------------------|--------------------------------|
| 1. Bumper fascia assembly | 2. Energy absorber     | 3. Bumper reinforcement        |
| 4. Bumper side stiffener  | 5. Bumper side bracket | 6. Bumper finisher A           |
| 7. Bumper finisher B      | 8. Bumper finisher     | 9. Front grille                |
| 10. License plate bracket | 11. Grommet            | 12. Hood seal assembly (front) |

# FRONT BUMPER

< ON-VEHICLE REPAIR >

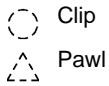

## Removal and Installation

INFOID:000000000961795

### REMOVAL

#### CAUTION:

Bumper fascia is made of resin. Do not apply strong force to it, and be careful to prevent contact with oil.

1. Fully open hood assembly.
2. Remove clips (A) of front bumper fascia upper side.

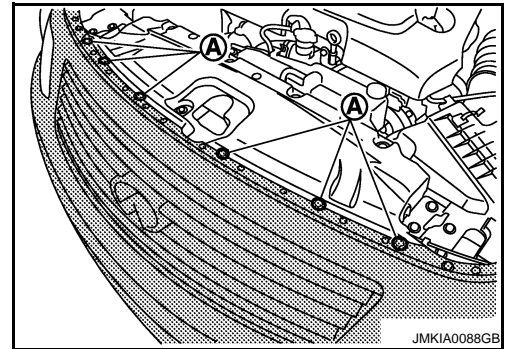

3. Remove radiator core support ornament. Refer to [DLK-196, "Removal and Installation"](#).
4. Remove clips (A) of hood seal assembly (side) LH/RH, and then remove hood seal assembly (1) located front portion. Refer to [DLK-199, "Removal and Installation"](#).

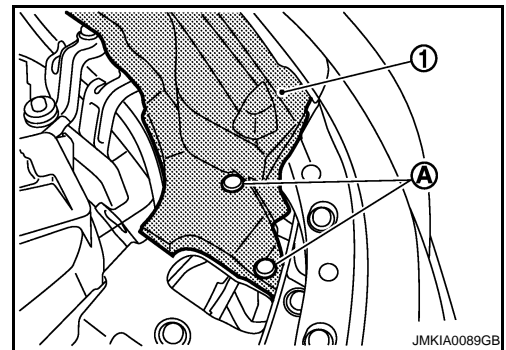

5. Remove bolts (A) of fixing bumper fascia and front fender (LH/RH), using a tool (B).

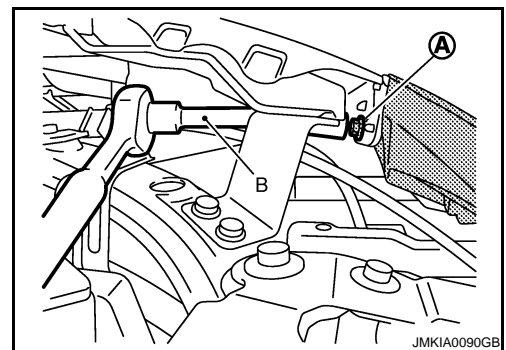

6. Remove bolts (A) of fixing engine lower cover (1) and front fender protector (2)

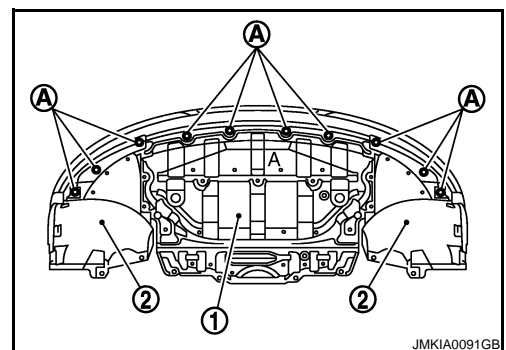

A  
B  
C  
D  
E  
F  
G  
H  
I  
J  
EXT  
L  
M  
N  
O  
P

# FRONT BUMPER

## < ON-VEHICLE REPAIR >

7. Remove fender protector (front) mounting bolts and clips, and then remove screws (A) of fixing bumper fascia left and right side.

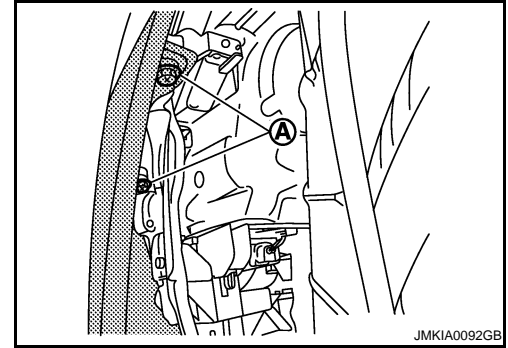

8. Remove bumper fascia assembly.

**CAUTION:**

**When removing bumper fascia, 2 workers are required so as to prevent it from dropping.**

9. Remove the following parts after removing bumper fascia.

- Front grille
- Hood seal assembly (front)
- License plate bracket
- Front bumper side bracket (LH/RH)
- Front bumper side stiffener (LH/RH)
- Front bumper finisher A
- Front bumper finisher B

10. Remove bumper energy absorber.

11. Remove bumper reinforcement mounting nuts and bolts, and then remove bumper reinforcement with power tool.

### INSTALLATION

Install in the reverse order of removal.

**NOTE:**

After installing, perform fitting adjustment.

	Portion	Clearance
Front bumper – Front grille	A – A	0.2 – 2.8 mm (0.008 – 0.110 in)
Front bumper – Front grille	B – B	0.2 – 2.8 mm (0.008 – 0.110 in)
Front bumper – Headlamp	C – C	0.5 – 3.2 mm (0.020 – 0.126 in)
Front bumper – Headlamp	D – D	0.5 – 3.2 mm (0.020 – 0.126 in)
Front bumper – Front fender	E – E	0.0 – 0.7 mm (0.000 – 0.028 in)

# REAR BUMPER

< ON-VEHICLE REPAIR >

## REAR BUMPER

Exploded View

INFOID:000000000961796

SEC. 850

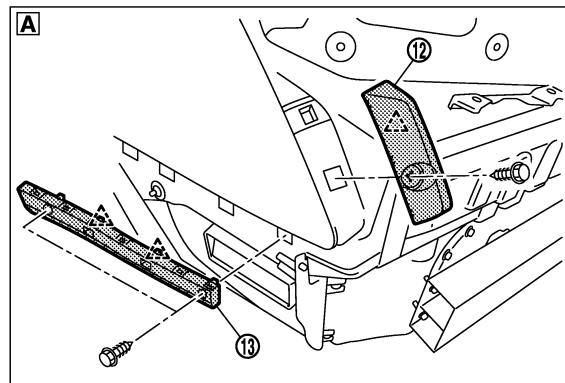
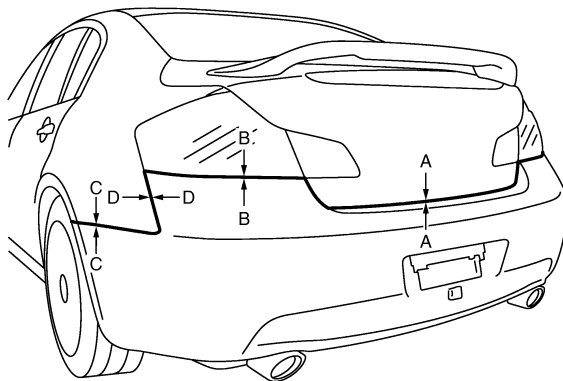
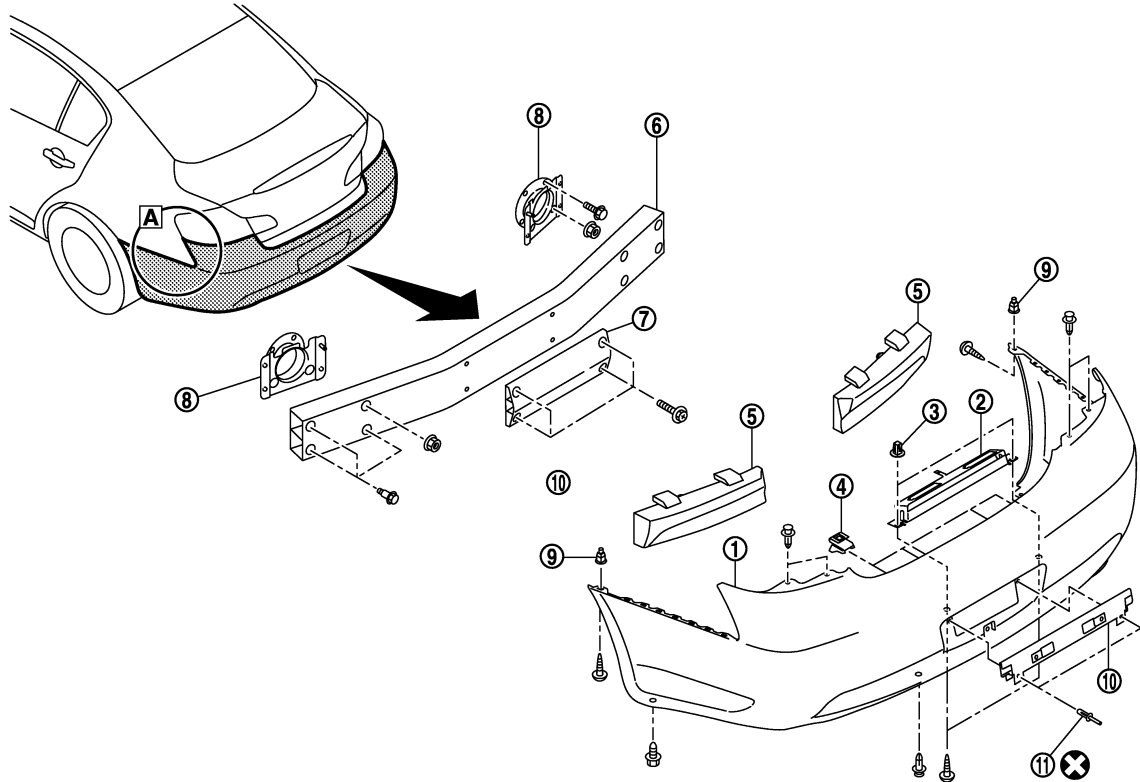

- |                                |                              |                           |
|--------------------------------|------------------------------|---------------------------|
| 1. Bumper fascia assembly      | 2. Rear license lamp bracket | 3. Grommet                |
| 4. Bumper clip                 | 5. Bumper energy absorber    | 6. Bumper reinforcement   |
| 7. Bumper over rider           | 8. Bumper stay               | 9. Bumper grommet         |
| 10. Rear license plate bracket | 11. Rivet                    | 12. Bumper side bracket B |
| 13. Bumper side bracket A      |                              |                           |

 Pawl

JMKIA0075GB

A  
B  
C  
D  
E  
F  
G  
H  
I  
J  
EXT  
L  
M  
N  
O  
P

# REAR BUMPER

< ON-VEHICLE REPAIR >

## Removal and Installation

INFOID:00000000961797

### REMOVAL

#### CAUTION:

Bumper fascia is made of resin. Do not apply strong force to it, and be careful to prevent contact with oil.

1. Fully open trunk lid assembly.
2. Remove rear combination lamp (LH/RH). Refer to [EXL-198. "Removal and Installation"](#).
3. Remove clips (A) located under rear combination lamp (LH/RH).

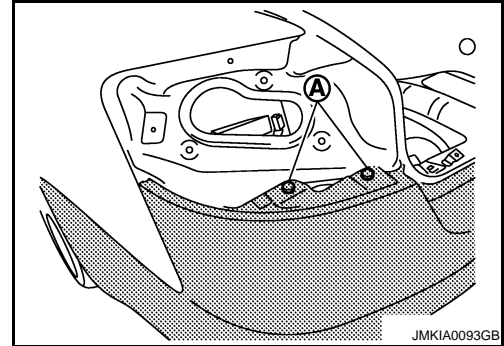

4. Remove screw (A) of bumper fascia underside.
5. Remove clips (B) of rear wheel house protector rear end (LH/RH).

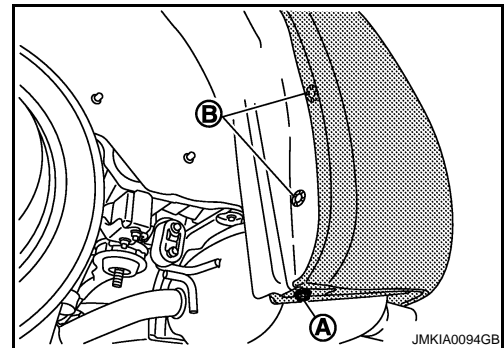

6. Remove screws (A) of bumper fascia front end upper (LH/RH).

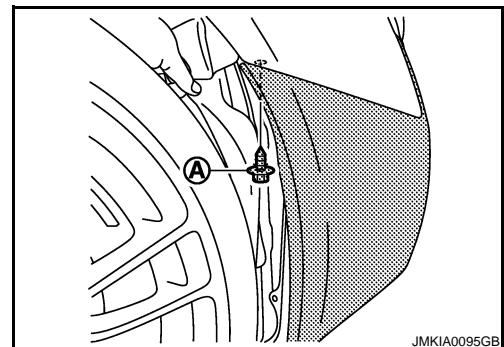

7. Remove clips of bumper fascia underside, and then pull out bumper fascia toward rear of vehicle.
8. Disconnect license plate lamp connector (A).

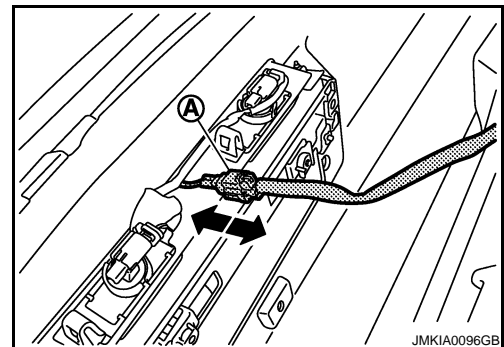

9. Remove bumper fascia assembly.

# REAR BUMPER

## < ON-VEHICLE REPAIR >

### CAUTION:

When removing bumper fascia, 2 workers are required so as to prevent it from dropping.

10. Remove the following parts after removing bumper fascia.
  - License lamp. Refer to [EXL-202. "Removal and Installation"](#).
  - License lamp bracket.
  - License plate bracket.
  - Bumper clip.
11. Remove bumper energy absorber.
12. Remove license lamp harness clamps of bumper reinforcement.
13. Remove bumper reinforcement mounting nuts and bolts, and then remove bumper reinforcement with power tool.

### INSTALLATION

Install in the reverse order of removal.

### NOTE:

After installing, perform fitting adjustment.

	Portion	Clearance
Rear bumper – Trunk lid	A – A	4.0 – 8.0 mm (0.157 – 0.315 in)
Rear bumper – Rear combination lamp	B – B	0.0 – 3.0 mm (0.000 – 0.118 in)
Rear bumper – Rear fender	C – C	0.0 – 0.8 mm (0.000 – 0.031 in)
Rear bumper – Rear fender	D – D	0.0 – 0.8 mm (0.000 – 0.031 in)

A  
B  
C  
D  
E  
F  
G  
H  
I  
J  
L  
M  
N  
O  
P

EXT

# FRONT GRILLE

< ON-VEHICLE REPAIR >

## FRONT GRILLE

Exploded View

INFOID:000000000961798

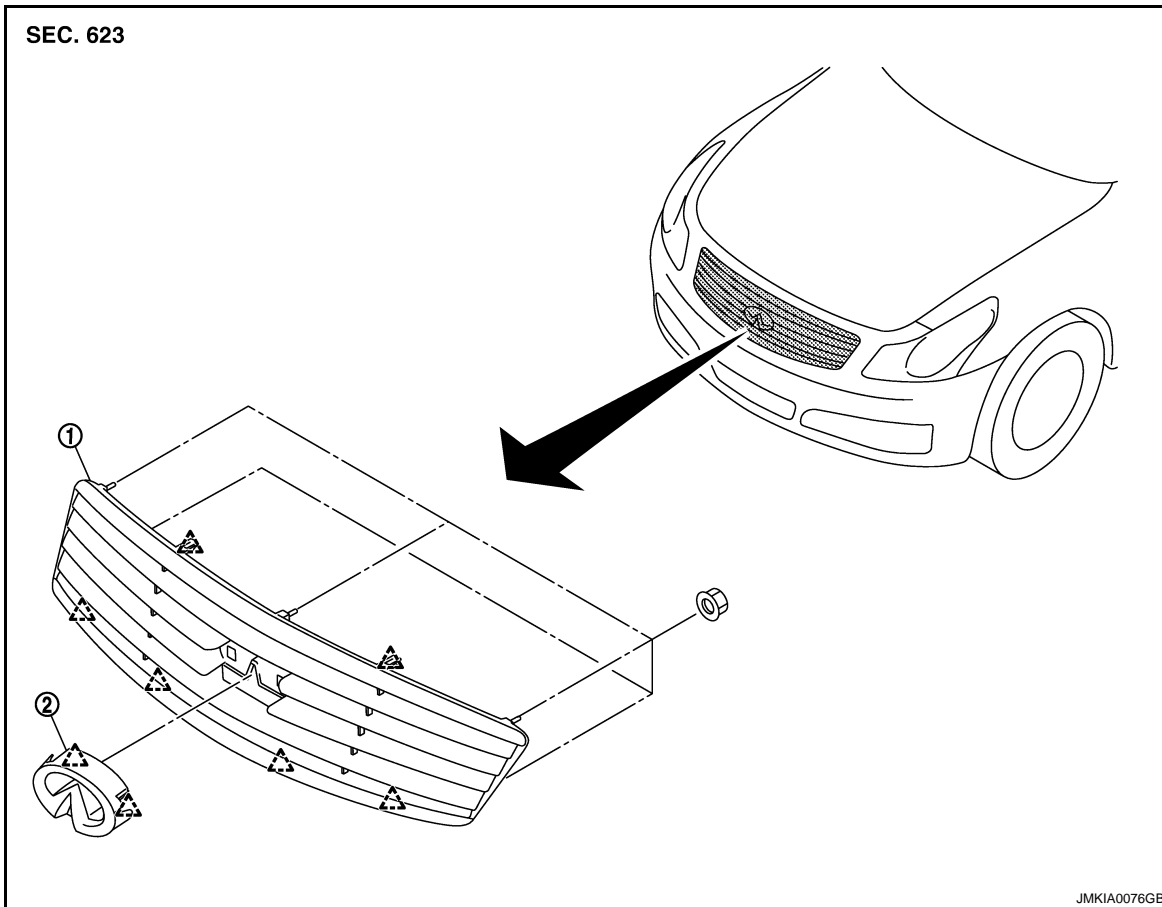

1. Front grille

2. Front emblem

 Pawl

## Removal and Installation

INFOID:000000000961799

### REMOVAL

#### **CAUTION:**

**Apply protection tape around outer circumference of front grille (bumper fascia side).**

1. Fully open hood assembly.
2. Remove reservoir tank. Refer to [CO-14. "Removal and Installation"](#).
3. Remove radiator core support ornament. Refer to [DLK-196. "Removal and Installation"](#).
4. Remove front grille mounting nuts (A).

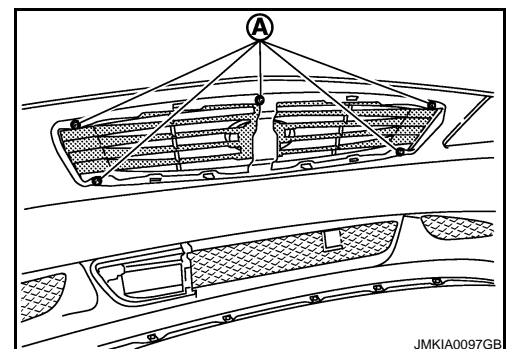

JMKIA0097GB



# FRONT GRILLE

## < ON-VEHICLE REPAIR >

5. Disengage pawls (A) of fixing front grille.

 : Pawl

6. Pull front grille out toward vehicle front.
7. Remove the following parts after removing front grille.  
Front emblem

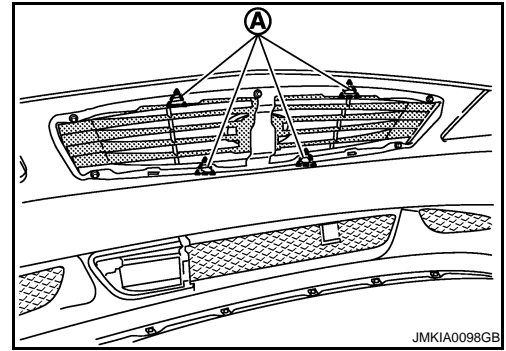

## INSTALLATION

Install in the reverse order of removal.

A  
B  
C  
D  
E  
F  
G  
H  
I  
J  
EXT  
L  
M  
N  
O  
P

# COWL TOP

< ON-VEHICLE REPAIR >



## COWL TOP

Exploded View

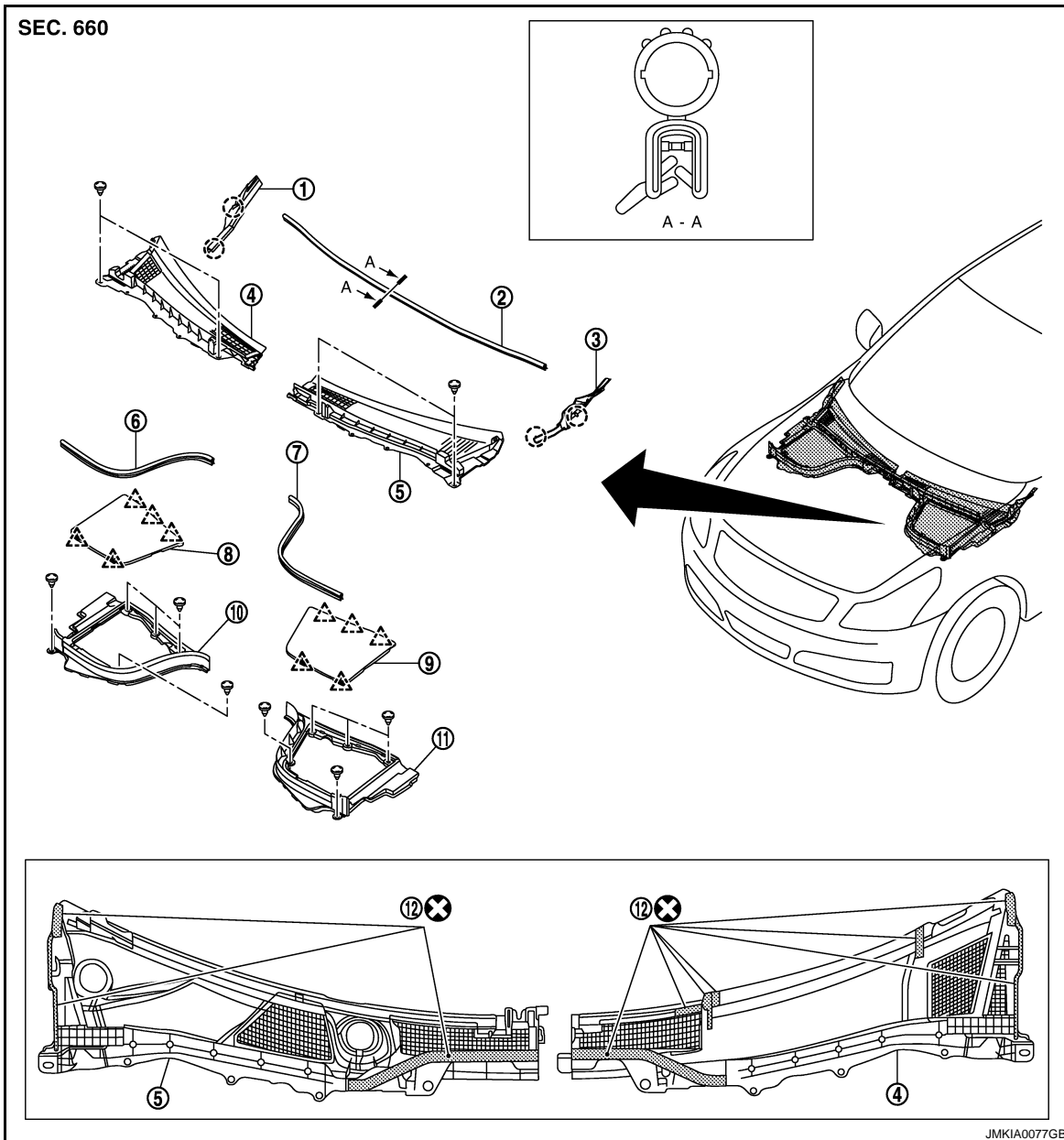
INFOID:000000000961800



- |                             |                          |                                |
|-----------------------------|--------------------------|--------------------------------|
| 1. Front fender cover (RH)  | 2. Cowl top seal         | 3. Front fender cover (LH)     |
| 4. Cowl top cover (RH)      | 5. Cowl top cover (LH)   | 6. Cowl top cover seal (RH)    |
| 7. Cowl top cover seal (LH) | 8. Battery cover         | 9. Brake master cylinder cover |
| 10. Hoodledge cover (RH)    | 11. Hoodledge cover (LH) | 12. EPT sealer                 |

-  Clip
-  Pawl

### Removal and Installation

INFOID:000000000961801

#### REMOVAL

1. Fully open hood assembly.
2. Remove front wiper arm (LH/RH) from vehicle. Refer to [WW-84, "Removal and Installation"](#).

# COWL TOP

## < ON-VEHICLE REPAIR >

3. Remove battery cover and brake master cylinder cover.
4. Remove hoodledge cover mounting clips and then remove hoodledge cover (LH/RH) and cowl top cover seal (LH/RH).
5. Remove cowl top seal.
6. Remove cowl top cover mounting clips.
7. Plastic pawl (A) is pull up and cowl top cover RH (2) is removed ahead of vehicles.

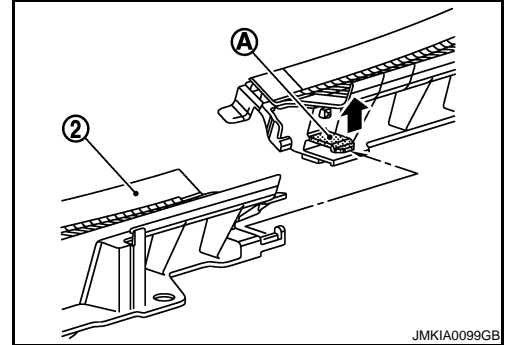

8. Plastic pawl (B) is push down and cowl top cover LH (1) is removed ahead of vehicles.

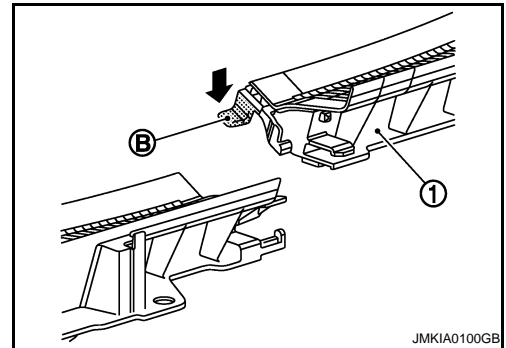

9. Remove the following parts after removing cowl top cover.
  - Front fender cover (LH/RH).
  - EPT sealer.

## INSTALLATION

Note the following, and install in the reverse order of removal.

- Install cowl top cover LH (1) with (C) (pin from front windshield glass) aligned with concave part.

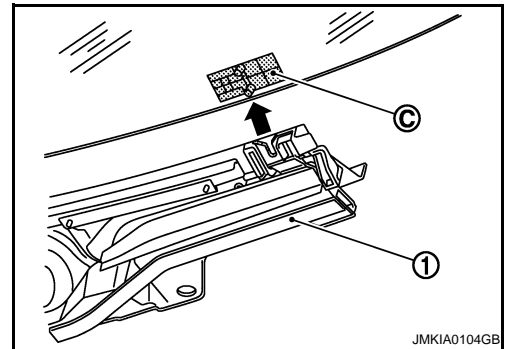

- Slide the pawl while aligning with the concave part of (E).
- Engage the joint of plastic pawl of (A) with (D), and then assemble cowl top covers LH (1) and RH (2).

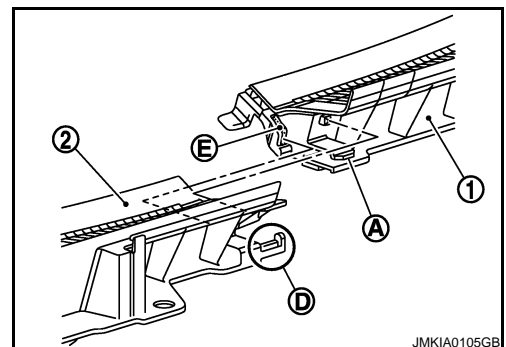

A  
B  
C  
D  
E  
F  
G  
H  
I  
J  
EXT  
L  
M  
N  
O  
P

## COWL TOP

< ON-VEHICLE REPAIR >

---

**CAUTION:**

After installing, perform adjustment of wiper arm. Refer to [WW-85, "Adjustment"](#).

# FENDER PROTECTOR

< ON-VEHICLE REPAIR >

## FENDER PROTECTOR

Exploded View

INFOID:000000000961802

FENDER PROTECTOR

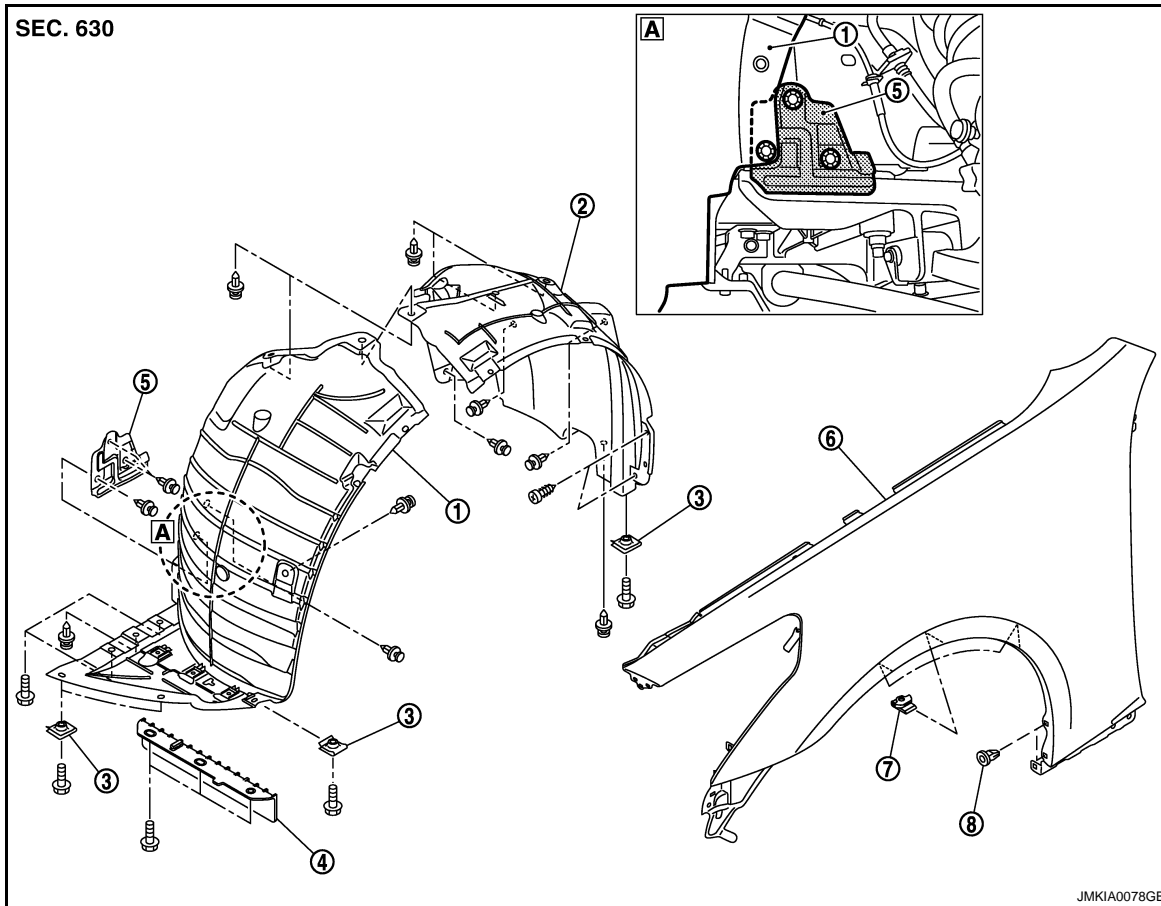

- |                             |                            |                 |
|-----------------------------|----------------------------|-----------------|
| 1. Fender protector (front) | 2. Fender protector (rear) | 3. U-nut        |
| 4. Fairing                  | 5. Splash guard            | 6. Front fender |
| 7. Fender clip              | 8. Grommet                 |                 |

REAR WHEEL HOUSE PROTECTOR

A  
B  
C  
D  
E  
F  
G  
H  
I  
J  
L  
M  
N  
O  
P

EXT

# FENDER PROTECTOR

< ON-VEHICLE REPAIR >

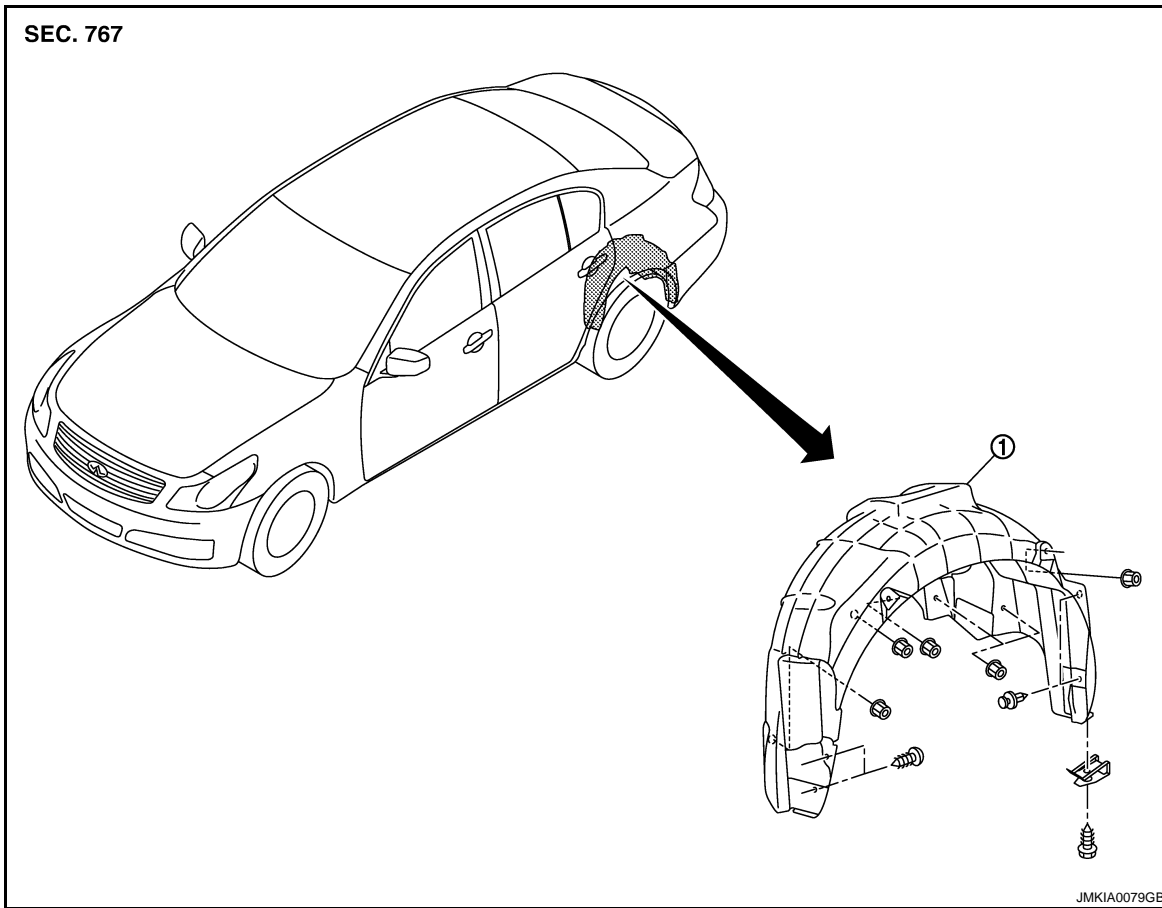

1. Rear wheel house protector

## Removal and Installation

INFOID:000000000961803

### REMOVAL

#### FENDER PROTECTOR

1. Remove bolt (A) of fender protector (rear) rear end.
2. Remove screws (B) of fender protector (rear) located center mud guard and front fender.

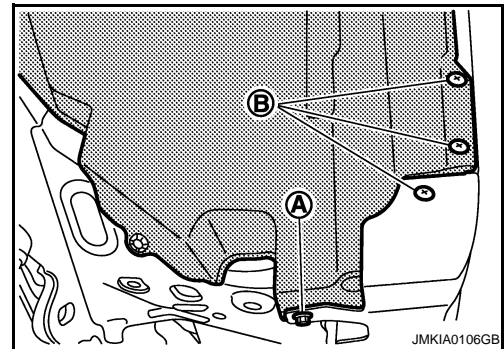

3. Remove clips of fender protector (rear).
4. Remove fender clip from wheelhouse arches, and then remove fender protector (rear) from wheel house.

# FENDER PROTECTOR

## < ON-VEHICLE REPAIR >

5. Remove bolts (A) of fender protector (front) located engine under cover and front bumper.

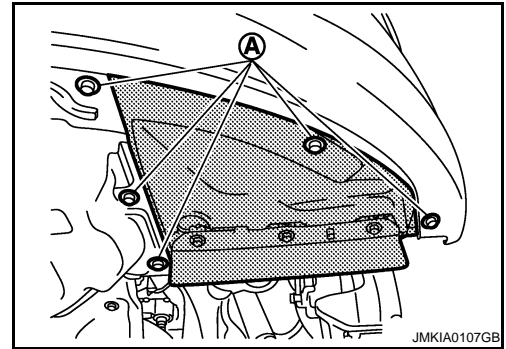

6. Remove fender protector (front) mounting clips.
7. Remove fender clip from wheel house arches, and then remove fender protector (front) from wheel house.
8. Remove the following parts after removing front fender protector.
  - Air guide
  - Fender clip

## REAR WHEEL HOUSE PROTECTOR

1. Remove bolt (A) of rear wheel house protector rear end.

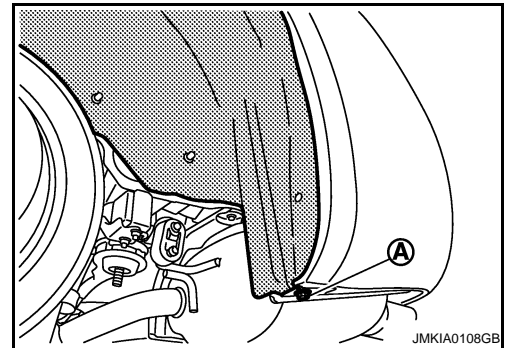

2. Remove screws (A) of rear wheel house protector located center mud guard.

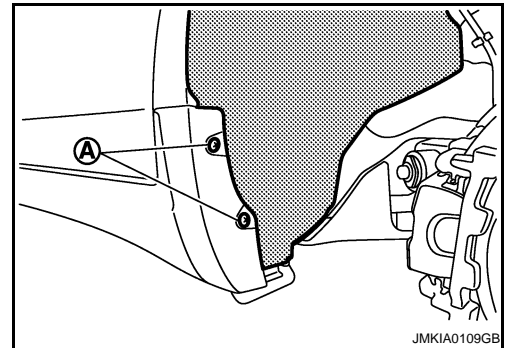

3. Remove rear wheel house protector mounting nuts and then remove rear wheel house protector.

## INSTALLATION

Install in the reverse order of removal.

A  
B  
C  
D  
E  
F  
G  
H  
I  
J  
EXT  
L  
M  
N  
O  
P

# CENTER MUD GUARD

< ON-VEHICLE REPAIR >

## CENTER MUD GUARD

Exploded View

INFOID:000000000961804

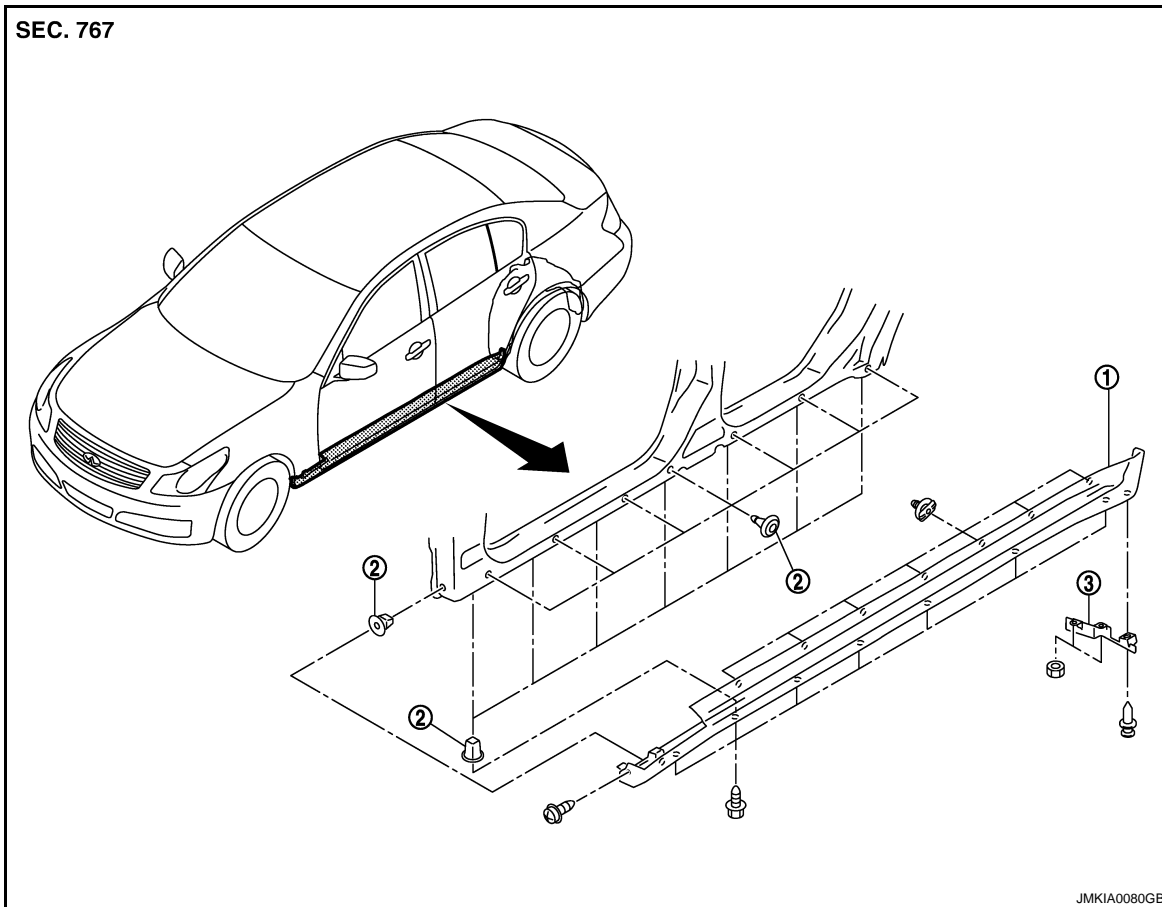

1. Center mud guard

2. Grommet

3. Wind deflector

## Removal and Installation

INFOID:000000000961805

### REMOVAL

1. Remove wind deflector mounting clip (A) and nuts (B), and then remove wind deflector (1).

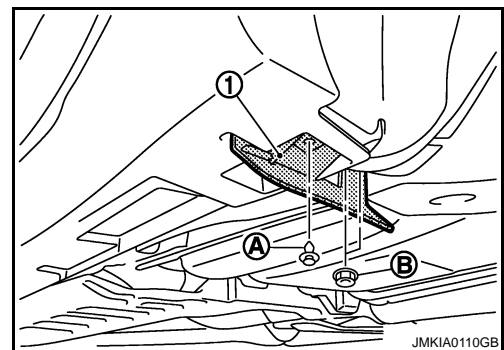



## CENTER MUD GUARD

### < ON-VEHICLE REPAIR >

2. Remove screw (A) and bolt (B) of center mudguard front end.

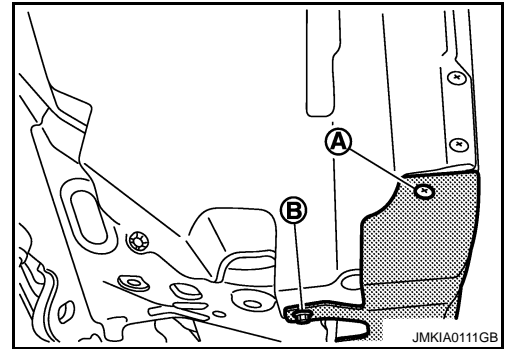

3. Remove screws (A) of center mudguard rear end.

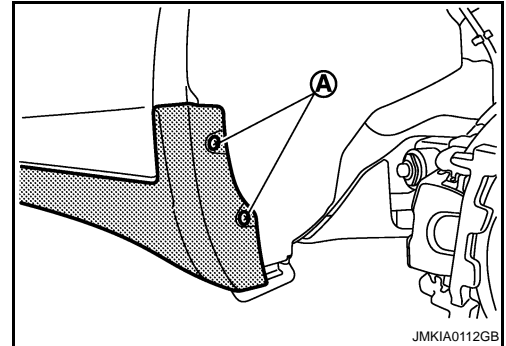

4. Remove screws of center mudguard underside.
5. Fully open front door and rear door.
6. Remove clips from back of center mudguard using remover tool.
7. Remove center mudguard from body side.

### INSTALLATION

Install in the reverse order of removal.

#### **CAUTION:**

**When installing center mud guard, make sure that clips are securely fitted in panel holes on body, and then press them in.**

A  
B  
C  
D  
E  
F  
G  
H  
I  
J  
L  
M  
N  
O  
P

EXT

# FLOOR SIDE FAIRING

< ON-VEHICLE REPAIR >

## FLOOR SIDE FAIRING

Exploded View

INFOID:000000000961806

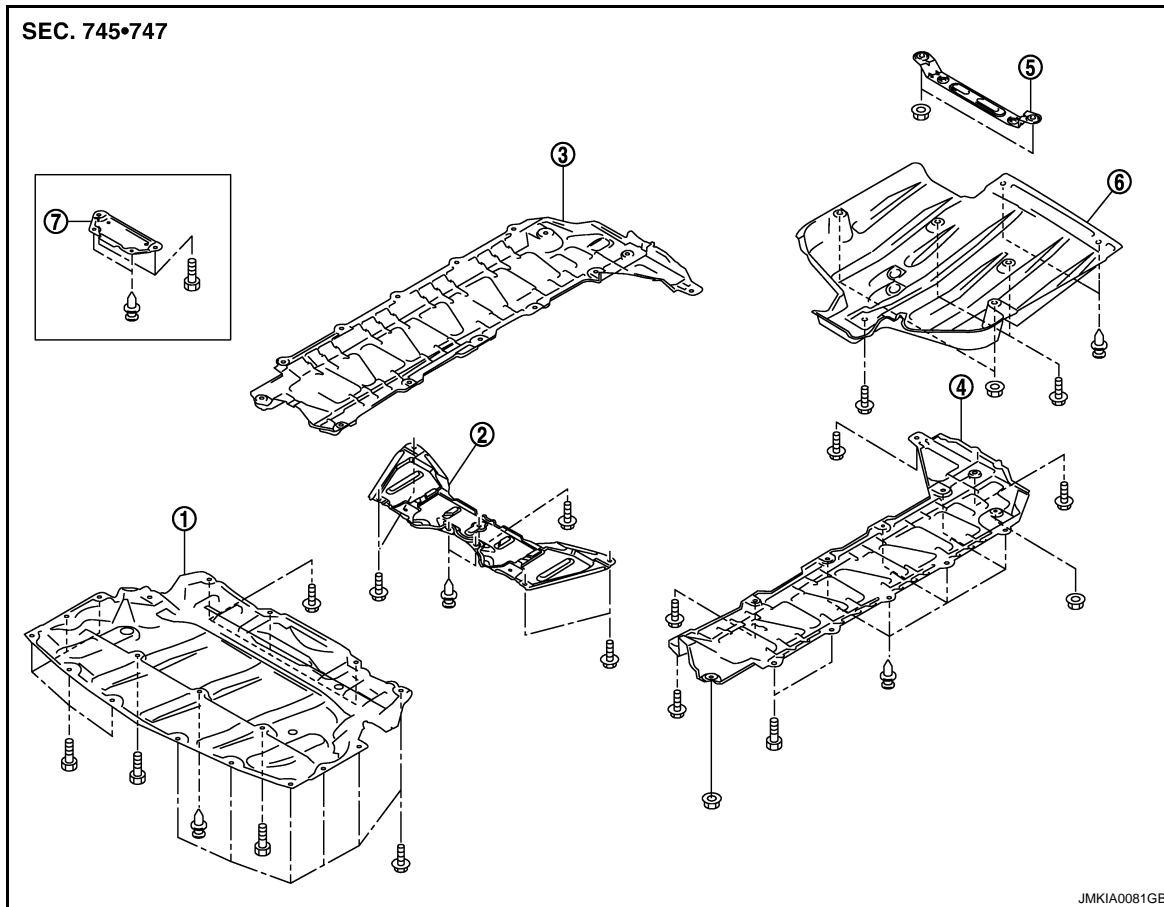

- |                                   |                                   |                           |
|-----------------------------------|-----------------------------------|---------------------------|
| 1. Engine lower cover             | 2. Front under cover (4WD models) | 3. Floor under cover (RH) |
| 4. Floor under cover (LH)         | 5. Rear diffuser bracket          | 6. Rear diffuser          |
| 7. Front under cover (2WD models) |                                   |                           |

## Removal and Installation

INFOID:000000000961807

### REMOVAL

#### ENGINE LOWER COVER

1. Remove engine lower cover mounting clip.
2. Remove engine lower cover mounting bolts with power tool.
3. Remove front under cover.

#### FLOOR UNDER COVER (LH/RH)

1. Remove floor under cover mounting clips.
2. Remove floor under cover mounting bolts and nuts with power tool.
3. Remove floor under cover.

#### REAR DIFFUSER

1. Remove rear diffuser mounting clips.
2. Remove rear diffuser mounting bolts and nuts with power tool.
3. Remove rear diffuser.

### INSTALLATION

# FLOOR SIDE FAIRING

< ON-VEHICLE REPAIR >

Install in the reverse order of removal.

- A
- B
- C
- D
- E
- F
- G
- H
- I
- J
- EXT**
- L
- M
- N
- O
- P

# ROOF SIDE MOLDING

< ON-VEHICLE REPAIR >

## ROOF SIDE MOLDING

Exploded View

INFOID:000000000961808

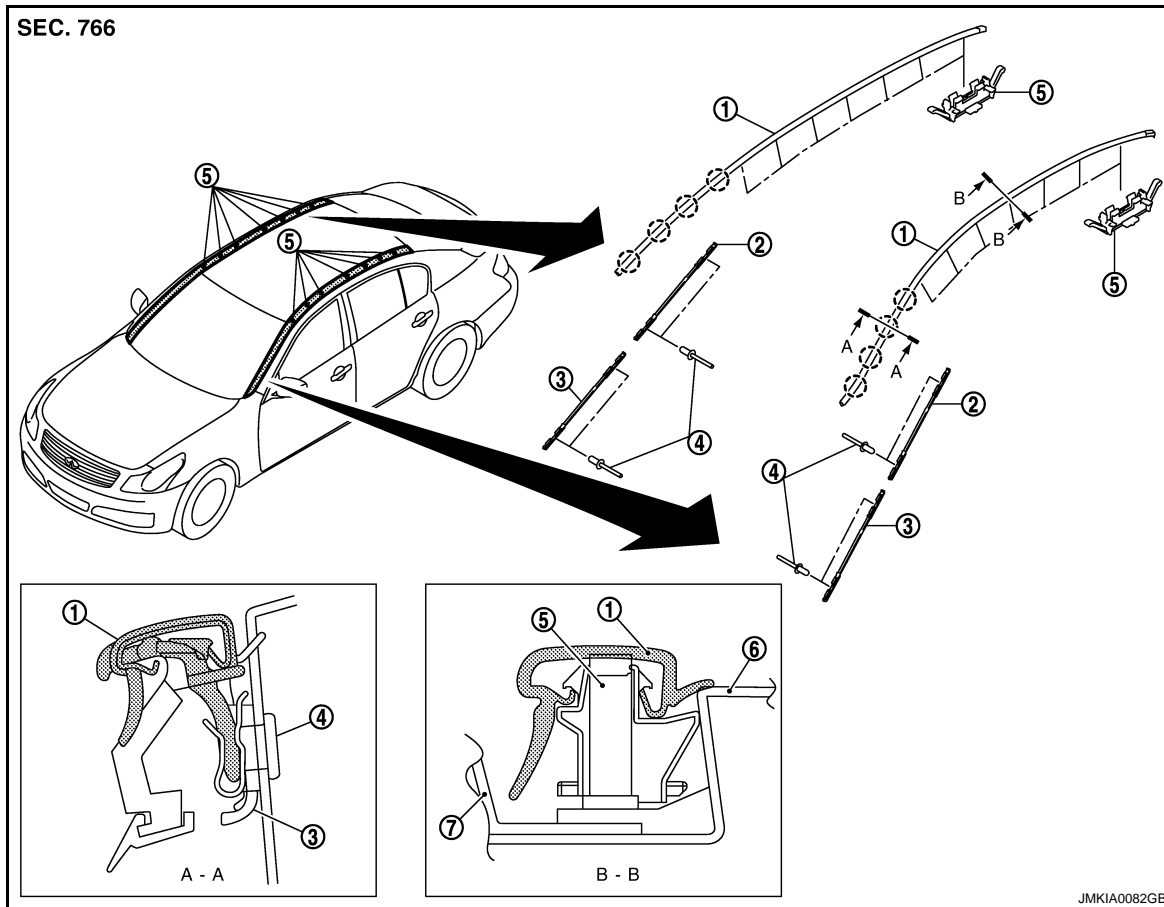

- |                      |                             |                             |
|----------------------|-----------------------------|-----------------------------|
| 1. Roof side molding | 2. Molding fastener (upper) | 3. Molding fastener (lower) |
| 4. Rivet             | 5. Roof side molding clip   | 6. Body side panel          |
| 7. Roof panel        |                             |                             |
- Clip

## Removal and Installation

INFOID:000000000961809

### REMOVAL

1. Remove front fender cover (LH/RH). Refer to [EXT-18. "Removal and Installation"](#).
2. Disengage clips while pinching molding from roof rear end to front end.

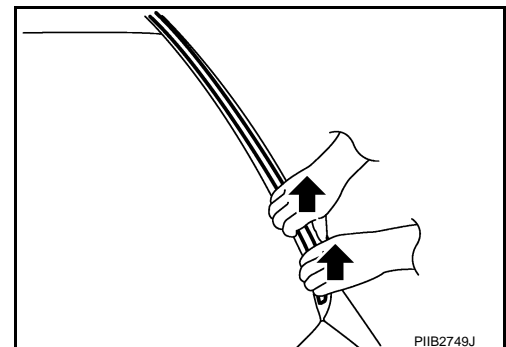

### INSTALLATION

Install from roof side molding rear end to front end in this order after temporarily holding.

# ROOF SIDE MOLDING

< ON-VEHICLE REPAIR >

## REMOVAL AND INSTALLATION OF ROOF SIDE MOLDING CLIP

### Removal

1. Remove roof side molding.
2. Heat adhesive tape interface using a dryer, and then peel roof side molding clips (body side) using long-nose pliers.

### **CAUTION:**

**Be careful not to damage the body.**

### Installation

1. Clean tape removed surface with a shop cloth soaked in white gasoline or IPA.
2. Use two-part epoxy adhesive.

**Adhesive** : 3M-weld DP-100 or equivalent

3. Apply adhesive evenly to clip tape surface.

**Thickness** : Approximately 0.5 mm (0.020 in)

4. Position applied parts to the proper location, and then sufficiently press-fit until the adhesive protrudes to tape side.

**Press-fit limit** : 19.6 N× 2 seconds×

5. Tape clips after press fit, and temporarily hold it for specified time based on the following.

**5 to 10 °C (41 to 50 °F)** : 1 hour or more

**11 to 23 °C (52 to 73 °F)** : 30 minutes or more

**24 °C or more (75 °F or more)** : 15 minutes or more

6. Install from roof side molding rear end to front end in this order after temporarily holding.

### **CAUTION:**

- Use double-faced adhesive tape after hardening for clips.
- Securely insert molding rear end cap onto roof rear end cutout (installation standard).
- When installing roof side molding of windshield portion, check that molding fastener is securely inserted and then press in.
- Do not wash the vehicle with in 24 hours so as to keep adhesive.

A  
B  
C  
D  
E  
F  
G  
H  
I  
J  
L  
M  
N  
O  
P

EXT

# DOOR SASH MOLDING

< ON-VEHICLE REPAIR >

## DOOR SASH MOLDING

Exploded View

INFOID:000000000961810

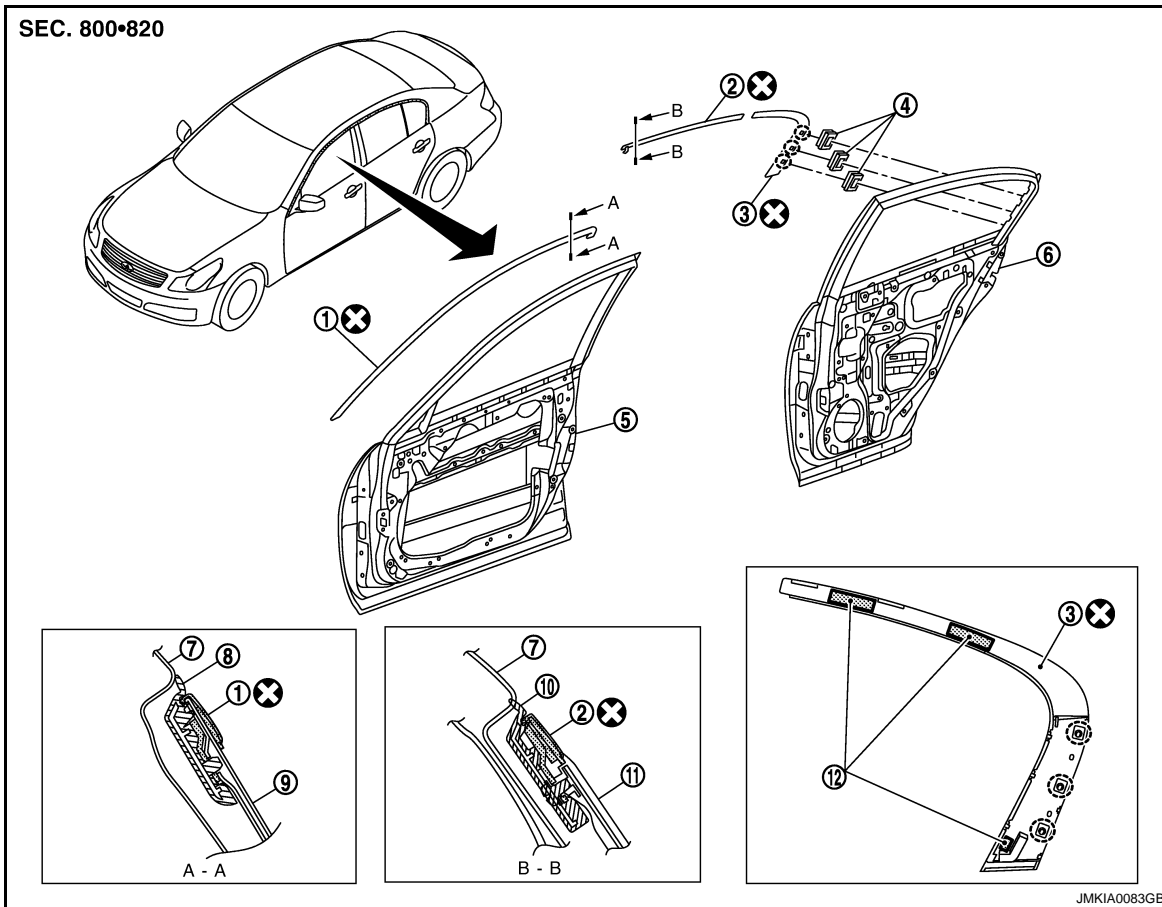

- |                             |                                   |                                  |
|-----------------------------|-----------------------------------|----------------------------------|
| 1. Front door sash molding  | 2. Rear door sash molding (front) | 3. Rear door sash molding (rear) |
| 4. Molding clip             | 5. Front door panel               | 6. Rear door panel               |
| 7. Body side outer panel    | 8. Front door weather strip       | 9. Front door sash               |
| 10. Rear door weather strip | 11. Rear door sash                | 12. Double-faced adhesive tape   |
- Clip

## Removal and Installation

INFOID:000000000961811

### FRONT DOOR SASH MOLDING

#### Removal

1. Remove door mirror assembly. Refer to [MIR-67, "Removal and Installation"](#).
2. Remove front door weather strip.
3. Release roof portion of glass run.

## DOOR SASH MOLDING

### < ON-VEHICLE REPAIR >

4. Remove front door sash molding (1) connection between door panel and molding from glass run side, using a remover tool (A).
5. Remove front door sash molding (1).

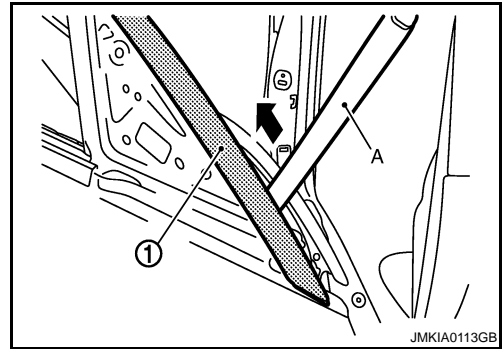

#### Installation

Install in the reverse order of removal.

### REAR DOOR SASH MOLDING

#### Removal

1. Remove rear door weather strip.
2. Release roof portion of glass run.
3. Remove rear door sash molding (1) connection between door panel and molding from glass run side, using a remover tool (A).
4. Remove rear door sash molding (front) (1).

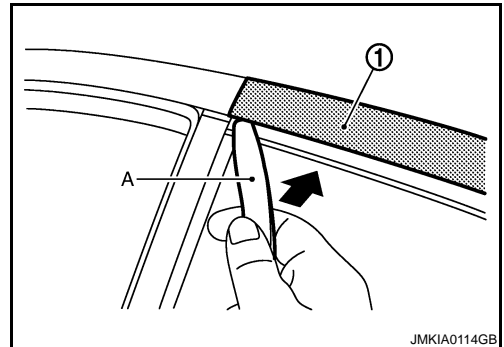

5. Release rear door sash molding connection between rear door panel and molding (1), using a remover tool (A), and take off double-faced adhesive tape.
6. Remove rear door sash molding (rear) (1).

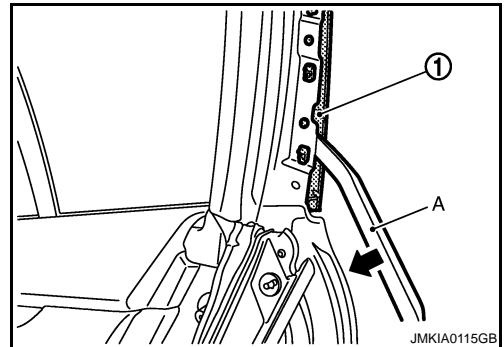

#### Installation

Install in the reverse order of removal.

#### **CAUTION:**

- I Do not let air between contact surfaces when installing.
- I To secure contact, do not wash vehicle within 24 hours after installation.
- Do not use a material for remover tool (A) which could damage door panel.

A  
B  
C  
D  
E  
F  
G  
H  
I  
J  
EXT  
L  
M  
N  
O  
P

# DOOR OUTSIDE MOLDING

< ON-VEHICLE REPAIR >

## DOOR OUTSIDE MOLDING

Exploded View

INFOID:000000000961812

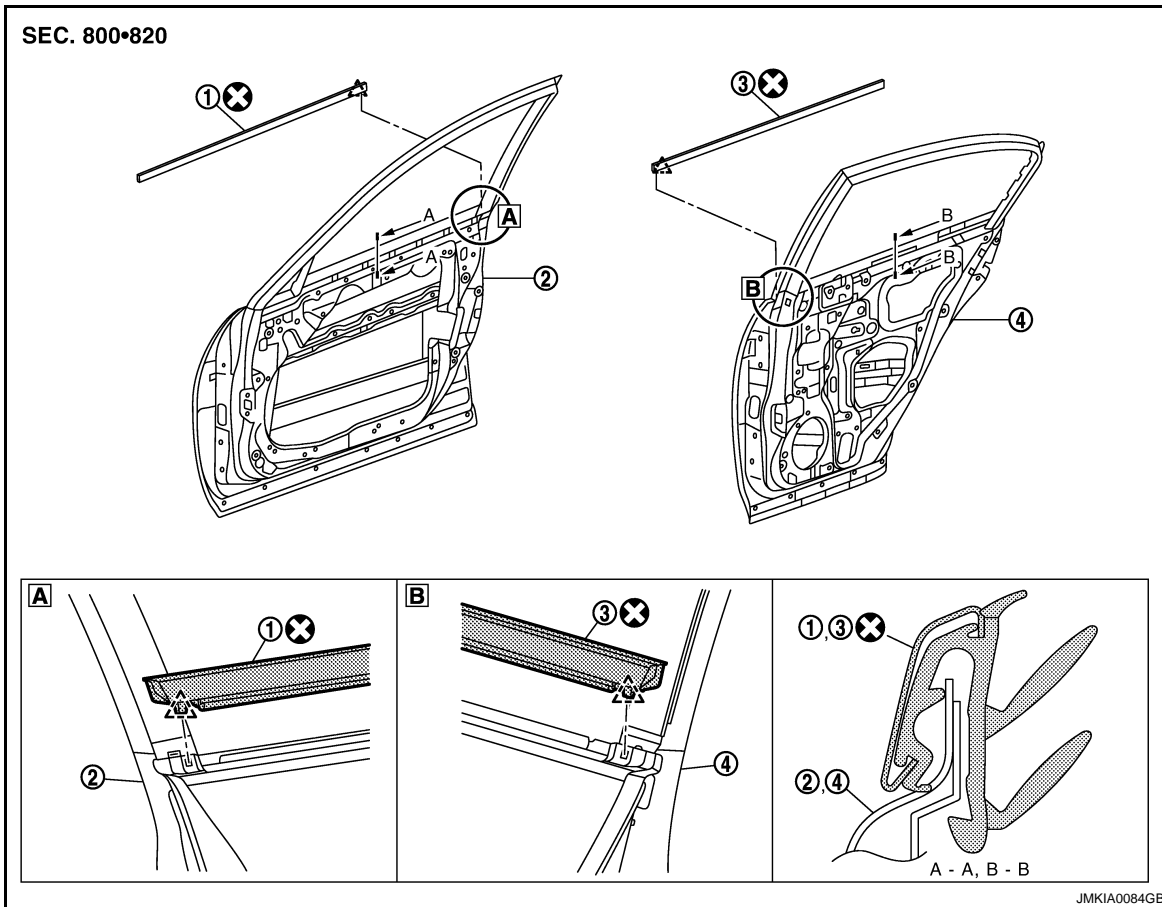

1. Front door outside molding      2. Front door panel      3. Rear door outside molding

4. Rear door panel

△ Pawl

## Removal and Installation

INFOID:000000000961813

### REMOVAL

#### FRONT DOOR OUTSIDE MOLDING

1. Remove front door finisher. Refer to [INT-10. "Removal and Installation"](#).
2. Remove door mirror assembly. Refer to [MIR-67. "Removal and Installation"](#).
3. Twists and pull up to upper side, and then remove front door outside molding (1).

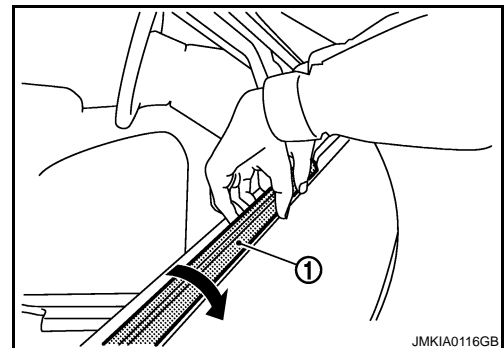

#### REAR DOOR OUTSIDE MOLDING



## DOOR OUTSIDE MOLDING

### < ON-VEHICLE REPAIR >

1. Remove rear door finisher. Refer to [INT-10, "Removal and Installation"](#).
2. Twists and pull up to upper side, and then remove rear door outside molding (1).

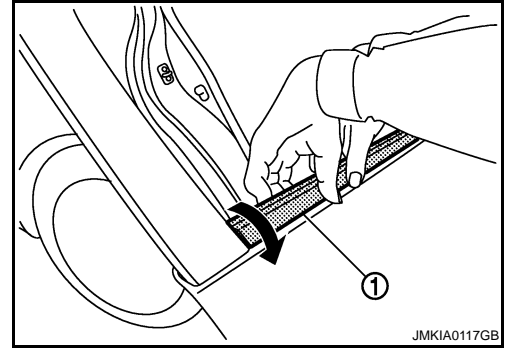

### INSTALLATION

Install in the reverse order of removal.

A  
B  
C  
D  
E  
F  
G  
H  
I  
J  
L  
M  
N  
O  
P

EXT

# DOOR PARTING SEAL

< ON-VEHICLE REPAIR >

## DOOR PARTING SEAL

Exploded View

INFOID:000000000961814

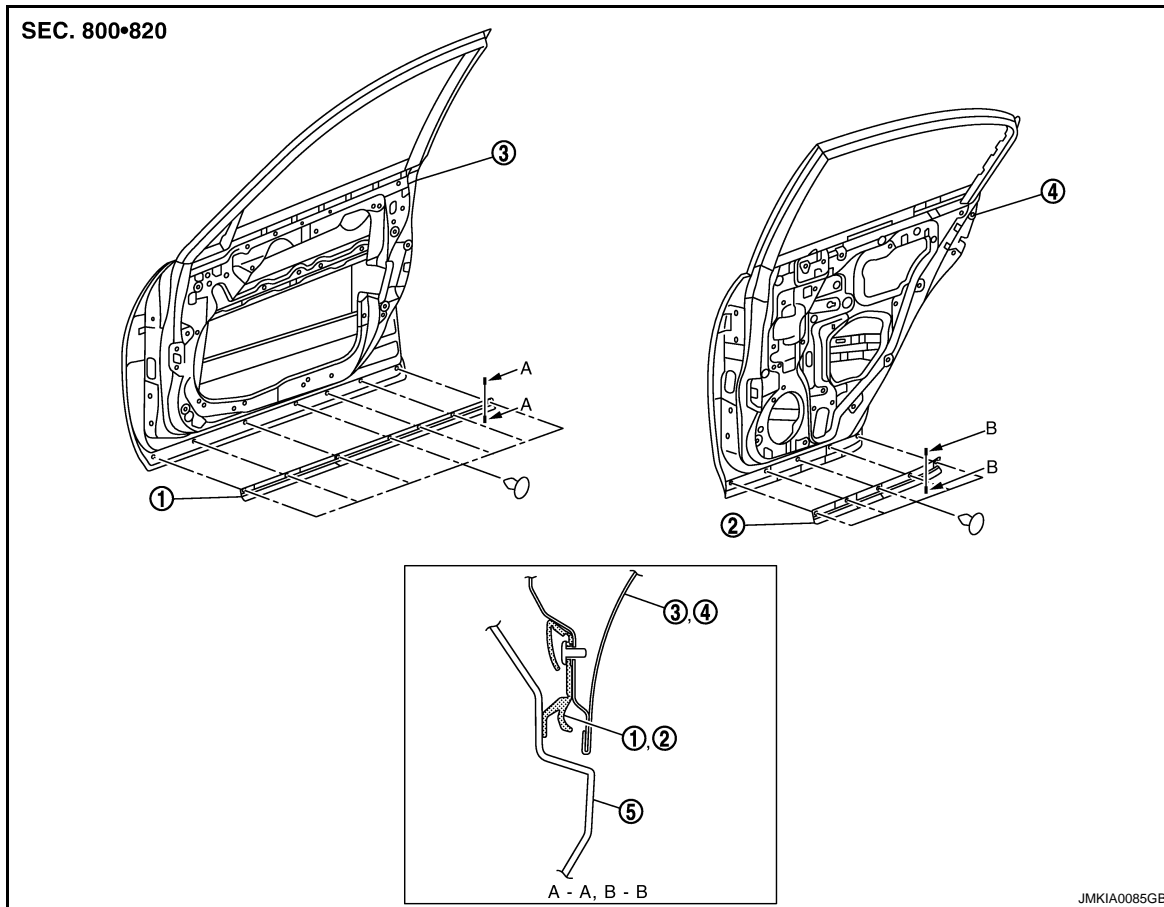

- |                            |                           |                     |
|----------------------------|---------------------------|---------------------|
| 1. Front door parting seal | 2. Rear door parting seal | 3. Front door panel |
| 4. Rear door panel         | 5. Center mud guard       |                     |

## Removal and Installation

INFOID:000000000961815

### REMOVAL

#### FRONT DOOR PARTING SEAL

1. Fully open front door.
2. Remove front door parting seal mounting plastic clips.
3. Remove front door parting seal.

#### REAR DOOR PARTING SEAL

1. Fully open rear door.
2. Remove rear door parting seal mounting plastic clips.
3. Remove rear door parting seal.

### INSTALLATION

Install in the reverse order of removal.

# TRUNK LID FINISHER

< ON-VEHICLE REPAIR >

## TRUNK LID FINISHER

Exploded View

INFOID:000000000961816

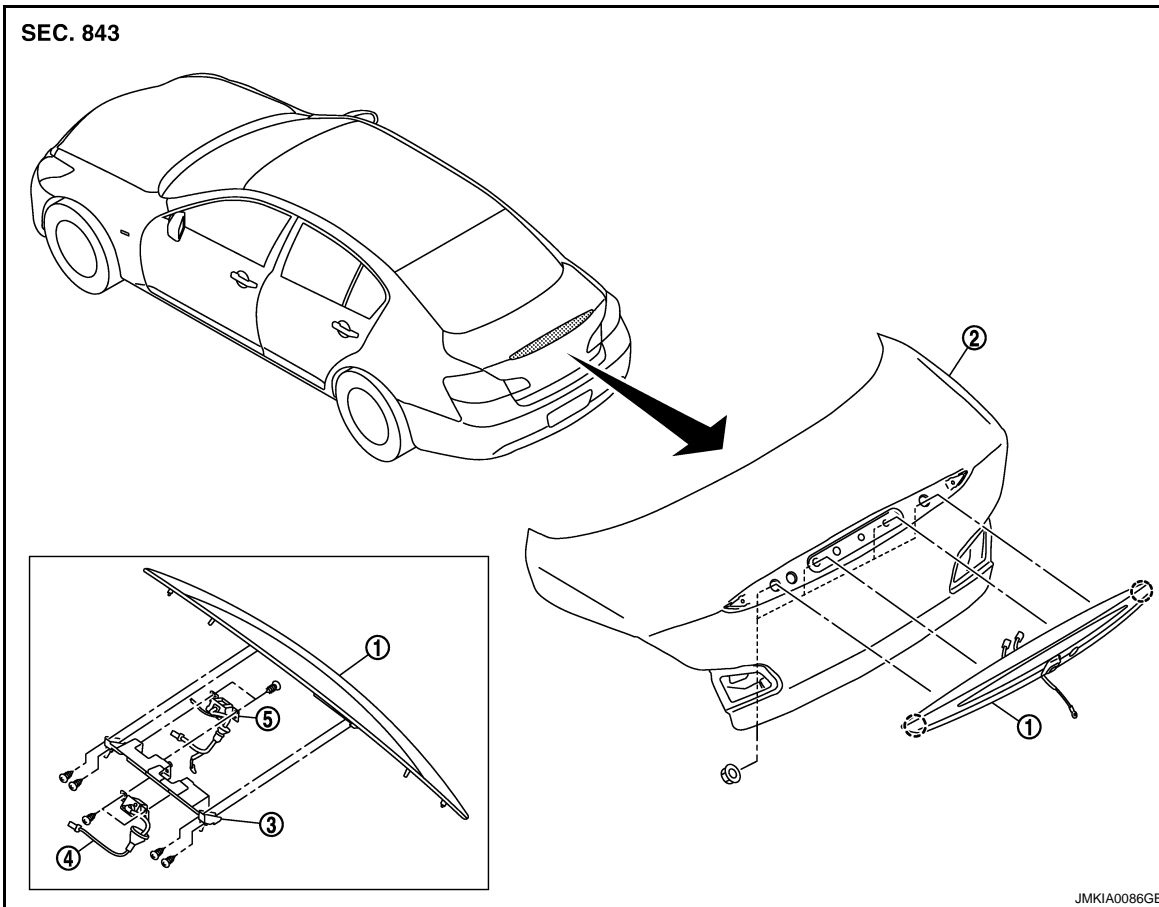

- 1. Trunk lid finisher outer
- 2. Trunk lid panel
- 3. Inner bracket
- 4. Rear view camera assembly
- 5. Trunk opener switch assembly

○ Clip

## Removal and Installation

INFOID:000000000961817

### REMOVAL

1. Fully open trunk lid.
2. Remove trunk lid finisher inner. Refer to [INT-27, "Removal and Installation"](#).
3. Disconnect rear view camera harness connector (A) and trunk opener request switch harness connector (B).
4. Remove harness grommet (C).
5. Remove bolt (D).

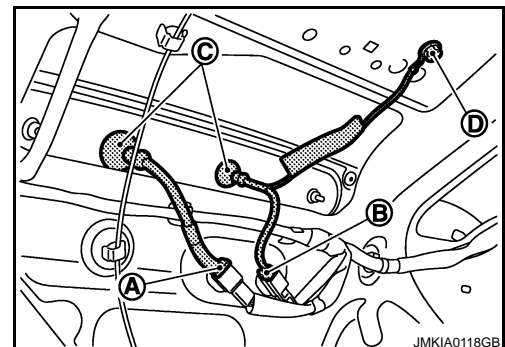

A  
B  
C  
D  
E  
F  
G  
H  
I  
J  
EXT  
L  
M  
N  
O  
P

## TRUNK LID FINISHER

### < ON-VEHICLE REPAIR >

6. Remove trunk lid finisher outer mounting nuts (A).

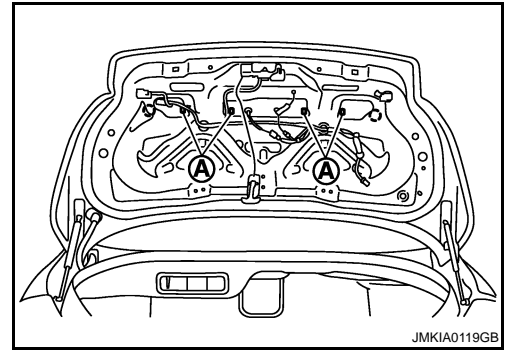

7. Apply protection tape (A) around outer circumference of trunk lid finisher outer (1).
8. Remove trunk lid finisher outer (1), using remover tool (B).

 : Clip

**CAUTION:**  
Be careful not to damage the body.

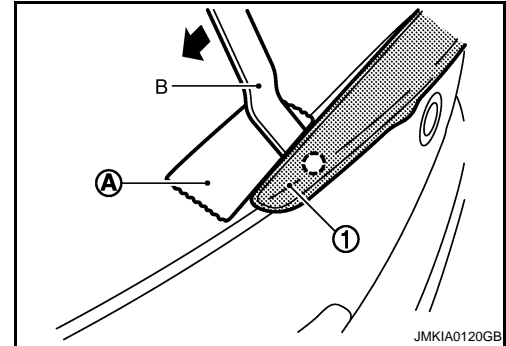

9. Remove the following parts after removing trunk lid finisher outer.
  - Rear view camera. Refer to [AV-550, "Removal and Installation"](#).
  - Trunk opener request switch. Refer to [DLK-224, "Removal and Installation"](#).

### INSTALLATION

Install in the reverse order of removal.

**CAUTION:**  
Install after cleaning adhesive parts of body side and back of finisher outer.

# REAR SPOILER

< ON-VEHICLE REPAIR >

## REAR SPOILER

Exploded View

INFOID:000000000961818

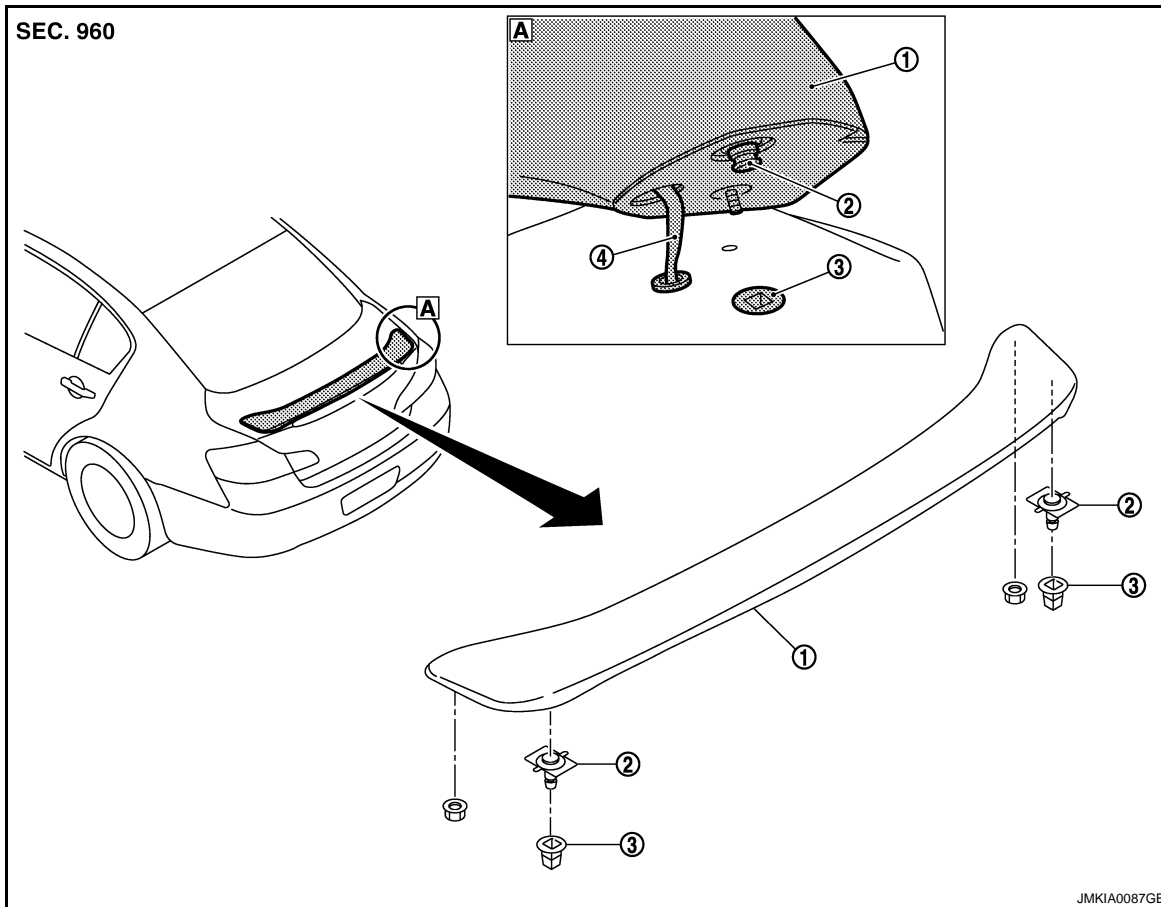

- 1. Rear spoiler
- 2. Rear spoiler clip
- 3. Grommet
- 4. High-mounted stop lamp harness

## Removal and Installation

INFOID:000000000961819

### REMOVAL

1. Remove trunk lid finisher inner. Refer to [INT-27. "Removal and Installation"](#).
2. Disconnect harness connector (A) of high-mounted stop lamp.

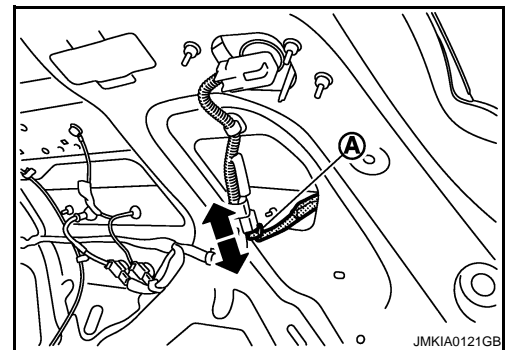

A  
B  
C  
D  
E  
F  
G  
H  
I  
J  
EXT  
L  
M  
N  
O  
P

## REAR SPOILER

### < ON-VEHICLE REPAIR >

3. Remove rear spoiler mounting nuts (A).

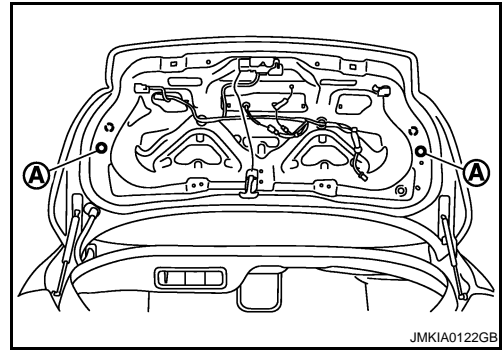

4. Disengage rear spoiler mounting clip (A) then disconnect grommet (B) of high-mounted stop lamp harness.
5. Remove rear spoiler (1).

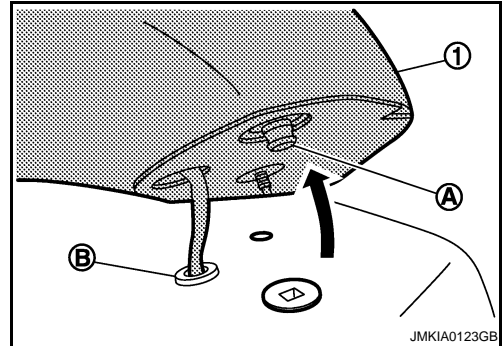

6. Remove following parts after removing rear spoiler.
  - High-mounted stop lamp. Refer to [EXL-199, "WITH REAR SPOILER : Removal and Installation"](#).
  - Rear spoiler clip and grommet.

### INSTALLATION

Install in the reverse order of removal.

#### **CAUTION:**

**Be careful not to damage the body.**