

SECTION **EXL**

EXTERIOR LIGHTING SYSTEM

A
B
C
D
E
F
G
H
I
J
K
EXL
M
N
O
P

CONTENTS

XENON TYPE	
BASIC INSPECTION	5
DIAGNOSIS AND REPAIR WORKFLOW	5
Work Flow	5
INSPECTION AND ADJUSTMENT	8
ADDITIONAL SERVICE WHEN REPLACING CONTROL UNIT	8
ADDITIONAL SERVICE WHEN REPLACING CONTROL UNIT : Description	8
ADDITIONAL SERVICE WHEN REPLACING CONTROL UNIT : Special Repair Requirement	8
LEVELIZER ADJUSTMENT	8
LEVELIZER ADJUSTMENT : Description	8
LEVELIZER ADJUSTMENT : Special Repair Requirement	8
FUNCTION DIAGNOSIS	9
HEADLAMP SYSTEM	9
System Diagram	9
System Description	9
Component Parts Location	10
Component Description	11
AUTO LIGHT SYSTEM	13
System Diagram	13
System Description	13
Component Parts Location	14
Component Description	14
DAYTIME RUNNING LIGHT SYSTEM	16
System Diagram	16
System Description	16
Component Parts Location	16
Component Description	17
ACTIVE ADAPTIVE FRONT-LIGHTING SYSTEM	19
System Diagram	19
System Description	19
Component Parts Location	21
Component Description	21
FRONT FOG LAMP SYSTEM	23
System Diagram	23
System Description	23
Component Parts Location	23
Component Description	24
TURN SIGNAL AND HAZARD WARNING LAMP SYSTEM	25
System Diagram	25
System Description	25
Component Parts Location	25
Component Description	26
PARKING, LICENSE PLATE AND TAIL LAMPS SYSTEM	27
System Diagram	27
System Description	27
Component Parts Location	27
Component Description	28
EXTERIOR LAMP BATTERY SAVER SYSTEM	29
System Diagram	29
System Description	29
Component Parts Location	29
Component Description	30
DIAGNOSIS SYSTEM (BCM)	31
COMMON ITEM	31
COMMON ITEM : CONSULT-III Function (BCM - COMMON ITEM)	31
HEADLAMP	31
HEADLAMP : CONSULT-III Function (BCM - HEAD LAMP)	31

FLASHER	33	Description	60
FLASHER : CONSULT-III Function (BCM - FLASHER)	33		
DIAGNOSIS SYSTEM (IPDM E/R)	35	POWER SUPPLY AND GROUND CIRCUIT	61
Diagnosis Description	35	BCM (BODY CONTROL MODULE)	61
CONSULT - III Function (IPDM E/R)	37	BCM (BODY CONTROL MODULE) : Diagnosis Procedure	61
DIAGNOSIS SYSTEM (AFS)	40	BCM (BODY CONTROL MODULE) : Special Re- pair Requirement	61
CONSULT-III Function (AFS)	40	IPDM E/R (INTELLIGENT POWER DISTRIBU- TION MODULE ENGINE ROOM)	61
COMPONENT DIAGNOSIS	42	IPDM E/R (INTELLIGENT POWER DISTRIBU- TION MODULE ENGINE ROOM) : Diagnosis Pro- cedure	61
B2503, B2504 SWIVEL ACTUATOR	42	AFS CONTROL UNIT	62
Description	42	AFS CONTROL UNIT : Diagnosis Procedure	62
DTC Logic	42	EXTERIOR LAMP FUSE	64
Diagnosis Procedure	43	Description	64
Component Inspection	46	Diagnosis Procedure	64
B2514 HEIGHT SENSOR UNUSUAL [RR]	47	HEADLAMP (HI) CIRCUIT	65
Description	47	Description	65
DTC Logic	47	Component Function Check	65
Diagnosis Procedure	47	Diagnosis Procedure	65
Component Inspection	49	HEADLAMP (LO) CIRCUIT	67
B2516 SHIFT SIGNAL [P, R]	51	Description	67
Description	51	Component Function Check	67
DTC Logic	51	Diagnosis Procedure	67
Diagnosis Procedure	51	XENON HEADLAMP	69
B2517 VEHICLE SPEED SIGNAL	52	Description	69
Description	52	Diagnosis Procedure	69
DTC Logic	52	HEADLAMP LEVELIZER CIRCUIT	71
Diagnosis Procedure	52	Description	71
B2519 LEVELIZER CALIBRATION	53	Component Function Check	71
Description	53	Diagnosis Procedure	71
DTC Logic	53	FRONT FOG LAMP CIRCUIT	73
Diagnosis Procedure	53	Component Function Check	73
B2521 ECU CIRCUIT	54	Diagnosis Procedure	73
Description	54	PARKING LAMP CIRCUIT	75
DTC Logic	54	Component Function Check	75
Diagnosis Procedure	54	Diagnosis Procedure	75
C0126 STEERING ANGLE SENSOR SIGNAL ..	57	TURN SIGNAL LAMP CIRCUIT	77
Description	57	Description	77
DTC Logic	57	Component Function Check	77
Diagnosis Procedure	57	Diagnosis Procedure	77
C0428 STEERING ANGLE SENSOR CALI- BRATION	58	OPTICAL SENSOR	80
Description	58	Description	80
DTC Logic	58	Component Function Check	80
Diagnosis Procedure	58	Diagnosis Procedure	80
U1000 CAN COMM CIRCUIT	59	HAZARD SWITCH	83
Description	59	Description	83
DTC Logic	59		
Diagnosis Procedure	59		
U1010 CONTROL UNIT (CAN)	60		

Component Function Check	83	SYMPTOM DIAGNOSIS	175
Diagnosis Procedure	83	EXTERIOR LIGHTING SYSTEM SYMPTOMS.	175
TAIL LAMP CIRCUIT	85	Symptom Table	175
Component Function Check	85	NORMAL OPERATING CONDITION	178
Diagnosis Procedure	85	Description	178
LICENSE PLATE LAMP CIRCUIT	87	BOTH SIDE HEADLAMPS DO NOT SWITCH	C
Component Function Check	87	TO HIGH BEAM	179
Diagnosis Procedure	87	Description	179
HEADLAMP SYSTEM	88	Diagnosis Procedure	179
Wiring Diagram —HEADLAMP—	88	BOTH SIDE HEADLAMPS (LO) ARE NOT	D
AUTO LIGHT SYSTEM	92	TURNED ON	180
Wiring Diagram —AUTO LIGHT SYSTEM—	92	Description	180
DAYTIME RUNNING LIGHT SYSTEM	96	Diagnosis Procedure	180
Wiring Diagram —DAYTIME LIGHT SYSTEM—	96	PARKING, LICENSE PLATE AND TAIL	F
FRONT FOG LAMP SYSTEM	100	LAMPS ARE NOT TURNED ON	181
Wiring Diagram —FRONT FOG LAMP—	100	Description	181
TURN SIGNAL AND HAZARD WARNING		Diagnosis Procedure	181
LAMP SYSTEM	103	BOTH SIDE FRONT FOG LAMPS ARE NOT	G
Wiring Diagram —TURN AND HAZARD WARN-		TURNED ON	182
ING LAMPS—	103	Description	182
PARKING, LICENSE PLATE AND TAIL		Diagnosis Procedure	182
LAMPS SYSTEM	107	PRECAUTION	183
Wiring Diagram —PARKING LICENSE PLATE		PRECAUTIONS	183
AND TAIL LAMPS—	107	Supplemental Restraint System (SRS) "AIR B	
STOP LAMP	111	AG" and "SEAT BELT PRE-TENSIONER"	183
Wiring Diagram —STOP LAMP—	111	Precautions For Xenon Headlamp Service	183
BACK-UP LAMP	114	ON-VEHICLE REPAIR	184
Wiring Diagram —BACK-UP LAMP—	114	FRONT COMBINATION LAMP	184
ECU DIAGNOSIS	117	Exploded View	184
BCM (BODY CONTROL MODULE)	117	Removal and Installation	185
Reference Value	117	Replacement	185
Wiring Diagram — BCM —	140	Disassembly and Assembly	186
Fail Safe	145	Adjustment	186
DTC Inspection Priority Chart	147	FRONT FOG LAMP	190
DTC Index	148	Exploded View	190
IPDM E/R (INTELLIGENT POWER DISTRI-		Adjustment	190
BUTION MODULE ENGINE ROOM)	151	OPTICAL SENSOR	191
Reference Value	151	Exploded View	191
Wiring Diagram — IPDM E/R —	158	Removal and Installation	191
Fail Safe	161	LIGHTING AND TURN SIGNAL SWITCH	192
DTC Index	163	Exploded View	192
AFS CONTROL UNIT	164	HAZARD SWITCH	193
Reference Value	164	Exploded View	193
Wiring Diagram —ACTIVE AFS—	167	AFS CONTROL UNIT	194
Fail Safe	172	Exploded View	194
DTC Inspection Priority Chart	173	Removal and Installation	194
DTC Index	173		

A
B
C
D
E
F
G
H
I
J
K
EXL
M
N
O
P

STEERING ANGLE SENSOR	195	WITH REAR SPOILER	199
Removal and Installation	195	WITH REAR SPOILER : Exploded View	199
AFS SWITCH	196	WITH REAR SPOILER : Removal and Installation. 199	
Exploded View	196	BACK-UP LAMP	201
Removal and Installation	196	Exploded View	201
HEIGHT SENSOR	197	Removal and Installation	201
Exploded View	197	Replacement	201
Removal and Installation	197	LICENSE PLATE LAMP	202
REAR COMBINATION LAMP	198	Exploded View	202
Exploded View	198	Removal and Installation	202
Removal and Installation	198	Replacement	202
Replacement	198	SERVICE DATA AND SPECIFICATIONS	
HIGH-MOUNTED STOP LAMP	199	(SDS)	204
WITHOUT REAR SPOILER	199	SERVICE DATA AND SPECIFICATIONS	
WITHOUT REAR SPOILER : Exploded View	199	(SDS)	204
WITHOUT REAR SPOILER : Removal and Instal-		Bulb Specifications	204
lation	199		

BASIC INSPECTION

DIAGNOSIS AND REPAIR WORKFLOW

Work Flow

INFOID:000000000962391

OVERALL SEQUENCE

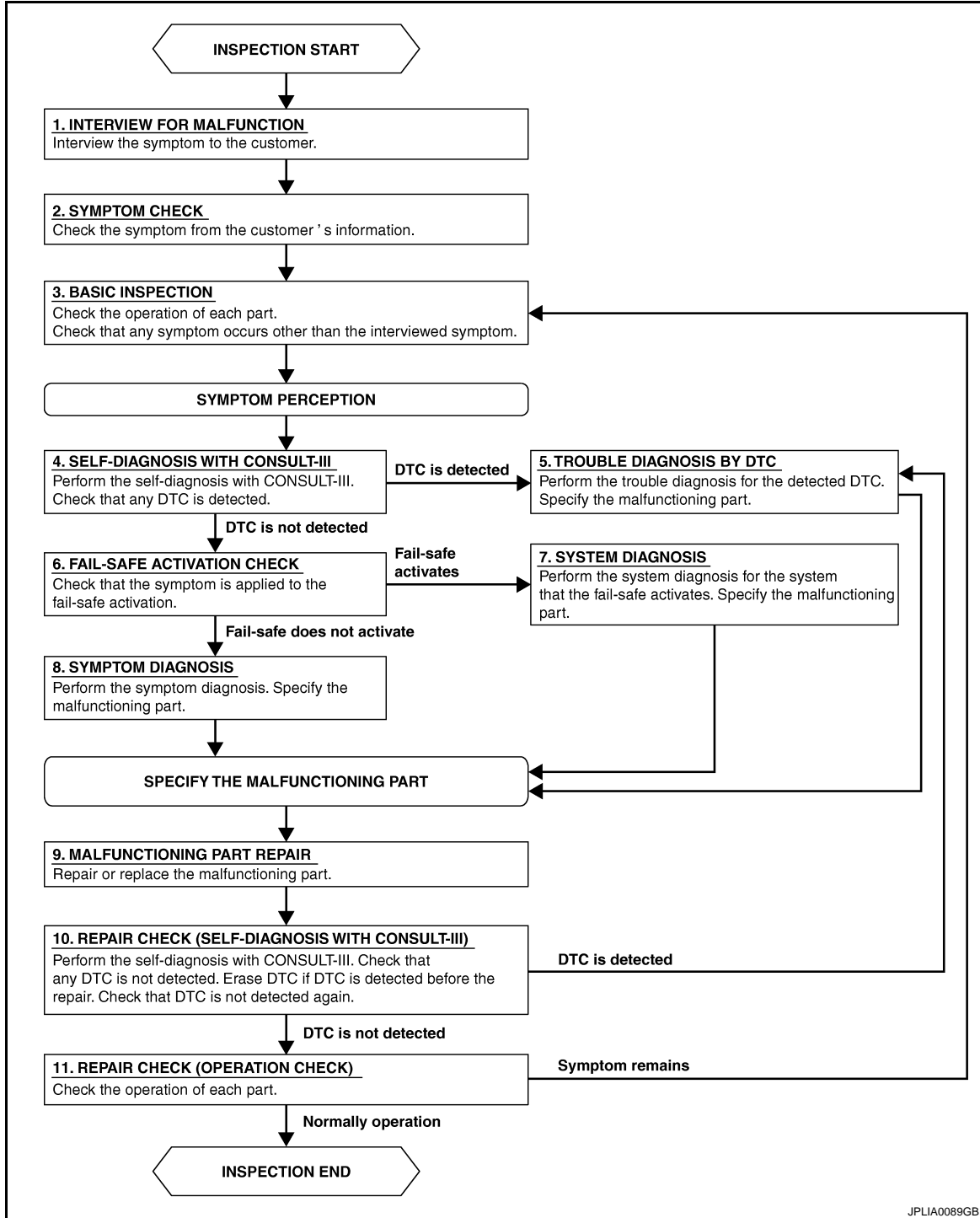

A
B
C
D
E
F
G
H
I
J
K
EXL
M
N
O
P

EXL

JPLIA0089GB

DIAGNOSIS AND REPAIR WORKFLOW

< BASIC INSPECTION >

[XENON TYPE]

DETAILED FLOW

1. INTERVIEW FOR MALFUNCTION

Interview the symptom to the customer.

>> GO TO 2.

2. SYMPTOM CHECK

Check the symptom from the customer's information.

>> GO TO 3.

3. BASIC INSPECTION

Check the operation of each part. Check that any symptom occurs other than the interviewed symptom.

>> GO TO 4.

4. SELF-DIAGNOSIS WITH CONSULT-III

Perform the self-diagnosis with CONSULT-III. Check that any DTC is detected.

Is any DTC detected?

YES >> GO TO 5.

NO >> GO TO 6.

5. TROUBLE DIAGNOSIS BY DTC

Perform the trouble diagnosis for the detected DTC. Specify the malfunctioning part.

>> GO TO 9.

6. FAIL-SAFE ACTIVATION CHECK

Check that the symptom is applied to the fail-safe activation.

Does the fail-safe activate?

YES >> GO TO 7.

NO >> GO TO 8.

7. SYSTEM DIAGNOSIS

Perform the system diagnosis for the system that the fail-safe activates. Specify the malfunctioning part.

>> GO TO 9.

8. SYMPTOM DIAGNOSIS

Perform the symptom diagnosis. Specify the malfunctioning part.

>> GO TO 9.

9. MALFUNCTION PART REPAIR

Repair or replace the malfunctioning part.

>> GO TO 11.

10. REPAIR CHECK (SELF-DIAGNOSIS WITH CONSULT-III)

Perform the self-diagnosis with CONSULT-III. Check that any DTC is not detected. Erase DTC if DTC is detected before the repair. Check that DTC is not detected again.

Is any DTC detected?

YES >> GO TO 5.

DIAGNOSIS AND REPAIR WORKFLOW

< BASIC INSPECTION >

[XENON TYPE]

NO >> GO TO 11.

11.REPAIR CHECK (OPERATION CHECK)

Check the operation of each part.

Does it operate normally?

YES >> INSPECTION END

NO >> GO TO 3.

A

B

C

D

E

F

G

H

I

J

K

EXL

M

N

O

P

INSPECTION AND ADJUSTMENT

ADDITIONAL SERVICE WHEN REPLACING CONTROL UNIT

ADDITIONAL SERVICE WHEN REPLACING CONTROL UNIT : Description

INFOID:000000000962392

Perform the levelizer adjustment with CONSULT-III when replacing the height sensor.

ADDITIONAL SERVICE WHEN REPLACING CONTROL UNIT : Special Repair Requirement

INFOID:000000000962393

1. LEVELIZER ADJUSTMENT

Perform the levelizer adjustment.

>> Refer to [EXL-8. "LEVELIZER ADJUSTMENT : Special Repair Requirement"](#).

LEVELIZER ADJUSTMENT

LEVELIZER ADJUSTMENT : Description

INFOID:000000000962394

Perform the levelizer adjustment when installing, removing, and replacing the height sensor and the suspension components.

LEVELIZER ADJUSTMENT : Special Repair Requirement

INFOID:000000000962395

1. VEHICLE CONDITION CHECK

1. Park the vehicle in the straight-forward position.
2. Unload the vehicle (no passenger aboard).

>> GO TO 2.

2. LEVELIZER ADJUSTMENT

CONSULT-III WORK SUPPORT

1. Select "LEVELIZER ADJUSTMENT" of ADAPTIVE LIGHT work support item.
2. Select "START".
3. When "ADJUSTMENT IS COMPLETED", select "END".

CAUTION:

If "CAN NOT BE TESTED" is indicated, AFS control unit detects that the height sensor signal changes. The levelizer adjustment is cancelled. In this case, turn the ignition switch OFF to prevent the vehicle from the height change. Perform the levelizer adjustment again.

Is the levelizer adjustment completed?

- YES >> GO TO 3.
NO >> Perform the levelizer adjustment again.

3. SELF-DIAGNOSIS RESULT CHECK

Perform the self-diagnosis with CONSULT-III. Check that any DTC is not detected.

Is any DTC detected?

- YES >> GO TO 2.
NO >> Levelizer adjustment completed

FUNCTION DIAGNOSIS

HEADLAMP SYSTEM

System Diagram

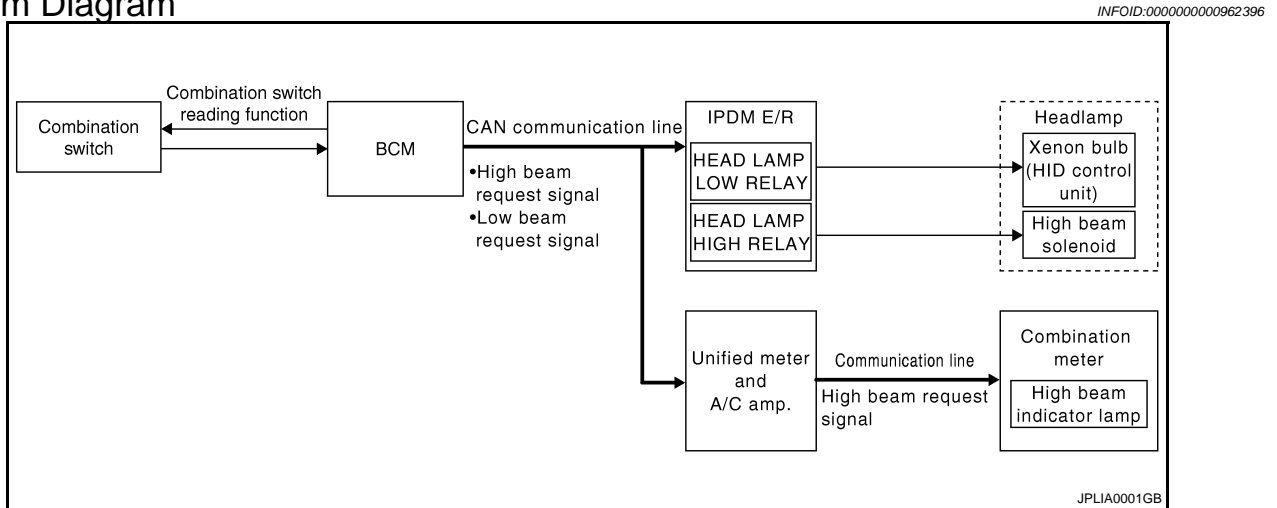

System Description

INFOID:000000000962397

OUTLINE

- Mobile valve shade type is adopted. Xenon headlamp switches the high beam and the low beam with one xenon bulb each on right and left.
- Headlamp is controlled by combination switch reading function and headlamp control function of BCM, and relay control function of IPDM E/R.

HEADLAMP BASIC OPERATION

- BCM detects the combination switch condition with the combination switch reading function.
- BCM transmits the low beam request signal to IPDM E/R with CAN communication according to the headlamp ON condition.

Headlamp ON condition

- Lighting switch 2ND
- Lighting switch PASS
- Lighting switch AUTO, and the auto light function ON judgment (with auto light system)
- IPDM E/R turns the integrated headlamp low relay ON, and turns the headlamp ON according to the low beam request signal.

HEADLAMP HI/LO SWITCHING OPERATION

- BCM transmits the high beam request signal to IPDM E/R and the combination meter (through unified meter and A/C amp.) with CAN communication according to the high beam switching condition.

High beam switching condition

- Lighting switch HI with the headlamp ON
- Lighting switch PASS
- Combination meter turns the high beam indicator lamp ON according to the high beam request signal.
- IPDM E/R turns the integrated headlamp high relay ON, and turns the headlamp ON according to the high beam request signal.

HEADLAMP SYSTEM

[XENON TYPE]

< FUNCTION DIAGNOSIS >

- When the headlamp high relay is turned ON, magnetic force is applied to the high beam solenoid (1) by a current. The mobile valve shade (3) is switched to the high beam position through the actuator rod (2).
- When the headlamp high relay is turned OFF, the current stops. The mobile valve shade returns to the low beam position automatically.

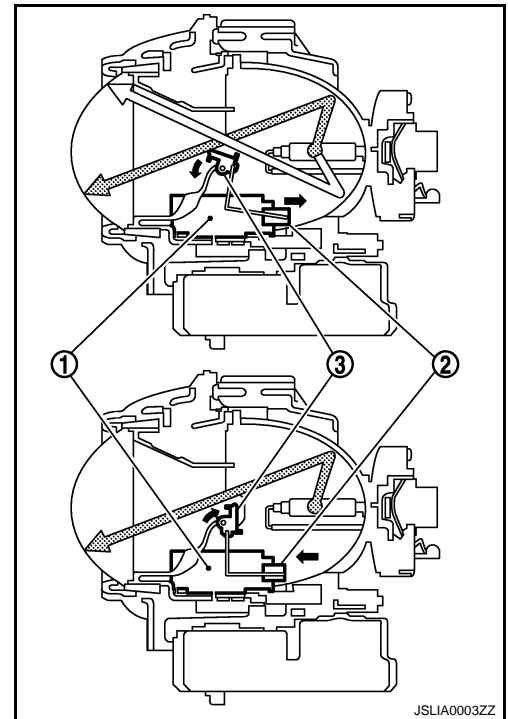

Component Parts Location

INFOID:000000000962398

HEADLAMP SYSTEM

< FUNCTION DIAGNOSIS >

[XENON TYPE]

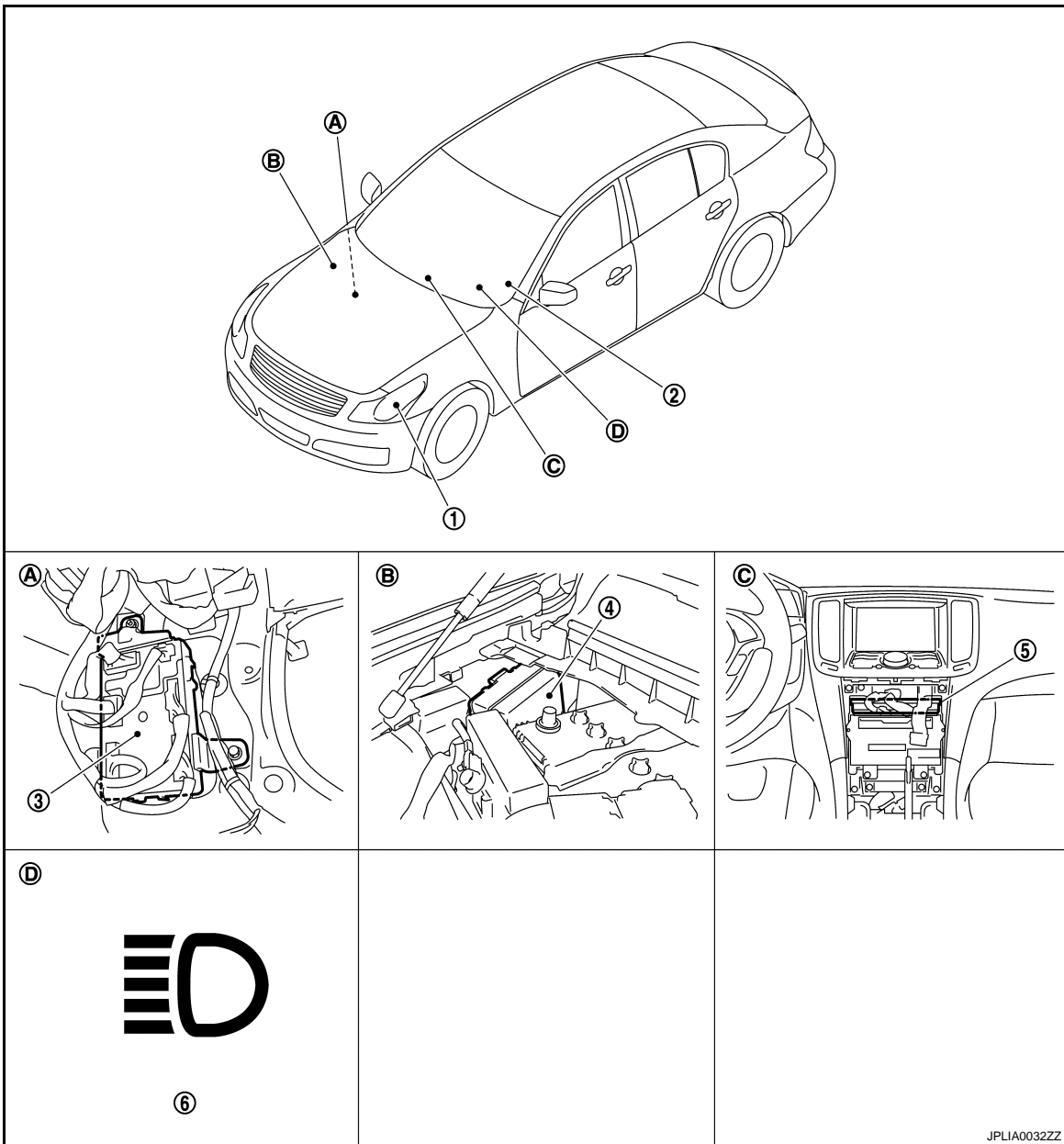

- | | | |
|-------------------------------------|--------------------------------|-----------------------------|
| 1. Headlamp | 2. Combination switch | 3. BCM |
| 4. IPDM E/R | 5. Unified meter and A/C amp. | 6. High beam indicator lamp |
| A. Dash side lower (Passenger side) | B. Engine room dash panel (RH) | C. Behind cluster lid C |
| D. On the combination meter | | |

Component Description

INFOID:000000000962399

Part	Description
BCM	<ul style="list-style-type: none"> Judges each switch condition by the combination switch reading function. Judges that the headlamp is turned ON according to the vehicle condition. - Requests the headlamp relay (HI/LO) ON to IPDM E/R (with CAN communication). - Requests the high beam indicator lamp ON to the combination meter [with CAN communication (through unified meter and A/C amp.)].
IPDM E/R	Controls the integrated relay, and supplies voltage to the load according to the request from BCM (with CAN communication).

A
B
C
D
E
F
G
H
I
J
K

EXL

M
N
O

P

HEADLAMP SYSTEM

< FUNCTION DIAGNOSIS >

[XENON TYPE]

Part	Description	
Combination switch (Lighting & turn signal switch)	Refer to BCS-5, "System Diagram" .	
Combination meter (High beam indicator lamp)	Turns the high beam indicator lamp ON according to the request from BCM [with CAN communication (through unified meter and A/C amp.)].	
Headlamp assembly	<ul style="list-style-type: none">• HID control unit• Xenon bulb	Refer to EXL-69, "Description" .
	High beam solenoid	Refer to EXL-65, "Description" .

AUTO LIGHT SYSTEM

System Diagram

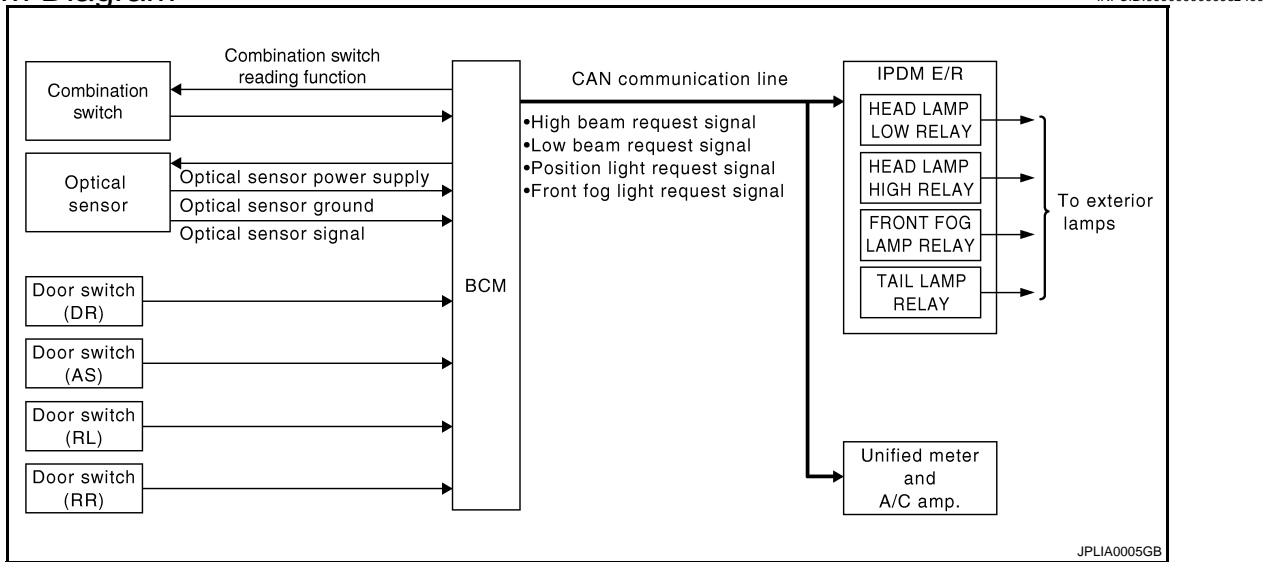

System Description

INFOID:000000000962401

OUTLINE

- Auto light system is controlled by each function of BCM and IPDM E/R.

Control by BCM

- Combination switch reading function
- Headlamp control function
- Auto light function
- Delay timer function

Control by IPDM E/R

- Relay control function
- Auto light system has the auto light function and the delay timer function.
- Auto light function turns the exterior lamps* and each illumination ON/OFF automatically according to the outside brightness.
- When auto light system turns the exterior lamps ON with the ignition switch OFF, delay timer function turns the exterior lamps OFF depending on the vehicle condition with the auto light function after a certain period of time.

*: Headlamp (LO/HI), parking lamp, tail lamp, and front fog lamp (Headlamp HI and front fog lamp depend on the combination switch condition.)

AUTO LIGHT FUNCTION

- BCM detects the combination switch condition with the combination switch reading function.
- BCM supplies voltage to optical sensor when the ignition switch is turned ON or ACC.
- Optical sensor converts outside brightness (lux) to voltage and transmits the optical sensor signal to BCM.
- BCM judges outside brightness from the optical sensor signal and judges ON/OFF condition of the exterior lamp and each illumination according to the outside brightness.
- BCM transmits each request signal to IPDM E/R with CAN communication according to ON/OFF condition by the auto light function.

NOTE:

ON/OFF timing differs based on the sensitivity from the setting. The setting can be set by CONSULT-III. Refer to [EXL-31, "HEADLAMP : CONSULT-III Function \(BCM - HEAD LAMP\)"](#).

DELAY TIMER FUNCTION

BCM turns the exterior lamp OFF depending on the vehicle condition with the auto light function when the ignition switch is turned OFF.

- Turns the exterior lamp OFF 5 minutes after detecting that any door opens (Door switch ON).
- Turns the exterior lamp OFF a certain period of time* after closing all doors (Door switch ON→OFF).

AUTO LIGHT SYSTEM

[XENON TYPE]

< FUNCTION DIAGNOSIS >

- Turns the exterior lamp OFF with the ignition switch ACC or the light switch OFF.
- *: The preset time is 45 seconds. The timer operating time can be set by CONSULT-III. Refer to [EXL-31, "HEADLAMP : CONSULT-III Function \(BCM - HEAD LAMP\)"](#).

NOTE:

When any position other than the light switch AUTO is set, the auto light system function switches to the exterior lamp battery saver function.

Component Parts Location

INFOID:000000000962402

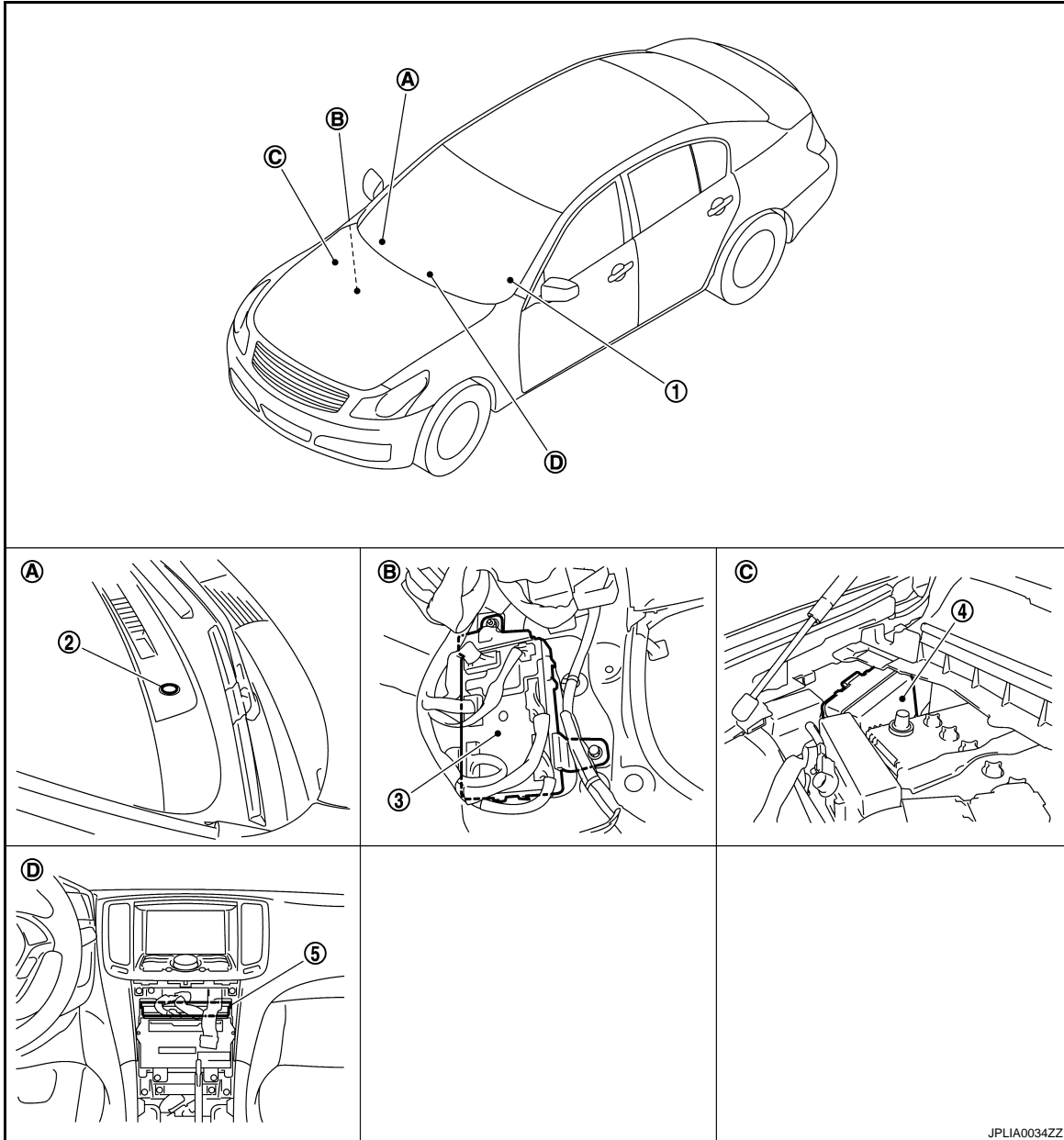

JPLIA0034ZZ

- | | | |
|--------------------------------|-------------------------------------|--------------------------------|
| 1. Combination switch | 2. Optical sensor | 3. BCM |
| 4. IPDM E/R | 5. unified meter and A/C amp. | |
| A. Instrument upper panel (RH) | B. Dash side lower (Passenger side) | C. Engine room dash panel (RH) |
| D. Behind cluster lid C | | |

Component Description

INFOID:000000000962403

AUTO LIGHT SYSTEM

< FUNCTION DIAGNOSIS >

[XENON TYPE]

Part	Description
BCM	<ul style="list-style-type: none"> • Judges each switch condition by the combination switch reading function. • Judges the outside brightness from the optical sensor signal. • Judges the OFF timing according to the vehicle condition. • Judges the ON/OFF status of the exterior lamp and each illumination according to the outside brightness and the vehicle condition. <p>Requests ON/OFF of each relay to IPDM E/R (with CAN communication).</p>
IPDM E/R	Controls the integrated relay, and supplies voltage to the load according to the request from BCM (with CAN communication).
Combination switch (Lighting & turn signal switch)	Refer to BCS-5. "System Diagram" .
Optical sensor	Refer to EXL-80. "Description" .

A
B
C
D
E
F
G
H
I
J
K
EXL
M
N
O
P

EXL

DAYTIME RUNNING LIGHT SYSTEM

< FUNCTION DIAGNOSIS >

[XENON TYPE]

DAYTIME RUNNING LIGHT SYSTEM

System Diagram

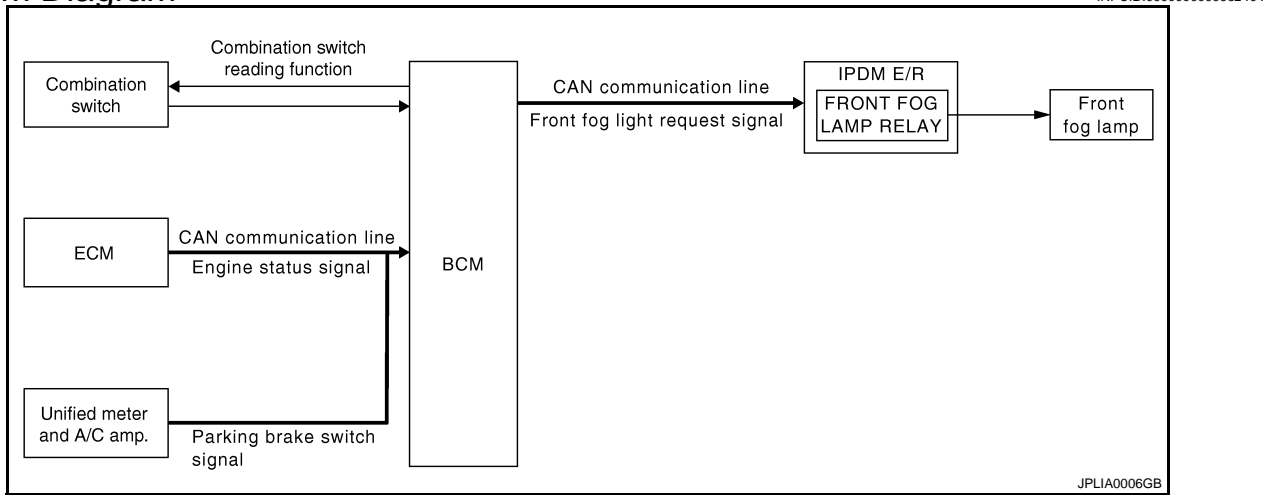

System Description

INFOID:000000000962405

OUTLINE

- Turns the front fog lamp ON as the daytime running light.
- Daytime running light is controlled by daytime running light control function and combination switch reading function of BCM, and relay control function of IPDM E/R.

DAYTIME RUNNING LIGHT OPERATION

- BCM detects the combination switch condition by the combination switch reading function.
- BCM detects the vehicle condition depending on the following signals.
 - Engine condition signal (received from ECM with CAN communication)
 - Parking brake switch signal (received from unified meter and A/C amp. with CAN communication)
- BCM transmits the front fog lamp request signal to IPDM E/R with CAN communication according to the daytime running light ON condition.

Daytime running light ON condition

- While the engine running with the parking brake released

Daytime running light OFF condition

- Engine stopped
- Headlamp ON (Passing included)
- IPDM E/R turns the integrated front fog lamp relay ON and turns the front fog lamp ON according to the front fog lamp request signal.

Component Parts Location

INFOID:000000000962406

DAYTIME RUNNING LIGHT SYSTEM

< FUNCTION DIAGNOSIS >

[XENON TYPE]

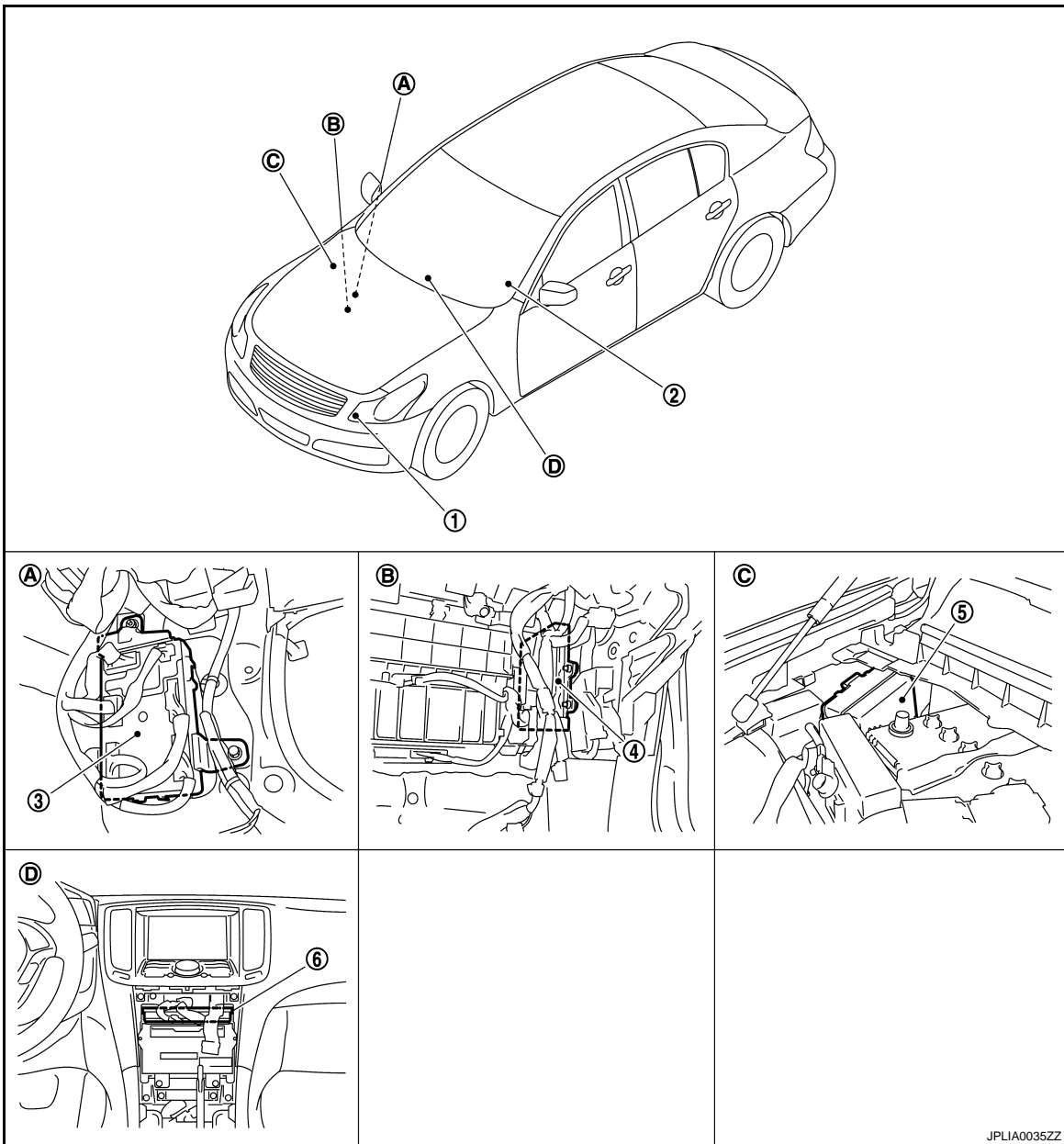

- | | | |
|---|-----------------------|--------------------------------|
| 1. Daytime running light (Front fog lamp) | 2. Combination switch | 3. BCM |
| 4. ECM | 5. IPDM E/R | 6. Unified meter and A/C amp. |
| A. Dash side lower (Passenger side) | B. Behind glove box | C. Engine room dash panel (RH) |
| D. Behind cluster lid C | | |

Component Description

INFOID:000000000962407

Part	Description
BCM	<ul style="list-style-type: none"> Judges each switch condition with the combination switch reading function. Judges the headlamp ON/OFF status according to the vehicle condition. Requests the front fog lamp relay ON to IPDM E/R (with CAN communication).
IPDM E/R	Controls the integrated relay and supplies voltage to the load according to the request from BCM (with CAN communication).
Combination switch (Lighting & turn signal switch)	Refer to BCS-5, "System Diagram" .

DAYTIME RUNNING LIGHT SYSTEM

< FUNCTION DIAGNOSIS >

[XENON TYPE]

Part	Description
ECM	Transmits the engine condition signal to BCM with CAN communication.
Unified meter and A/C amp.	Transmits the parking brake switch signal to BCM with CAN communication.

ACTIVE ADAPTIVE FRONT-LIGHTING SYSTEM

< FUNCTION DIAGNOSIS >

[XENON TYPE]

ACTIVE ADAPTIVE FRONT-LIGHTING SYSTEM

System Diagram

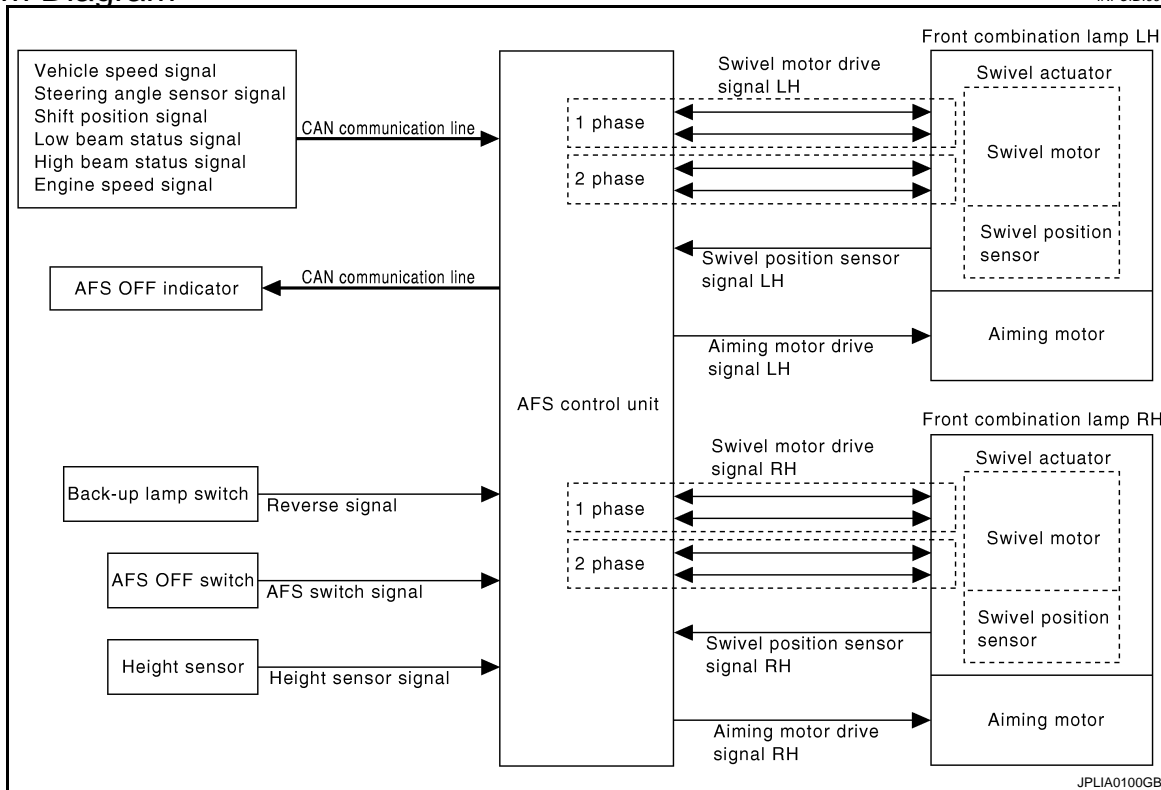

System Description

INFOID:000000000962409

OUTLINE

- AFS (ACTIVE ADAPTIVE FRONT-LIGHTING SYSTEM) is controlled by AFS control unit.
- AFS has AFS control (swivel control) and the headlamp auto aiming control.
- AFS control swivels the headlamp to the steering direction.
- Headlamp auto aiming control moves the headlamp light axis up/down according to the vehicle height.

AFS (ADAPTIVE FRONT-LIGHTING SYSTEM)

AFS Control Description

- AFS control controls the headlamp (right) only when the steering wheel is turned rightward, and the headlamp (left) only when the steering wheel is turned leftward.
- AFS control unit detects the vehicle condition necessary for AFS control with the following signals.
- AFS switch signal
- Steering angle sensor signal (received from steering angle sensor with CAN communication)
- Engine speed signal (received from ECM with CAN communication)
- Shift position signal (received from TCM with CAN communication)
- Reverse signal (received from back-up lamp switch)
- Low beam status and high beam status (received from IPDM E/R with CAN communication)
- Vehicle speed signal (received from unified meter and A/C amp. with CAN communication)
- When the operation conditions are satisfied, AFS control unit controls the swivel angle depending on the steering angle and the vehicle speed.

AFS operation condition

- Swivel actuator initialization completed
- AFS OFF switch OFF
- Headlamp ON
- While the engine running
- Selector lever position other than "P" or "R" (A/T models)
- Shift knob position other than reverse (M/T models)

A
B
C
D
E
F
G
H
I
J
K
EXL
M
N
O
P

ACTIVE ADAPTIVE FRONT-LIGHTING SYSTEM

[XENON TYPE]

< FUNCTION DIAGNOSIS >

- Vehicle speed approximately 25 km/h or more (left swivel only; Right swivel activates regardless of the vehicle speed.)

Swivel Actuator Initialization

- AFS control unit performs the swivel actuator initialization when detecting that the engine starts.
- Swivels the headlamp to the vehicle-center side until it hits the stopper.
- Returns the swivel angle from the stopper. Completes the initialization with regarding the returned position as the swivel angle 0° (straight-forward position).

Swivel Operation

- AFS control unit transmits the drive signal to the swivel actuator when activation conditions are satisfied. And swivels the headlamp.
- The swivel starts after steering approximately 20° or more from straight-forward position.

NOTE:

The steering angle differs between right turn and left turn.

- The swivel angle becomes the maximum angle toward the driving direction if the steering angle is approximately 90° or more depending on the vehicle speed. The swivel angle is maintained by shutting off the drive signal.
- The swivel starts, and returns to the swivel angle 0° (straight-forward position) when the steering is returned to the straight-forward position.
- AFS control unit returns the swivel angle to the straight-forward position, and stops the swivel regardless of the steering angle if the operation condition is not satisfied while the swivel angle is 0°.

AFS OFF Indicator Lamp

- AFS control unit transmits AFS OFF indicator lamp signal to the combination meter (through unified meter & A/C amp.) with CAN communication.
- Combination meter turns AFS OFF indicator lamp ON/OFF/blinking according to AFS OFF indicator lamp signal.
- AFS OFF indicator lamp is turned ON for 1 second for the AFS OFF indicator lamp bulb check when the ignition switch is turned ON. AFS OFF indicator lamp is turned OFF within 1 second when the engine starts.
- AFS OFF indicator lamp is turned OFF when AFS OFF switch is turned ON.
- AFS OFF indicator lamp blinks (1 second each) if AFS control unit detects a specific DTC.

NOTE:

Combination meter blinks AFS OFF indicator lamp (approximately 1 second each) if AFS OFF indicator lamp signal is not received from AFS control unit.

HEADLAMP AUTO AIMING

Headlamp Auto Aiming Control Description

- Headlamp auto aiming control controls the headlamp light axis height appropriately according to the vehicle height.
- AFS control unit detects the vehicle condition necessary for headlamp auto aiming control with the following signals.
- Height sensor signal
- Engine speed signal (received from ECM with CAN communication)
- Low beam status signal and high beam status signal (received from IPDM E/R with CAN communication)
- Vehicle speed signal (received from unified meter and A/C amp. with CAN communication)
- When the operation conditions are satisfied, AFS control unit transmits the aiming motor drive signal for adjusting the headlamp axis height.

Headlamp auto aiming operation condition

- Headlamp ON
- While the engine running
- Vehicle speed (Control mode is switched according to the driving condition.)

Headlamp Auto Aiming Operation

- AFS control unit calculates the vehicle pitch angle from the height sensor signal. AFS control unit judges the angle for adjusting the axis gap from the preset position.

CAUTION:

Adjusted axis position may differ from the preset position although the headlamp auto aiming activates properly if the suspension is replaced or worn.

- AFS control unit controls the headlamp axis by changing the aiming motor drive signal output according to the vehicle-rearward height when detecting the following vehicle condition. Output is maintained if other condition than following is detected.

ACTIVE ADAPTIVE FRONT-LIGHTING SYSTEM

[XENON TYPE]

< FUNCTION DIAGNOSIS >

- Engine starts.
- Headlamp is turned ON.
- Vehicle posture becomes stable after changing the vehicle posture change is detected with the headlamp ON and the vehicle stopped.
- Vehicle speed is maintained with the headlamp ON and the vehicle driven.

Component Parts Location

INFOID:000000000962410

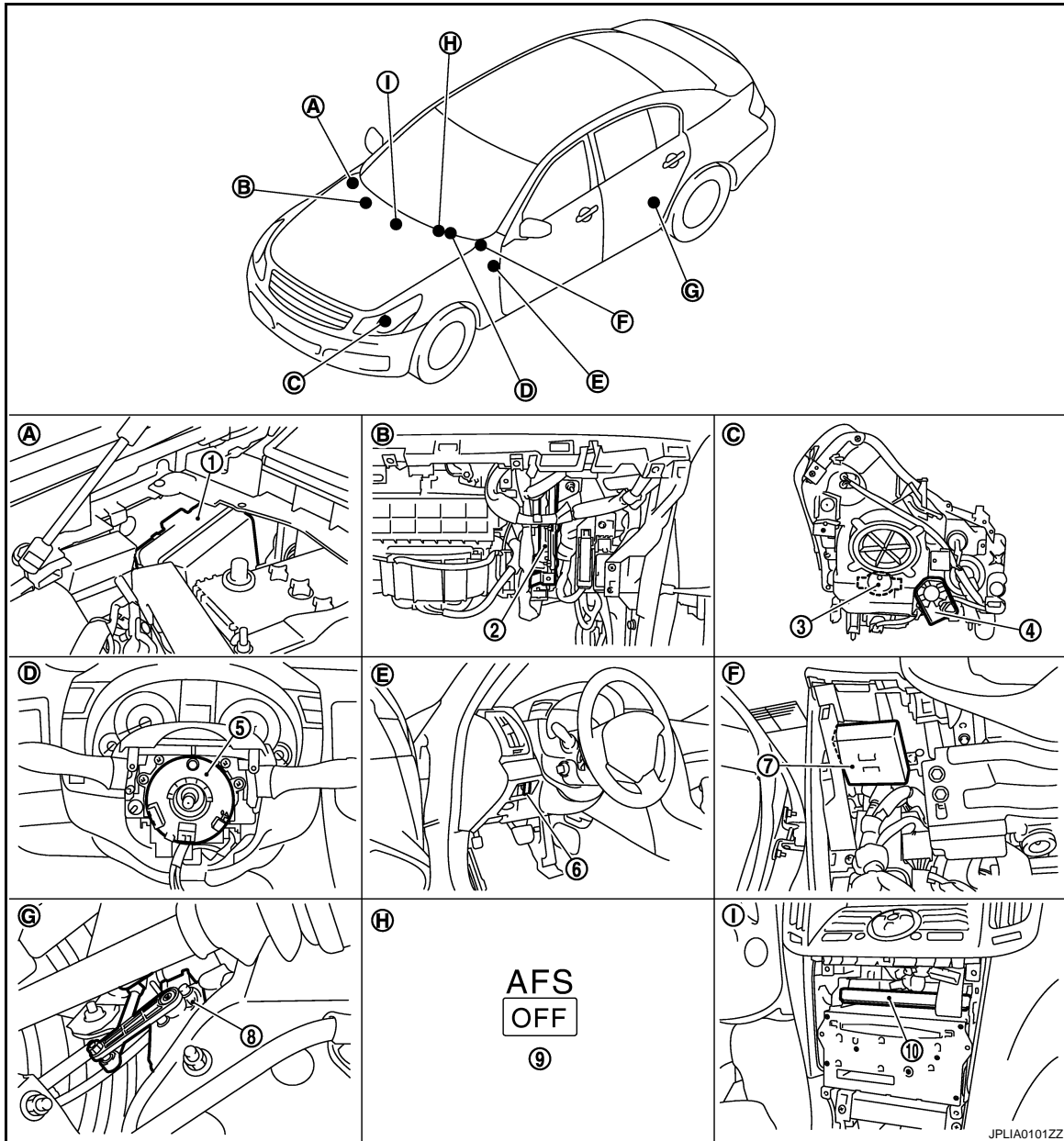

- | | | |
|-----------------------------------|----------------------------------|---|
| 1. IPDM E/R | 2. ECM | 3. Swivel actuator |
| 4. Aiming motor | 5. Steering angle sensor | 6. AFS OFF switch |
| 7. AFS control unit | 8. Height sensor | 9. AFS OFF indicator lamp |
| 10. Unified meter and A/C amp. | | |
| A. Engine room dash panel (RH) | B. Behind glove box | C. Front combination lamp (back) |
| D. Steering column cover (inside) | E. Instrument driver lower panel | F. Behind instrument driver lower panel |
| G. Left rear suspension member | H. Inside the combination meter | I. Behind cluster lid C |

Component Description

INFOID:000000000962411

A
B
C
D
E
F
G
H
I
J
K
EXL
M
N
O
P

ACTIVE ADAPTIVE FRONT-LIGHTING SYSTEM

< FUNCTION DIAGNOSIS >

[XENON TYPE]

Part	Description
AFS control unit	Refer to EXL-54. "Description" .
Swivel actuator	Refer to EXL-42. "Description" .
Aiming motor	Refer to EXL-71. "Description" .
AFS switch	Inputs AFS switch ON/OFF signal to AFS control unit.
Height sensor	Refer to EXL-47. "Description" .
Steering angle sensor	Refer to EXL-57. "Description" .
IPDM E/R	Transmits the headlamp (LO) ON signal and the headlamp (HI) ON signal to AFS control unit with CAN communication.
ECM	Transmits the engine speed signal to AFS control unit with CAN communication.
TCM	Refer to EXL-51. "Description" .
Unified meter and A/C amp.	Refer to EXL-52. "Description" .
Combination meter	Turns AFS OFF indicator lamp ON/OFF/blinking according to AFS control unit request [with CAN communication (through unified meter and A/C amp.)].

FRONT FOG LAMP SYSTEM

< FUNCTION DIAGNOSIS >

[XENON TYPE]

FRONT FOG LAMP SYSTEM

System Diagram

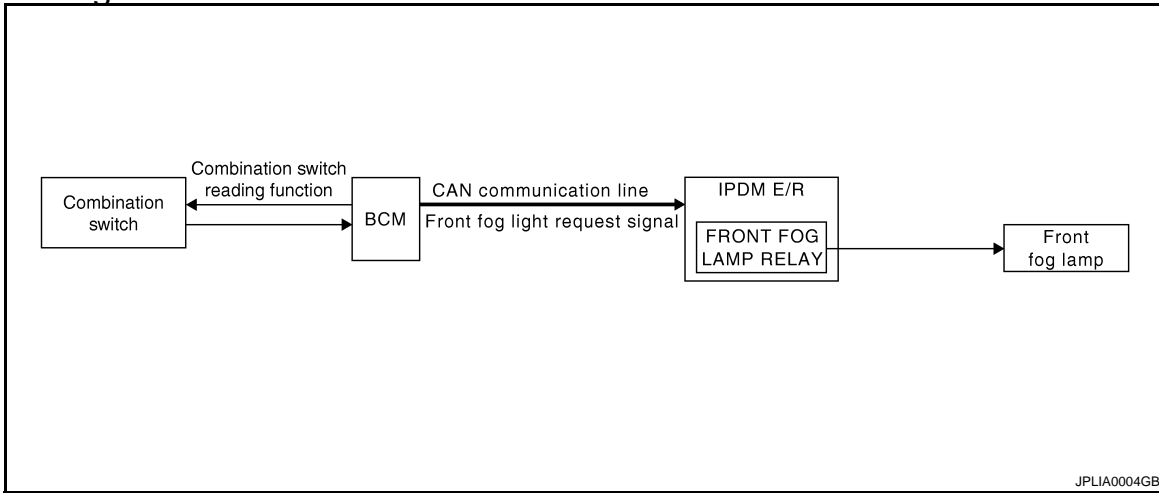

System Description

INFOID:000000000962413

OUTLINE

- Front fog lamp is integrated into the front combination lamp.
- Front fog lamp is controlled by combination switch reading function and front fog lamp control function of BCM, and relay control function of IPDM E/R.

NOTE:

For Canada models, the front fog lamp is turned ON as the daytime running light. Refer to [EXL-29. "System Diagram"](#) for the detail.

FRONT FOG LAMP OPERATION

- BCM detects the combination switch condition by the combination switch reading function.
- BCM transmits the front fog lamp request signal to IPDM E/R with CAN communication according to the front fog lamp ON condition.

Front fog lamp ON condition

- Front fog lamp switch ON with the headlamp ON (except for the high beam ON)
- IPDM E/R turns the integrated front fog lamp relay ON, and turns the front fog lamp ON according to the front fog lamp request signal.

Component Parts Location

INFOID:000000000962414

A
B
C
D
E
F
G
H
I
J
K
EXL
M
N
O
P

FRONT FOG LAMP SYSTEM

< FUNCTION DIAGNOSIS >

[XENON TYPE]

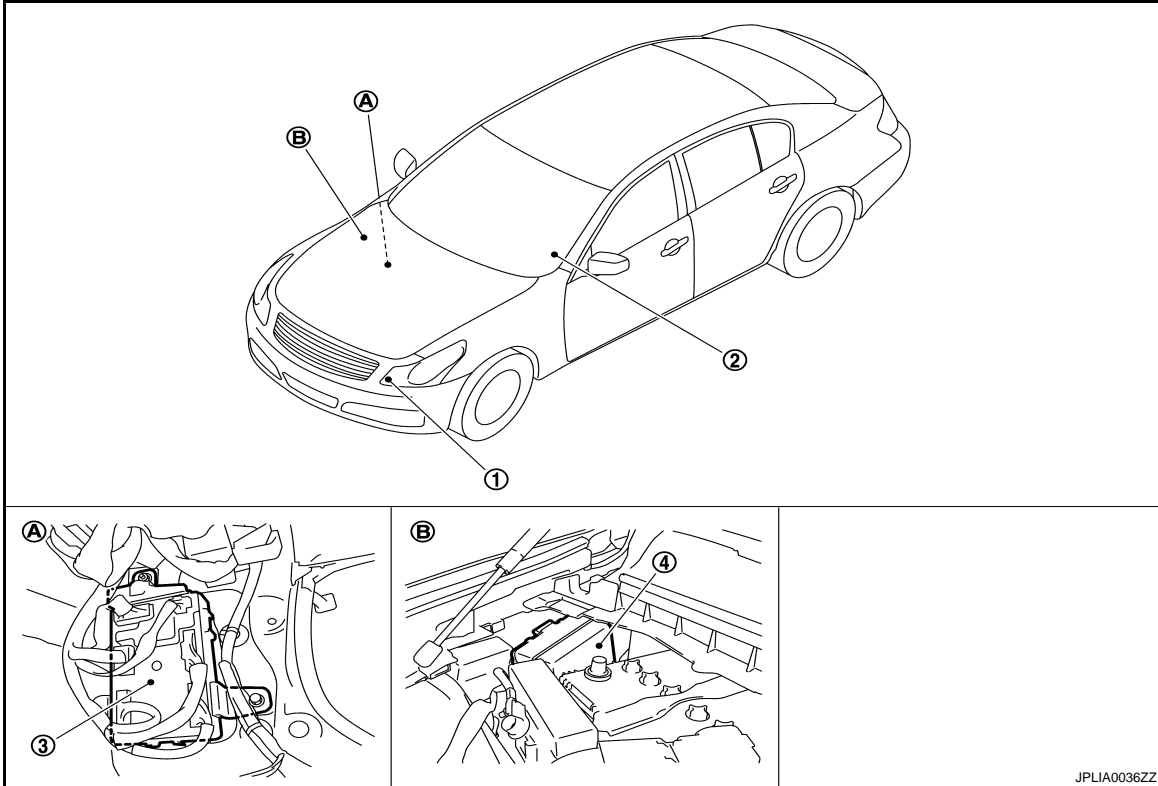

- 1. Front fog lamp
- 2. Combination switch
- 3. BCM
- 4. IPDM E/R
- A. Dash side lower (Passenger side)
- B. Engine room dash panel (RH)

Component Description

INFOID:000000000962415

Part	Description
BCM	<ul style="list-style-type: none"> • Judges each switch condition by the combination switch reading function. • Judges the front fog lamp ON/OFF status according to the vehicle condition. Requests the front fog lamp relay ON to IPDM E/R (with CAN communication).
IPDM E/R	Controls the integrated relay and supplies voltage to the load according to the request from BCM (with CAN communication).
Combination switch (Lighting & turn signal switch)	Refer to BCS-5, "System Diagram" .

TURN SIGNAL AND HAZARD WARNING LAMP SYSTEM

< FUNCTION DIAGNOSIS >

[XENON TYPE]

TURN SIGNAL AND HAZARD WARNING LAMP SYSTEM

System Diagram

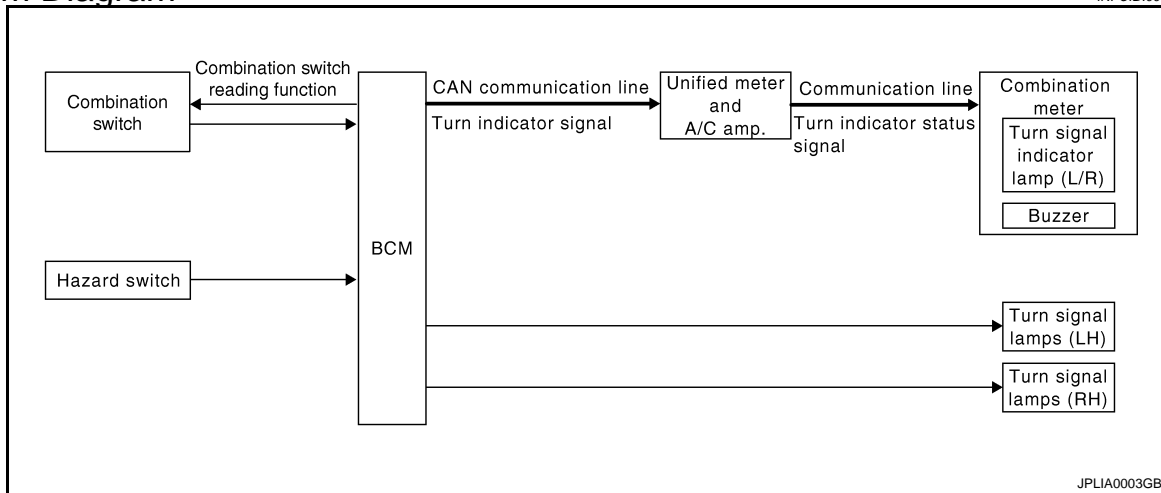

System Description

INFOID:000000000962417

OUTLINE

Turn signal lamp and the hazard warning lamp is controlled by combination switch reading function and the flasher control function of BCM.

TURN SIGNAL LAMP OPERATION

- BCM detects the combination switch condition by the combination switch reading function.
- BCM supplies voltage to the right (left) turn signal lamp circuit when the ignition switch is turned ON and the turn signal switch is in the right (left) position. BCM blinks the turn signal lamp.

HAZARD WARNING LAMP OPERATION

BCM supplies voltage to both turn signal lamp circuit when the hazard switch is turned ON. BCM blinks the hazard warning lamp.

TURN SIGNAL INDICATOR LAMP AND TURN SIGNAL OPERATION

- BCM transmits the turn signal indicator lamp signal to the combination meter (through unified meter and A/C amp.) with CAN communication while the turn signal lamp and the hazard warning lamp operating.
- Combination meter outputs the turn signal sound with the integrated buzzer while blinking the turn signal indicator lamp according to the turn signal indicator lamp signal.

HIGH FLASHER OPERATION (FAIL-SAFE)

- BCM detects the turn signal lamp circuit status from the terminal voltage.
- BCM increases the turn signal lamp blinking speed if the bulb or harness open is detected with the turn signal lamp operating.

NOTE:

The blinking speed is normal while operating the hazard warning lamp.

Component Parts Location

INFOID:000000000962418

TURN SIGNAL AND HAZARD WARNING LAMP SYSTEM

< FUNCTION DIAGNOSIS >

[XENON TYPE]

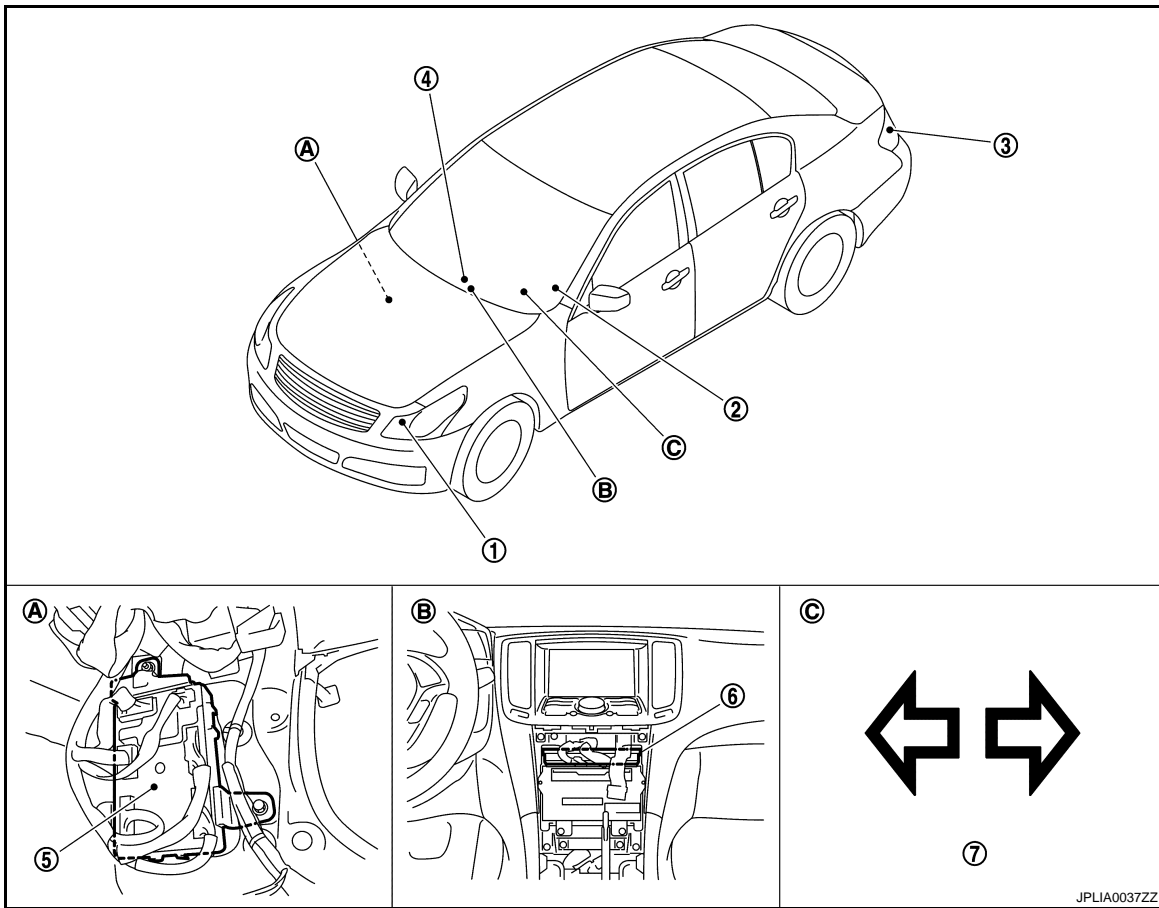

- | | | |
|-------------------------------------|-------------------------|-------------------------------|
| 1. Front turn signal lamp | 2. Combination switch | 3. Rear turn signal lamp |
| 4. Hazard warning switch | 5. BCM | 6. Unified meter and A/C amp. |
| 7. Turn signal indicator lamp | | |
| A. Dash side lower (Passenger side) | B. Behind cluster lid C | C. On the combination meter |

Component Description

INFOID:000000000962419

Part	Description
BCM	<ul style="list-style-type: none"> Judges each switch condition by the combination switch reading function. Judges the blinks of the turn signal lamp and the hazard warning lamp from each switch status. The applicable turn signal lamp blinks. Requests the turn signal indicator lamp blink to the combination meter (with CAN communication).
Combination switch (Lighting & turn signal switch)	Refer to BCS-5, "System Diagram" .
Hazard switch (Multifunction switch)	Refer to EXL-83, "Description" .
Combination meter (Turn signal indicator lamp & buzzer)	Blinks the turn signal indicator lamp and outputs the turn signal operating sound with integrated buzzer according to the request from BCM [with CAN communication (through unified meter and A/C amp.)].

PARKING, LICENSE PLATE AND TAIL LAMPS SYSTEM

< FUNCTION DIAGNOSIS >

[XENON TYPE]

PARKING, LICENSE PLATE AND TAIL LAMPS SYSTEM

System Diagram

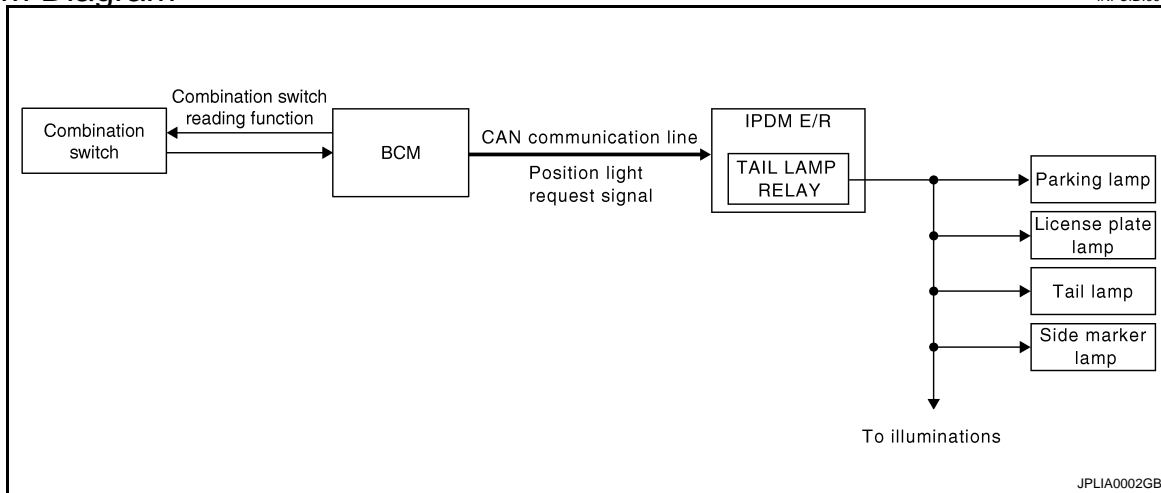

System Description

INFOID:000000000962421

OUTLINE

Parking, license plate, side marker and tail lamps are controlled by combination switch reading function and headlamp control function of BCM, and relay control function of IPDM E/R.

PARKING, LICENSE PLATE, SIDE MARKER AND TAIL LAMPS OPERATION

- BCM detects the combination switch condition by the combination switch reading function.
- BCM transmits the position light request signal to IPDM E/R with CAN communication according to the ON/OFF condition of the parking, license plate, side marker and tail lamps.

Parking, license plate, side marker and tail lamps ON condition

- Lighting switch 1ST
- Lighting switch 2ND
- Lighting switch AUTO, and the auto light function ON judgment (with auto light system)
- IPDM E/R turns the integrated tail lamp relay ON and turns the parking lamp, the license plate, side marker and tail lamps ON according to the position light request signal.

Component Parts Location

INFOID:000000000962422

A
B
C
D
E
F
G
H
I
J
K
EXL
M
N
O
P

PARKING, LICENSE PLATE AND TAIL LAMPS SYSTEM

< FUNCTION DIAGNOSIS >

[XENON TYPE]

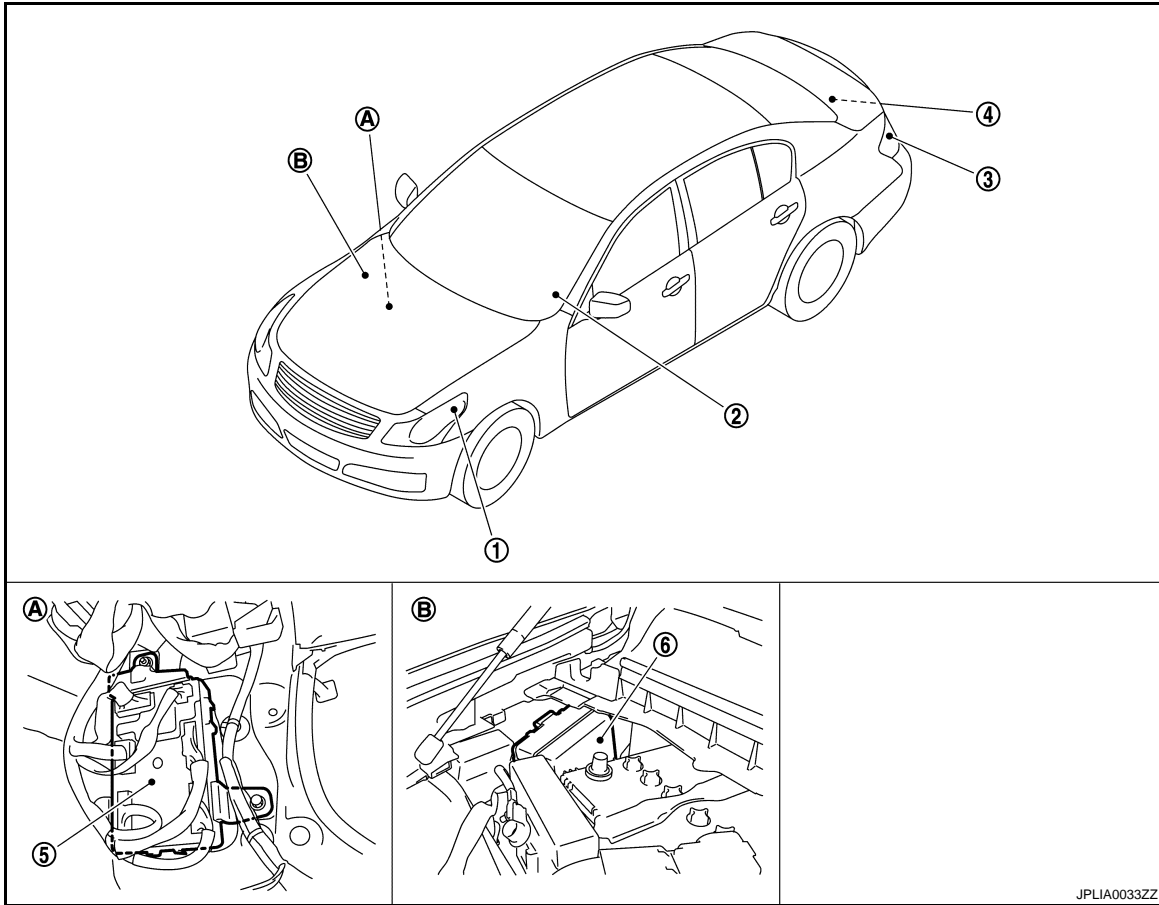

- | | | |
|--|--------------------------------|-----------------------------------|
| 1. Parking lamp (used with the side marker lamp) | 2. Combination switch | 3. Tail lamp and side marker lamp |
| 4. License plate lamp | 5. BCM | 6. IPDM E/R |
| A. Dash side lower (Passenger side) | B. Engine room dash panel (RH) | |

Component Description

INFOID:000000000962423

Part	Description
BCM	<ul style="list-style-type: none"> Judges each switch condition by the combination switch reading function. Judges the ON/OFF status of the clearance, license plate, side marker and tail lamps according to the vehicle condition. Requests the tail lamp relay ON to IPDM E/R (with CAN communication).
IPDM E/R	Controls the integrated relay and supplies voltage to the load according to the request from BCM (with CAN communication).
Combination switch (Lighting & turn signal switch)	Refer to BCS-5, "System Diagram" .

EXTERIOR LAMP BATTERY SAVER SYSTEM

< FUNCTION DIAGNOSIS >

[XENON TYPE]

EXTERIOR LAMP BATTERY SAVER SYSTEM

System Diagram

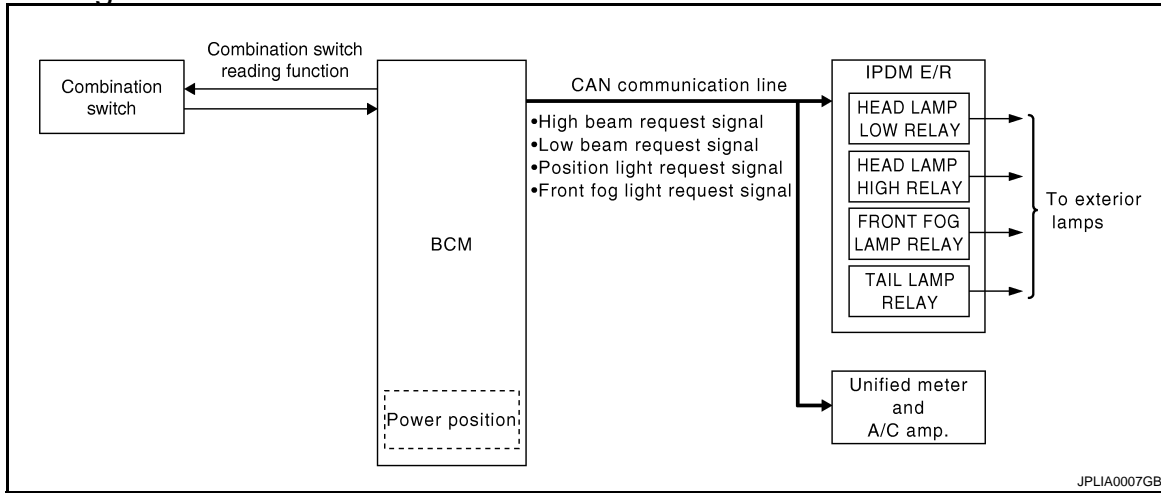

System Description

INFOID:000000000962425

OUTLINE

- Exterior lamp battery saver system is controlled by each function of BCM and IPDM E/R.

Control by BCM

- Combination switch reading function
- Headlamp control function
- Exterior lamp battery saver function

Control by IPDM E/R

- Relay control function
 - BCM turns the exterior lamp* OFF after a period of time to prevent the battery from over-discharge when the ignition switch is turned OFF with the exterior lamp ON.
- *: Headlamp (LO/Hi), parking lamp, tail lamp, side marker lamp, license plate lamp and front fog lamp

NOTE:

When the lighting switch is turned AUTO, the exterior lamp battery saver switches to the auto light system. Refer to [EXL-13. "System Diagram"](#).

EXTERIOR LAMP BATTERY SAVER ACTIVATION

BCM activates the timer and turns the exterior lamp OFF 5 minutes after the ignition switch is turned from ON → OFF with the exterior lamps ON.

NOTE:

- Headlamp control function turns the exterior lamps ON normally when the ignition switch is turned ACC or the engine started (both before and after the exterior lamp battery saver is turned OFF).
- The timer starts at the time that the lighting switch is turned from OFF → 1ST or 2ND with the exterior lamp OFF.

Component Parts Location

INFOID:000000000962426

EXTERIOR LAMP BATTERY SAVER SYSTEM

< FUNCTION DIAGNOSIS >

[XENON TYPE]

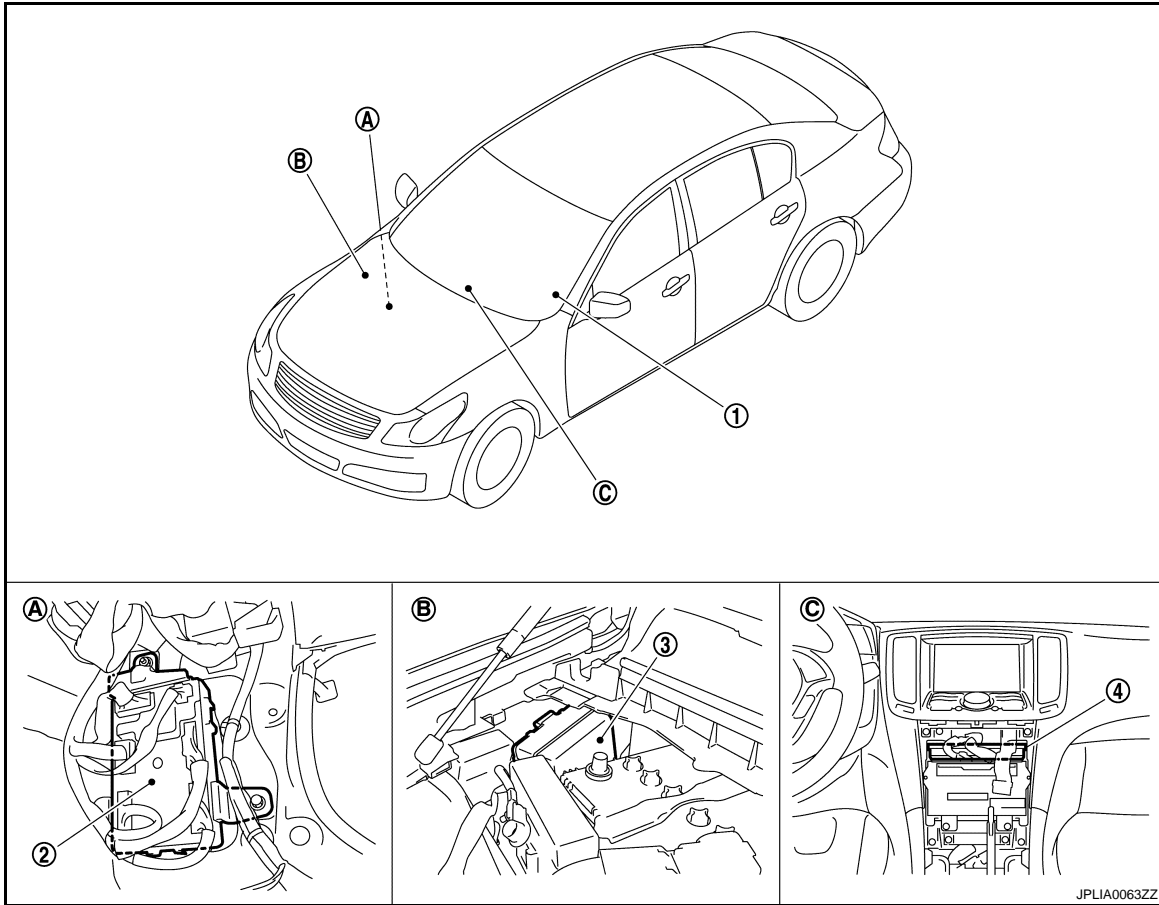

- | | | |
|-------------------------------------|--------------------------------|-------------------------|
| 1. Combination switch | 2. BCM | 3. IPDM E/R |
| 4. Unified meter and A/C amp. | B. Engine room dash panel (RH) | C. Behind cluster lid C |
| A. Dash side lower (Passenger side) | | |

Component Description

INFOID:000000000962427

Part	Description
BCM	<ul style="list-style-type: none"> Judges each switch condition by the combination switch reading function. Judges the exterior lamp OFF according to the vehicle condition. Requests each relay OFF to IPDM E/R (with CAN communication).
IPDM E/R	Controls the integrated relay according to the request from BCM (with CAN communication).
Combination switch (Lighting & turn signal switch)	Refer to BCS-5, "System Diagram" .

DIAGNOSIS SYSTEM (BCM)

< FUNCTION DIAGNOSIS >

[XENON TYPE]

DIAGNOSIS SYSTEM (BCM)

COMMON ITEM

COMMON ITEM : CONSULT-III Function (BCM - COMMON ITEM)

INFOID:000000000962428

APPLICATION ITEM

CONSULT-III performs the following functions via CAN communication with BCM.

Diagnosis mode	Function Description
WORK SUPPORT	Changes the setting for each system function.
SELF-DIAG RESULTS	Displays the diagnosis results judged by BCM. Refer to BCS-74, "DTC Index" .
CAN DIAG SUPPORT MNTR	Monitors the reception status of CAN communication viewed from BCM.
DATA MONITOR	The BCM input/output signals are displayed.
ACTIVE TEST	The signals used to activate each device are forcibly supplied from BCM.
ECU IDENTIFICATION	The BCM part number is displayed.
CONFIGURATION	This function is not used even though it is displayed.

SYSTEM APPLICATION

BCM can perform the following functions for each system.

NOTE:

It can perform the diagnosis modes except the following for all sub system selection items.

System	Sub system selection item	Diagnosis mode		
		WORK SUPPORT	DATA MONITOR	ACTIVE TEST
Door lock	DOOR LOCK	×	×	×
Rear window defogger	REAR DEFOGGER		×	×
Warning chime	BUZZER		×	×
Interior room lamp timer	INT LAMP	×	×	×
Exterior lamp	HEAD LAMP	×	×	×
Wiper and washer	WIPER	×	×	×
Turn signal and hazard warning lamps	FLASHER	×	×	×
Air conditioner*	AIR CONDITONER		×	
Intelligent Key system	INTELLIGENT KEY	×	×	×
Combination switch	COMB SW		×	
BCM	BCM	×		
IVIS - NATS	IMMU		×	×
Interior room lamp battery saver	BATTERY SAVER	×	×	×
Trunk open	TRUNK		×	
Vehicle security system	THEFT ALM	×	×	×
RAP system	RETAINED PWR		×	
Signal buffer system	SIGNAL BUFFER		×	×
TPMS	TPMS (AIR PRESSURE MONI-TOR)	×	×	×

*: This item is displayed, but is not used.

HEADLAMP

HEADLAMP : CONSULT-III Function (BCM - HEAD LAMP)

INFOID:000000000962429

WORK SUPPORT

DIAGNOSIS SYSTEM (BCM)

< FUNCTION DIAGNOSIS >

[XENON TYPE]

Service item	Setting item	Setting	
BATTERY SAVER SET	ON*	With the exterior lamp battery saver function	
	OFF	Without the exterior lamp battery saver function	
ILL DELAY SET	MODE 1*	45 sec.	Sets delay timer function timer operation time. (All doors closed)
	MODE 2	Without the function	
	MODE 3	30 sec.	
	MODE 4	60 sec.	
	MODE 5	90 sec.	
	MODE 6	120 sec.	
	MODE 7	150 sec.	
	MODE 8	180 sec.	
CUSTOM A/LIGHT SETTING	MODE 1*	Normal	
	MODE 2	More sensitive setting than normal setting (Turns ON earlier than normal operation.)	
	MODE 3	More sensitive setting than MODE 2 (Turns ON earlier than MODE 2.)	
	MODE 4	Less sensitive setting than normal setting (Turns ON later than normal operation.)	

*: Initial setting

DATA MONITOR

Monitor item [Unit]	Description
PUSH SW [ON/OFF]	The switch status input from push-button ignition switch
ENGINE STATE [STOP/STALL/CRANK/RUN]	The engine status received from ECM with CAN communication
VEH SPEED 1 [km/h]	The value of the vehicle speed received from unified meter and A/C amp. with CAN communication
KEY SW-SLOT [ON/OFF]	Key switch status input from key slot
TURN SIGNAL R [ON/OFF]	Each switch status that BCM judges from the combination switch reading function
TURN SIGNAL L [ON/OFF]	
TAIL LAMP SW [ON/OFF]	
HI BEAM SW [ON/OFF]	
HEAD LAMP SW1 [ON/OFF]	
HEAD LAMP SW2 [ON/OFF]	
PASSING SW [ON/OFF]	
AUTO LIGHT SW [ON/OFF]	
FR FOG SW [ON/OFF]	
RR FOG SW [ON/OFF]	

DIAGNOSIS SYSTEM (BCM)

< FUNCTION DIAGNOSIS >

[XENON TYPE]

Monitor item [Unit]	Description
DOOR SW-DR [ON/OFF]	The switch status input from front door switch (driver side)
DOOR SW-AS [ON/OFF]	The switch status input from front door switch (passenger side)
DOOR SW-RR [ON/OFF]	The switch status input from rear door switch RH
DOOR SW- RL [ON/OFF]	The switch status input from rear door switch LH
DOOR SW-BK [ON/OFF]	NOTE: The item is indicated, but not monitored.
OPTICAL SENSOR [V]	The value of exterior brightness voltage input from the optical sensor

ACTIVE TEST

Test item	Operation	Description
TAIL LAMP	ON	Transmits the position light request signal to IPDM E/R with CAN communication to turn the tail lamp ON.
	OFF	Stops the tail lamp request signal transmission.
HEAD LAMP	HI	Transmits the high beam request signal with CAN communication to turn the headlamp (HI).
	LO	Transmits the low beam request signal with CAN communication to turn the headlamp (LO).
	OFF	Stops the high & low beam request signal transmission.
FR FOG LAMP	ON	Transmits the front fog lights request signal to IPDM E/R with CAN communication to turn the front fog lamp ON.
	OFF	Stops the front fog lights request signal transmission.
RR FOG LAMP	ON	NOTE: The item is indicated, but cannot be tested.
	OFF	
DAYTIME RUNNING LIGHT	ON	NOTE: The item is indicated, but cannot be tested.
	OFF	
CORNERING LAMP	RH	NOTE: The item is indicated, but cannot be tested.
	LH	
	OFF	
ILL DIM SIGNAL	ON	NOTE: The item is indicated, but cannot be tested.
	OFF	

FLASHER

FLASHER : CONSULT-III Function (BCM - FLASHER)

INFOID:000000000962430

WORK SUPPORT

Service item	Setting item	Setting
HAZARD ANSWER BACK	LOCK ONLY*	With locking only
	UNLK ONLY	With unlocking only
	LOCK/UNLK	With locking/unlocking
	OFF	Without the function
		Sets the hazard warning lamp answer back function when the door is lock/unlock with the request switch or the key fob.

*: Initial setting

DATA MONITOR

DIAGNOSIS SYSTEM (BCM)

< FUNCTION DIAGNOSIS >

[XENON TYPE]

Monitor item [Unit]	Description
REQ SW-DR [ON/OFF]	The switch status input from the request switch (driver side)
REQ SW-AS [ON/OFF]	The switch status input from the request switch (passenger side)
PUSH SW [ON/OFF]	The switch status input from the push-button ignition switch
TURN SIGNAL R [ON/OFF]	Each switch condition that BCM judges from the combination switch reading function
TURN SIGNAL L [ON/OFF]	
HAZARD SW [ON/OFF]	The switch status input from the hazard switch
RKE-LOCK [ON/OFF]	Lock signal status received from the remote keyless entry receiver
RKE-UNLOCK [ON/OFF]	Unlock signal status received from the remote keyless entry receiver
RKE-PANIC [ON/OFF]	Panic alarm signal status received from the remote keyless entry receiver

ACTIVE TEST

Test item	Operation	Description
FLASHER	RH	Outputs the voltage to blink the right side turn signal lamps.
	LH	Outputs the voltage to blink the left side turn signal lamps.
	OFF	Stops the voltage to turn the turn signal lamps OFF.

DIAGNOSIS SYSTEM (IPDM E/R)

Diagnosis Description

INFOID:000000000962431

AUTO ACTIVE TEST

Description

In auto active test mode, the IPDM E/R sends a drive signal to the following systems to check their operation.

- Oil pressure warning lamp
- Front wiper (LO, HI)
- Parking lamps
- License plate lamps
- Side maker lamps
- Tail lamps
- Front fog lamps
- Headlamps (LO, HI)
- A/C compressor (magnet clutch)
- Cooling fan (cooling fan control module)

Operation Procedure

1. Close the hood and lift the wiper arms from the windshield. (Prevent windshield damage due to wiper operation)
NOTE:
When auto active test is performed with hood opened, sprinkle water on windshield beforehand.
2. Turn ignition switch OFF.
3. Turn the ignition switch ON, and within 20 seconds, press the driver door switch 10 times. Then turn the ignition switch OFF.
CAUTION:
Close passenger door.
4. Turn the ignition switch ON within 10 seconds. After that the horn sounds once and the auto active test starts.
5. The oil pressure warning lamp starts blinking when the auto active test starts.
6. After a series of the following operations is repeated 3 times, auto active test is completed.

NOTE:

When auto active test mode has to be cancelled halfway through test, turn ignition switch OFF.

CAUTION:

- If auto active test mode cannot be actuated, check door switch system. Refer to [DLK-65](#), "[Component Function Check](#)".
- Do not start the engine.

Inspection in Auto Active Test Mode

When auto active test mode is actuated, the following 6 steps are repeated 3 times.

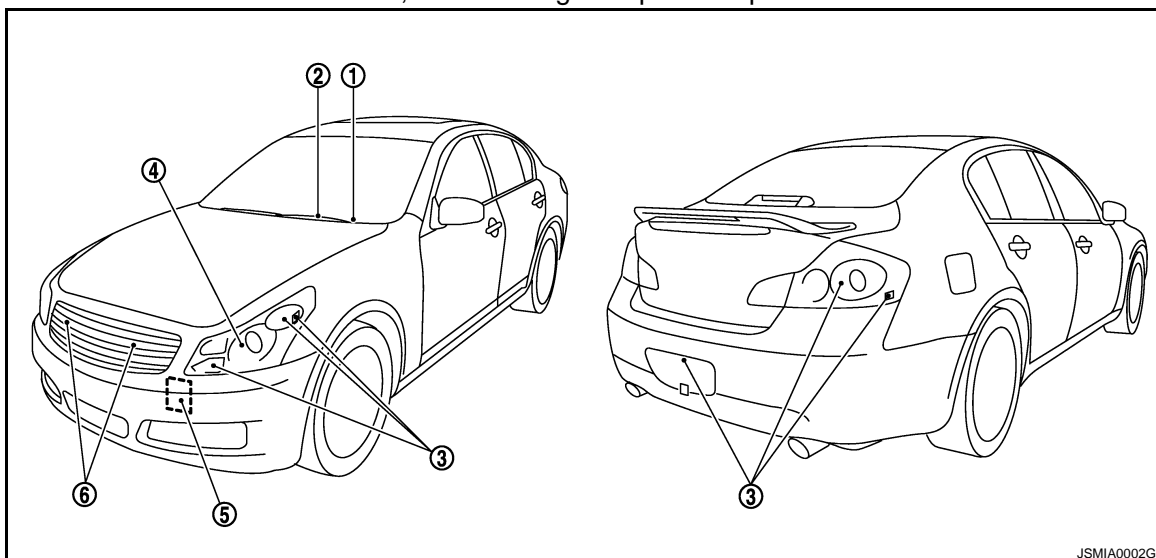

JSMIA0002GB

DIAGNOSIS SYSTEM (IPDM E/R)

< FUNCTION DIAGNOSIS >

[XENON TYPE]

Operation sequence	Inspection Location	Operation
1	Oil pressure warning lamp	Blinks continuously during operation of auto active test
2	Front wiper	LO for 5 seconds → HI for 5 seconds
3	<ul style="list-style-type: none"> • Parking lamps • License plate lamps • Side maker lamps • Tail lamps • Front fog lamps 	10 seconds
4	Headlamps	LO ↔ HI 5 times
5	A/C compressor (magnet clutch)	ON ↔ OFF 5 times
6*	Cooling fan	MID for 5 seconds → HI for 5 seconds

*: Outputs duty ratio of 50% for 5 seconds → duty ratio of 100% for 5 seconds on the cooling fan control module.

Concept of auto active test

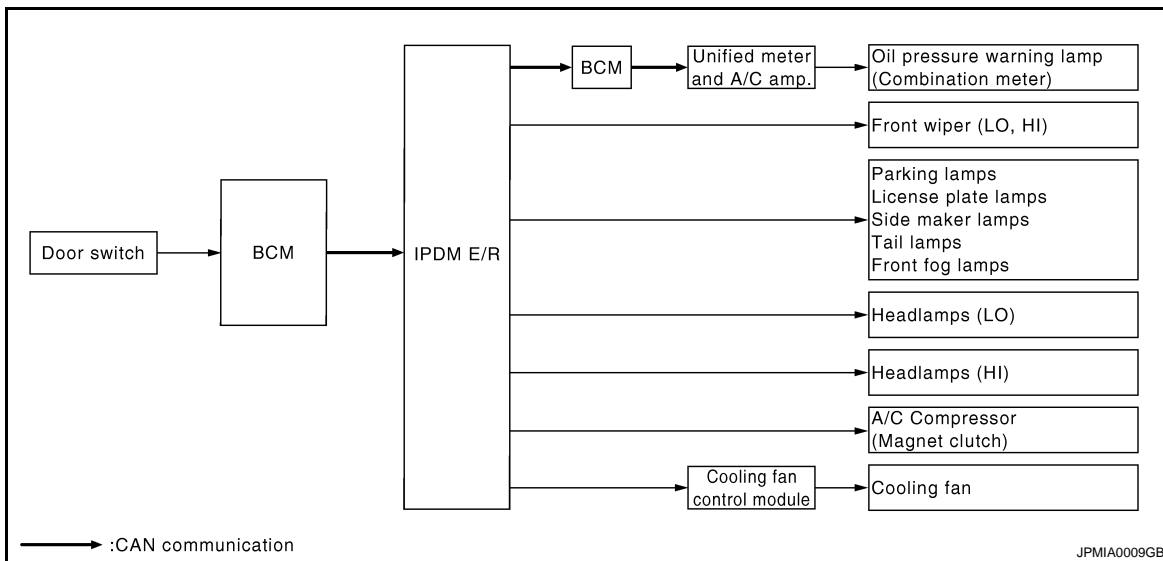

- IPDM E/R starts the auto active test with the door switch signals transmitted by BCM via CAN communication. Therefore, the CAN communication line between IPDM E/R and BCM is considered normal if the auto active test starts successfully.
- The auto active test facilitates troubleshooting if any systems controlled by IPDM E/R cannot be operated.

Diagnosis chart in auto active test mode

Symptom	Inspection contents	Possible cause	
Any of the following components do not operate <ul style="list-style-type: none"> • Parking lamps • License plate lamps • Side maker lamps • Tail lamps • Front fog lamps • Headlamp (HI, LO) • Front wiper 	Perform auto active test. Does the applicable system operate?	YES	BCM signal input circuit
		NO	<ul style="list-style-type: none"> • Lamp or motor • Lamp or motor ground circuit • Harness or connector between IPDM E/R and applicable system • IPDM E/R

DIAGNOSIS SYSTEM (IPDM E/R)

< FUNCTION DIAGNOSIS >

[XENON TYPE]

Symptom	Inspection contents		Possible cause
A/C compressor does not operate	Perform auto active test. Does the magnet clutch operate?.	YES	<ul style="list-style-type: none"> • Unified meter and A/C amp. signal input circuit • CAN communication signal between unified meter and A/C amp. and ECM • CAN communication signal between ECM and IPDM E/R
		NO	<ul style="list-style-type: none"> • Magnet clutch • Harness or connector between IPDM E/R and magnet clutch • IPDM E/R
Oil pressure warning lamp does not operate	Perform auto active test. Does the oil pressure warning lamp blink?	YES	<ul style="list-style-type: none"> • Harness or connector between IPDM E/R and oil pressure switch • Oil pressure switch • IPDM E/R
		NO	<ul style="list-style-type: none"> • CAN communication signal between IPDM E/R and BCM • CAN communication signal between BCM and unified meter and A/C amp. • Combination meter
Cooling fan does not operate	Perform auto active test. Does the cooling fan operate?	YES	<ul style="list-style-type: none"> • ECM signal input circuit • CAN communication signal between ECM and IPDM E/R
		NO	<ul style="list-style-type: none"> • Cooling fan • Harness or connector between cooling fan and cooling fan control module • Cooling fan control module • Harness or connector between IPDM E/R and cooling fan control module • Cooling fan relay • Harness or connector between IPDM E/R and cooling fan relay • IPDM E/R

A
B
C
D
E
F
G
H
I
J
K

EXL

CONSULT - III Function (IPDM E/R)

INFOID:000000000962432

APPLICATION ITEM

CONSULT-III performs the following functions via CAN communication with IPDM E/R.

Diagnosis mode	Description
Ecu Identification	Allows confirmation of IPDM E/R part number.
Self Diagnostic Result	Displays the diagnosis results judged by IPDM E/R.
Data Monitor	Displays the real-time input/output data from IPDM E/R input/output data.
Active Test	IPDM E/R can provide a drive signal to electronic components to check their operations.
CAN Diag Support Monitor	The results of transmit/receive diagnosis of CAN communication can be read.

M
N
O
P

SELF DIAGNOSTIC

Refer to [PCS-31, "DTC Index"](#).

DATA MONITOR

DIAGNOSIS SYSTEM (IPDM E/R)

[XENON TYPE]

< FUNCTION DIAGNOSIS >

Monitor item

Monitor Item [Unit]	MAIN SIG- NALS	Description
RADFAN REQ [%]	×	Displays the value of the cooling fan speed signal received from ECM via CAN communication.
AC COMP REQ [Off/On]	×	Displays the status of the A/C compressor request signal received from ECM via CAN communication.
TAIL&CLR REQ [Off/On]	×	Displays the status of the position light request signal received from BCM via CAN communication.
HL LO REQ [Off/On]	×	Displays the status of the low beam request signal received from BCM via CAN communication.
HL HI REQ [Off/On]	×	Displays the status of the high beam request signal received from BCM via CAN communication.
FR FOG REQ [Off/On]	×	Displays the status of the front fog light request signal received from BCM via CAN communication.
FR WIP REQ [Stop/1LOW/Low/Hi]	×	Displays the status of the front wiper request signal received from BCM via CAN communication.
WIP AUTO STOP [STOP P/ACT P]	×	Displays the status of the front wiper auto stop signal judged by IPDM E/R.
WIP PROT [Off/BLOCK]	×	Displays the status of the front wiper fail-safe operation judged by IPDM E/R.
IGN RLY1 -REQ [Off/On]		Displays the status of the ignition switch ON signal received from BCM via CAN communication.
IGN RLY [Off/On]	×	Displays the status of the ignition relay judged by IPDM E/R.
PUSH SW [Off/On]		Displays the status of the push-button ignition switch judged by IPDM E/R.
INTER/NP SW [Off/On]		Displays the status of the clutch interlock switch (M/T models) or A/T shift position (A/T models) judged by IPDM E/R.
ST RLY REQ [Off/On]		NOTE: The item is indicated, but not used.
ST RLY CONT [Off/On]		Displays the status of the starter relay status signal received from BCM via CAN communication.
IHBT RLY -REQ [Off/On]		Displays the status of the starter control relay signal received from BCM via CAN communication.
ST/INHI RLY [Off/ ST /INHI]		Displays the status of the starter relay and starter control relay judged by IPDM E/R.
DETENT SW [Off/On]		Displays the status of the A/T device (detention switch) judged by IPDM E/R.
S/L RLY -REQ [Off/On]		Displays the status of the steering lock relay request received from BCM via CAN communication.
S/L STATE [LOCK/UNLK/UNKWN]		Displays the status of the steering lock judged by IPDM E/R.
DTRL REQ [Off]		NOTE: The item is indicated, but not monitored.
OIL P SW [Open/Close]		Displays the status of the oil pressure switch judged by IPDM E/R.
HOOD SW [Off/On]		Displays the status of the hood switch judged by IPDM E/R.
HL WASHER REQ [Off]		NOTE: The item is indicated, but not monitored.
THFT HRN REQ [Off/On]		Displays the status of the theft warning horn request signal received from BCM via CAN communication.

DIAGNOSIS SYSTEM (IPDM E/R)

< FUNCTION DIAGNOSIS >

[XENON TYPE]

Monitor Item [Unit]	MAIN SIG- NALS	Description
HORN CHIRP [Off/On]		Displays the status of the horn reminder signal received from BCM via CAN communication.
CRNRNG LMP REQ [Off]		NOTE: The item is indicated, but not monitored.

ACTIVE TEST

Test item

Test item	Operation	Description
CORNERING LAMP	Off	NOTE: The item is indicated, but cannot be tested.
	LH	
	RH	
HORN	On	Operates horn relay 1 and horn relay 2 for 20 ms.
FRONT WIPER	Off	OFF
	Lo	Operates the front wiper relay.
	Hi	Operates the front wiper relay and front wiper high relay.
MOTOR FAN	1	OFF
	2	Outputs 50% pulse duty signal (PWM signal) to the cooling fan control module.
	3	Outputs 80% pulse duty signal (PWM signal) to the cooling fan control module.
	4	Outputs 100% pulse duty signal (PWM signal) to the cooling fan control module.
HEAD LAMP WASHER	On	NOTE: The item is indicated, but cannot be tested.
EXTERNAL LAMPS	Off	OFF
	TAIL	Operates the tail lamp relay.
	Lo	Operates the headlamp low relay.
	Hi	Operates the headlamp low relay and ON/OFF the headlamp high relay at 1 second intervals.
	Fog	Operates the front fog lamp relay.

A
B
C
D
E
F
G
H
I
J
K
EXL
M
N
O
P

EXL

DIAGNOSIS SYSTEM (AFS)

< FUNCTION DIAGNOSIS >

[XENON TYPE]

DIAGNOSIS SYSTEM (AFS)

CONSULT-III Function (AFS)

INFOID:000000000962433

APPLICATION ITEM

Diagnostic mode	Description
Work support	Sets each sensor.
Data monitor	Indicates AFS control unit input data in real time.
Active test	Provides the drive signal to the load. Checks operation.

WORK SUPPORT

Service item	Description
ST ANG SEN ADJUSTMENT*	—
LEVELIZER ADJUSTMENT	Adjusts the height sensor signal output value (AFS control unit recognized) in the unloaded vehicle condition.

*: Adjusts the steering angle sensor neutral position on ABS actuator and electrical unit (control unit) side. Refer to XX-XX.

DATA MONITOR

Monitor item [Unit]	Description
STR ANGLS SIG [deg]	The steering angle value judged by the steering angle sensor signal received from the steering angle sensor with CAN communication
VHCL SPD [km/h]	The vehicle speed signal value from the unified meter and A/C amp. with CAN communication
SLCT LVR POSI [P - 1]	The selector lever status judged by the position indicator signal received from TCM with CAN communication
HEAD LAMP [ON/OFF]	The headlamp ON/OFF status judged by the low beam headlamp (ON) signal received from IPDM E/R with CAN communication
AFS SW [ON/OFF]	The switch status input from AFS switch
HI SEN OTP RR [V]	The height sensor signal voltage value input from the height sensor
LEV ACTR VLTG [%]	The ratio value to the battery voltage generated by the levelizer activation signal control value judged by AFS control unit
SWVL SEN RH* [deg]	The head lamp swivel angle value judged by AFS control unit received from the swivel position sensor signal input from the swivel actuator
SWVL SEN LH* [deg]	
SWVL ANGLE RH* [deg]	The swivel angle command value to the swivel motor judged by AFS control unit
SWVL ANGLE LH* [deg]	

*: The swivel angle "0°" (feedback value) of the swivel position sensor signal may differ from the swivel angle "0°" of the swivel motor (AFS control unit command value). This causes that the swivel motor initializes the value based on the step number from the stopper.

ACTIVE TEST

DIAGNOSIS SYSTEM (AFS)

[XENON TYPE]

< FUNCTION DIAGNOSIS >

Test item	Operation item	Description
LOW BEAM TEST RIGHT	ORIGIN-FAST	Swivels the right headlamp to the swivel angle 0° in the normal speed.
	PEAK-FAST	Swivels the right headlamp to the swivel angle approximately 20° in the normal speed.
	ORIGIN-SLOW	Swivels the right headlamp to the swivel angle 0° in the speed at the initialization.
	PEAK-SLOW	Swivels the right headlamp to the swivel angle approximately 20° in the speed at the initialization.
LOW BEAM TEST LEFT	ORIGIN-FAST	Swivels the left headlamp to the swivel angle 0° in the normal speed.
	PEAK-FAST	Swivels the left headlamp to the swivel angle approximately 20° in the normal speed.
	ORIGIN-SLOW	Swivels the left headlamp to the swivel angle 0° in the speed at the initialization.
	PEAK-SLOW	Swivels the left headlamp to the swivel angle approximately 20° in the speed at the initialization.
LEVELIZER TEST	ORIGIN	Changes the aiming motor drive signal to approximately 70% of the battery voltage. Moves the headlamp upward and downward.
	PEAK	Changes the aiming motor drive signal to approximately 15% of the battery voltage. Moves the headlamp upward and downward.

NOTE:

FAST operation speed is as three times fast as SLOW.

A
B
C
D
E
F
G
H
I
J
K
M
N
O
P

EXL

COMPONENT DIAGNOSIS

B2503, B2504 SWIVEL ACTUATOR

Description

INFOID:000000000962434

SWIVEL ACTUATOR

The swivel actuator is installed in the headlamp unit. The swivel actuator consists of the swivel motor and the swivel position sensor.

SWIVEL MOTOR

- The swivel motor is the two-phase step motor.
- The swivel motor drives headlamp by exciting the two drive coils according to the drive signal from AFS control unit.
- The rotation direction of the swivel motor is changeable by changing the exciting pattern.

SWIVEL POSITION SENSOR

The swivel position sensor detects the headlamp swivel angle to transmit the swivel position sensor signal to AFS control unit.

DTC Logic

INFOID:000000000962435

DTC DETECTION LOGIC

- [B2503] Swivel actuator [RH]
- [B2504] Swivel actuator [LH]

DTC detection condition	DTC erase condition	Possible cause
<p>AFS control unit indicates an applicable DTC when detecting any of the following conditions continuously for 2 seconds or more.</p> <ul style="list-style-type: none"> • AFS control unit-recognized swivel position differs extremely from the swivel position sensor-input value while the swivel operating.* • The swivel position sensor signal does not change even though AFS control unit transmits the swivel motor driving signal while the swivel operating* . • The swivel motor short and open is detected while the swivel operating* . • The swivel position sensor power supply is 6 V or more, or 4 V or less. • The swivel position sensor signal is 0.25 V or less, or 4.75 V or more. 	<p>Ignition switch OFF</p>	<p>Swivel position sensor</p> <ul style="list-style-type: none"> • Swivel position sensor • Harness and connector • AFS control unit <p>Swivel motor</p> <ul style="list-style-type: none"> • Swivel motor • Harness and connector • AFS control unit

*: Initialization is not included.

DTC CONFIRMATION PROCEDURE

1. DTC ERASE

Erase the DTC memory of AFS with CONSULT-III.

>> GO TO 2.

2. CONFIRMATION DTC SELECTION

Select "B2503" or "B2504" for confirmation.

Which DTC is confirmation?

B2503 >> GO TO 3.

B2504 >> GO TO 4.

3. DTC CONFIRMATION (B2503)

1. Steer to the straight-forward position.
2. Start the engine.
3. Turn AFS OFF switch OFF.
4. Turn the headlamp ON.
5. Shift the selector lever to "N" (A/T models).
6. Shift the shift knob to neutral (M/T models).
7. Steer to the right. (Rotate it once or more.)

B2503, B2504 SWIVEL ACTUATOR

[XENON TYPE]

< COMPONENT DIAGNOSIS >

8. Perform the self-diagnosis with CONSULT-III.

Is "B2503" detected?

- YES >> Refer to [EXL-43, "Diagnosis Procedure"](#).
- NO >> Refer to [GI-39, "Intermittent Incident"](#).

4.DTC CONFIRMATION (B2504)

1. Steer to the straight-forward position.
2. Start the engine.
3. Turn AFS OFF switch OFF.
4. Turn the headlamp ON.
5. Drive at 25 km/h or more.
6. Steer to the left. (Rotate it once or more.)
7. Stop the vehicle.
8. Perform the self-diagnosis with CONSULT-III.

Is "B2504" detected?

- YES >> Refer to [EXL-43, "Diagnosis Procedure"](#).
- NO >> Refer to [GI-39, "Intermittent Incident"](#).

Diagnosis Procedure

INFOID:000000000962436

1.CHECK SWIVEL POSITION SENSOR SIGNAL INPUT

1. Turn the ignition switch ON.
2. Check the voltage between the AFS control unit harness connector and the ground.

Terminals				Voltage (Approx.)
(+)		(-)		
AFS control unit				
Connector		Terminal		Ground 0.25 - 4.75 V
RH	M16	9		
LH		29		

Is the measurement value within the standard value?

- YES >> GO TO 2.
- Less than the standard value >>GO TO 6.
- Higher than the standard value>>GO TO 9.

2.CHECK SWIVEL MOTOR

Check the swivel motor.[EXL-46, "Component Inspection"](#).

Is the inspection result normal?

- YES >> GO TO 3.
- NO >> Replace the front combination lamp.

3.CHECK SWIVEL MOTOR OPEN CIRCUIT

1. Turn the ignition switch OFF.
2. Disconnect AFS control unit connector and the headlamp swivel actuator connector.
3. Check continuity between the AFS control unit harness connector and the headlamp swivel actuator harness connector.

AFS control unit		Headlamp swivel actuator		Continuity
Connector	Terminal	Connector	Terminal	

B2503, B2504 SWIVEL ACTUATOR

< COMPONENT DIAGNOSIS >

[XENON TYPE]

		Terminals			
		(+)	(-)		
RH	M16	11	E29	8	Existed
		13		7	
		32		3	
		34		4	
LH	M16	15	E59	3	
		17		4	
		36		8	
		38		7	

Does continuity exist?

YES >> GO TO 4.

NO >> Repair the harnesses or connectors.

4. CHECK SWIVEL MOTOR SHORT CIRCUIT

Check continuity between the AFS control unit harness connector and the ground.

		Terminals			
		(+)	(-)		
		AFS control unit		Continuity	
		Connector	Terminal		
RH	M16		11	Ground	Not existed
			13		
			32		
			34		
LH	M16		15		
			17		
			36		
			38		

Does continuity exist?

YES >> Repair the harnesses or connectors.

NO >> GO TO 5.

5. CHECK SWIVEL MOTOR CIRCUIT VOLTAGE OUTPUT

1. Connect AFS control unit connector.
2. Turn the ignition switch ON.
3. Check the voltage between the AFS control unit harness connector and the ground.

		Terminals			
		(+)	(-)		
		AFS control unit		Voltage (Approx.)	
		Connector	Terminal		
RH	M16		11	Ground	9.5 - 11.5 V
			13		
			32		
			34		
LH	M16		15		
			17		
			36		
			38		

B2503, B2504 SWIVEL ACTUATOR

[XENON TYPE]

< COMPONENT DIAGNOSIS >

Is the measurement value within the standard value?

YES >> Replace the front combination lamp.

NO >> Replace AFS control unit.

6. CHECK SWIVEL POSITION SENSOR SIGNAL OUTPUT

Check the voltage between the AFS control unit harness connector and the ground.

Terminals				Voltage (Approx.)
(+)		(-)		
AFS control unit		Ground		
Connector		Terminal		
RH	M16	4		5 V
LH		24		

Is the measurement value normal?

YES >> GO TO 7.

NO >> GO TO 9.

7. CHECK SWIVEL POSITION SENSOR POWER SUPPLY CIRCUIT INPUT VOLTAGE

1. Turn the ignition switch OFF.
2. Disconnect the headlamp swivel actuator connector.
3. Turn the ignition switch ON.
4. Check the voltage between the headlamp swivel actuator harness connector and the ground.

Terminals				Voltage (Approx.)
(+)		(-)		
Headlamp swivel actuator		Ground		
Connector		Terminal		
RH	E29	2		5 V
LH	E59	2		

Is the measurement value normal?

YES >> GO TO 8.

NO >> Repair the harnesses or connectors.

8. CHECK SWIVEL POSITION SENSOR SIGNAL SHORT CIRCUIT

1. Turn the ignition switch OFF.
2. Disconnect AFS control unit connector.
3. Check continuity between the AFS control unit harness connector and the headlamp swivel actuator harness connector.

AFS control unit		Headlamp swivel actuator		Continuity
Connector	Terminal	Connector	Terminal	
RH	M16	E29	1	Existed
LH		29	E59	

Does continuity exist?

YES >> Replace the front combination lamp.

NO >> Repair the harnesses or connectors.

9. CHECK SWIVEL POSITION SENSOR GROUND CIRCUIT VOLTAGE OUTPUT

Check the voltage between the AFS control unit harness connector and the ground.

B2503, B2504 SWIVEL ACTUATOR

< COMPONENT DIAGNOSIS >

[XENON TYPE]

Terminals				Voltage (Approx.)
(+)		(-)		
AFS control unit				Ground
Connector		Terminal		
RH	M16	2		
LH		27		
				0 V

Is the measurement value normal?

YES >> GO TO 10.

NO >> Replace AFS control unit.

10. CHECK SWIVEL POSITION SENSOR SHORT GROUND CIRCUIT

1. Turn the ignition switch OFF.
2. Disconnect AFS control unit connector and the headlamp swivel actuator connector.
3. Check continuity between the AFS control unit harness connector and the headlamp swivel actuator harness connector.

AFS control unit			Headlamp swivel actuator		Continuity
Connector	Terminal		Connector	Terminal	
RH	M16	2	E29	6	Existed
LH		27	E59	6	

Does continuity exist?

YES >> Replace the front combination lamp.

NO >> Repair the harnesses or connectors.

Component Inspection

INFOID:000000000962437

1. CHECK SWIVEL MOTOR SINGLE PART

1. Disconnect the swivel actuator connector.
2. Check the resistance among each swivel actuator connector terminal.

Swivel actuator		Resistance (Approx.)
Terminal	Terminal	
3	7	7.2 Ω
4	8	7.2 Ω
3	4	10 MΩ or more

Is the measurement value normal?

YES >> Swivel actuator is normal.

NO >> Replace the front combination lamp.

B2514 HEIGHT SENSOR UNUSUAL [RR]

< COMPONENT DIAGNOSIS >

[XENON TYPE]

B2514 HEIGHT SENSOR UNUSUAL [RR]

Description

INFOID:000000000962438

The height sensor is installed to the rear suspension arm. The height sensor detects the suspension arm displacement as the vehicle height change. The height sensor transmits the height sensor signal to AFS control unit.

NOTE:

The sensor angle of the unloaded vehicle position is the reference value.

DTC Logic

INFOID:000000000962439

DTC DETECTION LOGIC

[B2514] Height sensor unusual [RR]

DTC detection condition	DTC erase condition	Possible cause
An applicable DTC is indicated when any of the following conditions is detected continuously for 2 seconds or more. <ul style="list-style-type: none">The height sensor power supply is 6 V or more, or 4 V or less.The height sensor signal is 0.25 V or less, or 4.75 V or more.	Ignition switch OFF	Height sensor <ul style="list-style-type: none">Height sensorHarness and connectorAFS control unit

DTC CONFIRMATION PROCEDURE

1. DTC ERASE

Erase the DTC memory of AFS with CONSULT-III.

>> GO TO 2.

2. DTC CONFIRMATION

1. Start the engine.
2. Turn the headlamp ON.
3. Select the self-diagnosis with CONSULT-III.
4. Check the self-diagnosis result. Refer to [EXL-173. "DTC Index"](#).

Is "B2514" detected?

YES >> Refer to [EXL-43. "Diagnosis Procedure"](#).

NO >> Refer to [GI-39. "Intermittent Incident"](#).

Diagnosis Procedure

INFOID:000000000962440

1. CHECK HEIGHT SENSOR POWER SUPPLY OUTPUT

1. Turn the ignition switch ON.
2. Check the voltage between the AFS control unit harness connector and the ground.

Terminals		Voltage (Approx.)
(+)	(-)	
AFS control unit		Ground
Connector	Terminal	
M16	6	

Is the measurement value within the standard value?

YES >> GO TO 2.

NO >> Replace AFS control unit.

2. CHECK HEIGHT SENSOR POWER SUPPLY INPUT

Check the voltage between the AFS control unit harness connector and the ground.

B2514 HEIGHT SENSOR UNUSUAL [RR]

[XENON TYPE]

< COMPONENT DIAGNOSIS >

Terminals		Voltage (Approx.)
(+)	(-)	
AFS control unit		Ground
Connector	Terminal	
M16	28	
		0.25 - 4.75 V

Is the measurement value within the standard value?

- YES >> Replace AFS control unit.
Less than the standard value >>GO TO 3.
Higher than the standard value>>GO TO 6.

3.CHECK HEIGHT SENSOR POWER SUPPLY CIRCUIT OUTPUT VOLTAGE

1. Turn the ignition switch OFF.
2. Disconnect the height sensor connector.
3. Turn the ignition switch ON.
4. Check the voltage between the height sensor harness connector and the ground.

Terminals		Voltage (Approx.)
(+)	(-)	
Height sensor		Ground
Connector	Terminal	
B32	1	
		4 - 6 V

Is the measurement value within the standard value?

- YES >> GO TO 4.
NO >> Repair the harnesses or connectors.

4.CHECK HEIGHT SENSOR SIGNAL OPEN CIRCUIT

1. Turn the ignition switch OFF.
2. Disconnect AFS control unit connector.
3. Check continuity between the AFS control unit harness connector and the height sensor harness connector.

AFS control unit		Height sensor		Continuity
Connector	Terminal	Connector	Terminal	
M16	28	B32	2	Existed

Does continuity exist?

- YES >> GO TO 5.
NO >> Repair the harnesses or connectors.

5.CHECK HEIGHT SENSOR SIGNAL SHORT CIRCUIT

Check continuity between the height sensor harness connector and the ground.

Terminals		Continuity
(+)	(-)	
Height sensor		Ground
Connector	Terminal	
B32	2	
		Not existed

Does continuity exist?

- YES >> Repair the harnesses or connectors.
NO >> Replace the height sensor.

6.CHECK HEIGHT SENSOR GROUND

B2514 HEIGHT SENSOR UNUSUAL [RR]

[XENON TYPE]

< COMPONENT DIAGNOSIS >

Check the voltage between the AFS control unit harness connector and the ground.

Terminals		Voltage (Approx.)
(+)	(-)	
AFS control unit		Ground
Connector	Terminal	
M16	8	
		0 V

Is the measurement value within the standard value?

YES >> GO TO 7.

NO >> Replace AFS control unit.

7.CHECK HEIGHT SENSOR GROUND CIRCUIT

- Turn the ignition switch OFF.
- Disconnect AFS control unit connector and the height sensor connector.
- Check continuity between the AFS control unit harness connector and the height sensor harness connector.

AFS control unit		Height sensor		Continuity
Connector	Terminal	Connector	Terminal	
M16	8	B32	3	Existed

Does continuity exist?

YES >> Replace the height sensor.

NO >> Repair the harnesses or connectors.

Component Inspection

INFOID:000000000962441

1.CHECK HEIGHT SENSOR

- Start the engine.
- Turn the light switch 2ND.
- Select "HI SEN OTP RR" of AFS data monitor item.
- Remove the height sensor link bracket nut.
- With moving the sensor lever, check the monitor status.

17-inch wheel models

Sensor angle	LEV ACTR VLTG (Approx.)	Reference value (Approx.)	"HI SEN OTP RR" Standard value (Approx.)
Detection limit (suspension expansion side)	70%	45°	4.5 V
Leveling operation upward edge (unloaded vehicle condition)	70%	0°	2.5 V
Leveling operation downward edge	34.6%	-25°	1.6 V
Detection limit (suspension contraction side)	34.6%	-45°	0.9 V

18-inch wheel models

Sensor angle	LEV ACTR VLTG (Approx.)	Reference value (Approx.)	"HI SEN OTP RR" Standard value (Approx.)
Detection limit (suspension expansion side)	70%	45°	4.5 V
Leveling operation upward edge (unloaded vehicle condition)	70%	0°	2.5 V

B2514 HEIGHT SENSOR UNUSUAL [RR]

[XENON TYPE]

< COMPONENT DIAGNOSIS >

Sensor angle	LEV ACTR VLTG (Approx.)	Reference value (Approx.)	"HI SEN OTP RR" Standard value (Approx.)
Leveling operation downward edge	36.2%	-22°	1.7 V
Detection limit (suspension contraction side)	36.2%	-45°	0.9 V

Is the output value normal?

- YES >> Height sensor is normal.
NO >> Replace the height sensor.

B2516 SHIFT SIGNAL [P, R]

< COMPONENT DIAGNOSIS >

[XENON TYPE]

B2516 SHIFT SIGNAL [P, R]

Description

INFOID:000000000962442

AFS control unit receives the shift position signal from TCM with CAN communication.

DTC Logic

INFOID:000000000962443

DTC DETECTION LOGIC

[B2516] Shift signal [P, R]

DTC detection condition	DTC erase condition	Possible causes
The shift position signal is not received.	Ignition switch OFF	<ul style="list-style-type: none">• A/T control unit• AFS control unit

DTC CONFIRMATION PROCEDURE

1. DTC ERASE

Erase the DTC memory of AFS with CONSULT-III.

>> GO TO 2.

2. DTC CONFIRMATION

1. Turn ignition ON.
2. Select the self-diagnosis with CONSULT-III.
3. Check the self-diagnosis result. Refer to [EXL-173, "DTC Index"](#).

Is "B2516" detected?

- YES >> Refer to [EXL-51, "Diagnosis Procedure"](#).
NO >> Refer to [GI-39, "Intermittent Incident"](#).

Diagnosis Procedure

INFOID:000000000962444

1. TCM SELF-DIAGNOSIS

Check the self-diagnosis result with CONSULT-III. Check that TCM does not detect any DTCs.

Is any DTC detected?

- YES >> Check TCM. Refer to [TM-180, "Reference Value"](#).
NO >> GO TO 2.

2. DTC ERASE

Erase the DTC memory of AFS with CONSULT-III.

Is the memory erased?

- YES >> Inspection end.
NO >> Replace AFS control unit.

A
B
C
D
E
F
G
H
I
J
K
L
M
N
O
P

EXL

B2517 VEHICLE SPEED SIGNAL

< COMPONENT DIAGNOSIS >

[XENON TYPE]

B2517 VEHICLE SPEED SIGNAL

Description

INFOID:000000000962445

AFS control unit receives the vehicle speed signal from the unified meter and A/C amp. with CAN communication.

DTC Logic

INFOID:000000000962446

DTC DETECTION LOGIC

[B2517] Vehicle speed signal

DTC detection condition	DTC erase condition	Possible causes
The vehicle speed signal is not received.	Ignition switch OFF	<ul style="list-style-type: none">Unified meter and A/C amp.AFS control unit

DTC CONFIRMATION PROCEDURE

1. DTC ERASE

Erase the DTC memory of AFS with CONSULT-III.

>> GO TO 2.

2. DTC CONFIRMATION

- Turn ignition ON.
- Select the self-diagnosis with CONSULT-III.
- Check the self-diagnosis result. Refer to [EXL-173, "DTC Index"](#).

Is "B2517" detected?

- YES >> Refer to [EXL-52, "Diagnosis Procedure"](#).
NO >> Refer to [GI-39, "Intermittent Incident"](#).

Diagnosis Procedure

INFOID:000000000962447

1. UNIFIED METER AND A/C AMP. SELF-DIAGNOSIS

Check the self-diagnosis result with CONSULT-III. Check that the unified meter and A/C amp. does not detect any DTCs.

Is any DTC detected?

- YES >> Check the unified meter and A/C amp. Refer to [MWI-80, "Reference Value"](#).
NO >> GO TO 2.

2. DTC ERASE

Erase the DTC memory of AFS with CONSULT-III.

Is the memory erased?

- YES >> Inspection end.
NO >> Replace AFS control unit.

B2519 LEVELIZER CALIBRATION

< COMPONENT DIAGNOSIS >

[XENON TYPE]

B2519 LEVELIZER CALIBRATION

Description

INFOID:000000000962448

AFS control unit transmits the height sensor signal from the height sensor.

DTC Logic

INFOID:000000000962449

[B2519] Levelizer calibration

DTC detection condition	DTC erase condition	Possible causes
The height sensor adjustment position is not recognized.	When the levelizer adjustment is completed	AFS control unit

Diagnosis Procedure

INFOID:000000000962450

1. LEVELIZER ADJUSTMENT

Perform the levelizer adjustment.

>> Refer to [EXL-8, "LEVELIZER ADJUSTMENT : Special Repair Requirement"](#).

A
B
C
D
E
F
G
H
I
J
K
L
M
N
O
P

EXL

B2521 ECU CIRCUIT

Description

INFOID:000000000962451

AFS control unit judges the vehicle condition from each signal. AFS control unit controls AFS function and the headlamp aiming.

DTC Logic

INFOID:000000000962452

DTC DETECTION LOGIC

[B2521] ECU circuit

Error detection condition	DTC erase condition	Possible cause
<ul style="list-style-type: none"> • AFS control unit indicates an applicable DTC when detecting any of the following conditions continuously for 2 seconds or more. - The swivel position sensor is shorted to the power supply or the ground. - The swivel position sensor signal is shorted to the ground. - The height sensor power supply is shorted to the power supply or the ground. - The height sensor signal is shorted to the ground. • AFS control unit RAM/ROM error 	Ignition switch OFF	Swivel position sensor <ul style="list-style-type: none"> • Swivel position sensor • Harness and connector • AFS control unit Height sensor <ul style="list-style-type: none"> • Height sensor • Harness and connector • AFS control unit AFS control unit (RAM/ROM) <ul style="list-style-type: none"> • AFS control unit

DTC CONFIRMATION PROCEDURE

1.DTC ERASE

Erase the DTC memory of AFS with CONSULT-III.

>> GO TO 2.

2.DTC CONFIRMATION PROCEDURE

1. Turn ignition ON.
2. Select the self-diagnosis with CONSULT-III.
3. Check the self-diagnosis result. Refer to [EXL-173, "DTC Index"](#).

Is "B2521" detected?

- YES >> Refer to [EXL-54, "Diagnosis Procedure"](#).
 NO >> Refer to [GI-39, "Intermittent Incident"](#).

Diagnosis Procedure

INFOID:000000000962453

1.CHECK EACH SENSOR POWER SUPPLY

1. Turn the ignition switch ON.
2. Check the voltage between the AFS control unit harness connector and the ground.

Terminals		Voltage (Approx.)
(+)	(-)	
AFS control unit		Ground
Connector	Terminal	
M16	4	
	6	
	24	
		4 - 6 V

Is the measurement value within the standard value?

- YES >> GO TO 2.
 Less than the standard value >>GO TO 3.
 Higher than the standard value>>GO TO 4.

B2521 ECU CIRCUIT

< COMPONENT DIAGNOSIS >

[XENON TYPE]

2. CHECK EACH SENSOR SIGNAL

Check the voltage between the AFS control unit harness connector and the ground.

Terminals		Voltage (Approx.)	
(+)	(-)		
AFS control unit		Ground	0.25 - 4.75 V
Connector	Terminal		
M16	9		
	28		
	29		

Is the measurement value within the standard value?

YES >> Replace AFS control unit.

Less than the standard value >> GO TO 5.

Higher than the standard value >> GO TO 6.

3. CHECK EACH SENSOR POWER SUPPLY SHORT CIRCUIT

1. Turn the ignition switch OFF.
2. Disconnect AFS control unit connector.
3. Check continuity between the AFS control unit harness connector and the ground.

Terminals		Continuity	
(+)	(-)		
AFS control unit		Ground	Not existed
Connector	Terminal		
M16	4		
	6		
	24		

Does continuity exist?

YES >> Repair the harnesses or connectors.

NO >> Replace AFS control unit.

4. CHECK EACH SENSOR POWER SUPPLY CIRCUIT

1. Turn the ignition switch OFF.
2. Disconnect AFS control unit connector.
3. Check the voltage between the AFS control unit harness connector and the ground.

Terminals		Voltage (Approx.)	
(+)	(-)		
AFS control unit		Ground	0 V
Connector	Terminal		
M16	4		
	6		
	24		

Is the measurement value normal?

YES >> Replace AFS control unit.

NO >> Repair the harnesses or connectors.

5. CHECK EACH SENSOR SIGNAL SHORT CIRCUIT

1. Turn the ignition switch OFF.
2. Disconnect AFS control unit connector.
3. Check continuity between the AFS control unit harness connector and the ground.

A
B
C
D
E
F
G
H
I
J
K
EXL
M
N
O
P

B2521 ECU CIRCUIT

[XENON TYPE]

< COMPONENT DIAGNOSIS >

Terminals		
(+)	(-)	
AFS control unit		Ground
Connector	Terminal	
M16	9	
	28	
	29	

Continuity

Not existed

Does continuity exist?

YES >> Repair the harnesses or connectors.

NO >> Replace AFS control unit.

6. CHECK EACH SENSOR SIGNAL SHORT CIRCUIT

1. Turn the ignition switch OFF.
2. Disconnect AFS control unit connector.
3. Turn the ignition switch ON.
4. Check the voltage between the AFS control unit harness connector and the ground.

Terminals		
(+)	(-)	
AFS control unit		Ground
Connector	Terminal	
M16	9	
	28	
	29	

Voltage
(Approx.)

0 V

Is the measurement value normal?

YES >> Replace AFS control unit.

NO >> Repair the harnesses or connectors.

C0126 STEERING ANGLE SENSOR SIGNAL

< COMPONENT DIAGNOSIS >

[XENON TYPE]

C0126 STEERING ANGLE SENSOR SIGNAL

Description

INFOID:000000000962454

AFS control unit receives the steering angle sensor signal from the steering angle sensor with CAN communication.

DTC Logic

INFOID:000000000962455

DTC DETECTION LOGIC

[C0126] Steering angle sensor signal

DTC detection condition	DTC erase condition	Possible causes
In any of the following conditions <ul style="list-style-type: none">The steering angle sensor signal is not received.The steering angle sensor signal error is received.Out-of-standard signal (-900°- +900°) is received.	The ignition switch OFF	<ul style="list-style-type: none">Steering angle sensorAFS control unit

DTC CONFIRMATION PROCEDURE

1. DTC ERASE

Erase the DTC memory of AFS with CONSULT-III.

>> GO TO 2.

2. DTC CONFIRMATION

- Start the engine.
- Turn the steering wheel to the maximum right/left.
- Select the self-diagnosis with CONSULT-III.
- Check the self-diagnosis result. Refer to [EXL-173, "DTC Index"](#).

Is "C0126" detected?

- YES >> Refer to [EXL-57, "Diagnosis Procedure"](#).
NO >> Refer to [GI-39, "Intermittent Incident"](#).

Diagnosis Procedure

INFOID:000000000962456

1. ABS ACTUATOR AND ELECTRICAL UNIT (CONTROL UNIT) SELF-DIAGNOSIS

Check the self-diagnosis result with CONSULT-III. Check that ABS actuator and electrical unit (control unit) does not detect any DTCs.

Is any DTC detected?

- YES >> Check ABS actuator and electrical unit (control unit). Refer to [BRC-77, "Reference Value"](#).
NO >> GO TO 2.

2. DTC ERASE

Erase DTC memory of AFS with CONSULT-III.

Is the memory erased?

- YES >> Inspection end.
NO >> Replace AFS control unit.

C0428 STEERING ANGLE SENSOR CALIBRATION

< COMPONENT DIAGNOSIS >

[XENON TYPE]

C0428 STEERING ANGLE SENSOR CALIBRATION

Description

INFOID:000000000962457

AFS control unit receives the steering angle sensor signal from the steering angle sensor with CAN communication.

DTC Logic

INFOID:000000000962458

[C0428] Steering angle sensor calibration

DTC detection condition	DTC erase condition	Possible causes
The steering angle sensor neutral position is not recognized.	When the steering angle sensor neutral position registration is completed	Steering angle sensor

Diagnosis Procedure

INFOID:000000000962459

1. STEERING ANGLE SENSOR NEUTRAL POSITION ADJUSTMENT

Perform the steering angle sensor neutral position adjustment.

CAUTION:

Perform the steering angle sensor neutral position adjustment on VDC side. VDC may activate incorrectly.

>> Refer to [BRC-8, "ADJUSTMENT OF STEERING ANGLE SENSOR NEUTRAL POSITION : Special Repair Requirement"](#).

U1000 CAN COMM CIRCUIT

< COMPONENT DIAGNOSIS >

[XENON TYPE]

U1000 CAN COMM CIRCUIT

Description

INFOID:000000000962460

CAN (Controller Area Network) is the serial transmission for real time application. CAN is the multiplex communication for the vehicle with superior data transmission speed and error detection ability. Many electronic control units are equipped on the vehicle. These control units do not operate individually, but associates with other control units by sharing information. In CAN communication, each control unit is connected with two communication lines (CAN-H and CAN-L). Much information is transmitted with fewer communication lines than before. Each control unit transmits/receives data and reads the necessary data only. CAN Communication Signal Chart. Refer to [LAN-28, "CAN Communication Signal Chart"](#).

DTC Logic

INFOID:000000000962461

DTC DETECTION LOGIC

[U1000] CAN communication circuit

DTC detection condition	DTC erase condition	Possible causes
When AFS control unit does not transmit/receive CAN communication signal continuously for 2 seconds or more	Ignition switch OFF	One or more following items of CAN communication system are error. <ul style="list-style-type: none">• Transmission• Reception (ECM)• Reception (Unified meter and A/C amp.)• Reception (TCM)• Reception (Steering angle sensor)• Reception (IPDM E/R)

Diagnosis Procedure

INFOID:000000000962462

1. PERFORM SELF DIAGNOSTIC

1. Turn ignition switch ON and wait for 2 seconds or more.
2. Check "Self Diagnostic Result".

Is "CAN COMM CIRCUIT" displayed?

- YES >> Refer to [LAN-18, "Trouble Diagnosis Flow Chart"](#).
NO >> Refer to [GI-39, "Intermittent Incident"](#).

A
B
C
D
E
F
G
H
I
J
K
EXL
M
N
O
P

U1010 CONTROL UNIT (CAN)

< COMPONENT DIAGNOSIS >

[XENON TYPE]

U1010 CONTROL UNIT (CAN)

Description

INFOID:000000000962463

When DTC U1010 is detected, replace AFS control unit.
during the initial diagnosis of CAN controller of AFS control unit.

POWER SUPPLY AND GROUND CIRCUIT

< COMPONENT DIAGNOSIS >

[XENON TYPE]

POWER SUPPLY AND GROUND CIRCUIT

BCM (BODY CONTROL MODULE)

BCM (BODY CONTROL MODULE) : Diagnosis Procedure

INFOID:000000000962464

1. CHECK FUSE AND FUSIBLE LINK

Check that the following fuse and fusible link are not blown.

Terminal No.	Signal name	Fuse and fusible link No.
1	Battery power supply	K
11		10

Is the fuse fusing?

YES >> Replace the blown fuse or fusible link after repairing the affected circuit if a fuse or fusible link is blown.

NO >> GO TO 2.

2. CHECK POWER SUPPLY CIRCUIT

1. Turn ignition switch OFF.
2. Disconnect BCM connectors.
3. Check voltage between BCM harness connector and ground.

Terminals		Voltage (Approx.)
(+)	(-)	
BCM		Ground Battery voltage
Connector	Terminal	
M118	1	
M119	11	

Is the measurement value normal?

YES >> GO TO 3.

NO >> Repair harness or connector.

3. CHECK GROUND CIRCUIT

Check continuity between BCM harness connector and ground.

BCM		Ground	Continuity
Connector	Terminal		
M119	13		Existed

Does continuity exist?

YES >> INSPECTION END

NO >> Repair harness or connector.

BCM (BODY CONTROL MODULE) : Special Repair Requirement

INFOID:000000000962465

1. REQUIRED WORK WHEN REPLACING BCM

Initialize IVIS by CONSULT-III. For the details of initialization refer to CONSULT-III operation manual NATS-IVIS/NVIS.

>> Work end.

IPDM E/R (INTELLIGENT POWER DISTRIBUTION MODULE ENGINE ROOM)

IPDM E/R (INTELLIGENT POWER DISTRIBUTION MODULE ENGINE ROOM) : Diagnosis Procedure

INFOID:000000000962466

A
B
C
D
E
F
G
H
I
J
K
EXL
M
N
O
P

POWER SUPPLY AND GROUND CIRCUIT

< COMPONENT DIAGNOSIS >

[XENON TYPE]

1.CHECK FUSES AND FUSIBLE LINK

Check that the following IPDM E/R fuses or fusible links are not blown.

Terminal No.	Signal name	Fuses and fusible link No.
1	Battery power supply	C
—		50
—		51

Is the fuse fusing?

YES >> Replace the blown fuse or fusible link after repairing the affected circuit if a fuse or fusible link is blown.

NO >> GO TO 2.

2.CHECK POWER SUPPLY CIRCUIT

1. Turn ignition switch OFF.
2. Disconnect IPDM E/R connector.
3. Check voltage between IPDM E/R harness connector and ground.

Terminals		Voltage (Approx.)
(+)	(-)	
IPDM E/R		Battery voltage
Connector	Terminal	
E4	1	
	2	

Is the measurement value normal?

YES >> GO TO 3.

NO >> Repair harness or connector.

3.CHECK GROUND CIRCUIT

Check continuity between IPDM E/R harness connectors and ground.

IPDM E/R		Ground	Continuity
Connector	Terminal		
E5	12		Existed
E6	41		

Does continuity exist?

YES >> INSPECTION END

NO >> Repair harness or connector.

AFS CONTROL UNIT

AFS CONTROL UNIT : Diagnosis Procedure

INFOID:000000000962467

1.FUSE INSPECTION

Check that the following fuses are not fusing.

Signal name	Connection position	Fuse No.	Capacity
Ignition power supply	FUSE BLOCK (J/B)	3	10 A

Is the fuse fusing?

YES >> Repair the applicable circuit. And then replace the fuse.

NO >> GO TO 2.

2.CHECK POWER SUPPLY CIRCUIT

POWER SUPPLY AND GROUND CIRCUIT

[XENON TYPE]

< COMPONENT DIAGNOSIS >

1. Turn ignition switch OFF.
2. Disconnect AFS control unit harness connector.
3. Check voltage between AFS control unit harness connector and ground.

Terminals		Voltage (Approx.)
(+)	(-)	
AFS control unit		Ground
Connector	Terminal	
M16	1	
		Battery voltage

Is the measurement value normal?

YES >> GO TO 3.

NO >> Repair harness or connector.

3.CHECK GROUND CIRCUIT

Check continuity between AFS control unit harness connectors and ground.

AFS control unit		Ground	Continuity
Connector	Terminal		
M16	25		Existed

Does continuity exist?

YES >> Repair harness or connector.

NO >> Power supply and ground circuit are normal.

A
B
C
D
E
F
G
H
I
J
K
L
M
N
O
P

EXL

EXTERIOR LAMP FUSE

< COMPONENT DIAGNOSIS >

[XENON TYPE]

EXTERIOR LAMP FUSE

Description

INFOID:000000000962468

Fuse list

Unit	Location	Fuse No.	Capacity
Headlamp HI (LH)	IPDM E/R	#54	10 A
Headlamp HI (RH)	IPDM E/R	#55	10 A
Headlamp LO (LH)	IPDM E/R	#56	15 A
Headlamp LO (RH)	IPDM E/R	#57	15 A
Front fog lamp	IPDM E/R	#58	15 A
Parking lamp (also used as the front side marker lamp)	IPDM E/R	#52	10 A
<ul style="list-style-type: none">• Tail lamp• Rear side marker lamp• License plate lamp• Each illumination	IPDM E/R	#53	10 A
Stop lamp	FUSE BLOCK (J/B)	#7	10 A
Back-up lamp	FUSE BLOCK (J/B)	#4	10 A

Diagnosis Procedure

INFOID:000000000962469

1. CHECK FUSE

Check that the following fuses are not fusing.

Unit	Location	Fuse No.	Capacity
Headlamp HI (LH)	IPDM E/R	#54	10 A
Headlamp HI (RH)	IPDM E/R	#55	10 A
Headlamp LO (LH)	IPDM E/R	#56	15 A
Headlamp LO (RH)	IPDM E/R	#57	15 A
Front fog lamp	IPDM E/R	#58	15 A
Parking lamp (also used as the front side marker lamp)	IPDM E/R	#52	10 A
<ul style="list-style-type: none">• Tail lamp• Rear side marker lamp• License plate lamp• Each illumination	IPDM E/R	#53	10 A
Stop lamp	FUSE BLOCK (J/B)	#7	10 A
Back-up lamp	FUSE BLOCK (J/B)	#4	10 A

Is the fuse fusing?

- YES >> Repair the applicable circuit. And then replace the fuse.
NO >> The fuse is normal.

HEADLAMP (HI) CIRCUIT

< COMPONENT DIAGNOSIS >

[XENON TYPE]

HEADLAMP (HI) CIRCUIT

Description

INFOID:000000000962470

The high beam solenoid drives the mobile valve shade. And the mobile valve shade switches the high beam and low beam of headlamp.

- When the head lamp high relay is turned ON, magnetic force is applied to the high beam solenoid (1) by a current. The mobile valve shade (3) is switched to the high beam position through the actuator rod (2).
- When the head lamp high relay is turned OFF, the current stops. The mobile valve shade returns to the low beam position automatically.

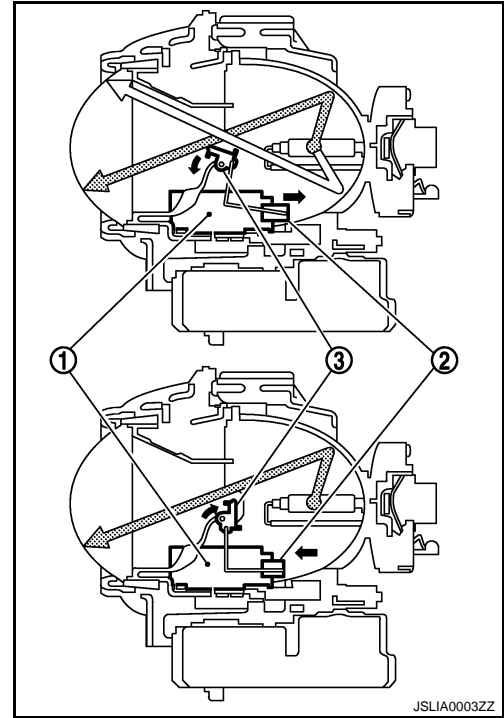

Component Function Check

INFOID:000000000962471

1. CHECK HEADLAMP (HI) OPERATION

IPDM E/R AUTO ACTIVE TEST

1. Start IPDM E/R auto active test. Refer to [PCS-10, "Diagnosis Description"](#).
2. Check that the headlamp switches to the high beam.

CONSULT-III ACTIVE TEST

1. Select "EXTERNAL LAMP" of IPDM E/R active test item.
2. With operating the test items, check that the headlamp switches to the high beam.

HI : Headlamp switches to the high beam.

OFF : Headlamp OFF

NOTE:

HI/LO is repeated 1 second each when using the IPDM E/R auto active test.

Does the headlamp switch to the high beam?

- YES >> Headlamp (HI) circuit is normal.
NO >> Refer to [EXL-65, "Diagnosis Procedure"](#).

Diagnosis Procedure

INFOID:000000000962472

1. CHECK HEADLAMP (HI) OUTPUT VOLTAGE

CONSULT-III ACTIVE TEST

1. Turn the ignition switch OFF.
2. Disconnect the front combination lamp connector.
3. Turn the ignition switch ON.
4. Select "EXTERNAL LAMP" of IPDM E/R active test item.
5. With operating the test items, check the voltage between the IPDM E/R harness connector and the ground.

HEADLAMP (HI) CIRCUIT

[XENON TYPE]

< COMPONENT DIAGNOSIS >

Terminals			Condition	Voltage (Approx.)
(+)		(-)		
IPDM E/R			External lamp	Battery voltage
Connector	Terminal			
RH	E8	89	Ground	HI
LH		90		OFF

Is the measurement value normal?

YES >> GO TO 2.

NO >> GO TO 3.

2. CHECK HEADLAMP (HI) OPEN CIRCUIT

1. Turn the ignition switch OFF.
2. Disconnect IPDM E/R connector.
3. Check continuity between the IPDM E/R harness connector and the front combination lamp harness connector.

IPDM E/R			Front combination lamp		Continuity
Connector	Terminal		Connector	Terminal	
RH	E8	89	E28	7	Existed
LH		90	E58	7	

Does continuity exist?

YES >> Replace the front combination lamp.

NO >> Repair the harnesses or connectors.

3. CHECK HEADLAMP (HI) FUSE

1. Turn the ignition switch OFF.
2. Check that the following fuses are not fusing.

Unit	Location	Fuse No.	Capacity
Headlamp HI (RH)	IPDM E/R	#55	10 A
Headlamp HI (LH)	IPDM E/R	#54	10 A

Is the fuse fusing?

YES >> GO TO 4.

NO >> Replace IPDM E/R.

4. CHECK FRONT COMBINATION LAMP (HI) SHORT CIRCUIT

1. Disconnect IPDM E/R connector.
2. Check continuity between the IPDM E/R harness connector terminal and the ground.

IPDM E/R			Ground	Continuity
Connector	Terminal			
RH	E8	89		Not existed
LH		90		

Does continuity exist?

YES >> Repair the harnesses or connectors. And then replace the fuse.

NO >> Replace the fuse. (Replace IPDM E/R if the fuse is fusing again.)

HEADLAMP (LO) CIRCUIT

< COMPONENT DIAGNOSIS >

[XENON TYPE]

HEADLAMP (LO) CIRCUIT

Description

INFOID:000000000962473

Headlamp (LO) circuit is connected to HID control unit integrated in the headlamp. Headlamp (LO) circuit turns xenon headlamp ON.

For the details of HID control unit and the xenon headlamp, refer to EXL-XX.

Component Function Check

INFOID:000000000962474

1. CHECK HEADLAMP (LO) OPERATION

IPDM E/R AUTO ACTIVE TEST

1. Start IPDM E/R auto active test. Refer to XX-XX auto active test.
2. Check that the headlamp is turned ON.

CONSULT-III ACTIVE TEST

1. Select "EXTERNAL LAMP" of IPDM E/R active test item.
2. With operating the test items, check that the headlamp is turned ON.

LO : Headlamp ON

OFF : Headlamp OFF

Is the headlamp turned ON?

YES >> Headlamp (LO) is normal.

NO >> Refer to [EXL-67, "Diagnosis Procedure"](#).

Diagnosis Procedure

INFOID:000000000962475

1. CHECK HEADLAMP (LO) OUTPUT VOLTAGE

CONSULT-III ACTIVE TEST

1. Turn the ignition switch OFF.
2. Disconnect the front combination lamp connector.
3. Turn the ignition switch ON.
4. Select "EXTERNAL LAMP" of IPDM E/R active test item.
5. With operating the test items, check the voltage between the IPDM E/R harness connector and the ground.

Terminals			Test item	Voltage (Approx.)
(+)	(-)			
IPDM E/R			External lamp	Battery voltage
Connector	Terminal			
RH	E8	83	LO	0 V
LH		84	OFF	

Is the measurement value normal?

YES >> GO TO 2.

NO >> GO TO 3.

2. CHECK HEADLAMP (LO) OPEN CIRCUIT

1. Turn the ignition switch OFF.
2. Disconnect IPDM E/R connector.
3. Check continuity between the IPDM E/R harness connector and the front combination lamp harness connector.

IPDM E/R		Front combination lamp		Continuity
Connector	Terminal	Connector	Terminal	

HEADLAMP (LO) CIRCUIT

[XENON TYPE]

< COMPONENT DIAGNOSIS >

RH	E8	83	E28	5	Existed
LH		84	E58	5	

Does continuity exist?

- YES >> GO TO 5.
 NO >> Repair the harnesses or connectors.

3.CHECK HEADLAMP (LO) FUSE

1. Turn the ignition switch OFF.
2. Check that the following fuses are not fusing.

Unit	Lotion	Fuse No.	Capacity
Headlamp LO (RH)	IPDM E/R	#57	15 A
Headlamp LO (LH)	IPDM E/R	#56	15 A

Is the fuse fusing?

- YES >> GO TO 4.
 NO >> Replace IPDM E/R.

4.CHECK HEADLAMP (LO) SHORT CIRCUIT

1. Disconnect IPDM E/R connector.
2. Check continuity between the IPDM E/R harness connector and the ground.

IPDM E/R		Ground	Continuity
Connector	Terminal		
RH	E8	83	Not existed
LH		84	

Does continuity exist?

- YES >> Repair the harnesses or connectors. And then replace the fuse.
 NO >> Replace the fuse. (Replace IPDM E/R if the fuse is fusing again.)

5.CHECK HEADLAMP GROUND OPEN CIRCUIT

Check continuity between the front combination lamp harness connector and the ground.

Front combination lamp			Ground	Continuity
Connector		Terminal		
RH	E28	3		Existed
LH		E58		

Does continuity exist?

- YES >> Perform the xenon headlamp diagnosis. Refer to [EXL-69. "Description"](#).
 NO >> Repair the harnesses or connectors.

XENON HEADLAMP

Description

INFOID:000000000962476

OUTLINE

- The lamp light source is by the arch discharge by applying high voltage into the xenon gas-filled bulb instead of the halogen bulb filament.
- Sight becomes more natural and brighter because the amount of light are gained adequately and the color of light is sunshine-like white.
- The xenon bulb drops the amount of light, repeats blinking, and illuminates in red if the bulb reaches the service life.

ILLUNMINATION PRINCIPLE

1. Discharging starts in high voltage pulse between bulb electrodes.
2. Xenon gas is activated by current between electrodes. Pale light is emitted.
3. The luminous tube (bulb) temperature elevates. Evaporated halide is activated by discharge. The color of light changes into white.

NOTE:

- Brightness and the color of light may change slightly immediately after the headlamp turned ON until the xenon bulb becomes stable. This is not malfunction.
- Illumination time lag may occur between right and left. This is not malfunction.

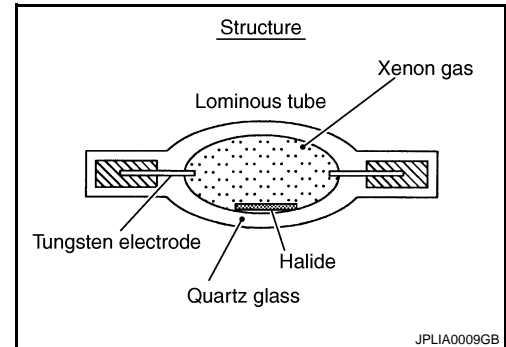

PRECAUTIONS FOR TROUBLE DIAGNOSIS

Representative malfunction examples are; "Light does not turn ON", "Light blinks", and "Brightness is inadequate." The cause often be the xenon bulb. Such malfunctions, however, are occurred occasionally by HID control unit malfunction or lamp case malfunction. Specify the malfunctioning part with diagnosis procedure.

WARNING:

- **Never touch the harness, HID control unit, the inside and metal part of lamp when turning the headlamp ON or operating the light switch.**
- **Never work with wet hands.**

CAUTION:

- **Never perform HID control unit circuit diagnosis with a circuit tester or an equivalent.**
- **Temporarily install the headlamp on the vehicle. Connect the battery to the connector (vehicle side) when checking ON/OFF status.**
- **Disconnect the battery negative terminal before disconnecting the lamp socket connector or the harness connector.**
- **Check for fusing of the fusible link(s), open around connector, short, disconnection if the symptom is caused by electric error.**

NOTE:

- Turn the switch OFF once before turning ON, if the ON/OFF is inoperative.
- The xenon bulb drops the amount of light, repeats blinking, and illuminates in red if the bulb reaches the service life.

Diagnosis Procedure

INFOID:000000000962477

1.CHECK XENON BULB

Install the normal bulb to the applicable headlamp. Check that the xenon bulb is turned ON.

Is the headlamp turned ON?

- YES >> Replace the xenon bulb.
- NO >> GO TO 2.

2.CHECK HID CONTROL UNIT

Install the normal HID control unit to the applicable headlamp. Check that the lamp is turned ON.

Is the headlamp turned ON?

XENON HEADLAMP

[XENON TYPE]

< COMPONENT DIAGNOSIS >

- YES >> Replace HID control unit.
- NO >> GO TO 3.

3.CHECK XENON HEADLAMP HOUSING ASSEMBLY

Install the normal xenon headlamp housing assembly to the applicable headlamp. Check that the xenon headlamp is turned ON.

Is the headlamp turned ON?

- YES >> Replace the front combination lamp. (Xenon headlamp housing voltage converter malfunctions.)
- NO >> Xenon headlamp is normal.

HEADLAMP LEVELIZER CIRCUIT

< COMPONENT DIAGNOSIS >

[XENON TYPE]

HEADLAMP LEVELIZER CIRCUIT

Description

INFOID:000000000962478

The headlamp levelizer adjusts the headlamp light axis upward and downward with the aiming motor integrated in the front combination lamp.

Component Function Check

INFOID:000000000962479

1. CHECK AIMING MOTOR OPERATION

CONSULT-III ACTIVE TEST

1. Start the engine.
2. Turn the lighting switch 2ND.
3. Select "LEVELIZER TEST" of ADAPTIVE LIGHT active test item.
4. With operating the test item, check the operation.

Test item	Light axis angle (Reference value)	10 m (32.8 ft)-forward light axis change refer- ence quantity (Approx.)
LEVELIZER TEST		
ORIGIN	0°	—
PEAK	2.5°	450 mm (17.9 in)

Is the operation normal?

- YES >> Headlamp levelizer circuit is normal.
 NO >> Refer to [EXL-71, "Diagnosis Procedure"](#).

Diagnosis Procedure

INFOID:000000000962480

1. CHECK AIMING MOTOR DRIVE SIGNAL OUTPUT

CONSULT-III ACTIVE TEST

1. Start the engine.
2. Turn the light switch 2ND.
3. Select "LEVELIZER TEST" of ADAPTIVE LIGHT active test item.
4. With operating the test item, check the voltage between the AFS control unit harness connector and the ground.

Terminals			Test item	Voltage (Approx.)		
(+)	(-)					
AFS control unit			LEVELIZER TEST			
Connector	Terminal					
RH	M16	19			ORIGIN	8.8 V
		PEAK			1.9 V	
LH	M16	40	ORIGIN	8.8 V		
			PEAK	1.9 V		

Is the measurement value normal?

- YES >> GO TO 2.
 NO >> GO TO 3.

2. CHECK AIMING MOTOR DRIVE SIGNAL CIRCUIT INPUT

1. Turn the ignition switch OFF.
2. Disconnect AFS control unit connector and aiming motor connector.
3. Check continuity between AFS control unit harness connector and the aiming motor harness connector.

HEADLAMP LEVELIZER CIRCUIT

< COMPONENT DIAGNOSIS >

[XENON TYPE]

Terminals					Continuity
(+)		(-)			
AFS control unit		Aiming motor			
Connector		Terminal	Connector	Terminal	Existed
RH	M16	19	E26	1	
LH		40	E56	1	

Does continuity exist?

- YES >> Replace the front combination lamp.
 NO >> Repair the harnesses and connectors.

3. CHECK AIMING MOTOR DRIVE SIGNAL SHORT CIRCUIT

1. Turn the ignition switch OFF.
2. Disconnect AFS control unit connector and aiming motor connector.
3. Check continuity between AFS control unit harness connector and ground.

Terminals					Continuity
(+)		(-)			
AFS control unit		Ground			
Connector		Terminal			Not existed
RH	M16	19			
LH		40			

Does continuity exist?

- YES >> Repair the harness and connectors.
 NO >> Replace AFS control unit.

FRONT FOG LAMP CIRCUIT

< COMPONENT DIAGNOSIS >

[XENON TYPE]

FRONT FOG LAMP CIRCUIT

Component Function Check

INFOID:000000000962481

1.CHECK FRONT FOG LAMP OPERATION

IPDM E/R AUTO ACTIVE TEST

1. Activate IPDM E/R auto active test. Refer to [PCS-10, "Diagnosis Description"](#).
2. Check that the front fog lamp is turned ON.

CONSULT-III ACTIVE TEST

1. Select "EXTERNAL LAMP" of IPDM E/R active test item.
2. With operating the test items, Check that the front fog lamp is turned ON.

FOG : Front fog lamp ON

OFF : Front fog lamp OFF

Is the front fog lamp turned ON?

- YES >> Front fog lamp circuit is normal.
NO >> Refer to [EXL-73, "Diagnosis Procedure"](#).

Diagnosis Procedure

INFOID:000000000962482

1.CHECK FRONT FOG LAMP FUSE

1. Turn the ignition switch OFF.
2. Check that the following fuses are not fusing.

Unit	Location	Fuse No.	Capacity
Front fog lamp	IPDM E/R	#58	15 A

Is the fuse fusing?

- YES >> GO TO 2.
NO >> GO TO 3.

2.CHECK FRONT FOG LAMP SHORT CIRCUIT

1. Disconnect IPDM E/R connector and the front combination lamp connector.
2. Check continuity between the IPDM E/R harness connector and the ground.

IPDM E/R		Ground	Continuity
Connector	Terminal		
RH	E8	86	Not existed
LH		87	

Does continuity exist?

- YES >> Repair the harnesses or connectors. And then replace the fuse.
NO >> Replace the fuse. (Replace IPDM E/R if the fuse is fusing again.)

3.CHECK FRONT FOG LAMP BULB

Check the applicable lamp bulb.

Is the bulb normal?

- YES >> GO TO 4.
NO >> Replace the bulb.

4.CHECK FRONT FOG LAMP OUTPUT VOLTAGE

CONSULT-III ACTIVE TEST

1. Disconnect the front combination lamp connector.
2. Turn the ignition switch ON.
3. Select "EXTERNAL LAMP" of IPDM E/R active test item.

FRONT FOG LAMP CIRCUIT

[XENON TYPE]

< COMPONENT DIAGNOSIS >

4. With operating the test items, check the voltage between the IPDM E/R harness connector and the ground.

Terminals			Test item	Voltage (Approx.)
(+)		(-)		
IPDM E/R			EXTERNAL LAMP	Battery voltage
Connector	Terminal			
RH	E8	86	FOG	0 V
LH		87	OFF	

Is the measurement value normal?

YES >> GO TO 5.

NO >> Replace IPDM E/R.

5. CHECK FRONT FOG LAMP OPEN CIRCUIT

1. Turn the ignition switch OFF.
2. Disconnect IPDM E/R connector.
3. Check continuity between the IPDM E/R harness connector and the front combination lamp harness connector.

IPDM E/R			Front combination lamp		Continuity
Connector	Terminal		Connector	Terminal	
RH	E8	86	E28	1	Existed
LH		87	E58	1	

Does continuity exist?

YES >> GO TO 6.

NO >> Repair the harnesses or connectors.

6. CHECK FRONT FOG LAMP GROUND CIRCUIT OPEN CIRCUIT

Check continuity between the front combination lamp harness connector and the ground.

Front combination lamp			Ground	Continuity
Connector	Terminal			
RH	E28	4	Ground	Existed
LH	E58	4		

Does continuity exist?

YES >> Replace the front combination lamp.

NO >> Repair the harnesses or connectors.

PARKING LAMP CIRCUIT

< COMPONENT DIAGNOSIS >

[XENON TYPE]

PARKING LAMP CIRCUIT

Component Function Check

INFOID:000000000962483

1. CHECK PARKING LAMP OPERATION

IPDM E/R AUTO ACTIVE TEST

1. Activate IPDM E/R auto active test. Refer to [PCS-10, "Diagnosis Description"](#).
2. Check that the parking lamp is turned ON.

CONSULT-III ACTIVE TEST

1. Select "EXTERNAL LAMP" of IPDM E/R active test item.
2. With operating the test items, check that the parking lamp is turned ON.

TAIL : Parking lamp ON
OFF : Parking lamp OFF

Is the parking lamp turned ON?

- YES >> Parking lamp circuit is normal.
NO >> Refer to [EXL-75, "Diagnosis Procedure"](#).

Diagnosis Procedure

INFOID:000000000962484

1. CHECK PARKING LAMP FUSE

1. Turn the ignition switch OFF.
2. Check that the following fuses are not fusing.

Unit	Location	Fuse No.	Capacity
Parking lamp	IPDM E/R	#52	10 A

Is the fuse fusing?

- YES >> GO TO 2.
NO >> GO TO 3.

2. CHECK PARKING LAMP SHORT CIRCUIT

1. Disconnect IPDM E/R connector and the front combination lamp connector.
2. Check continuity between the IPDM E/R harness connector and the ground.

IPDM E/R		Ground	Continuity
Connector	Terminal		
RH	E9	91	Not existed
LH		92	

Does continuity exist?

- YES >> Repair the harnesses or connectors. And then replace the fuse.
NO >> Replace the fuse. (Replace IPDM E/R if fusing is found again.)

3. CHECK PARKING LAMP BULB

Check the applicable lamp bulb.

Is the bulb normal?

- YES >> GO TO 4.
NO >> Replace the bulb.

4. CHECK PARKING LAMP OUTPUT VOLTAGE

CONSULT-III ACTIVE TEST

1. Disconnect the front combination lamp connector.
2. Turn the ignition switch ON.
3. Select "EXTERNAL LAMP" of IPDM E/R active test item.

PARKING LAMP CIRCUIT

[XENON TYPE]

< COMPONENT DIAGNOSIS >

4. With operating the test items, check the voltage between the IPDM E/R harness connector and the ground.

Terminals			Test item	Voltage (Approx.)
(+)		(-)		
IPDM E/R			EXTERNAL LAMP	Battery voltage
Connector	Terminal			
RH	E9	91	TAIL	0 V
LH		92	OFF	

Is the measurement value normal?

- YES >> GO TO 5.
 NO >> Replace IPDM E/R.

5. CHECK PARKING LAMP OPEN CIRCUIT

1. Turn the ignition switch OFF.
2. Disconnect IPDM E/R connector.
3. Check continuity between the IPDM E/R harness connector and the front combination lamp harness connector.

IPDM E/R			Front combination lamp		Continuity
Connector	Terminal		Connector	Terminal	
RH	E9	91	E28	8	Existed
LH		92	E58	8	

Does continuity exist?

- YES >> GO TO 6.
 NO >> Repair the harnesses or connectors.

6. CHECK PARKING LAMP GROUND OPEN CIRCUIT

Check continuity between the front combination lamp harness connector and the ground.

Front combination lamp			Ground	Continuity
Connector	Terminal			
RH	E28	4		Existed
LH	E58	4		

Does continuity exist?

- YES >> Replace the front combination lamp.
 NO >> Repair the harnesses or connectors.

TURN SIGNAL LAMP CIRCUIT

< COMPONENT DIAGNOSIS >

[XENON TYPE]

TURN SIGNAL LAMP CIRCUIT

Description

INFOID:000000000962485

BCM performs the high flasher operation (fail-safe) if any bulb or harness of the turn signal lamp circuit is open.

NOTE:

Turn signal lamp blinks at normal speed when using the hazard warning lamp.

Component Function Check

INFOID:000000000962486

1. CHECK TURN SIGNAL LAMP

ⓂCONSULT-III ACTIVE TEST

1. Select "FLASHER" of BCM (FLASHER) active test item.
2. With operating the test items, check that the turn signal lamp blinks.

LH : Turn signal lamp LH blinking

RH : Turn signal lamp RH blinking

OFF : The turn signal lamp OFF

Does the turn signal lamp blink?

YES >> Turn signal lamp circuit is normal.

NO >> Refer to [EXL-77. "Diagnosis Procedure"](#).

Diagnosis Procedure

INFOID:000000000962487

1. CHECK TURN SIGNAL LAMP BULB

Check the applicable lamp bulb.

Is the bulb normal?

YES >> GO TO 2.

NO >> Replace the bulb.

2. CHECK TURN SIGNAL LAMP OUTPUT VOLTAGE

ⓂCONSULT-III ACTIVE TEST

1. Turn the ignition switch OFF.
2. Disconnect the front combination lamp connector or the rear combination lamp connector.
3. Turn the ignition switch ON.
4. Select "FLASHER" of BCM (FLASHER) active test item.
5. With operating the turn signal switch, check the voltage between the BCM harness connector and the ground.

A
B
C
D
E
F
G
H
I
J
K
M
N
O
P

EXL

TURN SIGNAL LAMP CIRCUIT

< COMPONENT DIAGNOSIS >

[XENON TYPE]

Terminals			Test item	Voltage (Approx.)
(+)		(-)		
BCM			FLASHER	
Connector		Terminal		
Front RH	M119	17	LH or RH	
Front LH		18		
Rear RH	M120	20	OFF	0 V
Rear LH		25		

Is the measurement value normal?

- YES >> GO TO 3.
 NO >> Replace BCM.

3. CHECK TURN SIGNAL LAMP OPEN CIRCUIT

1. Turn the ignition switch OFF.
2. Disconnect BCM connector.
3. Check the voltage between the BCM harness connector and the front combination lamp or the rear combination lamp harness connector.

BCM		Front combination lamp / Rear combination lamp		Continuity
Connector	Terminal	Connector	Terminal	
Front RH	M119	17	E28	Existed
Front LH		18	E58	
Rear RH	M120	20	B67	
Rear LH		25	B60	

Does continuity exist?

- YES >> GO TO 4.
 NO >> Repair the harnesses or connectors.

4. CHECK TURN SIGNAL LAMP SHORT CIRCUIT

Check continuity between the BCM harness connector and the ground.

BCM			Ground	Continuity
Connector		Terminal		
Front RH	M119	17	Ground	Not existed
Front LH		18		
Rear RH	M120	20		
Rear LH		25		

Does continuity exist?

TURN SIGNAL LAMP CIRCUIT

[XENON TYPE]

< COMPONENT DIAGNOSIS >

YES >> Repair the harnesses or connectors.

NO >> GO TO 5.

5. CHECK TURN SIGNAL LAMP GROUND OPEN CIRCUIT

Check the voltage between the BCM harness connector and the front combination lamp or the rear combination lamp and the ground.

Front combination lamp / Rear combination lamp			Ground	Continuity
Connector		Terminal		
Front RH	E28	4	Existed	
Front LH	E58	4		
Rear RH	B67	4		
Rear LH	B60	4		

Does continuity exist?

YES >> Replace the front combination lamp or the rear combination lamp.

NO >> Repair the harnesses or connectors.

A
B
C
D
E
F
G
H
I
J
K
EXL
M
N
O
P

OPTICAL SENSOR

< COMPONENT DIAGNOSIS >

[XENON TYPE]

OPTICAL SENSOR

Description

INFOID:000000000962488

Optical sensor converts the outside brightness (lux) to voltage and transmits the optical sensor signal to BCM.

Component Function Check

INFOID:000000000962489

1. CHECK OPTICAL SENSOR SIGNAL BY CONSULT-III

CONSULT-III DATA MONITOR

1. Turn the ignition switch ON.
2. Select "OPTICAL SENSOR" of BCM (HEADLAMP) data monitor item.
3. Turn the lighting switch AUTO.
4. With the optical sensor illuminating, check the monitor status.

Monitor item	Condition		Voltage (Approx.)
OPTICAL SENSOR	Optical sensor	When illuminating	3.1 V or more *
		When shutting off light	0.6 V or less

*: Illuminates the optical sensor. The value may be less than the standard value if brightness is weak.

Is the item status normal?

- YES >> Optical sensor is normal.
NO >> Refer to [EXL-80, "Diagnosis Procedure"](#).

Diagnosis Procedure

INFOID:000000000962490

1. CHECK OPTICAL SENSOR POWER SUPPLY INPUT

1. Turn the ignition switch ON.
2. Turn the lighting switch AUTO.
3. Check the voltage between the optical sensor harness connector and the ground.

Terminals		Voltage (Approx.)
(+)	(-)	
Optical sensor		5 V
Connector	Terminal	
M94	1	

Is the measurement value normal?

- YES >> GO TO 2.
NO >> GO TO 4.

2. CHECK OPTICAL SENSOR GROUND INPUT

Check the voltage between the optical sensor harness connector and the ground.

Terminals		Voltage (Approx.)
(+)	(-)	
Optical sensor		0 V
Connector	Terminal	
M94	3	

Is the measurement value normal?

- YES >> GO TO 3.
NO >> GO TO 6.

OPTICAL SENSOR

[XENON TYPE]

< COMPONENT DIAGNOSIS >

3. CHECK OPTICAL SENSOR SIGNAL OUTPUT

With illuminating the optical sensor, check the voltage between the optical sensor harness connector and the ground.

Terminals		Condition	Voltage (Approx.)
(+)	(-)		
Optical sensor		Optical sensor	
Connector	Terminal		
M94	2	Ground	
		When illuminating	3.1 V or more *
		When shutting off light	0.6 V or less

*: Illuminate the optical sensor. The value may be less than the standard if brightness is weak.

Is the measurement value normal?

YES >> GO TO 7.

NO >> Replace the optical sensor.

4. CHECK OPTICAL SENSOR OPEN CIRCUIT

1. Turn the ignition switch OFF.
2. Disconnect the optical sensor connector and BCM connector.
3. Check continuity between the optical sensor harness connector and the BCM harness connector.

Optical sensor		BCM		Continuity
Connector	Terminal	Connector	Terminal	
M94	1	M123	138	Existed

Does continuity exist?

YES >> GO TO 5.

NO >> Repair the harnesses or connectors.

5. CHECK OPTICAL SENSOR SHORT CIRCUIT

Check the continuity between the optical sensor harness connector and the ground.

Optical sensor		Ground	Continuity
Connector	Terminal		
M94	1		Not existed

Does continuity exist?

YES >> Repair the harnesses or connectors.

NO >> Replace BCM.

6. CHECK OPTICAL SENSOR GROUND OPEN CIRCUIT

1. Turn the ignition switch OFF.
2. Disconnect the optical sensor connector and BCM connector.
3. Check continuity between the optical sensor harness connector and the BCM harness connector.

Optical sensor		BCM		Continuity
Connector	Terminal	Connector	Terminal	
M94	3	M123	137	Existed

Does continuity exist?

YES >> Replace BCM.

NO >> Repair the harnesses or connectors.

7. CHECK OPTICAL SENSOR SIGNAL OPEN CIRCUIT

OPTICAL SENSOR

[XENON TYPE]

< COMPONENT DIAGNOSIS >

1. Turn the ignition switch OFF.
2. Disconnect the optical sensor connector and BCM connector.
3. Check continuity between the optical sensor harness connector and the BCM harness connector.

Optical sensor		BCM		Continuity
Connector	Terminal	Connector	Terminal	
M94	2	M123	113	Existed

Does continuity exist?

YES >> GO TO 8.

NO >> Repair the harnesses or connectors.

8.CHECK OPTICAL SENSOR SHORT CIRCUIT

Check the continuity between the optical sensor harness connector and the ground.

Optical sensor		Ground	Continuity
Connector	Terminal		
M94	2		Not existed

Does continuity exist?

YES >> Repair the harnesses or connectors.

NO >> Replace BCM.

HAZARD SWITCH

< COMPONENT DIAGNOSIS >

[XENON TYPE]

HAZARD SWITCH

Description

INFOID:000000000962491

Hazard switch is integrated in the multifunction switch. Hazard switch inputs the signals to BCM when pressing the switch.

Component Function Check

INFOID:000000000962492

1.CHECK HAZARD SWITCH SIGNAL BY CONSULT-III

CONSULT-III DATA MONITOR

1. Turn the ignition switch ON.
2. Select "HAZARD SW" of BCM (FLASHER) data monitor item.
3. With operating the hazard switch, check the monitor status.

Monitor item	Condition		Monitor status
HAZARD SW	Hazard switch	While pressing the switch	ON
		While not pressing the switch	OFF

Is the item status normal?

- YES >> Hazard switch circuit is normal.
 NO >> Refer to [EXL-83, "Diagnosis Procedure"](#).

Diagnosis Procedure

INFOID:000000000962493

1.CHECK HAZARD SWITCH SIGNAL INPUT

With operating the hazard switch, check the voltage between the BCM harness connector and the ground.

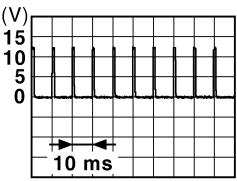
Terminals		Condition	Voltage (Approx.)
(+)	(-)		
BCM		Hazard switch	0 V
Connector	Terminal		
M122	110	While pressing the switch	
		While not pressing the switch	
	Ground		

JPMIA0012GB

Is the measurement value normal?

- YES >> Replace BCM.
 NO >> GO TO 2.

2.CHECK HAZARD SWITCH SIGNAL OPEN CIRCUIT

1. Turn the ignition switch OFF.
2. Disconnect the multifunction switch connector and BCM connector.
3. Check continuity between the multifunction switch harness connector and the BCM harness connector.

HAZARD SWITCH

[XENON TYPE]

< COMPONENT DIAGNOSIS >

Multifunction switch		BCM		Continuity
Connector	Terminal	Connector	Terminal	
M72	16	M122	110	Existed

Does continuity exist?

YES >> GO TO 3.

NO >> Repair the harnesses or connectors.

3.CHECK HAZARD SWITCH SIGNAL SHORT CIRCUIT

Check continuity between the multifunction switch harness connector and the ground.

Multifunction switch		Ground	Continuity
Connector	Terminal		
M72	16		Not existed

Does continuity exist?

YES >> Repair the harnesses or connectors.

NO >> GO TO 4.

4.CHECK HAZARD SWITCH GROUND OPEN CIRCUIT

Check continuity between the multifunction switch harness connector and the ground.

Multifunction switch		Ground	Continuity
Connector	Terminal		
M72	1		Existed

Does continuity exist?

YES >> Replace the hazard switch (multifunction switch).

NO >> Repair the harnesses or connectors.

TAIL LAMP CIRCUIT

< COMPONENT DIAGNOSIS >

[XENON TYPE]

TAIL LAMP CIRCUIT

Component Function Check

INFOID:000000000962494

1.CHECK TAIL LAMP OPERATION

IPDM E/R AUTO ACTIVE TEST

1. Activate IPDM E/R auto active test. Refer to [PCS-10, "Diagnosis Description"](#).
2. Check that the tail lamp is turned ON.

CONSULT-III ACTIVE TEST

1. Select "EXTERNAL LAMP" of IPDM E/R active test item.
2. With operating the test items, check that the tail lamp is turned ON.

TAIL : Tail lamp ON
OFF : Tail lamp OFF

Is the tail lamp turned ON?

- YES >> Tail lamp circuit is normal.
 NO >> Refer to [EXL-85, "Diagnosis Procedure"](#).

Diagnosis Procedure

INFOID:000000000962495

1.CHECK TAIL LAMP FUSE

1. Turn the ignition switch OFF.
2. Check that the following fuses are not fusing.

Unit	Location	Fuse No.	Capacity
<ul style="list-style-type: none"> • Tail lamp • Rear side marker lamp • License plate lamp 	IPDM E/R	#53	10 A

Is the fuse fusing?

- YES >> Repair the malfunctioning part before replacing the fuse.
 NO >> GO TO 2.

2.CHECK TAIL LAMP OUTPUT VOLTAGE

CONSULT-III ACTIVE TEST

1. Disconnect the rear combination lamp connector.
2. Turn the ignition switch ON.
3. Select "EXTERNAL LAMP" of IPDM E/R active test item.
4. With operating the test items, check the voltage between the IPDM E/R harness connector and the ground.

Terminals		Test item	Voltage (Approx.)
(+)	(-)		
IPDM E/R		EXTERNAL LAMP	Battery voltage
Connector	Terminal		
E5	7	TAIL	
		OFF	0 V

Is the measurement value normal?

- YES >> GO TO 3.
 NO >> Replace IPDM E/R.

3.CHECK TAIL LAMP OPEN CIRCUIT

1. Turn the ignition switch OFF.
2. Disconnect IPDM E/R connector.

A
B
C
D
E
F
G
H
I
J
K
M
N
O
P

EXL

TAIL LAMP CIRCUIT

[XENON TYPE]

< COMPONENT DIAGNOSIS >

3. Check continuity between the IPDM E/R harness connector and the rear combination lamp harness connector.

IPDM E/R		Rear combination lamp		Continuity	
Connector	Terminal	Connector	Terminal		
RH	E5	7	B67	1	Existed
LH			B60		

Does continuity exist?

YES >> GO TO 4.

NO >> Repair the harnesses or connectors.

4. CHECK TAIL LAMP GROUND OPEN CIRCUIT

Check continuity between the rear combination lamp harness connector and the ground.

Rear combination lamp			Ground	Continuity
Connector	Terminal			
RH	B67	4	Ground	Existed
LH	B60	4		

Does continuity exist?

YES >> Replace the rear combination lamp.

NO >> Repair the harnesses or connectors.

LICENSE PLATE LAMP CIRCUIT

< COMPONENT DIAGNOSIS >

[XENON TYPE]

LICENSE PLATE LAMP CIRCUIT

Component Function Check

INFOID:000000000962496

NOTE:

Check the tail lamp circuit if the tail lamp and the license plate lamp are not turned ON.

1.CHECK LICENSE PLATE LAMP OPERATION

⊗ IPDM E/R AUTO ACTIVE TEST

1. Activate IPDM E/R auto active test. Refer to [PCS-10, "Diagnosis Description"](#).
2. Check that the license plate lamp is turned ON.

Ⓜ CONSULT-III ACTIVE TEST

1. Select "EXTERNAL LAMP" of IPDM E/R active test item.
2. With operating the lighting switch, check that the license plate lamp is turned ON.

TAIL : License plate lamp ON

OFF : License plate lamp OFF

Is the license plate lamp turned ON?

YES >> License plate lamp circuit is normal.

NO >> Refer to [EXL-87, "Diagnosis Procedure"](#).

Diagnosis Procedure

INFOID:000000000962497

1.CHECK LICENSE PLATE LAMP BULB

Check the applicable lamp bulb.

Is the bulb normal?

YES >> GO TO 2.

NO >> Replace the bulb.

2.CHECK LICENSE PLATE LAMP OPEN CIRCUIT

1. Turn the ignition switch OFF.
2. Disconnect IPDM E/R connector and the license plate lamp connector.
3. Check continuity between the IPDM E/R harness connector and the license plate lamp harness connector.

IPDM E/R		License plate lamp		Continuity
Connector	Terminal	Connector	Terminal	
RH	E5	B93	1	Existed
LH		B92	1	

Does continuity exist?

YES >> GO TO 3.

NO >> Repair the harnesses or connectors.

3.CHECK LICENSE PLATE LAMP GROUND OPEN CIRCUIT

Check continuity between the license plate lamp harness connector and the ground.

License plate lamp			Ground	Continuity
Connector	Terminal			
RH	B93	2	Existed	
LH	B92	2		

Does continuity exist?

YES >> Replace the license plate lamp.

NO >> Repair the harnesses or connectors.

A
B
C
D
E
F
G
H
I
J
K
M
N
O
P

EXL

HEADLAMP SYSTEM

< COMPONENT DIAGNOSIS >

[XENON TYPE]

HEADLAMP SYSTEM

Wiring Diagram —HEADLAMP—

INFOID:000000000962498

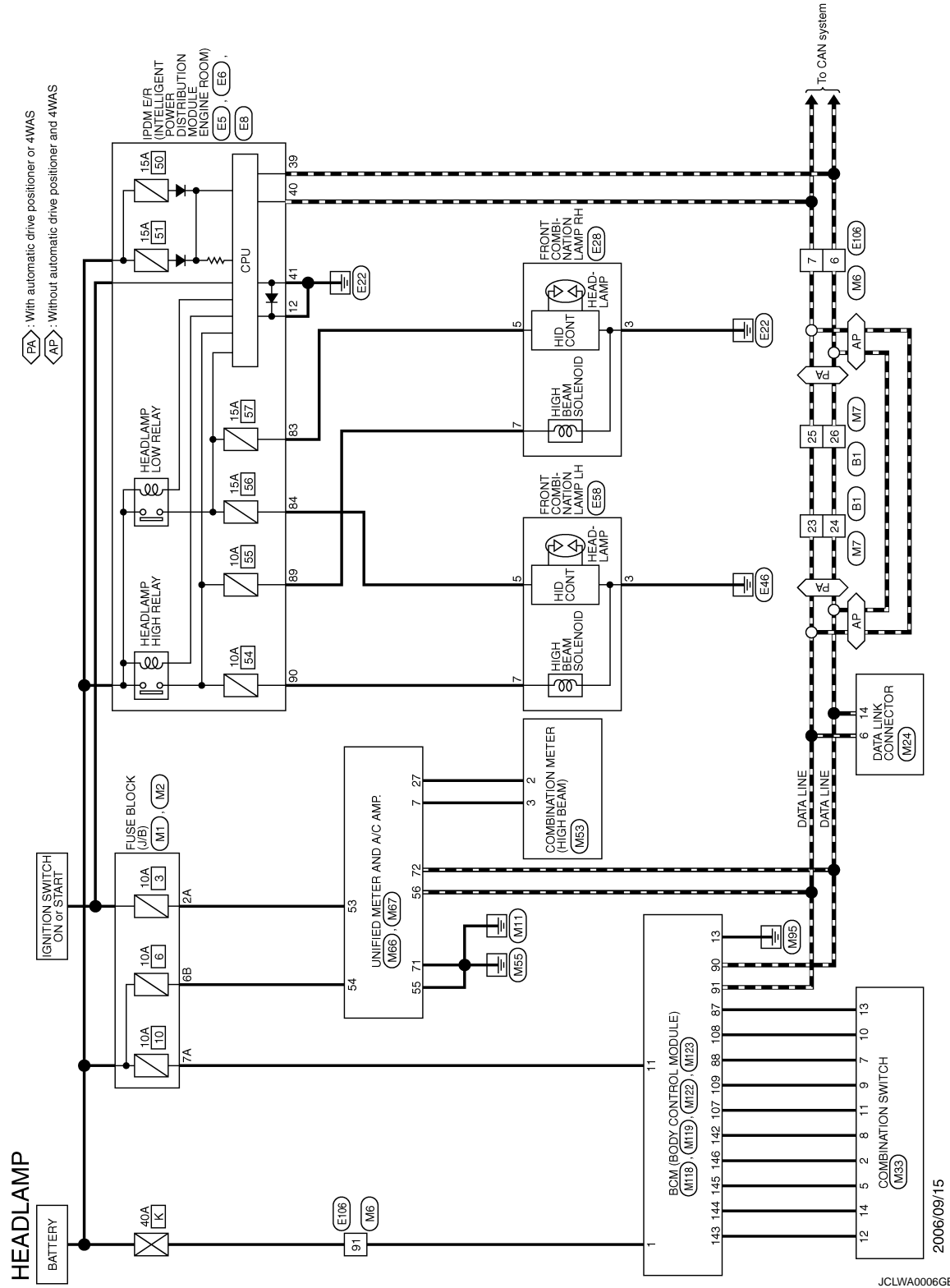





HEADLAMP SYSTEM

< COMPONENT DIAGNOSIS >

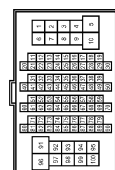
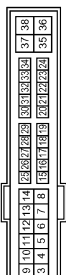
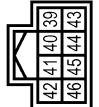
[XENON TYPE]

HEADLAMP

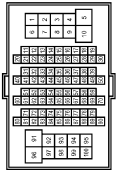
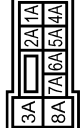
<p>Connector No. B1</p> <p>Connector Name WIRE TO WIRE</p> <p>Connector Type TH80FW-CS16-TM4</p> 	<p>Terminal No. 23</p> <p>Color of Wire L</p> <p>Signal Name -</p>	<p>Terminal No. 24</p> <p>Color of Wire P</p> <p>Signal Name -</p>	<p>Terminal No. 25</p> <p>Color of Wire L</p> <p>Signal Name -</p>	<p>Terminal No. 26</p> <p>Color of Wire P</p> <p>Signal Name -</p>
<p>Connector No. E5</p> <p>Connector Name IPDM E/R INTELLIGENT POWER DISTRIBUTION MODULE ENGINE ROOM)</p> <p>Connector Type TH20FW-CS12-M4-1V</p> 	<p>Terminal No. 12</p> <p>Color of Wire B/W</p> <p>Signal Name -</p>			
<p>Connector No. E6</p> <p>Connector Name IPDM E/R INTELLIGENT POWER DISTRIBUTION MODULE ENGINE ROOM)</p> <p>Connector Type TH40FW-NH</p> 	<p>Terminal No. 39</p> <p>Color of Wire P</p> <p>Signal Name -</p>	<p>Terminal No. 40</p> <p>Color of Wire L</p> <p>Signal Name -</p>	<p>Terminal No. 41</p> <p>Color of Wire B/W</p> <p>Signal Name -</p>	
<p>Connector No. E8</p> <p>Connector Name IPDM E/R INTELLIGENT POWER DISTRIBUTION MODULE ENGINE ROOM)</p> <p>Connector Type NS28FW-CS</p> 	<p>Terminal No. 83</p> <p>Color of Wire R</p> <p>Signal Name -</p>	<p>Terminal No. 84</p> <p>Color of Wire P</p> <p>Signal Name -</p>	<p>Terminal No. 88</p> <p>Color of Wire BR</p> <p>Signal Name -</p>	<p>Terminal No. 90</p> <p>Color of Wire P</p> <p>Signal Name -</p>
<p>Connector No. E28</p> <p>Connector Name FRONT COMBINATION LAMP RH</p> <p>Connector Type RS38FB-PR</p> 	<p>Terminal No. 3</p> <p>Color of Wire B</p> <p>Signal Name -</p>	<p>Terminal No. 5</p> <p>Color of Wire R</p> <p>Signal Name -</p>	<p>Terminal No. 7</p> <p>Color of Wire BR</p> <p>Signal Name -</p>	
<p>Connector No. E58</p> <p>Connector Name FRONT COMBINATION LAMP LH</p> <p>Connector Type RS38FB-PR</p> 	<p>Terminal No. 3</p> <p>Color of Wire B/W</p> <p>Signal Name -</p>	<p>Terminal No. 5</p> <p>Color of Wire P</p> <p>Signal Name -</p>	<p>Terminal No. 7</p> <p>Color of Wire P</p> <p>Signal Name -</p>	
<p>Connector No. E106</p> <p>Connector Name WIRE TO WIRE</p> <p>Connector Type TH80FW-CS16-TM4</p> 	<p>Terminal No. 6</p> <p>Color of Wire P</p> <p>Signal Name -</p>	<p>Terminal No. 7</p> <p>Color of Wire L</p> <p>Signal Name -</p>	<p>Terminal No. 91</p> <p>Color of Wire W</p> <p>Signal Name -</p>	
<p>Connector No. M1</p> <p>Connector Name FUSE BLOCK (J/B)</p> <p>Connector Type NS28FW-M2</p> 	<p>Terminal No. 2A</p> <p>Color of Wire G</p> <p>Signal Name -</p>	<p>Terminal No. 7A</p> <p>Color of Wire R</p> <p>Signal Name -</p>		

A
B
C
D
E
F
G
H
I
J
K
EXL
M
N
O
P

JCLWA0007GB

HEADLAMP SYSTEM

< COMPONENT DIAGNOSIS >

[XENON TYPE]

HEADLAMP

Connector No.	M2
Connector Name	FUSE BLOCK (J/B)
Connector Type	NS10FW-CS



Terminal No.	Color of Wire	Signal Name
6B	Y	-

Connector No.	M6
Connector Name	WIRE TO WIRE
Connector Type	TH80MW-CS16-TM4

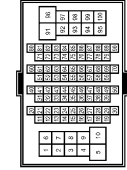

Terminal No.	Color of Wire	Signal Name
6	P	-
7	L	-
91	W	-

Connector No.	M7
Connector Name	WIRE TO WIRE
Connector Type	TH80MW-CS16-TM4

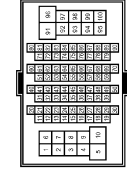

Terminal No.	Color of Wire	Signal Name
23	L	-
24	P	-
25	L	-
26	P	-

Connector No.	M24
Connector Name	DATA LINK CONNECTOR
Connector Type	BD16FW

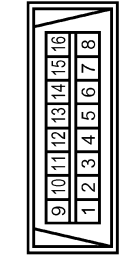

Terminal No.	Color of Wire	Signal Name
6	L	-
14	P	-

Connector No.	M33
Connector Name	COMBINATION SWITCH
Connector Type	TH16FW-RH

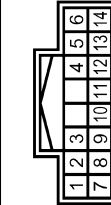

Terminal No.	Color of Wire	Signal Name
2	SB	OUTPUT 4
5	L	OUTPUT 3
7	V	INPUT 3
8	O	OUTPUT 5
9	Y	INPUT 2
10	R	INPUT 4
11	LG	INPUT 1
12	P	OUTPUT 1
13	BR	INPUT 5
14	G	OUTPUT 2

Connector No.	M53
Connector Name	COMBINATION METER
Connector Type	SAB40FW

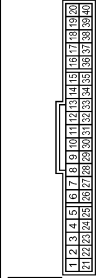

Terminal No.	Color of Wire	Signal Name
2	LG	COMM (METER->AMP)
3	GR	COMM (AMP->METER)

Connector No.	M66
Connector Name	UNIFIED METER AND A.C AMP.
Connector Type	TH40FW-NH

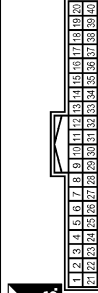

Terminal No.	Color of Wire	Signal Name
7	GR	COMM (AMP->METER)
27	LG	COMM (METER->AMP)

Connector No.	M67
Connector Name	UNIFIED METER AND A.C AMP.
Connector Type	TH82FW-NH

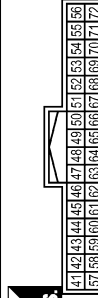

Terminal No.	Color of Wire	Signal Name
53	G	IGN
54	Y	BAT
65	B	GND
66	L	CAN-H
71	B	GND
72	P	CAN-L

JCLWA0008GB

HEADLAMP SYSTEM

< COMPONENT DIAGNOSIS >

[XENON TYPE]

HEADLAMP

Connector No.	M118
Connector Name	BCM (BODY CONTROL MODULE)
Connector Type	M03FB-LC



Terminal No.	Color of Wire	Signal Name
1	W	BAT (E/L)

Connector No.	M119
Connector Name	BCM (BODY CONTROL MODULE)
Connector Type	NS16FW-GS



Terminal No.	Color of Wire	Signal Name
11	R	BAT (FUSE)
13	B	GND

Connector No.	M122
Connector Name	BCM (BODY CONTROL MODULE)
Connector Type	TH40FB-NH



Terminal No.	Color of Wire	Signal Name
87	BR	COMBI SW INPUT 5
88	V	COMBI SW INPUT 3
89	P	CAN-L
90	L	CAN-H
107	LG	COMBI SW INPUT 1
108	R	COMBI SW INPUT 4
109	Y	COMBI SW INPUT 2

Connector No.	M123
Connector Name	BCM (BODY CONTROL MODULE)
Connector Type	TH40FG-NH



Terminal No.	Color of Wire	Signal Name
142	O	COMBI SW OUTPUT 5
143	P	COMBI SW OUTPUT 1
144	G	COMBI SW OUTPUT 2
145	L	COMBI SW OUTPUT 3
146	SB	COMBI SW OUTPUT 4

A
B
C
D
E
F
G
H
I
J
K
EXL
M
N
O
P

JCLWA0009GB

AUTO LIGHT SYSTEM

< COMPONENT DIAGNOSIS >

[XENON TYPE]

AUTO LIGHT SYSTEM

Wiring Diagram —AUTO LIGHT SYSTEM—

INFOID:000000000962499

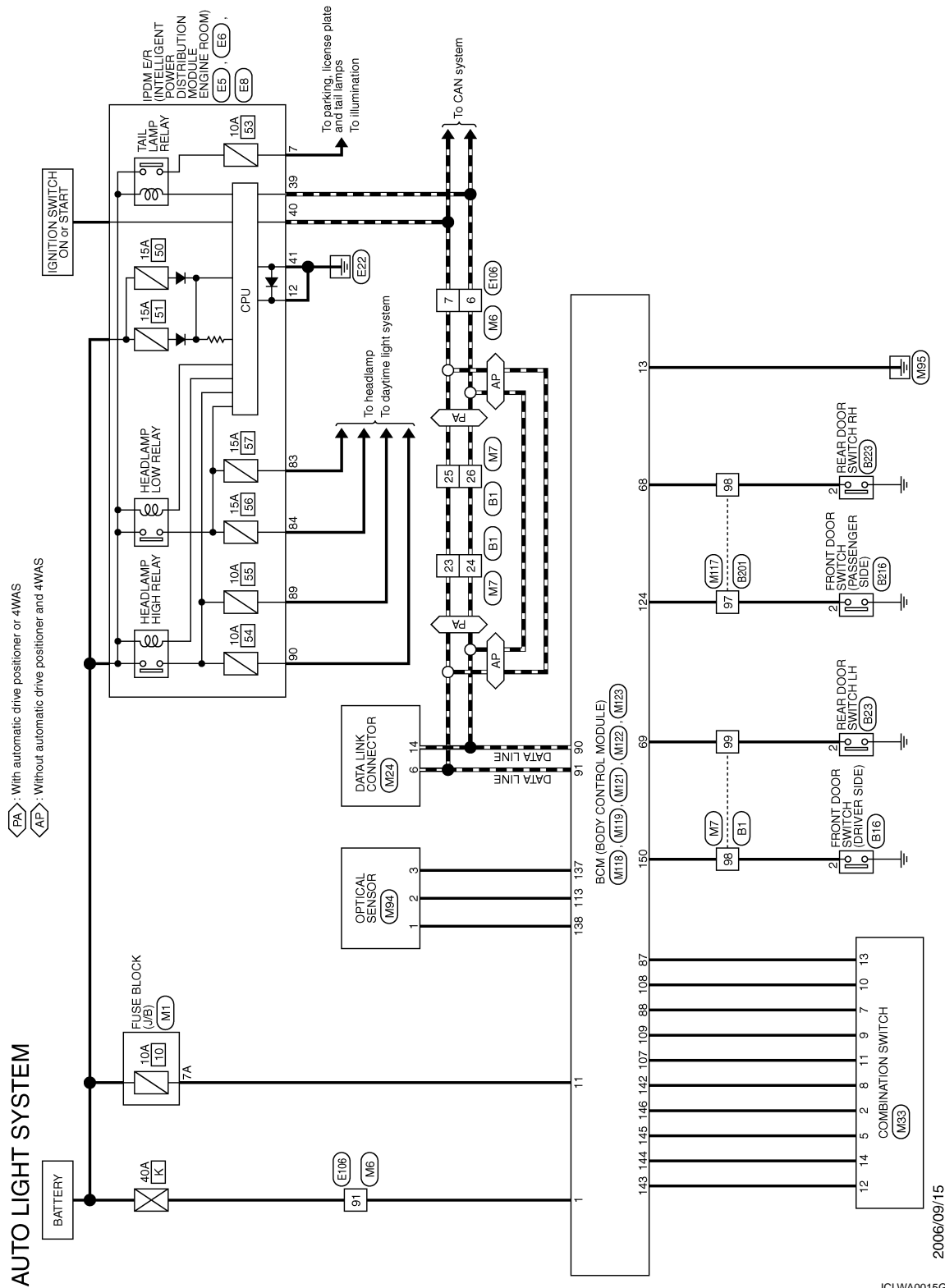

2006/09/15

JCLWA0015GB

AUTO LIGHT SYSTEM

< COMPONENT DIAGNOSIS >

[XENON TYPE]

AUTO LIGHT SYSTEM

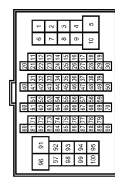
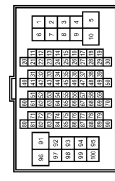
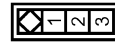
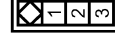
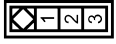
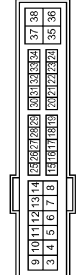
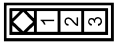
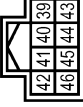
<table border="1" style="width: 100%; border-collapse: collapse;"> <tr><td>Connector No.</td><td>B1</td></tr> <tr><td>Connector Name</td><td>WIRE TO WIRE</td></tr> <tr><td>Connector Type</td><td>TH8DFW-CS16-TM4</td></tr> </table> 	Connector No.	B1	Connector Name	WIRE TO WIRE	Connector Type	TH8DFW-CS16-TM4	<table border="1" style="width: 100%; border-collapse: collapse;"> <tr><td>Terminal No.</td><td>Color of Wire</td><td>Signal Name</td></tr> <tr><td>23</td><td>L</td><td>-</td></tr> <tr><td>24</td><td>P</td><td>-</td></tr> <tr><td>25</td><td>L</td><td>-</td></tr> <tr><td>26</td><td>P</td><td>-</td></tr> <tr><td>38</td><td>V</td><td>-</td></tr> <tr><td>39</td><td>R</td><td>-</td></tr> </table>	Terminal No.	Color of Wire	Signal Name	23	L	-	24	P	-	25	L	-	26	P	-	38	V	-	39	R	-	<table border="1" style="width: 100%; border-collapse: collapse;"> <tr><td>Terminal No.</td><td>Color of Wire</td><td>Signal Name</td></tr> <tr><td>97</td><td>GR</td><td>-</td></tr> <tr><td>98</td><td>BR</td><td>-</td></tr> </table>	Terminal No.	Color of Wire	Signal Name	97	GR	-	98	BR	-	<table border="1" style="width: 100%; border-collapse: collapse;"> <tr><td>Connector No.</td><td>B201</td></tr> <tr><td>Connector Name</td><td>WIRE TO WIRE</td></tr> <tr><td>Connector Type</td><td>TH8DFW-CS16-TM4</td></tr> </table> 	Connector No.	B201	Connector Name	WIRE TO WIRE	Connector Type	TH8DFW-CS16-TM4	<table border="1" style="width: 100%; border-collapse: collapse;"> <tr><td>Terminal No.</td><td>Color of Wire</td><td>Signal Name</td></tr> <tr><td>39</td><td>P</td><td>-</td></tr> <tr><td>40</td><td>L</td><td>-</td></tr> <tr><td>41</td><td>B/W</td><td>-</td></tr> </table>	Terminal No.	Color of Wire	Signal Name	39	P	-	40	L	-	41	B/W	-
Connector No.	B1																																																									
Connector Name	WIRE TO WIRE																																																									
Connector Type	TH8DFW-CS16-TM4																																																									
Terminal No.	Color of Wire	Signal Name																																																								
23	L	-																																																								
24	P	-																																																								
25	L	-																																																								
26	P	-																																																								
38	V	-																																																								
39	R	-																																																								
Terminal No.	Color of Wire	Signal Name																																																								
97	GR	-																																																								
98	BR	-																																																								
Connector No.	B201																																																									
Connector Name	WIRE TO WIRE																																																									
Connector Type	TH8DFW-CS16-TM4																																																									
Terminal No.	Color of Wire	Signal Name																																																								
39	P	-																																																								
40	L	-																																																								
41	B/W	-																																																								
<table border="1" style="width: 100%; border-collapse: collapse;"> <tr><td>Connector No.</td><td>B16</td></tr> <tr><td>Connector Name</td><td>FRONT DOOR SWITCH (DRIVER SIDE)</td></tr> <tr><td>Connector Type</td><td>A03FW</td></tr> </table> 	Connector No.	B16	Connector Name	FRONT DOOR SWITCH (DRIVER SIDE)	Connector Type	A03FW	<table border="1" style="width: 100%; border-collapse: collapse;"> <tr><td>Terminal No.</td><td>Color of Wire</td><td>Signal Name</td></tr> <tr><td>2</td><td>V</td><td>-</td></tr> </table>	Terminal No.	Color of Wire	Signal Name	2	V	-	<table border="1" style="width: 100%; border-collapse: collapse;"> <tr><td>Terminal No.</td><td>Color of Wire</td><td>Signal Name</td></tr> <tr><td>2</td><td>R</td><td>-</td></tr> </table>	Terminal No.	Color of Wire	Signal Name	2	R	-	<table border="1" style="width: 100%; border-collapse: collapse;"> <tr><td>Connector No.</td><td>B23</td></tr> <tr><td>Connector Name</td><td>REAR DOOR SWITCH LH</td></tr> <tr><td>Connector Type</td><td>A03FW</td></tr> </table> 	Connector No.	B23	Connector Name	REAR DOOR SWITCH LH	Connector Type	A03FW	<table border="1" style="width: 100%; border-collapse: collapse;"> <tr><td>Terminal No.</td><td>Color of Wire</td><td>Signal Name</td></tr> <tr><td>7</td><td>R</td><td>-</td></tr> <tr><td>12</td><td>B/W</td><td>-</td></tr> </table>	Terminal No.	Color of Wire	Signal Name	7	R	-	12	B/W	-																					
Connector No.	B16																																																									
Connector Name	FRONT DOOR SWITCH (DRIVER SIDE)																																																									
Connector Type	A03FW																																																									
Terminal No.	Color of Wire	Signal Name																																																								
2	V	-																																																								
Terminal No.	Color of Wire	Signal Name																																																								
2	R	-																																																								
Connector No.	B23																																																									
Connector Name	REAR DOOR SWITCH LH																																																									
Connector Type	A03FW																																																									
Terminal No.	Color of Wire	Signal Name																																																								
7	R	-																																																								
12	B/W	-																																																								
<table border="1" style="width: 100%; border-collapse: collapse;"> <tr><td>Connector No.</td><td>B216</td></tr> <tr><td>Connector Name</td><td>FRONT DOOR SWITCH (PASSENGER SIDE)</td></tr> <tr><td>Connector Type</td><td>A03FW</td></tr> </table> 	Connector No.	B216	Connector Name	FRONT DOOR SWITCH (PASSENGER SIDE)	Connector Type	A03FW	<table border="1" style="width: 100%; border-collapse: collapse;"> <tr><td>Terminal No.</td><td>Color of Wire</td><td>Signal Name</td></tr> <tr><td>2</td><td>GR</td><td>-</td></tr> </table>	Terminal No.	Color of Wire	Signal Name	2	GR	-	<table border="1" style="width: 100%; border-collapse: collapse;"> <tr><td>Terminal No.</td><td>Color of Wire</td><td>Signal Name</td></tr> <tr><td>37</td><td>38</td><td>-</td></tr> <tr><td>39</td><td>40</td><td>-</td></tr> <tr><td>41</td><td>42</td><td>-</td></tr> <tr><td>43</td><td>44</td><td>-</td></tr> </table>	Terminal No.	Color of Wire	Signal Name	37	38	-	39	40	-	41	42	-	43	44	-	<table border="1" style="width: 100%; border-collapse: collapse;"> <tr><td>Connector No.</td><td>E5</td></tr> <tr><td>Connector Name</td><td>IPDM E/R (INTELLIGENT POWER DISTRIBUTION MODULE ENGINE ROOM)</td></tr> <tr><td>Connector Type</td><td>TH2DFW-CS2-M4-1V</td></tr> </table> 	Connector No.	E5	Connector Name	IPDM E/R (INTELLIGENT POWER DISTRIBUTION MODULE ENGINE ROOM)	Connector Type	TH2DFW-CS2-M4-1V	<table border="1" style="width: 100%; border-collapse: collapse;"> <tr><td>Terminal No.</td><td>Color of Wire</td><td>Signal Name</td></tr> <tr><td>39</td><td>P</td><td>-</td></tr> <tr><td>40</td><td>L</td><td>-</td></tr> <tr><td>41</td><td>B/W</td><td>-</td></tr> </table>	Terminal No.	Color of Wire	Signal Name	39	P	-	40	L	-	41	B/W	-									
Connector No.	B216																																																									
Connector Name	FRONT DOOR SWITCH (PASSENGER SIDE)																																																									
Connector Type	A03FW																																																									
Terminal No.	Color of Wire	Signal Name																																																								
2	GR	-																																																								
Terminal No.	Color of Wire	Signal Name																																																								
37	38	-																																																								
39	40	-																																																								
41	42	-																																																								
43	44	-																																																								
Connector No.	E5																																																									
Connector Name	IPDM E/R (INTELLIGENT POWER DISTRIBUTION MODULE ENGINE ROOM)																																																									
Connector Type	TH2DFW-CS2-M4-1V																																																									
Terminal No.	Color of Wire	Signal Name																																																								
39	P	-																																																								
40	L	-																																																								
41	B/W	-																																																								
<table border="1" style="width: 100%; border-collapse: collapse;"> <tr><td>Connector No.</td><td>B223</td></tr> <tr><td>Connector Name</td><td>REAR DOOR SWITCH RH</td></tr> <tr><td>Connector Type</td><td>A03FW</td></tr> </table> 	Connector No.	B223	Connector Name	REAR DOOR SWITCH RH	Connector Type	A03FW	<table border="1" style="width: 100%; border-collapse: collapse;"> <tr><td>Terminal No.</td><td>Color of Wire</td><td>Signal Name</td></tr> <tr><td>2</td><td>BR</td><td>-</td></tr> </table>	Terminal No.	Color of Wire	Signal Name	2	BR	-	<table border="1" style="width: 100%; border-collapse: collapse;"> <tr><td>Terminal No.</td><td>Color of Wire</td><td>Signal Name</td></tr> <tr><td>42</td><td>41</td><td>-</td></tr> <tr><td>40</td><td>39</td><td>-</td></tr> <tr><td>44</td><td>43</td><td>-</td></tr> </table>	Terminal No.	Color of Wire	Signal Name	42	41	-	40	39	-	44	43	-	<table border="1" style="width: 100%; border-collapse: collapse;"> <tr><td>Connector No.</td><td>E6</td></tr> <tr><td>Connector Name</td><td>IPDM E/R (INTELLIGENT POWER DISTRIBUTION MODULE ENGINE ROOM)</td></tr> <tr><td>Connector Type</td><td>TH08FW-NH</td></tr> </table> 	Connector No.	E6	Connector Name	IPDM E/R (INTELLIGENT POWER DISTRIBUTION MODULE ENGINE ROOM)	Connector Type	TH08FW-NH	<table border="1" style="width: 100%; border-collapse: collapse;"> <tr><td>Terminal No.</td><td>Color of Wire</td><td>Signal Name</td></tr> <tr><td>39</td><td>P</td><td>-</td></tr> <tr><td>40</td><td>L</td><td>-</td></tr> <tr><td>41</td><td>B/W</td><td>-</td></tr> </table>	Terminal No.	Color of Wire	Signal Name	39	P	-	40	L	-	41	B/W	-												
Connector No.	B223																																																									
Connector Name	REAR DOOR SWITCH RH																																																									
Connector Type	A03FW																																																									
Terminal No.	Color of Wire	Signal Name																																																								
2	BR	-																																																								
Terminal No.	Color of Wire	Signal Name																																																								
42	41	-																																																								
40	39	-																																																								
44	43	-																																																								
Connector No.	E6																																																									
Connector Name	IPDM E/R (INTELLIGENT POWER DISTRIBUTION MODULE ENGINE ROOM)																																																									
Connector Type	TH08FW-NH																																																									
Terminal No.	Color of Wire	Signal Name																																																								
39	P	-																																																								
40	L	-																																																								
41	B/W	-																																																								

JCLWA0016GB

A B C D E F G H I J K L M N O P

EXL

AUTO LIGHT SYSTEM

< COMPONENT DIAGNOSIS >

[XENON TYPE]

AUTO LIGHT SYSTEM

Connector No.	EB
Connector Name	IPDM E/R (INTELLIGENT POWER DISTRIBUTION MODULE ENGINE ROOM)
Connector Type	NS08FW-CS

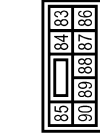

Terminal No.	Color of Wire	Signal Name
83	R	-
84	P	-
88	BR	-
90	P	-

Connector No.	E106
Connector Name	WIRE TO WIRE
Connector Type	TH80FW-CS16-TM4

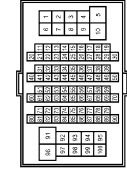

Terminal No.	Color of Wire	Signal Name
6	P	-
7	L	-
91	W	-

Connector No.	M1
Connector Name	FUSE BLOCK (J/B)
Connector Type	NS06FW-H2

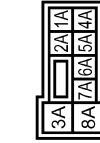

Terminal No.	Color of Wire	Signal Name
7A	R	-

Connector No.	M6
Connector Name	WIRE TO WIRE
Connector Type	TH80MW-CS16-TM4

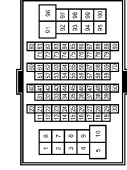

Terminal No.	Color of Wire	Signal Name
6	P	-
7	L	-
91	W	-

Connector No.	M7
Connector Name	WIRE TO WIRE
Connector Type	TH80MW-CS16-TM4

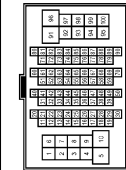

Terminal No.	Color of Wire	Signal Name
23	L	-
24	P	-
25	L	-
26	P	-
98	GR	-
99	R	-

Connector No.	M24
Connector Name	DATA LINK CONNECTOR
Connector Type	BD16FW

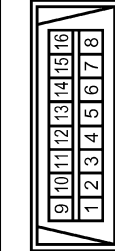

Terminal No.	Color of Wire	Signal Name
6	L	-
14	P	-

Connector No.	M33
Connector Name	COMBINATION SWITCH
Connector Type	TH16FW-NH

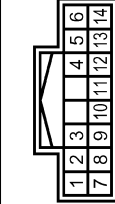

Terminal No.	Color of Wire	Signal Name
2	SB	OUTPUT 4
5	L	OUTPUT 3
7	V	INPUT 3
8	O	OUTPUT 5
9	Y	INPUT 2
10	R	INPUT 4
11	LG	INPUT 1
12	P	OUTPUT 1
13	BR	INPUT 5
14	G	OUTPUT 2

Connector No.	M84
Connector Name	OPTICAL SENSOR
Connector Type	TK03FW



Terminal No.	Color of Wire	Signal Name
1	Y	POWER
2	P	OUTPUT
3	B	GND

JCLWA0017GB

AUTO LIGHT SYSTEM

< COMPONENT DIAGNOSIS >

[XENON TYPE]

AUTO LIGHT SYSTEM

Connector No.	M117
Connector Name	WIRE TO WIRE
Connector Type	THROW-CS16-TM4

Terminal No.	Color of Wire	Signal Name
97	LG	-
98	BR	-

Connector No.	M118
Connector Name	BCM (BODY CONTROL MODULE)
Connector Type	M03FB-LC

Terminal No.	Color of Wire	Signal Name
1	W	BAT (F/L)

Connector No.	M119
Connector Name	BCM (BODY CONTROL MODULE)
Connector Type	NS18FW-CS

Terminal No.	Color of Wire	Signal Name
11	R	BAT (FUSE)
13	B	GND

Connector No.	M121
Connector Name	BCM (BODY CONTROL MODULE)
Connector Type	TH40FG-NH

Terminal No.	Color of Wire	Signal Name
68	BR	DOOR SW (RR RH)
69	R	DOOR SW (RR LH)

Connector No.	M122
Connector Name	BCM (BODY CONTROL MODULE)
Connector Type	TH40FB-NH

Terminal No.	Color of Wire	Signal Name
87	BR	COMBI SW INPUT 5
88	V	COMBI SW INPUT 3
90	P	CAN-L
91	L	CAN-H
107	LG	COMBI SW INPUT 1
108	R	COMBI SW INPUT 4
109	Y	COMBI SW INPUT 2

Connector No.	M123
Connector Name	BCM (BODY CONTROL MODULE)
Connector Type	TH40FG-NH

Terminal No.	Color of Wire	Signal Name
113	P	AUTO LIGHT SENSOR INPUT
124	LG	DOOR SW (AS)
137	O	SENSOR GND
138	V	AUTO LIGHT SENSOR-POER SUPPLY
142	O	COMBI SW OUTPUT 5
143	P	COMBI SW OUTPUT 1
144	G	COMBI SW OUTPUT 2
145	L	COMBI SW OUTPUT 3
146	SB	COMBI SW OUTPUT 4
150	GR	DOOR SW (DR)

Terminal No.	Color of Wire	Signal Name
87	BR	COMBI SW INPUT 5
88	V	COMBI SW INPUT 3
90	P	CAN-L
91	L	CAN-H
107	LG	COMBI SW INPUT 1
108	R	COMBI SW INPUT 4
109	Y	COMBI SW INPUT 2

A B C D E F G H I J K M N O P





EXL

DAYTIME RUNNING LIGHT SYSTEM

< COMPONENT DIAGNOSIS >

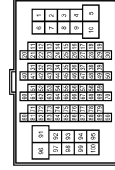
[XENON TYPE]

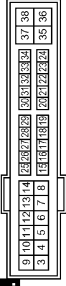
DAYTIME LIGHT SYSTEM

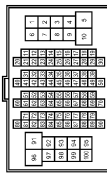
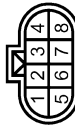
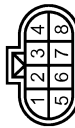
<table border="1"> <tr><td>Connector No.</td><td>B1</td></tr> <tr><td>Connector Name</td><td>WIRE TO WIRE</td></tr> <tr><td>Connector Type</td><td>TH80FW-CS16-TM4</td></tr> </table>  <p>H.S.</p> <table border="1"> <tr><td>Terminal No.</td><td>Color of Wire</td><td>Signal Name</td></tr> <tr><td>23</td><td>L</td><td>-</td></tr> <tr><td>24</td><td>P</td><td>-</td></tr> <tr><td>25</td><td>L</td><td>-</td></tr> <tr><td>26</td><td>P</td><td>-</td></tr> <tr><td>36</td><td>V</td><td>-</td></tr> </table>	Connector No.	B1	Connector Name	WIRE TO WIRE	Connector Type	TH80FW-CS16-TM4	Terminal No.	Color of Wire	Signal Name	23	L	-	24	P	-	25	L	-	26	P	-	36	V	-	<table border="1"> <tr><td>Connector No.</td><td>E6</td></tr> <tr><td>Connector Name</td><td>IPDM E/R (INTELLIGENT POWER DISTRIBUTION MODULE ENGINE ROOM)</td></tr> <tr><td>Connector Type</td><td>TH80FW-NH</td></tr> </table>  <p>H.S.</p> <table border="1"> <tr><td>Terminal No.</td><td>Color of Wire</td><td>Signal Name</td></tr> <tr><td>39</td><td>P</td><td>-</td></tr> <tr><td>40</td><td>L</td><td>-</td></tr> <tr><td>41</td><td>B/W</td><td>-</td></tr> </table>	Connector No.	E6	Connector Name	IPDM E/R (INTELLIGENT POWER DISTRIBUTION MODULE ENGINE ROOM)	Connector Type	TH80FW-NH	Terminal No.	Color of Wire	Signal Name	39	P	-	40	L	-	41	B/W	-
Connector No.	B1																																										
Connector Name	WIRE TO WIRE																																										
Connector Type	TH80FW-CS16-TM4																																										
Terminal No.	Color of Wire	Signal Name																																									
23	L	-																																									
24	P	-																																									
25	L	-																																									
26	P	-																																									
36	V	-																																									
Connector No.	E6																																										
Connector Name	IPDM E/R (INTELLIGENT POWER DISTRIBUTION MODULE ENGINE ROOM)																																										
Connector Type	TH80FW-NH																																										
Terminal No.	Color of Wire	Signal Name																																									
39	P	-																																									
40	L	-																																									
41	B/W	-																																									
<table border="1"> <tr><td>Connector No.</td><td>B14</td></tr> <tr><td>Connector Name</td><td>PARKING BRAKE SWITCH</td></tr> <tr><td>Connector Type</td><td>FO1FB-A</td></tr> </table>  <p>H.S.</p> <table border="1"> <tr><td>Terminal No.</td><td>Color of Wire</td><td>Signal Name</td></tr> <tr><td>1</td><td>V</td><td>-</td></tr> </table>	Connector No.	B14	Connector Name	PARKING BRAKE SWITCH	Connector Type	FO1FB-A	Terminal No.	Color of Wire	Signal Name	1	V	-	<table border="1"> <tr><td>Connector No.</td><td>E5</td></tr> <tr><td>Connector Name</td><td>IPDM E/R (INTELLIGENT POWER DISTRIBUTION MODULE ENGINE ROOM)</td></tr> <tr><td>Connector Type</td><td>TH20FW-CS12-M4-1V</td></tr> </table>  <p>H.S.</p> <table border="1"> <tr><td>Terminal No.</td><td>Color of Wire</td><td>Signal Name</td></tr> <tr><td>12</td><td>B/W</td><td>-</td></tr> </table>	Connector No.	E5	Connector Name	IPDM E/R (INTELLIGENT POWER DISTRIBUTION MODULE ENGINE ROOM)	Connector Type	TH20FW-CS12-M4-1V	Terminal No.	Color of Wire	Signal Name	12	B/W	-																		
Connector No.	B14																																										
Connector Name	PARKING BRAKE SWITCH																																										
Connector Type	FO1FB-A																																										
Terminal No.	Color of Wire	Signal Name																																									
1	V	-																																									
Connector No.	E5																																										
Connector Name	IPDM E/R (INTELLIGENT POWER DISTRIBUTION MODULE ENGINE ROOM)																																										
Connector Type	TH20FW-CS12-M4-1V																																										
Terminal No.	Color of Wire	Signal Name																																									
12	B/W	-																																									
<table border="1"> <tr><td>Connector No.</td><td>E3</td></tr> <tr><td>Connector Name</td><td>IPDM E/R (INTELLIGENT POWER DISTRIBUTION MODULE ENGINE ROOM)</td></tr> <tr><td>Connector Type</td><td>RS38FW-CS</td></tr> </table>  <p>H.S.</p> <table border="1"> <tr><td>Terminal No.</td><td>Color of Wire</td><td>Signal Name</td></tr> <tr><td>86</td><td>W</td><td>-</td></tr> <tr><td>87</td><td>L</td><td>-</td></tr> </table>	Connector No.	E3	Connector Name	IPDM E/R (INTELLIGENT POWER DISTRIBUTION MODULE ENGINE ROOM)	Connector Type	RS38FW-CS	Terminal No.	Color of Wire	Signal Name	86	W	-	87	L	-	<table border="1"> <tr><td>Connector No.</td><td>E106</td></tr> <tr><td>Connector Name</td><td>WIRE TO WIRE</td></tr> <tr><td>Connector Type</td><td>TH80FW-CS16-TM4</td></tr> </table>  <p>H.S.</p> <table border="1"> <tr><td>Terminal No.</td><td>Color of Wire</td><td>Signal Name</td></tr> <tr><td>6</td><td>P</td><td>-</td></tr> <tr><td>7</td><td>L</td><td>-</td></tr> <tr><td>18</td><td>O</td><td>-</td></tr> <tr><td>31</td><td>W</td><td>-</td></tr> </table>	Connector No.	E106	Connector Name	WIRE TO WIRE	Connector Type	TH80FW-CS16-TM4	Terminal No.	Color of Wire	Signal Name	6	P	-	7	L	-	18	O	-	31	W	-						
Connector No.	E3																																										
Connector Name	IPDM E/R (INTELLIGENT POWER DISTRIBUTION MODULE ENGINE ROOM)																																										
Connector Type	RS38FW-CS																																										
Terminal No.	Color of Wire	Signal Name																																									
86	W	-																																									
87	L	-																																									
Connector No.	E106																																										
Connector Name	WIRE TO WIRE																																										
Connector Type	TH80FW-CS16-TM4																																										
Terminal No.	Color of Wire	Signal Name																																									
6	P	-																																									
7	L	-																																									
18	O	-																																									
31	W	-																																									
<table border="1"> <tr><td>Connector No.</td><td>E28</td></tr> <tr><td>Connector Name</td><td>FRONT COMBINATION LAMP RH</td></tr> <tr><td>Connector Type</td><td>RS38FB-PR</td></tr> </table>  <p>H.S.</p> <table border="1"> <tr><td>Terminal No.</td><td>Color of Wire</td><td>Signal Name</td></tr> <tr><td>1</td><td>W</td><td>-</td></tr> <tr><td>4</td><td>B/W</td><td>-</td></tr> </table>	Connector No.	E28	Connector Name	FRONT COMBINATION LAMP RH	Connector Type	RS38FB-PR	Terminal No.	Color of Wire	Signal Name	1	W	-	4	B/W	-	<table border="1"> <tr><td>Connector No.</td><td>E33</td></tr> <tr><td>Connector Name</td><td>FRONT COMBINATION LAMP LH</td></tr> <tr><td>Connector Type</td><td>RS38FB-PR</td></tr> </table>  <p>H.S.</p> <table border="1"> <tr><td>Terminal No.</td><td>Color of Wire</td><td>Signal Name</td></tr> <tr><td>1</td><td>L</td><td>-</td></tr> <tr><td>4</td><td>B/W</td><td>-</td></tr> </table>	Connector No.	E33	Connector Name	FRONT COMBINATION LAMP LH	Connector Type	RS38FB-PR	Terminal No.	Color of Wire	Signal Name	1	L	-	4	B/W	-												
Connector No.	E28																																										
Connector Name	FRONT COMBINATION LAMP RH																																										
Connector Type	RS38FB-PR																																										
Terminal No.	Color of Wire	Signal Name																																									
1	W	-																																									
4	B/W	-																																									
Connector No.	E33																																										
Connector Name	FRONT COMBINATION LAMP LH																																										
Connector Type	RS38FB-PR																																										
Terminal No.	Color of Wire	Signal Name																																									
1	L	-																																									
4	B/W	-																																									

A
B
C
D
E
F
G
H
I
J
K
EXL
M
N
O
P

DAYTIME RUNNING LIGHT SYSTEM

< COMPONENT DIAGNOSIS >

[XENON TYPE]

DAYTIME LIGHT SYSTEM

Connector No.	E107
Connector Name	PARKING BRAKE SWITCH (A,T)
Connector Type	TBD1FW



Terminal No.	Color of Wire	Signal Name
1	O	-

Connector No.	M1
Connector Name	FUSE BLOCK (J/B)
Connector Type	NS06FW-M2



Terminal No.	Color of Wire	Signal Name
2A	G	-
7A	R	-

Connector No.	M2
Connector Name	FUSE BLOCK (J/B)
Connector Type	NS10FW-CS



Terminal No.	Color of Wire	Signal Name
6B	Y	-

Connector No.	M6
Connector Name	WIRE TO WIRE
Connector Type	TH80MW-CS16-TM4



Terminal No.	Color of Wire	Signal Name
6	P	-
7	L	-
18	V	-
91	W	-

Connector No.	M7
Connector Name	WIRE TO WIRE
Connector Type	TH80MW-CS16-TM4



Terminal No.	Color of Wire	Signal Name
23	L	-
24	P	-
25	L	-
26	P	-
96	V	-

Connector No.	M24
Connector Name	DATA LINK CONNECTOR
Connector Type	BD16FW

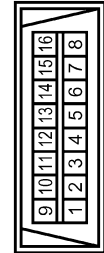

Terminal No.	Color of Wire	Signal Name
6	L	-
14	P	-

Connector No.	M33
Connector Name	COMBINATION SWITCH
Connector Type	TH16FW-NH

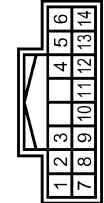

Terminal No.	Color of Wire	Signal Name
2	SB	OUTPUT 4
5	L	OUTPUT 3
7	V	INPUT 3
8	O	OUTPUT 5
9	Y	INPUT 2
10	R	INPUT 4
11	LG	INPUT 1
12	P	OUTPUT 1
13	BR	INPUT 5
14	G	OUTPUT 2

Connector No.	M53
Connector Name	COMBINATION METER
Connector Type	SAB40FW



Terminal No.	Color of Wire	Signal Name
2	LG	COMM (METER->AMP.)
3	GR	COMM (AMP->METER)
27	V	PARKING BRAKE SW

JCLWA0012GB

DAYTIME RUNNING LIGHT SYSTEM

< COMPONENT DIAGNOSIS >

[XENON TYPE]

DAYTIME LIGHT SYSTEM

Connector No.	M166
Connector Name	UNIFIED METER AND A/C AMP.
Connector Type	TH40FW-NH

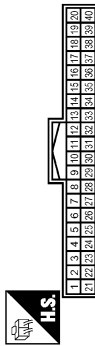

Terminal No.	Color of Wire	Signal Name
7	GR	COMM (AMP->METER)
27	LG	COMM (METER->AMP)

Connector No.	M167
Connector Name	UNIFIED METER AND A/C AMP.
Connector Type	TH43FEW-NH

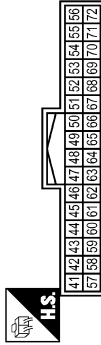

Terminal No.	Color of Wire	Signal Name
53	G	IGN
54	Y	BAT
55	B	GND
56	L	CAN-H
71	B	GND
72	P	CAN-L

Connector No.	M107
Connector Name	ECM
Connector Type	MAA24FGY-MAE48-LH-Z

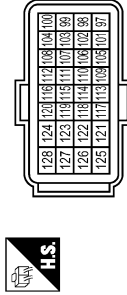

Terminal No.	Color of Wire	Signal Name
113	P	VHECANLLI
114	L	VHECANLHI

Connector No.	M118
Connector Name	BCM (BODY CONTROL MODULE)
Connector Type	M03FEB-LC



Terminal No.	Color of Wire	Signal Name
1	W	BAT (F/L)

Connector No.	M119
Connector Name	BCM (BODY CONTROL MODULE)
Connector Type	NS16FW-CS

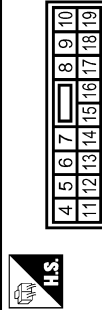

Terminal No.	Color of Wire	Signal Name
11	R	BAT (FUSE)
13	B	GND

Connector No.	M122
Connector Name	BCM (BODY CONTROL MODULE)
Connector Type	TH40FB-NH

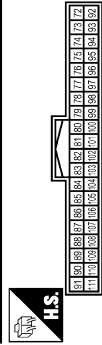

Terminal No.	Color of Wire	Signal Name
87	BR	COMBI SW INPUT 5
88	V	COMBI SW INPUT 3
90	P	CAN-L
91	L	CAN-H
107	LG	COMBI SW INPUT 1
108	R	COMBI SW INPUT 4
109	Y	COMBI SW INPUT 2

Connector No.	M123
Connector Name	BCM (BODY CONTROL MODULE)
Connector Type	TH40FG-NH

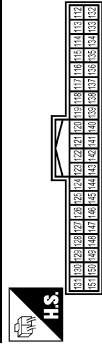

Terminal No.	Color of Wire	Signal Name
142	O	COMBI SW OUTPUT 5
143	P	COMBI SW OUTPUT 1
144	G	COMBI SW OUTPUT 2
145	L	COMBI SW OUTPUT 3
146	SB	COMBI SW OUTPUT 4

A
B
C
D
E
F
G
H
I
J
K
M
N
O
P

EXL

FRONT FOG LAMP SYSTEM

< COMPONENT DIAGNOSIS >

[XENON TYPE]

FRONT FOG LAMP SYSTEM

Wiring Diagram —FRONT FOG LAMP—

INFOID:000000000962501

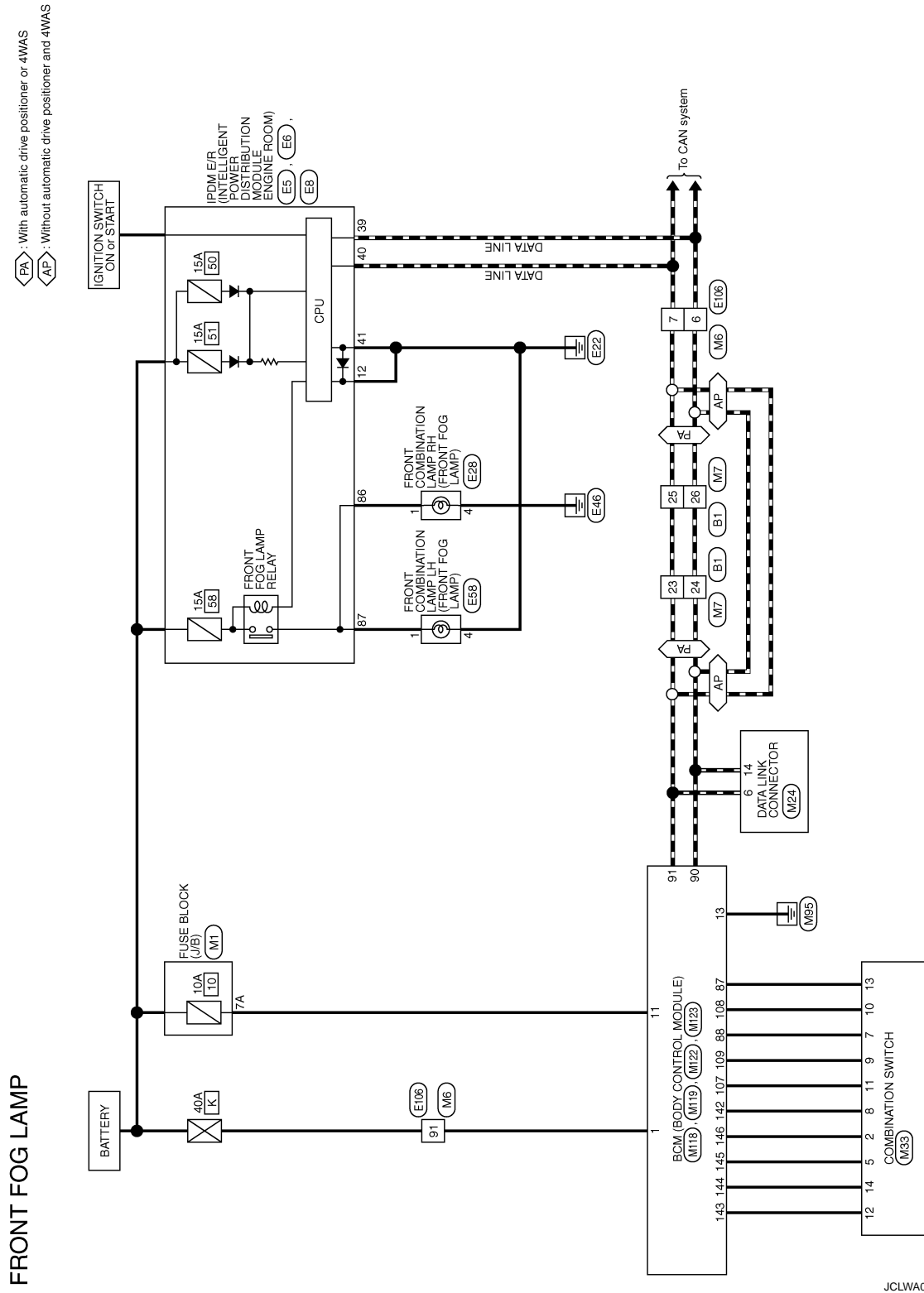

2006/09/15

JCLWA0026GB

FRONT FOG LAMP SYSTEM

< COMPONENT DIAGNOSIS >

[XENON TYPE]

FRONT FOG LAMP

Connector No.	B1	Connector No.	E6	Connector No.	E5	Connector No.	E8
Connector Name	WIRE TO WIRE	Connector Name	IPDM E/R (INTELLIGENT POWER DISTRIBUTION MODULE ENGINE ROOM)	Connector Name	IPDM E/R (INTELLIGENT POWER DISTRIBUTION MODULE ENGINE ROOM)	Connector Name	IPDM E/R (INTELLIGENT POWER DISTRIBUTION MODULE ENGINE ROOM)
Connector Type	TH80FW-CS16-TM4	Connector Type	TH80FW-NH	Connector Type	TH20FW-CS12-M4-1V	Connector Type	NS28FW-CS

Terminal No.	Color of Wire	Signal Name
23	L	-
24	P	-
25	L	-
26	P	-

Terminal No.	Color of Wire	Signal Name
39	P	-
40	L	-
41	B/W	-

Terminal No.	Color of Wire	Signal Name
86	W	-
87	L	-

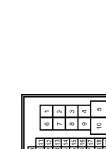
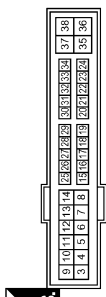
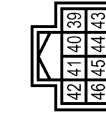
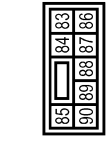

Connector No.	E28	Connector No.	E106	Connector No.	M1
Connector Name	FRONT COMBINATION LAMP RH	Connector Name	WIRE TO WIRE	Connector Name	FUSE BLOCK (J/B)
Connector Type	RS28FB-PR	Connector Type	TH80FW-CS16-TM4	Connector Type	NS28FW-M2

Terminal No.	Color of Wire	Signal Name
1	W	-
4	B/W	-

Terminal No.	Color of Wire	Signal Name
6	P	-
7	L	-
81	W	-

Terminal No.	Color of Wire	Signal Name
1	L	-
4	B/W	-

Terminal No.	Color of Wire	Signal Name
7A	R	-

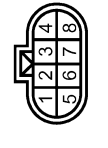
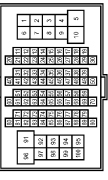
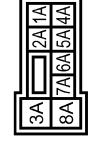

JCLWA0027GB



A
B
C
D
E
F
G
H
I
J
K
EXL
M
N
O
P

FRONT FOG LAMP SYSTEM

< COMPONENT DIAGNOSIS >

[XENON TYPE]

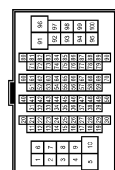
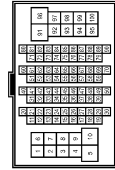
FRONT FOG LAMP

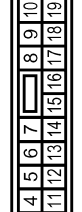
Connector No. M6	WIRE TO WIRE	TH80MW-CS16-TM4		Terminal No.	Color of Wire	Signal Name
Connector Name	WIRE TO WIRE	TH80MW-CS16-TM4		6	P	-
Connector Type	TH80MW-CS16-TM4			7	L	-
				91	W	-
Connector No. M7	WIRE TO WIRE	TH80MW-CS16-TM4		Terminal No.	Color of Wire	Signal Name
Connector Name	WIRE TO WIRE	TH80MW-CS16-TM4		23	L	-
Connector Type	TH80MW-CS16-TM4			24	P	-
				25	L	-
				26	P	-
Connector No. M8	BCM (BODY CONTROL MODULE)	M03FB-LC		Terminal No.	Color of Wire	Signal Name
Connector Name	BCM (BODY CONTROL MODULE)	M03FB-LC		1	W	BAT (F/L)
Connector Type	M03FB-LC					
Connector No. M9	BCM (BODY CONTROL MODULE)	M03FB-LC		Terminal No.	Color of Wire	Signal Name
Connector Name	BCM (BODY CONTROL MODULE)	M03FB-LC		1	W	BAT (FUSE)
Connector Type	M03FB-LC			13	B	GND
Connector No. M11	BCM (BODY CONTROL MODULE)	TH40FE-NH		Terminal No.	Color of Wire	Signal Name
Connector Name	BCM (BODY CONTROL MODULE)	TH40FE-NH		4	R	8
Connector Type	TH40FE-NH			5	L	9
				6	P	10
				7	L	11
				8	P	12
				9	L	13
				10	P	14
				11	L	15
				12	P	16
				13	L	17
				14	P	18
				15	L	19
				16	P	20
				17	L	21
				18	P	22
				19	L	23
				20	P	24
				21	L	25
				22	P	26
				23	L	27
				24	P	28
				25	L	29
				26	P	30
				27	L	31
				28	P	32
				29	L	33
				30	P	34
				31	L	35
				32	P	36
				33	L	37
				34	P	38
				35	L	39
				36	P	40
				37	L	41
				38	P	42
				39	L	43
				40	P	44
				41	L	45
				42	P	46
				43	L	47
				44	P	48
				45	L	49
				46	P	50
				47	L	51
				48	P	52
				49	L	53
				50	P	54
				51	L	55
				52	P	56
				53	L	57
				54	P	58
				55	L	59
				56	P	60
				57	L	61
				58	P	62
				59	L	63
				60	P	64
				61	L	65
				62	P	66
				63	L	67
				64	P	68
				65	L	69
				66	P	70
				67	L	71
				68	P	72
				69	L	73
				70	P	74
				71	L	75
				72	P	76
				73	L	77
				74	P	78
				75	L	79
				76	P	80
				77	L	81
				78	P	82
				79	L	83
				80	P	84
				81	L	85
				82	P	86
				83	L	87
				84	P	88
				85	L	89
				86	P	90
				87	L	91
				88	P	92
				89	L	93
				90	P	94
				91	L	95
				92	P	96
				93	L	97
				94	P	98
				95	L	99
				96	P	100
				97	L	101
				98	P	102
				99	L	103
				100	P	104
				101	L	105
				102	P	106
				103	L	107
				104	P	108
				105	L	109
				106	P	110
				107	L	111
				108	P	112
				109	L	113
				110	P	114
				111	L	115
				112	P	116
				113	L	117
				114	P	118
				115	L	119
				116	P	120
				117	L	121
				118	P	122
				119	L	123
				120	P	124
				121	L	125
				122	P	126
				123	L	127
				124	P	128
				125	L	129
				126	P	130
				127	L	131
				128	P	132
				129	L	133
				130	P	134
				131	L	135
				132	P	136
				133	L	137
				134	P	138
				135	L	139
				136	P	140
				137	L	141
				138	P	142
				139	L	143
				140	P	144
				141	L	145
				142	P	146
				143	L	147
				144	P	148
				145	L	149
				146	P	150
				147	L	151
				148	P	152
				149	L	153
				150	P	154
				151	L	155
				152	P	156
				153	L	157
				154	P	158
				155	L	159
				156	P	160
				157	L	161
				158	P	162
				159	L	163
				160	P	164
				161	L	165
				162	P	166
				163	L	167
				164	P	168
				165	L	169
				166	P	170
				167	L	171
				168	P	172
				169	L	173
				170	P	174
				171	L	175
				172	P	176
				173	L	177
				174	P	178
				175	L	179
				176	P	180
				177	L	181
				178	P	182
				179	L	183
				180	P	184
				181	L	185
				182	P	186
				183	L	187
				184	P	188
				185	L	189
				186	P	190
				187	L	191
				188	P	192
				189	L	193
				190	P	194
				191	L	195
				192	P	196
				193	L	197
				194	P	198
				195	L	199
				196	P	200
				197	L	201
				198	P	202
				199	L	203
				200	P	204
				201	L	205
				202	P	206
				203	L	207
				204	P	208
				205	L	209
				206	P	210
				207	L	211
				208	P	212
				209	L	213
				210	P	214
				211	L	215
				212	P	216
				213	L	217
				214	P	218
				215	L	219
				216	P	220
				217	L	221
				218	P	222
				219	L	223
				220	P	224
				221	L	225

TURN SIGNAL AND HAZARD WARNING LAMP SYSTEM

< COMPONENT DIAGNOSIS >

[XENON TYPE]

TURN SIGNAL AND HAZARD WARNING LAMP SYSTEM

Wiring Diagram —TURN AND HAZARD WARNING LAMPS—

INFOID:000000000962502

TURN SIGNAL AND HAZARD WARNING LAMPS

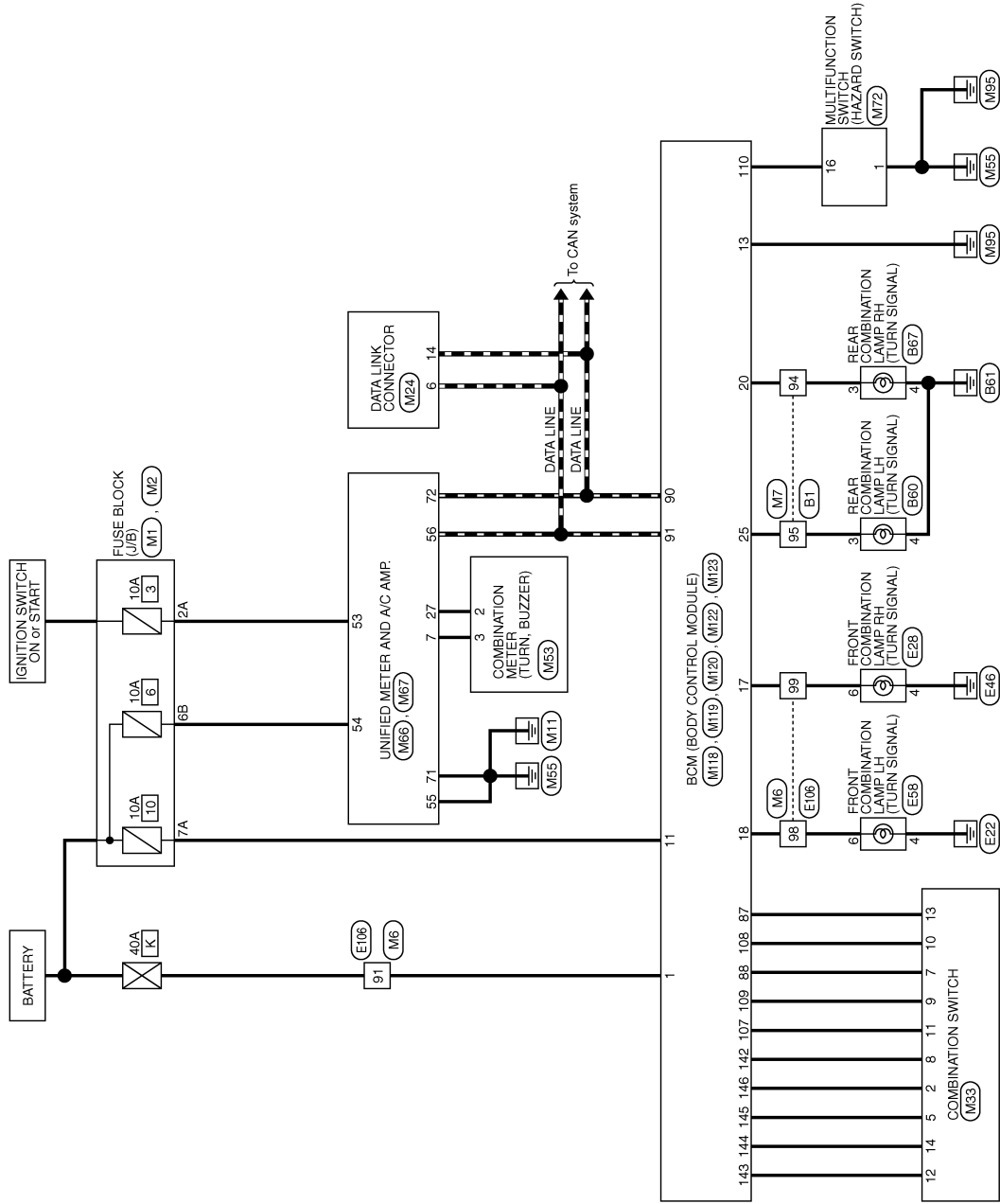

2006/09/15

JCLWA0030GB

A
B
C
D
E
F
G
H
I
J
K
EXL
M
N
O
P

TURN SIGNAL AND HAZARD WARNING LAMP SYSTEM

< COMPONENT DIAGNOSIS >

[XENON TYPE]

TURN SIGNAL AND HAZARD WARNING LAMPS

Connector No.	B1
Connector Name	WIRE TO WIRE
Connector Type	TH80FW-CS16-TM4

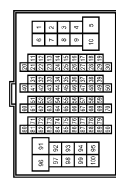

Terminal No.	Color of Wire	Signal Name
94	V	-
95	SB	-

Connector No.	B80
Connector Name	REAR COMBINATION LAMP LH
Connector Type	NS04FW-CS



Terminal No.	Color of Wire	Signal Name
3	SB	-
4	B	-

Connector No.	B87
Connector Name	REAR COMBINATION LAMP RH
Connector Type	NS04FW-CS



Terminal No.	Color of Wire	Signal Name
3	V	-
4	B	-

Connector No.	E28
Connector Name	FRONT COMBINATION LAMP RH
Connector Type	RS08FB-PR



Terminal No.	Color of Wire	Signal Name
4	B/W	-
6	V	-

Connector No.	E58
Connector Name	FRONT COMBINATION LAMP LH
Connector Type	RS08FB-PR



Terminal No.	Color of Wire	Signal Name
4	B/W	-
6	GR	-

Connector No.	E106
Connector Name	WIRE TO WIRE
Connector Type	TH80FW-CS16-TM4

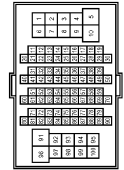

Terminal No.	Color of Wire	Signal Name
91	W	-
98	GR	-
99	V	-

Connector No.	M1
Connector Name	FUSE BLOCK (J/B)
Connector Type	NS10FW-M2

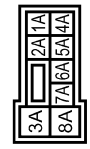

Terminal No.	Color of Wire	Signal Name
2A	G	-
7A	R	-

Connector No.	M2
Connector Name	FUSE BLOCK (J/B)
Connector Type	NS10FW-CS



Terminal No.	Color of Wire	Signal Name
6B	Y	-

TURN SIGNAL AND HAZARD WARNING LAMP SYSTEM

< COMPONENT DIAGNOSIS >

[XENON TYPE]

TURN SIGNAL AND HAZARD WARNING LAMPS

Connector No.	M16
Connector Name	WIRE TO WIRE
Connector Type	TH80WV-CS16-TM4

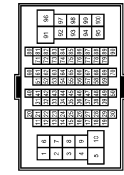

Terminal No.	Color of Wire	Signal Name
91	W	-
96	O	-
98	W	-

Connector No.	M17
Connector Name	WIRE TO WIRE
Connector Type	TH80WV-CS16-TM4

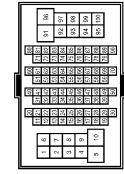

Terminal No.	Color of Wire	Signal Name
94	V	-
95	G	-

Connector No.	M24
Connector Name	DATA LINK CONNECTOR
Connector Type	BD18FW

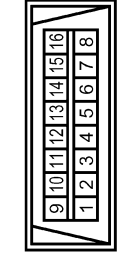

Terminal No.	Color of Wire	Signal Name
6	L	-
14	P	-

Connector No.	M33
Connector Name	COMBINATION SWITCH
Connector Type	TH18FW-NH

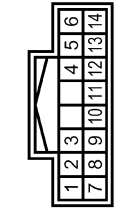

Terminal No.	Color of Wire	Signal Name
2	SB	OUTPUT 4
5	L	OUTPUT 3
7	V	INPUT 3
8	O	OUTPUT 5
9	Y	INPUT 2
10	R	INPUT 4
11	LG	INPUT 1
12	P	OUTPUT 1
13	BR	INPUT 5
14	G	OUTPUT 2

Connector No.	M53
Connector Name	COMBINATION METER
Connector Type	SAB40FW

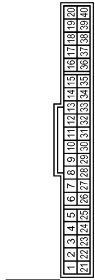

Terminal No.	Color of Wire	Signal Name
2	LG	COMM (METER->AMP)
3	GR	COMM (AMP->METER)

Connector No.	M66
Connector Name	UNIFIED METER AND A.C AMP.
Connector Type	TH40FW-NH

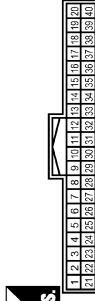

Terminal No.	Color of Wire	Signal Name
7	GR	COMM (AMP->METER)
27	LG	COMM (METER->AMP)

Connector No.	M67
Connector Name	UNIFIED METER AND A.C AMP.
Connector Type	TH32FW-NH



Terminal No.	Color of Wire	Signal Name
53	G	IGN
54	Y	BAT
55	B	GND
56	L	CAN-H
71	B	GND
72	P	CAN-L

Connector No.	M72
Connector Name	MULTIFUNCTION SWITCH
Connector Type	TH18FW-NH

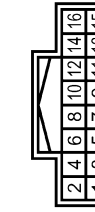

Terminal No.	Color of Wire	Signal Name
1	B	GND
16	G	HAZARD_ON

A
B
C
D
E
F
G
H
I
J
K
EXL
M
N
O
P

TURN SIGNAL AND HAZARD WARNING LAMP SYSTEM

< COMPONENT DIAGNOSIS >

[XENON TYPE]

TURN SIGNAL AND HAZARD WARNING LAMPS

Connector No.	M118
Connector Name	BCM (BODY CONTROL MODULE)
Connector Type	M03FE-LC



Terminal No.	Color of Wire	Signal Name
1	W	BAT (F/L)

Connector No.	M119
Connector Name	BCM (BODY CONTROL MODULE)
Connector Type	NS16FW-CS



Terminal No.	Color of Wire	Signal Name
11	R	BAT (FUSE)
13	B	GND
17	W	FRONT FLASHER OUTPUT(RIGHT)
18	O	FRONT FLASHER OUTPUT(LEFT)

Connector No.	M120
Connector Name	BCM (BODY CONTROL MODULE)
Connector Type	NS12FW-CS



Terminal No.	Color of Wire	Signal Name
20	V	REAR FLASHER OUTPUT(RIGHT)
25	G	REAR FLASHER OUTPUT(LEFT)

Connector No.	M122
Connector Name	BCM (BODY CONTROL MODULE)
Connector Type	TH40FB-NH



Terminal No.	Color of Wire	Signal Name
87	BR	COMBI SW INPUT 5
88	V	COMBI SW INPUT 3
90	P	CAN-L
91	L	CAN-H
107	LG	COMBI SW INPUT 1
108	R	COMBI SW INPUT 4
109	Y	COMBI SW INPUT 2
110	G	HAZARD SW

Connector No.	M123
Connector Name	BCM (BODY CONTROL MODULE)
Connector Type	TH40FG-NH

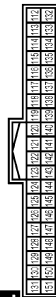

Terminal No.	Color of Wire	Signal Name
142	O	COMBI SW OUTPUT 5
143	P	COMBI SW OUTPUT 1
144	G	COMBI SW OUTPUT 2
145	L	COMBI SW OUTPUT 3
146	SB	COMBI SW OUTPUT 4

PARKING, LICENSE PLATE AND TAIL LAMPS SYSTEM

< COMPONENT DIAGNOSIS >

[XENON TYPE]

PARKING, LICENSE PLATE AND TAIL LAMPS

Connector No.	B1
Connector Name	WIRE TO WIRE
Connector Type	TH80FW-CS16-TM4

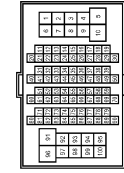

Connector No.	B6
Connector Name	FUSE BLOCK (J/B)
Connector Type	NS12FBR-CS



Connector No.	B80
Connector Name	REAR COMBINATION LAMP LH
Connector Type	NS04FW-CS



Connector No.	B64
Connector Name	WIRE TO WIRE
Connector Type	RK02F5Y



Terminal No.	Color of Wire	Signal Name
23	L	-
24	P	-
25	L	-
26	P	-

Terminal No.	Color of Wire	Signal Name
4G	R	-

Terminal No.	Color of Wire	Signal Name
1	R	-
4	B	-

Terminal No.	Color of Wire	Signal Name
1	R	-
2	B	-

Connector No.	B67
Connector Name	REAR COMBINATION LAMP RH
Connector Type	NS04FW-CS



Connector No.	B91
Connector Name	WIRE TO WIRE
Connector Type	RK02M4Y



Connector No.	B92
Connector Name	LICENSE PLATE LAMP LH
Connector Type	RV02FBR



Connector No.	B93
Connector Name	LICENSE PLATE LAMP RH
Connector Type	RV02FBR



Terminal No.	Color of Wire	Signal Name
1	R	-
4	B	-

Terminal No.	Color of Wire	Signal Name
1	-	-
2	-	-

Terminal No.	Color of Wire	Signal Name
1	G	-
2	B	-

Terminal No.	Color of Wire	Signal Name
1	G	-
2	B	-

JCLWA0042GB

PARKING, LICENSE PLATE AND TAIL LAMPS SYSTEM

< COMPONENT DIAGNOSIS >

[XENON TYPE]

PARKING, LICENSE PLATE AND TAIL LAMPS

Connector No.	E5
Connector Name	IPDM E/R (INTELLIGENT POWER DISTRIBUTION MODULE ENGINE ROOM)
Connector Type	TH20FW-CS12-AM-IV

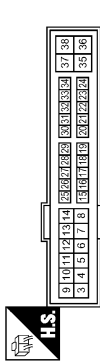

Terminal No.	Color of Wire	Signal Name
7	R	-
12	B/W	-

Connector No.	E6
Connector Name	IPDM E/R (INTELLIGENT POWER DISTRIBUTION MODULE ENGINE ROOM)
Connector Type	TH108FW-NH



Terminal No.	Color of Wire	Signal Name
39	P	-
40	L	-
41	B/W	-

Connector No.	E9
Connector Name	IPDM E/R (INTELLIGENT POWER DISTRIBUTION MODULE ENGINE ROOM)
Connector Type	TH18FW-NH



Terminal No.	Color of Wire	Signal Name
91	P	-
92	O	-

Connector No.	E28
Connector Name	FRONT COMBINATION LAMP RH
Connector Type	RS08FB-FR



Terminal No.	Color of Wire	Signal Name
4	B/W	-
8	P	-

Connector No.	E58
Connector Name	FRONT COMBINATION LAMP LH
Connector Type	RS08FB-FR



Terminal No.	Color of Wire	Signal Name
4	B/W	-
8	O	-

Connector No.	E103
Connector Name	FUSE BLOCK (J/B)
Connector Type	RS16FW-CS

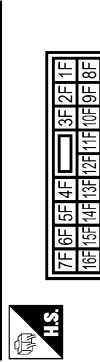

Terminal No.	Color of Wire	Signal Name
9F	R	-

Connector No.	E106
Connector Name	WIRE TO WIRE
Connector Type	TH80FW-CS16-TM4



Terminal No.	Color of Wire	Signal Name
6	P	-
7	L	-
91	W	-

Connector No.	M1
Connector Name	FUSE BLOCK (J/B)
Connector Type	NS08FW-M2

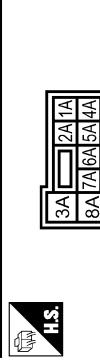

Terminal No.	Color of Wire	Signal Name
7A	R	-

A
B
C
D
E
F
G
H
I
J
K
L
M
N
O
P

EXL

PARKING, LICENSE PLATE AND TAIL LAMPS SYSTEM

< COMPONENT DIAGNOSIS >

[XENON TYPE]

PARKING, LICENSE PLATE AND TAIL LAMPS

Connector No.	M16
Connector Name	WIRE TO WIRE
Connector Type	TH80MW-CS16-TM4



Terminal No.	Color of Wire	Signal Name
6	P	-
7	L	-
91	W	-

Connector No.	M17
Connector Name	WIRE TO WIRE
Connector Type	TH80MW-CS16-TM4

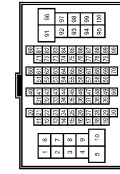

Terminal No.	Color of Wire	Signal Name
23	L	-
24	P	-
25	L	-
26	P	-

Connector No.	M24
Connector Name	DATA LINK CONNECTOR
Connector Type	BD18FW

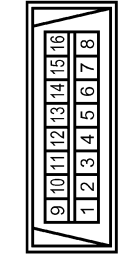

Terminal No.	Color of Wire	Signal Name
6	L	-
14	P	-

Connector No.	M33
Connector Name	COMBINATION SWITCH
Connector Type	TH18FW-NH

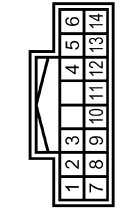

Terminal No.	Color of Wire	Signal Name
2	SB	OUTPUT 4
5	L	OUTPUT 3
7	V	INPUT 3
8	O	OUTPUT 5
9	Y	INPUT 2
10	R	INPUT 4
11	LG	INPUT 1
12	P	OUTPUT 1
13	BR	INPUT 5
14	G	OUTPUT 2

Connector No.	M118
Connector Name	BCM (BODY CONTROL MODULE)
Connector Type	M03FB-LC



Terminal No.	Color of Wire	Signal Name
1	W	BAT (F/L)

Connector No.	M119
Connector Name	BCM (BODY CONTROL MODULE)
Connector Type	NS18FW-CS



Terminal No.	Color of Wire	Signal Name
11	R	BAT (FUSE)
13	B	GND

Connector No.	M122
Connector Name	BCM (BODY CONTROL MODULE)
Connector Type	TH40FB-NH

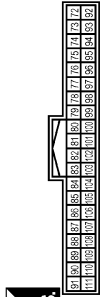

Terminal No.	Color of Wire	Signal Name
87	BR	COMBI SW INPUT 5
88	V	COMBI SW INPUT 3
90	P	CAN-L
91	L	CAN-H
107	LG	COMBI SW INPUT 1
108	R	COMBI SW INPUT 4
109	Y	COMBI SW INPUT 2

Connector No.	M123
Connector Name	BCM (BODY CONTROL MODULE)
Connector Type	TH40FG-NH

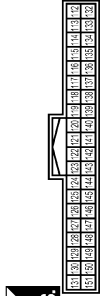

Terminal No.	Color of Wire	Signal Name
142	O	COMBI SW OUTPUT 5
143	P	COMBI SW OUTPUT 1
144	G	COMBI SW OUTPUT 2
145	L	COMBI SW OUTPUT 3
146	SB	COMBI SW OUTPUT 4

STOP LAMP

< COMPONENT DIAGNOSIS >

[XENON TYPE]

STOP LAMP

Wiring Diagram —STOP LAMP—

INFOID:000000000962504

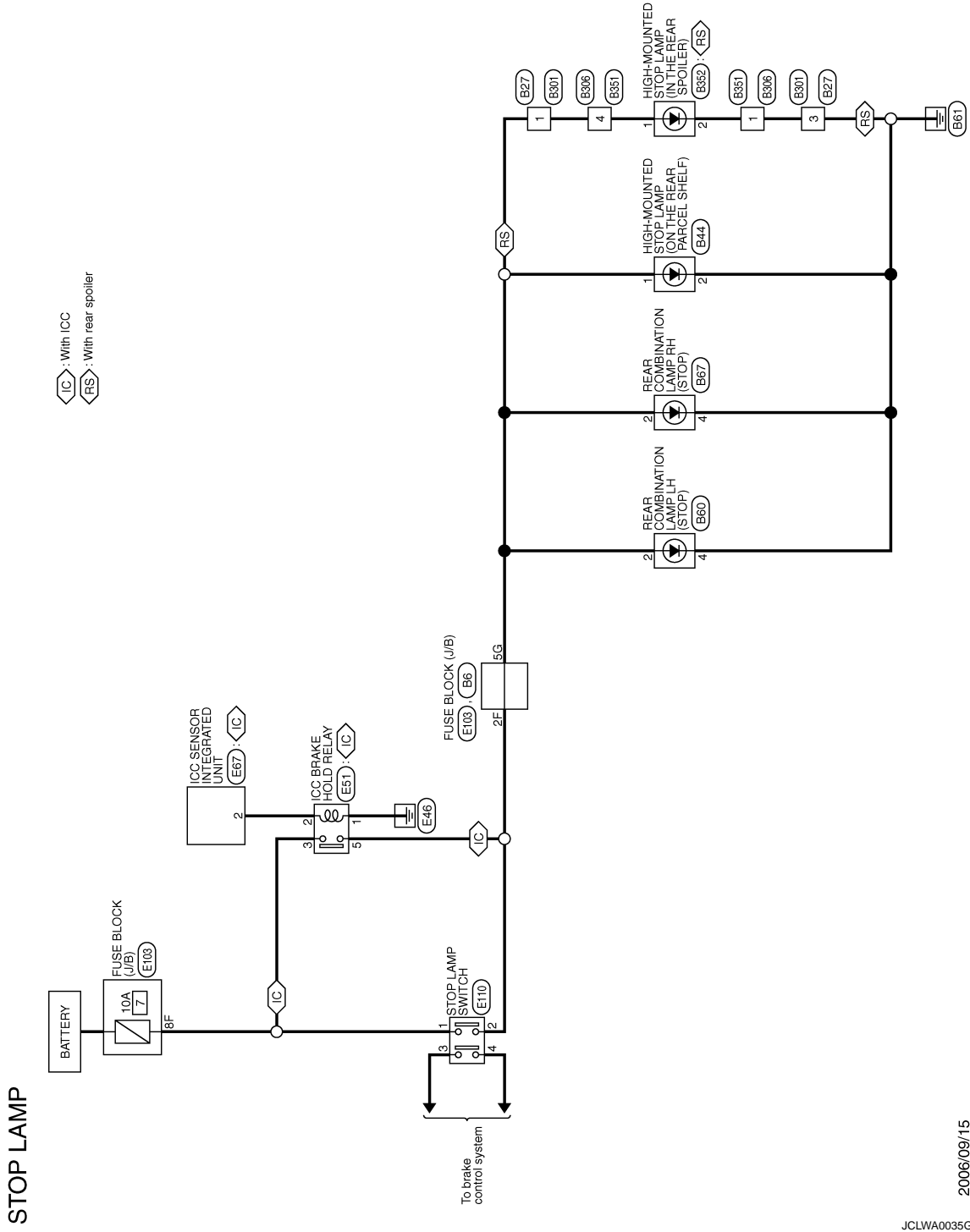

A
B
C
D
E
F
G
H
I
J
K
L
M
N
O
P

EXL

2006/09/15

JCLWA0035GB

STOP LAMP

< COMPONENT DIAGNOSIS >

[XENON TYPE]

STOP LAMP

Connector No. B6	FUSE BLOCK (J/B)	NS12FBE-CS		Terminal No. 5G	Color of Wire LG	Signal Name -
Connector No. B8	FUSE BLOCK (J/B)	NS12FBE-CS		Terminal No. 5G	Color of Wire LG	Signal Name -
Connector No. B27	WIRE TO WIRE	NS16MW-CS		Terminal No. 1	Color of Wire LG	Signal Name -
Connector No. B27	WIRE TO WIRE	NS16MW-CS		Terminal No. 3	Color of Wire B	Signal Name -
Connector No. B44	HIGH-MOUNTED STOP LAMP(ON THE REAR PARCEL SHELF)	TK02MBR-P		Terminal No. 1	Color of Wire LG	Signal Name -
Connector No. B44	HIGH-MOUNTED STOP LAMP(ON THE REAR PARCEL SHELF)	TK02MBR-P		Terminal No. 2	Color of Wire B	Signal Name -
Connector No. B60	REAR COMBINATION LAMP LH	NS04FW-CS		Terminal No. 2	Color of Wire LG	Signal Name -
Connector No. B60	REAR COMBINATION LAMP LH	NS04FW-CS		Terminal No. 4	Color of Wire B	Signal Name -
Connector No. B67	REAR COMBINATION LAMP RH	NS04FW-CS		Terminal No. 2	Color of Wire LG	Signal Name -
Connector No. B67	REAR COMBINATION LAMP RH	NS04FW-CS		Terminal No. 4	Color of Wire B	Signal Name -
Connector No. B301	WIRE TO WIRE	NS16FW-CS		Terminal No. 1	Color of Wire LG	Signal Name -
Connector No. B301	WIRE TO WIRE	NS16FW-CS		Terminal No. 3	Color of Wire B	Signal Name -
Connector No. B306	WIRE TO WIRE	TH04MW-NH		Terminal No. 1	Color of Wire B	Signal Name -
Connector No. B306	WIRE TO WIRE	TH04MW-NH		Terminal No. 4	Color of Wire LG	Signal Name -
Connector No. B351	WIRE TO WIRE	TH04FW-NH		Terminal No. 1	Color of Wire B	Signal Name -
Connector No. B351	WIRE TO WIRE	TH04FW-NH		Terminal No. 4	Color of Wire LG	Signal Name -

JCLWA0036GB

STOP LAMP

< COMPONENT DIAGNOSIS >

[XENON TYPE]

STOP LAMP

Connector No.	B332
Connector Name	HIGH-MOUNTED STOP LAMP (IN THE REAR SPOILER)
Connector Type	RS22FGY



Terminal No.	Color of Wire	Signal Name
1	LG	-
2	B	-

Connector No.	E51
Connector Name	ICC BRAKE HOLD RELAY
Connector Type	MS20FL-M2

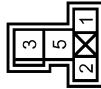

Terminal No.	Color of Wire	Signal Name
1	B	-
2	V	-
3	R	-
5	P	-

Connector No.	E67
Connector Name	ICC SENSOR INTEGRATED UNIT
Connector Type	RS20FE-PR



Terminal No.	Color of Wire	Signal Name
2	V	BRK LMP RLY

Connector No.	E103
Connector Name	FUSE BLOCK (J/B)
Connector Type	NST8FW-GS



Terminal No.	Color of Wire	Signal Name
2F	W	-
8F	L	-

Connector No.	E110
Connector Name	STOP LAMP SWITCH
Connector Type	RM2HW-LC



Terminal No.	Color of Wire	Signal Name
1	L	-
2	W	-
3	L	-
4	SB	-

A
B
C
D
E
F
G
H
I
J
K
EXL
M
N
O
P

BACK-UP LAMP

< COMPONENT DIAGNOSIS >

[XENON TYPE]

BACK-UP LAMP

Wiring Diagram —BACK-UP LAMP—

INFOID:000000000962505

BACK-UP LAMP

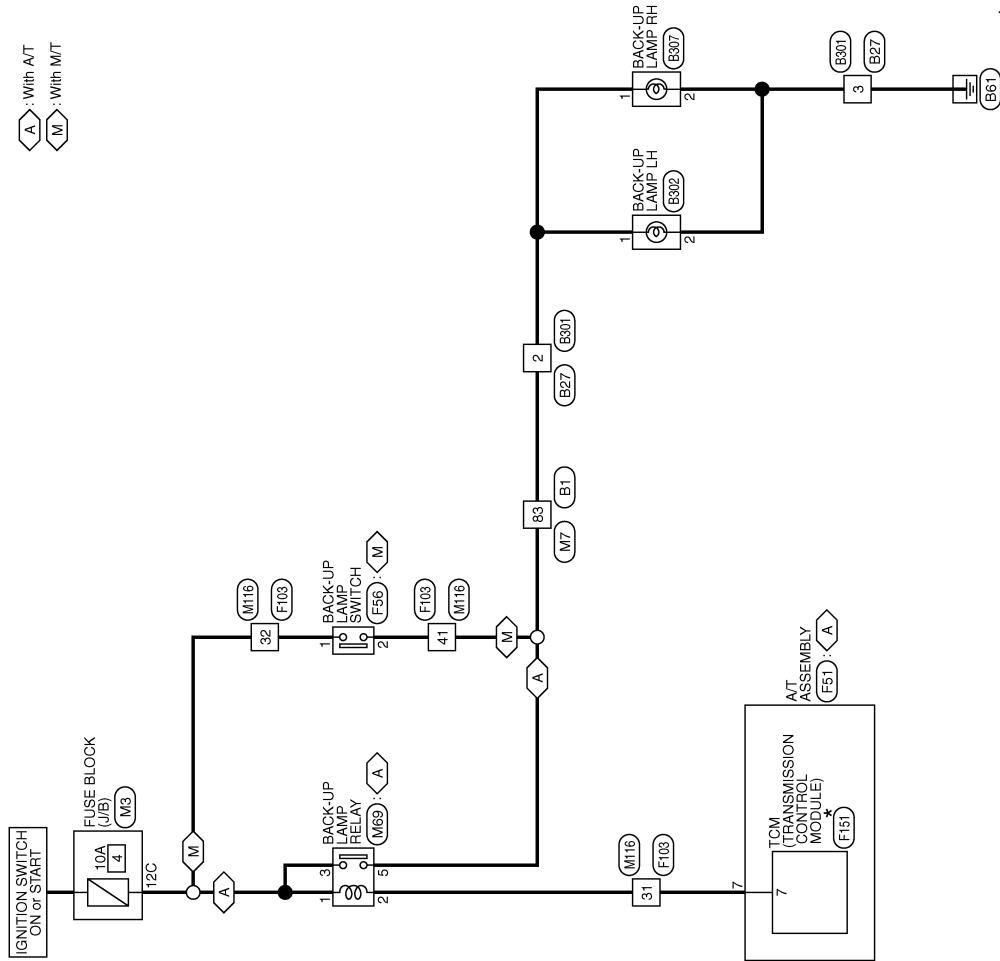

⬠ : With A/T
⬠ : With M/T

*: This connector is not shown in "Harness Layout".

2006/09/15

JCLWA0038GB

BACK-UP LAMP

< COMPONENT DIAGNOSIS >

[XENON TYPE]

BACK-UP LAMP

Connector No.	B1
Connector Name	WIRE TO WIRE
Connector Type	THROFW-CS16-TM4

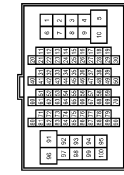

Terminal No.	Color of Wire	Signal Name
83	O	-

Connector No.	B27
Connector Name	WIRE TO WIRE
Connector Type	NS16MW-CS

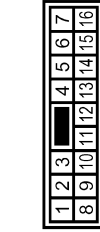

Terminal No.	Color of Wire	Signal Name
2	O	-
3	B	-

Connector No.	B301
Connector Name	WIRE TO WIRE
Connector Type	NS18FW-CS

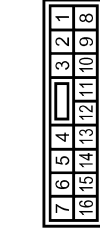

Terminal No.	Color of Wire	Signal Name
2	O	-
3	B	-

Connector No.	B302
Connector Name	BACK-UP LAMP LH
Connector Type	NS22FW-CS



Terminal No.	Color of Wire	Signal Name
1	O	-
2	B	-

Connector No.	B307
Connector Name	BACK-UP LAMP RH
Connector Type	NS22FW-CS

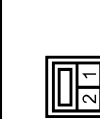

Terminal No.	Color of Wire	Signal Name
1	O	-
2	B	-

Connector No.	F51
Connector Name	A/T ASSEMBLY
Connector Type	RK10FG-DG1

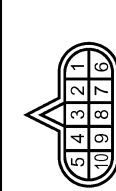

Terminal No.	Color of Wire	Signal Name
7	R	-

Connector No.	F35
Connector Name	BACK-UP LAMP SWITCH
Connector Type	RK02FB



Terminal No.	Color of Wire	Signal Name
1	R	-
2	O	-

Connector No.	F103
Connector Name	WIRE TO WIRE
Connector Type	TK38FW-TS10

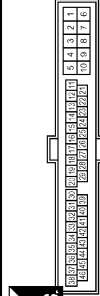

Terminal No.	Color of Wire	Signal Name
31	R	-
32	R	-
41	O	-

A
B
C
D
E
F
G
H
I
J
K
EXL
M
N
O
P

BACK-UP LAMP

< COMPONENT DIAGNOSIS >

[XENON TYPE]

BACK-UP LAMP

Connector No.	F1B1
Connector Name	TOM (TRANSMISSION CONTROL MODULE)
Connector Type	SP10FBGY

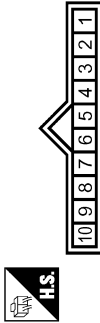

Terminal No.	7	Color of Wire	O	Signal Name	REV LAMP RLY
--------------	---	---------------	---	-------------	--------------

Connector No.	M3
Connector Name	FUSE BLOCK (J/B)
Connector Type	NS12FW-GS

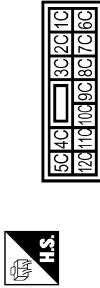

Terminal No.	12C	Color of Wire	R	Signal Name	-
--------------	-----	---------------	---	-------------	---

Connector No.	M7
Connector Name	WIRE TO WIRE
Connector Type	TH80MW-GS16-TM4



Terminal No.	83	Color of Wire	O	Signal Name	-
--------------	----	---------------	---	-------------	---

Connector No.	M69
Connector Name	BACK-UP LAMP RELAY
Connector Type	MS02FL-M2

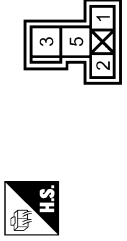

Terminal No.	1	Color of Wire	R	Signal Name	-
2	W	-	-	-	
3	LG	-	-	-	
5	O	-	-	-	

Connector No.	M116
Connector Name	WIRE TO WIRE
Connector Type	TK30MW-NS10

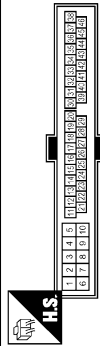

Terminal No.	31	Color of Wire	W	Signal Name	-
32	LG	-	-	-	
41	O	-	-	-	

JCLWA0040GB

BCM (BODY CONTROL MODULE)

< ECU DIAGNOSIS >

[XENON TYPE]

ECU DIAGNOSIS

BCM (BODY CONTROL MODULE)

Reference Value

INFOID:000000000962506

VALUES ON THE DIAGNOSIS TOOL

Monitor Item	Condition	Value/Status
FR WIPER HI	Other than front wiper switch HI	OFF
	Front wiper switch HI	ON
FR WIPER LOW	Other than front wiper switch LO	OFF
	Front wiper switch LO	ON
FR WASHER SW	Front washer switch OFF	OFF
	Front washer switch ON	ON
FR WIPER INT	Other than front wiper switch INT	OFF
	Front wiper switch INT	ON
FR WIPER STOP	Front wiper is not in STOP position	OFF
	Front wiper is in STOP position	ON
INT VOLUME	Wiper intermittent dial is in a dial position 1 - 7	Wiper intermittent dial position
TURN SIGNAL R	Other than turn signal switch RH	OFF
	Turn signal switch RH	ON
TURN SIGNAL L	Other than turn signal switch LH	OFF
	Turn signal switch LH	ON
TAIL LAMP SW	Other than lighting switch 1ST and 2ND	OFF
	Lighting switch 1ST or 2ND	ON
HI BEAM SW	Other than lighting switch HI	OFF
	Lighting switch HI	ON
HEAD LAMP SW 1	Other than lighting switch 2ND	OFF
	Lighting switch 2ND	ON
HEAD LAMP SW 2	Other than lighting switch 2ND	OFF
	Lighting switch 2ND	ON
PASSING SW	Other than lighting switch PASS	OFF
	Lighting switch PASS	ON
AUTO LIGHT SW	Other than lighting switch AUTO	OFF
	Lighting switch AUTO	ON
FR FOG SW	Front fog lamp switch OFF	OFF
	Front fog lamp switch ON	ON
RR FOG SW	NOTE: The item is indicated, but not monitored.	OFF
DOOR SW-DR	Driver door closed	OFF
	Driver door opened	ON
DOOR SW-AS	Passenger door closed	OFF
	Passenger door opened	ON
DOOR SW-RR	Rear RH door closed	OFF
	Rear RH door opened	ON

BCM (BODY CONTROL MODULE)

< ECU DIAGNOSIS >

[XENON TYPE]

Monitor Item	Condition	Value/Status
DOOR SW-RL	Rear LH door closed	OFF
	Rear LH door opened	ON
DOOR SW-BK	NOTE: The item is indicated, but not monitored.	OFF
CDL LOCK SW	Other than power door lock switch LOCK	OFF
	Power door lock switch LOCK	ON
CDL UNLOCK SW	Other than power door lock switch UNLOCK	OFF
	Power door lock switch UNLOCK	ON
KEY CYL LK-SW	Other than driver door key cylinder LOCK position	OFF
	Driver door key cylinder LOCK position	ON
KEY CYL UN-SW	Other than driver door key cylinder UNLOCK position	OFF
	Driver door key cylinder UNLOCK position	ON
KEY CYL SW-TR	NOTE: The item is indicated, but not monitored.	OFF
HAZARD SW	Hazard switch is not pressed	OFF
	Hazard switch is pressed	ON
REAR DEF SW	NOTE: The item is indicated, but not monitored.	OFF
H/L WASH SW	NOTE: The item is indicated, but not monitored.	OFF
TR CANCEL SW	Trunk lid opener cancel switch OFF	OFF
	Trunk lid opener cancel switch ON	ON
TR/BD OPEN SW	Trunk lid opener switch OFF	OFF
	While the trunk lid opener switch is turned ON	ON
TRNK/HAT MNTR	Trunk lid closed	OFF
	Trunk lid opened	ON
RKE-LOCK	LOCK button of Intelligent Key is not pressed	OFF
	LOCK button of Intelligent Key is pressed	ON
RKE-UNLOCK	UNLOCK button of Intelligent Key is not pressed	OFF
	UNLOCK button of Intelligent Key is pressed	ON
RKE-TR/BD	TRUNK OPEN button of Intelligent Key is not pressed	OFF
	TRUNK OPEN button of Intelligent Key is pressed	ON
RKE-PANIC	PANIC button of Intelligent Key is not pressed	OFF
	PANIC button of Intelligent Key is pressed	ON
RKE-P/W OPEN	UNLOCK button of Intelligent Key is not pressed	OFF
	UNLOCK button of Intelligent Key is pressed and held	ON
RKE-MODE CHG	LOCK/UNLOCK button of Intelligent Key is not pressed and held simultaneously	OFF
	LOCK/UNLOCK button of Intelligent Key is pressed and held simultaneously	ON
OPTICAL SENSOR	Outside of the vehicle bright	Close to 5 V
	Outside of the vehicle dark	Close to 0 V
REQ SW-DR	Driver door request switch is not pressed	OFF
	Driver door request switch is pressed	ON
REQ SW-AS	Passenger door request switch is not pressed	OFF
	Passenger door request switch is pressed	ON

BCM (BODY CONTROL MODULE)

< ECU DIAGNOSIS >

[XENON TYPE]

Monitor Item	Condition	Value/Status	
REQ SW-BD/TR	Trunk request switch is not pressed	OFF	A
	Trunk request switch is pressed	ON	
PUSH SW	Push-button ignition switch (push switch) is not pressed	OFF	B
	Push-button ignition switch (push switch) is pressed	ON	
IGN RLY2 -F/B	Ignition switch in OFF or ACC position	OFF	C
	Ignition switch in ON position	ON	
ACC RLY -F/B	Ignition switch in OFF position	OFF	D
	Ignition switch in ACC or ON position	ON	
CLUCH SW	The clutch pedal is not depressed	OFF	E
	The clutch pedal is depressed	ON	
BRAKE SW 1	The brake pedal is not depressed	ON	F
	The brake pedal is depressed	OFF	
DETE/CANCL SW	Selector lever in P position	OFF	G
	Selector lever in any position other than P	ON	
SFT PN/N SW	Selector lever in any position other than P and N	OFF	H
	Selector lever in P or N position	ON	
S/L -LOCK	Steering is locked	OFF	I
	Steering is unlocked	ON	
S/L -UNLOCK	Steering is unlocked	OFF	J
	Steering is locked	ON	
S/L RELAY-F/B	Ignition switch is OFF or ACC position	OFF	K
	Ignition switch is ON position	ON	
UNLK SEN-DR	Driver door is unlocked	OFF	EXL
	Driver door is locked	ON	
PUSH SW -IPDM	Push-button ignition switch (push-switch) is not pressed	OFF	M
	Push-button ignition switch (push-switch) is pressed	ON	
IGN RLY1 -F/B	Ignition switch is OFF or ACC position	OFF	N
	Ignition switch is ON position	ON	
DETE SW -IPDM	Selector lever in P position	OFF	O
	Selector lever in any position other than P	ON	
SFT PN -IPDM	Selector lever in any position other than P and N	OFF	P
	Selector lever in P or N position	ON	
SFT P -MET	Selector lever in any position other than P	OFF	
	Selector lever in P position	ON	
SFT N -MET	Selector lever in any position other than N	OFF	
	Selector lever in N position	ON	
ENGINE STATE	Engine stopped	STOP	
	While the engine stalls	STALL	
	At engine cranking	CRANK	
	Engine running	RUN	
S/L LOCK-IPDM	Steering is locked	OFF	
	Steering is unlocked	ON	
S/L UNLK-IPDM	Steering is unlocked	OFF	
	Steering is locked	ON	

BCM (BODY CONTROL MODULE)

< ECU DIAGNOSIS >

[XENON TYPE]

Monitor Item	Condition	Value/Status
S/L RELAY-REQ	Ignition switch in OFF or ACC position	OFF
	Ignition switch in ON position	ON
VEH SPEED 1	While driving	Equivalent to speedometer reading
VEH SPEED 2	While driving	Equivalent to speedometer reading
DOOR STAT-DR	Driver door is locked	LOCK
	Wait with selective UNLOCK operation (5 seconds)	READY
	Driver door is unlocked	UNLK
DOOR STAT-AS	Passenger door is locked	LOCK
	Wait with selective UNLOCK operation (5 seconds)	READY
	Passenger door is unlocked	UNLK
ID OK FLAG	Ignition switch in ACC or ON position	RESET
	Ignition switch in OFF position	SET
PRMT ENG STRT	The engine start is prohibited	RESET
	The engine start is permitted	SET
PRMT RKE STRT	NOTE: The item is indicated, but not monitored.	RESET
KEY SW -SLOT	Intelligent Key is not inserted into key slot	OFF
	Intelligent Key is inserted into key slot	ON
RKE OPE COUN1	During the operation of Intelligent Key	Operation frequency of Intelligent Key
RKE OPE COUN2	NOTE: The item is indicated, but not monitored.	—
AIR PRESS FL	Ignition switch ON (Only when the signal from the transmitter is received)	Air pressure of front LH tire
AIR PRESS FR	Ignition switch ON (Only when the signal from the transmitter is received)	Air pressure of front RH tire
AIR PRESS RR	Ignition switch ON (Only when the signal from the transmitter is received)	Air pressure of rear RH tire
AIR PRESS RL	Ignition switch ON (Only when the signal from the transmitter is received)	Air pressure of rear LH tire
ID REGST FL1	ID of front LH tire transmitter is registered	DONE
	ID of front LH tire transmitter is not registered	YET
ID REGST FR1	ID of front RH tire transmitter is registered	DONE
	ID of front RH tire transmitter is not registered	YET
ID REGST RR1	ID of rear RH tire transmitter is registered	DONE
	ID of rear RH tire transmitter is not registered	YET
ID REGST RL1	ID of rear LH tire transmitter is registered	DONE
	ID of rear LH tire transmitter is not registered	YET
WARNING LAMP	Tire pressure indicator OFF	OFF
	Tire pressure indicator ON	ON
BUZZER	Tire pressure warning alarm is not sounding	OFF
	Tire pressure warning alarm is sounding	ON

BCM (BODY CONTROL MODULE)

< ECU DIAGNOSIS >

[XENON TYPE]

TERMINAL LAYOUT

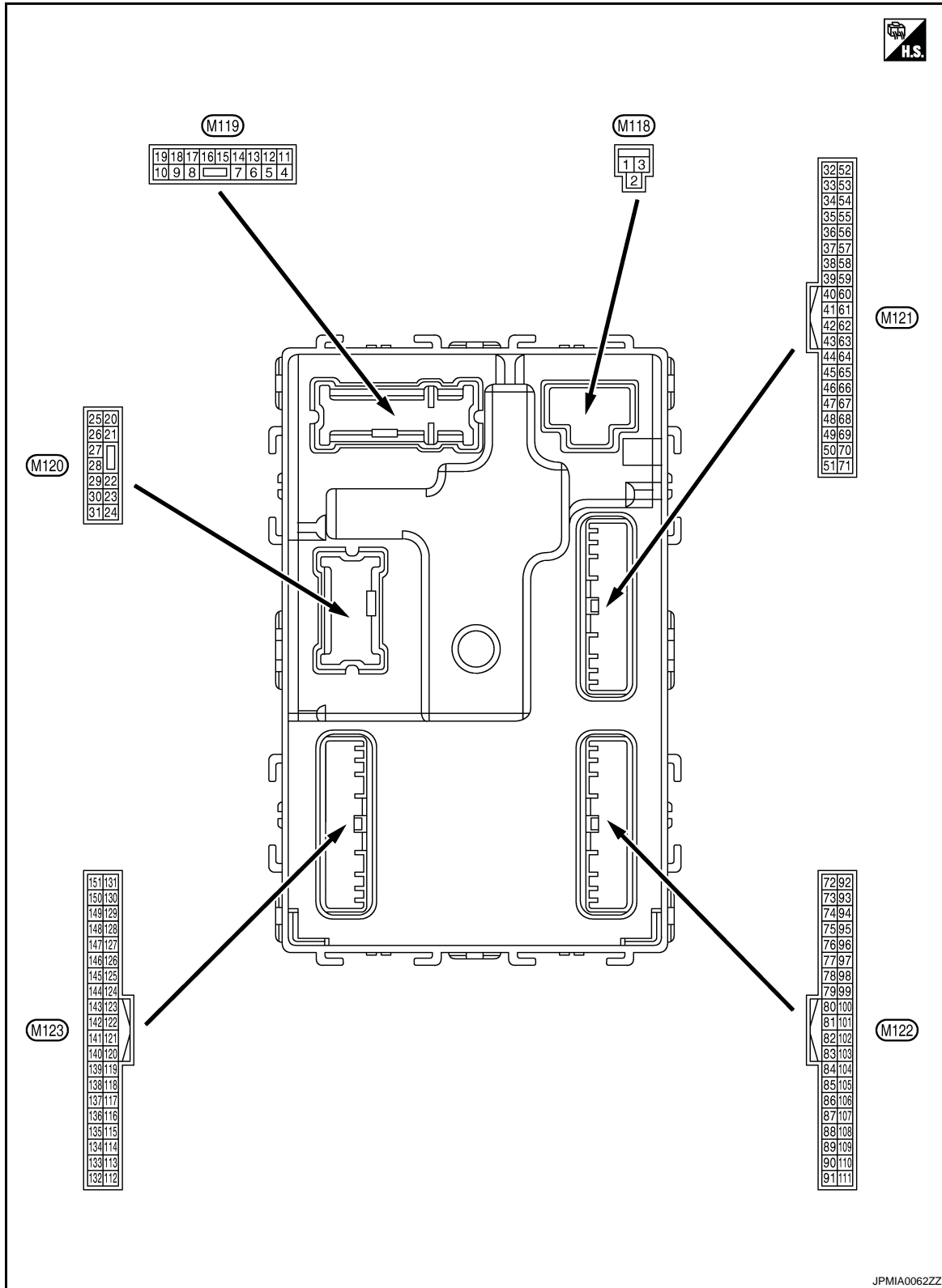

PHYSICAL VALUES

A
B
C
D
E
F
G
H
I
J
K
EXL
M
N
O
P

BCM (BODY CONTROL MODULE)

< ECU DIAGNOSIS >

[XENON TYPE]

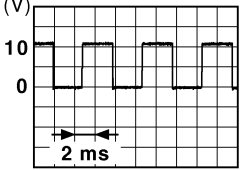
Terminal No. (Wire color)		Description		Condition		Value (Approx.)
+	-	Signal name	Input/ Output			
1 (W)	Ground	Battery power supply	Input	Ignition switch OFF		Battery voltage
2 (Y)	Ground	P/W power supply (BAT)	Output	Ignition switch OFF		Battery voltage
3 (O)	Ground	P/W power supply (RAP)	Output	Ignition switch ON		Battery voltage
4 (LG)	Ground	Interior room lamp power supply	Output	After passing the interior room lamp battery saver operation time		0 V
				Any other time after passing the interior room lamp battery saver operation time		Battery voltage
5 (V)	Ground	Passenger door UN- LOCK	Output	Passenger door	UNLOCK (Actuator is activated)	Battery voltage
					Other than UNLOCK (Actuator is not activated)	0 V
7 (Y)	Ground	Step lamp	Output	Step lamp	ON	0 V
					OFF	Battery voltage
8 (V)	Ground	All doors, fuel lid LOCK	Output	All doors, fuel lid	LOCK (Actuator is activated)	Battery voltage
					Other than LOCK (Actuator is not activated)	0 V
9 (G)	Ground	Driver door, fuel lid UNLOCK	Output	Driver door, fuel lid	UNLOCK (Actuator is activated)	Battery voltage
					Other than UNLOCK (Actuator is not activated)	0 V
10 (BR)	Ground	Rear RH door and rear LH door UN- LOCK	Output	Rear RH door and rear LH door	UNLOCK (Actuator is activated)	Battery voltage
					Other than UNLOCK (Actuator is not activated)	0 V
11 (R)	Ground	Battery power supply	Input	Ignition switch OFF		Battery voltage
13 (B)	Ground	Ground	—	Ignition switch ON		0 V
14 (W)	Ground	Push-button ignition switch illumination ground	Output	Tail lamp	OFF	0 V
					ON	<p>NOTE: When the illumination brightening/dimming level is in the neutral position</p>  <p style="text-align: right;">JSNIA0010GB</p>
15 (Y)	Ground	ACC indicator lamp	Output	Ignition switch	OFF	Battery voltage
					ACC or ON	0 V

BCM (BODY CONTROL MODULE)

< ECU DIAGNOSIS >

[XENON TYPE]

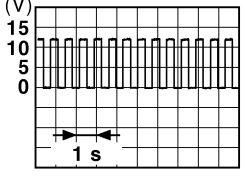
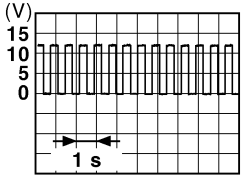
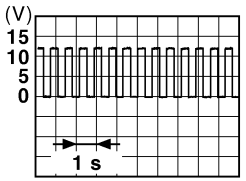
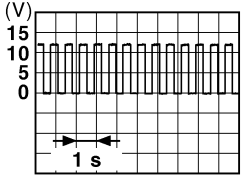
Terminal No. (Wire color)		Description		Condition	Value (Approx.)	
+	-	Signal name	Input/ Output			
17 (W)	Ground	Turn signal (front RH)	Output	Ignition switch ON	Turn signal switch OFF	0 V
				Turn signal switch RH	 <p style="text-align: center;">6.5 V</p>	
18 (O)	Ground	Turn signal (front LH)	Output	Ignition switch ON	Turn signal switch OFF	0 V
				Turn signal switch LH	 <p style="text-align: center;">6.5 V</p>	
19 (V)	Ground	Room lamp timer control	Output	Interior room lamp	OFF	Battery voltage
				ON	0 V	
20 (V)	Ground	Turn signal (rear RH)	Output	Ignition switch ON	Turn signal switch OFF	0 V
				Turn signal switch RH	 <p style="text-align: center;">6.5 V</p>	
23 (G)	Ground	Trunk lid opening.	Output	Trunk lid	Open (Trunk lid opener ac- tuator is activated)	Battery voltage
					Close (Trunk lid opener ac- tuator is not activated)	0 V
25 (G)	Ground	Turn signal (rear LH)	Output	Ignition switch ON	Turn signal switch OFF	0 V
				Turn signal switch LH	 <p style="text-align: center;">6.5 V</p>	
30 (R)	Ground	Trunk room lamp	Output	Trunk room lamp	ON	0 V
					OFF	Battery voltage

A
B
C
D
E
F
G
H
I
J
K
M
N
O
P

EXL

BCM (BODY CONTROL MODULE)

< ECU DIAGNOSIS >

[XENON TYPE]

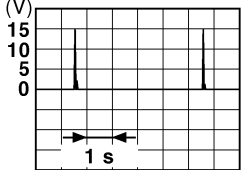
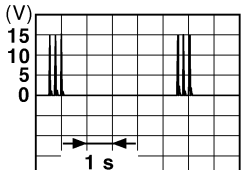
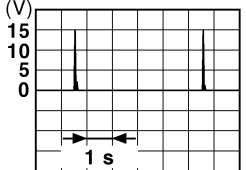
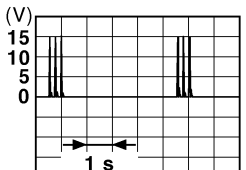
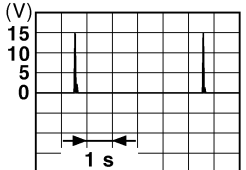
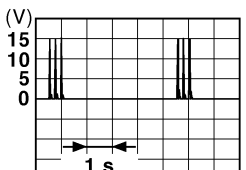
Terminal No. (Wire color)		Description		Condition	Value (Approx.)
+	-	Signal name	Input/ Output		
34 (SB)	Ground	Trunk room antenna 1 (-)	Output	Ignition switch OFF	 <p style="text-align: right; font-size: small;">JMKIA0062GB</p>
				When Intelligent Key is not in the passenger compart- ment	 <p style="text-align: right; font-size: small;">JMKIA0063GB</p>
35 (V)	Ground	Trunk room antenna 1 (+)	Output	Ignition switch OFF	 <p style="text-align: right; font-size: small;">JMKIA0062GB</p>
				When Intelligent Key is not in the passenger compart- ment	 <p style="text-align: right; font-size: small;">JMKIA0063GB</p>
38 (B)	Ground	Rear bumper anten- na (-)	Output	When the trunk lid request switch is operated with ignition switch OFF	 <p style="text-align: right; font-size: small;">JMKIA0062GB</p>
				When Intelligent Key is not in the antenna detection area	 <p style="text-align: right; font-size: small;">JMKIA0063GB</p>

BCM (BODY CONTROL MODULE)

< ECU DIAGNOSIS >

[XENON TYPE]

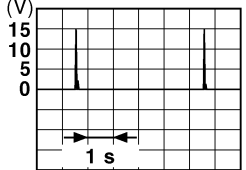
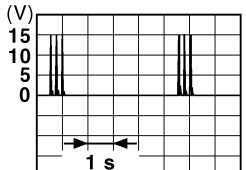
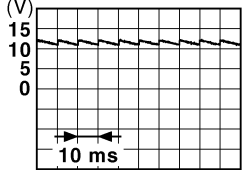
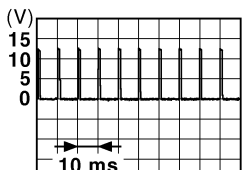
Terminal No. (Wire color)		Description		Condition	Value (Approx.)	
		Signal name	Input/ Output			
+	-					
39 (W)	Ground	Rear bumper antenna (+)	Output	When Intelligent Key is in the antenna detection area	 <p style="text-align: right; font-size: small;">JMKIA0062GB</p>	
				When Intelligent Key is not in the antenna detection area	 <p style="text-align: right; font-size: small;">JMKIA0063GB</p>	
47 (Y)	Ground	Ignition relay (IPDM E/R) control	Output	Ignition switch	OFF or ACC	Battery voltage
					ON	0 V
50 (R)	Ground	Trunk room lamp switch	Input	Trunk room lamp switch	OFF (Trunk is closed)	 <p style="text-align: right; font-size: small;">JPMIA0011GB</p> <p style="text-align: center;">11.8 V</p>
					ON (Trunk is open)	0 V
52 (SB)	Ground	Starter relay control	Output	Ignition switch OFF (M/T models)	When the clutch pedal is depressed	Battery voltage
					When the clutch pedal is not depressed	0 V
				Ignition switch ON (A/T models)	When selector lever is in P or N position and the brake is depressed	Battery voltage
					When selector lever is in P or N position and the brake is not depressed	0 V
61 (W)	Ground	Trunk request switch	Input	Trunk request switch	ON (Pressed)	0 V
					OFF (Not pressed)	 <p style="text-align: right; font-size: small;">JPMIA0016GB</p> <p style="text-align: center;">1.0 V</p>
64 (V)	Ground	Request switch buzzer	Output	Request switch buzzer	Sounding	0 V
					Not sounding	Battery voltage

A
B
C
D
E
F
G
H
I
J
K
EXL
M
N
O
P

BCM (BODY CONTROL MODULE)

< ECU DIAGNOSIS >

[XENON TYPE]

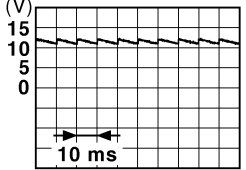
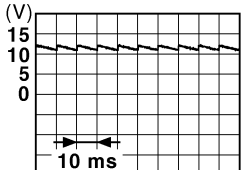
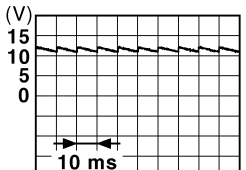
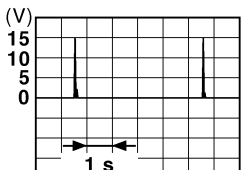
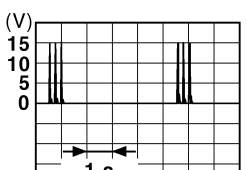
Terminal No. (Wire color)		Description		Condition	Value (Approx.)	
+	-	Signal name	Input/ Output			
67 (GR)	Ground	Trunk lid opener switch	Input	Trunk lid opener switch	Pressed	0 V
				Not pressed	 <p style="text-align: right; font-size: small;">JPMIA0011GB</p> <p style="text-align: center;">11.8 V</p>	
68 (BR)	Ground	Rear RH door switch	Input	Rear RH door switch	OFF (When rear RH door closes)	 <p style="text-align: right; font-size: small;">JPMIA0011GB</p> <p style="text-align: center;">11.8 V</p>
				ON (When rear RH door opens)	0 V	
69 (R)	Ground	Rear LH door switch	Input	Rear LH door switch	OFF (When rear LH door closes)	 <p style="text-align: right; font-size: small;">JPMIA0011GB</p> <p style="text-align: center;">11.8 V</p>
				ON (When rear LH door opens)	0 V	
72 (R)	Ground	Room antenna 2 (-) (center console)	Output	Ignition switch OFF	When Intelligent Key is in the passenger compart- ment	 <p style="text-align: right; font-size: small;">JMKIA0062GB</p>
				When Intelligent Key is not in the passenger compart- ment	 <p style="text-align: right; font-size: small;">JMKIA0063GB</p>	

BCM (BODY CONTROL MODULE)

< ECU DIAGNOSIS >

[XENON TYPE]

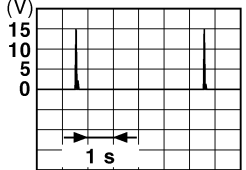
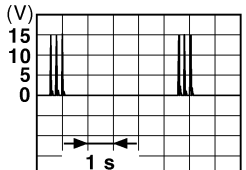
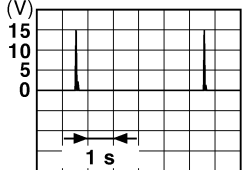
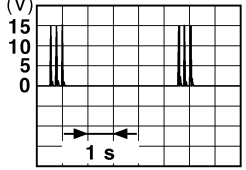
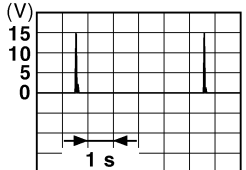
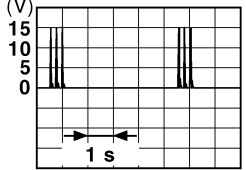
Terminal No. (Wire color)		Description		Condition	Value (Approx.)
		Signal name	Input/ Output		
+	-				
73 (G)	Ground	Room antenna 2 (+) (center console)	Output	Ignition switch OFF	 <p style="text-align: right; font-size: small;">JMKIA0062GB</p>
				When Intelligent Key is not in the passenger compart- ment	 <p style="text-align: right; font-size: small;">JMKIA0063GB</p>
74 (SB)	Ground	Passenger door an- tenna (-)	Output	When the pas- senger door re- quest switch is operated with ig- nition switch OFF	 <p style="text-align: right; font-size: small;">JMKIA0062GB</p>
				When Intelligent Key is not in the antenna detection area	 <p style="text-align: right; font-size: small;">JMKIA0063GB</p>
75 (BR)	Ground	Passenger door an- tenna (+)	Output	When the pas- senger door re- quest switch is operated with ig- nition switch OFF	 <p style="text-align: right; font-size: small;">JMKIA0062GB</p>
				When Intelligent Key is not in the antenna detection area	 <p style="text-align: right; font-size: small;">JMKIA0063GB</p>

A
B
C
D
E
F
G
H
I
J
K
M
N
O
P

EXL

BCM (BODY CONTROL MODULE)

< ECU DIAGNOSIS >

[XENON TYPE]

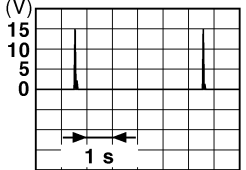
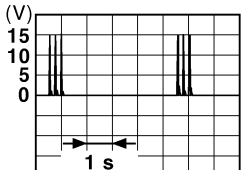
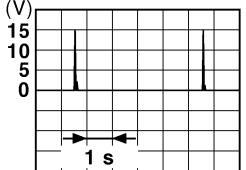
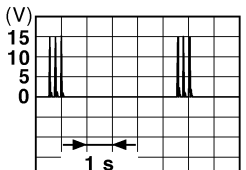
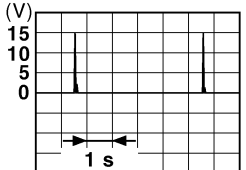
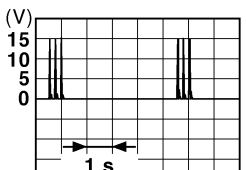
Terminal No. (Wire color)		Description		Condition	Value (Approx.)
+	-	Signal name	Input/ Output		
76 (V)	Ground	Driver door antenna (-)	Output	When Intelligent Key is in the antenna detection area	 <p style="text-align: right; font-size: small;">JMKIA0062GB</p>
				When Intelligent Key is not in the antenna detection area	 <p style="text-align: right; font-size: small;">JMKIA0063GB</p>
77 (LG)	Ground	Driver door antenna (+)	Output	When Intelligent Key is in the antenna detection area	 <p style="text-align: right; font-size: small;">JMKIA0062GB</p>
				When Intelligent Key is not in the antenna detection area	 <p style="text-align: right; font-size: small;">JMKIA0063GB</p>
78 (Y)	Ground	Room antenna (-) (in- strument panel)	Output	Ignition switch OFF	 <p style="text-align: right; font-size: small;">JMKIA0062GB</p>
				When Intelligent Key is not in the passenger compart- ment	 <p style="text-align: right; font-size: small;">JMKIA0063GB</p>

BCM (BODY CONTROL MODULE)

< ECU DIAGNOSIS >

[XENON TYPE]

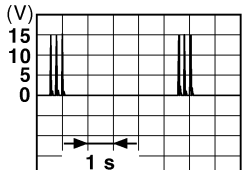
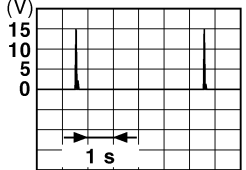
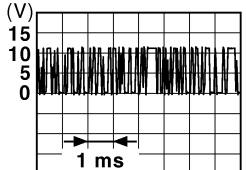
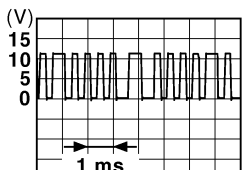

Terminal No. (Wire color)		Description		Condition	Value (Approx.)
+	-	Signal name	Input/ Output		
				When Intelligent Key is not in the passenger compart- ment	
79 (BR)	Ground	Room antenna (+) (instrument panel)	Output	Ignition switch OFF	
80 (GR)	Ground	NATS antenna amp (built in key slot)	Input/ Output	During waiting	Ignition switch is pressed while inserting the Intelli- gent Key into the key slot. Just after pressing ignition switch. Pointer of tester should move.
81 (W)	Ground	NATS antenna amp (built in key slot)	Input/ Output	During waiting	Ignition switch is pressed while inserting the Intelli- gent Key into the key slot. Just after pressing ignition switch. Pointer of tester should move.
82 (R)	Ground	Ignition relay (relay box) control	Output	Ignition switch	OFF or ACC 0 V ON Battery voltage
				During waiting	
83 (Y)	Ground	Remote keyless entry receiver signal	Input/ Output	When operating either button on Intelligent Key	

A
B
C
D
E
F
G
H
I
J
K
EXL
M
N
O
P

BCM (BODY CONTROL MODULE)

< ECU DIAGNOSIS >

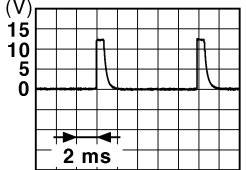

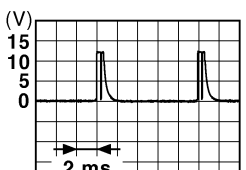
[XENON TYPE]

Terminal No. (Wire color)		Description		Condition	Value (Approx.)
+	-	Signal name	Input/ Output		
87 (BR)	Ground	Combination switch INPUT 5	Input	All switch OFF (Wiper intermittent dial 4)	 <small>JPMIA0041GB</small> 1.4 V
				Front fog lamp switch ON (Wiper intermittent dial 4)	 <small>JPMIA0037GB</small> 1.3 V
				Any of the conditions below with all switch OFF <ul style="list-style-type: none"> • Wiper intermittent dial 1 • Wiper intermittent dial 2 • Wiper intermittent dial 6 • Wiper intermittent dial 7 	 <small>JPMIA0040GB</small> 1.3 V

BCM (BODY CONTROL MODULE)

< ECU DIAGNOSIS >

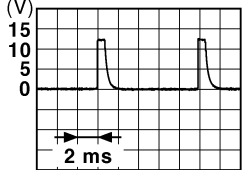
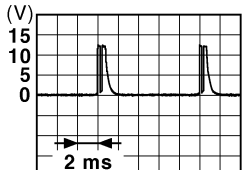
[XENON TYPE]

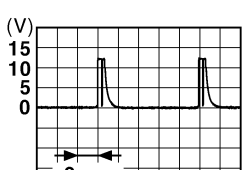
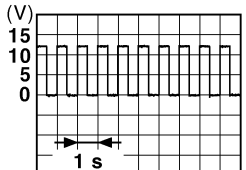
Terminal No. (Wire color)		Description		Condition	Value (Approx.)	
		Signal name	Input/ Output			
+	-					
88 (V)	Ground	Combination switch INPUT 3	Input	Combination switch	All switch OFF (Wiper intermittent dial 4)	 <small>JPMIA0041GB</small> 1.4 V
					Lighting switch HI (Wiper intermittent dial 4)	 <small>JPMIA0036GB</small> 1.3 V
					Lighting switch 2ND (Wiper intermittent dial 4)	 <small>JPMIA0037GB</small> 1.3 V
					Any of the conditions below with all switches OFF <ul style="list-style-type: none"> • Wiper intermittent dial 1 • Wiper intermittent dial 2 • Wiper intermittent dial 3 	 <small>JPMIA0040GB</small> 1.3 V
89 (BR)	Ground	Push-button ignition switch (push switch)	Input	Push-button igni- tion switch (push switch)	Pressed Not pressed 0 V Battery voltage	
90 (P)	Ground	CAN - L	Input/ Output	—	—	
91 (L)	Ground	CAN - H	Input/ Output	—	—	
92 (LG)	Ground	Key slot illumination	Output	Key slot illumina- tion	OFF	0 V
					Blinking	 <small>JPMIA0015GB</small> 6.5 V
					ON	Battery voltage

A
B
C
D
E
F
G
H
I
J
K

EXL

M
N
O
P

BCM (BODY CONTROL MODULE)

< ECU DIAGNOSIS >



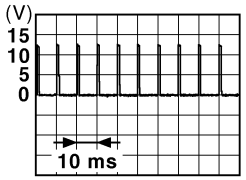
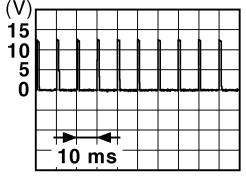

[XENON TYPE]

Terminal No. (Wire color)		Description		Condition		Value (Approx.)
+	-	Signal name	Input/ Output			
93 (V)	Ground	ON indicator lamp	Output	Ignition switch	OFF or ACC	0 V
					ON	Battery voltage
95 (O)	Ground	ACC relay control	Output	Ignition switch	OFF	0 V
					ACC or ON	Battery voltage
96 (GR)	Ground	A/T device (detention switch) power supply	Output	—		Battery voltage
97 (L)	Ground	Steering lock condition No. 1	Input	Steering lock	LOCK status	0 V
					UNLOCK status	Battery voltage
98 (P)	Ground	Steering lock condition No. 2	Input	Steering lock	LOCK status	Battery voltage
					UNLOCK status	0 V
99 (R)	Ground	Selector lever P position switch	Input	Selector lever	P position	0 V
					Any position other than P	Battery voltage
100 (G)	Ground	Passenger door request switch	Input	Passenger door request switch	ON (Pressed)	0 V
					OFF (Not pressed)	 <p style="text-align: right; font-size: small;">JPMIA0016GB</p>
101 (SB)	Ground	Driver door request switch	Input	Driver door request switch	ON (Pressed)	0 V
					OFF (Not pressed)	 <p style="text-align: right; font-size: small;">JPMIA0016GB</p>
102 (O)	Ground	Blower fan motor relay control	Output	Ignition switch	OFF or ACC	0 V
					ON	Battery voltage
103 (LG)	Ground	Remote keyless entry receiver power supply	Output	Ignition switch OFF		Battery voltage
106 (W)	Ground	Steering wheel lock unit power supply	Output	Ignition switch	OFF or ACC	Battery voltage
					ON	0 V

BCM (BODY CONTROL MODULE)

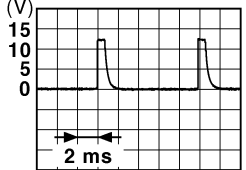
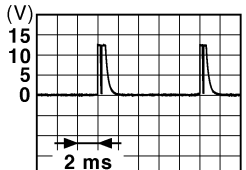
< ECU DIAGNOSIS >

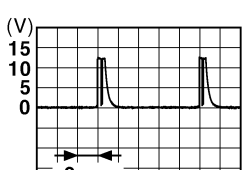
[XENON TYPE]

Terminal No. (Wire color)		Description		Condition	Value (Approx.)	
		Signal name	Input/ Output			
+	-					
107 (LG)	Ground	Combination switch INPUT 1	Input	Combination switch (Wiper intermittent dial 4)	All switch OFF	 1.4 V
					Turn signal switch LH	 1.3 V
					Turn signal switch RH	 1.3 V
					Front wiper switch LO	 1.3 V
					Front washer switch ON	 1.3 V

A
B
C
D
E
F
G
H
I
J
K
EXL
M
N
O
P

BCM (BODY CONTROL MODULE)

< ECU DIAGNOSIS >



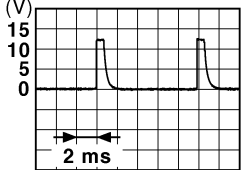
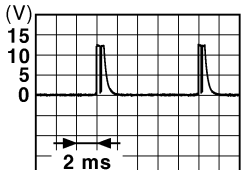
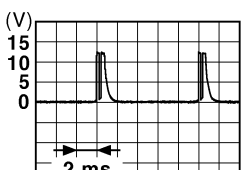
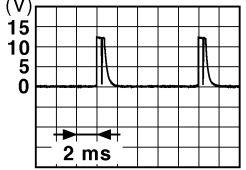

[XENON TYPE]

Terminal No. (Wire color)		Description		Condition	Value (Approx.)
+	-	Signal name	Input/ Output		
108 (R)	Ground	Combination switch INPUT 4	Input	All switch OFF (Wiper intermittent dial 4)	 <p style="text-align: right; font-size: small;">JPMIA0041GB</p> <p style="text-align: center;">1.4 V</p>
				Lighting switch AUTO (Wiper intermittent dial 4)	 <p style="text-align: right; font-size: small;">JPMIA0038GB</p> <p style="text-align: center;">1.3 V</p>
				Lighting switch 1ST (Wiper intermittent dial 4)	 <p style="text-align: right; font-size: small;">JPMIA0036GB</p> <p style="text-align: center;">1.3 V</p>
				Any of the conditions below with all switches OFF	<ul style="list-style-type: none"> • Wiper intermittent dial 1 • Wiper intermittent dial 5 • Wiper intermittent dial 6  <p style="text-align: right; font-size: small;">JPMIA0039GB</p> <p style="text-align: center;">1.3 V</p>

BCM (BODY CONTROL MODULE)

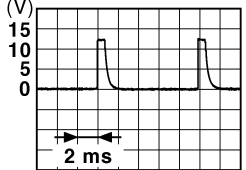
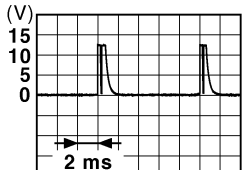
< ECU DIAGNOSIS >

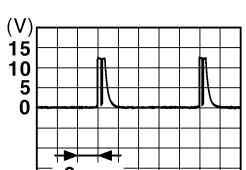
[XENON TYPE]

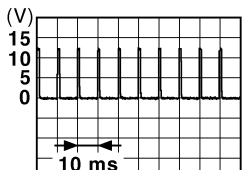
Terminal No. (Wire color)		Description		Condition	Value (Approx.)	
+	-	Signal name	Input/ Output			
109 (Y)	Ground	Combination switch INPUT 2	Input	Combination switch (Wiper intermittent dial 4)	All switch OFF	 1.4 V
					Lighting switch PASS	 1.3 V
					Lighting switch 2ND	 1.3 V
					Front wiper switch INT	 1.3 V
					Front wiper switch HI	 1.3 V
					Pressed	0 V
110 (G)	Ground	Hazard switch	Input	Hazard switch	Not pressed	 1.1 V

A
B
C
D
E
F
G
H
I
J
K
M
N
O
P

EXL

BCM (BODY CONTROL MODULE)

< ECU DIAGNOSIS >

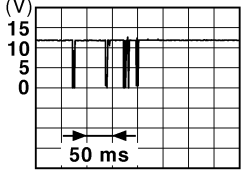
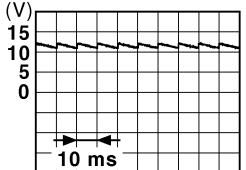

[XENON TYPE]

Terminal No. (Wire color)		Description		Condition	Value (Approx.)	
+	-	Signal name	Input/ Output			
111 (Y)	Ground	Steering lock unit communication	Input/ Output	Steering lock	LOCK status	Battery voltage
					LOCK or UNLOCK	 <p style="text-align: right; font-size: small;">JMkia0066GB</p>
					For 15 seconds after UN- LOCK	Battery voltage
					15 seconds or later after UNLOCK	0 V
113 (P)	Ground	Optical sensor signal	Input	Ignition switch ON	When bright outside of the vehicle	Close to 5 V
					When dark outside of the vehicle	Close to 0 V
114 (R)	Ground	Clutch interlock switch	Input	Clutch interlock switch	OFF (Clutch pedal is not depressed)	0 V
					ON (Clutch pedal is de- pressed)	Battery voltage
116 (SB)	Ground	Stop lamp switch 1	Input	—	—	Battery voltage
118 (P)	Ground	Stop lamp switch 2	Input	Stop lamp switch	OFF (Brake pedal is not depressed)	0 V
					ON (Brake pedal is de- pressed)	Battery voltage
				ICC brake hold relay (With ICC)	OFF	0 V
					ON	Battery voltage
119 (SB)	Ground	Front door lock as- sembly driver side (unlock sensor)	Input	Driver door	LOCK status	 <p style="text-align: right; font-size: small;">JPMIA0011GB</p>
					UNLOCK status	0 V
					11.8 V	
121 (R)	Ground	Key slot switch	Input	When Intelligent Key is inserted into key slot	Battery voltage	
				When Intelligent Key is not inserted into key slot	0 V	
122 (V)	Ground	ACC feedback signal	Input	Ignition switch	OFF	0 V
					ACC or ON	Battery voltage
123 (W)	Ground	IGN feedback signal	Input	Ignition switch	OFF or ACC	0 V
					ON	Battery voltage

BCM (BODY CONTROL MODULE)

< ECU DIAGNOSIS >

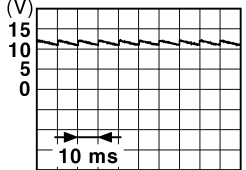
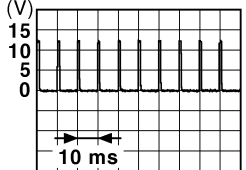
[XENON TYPE]

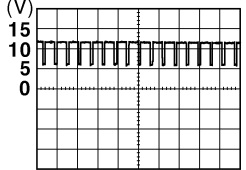
Terminal No. (Wire color)		Description		Condition	Value (Approx.)	
		Signal name	Input/ Output			
+	-					
124 (LG)	Ground	Passenger door switch	Input	Passenger door switch	OFF (When passenger door closes)  <small>JPMIA0011GB</small> 11.8 V	
					ON (When passenger door opens)	0 V
129 (O)	Ground	Trunk lid opener cancel switch	Input	Trunk lid opener cancel switch	CANCEL  <small>JPMIA0012GB</small> 1.1 V	
					ON	0 V
132 (V)	Ground	Power window switch communication	Input/ Output	Ignition switch ON	 <small>JPMIA0013GB</small> 10.2 V	
					Ignition switch OFF or ACC	0 V
133 (W)	Ground	Push-button ignition switch illumination	Output	Push-button ignition switch illumination	ON (When tail lamps OFF) 5.5 V ON (When tail lamps ON) NOTE: The pulse width of this wave is varied by the illumination brightening/dimming level.  <small>JPMIA0159GB</small>	
					OFF	0 V
					LOCK indicator lamp	ON 0 V OFF Battery voltage
134 (GR)	Ground	LOCK indicator lamp	Output	LOCK indicator lamp		
137 (O)	Ground	Receiver and sensor ground	Input	Ignition switch ON	0 V	
138 (V)	Ground	Receiver and sensor power supply output	Output	Ignition switch	OFF 0 V ACC or ON 5.0 V	

A
B
C
D
E
F
G
H
I
J
K
L
M
N
O
P

EXL

BCM (BODY CONTROL MODULE)

< ECU DIAGNOSIS >

[XENON TYPE]

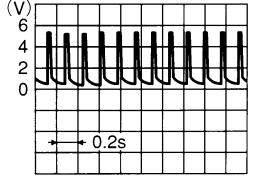
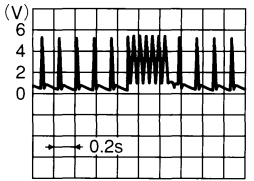
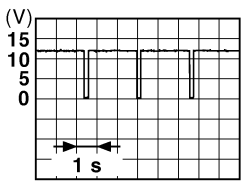
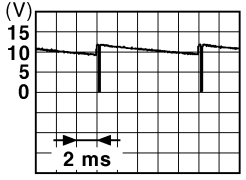
Terminal No. (Wire color)		Description		Condition	Value (Approx.)	
		Signal name	Input/ Output			
+	-					
139 (L)	Ground	Tire pressure receiver signal	Input/ Output	Ignition switch ON	Standby state	 <p style="text-align: right; font-size: small;">OCC3881D</p>
					When receiving the signal from the transmitter	 <p style="text-align: right; font-size: small;">OCC3880D</p>
140 (GR)	Ground	Selector lever P/N position signal	Input	Selector lever	P or N position	12.0 V
					Except P and N positions	0 V
141 (G)	Ground	Security indicator signal	Output	Security indicator	ON	0 V
					Blinking	 <p style="text-align: right; font-size: small;">JPMIA0014GB</p> <p style="text-align: center;">11.3 V</p>
142 (O)	Ground	Combination switch OUTPUT 5	Output	Combination switch (Wiper intermittent dial 4)	All switch OFF	0 V
					Lighting switch 1ST	 <p style="text-align: right; font-size: small;">JPMIA0031GB</p> <p style="text-align: center;">10.7 V</p>
143 (P)	Ground	Combination switch OUTPUT 1	Output	Combination switch	Turn signal switch RH	
					All switch OFF (Wiper intermittent dial 4)	0 V
					Front wiper switch HI (Wiper intermittent dial 4)	
					Any of the conditions below with all switch OFF	
					<ul style="list-style-type: none"> • Wiper intermittent dial 1 • Wiper intermittent dial 2 • Wiper intermittent dial 3 • Wiper intermittent dial 6 • Wiper intermittent dial 7 	

BCM (BODY CONTROL MODULE)

< ECU DIAGNOSIS >

[XENON TYPE]

Terminal No. (Wire color)		Description		Condition	Value (Approx.)		
		Signal name	Input/ Output				
+	-						
144 (G)	Ground	Combination switch OUTPUT 2	Output	Combination switch	All switch OFF (Wiper intermittent dial 4)	0 V	
					Front washer switch ON (Wiper intermittent dial 4)	<p style="text-align: right; font-size: small;">JPMIA0033GB</p>	
					Any of the conditions below with all switches OFF		10.7 V
145 (L)	Ground	Combination switch OUTPUT 3	Output	Combination switch (Wiper intermit- tent dial 4)	All switches OFF	0 V	
					Front wiper switch INT	<p style="text-align: right; font-size: small;">JPMIA0034GB</p>	
					Front wiper switch LO		10.7 V
					Lighting switch AUTO		
146 (SB)	Ground	Combination switch OUTPUT 4	Output	Combination switch (Wiper intermit- tent dial 4)	All switch OFF	0 V	
					Front fog lamp switch ON	<p style="text-align: right; font-size: small;">JPMIA0035GB</p>	
					Lighting switch 2ND		10.7 V
					Lighting switch PASS		
149 (W)	Ground	Tire pressure warn- ing check switch	Input	—	5 V		
					150 (GR)	Ground	Driver door switch
OFF (When driver door closes)	11.8 V						
151 (G)	Ground	Rear window defog- ger relay	Output	Rear window de- fogger	ON (When driver door opens)	0 V	
					Active	0 V	
					Not activated	Battery voltage	

A
B
C
D
E
F
G
H
I
J
K
EXL
M
N
O
P

BCM (BODY CONTROL MODULE)

< ECU DIAGNOSIS >

[XENON TYPE]

Wiring Diagram — BCM —

INFOID:00000000962507

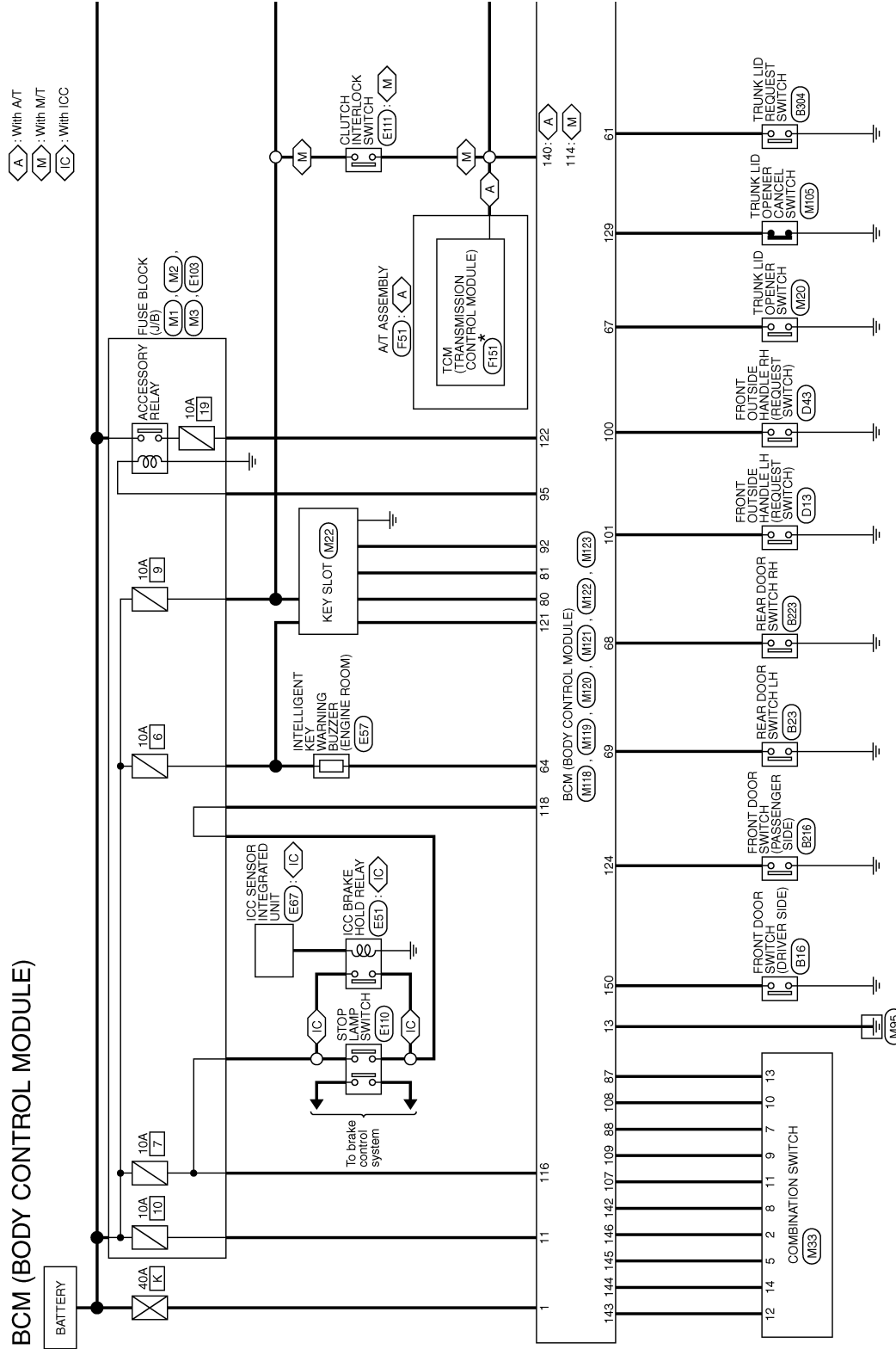

*: This connector is not shown in "Harness Layout".

2006/09/15

JCMWA0005Gf

BCM (BODY CONTROL MODULE)

< ECU DIAGNOSIS >

[XENON TYPE]

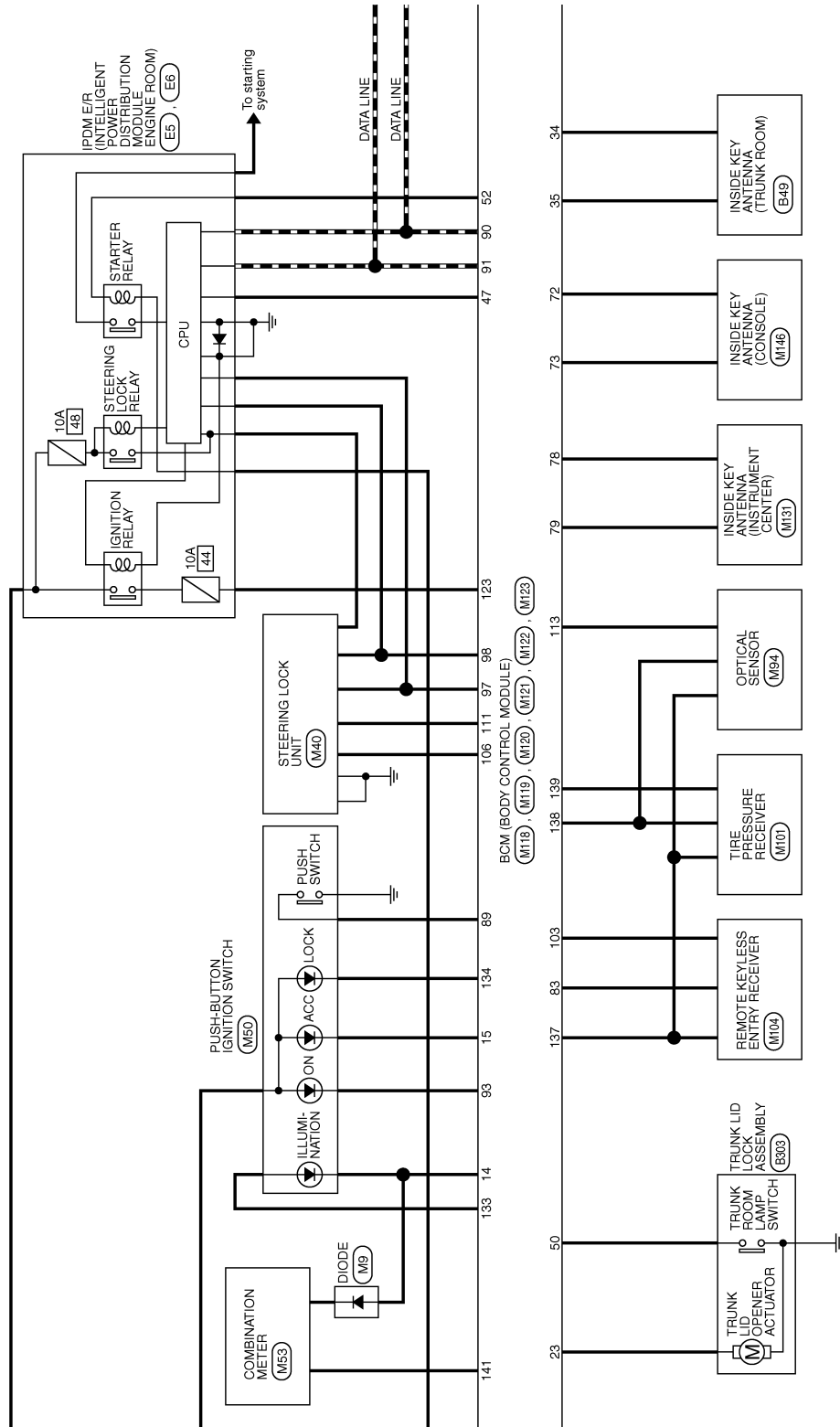

A
B
C
D
E
F
G
H
I
J
K
EXL
M
N
O
P

JCMWA0006GE

BCM (BODY CONTROL MODULE)

< ECU DIAGNOSIS >

[XENON TYPE]

- ◊ A : With AT
- ◊ NV : With NAVI
- ◊ ON : Without NAVI
- ◊ RE : With sunroof
- ◊ AN : With rear anti-pinch system
- ◊ OA : Without rear anti-pinch system
- ◊ SP : With sports seat
- ◊ PM : With automatic drive positioner

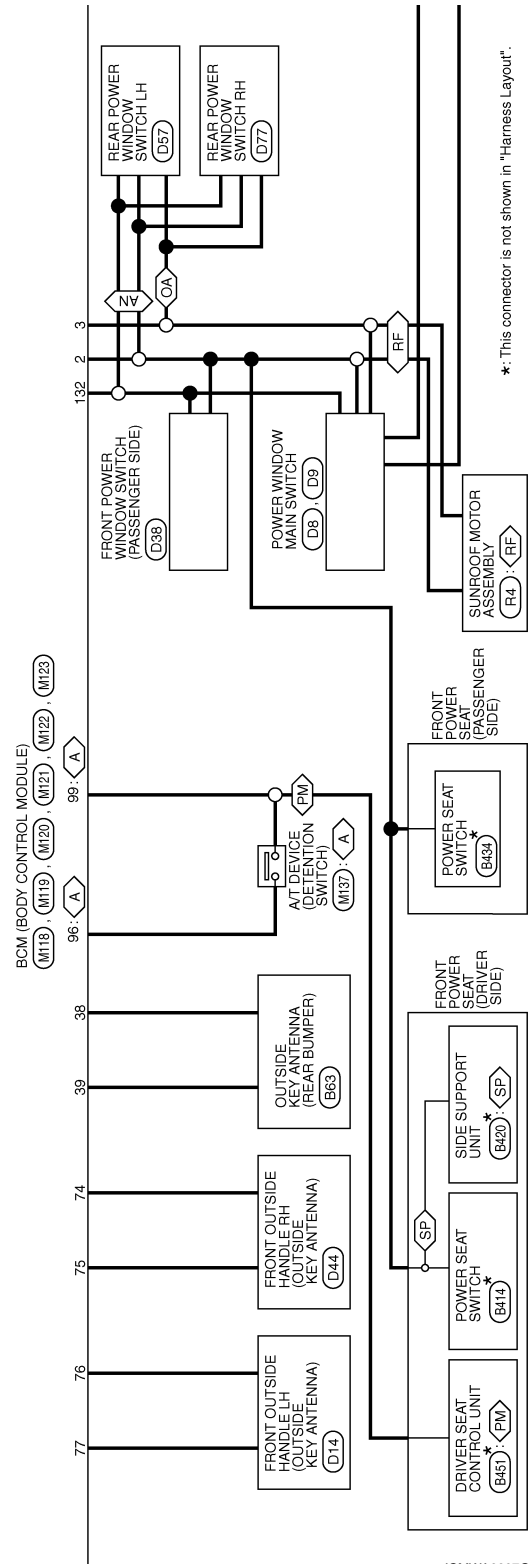
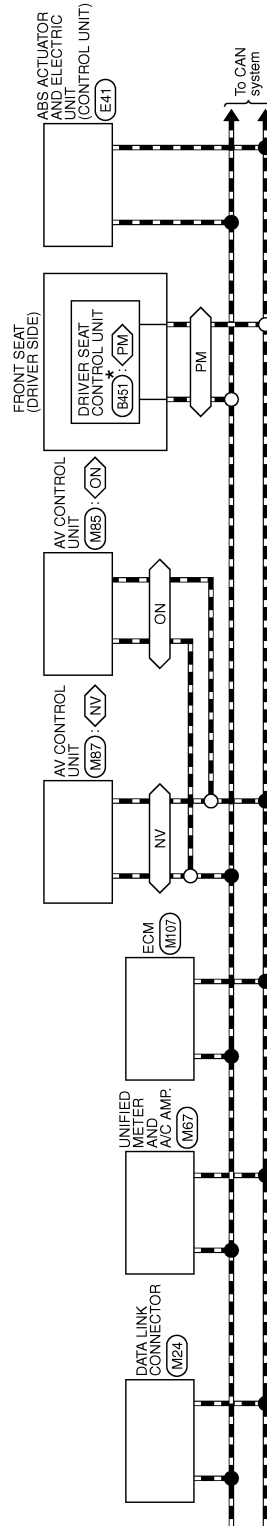

JCMWA0007G1

BCM (BODY CONTROL MODULE)

< ECU DIAGNOSIS >

[XENON TYPE]

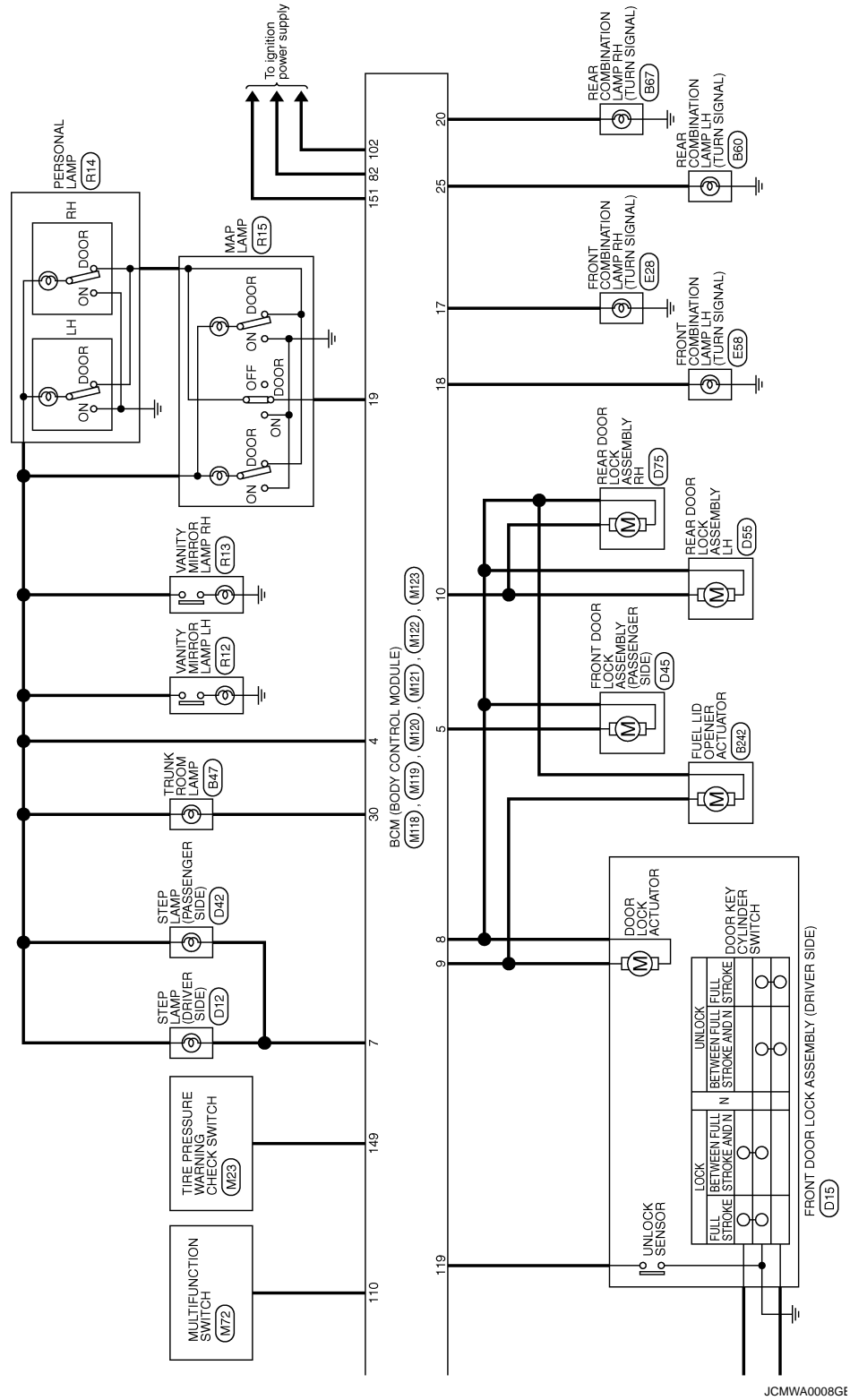

A
B
C
D
E
F
G
H
I
J
K
L
M
N
O
P

EXL

BCM (BODY CONTROL MODULE)

< ECU DIAGNOSIS >

[XENON TYPE]

BCM (BODY CONTROL MODULE)

Connector No.	M33
Connector Name	COMBINATION SWITCH
Connector Type	TH16FW-NH

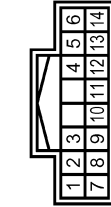

Terminal No.	Color of Wire	Signal Name
2	SB	OUTPUT 4
5	L	OUTPUT 3
7	V	INPUT 3
8	O	OUTPUT 5
9	Y	INPUT 2
10	R	INPUT 4
11	LG	INPUT 1
12	P	OUTPUT 1
13	BR	INPUT 5
14	G	OUTPUT 2

Connector No.	M120
Connector Name	BCM (BODY CONTROL MODULE)
Connector Type	NS12FW-CS

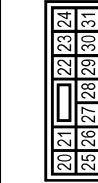

Terminal No.	Color of Wire	Signal Name
20	V	REAR FLASHER OUTPUT(RIGHT)
23	G	TRUNK OPENER OUTPUT
24	G	REAR FLASHER OUTPUT(LEFT)
30	R	TRUNK LAMP OUTPUT

Connector No.	M118
Connector Name	BCM (BODY CONTROL MODULE)
Connector Type	M03FB-LC



Terminal No.	Color of Wire	Signal Name
1	W	BAT (F/L)
2	Y	POWER WINDOW POWER SUPPLY(BAT)
3	O	POWER WINDOW POWER SUPPLY(RAP)

Connector No.	M121
Connector Name	BCM (BODY CONTROL MODULE)
Connector Type	TH40FGY-NH

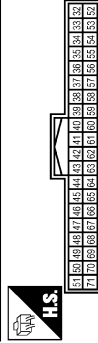

Terminal No.	Color of Wire	Signal Name
34	SB	TRUNK ANTI+
35	V	TRUNK ANTI-
38	B	BACK ANTI+
39	W	BACK ANTI-
47	Y	ING USM CONTI
50	R	TRUNK SW
52	SB	ST CONT USM
61	W	TRUNK REQUEST SW
64	V	BUZZER
67	GR	INTERIOR TRUNK SW
68	BR	DOOR SW (RR RH)

Connector No.	M119
Connector Name	BCM (BODY CONTROL MODULE)
Connector Type	NS18FW-CS

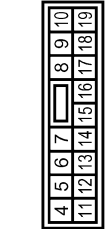

Terminal No.	Color of Wire	Signal Name
4	LG	BAT SAVER OUTPUT
5	V	DOOR UNLOCK OUTPUT (AS)
7	Y	STEP LAMP OUTPUT
8	Y	DOOR LOCK OUTPUT (ALL)
9	G	DOOR UNLOCK OUTPUT (RR)
10	BR	DOOR UNLOCK OUTPUT (RR)
11	R	BAT FUSE
13	B	GND
14	W	RING/SW LED GND
15	Y	ACC LED
17	W	FRONT FLASHER OUTPUT(RIGHT)

69	R	DOOR SW (RR LH)
----	---	-----------------

18	O	FRONT FLASHER OUTPUT(LEFT)
19	V	ROOM LAMP OUTPUT

JCMWA0009G1

BCM (BODY CONTROL MODULE)

< ECU DIAGNOSIS >

[XENON TYPE]

A
B
C
D
E
F
G
H
I
J
K
EXL
M
N
O
P

133	W	RMG/SW LED
134	GR	LOCK LED
137	O	SENSOR GND
138	V	AUTO LIGHT SENSOR POWER SUPPLY
139	L	RECEIVER SIGNAL
140	GR	SHIFT N/P
141	G	SECURITY INDICATOR OUTPUT
142	O	COMBI SW OUTPUT 5
143	P	COMBI SW OUTPUT 1
144	G	COMBI SW OUTPUT 2
145	L	COMBI SW OUTPUT 3
146	SB	COMBI SW OUTPUT 4
149	W	MODE TRG SW
150	GR	DOOR SW (DR)
151	G	REAR DEFOGGER OUTPUT

Connector No.	M123
Connector Name	BCM (BODY CONTROL MODULE)
Connector Type	TH40FC-NH

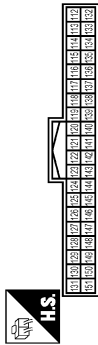

Terminal No.	Color of Wire	Signal Name
113	P	AUTO LIGHT SENSOR INPUT
114	R	CLUTCH SW
116	SB	STOP LAMP LOW
118	P	STOP LAMP HIGH
119	SB	DR CONDITION SW
121	R	KEY SWITCH SIGNAL
122	V	ACC F/B
123	W	IGN F/B
124	LG	DOOR SW (AS)
129	O	TRUNK CANCEL SW
132	V	POWER WINDOW SERIAL LINK

83	Y	KEYLESS TUNER SIGNAL
87	BR	COMBI SW INPUT 5
88	V	COMBI SW INPUT 3
89	BR	ENG SW
90	P	GAN-L
91	L	GAN-H
92	LG	KEY SLOT ILL ON LED
93	V	ACC CONT
95	O	A/T DEVICE
96	GR	S/L CONDITION 1
97	L	S/L CONDITION 2
98	P	AS REQUEST SW
99	R	SHIFT P
100	G	DR REQUEST SW
101	SB	IGN2 CONT
102	O	KEYLESS TUNER POWER SUPPLY
103	LG	S/L TRV (CRUI)
106	W	COMBI SW INPUT 1
107	LG	COMBI SW INPUT 4
108	R	COMBI SW INPUT 2
109	Y	HAZARD SW
110	G	S/L (K LINE)
111	Y	

BCM (BODY CONTROL MODULE)

Connector No.	M122
Connector Name	BCM (BODY CONTROL MODULE)
Connector Type	TH40FB-NH

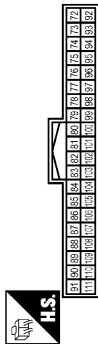

Terminal No.	Color of Wire	Signal Name
72	R	ROOM ANT2-
73	G	ROOM ANT2+
74	SB	AS DOOR ANT-
75	BR	AS DOOR ANT+
76	V	DR DOOR ANT-
77	LG	DR DOOR ANT+
78	Y	ROOM ANT1-
79	BR	ROOM ANT1+
80	GR	IMMOBI ANTENNA CONTROL
81	W	IMMOBI ANTENNA SIGNAL
82	R	IGN ELEC CONT

Fail Safe

JCMWA0010GE

INFOID:000000000962508

Display contents of CONSULT	Fail-safe	Cancellation
B2013: ID DISCORD BCM-S/L	Inhibit engine cranking	Erase DTC
B2014: CHAIN OF S/L-BCM	Inhibit engine cranking	Erase DTC
B2190: NATS ANTENNA AMP	Inhibit engine cranking	Erase DTC

BCM (BODY CONTROL MODULE)

< ECU DIAGNOSIS >

[XENON TYPE]

Display contents of CONSULT	Fail-safe	Cancellation
B2191: DIFFERENCE OF KEY	Inhibit engine cranking	Erase DTC
B2192: ID DISCORD BCM-ECM	Inhibit engine cranking	Erase DTC
B2193: CHAIN OF BCM-ECM	Inhibit engine cranking	Erase DTC
B2557: VEHICLE SPEED	Inhibit steering lock	When normal vehicle speed signals have been received from ABS actuator and electric unit (control unit) for 500 ms
B2560: STARTER CONT RELAY	Inhibit engine cranking	500 ms after the following CAN signal communication status has become consistent <ul style="list-style-type: none"> • Starter control relay signal • Starter relay status signal
B2563: HI VOLTAGE	<ul style="list-style-type: none"> • Inhibit engine cranking • Inhibit steering lock 	500 ms after the power supply voltage decreases to less than 18 V
B2601: SHIFT POSITION	Inhibit steering lock	500 ms after the following signal reception status becomes consistent <ul style="list-style-type: none"> • Selector lever P position switch signal • P range signal (CAN)
B2602: SHIFT POSITION	Inhibit steering lock	5 seconds after the following BCM recognition conditions are fulfilled <ul style="list-style-type: none"> • Ignition switch is in the ON position • Selector lever P position switch signal: Except P position (battery voltage) • Vehicle speed: 4 /h or more
B2603: SHIFT POSI STATUS	Inhibit steering lock	500 ms after the following BCM recognition conditions are fulfilled <ul style="list-style-type: none"> • Ignition switch is in the ON position • Selector lever P position switch signal: Except P position (battery voltage) • Selector lever P/N position signal: Except P and N positions (0 V)
B2604: PNP SW	Inhibit steering lock	500 ms after any of the following BCM recognition conditions is fulfilled <ul style="list-style-type: none"> • Status 1 <ul style="list-style-type: none"> - Ignition switch is in the ON position - Selector lever P/N position signal: P and N position (battery voltage) - P range signal or N range signal (CAN): ON • Status 2 <ul style="list-style-type: none"> - Ignition switch is in the ON position - Selector lever P/N position signal: Except P and N positions (0 V) - P range signal and N range signal (CAN): OFF
B2605: PNP SW	Inhibit steering lock	500 ms after any of the following BCM recognition conditions is fulfilled <ul style="list-style-type: none"> • Ignition switch is in the ON position <ul style="list-style-type: none"> - Power position: IGN - Selector lever P/N position signal: Except P and N positions (0 V) - Interlock/PNP switch signal (CAN): OFF • Status 2 <ul style="list-style-type: none"> - Ignition switch is in the ON position - Selector lever P/N position signal: P or N position (battery voltage) - PNP switch signal (CAN): ON
B2606: S/L RELAY	Inhibit engine cranking	500 ms after the following CAN signal communication status has become consistent <ul style="list-style-type: none"> • Steering lock relay signal (Request signal) • Steering lock relay signal (Condition signal)
B2607: S/L RELAY	Inhibit engine cranking	500 ms after the following CAN signal communication status has become consistent <ul style="list-style-type: none"> • Steering lock relay signal (Request signal) • Steering lock relay signal (Condition signal)

BCM (BODY CONTROL MODULE)

< ECU DIAGNOSIS >

[XENON TYPE]

Display contents of CONSULT	Fail-safe	Cancellation
B2608: STARTER RELAY	Inhibit engine cranking	500 ms after the following signal communication status becomes consistent <ul style="list-style-type: none"> • Starter motor relay control signal • Starter relay status signal (CAN)
B2609: S/L STATUS	<ul style="list-style-type: none"> • Inhibit engine cranking • Inhibit steering lock 	When the following steering lock conditions agree <ul style="list-style-type: none"> • BCM steering lock control status • Steering lock condition No. 1 signal status • Steering lock condition No. 2 signal status
B260A: IGNITION RELAY	Inhibit engine cranking	500 ms after the following conditions are fulfilled <ul style="list-style-type: none"> • IGN relay (IPDM E/R) control signal: OFF (Battery voltage) • Ignition ON signal (CAN to IPDM E/R): OFF (Request signal) • Ignition ON signal (CAN from IPDM E/R): OFF (Condition signal)
B260F: ENG STATE SIG LOST	Maintains the power supply position attained at the time of DTC detection	When any of the following conditions is fulfilled <ul style="list-style-type: none"> • Power position changes to ACC • Receives engine status signal (CAN)
B2612: S/L STATUS	<ul style="list-style-type: none"> • Inhibit engine cranking • Inhibit steering lock 	When any of the following conditions is fulfilled <ul style="list-style-type: none"> • Steering lock unit status signal (CAN) is received normally • The BCM steering lock control status matches the steering lock status recognized by the steering lock unit status signal (CAN from IPDM E/R)
B2617: STARTER RELAY CIRC	Inhibit engine cranking	1 second after the starter motor relay control inside BCM becomes normal
B2618: BCM	Inhibit engine cranking	1 second after the ignition relay (IPDM E/R) control inside BCM becomes normal
B2619: BCM	Inhibit engine cranking	1 second after the steering lock unit power supply output control inside BCM becomes normal
B261E: VEHICLE TYPE	Inhibit engine cranking	BCM initialization
B26E1: ENG STATE NO RECIV	Inhibit engine cranking	When any of the following conditions is fulfilled <ul style="list-style-type: none"> • Power position changes to ACC • Receives engine status signal (CAN)

DTC Inspection Priority Chart

INFOID:000000000962509

If some DTCs are displayed at the same time, perform inspections one by one based on the following priority chart.

Priority	DTC
1	<ul style="list-style-type: none"> • B2562: LOW VOLTAGE • B2563: HI VOLTAGE
2	<ul style="list-style-type: none"> • U1000: CAN COMM CIRCUIT • U1010: CONTROL UNIT (CAN)
3	<ul style="list-style-type: none"> • B2190: NATS ANTENA AMP • B2191: DIFFERENCE OF KEY • B2192: ID DISCORD BCM-ECM • B2193: CHAIN OF BCM-ECM

BCM (BODY CONTROL MODULE)

< ECU DIAGNOSIS >

[XENON TYPE]

Priority	DTC
4	<ul style="list-style-type: none"> • B2013: ID DISCORD BCM-S/L • B2014: CHAIN OF S/L-BCM • B2553: IGNITION RELAY • B2555: STOP LAMP • B2556: PUSH-BTN IGN SW • B2557: VEHICLE SPEED • B2560: STARTER CONT RELAY • B2601: SHIFT POSITION • B2602: SHIFT POSITION • B2603: SHIFT POSI STATUS • B2604: PNP SW • B2605: PNP SW • B2606: S/L RELAY • B2607: S/L RELAY • B2608: STARTER RELAY • B2609: S/L STATUS • B260A: IGNITION RELAY • B260B: STEERING LOCK UNIT • B260C: STEERING LOCK UNIT • B260D: STEERING LOCK UNIT • B260F: ENG STATE SIG LOST • B2611: ACC RELAY • B2612: S/L STATUS • B2614: ACC RELAY CIRC • B2615: BLOWER RELAY CIRC • B2616: IGN RELAY CIRC • B2617: STARTER RELAY CIRC • B2618: BCM • B2619: BCM • B261A: PUSH-BTN IGN SW • B261E: VEHICLE TYPE • B26E1: ENG STATE NO RECIV • C1729: VHCL SPEED SIG ERR • U0415: VEHICLE SPEED SIG
5	<ul style="list-style-type: none"> • C1704: LOW PRESSURE FL • C1705: LOW PRESSURE FR • C1706: LOW PRESSURE RR • C1707: LOW PRESSURE RL • C1708: [NO DATA] FL • C1709: [NO DATA] FR • C1710: [NO DATA] RR • C1711: [NO DATA] RL • C1712: [CHECKSUM ERR] FL • C1713: [CHECKSUM ERR] FR • C1714: [CHECKSUM ERR] RR • C1715: [CHECKSUM ERR] RL • C1716: [PRESSDATA ERR] FL • C1717: [PRESSDATA ERR] FR • C1718: [PRESSDATA ERR] RR • C1719: [PRESSDATA ERR] RL • C1720: [CODE ERR] FL • C1721: [CODE ERR] FR • C1722: [CODE ERR] RR • C1723: [CODE ERR] RL • C1724: [BATT VOLT LOW] FL • C1725: [BATT VOLT LOW] FR • C1726: [BATT VOLT LOW] RR • C1727: [BATT VOLT LOW] RL • C1734: CONTROL UNIT
6	<ul style="list-style-type: none"> • B2621: INSIDE ANTENNA • B2622: INSIDE ANTENNA • B2623: INSIDE ANTENNA

BCM (BODY CONTROL MODULE)

[XENON TYPE]

< ECU DIAGNOSIS >

NOTE:

- Details of time display
- CRNT: Displays when there is a malfunction now or after returning to the normal condition until turning ignition switch OFF → ON again.
- 1 - 39: Displayed if any previous malfunction is present when current condition is normal. It increases like 1 → 2 → 3...38 → 39 after returning to the normal condition whenever ignition switch OFF → ON. The counter remains at 39 even if the number of cycles exceeds it. It is counted from 1 again when turning ignition switch OFF → ON after returning to the normal condition if the malfunction is detected again.

CONSULT display	Fail-safe	Intelligent Key warning lamp ON	Tire pressure monitor warning lamp ON	Reference page
No DTC is detected. further testing may be required.	—	—	—	—
U1000: CAN COMM CIRCUIT	—	—	—	BCS-33
U1010: CONTROL UNIT (CAN)	—	—	—	BCS-34
U0415: VEHICLE SPEED SIG	—	—	—	BCS-35
B2013: ID DISCORD BCM-S/L	×	—	—	SEC-43
B2014: CHAIN OF S/L-BCM	×	—	—	SEC-44
B2190: NATS ANTENA AMP	×	—	—	SEC-37
B2191: DIFFERENCE OF KEY	×	—	—	SEC-40
B2192: ID DISCORD BCM-ECM	×	—	—	SEC-41
B2193: CHAIN OF BCM-ECM	×	—	—	SEC-42
B2553: IGNITION RELAY	—	—	—	PCS-48
B2555: STOP LAMP	—	—	—	SEC-47
B2556: PUSH-BTN IGN SW	—	×	—	SEC-49
B2557: VEHICLE SPEED	×	×	—	SEC-51
B2560: STARTER CONT RELAY	×	×	—	SEC-52
B2562: LOW VOLTAGE	—	—	—	BCS-36
B2563: HI VOLTAGE	×	×	—	BCS-37
B2601: SHIFT POSITION	×	×	—	SEC-53
B2602: SHIFT POSITION	×	×	—	SEC-56
B2603: SHIFT POSI STATUS	×	×	—	SEC-58
B2604: PNP SW	×	×	—	SEC-61
B2605: PNP SW	×	×	—	SEC-63
B2606: S/L RELAY	×	×	—	SEC-65
B2607: S/L RELAY	×	×	—	SEC-66
B2608: STARTER RELAY	×	×	—	SEC-68
B2609: S/L STATUS	×	×	—	SEC-70
B260A: IGNITION RELAY	×	×	—	PCS-50
B260B: STEERING LOCK VNIT	—	×	—	SEC-74
B260C: STEERING LOCK VNIT	—	×	—	SEC-75
B260D: STEERING LOCK VNIT	—	×	—	SEC-76
B260F: ENG STATE SIG LOST	×	×	—	SEC-77
B2611: ACC RELAY	—	—	—	PCS-52
B2612: S/L STATUS	×	×	—	SEC-79
B2614: ACC RELAY CIRC	—	×	—	PCS-54
B2615: BLOWER RELAY CIRC	—	×	—	PCS-57

A
B
C
D
E
F
G
H
I
J
K
EXL
M
N
O
P

BCM (BODY CONTROL MODULE)

< ECU DIAGNOSIS >

[XENON TYPE]

CONSULT display	Fail-safe	Intelligent Key warning lamp ON	Tire pressure monitor warning lamp ON	Reference page
B2616: IGN RELAY CIRC	—	×	—	PCS-60
B2617: STARTER RELAY CIRC	×	×	—	SEC-83
B2618: BCM	×	×	—	PCS-63
B2619: BCM	×	×	—	SEC-85
B261A: PUSH-BTN IGN SW	—	×	—	SEC-86
B261E: VEHICLE TYPE	×	× (Turn ON for 15 seconds)	—	SEC-88
B2621: INSIDE ANTENNA	—	—	—	DLK-58
B2622: INSIDE ANTENNA	—	—	—	DLK-60
B2623: INSIDE ANTENNA	—	—	—	DLK-62
B26E1: ENG STATE NO RES	×	×	—	SEC-78
C1704: LOW PRESSURE FL	—	—	×	WT-14
C1705: LOW PRESSURE FR	—	—	×	WT-14
C1706: LOW PRESSURE RR	—	—	×	WT-14
C1707: LOW PRESSURE RL	—	—	×	WT-14
C1708: [NO DATA] FL	—	—	×	WT-16
C1709: [NO DATA] FR	—	—	×	WT-16
C1710: [NO DATA] RR	—	—	×	WT-16
C1711: [NO DATA] RL	—	—	×	WT-16
C1712: [CHECKSUM ERR] FL	—	—	×	WT-19
C1713: [CHECKSUM ERR] FR	—	—	×	WT-19
C1714: [CHECKSUM ERR] RR	—	—	×	WT-19
C1715: [CHECKSUM ERR] RL	—	—	×	WT-19
C1716: [PRESSDATA ERR] FL	—	—	×	WT-22
C1717: [PRESSDATA ERR] FR	—	—	×	WT-22
C1718: [PRESSDATA ERR] RR	—	—	×	WT-22
C1719: [PRESSDATA ERR] RL	—	—	×	WT-22
C1720: [CODE ERR] FL	—	—	×	WT-24
C1721: [CODE ERR] FR	—	—	×	WT-24
C1722: [CODE ERR] RR	—	—	×	WT-24
C1723: [CODE ERR] RL	—	—	×	WT-24
C1724: [BATT VOLT LOW] FL	—	—	×	WT-27
C1725: [BATT VOLT LOW] FR	—	—	×	WT-27
C1726: [BATT VOLT LOW] RR	—	—	×	WT-27
C1727: [BATT VOLT LOW] RL	—	—	×	WT-27
C1729: VHCL SPEED SIG ERR	—	—	×	WT-30
C1734: CONTROL UNIT	—	—	×	WT-31

IPDM E/R (INTELLIGENT POWER DISTRIBUTION MODULE ENGINE ROOM)

< ECU DIAGNOSIS >

[XENON TYPE]

IPDM E/R (INTELLIGENT POWER DISTRIBUTION MODULE ENGINE ROOM)

Reference Value

INFOID:000000000962511

VALUES ON THE DIAGNOSIS TOOL

Monitor Item	Condition		Value/Status
RADFAN REQ	Engine idle speed	Changes depending on engine coolant temperature, air conditioner operation status, vehicle speed, etc.	0 - 100 %
AC COMP REQ	Engine running	A/C switch OFF	Off
		A/C switch ON (Compressor is operating)	On
TAIL&CLR REQ	Lighting switch OFF		Off
	Lighting switch 1ST, 2ND, HI or AUTO (Light is illuminated)		On
HL LO REQ	Lighting switch OFF		Off
	Lighting switch 2ND HI or AUTO (Light is illuminated)		On
HL HI REQ	Lighting switch OFF		Off
	Lighting switch HI		On
FR FOG REQ	Lighting switch 2ND or AUTO (Light is illuminated)	Front fog lamp switch OFF	Off
		<ul style="list-style-type: none"> • Front fog lamp switch ON • Daytime running light activated (Only for Canada) 	On
FR WIP REQ	Ignition switch ON	Front wiper switch OFF	STOP
		Front wiper switch INT	1LOW
		Front wiper switch LO	Low
		Front wiper switch HI	Hi
WIP AUTO STOP	Ignition switch ON	Front wiper stop position	STOP P
		Any position other than front wiper stop position	ACT P
WIP PROT	Ignition switch ON	Front wiper operates normally	Off
		Front wiper stops at fail-safe operation	BLOCK
IGN RLY1 -REQ	Ignition switch OFF or ACC		Off
	Ignition switch ON		On
IGN RLY	Ignition switch OFF or ACC		Off
	Ignition switch ON		On
PUSH SW	Release the push-button ignition switch		Off
	Press the push-button ignition switch		On
INTER/NP SW	Ignition switch ON	A/T selector lever in any position other than P or N (A/T models)	Off
		Release clutch pedal (M/T models)	
	Ignition switch ON	A/T selector lever in P or N position (A/T models)	On
		Depress clutch pedal (M/T models)	
ST RLY REQ	Ignition switch ON		Off
	At engine cranking		On

IPDM E/R (INTELLIGENT POWER DISTRIBUTION MODULE ENGINE ROOM)

< ECU DIAGNOSIS >

[XENON TYPE]

Monitor Item	Condition	Value/Status
ST RLY CONT	Ignition switch ON	Off
	At engine cranking	On
IHBT RLY -REQ	Ignition switch ON	Off
	At engine cranking	On
ST/INHI RLY	Ignition switch ON	Off
	At engine cranking	ST →INHI
	The status of starter relay or starter control relay cannot be recognized by the battery voltage malfunction, etc. when the starter relay is ON and the starter control relay is OFF	UNKWN
DETENT SW	Ignition switch ON <ul style="list-style-type: none"> • Press the selector button with A/T selector lever in P position • A/T selector lever in any position other than P 	Off
	Release the A/T selector button with A/T selector lever in P position NOTE: The lever is fixed ON for M/T	On
S/L RLY -REQ	None of the conditions below are present	Off
	<ul style="list-style-type: none"> • Open the driver door after the ignition switch is turned OFF (for a few seconds) • Press the push-button ignition switch when the steering lock is activated • Depress the clutch pedal when the steering lock is activated 	On
S/L STATE	Steering lock is activated	LOCK
	Steering lock is deactivated	UNLK
	[DTC B210A] is detected	UNKWN
DTRL REQ	NOTE: The item is indicated, but not monitored.	Off
OIL P SW	Ignition switch OFF, ACC or engine running	Open
	Ignition switch ON	Close
HOOD SW	Close the hood	Off
	Open the hood	On
HL WASHER REQ	NOTE: The item is indicated, but not monitored.	Off
THFT HRN REQ	Not operation	Off
	<ul style="list-style-type: none"> • Panic alarm is activated • Horn is activated with VEHICLE SECURITY (THEFT WARNING) SYSTEM 	On
HORN CHIRP	Not operating	Off
	Door locking with Intelligent Key (horn chirp mode)	On
CRNRNG LMP REQ	NOTE: The item is indicated, but not monitored.	Off

IPDM E/R (INTELLIGENT POWER DISTRIBUTION MODULE ENGINE ROOM)

< ECU DIAGNOSIS >

[XENON TYPE]

TERMINAL LAYOUT

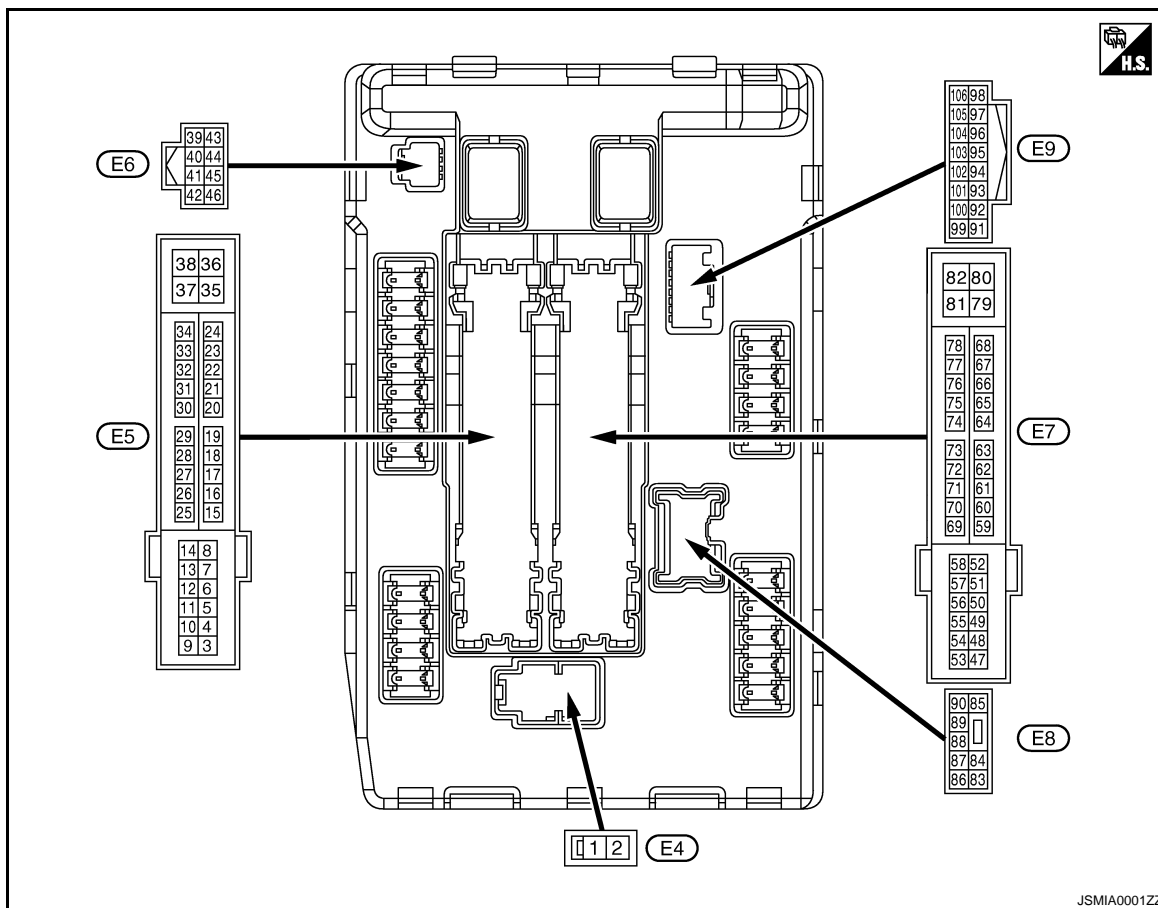

PHYSICAL VALUES

Terminal No. (Wire color)		Description		Condition		Value (Approx.)
+	-	Signal name	Input/ Output			
1 (W)	Ground	Battery power supply	Input	Ignition switch OFF		Battery voltage
2 (L)	Ground	Battery power supply	Input	Ignition switch OFF		Battery voltage
4 (V)	Ground	Front wiper LO	Output	Ignition switch OFF	Front wiper switch OFF	0 V
				Ignition switch ON	Front wiper switch LO	Battery voltage
5 (L)	Ground	Front wiper HI	Output	Ignition switch OFF	Front wiper switch OFF	0 V
				Ignition switch ON	Front wiper switch HI	Battery voltage
7 (R)	Ground	Tail, license plate lamps & interior lamps	Output	Ignition switch OFF	Lighting switch OFF	0 V
				Ignition switch ON	Lighting switch 1ST	Battery voltage
11 (BR)	Ground	Steering lock unit power supply	Output	Ignition switch OFF	A few seconds after open- ing the driver door	Battery voltage
				Ignition switch LOCK	Press the push-button ig- nition switch	Battery voltage
				Ignition switch ACC or ON		0 V
12 (B/W)	Ground	Ground	—	Ignition switch ON		0 V

IPDM E/R (INTELLIGENT POWER DISTRIBUTION MODULE ENGINE ROOM)

< ECU DIAGNOSIS >

[XENON TYPE]

Terminal No. (Wire color)		Description		Condition		Value (Approx.)
+	-	Signal name	Input/ Output			
13 (Y)	Ground	Fuel pump power supply	Output	Approximately 1 second or more after turning the ignition switch ON		0 V
				<ul style="list-style-type: none"> • Approximately 1 second after turning the ignition switch ON • Engine running 		Battery voltage
16 (LG)	Ground	Front wiper auto stop	Input	Ignition switch ON	Front wiper stop position	0 V
					Any position other than front wiper stop position	Battery voltage
19 (W)	Ground	Ignition relay power supply	Output	Ignition switch OFF		0 V
				Ignition switch ON		Battery voltage
25 (G)	Ground	Ignition relay power supply	Output	Ignition switch OFF		0 V
				Ignition switch ON		Battery voltage
26*1 (R)	Ground	Ignition relay power supply	Output	Ignition switch OFF		0 V
				Ignition switch ON		Battery voltage
27 (O)	Ground	Ignition relay monitor	Input	Ignition switch OFF or ACC		Battery voltage
				Ignition switch ON		0 V
28 (L)	Ground	Push-button ignition switch	Input	Press the push-button ignition switch		0 V
				Release the push-button ignition switch		Battery voltage
30 (GR)	Ground	Starter relay control	Input	A/T models	A/T selector lever in any position other than P or N (ignition switch ON)	0 V
					A/T selector lever P or N (ignition switch ON)	Battery voltage
				M/T models	Release the clutch pedal	0 V
					Depress the clutch pedal	Battery voltage
32 (L)	Ground	Steering lock unit condition-1	Input	Steering lock is activated		0 V
				Steering lock is deactivated		Battery voltage
33 (P)	Ground	Steering lock unit condition-2	Input	Steering lock is activated		Battery voltage
				Steering lock is deactivated		0 V
36 (G)	Ground	Battery power supply	Input	Ignition switch OFF		Battery voltage
39 (P)	—	CAN - L	Input/ Output	—	—	
40 (L)	—	CAN - H	Input/ Output	—	—	
41 (B/W)	Ground	Ground	—	Ignition switch ON		0 V
42 (Y)	Ground	Cooling fan relay control	Input	Ignition switch OFF or ACC		0 V
				Ignition switch ON		0.7 V
43 (SB)	Ground	A/T device (Detention switch)	Input	Ignition switch ON	Press the A/T selector button (A/T selector lever P)	Battery voltage
					<ul style="list-style-type: none"> • A/T selector lever in any position other than P • Release the A/T selector button (A/T selector lever P) 	
44 (W)	Ground	Horn relay control	Input	The horn is deactivated		Battery voltage
				The horn is activated		0 V

IPDM E/R (INTELLIGENT POWER DISTRIBUTION MODULE ENGINE ROOM)

< ECU DIAGNOSIS >

[XENON TYPE]

Terminal No. (Wire color)		Description		Condition	Value (Approx.)	
		Signal name	Input/ Output			
+	-					
45 (G)	Ground	Anti theft horn relay control	Input	The horn is deactivated	Battery voltage	
				The horn is activated	0 V	
46 (BR)	Ground	Starter relay control	Input	A/T models	A/T selector lever in any position other than P or N (ignition switch ON)	0 V
					A/T selector lever P or N (ignition switch ON)	Battery voltage
				M/T models	Release the clutch pedal	0 V
					Depress the clutch pedal	Battery voltage
48 (L)	Ground	A/C relay power supply	Output	Engine running	A/C switch OFF	0 V
					A/C switch ON (A/C compressor is operating)	Battery voltage
49 (R)	Ground	ECM relay power supply	Output	Ignition switch OFF (For a few seconds after turning ignition switch OFF)	0 V	
				<ul style="list-style-type: none"> Ignition switch ON Ignition switch OFF (More than a few seconds after turning ignition switch OFF) 	Battery voltage	
51 (G)	Ground	Ignition relay power supply	Output	Ignition switch OFF	0 V	
				Ignition switch ON	Battery voltage	
53 (W)	Ground	ECM relay power supply	Output	Ignition switch OFF (For a few seconds after turning ignition switch OFF)	0 V	
				<ul style="list-style-type: none"> Ignition switch ON Ignition switch OFF (More than a few seconds after turning ignition switch OFF) 	Battery voltage	
54 (R)	Ground	Throttle control motor relay power supply	Output	Ignition switch OFF (For a few seconds after turning ignition switch OFF)	0 V	
				<ul style="list-style-type: none"> Ignition switch ON Ignition switch OFF (More than a few seconds after turning ignition switch OFF) 	Battery voltage	
55 (BR)	Ground	ECM power supply	Output	Ignition switch OFF	Battery voltage	
56 (V)	Ground	Ignition relay power supply	Output	Ignition switch OFF	0 V	
				Ignition switch ON	Battery voltage	
57 (R)	Ground	Ignition relay power supply	Output	Ignition switch OFF	0 V	
				Ignition switch ON	Battery voltage	
58 (Y)	Ground	Ignition relay power supply	Output	Ignition switch OFF	0 V	
				Ignition switch ON	Battery voltage	
69 (W)	Ground	ECM relay control	Output	Ignition switch OFF (For a few seconds after turning ignition switch OFF)	Battery voltage	
				<ul style="list-style-type: none"> Ignition switch ON Ignition switch OFF (More than a few seconds after turning ignition switch OFF) 	0 - 1.5 V	

A
B
C
D
E
F
G
H
I
J
K
EXL
M
N
O
P

IPDM E/R (INTELLIGENT POWER DISTRIBUTION MODULE ENGINE ROOM)

< ECU DIAGNOSIS >

[XENON TYPE]

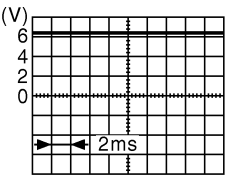
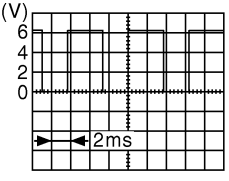
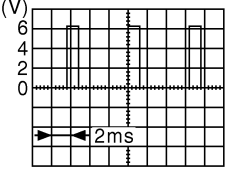
Terminal No. (Wire color)		Description		Condition		Value (Approx.)
+	-	Signal name	Input/ Output			
70 (O)	Ground	Throttle control motor re- lay control	Output	Ignition switch ON → OFF		0 -1.0 V ↓ Battery voltage ↓ 0 V
				Ignition switch ON		0 - 1.0 V
73*2 (P)	Ground	Ignition relay power supply	Output	Ignition switch OFF		0 V
				Ignition switch ON		Battery voltage
74 (G)	Ground	Ignition relay power supply	Output	Ignition switch OFF		0 V
				Ignition switch ON		Battery voltage
75 (Y)	Ground	Oil pressure switch	Input	Ignition switch ON	Engine stopped	0 V
					Engine running	Battery voltage
76 (V)	Ground	Power generation com- mand signal	Output	Ignition switch ON		 <p style="text-align: right; font-size: small;">JPMAI0001GB</p> <p style="text-align: center;">6.3 V</p>
				40% is set on "ACTIVE TEST", "AL- TERNATOR DUTY" of "ENGINE"		 <p style="text-align: right; font-size: small;">JPMAI0002GB</p> <p style="text-align: center;">3.8 V</p>
				80% is set on "ACTIVE TEST", "AL- TERNATOR DUTY" of "ENGINE"		 <p style="text-align: right; font-size: small;">JPMAI0003GB</p> <p style="text-align: center;">1.4 V</p>
77 (L)	Ground	Fuel pump relay control	Output	<ul style="list-style-type: none"> • Approximately 1 second after turning the ignition switch ON • Engine running 		0 - 1.0 V
				Approximately 1 second or more after turning the ignition switch ON		Battery voltage
80 (W)	Ground	Starter motor	Output	At engine cranking		Battery voltage
83 (R)	Ground	Headlamp LO (RH)	Output	Ignition switch ON	Lighting switch OFF	0 V
					Lighting switch 2ND	Battery voltage
84 (P)	Ground	Headlamp LO (LH)	Output	Ignition switch ON	Lighting switch OFF	0 V
					Lighting switch 2ND	Battery voltage

IPDM E/R (INTELLIGENT POWER DISTRIBUTION MODULE ENGINE ROOM)

< ECU DIAGNOSIS >

[XENON TYPE]

Terminal No. (Wire color)		Description		Condition		Value (Approx.)
+	-	Signal name	Input/ Output			
86 (W)	Ground	Front fog lamp (RH)	Output	Lighting switch 2ND	<ul style="list-style-type: none"> • Front fog lamp switch ON • Daytime running light activated (Only for Canada) 	Battery voltage
				Front fog lamp switch OFF	0 V	
87 (L)	Ground	Front fog lamp (LH)	Output	Lighting switch 2ND	<ul style="list-style-type: none"> • Front fog lamp switch ON • Daytime running light activated (Only for Canada) 	Battery voltage
				Front fog lamp switch OFF	0 V	
88 (G)	Ground	Washer pump power supply	Output	Ignition switch ON		Battery voltage
89 (BR)	Ground	Headlamp HI (RH)	Output	Ignition switch ON	<ul style="list-style-type: none"> • Lighting switch HI • Lighting switch PASS 	Battery voltage
				Lighting switch OFF	0 V	
90 (P)	Ground	Headlamp HI (LH)	Output	Ignition switch ON	<ul style="list-style-type: none"> • Lighting switch HI • Lighting switch PASS 	Battery voltage
				Lighting switch OFF	0 V	
91 (P)	Ground	Parking lamp (RH)	Output	Ignition switch ON	Lighting switch 1ST	Battery voltage
				Lighting switch OFF	0 V	
92 (O)	Ground	Parking lamp (LH)	Output	Ignition switch ON	Lighting switch 1ST	Battery voltage
				Lighting switch OFF	0 V	
97 (V)	Ground	Cooling fan control	Output	Engine idling		0 - 5 V
104 (LG)	Ground	Hood switch	Input	Close the hood		Battery voltage
				Open the hood		0 V

*1: Only for the models with ICC system

*2: M/T models only

A
B
C
D
E
F
G
H
I
J
K

M
N
O
P

EXL

IPDM E/R (INTELLIGENT POWER DISTRIBUTION MODULE ENGINE ROOM)

< ECU DIAGNOSIS >

[XENON TYPE]

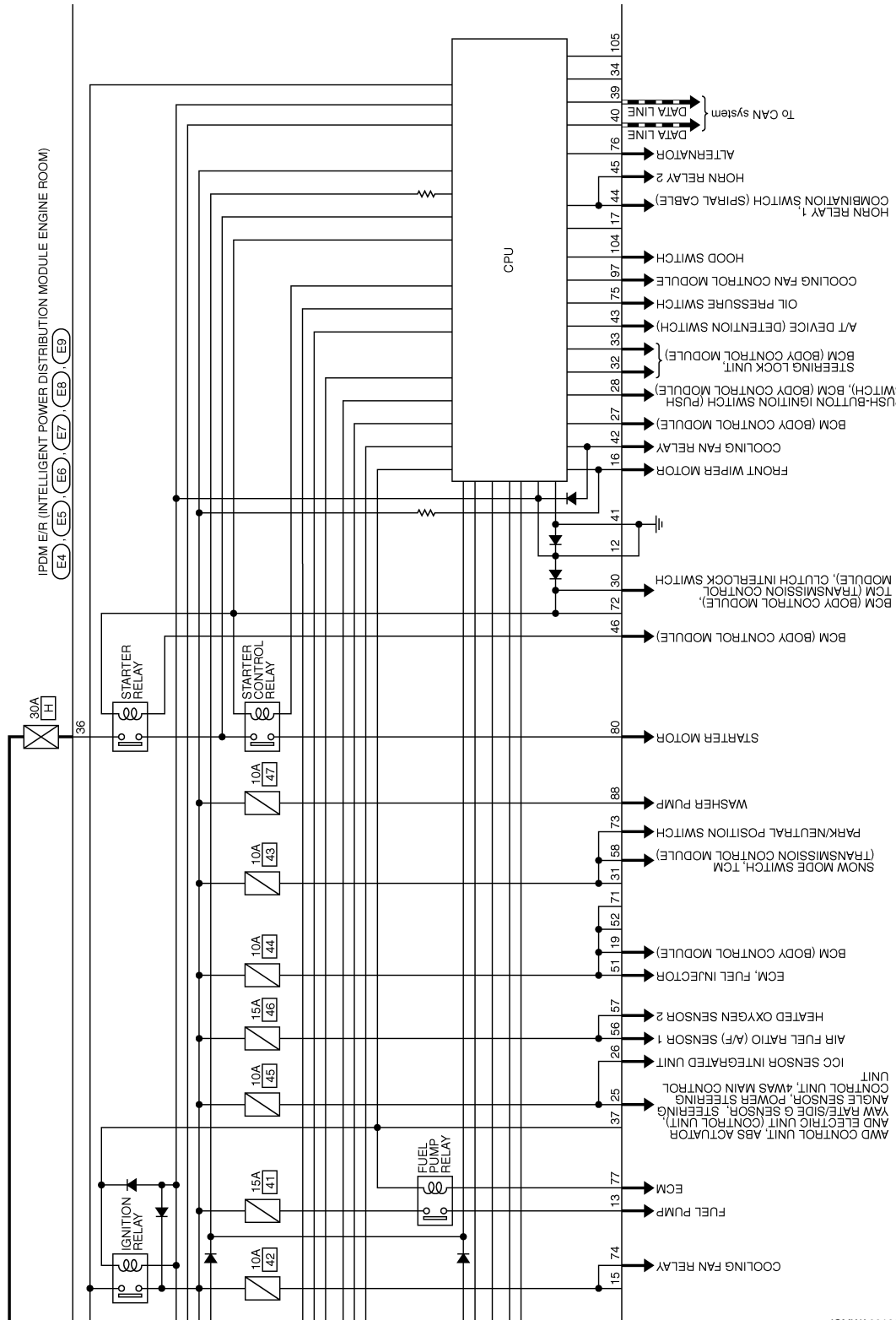

A
B
C
D
E
F
G
H
I
J
K
EXL
M
N
O
P

JCMWA0018GE

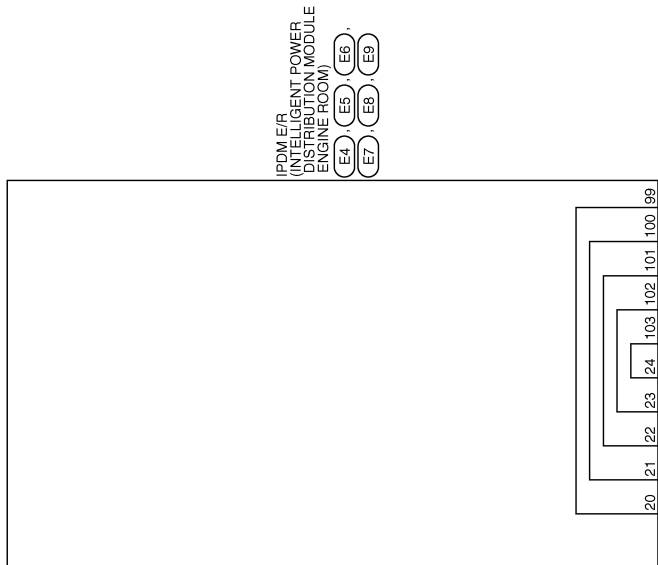

JCMWA0019GE

IPDM E/R (INTELLIGENT POWER DISTRIBUTION MODULE ENGINE ROOM)

< ECU DIAGNOSIS >

[XENON TYPE]

IPDM E/R (INTELLIGENT POWER DISTRIBUTION MODULE ENGINE ROOM)

Connector No.	E4
Connector Name	IPDM E/R (INTELLIGENT POWER DISTRIBUTION MODULE ENGINE ROOM)
Connector Type	L02FB-MC



Terminal No.	Color of Wire	Signal Name
1	W	-
2	L	-

Connector No.	E5
Connector Name	IPDM E/R (INTELLIGENT POWER DISTRIBUTION MODULE ENGINE ROOM)
Connector Type	TH20FW-CS12-M4-TV



Terminal No.	Color of Wire	Signal Name
4	V	-
5	L	-
6	-	-
7	R	-
10	-	-
11	BR	-
12	B/W	-
13	Y	-
15	-	-
16	LG	-
17	-	-

19	W	-
20	-	-
21	-	-
22	-	-
23	-	-
24	-	-
25	G	-
26	R	-
27	O	-
28	L	-
30	GR	-
31	-	-
32	L	-
33	P	-
34	-	-
36	G	-
37	-	-

Connector No.	E6
Connector Name	IPDM E/R (INTELLIGENT POWER DISTRIBUTION MODULE ENGINE ROOM)
Connector Type	TH08FW-NH



Terminal No.	Color of Wire	Signal Name
33	P	-
40	L	-
41	B/W	-
42	Y	-
43	SB	-
44	W	-
45	G	-
46	BR	-

Connector No.	E7
Connector Name	IPDM E/R (INTELLIGENT POWER DISTRIBUTION MODULE ENGINE ROOM)
Connector Type	TH20FW-CS12-M4

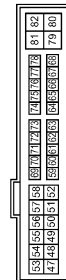

Terminal No.	Color of Wire	Signal Name
48	L	-
48	R	-
51	G	-
52	-	-
53	W	-
54	R	-
55	BR	-
56	V	-
57	R	-
58	Y	-
69	W	-

Connector No.	E8
Connector Name	IPDM E/R (INTELLIGENT POWER DISTRIBUTION MODULE ENGINE ROOM)
Connector Type	NS08FW-CS

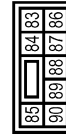

Terminal No.	Color of Wire	Signal Name
83	R	-
84	P	-
86	W	-
87	L	-
88	G	-
89	BR	-
80	P	-

Connector No.	E9
Connector Name	IPDM E/R (INTELLIGENT POWER DISTRIBUTION MODULE ENGINE ROOM)
Connector Type	TH18FW-NH



Terminal No.	Color of Wire	Signal Name
91	P	-
92	O	-
93	-	-
94	-	-
97	V	-
99	-	-
100	-	-
101	-	-
102	-	-
103	-	-
104	LG	-
105	-	-

Fail Safe

CAN COMMUNICATION CONTROL

When CAN communication with ECM and BCM is impossible, IPDM E/R performs fail-safe control. After CAN communication recovers normally, it also returns to normal control.

If No CAN Communication Is Available With ECM

JCMWA0020GE

INFOID:000000000962513

A
B
C
D
E
F
G
H
I
J
K
EXL
M
N
O
P

IPDM E/R (INTELLIGENT POWER DISTRIBUTION MODULE ENGINE ROOM)

< ECU DIAGNOSIS >

[XENON TYPE]

Control part	Fail-safe operation
Cooling fan	<ul style="list-style-type: none"> • Outputs the pulse duty signal (PWM signal) 100% when the ignition switch is turned ON • Outputs the pulse duty signal (PWM signal) 0% when the ignition switch is turned OFF
A/C compressor	A/C relay OFF
Alternator	Outputs the power generation command signal (PWM signal) 0%

If No CAN Communication Is Available With BCM

Control part	Fail-safe operation
Headlamp	<ul style="list-style-type: none"> • Turns ON the headlamp low relay when the ignition switch is turned ON • Turns OFF the headlamp low relay when the ignition switch is turned OFF • Headlamp high relay OFF
<ul style="list-style-type: none"> • Parking lamps • License plate lamps • Side maker lamps • Illuminations • Tail lamps 	<ul style="list-style-type: none"> • Turns ON the tail lamp relay when the ignition switch is turned ON • Turns OFF the tail lamp relay when the ignition switch is turned OFF
Front wiper	<ul style="list-style-type: none"> • The status just before activation of fail-safe control is maintained until the ignition switch is turned OFF while the front wiper is operating at LO or HI speed. • The wiper is operated at LO speed until the ignition switch is turned OFF if the fail-safe control is activated while the front wiper is set in the INT mode and the front wiper motor is operating.
Front fog lamps	Front fog lamp relay OFF
Horn	Horn OFF
Ignition relay	The status just before activation of fail-safe is maintained.
Starter motor	Starter control relay OFF
Steering lock unit	Steering lock relay OFF

IGNITION RELAY MALFUNCTION DETECTION FUNCTION

- IPDM E/R monitors the voltage at the contact circuit and excitation coil circuit of the ignition relay inside it.
- IPDM E/R judges the ignition relay error if the voltage differs between the contact circuit and the excitation coil circuit.
- If the ignition relay cannot turn OFF due to contact seizure, it activates the tail lamp relay for 10 minutes to alert the user to the ignition relay malfunction when the ignition switch is turned OFF.

DTC	Ignition switch	Ignition relay	Tail lamp relay
—	ON	ON	—
—	OFF	OFF	—
B2098: IGN RELAY ON	OFF	ON	ON (10 minutes)
B2099: IGN RELAY OFF	ON	OFF	—

NOTE:

The tail lamp turns OFF when the ignition switch is turned ON.

FRONT WIPER CONTROL

IPDM E/R detects front wiper stop position by a front wiper auto stop signal.

When a front wiper auto stop signal is in the conditions listed below, IPDM E/R stops power supply to wiper after repeating a front wiper 10 second activation and 20 second stop five times.

Ignition switch	Front wiper switch	Auto stop signal
ON	OFF	Front wiper stop position signal cannot be input 10 seconds.
	ON	The signal does not change for 10 seconds.

NOTE:

IPDM E/R (INTELLIGENT POWER DISTRIBUTION MODULE ENGINE ROOM)

< ECU DIAGNOSIS >

[XENON TYPE]

This operation status can be confirmed on the IPDM E/R “Data Monitor” that displays “BLOCK” for the item “WIP PROT” while the wiper is stopped.

STARTER MOTOR PROTECTION FUNCTION

IPDM E/R turns OFF the starter control relay to protect the starter motor when the starter control relay remains active for 90 seconds.

DTC Index

INFOID:000000000962514

CONSULT display	Fail-safe	TIME ^{NOTE}		Refer to
No DTC is detected. further testing may be required.	—	—	—	—
U1000: CAN COMM CIRCUIT	×	CRNT	1–39 ^{*1} CRNT ^{*2}	PCS-15
B2098: IGN RELAY ON	×	CRNT	1–39	PCS-16
B2099: IGN RELAY OFF	—	CRNT	1–39	PCS-17
B2108: STRG LCK RELAY ON	—	CRNT	1–39	SEC-89
B2109: STRG LCK RELAY OFF	—	CRNT	1–39	SEC-90
B210A: STRG LCK STATE SW	—	CRNT	1–39	SEC-91
B210B: START CONT RLY ON	—	CRNT	1–39	SEC-95
B210C: START CONT RLY OFF	—	CRNT	1–39	SEC-96
B210D: STARTER RELAY ON	—	CRNT	1–39	SEC-97
B210E: STARTER RELAY OFF	—	CRNT	1–39	SEC-98
B210F: INTRLCK/PNP SW ON	—	CRNT	1–39	SEC-100
B2110: INTRLCK/PNP SW OFF	—	CRNT	1–39	SEC-104

*1: Only for the models with AFS

*2: Only for the models without AFS (The display is fixed to CRNT until the self-diagnosis results are erased when the malfunctions were found in the past.)

NOTE:

The details of TIME display are as follows.

- CRNT: The malfunctions that are detected now
- 1 - 39: The number is indicated when it is normal at present and a malfunction was detected in the past. It increases like 0 → 1 → 2 . . . 38 → 39 after returning to the normal condition whenever IGN OFF → ON. It is fixed to 39 until the self-diagnosis results are erased if it is over 39. It returns to 0 when a malfunction is detected again in the process.

AFS CONTROL UNIT

< ECU DIAGNOSIS >

[XENON TYPE]

AFS CONTROL UNIT

Reference Value

INFOID:000000000962515

VALUES ON THE DIAGNOSIS TOOL

Monitor Item	Condition		Value/Status
STR ANGLE SIG	Steering	Straight-forward	Approx. 0°
		Steering	Approx. -900° - +900°
VHCL SPD	Driving at 40 km/h		40 km/h
SLCT LVR POSI	Selector lever operation		P - 1
HEAD LAMP	Light switch	2ND	ON
		Other than 2ND	OFF
AFS switch	AFS switch	ON	ON
		OFF	OFF
HI SEN OTP RR	Vehicle rear height (17-inch wheel models)	Unloaded vehicle condition	Approx. 2.5 V
		Low (Leveling operation downward edge)	Approx. 1.6 V
	Vehicle rear height (18-inch wheel models)	Unloaded vehicle condition	Approx. 2.5 V
		Low (Leveling operation downward edge)	Approx. 1.7 V
LEV ACTR VLTG	Headlamp leveling (17-inch wheel models)	Unloaded vehicle condition	Approx. 70.0%
		Low (Leveling operation downward edge)	Approx. 34.6%
	Headlamp leveling (18-inch wheel models)	Unloaded vehicle condition	Approx. 70.0%
		Low (Leveling operation downward edge)	Approx. 36.2%
SWVL SEN RH	Right headlamp swivel activation	Standard position	Approx. 0°
		Activation	Positive degree (+°)
SWVL SEN LH	Left headlamp swivel activation	Standard position	Approx. 0°
		Activation	Positive degree (+°)
SWVL ANGLE RH	Right headlamp swivel activation	Standard position	Approx. 0°
		Activation	Positive degree (+°)
SWVL ANGLE LH	Left headlamp swivel activation	Standard position	Approx. 0°
		Activation	Positive degree (+°)

TERMINAL LAYOUT

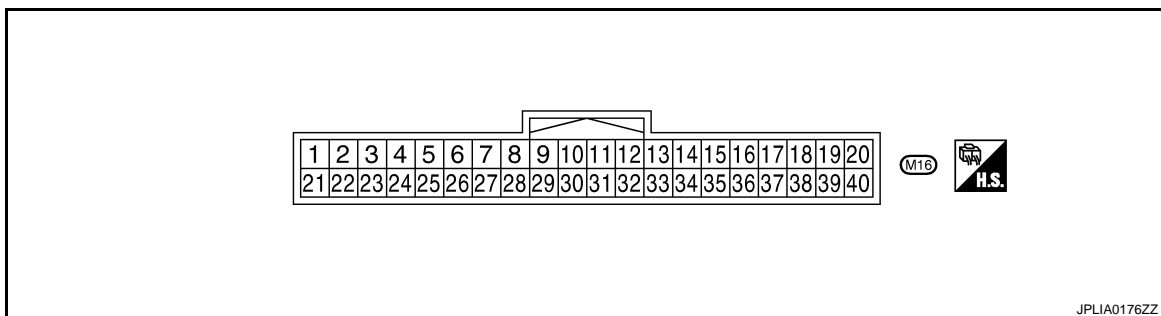

PHYSICAL VALUES

AFS CONTROL UNIT

< ECU DIAGNOSIS >

[XENON TYPE]

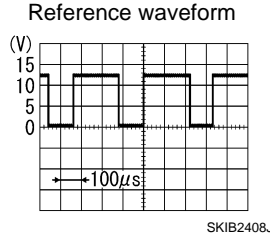
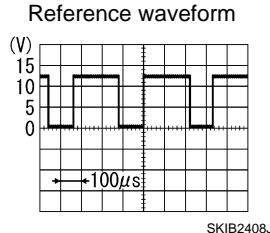
Terminal No. (Wire color)		Description		Condition		Value (Approx.)
+	-	Signal name	Input/ output			
1 (Y)	Ground	Ignition power supply	Input	The ignition switch ON		Battery voltage
2 (LG)	Ground	Right swivel position sensor ground	Input	The ignition switch ON		0 V
3 (GR)	Ground	AFS switch signal	Input	AFS switch	ON	0 V
					OFF	Battery voltage
4 (Y)	Ground	Right swivel position sensor power supply	Output	The ignition switch ON		5 V
6 (W)	Ground	Height sensor power supply	Output	The ignition switch ON		5 V
7 (P)	Ground	CAN-L	Input/ output	—		—
8 (B)	Ground	Height sensor ground	Input	The ignition switch ON		0 V
9 (GR)	Ground	Right swivel position sensor signal	Output	Right headlamp swivel angle	0°	1.0 V
					20°	2.8 V
11 (R)	Ground	Right swivel motor 1-phase (-)	Output	Right headlamp swivel	Activation	Reference waveform 
						8 - 12 V
13 (B)	Ground	Right swivel motor 2-phase (-)	Output	Right headlamp swivel	Stopped	9.5 - 11.5 V
15 (G)	Ground	Left swivel motor 1-phase (+)	Output	Left headlamp swivel	Activation	Reference waveform 
						8 - 12 V
17 (W)	Ground	Left swivel motor 2-phase (+)	Output	Left headlamp swivel	Stopped	9.5 - 11.5 V
19 (SB)	Ground	Right levelizer signal	Output	Right headlamp leveling (17-inch wheel models)	Unloaded vehicle condition	8.8 V
					Leveling operation downward edge	4.3 V
				Right headlamp leveling (18-inch wheel models)	Unloaded vehicle condition	8.8 V
					Leveling operation downward edge	4.5 V
24 (V)	Ground	Left swivel position sensor power supply	Output	The ignition switch ON		5 V

A
B
C
D
E
F
G
H
I
J
K
L
M
N
O
P

EXL

AFS CONTROL UNIT

< ECU DIAGNOSIS >

[XENON TYPE]

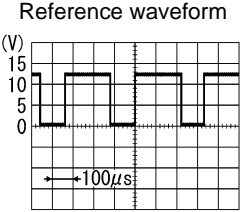
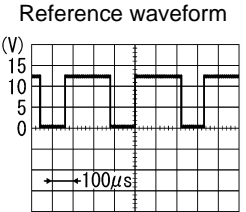
Terminal No. (Wire color)		Description		Condition		Value (Approx.)
+	-	Signal name	Input/ output			
25 (B)	Ground	Ground	—	The ignition switch ON		0 V
27 (BR)	Ground	Left swivel position sensor ground	Input	The ignition switch ON		0 V
28 (SB)	Ground	Height sensor signal	Output	Vehicle rear height	Unloaded vehicle condition	2.5 V
					Low (Leveling operation downward edge)	1.4 V
29 (O)	Ground	Left swivel position sensor signal	Output	Left headlamp swivel angle	0°	1.0 V
					20°	2.8 V
30 (L)	Ground	CAN-H	Input/ output	—		—
32 (G)	Ground	Right swivel motor 2-phase (+)	Output	Right headlamp swivel	Activation	 <p style="text-align: right; font-size: small;">Reference waveform SKIB2408J</p>
						8 - 12 V
34 (W)	Ground	Right swivel motor 1-phase (+)	Output	Right headlamp swivel	Stopped	9.5 - 11.5 V
36 (R)	Ground	Left swivel motor 2-phase (-)	Output	Left headlamp swivel	Activation	 <p style="text-align: right; font-size: small;">Reference waveform SKIB2408J</p>
						8 - 12 V
37 (O)	Ground	Reverse signal	Input	Back-up lamp switch	ON	Battery voltage
					OFF	0 V
38 (B)	Ground	Left swivel motor 1-phase (-)	Output	Left headlamp swivel	Stopped	9.5 - 11.5 V
40 (O)	Ground	Left levelizer signal	Output	Left headlamp leveling (17-inch wheel models)	Unloaded vehicle condition	8.8 V
					Leveling operation downward edge	4.3 V
				Left headlamp leveling (18-inch wheel models)	Unloaded vehicle condition	8.8 V
					Leveling operation downward edge	4.5 V

AFS CONTROL UNIT

< ECU DIAGNOSIS >

[XENON TYPE]

Wiring Diagram -ACTIVE AFS-

INFOID:000000000962516

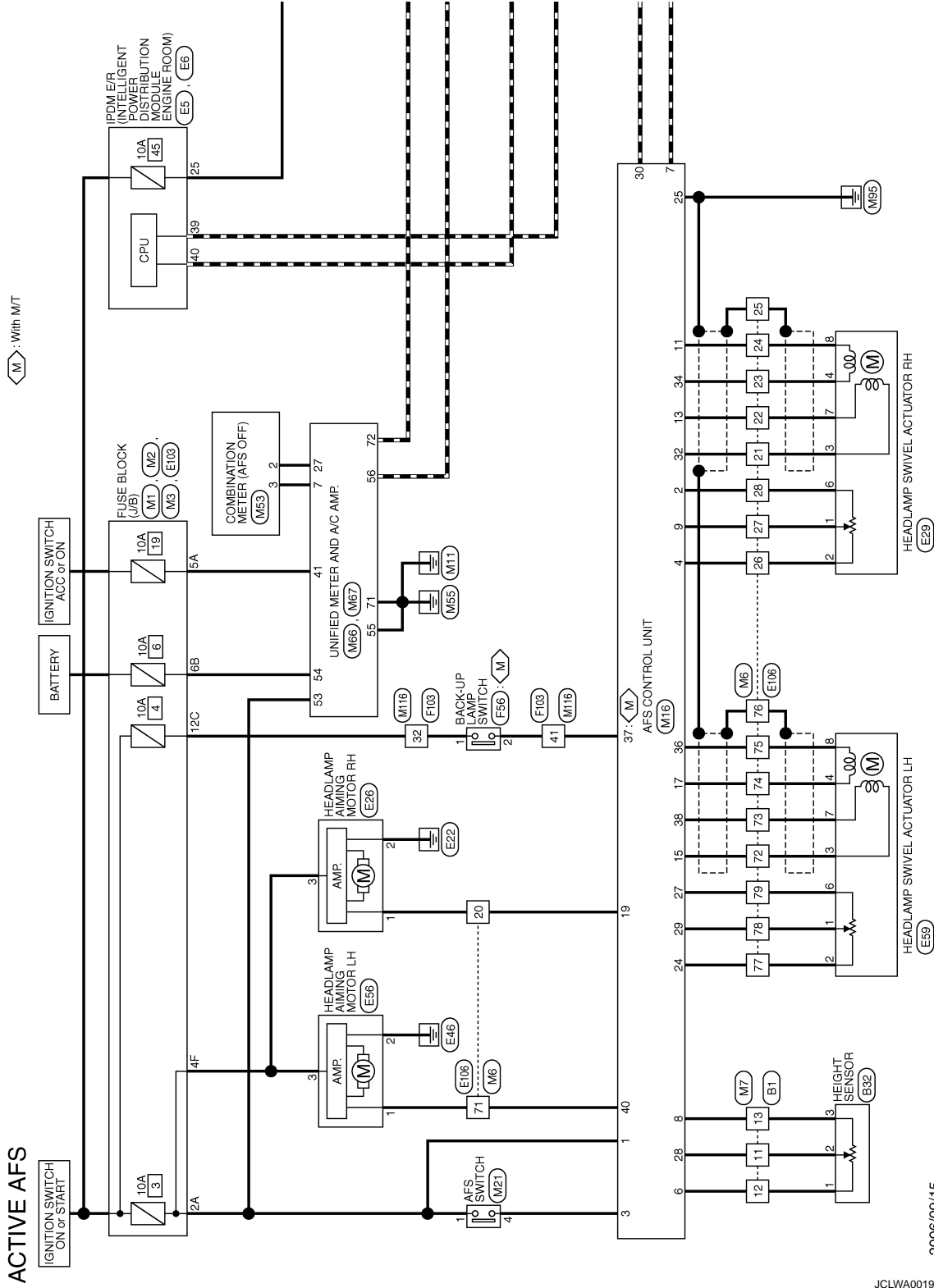

A
B
C
D
E
F
G
H
I
J
K
L
M
N
O
P

EXL



2006/09/15

JCLWA0019GB

AFS CONTROL UNIT

< ECU DIAGNOSIS >

[XENON TYPE]

-  : With A/T
-  : With automatic drive positioner or 4WAS
-  : Without automatic drive positioner and 4WAS

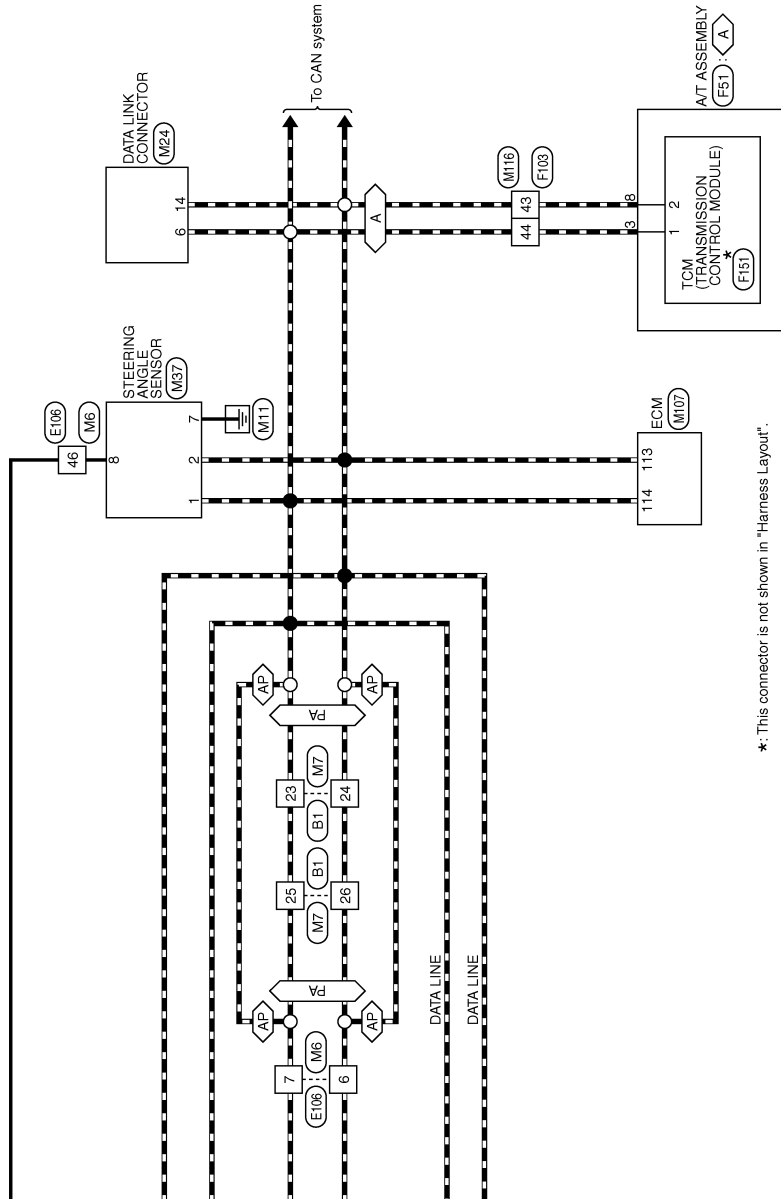

JCLWA0020GB

AFS CONTROL UNIT

< ECU DIAGNOSIS >

[XENON TYPE]

ACTIVE AFS

Connector No.	B1
Connector Name	WIRE TO WIRE
Connector Type	TH08FW-CS16-TM4

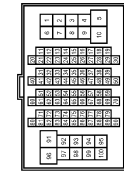

Terminal No.	Color of Wire	Signal Name
11	SB	-
12	V	-
13	GR	-
23	L	-
24	P	-
25	L	-
26	P	-

Connector No.	E32
Connector Name	HEIGHT SENSOR
Connector Type	RH03FB



Terminal No.	Color of Wire	Signal Name
1	V	-
2	SB	-
3	GR	-

Connector No.	E5
Connector Name	IPDM E/R (INTELLIGENT POWER DISTRIBUTION MODULE ENGINE ROOM)
Connector Type	TH20FW-CS12-M4-1V

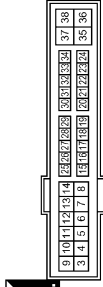

Terminal No.	Color of Wire	Signal Name
25	G	-

Connector No.	E6
Connector Name	IPDM E/R (INTELLIGENT POWER DISTRIBUTION MODULE ENGINE ROOM)
Connector Type	TH08FW-NH

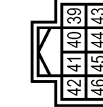

Terminal No.	Color of Wire	Signal Name
39	P	-
40	L	-

Connector No.	E26
Connector Name	HEADLAMP AIMING MOTOR RH
Connector Type	HS03FG



Terminal No.	Color of Wire	Signal Name
1	SB	-
2	B	-
3	G	-

Connector No.	E29
Connector Name	HEADLAMP SWIVEL ACTUATOR RH
Connector Type	RS08FGY-PR



Terminal No.	Color of Wire	Signal Name
1	LG	-
2	V	-
3	W	-
4	G	-
5	W	-
6	W	-
7	B	-
8	R	-

Connector No.	E58
Connector Name	HEADLAMP AIMING MOTOR LH
Connector Type	HS03FG



Terminal No.	Color of Wire	Signal Name
1	O	-
2	B/W	-
3	G	-

Connector No.	E59
Connector Name	HEADLAMP SWIVEL ACTUATOR LH
Connector Type	RS08FGY-PR



Terminal No.	Color of Wire	Signal Name
1	BR	-
2	V	-
3	W	-
4	R	-
5	O	-
6	B	-
7	B	-
8	G	-

A
B
C
D
E
F
G
H
I
J
K
EXL
M
N
O
P

AFS CONTROL UNIT

< ECU DIAGNOSIS >

[XENON TYPE]

ACTIVE AFS

Connector No.	E103
Connector Name	FUSE BLOCK (J/B)
Connector Type	NS16FW-CS



Terminal No.	4F	Color of Wire	G	Signal Name	-
--------------	----	---------------	---	-------------	---

Connector No.	E106
Connector Name	WIRE TO WIRE
Connector Type	TH80FW-CS18F-TM4

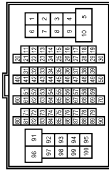

Terminal No.	6	Color of Wire	P	Signal Name	-
7	L	-	-	-	-
20	SR	-	-	-	-
21	W	-	-	-	-
22	B	-	-	-	-
23	G	-	-	-	-
24	R	-	-	-	-
25	SHIELD	-	-	-	-
26	Y	-	-	-	-
27	LG	-	-	-	-
28	W	-	-	-	-

46	LG	-	-	-	-
71	O	-	-	-	-
72	W	-	-	-	-
73	B	-	-	-	-
74	R	-	-	-	-
75	G	-	-	-	-
76	SHIELD	-	-	-	-
77	V	-	-	-	-
78	BR	-	-	-	-
79	O	-	-	-	-

Connector No.	F51
Connector Name	A/T ASSEMBLY
Connector Type	RK10FG-DGY

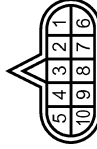

Terminal No.	3	Color of Wire	L	Signal Name	-
8	P	-	-	-	-

Connector No.	F56
Connector Name	BACK-UP LAMP SWITCH
Connector Type	RK02FB



Terminal No.	1	Color of Wire	R	Signal Name	-
2	O	-	-	-	-

Connector No.	F103
Connector Name	WIRE TO WIRE
Connector Type	TK38FW-NS10



Terminal No.	32	Color of Wire	R	Signal Name	-
41	O	-	-	-	-
43	P	-	-	-	-
44	L	-	-	-	-

Connector No.	F151
Connector Name	TCM (TRANSMISSION CONTROL MODULE)
Connector Type	SPI0FEGY



Terminal No.	1	Color of Wire	BR	Signal Name	CAN-H
2	L/Y	-	-	-	CAN-L

Connector No.	M1
Connector Name	FUSE BLOCK (J/B)
Connector Type	NS08FW-M2



Terminal No.	2A	Color of Wire	G	Signal Name	-
5A	V	-	-	-	-

AFS CONTROL UNIT

< ECU DIAGNOSIS >

[XENON TYPE]

ACTIVE AFS

Connector No.	M2
Connector Name	FUSE BLOCK (J/B)
Connector Type	NS10FW-CS

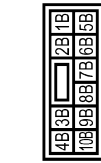

Terminal No.	Color of Wire	Signal Name
6B	Y	-

Connector No.	M3
Connector Name	FUSE BLOCK (J/B)
Connector Type	NS12FW-CS

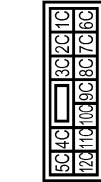

Terminal No.	Color of Wire	Signal Name
12C	R	-

Connector No.	M6
Connector Name	WIRE TO WIRE
Connector Type	TH80MW-CS16-TM4

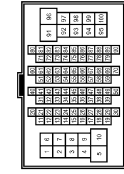

Terminal No.	Color of Wire	Signal Name
6	P	-
7	L	-
20	SB	-
21	G	-
22	B	-
23	W	-
24	R	-
25	SHIELD	-
26	Y	-
27	GR	-
28	LG	-

46	G	-
71	O	-
72	G	-
73	B	-
74	W	-
76	R	-
76	SHIELD	-
77	V	-
78	O	-
79	BR	-

Connector No.	M7
Connector Name	WIRE TO WIRE
Connector Type	TH80MW-CS16-TM4

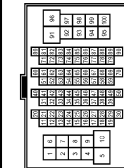

Terminal No.	Color of Wire	Signal Name
11	SB	-
12	W	-
13	B	-
23	L	-
24	P	-
25	L	-
26	P	-

Connector No.	M16
Connector Name	AFS CONTROL UNIT
Connector Type	TH40FW-NH

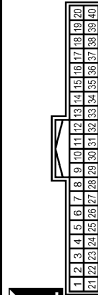

Terminal No.	Color of Wire	Signal Name
1	Y	IGN
2	LG	PSG-R
3	GR	SW
4	Y	PSV-R
6	W	HSV-R
7	P	CAN-L
8	B	HSG-R
9	GR	PS-R
11	R	SMR-1 (-)
13	B	SMR-2 (-)
15	G	SML-1 (+)

Terminal No.	Color of Wire	Signal Name
17	W	SML-2 (+)
19	SB	AMDS-R
24	Y	PSV-L
25	B	IGN
27	BR	PSG-L
28	SB	HS-R
29	O	PS-L
30	L	CAN-H
32	G	SMR-2 (+)
34	W	SMR-1 (+)
36	R	SML-2 (-)
37	O	REV
38	B	SML-1 (-)
40	O	AMDS-L

Connector No.	M21
Connector Name	AFS SWITCH
Connector Type	TK08FW-1V



Terminal No.	Color of Wire	Signal Name
1	Y	-
4	GR	-

JCLWA0023GB





A
B
C
D
E
F
G
H
I
J
K
EXL
M
N
O
P

AFS CONTROL UNIT

< ECU DIAGNOSIS >

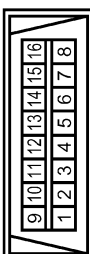
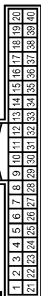
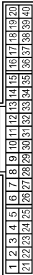
[XENON TYPE]

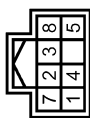
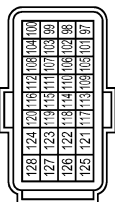
ACTIVE AFS

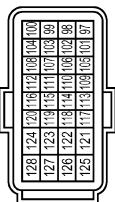
<table border="1"> <tr><td>Connector No.</td><td>M24</td></tr> <tr><td>Connector Name</td><td>DATA LINK CONNECTOR</td></tr> <tr><td>Connector Type</td><td>BD16FW</td></tr> </table>  <table border="1"> <tr><td>Terminal No.</td><td>Color of Wire</td><td>Signal Name</td></tr> <tr><td>6</td><td>L</td><td>-</td></tr> <tr><td>14</td><td>P</td><td>-</td></tr> </table>	Connector No.	M24	Connector Name	DATA LINK CONNECTOR	Connector Type	BD16FW	Terminal No.	Color of Wire	Signal Name	6	L	-	14	P	-	<table border="1"> <tr><td>Connector No.</td><td>M66</td></tr> <tr><td>Connector Name</td><td>UNIFIED METER AND A/C AMP.</td></tr> <tr><td>Connector Type</td><td>TH40FW-NH</td></tr> </table>  <table border="1"> <tr><td>Terminal No.</td><td>Color of Wire</td><td>Signal Name</td></tr> <tr><td>7</td><td>GR</td><td>COMM (AMP->METER)</td></tr> <tr><td>27</td><td>LG</td><td>COMM (METER->AMP)</td></tr> </table>	Connector No.	M66	Connector Name	UNIFIED METER AND A/C AMP.	Connector Type	TH40FW-NH	Terminal No.	Color of Wire	Signal Name	7	GR	COMM (AMP->METER)	27	LG	COMM (METER->AMP)															
Connector No.	M24																																													
Connector Name	DATA LINK CONNECTOR																																													
Connector Type	BD16FW																																													
Terminal No.	Color of Wire	Signal Name																																												
6	L	-																																												
14	P	-																																												
Connector No.	M66																																													
Connector Name	UNIFIED METER AND A/C AMP.																																													
Connector Type	TH40FW-NH																																													
Terminal No.	Color of Wire	Signal Name																																												
7	GR	COMM (AMP->METER)																																												
27	LG	COMM (METER->AMP)																																												
<table border="1"> <tr><td>Connector No.</td><td>M53</td></tr> <tr><td>Connector Name</td><td>COMBINATION METER</td></tr> <tr><td>Connector Type</td><td>SAB40FW</td></tr> </table>  <table border="1"> <tr><td>Terminal No.</td><td>Color of Wire</td><td>Signal Name</td></tr> <tr><td>2</td><td>LG</td><td>COMM (METER->AMP)</td></tr> <tr><td>3</td><td>GR</td><td>COMM (AMP->METER)</td></tr> </table>	Connector No.	M53	Connector Name	COMBINATION METER	Connector Type	SAB40FW	Terminal No.	Color of Wire	Signal Name	2	LG	COMM (METER->AMP)	3	GR	COMM (AMP->METER)	<table border="1"> <tr><td>Connector No.</td><td>M116</td></tr> <tr><td>Connector Name</td><td>WIRE TO WIRE</td></tr> <tr><td>Connector Type</td><td>TK3BMW-NS10</td></tr> </table>  <table border="1"> <tr><td>Terminal No.</td><td>Color of Wire</td><td>Signal Name</td></tr> <tr><td>32</td><td>LG</td><td>-</td></tr> <tr><td>41</td><td>O</td><td>-</td></tr> <tr><td>43</td><td>P</td><td>-</td></tr> <tr><td>44</td><td>L</td><td>-</td></tr> </table>	Connector No.	M116	Connector Name	WIRE TO WIRE	Connector Type	TK3BMW-NS10	Terminal No.	Color of Wire	Signal Name	32	LG	-	41	O	-	43	P	-	44	L	-									
Connector No.	M53																																													
Connector Name	COMBINATION METER																																													
Connector Type	SAB40FW																																													
Terminal No.	Color of Wire	Signal Name																																												
2	LG	COMM (METER->AMP)																																												
3	GR	COMM (AMP->METER)																																												
Connector No.	M116																																													
Connector Name	WIRE TO WIRE																																													
Connector Type	TK3BMW-NS10																																													
Terminal No.	Color of Wire	Signal Name																																												
32	LG	-																																												
41	O	-																																												
43	P	-																																												
44	L	-																																												
<table border="1"> <tr><td>Connector No.</td><td>M57</td></tr> <tr><td>Connector Name</td><td>STEERING ANGLE SENSOR</td></tr> <tr><td>Connector Type</td><td>TH08FW-NH</td></tr> </table>  <table border="1"> <tr><td>Terminal No.</td><td>Color of Wire</td><td>Signal Name</td></tr> <tr><td>1</td><td>L</td><td>CAN-H</td></tr> <tr><td>2</td><td>P</td><td>CAN-L</td></tr> <tr><td>7</td><td>B</td><td>GND</td></tr> <tr><td>8</td><td>G</td><td>IGN</td></tr> </table>	Connector No.	M57	Connector Name	STEERING ANGLE SENSOR	Connector Type	TH08FW-NH	Terminal No.	Color of Wire	Signal Name	1	L	CAN-H	2	P	CAN-L	7	B	GND	8	G	IGN	<table border="1"> <tr><td>Connector No.</td><td>M107</td></tr> <tr><td>Connector Name</td><td>ECM</td></tr> <tr><td>Connector Type</td><td>MAA24GY-MEAB-LH-Z</td></tr> </table>  <table border="1"> <tr><td>Terminal No.</td><td>Color of Wire</td><td>Signal Name</td></tr> <tr><td>113</td><td>P</td><td>VHECAN L1</td></tr> <tr><td>114</td><td>L</td><td>VHECAN HI</td></tr> </table>	Connector No.	M107	Connector Name	ECM	Connector Type	MAA24GY-MEAB-LH-Z	Terminal No.	Color of Wire	Signal Name	113	P	VHECAN L1	114	L	VHECAN HI									
Connector No.	M57																																													
Connector Name	STEERING ANGLE SENSOR																																													
Connector Type	TH08FW-NH																																													
Terminal No.	Color of Wire	Signal Name																																												
1	L	CAN-H																																												
2	P	CAN-L																																												
7	B	GND																																												
8	G	IGN																																												
Connector No.	M107																																													
Connector Name	ECM																																													
Connector Type	MAA24GY-MEAB-LH-Z																																													
Terminal No.	Color of Wire	Signal Name																																												
113	P	VHECAN L1																																												
114	L	VHECAN HI																																												
<table border="1"> <tr><td>Connector No.</td><td>M67</td></tr> <tr><td>Connector Name</td><td>UNIFIED METER AND A/C AMP.</td></tr> <tr><td>Connector Type</td><td>TH82FW-NH</td></tr> </table>  <table border="1"> <tr><td>Terminal No.</td><td>Color of Wire</td><td>Signal Name</td></tr> <tr><td>41</td><td>V</td><td>ACC</td></tr> <tr><td>53</td><td>G</td><td>IGN</td></tr> <tr><td>54</td><td>Y</td><td>BAT</td></tr> <tr><td>55</td><td>B</td><td>GND</td></tr> <tr><td>56</td><td>L</td><td>CAN-H</td></tr> <tr><td>71</td><td>B</td><td>GND</td></tr> <tr><td>72</td><td>P</td><td>CAN-L</td></tr> </table>	Connector No.	M67	Connector Name	UNIFIED METER AND A/C AMP.	Connector Type	TH82FW-NH	Terminal No.	Color of Wire	Signal Name	41	V	ACC	53	G	IGN	54	Y	BAT	55	B	GND	56	L	CAN-H	71	B	GND	72	P	CAN-L	<table border="1"> <tr><td>Connector No.</td><td>M107</td></tr> <tr><td>Connector Name</td><td>ECM</td></tr> <tr><td>Connector Type</td><td>MAA24GY-MEAB-LH-Z</td></tr> </table>  <table border="1"> <tr><td>Terminal No.</td><td>Color of Wire</td><td>Signal Name</td></tr> <tr><td>113</td><td>P</td><td>VHECAN L1</td></tr> <tr><td>114</td><td>L</td><td>VHECAN HI</td></tr> </table>	Connector No.	M107	Connector Name	ECM	Connector Type	MAA24GY-MEAB-LH-Z	Terminal No.	Color of Wire	Signal Name	113	P	VHECAN L1	114	L	VHECAN HI
Connector No.	M67																																													
Connector Name	UNIFIED METER AND A/C AMP.																																													
Connector Type	TH82FW-NH																																													
Terminal No.	Color of Wire	Signal Name																																												
41	V	ACC																																												
53	G	IGN																																												
54	Y	BAT																																												
55	B	GND																																												
56	L	CAN-H																																												
71	B	GND																																												
72	P	CAN-L																																												
Connector No.	M107																																													
Connector Name	ECM																																													
Connector Type	MAA24GY-MEAB-LH-Z																																													
Terminal No.	Color of Wire	Signal Name																																												
113	P	VHECAN L1																																												
114	L	VHECAN HI																																												

Fail Safe

JCLWA0024GB

INFOID:000000000962517

AFS CONTROL UNIT

< ECU DIAGNOSIS >

[XENON TYPE]

CONSULT indication	Fail-safe	AFS OFF indicator lamp	Cancellation
CAN COMM CIRCUIT [U1000]	<ul style="list-style-type: none"> Right and left swivel motors stop at the position when DTC is detected. Right and left aiming motors stop at the position when DTC is detected. 	Blinks 1 second each.	The ignition switch OFF
CONTROL UNIT (CAN) [U1010]	<ul style="list-style-type: none"> Right and left swivel motors stop at the position when DTC is detected. Right and left aiming motors stop at the position when DTC is detected. 	Blinks 1 second each.	The ignition switch OFF
SWIVEL ACTUATOR [RH, LH] [B2503, B2504]	<ul style="list-style-type: none"> Right and left swivel motors stop at the position when DTC is detected. The signal, approximately 2 V decreased from the levelizer signal when DTC detected, is output. 	Blinks 1 second each.	The ignition switch OFF
HI SEN UNUSUAL [RR] [B2514]	<ul style="list-style-type: none"> Right and left aiming motors stop at the position when DTC is detected. 	—	The ignition switch OFF
ST ANG SEN SIG [C0126]	<ul style="list-style-type: none"> Right and left swivel motor swivel angle returns to 0° and fixed. 	Blinks 1 second each.	The ignition switch OFF
SHIFT SIG [P, R] [B2516]	<ul style="list-style-type: none"> Right and left swivel motor swivel angle returns to 0° and fixed. 	Blinks 1 second each.	The ignition switch OFF
VEHICLE SPEED SIG [B2517]	<ul style="list-style-type: none"> Right and left swivel motor swivel angle returns to 0° and fixed. Right and left aiming motors stop at the position when DTC is detected. 	Blinks 1 second each.	The ignition switch OFF
LEVELIZER CALIB [B2519]	<ul style="list-style-type: none"> Right and left aiming motors stop at the position when DTC is detected. 	—	When the levelizer adjustment is completed.
ST ANGLE SEN CALIB [C0428]	<ul style="list-style-type: none"> Right and left swivel motor swivel angle returns to 0° and fixed. 	Blinks 1 second each.	When the steering angle sensor neutral position registration is completed
ECU CIRC [B2521]	<ul style="list-style-type: none"> Right and left swivel motors stop at the position when DTC is detected. Right and left aiming motors stop at the position when DTC is detected. 	Blinks 1 second each.	The ignition switch OFF

DTC Inspection Priority Chart

INFOID:000000000962518

If some DTCs are displayed at the same time, perform inspections one by one based on the following priority chart.

NOTE:

- If DTC U1000 is displayed with other DTC, first perform the trouble diagnosis for DTC U1000.
- If DTC U1010 is displayed with other DTC, first perform the trouble diagnosis for DTC U1010.

Priority	Detected items (DTC)
1	<ul style="list-style-type: none"> U1000 CAN COMM CIRCUIT U1010 CONTROL UNIT (CAN)
2	<ul style="list-style-type: none"> B2519 LEVELIZER CALIB B2521 ECU CIRC C0428 ST ANG SEN CALIB
3	<ul style="list-style-type: none"> B2503 SWIVEL ACTUATOR [RH] B2504 SWIVEL ACTUATOR [LH] B2514 HI SEN UNUSUAL [RR] B2516 SHIFT SIG [P, R] B2517 VEHICLE SPEED SIG C0126 ST ANG SEN SIG

DTC Index

INFOID:000000000962519

AFS CONTROL UNIT

< ECU DIAGNOSIS >

[XENON TYPE]

CONSULT indication	Fail-safe	AFS OFF indicator lamp	Reference
U1000: CAN COMM CIRCUIT	×	×	EXL-59. "Description"
U1010: CONTROL UNIT (CAN)	×	×	EXL-60. "Description"
B2503, B2504: SWIVEL ACTUATOR [RH, LH]	×	×	EXL-42. "Description"
B2514: HI SEN UNUSUAL [RR]	×		EXL-47. "Description"
B2516: SHIFT SIG [P, R]	×	×	EXL-51. "Description"
B2517: VEHICLE SPEED SIG	×	×	EXL-52. "Description"
B2519: LEVELIZER CALIB	×		EXL-53. "Description"
B2521: ECU CIRC	×	×	EXL-54. "Description"
C0126: ST ANG SEN SIG	×	×	EXL-57. "Description"
C0428: ST ANGLE SEN CALIB	×	×	EXL-58. "Description"

EXTERIOR LIGHTING SYSTEM SYMPTOMS

< SYMPTOM DIAGNOSIS >

[XENON TYPE]

SYMPTOM DIAGNOSIS

EXTERIOR LIGHTING SYSTEM SYMPTOMS

Symptom Table

INFOID:000000000962520

CAUTION:

Perform the self-diagnosis with CONSULT-III before the symptom diagnosis. Perform the trouble diagnosis if any DTC is detected.

Symptom		Possible cause	Inspection item
Headlamp does not switch to the high beam.	One side	<ul style="list-style-type: none"> • Fuse • Harness between IPDM E/R and the front combination lamp • Front combination lamp (High beam solenoid) • IPDM E/R 	Headlamp (HI) circuit Refer to EXL-65 .
	Both sides	Symptom diagnosis "BOTH SIDE HEADLAMPS DO NOT SWITCH TO HIGH BEAM" Refer to EXL-179 .	
High beam indicator lamp is not turned ON. (Headlamp switches to the high beam.)		<ul style="list-style-type: none"> • Combination meter • Unified meter and A/C amp. 	<ul style="list-style-type: none"> • Unified meter and A/C amp. Data monitor "HI-BEAM IND" • BCM (HEAD LAMP) Active test "HEADLAMP"
Headlamp does not switch to the low beam.	One side	Front combination lamp (High beam solenoid)	—
	Both sides	<ul style="list-style-type: none"> • Combination switch • Harness between the combination switch and BCM • BCM 	Combination switch Refer to BCS-77 .
		High beam request signal	IPDM E/R Data monitor "HL HI REQ"
		IPDM E/R	—
Headlamp is not turned ON.	One side	<ul style="list-style-type: none"> • Fuse • Xenon bulb • Harness between IPDM E/R and the front combination lamp • Front combination lamp (xenon headlamp) • IPDM E/R 	Headlamp (LO) circuit Refer to EXL-67 .
	Both sides	Symptom diagnosis "BOTH SIDE HEADLAMPS (LO) ARE NOT TURNED ON" Refer to EXL-179 .	
Headlamp is not turned OFF.	When the ignition switch is turned ON		
	The ignition switch is turned OFF (After activating the battery saver).	IPDM E/R	—
Headlamp is not turned ON/OFF with the lighting switch AUTO.		<ul style="list-style-type: none"> • Combination switch • Harness between the combination switch and BCM • BCM 	Combination switch Refer to BCS-77 .
		<ul style="list-style-type: none"> • Optical sensor • Harness between the optical sensor and BCM • BCM 	Optical sensor Refer to EXL-80 .

A
B
C
D
E
F
G
H
I
J
K
M
N
O
P

EXL

EXTERIOR LIGHTING SYSTEM SYMPTOMS

< SYMPTOM DIAGNOSIS >

[XENON TYPE]

Symptom		Possible cause	Inspection item
Front fog lamp is not turned ON.	One side	<ul style="list-style-type: none"> • Front fog lamp bulb • Harness between IPDM E/R and the front combination lamp • Front combination lamp • IPDM E/R 	Front fog lamp circuit Refer to EXL-73 .
	Both side	Symptom diagnosis "BOTH SIDE FRONT FOG LAMPS ARE NOT TURNED ON" Refer to EXL-182 .	
Front fog lamp is not turned ON.			
Parking lamp is not turned ON.		<ul style="list-style-type: none"> • Fuse • Parking lamp bulb • Harness between IPDM E/R and the front combination lamp • Front combination lamp • IPDM E/R 	Parking lamp circuit Refer to EXL-75 .
Tail lamp is not turned ON.		<ul style="list-style-type: none"> • Harness between IPDM E/R and the rear combination lamp • Rear combination lamp 	Tail lamp circuit Refer to EXL-85 .
License plate lamp is not turned ON.		<ul style="list-style-type: none"> • Harness between IPDM E/R and the license plate lamp • License plate lamp 	License plate lamp circuit Refer to EXL-87 .
Tail lamp and the license plate lamp are not turned ON.		<ul style="list-style-type: none"> • Fuse • Harness between IPDM E/R and the rear combination lamp • IPDM E/R 	Tail lamp circuit Refer to EXL-85 .
<ul style="list-style-type: none"> • Parking lamp, the tail lamp and the license plate lamp are not turned ON. • Parking lamp, the tail lamp and the license plate lamp are not turned OFF. (Each illumination is turned ON/OFF.)		Symptom diagnosis "PARKING, LICENSE PLATE AND TAIL LAMPS ARE NOT TURNED ON" Refer to EXL-181 .	
Turn signal lamp does not blink.	Indicator lamp is normal. (The applicable side performs the high flasher activation.)	<ul style="list-style-type: none"> • Harness between BCM and each turn signal lamp • Turn signal lamp bulb 	Turn signal circuit Refer to EXL-77 .
	Indicator lamp is included	<ul style="list-style-type: none"> • Combination switch • Harness between the combination switch and BCM • BCM 	Combination switch Refer to BCS-77 .
Turn signal indicator lamp does not blink. (The turn signal indicator lamp is normal.)	One side	Combination meter	—
	Both sides (Always)	<ul style="list-style-type: none"> • Turn signal indicator lamp signal - Unified meter and A/C amp. - BCM • Combination meter 	<ul style="list-style-type: none"> • Unified meter and A/C amp. Data monitor "TURN IND" • BCM (FLASHER) Active test "FLASHER"
	Both sides (Only when activating the hazard warning lamp with the ignition switch OFF)	<ul style="list-style-type: none"> • The combination meter power supply and the ground circuit • Combination meter 	Combination meter Power supply and the ground circuit Refer to MWI-49 .
<ul style="list-style-type: none"> • Hazard warning lamp does not activate. • Hazard warning lamp continues activating. (Turn signal is normal.)		<ul style="list-style-type: none"> • Hazard switch • Harness between the hazard switch and BCM • BCM 	Hazard switch Refer to EXL-83 .

EXTERIOR LIGHTING SYSTEM SYMPTOMS

< SYMPTOM DIAGNOSIS >

[XENON TYPE]

Symptom	Possible cause	Inspection item
Headlamp auto aiming does not activate. (AFS is normal.)	<ul style="list-style-type: none"> • Harness between AFS control unit and aiming motor • Front combination lamp (Aiming motor) • AFS control unit 	Aiming motor Refer to EXL-71 .
AFS OFF indicator lamp is not turned ON.	<ul style="list-style-type: none"> • AFS OFF indicator lamp signal - Unified meter and A/C amp. - AFS control unit • Combination meter 	Unified meter and A/C amp. Data monitor "AFS OFF IND"

A
B
C
D
E
F
G
H
I
J
K
EXL
M
N
O
P

EXL

NORMAL OPERATING CONDITION

Description

INFOID:000000000962521

XENON HEADLAMP

- Brightness and the color of light may change slightly immediately after turning the headlamp ON until the xenon bulb becomes stable. This is normal.
- Illumination time lag may occur between right and left. This is normal.

AUTO LIGHT SYSTEM

The headlamp may not be turned ON/OFF immediately after passing dark area or bright area (short tunnel, sky bridge, shadowed area etc.) while using the auto light system. This causes for the control difference. This is normal.

BOTH SIDE HEADLAMPS DO NOT SWITCH TO HIGH BEAM

< SYMPTOM DIAGNOSIS >

[XENON TYPE]

BOTH SIDE HEADLAMPS DO NOT SWITCH TO HIGH BEAM

Description

INFOID:000000000962522

The headlamp (both sides) does not switch to the high beam when setting to the lighting switch HI or PASS.

Diagnosis Procedure

INFOID:000000000962523

1.COMBINATION SWITCH INSPECTION

Check the combination switch. Refer to [BCS-77](#).

Is the combination switch normal?

YES >> GO TO 2.

NO >> Repair or replace the malfunctioning part.

2.CHECK HEDLAMP (HI) REQUEST SIGNAL INPUT

 CONSULT-III DATA MONITOR

1. Select "HL HI REQ" of IPDM E/R data monitor item.

2. With operating the lighting switch, check the monitor status.

Monitor item	Condition		Monitor status
HL HI REQ	Lighting switch (2ND)	HI or PASS	ON
		Except for HI or PASS	OFF

Is the item status normal?

YES >> GO TO 3.

NO >> Replace BCM.

3.HEADLAMP (HI) CIRCUIT INSPECTION

Check the headlamp (HI) circuit. Refer to [EXL-65](#).

Is the headlamp (HI) circuit normal?

YES >> Replace IPDM E/R.

NO >> Repair or replace the malfunctioning part.

A
B
C
D
E
F
G
H
I
J
K
M
N
O
P

EXL

BOTH SIDE HEADLAMPS (LO) ARE NOT TURNED ON

< SYMPTOM DIAGNOSIS >

[XENON TYPE]

BOTH SIDE HEADLAMPS (LO) ARE NOT TURNED ON

Description

INFOID:000000000962524

The headlamps (both sides) are not turned ON in any condition.

Diagnosis Procedure

INFOID:000000000962525

1. CHECK COMBINATION SWITCH

Check the combination switch. Refer to [BCS-77](#).

Is the combination switch normal?

YES >> GO TO 2.

NO >> Repair or replace the malfunctioning part.

2. CHECK HEADLAMP (LO) REQUEST SIGNAL INPUT

ⓂCONSULT-III DATA MONITOR

1. Select "HL LO REQ" of IPDM E/R data monitor item.
2. With operating the lighting switch, check the monitor status.

Monitor item	Condition	Monitor status	
HL LO REQ	Lighting switch	2ND	ON
		OFF	OFF

Is the item status normal?

YES >> GO TO 3.

NO >> Replace BCM.

3. HEADLAMP (LO) CIRCUIT INSPECTION

Check the headlamp (LO) circuit. Refer to [EXL-67](#).

Is the headlamp (LO) circuit normal?

YES >> Replace IPDM E/R.

NO >> Repair or replace the malfunctioning part.

PARKING, LICENSE PLATE AND TAIL LAMPS ARE NOT TURNED ON

< SYMPTOM DIAGNOSIS >

[XENON TYPE]

PARKING, LICENSE PLATE AND TAIL LAMPS ARE NOT TURNED ON

Description

INFOID:000000000962526

The parking, license plate, tail, side marker lamps and each illumination are not turned ON in any condition.

Diagnosis Procedure

INFOID:000000000962527

1.COMBINATION SWITCH INSPECTION

Check the combination switch. Refer to [BCS-77](#).

Is the combination switch normal?

YES >> GO TO 2.

NO >> Repair or replace the malfunctioning part.

2.CHECK TAIL LAMP RELAY REQUEST SIGNAL INPUT

 CONSULT-III DATA MONITOR

1. Select "TAIL & CLR REQ" of IPDM E/R data monitor item.
2. With operating the lighting switch, check the monitor status.

Monitor item	Condition	Monitor status	
TAIL & CLR REQ	Lighting switch	1ST	ON
		OFF	OFF

Is the item status normal?

YES >> GO TO 3.

NO >> Replace BCM.

3.TAIL LAMP CIRCUIT INSPECTION

Check the tail lamp circuit. Refer to [EXL-85](#).

Is the tail lamp circuit normal?

YES >> Replace IPDM E/R.

NO >> Repair or replace the malfunctioning part.

A
B
C
D
E
F
G
H
I
J
K
M
N
O
P

EXL

BOTH SIDE FRONT FOG LAMPS ARE NOT TURNED ON

< SYMPTOM DIAGNOSIS >

[XENON TYPE]

BOTH SIDE FRONT FOG LAMPS ARE NOT TURNED ON

Description

INFOID:000000000962528

The front fog lamps are not turned ON in any condition.

Diagnosis Procedure

INFOID:000000000962529

1.COMBINATION SWITCH INSPECTION

Check the combination switch. Refer to [BCS-77](#).

Is the combination switch normal?

YES >> GO TO 2.

NO >> Repair or replace the malfunctioning part.

2.CHECK FRONT FOG LAMP REQUEST SIGNAL INPUT

ⓑCONSULT-III DATA MONITOR

1. Select "FR FOG REQ" of IPDM E/R data monitor item.
2. With operating the front fog lamp switch, check the monitor status.

Monitor item	Condition	Monitor status	
FR FOG REQ	Front fog lamp switch (Lighting switch 2ND)	ON	ON
		OFF	OFF

Is the item status normal?

YES >> GO TO 3.

NO >> Replace BCM.

3.FRONT FOG LAMP CIRCUIT INSPECTION

Check the front fog lamp circuit. Refer to [EXL-73](#).

Is the front fog lamp circuit normal?

YES >> Replace IPDM E/R.

NO >> Repair or replace the malfunctioning part.

PRECAUTION

PRECAUTIONS

Supplemental Restraint System (SRS) "AIR BAG" and "SEAT BELT PRE-TENSIONER"

INFOID:000000000962530

The Supplemental Restraint System such as "AIR BAG" and "SEAT BELT PRE-TENSIONER", used along with a front seat belt, helps to reduce the risk or severity of injury to the driver and front passenger for certain types of collision. This system includes seat belt switch inputs and dual stage front air bag modules. The SRS system uses the seat belt switches to determine the front air bag deployment, and may only deploy one front air bag, depending on the severity of a collision and whether the front occupants are belted or unbelted. Information necessary to service the system safely is included in the SRS and SB section of this Service Manual.

WARNING:

- To avoid rendering the SRS inoperative, which could increase the risk of personal injury or death in the event of a collision which would result in air bag inflation, all maintenance must be performed by an authorized NISSAN/INFINITI dealer.
- Improper maintenance, including incorrect removal and installation of the SRS, can lead to personal injury caused by unintentional activation of the system. For removal of Spiral Cable and Air Bag Module, see the SRS section.
- Do not use electrical test equipment on any circuit related to the SRS unless instructed to in this Service Manual. SRS wiring harnesses can be identified by yellow and/or orange harnesses or harness connectors.

Precautions For Xenon Headlamp Service

INFOID:000000000962531

WARNING:

Comply with the following warnings to prevent any serious accident.

- Disconnect the battery cable (negative terminal) or the power supply fuse before installing, removing, or touching the xenon headlamp (bulb included). The xenon headlamp contains high-voltage generated parts.
- Never work with wet hands.
- Check the xenon headlamp ON-OFF status after assembling it to the vehicle. Never turn the xenon headlamp ON in other conditions. Connect the power supply to the vehicle-side connector. (Turning it ON outside the lamp case may cause fire or visual impairments.)
- Never touch the bulb glass immediately after turning it OFF. It is extremely hot.

CAUTION:

Comply with the following cautions to prevent any error and malfunction.

- Install the xenon bulb securely. (Insufficient bulb socket installation may melt the bulb, the connector, the housing, etc. by high-voltage leakage or corona discharge.)
- Never perform HID circuit inspection with a tester.
- Never touch the xenon bulb glass with hands. Never put oil and grease on it.
- Dispose of the used xenon bulb after packing it in thick vinyl without breaking it.
- Never wipe out dirt and contamination with organic solvent (thinner, gasoline, etc.).

A
B
C
D
E
F
G
H
I
J
K
L
M
N
O
P

EXL

FRONT COMBINATION LAMP

< ON-VEHICLE REPAIR >

[XENON TYPE]

ON-VEHICLE REPAIR

FRONT COMBINATION LAMP

Exploded View

INFOID:000000000962532

REMOVAL

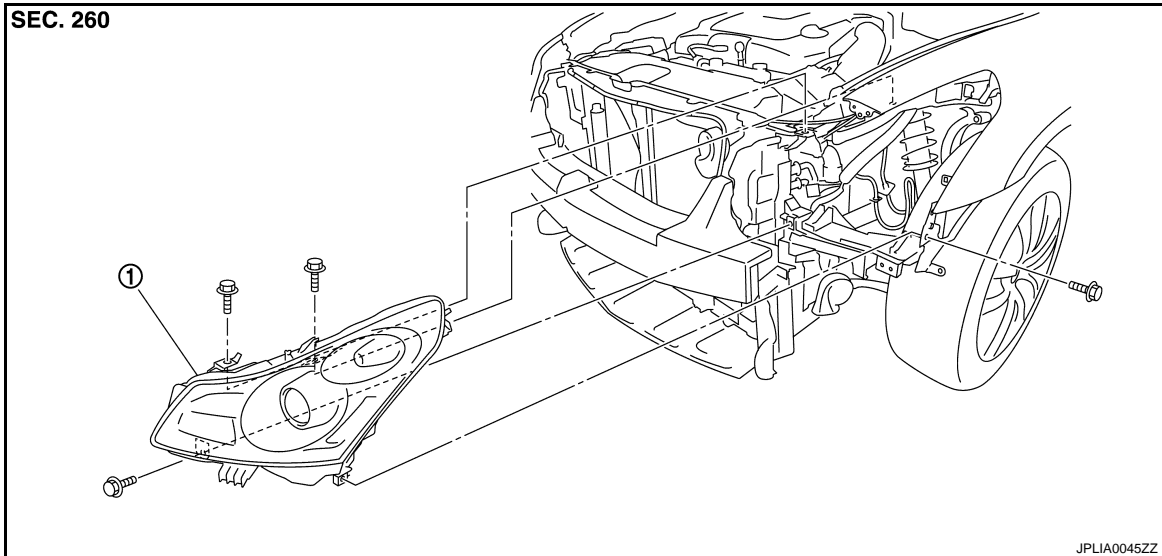

1. Front combination lamp

DISASSEMBLY

Without AFS

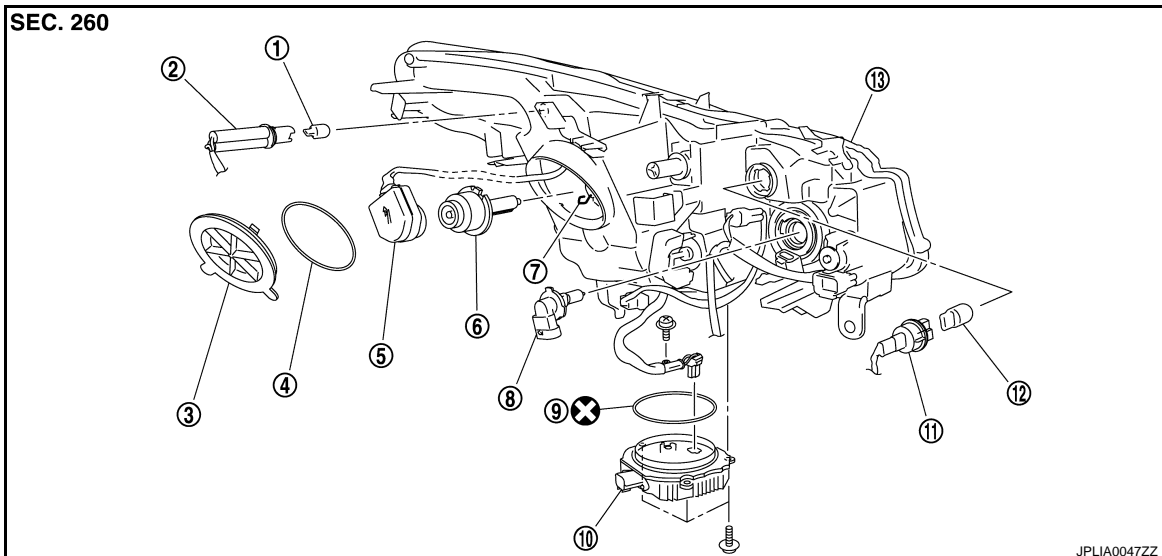

- | | | |
|-------------------------------|--|---------------------------------|
| 1. Parking lamp bulb | 2. Parking lamp bulb socket | 3. Resin cap |
| 4. Seal packing | 5. Xenon bulb socket | 6. Xenon bulb |
| 7. Retaining spring | 8. Front fog lamp bulb | 9. Seal packing |
| 10. HID control unit | 11. Front turn signal lamp bulb socket | 12. Front turn signal lamp bulb |
| 13. Headlamp housing assembly | | |

Refer to [GI-3, "Contents"](#) for symbols not described above.

With AFS

FRONT COMBINATION LAMP

< ON-VEHICLE REPAIR >

[XENON TYPE]

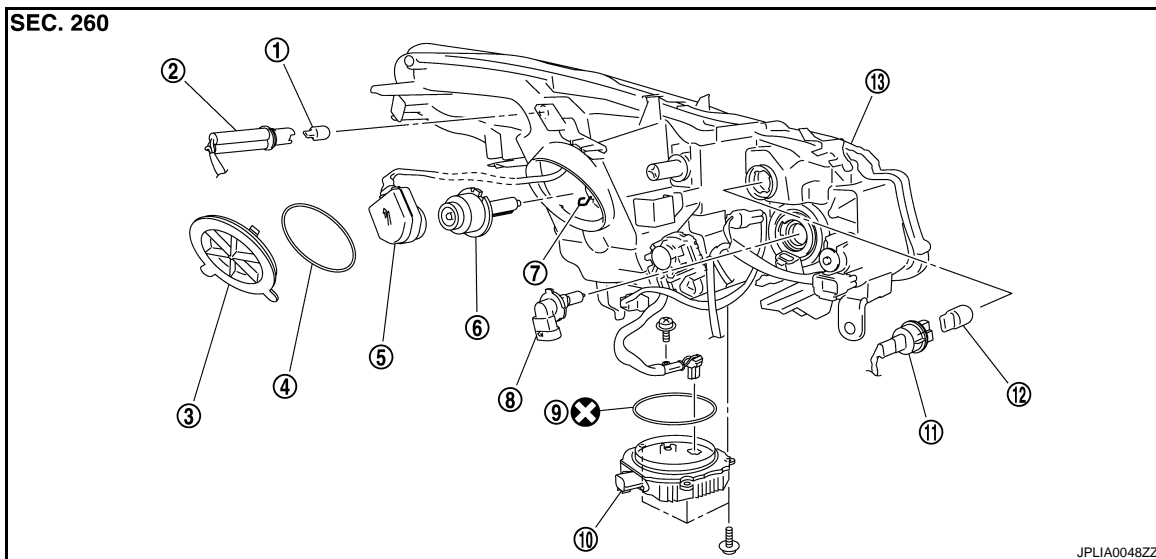

- | | | |
|-------------------------------|--|---------------------------------|
| 1. Parking lamp bulb | 2. Parking lamp bulb socket | 3. Resin cap |
| 4. Seal packing | 5. Xenon bulb socket | 6. Xenon bulb |
| 7. Retaining spring | 8. Front fog lamp bulb | 9. Seal packing |
| 10. HID control unit | 11. Front turn signal lamp bulb socket | 12. Front turn signal lamp bulb |
| 13. Headlamp housing assembly | | |

Refer to [GI-3, "Contents"](#) for symbols not described above.

Removal and Installation

INFOID:000000000962533

REMOVAL

CAUTION:

Disconnect the battery negative terminal or the fuse.

1. Remove front bumper fascia. Refer to [EXT-10, "Exploded View"](#).
2. Remove the headlamp mounting bolts.
3. Remove the pawl (A) and the harness clip (B).
4. Pull out the headlamp assembly forward the vehicle.
5. Disconnect the connector before removing the headlamp assembly.

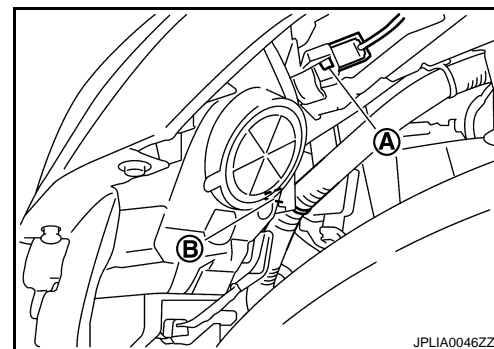

INSTALLATION

Install in the reverse order of removal.

NOTE:

After installation, perform aiming adjustment. Refer to [EXL-186, "Adjustment"](#).

Replacement

INFOID:000000000962534

CAUTION:

- **Disconnect the battery negative terminal or the fuse.**
- **After installing the bulb, install the resin cap and the bulb socket securely for watertightness.**

HEADLAMP BULB

1. Remove the fender protector. Keep a service area.

FRONT COMBINATION LAMP

[XENON TYPE]

< ON-VEHICLE REPAIR >

2. Rotate the resin cap counterclockwise and unlock it.
3. Rotate the bulb socket counterclockwise and unlock it.
4. Remove the retaining spring lock. Remove the bulb from the headlamp.

CAUTION:

Never break the xenon bulb ceramic tube when replacing the bulb.

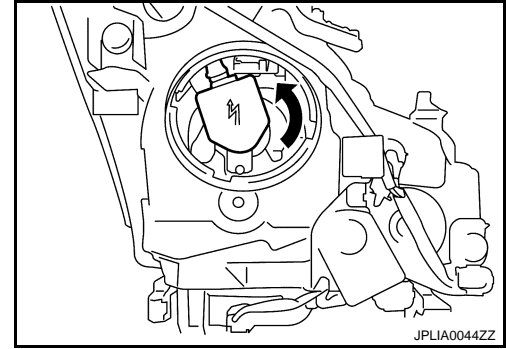

PARKING LAMP BULB

1. Remove the fender protector. Keep a service area.
2. Rotate the bulb socket counterclockwise and unlock it.
3. Remove the bulb from the bulb socket.

FRONT TURN SIGNAL LAMP BULB

1. Remove the air cleaner case.
2. Rotate the bulb socket counterclockwise and unlock it.
3. Remove the bulb from the bulb socket.

FRONT FOG LAMP BULB

1. Remove the air cleaner case.
2. Remove the front fog lamp bulb connector.
3. Rotate the bulb socket counterclockwise and unlock it.

Disassembly and Assembly

INFOID:000000000962535

DISASSEMBLY

1. Rotate the resin cap counterclockwise and unlock it.
2. Rotate the xenon bulb socket counterclockwise and unlock it.
3. Remove the retaining spring lock. Remove the xenon bulb.
4. Remove the HID control unit installation screw.
5. Remove the screw. Disconnect the connector from HID control unit.
6. Pull out the xenon bulb socket from the headlamp housing assembly.
7. Rotate the parking lamp bulb socket counterclockwise and unlock it.
8. Remove the bulb from the parking lamp bulb socket.
9. Rotate the front turn signal lamp bulb socket counterclockwise and unlock it.
10. Remove the bulb from the front turn signal lamp bulb socket.
11. Rotate the front fog lamp bulb socket counterclockwise. Remove the bulb.

ASSEMBLY

Assemble in the reverse order of disassembly.

CAUTION:

- Install HID control unit securely.
- After installing the bulb, install the resin cap and the bulb socket securely for watertightness.

Adjustment

INFOID:000000000962536

PREPARATION BEFORE ADJUSTING

NOTE:

- For details, refer to the regulations in your own country.
- Perform aiming if the vehicle front body has been repaired and/or the headlamp assembly has been replaced.

FRONT COMBINATION LAMP

< ON-VEHICLE REPAIR >

[XENON TYPE]

Before performing aiming adjustment, check the following.

- Adjust the tire pressure to the specification.
- Fill with gasoline, engine coolant and each oil.
- Maintain the unloaded vehicle condition. (Remove luggage from the passenger compartment and the trunk room.)

NOTE:

Do not remove the temporary tire, jack and on-vehicle tool.

- Wipe out dirt on the headlamp.

CAUTION:

Never use organic solvent (thinner, gasoline etc.)

- Ride alone on the driver seat.

AIMING ADJUSTMENT SCREW

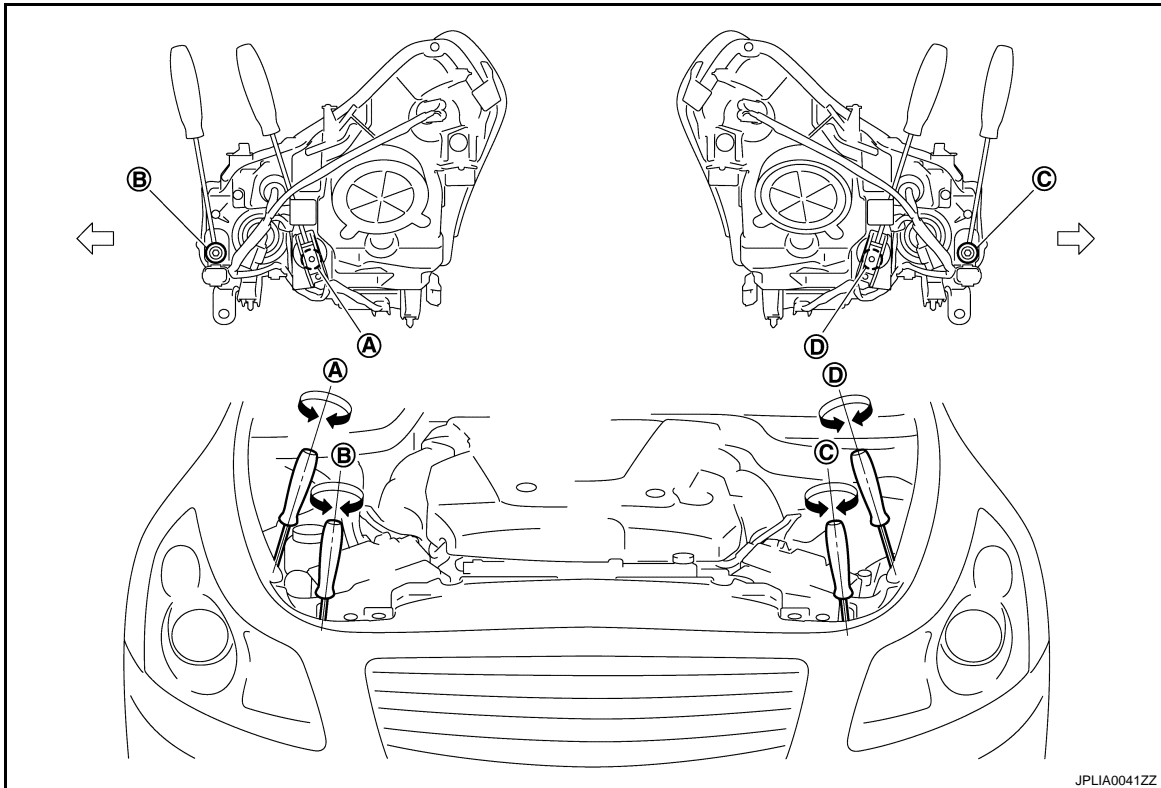

- A Headlamp (RH) adjustment screw
- B Front fog lamp (RH) adjustment screw
- C Front fog lamp (LH) adjustment screw
- D Headlamp (LH) adjustment screw

↔: Vehicle center

NOTE:

The figure is the vehicle without AFS. Each adjustment screw is applied to the vehicle with AFS.

Adjustment screw	Screw driver rotation	Facing direction
A Headlamp (RH)	Clockwise	UP
	Counterclockwise	DOWN
B Front fog lamp (RH)	Clockwise	UP
	Counterclockwise	DOWN
C Front fog lamp (LH)	Clockwise	UP
	Counterclockwise	DOWN
D Headlamp (LH)	Clockwise	UP
	Counterclockwise	DOWN

A
B
C
D
E
F
G
H
I
J
K

EXL

M
N

O
P

FRONT COMBINATION LAMP

< ON-VEHICLE REPAIR >

[XENON TYPE]

AIMING ADJUSTMENT PROCEDURE (HEADLAMP)

- Place the screen.
 - NOTE:**
 - Stop the vehicle facing the wall.
 - Place the board on a plain road vertically.
- Face the vehicle with the screen. Maintain 10 m (32.8 ft) between the headlamp center and the screen.
- Start the engine. Turn the headlamp (LO) ON.
 - NOTE:** Shut off the headlamp light with the board to prevent from illuminating the adjustment screen.
 - CAUTION:** **Never cover the lens surface with a tape etc. The lens is made of resin.**
- Measure the distance (X) between the horizontal center line of headlamp (H) and the cutoff line (A) within the light axis measurement range (R) from the vertical center line ahead of headlamp (V).

Light axis measurement range (R) : 350 ± 175 mm (13.78 ± 6.89 in)

Low beam distribution on the screen

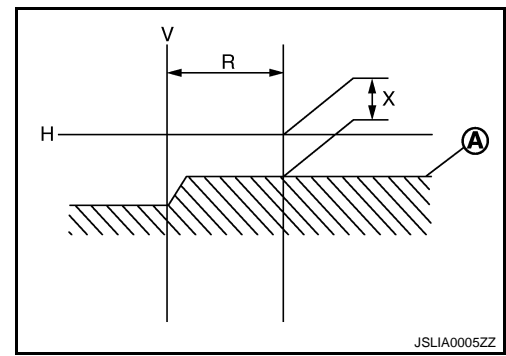

- Adjust the cutoff line height (X) with the aiming adjustment screw so as to enter in the adjustment range (M–N) according to the horizontal center line of headlamp (H).

unit: mm (in)

Horizontal center line of headlamp (H)	Highest cutoff line height (M)	Lowest cutoff line height (N)
700 (27.56) or less	4 (0.16)	30 (1.18)
701(27.60) – 800 (31.50)	4 (0.16)	30 (1.18)
801 (31.54) or more	17 (0.67)	44 (1.73)

Side view

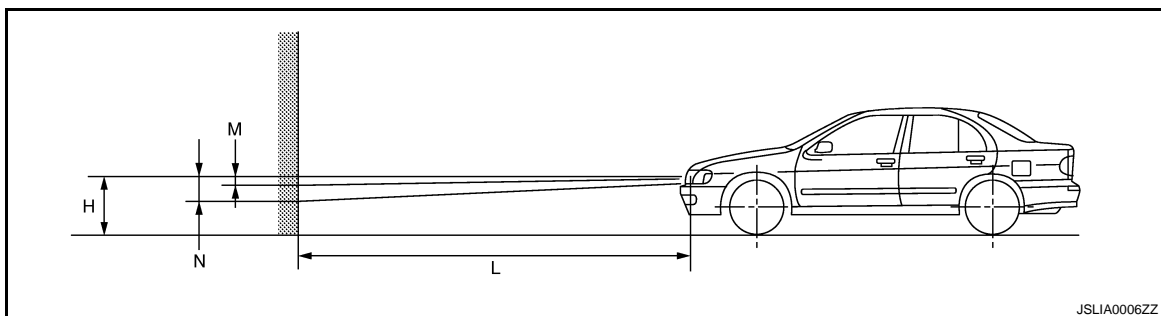

Distance between the headlamp center and the screen (L) : 10 m (32.81 ft)

AIMING ADJUSTMENT PROCEDURE (FRONT FOG LAMP)

- Place the screen.
 - NOTE:**
 - Stop the vehicle facing the wall.
 - Place the board on a plain road vertically.

FRONT COMBINATION LAMP

[XENON TYPE]

< ON-VEHICLE REPAIR >

2. Face the vehicle with the screen. Maintain 10 m (32.8 ft) between the front fog lamp center and the screen.
3. Start the engine. Turn the front fog lamp ON.
NOTE:
Shut off the headlamp light with the board to prevent from illuminating the adjustment screen.
CAUTION:
Never cover the lens surface with a tape etc. The lens is made of resin.
4. Adjust the cutoff line height (A) with the aiming adjustment screw so that the distance (X) between the horizontal center line of front fog lamp (H) and (A) becomes 200 mm (7.87 in).

Front fog lamp light distribution on the screen

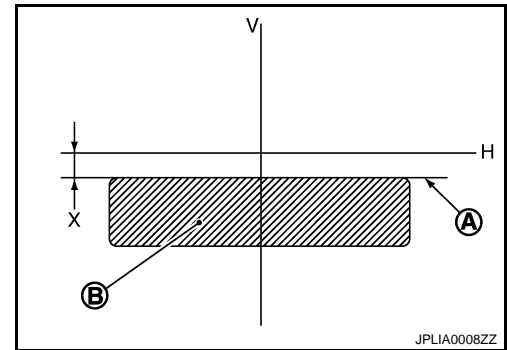

- A : Cutoff line
- B : High illuminance area
- H : Horizontal center line of front fog lamp
- V : Vertical center line of front fog lamp
- X : Cutoff line height

A
B
C
D
E
F
G
H
I
J
K
L
M
N
O
P

EXL

FRONT FOG LAMP

< ON-VEHICLE REPAIR >

[XENON TYPE]

FRONT FOG LAMP

Exploded View

INFOID:000000000962537

The front fog lamp is integrated in the front combination lamp. Refer to [EXL-184. "Exploded View"](#).

Adjustment

INFOID:000000000962538

The front fog lamp is integrated in the front combination lamp. Refer to [EXL-186. "Adjustment"](#).

OPTICAL SENSOR

Exploded View

INFOID:000000000962539

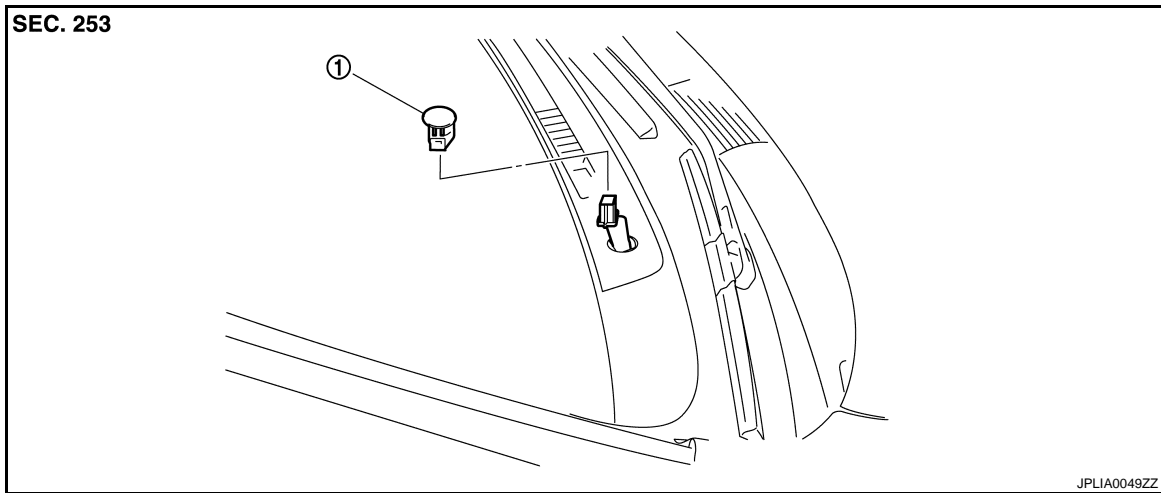

1. Optical sensor

Removal and Installation

INFOID:000000000962540

REMOVAL

1. Insert an appropriate tool between the optical sensor and the instrument upper panel. Pull out the optical sensor upward.
2. Disconnect the connector. Remove the optical sensor.

INSTALLATION

Install in the reverse order of removal.

A
B
C
D
E
F
G
H
I
J
K
L
M
N
O
P

EXL

LIGHTING AND TURN SIGNAL SWITCH

< ON-VEHICLE REPAIR >

[XENON TYPE]

LIGHTING AND TURN SIGNAL SWITCH

Exploded View

INFOID:000000000962541

Lighting and turn signal switch is integrated in the combination switch. [BCS-80. "Exploded View"](#).

HAZARD SWITCH

< ON-VEHICLE REPAIR >

[XENON TYPE]

HAZARD SWITCH

Exploded View

INFOID:000000000962542

The hazard warning switch is integrated in the multifunction switch. Refer to [AV-119. "Exploded View"](#).

A

B

C

D

E

F

G

H

I

J

K

EXL

M

N

O

P

AFS CONTROL UNIT

Exploded View

INFOID:000000000962543

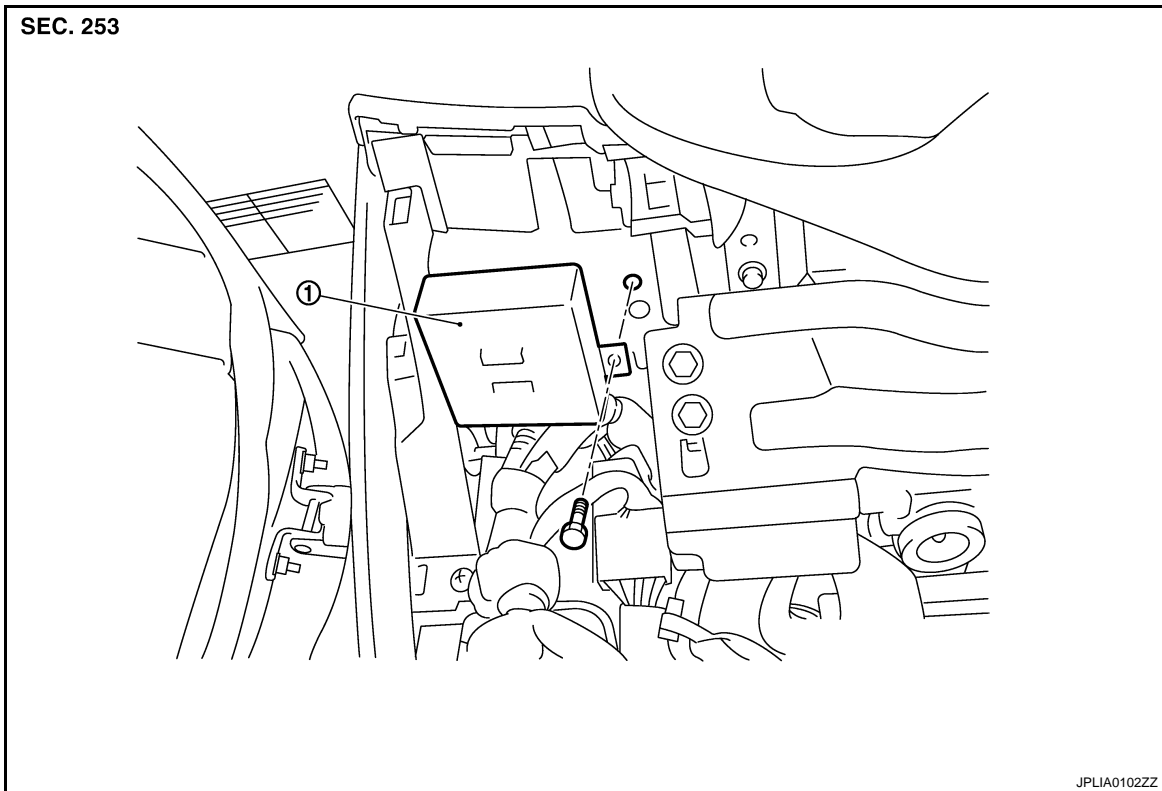

1. AFS control unit

Removal and Installation

INFOID:000000000962544

REMOVAL

1. Remove the instrument driver lower panel. Refer to [IP-11, "Exploded View"](#).
2. Remove the instrument finisher A. Refer to [IP-11, "Exploded View"](#).
3. Remove AFS control unit mounting bolt.
4. Disconnect AFS control unit connector.
5. Remove AFS control unit.

INSTALLATION

Install in the reverse order of removal.

STEERING ANGLE SENSOR

< ON-VEHICLE REPAIR >

[XENON TYPE]

STEERING ANGLE SENSOR

Removal and Installation

INFOID:000000000962545

Refer to [SR-7, "Removal and Installation"](#).

A

B

C

D

E

F

G

H

I

J

K

EXL

M

N

O

P

AFS SWITCH

Exploded View

INFOID:000000000962546

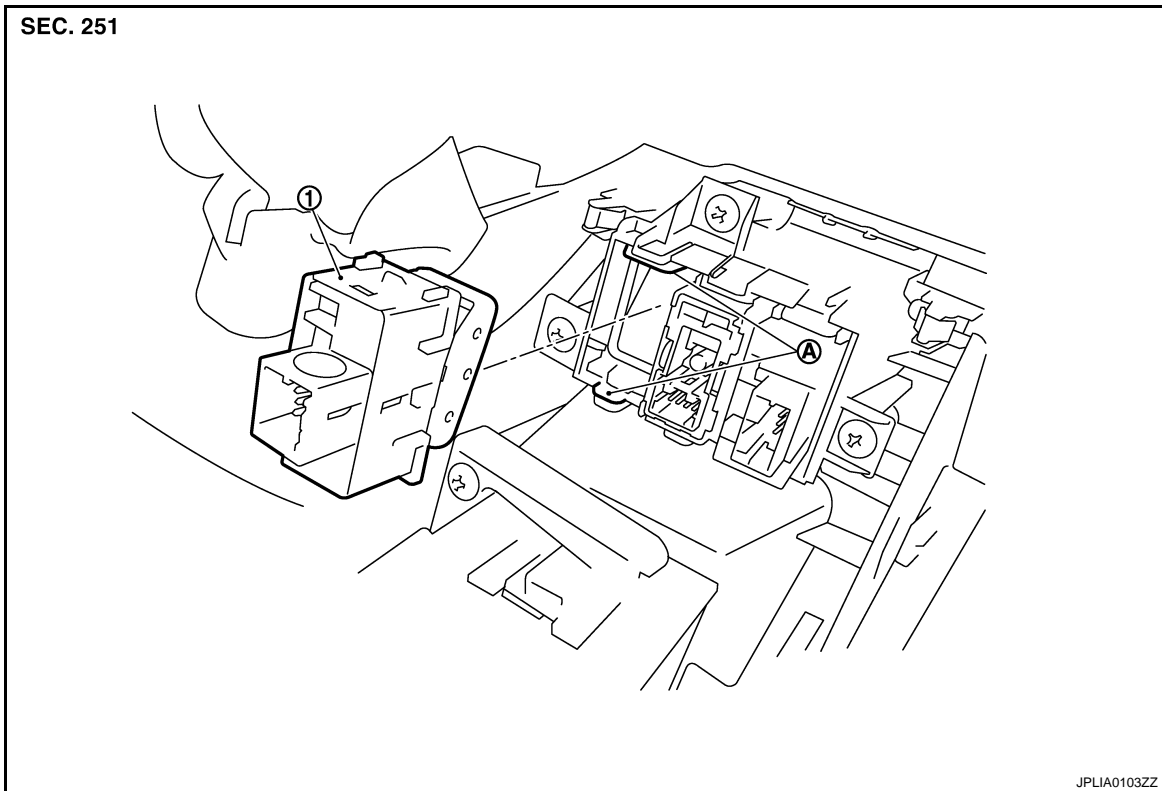

- 1. AFS switch
- A Pawls

Removal and Installation

INFOID:000000000962547

REMOVAL

1. Remove the instrument driver lower panel. Refer to [IP-11. "Exploded View"](#).
2. Widen the pawl. And then remove AFS switch.

INSTALLATION

Install in the reverse order of removal.

HEIGHT SENSOR

< ON-VEHICLE REPAIR >

[XENON TYPE]

HEIGHT SENSOR

Exploded View

INFOID:000000000962548

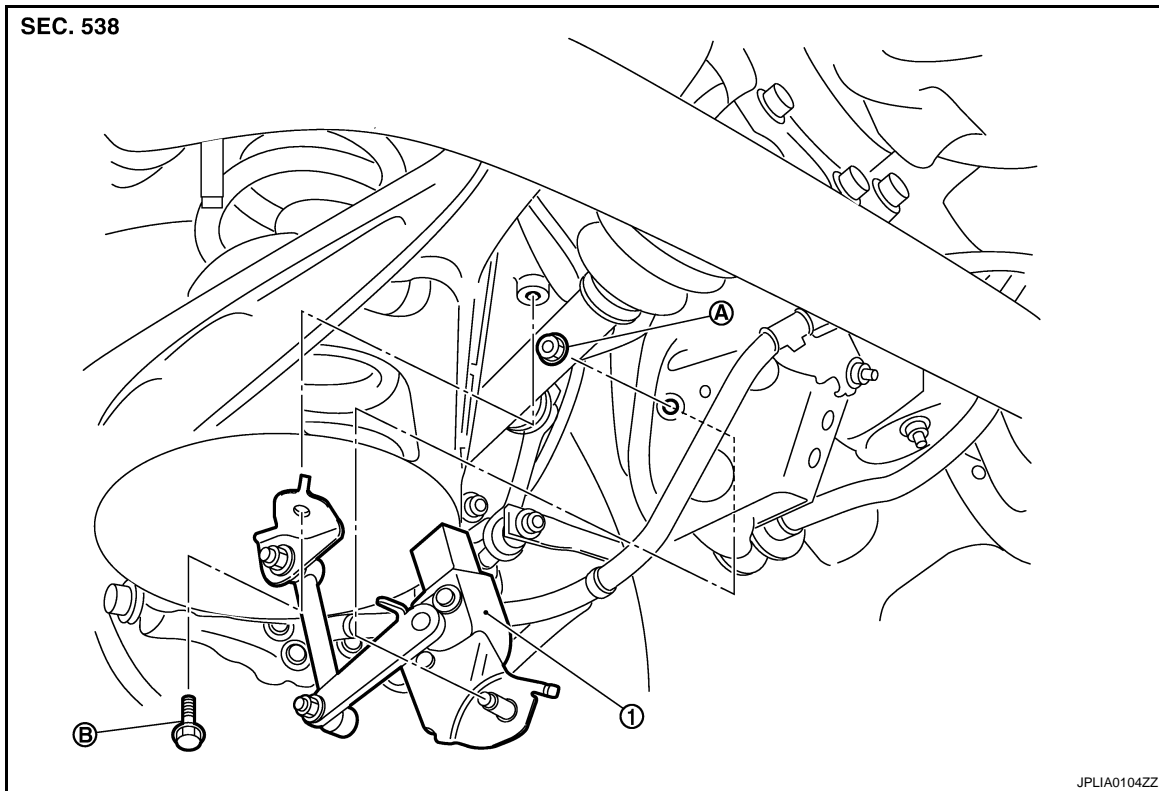

- 1. Height sensor
- A Height sensor mounting nut
- B. Height sensor lever link bracket mounting bolt

Removal and Installation

INFOID:000000000962549

REMOVAL

1. Remove the height sensor mounting nut.
2. Remove the height sensor lever link bracket mounting bolt.
3. Disconnect the height sensor connector.
4. Disconnect the height sensor.

INSTALLATION

Install in the reverse order of removal.

CAUTION:

Perform the levelizer adjustment when removing the height sensor. Refer to [EXL-8. "LEVELIZER ADJUSTMENT : Special Repair Requirement"](#).

REAR COMBINATION LAMP

< ON-VEHICLE REPAIR >

[XENON TYPE]

REAR COMBINATION LAMP

Exploded View

INFOID:000000000962550

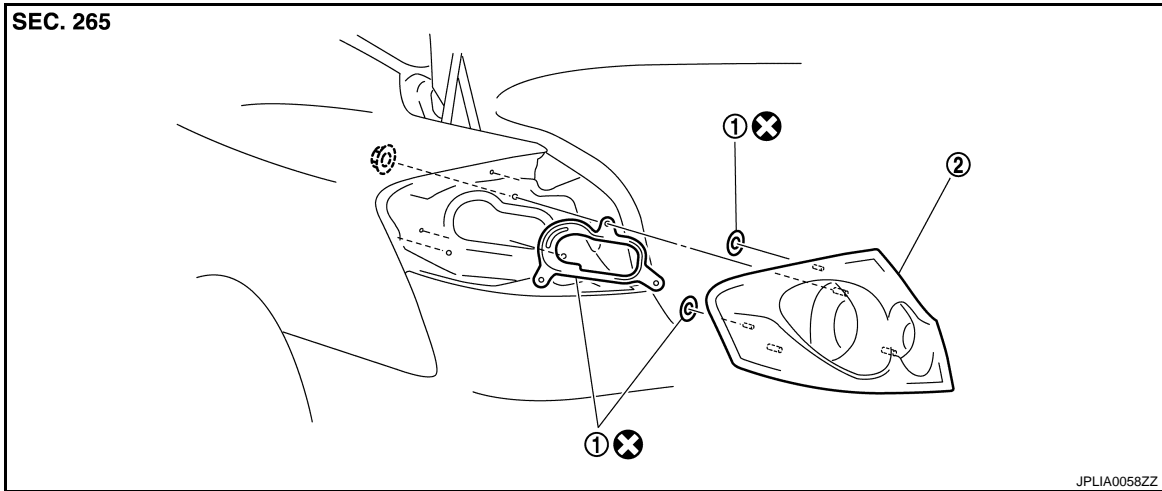

1. Seal packing
2. Rear combination lamp

Refer to [GI-3, "Contents"](#) for symbols in the figure.

Removal and Installation

INFOID:000000000962551

CAUTION:

Disconnect the battery negative terminal or the fuse.

REMOVAL

1. Remove trunk side finisher. Refer to [INT-26, "Exploded View"](#).
2. Disconnect rear combination lamp connector.
3. Remove rear combination lamp mounting nuts.
4. Pull the rear combination lamp toward rear of the vehicle. Remove the rear combination lamp.

INSTALLATION

Install in the reverse order of removal.

Replacement

INFOID:000000000962552

REAR TURN SIGNAL LAMP BULB

CAUTION:

Disconnect the battery negative terminal or the fuse.

1. Remove trunk side finisher. Refer to [INT-26, "Exploded View"](#).
2. Turn the rear turn signal lamp bulb socket (1) counterclockwise and unlock it.
3. Remove the bulb (2) from the socket.

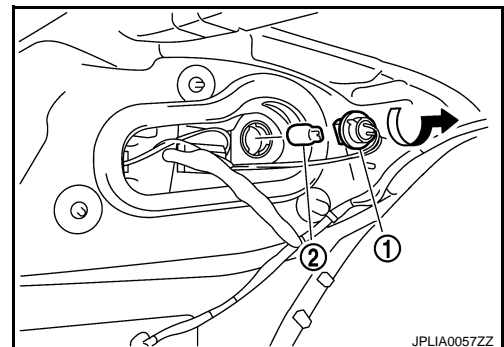

HIGH-MOUNTED STOP LAMP

< ON-VEHICLE REPAIR >

[XENON TYPE]

HIGH-MOUNTED STOP LAMP WITHOUT REAR SPOILER

WITHOUT REAR SPOILER : Exploded View

INFOID:000000000962553

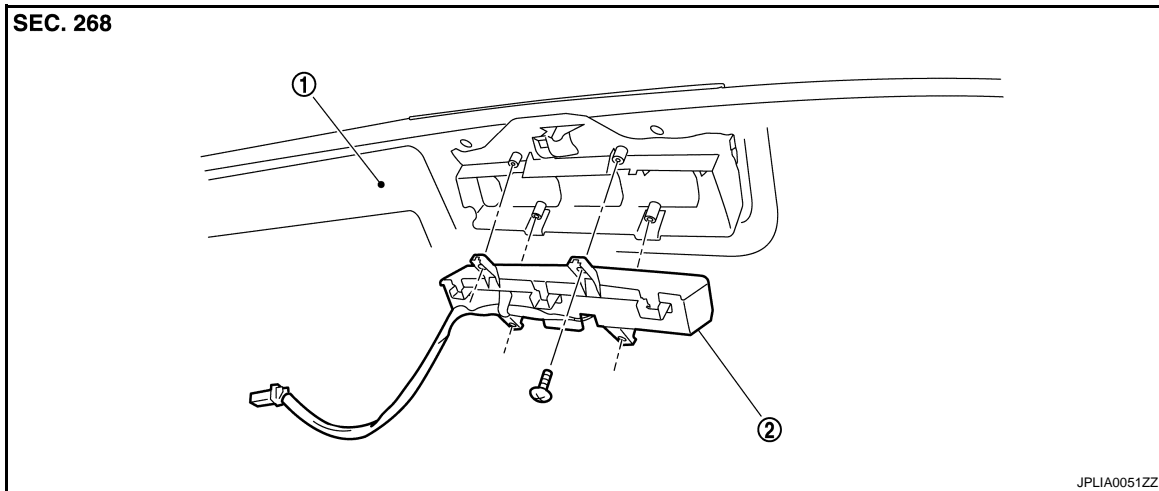

1. Rear parcel shelf finisher
2. High-mounted stop lamp

WITHOUT REAR SPOILER : Removal and Installation

INFOID:000000000962554

REMOVAL

1. Remove rear parcel shelf finisher. Refer to [INT-18, "Exploded View"](#).
2. Remove screws and remove high-mounted stop lamp from rear parcel shelf finisher.

INSTALLATION

Install in the reverse order of removal.

WITH REAR SPOILER

WITH REAR SPOILER : Exploded View

INFOID:000000000962555

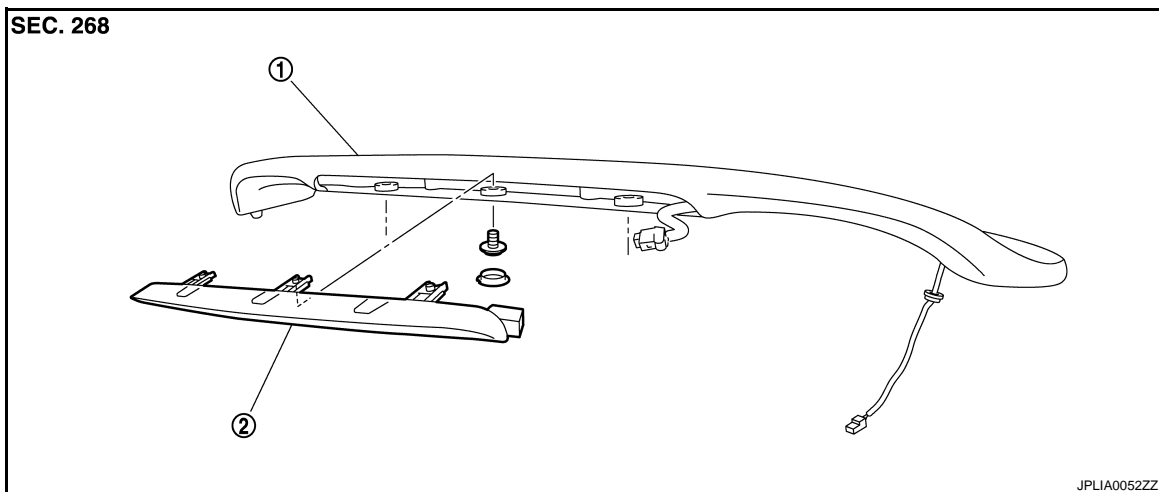

1. Rear spoiler
2. High-mounted stop lamp

WITH REAR SPOILER : Removal and Installation

INFOID:000000000962556

REMOVAL

A
B
C
D
E
F
G
H
I
J
K
EXL
M
N
O
P

HIGH-MOUNTED STOP LAMP

[XENON TYPE]

< ON-VEHICLE REPAIR >

1. Remove rear spoiler. Refer to [EXT-37. "Exploded View"](#).
2. Remove the cap. Remove the high-mounted stop lamp mounting screw.
3. Remove the high-mounted stop lamp from rear spoiler. And then disconnect the connector.

INSTALLATION

Install in the reverse order of removal.

BACK-UP LAMP

< ON-VEHICLE REPAIR >

[XENON TYPE]

BACK-UP LAMP

Exploded View

INFOID:000000000962557

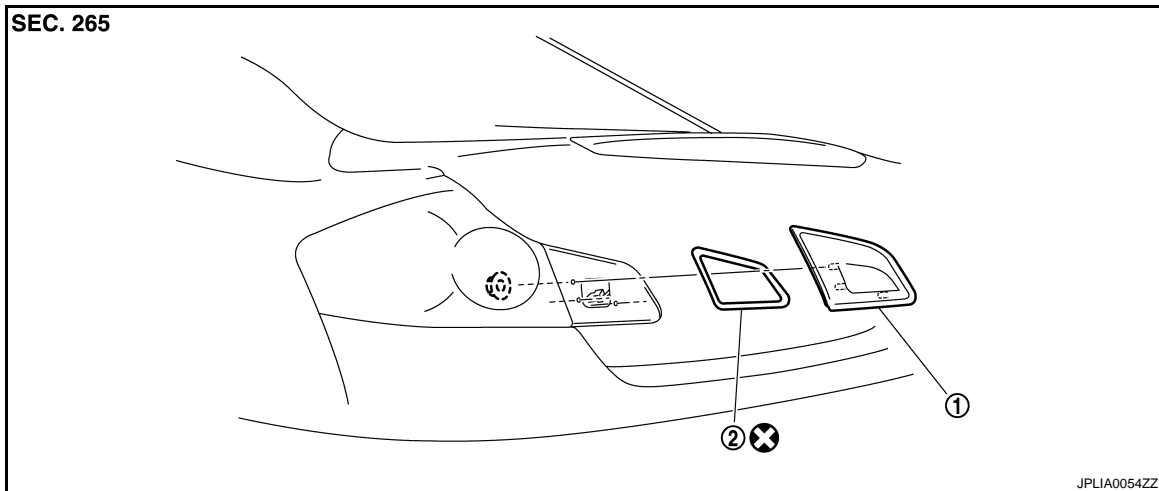

1. Back-up lamp
2. Seal packing

Refer to GI-XX for symbols in the figure.

Removal and Installation

INFOID:000000000962558

CAUTION:

Disconnect the battery negative terminal or the fuse.

REMOVAL

1. Remove trunk lid finisher inner. Refer to [EXT-35, "Exploded View"](#).
2. Disconnect back-up lamp connector.
3. Remove back-up lamp mounting nuts. And then remove back-up lamp.

INSTALLATION

Install in the reverse order of removal.

CAUTION:

Seal packing cannot be reused.

Replacement

INFOID:000000000962559

CAUTION:

Disconnect the battery negative terminal or the fuse.

BACK-UP LAMP BULB

1. Remove trunk lid finisher inner. Refer to [EXT-35, "Exploded View"](#).
2. Disconnect the back-up lamp connector.
3. Turn the bulb socket (1) counterclockwise and unlock it.
4. Remove the bulb (2) from the socket.

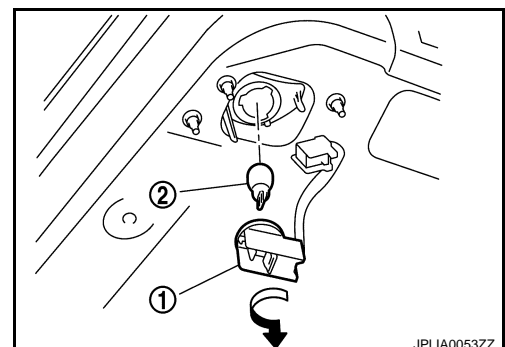

LICENSE PLATE LAMP

< ON-VEHICLE REPAIR >

[XENON TYPE]

LICENSE PLATE LAMP

Exploded View

INFOID:000000000962560

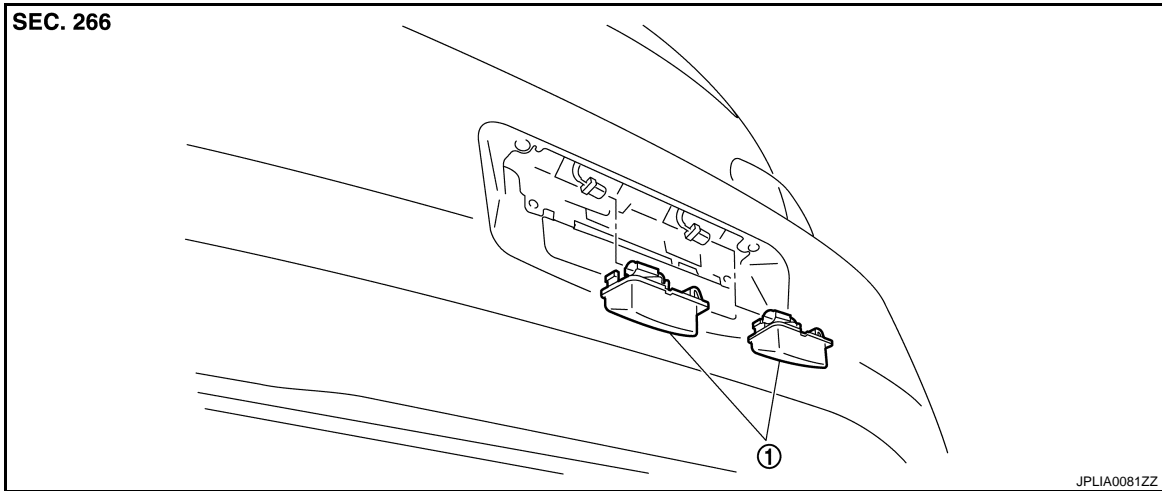

1. License plate lamp

Removal and Installation

INFOID:000000000962561

CAUTION:

Disconnect the battery negative terminal or the fuse.

REMOVAL

1. Remove the license plate lamp in numerical order.
2. Disconnect the connector.
3. Remove license plate lamp.

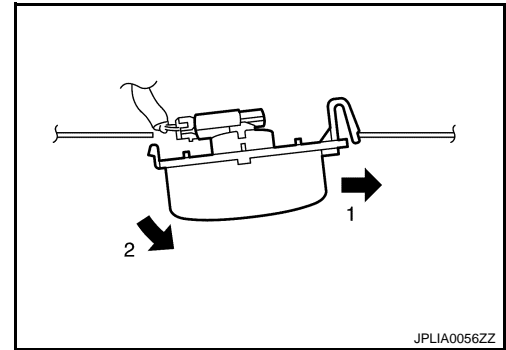

INSTALLATION

1. Connect the connector.
2. Fix the pawl side. And then push the resin clip side.

Replacement

INFOID:000000000962562

CAUTION:

Disconnect the battery negative terminal or the fuse.

LICENSE PLATE LAMP BULB

1. Remove license plate lamp.

LICENSE PLATE LAMP

< ON-VEHICLE REPAIR >

[XENON TYPE]

2. Turn the bulb socket (1) counterclockwise and unlock it.
3. Remove the bulb (2) from the socket.

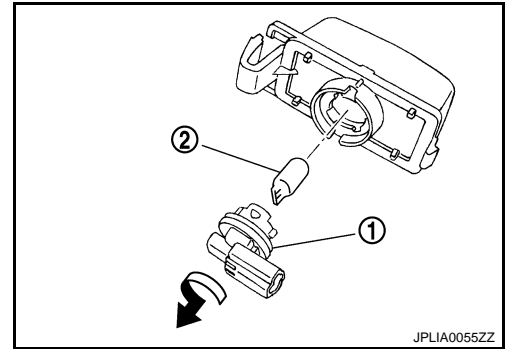

A
B
C
D
E
F
G
H
I
J
K
EXL
M
N
O
P

SERVICE DATA AND SPECIFICATIONS (SDS)

< SERVICE DATA AND SPECIFICATIONS (SDS)

[XENON TYPE]

SERVICE DATA AND SPECIFICATIONS (SDS)

SERVICE DATA AND SPECIFICATIONS (SDS)

Bulb Specifications

INFOID:000000000962563

Item	Type	Wattage (W)	
Front combination lamp	Headlamp (HI/LO)	D2S (XENON)	35
	Front turn signal lamp	WY21W (Amber)	21
	Parking lamp (With front side marker lamp)	WY5W (Amber)	5
	Front fog lamp	HB4	51
Rear combination lamp	Stop lamp/Tail lamp	LED	—
	Rear turn signal lamp	W21W	21
	Rear side marker lamp	LED	—
Back-up lamp	W16W	18	
License plate lamp	W5W	5	
High-mounted stop lamp	LED	—	