

# SECTION **ADP**

## AUTOMATIC DRIVE POSITIONER

A  
B  
C  
D  
E  
F  
G  
H  
I  
ADP  
K  
L  
M  
N  
O  
P

### CONTENTS

<p><b>BASIC INSPECTION</b> ..... 5</p> <p><b>DIAGNOSIS AND REPAIR WORKFLOW</b> ..... 5</p> <p style="padding-left: 20px;">Work Flow .....5</p> <p><b>INSPECTION AND ADJUSTMENT</b> ..... 8</p> <p><b>ADDITIONAL SERVICE WHEN REMOVING BATTERY NEGATIVE TERMINAL</b> .....8</p> <p style="padding-left: 20px;">ADDITIONAL SERVICE WHEN REMOVING BATTERY NEGATIVE TERMINAL : Description .....8</p> <p style="padding-left: 20px;">ADDITIONAL SERVICE WHEN REMOVING BATTERY NEGATIVE TERMINAL : Special Repair Requirement .....8</p> <p><b>ADDITIONAL SERVICE WHEN REPLACING CONTROL UNIT</b> .....8</p> <p style="padding-left: 20px;">ADDITIONAL SERVICE WHEN REPLACING CONTROL UNIT : Description .....8</p> <p style="padding-left: 20px;">ADDITIONAL SERVICE WHEN REPLACING CONTROL UNIT : Special Repair Requirement .....9</p> <p><b>SYSTEM INITIALIZATION</b> .....9</p> <p style="padding-left: 20px;">SYSTEM INITIALIZATION : Description .....9</p> <p style="padding-left: 20px;">SYSTEM INITIALIZATION : Special Repair Requirement .....9</p> <p><b>MEMORY STORING</b> .....9</p> <p style="padding-left: 20px;">MEMORY STORING : Description .....10</p> <p style="padding-left: 20px;">MEMORY STORING : Special Repair Requirement .....10</p> <p><b>SYSTEM SETTING</b> .....11</p> <p style="padding-left: 20px;">SYSTEM SETTING : Description .....11</p> <p style="padding-left: 20px;">SYSTEM SETTING : Special Repair Requirement .....11</p> <p><b>FUNCTION DIAGNOSIS</b> .....13</p> <p><b>AUTOMATIC DRIVE POSITIONER SYSTEM</b>.....13</p> <p><b>AUTOMATIC DRIVE POSITIONER SYSTEM</b> .....13</p>	<p><b>AUTOMATIC DRIVE POSITIONER SYSTEM :</b></p> <p style="padding-left: 20px;">System Diagram .....13</p> <p><b>AUTOMATIC DRIVE POSITIONER SYSTEM :</b></p> <p style="padding-left: 20px;">Component Parts Location .....14</p> <p><b>AUTOMATIC DRIVE POSITIONER SYSTEM :</b></p> <p style="padding-left: 20px;">System Description .....15</p> <p><b>AUTOMATIC DRIVE POSITIONER SYSTEM :</b></p> <p style="padding-left: 20px;">Component Description .....16</p> <p><b>MANUAL FUNCTION</b> .....17</p> <p style="padding-left: 20px;">MANUAL FUNCTION : System Diagram .....18</p> <p style="padding-left: 20px;">MANUAL FUNCTION : System Description .....18</p> <p style="padding-left: 20px;">MANUAL FUNCTION : Component Parts Location .....20</p> <p style="padding-left: 20px;">MANUAL FUNCTION : Component Description .....21</p> <p><b>SEAT SYNCHRONIZATION FUNCTION</b> .....22</p> <p style="padding-left: 20px;">SEAT SYNCHRONIZATION FUNCTION : System Diagram .....23</p> <p style="padding-left: 20px;">SEAT SYNCHRONIZATION FUNCTION : System Description .....23</p> <p style="padding-left: 20px;">SEAT SYNCHRONIZATION FUNCTION : Component Parts Location .....25</p> <p style="padding-left: 20px;">SEAT SYNCHRONIZATION FUNCTION : Component Description .....26</p> <p><b>MEMORY FUNCTION</b> .....27</p> <p style="padding-left: 20px;">MEMORY FUNCTION : System Diagram .....28</p> <p style="padding-left: 20px;">MEMORY FUNCTION : System Description .....28</p> <p style="padding-left: 20px;">MEMORY FUNCTION : Component Parts Location .....30</p> <p style="padding-left: 20px;">MEMORY FUNCTION : Component Description.....31</p> <p><b>EXIT ASSIST FUNCTION</b> .....32</p> <p style="padding-left: 20px;">EXIT ASSIST FUNCTION : System Diagram .....33</p> <p style="padding-left: 20px;">EXIT ASSIST FUNCTION : System Description .....33</p> <p style="padding-left: 20px;">EXIT ASSIST FUNCTION : Component Parts Location .....34</p> <p style="padding-left: 20px;">EXIT ASSIST FUNCTION :</p> <p style="padding-left: 40px;">Component Description .....36</p> <p><b>ENTRY ASSIST FUNCTION</b> .....36</p>
---	---

ENTRY ASSIST FUNCTION : System Diagram ....	37	<b>B2127 PARKING BRAKE SWITCH .....</b>	<b>62</b>
ENTRY ASSIST FUNCTION : System Description	... 37	Description .....	62
ENTRY ASSIST FUNCTION : Component Parts		DTC Logic .....	62
Location .....	38	Diagnosis Procedure .....	62
ENTRY ASSIST FUNCTION :		Component Inspection .....	63
Component Description .....	40	<b>B2128 UART COMMUNICATION LINE .....</b>	<b>64</b>
<b>INTELLIGENT KEY INTERLOCK FUNCTION .....</b>	<b>40</b>	Description .....	64
INTELLIGENT KEY INTERLOCK FUNCTION :		DTC Logic .....	64
System Diagram .....	41	Diagnosis Procedure .....	64
INTELLIGENT KEY INTERLOCK FUNCTION :		<b>POWER SUPPLY AND GROUND CIRCUIT ....</b>	<b>66</b>
System Description .....	41	<b>BCM .....</b>	<b>66</b>
INTELLIGENT KEY INTERLOCK FUNCTION :		BCM : Diagnosis Procedure .....	66
Component Parts Location .....	42	BCM : Special Repair Requirement .....	66
INTELLIGENT KEY INTERLOCK FUNCTION :		<b>DRIVER SEAT CONTROL UNIT .....</b>	<b>66</b>
Component Description .....	44	DRIVER SEAT CONTROL UNIT :	
<b>SIDE SUPPORT SYSTEM .....</b>	<b>44</b>	Diagnosis Procedure .....	66
SIDE SUPPORT SYSTEM : System Description ...	44	DRIVER SEAT CONTROL UNIT : Special Repair	
SIDE SUPPORT SYSTEM : Component Parts Lo-		Requirement .....	67
cation .....	45	<b>AUTOMATIC DRIVE POSITIONER CONTROL</b>	
SIDE SUPPORT SYSTEM :		<b>UNIT .....</b>	<b>67</b>
Component Description .....	46	AUTOMATIC DRIVE POSITIONER CONTROL	
<b>DIAGNOSIS SYSTEM (DRIVER SEAT C/U) ....</b>	<b>48</b>	UNIT : Diagnosis Procedure .....	67
Diagnosis Description .....	48	AUTOMATIC DRIVE POSITIONER CONTROL	
CONSULT-III Function .....	48	UNIT : Special Repair Requirement .....	68
<b>COMPONENT DIAGNOSIS .....</b>	<b>51</b>	<b>SIDE SUPPORT UNIT .....</b>	<b>68</b>
<b>U1000 CAN COMM CIRCUIT .....</b>	<b>51</b>	SIDE SUPPORT UNIT : Diagnosis Procedure .....	68
Description .....	51	<b>SLIDING SWITCH .....</b>	<b>70</b>
DTC Logic .....	51	Description .....	70
Diagnosis Procedure .....	51	Component Function Check .....	70
Special Repair Requirement .....	51	Diagnosis Procedure .....	70
<b>B2112 SLIDING MOTOR .....</b>	<b>52</b>	Component Inspection .....	71
Description .....	52	<b>RECLINING SWITCH .....</b>	<b>72</b>
DTC Logic .....	52	Description .....	72
Diagnosis Procedure .....	52	Component Function Check .....	72
<b>B2113 RECLINING MOTOR .....</b>	<b>53</b>	Diagnosis Procedure .....	72
Description .....	53	Component Inspection .....	73
DTC Logic .....	53	<b>LIFTING SWITCH (FRONT) .....</b>	<b>74</b>
Diagnosis Procedure .....	53	Description .....	74
<b>B2118 TILT SENSOR .....</b>	<b>54</b>	Component Function Check .....	74
Description .....	54	Diagnosis Procedure .....	74
DTC Logic .....	54	Component Inspection .....	75
Diagnosis Procedure .....	54	<b>LIFTING SWITCH (REAR) .....</b>	<b>76</b>
<b>B2119 TELESCOPIC SENSOR .....</b>	<b>57</b>	Description .....	76
Description .....	57	Component Function Check .....	76
DTC Logic .....	57	Diagnosis Procedure .....	76
Diagnosis Procedure .....	57	Component Inspection .....	77
<b>B2126 DETENT SW .....</b>	<b>60</b>	<b>TILT SWITCH .....</b>	<b>78</b>
Description .....	60	Description .....	78
DTC Logic .....	60	Component Function Check .....	78
Diagnosis Procedure .....	60	Diagnosis Procedure .....	78
		Component Inspection .....	79

<b>TELESCOPIC SWITCH</b> .....	<b>80</b>	Description .....	102	
Description .....	80	Component Function Check .....	102	A
Component Function Check .....	80	Diagnosis Procedure .....	102	
Diagnosis Procedure .....	80			
Component Inspection .....	81			
<b>SEAT MEMORY SWITCH</b> .....	<b>82</b>	<b>LIFTING SENSOR (FRONT)</b> .....	<b>105</b>	B
Description .....	82	Description .....	105	
Component Function Check .....	82	Component Function Check .....	105	
Diagnosis Procedure .....	82	Diagnosis Procedure .....	105	C
Component Inspection .....	83			
<b>DOOR MIRROR REMOTE CONTROL SWITCH</b> .....	<b>85</b>	<b>LIFTING SENSOR (REAR)</b> .....	<b>108</b>	D
<b>CHANGEOVER SWITCH</b> .....	<b>85</b>	Description .....	108	
CHANGEOVER SWITCH : Description .....	85	Component Function Check .....	108	
CHANGEOVER SWITCH : Component Function Check .....	85	Diagnosis Procedure .....	108	
CHANGEOVER SWITCH : Diagnosis Procedure .....	85			
CHANGEOVER SWITCH : Component Inspection .....	86	<b>TILT SENSOR</b> .....	<b>111</b>	E
<b>MIRROR SWITCH</b> .....	<b>87</b>	Description .....	111	
MIRROR SWITCH : Description .....	87	Component Function Check .....	111	
MIRROR SWITCH : Component Function Check .....	87	Diagnosis Procedure .....	111	
MIRROR SWITCH : Diagnosis Procedure .....	87	<b>TELESCOPIC SENSOR</b> .....	<b>114</b>	F
MIRROR SWITCH : Component Inspection .....	88	Description .....	114	
<b>POWER SEAT SWITCH GROUND CIRCUIT</b> .....	<b>90</b>	Component Function Check .....	114	
Diagnosis Procedure .....	90	Diagnosis Procedure .....	114	G
<b>SIDE SUPPORT SWITCH</b> .....	<b>91</b>	<b>MIRROR SENSOR</b> .....	<b>117</b>	
Description .....	91	<b>DRIVER SIDE</b> .....	<b>117</b>	H
Component Function Check .....	91	DRIVER SIDE : Description .....	117	
Diagnosis Procedure .....	91	DRIVER SIDE : Component Function Check .....	117	
Component Inspection .....	91	DRIVER SIDE : Diagnosis Procedure .....	117	I
<b>DETENTION SWITCH</b> .....	<b>93</b>	<b>PASSENGER SIDE</b> .....	<b>119</b>	
Description .....	93	PASSENGER SIDE : Description .....	119	
Component Function Check .....	93	PASSENGER SIDE :		
Diagnosis Procedure .....	93	Component Function Check .....	119	
Component Inspection .....	93	PASSENGER SIDE : Diagnosis Procedure .....	119	
<b>PARKING BRAKE SWITCH</b> .....	<b>95</b>	<b>SLIDING MOTOR</b> .....	<b>122</b>	K
Description .....	95	Description .....	122	
Component Function Check .....	95	Component Function Check .....	122	
Diagnosis Procedure .....	95	Diagnosis Procedure .....	122	L
Component Inspection .....	96	<b>RECLINING MOTOR</b> .....	<b>124</b>	
<b>FRONT DOOR SWITCH (DRIVER SIDE)</b> .....	<b>97</b>	Description .....	124	M
Description .....	97	Component Function Check .....	124	
Component Function Check .....	97	Diagnosis Procedure .....	124	
Diagnosis Procedure .....	97	<b>LIFTING MOTOR (FRONT)</b> .....	<b>126</b>	N
Component Inspection .....	98	Description .....	126	
<b>SLIDING SENSOR</b> .....	<b>99</b>	Component Function Check .....	126	
Description .....	99	Diagnosis Procedure .....	126	O
Component Function Check .....	99	<b>LIFTING MOTOR (REAR)</b> .....	<b>128</b>	
Diagnosis Procedure .....	99	Description .....	128	
<b>RECLINING SENSOR</b> .....	<b>102</b>	Component Function Check .....	128	
		Diagnosis Procedure .....	128	P
		<b>TILT MOTOR</b> .....	<b>130</b>	
		Description .....	130	
		Component Function Check .....	130	
		Diagnosis Procedure .....	130	

<b>TELESCOPIC MOTOR</b> .....	<b>132</b>	<b>ADP SYSTEM SYMPTOMS</b> .....	<b>211</b>
Description .....	132	Symptom Table .....	211
Component Function Check .....	132	<b>NORMAL OPERATING CONDITION</b> .....	<b>213</b>
Diagnosis Procedure .....	132	Description .....	213
<b>DOOR MIRROR MOTOR</b> .....	<b>134</b>	<b>PRECAUTION</b> .....	<b>214</b>
Description .....	134	<b>PRECAUTIONS</b> .....	<b>214</b>
Component Function Check .....	134	Precaution for Supplemental Restraint System (SRS) "AIR BAG" and "SEAT BELT PRE-TEN- SIONER" .....	214
Diagnosis Procedure .....	134	Service .....	214
Component Inspection .....	136	Work .....	214
<b>SIDE SUPPORT UNIT</b> .....	<b>137</b>	<b>ON-VEHICLE MAINTENANCE</b> .....	<b>215</b>
Description .....	137	<b>PRE-INSPECTION FOR DIAGNOSTIC</b> .....	<b>215</b>
Component Function Check .....	137	Basic Inspection .....	215
Diagnosis Procedure .....	137	<b>ON-VEHICLE REPAIR</b> .....	<b>217</b>
<b>SEAT MEMORY INDICATOR LAMP</b> .....	<b>138</b>	<b>DRIVER SEAT CONTROL UNIT</b> .....	<b>217</b>
Description .....	138	Exploded View .....	217
Component Function Check .....	138	Removal and Installation .....	217
Diagnosis Procedure .....	138	<b>AUTOMATIC DRIVE POSITIONER CON- TROL UNIT</b> .....	<b>218</b>
Component Inspection .....	139	Exploded View .....	218
<b>ECU DIAGNOSIS</b> .....	<b>140</b>	Removal and Installation .....	218
<b>DRIVER SEAT CONTROL UNIT</b> .....	<b>140</b>	<b>SEAT MEMORY SWITCH</b> .....	<b>219</b>
Reference Value .....	140	Exploded View .....	219
Wiring Diagram—AUTOMATIC DRIVE POSI- TIONER CONTROL SYSTEM— .....	145	Removal and Installation .....	219
Fail Safe .....	155	<b>POWER SEAT SWITCH</b> .....	<b>220</b>
DTC Index .....	156	Exploded View .....	220
<b>AUTOMATIC DRIVE POSITIONER CON- TROL UNIT</b> .....	<b>157</b>	Removal and Installation .....	220
Reference Value .....	157	<b>SIDE SUPPORT SWITCH</b> .....	<b>221</b>
Wiring Diagram—AUTOMATIC DRIVE POSI- TIONER CONTROL SYSTEM— .....	161	Exploded View .....	221
<b>BCM (BODY CONTROL MODULE)</b> .....	<b>172</b>	Removal and Installation .....	221
Reference Value .....	172	<b>TILT&amp;TELESCOPIC SWITCH</b> .....	<b>222</b>
Wiring Diagram—AUTOMATIC DRIVE POSI- TIONER CONTROL SYSTEM— .....	195	Exploded View .....	222
Fail Safe .....	205	Removal and Installation .....	222
DTC Inspection Priority Chart .....	207	<b>SYMPTOM DIAGNOSIS</b> .....	<b>211</b>
DTC Index .....	208		

# DIAGNOSIS AND REPAIR WORKFLOW

< BASIC INSPECTION >

## BASIC INSPECTION

### DIAGNOSIS AND REPAIR WORKFLOW

Work Flow

INFOID:000000000960576

OVERALL SEQUENCE

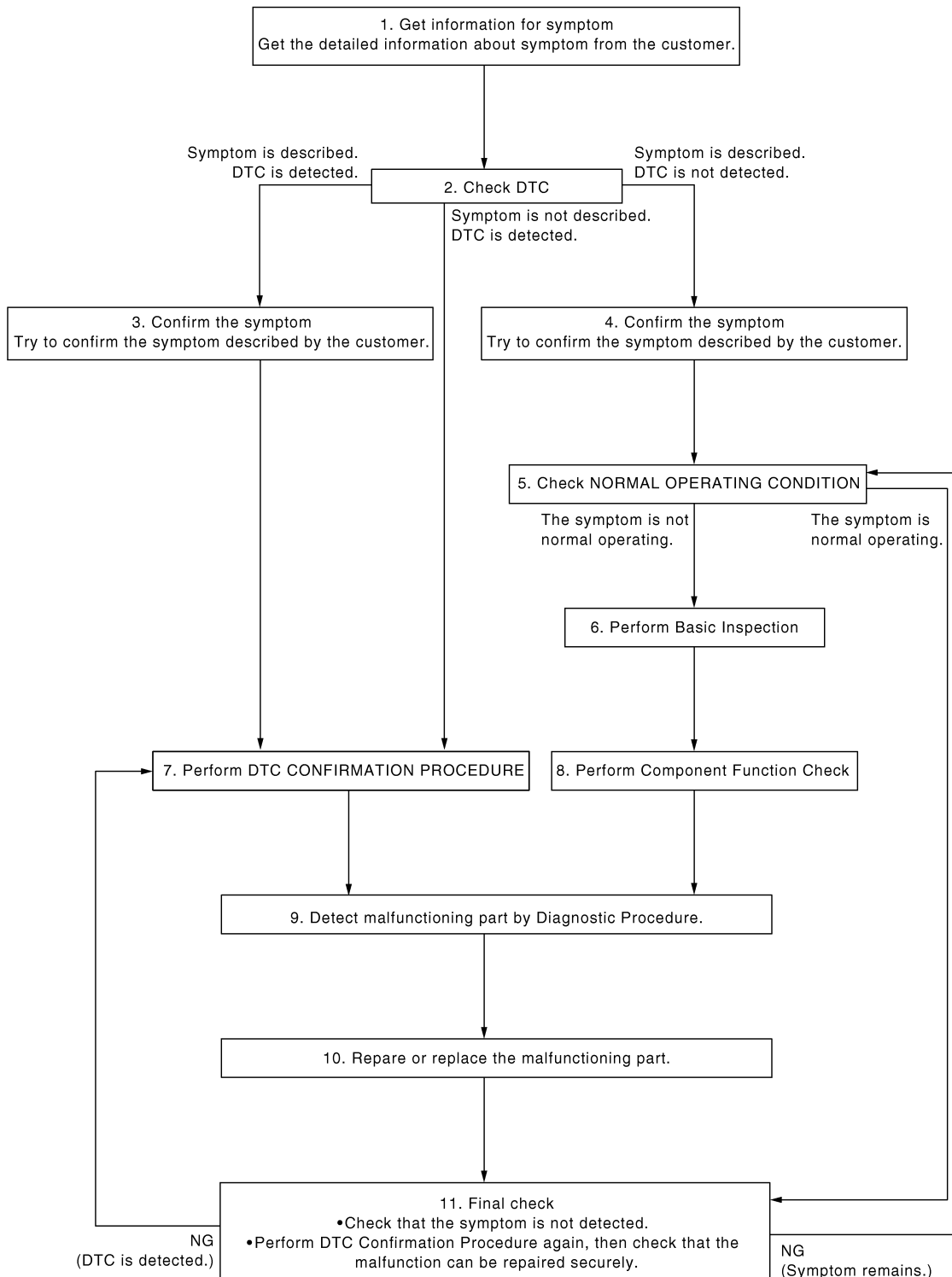

A  
B  
C  
D  
E  
F  
G  
H  
I  
ADP  
K  
L  
M  
N  
O  
P

DETAILED FLOW

# DIAGNOSIS AND REPAIR WORKFLOW

< BASIC INSPECTION >

---

## 1.GET INFORMATION FOR SYMPTOM

---

Get the detailed information from the customer about the symptom (the condition and the environment when the incident/malfunction occurred).

>> GO TO 2.

## 2.CHECK DTC WITH AUTOMATIC DRIVE POSITIONER SYSTEM

---

Check "Self Diagnostic Result" with CONSULT-III.

Is any symptom described and any DTC is displayed? [ADP-156. "DTC Index"](#).

Symptom is described, DTC is displayed.>>GO TO 3.

Symptom is not described, DTC is displayed.>>GO TO 7.

Symptom is described, DTC is not displayed.>>GO TO 4.

## 3.CONFIRM THE SYMPTOM

---

Try to confirm the symptom described by the customer.

>> GO TO 7.

## 4.CONFIRM THE SYMPTOM

---

Try to confirm the symptom described by the customer.

>> GO TO 5.

## 5.CHECK NORMAL OPERATING CONDITION

---

Check normal operating condition. Refer to [ADP-213. "Description"](#).

Is the incident normal operation?

YES >> INSPECTION END

NO >> GO TO 6.

## 6.PERFORM BASIC INSPECTION

---

Isolate the malfunctioning point with the basic inspection. Refer to .

>> GO TO 8.

## 7.PERFORM DTC CONFIRMATION PROCEDURE

---

Perform the confirmation procedure for the detected DTC.

Is the DTC displayed?

YES >> GO TO 9.

NO >> Check intermittent incident. Refer to [GI-39. "Intermittent Incident"](#).

## 8.PERFORM COMPONENT FUNCTION CHECK

---

Perform the component function check for the isolated malfunctioning point.

>> GO TO 9.

## 9.DETECT MALFUNCTIONING PART BY DIAGNOSTIC PROCEDURE

---

Isolate the malfunctioning point by performing the diagnosis procedure relevant to the symptom during the component diagnosis.

>> GO TO 10.

## 10.REPARE OR REPLACE

---

Repair or replace the malfunctioning part.

>> GO TO 11.

# DIAGNOSIS AND REPAIR WORKFLOW

< BASIC INSPECTION >

---

## 11.FINAL CHECK

---

Perform the DTC confirmation procedure (if DTC is detected) or component function check (if no DTC is detected) again, and then check that the malfunction can be repaired securely.

Are symptom and DTC not detected?

YES >> INSPECTION END

Symptom is detected.>> GO TO 4.

DTC is detected.>> GO TO 7.

A  
B  
C  
D  
E  
F  
G  
H  
I  
K  
L  
M  
N  
O  
P

ADP

# INSPECTION AND ADJUSTMENT

< BASIC INSPECTION >

## INSPECTION AND ADJUSTMENT

### ADDITIONAL SERVICE WHEN REMOVING BATTERY NEGATIVE TERMINAL

#### ADDITIONAL SERVICE WHEN REMOVING BATTERY NEGATIVE TERMINAL : Description

INFOID:000000000960577

Each function is reset to the following condition when the battery terminal is disconnected.

Function	Condition	Procedure
Memory (Seat, steering, mirror)	Erased	Perform storing
Entry/exit assist <sup>*1</sup>	OFF	Perform initialization
		Set slide amount <sup>*2</sup>
Intelligent Key interlock	Erased	Perform initialization
		Perform storing
Seat synchronization	OFF	—

\*1: This function only for AT model.

\*2: Default value is 40mm.

#### NOTE:

Notice that disconnecting the battery when detected DTC are present will erase the DTC memory.

### ADDITIONAL SERVICE WHEN REMOVING BATTERY NEGATIVE TERMINAL : Special Repair Requirement

INFOID:000000000960578

#### 1. SYSTEM INITIALIZATION

Perform system initialization. Refer to [ADP-9, "SYSTEM INITIALIZATION : Description"](#).

>> GO TO 2.

#### 2. SYSTEM SETTING

Perform system setting. Refer to [ADP-11, "SYSTEM SETTING : Description"](#).

>> GO TO 3.

#### 3. MEMORY STORAGE

Perform memory storage. Refer to [ADP-10, "MEMORY STORING : Description"](#).

>> END

### ADDITIONAL SERVICE WHEN REPLACING CONTROL UNIT

#### ADDITIONAL SERVICE WHEN REPLACING CONTROL UNIT : Description

INFOID:000000000960579

Each function is reset to the following condition when the driver seat control unit is replaced.

Function	Condition	Procedure
Memory (Seat, steering, mirror)	Erased	Perform storing
Entry/exit assist <sup>*1</sup>	OFF	Perform initialization
		Set slide amount <sup>*2</sup>
Intelligent Key interlock	Erased	Perform initialization
		Perform storing
Seat synchronization	OFF	—

\*1: This function only for AT model.



# INSPECTION AND ADJUSTMENT

## < BASIC INSPECTION >

---

\*2: Default value is 40mm.

### **NOTE:**

Notice that disconnecting the battery when detected DTC are present will erase the DTC memory.

## ADDITIONAL SERVICE WHEN REPLACING CONTROL UNIT : Special Repair Requirement

INFOID:000000000960580

### 1. SYSTEM INITIALIZATION

---

Perform system initialization. Refer to [ADP-9. "SYSTEM INITIALIZATION : Description"](#).

>> GO TO 2.

### 2. SYSTEM SETTING

---

Perform system setting. Refer to [ADP-11. "SYSTEM SETTING : Description"](#).

>> GO TO 3.

### 3. MEMORY STORAGE

---

Perform memory storage. Refer to [ADP-10. "MEMORY STORING : Description"](#).

>> END

## SYSTEM INITIALIZATION

### SYSTEM INITIALIZATION : Description

INFOID:000000000960581

Always perform the initialization when the battery terminal is disconnected or the driver seat control unit is replaced.

The entry/exit assist function and Intelligent Key interlock function will not operate normally if no initialization is performed.

### SYSTEM INITIALIZATION : Special Repair Requirement

INFOID:000000000960582

ADP

## INITIALIZATION PROCEDURE

### 1. CHOOSE METHOD

---

There are two initialization methods.

#### Which method do you use?

With door switch>>GO TO 2.

With vehicle speed>>GO TO 4.

### 2. STEP A-1

---

Turn ignition switch from ACC to OFF position.

>> GO TO 2.

### 3. STEP A-2

---

Driver door switch is ON (open) → OFF (close) → ON (open).

>> END

### 4. STEP B-1

---

Drive the vehicle at more than 25 km/h (16 MPH).

>> END

## MEMORY STORING

# INSPECTION AND ADJUSTMENT

< BASIC INSPECTION >

---

## MEMORY STORING : Description

INFOID:000000000960583

Always perform the memory storage when the battery terminal is disconnected or the driver seat control unit is replaced. The memory function and Intelligent Key interlock function will not operate normally if no memory storage is performed.

## MEMORY STORING : Special Repair Requirement

INFOID:000000000960584

### Memory Storage Procedure

Two positions for the driver seat, steering column and outside mirror can be stored for memory operation by following procedure.

#### 1.STEP 1

---

Shift AT selector lever to P position (AT model) or applied parking brake (MT model).

>> GO TO 2.

#### 2.STEP 2

---

Turn ignition switch ON.

>> GO TO 3.

#### 3.STEP 3

---

Adjust driver seat, steering column and outside mirror position manually.

>> GO TO 4.

#### 4.STEP 4

---

1. Push set switch.

**NOTE:**

- Memory indicator for which driver seat position is already retained in memory is illuminated for 5 seconds.
- Memory indicator for which driver seat position is not retained in memory is illuminated for 0.5 second.

2. Push the memory switch (1 or 2) for at least 1 second within 5 seconds after pushing the set switch.

**NOTE:**

- To enter driver seat positions into blank memory, memory indicator will be turned on for 5 seconds.
- To modify driver seat positions, memory indicator will be turned OFF for 0.5 second, then turned ON for 5 seconds.

**NOTE:**

If memory is stored in the same memory switch, the previous memory will be deleted.

#### Do you need linking of Intelligent Key?

YES >> GO TO 6.

NO >> GO TO 5.

#### 5.STEP 5

---

Confirm the operation of each part with memory operation.

>> END

#### 6.STEP 6

---

Push the Intelligent Key unlock button within 5 seconds after pushing memory switch (while the memory indicator is turned ON).

>> GO TO 7.

#### 7.STEP 7

---

Confirm the operation of each part with memory operation and Intelligent Key interlock operation.

# INSPECTION AND ADJUSTMENT

< BASIC INSPECTION >

>> END

## SYSTEM SETTING

### SYSTEM SETTING : Description

INFOID:000000000960585

The settings of the automatic driving positioner system can be changed, using CONSULT-III, the display unit in the center of the instrument panel and the set switch. Always check the settings before and after disconnecting the battery terminal or replacing driver seat control unit.

#### Setting Change ( For AT models)

x: Applicable

Item	Content	CONSULT-III	Display	Set switch	Factory setting
Amount of seat sliding for entry/exit assist	The amount of seat sliding for entry/exit assist can be selected from 3 items. [40mm/80mm/150mm]	x	—	—	40mm
Entry/exit assist (seat)	Entry/exit assist (seat) can be selected: ON (operated) – OFF (not operated)	x	x	x	OFF
Entry/exit assist (steering column)	Entry/exit assist (steering column) can be selected: ON (operated) – OFF (not operated)	x	x		OFF
Seat synchronization	Seat synchronization can be selected: ON (operated) – OFF (not operated)	<b>NOTE:</b> *1			OFF
Reset custom settings	All settings can be set to default (factory setting).	—	x	—	—

\*1: If either of entry/exit assist (seat) or entry/exit assist (steering column) is turned OFF, seat synchronizaton function is also turned OFF.

#### Setting Change (For MT models)

x: Applicable

Item	Content	Set switch	Factory setting
Seat synchronization	Seat synchronization can be selected: ON (operated) – OFF (not operated)	x	OFF

### SYSTEM SETTING : Special Repair Requirement

INFOID:000000000960586

#### 1. CHECK TYPE OF TRANSMISSION

Check type of transmission for the vehicle.

Which type of transmission is used for the vehicle?

MT >> GO TO 2.

AT >> GO TO 4.

#### 2. STEP 1 (FOR MT MODELS)

Turn ignition switch OFF.

>> GO TO 3.

#### 3. STEP 2 (FOR MT MODELS)

Push setting button and hold for more than 10 seconds, then confirm blinking of the memory switch indicator.

- Seat synchronization function is ON: Memory switch indicator blink two times.
- Seat synchronization is OFF: Memory switch indicator blink once.

>> END

#### 4. CHOOSE METHOD

There are three way of setting method.

## INSPECTION AND ADJUSTMENT

### < BASIC INSPECTION >

---

#### Which method do you choose?

With display>>GO TO 5.

With set switch>>GO TO 7.

With CONSULT-III>>GO TO 9.

#### **5.** WITH DISPLAY - STEP 1 (FOR AT MODELS)

---

Turn ignition switch ON.

>> GO TO 6.

#### **6.** WITH DISPLAY - STEP 2 (FOR AT MODELS)

---

1. Push "SETTING" button.
2. Select "Comfort & convenience".
3. Select "Lift Steering Wheel ON Exit" or "Slide Driver's Seat Back ON Exit" on display, then push
  - Lift Steering Wheel ON Exit: Entry/exit assist (steering column)
  - Slide Driver's Seat Back On Exit: Entry/exit assist (seat)

#### **NOTE:**

If either of entry/exit assist (seat) or entry/exit assist (steering column) is turned OFF, seat synchronization function is also turned OFF.

>> END

#### **7.** WITH SET SWITCH - STEP 1 (FOR AT MODELS)

---

Turn ignition switch OFF.

>> GO TO 8.

#### **8.** WITH SET SWITCH - STEP 2 (FOR AT MODELS)

---

Push setting button and hold for more than 10 seconds, then confirm blinking of the memory switch indicator.

- Entry/exit assist (seat/steering column) and seat synchronization are ON: Memory switch indicator blink two times.
- Entry/exit assist (seat/steering column) and seat synchronization are OFF: Memory switch indicator blink once.

>> END

#### **9.** WITH CONSULT-III - STEP 1 (FOR AT MODELS)

---

Select "Work support".

>> GO TO 10.

#### **10.** WITH CONSULT-III - STEP 2 (FOR AT MODELS)

---

1. Select "EXIT SEAT SLIDE SETTING", "EXIT TILT SETTING" or "SEAT SLIDE VOLUME SET" then touch display to change between ON and OFF.
  - EXIT SEAT SLIDE SETTING: Entry/exit assist (seat)
  - EXIT TILT SETTING: Entry/exit assist (steering column)
2. Then touch "OK".

#### **NOTE:**

If either of entry/exit assist (seat) or entry/exit assist (steering column) is turned OFF, seat synchronization function is also turned OFF.

>> END

# AUTOMATIC DRIVE POSITIONER SYSTEM

< FUNCTION DIAGNOSIS >

## FUNCTION DIAGNOSIS

AUTOMATIC DRIVE POSITIONER SYSTEM

AUTOMATIC DRIVE POSITIONER SYSTEM

AUTOMATIC DRIVE POSITIONER SYSTEM : System Diagram

INFOID:000000000960587

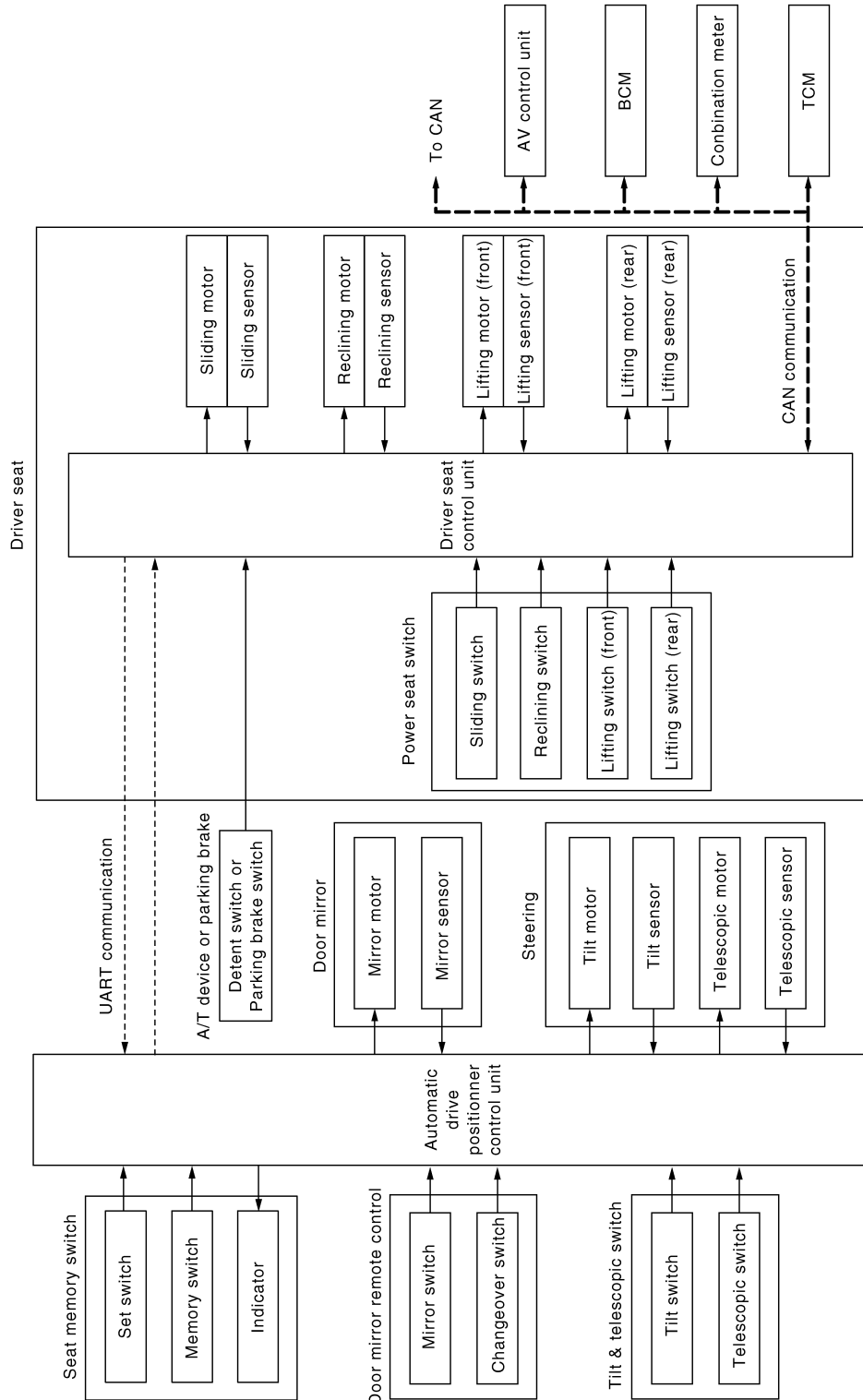

A  
B  
C  
D  
E  
F  
G  
H  
I  
K  
L  
M  
N  
O  
P

ADP

JMJIA0113GB

# AUTOMATIC DRIVE POSITIONER SYSTEM

< FUNCTION DIAGNOSIS >

## AUTOMATIC DRIVE POSITIONER SYSTEM : Component Parts Location INFOID:000000000960588

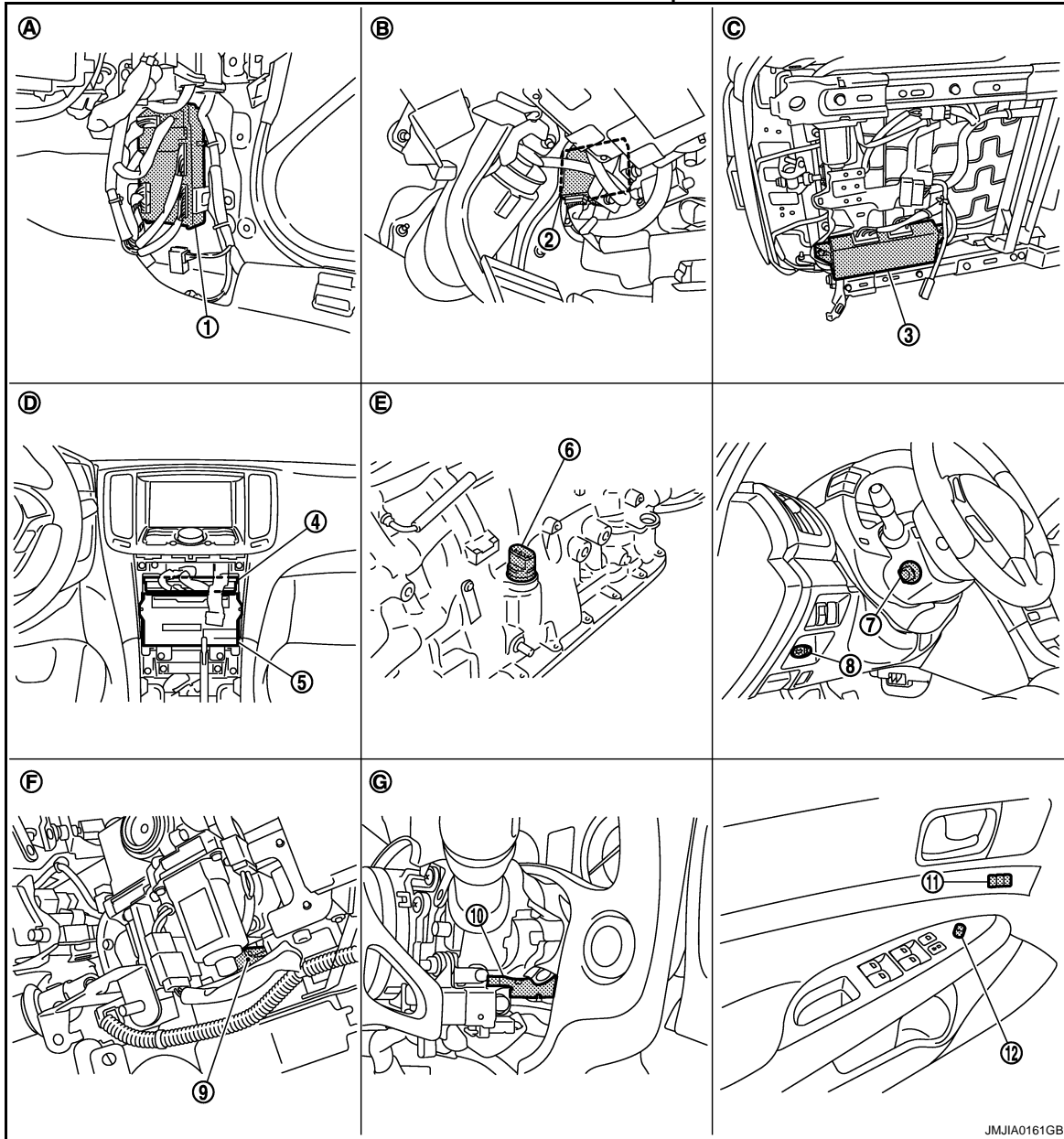

JMJA0161GB

- |   |   |   |
|---|---|---|
| <p>1. BCM M118, M119, M122, M123</p> <p>4. Unified meter and A/C amp. M67</p> <p>7. Tilt &amp; telescopic switch M31</p> <p>10. Telescopic sensor M48</p> <p>A. Dash side lower (Passenger side)</p> <p>D. Behind cluster lid C</p> <p>G. View with steering column cover lower and upper removed</p> | <p>2. Automatic drive positioner control unit M51, M52</p> <p>5. AV control unit<br/>With NAVI M87, M88<br/>Without NAVI M83, M85</p> <p>8. Key slot M22</p> <p>11. Seat memory switch D5</p> <p>B. View with instrument driver lower panel removed</p> <p>E. AT assembly (TCM is built in AT assembly)</p> | <p>3. Driver seat control unit B451, B452</p> <p>6. AT assembly connector F51</p> <p>9. Tilt sensor M48</p> <p>12. Door mirror remote control switch D17</p> <p>C. Backside of seat cushion (driver side)</p> <p>F. View with instrument driver lower panel removed</p> |
|---|---|---|

# AUTOMATIC DRIVE POSITIONER SYSTEM

## < FUNCTION DIAGNOSIS >

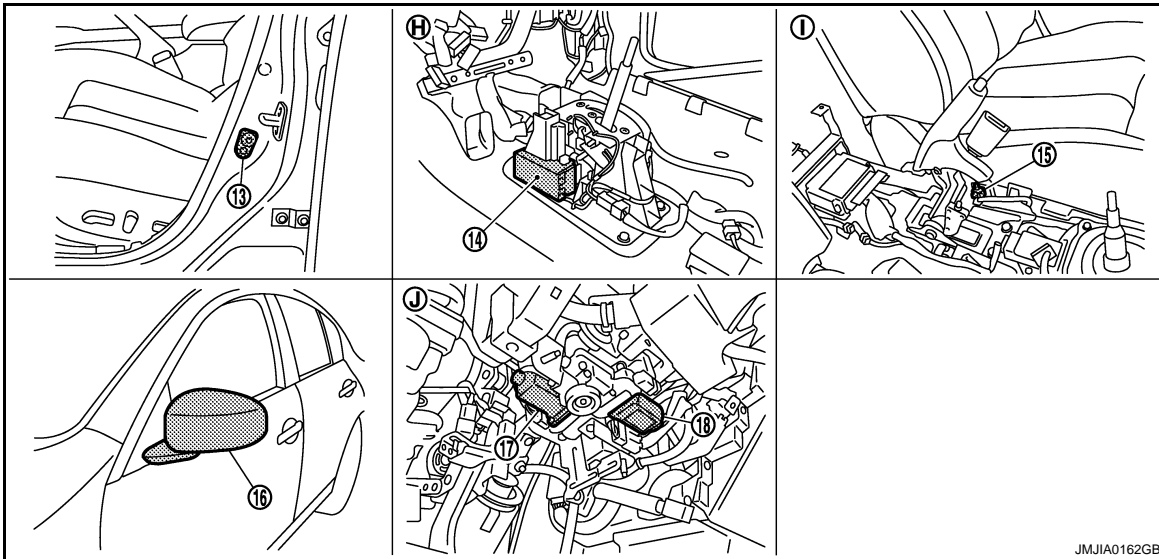

- |  |  |  |
|--|--|--|
| 13. Front door switch (driver side) B16      | 14. AT device (detention switch) M137        | 15. Parking brake switch B14                       |
| 16. Door mirror (driver side) D3             | 17. Telescopic motor M49                     | 18. Tilt motor M49                                 |
| H. View with center console assembly removed | I. View with center console assembly removed | J. View with instrument driver lower panel removed |

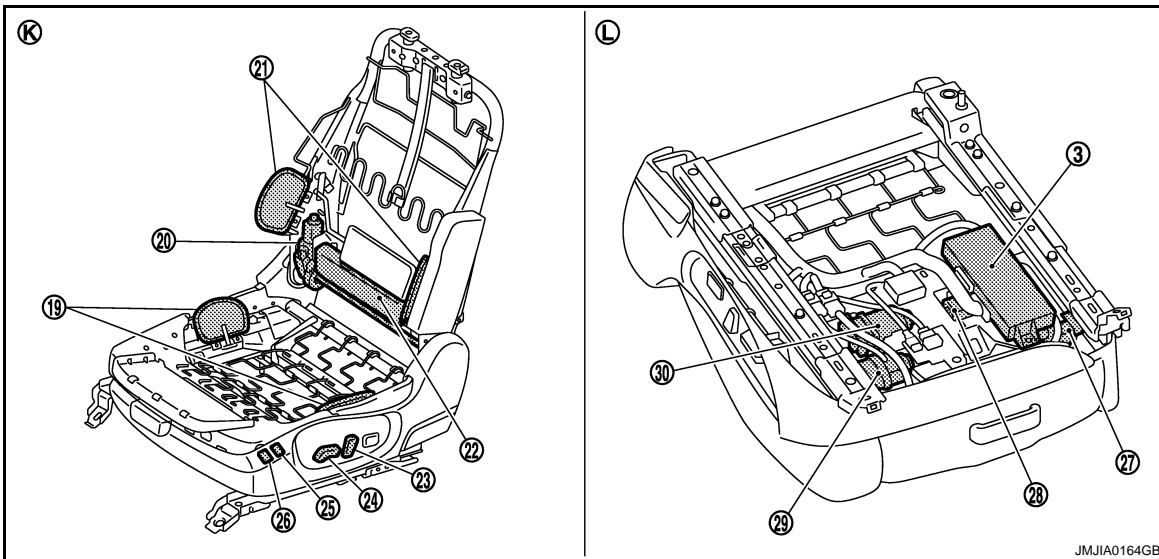

- |   |  |   |
|---|--|---|
| 19. Side support (seat cushion)<br>(Side support unit B420) | 20. Reclining motor B454                         | 21. Side support (seatback)<br>(Side support unit B420) |
| 22. Side support unit B420                                  | 23. Reclining switch<br>(Power seat switch B459) | 24. Sliding, lifting switch<br>(Power seat switch B459) |
| 25. Side support switch (seat back side)<br>B419            | 26. Side support switch (cushion side)<br>B419   | 27. Sliding sensor B453                                 |
| 28. Lifting motor (front) B455                              | 29. Sliding motor B461                           | 30. Lifting motor (rear) B456                           |
| K. View with seat cushion pad and seat-back pad removed     | L. Backside of the seat cushion                  |   |

## AUTOMATIC DRIVE POSITIONER SYSTEM : System Description

INFOID:000000000960589

### OUTLINE

The system automatically moves the driver seat, steering column and door mirror position by the driver seat control unit and the automatic drive positioner control unit. The driver seat control unit corresponds with the automatic drive positioner control unit by UART communication.

# AUTOMATIC DRIVE POSITIONER SYSTEM

## < FUNCTION DIAGNOSIS >

Function		Description
Manual function		The driving position (seat, steering column and door mirror position) can be adjusted by using the power seat switch, tilt & telescopic switch or door mirror remote control switch.
Seat synchronization function		The positions of the steering column and door mirror are adjusted to the proper position automatically while linking with manual operation [seat sliding, seat lifting (rear) or seat reclining].
Memory function		The seat, steering column and outside mirror move to the stored driving position by pressing seat memory switch (1 or 2).
Entry/Exit assist function	Exit	On exit, the seat moves backward and the steering column moves upward and forward.
	Entry	On entry, the seat and steering column returns from exiting position to the previous driving position.
Intelligent Key interlock function		Perform memory operation, exiting operation and entry operation by Intelligent Key unlock operation or driver side door request switch unlock operation .

### NOTE:

The lumbar support system and the side support system are controlled independently with no link to the automatic drive positioner system.

## AUTOMATIC DRIVE POSITIONER SYSTEM : Component Description

INFOID:000000000960590

### CONTROL UNITS

Item	Function
Driver seat control unit	<ul style="list-style-type: none"> <li>• Main units of automatic drive positioner system</li> <li>• It is connected to the CAN.</li> <li>• It communicates with the automatic drive positioner control via UART communication.</li> </ul>
Automatic drive positioner control unit	<ul style="list-style-type: none"> <li>• It communicates with the driver seat control unit via UART communication.</li> <li>• Perform various controls with the instructions of driver seat control unit.</li> <li>• Perform the controls of the tilt &amp; telescopic, door mirror and the seat memory switch.</li> </ul>
BCM	Transmit the following status to the driver seat control unit via CAN communication. <ul style="list-style-type: none"> <li>• Driver door: OPEN/CLOSE</li> <li>• Ignition switch position: ACC/ON</li> <li>• Door lock: UNLOCK (with Intelligent Key or driver side door request switch operation)</li> <li>• Key ID</li> <li>• Key switch: Insert/Pull out Intelligent Key</li> <li>• Starter: CRANKING/OTHER</li> </ul>
Unified meter and A/C amp.	Transmit the vehicle speed signal to the driver seat control unit via CAN communication.
NAVI control unit/AV control unit	The setting change of auto drive positioner system can be performed on the display. (only for AT models)
TCM	Transmit the shift position signal (P range) to the driver seat control unit via CAN communication.

### INPUT PARTS

#### Switches

Item	Function
Key slot	The key switch is installed to detect the key inserted/removed status.
Front door switch (driver side)	Detect front door (driver side) open/close status.
A/T device (detention switch)	Detect the P range position of AT selector lever. (only for AT models)
Parking break switch	Detect the parking brake status. (only for MT models)



# AUTOMATIC DRIVE POSITIONER SYSTEM

## < FUNCTION DIAGNOSIS >

Item	Function
Set switch	The registration and system setting can be performed with its operation.
Memory switch 1/2	The registration and operation can be performed with its operation.
Power seat switch	The following switch is installed. <ul style="list-style-type: none"> <li>• Reclining switch</li> <li>• Lifting switch (front)</li> <li>• Lifting switch (rear)</li> <li>• Sliding switch</li> </ul> The specific parts can be operated with the operation of each switch.
Tilt & telescopic switch	The following switch is installed. <ul style="list-style-type: none"> <li>• Tilt switch</li> <li>• Telescopic switch</li> </ul> The specific parts can be operated with the operation of each switch.
Door mirror remote control switch	The following switch is installed. <ul style="list-style-type: none"> <li>• Mirror switch</li> <li>• Changeover switch</li> </ul> The specific parts can be operated with the operation of each switch.

## Sensors

Item	Function
Door mirror sensor (driverside/passenger side)	Detect the up/down and left/right position of outside mirror face.
Tilt and telescopic sensor	Detect the up/down and left/right position of steering column.
Lifting sensor (front)	Detect the up/down position of seat lifting (front).
Lifting sensor (rear)	Detect the up/down position of seat lifting (rear).
Reclining sensor	Detect the tilt of seatback.
Sliding sensor	Detect the front/rear position of seat.

## OUTPUT PARTS

Item	Function
Door mirror motor (driverside/passenger side)	Move the outside mirror face upward/downward and leftward/rightward.
Tilt and telescopic motor	Move the steering column upward/downward and frontward/rearward.
Lifting motor (front)	Move the seat lifting (front) upward/downward.
Lifting motor (rear)	Move the seat lifting (rear) upward/downward.
Reclining motor	Tilt and raise up the seatback.
Sliding motor	Slide the seat frontward/rearward.
Memory indicator	Illuminates or flashes according to the registration/operation status.

## MANUAL FUNCTION

A  
B  
C  
D  
E  
F  
G  
H  
I  
K  
L  
M  
N  
O  
P

ADP

# AUTOMATIC DRIVE POSITIONER SYSTEM

< FUNCTION DIAGNOSIS >

## MANUAL FUNCTION : System Diagram

INFOID:000000000960591

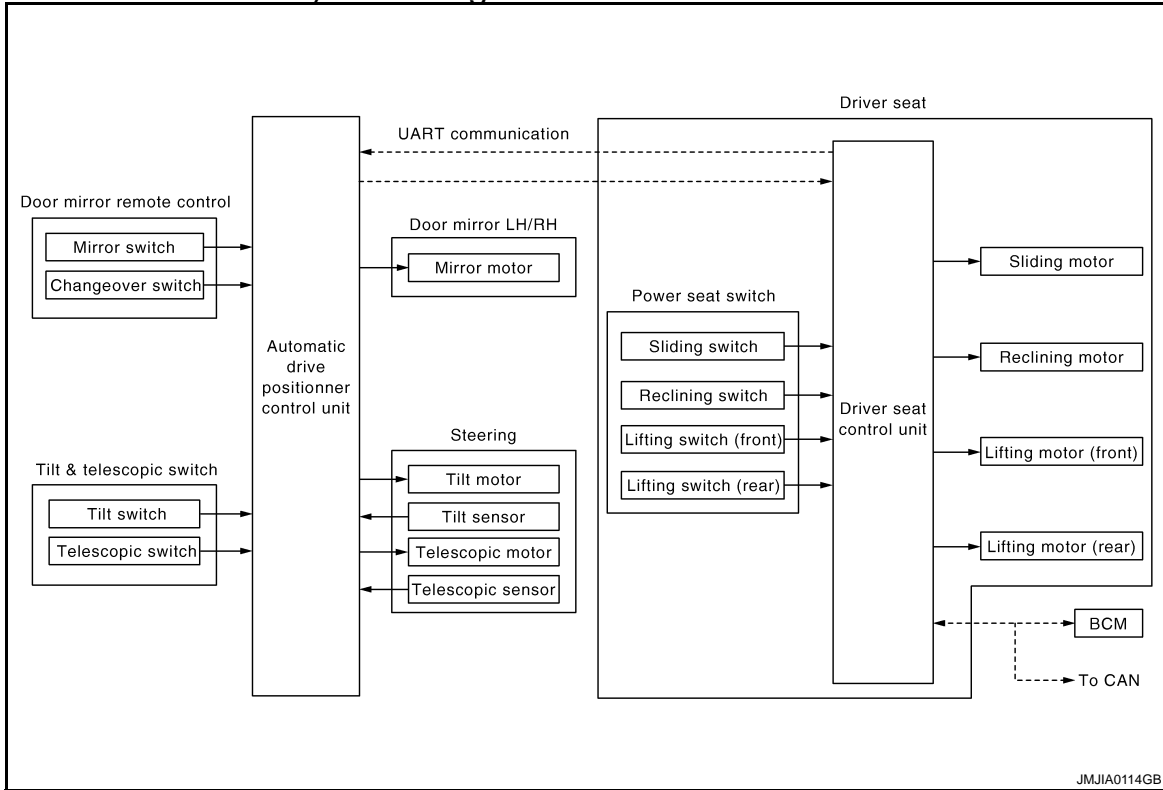

## MANUAL FUNCTION : System Description

INFOID:000000000960592

### OUTLINE

The driving position (seat, steering column and door mirror position) can be adjusted manually with power seat switch, tilt & telescopic switch and door mirror remote control switch.

### OPERATION PROCEDURE

1. Turn ignition switch ON.
2. Operate power seat switch, tilt & telescopic switch or door mirror remote control switch.
3. The driver seat, steering column or door mirror operates according to the operation of each switch.

### DETAIL FLOW

#### Seat

Order	Input	Output	Control unit condition
1	Power seat switch (sliding, lifting, reclining)	—	The power seat switch signal is inputted to the driver seat control unit when the power seat switch is operated.
2	—	Motors (sliding, lifting, reclining)	The driver seat control unit outputs signals to each motor according to the power seat switch input signal.

#### Tilt & Telescopic

Order	Input	Output	Control unit condition
1	Tilt & telescopic switch	—	The tilt & telescopic switch signal is inputted to the automatic drive positioner control unit when the tilt & telescopic switch is operated.

# AUTOMATIC DRIVE POSITIONER SYSTEM

## < FUNCTION DIAGNOSIS >

Order	Input	Output	Control unit condition
2	—	Motors (Tilt, telescopic)	The automatic drive positioner control unit actuates each motor according to the operation of the tilt & telescopic switch.
3	Sensors (Tilt, telescopic)	—	The automatic drive positioner control unit recognizes any operation limit of each actuator via each sensor and will not operate the actuator anymore at that time.*

\*: Tilt does not operate upward when tilt sensor voltage is less than 1.2 V, tilt does not operate downward when the sensor value is bigger than 3.4 V. Telescopic does not operate backward when telescopic sensor value is less than 0.8 V, telescopic does not operate forward when the sensor value is bigger than 3.4 V.

### Door Mirror

Order	Input	Output	Control unit condition
1	Door mirror remote control switch	—	The door mirror remote control switch signal is inputted to the automatic drive positioner control unit when the door mirror remote control switch is operated.
2	—	Motors (Door mirror motor)	The automatic drive positioner control unit actuates each motor according to the operation of the door mirror remote control switch.

#### NOTE:

The door mirrors can be operated manually when ignition switch is in either ACC or ON position. The ignition switch signal (ACC/ON) is transmitted from BCM to the driver seat control unit via CAN communication and from the driver seat control unit to the automatic drive positioner control unit via UART communication.

A  
B  
C  
D  
E  
F  
G  
H  
I  
K  
L  
M  
N  
O  
P

ADP

# AUTOMATIC DRIVE POSITIONER SYSTEM

< FUNCTION DIAGNOSIS >

## MANUAL FUNCTION : Component Parts Location

INFOID:000000000960593

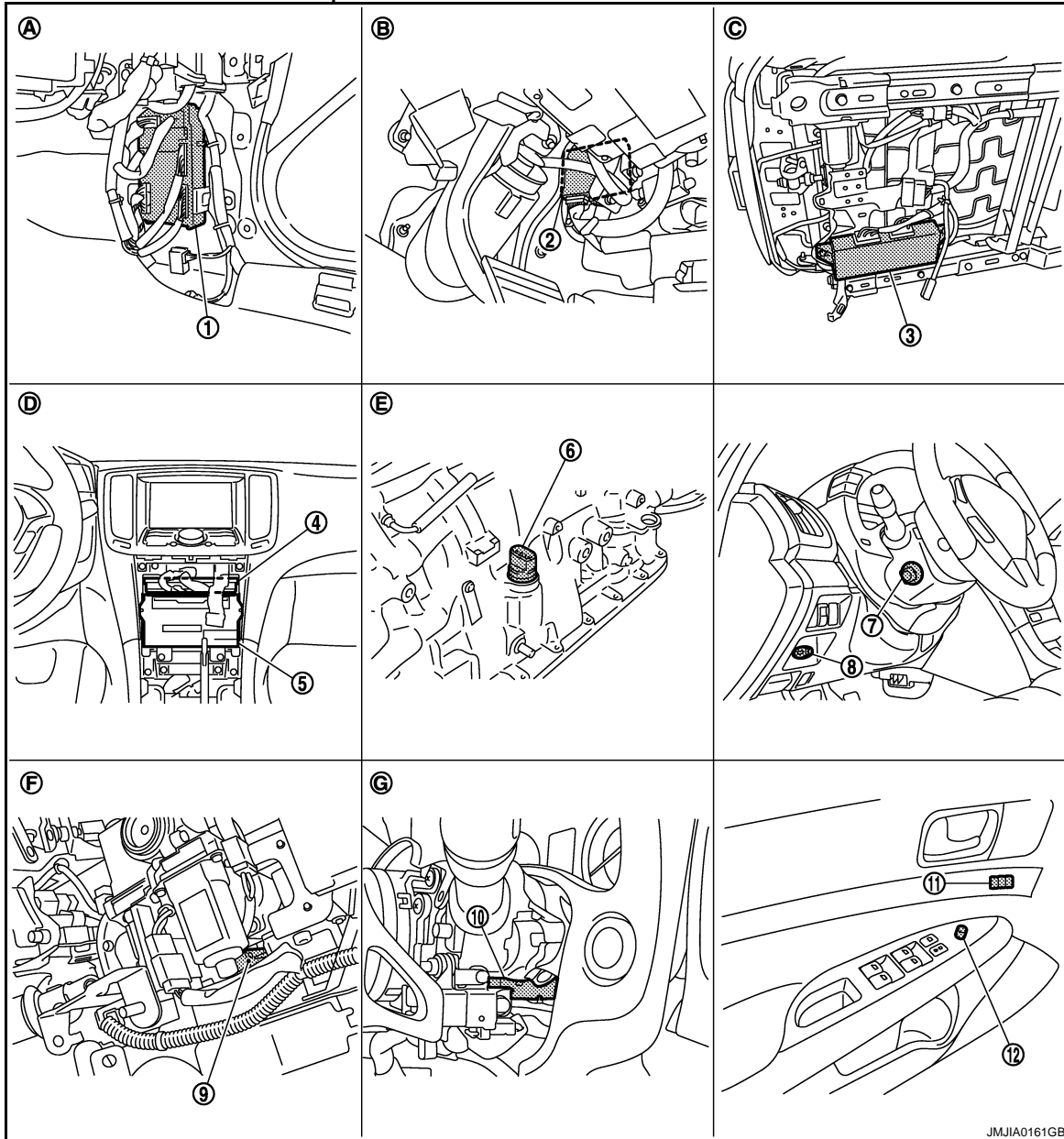

JMJIA0161GB

- |  |   |  |
|--|---|--|
| 1. BCM M118, M119, M122, M123                              | 2. Automatic drive positioner control unit M51, M52               | 3. Driver seat control unit B451, B452             |
| 4. Unified meter and A/C amp. M67                          | 5. AV control unit<br>With NAVI M87, M88<br>Without NAVI M83, M85 | 6. AT assembly connector F51                       |
| 7. Tilt & telescopic switch M31                            | 8. Key slot M22   | 9. Tilt sensor M48                                 |
| 10. Telescopic sensor M48                                  | 11. Seat memory switch D5   | 12. Door mirror remote control switch D17          |
| A. Dash side lower (Passenger side)                        | B. View with instrument driver lower panel removed                | C. Backside of seat cushion (driver side)          |
| D. Behind cluster lid C                                    | E. AT assembly (TCM is built in AT assembly)                      | F. View with instrument driver lower panel removed |
| G. View with steering column cover lower and upper removed |   |  |

# AUTOMATIC DRIVE POSITIONER SYSTEM

## < FUNCTION DIAGNOSIS >

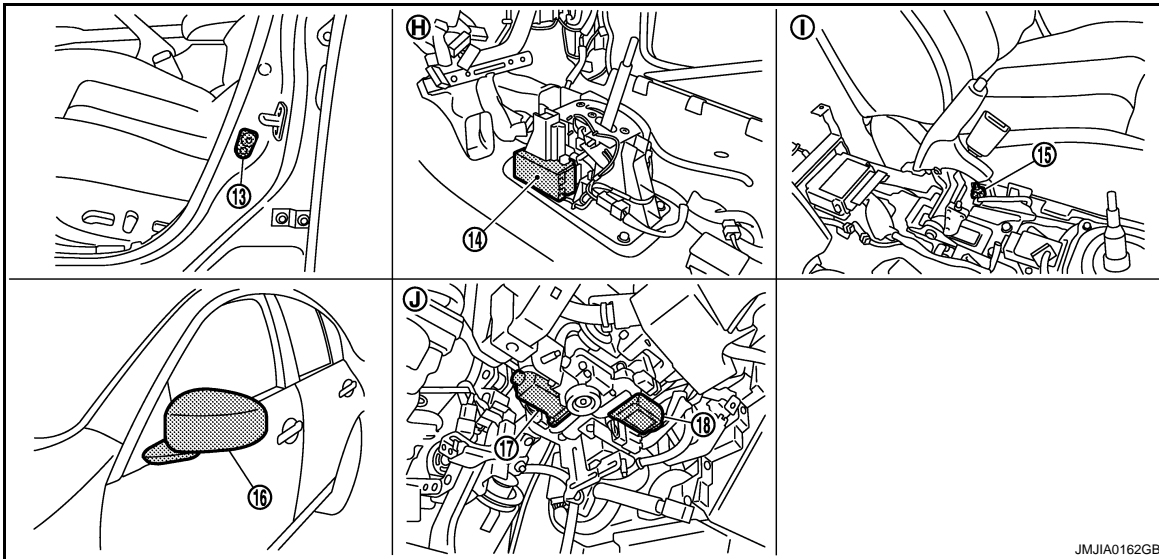

- |  |  |  |
|--|--|--|
| 13. Front door switch (driver side) B16      | 14. AT device (detention switch) M137        | 15. Parking brake switch B14                       |
| 16. Door mirror (driver side) D3             | 17. Telescopic motor M49                     | 18. Tilt motor M49                                 |
| H. View with center console assembly removed | I. View with center console assembly removed | J. View with instrument driver lower panel removed |

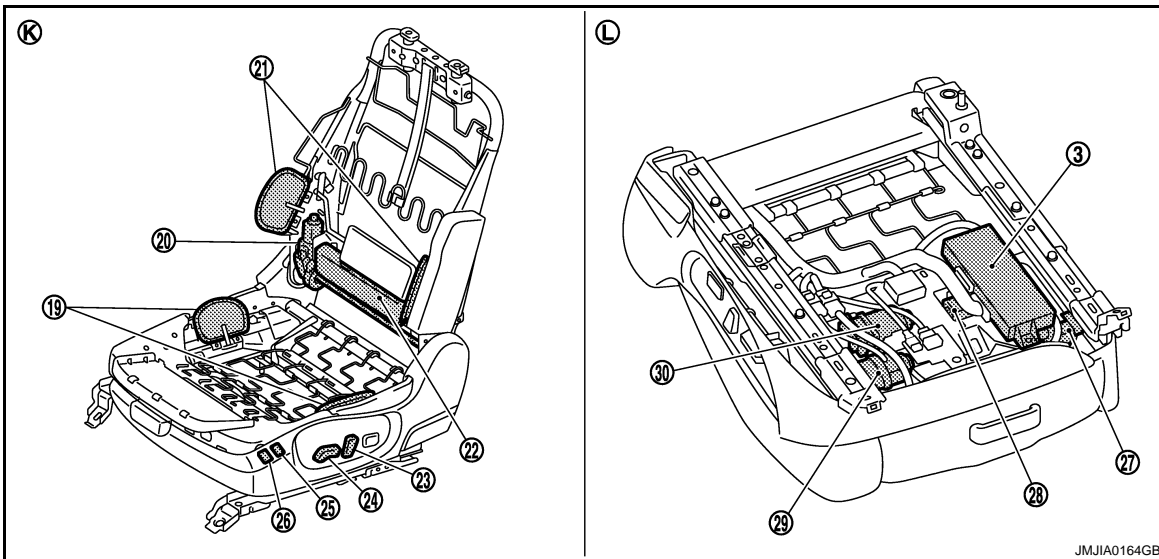

- |  |   |  |
|--|---|--|
| 19. Side support (seat cushion) (Side support unit B420) | 20. Reclining motor B454                      | 21. Side support (seatback) (Side support unit B420) |
| 22. Side support unit B420                               | 23. Reclining switch (Power seat switch B459) | 24. Sliding, lifting switch (Power seat switch B459) |
| 25. Side support switch (seat back side) B419            | 26. Side support switch (cushion side) B419   | 27. Sliding sensor B453                              |
| 28. Lifting motor (front) B455                           | 29. Sliding motor B461                        | 30. Lifting motor (rear) B456                        |
| K. View with seat cushion pad and seat-back pad removed  | L. Backside of the seat cushion               |  |

## MANUAL FUNCTION : Component Description

INFOID:000000000960594

## CONTROL UNITS

# AUTOMATIC DRIVE POSITIONER SYSTEM

## < FUNCTION DIAGNOSIS >

Item	Function
Driver seat control unit	<ul style="list-style-type: none"><li>• Operates the specific seat motor with the signal from the power seat switch.</li><li>• Transmits the ignition switch signal (ACC/ON) via UART communication to the automatic drive positioner control unit.</li></ul>
Automatic drive positioner control unit	Operates the specific motor with the signal from tilt & telescopic switch or door mirror remote control switch.
BCM	Recognizes the following status and transmits it to the driver seat control unit via CAN communication. <ul style="list-style-type: none"><li>• Ignition position: ACC/ON</li></ul>

## INPUT PARTS

### Switches

Item	Function
Power seat switch	The following switch is installed. <ul style="list-style-type: none"><li>• Reclining switch</li><li>• Lifting switch (front)</li><li>• Lifting switch (rear)</li><li>• Sliding switch</li></ul> The specific parts can be operated with the operation of each switch.
Tilt & telescopic switch	The following switch is installed. <ul style="list-style-type: none"><li>• Tilt switch</li><li>• Telescopic switch</li></ul> The specific parts can be operated with the operation of each switch.
Door mirror remote control switch	The following switch is installed. <ul style="list-style-type: none"><li>• Mirror switch</li><li>• Changeover switch</li></ul> The specific parts can be operated with the operation of each switch.

### Sensors

Item	Function
Tilt and telescopic sensor	Detect the up/down and left/right position of steering column.

## OUTPUT PARTS

Item	Function
Door mirror motor (driverside/passenger side)	Move the outside mirror face upward/downward and leftward/rightward.
Tilt & telescopic motor	Move the steering column upward/downward and frontward/rearward.
Lifting motor (front)	Move the seat lifter (front) upward/downward.
Lifting motor (rear)	Move the seat lifter (rear) upward/downward.
Reclining motor	Tilt and raise up the seatback.
Sliding motor	Slide the seat frontward/rearward.

## SEAT SYNCHRONIZATION FUNCTION

# AUTOMATIC DRIVE POSITIONER SYSTEM

< FUNCTION DIAGNOSIS >

## SEAT SYNCHRONIZATION FUNCTION : System Diagram

INFOID:000000000960595

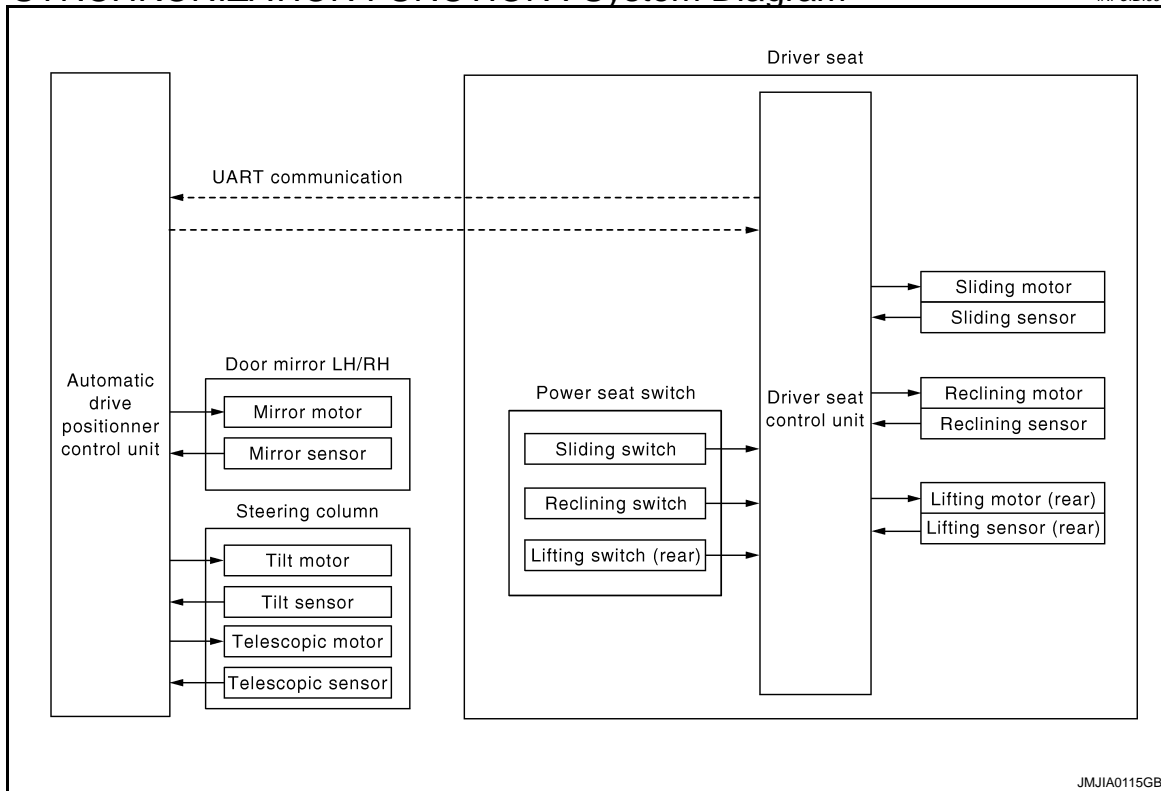

JMJIA0115GB

## SEAT SYNCHRONIZATION FUNCTION : System Description

INFOID:000000000960596

### OUTLINE

The steering column position and door mirror position is adjusted to the position automatically according to the direction and distance of seat movement when performing the manual operation of sliding, reclining or lifting (rear). This function saves adjusting the mirror and steering column when adjusting the seat.

### NOTE:

- This function is set to OFF before delivery (initial setting).
- This function can be stopped by turning both or either of the entry/exit assist function (seat) and the entry/exit assist function (steering) OFF. (only for AT models)  
For the system setting procedure. Refer to [ADP-11. "SYSTEM SETTING : Description"](#).

### OPERATION PROCEDURE

1. Turn ignition switch ON.
2. Adjust seat position [sliding, reclining, lifting (rear)].
3. The steering and outside mirror is adjusted automatically.

### NOTE:

- The seat synchronization function will not operate if seat adjusting value is more than limit value.

Item	Limit value
Seat sliding	76 [mm]
Seat reclining	9.1 [degrees]
Seat lifter (rear)	20 [mm]

- The seat synchronization function will not operate if the steering column or door mirror moves to the operating end while this function is operating. Perform memory function or drive the vehicle at vehicle speed of 7 km/h or more once to activate this function again.
- If the seat position is uncomfortable after the adjustment, seat position can be adjusted easily by memory operation.

### OPERATION CONDITION

Satisfy all of the following items. The seat synchronization function is not performed if these items are not satisfied.

# AUTOMATIC DRIVE POSITIONER SYSTEM

## < FUNCTION DIAGNOSIS >

Item	Request status
Ignition position	ON
System setting [Entry/exit assist function (seat/steering)]	ON
Switch inputs <ul style="list-style-type: none"> <li>• Power seat switch</li> <li>• Tilt &amp; telescopic switch</li> <li>• Door mirror remote control switch</li> <li>• Set switch</li> <li>• Memory switch</li> </ul>	OFF (Not operated)
AT selector lever (only for AT model)	P position
Parking break (only for MT models)	Applied

## DETAIL FLOW

Order	Input	Output	Control unit condition
1	—	—	Perform Manual operation [Sliding, reclining or lifting (rear)].
2	Sensors [Sliding, reclining, lifting (rear)]	—	The driver seat control unit judges the direction and distance of seat movement according to the signal input from each seat sensor during manual operation.
3	—	Motors (Tilt, telescopic, out- side mirror)	Driver seat control unit requests the operation to position according to the direction and distance of seat movement to the automatic drive positioner control unit via UART communication. The automatic drive positioner control unit operates each motor.
	Sensors (Tilt, telescopic, outside mirror)	—	Driver seat control unit stops the operation of each motor when the value of each sensor that is input to automatic drive positioner control unit via UART communication reaches the target address.



# AUTOMATIC DRIVE POSITIONER SYSTEM

< FUNCTION DIAGNOSIS >

## SEAT SYNCHRONIZATION FUNCTION : Component Parts Location

INFOID:000000000960597

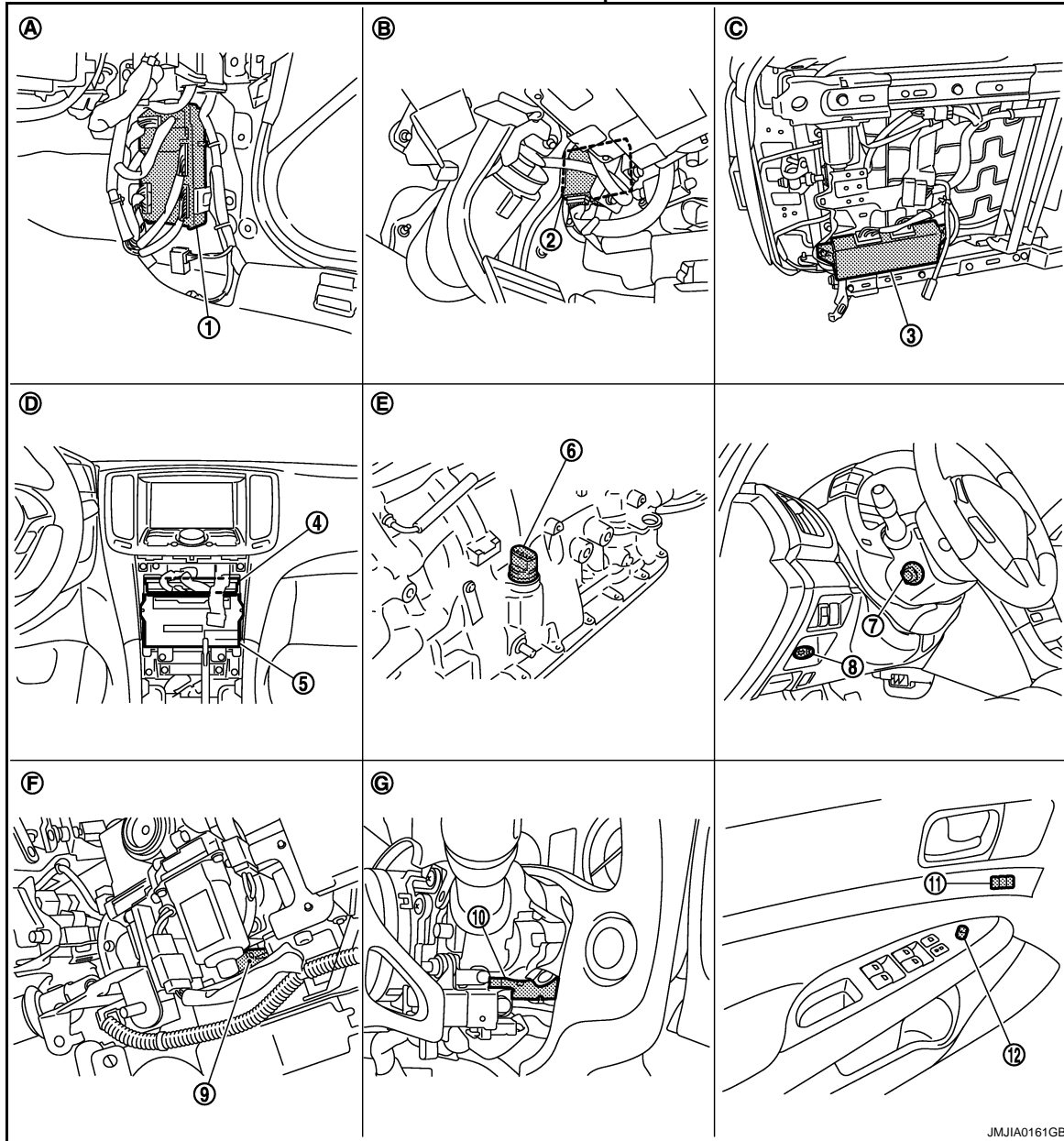

- |  |   |  |
|--|---|--|
| 1. BCM M118, M119, M122, M123                              | 2. Automatic drive positioner control unit M51, M52               | 3. Driver seat control unit B451, B452             |
| 4. Unified meter and A/C amp. M67                          | 5. AV control unit<br>With NAVI M87, M88<br>Without NAVI M83, M85 | 6. AT assembly connector F51                       |
| 7. Tilt & telescopic switch M31                            | 8. Key slot M22   | 9. Tilt sensor M48                                 |
| 10. Telescopic sensor M48                                  | 11. Seat memory switch D5   | 12. Door mirror remote control switch D17          |
| A. Dash side lower (Passenger side)                        | B. View with instrument driver lower panel removed                | C. Backside of seat cushion (driver side)          |
| D. Behind cluster lid C                                    | E. AT assembly (TCM is built in AT assembly)                      | F. View with instrument driver lower panel removed |
| G. View with steering column cover lower and upper removed |   |  |

A  
B  
C  
D  
E  
F  
G  
H  
I  
ADP  
K  
L  
M  
N  
O  
P

# AUTOMATIC DRIVE POSITIONER SYSTEM

## < FUNCTION DIAGNOSIS >

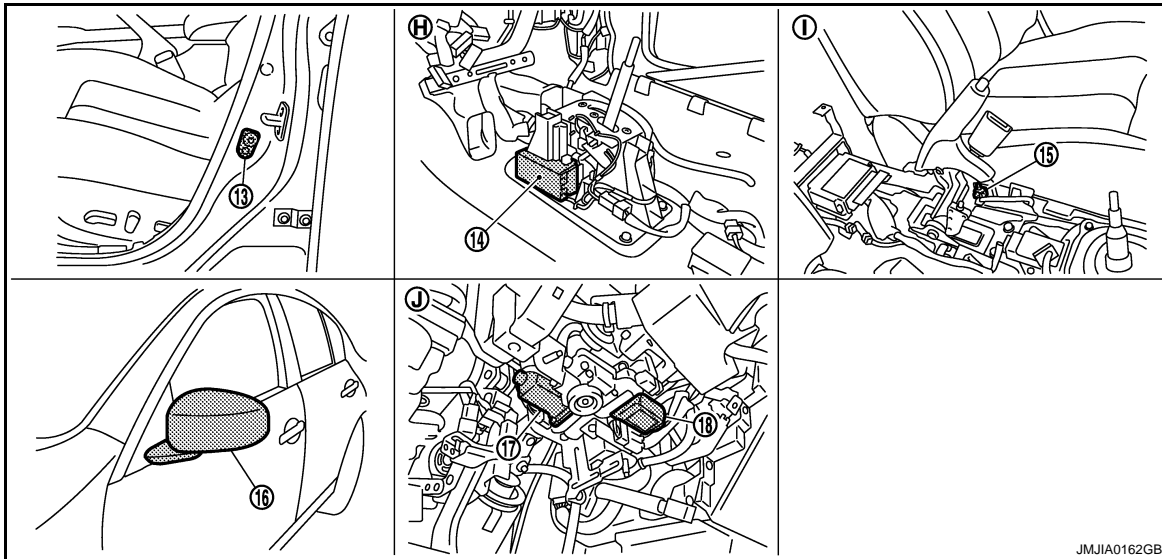

- |  |  |  |
|--|--|--|
| 13. Front door switch (driver side) B16      | 14. AT device (detention switch) M137        | 15. Parking brake switch B14                       |
| 16. Door mirror (driver side) D3             | 17. Telescopic motor M49                     | 18. Tilt motor M49                                 |
| H. View with center console assembly removed | I. View with center console assembly removed | J. View with instrument driver lower panel removed |

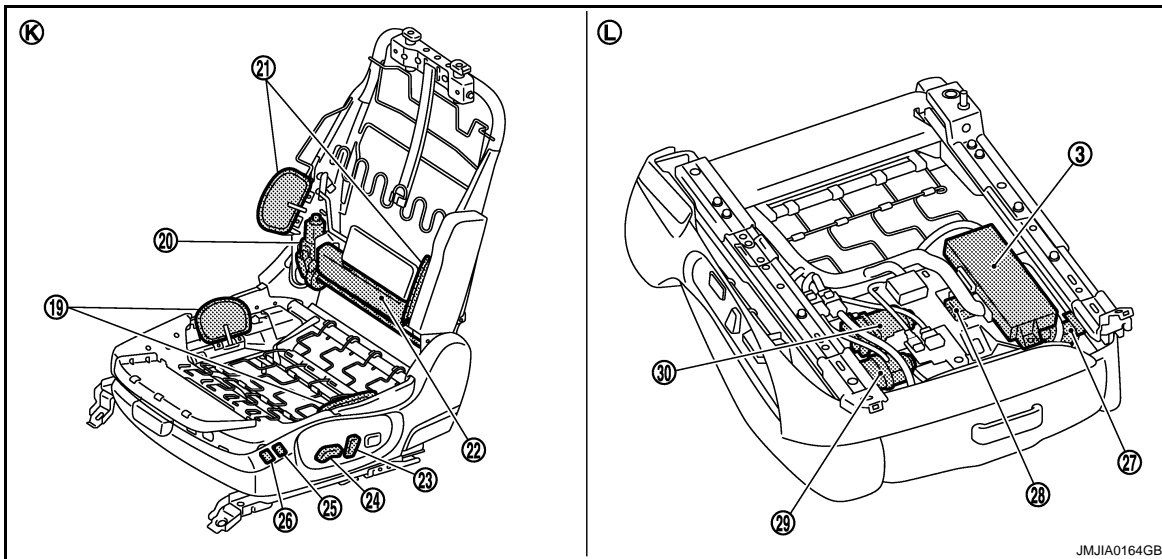

- |   |  |   |
|---|--|---|
| 19. Side support (seat cushion)<br>(Side support unit B420) | 20. Reclining motor B454                         | 21. Side support (seatback)<br>(Side support unit B420) |
| 22. Side support unit B420                                  | 23. Reclining switch<br>(Power seat switch B459) | 24. Sliding, lifting switch<br>(Power seat switch B459) |
| 25. Side support switch (seat back side)<br>B419            | 26. Side support switch (cushion side)<br>B419   | 27. Sliding sensor B453                                 |
| 28. Lifting motor (front) B455                              | 29. Sliding motor B461                           | 30. Lifting motor (rear) B456                           |
| K. View with seat cushion pad and seat-back pad removed     | L. Backside of the seat cushion                  |   |

## SEAT SYNCHRONIZATION FUNCTION : Component Description

INFOID:000000000960598

### CONTROL UNITS

# AUTOMATIC DRIVE POSITIONER SYSTEM

## < FUNCTION DIAGNOSIS >

Item	Function
Driver seat control unit	Operates the specific seat motor with the signal from the power seat switch.
Automatic drive positioner control unit	Operates the steering motor and door mirror with the instructions from the driver seat control unit.

## INPUT PARTS

### Switches

Item	Function
Power seat switch	The following switch is installed. <ul style="list-style-type: none"><li>• Reclining switch</li><li>• Lifting switch (front)</li><li>• Lifting switch (rear)</li><li>• Sliding switch</li></ul> The specific parts can be operated with the operation of each switch.

### Sensors

Item	Function
Door mirror sensor (driver side/passenger side)	Detect the up/down and left/right position of outside mirror face.
Tilt and telescopic sensor	Detect the up/down and left/right position of steering column.
Lifting sensor (rear)	Detect the up/down position of seat lifter (rear).
Reclining sensor	Detect the tilt of seatback.
Sliding sensor	Detect the front/rear position of seat.

## OUTPUT PARTS

Item	Function
Door mirror motor (driver side/passenger side)	Move the outside mirror face upward/downward and leftward/rightward.
Tilt & telescopic motor	Move the steering column upward/downward and frontward/rearward.
Lifting motor (rear)	Move the seat lifter (rear) upward/downward.
Reclining motor	Tilt and raise up the seatback.
Sliding motor	Slide the seat frontward/rearward.

## MEMORY FUNCTION

A  
B  
C  
D  
E  
F  
G  
H  
I  
K  
L  
M  
N  
O  
P

ADP

# AUTOMATIC DRIVE POSITIONER SYSTEM

< FUNCTION DIAGNOSIS >

## MEMORY FUNCTION : System Diagram

INFOID:000000000960599

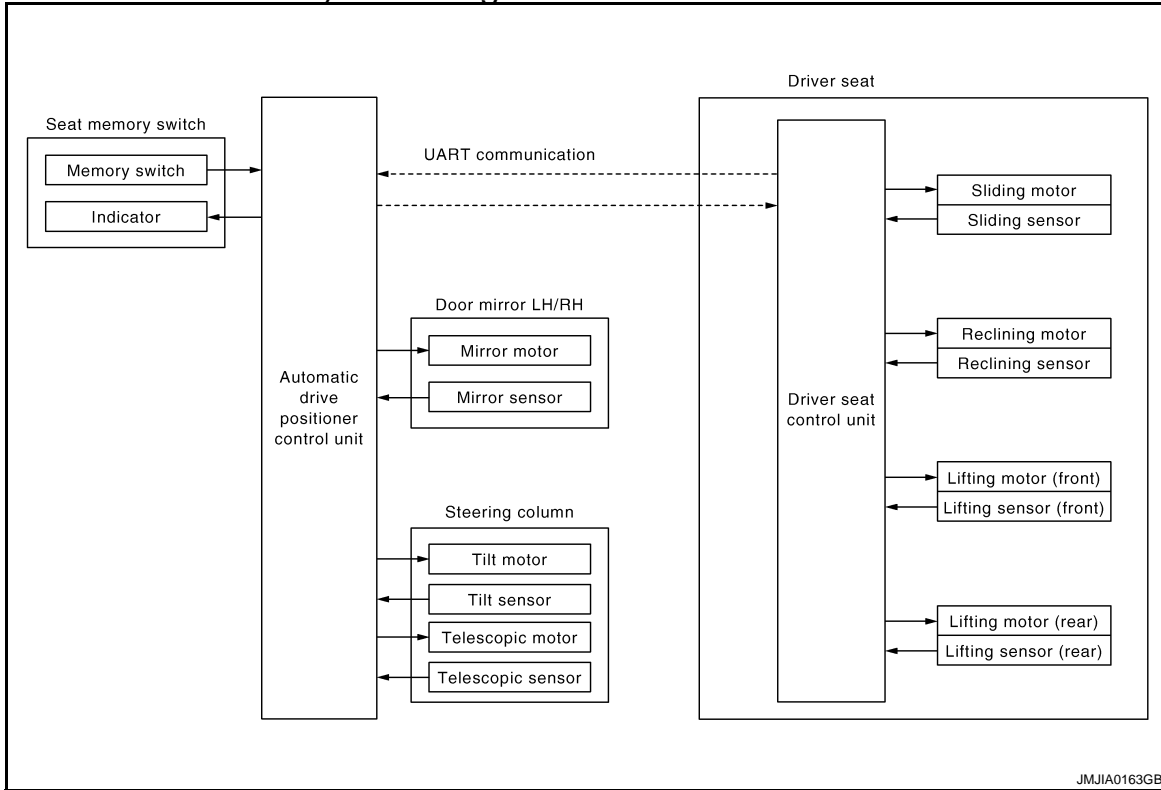

## MEMORY FUNCTION : System Description

INFOID:000000000960600

### OUTLINE

The driver seat control unit can store the optimum driving positions (seat, steering column and door mirror position) for 2 people. If the front seat position is changed, one-touch (pressing desired memory switch for more than 0.5 second) operation allows changing to the other driving position.

### NOTE:

Further information for the memory storage procedure. Refer to [ADP-10. "MEMORY STORING : Description"](#).

### OPERATION PROCEDURE

1. Turn ignition switch ON
2. Press desired memory switch for more than 0.5 second.
3. Driver seat, steering and door mirror will move to the memorized position.

### OPERATION CONDITION

Satisfy all of the following items. The memory function is not performed if these items are not satisfied.

Item	Request status
Ignition position	ON
Switch inputs <ul style="list-style-type: none"> <li>• Power seat switch</li> <li>• Tilt &amp; telescopic switch</li> <li>• Door mirror control switch</li> <li>• Set switch</li> <li>• Memory switch</li> </ul>	OFF (Not operated)
AT selector lever (only for AT model)	P position
Parking break (only for MT models)	Applied

### DETAIL FLOW

# AUTOMATIC DRIVE POSITIONER SYSTEM

## < FUNCTION DIAGNOSIS >

Order	Input	Output	Control unit condition
1	Memory switch	—	The memory switch signal is inputted to the automatic drive positioner control unit when memory switch 1 or 2 is operated. Memory switch signal is input to driver seat control unit via UART communication.
2	—	Motors (Seat, Steering, door mirror)	Driver seat control unit operates each motor of seat when it recognizes the memory switch pressed for 0.5 second or more and requests each motor operation to automatic drive positioner control unit via UART communication. The automatic drive positioner control unit operates each motor.
		Memory switch Indicator	Driver seat control unit requests the flashing of memory indicator to automatic drive positioner control unit via UART communication while either of the motors is operating. The automatic drive positioner control unit illuminates the memory indicator.
3	Sensors (Seat, steering column, door mirror)	—	Driver seat control unit judges the operating seat position with each seat sensor input. The positions of the steering column and outside mirror are monitored with each sensor signal that is input from auto drive positioner control unit via UART communication. Driver seat control unit stops the operation of each motor when each part reaches the recorded address.
4	—	Memory switch Indicator	Driver seat control unit requests the illumination of memory indicator to auto drive positioner control unit via UART communication after all motors stop. The auto driving positioner control unit illuminates the memory indicator for 5 seconds.

A  
B  
C  
D  
E  
F  
G  
H  
I  
K  
L  
M  
N  
O  
P

ADP

# AUTOMATIC DRIVE POSITIONER SYSTEM

< FUNCTION DIAGNOSIS >

## MEMORY FUNCTION : Component Parts Location

INFOID:000000000960601

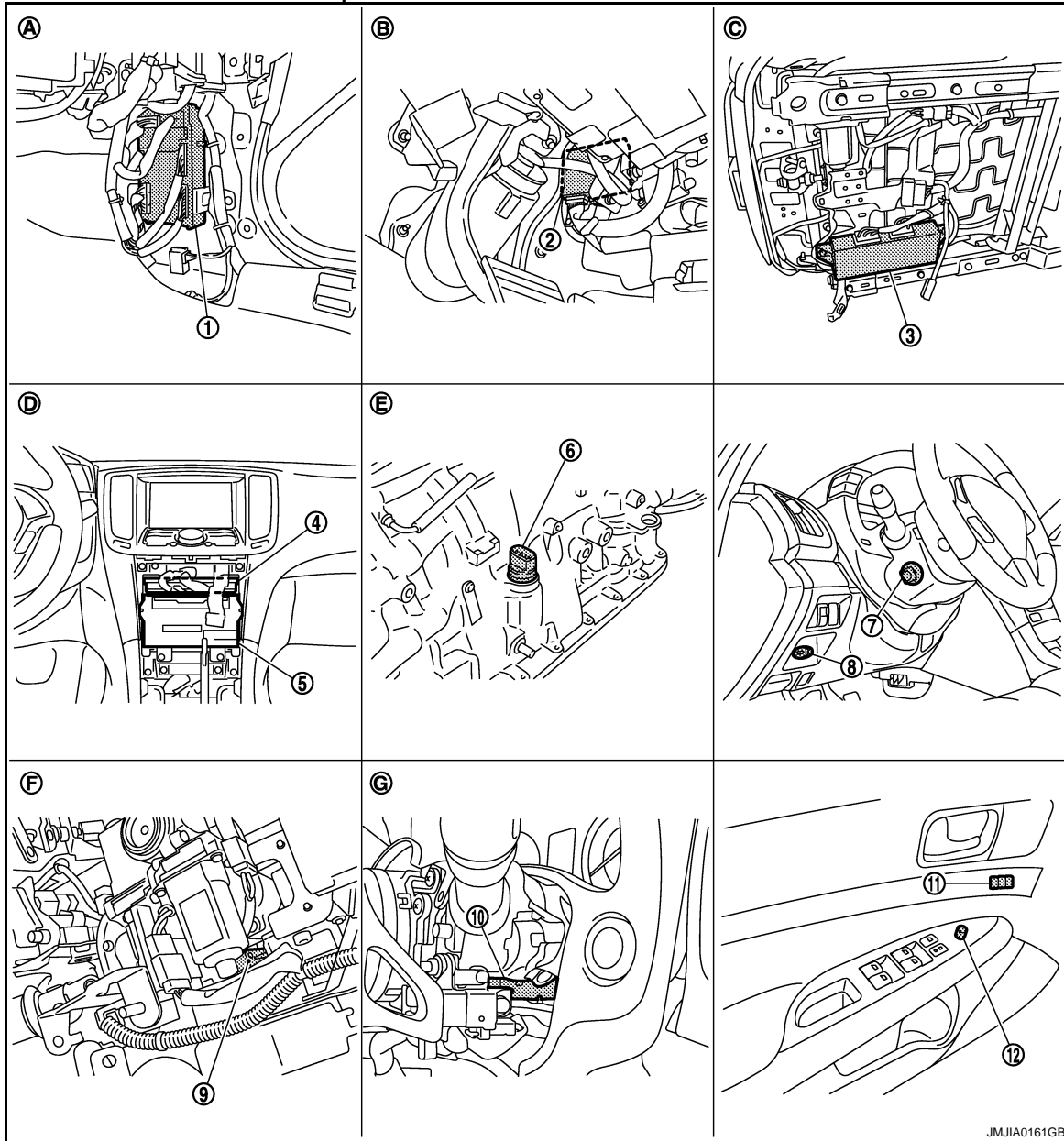

JMJIA0161GB

- |  |   |  |
|--|---|--|
| 1. BCM M118, M119, M122, M123                              | 2. Automatic drive positioner control unit M51, M52               | 3. Driver seat control unit B451, B452             |
| 4. Unified meter and A/C amp. M67                          | 5. AV control unit<br>With NAVI M87, M88<br>Without NAVI M83, M85 | 6. AT assembly connector F51                       |
| 7. Tilt & telescopic switch M31                            | 8. Key slot M22   | 9. Tilt sensor M48                                 |
| 10. Telescopic sensor M48                                  | 11. Seat memory switch D5   | 12. Door mirror remote control switch D17          |
| A. Dash side lower (Passenger side)                        | B. View with instrument driver lower panel removed                | C. Backside of seat cushion (driver side)          |
| D. Behind cluster lid C                                    | E. AT assembly (TCM is built in AT assembly)                      | F. View with instrument driver lower panel removed |
| G. View with steering column cover lower and upper removed |   |  |

# AUTOMATIC DRIVE POSITIONER SYSTEM

## < FUNCTION DIAGNOSIS >

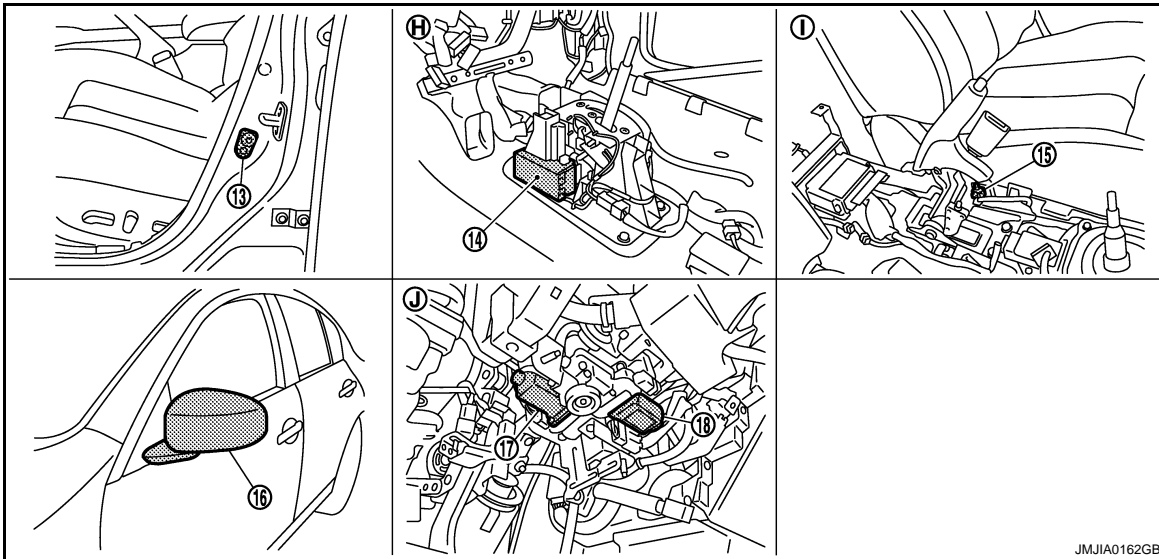

- |  |  |  |
|--|--|--|
| 13. Front door switch (driver side) B16      | 14. AT device (detention switch) M137        | 15. Parking brake switch B14                       |
| 16. Door mirror (driver side) D3             | 17. Telescopic motor M49                     | 18. Tilt motor M49                                 |
| H. View with center console assembly removed | I. View with center console assembly removed | J. View with instrument driver lower panel removed |

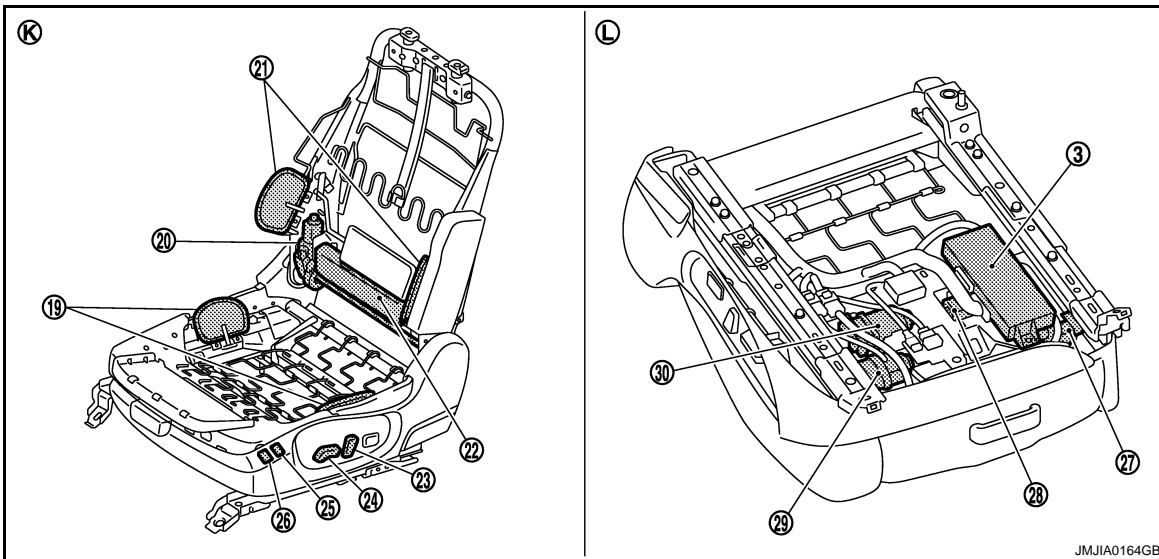

- |   |  |   |
|---|--|---|
| 19. Side support (seat cushion)<br>(Side support unit B420) | 20. Reclining motor B454                         | 21. Side support (seatback)<br>(Side support unit B420) |
| 22. Side support unit B420                                  | 23. Reclining switch<br>(Power seat switch B459) | 24. Sliding, lifting switch<br>(Power seat switch B459) |
| 25. Side support switch (seat back side)<br>B419            | 26. Side support switch (cushion side)<br>B419   | 27. Sliding sensor B453                                 |
| 28. Lifting motor (front) B455                              | 29. Sliding motor B461                           | 30. Lifting motor (rear) B456                           |
| K. View with seat cushion pad and seat-back pad removed     | L. Backside of the seat cushion                  |   |

## MEMORY FUNCTION : Component Description

INFOID:000000000960602

## CONTROL UNITS

# AUTOMATIC DRIVE POSITIONER SYSTEM

## < FUNCTION DIAGNOSIS >

Item	Function
Driver seat control unit	<ul style="list-style-type: none"><li>• The address of each part is recorded.</li><li>• Operates each motor of seat to the registered position.</li><li>• Requests the operations of steering column and door mirror to automatic drive positioner control unit</li></ul>
Automatic drive positioner control unit	Operates the steering column and door mirror with the instructions from the driver seat control.

## INPUT PARTS

### Switches

Item	Function
Memory switch 1/2	The registration and memory function can be performed with its operation.

### Sensors

Item	Function
Door mirror sensor (driver side/passenger side)	Detect the up/down and left/right position of outside mirror face.
Tilt & telescopic sensor	Detect the up/down and left/right position of steering column.
Lifting sensor (front)	Detect the up/down position of seat lifting (front).
Lifting sensor (rear)	Detect the up/down position of seat lifting (rear).
Reclining sensor	Detect the tilt of seatback.
Sliding sensor	Detect the front/rear position of seat.

## OUTPUT PARTS

Item	Function
Door mirror motor (driver side/passenger side)	Move the outside mirror face upward/downward and leftward/rightward.
Tilt and telescopic motor	Move the steering column upward/downward and frontward/rearward.
Lifting motor (front)	Move the seat lifter (front) upward/downward.
Lifting motor (rear)	Move the seat lifter (rear) upward/downward.
Reclining motor	Tilt and raise up the seatback.
Sliding motor	Slide the seat frontward/rearward.
Memory indicator	Illuminates or blinks according to the registration/operation status.

## EXIT ASSIST FUNCTION



# AUTOMATIC DRIVE POSITIONER SYSTEM

< FUNCTION DIAGNOSIS >

## EXIT ASSIST FUNCTION : System Diagram

INFOID:000000000960603

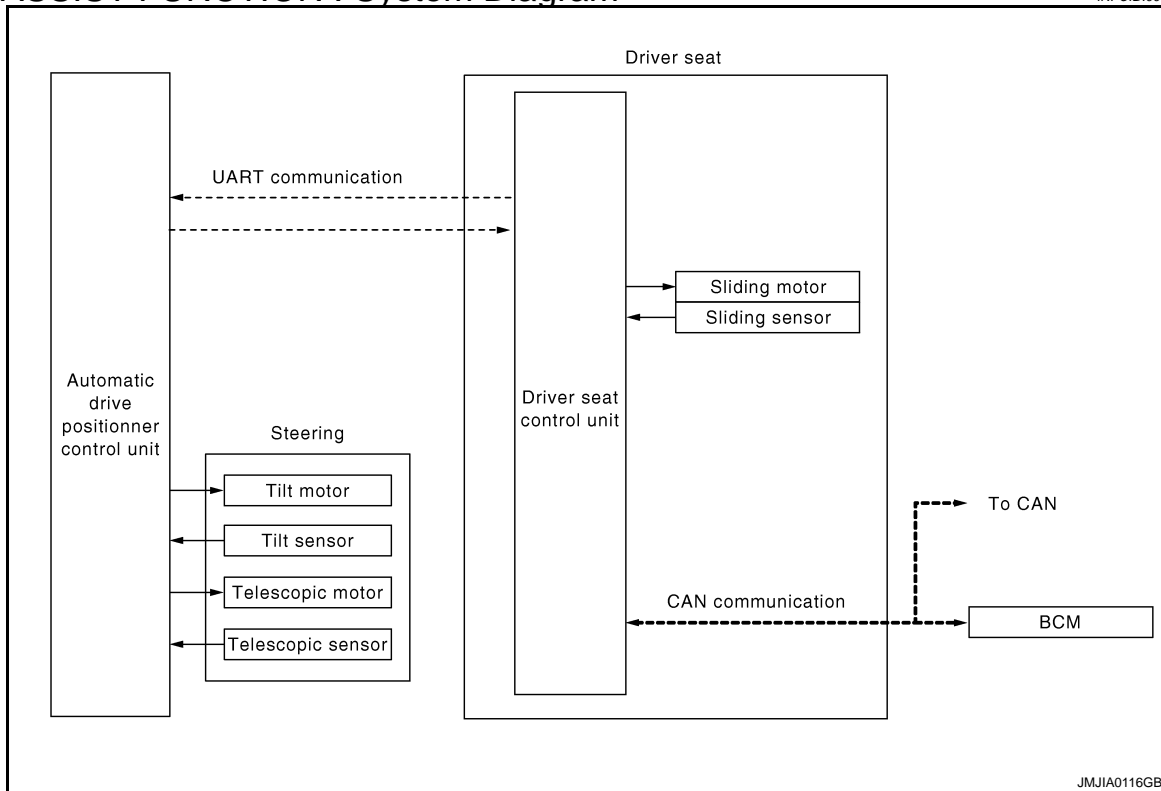

A  
B  
C  
D  
E  
F  
G  
H

## EXIT ASSIST FUNCTION : System Description

INFOID:000000000960604

### OUTLINE

When exiting, the condition is satisfied, the seat is moved backward 40 mm (1.57 in) from normal sitting position and the steering is moved to the most upper position and front position. The seat slide amount and the steering operation at entry/exit operation can be changed.

### NOTE:

- This function is set to OFF before delivery (initial setting).
- Further information for the system setting procedure. Refer to [ADP-9, "SYSTEM INITIALIZATION : Description"](#).

ADP

### OPERATION PROCEDURE

1. Open the driver door with ignition switch in OFF position.
2. Driver seat and steering column will move to the exiting position.

### OPERATION CONDITION

Satisfy all of the following items. The exit assist function is not performed if these items are not satisfied.

Item	Request status
Ignition position	OFF
System setting [Entry/exit assist function (seat/steering)]	ON
Initialization	Done
Switch inputs <ul style="list-style-type: none"> <li>• Power seat switch</li> <li>• Tilt &amp; telescopic switch</li> <li>• Door mirror remote control switch</li> <li>• Set switch</li> <li>• Memory switch</li> </ul>	OFF (Not operated)
AT selector lever	P position

K  
L  
M  
N  
O  
P

### DETAIL FLOW

# AUTOMATIC DRIVE POSITIONER SYSTEM

## < FUNCTION DIAGNOSIS >

Order	Input	Output	Control unit condition
1	Door switch (Driver side)	—	Driver seat control unit receives door switch signal (driver side/ open) from BCM via CAN communication.
2	—	Motors (Seat sliding, tilt, telescopic )	Driver seat control unit operates the seat sliding motor, which recognizes that the driver side door is opened with ignition switch OFF. Driver seat control unit then requests the operations of tilt motor and telescopic motor to auto drive positioner control unit via UART communication. The automatic drive positioner control unit operates each motor for a constant amount.

## EXIT ASSIST FUNCTION : Component Parts Location

INFOID:000000000960605

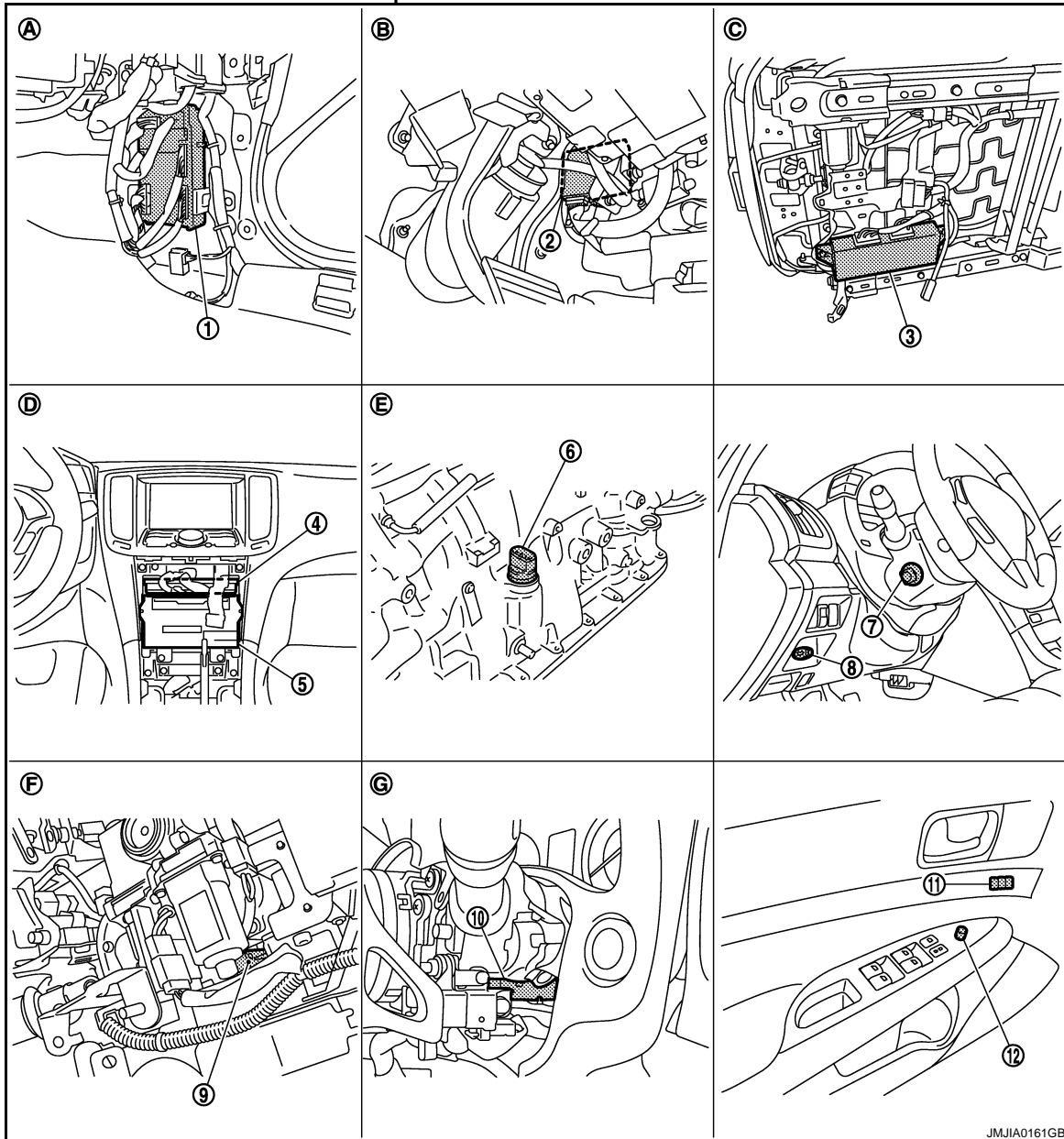

JMJIA0161GB

- |                                   |   |  |
|-----------------------------------|---|--|
| 1. BCM M118, M119, M122, M123     | 2. Automatic drive positioner control unit M51, M52               | 3. Driver seat control unit B451, B452 |
| 4. Unified meter and A/C amp. M67 | 5. AV control unit<br>With NAVI M87, M88<br>Without NAVI M83, M85 | 6. AT assembly connector F51           |
| 7. Tilt & telescopic switch M31   | 8. Key slot M22   | 9. Tilt sensor M48                     |

# AUTOMATIC DRIVE POSITIONER SYSTEM

## < FUNCTION DIAGNOSIS >

- |  |  |  |
|--|--|--|
| 10. Telescopic sensor M48                                  | 11. Seat memory switch D5                          | 12. Door mirror remote control switch D17          |
| A. Dash side lower (Passenger side)                        | B. View with instrument driver lower panel removed | C. Backside of seat cushion (driver side)          |
| D. Behind cluster lid C                                    | E. AT assembly (TCM is built in AT assembly)       | F. View with instrument driver lower panel removed |
| G. View with steering column cover lower and upper removed |  |  |

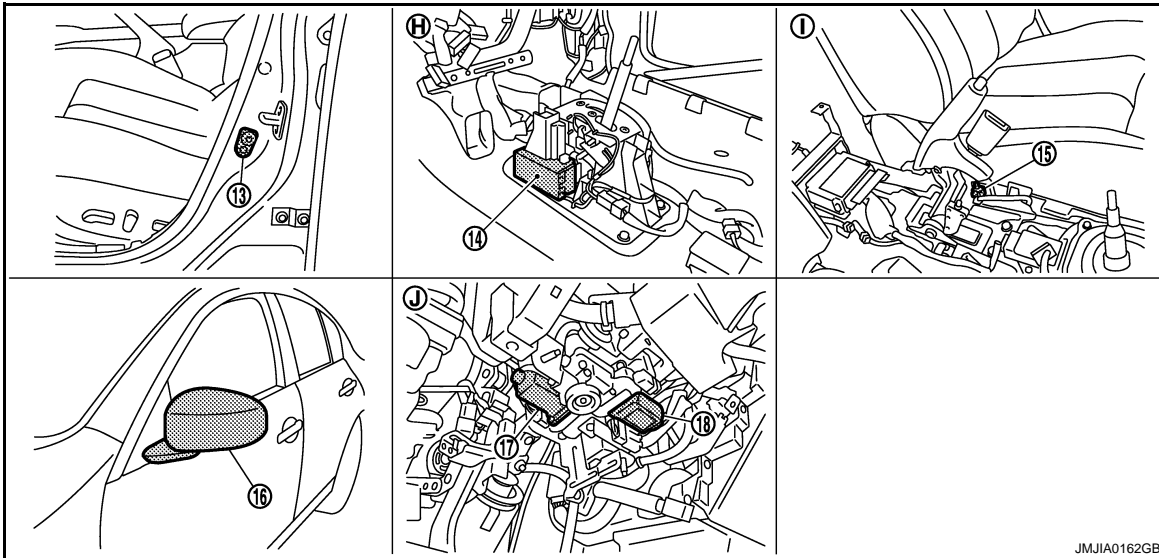

- |  |  |  |
|--|--|--|
| 13. Front door switch (driver side) B16      | 14. AT device (detention switch) M137        | 15. Parking brake switch B14                       |
| 16. Door mirror (driver side) D3             | 17. Telescopic motor M49                     | 18. Tilt motor M49                                 |
| H. View with center console assembly removed | I. View with center console assembly removed | J. View with instrument driver lower panel removed |

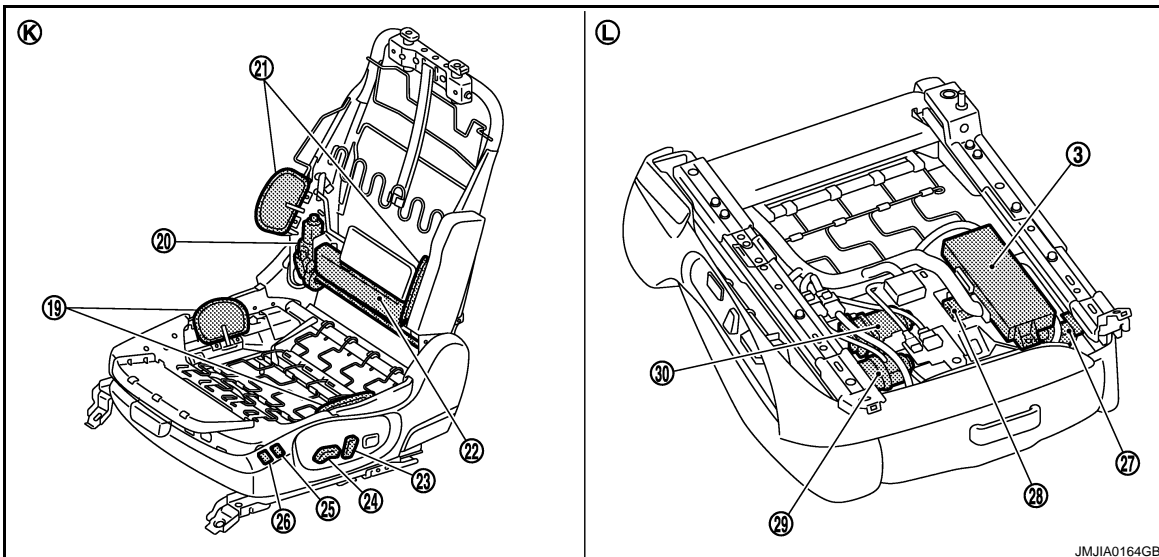

- |  |   |  |
|--|---|--|
| 19. Side support (seat cushion) (Side support unit B420) | 20. Reclining motor B454                      | 21. Side support (seatback) (Side support unit B420) |
| 22. Side support unit B420                               | 23. Reclining switch (Power seat switch B459) | 24. Sliding, lifting switch (Power seat switch B459) |
| 25. Side support switch (seat back side) B419            | 26. Side support switch (cushion side) B419   | 27. Sliding sensor B453                              |

# AUTOMATIC DRIVE POSITIONER SYSTEM

## < FUNCTION DIAGNOSIS >

28. Lifting motor (front) B455                      29. Sliding motor B461                      30. Lifting motor (rear) B456  
K. View with seat cushion pad and seat-    L. Backside of the seat cushion  
back pad removed

## EXIT ASSIST FUNCTION : Component Description

INFOID:000000000960606

### CONTROL UNITS

Item	Function
Driver seat control unit	<ul style="list-style-type: none"><li>Operates the seat sliding motor for a constant amount.</li><li>Requests the operations of tilt motor and telescopic motor to automatic drive positioner control unit.</li></ul>
Automatic drive positioner control unit	Operates the tilt motor and telescopic motor with the request from the driver seat control.
BCM	Recognizes the following status and transmits it to the driver seat control unit via CAN communication. <ul style="list-style-type: none"><li>Driver door: OPEN/CLOSE</li></ul>

### INPUT PARTS

#### Switches

Item	Function
Front door switch (driver side)	Detect front door (driver side) open/close status.

#### Sensors

Item	Function
Tilt and telescopic sensor	Detect the up/down and left/right position of steering column.
Sliding sensor	Detect the front/rear position of seat.

### OUTPUT PARTS

Item	Function
Tilt and telescopic motor	Move the steering column upward/downward and frontward/rearward.
Sliding motor	Slide the seat frontward/rearward.

### ENTRY ASSIST FUNCTION

# AUTOMATIC DRIVE POSITIONER SYSTEM

< FUNCTION DIAGNOSIS >

## ENTRY ASSIST FUNCTION : System Diagram

INFOID:000000000960607

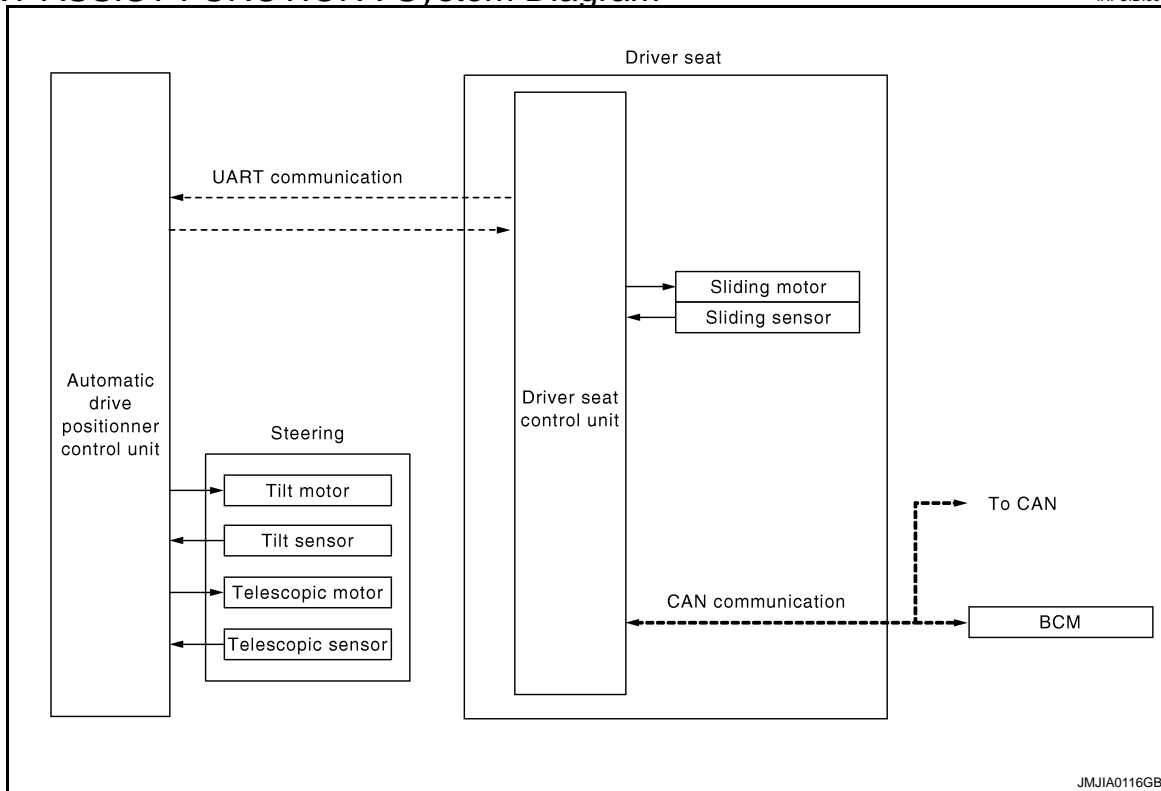

A  
B  
C  
D  
E  
F  
G  
H

## ENTRY ASSIST FUNCTION : System Description

INFOID:000000000960608

### OUTLINE

The seat is in the exiting position when either following condition (A or B) is satisfied, the seat returns from exiting position to the previous driving position.

#### NOTE:

- This function is set to OFF before delivery (initial setting).
- Further information for the system setting procedure. Refer to [ADP-11, "SYSTEM SETTING : Description"](#).

ADP

### OPERATION PROCEDURE

1. A: Turn the ignition switch ON.  
B: Turn the ignition switch from OFF to ACC after closing the driver door.
2. Driver seat and steering column will return from the exiting position to entry position.

K

### OPERATION CONDITION

Satisfy all of the following items. The entry assist function is not performed if these items are not satisfied.

Item	Request status
Seat, steering column	The vehicle is not moved after performing the exit assist function.
Switch inputs <ul style="list-style-type: none"> <li>• Power seat switch</li> <li>• Tilt &amp; telescopic switch</li> <li>• Door mirror control switch</li> <li>• Set switch</li> <li>• Memory switch</li> </ul>	OFF (Not operated)
AT selector lever (only for AT model)	P position
Parking break (only for MT models)	Applied

N

O

P

### DETAIL FLOW

# AUTOMATIC DRIVE POSITIONER SYSTEM

## < FUNCTION DIAGNOSIS >

Order	Input	Output	Control unit condition
1	Door switch/Ignition switch	—	Driver seat control unit receives the signals of [ignition switch signal] and [driver side door switch] from BCM via CAN communication.
2	—	Motors (Sliding, tilt, telescopic)	Driver side control unit operates the sliding motor when the operating conditions are satisfied and requests the operations of tilt motor and telescopic motor to automatic drive positioner control unit via UART communication. The automatic drive positioner operates each motor.
	Sensors (Sliding, tilt, telescopic)	—	Each sensor monitors the operating positions of seat and steering, and then stops the operation of each motor when each part reaches the recorded address.

## ENTRY ASSIST FUNCTION : Component Parts Location

INFOID:000000000960609

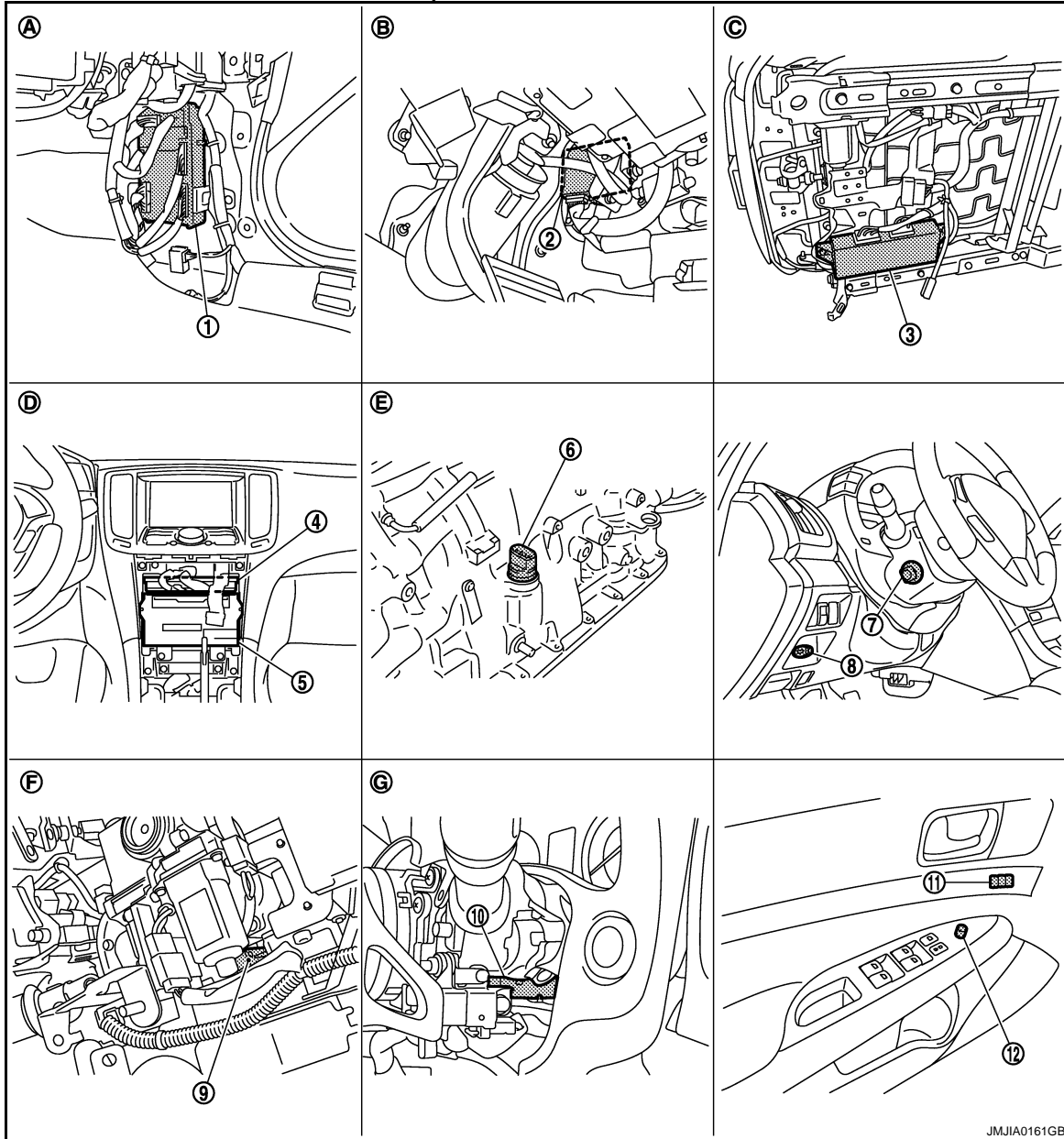

JMJIA0161GB

- |                                   |   |  |
|-----------------------------------|---|--|
| 1. BCM M118, M119, M122, M123     | 2. Automatic drive positioner control unit M51, M52               | 3. Driver seat control unit B451, B452 |
| 4. Unified meter and A/C amp. M67 | 5. AV control unit<br>With NAVI M87, M88<br>Without NAVI M83, M85 | 6. AT assembly connector F51           |
| 7. Tilt & telescopic switch M31   | 8. Key slot M22   | 9. Tilt sensor M48                     |

# AUTOMATIC DRIVE POSITIONER SYSTEM

## < FUNCTION DIAGNOSIS >

- |  |  |  |
|--|--|--|
| 10. Telescopic sensor M48                                  | 11. Seat memory switch D5                          | 12. Door mirror remote control switch D17          |
| A. Dash side lower (Passenger side)                        | B. View with instrument driver lower panel removed | C. Backside of seat cushion (driver side)          |
| D. Behind cluster lid C                                    | E. AT assembly (TCM is built in AT assembly)       | F. View with instrument driver lower panel removed |
| G. View with steering column cover lower and upper removed |  |  |

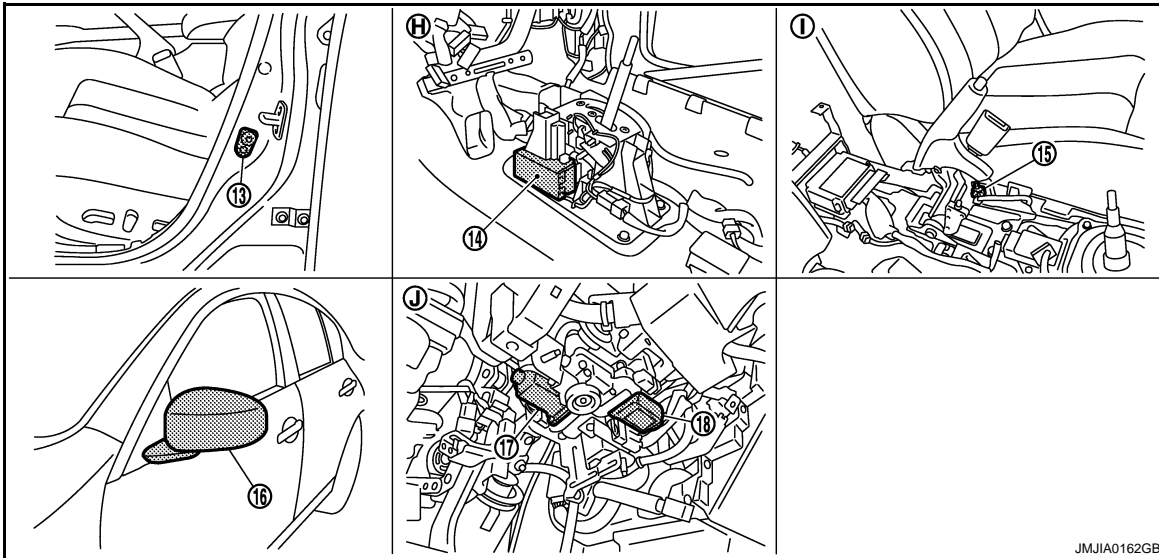

- |  |  |  |
|--|--|--|
| 13. Front door switch (driver side) B16      | 14. AT device (detention switch) M137        | 15. Parking brake switch B14                       |
| 16. Door mirror (driver side) D3             | 17. Telescopic motor M49                     | 18. Tilt motor M49                                 |
| H. View with center console assembly removed | I. View with center console assembly removed | J. View with instrument driver lower panel removed |

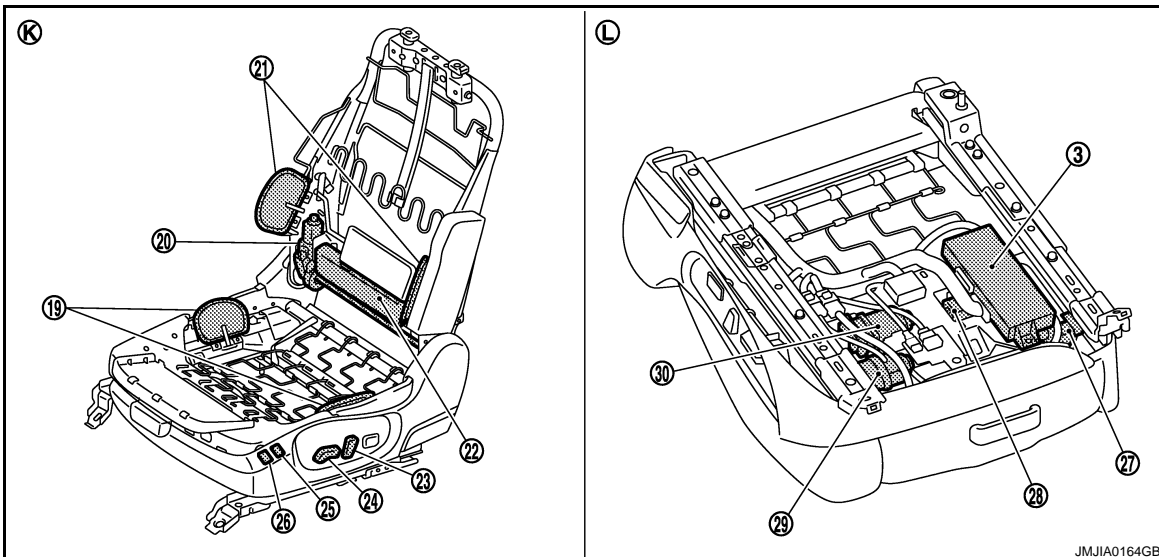

- |  |   |  |
|--|---|--|
| 19. Side support (seat cushion) (Side support unit B420) | 20. Reclining motor B454                      | 21. Side support (seatback) (Side support unit B420) |
| 22. Side support unit B420                               | 23. Reclining switch (Power seat switch B459) | 24. Sliding, lifting switch (Power seat switch B459) |
| 25. Side support switch (seat back side) B419            | 26. Side support switch (cushion side) B419   | 27. Sliding sensor B453                              |

# AUTOMATIC DRIVE POSITIONER SYSTEM

## < FUNCTION DIAGNOSIS >

28. Lifting motor (front) B455      29. Sliding motor B461      30. Lifting motor (rear) B456  
K. View with seat cushion pad and seat-      L. Backside of the seat cushion  
back pad removed

## ENTRY ASSIST FUNCTION : Component Description

INFOID:000000000960610

### CONTROL UNITS

Item	Function
Driver seat control unit	According to the ignition signal and door switch signal (driver side) from BCM, <ul style="list-style-type: none"><li>• Operates the seat sliding motor for a constant amount.</li><li>• Requests the operations of tilt motor and telescopic motor to automatic drive positioner control unit.</li></ul>
Automatic drive positioner control unit	Operates the tilt motor and telescopic motor with the instructions from the driver seat control.
BCM	Recognizes the following status and transmits it to the driver seat control unit via CAN communication. <ul style="list-style-type: none"><li>• Driver door: OPEN/CLOSE</li><li>• Ignition switch position: ACC/ON</li></ul>

### INPUT PARTS

#### Switches

Item	Function
Front door switch (driver side)	Detect front door (driver side) open/close status.

#### Sensors

Item	Function
Tilt & telescopic sensor	Detect the up/down and left/right position of steering column.
Sliding sensor	Detect the front/rear position of seat.

### OUTPUT PARTS

Item	Function
Tilt & telescopic motor	Move the steering column upward/downward and frontward/rearward.
Sliding motor	Slide the seat frontward/rearward.

### INTELLIGENT KEY INTERLOCK FUNCTION



# AUTOMATIC DRIVE POSITIONER SYSTEM

< FUNCTION DIAGNOSIS >

## INTELLIGENT KEY INTERLOCK FUNCTION : System Diagram

INFOID:000000000960611

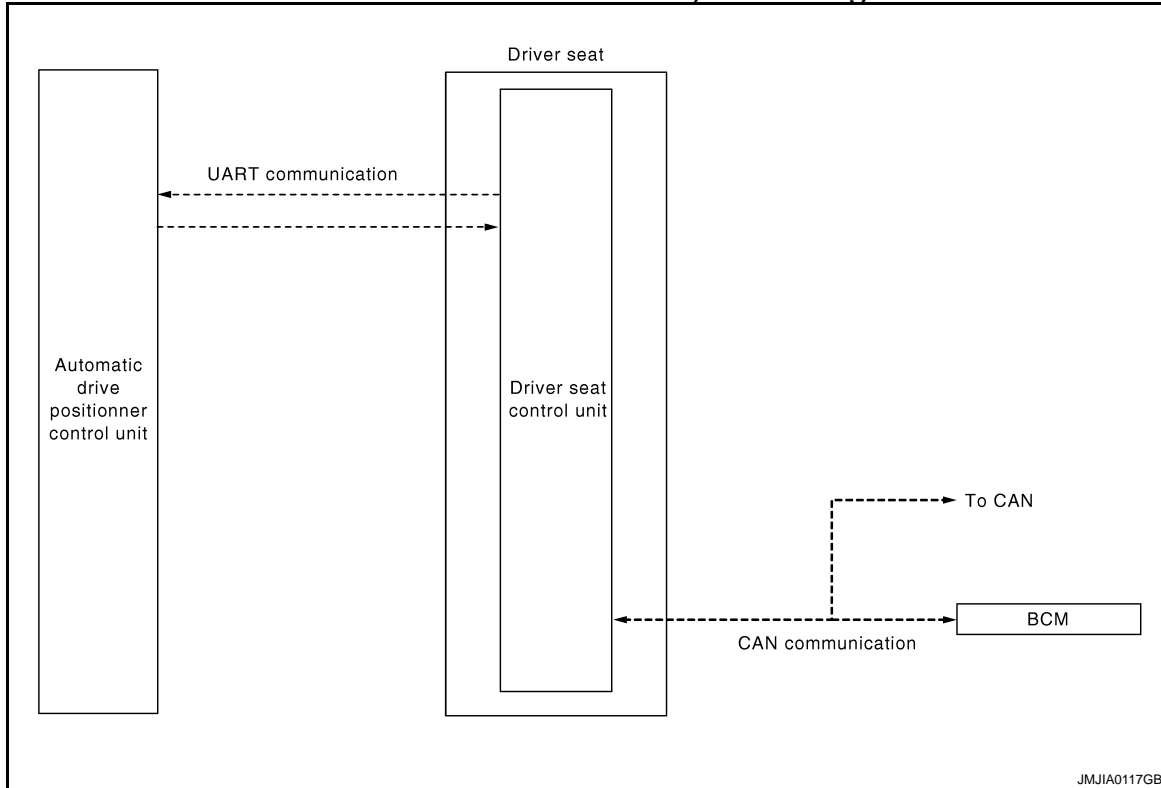

A  
B  
C  
D  
E  
F  
G  
H

## INTELLIGENT KEY INTERLOCK FUNCTION : System Description

INFOID:000000000960612

### OUTLINE

When unlocking doors by using Intelligent Key or driver side door request switch, the system performs memory operation, exiting operation then entry operation.

ADP

### OPERATION PROCEDURE

1. Unlock doors by using Intelligent Key or driver side door request switch.
2. The system performs memory operation, and then performs exit assist operation.

#### NOTE:

If the seat position is in memorized position before unlocking doors, memory operation does not perform.

#### NOTE:

Further information for Intelligent Key interlock function. Refer to [ADP-10. "MEMORY STORING : Description"](#).

K  
L

### OPERATION CONDITION

Satisfy all of the following items. The Intelligent Key interlock function is not performed if these items are not satisfied.

Item	Request status
Ignition position	OFF
System setting [Entry/exit function (seat/steering)]	ON
Key switch	OFF (Key is removed.)
Switch inputs <ul style="list-style-type: none"> <li>• Power seat switch</li> <li>• Tilt &amp; telescopic switch</li> <li>• Door mirror control switch</li> <li>• Set switch</li> <li>• Memory switch</li> </ul>	OFF (Not operated)
AT selector lever (only for AT model)	P position
Parking break (only for MT models)	Applied

M  
N  
O  
P

# AUTOMATIC DRIVE POSITIONER SYSTEM

## < FUNCTION DIAGNOSIS >

### DETAIL FLOW

Order	Input	Output	Control unit condition
1	<ul style="list-style-type: none"> <li>• Door unlock signal (CAN)</li> <li>• Key ID signal (CAN)</li> </ul>	—	Driver seat control unit receives the door unlock signal and the key ID signal from BCM when unlocking the door with Intelligent Key or driver side door request switch.
2	—	—	Driver seat control unit performs the memory function.
3	—	—	Driver seat control unit performs the exit assist function after performing the memory function.
4	—	—	Driver seat control unit performs the entry assist function.

## INTELLIGENT KEY INTERLOCK FUNCTION : Component Parts Location INFOID:000000000960613

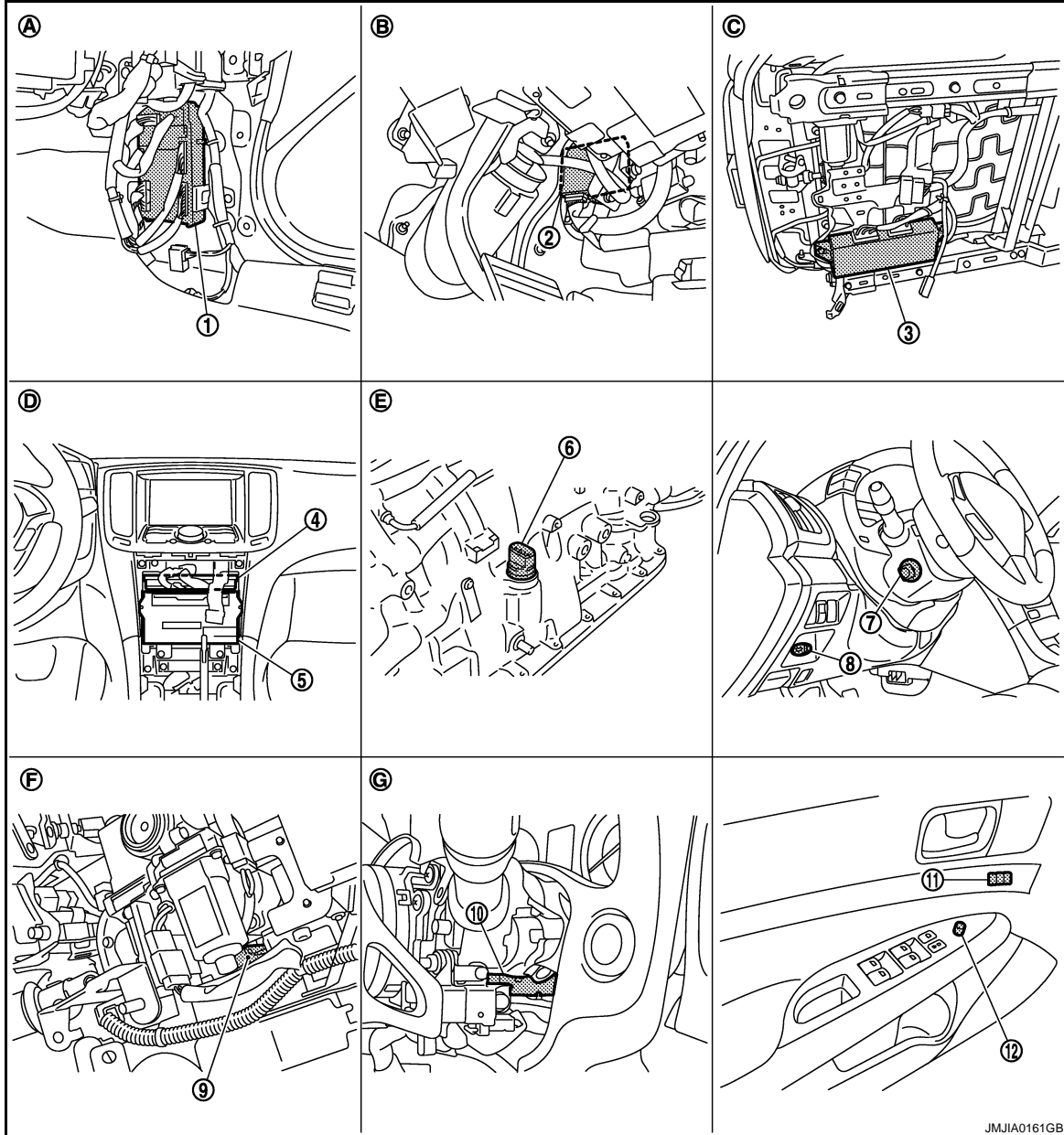

JMJIA0161GB

- |                                   |   |  |
|-----------------------------------|---|--|
| 1. BCM M118, M119, M122, M123     | 2. Automatic drive positioner control unit M51, M52               | 3. Driver seat control unit B451, B452 |
| 4. Unified meter and A/C amp. M67 | 5. AV control unit<br>With NAVI M87, M88<br>Without NAVI M83, M85 | 6. AT assembly connector F51           |
| 7. Tilt & telescopic switch M31   | 8. Key slot M22   | 9. Tilt sensor M48                     |

# AUTOMATIC DRIVE POSITIONER SYSTEM

## < FUNCTION DIAGNOSIS >

- |  |  |  |
|--|--|--|
| 10. Telescopic sensor M48                                  | 11. Seat memory switch D5                          | 12. Door mirror remote control switch D17          |
| A. Dash side lower (Passenger side)                        | B. View with instrument driver lower panel removed | C. Backside of seat cushion (driver side)          |
| D. Behind cluster lid C                                    | E. AT assembly (TCM is built in AT assembly)       | F. View with instrument driver lower panel removed |
| G. View with steering column cover lower and upper removed |  |  |

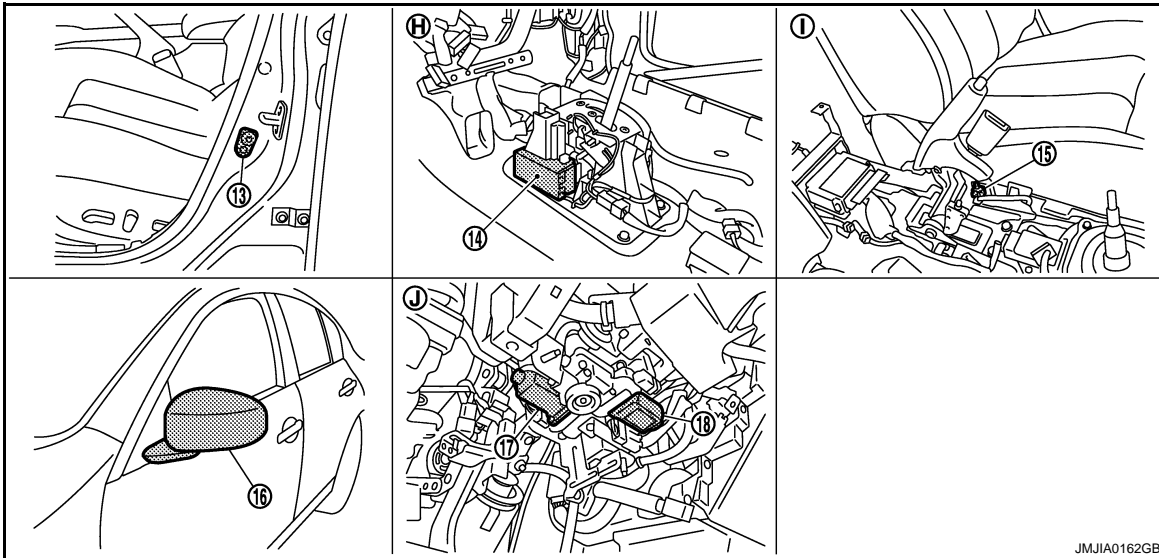

- |  |  |  |
|--|--|--|
| 13. Front door switch (driver side) B16      | 14. AT device (detention switch) M137        | 15. Parking brake switch B14                       |
| 16. Door mirror (driver side) D3             | 17. Telescopic motor M49                     | 18. Tilt motor M49                                 |
| H. View with center console assembly removed | I. View with center console assembly removed | J. View with instrument driver lower panel removed |

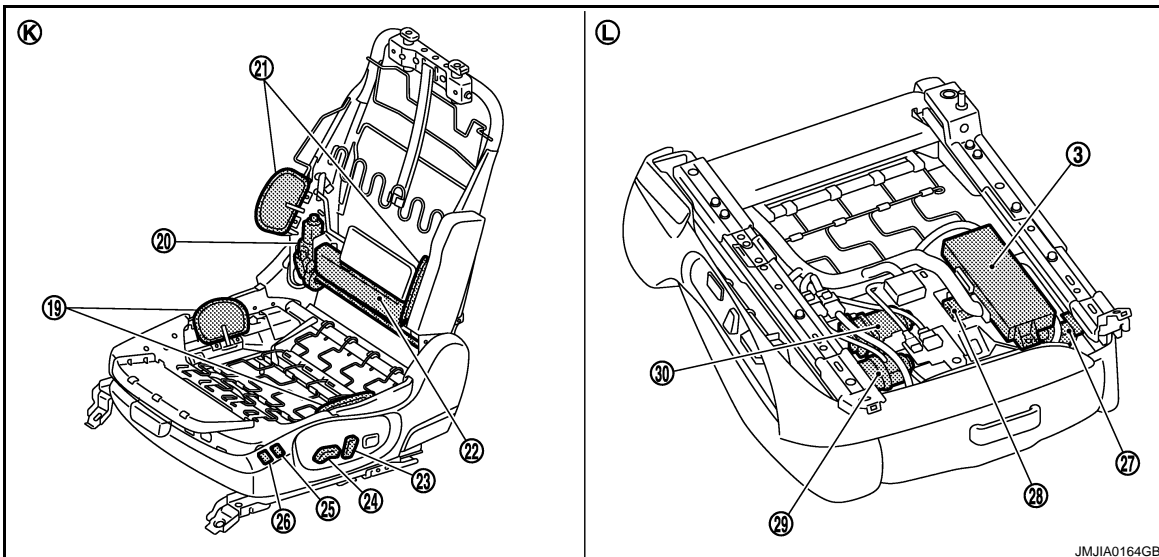

- |  |   |  |
|--|---|--|
| 19. Side support (seat cushion) (Side support unit B420) | 20. Reclining motor B454                      | 21. Side support (seatback) (Side support unit B420) |
| 22. Side support unit B420                               | 23. Reclining switch (Power seat switch B459) | 24. Sliding, lifting switch (Power seat switch B459) |
| 25. Side support switch (seat back side) B419            | 26. Side support switch (cushion side) B419   | 27. Sliding sensor B453                              |

# AUTOMATIC DRIVE POSITIONER SYSTEM

## < FUNCTION DIAGNOSIS >

28. Lifting motor (front) B455                      29. Sliding motor B461                      30. Lifting motor (rear) B456  
K. View with seat cushion pad and seat- L. Backside of the seat cushion  
back pad removed

## INTELLIGENT KEY INTERLOCK FUNCTION : Component Description

INFOID:000000000960614

### CONTROL UNITS

Item	Function
Driver seat control unit	It performs memory function and entry/exit assist function after receiving the door unlock signal from BCM.
Automatic drive positioner control unit	Operates the steering column and door mirror with the instructions from the driver seat control unit.
BCM	Recognizes the following status and transmits it to the driver seat control unit via CAN communication. <ul style="list-style-type: none"><li>• Door lock: UNLOCK (with Intelligent Key or driver side door request switch)</li></ul>

## SIDE SUPPORT SYSTEM

### SIDE SUPPORT SYSTEM : System Description

INFOID:000000000960615

#### OUTLINE

- While operating the side support switch, the pump located inside side support unit operates and adjust their pressure in seat cushion and seatback side support.
- It is possible to soften the side support, by allowing some air to escape, by deflating the solenoid located in side support.
- It is possible to adjust seat cushion and seatback differently while inflating or deflating solenoid located inside support unit.

#### NOTE:

The side support system is controlled independently with no link to the automatic drive positioner system.

# AUTOMATIC DRIVE POSITIONER SYSTEM

< FUNCTION DIAGNOSIS >

## SIDE SUPPORT SYSTEM : Component Parts Location

INFOID:000000000960616

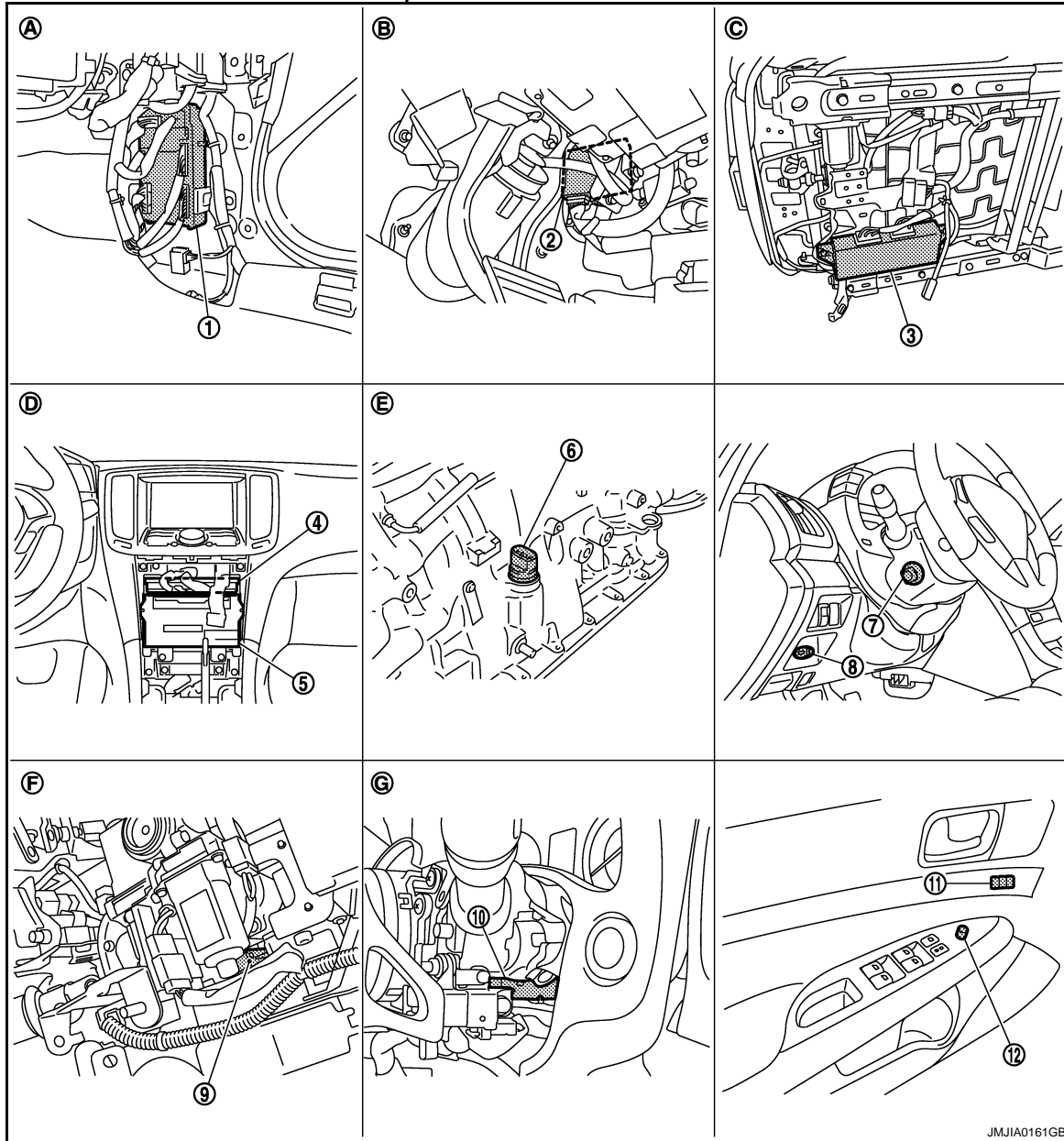

- |  |   |  |
|--|---|--|
| 1. BCM M118, M119, M122, M123                              | 2. Automatic drive positioner control unit M51, M52               | 3. Driver seat control unit B451, B452             |
| 4. Unified meter and A/C amp. M67                          | 5. AV control unit<br>With NAVI M87, M88<br>Without NAVI M83, M85 | 6. AT assembly connector F51                       |
| 7. Tilt & telescopic switch M31                            | 8. Key slot M22   | 9. Tilt sensor M48                                 |
| 10. Telescopic sensor M48                                  | 11. Seat memory switch D5   | 12. Door mirror remote control switch D17          |
| A. Dash side lower (Passenger side)                        | B. View with instrument driver lower panel removed                | C. Backside of seat cushion (driver side)          |
| D. Behind cluster lid C                                    | E. AT assembly (TCM is built in AT assembly)                      | F. View with instrument driver lower panel removed |
| G. View with steering column cover lower and upper removed |   |  |

# AUTOMATIC DRIVE POSITIONER SYSTEM

## < FUNCTION DIAGNOSIS >

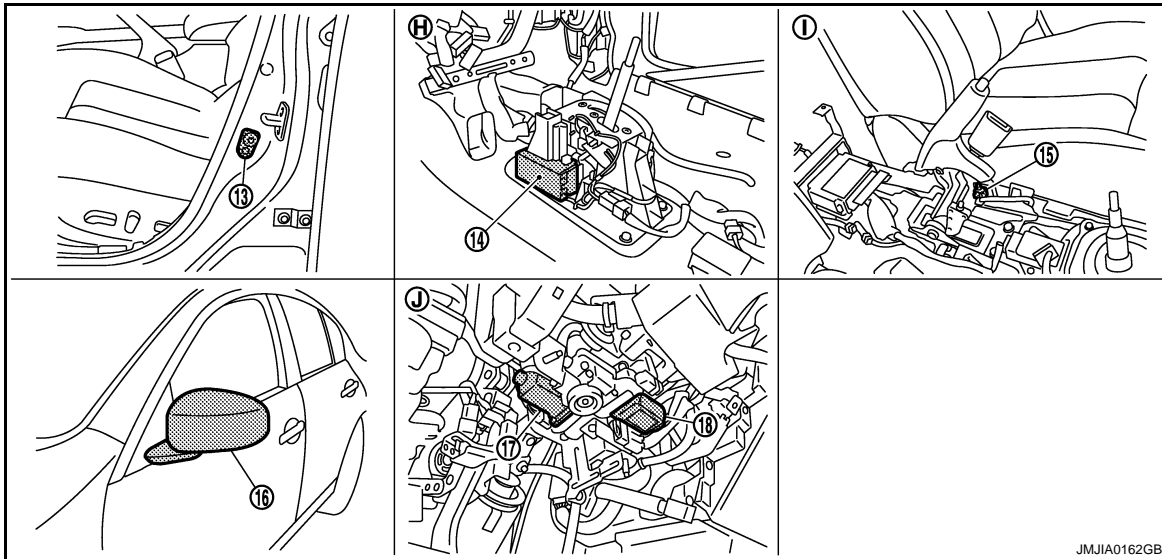

JMJIA0162GB

- |  |  |  |
|--|--|--|
| 13. Front door switch (driver side) B16      | 14. AT device (detention switch) M137        | 15. Parking brake switch B14                       |
| 16. Door mirror (driver side) D3             | 17. Telescopic motor M49                     | 18. Tilt motor M49                                 |
| H. View with center console assembly removed | I. View with center console assembly removed | J. View with instrument driver lower panel removed |

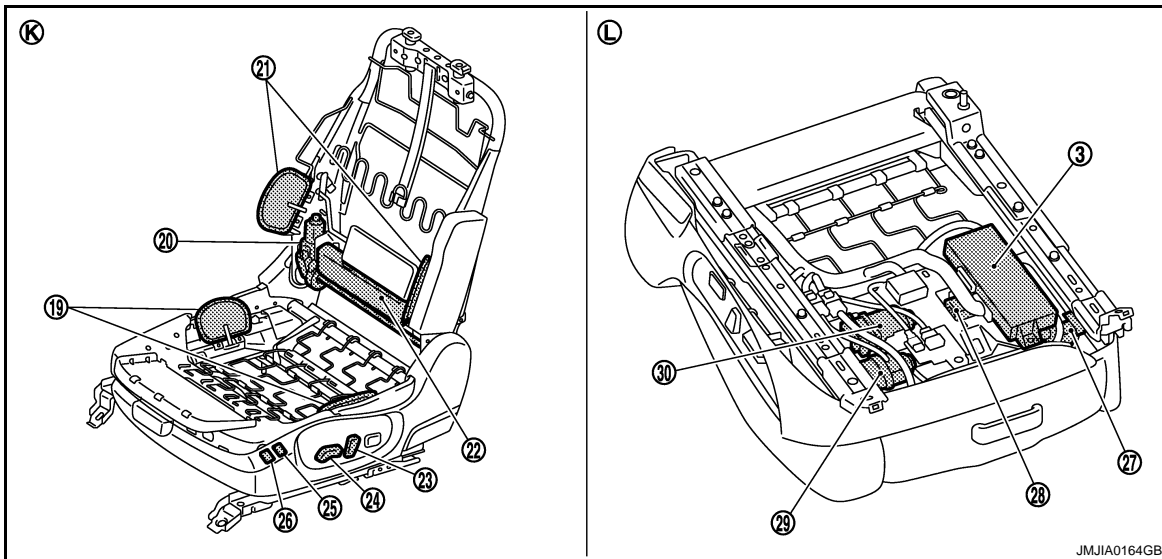

JMJIA0164GB

- |   |  |   |
|---|--|---|
| 19. Side support (seat cushion)<br>(Side support unit B420) | 20. Reclining motor B454                         | 21. Side support (seatback)<br>(Side support unit B420) |
| 22. Side support unit B420                                  | 23. Reclining switch<br>(Power seat switch B459) | 24. Sliding, lifting switch<br>(Power seat switch B459) |
| 25. Side support switch (seat back side)<br>B419            | 26. Side support switch (cushion side)<br>B419   | 27. Sliding sensor B453                                 |
| 28. Lifting motor (front) B455                              | 29. Sliding motor B461                           | 30. Lifting motor (rear) B456                           |
| K. View with seat cushion pad and seat-back pad removed     | L. Backside of the seat cushion                  |   |

## SIDE SUPPORT SYSTEM : Component Description

INFOID:000000000960617

### CONTROL UNITS

# AUTOMATIC DRIVE POSITIONER SYSTEM

## < FUNCTION DIAGNOSIS >

Item	Function
Side support unit	Built in pump, pump relay and solenoid, operates when pressing ON/OFF on side support switch.
Side support switch	With a built-in cushion side and seat back side, controls the power supplied to pump and to each solenoid.

A

B

C

D

E

F

G

H

I

ADP

K

L

M

N

O

P

# DIAGNOSIS SYSTEM (DRIVER SEAT C/U)

< FUNCTION DIAGNOSIS >

## DIAGNOSIS SYSTEM (DRIVER SEAT C/U)

### Diagnosis Description

INFOID:000000000960618

The auto drive positioner system can be checked and diagnosed for component operation with CONSULT-III.

### DIAGNOSTIC MODE

Diagnostic mode [AUTO DRIVE POS.]	Description
WORK SUPPORT	Changes the setting of each function.
SELF-DIAG RESULTS	Performs self-diagnosis for the auto drive positioner system and displays the results.
DATA MONITOR	Displays input signals transmitted from various switches and sensors to driver seat control unit in real time.
CAN DIAG SUPPORT MNTR	The result of transmit/receive diagnosis of CAN communication can be read.
ACTIVE TEST	Drive each output device.
ECU PART NUMBER	Displays part numbers of driver seat control unit parts.

### CONSULT-III Function

INFOID:000000000960619

### SELF-DIAGNOSIS RESULTS

Refer to [ADP-156. "DTC Index"](#).

### DATA MONITOR

Monitor Item	Unit	Main Signals	Selection From Menu	Contents
SET SW	"ON/OFF"	×	×	ON/OFF status judged from the setting switch signal.
MEMORY SW 1	"ON/OFF"	×	×	ON/OFF status judged from the seat memory switch 1 signal.
MEMORY SW 2	"ON/OFF"	×	×	ON/OFF status judged from the seat memory switch 2 signal.
SLIDE SW-FR	"ON/OFF"	×	×	ON/OFF status judged from the sliding switch (forward) signal.
SLIDE SW-RR	"ON/OFF"	×	×	ON/OFF status judged from the sliding switch (backward) signal.
RECLN SW-FR	"ON/OFF"	×	×	ON/OFF status judged from the reclining switch (forward) signal.
RECLN SW-RR	"ON/OFF"	×	×	ON/OFF status judged from the reclining switch (backward) signal.
LIFT FR SW-UP	"ON/OFF"	×	×	ON/OFF status judged from the lifting switch front (up) signal.
LIFT FR SW-DN	"ON/OFF"	×	×	ON/OFF status judged from the lifting switch front (down) signal.
LIFT RR SW-UP	"ON/OFF"	×	×	ON/OFF status judged from the lifting switch rear (up) signal.
LIFT RR SW-DN	"ON/OFF"	×	×	ON/OFF status judged from the lifting switch rear (down) signal.
MIR CON SW-UP	"ON/OFF"	×	×	ON/OFF status judged from the mirror switch (up) signal.
MIR CON SW-DN	"ON/OFF"	×	×	ON/OFF status judged from the mirror switch (down) signal.
MIR CON SW-RH	"ON/OFF"	×	×	ON/OFF status judged from the door mirror remote control switch (passenger side) signal.
MIR CON SW-LH	"ON/OFF"	×	×	ON/OFF status judged from the door mirror remote control switch (driver side) signal.



# DIAGNOSIS SYSTEM (DRIVER SEAT C/U)

## < FUNCTION DIAGNOSIS >

Monitor Item	Unit	Main Signals	Selection From Menu	Contents
MIR CHNG SW-R	"ON/OFF"	×	×	ON/OFF status judged from the door mirror remote control switch (switching to right) signal.
MIR CHNG SW-L	"ON/OFF"	×	×	ON/OFF status judged from the door mirror remote control switch (switching to left) signal.
TILT SW-UP	"ON/OFF"	×	×	ON/OFF status judged from the tilt switch (up) signal.
TILT SW-DOWN	"ON/OFF"	×	×	ON/OFF status judged from the tilt switch (down) signal.
TELESCO SW-FR	"ON/OFF"	×	×	ON/OFF status judged from the telescoping switch (forward) signal.
TELESCO SW-RR	"ON/OFF"	×	×	ON/OFF status judged from the telescoping switch (backward) signal.
DETENT SW* <sup>1</sup>	"ON/OFF"	×	×	The selector lever position "OFF (P position) / ON (other than P position)" judged from the detention switch signal.
PARK BRAKE SW* <sup>2</sup>	"ON/OFF"	×	×	The parking brake condition "ON (applied) / OFF (release)" judged from the parking brake switch signal.
STARTER SW	"ON/OFF"	×	×	Ignition key switch ON (START, ON) / OFF (ACC, OFF) status judged from the ignition switch signal.
SLIDE PULSE	—	—	×	Value (32768) when battery connections are standard. If it moves backward, the value increases. If it moves forward, the value decreases.
RECLN PULSE	—	—	×	Value (32768) when battery connections are standard. If it moves backward, the value increases. If it moves forward, the value decreases.
LIFT FR PULSE	—	—	×	Value (32768) when battery connections are standard. If it moves DOWN, the value increases. If it moves UP, the value decreases.
LIFT RR PULSE	—	—	×	Value (32768) when battery connections are standard. If it moves DOWN, the value increases. If it moves UP, the value decreases.
MIR/SEN RH U-D	"V"	—	×	Voltage input from door mirror sensor (passenger side) up/down is displayed.
MIR/SEN RH R-L	"V"	—	×	Voltage input from door mirror sensor (passenger side) left/right is displayed.
MIR/SEN LH U-D	"V"	—	×	Voltage input from door mirror sensor (driver side) up/down is displayed.
MIR/SEN LH R-L	"V"	—	×	Voltage input from door mirror sensor (driver side) left/right is displayed.
TILT SEN	"V"	—	×	Voltage input from tilt sensor is displayed.
TELESCO SEN	"V"	—	×	Voltage input from telescopic sensor is displayed.

\*<sup>1</sup>:Only for AT models.

\*<sup>2</sup>:Only for MT models.

### ACTIVE TEST

#### CAUTION:

**When driving vehicle, do not perform active test.**

Test item	Description
SEAT SLIDE	Activates/deactivates the sliding motor.
SEAT RECLINING	Activates/deactivates the reclining motor.
SEAT LIFTER FR	Activates/deactivates the lifting motor (front).
SEAT LIFTER RR	Activates/deactivates the lifting motor (rear).
TILT MOTOR	Activates/deactivates the tilt motor.

## DIAGNOSIS SYSTEM (DRIVER SEAT C/U)

### < FUNCTION DIAGNOSIS >

Test item	Description
TELESCO MOTOR	Activates/deactivates the telescopic motor.
MIRROR MOTOR RH	Activates/deactivates the mirror motor (passenger side).
MIRROR MOTOR LH	Activates/deactivates the mirror motor (driver side).
MEMORY SW INDCTR	Turns ON/OFF the memory indicator.

### WORK SUPPORT

**NOTE:**

This mode is only for AT model.

Work item	Content	Item
SEAT SLIDE VOLUME SET	The amount of seat sliding for entry/exit assist can be selected from 3 items.	40 mm
		80 mm
		150 mm
EXIT TILT SETTING	Entry/exit assist (steering column) can be selected: ON (operated) – OFF (not operated)	ON
		OFF
EXIT SEAT SLIDE SETTING	Entry/exit assist (seat) can be selected: ON (operated) – OFF (not operated)	ON
		OFF

# U1000 CAN COMM CIRCUIT

< COMPONENT DIAGNOSIS >

## COMPONENT DIAGNOSIS

### U1000 CAN COMM CIRCUIT

#### Description

INFOID:000000000960620

CAN (Controller Area Network) is a serial communication line for real time applications. It is an on-vehicle multiplex communication line with high data communication speed and excellent error detection ability. Modern vehicle is equipped with many electronic control unit, and each control unit shares information and links with other control units during operation (not independent). In CAN communication, control units are connected with 2 communication lines (CAN H-line, CAN L-line) allowing a high rate of information transmission with less wiring. Each control unit transmits/receives data but selectively reads required data only. CAN Communication Signal Chart. Refer to [LAN-28, "CAN Communication Signal Chart"](#).

#### DTC Logic

INFOID:000000000960621

#### DTC DETECTION LOGIC

DTC	Trouble diagnosis name	DTC detecting condition	Possible cause
U1000	CAN COMM CIRCUIT	<ul style="list-style-type: none"><li>• Driver seat control unit cannot communicate to other control units.</li><li>• Driver seat control unit cannot communicate for more than the specified time.</li></ul>	<ul style="list-style-type: none"><li>• Harness or connectors (CAN communication line is open or shorted)</li></ul>

#### DTC CONFIRMATION PROCEDURE

##### 1.STEP 1

Turn ignition switch ON and wait at least 3 seconds.

>> GO TO 2.

##### 2.STEP 2

Check "Self diagnostic result" with CONSULT-III.

Is the DTC detected?

- YES >> Perform diagnosis procedure. Refer to [ADP-51, "Diagnosis Procedure"](#).  
NO >> INSPECTION END

#### Diagnosis Procedure

INFOID:000000000960622

Refer to [LAN-18, "Trouble Diagnosis Flow Chart"](#).

#### Special Repair Requirement

INFOID:000000000960623

Refer to [ADP-9, "SYSTEM INITIALIZATION : Description"](#).

# B2112 SLIDING MOTOR

< COMPONENT DIAGNOSIS >

## B2112 SLIDING MOTOR

### Description

INFOID:000000000960624

- The seat sliding motor is installed to the seat cushion frame.
- The seat sliding motor is installed with the driver seat control unit.
- Slides the seat frontward/ rearward by changing the rotation direction of sliding motor.

### DTC Logic

INFOID:000000000960625

### DTC DETECTION LOGIC

DTC No.	Trouble diagnosis name	DTC detecting condition	Possible cause
P2112	SEAT SLIDE	The driver seat control unit detects the output of sliding motor output terminal for 0.1 second or more even if the sliding switch is not input.	<ul style="list-style-type: none"><li>• Driver seat control unit</li></ul>

### DTC CONFIRMATION PROCEDURE

#### 1.STEP 1

Turn ignition switch ON.

>> GO TO 2.

#### 2.STEP 2

Check "Self diagnostic result" with CONSULT-III.

Is the DTC detected?

YES >> Perform diagnosis procedure. Refer to [ADP-52, "Diagnosis Procedure"](#).

NO >> INSPECTION END

#### NOTE:

First perform diagnosis for B2126 or B2127 if B2126 or B2127 is detected.

### Diagnosis Procedure

INFOID:000000000960626

#### 1.PERFORM DTC CONFIRMATION PROCEDURE

1. Turn ignition switch ON.
2. Check "Self diagnostic result" with CONSULT-III.
3. Erase the DTC.
4. Perform DTC confirmation procedure. Refer to [ADP-52, "DTC Logic"](#).

Is the DTC displayed again?

YES >> GO TO 2.

NO >> Check intermittent incident. Refer to [GI-39, "Intermittent Incident"](#).

#### 2.REPLACE DRIVER SEAT CONTROL UNIT

Replace driver seat control unit. Refer to [ADP-217, "Removal and Installation"](#).

>> INSPECTION END

# B2113 RECLINING MOTOR

< COMPONENT DIAGNOSIS >

## B2113 RECLINING MOTOR

### Description

INFOID:000000000960627

- The seat reclining motor is installed to the seatback frame.
- The seat reclining motor is activated with the driver seat control unit.
- Tilts the seatback frontward/rearward by changing the rotation direction of reclining motor.

### DTC Logic

INFOID:000000000960628

### DTC DETECTION LOGIC

DTC No.	Trouble diagnosis name	DTC detecting condition	Possible cause
P2113	SEAT RECLINING	The driver seat control unit detects the output of reclining motor output terminal for 0.1 second or more even if the reclining switch is not input.	<ul style="list-style-type: none"><li>• Driver seat control unit</li></ul>

### DTC CONFIRMATION PROCEDURE

#### 1.STEP 1

Turn ignition switch ON.

>> GO TO 2.

#### 2.STEP 2

Check "Self diagnostic result" with CONSULT-III.

Is the DTC detected?

YES >> Perform diagnosis procedure. Refer to [ADP-53, "Diagnosis Procedure"](#).

NO >> INSPECTION END

#### NOTE:

First perform diagnosis for B2126 or B2127 if B2126 or B2127 is detected.

### Diagnosis Procedure

INFOID:000000000960629

#### 1.PERFORM DTC CONFIRMATION PROCEDURE

1. Turn ignition switch ON.
2. Check "Self diagnostic result" with CONSULT-III.
3. Erase the DTC.
4. Perform DTC confirmation procedure. Refer to [ADP-53, "DTC Logic"](#).

Is the DTC displayed again?

YES >> GO TO 2.

NO >> Check intermittent incident. Refer to [GI-39, "Intermittent Incident"](#).

#### 2.REPLACE DRIVER SEAT CONTROL UNIT

Replace driver seat control unit. Refer to [ADP-217, "Removal and Installation"](#).

>> INSPECTION END

# B2118 TILT SENSOR

< COMPONENT DIAGNOSIS >

## B2118 TILT SENSOR

### Description

INFOID:000000000960630

- The tilt sensor is installed to the steering column assembly.
- The resistance of tilt sensor is changed according to the up/down position of steering column.
- The terminal voltage of automatic drive positioner control unit will be changed according to a change of tilt sensor resistance. Automatic drive positioner control unit calculates the tilt position from the voltage.

### DTC Logic

INFOID:000000000960631

### DTC DETECTION LOGIC

DTC No.	Trouble diagnosis name	DTC detecting condition	Possible cause
P2118	TILT SENSOR	The input voltage of tilt sensor is 0.1V or less or 4.9V or more.	<ul style="list-style-type: none"><li>• Harness and connectors (Tilt sensor circuit is opened/shorted, tilt sensor power supply circuit is opened/shorted.)</li><li>• Tilt sensor</li></ul>

### DTC CONFIRMATION PROCEDURE

#### 1.STEP 1

Turn ignition switch ON.

>> GO TO 2.

#### 2.STEP 2

Check "Self diagnostic result" with CONSULT-III.

Is the DTC detected?

- YES >> Perform diagnosis procedure. Refer to [ADP-54. "Diagnosis Procedure"](#).  
NO >> INSPECTION END

### Diagnosis Procedure

INFOID:000000000960632

#### 1.CHECK TILT SENSOR SIGNAL

1. Turn ignition switch ON.
2. Select "TILT SEN" in "Data monitor" mode with CONSULT-III.
3. Check tilt sensor signal under the following condition.

Monitor item	Condition	Value	
TILT SEN	Tilt position	Top	1.2 [V]
		Bottom	3.4 [V]

Is the value normal?

- YES >> GO TO 7.  
NO >> GO TO 2.

#### 2.CHECK TILT SENSOR CIRCUIT

1. Turn ignition switch OFF.
2. Disconnect automatic drive positioner control unit and tilt & telescopic sensor connector.
3. Check continuity between automatic drive positioner control unit harness connector and tilt & telescopic sensor harness connector.

Automatic drive positioner control unit connector	Terminal	Tilt & telescopic sensor connector	Terminal	Continuity
M51	7	M48	3	Existed

## B2118 TILT SENSOR

### < COMPONENT DIAGNOSIS >

4. Check continuity between automatic drive positioner control unit harness connector and ground.

Automatic drive positioner control unit connector	Terminal	Ground	Continuity
M51	7		Not existed

Is the inspection result normal?

YES >> GO TO 3.

NO >> Repair or replace harness.

### 3. CHECK TILT SENSOR POWER SUPPLY

1. Connect automatic drive positioner control unit connector.
2. Turn ignition switch ON.
3. Check voltage between tilt & telescopic sensor harness connector and ground.

Terminals		Voltage (V) (Approx.)
(+)	(-)	
Tilt & telescopic sensor	Terminal	
M48	1	Ground 5

Is the inspection result normal?

YES >> GO TO 5.

NO >> GO TO 4.

### 4. CHECK TILT SENSOR POWER SUPPLY CIRCUIT

1. Turn ignition switch OFF.
2. Disconnect automatic drive positioner control unit connector.
3. Check continuity between automatic drive positioner control unit harness connector and tilt & telescopic sensor harness connector.

Automatic drive positioner control unit connector	Terminal	Tilt & telescopic sensor connector	Terminal	Continuity
M52	33	M48	1	Existed

4. Check continuity between automatic drive positioner control unit harness connector and ground.

Automatic drive positioner control unit connector	Terminal	Ground	Continuity
M52	33		Not existed

Is the inspection result normal?

YES >> GO TO 6.

NO >> Repair or replace harness.

### 5. CHECK TILT SENSOR GROUND CIRCUIT

1. Turn ignition switch OFF.
2. Disconnect automatic drive positioner control unit connector.
3. Check continuity between automatic drive positioner control unit harness connector and tilt & telescopic sensor harness connector.

Automatic drive positioner control unit connector	Terminal	Tilt & telescopic sensor connector	Terminal	Continuity
M52	41	M48	4	Existed

Is the inspection result normal?

YES >> GO TO 6.

NO >> Repair or replace harness.

### 6. CHECK DOOR MIRROR OPERATION

1. Connect automatic drive positioner control unit connector and tilt & telescopic sensor connector.

## B2118 TILT SENSOR

### < COMPONENT DIAGNOSIS >

---

2. Turn ignition switch ON.
3. Check door mirror operation with memory function.

#### Is the operation normal?

- YES >> Replace tilt & telescopic sensor. (Built in steering column assembly.)  
NO >> Replace automatic drive positioner control unit.

### **7**.CHECK INTERMITTENT INCIDENT

---

Refer to [GI-39. "Intermittent Incident"](#).

#### Is the inspection result normal?

- YES >> Replace automatic drive positioner control unit.  
NO >> Repair or replace the malfunctioning part.



# B2119 TELESCOPIC SENSOR

< COMPONENT DIAGNOSIS >

## B2119 TELESCOPIC SENSOR

### Description

INFOID:000000000960633

- The telescopic sensor is installed to the steering column assembly.
- The resistance of telescopic sensor is changed according to the forward/backward position of steering column.
- The terminal voltage of automatic drive positioner control unit will be changed according to a change of telescopic sensor resistance. Automatic drive positioner control unit calculates the telescopic position from the voltage.

### DTC Logic

INFOID:000000000960634

### DTC DETECTION LOGIC

DTC No.	Trouble diagnosis name	DTC detecting condition	Possible cause
P2119	TELESCOPIC SENSOR	The input voltage of telescopic sensor is 0.1V or less or 4.9V or more.	<ul style="list-style-type: none"><li>• Harness and connectors (Telescopic sensor circuit is opened/shorted, telescopic sensor power supply circuit is opened/shorted.)</li><li>• Telescopic sensor</li></ul>

### DTC CONFIRMATION PROCEDURE

#### 1.STEP 1

Turn ignition switch ON.

>> GO TO 2.

#### 2.STEP 2

Check "Self diagnostic result" with CONSULT-III.

Is the DTC is detected?

- YES >> Perform diagnosis procedure. Refer to [ADP-57, "Diagnosis Procedure"](#).  
NO >> INSPECTION END

### Diagnosis Procedure

INFOID:000000000960635

#### 1.CHECK TELESCOPIC SENSOR SIGNAL

1. Turn ignition switch ON.
2. Select "TELESCO SEN" in "Data monitor" mode with CONSULT-III.
3. Check the tilt sensor signal under the following condition.

Monitor item	Condition	Value
TELESCO SEN	Rear	0.8 [V]
	Front	3.4 [V]

Is the valve normal?

- YES >> GO TO 7.  
NO >> GO TO 2.

#### 2.CHECK TELESCOPIC SENSOR CIRCUIT

1. Turn ignition switch OFF.
2. Disconnect automatic drive positioner control unit and tilt & telescopic sensor connector.
3. Check continuity between automatic drive positioner control unit harness connector and tilt & telescopic sensor harness connector.

## B2119 TELESCOPIC SENSOR

### < COMPONENT DIAGNOSIS >

Automatic drive positioner control unit connector	Terminal	Tilt & telescopic sensor connector	Terminal	Continuity
M51	23	M48	2	Existed

4. Check continuity between automatic drive positioner control unit harness connector and ground.

Automatic drive positioner control unit connector	Terminal	Ground	Continuity
M51	23		Not existed

Is the inspection result normal?

YES >> GO TO 3.

NO >> Repair or replace harness.

### 3. CHECK TELESCOPIC SENSOR POWER SUPPLY

1. Connect automatic drive positioner control unit connector.
2. Turn ignition switch ON.
3. Check voltage between tilt & telescopic sensor harness connector and ground.

Terminals			Voltage (V) (Approx.)
(+)		(-)	
Tilt & telescopic sensor	Terminal		
M48	2	Ground	5

Is the inspection result normal?

YES >> GO TO 5.

NO >> GO TO 4.

### 4. CHECK TELESCOPIC SENSOR POWER SUPPLY CIRCUIT

1. Turn ignition switch OFF.
2. Disconnect automatic drive positioner control unit connector.
3. Check continuity between automatic drive positioner control unit harness connector and tilt & telescopic sensor harness connector.

Automatic drive positioner control unit connector	Terminal	Tilt & telescopic sensor connector	Terminal	Continuity
M52	33	M48	1	Existed

4. Check continuity between automatic drive positioner control unit harness connector and ground.

Automatic drive positioner control unit connector	Terminal	Ground	Continuity
M52	33		Not existed

Is the inspection result normal?

YES >> GO TO 6.

NO >> Repair or replace harness.

### 5. CHECK TELESCOPIC SENSOR GROUND CIRCUIT

1. Turn ignition switch OFF.
2. Disconnect automatic drive positioner control unit connector.
3. Check continuity between automatic drive positioner control unit harness connector and tilt & telescopic sensor harness connector.

Automatic drive positioner control unit connector	Terminal	Tilt & telescopic sensor connector	Terminal	Continuity
M52	41	M48	4	Existed

Is the inspection result normal?

YES >> GO TO 6.

## B2119 TELESCOPIC SENSOR

### < COMPONENT DIAGNOSIS >

---

NO >> Repair or replace harness.

#### 6.CHECK DOOR MIRROR OPERATION

---

1. Connect automatic drive positioner control unit connector and tilt & telescopic sensor connector.
2. Turn ignition switch ON
3. Check door mirror operation with memory function.

Is the operation normal?

YES >> Replace tilt & telescopic sensor. (Built in steering column assembly.)

NO >> Repair or replace harness.

#### 7.CHECK INTERMITTENT INCIDENT

---

Refer to [GI-39. "Intermittent Incident"](#).

Is the inspection result normal?

YES >> Replace automatic drive positioner control unit.

NO >> Repair or replace the malfunctioning part.

A

B

C

D

E

F

G

H

I

ADP

K

L

M

N

O

P

# B2126 DETENT SW

< COMPONENT DIAGNOSIS >

## B2126 DETENT SW

### Description

INFOID:000000000960636

- Detention switch is installed on AT device. It is turned OFF when the AT selector lever is in P position.
- The driver seat control unit judges that the AT selector lever is in P position if continuity does not exist in this circuit.

### DTC Logic

INFOID:000000000960637

### DTC DETECTION LOGIC

DTC No.	Trouble diagnosis name	DTC detecting condition	Possible cause
P2126	DETENT SW	AT selector lever is in P position and the vehicle speed of 7±4km/h is detected.	<ul style="list-style-type: none"><li>• Harness and connectors (Detention switch circuit is opened/shorted.)</li><li>• Detention switch</li><li>• Combination meter (CAN communication)</li></ul>

### DTC CONFIRMATION PROCEDURE

#### 1.STEP 1

Drive the vehicle at 7±4km/h or more.

>> GO TO 2.

#### 2.STEP 2

Check "Self diagnostic result" with CONSULT-III.

Is the DTC detected?

- YES >> Perform diagnosis procedure. Refer to [ADP-60, "Diagnosis Procedure"](#).  
NO >> INSPECTION END

### Diagnosis Procedure

INFOID:000000000960638

#### 1.CHECK DTC WITH "BCM"

Check "Self diagnostic result" for BCM with CONSULT-III.

Is the either DTC B2602, B2603, B2604, B2605 or B2606 detected?

- YES >> Check The DTC. Refer to [SEC-167, "DTC Index"](#).  
NO >> GO TO 2.

#### 2.CHECK DETENTION SWITCH SIGNAL

1. Turn ignition switch ON.
2. Select "DETENT SW" in "Data Monitor" mode with CONSULT-III.
3. Check detention switch signal under the following condition.

Monitor item	Condition		Status
DETENT SW	AT selector lever	P position	OFF
		Other than above	ON

Is the status normal?

- YES >> GO TO 4.  
NO >> GO TO 3.

#### 3.CHECK DETENTION SWITCH CIRCUIT

1. Turn ignition switch OFF.
2. Disconnect driver seat control unit and AT device connector.
3. Check continuity between driver seat control unit harness connector and AT device harness connector.

# B2126 DETENT SW

## < COMPONENT DIAGNOSIS >

Driver seat control unit connector	Terminal	AT device connector	Terminal	Continuity
B451	21	M137	11	Existed

4. Check continuity between driver seat control unit harness connector and ground.

Driver seat control unit connector	Terminal	Ground	Continuity
B451	21		Not existed

Is the inspection result normal?

YES >> GO TO 4.

NO >> Repair or replace harness.

### 4.CHECK INTERMITTENT INCIDENT

Refer to [GI-39. "Intermittent Incident"](#).

Is the inspection result normal?

YES >> Replace driver seat control unit.

NO >> Repair or replace the malfunctioning part.

A  
B  
C  
D  
E  
F  
G  
H  
I  
K  
L  
M  
N  
O  
P

ADP

# B2127 PARKING BRAKE SWITCH

< COMPONENT DIAGNOSIS >

## B2127 PARKING BRAKE SWITCH

### Description

INFOID:000000000960639

- Parking brake switch is installed on parking brake lever. It is turned ON when the parking brake is applied.
- The driver seat control unit judges that the parking brake is engaged if continuity exists in this circuit.

### DTC Logic

INFOID:000000000960640

### DTC DETECTION LOGIC

DTC No.	Trouble diagnosis name	DTC detecting condition	Possible cause
P2127	PARKING BRAKE	Parking brake is engaged and the vehicle speed of 7±4km/h is detected.	<ul style="list-style-type: none"><li>• Harness and connectors (Parking brake switch circuit is opened/shorted.)</li><li>• Parking brake switch</li><li>• Combination meter (CAN communication)</li></ul>

### DTC CONFIRMATION PROCEDURE

#### 1.STEP 1

Drive the vehicle at 7±4km/h or more.

>> GO TO 2.

#### 2.STEP 2

Check "Self diagnostic result" with CONSULT-III.

Is the DTC detected?

YES >> Perform diagnosis procedure. Refer to [ADP-62, "Diagnosis Procedure"](#).

NO >> INSPECTION END

### Diagnosis Procedure

INFOID:000000000960641

#### 1.CHECK PARKING BRAKE SWITCH SIGNAL

1. Turn ignition switch ON.
2. Select "PARK BRAKE SW" in "Data monitor" mode with CONSULT-III.
3. Check parking brake switch signal under the following condition.

Monitor item	Condition	Status
PARK BRAKE SW	Parking brake	Applied ON
		Release OFF

Is the status normal?

YES >> GO TO 4.

NO >> GO TO 2.

#### 2.CHECK PARKING BRAKE SWITCH HARNESS CONTINUITY

1. Turn ignition switch OFF.
2. Disconnect driver seat control unit and parking brake switch connector.
3. Check continuity between driver seat control unit harness connector and parking brake switch harness connector.

Driver seat control unit connector	Terminal	Parking brake switch	Terminal	Continuity
M51	8	B14	1	Existed

4. Check continuity between driver seat control unit harness connector and ground.

# B2127 PARKING BRAKE SWITCH

## < COMPONENT DIAGNOSIS >

Driver seat control unit connector	Terminal	Ground	Continuity
M51	8		Not existed

Is the inspection result normal?

- YES >> GO TO 3.  
 NO >> Repair or replace harness.

### 3.CHECK PARKING BRAKE SWITCH

Refer to [ADP-63, "Component Inspection"](#).

Is the inspection result normal?

- YES >> GO TO 4.  
 NO >> Adjust or replace parking brake switch.

### 4.CHECK INTERMITTENT INCIDENT

Refer to [GI-39, "Intermittent Incident"](#).

Is the inspection result normal?

- YES >> Replace driver seat control unit.  
 NO >> Repair or replace the malfunctioning part.

## Component Inspection

INFOID:000000000960642

### 1.CHECK PARKING BRAKE SWITCH

- Turn ignition switch OFF.
- Disconnect parking brake switch connector.
- Check continuity between parking brake switch terminal and ground part of parking brake switch.

Terminal		Condition	Continuity
Parking brake switch			
1	Ground part of parking brake switch	Parking brake	Applied
			Other than above
			Existed
			Not existed

Is the inspection result normal?

- YES >> INSPECTION END  
 NO >> Adjust or replace parking brake switch.

A  
B  
C  
D  
E  
F  
G  
H  
I  
K  
L  
M  
N  
O  
P

ADP

# B2128 UART COMMUNICATION LINE

< COMPONENT DIAGNOSIS >

## B2128 UART COMMUNICATION LINE

### Description

INFOID:000000000960643

Driver seat control unit performs UART communication with the automatic drive positioner control unit using 2 communication lines, TX and RX line. Driver seat control unit receives the operation signals of tilt & telescopic switch, door mirror remote control switch, set switch and memory switch and the position signals of tilt & telescopic sensor and door mirror sensor from the automatic drive positioner control unit and transmits the operation request signal.

### DTC Logic

INFOID:000000000960644

### DTC DETECTION LOGIC

DTC No.	Trouble diagnosis name	DTC detecting condition	Possible cause
P2128	UART COMM	The communication between driver seat control unit and auto drive positioner control unit is interrupted for a period of time.	<ul style="list-style-type: none"><li>• UART communication line (UART communication line is open or shorted)</li><li>• Driver seat control unit</li><li>• Automatic drive positioner control unit</li></ul>

### DTC CONFIRMATION PROCEDURE

#### 1.STEP 1

Turn ignition switch ON.

>> GO TO 2.

#### 2.STEP 2

Operate tilt & telescopic switch for more than 2seconds.

>> GO TO 3.

#### 3.PROCEDURE 3

Check "Self diagnostic result" with CONSULT-III.

Is the DTC detected?

YES >> Perform diagnosis procedure. Refer to [ADP-64, "Diagnosis Procedure"](#).

NO >> INSPECTION END

### Diagnosis Procedure

INFOID:000000000960645

#### 1.CHECK UART COMMUNICATION LINE CONTINUITY

1. Turn ignition switch OFF.
2. Disconnect driver seat control unit and automatic drive positioner control unit connector.
3. Check continuity between driver seat control unit harness connector and automatic drive positioner control unit harness connector.

Driver seat control unit connector	Terminal	Automatic drive positioner control unit connector	Terminal	Continuity
B451	1	M51	10	Existed
	17		26	

4. Check continuity between driver seat control unit harness connector and ground.



# B2128 UART COMMUNICATION LINE

## < COMPONENT DIAGNOSIS >

Driver seat control unit connector	Terminal	Ground	Continuity
B451	1		Not existed
	17		

Is the inspection result normal?

- YES >> Check intermittent incident. Refer to [GI-39, "Intermittent Incident"](#).
- NO >> Repair or replace harness.

A  
B  
C  
D  
E  
F  
G  
H  
I  
K  
L  
M  
N  
O  
P

ADP

# POWER SUPPLY AND GROUND CIRCUIT

< COMPONENT DIAGNOSIS >

## POWER SUPPLY AND GROUND CIRCUIT

### BCM

#### BCM : Diagnosis Procedure

INFOID:000000000960646

#### 1. CHECK FUSE AND FUSIBLE LINK

Check that the following fuse and fusible link are not blown.

Terminal No.	Signal name	Fuse and fusible link No.
1	Battery power supply	K
11		10

Is the fuse fusing?

YES >> Replace the blown fuse or fusible link after repairing the affected circuit if a fuse or fusible link is blown.

NO >> GO TO 2.

#### 2. CHECK POWER SUPPLY CIRCUIT

1. Turn ignition switch OFF.
2. Disconnect BCM connectors.
3. Check voltage between BCM harness connector and ground.

Terminals		Voltage (Approx.)
(+)	(-)	
BCM		Ground  Battery voltage
Connector	Terminal	
M118	1	
M119	11	

Is the measurement value normal?

YES >> GO TO 3.

NO >> Repair harness or connector.

#### 3. CHECK GROUND CIRCUIT

Check continuity between BCM harness connector and ground.

BCM		Ground	Continuity
Connector	Terminal		
M119	13		Existed

Does continuity exist?

YES >> INSPECTION END

NO >> Repair harness or connector.

#### BCM : Special Repair Requirement

INFOID:000000000960647

#### 1. REQUIRED WORK WHEN REPLACING BCM

Initialize IVIS by CONSULT-III. For the details of initialization refer to CONSULT-III operation manual NATS-IVIS/NVIS.

>> Work end.

### DRIVER SEAT CONTROL UNIT

#### DRIVER SEAT CONTROL UNIT : Diagnosis Procedure

INFOID:000000000960648

# POWER SUPPLY AND GROUND CIRCUIT

## < COMPONENT DIAGNOSIS >

### NOTE:

Do not disconnect the battery negative terminal and the driver seat control unit connector until DTC is confirmed with CONSULT-III.

### 1.CHECK POWER SUPPLY CIRCUIT

1. Turn ignition switch OFF.
2. Check voltage between driver seat control unit harness connector and ground.

Terminals		Voltage (V) (Approx.)
(+)	(-)	
Driver seat control unit connector	Terminal	Battery voltage
B452	33	
	40	

Is the inspection result normal?

YES >> GO TO 2.

NO >> Check the following.

- Repair or replace harness between driver seat control unit and fuse block (J/B).
- Circuit breaker.

### 2.CHECK GROUND CIRCUIT

Check continuity between the driver seat control unit harness connector and ground.

Driver seat control unit connector	Terminal	Ground	Continuity
B451	32		Ground
B452	48		

Is the inspection result normal?

YES >> Driver seat control unit power supply and ground circuit are OK.

NO >> Repair or replace harness between driver seat control unit and ground.

## DRIVER SEAT CONTROL UNIT : Special Repair Requirement

INFOID:000000000960649

ADP

### 1.PERFORM ADDITIONAL SERVICE

Perform additional service when removing battery negative terminal.

>> Refer to [ADP-8. "ADDITIONAL SERVICE WHEN REMOVING BATTERY NEGATIVE TERMINAL : Description"](#).

## AUTOMATIC DRIVE POSITIONER CONTROL UNIT

### AUTOMATIC DRIVE POSITIONER CONTROL UNIT : Diagnosis Procedure

INFOID:000000000960650

### NOTE:

Do not disconnect the battery negative terminal and the driver seat control unit connector until DTC is confirmed with CONSULT-III.

### 1.CHECK POWER SUPPLY CIRCUIT

1. Turn ignition switch OFF.
2. Check voltage between automatic drive positioner control unit harness connector and ground.

# POWER SUPPLY AND GROUND CIRCUIT

## < COMPONENT DIAGNOSIS >

Terminals		Voltage (V) (Approx.)
(+)	(-)	
Automatic drive positioner control unit connector	Terminal	
M52	34	Ground Battery voltage
	39	

Is the inspection result normal?

YES >> GO TO 2.

NO >> Repair or replace harness between automatic drive positioner control unit and fuse block (J/B).

## 2.CHECK GROUND CIRCUIT

Check continuity between the automatic drive positioner control unit harness connector and ground.

Automatic drive positioner control unit connector	Terminal	Ground	Continuity
M52	40		
	48		

Is the inspection result normal?

YES >> Automatic drive positioner control unit power supply and ground circuit are OK.

NO >> Repair or replace harness between automatic drive positioner control unit and ground.

## AUTOMATIC DRIVE POSITIONER CONTROL UNIT : Special Repair Requirement

INFOID:000000000960651

## 1.PERFORM ADDITIONAL SERVICE

Perform additional service when removing battery negative terminal.

>> Refer to [ADP-8, "ADDITIONAL SERVICE WHEN REMOVING BATTERY NEGATIVE TERMINAL : Description"](#).

## SIDE SUPPORT UNIT

### SIDE SUPPORT UNIT : Diagnosis Procedure

INFOID:000000000960652

## 1.CHECK POWER SUPPLY CIRCUIT

1. Turn ignition switch OFF.
2. Disconnect side support unit connector.
3. Check voltage between side support unit harness connector and ground.

Terminals		Voltage (V) (Approx.)
(+)	(-)	
Side support unit connector	Terminal	
B420	1	Ground Battery voltage

Is the inspection result normal?

YES >> GO TO 2.

NO >> Check the following.

- Repair or replace harness between fusible link and side support unit.
- Circuit breaker.

## 2.CHECK GROUND CIRCUIT

Check continuity between side support unit harness connector and ground.

Side support unit connector	Terminal	Ground	Continuity
B420	2		

# POWER SUPPLY AND GROUND CIRCUIT

## < COMPONENT DIAGNOSIS >

---

Is the inspection result normal?

YES >> Perform diagnosis procedure. Refer to [ADP-68, "SIDE SUPPORT UNIT : Diagnosis Procedure"](#).

NO >> Repair or replace harness between side support unit and ground.

A

B

C

D

E

F

G

H

I

ADP

K

L

M

N

O

P

# SLIDING SWITCH

< COMPONENT DIAGNOSIS >

## SLIDING SWITCH

### Description

INFOID:000000000960653

Sliding switch is equipped to the power seat switch on the seat cushion side surface. The operation signal is inputted to the driver seat control unit when the sliding switch is operated.

### Component Function Check

INFOID:000000000960654

#### 1. CHECK FUNCTION

1. Select "SLIDE SW-FR", "SLIDE SW-RR" in "Data monitor" mode with CONSULT-III.
2. Check sliding switch signal under the following conditions.

Monitor item	Condition	Status	
SLIDE SW-FR	Sliding switch (forward)	Operate	ON
		Release	OFF
SLIDE SW-RR	Sliding switch (backward)	Operate	ON
		Release	OFF

Is the indication normal?

YES >> INSPECTION END

NO >> Perform diagnosis procedure. Refer to [ADP-70, "Diagnosis Procedure"](#).

### Diagnosis Procedure

INFOID:000000000960655

#### 1. CHECK SLIDING SWITCH SIGNAL

1. Turn ignition switch ON.
2. Check voltage between driver seat control unit harness connector and ground.

Driver seat control unit connector	Terminals		Condition	Voltage (V) (Approx.)
	(+)	(-)		
B451	11	Ground	Operate (backward)	0
			Release	Battery voltage
	26		Operate (forward)	0
			Release	Battery voltage

Is the inspection result normal?

YES >> GO TO 5.

NO >> GO TO 2.

#### 2. CHECK SLIDING SWITCH CIRCUIT

1. Turn ignition switch OFF.
2. Disconnect driver seat control unit and power seat switch connector.
3. Check continuity between driver seat control unit harness connector and power seat switch harness connector.

Driver seat control unit connector	Terminal	Power seat switch connector	Terminal	Continuity
B451	11	B459	11	Existed
	26		26	

4. Check continuity between driver seat control unit harness connector and ground.

# SLIDING SWITCH

## < COMPONENT DIAGNOSIS >

Driver seat control unit connector	Terminal	Ground	Continuity
B451	11		
	26		

Is the inspection result normal?

YES >> GO TO 3.

NO >> Repair or replace harness.

### 3.CHECK DRIVER SEAT CONTROL UNIT OUTPUT

1. Connect the driver seat control unit connector.
2. Turn ignition switch ON.
3. Check voltage between driver seat control unit harness connector and ground.

Driver seat control unit connector	Terminals		Voltage (V) (Approx.)
	(+)	(-)	
B451	11	Ground	Battery voltage
	26		

Is the inspection result normal?

YES >> GO TO 4.

NO >> Replace driver seat control unit.

### 4.CHECK SLIDING SWITCH

Refer to [ADP-71, "Component Inspection"](#).

Is the inspection result normal?

YES >> GO TO 5.

NO >> Replace power seat switch.

### 5.CHECK INTERMITTENT INCIDENT

Refer to [GI-39, "Intermittent Incident"](#).

Is the inspection result normal?

YES >> Replace driver seat control unit.

NO >> Repair or replace malfunctioning part.

## Component Inspection

INFOID:000000000960656

### 1.CHECK SLIDING SWITCH

1. Turn ignition switch OFF.
2. Disconnect power seat switch (sliding switch) connector.
3. Check continuity between power seat switch (sliding switch) terminals.

Terminal		Condition	Continuity	
Power seat switch (Sliding switch)				
32	11	Sliding switch (backward)	Operate	Existed
			Release	Not existed
	26	Sliding switch (forward)	Operate	Existed
			Release	Not existed

Is the inspection result normal?

YES >> INSPECTION END

NO >> Replace power seat switch.

# RECLINING SWITCH

< COMPONENT DIAGNOSIS >

## RECLINING SWITCH

### Description

INFOID:000000000960657

Reclining switch is equipped to the power seat switch on the seat cushion side surface. The operation signal is inputted to the driver seat control unit when the reclining switch is operated.

### Component Function Check

INFOID:000000000960658

#### 1. CHECK FUNCTION

1. Select "RECLN SW-FR", "RECLN SW-RR" in "Data monitor" mode with CONSULT-III.
2. Check reclining switch signal under the following conditions.

Monitor item	Condition		Status
RECLINE SW-FR	Reclining switch (forward)	Operate	ON
		Release	OFF
RECLINE SW-RR	Reclining switch (backward)	Operate	ON
		Release	OFF

Is the indication normal?

YES >> INSPECTION END

NO >> Perform diagnosis procedure. Refer to [ADP-72, "Diagnosis Procedure"](#).

### Diagnosis Procedure

INFOID:000000000960659

#### 1. CHECK RECLINING SWITCH SIGNAL

1. Turn ignition switch ON.
2. Check voltage between driver seat control unit harness connector and ground.

Driver seat control unit connector	Terminals		Condition	Voltage (V) (Approx.)
	(+)	(-)		
B451	12	Ground	Operate (forward)	0
			Release	Battery voltage
	27		Operate (backward)	0
			Release	Battery voltage

Is the inspection result normal?

YES >> GO TO 5.

NO >> GO TO 2.

#### 2. CHECK RECLINING SWITCH CIRCUIT

1. Turn ignition switch OFF.
2. Disconnect driver seat control unit and power seat switch connector.
3. Check continuity between driver seat control unit harness connector and power seat switch harness connector.

Driver seat control unit connector	Terminal	Power seat switch connector	Terminal	Continuity
B451	12	B459	12	Existed
	27		27	

4. Check continuity between driver seat control unit harness connector and ground.



# RECLINING SWITCH

## < COMPONENT DIAGNOSIS >

Driver seat control unit connector	Terminal	Ground	Continuity
B451	12		
	27		

Is the inspection result normal?

YES >> GO TO 3.

NO >> Repair or replace harness.

### 3.CHECK DRIVER SEAT CONTROL UNIT OUTPUT

1. Connect the driver seat control unit connector.
2. Turn ignition switch ON.
3. Check voltage between driver seat control unit harness connector and ground.

Driver seat control unit connector	Terminals		Voltage (V) (Approx.)
	(+)	(-)	
B451	12	Ground	Battery voltage
	27		

Is the inspection result normal?

YES >> GO TO 4.

NO >> Replace driver seat control unit.

### 4.CHECK RECLINING SWITCH

Refer to [ADP-73, "Component Inspection"](#).

Is the inspection result normal?

YES >> GO TO 5.

NO >> Replace power seat switch.

### 5.CHECK INTERMITTENT INCIDENT

Refer to [GI-39, "Intermittent Incident"](#).

Is the inspection result normal?

YES >> Replace driver seat control unit.

NO >> Repair or replace the malfunctioning part.

## Component Inspection

INFOID:000000000960660

### 1.CHECK RECLINING SWITCH

1. Turn ignition switch OFF.
2. Disconnect power seat switch (reclining switch) connector.
3. Check continuity between power seat switch (reclining switch) terminals.

Terminal		Condition	Continuity	
Power seat switch (Reclining switch)				
32	12	Reclining switch (backward)	Operate	Existed
			Release	Not existed
	27	Reclining switch (forward)	Operate	Existed
			Release	Not existed

Is the inspection result normal?

YES >> INSPECTION END

NO >> Replace power seat switch.

# LIFTING SWITCH (FRONT)

< COMPONENT DIAGNOSIS >

## LIFTING SWITCH (FRONT)

### Description

INFOID:000000000960661

Lifting switch (front) is equipped to the power seat switch on the seat cushion side surface. The operation signal is inputted to the driver seat control unit when the lifting switch (front) is operated.

### Component Function Check

INFOID:000000000960662

#### 1.CHECK FUNCTION

1. Select "LIFT FR SW-UP", "LIFT FR SW-DN" in "DATA MONITOR" mode with CONSULT-III.
2. Check lifting switch (front) signal under the following conditions.

Monitor item	Condition		Status
LIFT FR SW-UP	Lifting switch front (up)	Operate	ON
		Release	OFF
LIFT FR SW-DN	Lifting switch front (down)	Operate	ON
		Release	OFF

Is the indication normal?

YES >> INSPECTION END

NO >> Perform diagnosis procedure. Refer to [ADP-74, "Diagnosis Procedure"](#).

### Diagnosis Procedure

INFOID:000000000960663

#### 1.CHECK LIFTING SWITCH SIGNAL

1. Turn ignition switch ON.
2. Check voltage between driver seat control unit harness connector and ground.

Driver seat control unit connector	Terminals		Condition	Voltage (V) (Approx.)
	(+)	(-)		
B451	13	Ground	Operate (down)	Battery voltage
			Release	
	28		Operate (up)	
			Release	

Is the inspection result normal?

YES >> GO TO 5.

NO >> GO TO 2.

#### 2.CHECK LIFTING SWITCH (FRONT) CIRCUIT

1. Turn ignition switch OFF.
2. Disconnect driver seat control unit and power seat switch connector.
3. Check continuity between driver seat control unit harness connector and power seat switch harness connector.

Driver seat control unit connector	Terminal	Power seat switch connector	Terminal	Continuity
B451	13	B459	13	Existed
	28		28	

4. Check continuity between driver seat control unit harness connector and ground.

# LIFTING SWITCH (FRONT)

## < COMPONENT DIAGNOSIS >

Driver seat control unit connector	Terminal	Ground	Continuity
B451	13		
	28		

Is the inspection result normal?

YES >> GO TO 3.

NO >> Repair or replace harness.

### 3.CHECK DRIVER SEAT CONTROL UNIT OUTPUT

1. Connect the driver seat control unit connector.
2. Turn ignition switch ON.
3. Check voltage between driver seat control unit harness connector and ground.

Driver seat control unit connector	Terminals		Voltage (V) (Approx.)
	(+)	(-)	
B451	13	Ground	Battery voltage
	28		

Is the inspection result normal?

YES >> GO TO 4.

NO >> Replace driver seat control unit.

### 4.CHECK LIFTING SWITCH (FRONT)

Refer to [ADP-75, "Component Inspection"](#).

Is the inspection result normal?

YES >> GO TO 5.

NO >> Replace power seat switch.

### 5.CHECK INTERMITTENT INCIDENT

Refer to [GI-39, "Intermittent Incident"](#).

Is the inspection result normal?

YES >> Replace driver seat control unit.

NO >> Repair or replace the malfunctioning part.

## Component Inspection

INFOID:000000000960664

### 1.CHECK LIFTING SWITCH (FRONT)

1. Turn ignition switch OFF.
2. Disconnect power seat switch (lifting switch front) connector.
3. Check continuity between power seat switch (lifting switch front) terminals.

Terminal		Condition	Continuity	
Power seat switch (lifting switch front)				
32	13	Lifting switch front (down)	Operate	Existed
			Release	Not existed
	28	Lifting switch front (up)	Operate	Existed
			Release	Not existed

Is the inspection result normal?

YES >> INSPECTION END

NO >> Replace power seat switch.

# LIFTING SWITCH (REAR)

< COMPONENT DIAGNOSIS >

## LIFTING SWITCH (REAR)

### Description

INFOID:000000000960665

Lifting switch (rear) is equipped to the power seat switch on the seat cushion side surface. The operation signal is inputted to the driver seat control unit when the lifting switch (rear) is operated.

### Component Function Check

INFOID:000000000960666

#### 1. CHECK FUNCTION

1. Select "LIFT RR SW-UP", "LIFT RR SW-DN" in "Data monitor" mode with CONSULT-III.
2. Check lifting switch (rear) signal under the following conditions.

Monitor item	Condition	Status	
LIFT RR SW-UP	Lifting switch rear (up)	Operate	ON
		Release	OFF
LIFT RR SW-DN	Lifting switch rear (down)	Operate	ON
		Release	OFF

Is the indication normal?

YES >> INSPECTION END

NO >> Perform diagnosis procedure. Refer to [ADP-76, "Diagnosis Procedure"](#).

### Diagnosis Procedure

INFOID:000000000960667

#### 1. CHECK LIFTING SWITCH (REAR) SIGNAL

1. Turn ignition switch ON.
2. Check voltage between driver seat control unit harness connector and ground.

Driver seat control unit connector	Terminals		Condition	Voltage (V) (Approx.)
	(+)	(-)		
B451	14	Ground	Operate (down)	0
			Release	Battery voltage
	29		Operate (up)	0
			Release	Battery voltage

Is the inspection result normal?

YES >> GO TO 5.

NO >> GO TO 2.

#### 2. CHECK LIFTING SWITCH (REAR) CIRCUIT

1. Turn ignition switch OFF.
2. Disconnect driver seat control unit and power seat switch connector.
3. Check continuity between driver seat control unit harness connector and power seat switch harness connector.

Driver seat control unit connector	Terminal	Power seat switch connector	Terminal	Continuity
B451	14	B459	14	Existed
	29		29	

4. Check continuity between driver seat control unit harness connector and ground.

# LIFTING SWITCH (REAR)

## < COMPONENT DIAGNOSIS >

Driver seat control unit connector	Terminal	Ground	Continuity
B451	14		
	29		

Is the inspection result normal?

YES >> GO TO 3.

NO >> Repair or replace harness.

### 3.CHECK DRIVER SEAT CONTROL UNIT OUTPUT

1. Connect the driver seat control unit connector.
2. Turn ignition switch ON.
3. Check voltage between driver seat control unit harness connector and ground.

Driver seat control unit connector	Terminals		Voltage (V) (Approx.)
	(+)	(-)	
B451	14	Ground	Battery voltage
	29		

Is the inspection result normal?

YES >> GO TO 4.

NO >> Replace driver seat control unit.

### 4.CHECK LIFTING SWITCH (REAR)

Refer to [ADP-77, "Component Inspection"](#).

Is the inspection result normal?

YES >> GO TO 5.

NO >> Replace power seat switch.

### 5.CHECK INTERMITTENT INCIDENT

Refer to [GI-39, "Intermittent Incident"](#).

Is the inspection result normal?

YES >> Replace driver seat control unit.

NO >> Repair or replace the malfunctioning part.

## Component Inspection

INFOID:000000000960668

### 1.CHECK LIFTING SWITCH (REAR)

1. Turn ignition switch OFF.
2. Disconnect power seat switch (lifting switch rear) connector.
3. Check continuity between power seat switch (lifting switch rear) terminals.

Terminal		Condition	Continuity	
Power seat switch (lifting switch rear)				
32	14	Lifting switch rear (up)	Operate	Existed
			Release	Not existed
	29	Lifting switch rear (down)	Operate	Existed
			Release	Not existed

Is the inspection result normal?

YES >> INSPECTION END

NO >> Replace power seat switch.

# TILT SWITCH

< COMPONENT DIAGNOSIS >

## TILT SWITCH

### Description

INFOID:000000000960669

Tilt switch is equipped to the steering column. The operation signal is inputted to the automatic drive positioner control unit when the tilt switch is operated.

### Component Function Check

INFOID:000000000960670

#### 1.CHECK FUNCTION

1. Select "TILT SW-UP", "TILT SW-DN" in "Data monitor" mode with CONSULT-III.
2. Check tilt switch signal under the following conditions.

Monitor item	Condition	Status	
TILT SW-UP	Tilt switch (up)	Operate	ON
		Release	OFF
TILT SW-DN	Tilt switch (down)	Operate	ON
		Release	OFF

Is the indication normal?

YES >> INSPECTION END

NO >> Perform diagnosis procedure. Refer to [ADP-78, "Diagnosis Procedure"](#).

### Diagnosis Procedure

INFOID:000000000960671

#### 1.CHECK TILT SWITCH SIGNAL

1. Turn ignition switch ON.
2. Check voltage between automatic drive positioner control unit harness connector and ground.

Automatic drive positioner control unit connector	Terminals		Condition	Voltage (V) (Approx.)
	(+)	(-)		
M51	1	Ground	Operate (up)	0
			Release	Battery voltage
	17		Operate (down)	0
			Release	Battery voltage

Is the inspection result normal?

YES >> GO TO 5.

NO >> GO TO 2.

#### 2.CHECK TILT SWITCH CIRCUIT

1. Turn ignition switch OFF.
2. Disconnect automatic drive positioner control unit and tilt & telescopic switch connector.
3. Check continuity between automatic drive positioner control unit harness connector and tilt & telescopic switch harness connector.

Automatic drive positioner control unit connector	Terminal	Tilt & telescopic switch connector	Terminal	Continuity
M51	1	M31	4	Existed
	17		5	

4. Check continuity between automatic drive positioner control unit harness connector and ground.

# TILT SWITCH

## < COMPONENT DIAGNOSIS >

Automatic drive positioner control unit connector	Terminal	Ground	Continuity
M51	1		
	17		

Is the inspection result normal?

YES >> GO TO 3.

NO >> Repair or replace harness.

### 3.CHECK AUTOMATIC DRIVE POSITIONER CONTROL UNIT OUTPUT

1. Connect the automatic drive positioner control unit connector.
2. Turn ignition switch ON.
3. Check voltage between automatic drive positioner control unit harness connector and ground.

Automatic drive positioner control unit connector	Terminals		Voltage (V) (Approx.)
	(+)	(-)	
M51	1	Ground	Battery voltage
	17		

Is the inspection result normal?

YES >> GO TO 4.

NO >> Replace automatic drive positioner control unit.

### 4.CHECK TILT SWITCH

Refer to [ADP-79, "Component Inspection"](#).

Is the inspection result normal?

YES >> GO TO 5.

NO >> Replace tilt & telescopic switch.

### 5.CHECK INTERMITTENT INCIDENT

Refer to [GI-39, "Intermittent Incident"](#).

Is the inspection result normal?

YES >> Replace automatic drive positioner control unit.

NO >> Repair or replace the malfunctioning part.

## Component Inspection

INFOID:000000000960672

### 1.CHECK TILT SWITCH

1. Turn ignition switch OFF.
2. Disconnect tilt & telescopic switch connector.
3. Check continuity between tilt & telescopic switch terminals.

Terminal		Condition	Continuity	
Tilt switch				
1	4	Tilt switch (up)	Operate	Existed
			Release	Not existed
	5	Tilt switch (down)	Operate	Existed
			Release	Not existed

Is the inspection result normal?

YES >> INSPECTION END

NO >> Replace tilt & telescopic switch.

# TELESCOPIC SWITCH

< COMPONENT DIAGNOSIS >

## TELESCOPIC SWITCH

### Description

INFOID:000000000960673

Telescopic switch is equipped to the steering column. The operation signal is inputted to the automatic drive positioner control unit when the telescopic switch is operated.

### Component Function Check

INFOID:000000000960674

#### 1. CHECK FUNCTION

1. Select "TELESCO SW-FR", "TELESCO SW-RR" in "Data monitor" mode with CONSULT-III.
2. Check telescopic switch signal under the following conditions.

Monitor item	Condition		Status
TELESCO SW-FR	Telesco switch (forward)	Operate	ON
		Release	OFF
TELESCO SW-RR	Telesco switch (backward)	Operate	ON
		Release	OFF

Is the indication normal?

YES >> INSPECTION END

NO >> Perform diagnosis procedure. Refer to [ADP-80, "Diagnosis Procedure"](#).

### Diagnosis Procedure

INFOID:000000000960675

#### 1. CHECK TELESCOPIC SWITCH SIGNAL

1. Turn ignition switch ON.
2. Check voltage between automatic drive positioner control unit harness connector and ground.

Automatic drive positioner control unit connector	Terminals		Condition	Voltage (V) (Approx.)
	(+)	(-)		
M51	11	Ground	Operate (forward)	0
			Release	Battery voltage
	27		Operate (backward)	0
			Release	Battery voltage

Is the inspection result normal?

YES >> GO TO 5.

NO >> GO TO 2.

#### 2. CHECK TELESCOPIC SWITCH CIRCUIT

1. Turn ignition switch OFF.
2. Disconnect automatic drive positioner control unit and tilt & telescopic switch connector.
3. Check continuity between automatic drive positioner control unit harness connector and tilt & telescopic switch harness connector.

Automatic drive positioner control unit connector	Terminal	Tilt & telescopic switch connector	Terminal	Continuity
M51	11	M31	2	Existed
	27		3	

4. Check continuity between automatic drive positioner control unit harness connector and ground.



# TELESCOPIC SWITCH

## < COMPONENT DIAGNOSIS >

Automatic drive positioner control unit connector	Terminal	Ground	Continuity
M51	11		
	27		

Is the inspection result normal?

YES >> GO TO 3.

NO >> Repair or replace harness.

### 3.CHECK AUTOMATIC DRIVE POSITIONER CONTROL UNIT OUTPUT

1. Connect the automatic drive positioner control unit connector.
2. Turn ignition switch ON.
3. Check voltage between automatic drive positioner control unit harness connector and ground.

Automatic drive positioner control unit connector	Terminals		Voltage (V) (Approx.)
	(+)	(-)	
M51	11	Ground	Battery voltage
	27		

Is the inspection result normal?

YES >> GO TO 4.

NO >> Replace automatic drive positioner control unit.

### 4.CHECK TELESCOPIC SWITCH

Refer to [ADP-81, "Component Inspection"](#).

Is the inspection result normal?

YES >> GO TO 5.

NO >> Replace tilt & telescopic switch.

### 5.CHECK INTERMITTENT INCIDENT

Refer to [GI-39, "Intermittent Incident"](#).

Is the inspection result normal?

YES >> Replace automatic drive positioner control unit.

NO >> Repair or replace the malfunctioning part.

## Component Inspection

INFOID:000000000960676

### 1.CHECK TELESCOPIC SWITCH

1. Turn ignition switch OFF.
2. Disconnect tilt & telescopic switch connector.
3. Check continuity between tilt & telescopic switch terminals.

Terminal		Condition	Continuity	
Telescopic switch				
1	2	Telescopic switch (forward)	Operate	Existed
			Release	Not existed
	3	Telescopic switch (backward)	Operate	Existed
			Release	Not existed

Is the inspection result normal?

YES >> INSPECTION END

NO >> Replace tilt & telescopic switch.

# SEAT MEMORY SWITCH

< COMPONENT DIAGNOSIS >

## SEAT MEMORY SWITCH

### Description

INFOID:000000000960677

Memory switch is equipped on the seat memory switch installed to the driver side door trim. The operation signal is inputted to the automatic drive positioner control unit when the memory switch is operated.

### Component Function Check

INFOID:000000000960678

#### 1. CHECK FUNCTION

1. Select "MEMORY SW 1", "MEMORY SW 2" in "Data monitor" mode with CONSULT-III.
2. Check seat memory switch signal under the following conditions.

Monitor item	Condition		Status
MEMORY SW 1	Memory switch 1	Push	ON
		Release	OFF
MEMORY SW 2	Memory switch 2	Push	ON
		Release	OFF

Is the indication normal?

YES >> INSPECTION END

NO >> Perform diagnosis procedure. Refer to [ADP-82, "Diagnosis Procedure"](#).

### Diagnosis Procedure

INFOID:000000000960679

#### 1. CHECK SEAT MEMORY SWITCH SIGNAL

1. Turn ignition switch ON.
2. Check voltage between automatic drive positioner control unit harness connector and ground.

Automatic drive positioner control unit connector	Terminals		Condition	Voltage (V) (Approx.)	
	(+)	(-)			
M51	9	Ground	Memory switch 1	Push	0
			Release	5	
	25		Memory switch 2	Push	0
			Release	5	

Is the inspection result normal?

YES >> GO TO 6.

NO >> GO TO 2.

#### 2. CHECK MEMORY SWITCH CIRCUIT

1. Turn ignition switch OFF.
2. Disconnect automatic drive positioner control unit and seat memory switch connector.
3. Check continuity between automatic drive positioner control unit harness connector and seat memory switch harness connector.

Automatic drive positioner control unit connector	Terminal	Seat memory switch connector	Terminal	Continuity
M51	9	D5	1	Existed
	25		2	

4. Check continuity between automatic drive positioner control unit harness connector and ground.

# SEAT MEMORY SWITCH

## < COMPONENT DIAGNOSIS >

Automatic drive positioner control unit connector	Terminal	Ground	Continuity
M51	9		
	25		

Is the inspection result normal?

YES >> GO TO 3.

NO >> Repair or replace harness.

### 3.CHECK MEMORY SWITCH GROUND CIRCUIT

Check continuity between seat memory switch harness connector and ground.

Seat memory switch connector	Terminal	Ground	Continuity
D5	4		

Is the inspection result normal?

YES >> GO TO 4.

NO >> Repair or replace harness.

### 4.CHECK AUTOMATIC DRIVE POSITIONER CONTROL UNIT OUTPUT

1. Connect the automatic drive positioner control unit connector.
2. Turn ignition switch ON.
3. Check voltage between automatic drive positioner control unit harness connector and ground.

Automatic drive positioner control unit connector	Terminals		Voltage (V) (Approx.)
	(+)	(-)	
M51	9	Ground	5
	25		

Is the inspection result normal?

YES >> GO TO 5.

NO >> Replace automatic drive positioner control unit.

### 5.CHECK SEAT MEMORY SWITCH

Refer to [ADP-83, "Component Inspection"](#).

Is the inspection result normal?

YES >> GO TO 6.

NO >> Replace seat memory switch.

### 6.CHECK INTERMITTENT INCIDENT

Refer to [GI-39, "Intermittent Incident"](#).

Is the inspection result normal?

YES >> Replace automatic drive positioner control unit.

NO >> Repair or replace the malfunctioning part.

## Component Inspection

INFOID:000000000960680

### 1.CHECK SEAT MEMORY SWITCH

1. Turn ignition switch OFF.
2. Disconnect seat memory switch connector.
3. Check continuity between seat memory switch terminals.

## SEAT MEMORY SWITCH

< COMPONENT DIAGNOSIS >

Terminal		Condition		Continuity
Seat memory switch				
4	1	Memory switch 1	Push	Existed
			Release	Not existed
	2	Memory switch 2	Push	Existed
			Release	Not existed

Is the inspection result normal?

YES >> INSPECTION END

NO >> Replace seat memory switch.

# DOOR MIRROR REMOTE CONTROL SWITCH

< COMPONENT DIAGNOSIS >

## DOOR MIRROR REMOTE CONTROL SWITCH CHANGEOVER SWITCH

### CHANGEOVER SWITCH : Description

INFOID:000000000960681

Changeover switch is integrated into door mirror remote control switch.  
Changeover switch has three positions (L, N and R).  
It changes door mirror motor operation by transmitting control signal to automatic drive positioner control unit.

### CHANGEOVER SWITCH : Component Function Check

INFOID:000000000960682

#### 1. CHECK CHANGEOVER SWITCH FUNCTION

Check the operation on "MIR CHNG SW-R" or "MIR CHNG SW-L" in "DATA MONITOR" mode with CONSULT-III.

Refer to [ADP-48, "CONSULT-III Function"](#).

Is the inspection result normal?

YES >> Changeover switch function is OK.

NO >> Refer to [ADP-85, "CHANGEOVER SWITCH : Diagnosis Procedure"](#).

### CHANGEOVER SWITCH : Diagnosis Procedure

INFOID:000000000960683

#### 1. CHECK CHANGEOVER SWITCH SIGNAL

1. Turn ignition switch ON.
2. Check voltage between automatic drive positioner control unit connector and ground.

Terminals		(-)	Change over switch condition	Voltage (V) (Approx.)
(+)	Terminal			
Automatic drive positioner control unit connector	2	Ground	RIGHT	0
			Other than above	5
	18		LEFT	0
			Other than above	5

Is the inspection result normal?

YES >> GO TO 6.

NO >> GO TO 2.

#### 2. CHECK HARNESS CONTINUITY

1. Turn ignition switch OFF.
2. Disconnect automatic drive positioner control unit and door mirror remote control switch connector.
3. Check continuity between automatic drive positioner control unit connector and door mirror remote control switch connector.

Automatic drive positioner control unit connector	Terminal	Door mirror remote control switch connector	Terminal	Continuity
M51	2	D7	11	Existed
	18		10	

4. Check continuity between automatic drive positioner control unit connector and ground.

Automatic drive positioner control unit connector	Terminal	Ground	Continuity
M51	2		Not existed
	18		

Is the inspection result normal?

# DOOR MIRROR REMOTE CONTROL SWITCH

## < COMPONENT DIAGNOSIS >

- YES >> GO TO 3.  
 NO >> Repair or replace harness.

### 3.CHECK DOOR MIRROR REMOTE CONTROL SWITCH GROUND CIRCUIT

Check continuity between door mirror remote control switch connector and ground.

Door mirror remote control switch connector	Terminal	Ground	Continuity
D7	7		Existed

Is the inspection result normal?

- YES >> GO TO 4.  
 NO >> Repair or replace harness.

### 4.CHECK AUTOMATIC DRIVE POSITIONER CONTROL UNIT OUTPUT SIGNAL

1. Connect automatic drive positioner control unit connector.
2. Turn ignition switch ON.
3. Check voltage between automatic drive positioner control unit connector and ground.

Terminals		Voltage (V) (Approx.)
(+)	(-)	
Automatic drive positioner control unit connector	Terminal	5
M51	2	
	18	
	Ground	

Is the inspection result normal?

- YES >> GO TO 5.  
 NO >> Replace automatic drive positioner control unit. Refer to [ADP-218, "Removal and Installation"](#).

### 5.CHECK CHANGEOVER SWITCH

Check changeover switch.

Refer to [ADP-86, "CHANGEOVER SWITCH : Component Inspection"](#).

Is the inspection result normal?

- YES >> Refer to [GI-39, "Intermittent Incident"](#).  
 NO >> Replace door mirror remote control switch. Refer to [MIR-68, "Removal and Installation"](#).

### 6.CHECK INTERMITTENT INCIDENT

Check intermittent incident.

Refer to [GI-39, "Intermittent Incident"](#).

Is the inspection result normal?

- YES >> Replace automatic drive positioner control unit. Refer to [ADP-218, "Removal and Installation"](#).  
 NO >> Repair or replace the malfunctioning parts.

## CHANGEOVER SWITCH : Component Inspection

INFOID:000000000960684

### 1.CHECK CHANGEOVER SWITCH

Check door mirror remote control switch.

Terminal	Change over switch condition	Continuity
Door mirror remote control switch		
10	LEFT	Existed
	Other than above	Not existed
11	RIGHT	Existed
	Other than above	Not existed

Is the inspection result normal?

- YES >> INSPECTION END.

# DOOR MIRROR REMOTE CONTROL SWITCH

## < COMPONENT DIAGNOSIS >

NO >> Replace door mirror remote control switch. Refer to [MIR-68, "Removal and Installation"](#).

## MIRROR SWITCH

### MIRROR SWITCH : Description

INFOID:000000000960685

It operates angle of the door mirror face.

It transmits mirror face adjust operation to AUTOMATIC DRIVE POSITIONER CONTROL UNIT.

### MIRROR SWITCH : Component Function Check

INFOID:000000000960686

#### 1.CHECK MIRROR SWITCH FUNCTION

Check the operation on "MIR CON SW-UP/DN" and "MIR CON SW-RH/LH" in "DATA MONITOR" mode with CONSULT-III.

Refer to [ADP-48, "CONSULT-III Function"](#).

Is the inspection result normal?

YES >> Mirror switch function is OK.

NO >> Refer to [ADP-87, "MIRROR SWITCH : Diagnosis Procedure"](#).

### MIRROR SWITCH : Diagnosis Procedure

INFOID:000000000960687

#### 1.CHECK MIRROR SWITCH FUNCTION

1. Turn ignition switch ON.
2. Check voltage between automatic drive positioner control unit connector and ground.

Terminals		(-)	Mirror switch Condition	Voltage (V) (Approx.)
(+)	Terminal			
Automatic drive positioner control unit connector  M51	3	Ground	UP	0
			Other than above	5
	4		LEFT	0
			Other than above	5
	19		DOWN	0
			Other than above	5
	20		RIGHT	0
			Other than above	5

Is the inspection result normal?

YES >> GO TO 6.

NO >> GO TO 2.

#### 2.CHECK HARNESS CONTINUITY

1. Turn ignition switch OFF.
2. Disconnect automatic drive positioner control unit and door mirror remote control switch connector.
3. Check continuity between automatic drive positioner control unit connector and door mirror remote control switch connector.

Automatic drive positioner control unit connector	Terminal	Door mirror remote control switch connector	Terminal	Continuity
M51	3	D7	15	Existed
	4		13	
	19		12	
	20		4	

4. Check continuity between automatic drive positioner control unit connector and ground.

# DOOR MIRROR REMOTE CONTROL SWITCH

## < COMPONENT DIAGNOSIS >

Automatic drive positioner control unit connector	Terminal		Continuity
M51	3	Ground	Not existed
	4		
	19		
	20		

Is the inspection result normal?

YES >> GO TO 3.

NO >> Repair or replace harness.

### 3.CHECK DOOR MIRROR REMOTE CONTROL SWITCH GROUND CIRCUIT

Check continuity between door mirror remote control switch connector and ground.

Door mirror remote control switch connector	Terminal		Continuity
D7	7	Ground	Existed

Is the inspection result normal?

YES >> GO TO 4.

NO >> Repair or replace harness.

### 4.CHECK AUTOMATIC DRIVE POSITIONER CONTROL UNIT OUTPUT SIGNAL

1. Connect automatic drive positioner control unit connector.
2. Turn ignition switch ON.
3. Check voltage between automatic drive positioner control unit and ground.

Terminals			Voltage (V) (Approx.)
(+)		(-)	
Automatic drive positioner control unit connector	Terminal	Ground	5
M51	3		
	4		
	19		
	20		

Is the inspection result normal?

YES >> GO TO 5.

NO >> Replace automatic drive positioner control unit. Refer to [ADP-218, "Removal and Installation"](#).

### 5.CHECK MIRROR SWITCH

Check mirror switch

Refer to [ADP-88, "MIRROR SWITCH : Component Inspection"](#).

Is the inspection result normal?

YES >> Refer to [GI-39, "Intermittent Incident"](#).

NO >> Replace door mirror remote control switch. Refer to [MIR-68, "Removal and Installation"](#).

### 6.CHECK INTERMITTENT INCIDENT

Check intermittent incident.

Refer to [GI-39, "Intermittent Incident"](#).

Is the inspection result normal?

YES >> Replace automatic drive positioner control unit. Refer to [ADP-218, "Removal and Installation"](#).

NO >> Repair or replace the malfunctioning parts.

## MIRROR SWITCH : Component Inspection

INFOID:000000000960688

### 1.CHECK MIRROR SWITCH



# DOOR MIRROR REMOTE CONTROL SWITCH

## < COMPONENT DIAGNOSIS >

Check door mirror remote control switch.

Terminal		Mirror switch condition	Continuity
Door mirror remote control switch			
4	7	RIGHT	Existed
		Other than above	Not existed
13		LEFT	Existed
		Other than above	Not existed
15		UP	Existed
		Other than above	Not existed
12		DOWN	Existed
		Other than above	Not existed

Is the inspection result normal?

YES >> INSPECTION END.

NO >> Replace door mirror remote control switch. Refer to [MIR-68, "Removal and Installation"](#).

A  
B  
C  
D  
E  
F  
G  
H  
I  
K  
L  
M  
N  
O  
P

ADP

# POWER SEAT SWITCH GROUND CIRCUIT

< COMPONENT DIAGNOSIS >

## POWER SEAT SWITCH GROUND CIRCUIT

### Diagnosis Procedure

INFOID:000000000960689

#### 1. CHECK POWER SEAT SWITCH GROUND CIRCUIT

1. Turn ignition switch OFF.
2. Disconnect power seat switch connector.
3. Check continuity between power seat switch connector and ground.

Power seat switch connector	Terminal	Ground	Continuity
B459	32		Existed

Is the inspection result normal?

- YES >> Check intermittent incident. Refer to [GI-39, "Intermittent Incident"](#).  
NO >> Repair or replace harness.

# SIDE SUPPORT SWITCH

< COMPONENT DIAGNOSIS >

## SIDE SUPPORT SWITCH

### Description

INFOID:000000000960690

With a built-in cushion side and seatback side, side support switch controls the power supplied to pump and to each solenoid.

### Component Function Check

INFOID:000000000960691

#### 1.CHECK SIDE SUPPORT SWITCH FUNCTION

Check side support operation with side support switch.

Is the inspection results normal?

- YES >> Side support switch is OK.
- NO >> Refer to [ADP-91, "Diagnosis Procedure"](#).

### Diagnosis Procedure

INFOID:000000000960692

#### 1.CHECK GROUND CIRCUIT

1. Turn ignition switch OFF.
2. Disconnect side support switch connector.
3. Check continuity between side support switch and ground.

Side support switch connector	Terminal	Ground	Continuity
B419	2		Existed

Is the inspection result normal?

- YES >> GO TO 2.
- NO >> Repair or replace ground circuit.

#### 2.CHECK SIDE SUPPORT SWITCH

Check side support switch function.

Refer to [ADP-91, "Component Inspection"](#).

Is the inspection result normal?

- YES >> Side support switch is OK.
- NO >> Replace side support switch.

### Component Inspection

INFOID:000000000960693

#### 1.CHECK SIDE SUPPORT SWITCH

1. Turn ignition switch OFF.
2. Remove side support switch.
3. Detect the malfunctioning switch.

Which switch is malfunctioning?

- CUSHION SIDE>>GO TO 2.
- SEATBACK SIDE>>GO TO 3.

#### 2.CHECK CUSHION SIDE SWITCH

Check continuity between side support switch (cushion side) terminals.

Terminal	Cushion side switch condition	Continuity
15	Inflate	Existed
	Neutral	Not existed
	Deflate	Not existed
16	Inflate	Not existed
	Neutral	Not existed
	Deflate	Existed

A  
B  
C  
D  
E  
F  
G  
H  
I  
K  
L  
M  
N  
O  
P

ADP

## SIDE SUPPORT SWITCH

### < COMPONENT DIAGNOSIS >

---

#### Is the inspection result normal?

YES >> Side support switch (cushion side) is OK.

NO >> Replace side support switch. Refer to [SE-110. "Removal and Installation"](#).

### 3. CHECK SEATBACK SIDE SWITCH

---

Check continuity between power seat switch terminals.

Terminal		Seatback side switch condition	Continuity
17	2	Inflate	Existed
		Neutral	Not existed
		Deflate	Not existed
18		Inflate	Not existed
		Neutral	Not existed
		Deflate	Existed

#### Is the inspection result normal?

YES >> Side support switch (seatback side) is OK.

NO >> Replace side support switch. Refer to [SE-110. "Removal and Installation"](#).

# DETENTION SWITCH

< COMPONENT DIAGNOSIS >

## DETENTION SWITCH

### Description

INFOID:000000000960694

Detention switch is installed on AT device. It is turned OFF when the AT selector lever is in P position. The driver seat control unit judges that the AT selector lever is in P position if continuity does not exist in this circuit.

### Component Function Check

INFOID:000000000960695

#### 1. CHECK FUNCTION

1. Select "DETENT SW" signal in "Data monitor" mode with CONSULT-III.
2. Check detention switch signal under the following conditions.

Monitor item	Condition		Status
DETENT SW	AT selector lever	P position	OFF
		Other than above	ON

Is the indication normal?

YES >> INSPECTION END

NO >> Perform diagnosis procedure. Refer to [ADP-93, "Diagnosis Procedure"](#).

### Diagnosis Procedure

INFOID:000000000960696

#### 1. CHECK DTC WITH "BCM"

Check "Self Diagnostic Result" for BCM with CONSULT-III.

Is the either DTC B2602, B2603, B2604, B2605 or B2606 detected?

YES >> Check the DTC. Refer to [SEC-167, "DTC Index"](#).

NO >> GO TO 2.

#### 2. CHECK DETENTION SWITCH INPUT SIGNAL

1. Turn ignition switch ON.
2. Check voltage between driver seat control unit harness connector and ground.

Driver seat control unit connector	Terminal		Condition	Voltage (V) (Approx.)
	(+)	(-)		
B451	21	Ground	AT selector lever P position	0
			Other than above	Battery voltage

Is the inspection result normal?

YES >> GO TO 4.

NO >> GO TO 3.

#### 3. CHECK DETENTION SWITCH CIRCUIT

1. Turn ignition switch OFF.
2. Disconnect driver seat control unit and AT device connector.
3. Check continuity between driver seat control unit harness connector and AT device harness connector.

Driver seat control unit connector	Terminal	AT device connector	Terminal	Continuity
B451	21	M137	11	Existed

4. Check continuity between driver seat control unit harness connector and ground.

Driver seat control unit connector	Terminal	Ground	Continuity
B451	21		Not existed

Is the inspection result normal?

A  
B  
C  
D  
E  
F  
G  
H  
I  
K  
L  
M  
N  
O  
P

ADP

## DETENTION SWITCH

### < COMPONENT DIAGNOSIS >

---

- YES >> GO TO 4.
- NO >> Repair or replace harness.

### 4.CHECK INTERMITTENT INCIDENT

---

Refer to [GI-39. "Intermittent Incident"](#).

Is the inspection result normal?

- YES >> Replace driver seat control unit.
- NO >> Repair or replace the malfunctioning part.

# PARKING BRAKE SWITCH

< COMPONENT DIAGNOSIS >

## PARKING BRAKE SWITCH

### Description

INFOID:000000000960697

Parking brake switch is installed on parking brake lever. It is turned ON when the parking brake is applied. The driver seat control unit judges that the parking brake is engaged if continuity exists in this circuit.

### Component Function Check

INFOID:000000000960698

#### 1.CHECK PARKING BRAKE SWITCH INPUT SIGNAL

1. Turn ignition switch ON.
2. Select "PARK BRAKE SW" in "Data monitor" mode with CONSULT-III.
3. Check parking brake switch signal under the following conditions.

Monitor item	Condition		Status
PARK BRAKE SW	Parking brake	Applied	ON
		Release	OFF

Is the indication normal?

YES >> INSPECTION END

NO >> Perform diagnosis procedure. Refer to [ADP-95, "Diagnosis Procedure"](#).

### Diagnosis Procedure

INFOID:000000000960699

#### 1.CHECK PARKING BRAKE SWITCH SIGNAL

1. Turn ignition switch ON.
2. Check voltage between driver seat control harness connector unit and ground.

Driver seat control unit connector	Terminal		Condition	Voltage (V) (Approx.)
	(+)	(-)		
M51	8	Ground	Parking brake Applied	0
			Release	Battery voltage

Is the inspection result normal?

YES >> GO TO 4.

NO >> GO TO 2.

#### 2.CHECK PARKING BRAKE SWITCH CIRCUIT

1. Turn ignition switch OFF.
2. Disconnect driver seat control unit and parking brake switch connector.
3. Check continuity between driver seat control unit harness connector and parking brake switch harness connector.

Driver seat control unit connector	Terminal	Parking brake switch	Terminal	Continuity
M51	8	B14	1	Existed

4. Check continuity between driver seat control unit harness connector and ground.

Driver seat control unit connector	Terminal	Ground	Continuity
M51	8		Not existed

Is the inspection result normal?

YES >> GO TO 3.

NO >> Repair or replace harness.

#### 3.CHECK PARKING BRAKE SWITCH

Refer to [ADP-96, "Component Inspection"](#).

A  
B  
C  
D  
E  
F  
G  
H  
I  
K  
L  
M  
N  
O  
P

ADP

# PARKING BRAKE SWITCH

## < COMPONENT DIAGNOSIS >

### Is the inspection result normal?

- YES >> GO TO 4.  
NO >> Adjust or replace parking brake switch.

## 4.CHECK INTERMITTENT INCIDENT

Refer to [GI-39. "Intermittent Incident"](#).

### Is the inspection result normal?

- YES >> Replace driver seat control unit.  
NO >> Repair or replace malfunctioning part.

## Component Inspection

INFOID:000000000960700

## 1.CHECK PARKING BRAKE SWITCH

1. Turn ignition switch OFF.
2. Disconnect parking brake switch connector.
3. Check continuity between parking brake switch terminal and ground part of parking brake switch.

Terminal		Condition	Continuity
Parking brake switch			
1	Ground part of parking brake switch	Parking brake	Applied Existed
			Release Not existed

### Is the inspection result normal?

- YES >> INSPECTION END  
NO >> Adjust or replace parking brake switch.



# FRONT DOOR SWITCH (DRIVER SIDE)

< COMPONENT DIAGNOSIS >

## FRONT DOOR SWITCH (DRIVER SIDE)

### Description

INFOID:000000000960701

Detects front door (driver side) open/close condition.

### Component Function Check

INFOID:000000000960702

#### 1. CHECK FUNCTION

1. Select "DOOR SW-DR" in "Data monitor" mode with CONSULT-III.
2. Check the front door switch (driver side) signal under the following conditions.

Monitor item	Condition		Status
DOOR SW-DR	Front door switch (driver side)	Open	ON
		Close	OFF

Is the inspection result normal?

YES >> INSPECTION END

NO >> Perform diagnosis procedure. Refer to [ADP-97, "Diagnosis Procedure"](#).

### Diagnosis Procedure

INFOID:000000000960703

#### 1. CHECK FRONT DOOR SWITCH (DRIVER SIDE) SIGNAL

1. Turn ignition switch OFF.
2. Check signal between BCM connector and ground with oscilloscope.

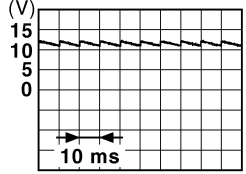
Terminals			Condition	Voltage (V) (Approx.)
(+)		(-)		
BCM connector	Terminal			
M123	150	Ground	Open	0
			Close	 <p>JPMIA0011GB</p>

Is the inspection result normal?

YES >> GO TO 4.

NO >> GO TO 2.

#### 2. CHECK FRONT DOOR SWITCH (DRIVER SIDE) CIRCUIT

1. Disconnect BCM connector.
2. Check continuity between BCM connector and front door switch (driver side) connector.

BCM connector	Terminal	Door switch connector	Terminal	Continuity
M123	150	B16 (Driver side)	2	Existed

3. Check continuity between BCM connector and ground.

BCM connector	Terminal	Ground	Continuity
M123	150		Not existed

Is the inspection result normal?

YES >> GO TO 3.

# FRONT DOOR SWITCH (DRIVER SIDE)

## < COMPONENT DIAGNOSIS >

NO >> Repair or replace harness.

### 3.CHECK FRONT DOOR SWITCH (DRIVER SIDE)

Refer to [ADP-98. "Component Inspection"](#).

Is the inspection result normal?

YES >> GO TO 4.

NO >> Replace front door switch (driver side).

### 4.CHECK INTERMITTENT INCIDENT

Refer to [GI-39. "Intermittent Incident"](#).

Is the inspection result normal?

YES >> Replace BCM.

NO >> Repair or replace the malfunctioning part.

## Component Inspection

INFOID:000000000960704

### 1.CHECK FRONT DOOR SWITCH (DRIVER SIDE)

1. Turn ignition switch OFF.
2. Disconnect front door switch (driver side) connector.
3. Check continuity between front door switch (driver side) terminals.

Terminal		Condition		Continuity
Front door switch (driver side)				
2	Ground part of door switch	Front door switch (driver side)	Pushed	Not existed
			Released	Existed

Is the inspection result normal?

YES >> INSPECTION END

NO >> Replace front door switch (driver side).

# SLIDING SENSOR

< COMPONENT DIAGNOSIS >

## SLIDING SENSOR

### Description

INFOID:000000000960705

- The sliding sensor is installed to the seat slide cushion frame.
- The pulse signal is inputted to the driver seat control unit when sliding is performed.
- The driver seat control unit counts the pulse and calculates the sliding amount of the seat.

### Component Function Check

INFOID:000000000960706

#### 1. CHECK FUNCTION

1. Select "SLIDE PULSE" in "Data monitor" mode with CONSULT-III.
2. Check sliding sensor signal under the following conditions.

Monitor item	Condition		Valve
SLIDE PULSE	Seat sliding	Operate (forward)	Change (increase)*1
		Operate (backward)	Change (decrease)
		Release	No change*1

\*1: The value at the seat position attained when the battery is connected is considered to be 32768.

#### Is the indication normal?

YES >> INSPECTION END

NO >> Perform diagnosis procedure. Refer to [ADP-99, "Diagnosis Procedure"](#).

### Diagnosis Procedure

INFOID:000000000960707

#### 1. CHECK SLIDING SENSOR SIGNAL

1. Turn ignition switch ON.
2. Read voltage signal between driver seat control unit harness connector and ground with oscilloscope.

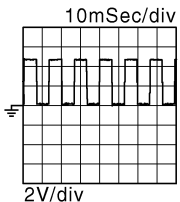
Terminals		(-)	Condition	Voltage signal
(+)	Terminal			
Sliding sensor connector				
B453	24	Ground	Seat sliding	 <p>10mSec/div 2V/div JMJA0119ZZ</p>
			Other than above	0 or 5

#### Is the inspection result normal?

YES >> GO TO 7.

NO >> GO TO 2.

#### 2. CHECK SLIDING SENSOR CIRCUIT

1. Turn ignition switch OFF.
2. Disconnect driver seat control unit and sliding sensor connector.
3. Check continuity between driver seat control unit harness connector and sliding sensor harness connector.

Driver seat control unit connector	Terminal	Sliding sensor connector	Terminal	Continuity
B451	24	B453	24	Existed

# SLIDING SENSOR

## < COMPONENT DIAGNOSIS >

4. Check continuity between driver seat control unit harness connector and ground.

Driver seat control unit connector	Terminal	Ground	Continuity
B451	24		Not existed

Is the inspection result normal?

YES >> GO TO 3.

NO >> Repair or replace harness.

### 3.CHECK SLIDING SENSOR POWER SUPPLY

1. Connect driver seat control unit connector.
2. Turn ignition switch ON.
3. Check sliding sensor harness connector and ground.

Terminals			Voltage (V) (Approx.)
(+)		(-)	
Sliding sensor connector	Terminal		
B453	16	Ground	5

Is the inspection result normal?

YES >> GO TO 5.

NO >> GO TO 4.

### 4.CHECK SLIDING SENSOR POWER SUPPLY CIRCUIT

1. Turn ignition switch OFF.
2. Disconnect driver seat control unit connector.
3. Check continuity between driver seat control unit harness connector and sliding sensor harness connector.

Driver seat control unit connector	Terminal	Sliding sensor connector	Terminal	Continuity
B451	16	B453	16	Existed

4. Check continuity between driver seat control unit harness connector and ground.

Driver seat control unit connector	Terminal	Ground	Continuity
B451	16		Not existed

Is the inspection result normal?

YES >> GO TO 6.

NO >> Repair or replace harness.

### 5.CHECK SLIDING SENSOR GROUND

1. Turn ignition switch OFF.
2. Disconnect driver seat control unit connector.
3. Check continuity between driver seat control unit harness connector and sliding sensor harness connector.

Driver seat control unit connector	Terminal	Sliding sensor connector	Terminal	Continuity
B451	31	B453	31	Existed

Is the inspection result normal?

YES >> GO TO 6.

NO >> Repair or replace harness.

### 6.CHECK SEAT OPERATION

1. Connect driver seat control unit and sliding sensor connector.

# SLIDING SENSOR

## < COMPONENT DIAGNOSIS >

---

2. Check seat operation (except sliding operation) with memory function.

Is the operation normal?

YES >> Replace sliding sensor. (Built in seat slide cushion frame.)

NO >> Replace driver seat control unit.

## 7. CHECK INTERMITTENT INCIDENT

---

Refer to [GI-39, "Intermittent Incident"](#).

Is the inspection result normal?

YES >> Replace driver seat control unit.

NO >> Repair or replace the malfunctioning part.

A

B

C

D

E

F

G

H

I

ADP

K

L

M

N

O

P

# RECLINING SENSOR

< COMPONENT DIAGNOSIS >

## RECLINING SENSOR

### Description

INFOID:000000000960708

- The reclining motor is installed to the seatback frame.
- The pulse signal is inputted to the driver seat control unit when the reclining is operated.
- The driver seat control unit counts the pulse and calculates the reclining amount of the seat.

### Component Function Check

INFOID:000000000960709

#### 1. CHECK FUNCTION

1. Select "RECLN PULSE" in "Data monitor" mode with CONSULT-III.
2. Check reclining sensor signal under the following conditions.

Monitor item	Condition		Value
RECLN PULSE	Seat reclining	Operate (forward)	Change (increase) <sup>*1</sup>
		Operate (backward)	Change (decrease) <sup>*1</sup>
		Release	No change <sup>*1</sup>

\*1: The value at the seat position attained when the battery is connected is considered to be 32768.

Is the indication normal?

YES >> INSPECTION END

NO >> Perform diagnosis procedure. Refer to [ADP-102, "Diagnosis Procedure"](#).

### Diagnosis Procedure

INFOID:000000000960710

#### 1. CHECK RECLINING SENSOR SIGNAL

1. Turn ignition switch ON.
2. Read voltage signal between driver seat control unit harness connector and ground with oscilloscope.

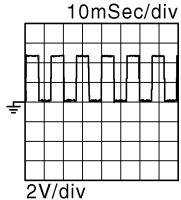
Terminals		(-)	Condition	Voltage signal
(+)	Terminal			
Reclining motor connector				
B454	9	Ground	Seat reclining	 <p>10mSec/div 2V/div JMJA0119ZZ</p>
			Other than above	0 or 5

Is the inspection result normal?

YES >> GO TO 7.

NO >> GO TO 2.

#### 2. CHECK RECLINING SENSOR CIRCUIT

1. Turn ignition switch OFF.
2. Disconnect driver seat control unit and reclining motor connector.
3. Check continuity between driver seat control unit harness connector and reclining motor harness connector.

# RECLINING SENSOR

## < COMPONENT DIAGNOSIS >

Driver seat control unit connector	Terminal	Reclining motor connector	Terminal	Continuity
B451	9	B354	9	Existed

4. Check continuity between driver seat control unit harness connector and ground.

Driver seat control unit connector	Terminal	Ground	Continuity
B451	9		Not existed

Is the inspection result normal?

YES >> GO TO 3.

NO >> Repair or replace harness.

### 3.CHECK RECLINING SENSOR POWER SUPPLY

1. Connect driver seat control unit connector.
2. Turn ignition switch ON.
3. Check voltage between reclining motor harness connector and ground.

Terminals			Voltage (V) (Approx.)
(+)		(-)	
Reclining motor connector	Terminal		
B454	16	Ground	5

Is the inspection result normal?

YES >> GO TO 5.

NO >> GO TO 4.

### 4.CHECK RECLINING SENSOR POWER SUPPLY CIRCUIT

1. Turn ignition switch OFF.
2. Disconnect driver seat control unit connector.
3. Check continuity between driver seat control unit harness connector and reclining motor harness connector.

Driver seat control unit connector	Terminal	Reclining motor connector	Terminal	Continuity
B451	16	B454	16	Existed

4. Check continuity between driver seat control unit harness connector and ground.

Driver seat control unit connector	Terminal	Ground	Continuity
B451	16		Not existed

Is the inspection result normal?

YES >> GO TO 7.

NO >> Repair or replace harness.

### 5.CHECK RECLINING SENSOR GROUND

1. Turn ignition switch OFF.
2. Disconnect driver seat control unit connector.
3. Check continuity between driver seat control unit harness connector and reclining motor harness connector.

Driver seat control unit connector	Terminal	Reclining motor connector	Terminal	Continuity
B451	31	B454	31	Existed

Is the inspection result normal?

YES >> GO TO 6.

## RECLINING SENSOR

### < COMPONENT DIAGNOSIS >

---

NO >> Repair or replace harness.

### 6.CHECK SEAT OPERATION

---

1. Connect driver seat control unit and sliding sensor connector.
2. Check seat operation (except reclining operation) with memory function.

#### Is the operation normal?

YES >> Replace reclining motor. (Built in seat slide cushion frame.)

NO >> Replace driver seat control unit.

### 7.CHECK INTERMITTENT INCIDENT

---

Refer to [GI-39. "Intermittent Incident"](#).

#### Is the inspection result normal?

YES >> Replace driver seat control unit.

NO >> Repair or replace the malfunctioning part.



# LIFTING SENSOR (FRONT)

< COMPONENT DIAGNOSIS >

## LIFTING SENSOR (FRONT)

### Description

INFOID:000000000960711

- The lifting sensor (front) is installed to the seat slide cushion frame.
- The pulse signal is inputted to the driver seat control unit when the lifting (front) is operated.
- The driver seat control unit counts the pulse and calculates the lifting (front) amount of the seat.

### Component Function Check

INFOID:000000000960712

#### 1. CHECK FUNCTION

1. Select "LIFT FR PULSE" in "Data monitor" mode with CONSULT-III.
2. Check the lifting sensor (front) signal under the following conditions.

Monitor item	Condition		Value
LIFT FR PULSE	Seat lifting (front)	Operate (Up)	Change (increase) <sup>*1</sup>
		Operate (Down)	Change (decrease) <sup>*1</sup>
		Release	No change <sup>*1</sup>

\*1: The value at the seat position attained when the battery is connected is considered to be 32768.

Is the indication normal?

YES >> INSPECTION END

NO >> Perform diagnosis procedure. Refer to [ADP-105, "Diagnosis Procedure"](#).

### Diagnosis Procedure

INFOID:000000000960713

#### 1. CHECK LIFTING SENSOR (FRONT) SIGNAL

1. Turn ignition switch ON.
2. Read the voltage signal driver seat control unit harness connector and ground with an oscilloscope.

Terminals		Condition	Voltage signal
(+)	(-)		
Lifting motor (front) connector	Terminal		
B455	25	Seat Lifting (front) Operate	
		Other than above	0 or 5

Is the inspection result normal?

YES >> GO TO 7.

NO >> GO TO 2.

#### 2. CHECK LIFTING SENSOR (FRONT) CIRCUIT

1. Turn ignition switch OFF.
2. Disconnect driver seat control unit and lifting motor (front) connector.
3. Check continuity between driver seat control unit harness connector and lifting motor (front) harness connector.

# LIFTING SENSOR (FRONT)

## < COMPONENT DIAGNOSIS >

Driver seat control unit connector	Terminal	Lifting motor (front) connector	Terminal	Continuity
B451	25	B455	25	Existed

4. Check continuity between driver seat control unit harness connector and ground.

Driver seat control unit connector	Terminal	Ground	Continuity
B451	25		Not existed

Is the inspection result normal?

YES >> GO TO 3.

NO >> Repair or replace harness.

### 3.CHECK LIFTING SENSOR (FRONT) POWER SUPPLY

1. Connect driver seat control unit connector.
2. Turn ignition switch ON.
3. Check voltage between lifting motor (front) harness connector and ground.

Terminals			Voltage (V) (Approx.)
(+)		(-)	
Lifting motor (front) connector	Terminal		
B455	16	Ground	5

Is the inspection result normal?

YES >> GO TO 5.

NO >> GO TO 4.

### 4.CHECK LIFTING SENSOR (FRONT) POWER SUPPLY CIRCUIT

1. Turn ignition switch OFF.
2. Disconnect driver seat control unit connector.
3. Check continuity between driver seat control unit harness connector and lifting motor (front) harness connector.

Driver seat control unit connector	Terminal	Lifting motor (front) connector	Terminal	Continuity
B451	16	B455	16	Existed

4. Check continuity between driver seat control unit harness connector and ground.

Driver seat control unit connector	Terminal	Ground	Continuity
B451	16		Not existed

Is the inspection result normal?

YES >> GO TO 7.

NO >> Repair or replace harness.

### 5.CHECK LIFTING SENSOR (FRONT) GROUND

1. Turn ignition switch OFF.
2. Disconnect driver seat control unit connector.
3. Check continuity between driver seat control unit harness connector and lifting motor (front) harness connector.

Driver seat control unit connector	Terminal	Lifting motor (front) connector	Terminal	Continuity
B451	31	B455	31	Existed

Is the inspection result normal?

YES >> GO TO 6.

# LIFTING SENSOR (FRONT)

## < COMPONENT DIAGNOSIS >

---

NO >> Repair or replace harness.

### 6.CHECK SEAT OPERATION

---

1. Connect driver seat control unit and sliding sensor connector.
2. Check seat operation [except lifting (front) operation] with memory function.

Is the operation normal?

YES >> Replace lifting motor (front). (Built in seat slide cushion frame.)

NO >> Replace driver seat control unit.

### 7.CHECK INTERMITTENT INCIDENT

---

Refer to [GI-39. "Intermittent Incident"](#).

Is the inspection result normal?

YES >> Replace driver seat control unit.

NO >> Repair or replace the malfunctioning part.

A  
B  
C  
D  
E  
F  
G  
H  
I  
K  
L  
M  
N  
O  
P

ADP

# LIFTING SENSOR (REAR)

< COMPONENT DIAGNOSIS >

## LIFTING SENSOR (REAR)

### Description

INFOID:000000000960714

- The lifting sensor (rear) is installed to the seat slide cushion frame.
- The pulse signal is inputted to the driver seat control unit when the lifting (rear) is operated.
- The driver seat control unit counts the pulse and calculates the lifting (rear) amount of the seat.

### Component Function Check

INFOID:000000000960715

#### 1. CHECK FUNCTION

1. Select "LIFT RR PULSE" in "Data monitor" mode with CONSULT-III.
2. Check lifting sensor (rear) signal under the following conditions.

Monitor item	Condition		Value
LIFT RR PULSE	Seat lifting (rear)	Operate (Up)	Change (increase) <sup>*1</sup>
		Operate (Down)	Change (decrease) <sup>*1</sup>
		Release	No change <sup>*1</sup>

\*1: The value at the seat position attained when the battery is connected is considered to be 32768.

#### Is the indication normal?

YES >> INSPECTION END

NO >> Perform diagnosis procedure. Refer to [ADP-108, "Diagnosis Procedure"](#).

### Diagnosis Procedure

INFOID:000000000960716

#### 1. CHECK LIFTING SENSOR (REAR) SIGNAL

1. Turn ignition switch ON.
2. Read voltage signal between driver seat control unit harness connector and ground with oscilloscope.

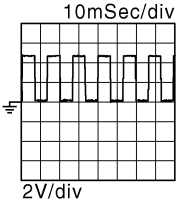
Terminals		(-)	Condition	Voltage signal
(+)	Terminal			
Lifting motor (rear) connector				
B456	25	Ground	Seat Lifting (rear) Operate	 <p>10mSec/div 2V/div JMJA0119ZZ</p>
			Other than above	0 or 5

#### Is the inspection result normal?

YES >> GO TO 7.

NO >> GO TO 2.

#### 2. CHECK LIFTING SENSOR (REAR) CIRCUIT

1. Turn ignition switch OFF.
2. Disconnect driver seat control unit and lifting motor (rear) connector.
3. Check the continuity between driver seat control unit harness connector and lifting motor (rear) harness connector.

Driver seat control unit connector	Terminal	Lifting motor (rear) connector	Terminal	Continuity
B451	10	B456	25	Existed

# LIFTING SENSOR (REAR)

## < COMPONENT DIAGNOSIS >

4. Check the continuity between driver seat control unit harness connector and ground.

Driver seat control unit connector	Terminal	Ground	Continuity
B451	10		Not Existed

Is the inspection result normal?

YES >> GO TO 3.

NO >> Repair or replace harness.

### 3.CHECK LIFTING SENSOR (REAR) POWER SUPPLY

1. Connect driver seat control unit connector.
2. Turn ignition switch ON.
3. Check the voltage between lifting motor (rear) harness connector and ground.

Terminals		Voltage (V) (Approx.)
(+)	(-)	
Lifting motor (rear)	Terminal	
B456	16	Ground
		5

Is the inspection result normal?

YES >> GO TO 5.

NO >> GO TO 4.

### 4.CHECK LIFTING SENSOR (REAR) POWER SUPPLY CIRCUIT

1. Turn ignition switch OFF.
2. Disconnect driver seat control unit connector.
3. Check the continuity between driver seat control unit harness connector and lifting motor (rear) harness connector.

Driver seat control unit connector	Terminal	Lifting motor (rear) connector	Terminal	Continuity
B451	16	B456	16	Existed

4. Check the continuity between driver seat control unit harness connector and ground.

Driver seat control unit connector	Terminal	Ground	Continuity
B451	16		Not existed

Is the inspection result normal?

YES >> GO TO 7.

NO >> Repair or replace harness.

### 5.CHECK LIFTING SENSOR (REAR) GROUND

1. Turn ignition switch OFF.
2. Disconnect driver seat control unit connector.
3. Check the continuity between driver seat control unit harness connector and lifting motor (rear) harness connector.

Driver seat control unit connector	Terminal	Lifting motor (rear) connector	Terminal	Continuity
B451	31	B456	31	Existed

Is the inspection result normal?

YES >> GO TO 6.

NO >> Repair or replace harness.

### 6.CHECK SEAT OPERATION

1. Connect driver seat control unit and sliding sensor connector.

## LIFTING SENSOR (REAR)

### < COMPONENT DIAGNOSIS >

---

2. Check the seat operation [except lifting (rear) operation] with memory function.

Is the operation normal?

YES >> Replace lifting motor (rear). (Built in seat slide cushion frame.)

NO >> Replace driver seat control unit.

### 7. CHECK INTERMITTENT INCIDENT

---

Refer to [GI-39, "Intermittent Incident"](#).

Is the inspection result normal?

YES >> Replace driver seat control unit.

NO >> Repair or replace the malfunctioning part.

# TILT SENSOR

< COMPONENT DIAGNOSIS >

## TILT SENSOR

### Description

INFOID:000000000960717

- The tilt sensor is installed to the steering column assembly.
- The resistance of tilt sensor is changed according to the up/down position of steering column.
- The terminal voltage of automatic drive positioner control unit will be changed according to a change of tilt sensor resistance. Automatic drive positioner control unit calculates the tilt position from the voltage.

### Component Function Check

INFOID:000000000960718

#### 1.CHECK FUNCTION

1. Select "TILT SEN" in "Data monitor" mode with CONSULT-III.
2. Check the tilt sensor signal under the following condition.

Monitor item	Condition		Value
TILT SEN	Tilt position	Top	1.2 [V]
		Bottom	3.4 [V]

Is the indication normal?

YES >> INSPECTION END

NO >> Perform diagnosis procedure. Refer to [ADP-111, "Diagnosis Procedure"](#).

### Diagnosis Procedure

INFOID:000000000960719

#### 1.CHECK TILT SENSOR SIGNAL

1. Turn ignition switch ON.
2. Check voltage automatic drive positioner control unit harness connector and ground.

Terminal		(-)	Condition	Voltage (V) (Approx.)	
(+)	Terminal				
Tilt & telescopic sensor connector	M48	Ground	Tilt position	Top	1.2 [V]
				Bottom	3.4 [V]

Is the inspection result normal?

YES >> GO TO 7.

NO >> GO TO 2.

#### 2.CHECK TILT SENSOR CIRCUIT

1. Turn ignition switch OFF.
2. Disconnect automatic drive positioner control unit and tilt & telescopic sensor connector.
3. Check continuity between automatic drive positioner control unit harness connector and tilt & telescopic sensor harness connector.

Automatic drive positioner control unit connector	Terminal	Tilt & telescopic sensor connector	Terminal	Continuity
M51	7	M48	3	Existed

4. Check continuity between automatic drive positioner control unit harness connector and ground.

Automatic drive positioner control unit connector	Terminal	Ground	Continuity
M51	7		Not existed

Is the inspection result normal?

YES >> GO TO 3.

NO >> Repair or replace harness.

A  
B  
C  
D  
E  
F  
G  
H  
I  
K  
L  
M  
N  
O  
P

ADP

# TILT SENSOR

## < COMPONENT DIAGNOSIS >

### 3. CHECK TILT SENSOR POWER SUPPLY

1. Connect automatic drive positioner control unit connector.
2. Turn ignition switch ON.
3. Check voltage between tilt & telescopic sensor harness connector and ground.

Terminal			Voltage (V) (Approx.)
(+)		(-)	
Tilt & telescopic sensor	Terminal		
M48	1	Ground	5

Is the inspection result normal?

YES >> GO TO 5.

NO >> GO TO 4.

### 4. CHECK TILT SENSOR POWER SUPPLY CIRCUIT

1. Turn ignition switch OFF.
2. Disconnect automatic drive positioner control unit connector.
3. Check continuity between automatic drive positioner control unit harness connector and tilt & telescopic sensor harness connector.

Automatic drive positioner control unit connector	Terminal	Tilt & telescopic sensor connector	Terminal	Continuity
M52	33	M48	1	Existed

4. Check continuity between automatic drive positioner control unit harness connector and ground.

Automatic drive positioner control unit connector	Terminal	Ground	Continuity
M52	33		Not existed

Is the inspection result normal?

YES >> GO TO 6.

NO >> Repair or replace harness.

### 5. CHECK TILT SENSOR GROUND CIRCUIT

1. Turn ignition switch OFF.
2. Disconnect automatic drive positioner control unit connector.
3. Check continuity between automatic drive positioner control unit harness connector and tilt & telescopic sensor harness connector.

Automatic drive positioner control unit connector	Terminal	Tilt & telescopic sensor connector	Terminal	Continuity
M52	41	M48	4	Existed

Is the inspection result normal?

YES >> GO TO 6.

NO >> Repair or replace harness.

### 6. CHECK DOOR MIRROR OPERATION

1. Connect automatic drive positioner control unit connector and tilt & telescopic sensor connector.
2. Turn ignition switch ON.
3. Check door mirror operation with memory function.

Is the operation normal?

YES >> Replace tilt sensor. (Built in steering column assembly.)

NO >> Replace automatic drive positioner control unit.

### 7. CHECK INTERMITTENT INCIDENT

Refer to [GI-39, "Intermittent Incident"](#).

Is the inspection result normal?



# TILT SENSOR

## < COMPONENT DIAGNOSIS >

---

- YES >> Replace automatic drive positioner control unit.
- NO >> Repair or replace the malfunctioning part.

A

B

C

D

E

F

G

H

I

ADP

K

L

M

N

O

P

# TELESCOPIC SENSOR

< COMPONENT DIAGNOSIS >

## TELESCOPIC SENSOR

### Description

INFOID:000000000960720

- The telescopic sensor is installed to the steering column assembly.
- The resistance of telescopic sensor is changed according to the forward/backward position of steering column.
- The terminal voltage of automatic drive positioner control unit will be changed according to a change of telescopic sensor resistance. Automatic drive positioner control unit calculates the telescopic position from the voltage.

### Component Function Check

INFOID:000000000960721

#### 1.CHECK FUNCTION

1. Select "TELESCO SEN" in "Data monitor" mode with CONSULT-III.
2. Check the tilt sensor signal under the following conditions.

Monitor item	Condition		Value
TELESCO SEN	Telescopic position	Rear	0.8 [V]
		Front	3.4 [V]

Is the indication normal?

YES >> INSPECTION END.

NO >> Perform diagnosis procedure. Refer to [ADP-114, "Diagnosis Procedure"](#).

### Diagnosis Procedure

INFOID:000000000960722

#### 1.CHECK TELESCOPIC SENSOR SIGNAL

1. Turn ignition switch ON.
2. Check voltage automatic drive positioner control unit harness connector and ground.

Terminal		(-)	Condition	Voltage (V) (Approx.)	
(+)	Terminal				
Tilt & telescopic sensor connector	M48	Ground	Telescopic position	Rear	0.8 [V]
			Front	3.4 [V]	

Is the inspection result normal?

YES >> GO TO 7.

NO >> GO TO 2.

#### 2.CHECK TELESCOPIC SENSOR CIRCUIT

1. Turn ignition switch OFF.
2. Disconnect automatic drive positioner control unit and tilt & telescopic sensor connector.
3. Check continuity between automatic drive positioner control unit harness connector and tilt & telescopic sensor harness connector.

Automatic drive positioner control unit connector	Terminal	Tilt & telescopic sensor connector	Terminal	Continuity
M51	23	M48	2	Existed

4. Check continuity between automatic drive positioner control unit harness connector and ground.

Automatic drive positioner control unit connector	Terminal	Ground	Continuity
M51	23		Not existed

Is the inspection result normal?

# TELESCOPIC SENSOR

## < COMPONENT DIAGNOSIS >

- YES >> GO TO 3.  
NO >> Repair or replace harness.

### 3.CHECK TELESCOPIC SENSOR POWER SUPPLY

1. Connect automatic drive positioner control unit connector.
2. Turn ignition switch ON.
3. Check voltage between tilt & telescopic sensor harness connector and ground.

Terminal			Voltage (V) (Approx.)
(+)		(-)	
Tilt & telescopic sensor	Terminal		
M48	2	Ground	5

Is the inspection result normal?

- YES >> GO TO 5.  
NO >> GO TO 4.

### 4.CHECK TELESCOPIC SENSOR POWER SUPPLY CIRCUIT

1. Turn ignition switch OFF.
2. Disconnect automatic drive positioner control unit connector.
3. Check continuity between automatic drive positioner control unit harness connector and tilt & telescopic sensor harness connector.

Automatic drive positioner control unit connector	Terminal	Tilt & telescopic sensor connector	Terminal	Continuity
M52	33	M48	1	Existed

4. Check continuity between automatic drive positioner control unit harness connector and ground.

Automatic drive positioner control unit connector	Terminal	Ground	Continuity
M52	33		Not existed

Is the inspection result normal?

- YES >> GO TO 6.  
NO >> Repair or replace harness.

### 5.CHECK TELESCOPIC SENSOR GROUND CIRCUIT

1. Turn ignition switch OFF.
2. Disconnect automatic drive positioner control unit connector.
3. Check continuity between automatic drive positioner control unit harness connector and tilt & telescopic sensor harness connector.

Automatic drive positioner control unit connector	Terminal	Tilt & telescopic sensor connector	Terminal	Continuity
M52	41	M48	4	Existed

Is the inspection result normal?

- YES >> GO TO 6.  
NO >> Repair or replace harness.

### 6.CHECK DOOR MIRROR OPERATION

1. Connect automatic drive positioner control unit connector and tilt & telescopic sensor connector.
2. Turn ignition switch ON.
3. Check door mirror operation with memory function.

Is the operation normal?

- YES >> Replace telescopic sensor. (Built in steering column assembly.)  
NO >> Repair or replace harness.

### 7.CHECK INTERMITTENT INCIDENT

## TELESCOPIC SENSOR

< COMPONENT DIAGNOSIS >

---

Refer to [GI-39, "Intermittent Incident"](#).

Is the inspection result normal?

- YES >> Replace automatic drive positioner control unit.
- NO >> Repair or replace the malfunctioning part.

# MIRROR SENSOR

< COMPONENT DIAGNOSIS >

## MIRROR SENSOR

### DRIVER SIDE

#### DRIVER SIDE : Description

INFOID:000000000960723

- The mirror sensor (driver side) is installed to the door mirror (driver side).
- The resistance of 2 sensors (horizontal and vertical) is changed when the door mirror (driver side) is operated.
- Automatic drive positioner control unit calculates the door mirror position according to the change of the voltage of 2 sensor input terminals.

#### DRIVER SIDE : Component Function Check

INFOID:000000000960724

### 1.CHECK FUNCTION

1. Select "MIR/SEN LH U-D", "MIR/SEN LH R-L" in "Data monitor" with CONSULT-III.
2. Check mirror sensor (driver side) signal under the following condition.

Monitor item	Condition	Value
MIR/SEN LH U-D	Close to peak	3.4 [V]
	Close to valley	0.6 [V]
MIR/SEN LH R-L	Close to right edge	3.4 [V]
	Close to left edge	0.6 [V]

Is the indication normal?

YES >> INSPECTION END

NO >> Perform diagnosis procedure. Refer to [ADP-117, "DRIVER SIDE : Diagnosis Procedure"](#).

#### DRIVER SIDE : Diagnosis Procedure

INFOID:000000000960725

### 1.CHECK DOOR MIRROR (DRIVER SIDE) SENSOR SIGNAL

1. Turn ignition switch ON.
2. Check voltage between door mirror (driver side) harness connector and ground.

Terminals		Condition	Voltage (V) (Approx.)	
(+)	(-)			
Door mirror (driver side) connector	Terminal	Door mirror (Driver side)	Close to peak	3.4
			Close to valley	0.6
D3	9		Close to right edge	3.4
			Close to left edge	0.6
D3	10	Ground	Close to peak	3.4
			Close to valley	0.6
D3	9		Close to right edge	3.4
			Close to left edge	0.6

Is the inspection result normal?

YES >> GO TO 7.

NO >> GO TO 2.

### 2.CHECK DOOR MIRROR (DRIVER SIDE) SENSOR CIRCUIT

1. Turn ignition switch OFF.
2. Disconnect automatic drive positioner control unit and door mirror (driver side) connector.
3. Check continuity between automatic drive positioner control unit harness connector and door mirror (driver side) harness connector.

Automatic drive positioner control unit connector	Terminal	Door mirror (driver side) connector	Terminal	Continuity
M51	6	D3	9	Existed
	22		10	

## MIRROR SENSOR

### < COMPONENT DIAGNOSIS >

4. Check continuity between automatic drive positioner control unit harness connector and ground.

Automatic drive positioner control unit connector	Terminal	Ground	Continuity	
M51	6			Not existed
	22			

Is the inspection result normal?

YES >> GO TO 3.

NO >> Repair or replace harness.

### 3. CHECK DOOR MIRROR (DRIVER SIDE) SENSOR POWER SUPPLY

1. Connect automatic drive positioner control unit connector.
2. Turn ignition switch ON.
3. Check voltage between door mirror (driver side) harness connector and ground.

Terminals		Voltage (V) (Approx.)
(+)	(-)	
Door mirror (driver side) connector	Terminal	
D3	11	Ground 5

Is the inspection result normal?

YES >> GO TO 5.

NO >> GO TO 4.

### 4. CHECK DOOR MIRROR (DRIVER SIDE) SENSOR POWER SUPPLY CIRCUIT

1. Turn ignition switch OFF.
2. Disconnect automatic drive positioner control unit connector.
3. Check continuity between automatic drive positioner control unit harness connector and door mirror (driver side) harness connector.

Automatic drive positioner control unit connector	Terminal	Door mirror (driver side) connector	Terminal	Continuity
M52	33	D3	11	Existed

4. Check continuity between automatic drive positioner control unit harness connector and ground.

Automatic drive positioner control unit connector	Terminal	Ground	Continuity
M52	33		

Is the inspection result normal?

YES >> GO TO 7.

NO >> Repair or replace harness.

### 5. CHECK DOOR MIRROR (DRIVER SIDE) SENSOR GROUND

1. Turn ignition switch OFF.
2. Disconnect driver seat control unit connector.
3. Check continuity between automatic drive positioner control unit harness connector and door mirror (driver side) harness connector.

Automatic drive positioner control unit connector	Terminal	Door mirror (driver side) connector	Terminal	Continuity
M52	41	D3	12	Existed

Is the inspection result normal?

YES >> GO TO 6.

NO >> Repair or replace harness.

# MIRROR SENSOR

## < COMPONENT DIAGNOSIS >

### 6. CHECK TILT & TELESCOPIC OPERATION

1. Connect driver seat control unit connector and door mirror (driver side) connector.
2. Turn ignition switch ON.
3. Check tilt & telescopic operation with memory function.

#### Is the operation normal?

- YES >> Replace door mirror sensor. (Built in driver side door mirror.)  
 NO >> Replace automatic drive positioner control unit.

### 7. CHECK INTERMITTENT INCIDENT

Refer to [GI-39. "Intermittent Incident"](#).

#### Is the inspection result normal?

- YES >> Replace automatic drive positioner control unit.  
 NO >> Repair or replace the malfunctioning part.

## PASSENGER SIDE

### PASSENGER SIDE : Description

INFOID:000000000960726

- The mirror sensor (passenger side) is installed to the door mirror (passenger side).
- The resistance of 2 sensors (horizontal and vertical) is changed when the door mirror (passenger side) is operated.
- Automatic drive positioner control unit calculates the door mirror position according to the change of the voltage of 2 sensor input terminals.

### PASSENGER SIDE : Component Function Check

INFOID:000000000960727

#### 1. CHECK FUNCTION

1. Select "MIR/SEN RH U-D", "MIR/SEN RH R-L" in "Data monitor" with CONSULT-III.
2. Check the mirror sensor (passenger side) signal under the following conditions.

Monitor item	Condition	Value
MIR/SEN RH U-D	Close to peak	3.4 [V]
	Close to valley	0.6 [V]
MIR/SEN RH R-L	Close to right edge	3.4 [V]
	Close to left edge	0.6 [V]

#### Is the indication normal?

- YES >> INSPECTION END  
 NO >> Perform diagnosis procedure. Refer to [ADP-119. "PASSENGER SIDE : Diagnosis Procedure"](#).

### PASSENGER SIDE : Diagnosis Procedure

INFOID:000000000960728

#### 1. CHECK DOOR MIRROR (PASSENGER SIDE) SENSOR SIGNAL

1. Turn ignition switch ON.
2. Check voltage between door mirror (passenger side) harness connector and ground.

Terminals		Condition	Voltage (V) (Approx.)
(+)	(-)		
Door mirror (passenger side) connector	Terminal	Door mirror (passenger side)	Close to peak
	D33		9
10			Ground

#### Is the inspection result normal?

# MIRROR SENSOR

## < COMPONENT DIAGNOSIS >

YES >> GO TO 7.

NO >> GO TO 2.

### 2. CHECK DOOR MIRROR (PASSENGER SIDE) SENSOR HARNESS CONTINUITY

1. Turn ignition switch OFF.
2. Disconnect automatic drive positioner control unit and door mirror (passenger side) connector.
3. Check continuity between automatic drive positioner control unit harness connector and door mirror (passenger side) harness connector.

Automatic drive positioner control unit connector	Terminal	Door mirror (passenger side) connector	Terminal	Continuity
M51	5	D33	9	Existed
	21		10	

4. Check continuity between automatic drive positioner control unit harness connector and ground.

Automatic drive positioner control unit connector	Terminal	Ground	Continuity
M51	5	Ground	Not existed
	21		

Is the inspection result normal?

YES >> GO TO 3.

NO >> Repair or replace harness.

### 3. CHECK DOOR MIRROR SENSOR (PASSENGER SIDE) POWER SUPPLY

1. Connect automatic drive positioner control unit connector.
2. Turn ignition switch ON.
3. Check voltage between door mirror (passenger side) harness connector and ground.

Terminals		Voltage (V) (Approx.)
(+)	(-)	
Door mirror (passenger side) connector	Terminal	5
D33	11	

Is the inspection result normal?

YES >> GO TO 5.

NO >> GO TO 4.

### 4. CHECK DOOR MIRROR (PASSENGER SIDE) SENSOR POWER SUPPLY CIRCUIT

1. Turn ignition switch OFF.
2. Disconnect automatic drive positioner control unit connector.
3. Check continuity between automatic drive positioner control unit harness connector and door mirror (passenger side) harness connector.

Automatic drive positioner control unit connector	Terminal	Door mirror (passenger side) connector	Terminal	Continuity
M52	33	D33	11	Existed

4. Check continuity between automatic drive positioner control unit harness connector and ground.

Automatic drive positioner control unit connector	Terminal	Ground	Continuity
M52	33	Ground	Not existed

Is the inspection result normal?

YES >> GO TO 7.

NO >> Repair or replace harness.



# MIRROR SENSOR

## < COMPONENT DIAGNOSIS >

### 5. CHECK DOOR MIRROR (PASSENGER SIDE) SENSOR GROUND

1. Turn ignition switch OFF.
2. Disconnect automatic drive positioner control unit connector.
3. Check continuity between automatic drive positioner control unit harness connector and door mirror (passenger side) connector.

Automatic drive positioner control unit connector	Terminal	Door mirror (passenger side) connector	Terminal	Continuity
M52	41	D33	12	Existed

Is the inspection result normal?

- YES >> GO TO 6.  
NO >> Repair or replace harness.

### 6. CHECK TILT & TELESCOPIC OPERATION

1. Connect driver seat control unit connector and door mirror (passenger side) connector.
2. Turn ignition switch ON.
3. Check tilt & telescopic operation with memory function.

Is the operation normal?

- YES >> Replace door mirror sensor. (Built in passenger side door mirror.)  
NO >> Replace automatic drive positioner control unit.

### 7. CHECK INTERMITTENT INCIDENT

Refer to [GI-39, "Intermittent Incident"](#).

Is the inspection result normal?

- YES >> Replace automatic drive positioner control unit.  
NO >> Repair or replace the malfunctioning part.

A  
B  
C  
D  
E  
F  
G  
H  
I  
K  
L  
M  
N  
O  
P

ADP

# SLIDING MOTOR

< COMPONENT DIAGNOSIS >

## SLIDING MOTOR

### Description

INFOID:000000000960729

- The seat sliding motor is installed to the seat cushion frame.
- The seat sliding motor is installed with the driver seat control unit.
- The seat is slid forward/rearward by changing the rotation direction of sliding motor.

### Component Function Check

INFOID:000000000960730

#### 1.CHECK FUNCTION

1. Select "SEAT SLIDE" in "Active test" mode with CONSULT-III.
2. Check the sliding motor operation.

Test item		Description	
SEAT SLIDE	OFF	Seat sliding	Stop
	FR		Forward
	RR		Backward

Is the operation of relevant parts normal?

YES >> INSPECTION END

NO >> Perform diagnosis procedure. Refer to [ADP-122. "Diagnosis Procedure"](#).

### Diagnosis Procedure

INFOID:000000000960731

#### 1.CHECK SLIDING MOTOR POWER SUPPLY

1. Turn ignition switch OFF.
2. Disconnect sliding motor connector.
3. Turn the ignition switch ON.
4. Perform "Active test" ("SEAT SLIDE") with CONSULT-III
5. Check voltage between sliding motor harness connector and ground.

Terminal		Test item	Voltage (V) (Approx.)
(+)	(-)		
Sliding motor connector	Terminal		
B461	35	OFF	0
		FR (forward)	Battery voltage
		RR (backward)	0
	42	OFF	0
		FR (forward)	0
		RR (backward)	Battery voltage

Is the inspection result normal?

YES >> Replace sliding motor. (Built in seat slide cushion frame.)

NO >> GO TO 2.

#### 2.CHECK SLIDING MOTOR CIRCUIT

1. Turn ignition switch OFF.
2. Disconnect driver seat control unit connector.
3. Check continuity between driver seat control unit harness connector and sliding motor harness connector.

Driver seat control unit connector	Terminal	Sliding motor connector	Terminal	Continuity
B452	35	B461	35	Existed
	42		42	

# SLIDING MOTOR

## < COMPONENT DIAGNOSIS >

4. Check continuity between driver seat control unit harness connector and ground.

Driver seat control unit connector	Terminal	Ground	Continuity
B452	35		
	42		Not existed

Is the inspection result normal?

YES >> GO TO 3.

NO >> Repair or replace harness.

### 3.CHECK INTERMITTENT INCIDENT

Refer to [GI-39, "Intermittent Incident"](#).

Is the inspection result normal?

YES >> Replace driver seat control unit.

NO >> Repair or replace the malfunctioning part.

A  
B  
C  
D  
E  
F  
G  
H  
I  
K  
L  
M  
N  
O  
P

ADP

# RECLINING MOTOR

< COMPONENT DIAGNOSIS >

## RECLINING MOTOR

### Description

INFOID:000000000960732

- The seat reclining motor is installed to the seat back frame.
- The seat reclining motor is activated with the driver seat control unit.
- The seatback is reclined frontward/rearward by changing the rotation direction of reclining motor.

### Component Function Check

INFOID:000000000960733

#### 1.CHECK FUNCTION

1. Select "SEAT RECLINING" in "Active test" mode with CONSULT-III.
2. Check the reclining motor operation.

Test item		Description	
SEAT RECLINING	OFF	Seat reclining	Stop
	FR		Forward
	RR		Backward

Is the operation of relevant parts normal?

YES >> INSPECTION END

NO >> Perform diagnosis procedure. Refer to [ADP-124. "Diagnosis Procedure"](#).

### Diagnosis Procedure

INFOID:000000000960734

#### 1.CHECK RECLINING MOTOR POWER SUPPLY

1. Turn ignition switch OFF.
2. Disconnect reclining motor connector.
3. Turn the ignition switch ON.
4. Perform "Active test" ("SEAT RECLINING") with CONSULT-III
5. Check voltage between reclining motor harness connector and ground.

Terminal		Test item	Voltage (V) (Approx.)
(+)	(-)		
Reclining motor connector	Terminal		
B454	36	OFF	0
		FR (forward)	Battery voltage
		RR (backward)	0
	44	OFF	0
		FR (forward)	0
		RR (backward)	Battery voltage

Is the inspection result normal?

YES >> Replace reclining motor. (Built in seat back frame.)

NO >> GO TO 2.

#### 2.CHECK RECLINING MOTOR CIRCUIT

1. Turn ignition switch OFF.
2. Disconnect driver seat control unit connector.
3. Check continuity between driver seat control unit harness connector and reclining motor harness connector.

# RECLINING MOTOR

## < COMPONENT DIAGNOSIS >

Driver seat control unit connector	Terminal	Reclining motor connector	Terminal	Continuity
B452	36	B454	36	Existed
	44		44	

4. Check continuity between driver seat control unit harness connector and ground.

Driver seat control unit connector	Terminal	Ground	Continuity
B452	36		Continuity
	44		Not existed

Is the inspection result normal?

YES >> GO TO 3.

NO >> Repair or replace harness.

### 3.CHECK INTERMITTENT INCIDENT

Refer to [GI-39, "Intermittent Incident"](#).

Is the inspection result normal?

YES >> Replace driver seat control unit.

NO >> Repair or replace the malfunctioning part.

A  
B  
C  
D  
E  
F  
G  
H  
I  
K  
L  
M  
N  
O  
P

ADP

# LIFTING MOTOR (FRONT)

< COMPONENT DIAGNOSIS >

## LIFTING MOTOR (FRONT)

### Description

INFOID:000000000960735

- The lifting motor (front) is installed to the seat slide cushion frame.
- The lifting motor (front) is activated with the driver seat control unit.
- The lifter (front) is moved upward/downward by changing the rotation direction of lifting motor (front).

### Component Function Check

INFOID:000000000960736

#### 1.CHECK FUNCTION

1. Select "SEAT LIFTER FR" in "Active test" mode with CONSULT-III.
2. Check the lifting motor (front) operation.

Test item		Description	
SEAT LIFTER FR	OFF	Seat lifting (front)	Stop
	UP		Upward
	DWN		Downward

Is the operation of relevant parts normal?

YES >> INSPECTION END

NO >> Perform diagnosis procedure. Refer to [ADP-126. "Diagnosis Procedure"](#).

### Diagnosis Procedure

INFOID:000000000960737

#### 1.CHECK LIFTING MOTOR (FRONT) POWER SUPPLY

1. Turn ignition switch OFF.
2. Disconnect lifting motor (front) connector.
3. Turn the ignition switch ON.
4. Perform "Active test" ("SEAT LIFTER FR") with CONSULT-III.
5. Check voltage between lifting motor (front) harness connector and ground.

Terminal		Test item	Voltage (V) (Approx.)	
(+)	(-)			
Lifting motor (front) connector	Terminal			
B455	37	SEAT LIFTER FR	OFF	0
			UP	0
	DWN (down)		Battery voltage	
	45	Ground	OFF	0
			UP	Battery voltage
			DWN (down)	0

Is the inspection result normal?

YES >> Replace lifting motor (front). (Built in seat slide cushion frame.)

NO >> GO TO 2.

#### 2.CHECK LIFTING MOTOR (FRONT) CIRCUIT

1. Turn ignition switch OFF.
2. Disconnect driver seat control unit connector.
3. Check continuity between driver seat control unit harness connector and lifting motor (front) harness connector.

# LIFTING MOTOR (FRONT)

## < COMPONENT DIAGNOSIS >

Driver seat control unit connector	Terminal	Lifting motor (front) connector	Terminal	Continuity
B452	37	B455	37	Existed
	45		45	

4. Check continuity between driver seat control unit harness connector and ground.

Driver seat control unit connector	Terminal	Ground	Continuity
B452	37		Not existed
	45		

Is the inspection result normal?

YES >> GO TO 3.

NO >> Repair or replace harness.

### 3.CHECK INTERMITTENT INCIDENT

Refer to [GI-39, "Intermittent Incident"](#).

Is the inspection result normal?

YES >> Replace driver seat control unit.

NO >> Repair or replace the malfunctioning part.

A  
B  
C  
D  
E  
F  
G  
H  
I  
K  
L  
M  
N  
O  
P

ADP

# LIFTING MOTOR (REAR)

< COMPONENT DIAGNOSIS >

## LIFTING MOTOR (REAR)

### Description

INFOID:000000000960738

- The lifting motor (rear) is installed to the seat slide cushion frame.
- The lifting motor (rear) is activated with the driver seat control unit.
- The seat lifter (rear) is moved upward/downward by changing the rotation direction of lifting motor (rear).

### Component Function Check

INFOID:000000000960739

#### 1. CHECK FUNCTION

1. Select "SEAT LIFTER RR" in "Active test" mode with CONSULT-III.
2. Check the lifting motor (rear) operation.

Test item		Description	
SEAT LIFTER RR	OFF	Seat lifting (rear)	Stop
	UP		Upward
	DWN		Downward

Is the operation of relevant parts normal?

YES >> INSPECTION END

NO >> Perform diagnosis procedure. Refer to [ADP-128. "Diagnosis Procedure"](#).

### Diagnosis Procedure

INFOID:000000000960740

#### 1. CHECK LIFTING MOTOR (REAR) POWER SUPPLY

1. Turn ignition switch OFF.
2. Disconnect lifting motor (rear) connector.
3. Turn the ignition switch ON.
4. Perform "Active test" ("SEAT LIFTER RR") with CONSULT-III
5. Check voltage between lifting motor (rear) harness connector and ground.

Terminal		Test item	Voltage (V) (Approx.)	
(+)	(-)			
Lifting motor (rear) connector	Terminal	SEAT LIFTER RR	OFF	0
			UP	Battery voltage
DWN (DOWN)	0			
OFF	0			
UP	0			
DWN (DOWN)	Battery voltage			
B456	38	Ground		
	39			

Is the inspection result normal?

YES >> Replace lifting motor (rear). (Built in seat slide cushion frame.)

NO >> GO TO 2.

#### 2. CHECK LIFTING MOTOR (REAR) CIRCUIT

1. Turn ignition switch OFF.
2. Disconnect driver seat control unit connector and lifting motor (rear) connector.
3. Check continuity between driver seat control unit harness connector and lifting motor (rear) harness connector.



## LIFTING MOTOR (REAR)

### < COMPONENT DIAGNOSIS >

Driver seat control unit connector	Terminal	Lifting motor (rear) connector	Terminal	Continuity
B452	38	B456	38	Existed
	39		39	

4. Check continuity between driver seat control unit harness connector and ground.

Driver seat control unit connector	Terminal	Ground	Continuity
B452	38		Continuity
	39		Not existed

Is the inspection result normal?

YES >> GO TO 3.

NO >> Repair or replace harness.

### 3.CHECK INTERMITTENT INCIDENT

Refer to [GI-39, "Intermittent Incident"](#).

Is the inspection result normal?

YES >> Replace driver seat control unit.

NO >> Repair or replace the malfunctioning part.

A  
B  
C  
D  
E  
F  
G  
H  
I  
K  
L  
M  
N  
O  
P

ADP

# TILT MOTOR

< COMPONENT DIAGNOSIS >

## TILT MOTOR

### Description

INFOID:000000000960741

- The tilt motor is installed to the steering column assembly.
- The tilt motor is activated with the automatic drive positioner control unit.
- The steering column is tilted upward/downward by changing the rotation direction of tilt motor.

### Component Function Check

INFOID:000000000960742

#### 1.CHECK FUNCTION

1. Select "TILT MOTOR" in "Active test" mode with CONSULT-III.
2. Check the tilt motor operation.

Test item		Description	
TILT MOTOR	OFF	Steering tilt	Stop
	UP		Upward
	DWN		Downward

Is the operation of relevant parts normal?

YES >> INSPECTION END

NO >> Perform diagnosis procedure. Refer to [ADP-130. "Diagnosis Procedure"](#).

### Diagnosis Procedure

INFOID:000000000960743

#### 1.CHECK TILT MOTOR POWER SUPPLY

1. Turn ignition switch OFF.
2. Disconnect tilt & telescopic motor connector.
3. Turn the ignition switch ON.
4. Perform "Active test" ("TILT MOTOR") with CONSULT-III.
5. Check voltage between tilt & telescopic motor harness connector and ground.

Terminal		Test item	Voltage (V) (Approx.)
(+)	(-)		
Tilt & telescopic motor connector	Terminal		
M49	3	OFF	0
		UP	0
		DWN (down)	Battery voltage
	4	OFF	0
		UP	Battery voltage
		DWN (down)	0

Is the inspection result normal?

YES >> Replace tilt motor. (Built in steering column assembly.)

NO >> GO TO 2.

#### 2.CHECK TILT MOTOR CIRCUIT

1. Turn ignition switch OFF.
2. Disconnect automatic drive positioner control unit and tilt & telescopic motor connector.
3. Check continuity between automatic drive positioner control unit harness connector and tilt & telescopic motor harness connector.

# TILT MOTOR

## < COMPONENT DIAGNOSIS >

Automatic drive positioner control unit connector	Terminal	Tilt & telescopic motor connector	Terminal	Continuity
M52	35	M49	4	Existed
	42		3	

4. Check continuity between automatic drive positioner control unit harness connector and ground.

automatic drive positioner control unit connector	Terminal	Ground	Continuity
M52	35		
	42		

Is the inspection result normal?

YES >> GO TO 3.

NO >> Repair or replace harness.

### 3.CHECK INTERMITTENT INCIDENT

Refer to [GI-39, "Intermittent Incident"](#).

Is the inspection result normal?

YES >> Replace automatic drive positioner control unit.

NO >> Repair or replace the malfunctioning part.

A  
B  
C  
D  
E  
F  
G  
H  
I  
K  
L  
M  
N  
O  
P

ADP

# TELESCOPIC MOTOR

< COMPONENT DIAGNOSIS >

## TELESCOPIC MOTOR

### Description

INFOID:000000000960744

- The tilt motor is installed to the steering column assembly.
- The tilt motor is activated with the automatic drive positioner control unit.
- Compresses the steering column by changing the rotation direction of tilt motor.

### Component Function Check

INFOID:000000000960745

#### 1.CHECK FUNCTION

1. Select "TELESCO MOTOR" in "Active test" mode with CONSULT-III.
2. Check the telescopic motor operation.

Test item		Description	
TELESCO MOTOR	OFF	Steering telescopic	Stop
	FR		Forward
	RR		Backward

Is the operation of relevant parts normal?

YES >> INSPECTION END

NO >> Perform diagnosis procedure. Refer to [ADP-132. "Diagnosis Procedure"](#).

### Diagnosis Procedure

INFOID:000000000960746

#### 1.CHECK TELESCOPIC MOTOR POWER SUPPLY

1. Turn ignition switch OFF.
2. Disconnect tilt & telescopic motor connector.
3. Turn the ignition switch ON.
4. Perform "Active test" ("TELESCO MOTOR") with CONSULT-III
5. Check voltage between tilt & telescopic motor harness connector and ground.

Terminal		Test item	Voltage (V) (Approx.)
(+)	(-)		
Tilt & telescopic motor connector	Terminal		
M49	1	Ground	TELESCOP-IC MOTOR
		OFF	0
		FR (forward)	0
	2	RR (backward)	Battery voltage
		OFF	0
		FR (forward)	Battery voltage
		RR (backward)	0

Is the inspection result normal?

YES >> Replace telescopic motor. (Built in steering column assembly.)

NO >> GO TO 2.

#### 2.CHECK TELESCOPIC MOTOR CIRCUIT

1. Turn ignition switch OFF.
2. Disconnect automatic drive positioner control unit and tilt & telescopic motor connector.
3. Check continuity between automatic drive positioner control unit harness connector and tilt & telescopic motor harness connector.

# TELESCOPIC MOTOR

## < COMPONENT DIAGNOSIS >

Automatic drive positioner control unit connector	Terminal	Tilt & telescopic motor connector	Terminal	Continuity
M52	36	M49	2	Existed
	44		1	

4. Check continuity between automatic drive positioner control unit harness connector and ground.

Automatic drive positioner control unit connector	Terminal	Ground	Continuity
M52	36		Continuity
	44		Not existed

Is the inspection result normal?

YES >> GO TO 3.

NO >> Repair or replace harness.

### 3.CHECK INTERMITTENT INCIDENT

Refer to [GI-39, "Intermittent Incident"](#).

Is the inspection result normal?

YES >> Replace automatic drive positioner control unit.

NO >> Repair or replace the malfunctioning part.

A  
B  
C  
D  
E  
F  
G  
H  
I  
K  
L  
M  
N  
O  
P

ADP

# DOOR MIRROR MOTOR

< COMPONENT DIAGNOSIS >

## DOOR MIRROR MOTOR

### Description

INFOID:000000000960747

It makes mirror face operate from side to side and up and down with the electric power that AUTOMATIC DRIVE POSITIONER CONTROL UNIT supplies.

### Component Function Check

INFOID:000000000960748

#### 1. CHECK DOOR MIRROR MOTOR FUNCTION

Check the operation with "MIRROR MOTOR RH" and "MIRROR MOTOR LH" in "ACTIVE TEST" mode with CONSULT-III

Refer to [ADP-48, "CONSULT-III Function"](#).

Is the inspection result normal?

- YES >> Door mirror motor function is OK.  
 NO >> Refer to [ADP-134, "Diagnosis Procedure"](#).

### Diagnosis Procedure

INFOID:000000000960749

#### 1. CHECK DOOR MIRROR MOTOR INPUT SIGNAL

1. Turn ignition switch ON.
2. Check voltage between door mirror connector and ground.

Terminals		(-)	Door mirror remote control switch condition	Voltage (V) (Approx.)
(+)				
Door mirror connector	Terminal	Ground		
D3 (Driver side) D33 (Passenger side)	5		UP	Battery voltage
			Other than above	0
	6		LEFT	Battery voltage
			Other than above	0
	7		DOWN / RIGHT	Battery voltage
		Other than above	0	

Is the inspection result normal?

- YES >> Refer to [ADP-136, "Component Inspection"](#).  
 NO >> GO TO 2.

#### 2. CHECK HARNESS CONTINUITY

1. Turn ignition switch OFF.
2. Disconnect automatic drive positioner control unit connector and door mirror connector.
3. Check continuity between automatic drive positioner control unit connector and door mirror connector.

[Door mirror driver side]

Automatic drive positioner control unit connector	Terminal	Door mirror (driver side) connector	Terminal	Continuity
M51	16	D3	7	Existed
	31		5	
	32		6	

[Door mirror passenger side]

Automatic drive positioner control unit connector	Terminal	Door mirror (passenger side) connector	Terminal	Continuity
M51	14	D33	5	Existed
	15		6	
	30		7	

# DOOR MIRROR MOTOR

## < COMPONENT DIAGNOSIS >

4. Check continuity between automatic drive positioner control unit connector and ground.

[Door mirror driver side]

Automatic drive positioner control unit connector	Terminal	Ground	Continuity	
M51	16		Ground	Not existed
	31			
	32			

[Door mirror passenger side]

Automatic drive positioner control unit connector	Terminal	Ground	Continuity	
M51	14		Ground	Not existed
	15			
	30			

Is the inspection result normal?

YES >> GO TO 3.

NO >> Repair or replace harness.

## 3.CHECK AUTOMATIC DRIVE POSITIONER CONTROL UNIT OUTPUT SIGNAL

1. Connect automatic drive positioner control unit connector.
2. Turn ignition switch ON.
3. Check voltage between automatic drive positioner control unit connector and ground.

[Door mirror driver side]

Terminals		(-)	Mirror switch condition	Voltage (V) (Approx.)
(+)	Terminal			
Automatic drive positioner control unit connector	16	Ground	DOWN / RIGHT	Battery voltage
			Other than above	0
	31		UP	Battery voltage
			Other than above	0
	32		LEFT	Battery voltage
			Other than above	0

[Door mirror passenger side]

Terminals		(-)	Mirror switch condition	Voltage (V) (Approx.)
(+)	Terminal			
Automatic drive positioner control unit connector	14	Ground	UP	Battery voltage
			Other than above	0
	15		LEFT	Battery voltage
			Other than above	0
	30		DOWN / RIGHT	Battery voltage
			Other than above	0

Is the inspection result normal?

YES >> Refer to [ADP-136. "Component Inspection"](#).

NO >> Replace automatic drive positioner control unit. Refer to [ADP-218. "Removal and Installation"](#).

## 4.CHECK DOOR MIRROR MOTOR

Check door mirror motor.

Refer to [ADP-136. "Component Inspection"](#).

# DOOR MIRROR MOTOR

## < COMPONENT DIAGNOSIS >

### Is the inspection result normal?

YES >> Refer to [GI-39, "Intermittent Incident"](#).

NO >> Replace door mirror. Refer to [MIR-67, "Removal and Installation"](#).

## Component Inspection

INFOID:000000000960750

### 1. CHECK DOOR MIRROR MOTOR-I

Check that door mirror motor does not trap foreign objects and does not have any damage.

Refer to [MIR-69, "Exploded View"](#).

### Is the inspection result normal?

YES >> GO TO 2.

NO >> Replace door mirror. Refer to [MIR-67, "Removal and Installation"](#).

### 2. CHECK DOOR MIRROR MOTOR-II

1. Turn ignition switch OFF.
2. Disconnect door mirror connector.
3. Apply 12V to each power supply terminal of door mirror motor.

Door mirror connector	Terminal		Operational direction
	(+)	(-)	
D3 (Driver side) D33 (Passenger side)	7	6	RIGHT
	6	7	LEFT
	5	7	UP
	7	5	DOWN

### Is the inspection result normal?

YES >> INSPECTION END.

NO >> Replace door mirror. Refer to [MIR-67, "Removal and Installation"](#).



# SIDE SUPPORT UNIT

< COMPONENT DIAGNOSIS >

## SIDE SUPPORT UNIT

### Description

INFOID:000000000960751

Built-in pump, pump relay and solenoid, side support unit operates when pressing ON/OFF on side support switch.

### Component Function Check

INFOID:000000000960752

#### 1.CHECK SIDE SUPPORT UNIT FUNCTION

Check side support operation with side support switch.

Is the inspection results normal?

YES >> Side support unit is OK.

NO >> Refer to [ADP-137, "Diagnosis Procedure"](#).

### Diagnosis Procedure

INFOID:000000000960753

#### 1.CHECK SIDE SUPPORT UNIT SIGNAL CIRCUIT

1. Turn ignition switch OFF.
2. Disconnect side support unit and side support switch connectors.
3. Check continuity between side support unit and side support switch connector.

Side support unit connector	Terminal	Side support switch connector	Terminal	Continuity
B420	15	B419	15	Existed
	16		16	
	17		17	
	18		18	

4. Check continuity between side support unit and ground.

Side support unit connector	Terminal		Continuity
B420	15	Ground	Not existed
	16		
	17		
	18		

Is the inspection result normal?

YES >> GO TO 2.

NO >> Repair or replace circuit.

#### 2.CHECK SIDE SUPPORT UNIT GROUND CIRCUIT

Check continuity between side support unit and ground.

Side support unit connector	Terminal	Ground	Continuity
B420	2	Ground	Existed

Is the inspection result normal?

YES >> GO TO 3.

NO >> Repair or replace circuit.

#### 3.CHECK INTERMITTENT INCIDENT

Check intermittent incident.

Refer to [GI-39, "Intermittent Incident"](#).

Is the inspection result normal?

YES >> Replace side support unit.

NO >> Repair or replace malfunction part.

A  
B  
C  
D  
E  
F  
G  
H  
I  
K  
L  
M  
N  
O  
P

ADP

# SEAT MEMORY INDICATOR LAMP

< COMPONENT DIAGNOSIS >

## SEAT MEMORY INDICATOR LAMP

### Description

INFOID:000000000960754

- Memory switch is equipped on the seat memory switch installed to the driver side door trim. The operation signal is inputted to the automatic drive positioner control unit when the memory switch is operated.
- The status of automatic drive positioner system can be checked according to the illuminating/flashing status.

### Component Function Check

INFOID:000000000960755

#### 1. CHECK FUNCTION

1. Select "MEMORY SW INDCTR" in "Active test" mode with CONSULT-III.
2. Check the memory indicator operation.

Test item		Description	
MEMORY SW INDCTR	OFF	Memory switch indicator	OFF
	ON-1		Indicator 1: ON
	ON-2		Indicator 2: ON

Is the operation of relevant parts normal?

YES >> INSPECTION END

NO >> Perform diagnosis procedure. Refer to [ADP-138. "Diagnosis Procedure"](#).

### Diagnosis Procedure

INFOID:000000000960756

#### 1. CHECK MEMORY INDICATOR CIRCUIT

1. Turn ignition switch OFF.
2. Disconnect automatic drive positioner control unit and seat memory switch connector.
3. Check continuity between automatic drive positioner control unit harness connector and seat memory switch harness connector.

Automatic drive positioner control unit connector	Terminal	Seat memory switch connector	Terminal	Continuity
M51	12	D5	6	Existed
	13		7	

4. Check continuity between automatic drive positioner control unit harness connector and ground.

Automatic drive positioner control unit connector	Terminal	Ground	Continuity
M51	12	Ground	Not existed
	13		

Is the inspection result normal?

YES >> GO TO 2.

NO >> Repair or replace harness.

#### 2. CHECK MEMORY INDICATOR POWER SUPPLY

Check voltage between seat memory switch harness connector and ground.

Seat memory switch connector	Terminals		Voltage (V) (Approx.)
	(+)	(-)	
D5	5	Ground	Battery voltage

Is the inspection result normal?

YES >> GO TO 3.

NO >> Check the following.

- Fuse

# SEAT MEMORY INDICATOR LAMP

## < COMPONENT DIAGNOSIS >

- Harness for open or short between memory indicator and fuse.

### 3.CHECK MEMORY INDICATOR

Refer to [ADP-139, "Component Inspection"](#).

Is the inspection result normal?

- YES >> GO TO 4.  
NO >> Replace seat memory switch.

### 4.CHECK INTERMITTENT INCIDENT

Refer to [GI-39, "Intermittent Incident"](#).

Is the inspection result normal?

- YES >> Replace automatic drive positioner control unit.  
NO >> Repair or replace the malfunctioning part.

## Component Inspection

INFOID:000000000960757

### 1.CHECK SEAT MEMORY INDICATOR

1. Disconnect seat memory switch connector.
2. Check continuity between seat memory switch terminals.

Terminal		Continuity
Seat memory switch		
(+)	(-)	
6	5	Existed
7		

Is the inspection result normal?

- YES >> INSPECTION END  
NO >> Replace seat memory switch.

A  
B  
C  
D  
E  
F  
G  
H  
I  
K  
L  
M  
N  
O  
P

ADP

# DRIVER SEAT CONTROL UNIT

< ECU DIAGNOSIS >

## ECU DIAGNOSIS

### DRIVER SEAT CONTROL UNIT

Reference Value

INFOID:000000000960758

VALUES ON THE DIAGNOSIS TOOL

Monitor Item	Condition		Value/Status
SET SW	Set switch	Push	ON
		Release	OFF
MEMORY SW1	Memory switch 1	Push	ON
		Release	OFF
MEMORY SW2	Memory switch 2	Push	ON
		Release	OFF
SLIDE SW-FR	Sliding switch (front)	Operate	ON
		Release	OFF
SLIDE SW-RR	Sliding switch (rear)	Operate	ON
		Release	OFF
RECLN SW-FR	Reclining switch (front)	Operate	ON
		Release	OFF
RECLN SW-RR	Reclining switch (rear)	Operate	ON
		Release	OFF
LIFT FR SW-UP	Lifting switch front (up)	Operate	ON
		Release	OFF
LIFT FR SW-DN	Lifting switch front (down)	Operate	ON
		Release	OFF
LIFT RR SW-UP	Lifting switch rear (up)	Operate	ON
		Release	OFF
LIFT RR SW-DN	Lifting switch rear (down)	Operate	ON
		Release	OFF
MIR CON SW-UP	Mirror switch	Up	ON
		Other than above	OFF
MIR CON SW-DN	Mirror switch	Down	ON
		Other than above	OFF
MIR CON SW-RH	Mirror switch	Right	ON
		Other than above	OFF
MIR CON SW-LH	Mirror switch	Left	ON
		Other than above	OFF
MIR CHNG SW-R	Changeover switch	Right	ON
		Other than above	OFF
MIR CHNG SW-L	Changeover switch	Left	ON
		Other than above	OFF
TILT SW-UP	Tilt switch	Up	ON
		Other than above	OFF
TILT SW-DOWN	Tilt switch	Down	ON
		Other than above	OFF

# DRIVER SEAT CONTROL UNIT

## < ECU DIAGNOSIS >

Monitor Item	Condition		Value/Status
TELESCO SW-FR	Telescopic switch	Forward	ON
		Other than above	OFF
TELESCO SW-RR	Tilt switch	Backward	ON
		Other than above	OFF
DETENT SW <sup>*1</sup>	AT selector lever	P position	OFF
		Other than above	ON
PARK BRAKE SW <sup>*2</sup>	Parking brake	Applied	ON
		Release	OFF
STARTER SW	Ignition position	Cranking	ON
		Other than above	OFF
SLIDE PULSE	Seat sliding	Forward	The numeral value decreases <sup>*3</sup>
		Backward	The numeral value increases <sup>*3</sup>
		Other than above	No change to numeral value <sup>*3</sup>
RECLN PULSE	Seat reclining	Forward	The numeral value decreases <sup>*3</sup>
		Backward	The numeral value increases <sup>*3</sup>
		Other than above	No change to numeral value <sup>*3</sup>
LIFT FR PULSE	Seat lifter (front)	Up	The numeral value decreases <sup>*3</sup>
		Down	The numeral value increases <sup>*3</sup>
		Other than above	No change to numeral value <sup>*3</sup>
LIFT RR PULSE	Seat lifter (rear)	Up	The numeral value decreases <sup>*3</sup>
		Down	The numeral value increases <sup>*3</sup>
		Other than above	No change to numeral value <sup>*3</sup>
MIR/SEN RH U-D	Door mirror (passenger side)	Close to peak	3.4
		Close to valley	0.6
MIR/SEN RH R-L	Door mirror (passenger side)	Close to left edge	3.4
		Close to right edge	0.6
MIR/SEN LH U-D	Door mirror (driver side)	Close to peak	3.4
		Close to valley	0.6
MIR/SEN LH R-L	Door mirror (driver side)	Close to left edge	0.6
		Close to right edge	3.4
TILT SEN	Tilt position	Top	1.2
		Bottom	3.4
TELESCO SEN	Telescopic position	Top	3.4
		Bottom	0.8

<sup>\*1</sup>: Only for AT model

<sup>\*2</sup>: Only for MT model

<sup>\*3</sup>: The value at the position attained when the battery is connected is regarded as 32768.

A  
B  
C  
D  
E  
F  
G  
H  
I  
K  
L  
M  
N  
O  
P

ADP

# DRIVER SEAT CONTROL UNIT

< ECU DIAGNOSIS >

## TERMINAL LAYOUT

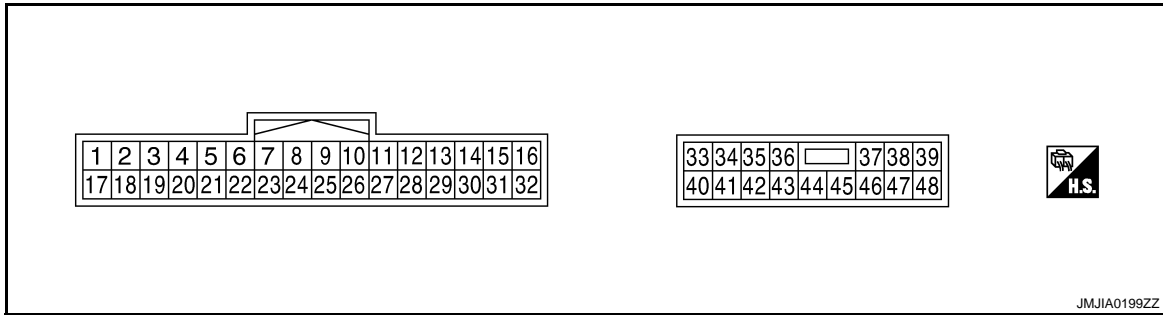

## PHYSICAL VALUES

Terminal No.		Wire color	Description		Condition	Voltage (V) (Approx)	
+	-		Signal name	Input/Output			
1	Ground	L/W	UART communication (RX)	Input	Ignition switch ON	<p style="text-align: right; font-size: x-small;">JMJA0118ZZ</p>	
3	—	R/Y	CAN-H	—	—	—	
8*1	Ground	LG	Parking brake switch signal	Input	Parking brake	Applied	0
						Release	Battery voltage
9	Ground	W/G	Reclining sensor signal	Input	Seat reclining	Operate	<p style="text-align: right; font-size: x-small;">JMJA0119ZZ</p>
						Stop	0 or 5
10	Ground	P/B	Lifting sensor (rear) signal	Input	Seat lifting (rear)	Operate	<p style="text-align: right; font-size: x-small;">JMJA0119ZZ</p>
						Stop	0 or 5
11	Ground	BR	Sliding switch backward signal	Input	Sliding switch	Operate (backward)	0
						Release	Battery voltage
12	Ground	SB	Reclining switch backward signal	Input	Reclining switch	Operate (backward)	0
						Release	Battery voltage

# DRIVER SEAT CONTROL UNIT

## < ECU DIAGNOSIS >

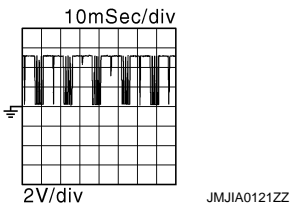
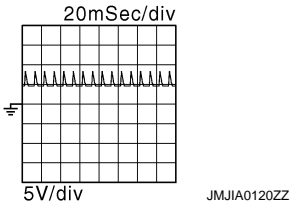
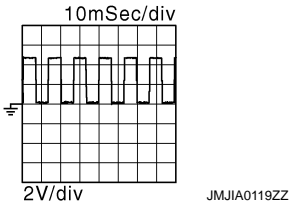
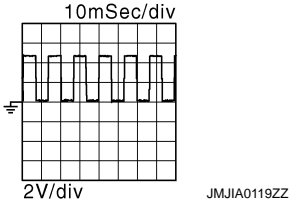
Terminal No.		Wire color	Description		Condition		Voltage (V) (Approx)
+	-		Signal name	Input/Output			
13	Ground	LG/R	Lifting switch (front) down signal	Input	Lifting switch (front)	Operate (down)	0
						Release	Battery voltage
14	Ground	GB	Lifting switch (rear) down signal	Input	Lifting switch (rear)	Operate (down)	0
						Release	Battery voltage
16	Ground	O	Sensor power supply	Output	—		5
17	Ground	Y/R	UART communication (TX)	Output	Ignition switch ON		
19	—	V	CAN-L	—	—		—
21*2	Ground	L/Y	Detention switch	Input	A/T selector lever	P position	0
						Except P position	
24	Ground	R	Sliding sensor signal	Input	Seat sliding	Operate	
						Stop	0 or 5
25	Ground	Y/B	Lifting sensor (front) signal	Input	Seat lifting (front)	Operate	
						Stop	0 or 5
26	Ground	Y	Sliding switch forward signal	Input	Sliding switch	Operate (forward)	0
						Release	Battery voltage
27	Ground	R/G	Reclining switch forward signal	Input	Reclining switch	Operate (forward)	0
						Release	Battery voltage
28	Ground	W/B	Lifting switch (front) up signal	Input	Seat lifting switch (front)	Operate (up)	0
						Release	Battery voltage

A  
B  
C  
D  
E  
F  
G  
H  
I  
K  
L  
M  
N  
O  
P

ADP

# DRIVER SEAT CONTROL UNIT

## < ECU DIAGNOSIS >

Terminal No.		Wire color	Description		Condition		Voltage (V) (Approx)
+	-		Signal name	Input/Output			
29	Ground	P/L	Lifting switch (rear) up signal	Input	Seat lifting switch (rear)	Operate (up)	0
						Release	Battery voltage
31	Ground	GR	Sensor ground	—	—	—	0
32	Ground	B/W	Ground (signal)	—	—	—	0
33	Ground	R	Power source (C/B)	Input	—	—	Battery voltage
35	Ground	W/R	Sliding motor forward output signal	Output	Seat sliding	Operate (forward)	Battery voltage
						Release	0
36	Ground	G/Y	Reclining motor forward output signal	Output	Seat reclining	Operate (forward)	Battery voltage
						Release	0
37	Ground	G/W	Lifting motor (front) down output signal	Output	Seat lifting (front)	Operate (down)	Battery voltage
						Stop	0
38	Ground	L/Y	Lifting motor (rear) up output signal	Output	Seat lifting (rear)	Operate (up)	Battery voltage
						Stop	0
39	Ground	R/B	Lifting motor (rear) down output signal	Output	Seat lifting (rear)	Operate (down)	Battery voltage
						Stop	0
40	Ground	R/W	Power source (Fuse)	Input	—	—	Battery voltage
42	Ground	W/B	Sliding motor backward output signal	Output	Seat sliding	Operate (backward)	Battery voltage
						Stop	0
44	Ground	P	Reclining motor backward output signal	Output	Seat reclining	Operate (backward)	Battery voltage
						Stop	0
45	Ground	L/R	Lifting motor (front) up output signal	Output	Seat lifting (front)	Operate (up)	Battery voltage
						Stop	0
48	Ground	B	Ground (power)	—	—	—	0

\*1: Only for MT models

\*2: Only for AT models



# DRIVER SEAT CONTROL UNIT

< ECU DIAGNOSIS >

## Wiring Diagram—AUTOMATIC DRIVE POSITIONER CONTROL SYSTEM—

INFOID:000000000960759

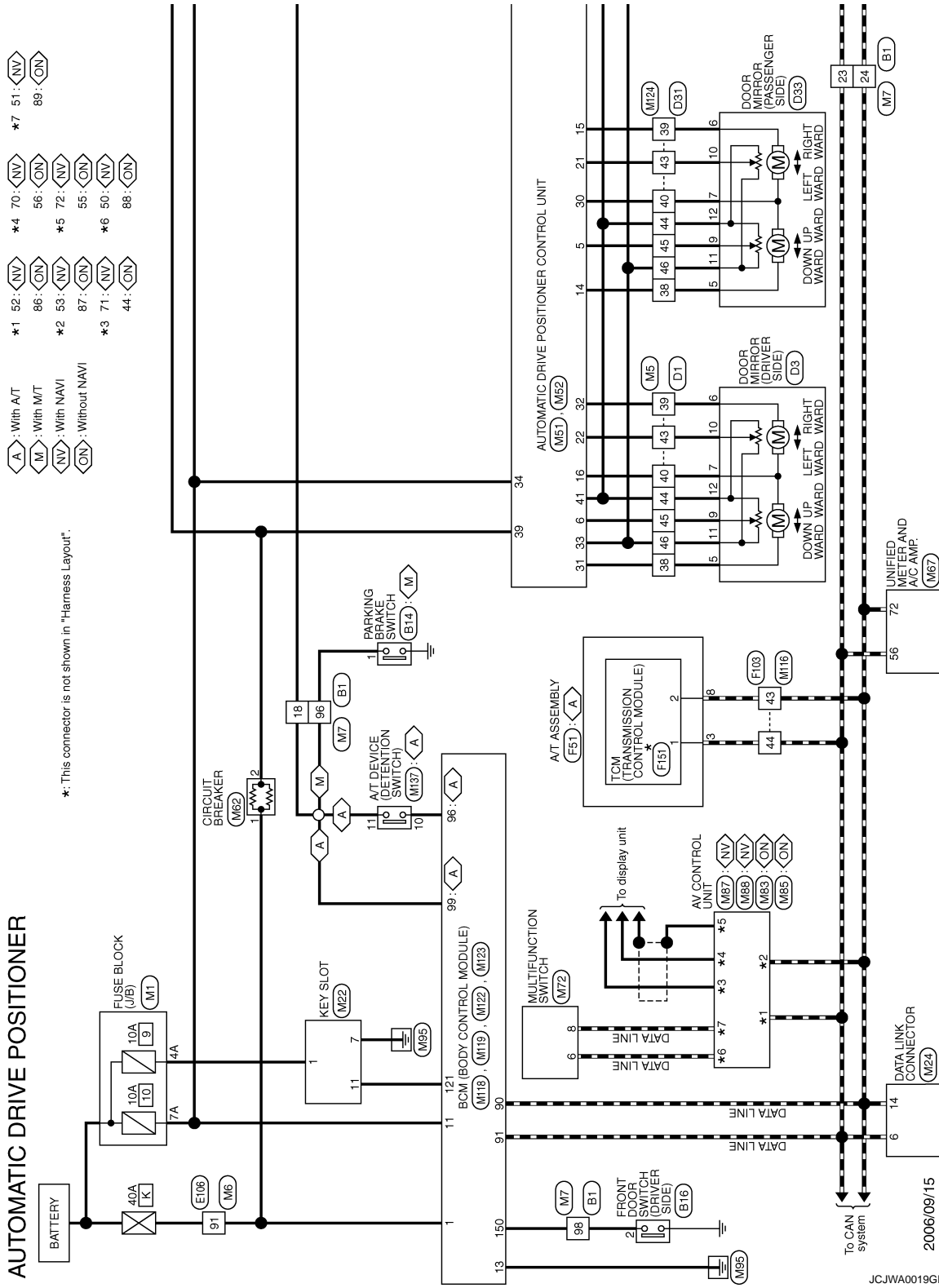

A  
B  
C  
D  
E  
F  
G  
H  
I  
ADP  
K  
L  
M  
N  
O  
P

# DRIVER SEAT CONTROL UNIT

< ECU DIAGNOSIS >

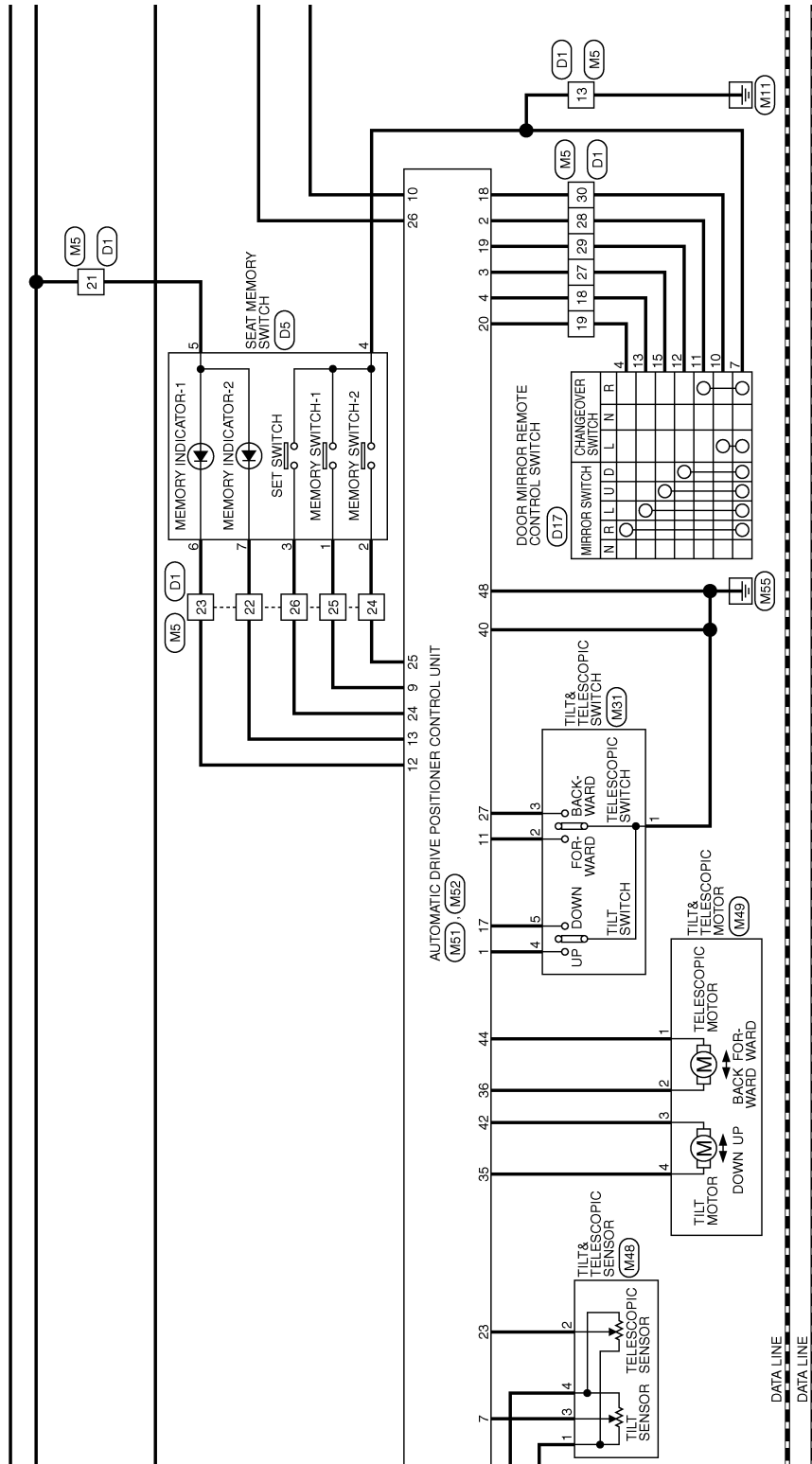

JCJWA0020GB

# DRIVER SEAT CONTROL UNIT

< ECU DIAGNOSIS >

-  : With AT
-  : With M/T
-  : With sports seat

\*: This connector is not shown in "Harness Layout".

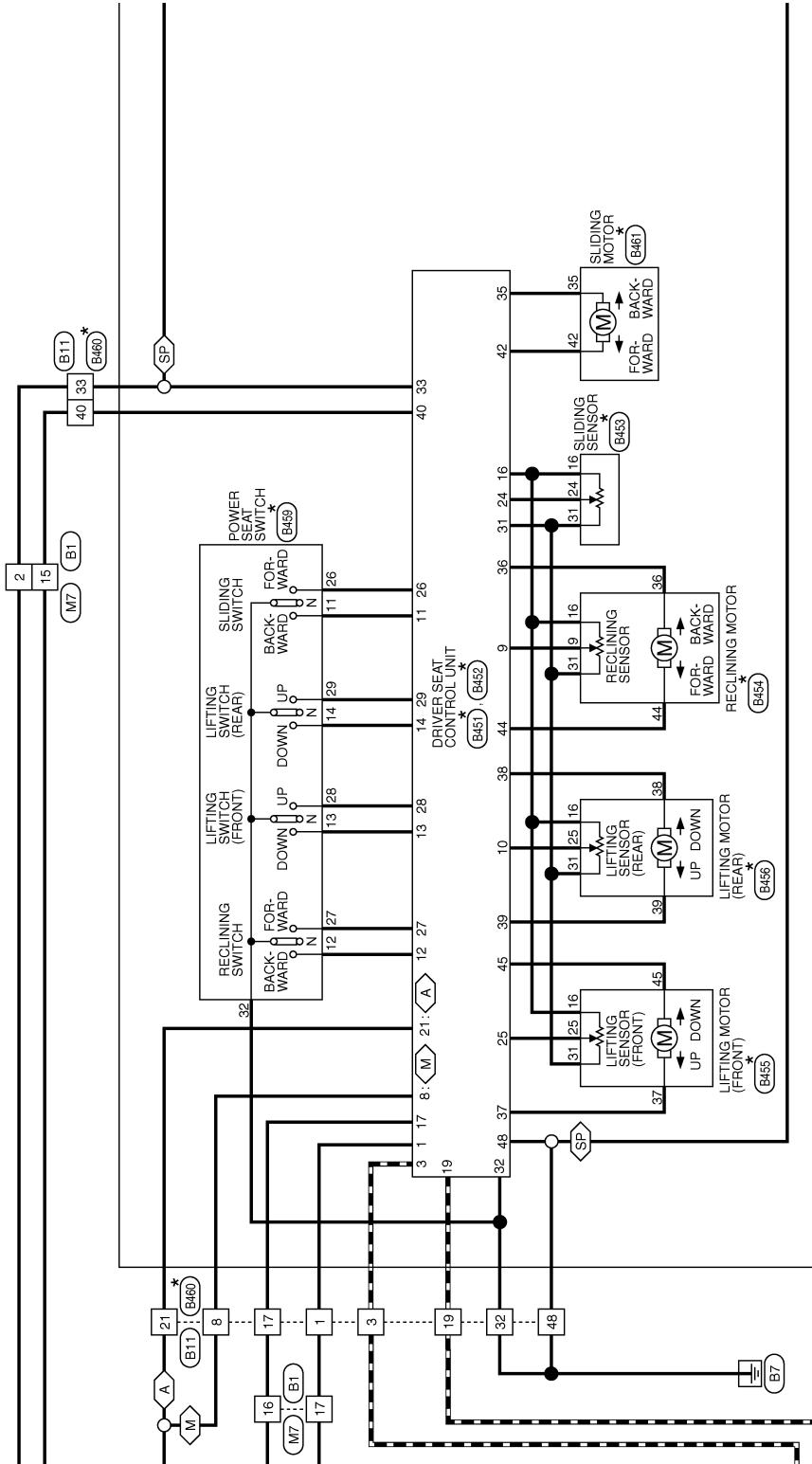

JCJWA0021GB

A  
B  
C  
D  
E  
F  
G  
H  
I  
ADP  
K  
L  
M  
N  
O  
P

# DRIVER SEAT CONTROL UNIT

< ECU DIAGNOSIS >

◁ SP ▷ : With sports seat

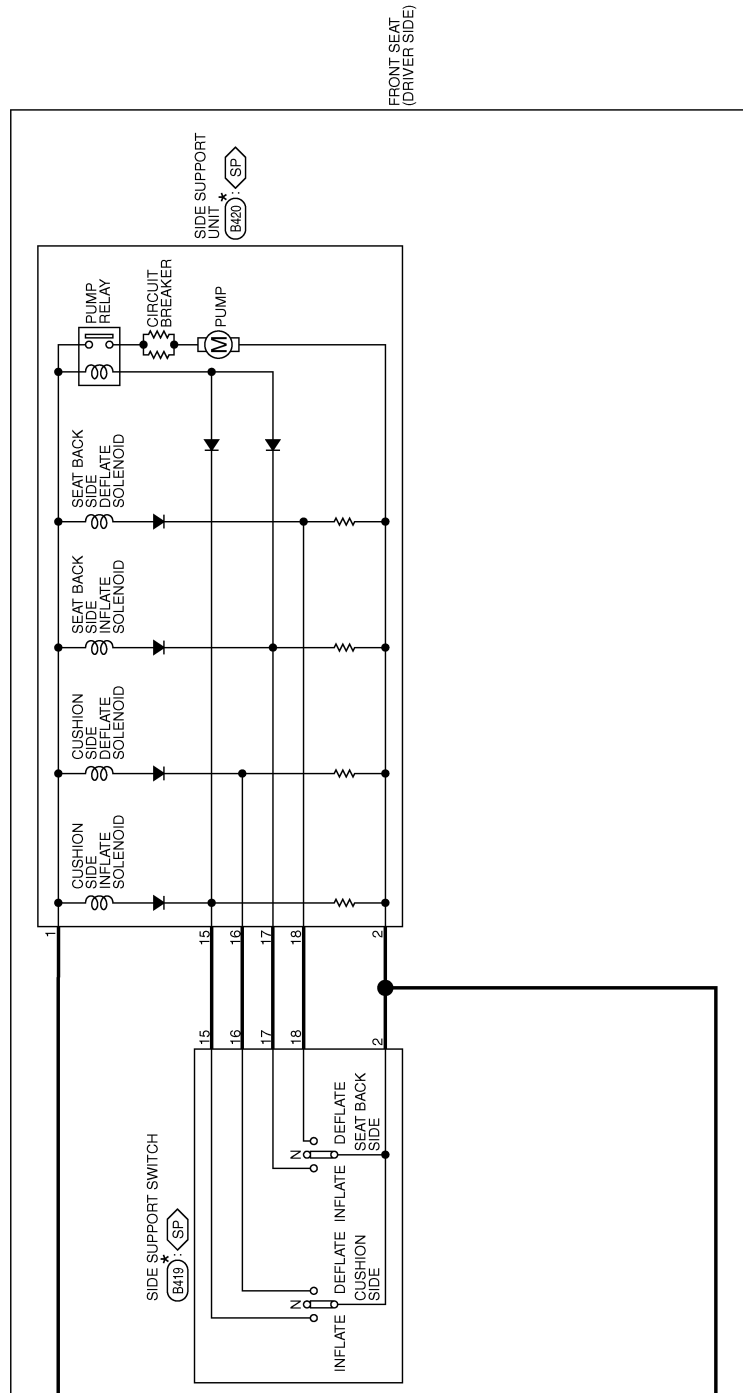

JCJWA0022GB

# DRIVER SEAT CONTROL UNIT

< ECU DIAGNOSIS >

## AUTOMATIC DRIVE POSITIONER

Connector No.	B1
Connector Name	WIRE TO WIRE
Connector Type	TH06FW-CS16-TM4

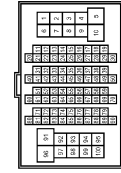

Terminal No.	Color of Wire	Signal Name
2	SB	-
15	BR	-
16	LG	-
17	LG	-
18	Y	-
23	L	-
24	P	-
96	V	-
98	V	-

Connector No.	B11
Connector Name	WIRE TO WIRE (With automatic drive positioner)
Connector Type	NS116FW-CS

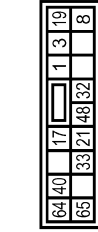

Terminal No.	Color of Wire	Signal Name
1	G	-
3	L	-
8	Y	-
17	LG	-
19	P	-
21	Y	-
32	B	-
33	SB	-
40	BR	-
48	B	-

Connector No.	B14
Connector Name	PARKING BRAKE SWITCH
Connector Type	P01FB-A



Terminal No.	Color of Wire	Signal Name
1	V	-

Connector No.	B18
Connector Name	FRONT DOOR SWITCH (DRIVER SIDE)
Connector Type	A03FW

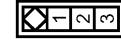

Terminal No.	Color of Wire	Signal Name
2	V	-

Connector No.	B419
Connector Name	SIDE SUPPORT SWITCH
Connector Type	NS06FW-CS

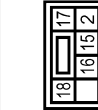

Terminal No.	Color of Wire	Signal Name
2	B	-
15	G	- [With automatic drive positioner]
16	B/R	- [With automatic drive positioner]
17	V/W	- [With automatic drive positioner]
18	R/L	- [With automatic drive positioner]

Connector No.	B420
Connector Name	SIDE SUPPORT UNIT
Connector Type	NS06FW-CS

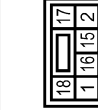

Terminal No.	Color of Wire	Signal Name
1	R	-
2	B	-
15	G	- [With automatic drive positioner]
16	B/R	- [With automatic drive positioner]
17	V/W	- [With automatic drive positioner]
18	R/L	- [With automatic drive positioner]

Connector No.	B451
Connector Name	DRIVER SEAT CONTROL UNIT
Connector Type	TH32FW

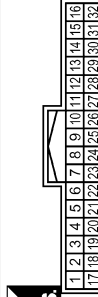

Terminal No.	Color of Wire	Signal Name
1	L/W	RX
3	R/Y	CAN-H
8	LG	PARKING BRAKE SW
9	W/G	PULSE(RECLINING)
10	P/B	PULSE(R LIFTING)
11	BR	SLIDING (SWBACKWARD)
12	SB	RECLINING (SWBACKWARD)
13	LG/R	FRONT LIFTING (SWDOWNWARD)
14	G/B	REAR LIFTING (SWDOWNWARD)
16	O	VCC
17	Y/R	TX

Terminal No.	Color of Wire	Signal Name
19	V	CAN-L
21	L/Y	P RANGE SW
24	R	PULSE(SLIDING)
25	Y/B	PULSE(R LIFTING)
26	Y	SLIDING (SWFORWARD)
27	R/G	RECLINING (SWFORWARD)
28	W/B	FRONT LIFTING (SWUPWARD)
29	P/L	REAR LIFTING (SWUPWARD)
31	GR	SENSOR GND
32	B/W	GND(SIGNAL)

JCJWA0023GB

A B C D E F G H I K L M N O P

# DRIVER SEAT CONTROL UNIT

< ECU DIAGNOSIS >

## AUTOMATIC DRIVE POSITIONER

Connector No.	B452
Connector Name	DRIVER SEAT CONTROL UNIT
Connector Type	NS16FW-CS



33	34	35	36	37	38	39
40	41	42	43	44	45	46
47	48					

Terminal No.	Color of Wire	Signal Name
33	R	BAT(C/B)
35	W/R	SLIDING MOTOR(FORWARD)
36	G/Y	RECLINING MOTOR(FORWARD)
37	G/W	FRONT LIFTING MOTOR(DOWNWARD)
38	L/Y	REAR LIFTING MOTOR(UPWARD)
38	R/B	REAR LIFTING MOTOR(BACKWARD)
40	R/W	BAT(FUSE)
42	W/B	SLIDING MOTOR(BACKWARD)
44	P	RECLINING MOTOR(BACKWARD)
45	L/R	FRONT LIFTING MOTOR(UPWARD)
48	B	GND(POWER)



38	39
16	31
25	37

Connector No.	B456
Connector Name	LIFTING MOTOR(REAR/DRIVER SIDE)
Connector Type	NS06FB-CS

Terminal No.	Color of Wire	Signal Name
16	O	
25	P/B	
31	GR	
38	L/Y	
38	R/B	

Connector No.	B453
Connector Name	SLIDING SENSOR
Connector Type	6038-0241



24	31	16
----	----	----

Terminal No.	Color of Wire	Signal Name
16	O	
24	R	
31	GR	

Connector No.	B459
Connector Name	POWER SEAT SWITCH(DRIVER SIDE)
Connector Type	NS10FW-CS



32	14	29
12	27	11
26	13	28

Terminal No.	Color of Wire	Signal Name
11	BR	
12	SB	
13	L/G/R	
14	G/B	
26	Y	
27	R/G	
28	W/B	
29	P/L	
32	B/W	

Connector No.	B454
Connector Name	RECLINING MOTOR
Connector Type	NS06FW-CS



36	44
16	31
9	19

Terminal No.	Color of Wire	Signal Name
9	W/G	
16	O	
31	GR	
36	G/Y	
44	P	

Connector No.	B480
Connector Name	WIRE TO WIRE (With automatic drive positioner)
Connector Type	NS16MW-CS



19	3	1	17	40	64
8	32	48	21	33	65

Terminal No.	Color of Wire	Signal Name
1	L/W	
3	R/Y	
8	L/G	
17	Y/R	
19	V	
21	L/Y	
32	B/W	
33	R	
40	R/W	
48	B	

Connector No.	B455
Connector Name	LIFTING MOTOR(FRONT/DRIVER SIDE)
Connector Type	NS08FW-CS



45	37
16	31
25	37

Terminal No.	Color of Wire	Signal Name
16	O	
25	Y/B	
31	GR	
37	G/W	
45	L/R	

Connector No.	B461
Connector Name	SLIDING MOTOR(DRIVER SIDE)
Connector Type	6098-0239



42	35
----	----

Terminal No.	Color of Wire	Signal Name
35	W/R	
42	W/B	

# DRIVER SEAT CONTROL UNIT

< ECU DIAGNOSIS >

## AUTOMATIC DRIVE POSITIONER

Connector No.	D1
Connector Name	WIRE TO WIRE
Connector Type	TH40FW-CS15

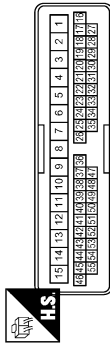

Terminal No.	Color of Wire	Signal Name
13	B	-
18	W	-
19	BR	-
21	R	-
22	P	-
23	O	-
24	BR	-
25	L	-
26	GR	-
27	Y	-
28	LG	-

Connector No.	D17
Connector Name	DOOR MIRROR REMOTE CONTROL SWITCH (With automatic drive positioner)
Connector Type	TK16FBR

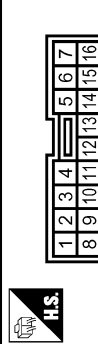

Terminal No.	Color of Wire	Signal Name
4	BR	-
7	B	-
10	GR	-
11	LG	-
12	G	-
13	W	-
15	Y	-

29	G	-
30	GR	-
38	O	-
39	GR	-
40	G	-
43	BR	-
44	V	-
45	P	-
46	W	-

Connector No.	D31
Connector Name	WIRE TO WIRE
Connector Type	TH40FW-CS15

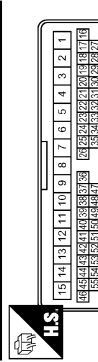

Terminal No.	Color of Wire	Signal Name
38	W	- [with A/T]
38	O	- [with M/T]
39	G	- [with A/T]
39	GR	- [with M/T]
40	Y	- [with A/T]
40	G	- [with M/T]
43	BR	-
44	V	-
45	P	-
46	W	-

Connector No.	D3
Connector Name	DOOR MIRROR (DRIVER SIDE)
Connector Type	TH12MW-NH



Terminal No.	Color of Wire	Signal Name
5	O	- [With automatic drive positioner]
6	GR	- [With automatic drive positioner]
7	G	- [With automatic drive positioner]
9	P	-
10	BR	-
11	W	-
12	V	-

Connector No.	D33
Connector Name	DOOR MIRROR (PASSENGER SIDE)
Connector Type	TH12MW-NH



Terminal No.	Color of Wire	Signal Name
5	W	- [With automatic drive positioner]
6	G	- [With automatic drive positioner]
7	Y	- [With automatic drive positioner]
10	BR	-
11	W	-
12	V	-

Connector No.	D5
Connector Name	SEAT MEMORY SWITCH
Connector Type	A08FW

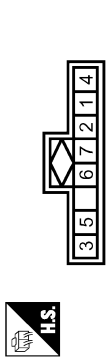

Terminal No.	Color of Wire	Signal Name
1	L	-
2	BR	-
3	GR	-
4	B	-
5	R	-
6	O	-
7	P	-

Connector No.	E106
Connector Name	WIRE TO WIRE
Connector Type	TH80FW-CS16-TM4

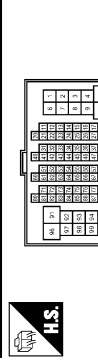

Terminal No.	Color of Wire	Signal Name
91	W	-

A  
B  
C  
D  
E  
F  
G  
H  
I  
ADP  
K  
L  
M  
N  
O  
P

# DRIVER SEAT CONTROL UNIT

< ECU DIAGNOSIS >

## AUTOMATIC DRIVE POSITIONER

Connector No.	F51
Connector Name	A/T ASSEMBLY
Connector Type	BK10FG-DGY

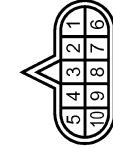

Terminal No.	Color of Wire	Signal Name
3	L	-
8	P	-

Connector No.	F103
Connector Name	WIRE TO WIRE
Connector Type	TK438FW-NS10

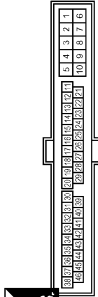

Terminal No.	Color of Wire	Signal Name
43	P	-
44	L	-

Connector No.	F151
Connector Name	TCM (TRANSMISSION CONTROL MODULE)
Connector Type	SPT08FGY



Terminal No.	Color of Wire	Signal Name
1	BR	CAN-H
2	L/Y	CAN-L

Connector No.	M1
Connector Name	FUSE BLOCK (J/B)
Connector Type	NSC8FW-MZ

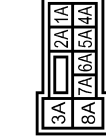

Terminal No.	Color of Wire	Signal Name
4A	P	-
7A	R	-

Connector No.	M5
Connector Name	WIRE TO WIRE
Connector Type	TH80MW-CS15

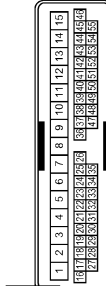

Terminal No.	Color of Wire	Signal Name
13	B	-
18	V	-
19	BR	-
21	R	-
22	P	-
23	O	-
24	SB	-
25	L	-
26	R	-
27	G	-
28	LG	-

29	SB	-
30	P	-
38	LG	-
39	L	-
40	Y	-
43	G	-
44	R	-
45	GR	-
46	R	-

Connector No.	M6
Connector Name	WIRE TO WIRE
Connector Type	TH80MW-CS16-TM4



Terminal No.	Color of Wire	Signal Name
91	W	-

Connector No.	M7
Connector Name	WIRE TO WIRE
Connector Type	TH80MW-GS16-TM4



Terminal No.	Color of Wire	Signal Name
2	SB	- [With automatic drive positioner]
15	BR	-
16	Y	-
17	V	-
18	R	- [With A/T]
19	Y	- [With M/T]
23	L	-
24	P	-
96	V	-
98	GR	-

JCJWA0026GB



# DRIVER SEAT CONTROL UNIT

< ECU DIAGNOSIS >

## AUTOMATIC DRIVE POSITIONER

Connector No.	M22
Connector Name	KEY SLOT
Connector Type	TH12FW-NH

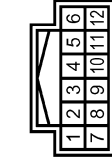

Terminal No.	Color of Wire	Signal Name
1	R	BAT
2	B	GND
11	R	KEY SWITCH SIGNAL

Connector No.	M24
Connector Name	DATA LINK CONNECTOR
Connector Type	BD16FW

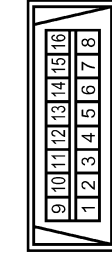

Terminal No.	Color of Wire	Signal Name
6	L	-
14	P	-

Connector No.	M31
Connector Name	TILT & TELESCOPIC SWITCH
Connector Type	TK08FGY

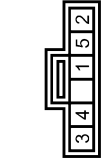

Terminal No.	Color of Wire	Signal Name
1	B	-
2	GR	-
3	G	-
4	Y	-
5	W	-

Connector No.	M48
Connector Name	TILT & TELESCOPIC SENSOR
Connector Type	TK04FW

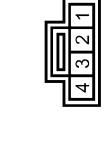

Terminal No.	Color of Wire	Signal Name
1	W	-
2	P	-
3	O	-
4	Y	-

Connector No.	M49
Connector Name	TILT & TELESCOPIC MOTOR
Connector Type	NS04FW-CS



Terminal No.	Color of Wire	Signal Name
1	G	-
2	GR	-
3	O	-
4	L	-

Connector No.	M51
Connector Name	AUTOMATIC DRIVE POSITIONER CONTROL UNIT
Connector Type	TH02FW-NH

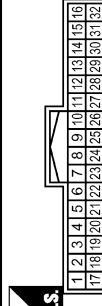

Terminal No.	Color of Wire	Signal Name
1	Y	TILT SW (UPWARD)
2	LG	MIRROR SELECT SW (RH)
3	G	MIRROR SW (UPWARD)
4	V	MIRROR SW (LEFTWARD)
5	R	MIRROR SENSOR (RH VERTICAL)
6	GR	MIRROR SENSOR (LH VERTICAL)
7	O	TILT SENSOR
9	L	ADDRESS
10	V	TX (UART)
11	GR	TELESCOPIC SW (FRONTWARD)
12	O	IND1

Terminal No.	Color of Wire	Signal Name
13	P	IND2
14	W	MIRROR MOTOR (RH VERTICAL)
15	GR	MIRROR MOTOR (RH HORIZONTAL) [With A/T]
15	G	MIRROR MOTOR (RH HORIZONTAL) [With M/T]
16	Y	MIRROR MOTOR (LH COMMON)
17	W	TILT SW (DOWNWARD)
18	P	MIRROR SELECT SW (LH)
19	SB	MIRROR SW (DOWNWARD)
20	BR	MIRROR SW (RIGHTWARD)
21	L	MIRROR SENSOR (RH HORIZONTAL)
22	G	MIRROR SENSOR (LH HORIZONTAL)
23	P	TELESCOPIC SENSOR
24	R	SET SW
25	SB	ADDRESS
26	Y	RX (UART)
27	G	TELESCOPIC SW (BACKWARD)
30	G	MIRROR MOTOR (RH COMMON) [With A/T]
30	R	MIRROR MOTOR (RH COMMON) [With M/T]
31	LG	MIRROR MOTOR (LH VERTICAL)
32	L	MIRROR MOTOR (LH HORIZONTAL)

Connector No.	M52
Connector Name	AUTOMATIC DRIVE POSITIONER CONTROL UNIT
Connector Type	NS18FW-CS

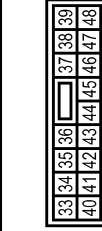

Terminal No.	Color of Wire	Signal Name
33	R	POWER SUPPLY (SENSOR) [With automatic drive positioner]
34	R	BAT (FUSE)
35	L	TILT MOTOR (UPWARD)
36	GR	TELESCOPIC MOTOR (FORWARD)
39	W	BAT (G/B)
40	B	GND(SIGNAL)
41	R	GND(SENSOR) [With automatic drive positioner]
42	O	TILT MOTOR (DOWNWARD)
44	G	TELESCOPIC MOTOR (BACKWARD)
48	B	GND(POWER)

A  
B  
C  
D  
E  
F  
G  
H  
I  
ADP  
K  
L  
M  
N  
O  
P

# DRIVER SEAT CONTROL UNIT

< ECU DIAGNOSIS >

## AUTOMATIC DRIVE POSITIONER

Connector No.	M62
Connector Name	CIRCUIT BREAKER
Connector Type	M02FW-P-LC



Terminal No.	Color of Wire	Signal Name
1	W	-
2	SB	[With automatic drive positioner]

Connector No.	M67
Connector Name	UNIFIED METER AND A/C AMP.
Connector Type	T1432FW-NH



Terminal No.	Color of Wire	Signal Name
56	L	CAN-H
72	P	CAN-L

Connector No.	M72
Connector Name	MULTIFUNCTION SWITCH
Connector Type	T118FW-NH

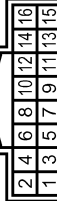

Terminal No.	Color of Wire	Signal Name
6	LG	AV COMM (H)
8	V	AV COMM (L)

Connector No.	M83
Connector Name	AV CONTROL UNIT
Connector Type	T124FW-NH

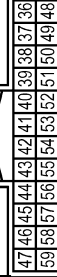

Terminal No.	Color of Wire	Signal Name
44	BR	COMM (DISP->CONT)
50	SHIELD	SHIELD
51	-	-
52	-	-
53	SHIELD	SHIELD
55	Y	COMM (CONT->DISP)

Connector No.	M85
Connector Name	AV CONTROL UNIT
Connector Type	T1282FW-NH



Terminal No.	Color of Wire	Signal Name
86	L	CAN-H
87	P	CAN-L
88	G	AV COMM (H) [With BOSE system]
88	R	AV COMM (L) [With BOSE system]

Connector No.	M87
Connector Name	AV CONTROL UNIT
Connector Type	T1440FW-NH



Terminal No.	Color of Wire	Signal Name
44	-	-
50	V	AV COMM (H)
51	LG	AV COMM (L)
52	L	CAN-H
53	P	CAN-L
55	-	-
56	-	-

Connector No.	M88
Connector Name	AV CONTROL UNIT
Connector Type	T112FW-NH

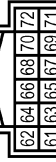

Terminal No.	Color of Wire	Signal Name
70	BR	COMM (CONT->DISP)
71	Y	COMM (DISP->CONT)
72	SHIELD	SHIELD

Connector No.	M116
Connector Name	WIRE TO WIRE
Connector Type	T1368MW-1S10



Terminal No.	Color of Wire	Signal Name
43	P	-
44	L	-

# DRIVER SEAT CONTROL UNIT

< ECU DIAGNOSIS >

## AUTOMATIC DRIVE POSITIONER

Connector No.	M118
Connector Name	BCM (BODY CONTROL MODULE)
Connector Type	M03FB-LG



Terminal No.	Color of Wire	Signal Name
1	W	BAT (E/L)

Connector No.	M119
Connector Name	BCM (BODY CONTROL MODULE)
Connector Type	NS16FW-GS



Terminal No.	Color of Wire	Signal Name
11	R	BAT (FUSE)
13	B	GND

Connector No.	M122
Connector Name	BCM (BODY CONTROL MODULE)
Connector Type	TH40FB-NH



Terminal No.	Color of Wire	Signal Name
90	P	CAN-L
91	L	CAN-H
96	GR	A/T DEVICE
99	R	SHIFT P

Connector No.	M123
Connector Name	BCM (BODY CONTROL MODULE)
Connector Type	TH40FG-NH



Terminal No.	Color of Wire	Signal Name
121	R	KEY SWITCH SIGNAL
150	GR	DOOR SW (DR)

Connector No.	M124
Connector Name	WIRE TO WIRE
Connector Type	TH40MW-CS15

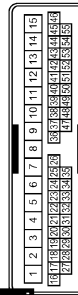

Terminal No.	Color of Wire	Signal Name
38	W	-
39	GR	- [With A/T]
38	G	- [With M/T]
40	G	- [With A/T]
40	R	- [With M/T]
43	L	-
44	Y	-
45	R	-
46	W	-

Connector No.	M137
Connector Name	A/T DEVICE
Connector Type	TH12FW-NH



Terminal No.	Color of Wire	Signal Name
10	GR	-
11	R	-

## Fail Safe

The fail-safe mode may be activated if the following symptoms are observed.

JCJWA0029GB

INFOID:000000000960760

A  
B  
C  
D  
E  
F  
G  
H  
I  
K  
L  
M  
N  
O  
P

# DRIVER SEAT CONTROL UNIT

## < ECU DIAGNOSIS >

Operating in fail-safe mode	Malfunction Item	Related DTC	Diagnosis
Only manual functions operate normally.	CAN communication	U1000	<a href="#">ADP-51</a>
	Tilt sensor	B2118	<a href="#">ADP-54</a>
	Telescopic sensor	B2119	<a href="#">ADP-57</a>
	Detent switch	B2126	<a href="#">ADP-60</a>
	Parking brake switch	B2127	<a href="#">ADP-62</a>
Only manual functions, except door mirror, operate normally.	UART communication	B2128	<a href="#">ADP-64</a>
Only manual functions, except seat sliding, operate normally.	Seat sliding output	B2112	<a href="#">ADP-52</a>
Only manual functions, except seat reclining, operate normally.	Seat reclining output	B2113	<a href="#">ADP-52</a>

## DTC Index

INFOID:000000000960761

CONSULT-III display	Timing*1		Item	Reference page
	Current malfunction	Previous malfunction		
CAN COMM CIRCUIT [U1000]	0	1-39	CAN communication	<a href="#">ADP-51</a>
SEAT SLIDE [B2112]	0	1-39	Seat slide motor output	<a href="#">ADP-52</a>
SEAT RECLINING [B2113]	0	1-39	Seat reclining motor output	<a href="#">ADP-53</a>
TILT SENSOR [B2118]	0	1-39	Tilt sensor input	<a href="#">ADP-54</a>
TELESCO SENSOR [B2119]	0	1-39	Telescopic sensor input	<a href="#">ADP-57</a>
DETENT SW [B2126]	0	1-39	Detention switch condition	<a href="#">ADP-60</a>
PARKING BRAKE [B2127]	0	1-39	Parking brake switch condition	<a href="#">ADP-62</a>
UART COMM [B2128]	0	1-39	UART communication	<a href="#">ADP-64</a>

\*1.

- 0: Current malfunction is present
- 1-39: Displayed if any previous malfunction is present when current condition is normal. The numeral value increases by one at each IGN ON to OFF cycle from 1 to 39. The counter remains at 39 even if the number of cycles exceeds it. However, the counter is reset to 1 if any malfunction is detected again, the normal operation is resumed and the ignition switch is turned from OFF to ON.

# AUTOMATIC DRIVE POSITIONER CONTROL UNIT

< ECU DIAGNOSIS >

## AUTOMATIC DRIVE POSITIONER CONTROL UNIT

Reference Value

INFOID:000000000960762

### TERMINAL LAYOUT

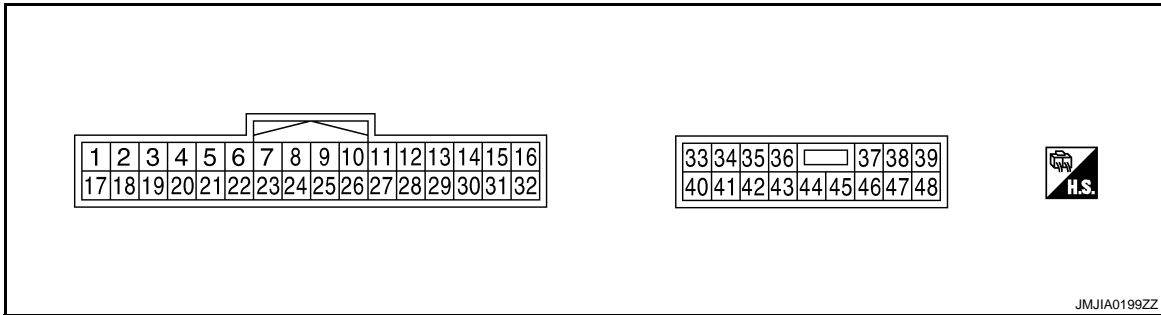

### PHYSICAL VALUES

Terminal No.		Wire color	Description		Condition	Voltage (V) (Approx.)
+	-		Signal name	Input/ Output		
1	Ground	Y	Tilt switch up signal	Input	Tilt switch	Operate (up) 0
					Other than above	5
2	Ground	LG	Changeover switch RH signal	Input	Changeover switch position	RH 0
					Neutral or LH	5
3	Ground	G	Mirror switch up signal	Input	Mirror switch	Operated (up) 0
					Other than above	5
4	Ground	V	Mirror switch left signal	Input	Mirror switch	Operated (left) 0
					Other than above	5
5	Ground	R	Door mirror sensor (RH) up/down signal	Input	Door mirror RH position	Peak 3.4
					Valley	0.6
6	Ground	GR	Door mirror sensor (LH) up/down signal	Input	Door mirror LH position	Peak 3.4
					Valley	0.6
7	Ground	O	Tilt sensor signal	Input	Tilt position	Top 1.2
					Bottom	3.4
9	Ground	L	Memory switch 1 signal	Input	Memory switch 1	Push 0
					Other than above	5
10	Ground	V	UART communication (TX)	Output	Ignition switch ON	

A  
B  
C  
D  
E  
F  
G  
H  
I  
K  
L  
M  
N  
O  
P

ADP

# AUTOMATIC DRIVE POSITIONER CONTROL UNIT

## < ECU DIAGNOSIS >

Terminal No.		Wire color	Description		Condition	Voltage (V) (Approx.)	
+	-		Signal name	Input/ Output			
11	Ground	GR	Telescopic switch forward signal	Input	Telescopic switch	Operate (forward)	0
						Other than above	5
12	Ground	O	Memory indicator 1 signal	Output	Memory indicator 1	Illuminate	0
						Other than above	Battery voltage
13	Ground	P	Memory indicator 2 signal	Output	Memory indicator 2	Illuminate	0
						Other than above	Battery voltage
14	Ground	W	Door mirror motor (RH) up output signal	Output	Door mirror RH	Operate (up)	Battery voltage
						Other than above	0
15	Ground	GR <sup>*1</sup> G <sup>*2</sup>	Door mirror motor (RH) left output signal	Output	Door mirror RH	Operate (left)	Battery voltage
						Other than above	0
16	Ground	Y	Door mirror motor (LH) down output signal	Output	Door mirror (LH)	Operate (down)	Battery voltage
						Other than above	0
			Door mirror motor (LH) right output signal			Operate (right)	Battery voltage
						Other than above	0
17	Ground	W	Tilt switch down signal	Input	Tilt switch	Operate (down)	0
						Other than above	5
18	Ground	P	Changeover switch LH signal	Input	Changeover switch position	LH	0
						Neutral or RH	5
19	Ground	SB	Mirror switch down signal	Input	Mirror switch	Operate (down)	0
						Other than above	5
20	Ground	BR	Mirror switch right signal	Input	Mirror switch	Operate (right)	0
						Other than above	5
21	Ground	L	Door mirror sensor (RH) left/right signal	Input	Door mirror RH position	Left edge	3.4
						Right edge	0.6
22	Ground	G	Door mirror sensor (LH) left/right signal	Input	Door mirror LH position	Left edge	0.6
						Right edge	3.4
23	Ground	P	Telescopic sensor signal	Input	Telescopic position	Top	0.8
						Bottom	3.4

# AUTOMATIC DRIVE POSITIONER CONTROL UNIT

## < ECU DIAGNOSIS >

Terminal No.		Wire color	Description		Condition		Voltage (V) (Approx.)
+	-		Signal name	Input/ Output			
24	Ground	R	Set switch signal	Input	Set switch	Push	0
						Other than above	5
25	Ground	SB	Memory switch 2 signal	Input	Memory switch 2	Push	0
						Other than above	5
26	Ground	Y	UART communication (RX)	Input	Ignition switch ON		
27	Ground	G	Telescopic switch backward signal	Input	Telescopic switch	Operate (backward)	0
						Other than above	5
30	Ground	G*1 R*2	Door mirror motor (RH) down output signal	Output	Door mirror (RH)	Operate (down)	Battery voltage
						Other than above	0
			Door mirror motor (RH) right output signal			Operate (right)	Battery voltage
						Other than above	0
31	Ground	LG	Door mirror motor (LH) up output signal	Output	Door mirror (LH)	Operate (up)	Battery voltage
						Other than above	0
32	Ground	L	Door mirror motor (LH) left output signal	Output	Door mirror (LH)	Operate (left)	Battery voltage
						Other than above	0
33	Ground	R	Sensor power supply	Input	—	5	
34	Ground	R	Power source (Fuse)	Input	—	Battery voltage	
35	Ground	L	Tilt motor up output signal	Output	Steering tilt	Operate (up)	Battery voltage
						Other than above	0
36	Ground	GR	Telescopic motor forward output signal	Output	Steering telescopic	Operate (forward)	Battery voltage
						Other than above	0
39	Ground	W	Power source (C/B)	—	—	Battery voltage	
40	Ground	B	Ground	—	—	0	
41	Ground	R	Sensor ground	—	—	0	

A  
B  
C  
D  
E  
F  
G  
H  
I  
K  
L  
M  
N  
O  
P

ADP

# AUTOMATIC DRIVE POSITIONER CONTROL UNIT

## < ECU DIAGNOSIS >

Terminal No.		Wire color	Description		Condition	Voltage (V) (Approx.)
+	-		Signal name	Input/ Output		
42	Ground	O	Tilt motor down output signal	Output	Steering tilt	Battery voltage
					Operate (down)	0
44	Ground	G	Telescopic motor backward output signal	Output	Steering telescopic	Battery voltage
					Operate (backward)	0
48	Ground	B	Ground	—	—	0

\*1: For AT models

\*2: For MT models



# AUTOMATIC DRIVE POSITIONER CONTROL UNIT

< ECU DIAGNOSIS >

## Wiring Diagram—AUTOMATIC DRIVE POSITIONER CONTROL SYSTEM—

INFOID:000000000960763

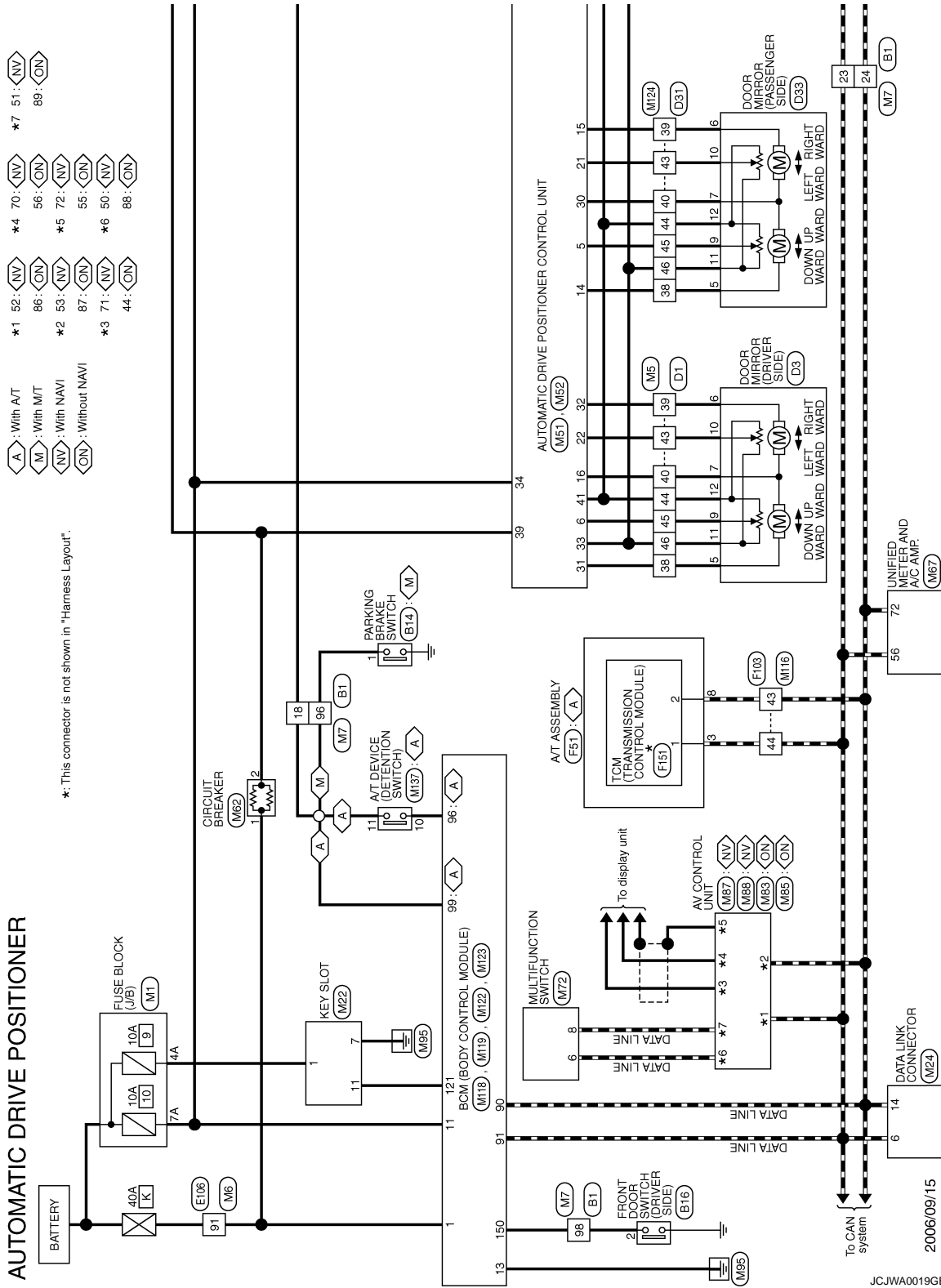

- \*1 52: <NV> 86: <ON> \*4 70: <NV> 56: <NV>
  - \*2 53: <NV> 87: <ON> \*5 72: <NV> 55: <ON>
  - \*3 71: <NV> 44: <ON> \*6 50: <NV> 88: <ON>
  - \*7 51: <NV> 89: <ON>
- <A> : With A/T  
 <M> : With M/T  
 <NV> : With NAVI  
 <ON> : Without NAVI

\*: This connector is not shown in "Harness Layout".

A B C D E F G H I K L M N O P

ADP

# AUTOMATIC DRIVE POSITIONER CONTROL UNIT

< ECU DIAGNOSIS >

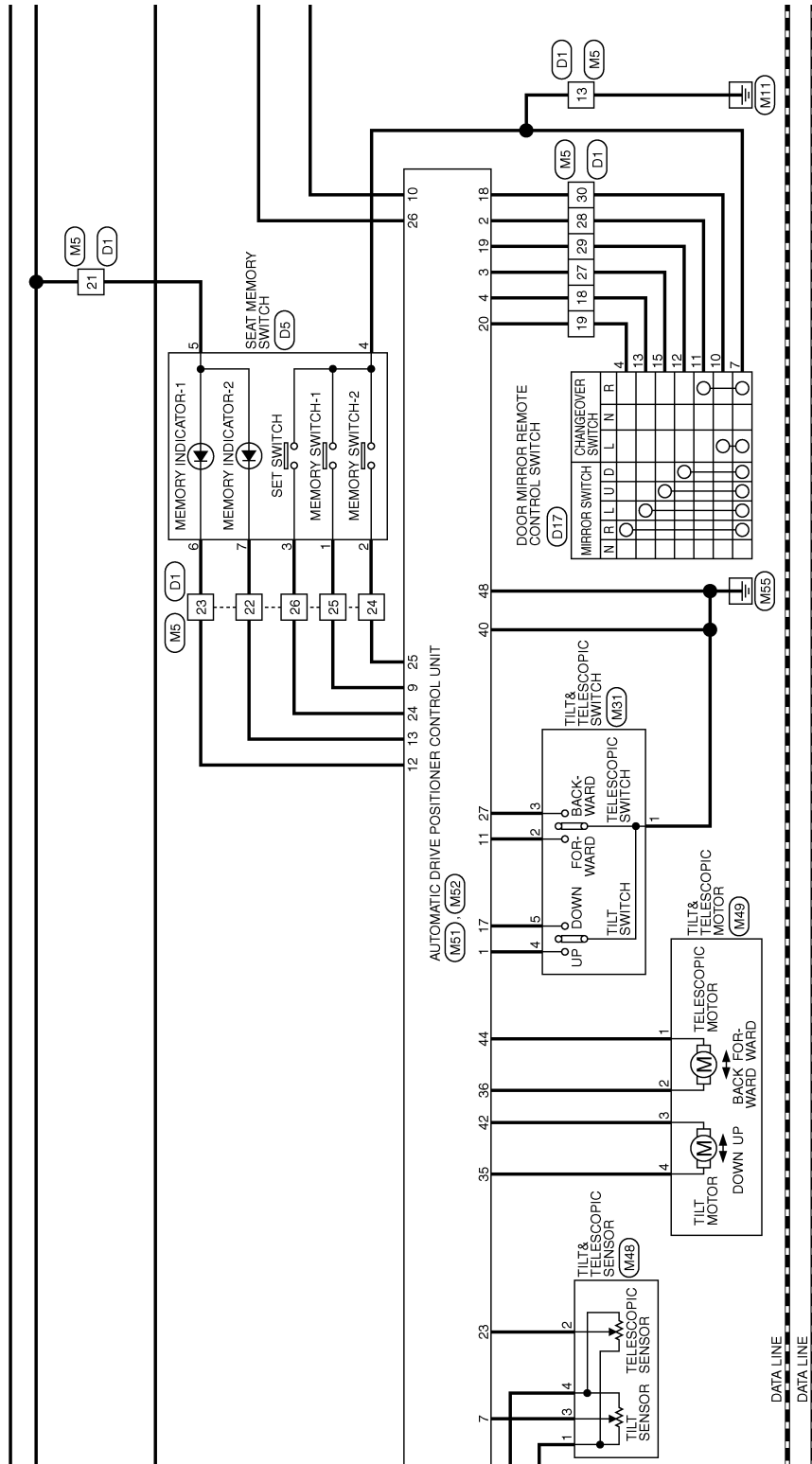

JCJWA0020GB

# AUTOMATIC DRIVE POSITIONER CONTROL UNIT

< ECU DIAGNOSIS >

A : With AT  
M : With M/T  
SP : With sports seat

\*: This connector is not shown in "Harness Layout".

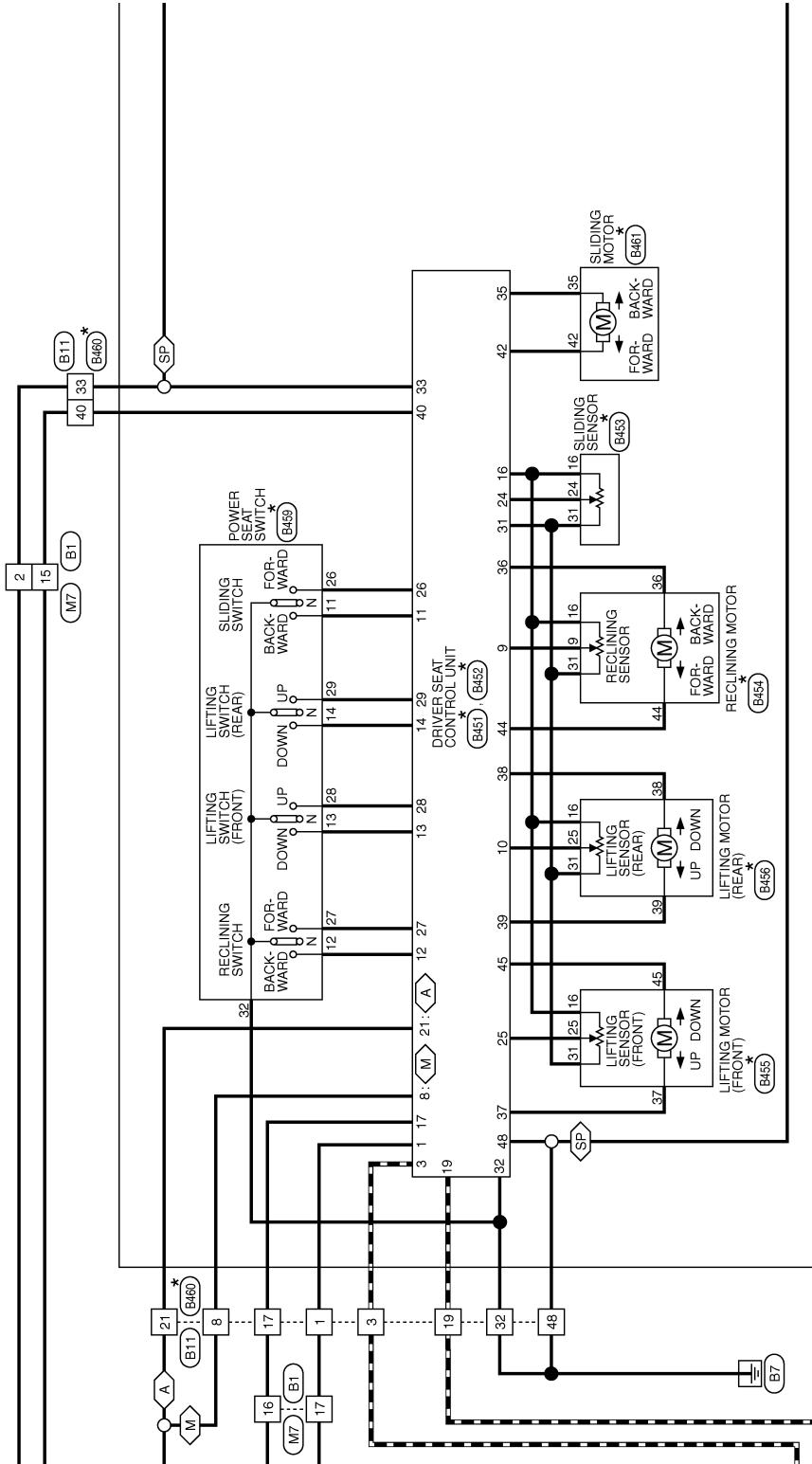

JCJWA0021GB

A  
B  
C  
D  
E  
F  
G  
H  
I  
ADP  
K  
L  
M  
N  
O  
P

# AUTOMATIC DRIVE POSITIONER CONTROL UNIT

< ECU DIAGNOSIS >

◁ SP ▷ : With sports seat

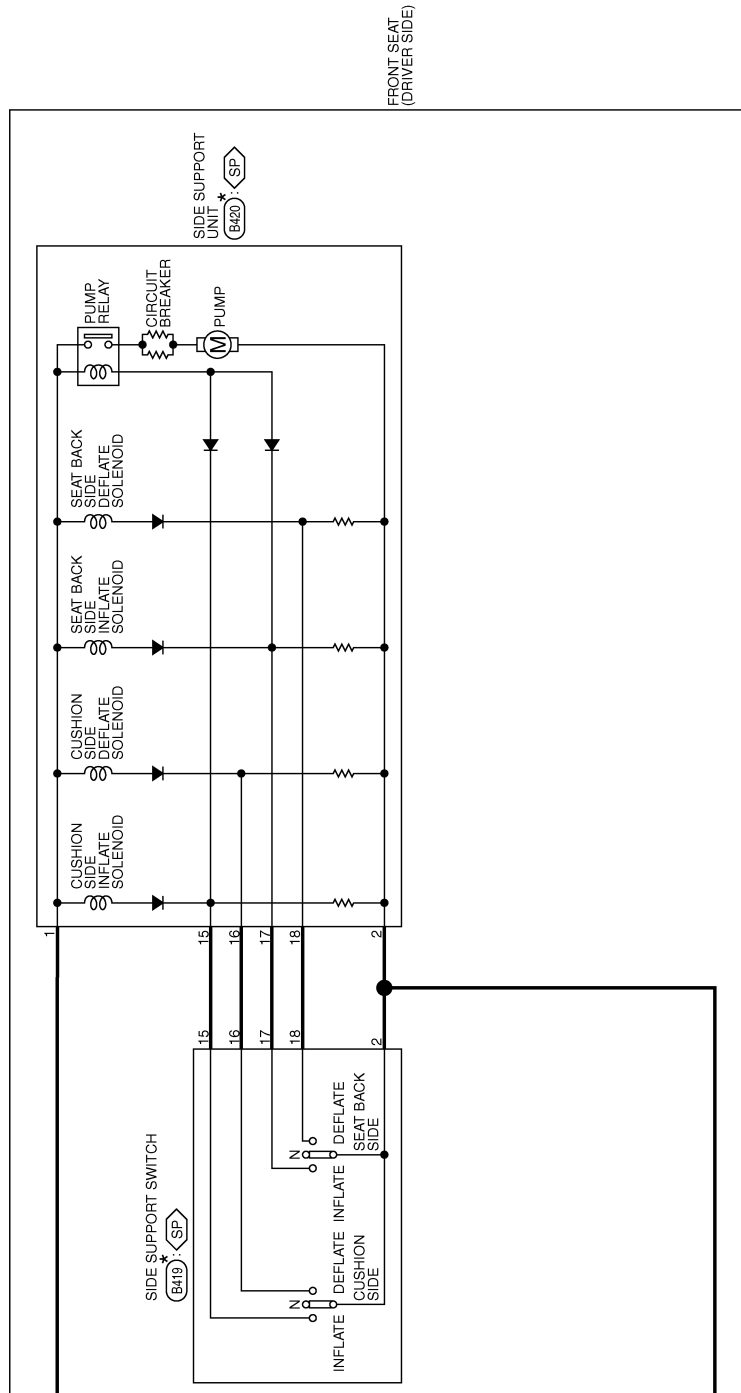

JCJWA0022GB

# AUTOMATIC DRIVE POSITIONER CONTROL UNIT

< ECU DIAGNOSIS >

## AUTOMATIC DRIVE POSITIONER

Connector No.	B1
Connector Name	WIRE TO WIRE
Connector Type	TH30FW-CS16-TM4

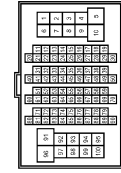

Terminal No.	Color of Wire	Signal Name
2	SB	-
15	BR	-
16	LG	-
17	LG	-
18	Y	-
23	L	-
24	P	-
96	V	-
98	V	-

Connector No.	B11
Connector Name	WIRE TO WIRE (With automatic drive positioner)
Connector Type	NS116FW-CS

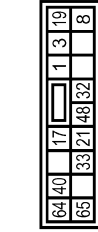

Terminal No.	Color of Wire	Signal Name
1	G	-
3	L	-
8	Y	-
17	LG	-
19	P	-
21	Y	-
32	B	-
33	SB	-
40	BR	-
48	B	-

Connector No.	B14
Connector Name	PARKING BRAKE SWITCH
Connector Type	P01FB-A



Terminal No.	Color of Wire	Signal Name
1	V	-

Connector No.	B18
Connector Name	FRONT DOOR SWITCH (DRIVER SIDE)
Connector Type	A03FW

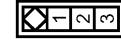

Terminal No.	Color of Wire	Signal Name
2	V	-

Connector No.	B419
Connector Name	SIDE SUPPORT SWITCH
Connector Type	NS06FW-CS

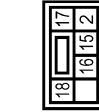

Terminal No.	Color of Wire	Signal Name
2	B	-
15	G	- [With automatic drive positioner]
16	B/R	- [With automatic drive positioner]
17	V/W	- [With automatic drive positioner]
18	R/L	- [With automatic drive positioner]

Connector No.	B420
Connector Name	SIDE SUPPORT UNIT
Connector Type	NS06FW-CS



Terminal No.	Color of Wire	Signal Name
1	R	-
2	B	-
15	G	- [With automatic drive positioner]
16	B/R	- [With automatic drive positioner]
17	V/W	- [With automatic drive positioner]
18	R/L	- [With automatic drive positioner]

Connector No.	B451
Connector Name	DRIVER SEAT CONTROL UNIT
Connector Type	TH32FW

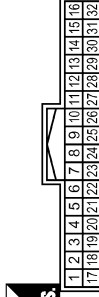

Terminal No.	Color of Wire	Signal Name
1	L/W	RX
3	R/Y	CAN-H
8	LG	PARKING BRAKE SW
9	W/G	PULSE(RECLINING)
10	P/B	PULSE(R LIFTING)
11	BR	SLIDING SW(BACKWARD)
12	SB	RECLINING SW(BACKWARD)
13	LG/R	FRONT LIFTING SW(DOWNWARD)
14	G/B	REAR LIFTING SW(DOWNWARD)
16	O	VCC
17	Y/R	TX

Terminal No.	Color of Wire	Signal Name
19	V	CAN-L
21	L/Y	P RANGE SW
24	R	PULSE(SLIDING)
25	Y/B	PULSE(R LIFTING)
26	Y	SLIDING SW(FORWARD)
27	R/G	RECLINING SW(FORWARD)
28	W/B	FRONT LIFTING SW(FORWARD)
29	P/L	REAR LIFTING SW(FORWARD)
31	GR	SENSOR GND
32	B/W	GND(SIGNAL)

JCJWA0023GB

A B C D E F G H I K L M N O P

ADP

# AUTOMATIC DRIVE POSITIONER CONTROL UNIT

< ECU DIAGNOSIS >

## AUTOMATIC DRIVE POSITIONER

Connector No.	B432
Connector Name	DRIVER SEAT CONTROL UNIT
Connector Type	NS16FW-CS



33	34	35	36	37	38	39
40	41	42	43	44	45	46
47	48					

Terminal No.	Color of Wire	Signal Name
33	R	BAT(C/B)
35	W/R	SLIDING MOTOR(FORWARD)
36	G/Y	RECLINING MOTOR(FORWARD)
37	G/W	FRONT LIFTING MOTOR(DOWNWARD)
38	L/Y	REAR LIFTING MOTOR(UPWARD)
38	R/B	REAR LIFTING MOTOR(BACKWARD)
40	R/W	BAT(FUSE)
42	W/B	SLIDING MOTOR(BACKWARD)
44	P	RECLINING MOTOR(BACKWARD)
45	L/R	FRONT LIFTING MOTOR(UPWARD)
48	B	GND(POWER)

Connector No.	B436
Connector Name	LIFTING MOTOR(REAR/DRIVER SIDE)
Connector Type	NS06FB-CS



38	39
16	31
25	37

Terminal No.	Color of Wire	Signal Name
16	O	-
25	P/B	-
31	GR	-
38	L/Y	-
38	R/B	-

Connector No.	B453
Connector Name	SLIDING SENSOR
Connector Type	6038-0241



24	31	16
----	----	----

Terminal No.	Color of Wire	Signal Name
16	O	-
24	R	-
31	GR	-

Connector No.	B459
Connector Name	POWER SEAT SWITCH(DRIVER SIDE)
Connector Type	NS10FW-CS



32	14	29
12	27	11
26	13	28

Terminal No.	Color of Wire	Signal Name
11	BR	-
12	SR	-
13	L/G/R	-
14	G/B	-
26	Y	-
27	R/G	-
28	W/B	-
29	P/L	-
32	B/W	-

Connector No.	B454
Connector Name	RECLINING MOTOR
Connector Type	NS06FW-CS



36	44
16	31
9	19

Terminal No.	Color of Wire	Signal Name
9	W/G	-
16	O	-
31	GR	-
36	G/Y	-
44	P	-

Connector No.	B480
Connector Name	WIRE TO WIRE (With automatic drive positioner)
Connector Type	NS18MW-CS



19	3	1	17	40	64
8	32	48	21	33	65

Terminal No.	Color of Wire	Signal Name
1	L/W	-
3	R/Y	-
8	L/G	-
17	Y/R	-
19	V	-
21	L/Y	-
32	B/W	-
33	R	-
40	R/W	-
48	B	-

Connector No.	B455
Connector Name	LIFTING MOTOR(FRONT/DRIVER SIDE)
Connector Type	NS08FW-CS



45	37
16	31
25	37

Terminal No.	Color of Wire	Signal Name
16	O	-
25	Y/B	-
31	GR	-
37	G/W	-
45	L/R	-

Connector No.	B461
Connector Name	SLIDING MOTOR(DRIVER SIDE)
Connector Type	6038-0239



42	35
----	----

Terminal No.	Color of Wire	Signal Name
35	W/R	-
42	W/B	-

# AUTOMATIC DRIVE POSITIONER CONTROL UNIT

< ECU DIAGNOSIS >

## AUTOMATIC DRIVE POSITIONER

Connector No.	D1
Connector Name	WIRE TO WIRE
Connector Type	TH40FW-CS15

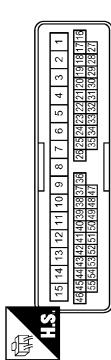

Terminal No.	Color of Wire	Signal Name
13	B	-
18	W	-
19	BR	-
21	R	-
22	P	-
23	O	-
24	BR	-
25	L	-
26	GR	-
27	Y	-
28	LG	-

Connector No.	D17
Connector Name	DOOR MIRROR REMOTE CONTROL SWITCH (With automatic drive positioner)
Connector Type	TK16FBR



Terminal No.	Color of Wire	Signal Name
4	BR	-
7	B	-
10	GR	-
11	LG	-
12	G	-
13	W	-
15	Y	-

29	G	-
30	GR	-
38	O	-
39	GR	-
40	G	-
43	BR	-
44	V	-
45	P	-
46	W	-

Terminal No.	Color of Wire	Signal Name
5	O	- [With automatic drive positioner]
6	GR	- [With automatic drive positioner]
7	G	- [With automatic drive positioner]
9	P	-
10	BR	-
11	W	-
12	V	-

Connector No.	D33
Connector Name	DOOR MIRROR (PASSENGER SIDE)
Connector Type	TH12MW-NH



Terminal No.	Color of Wire	Signal Name
5	W	- [With automatic drive positioner]
6	G	- [With automatic drive positioner]
7	Y	- [With automatic drive positioner]
9	P	-
10	BR	-
11	W	-
12	V	-

Connector No.	D5
Connector Name	SEAT MEMORY SWITCH
Connector Type	A08FW

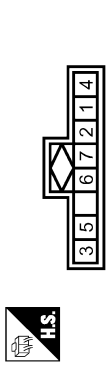

Terminal No.	Color of Wire	Signal Name
1	L	-
2	BR	-
3	GR	-
4	B	-
5	R	-
6	O	-
7	P	-

Connector No.	E106
Connector Name	WIRE TO WIRE
Connector Type	TH80FW-CS16-TM4

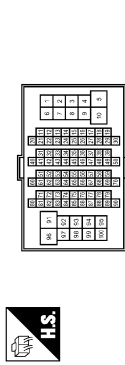

Terminal No.	Color of Wire	Signal Name
91	W	-

A  
B  
C  
D  
E  
F  
G  
H  
I  
ADP  
K  
L  
M  
N  
O  
P

# AUTOMATIC DRIVE POSITIONER CONTROL UNIT

< ECU DIAGNOSIS >

## AUTOMATIC DRIVE POSITIONER

Connector No.	F51
Connector Name	A/T ASSEMBLY
Connector Type	BK10FG-D6Y

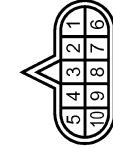

Terminal No.	Color of Wire	Signal Name
3	L	-
8	P	-

Connector No.	F103
Connector Name	WIRE TO WIRE
Connector Type	TK438FW-NS10

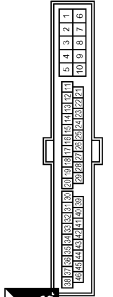

Terminal No.	Color of Wire	Signal Name
43	P	-
44	L	-

Connector No.	F151
Connector Name	TCM (TRANSMISSION CONTROL MODULE)
Connector Type	SPT08FGY

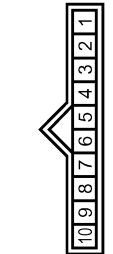

Terminal No.	Color of Wire	Signal Name
1	BR	CAN-H
2	L/Y	CAN-L

Connector No.	M1
Connector Name	FUSE BLOCK (J/B)
Connector Type	NSC8FW-M2

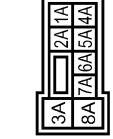

Terminal No.	Color of Wire	Signal Name
4A	P	-
7A	R	-

Connector No.	M5
Connector Name	WIRE TO WIRE
Connector Type	TH80MW-CS15

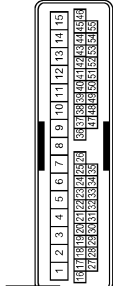

Terminal No.	Color of Wire	Signal Name
13	B	-
18	V	-
19	BR	-
21	R	-
22	P	-
23	O	-
24	SB	-
25	L	-
26	R	-
27	G	-
28	LG	-

29	SB	-
30	P	-
38	LG	-
39	L	-
40	Y	-
43	G	-
44	R	-
45	GR	-
46	R	-

Connector No.	M6
Connector Name	WIRE TO WIRE
Connector Type	TH80MW-CS16-TM4

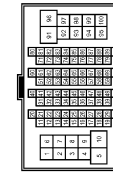

Terminal No.	Color of Wire	Signal Name
91	W	-

Connector No.	M7
Connector Name	WIRE TO WIRE
Connector Type	TH80MW-GS16-TM4



Terminal No.	Color of Wire	Signal Name
2	SB	- [With automatic drive positioner]
15	BR	-
16	Y	-
17	V	-
18	R	- [With A/T]
19	Y	- [With M/T]
23	L	-
24	P	-
96	V	-
98	GR	-

JCJWA0026GB



# AUTOMATIC DRIVE POSITIONER CONTROL UNIT

< ECU DIAGNOSIS >

## AUTOMATIC DRIVE POSITIONER

Connector No.	M22
Connector Name	KEY SLOT
Connector Type	TH12FW-NH

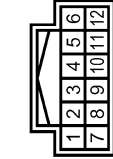

Terminal No.	Color of Wire	Signal Name
1	R	BAT
7	B	GND
11	R	KEY SWITCH SIGNAL

Connector No.	M24
Connector Name	DATA LINK CONNECTOR
Connector Type	BD16FW

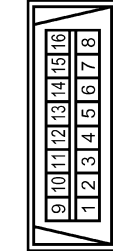

Terminal No.	Color of Wire	Signal Name
6	L	-
14	P	-

Connector No.	M31
Connector Name	TILT & TELESCOPIC SWITCH
Connector Type	TK08FGY

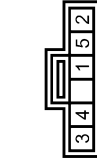

Terminal No.	Color of Wire	Signal Name
1	B	-
2	GR	-
3	G	-
4	Y	-
5	W	-

Connector No.	M48
Connector Name	TILT & TELESCOPIC SENSOR
Connector Type	TK04FW



Terminal No.	Color of Wire	Signal Name
1	W	-
2	P	-
3	O	-
4	Y	-

Connector No.	M49
Connector Name	TILT & TELESCOPIC MOTOR
Connector Type	NS04FW-CS

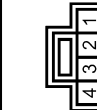

Terminal No.	Color of Wire	Signal Name
1	G	-
2	GR	-
3	O	-
4	L	-

Connector No.	M51
Connector Name	AUTOMATIC DRIVE POSITIONER CONTROL UNIT
Connector Type	TH02FW-NH

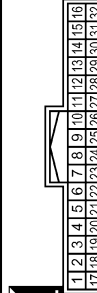

Terminal No.	Color of Wire	Signal Name
1	Y	TILT SW (UPWARD)
2	LG	MIRROR SELECT SW (RH)
3	G	MIRROR SW (UPWARD)
4	V	MIRROR SW (LEFTWARD)
5	R	MIRROR SENSOR (RH VERTICAL)
6	GR	MIRROR SENSOR (LH VERTICAL)
7	O	TILT SENSOR
9	L	ADDRESS
10	V	TX (UART)
11	GR	TELESCOPIC SW (FRONTWARD)
12	O	IND1

Terminal No.	Color of Wire	Signal Name
13	P	IND2
14	W	MIRROR MOTOR (RH VERTICAL)
15	GR	MIRROR MOTOR (RH HORIZONTAL) [With A/T]
15	G	MIRROR MOTOR (RH HORIZONTAL) [With M/T]
16	Y	MIRROR MOTOR (LH COMMON)
17	W	TILT SW (DOWNWARD)
18	P	MIRROR SELECT SW (LH)
19	SB	MIRROR SW (DOWNWARD)
20	BR	MIRROR SW (RIGHTWARD)
21	L	MIRROR SENSOR (RH HORIZONTAL)
22	G	MIRROR SENSOR (LH HORIZONTAL)
23	P	TELESCOPIC SENSOR
24	R	SET SW
25	SB	ADDRESS
26	Y	RX (UART)
27	G	TELESCOPIC SW (BACKWARD)
30	G	MIRROR MOTOR (RH COMMON) [With A/T]
30	R	MIRROR MOTOR (RH COMMON) [With M/T]
31	LG	MIRROR MOTOR (LH VERTICAL)
32	L	MIRROR MOTOR (LH HORIZONTAL)

Connector No.	M52
Connector Name	AUTOMATIC DRIVE POSITIONER CONTROL UNIT
Connector Type	NS18FW-CS

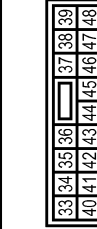

Terminal No.	Color of Wire	Signal Name
33	R	POWER SUPPLY (SENSOR) [With automatic drive positioner]
34	R	BAT (FUSE)
35	L	TILT MOTOR (UPWARD)
36	GR	TELESCOPIC MOTOR (FORWARD)
39	W	BAT (G/B)
40	B	GND(SIGNAL)
41	R	GND(SENSOR) [With automatic drive positioner]
42	O	TILT MOTOR (DOWNWARD)
44	G	TELESCOPIC MOTOR (BACKWARD)
48	B	GND(POWER)

A  
B  
C  
D  
E  
F  
G  
H  
I  
K  
L  
M  
N  
O  
P

ADP

# AUTOMATIC DRIVE POSITIONER CONTROL UNIT

< ECU DIAGNOSIS >

## AUTOMATIC DRIVE POSITIONER

Connector No.	M62
Connector Name	CIRCUIT BREAKER
Connector Type	M02FW-P-LC



Terminal No.	Color of Wire	Signal Name
1	W	-
2	SB	[With automatic drive positioner]

Connector No.	M67
Connector Name	UNIFIED METER AND A/C AMP.
Connector Type	TH32FW-NH



Terminal No.	Color of Wire	Signal Name
56	L	CAN-H
72	P	CAN-L

Connector No.	M72
Connector Name	MULTIFUNCTION SWITCH
Connector Type	TH18FW-NH

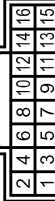

Terminal No.	Color of Wire	Signal Name
6	LG	AV COMM (H)
8	V	AV COMM (L)

Connector No.	M83
Connector Name	AV CONTROL UNIT
Connector Type	TH24FW-NH

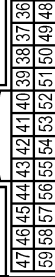

Terminal No.	Color of Wire	Signal Name
44	BR	COMM (DISP->CONT)
50	SHIELD	SHIELD
51	-	-
52	-	-
53	SHIELD	SHIELD
55	Y	COMM (CONT->DISP)

Connector No.	M85
Connector Name	AV CONTROL UNIT
Connector Type	TH22FW-NH



Terminal No.	Color of Wire	Signal Name
86	L	CAN-H
87	P	CAN-L
88	G	AV COMM (H) [With BOSE system]
88	R	AV COMM (L) [With BOSE system]

Connector No.	M87
Connector Name	AV CONTROL UNIT
Connector Type	TH40FW-NH



Terminal No.	Color of Wire	Signal Name
44	-	-
50	V	AV COMM (H)
51	LG	AV COMM (L)
52	L	CAN-H
53	P	CAN-L
55	-	-
56	-	-

Connector No.	M88
Connector Name	AV CONTROL UNIT
Connector Type	TH12FW-NH



Terminal No.	Color of Wire	Signal Name
70	BR	COMM (CONT->DISP)
71	Y	COMM (DISP->CONT)
72	SHIELD	SHIELD

Connector No.	M116
Connector Name	WIRE TO WIRE
Connector Type	TK36MW-NS10



Terminal No.	Color of Wire	Signal Name
43	P	-
44	L	-

# AUTOMATIC DRIVE POSITIONER CONTROL UNIT

< ECU DIAGNOSIS >

## AUTOMATIC DRIVE POSITIONER

Connector No.	M118
Connector Name	BCM (BODY CONTROL MODULE)
Connector Type	M03FB-LG



Terminal No.	Color of Wire	Signal Name
1	W	BAT (E/L)

Connector No.	M119
Connector Name	BCM (BODY CONTROL MODULE)
Connector Type	NS16FW-GS



Terminal No.	Color of Wire	Signal Name
11	R	BAT (FUSE)
13	B	GND

Connector No.	M122
Connector Name	BCM (BODY CONTROL MODULE)
Connector Type	TH40FB-NH



Terminal No.	Color of Wire	Signal Name
90	P	CAN-L
91	L	CAN-H
96	GR	A/T DEVICE
99	R	SHIFT P

Connector No.	M123
Connector Name	BCM (BODY CONTROL MODULE)
Connector Type	TH40FG-NH



Terminal No.	Color of Wire	Signal Name
121	R	KEY SWITCH SIGNAL
150	GR	DOOR SW (DR)

Connector No.	M124
Connector Name	WIRE TO WIRE
Connector Type	TH40MW-CS15

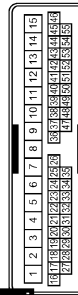

Terminal No.	Color of Wire	Signal Name
38	W	-
39	GR	- [With A/T]
40	G	- [With M/T]
43	L	- [With A/T]
44	Y	- [With M/T]
45	R	-
46	W	-

Connector No.	M137
Connector Name	A/T DEVICE
Connector Type	TH12FW-NH



Terminal No.	Color of Wire	Signal Name
10	GR	-
11	R	-

A  
B  
C  
D  
E  
F  
G  
H  
I  
K  
L  
M  
N  
O  
P

ADP

# BCM (BODY CONTROL MODULE)

< ECU DIAGNOSIS >

## BCM (BODY CONTROL MODULE)

Reference Value

INFOID:000000000960764

### VALUES ON THE DIAGNOSIS TOOL

Monitor Item	Condition	Value/Status
FR WIPER HI	Other than front wiper switch HI	OFF
	Front wiper switch HI	ON
FR WIPER LOW	Other than front wiper switch LO	OFF
	Front wiper switch LO	ON
FR WASHER SW	Front washer switch OFF	OFF
	Front washer switch ON	ON
FR WIPER INT	Other than front wiper switch INT	OFF
	Front wiper switch INT	ON
FR WIPER STOP	Front wiper is not in STOP position	OFF
	Front wiper is in STOP position	ON
INT VOLUME	Wiper intermittent dial is in a dial position 1 - 7	Wiper intermittent dial position
TURN SIGNAL R	Other than turn signal switch RH	OFF
	Turn signal switch RH	ON
TURN SIGNAL L	Other than turn signal switch LH	OFF
	Turn signal switch LH	ON
TAIL LAMP SW	Other than lighting switch 1ST and 2ND	OFF
	Lighting switch 1ST or 2ND	ON
HI BEAM SW	Other than lighting switch HI	OFF
	Lighting switch HI	ON
HEAD LAMP SW 1	Other than lighting switch 2ND	OFF
	Lighting switch 2ND	ON
HEAD LAMP SW 2	Other than lighting switch 2ND	OFF
	Lighting switch 2ND	ON
PASSING SW	Other than lighting switch PASS	OFF
	Lighting switch PASS	ON
AUTO LIGHT SW	Other than lighting switch AUTO	OFF
	Lighting switch AUTO	ON
FR FOG SW	Front fog lamp switch OFF	OFF
	Front fog lamp switch ON	ON
RR FOG SW	<b>NOTE:</b> The item is indicated, but not monitored.	OFF
DOOR SW-DR	Driver door closed	OFF
	Driver door opened	ON
DOOR SW-AS	Passenger door closed	OFF
	Passenger door opened	ON
DOOR SW-RR	Rear RH door closed	OFF
	Rear RH door opened	ON
DOOR SW-RL	Rear LH door closed	OFF
	Rear LH door opened	ON

## BCM (BODY CONTROL MODULE)

### < ECU DIAGNOSIS >

Monitor Item	Condition	Value/Status	
DOOR SW-BK	<b>NOTE:</b> The item is indicated, but not monitored.	OFF	A
CDL LOCK SW	Other than power door lock switch LOCK	OFF	B
	Power door lock switch LOCK	ON	
CDL UNLOCK SW	Other than power door lock switch UNLOCK	OFF	C
	Power door lock switch UNLOCK	ON	
KEY CYL LK-SW	Other than driver door key cylinder LOCK position	OFF	D
	Driver door key cylinder LOCK position	ON	
KEY CYL UN-SW	Other than driver door key cylinder UNLOCK position	OFF	D
	Driver door key cylinder UNLOCK position	ON	
KEY CYL SW-TR	<b>NOTE:</b> The item is indicated, but not monitored.	OFF	E
HAZARD SW	Hazard switch is not pressed	OFF	F
	Hazard switch is pressed	ON	
REAR DEF SW	<b>NOTE:</b> The item is indicated, but not monitored.	OFF	G
H/L WASH SW	<b>NOTE:</b> The item is indicated, but not monitored.	OFF	G
TR CANCEL SW	Trunk lid opener cancel switch OFF	OFF	H
	Trunk lid opener cancel switch ON	ON	
TR/BD OPEN SW	Trunk lid opener switch OFF	OFF	I
	While the trunk lid opener switch is turned ON	ON	
TRNK/HAT MNTR	Trunk lid closed	OFF	I
	Trunk lid opened	ON	
RKE-LOCK	LOCK button of Intelligent Key is not pressed	OFF	ADP
	LOCK button of Intelligent Key is pressed	ON	
RKE-UNLOCK	UNLOCK button of Intelligent Key is not pressed	OFF	K
	UNLOCK button of Intelligent Key is pressed	ON	
RKE-TR/BD	TRUNK OPEN button of Intelligent Key is not pressed	OFF	L
	TRUNK OPEN button of Intelligent Key is pressed	ON	
RKE-PANIC	PANIC button of Intelligent Key is not pressed	OFF	M
	PANIC button of Intelligent Key is pressed	ON	
RKE-P/W OPEN	UNLOCK button of Intelligent Key is not pressed	OFF	M
	UNLOCK button of Intelligent Key is pressed and held	ON	
RKE-MODE CHG	LOCK/UNLOCK button of Intelligent Key is not pressed and held simultaneously	OFF	N
	LOCK/UNLOCK button of Intelligent Key is pressed and held simultaneously	ON	
OPTICAL SENSOR	Outside of the vehicle bright	Close to 5 V	O
	Outside of the vehicle dark	Close to 0 V	
REQ SW-DR	Driver door request switch is not pressed	OFF	P
	Driver door request switch is pressed	ON	
REQ SW-AS	Passenger door request switch is not pressed	OFF	P
	Passenger door request switch is pressed	ON	
REQ SW-BD/TR	Trunk request switch is not pressed	OFF	P
	Trunk request switch is pressed	ON	

## BCM (BODY CONTROL MODULE)

### < ECU DIAGNOSIS >

Monitor Item	Condition	Value/Status
PUSH SW	Push-button ignition switch (push switch) is not pressed	OFF
	Push-button ignition switch (push switch) is pressed	ON
IGN RLY2 -F/B	Ignition switch in OFF or ACC position	OFF
	Ignition switch in ON position	ON
ACC RLY -F/B	Ignition switch in OFF position	OFF
	Ignition switch in ACC or ON position	ON
CLUCH SW	The clutch pedal is not depressed	OFF
	The clutch pedal is depressed	ON
BRAKE SW 1	The brake pedal is not depressed	ON
	The brake pedal is depressed	OFF
DETE/CANCL SW	Selector lever in P position	OFF
	Selector lever in any position other than P	ON
SFT PN/N SW	Selector lever in any position other than P and N	OFF
	Selector lever in P or N position	ON
S/L -LOCK	Steering is locked	OFF
	Steering is unlocked	ON
S/L -UNLOCK	Steering is unlocked	OFF
	Steering is locked	ON
S/L RELAY-F/B	Ignition switch is OFF or ACC position	OFF
	Ignition switch is ON position	ON
UNLK SEN-DR	Driver door is unlocked	OFF
	Driver door is locked	ON
PUSH SW -IPDM	Push-button ignition switch (push-switch) is not pressed	OFF
	Push-button ignition switch (push-switch) is pressed	ON
IGN RLY1 -F/B	Ignition switch is OFF or ACC position	OFF
	Ignition switch is ON position	ON
DETE SW -IPDM	Selector lever in P position	OFF
	Selector lever in any position other than P	ON
SFT PN -IPDM	Selector lever in any position other than P and N	OFF
	Selector lever in P or N position	ON
SFT P -MET	Selector lever in any position other than P	OFF
	Selector lever in P position	ON
SFT N -MET	Selector lever in any position other than N	OFF
	Selector lever in N position	ON
ENGINE STATE	Engine stopped	STOP
	While the engine stalls	STALL
	At engine cranking	CRANK
	Engine running	RUN
S/L LOCK-IPDM	Steering is locked	OFF
	Steering is unlocked	ON
S/L UNLK-IPDM	Steering is unlocked	OFF
	Steering is locked	ON
S/L RELAY-REQ	Ignition switch in OFF or ACC position	OFF
	Ignition switch in ON position	ON

## BCM (BODY CONTROL MODULE)

### < ECU DIAGNOSIS >

Monitor Item	Condition	Value/Status	
VEH SPEED 1	While driving	Equivalent to speedometer reading	A
VEH SPEED 2	While driving	Equivalent to speedometer reading	
DOOR STAT-DR	Driver door is locked	LOCK	B
	Wait with selective UNLOCK operation (5 seconds)	READY	
	Driver door is unlocked	UNLK	
DOOR STAT-AS	Passenger door is locked	LOCK	C
	Wait with selective UNLOCK operation (5 seconds)	READY	
	Passenger door is unlocked	UNLK	D
ID OK FLAG	Ignition switch in ACC or ON position	RESET	
	Ignition switch in OFF position	SET	E
PRMT ENG STRT	The engine start is prohibited	RESET	
	The engine start is permitted	SET	F
PRMT RKE STRT	<b>NOTE:</b> The item is indicated, but not monitored.	RESET	
KEY SW -SLOT	Intelligent Key is not inserted into key slot	OFF	G
	Intelligent Key is inserted into key slot	ON	
RKE OPE COUN1	During the operation of Intelligent Key	Operation frequency of Intelligent Key	
RKE OPE COUN2	<b>NOTE:</b> The item is indicated, but not monitored.	—	H
AIR PRESS FL	Ignition switch ON (Only when the signal from the transmitter is received)	Air pressure of front LH tire	I
AIR PRESS FR	Ignition switch ON (Only when the signal from the transmitter is received)	Air pressure of front RH tire	
AIR PRESS RR	Ignition switch ON (Only when the signal from the transmitter is received)	Air pressure of rear RH tire	ADP
AIR PRESS RL	Ignition switch ON (Only when the signal from the transmitter is received)	Air pressure of rear LH tire	
ID REGST FL1	ID of front LH tire transmitter is registered	DONE	K
	ID of front LH tire transmitter is not registered	YET	
ID REGST FR1	ID of front RH tire transmitter is registered	DONE	L
	ID of front RH tire transmitter is not registered	YET	
ID REGST RR1	ID of rear RH tire transmitter is registered	DONE	M
	ID of rear RH tire transmitter is not registered	YET	
ID REGST RL1	ID of rear LH tire transmitter is registered	DONE	N
	ID of rear LH tire transmitter is not registered	YET	
WARNING LAMP	Tire pressure indicator OFF	OFF	O
	Tire pressure indicator ON	ON	
BUZZER	Tire pressure warning alarm is not sounding	OFF	P
	Tire pressure warning alarm is sounding	ON	

# BCM (BODY CONTROL MODULE)

< ECU DIAGNOSIS >

## TERMINAL LAYOUT

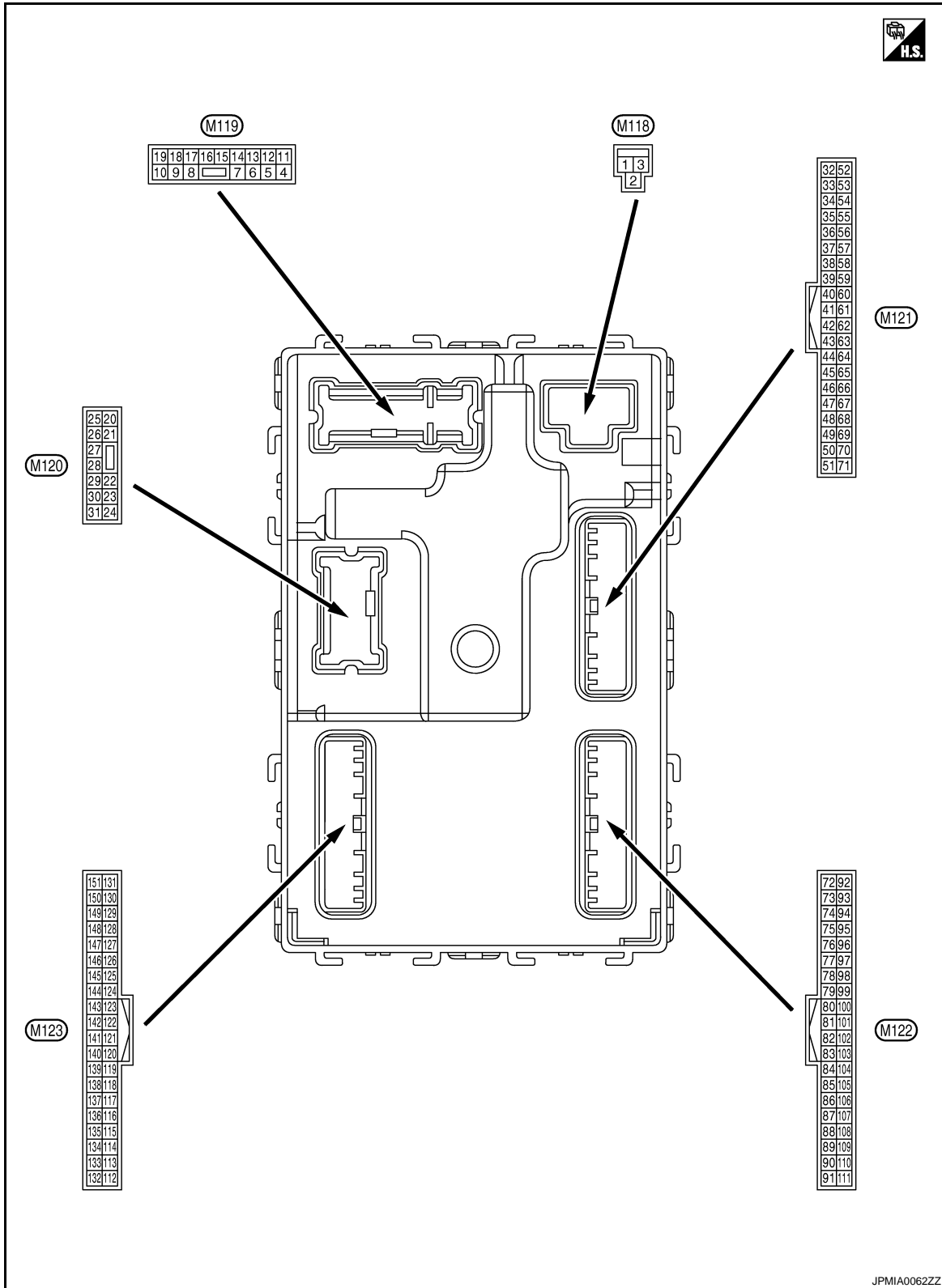

PHYSICAL VALUES



# BCM (BODY CONTROL MODULE)

## < ECU DIAGNOSIS >

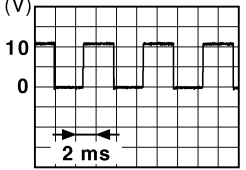
Terminal No. (Wire color)		Description		Condition		Value (Approx.)
		Signal name	Input/ Output			
+	-					
1 (W)	Ground	Battery power supply	Input	Ignition switch OFF		Battery voltage
2 (Y)	Ground	P/W power supply (BAT)	Output	Ignition switch OFF		Battery voltage
3 (O)	Ground	P/W power supply (RAP)	Output	Ignition switch ON		Battery voltage
4 (LG)	Ground	Interior room lamp power supply	Output	After passing the interior room lamp battery saver operation time		0 V
				Any other time after passing the interior room lamp battery saver operation time		Battery voltage
5 (V)	Ground	Passenger door UN- LOCK	Output	Passenger door	UNLOCK (Actuator is activ- ated)	Battery voltage
					Other than UNLOCK (Actu- ator is not activated)	0 V
7 (Y)	Ground	Step lamp	Output	Step lamp	ON	0 V
					OFF	Battery voltage
8 (V)	Ground	All doors, fuel lid LOCK	Output	All doors, fuel lid	LOCK (Actuator is activat- ed)	Battery voltage
					Other than LOCK (Actuator is not activated)	0 V
9 (G)	Ground	Driver door, fuel lid UNLOCK	Output	Driver door, fuel lid	UNLOCK (Actuator is activ- ated)	Battery voltage
					Other than UNLOCK (Actu- ator is not activated)	0 V
10 (BR)	Ground	Rear RH door and rear LH door UN- LOCK	Output	Rear RH door and rear LH door	UNLOCK (Actuator is activ- ated)	Battery voltage
					Other than UNLOCK (Actu- ator is not activated)	0 V
11 (R)	Ground	Battery power supply	Input	Ignition switch OFF		Battery voltage
13 (B)	Ground	Ground	—	Ignition switch ON		0 V
14 (W)	Ground	Push-button ignition switch illumination ground	Output	Tail lamp	OFF	0 V
					ON	<p><b>NOTE:</b> When the illumination brighten- ing/dimming level is in the neutral position</p>  <p style="text-align: right; font-size: small;">JSNIA0010GB</p>
15 (Y)	Ground	ACC indicator lamp	Output	Ignition switch	OFF	Battery voltage
					ACC or ON	0 V

A  
B  
C  
D  
E  
F  
G  
H  
I  
ADP  
K  
L  
M  
N  
O  
P

# BCM (BODY CONTROL MODULE)

## < ECU DIAGNOSIS >

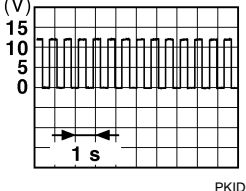
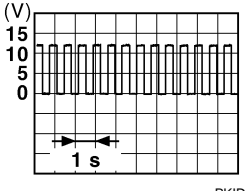
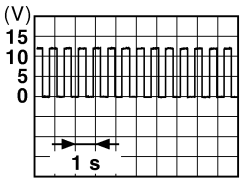
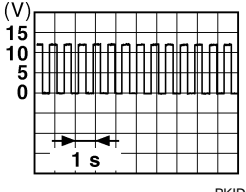
Terminal No. (Wire color)		Description		Condition	Value (Approx.)	
+	-	Signal name	Input/ Output			
17 (W)	Ground	Turn signal (front RH)	Output	Ignition switch ON	Turn signal switch OFF	0 V
				Turn signal switch RH	 <p style="text-align: center;">6.5 V</p>	
18 (O)	Ground	Turn signal (front LH)	Output	Ignition switch ON	Turn signal switch OFF	0 V
				Turn signal switch LH	 <p style="text-align: center;">6.5 V</p>	
19 (V)	Ground	Room lamp timer control	Output	Interior room lamp	OFF	Battery voltage
				ON	0 V	
20 (V)	Ground	Turn signal (rear RH)	Output	Ignition switch ON	Turn signal switch OFF	0 V
				Turn signal switch RH	 <p style="text-align: center;">6.5 V</p>	
23 (G)	Ground	Trunk lid opening.	Output	Trunk lid	Open (Trunk lid opener actuator is activated)	Battery voltage
				Close (Trunk lid opener actuator is not activated)	0 V	
25 (G)	Ground	Turn signal (rear LH)	Output	Ignition switch ON	Turn signal switch OFF	0 V
				Turn signal switch LH	 <p style="text-align: center;">6.5 V</p>	
30 (R)	Ground	Trunk room lamp	Output	Trunk room lamp	ON	0 V
				OFF	Battery voltage	

# BCM (BODY CONTROL MODULE)

## < ECU DIAGNOSIS >

Terminal No. (Wire color)		Description		Condition	Value (Approx.)
+	-	Signal name	Input/ Output		
34 (SB)	Ground	Trunk room antenna 1 (-)	Output	Ignition switch OFF	<p>JMKIA0062GB</p>
				When Intelligent Key is not in the passenger compart- ment	<p>JMKIA0063GB</p>
35 (V)	Ground	Trunk room antenna 1 (+)	Output	Ignition switch OFF	<p>JMKIA0062GB</p>
				When Intelligent Key is not in the passenger compart- ment	<p>JMKIA0063GB</p>
38 (B)	Ground	Rear bumper anten- na (-)	Output	When the trunk lid request switch is operated with ignition switch OFF	<p>JMKIA0062GB</p>
				When Intelligent Key is not in the antenna detection area	<p>JMKIA0063GB</p>

A  
B  
C  
D  
E  
F  
G  
H  
I  
ADP  
K  
L  
M  
N  
O  
P

# BCM (BODY CONTROL MODULE)

## < ECU DIAGNOSIS >

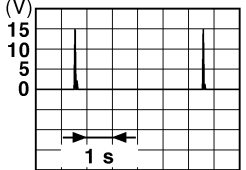
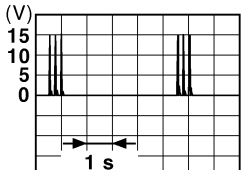
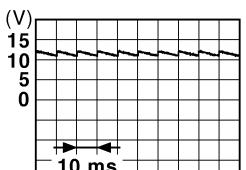
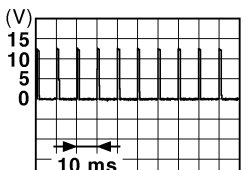
Terminal No. (Wire color)		Description		Condition		Value (Approx.)
+	-	Signal name	Input/ Output			
39 (W)	Ground	Rear bumper antenna (+)	Output	When the trunk lid request switch is operated with ignition switch OFF	When Intelligent Key is in the antenna detection area	 JMKIA0062GB
					When Intelligent Key is not in the antenna detection area	 JMKIA0063GB
47 (Y)	Ground	Ignition relay (IPDM E/R) control	Output	Ignition switch	OFF or ACC	Battery voltage
					ON	0 V
50 (R)	Ground	Trunk room lamp switch	Input	Trunk room lamp switch	OFF (Trunk is closed)	 11.8 V JPMIA0011GB
					ON (Trunk is open)	0 V
52 (SB)	Ground	Starter relay control	Output	Ignition switch OFF (M/T models)	When the clutch pedal is depressed	Battery voltage
					When the clutch pedal is not depressed	0 V
				Ignition switch ON (A/T models)	When selector lever is in P or N position and the brake is depressed	Battery voltage
					When selector lever is in P or N position and the brake is not depressed	0 V
61 (W)	Ground	Trunk request switch	Input	Trunk request switch	ON (Pressed)	0 V
					OFF (Not pressed)	 1.0 V JPMIA0016GB
64 (V)	Ground	Request switch buzzer	Output	Request switch buzzer	Sounding	0 V
					Not sounding	Battery voltage

# BCM (BODY CONTROL MODULE)

## < ECU DIAGNOSIS >

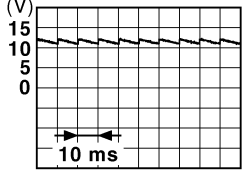
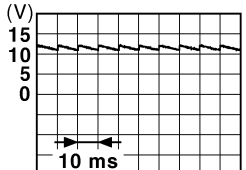
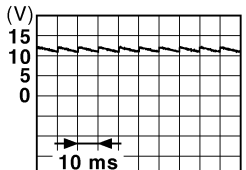
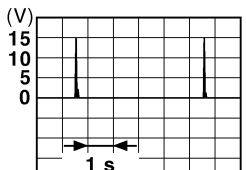
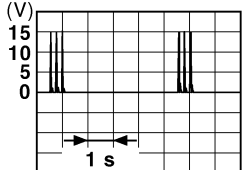
Terminal No. (Wire color)		Description		Condition	Value (Approx.)	
		Signal name	Input/ Output			
+	-					
67 (GR)	Ground	Trunk lid opener switch	Input	Trunk lid opener switch	Pressed	0 V
					Not pressed	 <p style="text-align: right; font-size: small;">JPMIA0011GB</p> <p style="text-align: center;">11.8 V</p>
68 (BR)	Ground	Rear RH door switch	Input	Rear RH door switch	OFF (When rear RH door closes)	 <p style="text-align: right; font-size: small;">JPMIA0011GB</p> <p style="text-align: center;">11.8 V</p>
					ON (When rear RH door opens)	0 V
69 (R)	Ground	Rear LH door switch	Input	Rear LH door switch	OFF (When rear LH door closes)	 <p style="text-align: right; font-size: small;">JPMIA0011GB</p> <p style="text-align: center;">11.8 V</p>
					ON (When rear LH door opens)	0 V
72 (R)	Ground	Room antenna 2 (-) (center console)	Output	Ignition switch OFF	When Intelligent Key is in the passenger compart- ment	 <p style="text-align: right; font-size: small;">JMKIA0062GB</p>
					When Intelligent Key is not in the passenger compart- ment	 <p style="text-align: right; font-size: small;">JMKIA0063GB</p>

A  
B  
C  
D  
E  
F  
G  
H  
I  
K  
L  
M  
N  
O  
P

ADP

# BCM (BODY CONTROL MODULE)

## < ECU DIAGNOSIS >

Terminal No. (Wire color)		Description		Condition	Value (Approx.)
+	-	Signal name	Input/ Output		
73 (G)	Ground	Room antenna 2 (+) (center console)	Output	Ignition switch OFF	<p style="text-align: right; font-size: small;">JMKIA0062GB</p>
				When Intelligent Key is not in the passenger compart- ment	<p style="text-align: right; font-size: small;">JMKIA0063GB</p>
74 (SB)	Ground	Passenger door an- tenna (-)	Output	When the pas- senger door re- quest switch is operated with ig- nition switch OFF	<p style="text-align: right; font-size: small;">JMKIA0062GB</p>
				When Intelligent Key is not in the antenna detection area	<p style="text-align: right; font-size: small;">JMKIA0063GB</p>
75 (BR)	Ground	Passenger door an- tenna (+)	Output	When the pas- senger door re- quest switch is operated with ig- nition switch OFF	<p style="text-align: right; font-size: small;">JMKIA0062GB</p>
				When Intelligent Key is not in the antenna detection area	<p style="text-align: right; font-size: small;">JMKIA0063GB</p>

# BCM (BODY CONTROL MODULE)

## < ECU DIAGNOSIS >

Terminal No. (Wire color)		Description		Condition	Value (Approx.)
		Signal name	Input/ Output		
+	-				
76 (V)	Ground	Driver door antenna (-)	Output	When Intelligent Key is in the antenna detection area	<p style="text-align: right; font-size: small;">JMKIA0062GB</p>
				When the driver door request switch is operat- ed with ignition switch OFF	<p style="text-align: right; font-size: small;">JMKIA0063GB</p>
77 (LG)	Ground	Driver door antenna (+)	Output	When Intelligent Key is in the antenna detection area	<p style="text-align: right; font-size: small;">JMKIA0062GB</p>
				When the driver door request switch is operat- ed with ignition switch OFF	<p style="text-align: right; font-size: small;">JMKIA0063GB</p>
78 (Y)	Ground	Room antenna (-) (in- strument panel)	Output	Ignition switch OFF	<p style="text-align: right; font-size: small;">JMKIA0062GB</p>
				When Intelligent Key is not in the passenger compart- ment	<p style="text-align: right; font-size: small;">JMKIA0063GB</p>

A  
B  
C  
D  
E  
F  
G  
H  
I  
K  
L  
M  
N  
O  
P

ADP

# BCM (BODY CONTROL MODULE)



## < ECU DIAGNOSIS >

Terminal No. (Wire color)		Description		Condition	Value (Approx.)	
+	-	Signal name	Input/ Output			
79 (BR)	Ground	Room antenna (+) (instrument panel)	Output	Ignition switch OFF	<p style="text-align: right; font-size: small;">JMKIA0062GB</p>	
				When Intelligent Key is not in the passenger compart- ment	<p style="text-align: right; font-size: small;">JMKIA0063GB</p>	
80 (GR)	Ground	NATS antenna amp (built in key slot)	Input/ Output	During waiting	Ignition switch is pressed while inserting the Intelli- gent Key into the key slot.	Just after pressing ignition switch. Pointer of tester should move.
81 (W)	Ground	NATS antenna amp (built in key slot)	Input/ Output	During waiting	Ignition switch is pressed while inserting the Intelli- gent Key into the key slot.	Just after pressing ignition switch. Pointer of tester should move.
82 (R)	Ground	Ignition relay (relay box) control	Output	Ignition switch	OFF or ACC	0 V
				ON	Battery voltage	
83 (Y)	Ground	Remote keyless entry receiver signal	Input/ Output	During waiting		<p style="text-align: right; font-size: small;">JMKIA0064GB</p>
				When operating either button on Intelligent Key	<p style="text-align: right; font-size: small;">JMKIA0065GB</p>	

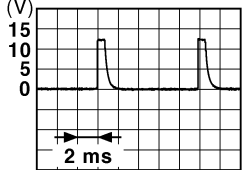
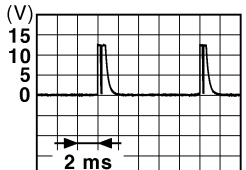

# BCM (BODY CONTROL MODULE)

## < ECU DIAGNOSIS >



Terminal No. (Wire color)		Description		Condition	Value (Approx.)	
+	-	Signal name	Input/ Output			
87 (BR)	Ground	Combination switch INPUT 5	Input	Combination switch	All switch OFF (Wiper intermittent dial 4)	 1.4 V
					Front fog lamp switch ON (Wiper intermittent dial 4)	 1.3 V
					Any of the conditions below with all switch OFF	 1.3 V

A  
B  
C  
D  
E  
F  
G  
H  
I  
K  
L  
M  
N  
O  
P

ADP

# BCM (BODY CONTROL MODULE)

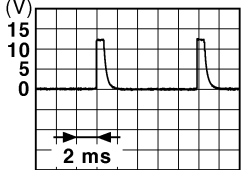
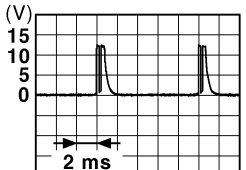
## < ECU DIAGNOSIS >

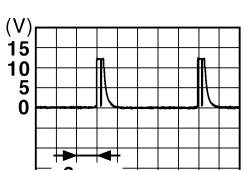
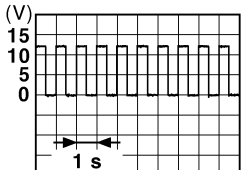
Terminal No. (Wire color)		Description		Condition	Value (Approx.)	
+	-	Signal name	Input/ Output			
88 (V)	Ground	Combination switch INPUT 3	Input	Combination switch	All switch OFF (Wiper intermittent dial 4)	 <p style="text-align: right; font-size: small;">JPMIA0041GB</p> <p style="text-align: center;">1.4 V</p>
					Lighting switch HI (Wiper intermittent dial 4)	 <p style="text-align: right; font-size: small;">JPMIA0036GB</p> <p style="text-align: center;">1.3 V</p>
					Lighting switch 2ND (Wiper intermittent dial 4)	 <p style="text-align: right; font-size: small;">JPMIA0037GB</p> <p style="text-align: center;">1.3 V</p>
					Any of the conditions below with all switches OFF	<ul style="list-style-type: none"> <li>• Wiper intermittent dial 1</li> <li>• Wiper intermittent dial 2</li> <li>• Wiper intermittent dial 3</li> </ul>  <p style="text-align: right; font-size: small;">JPMIA0040GB</p> <p style="text-align: center;">1.3 V</p>
89 (BR)	Ground	Push-button ignition switch (push switch)	Input	Push-button igni- tion switch (push switch)	Pressed	0 V
					Not pressed	Battery voltage
90 (P)	Ground	CAN - L	Input/ Output	—	—	
91 (L)	Ground	CAN - H	Input/ Output	—	—	
92 (LG)	Ground	Key slot illumination	Output	Key slot illumina- tion	OFF	0 V
					Blinking	 <p style="text-align: right; font-size: small;">JPMIA0015GB</p> <p style="text-align: center;">6.5 V</p>
					ON	Battery voltage

# BCM (BODY CONTROL MODULE)

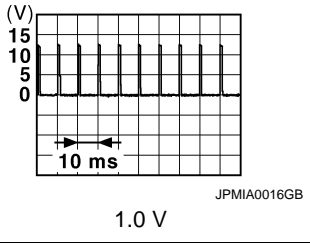
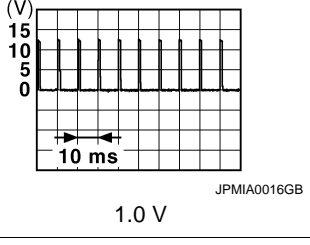

## < ECU DIAGNOSIS >

Terminal No. (Wire color)		Description		Condition		Value (Approx.)
+	-	Signal name	Input/ Output			
93 (V)	Ground	ON indicator lamp	Output	Ignition switch	OFF or ACC	0 V
					ON	Battery voltage
95 (O)	Ground	ACC relay control	Output	Ignition switch	OFF	0 V
					ACC or ON	Battery voltage
96 (GR)	Ground	A/T device (detention switch) power supply	Output	—		Battery voltage
97 (L)	Ground	Steering lock condition No. 1	Input	Steering lock	LOCK status	0 V
					UNLOCK status	Battery voltage
98 (P)	Ground	Steering lock condition No. 2	Input	Steering lock	LOCK status	Battery voltage
					UNLOCK status	0 V
99 (R)	Ground	Selector lever P position switch	Input	Selector lever	P position	0 V
					Any position other than P	Battery voltage
100 (G)	Ground	Passenger door request switch	Input	Passenger door request switch	ON (Pressed)	0 V
					OFF (Not pressed)	
101 (SB)	Ground	Driver door request switch	Input	Driver door request switch	ON (Pressed)	0 V
					OFF (Not pressed)	
102 (O)	Ground	Blower fan motor relay control	Output	Ignition switch	OFF or ACC	0 V
					ON	Battery voltage
103 (LG)	Ground	Remote keyless entry receiver power supply	Output	Ignition switch OFF		Battery voltage
106 (W)	Ground	Steering wheel lock unit power supply	Output	Ignition switch	OFF or ACC	Battery voltage
					ON	0 V

A  
B  
C  
D  
E  
F  
G  
H  
I  
ADP  
K  
L  
M  
N  
O  
P

# BCM (BODY CONTROL MODULE)

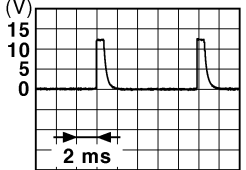
## < ECU DIAGNOSIS >

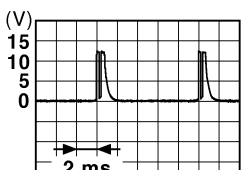
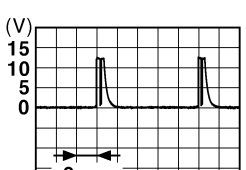
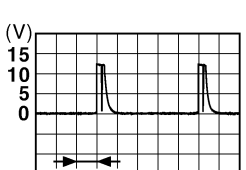
Terminal No. (Wire color)		Description		Condition	Value (Approx.)	
+	-	Signal name	Input/ Output			
107 (LG)	Ground	Combination switch INPUT 1	Input	Combination switch (Wiper intermittent dial 4)	All switch OFF	 <p style="text-align: right; font-size: small;">JPMIA0041GB</p> <p style="text-align: center;">1.4 V</p>
					Turn signal switch LH	 <p style="text-align: right; font-size: small;">JPMIA0037GB</p> <p style="text-align: center;">1.3 V</p>
					Turn signal switch RH	 <p style="text-align: right; font-size: small;">JPMIA0036GB</p> <p style="text-align: center;">1.3 V</p>
					Front wiper switch LO	 <p style="text-align: right; font-size: small;">JPMIA0038GB</p> <p style="text-align: center;">1.3 V</p>
					Front washer switch ON	 <p style="text-align: right; font-size: small;">JPMIA0039GB</p> <p style="text-align: center;">1.3 V</p>

# BCM (BODY CONTROL MODULE)

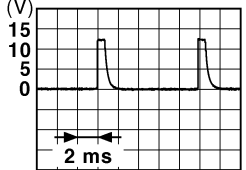
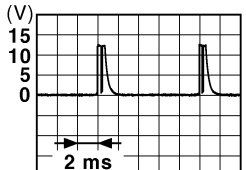
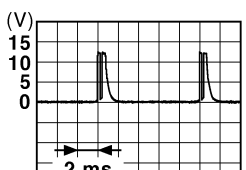
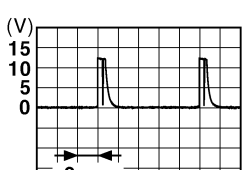

## < ECU DIAGNOSIS >

Terminal No. (Wire color)		Description		Condition	Value (Approx.)	
		Signal name	Input/ Output			
+	-					
108 (R)	Ground	Combination switch INPUT 4	Input	Combination switch	All switch OFF (Wiper intermittent dial 4)	 <p style="text-align: right;">1.4 V</p>
					Lighting switch AUTO (Wiper intermittent dial 4)	 <p style="text-align: right;">1.3 V</p>
					Lighting switch 1ST (Wiper intermittent dial 4)	 <p style="text-align: right;">1.3 V</p>
					Any of the conditions below with all switches OFF <ul style="list-style-type: none"> <li>• Wiper intermittent dial 1</li> <li>• Wiper intermittent dial 5</li> <li>• Wiper intermittent dial 6</li> </ul>	 <p style="text-align: right;">1.3 V</p>

A  
B  
C  
D  
E  
F  
G  
H  
I  
ADP  
K  
L  
M  
N  
O  
P

# BCM (BODY CONTROL MODULE)

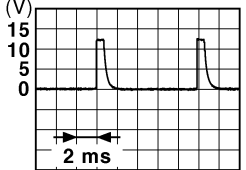
## < ECU DIAGNOSIS >

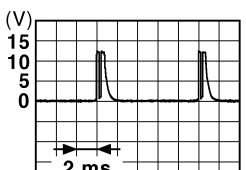
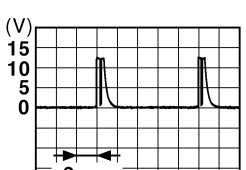
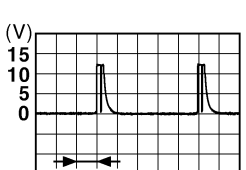
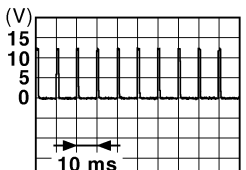
Terminal No. (Wire color)		Description		Condition	Value (Approx.)	
+	-	Signal name	Input/ Output			
109 (Y)	Ground	Combination switch INPUT 2	Input	Combination switch (Wiper intermittent dial 4)	All switch OFF	 <p style="text-align: right;">1.4 V</p>
					Lighting switch PASS	 <p style="text-align: right;">1.3 V</p>
					Lighting switch 2ND	 <p style="text-align: right;">1.3 V</p>
					Front wiper switch INT	 <p style="text-align: right;">1.3 V</p>
					Front wiper switch HI	 <p style="text-align: right;">1.3 V</p>
110 (G)	Ground	Hazard switch	Input	Hazard switch	Pressed	0 V
				Not pressed	 <p style="text-align: right;">1.1 V</p>	

# BCM (BODY CONTROL MODULE)

## < ECU DIAGNOSIS >

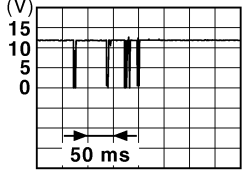
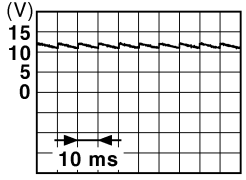
Terminal No. (Wire color)		Description		Condition	Value (Approx.)	
+	-	Signal name	Input/ Output			
111 (Y)	Ground	Steering lock unit communication	Input/ Output	Steering lock	LOCK status	Battery voltage
					LOCK or UNLOCK	 <p style="text-align: right; font-size: small;">JMKIA0066GB</p>
					For 15 seconds after UN- LOCK	Battery voltage
					15 seconds or later after UNLOCK	0 V
113 (P)	Ground	Optical sensor signal	Input	Ignition switch ON	When bright outside of the vehicle	Close to 5 V
				When dark outside of the vehicle	Close to 0 V	
114 (R)	Ground	Clutch interlock switch	Input	Clutch interlock switch	OFF (Clutch pedal is not depressed)	0 V
					ON (Clutch pedal is de- pressed)	Battery voltage
116 (SB)	Ground	Stop lamp switch 1	Input	—	Battery voltage	
118 (P)	Ground	Stop lamp switch 2	Input	Stop lamp switch	OFF (Brake pedal is not depressed)	0 V
					ON (Brake pedal is de- pressed)	Battery voltage
				ICC brake hold relay (With ICC)	OFF	0 V
					ON	Battery voltage
119 (SB)	Ground	Front door lock as- sembly driver side (unlock sensor)	Input	Driver door	LOCK status	 <p style="text-align: right; font-size: small;">JPMIA0011GB</p> <p style="text-align: center;">11.8 V</p>
					UNLOCK status	0 V
					—	—
121 (R)	Ground	Key slot switch	Input	When Intelligent Key is inserted into key slot	Battery voltage	
				When Intelligent Key is not inserted into key slot	0 V	
122 (V)	Ground	ACC feedback signal	Input	Ignition switch	OFF	0 V
				ACC or ON	Battery voltage	
123 (W)	Ground	IGN feedback signal	Input	Ignition switch	OFF or ACC	0 V
				ON	Battery voltage	

A  
B  
C  
D  
E  
F  
G  
H  
I  
K  
L  
M  
N  
O  
P

ADP

# BCM (BODY CONTROL MODULE)



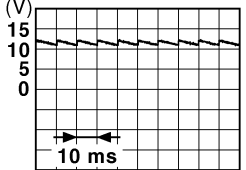
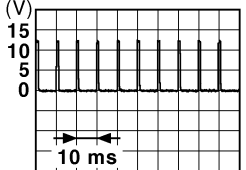
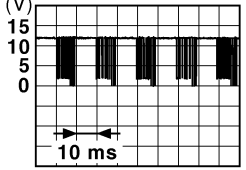
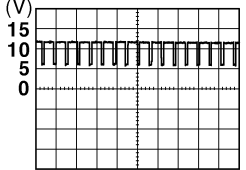

## < ECU DIAGNOSIS >

Terminal No. (Wire color)		Description		Condition		Value (Approx.)
+	-	Signal name	Input/ Output			
124 (LG)	Ground	Passenger door switch	Input	Passenger door switch	OFF (When passenger door closes)	 <p style="text-align: right; font-size: small;">JPMIA0011GB</p> <p style="text-align: center;">11.8 V</p>
					ON (When passenger door opens)	0 V
129 (O)	Ground	Trunk lid opener cancel switch	Input	Trunk lid opener cancel switch	CANCEL	 <p style="text-align: right; font-size: small;">JPMIA0012GB</p> <p style="text-align: center;">1.1 V</p>
					ON	0 V
132 (V)	Ground	Power window switch communication	Input/ Output	Ignition switch ON	 <p style="text-align: right; font-size: small;">JPMIA0013GB</p> <p style="text-align: center;">10.2 V</p>	
				Ignition switch OFF or ACC	0 V	
133 (W)	Ground	Push-button ignition switch illumination	Output	Push-button igni- tion switch illumi- nation	ON (When tail lamps OFF)	5.5 V
					ON (When tail lamps ON)	<p><b>NOTE:</b> The pulse width of this wave is varied by the illumination bright- ening/dimming level.</p>  <p style="text-align: right; font-size: small;">JPMIA0159GB</p>
					OFF	0 V
134 (GR)	Ground	LOCK indicator lamp	Output	LOCK indicator lamp	ON	0 V
				OFF	Battery voltage	
137 (O)	Ground	Receiver and sensor ground	Input	Ignition switch ON		0 V
138 (V)	Ground	Receiver and sensor power supply output	Output	Ignition switch	OFF	0 V
					ACC or ON	5.0 V

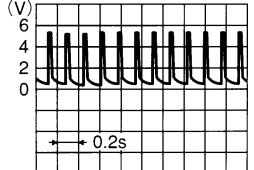

# BCM (BODY CONTROL MODULE)

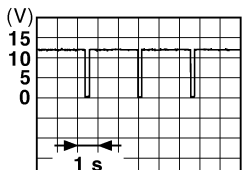
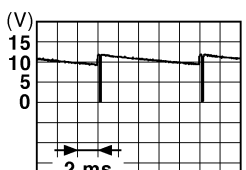
## < ECU DIAGNOSIS >

Terminal No. (Wire color)		Description		Condition	Value (Approx.)				
+	-	Signal name	Input/ Output						
139 (L)	Ground	Tire pressure receiver signal	Input/ Output	Ignition switch ON	Standby state  OCC3881D				
				When receiving the signal from the transmitter  OCC3880D					
140 (GR)	Ground	Selector lever P/N position signal	Input	Selector lever	P or N position: 12.0 V Except P and N positions: 0 V				
				141 (G)	Ground	Security indicator signal	Output	Security indicator	ON: 0 V Blinking:  JPMIA0014GB 11.3 V
OFF: Battery voltage									
142 (O)	Ground	Combination switch OUTPUT 5	Output	Combination switch (Wiper intermittent dial 4)	All switch OFF: 0 V Lighting switch 1ST Lighting switch HI Lighting switch 2ND Turn signal switch RH  JPMIA0031GB 10.7 V				
				143 (P)	Ground	Combination switch OUTPUT 1	Output	Combination switch	All switch OFF (Wiper intermittent dial 4): 0 V Front wiper switch HI (Wiper intermittent dial 4) Any of the conditions below with all switch OFF: • Wiper intermittent dial 1 • Wiper intermittent dial 2 • Wiper intermittent dial 3 • Wiper intermittent dial 6 • Wiper intermittent dial 7  JPMIA0032GB 10.7 V

A  
B  
C  
D  
E  
F  
G  
H  
I  
K  
L  
M  
N  
O  
P

ADP

# BCM (BODY CONTROL MODULE)

## < ECU DIAGNOSIS >

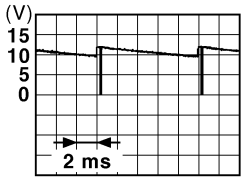
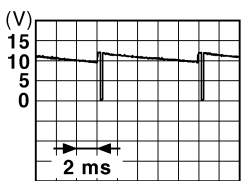
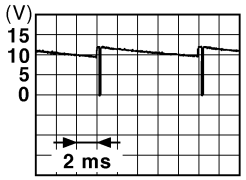
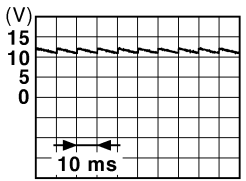
Terminal No. (Wire color)		Description		Condition	Value (Approx.)	
+	-	Signal name	Input/ Output			
144 (G)	Ground	Combination switch OUTPUT 2	Output	Combination switch	All switch OFF (Wiper intermittent dial 4)	0 V
					Front washer switch ON (Wiper intermittent dial 4)	 <p style="text-align: center;">10.7 V</p>
145 (L)	Ground	Combination switch OUTPUT 3	Output	Combination switch (Wiper intermit- tent dial 4)	All switches OFF	
					Front wiper switch INT	 <p style="text-align: center;">10.7 V</p>
					Front wiper switch LO	
					Lighting switch AUTO	
146 (SB)	Ground	Combination switch OUTPUT 4	Output	Combination switch (Wiper intermit- tent dial 4)	All switch OFF	0 V
					Front fog lamp switch ON	 <p style="text-align: center;">10.7 V</p>
					Lighting switch 2ND	
					Lighting switch PASS	
					Turn signal switch LH	
149 (W)	Ground	Tire pressure warn- ing check switch	Input	—	5 V	
150 (GR)	Ground	Driver door switch	Input	Driver door switch	OFF (When driver door closes)	 <p style="text-align: center;">11.8 V</p>
					ON (When driver door opens)	
151 (G)	Ground	Rear window defog- ger relay	Output	Rear window de- fogger	Active	0 V
					Not activated	Battery voltage

# BCM (BODY CONTROL MODULE)

< ECU DIAGNOSIS >

## Wiring Diagram—AUTOMATIC DRIVE POSITIONER CONTROL SYSTEM—

INFOID:000000000960765

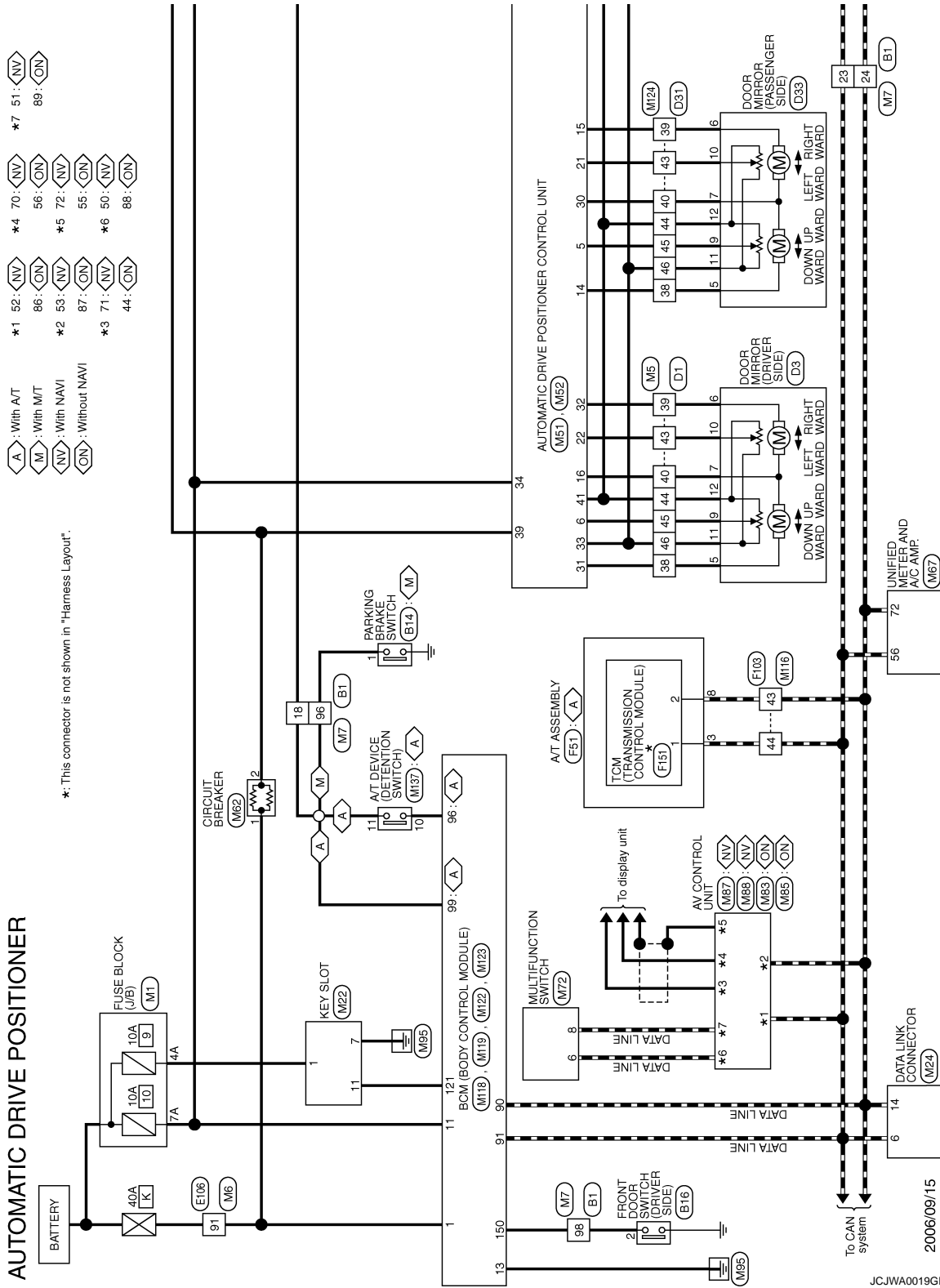

A  
B  
C  
D  
E  
F  
G  
H  
I  
ADP  
K  
L  
M  
N  
O  
P

# BCM (BODY CONTROL MODULE)

< ECU DIAGNOSIS >

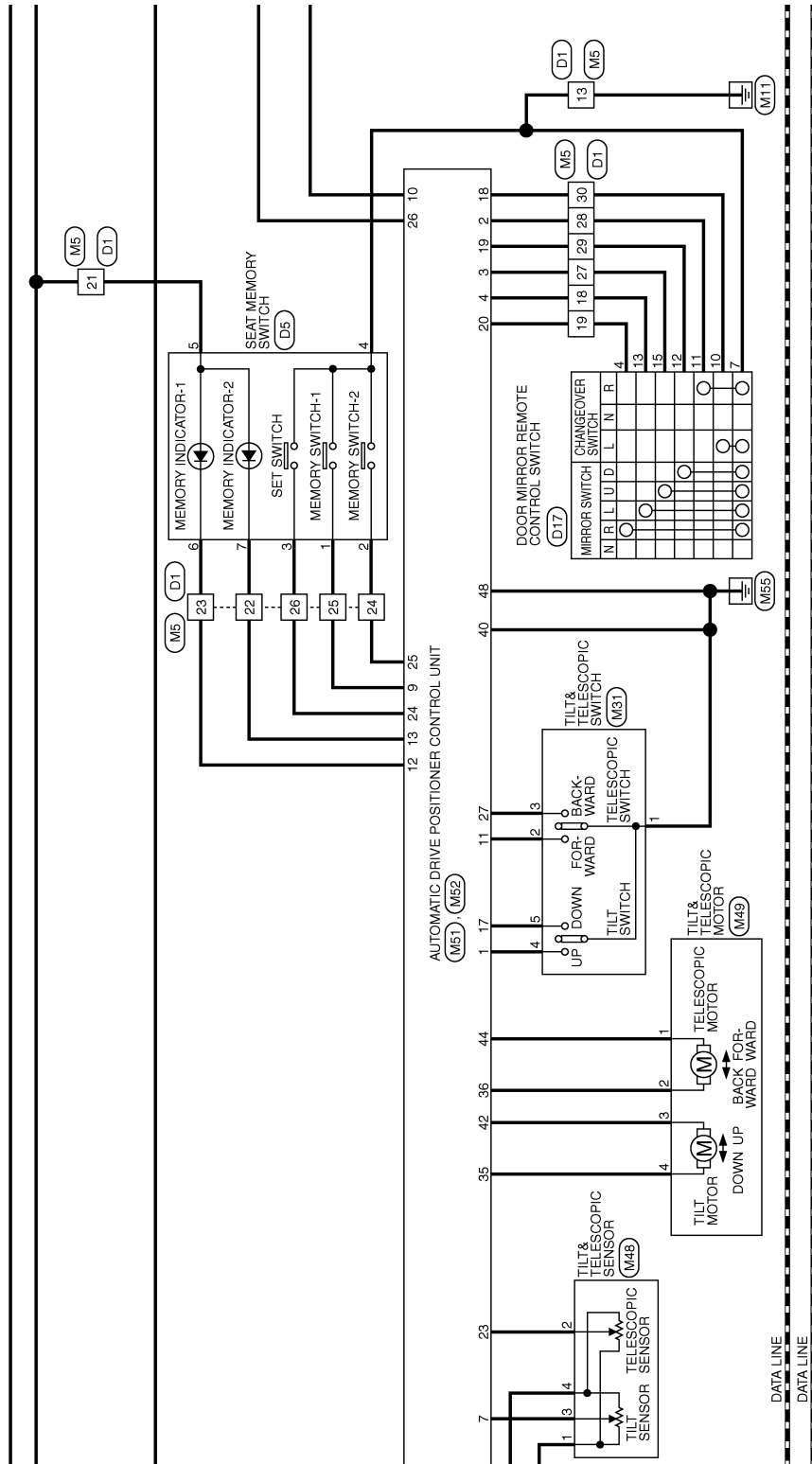

JCJWA0020GB

# BCM (BODY CONTROL MODULE)

< ECU DIAGNOSIS >

A : With AT  
M : With M/T  
SP : With sports seat

\*: This connector is not shown in "Harness Layout".

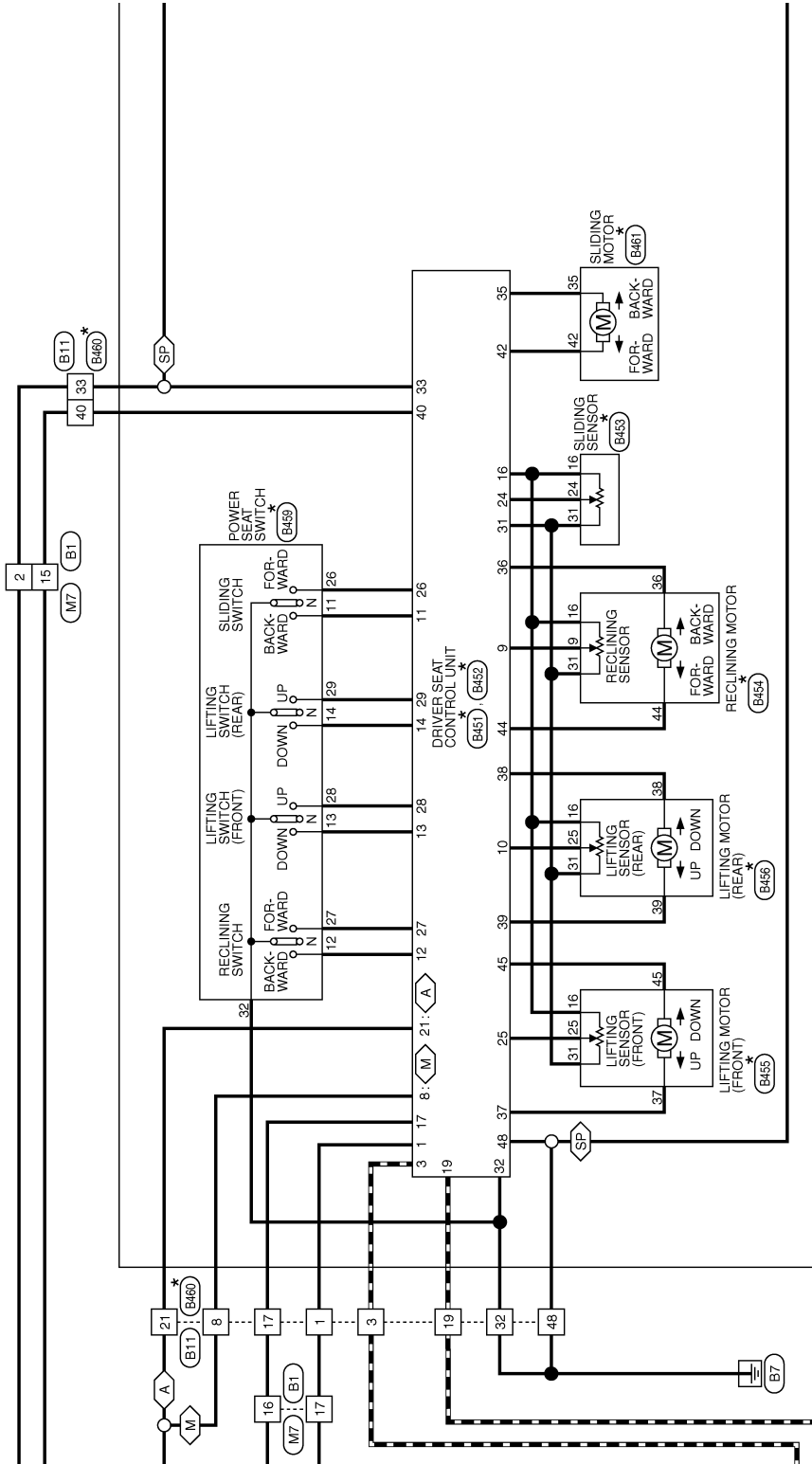

JCJWA0021GB

A  
B  
C  
D  
E  
F  
G  
H  
I  
ADP  
K  
L  
M  
N  
O  
P

# BCM (BODY CONTROL MODULE)

< ECU DIAGNOSIS >

◁ SP ▷ : With sports seat

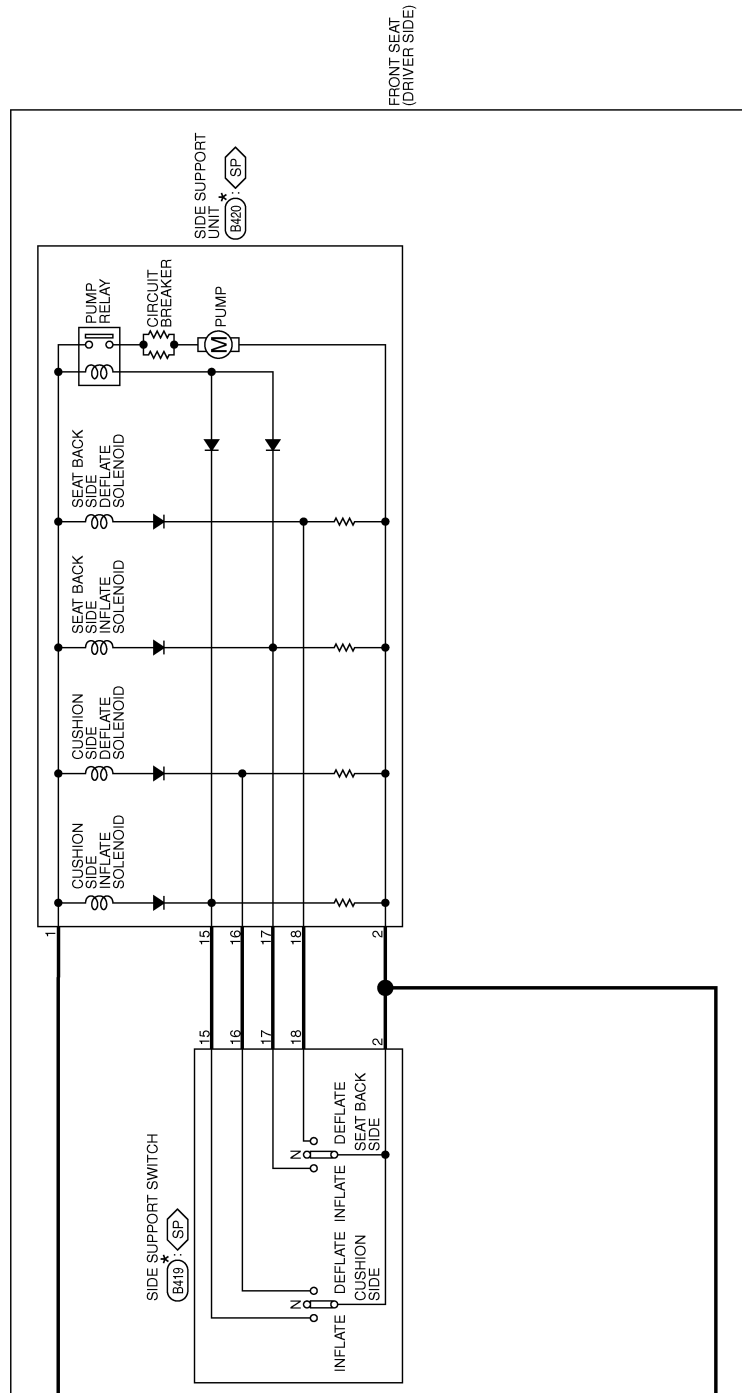

JCJWA0022GB

# BCM (BODY CONTROL MODULE)

< ECU DIAGNOSIS >

## AUTOMATIC DRIVE POSITIONER

Connector No.	B1
Connector Name	WIRE TO WIRE
Connector Type	TH30FW-CS16-TM4

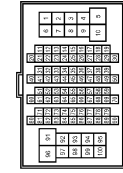

Terminal No.	Color of Wire	Signal Name
2	SB	-
15	BR	-
16	LG	-
17	LG	-
18	Y	-
23	L	-
24	P	-
96	V	-
98	V	-

Connector No.	B11
Connector Name	WIRE TO WIRE (With automatic drive positioner)
Connector Type	NS116FW-CS

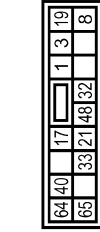

Terminal No.	Color of Wire	Signal Name
1	G	-
3	L	-
8	Y	-
17	LG	-
19	P	-
21	Y	-
32	B	-
33	SB	-
40	BR	-
48	B	-

Connector No.	B14
Connector Name	PARKING BRAKE SWITCH
Connector Type	P01FB-A



Terminal No.	Color of Wire	Signal Name
1	V	-

Connector No.	B18
Connector Name	FRONT DOOR SWITCH (DRIVER SIDE)
Connector Type	A03FW

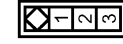

Terminal No.	Color of Wire	Signal Name
2	V	-

Connector No.	B419
Connector Name	SIDE SUPPORT SWITCH
Connector Type	NS06FW-CS

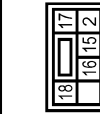

Terminal No.	Color of Wire	Signal Name
2	B	-
15	G	- [With automatic drive positioner]
16	B/R	- [With automatic drive positioner]
17	V/W	- [With automatic drive positioner]
18	R/L	- [With automatic drive positioner]

Connector No.	B420
Connector Name	SIDE SUPPORT UNIT
Connector Type	NS06FW-CS

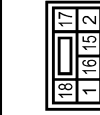

Terminal No.	Color of Wire	Signal Name
1	R	-
2	B	-
15	G	- [With automatic drive positioner]
16	B/R	- [With automatic drive positioner]
17	V/W	- [With automatic drive positioner]
18	R/L	- [With automatic drive positioner]

Connector No.	B451
Connector Name	DRIVER SEAT CONTROL UNIT
Connector Type	TH32FW

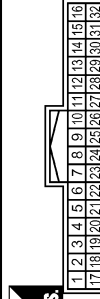

Terminal No.	Color of Wire	Signal Name
1	L/W	RX
3	R/Y	CAN-H
8	LG	PARKING BRAKE SW
9	W/G	PULSE(RECLINING)
10	P/B	PULSE(R LIFTING)
11	BR	SLIDING SW(BACKWARD)
12	SB	RECLINING SW(BACKWARD)
13	LG/R	FRONT LIFTING SW(DOWNWARD)
14	G/B	REAR LIFTING SW(DOWNWARD)
16	O	VCC
17	Y/R	TX

Terminal No.	Color of Wire	Signal Name
19	V	CAN-L
21	L/Y	P RANGE SW
24	R	PULSE(SLIDING)
25	Y/B	PULSE(R LIFTING)
26	Y	SLIDING SW(FORWARD)
27	R/G	RECLINING SW(FORWARD)
28	W/B	FRONT LIFTING SW(FORWARD)
29	P/L	REAR LIFTING SW(FORWARD)
31	GR	SENSOR GND
32	B/W	GND(SIGNAL)

JCJWA0023GB

A B C D E F G H I K L M N O P

# BCM (BODY CONTROL MODULE)

< ECU DIAGNOSIS >

## AUTOMATIC DRIVE POSITIONER

Connector No.	B432
Connector Name	DRIVER SEAT CONTROL UNIT
Connector Type	NS16FW-CS



33	34	35	36	37	38	39
40	41	42	43	44	45	46
47	48					

Terminal No.	Color of Wire	Signal Name
33	R	BAT(C/B)
35	W/R	SLIDING MOTOR(FORWARD)
36	G/Y	RECLINING MOTOR(FORWARD)
37	G/Y	FRONT LIFTING MOTOR(DOWNWARD)
38	L/Y	REAR LIFTING MOTOR(UPWARD)
38	R/B	REAR LIFTING MOTOR(BACKWARD)
40	R/W	BAT(FUSE)
42	W/B	SLIDING MOTOR(BACKWARD)
44	P	RECLINING MOTOR(BACKWARD)
45	L/R	FRONT LIFTING MOTOR(UPWARD)
48	B	GND(POWER)

Connector No.	B436
Connector Name	LIFTING MOTOR(REAR/DRIVER SIDE)
Connector Type	NS06FB-CS



38	39
16	31
25	38

Terminal No.	Color of Wire	Signal Name
16	O	
25	P/B	
31	GR	
38	L/Y	
38	R/B	

Connector No.	B453
Connector Name	SLIDING SENSOR
Connector Type	6038-0241



24	31	16
----	----	----

Terminal No.	Color of Wire	Signal Name
16	O	
24	R	
31	GR	

Connector No.	B459
Connector Name	POWER SEAT SWITCH(DRIVER SIDE)
Connector Type	NS10FW-CS



32	14	29
12	27	11
26	13	28

Terminal No.	Color of Wire	Signal Name
11	BR	
12	SR	
13	L/G/R	
14	G/B	
26	Y	
27	R/G	
28	W/B	
29	P/L	
32	B/W	

Connector No.	B454
Connector Name	RECLINING MOTOR
Connector Type	NS06FW-CS



36	44
16	31
9	19

Terminal No.	Color of Wire	Signal Name
9	W/G	
16	O	
31	GR	
36	G/Y	
44	P	

Connector No.	B480
Connector Name	WIRE TO WIRE (With automatic drive positioner)
Connector Type	NS16MW-CS



19	3	1	17	40	64
8	32	48	21	33	65

Terminal No.	Color of Wire	Signal Name
1	L/W	
3	R/Y	
8	L/G	
17	Y/R	
19	V	
21	L/Y	
32	B/W	
33	R	
40	R/W	
48	B	

Connector No.	B455
Connector Name	LIFTING MOTOR(FRONT/DRIVER SIDE)
Connector Type	NS08FW-CS



45	37
16	31
25	38

Terminal No.	Color of Wire	Signal Name
16	O	
25	Y/B	
31	GR	
37	G/W	
45	L/R	

Connector No.	B461
Connector Name	SLIDING MOTOR(DRIVER SIDE)
Connector Type	6098-0239



42	35
----	----

Terminal No.	Color of Wire	Signal Name
35	W/R	
42	W/B	



# BCM (BODY CONTROL MODULE)

< ECU DIAGNOSIS >

## AUTOMATIC DRIVE POSITIONER

Connector No.	D1
Connector Name	WIRE TO WIRE
Connector Type	TH40FW-CS15

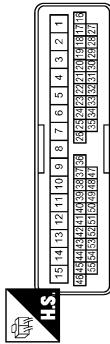

Terminal No.	Color of Wire	Signal Name
13	B	-
18	W	-
19	BR	-
21	R	-
22	P	-
23	O	-
24	BR	-
25	L	-
26	GR	-
27	Y	-
28	LG	-

Connector No.	D17
Connector Name	DOOR MIRROR REMOTE CONTROL SWITCH (With automatic drive positioner)
Connector Type	TK16FBR

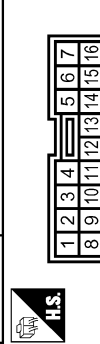

Terminal No.	Color of Wire	Signal Name
4	BR	-
7	B	-
10	GR	-
11	LG	-
12	G	-
13	W	-
15	Y	-

29	G	-
30	GR	-
38	O	-
39	GR	-
40	G	-
43	BR	-
44	V	-
45	P	-
46	W	-

Connector No.	D31
Connector Name	WIRE TO WIRE
Connector Type	TH40FW-CS15

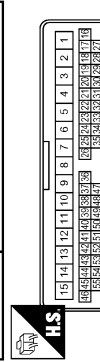

Terminal No.	Color of Wire	Signal Name
38	W	- [with A.T.]
38	O	- [with M.T.]
39	G	- [with A.T.]
39	GR	- [with M.T.]
40	Y	- [with A.T.]
40	G	- [with M.T.]
43	BR	-
44	V	-
45	P	-
46	W	-

Connector No.	D3
Connector Name	DOOR MIRROR (DRIVER SIDE)
Connector Type	TH12MW-NH



Terminal No.	Color of Wire	Signal Name
5	O	- [With automatic drive positioner]
6	GR	- [With automatic drive positioner]
7	G	- [With automatic drive positioner]
9	P	-
10	BR	-
11	W	-
12	V	-

Connector No.	D33
Connector Name	DOOR MIRROR (PASSENGER SIDE)
Connector Type	TH12MW-NH



Terminal No.	Color of Wire	Signal Name
5	W	- [With automatic drive positioner]
6	G	- [With automatic drive positioner]
7	Y	- [With automatic drive positioner]
9	P	-
10	BR	-
11	W	-
12	V	-

Connector No.	D5
Connector Name	SEAT MEMORY SWITCH
Connector Type	A08FW

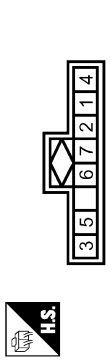

Terminal No.	Color of Wire	Signal Name
1	L	-
2	BR	-
3	GR	-
4	B	-
5	R	-
6	O	-
7	P	-

Connector No.	E106
Connector Name	WIRE TO WIRE
Connector Type	TH80FW-CS16-TM4

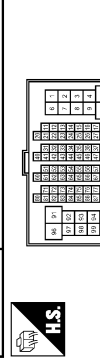

Terminal No.	Color of Wire	Signal Name
91	W	-

A  
B  
C  
D  
E  
F  
G  
H  
I  
ADP  
K  
L  
M  
N  
O  
P

# BCM (BODY CONTROL MODULE)

< ECU DIAGNOSIS >

## AUTOMATIC DRIVE POSITIONER

Connector No.	F51
Connector Name	A/T ASSEMBLY
Connector Type	BK10FG-D6Y

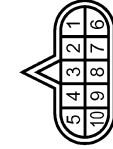

Terminal No.	Color of Wire	Signal Name
3	L	-
8	P	-

Connector No.	F103
Connector Name	WIRE TO WIRE
Connector Type	TK438FW-NS10

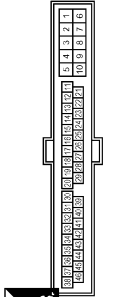

Terminal No.	Color of Wire	Signal Name
43	P	-
44	L	-

Connector No.	F151
Connector Name	TCM (TRANSMISSION CONTROL MODULE)
Connector Type	SPT08FGY

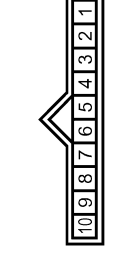

Terminal No.	Color of Wire	Signal Name
1	BR	CAN-H
2	L/Y	CAN-L

Connector No.	M1
Connector Name	FUSE BLOCK (J/B)
Connector Type	NSC8FW-M2

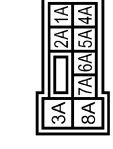

Terminal No.	Color of Wire	Signal Name
4A	P	-
7A	R	-

Connector No.	M5
Connector Name	WIRE TO WIRE
Connector Type	TH80MW-CS15

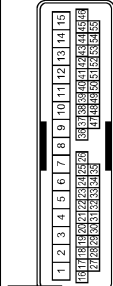

Terminal No.	Color of Wire	Signal Name
13	B	-
18	V	-
19	BR	-
21	R	-
22	P	-
23	O	-
24	SB	-
25	L	-
26	R	-
27	G	-
28	LG	-

29	SB	-
30	P	-
38	LG	-
39	L	-
40	Y	-
43	G	-
44	R	-
45	GR	-
46	R	-

Connector No.	M6
Connector Name	WIRE TO WIRE
Connector Type	TH80MW-CS16-TM4

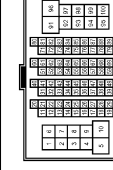

Terminal No.	Color of Wire	Signal Name
91	W	-

Connector No.	M7
Connector Name	WIRE TO WIRE
Connector Type	TH80MW-GS16-TM4

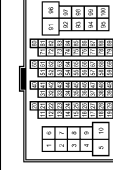

Terminal No.	Color of Wire	Signal Name
2	SB	- [With automatic drive positioner]
15	BR	-
16	Y	-
17	V	-
18	R	- [With A/T]
19	Y	- [With M/T]
23	L	-
24	P	-
96	V	-
98	GR	-

JCJWA0026GB

# BCM (BODY CONTROL MODULE)

< ECU DIAGNOSIS >

## AUTOMATIC DRIVE POSITIONER

Connector No.	M22
Connector Name	KEY SLOT
Connector Type	TH12FW-NH

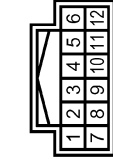

Terminal No.	Color of Wire	Signal Name
1	R	BAT
7	B	GND
11	R	KEY SWITCH SIGNAL

Connector No.	M24
Connector Name	DATA LINK CONNECTOR
Connector Type	BD16FW

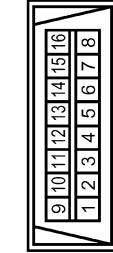

Terminal No.	Color of Wire	Signal Name
6	L	-
14	P	-

Connector No.	M31
Connector Name	TILT & TELESCOPIC SWITCH
Connector Type	TK08FGY

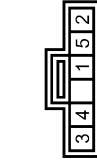

Terminal No.	Color of Wire	Signal Name
1	B	-
2	GR	-
3	G	-
4	Y	-
5	W	-

Connector No.	M48
Connector Name	TILT & TELESCOPIC SENSOR
Connector Type	TK04FW



Terminal No.	Color of Wire	Signal Name
1	W	-
2	P	-
3	O	-
4	Y	-

Connector No.	M49
Connector Name	TILT & TELESCOPIC MOTOR
Connector Type	NS04FW-CS

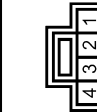

Terminal No.	Color of Wire	Signal Name
1	G	-
2	GR	-
3	O	-
4	L	-

Connector No.	M51
Connector Name	AUTOMATIC DRIVE POSITIONER CONTROL UNIT
Connector Type	TH02FW-NH

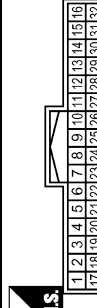

Terminal No.	Color of Wire	Signal Name
1	Y	TILT SW (UPWARD)
2	LG	MIRROR SELECT SW (RH)
3	G	MIRROR SW (UPWARD)
4	V	MIRROR SW (LEFTWARD)
5	R	MIRROR SENSOR (RH VERTICAL)
6	GR	MIRROR SENSOR (LH VERTICAL)
7	O	TILT SENSOR
9	L	ADDRESS
10	V	TX (UART)
11	GR	TELESCOPIC SW (FRONTWARD)
12	O	IND1

Terminal No.	Color of Wire	Signal Name
13	P	IND2
14	W	MIRROR MOTOR (RH VERTICAL)
15	GR	MIRROR MOTOR (RH HORIZONTAL) [With A/T]
15	G	MIRROR MOTOR (RH HORIZONTAL) [With M/T]
16	Y	MIRROR MOTOR (LH COMMON)
17	W	TILT SW (DOWNWARD)
18	P	MIRROR SELECT SW (LH)
19	SB	MIRROR SW (DOWNWARD)
20	BR	MIRROR SW (RIGHTWARD)
21	L	MIRROR SENSOR (RH HORIZONTAL)
22	G	MIRROR SENSOR (LH HORIZONTAL)
23	P	TELESCOPIC SENSOR
24	R	SET SW
25	SB	ADDRESS
26	Y	RX (UART)
27	G	TELESCOPIC SW (BACKWARD)
30	G	MIRROR MOTOR (RH COMMON) [With A/T]
30	R	MIRROR MOTOR (RH COMMON) [With M/T]
31	LG	MIRROR MOTOR (LH VERTICAL)
32	L	MIRROR MOTOR (LH HORIZONTAL)

Connector No.	M52
Connector Name	AUTOMATIC DRIVE POSITIONER CONTROL UNIT
Connector Type	NS18FW-CS

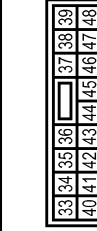

Terminal No.	Color of Wire	Signal Name
33	R	POWER SUPPLY (SENSOR) [With automatic drive positioner]
34	R	BAT (FUSE)
35	L	TILT MOTOR (UPWARD)
36	GR	TELESCOPIC MOTOR (FORWARD)
39	W	BAT (G/B)
40	B	GND(SIGNAL)
41	R	GND(SENSOR) [With automatic drive positioner]
42	O	TILT MOTOR (DOWNWARD)
44	G	TELESCOPIC MOTOR (BACKWARD)
48	B	GND(POWER)

A  
B  
C  
D  
E  
F  
G  
H  
I  
K  
L  
M  
N  
O  
P

ADP

# BCM (BODY CONTROL MODULE)

< ECU DIAGNOSIS >

## AUTOMATIC DRIVE POSITIONER

Connector No.	M62
Connector Name	CIRCUIT BREAKER
Connector Type	M02FW-P-LC



Terminal No.	Color of Wire	Signal Name
1	W	-
2	SB	[With automatic drive positioner]

Connector No.	M67
Connector Name	UNIFIED METER AND A/C AMP.
Connector Type	TH32FW-NH



Terminal No.	Color of Wire	Signal Name
56	L	CAN-H
72	P	CAN-L

Connector No.	M72
Connector Name	MULTIFUNCTION SWITCH
Connector Type	TH18FW-NH

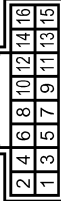

Terminal No.	Color of Wire	Signal Name
6	LG	AV COMM (H)
8	V	AV COMM (L)

Connector No.	M83
Connector Name	AV CONTROL UNIT
Connector Type	TH24FW-NH

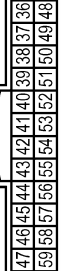

Terminal No.	Color of Wire	Signal Name
44	BR	COMM (DISP->CONT)
50	SHIELD	SHIELD
51	-	-
52	-	-
53	SHIELD	SHIELD
55	Y	COMM (CONT->DISP)

Connector No.	M85
Connector Name	AV CONTROL UNIT
Connector Type	TH32FW-NH



Terminal No.	Color of Wire	Signal Name
86	L	CAN-H
87	P	CAN-L
88	G	AV COMM (H) [With BOSE system]
88	R	AV COMM (L) [With BOSE system]

Connector No.	M87
Connector Name	AV CONTROL UNIT
Connector Type	TH40FW-NH



Terminal No.	Color of Wire	Signal Name
44	-	-
50	V	AV COMM (H)
51	LG	AV COMM (L)
52	L	CAN-H
53	P	CAN-L
55	-	-
56	-	-

Connector No.	M88
Connector Name	AV CONTROL UNIT
Connector Type	TH12FW-NH

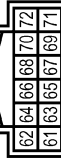

Terminal No.	Color of Wire	Signal Name
70	BR	COMM (CONT->DISP)
71	Y	COMM (DISP->CONT)
72	SHIELD	SHIELD

Connector No.	M116
Connector Name	WIRE TO WIRE
Connector Type	TK36MW-NS10



Terminal No.	Color of Wire	Signal Name
43	P	-
44	L	-

# BCM (BODY CONTROL MODULE)

< ECU DIAGNOSIS >

## AUTOMATIC DRIVE POSITIONER

Connector No.	M118
Connector Name	BCM (BODY CONTROL MODULE)
Connector Type	M03FB-LG

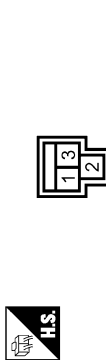

Terminal No.	1	2
Color of Wire	W	
Signal Name	BAT (E/L)	

Connector No.	M119
Connector Name	BCM (BODY CONTROL MODULE)
Connector Type	NS16FW-GS

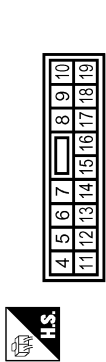

Terminal No.	11	13
Color of Wire	R	B
Signal Name	BAT (FUSE)	
		GND

Connector No.	M122
Connector Name	BCM (BODY CONTROL MODULE)
Connector Type	TH40FB-NH

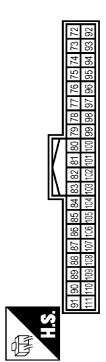

Terminal No.	90	91	96	99
Color of Wire	P	L	GR	R
Signal Name	CAN-L	CAN-H	A/T DEVICE	SHIFT P

Connector No.	M123
Connector Name	BCM (BODY CONTROL MODULE)
Connector Type	TH40FG-NH

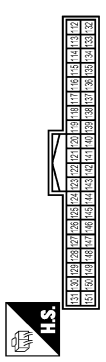

Terminal No.	121	150
Color of Wire	R	GR
Signal Name	KEY SWITCH SIGNAL	
		DOOR SW (DR)

Connector No.	M124
Connector Name	WIRE TO WIRE
Connector Type	TH40MW-CS15

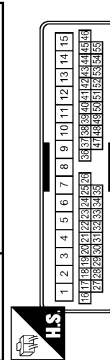

Terminal No.	38	39	40	43	44	45	46
Color of Wire	W	GR	G	R	Y	R	W
Signal Name	-						
	- [With A/T]						
	- [With M/T]						
	- [With A/T]						
	- [With M/T]						

Connector No.	M137
Connector Name	A/T DEVICE
Connector Type	TH12FW-NH

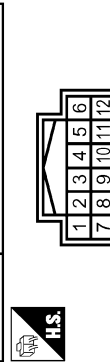

Terminal No.	10	11
Color of Wire	GR	R
Signal Name	-	

## Fail Safe

Display contents of CONSULT	Fail-safe	Cancellation
B2013: ID DISCORD BCM-S/L	Inhibit engine cranking	Erase DTC
B2014: CHAIN OF S/L-BCM	Inhibit engine cranking	Erase DTC

JCJWA0029GB

INFOID:000000000960766

A  
B  
C  
D  
E  
F  
G  
H  
I  
ADP  
K  
L  
M  
N  
O  
P

## BCM (BODY CONTROL MODULE)

### < ECU DIAGNOSIS >

Display contents of CONSULT	Fail-safe	Cancellation
B2190: NATS ANTENA AMP	Inhibit engine cranking	Erase DTC
B2191: DIFFERENCE OF KEY	Inhibit engine cranking	Erase DTC
B2192: ID DISCORD BCM-ECM	Inhibit engine cranking	Erase DTC
B2193: CHAIN OF BCM-ECM	Inhibit engine cranking	Erase DTC
B2557: VEHICLE SPEED	Inhibit steering lock	When normal vehicle speed signals have been received from ABS actuator and electric unit (control unit) for 500 ms
B2560: STARTER CONT RELAY	Inhibit engine cranking	500 ms after the following CAN signal communication status has become consistent <ul style="list-style-type: none"> <li>• Starter control relay signal</li> <li>• Starter relay status signal</li> </ul>
B2563: HI VOLTAGE	<ul style="list-style-type: none"> <li>• Inhibit engine cranking</li> <li>• Inhibit steering lock</li> </ul>	500 ms after the power supply voltage decreases to less than 18 V
B2601: SHIFT POSITION	Inhibit steering lock	500 ms after the following signal reception status becomes consistent <ul style="list-style-type: none"> <li>• Selector lever P position switch signal</li> <li>• P range signal (CAN)</li> </ul>
B2602: SHIFT POSITION	Inhibit steering lock	5 seconds after the following BCM recognition conditions are fulfilled <ul style="list-style-type: none"> <li>• Ignition switch is in the ON position</li> <li>• Selector lever P position switch signal: Except P position (battery voltage)</li> <li>• Vehicle speed: 4 /h or more</li> </ul>
B2603: SHIFT POSI STATUS	Inhibit steering lock	500 ms after the following BCM recognition conditions are fulfilled <ul style="list-style-type: none"> <li>• Ignition switch is in the ON position</li> <li>• Selector lever P position switch signal: Except P position (battery voltage)</li> <li>• Selector lever P/N position signal: Except P and N positions (0 V)</li> </ul>
B2604: PNP SW	Inhibit steering lock	500 ms after any of the following BCM recognition conditions is fulfilled <ul style="list-style-type: none"> <li>• Status 1 <ul style="list-style-type: none"> <li>- Ignition switch is in the ON position</li> <li>- Selector lever P/N position signal: P and N position (battery voltage)</li> <li>- P range signal or N range signal (CAN): ON</li> </ul> </li> <li>• Status 2 <ul style="list-style-type: none"> <li>- Ignition switch is in the ON position</li> <li>- Selector lever P/N position signal: Except P and N positions (0 V)</li> <li>- P range signal and N range signal (CAN): OFF</li> </ul> </li> </ul>
B2605: PNP SW	Inhibit steering lock	500 ms after any of the following BCM recognition conditions is fulfilled <ul style="list-style-type: none"> <li>• Ignition switch is in the ON position <ul style="list-style-type: none"> <li>- Power position: IGN</li> <li>- Selector lever P/N position signal: Except P and N positions (0 V)</li> <li>- Interlock/PNP switch signal (CAN): OFF</li> </ul> </li> <li>• Status 2 <ul style="list-style-type: none"> <li>- Ignition switch is in the ON position</li> <li>- Selector lever P/N position signal: P or N position (battery voltage)</li> <li>- PNP switch signal (CAN): ON</li> </ul> </li> </ul>
B2606: S/L RELAY	Inhibit engine cranking	500 ms after the following CAN signal communication status has become consistent <ul style="list-style-type: none"> <li>• Steering lock relay signal (Request signal)</li> <li>• Steering lock relay signal (Condition signal)</li> </ul>
B2607: S/L RELAY	Inhibit engine cranking	500 ms after the following CAN signal communication status has become consistent <ul style="list-style-type: none"> <li>• Steering lock relay signal (Request signal)</li> <li>• Steering lock relay signal (Condition signal)</li> </ul>

## BCM (BODY CONTROL MODULE)

### < ECU DIAGNOSIS >

Display contents of CONSULT	Fail-safe	Cancellation
B2608: STARTER RELAY	Inhibit engine cranking	500 ms after the following signal communication status becomes consistent <ul style="list-style-type: none"> <li>• Starter motor relay control signal</li> <li>• Starter relay status signal (CAN)</li> </ul>
B2609: S/L STATUS	<ul style="list-style-type: none"> <li>• Inhibit engine cranking</li> <li>• Inhibit steering lock</li> </ul>	When the following steering lock conditions agree <ul style="list-style-type: none"> <li>• BCM steering lock control status</li> <li>• Steering lock condition No. 1 signal status</li> <li>• Steering lock condition No. 2 signal status</li> </ul>
B260A: IGNITION RELAY	Inhibit engine cranking	500 ms after the following conditions are fulfilled <ul style="list-style-type: none"> <li>• IGN relay (IPDM E/R) control signal: OFF (Battery voltage)</li> <li>• Ignition ON signal (CAN to IPDM E/R): OFF (Request signal)</li> <li>• Ignition ON signal (CAN from IPDM E/R): OFF (Condition signal)</li> </ul>
B260F: ENG STATE SIG LOST	Maintains the power supply position attained at the time of DTC detection	When any of the following conditions is fulfilled <ul style="list-style-type: none"> <li>• Power position changes to ACC</li> <li>• Receives engine status signal (CAN)</li> </ul>
B2612: S/L STATUS	<ul style="list-style-type: none"> <li>• Inhibit engine cranking</li> <li>• Inhibit steering lock</li> </ul>	When any of the following conditions is fulfilled <ul style="list-style-type: none"> <li>• Steering lock unit status signal (CAN) is received normally</li> <li>• The BCM steering lock control status matches the steering lock status recognized by the steering lock unit status signal (CAN from IPDM E/R)</li> </ul>
B2617: STARTER RELAY CIRC	Inhibit engine cranking	1 second after the starter motor relay control inside BCM becomes normal
B2618: BCM	Inhibit engine cranking	1 second after the ignition relay (IPDM E/R) control inside BCM becomes normal
B2619: BCM	Inhibit engine cranking	1 second after the steering lock unit power supply output control inside BCM becomes normal
B261E: VEHICLE TYPE	Inhibit engine cranking	BCM initialization
B26E1: ENG STATE NO RECIV	Inhibit engine cranking	When any of the following conditions is fulfilled <ul style="list-style-type: none"> <li>• Power position changes to ACC</li> <li>• Receives engine status signal (CAN)</li> </ul>

A  
B  
C  
D  
E  
F  
G  
H  
I  
ADP

### DTC Inspection Priority Chart

INFOID:000000000960767

If some DTCs are displayed at the same time, perform inspections one by one based on the following priority chart.

Priority	DTC
1	<ul style="list-style-type: none"> <li>• B2562: LOW VOLTAGE</li> <li>• B2563: HI VOLTAGE</li> </ul>
2	<ul style="list-style-type: none"> <li>• U1000: CAN COMM CIRCUIT</li> <li>• U1010: CONTROL UNIT (CAN)</li> </ul>
3	<ul style="list-style-type: none"> <li>• B2190: NATS ANTENA AMP</li> <li>• B2191: DIFFERENCE OF KEY</li> <li>• B2192: ID DISCORD BCM-ECM</li> <li>• B2193: CHAIN OF BCM-ECM</li> </ul>

K  
L  
M  
N  
O  
P

# BCM (BODY CONTROL MODULE)

## < ECU DIAGNOSIS >

Priority	DTC
4	<ul style="list-style-type: none"> <li>• B2013: ID DISCORD BCM-S/L</li> <li>• B2014: CHAIN OF S/L-BCM</li> <li>• B2553: IGNITION RELAY</li> <li>• B2555: STOP LAMP</li> <li>• B2556: PUSH-BTN IGN SW</li> <li>• B2557: VEHICLE SPEED</li> <li>• B2560: STARTER CONT RELAY</li> <li>• B2601: SHIFT POSITION</li> <li>• B2602: SHIFT POSITION</li> <li>• B2603: SHIFT POSI STATUS</li> <li>• B2604: PNP SW</li> <li>• B2605: PNP SW</li> <li>• B2606: S/L RELAY</li> <li>• B2607: S/L RELAY</li> <li>• B2608: STARTER RELAY</li> <li>• B2609: S/L STATUS</li> <li>• B260A: IGNITION RELAY</li> <li>• B260B: STEERING LOCK UNIT</li> <li>• B260C: STEERING LOCK UNIT</li> <li>• B260D: STEERING LOCK UNIT</li> <li>• B260F: ENG STATE SIG LOST</li> <li>• B2611: ACC RELAY</li> <li>• B2612: S/L STATUS</li> <li>• B2614: ACC RELAY CIRC</li> <li>• B2615: BLOWER RELAY CIRC</li> <li>• B2616: IGN RELAY CIRC</li> <li>• B2617: STARTER RELAY CIRC</li> <li>• B2618: BCM</li> <li>• B2619: BCM</li> <li>• B261A: PUSH-BTN IGN SW</li> <li>• B261E: VEHICLE TYPE</li> <li>• B26E1: ENG STATE NO RECIV</li> <li>• C1729: VHCL SPEED SIG ERR</li> <li>• U0415: VEHICLE SPEED SIG</li> </ul>
5	<ul style="list-style-type: none"> <li>• C1704: LOW PRESSURE FL</li> <li>• C1705: LOW PRESSURE FR</li> <li>• C1706: LOW PRESSURE RR</li> <li>• C1707: LOW PRESSURE RL</li> <li>• C1708: [NO DATA] FL</li> <li>• C1709: [NO DATA] FR</li> <li>• C1710: [NO DATA] RR</li> <li>• C1711: [NO DATA] RL</li> <li>• C1712: [CHECKSUM ERR] FL</li> <li>• C1713: [CHECKSUM ERR] FR</li> <li>• C1714: [CHECKSUM ERR] RR</li> <li>• C1715: [CHECKSUM ERR] RL</li> <li>• C1716: [PRESSDATA ERR] FL</li> <li>• C1717: [PRESSDATA ERR] FR</li> <li>• C1718: [PRESSDATA ERR] RR</li> <li>• C1719: [PRESSDATA ERR] RL</li> <li>• C1720: [CODE ERR] FL</li> <li>• C1721: [CODE ERR] FR</li> <li>• C1722: [CODE ERR] RR</li> <li>• C1723: [CODE ERR] RL</li> <li>• C1724: [BATT VOLT LOW] FL</li> <li>• C1725: [BATT VOLT LOW] FR</li> <li>• C1726: [BATT VOLT LOW] RR</li> <li>• C1727: [BATT VOLT LOW] RL</li> <li>• C1734: CONTROL UNIT</li> </ul>
6	<ul style="list-style-type: none"> <li>• B2621: INSIDE ANTENNA</li> <li>• B2622: INSIDE ANTENNA</li> <li>• B2623: INSIDE ANTENNA</li> </ul>



## BCM (BODY CONTROL MODULE)

### < ECU DIAGNOSIS >

#### NOTE:

- Details of time display
- CRNT: Displays when there is a malfunction now or after returning to the normal condition until turning ignition switch OFF → ON again.
  - 1 - 39: Displayed if any previous malfunction is present when current condition is normal. It increases like 1 → 2 → 3...38 → 39 after returning to the normal condition whenever ignition switch OFF → ON. The counter remains at 39 even if the number of cycles exceeds it. It is counted from 1 again when turning ignition switch OFF → ON after returning to the normal condition if the malfunction is detected again.

CONSULT display	Fail-safe	Intelligent Key warning lamp ON	Tire pressure monitor warning lamp ON	Reference page
No DTC is detected. further testing may be required.	—	—	—	—
U1000: CAN COMM CIRCUIT	—	—	—	<a href="#">BCS-33</a>
U1010: CONTROL UNIT (CAN)	—	—	—	<a href="#">BCS-34</a>
U0415: VEHICLE SPEED SIG	—	—	—	<a href="#">BCS-35</a>
B2013: ID DISCORD BCM-S/L	×	—	—	<a href="#">SEC-43</a>
B2014: CHAIN OF S/L-BCM	×	—	—	<a href="#">SEC-44</a>
B2190: NATS ANTENNA AMP	×	—	—	<a href="#">SEC-37</a>
B2191: DIFFERENCE OF KEY	×	—	—	<a href="#">SEC-40</a>
B2192: ID DISCORD BCM-ECM	×	—	—	<a href="#">SEC-41</a>
B2193: CHAIN OF BCM-ECM	×	—	—	<a href="#">SEC-42</a>
B2553: IGNITION RELAY	—	—	—	<a href="#">PCS-48</a>
B2555: STOP LAMP	—	—	—	<a href="#">SEC-47</a>
B2556: PUSH-BTN IGN SW	—	×	—	<a href="#">SEC-49</a>
B2557: VEHICLE SPEED	×	×	—	<a href="#">SEC-51</a>
B2560: STARTER CONT RELAY	×	×	—	<a href="#">SEC-52</a>
B2562: LOW VOLTAGE	—	—	—	<a href="#">BCS-36</a>
B2563: HI VOLTAGE	×	×	—	<a href="#">BCS-37</a>
B2601: SHIFT POSITION	×	×	—	<a href="#">SEC-53</a>
B2602: SHIFT POSITION	×	×	—	<a href="#">SEC-56</a>
B2603: SHIFT POSI STATUS	×	×	—	<a href="#">SEC-58</a>
B2604: PNP SW	×	×	—	<a href="#">SEC-61</a>
B2605: PNP SW	×	×	—	<a href="#">SEC-63</a>
B2606: S/L RELAY	×	×	—	<a href="#">SEC-65</a>
B2607: S/L RELAY	×	×	—	<a href="#">SEC-66</a>
B2608: STARTER RELAY	×	×	—	<a href="#">SEC-68</a>
B2609: S/L STATUS	×	×	—	<a href="#">SEC-70</a>
B260A: IGNITION RELAY	×	×	—	<a href="#">PCS-50</a>
B260B: STEERING LOCK VNIT	—	×	—	<a href="#">SEC-74</a>
B260C: STEERING LOCK VNIT	—	×	—	<a href="#">SEC-75</a>
B260D: STEERING LOCK VNIT	—	×	—	<a href="#">SEC-76</a>
B260F: ENG STATE SIG LOST	×	×	—	<a href="#">SEC-77</a>
B2611: ACC RELAY	—	—	—	<a href="#">PCS-52</a>
B2612: S/L STATUS	×	×	—	<a href="#">SEC-79</a>
B2614: ACC RELAY CIRC	—	×	—	<a href="#">PCS-54</a>
B2615: BLOWER RELAY CIRC	—	×	—	<a href="#">PCS-57</a>

## BCM (BODY CONTROL MODULE)

### < ECU DIAGNOSIS >

CONSULT display	Fail-safe	Intelligent Key warning lamp ON	Tire pressure monitor warning lamp ON	Reference page
B2616: IGN RELAY CIRC	—	×	—	<a href="#">PCS-60</a>
B2617: STARTER RELAY CIRC	×	×	—	<a href="#">SEC-83</a>
B2618: BCM	×	×	—	<a href="#">PCS-63</a>
B2619: BCM	×	×	—	<a href="#">SEC-85</a>
B261A: PUSH-BTN IGN SW	—	×	—	<a href="#">SEC-86</a>
B261E: VEHICLE TYPE	×	× (Turn ON for 15 seconds)	—	<a href="#">SEC-88</a>
B2621: INSIDE ANTENNA	—	—	—	<a href="#">DLK-58</a>
B2622: INSIDE ANTENNA	—	—	—	<a href="#">DLK-60</a>
B2623: INSIDE ANTENNA	—	—	—	<a href="#">DLK-62</a>
B26E1: ENG STATE NO RES	×	×	—	<a href="#">SEC-78</a>
C1704: LOW PRESSURE FL	—	—	×	<a href="#">WT-14</a>
C1705: LOW PRESSURE FR	—	—	×	<a href="#">WT-14</a>
C1706: LOW PRESSURE RR	—	—	×	<a href="#">WT-14</a>
C1707: LOW PRESSURE RL	—	—	×	<a href="#">WT-14</a>
C1708: [NO DATA] FL	—	—	×	<a href="#">WT-16</a>
C1709: [NO DATA] FR	—	—	×	<a href="#">WT-16</a>
C1710: [NO DATA] RR	—	—	×	<a href="#">WT-16</a>
C1711: [NO DATA] RL	—	—	×	<a href="#">WT-16</a>
C1712: [CHECKSUM ERR] FL	—	—	×	<a href="#">WT-19</a>
C1713: [CHECKSUM ERR] FR	—	—	×	<a href="#">WT-19</a>
C1714: [CHECKSUM ERR] RR	—	—	×	<a href="#">WT-19</a>
C1715: [CHECKSUM ERR] RL	—	—	×	<a href="#">WT-19</a>
C1716: [PRESSDATA ERR] FL	—	—	×	<a href="#">WT-22</a>
C1717: [PRESSDATA ERR] FR	—	—	×	<a href="#">WT-22</a>
C1718: [PRESSDATA ERR] RR	—	—	×	<a href="#">WT-22</a>
C1719: [PRESSDATA ERR] RL	—	—	×	<a href="#">WT-22</a>
C1720: [CODE ERR] FL	—	—	×	<a href="#">WT-24</a>
C1721: [CODE ERR] FR	—	—	×	<a href="#">WT-24</a>
C1722: [CODE ERR] RR	—	—	×	<a href="#">WT-24</a>
C1723: [CODE ERR] RL	—	—	×	<a href="#">WT-24</a>
C1724: [BATT VOLT LOW] FL	—	—	×	<a href="#">WT-27</a>
C1725: [BATT VOLT LOW] FR	—	—	×	<a href="#">WT-27</a>
C1726: [BATT VOLT LOW] RR	—	—	×	<a href="#">WT-27</a>
C1727: [BATT VOLT LOW] RL	—	—	×	<a href="#">WT-27</a>
C1729: VHCL SPEED SIG ERR	—	—	×	<a href="#">WT-30</a>
C1734: CONTROL UNIT	—	—	×	<a href="#">WT-31</a>

# ADP SYSTEM SYMPTOMS

< SYMPTOM DIAGNOSIS >

## SYMPTOM DIAGNOSIS

### ADP SYSTEM SYMPTOMS

#### Symptom Table

INFOID:000000000960769

**NOTE:**

Always perform the "Basic Inspection" before performing diagnosis in the following table. Refer to [ADP-215](#), "Basic Inspection".

#### SYMPTOM 1

Symptom	Diagnosis procedure	Reference page
Manual functions (for specific part) do not operate	Sliding operation	Check sliding switch. <a href="#">ADP-70</a>
	Reclining operation	Check reclining switch. <a href="#">ADP-72</a>
	Lifting operation (front)	Check lifting switch (front). <a href="#">ADP-74</a>
	Lifting operation (rear)	Check lifting switch (rear). <a href="#">ADP-76</a>
	Tilt operation	1. Check tilt switch. <a href="#">ADP-78</a>
		2. Check tilt sensor. <a href="#">ADP-111</a>
	Telescopic operation	1. Check telescopic switch. <a href="#">ADP-80</a>
		2. Check telescopic sensor. <a href="#">ADP-114</a>
	Door mirror operation	1. Changeover switch. <a href="#">ADP-85</a>
2. Mirror switch <a href="#">ADP-87</a>		
All parts of seat	Check power seat switch ground circuit. <a href="#">ADP-90</a>	

#### SYMPTOM 2

Symptom	Diagnosis procedure	Reference page
Memory functions (for specific part) do not operate	Sliding operation	Check sliding sensor. <a href="#">ADP-99</a>
	Reclining operation	Check reclining sensor. <a href="#">ADP-102</a>
	Lifting operation (front)	Check lifting sensor (front). <a href="#">ADP-105</a>
	Lifting operation (rear)	Check lifting sensor (rear). <a href="#">ADP-108</a>
	Tilt operation	Check tilt sensor. <a href="#">ADP-111</a>
	Telescopic operation	Check telescopic sensor. <a href="#">ADP-114</a>
	Door mirror operation	Check door mirror sensor. Driver side: <a href="#">ADP-117</a> Passenger side: <a href="#">ADP-119</a>

#### SYMPTOM 3

# ADP SYSTEM SYMPTOMS

## < SYMPTOM DIAGNOSIS >

Symptom	Diagnosis procedure	Reference page
Memory functions and manual functions (for specific part) do not operate	Sliding operation	Check sliding motor. <a href="#">ADP-122</a>
	Reclining operation	Check reclining motor. <a href="#">ADP-124</a>
	Lifting operation (front)	Check lifting motor (front). <a href="#">ADP-126</a>
	Lifting operation (rear)	Check lifting motor (rear). <a href="#">ADP-128</a>
	Tilt operation	Check tilt motor. <a href="#">ADP-130</a>
	Telescopic operation	Check telescopic motor. <a href="#">ADP-132</a>
	Door mirror operation	Check door mirror motor. <a href="#">ADP-134</a>

### SYMPTOM 4

Symptom	Diagnosis procedure	Reference page
Entry/Exit assist function does not operate.	1. Check system setting.	<a href="#">ADP-11</a>
	2. Perform initialization.	<a href="#">ADP-9</a>
	3. Check front door switch (driver side).	<a href="#">ADP-97</a>
Seat synchronization function does not operate.	Check system setting.	<a href="#">ADP-11</a>
Intelligent Key interlock function does not operate. (Other automatic operations and Intelligent Key system are normal)	1. Check door lock function.	<a href="#">DLK-6</a>
	2. Perform memory storing.	<a href="#">ADP-11</a>

### SYMPTOM 5

Symptom	Diagnosis procedure	Reference page
Memory indicators 1 and/or 2 do not illuminate.	1. Check seat memory switch.	<a href="#">ADP-82</a>
	2. Check seat memory indicator.	<a href="#">ADP-138</a>

### SYMPTOM 6

Symptom	Diagnosis procedure	Reference page
Memory operation does not operate.	Check detention switch/parking break switch.	AT model: <a href="#">ADP-93</a>
		MT model: <a href="#">ADP-95</a>

### SYMPTOM 7

Symptom	Diagnosis procedure	Reference page
All of side support components dose not operate.	Check power supply and ground circuit of side support unit.	<a href="#">ADP-68</a>
Seat back side support dose not operate.	Check side support unit.	<a href="#">ADP-137</a>
	Check side support switch.	<a href="#">ADP-91</a>
Seat cushion side support dose not operate.	Check side support unit.	<a href="#">ADP-137</a>
	Check side support switch.	<a href="#">ADP-91</a>

# NORMAL OPERATING CONDITION

< SYMPTOM DIAGNOSIS >

## NORMAL OPERATING CONDITION

### Description

INFOID:000000000960770

The following symptoms are normal operations, and they do not indicate a malfunction.

Symptom	Cause	Action to take	Reference page
Entry/exit assist function and seat synchronization do not operate.	No initialization has been performed.	Perform initialization.	<a href="#">ADP-9</a>
	Entry/exit assist function is disabled. <b>NOTE:</b> The entry/exit assist function and seat synchronization function are disabled before delivery (initial setting).	Change the settings.	<a href="#">ADP-11</a>
Entry assist function does not operate.	Manual operation with power seat switch was performed after exit assist function execution.	Perform the memory function.	<a href="#">ADP-23</a>
Seat synchronization function does not operate.	Either the entry/exit assist function (seat) or the entry/exit assist function (steering) is disabled. (only for AT models)	Enable both functions.	<a href="#">ADP-11</a>
	The synchronization function will not operate if the steering (tilt, telescopic) or the door mirror moves to the operating end while the seat synchronization function is operating.	Perform the memory function or drive the vehicle at more than 7km/h (4 MPH).	<a href="#">ADP-23</a>
	Seat adjustment load has exceed any of the volumes below. • Seat sliding: 76 mm • Seat reclining: 9.1 degrees • Seat lifting (rear): 20 mm	—	—
Side support or lumbar support does not perform memory operation.	The side support system and the lumbar support system are controlled independently with no link to the automatic drive positioner system.	—	Side support system: <a href="#">ADP-44</a>
			Lumbar support system: <a href="#">SE-5</a>
Memory function, entry/exit assist function, seat synchronization function, or Intelligent Key interlock function does not operate.	The operating conditions are not fulfilled.	Fulfill the operation conditions.	Memory function: <a href="#">ADP-28</a>
			Exit assist function: <a href="#">ADP-33</a>
			Entry assist function: <a href="#">ADP-37</a>
			Seat synchronization function: <a href="#">ADP-23</a>
			Intelligent Key interlock function: <a href="#">ADP-41</a>

A  
B  
C  
D  
E  
F  
G  
H  
I  
K  
L  
M  
N  
O  
P

ADP

# PRECAUTIONS

< PRECAUTION >

## PRECAUTION

### PRECAUTIONS

#### Precaution for Supplemental Restraint System (SRS) "AIR BAG" and "SEAT BELT PRE-TENSIONER"

INFOID:000000000960771

The Supplemental Restraint System such as "AIR BAG" and "SEAT BELT PRE-TENSIONER", used along with a front seat belt, helps to reduce the risk or severity of injury to the driver and front passenger for certain types of collision. This system includes seat belt switch inputs and dual stage front air bag modules. The SRS system uses the seat belt switches to determine the front air bag deployment, and may only deploy one front air bag, depending on the severity of a collision and whether the front occupants are belted or unbelted. Information necessary to service the system safely is included in the SRS and SB section of this Service Manual.

#### **WARNING:**

- **To avoid rendering the SRS inoperative, which could increase the risk of personal injury or death in the event of a collision which would result in air bag inflation, all maintenance must be performed by an authorized NISSAN/INFINITI dealer.**
- **Improper maintenance, including incorrect removal and installation of the SRS, can lead to personal injury caused by unintentional activation of the system. For removal of Spiral Cable and Air Bag Module, see the SRS section.**
- **Do not use electrical test equipment on any circuit related to the SRS unless instructed to in this Service Manual. SRS wiring harnesses can be identified by yellow and/or orange harnesses or harness connectors.**

#### Service

INFOID:000000000960772

- When removing or installing various parts, place a cloth or padding onto the vehicle body to prevent scratches.
- Handle trim, molding, instruments, grille, etc. carefully during removing or installing. Be careful not to oil or damage them.
- Apply sealing compound where necessary when installing parts.
- When applying sealing compound, be careful that the sealing compound does not protrude from parts.
- When replacing any metal parts (for example body outer panel, members, etc.), be sure to take rust prevention measures.

#### Work

INFOID:000000000960773

- When removing or disassembling each component, be careful not to damage or deform it. If a component may be subject to interference, be sure to protect it with a shop cloth.
- When removing (disengaging) components with a screwdriver or similar tool, be sure to wrap the component with a shop cloth or vinyl tape to protect it.
- Protect the removed parts with a shop cloth and keep them.
- Replace a deformed or damaged clip.
- If a part is specified as a non-reusable part, always replace it with new one.
- Be sure to tighten bolts and nuts securely to the specified torque.
- After re-installation is completed, be sure to check that each part works normally.
- Follow the steps below to clean components.
  - Water soluble foul: Dip a soft cloth into lukewarm water, and wring the water out of the cloth to wipe the fouled area.  
Then rub with a soft and dry cloth.
  - Oily foul: Dip a soft cloth into lukewarm water with mild detergent (concentration: within 2 to 3%), and wipe the fouled area.  
Then dip a cloth into fresh water, and wring the water out of the cloth to wipe the detergent off. Then rub with a soft and dry cloth.
- Do not use organic solvent such as thinner, benzene, alcohol, and gasoline.
- For genuine leather seats, use a genuine leather seat cleaner.

# PRE-INSPECTION FOR DIAGNOSTIC

< ON-VEHICLE MAINTENANCE >

## ON-VEHICLE MAINTENANCE

### PRE-INSPECTION FOR DIAGNOSTIC

#### Basic Inspection

INFOID:000000000960774

#### 1. CHECK POWER SUPPLY AND GROUND CIRCUIT

Check the power supply and ground circuit as shown below.

- Driver seat control unit : Refer to [ADP-66, "DRIVER SEAT CONTROL UNIT : Diagnosis Procedure"](#).
- Automatic drive positioner control unit: Refer to [ADP-67, "AUTOMATIC DRIVE POSITIONER CONTROL UNIT : Diagnosis Procedure"](#).

Is the inspection result normally?

YES >> GO TO 2.

NO >> Repair or replace the malfunctioning part.

#### 2. CHECK MANUAL FUNCTION

Check the manual function operations by operating the relevant switches as shown below.

- Seat (slide, reclining, lifting front, lifting rear)
- Steering column (tilt, telescopic)
- Door mirror
- Side support

Do all manual functions operate normally?

YES >> GO TO 3.

NO (Seat, steering, door mirror)>>Go to SYMPTOM 1, refer to [ADP-211, "Symptom Table"](#). And, GO TO 4 if the result of SYMPTOM 1 is OK.

NO (Side support)>>Go to SYMPTOM 7, refer to [ADP-211, "Symptom Table"](#).

#### 3. CHECK MEMORY FUNCTION 1

Register the seat positions (refer to [ADP-10, "MEMORY STORING : Description"](#)) and check that all parts of the seat, steering column, and door mirrors move to their memory positions correctly.

Are the operations normal?

YES >> Check each malfunction according to the instruction of the SYMPTOM 4, refer to [ADP-211, "Symptom Table"](#).

No (memory indicator operates normally)>> Go to SYMPTOM 2, refer to [ADP-211, "Symptom Table"](#).

No (memory indicator does not operate normally either)>> GO TO 5.

#### 4. CHECK MEMORY FUNCTION 2

Register the seat positions (refer to [ADP-10, "MEMORY STORING : Description"](#)) and check that all parts of the seat, steering column, and door mirrors move to their memory positions correctly.

Are the operations normal?

YES >> Check intermittent incident. Refer to [GI-39, "Intermittent Incident"](#).

NO >> GO TO 7.

#### 5. CHECK SEAT MEMORY SWITCH/MEMORY INDICATOR

Check the seat memory switch/memory switch indicator of the SYMPTOM 5, refer to [ADP-211, "Symptom Table"](#).

Is the inspection result normal?

YES >> GO TO 6.

NO >> Repair or replace the malfunctioning part.

#### 6. CHECK OPERATION CONDITION

Check the memory operation conditions (refer to [ADP-23, "SEAT SYNCHRONIZATION FUNCTION : System Description"](#)).

Are all operation conditions fulfilled?

YES >> Go to SYMPTOM 6, refer to [ADP-211, "Symptom Table"](#).

NO >> Fulfill the operation conditions. Refer to [ADP-28, "MEMORY FUNCTION : System Description"](#).

A  
B  
C  
D  
E  
F  
G  
H  
I  
J  
K  
L  
M  
N  
O  
P

ADP

## PRE-INSPECTION FOR DIAGNOSTIC

< ON-VEHICLE MAINTENANCE >

---

### 7. CHECK MECHANISM

---

Check for the following.

- Mechanism deformation or pinched foreign materials.
- Interference with other parts because of poor installation.

Is any malfunction present in the relevant parts?

- YES >> Go to SYMPTOM 3, refer to [ADP-211, "Symptom Table"](#).
- NO >> Repair or replace the malfunctioning part.



# DRIVER SEAT CONTROL UNIT

< ON-VEHICLE REPAIR >

## ON-VEHICLE REPAIR

### DRIVER SEAT CONTROL UNIT

#### Exploded View

INFOID:000000000960775

Refer to [IP-11, "Exploded View"](#).

#### Removal and Installation

INFOID:000000000960776

#### REMOVAL

##### **CAUTION:**

**When removing and installing, use shop cloths to protect parts from damage.**

1. Remove the driver seat (1). Refer to [SE-95, "Removal and Installation"](#).
2. Remove the mounting bolts (A).
3. Remove driver seat control unit (2).

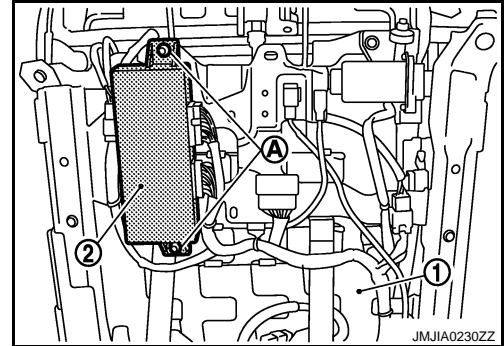

#### INSTALLATION

Install in the reverse order of removal.

##### **CAUTION:**

- **Clamp the harness in position.**

##### **NOTE:**

After installing the driver seat, perform additional service when replacing control unit. Refer to [ADP-8, "ADDITIONAL SERVICE WHEN REPLACING CONTROL UNIT : Description"](#).

A  
B  
C  
D  
E  
F  
G  
H  
I  
K  
L  
M  
N  
O  
P

ADP

# AUTOMATIC DRIVE POSITIONER CONTROL UNIT

< ON-VEHICLE REPAIR >

## AUTOMATIC DRIVE POSITIONER CONTROL UNIT

### Exploded View

INFOID:000000000960777

Refer to [IP-11, "Exploded View"](#).

### Removal and Installation

INFOID:000000000960778

#### REMOVAL

##### **CAUTION:**

**When removing and installing, use shop cloths to protect parts from damage.**

1. Remove the battery negative terminal.
2. Remove the instrument driver lower panel. Refer to [IP-12, "Removal and Installation"](#).
3. Remove the screws (A).
4. Remove automatic drive positioner control unit (1).

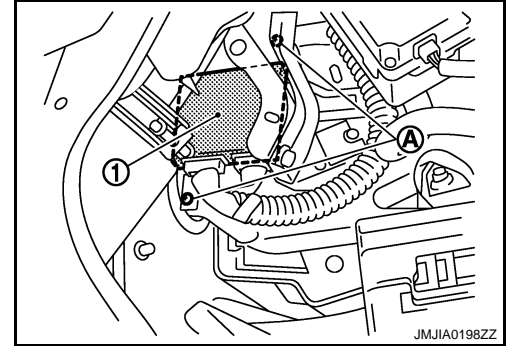

#### INSTALLATION

Install in the reverse order of removal.

##### **CAUTION:**

- Clamp the harness in position.

##### **NOTE:**

After installing the driver seat, perform additional service when removing battery negative terminal. Refer to [ADP-8, "ADDITIONAL SERVICE WHEN REMOVING BATTERY NEGATIVE TERMINAL : Description"](#).

# SEAT MEMORY SWITCH

< ON-VEHICLE REPAIR >

## SEAT MEMORY SWITCH

### Exploded View

INFOID:000000000960779

Refer to [INT-10, "Exploded View"](#).

### Removal and Installation

INFOID:000000000960780

#### REMOVAL

##### **CAUTION:**

**When removing and installing, use shop cloths to protect parts from damage.**

1. Disconnect battery negative terminal.
2. Remove the front door finisher (1). Refer to [INT-10, "Removal and Installation"](#).
3. Press pawls and remove seat memory switch (2) from front door finisher (1).

 Pawl

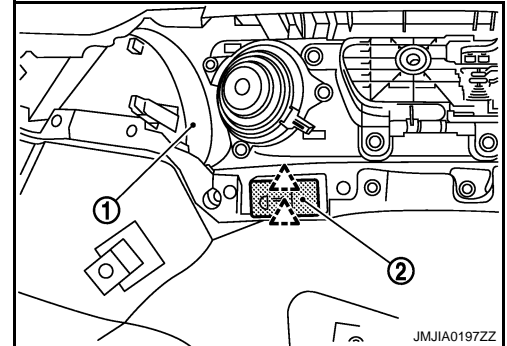

#### INSTALLATION

Install in the reverse order of removal.

##### **CAUTION:**

- **Clamp the harness in position.**

##### **NOTE:**

After installing the driver seat, perform additional service when removing battery negative terminal. Refer to [ADP-8, "ADDITIONAL SERVICE WHEN REMOVING BATTERY NEGATIVE TERMINAL : Description"](#).

A  
B  
C  
D  
E  
F  
G  
H  
I  
K  
L  
M  
N  
O  
P

ADP

# POWER SEAT SWITCH

< ON-VEHICLE REPAIR >

## POWER SEAT SWITCH

### Exploded View

INFOID:000000000960781

Refer to [SE-92. "Exploded View"](#).

### Removal and Installation

INFOID:000000000960782

#### REMOVAL

##### **CAUTION:**

**When removing and installing, use shop cloths to protect parts from damage.**

1. Remove the seat cushion outer finisher (1). Refer to [SE-96. "Disassembly and Assembly"](#).
2. Remove the screws (A).
3. Remove the power seat switch (2) from the seat cushion outer finisher (1).

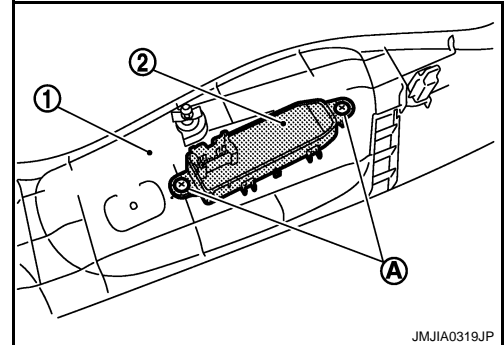

#### INSTALLATION

Install in the reverse order of removal.

##### **CAUTION:**

- **Clamp the harness in position.**

##### **NOTE:**

After installing the driver seat, perform additional service when removing battery negative terminal. Refer to [ADP-8. "ADDITIONAL SERVICE WHEN REMOVING BATTERY NEGATIVE TERMINAL : Description"](#).

# SIDE SUPPORT SWITCH

< ON-VEHICLE REPAIR >

## SIDE SUPPORT SWITCH

### Exploded View

INFOID:000000000960783

Refer to [SE-92. "Exploded View"](#).

### Removal and Installation

INFOID:000000000960784

#### REMOVAL

##### **CAUTION:**

**When removing and installing, use shop cloths to protect parts from damage.**

1. Remove the seat cushion outer finisher (1). Refer to [SE-95. "Removal and Installation"](#).
2. Remove the screws (A).
3. Remove side support switch (2) from the seat cushion outer finisher.

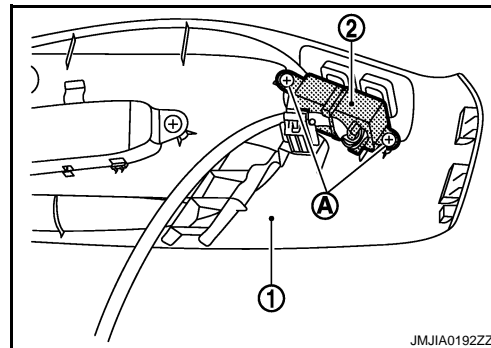

#### INSTALLATION

Install in the reverse order of removal.

##### **CAUTION:**

- **Clamp the harness in position.**

##### **NOTE:**

After installing the driver seat, perform additional service when removing battery negative terminal. Refer to [ADP-8. "ADDITIONAL SERVICE WHEN REMOVING BATTERY NEGATIVE TERMINAL : Description"](#).

A  
B  
C  
D  
E  
F  
G  
H  
I  
K  
L  
M  
N  
O  
P

ADP

# TILT&TELESCOPIC SWITCH

< ON-VEHICLE REPAIR >

## TILT&TELESCOPIC SWITCH

### Exploded View

INFOID:000000000960785

Refer to [IP-11, "Exploded View"](#).

### Removal and Installation

INFOID:000000000960786

#### REMOVAL

##### **CAUTION:**

**When removing and installing, use shop cloths to protect parts from damage.**

1. Disconnect battery negative terminal.
2. Remove the steering column mask (1). Refer to [IP-12, "Removal and Installation"](#).
3. Press pawls and remove tilt & telescopic switch (2) from the steering column mask (1).

 Pawl

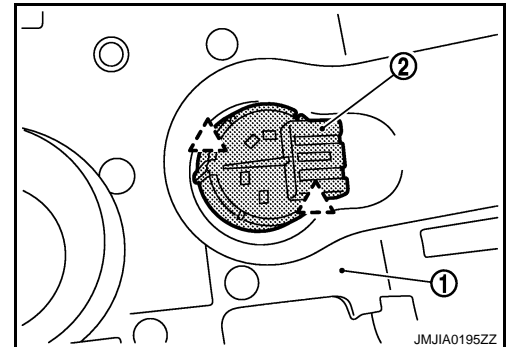

#### INSTALLATION

Install in the reverse order of removal.

##### **CAUTION:**

- **Clamp the harness in position.**

##### **NOTE:**

After installing the driver seat, perform additional service when removing battery negative terminal. Refer to [ADP-8, "ADDITIONAL SERVICE WHEN REMOVING BATTERY NEGATIVE TERMINAL : Description"](#).