

A
B
C
D
E
F
G
H
I
J
L
M

SECTION SC

STARTING & CHARGING SYSTEM

CONTENTS

PRECAUTIONS	2	PERATURE	17
Precautions for Supplemental Restraint System (SRS) "AIR BAG" and "SEAT BELT PRE-TENSIONER"	2	Removal and Installation	18
PREPARATION	3	2WD MODELS	18
Special Service Tools	3	AWD MODELS	19
Commercial Service Tools	3	Disassembly and Assembly	20
BATTERY	4	2WD MODELS	20
How to Handle Battery	4	AWD MODELS	21
METHODS OF PREVENTING OVER-DISCHARGE	4	INSPECTION AFTER DISASSEMBLY	21
CHECKING ELECTROLYTE LEVEL	5	CHARGING SYSTEM	22
SPECIFIC GRAVITY CHECK	5	System Description	22
CHARGING THE BATTERY	6	MALFUNCTION INDICATOR	22
Trouble Diagnosis with Battery/Starting/Charging System Tester (Battery)	6	Wiring Diagram — CHARGE —	23
DIAGNOSTIC RESULT ITEM CHART	8	2WD MODELS	23
Removal and Installation	8	AWD MODELS	24
STARTING SYSTEM	9	Trouble Diagnosis with Battery/Starting/Charging System Tester (Charging)	25
System Description	9	DIAGNOSTIC RESULT ITEM CHART	26
M/T MODELS	9	WORK FLOW	27
A/T MODELS	10	PRELIMINARY INSPECTION	28
Wiring Diagram — START —	11	DIAGNOSTIC PROCEDURE 1	29
M/T MODELS	11	DIAGNOSTIC PROCEDURE 2	30
A/T MODELS	13	DIAGNOSTIC PROCEDURE 3	30
Trouble Diagnosis with Battery/Starting/Charging System Tester (Starting)	14	DIAGNOSTIC PROCEDURE 4	31
DIAGNOSTIC RESULT ITEM CHART	14	Removal and Installation	32
WORK FLOW	15	A/T (2WD) MODELS	32
DIAGNOSTIC PROCEDURE 1	16	ALTERNATOR PULLEY INSPECTION	33
DIAGNOSTIC PROCEDURE 2	17	A/T (AWD) AND M/T MODELS	33
MINIMUM SPECIFICATION OF CRANKING VOLTAGE REFERENCING COOLANT TEM-		ALTERNATOR PULLEY INSPECTION	34
		Disassembly and Assembly	35
		SERVICE DATA AND SPECIFICATIONS (SDS)	36
		Battery	36
		Starter	36
		Alternator	36

PRECAUTIONS

PRECAUTIONS

PFP:00001

Precautions for Supplemental Restraint System (SRS) “AIR BAG” and “SEAT BELT PRE-TENSIONER”

NKS000S2

The Supplemental Restraint System such as “AIR BAG” and “SEAT BELT PRE-TENSIONER”, used along with a front seat belt, helps to reduce the risk or severity of injury to the driver and front passenger for certain types of collision. This system includes seat belt switch inputs and dual stage front air bag modules. The SRS system uses the seat belt switches to determine the front air bag deployment, and may only deploy one front air bag, depending on the severity of a collision and whether the front occupants are belted or unbelted. Information necessary to service the system safely is included in the SRS and SB section of this Service Manual.

WARNING:

- To avoid rendering the SRS inoperative, which could increase the risk of personal injury or death in the event of a collision which would result in air bag inflation, all maintenance must be performed by an authorized NISSAN/INFINITI dealer.
- Improper maintenance, including incorrect removal and installation of the SRS, can lead to personal injury caused by unintentional activation of the system. For removal of Spiral Cable and Air Bag Module, see the SRS section.
- Do not use electrical test equipment on any circuit related to the SRS unless instructed to in this Service Manual. SRS wiring harnesses can be identified by yellow and/or orange harnesses or harness connectors.

PREPARATION

PREPARATION

PFP:00002

Special Service Tools

NKS000S4

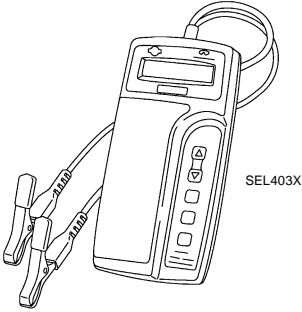
Tool number Tool name	Description
J-44373 Model 620 Battery/Starting/Charging system tester	

Commercial Service Tools

NKS000S5

Tool number Tool name	Description
Power tool	Loosening bolts and nuts

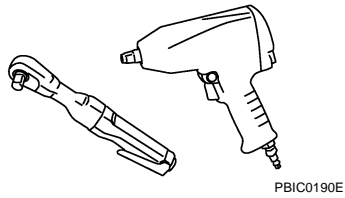

A
B
C
D
E
F
G
H
I
J

SC

L
M

BATTERY

BATTERY

PFP:AYBGL

How to Handle Battery

NKS000S6

CAUTION:

- If it becomes necessary to start the engine with a booster battery and jumper cables, use a 12-volt booster battery.
- After connecting battery cables, ensure that they are tightly clamped to battery terminals for good contact.

METHODS OF PREVENTING OVER-DISCHARGE

The following precautions must be taken to prevent over-discharging a battery.

- The battery surface (particularly its top) should always be kept clean and dry.
- The terminal connections should be clean and tight.
- At every routine maintenance, check the electrolyte level. This also applies to batteries designated as “low maintenance” and “maintenance-free”.
- When the vehicle is not going to be used over a long period of time, disconnect the battery cable from the negative terminal.
- Check the charge condition of the battery. Periodically check the specific gravity of the electrolyte. Keep a close check on charge condition to prevent over-discharge.

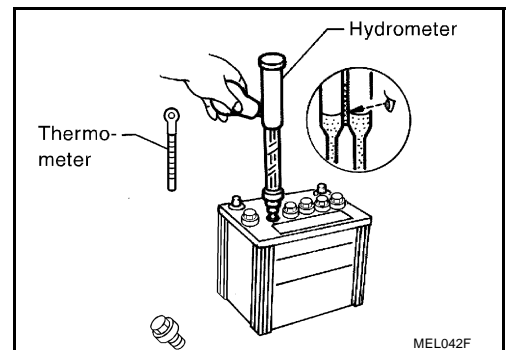
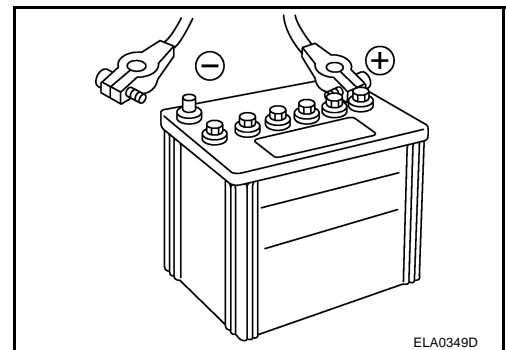
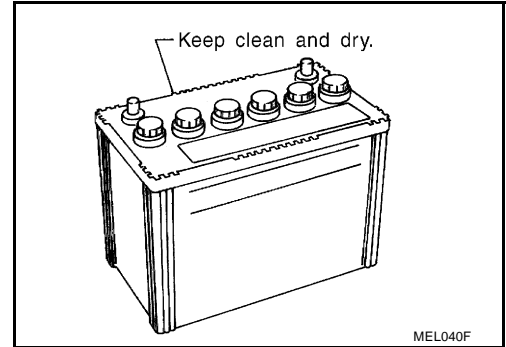

BATTERY

CHECKING ELECTROLYTE LEVEL

WARNING:

Never allow battery fluid to come in contact with skin, eyes, fabrics, or painted surfaces. After touching a battery, never touch or rub your eyes until you have thoroughly washed your hands. If acid contacts eyes, skin or clothing, immediately flush with water for 15 minutes and seek medical attention.

- Remove the cell plug using a suitable tool.
- Add distilled water up to the MAX level.

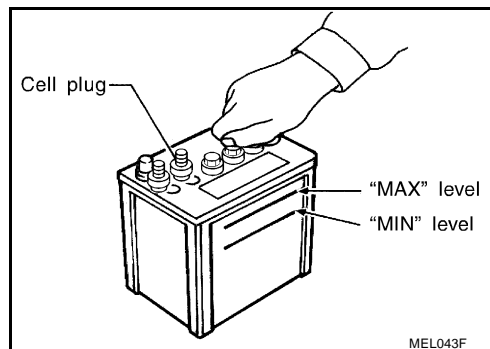

Sulphation

A battery will be completely discharged if it is left unattended for a long time and the specific gravity will become less than 1.100. This may result in sulphation on the cell plates.

To determine if a battery has been “sulphated”, note its voltage and current when charging it. As shown in the figure, less current and higher voltage are observed in the initial stage of charging sulphated batteries.

A sulphated battery may sometimes be brought back into service by means of a long, slow charge, 12 hours or more, followed by a battery capacity test.

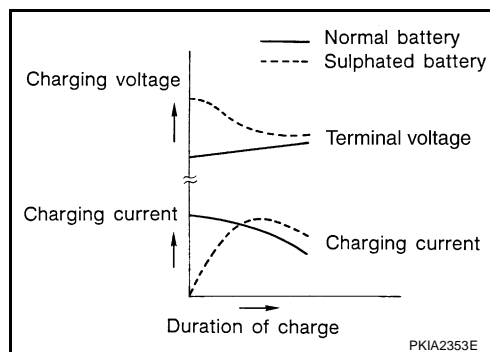

SPECIFIC GRAVITY CHECK

1. Read hydrometer and thermometer indications at eye level.
2. Use the chart below to correct your hydrometer reading according to electrolyte temperature.

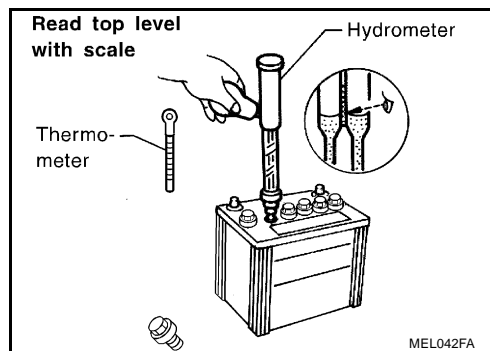

Hydrometer Temperature Correction

Battery electrolyte temperature °C (°F)	Add to specific gravity reading
71 (160)	0.032
66 (150)	0.028
60 (140)	0.024
54 (130)	0.020
49 (120)	0.016
43 (110)	0.012
38 (100)	0.008
32 (90)	0.004
27 (80)	0
21 (70)	-0.004

BATTERY

Battery electrolyte temperature °C (°F)	Add to specific gravity reading
16 (60)	-0.008
10 (50)	-0.012
4 (40)	-0.016
-1 (30)	-0.020
-7 (20)	-0.024
-12 (10)	-0.028
-18 (0)	-0.032

Corrected specific gravity	Approximate charge condition
1.260 - 1.280	Fully charged
1.230 - 1.250	3/4 charged
1.200 - 1.220	1/2 charged
1.170 - 1.190	1/4 charged
1.140 - 1.160	Almost discharged
1.110 - 1.130	Completely discharged

CHARGING THE BATTERY

CAUTION:

- Never “quick charge” a fully discharged battery.
- Keep the battery away from open flame while it is being charged.
- When connecting the charger, connect the leads first, then turn on the charger. Never turn on the charger first, as this may cause a spark.
- If battery electrolyte temperature rises above 55 °C (131 °F), stop charging. Always charge battery at a temperature below 55 °C (131 °F).

Charging Rates

Amp	Time
50	1 hour
25	2 hours
10	5 hours
5	10 hours

Never charge at more than 50 ampere rate.

NOTE:

The ammeter reading on your battery charger will automatically decrease as the battery charges. This indicates that the voltage of the battery is increasing normally as the state of charge improves. The charging amps indicated above refer to initial charge rate.

- If, after charging, the specific gravity of any two cells varies more than 0.050, the battery should be replaced.

Trouble Diagnosis with Battery/Starting/Charging System Tester (Battery)

NKS000S7

CAUTION:

When working with batteries, always wear appropriate eye protection.

NOTE:

- To ensure a complete and thorough diagnosis, the battery, starter and alternator test segments must be done as a set from start to finish.
- If battery surface charge is detected while testing, the tester will prompt you to turn on the headlights to remove the surface charge.
- If necessary, the tester will prompt you to determine if the battery temperature is above or below 0 °C (32 °F). Choose the appropriate selection by pressing the up or down arrow button, then press “ENTER” to make the selection.

BATTERY

1. Turn off all loads on the vehicle electrical system. Clean or repair as necessary.
2. Visually inspect the battery, battery terminals and cable ends with ignition switch in "OFF" position.

NOTE:

The contact surface between the battery terminals, cable ends and tester leads must be clean for a valid test. A poor connection will prevent testing and a "CHECK CONNECTION" message will appear during the test procedures. If this occurs, clean the battery terminals, reconnect them and restart the test.

3. Connect the red tester lead clamp to the positive battery terminal, and the black to the negative terminal.
4. The tester will turn on automatically. Using the arrow keys, select "IN-VEHICLE" on the tester and then press the "ENTER" key.

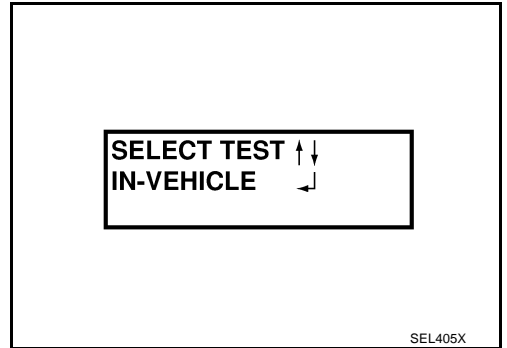
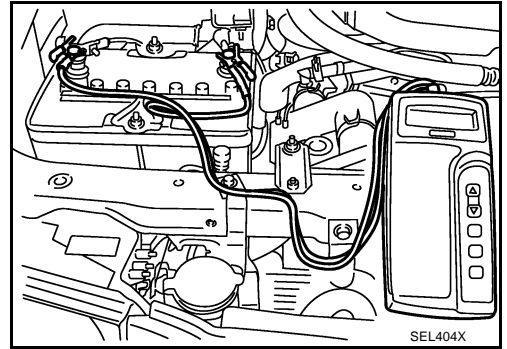

5. Locate the battery **type** and **rating** stamped or written on the top case of the battery to be tested.

NOTE:

The battery **rating** will have either of the following.

- **CCA:** Cold Cranking Amps (490 CCA, 550 CCA, etc.)
- **JIS:** Japanese Industrial Standard.

When using the battery tester: Use the CCA rating only.

- The tester requires the CCA rating for the battery be entered exactly as it is written or stamped on the battery.
- **U.S. market:** Refer to the latest "Battery Testing" Technical Service Bulletin (TSB) for a chart which contains these ratings listed by vehicle.
- **You must not use the JIS rating.**

6. Using the arrow and "ENTER" keys alternately, select the battery type and rating.

NOTE:

The tester lists five choices; CCA, JIS, IEC, DIN, and EN. **Use only the CCA choice** .

7. Press "ENTER" to begin the test. Diagnosis results are displayed on the tester. Refer to [SC-8, "DIAGNOSTIC RESULT ITEM CHART"](#) .

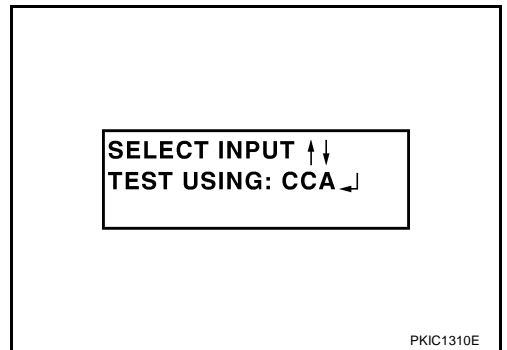

A
B
C
D
E
F
G
H
I
J
SC
L
M

BATTERY

8. Press "ENTER", then test output code is displayed. Record the test output code on the repair order.
9. Toggle back to the "DIAGNOSTIC SCREEN" for test results.

NOTE:

- If necessary, the tester will ask the user to determine if the battery has just been charged. Choose the appropriate selection by pressing the up or down arrow button and then press the "ENTER" button to make the selection.
- When testing a battery installed in a vehicle that has recently been driven, select "BEFORE CHARGE".
- If the battery has just been slow charged due to a "CHARGE & RETEST" decision by the tester, and the tester asks the user "BEFORE CHARGE/AFTER CHARGE", select "AFTER CHARGE".

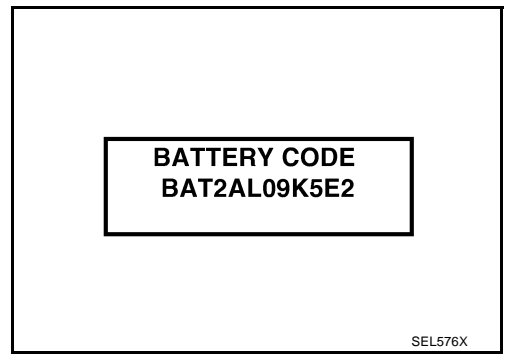

the user "BEFORE CHARGE/AFTER CHARGE", select "AFTER CHARGE".

DIAGNOSTIC RESULT ITEM CHART

Diagnostic item	Service procedure
GOOD BATTERY	Battery is OK, go to "Trouble Diagnosis", "STARTING SYSTEM". Refer to SC-14. "Trouble Diagnosis with Battery/Starting/Charging System Tester (Starting)" .
REPLACE BATTERY	Replace battery. Before replacing battery, clean the battery cable clamps and battery posts. Perform battery test again with Battery/Starting/Charging system tester. If second test result is "Replace Battery", then do so. Perform battery test again to confirm repair.
BAD CELL-REPLACE	Replace the battery. Perform battery test again with Battery/Starting/Charging system tester to confirm repair.
GOOD-RECHARGE	Perform the slow battery charging procedure. (Initial rate of charge is 10A for 12 hours.)
CHARGE & RETEST	Perform the slow battery charging. (Initial rate of charge is 10A for 12 hours.) Perform battery test again with Battery/Starting/Charging system tester to confirm repair. NOTE: If the tester asks the user "BEFORE CHARGE/AFTER CHARGE", select "AFTER CHARGE".

Removal and Installation

NKS000SB

Remove the hoodledge cover (right) and observe the following to ensure proper servicing.

CAUTION:

- When disconnecting, disconnect the battery cable from the negative terminal first. But when connecting, connect the battery cable to the positive terminal first.
- Tighten parts to the specified torque shown below.

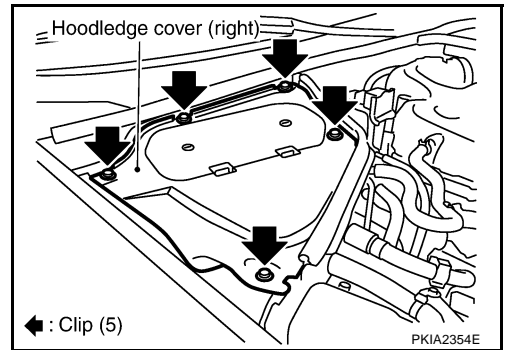

Battery fix frame mounting nut:

: 4.4 N-m (0.45 kg-m, 39 in-lb)

Battery terminal nut:

: 5.4 N-m (0.55 kg-m, 48 in-lb)

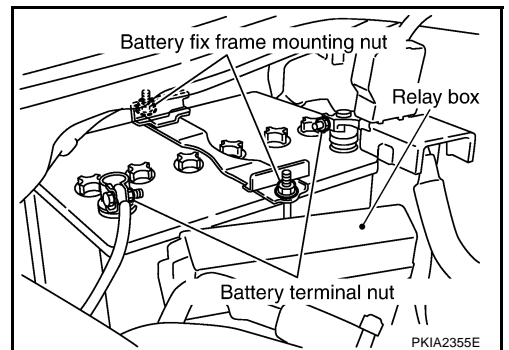

STARTING SYSTEM

STARTING SYSTEM

PFP:23300

System Description M/T MODELS

NKS000S9

Power is supplied at all times

- through 40A fusible link (letter M, located in the fuse and fusible link block)
- to ignition switch terminal 1,
- through 15A fuse (No. 78, located in the IPDM E/R)
- to CPU of IPDM E/R,
- through 10A fuse (No. 71, located in the IPDM E/R)
- to CPU of IPDM E/R.

With the ignition switch in the ON or START position, power is supplied

- through ignition relay
- to CPU of IPDM E/R,
- through 10A fuse (No. 89, located in the IPDM E/R)
- through IPDM E/R terminal 25
- to clutch interlock switch terminal 1.

When the clutch pedal is depressed, power is supplied

- through clutch interlock switch terminal 2
- to IPDM E/R terminal 53.

Ground is supplied

- to IPDM E/R terminals 38, 50 and 60
- from grounds E17 and E43.

Then starter relay is turn ON.

With the ignition switch in the START position, IPDM E/R is energized and power is supplied

- from ignition switch terminal 5
- to IPDM E/R terminal 4 and
- through IPDM E/R terminal 3
- to starter motor terminal 1.

The starter motor plunger closes and provides a closed circuit between the battery and starter motor. The starter motor is grounded to the engine block. With power and ground supplied, cranking occurs and the engine starts.

A
B
C
D
E
F
G
H
I
J
SC
L
M

STARTING SYSTEM

A/T MODELS

Power is supplied at all times

- through 40A fusible link (letter M, located in the fuse and fusible link block)
- to ignition switch terminal 1,
- through 15A fuse (No. 78, located in the IPDM E/R)
- to CPU of IPDM E/R,
- through 10A fuse (No. 71, located in the IPDM E/R)
- to CPU of IPDM E/R.

With the ignition switch in the ON or START position, power is supplied

- through ignition relay
- to CPU of IPDM E/R.

When the selector lever in the P or N position, power is supplied

- from A/T assembly terminal 9
- to IPDM E/R terminal 53.

Ground is supplied

- to IPDM E/R terminals 38, 50 and 60
- from grounds E17 and E43.

Then starter relay is turn ON.

With the ignition switch in the START position, IPDM E/R is energized and power is supplied

- from ignition switch terminal 5
- to IPDM E/R terminal 4 and
- through IPDM E/R terminal 3
- to starter motor terminal 1.

The starter motor plunger closes and provides a closed circuit between the battery and starter motor. The starter motor is grounded to the engine block. With power and ground supplied, cranking occurs and the engine starts.

STARTING SYSTEM

Wiring Diagram — START — M/T MODELS

NKS000SA

SC-START-01

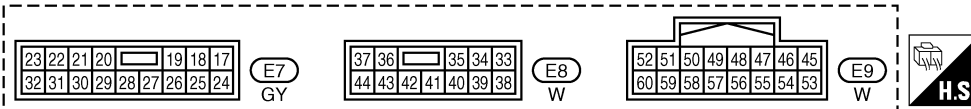
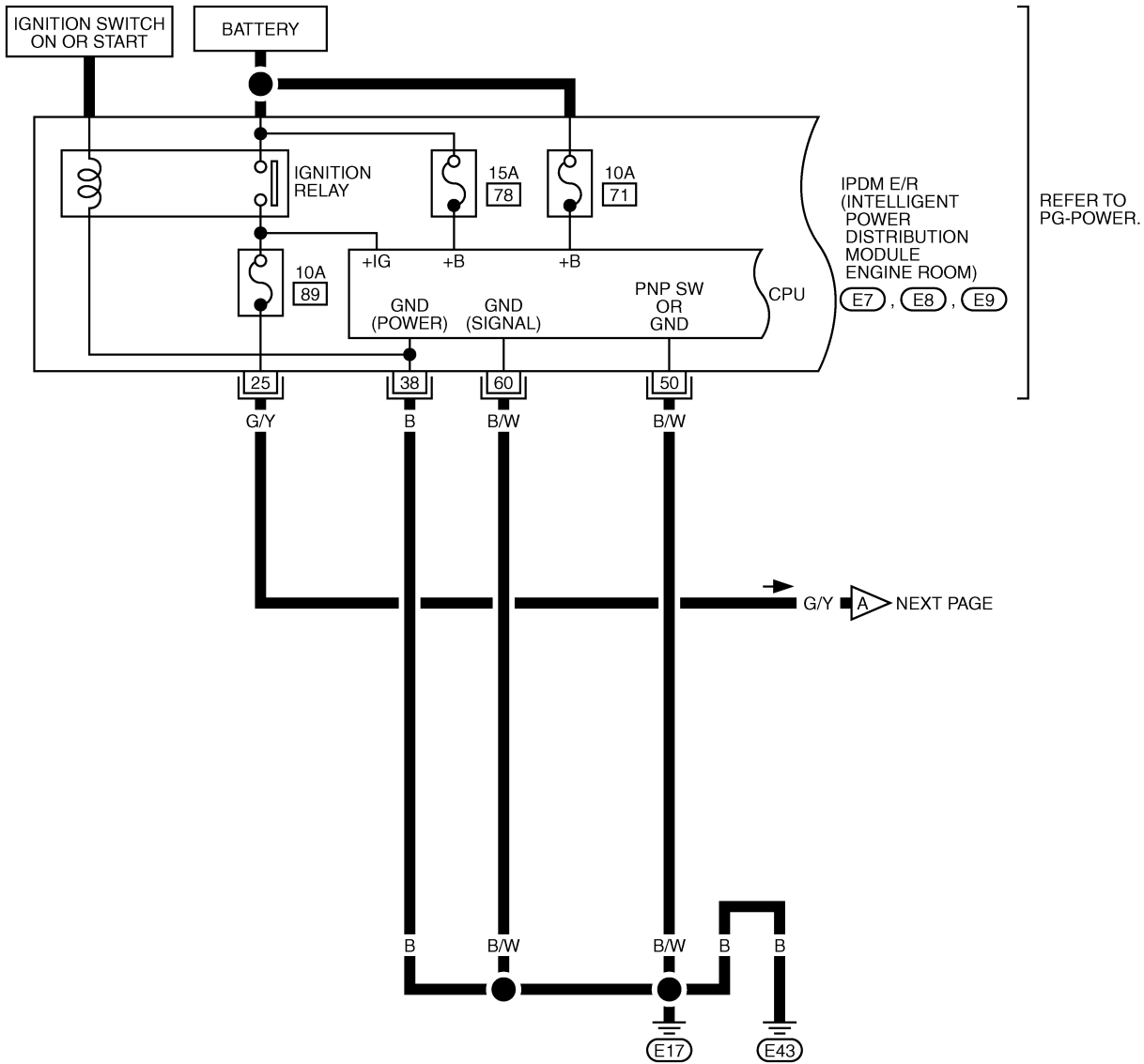

TKWM2115E

STARTING SYSTEM

SC-START-02

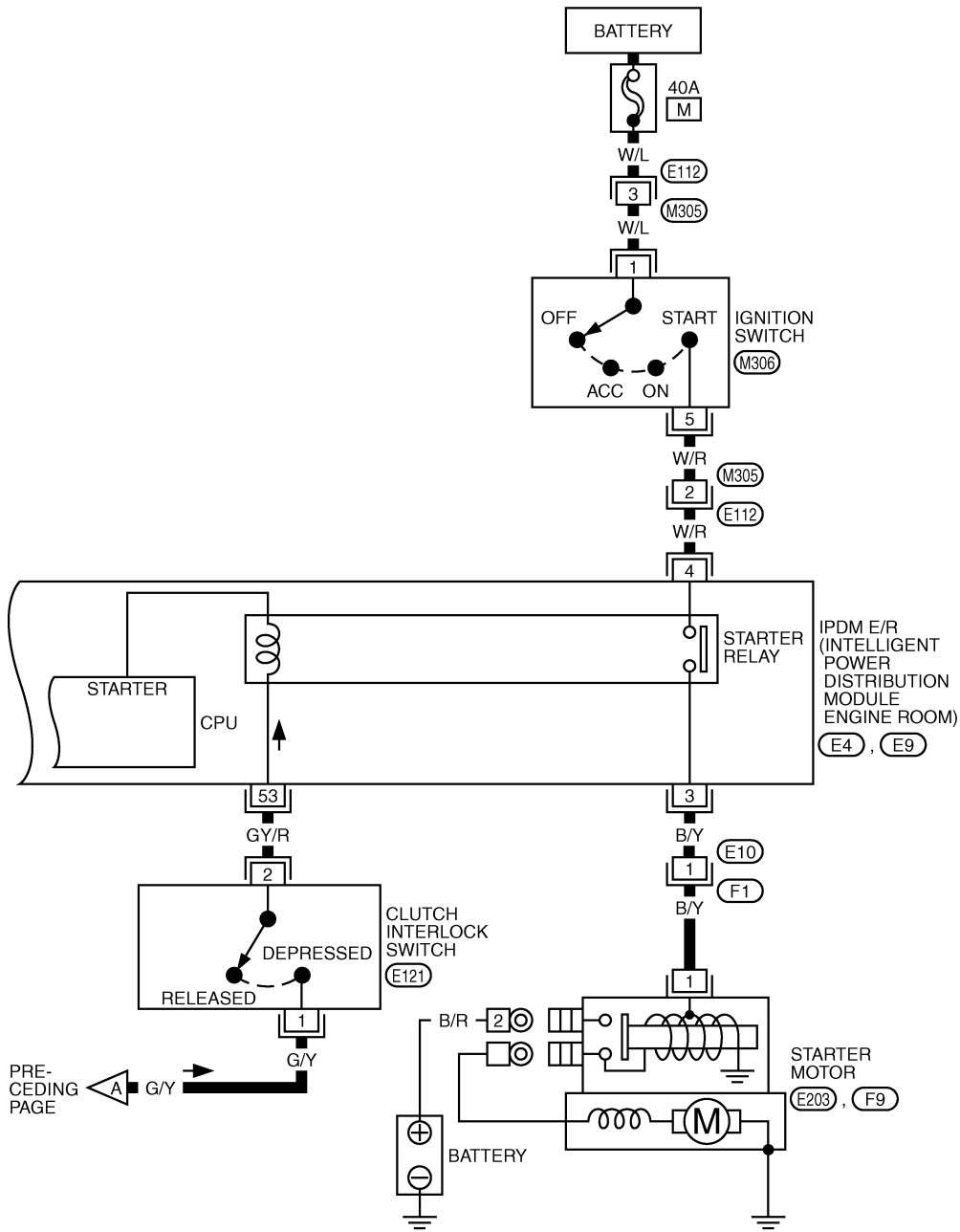

REFER TO PG-POWER.

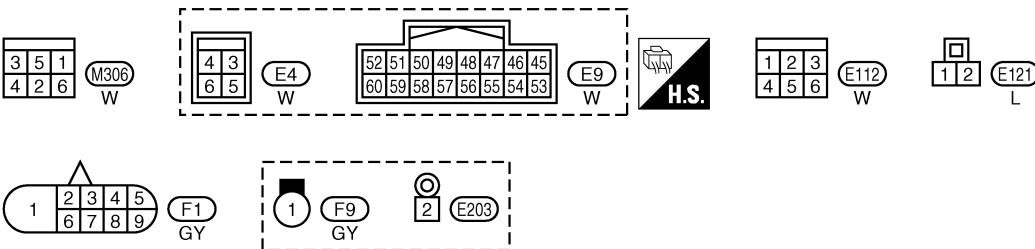

TKWM2116E

STARTING SYSTEM

A/T MODELS

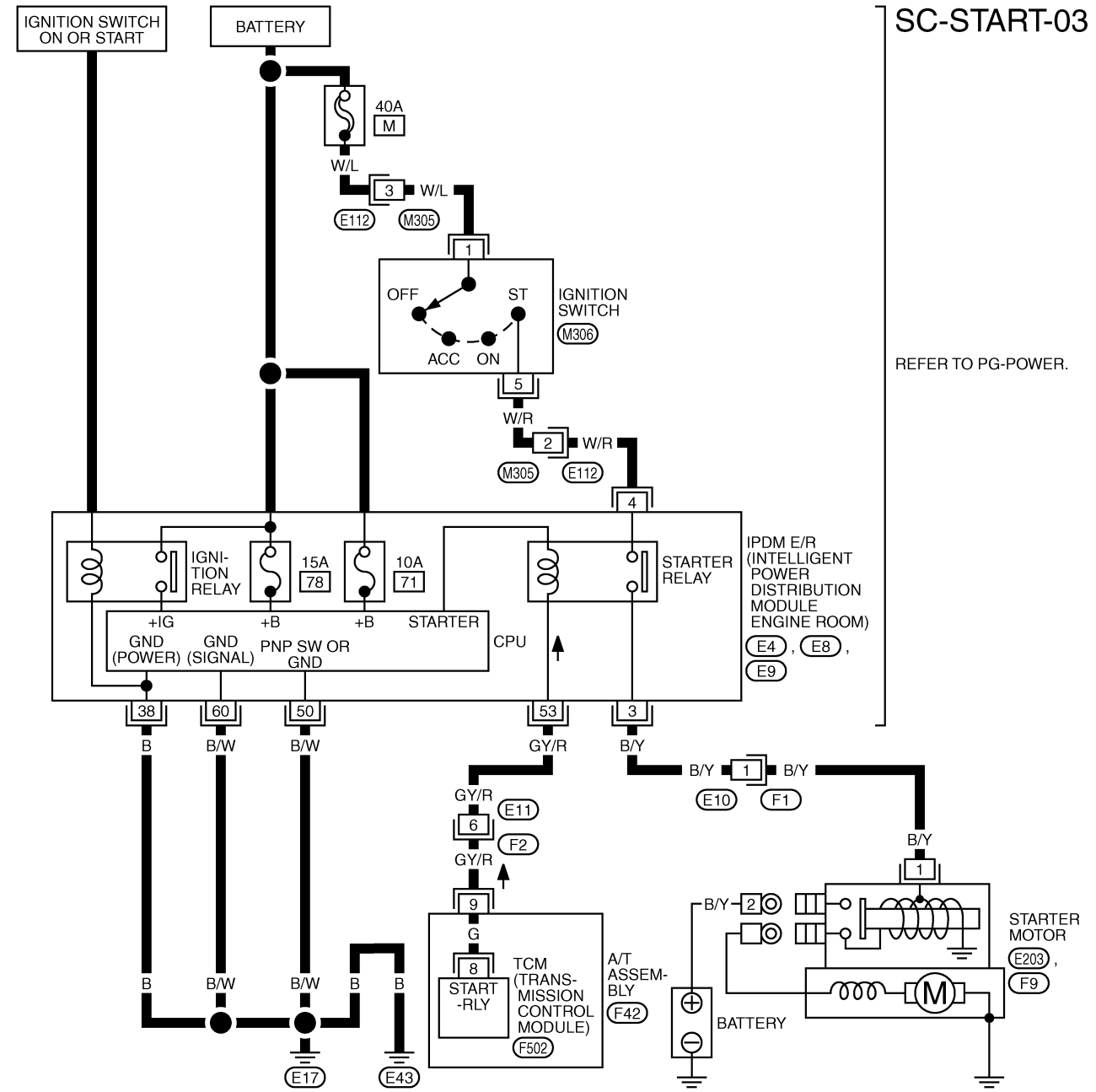

A
B
C
D
E
F
G
H
I
J
SC
L
M

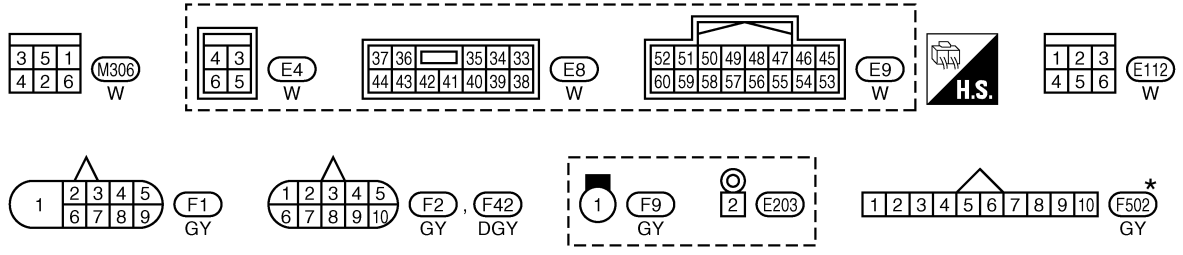

*: THIS CONNECTOR IS NOT SHOWN IN "HARNESS LAYOUT", PG SECTION.

STARTING SYSTEM

Trouble Diagnosis with Battery/Starting/Charging System Tester (Starting)

NKS000SB

NOTE:

To ensure a complete and thorough diagnosis, the battery, starter and alternator test segments must be done as a set from start to finish.

1. Turn off all loads on the vehicle electrical system.
2. Perform battery test with Battery/Starting/Charging system tester. Refer to [SC-6, "Trouble Diagnosis with Battery/Starting/Charging System Tester \(Battery\)"](#).
3. Press "ENTER" to begin the starting system test.

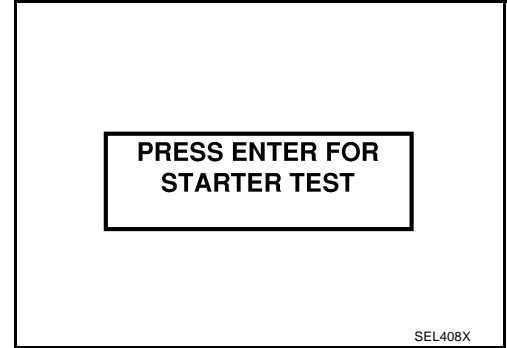

4. Start the engine.

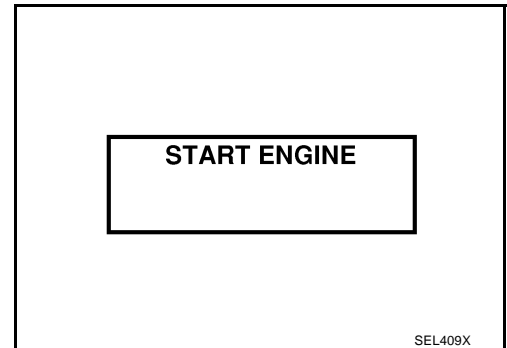

5. Diagnostic result is displayed on the tester. Refer to [SC-14, "DIAGNOSTIC RESULT ITEM CHART"](#).

NOTE:

- If the starter performs normally but the engine does not start, perform engine diagnosis.
- For intermittent "NO CRANK" or "NO STARTER OPERATION" incidents, refer to [SC-17, "DIAGNOSTIC PROCEDURE 2"](#).

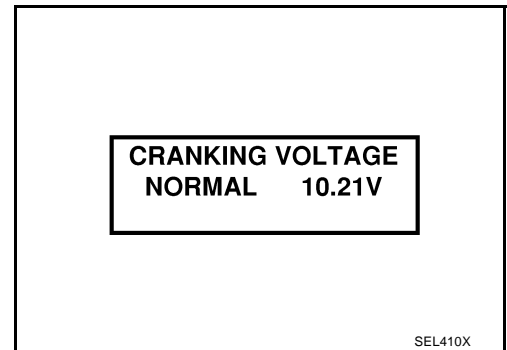

DIAGNOSTIC RESULT ITEM CHART

Diagnostic item	Service procedure
CRANKING VOLTAGE NORMAL	Go to SC-15, "WORK FLOW" .
CRANKING VOLTAGE LOW	
CHARGE BATTERY	Perform the slow battery charging procedure. (Initial rate of charge is 10A for 12 hours.) Perform battery test again with Battery/Starting/Charging system tester. Refer to SC-6, "Trouble Diagnosis with Battery/Starting/Charging System Tester (Battery)" .
REPLACE BATTERY	Before replacing battery, clean the battery cable clamps and battery posts. Perform battery test again with Battery/Starting/Charging system tester. Refer to SC-6, "Trouble Diagnosis with Battery/Starting/Charging System Tester (Battery)" . If second test result is "REPLACE BATTERY", then do so. Perform battery test again to confirm repair.

STARTING SYSTEM

WORK FLOW

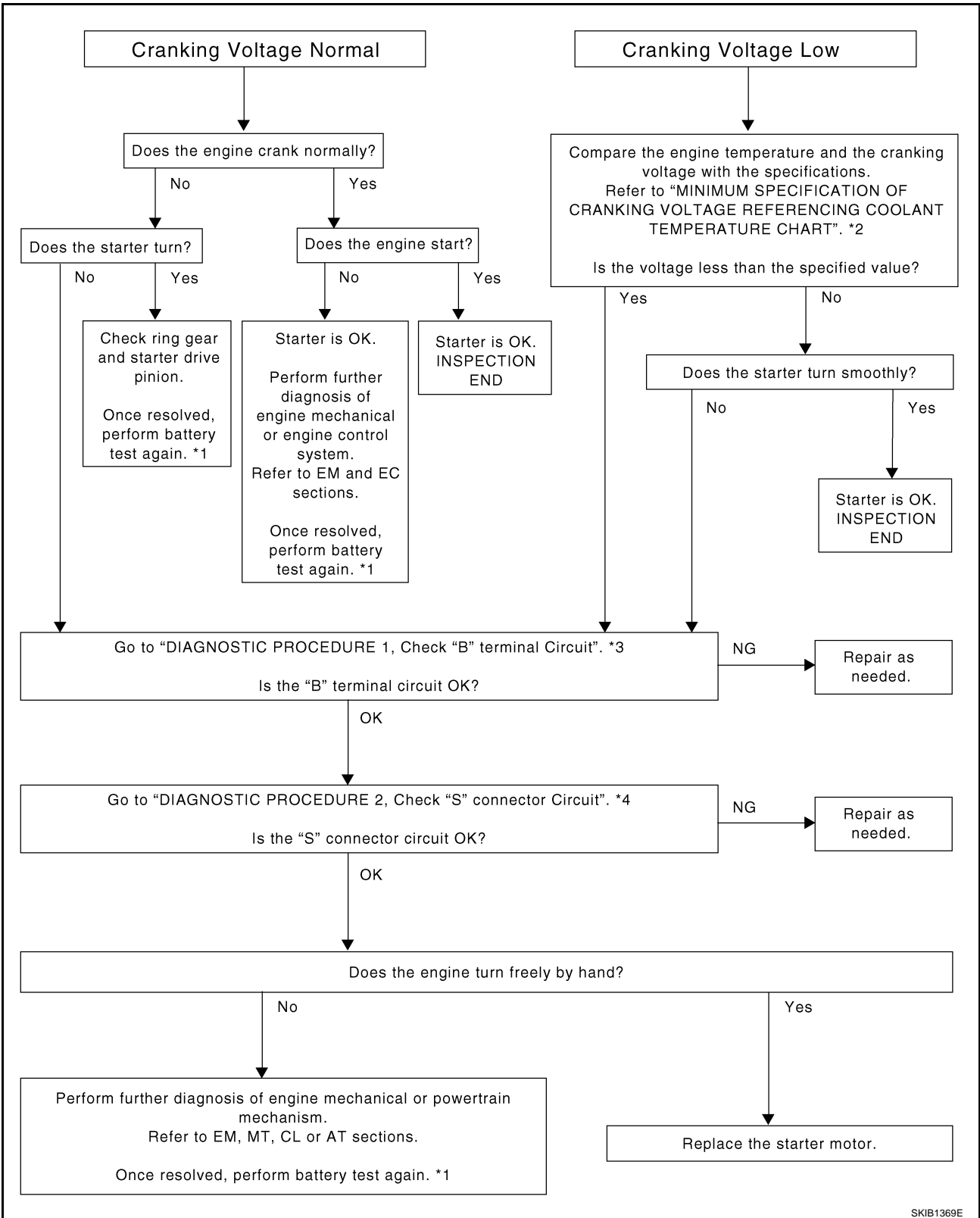

A
B
C
D
E
F
G
H
I
J
SC
L
M

*1 [SC-6. "Trouble Diagnosis with Battery/Starting/Charging System Tester \(Battery\)"](#)

*2 [SC-17. "MINIMUM SPECIFICATION OF CRANKING VOLTAGE REFERENCING COOLANT TEMPERATURE"](#)

*3 [SC-16. "Check "B" Terminal Circuit"](#)

*4 [SC-17. "Check "S" Connector Circuit"](#)

SKIB1369E

STARTING SYSTEM

DIAGNOSTIC PROCEDURE 1

Check "B" Terminal Circuit

1. CHECK POWER SUPPLY FOR STARTER MOTOR "B" TERMINAL

1. Remove fuel pump fuse.
2. Crank or start the engine (where possible) until the fuel pressure is released.
3. Turn ignition switch OFF.
4. Make sure that the starter motor "B" terminal E203 terminal 2 (B/R)(M/T models) or (B/Y)(A/T models) connection is clean and tight.
5. Check voltage between starter motor "B" terminal E203 terminal 2 (B/R)(M/T models) or (B/Y)(A/T models) and ground.

M/T models

2 (B/R) – Ground : Battery voltage

A/T models

2 (B/Y) – Ground : Battery voltage

OK or NG

OK >> GO TO 2.

NG >> Check harness between battery and starter motor for open circuit.

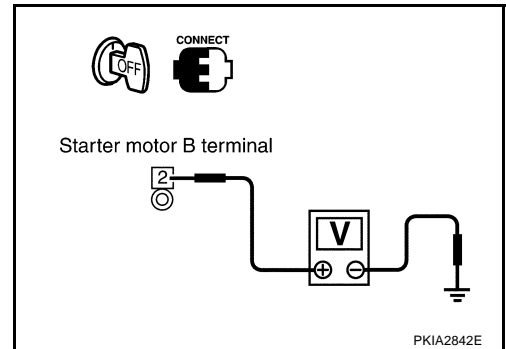

2. CHECK BATTERY CABLE CONNECTION (VOLTAGE DROP TEST)

Check voltage between starter motor "B" terminal E203 terminal 2 (B/R)(M/T models) or (B/Y)(A/T models) and battery positive terminal.

2 (B/R) – Ground (M/T models)

When ignition switch is in START : Less than 0.5 V position

2 (B/Y) – Ground (A/T models)

When ignition switch is in START : Less than 0.5 V position

OK or NG

OK >> GO TO 3.

NG >> Check harness between battery and starter motor for poor continuity.

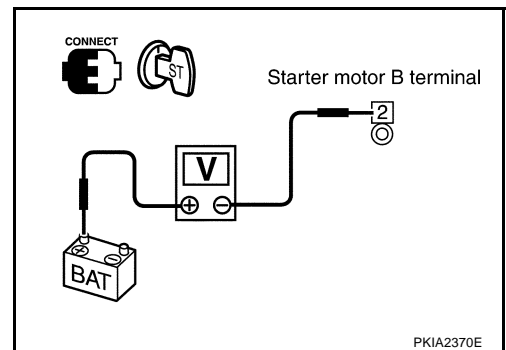

3. CHECK STARTER MOTOR GROUND CIRCUIT (VOLTAGE DROP TEST)

1. Turn ignition switch OFF.
2. Check voltage between starter motor case and battery negative terminal.

Starter motor case – Battery negative terminal

When ignition switch is in START position : Less than 0.2 V

OK or NG

OK >> "B" terminal circuit is OK. Further inspection necessary. Refer to [SC-15, "WORK FLOW"](#).

NG >> Check starter motor case and ground for poor continuity.

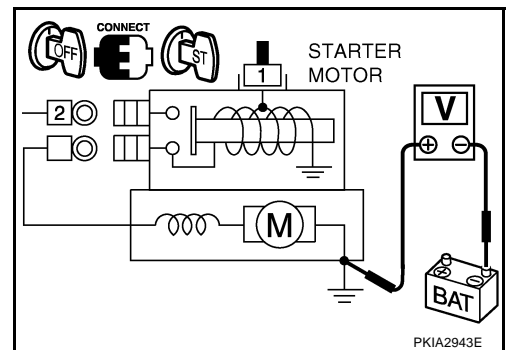

STARTING SYSTEM

DIAGNOSTIC PROCEDURE 2

Check "S" Connector Circuit

1. CHECK POWER SUPPLY FOR STARTER MOTOR "S" TERMINAL

1. Remove fuel pump fuse.
2. Crank or start the engine (where possible) until the fuel pressure is released.
3. Turn ignition switch OFF.
4. Disconnect starter motor connector.
5. Check voltage between starter motor connector F9 terminal 1 (B/Y) and ground.

1 (B/Y) – Ground

When ignition switch is in START : Battery voltage position

OK or NG

- OK >> "S" connector circuit is OK. Further inspection necessary. Refer to [SC-15, "WORK FLOW"](#) .
- NG >> Check the following.
- 40A fusible link (letter M, located in fuse and fusible link block)
 - Ignition switch
 - Starter relay (within the IPDM E/R)
 - Harness between starter motor and IPDM E/R

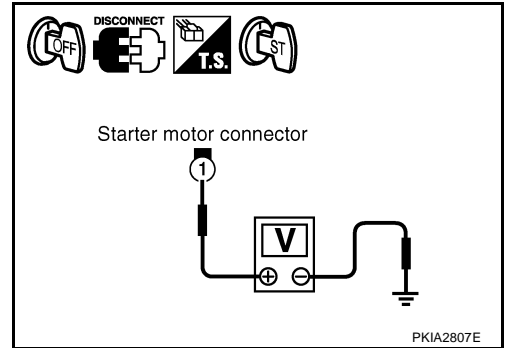

MINIMUM SPECIFICATION OF CRANKING VOLTAGE REFERENCING COOLANT TEMPERATURE

Engine coolant temperature	Voltage [V]
-30 °C to -20 °C (-22 °F to -4 °F)	8.4
-19 °C to -10 °C (-2 °F to 14 °F)	8.9
-9 °C to 0 °C (16 °F to 32 °F)	9.3
More than 1 °C (More than 34 °F)	9.7

STARTING SYSTEM

NKS000SC

Removal and Installation 2WD MODELS

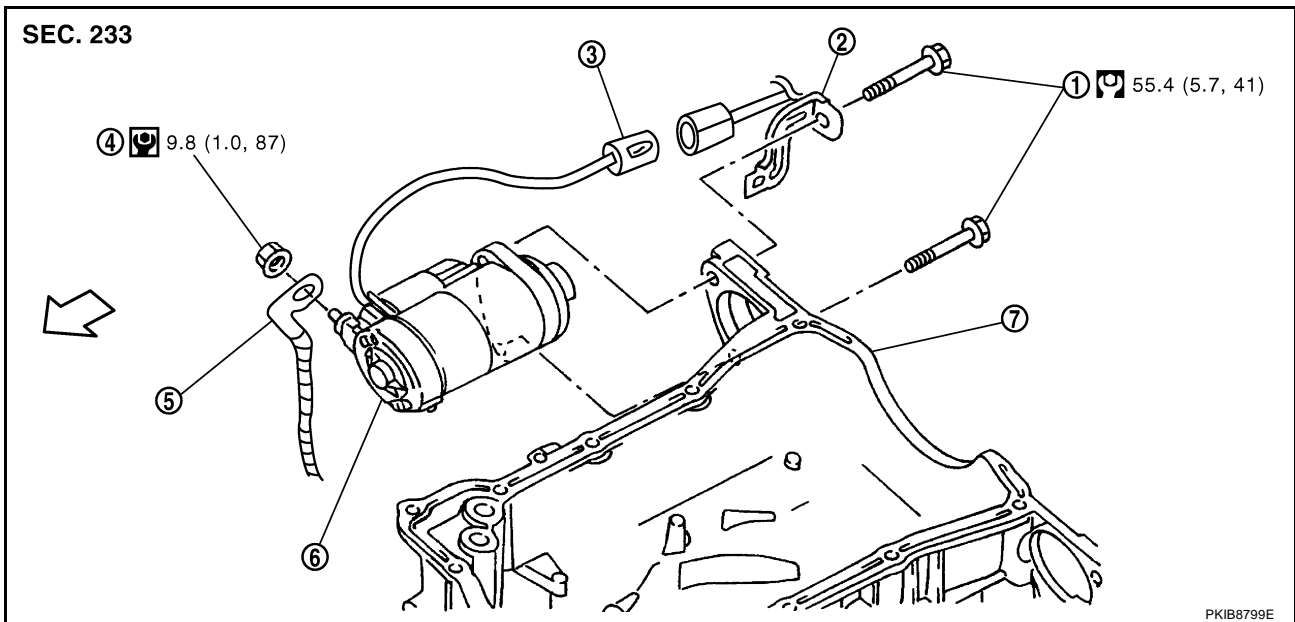

1. Starter motor mounting bolt

2. Harness clip bracket

3. S connector

4. B terminal nut

5. B terminal harness

6. Starter motor

7. Oil pan

: N·m (kg·m, ft·lb)

: N·m (kg·m, in·lb)

: Engine front

Removal

1. Disconnect the battery cable from the negative terminal.
2. Remove engine rear undercover, using power tools.
3. Disconnect "S" connector.
4. Remove "B" terminal nut.
5. Remove starter motor mounting bolts and harness connector clip bracket, using power tools.
6. Remove starter motor downward.

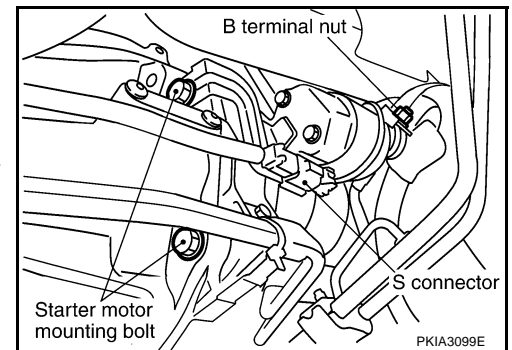

Installation

Installation is the reverse order of removal.

CAUTION:

Be sure to tighten "B" terminal nut carefully.

STARTING SYSTEM

AWD MODELS

SEC. 233

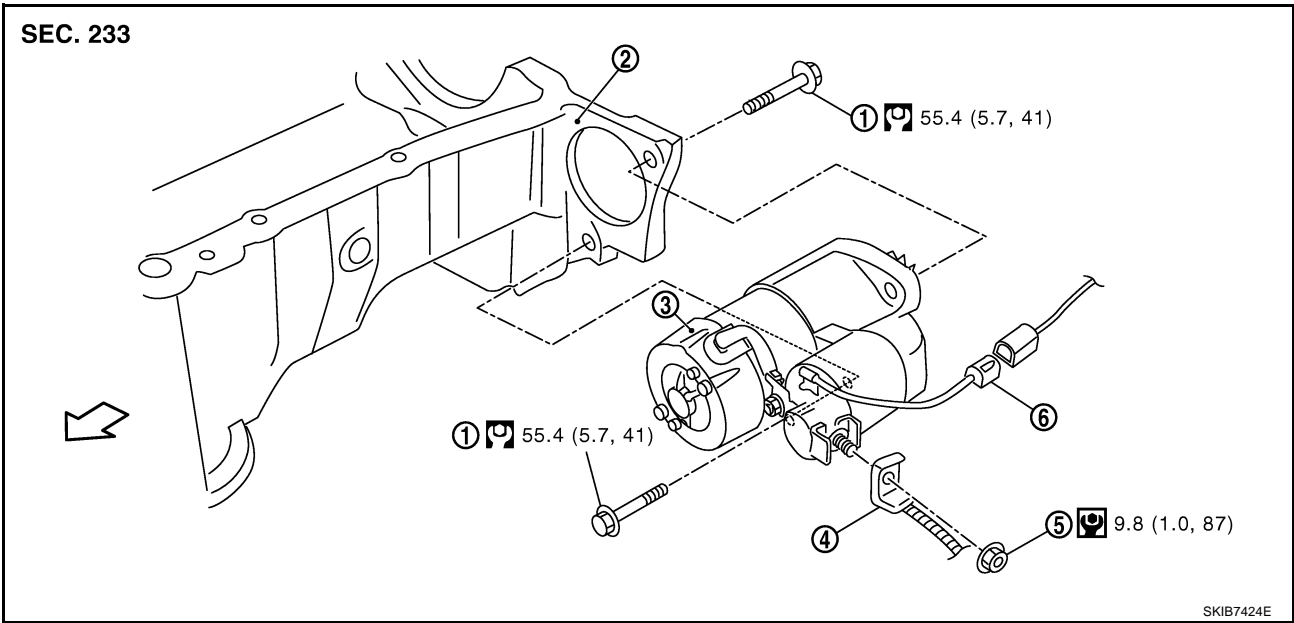

1. Starter motor mounting bolt

2. Oil pan

3. Starter motor

4. B terminal harness

5. B terminal nut

6. S connector

: N·m (kg-m, ft-lb)

: N·m (kg-m, in-lb)

: Engine front

Removal

1. Disconnect the battery cable from the negative terminal.
2. Remove engine front and rear undercover, using power tools.
3. Disconnect "S" connector.
4. Remove "B" terminal nut.
5. Remove starter motor mounting bolts and harness connector clip bracket, using power tools.
6. Remove starter motor downward.

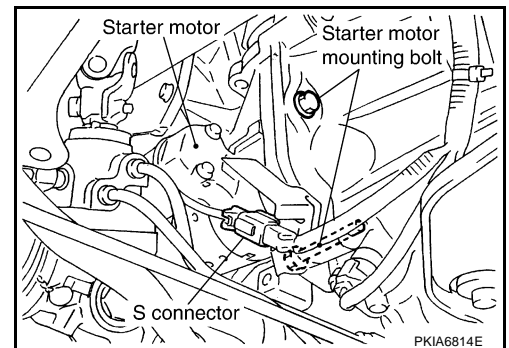

Installation

Installation is the reverse order of removal.

CAUTION:

Be sure to tighten "B" terminal nut carefully.

STARTING SYSTEM

Disassembly and Assembly 2WD MODELS

NKS000SD

SEC. 233
S114-880

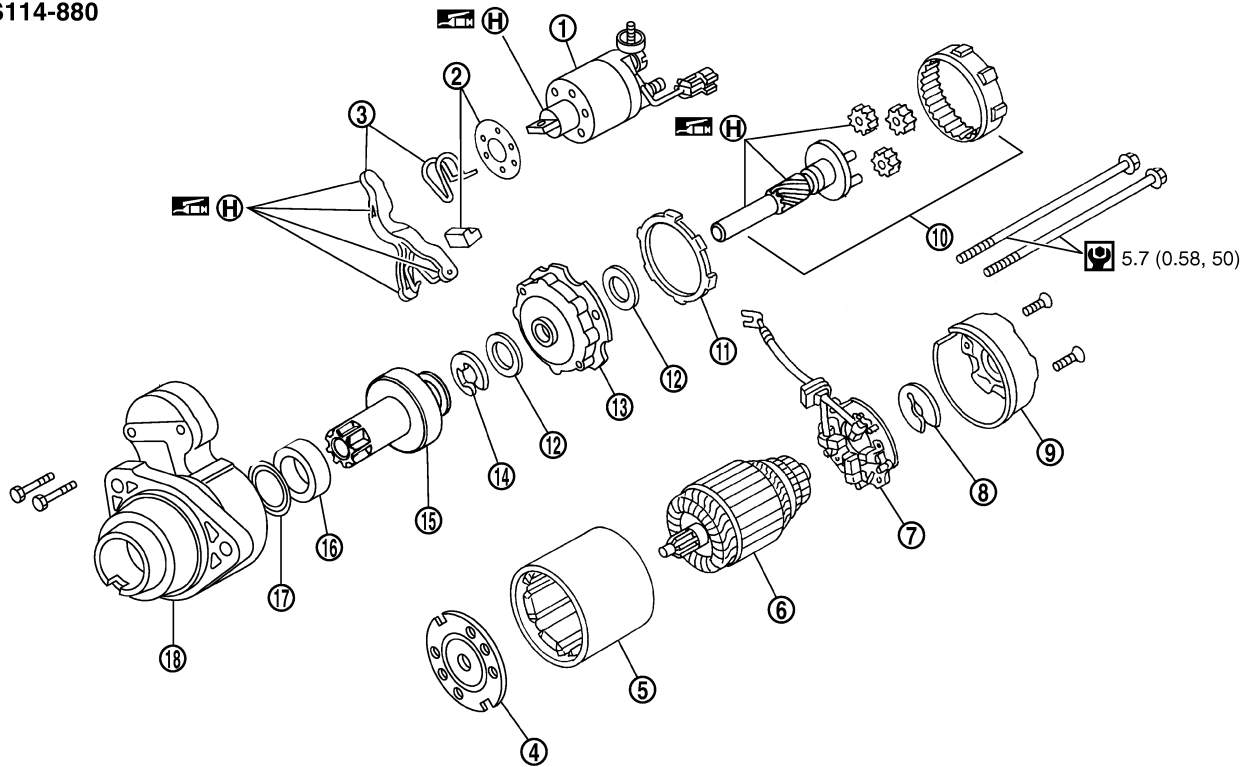

PKIB8804E

- | | | |
|-----------------------------|-------------------|------------------------|
| 1. Magnetic switch assembly | 2. Dust cover kit | 3. Shift lever set |
| 4. Center bracket (A) | 5. Yoke assembly | 6. Armature assembly |
| 7. Brush holder assembly | 8. Thrust washer | 9. Rear cover assembly |
| 10. Shaft gear assembly | 11. Packing | 12. Thrust washer |
| 13. Center bracket (P) | 14. E-ring | 15. Pinion assembly |
| 16. Ball bearing | 17. Caul | 18. Gear case assembly |

 : N·m (kg-m, in-lb)

 (H): High-temperature grease point

STARTING SYSTEM

AWD MODELS

SEC. 233
S114-881

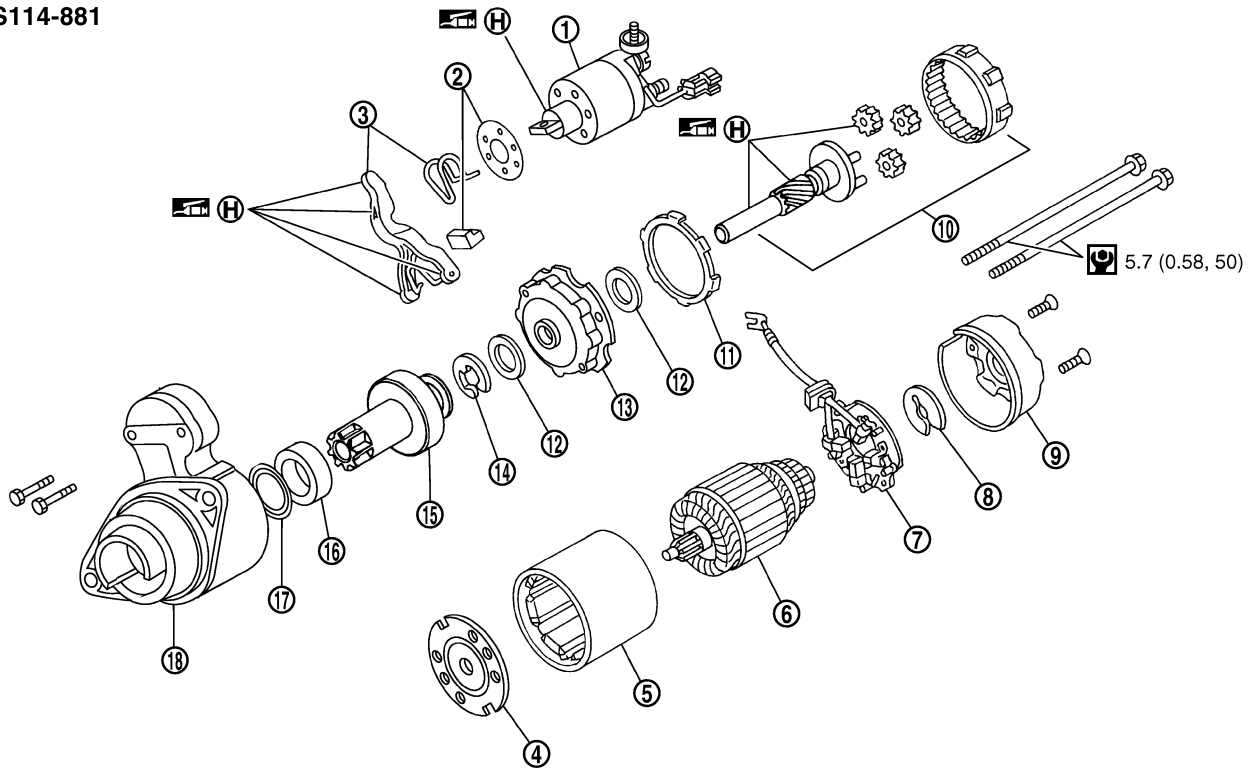

PKIB8805E

- | | | |
|-----------------------------|-------------------|------------------------|
| 1. Magnetic switch assembly | 2. Dust cover kit | 3. Shift lever set |
| 4. Center bracket (A) | 5. Yoke assembly | 6. Armature assembly |
| 7. Brush holder assembly | 8. Thrust washer | 9. Rear cover assembly |
| 10. Shaft gear assembly | 11. Packing | 12. Thrust washer |
| 13. Center bracket (P) | 14. E-ring | 15. Pinion assembly |
| 16. Ball bearing | 17. Caul | 18. Gear case assembly |

: N·m (kg-m, in-lb)

(H): High-temperature grease point

INSPECTION AFTER DISASSEMBLY

Pinion/Clutch Check

- Inspect pinion teeth.
 - Replace pinion if teeth are worn or damaged. (Also check condition of ring gear teeth.)
- Inspect reduction gear teeth.
 - Replace reduction gear if teeth are worn or damaged. (Also check condition of armature shaft gear teeth.)
- Check to see if pinion locks in one direction and rotates smoothly in the opposite direction.
 - If it locks or rotates in both directions, or unusual resistance is evident, replace.

CHARGING SYSTEM

CHARGING SYSTEM

PFP:23100

System Description

NKS000SE

The alternator provides DC voltage to operate the vehicle's electrical system and to keep the battery charged. The voltage output is controlled by the IC regulator.

Power is supplied at all times

- 10A fuse (No. 36, located in the fuse and fusible link block)
- to alternator terminal 4 ("S" terminal).

"B" terminal supplies power to charge the battery and operate the vehicle's electrical system. Output voltage is controlled by the IC regulator at terminal 4 ("S" terminal) detecting the input voltage.

The charging circuit is protected by the 120A fusible link (AWD).

The alternator is grounded to the engine block.

With the ignition switch in the ON or START position, power is supplied

- through 10A fuse [No. 14, located in the fuse block (J/B)]
- to combination meter terminals 22 and 23 for the charge warning lamp.

Ground is supplied

- to combination meter terminal 41
- through alternator terminal 3 ("L" terminal)
- to alternator terminal 2 ("E" terminal)
- through grounds E212 and E213.

The charge warning lamp will illuminate.

When the alternator is providing sufficient voltage with the engine running, the ground is opened and the charge warning lamp will go off.

If the charge warning lamp illuminates with the engine running, a malfunction is indicated.

MALFUNCTION INDICATOR

The IC regulator warning function activates to illuminate charge warning lamp, if any of the following symptoms occur while alternator is operating:

- Excessive voltage is produced.
- No voltage is produced.

CHARGING SYSTEM

Wiring Diagram — CHARGE — 2WD MODELS

NKS000SF

SC-CHARGE-01

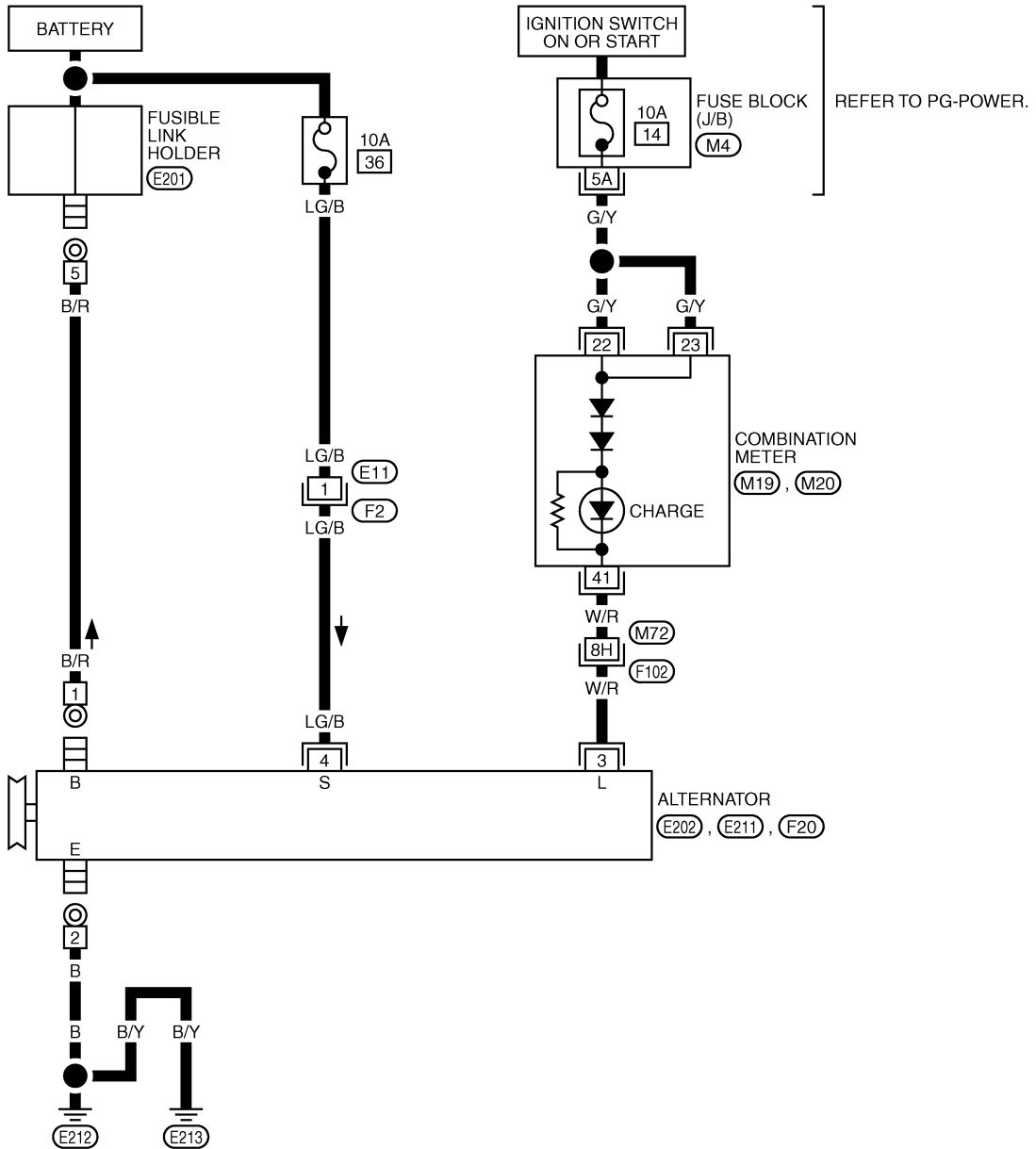

A
B
C
D
E
F
G
H
I
J
SC
L
M

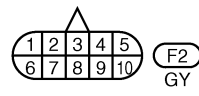
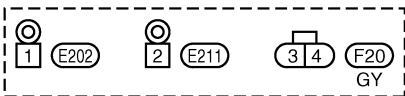
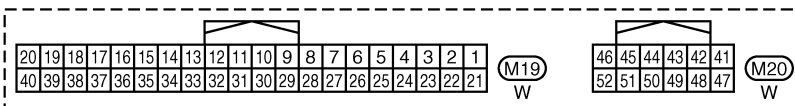

REFER TO THE FOLLOWING.

- F102 -SUPER MULTIPLE JUNCTION (SMJ)
- M4 -FUSE BLOCK-JUNCTION BOX (J/B)

TKWM2118E

CHARGING SYSTEM

AWD MODELS

SC-CHARGE-02

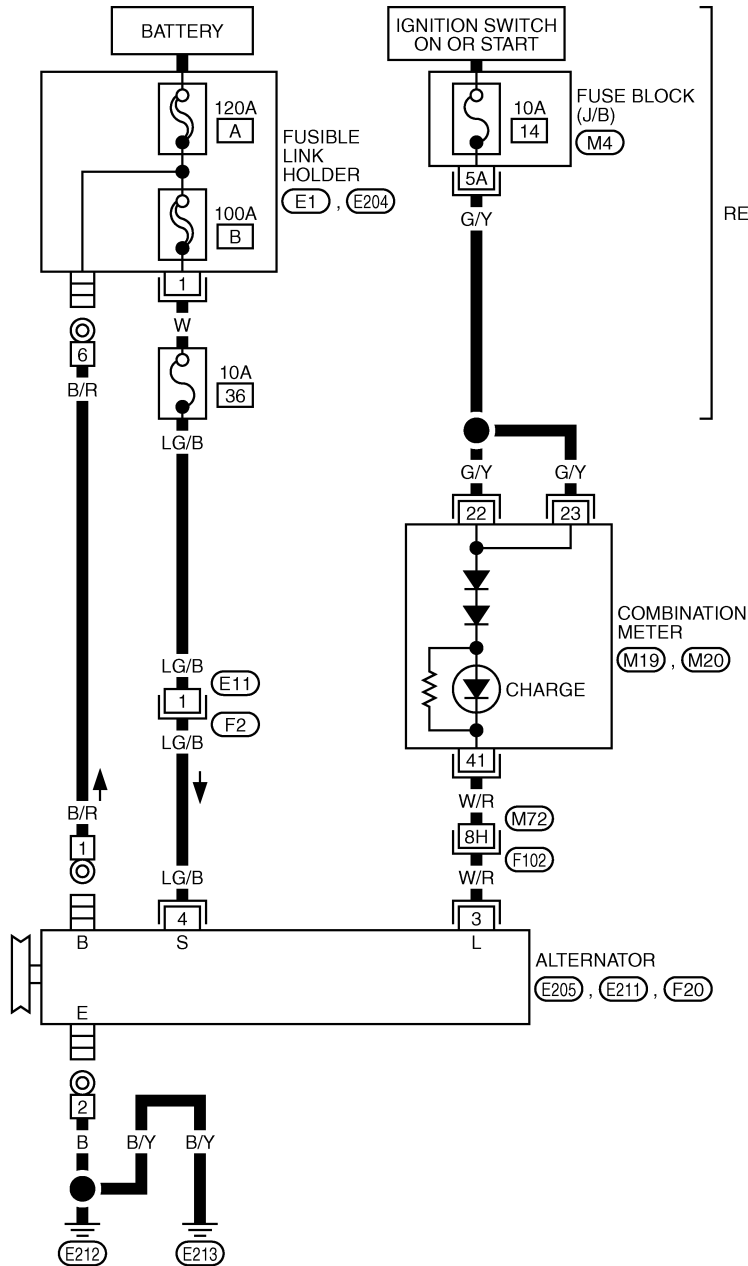

REFER TO PG-POWER.

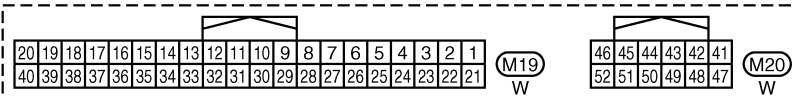

REFER TO THE FOLLOWING.

- (F102) -SUPER MULTIPLE JUNCTION (SMJ)
- (M4) -FUSE BLOCK-JUNCTION BOX (J/B)

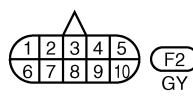
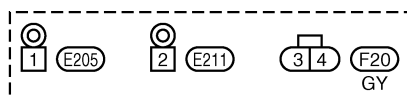
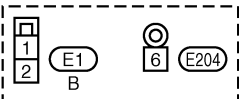

TKWM2119E

CHARGING SYSTEM

Trouble Diagnosis with Battery/Starting/Charging System Tester (Charging) NKS000SG

NOTE:

To ensure a complete and thorough diagnosis, the battery, starter and alternator test segments must be done as a set from start to finish.

Before starting, perform the preliminary inspection. Refer to [SC-28, "PRELIMINARY INSPECTION"](#).

1. Turn off all loads on the vehicle electrical system.
2. Perform battery and starting system test with Battery/Starting/Charging system tester.
3. Press "ENTER" to begin the charging system test.
4. Start engine.



PRESS ENTER FOR
CHARGING TEST

SEL417X

5. Press "ENTER" until "LOADS OFF REV ENGINE 5 SEC" is displayed.
6. Raise and hold the engine speed at 1,500 to 2,000 rpm for about 5 seconds, then return the engine to idle. Once the increase in engine rpm is detected, press "ENTER" to continue.

NOTE:

- If after 30 seconds an increase in engine idle speed is not detected, "RPM NOT DETECTED" will display.
- Some engines may have a higher idle speed initially after starting, particularly when the engine is cold. The tester may detect this without any other action being taken. If this occurs, continue on with the testing process. The final results will not be affected.



LOADS OFF
REV ENGINE 5 SEC

SEL418X

7. The tester now checks the engine at idle and performs the "DIODE/RIPPLE" check.
8. When complete, the tester will prompt you to turn on the following electrical loads.
 - Heater fan set to highest speed. Do not run the A/C or windshield defroster.
 - Headlamp high beam
 - Rear window defogger

NOTE:

Do not run the windshield wipers or any other cyclical loads.



*** TESTING ***
ENGINE AT IDLE

*** TESTING ***
DIODE/RIPPLE

SEL419X

9. Press "ENTER" to continue.



TURN LOADS ON
ENTER TO CONT...

SEL420X

CHARGING SYSTEM

10. Raise and hold the engine speed at 1,500 to 2,000 rpm for about 5 seconds, then return the engine to idle. Once the increase in engine rpm is detected, press "ENTER" to continue.

NOTE:

If after 30 seconds an increase in engine idle speed is not detected, "RPM NOT DETECTED" will be displayed. Press "ENTER" to restart the test.

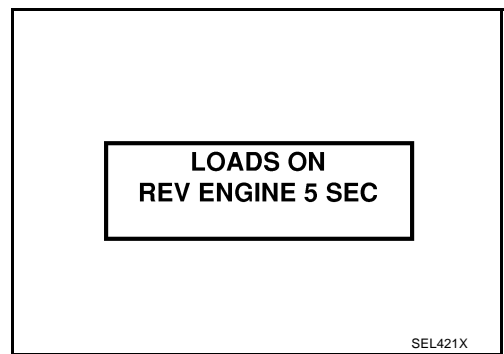

11. Diagnostic result is displayed on the tester. Refer to [SC-26, "DIAGNOSTIC RESULT ITEM CHART"](#) .

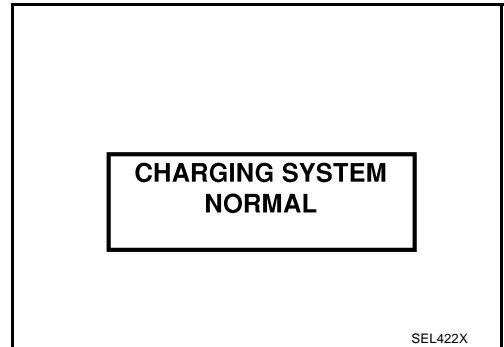

12. Press "ENTER" then test output code is displayed. Record the test output code on the repair order.
 13. Toggle back to the "DIAGNOSTIC SCREEN" for test results.

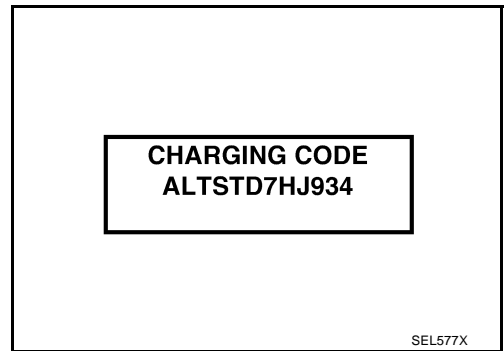

DIAGNOSTIC RESULT ITEM CHART

Diagnostic item	Service procedure
CHARGING SYSTEM NORMAL	Charging system is normal and will also show "DIODE RIPPLE" test result.
NO CHARGING VOLTAGE	Go to SC-27, "WORK FLOW" .
LOW CHARGING VOLTAGE	
HIGH CHARGING VOLTAGE	
DIODE RIPPLE NORMAL	Diode ripple is OK and will also show "CHARGING VOLTAGE" test result.
EXCESS RIPPLE DETECTED	Replace the alternator. Perform "DIODE RIPPLE" test again using Battery/Starting/Charging system tester to confirm repair.
DIODE RIPPLE NOT DETECTED	Go to SC-27, "WORK FLOW" .

CHARGING SYSTEM

WORK FLOW

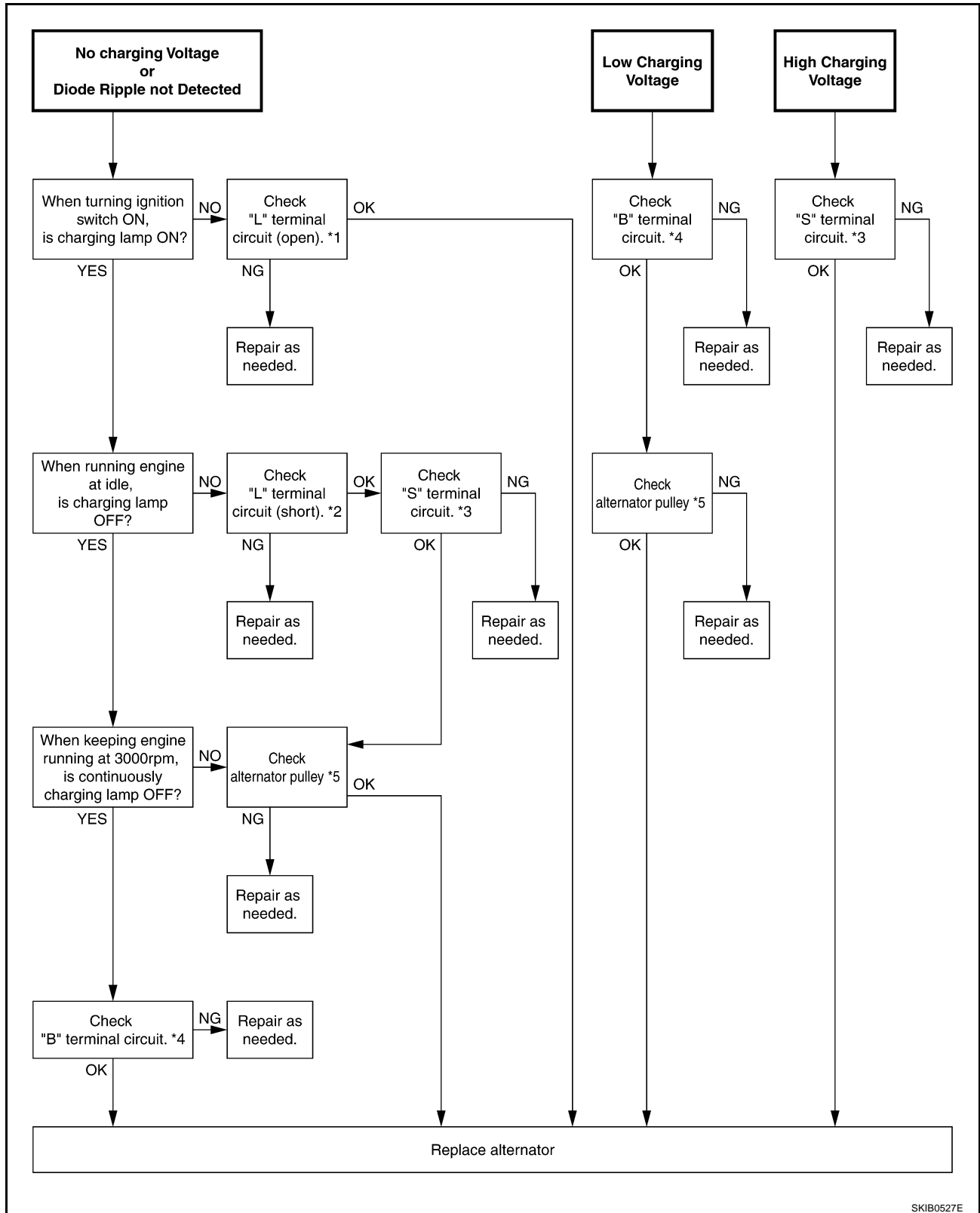

A
B
C
D
E
F
G
H
I
J
SC
L
M

SC

SKIB0527E

- *1 [SC-29, "Check "L" Terminal Circuit \(Open\)"](#)
- *2 [SC-30, "Check "L" Terminal Circuit \(Short\)"](#)
- *3 [SC-30, "Check "S" Terminal Circuit"](#)
- *4 [SC-31, "Check "B" Terminal Circuit"](#)
- *5 [SC-33, "ALTERNATOR PULLEY INSPECTION"](#)

CHARGING SYSTEM

PRELIMINARY INSPECTION

1. CHECK BATTERY TERMINALS CONNECTION

Check if battery terminals are clean and tight.

OK or NG

OK >> GO TO 2.

NG >> Repair battery terminals connection.

2. CHECK FUSE AND FUSIBLE LINK

Check for blown alternator and combination meter fuses.

Unit	Power source (Power supply terminals)	Fuse No.
Alternator	Battery ("S" terminal)	36
Combination meter	Ignition switch ON ("L" terminal)	14

OK or NG

OK >> GO TO 3.

NG >> Be sure to eliminate cause of malfunction before installing new fuse. Refer to [PG-3, "POWER SUPPLY ROUTING CIRCUIT"](#) .

3. CHECK "E" TERMINAL CONNECTION

Check if "E" terminal is clean and tight.

OK or NG

OK >> GO TO 4.

NG >> Repair "E" terminal connection.

4. CHECK ALTERNATOR AND POWER STEERING OIL PUMP BELT TENSION

Check alternator and power steering oil pump belt tension. Refer to [EM-15, "Checking Drive Belts"](#) .

OK or NG

OK >> INSPECTION END

NG >> Repair as needed.

CHARGING SYSTEM

DIAGNOSTIC PROCEDURE 1

Check "L" Terminal Circuit (Open)

1. CHECK "L" TERMINAL CONNECTION

1. Turn ignition switch OFF.
2. Check if "L" terminal is clean and tight.

OK or NG

OK >> GO TO 2.

NG >> Repair "L" terminal connection. Confirm repair by performing complete Battery/Starting/Charging system test.

2. CHECK "L" TERMINAL CIRCUIT (OPEN)

1. Disconnect alternator connector.
2. Apply ground to alternator harness connector F20 terminal 3 (W/R) with ignition switch in the ON position.

3 (W/R) – Ground : Charge warning lamp should light up.

OK or NG

OK >> Go to [SC-27, "WORK FLOW"](#) .

NG >> Check the following.

- Charge warning lamp (combination meter)
- Harness for open between combination meter and fuse
- Harness for open between combination meter and alternator

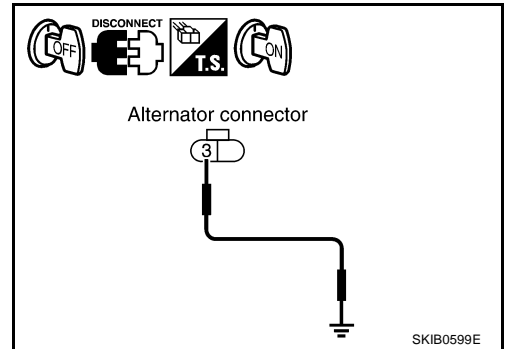

A
B
C
D
E
F
G
H
I
J
SC
L
M

CHARGING SYSTEM

DIAGNOSTIC PROCEDURE 2

Check "L" Terminal Circuit (Short)

1. CHECK "L" TERMINAL CIRCUIT (SHORT)

1. Turn ignition switch OFF.
2. Disconnect alternator connector.
3. Turn ignition switch ON.

Charge warning lamp should light up?

YES >> Check the following.

- Harness for short between combination meter and alternator
- Charge warning lamp (Combination meter)

NO >> Go to [SC-27, "WORK FLOW"](#) .

DIAGNOSTIC PROCEDURE 3

Check "S" Terminal Circuit

1. CHECK "S" TERMINAL CONNECTION

1. Turn ignition switch OFF.
2. Check if "S" terminal is clean and tight.

OK or NG

OK >> GO TO 2.

NG >> Repair "S" terminal connection. Confirm repair by performing complete Battery/Starting/Charging system test.

2. CHECK ALTERNATOR "S" TERMINAL CIRCUIT

1. Disconnect alternator connector.
2. Check voltage between alternator harness connector F20 terminal 4 (LG/B) and ground using.

4 (LG/B) – Ground : Battery voltage

OK or NG

OK >> Go to [SC-27, "WORK FLOW"](#) .

NG >> Check harness for open between alternator and fuse.

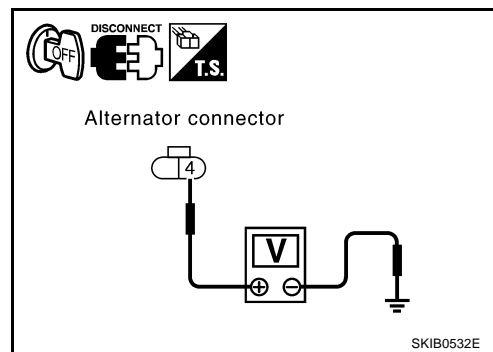

CHARGING SYSTEM

DIAGNOSTIC PROCEDURE 4

Check "B" Terminal Circuit

1. CHECK "B" TERMINAL CONNECTION

1. Turn ignition switch OFF.
2. Check if "B" terminal is clean and tight.

OK or NG

OK >> GO TO 2.

NG >> Repair "B" terminal connection. Confirm repair by performing complete Battery/Starting/Charging system test.

2. CHECK ALTERNATOR "B" TERMINAL CIRCUIT

Check voltage between alternator "B" terminal E202 (2WD) or E205 (AWD) terminal 1 (B/R) and ground.

1 (B/R) – Ground : Battery voltage

OK or NG

OK >> GO TO 3.

NG >> Check the following.

- Harness for open between alternator and fusible link (AWD)
- Harness for open between alternator and battery (2WD)

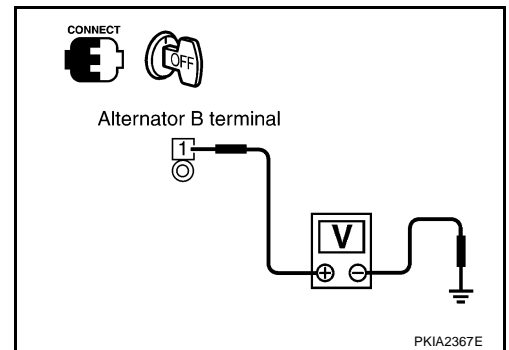

3. CHECK "B" TERMINAL CONNECTION (VOLTAGE DROP TEST)

1. Start engine.
2. When engine running at idle and warm, check voltage between alternator "B" terminal E202 (2WD) or E205 (AWD) terminal 1 (B/R) and battery positive terminal.

1 (B/R) – Battery positive terminal : Less than 0.2 V

OK or NG

OK >> Go to [SC-27, "WORK FLOW"](#).

NG >> Check harness between battery and alternator for poor continuity.

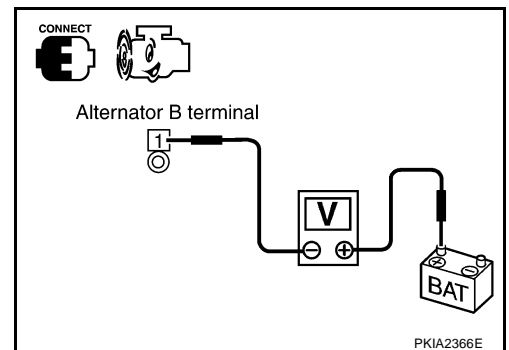

A
B
C
D
E
F
G
H
I
J
SC
L
M

CHARGING SYSTEM

Removal and Installation

NKS000SH

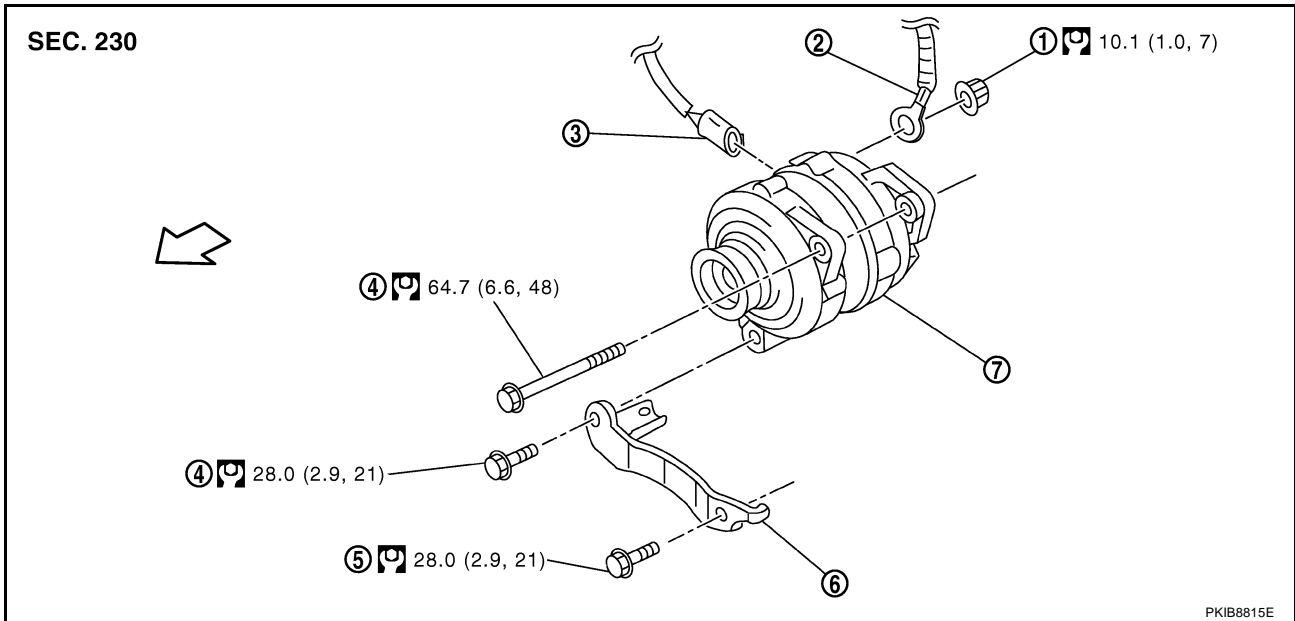

A/T (2WD) MODELS

Removal

1. Disconnect the battery cable from the negative terminal.
2. Remove engine undercover, using power tools.
3. Remove stabilizer clamps (1). Refer to [FSU-6, "FRONT SUSPENSION ASSEMBLY"](#).
4. Slide stabilizer (2) downward.
5. Remove alternator and power steering oil pump belt. Refer to [EM-16, "Removal and Installation"](#).
6. Remove oil pressure switch harness clip (A) from alternator stay (1).
7. Disconnect oil pressure switch connector (2).
8. Remove alternator stay mounting bolts (B) and alternator stay (1), using power tools.
9. Remove alternator mounting bolt (C), using power tools.

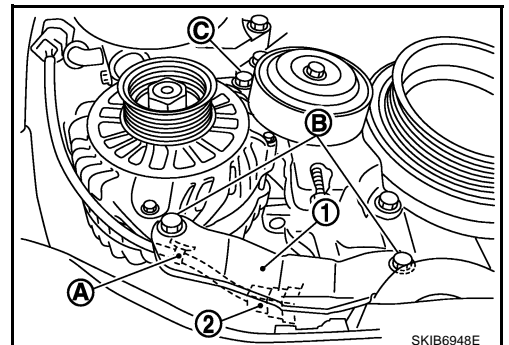
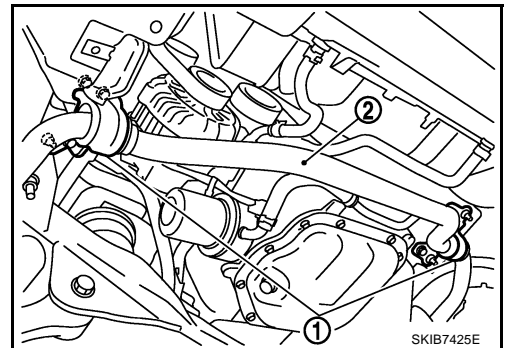

CHARGING SYSTEM

10. Disconnect alternator connector (1).
11. Remove "B" terminal nut (2).
12. Remove harness clip and water hose bracket bolts (A) from alternator.
13. Remove alternator assembly downward.

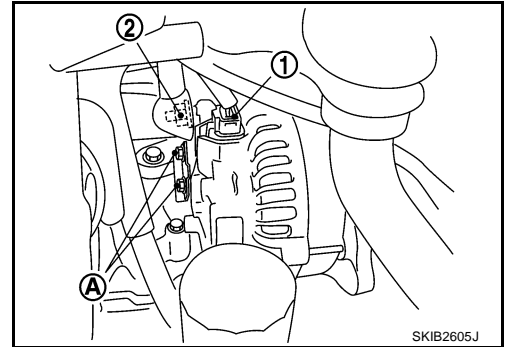

A
B
C
D

ALTERNATOR PULLEY INSPECTION

Perform the following.

- Make sure that alternator pulley does not rattle.
- Make sure that alternator pulley nut is tight.

Alternator pulley nut:

: 118 N·m (12.0 kg·m, 87 ft·lb)

Installation

Installation is the reverse order of removal.

- Install alternator, and check tension of belt. Refer to [MA-12, "Checking Drive Belts"](#).

CAUTION:

Be sure to tighten B terminal nut carefully.

A/T (AWD) AND M/T MODELS

Removal

1. Disconnect the battery cable from the negative terminal.
2. Remove engine undercover, using power tools.
3. Remove radiator cooling fan assembly. Refer to [CO-13, "RADIATOR"](#).
4. Remove alternator and power steering oil pump belt. Refer to [EM-16, "Removal and Installation"](#).
5. Disconnect oil temperature sensor switch harness connector (1) (M/T models).
6. Disconnect oil temperature sensor switch connector (2) (M/T models).

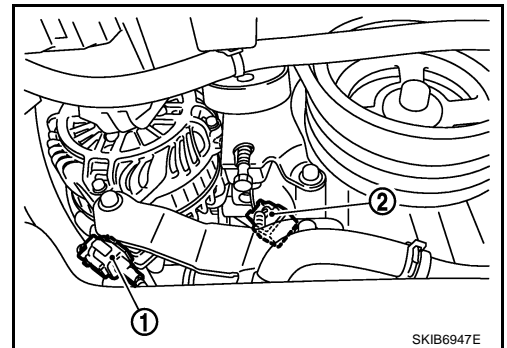

SC

7. Remove oil pressure switch harness clip (A) from alternator stay (1).
8. Disconnect oil pressure switch connector (2).
9. Remove alternator stay mounting bolts (B) and alternator stay (1), using power tools.
10. Remove alternator mounting bolt (C), using power tools.

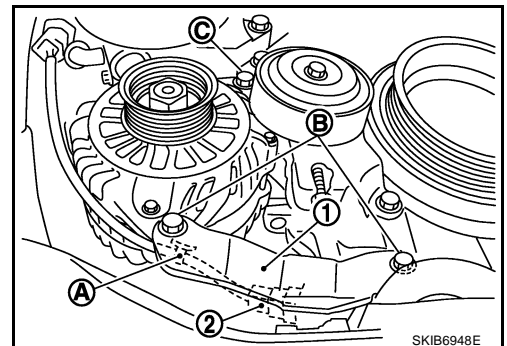

L
M

CHARGING SYSTEM

11. Disconnect alternator connector (1).
12. Remove "B" terminal nut (2).
13. Remove harness clip and water hose bracket bolts (A) from alternator.
14. Remove alternator assembly downward.

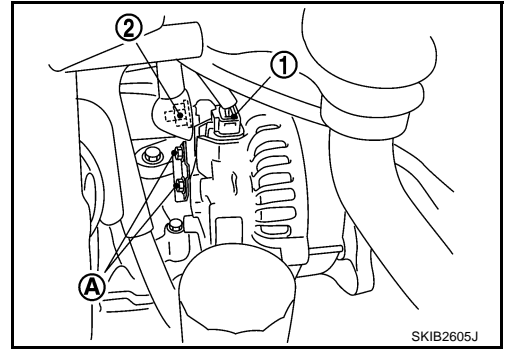

ALTERNATOR PULLEY INSPECTION

Perform the following.

- Make sure that alternator pulley does not rattle.
- Make sure that alternator pulley nut is tight.

Alternator pulley nut:

: 118 N·m (12.0 kg·m, 87 ft·lb)

Installation

Installation is the reverse order of removal.

- Install alternator, and check tension of belt. Refer to [MA-12, "Checking Drive Belts"](#).

CAUTION:

Be sure to tighten "B" terminal nut carefully.

CHARGING SYSTEM

Disassembly and Assembly

NKS000SI

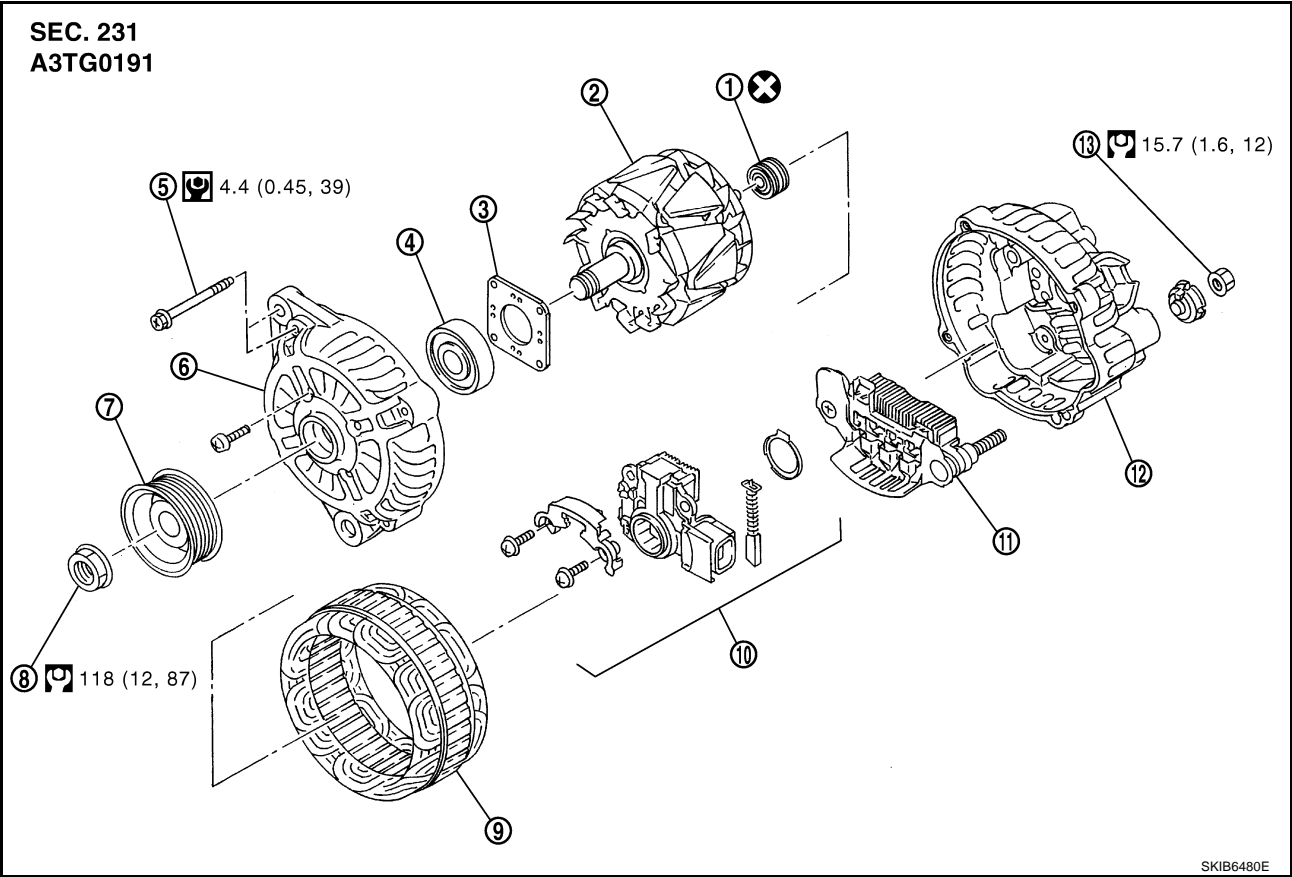

- | | | |
|-----------------------------------|--------------------|---------------------------|
| 1. Rear bearing | 2. Rotor assembly | 3. Retainer |
| 4. Front bearing | 5. Through-bolt | 6. Front bracket assembly |
| 7. Pulley | 8. Pulley nut | 9. Stator assembly |
| 10. IC voltage regulator assembly | 11. Diode assembly | 12. Rear bracket assembly |
| 13. B terminal nut | | |

: N·m (kg·m, in·lb)

: N·m (kg·m, ft·lb)

: Always replace after every disassembly

A
B
C
D
E
F
G
H
I
J
SC
L
M

SERVICE DATA AND SPECIFICATIONS (SDS)

SERVICE DATA AND SPECIFICATIONS (SDS)

PFP:00030

Battery

NKS000SJ

Type	80D23L
20 hour rate capacity	12 V - 62 AH
Cold cranking current (For reference value)	582 A

Starter

NKS000SK

Applied model	2WD	AWD
	S114-880	S114-881
Type	HITACHI make	
	Reduction gear type	
System voltage	12 V	
No-load	Terminal voltage	11 V
	Current	Less than 90 A
	Revolution	More than 2,880 rpm
Minimum diameter of commutator	28.0 mm (1.102 in)	
Minimum length of brush	10.5 mm (0.413 in)	
Brush spring tension	16.2 N (1.65 kg, 3.6 lb)	
Clearance between bearing metal and armature shaft	Less than 0.2 mm (0.008 in)	
Movement in height of pinion assembly	0.3 - 2.5 mm (0.012 - 0.098 in)	

Alternator

NKS000SL

Type	A3TG0191
	MITSUBISHI make
Nominal rating	12 V - 110 A
Ground polarity	Negative
Minimum revolution under no-load (When 13.5 V is applied)	Less than 1,000 rpm
Hot output current (When 13.5 V is applied)	More than 37 A/1,300 rpm More than 92 A/2,500 rpm More than 103 A/5,000 rpm
Regulated output voltage	14.1 - 14.7 V
Minimum length of brush	More than 5.00 mm (0.197 in)
Brush spring pressure	4.8 - 6.0 N (490 - 612 g, 17.28 - 21.60 oz)
Slip ring minimum outer diameter	More than 22.1 mm (0.870 in)
Rotor (Field coil) resistance	1.7 - 2.1 Ω