

SECTION **RFD**  
REAR FINAL DRIVE

A  
B  
C

RFD

CONTENTS

E

<b>PRECAUTIONS</b> .....	<b>2</b>	<b>COMPONENTS</b> .....	<b>18</b>	<b>F</b>
Service Notice or Precautions .....	2	<b>REMOVAL</b> .....	18	
<b>PREPARATION</b> .....	<b>3</b>	<b>INSTALLATION</b> .....	19	
Special Service Tools .....	3	Disassembly and Assembly (R200 2-Pinion) .....	20	<b>G</b>
Commercial Service Tools .....	6	<b>COMPONENTS</b> .....	20	
<b>NOISE, VIBRATION AND HARSHNESS (NVH)</b>		<b>ASSEMBLY INSPECTION AND ADJUSTMENT..</b>	21	
<b>TROUBLESHOOTING</b> .....	<b>7</b>	<b>DISASSEMBLY</b> .....	25	<b>H</b>
NVH Troubleshooting Chart .....	7	<b>INSPECTION AFTER DISASSEMBLY</b> .....	29	
<b>DESCRIPTION</b> .....	<b>8</b>	<b>ADJUSTMENT AND SELECTION OF ADJUST-</b>		
Cross-Sectional View .....	8	<b>ING WASHERS</b> .....	29	
2WD MODELS .....	8	<b>ASSEMBLY</b> .....	34	<b>I</b>
AWD MODELS .....	9	Disassembly and Assembly (R200V LSD) .....	40	
<b>DIFFERENTIAL GEAR OIL</b> .....	<b>10</b>	<b>COMPONENTS</b> .....	40	
Changing Differential Gear Oil .....	10	<b>ASSEMBLY INSPECTION AND ADJUSTMENT..</b>	41	<b>J</b>
<b>DRAINING</b> .....	10	<b>DISASSEMBLY</b> .....	45	
<b>FILLING</b> .....	10	<b>INSPECTION AFTER DISASSEMBLY</b> .....	49	
Checking Differential Gear Oil .....	10	<b>ADJUSTMENT AND SELECTION OF ADJUST-</b>		
<b>OIL LEAKAGE AND OIL LEVEL</b> .....	10	<b>ING WASHERS</b> .....	49	<b>K</b>
<b>FRONT OIL SEAL</b> .....	<b>11</b>	<b>ASSEMBLY</b> .....	54	
Removal and Installation .....	11	<b>SERVICE DATA AND SPECIFICATIONS (SDS) .....</b>	<b>60</b>	<b>L</b>
<b>IDENTIFICATION STAMP OF REPLACEMENT</b>		General Specifications .....	60	
<b>FREQUENCY OF FRONT OIL SEAL</b> .....	11	2WD MODELS .....	60	
<b>REMOVAL</b> .....	12	AWD MODELS .....	60	
<b>INSTALLATION</b> .....	13	Inspection and Adjustment .....	60	<b>M</b>
<b>SIDE OIL SEAL</b> .....	<b>16</b>	<b>DRIVE GEAR RUNOUT</b> .....	60	
Removal and Installation .....	16	<b>DIFFERENTIAL SIDE GEAR CLEARANCE</b> .....	60	
<b>REMOVAL</b> .....	16	<b>PRELOAD TORQUE</b> .....	60	
<b>INSTALLATION</b> .....	16	<b>BACKLASH</b> .....	60	
<b>REAR FINAL DRIVE ASSEMBLY</b> .....	<b>18</b>	<b>COMPANION FLANGE RUNOUT</b> .....	61	
Removal and Installation .....	18	<b>SELECTIVE PARTS</b> .....	61	

# PRECAUTIONS

---

## PRECAUTIONS

PFP:00001

### Service Notice or Precautions

NDS00045

- Check for the correct installation status prior to removal or disassembly. If matching marks are required, be certain they do not interfere with the function of the parts when applied.
- Overhaul should be done in a clean work area, it is preferable to work in dustproof area.
- Before disassembly, using steam or white gasoline, completely remove sand and mud from the exterior of the unit, preventing them from entering into the unit during disassembly or assembly.
- Check appearance of the disassembled parts for damage, deformation, and unusual wear. Replace them with a new ones if necessary.
- Gaskets, seals and O-rings should be replaced any time when the unit is disassembled.
- In principle, tighten bolts or nuts gradually in several steps working diagonally from inside to outside. If tightening sequence is specified, observe it.
- Clean and flush the parts sufficiently and blow-dry them.
- Be careful not to damage sliding surfaces and mating surfaces.
- When applying sealant, remove the old sealant from the mounting surface; then remove any moisture, oil, and foreign materials from the application and mounting surfaces.
- Always use shop paper for cleaning the inside of components.
- Avoid using cotton gloves or shop rags to prevent entering of lint.
- During assembly, observe the specified tightening torque, and apply new gear oil, petroleum jelly, or multi-purpose grease as specified for each vehicle, if necessary.

# PREPARATION

## PREPARATION

PPF:00002

### Special Service Tools

NDS00046

The actual shapes of Kent-Moore tools may differ from those of special service tools illustrated here.

Tool number (Kent-Moore No.) Tool name	Description
KV40104000 ( — ) Flange wrench a: 85 mm (3.35 in) dia. b: 65 mm (2.56 in) dia.	Removing and installing drive pinion lock nut
KV381054S0 (J-34286) Puller	Removing front oil seal
ST30720000 (J-25405) Drift a: 77 mm (3.03 in) dia. b: 55.5 mm (2.185 in) dia.	<ul style="list-style-type: none"> <li>● Installing front oil seal</li> <li>● Installing pinion rear bearing outer race</li> </ul>
KV40104100 ( — ) Attachment	Removing side flange
ST36230000 (J-25840-A) Sliding hammer	Removing side flange
KV38100200 (J-26233) Drift a: 65 mm (2.56 in) dia. b: 49 mm (1.93 in) dia.	Installing side oil seal
KV38107900 (J-39352) Protector	Installing side flange

A  
B  
C  
RFD  
E  
F  
G  
H  
I  
J  
K  
L  
M

# PREPARATION

Tool number (Kent-Moore No.) Tool name	Description
KV38100800 (J-25604-01) Attachment a: 541 mm (21.30 in) b: 200 mm (7.87 in)	Fixing unit assembly
ST3127S000 (J-25765-A) Preload gauge 1: GG91030000 (J-25765) Torque wrench 2: HT62940000 ( — ) Socket adapter (1/2") 3: HT62900000 ( — ) Socket adapter (3/8")	Measuring pinion bearing preload and total preload
KV10111100 (J-37228) Seal cutter	Removing rear cover
ST3306S001 (J-22888-D) Differential side bearing puller set 1: ST33051001 (J-22888-20) Puller 2: ST33061000 (J-8107-2) Base a: 28.5 mm (1.122 in) dia. b: 38 mm (1.50 in) dia.	Removing and installing side bearing inner race
ST30031000 (J-22912-01) Replacer	Removing pinion rear bearing inner race
KV40105230 ( — ) Drift a: 92 mm (3.62 in) dia. b: 86 mm (3.39 in) dia. c: 45 mm (1.77 in) dia.	Installing pinion rear bearing outer race

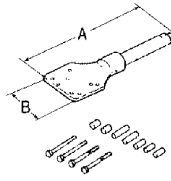

SDIA0267E

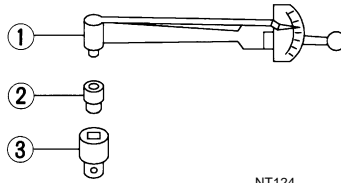

NT124

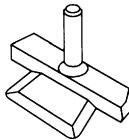

S-NT046

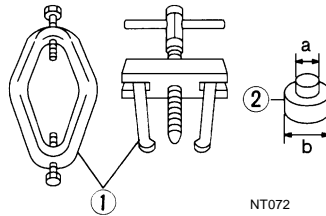

NT072

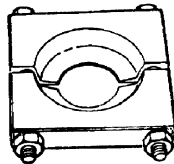

ZZA0700D

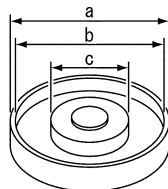

PDIA0591E

# PREPARATION

Tool number (Kent-Moore No.) Tool name	Description	
ST30613000 (J-25742-3) Drift a: 72 mm (2.83 in) dia. b: 48 mm (1.89 in) dia.	Installing pinion front bearing outer race	A B C
ST30611000 (J-25742-1) Drift bar	Installing pinion front bearing outer race (Use with ST30613000)	RFD E
ST30901000 (J-26010-01) Drift a: 79 mm (3.11 in) dia. b: 45 mm (1.77 in) dia. c: 35.2 mm (1.386 in) dia.	Installing pinion rear bearing inner race	F G H
KV38100300 (J-25523) Drift a: 54 mm (2.13 in) dia. b: 46 mm (1.81 in) dia. c: 32 mm (1.26 in) dia.	Installing side bearing inner race	I J
(J-8129) Spring gauge	Measuring turning torque	K L
(J-34309) Differential shim selector tool	Adjusting bearing preload and pinion gear height	M
(J-25269-4) Side bearing disc (2 Req'd)	Selecting pinion height adjusting washer	

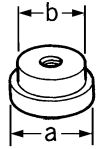

ZZA1000D

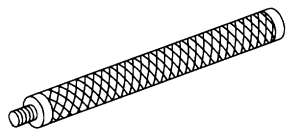

S-NT090

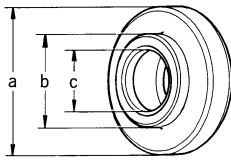

ZZA0978D

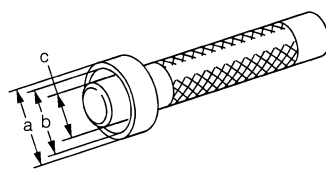

ZZA1046D

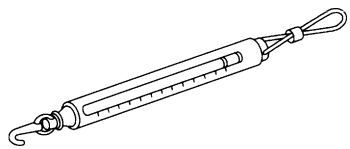

NT127

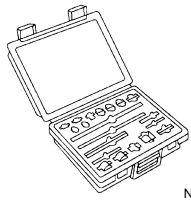

NT134

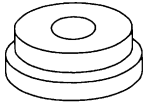

NT136

# PREPARATION

## Commercial Service Tools

NDS00047

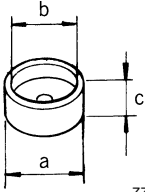
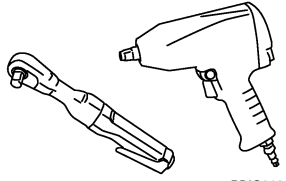
Tool name	Description
<p>Spacer</p> <p>a: 60 mm (2.36 in) dia. b: 36 mm (1.42 in) dia. c: 30 mm (1.18 in)</p>  <p>ZZA1133D</p>	<p>Installing pinion front bearing inner race</p>
<p>Power tool</p>  <p>PBIC0190E</p>	<p>Loosening nuts and bolts</p>

# NOISE, VIBRATION AND HARSHNESS (NVH) TROUBLESHOOTING

## NOISE, VIBRATION AND HARSHNESS (NVH) TROUBLESHOOTING

PFP:00003

### NVH Troubleshooting Chart

NDS00048

Use the chart below to help you find the cause of the symptom. If necessary, repair or replace these parts.

Symptom	Noise	Reference page	Possible cause and SUSPECTED PARTS
x		Refer to <a href="#">RFD-29</a> (R200 2-pinion), <a href="#">RFD-49</a> (R200V LSD).	Gear tooth rough
x		Refer to <a href="#">RFD-22</a> (R200 2-pinion), <a href="#">RFD-42</a> (R200V LSD).	Gear contact improper
x		Refer to <a href="#">RFD-29</a> (R200 2-pinion), <a href="#">RFD-49</a> (R200V LSD).	Tooth surfaces worn
x		Refer to <a href="#">RFD-23</a> (R200 2-pinion), <a href="#">RFD-43</a> (R200V LSD).	Backlash incorrect
x		Refer to <a href="#">RFD-24</a> (R200 2-pinion), <a href="#">RFD-44</a> (R200V LSD).	Companion flange excessive runout
x		Refer to <a href="#">RFD-10</a> .	Gear oil improper
x		NVH in PR section	PROPELLER SHAFT
x		NVH in FAX, RAX, FSU and RSU sections	AXLE AND SUSPENSION
x		NVH in WT section	TIRES
x		NVH in WT section	ROAD WHEEL
x		NVH in FAX and RAX section	DRIVE SHAFT
x		NVH in BR section	BRAKES
x		NVH in PS section	STEERING

x: Applicable

A  
B  
C  
**RFD**  
E  
F  
G  
H  
I  
J  
K  
L  
M

# DESCRIPTION

## DESCRIPTION

PFP:00000

### Cross-Sectional View 2WD MODELS

NDS00049

#### R200 (2-pinion)

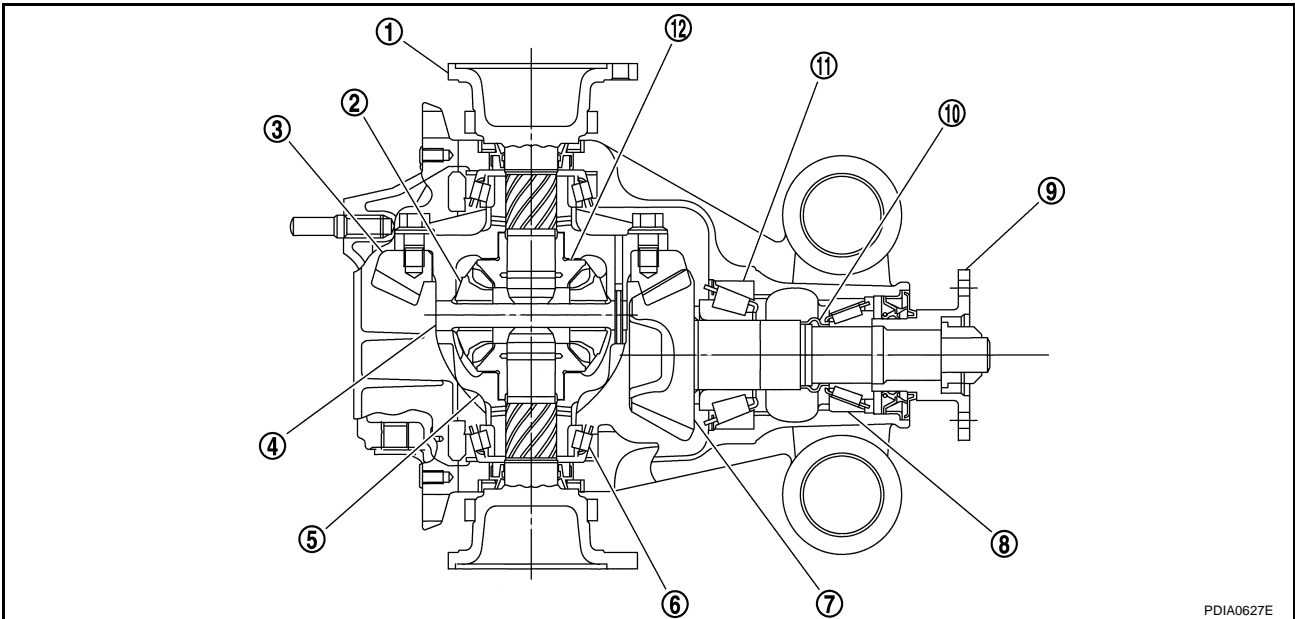

PDIA0627E

- |                        |                         |                     |
|------------------------|-------------------------|---------------------|
| 1. Side flange         | 2. Pinion mate gear     | 3. Drive gear       |
| 4. Pinion mate shaft   | 5. Differential case    | 6. Side bearing     |
| 7. Drive pinion        | 8. Pinion front bearing | 9. Companion flange |
| 10. Collapsible spacer | 11. Pinion rear bearing | 12. Side gear       |

#### R200V (LSD)

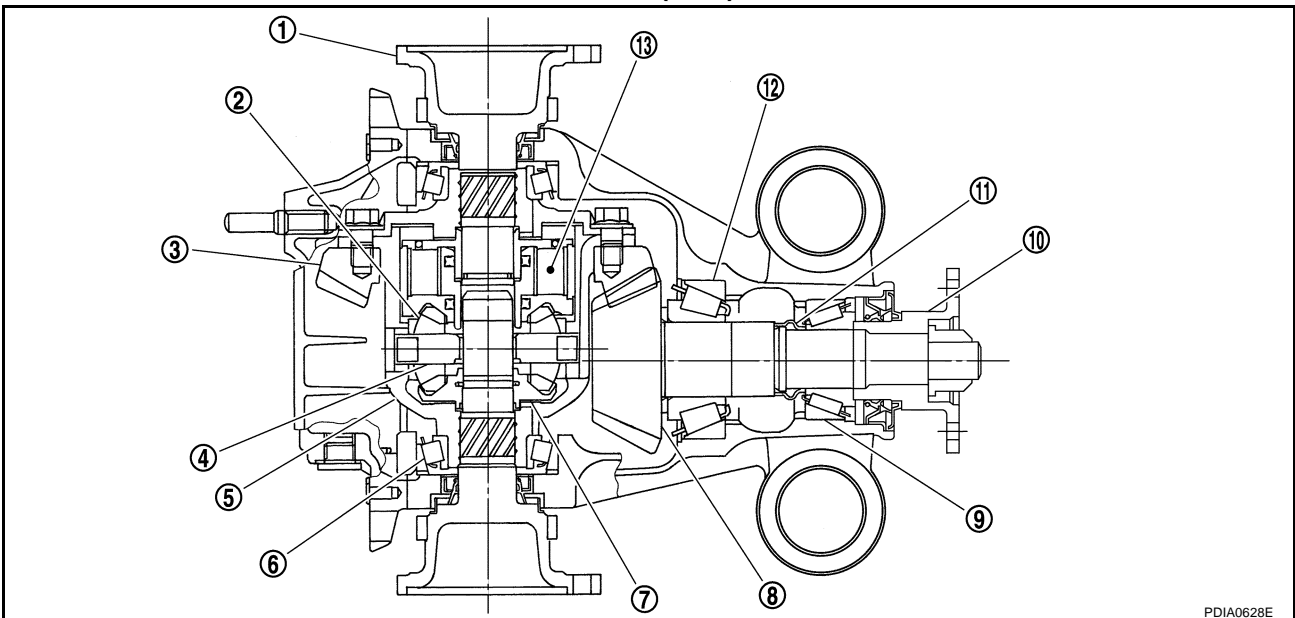

PDIA0628E

- |                      |                        |                         |
|----------------------|------------------------|-------------------------|
| 1. Side flange       | 2. Pinion mate gear    | 3. Drive gear           |
| 4. Pinion mate shaft | 5. Differential case   | 6. Side bearing         |
| 7. Side gear         | 8. Drive pinion        | 9. Pinion front bearing |
| 10. Companion flange | 11. Collapsible spacer | 12. Pinion rear bearing |
| 13. Viscous coupling |                        |                         |



# DESCRIPTION

## AWD MODELS

### R200 (2-pinion)

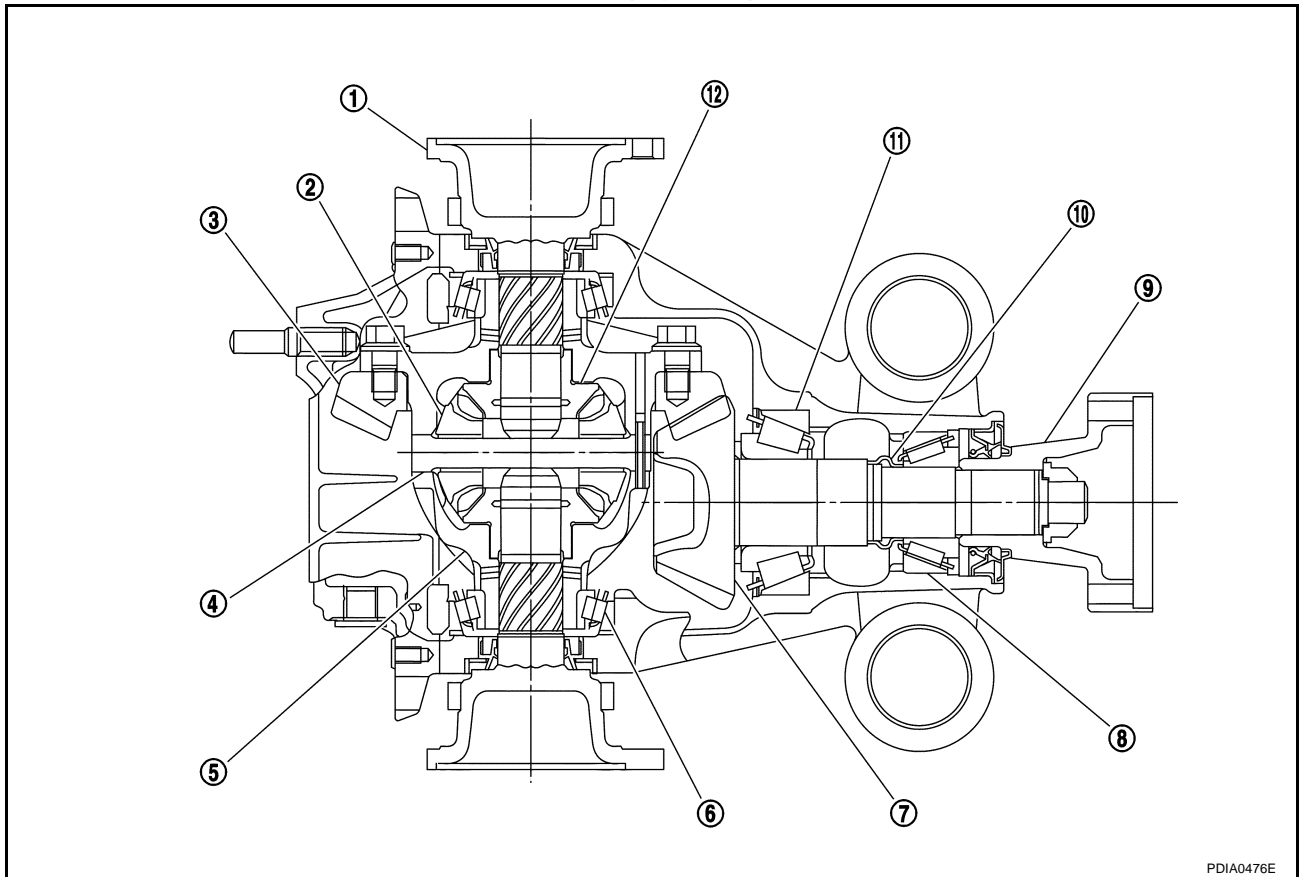

- |                        |                         |                     |
|------------------------|-------------------------|---------------------|
| 1. Side flange         | 2. Pinion mate gear     | 3. Drive gear       |
| 4. Pinion mate shaft   | 5. Differential case    | 6. Side bearing     |
| 7. Drive pinion        | 8. Pinion front bearing | 9. Companion flange |
| 10. Collapsible spacer | 11. Pinion rear bearing | 12. Side gear       |

A  
B  
C  
RFD  
E  
F  
G  
H  
I  
J  
K  
L  
M

# DIFFERENTIAL GEAR OIL

PF:KLD30

## DIFFERENTIAL GEAR OIL

### Changing Differential Gear Oil DRAINING

NDS0004A

1. Stop engine.
2. Remove drain plug and drain gear oil.
3. Set a gasket on drain plug and install it to final drive assembly and tighten to the specified torque. Refer to [RFD-20, "COMPONENTS"](#) (R200 2-pinion) or [RFD-40, "COMPONENTS"](#) (R200V LSD).

**CAUTION:**

**Do not reuse gasket.**

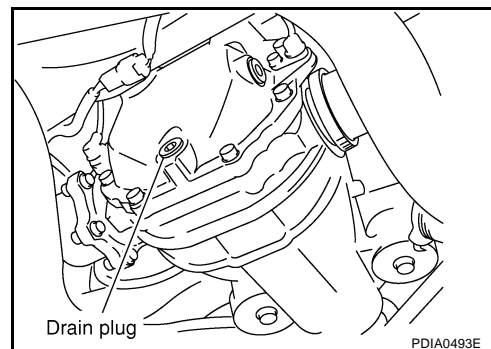

### FILLING

1. Remove filler plug. Fill with new gear oil until oil level reaches the specified level near filler plug mounting hole.

**Oil grade and Viscosity:**

Refer to [MA-10, "Fluids and Lubricants"](#).

**Oil capacity:**

**Approx. 1.4 l (3 US pt, 2-1/2 Imp pt)**

2. After refilling oil, check oil level. Set a gasket to filler plug, then install it to final drive assembly. Refer to [RFD-20, "COMPONENTS"](#) (R200 2-pinion) or [RFD-40, "COMPONENTS"](#) (R200V LSD).

**CAUTION:**

**Do not reuse gasket.**

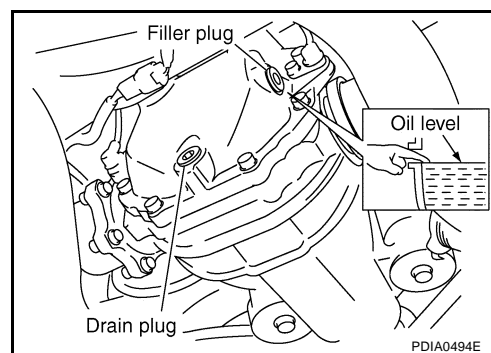

### Checking Differential Gear Oil OIL LEAKAGE AND OIL LEVEL

NDS0004B

- Make sure that oil is not leaking from final drive assembly or around it.
- Check oil level from filler plug mounting hole as shown in the figure.

**CAUTION:**

**Do not start engine while checking oil level.**

- Set a gasket on filler plug and install it on final drive assembly. Refer to [RFD-20, "COMPONENTS"](#) (R200 2-pinion) or [RFD-40, "COMPONENTS"](#) (R200V LSD).

**CAUTION:**

**Do not reuse gasket.**

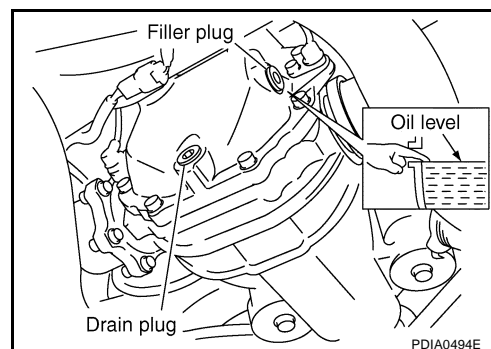

# FRONT OIL SEAL

PFP:38189

## FRONT OIL SEAL

### Removal and Installation

NDS0009F

**CAUTION:**

Verify identification stamp of replacement frequency put in the lower part of gear carrier to determine replacement for collapsible spacer when replacing front oil seal. Refer to [RFD-11, "IDENTIFICATION STAMP OF REPLACEMENT FREQUENCY OF FRONT OIL SEAL"](#) . If necessary collapsible spacer replacement, remove final drive assembly and disassemble it to replace front oil seal and collapsible spacer. Refer to [RFD-18, "Removal and Installation"](#) , [RFD-20, "Disassembly and Assembly \(R200 2-Pinion\)"](#) and/or [RFD-40, "Disassembly and Assembly \(R200V LSD\)"](#) .

**NOTE:**

The reuse of collapsible spacer is prohibited in principle. However, it is reusable on a one-time basis only in cases when replacing front oil seal.

### IDENTIFICATION STAMP OF REPLACEMENT FREQUENCY OF FRONT OIL SEAL

- The diagonally shaded area in the figure shows stamping point for replacement frequency of front oil seal.
- The following table shows if collapsible spacer replacement is needed before replacing front oil seal. When collapsible spacer replacement is required, disassemble final drive assembly to replace collapsible spacer and front oil seal. Refer to [RFD-20, "Disassembly and Assembly \(R200 2-Pinion\)"](#) or [RFD-40, "Disassembly and Assembly \(R200V LSD\)"](#)

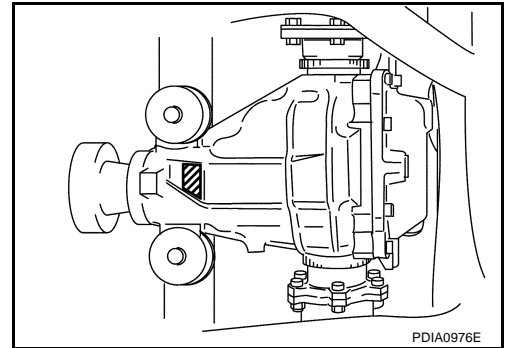

Stamp	collapsible spacer replacement
No stamp	Not required
"0" or "0" on the far right of stamp	Required
"01" or "1" on the far right of stamp	Not required

**CAUTION:**

**Be sure to make a stamping after replacing front oil seal.**

- After replacing front oil seal, make a stamping on the stamping point in accordance with the table below in order to identify replacement frequency.

**CAUTION:**

**Stamping shall be made from left to right.**

Stamp before stamping	Stamping on the far right	Stamping
No stamp	0	0
"0" (Front oil seal was replaced once.)	1	01
"01" (Collapsible spacer and front oil seal were replaced last time.)	0	010
"0" is on the far right. (Only front oil seal was replaced last time.)	1	...01
"1" is on the far right. (Collapsible spacer and front oil seal were replaced last time.)	0	...010

# FRONT OIL SEAL

## REMOVAL

1. Drain gear oil. Refer to [RFD-10, "DRAINING"](#).
2. Make a judgment if a collapsible spacer replacement is required. Refer to [RFD-11, "IDENTIFICATION STAMP OF REPLACEMENT FREQUENCY OF FRONT OIL SEAL"](#).
3. Remove rear wheel sensor. Refer to [BRC-59, "WHEEL SENSOR"](#).
4. Remove drive shaft from final drive. Then suspend it by wire etc. Refer to [RAX-10, "Removal and Installation"](#).
5. Install attachment to side flange, and then pull out the side flange with the sliding hammer.

**Tool number**    **A: KV40104100 ( — )**  
                          **B: ST36230000 (J-25840-A)**

**NOTE:**

Model	Circular clip installation position	
	Right side	Left side
R200 (2-pinion)	Final drive side	
R200V (LSD)	Final drive side	Side flange side

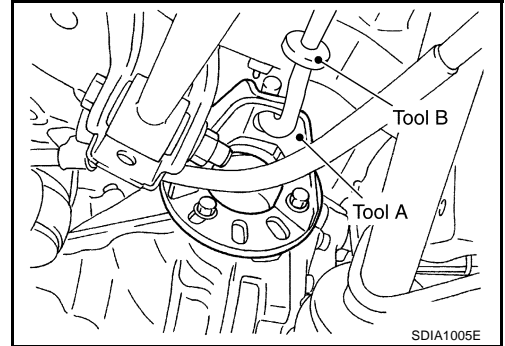

6. Remove propeller shaft. Refer to [PR-5, "Removal and Installation"](#) (2WD) or [PR-17, "Removal and Installation"](#) (AWD).
7. Measure the total preload with the preload gauge.

**Tool number**    **A: ST3127S000 (J-25765-A)**

**NOTE:**

**Record the preload measurement.**

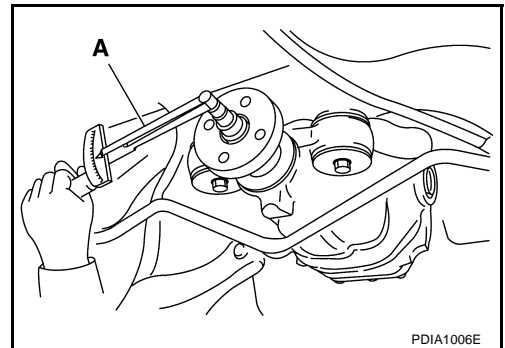

8. Remove drive pinion lock nut using the flange wrench.

**Tool number**    **: KV40104000 ( — )**

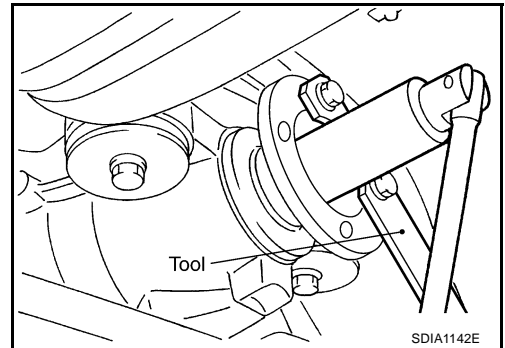

9. Put matching mark on the end of the drive pinion. The matching mark should be in line with the matching mark A on companion flange.

**CAUTION:**

**For matching mark, use paint. Do not damage drive pinion.**

**NOTE:**

The matching mark A on the final drive companion flange indicates the maximum vertical runout position.

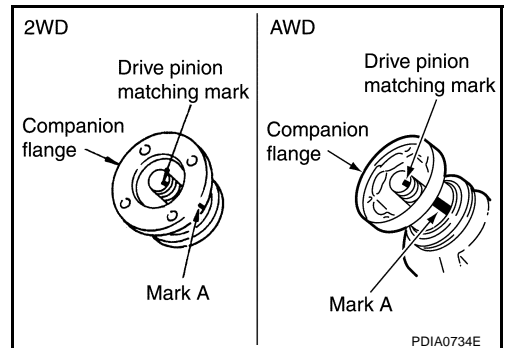

# FRONT OIL SEAL

10. Remove companion flange using a puller.

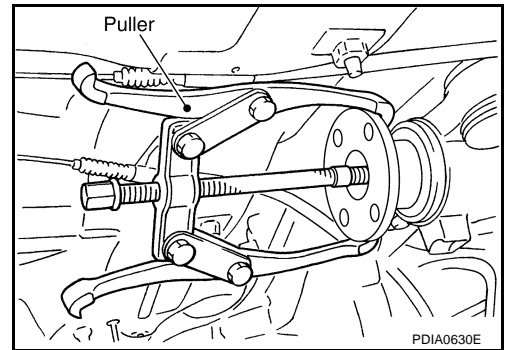

11. Remove front oil seal using the puller.

**Tool number A: KV381054S0 (J-34286)**

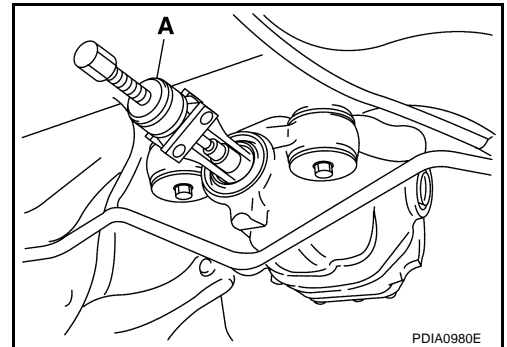

## INSTALLATION

1. Apply multi-purpose grease to front oil seal lips.
2. Install front oil seal using the drift as shown in the figure.

**Tool number A: ST30720000 (J-25405)**

### CAUTION:

- Do not reuse oil seal.
- Do not incline oil seal when installing.

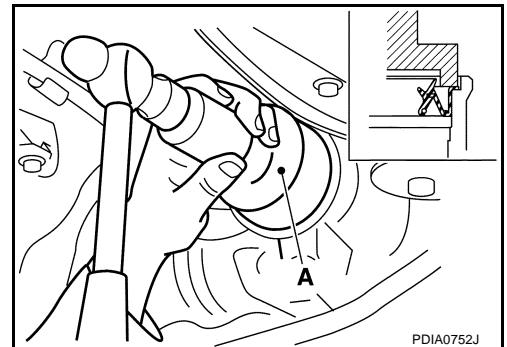

3. Align the matching mark of drive pinion with the matching mark of companion flange, and then install the companion flange.

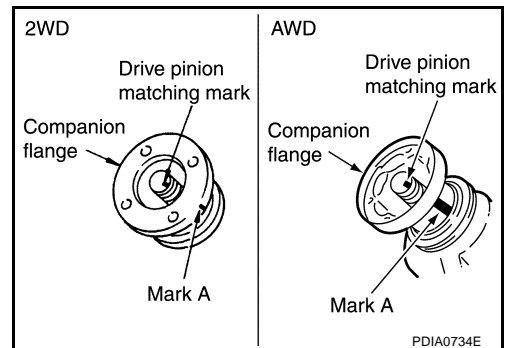

A  
B  
C  
RFD  
E  
F  
G  
H  
I  
J  
K  
L  
M

## FRONT OIL SEAL

4. Apply anti-corrosion oil to the thread and seat of new drive pinion lock nut, and temporarily tighten drive pinion lock nut to drive pinion.

**CAUTION:**

**Do not reuse drive pinion lock nut.**

5. Tighten to drive pinion lock nut, while adjust total preload torque.

**Tool number A: ST3127S000 (J-25765-A)**

**Drive pinion lock nut tightening torque:**

**147 – 323 N·m (15 – 32 kg·m, 109 – 238 ft·lb)**

**Total preload torque:**

**Total preload torque should equal the measurement taken during removal plus an additional 0.1 – 0.4 N·m (0.01 – 0.04 kg·m, 1 – 3 in·lb).**

**CAUTION:**

- Adjust to the lower limit of the drive pinion lock nut tightening torque first.
- If the preload torque exceeds the specified value, replace collapsible spacer and tighten it again to adjust. Do not loosen drive pinion lock nut to adjust the preload torque.

6. Make a stamping for identification of front oil seal replacement frequency. Refer to [RFD-11, "IDENTIFICATION STAMP OF REPLACEMENT FREQUENCY OF FRONT OIL SEAL"](#).

**CAUTION:**

**Be sure to make a stamping after replacing front oil seal.**

7. Install propeller shaft. Refer to [PR-5, "Removal and Installation"](#) (2WD) or [PR-17, "Removal and Installation"](#) (AWD).
8. Install side flange with the following procedure.

**NOTE:**

Install the RH side flange, then install the LH side flange. If LH side flange is installed first, the RH side flange comes out sometimes from the shock of installing the RH side flange. [For R200V (with LSD)]

- a. Attach the protector to side oil seal.

**Tool number : KV38107900 (J-39352)**

- b. After the side flange is inserted and the serrated part of side gear has engaged the serrated part of flange, remove the protector.

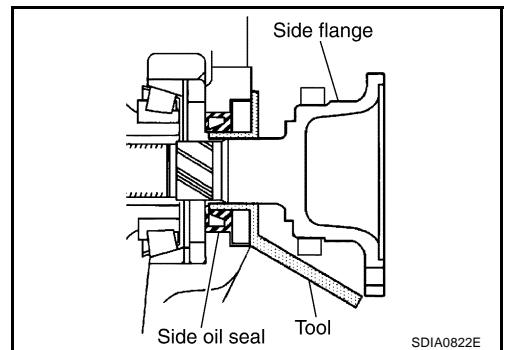
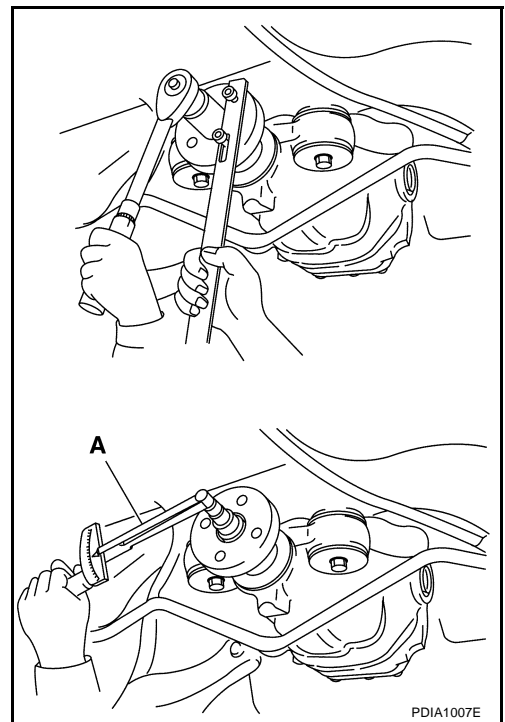

# FRONT OIL SEAL

- c. Put a suitable drift on the center of side flange, then drive it until sound changes.

**NOTE:**

When installation is completed, driving sound of the side flange turns into a sound which seems to affect the whole final drive.

- d. Confirm that the dimension of the side flange installation (Measurement A) in the figure comes into the following.

**Measurement A: 326 – 328 mm (12.83 – 12.91 in)**

9. Install drive shaft. Refer to [RAX-10, "Removal and Installation"](#) .
10. Install rear wheel sensor. Refer to [BRC-59, "WHEEL SENSOR"](#) .
11. Refill gear oil to the final drive and check oil level. Refer to [RFD-10, "FILLING"](#) .
12. Check the final drive for oil leakage. Refer to [RFD-10, "OIL LEAKAGE AND OIL LEVEL"](#) .

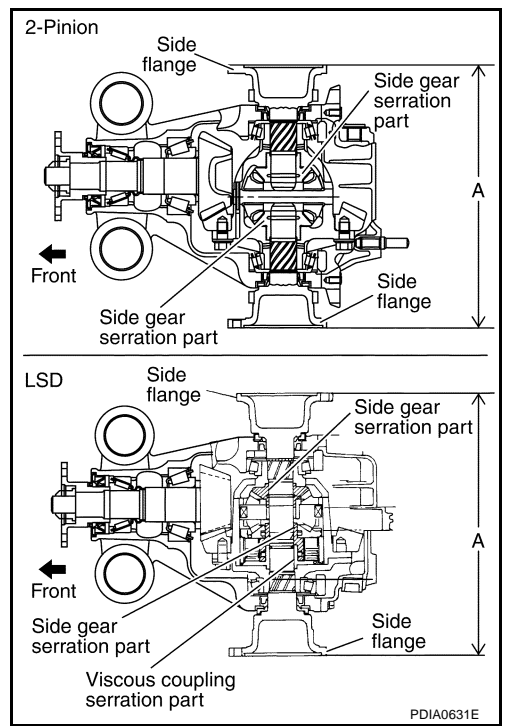

A  
B  
C  
RFD  
E  
F  
G  
H  
I  
J  
K  
L  
M

# SIDE OIL SEAL

## SIDE OIL SEAL

PFP:33142

### Removal and Installation

NDS0004D

1. Remove rear wheel sensor. Refer to [BRC-59, "WHEEL SENSOR"](#).
2. Remove drive shaft from final drive. Then suspend it by wire etc. Refer to [RAX-10, "Removal and Installation"](#).
3. Install attachment to side flange, and then pull out the side flange with the sliding hammer.

**Tool number**     **A: KV40104100 ( — )**  
                          **B: ST36230000 (J-25840-A)**

#### NOTE:

Model	Circular clip installation position	
	Right side	Left side
R200 (2-pinion)	Final drive side	
R200V (LSD)	Final drive side	Side flange side

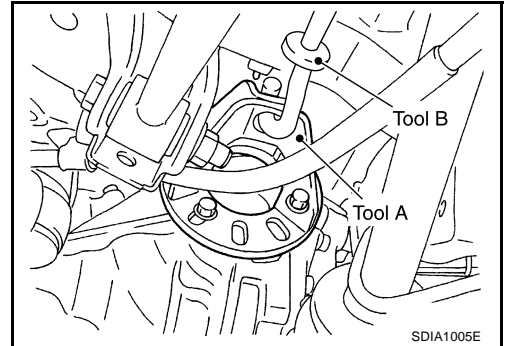

4. Remove side oil seal, using a flat-bladed screwdriver.

**CAUTION:**  
Be careful not to damage gear carrier.

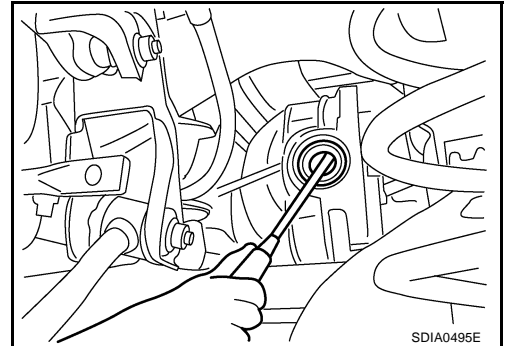

### INSTALLATION

1. Apply multi-purpose grease to side oil seal lips.
2. Install side oil seal until it becomes flush with the case end, using the drift.

**Tool number**     **: KV38100200 (J-26233)**

**CAUTION:**

- Do not reuse oil seal.
- When installing, do not incline oil seal.

3. Install side flange with the following procedure.

#### NOTE:

Install the RH side flange, then install the LH side flange. If LH side flange is installed first, the RH side flange comes out sometimes from the shock of installing the RH side flange. [For R200V (with LSD)]

- a. Attach the protector to side oil seal.

**Tool number**     **: KV38107900 (J-39352)**

- b. After the side flange is inserted and the serrated part of side gear has engaged the serrated part of flange, remove the protector.

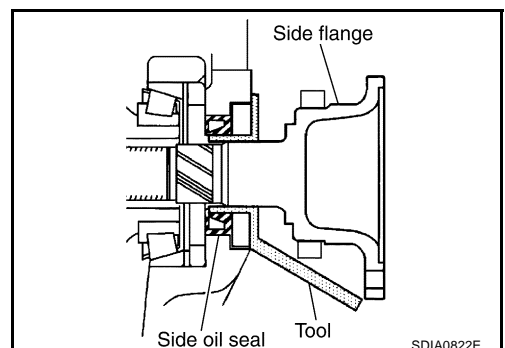
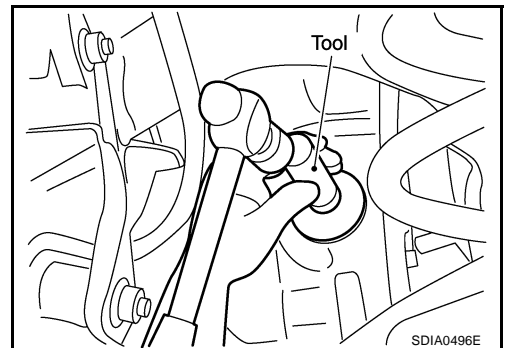



## SIDE OIL SEAL

- c. Put a suitable drift on the center of side flange, then drive it until sound changes.

**NOTE:**

When installation is completed, driving sound of the side flange turns into a sound which seems to affect the whole final drive.

- d. Confirm that the dimension of the side flange installation (Measurement A) in the figure comes into the following.

**Measurement A: 326 – 328 mm (12.83 – 12.91 in)**

4. Install drive shaft. Refer to [RAX-10, "Removal and Installation"](#) .  
5. Install rear wheel sensor. Refer to [BRC-59, "WHEEL SENSOR"](#)

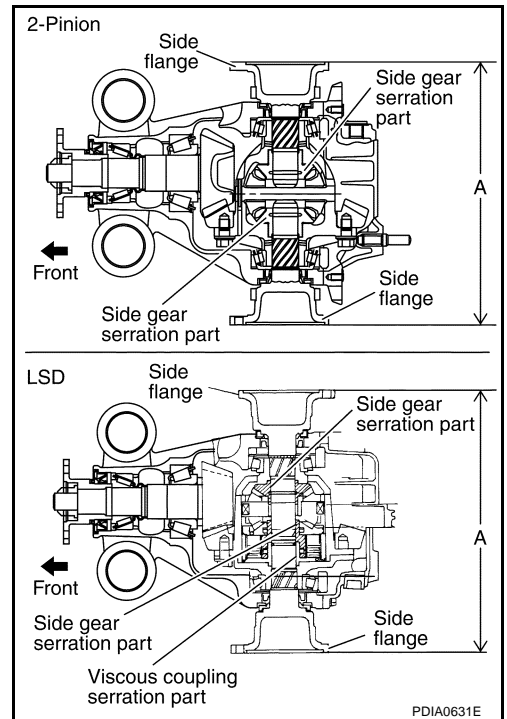

A  
B  
C

RFD

E  
F  
G

H

I

J

K

L

M

# REAR FINAL DRIVE ASSEMBLY

## REAR FINAL DRIVE ASSEMBLY

PFP:38300

### Removal and Installation COMPONENTS

NDS0004E

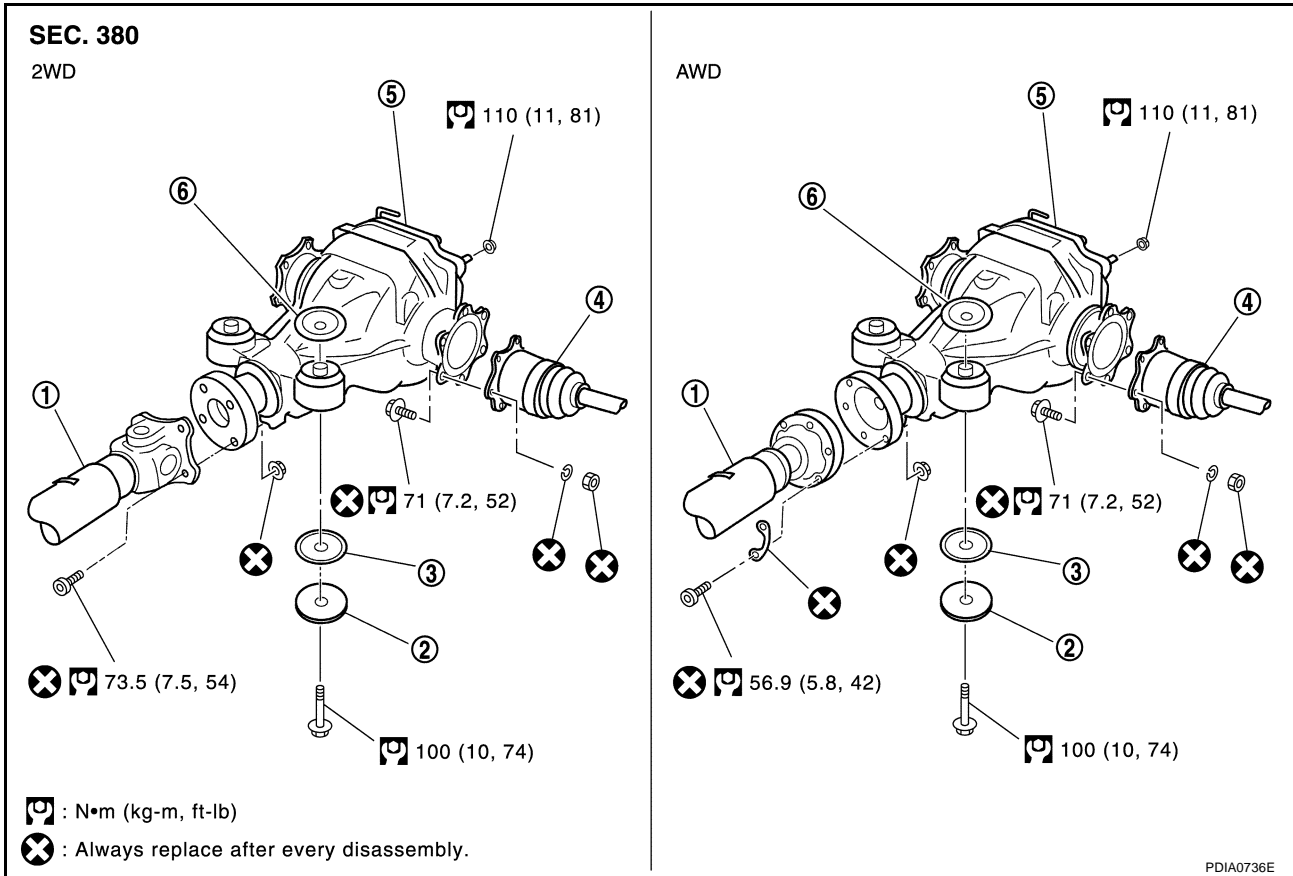

- |                    |                              |                  |
|--------------------|------------------------------|------------------|
| 1. Propeller shaft | 2. Washer                    | 3. Lower stopper |
| 4. Drive shaft     | 5. Rear final drive assembly | 6. Upper stopper |

### REMOVAL

1. Remove exhaust center tube with power tool. Refer to [EX-4, "Removal and Installation"](#).
2. Remove rear stabilizer bar with power tool. Refer to [RSU-16, "Removal and Installation"](#).
3. Remove rear propeller shaft from the final drive. Refer to [PR-5, "Removal and Installation"](#) (2WD) or [PR-17, "Removal and Installation"](#) (AWD).
4. Remove rear drive shaft from final drive. Then suspend it by wire etc. Refer to [RAX-10, "Removal and Installation"](#).
5. Remove wheel sensor. Refer to [BRC-59, "WHEEL SENSOR"](#).

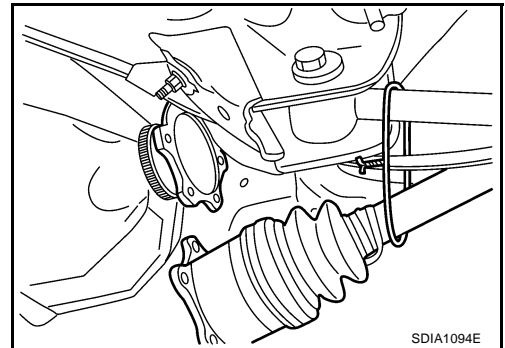

## REAR FINAL DRIVE ASSEMBLY

6. Set a suitable jack to rear final drive assembly.

**CAUTION:**

**Do not place a suitable jack on the rear cover (aluminum case).**

7. Remove the mounting bolts and nuts connecting to the suspension member, and remove rear final drive assembly.

**CAUTION:**

**Secure rear final drive assembly to a suitable jack while removing it.**

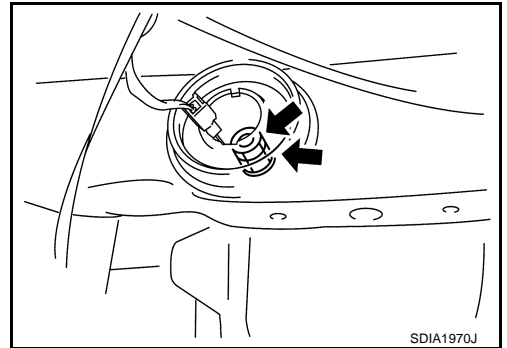
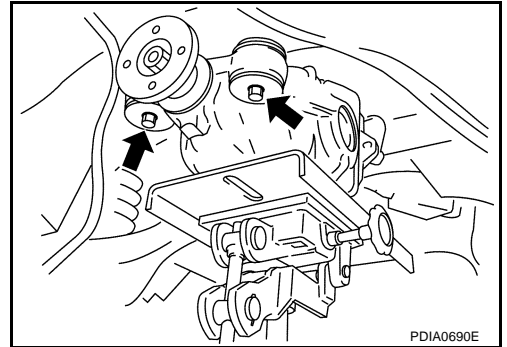

### INSTALLATION

Note the following, and installation is in the reverse order of removal.

- Refer to [RFD-20, "COMPONENTS"](#) (R200 2-pinion) or [RFD-40, "COMPONENTS"](#) (R200V LSD) about each tightening torque.
- When oil leaks while removing final drive assembly, check oil level after the installation. Refer to [RFD-10, "Checking Differential Gear Oil"](#) .

A

B

C

RFD

E

F

G

H

I

J

K

L

M

# REAR FINAL DRIVE ASSEMBLY

## Disassembly and Assembly (R200 2-Pinion) COMPONENTS

NDS0004F

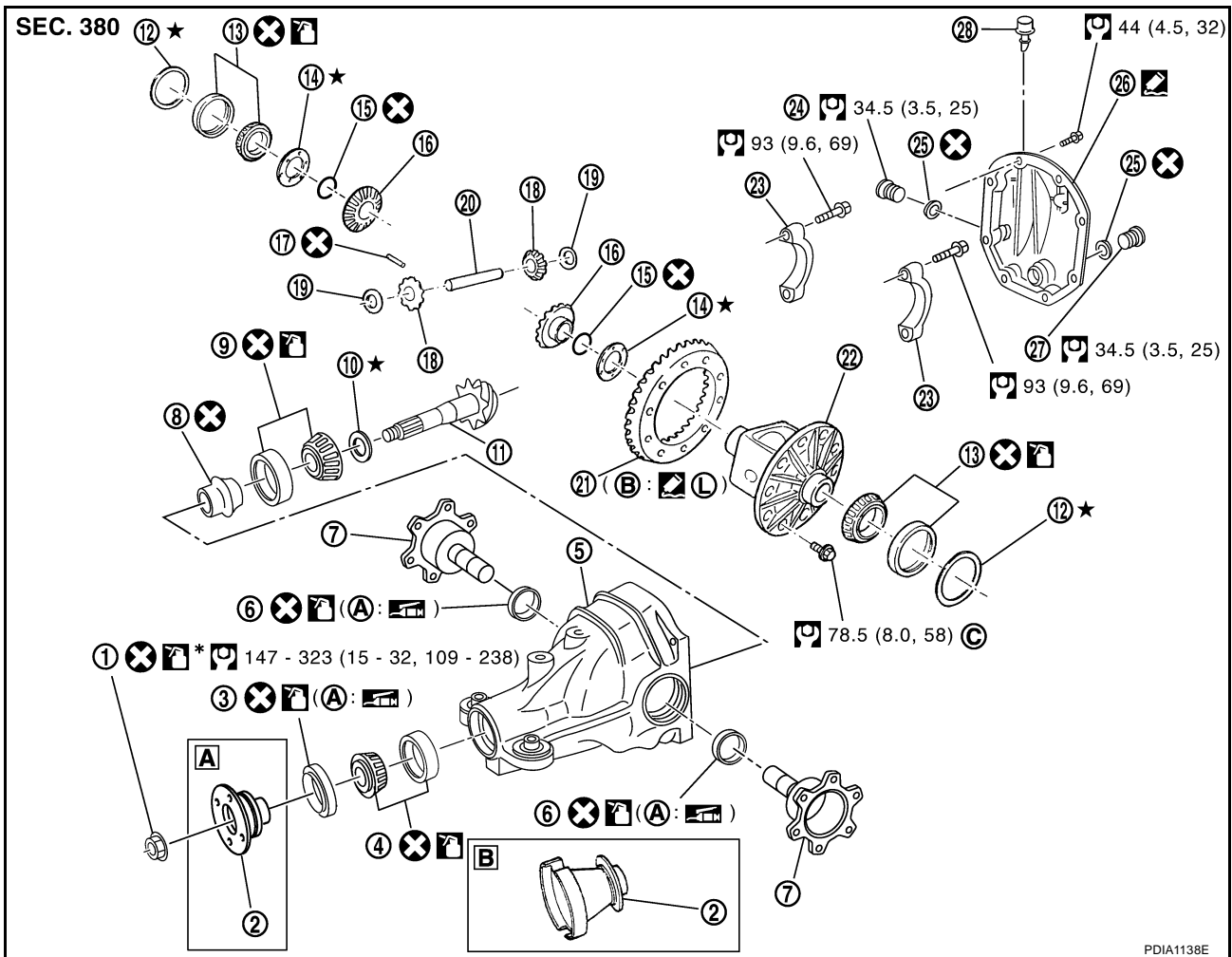

PDIA1138E

- |                                    |                             |                                   |
|------------------------------------|-----------------------------|-----------------------------------|
| 1. Drive pinion lock nut           | 2. Companion flange         | 3. Front oil seal                 |
| 4. Pinion front bearing            | 5. Gear carrier             | 6. Side oil seal                  |
| 7. Side flange                     | 8. Collapsible spacer       | 9. Pinion rear bearing            |
| 10. Pinion height adjusting washer | 11. Drive pinion            | 12. Side bearing adjusting washer |
| 13. Side bearing                   | 14. Side gear thrust washer | 15. Circular clip                 |
| 16. Side gear                      | 17. Lock pin                | 18. Pinion mate gear              |
| 19. Pinion mate thrust washer      | 20. Pinion mate shaft       | 21. Drive gear                    |
| 22. Differential case              | 23. Bearing cap             | 24. Filler plug                   |
| 25. Gasket                         | 26. Rear cover              | 27. Drain plug                    |
| 28. Air breather                   |                             |                                   |
- A: 2WD models      B: AWD models

A: Oil seal lip

B: Screw hole

C: After tightening the bolts to the specified torque, tighten the bolts additionally by turning the bolts 31 to 36 degrees.

Refer to [GI-10. "Components"](#) and the followings for the symbols in the figure.



Apply gear oil.



Apply anti-corrosion oil.



Apply Genuine Silicone RTV or equivalent. Refer to [GI-47. "Recommended Chemical Products and Sealants"](#).



Apply Genuine High Strength Thread Locking Sealant or equivalent. Refer to [GI-47. "Recommended Chemical Products and Sealants"](#).

# REAR FINAL DRIVE ASSEMBLY

## ASSEMBLY INSPECTION AND ADJUSTMENT

- Before inspection and adjustment, drain gear oil.

### Total Preload Torque

1. Secure final drive assembly onto an attachment.

**Tool number : KV38100800 (J-25604-01)**

2. Remove side flanges.
3. Rotate drive pinion back and forth 2 to 3 times to check for unusual noise and rotation malfunction.
4. Rotate drive pinion at least 20 times to check for smooth operation of the bearing.
5. Measure total preload with the preload gauge.

**Tool number : ST3127S000 (J-25765-A)**

**Total preload torque:**

**2.85 – 3.75 N·m (0.29 – 0.38 kg-m, 26 – 33 in-lb)**

### NOTE:

**Total preload torque = Pinion bearing preload torque + Side bearing preload torque**

- If measured value is out of the specification, disassemble it to check and adjust each part. Adjust the pinion bearing preload and side bearing preload. Adjust the pinion bearing preload first, then adjust the side bearing preload.

**When the preload torque is large**

**On pinion bearings: Replace the collapsible spacer.**

**On side bearings: Use thinner side bearing adjusting washers by the same amount to each side. Refer to [RFD-61, "Side Bearing Adjusting Washer"](#) .**

**When the preload is small**

**On pinion bearings: Tighten the drive pinion lock nut.**

**On side bearings: Use thicker side bearing adjusting washers by the same amount to each side. Refer to [RFD-61, "Side Bearing Adjusting Washer"](#) .**

### Drive Gear Runout

1. Remove rear cover. Refer to [RFD-25, "Differential Assembly"](#) .
2. Fit a dial indicator to the drive gear back face.
3. Rotate the drive gear to measure runout.

**Runout limit: 0.05 mm (0.0020 in) or less**

- If the runout is outside of the repair limit, check drive gear assembly condition; foreign material may be caught between drive gear and differential case, or differential case or drive gear may be deformed, etc.

### CAUTION:

**Replace drive gear and drive pinion gear as a set.**

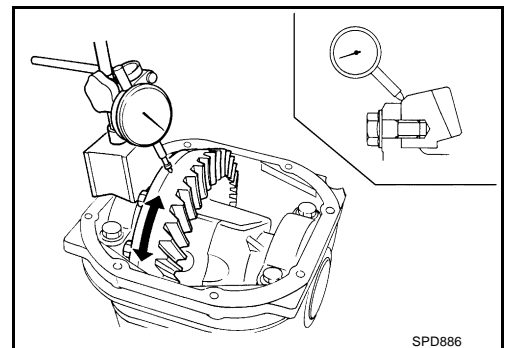
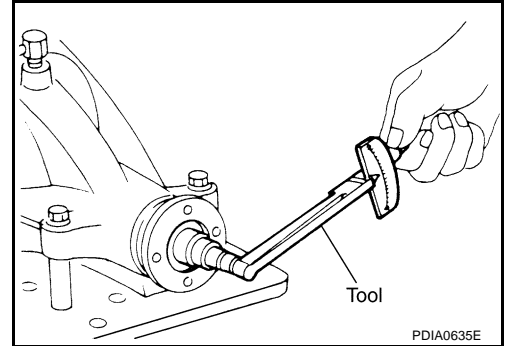

A  
B  
C  
RFD  
E  
F  
G  
H  
I  
J  
K  
L  
M

# REAR FINAL DRIVE ASSEMBLY

## Tooth Contact

1. Remove rear cover. Refer to [RFD-25, "Differential Assembly"](#) .
2. Apply red lead to drive gear.

**CAUTION:**

Apply red lead to both the faces of 3 to 4 gears at 4 locations evenly spaced on drive gear.

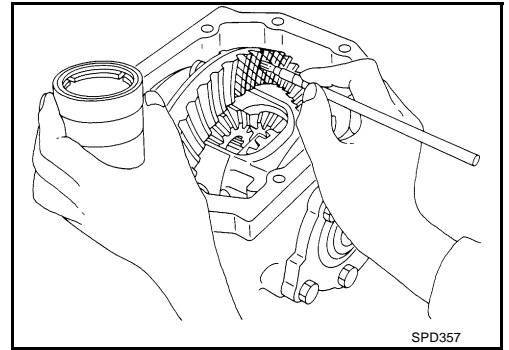

3. Rotate drive gear back and forth several times, check drive pinion gear to drive gear tooth contact.

**CAUTION:**

Check tooth contact on drive side and reverse side.

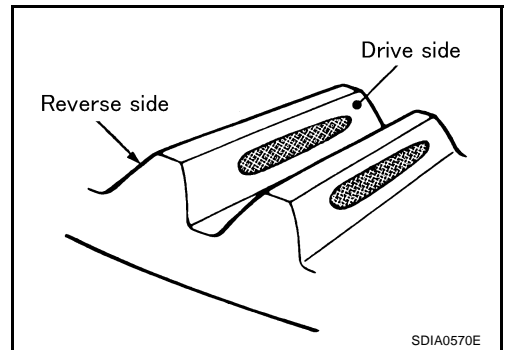

Tooth contact condition		Pinion height adjusting washer selection valve [ mm (in) ]	Adjustment (Yes/No)	Possible cause	
Drive side	Back side				
Heel side Toe side 	Toe side Heel side 	↑ Thicker	Yes	Occurrence of noise and scoring sound in all speed ranges.	
				+0.06 (+0.0024)	Occurrence of noise when accelerating.
				+0.03 (+0.0012)	
		↓ Thinner	No	—	
				0	
				-0.03 (-0.0012)	
				-0.06 (-0.0024)	Occurrence of noise at constant speed and decreasing speed.
			Yes	Occurrence of noise and scoring sound in all speed ranges.	

SDIA0207E

# REAR FINAL DRIVE ASSEMBLY

4. If tooth contact is improperly adjusted, follow the procedure below to adjust the pinion height (dimension X).

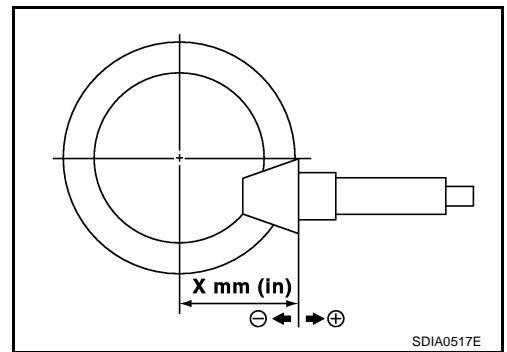

- If the tooth contact is near the face (face contact), or near the heel (heel contact), thicken pinion height adjusting washers to move drive pinion closer to drive gear. Refer to [RFD-61, "Pinion Height Adjusting Washer"](#).

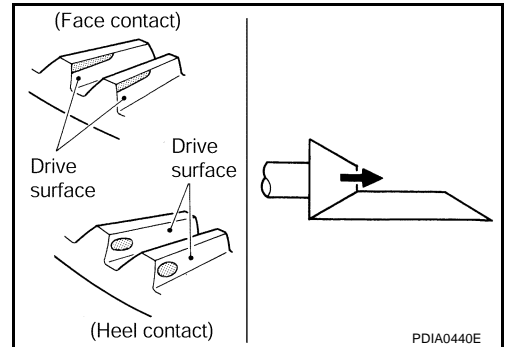

- If the tooth contact is near the flank (flank contact), or near the toe (toe contact), thin pinion height adjusting washers to move drive pinion farther from drive gear. Refer to [RFD-61, "Pinion Height Adjusting Washer"](#).

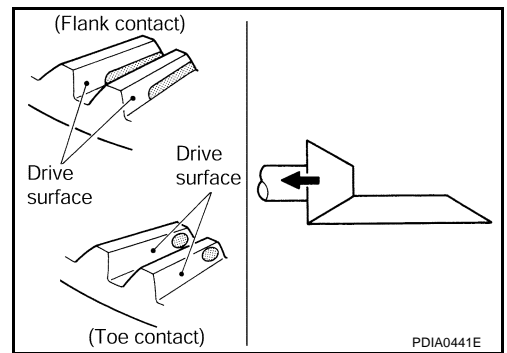

## Backlash

1. Remove rear cover. Refer to [RFD-25, "Differential Assembly"](#).
2. Fit a dial indicator to the drive gear face to measure the backlash.

**Backlash: 0.10 – 0.15 mm (0.0039 – 0.0059 in)**

- If the backlash is outside of the specified value, change the thickness of side bearing adjusting washer.

### When the backlash is large:

**Make drive gear back side adjusting washer thicker, and drive gear tooth side adjusting washer thinner by the same amount. Refer to [RFD-61, "Side Bearing Adjusting Washer"](#).**

### When the backlash is small:

**Make drive gear back side adjusting washer thinner, and drive gear tooth side adjusting washer thicker by the same amount. Refer to [RFD-61, "Side Bearing Adjusting Washer"](#).**

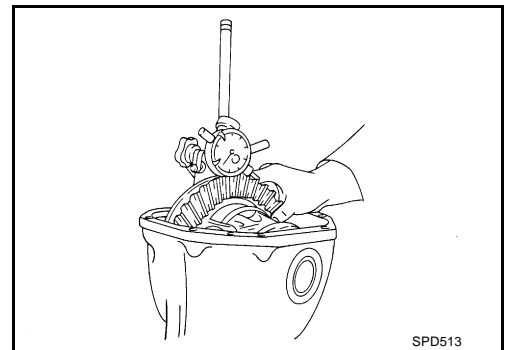

## CAUTION:

**Do not change the total amount of washers as it will change the bearing preload.**

# REAR FINAL DRIVE ASSEMBLY

## Companion Flange Runout (2WD Models)

1. Fit a dial indicator onto the companion flange face (inner side of the propeller shaft mounting bolt holes).
2. Rotate the companion flange to check for runout.

**Runout limit : 0.08 mm (0.0031 in)**

3. Fit a test indicator to the inner side of the companion flange (socket diameter).
4. Rotate the companion flange to check for runout.

**Runout limit : 0.08 mm (0.0031 in)**

5. If the runout value is outside the repair limit, follow the procedure below to adjust.
  - a. Check for runout while changing the phase between companion flange and drive pinion gear by 90° step, and search for the position where the runout is the minimum.
  - b. If the runout value is still outside of the limit after the phase has been changed, possible cause will be an assembly malfunction of drive pinion and pinion bearing and malfunction of pinion bearing. Check for these items and repair if necessary.
  - c. If the runout value is still outside of the limit after the check and repair, replace companion flange.

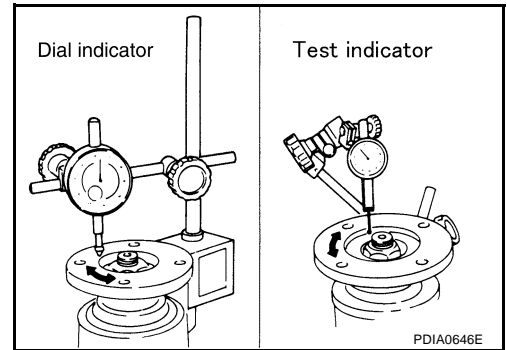

## Companion Flange Runout (AWD Models)

1. Fit a test indicator to the inner side of the companion flange (socket diameter).
2. Rotate the companion flange to check for runout.

**Runout limit : 0.08 mm (0.0031 in)**

3. If the runout value is outside the repair limit, follow the procedure below to adjust.
  - a. Check for runout while changing the phase between companion flange and drive pinion gear by 90° step, and search for the position where the runout is the minimum.
  - b. If the runout value is still outside of the limit after the phase has been changed, possible cause will be an assembly malfunction of drive pinion and pinion bearing and malfunction of pinion bearing. Check for these items and repair if necessary.
  - c. If the runout value is still outside of the limit after the check and repair, replace companion flange.

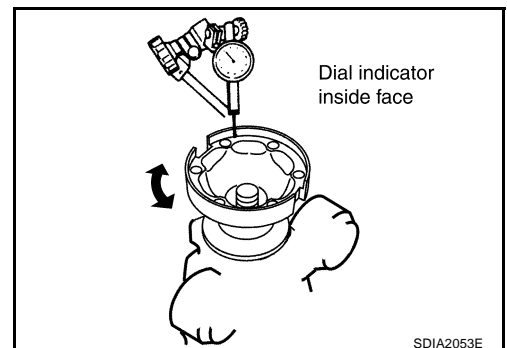



# REAR FINAL DRIVE ASSEMBLY

## DISASSEMBLY

### Differential Assembly

1. Drain gear oil, if necessary.
2. Remove side flange.
3. Remove rear cover mounting bolts.
4. Remove rear cover to insert the seal cutter between gear carrier and rear cover.

**Tool number** : KV10111100 (J-37228)

#### CAUTION:

- Be careful not to damage the mating surface.
- Do not insert flat-bladed screwdriver, this way damage the mating surface.

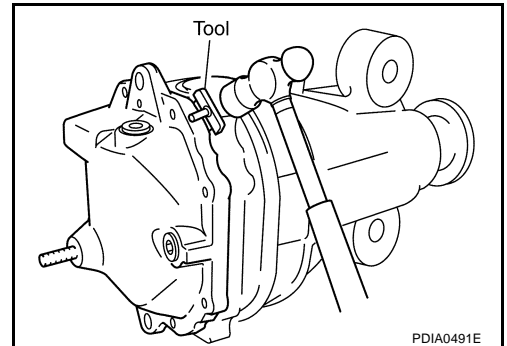

5. Using two 45 mm (1.77 in) spacers, mount carrier on the attachment.

**Tool number** : KV38100800 (J-25604-01)

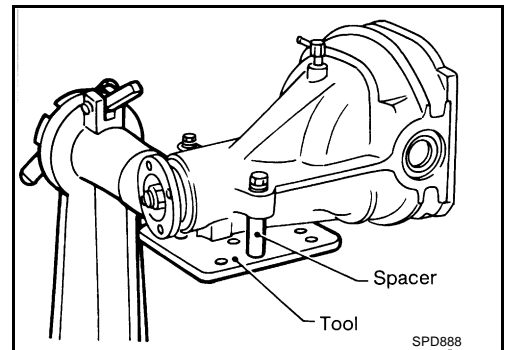

6. For proper reinstallation, paint matching marks on one side of the bearing cap.

#### CAUTION:

- For matching marks, use paint. Do not damage bearing caps and gear carrier.
- Bearing caps are line-board during manufacture. The matching marks are used to reinstall them in their original positions.

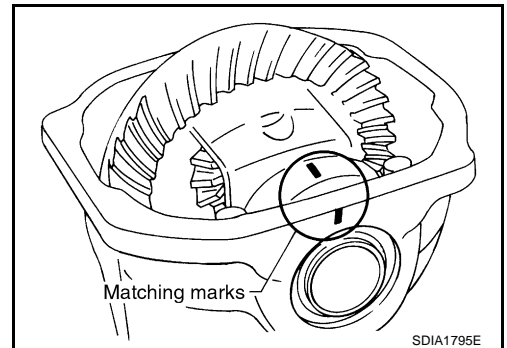

7. Remove bearing caps.

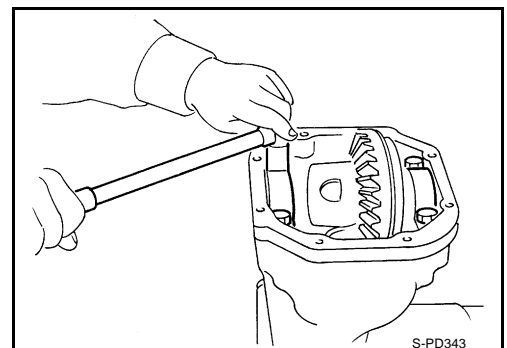

A  
B  
C  
RFD  
E  
F  
G  
H  
I  
J  
K  
L  
M

## REAR FINAL DRIVE ASSEMBLY

8. Lift differential case assembly out with a suitable tool.

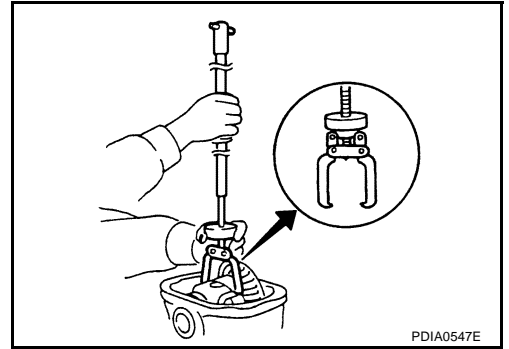

- Keep side bearing outer races together with inner race. Do not mix them up. Also, keep side bearing adjusting washers together with bearings.

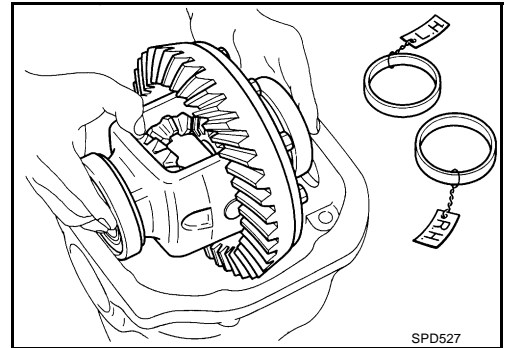

9. Remove side bearing inner race.  
To prevent damage to bearing, engage puller jaws in groove.

**Tool number**     **A: ST33051001 (J-22888-20)**  
                              **B: ST33061000 (J-8107-2)**

**CAUTION:**

- To prevent damage to the side bearing and drive gear, place copper plates between these parts and vise.
- It is not necessary to remove side bearing inner race except it is replaced.

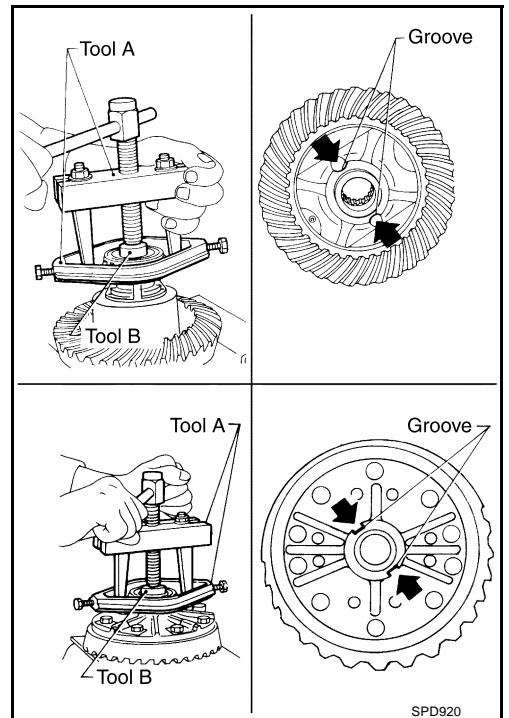

10. For proper reinstallation, paint matching marks on one differential case assembly.

**CAUTION:**

**For matching marks, use paint. Do not damage differential case and drive gear.**

11. Remove drive gear mounting bolts.  
12. Tap drive gear off differential case assembly with a soft hammer.

**CAUTION:**

**Tap evenly all around to keep drive gear from bending.**

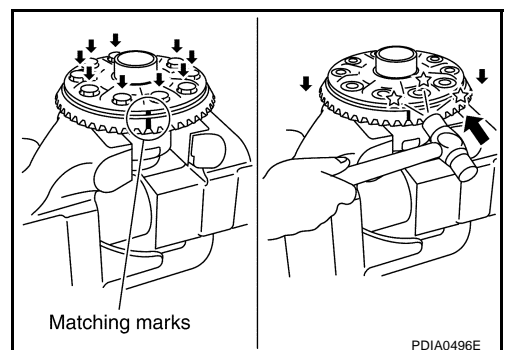

# REAR FINAL DRIVE ASSEMBLY

13. Remove lock pin of pinion mate shaft with a punch from drive gear side.

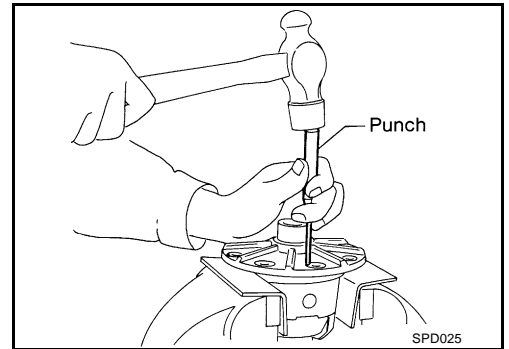

14. Remove pinion mate shaft.

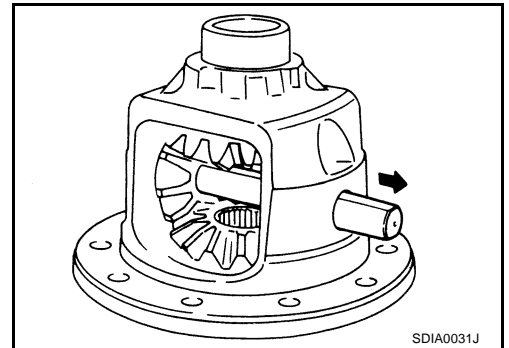

15. Turn pinion mate gear, then remove pinion mate gear, pinion mate thrust washer, side gear and side gear thrust washer from differential case.

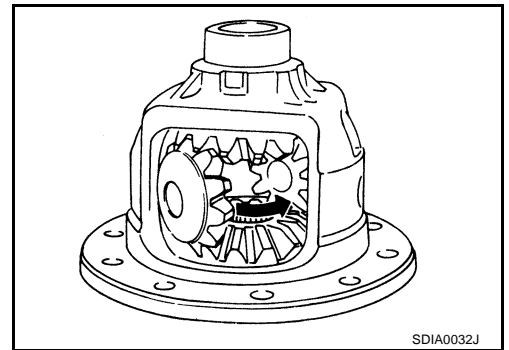

## Drive Pinion Assembly

1. Remove differential assembly. Refer to [RFD-25, "Differential Assembly"](#).
2. Remove drive pinion lock nut with the flange wrench.

**Tool number** : KV40104000 ( — )

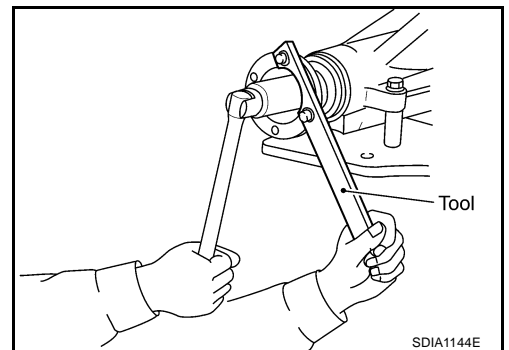

A  
B  
C  
RFD  
E  
F  
G  
H  
I  
J  
K  
L  
M

## REAR FINAL DRIVE ASSEMBLY

3. Put matching mark on the end of drive pinion. The matching mark should be in line with the matching mark A on companion flange.

**CAUTION:**

**For matching mark, use paint. Do not damage companion flange and drive pinion.**

**NOTE:**

The matching mark A on the final drive companion flange indicates the maximum vertical runout position. When replacing companion flange, matching mark is not necessary.

4. Remove companion flange using the suitable puller.

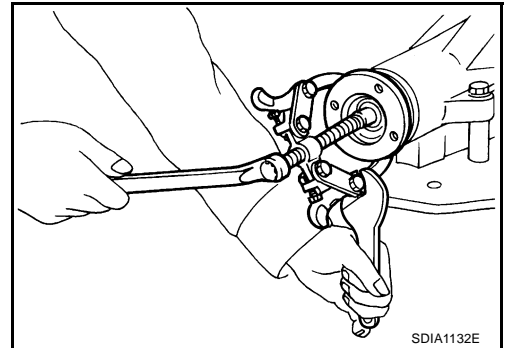
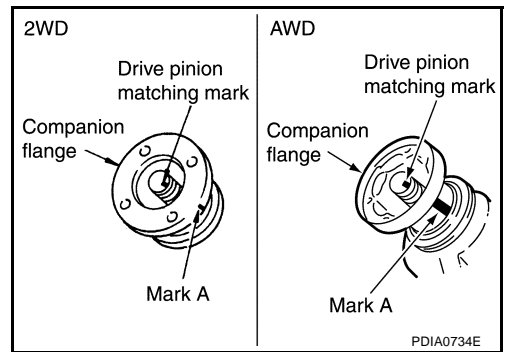

5. Press drive pinion assembly out of gear carrier.

**CAUTION:**

**Do not drop drive pinion assembly.**

6. Remove front oil seal.  
7. Remove side oil seal.  
8. Remove pinion front bearing inner race.  
9. Remove collapsible spacer.

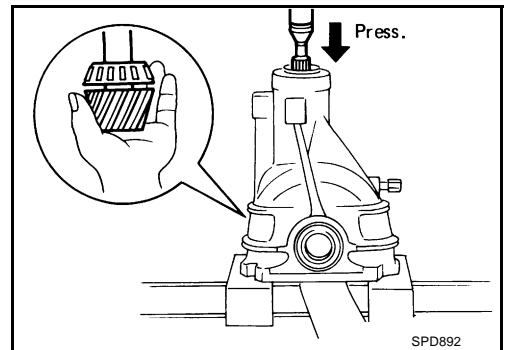

10. Remove pinion rear bearing inner race and pinion height adjusting washer with the replacer.

**Tool number : ST30031000 (J-22912-01)**

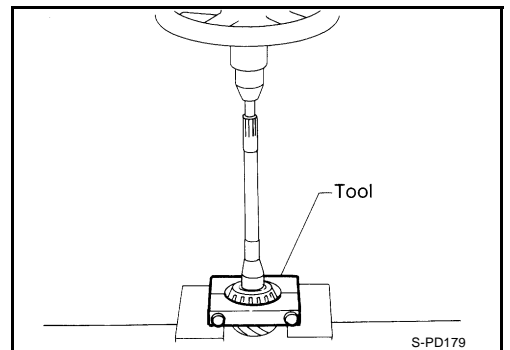

11. Tap pinion front/rear bearing outer races uniformly a brass rod or equivalent to removed.

**CAUTION:**

**Be careful not to damage gear carrier.**

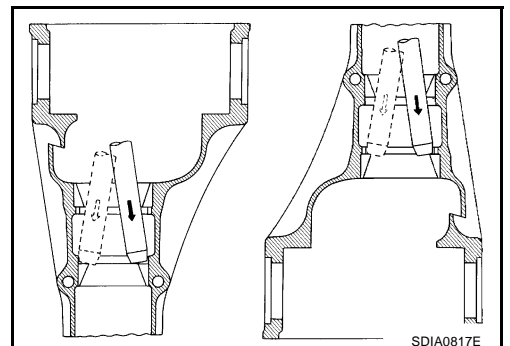

# REAR FINAL DRIVE ASSEMBLY

## INSPECTION AFTER DISASSEMBLY

Clean up the disassembled parts. Then, inspect if the parts are worn or damaged. If so, follow the measures below.

Content	Conditions and Measures
Hypoid gear	<ul style="list-style-type: none"> <li>● If the gear teeth do not mesh or line-up correctly, determine the cause and adjust or replace as necessary.</li> <li>● If the gears are worn, cracked, damaged, pitted or chipped (by friction) noticeably, replace with new drive gear and drive pinion as a set.</li> </ul>
Bearing	<ul style="list-style-type: none"> <li>● If any chipped (by friction), pitted, worn, rusted or scratched mark, or unusual noise from the bearing is observed, replace as a bearing assembly (as a new set).</li> </ul>
Side gear and Pinion mate gear	<ul style="list-style-type: none"> <li>● If any cracks or damage on the surface of the tooth is found, replace.</li> <li>● If any worn or chipped mark on the contact sides of the thrust washer is found, replace.</li> </ul>
Side gear thrust washer and pinion mate thrust washer	<ul style="list-style-type: none"> <li>● If it is chipped (by friction), damaged, or unusually worn, replace.</li> </ul>
Oil seal	<ul style="list-style-type: none"> <li>● Whenever disassembled, replace.</li> <li>● If wear, deterioration of adherence (sealing force lips), or damage is detected on the lips, replace them.</li> </ul>
Differential case	<ul style="list-style-type: none"> <li>● If any wear or crack on the contact sides of the differential case is found, replace.</li> </ul>
Companion flange	<ul style="list-style-type: none"> <li>● If any chipped mark (about 0.1 mm, 0.004 in) or other damage on the contact sides of the lips of the companion flange is found, replace.</li> </ul>

## ADJUSTMENT AND SELECTION OF ADJUSTING WASHERS

### Differential Side Gear Clearance

- Assemble the differential parts if they are disassembled. Refer to [RFD-36, "Differential Assembly"](#).
1. Place differential case straight up so that side gear to be measured comes upward.

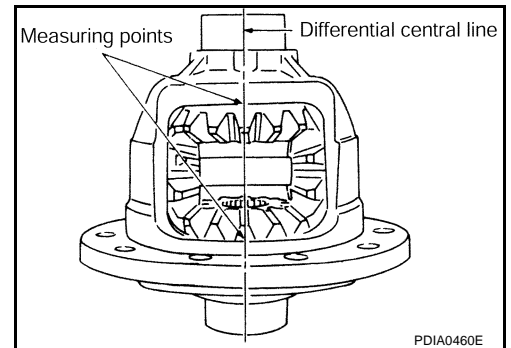

## REAR FINAL DRIVE ASSEMBLY

- Using feeler gauge, measure the clearance between side gear back and differential case at 3 different points, while rotating side gear. Average the 3 readings, and then measure the clearance of the other side as well.

### Side gear back clearance specification:

**0.2 mm (0.008 in) or less (Each gear should rotate smoothly without excessive resistance during differential motion.)**

### CAUTION:

To prevent side gear from tilting, insert feeler gauges with the same thickness from both sides.

- If the back clearance is outside the specification, use a thicker/thinner side gear thrust washer to adjust. Refer to [RFD-61, "Side Gear Thrust Washer"](#).

**When the back clearance is large:**

**Use a thicker thrust washer.**

**When the back clearance is small:**

**Use a thinner thrust washer.**

### CAUTION:

Select a side gear thrust washer for right and left individually.

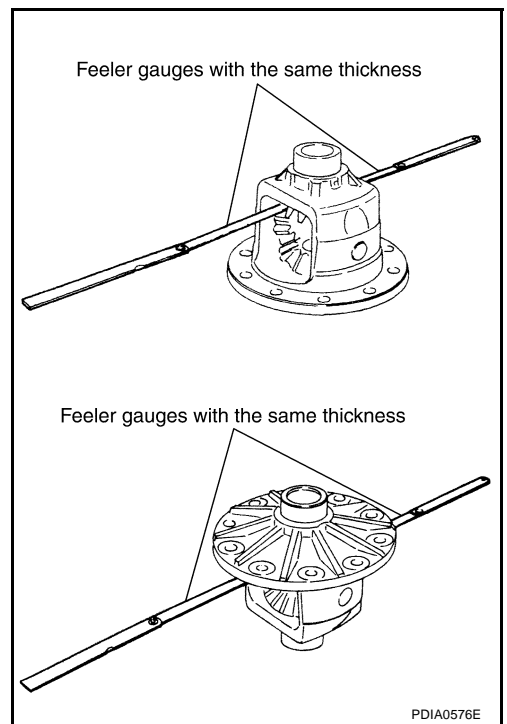

### Side Bearing Preload

- Selecting carrier side bearing adjusting washers is required for successful completion of this procedure.
- Make sure all parts are clean. Also, make sure the bearings are well lubricated with gear oil.
  - Place the differential case, with side bearings and bearing races installed, into gear carrier.

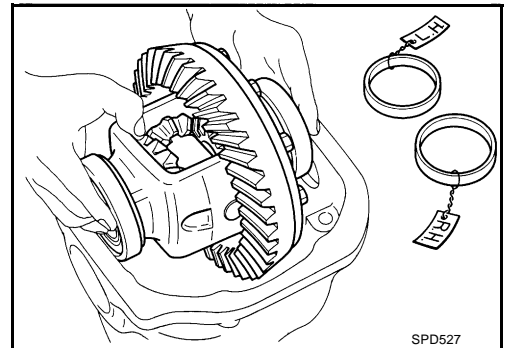

- Insert left and right original side bearing adjusting washers in place between side bearings and gear carrier.

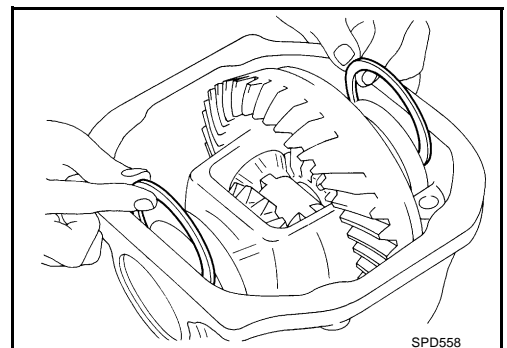

## REAR FINAL DRIVE ASSEMBLY

- Install bearing caps in their correct locations and tighten bearing cap mounting bolts to the specified torque. Refer to [RFD-20, "COMPONENTS"](#).
- Turn the carrier several times to seat the bearings.

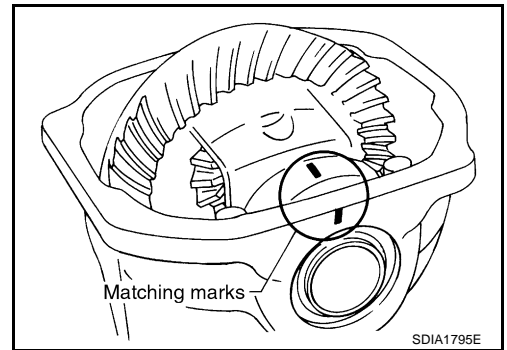

- Measure the turning torque of the carrier at the drive gear mounting bolts with a spring gauge.

**Tool number** : — (J-8129)

**Specification:**

**34.2 – 39.2 N (3.5 – 4.0 kg, 7.7 – 8.8 lb) of pulling force at the drive gear bolt**

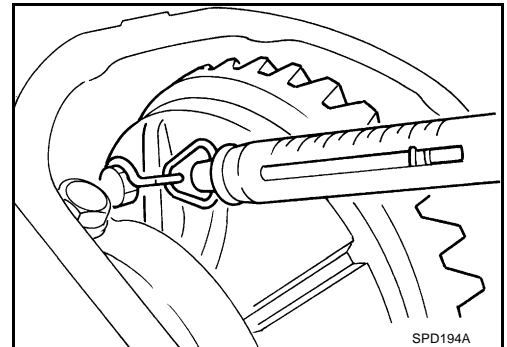

- If the turning torque is outside the specification, use a thicker/thinner side bearing adjusting washer to adjust. Refer to [RFD-61, "Side Bearing Adjusting Washer"](#).

**If the turning torque is less than the specified range:**

**Use a thicker thrust washer.**

**If the turning torque is greater than the specification:**

**Use a thinner thrust washer.**

**CAUTION:**

**Select a side bearing adjusting washer for right and left individually.**

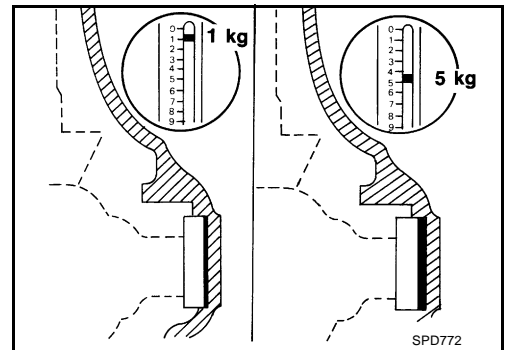

- Record the total amount of washer thickness required for the correct carrier side bearing preload.

### Pinion Gear Height

- Make sure all parts are clean and that the bearings are well lubricated.
- Assemble the pinion gear bearings into the differential shim selector tool.

**Tool number** : — (J-34309)

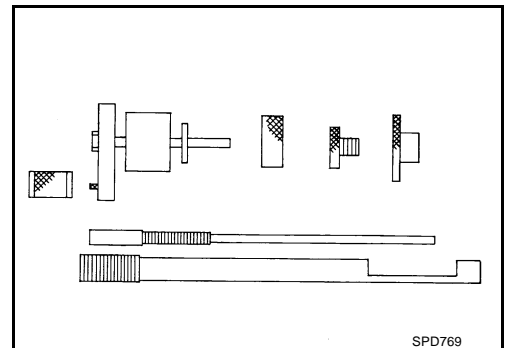

A  
B  
C  
RFD  
E  
F  
G  
H  
I  
J  
K  
L  
M

## REAR FINAL DRIVE ASSEMBLY

- **Pinion front bearing;** make sure the J-34309-3 pinion front bearing seat is secured tightly against the J-34309-2 gauge anvil. Then turn the pinion front bearing pilot, J-34309-5, to secure the bearing in its proper position.
- **Pinion rear bearing;** the pinion rear bearing pilot, J-34309-8, is used to center the pinion rear bearing only. The pinion rear bearing locking seat, J-34309-4, is used to lock the bearing to the assembly.
- **Installation of J-34309-9 and J-34309-16;** place a suitable 2.5 mm (0.098 in) thick plain washer between J-34309-9 and J-34309-16. Both surfaces of J-34309-9 and J-34309-16 must be parallel with a clearance of 2.5 mm (0.098 in).

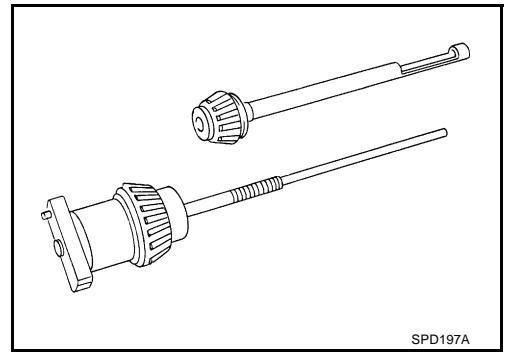

3. Install the pinion rear bearing inner race into gear carrier. Then place the pinion preload shim selector tool, J-34309-1, gauge screw assembly.

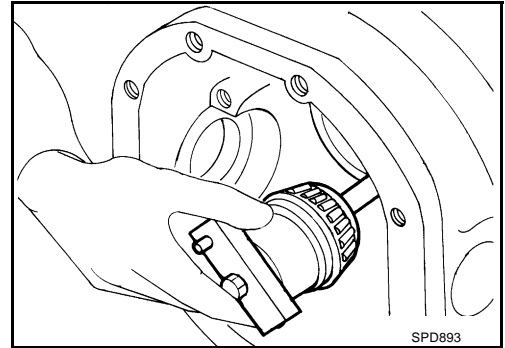

4. Assemble the pinion front bearing inner race and the J-34309-2 gauge anvil. Assemble them together with the J-34309-1 gauge screw in gear carrier. Make sure that the pinion height gauge plate, J-34309-16, will turn a full 360 degrees. Tighten the two sections together by hand.

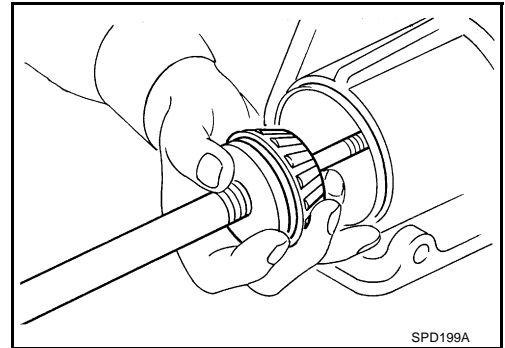

5. Turn the assembly several times to seat the bearings.

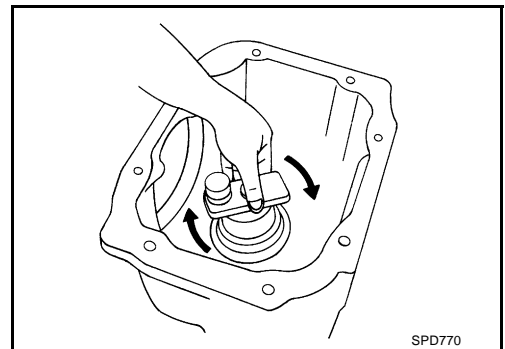

6. Measure the turning torque at the end of the J-34309-2 gauge anvil using preload gauge.

**Tool number : ST3127S000 (J-25765- A)**

**Turning torque specification:**

**1.0 – 1.3 N-m (0.11 – 0.13 kg-m, 9 – 11 in-lb)**

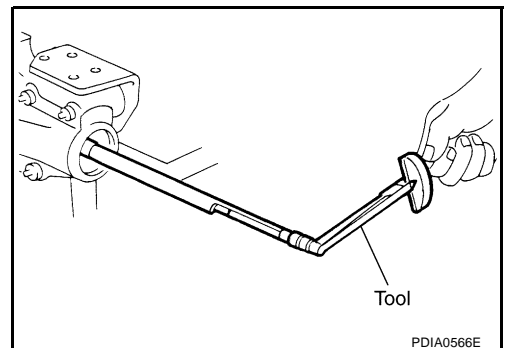



## REAR FINAL DRIVE ASSEMBLY

7. Place the J-34309-11 "R200A" pinion height adapter onto the gauge plate and tighten it by hand.

**CAUTION:**

**Make sure all machined surfaces are clean.**

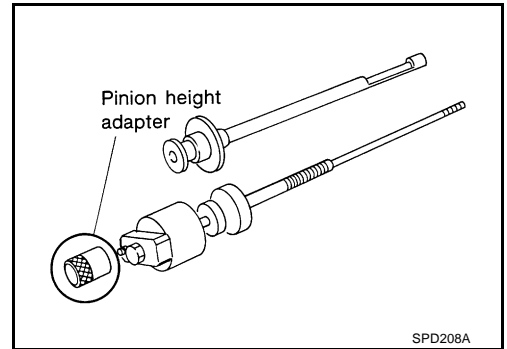

8. Position the side bearing discs, J-25269-4, and arbor firmly into the side bearing bores. Install the bearing caps and tighten bearing cap mounting bolts to the specified torque. Refer to [RFD-20, "COMPONENTS"](#).

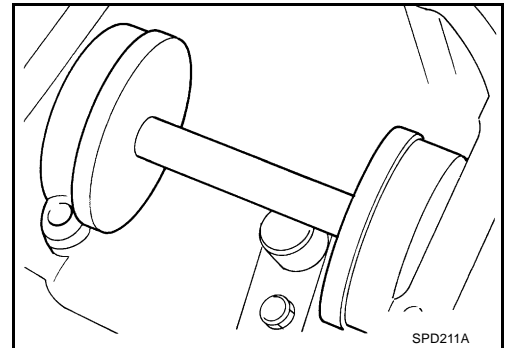

9. Select the correct standard pinion height adjusting washer thickness. Select by using a standard gauge of 3 mm (0.12 in) and your J-34309-101 feeler gauge. Measure the distance between the J-34309-11 pinion height adapter including the standard gauge and the arbor.

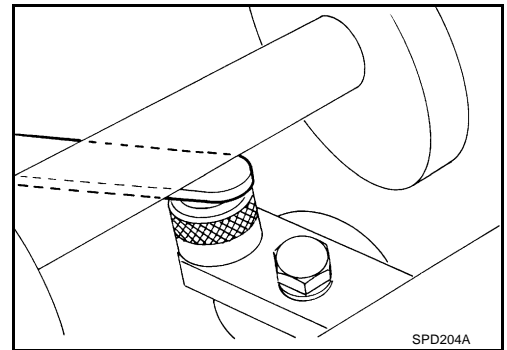

10. Write down exact measurement (the value of feeler gauge).

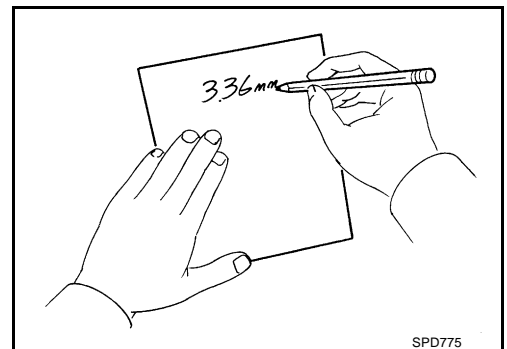

11. Correct the pinion height washer size by referring to the "pinion head number".

**There are two numbers painted on the drive pinion. The first one refers to the drive pinion and drive gear as a matched set. This number should be the same as the number on the drive gear. The second number is the "pinion head height number". It refers to the ideal pinion height from standard for quietest operation. Use the following chart to determine the correct pinion height washer.**

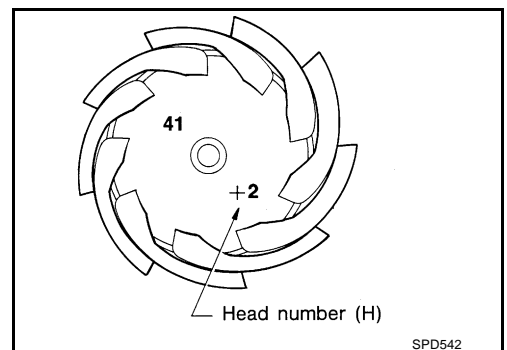

A  
B  
C  
RFD

E  
F  
G

H  
I  
J  
K

L  
M

# REAR FINAL DRIVE ASSEMBLY

Pinion head height number	Add or remove from the standard pinion height adjusting washer thickness measurement
- 6	Add 0.06 mm (0.0024 in)
- 5	Add 0.05 mm (0.0020 in)
- 4	Add 0.04 mm (0.0016 in)
- 3	Add 0.03 mm (0.0012 in)
- 2	Add 0.02 mm (0.0008 in)
- 1	Add 0.01 mm (0.0004 in)
0	Use the selected washer thickness
+1	Subtract 0.01 mm (0.0004 in)
+2	Subtract 0.02 mm (0.0008 in)
+3	Subtract 0.03 mm (0.0012 in)
+4	Subtract 0.04 mm (0.0016 in)
+5	Subtract 0.05 mm (0.0020 in)
+6	Subtract 0.06 mm (0.0024 in)

- Select the correct pinion height adjusting washer. Refer to [RFD-61, "Pinion Height Adjusting Washer"](#) .
- Remove the J-34309 differential shim selector tool from the final drive housing. Then disassemble to retrieve the pinion bearings.

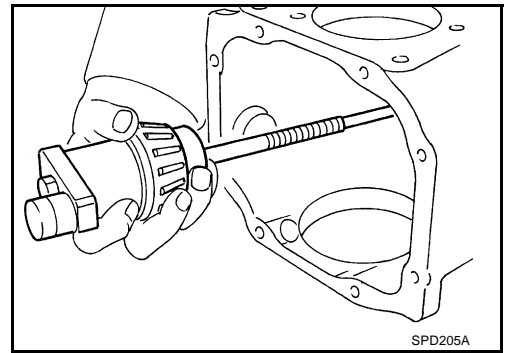

## ASSEMBLY

### Drive Pinion Assembly

- Install front and rear bearing outer races using drifts.

**Tool number**    **A: ST30720000 (J-25405)**  
                           **B: KV40105230 ( — )**  
                           **C: ST30611000 (J-25742-1)**  
                           **D: ST30613000 (J-25742-3)**

#### CAUTION:

- At first, using a hammer, tap bearing outer race until it becomes flat to gear carrier.
  - Do not reuse pinion front and rear bearing outer race.
- Select pinion height adjusting washer. Refer to [RFD-31, "Pinion Gear Height"](#) .

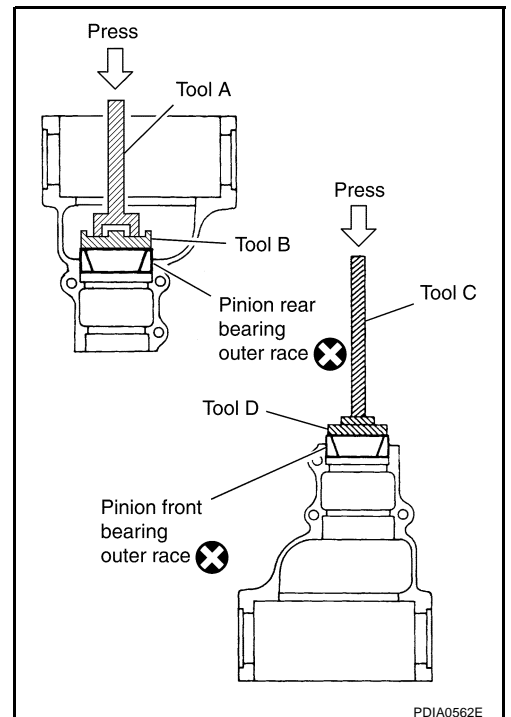

## REAR FINAL DRIVE ASSEMBLY

3. Install selected pinion height adjusting washer to drive pinion. Press pinion rear bearing inner race to it, using drift.

**Tool number : ST30901000 (J-26010-01)**

**CAUTION:**

- Pay attention to the direction of pinion height adjusting washer. (Assemble as shown in the figure.)
- Do not reuse pinion rear bearing inner race.

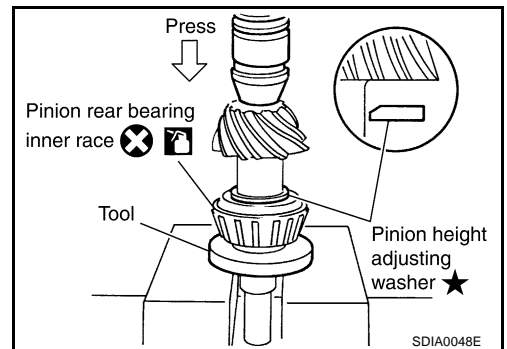

4. Assemble collapsible spacer to drive pinion.

**CAUTION:**

**Do not reuse collapsible spacer.**

5. Apply gear oil to pinion rear bearing, and assemble drive pinion into gear carrier.
6. Apply gear oil to pinion front bearing, and assemble pinion front bearing inner race to drive pinion assembly.

**CAUTION:**

**Do not reuse pinion front bearing inner race.**

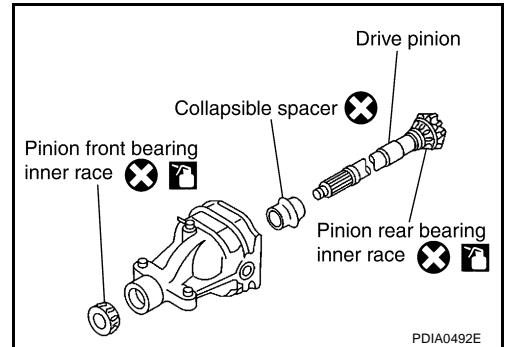

7. Using suitable spacer, press the pinion front bearing inner race to drive pinion as far as drive pinion nut can be tightened.

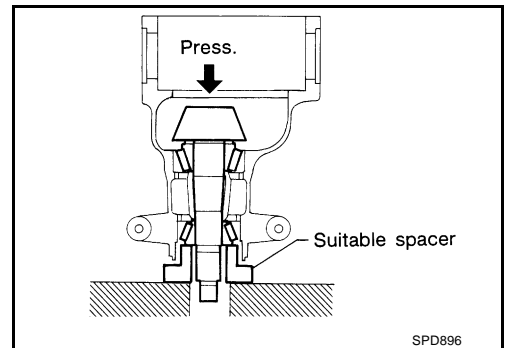

8. Using the drift, install front oil seal as shown in the figure.

**Tool number : ST30720000 (J-25405)**

**CAUTION:**

- Do not reuse oil seal.
- When installing, do not incline oil seal.
- Apply multi-purpose grease onto oil seal lips, and gear oil onto the circumference of oil seal.

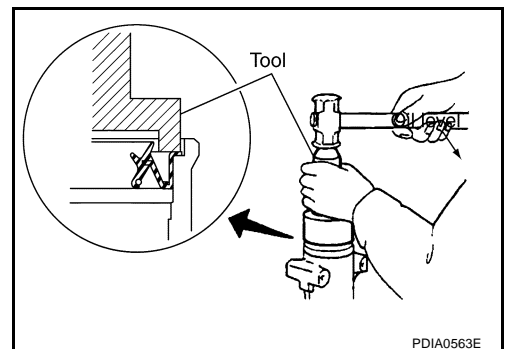

9. Install companion flange.

**NOTE:**

When reusing drive pinion, align the matching mark of drive pinion with the matching mark A of companion flange, then install companion flange.

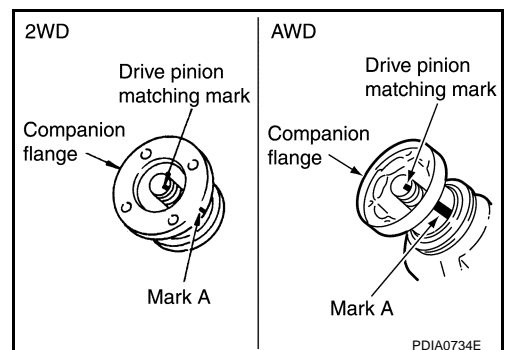

A  
B  
C  
RFD  
E  
F  
G  
H  
I  
J  
K  
L  
M

## REAR FINAL DRIVE ASSEMBLY

10. Apply anti-corrosion oil to the thread and seat of drive pinion lock nut, and temporarily tighten drive pinion lock nut to drive pinion.

**CAUTION:**

**Do not reuse drive pinion lock nut.**

11. Adjust to the drive pinion lock nut tightening torque and pinion bearing preload torque.

**Tool number**     **A: KV40104000 ( — )**  
                          **B: ST3127S000 (J-25765-A)**

**Drive pinion lock nut tightening torque:**

**147 – 323 N·m (15 – 32 kg-m, 109 – 238 ft-lb)**

**Drive pinion bearing preload:**

**2.65 – 3.23 N·m (0.27 – 0.32 kg-m, 24 – 28 in-lb)**

**CAUTION:**

- Adjust to the lower limit of the drive pinion lock nut tightening torque first.
- If the preload torque exceeds the specified value, replace collapsible spacer and tighten it again to adjust. Do not loosen drive pinion lock nut to adjust the preload torque.
- After adjustment, rotate drive pinion back and forth 2 to 3 times to check for unusual noise, rotation malfunction, and other malfunctions.

12. Install differential case assembly. Refer to [RFD-36, "Differential Assembly"](#) .

**CAUTION:**

**Do not install rear cover yet.**

13. Check and adjust drive gear runout, tooth contact, drive gear to drive pinion backlash, and companion flange runout. Refer to [RFD-21, "Drive Gear Runout"](#) , [RFD-22, "Tooth Contact"](#) , [RFD-23, "Backlash"](#) , [RFD-24, "Companion Flange Runout \(2WD Models\)"](#) and/or [RFD-24, "Companion Flange Runout \(AWD Models\)"](#) .

Recheck above items. Readjust the above description, if necessary.

14. Check total preload torque. Refer to [RFD-21, "Total Preload Torque"](#) .
15. Install rear cover. Refer to [RFD-36, "Differential Assembly"](#) .

### Differential Assembly

1. Install side gear thrust washers with the same thickness as the ones installed prior to disassembly or reinstall the old ones on the side gears.

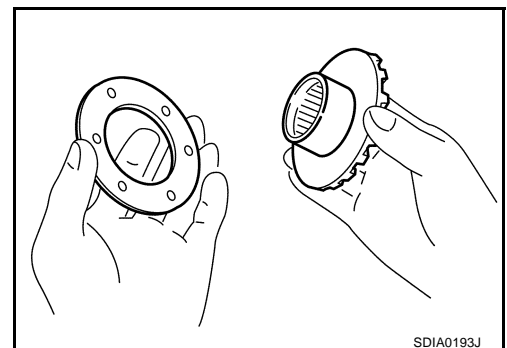
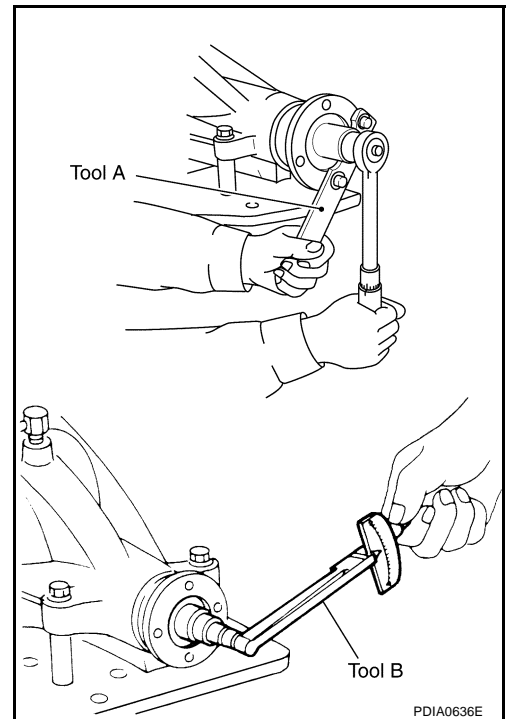

## REAR FINAL DRIVE ASSEMBLY

2. Install side gears and thrust washers into differential case.

**CAUTION:**

**Make sure that the circular clip is installed to side gears.**

3. Align 2 pinion mate gears in diagonally opposite positions, then rotate and install them into differential case after installing thrust washer to pinion mate gear.

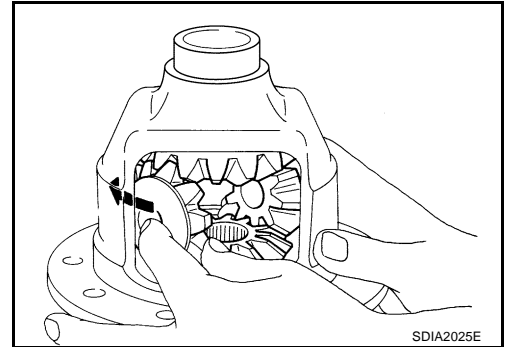

A  
B  
C

4. Align the lock pin holes on differential case with shaft, and install pinion mate shaft.

5. Measure side gear end play. If necessary, select the appropriate side gear thrust washers. Refer to [RFD-29, "Differential Side Gear Clearance"](#).

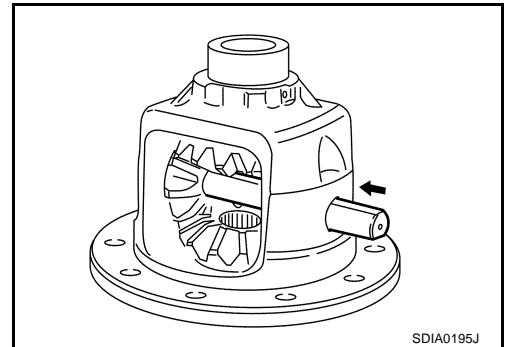

RFD

E  
F  
G

6. Drive a lock pin into pinion mate shaft, using a punch. Make sure lock pin is flush with differential case.

**CAUTION:**

**Do not reuse lock pin.**

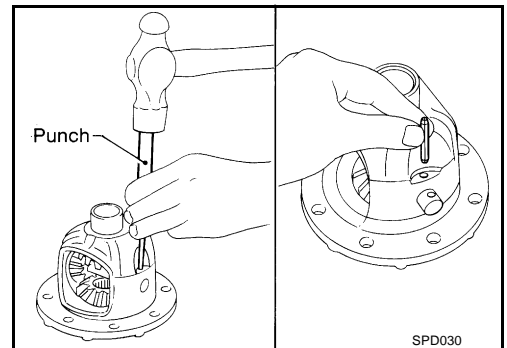

H  
I  
J

7. Align the matching mark of differential case with the mark of drive gear, then place drive gear.

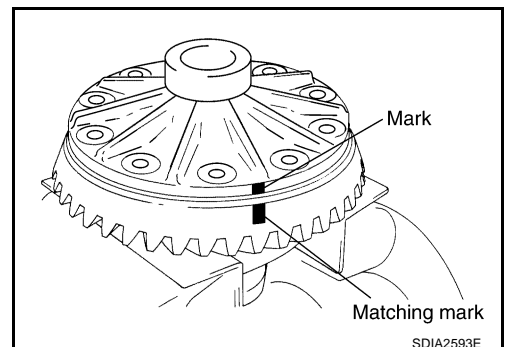

K  
L  
M

8. Apply thread locking sealant into the thread hole of drive gear.

- Use Genuine High Strength Thread Locking Sealant or equivalent. Refer to [GI-47, "Recommended Chemical Products and Sealants"](#).

**CAUTION:**

**Drive gear back and threaded holes shall be cleaned and degreased sufficiently.**

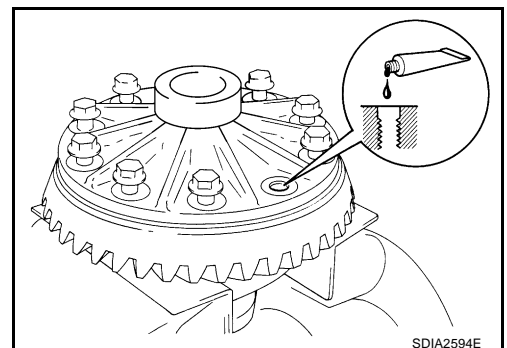

## REAR FINAL DRIVE ASSEMBLY

9. Install drive gear on the mounting bolts, and then tighten to the specified torque. Refer to [RFD-20, "COMPONENTS"](#).

**CAUTION:**

- Tighten bolts in a crisscross fashion.
- After tightening the bolts to the specified torque, tighten the bolts additionally by turning the bolts 31 to 36 degrees.

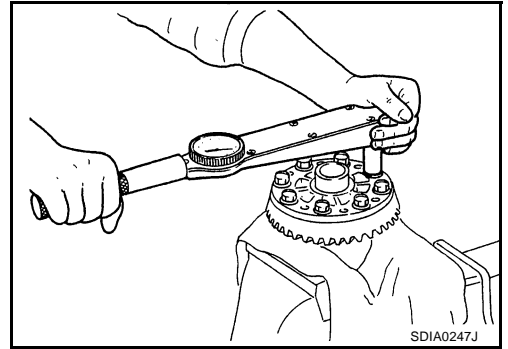

10. Press side bearing inner races to differential case, using the drift and the base.

**Tool number**     **A: KV38100300 (J-25523)**

**B: ST33061000 (J-8107-2)**

**CAUTION:**

**Do not reuse side bearing inner race.**

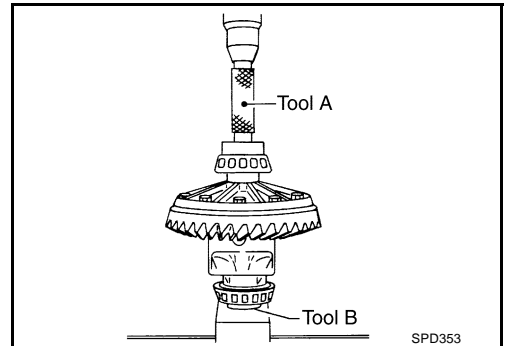

11. Install differential case assembly with side bearing outer races into gear carrier.

12. Measure side bearing preload. If necessary, select the appropriate side bearing adjusting washers. Refer to [RFD-30, "Side Bearing Preload"](#).

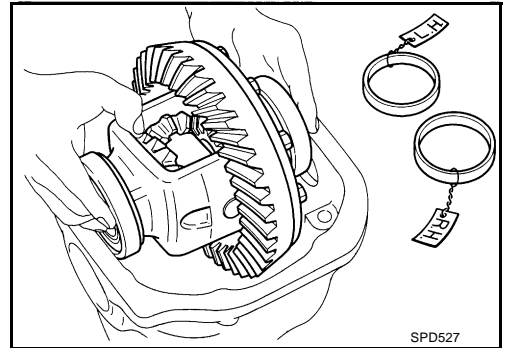

13. Insert selected left and right side bearing adjusting washers in place between side bearings and gear carrier.

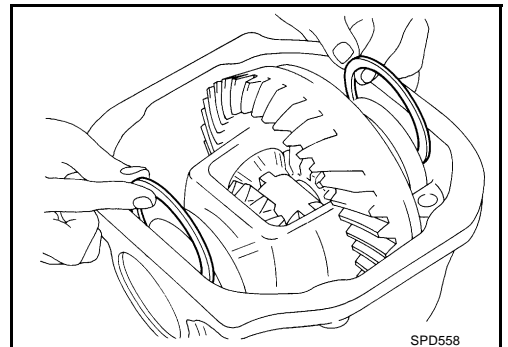

14. Align matching marks on bearing cap with that on gear carrier.
15. Install bearing caps and tighten bearing cap mounting bolts to the specified torque. Refer to [RFD-20, "COMPONENTS"](#).

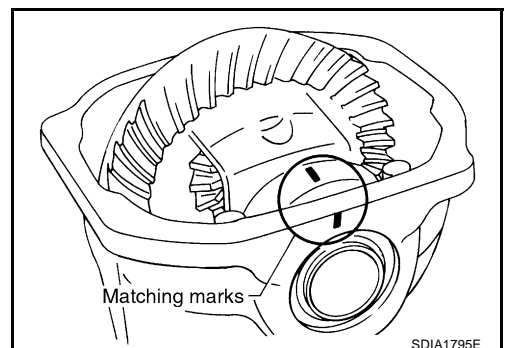

# REAR FINAL DRIVE ASSEMBLY

16. Using the drift, drive side oil seals until it becomes flush with the case end.

**Tool number : KV38100200 (J-26233)**

**CAUTION:**

- Do not reuse oil seal.
- When installing, do not incline oil seal.
- Apply multi-purpose grease onto oil seal lips, and gear oil onto the circumference of oil seal.

17. Check and adjust drive gear runout, tooth contact, drive gear to drive pinion backlash, and total preload torque. Refer to [RFD-21, "Drive Gear Runout"](#) , [RFD-22, "Tooth Contact"](#) , [RFD-23, "Backlash"](#) and [RFD-21, "Total Preload Torque"](#) .  
Recheck above items. Readjust the above description, if necessary.

18. Apply sealant to mating surface of rear cover.

- Use Genuine Silicone RTV or equivalent. Refer to [GI-47, "RECOMMENDED CHEMICAL PRODUCTS AND SEALANTS"](#) .

**CAUTION:**

Remove old sealant adhering to mounting surfaces. Also remove any moisture, oil, or foreign material adhering to application and mounting surfaces.

19. Install rear cover on gear carrier and tighten mounting bolts with the specified torque. Refer to [RFD-20, "COMPONENTS"](#) .

20. Install side flange with the following procedure.

- a. Attach the protector to side oil seal.

**Tool number : KV38107900 (J-39352)**

- b. After the side flange is inserted and the serrated part of side gear has engaged the serrated part of flange, remove the protector.

- c. Put a suitable drift on the center of side flange, then drive it until sound changes.

**NOTE:**

When installation is completed, driving sound of the side flange turns into a sound which seems to affect the whole final drive.

- d. Confirm that the dimension of the side flange installation (Measurement A) in the figure comes into the following.

**Measurement A: 326 – 328 mm (12.83 – 12.91 in)**

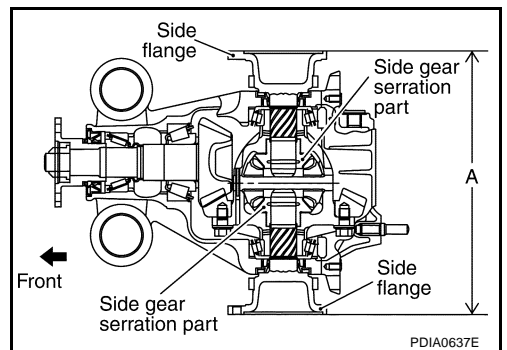
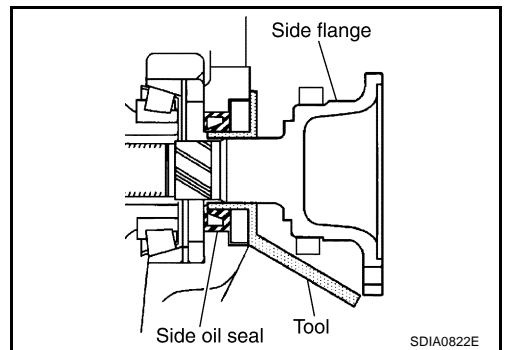
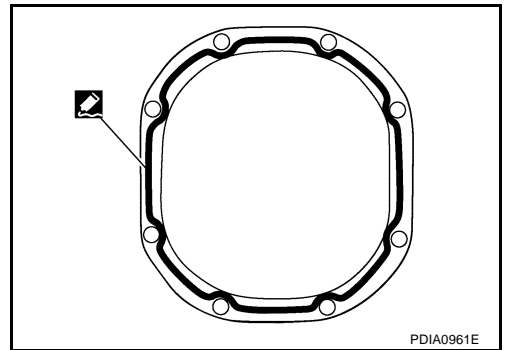
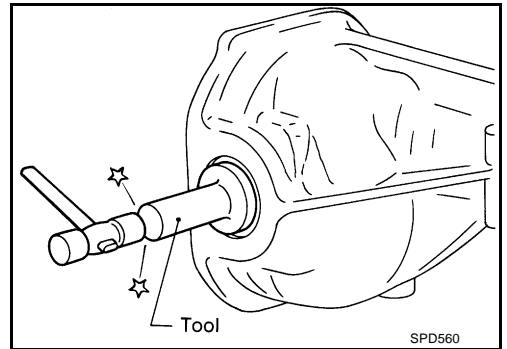

A  
B  
C  
RFD  
E  
F  
G  
H  
I  
J  
K  
L  
M



# REAR FINAL DRIVE ASSEMBLY

## Disassembly and Assembly (R200V LSD) COMPONENTS

NDS0004G

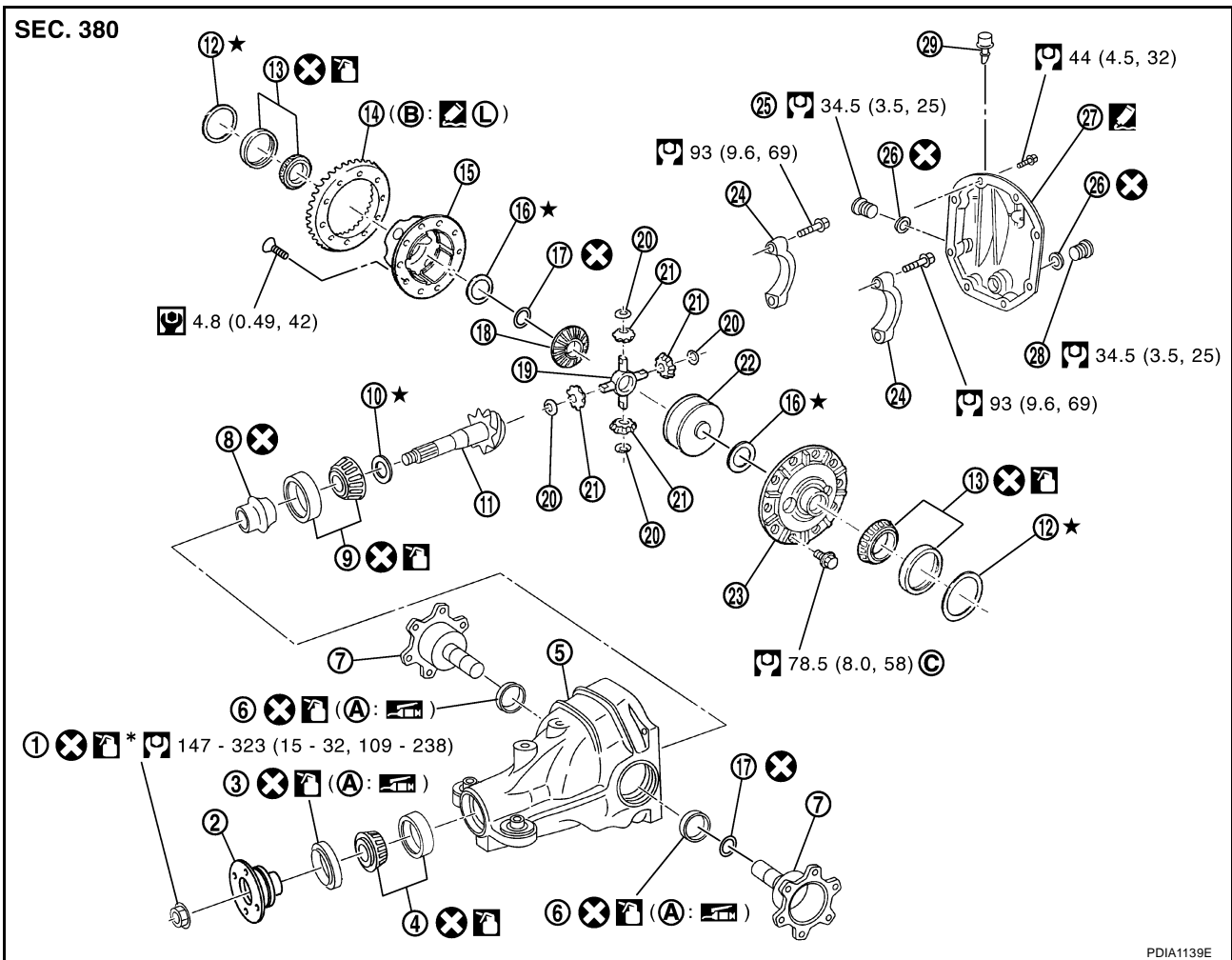

PDIA1139E

- |                                    |                               |                                   |
|------------------------------------|-------------------------------|-----------------------------------|
| 1. Drive pinion lock nut           | 2. Companion flange           | 3. Front oil seal                 |
| 4. Pinion front bearing            | 5. Gear carrier               | 6. Side oil seal                  |
| 7. Side flange                     | 8. Collapsible spacer         | 9. Pinion rear bearing            |
| 10. Pinion height adjusting washer | 11. Drive pinion              | 12. Side bearing adjusting washer |
| 13. Side bearing                   | 14. Drive gear                | 15. Differential case B           |
| 16. Side gear thrust washer        | 17. Circular clip             | 18. Side gear                     |
| 19. Pinion mate shaft              | 20. Pinion mate thrust washer | 21. Pinion mate gear              |
| 22. Viscous coupling               | 23. Differential case A       | 24. Bearing cap                   |
| 25. Filler plug                    | 26. Gasket                    | 27. Rear cover                    |
| 28. Drain plug                     | 29. Air breather              |                                   |

A: Oil seal lip

B: Screw hole

C: After tightening the bolts to the specified torque, tighten the bolts additionally by turning the bolts 31 to 36 degrees.

Refer to [GI-10. "Components"](#) and the followings for the symbols in the figure.



Apply gear oil.



Apply anti-corrosion oil.



Apply Genuine Silicone RTV or equivalent. Refer to [GI-47. "Recommended Chemical Products and Sealants"](#).



Apply Genuine High Strength Thread Locking Sealant or equivalent. Refer to [GI-47. "Recommended Chemical Products and Sealants"](#).



# REAR FINAL DRIVE ASSEMBLY

## ASSEMBLY INSPECTION AND ADJUSTMENT

- Before inspection and adjustment, drain gear oil.

### Total Preload Torque

1. Secure final drive assembly onto an attachment.

**Tool number : KV38100800 (J-25604-01)**

2. Remove side flanges.
3. Rotate drive pinion back and forth 2 to 3 times to check for unusual noise and rotation malfunction.
4. Rotate drive pinion at least 20 times to check for smooth operation of the bearing.
5. Measure total preload with the preload gauge.

**Tool number : ST3127S000 (J-25765-A)**

**Total preload torque:**

**2.85 – 3.75 N·m (0.29 – 0.38 kg-m, 26 – 33 in-lb)**

#### NOTE:

**Total preload torque = Pinion bearing preload torque + Side bearing preload torque**

- If measured value is out of the specification, disassemble it to check and adjust each part. Adjust the pinion bearing preload and side bearing preload. Adjust the pinion bearing preload first, then adjust the side bearing preload.

**When the preload torque is large**

**On pinion bearings: Replace the collapsible spacer.**

**On side bearings: Use thinner side bearing adjusting washers by the same amount to each side. Refer to [RFD-61, "Side Bearing Adjusting Washer"](#) .**

**When the preload is small**

**On pinion bearings: Tighten the drive pinion lock nut.**

**On side bearings: Use thicker side bearing adjusting washers by the same amount to each side. Refer to [RFD-61, "Side Bearing Adjusting Washer"](#) .**

### Drive Gear Runout

1. Remove rear cover. Refer to [RFD-45, "Differential Assembly"](#) .
2. Fit a dial indicator to the drive gear back face.
3. Rotate the drive gear to measure runout.

**Runout limit: 0.05 mm (0.0020 in) or less**

- If the runout is outside of the repair limit, check drive gear assembly condition; foreign material may be caught between drive gear and differential case, or differential case or drive gear may be deformed, etc.

#### CAUTION:

**Replace drive gear and drive pinion gear as a set.**

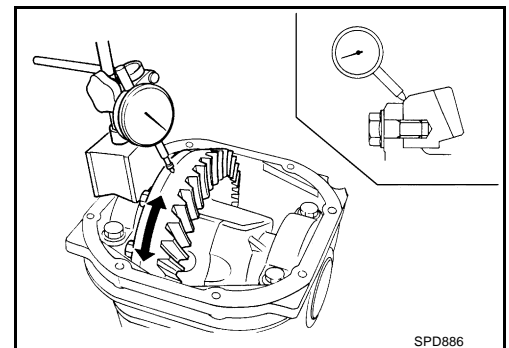
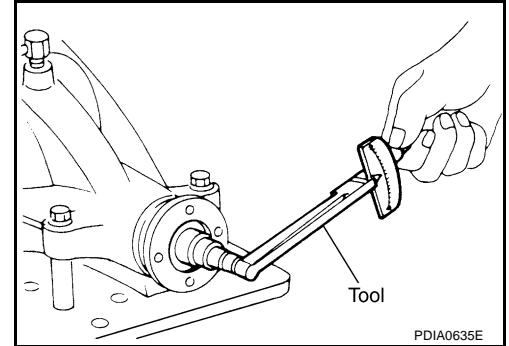

A

B

C

RFD

E

F

G

H

I

J

K

L

M

# REAR FINAL DRIVE ASSEMBLY

## Tooth Contact

1. Remove rear cover. Refer to [RFD-45, "Differential Assembly"](#) .
2. Apply red lead to drive gear.

**CAUTION:**

Apply red lead to both the faces of 3 to 4 gears at 4 locations evenly spaced on drive gear.

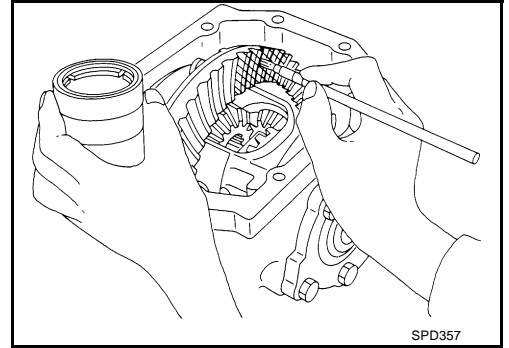

3. Rotate drive gear back and forth several times, check drive pinion gear to drive gear tooth contact.

**CAUTION:**

Check tooth contact on drive side and reverse side.

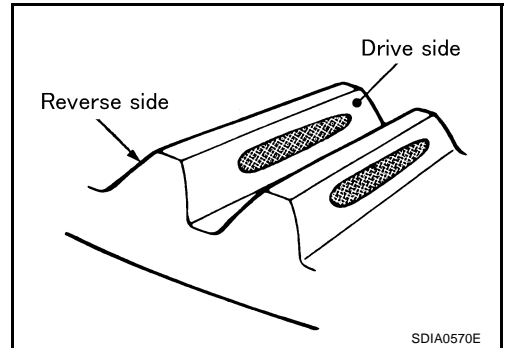

Tooth contact condition		Pinion height adjusting washer selection valve [ mm (in) ]	Adjustment (Yes/No)	Possible cause	
Drive side	Back side				
Heel side Toe side 	Toe side Heel side 	↑ Thicker	Yes	Occurrence of noise and scoring sound in all speed ranges.	
				+0.06 (+0.0024)	Occurrence of noise when accelerating.
				+0.03 (+0.0012)	
		↓ Thinner	No	—	
				0	
				-0.03 (-0.0012)	
				-0.06 (-0.0024)	Occurrence of noise at constant speed and decreasing speed.
			Yes	Occurrence of noise and scoring sound in all speed ranges.	

# REAR FINAL DRIVE ASSEMBLY

4. If tooth contact is improperly adjusted, follow the procedure below to adjust the pinion height (dimension X).

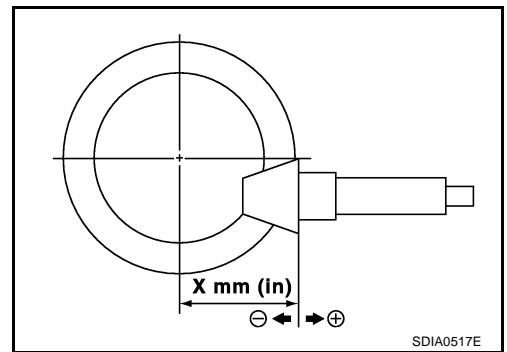

- If the tooth contact is near the face (face contact), or near the heel (heel contact), thicken pinion height adjusting washers to move drive pinion closer to drive gear. Refer to [RFD-61, "Pinion Height Adjusting Washer"](#).

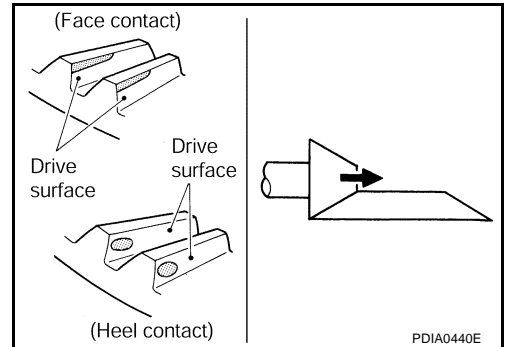

- If the tooth contact is near the flank (flank contact), or near the toe (toe contact), thin pinion height adjusting washers to move drive pinion farther from drive gear. Refer to [RFD-61, "Pinion Height Adjusting Washer"](#).

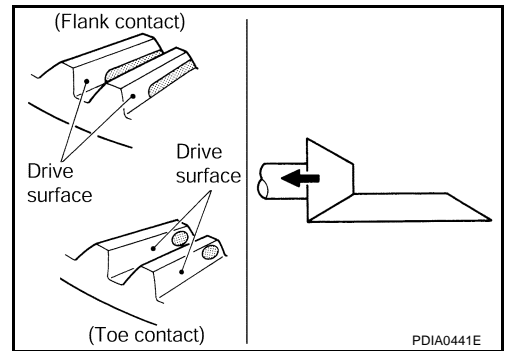

## Backlash

1. Remove rear cover. Refer to [RFD-45, "Differential Assembly"](#).
2. Fit a dial indicator to the drive gear face to measure the backlash.

**Backlash:**            **0.10 – 0.15 mm (0.0039 – 0.0059 in)**

- If the backlash is outside of the specified value, change the thickness of side bearing adjusting washer.

### When the backlash is large:

**Make drive gear back side adjusting washer thicker, and drive gear tooth side adjusting washer thinner by the same amount. Refer to [RFD-61, "Side Bearing Adjusting Washer"](#).**

### When the backlash is small:

**Make drive gear back side adjusting washer thinner, and drive gear tooth side adjusting washer thicker by the same amount. Refer to [RFD-61, "Side Bearing Adjusting Washer"](#).**

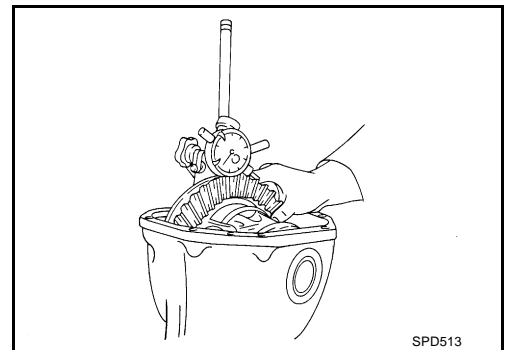

## CAUTION:

**Do not change the total amount of washers as it will change the bearing preload.**

A  
B  
C  
RFD  
E  
F  
G  
H  
I  
J  
K  
L  
M

## REAR FINAL DRIVE ASSEMBLY

### Companion Flange Runout

1. Fit a dial indicator onto the companion flange face (inner side of the propeller shaft mounting bolt holes).
2. Rotate the companion flange to check for runout.

**Runout limit : 0.08 mm (0.0031 in)**

3. Fit a test indicator to the inner side of the companion flange (socket diameter).
4. Rotate the companion flange to check for runout.

**Runout limit : 0.08 mm (0.0031 in)**

5. If the runout value is outside the repair limit, follow the procedure below to adjust.
  - a. Check for runout while changing the phase between companion flange and drive pinion gear by 90° step, and search for the position where the runout is the minimum.
  - b. If the runout value is still outside of the limit after the phase has been changed, possible cause will be an assembly malfunction of drive pinion and pinion bearing and malfunction of pinion bearing. Check for these items and repair if necessary.
  - c. If the runout value is still outside of the limit after the check and repair, replace companion flange.

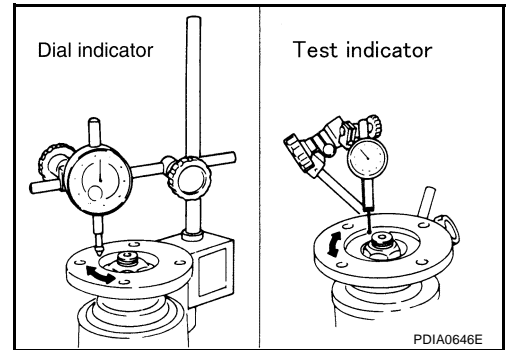

# REAR FINAL DRIVE ASSEMBLY

## DISASSEMBLY

### Differential Assembly

1. Drain gear oil, if necessary.
2. Remove side flange.
3. Remove rear cover mounting bolts.
4. Remove rear cover to insert the seal cutter between gear carrier and rear cover.

**Tool number** : KV10111100 (J-37228)

#### CAUTION:

- Be careful not to damage the mating surface.
- Do not insert flat-bladed screwdriver, this way damage the mating surface.

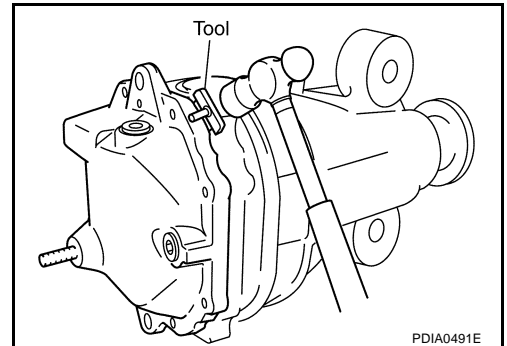

5. Using two 45 mm (1.77 in) spacers, mount carrier on the attachment.

**Tool number** : KV38100800 (J-25604-01)

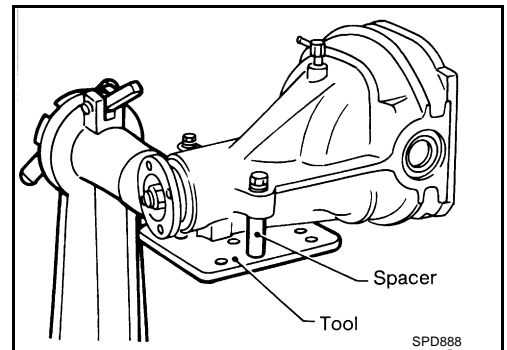

6. For proper reinstallation, paint matching marks on one side of the bearing cap.

#### CAUTION:

- For matching marks, use paint. Do not damage bearing caps and gear carrier.
- Bearing caps are line-board during manufacture. The matching marks are used to reinstall them in their original positions.

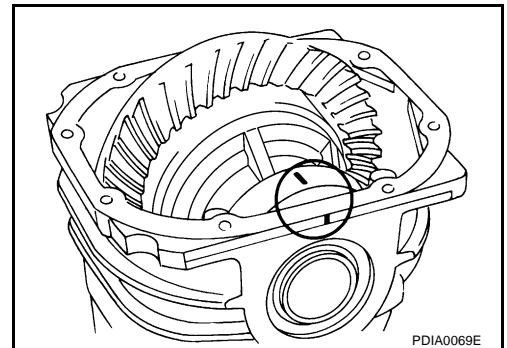

7. Remove bearing caps.

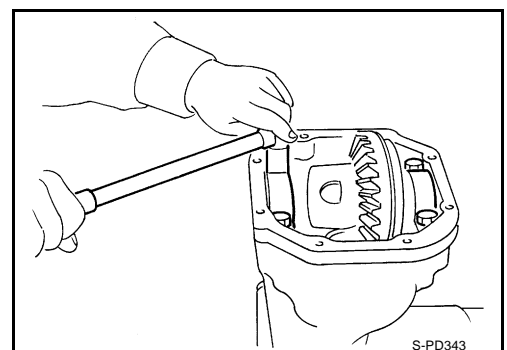

A  
B  
C  
RFD  
E  
F  
G  
H  
I  
J  
K  
L  
M

## REAR FINAL DRIVE ASSEMBLY

8. Lift differential case assembly out with a suitable tool.

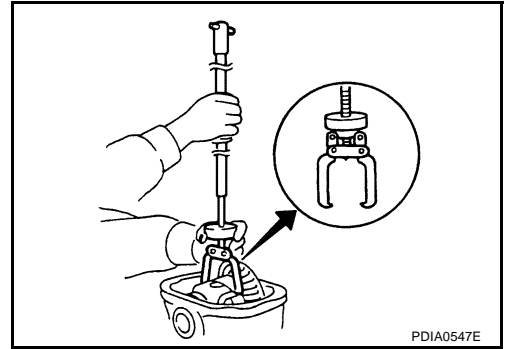

- Keep side bearing outer races together with inner race. Do not mix them up. Also, keep side bearing adjusting washers together with bearings.

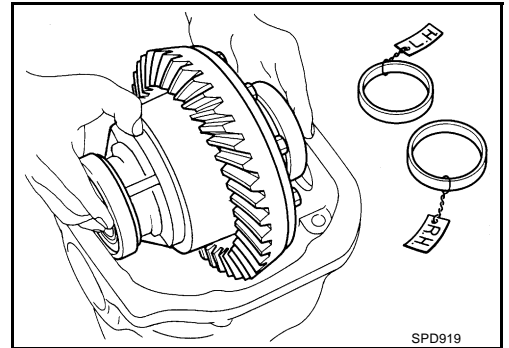

9. Remove side bearing inner race.  
To prevent damage to bearing, engage puller jaws in groove.

**Tool number**     **A: ST33051001 (J-22888-20)**  
                              **B: ST33061000 (J-8107-2)**

**CAUTION:**

- To prevent damage to the side bearing and drive gear, place copper plates between these parts and vise.
- It is not necessary to remove side bearing inner race except it is replaced.

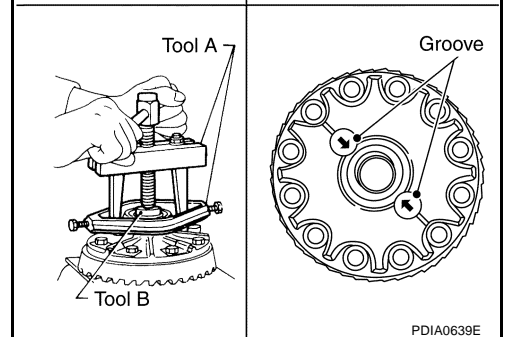
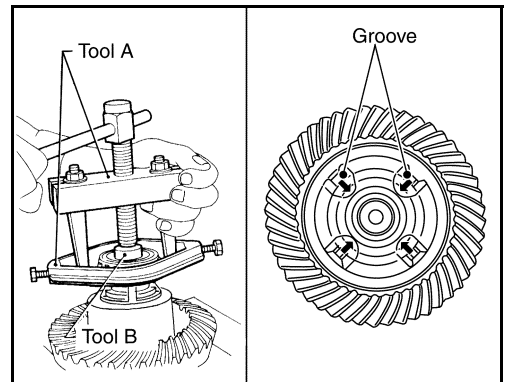

10. For proper reinstallation, paint matching marks on one differential case assembly.

**CAUTION:**

**For matching marks, use paint. Do not damage differential case and drive gear.**

11. Remove drive gear mounting bolts.  
12. Tap drive gear off differential case assembly with a soft hammer.

**CAUTION:**

**Tap evenly all around to keep drive gear from bending.**

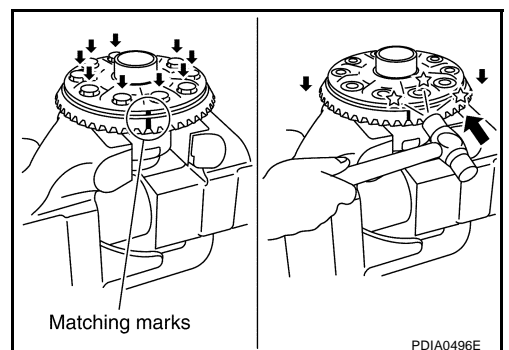

# REAR FINAL DRIVE ASSEMBLY

13. Put matching marks with paint.

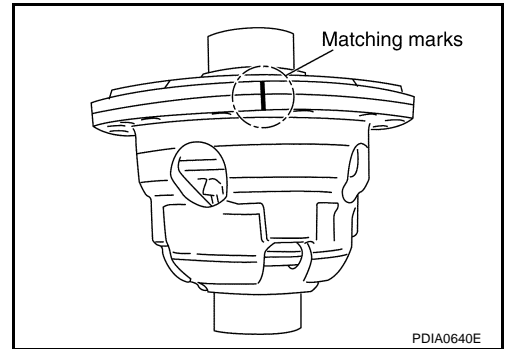

A  
B  
C

RFD

14. Loosen screws on differential cases A and B.

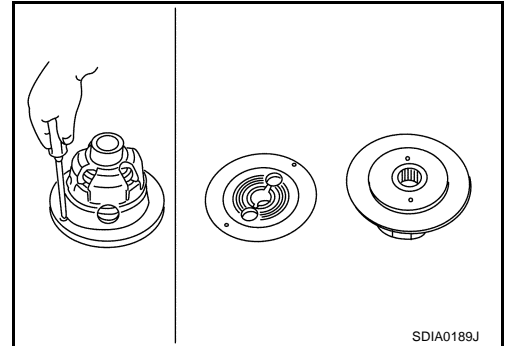

E  
F  
G

15. Separate differential case A and B, then remove viscous coupling, pinion mate gear, pinion mate thrust washer, side gear and side gear thrust washer from differential cases.

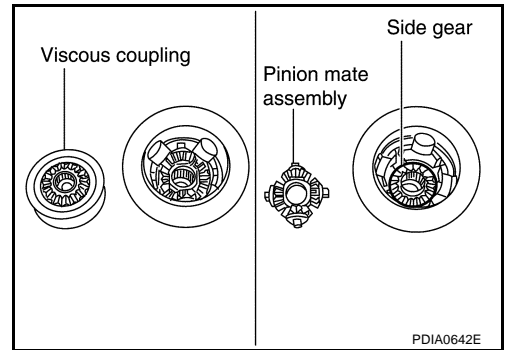

H  
I  
J

K

## Drive Pinion Assembly

1. Remove differential assembly. Refer to [RFD-45, "Differential Assembly"](#).
2. Remove drive pinion lock nut with the flange wrench.

**Tool number** : KV40104000 ( — )

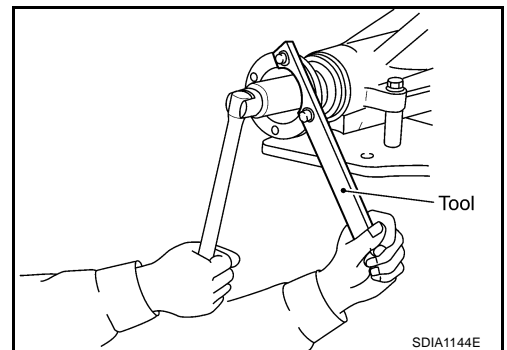

L  
M

## REAR FINAL DRIVE ASSEMBLY

- Put matching mark on the end of drive pinion. The matching mark should be in line with the matching mark A on companion flange.

**CAUTION:**

**For matching mark, use paint. Do not damage companion flange and drive pinion.**

**NOTE:**

The matching mark A on the final drive companion flange indicates the maximum vertical runout position. When replacing companion flange, matching mark is not necessary.

- Remove companion flange using the suitable puller.

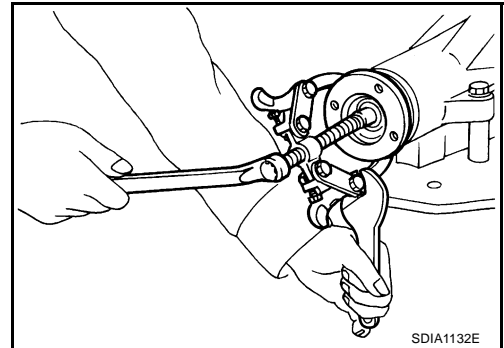
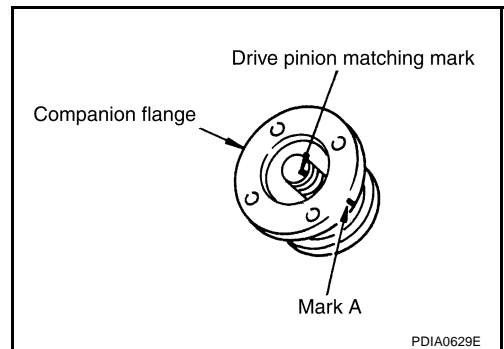

- Press drive pinion assembly out of gear carrier.

**CAUTION:**

**Do not drop drive pinion assembly.**

- Remove front oil seal.
- Remove side oil seal.
- Remove pinion front bearing inner race.
- Remove collapsible spacer.

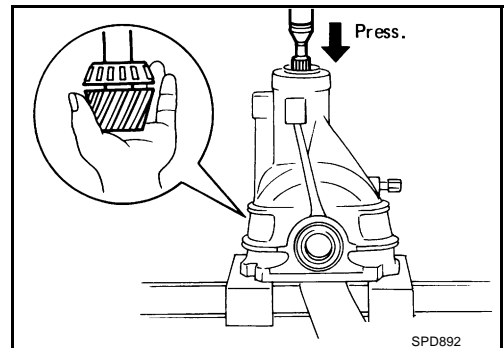

- Remove pinion rear bearing inner race and pinion height adjusting washer with the replacer.

**Tool number : ST30031000 (J-22912-01)**

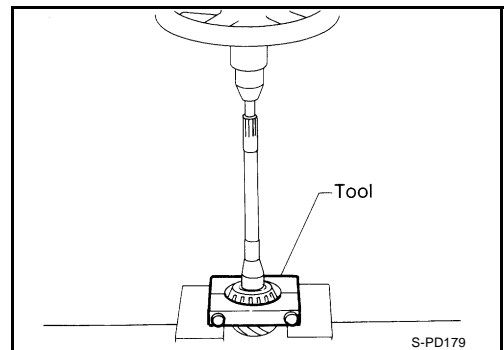

- Tap pinion front/rear bearing outer races uniformly a brass rod or equivalent to removed.

**CAUTION:**

**Be careful not to damage gear carrier.**

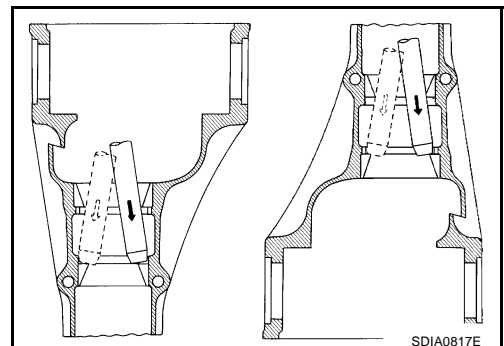



# REAR FINAL DRIVE ASSEMBLY

## INSPECTION AFTER DISASSEMBLY

Clean up the disassembled parts. Then, inspect if the parts are worn or damaged. If so, follow the measures below.

Content	Conditions and Measures
Hypoid gear	<ul style="list-style-type: none"> <li>● If the gear teeth do not mesh or line-up correctly, determine the cause and adjust or replace as necessary.</li> <li>● If the gears are worn, cracked, damaged, pitted or chipped (by friction) noticeably, replace with new drive gear and drive pinion as a set.</li> </ul>
Bearing	<ul style="list-style-type: none"> <li>● If any chipped (by friction), pitted, worn, rusted or scratched mark, or unusual noise from the bearing is observed, replace as a bearing assembly (as a new set).</li> </ul>
Side gear and Pinion mate gear	<ul style="list-style-type: none"> <li>● If any cracks or damage on the surface of the tooth is found, replace.</li> <li>● If any worn or chipped mark on the contact sides of the thrust washer is found, replace.</li> </ul>
Side gear thrust washer and pinion mate thrust washer	<ul style="list-style-type: none"> <li>● If it is chipped (by friction), damaged, or unusually worn, replace.</li> </ul>
Oil seal	<ul style="list-style-type: none"> <li>● Whenever disassembled, replace.</li> <li>● If wear, deterioration of adherence (sealing force lips), or damage is detected on the lips, replace them.</li> </ul>
Differential case	<ul style="list-style-type: none"> <li>● If any wear or crack on the contact sides of the differential case is found, replace.</li> </ul>
Companion flange	<ul style="list-style-type: none"> <li>● If any chipped mark (about 0.1 mm, 0.004 in) or other damage on the contact sides of the lips of the companion flange is found, replace.</li> </ul>

## ADJUSTMENT AND SELECTION OF ADJUSTING WASHERS

### Differential Side Gear Clearance

- Assemble the differential parts if they are disassembled. Refer to [RFD-56, "Differential Assembly"](#) .

1. Place differential assembly so that right side gear is on the upper side.
2. Measure the clearance between right side gear back and differential case using feeler gauge, while rotating right side gear with a suitable tool attached to splines.

#### Side gear back clearance specification:

**0.15 mm (0.0059 in) or less (Each gear should rotate smoothly without excessive resistance during differential motion.)**

#### CAUTION:

- Do not place feeler gauge at groove side of differential case.
  - To prevent side gear from tilting, insert feeler gauges with the same thickness from both sides.
3. If the back clearance is outside the specification, use a thicker/thinner side gear thrust washer to adjust. Refer to [RFD-61, "Side Gear Thrust Washer"](#) .

**When the back clearance is large:**

**Use a thicker thrust washer.**

**When the back clearance is small:**

**Use a thinner thrust washer.**

#### CAUTION:

- Adjust the clearance with the left side gear thrust washer only.
- Only one side gear thrust washer can be selected.

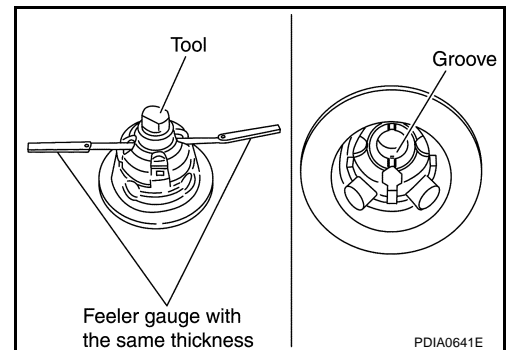

# REAR FINAL DRIVE ASSEMBLY

## Side Bearing Preload

- Selecting carrier side bearing adjusting washers is required for successful completion of this procedure.

1. Make sure all parts are clean. Also, make sure the bearings are well lubricated with gear oil.
2. Place the differential case, with side bearings and bearing races installed, into gear carrier.

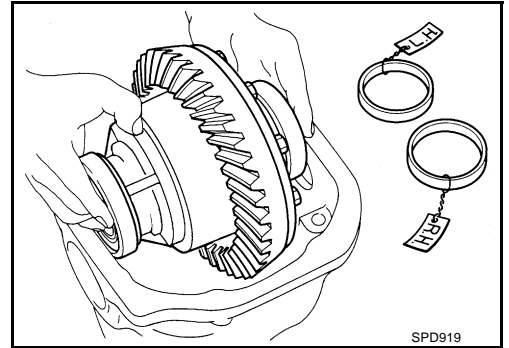

3. Insert left and right original side bearing adjusting washers in place between side bearings and gear carrier.

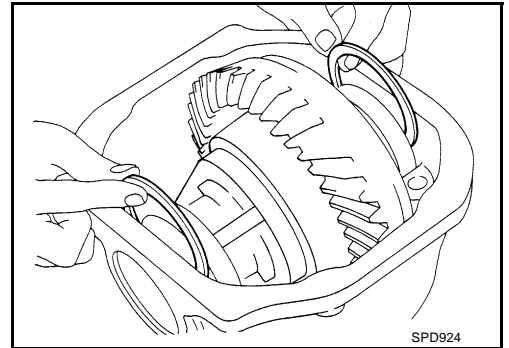

4. Install bearing caps in their correct locations and tighten bearing cap mounting bolts to the specified torque. Refer to [RFD-40. "COMPONENTS"](#).
5. Turn the carrier several times to seat the bearings.

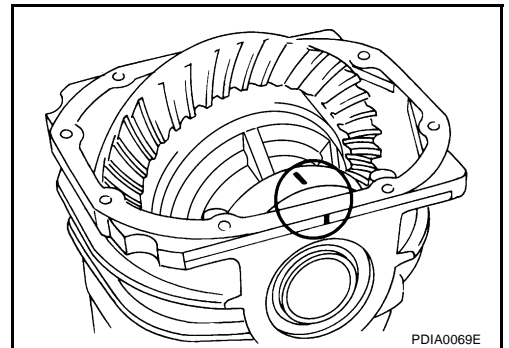

6. Measure the turning torque of the carrier at the drive gear mounting bolts with a spring gauge.

**Tool number : — (J-8129)**

### Specification:

**34.2 – 39.2 N (3.5 – 4.0 kg, 7.7 – 8.8 lb) of pulling force at the drive gear bolt**

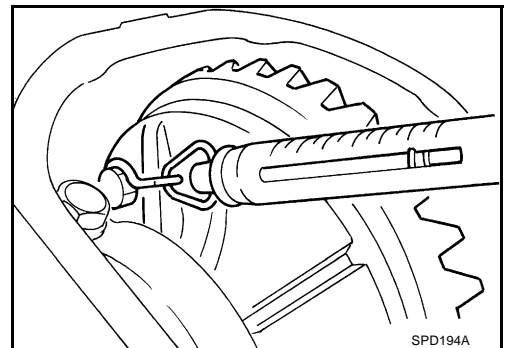

# REAR FINAL DRIVE ASSEMBLY

7. If the turning torque is outside the specification, use a thicker/thinner side bearing adjusting washer to adjust. Refer to [RFD-61, "Side Bearing Adjusting Washer"](#) .

**If the turning torque is less than the specified range:**

**Use a thicker thrust washer.**

**If the turning torque is greater than the specification:**

**Use a thinner thrust washer.**

**CAUTION:**

**Select a side bearing adjusting washer for right and left individually.**

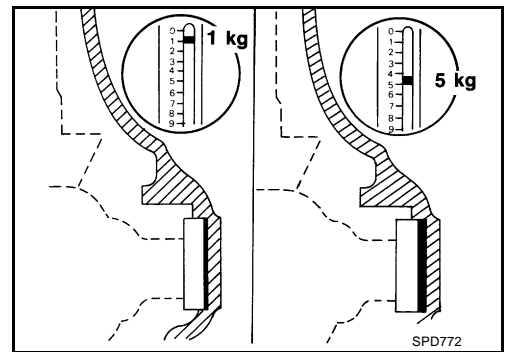

8. Record the total amount of washer thickness required for the correct carrier side bearing preload.

## Pinion Gear Height

1. Make sure all parts are clean and that the bearings are well lubricated.
2. Assemble the pinion gear bearings into the differential shim selector tool.

**Tool number : — (J-34309)**

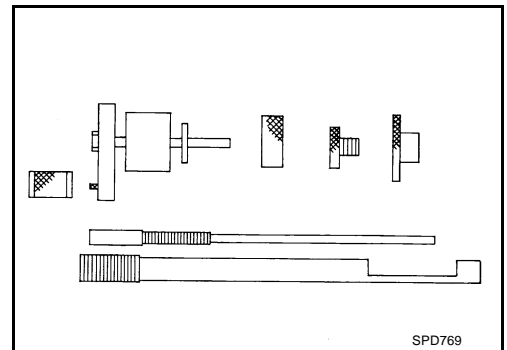

- **Pinion front bearing;** make sure the J-34309-3 pinion front bearing seat is secured tightly against the J-34309-2 gauge anvil. Then turn the pinion front bearing pilot, J-34309-5, to secure the bearing in its proper position.
- **Pinion rear bearing;** the pinion rear bearing pilot, J-34309-8, is used to center the pinion rear bearing only. The pinion rear bearing locking seat, J-34309-4, is used to lock the bearing to the assembly.
- **Installation of J-34309-9 and J-34309-16;** place a suitable 2.5 mm (0.098 in) thick plain washer between J-34309-9 and J-34309-16. Both surfaces of J-34309-9 and J-34309-16 must be parallel with a clearance of 2.5 mm (0.098 in).

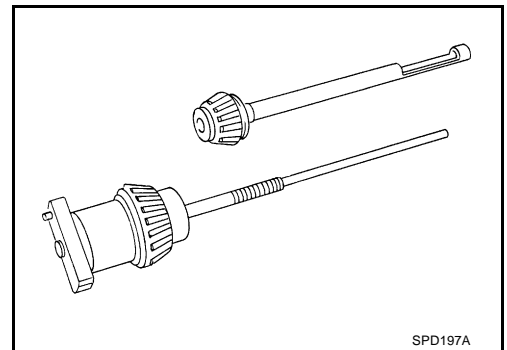

3. Install the pinion rear bearing inner race into gear carrier. Then place the pinion preload shim selector tool, J-34309-1, gauge screw assembly.

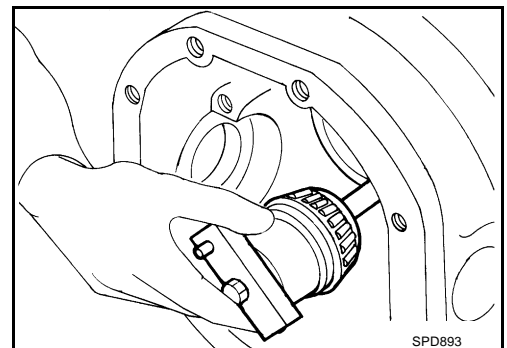

A  
B  
C  
RFD  
E  
F  
G  
H  
I  
J  
K  
L  
M

## REAR FINAL DRIVE ASSEMBLY

4. Assemble the pinion front bearing inner race and the J-34309-2 gauge anvil. Assemble them together with the J-34309-1 gauge screw in gear carrier. Make sure that the pinion height gauge plate, J-34309-16, will turn a full 360 degrees. Tighten the two sections together by hand.

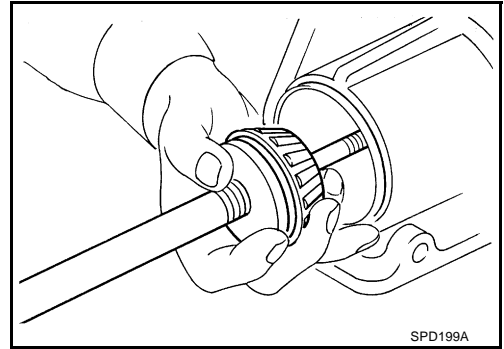

5. Turn the assembly several times to seat the bearings.

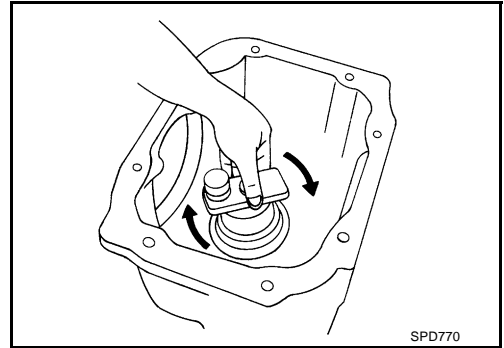

6. Measure the turning torque at the end of the J-34309-2 gauge anvil using preload gauge.

**Tool number : ST3127S000 (J-25765- A)**

**Turning torque specification:**

**1.0 – 1.3 N·m (0.11 – 0.13 kg·m, 9 – 11 in·lb)**

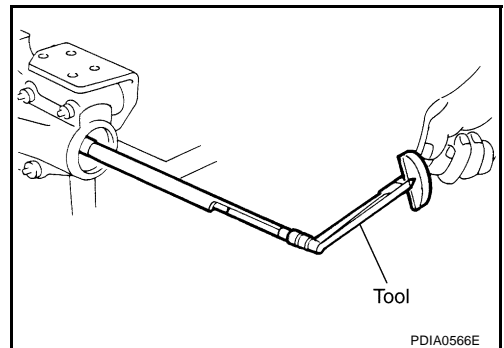

7. Place the J-34309-11 "R200A" pinion height adapter onto the gauge plate and tighten it by hand.

**CAUTION:**

**Make sure all machined surfaces are clean.**

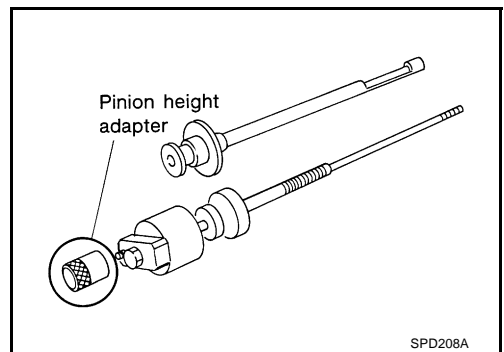

8. Position the side bearing discs, J-25269-4, and arbor firmly into the side bearing bores. Install the bearing caps and tighten bearing cap mounting bolts to the specified torque. Refer to [RFD-40, "COMPONENTS"](#).

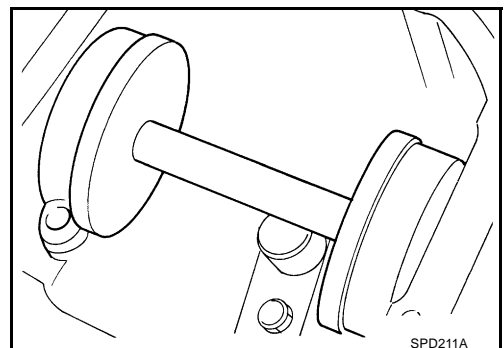

# REAR FINAL DRIVE ASSEMBLY

9. Select the correct standard pinion height adjusting washer thickness. Select by using a standard gauge of 3 mm (0.12 in) and your J-34309-101 feeler gauge. Measure the distance between the J-34309-11 pinion height adapter including the standard gauge and the arbor.

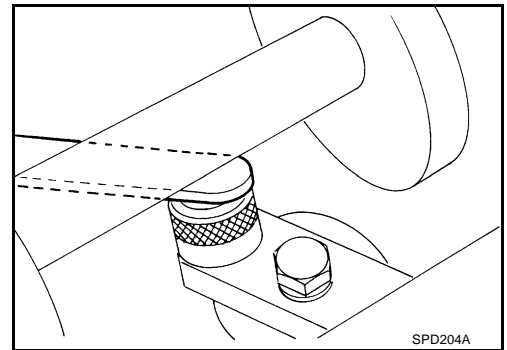

10. Write down exact measurement (the value of feeler gauge).

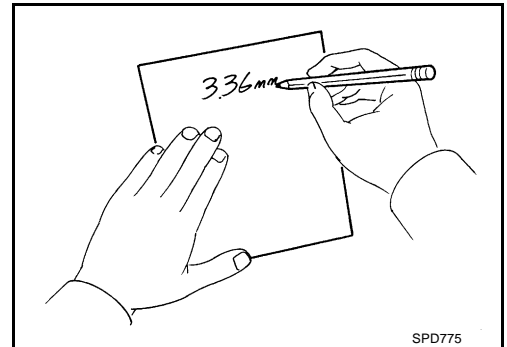

11. Correct the pinion height washer size by referring to the "pinion head number".

**There are two numbers painted on the drive pinion. The first one refers to the drive pinion and drive gear as a matched set. This number should be the same as the number on the drive gear. The second number is the "pinion head height number". It refers to the ideal pinion height from standard for quietest operation. Use the following chart to determine the correct pinion height washer.**

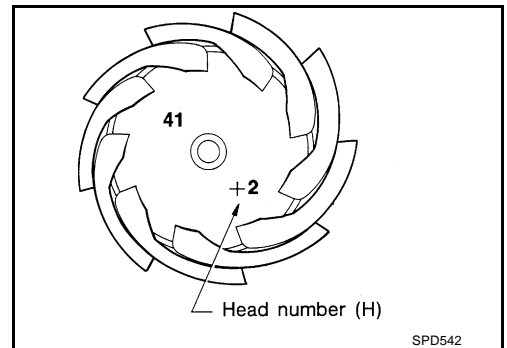

Pinion head height number	Add or remove from the standard pinion height adjusting washer thickness measurement
- 6	Add 0.06 mm (0.0024 in)
- 5	Add 0.05 mm (0.0020 in)
- 4	Add 0.04 mm (0.0016 in)
- 3	Add 0.03 mm (0.0012 in)
- 2	Add 0.02 mm (0.0008 in)
- 1	Add 0.01 mm (0.0004 in)
0	Use the selected washer thickness
+1	Subtract 0.01 mm (0.0004 in)
+2	Subtract 0.02 mm (0.0008 in)
+3	Subtract 0.03 mm (0.0012 in)
+4	Subtract 0.04 mm (0.0016 in)
+5	Subtract 0.05 mm (0.0020 in)
+6	Subtract 0.06 mm (0.0024 in)

12. Select the correct pinion height adjusting washer. Refer to [RFD-61, "Pinion Height Adjusting Washer"](#) .

A  
B  
C  
RFD  
E  
F  
G  
H  
I  
J  
K  
L  
M

# REAR FINAL DRIVE ASSEMBLY

13. Remove the J-34309 differential shim selector tool from the final drive housing. Then disassemble to retrieve the pinion bearings.

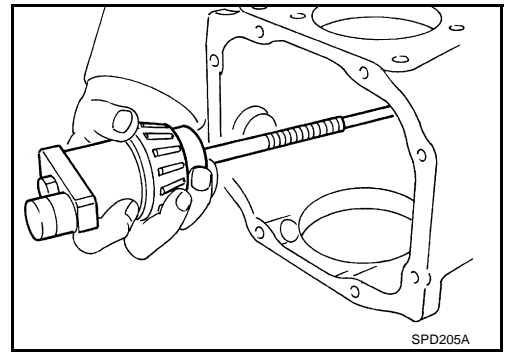

## ASSEMBLY

### Drive Pinion Assembly

1. Install front and rear bearing outer races using drifts.

**Tool number**    **A: ST30720000 (J-25405)**  
                          **B: KV40105230 ( — )**  
                          **C: ST30611000 (J-25742-1)**  
                          **D: ST30613000 (J-25742-3)**

#### CAUTION:

- At first, using a hammer, tap bearing outer race until it becomes flat to gear carrier.
  - Do not reuse pinion front and rear bearing outer race.
2. Select pinion height adjusting washer. Refer to [RFD-51, "Pinion Gear Height"](#) .

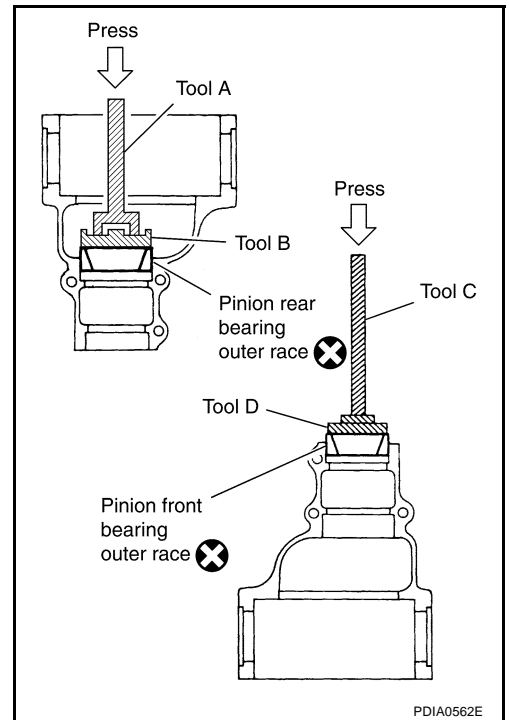

3. Install selected pinion height adjusting washer to drive pinion. Press pinion rear bearing inner race to it, using drift.

**Tool number**    : **ST30901000 (J-26010-01)**

#### CAUTION:

- Pay attention to the direction of pinion height adjusting washer. (Assemble as shown in the figure.)
- Do not reuse pinion rear bearing inner race.

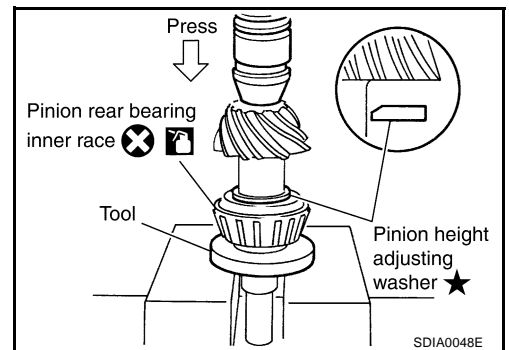

## REAR FINAL DRIVE ASSEMBLY

4. Assemble collapsible spacer to drive pinion.

**CAUTION:**

**Do not reuse collapsible spacer.**

5. Apply gear oil to pinion rear bearing, and assemble drive pinion into gear carrier.  
6. Apply gear oil to pinion front bearing, and assemble pinion front bearing inner race to drive pinion assembly.

**CAUTION:**

**Do not reuse pinion front bearing inner race.**

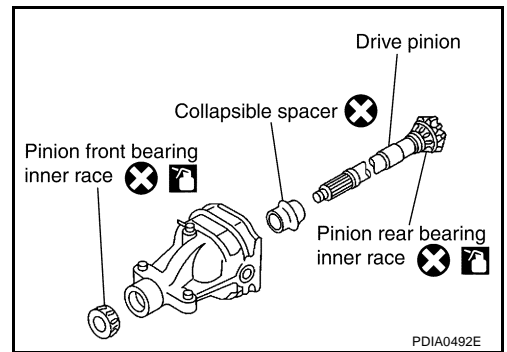

7. Using suitable spacer, press the pinion front bearing inner race to drive pinion as far as drive pinion nut can be tightened.

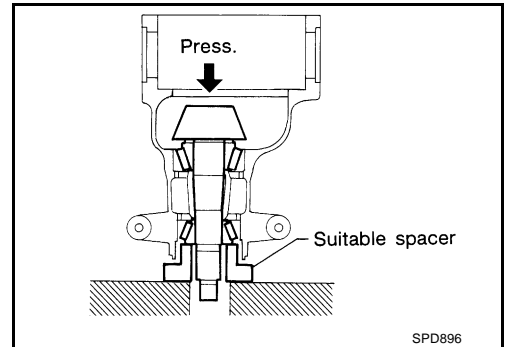

8. Using the drift, install front oil seal as shown in the figure.

**Tool number : ST30720000 (J-25405)**

**CAUTION:**

- Do not reuse oil seal.
- When installing, do not incline oil seal.
- Apply multi-purpose grease onto oil seal lips, and gear oil onto the circumference of oil seal.

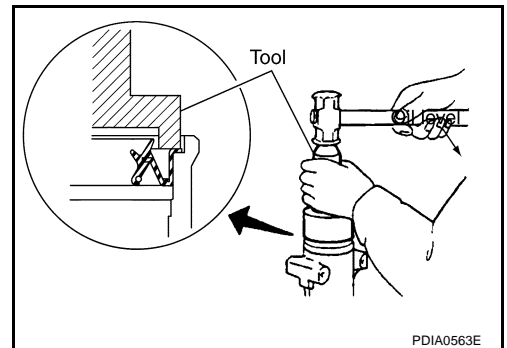

9. Install companion flange.

**NOTE:**

When reusing drive pinion, align the matching mark of drive pinion with the matching mark A of companion flange, then install companion flange.

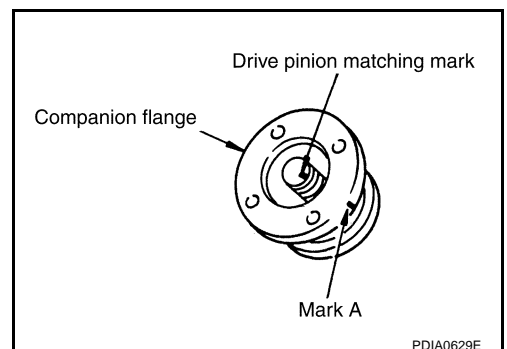

A

B

C

RFD

E

F

G

H

I

J

K

L

M

## REAR FINAL DRIVE ASSEMBLY

10. Apply anti-corrosion oil to the thread and seat of drive pinion lock nut, and temporarily tighten drive pinion lock nut to drive pinion.

**CAUTION:**

**Do not reuse drive pinion lock nut.**

11. Adjust to the drive pinion lock nut tightening torque and pinion bearing preload torque.

**Tool number**     **A:** KV40104000 ( — )  
                          **B:** ST3127S000 (J-25765-A)

**Drive pinion lock nut tightening torque:**

147 – 323 N·m (15 – 32 kg·m, 109 – 238 ft·lb)

**Drive pinion bearing preload:**

2.65 – 3.23 N·m (0.27 – 0.32 kg·m, 24 – 28 in·lb)

**CAUTION:**

- Adjust to the lower limit of the drive pinion lock nut tightening torque first.
  - If the preload torque exceeds the specified value, replace collapsible spacer and tighten it again to adjust. Do not loosen drive pinion lock nut to adjust the preload torque.
  - After adjustment, rotate drive pinion back and forth 2 to 3 times to check for unusual noise, rotation malfunction, and other malfunctions.
12. Install differential case assembly. Refer to [RFD-56, "Differential Assembly"](#).

**CAUTION:**

**Do not install rear cover yet.**

### Differential Assembly

1. Install side gear thrust washer with the same thickness as the ones installed prior to disassembly or reinstall the old ones on the side gear.

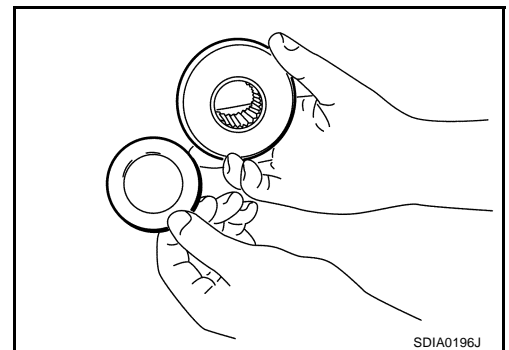
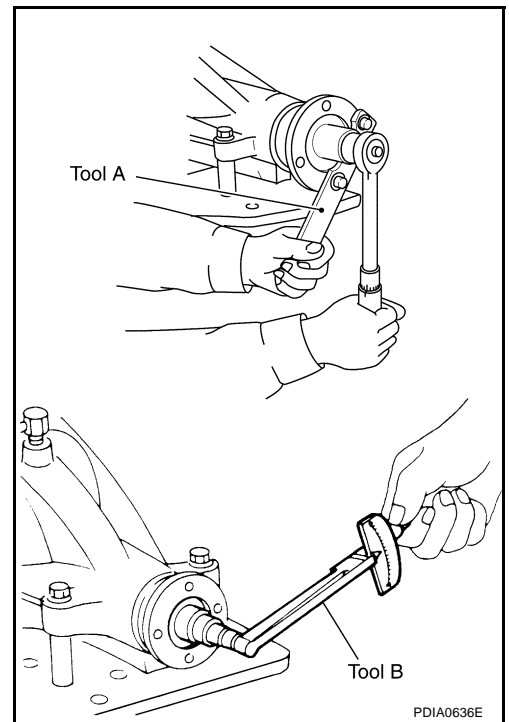



## REAR FINAL DRIVE ASSEMBLY

2. Install side gear and thrust washer into differential case B.

**CAUTION:**

**Make sure that the circular clip is installed to side gear.**

3. Install pinion mate assembly (pinion mate shaft, pinion mate gears and pinion mate thrust washers) into differential case B.

**CAUTION:**

**The pinion mate shaft groove side shall be installed to side gear.**

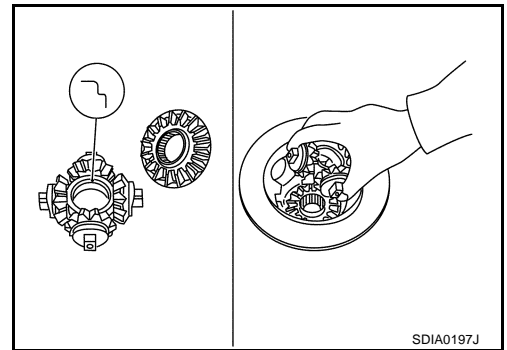

A  
B  
C

4. Install viscous coupling into differential case B.  
5. Install side gear thrust washer with the same thickness as the ones installed prior to disassembly or reinstall the old ones on the viscous coupling.

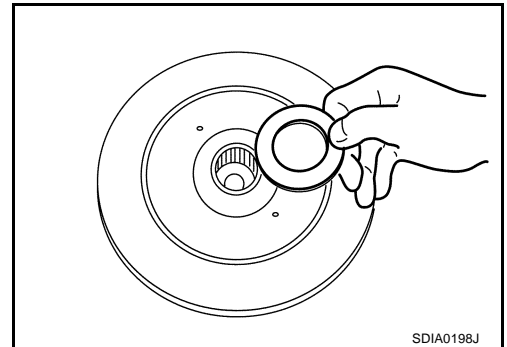

RFD

E  
F  
G

6. Align the matching marks and install differential case A into differential case B.  
7. Measure side gear end play. If necessary, select the appropriate side gear thrust washer. Refer to [RFD-49, "Differential Side Gear Clearance"](#).

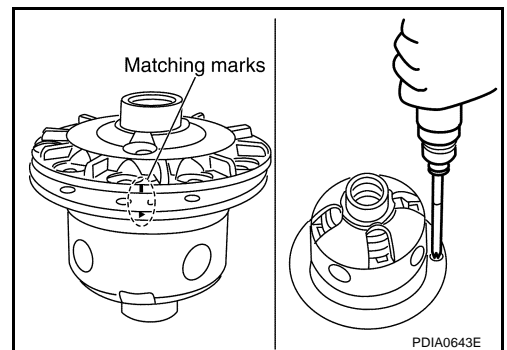

H  
I  
J

8. Align the matching mark of differential case with the mark of drive gear, then place drive gear.

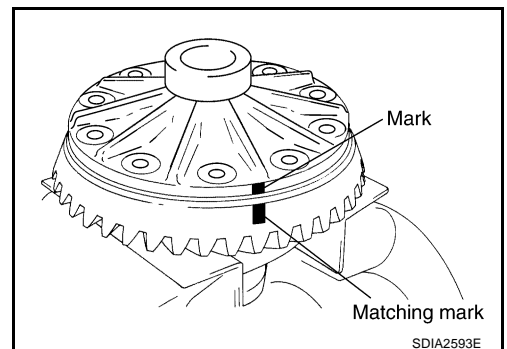

L  
M

9. Apply thread locking sealant into the thread hole of drive gear.  
● **Use Genuine High Strength Thread Locking Sealant or equivalent. Refer to [GI-47, "Recommended Chemical Products and Sealants"](#).**

**CAUTION:**

**Drive gear back and threaded holes shall be cleaned and degreased sufficiently.**

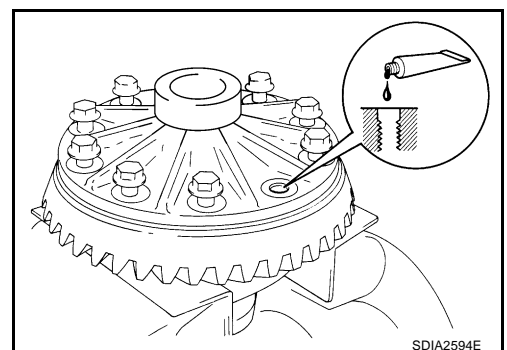

## REAR FINAL DRIVE ASSEMBLY

10. Install drive gear on the mounting bolts, and then tighten to the specified torque. Refer to [RFD-40, "COMPONENTS"](#).

**CAUTION:**

- Tighten bolts in a crisscross fashion.
- After tightening the bolts to the specified torque, tighten the bolts additionally by turning the bolts 31 to 36 degrees.

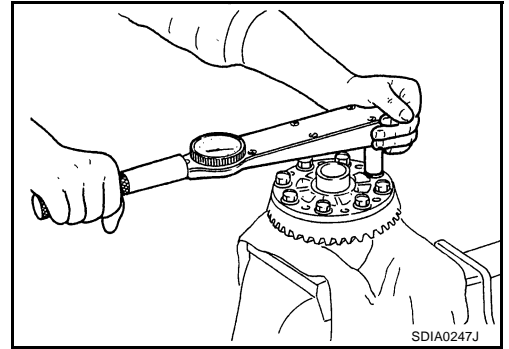

11. Press side bearing inner races to differential case, using the drift and the base.

**Tool number**      **A: KV38100300 (J-25523)**

**B: ST33061000 (J-8107-2)**

**CAUTION:**

**Do not reuse side bearing inner race.**

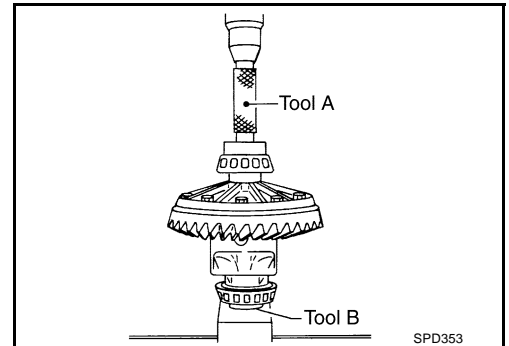

12. Install differential case assembly with side bearing outer races into gear carrier.

13. Measure side bearing preload. If necessary, select the appropriate side bearing adjusting washers. Refer to [RFD-50, "Side Bearing Preload"](#).

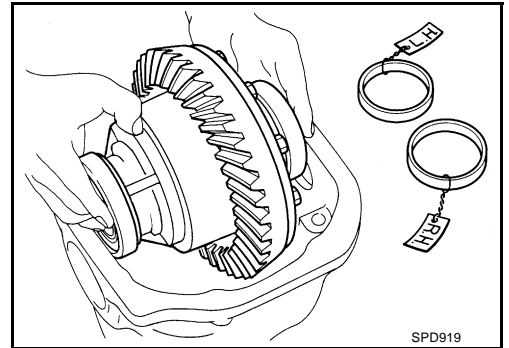

14. Insert selected left and right side bearing adjusting washers in place between side bearings and gear carrier.

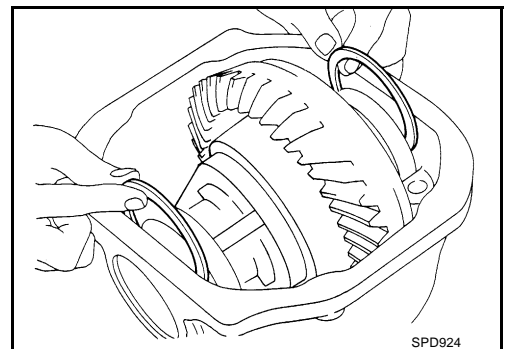

15. Align matching marks on bearing cap with that on gear carrier.
16. Install bearing caps and tighten bearing cap mounting bolts to the specified torque. Refer to [RFD-40, "COMPONENTS"](#).

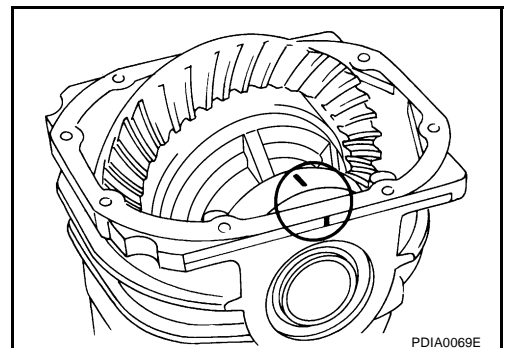

# REAR FINAL DRIVE ASSEMBLY

17. Using the drift, drive side oil seals until it becomes flush with the case end.

**Tool number : KV38100200 (J-26233)**

**CAUTION:**

- Do not reuse oil seal.
- When installing, do not incline oil seal.
- Apply multi-purpose grease onto oil seal lips, and gear oil onto the circumference of oil seal.

18. Check and adjust drive gear runout, tooth contact, drive gear to drive pinion backlash, and total preload torque. Refer to [RFD-41, "Drive Gear Runout"](#) , [RFD-42, "Tooth Contact"](#) , [RFD-43, "Backlash"](#) and [RFD-41, "Total Preload Torque"](#) .  
Recheck above items. Readjust the above description, if necessary.

19. Apply sealant to mating surface of rear cover.

- Use **Genuine Silicone RTV or equivalent**. Refer to [GI-47, "Recommended Chemical Products and Sealants"](#) .

**CAUTION:**

Remove old sealant adhering to mounting surfaces. Also remove any moisture, oil, or foreign material adhering to application and mounting surfaces.

20. Install rear cover on gear carrier and tighten mounting bolts with the specified torque. Refer to [RFD-40, "COMPONENTS"](#) .

21. Install side flange with the following procedure.

**NOTE:**

Install the RH side flange, then install the LH side flange. If LH side flange is installed first, the RH side flange comes out sometimes from the shock of installing the RH side flange.

- a. Attach the protector to side oil seal.

**Tool number : KV38107900 (J-39352)**

- b. After the side flange is inserted and the serrated part of side gear has engaged the serrated part of flange, remove the protector.

- c. Put a suitable drift on the center of side flange, then drive it until sound changes.

**NOTE:**

When installation is completed, driving sound of the side flange turns into a sound which seems to affect the whole final drive.

- d. Confirm that the dimension of the side flange installation (Measurement A) in the figure comes into the following.

**Measurement A: 326 – 328 mm (12.83 – 12.91 in)**

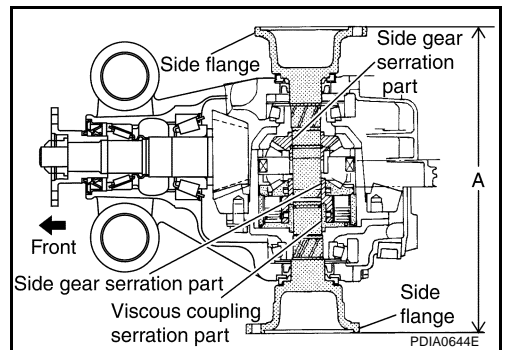
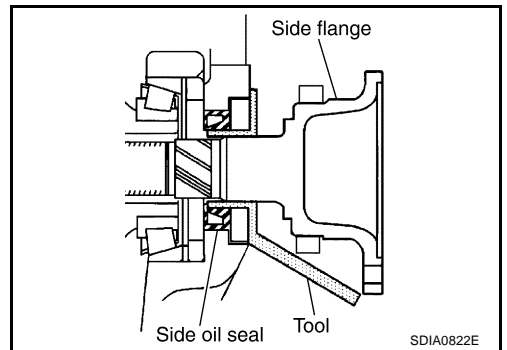
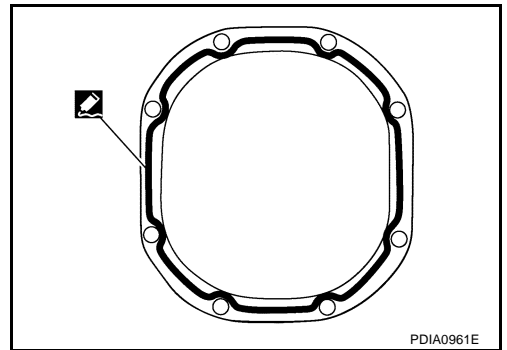
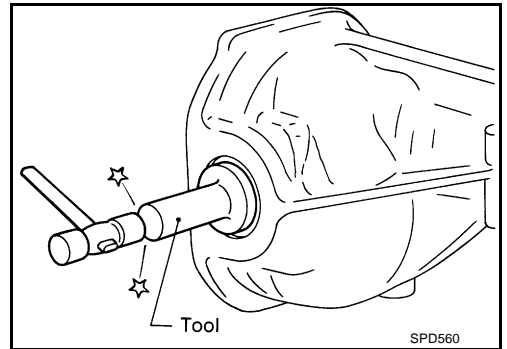

A  
B  
C  
RFD  
E  
F  
G  
H  
I  
J  
K  
L  
M

# SERVICE DATA AND SPECIFICATIONS (SDS)

## SERVICE DATA AND SPECIFICATIONS (SDS)

PFP:00030

### General Specifications 2WD MODELS

NDS0004H

Applied model	VQ35DE	
	A/T	M/T
Final drive model	R200	R200V (With LSD)
Gear ratio	3.538	
Number of teeth (Drive gear/Drive pinion)	46/13	
Oil capacity (Approx.) ℓ (US pt, Imp pt)	1.4 (3, 2-1/2)	
Number of pinion gears	2	4
Drive pinion adjustment spacer type	Collapsible	

### AWD MODELS

Applied model	VQ35DE	
	A/T	
Final drive model	R200	
Gear ratio	3.538	
Number of teeth (Drive gear/Drive pinion)	46/13	
Oil capacity (Approx.) ℓ (US pt, Imp pt)	1.4 (3, 2-1/2)	
Number of pinion gears	2	
Drive pinion adjustment spacer type	Collapsible	

### Inspection and Adjustment DRIVE GEAR RUNOUT

NDS0004I

Item	Runout limit
Drive gear back face	0.05 mm (0.0020 in) or less

### DIFFERENTIAL SIDE GEAR CLEARANCE

Item	Specification	
	R200	R200V (With LSD)
Side gear backlash (Clearance between side gear and differential case)	0.2 mm (0.008 in) or less (Each gear should rotate smoothly without excessive resistance during differential motion.)	0.15 mm (0.0059 in) or less (Each gear should rotate smoothly without excessive resistance during differential motion.)

### PRELOAD TORQUE

Item	Specification
Pinion bearing (P1 )	2.65 – 3.23 N·m (0.27 – 0.32 kg-m, 24 – 28 in-lb)
Side bearing (P2 )	0.20 – 0.52 N·m (0.02 – 0.05 kg-m, 2 – 4 in-lb)
Side bearing to pinion bearing (Total preload) (Total preload = P1 + P2 )	2.85 – 3.75 N·m (0.29 – 0.38 kg-m, 26 – 33 in-lb)

### BACKLASH

Item	Specification
Drive gear to drive pinion gear	0.10 – 0.15 mm (0.0039 – 0.0059 in)

# SERVICE DATA AND SPECIFICATIONS (SDS)

## COMPANION FLANGE RUNOUT

### 2WD models

Item	Runout limit
Companion flange face	0.08 mm (0.0031 in) or less
Inner side of the companion flange	0.08 mm (0.0031 in) or less

### AWD models

Item	Runout limit
Inner side of the companion flange	0.08 mm (0.0031 in) or less

## SELECTIVE PARTS

### Side Gear Thrust Washer

Unit: mm (in)

R200		R200V			
Thickness	Part number*	Thickness	Part number*	Thickness	Part number*
0.75 (0.0295)	38424 EC000	0.80 (0.0315)	38424 40F60	1.16 (0.0457)	38424 40F72
0.78 (0.0307)	38424 EC001	0.83 (0.0327)	38424 40F61	1.19 (0.0469)	38424 40F73
0.81 (0.0319)	38424 EC002	0.86 (0.0339)	38424 40F62	1.22 (0.0480)	38424 40F74
0.84 (0.0331)	38424 EC003	0.89 (0.0350)	38424 40F63	1.25 (0.0492)	38424 40F75
0.87 (0.0343)	38424 EC004	0.92 (0.0362)	38424 40F64	1.28 (0.0504)	38424 40F76
0.90 (0.0350)	38424 EC005	0.95 (0.0374)	38424 40F65	1.31 (0.0516)	38424 40F77
0.93 (0.0366)	38424 EC006	0.98 (0.0386)	38424 40F66	1.34 (0.0528)	38424 40F78
		1.01 (0.0398)	38424 40F67	1.37 (0.0539)	38424 40F79
		1.04 (0.0409)	38424 40F68	1.40 (0.0551)	38424 40F80
		1.07 (0.0421)	38424 40F69	1.43 (0.0563)	38424 40F81
		1.10 (0.0433)	38424 40F70	1.46 (0.0575)	38424 40F82
		1.13 (0.0445)	38424 40F71	1.49 (0.0587)	38424 40F83

\*: Always check with the Parts Department for the latest parts information.

### Pinion Height Adjusting Washer

Unit: mm (in)

R200, R200V			
Thickness	Part number*	Thickness	Part number*
3.05 (0.1201)	38154 0C000	3.29 (0.1295)	38154 0C008
3.08 (0.1213)	38154 0C001	3.32 (0.1307)	38154 0C009
3.11 (0.1224)	38154 0C002	3.35 (0.1319)	38154 0C010
3.14 (0.1236)	38154 0C003	3.38 (0.1331)	38154 0C011
3.17 (0.1248)	38154 0C004	3.41 (0.1343)	38154 0C012
3.20 (0.1260)	38154 0C005	3.44 (0.1354)	38154 0C013
3.23 (0.1272)	38154 0C006	3.47 (0.1366)	38154 0C014
3.26 (0.1283)	38154 0C007	3.50 (0.1378)	38154 0C015

\*: Always check with the Parts Department for the latest parts information.

### Side Bearing Adjusting Washer

Unit: mm (in)

R200, R200V			
Thickness	Part number*	Thickness	Part number*
2.00 (0.0787)	38453 N3100	2.35 (0.0925)	38453 N3107
2.05 (0.0807)	38453 N3101	2.40 (0.0945)	38453 N3108
2.10 (0.0827)	38453 N3102	2.45 (0.0965)	38453 N3109
2.15 (0.0846)	38453 N3103	2.50 (0.0984)	38453 N3110
2.20 (0.0866)	38453 N3104	2.55 (0.1004)	38453 N3111
2.25 (0.0886)	38453 N3105	2.60 (0.1024)	38453 N3112
2.30 (0.0906)	38453 N3106	2.65 (0.1043)	38453 N3113

\*: Always check with the Parts Department for the latest parts information.

# SERVICE DATA AND SPECIFICATIONS (SDS)

---