

DI

SECTION

DRIVER INFORMATION SYSTEM

A
B
C
D
E
F
G
H
I
J
L
M

CONTENTS

<p>PRECAUTION 3</p> <p> Precautions for Supplemental Restraint System (SRS) "AIR BAG" and "SEAT BELT PRE-TENSIONER" 3</p> <p>COMBINATION METERS 4</p> <p> System Description 4</p> <p> UNIFIED METER CONTROL UNIT 4</p> <p> POWER SUPPLY AND GROUND CIRCUIT 4</p> <p> SPEEDOMETER 4</p> <p> TACHOMETER 5</p> <p> WATER TEMPERATURE GAUGE 5</p> <p> FUEL GAUGE 5</p> <p> ODO/TRIP METER 6</p> <p> SHIFT-UP INDICATOR 6</p> <p> Component Parts and Harness Connector Location... 8</p> <p> Arrangement of Combination Meter 9</p> <p> Schematic 10</p> <p> Wiring Diagram — METER — 11</p> <p> Terminals and Reference Value for Combination Meter 12</p> <p> Self-Diagnosis Mode of Combination Meter 12</p> <p> SELF-DIAGNOSIS FUNCTION 12</p> <p> OPERATION PROCEDURE 12</p> <p> Trouble Diagnosis 13</p> <p> HOW TO PERFORM TROUBLE DIAGNOSIS ... 13</p> <p> PRELIMINARY CHECK 13</p> <p> Symptom Chart 14</p> <p> Power Supply and Ground Circuit Inspection 14</p> <p> Vehicle Speed Signal Inspection 15</p> <p> Engine Speed Signal Inspection 15</p> <p> Engine Coolant Temperature Signal Inspection ... 15</p> <p> Fuel Level Sensor Signal Inspection 15</p> <p> Fuel Gauge Pointer Fluctuates, Indicator Wrong Value or Varies 17</p> <p> Fuel Gauge Does Not Move to FULL Position 17</p> <p> Electrical Components Inspection 18</p> <p> FUEL LEVEL SENSOR UNIT 18</p> <p> Removal and Installation for Combination Meter ... 19</p> <p> REMOVAL 19</p>	<p> INSTALLATION 19</p> <p> Disassembly and Assembly for Combination Meter.. 20</p> <p> DISASSEMBLY 20</p> <p> ASSEMBLY 20</p> <p>WARNING LAMPS 21</p> <p> System Description 21</p> <p> OIL PRESSURE WARNING LAMP 21</p> <p> Schematic 22</p> <p> Wiring Diagram — WARN — 23</p> <p> Oil Pressure Warning Lamp Stays Off (Ignition Switch ON) 31</p> <p> Oil Pressure Warning Lamp Does Not Turn Off (Oil Pressure Is Normal) 32</p> <p> Component Inspection 33</p> <p> OIL PRESSURE SWITCH 33</p> <p>A/T INDICATOR 34</p> <p> System Description 34</p> <p> MANUAL MODE 34</p> <p> NOT MANUAL MODE 34</p> <p> Wiring Diagram — AT/IND — 35</p> <p> A/T Indicator Does Not Illuminate 36</p> <p>WARNING CHIME 37</p> <p> System Description 37</p> <p> FUNCTION 37</p> <p> IGNITION KEY WARNING CHIME (WITHOUT INTELLIGENT KEY) 37</p> <p> IGNITION KEY WARNING CHIME (WITH INTELLIGENT KEY) 38</p> <p> LIGHT WARNING CHIME 38</p> <p> SEAT BELT WARNING CHIME 39</p> <p> Component Parts and Harness Connector Location.. 39</p> <p> Schematic 40</p> <p> Wiring Diagram — CHIME — 41</p> <p> Terminals and Reference Value for BCM 44</p> <p> CONSULT-II Function (BCM) 48</p> <p> DIAGNOSIS ITEMS DESCRIPTION 48</p> <p> CONSULT-II BASIC OPERATION PROCEDURE ... 48</p> <p> DATA MONITOR 49</p> <p> ACTIVE TEST</p>
--	--

SELF-DIAG RESULTS	50	COMPASS	61
Trouble Diagnosis	50	System Description	61
HOW TO PERFORM TROUBLE DIAGNOSIS ...	50	DIRECTION DISPLAY	61
Symptom Chart	51	Wiring Diagram — COMPASS —	62
Power Supply and Ground Circuit Inspection	52	Fail-Safe System	63
Combination Meter Buzzer Circuit Inspection	53	DESCRIPTION	63
Front Door Switch (Driver Side) Signal Inspection..	53	Power Supply and Ground Circuit Inspection	63
Key Switch Signal Inspection (Without Intelligent		Compass Does not Display	63
Key)	54	Compass Displays “— — —”	64
Key Switch and Ignition Knob Switch Signal Inspec-		Forward Direction Indication Slips Off The Mark or	
tion (With Intelligent Key, When Mechanical Key Is		Incorrect	65
Used)	56	Compass Reading Remains Unchanged	65
Lighting Switch Signal Inspection	57	Calibration Procedure for Compass	66
Seat Belt Buckle Switch (Driver Side) Signal Inspec-		CORRECTION FUNCTIONS OF COMPASS	67
tion	57	INITIAL CORRECTION PROCEDURE FOR	
Component Inspection	59	COMPASS	67
FRONT DOOR SWITCH (DRIVER SIDE)	59	Removal and Installation of Compass	67
KEY SWITCH	59	REMOVAL	67
KEY SWITCH AND IGNITION KNOB SWITCH..	59	INSTALLATION	67
SEAT BELT BUCKLE SWITCH (DRIVER SIDE)..	59	CLOCK	68
CAN COMMUNICATION	60	Removal and Installation of Clock	68
System Description	60	REMOVAL	68
CAN Communication Unit	60	INSTALLATION	68

PRECAUTION

PRECAUTION

PF0:00011

Precautions for Supplemental Restraint System (SRS) “AIR BAG” and “SEAT BELT PRE-TENSIONER”

NKS000XJ

The Supplemental Restraint System such as “AIR BAG” and “SEAT BELT PRE-TENSIONER”, used along with a front seat belt, helps to reduce the risk or severity of injury to the driver and front passenger for certain types of collision. This system includes seat belt switch inputs and dual stage front air bag modules. The SRS system uses the seat belt switches to determine the front air bag deployment, and may only deploy one front air bag, depending on the severity of a collision and whether the front occupants are belted or unbelted. Information necessary to service the system safely is included in the SRS and SB section of this Service Manual.

WARNING:

- To avoid rendering the SRS inoperative, which could increase the risk of personal injury or death in the event of a collision which would result in air bag inflation, all maintenance must be performed by an authorized NISSAN/INFINITI dealer.
- Improper maintenance, including incorrect removal and installation of the SRS, can lead to personal injury caused by unintentional activation of the system. For removal of Spiral Cable and Air Bag Module, see the SRS section.
- Do not use electrical test equipment on any circuit related to the SRS unless instructed to in this Service Manual. SRS wiring harnesses can be identified by yellow and/or orange harnesses or harness connectors.

A
B
C
D
E
F
G
H
I
J
DI
L
M

DI

COMBINATION METERS

COMBINATION METERS

PFP:24814

System Description

NKS000XL

UNIFIED METER CONTROL UNIT

- Speedometer, odo/trip meter, tachometer, fuel gauge and water temperature gauge are controlled by the unified meter control unit, which is built into the combination meter.
- Shift-up indicator is adopted in the combination meter (M/T models). Setting of shift-up engine speed (rpm) can be set with odo/trip meter.
- Odo/trip meter and A/T indicator segments can be checked in self-diagnosis mode.
- Meters/gauges can be checked in self-diagnosis mode.

POWER SUPPLY AND GROUND CIRCUIT

Power is supplied at all times

- through 10A fuse [No. 19, located in the fuse block (J/B)]
- to combination meter terminal 21.

With the ignition switch in the ON or START position, power is supplied

- through 10A fuse [No. 14, located in the fuse block (J/B)]
- to combination meter terminals 22 and 23.

With the ignition switch in the ACC or ON position, power is supplied

- through 10A fuse [No. 6, located in the fuse block (J/B)]
- to combination meter terminal 18.

Ground is supplied

- to combination meter terminals 1, 24 and 25
- through grounds M30 and M66.

SPEEDOMETER

The speedometer indicates the vehicle speed.

- VDC/TCS/ABS control unit provides a vehicle speed signal to combination meter with CAN communication.
- Combination meter indicates the vehicle speed according to vehicle speed signal.

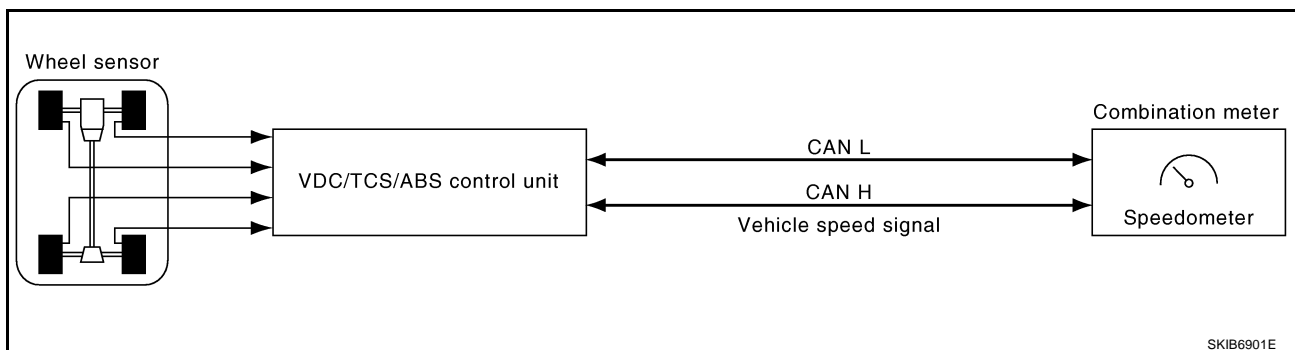

COMBINATION METERS

TACHOMETER

The tachometer indicates engine speed in revolutions per minute (rpm).

- ECM provides engine speed signal to combination meter with CAN communication.
- Combination meter indicates the engine speed according to engine speed signal.

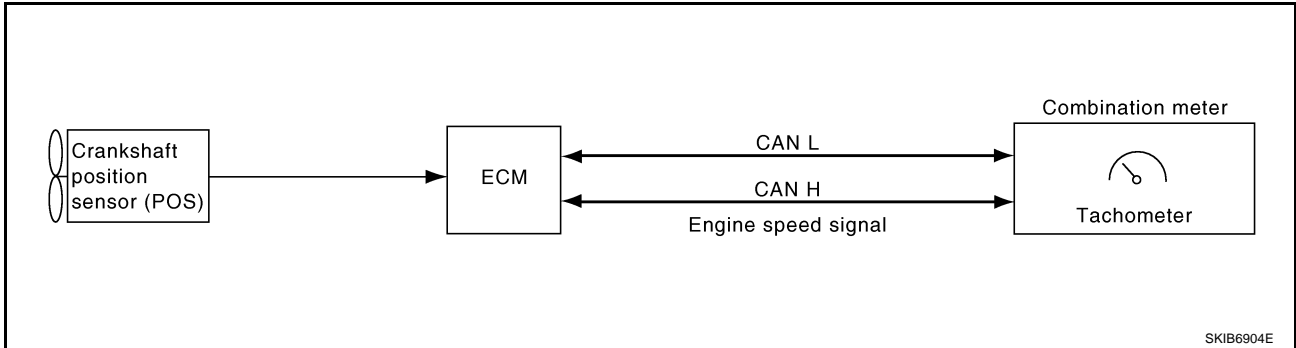

WATER TEMPERATURE GAUGE

The water temperature gauge indicates the engine coolant temperature.

- ECM provides engine coolant temperature signal to combination meter with CAN communication.
- Combination meter indicates the engine coolant temperature according to engine coolant temperature signal.

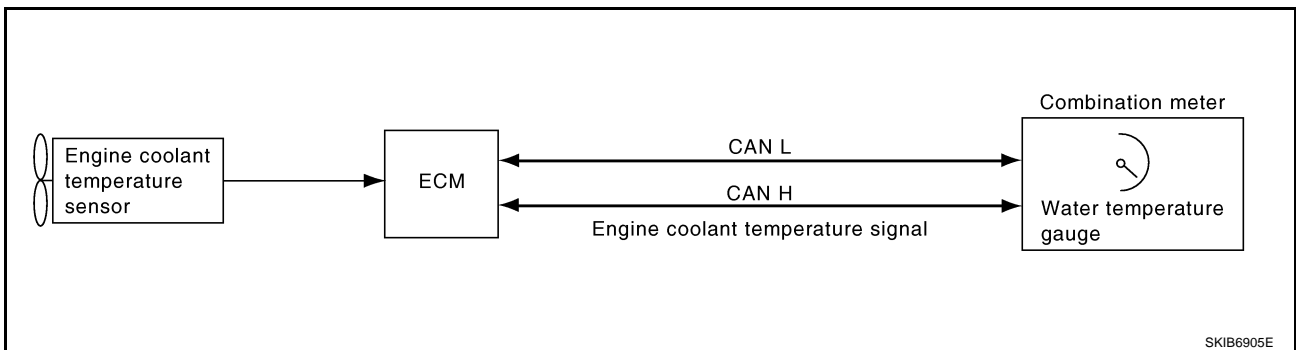

FUEL GAUGE

The fuel gauge indicates the approximate fuel level in the fuel tank.

- Combination meter reads a resistor signal from fuel level sensor.

Signal is supplied

- through grounds M30 and M66
- through terminals 5 and 2 of the fuel level sensor unit and fuel pump (main) and
- through terminals 2 and 1 of the fuel level sensor unit (sub)
- to combination meter terminal 7 for the fuel gauge.
- Combination meter indicates the approximate fuel level according to the resistor signal from fuel level sensor.

A
B
C
D
E
F
G
H
I
J
DI
L
M

COMBINATION METERS

ODO/TRIP METER

- VDC/TCS/ABS control unit provides a vehicle speed signal to combination meter with CAN communication.
- Combination meter converts the vehicle speed signal to the 8-pulse signal.
- Combination meter uses the 8-pulse signal to calculate the mileage, and displays it.

How to Change The Display For Odo/trip Meter

Operating the odo/trip meter switch allows switching the mode in the following order.

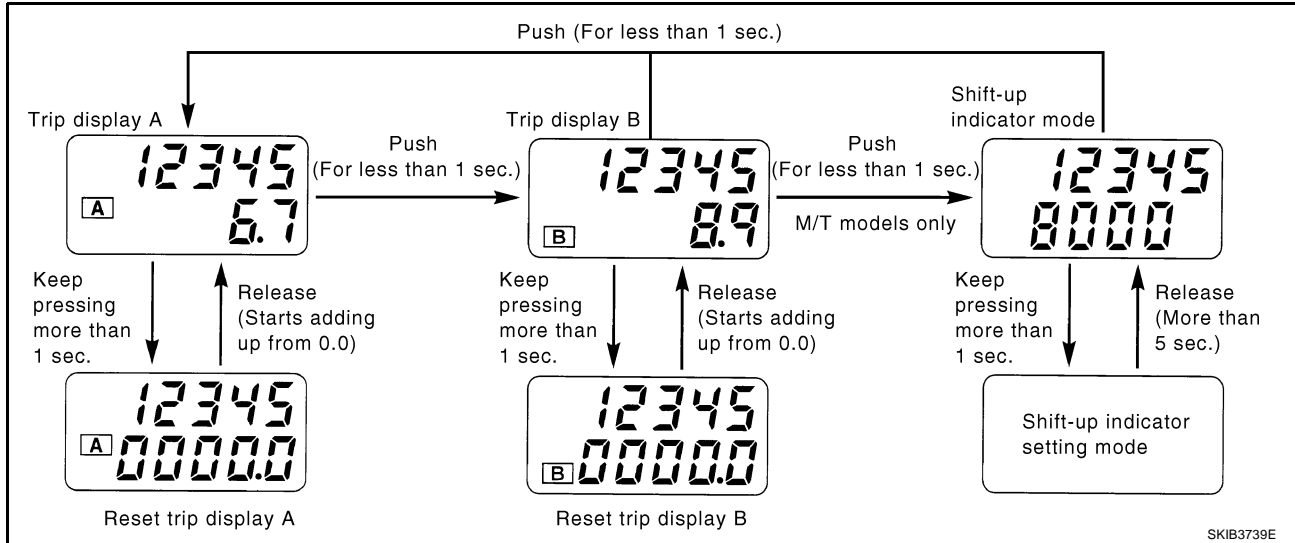

- Switching odo/trip meter display to the setting of engine speed (rpm) (M/T models) and reset of trip can be changed by time while pressing odo/trip switch.
- When resetting with “trip A” displayed, only “trip A” display is reset.

NOTE:

- The record of the odo meter is kept even if the battery cable is disconnected. The record of the trip meter is erased when the battery cable is disconnected.
- Refer to [DI-7](#) for the operation and setting of shift-up indicator.

SHIFT-UP INDICATOR

Shift-up indicator can be used when shifting up at a constant engine speed from any gear while driving. It becomes a guide for shift-up timing.

- Combination meter receives engine speed signal (CAN communication signal) from ECM.
- Shift-up indicator (1) flashes before reaching engine speed set, approximately 500 rpm before, then it illuminates when reaching the engine speed set.

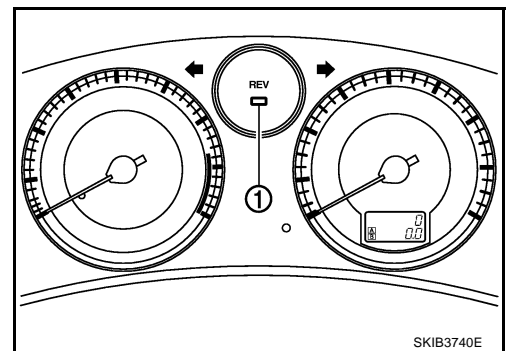

COMBINATION METERS

Setting Procedure of Shift-up Engine Speed (rpm)

Setting of shift-up engine speed with odo/trip meter.

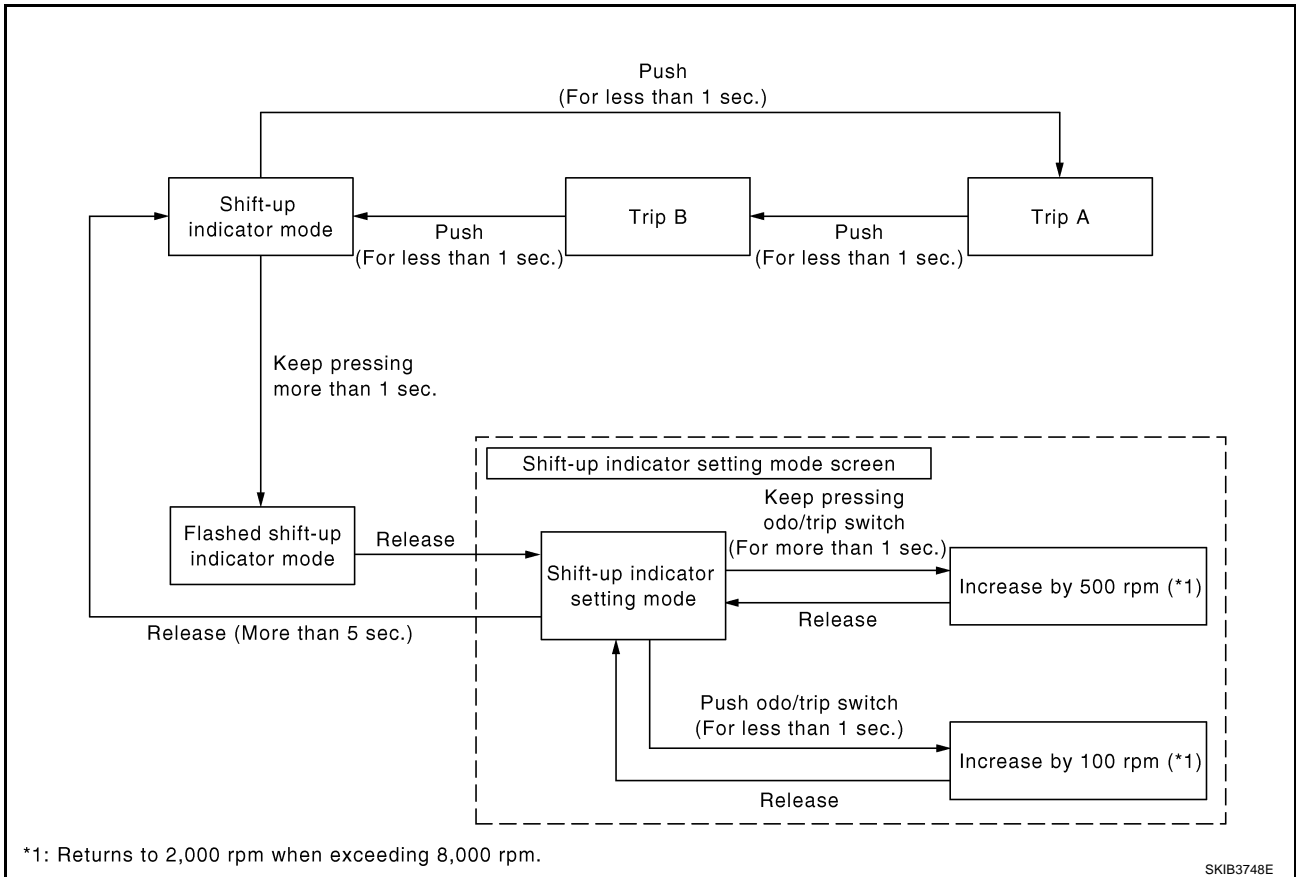

1. Push odo/trip switch (for less than 1 sec.) to change trip meter display to “trip A” → “trip B” → shift-up indicator mode.
2. Keep pressing odo/trip switch (for more than 1 sec.), then release odo/trip switch (display flashes and changes to shift-up indicator setting mode).
3. Set according to the following.
 - a. Keep pressing odo/trip switch (for more than 1 sec.): Increase setting engine speed by 500 rpm.
 - b. Push odo/trip switch (for less than 1 sec.): Increase setting engine speed by 100 rpm.

NOTE:

The range of engine speed is 2,000 - 8,000 rpm (Pushing odo/trip switch when exceeding 8,000 rpm returns to 2,000 rpm).

4. Stop the flash when not pushing odo/trip switch for more than 5 sec. (Shift-up engine speed is set.)

NOTE:

Setting is 8,000 rpm (the initial setting rpm) when disconnecting the battery cable.

COMBINATION METERS

Component Parts and Harness Connector Location

NKS000XO

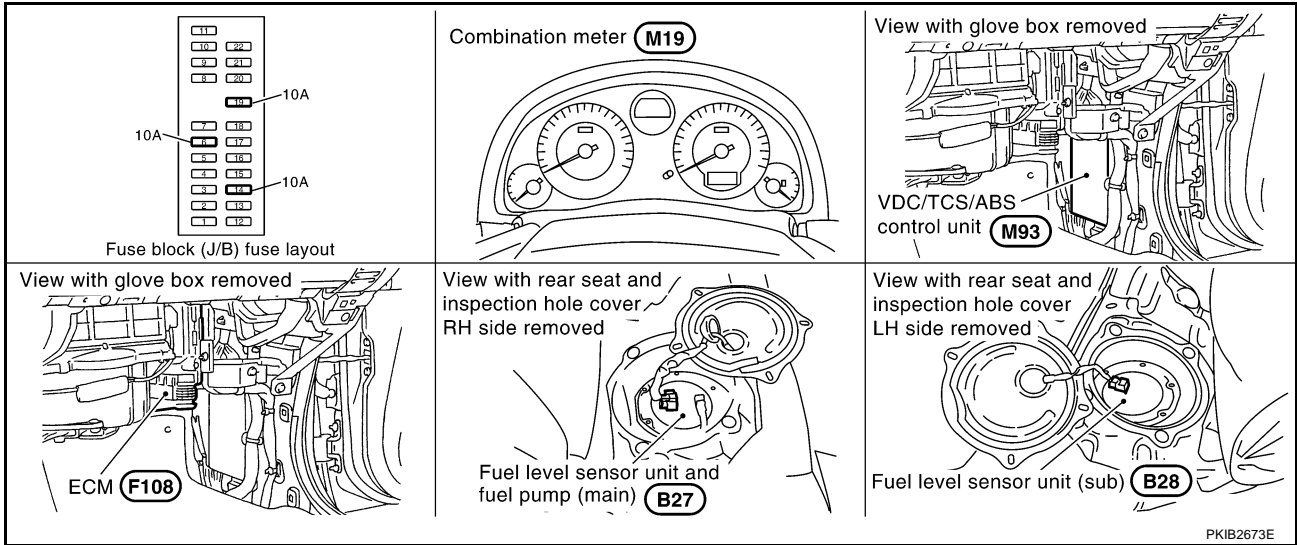

COMBINATION METERS

Arrangement of Combination Meter

NKS000XP

A
B
C
D
E
F
G
H
I
J
DI
L
M

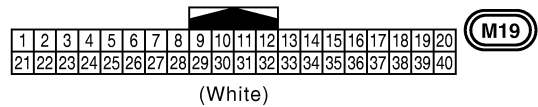
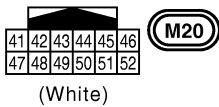
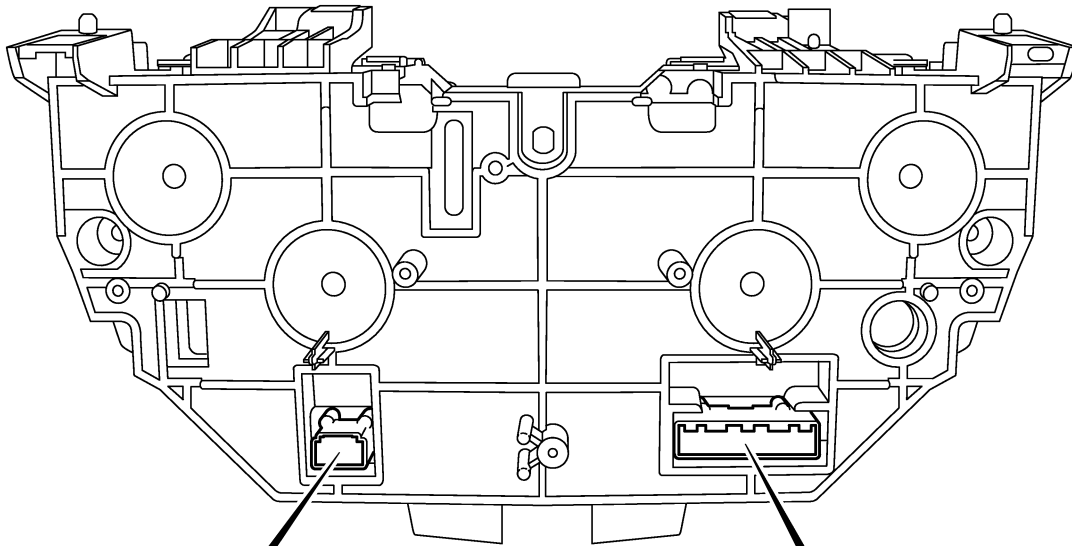
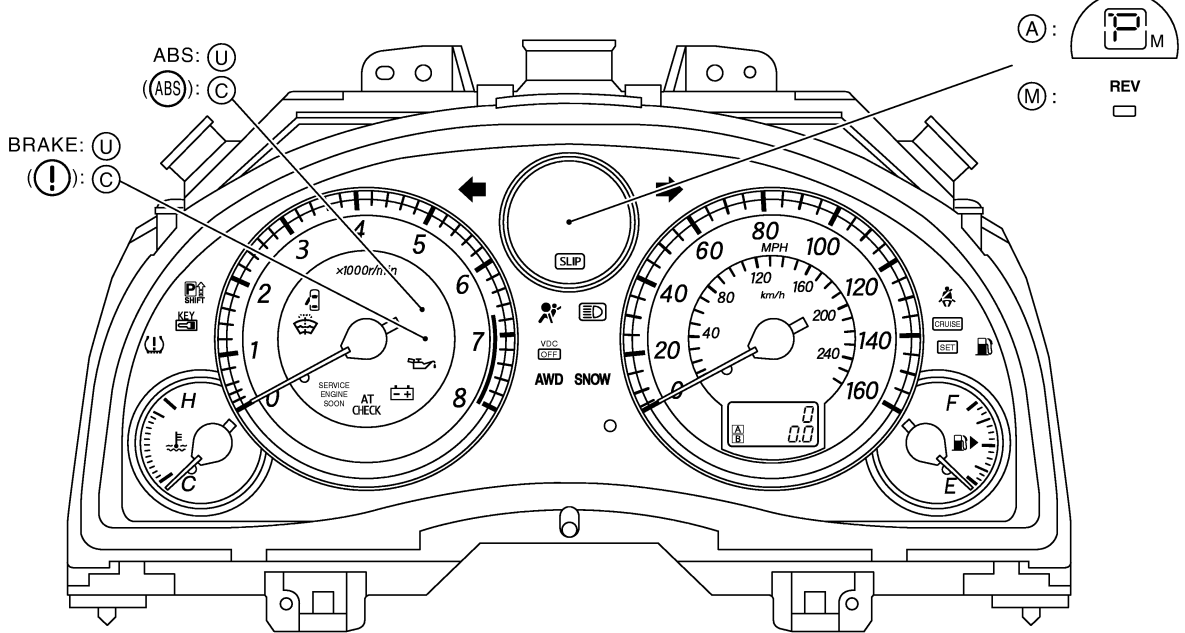

- (U) : For U.S.A.
- (C) : For Canada
- (A) : A/T models
- (M) : M/T models

PKIB7244E

COMBINATION METERS

Schematic

NKS000XQ

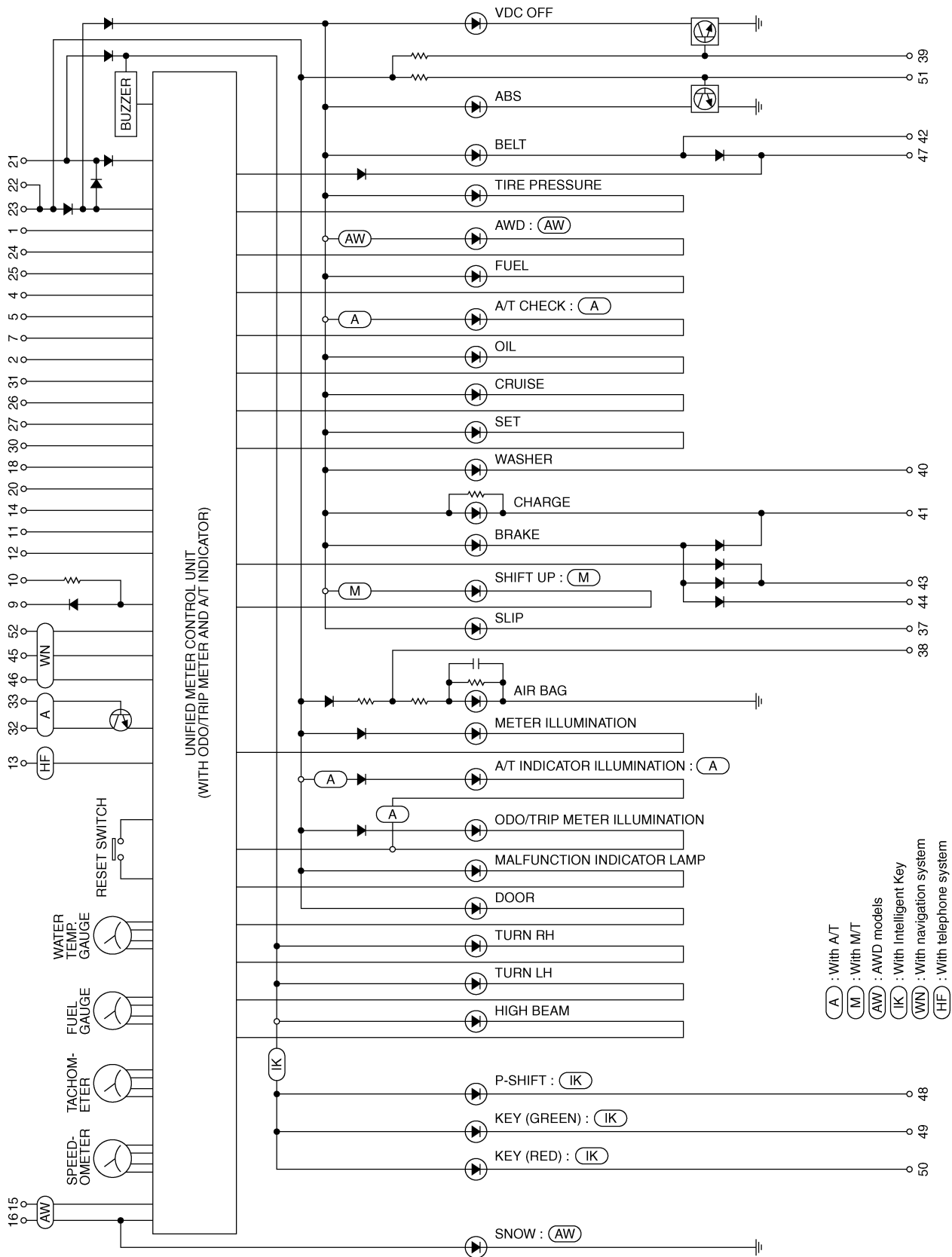

TKWM3396E

COMBINATION METERS

Wiring Diagram — METER —

NKS000XR

DI-METER-01

█ : DATA LINE

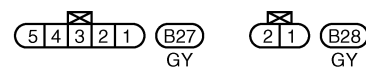
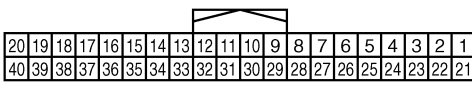
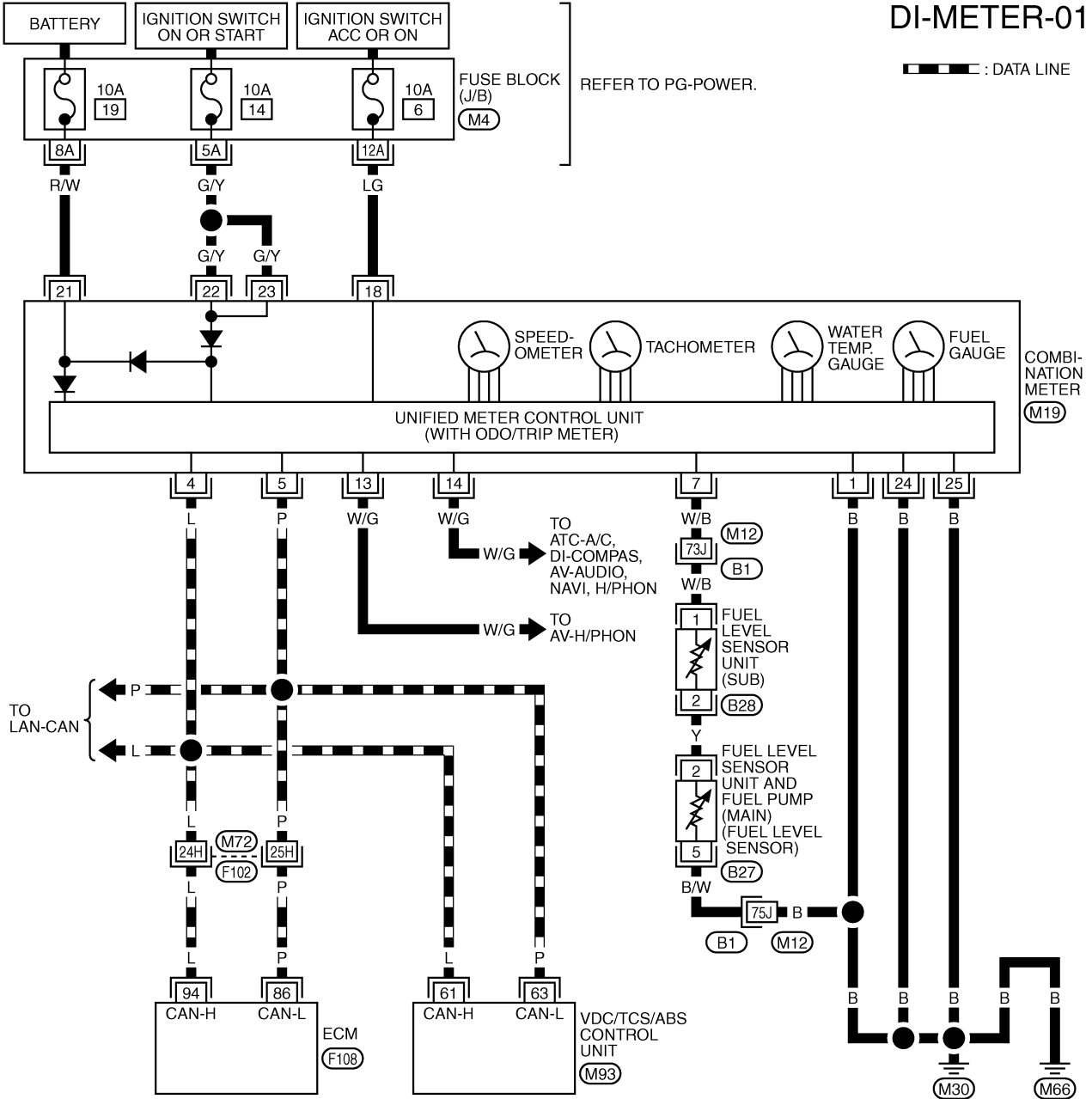

REFER TO THE FOLLOWING.
 (F102), (B1) -SUPER MULTIPLE JUNCTION (SMJ)
 (M4) -FUSE BLOCK-JUNCTION BOX (J/B)
 (M93), (F108) -ELECTRICAL UNITS

COMBINATION METERS

Terminals and Reference Value for Combination Meter

NKS000XS

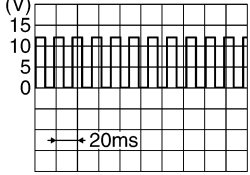
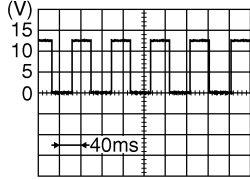
Terminal No.	Wire color	Item	Condition		Reference value
			Ignition switch	Operation or condition	
1	B	Ground	ON	—	Approx. 0 V
4	L	CAN H	—	—	—
5	P	CAN L	—	—	—
7	W/B	Fuel level sensor signal	—	—	Refer to DI-18. "FUEL LEVEL SENSOR UNIT" .
13	W/G	Vehicle speed signal (8-pulse)	ON	Speedometer operated [When vehicle speed is approx. 40 km/h (25 MPH)]	<p>NOTE: Maximum voltage may be 5 V due to specifications (connected units).</p> 
14	W/G	Vehicle speed signal (2-pulse)	ON	Speedometer operated [When vehicle speed is approx. 40 km/h (25 MPH)]	<p>NOTE: Maximum voltage may be 5 V due to specifications (connected units).</p> 
18	LG	ACC power supply	ACC	—	Battery voltage
21	R/W	Battery power supply	OFF	—	Battery voltage
22	G/Y	Ignition power supply	ON	—	Battery voltage
23					
24	B	Ground	ON	—	Approx. 0 V
25					

Self-Diagnosis Mode of Combination Meter SELF-DIAGNOSIS FUNCTION

NKS000XT

- Odo/trip meter and A/T indicator segments operation can be checked in self-diagnosis mode.
- Meters/gauges can be checked in self-diagnosis mode.

OPERATION PROCEDURE

1. Turn ignition switch ON, and switch the odo/trip meter to "trip A" or "trip B".

NOTE:

If the self-diagnosis function is activated with the "trip A" displayed, only "trip A" display is reset.

2. Turn ignition switch OFF.
3. While pushing the odo/trip meter switch, turn ignition switch ON again.
4. Make sure that the trip meter displays "0000.0".
5. Push the odo/trip meter switch at least 3 times (within 7 seconds after the ignition switch is turned ON).

COMBINATION METERS

6. All the segments on the odo/trip meter and A/T indicator illuminate, and simultaneously the low-fuel warning lamp indicator illuminates. At this time, the unified meter control unit is turned to self-diagnosis mode.

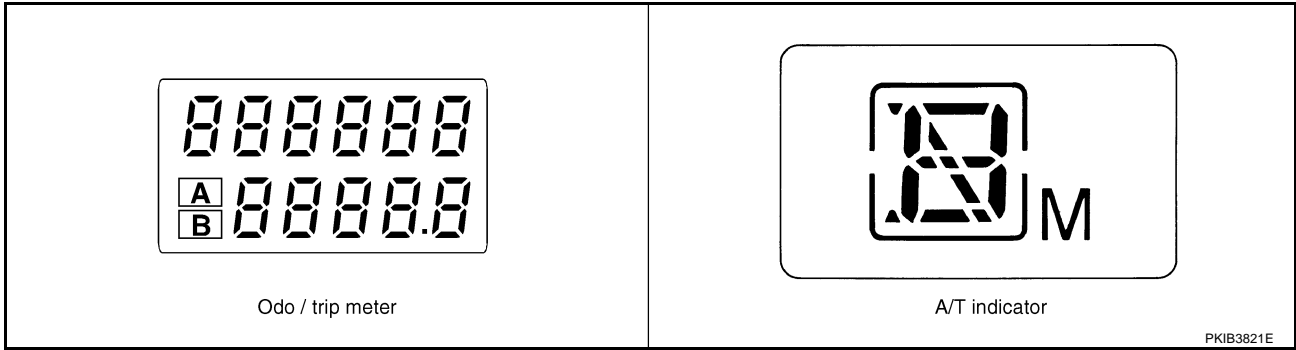

NOTE:

- Check combination meter power supply and ground circuit when self-diagnosis mode of combination meter does not start. Replace combination meter if the results of the check are normal.
 - If any of the segments are not displayed, replace combination meter.
7. Each meter/gauge activates during pressing odo/trip meter switch. (Then low-fuel warning lamp turns OFF.)

NOTE:

- If any of the meters/gauges are not activated, replace the combination meter.
- The figure is reference.

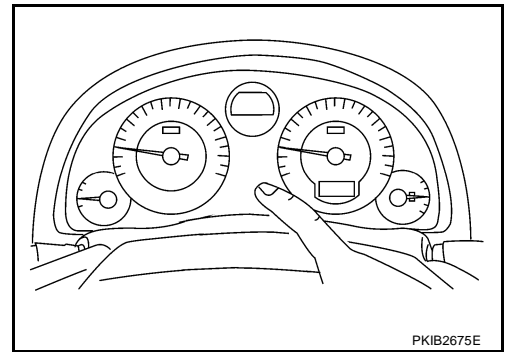

Trouble Diagnosis

HOW TO PERFORM TROUBLE DIAGNOSIS

1. Confirm the symptom or customer complaint.
2. Perform preliminary check. Refer to [DI-13, "PRELIMINARY CHECK"](#).
3. According to the symptom chart, repair or replace the cause of the symptom. Refer to [DI-14, "Symptom Chart"](#).
4. Does the meter operate normally? If so, GO TO 5. If not, GO TO 2.
5. INSPECTION END

PRELIMINARY CHECK

1. CHECK COMBINATION METER SELF-DIAGNOSIS OPERATION

Perform self-diagnosis mode of combination meter. Refer to [DI-12, "OPERATION PROCEDURE"](#).

Does self-diagnosis function operate?

- YES >> INSPECTION END
NO >> GO TO 2.

2. CHECK POWER SUPPLY AND GROUND CIRCUIT

Check power supply and ground circuit. Refer to [DI-14, "Power Supply and Ground Circuit Inspection"](#).

OK or NG

- OK >> Replace combination meter.
NG >> Repair malfunctioning part.

COMBINATION METERS

Symptom Chart

NKS0016A

Symptom	Possible cause
Speedometer and odo/trip meter indication is malfunction.	Refer to DI-15, "Vehicle Speed Signal Inspection" .
Tachometer indication is malfunction.	Refer to DI-15, "Engine Speed Signal Inspection" .
Water temperature gauge indication is malfunction.	Refer to DI-15, "Engine Coolant Temperature Signal Inspection" .
Low-fuel warning lamp indication is irregular.	Refer to DI-15, "Fuel Level Sensor Signal Inspection" .
Fuel gauge indication is malfunction.	
A/T position indicator is malfunction.	Refer to DI-36, "A/T Indicator Does Not Illuminate" .

Power Supply and Ground Circuit Inspection

NKS000XV

1. CHECK FUSE

Check for blown combination meter fuses.

Power source	Fuse No.
Battery power supply	19
Ignition power supply	14
ACC power supply	6

OK or NG

OK >> GO TO 2.

NG >> Be sure to eliminate cause of malfunction before installing new fuse. Refer to [PG-3, "POWER SUPPLY ROUTING CIRCUIT"](#) .

2. CHECK POWER SUPPLY CIRCUIT

Check voltage between combination meter harness connector M19 terminals 18 (LG), 21 (R/W), 22 (G/Y), 23 (G/Y) and ground.

Terminals		Ignition switch position			
Connector	(+)	(-)	OFF	ACC	ON
	Terminal (Wire color)				
M19	18 (LG)	Ground	0 V	Battery voltage	Battery voltage
	21 (R/W)		Battery voltage	Battery voltage	Battery voltage
	22 (G/Y)		0 V	0 V	Battery voltage
	23 (G/Y)				

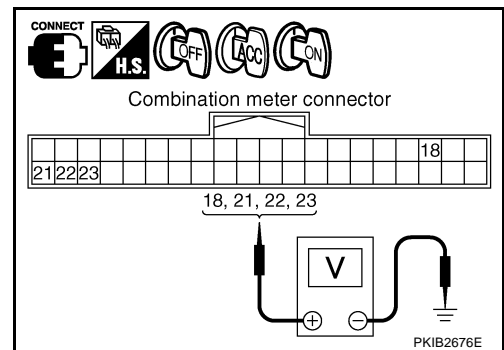

OK or NG

OK >> GO TO 3.

NG >> Check harness between combination meter and fuse.

COMBINATION METERS

3. CHECK GROUND CIRCUIT

1. Turn ignition switch OFF.
2. Disconnect combination meter connector.
3. Check continuity between combination meter harness connector M19 terminals 1 (B), 24 (B), 25 (B) and ground.

1 (B) – Ground

24 (B) – Ground : Continuity should exist.

25 (B) – Ground

OK or NG

OK >> INSPECTION END

NG >> Repair harness or connector.

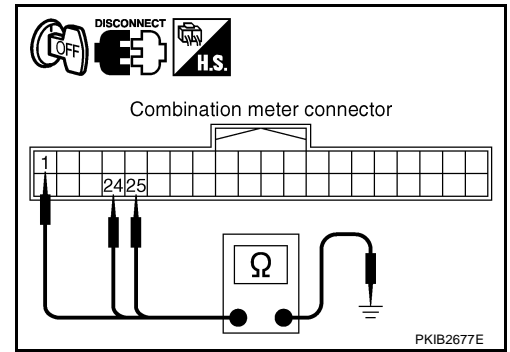

Vehicle Speed Signal Inspection

NKS000XW

Symptom: Speedometer and odo/trip meter indication is malfunction.

1. CHECK VDC/TCS/ABS CONTROL UNIT SELF-DIAGNOSIS

Perform self-diagnosis of VDC/TCS/ABS control unit. Refer to [BRC-24, "CONSULT-II Functions \(VDC/TCS/ABS\)"](#).

Self-diagnosis results

No malfunction detected >> Replace combination meter.

Malfunction detected >> Check applicable parts, and repair or replace corresponding parts.

Engine Speed Signal Inspection

NKS000XX

Symptom: Tachometer indication is malfunction.

1. CHECK ECM SELF-DIAGNOSIS

Perform self-diagnosis of ECM. Refer to [EC-122, "CONSULT-II Function \(ENGINE\)"](#).

Self-diagnosis results

No malfunction detected >> Replace combination meter.

Malfunction detected >> Check applicable parts, and repair or replace corresponding parts.

Engine Coolant Temperature Signal Inspection

NKS000XY

Symptom: Water temperature gauge indication is malfunction.

1. CHECK ECM SELF-DIAGNOSIS

Perform self-diagnosis of ECM. Refer to [EC-122, "CONSULT-II Function \(ENGINE\)"](#).

Self-diagnosis results

No malfunction detected >> Replace combination meter.

Malfunction detected >> Check applicable parts, and repair or replace corresponding parts.

Fuel Level Sensor Signal Inspection

NKS000XZ

Symptom:

- Fuel gauge indication is malfunction.
- Low-fuel warning lamp indication is irregular.

NOTE:

The following symptoms are not malfunction.

Fuel gauge

- Depending on vehicle position or driving circumstance, the fuel in the tank varies and the pointer may fluctuate.
- If the vehicle is fueled with the ignition switch ON, the pointer will move slowly.

COMBINATION METERS

Low-fuel warning lamp

- Depending on vehicle position or driving circumstance, the fuel in the tank flows and the warning lamp ON timing may change.

1. CHECK HARNESS CONNECTOR

Check combination meter and fuel level sensor unit terminals (meter side, unit side, harness side) for looseness or bent terminals.

OK or NG

- OK >> GO TO 2.
- NG >> Repair terminal or connector.

2. CHECK COMBINATION METER CIRCUIT

- Turn ignition switch OFF.
- Disconnect combination meter connector and fuel level sensor unit (sub) connector.
- Check continuity between combination meter harness connector M19 terminal 7 (W/B) and fuel level sensor unit (sub) harness connector B28 terminal 1 (W/B).

7 (W/B) – 1 (W/B) : Continuity should exist.

- Check continuity between combination meter harness connector M19 terminal 7 (W/B) and ground.

7 (W/B) – Ground : Continuity should not exist.

OK or NG

- OK >> GO TO 3.
- NG >> Repair harness or connector.

3. CHECK FUEL LEVEL SENSOR CIRCUIT

- Disconnect fuel level sensor unit and fuel pump (main) connector.
- Check continuity between fuel level sensor unit (sub) harness connector B28 terminal 2 (Y) and fuel level sensor unit and fuel pump (main) harness connector B27 terminal 2 (Y).

2 (Y) – 2 (Y) : Continuity should exist.

- Check continuity between fuel level sensor unit (sub) harness connector B28 terminal 2 (Y) and ground.

2 (Y) – Ground : Continuity should not exist.

OK or NG

- OK >> GO TO 4.
- NG >> Repair harness or connector.

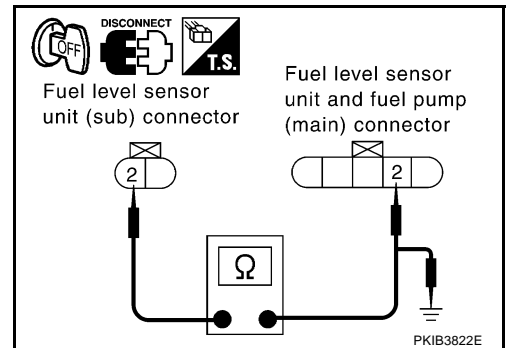
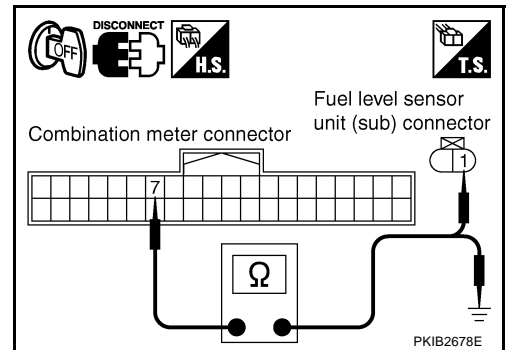

COMBINATION METERS

4. CHECK GROUND CIRCUIT

Check continuity between fuel level sensor unit and fuel pump (main) harness connector B27 terminal 5 (B/W) and ground.

5 (B/W) – Ground : Continuity should exist.

OK or NG

OK >> GO TO 5.

NG >> Repair harness or connector.

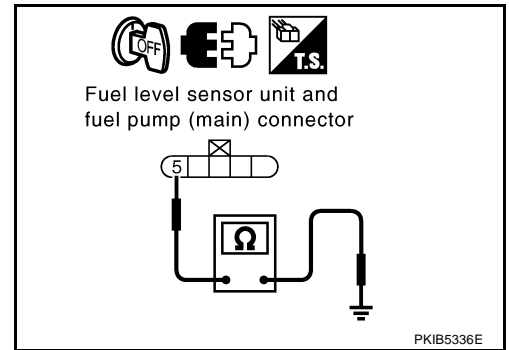

5. CHECK FUEL LEVEL SENSOR

Check fuel level sensor units. Refer to [DI-18, "FUEL LEVEL SENSOR UNIT"](#) .

OK or NG

OK >> Check fuel level sensor unit installation, and check whether the float arm interferes or binds with any of the internal components in the fuel tank. Repair or replace malfunctioning part, if necessary.

NG >> Replace fuel level sensor unit and fuel pump (main) or fuel level sensor unit (sub).

Fuel Gauge Pointer Fluctuates, Indicator Wrong Value or Varies

NKS000Y0

1. CHECK FUEL GAUGE FLUCTUATION

Test drive vehicle to see if gauge fluctuates only during driving or at the instant of stopping.

Does the indication value vary only during driving or at the instant of stopping?

YES >> The pointer fluctuation may be caused by fuel level change in the fuel tank. Condition is normal.

NO >> Ask the customer about the situation when the symptom occurs in detail, and perform the trouble diagnosis.

Fuel Gauge Does Not Move to FULL Position

NKS000Y1

1. QUESTION 1

Does it take a long time for the pointer to move to FULL position?

YES >> GO TO 2.

NO >> GO TO 3.

2. QUESTION 2

Was the vehicle fueled with the ignition switch ON?

YES >> Be sure to fuel the vehicle with the ignition switch OFF. Otherwise, it will take a long time to move to FULL position because of the characteristic of the fuel gauge.

NO >> GO TO 3.

3. QUESTION 3

Is the vehicle parked on an incline?

YES >> Check the fuel level indication with vehicle on a level surface.

NO >> GO TO 4.

COMBINATION METERS

4. QUESTION 4

During driving, does the fuel gauge pointer move gradually toward EMPTY position?

YES >> Check the fuel level sensor unit. Refer to [DI-18, "FUEL LEVEL SENSOR UNIT"](#) .

NO >> The float arm may interfere or bind with any of the components in the fuel tank.

Electrical Components Inspection FUEL LEVEL SENSOR UNIT

NKS000Y2

For removal, refer to [FL-4, "FUEL LEVEL SENSOR UNIT, FUEL FILTER AND FUEL PUMP ASSEMBLY"](#) .

Fuel Level Sensor Unit and Fuel Pump (Main)

Check the resistance between terminals 2 and 5.

Terminal		Float position [mm (in)]			Resistance value [Ω]
2	5	*1	Full	9.0 (0.35)	Approx. 3
		*2	Empty	175 (6.89)	Approx. 80

*1 and *2: When float rod is in contact with stopper.

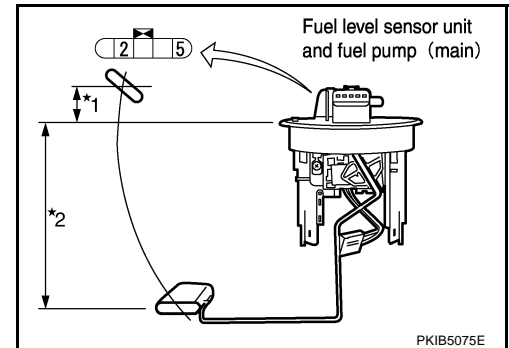

Fuel Level Sensor Unit (Sub)

Check the resistance between terminals 1 and 2.

Terminal		Float position [mm (in)]			Resistance value [Ω]
1	2	*1	Full	9.4 (0.37)	Approx. 3
		*2	Empty	179 (7.05)	Approx. 43

*1 and *2: When float rod is in contact with stopper.

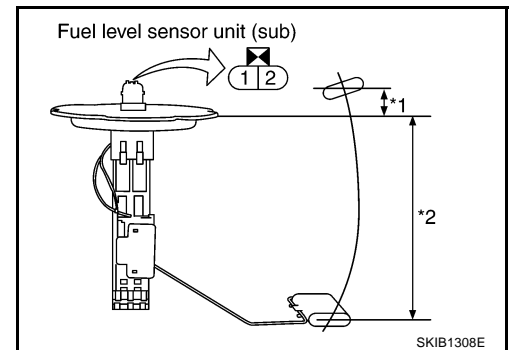

COMBINATION METERS

Removal and Installation for Combination Meter

NKS000Y3

REMOVAL

1. Remove steering column cover. Refer to [IP-10, "INSTRUMENT PANEL ASSEMBLY"](#) .
2. Remove lighting and turn signal switch. Refer to [LT-120, "LIGHTING AND TURN SIGNAL SWITCH"](#) .
3. Remove front wiper and washer switch. Refer to [WW-35, "Removal and Installation of Front Wiper and Washer Switch"](#) .
4. Remove instrument lower driver panel. Refer to [IP-10, "INSTRUMENT PANEL ASSEMBLY"](#) .
5. Remove the screws (4) and remove cluster lid A and combination meter assembly. Refer to [IP-10, "INSTRUMENT PANEL ASSEMBLY"](#) .
6. Disconnect connectors and remove combination meter.
7. Remove the screw (1) and remove Intelligent Key warning buzzer (with Intelligent Key).

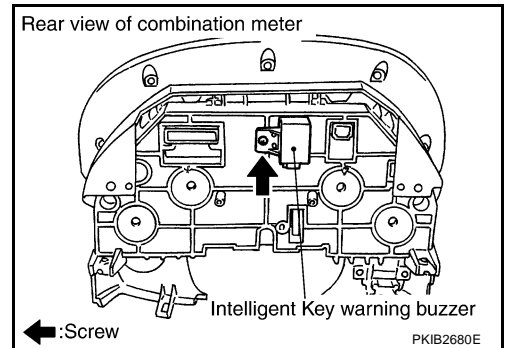

8. Remove the screws (9) and disassemble cluster lid A and combination meter.

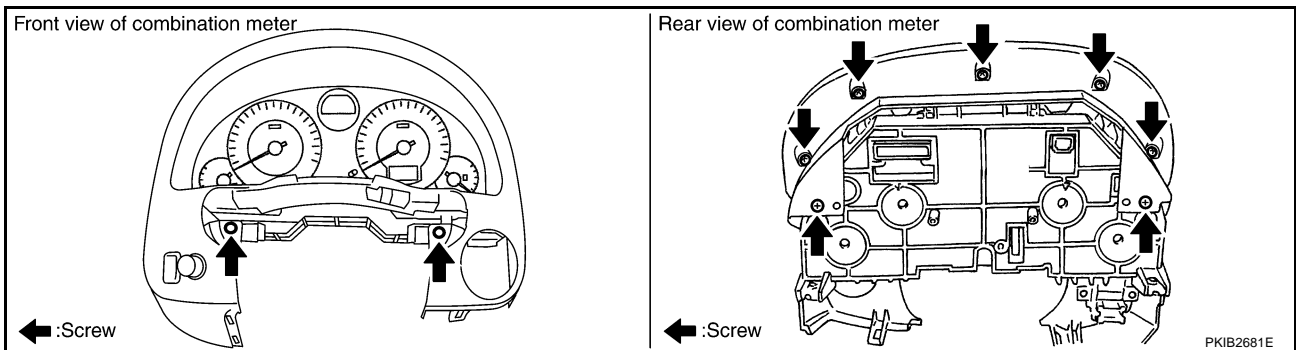

INSTALLATION

Installation is the reverse order of removal.

COMBINATION METERS

Disassembly and Assembly for Combination Meter

NKS000Y4

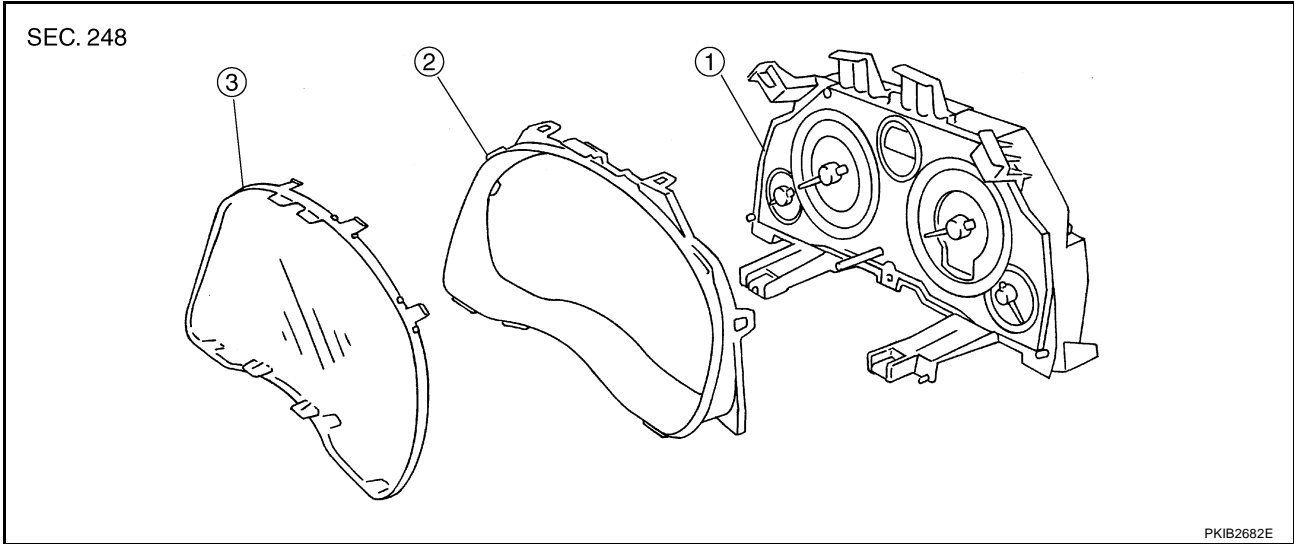

1. Unified meter control unit assembly 2. Upper housing 3. Front cover

DISASSEMBLY

1. Disengage the tabs (8) to separate front cover and upper housing assembly.
2. Disengage the tabs (8) to separate front cover.

ASSEMBLY

Assembly is the reverse order of disassembly.

WARNING LAMPS

WARNING LAMPS

PFP:24814

System Description

NKS0016B

OIL PRESSURE WARNING LAMP

Oil pressure warning lamp turns ON when engine oil pressure reducing abnormally.

- IPDM E/R reads oil pressure switch signal from oil pressure switch, and transmits the signal to combination meter with CAN communication.
- Combination meter turns oil pressure warning lamp ON with received oil pressure switch signal.

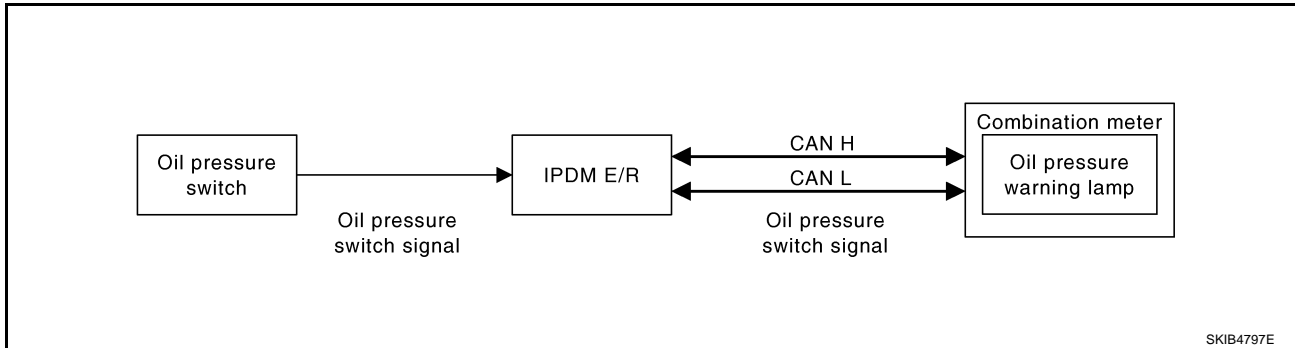

A
B
C
D
E
F
G
H
I
J
DI
L
M

WARNING LAMPS

NKS000YF

Schematic

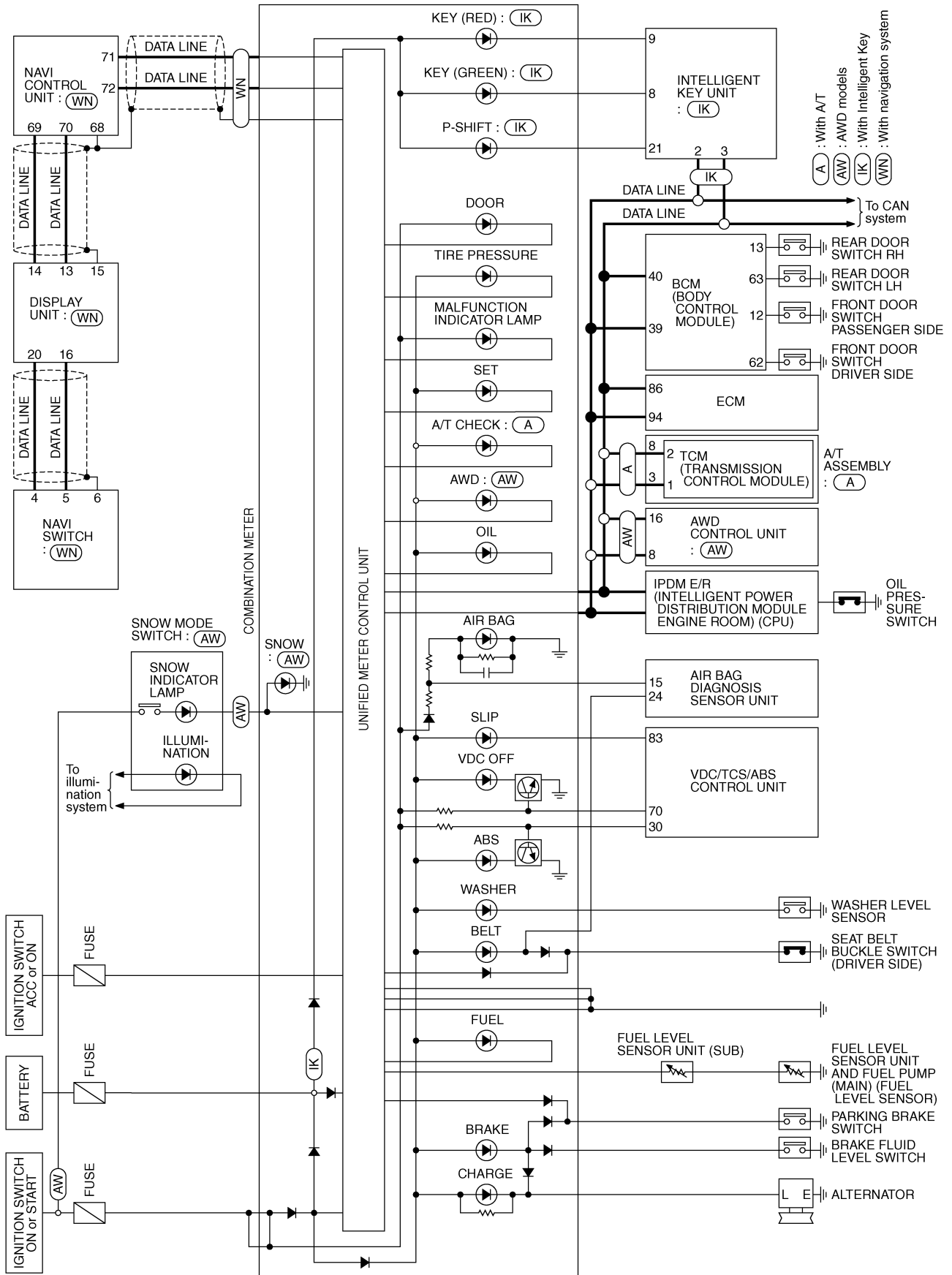

TKWM3398E

WARNING LAMPS

Wiring Diagram — WARN —

NKS000YG

DI-WARN-01

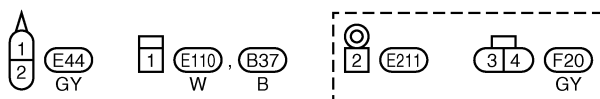
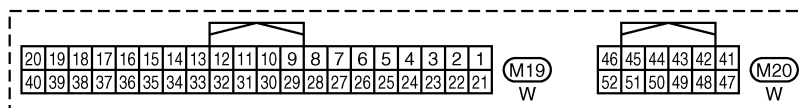
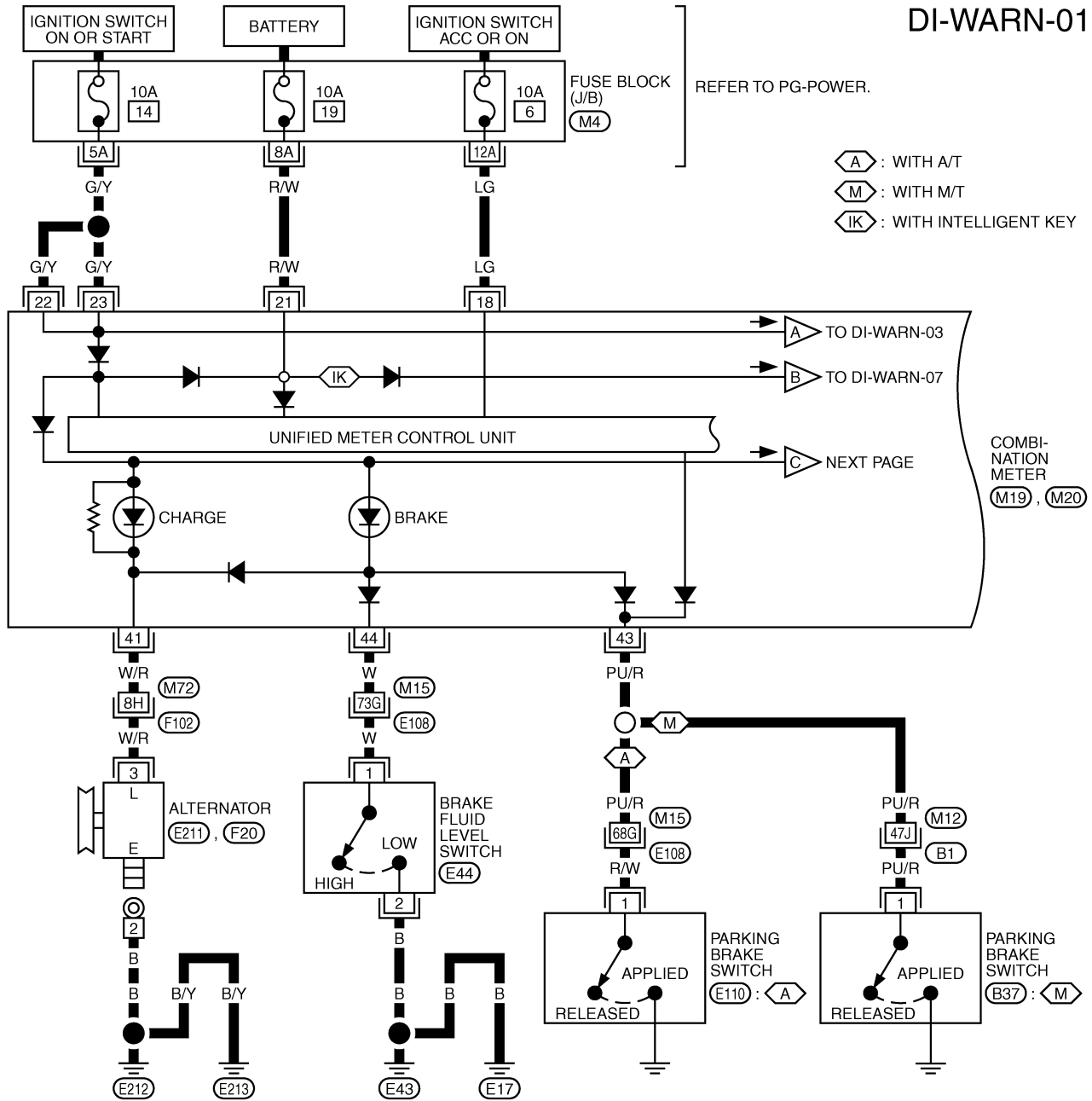

REFER TO THE FOLLOWING.

(E108), (F102), (B1) -SUPER MULTIPLE JUNCTION (SMJ)

(M4) -FUSE BLOCK-JUNCTION BOX (J/B)

TKWM2124E

WARNING LAMPS

DI-WARN-02

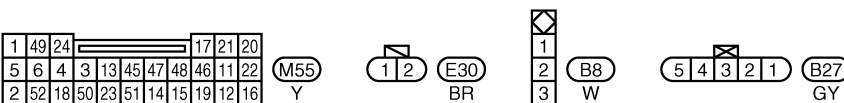
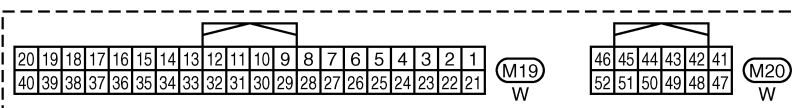
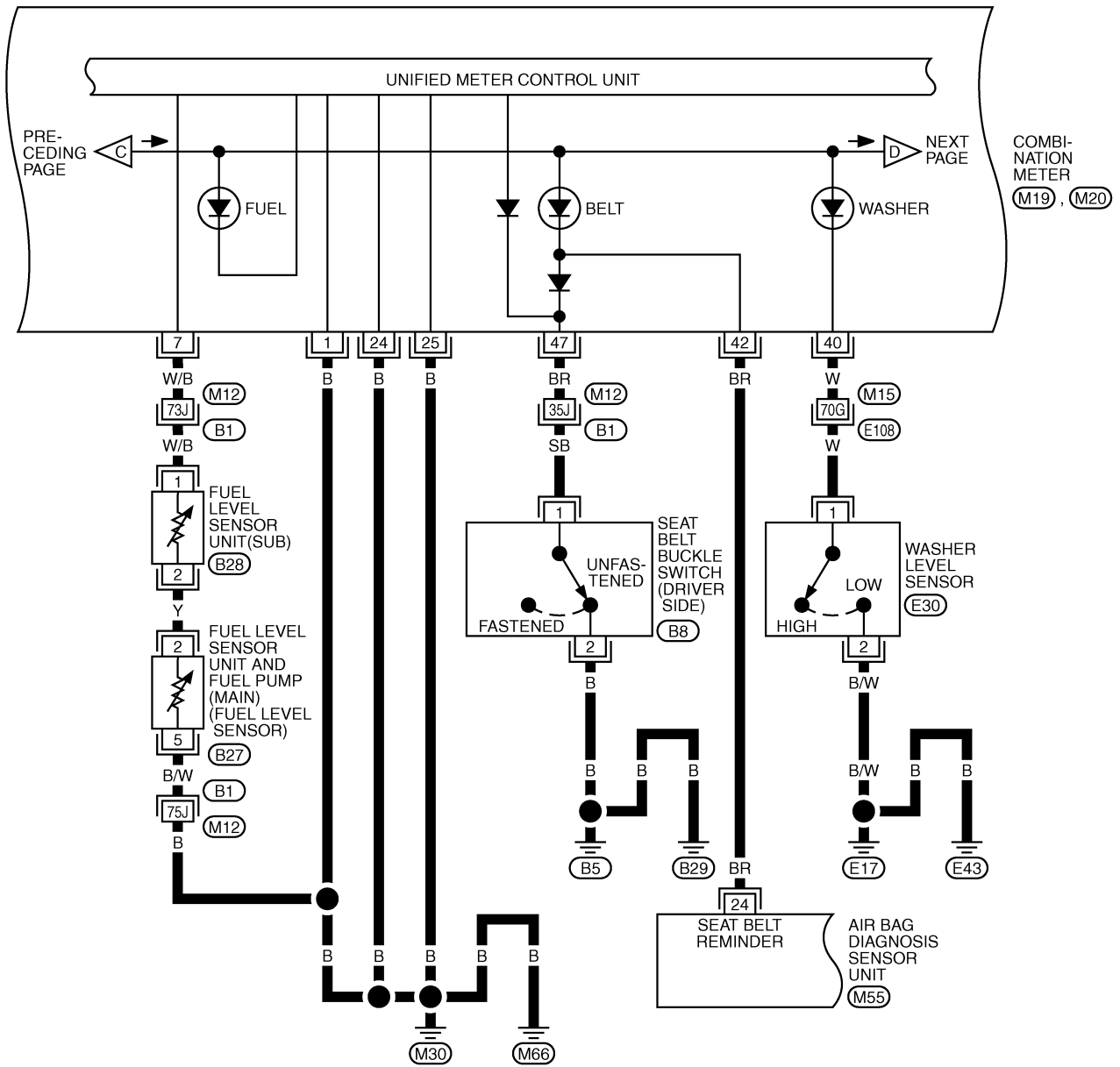

REFER TO THE FOLLOWING.
(E108), **(B1)** -SUPER MULTIPLE JUNCTION (SMJ)

TKWM3399E

WARNING LAMPS

DI-WARN-03

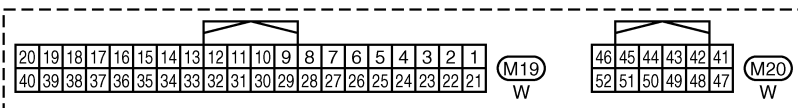
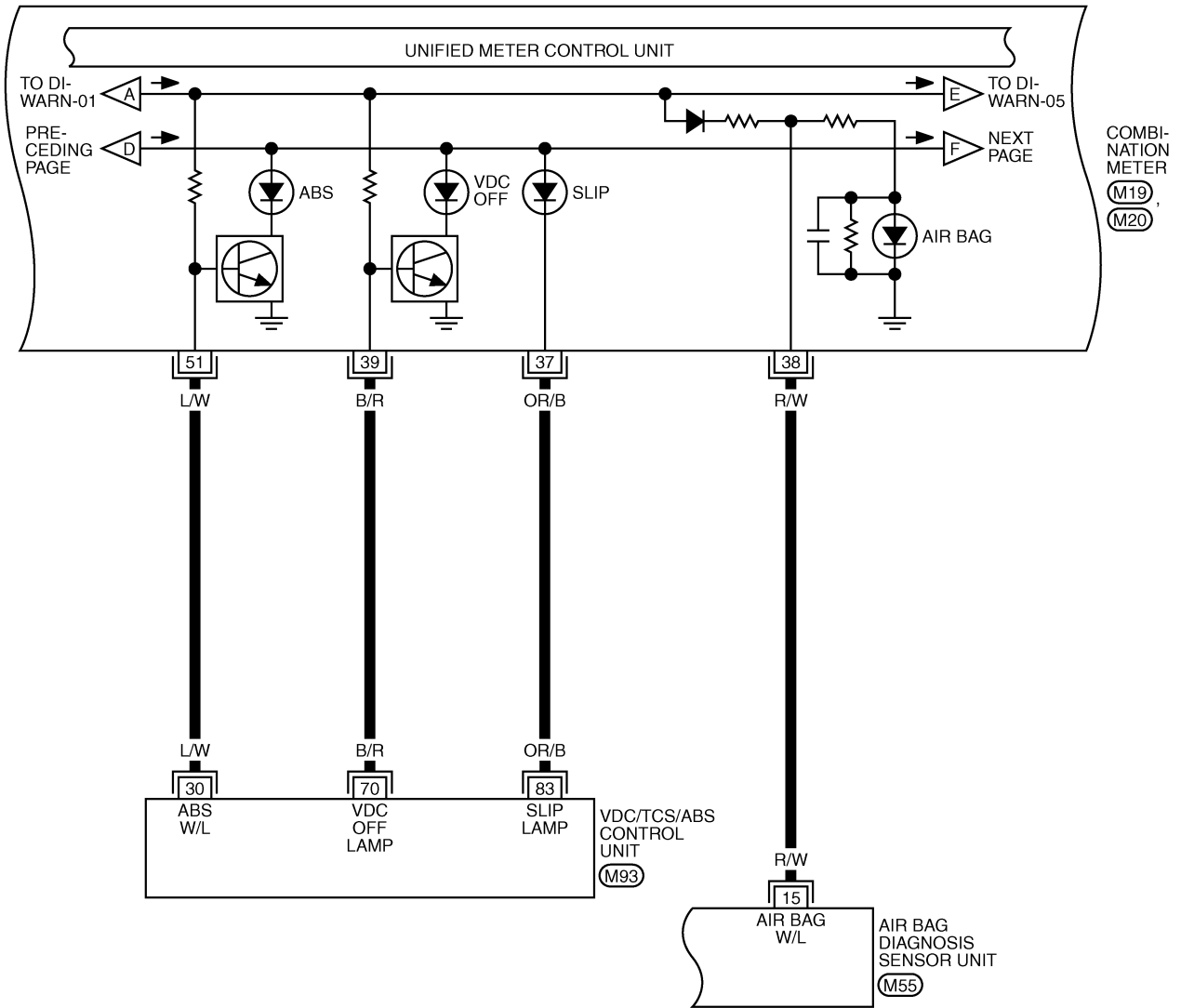

REFER TO THE FOLLOWING.
(M93) -ELECTRICAL UNITS

TKWM3400E

WARNING LAMPS

DI-WARN-04

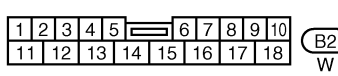
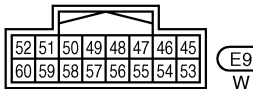
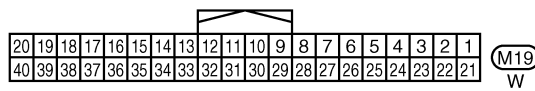
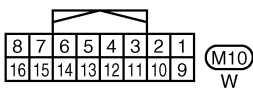
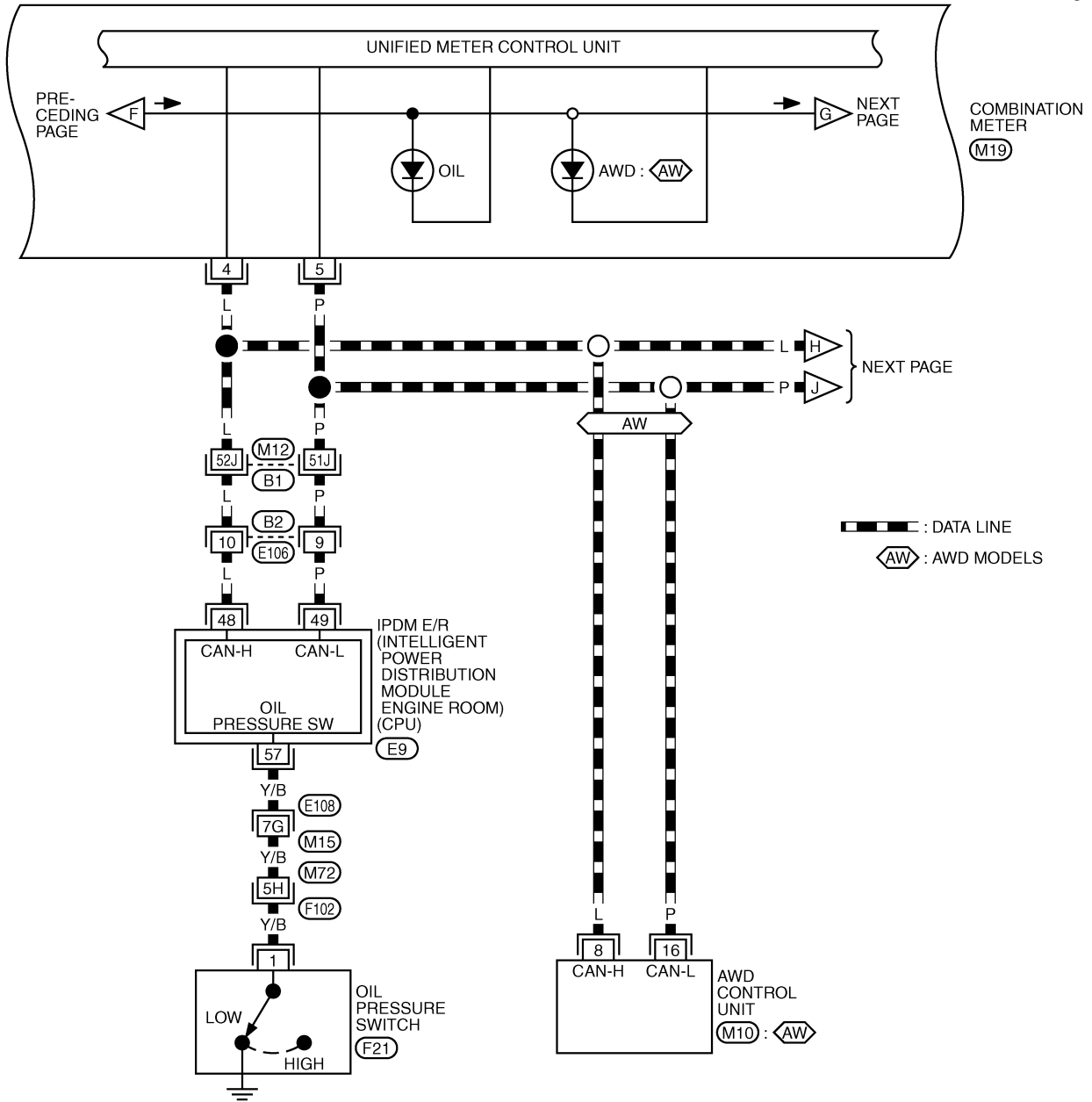

REFER TO THE FOLLOWING.
 (E108), (F102), (B1) -SUPER
 MULTIPLE JUNCTION (SMJ)

TKWM2943E

WARNING LAMPS

DI-WARN-05

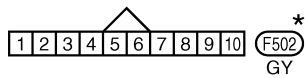
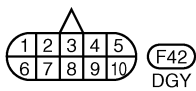
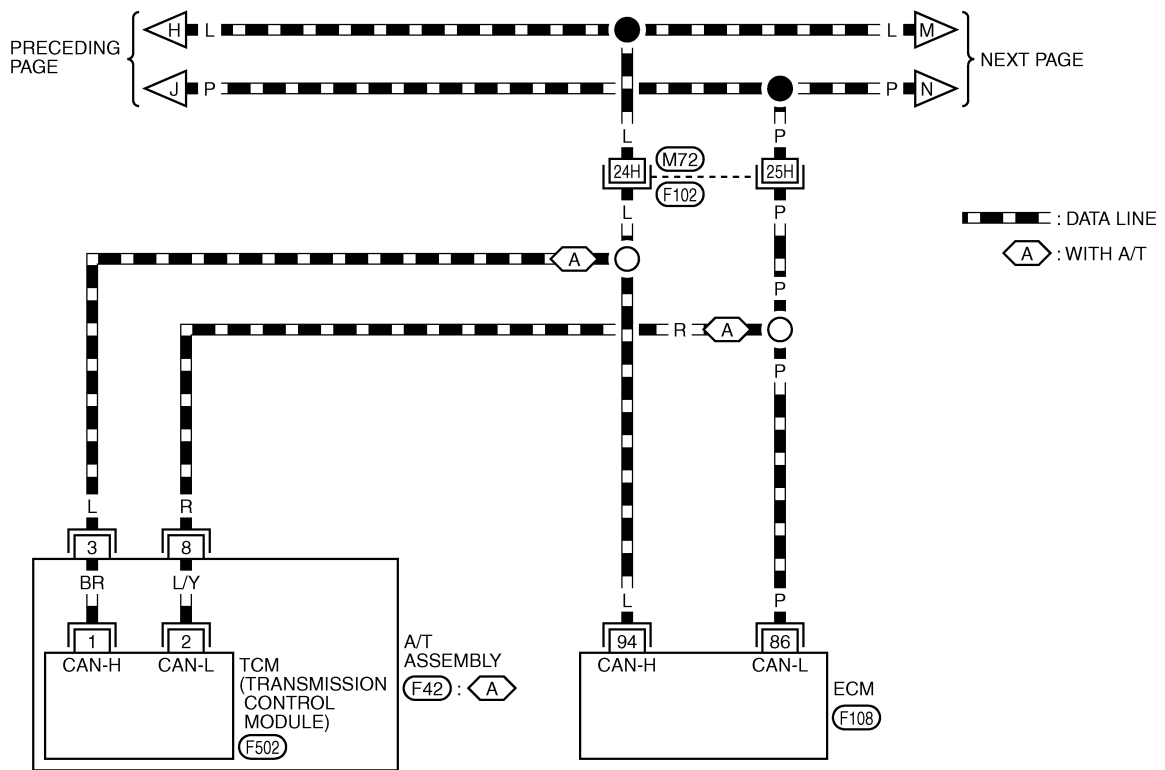
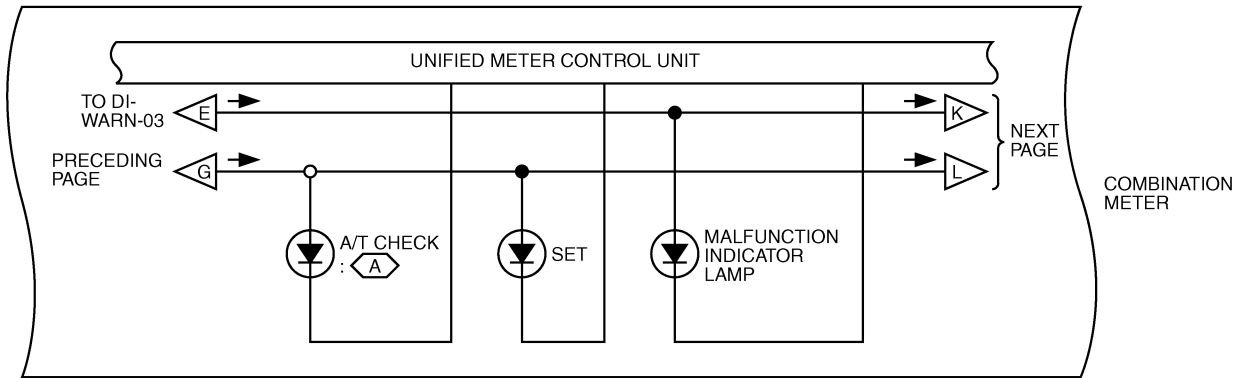

REFER TO THE FOLLOWING.
 (F102) -SUPER MULTIPLE JUNCTION (SMJ)
 (F108) -ELECTRICAL UNITS

*: THIS CONNECTOR IS NOT SHOWN IN "HARNES LAYOUT", PG SECTION.

A
B
C
D
E
F
G
H
I
J
K
L
M

DI

WARNING LAMPS

DI-WARN-06

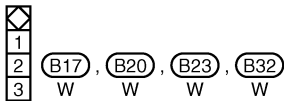
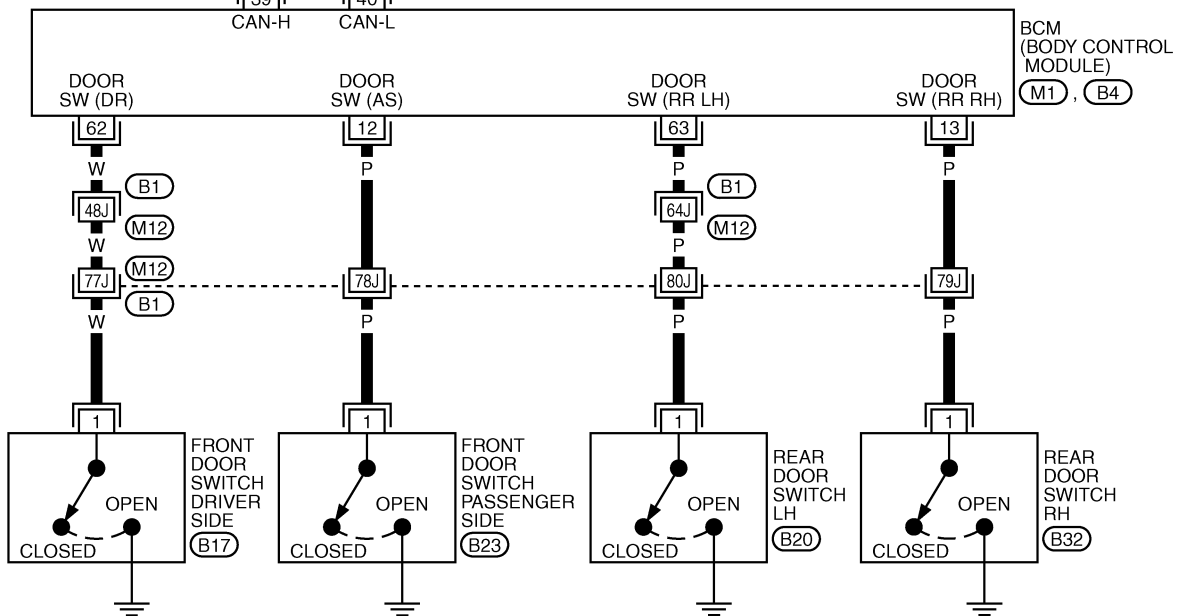
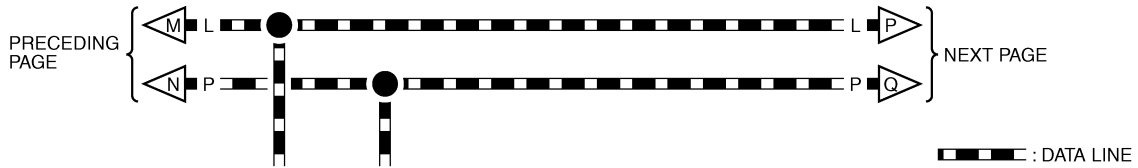
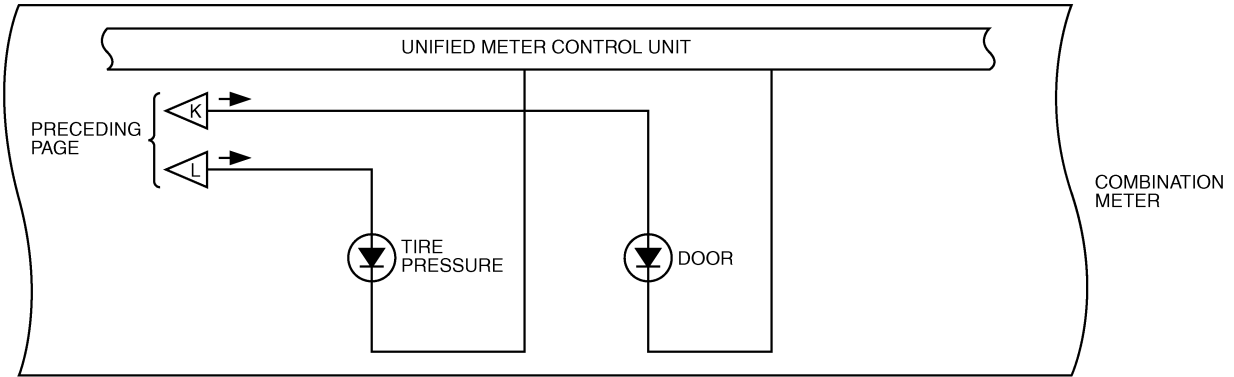

REFER TO THE FOLLOWING.

(B1) -SUPER MULTIPLE JUNCTION (SMJ)

(M1), (B4) -ELECTRICAL UNITS

TKWM2945E

WARNING LAMPS

DI-WARN-07

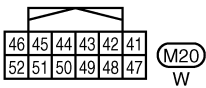
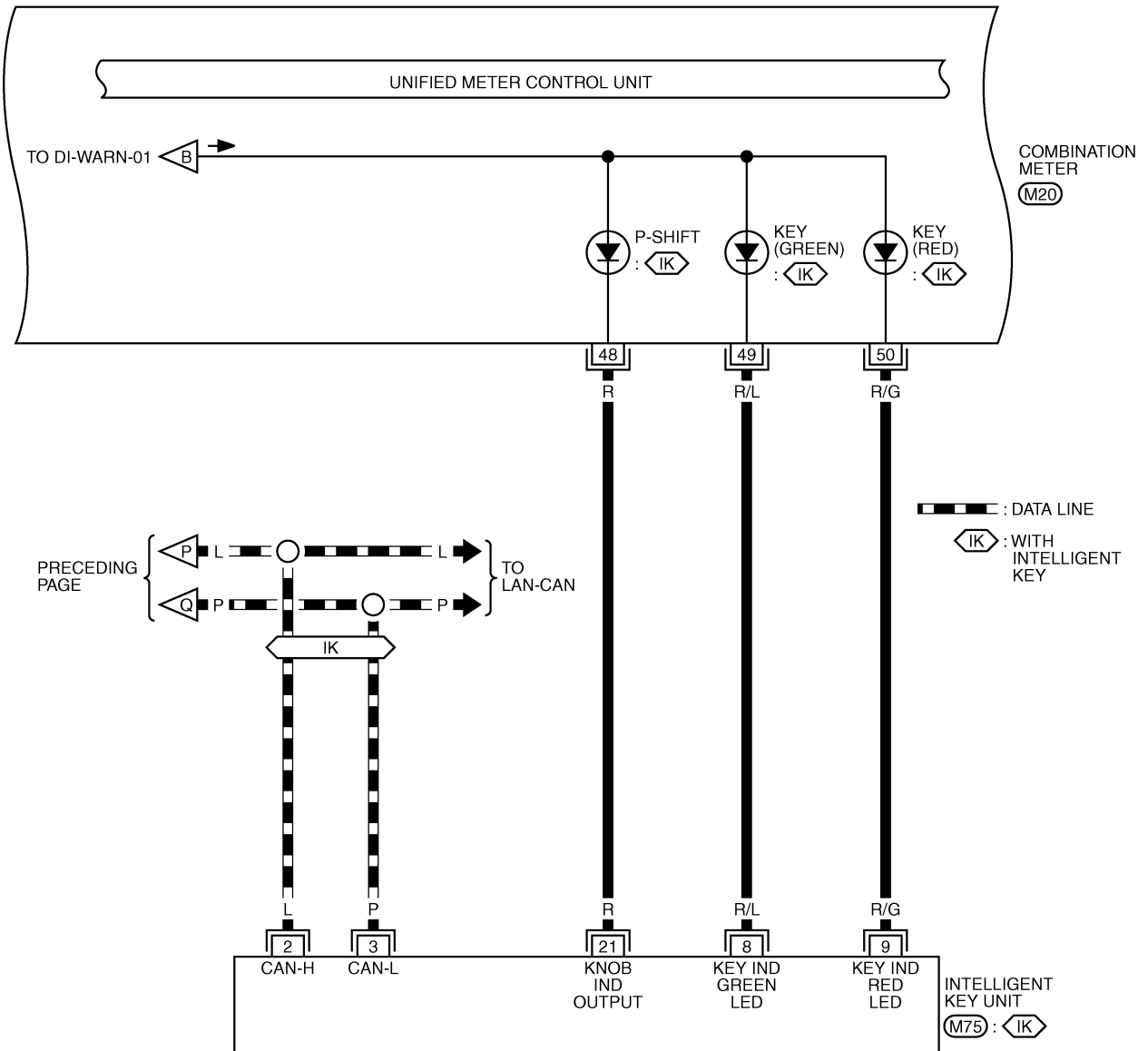

REFER TO THE FOLLOWING.
(M75) -ELECTRICAL UNITS

TKWM3401E

WARNING LAMPS

DI-WARN-08

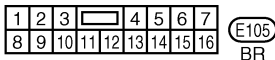
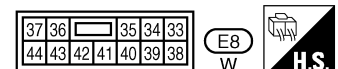
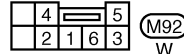
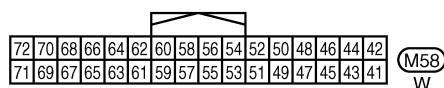
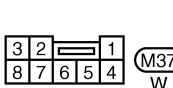
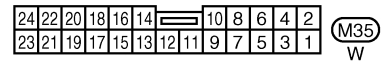
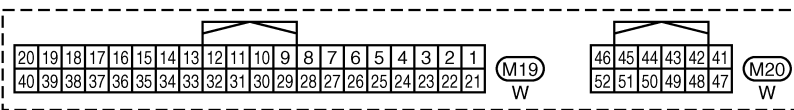
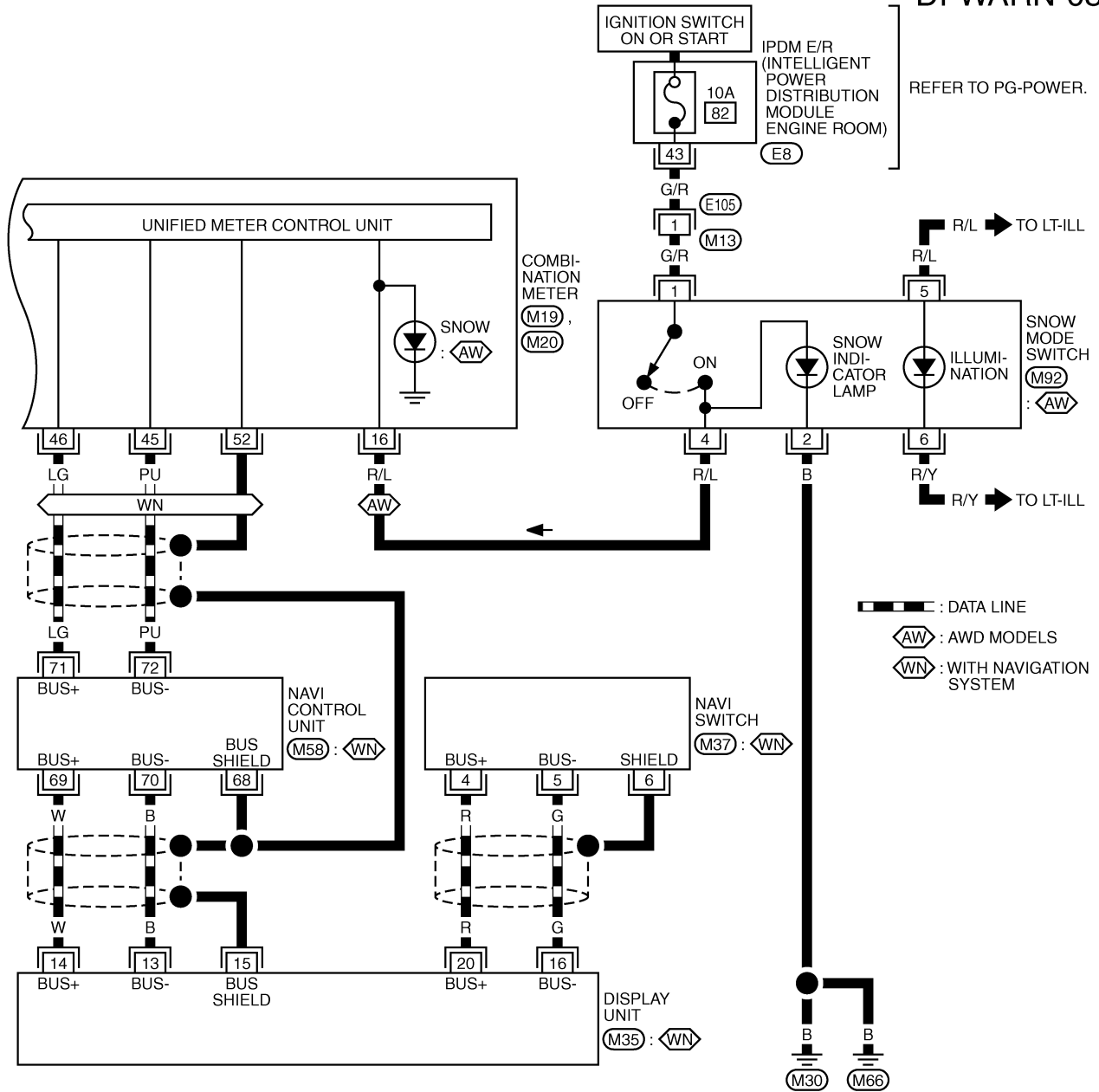

TKWM3402E

WARNING LAMPS

Oil Pressure Warning Lamp Stays Off (Ignition Switch ON)

NKS000YH

1. CHECK OIL PRESSURE WARNING LAMP OPERATION

Activate IPDM E/R auto active test. Refer to [PG-22, "Auto Active Test"](#).

Does oil pressure warning lamp blink?

- YES >> GO TO 2.
- NO >> GO TO 5.

2. CHECK IPDM E/R INPUT SIGNAL

1. Turn ignition switch ON.
2. Check voltage between IPDM E/R harness connector E9 terminal 57 (Y/B) and ground.

57 (Y/B) – Ground : Approx. 0 V

OK or NG

- OK >> Replace IPDM E/R. Refer to [PG-28, "Removal and Installation of IPDM E/R"](#).
- NG >> GO TO 3.

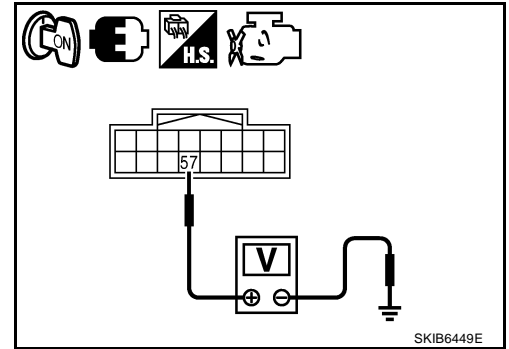

3. CHECK OIL PRESSURE SWITCH

1. Turn ignition switch OFF.
2. Disconnect oil pressure switch connector.
3. Check oil pressure switch. Refer to [DI-33, "OIL PRESSURE SWITCH"](#).

OK or NG

- OK >> GO TO 4.
- NG >> Replace oil pressure switch.

4. CHECK OIL PRESSURE SWITCH CIRCUIT

1. Disconnect IPDM E/R connector.
2. Check continuity between IPDM E/R harness connector E9 terminal 57 (Y/B) and oil pressure switch harness connector F21 terminal 1 (Y/B).

57 (Y/B) – 1 (Y/B) : Continuity should exist.

OK or NG

- OK >> Replace IPDM E/R. Refer to [PG-28, "Removal and Installation of IPDM E/R"](#).
- NG >> Repair harness or connector.

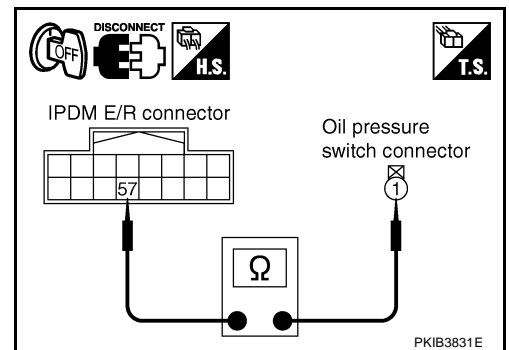

5. CHECK CAN COMMUNICATION

Perform self-diagnosis of IPDM E/R. Refer to [PG-18, "CONSULT-II Function \(IPDM E/R\)"](#).

Self-diagnosis results

- No malfunction detected >> GO TO 6.
- Malfunction detected >> Check applicable parts, and repair or replace corresponding parts.

WARNING LAMPS

6. CHECK IPDM E/R INPUT SIGNAL (CONSULT-II)

1. Select "IPDM E/R" on CONSULT-II.
2. Select "DATA MONITOR" on "SELECT DIAG MODE" screen.
3. Operate ignition switch with "OIL P SW" of "DATA MONITOR" and check operation status.

"OIL P SW"

When ignition switch is in ON position : CLOSE
(Engine stopped)

When engine running : OPEN

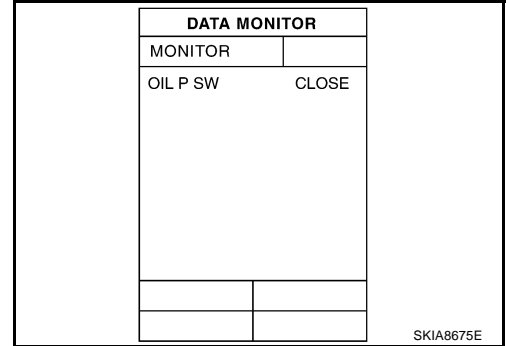

OK or NG

OK >> Replace combination meter.

NG >> Replace IPDM E/R. Refer to [PG-28, "Removal and Installation of IPDM E/R"](#) .

Oil Pressure Warning Lamp Does Not Turn Off (Oil Pressure Is Normal)

NKS000YI

NOTE:

For oil pressure inspection, refer to [LU-8, "OIL PRESSURE CHECK"](#) .

1. CHECK OIL PRESSURE WARNING LAMP OPERATION

Activate IPDM E/R auto active test. Refer to [PG-22, "Auto Active Test"](#) .

Does oil pressure warning lamp blink?

YES >> GO TO 2.

NO >> GO TO 5.

2. CHECK IPDM E/R OUTPUT SIGNAL

1. Turn ignition switch OFF.
2. Disconnect oil pressure switch connector.
3. Turn ignition switch ON.
4. Check voltage between oil pressure switch harness connector F21 terminal 1 (Y/B) and ground.

1 (Y/B) – Ground : Approx. 12 V

OK or NG

OK >> GO TO 3.

NG >> GO TO 4.

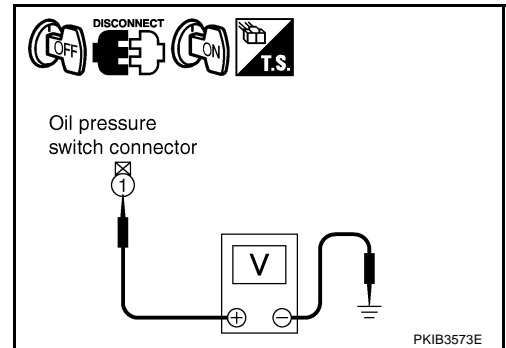

3. CHECK OIL PRESSURE SWITCH

1. Turn ignition switch OFF.
2. Check oil pressure switch. Refer to [DI-33, "OIL PRESSURE SWITCH"](#) .

OK or NG

OK >> Replace IPDM E/R. Refer to [PG-28, "Removal and Installation of IPDM E/R"](#) .

NG >> Replace oil pressure switch.

WARNING LAMPS

4. CHECK OIL PRESSURE SWITCH CIRCUIT

1. Turn ignition switch OFF.
2. Disconnect IPDM E/R connector.
3. Check continuity between IPDM E/R harness connector E9 terminal 57 (Y/B) and ground.

57 (Y/B) – Ground : Continuity should not exist.

OK or NG

- OK >> Replace IPDM E/R. Refer to [PG-28, "Removal and Installation of IPDM E/R"](#) .
- NG >> Repair harness or connector.

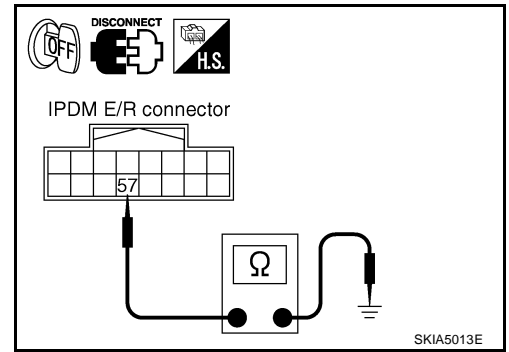

5. CHECK IPDM E/R (CONSULT-II)

Perform self-diagnosis of IPDM E/R. Refer to [PG-18, "CONSULT-II Function \(IPDM E/R\)"](#) .

Self-diagnosis results

- No malfunction detected >> Replace combination meter.
- Malfunction detected >> Check applicable parts, and repair or replace corresponding parts.

Component Inspection OIL PRESSURE SWITCH

Check continuity between the oil pressure switch and ground.

Condition	Oil pressure [kPa (kg/cm ² , psi)]	Continuity
Engine stopped	Less than 29 (0.3, 4)	Yes
Engine running	More than 29 (0.3, 4)	No

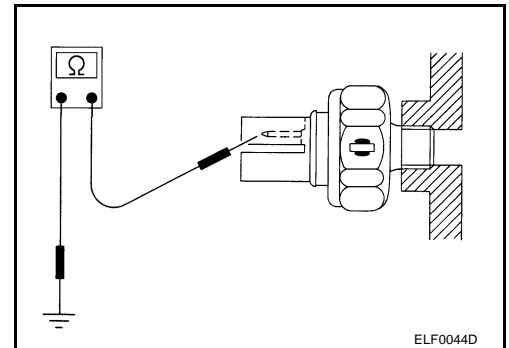

A/T INDICATOR

A/T INDICATOR

PFP:24814

System Description

NKS0016C

A/T position is displayed in the segment display in the combination meter.

MANUAL MODE

- Combination meter reads manual mode signal and shift-up/down signal from A/T device (manual mode switch), and transmits the signals to TCM with CAN communication.
- TCM processes manual mode signal and shift-up/down signal, and transmits A/T position indicator signal and manual mode indicator signal to combination meter with CAN communication.
- Combination meter indicates A/T gear position and manual mode indicator when receiving A/T position indicator signal and manual mode indication signal.

NOT MANUAL MODE

- Combination meter reads not manual mode signal from A/T device (manual mode switch), and transmits the signals to TCM with CAN communication.
- TCM transmits A/T position indicator signal to combination meter with CAN communication.
- Combination meter indicates A/T shift position when receiving A/T position indicator signal.

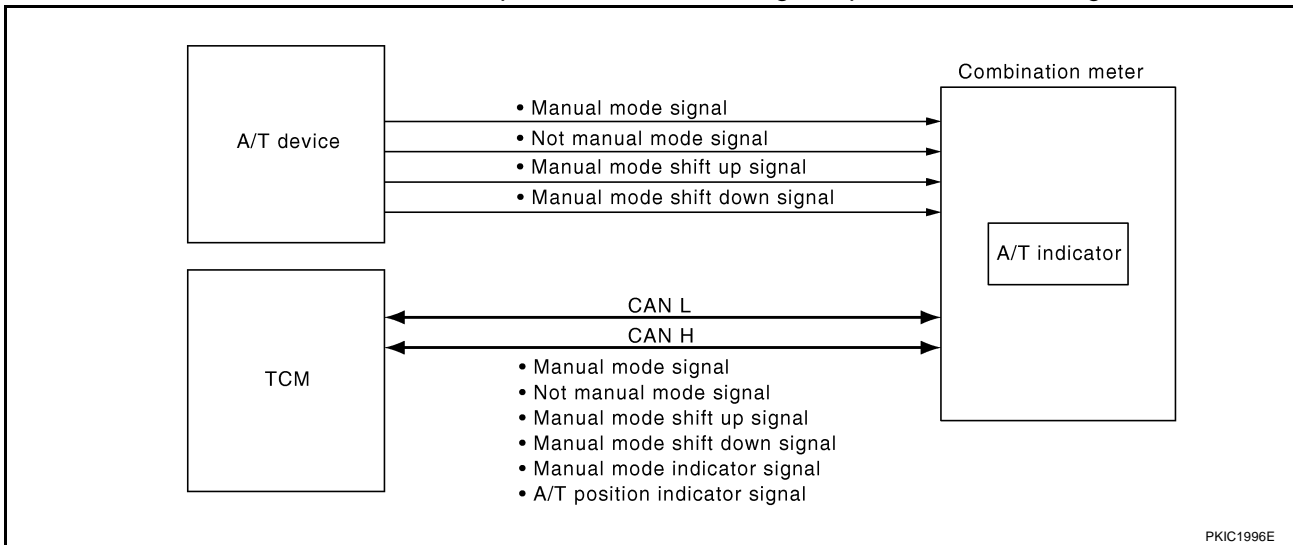

A/T INDICATOR

Wiring Diagram — AT/IND —

NKS000YK

DI-AT/IND-01

DATA LINE

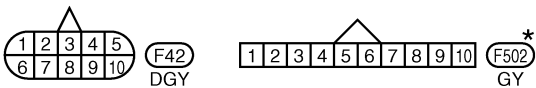
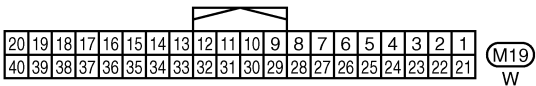
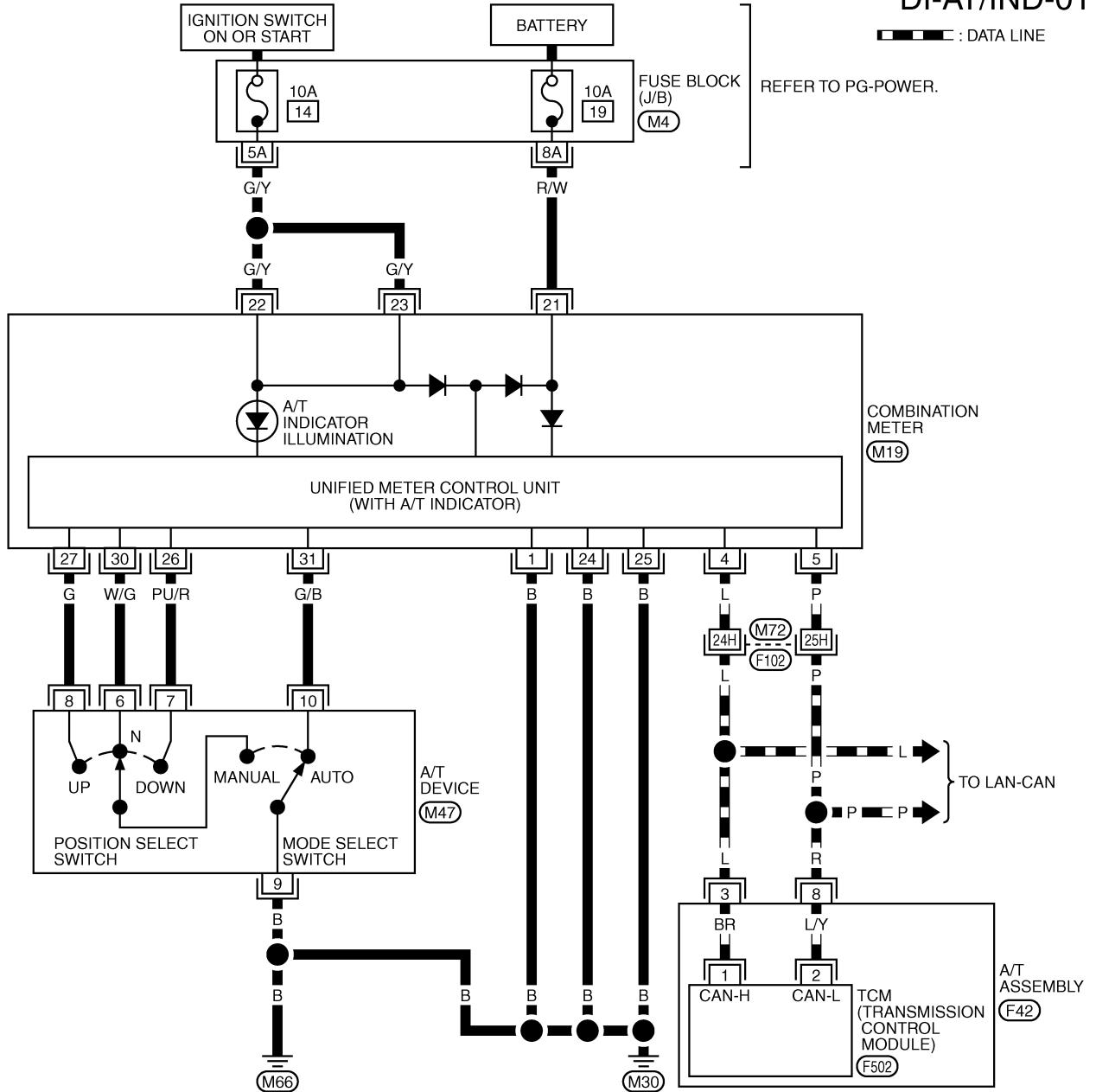

*: THIS CONNECTOR IS NOT SHOWN IN "HARNESS LAYOUT", PG SECTION.

REFER TO THE FOLLOWING.

- (F102) -SUPER MULTIPLE JUNCTION (SMJ)
- (M4) -FUSE BLOCK-JUNCTION BOX (J/B)

TKWM3403E

A/T INDICATOR

A/T Indicator Does Not Illuminate

NKS000YL

1. CHECK SEGMENTS OF A/T INDICATOR

Perform self-diagnosis mode of combination meter. Refer to [DI-12, "OPERATION PROCEDURE"](#) .

Are all segments displayed?

YES >> GO TO 2.

NO >> Replace combination meter.

2. CHECK TCM (CONSULT-II)

Perform self-diagnosis of TCM. Refer to [AT-87, "CONSULT-II Function \(A/T\)"](#) .

Self-diagnosis results

No malfunction detected >> Replace combination meter.

Malfunction detected >> Check applicable parts, and repair or replace corresponding parts.

WARNING CHIME

PPF:24814

System Description

NKS000YM

- The warning chime is controlled by the BCM.
- The warning chime is located in the combination meter.
- When combination meter receives buzzer signal from BCM with CAN communication line, the warning chime will sound.

FUNCTION

Power is supplied at all times

- through 50A fusible link (letter F, located in the fuse and fusible link block)
- to BCM terminal 55,
- through 10A fuse [No. 18, located in the fuse block (J/B)]
- to BCM terminal 42,
- through 10A fuse [No. 21, located in the fuse block (J/B)]
- to key switch terminal 2 (without Intelligent Key),
- through 15A fuse (No. 33, located in the fuse and fusible link block)
- to key switch and ignition knob switch terminals 1 and 3 (with Intelligent Key),
- through 10A fuse [No. 19, located in the fuse block (J/B)]
- to combination meter terminal 21.

With ignition switch in the ON or START position, power is supplied

- through 10A fuse [No. 1, located in the fuse block (J/B)]
- to BCM terminal 38,
- through 10A fuse [No. 14, located in the fuse block (J/B)]
- to combination meter terminals 22 and 23.

Ground is supplied

- to BCM terminal 52
- through grounds M30 and M66,
- to combination meter terminals 1, 24 and 25
- through grounds M30 and M66.

IGNITION KEY WARNING CHIME (WITHOUT INTELLIGENT KEY)

With the key inserted into the key switch, and the ignition switch in OFF or ACC position, when driver's door is opened, the ignition key warning chime will sound.

- BCM detects key inserted into the key switch, ignition switch in OFF or ACC position, and front door switch (driver side) ON. And then, transmits buzzer output signal (ignition key warning chime) to combination meter with CAN communication.
- When combination meter receives buzzer output signal (ignition key warning chime), it sounds the buzzer.

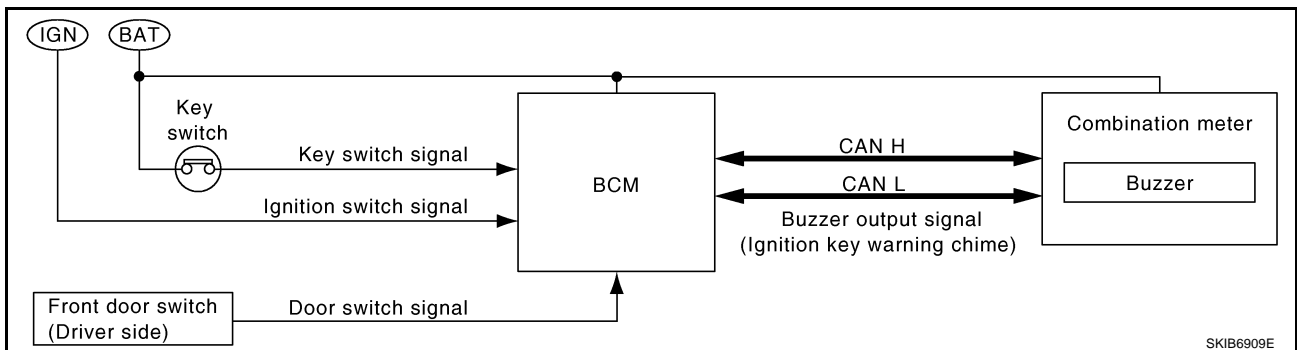

WARNING CHIME

IGNITION KEY WARNING CHIME (WITH INTELLIGENT KEY)

When Mechanical Key Is Used

With the key inserted into the key switch, and the ignition switch in LOCK or ACC position, when driver's door is opened, the ignition key warning chime will sound.

- BCM detects key inserted into the key switch, ignition switch in LOCK or ACC position, and front door switch (driver side) ON. And then, transmits buzzer output signal (ignition key warning chime) to combination meter with CAN communication.
- When combination meter receives buzzer output signal (ignition key warning chime), it sounds the buzzer.

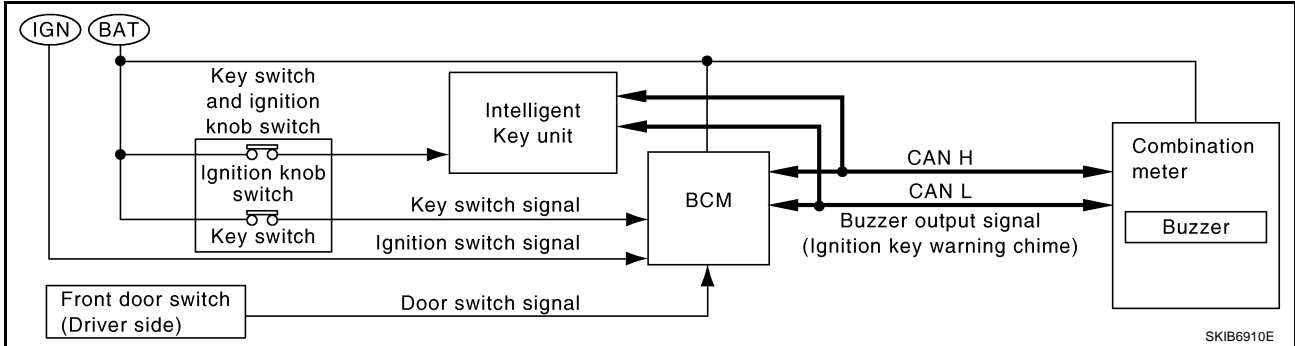

When Intelligent Key Is Carried With The Driver

Refer to [BL-108, "WARNING CHIME FUNCTION"](#) .

LIGHT WARNING CHIME

With ignition switch in OFF or ACC position, driver's door is opened, and lighting switch in 1ST or 2ND position, the light warning chime will sound.

NOTE:

BCM detects lighting switch in the 1ST or 2ND position. Refer to [LT-127, "Combination Switch Reading Function"](#) .

- BCM detects ignition switch in OFF or ACC position, front door switch (driver side) ON, and lighting switch in 1ST or 2ND position. And then, transmits buzzer output signal (light warning chime) to combination meter with CAN communication.
- When combination meter receives buzzer output signal (light warning chime), it sounds the buzzer.

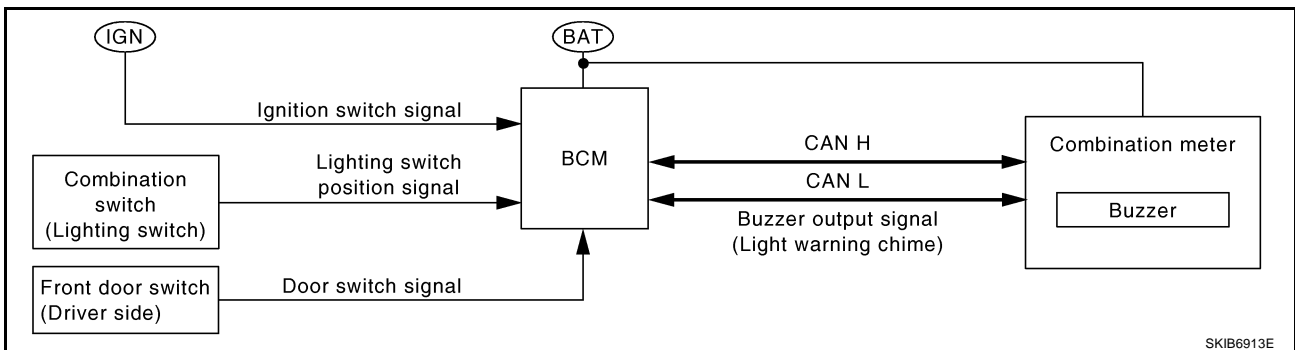

WARNING CHIME

SEAT BELT WARNING CHIME

With ignition switch turned ON and driver's seat belt unfastened, seat belt warning chime will sound for approximately 6 seconds.

- Combination meter reads a ON/OFF signal from seat belt buckle switch (driver side), and transmits seat belt buckle switch signal to BCM with CAN communication.
- BCM detects ignition switch turned ON and seat belt buckle switch (driver side) ON. And then, transmits buzzer output signal (seat belt warning chime) to combination meter with CAN communication.
- When combination meter receives buzzer output signal (seat belt warning chime), it sounds the buzzer.

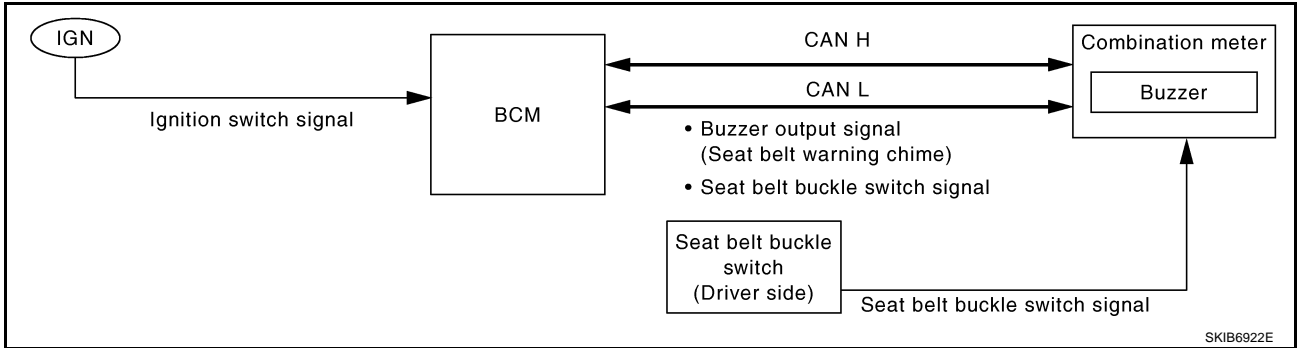

NOTE:

When ignition key warning chime, light warning chime, and seat belt warning chime should be performed at the same time, the priorities for each chime are the following.

1. Seat belt warning chime
2. Light warning chime
3. Ignition key warning chime

Component Parts and Harness Connector Location

NKS000YP

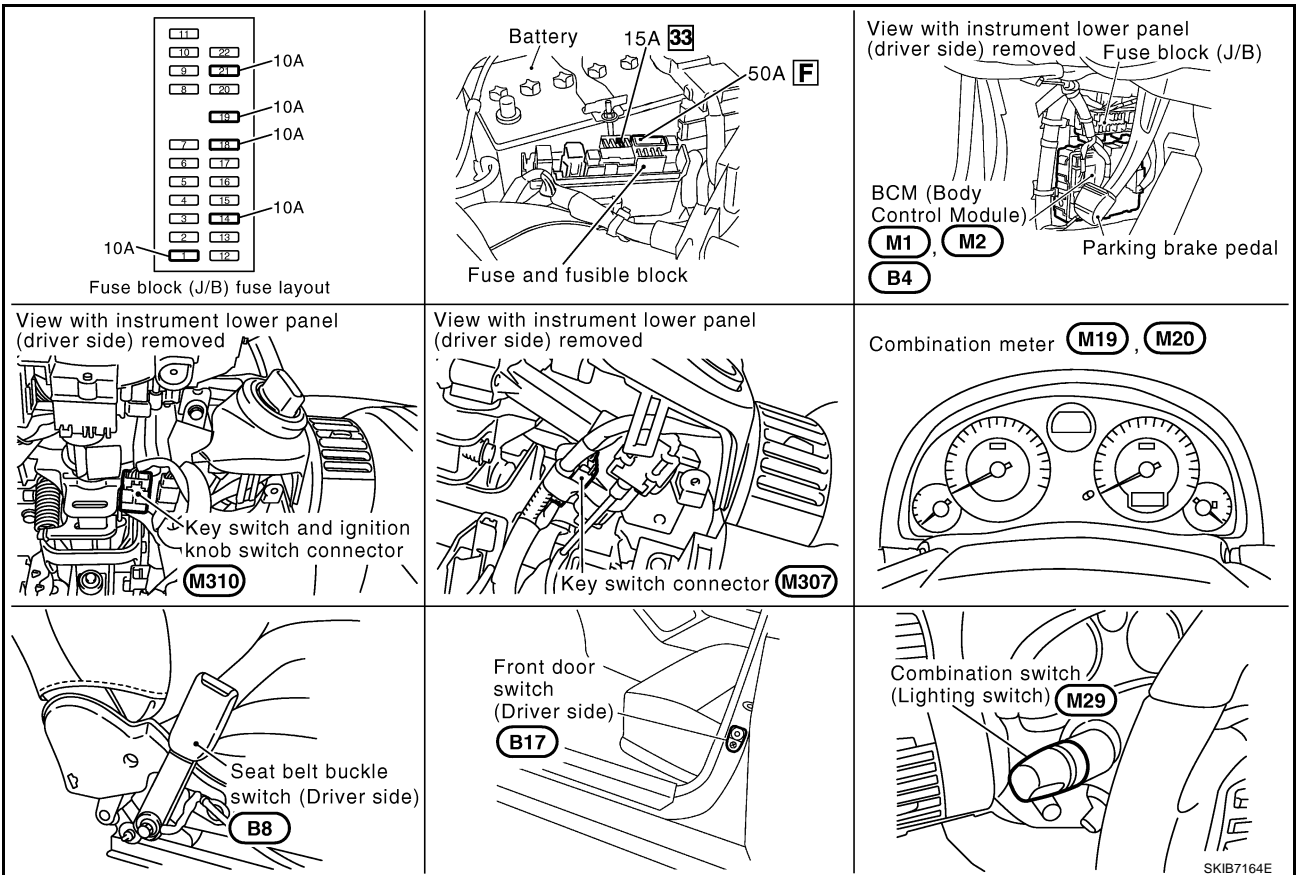

WARNING CHIME

Schematic

NKS000YQ

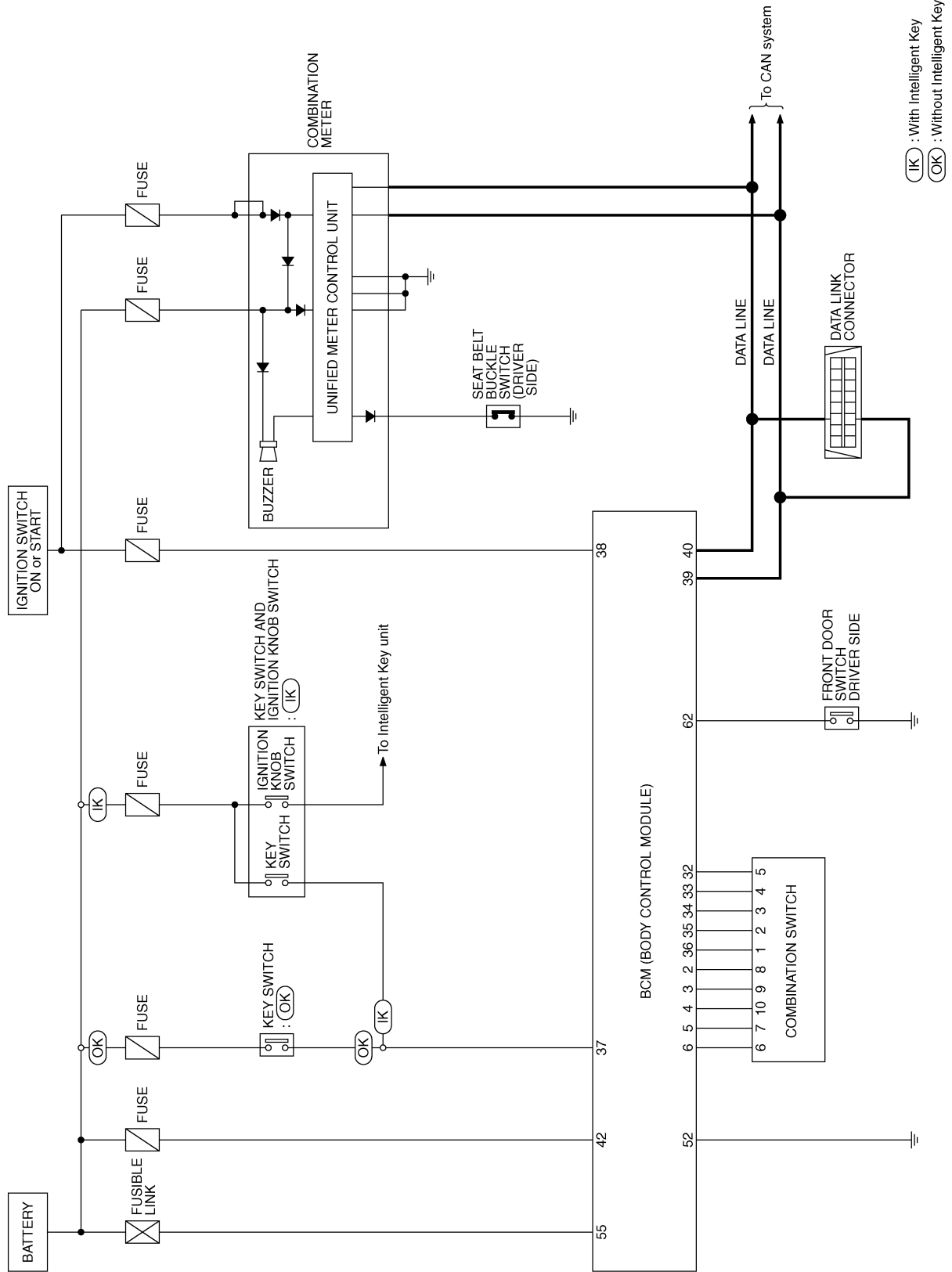

TKWM3404E

WARNING CHIME

Wiring Diagram — CHIME —

NKS000YR

DI-CHIME-01

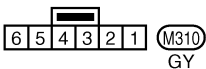
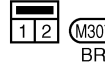
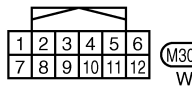
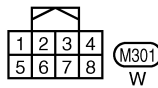
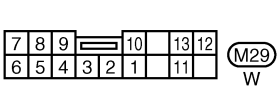
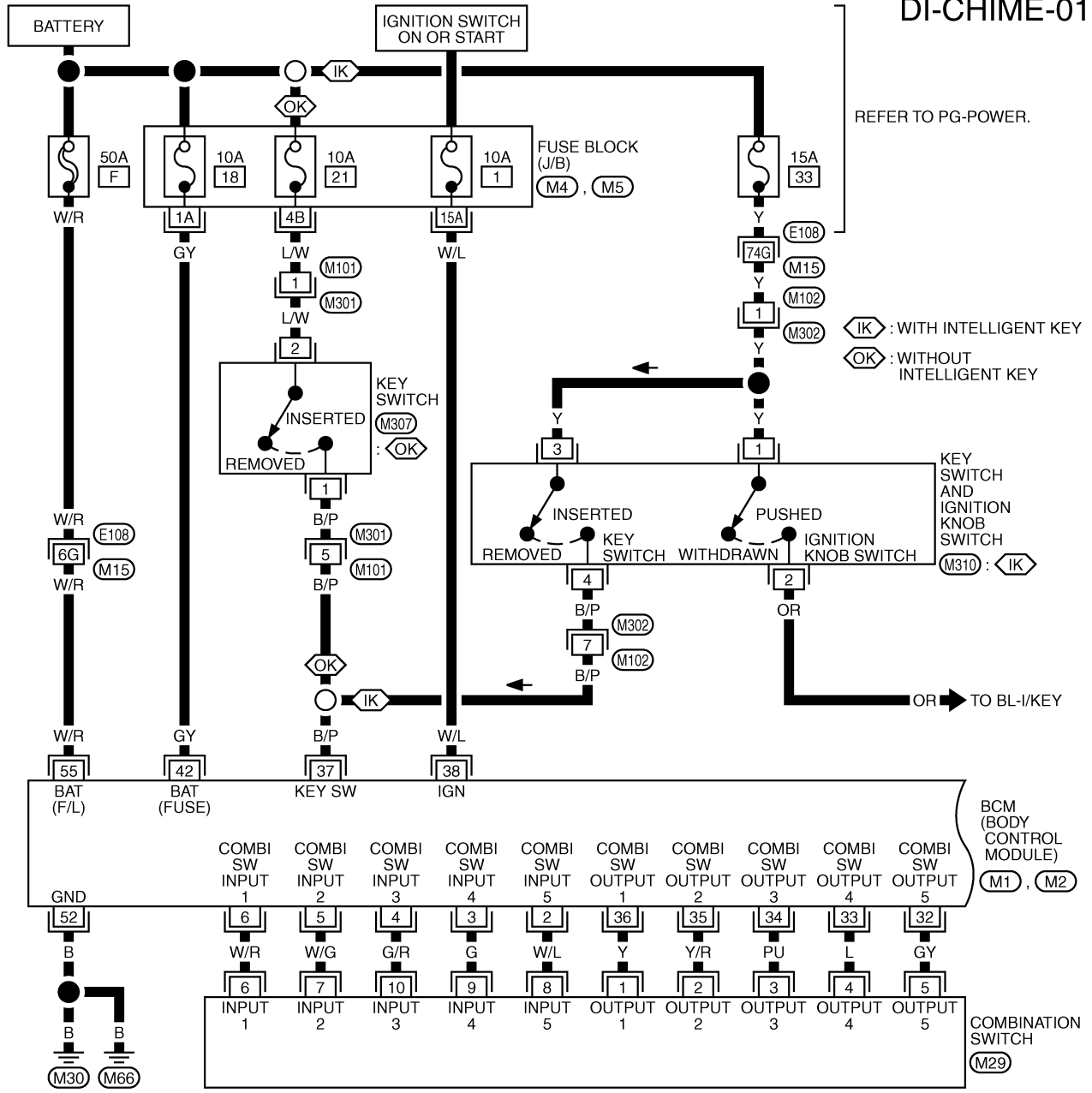

REFER TO THE FOLLOWING.

- E108 -SUPER MULTIPLE JUNCTION (SMJ)
- M4, M5 -FUSE BLOCK-JUNCTION BOX (J/B)
- M1, M2 -ELECTRICAL UNITS

TKWM2134E

WARNING CHIME

DI-CHIME-02

▬ : DATA LINE

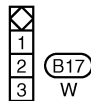
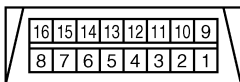
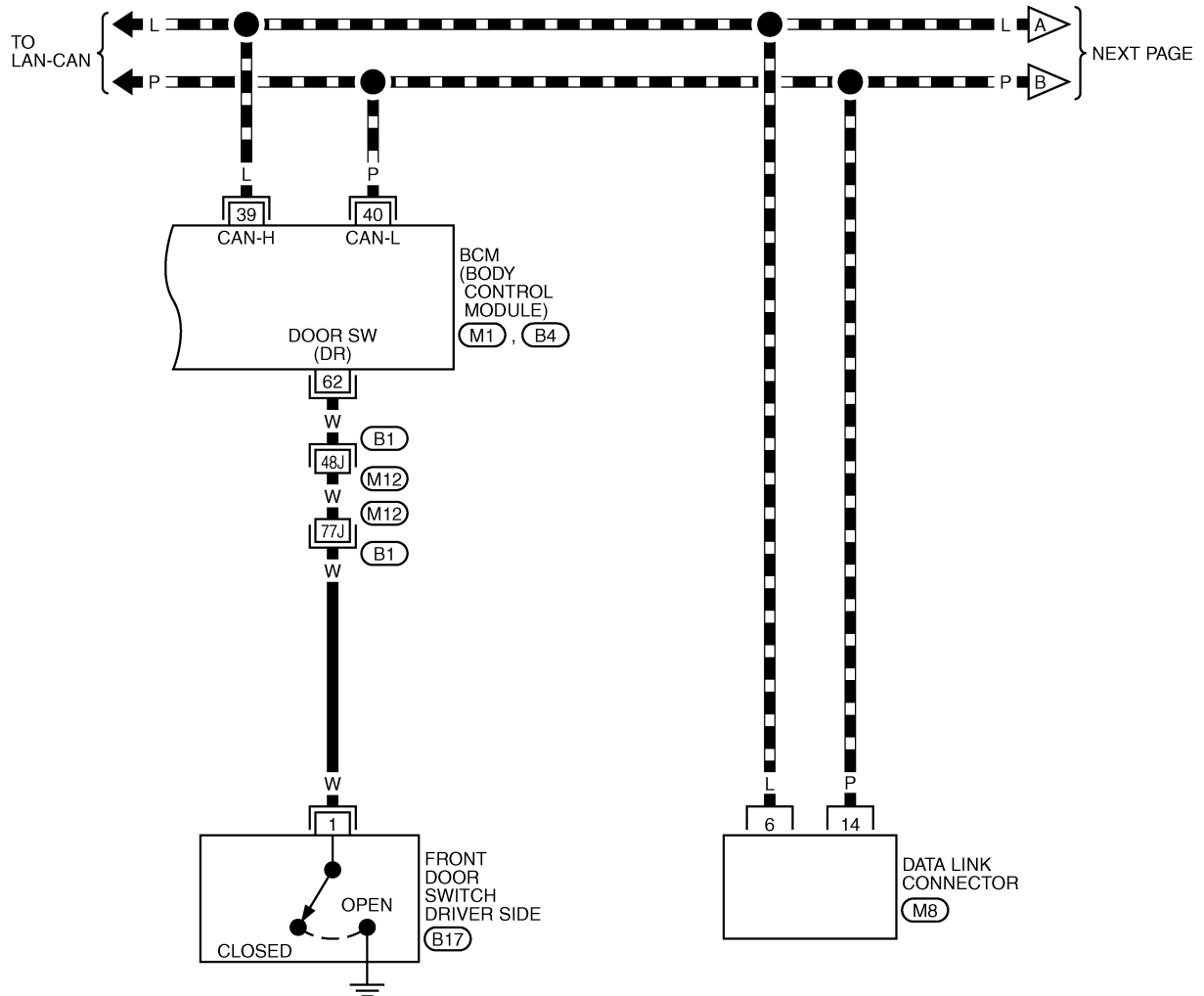

REFER TO THE FOLLOWING.

- (B1) -SUPER MULTIPLE JUNCTION (SMJ)
- (M1), (B4) -ELECTRICAL UNITS

TKWM2135E

WARNING CHIME

DI-CHIME-03

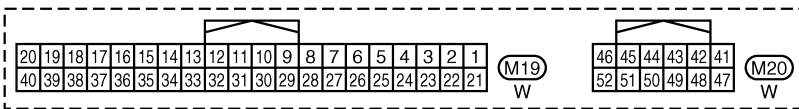
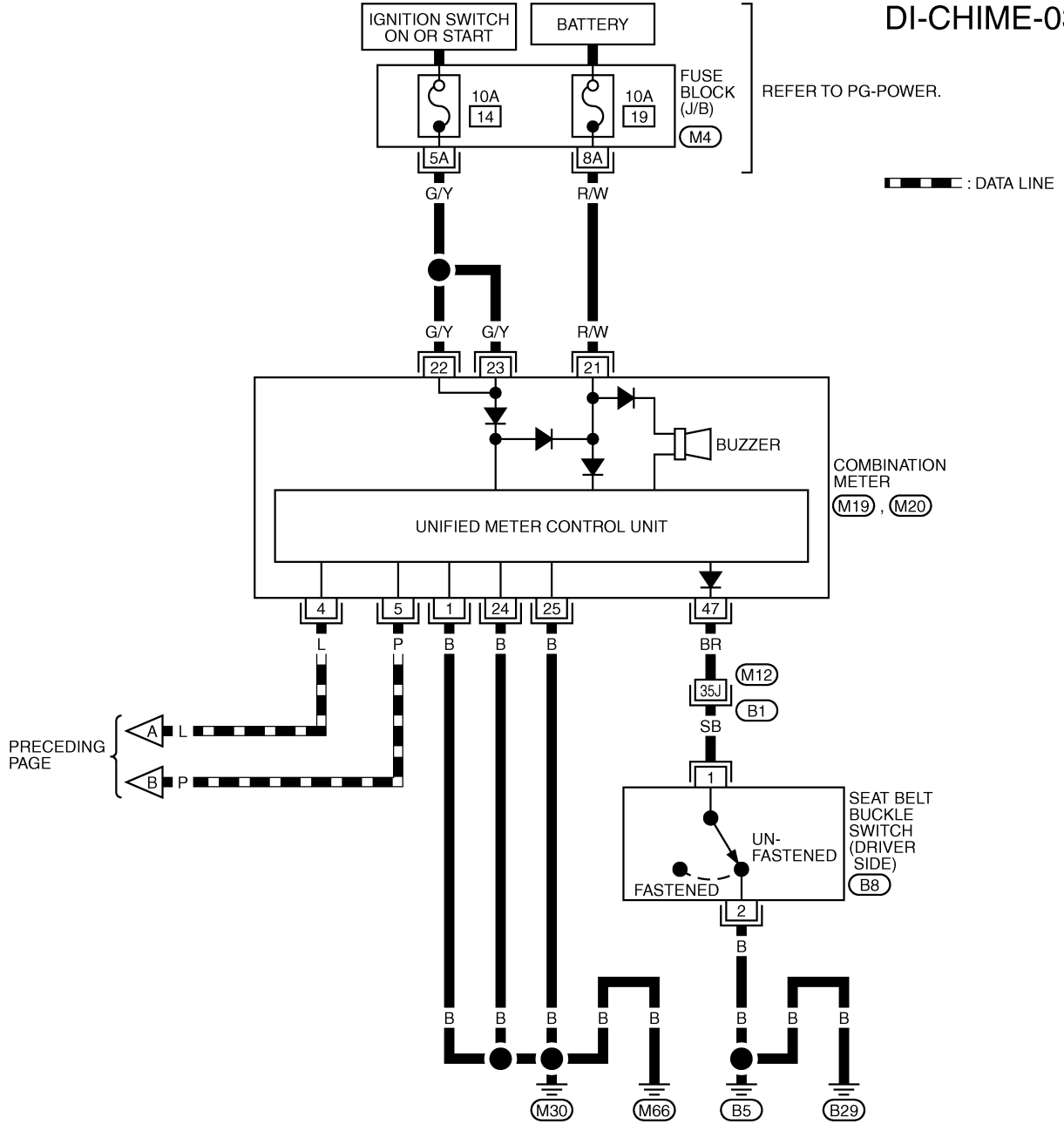

REFER TO THE FOLLOWING.

(B1) -SUPER MULTIPLE JUNCTION (SMJ)

(M4) -FUSE BLOCK-JUNCTION BOX (J/B)

TKWM2136E

WARNING CHIME

Terminals and Reference Value for BCM

NKS000YS

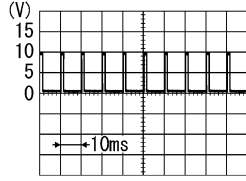
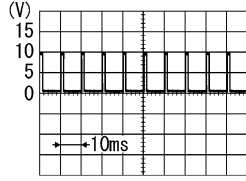
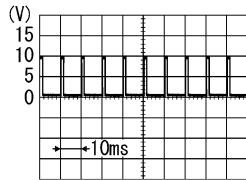
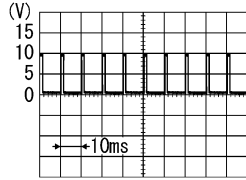
Terminal No.	Wire color	Signal name	Measuring condition		Reference value
			Ignition switch	Operation or condition	
2	W/L	Combination switch input 5	ON	OFF	Approx. 0 V
				Any of the conditions below <ul style="list-style-type: none"> ● Lighting switch 1ST ● Lighting switch HIGH beam (Operates only HIGH beam switch) ● Turn signal switch to right 	 <p style="text-align: center;">Approx. 1.0 V</p>
				Lighting, turn, wiper switch (Wiper intermittent dial position 4)	Lighting switch 2ND
3	G	Combination switch input 4	ON	OFF	Approx. 0 V
				Any of the conditions below <ul style="list-style-type: none"> ● Lighting switch 2ND ● Lighting switch PASSING (Operates only PASSING switch) ● Turn signal switch to left 	 <p style="text-align: center;">Approx. 1.0 V</p>
4	G/R	Combination switch input 3	ON	OFF	Approx. 0 V
				Any of the conditions below <ul style="list-style-type: none"> ● Front wiper switch MIST ● Front wiper switch INT ● Front wiper switch LO 	 <p style="text-align: center;">Approx. 1.0 V</p>
5	W/G	Combination switch input 2	ON	OFF (Wiper intermittent dial position 4)	Approx. 0 V
				Any of the conditions below <ul style="list-style-type: none"> ● Front washer switch ● Wiper intermittent dial position 1 ● Wiper intermittent dial position 5 ● Wiper intermittent dial position 6 	 <p style="text-align: center;">Approx. 1.0 V</p>

WARNING CHIME

Terminal No.	Wire color	Signal name	Measuring condition		Reference value	
			Ignition switch	Operation or condition		
6	W/R	Combination switch input 1	ON	Lighting, turn, wiper switch	OFF (Wiper intermittent dial position 4)	Approx. 0 V
					Any of the conditions below <ul style="list-style-type: none"> ● Front wiper switch HI ● Wiper intermittent dial position 3 	 PKIB4959J Approx. 1.0 V
					Any of the conditions below <ul style="list-style-type: none"> ● Wiper intermittent dial position 1 ● Wiper intermittent dial position 2 	 PKIB4952J Approx. 1.7 V
					Any of the conditions below <ul style="list-style-type: none"> ● Wiper intermittent dial position 6 ● Wiper intermittent dial position 7 	 PKIB4955J Approx. 0.8 V
32	GY	Combination switch output 5	ON	Lighting, turn, wiper switch	OFF (Wiper intermittent dial position 4)	 PKIB4960J Approx. 7.2 V
					Any of the conditions below <ul style="list-style-type: none"> ● Wiper intermittent dial position 1 ● Wiper intermittent dial position 2 ● Wiper intermittent dial position 6 ● Wiper intermittent dial position 7 	 PKIB4956J Approx. 1.0 V

A
B
C
D
E
F
G
H
I
J
DI
L
M

WARNING CHIME

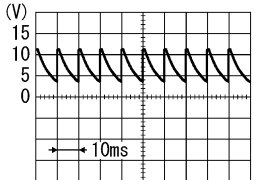
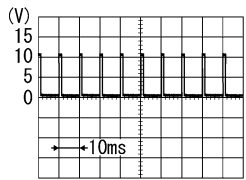
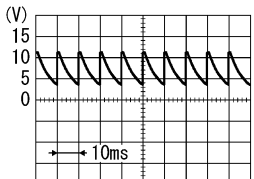
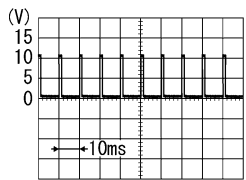
Terminal No.	Wire color	Signal name	Measuring condition		Reference value
			Ignition switch	Operation or condition	
33	L	Combination switch output 4	ON	Lighting, turn, wiper switch	OFF (Wiper intermittent dial position 4)  <p style="text-align: right;">PKIB4960J</p> <p style="text-align: center;">Approx. 7.2 V</p>
					Any of the conditions below <ul style="list-style-type: none"> ● Lighting switch 1ST (The same result with lighting switch 2ND) ● Wiper intermittent dial position 1 ● Wiper intermittent dial position 5 ● Wiper intermittent dial position 6  <p style="text-align: right;">PKIB4958J</p> <p style="text-align: center;">Approx. 1.2 V</p>
34	PU	Combination switch output 3	ON	Lighting, turn, wiper switch	OFF (Wiper intermittent dial position 4)  <p style="text-align: right;">PKIB4960J</p> <p style="text-align: center;">Approx. 7.2 V</p>
					Any of the conditions below <ul style="list-style-type: none"> ● Lighting switch 2ND ● Lighting switch HI beam (Operates only HI beam switch) ● Wiper intermittent dial position 1 ● Wiper intermittent dial position 2 ● Wiper intermittent dial position 3  <p style="text-align: right;">PKIB4958J</p> <p style="text-align: center;">Approx. 1.2 V</p>

WARNING CHIME

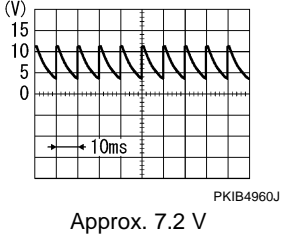
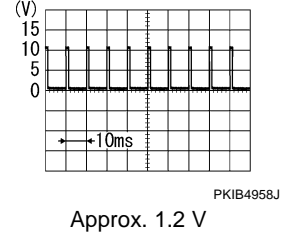
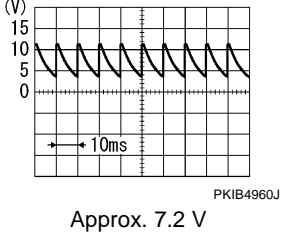
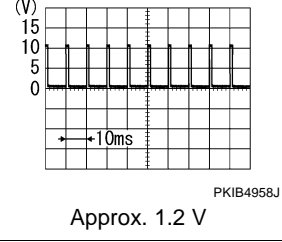
Terminal No.	Wire color	Signal name	Measuring condition		Reference value
			Ignition switch	Operation or condition	
35	Y/R	Combination switch output 2	ON	Lighting, turn, wiper switch (Wiper intermittent dial position 4)	OFF 
					Any of the conditions below <ul style="list-style-type: none"> ● Lighting switch 2ND ● Lighting switch PASSING (Operates only PASSING switch) ● Front wiper switch INT ● Front wiper switch HI 
36	Y	Combination switch output 1	ON	Lighting, turn, wiper switch (Wiper intermittent dial position 4)	OFF 
					Any of the conditions below <ul style="list-style-type: none"> ● Turn signal switch to right ● Turn signal switch to left ● Front wiper switch MIST ● Front wiper switch LO ● Front washer switch 
37	B/P	Key switch signal	OFF	Key is removed	Approx. 0 V
				Key is inserted	Approx. 12 V
38	W/L	Ignition power supply	ON	—	Battery voltage
39	L	CAN H	—	—	—
40	P	CAN L	—	—	—
42	GY	Battery power supply (FUSE)	OFF	—	Battery voltage
52	B	Ground	ON	—	Approx. 0 V
55	W/R	Battery power supply (F/L)	OFF	—	Battery voltage
62	W	Front door switch signal	OFF	Driver's door	ON (open) Approx. 0 V
				OFF (close) Approx. 5 V	

A
B
C
D
E
F
G
H
I
J
DI
L
M



WARNING CHIME

NKS000YU

CONSULT-II Function (BCM)

CONSULT-II can display each diagnostic item using the diagnostic test modes shown following.

DIAGNOSIS ITEMS DESCRIPTION

BCM diagnosis position	Diagnosis mode	Description	Reference page
BUZZER	DATA MONITOR	Displays BCM input data in real time.	DI-49
	ACTIVE TEST	Operation of electrical loads can be checked by sending driving signal to them.	DI-49
BCM	SELF-DIAG RESULTS	BCM performs self-diagnosis of CAN communication.	DI-50

CONSULT-II BASIC OPERATION PROCEDURE

CAUTION:

If CONSULT-II is used with no connection of CONSULT-II CONVERTER, malfunctions might be detected in self-diagnosis depending on control unit which carry out CAN communication.

1. With the ignition switch OFF, connect "CONSULT-II" and "CONSULT-II CONVERTER" to the data link connector, and then turn the ignition switch ON.

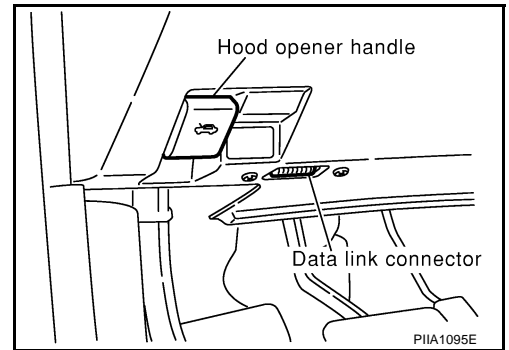

2. Touch "START (NISSAN BASED VHCL)".

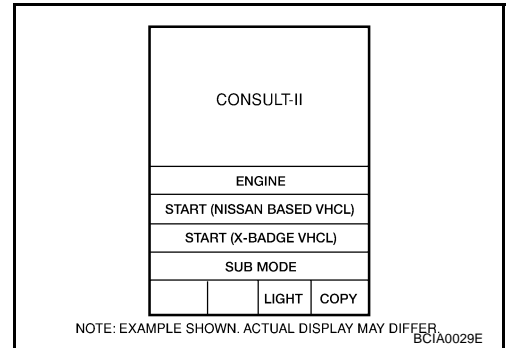

3. Touch "BCM" on "SELECT SYSTEM" screen. If "BCM" is not indicated, go to [GI-39, "CONSULT-II Data Link Connector \(DLC\) Circuit"](#).

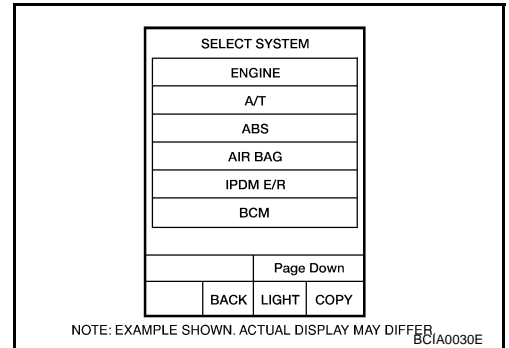

WARNING CHIME

4. Touch "BUZZER" or "BCM" on "SELECT TEST ITEM" screen.

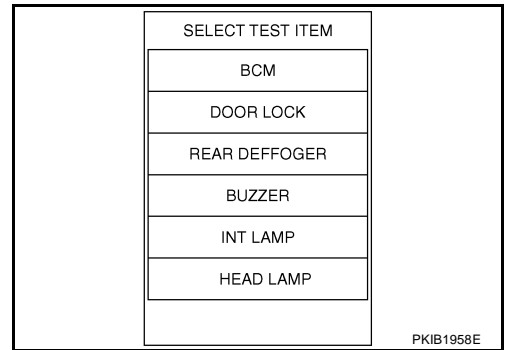

5. Select "DATA MONITOR", "ACTIVE TEST" or "SELF-DIAG RESULTS" on "SELECT DIAG MODE" screen.

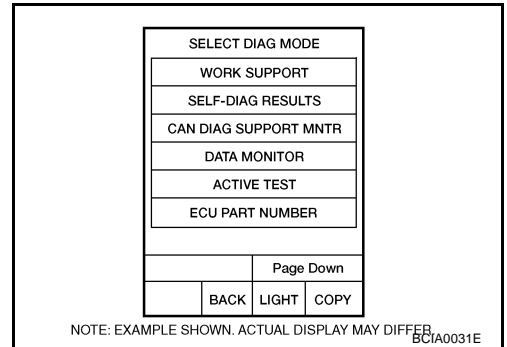

DATA MONITOR

Operation Procedure

1. Touch "BUZZER" on "SELECT TEST ITEM" screen.
2. Touch "DATA MONITOR" on "SELECT DIAG MODE" screen.
3. Touch "ALL SIGNALS" or "SELECTION FROM MENU" on "DATA MONITOR" screen.

ALL SIGNALS	Monitors all items.
SELECTION FROM MENU	Selects and monitors items.

4. If "SELECTION FROM MENU" is selected, touch the desired monitor item. If "ALL SIGNALS" is selected, all items required to control are monitored.
5. Touch "START".
6. During monitoring, touching "RECORD" can start recording the monitored item status.

Display Item List

Monitored item	Description
IGN ON SW	Indicates [ON/OFF] condition of ignition switch.
KEY ON SW	Indicates [ON/OFF] condition of key switch.
DOOR SW-DR	Indicates [ON/OFF] condition of front door switch (driver side).
LIGHT SW 1ST	Indicates [ON/OFF] condition of lighting switch.
BUCKLE SW	Indicates [ON/OFF] condition of seat belt buckle switch (driver side).

ACTIVE TEST

Operation Procedure

1. Touch "BUZZER" on "SELECT TEST ITEM" screen.
2. Touch "ACTIVE TEST" on "SELECT DIAG MODE" screen.
3. Touch the item to be tested, and check the operation.
4. During the operation check, touching "OFF" deactivates the operation.

WARNING CHIME

Display Item List

Test item	Malfunction is detected when...
LIGHT WARN ALM	This test is able to check light warning chime operation.
IGN KEY WARN ALM	This test is able to check ignition key warning chime operation.
SEAT BELT WARN TEST	This test is able to check seat belt warning chime operation.

SELF-DIAG RESULTS

Operation Procedure

1. Touch "BCM" on "SELECT TEST ITEM" screen.
2. Touch "SELF-DIAG RESULTS" on "SELECT DIAG MODE" screen.
3. Self-diagnostic results are displayed.

Display Item List

Monitored Item	Display item [Code]	Description
CAN communication	CAN communication [U1000]	Malfunction is detected in CAN communication.

NOTE:

If "CAN communication [U1000]" is indicated, after printing the monitor item, go to "LAN system". Refer to [LAN-3, "Precautions When Using CONSULT-II"](#).

Trouble Diagnosis

NKS000YT

HOW TO PERFORM TROUBLE DIAGNOSIS

1. Confirm the symptom or customer complaint.
2. Understand operation description and function description. Refer to [DI-37, "System Description"](#).
3. Referring to trouble diagnosis chart, repair or replace the cause of the malfunction. Refer to [DI-51, "Symptom Chart"](#).
4. Does the warning chime operate normally? If so, GO TO 5. If not, GO TO 3.
5. INSPECTION END

WARNING CHIME

Symptom Chart

NKS001M0

Symptom	Diagnoses/Service procedure
All warning chimes do not activate.	Perform the following inspections. 1. DI-52, "Power Supply and Ground Circuit Inspection" . 2. DI-53, "Combination Meter Buzzer Circuit Inspection" . Replace BCM, found normal function in the above inspections.
Ignition key warning chime does not activate.	Without Intelligent Key. Perform the following inspections. 1. DI-54, "Key Switch Signal Inspection (Without Intelligent Key)" . 2. DI-53, "Front Door Switch (Driver Side) Signal Inspection" . Replace BCM, found normal function in the above inspection.
	With Intelligent Key, when mechanical key is used. Perform the following inspections. 1. DI-56, "Key Switch and Ignition Knob Switch Signal Inspection (With Intelligent Key, When Mechanical Key Is Used)" . 2. DI-53, "Front Door Switch (Driver Side) Signal Inspection" . Replace BCM, found normal function in the above inspection.
	With Intelligent Key, when Intelligent Key is carried with the driver. Refer to BL-155, "WARNING CHIME FUNCTION MALFUNCTION" .
Light warning chime does not activate.	Perform the following inspections. 1. DI-57, "Lighting Switch Signal Inspection" . 2. DI-53, "Front Door Switch (Driver Side) Signal Inspection" . Replace BCM, found normal function in the above inspection.
Seat belt warning chime does not activate.	Perform DI-57, "Seat Belt Buckle Switch (Driver Side) Signal Inspection" . Replace BCM, found normal function in the above inspection.

A
B
C
D
E
F
G
H
I
J
L
M

DI

WARNING CHIME

Power Supply and Ground Circuit Inspection

NKS001M1

1. CHECK FUSE AND FUSIBLE LINK

Check for blown fuse and fusible link of BCM.

Power source	Fuse and fusible link No.
Battery power supply	F
	18
Ignition power supply	1

OK or NG

OK >> GO TO 2.

NG >> Be sure to eliminate cause of malfunction before installing new fuse or fusible link. Refer to [PG-3](#), "[POWER SUPPLY ROUTING CIRCUIT](#)".

2. CHECK POWER SUPPLY CIRCUIT

Check voltage between BCM connector and ground.

Terminals		Ignition switch position		
(+)		(-)		
Connector	Terminal (Wire color)		OFF	ON
M2	55 (W/R)	Ground	Battery voltage	Battery voltage
	42 (GY)		0 V	Battery voltage
M1	38 (W/L)		0 V	Battery voltage

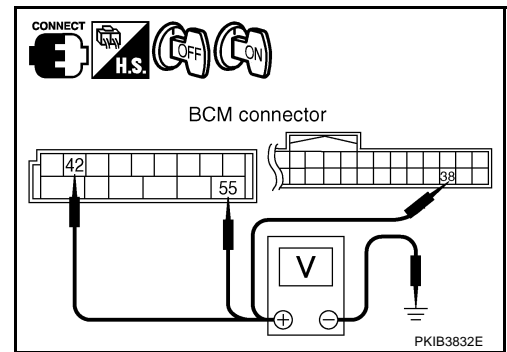

OK or NG

OK >> GO TO 3.

NG >> Check harness between BCM and fuse.

3. CHECK GROUND CIRCUIT

1. Turn ignition switch OFF.
2. Disconnect BCM connector.
3. Check continuity between BCM harness connector M2 terminal 52 (B) and ground.

52 (B) – Ground : Continuity should exist.

OK or NG

OK >> INSPECTION END

NG >> Repair harness or connector.

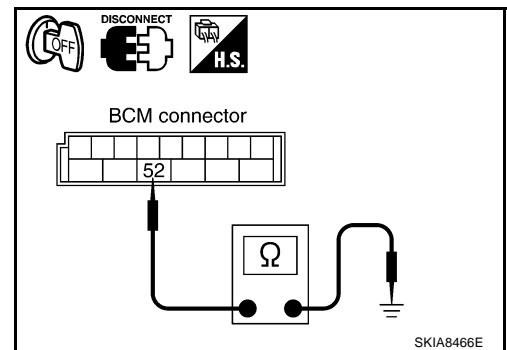

WARNING CHIME

Combination Meter Buzzer Circuit Inspection

NKS000YV

1. CHECK OPERATION OF COMBINATION METER BUZZER

1. Select "BUZZER" of "BCM" on CONSULT-II.
2. Perform "LIGHT WARN ALM", "IGN KEY WARN ALM" or "SEAT BELT WARN TEST" of "ACTIVE TEST".

Does chime sound?

- YES >> INSPECTION END
 NO >> GO TO 2.

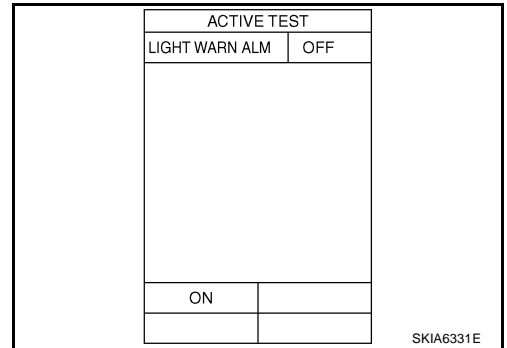

2. CHECK BCM (CONSULT-II)

Perform self-diagnosis of BCM. Refer to [BCS-15. "CONSULT-II Function \(BCM\)"](#) .

Self-diagnosis results

- No malfunction detected >> GO TO 3.
 Malfunction detected >> Check applicable parts, and repair or replace corresponding parts.

3. CHECK BATTERY POWER SUPPLY CIRCUIT OF COMBINATION METER

Check battery power supply circuit of combination meter. Refer to [DI-14. "Power Supply and Ground Circuit Inspection"](#) .

OK or NG

- OK >> Replace combination meter.
 NG >> Check harness between combination meter and fuse.

Front Door Switch (Driver Side) Signal Inspection

NKS000YV

1. CHECK BCM INPUT SIGNAL

With CONSULT-II

1. Select "BCM".
2. With "DATA MONITOR" of "BUZZER", confirm "DOOR SW-DR" when the driver side door is operated.

"DOOR SW-DR"

- When driver side door is opened : ON**
When driver side door is closed : OFF

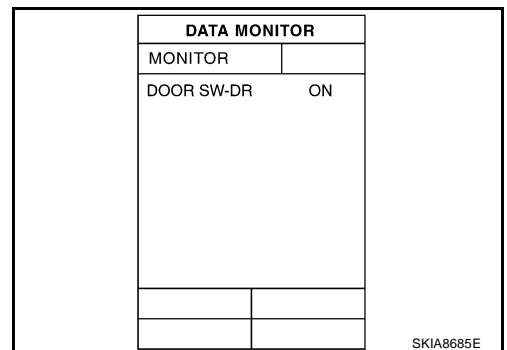

Without CONSULT-II

Check voltage between BCM harness connector B4 terminal 62 (W) and ground.

62 (W) – Ground

- When driver side door is opened : Approx. 0 V**
When driver side door is closed : Approx. 5 V

OK or NG

- OK >> INSPECTION END
 NG >> GO TO 2.

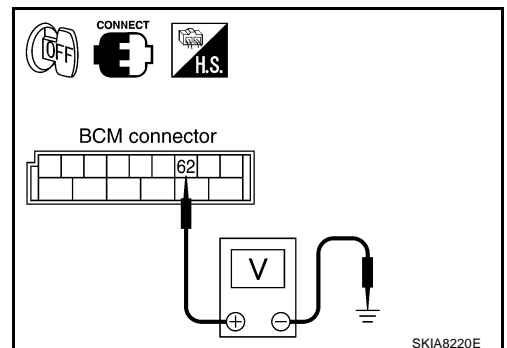

WARNING CHIME

2. CHECK FRONT DOOR SWITCH (DRIVER SIDE) CIRCUIT

1. Turn ignition switch OFF.
2. Disconnect BCM connector and front door switch (driver side) connector.
3. Check continuity between BCM harness connector B4 terminal 62 (W) and front door switch (driver side) harness connector B17 terminal 1 (W).

62 (W) – 1 (W) : Continuity should exist.

4. Check continuity between BCM harness connector B4 terminal 62 (W) and ground.

62 (W) – Ground : Continuity should not exist.

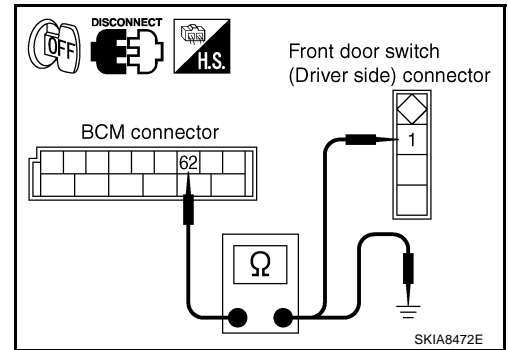

OK or NG

OK >> GO TO 3.

NG >> Repair harness or connector.

3. CHECK FRONT DOOR SWITCH (DRIVER SIDE)

Check front door switch (driver side). Refer to [DI-59, "FRONT DOOR SWITCH \(DRIVER SIDE\)"](#).

OK or NG

OK >> Replace BCM. Refer to [BCS-18, "Removal and Installation of BCM"](#).

NG >> Replace front door switch (driver side).

Key Switch Signal Inspection (Without Intelligent Key)

NKS000YX

1. CHECK BCM INPUT SIGNAL

With CONSULT-II

1. Select "BCM".
2. With "DATA MONITOR" of "BUZZER", confirm "KEY ON SW" when the key switch is operated.

"KEY ON SW"

When key is inserted to ignition key cylinder : ON

When key is removed from ignition key cylinder : OFF

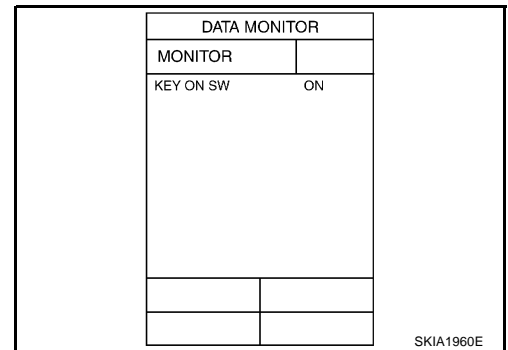

Without CONSULT-II

Check voltage between BCM harness connector M1 terminal 37 (B/P) and ground.

37 (B/P) – Ground

When key is inserted to ignition key cylinder : Approx. 12 V

When key is removed from ignition key cylinder : Approx. 0 V

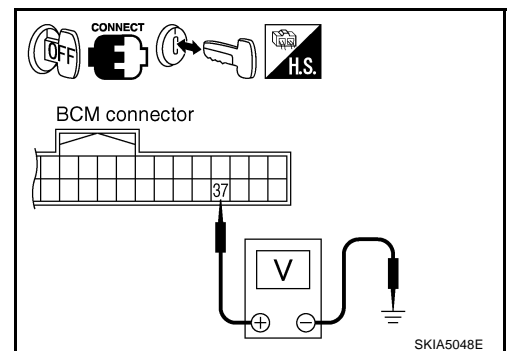

OK or NG

OK >> INSPECTION END

NG >> GO TO 2.

WARNING CHIME

2. CHECK KEY SWITCH

1. Turn ignition switch OFF.
2. Disconnect key switch connector.
3. Check key switch. Refer to [DI-59, "KEY SWITCH"](#) .

OK or NG

- OK >> GO TO 3.
NG >> Replace key switch.

3. CHECK KEY SWITCH CIRCUIT

1. Disconnect BCM connector.
2. Check continuity between BCM harness connector M1 terminal 37 (B/P) and key switch harness connector M307 terminal 1 (B/P).

37 (B/P) – 1 (B/P) : Continuity should exist.

3. Check continuity between BCM harness connector M1 terminal 37 (B/P) and ground.

37 (B/P) – Ground : Continuity should not exist.

OK or NG

- OK >> GO TO 4.
NG >> Repair harness or connector.

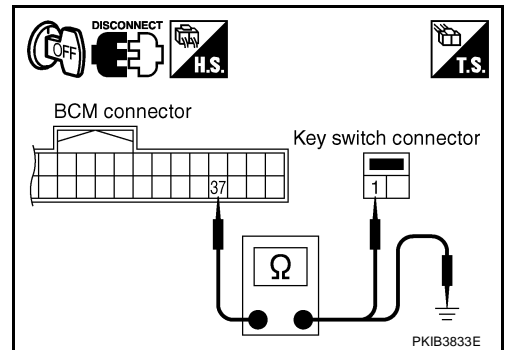

4. CHECK KEY SWITCH POWER SUPPLY CIRCUIT

- Check voltage between key switch harness connector M307 terminal 2 (L/W) and ground.

2 (L/W) – Ground : Battery voltage

OK or NG

- OK >> Replace BCM. Refer to [BCS-18, "Removal and Installation of BCM"](#) .
NG >> Check continuity between key switch and fuse.

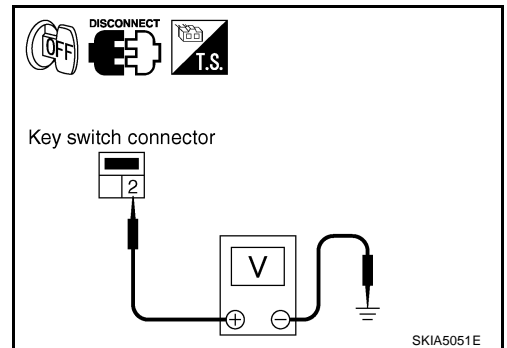

WARNING CHIME

Key Switch and Ignition Knob Switch Signal Inspection (With Intelligent Key, When Mechanical Key Is Used)

NKS000YY

1. CHECK BCM INPUT SIGNAL

④ With CONSULT-II

1. Select "BCM".
2. With "DATA MONITOR" of "BUZZER", confirm "KEY ON SW" when the key is operated.

"KEY ON SW"

When key is inserted to ignition key cylinder : ON

When key is removed from ignition key cylinder : OFF

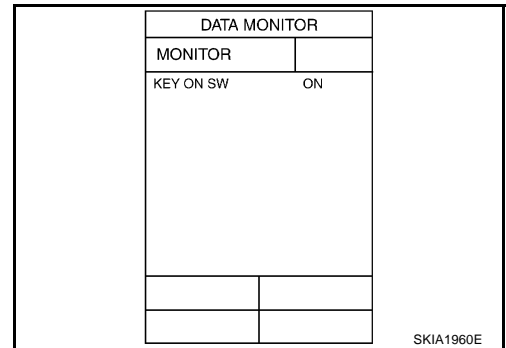

⊗ Without CONSULT-II

Check voltage between BCM harness connector M1 terminal 37 (B/P) and ground.

37 (B/P) – Ground

When key is inserted to ignition key cylinder : Approx. 12 V

When key is removed from ignition key cylinder : Approx. 0 V

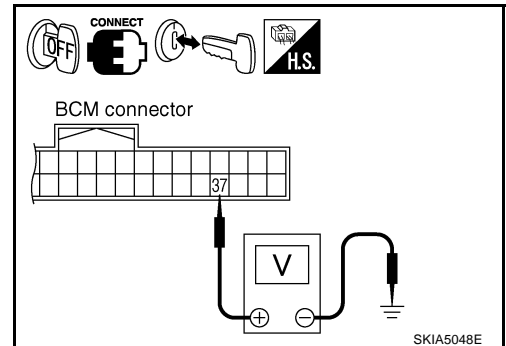

OK or NG

- OK >> INSPECTION END
NG >> GO TO 2.

2. CHECK KEY SWITCH AND IGNITION KNOB SWITCH

1. Turn ignition switch OFF.
2. Disconnect key switch and ignition knob switch connector.
3. Check key switch and ignition knob switch. Refer to [DI-59, "KEY SWITCH AND IGNITION KNOB SWITCH"](#).

OK or NG

- OK >> GO TO 4.
NG >> Replace key switch and ignition knob switch.

3. CHECK KEY SWITCH AND IGNITION KNOB SWITCH CIRCUIT

1. Disconnect BCM connector.
2. Check continuity between BCM harness connector M1 terminal 37 (B/P) and key switch and ignition knob switch harness connector M310 terminal 4 (B/P).

37 (B/P) – 4 (B/P) : Continuity should exist.

3. Check continuity between BCM harness connector M1 terminal 37 (B/P) and ground.

37 (B/P) – Ground : Continuity should not exist.

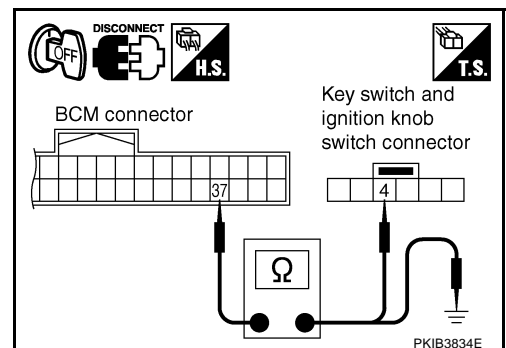

OK or NG

- OK >> GO TO 4.
NG >> Repair harness or connector.

WARNING CHIME

4. CHECK KEY SWITCH AND IGNITION KNOB SWITCH POWER SUPPLY CIRCUIT

Check voltage between key switch and ignition knob switch harness connector M310 terminal 3 (Y) and ground.

3 (Y) – Ground : Battery voltage

OK or NG

- OK >> Replace BCM. Refer to [BCS-18, "Removal and Installation of BCM"](#).
- NG >> Check harness between key switch and ignition knob switch and fuse.

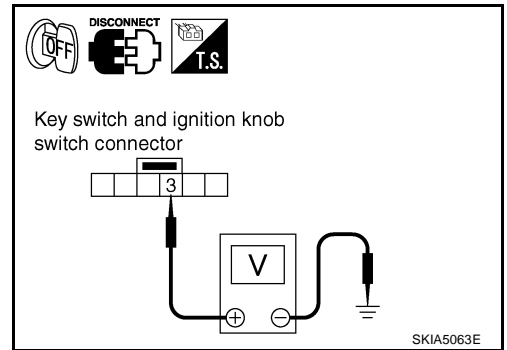

Lighting Switch Signal Inspection

1. CHECK BCM INPUT SIGNAL

1. Select "BCM" on CONSULT-II.
2. With "DATA MONITOR" of "BUZZER", confirm "LIGHT SW 1ST" when the lighting switch is operated.

"LIGHT SW 1ST"

Lighting switch (1st position) : ON

Lighting switch (OFF) : OFF

OK or NG

- OK >> INSPECTION END
- NG >> Check lighting switch. Refer to [LT-128, "Combination Switch Inspection"](#).

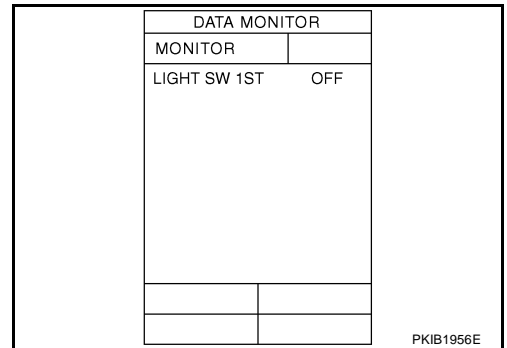

Seat Belt Buckle Switch (Driver Side) Signal Inspection

1. CHECK BCM INPUT SIGNAL

1. Select "BCM" on CONSULT-II.
2. With "DATA MONITOR" of "BUZZER", confirm "BUCKLE SW" when the seat belt buckle switch (driver side) is operated.

"BUCKLE SW"

When seat belt is fastened : OFF

When seat belt is unfastened : ON

OK or NG

- OK >> INSPECTION END
- NG >> GO TO 2.

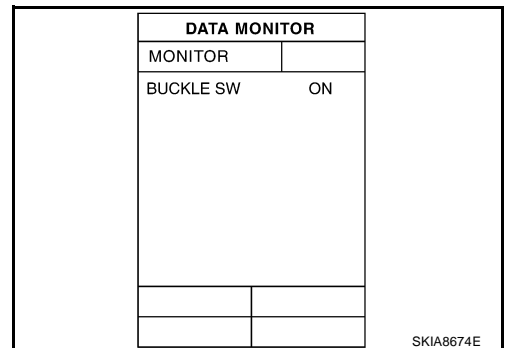

2. CHECK COMBINATION METER INPUT SIGNAL

1. Turn ignition switch ON.
2. Check voltage between combination meter harness connector M20 terminal 47 (BR) and ground.

47 (BR) – Ground

When seat belt is fastened : Approx. 12 V

When seat belt is unfastened : Approx. 0 V

OK or NG

- OK >> Replace combination meter.
- NG >> GO TO 3.

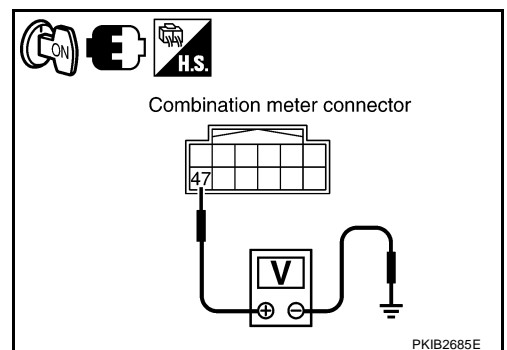

WARNING CHIME

3. CHECK SEAT BELT BUCKLE SWITCH (DRIVER SIDE) CIRCUIT

1. Turn ignition switch OFF.
2. Disconnect combination meter connector and seat belt buckle switch (driver side) connector.
3. Check continuity between combination meter harness connector M20 terminal 47 (BR) and seat belt buckle switch (driver side) harness connector B8 terminal 1 (SB).

47 (BR) – 1 (SB) : Continuity should exist.

4. Check continuity between combination meter harness connector M20 terminal 1 (BR) and ground.

47 (BR) – Ground : Continuity should not exist.

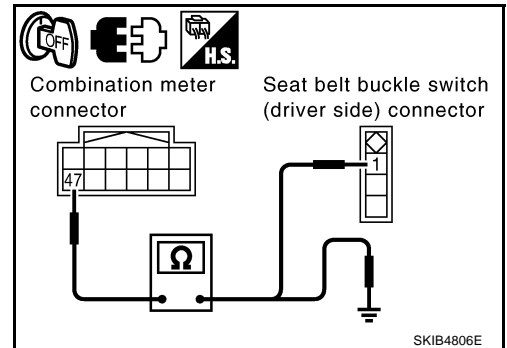

OK or NG

OK >> GO TO 4.

NG >> Repair harness or connector.

4. CHECK SEAT BELT BUCKLE SWITCH (DRIVER SIDE)

Check seat belt buckle switch (driver side). Refer to [DI-59, "SEAT BELT BUCKLE SWITCH \(DRIVER SIDE\)"](#).

OK or NG

OK >> Check seat belt buckle switch (driver side) ground circuit.

NG >> Replace seat belt buckle switch (driver side).

WARNING CHIME

NKS001M3

Component Inspection FRONT DOOR SWITCH (DRIVER SIDE)

Check continuity between terminal 1 and door switch case ground.

1 – Door switch case ground

When front door switch (driver side) is released : Continuity should exist.

When front door switch (driver side) is pushed : Continuity should not exist.

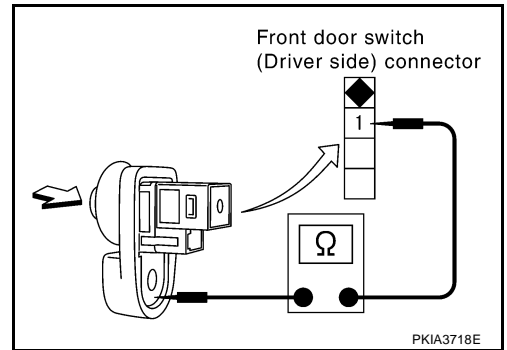

KEY SWITCH

Check continuity between terminals 1 and 2.

1 – 2

When key is inserted to ignition key cylinder : Continuity should exist.

When key is removed from ignition key cylinder : Continuity should not exist.

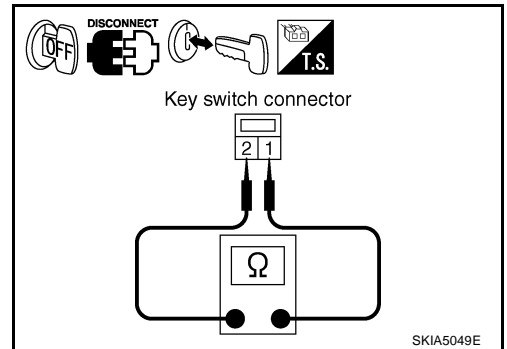

KEY SWITCH AND IGNITION KNOB SWITCH

Check continuity between terminals 3 and 4.

3 – 4

When key is inserted to ignition key cylinder : Continuity should exist.

When key is removed from ignition key cylinder : Continuity should not exist.

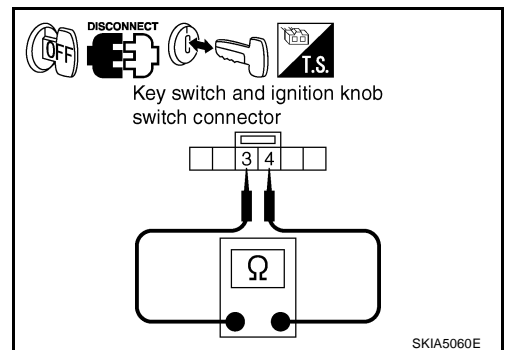

SEAT BELT BUCKLE SWITCH (DRIVER SIDE)

Check continuity between terminals 1 and 2.

1 – 2

When seat belt (driver side) is fastened : Continuity should not exist.

When seat belt (driver side) is unfastened : Continuity should exist.

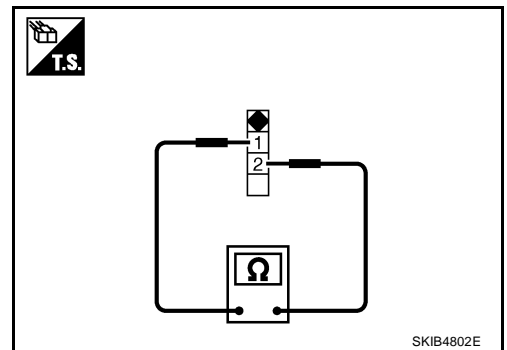

CAN COMMUNICATION

CAN COMMUNICATION

PFP:23710

System Description

NKS0016D

CAN (Controller Area Network) is a serial communication line for real time application. It is an on-vehicle multiplex communication line with high data communication speed and excellent error detection ability. Many electronic control units are equipped onto a vehicle, and each control unit shares information and links with other control units during operation (not independent). In CAN communication, control units are connected with 2 communication lines (CAN H line, CAN L line) allowing a high rate of information transmission with less wiring. Each control unit transmits/receives data but selectively reads required data only.

CAN Communication Unit

NKS0016E

Refer to [LAN-27, "CAN Communication Unit"](#) in "LAN SYSTEM".

COMPASS

COMPASS

PF2:24835

System Description

NKS000Y5

Display and A/C auto amp. displays earth magnetism and heading direction of vehicle.

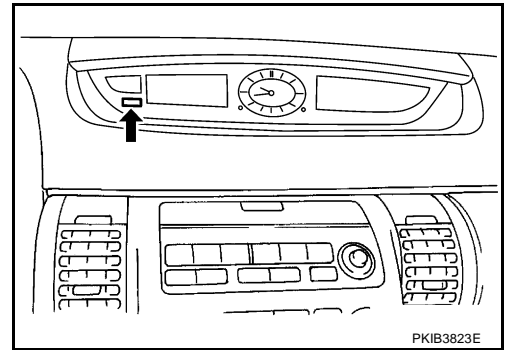

DIRECTION DISPLAY

Push the switch when the ignition switch is in the ON or START position. The direction will be displayed.

A
B
C
D
E
F
G
H
I
J
DI
L
M

COMPASS

NKS000Y6

Wiring Diagram — COMPASS —

DI-COMPAS-01

▬ : DATA LINE

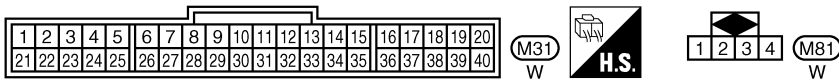
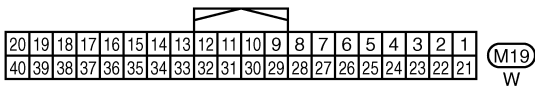
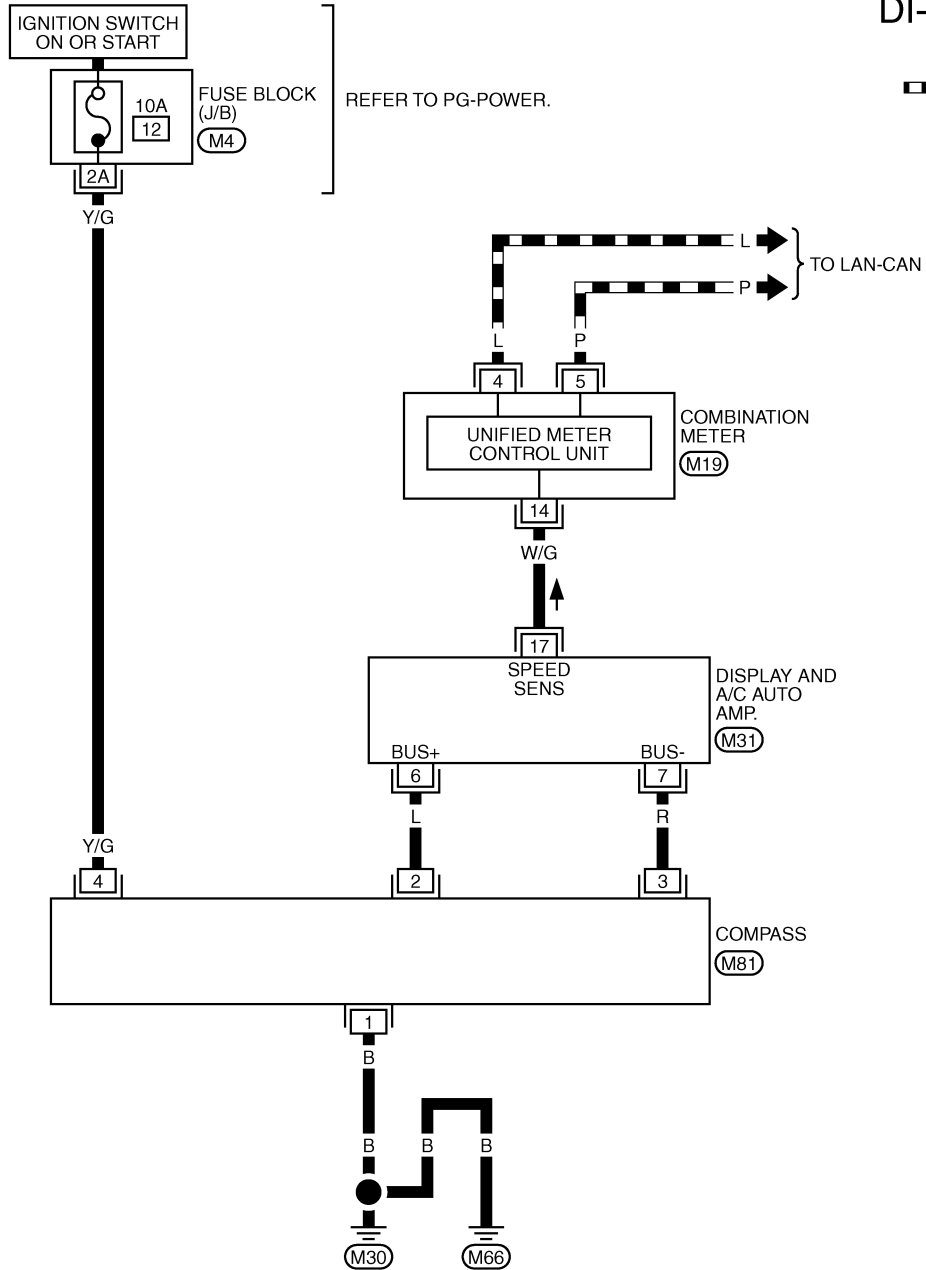

REFER TO THE FOLLOWING.

(M4) - FUSE BLOCK-JUNCTION BOX (J/B)

TKWM2122E

Fail-Safe System

NKS000Y7

DESCRIPTION

- If there is no response from display and A/C auto amp., previous display is kept for 10 minutes. After 10 minutes, “---” is displayed. (Only when there is no response continuously for 10 minutes.)
- If display and A/C auto amp. receives normal data within 10 minutes, normal operation will be recovered.
- If display and A/C auto amp. receives normal data while “---” is being displayed, normal operation will be recovered.
- If ignition switch is turned OFF within 10 minutes: Previously retained data is displayed when ignition switch is turned ON again. Then after 10 minutes, “---” is displayed.
- If response is never received after battery is turned ON, no data is retained. Therefore nothing is displayed for 10 minutes.

Power Supply and Ground Circuit Inspection

NKS000Y8

1. CHECK FUSE

Check if the compass 10A fuse [No. 12, located in fuse block (J/B)] is blown.

OK or NG

OK >> GO TO 2.

NG >> Be sure to eliminate cause of malfunction before installing new fuse. Refer to [PG-3, "POWER SUPPLY ROUTING CIRCUIT"](#).

2. CHECK POWER SUPPLY CIRCUIT

1. Turn ignition switch ON.
2. Check voltage between compass harness connector M81 terminal 4 (Y/G) and ground.

4 (Y/G) – Ground : Battery voltage

OK or NG

OK >> GO TO 3.

NG >> Check harness between compass and fuse.

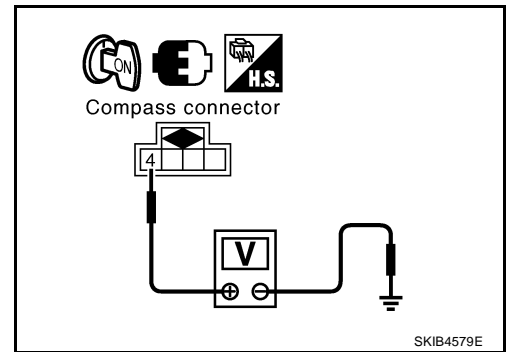

3. CHECK GROUND CIRCUIT

1. Turn ignition switch OFF.
2. Disconnect compass connector.
3. Check continuity between compass harness connector M81 terminal 1 (B) and ground.

1 (B) – Ground : Continuity should exist.

OK or NG

OK >> INSPECTION END

NG >> Repair harness or connector.

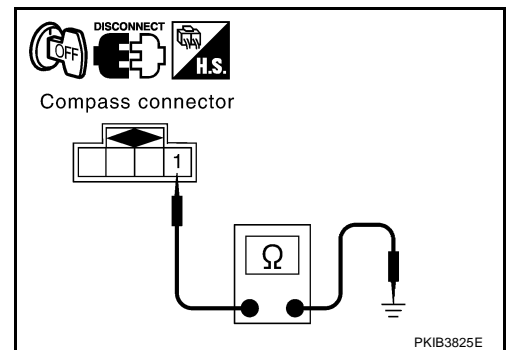

Compass Does not Display

NKS000Y9

1. CHECK DISPLAY AND A/C AUTO AMP. SELF-DIAGNOSIS

Check display and A/C auto amp. self-diagnosis. Refer to [ATC-52, "FUNCTION CONFIRMATION PROCEDURE"](#).

Are all segments of display and A/C auto amp. displayed?

YES >> Check fail-safe system. Refer to [DI-63, "Fail-Safe System"](#).

NO >> Replace display and A/C auto amp.

COMPASS

NKS000YA

Compass Displays “- - -”

1. CHECK FAIL-SAFE MODE

Make sure that fail-safe mode is not activated. Refer to [DI-63, "Fail-Safe System"](#) .

Is fail-safe mode activated?

- YES >> GO TO 3.
- NO >> GO TO 2.

2. CHECK DISPLAY AND A/C AUTO AMP. SELF-DIAGNOSIS

Check display and A/C auto amp. self-diagnosis. Refer to [ATC-52, "FUNCTION CONFIRMATION PROCEDURE"](#) .

Are all segments of display and A/C auto amp. displayed?

- YES >> INSPECTION END
- NO >> Replace display and A/C auto amp.

3. CHECK POWER AND GROUND CIRCUIT

Check power and ground circuit. Refer to [DI-63, "Power Supply and Ground Circuit Inspection"](#) .

OK or NG

- OK >> GO TO 4.
- NG >> Repair malfunctioning part.

4. CHECK COMPASS CIRCUIT

1. Disconnect display and A/C auto amp. connector.
2. Check continuity between compass harness connector M81 terminal 2 (L) and display and A/C auto amp. harness connector M31 terminal 6 (L).

2 (L) – 6 (L) : Continuity should exist.

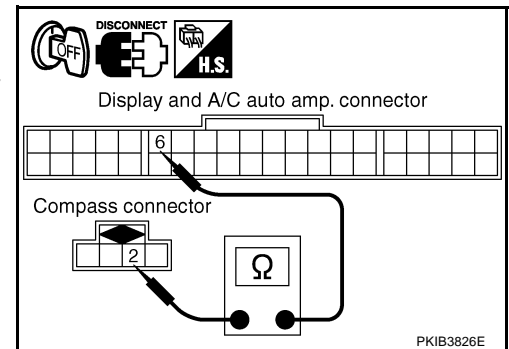

3. Check continuity between compass harness connector M81 terminal 3 (R) and display and A/C auto amp. harness connector M31 terminal 7 (R).

3 (R) – 7 (R) : Continuity should exist.

OK or NG

- OK >> GO TO 5.
- NG >> Repair harness or connector.

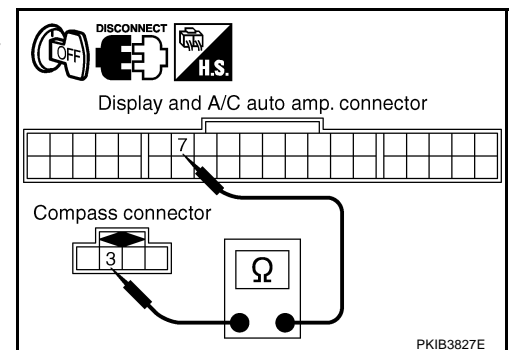

COMPASS

5. CHECK COMPASS SIGNAL

1. Turn ignition switch OFF.
2. Connect compass connector and display and A/C auto amp. connector.
3. Turn ignition switch ON.
4. Check voltage signal between compass harness connector M81 terminal 2 (L) and ground.

2 (L) – Ground:

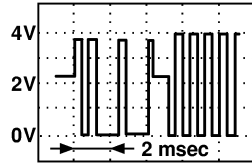

RJIA0867E

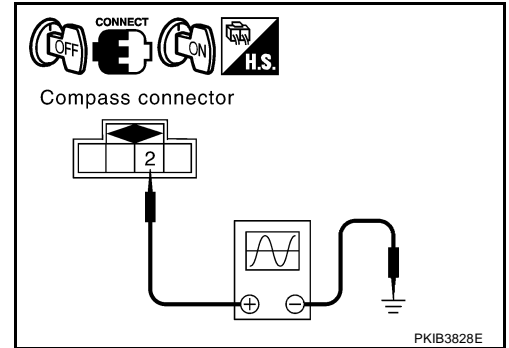

5. Check voltage signal between compass harness connector M81 terminal 3 (R) and ground.

3 (R) – Ground:

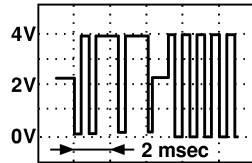

RJIA0868E

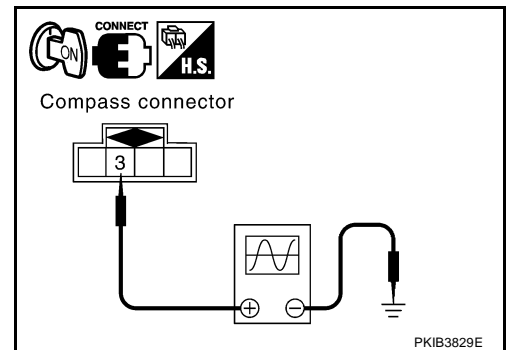

OK or NG

- OK >> Replace display and A/C auto amp.
- NG >> Replace compass.

Forward Direction Indication Slips Off The Mark or Incorrect

NKS000YB

1. ZONE VARIATION CHANGE IS NOT DONE

Perform the zone variation change.

OK or NG

- OK >> INSPECTION END
- NG >> Replace compass.

Compass Reading Remains Unchanged

NKS000YC

1. CHECK POWER AND GROUND CIRCUIT

Check power and ground circuit. Refer to [DI-63, "Power Supply and Ground Circuit Inspection"](#).

OK or NG

- OK >> Replace compass.
- NG >> Repair malfunctioning part.

COMPASS

NKS000YD

Calibration Procedure for Compass

The difference between magnetic North and geographical North can sometimes be great enough to cause false compass readings.

In order for the compass to operate accurately in a particular zone, it must be calibrated using the following procedure.

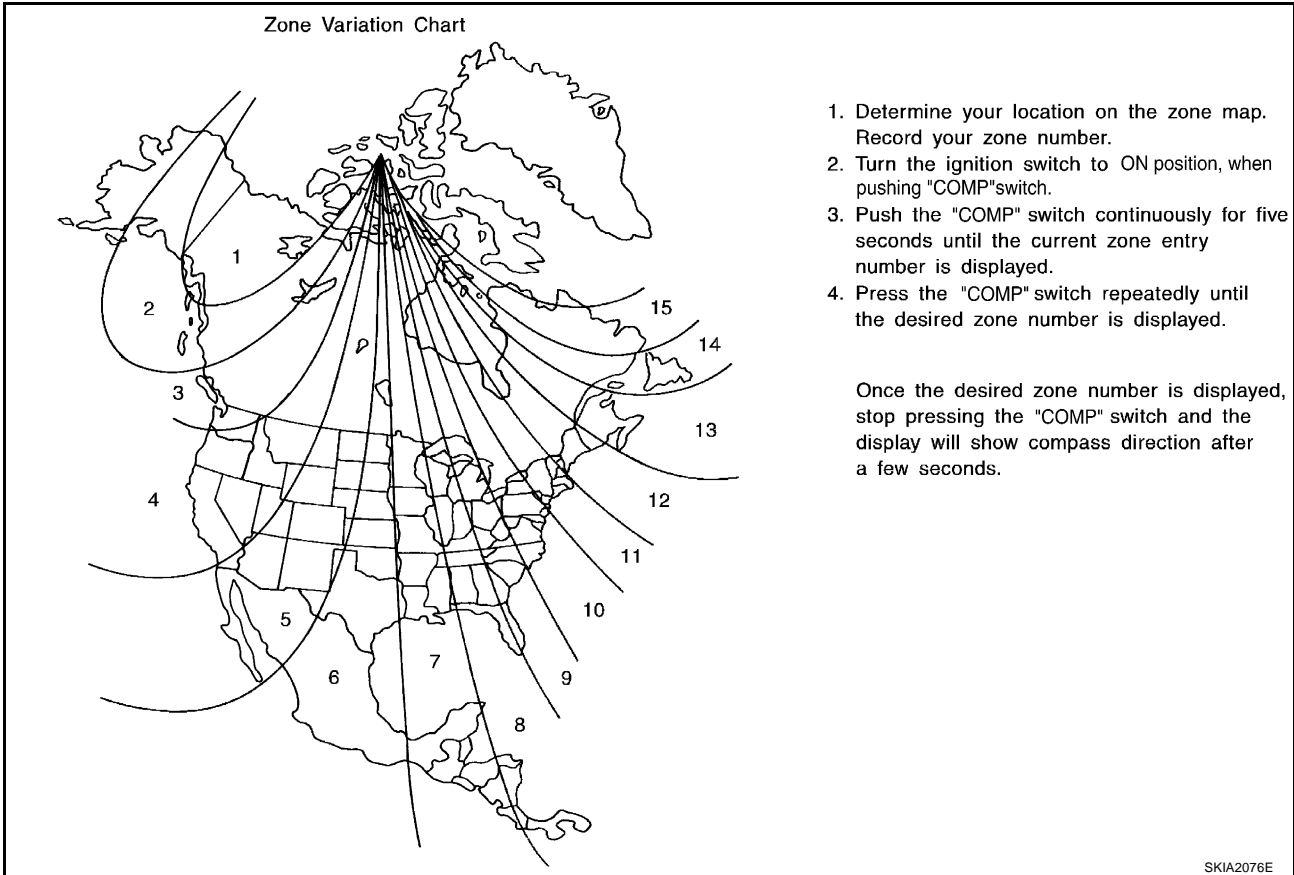

COMPASS

CORRECTION FUNCTIONS OF COMPASS

If the direction is not shown correctly, perform initial correction.

INITIAL CORRECTION PROCEDURE FOR COMPASS

1. Pushing the "COMP" switch for about 10 seconds will enter the initial correction mode. The direction bar starts blinking.
2. Turn off all electrical equipment (turn signals, hazard signal, A/C, lights, etc.). In a broad, flat, and safe location, drive the vehicle slowly [approximately 5 km/h (3 MPH) or less], and turn the vehicle 360° or more several times. When the direction appears on the display, correction is complete.

NOTE:

The correct direction may not be shown in locations where the earth's magnetic field is disrupted, such as those listed below.

- Elevated bridges
- Railroad crossings
- Streets lined with large buildings
- Iron bridges
- Tunnels
- Locations above subways
- Underground parking areas
- Near large vehicles
- Electric power substations

If display correction is performed in any of the above locations, accurate correction may not be possible.

- When heater or A/C fan speed is at maximum, the direction indicator display may move. This is not a malfunction. It will return to normal when the heater or A/C fan speed is reduced.

Removal and Installation of Compass

REMOVAL

1. Remove instrument panel and pad. Refer to [IP-10, "INSTRUMENT PANEL ASSEMBLY"](#).
2. Remove screw (1), and remove compass.

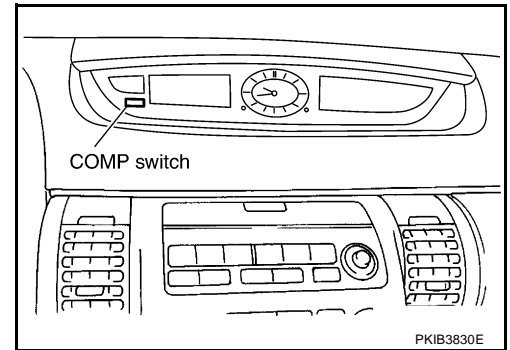

NKS000YE

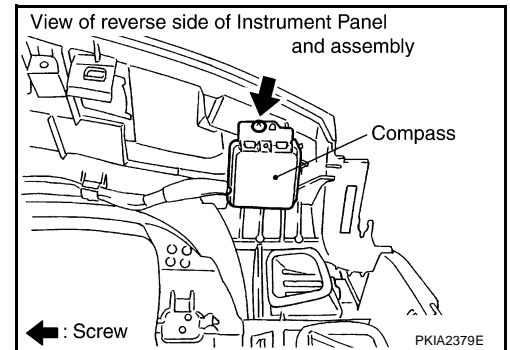

INSTALLATION

Installation is the reverse order of removal.

CLOCK

CLOCK

PFP:25820

Removal and Installation of Clock REMOVAL

NKS00022

1. Remove the display and A/C auto amp. and clock assembly. Refer to [ATC-116, "Removal and Installation of Display and A/C Auto Amp."](#)

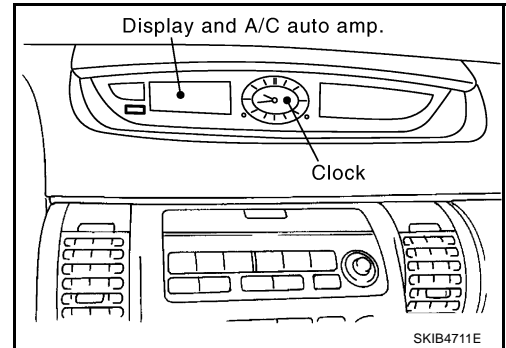

2. Disconnect clock connector.
3. Disengage tabs (4), and remove clock.

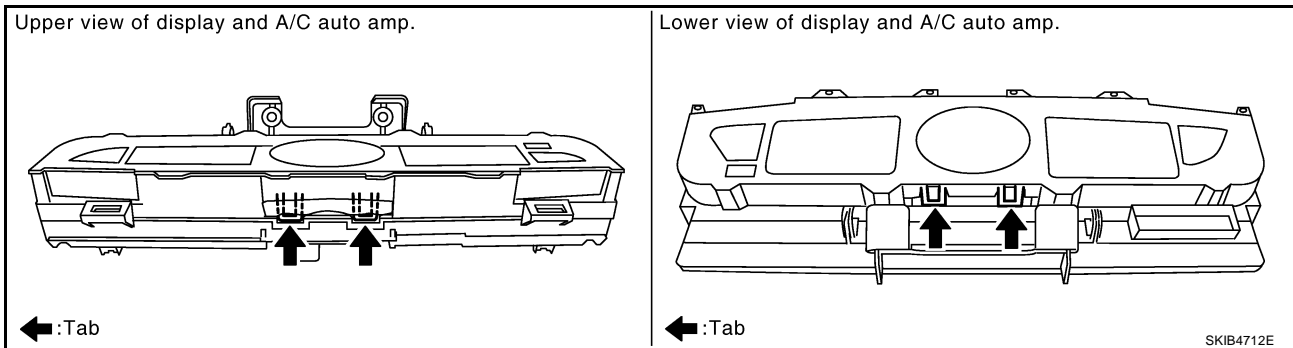

INSTALLATION

Installation is the reverse order of removal.