

SECTION **RSU**
 REAR SUSPENSION

A
B
C
D

RSU

CONTENTS

PRECAUTIONS	2	SUSPENSION ARM	11	F
Precautions	2	Removal and Installation	11	
PREPARATION	3	REMOVAL	11	G
Special Service Tools (SST)	3	INSPECTION AFTER REMOVAL	11	
Commercial Service Tools	3	INSTALLATION	12	H
NOISE, VIBRATION AND HARSHNESS (NVH)		RADIUS ROD	13	
TROUBLESHOOTING	4	Removal and Installation	13	I
NVH Troubleshooting Chart	4	REMOVAL	13	J
REAR SUSPENSION ASSEMBLY	5	INSPECTION AFTER REMOVAL	13	
On-Vehicle Inspection and Service	5	INSTALLATION	13	K
INSPECTION OF SUSPENSION ARM BALL		FRONT LOWER LINK	14	L
JOINT END PLAY	5	Removal and Installation	14	
SHOCK ABSORBER INSPECTION	5	REMOVAL	14	M
Wheel Alignment Inspection	5	INSPECTION AFTER REMOVAL	14	
DESCRIPTION	5	INSTALLATION	14	
PRELIMINARY INSPECTION	5	REAR LOWER LINK & COIL SPRING	15	
CAMBER INSPECTION	5	Removal and Installation	15	
TOE-IN	6	REMOVAL	15	
Components	7	INSPECTION AFTER REMOVAL	15	
Removal and Installation	8	INSTALLATION	15	
REMOVAL	8	STABILIZER BAR	16	
INSTALLATION	8	Removal and Installation	16	
SHOCK ABSORBER	9	REMOVAL	16	
Removal and Installation	9	INSPECTION AFTER REMOVAL	16	
REMOVAL	9	INSTALLATION	16	
INSPECTION AFTER REMOVAL	9	REAR SUSPENSION MEMBER	17	
INSTALLATION	9	Removal and Installation	17	
Disassembly and Assembly	9	REMOVAL	17	
DISASSEMBLY	9	INSPECTION AFTER REMOVAL	17	
INSPECTION AFTER DISASSEMBLY	10	INSTALLATION	17	
ASSEMBLY	10	SERVICE DATA	18	
		Wheel Alignment (Unladen *)	18	
		Ball Joint	18	
		Wheelarch Height (Unladen*)	18	

PRECAUTIONS

PRECAUTIONS

PFP:00001

Precautions

AES0000C

- When installing rubber bushings, final tightening must be carried out under unladen conditions with tires on ground. Oil will shorten the life of rubber bushings. Be sure to wipe off any spilled oil.
- Unladen conditions mean that fuel, engine coolant and lubricant are full. Spare tire, jack, hand tools and mats are in designated positions.
- After servicing suspension parts, be sure to check wheel alignment.
- Caulking nuts are not reusable. Always use new ones when installing. Since new caulking nuts are pre-oiled, tighten as they are.

PREPARATION

PREPARATION

PPF:00002

Special Service Tools (SST)

AES0000D

The actual shapes of Kent-Moore tools may differ from those of special service tools illustrated here.

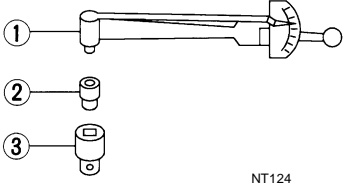
Tool number (Kent-Moore No.) Tool name	Description
ST3127S000 (See J25742-1) Preload Gauge 1. GG91030000 Torque wrench (J25765) 2. HT62940000 (—) Socket adapter (1/2") 3. HT62900000 (—) Socket adapter (3/8")	 <p style="text-align: right;">NT124</p> Measuring rotating torque of ball joint

A
B
C
D
RSU

Commercial Service Tools

AES0002I

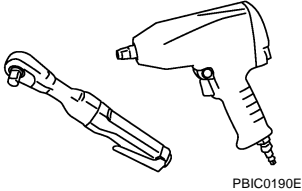
Tool name	Description
Power tool	 <p style="text-align: right;">PBIC0190E</p> <ul style="list-style-type: none"> ● Removing wheel nuts ● Removing brake caliper assembly ● Removing rear suspension component parts

F
G
H
I
J
K
L
M

NOISE, VIBRATION AND HARSHNESS (NVH) TROUBLESHOOTING

NOISE, VIBRATION AND HARSHNESS (NVH) TROUBLESHOOTING

PF0:00003

NVH Troubleshooting Chart

AES0000E

Use chart below to help you find the cause of the symptom. If necessary, repair or replace these parts.

Symptom		Possible cause and SUSPECTED PARTS														Reference page		
		Improper installation, looseness	Shock absorber deformation, damage or deflection	Bushing or mounting deterioration	Parts interference	Spring fatigue	Suspension looseness	Incorrect wheel alignment	Stabilizer bar fatigue	PROPELLER SHAFT	DIFFERENTIAL	REAR AXLE AND REAR SUSPENSION	TIRES	ROAD WHEEL	DRIVE SHAFT		BRAKES	STEERING
REAR SUSPENSION	Noise	x	x	x	x	x	x			x	x	x	x	x	x	x	x	RSU-7 RSU-10 — — — RSU-7 RSU-5 RSU-16 NVH in PR section. NVH in RFD section. NVH in RAX and RSU sections. NVH in WT section. NVH in WT section. NVH in RAX section. NVH in BR section. NVH in PS section.
	Shake	x	x	x	x		x			x		x	x	x	x	x	x	
	Vibration	x	x	x	x	x				x		x	x		x		x	
	Shimmy	x	x	x	x			x				x	x	x		x	x	
	Judder	x	x	x								x	x	x		x	x	
	Poor quality ride or handling	x	x	x	x	x		x	x			x	x	x				

x: Applicable

REAR SUSPENSION ASSEMBLY

REAR SUSPENSION ASSEMBLY

PFP:55020

On-Vehicle Inspection and Service

AES0000G

Make sure the mounting conditions (looseness, back lash) of each component and component status (wear, damage) are normal.

INSPECTION OF SUSPENSION ARM BALL JOINT END PLAY

- Measure axial end play by installing and moving up/down with an iron pry bar or something similar between suspension arm and axle.

Standard value

Axial end play : 0 mm (0 in)

CAUTION:

Be careful not to damage ball joint boot.

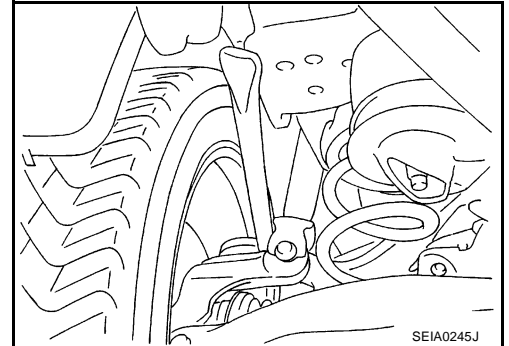

SHOCK ABSORBER INSPECTION

Check shock absorber for oil leakage, damage and replace if necessary.

Wheel Alignment Inspection DESCRIPTION

AES0000H

- Measure wheel alignment under unladen conditions. "Unladen conditions" means that fuel, engine coolant, and lubricant are full. Spare tire, jack, hand tools and mats in designated positions.

PRELIMINARY INSPECTION

1. Check tires for improper air pressure and wear.
2. Check road wheels for runout.
3. Check wheel bearing axial end play.
4. Check ball joint axial end play of suspension arm.
5. Check shock absorber operation.
6. Check each mounting point of axle and suspension for looseness and deformation.
7. Check each link, arm and member for cracks, deformation, and other damage.
8. Check vehicle posture.

CAMBER INSPECTION

- Measure camber of both right and left wheels with a suitable alignment gauge and adjust in accordance with the following procedures.

Standard value

Camber : Refer to [RSU-18, "SERVICE DATA"](#)

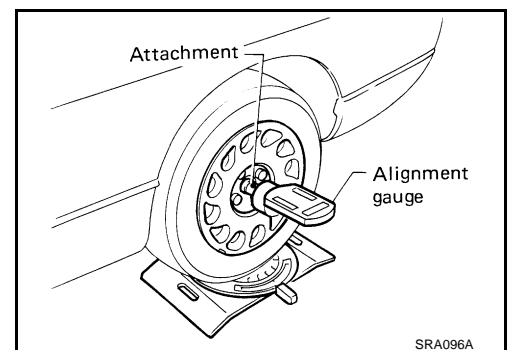

REAR SUSPENSION ASSEMBLY

If outside the standard value, adjust with adjusting bolt in front lower link.

NOTE:

After adjusting camber, be sure to check toe-in.

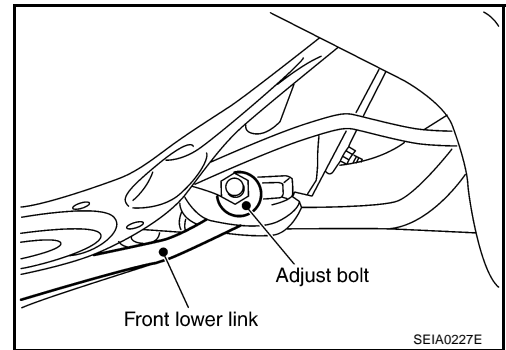

TOE-IN

Measure toe-in using following procedure. If out of specification, inspect and replace any damaged or worn rear suspension parts.

WARNING:

- Always perform the following procedure on a flat surface.
- Make sure that no person is in front of vehicle before pushing it.

1. Bounce rear of vehicle up and down to stabilize the posture.
2. Push vehicle straight ahead about 5 m (16 ft).
3. Put a mark on base line of the tread (rear side) of both tires at the same height of hub center. These are measuring point.
4. Measure distance "A" (rear side).

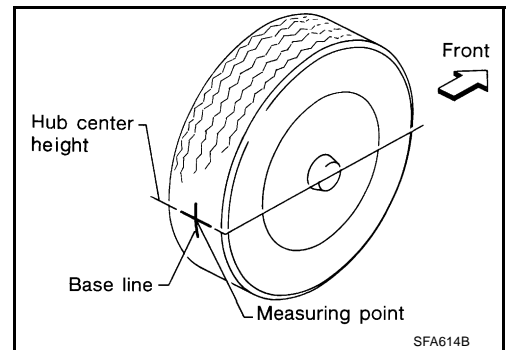

5. Push vehicle slowly ahead to rotate wheels 180 degrees (1/2 turn).
If wheels have rotated more than 180 degrees (1/2 turn), try the above procedure again from the beginning. Never push vehicle backward.

6. Measure distance "B" (front side).

Standard value

Total toe-in : Refer to [RSU-18, "SERVICE DATA"](#) .

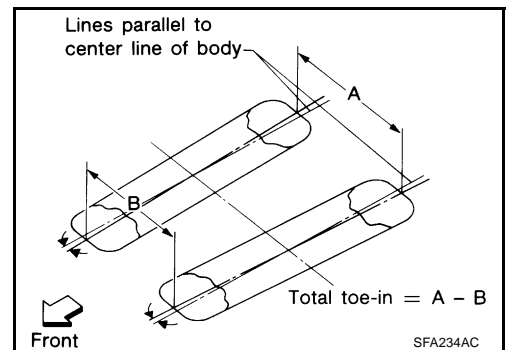

7. If outside the standard value, adjust with adjusting bolt in rear lower link.

CAUTION:

Be sure to adjust equally on RH and LH side with adjusting bolt.

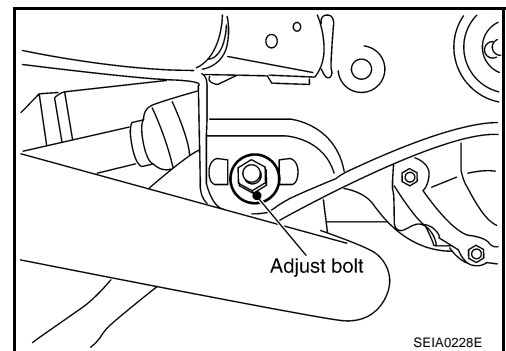

REAR SUSPENSION ASSEMBLY

Components

AES0000F

A
B
C
D
E
F
G
H
I
J
K
L
M

RSU

SEC.430·431

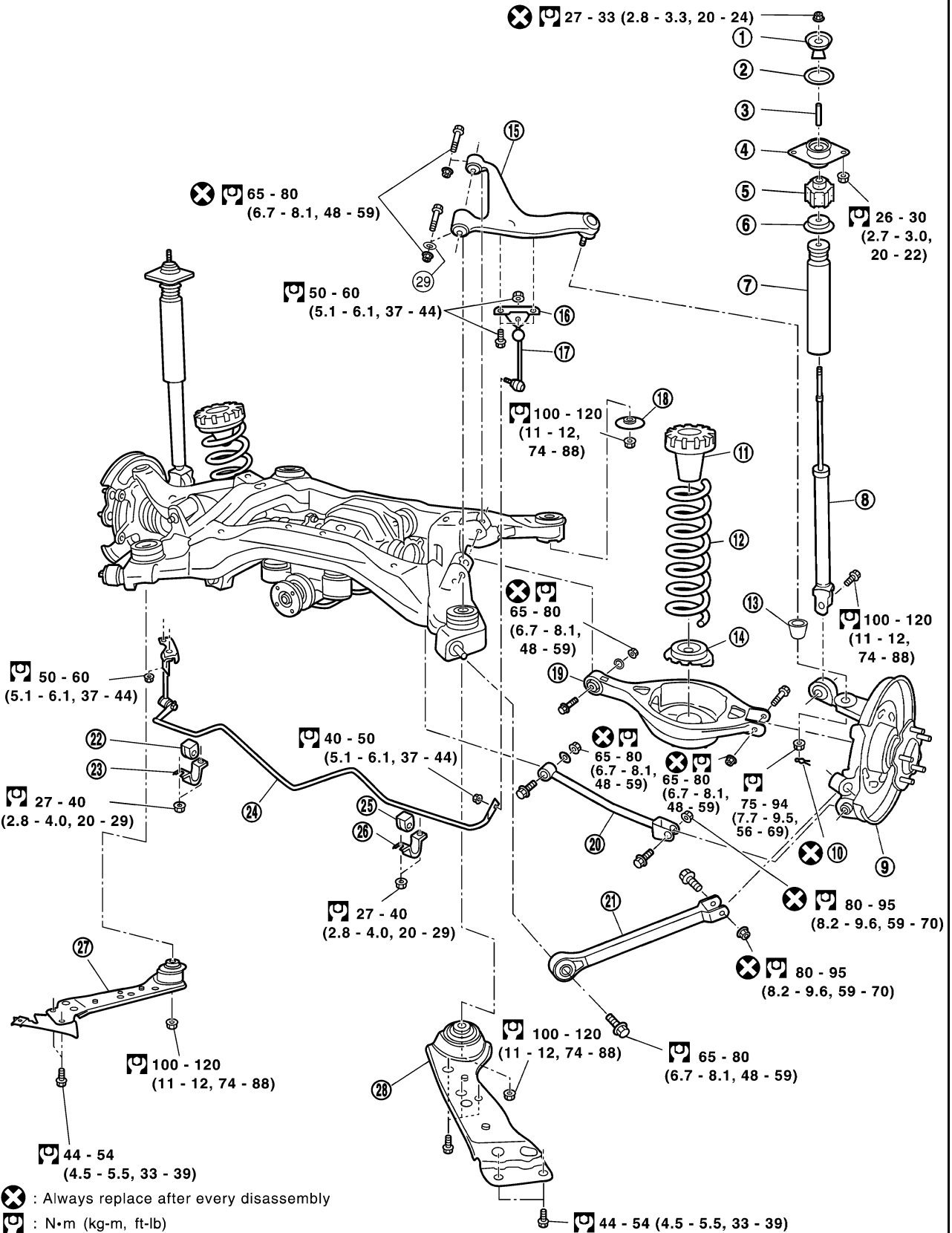

SEIA0421E

REAR SUSPENSION ASSEMBLY

- | | | |
|--------------------------------------|---------------------------------|-----------------------|
| 1. Washer | 2. Shock absorber mounting seal | 3. Distance tube |
| 4. Shock absorber mounting insulator | 5. Bushing | 6. Bound bumper cover |
| 7. Bound bumper | 8. Shock absorber | 9. Axle assembly |
| 10. Cotter pin | 11. Upper seat | 12. Coil spring |
| 13. Ball seat | 14. Rubber seat | 15. Suspension arm |
| 16. Connecting rod mounting bracket | 17. Connecting rod | 18. Mount stopper |
| 19. Rear lower link | 20. Front lower link | 21. Radius rod |
| 22. Bushing | 23. Clamp | 24. Stabilizer bar |
| 25. Bushing | 26. Clamp | 27. Member stay |
| 28. Member stay | 29. Stopper rubber | |

Removal and Installation REMOVAL

AES00001

1. Remove tire with power tool.
2. Remove brake caliper with power tool. Hang it in a place where it will not interfere with work. Refer to [BR-38, "REAR DISC BRAKE"](#).

NOTE:

Avoid depressing brake pedal while brake caliper is removed.

3. Remove stabilizer bar. Refer to [RSU-16, "STABILIZER BAR"](#).
4. Remove rear exhaust tube. Refer to [EX-3, "EXHAUST SYSTEM"](#).
5. Remove rear propeller shaft. Refer to [PR-4, "REAR PROPELLER SHAFT"](#) (2WD models), [PR-16, "REAR PROPELLER SHAFT"](#) (AWD models).
6. Separate attachment bolts between parking brake cable and vehicle and rear suspension member. Refer to [PB-5, "PARKING BRAKE CONTROL"](#).
7. Remove wheel sensor from rear final drive.
8. Remove rear lower link and coil spring. Refer to [RSU-15, "REAR LOWER LINK & COIL SPRING"](#).
9. Remove fixing bolt in upper side of mounting seal bracket. Refer to [RSU-9, "SHOCK ABSORBER"](#).
10. Set jack under rear final drive.
11. Remove member stay from vehicle.
12. Remove mount stopper mounting nut.
13. Gradually lowering jack, remove rear suspension assembly.

INSTALLATION

- Refer to [RSU-7, "Components"](#) for tightening torque. Install in the reverse order of removal.

NOTE:

Refer to component parts location and do not reuse non-reusable parts.

- Perform final tightening of installation position of links (rubber bushing) under unladen condition with tires on level ground. Check wheel alignment. Refer to [RSU-18, "SERVICE DATA"](#).

SHOCK ABSORBER

SHOCK ABSORBER

PPF:56210

Removal and Installation

AES0001Y

REMOVAL

1. Remove tire with power tool.
2. Set jack under rear lower link.
3. Remove rear seat cushion, rear seat back and rear parcel shelf finisher.
4. Remove shock absorber mounting insulator fixing nuts of shock absorber upper side with tool and remove shock absorber from vehicle.

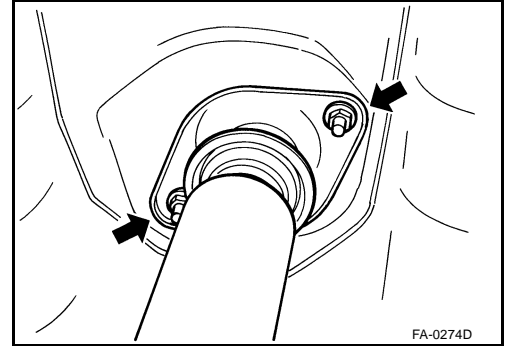

INSPECTION AFTER REMOVAL

- Check shock absorber assembly for deformation, cracks, damage, and replace if necessary.
- Check piston rod for damage, uneven wear or distortion, and replace if necessary.
- Check welded and sealed areas for oil leakage, and replace if necessary.

INSTALLATION

- Refer to [RSU-7, "Components"](#) for tightening torque. Install in the reverse order of removal.

NOTE:

Refer to component parts location and do not reuse non-reusable parts.

- Perform final tightening of shock absorber assembly lower side (rubber bushing) under unladen condition with tires on level ground. Check wheel alignment. Refer to [RSU-5, "Wheel Alignment Inspection"](#).

Disassembly and Assembly

DISASSEMBLY

AES0002N

CAUTION:

Make sure piston rod on shock absorber is not damaged when removing components from shock absorber.

1. Remove shock absorber mounting seal from shock absorber mounting insulator.
2. Wrap a shop cloth around lower side of shock absorber and fix it in a vise.

CAUTION:

Do not set the cylindrical part of shock absorber in vise.

3. Secure piston rod tip so that piston rod does not turn, and remove piston rod lock nut.
4. Remove washer, distance tube, bushing, bound bumper cover and bound bumper from shock absorber.

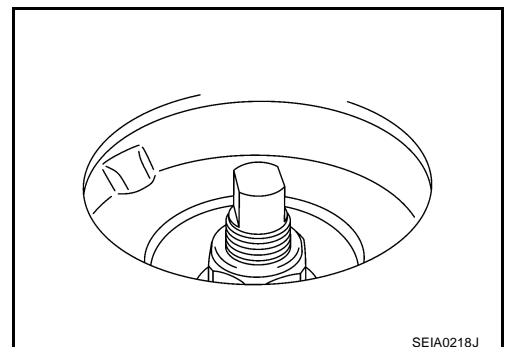

SHOCK ABSORBER

INSPECTION AFTER DISASSEMBLY

Bound Bumper and Bushing

- Check bound bumper and bushing for cracks, deformation or other damage. Replace if necessary.

ASSEMBLY

- Refer to [RSU-7, "Components"](#) for tightening torque. Install in the reverse order of removal.

NOTE:

Refer to component parts location and do not reuse non-reusable parts.

CAUTION:

Make sure piston rod on shock absorber is not damaged when attaching components to shock absorber.

SUSPENSION ARM

PFP:55501

Removal and Installation

REMOVAL

1. Remove tire with power tool.
2. Remove drive shaft. Refer to [RAX-10, "REAR DRIVE SHAFT"](#).
3. Remove connecting rod mounting bracket from suspension arm with power tool.
4. Remove fixing nuts and bolts between suspension arm and rear suspension member.
5. Remove cotter pin of suspension arm ball joint, and loosen nut.
6. Use a ball joint remover (suitable tool) to remove suspension arm from axle. Be careful not to damage ball joint boot.

CAUTION:

Tighten temporarily mounting nut to prevent damage to threads and to prevent ball joint remover (suitable tool) from coming off.

7. Remove suspension arm and stopper rubber from vehicle.

INSPECTION AFTER REMOVAL

Visual Inspection

- Check suspension arm and bushing for deformation, cracks or damage. If any non-standard condition is found, replace it.
- Check boot of ball joint for cracks or damage, and also for grease leakage.

Ball Joint Inspection

- Manually move ball joint at least ten times by hand to check for smooth movement.

Swing Torque Inspection

- Hook spring scale at cotter pin mounting hole. Confirm spring scale measurement value is within specifications when ball stud begins moving.

Standard value

Swing torque:

0.5 - 3.4 N·m (0.06 - 0.34 kg·m, 5 - 30 in·lb)

Measured value of spring scale:

8.06 - 54.8 N (0.82 - 5.5 kg, 1.81 - 12.32 lb)

- If it is outside the specified range, replace suspension arm assembly.

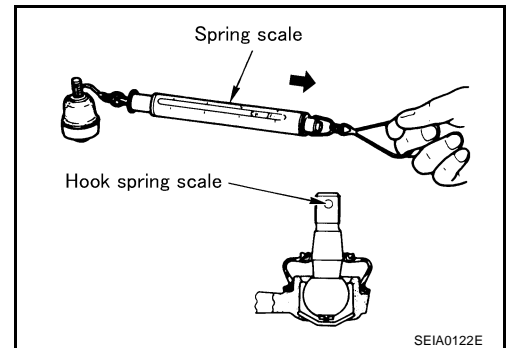

Rotating Torque Inspection

- Attach mounting nut to ball stud. Make sure that rotating torque is within the specifications with a preload gauge (SST)

Standard value

Rotating torque:

0.5 - 3.4 N·m (0.06 - 0.34 kg·m, 5 - 30 in·lb)

- If it is outside the specified range, replace suspension arm assembly.

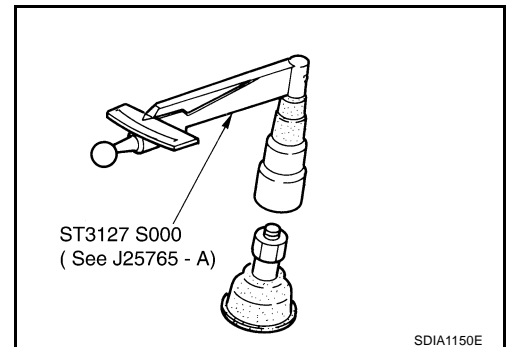

Axial End Play Inspection

- Move tip of ball joint in axial direction to check for looseness.

Standard value

Axial end play : 0 mm (0 in)

- If it is outside the specified range, replace suspension arm assembly.

SUSPENSION ARM

INSTALLATION

- Refer to [RSU-7, "Components"](#) for tightening torque. Install in the reverse order of removal.

NOTE:

Refer to component parts location and do not reuse non-reusable parts.

- Perform final tightening of rear suspension member installation position (rubber bushing) under unladen condition with tires on level ground. Refer to [RSU-5, "Wheel Alignment Inspection"](#) .

RADIUS ROD

RADIUS ROD

PPF:55110

Removal and Installation

AES0001U

REMOVAL

1. Remove tire with power tool.
2. Remove brake caliper with power tool. Hang it in a place where it will not interfere with work. Refer to [BR-38, "REAR DISC BRAKE"](#).

NOTE:

Avoid depressing brake pedal while brake caliper is removed.

3. Remove fixing bolt and nut in axle side of radius rod with power tool.
4. Remove rear lower link and coil spring. Refer to [RSU-15, "REAR LOWER LINK & COIL SPRING"](#).
5. Remove fixing bolt in lower side of shock absorber with power tool.
6. Remove fixing bolt and nut in axle side of front lower link with power tool.
7. Remove fixing bolt in rear suspension member side of radius rod with power tool, then remove radius rod from vehicle.

INSPECTION AFTER REMOVAL

- Check radius rod and bushing for any deformation, cracks, or damage. Replace if necessary.

INSTALLATION

- Refer to [RSU-7, "Components"](#) for each tightening torque. Install in the reverse order of removal.

NOTE:

Refer to component parts location and do not reuse non-reusable parts.

- Perform final tightening of rear suspension member and axle installation position (rubber bushing) under unladen condition with tires on level ground. Check wheel alignment. Refer to [RSU-5, "Wheel Alignment Inspection"](#).

FRONT LOWER LINK

FRONT LOWER LINK

PFP:55110

Removal and Installation

AES0001V

REMOVAL

1. Remove tire with power tool.
2. Set jack under rear lower link.
3. Remove fixing nut and bolt between front lower link and rear suspension member with power tool.
4. Remove fixing nut and bolt between front lower link and axle with power tool.
5. Remove front lower link from vehicle.

INSPECTION AFTER REMOVAL

- Check front lower link and bushing for any deformation, cracks, or damage. Replace if necessary.

INSTALLATION

- Refer to [RSU-7, "Components"](#) for tightening torque. Install in the reverse order of removal.

NOTE:

Refer to component parts location and do not reuse non-reusable parts.

- Perform final tightening of rear suspension member and axle installation position (rubber bushing) under unladen condition with tires on level ground. Check wheel alignment. Refer to [RSU-5, "Wheel Alignment Inspection"](#).

REAR LOWER LINK & COIL SPRING

REAR LOWER LINK & COIL SPRING

PFP:551B0

Removal and Installation

AES0001W

REMOVAL

1. Remove tire with power tool.
2. Set jack under rear lower link.
3. Loosen fixing bolt and nut of rear lower link in side of suspension member, and then remove fixing bolt and nut in side of axle with power tool.
4. Slowly lower jack, then remove upper seat, coil spring and rubber sheet from rear lower link.
5. Remove fixing bolt and nut in side of suspension member to remove rear lower link with power tool.

INSPECTION AFTER REMOVAL

- Check rear lower link, bushing and coil spring for deformation, cracks, and damage. Replace rear lower link and coil spring if necessary.

INSTALLATION

- Refer to [RSU-7, "Components"](#) for tightening torque. Install in the reverse order of removal.

NOTE:

Refer to component parts location and do not reuse non-reusable parts.

- Check that upper seat is attached as shown in the figure.

NOTE:

Insert bracket tabs (3) and the inside protrusion on upper seat into each other beforehand as shown in the figure.

- Match up rubber seat indentions and rear lower link grooves and attach.

NOTE:

Make sure spring is not up side down. The top and bottom are indicated by paint color.

- Perform final tightening of rear suspension member and axle installation position (rubber bushing) under unladen condition with tires on level ground. Check wheel alignment. Refer to [RSU-5, "Wheel Alignment Inspection"](#).

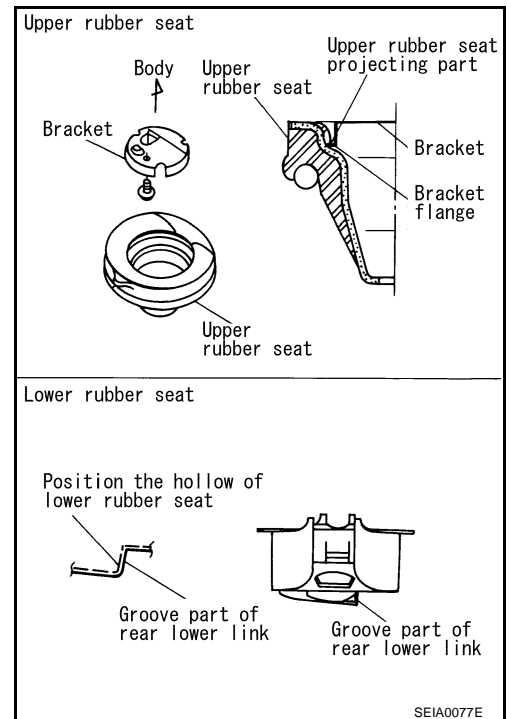

STABILIZER BAR

STABILIZER BAR

PFP:56230

Removal and Installation

AES0001X

REMOVAL

1. Remove dynamic damper of exhaust tube.
2. Remove lower side fixing nut on stabilizer connecting rod and remove stabilizer connecting rod from stabilizer bar with power tool.
3. Remove fixing nut on stabilizer clamp and remove stabilizer from vehicle with power tool.

INSPECTION AFTER REMOVAL

- Check stabilizer bar, stabilizer bushings, stabilizer clamp, stabilizer connecting rod, stabilizer connecting rod mounting bracket for any deformation, crack or damage. Replace if necessary.

INSTALLATION

- Refer to [RSU-7, "Components"](#) for tightening torque. Install in the reverse order of removal.

NOTE:

Refer to component parts location and do not reuse non-reusable parts.

- Stabilizer bar uses pillow ball type connecting rod, position ball joint with case on pillow ball head parallel to stabilizer bar.

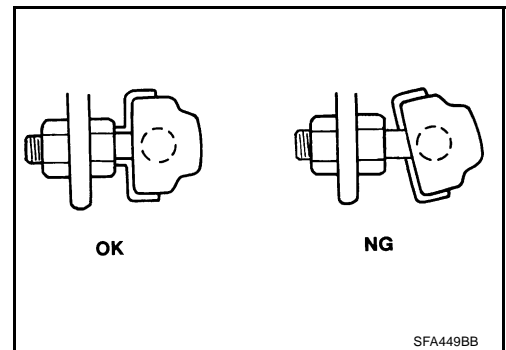

REAR SUSPENSION MEMBER

REAR SUSPENSION MEMBER

PFP:55501

Removal and Installation

AES000TT

REMOVAL

1. Remove tire with power tool.
2. Remove brake caliper with power tool. Hang it in a place where it will not interfere with work. Refer to [BR-38, "REAR DISC BRAKE"](#).

NOTE:

Avoid depressing brake pedal while brake caliper is removed.

3. Remove rear exhaust tube. Refer to [EX-3, "EXHAUST SYSTEM"](#).
4. Remove stabilizer bar. Refer to [RSU-16, "STABILIZER BAR"](#).
5. Remove drive shaft. Refer to [RAX-10, "REAR DRIVE SHAFT"](#).
6. Remove final drive. Refer to [RFD-15, "REAR FINAL DRIVE ASSEMBLY"](#).
7. Separate the attachment between parking brake cable and vehicle and rear suspension member. Refer to [PB-5, "PARKING BRAKE CONTROL"](#).
8. Remove rear lower link and coil spring. Refer to [RSU-15, "REAR LOWER LINK & COIL SPRING"](#).
9. Remove fixing bolt in lower side of shock absorber.
10. Set jack under rear suspension member.
11. Remove mounting bolts and nuts of member stay from vehicle.
12. Remove mounting nuts of mount stopper.
13. Slowly lowering jack, then remove rear suspension member, suspension arm, radius rod, front lower link and axle from vehicle as a unit.
14. Remove fixing bolts and nuts, then remove suspension arm, front lower link, radius rod from rear suspension member.

INSPECTION AFTER REMOVAL

- Check rear suspension member for deformation, cracks, and other damage and replace if necessary.

INSTALLATION

- Refer to [RSU-7, "Components"](#) for tightening torque. Install in the reverse order of removal.

NOTE:

Refer to component parts location and do not reuse non-reusable parts.

- Perform final tightening of installation position of links (rubber bushing) under unladen condition with tires on level ground. Check wheel alignment. Refer to [RSU-18, "SERVICE DATA"](#).

SERVICE DATA

SERVICE DATA

PFP:00030

Wheel Alignment (Unladen *)

AES0014W

Tire		18 inch	Except 18 inch
Camber Degree minute (Decimal degree)	Minimum	- 1°10' (-1.17°)	- 1°05' (- 1.08°)
	Nominal	- 0° 40' (-0.67°)	- 0°35' (- 0.58°)
	Maximum	- 0° 10' (-0.17°)	- 0°05' (- 0.08°)
	Left and right difference	45' (0.75°)	
Total toe-in	Distance (A - B)	Minimum	0.1 mm (0.004 in)
		Nominal	2.8 mm (0.110 in)
		Maximum	5.5 mm (0.217 in)

Ball Joint

AES0014X

Axial end play	0 mm (0 in)
Swing torque	0.5 - 3.4 N·m (0.06 - 0.34 kg-m, 5 - 30 in-lb)
Measurement on spring balance (cotter pinhole position)	8.06 - 54.8 N (0.83 - 5.5 kg, 1.81 - 12.32 lb)
Rotating torque	0.5 - 3.4 N·m (0.06 - 0.34 kg-m, 5 - 30 in-lb)

Wheelarch Height (Unladen*)

AES0014Y

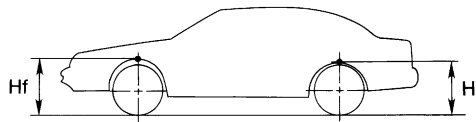

SFA818A

Tire	215/55R17	235/45R18
Front (Hf)	711 mm (27.99 in)	714 mm (28.11 in)
Rear (Hr)	704 mm (27.72 in)	705 mm (27.76 in)

*: Fuel, engine coolant and engine oil full. Spare tire, jack, hand tools and mats in designated positions.