

A
B
C
D
E
F
PS
H
I
J
K
L
M

SECTION PS

POWER STEERING SYSTEM

CONTENTS

PRECAUTIONS	2	STEERING COLUMN ASSEMBLY	12
Precautions for Supplemental Restraint System (SRS) "AIR BAG" and "SEAT BELT PRE-TENSIONER"	2	Disassembly and Assembly	13
Precautions for Steering System	2	DISASSEMBLY	13
PREPARATION	3	ASSEMBLY	14
Special Service Tools (SST)	3	POWER STEERING GEAR AND LINKAGE	15
Commercial Service Tools	4	Removal and Installation	15
NOISE, VIBRATION AND HARSHNESS (NVH)		REMOVAL	15
TROUBLESHOOTING	5	INSTALLATION	16
NVH Troubleshooting Chart	5	INSPECTION AFTER INSTALLATION	16
POWER STEERING FLUID	6	POWER STEERING GEAR	17
Checking Fluid Level	6	Component	17
Checking Fluid Leakage	6	Disassembly and Assembly	18
Air Bleeding Hydraulic System	6	DISASSEMBLY	18
STEERING WHEEL	8	INSPECTION AFTER DISASSEMBLY	19
On-Vehicle Inspection and Service	8	ASSEMBLY	20
CHECKING CONDITION OF INSTALLATION	8	POWER STEERING OIL PUMP	25
CHECKING STEERING WHEEL PLAY	8	On-Vehicle Inspection and Service	25
CHECKING NEUTRAL POSITION ON STEERING WHEEL	8	CHECKING RELIEF OIL PRESSURE	25
CHECKING STEERING WHEEL TURNING FORCE	8	Removal and Installation	25
CHECKING FRONT WHEEL TURNING ANGLE	8	REMOVAL	25
Removal and Installation	9	INSTALLATION	26
STEERING COLUMN	10	Disassembly and Assembly	26
Removal and Installation	10	INSPECTION BEFORE DISASSEMBLY	26
REMOVAL OF LOWER JOINT AND HOLE COVER	10	DISASSEMBLY	26
INSTALLATION OF LOWER JOINT AND HOLE COVER	11	INSPECTION AFTER DISASSEMBLY	27
REMOVAL OF STEERING COLUMN ASSEMBLY	11	ASSEMBLY	27
INSPECTION AFTER REMOVAL	11	HYDRAULIC LINE	30
INSTALLATION OF STEERING COLUMN ASSEMBLY	12	Removal and Installation (For A/T models)	30
INSPECTION AFTER INSTALLATION OF		Removal and Installation (For M/T models)	31
		Removal and Installation (For AWD models)	32
		SERVICE DATA AND SPECIFICATIONS (SDS)	33
		Steering Wheel	33
		Steering Angle	33
		Steering Column	33
		Steering Outer Socket and Inner Socket	33
		Steering Gear	34
		Oil Pump	34
		Steering Fluid	34

PRECAUTIONS

PRECAUTIONS

PF:00001

Precautions for Supplemental Restraint System (SRS) “AIR BAG” and “SEAT BELT PRE-TENSIONER”

AGS0001P

The Supplemental Restraint System such as “AIR BAG” and “SEAT BELT PRE-TENSIONER”, used along with a front seat belt, helps to reduce the risk or severity of injury to the driver and front passenger for certain types of collision. This system includes seat belt switch inputs and dual stage front air bag modules. The SRS system uses the seat belt switches to determine the front air bag deployment, and may only deploy one front air bag, depending on the severity of a collision and whether the front occupants are belted or unbelted. Information necessary to service the system safely is included in the SRS and SB section of this Service Manual.

WARNING:

- To avoid rendering the SRS inoperative, which could increase the risk of personal injury or death in the event of a collision which would result in air bag inflation, all maintenance must be performed by an authorized NISSAN/INFINITI dealer.
- Improper maintenance, including incorrect removal and installation of the SRS, can lead to personal injury caused by unintentional activation of the system. For removal of Spiral Cable and Air Bag Module, see the SRS section.
- Do not use electrical test equipment on any circuit related to the SRS unless instructed to in this Service Manual. SRS wiring harnesses can be identified by yellow and/or orange harnesses or harness connectors.

Precautions for Steering System

AGS0001M

- Before disassembly, thoroughly clean the outside of the unit.
- Disassembly should be done in a clean work area. It is important to prevent the internal parts from becoming contaminated by dirt or other foreign matter.
- For easier and proper assembly, place disassembled parts in order on a parts rack.
- Use nylon cloth or paper towels to clean the parts; common shop rags can leave lint that might interfere with their operation.
- Before inspection or reassembly, carefully clean all parts in order on a parts.
- Before assembly, apply a coat of recommended Genuine NISSAN PSF or equivalent to hydraulic parts. Petroleum jelly may be applied to O-rings and seals. Do not use any grease.
- Replace all gaskets, seals and O-rings. Avoid damaging O-rings, seals and gaskets during installation. Perform functional tests whenever designated.

PREPARATION

PREPARATION

PF0:00002

Special Service Tools (SST)

AGS00003

The actual shapes of Kent-Moore tools may differ from those of special service tools illustrated here.

A
B
C
D
E
F
PS
H
I
J
K
L
M

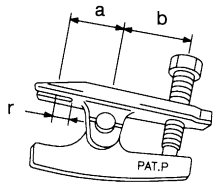
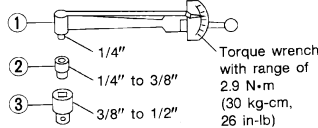
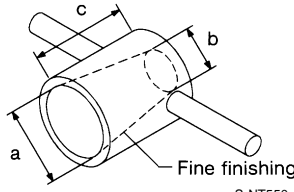
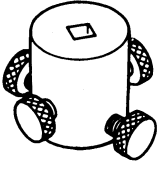
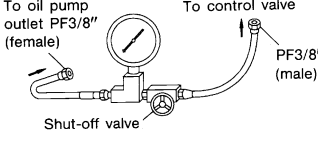
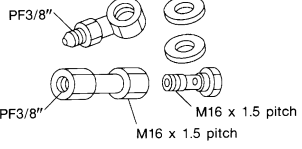
Tool number (Kent - Moore No.) Tool name	Description
HT2520000 (J25730-A) Ball joint remover a: 33 mm (1.30 in) b: 50 mm (1.97 in) r: 11.5 mm (0.453 in)	 <p>NT546</p> <p>Removing outer socket ball joint</p>
ST3127S000 (J25765 - A) Preload gauge 1. GG9103000 (J25765 - A) Torque wrench 2. HT62940000 (-) Socket adapter 3. HT62900000 (-) Socket adapter	 <p>S-NT541</p> <p>Torque wrench with range of 2.9 N·m (30 kg-cm, 26 in-lb)</p> <p>Inspecting of rotating torque for ball joint</p>
KV48104400 (-) Teflon ring installation tool a: 50 mm (1.97 in) dia. b: 36 mm (1.42 in) dia. c: 100 mm (3.94 in)	 <p>S-NT550</p> <p>Fine finishing</p> <p>Installing of rack Teflon ring</p>
KV48103400 (-) Torque adapter	 <p>ZZA0824D</p> <p>Inspecting rotating torque</p>
KV48103500 (J26357) Pressure gauge	 <p>NT547</p> <p>Measuring oil pump relief pressure</p>
KV48102500 (J33914) Pressure gauge adapter	 <p>NT542</p> <p>Measuring oil pump relief pressure</p>

PREPARATION

Commercial Service Tools

AGS0001Q

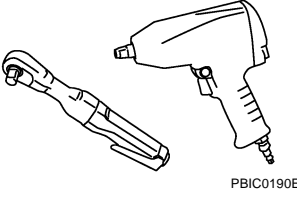
Tool name	Description
<p data-bbox="172 357 284 383">Power tool</p>  <p data-bbox="837 463 909 485">PBIC0190E</p>	<p data-bbox="991 357 1348 383">Removing oil pump and wheel nuts</p>

POWER STEERING FLUID

PFP:KLF20

POWER STEERING FLUID

AGS00006

Checking Fluid Level

- Stop engine before performing a fluid level check.
- Ensure that fluid level is between the MAX range and MIN level.
- Because fluid level differs within the HOT range and the COLD range, check it carefully.

HOT : Fluid temperatures from 50 to 80°C (122 to 176°F)

COLD : Fluid temperatures from 0 to 30°C (32 to 86°F)

CAUTION:

- Do not overfill the MAX level.
- Do not reuse any used power steering fluid.
- Recommended fluid is Genuine NISSAN PSF or equivalent.

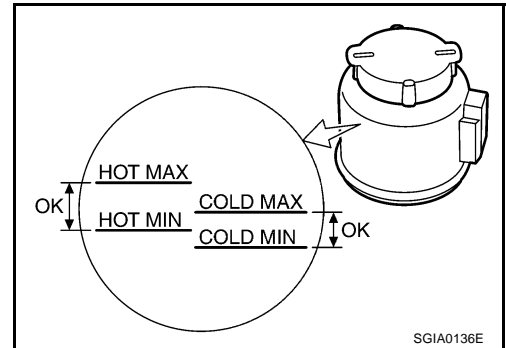

Checking Fluid Leakage

AGS00007

Check the hydraulic piping lines for improper attachment and for leaks, cracks, damage, loose connections, chafing or deterioration.

1. Run engine until fluid temperature reaches 50 to 80° C (122 to 176°F) in reservoir tank. Keep engine speed idle.
2. Turn steering wheel right-to-left several times.
3. Hold steering wheel at each "lock" position for five seconds to check fluid leakage.

CAUTION:

Do not hold steering wheel in a locked position for more than 10 seconds. (There is the possibility that oil pump may be damaged.)

4. If fluid leakage at connections is noticed, then loosen flare nut and then retighten. Do not over tighten connector as this can damage O-ring, washer and connector.
5. If fluid leakage from oil pump is noticed, check oil pump. Refer to [PS-25. "POWER STEERING OIL PUMP"](#) .
6. Check steering gear boots for accumulation of fluid indicating a from steering gear.

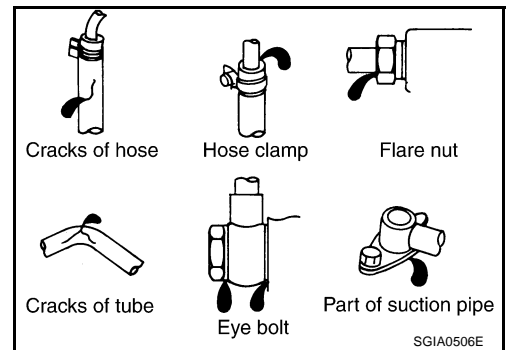

Air Bleeding Hydraulic System

AGS00008

Incomplete air bleeding causes the following. When this happens, bleed air again.

- Generation of air bubbles in reservoir tank.
- Generation of clicking noise in oil pump.
- Excessive buzzing in oil pump.

NOTE:

When vehicle is stationary or while steering wheel is being turned slowly, some noise may be heard from oil pump or gear. This noise is normal and does not affect any system.

1. Stop engine, and then turn steering wheel fully to right and left several times.

CAUTION:

Do not allow steering fluid reservoir tank to go below the low-level line. Check tank frequently and add fluid as needed.

2. Run engine at idle speed. Turn steering wheel fully to the right and then fully to the left, and keep for about three seconds. Then check whether a fluid leakage has occurred.
3. Repeat the 2nd procedure several times at about three seconds intervals.

CAUTION:

Do not hold steering wheel in the locked position more than 10 seconds. (There is the possibility that oil pump may be damaged.)

4. Check generation of air bubbles and cloud in fluid.

POWER STEERING FLUID

5. If air bubbles and the cloud don't fade, stop engine, hold air bleeding until air bubbles and the cloud fade. Perform the 2nd and the 3rd procedures again.
6. Stop engine, check fluid level.

A

B

C

D

E

F

PS

H

I

J

K

L

M

STEERING WHEEL

STEERING WHEEL

PFP:48430

On-Vehicle Inspection and Service

AGS00009

CHECKING CONDITION OF INSTALLATION

- Check installation condition of steering gear assembly, front suspension, axle and steering column.
- Check if movement exists when steering wheel is moved up and down, to the left and right and to the axial direction.

End play of the axle direction for steering wheel : 0 mm (0 in)

- Check if the mounting bolts for steering gear assembly are looser not. Refer to [PS-15, "POWER STEERING GEAR AND LINKAGE"](#) .

CHECKING STEERING WHEEL PLAY

1. Set tires to the straight ahead, start engine, then turn steering wheel to the left and right lightly, and measure steering wheel movement on the outer circumference when steering wheel is turned up to the point where tires start moving.

Steering wheel play on the outer circumference : 0 – 35 mm (0 – 1.38 in)

CHECKING NEUTRAL POSITION ON STEERING WHEEL

- Check neutral position on steering wheel after confirming that front wheel alignment is correct. Refer to [FSU-7, "Wheel Alignment Inspection"](#) (2WD models), [FSU-24, "Wheel Alignment Inspection"](#) (AWD) models.
1. Set vehicle to the straight direction, check if steering wheel is in the neutral position.
 2. If it is not in the neutral position, remove steering wheel and reinstall it correctly.
 3. If the neutral position cannot adjust in the two teeth of steering gear assembly, loosen tie-rod lock nuts of steering outer sockets, then adjust tie-rods by the same amount in the opposite direction.

CHECKING STEERING WHEEL TURNING FORCE

1. Park vehicle on a level and dry surface, set parking brake.
2. Start engine.
3. Bring power steering fluid up to adequate operating temperature. [Make sure temperature of fluid is approximately 50 to 80°C (122 to 176°F).]
Tires need to be inflated normal pressure.
4. Check steering wheel turning force when steering wheel has been turned 360° from the neutral position.

**Steering wheel turning force:
36 N (3.7 kg, 8.2 lb) or less**

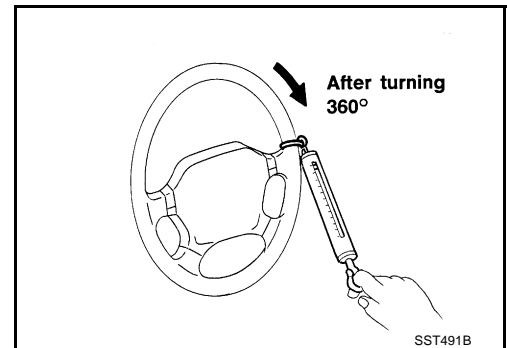

5. If steering wheel turning force is out of specification, check relief oil pressure of oil pump. Refer to [PS-25, "POWER STEERING OIL PUMP"](#) .

CHEKING FRONT WHEEL TURNING ANGLE

- Check front wheel turning angle after the toe-in inspection. Place front wheels on turning radius gauges and rear wheels on stands so that vehicle can be level. Check the maximum inner and outer wheel turning angles for LH and RH road wheels.

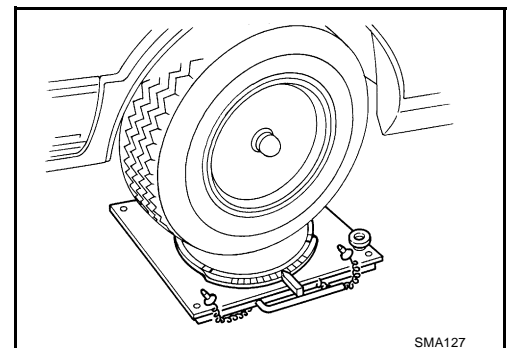

STEERING WHEEL

- Start engine and run at idle, turn steering wheel all the way right and left, measure the turning angle.

Inner wheel (Angle: A)	Minimum	: 37°30' (37.5°) (2WD models)
		: 38°00' (38.0°) (AWD models)
	Nominal	: 40°30' (40.5°) (2WD models)
		: 41°00' (41.0°) (AWD models)
Outer wheel (Angle: B)	Minimum	: 41°30' (41.5°) (2WD models)
		: 42°00' (42.0°) (AWD models)
	Nominal	: 32°30' (32.5°) (2WD models)
		: 31°40' (31.7°) (AWD models)

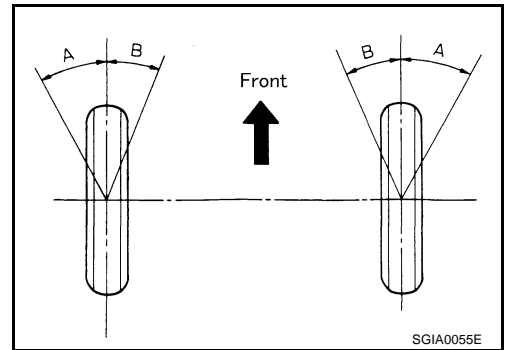

- If it is not within specification, measure the rack strokes.

Rack stroke "L"	: 66.6 mm (2.622 in) (2WD models)
	: 66.0 mm (2.598 in) (AWD models)

- If the rack stroke is outside of the specification, disassemble the steering gear to check the rack stroke.
- Turning angles are not adjustable. If any of the steering angles is not within specification, check following components for wear or damage.
 - Steering gear
 - Steering column
 - Front suspension components

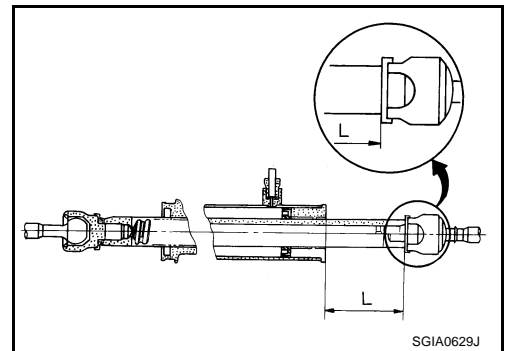

Removal and Installation

Refer to [PS-10, "STEERING COLUMN"](#) .

AGS0000A

STEERING COLUMN

PF:48810

STEERING COLUMN

Removal and Installation

AGS0000B

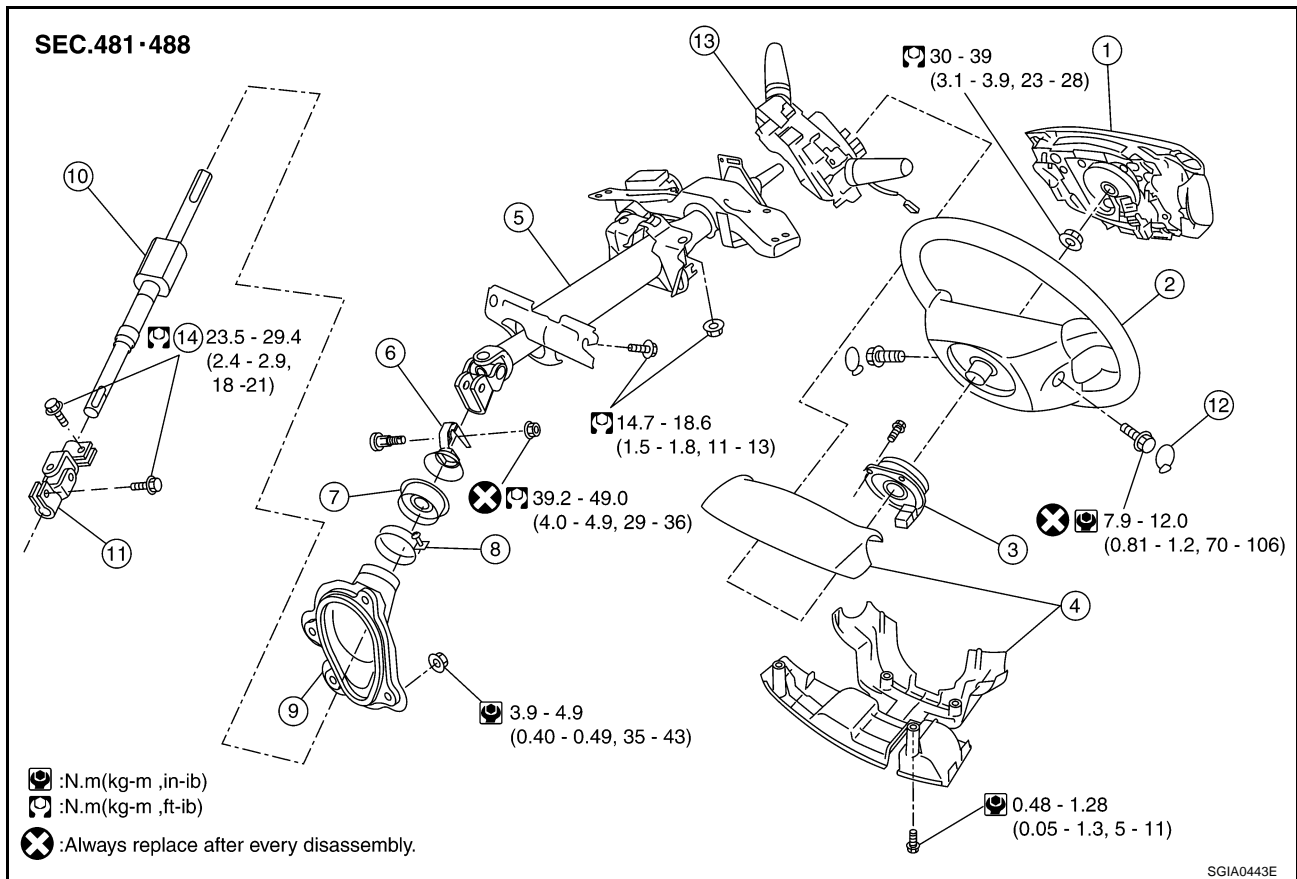

- | | | |
|------------------------|-----------------------------|-----------------|
| 1. Air bag module | 2. Steering wheel | 3. Spiral cable |
| 4. Column cover | 5. Steering column assembly | 6. Collar |
| 7. Hole cover seal | 8. Clamp | 9. Hole cover |
| 10. Lower shaft | 11. Lower joint | 12. Side lid |
| 13. Combination switch | 14. Pinch bolt | |

CAUTION:

- Care must be taken not to give axial impact to steering column assembly during removal and installation.
- Care must be taken not to move steering gear during removal of steering column assembly.

REMOVAL OF LOWER JOINT AND HOLE COVER

1. Raise the vehicle with the front wheels in the straight-ahead direction.
2. Mark lower joint and steering gear with paint for easy installation. Remove pinch bolt from lower side of lower joint.
3. Remove mounting bolt and nut from upper side of lower joint.
4. Remove hole cover and lower joint from vehicle.
5. Remove clamp and hole cover seal from hole cover.

STEERING COLUMN

INSTALLATION OF LOWER JOINT AND HOLE COVER

- Refer to [PS-10, "Removal and Installation"](#) for tightening torque. Install in the reverse order of removal.
- Install lower joint to steering gear, slot on lower portion of lower joint engaged with guide tip projection.

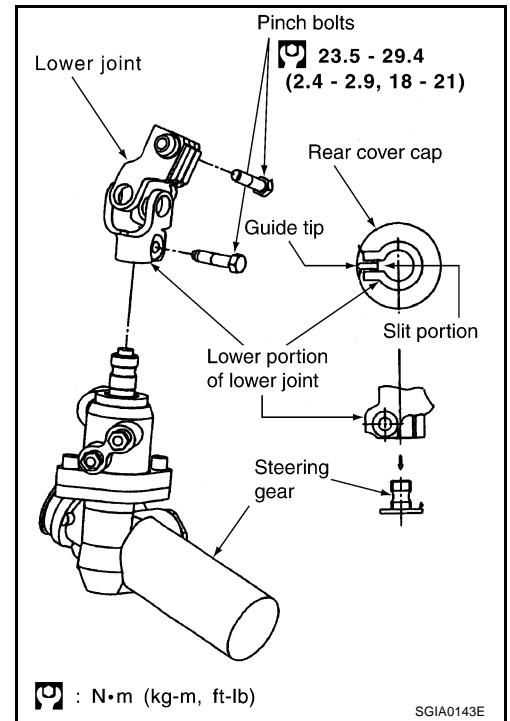

REMOVAL OF STEERING COLUMN ASSEMBLY

1. Set vehicle to the straight ahead-direction.
2. Remove driver air bag module from steering wheel. Refer to [SRS-36, "DRIVER AIR BAG MODULE"](#) .
3. Remove steering wheel lock nut, then remove steering wheel. Refer to [SRS-38, "SPIRAL CABLE"](#) .
4. Remove instrument lower driver panel. Refer to [IP-10, "INSTRUMENT PANEL ASSEMBLY"](#) .
5. Remove steering column cover. Refer to [IP-10, "INSTRUMENT PANEL ASSEMBLY"](#) .
6. Remove combination switch and spiral cable. Refer to [SRS-38, "SPIRAL CABLE"](#) .
7. Remove key interlock cable from steering column assembly. Refer to [AT-234, "KEY INTERLOCK CABLE"](#) .
8. Disconnect harness connector from each switch on steering column shaft, then separate vehicle side harness from it.
9. Remove the meter control unit assembly and cluster lid from steering column assembly. Refer to [IP-10, "INSTRUMENT PANEL ASSEMBLY"](#) .
10. Remove steering column assembly mounting nut and remove steering column assembly from vehicle.

CAUTION:

Do not deform lower side column cover on steering column assembly during removal or installation.

INSPECTION AFTER REMOVAL

- Check if there is something wrong with jacket tube of steering column assembly and collar etc. And then if they are damaged, replace with new one.

STEERING COLUMN

- If vehicle has a collision light socked, check column length “L” as shown in the figure. Then if it is out of the specified value, replace with new one.

Steering column length “L”:

547 - 549 mm (21.54 - 21.61 in)

- Check the turning torque of steering column with preload gauge (SST). If it is out of the specified value, repair it or replace with new one.

Turning torque : 0 – 0.2 N·m (0 – 0.021 kg·m, 0 – 1 in·lb)

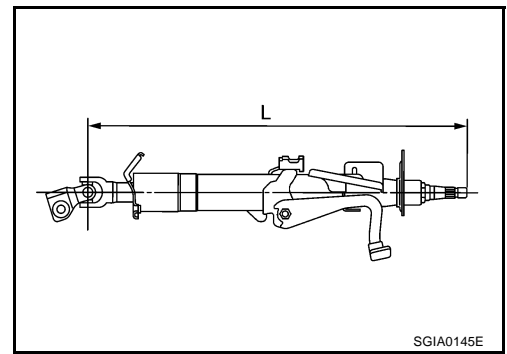

INSTALLATION OF STEERING COLUMN ASSEMBLY

- Refer to [PS-10, "Removal and Installation"](#) for tightening torque. Install in the reverse order of removal.

NOTE:

Refer to component parts location and do not reuse non-reusable parts.

INSPECTION AFTER INSTALLATION OF STEERING COLUMN ASSEMBLY

- After installing steering column to vehicle, check tilt device and it's operation range. Ranges of operation are shown in the figure.
- Check if steering wheel operation can turn to the end of the left and right smoothly.
- When tilt lever cannot be locked, adjust as per the following steps.

Tilt lever force : 70 - 100 N (7.1 - 10.2 kg, 15.7 - 22.5 lb)

1. Remove instrument driver lower panel.
2. Remove knee protector lower.
3. Disconnect harness clip from steering column assembly.
4. Set tilt lever in the lowermost position.

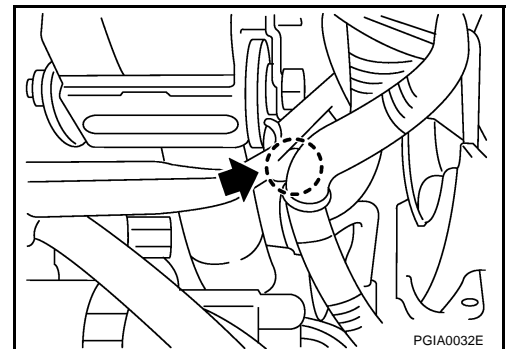
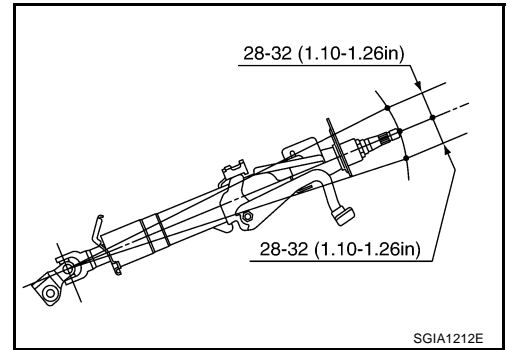

5. Loosen lock nut of adjust bolt of the steering.

NOTE:

Degradation in application force of lock cannot be arrested because adjusting bolt cannot be tightened by tightening only adjusting bolt lock nut of the steering.

6. Set tilt lever in the lock position.

CAUTION:

Tilt lever must be flush with the steering column cover.

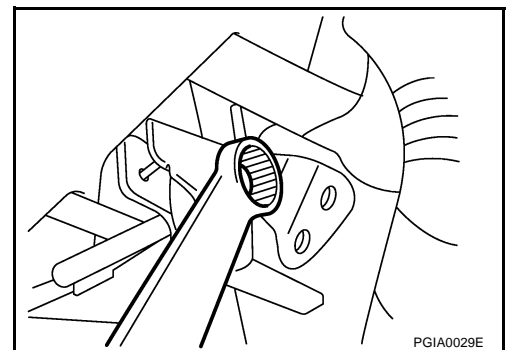

STEERING COLUMN

7. Tighten steering adjust bolt to the specified torque.

 : 9.4 N·m (0.96 kg-m, 83 in-lb)

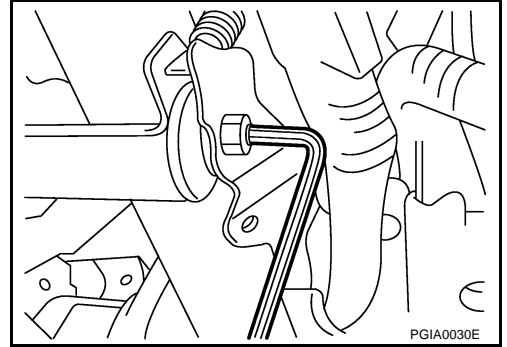

8. With adjusting bolt of the steering fixed, tighten lock nut to the specified torque.

 : 16.1 N·m (1.6 kg-m, 12 ft-lb)

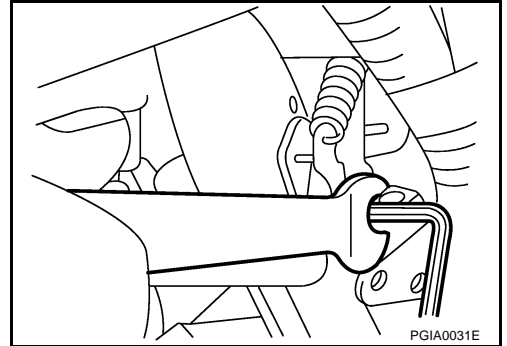

9. Check application force of tilt lever.

Tilt lever force : 70 - 100 N (7.1 - 10.2 kg, 15.7 - 22.5 lb)

Disassembly and Assembly

AGS0000C

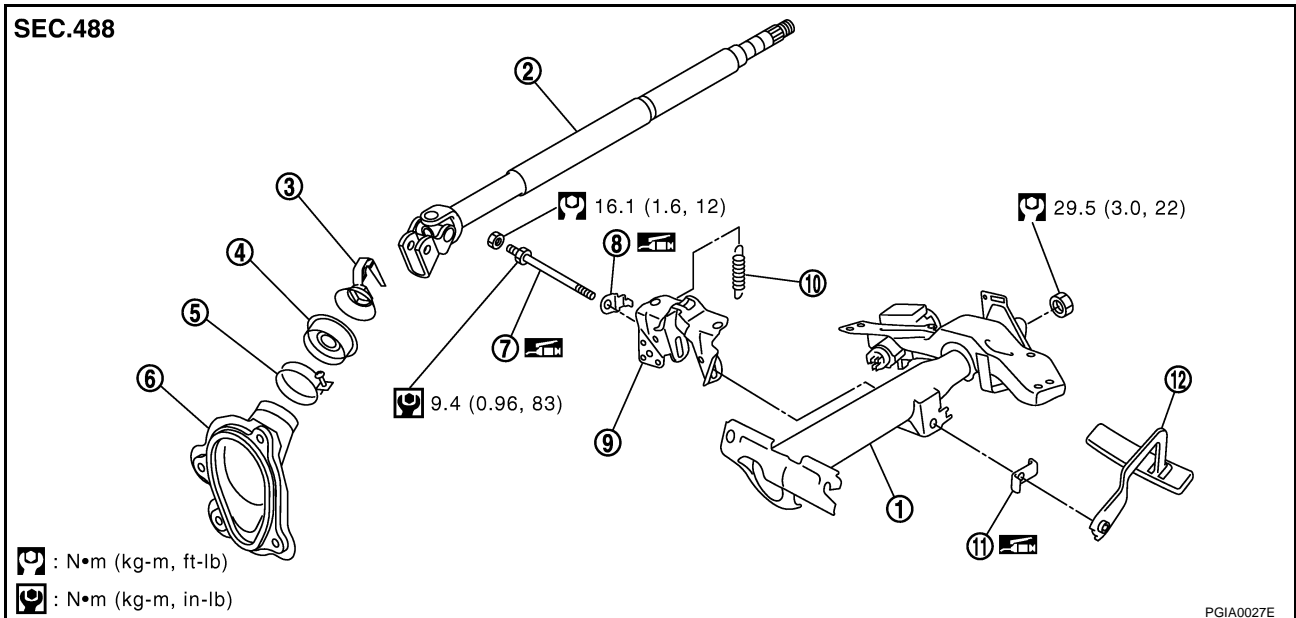

- | | | |
|--------------------|------------------------|-------------------------|
| 1. Jacket tube | 2. Column shaft | 3. Collar |
| 4. Hole cover seal | 5. Clamp | 6. Hole cover |
| 7. Adjusting bolt | 8. Adjusting stopper | 9. Column mount bracket |
| 10. Spring | 11. Tilt lever stopper | 12. Tilt lever |

DISASSEMBLY

NOTE:

Disassembly and assembly procedures should be done with steering lock unlocked.

1. Remove jacket tube-to-column shaft mounting nut and remove column shaft from jacket tube.
2. Remove spring from column mount bracket.
3. Remove mounting lock nut and adjusting stopper.
4. Remove adjusting bolt and remove tilt lever stopper and tilt lever.

STEERING COLUMN

ASSEMBLY

- Refer to [PS-13, "Disassembly and Assembly"](#) for tightening torque. Install in the reverse order of disassembly.

POWER STEERING GEAR AND LINKAGE

POWER STEERING GEAR AND LINKAGE

PPF:49001

Removal and Installation

AGS0000E

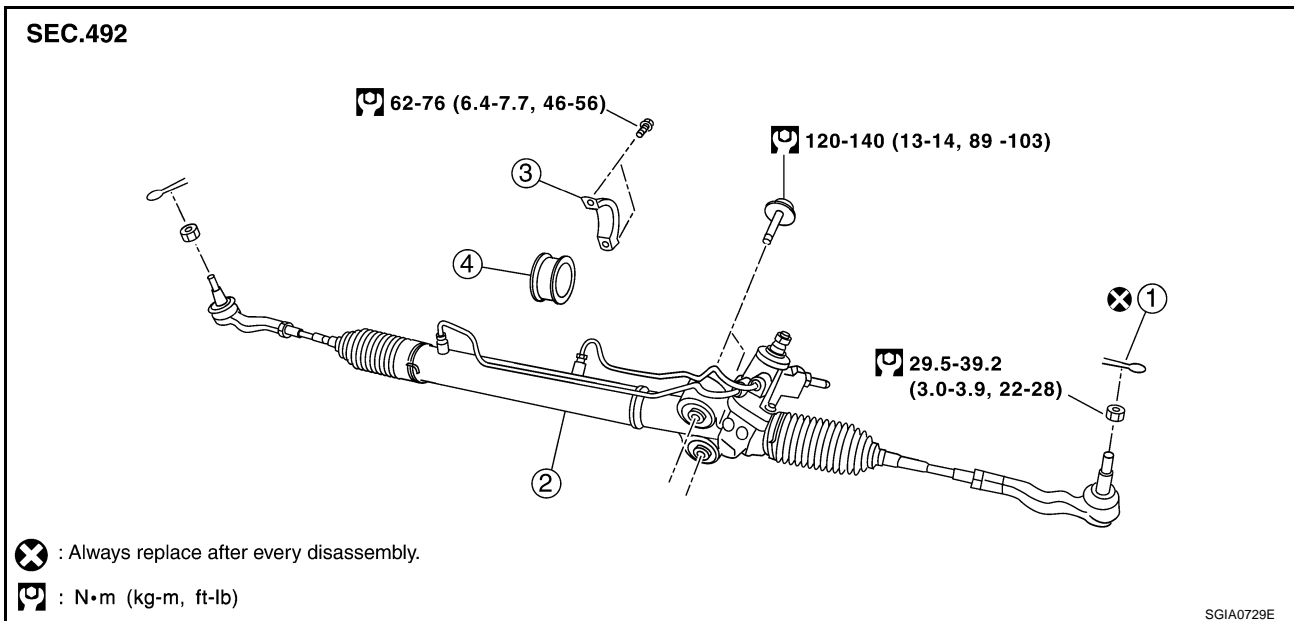

1. Cotter pin
2. Steering gear assembly
3. Rack mounting bracket
4. Rack mounting insulator

REMOVAL

CAUTION:

Spiral cable may snap due to steering operation if steering column is separated from steering gear assembly. Therefore fix steering wheel with a string to avoid turns.

1. Set wheels in the straight-ahead position.
2. Remove tires from vehicle with power tool.
3. Remove undercover with power tool.
4. Remove cotter pin at steering outer socket, then loosen mounting nut.
5. Use a ball joint remover (SST) to remove steering outer socket from steering knuckle. Be careful not to damage ball joint boot.

CAUTION:

Tighten temporarily mounting nut to prevent damage to threads and to prevent ball joint remover (SST) from coming off.

6. Remove pinch bolt of lower-side for lower joint.
7. Loosen pinch bolt of upper-side for lower joint.
8. Remove oil pipings (high pressure side and low pressure side) from steering gear assembly, then drain fluid from pipings.
9. Remove mounting bolts of steering gear assembly with power tool, and then remove rack mounting bracket, rack mounting insulator and steering gear assembly from vehicle.

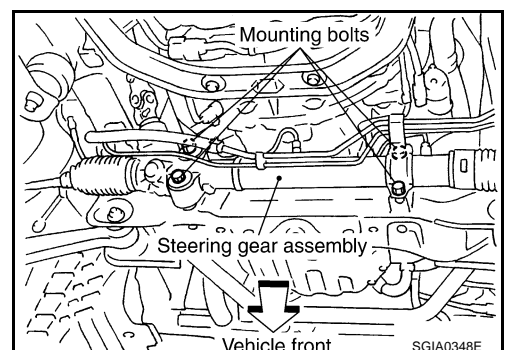
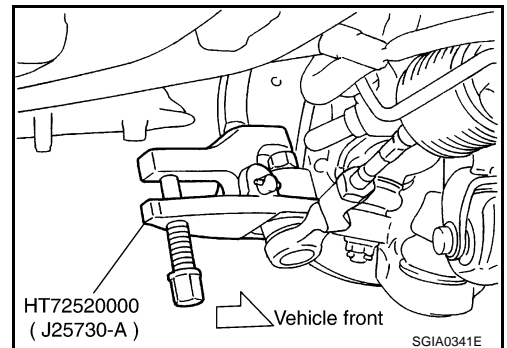

POWER STEERING GEAR AND LINKAGE

INSTALLATION

- Refer to [PS-15, "Removal and Installation"](#) for tightening torque. Install in the reverse order of removal.

NOTE:

Refer to component parts location and do not reuse non-reusable parts.

- Install the steering gear to the vehicle, refer to the tightening order shown in the figure.

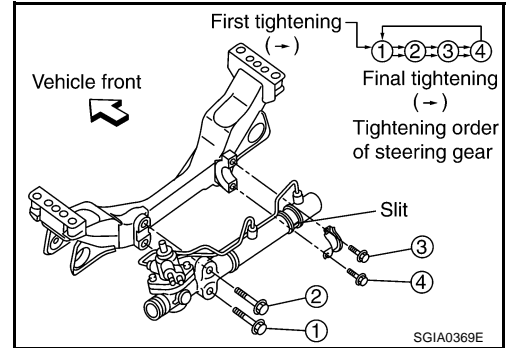

- Confirm if rear cover cap on steering gear consists with steering gear when front wheels are set in the straight-ahead direction as shown in the figure.

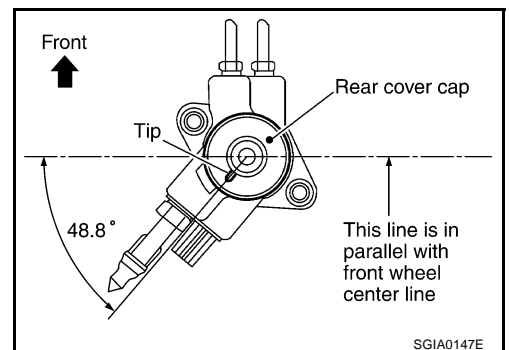

- Install lower joint to steering gear, engage the guide tip on rear cover cap with slit portion in the lower portion of lower joint.
- After installation, bleed air from piping. Refer to [PS-6, "Air Bleeding Hydraulic System"](#).

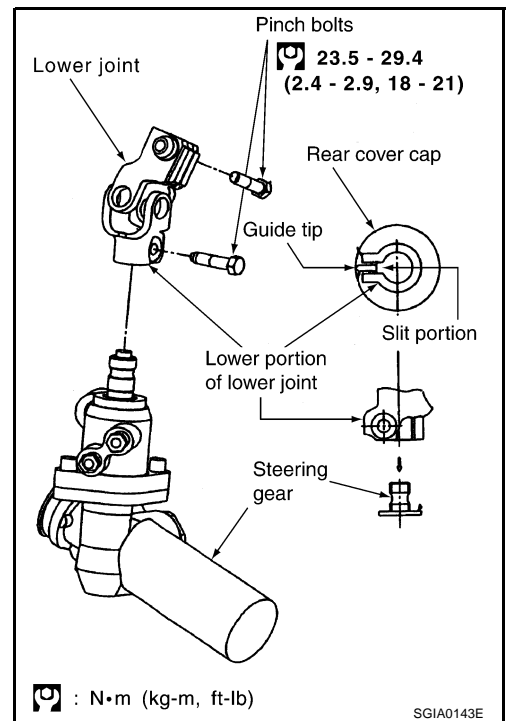

INSPECTION AFTER INSTALLATION

- Check if steering wheel turns smoothly when it is turned several times fully to the end of the left and right.

POWER STEERING GEAR

POWER STEERING GEAR

PF0:49001

Component

AGS0001R

SEC.492

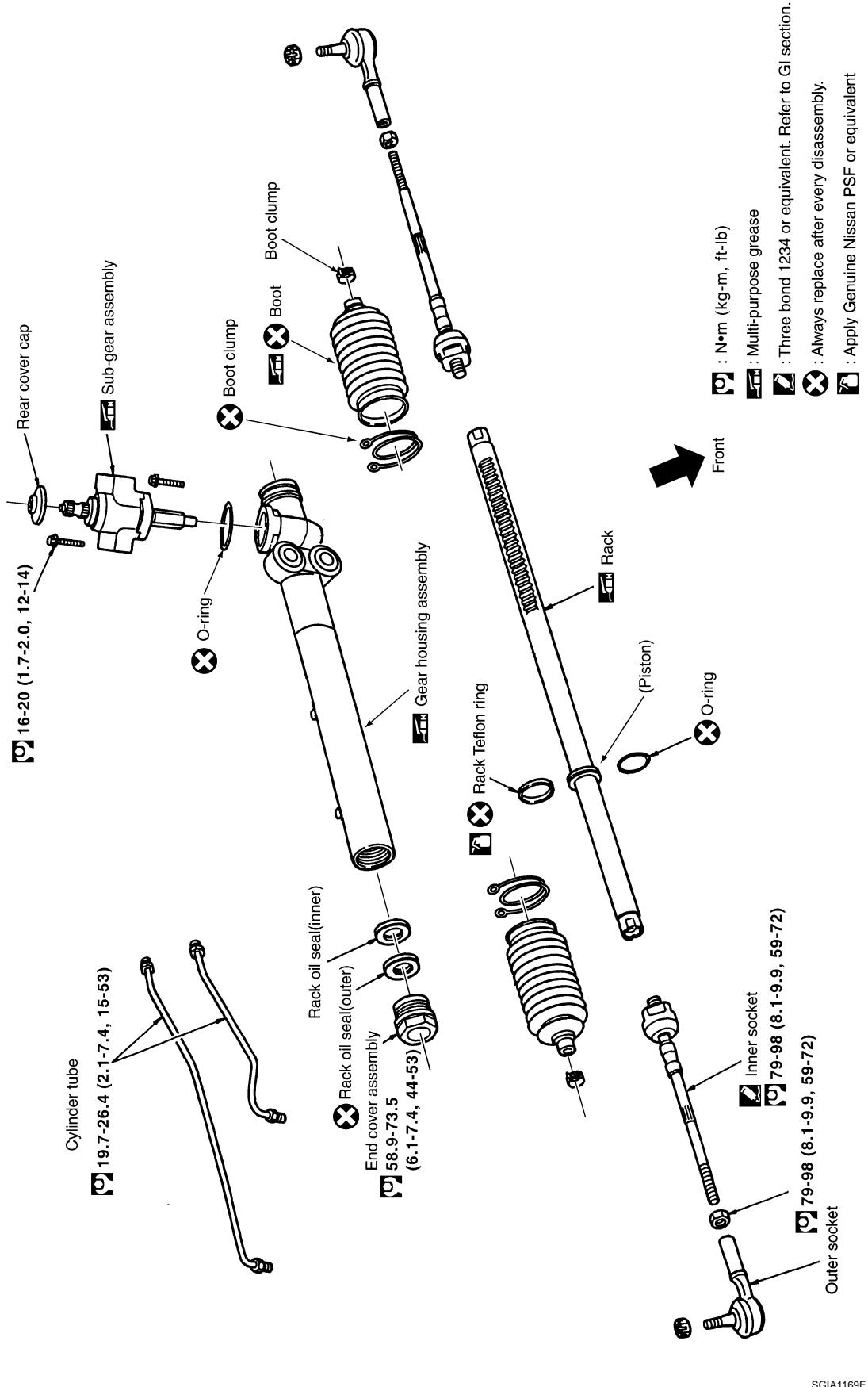

SGIA1169E

A
B
C
D
E
F
PS
H
I
J
K
L
M

POWER STEERING GEAR

Disassembly and Assembly

AGS0001S

CAUTION:

- Secure steering gear assembly with a vise, using copper plates or something similar to prevent it from being damaged. Do not grip cylinder in a vise.
- Before performing disassembly, clean steering gear assembly with kerosene. Be careful not to bring any kerosene into contact with the discharge and return port connectors.

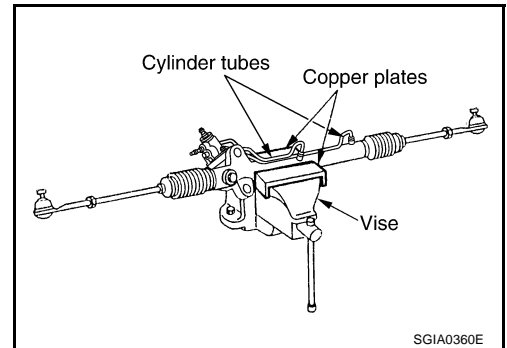

DISASSEMBLY

1. Remove cylinder tubes from gear housing assembly.
2. Remove rear cover cap from sub-gear assembly.
3. Measure adjusting screw height from gear housing assembly, then loosen adjusting screw.

CAUTION:

- Do not turn adjusting screw more than twice.
 - Replace steering gear assembly when adjusting screw is removed or more than twice.
4. Remove fixing bolts of sub-gear assembly and remove sub-gear assembly and O-ring from gear housing assembly.
 5. Loosen nut of outer socket, and remove outer socket.
 6. Remove boot clamps of the small diameter side and the large diameter side, then remove boot.

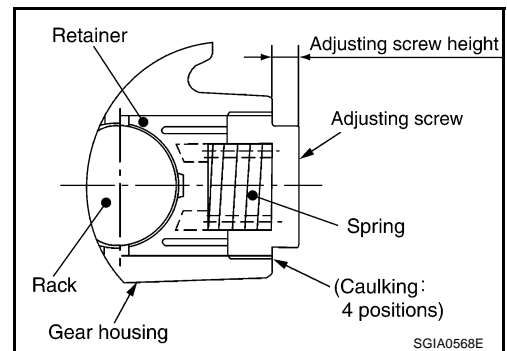

CAUTION:

When removing boots, be careful not to damage inner socket and gear housing assembly. If they are damaged, change them to avoid oil leaks.

7. Remove inner socket from rack.
8. Drill out the clinching part of cylinder outer rim with a 3 mm (0.12 in) drill in 1.5 mm (0.059 in) depth.
9. Remove end cover assembly with a 42 mm (1.65 in) open head (suitable tool).

CAUTION:

Be careful not to damage rack. If it is damaged, replace rack. Otherwise, oil leaks may result.

10. Pull rack assembly with rack oil seal out of gear housing assembly.

CAUTION:

Be careful not to damage cylinder. If it is damaged, replace gear housing assembly. Otherwise, oil leaks may result.

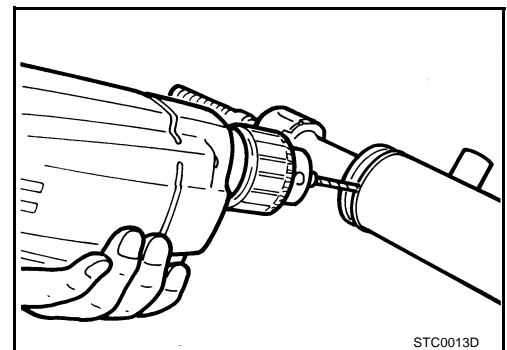

11. Heat rack Teflon ring to approximately 40°C (104°F) with a dryer, then remove it and O-ring from rack.

CAUTION:

Be careful not to damage rack. If it is damaged, change to a new one to avoid oil leaks.

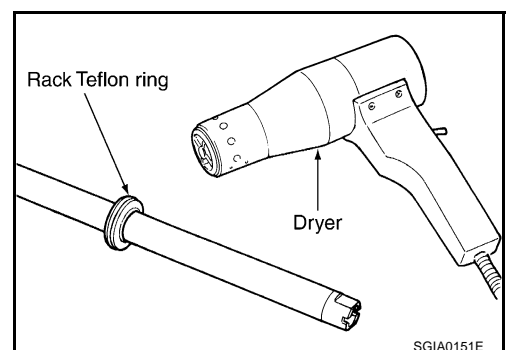

POWER STEERING GEAR

12. Use a taped 29 mm (1.14 in) socket and an extension bar. Remove rack oil seal from gear housing assembly.

CAUTION:

Be careful not to damage gear housing assembly and cylinder inner wall. If it is damaged, gear housing assembly must be replaced. Otherwise, oil leaks will result.

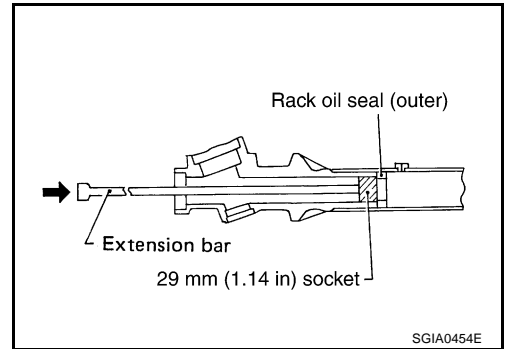

INSPECTION AFTER DISASSEMBLY

Boot

Check boot for cracks and deformation. Replace it, if necessary.

Rack

Check rack for damage and wear. Replace it, if necessary.

Sub-Gear Assembly

- Check pinion gear for damage and wear. Replace it, if necessary.
- Check bearing while rotating it. Replace bearing if bearing ball race was dented, worn, or damaged.

Gear Housing Assembly

Check gear housing assembly for damage and scratches (inner wall). Replace it, if necessary.

Outer Socket and Inner Socket

Swing Torque

- Hook a spring balance at the point shown in the figure. Confirm if the reading is within the specification. When ball stud and inner socket start moving the measured value must be within the specification. If the reading is outside the specification, replace socket.

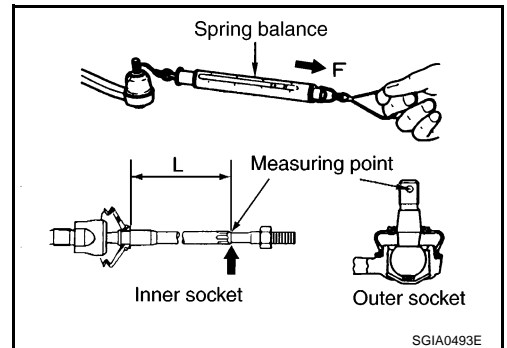

Specified value

Item	Outer socket	Inner socket
Measuring point	Cotter pin hole of stud	Shown as L: 48.5 mm (1.91 in)
Swing torque	0.3 - 2.9 N·m (0.03 - 0.29 kg·m, 3 - 25 in·lb)	1.0 - 7.8 N·m (0.11 - 0.79 kg·m, 9 - 69 in·lb)
Measuring value	4.42 - 42.7 N (0.45 - 4.3 kg, 1.0 - 9.6 lb)	10 - 78 N (1.1 - 7.9 kg, 2.25 - 17.5 lb)

Rotating torque

- Using a preload gauge (SST), check if reading is within the value specified below. If the value is outside the standard, replace outer sockets.

Rotating torque 0.30 - 2.90 N·m (0.03 - 0.29 kg·m, 3 - 25 in·lb)

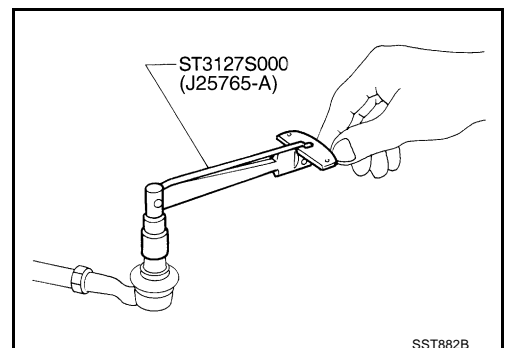

POWER STEERING GEAR

Axial End Play

- Apply load of 490 N (50 kg, 110 lb) to ball stud axially. Use a dial gauge to measure the amount of the movement that the stud makes. Check if the reading is within the specified below. If the value is outside the standard, replace outer and inner sockets.

Outer socket	0.5 mm (0.020 in) or less
Inner socket	0.2 mm (0.008 in) or less

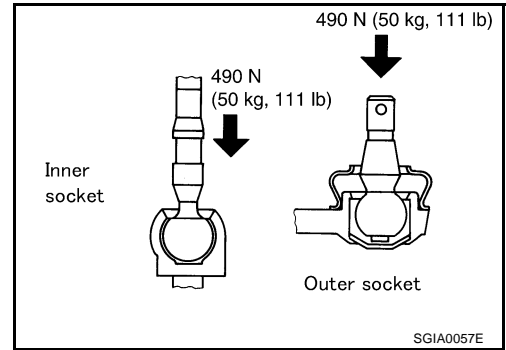

ASSEMBLY

- Apply Genuine NISSAN PSF or equivalent to O-ring. Put an O-ring into rack Teflon ring.

NOTE:

Do not reuse O-ring.

- Heat rack Teflon ring to approximately 40°C (104°F) with a dryer. Assemble it to mounting groove of rack.

NOTE:

Do not reuse rack Teflon ring.

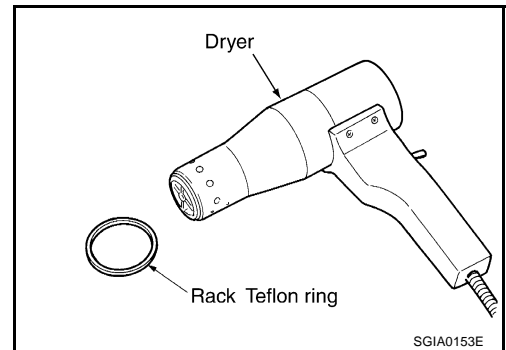

- To fit rack Teflon ring on rack, use rack Teflon ring installation tool (SST) from tooth side. Compress rim of ring with the tool.
- Apply Multi-purpose grease or equivalent to rack oil seal. Insert rack oil seal, then insert rack to gear housing assembly.

NOTE:

Do not reuse rack oil seal.

CAUTION:

- When inserting rack, do not damage retainer sliding part. If it is damaged, replace gear housing assembly.
- When unstringing rack, do not damage cylinder inner wall. If it is damaged, it may cause oil leaks. Replace gear housing assembly.
- Attach rack oil seal. Both inner lip and outer lip should face each other.

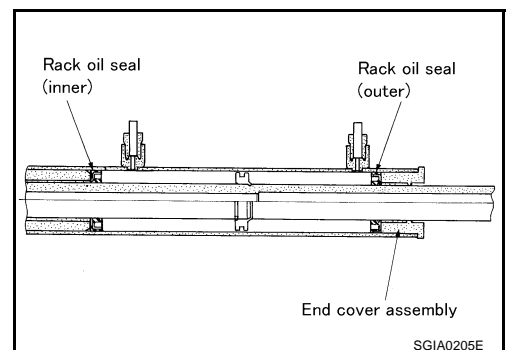
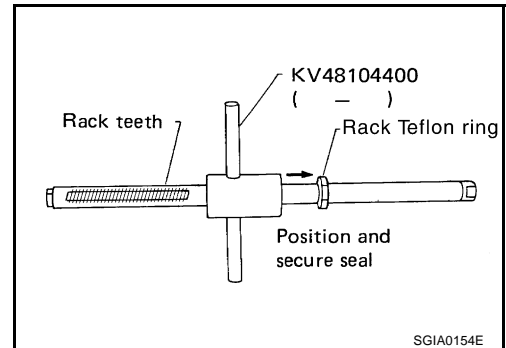

POWER STEERING GEAR

- a. To avoid damaging inner rack oil seal, wrap an OHP sheet [approximately. 70 mm (2.76 in) × 100 mm (3.94 in)] around rack tooth. Place oil seal on sheet. Then, pull oil seal along with OHP sheet until they pass the toothed section of rack, then remove it.

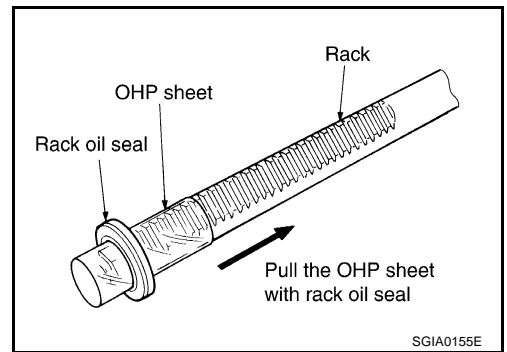

- b. Insert rack oil seal (inner) to piston (rack Teflon ring) position and push retainer to adjust screw side with fingers lightly, and then make rack move in gear housing assembly, install rack oil seal (inner) to fit in with gear housing assembly.

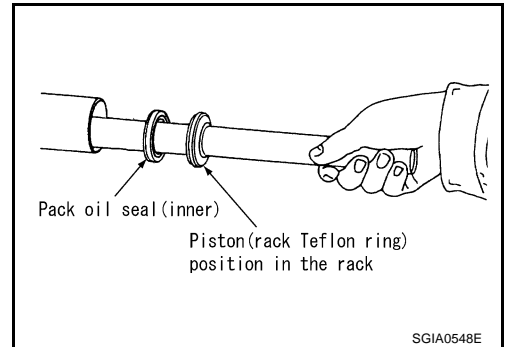

- c. When installing outer rack oil seal, cover the end of rack with an OHP sheet [70 mm (2.76 in) × 100 mm (3.94 in)]. It will avoid damaging rack oil seal. Then place oil seal on sheet. Pull rack oil seal along with OHP sheet until they pass rack end. Then remove OHP sheet.
- d. Install end cover assembly to rack, move it to gear housing assembly.

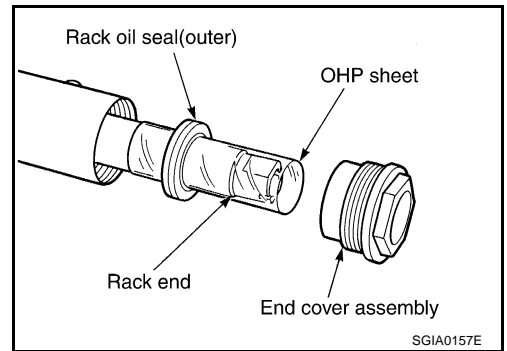

5. Using a 42 mm (1.65 in) open head (suitable tool), tighten end cover assembly at the specified torque.

CAUTION:

Do not damage rack surface. If it is damaged, it may cause oil leaks. Replace rack assembly.

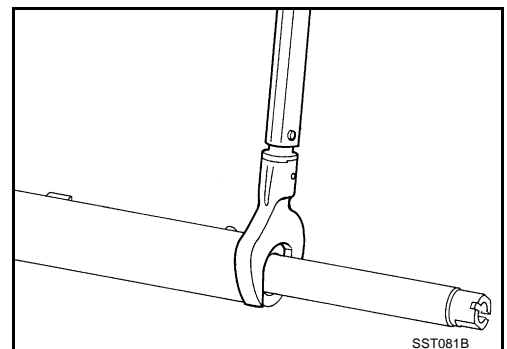

6. After tightening end cover assembly, caulk cylinder at one point as shown in the figure using a punch. This will prevent end cover from getting loose.
7. Apply Genuine NISSAN PSF or equivalent to O-ring. Install O-ring to gear housing assembly.

NOTE:

Do not reuse O-ring.

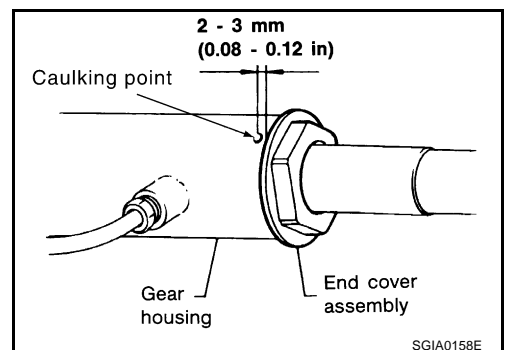

A
B
C
D
E
F
PS
H
I
J
K
L
M

POWER STEERING GEAR

8. Install gear sub-assembly to gear housing assembly.

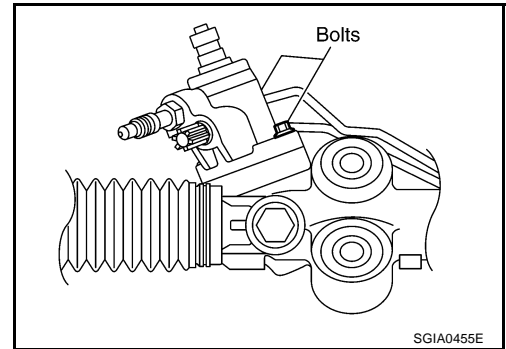

9. Decide neutral position of rack gear.

Rack stroke "L" : 66.6 mm (2.622 in) (2WD models)
 : 66.0 mm (2.598 in) (AWD models)

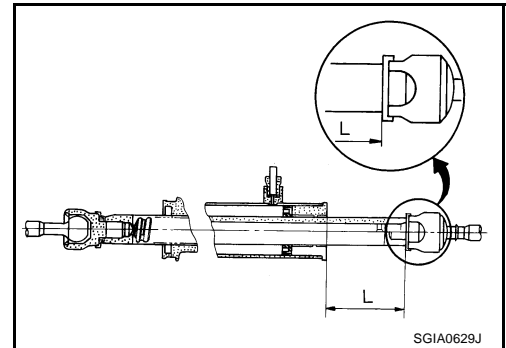

10. Install rear cover cap to the sub-gear assembly, holding relation between projection part (Tip) of rear cover on the sub-gear assembly and the line that is in parallel with front wheel center line as shown in the figure.

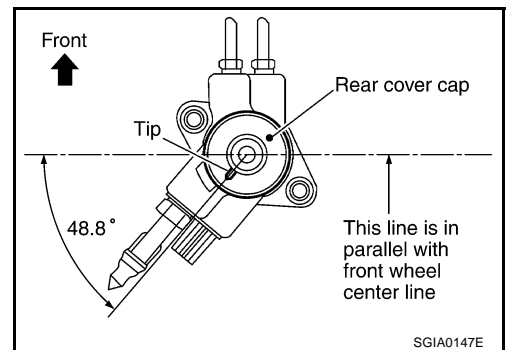

11. Apply thread locking adhesive (Three Bound TB1111B or equivalent) to the thread of adjusting screw to the adjusting screw height from gear housing assembly. The adjusting screw height is the same as it was measured in the overhaul in advance.

12. Rotate pinion ten times whole range of rack so that parts get to fit with each other.

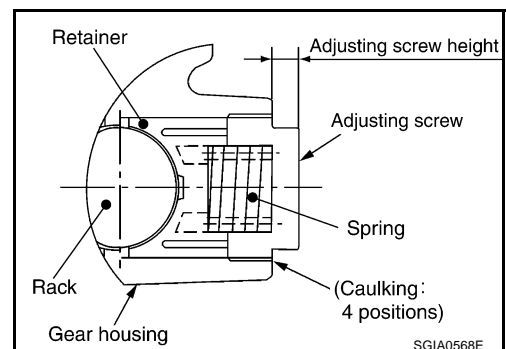

13. Measure pinion rotating torque within from -180° to $+180^\circ$ make preload gauge (SST) and torque adapter (SST) in rack neutral position, then hold preload gauge (SST) at maximum torque.

14. After loosening adjusting screw once, tighten it again with torque of 4.9 – 5.9 N·m (0.50 – 0.60 kg·m, 44 – 52 in·lb). After that loosen it within from 20° to 40° .

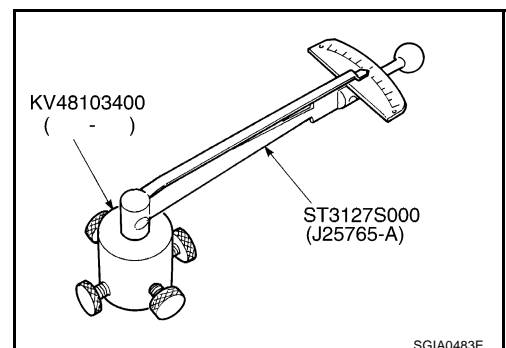

POWER STEERING GEAR

15. Measure pinion rotating torque with torque adapter (SST) and preload gauge (SST), then confirm whether its reading is within the specified value. If the reading is not within the specified value, readjust screw angle with adjusting screw. Change gear assembly to new one, if the reading is still not within the specified value or the rotating torque of adjusting screw is less than 5 N·m (0.51 kg·m, 44 in·lb)

Pinion rotation torque:

Around neutral position (within $\pm 100^\circ$)

Average "A":

0.8 - 2.0 N·m (0.09 - 0.20 kg·m, 7 - 17 in·lb)

Other than above (more than $\pm 100^\circ$)

Maximum variation "B":

2.3 N·m (0.23 kg·m, 20 in·lb)

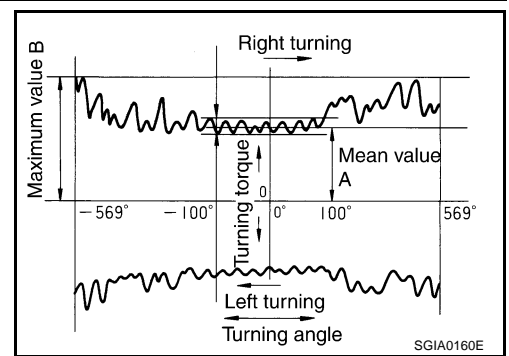

16. Turn pinion fully to the end of the left with outer socket to rack.
 17. Set dial gauge to rack as shown in the figure. Measure vertical movement of rack when pinion is turned counterclockwise with torque of 19.6 N·m (2.0 kg·m, 14 ft·lb). Check reading is within the specified value. If reading is outside of the specification, readjust screw angle with adjusting screw. If reading is till out side of specification, or if the rotating torque of adjusting screw is less than 5 N·m (0.51 kg·m, 44 in·lb), replace steering gear assembly.

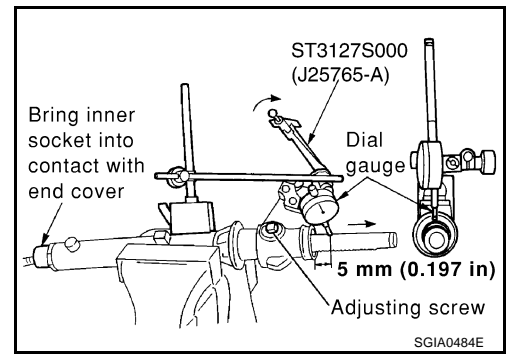

Amount of vertical movement with rack	Less than 0.265 mm (0.010 in)	
Measuring point	Axial direction	5 mm (0.197 in) away from end of gear hosing assembly
	Radius direction of rack	Shaft direction of adjusting screw

18. Install large-diameter side of boot to gear hosing assembly.
 19. Install small-diameter side of boot to the mounting groove of inner socket boot.
 20. Install boot clamp to the small-diameter side of boot.
 21. Install boot clamp to the large-diameter side of boot.

NOTE:

Do not reuse boot clamp.

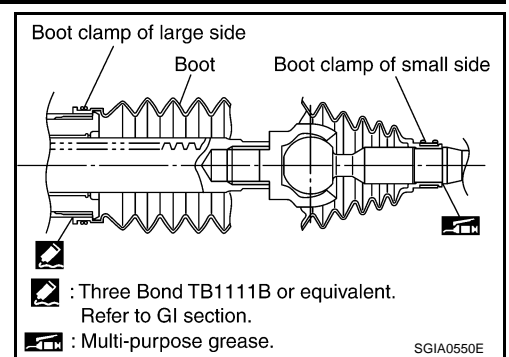

- a. Tighten large-diameter side of RH/LH boot with boot clamp (stainless wire).

Wire length "L" : 370 mm (14.57 in)

- b. After wrapping clamp around boot groove for two turns, insert screwdriver in loop on both ends of wire. Twist 4 to 4.5 turns while pulling with a force of approx. 98 N (10 kg, 22.1 lb).

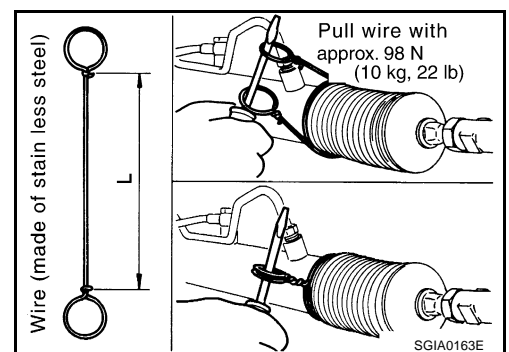

POWER STEERING GEAR

- c. Twist boot clamp as shown in the figure, pay attention to relationship between winding and twisting directions.

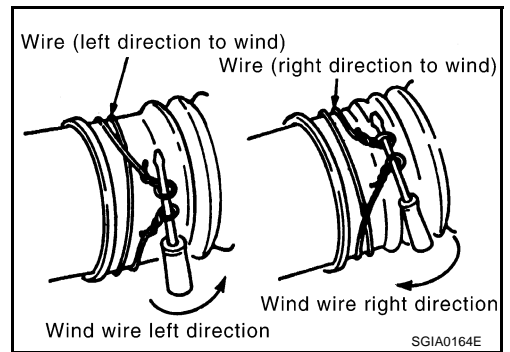

- d. Confirm the twisted point with clamp faces in the opposite direction to adjusting screw within 30° as shown in the figure.

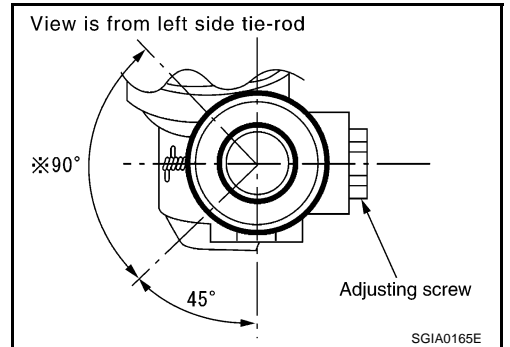

- e. After twisting wire 4 to 4.5 turns, bend cut end of wire. Cut end of wire should not touch boot. Be sure wire end is at least 5 mm (0.20 in) away from clearance for tube.

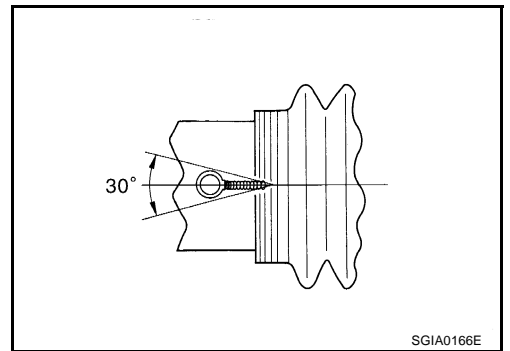

22. Install cylinder tubes to gear housing assembly.

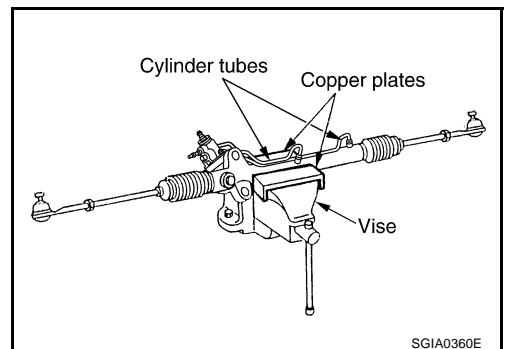

23. Tighten lightly outer socket in specified length "L", then tighten lock nut at specified torque. Refer to [PS-17, "Component"](#). Reconfirm if outer socket length is within limit of specified length "L".

Inner socket length "L" : 106.3 mm (4.185 in)

CAUTION:

Perform toe-in adjustment after this procedure. Length achieved after toe-in adjustment is not necessarily value given here.

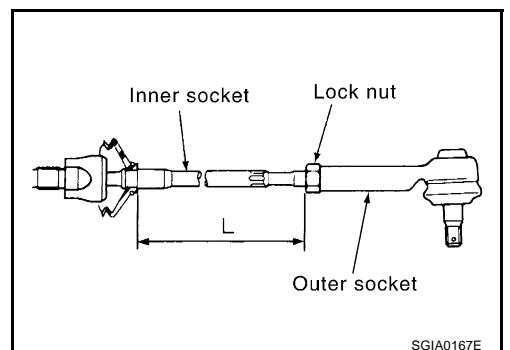

POWER STEERING OIL PUMP

POWER STEERING OIL PUMP

PFP:49110

On-Vehicle Inspection and Service CHECKING RELIEF OIL PRESSURE

AGS0000H

CAUTION:

Before starting work, confirm belt tension is proper.

1. Connect oil pressure gauge (SST) and oil pressure gauge adapter (SST) between oil pump discharge connector and high pressure hose and then bleed air from the hydraulic circuit.

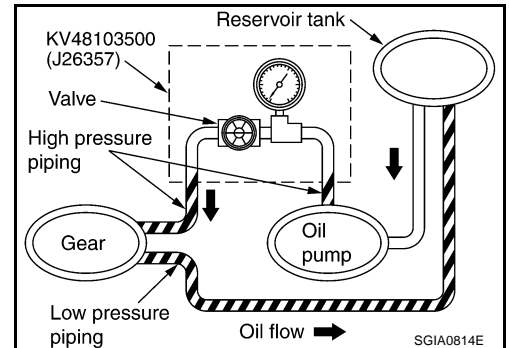

2. Start engine. Allow engine to run until tank temperature reaches 50 to 80°C (122 to 176°F).

CAUTION:

- Warm up engine with shut-off valve fully opened. If engine is started with shut-off valve closed, fluid pressure in power steering pump increase to maximum. This will raise fluid temperature excessively.
 - Be careful not to contact hose with belt when engine is started.
3. With engine at idle, close shut-off valve and read the relief oil pressure.

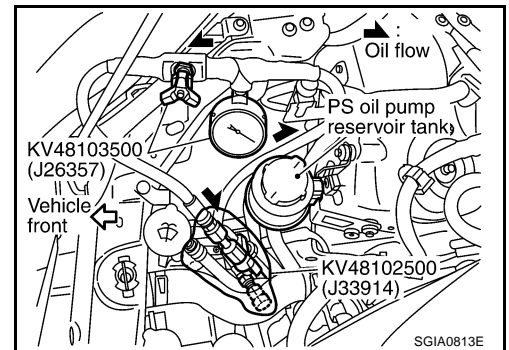

Relief oil pressure specification:

9,600 - 10,200 kPa (98 - 104 kg/cm² , 1,390 - 1,480 psi)

4. After measurement, open shut-off valve slowly.
 - If relief oil pressure is outside the specification, disassemble and repair oil pump. Refer to [PS-26, "Disassembly and Assembly"](#) .
5. After inspection, disconnect oil pressure gauge (SST) and oil pressure gauge adapter (SST) from hydraulic circuit, connect oil pump discharge connector and high pressure hose. Add fluid and bleed air from hydraulic circuit thoroughly. Refer to [PS-6, "Air Bleeding Hydraulic System"](#) .

Removal and Installation

REMOVAL

AGS0000I

1. Remove engine cover.
2. Remove air cleaner box.
3. Drain water from radiator upper tank, then remove radiator upper hose.
4. Remove radiator fan shroud. Refer to [CO-21, "Removal and Installation"](#) .
5. Loosen idler pulley, then remove belt.
6. Drain power steering fluid from reservoir tank.
7. Remove piping of high pressure and low pressure (drain fluid from their pipings)
8. Remove bolt common to water pump and power steering pump.
9. Remove bolt then remove power steering pump.

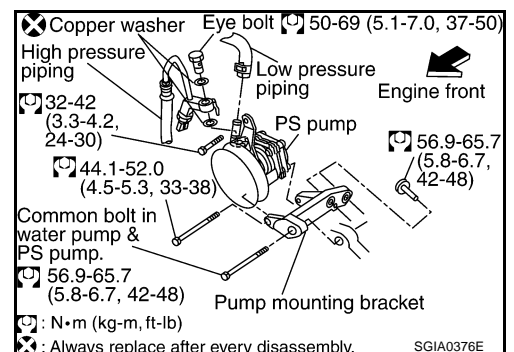

POWER STEERING OIL PUMP

INSTALLATION

Refer to [PS-30, "HYDRAULIC LINE"](#) for tightening torque. Install in the reverse order of removal.

- After installation, adjust belt tension. Refer to [EM-14, "DRIVE BELTS"](#).
- After installation, bleed air. Refer to [PS-6, "Air Bleeding Hydraulic System"](#).

Disassembly and Assembly

AGS000J

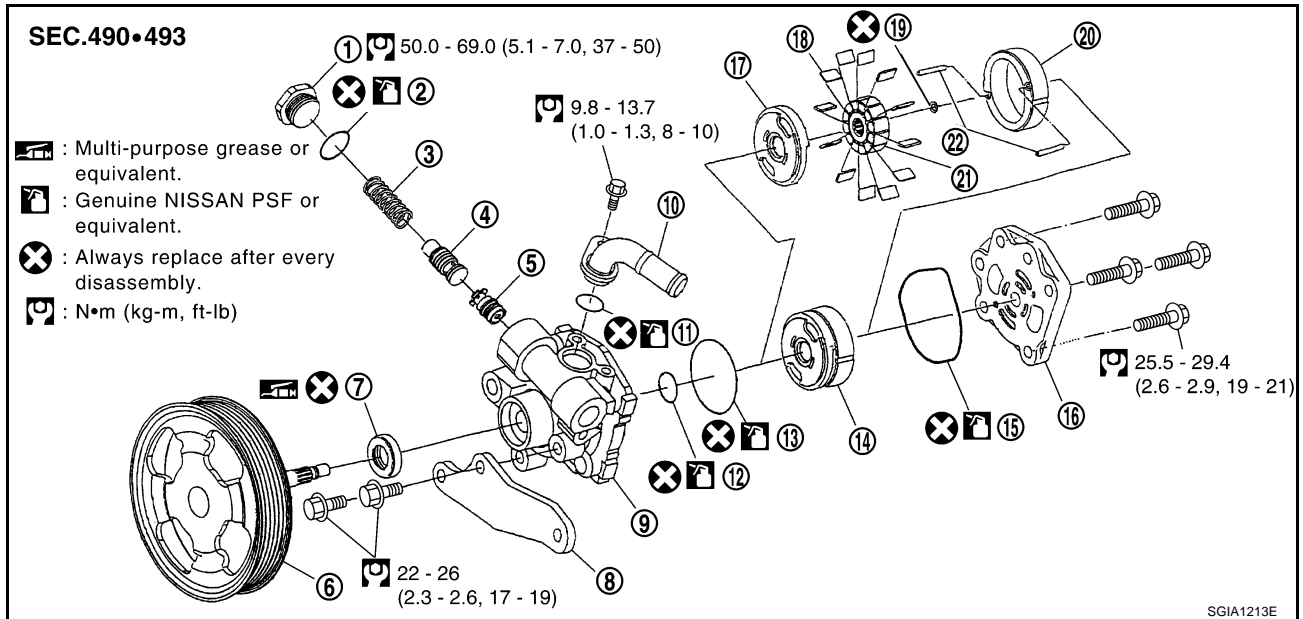

- | | | |
|--------------------------------|--------------------------------|------------------------------|
| 1. Plug | 2. O-ring D | 3. Flow control valve spring |
| 4. Relief valve assembly | 5. Flow control valve assembly | 6. Shaft kit |
| 7. Oil seal | 8. Bracket | 9. Body assembly |
| 10. Suction connector assembly | 11. O-ring E | 12. O-ring C |
| 13. O-ring B | 14. Cartridge assembly | 15. O-ring A |
| 16. Cover assembly | 17. Side plate | 18. Vane |
| 19. Rotor snap ring | 20. Cam ring | 21. Rotor |
| 22. Dowel pin | | |

INSPECTION BEFORE DISASSEMBLY

Disassemble the power steering oil pump only if following items are found.

- Oil leakage from oil pump
- Deformed or damaged pulley
- Poor performance

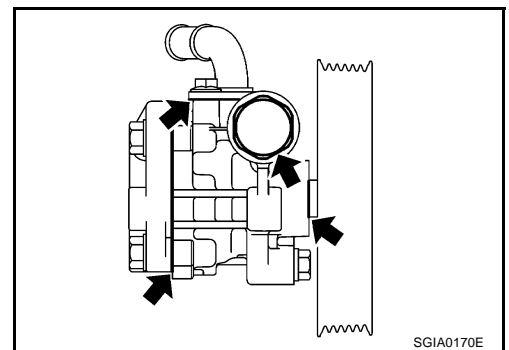

DISASSEMBLY

NOTE:

Fix oil pump in vise as the occasion demands.

CAUTION:

When retaining drive shaft in a vise, always use copper or aluminium plates between vise and shaft.

1. Unscrew two front bracket bolts and remove bracket from body assembly.
2. Unscrew four cover assembly bolts and remove cover assembly from body assembly.
3. Remove O-ring A from body assembly.

POWER STEERING OIL PUMP

4. Remove rotor snap ring with snap ring pliers, and remove shaft kit from body assembly.

CAUTION:

When removing rotor snap ring, be careful not to damage pulley shaft of shaft kit.

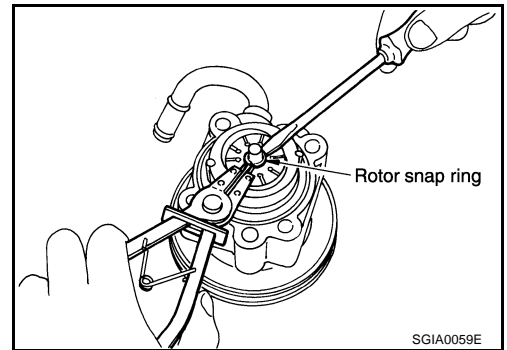

5. Using a screw driver, remove oil seal for body assembly.
6. Remove cam ring, rotor, vane, side plate, O-ring B and O-ring C from body assembly.
7. Remove plug, then remove O-ring D, flow control valve spring, relief valve assembly and flow control valve assembly from body assembly.

CAUTION:

Be careful not to drop and deform relief valve assembly and flow control valve assembly.

8. Remove fixing bolt of suction connector assembly, then remove suction connector assembly and O-ring E from body assembly.

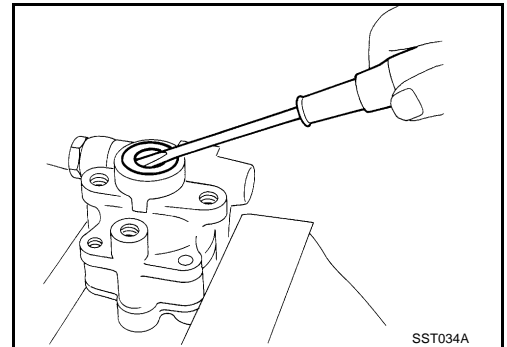

INSPECTION AFTER DISASSEMBLY

Body Assembly and Cover Assembly Inspection

- Check body assembly and cover assembly for damage. If any damage is found, replace with new part for cover assembly, and replace with new power steering pump assembly for body assembly.

Cartridge Assembly Inspection

- Check cam ring, side plate, rotor and vanes for damage. If any damage is found, replace cartridge assembly with new one.

Relief Valve Assembly Inspection

- Check relief valve assembly for damage. If any damage is found, replace it with new one.

Flow Control Valve Assembly Inspection

- Check flow control valve assembly for damage. If any damage is found, replace it with new one.

ASSEMBLY

NOTE:

Fix oil pump in vise as occasion demands.

CAUTION:

When retaining drive shaft in a vise, always use copper or aluminum plates between vise and shaft.

1. Apply a coat of Multi-purpose grease or equivalent to oil seal lip and to the circumference of oil seal. Using proper tool such as hand press machine, install it to the body assembly.

NOTE:

Do not reuse oil seal.

2. Install shaft kit to body assembly.
3. Apply a coat of NISSAN PSF or equivalent to O-ring B and O-ring C, then install O-ring B and O-ring C to body assembly.

NOTE:

Do not reuse O-ring B and O-ring C.

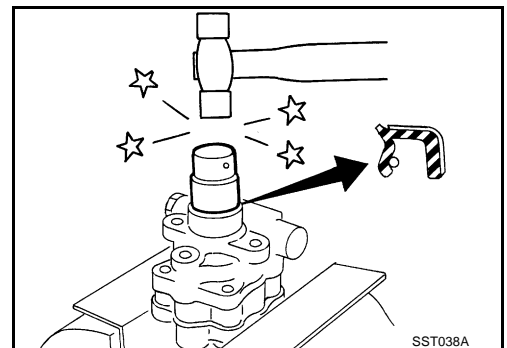

A

B

C

D

E

F

PS

H

I

J

K

L

M

POWER STEERING OIL PUMP

4. Set dowel pin at the illustration position (The position is the same regardless of right or left direction), and install side plate to body assembly.

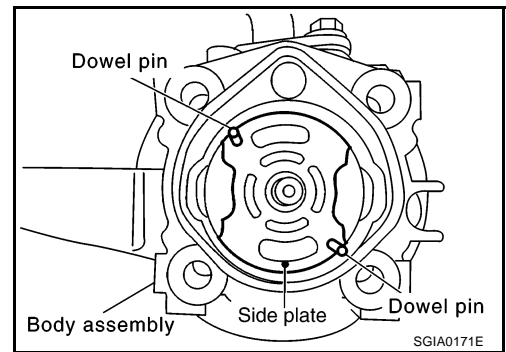

5. Install cam ring on side plate as follows;
- Turn chamfered edge side of cam ring to side plate as shown in the figure.
 - Position large chamfered side of cam ring as shown in the figure.

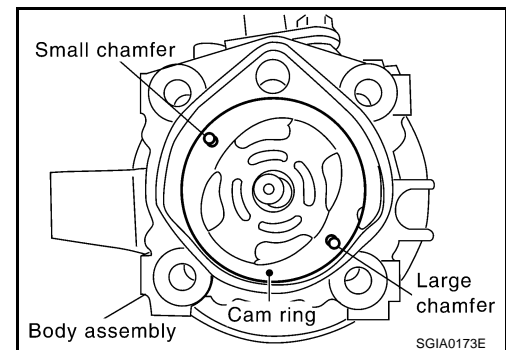
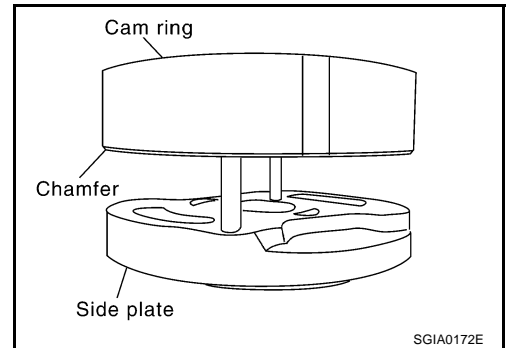

6. Install rotor to shaft of shaft kit (rotor direction is the same regardless of the front and back).
7. Install vane to rotor (vane direction is the same regardless of inside and outside).
8. Install rotor snap ring to shaft of shaft kit.

NOTE:

Do not reuse rotor snap ring.

CAUTION:

Be careful not to damage rotor and pulley shaft.

9. Apply a coat of NISSAN PSF or equivalent to O-ring A, then install O-ring A to body assembly.

NOTE:

Do not reuse O-ring A.

10. Attach cover assembly to body assembly and tighten fixing bolts diagonally at the specified torque.
11. Install flow control valve assembly, relief valve assembly and flow control valve spring to body assembly.
12. Apply a coat of NISSAN PSF or equivalent to O-ring D and install to plug, then tighten plug at the specified torque.

NOTE:

Do not reuse O-ring D.

13. Apply a coat NISSAN PSF or equivalent to O-ring E and install to suction connector assembly, then install suction connector to body assembly.

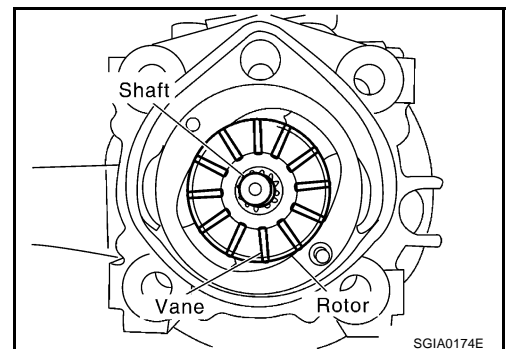

POWER STEERING OIL PUMP

NOTE:

Do not reuse O-ring E.

A

B

C

D

E

F

PS

H

I

J

K

L

M

HYDRAULIC LINE

HYDRAULIC LINE

PFP:49721

Removal and Installation (For A/T models)

AGS0001N

SEC.497

How to install eye joint :
Bring eye joint contact with installation face of pump connector correctly, tighten eye bolt by hand, then tighten it at specified torque.

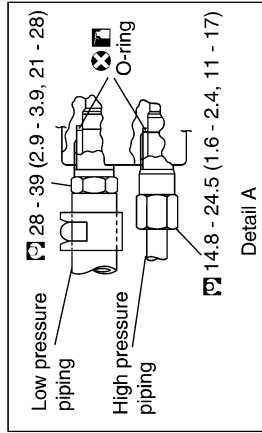
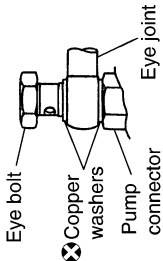

3.0 - 3.9 (0.31 - 0.39, 27 - 34)

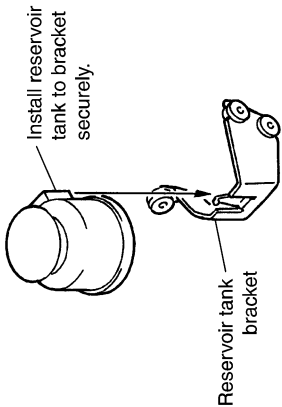

Reservoir tank installation

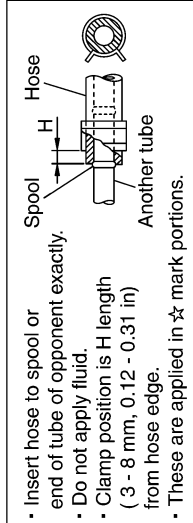

Install with position mark facing to return port.

Suction hose

Install with position mark facing to out of vehicle.

Return hose

Tube & hose set

Closing plate

Eye bolt

50 - 69 (5.1 - 7.0, 37 - 50)

Copper washers

Suction hose

Install with AM6 mark facing front of vehicle. ☆ (Insert hose into opponent spool.)

Install the projection to cut portion of pump outlet securely.

32 - 42 (3.3 - 4.2, 24 - 30)

PS oil pump

Detail B

44.1 - 52.0 (4.5 - 5.3, 33 - 38)

56.9 - 65.7 (5.8 - 6.7, 42 - 48)

Engine side bracket

Engine

Engine

Connect pressure sensor to opponent harness connector securely.

Side member

PS oil pump

Steering gear assembly

Install with position mark turning to top of vehicle.

3.0 - 3.9 (0.31 - 0.39, 27 - 34)
Install on upper bracket of rack mounting.

☆ : N·m (kg-m, ft-lb)

☞ : N·m (kg-m, in-lb)

☛ : Apply Genuine Nissan PSF or equivalent.

⊗ : Always replace after every disassembly.



Vehicle front

SGIA0734E

Removal and Installation (For M/T models)

AGS0001F

A
B
C
D
E
F
PS
H
I
J
K
L
M

SEC.497

How to install eye joint :
Bring eye joint contact with installation face of pump connector correctly, tighten eye bolt by hand, then tighten it at specified torque.

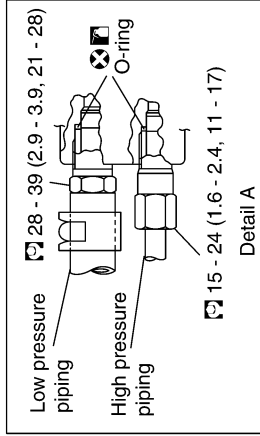
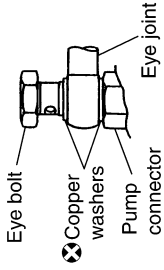

3.0 - 3.9 (0.31 - 0.39, 27 - 34)

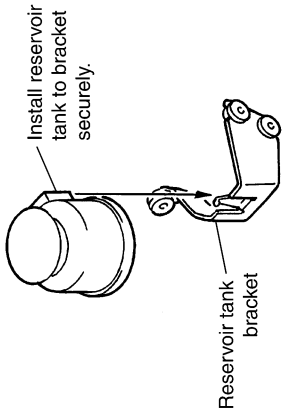

Reservoir tank installation

· Insert hose to spool or end of tube of opponent exactly.
· Do not apply fluid.
· Clamp position is H length (3 - 8 mm, 0.12 - 0.31 in) from hose edge.
· These are applied in ☆ mark portions.

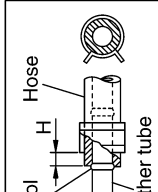

Install with position mark facing to return port.

Install with position mark facing to out of vehicle.

3.0 - 3.9 (0.31 - 0.39, 27 - 34)
Install on upper bracket of rack mounting.

Install with position mark turning to top of vehicle.

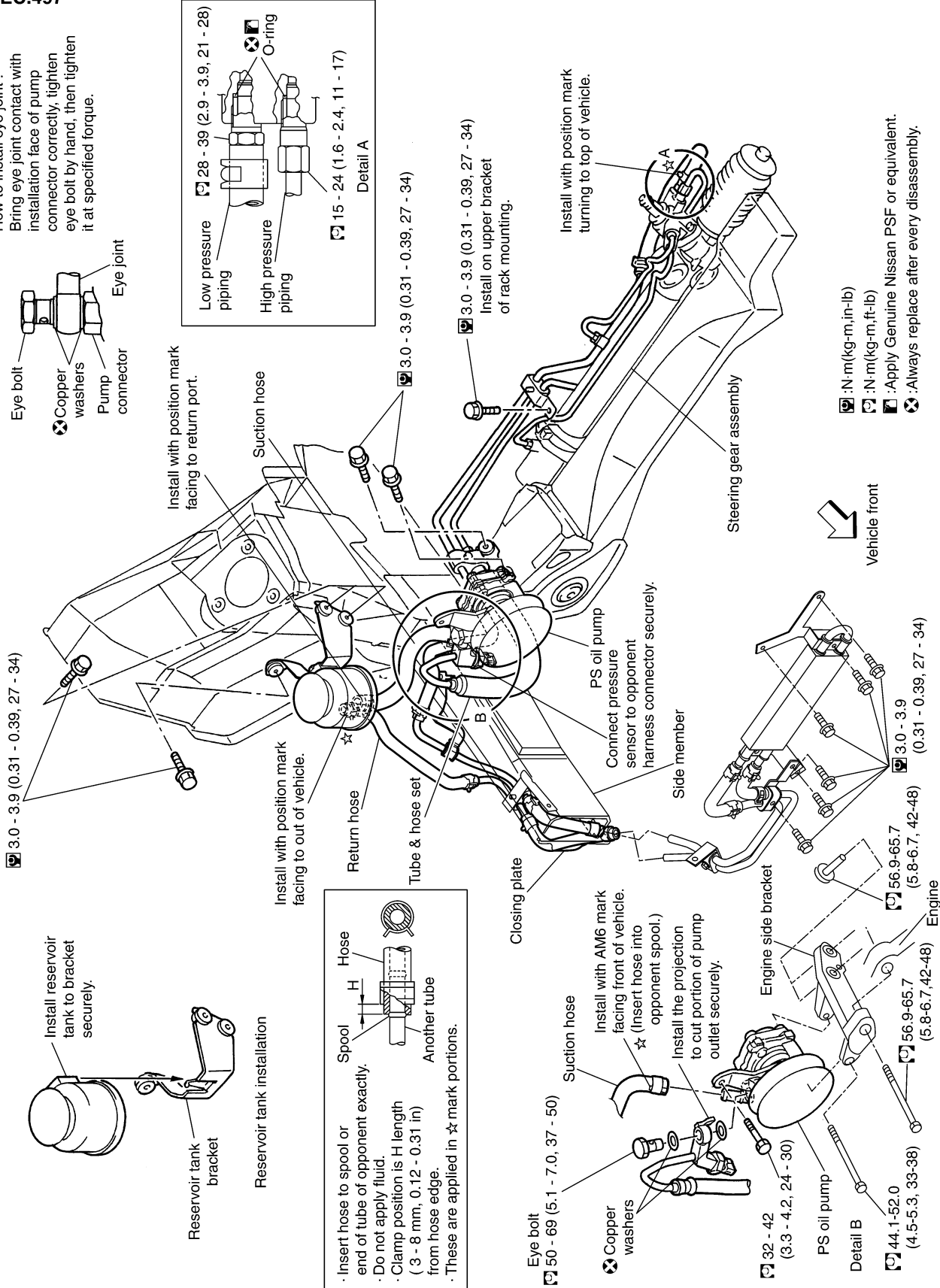

☆ :N·m(kg·m, in·lb)
□ :N·m(kg·m, ft·lb)
■ :Apply Genuine Nissan PSF or equivalent.
⊗ :Always replace after every disassembly.

Vehicle front

3.0 - 3.9 (0.31 - 0.39, 27 - 34)

56.9-65.7 (5.8-6.7, 42-48)

56.9-65.7 (5.8-6.7, 42-48)

44.1-52.0 (4.5-5.3, 33-38)

SGIA0737E

Removal and Installation (For AWD models)

AGS000JA

SEC.497

How to install eye joint :
Bring eye joint contact with installation face of pump connector correctly, tighten eye bolt by hand, then tighten it at specified torque.

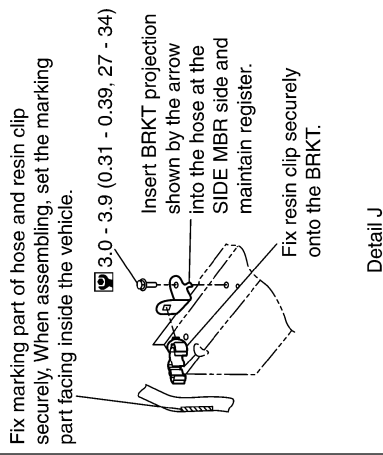
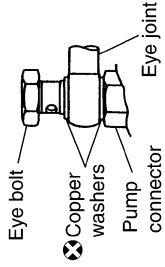

Detail J

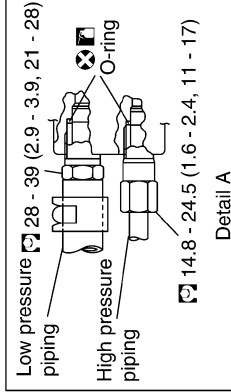

Detail A

3.0 - 3.9 (0.31 - 0.39, 27 - 34)

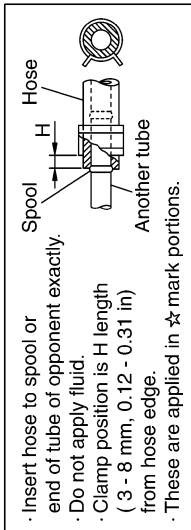

Install with position mark facing to out of vehicle.
Tube & hose set
Connect pressure sensor to opponent harness connector securely.

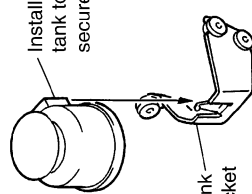

Reservoir tank bracket
Reservoir tank installation

Eye bolt
50 - 69 (5.1 - 7.0, 37 - 50)

Copper washers

Suction hose

Install with AM6 mark facing front of vehicle. ☆ (Insert hose into opponent spool.)

Install the projection to cut portion of pump outlet securely.

32 - 42 (3.3 - 4.2, 24 - 30)

PS oil pump

Detail B

44.1-52.0 (4.5-5.3, 33-38)

Engine side bracket

56.9-65.7 (5.8-6.7, 42-48)

Engine

Side member

PS oil pump

Steering gear assembly

Install with position mark turning to top of vehicle.

3.0 - 3.9 (0.31 - 0.39, 27 - 34)
3.0 - 3.9 (0.31 - 0.39, 27 - 34)
Install on upper bracket of rack mounting.

Ⓜ : N·m (kg·m, in·lb)

Ⓜ : N·m (kg·m, ft·lb)

Ⓜ : Apply Genuine Nissan PSF or equivalent.

Ⓜ : Always replace after every disassembly.

Vehicle front

SGIA0736E

SERVICE DATA AND SPECIFICATIONS (SDS)

SERVICE DATA AND SPECIFICATIONS (SDS)

PPF:00030

Steering Wheel

AGS0000K

End play of the direction for steering wheel	0 mm (0 in)
Steering wheel play on the outer circumference	0 - 35 mm (0 - 1.38 in)

Steering Angle

AGS0000L

Inner wheel Degree minute (Decimal degree)	Minimum	37°30' (37.5°) (2WD models) 38°00' (38.0°) (AWD models)
	Nominal	40°30' (40.5°) (2WD models) 41°00' (41.0°) (AWD models)
	Maximum	41°30' (41.5°) (2WD models) 42°00' (42.0°) (AWD models)
Outer wheel Degree minute (Decimal degree)	Nominal	32°30' (32.5°) (2WD models) 31°40' (31.7°) (AWD models)

Steering Column

AGS0000M

Steering column length "L"	547 - 549 mm (21.54 - 21.61 in)
----------------------------	---------------------------------

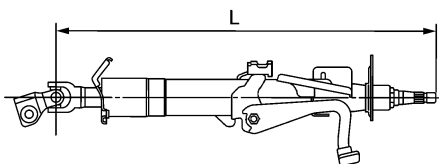

SGIA0145E

Steering Outer Socket and Inner Socket

AGS0000N

Steering gear type		PR26AD
Outer socket ball joint	Swing torque	0.3 - 2.9 N·m (0.03 - 0.29 kg·m, 3 - 25 in·lb)
	Measurement on spring balance (Measuring point: stud cotter pin hole)	4.42 - 42.7 N (0.45 - 4.4 kg, 1.0 - 9.7 lb)
	Rotating torque	0.3 - 2.9 N·m (0.03 - 0.29 kg·m, 3 - 25 in·lb)
	Axial end play	0.5 mm (0.02 in) or less
Inner socket ball joint	Swinging torque	1.0 - 7.8 N·m (0.11 - 0.79 kg·m, 9 - 69 in·lb)
	Measurement on spring balance (measuring point: ↓ mark see below)	10 - 78 N (1.1 - 7.9 kg, 2.43 - 17.44 lb)
	Axial end play	0.2 mm (0.08 in) or less

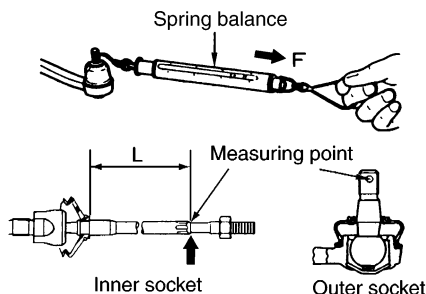

SGIA0493E

SERVICE DATA AND SPECIFICATIONS (SDS)

Steering gear type	PR26AD
Inner socket length "L"	106.3 mm (4.185 in)

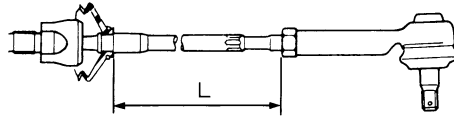

STC1030D

Steering Gear

AGS00000

Steering gear model	PR26AD
Rack neutral position, dimension "L" (rack stroke)	66.6 mm (2.622 in) (2WD models) 66.0 mm (2.598 in) (AWD models)

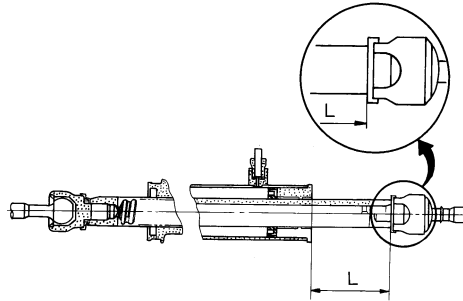

SGIA0629J

Oil Pump

AGS0000P

Oil pump relief hydraulic pressure	9,600 - 10,200 kPa (98 - 104 kg/cm ² , 1,390 - 1,480 psi)
------------------------------------	--

Steering Fluid

AGS0000Q

Fluid capacity	Approx. 1.0 ℓ (1-1/8 US qt, 7/8 Imp qt)
----------------	---