

SECTION **RAX**
REAR AXLE

A
B
C

RAX

CONTENTS

E

PRECAUTIONS	2	REAR DRIVE SHAFT	9	F
Precautions	2	Removal and Installation	9	
PREPARATION	3	REMOVAL	9	
Special Service Tools	3	INSPECTION AFTER REMOVAL	9	G
Commercial Service Tools	3	INSTALLATION	9	
NOISE, VIBRATION AND HARSHNESS (NVH)		Disassembly and Assembly	9	
TROUBLESHOOTING	4	INSPECTION BEFORE DISASSEMBLY	10	H
NVH Troubleshooting Chart	4	DISASSEMBLY	10	
WHEEL HUB	5	INSPECTION AFTER DISASSEMBLY	11	
On-Vehicle Service Inspection	5	ASSEMBLY	11	I
REAR WHEEL BEARING	5	SERVICE DATA	15	
Removal and Installation	5	Wheel Bearing	15	
REMOVAL	5	Drive Shaft	15	J
INSTALLATION	6	Z100D90F	15	
Disassembly and Assembly	6			
DISASSEMBLY	6			K
INSPECTION AFTER DISASSEMBLY	7			
ASSEMBLY	7			L

M

PRECAUTIONS

PRECAUTIONS

PFP:00001

Precautions

ADS0009

- When installing rubber parts, final tightening must be carried out under unladen condition*: with tires on ground.
Oil will shorten the life of rubber bushes. Be sure to wipe off any spilled oil.
*: Fuel, radiator coolant and engine oil full. Spare tire, jack, hand tools and mats in designated positions.
- After installing removed suspension parts, check wheel alignment and adjust if necessary.
- Do not jack up at lower arm.
- Use flare nut wrench when removing or installing brake lines.
- Always torque brake lines when installing.

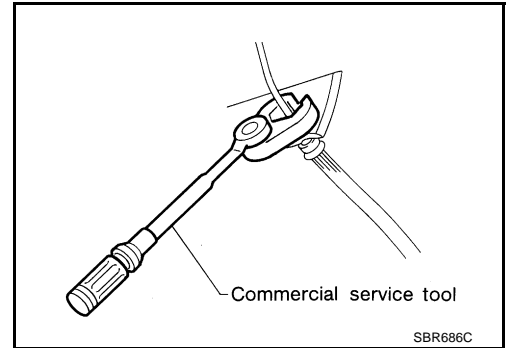

CAUTION:

Observe the following precautions when disassembling and servicing drive shaft.

- Perform work in a location which is as dust-free as possible.
- Before disassembling and servicing, clean the outside of parts.
- Disassembly and service location must be taken to prevent the entry of foreign objects.
- Disassembled parts must be carefully reassembled in the correct order. If work is interrupted, a clean cover must be placed over parts.
- Paper shop cloths must be used. Fabric shop cloths must not be used because of the danger of lint adhering to parts.
- Disassembled parts (except for rubber parts) should be cleaned with kerosene which shall be removed by blowing with air or wiping with paper shop cloths.

PREPARATION

PREPARATION

PFP:00002

Special Service Tools

ADS0001E

The actual shapes of Kent-Moore tools may differ from those of special service tools illustrated here.

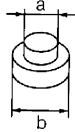
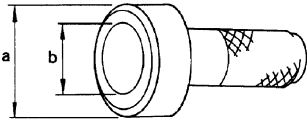
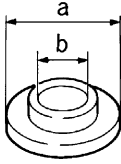
Tool number (Kent-Moore No.) Tool name	Description
ST33061000 (J 8107-2) Drift a: 28.5 mm (1.122 in) dia. b: 38.0 mm (1.496 in) dia.	 <p style="text-align: center;">ZZA0969D</p> Removing inner race of outer-side bearing
KV381 00500 (—) Drift a: 80 mm (3.15 in) dia. b: 60 mm (2.36 in) dia.	 <p style="text-align: center;">ZZA0701D</p> Installing drive shaft plug
KV381 02200 (—) Drift a: 90 mm (3.54 in) dia. b: 31 mm (1.22 in) dia.	 <p style="text-align: center;">ZZA0920D</p> Installing drive shaft plug

A
 B
 C
RAX
 E
 F
 G
 H
 I
 J
 K
 L
 M

Commercial Service Tools

ADS0000B

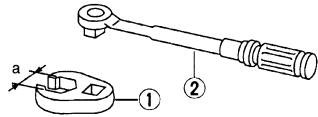
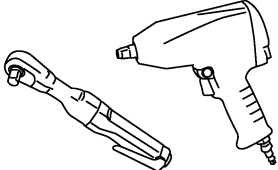
Tool name	Description
1. Flare nut crowfoot a: 10 mm (0.39 in) 2. Torque wrench	 <p style="text-align: center;">S-NT360</p> Removing and installing each brake piping
Power tool	 <p style="text-align: center;">PBIC0190E</p> <ul style="list-style-type: none"> ● Removing wheel nuts ● Removing brake caliper assembly

NOISE, VIBRATION AND HARSHNESS (NVH) TROUBLESHOOTING

NOISE, VIBRATION AND HARSHNESS (NVH) TROUBLESHOOTING

PF0:00003

NVH Troubleshooting Chart

ADS0000C

Use chart below to help you find the cause of the symptom. If necessary, repair or replace these parts.

Symptom		Possible cause and SUSPECTED PARTS												
		Excessive joint angle	Joint sliding resistance	Imbalance	Improper installation, looseness	Parts interference	PROPELLER SHAFT	DIFFERENTIAL	FRONT AXLE AND FRONT SUSPENSION	REAR AXLE	TIRES	ROAD WHEEL	DRIVE SHAFT	BRAKES
DRIVE SHAFT	Noise	x	x				x	x	x	x	x		x	x
	Shake	x		x			x		x	x	x		x	x
REAR AXLE					x	x	x	x		x	x	x	x	x
					x	x	x		x		x	x	x	x
	Vibration				x	x	x		x		x		x	x
	Shimmy				x	x			x		x		x	x
	Judder				x				x		x	x		x
	Poor quality ride or handling				x	x			x		x			

x: Applicable

WHEEL HUB

WHEEL HUB

PPF:43202

On-Vehicle Service Inspection

ADS0000D

Check rear axle parts for excessive play, cracks, wear or other damage.

- Shake each rear wheel to check for excessive play.
- Retighten all nuts and bolts to the specified torque.
- Make sure that cotter pin is inserted.

REAR WHEEL BEARING

With vehicle raised, inspect the following.

- Move wheel hub in the axial direction by hand. Check that there is no looseness of rear wheel bearings.

Axial end play : 0.05 mm (0.002 in) or less

- Rotate wheel hub and check that there is no unusual noise or other irregular conditions. If there are any irregular conditions, replace wheel bearings.

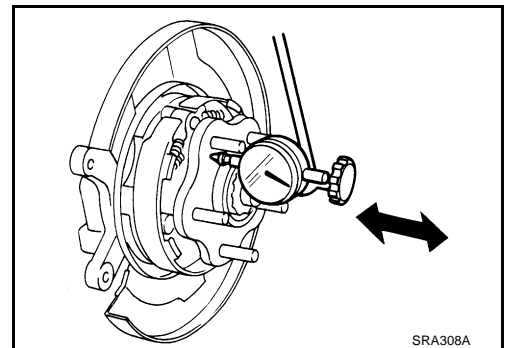

Removal and Installation

ADS0000E

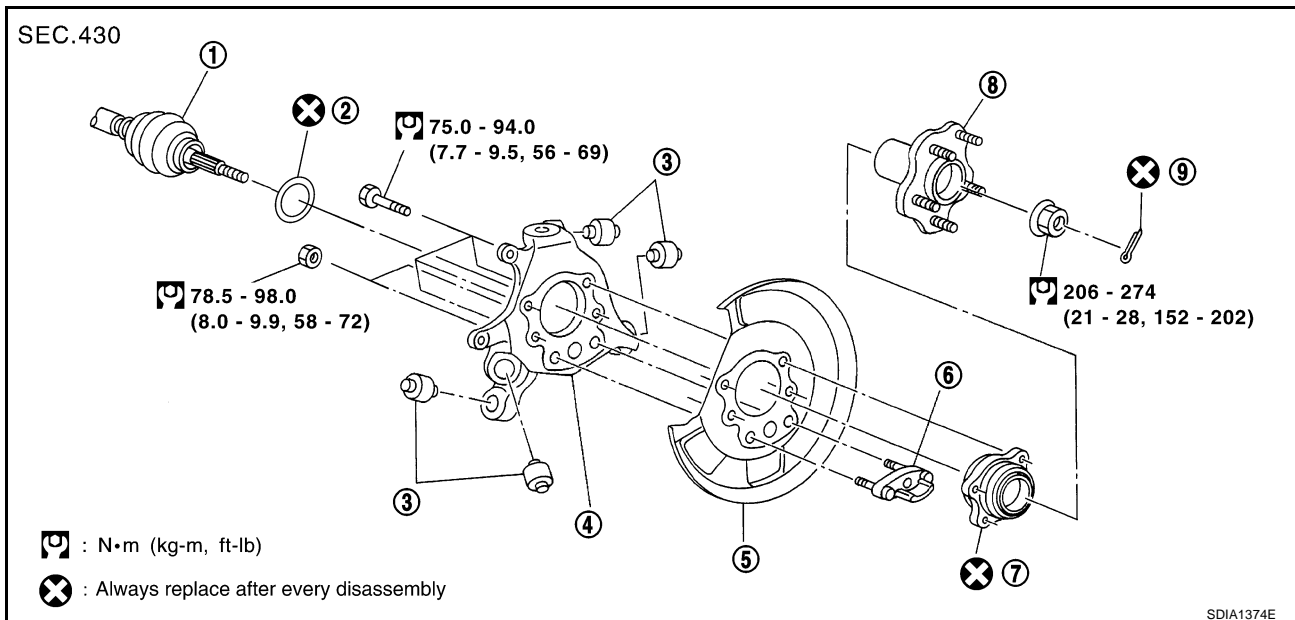

REMOVAL

- | | | |
|------------------|----------------|-----------------|
| 1. Drive shaft | 2. Dust shield | 3. Bushing |
| 4. Axle housing | 5. Back plate | 6. Anchor block |
| 7. Wheel bearing | 8. Wheel hub | 9. Cotter pin |

1. Remove tire with power tool.
2. Remove cotter pin. Then remove lock nut from drive shaft.

CAUTION:

Wheel bearing does not require maintenance. If any of the following symptoms are noted, replace wheel bearing assembly.

- Growling noise is emitted from wheel bearing during operation.
- Wheel hub bearing drags or turns roughly. This occurs when turning hub by hand after bearing lock nut is tightened to specified torque.
- After wheel bearing is removed from hub.

WHEEL HUB

3. Remove brake caliper from axle housing with power tool. Hang it in a place where it will not interfere with work.

CAUTION:

- **Avoid depressing brake pedal while brake caliper is removed.**

4. Remove disc rotor. Then remove parking cable and parking brake shoe from back plate. Refer to [PB-5, "PARKING BRAKE CONTROL"](#) , [PB-7, "PARKING BRAKE SHOE"](#) .
5. Remove radius rod.
6. Set mission jack on rear lower link, retighten fitting bolt and nut in front lower link and rear lower link.
7. Remove fitting bolt and nut in lower side of shock absorber.
8. Slowly transmission jack, then remove coil spring from rear lower link.
9. Remove shock absorber, front lower link and rear lower link from axle housing.
10. Remove drive shaft from axle housing.
11. Remove cotter pin and nut from suspension arm. Then remove suspension arm from axle housing using ball joint remover.

CAUTION:

- **While ball joint remover, temporarily tighten nut so as not to damage screw part.**

INSTALLATION

- Refer to [RAX-5, "Removal and Installation"](#) for tightening torque. Install in the reverse order of removal.

CAUTION:

Refer to component parts location and do not reuse non-reusable parts.

Disassembly and Assembly

ADS0000F

DISASSEMBLY

1. Remove wheel hub assembly, back plate and anchor block from axle housing.
2. Remove wheel hub from wheel bearing using a suitable Tool.

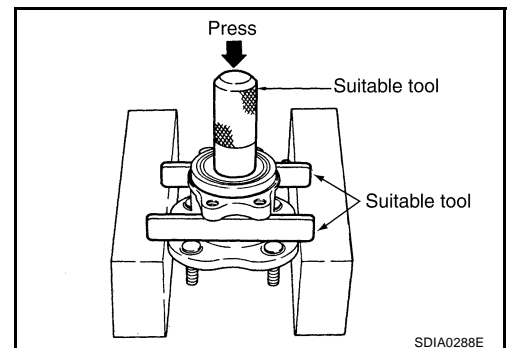

3. Use a bearing replacer, puller, and drift (special service tool) to remove inner race of outer-side wheel bearing from wheel hub.

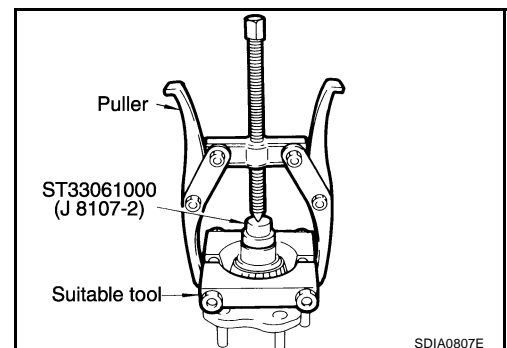

WHEEL HUB

- Remove each bushing using suitable drift.

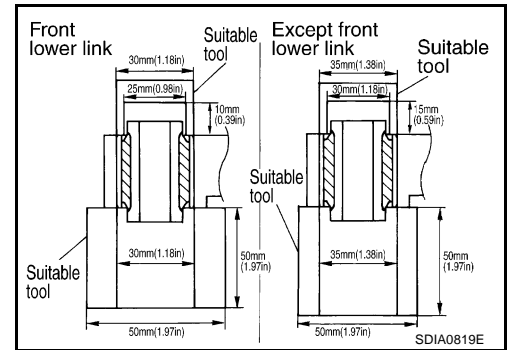

A
B
C

RAX

INSPECTION AFTER DISASSEMBLY

Wheel Hub

- Inspect wheel hub for deformation, cracks, and other damage. If any irregular conditions are found, replace wheel hub.

Axle Housing

- Inspect axle housing for deformation, cracks, and other damage. If any irregular conditions are found, replace axle housing.

Back Plate

- Inspect back plate for deformation, cracks, and other damage. If any irregular conditions are found, replace back plate.

ASSEMBLY

- Use a drift to install each bushing onto axle housing.

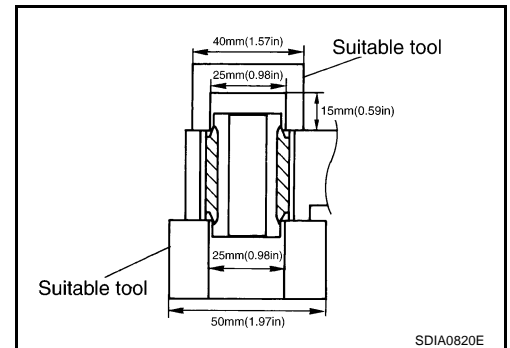

E
F
G

- Use a drift to install wheel hub onto wheel bearing.

CAUTION:

- Do not reuse wheel bearing.

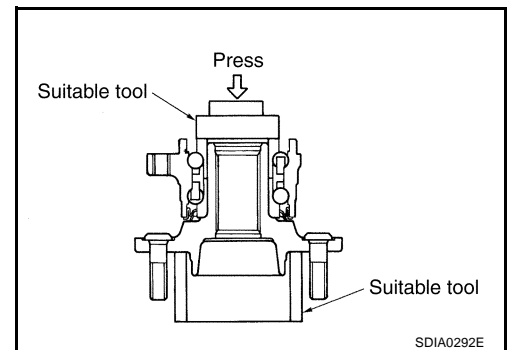

H
I
J
K
L
M

- With wheel bearing pressed into axle housing, apply 49,033 N (5,000 kg, 11,000 lb) to wheel hub and rotate both clockwise and counterclockwise 10 times to minimize resistance.

NOTE:

Install to drive shaft and tighten wheel hub lock nuts to specified torque. Rotate in forward and reverse direction 10 times each to ensure a good fit.

- Install back plate and wheel bearing onto axle housing.

WHEEL HUB

5. Attach spring scale in the position shown in illustration and pull at a rate of 10 ± 2 rpm to measure rotating torque.

Rotating torque:

Less than 1.88 N-m (0.19 kg-m, 17 in-lb)

Spring scale reading:

Less than 18.5 N (1.89 kg, 4.16 lb)

- If measured value is outside specifications, replace wheel bearing.
6. Inspect to check that there is no excessive play.
 7. Install anchor block onto axle housing.

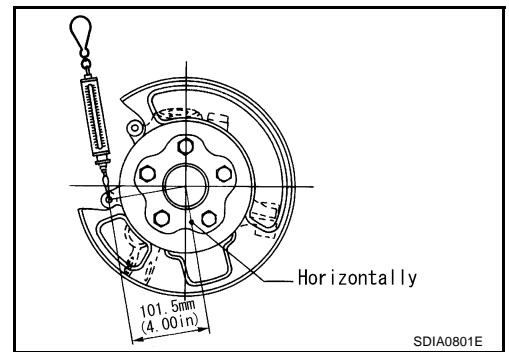

REAR DRIVE SHAFT

REAR DRIVE SHAFT

PFP:39600

Removal and Installation

ADS0000H

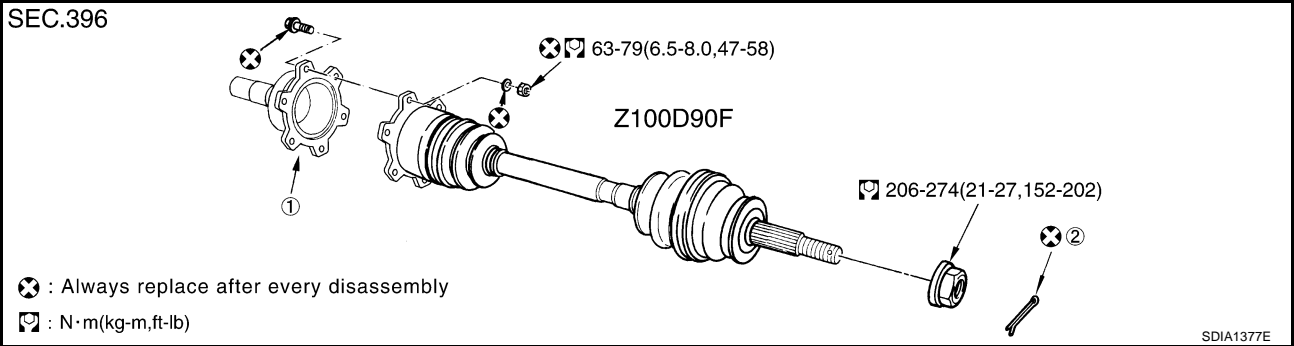

1. Side flange

2. Cotter pin

REMOVAL

1. Remove tire with power tool.
2. Remove cotter pin. Then remove lock nut from drive shaft.
3. Remove stabilizer connecting rod mounting bracket fixing nuts and free stabilizer connecting rod.
4. Remove fixing bolt and nut in rear drive shaft.
5. Remove rear drive shaft from vehicle.

INSPECTION AFTER REMOVAL

- Move joint in up/down, left/right, and axial direction. Check for any rough movement or significant looseness.
- Check boot for cracks or other damage, and also for grease leakage.

INSTALLATION

- Refer to [RAX-9, "Removal and Installation"](#) for tightening torque. Install in the reverse order of removal.

CAUTION:

Refer to component parts location and do not reuse non-reusable parts.

Disassembly and Assembly

ADS0000I

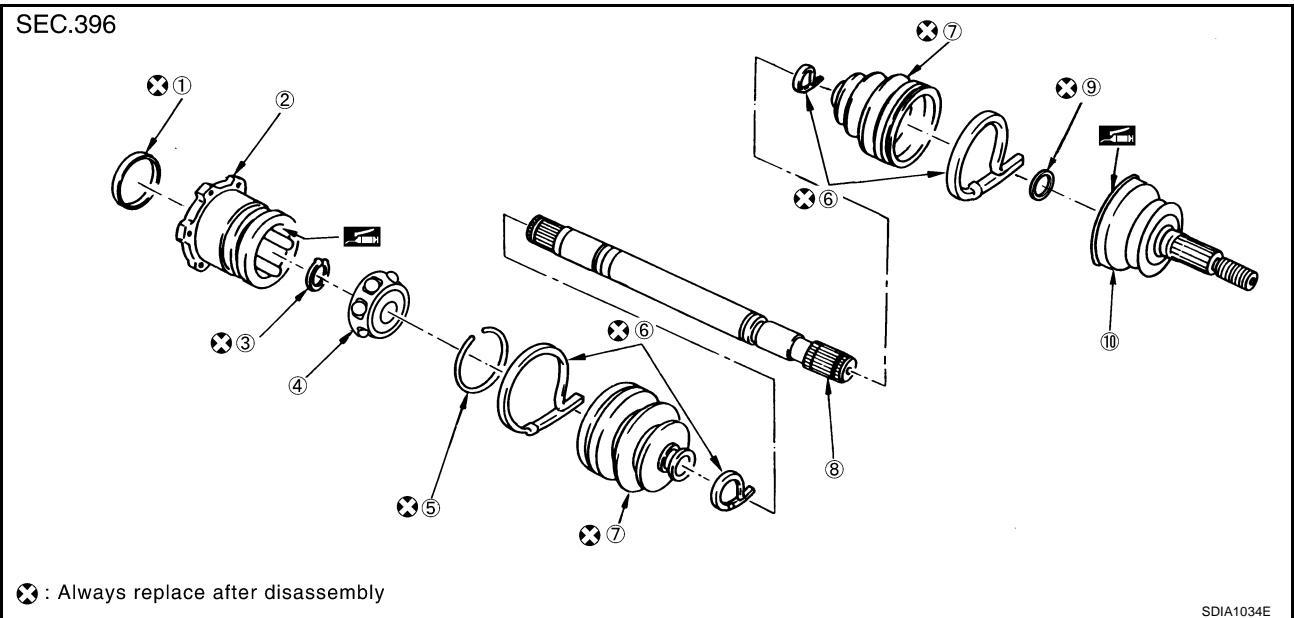

1. Plug

2. Housing

3. Snap ring

4. Ball cage/Steel ball/Inner race assembly

5. Stopper ring

6. Boot band

REAR DRIVE SHAFT

7. Boot

8. Shaft

9. Circular clip

10. Joint sub-assembly

INSPECTION BEFORE DISASSEMBLY

- Move joint in up/down, left/right, and axial direction. Check for any rough movement or significant looseness.
- Check boot for cracks or other damage, and also for grease leakage.

DISASSEMBLY

Wheel Side

1. Place drive shaft in a vise.

CAUTION:

When retaining drive shaft in a vise, always use copper or aluminum plates between vise and shaft.

2. Remove boot bands. Then remove boot from joint sub-assembly.
3. Screw a drive shaft puller 30 mm (1.18 in) or more into threaded part of joint sub-assembly. Pull joint sub-assembly out of shaft.

CAUTION:

If joint sub - assembly cannot be removed after five or more unsuccessful attempts, replace the entire drive shaft assembly.

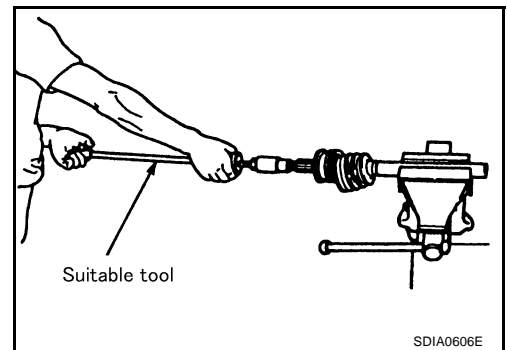

4. Remove boot from shaft.
5. Remove circular clip from shaft.
6. While rotating ball cage, remove old grease on joint sub-assembly with paper towels.

Final Drive Side

1. Remove boot bands.
2. Press shaft in a vise.

CAUTION:

When retaining drive shaft in a vise, always use copper or aluminum plates between vise and shaft.

3. If plug needs to be removed, move boot to wheel side, and drive it out with a plastic hammer.
4. Remove stopper ring with a flat-bladed screwdriver, and pull out housing.

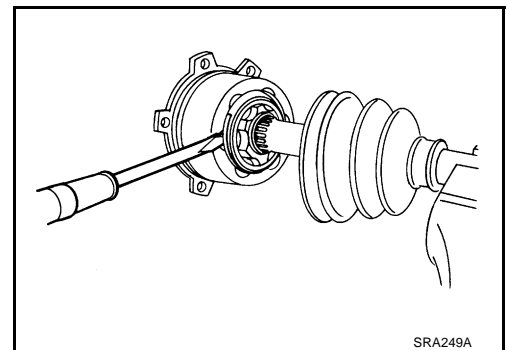

REAR DRIVE SHAFT

5. Remove snap ring, then remove ball cage, inner race and balls as a unit

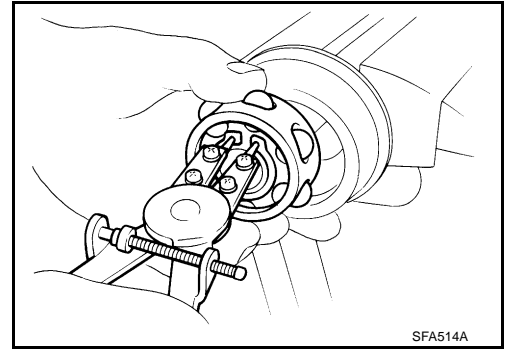

6. Remove boot from shaft.

CAUTION:

- Cover drive shaft serration with tape to prevent damage to boot.

7. Remove old grease on housing with paper towels.

INSPECTION AFTER DISASSEMBLY

Drive Shaft

- Replace shaft if there is any runout, cracking, or other damage.

Joint Sub-Assembly (Fixed Joint Side)

- Check that there is no rough rotation or unusual axial looseness.
- Check that there is no foreign material inside joint.

CAUTION:

If there are any irregular conditions of joint assembly components, replace the entire joint assembly.

Housing (Sliding Joint Side)

- Check that there is no damage or unusual wear of ball rolling surface.
- Check that there is no damage to shaft screws.
- Check that there is no deformation of boot installation parts.

Ball Cage

- Check that there is no damage or other irregular conditions of sliding surface.

Steel Ball

- Check that there is no damage or unusual wear.

Inner Race

- Check that there is no damage or unusual wear of ball rolling surface.
- Check that there is no damage to serrated part.

ASSEMBLY

Wheel Side

1. Insert the amount grease (Nissan genuine grease or equivalent) into joint sub-assembly serration hole until grease begins to ooze from ball groove and serration hole. After insert grease, use a shop cloth to wipe off old grease that has oozed out.

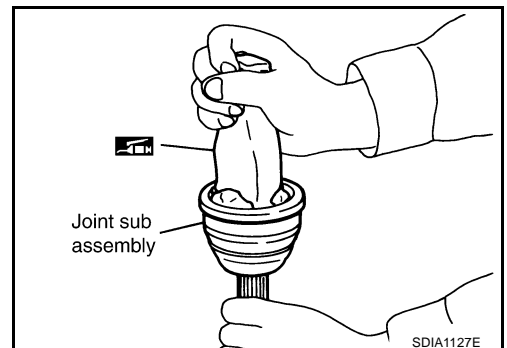

A
B
C

RAX

E

F

G

H

I

J

K

L

M

REAR DRIVE SHAFT

2. Wind serrated part of drive shaft with tape. Install boot band and boot to shaft. Be careful not to damage boot.

CAUTION:

Discard old boot band and boot; replace with new ones.

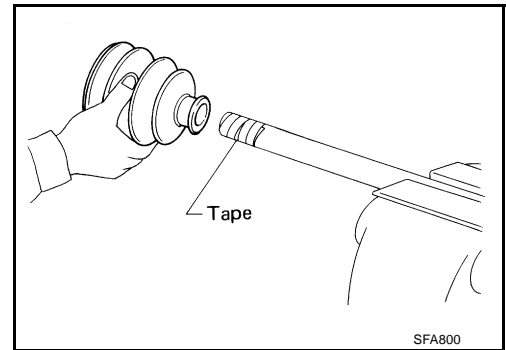

3. Remove protective tape wound around serrated part of shaft.

4. Attach circular clip to shaft. At this time, circular clip must fit securely into shaft groove. Attach nut to joint sub-assembly. Use a wooden hammer to press-fit.

CAUTION:

Discard old circular clip; replace with a new one.

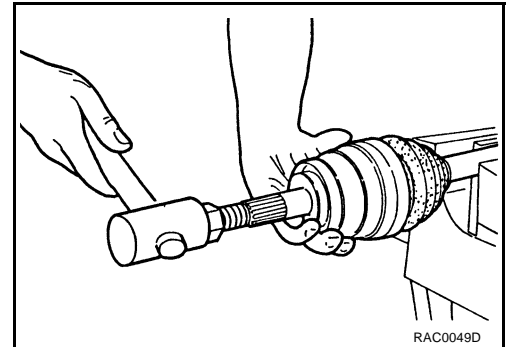

5. Insert the amount grease (Nissan genuine grease or equivalent) listed below into housing from large end of boot.

Grease amount : 86 - 96 g (3.03 - 3.39 oz)

6. Install boot securely into grooves (indicated by * marks) shown in the figure.

CAUTION:

If there is grease on boot mounting surfaces (indicated by * marks) of joint, boot may come off. Remove all grease from surfaces.

7. Check that boot installation length "L" is the length indicated below. Insert a flat-bladed screwdriver or similar tool into smaller side of boot. Remove air from boot to prevent boot deformation.

Boot installation length ("L") :97 mm (3.82 in)

CAUTION:

- **Boot may brake if boot installation length is than standard value**
- **Be careful that screwdriver tip does not contact inside surface of boot.**

8. Secure big and small ends of boot with new boot bands as shown in the figure.

CAUTION:

Check that boot installation position does not change. If position changes, reinstall boot bands.

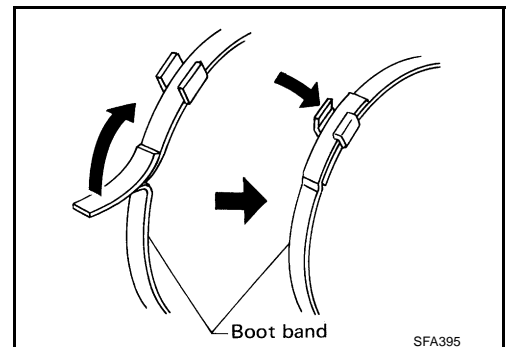
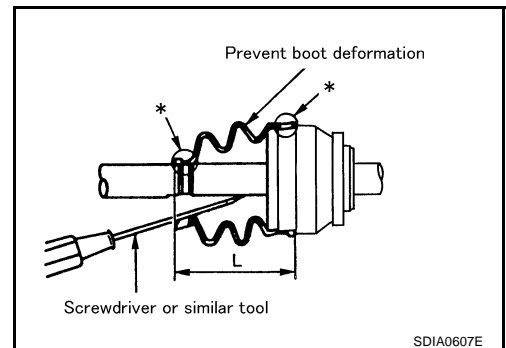

REAR DRIVE SHAFT

Final Drive Side

1. If plug has been removed, use a drift (special service tool) to press in a new one.

CAUTION:

Discard old plug; replace with new ones.

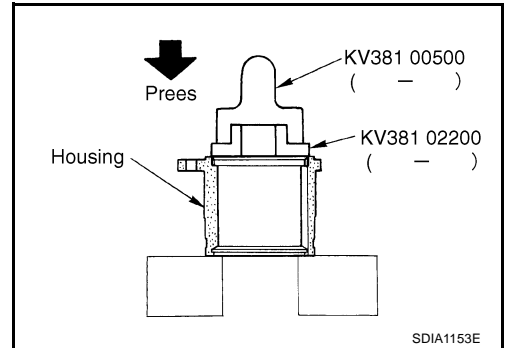

2. Wind serrated part of drive shaft with tape. Install boot band and boot to shaft. Be careful not to damage boot.

CAUTION:

Discard old boot band and boot; replace with new ones.

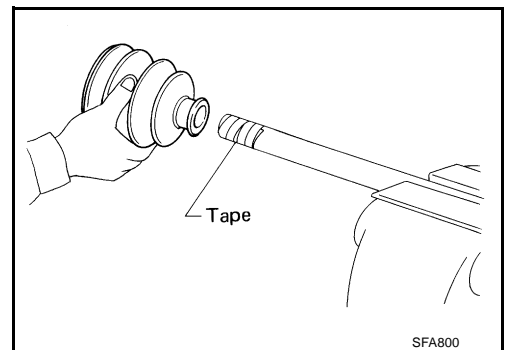

3. Remove protective tape wound around serrated part of shaft.
4. Install ball cage/steel ball/inner race assembly to shaft, and secure them tightly with a snap ring.

CAUTION:

Discard old snap ring; replace with new ones.

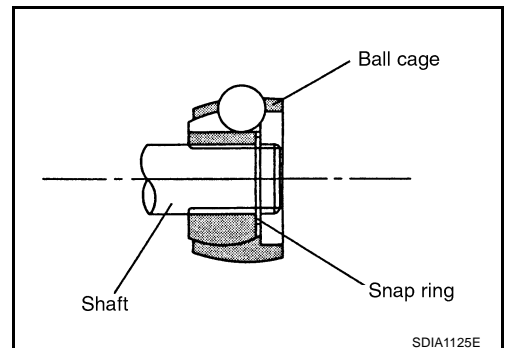

5. Insert the amount grease (Nissan genuine grease or equivalent) onto housing (* point) to the quantity mentioned below, and install it to shaft.

Specified amount of grease:

124 - 134 g (4.37 - 4.73 oz)

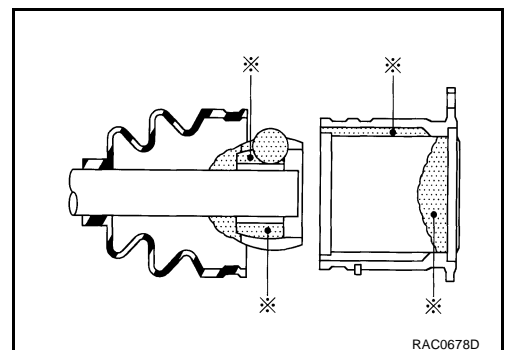

6. Install stopper ring to housing.
7. After installed, pull shaft to check engagement between joint sub-assembly and stopper ring.

A
B
C
RAX
E
F
G
H
I
J
K
L
M

REAR DRIVE SHAFT

8. Install boot securely into grooves (indicated by* marks) shown in the figure.

CAUTION:

If there is grease on boot mounting surfaces (indicated by* marks) of shaft and housing, boot may come off. Remove all grease from surfaces.

9. Check that boot installation length "L" is the length indicated below. Insert a flat-bladed screwdriver or similar tool into smaller side of boot. Remove air from boot to prevent boot deformation.

Length "L" : 93.9 mm (3.697 in)

CAUTION:

- Boot may break if boot installation length is than standard value.
- Take care not to touch tip of screw driver to inside of boot.

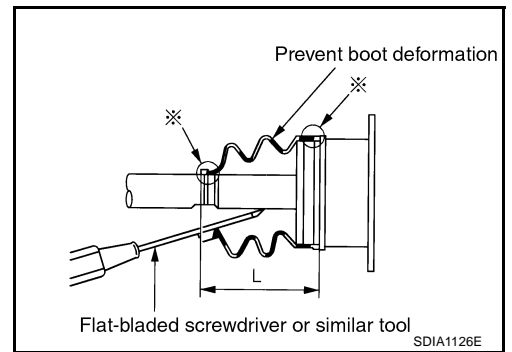

10. Secure big and small ends of boot with new boot bands as shown in the figure.

CAUTION:

Check that boot installation position does not change. If position changes, reinstall boot bands.

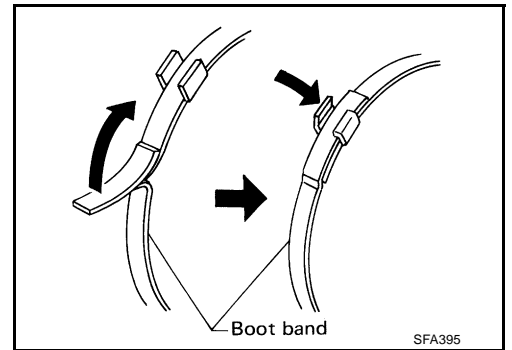

11. After installing housing and shaft, rotate boot to check whether or not the actual position is correct. If boot position is not correct, secure boot with new boot band again.

SERVICE DATA

SERVICE DATA

PPF:00030

Wheel Bearing

ADS0000J

A

B

C

End play in axial direction	0.05 mm (0.002 in) or less
Rotational torque	Less than 1.88 N-m (0.19 kg-m, 17 in-lb)
Measurement of spring scale (Measuring point: Brake caliper)	Less than 18.5 N (1.89 kg, 4.16 lb)

Drive Shaft Z100D90F

ADS0000K

RAX

E

F

G

H

I

J

K

L

M

Joint type	Wheel side	Z100
	Final drive side	D90F
Grease quantity	Wheel side	86 - 96 g (3.03 - 3.39 oz)
	Final drive side	124 - 134 g (4.37 - 4.73 oz)
Boots installed length	Wheel side	97 mm (3.82 in)
	Final drive side	93.9 mm (3.697 in)

SERVICE DATA
