

A  
B  
MT  
D  
E  
F  
G  
H  
I  
J  
K  
L  
M

# SECTION **MT**

## MANUAL TRANSMISSION

### CONTENTS

<p><b>PRECAUTIONS</b> ..... 2</p> <p style="padding-left: 20px;">Precautions for Battery Service ..... 2</p> <p style="padding-left: 20px;">Service Notice or Precautions ..... 2</p> <p><b>PREPARATION</b> ..... 3</p> <p style="padding-left: 20px;">Special Service Tools ..... 3</p> <p style="padding-left: 20px;">Commercial Service Tools ..... 5</p> <p><b>NOISE, VIBRATION AND HARSHNESS (NVH)</b></p> <p><b>TROUBLESHOOTING</b> ..... 6</p> <p style="padding-left: 20px;">NVH Troubleshooting Chart ..... 6</p> <p><b>DESCRIPTION</b> ..... 7</p> <p style="padding-left: 20px;">Cross-Sectional View ..... 7</p> <p style="padding-left: 40px;">DOUBLE-CONE SYNCHRONIZER ..... 7</p> <p style="padding-left: 40px;">TRIPLE-CONE SYNCHRONIZER ..... 8</p> <p><b>M/T OIL</b> ..... 9</p> <p style="padding-left: 20px;">Changing M/T Oil ..... 9</p> <p style="padding-left: 40px;">DRAINING ..... 9</p> <p style="padding-left: 40px;">FILLING ..... 9</p> <p style="padding-left: 20px;">Checking M/T Oil ..... 9</p> <p style="padding-left: 40px;">OIL LEAKAGE AND OIL LEVEL ..... 9</p> <p><b>REAR OIL SEAL</b> ..... 10</p> <p style="padding-left: 20px;">Removal and Installation ..... 10</p> <p style="padding-left: 40px;">REMOVAL ..... 10</p> <p style="padding-left: 40px;">INSTALLATION ..... 10</p> <p><b>POSITION SWITCH</b> ..... 11</p> <p style="padding-left: 20px;">Checking ..... 11</p> <p style="padding-left: 40px;">COMPONENT LOCATION ..... 11</p> <p style="padding-left: 40px;">BACK-UP LAMP SWITCH ..... 11</p> <p style="padding-left: 40px;">PARK/NEUTRAL POSITION SWITCH ..... 11</p>	<p><b>SHIFT CONTROL</b> ..... 12</p> <p style="padding-left: 20px;">Removal and Installation ..... 12</p> <p style="padding-left: 40px;">COMPONENTS ..... 12</p> <p style="padding-left: 40px;">REMOVAL ..... 12</p> <p style="padding-left: 40px;">INSTALLATION ..... 14</p> <p style="padding-left: 40px;">INSPECTION AFTER INSTALLATION ..... 16</p> <p><b>AIR BREATHER HOSE</b> ..... 17</p> <p style="padding-left: 20px;">Removal and Installation ..... 17</p> <p><b>TRANSMISSION ASSEMBLY</b> ..... 18</p> <p style="padding-left: 20px;">Removal and Installation ..... 18</p> <p style="padding-left: 40px;">COMPONENTS ..... 18</p> <p style="padding-left: 40px;">REMOVAL ..... 18</p> <p style="padding-left: 40px;">INSTALLATION ..... 20</p> <p style="padding-left: 20px;">Disassembly and Assembly ..... 21</p> <p style="padding-left: 40px;">COMPONENTS ..... 21</p> <p style="padding-left: 40px;">DISASSEMBLY ..... 26</p> <p style="padding-left: 40px;">INSPECTION AFTER DISASSEMBLY ..... 37</p> <p style="padding-left: 40px;">ASSEMBLY ..... 40</p> <p><b>SERVICE DATA AND SPECIFICATIONS (SDS)</b> ..... 59</p> <p style="padding-left: 20px;">General Specifications ..... 59</p> <p style="padding-left: 20px;">End Play ..... 59</p> <p style="padding-left: 20px;">Snap Rings ..... 60</p> <p style="padding-left: 20px;">Baulk Ring Clearance ..... 61</p>
---	--

# PRECAUTIONS

---

## PRECAUTIONS

PFP:00001

### Precautions for Battery Service

NCS000AG

Before disconnecting the battery, lower both the driver and passenger windows. This will prevent any interference between the window edge and the vehicle when the door is opened/closed. During normal operation, the window slightly raises and lowers automatically to prevent any window to vehicle interference. The automatic window function will not work with the battery disconnected.

### Service Notice or Precautions

NCS000AH

- Do not reuse transmission oil, once it has been drained.
- Check oil level or replace oil with vehicle on level ground.
- During removal or installation, keep inside of transmission clear of dust or dirt.
- Check for the correct installation status prior to removal or disassembly. If matching marks are required, be certain they do not interfere with the function of the parts they are applied to.
- In principle, tighten bolts or nuts gradually in several steps working diagonally from inside to outside. If tightening sequence is specified, observe it.
- Be careful not to damage sliding surfaces and mating surfaces.
- Do not hold control lever housing to prevent bushing of control lever housing from deformation when moving transmission assembly.

# PREPARATION



## PREPARATION

PF0:00002

### Special Service Tools

NCS000AI

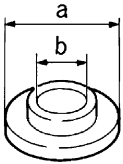
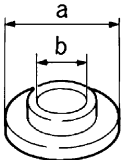
The actual shapes of Kent-Moore tools may differ from those of special service tools illustrated here.

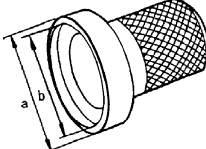
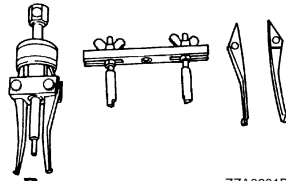
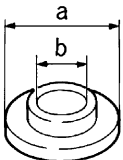
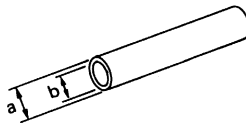
Tool number (Kent-Moore No.) Tool name	Description
ST30911000 ( — ) Inserter a: 98 mm (3.86 in) dia. b: 40 mm (1.57 in) dia.	 <p>ZZA0920D</p> <ul style="list-style-type: none"> <li>● Main shaft bearing installation</li> <li>● 5th-6th synchronizer assembly installation</li> <li>● Reverse main gear bushing installation</li> <li>● 3rd gear bushing installation</li> <li>● 3rd-4th synchronizer assembly installation</li> </ul>
ST30022000 ( — ) Inserter a: 110 mm (4.33 in) dia. b: 46 mm (1.81 in) dia.	 <p>ZZA0920D</p> <ul style="list-style-type: none"> <li>● 3rd main gear installation</li> <li>● 4th main gear installation</li> </ul>
ST27861000 ( — ) Support ring a: 62 mm (2.44 in) dia. b: 52 mm (2.05 in) dia.	 <p>ZZA0832D</p> <ul style="list-style-type: none"> <li>● 1st-2nd synchronizer assembly installation</li> <li>● 1st gear bushing installation</li> </ul>
ST33400001 (J-26082) Drift a: 60 mm (2.36 in) dia. b: 47 mm (1.85 in) dia.	 <p>ZZA0814D</p> <p>Rear oil seal installation</p>
KV381054S0 ( — ) Oil seal puller	 <p>ZZA0601D</p> <p>Remove rear oil seal</p>
ST30032000 (J-26010-01) Inserter a: 80 mm (3.15 in) dia. b: 31 mm (1.22 in) dia.	 <p>ZZA0920D</p> <p>Counter rear bearing inner race installation</p>
KV32102700 ( — ) Drift a: 48 mm (1.89 in) dia. b: 41 mm (1.61 in) dia.	 <p>ZZA0534D</p> <p>Main drive gear bearing installation</p>

A  
B  
MT  
D  
E  
F  
G  
H  
I  
J  
K  
L  
M

# PREPARATION

Tool number (Kent-Moore No.) Tool name	Description
ST23860000 ( — ) Drift a: 38 mm (1.50 in) dia. b: 33 mm (1.30 in) dia.	Reverse counter gear installation
ST01530000 ( — ) Drift a: 50 mm (1.97 in) dia. b: 41 mm (1.61 in) dia.	Reverse synchronizer assembly installation
ST35291000 ( — ) Drift a: 40 mm (1.57 in) dia. b: 29.5 mm (1.161 in) dia. c: 22.5 mm (0.886 in) dia.	Striking rod oil seal installation
KV40100630 (J-26092) Inserter a: 67 mm (2.64 in) dia. b: 38 mm (1.50 in) dia.	4th counter gear thrust washer installation
KV38102100 (J-25803-01) Drift a: 44 mm (2.36 in) dia. b: 36 mm (1.42 in) dia. c: 24.5 mm (0.965 in) dia.	Front cover oil seal installation
KV32103300 (J-46529) Press plate	Reverse synchronizer assembly installation

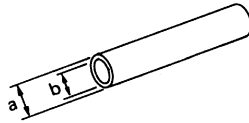

ZZA0534D

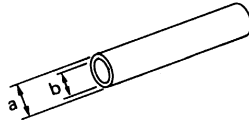

ZZA0534D

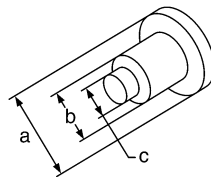

SCIA1575E

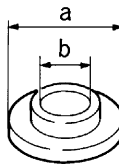

ZZA0920D

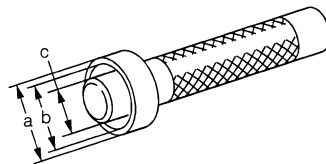

ZZA1046D

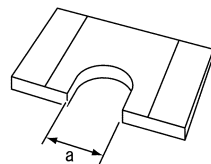

PCIB0165J

# PREPARATION

Tool number (Kent-Moore No.) Tool name	Description
ST30031000 (J-22912-01) Puller	Inner baulk ring support
ST22490000 ( — ) Adapter setting plate	Hold adapter plate

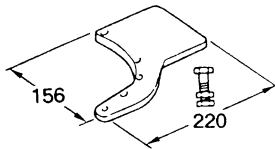
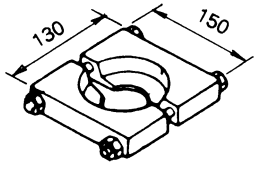

A  
B  
**MT**  
D  
E  
F  
G  
H  
I  
J  
K  
L  
M

## Commercial Service Tools

NCS000AJ

Tool name	Description
Puller	Each bearing, gear and bushing removal
Pin punch Tip diameter: 6.0 mm (0.24 in) dia.	Each retaining pin removal and installation
Puller	<ul style="list-style-type: none"> <li>● Reverse synchronizer assembly removal</li> <li>● Reverse counter gear removal</li> <li>● Reverse main gear removal</li> </ul>
Power tool	Loosening bolts and nuts

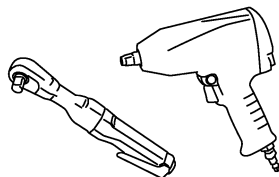
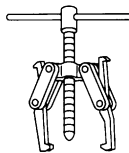
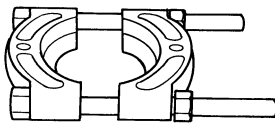

# NOISE, VIBRATION AND HARSHNESS (NVH) TROUBLESHOOTING

## NOISE, VIBRATION AND HARSHNESS (NVH) TROUBLESHOOTING

PF0:00003

### NVH Troubleshooting Chart

NCS000AK

Use the chart below to help you find the cause of the symptom. The numbers indicate the order of the inspection. If necessary, repair or replace these parts.

Reference page		<a href="#">MT-9</a>	<a href="#">MT-9</a>	<a href="#">MT-9</a>	<a href="#">MT-21</a>	<a href="#">MT-21</a>	<a href="#">MT-12</a>	<a href="#">MT-24</a>	<a href="#">MT-24</a>	<a href="#">MT-22</a>	<a href="#">MT-22</a>	<a href="#">MT-22</a>	<a href="#">MT-22</a>
SUSPECTED PARTS (Possible cause)		OIL (Oil level is low.)	OIL (Wrong oil.)	OIL (Oil level is high.)	GASKET (Damaged)	OIL SEAL (Worn or damaged)	SHIFT CONTROL LINKAGE (Worn)	CHECK PLUG RETURN SPRING AND CHECK BALL (Worn or damaged)	SHIFT FORK (Worn)	GEAR (Worn or damaged)	BEARING (Worn or damaged)	BAULK RING (Worn or damaged)	INSERT SPRING (Damaged)
Symptoms	Noise	1	2							3	3		
	Oil leakage		3	1	2	2							
	Hard to shift or will not shift		1	1			2					2	2
	Jumps out of gear						1	1	2	2			

# DESCRIPTION

## DESCRIPTION

PFP:00000

### Cross-Sectional View

NCS000AL

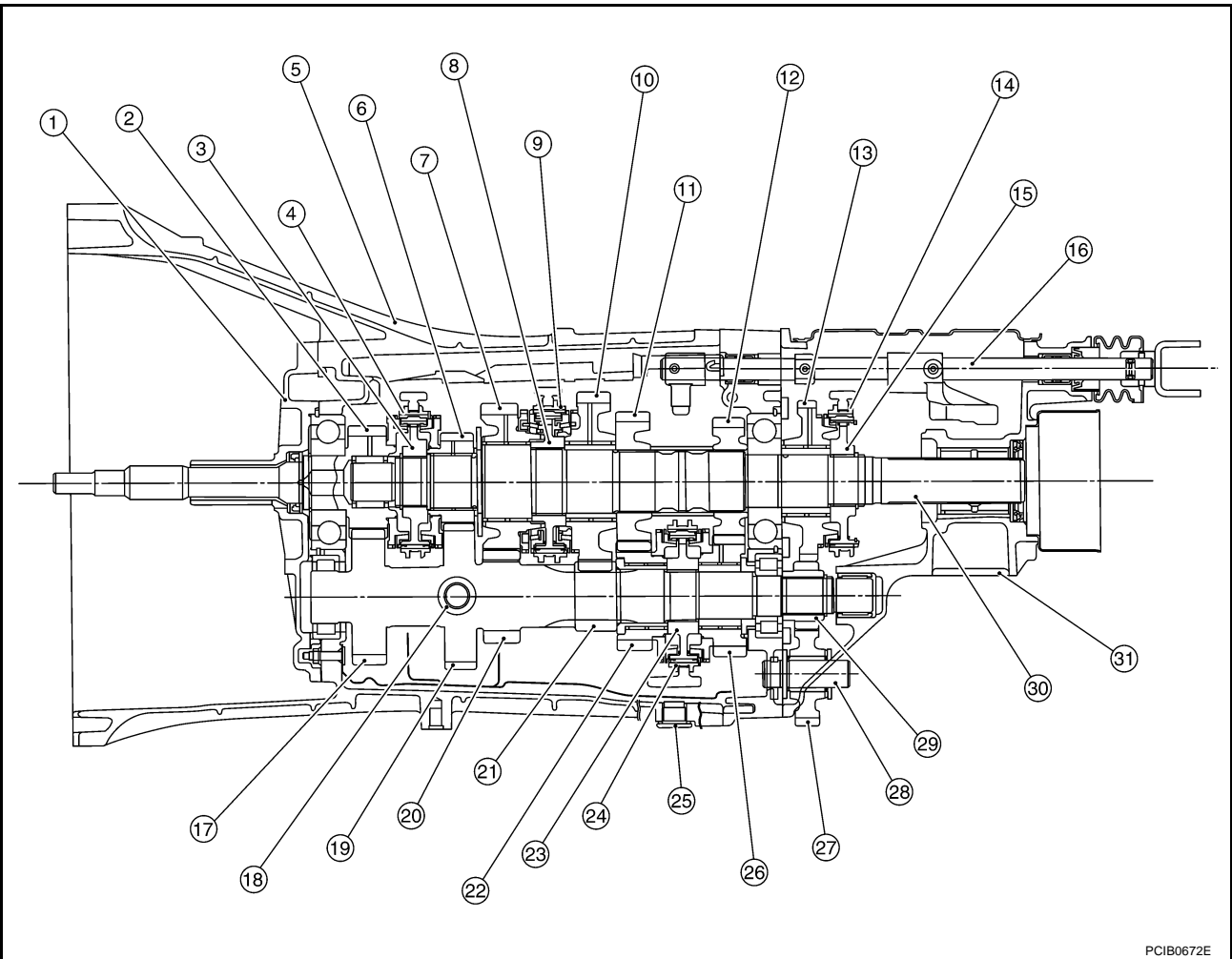

- |                            |                              |                              |
|----------------------------|------------------------------|------------------------------|
| 1. Front cover             | 2. Main drive gear           | 3. 5th-6th synchronizer hub  |
| 4. 5th-6th coupling sleeve | 5. Transmission case         | 6. 6th main gear             |
| 7. 2nd main gear           | 8. 1st-2nd synchronizer hub  | 9. 1st-2nd coupling sleeve   |
| 10. 1st main gear          | 11. 3rd main gear            | 12. 4th main gear            |
| 13. Reverse main gear      | 14. Reverse coupling sleeve  | 15. Reverse synchronizer hub |
| 16. Striking rod           | 17. Counter shaft            | 18. Filler plug              |
| 19. 6th counter gear       | 20. 2nd counter gear         | 21. 1st counter gear         |
| 22. 3rd counter gear       | 23. 3rd-4th synchronizer hub | 24. 3rd-4th coupling sleeve  |
| 25. Drain plug             | 26. 4th counter gear         | 27. Reverse idler gear       |
| 28. Reverse idler shaft    | 29. Reverse counter gear     | 30. Main shaft               |
| 31. Rear extension         |                              |                              |

### DOUBLE-CONE SYNCHRONIZER

The 4th gear is equipped with a double-cone synchronizer to reduce the operating force of the shift lever.

## DESCRIPTION

### TRIPLE-CONE SYNCHRONIZER

The 1st, 2nd and 3rd gears is equipped with a triple-cone synchronizer to reduce the operating force of the shift lever.

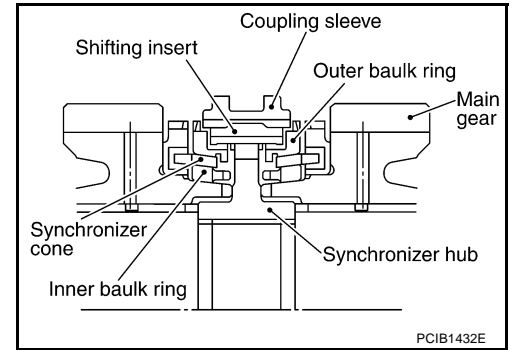



## M/T OIL

PFP:KLD20

### Changing M/T Oil DRAINING

NCS000AM

1. Start the engine and warm up the transmission unit sufficiently.
2. After stopping engine, remove filler plug and drain plug to drain oil.
3. Replace gasket on drain plug with new one. Screw drain plug into transmission case, and tighten to the specified torque. Refer to [MT-21, "Case Components"](#).

**CAUTION:**

**Do not reuse gasket.**

### FILLING

1. Fill new oil into the transmission to the level of the filler plug mounting hole.

**Oil grade and viscosity**

: Refer to [MA-10, "RECOMMENDED FLUIDS AND LUBRICANTS"](#).

**Oil capacity**

: **Approx. 2.9 ℓ (3-1/8 US qt, 2-1/2 Imp qt)**

2. Replace gasket on filler plug with new one. Screw filler plug into transmission case, and tighten to the specified torque. Refer to [MT-21, "Case Components"](#).

**CAUTION:**

**Do not reuse gasket.**

### Checking M/T Oil

#### OIL LEAKAGE AND OIL LEVEL

NCS000AN

- Check if oil is leaking from transmission or around it.
- Check oil level from filler plug mounting hole as shown in the figure.

**CAUTION:**

**Never start engine while checking oil level.**

- When screwing in filler plug with a new gasket, first screw into the transmission by hand, then tighten to the specified torque. Refer to [MT-21, "Case Components"](#).

**CAUTION:**

**Do not reuse gasket.**

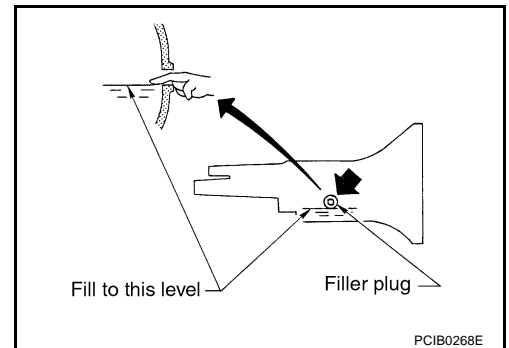

# REAR OIL SEAL

PFP:33140

NCS000AO

## REAR OIL SEAL

### Removal and Installation

#### REMOVAL

1. Remove propeller shaft. Refer to [PR-4, "Removal and Installation"](#).
2. Remove rear oil seal using oil seal puller.

**Tool number** : KV381054S0 ( — )

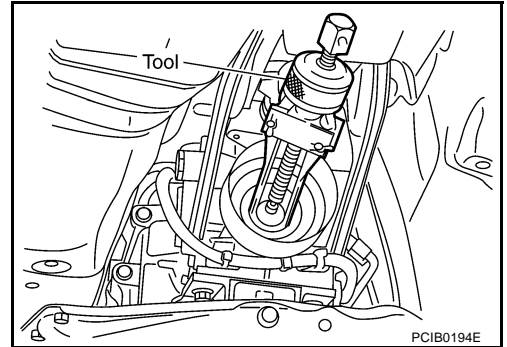

#### INSTALLATION

1. Apply multi-purpose grease to rear oil seal lip. Drive in rear oil seal until the edge is approximately 1.2 - 2.2 mm (0.047 - 0.087 in) above the boss edge using drift.

**Tool number** : ST33400001 (J-26082)

#### CAUTION:

- Do not reuse rear oil seal.
- When installing, do not tilt oil seal.

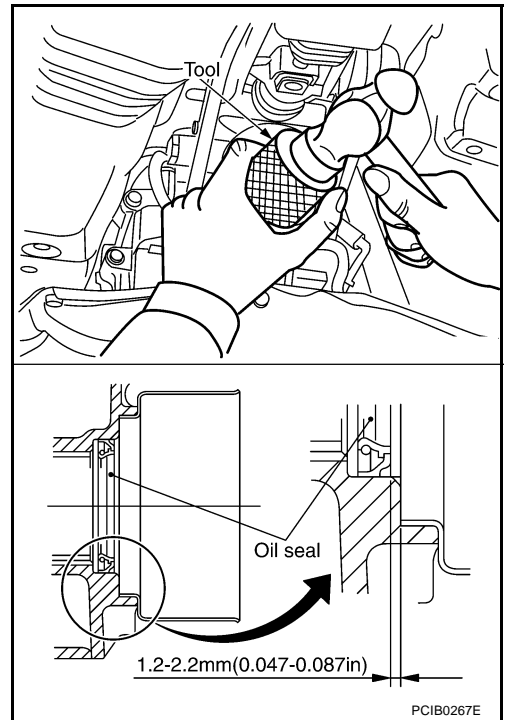

2. Install propeller shaft. Refer to [PR-4, "Removal and Installation"](#).

#### CAUTION:

- If lubricant leak has occurred during the repair work, check oil level after finishing work. Refer to [MT-9, "Checking M/T Oil"](#).

# POSITION SWITCH

## POSITION SWITCH

PFP:32005

### Checking COMPONENT LOCATION

NCS000AP

A  
B  
MT  
D  
E  
F  
G  
H  
I  
J  
K  
L  
M

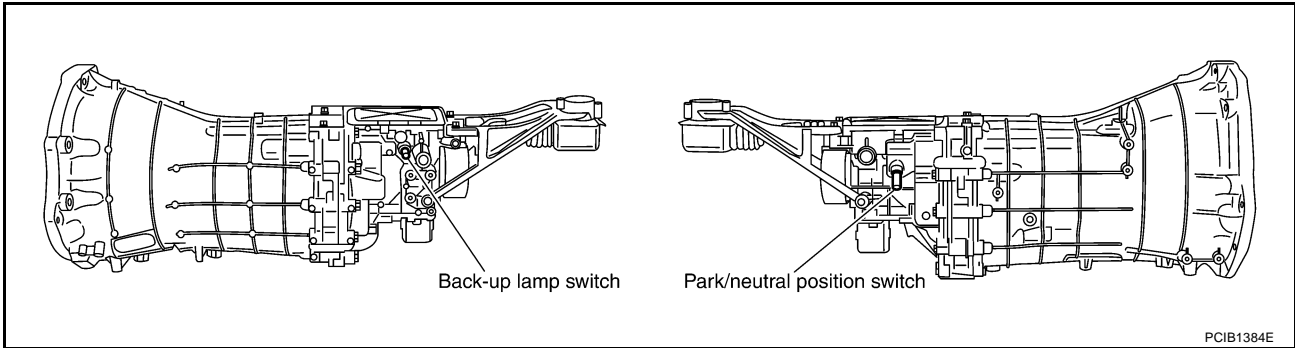

### BACK-UP LAMP SWITCH

- Check continuity.

Gear position	Continuity
Reverse	Yes
Except reverse	No

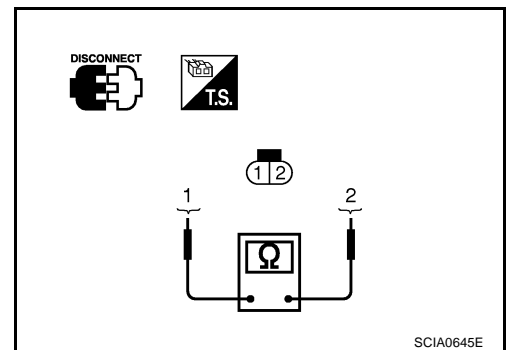

### PARK/NEUTRAL POSITION SWITCH

- Check continuity.

Gear position	Continuity
Neutral	Yes
Except neutral	No

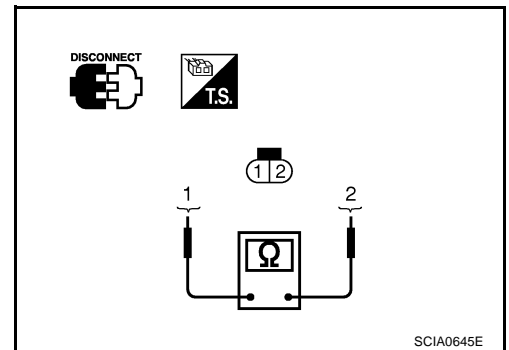

# SHIFT CONTROL

PFP:34103

NCS001AF

## SHIFT CONTROL

### Removal and Installation COMPONENTS

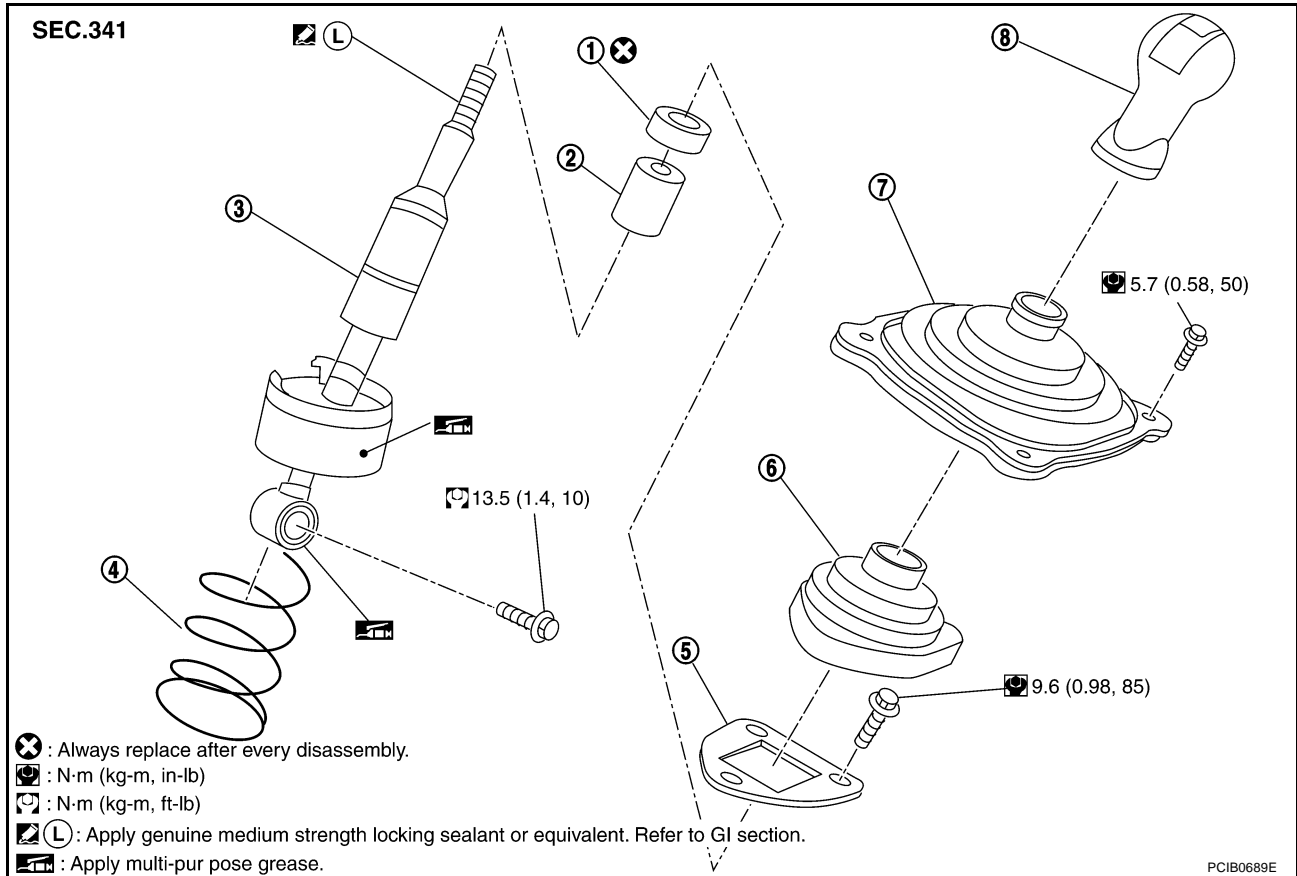

- |                         |                |                           |
|-------------------------|----------------|---------------------------|
| 1. Insulator            | 2. Seat        | 3. Control lever assembly |
| 4. Control lever spring | 5. Guide plate | 6. Control lever boot     |
| 7. Hole cover           | 8. Shift knob  |                           |

### REMOVAL

1. Remove shift knob with the following procedure.
  - a. Release metal clips on console boot from center console. Refer to [IP-11, "Removal and Installation"](#).

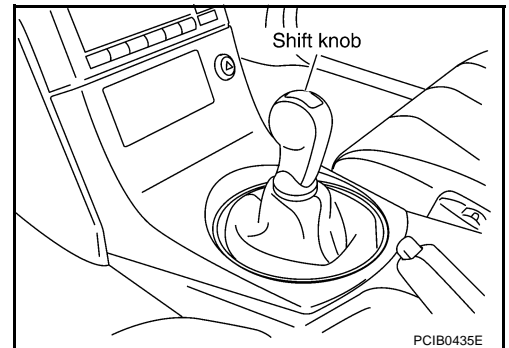

# SHIFT CONTROL

- b. Lift console boot, and push down hole cover. Set water pump pliers or a suitable tool to control lever assembly.

**CAUTION:**

Put waste cloth between water pump pliers and control lever assembly to avoid damaging control lever assembly.

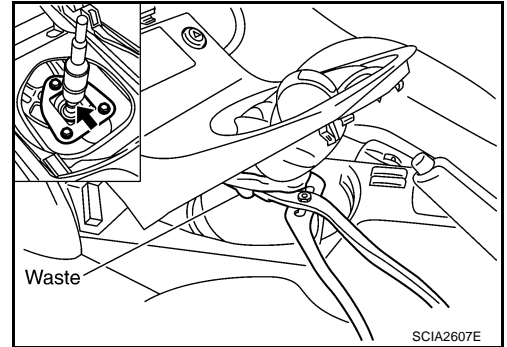

- c. Set monkey wrench to shift knob.

**CAUTION:**

Put waste cloth between shift knob and monkey wrench to avoid damaging shift knob.

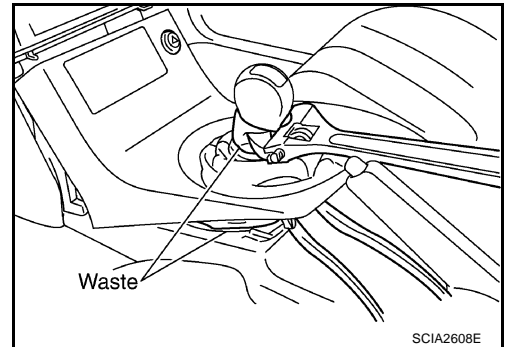

- d. Keeping control lever in place with water pump pliers, turn monkey wrench counterclockwise to loosen shift knob.

**NOTE:**

Remove shift knob from control lever keeping water pump pliers in place because a certain power to turn shift knob is still necessary even after adhesive is peeled.

2. Remove console boot. Refer to [IP-11, "Removal and Installation"](#).

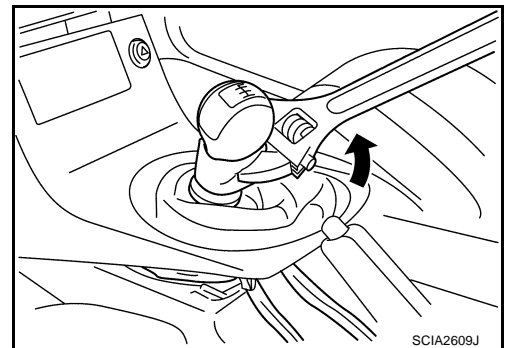

3. Release the boot, remove control rod mounting bolt, and separate control lever and control rod.

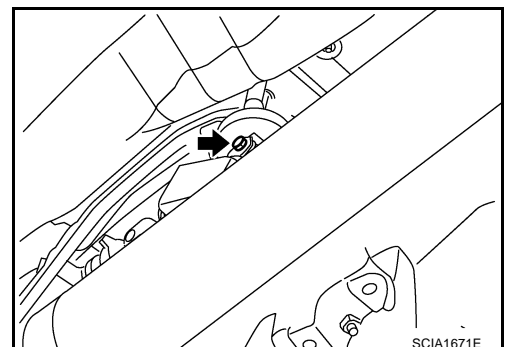

4. Remove the mounting bolts to remove hole cover.  
5. Remove the control lever boot.

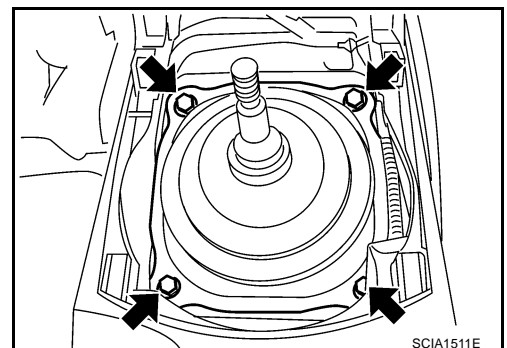

A  
B  
MT  
D  
E  
F  
G  
H  
I  
J  
K  
L  
M

# SHIFT CONTROL

6. Remove guide plate mounting bolts, and then remove control lever assembly and control lever spring from control lever housing.

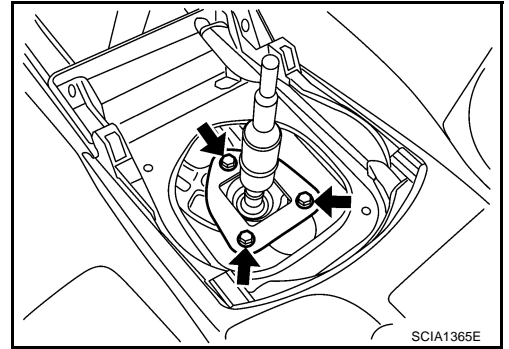

## INSTALLATION

1. Set control lever and control lever assembly spring in the control lever housing and loosely mount guide plate.
2. After installing control lever in control rod, tighten bolt to the specified torque. Refer to [MT-12, "Removal and Installation"](#).

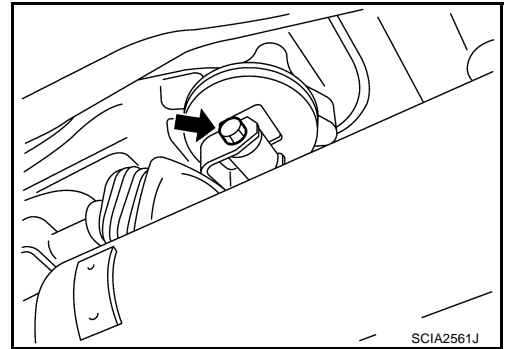

3. After shifting control lever assembly into 6th gear, push it toward reverse gear (to the right) until it comes to a stop.
4. At the point where the control lever assembly stops, bring the guide plate closer until guide plate stopper contacts control lever assembly claw, and then loosely tighten mounting bolt A.

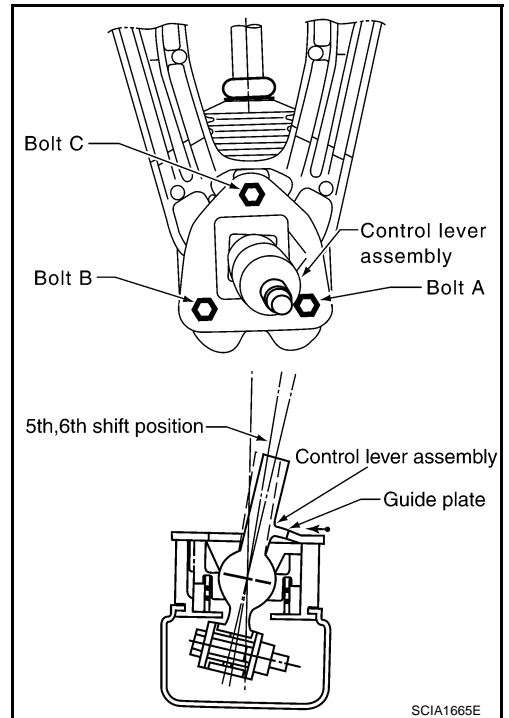

# SHIFT CONTROL

5. After shifting control lever assembly into 5th gear, push it toward reverse gear (to the right) until it comes to a stop.
6. At the point where control lever assembly stops, bring guide plate closer until the guide plate stopper contacts control lever assembly claw, and then tighten mounting bolt C to the specified torque. Refer to [MT-12, "Removal and Installation"](#).
7. Tighten guide plate bolts A and B to the specified torque. Refer to [MT-12, "Removal and Installation"](#).
8. Install control lever boot.
9. Install hole cover and tighten bolts to the specified torque. Refer to [MT-12, "Removal and Installation"](#).
10. Install console boot to the center console. Refer to [IP-11, "Removal and Installation"](#).

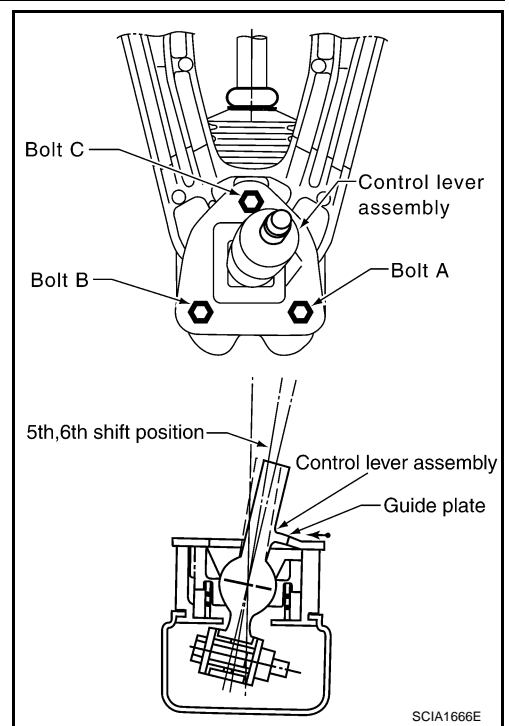

11. As shown in the figure, assemble seat and insulator to control lever assembly.

**CAUTION:**  
Do not reuse insulator.

12. Apply locking sealant to control lever threads, install shift knob.

**CAUTION:**  
Remove the remaining adhesive on control lever and shift knob threads.

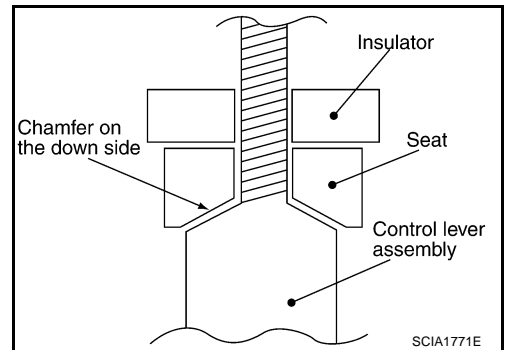

13. Put the shift knob in the correct position as the following indicates.

- a. When tightening shift knob, if shift knob comes to the proper position within 1/2 turn from the position at which resistance begins to be felt, tighten it 1 more turn to set it in the proper position.
- b. If it takes more than 1/2 turn from the position at which resistance begins to be felt, tighten it to set it in the proper position.

**CAUTION:**

- Do not adjust the knob with loosening.
- After adjusting to the regular position, until 30 minutes pass, do not operate the shift intensely such as screwing or turning the shift knob to opposite direction since a locking sealant because stiff.

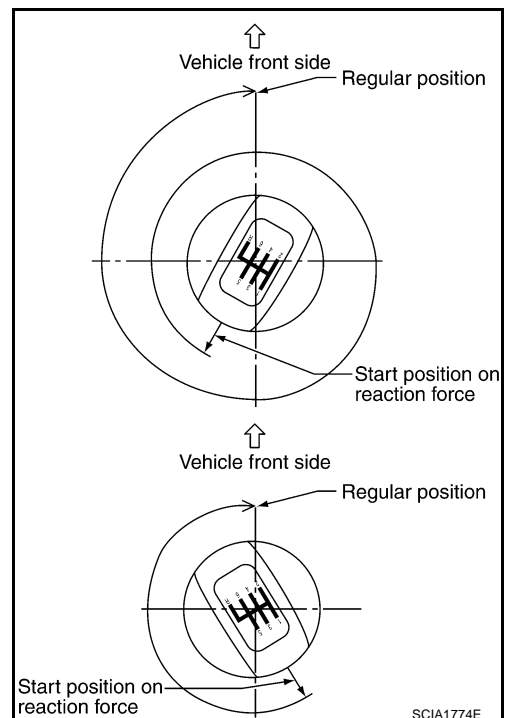

# SHIFT CONTROL

---

## INSPECTION AFTER INSTALLATION

After installing, confirm the following items:

- When control lever assembly is shifted to each position, make sure there is no binding or disconnection in each boot.
- When shifted to each position, make sure there is no noise, binding, and backlash. Especially when control lever assembly is shifted to 5th, 6th without pressing downward, check for binding.
- When control lever assembly is shifted to 1st, 2nd side and 5th, 6th side, confirm control lever assembly returns to neutral position smoothly.
- In any position other than reverse, confirm that control lever assembly can be pressed downward.
- With control lever assembly pressed downward, confirm that it can be shifted to reverse.
- When shifted from reverse to neutral position, confirm control lever assembly returns to neutral position smoothly with spring power.
- Without control lever assembly pressed downward, confirm that it cannot be shifted to reverse.



# AIR BREATHER HOSE

PFP:31098

## AIR BREATHER HOSE Removal and Installation

NCS000AR

Refer to the figure for air breather hose removal and installation information.

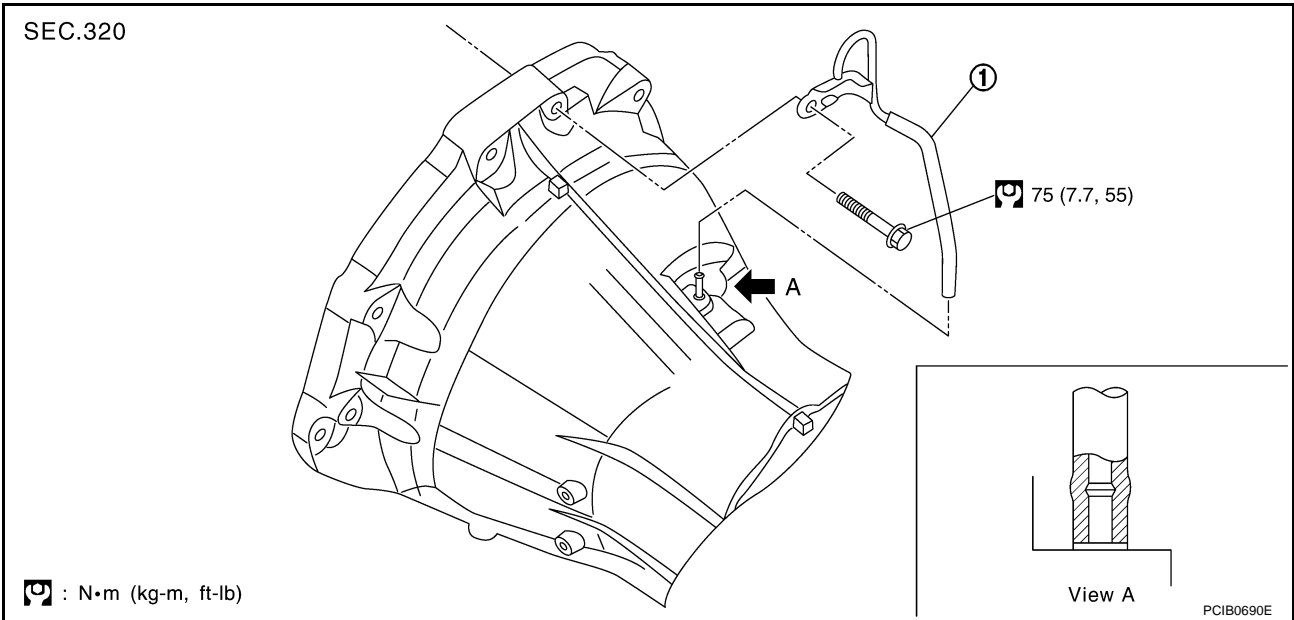

1. Air breather hose

### CAUTION:

- Make sure there are no pinched or blocked areas on the air breather hose caused by bending when installing it.
- Insert overlap width of air breather hose as far as it will go.

A  
B  
MT  
D  
E  
F  
G  
H  
I  
J  
K  
L  
M

# TRANSMISSION ASSEMBLY

## TRANSMISSION ASSEMBLY

PFP:32010

### Removal and Installation COMPONENTS

NCS001AG

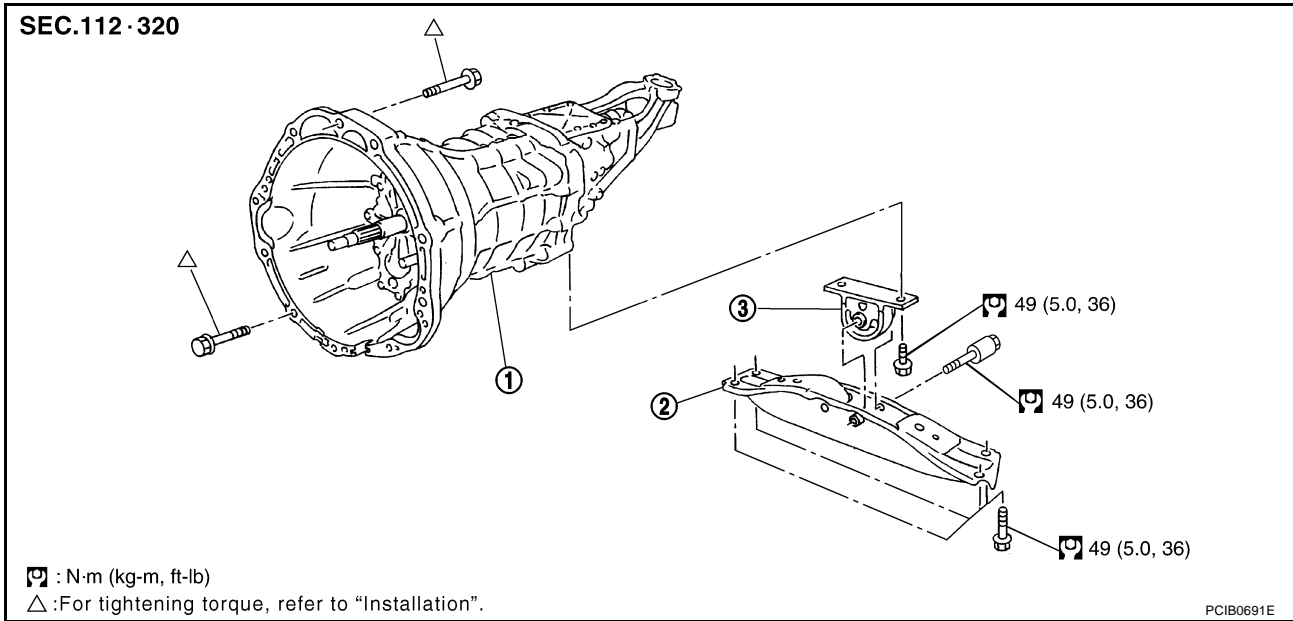

1. Transmission case
2. Rear engine mounting member
3. Insulator

### REMOVAL

1. Disconnect the battery cable from the negative terminal.
2. Remove front cross bar with power tool. Refer to [FSU-9, "REMOVAL"](#).
3. Remove catalytic converter stay mounting nuts and bolts, and then remove exhaust mounting bracket. Refer to [EX-3, "Removal and Installation"](#).

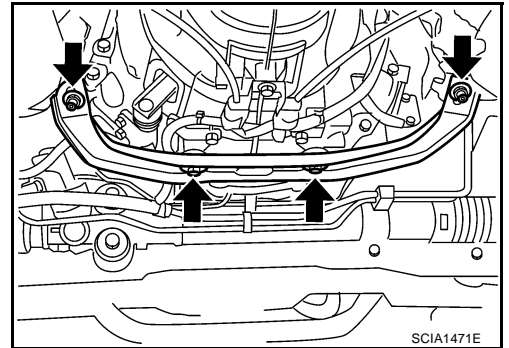

4. Remove nut connecting catalytic converter to exhaust manifold, and then remove three way catalyst and exhaust front tube as one unit.
5. Remove propeller shaft. Refer to [PR-4, "Removal and Installation"](#).
6. Remove control rod mounting bolts and then separate control lever assembly from the control rod assembly.

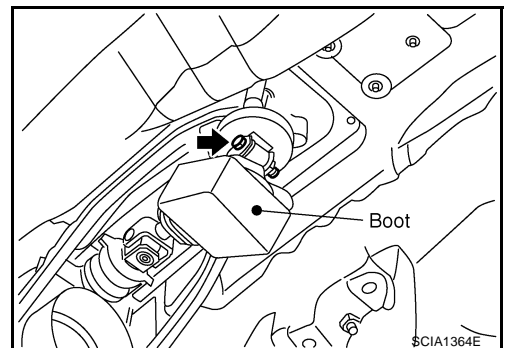

# TRANSMISSION ASSEMBLY

7. Using a suitable tool, release claws and separate console boot from center console. Refer to [IP-11, "Removal and Installation"](#).

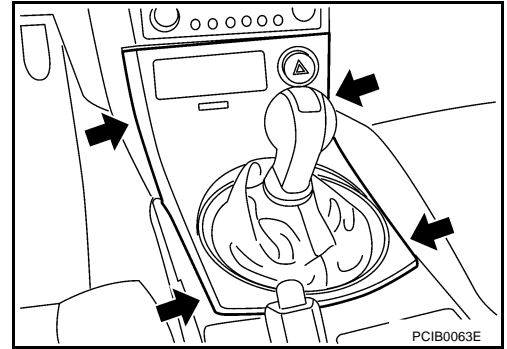

8. Remove hole cover mounting bolts and then separate hole cover from the floor panel.  
9. Separate control lever boot from guide plate.

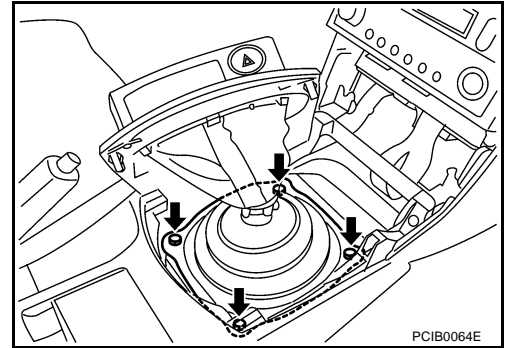

10. Remove guide plate mounting bolts and then separate control lever assembly from the control lever housing.

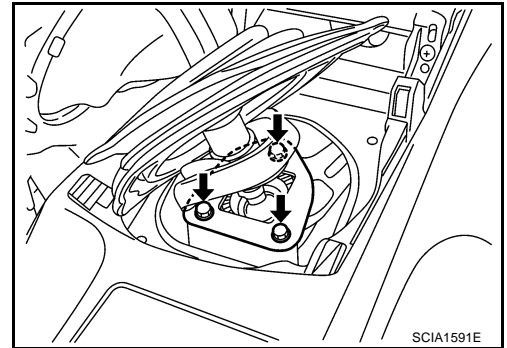

11. Remove clutch operating cylinder mounting bolts and then separate clutch operating cylinder from the transmission case. Refer to [CL-11, "Components"](#).  
12. Remove crankshaft position sensor (POS).

**CAUTION:**

- Do not subject it to impact by dropping or hitting.
- Do not disassemble.
- Do not allow iron dust, etc., to get on the sensor's front edge magnetic area.
- Do not place in an area affected by magnetism.

13. Disconnect PNP switch and back-up lamp switch.  
14. Separate heated oxygen sensor 2 wire harness, crankshaft position sensor (POS) wire harness, back-up lamp switch wire harness and PNP switch wire harness from the transmission.

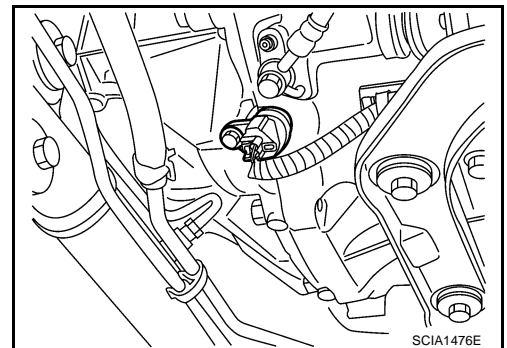

15. Remove starter motor. Refer to [SC-19, "Removal and Installation"](#).  
16. Set transmission jack to the transmission.

**CAUTION:**

When setting transmission jack, be careful so that it does not contact with the switch.

A  
B  
MT  
D  
E  
F  
G  
H  
I  
J  
K  
L  
M

# TRANSMISSION ASSEMBLY

17. Remove rear engine mounting member. Refer to [EM-131, "Removal and Installation"](#).
18. Remove engine and transmission mounting bolts with power tool.
19. Remove transmission from the vehicle.

**CAUTION:**

Do not hold control lever housing to prevent bushing of control lever housing from deformation when moving transmission assembly.

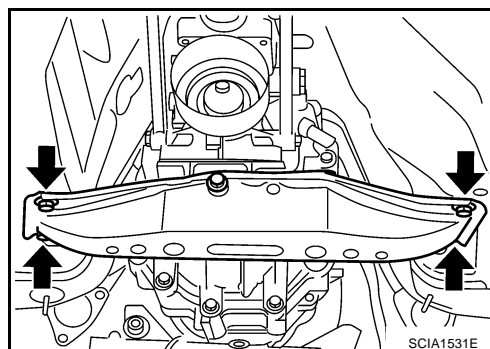

## INSTALLATION

Install in the reverse order of removal procedure, following the cautions below:

- When installing transmission to the engine, install mounting bolts in accordance with the standards below.

Bolt No.	1	2	3
Quantity	1	5	2
" $\ell$ " mm (in)	55 (2.17)	65 (2.56)	35 (1.38)
Tightening torque N·m (kg·m, ft·lb)	75 (7.7, 55)		46.6 (4.8, 34)

**CAUTION:**

- When installing, be careful to avoid interference between transmission main drive shaft and clutch cover.
- If flywheel is removed, align dowel pin with the smallest hole of flywheel. Refer to [EM-143, "ASSEMBLY"](#).
- Refer to [MT-14, "INSTALLATION"](#) and [MT-16, "INSPECTION AFTER INSTALLATION"](#) for control lever installation information.
- After installation, check for oil leakage, oil level and proper operation of shifting mechanism.
- Do not hold control lever housing to prevent bushing of control lever housing from deformation when moving transmission assembly.

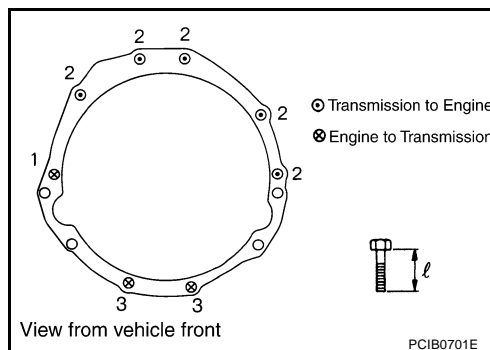

# TRANSMISSION ASSEMBLY

NCS001AH

## Disassembly and Assembly COMPONENTS

### Case Components

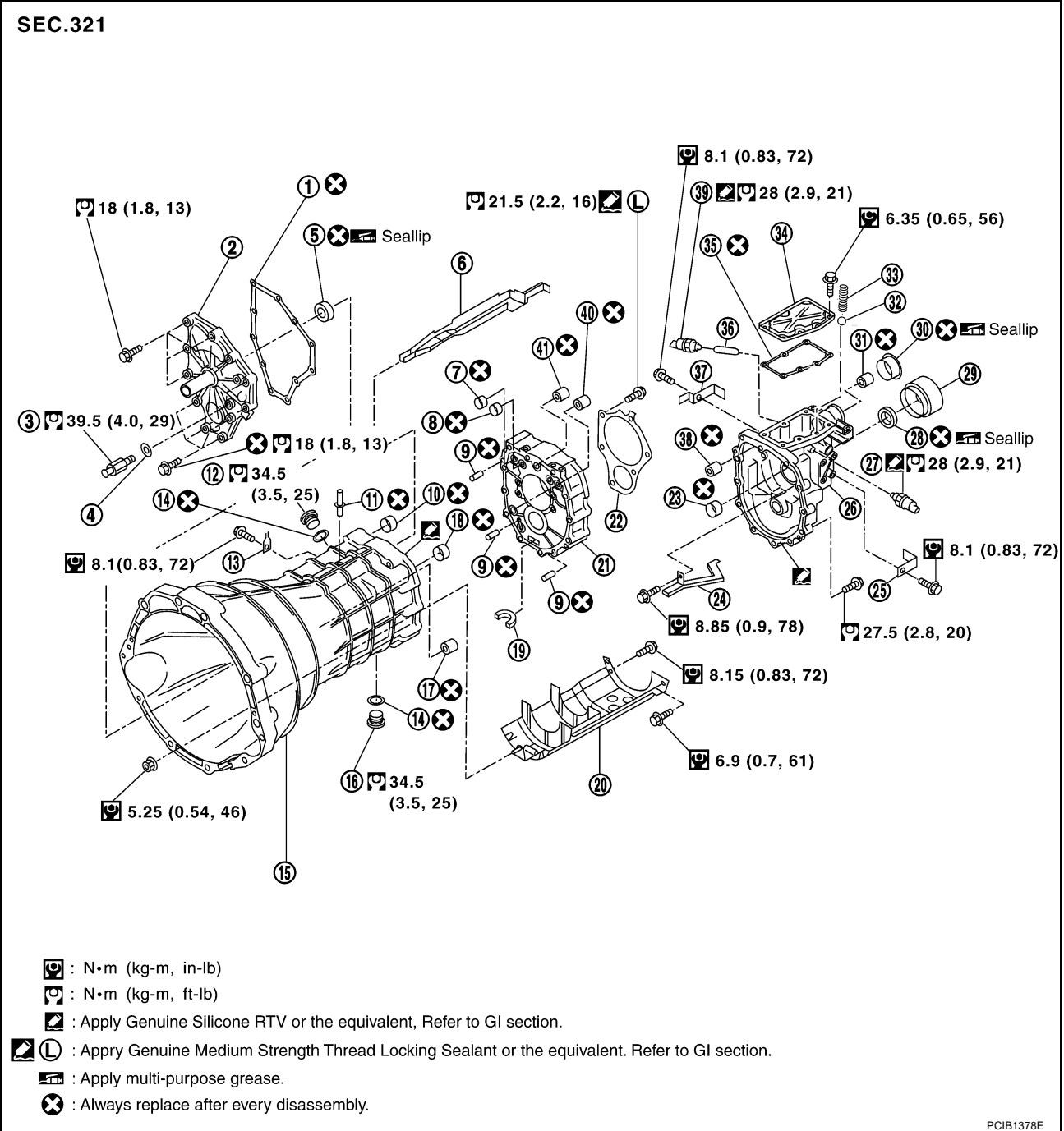

PCIB1378E

- |                                 |                               |                               |
|---------------------------------|-------------------------------|-------------------------------|
| 1. Front cover gasket           | 2. Front cover                | 3. Withdrawal lever ball pin  |
| 4. Washer                       | 5. Front cover oil seal       | 6. Oil gutter                 |
| 7. Bushing                      | 8. Bushing                    | 9. Dowel pin                  |
| 10. Bushing                     | 11. Breather                  | 12. Filler plug               |
| 13. Bracket                     | 14. Gasket                    | 15. Transmission case         |
| 16. Drain plug                  | 17. Sliding ball bearing      | 18. Bushing                   |
| 19. Magnet                      | 20. Baffle plate              | 21. Adapter plate             |
| 22. Main shaft bearing retainer | 23. Bushing                   | 24. Rear extension oil gutter |
| 25. Bracket                     | 26. Rear extension            | 27. Back-up lamp switch       |
| 28. Rear oil seal               | 29. Rear extension dust cover | 30. Striking rod oil seal     |

# TRANSMISSION ASSEMBLY

- |                                |                                       |                         |
|--------------------------------|---------------------------------------|-------------------------|
| 31. Sliding ball bearing       | 32. Check ball                        | 33. Check select spring |
| 34. Rear extension upper cover | 35. Rear extension upper cover gasket | 36. Plunger             |
| 37. Bracket                    | 38. Sliding ball bearing              | 39. PNP switch          |
| 40. Sliding ball bearing       | 41. Sliding ball bearing              |                         |

## Gear Components

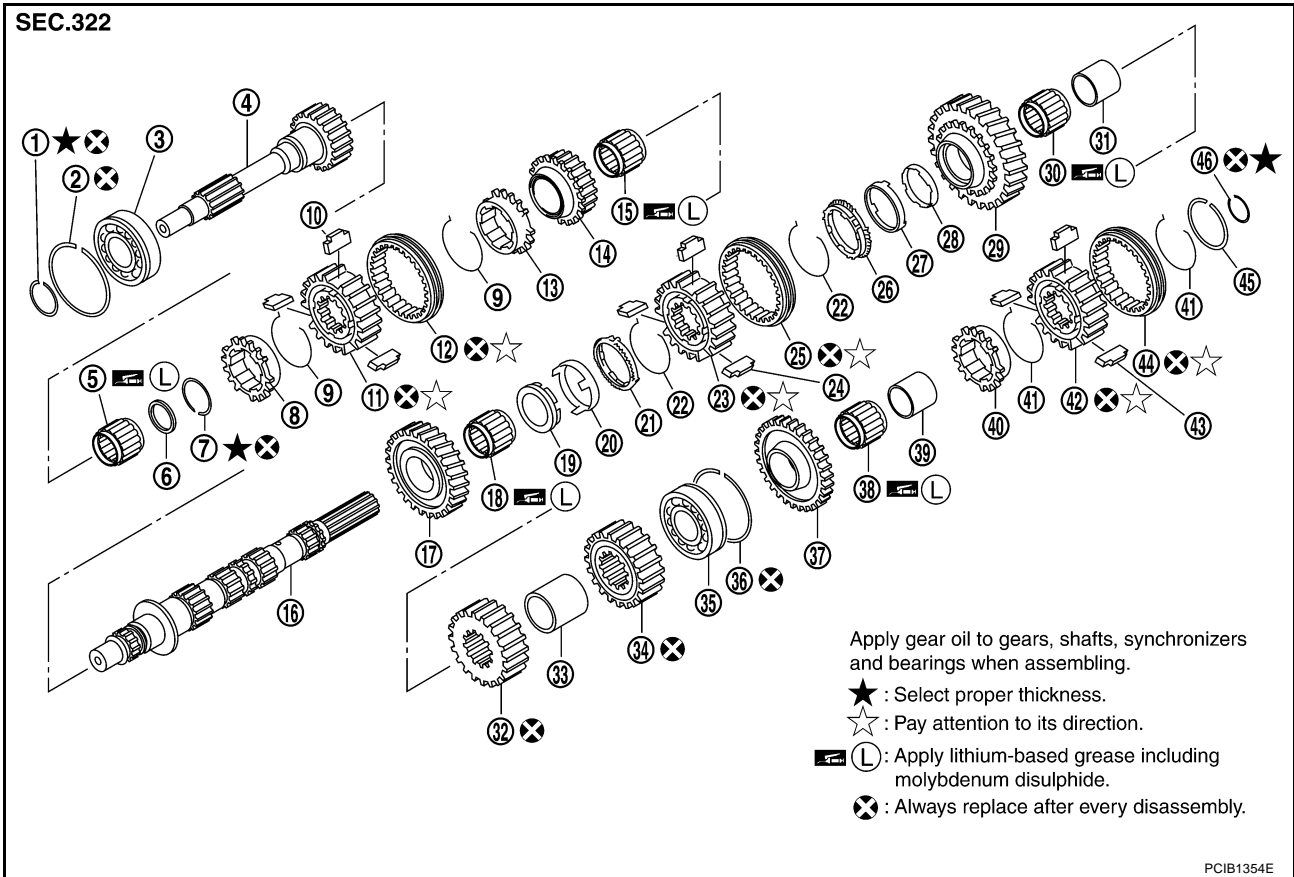

- |                             |                                 |                               |
|-----------------------------|---------------------------------|-------------------------------|
| 1. Snap ring                | 2. Snap ring                    | 3. Main drive gear bearing    |
| 4. Main drive gear          | 5. Main pilot bearing           | 6. Pilot bearing spacer       |
| 7. Snap ring                | 8. 5th baulk ring               | 9. 5th-6th spread spring      |
| 10. 5th-6th shifting insert | 11. 5th-6th synchronizer hub    | 12. 5th-6th coupling sleeve   |
| 13. 6th baulk ring          | 14. 6th main gear               | 15. 6th needle bearing        |
| 16. Main shaft              | 17. 2nd main gear               | 18. 2nd needle bearing        |
| 19. 2nd inner baulk ring    | 20. 2nd synchronizer cone       | 21. 2nd outer baulk ring      |
| 22. 1st-2nd spread spring   | 23. 1st-2nd synchronizer hub    | 24. 1st-2nd shifting insert   |
| 25. 1st-2nd coupling sleeve | 26. 1st outer baulk ring        | 27. 1st synchronizer cone     |
| 28. 1st inner baulk ring    | 29. 1st main gear               | 30. 1st needle bearing        |
| 31. 1st gear bushing        | 32. 3rd main gear               | 33. 3rd-4th main spacer       |
| 34. 4th main gear           | 35. Main shaft bearing          | 36. Snap ring                 |
| 37. Reverse main gear       | 38. Reverse main needle bearing | 39. Reverse main gear bushing |
| 40. Reverse baulk ring      | 41. Reverse spread spring       | 42. Reverse synchronizer hub  |
| 43. Reverse shifting insert | 44. Reverse coupling sleeve     | 45. Snap ring                 |
| 46. Snap ring               |                                 |                               |

# TRANSMISSION ASSEMBLY

A  
B  
MT  
D  
E  
F  
G  
H  
I  
J  
K  
L  
M

MT

SEC.322

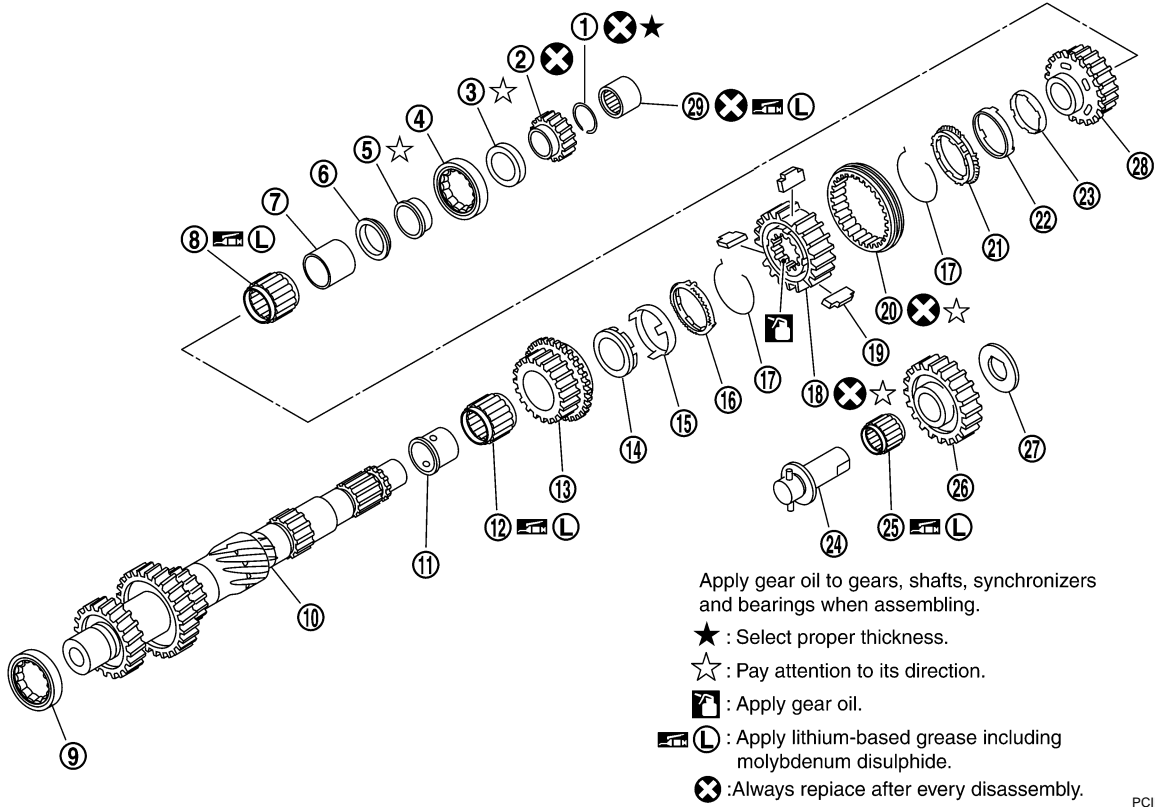

- |                                  |                                    |                                   |
|----------------------------------|------------------------------------|-----------------------------------|
| 1. Snap ring                     | 2. Reverse counter gear            | 3. Counter rear bearing spacer    |
| 4. Counter rear bearing          | 5. Counter rear bearing inner race | 6. 4th counter gear thrust washer |
| 7. 4th gear bushing              | 8. 4th needle bearing              | 9. Counter front bearing          |
| 10. Counter shaft                | 11. 3rd gear bushing               | 12. 3rd needle bearing            |
| 13. 3rd counter gear             | 14. 3rd inner baulk ring           | 15. 3rd synchronizer cone         |
| 16. 3rd outer baulk ring         | 17. 3rd-4th spread spring          | 18. 3rd-4th synchronizer hub      |
| 19. 3rd-4th shifting insert      | 20. 3rd-4th coupling sleeve        | 21. 4th outer baulk ring          |
| 22. 4th synchronizer cone        | 23. 4th inner baulk ring           | 24. Reverse idler shaft           |
| 25. Reverse idler needle bearing | 26. Reverse idler gear             | 27. Reverse idler thrust washer   |
| 28. 4th counter gear             | 29. Counter end bearing            |                                   |

# TRANSMISSION ASSEMBLY

## Shift Control Components

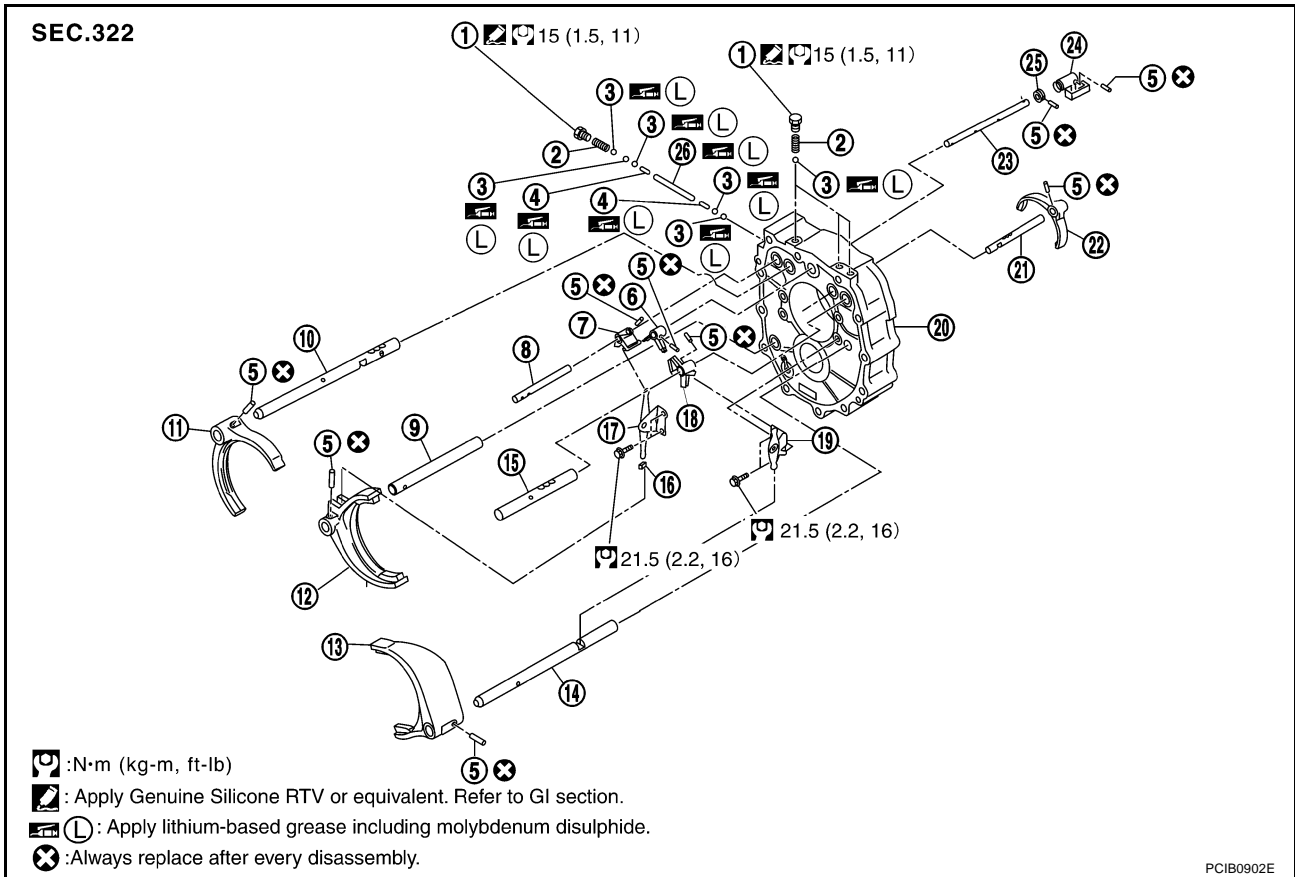

- |                             |                                      |                                     |
|-----------------------------|--------------------------------------|-------------------------------------|
| 1. Check ball plug          | 2. Check ball spring                 | 3. Check ball                       |
| 4. Interlock pin            | 5. Retaining pin                     | 6. Striking lever                   |
| 7. 3rd-4th fork rod bracket | 8. 3rd-4th fork rod                  | 9. 3rd-4th fork rod (reversal side) |
| 10. 1st-2nd fork rod        | 11. 1st-2nd shift fork               | 12. 3rd-4th shift fork              |
| 13. 5th-6th shift fork      | 14. 5th-6th fork rod (reversal side) | 15. 5th-6th fork rod                |
| 16. Shifter cap             | 17. 3rd-4th control lever            | 18. 5th-6th fork rod bracket        |
| 19. 5th-6th control lever   | 20. Adapter plate                    | 21. Reverse fork rod                |
| 22. Reverse shift fork      | 23. Striking rod                     | 24. Low/high control lever          |
| 25. Stopper ring            | 26. Interlock plunger                |                                     |



# TRANSMISSION ASSEMBLY

## SEC.321

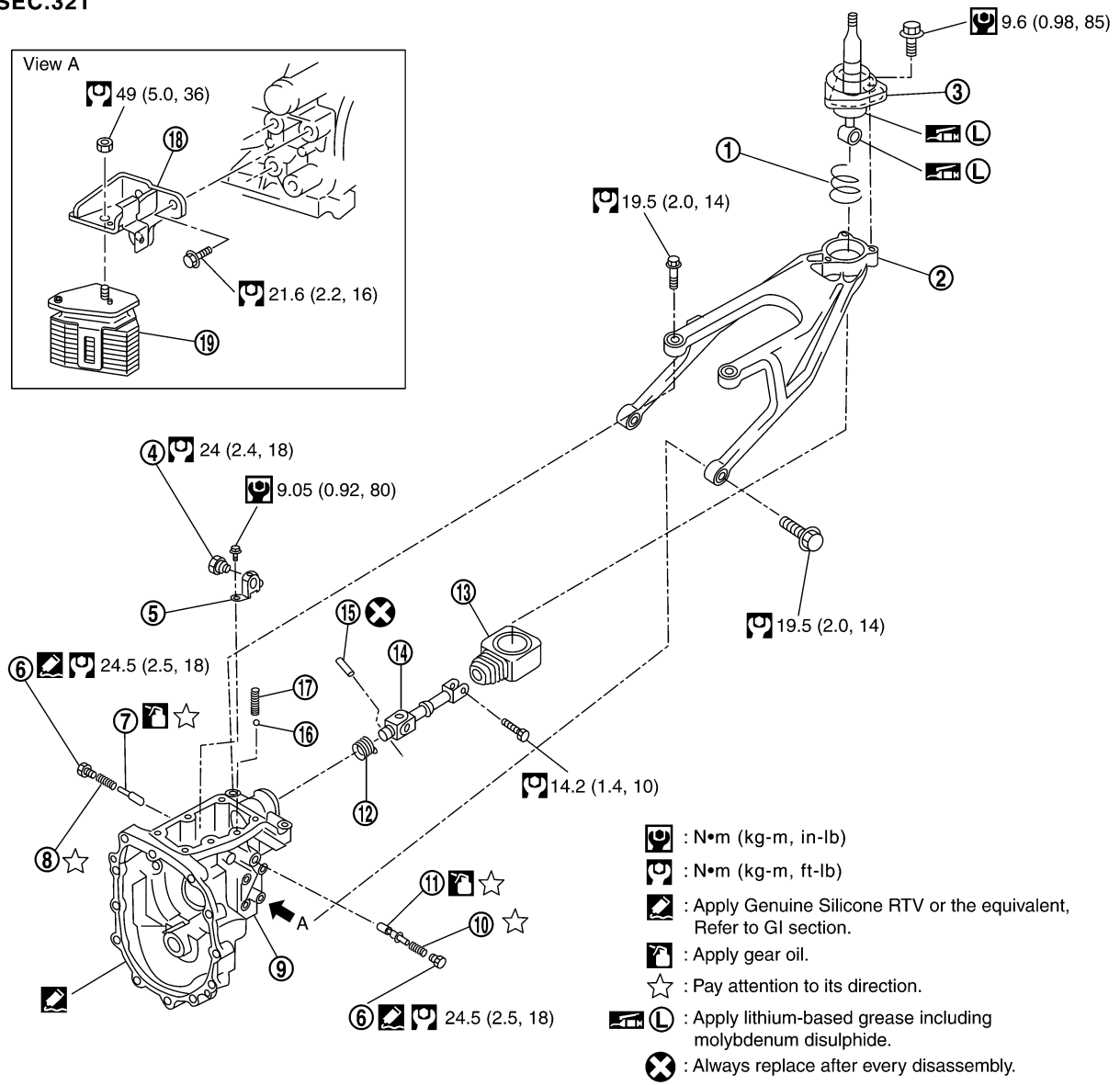
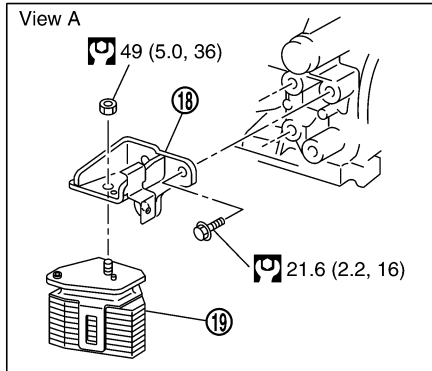

- : N·m (kg-m, in-lb)
- : N·m (kg-m, ft-lb)
- : Apply Genuine Silicone RTV or the equivalent, Refer to GI section.
- : Apply gear oil.
- : Pay attention to its direction.
- : Apply lithium-based grease including molybdenum disulphide.
- : Always replace after every disassembly.

PCIB1433E

- |                          |                           |                            |
|--------------------------|---------------------------|----------------------------|
| 1. Control lever spring  | 2. Control lever housing  | 3. Control lever assembly  |
| 4. Check shift pin       | 5. Control bracket        | 6. Return spring plug      |
| 7. Return spring plunger | 8. Return spring          | 9. Rear extension          |
| 10. Return spring        | 11. Return spring plunger | 12. Boot                   |
| 13. Boot                 | 14. Control rod           | 15. Retaining pin          |
| 16. Check ball           | 17. Check select spring   | 18. Dynamic damper bracket |
| 19. Dynamic damper       |                           |                            |

A  
B  
MT  
D  
E  
F  
G  
H  
I  
J  
K  
L  
M

# TRANSMISSION ASSEMBLY

## DISASSEMBLY

### Case Components

1. Remove rear extension upper cover mounting bolts, rear extension upper cover and rear extension upper cover gasket from rear extension.

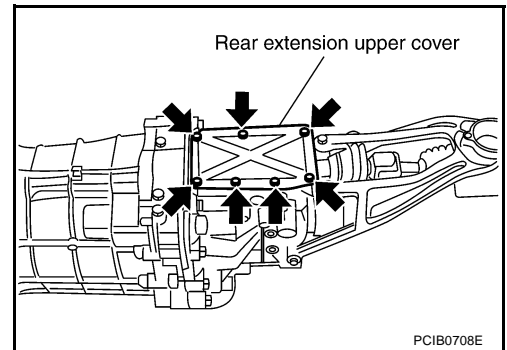

2. Remove check select spring and check ball from rear extension.

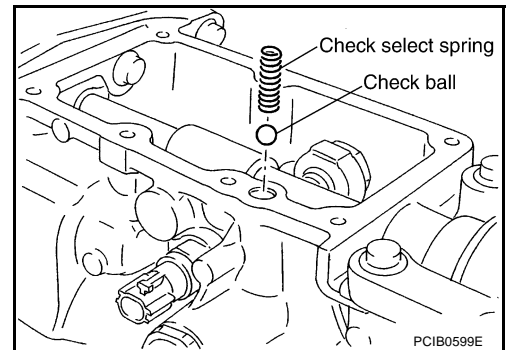

3. Drive out retaining pin using a pin punch [6 mm (0.24 in) dia.], and remove control rod.
4. Remove PNP switch, plunger and back-up lamp switch from rear extension.

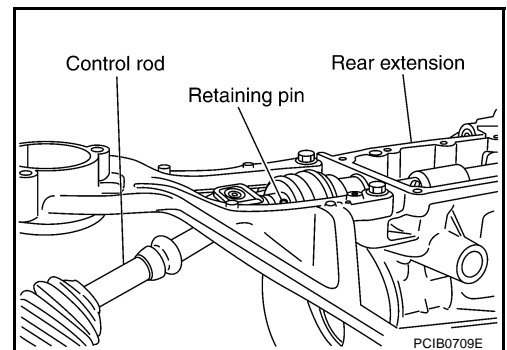

5. Remove control bracket mounting bolts. Then remove check shift pin and control bracket as one unit from rear extension.

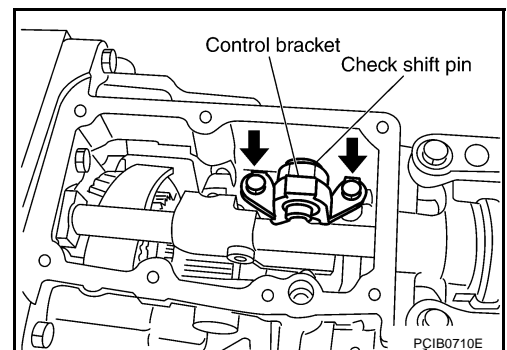

# TRANSMISSION ASSEMBLY

6. Remove right and left return spring plugs. Then remove return spring and return spring plunger from rear extension.

**CAUTION:**

Return springs and return spring plungers have different lengths for right and left sides. Identify right and left side and then store.

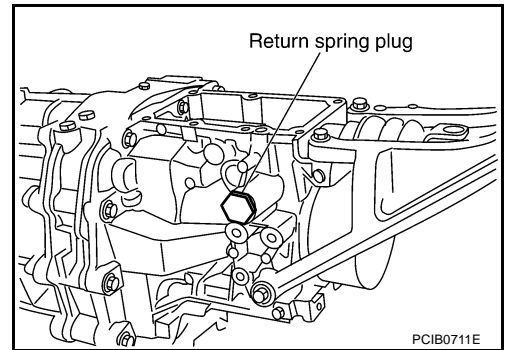

7. Remove rear oil seal from rear extension using the oil seal puller.

**Tool number** : KV381054S0 ( — )

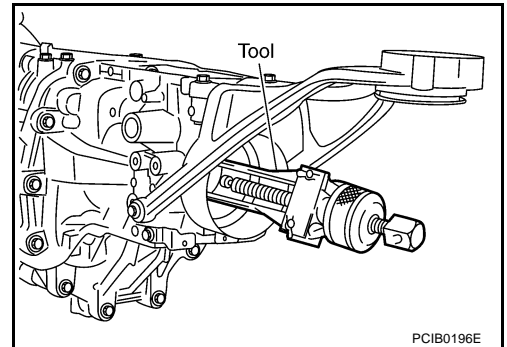

8. Remove rear extension mounting bolts. Using a soft hammer, tap rear extension assembly to remove.

**CAUTION:**

Do not hold control lever housing to prevent bushing of control lever housing from deformation when moving transmission assembly.

9. Remove control lever housing mounting bolts and control lever housing from rear extension.
10. Remove striking rod oil seal from rear extension. Refer to [MT-21, "Case Components"](#) .
11. Remove rear extension oil gutter mounting bolt and rear extension oil gutter from rear extension. Refer to [MT-21, "Case Components"](#) .

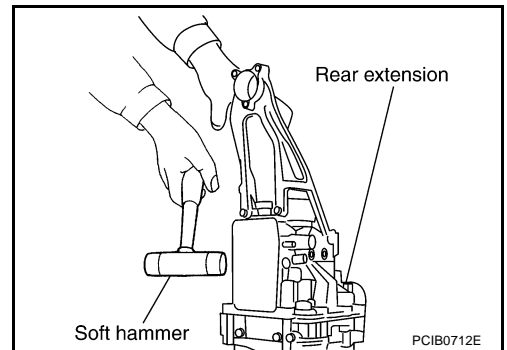

12. Remove reverse idler thrust washer, reverse idler gear and reverse idler needle bearing from reverse idler shaft.
13. Remove reverse idler shaft from adapter plate.

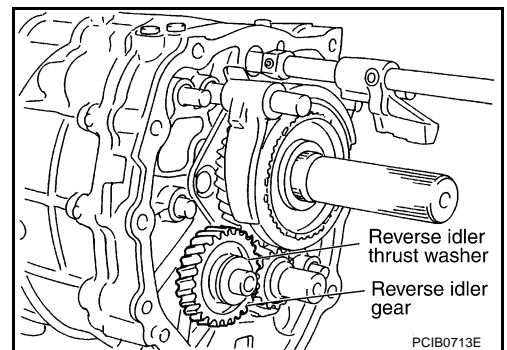

A  
B  
MT  
D  
E  
F  
G  
H  
I  
J  
K  
L  
M

# TRANSMISSION ASSEMBLY

14. Remove withdrawal lever ball pin and washer from front cover.
15. Remove front cover mounting bolts. Then remove front cover and front cover gasket from transmission case.

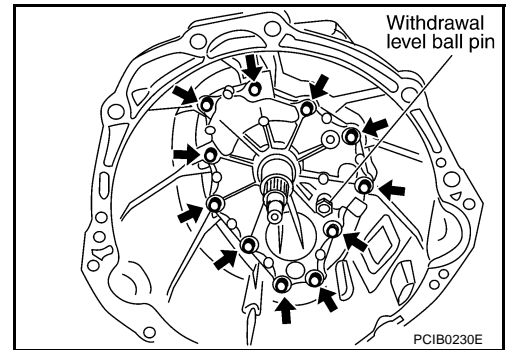

16. Remove front cover oil seal from front cover using a flat-bladed screwdriver.

**CAUTION:**

**Be careful not to damage front cover mating surface.**

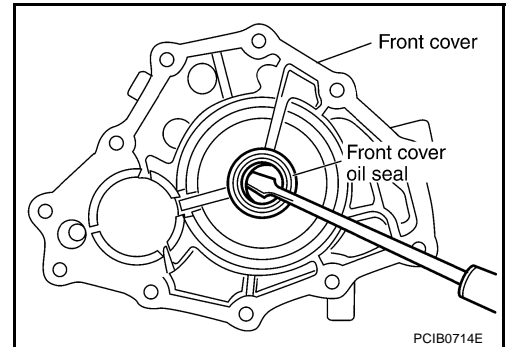

17. Remove baffle plate mounting nut from transmission case.

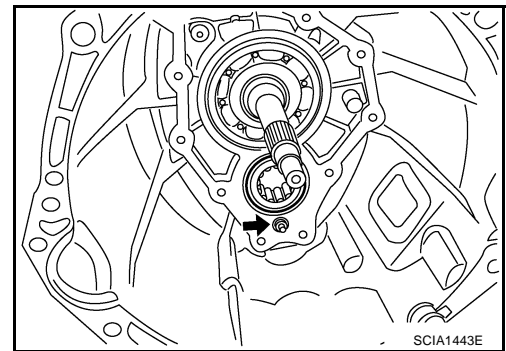

18. Remove snap ring from main drive gear bearing using snap ring pliers.

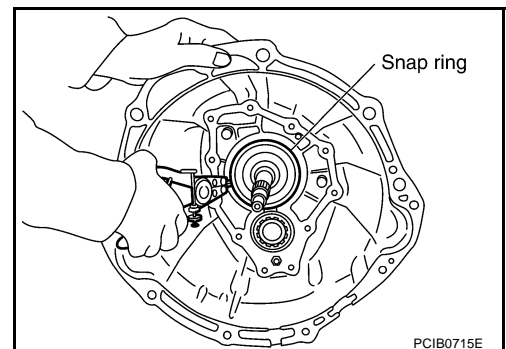

19. Carefully tap on transmission case to separate it from adapter plate using a soft hammer.

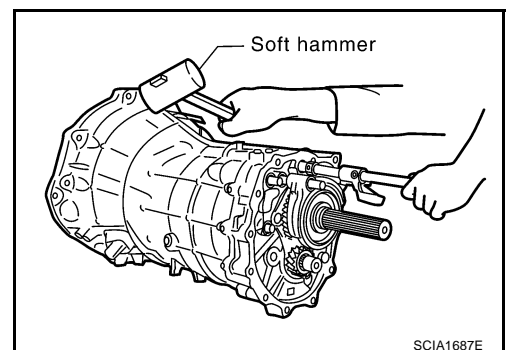

# TRANSMISSION ASSEMBLY

20. Remove counter front bearing from transmission case.
21. Remove oil gutter from transmission case.

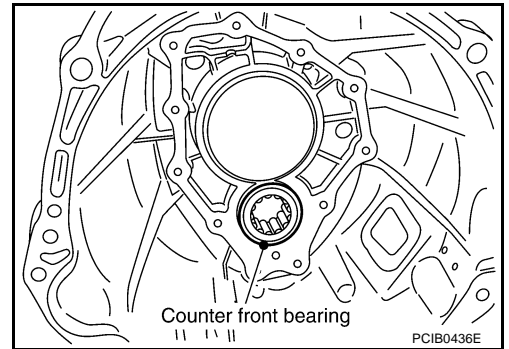

## Shift Control Components

1. Install adapter setting plate to adapter plate, and then secure adapter setting plate in a vise.

**Tool number** : ST22490000 ( — )

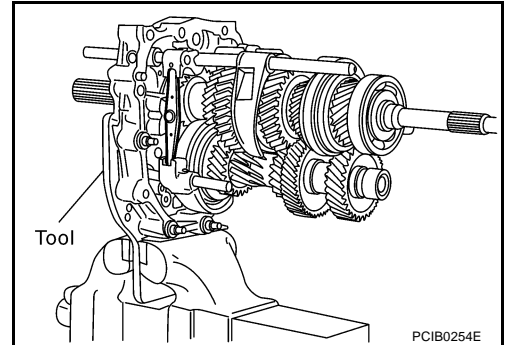

2. Remove baffle plate mounting bolts and baffle plate from adapter plate.

### NOTE:

Mounting bolts are installed both from the front side and the reverse side of adapter plate.

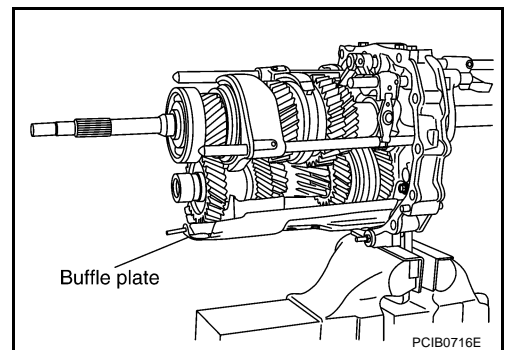

3. Remove magnet from adapter plate.
4. Drive out retaining pin using a pin punch [6 mm (0.24 in) dia.], and remove striking lever and striking rod.

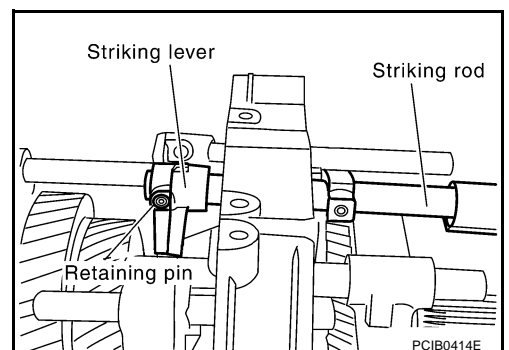

A  
B  
MT  
D  
E  
F  
G  
H  
I  
J  
K  
L  
M

# TRANSMISSION ASSEMBLY

5. Remove check ball plugs, check ball springs and check balls from adapter plate.

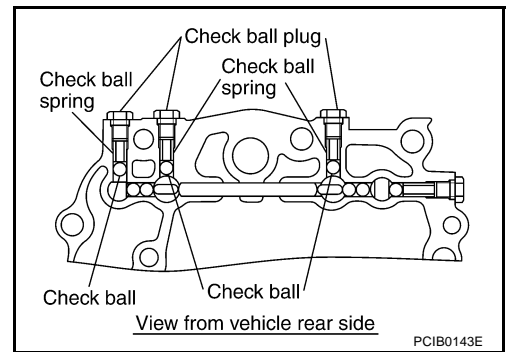

6. Remove 3rd-4th control lever mounting bolts and 3rd-4th control lever from adapter plate.

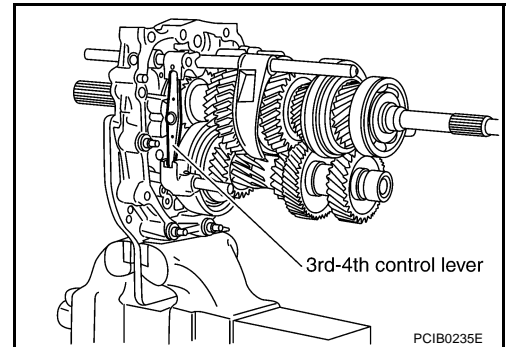

7. Remove shifter cap from 3rd-4th control lever.
8. Remove check ball plug, check ball spring and check ball from adapter plate.

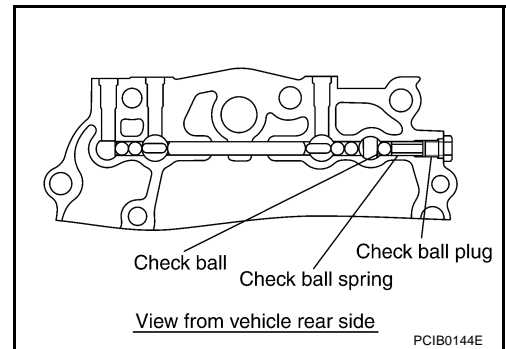

9. Drive out retaining pin using a pin punch [6mm (0.24 in) dia.], and remove 3rd-4th fork rod bracket and 3rd-4th fork rod.

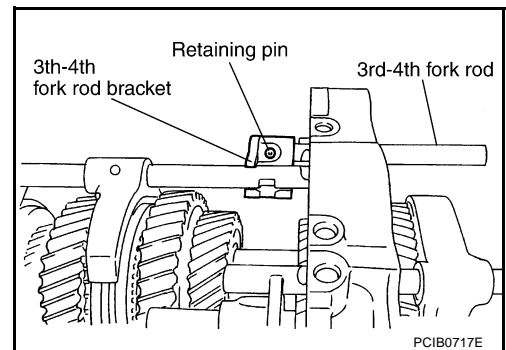

# TRANSMISSION ASSEMBLY

10. Drive out retaining pin using a pin punch [6 mm (0.24 in) dia.], and remove 3rd-4th fork rod (reversal side) and 3rd-4th shift fork.

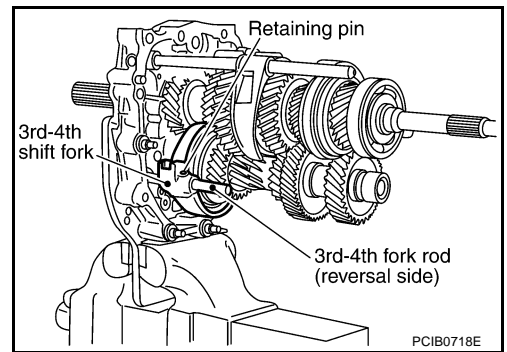

11. Remove check balls and interlock pin from adapter plate.

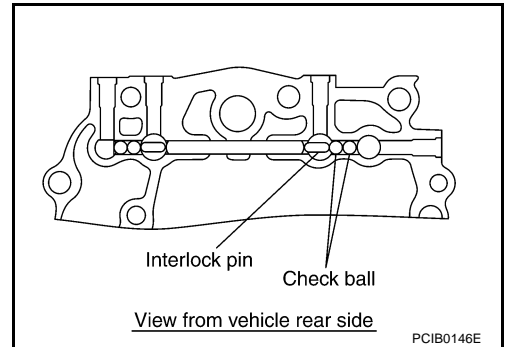

12. Drive out retaining pin using a pin punch [6 mm (0.24 in) dia.], and remove 1st-2nd fork rod and 1st-2nd shift fork.

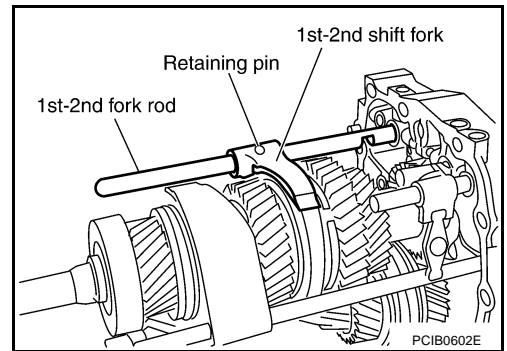

13. Remove interlock plunger and interlock pin from adapter plate.

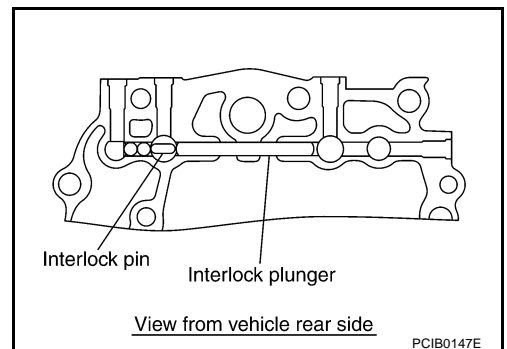

14. Drive out retaining pin using a pin punch [6 mm (0.24 in) dia.], and remove reverse fork rod and reverse shift fork.

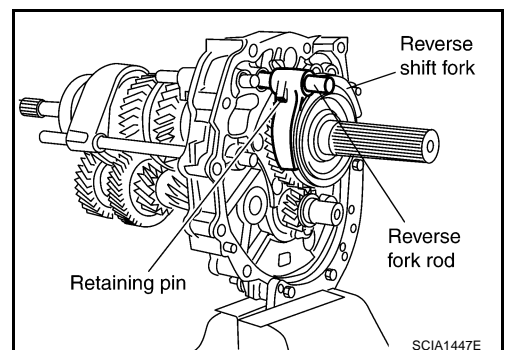

A  
B  
MT  
D  
E  
F  
G  
H  
I  
J  
K  
L  
M

# TRANSMISSION ASSEMBLY

15. Remove check balls from adapter plate.

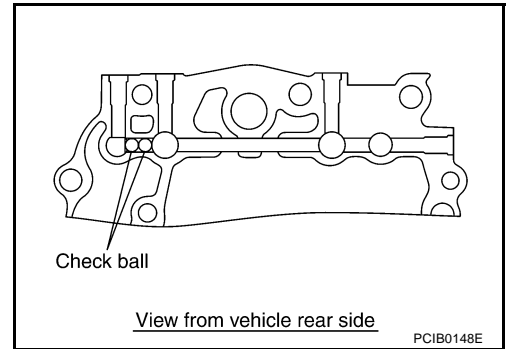

16. Remove 5th-6th control lever mounting bolts, and 5th-6th control lever from adapter plate.

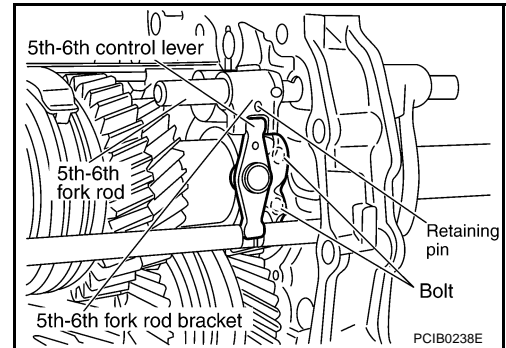

17. Drive out retaining pin using a pin punch [6 mm (0.24 in) dia.], and remove 5th-6th fork rod and 5th-6th fork rod bracket.

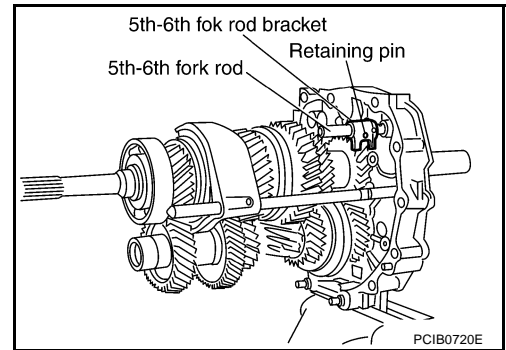

18. Drive out retaining pin using a pin punch [6 mm (0.24 in) dia.], and remove 5th-6th fork rod (reversal side) and 5th-6th shift fork.

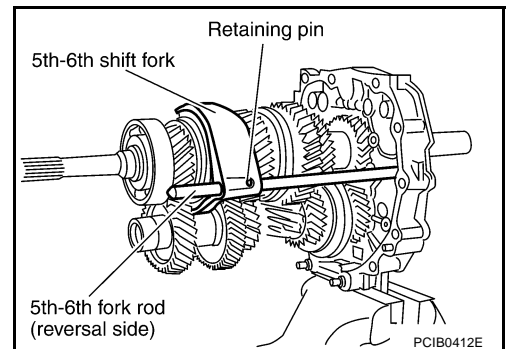

## Gear Components

- Before disassembly, measure end play for each position. If the end play is outside the specifications, disassemble and inspect.



# TRANSMISSION ASSEMBLY

- Main drive gear

**End play : 0 - 0.1 mm (0 - 0.004 in)**

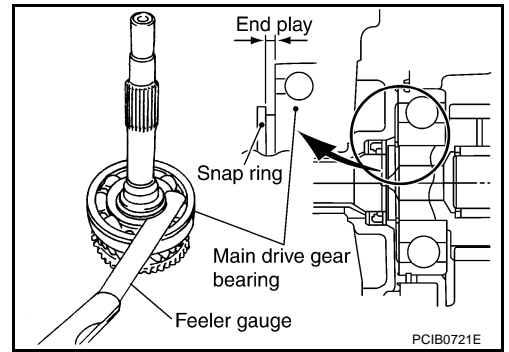

- Main shaft rear side

**End play : 0 - 0.1 mm (0 - 0.004 in)**

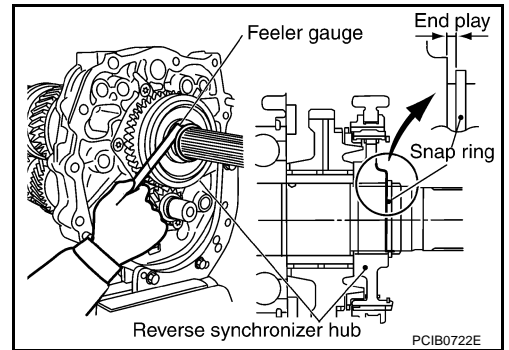

- Counter shaft

**End play : 0 - 0.1 mm (0 - 0.004 in)**

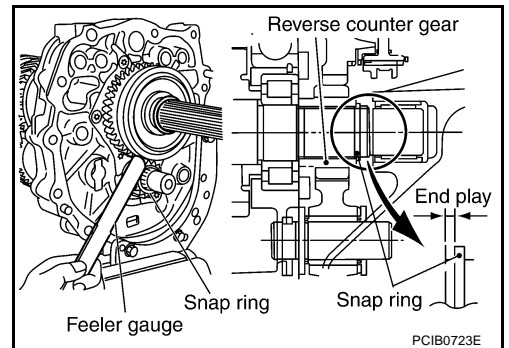

1. After removing snap ring, remove reverse synchronizer assembly and reverse main gear from main shaft using a puller.
2. Remove reverse main needle bearing from main shaft.

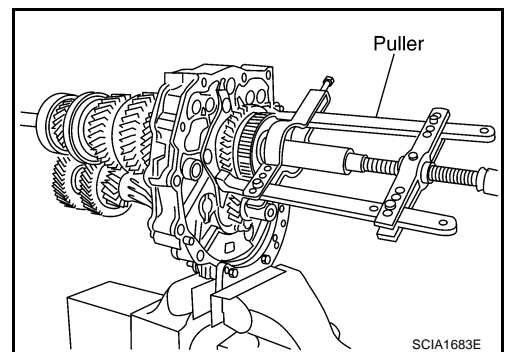

A  
B  
MT  
D  
E  
F  
G  
H  
I  
J  
K  
L  
M

# TRANSMISSION ASSEMBLY

3. Remove main shaft bearing retainer mounting bolts and main shaft bearing retainer from adapter plate.

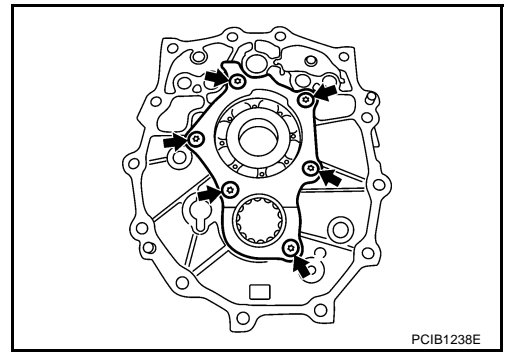

4. After removing snap ring, remove reverse counter gear and counter rear bearing spacer using a puller.

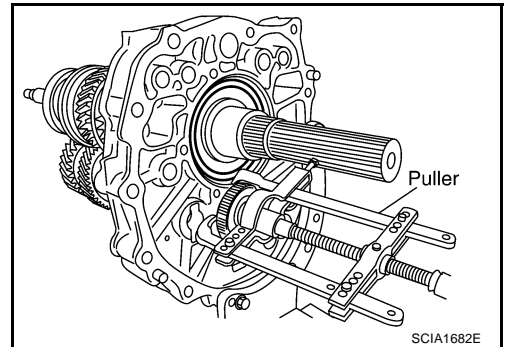

5. Remove snap ring from main shaft bearing.

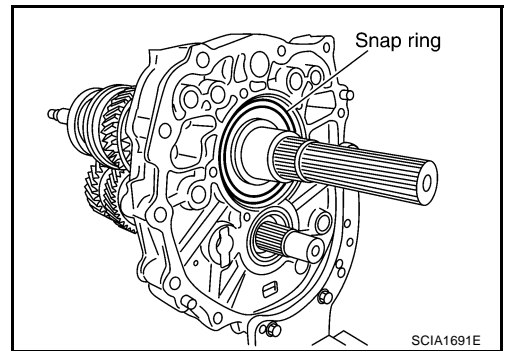

6. Remove main shaft assembly and counter shaft assembly together from adapter plate.

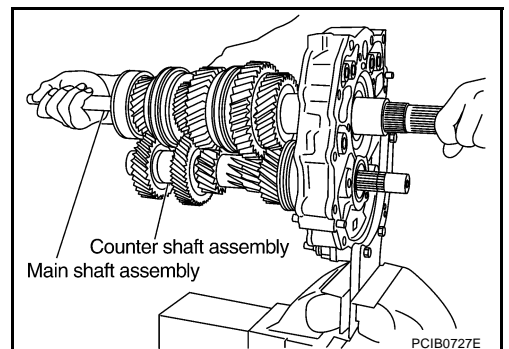

7. Remove counter rear bearing from adapter plate.

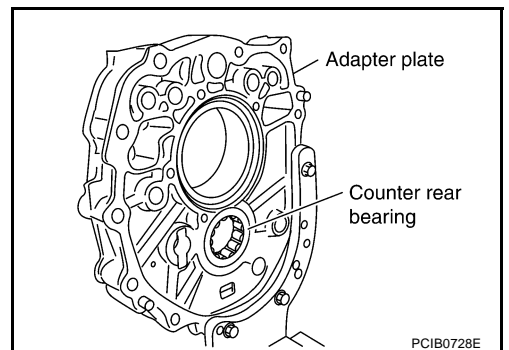

# TRANSMISSION ASSEMBLY

8. Remove main drive gear, main pilot bearing, pilot bearing spacer and 5th baulk ring from main shaft.
9. Remove snap ring from main drive gear using snap ring pliers.

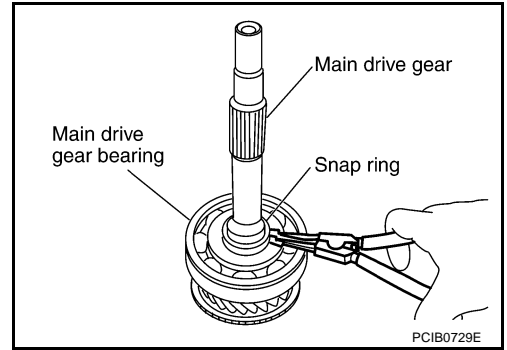

10. Set a puller on main drive gear bearing, and remove main drive gear bearing from main drive gear using a press.

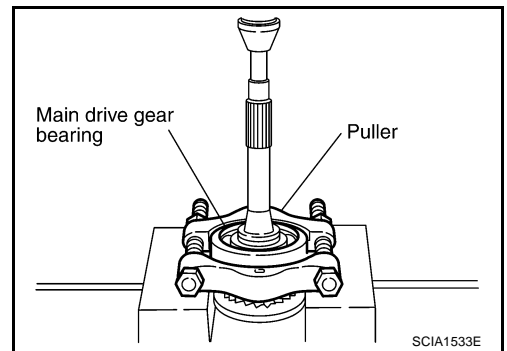

11. Set a puller on 4th main gear, and remove reverse main gear bushing, main shaft bearing and 4th main gear from main shaft using a press.

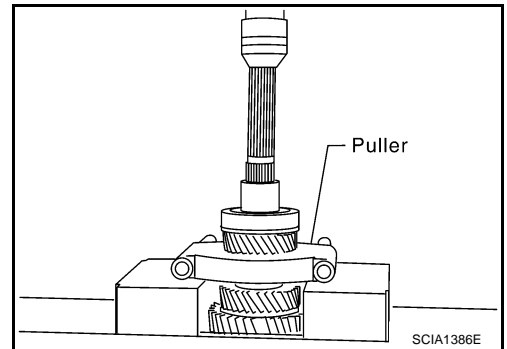

12. Remove 3rd-4th main spacer from main shaft.
13. Set a puller on 1st main gear, and remove 3rd main gear and 1st main gear from main shaft using a press.

**CAUTION:**  
**Be careful not to damage baulk ring.**

14. Remove 1st needle bearing from main shaft.

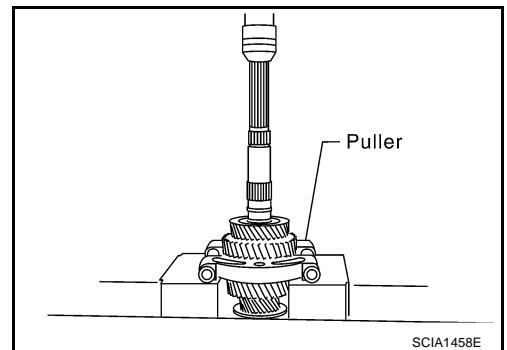

A  
B  
MT  
D  
E  
F  
G  
H  
I  
J  
K  
L  
M

# TRANSMISSION ASSEMBLY

15. Set a puller on 2nd main gear, and remove 1st-2nd synchronizer assembly and 2nd main gear from main shaft using a press.

**CAUTION:**

**Be aware that when using the press, if the main shaft gear positioner catches on the V-block, etc., the main shaft could be damaged.**

16. Remove 2nd needle bearing from the main shaft.

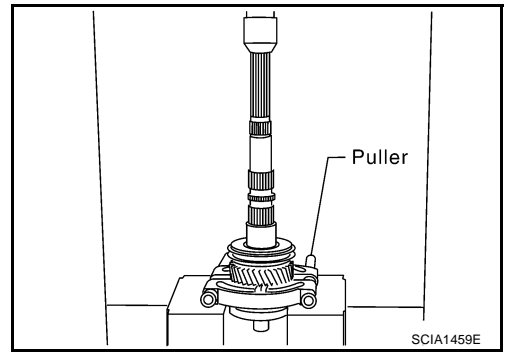

17. Remove snap ring, then set a puller on 6th main gear, and remove 5th-6th synchronizer assembly, 6th baulk ring and 6th main gear from main shaft using a press.

18. Remove 6th needle bearing from main shaft.

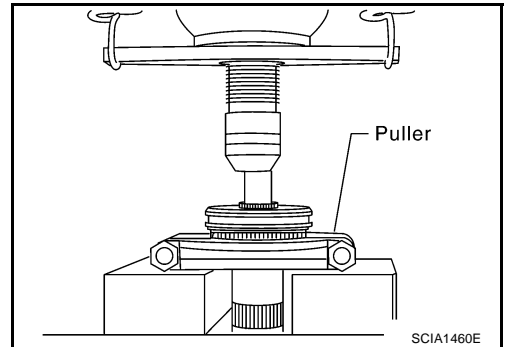

19. Set a puller on 3rd counter gear, and remove counter rear bearing inner race, 4th counter gear thrust washer, 4th counter gear, 4th inner baulk ring, 4th synchronizer cone, 4th outer baulk ring, 4th needle bearing, 4th gear bushing, 3rd-4th synchronizer assembly, 3rd outer baulk ring, 3rd synchronizer cone, 3rd inner baulk ring and 3rd counter gear from counter shaft using a press.

20. Remove 3rd needle bearing from counter shaft.

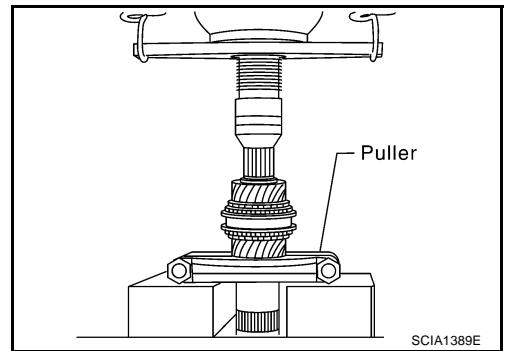

21. Set a puller on 3rd gear bushing, and remove 3rd gear bushing from counter shaft using a press.

**CAUTION:**

**Do not use oil hole of 3rd gear bushing when press out.**

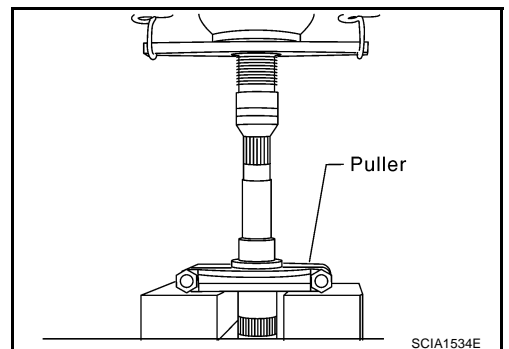

# TRANSMISSION ASSEMBLY

## INSPECTION AFTER DISASSEMBLY

### Shift Control

If the contact surface on striking lever, fork rod, shift fork, etc. has excessive wear, abrasion, bend, or any other damage, replace the components.

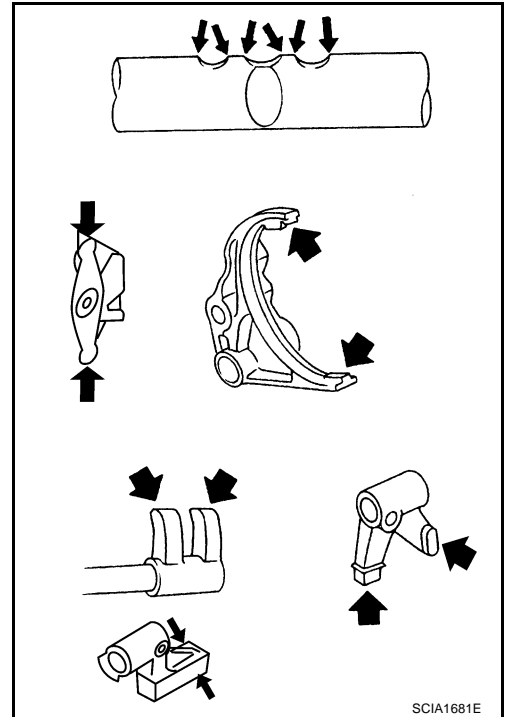

### Gear and Shaft

If the contact surface on each gear, main shaft, main drive gear, and counter shaft, etc. has damage, peeling, abrasion, dent, bent, or any other damage, replace the components.

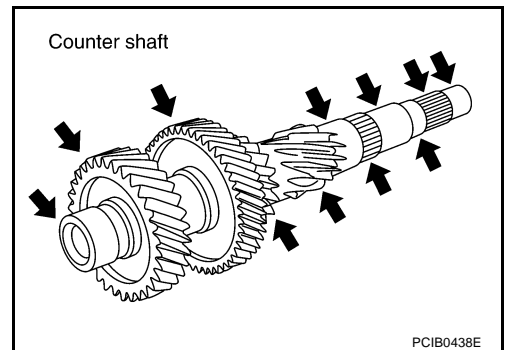
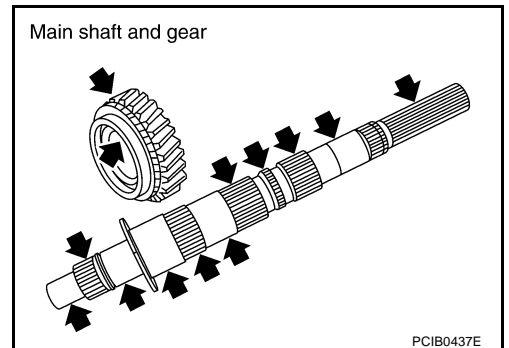

A  
B  
MT  
D  
E  
F  
G  
H  
I  
J  
K  
L  
M

# TRANSMISSION ASSEMBLY

## Synchronizer

- If the contact surface on coupling sleeve, synchronizer hub, and shifting insert has damage or abrasion, replace the components.
- Coupling sleeve and synchronizer hub shall move smoothly.

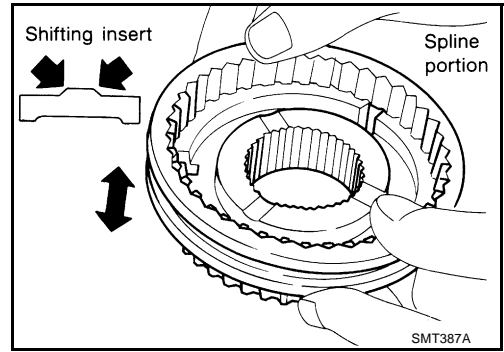

- If the cam surface on baulk ring or contact surface on insert has damage or excessive wear, replace with a new one.
- If spread spring is damaged, replace with a new one.

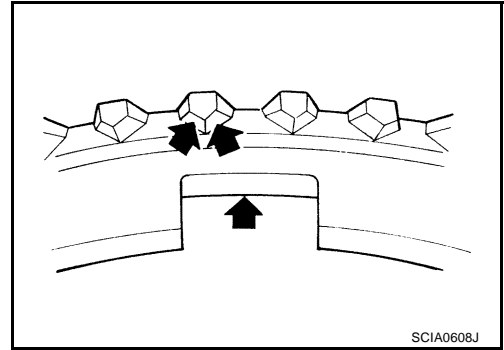

## Baulk Ring Clearance

- **Single cone synchronizer (5th and 6th)**
  - Push baulk ring on the cone and measure baulk ring back surface clearance at two locations or more on opposite sides, find the average value, and replace it if it is outside the limit value.

### Clearance

**Standard value : 0.70 - 1.35 mm (0.028 - 0.053 in)**

**Limit value : 0.5 mm (0.020 in) or less**

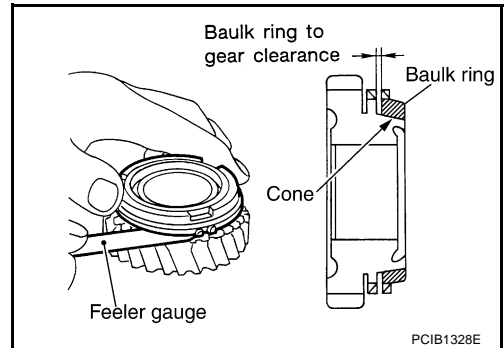

- **Double cone synchronizer (4th)**  
Follow the instructions below and inspect the clearance of the outer baulk ring, synchronizer cone, inner baulk ring.

### CAUTION:

**Clearances "A" and "B" of the outer baulk ring, synchronizer cone, and inner baulk ring are controlled as a set, so if the clearance is outside the limit value, replace the synchronizer assembly.**

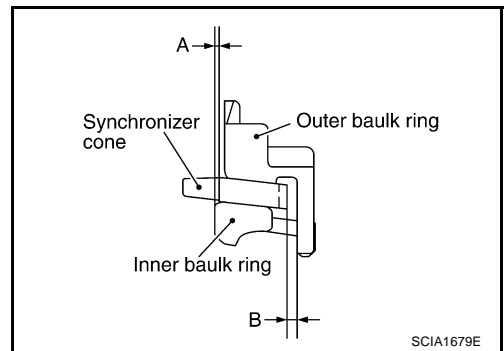

# TRANSMISSION ASSEMBLY

- Using a dial gauge, measure clearance A at 2 or more points diagonally opposite, and calculate mean value.

## Clearance A

**Standard value** : 0.50 - 0.70 mm (0.020 - 0.028 in)

**Limit value** : 0.3 mm (0.012 in) or less

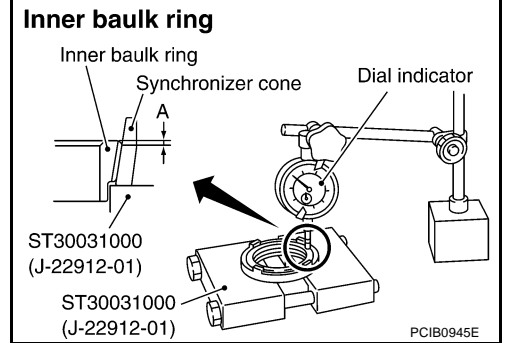

- Using a feeler gauge, measure clearance B at 2 or more points diagonally opposite, and calculate mean value.

## Clearance B

**Standard value** : 0.85 - 1.35mm (0.033 - 0.053 in)

**Limit value** : 0.7mm (0.028 in) or less

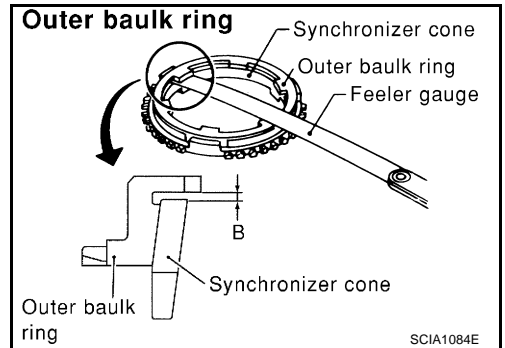

- Triple cone synchronizer (1st, 2nd and 3rd)**

Check clearance for outer baulk ring, synchronizer cone and inner baulk ring of triple cone synchronizer following the direction.

### NOTE:

Outer baulk ring, synchronizer cone and inner baulk ring, three control "clearance A, B and C" as a three-piece suite. If the value exceeds the limit value, replace them as a three-piece suite.

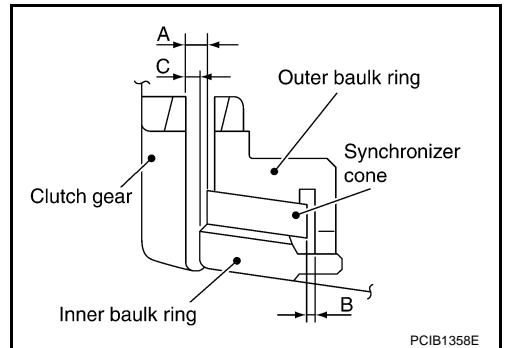

- Using feeler gauge put and press baulk ring on gear taper cone, and then measure "clearance A" at more than 2 diagonal points, and calculate the average.

## Clearance A

**Standard value** : 0.65 - 1.25 mm (0.026 - 0.049 in) (1st)

**Standard value** : 0.60 - 1.30 mm (0.024 - 0.051 in) (2nd, 3rd)

**Limit value** : 0.3mm (0.012 in) or less

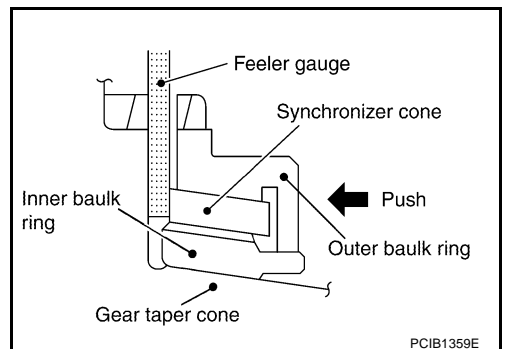

- Using feeler gauge measure "clearance B" at more than 2 diagonal positions, and calculate the average.

## Clearance B

**Standard value** : 0.85 - 1.35 mm (0.033 - 0.053 in)

**Limit value** : 0.7mm (0.028 in) or less

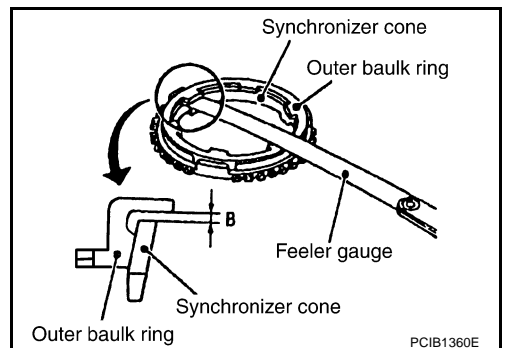

A  
B  
MT  
D  
E  
F  
G  
H  
I  
J  
K  
L  
M

# TRANSMISSION ASSEMBLY

3. Using filler gauge put and press baulk ring on gear taper cone, and then measure "clearance C" at more than 2 diagonal points, and calculate the average.

## Clearance C

**Standard value** : 0.80 - 1.2 mm (0.031 - 0.047 in)  
(1st)

**Standard value** : 0.75 - 1.25 mm (0.030 - 0.049 in)  
(2nd,3rd)

**Limit value** : 0.3 mm (0.012 in) or less

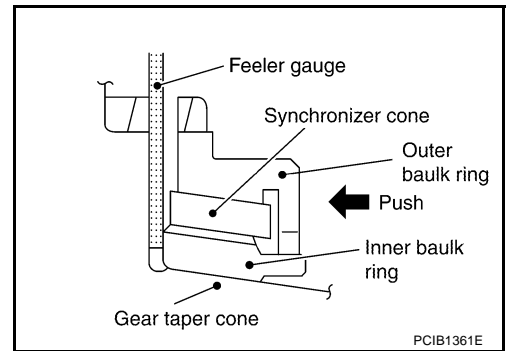

## Reverse synchronizer

Push baulk ring on the cone and measure baulk ring back surface clearance at two locations or more on opposite sides, find the average value, and replace if it is outside the limit value.

## Clearance

**Standard value** : 0.75 - 1.20 mm (0.030 - 0.047 in)

**Limit value** : 0.5 mm (0.020 in) or less

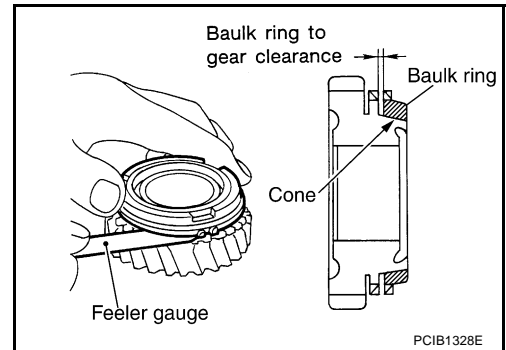

## Bearing

If the bearing does not rotate smoothly or the contact surface on ball or race is damaged or peeled, replace with new ones.

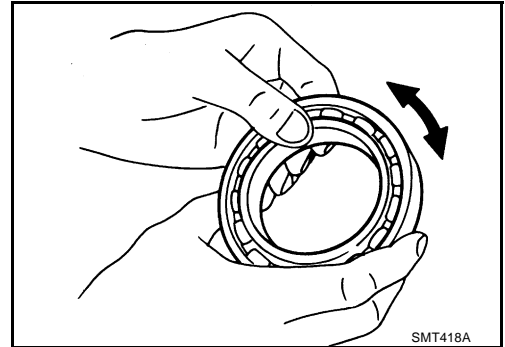

## ASSEMBLY

### Gear Components

1. Install 5th-6th coupling sleeve and 5th-6th shifting insert in the 5th-6th synchronizer hub.

### CAUTION:

- Install 5th-6th coupling sleeve with the thicker flange on the front side.
- Do not reuse 5th-6th coupling sleeve and 5th-6th synchronizer hub.
- Replace 5th-6th coupling sleeve and 5th-6th synchronizer hub as a set.

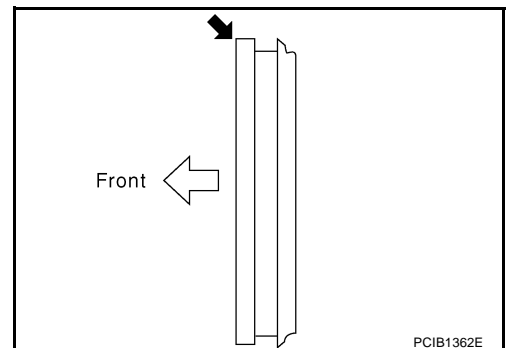



# TRANSMISSION ASSEMBLY

2. Install 5th-6th spread spring in the 5th-6th shifting insert.

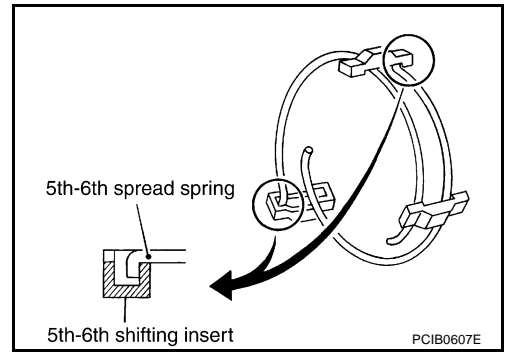

**CAUTION:**

- Do not install 5th-6th spread spring hook onto the same 5th-6th shifting insert.
- Be careful with the shape of reverse shifting insert to avoid misassembly.

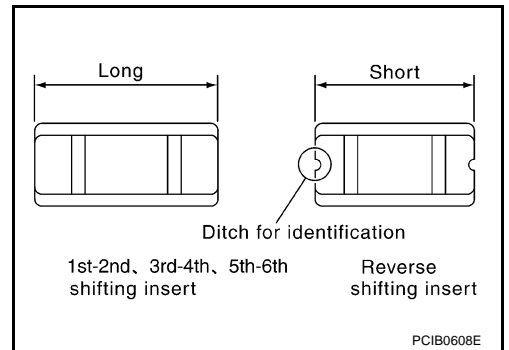

3. Install 6th needle bearing, 6th main gear, and 6th baulk ring on the main shaft and then using an inserter and a press to press fit the 5th-6th synchronizer assembly.

Tool number : ST30911000 ( — )

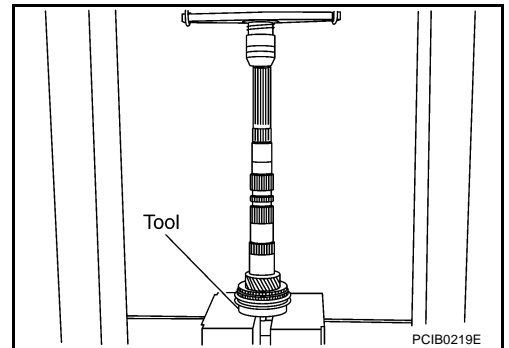

**CAUTION:**

- Do not reuse 5th-6th synchronizer hub.
- When press fitting, install with the side having the three boss edge oil grooves facing the rear side.

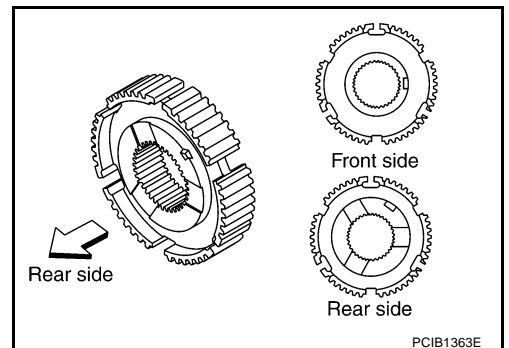

A  
B  
MT  
D  
E  
F  
G  
H  
I  
J  
K  
L  
M

# TRANSMISSION ASSEMBLY

**NOTE:**

5th and 6th baulk rings have three spaces that four gear teeth are missing as shown in the figure.

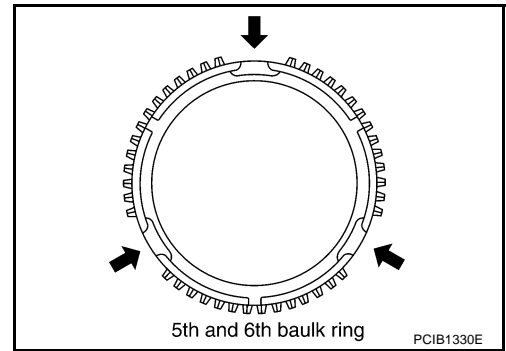

4. Select and install a snap ring so that the end play comes within the standard value. Refer to [MT-60, "Snap Rings"](#).

**End play : 0 - 0.10 mm (0 - 0.004 in)**

**CAUTION:**

**Do not reuse snap ring.**

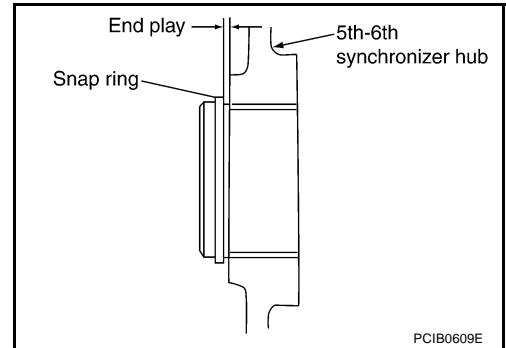

5. Install 1st-2nd coupling sleeve and 1st-2nd shifting insert into the 1st-2nd synchronizer hub.

**CAUTION:**

**Install 1st-2nd coupling sleeve with the thicker flange faced the front side.**

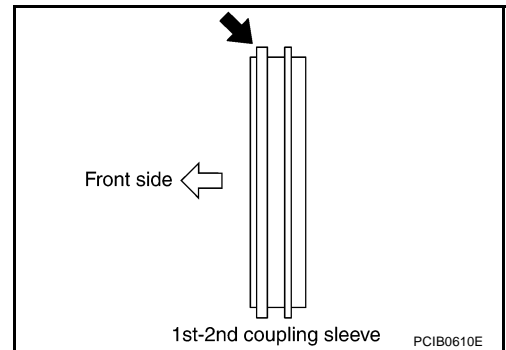

6. Install 1st-2nd spread spring in the 1st-2nd shifting insert.

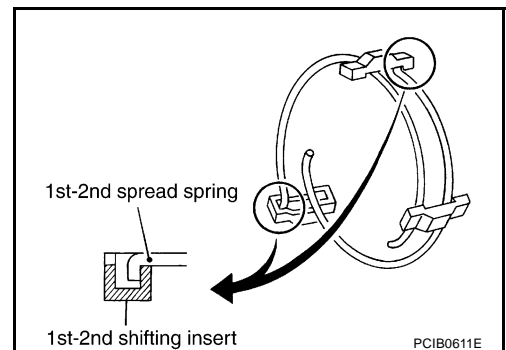

# TRANSMISSION ASSEMBLY

**CAUTION:**

- Do not install 1st-2nd spread spring hook onto the same 1st-2nd shifting insert.
- Be careful with the shape of reverse shifting insert to avoid misassembly.

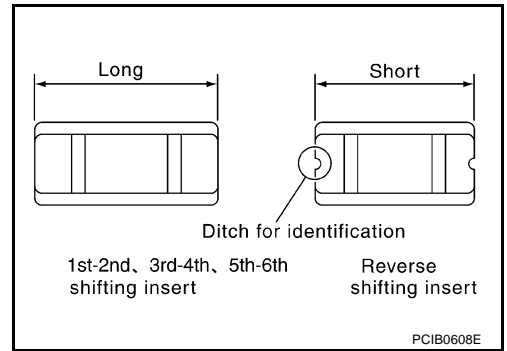

7. Install 2nd main gear, 2nd needle bearing, 2nd inner baulk ring, 2nd synchronizer cone, 2nd outer baulk ring on the main shaft and then using a support ring and a press to press fit the 1st-2nd synchronizer assembly.

Tool number : ST27861000 ( — )

**CAUTION:**

Replace 2nd inner baulk ring, 2nd synchronizer cone and 2nd outer baulk ring as a set.

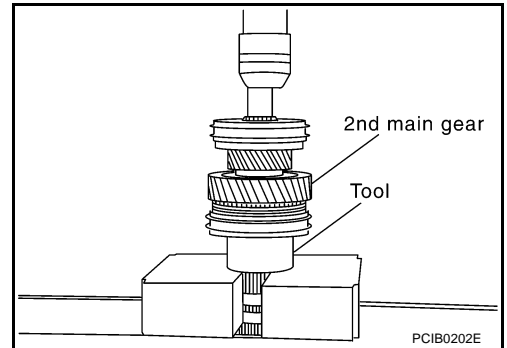

**CAUTION:**

- Do not reuse 1st-2nd synchronizer hub.
- When press fitting, install with the side having the three boss edge oil grooves facing the front side.

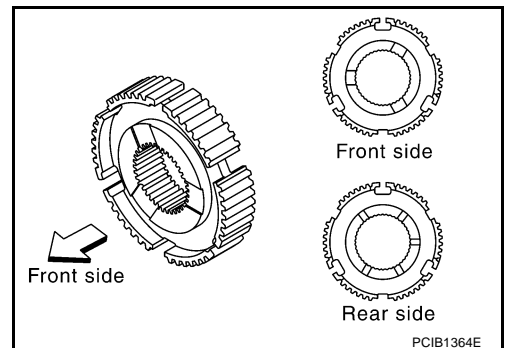

**NOTE:**

1st baulk ring has three spaces that four gear tooth is missing and 2nd baulk ring has three spaces that two gear teeth are missing.

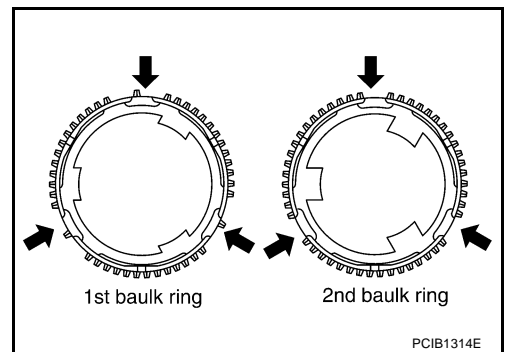

A  
B  
MT  
D  
E  
F  
G  
H  
I  
J  
K  
L  
M

# TRANSMISSION ASSEMBLY

8. Using a support ring and a press to press fit the 1st gear bushing.

**Tool number** : ST27861000 ( — )

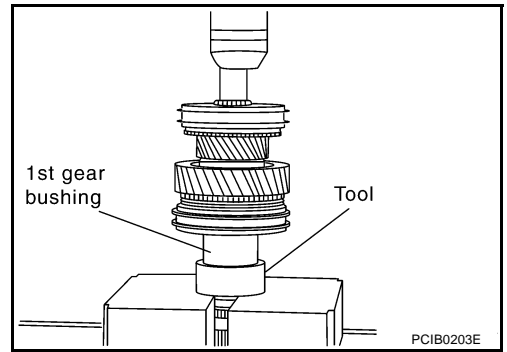

9. Install 1st outer baulk ring, 1st synchronizer cone, 1st inner baulk ring, 1st needle bearing, and 1st main gear on the main shaft and then using the inserter and a press to press fit the 3rd main gear.

**Tool number** : ST30022000 ( — )

**CAUTION:**

**Do not reuse 3rd main gear.**

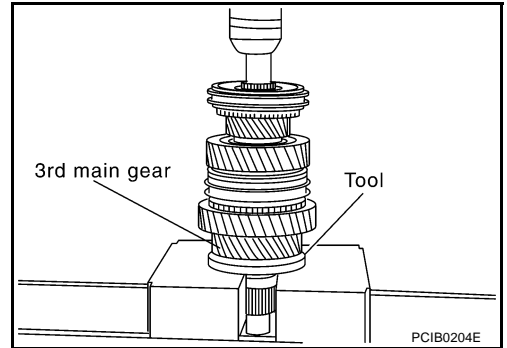

10. Install 3rd-4th main spacer on the main shaft and then using the inserter and a press to press fit the 4th main gear.

**Tool number** : ST30022000 ( — )

**CAUTION:**

- **Do not reuse 4th main gear.**
- **When installing, set boss to rear side.**

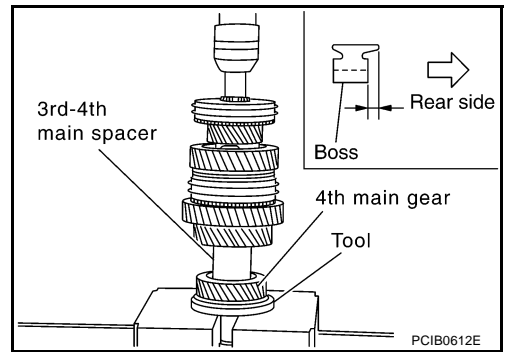

11. Using the inserter and a press to press fit the main shaft bearing onto the main shaft.

**Tool number** : ST30911000 ( — )

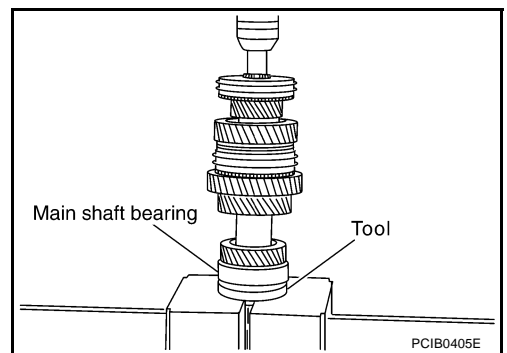

12. Using the inserter and a press to press fit the reverse main gear bushing onto the main shaft.

**Tool number** : ST30911000 ( — )

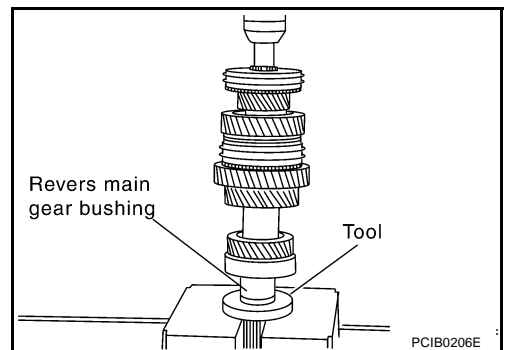

# TRANSMISSION ASSEMBLY

13. Using the inserter and a press to press fit the 3rd gear bushing onto the counter shaft.

**Tool number** : ST30911000 ( — )

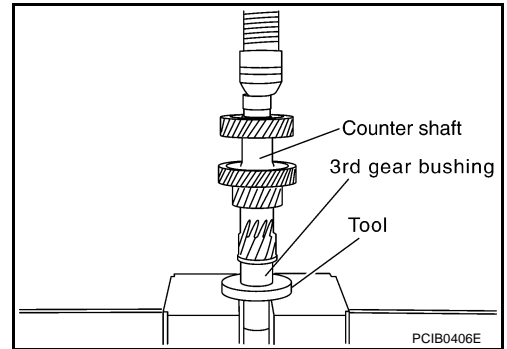

14. Install 3rd-4th coupling sleeve and 3rd-4th shifting insert into the 3rd-4th synchronizer hub.

**CAUTION:**

- Install 3rd-4th coupling sleeve with the thicker flange faced the front side.

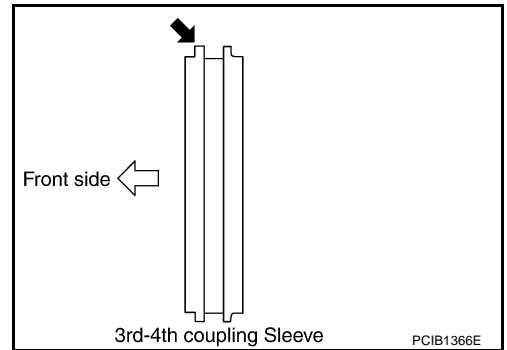

15. Install 3rd-4th spread spring in the 3rd-4th shifting insert.

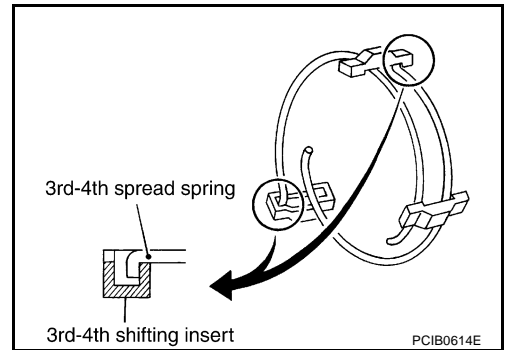

**CAUTION:**

- Do not install 3rd-4th spread spring hook onto the same shifting insert.
- Be careful with the shape of reverse shifting insert to avoid misassembly.

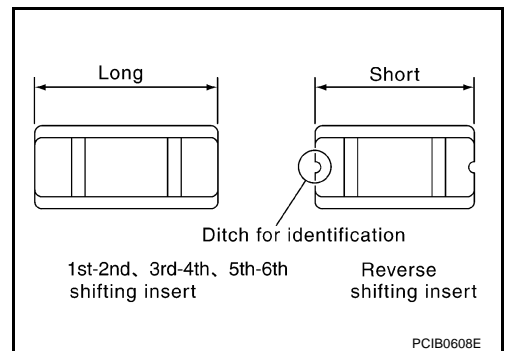

A  
B  
MT  
D  
E  
F  
G  
H  
I  
J  
K  
L  
M

# TRANSMISSION ASSEMBLY

16. Install 3rd needle bearing, 3rd counter gear, 3rd inner baulk ring, 3rd synchronizer cone, and 3rd outer baulk ring on the counter shaft and then using the inserter and a press to press fit the 3rd-4th synchronizer assembly.

**Tool number** : ST30911000 ( — )

**CAUTION:**

- Do not reuse 3rd-4th synchronizer hub.
- The 3rd-4th synchronizer hub must apply the gear oil on the hole spline press fitting side.

**NOTE:**

4th baulk ring has three spaces that one gear tooth is missing but 3rd baulk ring doesn't.

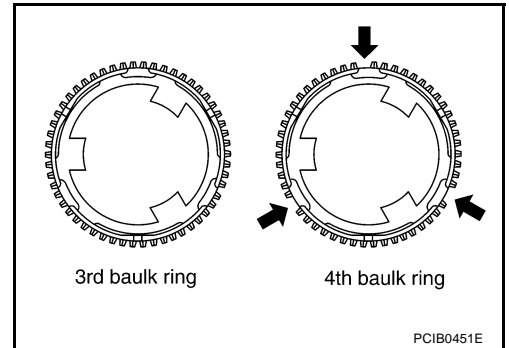
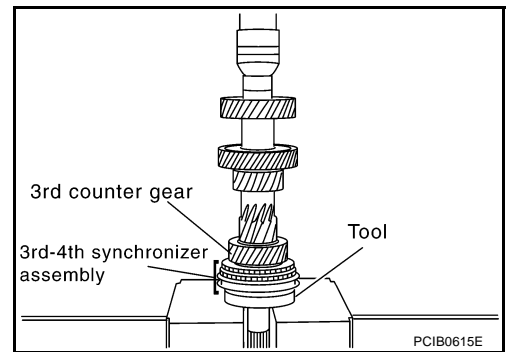

17. Install 4th outer baulk ring, 4th synchronizer cone, 4th inner baulk ring, 4th needle bearing, and 4th counter gear onto the counter shaft and then using the drift and a press to press fit the 4th gear bushing and 4th counter gear thrust washer.

**Tool number** : KV40100630 (J-26092)

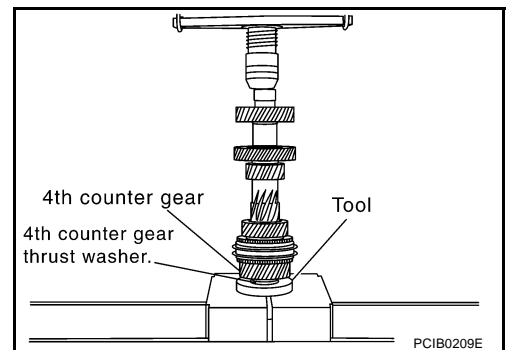

18. Using the inserter and a press to press fit the counter rear bearing inner race onto the counter shaft.

**Tool number** : ST30032000 (J-26010-01)

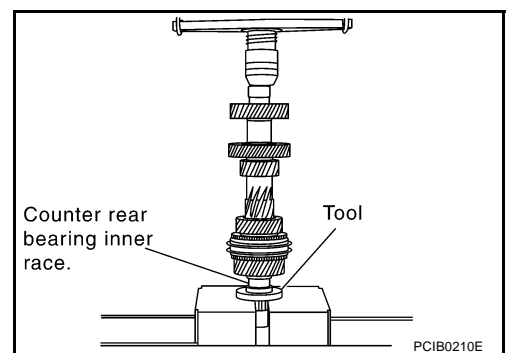

19. Using the drift and a press to press fit the main drive gear bearing onto the main drive gear.

**Tool number** : KV32102700 ( — )

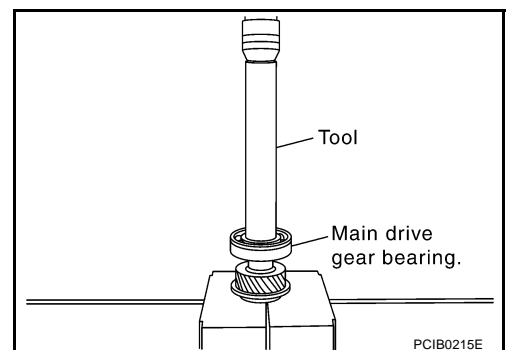

# TRANSMISSION ASSEMBLY

20. Select and install a snap ring to the main drive gear bearing so that the end play comes within the standard value. Refer to [MT-60, "Snap Rings"](#) .

**End play : 0 - 0.10 mm (0 - 0.004 in)**

**CAUTION:**

**Do not reuse snap ring.**

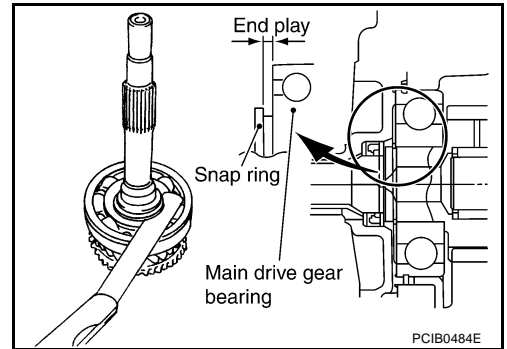

21. Install main shaft and counter shaft combined in one unit to adapter plate, and fix bearing with snap ring.

**CAUTION:**

**Do not reuse snap ring.**

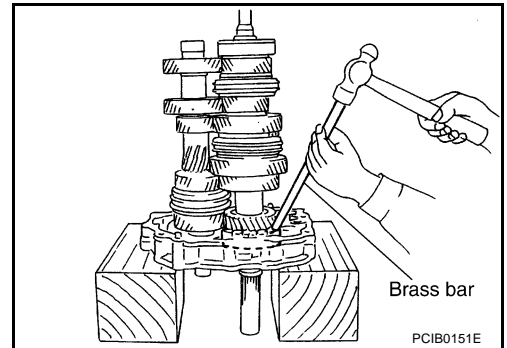

22. Install counter rear bearing onto the adapter plate using soft hammer or the equivalent.

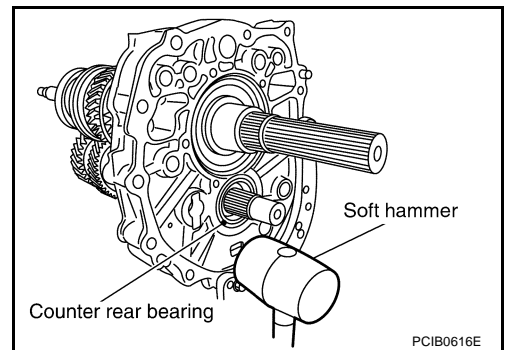

23. Apply thread locking sealant to the end of the bolt (first 3 to 4 threads), screw the bolts into the main shaft bearing retainer plate, and tighten it to the specified torque. Refer to [MT-21, "Case Components"](#) .

- **Use Genuine Medium Strength Thread Locking Sealant or equivalent. Refer to [GI-46, "RECOMMENDED CHEMICAL PRODUCTS AND SEALANTS"](#) .**

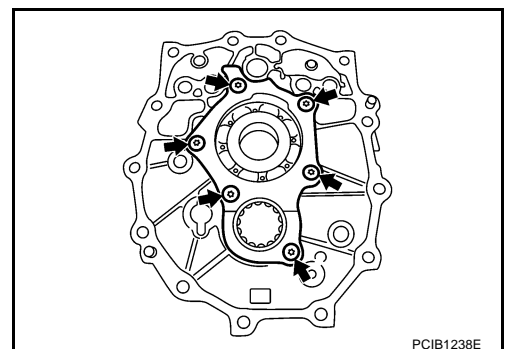

24. Install reverse coupling sleeve and reverse shifting insert into the reverse synchronizer hub.

**CAUTION:**

**Install reverse coupling sleeve with the flat flange on the rear side.**

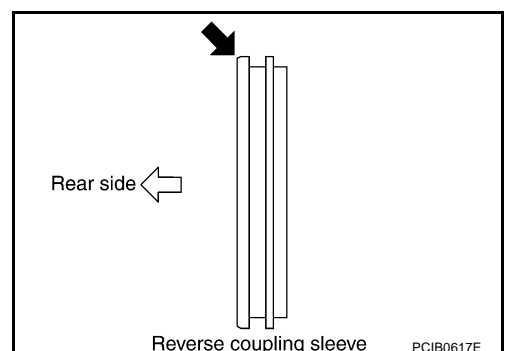

A  
B  
MT  
D  
E  
F  
G  
H  
I  
J  
K  
L  
M

# TRANSMISSION ASSEMBLY

25. Install reverse spread spring in the reverse shifting insert.

**CAUTION:**

Do not install reverse spread spring hook onto the same reverse shifting insert.

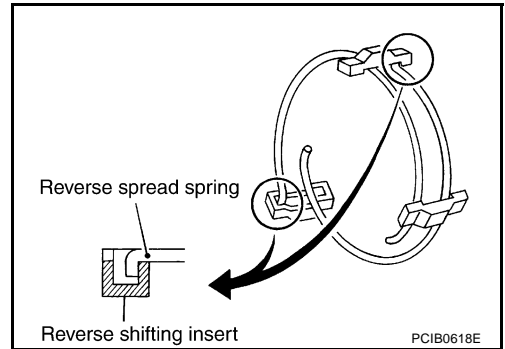

26. Install snap rings to reverse synchronizer hub.

**CAUTION:**

- Do not reuse snap ring.
- Do not align the snap ring notch with synchronizer hub groove when assembling.

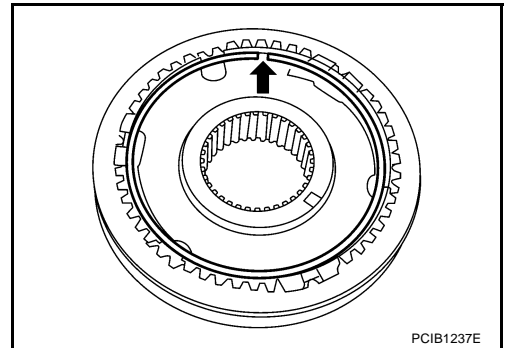

27. After installing reverse main gear bushing, reverse main needle bearing, reverse main gear, and reverse baulk ring onto the main shaft, using the drift and press plate and a press to press fit the reverse synchronizer assembly.

Tool number (A) : KV32103300 (J-46529)

Tool number (B) : ST01530000 ( — )

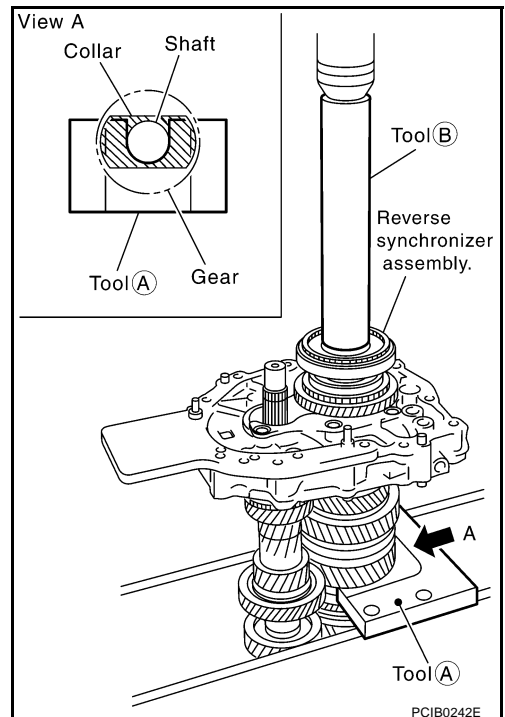

**CAUTION:**

- Do not reuse reverse synchronizer hub.



# TRANSMISSION ASSEMBLY

- When installing, face the side with three ditches to the front side.

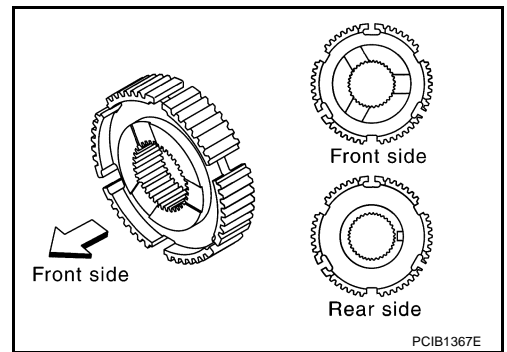

**NOTE:**

Reverse baulk ring has three spaces that two gear teeth are missing, and each space has small ditch for identification as shown in the figure.

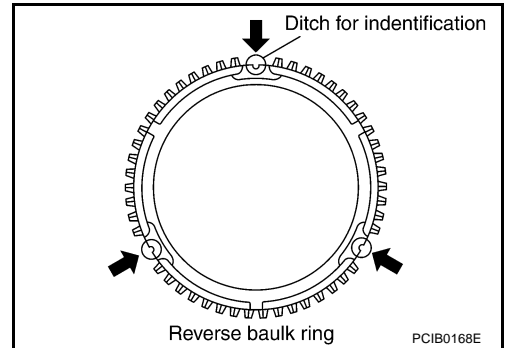

28. Select and install a snap ring so that the end play comes within the standard value. Refer to [MT-60. "Snap Rings"](#).

**End play** : 0 - 0.10 mm ( 0 - 0.004 in )

**CAUTION:**  
Do not reuse snap ring.

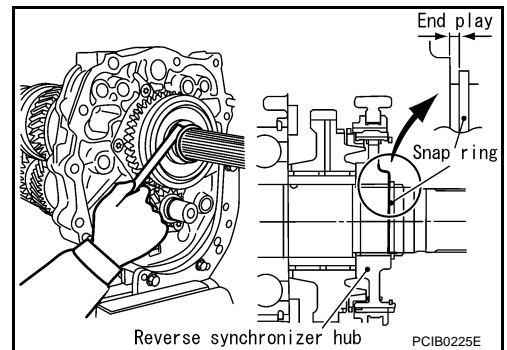

29. After installing counter rear bearing spacer, press and fit reverse counter gear onto counter shaft with drift and press.

**Tool number** : ST23860000 ( — )

**CAUTION:**

- Do not reuse reverse counter gear.
- When installing counter rear bearing spacer, identification ditch should face to the rear side.

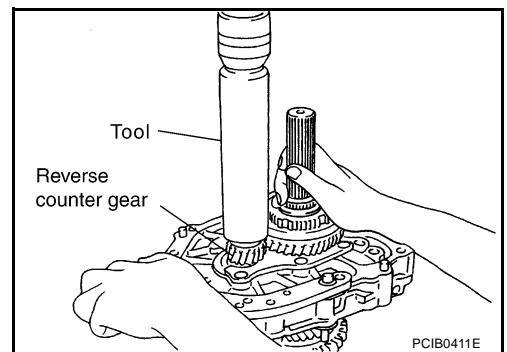

A  
B  
MT  
D  
E  
F  
G  
H  
I  
J  
K  
L  
M

# TRANSMISSION ASSEMBLY

30. Select and install a snap ring so that the end play comes within the standard value. Refer to [MT-60, "Snap Rings"](#).

**End play : 0 - 0.10 mm (0 - 0.004 in)**

**CAUTION:**

**Do not reuse snap ring.**

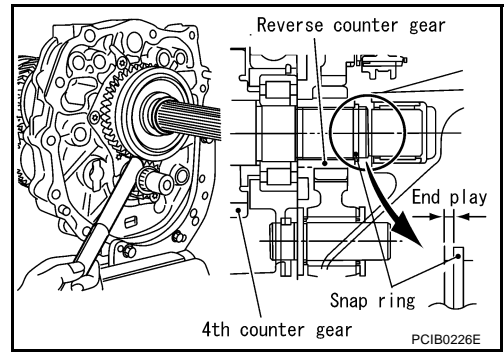

## Shift Control Components

1. Install 5th-6th shift fork to the 5th-6th coupling sleeve.
2. Install 5th-6th fork rod (reversal side) to the 5th-6th shift fork.
3. Using a pin punch [6 mm (0.24 in) dia.] to tap the retaining pin into the 5th-6th shift fork.

**CAUTION:**

**Do not reuse retaining pin.**

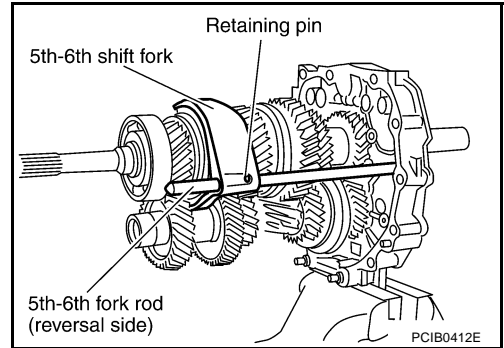

4. Install 5th-6th fork rod to the adapter plate.
5. Install 5th-6th fork rod bracket to the 5th-6th fork rod.
6. Using a pin punch [6 mm (0.24 in) dia.] to tap the retaining pin into the 5th-6th fork rod bracket.

**CAUTION:**

**Do not reuse retaining pin.**

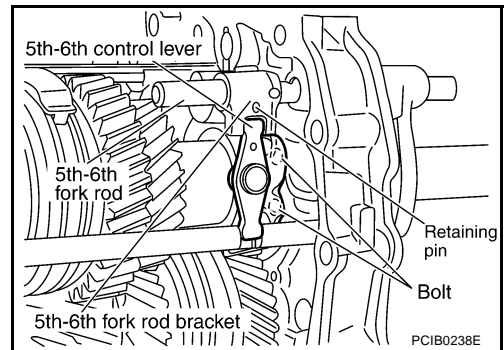

7. Install 5th-6th control lever to the adapter plate and then tighten mounting bolts to the specified torque. Refer to [MT-24, "Shift Control Components"](#).

**CAUTION:**

**Set the projection upward.**

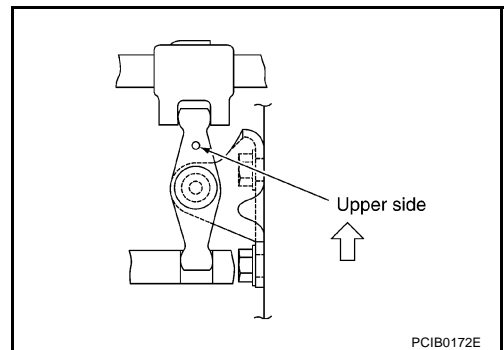

# TRANSMISSION ASSEMBLY

8. Install check balls to the adapter plate.

**CAUTION:**

**Apply lithium-based grease check ball.**

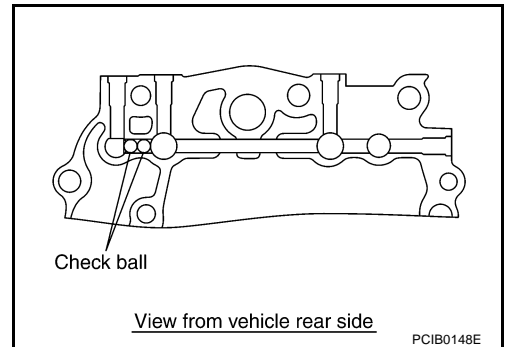

9. Install reverse shift fork to the reverse coupling sleeve.  
10. Install reverse fork rod to the reverse shift fork.  
11. Using a pin punch [6 mm (0.24 in) dia.] to tap the retaining pin into the reverse shift fork.

**CAUTION:**

**Do not reuse retaining pin.**

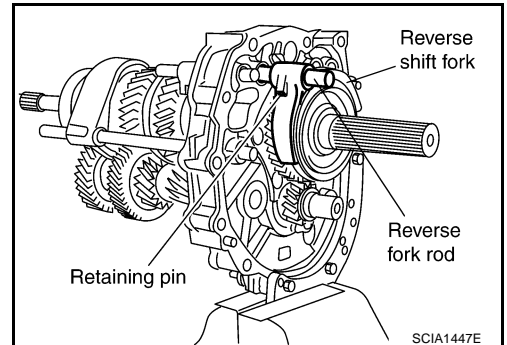

12. Install interlock pin and interlock plunger to the adapter plate.

**CAUTION:**

**Apply lithium-based grease check ball.**

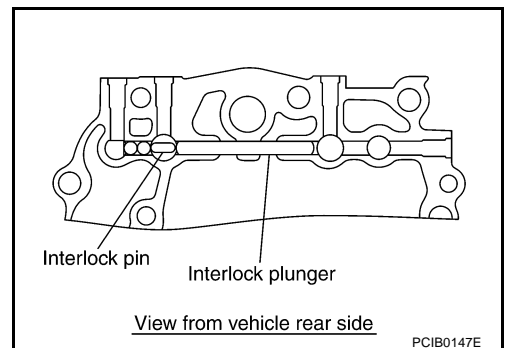

13. Install 1st-2nd shift fork to the 1st-2nd coupling sleeve.  
14. Install 1st-2nd fork rod to the 1st-2nd shift fork.  
15. Using a pin punch [6 mm (0.24 in) dia.] to tap the retaining pin into the 1st-2nd shift fork.

**CAUTION:**

**Do not reuse retaining pin.**

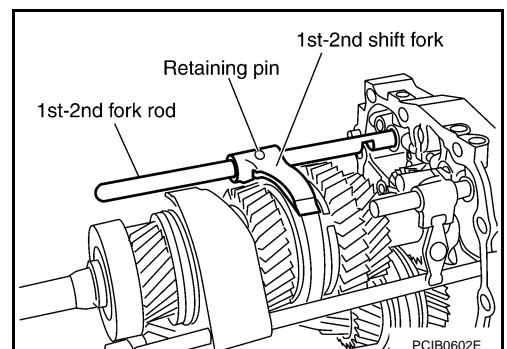

16. Install 3rd-4th shift fork to the 3rd-4th coupling sleeve.  
17. Install 3rd-4th fork rod (reversal side) to 3rd-4th shift fork.  
18. Using a pin punch [6 mm (0.24 in) dia.] to tap the retaining pin into the 3rd-4th shift fork (reversal side).

**CAUTION:**

**Do not reuse retaining pin.**

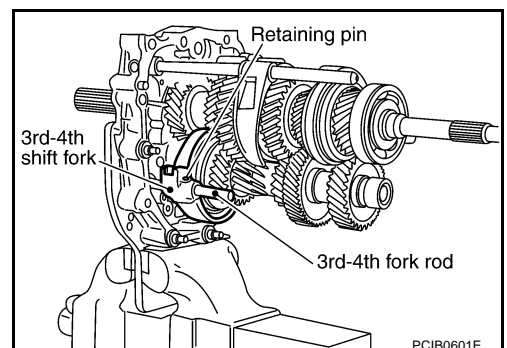

A  
B  
MT  
D  
E  
F  
G  
H  
I  
J  
K  
L  
M

## TRANSMISSION ASSEMBLY

19. Install interlock pin and check balls to the adapter plate.

**CAUTION:**

Apply lithium-based grease check ball.

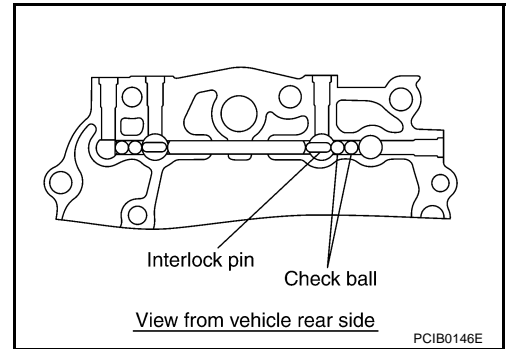

20. Install 3rd-4th fork rod to the adapter plate.  
21. Install 3rd-4th fork rod bracket to the 3rd-4th fork rod.  
22. Using a pin punch [6 mm (0.24 in) dia.] to tap the retaining pin into the 3rd-4th fork rod bracket.

**CAUTION:**

Do not reuse retaining pin.

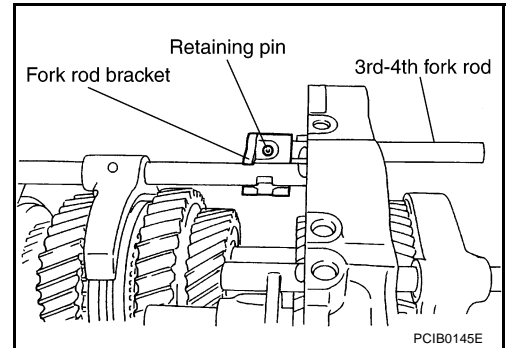

23. Install check ball, check ball spring into the adapter plate, apply liquid gasket to the check ball plug threads, and tighten check ball plug to the specified torque. Refer to [MT-24, "Shift Control Components"](#).

- Use Genuine Silicone RTV or equivalent. Refer to [GI-46, "RECOMMENDED CHEMICAL PRODUCTS AND SEALANTS"](#).

**CAUTION:**

Apply lithium-based grease check ball.

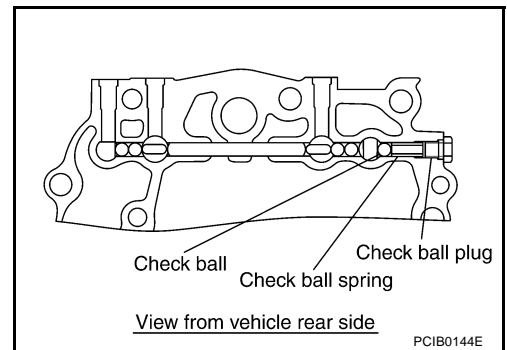

24. Install 3rd-4th control lever to the adapter plate, and then tighten mounting bolts to the specified torque. Refer to [MT-24, "Shift Control Components"](#).

**CAUTION:**

Make sure the top and bottom are oriented correctly.

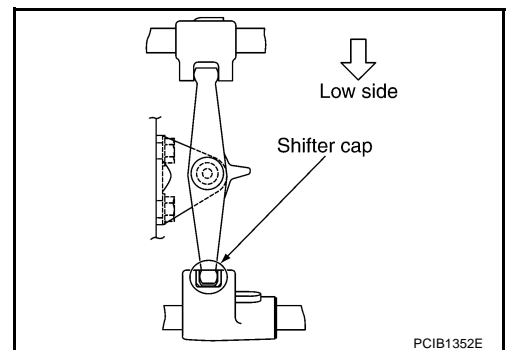

# TRANSMISSION ASSEMBLY

25. Install check balls, check ball springs into the adapter plate, apply liquid gasket to the check ball plugs threads, and tighten check ball plugs to the specified torque. Refer to [MT-24, "Shift Control Components"](#) .

- Use Genuine Silicone RTV or equivalent. Refer to [GI-46, "RECOMMENDED CHEMICAL PRODUCTS AND SEALANTS"](#) .

**CAUTION:**

Apply lithium-based grease check ball.

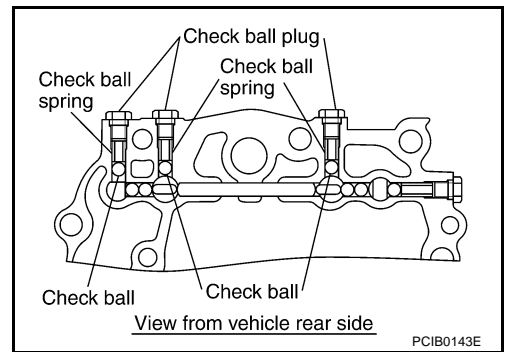

26. Install striking rod to the adapter plate.  
27. Install striking lever to the striking rod.  
28. Using a pin punch [6 mm (0.24 in) dia.] to tap the retaining pin into the striking lever.

**CAUTION:**

Do not reuse retaining pin.

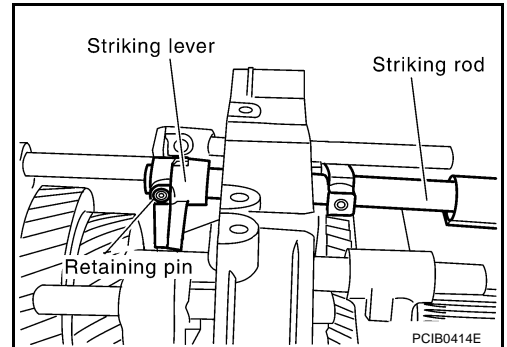

29. Install magnet to the adapter plate.  
30. Install baffle plate to the adapter plate, and then tighten mounting bolts to the specified torque. Refer to [MT-21, "Case Components"](#) .

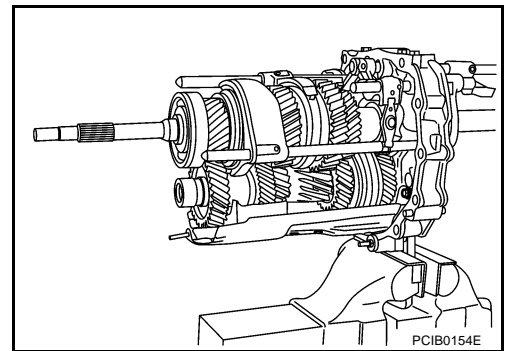

## Case Components

1. Install counter front bearing to the transmission case.
2. Install oil gutter to transmission case.
3. Install breather to transmission.

**CAUTION:**

Do not reuse breather.

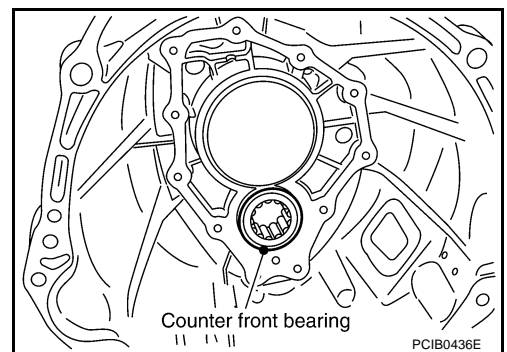

A  
B  
MT  
D  
E  
F  
G  
H  
I  
J  
K  
L  
M

## TRANSMISSION ASSEMBLY

4. Apply liquid gasket to the transmission case adapter plate mounting surface as shown in the figure.

- Use Genuine Silicone RTV or equivalent. Refer to [GI-46, "RECOMMENDED CHEMICAL PRODUCTS AND SEALANTS"](#).

**CAUTION:**

Complete remove all moisture and oil, etc., from the transmission case and adapter plate mounting surfaces.

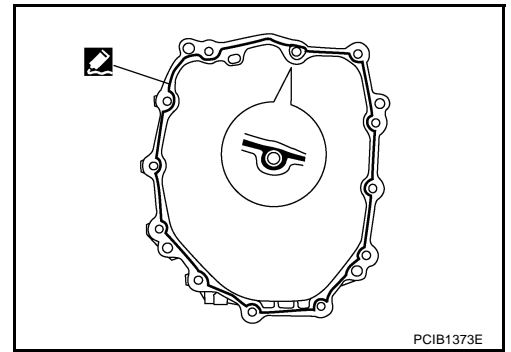

5. Place the adapter plate in the transmission case, using a soft hammer to tap the adapter plate to install it into the transmission case.

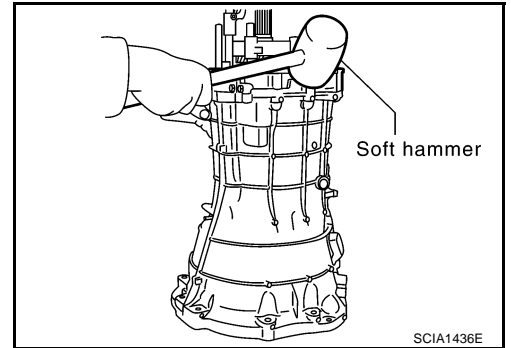

6. Install snap ring to main drive gear bearing, using snap ring pliers.

**CAUTION:**

Do not reuse snap ring.

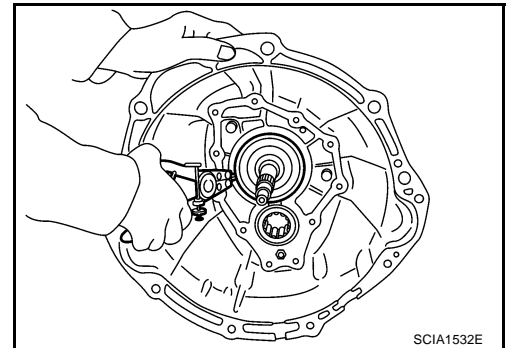

7. Tighten baffle plate mounting nut to the specified torque. Refer to [MT-21, "Case Components"](#).

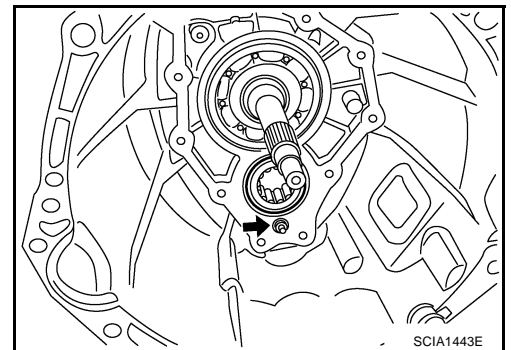

# TRANSMISSION ASSEMBLY

8. Apply multi-purpose grease to the lip of the front cover oil seal. Using a drift, to install oil seal approx. 8.55-9.55 mm (0.336-0.376 in) above from the front cover edge surface.

**Tool number** : KV38102100 (J-25803-01)

**CAUTION:**

- Do not reuse front cover oil seal.
- When installing, do not incline the front cover oil seal.

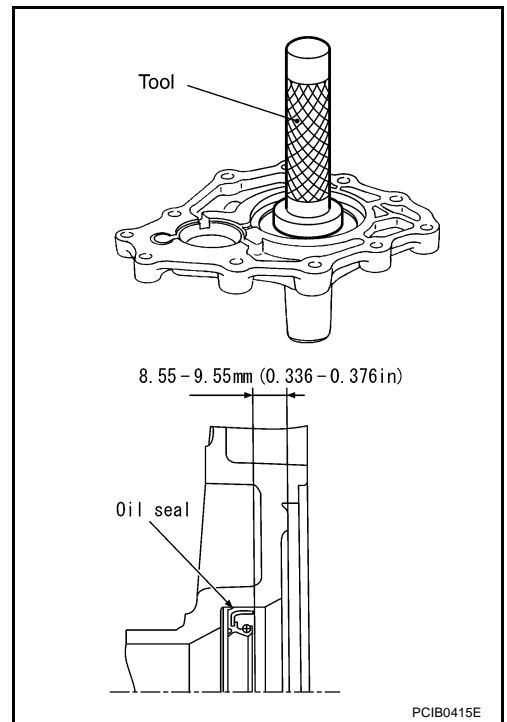

9. Install front cover gasket and front cover to the transmission case.

**CAUTION:**

**Do not reuse front cover gasket.**

10. Temporary tightening 2 bolts in the positions shown in the figure.

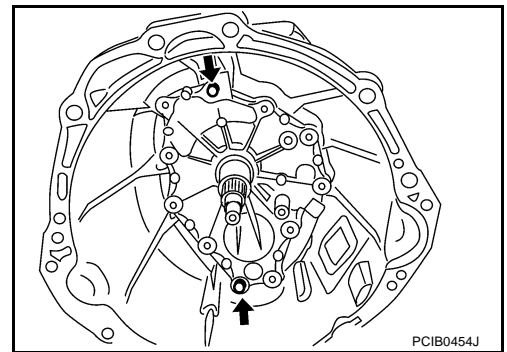

11. Temporary tightening remaining 9 bolts.

**CAUTION:**

**Four bolts pointed by arrows in the figure are not reusable.**

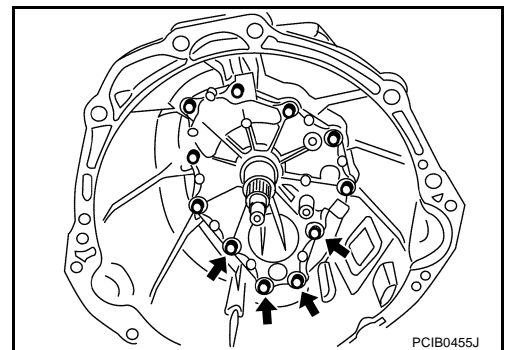

12. Tighten bolts to the specified torque in order as shown on the figure. Refer to [MT-21, "Case Components"](#).

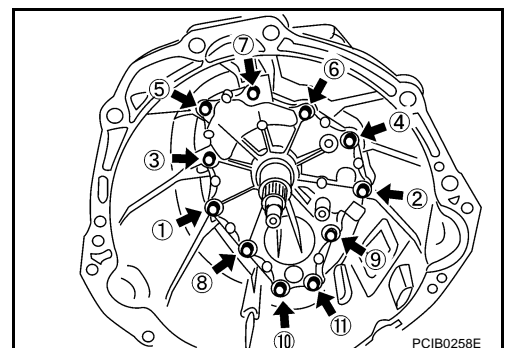

A  
B  
MT  
D  
E  
F  
G  
H  
I  
J  
K  
L  
M

# TRANSMISSION ASSEMBLY

13. Install washer to the withdrawal lever ball pin and then install it to front cover. Tighten withdrawal lever ball pin to the specified torque. Refer to [MT-21, "Case Components"](#) .

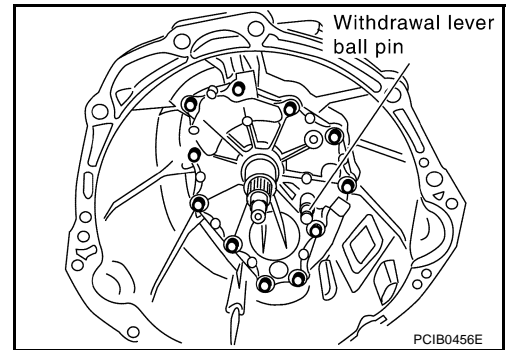

14. Install rear extension oil gutter to rear extension, and then tighten bolt to specified torque. Refer to [MT-21, "Case Components"](#) .
15. Install reverse idler shaft, reverse idler needle bearing, reverse idler gear, and reverse idler thrust washer to the adapter plate.
16. Apply multi -purpose grease to the striking rod oil seal lip, and then using the drift to install striking rod oil seal.

**Tool number** : ST35291000 ( — )

**CAUTION:**

- Do not reuse striking rod oil seal.
- When installing, do not incline the striking rod oil seal.

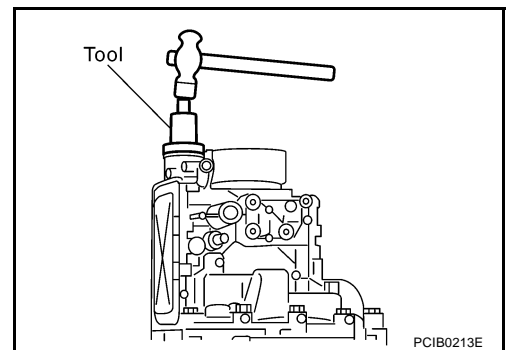

17. Apply multi - purpose grease to the lip of the rear oil seal. Using a drift, to install rear oil seal. 1.2-2.2 mm (0.047-0.087 in) above from the rear extension edge surface.

**Tool number** : ST33400001 (J-26082)

**CAUTION:**

- Do not reuse rear oil seal.
- When installing, do not incline the rear oil seal.

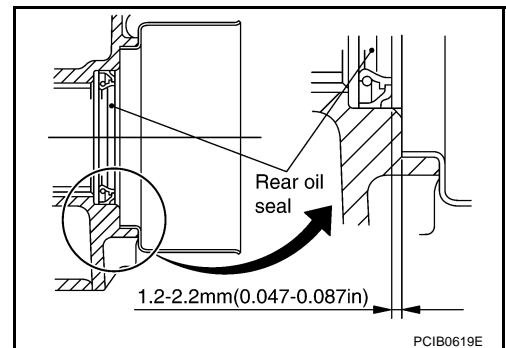

18. Apply liquid gasket to the adapter plate rear extension mounting surface as shown in the figure.

- Use **Genuine Silicone RTV or equivalent**. Refer to [GI-46, "RECOMMENDED CHEMICAL PRODUCTS AND SEALANTS"](#) .

**CAUTION:**

**Completely remove all moisture, oil, etc., from the adapter plate and rear extension mounting surfaces.**

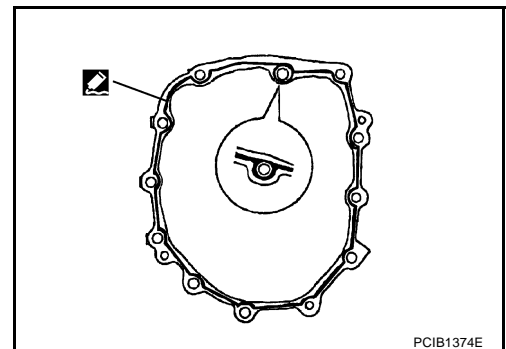



# TRANSMISSION ASSEMBLY

19. Install rear extension to adapter plate and then tighten mounting bolts to the specified torque in order as shown on the figure. Refer to [MT-21, "Case Components"](#) .

20. Install control lever housing to the rear extension and then tighten mounting bolts to the specified torque. Refer to [MT-24, "Shift Control Components"](#) .

**CAUTION:**

**Do not hold control lever housing to prevent bushing of control lever housing from deformation when moving transmission assembly.**

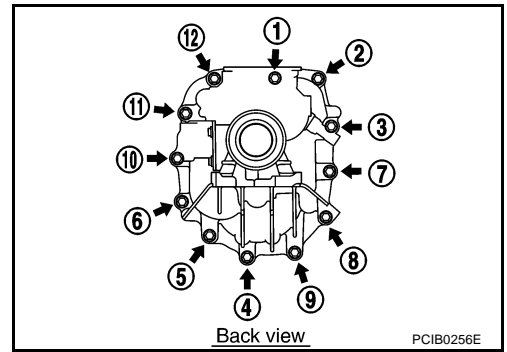

21. Install return spring plungers and return springs into the rear extension, apply liquid gasket to the return spring plug threads, and then tighten return spring plug to the specified torque. Refer to [MT-24, "Shift Control Components"](#) .

- Use Genuine Silicone RTV or equivalent. Refer to [GI-46, "RECOMMENDED CHEMICAL PRODUCTS AND SEALANTS"](#) .

Region	Return spring identification mark	Plunger notch
RH	Brown	No
LH	Blue	Yes

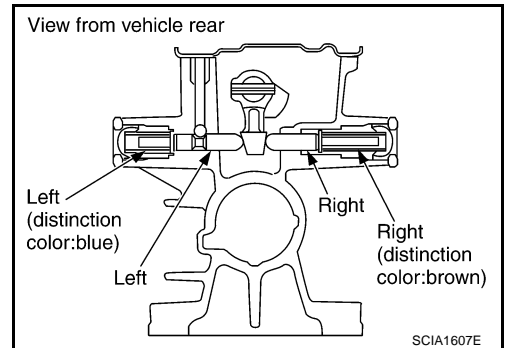

**CAUTION:**

**The right and left return spring and return spring plunger are different, so make sure they are installed correctly.**

22. Install shift check pin as a one unit with the control bracket to rear extension and then tighten mounting bolts to the specified torque. Refer to [MT-24, "Shift Control Components"](#) .

23. Install plunger to the rear extension, and then screwing PNP switch and back-up lamp switch to the rear extension with 1-2 pitches. Apply liquid gasket to the switch threads, and tighten switch to the specified torque. Refer to [MT-21, "Case Components"](#) .

- Use Genuine Silicone RTV or equivalent. Refer to [GI-46, "RECOMMENDED CHEMICAL PRODUCTS AND SEALANTS"](#) .

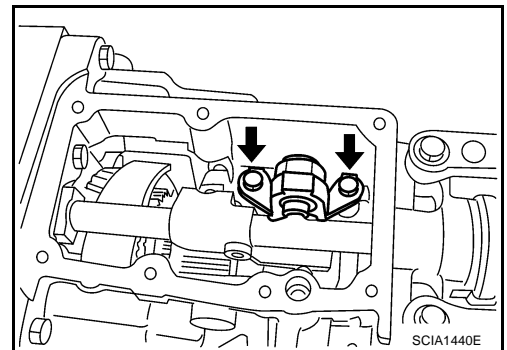

24. Install retaining pin into the control rod, using a pin punch [6 mm (0.24 in) dia.].

**CAUTION:**

**Do not reuse retaining pin.**

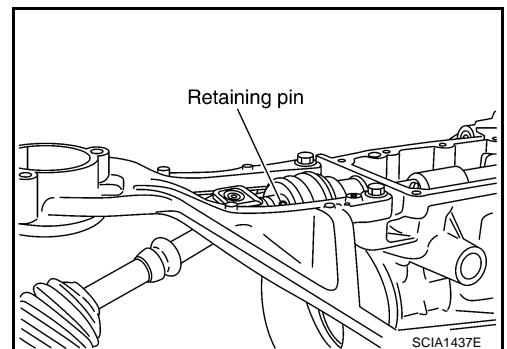

# TRANSMISSION ASSEMBLY

25. Install check ball and check select spring into the rear extension.

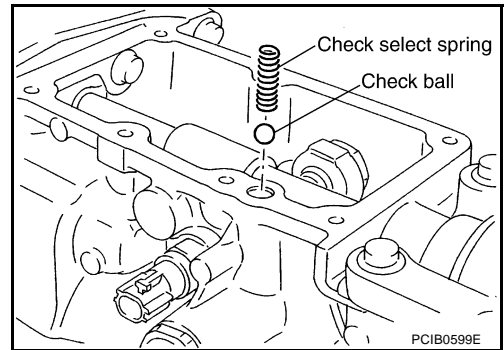

26. Install rear extension upper cover gasket and rear extension upper cover to rear extension.

**CAUTION:**

- Do not reuse rear extension upper cover gasket.
- Avoid tangling check select spring.

27. Tighten rear extension upper cover bolts to the specified torque in order as shown on the figure. Refer to [MT-21, "Case Components"](#) .

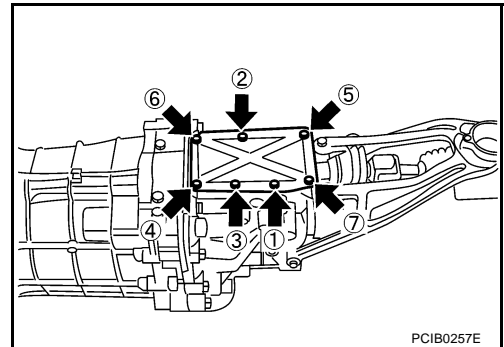

# SERVICE DATA AND SPECIFICATIONS (SDS)

## SERVICE DATA AND SPECIFICATIONS (SDS)

PFP:00030

### General Specifications

NCS000AV

Applied model	VQ35DE	
Transmission	FS6R31A	
Model code number	CD009	
Number of speed	6	
Shift pattern		
Synchromesh type	Warner	
Gear ratio	1st	3.794
	2nd	2.324
	3rd	1.624
	4th	1.271
	5th	1.000
	6th	0.794
	Reverse	3.446
Main gear (Number of teeth)	Drive	26
	1st	37
	2nd	34
	3rd	33
	4th	31
	6th	31
	Reverse	42
Counter shaft gear (Number of teeth)	Drive	32
	1st	12
	2nd	18
	3rd	25
	4th	30
	6th	48
	Reverse	15
Reverse idler gear (Number of teeth)	26	
Oil capacity	ℓ (US qt, Imp qt)	Approx. 2.9 (3-1/8, 2-1/2)
Remarks	Reverse synchronizer	Installed
	Double cone synchronizer	4th
	Triple cone synchronizer	1st, 2nd and 3rd

### End Play

NCS000AV

Unit: mm (in)

Item	Standard
Counter shaft	0 - 0.10 (0 - 0.004)
Main drive gear	0 - 0.10 (0 - 0.004)
Main shaft	0 - 0.10 (0 - 0.004)

# SERVICE DATA AND SPECIFICATIONS (SDS)

## Snap Rings

NCS000AX

Unit: mm (in)

Selective parts	Thickness	Part number*	
Main drive gear	1.89 (0.0744)	32204 01G60	
	1.95 (0.0768)	32204 01G61	
	1.99 (0.0783)	32204 01G62	
	2.03 (0.0799)	32204 01G63	
	2.07 (0.0815)	32204 01G64	
	2.11 (0.0831)	32204 01G65	
Counter shaft	1.96 (0.0772)	32236 CD000	
	2.02 (0.0795)	32236 CD001	
	2.08 (0.0819)	32236 CD002	
	2.14 (0.0843)	32236 CD003	
	2.20 (0.0866)	32236 CD004	
	2.26 (0.0890)	32236 CD005	
	2.32 (0.0913)	32236 CD006	
	2.38 (0.0937)	32236 CD007	
	2.44 (0.0961)	32236 CD008	
	2.50 (0.0984)	32236 CD009	
	2.56 (0.1008)	32236 CD010	
	2.62 (0.1031)	32236 CD011	
Main shaft	Front side	2.08 (0.0819)	32204 CD000
		2.14 (0.0843)	32204 CD001
		2.20 (0.0866)	32204 CD002
		2.26 (0.0890)	32204 CD003
	Shaft rear end	2.08 (0.0819)	32204 CD000
		2.14 (0.0843)	32204 CD001
		2.20 (0.0866)	32204 CD002
		2.26 (0.0890)	32204 CD003
		2.32 (0.0913)	32204 CD004
		2.38 (0.0937)	32204 CD005
		2.44 (0.0961)	32204 CD006
		2.50 (0.0984)	32204 CD007
		2.56 (0.1008)	32204 CD008
		2.62 (0.1031)	32204 CD009
		2.68 (0.1055)	32204 CD010
		2.74 (0.1079)	32204 CD011
		2.80 (0.1102)	32204 CD012
		2.86 (0.1126)	32204 CD013
2.92 (0.1150)	32204 CD014		
2.98 (0.1173)	32204 CD015		

\*: Always check with the Parts Department for the latest parts information.

# SERVICE DATA AND SPECIFICATIONS (SDS)

## Baulk Ring Clearance

NCS000AY

Unit: mm (in)

Measurement point	Standard	Limit value
4th (Double-cone synchronizer)	<ul style="list-style-type: none"> <li>● Clearance between synchronizer cone and inner baulk ring end face "A"</li> </ul>	A: 0.50 - 0.70 (0.020 - 0.028)
	<ul style="list-style-type: none"> <li>● Clearance between outer baulk ring pawl and synchronizer cone "B"</li> </ul>	B: 0.85 - 1.35 (0.033 - 0.053)
1st, 2nd and 3rd (Triple-cone synchronizer)	<ul style="list-style-type: none"> <li>● Clearance between synchronizer cone and clutch gear end face "A"</li> </ul>	A(1st): 0.65 - 1.25 (0.026 - 0.049) A(2nd, 3rd): 0.60 - 1.30 (0.024 - 0.051)
	<ul style="list-style-type: none"> <li>● Clearance between outer baulk ring pawl and synchronizer cone "B"</li> </ul>	B: 0.85 - 1.35 (0.033 - 0.053)
	<ul style="list-style-type: none"> <li>● Clearance between inner baulk ring and clutch gear end face "C"</li> </ul>	C(1st): 0.80 - 1.2 (0.031 - 0.047) C(2nd, 3rd): 0.75 - 1.25 (0.030 - 0.049)
5th and 6th		0.70 - 1.35 (0.028 - 0.053)
Reverse		0.75 - 1.20 (0.030 - 0.047)

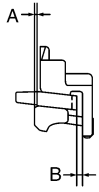

PCIB0249E

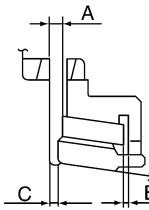

PCIB0772E

A  
B  
MT  
D  
E  
F  
G  
H  
I  
J  
K  
L  
M

# SERVICE DATA AND SPECIFICATIONS (SDS)

---