

BR
SECTION
BRAKE SYSTEM

A
 B
 C
 D
 E
 BR
 G
 H
 I
 J
 K
 L
 M

CONTENTS

<p>PRECAUTIONS 3</p> <p style="padding-left: 20px;">Precautions for Supplemental Restraint System (SRS) "AIR BAG" and "SEAT BELT PRE-TENSIONER" 3</p> <p style="padding-left: 20px;">Precautions for Battery Service 3</p> <p style="padding-left: 20px;">Precautions for Brake System 3</p> <p>PREPARATION 4</p> <p style="padding-left: 20px;">Commercial Service Tools 4</p> <p>NOISE, VIBRATION AND HARSHNESS (NVH)</p> <p>TROUBLESHOOTING 5</p> <p style="padding-left: 20px;">NVH Troubleshooting Chart 5</p> <p>BRAKE PEDAL 6</p> <p style="padding-left: 20px;">Inspection and Adjustment 6</p> <p style="padding-left: 40px;">ADJUSTMENT 6</p> <p style="padding-left: 20px;">Components 7</p> <p style="padding-left: 20px;">Removal and Installation 7</p> <p style="padding-left: 40px;">REMOVAL 7</p> <p style="padding-left: 40px;">INSPECTION AFTER REMOVAL 7</p> <p style="padding-left: 40px;">INSTALLATION 8</p> <p>BRAKE FLUID 9</p> <p style="padding-left: 20px;">Checking Brake Fluid Level 9</p> <p style="padding-left: 20px;">Drain and Refill 9</p> <p style="padding-left: 20px;">Bleeding Brake System 10</p> <p>BRAKE PIPING AND HOSE 11</p> <p style="padding-left: 20px;">Hydraulic Circuit 11</p> <p style="padding-left: 20px;">Removal and Installation of Front Brake Piping and Hose 11</p> <p style="padding-left: 40px;">REMOVAL 11</p> <p style="padding-left: 40px;">INSTALLATION 12</p> <p style="padding-left: 20px;">Removal and Installation of Rear Brake Piping and Hose 12</p> <p style="padding-left: 40px;">REMOVAL 12</p> <p style="padding-left: 40px;">INSTALLATION 12</p> <p style="padding-left: 20px;">Inspection after Installation 13</p> <p>BRAKE MASTER CYLINDER 14</p> <p style="padding-left: 20px;">On-Vehicle Inspection 14</p> <p style="padding-left: 40px;">LEAK INSPECTION 14</p> <p style="padding-left: 20px;">Removal and Installation 14</p> <p style="padding-left: 40px;">REMOVAL 14</p> <p style="padding-left: 40px;">INSTALLATION 14</p>	<p style="padding-left: 20px;">Components 15</p> <p style="padding-left: 20px;">Disassembly and Assembly 15</p> <p style="padding-left: 40px;">DISASSEMBLY 15</p> <p style="padding-left: 40px;">ASSEMBLY 16</p> <p>BRAKE BOOSTER 17</p> <p style="padding-left: 20px;">On-Vehicle Inspection 17</p> <p style="padding-left: 40px;">OPERATING CHECK 17</p> <p style="padding-left: 40px;">AIRTIGHT CHECK 17</p> <p style="padding-left: 20px;">Components 17</p> <p style="padding-left: 20px;">Removal and Installation 18</p> <p style="padding-left: 40px;">REMOVAL 18</p> <p style="padding-left: 40px;">INSPECTION AFTER REMOVAL 18</p> <p style="padding-left: 40px;">INSTALLATION 18</p> <p>VACUUM LINES 19</p> <p style="padding-left: 20px;">Components 19</p> <p style="padding-left: 20px;">Removal and Installation 19</p> <p style="padding-left: 20px;">Inspection 20</p> <p style="padding-left: 40px;">VISUAL INSPECTION 20</p> <p style="padding-left: 40px;">CHECK VALVE INSPECTION 20</p> <p>FRONT DISC BRAKE 21</p> <p style="padding-left: 20px;">On-Vehicle Inspection 21</p> <p style="padding-left: 40px;">PAD WEAR INSPECTION 21</p> <p style="padding-left: 20px;">Components 21</p> <p style="padding-left: 20px;">Removal and Installation of Brake Pad 22</p> <p style="padding-left: 40px;">REMOVAL 22</p> <p style="padding-left: 40px;">INSTALLATION 22</p> <p style="padding-left: 20px;">Removal and Installation of Brake Caliper Assembly</p> <p style="padding-left: 40px;">... 23</p> <p style="padding-left: 40px;">REMOVAL 23</p> <p style="padding-left: 40px;">INSTALLATION 23</p> <p style="padding-left: 20px;">Disassembly and Assembly of Brake Caliper Assembly 23</p> <p style="padding-left: 40px;">DISASSEMBLY 24</p> <p style="padding-left: 40px;">INSPECTION AFTER DISASSEMBLY 24</p> <p style="padding-left: 40px;">ASSEMBLY 25</p> <p style="padding-left: 40px;">DISC ROTOR INSPECTION 26</p> <p style="padding-left: 20px;">Brake Burnishing Procedure 26</p> <p>REAR DISC BRAKE 27</p> <p style="padding-left: 20px;">On-Vehicle Inspection 27</p> <p style="padding-left: 40px;">PAD WEAR INSPECTION 27</p>
--	--

Components	27	ASSEMBLY	30
Removal and Installation of Brake Pad	28	DISC ROTOR INSPECTION	32
REMOVAL	28	Brake Burnishing Procedure	32
INSTALLATION	28	SERVICE DATA AND SPECIFICATIONS (SDS)	33
Removal and Installation of Caliper Assembly	28	General Specifications	33
REMOVAL	28	Brake Pedal	33
INSTALLATION	29	Check Valve	33
Disassembly and Assembly of Caliper Assembly...	29	Brake Booster	33
DISASSEMBLY	29	Front Disc Brake	33
INSPECTION AFTER DISASSEMBLY	30	Rear Disc Brake	33

PRECAUTIONS

PRECAUTIONS

PF0:00001

Precautions for Supplemental Restraint System (SRS) “AIR BAG” and “SEAT BELT PRE-TENSIONER”

NFS00054

The Supplemental Restraint System such as “AIR BAG” and “SEAT BELT PRE-TENSIONER”, used along with a front seat belt, helps to reduce the risk or severity of injury to the driver and front passenger for certain types of collision. This system includes seat belt switch inputs and dual stage front air bag modules. The SRS system uses the seat belt switches to determine the front air bag deployment, and may only deploy one front air bag, depending on the severity of a collision and whether the front occupants are belted or unbelted. Information necessary to service the system safely is included in the SRS and SB section of this Service Manual.

WARNING:

- To avoid rendering the SRS inoperative, which could increase the risk of personal injury or death in the event of a collision which would result in air bag inflation, all maintenance must be performed by an authorized NISSAN/INFINITI dealer.
- Improper maintenance, including incorrect removal and installation of the SRS, can lead to personal injury caused by unintentional activation of the system. For removal of Spiral Cable and Air Bag Module, see the SRS section.
- Do not use electrical test equipment on any circuit related to the SRS unless instructed to in this Service Manual. SRS wiring harnesses can be identified by yellow and/or orange harnesses or harness connectors.

Precautions for Battery Service

NFS000HS

Before disconnecting the battery, lower both the driver and passenger windows. This will prevent any interference between the window edge and the vehicle when the door is opened/closed. During normal operation, the window slightly raises and lowers automatically to prevent any window to vehicle interference. The automatic window function will not work with the battery disconnected.

Precautions for Brake System

NFS00055

- Recommended fluid is brake fluid “DOT 3”. Refer to [MA-10, "Fluids and Lubricants"](#) .
- Never reuse drained brake fluid.
- Be careful not to splash brake fluid on painted areas.
- To clean or wash all parts of master cylinder, disc brake caliper and wheel cylinder, use clean brake fluid.
- Never use mineral oils such as gasoline or kerosene. They will ruin rubber parts of the hydraulic system.
- Use a flare nut wrench when removing a brake tube and use a flare nut torque wrench when installing a brake tube.
- When installing brake piping, be sure to check torque.
- Before working, turn ignition switch OFF and disconnect connectors of VDC/TCS/ABS control unit or the battery negative terminal.
- Burnish the brake contact surfaces after refinishing or replacing drums or rotors, after replacing pads or linings, or if a soft pedal occurs at very low mileage. Refer to [BR-26, "Brake Burnishing Procedure"](#) (Front) and/or [BR-32, "Brake Burnishing Procedure"](#) (Rear).

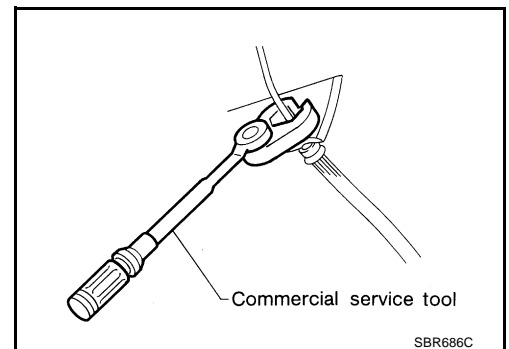

WARNING:

Clean brake pads and shoes with a waste cloth, then wipe with a dust collector.

PREPARATION

PREPARATION

PFP:00002

Commercial Service Tools

NFS00056

Tool name	Description
<p>1. Flare nut crowfoot a:10 mm (0.39 in) (Other) a:12 mm (0.47 in) (Between VDC actuator and master cylinder)</p> <p>2. Torque wrench</p>	<p>Installing brake piping</p>
<p>Power tool</p>	<p>Loosening bolts and nuts</p>
<p>Pin punch Tip diameter: 4 mm (0.16 in) dia</p>	<p>Removing and installing reservoir tank pin</p>

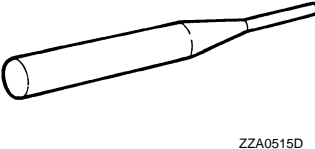
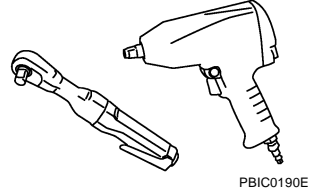
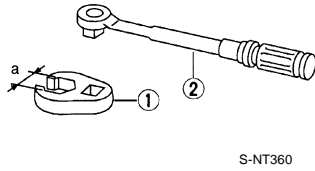

BRAKE PEDAL

PFP:46501

NFS00058

BRAKE PEDAL

Inspection and Adjustment

Play and clearance between brake pedal and floor panel with pedal depressed

1. Check brake pedal play.
2. Check brake pedal free height from dash lower panel.
3. Adjust the height referring to the following specifications.

Brake pedal free height "H" (from dash lower panel top surface)

M/T models: 153.2 – 163.2 mm (6.03 – 6.43 in)

A/T models: 161.5 – 171.5 mm (6.36 – 6.75 in)

Brake pedal depressed height "D" [under a force of 490 N (50 kg, 110 lb) with the engine running]

M/T models: 90 mm (3.54 in) or more

A/T models: 95 mm (3.74 in) or more

Clearance "C" between stopper rubber and the threaded end of stop lamp switch and ASCD cancel switch:

0.74 – 1.96 mm (0.0291 – 0.0772 in)

Pedal play "A": 3 – 11 mm (0.12 – 0.43 in)

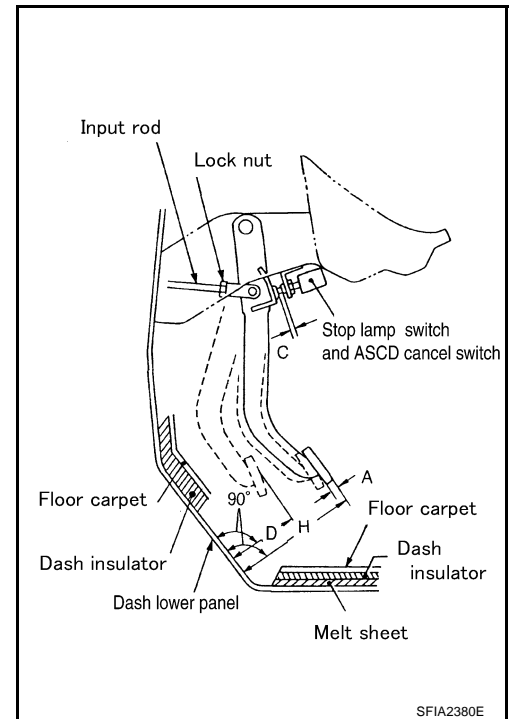

ADJUSTMENT

1. Loosen stop lamp switch and ASCD cancel switch by rotating it counterclockwise by 45°.
2. Loosen lock nut (A) on input rod, then rotate input rod to set pedal to the specified height, and tighten lock nut (A). Refer to [BR-17, "Components"](#).

CAUTION:

Make sure that the threaded end of input rod stays inside clevis.

3. With the pedal pulled and held by hand, press stop lamp switch and ASCD cancel switch until its threaded end contacts stopper rubber.
4. With the threaded end of stop lamp switch and ASCD cancel switch contacting stopper rubber, rotate the switch clockwise by 45° to secure.

CAUTION:

Make sure that the clearance "C" between stopper rubber and threaded end of stop lamp switch and ASCD cancel switch is within the standard.

5. Check the pedal play.

CAUTION:

Make sure that stop lamps go off when pedal is released.

6. Start engine to check brake pedal depressed height.

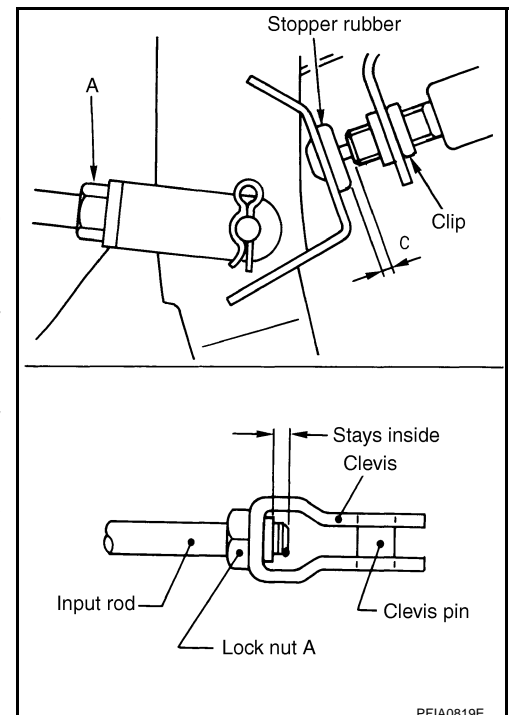

BRAKE PEDAL

Components

NFS00019

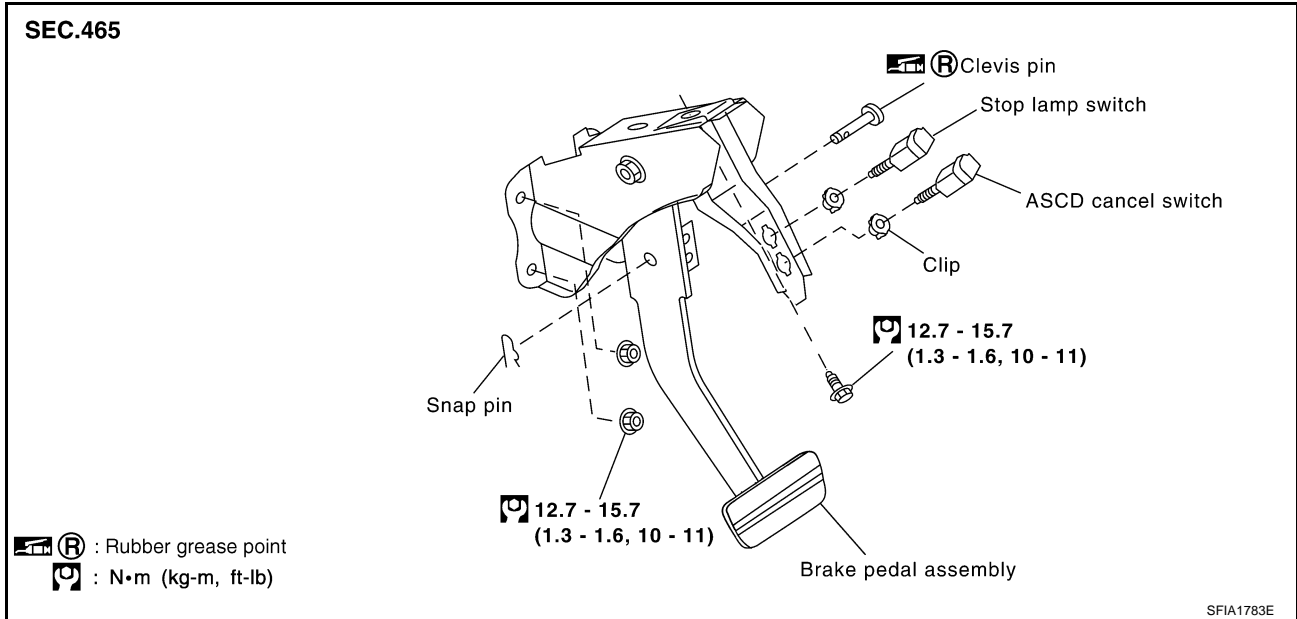

A
B
C
D
E
BR

Removal and Installation

NFS00059

REMOVAL

1. Remove the instrument driver lower panel. Refer to [IP-13, "\(J\) Instrument Driver Lower Panel"](#).
2. Remove stop lamp switch and ASCD cancel switch from pedal assembly.
3. Remove snap pin and clevis pin from clevis of brake booster.
4. Remove mounting nuts and bolt from bracket, and remove pedal assembly from vehicle.

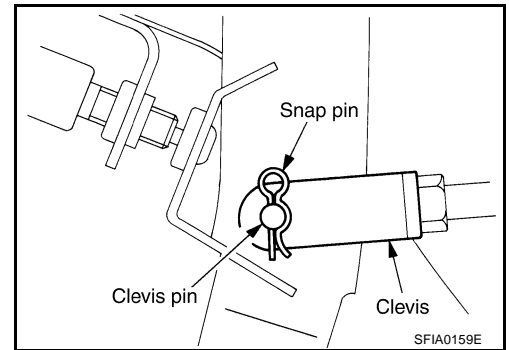

G
H
I
J
K

INSPECTION AFTER REMOVAL

- Check brake pedal upper rivet for deformation.
 - Make sure that the lapping length of sub-bracket and slide plate is at least 5.5 mm (0.217 in).
 - Check brake pedal for bend, damage, and cracks on the welded parts.
 - Replace brake pedal assembly if any non-standard condition is detected.
- Check clevis pin and plastic stopper for damage and deformation. Replace clevis pin if there are.

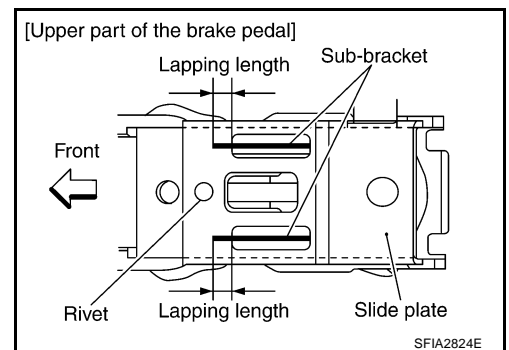

L
M

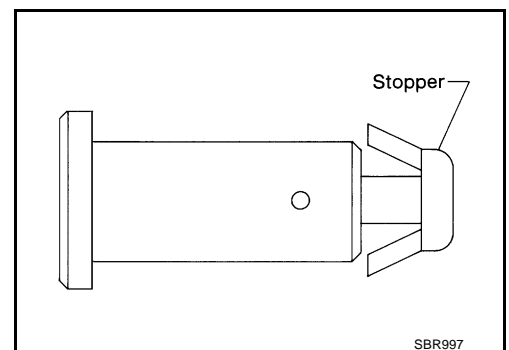

BRAKE PEDAL

INSTALLATION

Installation is in the reverse order of the removal. Tightening torques for brake pedal assembly mounting nuts and bolt are referred to [BR-7, "Components"](#) . Tightening torque for lock nut is referred to [BR-17, "Components"](#) .

- After installing brake pedal assembly to vehicle, adjust brake pedal. Refer to [BR-6, "ADJUSTMENT"](#) .

BRAKE FLUID

BRAKE FLUID

PFP:KN100

Checking Brake Fluid Level

NFS0005A

- Check fluid level in reservoir tank. It should be between Max and Min lines on reservoir tank.
- If fluid level is extremely low, check brake system for leaks.
- Release parking brake lever or pedal, and then see if brake warning lamp goes off. If not, check brake system for leaks.

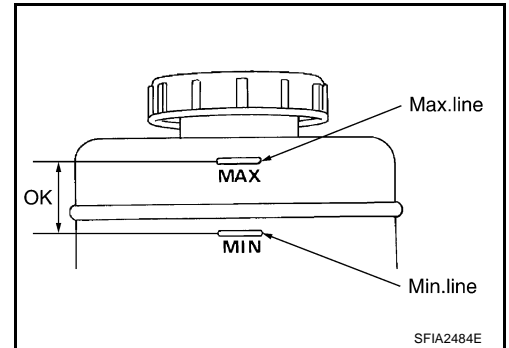

Drain and Refill

NFS0005B

CAUTION:

- Carefully monitor brake fluid level in reservoir tank during draining operation.
 - Refill with new brake fluid "DOT3".
 - Never reuse drained brake fluid.
 - Do not let brake fluid splash on painted surfaces of body. This might damage the paint, when splashing it on the surfaces, immediately wipe off the m with cloth and wash it away with water.
1. Turn ignition switch OFF and disconnect VDC actuator connectors or the battery negative terminal.
 2. Connect a vinyl tube to bleed valve.
 3. Depress brake pedal, loosen bleed valve, and gradually remove brake fluid.

BR

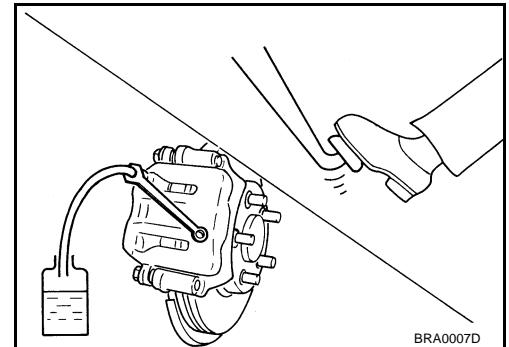

4. Make sure there is no foreign material in the reservoir tank, and refill with new brake fluid.
5. Rest foot on brake pedal. Loosen bleed valve. Slowly depress brake pedal until it stops. Tighten bleed valve. Release brake pedal. Repeat this process a few times, then pause to add new brake fluid to reservoir tank. Continue until new brake fluid flows out.
6. Bleed Air. Refer to [BR-10, "Bleeding Brake System"](#) .

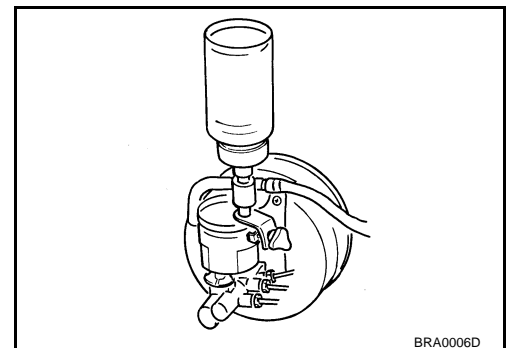

BRAKE FLUID

Bleeding Brake System

NFS0005C

CAUTION:

- Carefully monitor brake fluid level in reservoir tank during bleeding operation.
- Fill reservoir with new brake fluid "DOT 3". Make sure it is at least half way at all times while bleeding air out of system.
- Place a container under master cylinder to avoid spillage of brake fluid.
- Turn ignition switch OFF and disconnect VDC actuator connectors or the battery negative terminal.

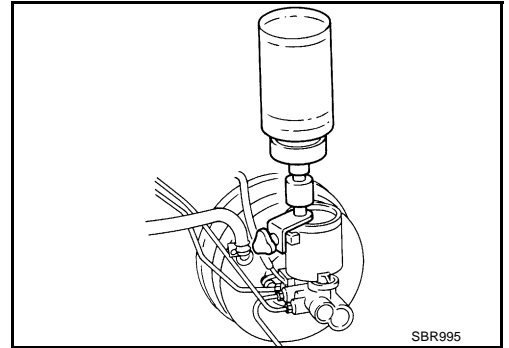

- Bleed air in the following order. Right rear brake → Left front brake → Left rear brake → Right front brake

1. Connect a transparent vinyl tube to bleed valve.
2. Fully depress brake pedal several times.
3. With brake pedal depressed, open bleed valve to release air.
4. Close bleed valve to the specified torque. Refer to [BR-21, "Components"](#) (front disc brake), [BR-27, "Components"](#) (rear disc brake).
5. Release brake pedal slowly.
6. Repeat steps 2 through 5 until clear brake fluid comes out of bleed valve.

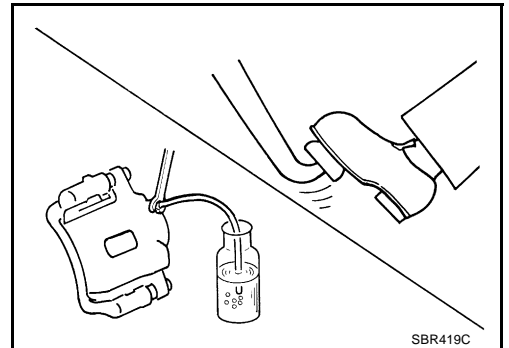

BRAKE PIPING AND HOSE

BRAKE PIPING AND HOSE

PFP:46210

Hydraulic Circuit

NFS0005D

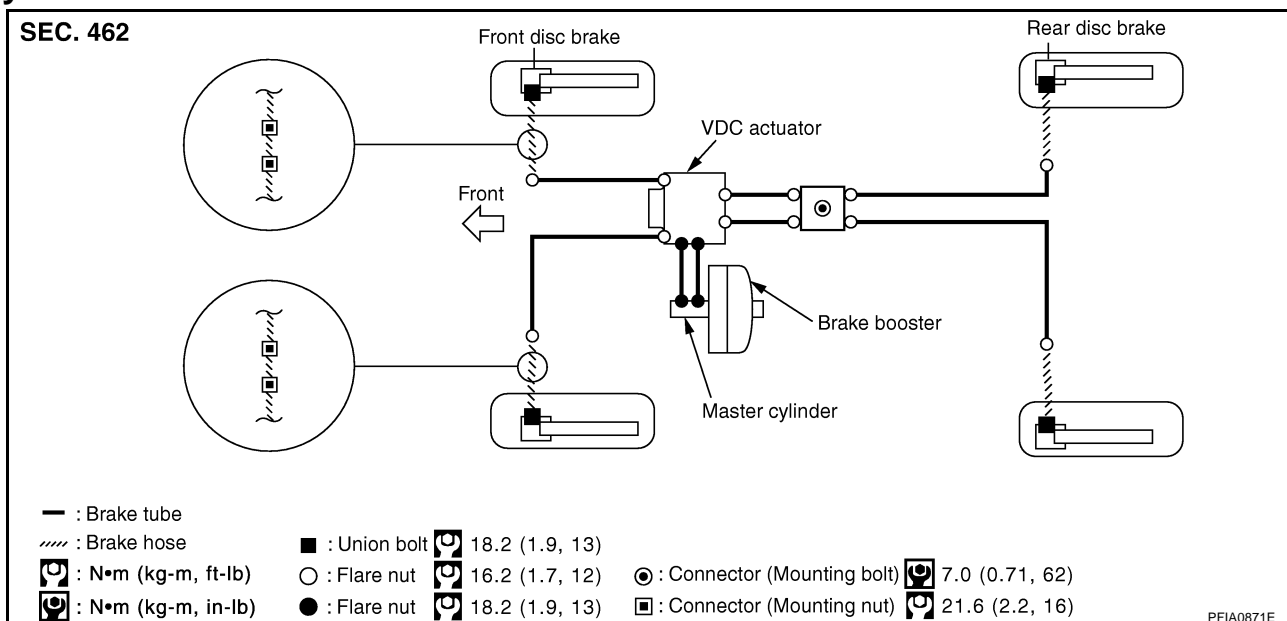

CAUTION:

- All hoses and piping (tubes) must be free from excessive bending, twisting and pulling.
- Make sure there is no interference with other parts when turning steering both clockwise and counterclockwise.
- The brake tubes and hoses are an important safety parts. If a brake fluid leak is detected, always disassemble the parts. Replace applicable part with a new one, if necessary.
- Be careful not to splash brake fluid on painted areas; it may cause paint damage. If brake fluid is splashed on painted surfaces of body, immediately wipe it off with cloth and then wash it away with water.
- Do not bend or twist brake hose sharply, or strongly pull it.
- When removing components, cover brake line connections so that no dirt, dust, or other foreign matter gets in.
- Refill with new brake fluid "DOT 3".
- Never reuse drained brake fluid.

Removal and Installation of Front Brake Piping and Hose

NFS0005E

REMOVAL

1. Drain brake fluid. Refer to [BR-9, "Drain and Refill"](#).
2. Using a flare nut wrench, remove brake tube from brake hose. Remove union bolt, and remove brake hose from caliper assembly.
3. Remove lock plate.
4. Remove mounting nuts, and remove brake hose from vehicle.

BRAKE PIPING AND HOSE

INSTALLATION

1. Assemble union bolt and copper washers to brake hose.
2. Position the metal fitting of brake hose by aligning with the protrusion on the caliper assembly, and tighten union bolt to the specified torque.

CAUTION:

- Do not reuse copper washer.
- Refill with new brake fluid "DOT3".
- Never reuse drained brake fluid.

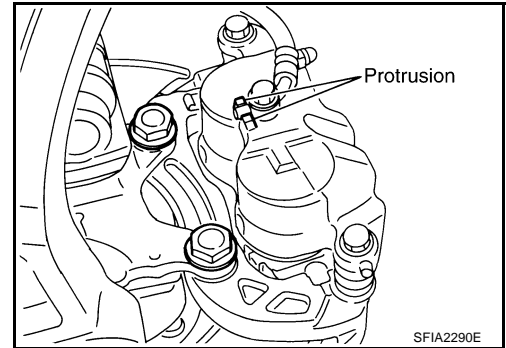

3. Connect brake hose to brake tube on vehicle, and temporarily tighten flare nut by hand until as much as possible. Fix it with lock plate, and tighten flare nut to the specified torque with a flare nut torque wrench. Refer to [BR-11, "Hydraulic Circuit"](#).
4. Install brake hose to vehicle, and tighten mounting nuts to the specified torque. Refer to [BR-11, "Hydraulic Circuit"](#).
5. After the work, bleed air. Refer to [BR-10, "Bleeding Brake System"](#).

- Do not reuse brake mounting nuts.

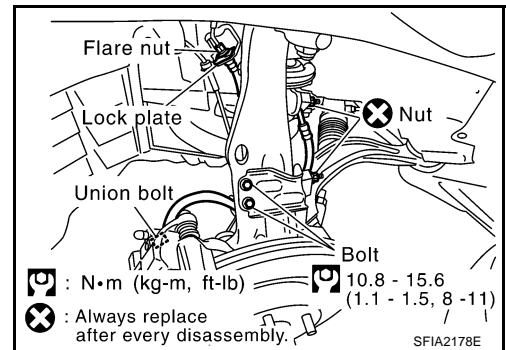

Removal and Installation of Rear Brake Piping and Hose

NFS0005F

REMOVAL

1. Drain brake fluid. Refer to [BR-9, "Drain and Refill"](#).
2. Using a flare nut wrench, remove brake tube from brake hose.
3. Remove union bolt, and then remove brake hose from caliper assembly.
4. Remove lock plate, and remove brake hose from vehicle.

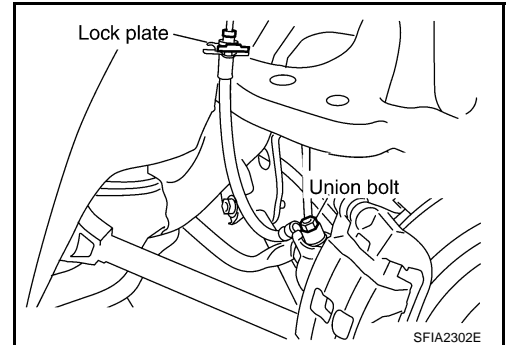

INSTALLATION

1. Assemble union bolt and copper washers to brake hose.
2. Position the L-shape metal fitting of the brake hose to the brake caliper assembly positioning hole, and then tighten union bolt to the specified torque. Refer to [BR-11, "Hydraulic Circuit"](#).

CAUTION:

- Do not reuse copper washer.
- Refill with new brake fluid "DOT3".
- Never reuse drained brake fluid.

3. Connect brake hose to brake tube on the vehicle, and temporarily tighten flare nut by hand as much as possible. Secure it to bracket with lock plate, and tighten flare nut to the specified torque with a flare nut torque wrench. Refer to [BR-11, "Hydraulic Circuit"](#).
4. After the work, bleed air. Refer to [BR-10, "Bleeding Brake System"](#).

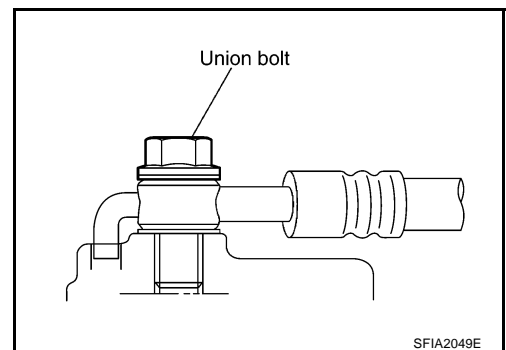

BRAKE PIPING AND HOSE

Inspection after Installation

NFS0005G

CAUTION:

If leak is detected at the connections, retighten it or replace the damaged part.

1. Check brake hoses, tubes, and connections for fluid leaks, damage, twist, deformation, contact with other parts, and loose connections.
2. While depressing brake pedal under a force of 785 N (80 kg, 177 lb) with the engine running for approximately 5 seconds, check for fluid leak from each part.

A

B

C

D

E

BR

G

H

I

J

K

L

M

BRAKE MASTER CYLINDER

BRAKE MASTER CYLINDER

PFP:46010

On-Vehicle Inspection LEAK INSPECTION

NFS0005H

- Check for leaking in a master cylinder installation surface, a reservoir tank installation surface, and brake tube connections.

Removal and Installation

NFS0005I

CAUTION:

- Be careful not to splash brake fluid on painted areas; it may cause paint damage. If brake fluid is splashed on painted areas, immediately wipe it off with cloth and wash it away with water.
- Do not operate with primary piston when removing and installing.

REMOVAL

1. Drain brake fluid. Refer to [BR-9, "Drain and Refill"](#) .
2. Remove harness connector for brake fluid level switch.
3. Using a flare nut wrench, remove brake tube from master cylinder.
4. Remove mounting nuts, and remove master cylinder assembly from vehicle. Refer to [BR-18, "Removal and Installation"](#) .

INSTALLATION

CAUTION:

- Refill with new brake fluid "DOT3".
 - Never reuse drained brake fluid.
1. Install master cylinder to brake booster assembly, and tighten mounting nuts to the specified torque. Refer to [BR-17, "Components"](#) .

CAUTION:

- Check if the lot of primary piston has dust or scratch.
- Do not damage and stain rod of primary piston.
- Do not reuse O-ring.
- Apply PBC (Poly Butyl Cuprysil) grease or silicone-based grease to O-ring and primary piston.
- Apply PBC (Poly Butyl Cuprysil) grease or silicone-based grease to the master cylinder insertion of brake booster.

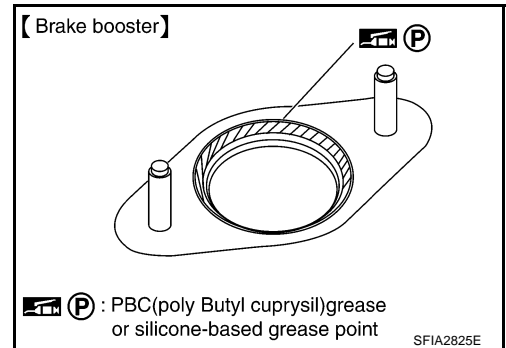

2. Install brake tube to master cylinder, and temporarily tighten the flare nuts on the brake tube to master cylinder by hand.
3. Using a flare nut torque wrench, tighten flare nut on the brake tube to the specified torque. Refer to [BR-11, "Hydraulic Circuit"](#) .
4. Install harness connector of brake fluid level switch.
5. Refill new brake fluid and bleed air. Refer to [BR-10, "Bleeding Brake System"](#) .

BRAKE MASTER CYLINDER

Components

NFS0001A

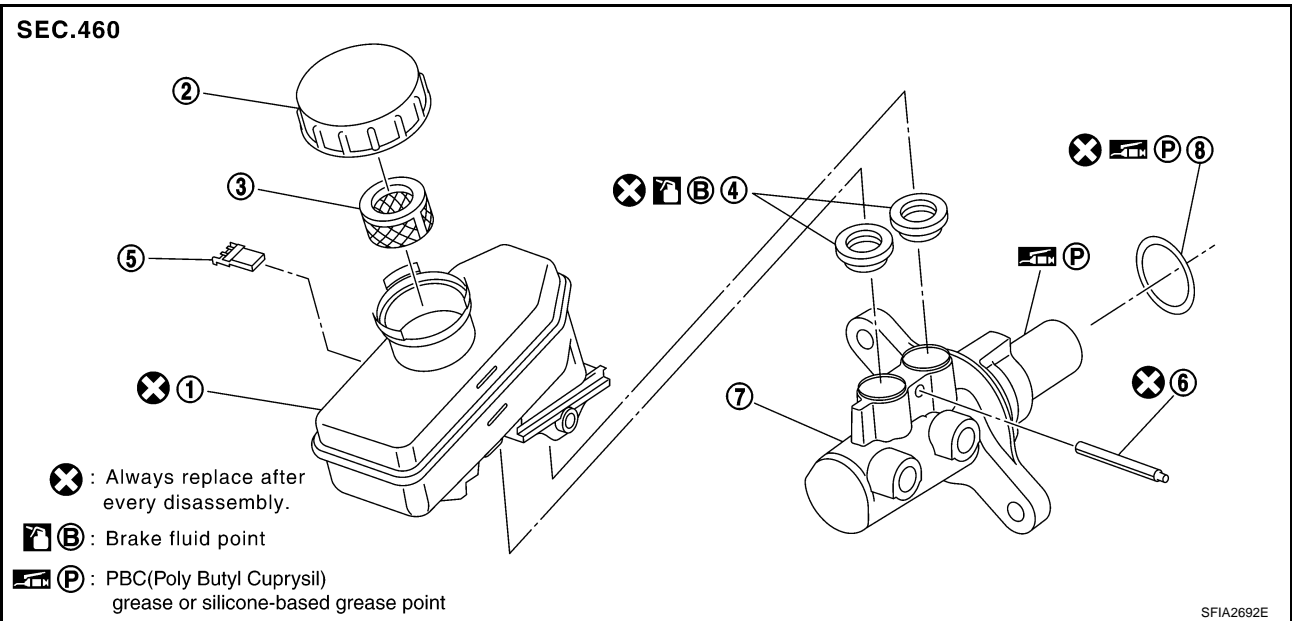

- | | | |
|-------------------|---------------------------------------|---------------|
| 1. Reservoir tank | 2. Reservoir cap | 3. Oil filter |
| 4. Grommet | 5. Brake fluid level switch connector | 6. Pin |
| 7. Cylinder body | 8. O-ring | |

Disassembly and Assembly

DISASSEMBLY

NFS0005J

CAUTION:

- Master cylinder cannot be disassembled.
- Remove the reservoir tank only when absolutely necessary.

1. Clamp flange of cylinder body in vise as shown in the figure.

CAUTION:

- Using copper plate or cloth to cover flange for securing vise.
- When securing master cylinder assembly in a vise, be sure not to over tighten.
- Be sure to fix the flange part with the brake tube installation side of cylinder body brake tube up.

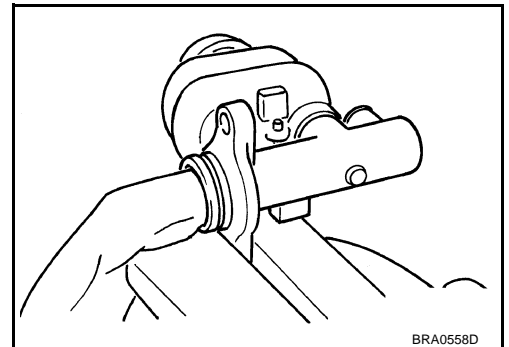

2. Using a pin punch [commercial service tool: diameter approx. 4 mm (0.16 in)], remove pin from reservoir tank.
3. Remove master cylinder assembly from vise.
4. Remove reservoir tank and grommet from cylinder body.

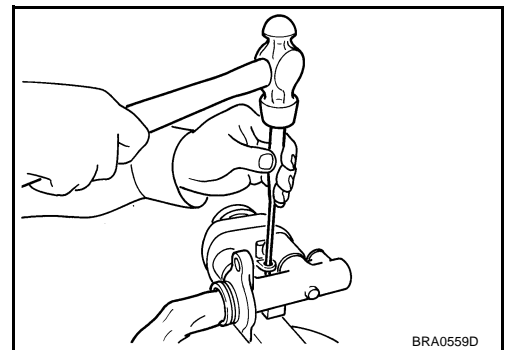

BRAKE MASTER CYLINDER

ASSEMBLY

CAUTION:

- Do not use mineral oils such as kerosene, gasoline during the cleaning and assembly process.
 - Do not drop parts. If a part is dropped, do not use it.
1. Apply brake fluid to a grommet, and place it into master cylinder to install.

CAUTION:

Do not reuse grommet.

2. Install reservoir tank to master cylinder.

CAUTION:

- Do not reuse reservoir tank and reservoir tank mounting pin.
- Pay attention to the orientation of reservoir tank.

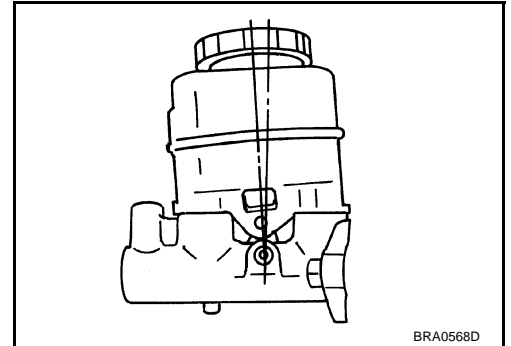

3. Secure flange of cylinder body as shown in the figure.

CAUTION:

- Using copper plate or cloth to cover flange for securing in a vise.
- When securing master cylinder assembly in a vise, be sure not to over tighten.
- Be sure to fix the flange part with the brake tube installation side of cylinder body up.

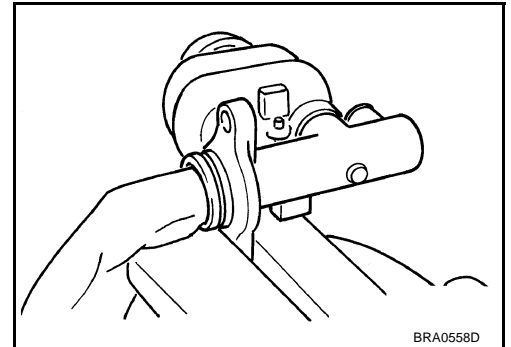

4. Using a pin punch [commercial service tool: diameter approx. 4 mm (0.16 in)], insert the reservoir tank mounting pin into the pin hole so that the attachment side and the opposite side are identical.

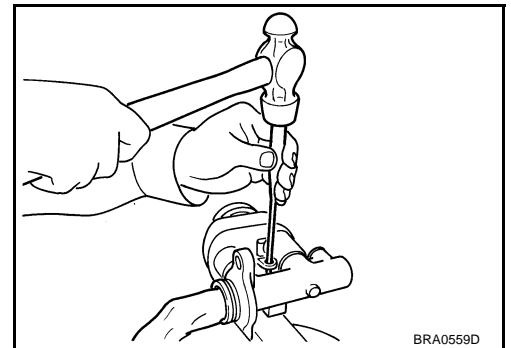

BRAKE BOOSTER

BRAKE BOOSTER

PF:47200

On-Vehicle Inspection OPERATING CHECK

NFS0005K

With the engine stopped, change the vacuum to the atmospheric pressure by depressing brake pedal several times. Then with brake pedal fully depressed, start engine and when the vacuum pressure reaches the standard, make sure that the clearance between brake pedal and floor panel decreases.

CAUTION:

Depressing pedal interval is approximately 5 seconds.

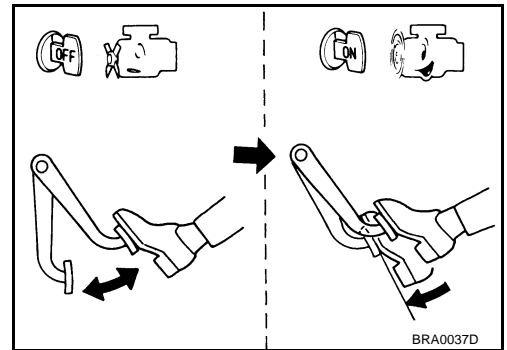

AIRTIGHT CHECK

- Run engine at idle for approximately 1 minute, and stop it after applying vacuum to booster. Depress brake pedal normally to change the vacuum to the atmospheric pressure. Make sure that distance between brake pedal and floor panel gradually increases.
- Depress brake pedal while engine is running, and stop engine with pedal depressed. The pedal stroke should not change after holding pedal down for 30 seconds.

CAUTION:

Depressing pedal interval is approximately 5 seconds.

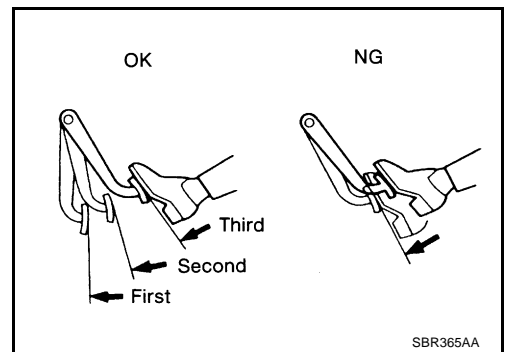

Components

NFS0001B

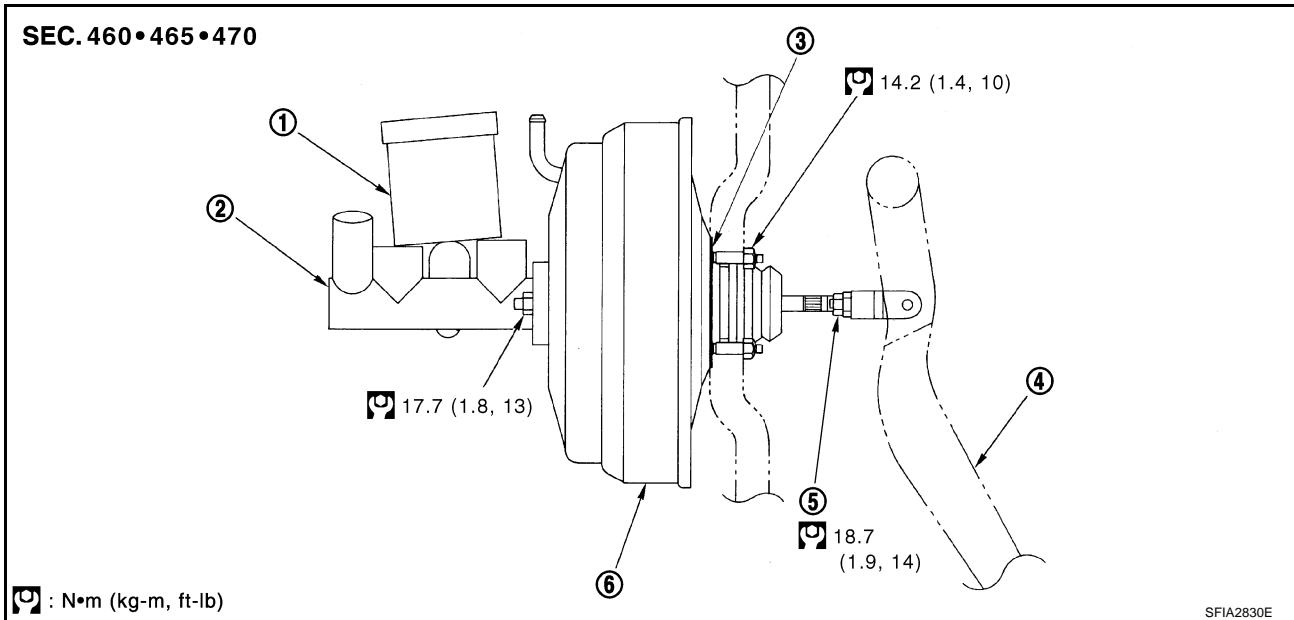

: N•m (kg-m, ft-lb)

- | | | |
|-------------------|------------------|------------------|
| 1. Reservoir tank | 2. Cylinder body | 3. Gasket |
| 4. Brake pedal | 5. Lock nut | 6. Brake booster |

BRAKE BOOSTER

NFS0005L

Removal and Installation

REMOVAL

CAUTION:

- Be careful not to splash brake fluid on painted areas such as body. It may cause paint damage. If brake fluid is splashed on painted surfaces of body, wipe it off with cloth immediately and then, wash it away with water.
 - Be careful not to deform or bend brake piping while removing and installing brake booster.
 - Replace clevis pin if it is damaged.
 - Be careful not to damage brake booster stud bolt threads. If brake booster is tilted or inclined during installation, dash panel may damage the threads.
 - Be sure to install check valve in the correct orientation.
1. Remove vacuum hose from brake booster.
 2. Remove master cylinder. Refer to [BR-14, "Removal and Installation"](#).
 3. Remove snap pin and clevis pin on the clevis of the brake booster, and remove input rod from brake pedal. Refer to [BR-7, "Components"](#).
 4. Remove brake pedal mounting nuts on brake pedal assembly.
 5. Remove brake booster from dash panel.

INSPECTION AFTER REMOVAL

Output Rod Length Inspection

1. Using a handy vacuum pump, apply a vacuum of -66.7 kPa (-500 mmHg, -19.69 inHg) to brake booster.
2. Check output rod length.

Standard dimension when vacuuming
 -66.7 kPa (-500 mmHg, -19.69 inHg)
: 30.5 mm (1.201 in)

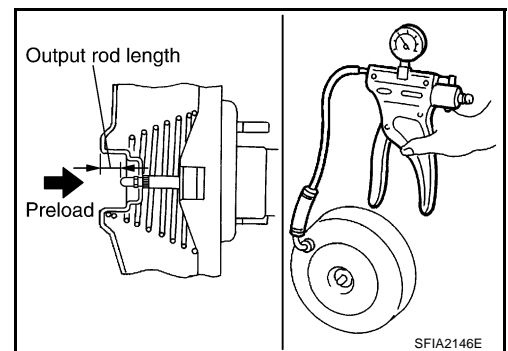

INSTALLATION

1. Loosen lock nut to adjust input rod length so that the length "B" (shown in the figure) satisfies the specified value.

Length "B" : 125 mm (4.92 in)

2. After adjusting length "B", temporarily tighten lock nut to install brake booster assembly to dash panel. At this time, make sure to install a gasket between brake booster and dash panel.
3. Connect brake pedal to clevis of input rod with the clevis pin and snap pin.
4. Install brake pedal assembly mounting nuts and tighten them to the specified torque. Refer to [BR-17, "Components"](#).
5. Install vacuum hose into brake booster. Refer to [BR-19, "Removal and Installation"](#).
6. Install master cylinder to brake booster. Refer to [BR-14, "Removal and Installation"](#).
7. Adjust the height and play of brake pedal. Refer to [BR-6, "ADJUSTMENT"](#).
8. Tighten lock nut of input rod to the specified torque.
9. Bleed air. Refer to [BR-10, "Bleeding Brake System"](#).

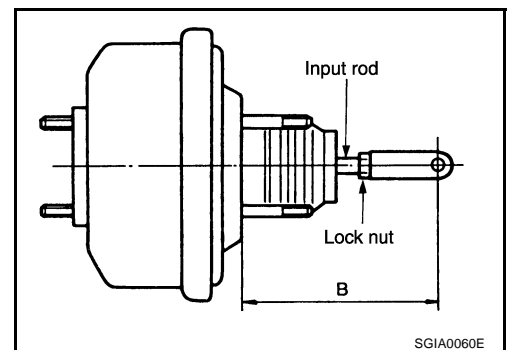

VACUUM LINES

VACUUM LINES

PPF:41920

Components

NFS0001C

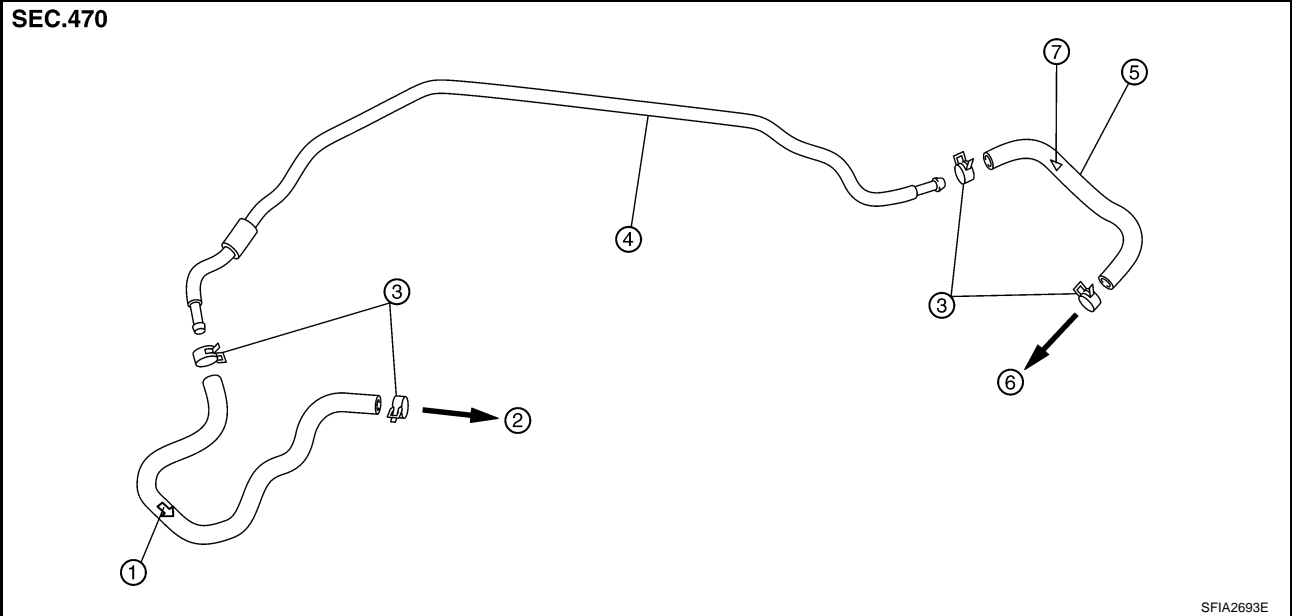

- | | | |
|--|------------------------|----------------------|
| 1. Engine direction indicator stamp (built in check valve) | 2. For intake manifold | 3. Clamp |
| 4. Vacuum piping | 5. Vacuum hose | 6. For brake booster |
| 7. Orifice mark | | |

Removal and Installation

NFS0005M

CAUTION:

- Because vacuum hose contains a check valve, it must be installed in the correct orientation. Refer to the stamp or label to confirm correct installation. Brake booster will not operate normally if hose is installed in the wrong direction.
- Insert vacuum hose for at least 24 mm (0.94 in).
- Never use lubricating oil during assembly.

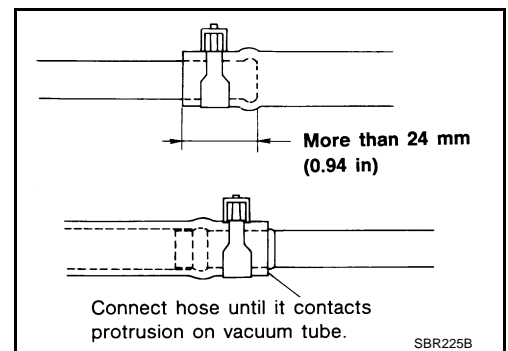

VACUUM LINES

NFS0005N

Inspection

VISUAL INSPECTION

Check for improper assembly, damage and aging.

CHECK VALVE INSPECTION

Airtightness Inspection

Use a handy vacuum pump to check.

When connected to booster side (1):

Vacuum decrease should be within 1.3 kPa (10 mmHg, 0.39 inHg) for 15 seconds under a vacuum of -66.7 kPa (-500 mmHg, -19.69 inHg)

When connected to engine side (2):

No vacuum will be applied

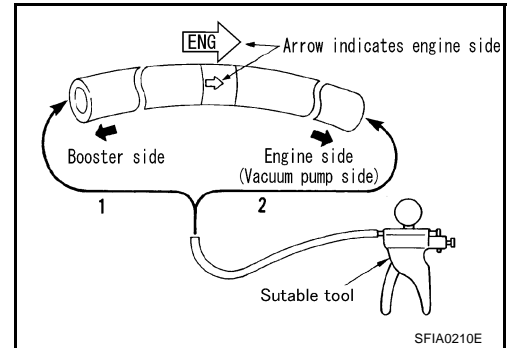

FRONT DISC BRAKE

FRONT DISC BRAKE

PFP:41000

On-Vehicle Inspection PAD WEAR INSPECTION

NFS000JU

- Check pad thickness from an inspection hole on cylinder body. Use a scale for inspection if necessary.

Standard thickness : 11.0 mm (0.433 in)

Repair limit thickness : 2.0 mm (0.079 in)

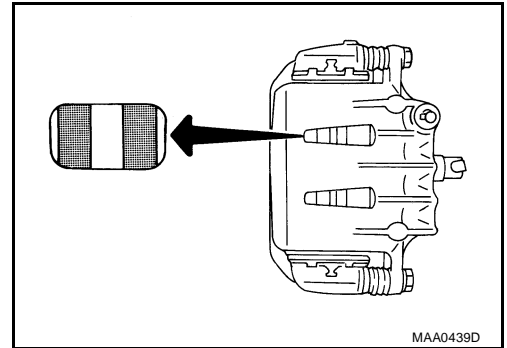

Components

NFS000JV

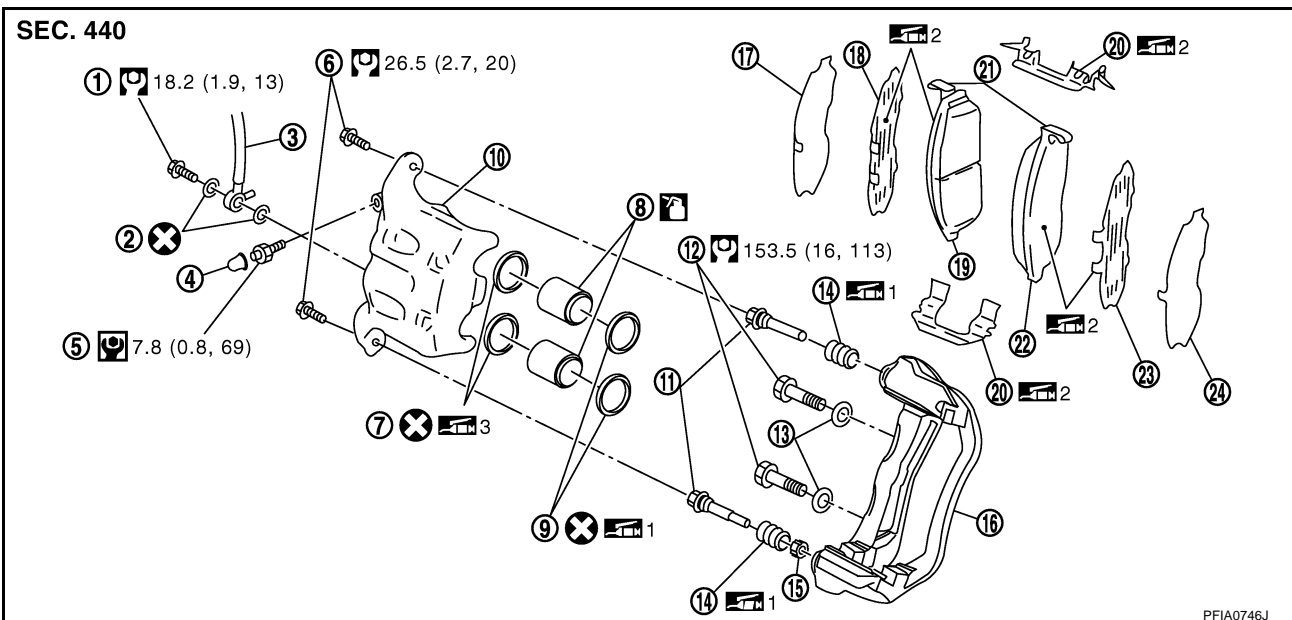

- | | | |
|-------------------|----------------------|---------------------------------|
| 1. Union bolt | 2. Copper washer | 3. Brake hose |
| 4. Cap | 5. Bleed valve | 6. Sliding pin bolt |
| 7. Piston seal | 8. Piston | 9. Piston boot |
| 10. Cylinder body | 11. Sliding pin | 12. Torque member mounting bolt |
| 13. Washer | 14. Sliding pin boot | 15. Bushing |
| 16. Torque member | 17. inner shim cover | 18. inner shim |
| 19. Inner pad | 20. Pad retainer | 21. Pad wear sensor |
| 22. Outer pad | 23. Outer shim | 24. Outer shim cover |

Refer to [GI-10. "Components"](#) and the followings for the symbols in the figure.

1: Apply rubber grease.

2: Apply PBC (Poly Butyl Cuprysil) grease or silicone-based grease.

3: Apply polyglycol ether based lubricant.

: Apply brake fluid.

WARNING:

Clean dust on caliper and brake pad with a vacuum dust collector to minimize the hazard of airborne particles or other materials.

CAUTION:

- While removing cylinder body, do not depress brake pedal because piston will pop out.

FRONT DISC BRAKE

- It is not necessary to remove torque member mounting bolts on torque member and brake hose except for disassembly or replacement of caliper assembly. In this case, hang cylinder body with a wire so as not to stretch brake hose.
- Do not damage piston boot.
- If any shim is subject to serious corrosion, replace it with a new one.
- Always replace shim and shim covers as a set when replacing brake pads.
- Keep rotor clean, from brake fluid.
- Burnish the brake pads and disc rotor mutually contacting surfaces after refinishing or replacing rotors, after replacing pads, or if a soft pedal occurs at very low mileage. Refer to [BR-26, "Brake Burnishing Procedure"](#).

Removal and Installation of Brake Pad REMOVAL

NFS000JW

1. Remove tires from vehicle with a power tool.
2. Remove lower sliding pin bolt.

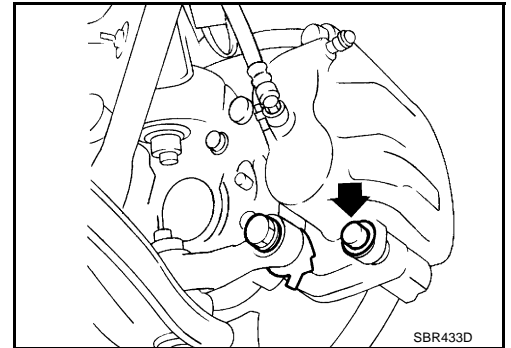

3. Hang cylinder body with a wire, and remove pads, shims, shim covers and pad retainers from torque member.

CAUTION:

- When removing pad retainer from torque member, lift pad retainer in the direction shown by arrow (shown in the figure) so as not to deform it.
- Do not damage piston boot.
- Keep rotor clean, from brake fluid.

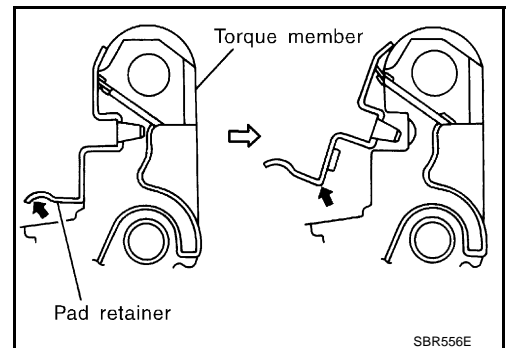

INSTALLATION

1. Apply PBC (Poly Butyl Cuprysil) grease or silicone-based grease between pad retainer and pad.
2. Install pad retainers and pad assemblies to torque member.

CAUTION:

Inner pad and outer pad have pad-return mechanism on upper side of pad retainer. When installing pad to torque member, be sure to install pad return lever to pad wear sensor securely.

3. Push the piston in so that the pad is firmly installed, and install cylinder body to torque member.

CAUTION:

When replacing pads with new ones, press in piston until pads can be installed. In this case, carefully monitor brake fluid level in reservoir tank because brake fluid will return to master cylinder reservoir tank.

NOTE:

Use a disc brake piston tool (commercial service tool) to easily press piston.

4. Install lower sliding pin bolt, and tighten it to the specified torque. Refer to [BR-21, "Components"](#).
5. Secure disc rotor with wheel nuts. Depress brake pedal a few times until it gets a responsive touch.

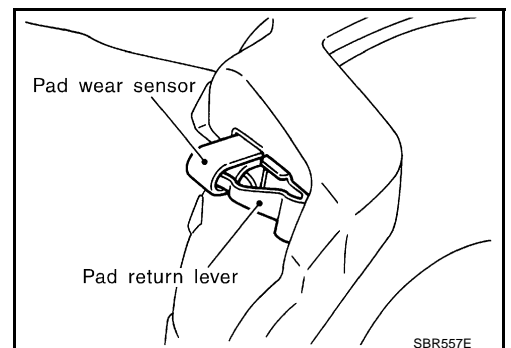

FRONT DISC BRAKE

6. Check brake for drag.
7. Install tires to vehicle.

Removal and Installation of Brake Caliper Assembly

NFS000JX

REMOVAL

1. Remove tires from vehicle with a power tool.
2. Fasten disc rotor using wheel nut.
3. Drain brake fluid. Refer to [BR-9, "Drain and Refill"](#) .
4. Remove union bolt and then remove brake hose from caliper assembly.
5. Remove torque member mounting bolts (from torque member), and remove caliper assembly (from vehicle with a power tool).

CAUTION:

Do not drop brake pad.

6. Remove disc rotor.

CAUTION:

Put matching marks on wheel hub assembly and disc rotor, when if it necessary to removing disc rotor.

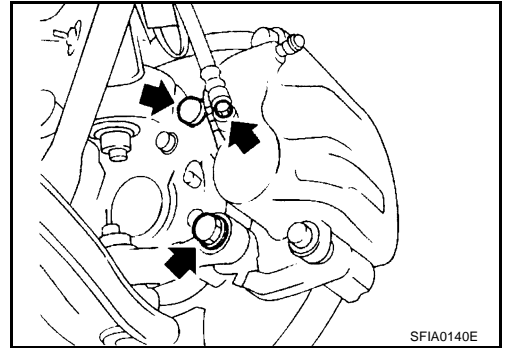

INSTALLATION

CAUTION:

- Refill with new brake fluid "DOT 3".
- Never reuse drained brake fluid.

1. Install disc rotor.

CAUTION:

Matching marks of disc rotor and wheel hub put at the time of removal when reusing disc rotor.

2. Install caliper assembly to vehicle, and tighten torque member mounting bolts to the specified torque. Refer to [BR-21, "Components"](#) .

CAUTION:

Before installing caliper assembly to vehicle, wipe oil and grease on washer seats on steering knuckle and mounting surface of caliper assembly.

3. Install a projection of brake hose metal fitting by aligning with protrusions on cylinder body, and tighten union bolt to the specified torque. Refer to [BR-21, "Components"](#) .

CAUTION:

- Do not reuse copper washers for union bolts.
- Assemble brake hose securely on caliper assembly.

4. Insert new brake fluid and bleed air. Refer to [BR-10, "Bleeding Brake System"](#) .
5. Check brake for drag.
6. Install tires to vehicle.

Disassembly and Assembly of Brake Caliper Assembly

NFS000JY

NOTE:

Do not remove torque member, brake pads, shims, shim covers and pad retainers when disassembling and assembling cylinder body.

FRONT DISC BRAKE

DISASSEMBLY

1. Remove caliper assembly from vehicle. Refer to [BR-23, "Removal and Installation of Brake Caliper Assembly"](#).
2. Remove sliding pin bolts from cylinder body, and remove pads, shims, shim covers and pad retainers from torque member.

CAUTION:

When removing pad retainer from torque member, lift pad retainer in the direction shown by arrow (shown in the figure) so as not to deform it.

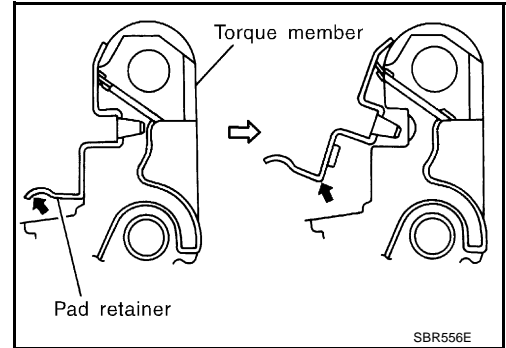

3. Remove sliding pins and sliding pin boots from torque member.
4. Place a wooden block as shown in the figure, and blow air from union bolt mounting hole to remove pistons and piston boots.

CAUTION:

Do not get fingers caught in the pistons.

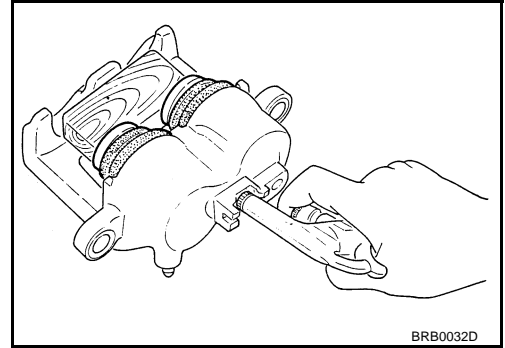

5. Using a flat-bladed screwdriver, remove piston seals from cylinder body.

CAUTION:

Be careful not to damage the inner wall of cylinder.

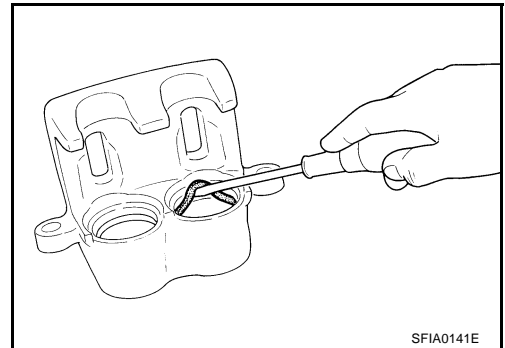

INSPECTION AFTER DISASSEMBLY

Cylinder Body

CAUTION:

Use new brake fluid to clean. Do not use mineral oils such as gasoline or kerosene.

- Check the inner wall of cylinder for corrosion, wear, and damage. If a malfunction is detected, replace cylinder body.
- Minor flaws caused by corrosion or a foreign material can be removed by polishing a surface of the inner wall with a fine sandpaper. Replace cylinder body, if a malfunction is detected.

Torque Member

Check for wear, cracks, and damage. If a malfunction is detected, replace applicable part.

Piston

CAUTION:

The piston sliding surface is plated. Do not polish with sandpaper.

Check piston surface for corrosion, wear, and damage. If a malfunction is detected, replace applicable part.

Sliding Pin, Sliding Pin Bolt, and Sliding Pin Boot

Check sliding pins, sliding pin bolts and sliding pin boots for wear, damage, and cracks. If a malfunction is detected, replace applicable part.

FRONT DISC BRAKE

ASSEMBLY

1. Apply polyglycol ether based lubricant to the piston seal, and install them to the cylinder body.

CAUTION:

Do not reuse piston seal.

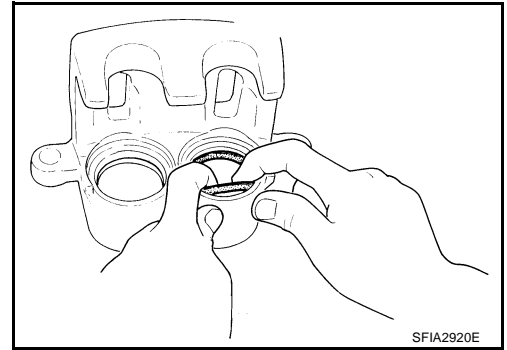

2. Apply rubber grease to piston boots. Cover the piston end with piston boot, and install cylinder-side lip on piston boot properly into groove on cylinder body.

CAUTION:

Do not reuse piston boot.

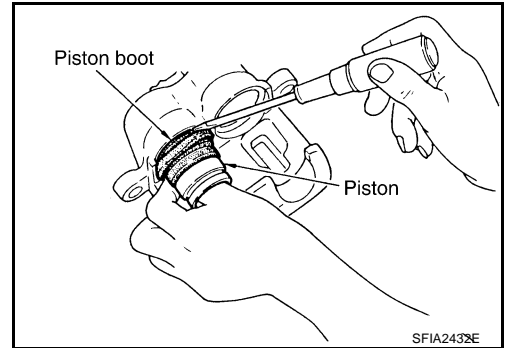

3. Apply brake fluid to piston, and press piston into cylinder body by hand to assemble piston-side lip on piston boot properly into a groove on piston.

CAUTION:

Press piston evenly and change pressing point to prevent inner wall of cylinder from being rubbed.

4. Install sliding pins and sliding pin boots to the torque member.

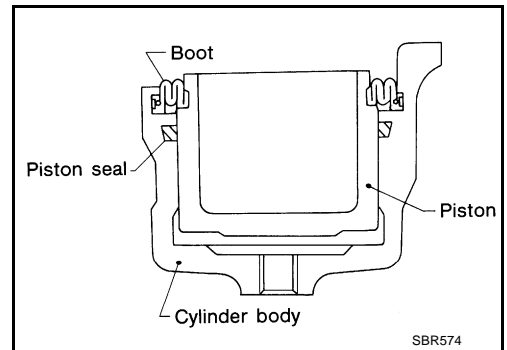

5. Install the torque member to the steering knuckle and tighten the mounting bolts to the specified torque. Refer to [BR-21, "Components"](#).

CAUTION:

Before installing torque member to vehicle, wipe off oil and grease on the washer seats on steering knuckle and the mounting surface of the torque member.

6. Install pad retainers and pad assemblies to torque member.

CAUTION:

Inner pad and outer pad have pad-return mechanism on upper side of pad retainer. When installing pad to torque member, be sure to install pad return lever to pad wear sensor securely.

7. Press in piston until pads can be installed, and then install cylinder body to torque member.

8. Install cylinder body, and tighten sliding pin bolt to the specified torque. Refer to [BR-21, "Components"](#).

9. Position a projection of brake hose metal fitting by aligning with protrusions on cylinder body and tighten union bolt to specified torque. Refer to [BR-21, "Components"](#).

CAUTION:

- Assemble brake hose securely to cylinder body.
- Do not reuse copper washer for union bolts.

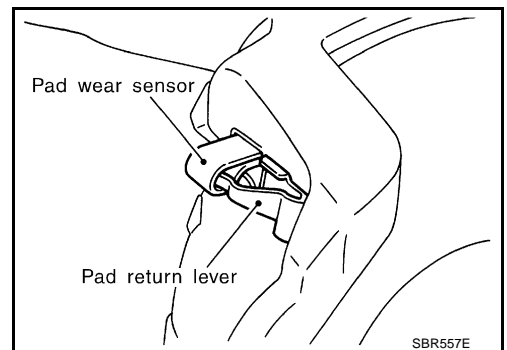

FRONT DISC BRAKE

10. After installing caliper assembly, refill with new brake fluid and bleed air. Refer to [BR-10, "Bleeding Brake System"](#).

DISC ROTOR INSPECTION

Visual Inspection

Check surfaces of disc rotor for uneven wear, cracks, and serious damage. If a malfunction is detected, replace applicable part.

Runout Inspection

1. Using wheel nuts, secure disc rotor to wheels hub. (2 or more positions)
2. Using a dial gauge, check runout.

Measurement point:

At a point 10.0 mm (0.394 in) from outer edge of disc rotor

Runout limit (with it attached to the vehicle):

0.035 mm (0.0014 in) or less

NOTE:

Make sure that wheel bearing axial end play is within the specification before measuring runout. Refer to [FAX-4, "WHEEL BEARING INSPECTION"](#)

3. If runout is outside limit, find the minimum runout point by shifting the mounting positions of disc rotor and wheel hub by one hole.
4. If runout is still out of specification, grind rotor with on-car brake lathe ("MAD, DL-8700", "AMMCO 700 and 705" or equivalent) until runout becomes within the specified limit.

Thickness Inspection

Using a micrometer, check thickness of disc rotor. If thickness is outside standard, replace disc rotor.

Standard thickness : 28.0 mm (1.102 in)

Repair limit thickness : 26.0 mm (1.024 in)

**Maximum uneven wear (measured at 8 positions)
: 0.015 mm (0,0006 in) or less**

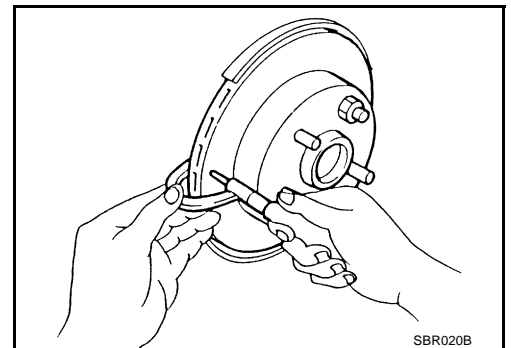
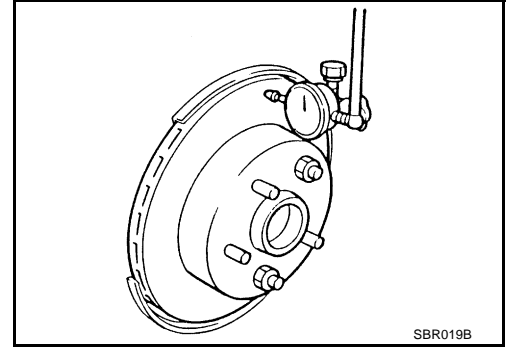

Brake Burnishing Procedure

NFS000JZ

Burnish the brake pad and disc rotor mutually contacting surfaces of disc rotor according to following procedure after refinishing or replacing rotors, after replacing pads, or if a soft pedal occurs at very low mileage.

CAUTION:

- **Be careful of vehicle speed because brake does not operate easily until pad and disc rotor are securely fitted.**
 - **Only perform this procedure under safe road and traffic conditions. Use extreme caution.**
1. Drive vehicle on straight, flat road.
 2. Depress brake pedal with the power to stop vehicle within 3 to 5 seconds until the vehicle stops.
 3. Drive without depressing brake for a few minutes to cool brake.
 4. Repeat steps 1 to 3 until pad and disc rotor are securely fitted.

REAR DISC BRAKE

REAR DISC BRAKE

PFP:44000

On-Vehicle Inspection PAD WEAR INSPECTION

NFS000K0

- Inspect the thickness from an inspection hole on cylinder body. Use a scale for inspection if necessary.

Standard thickness : 8.5 mm (0.335 in)

Repair limit thickness : 2.0 mm (0.079 in)

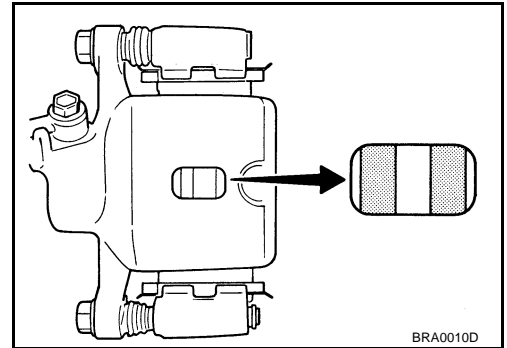

BRA0010D

Components

NFS000K1

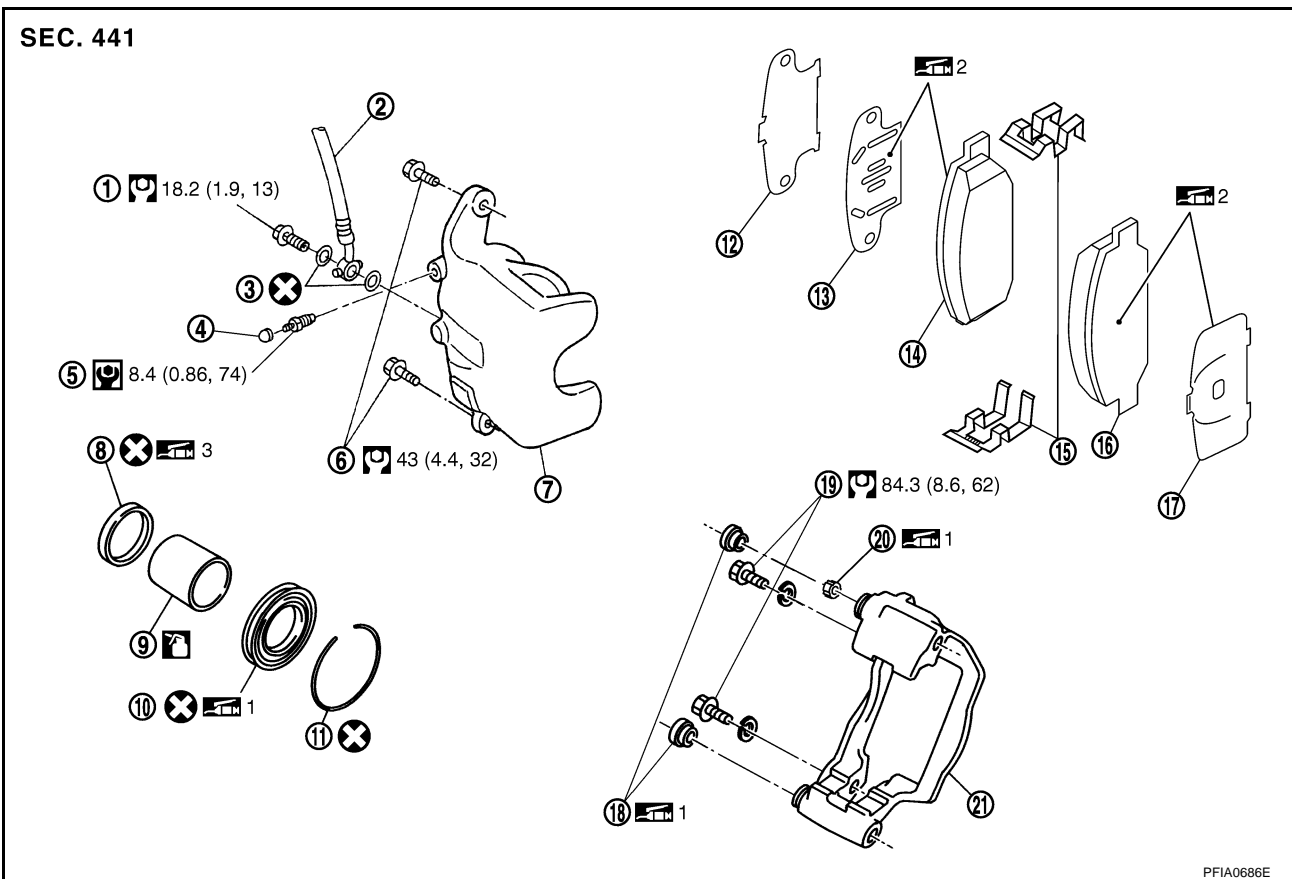

PFA0686E

- | | | |
|---------------------------------|--------------------|----------------------|
| 1. Union bolt | 2. Brake hose | 3. Copper washer |
| 4. Cap | 5. Bleed valve | 6. Sliding pin bolt |
| 7. Cylinder body | 8. Piston seal | 9. Piston |
| 10. Piston boot | 11. Retaining ring | 12. Inner shim cover |
| 13. Inner shim | 14. Inner pad | 15. Pad retainer |
| 16. Outer pad | 17. Outer shim | 18. Slide pin boot |
| 19. Torque member mounting bolt | 20. Bushing | 21. Torque member |

Refer to [GI-10. "Components"](#) and the followings for the symbols in the figure.

1: Apply rubber grease.

2: Apply PBC (Poly Butyl Cuprysil) grease or silicone-based grease.

REAR DISC BRAKE

 3: Apply polyglycol ether based lubricant.

 : Apply brake fluid.

WARNING:

Clean dust on caliper and brake pad with a vacuum dust collector to minimize the hazard of airborne particles or other materials.

CAUTION:

- While removing cylinder body, never depress the brake pedal because the piston will pop out.
- It is not necessary to remove torque member mounting bolts on torque member and brake hose except for disassembly or replacement of the caliper assembly. In this case, hang cylinder body with a wire so as not to stretch brake hose.
- Do not damage piston boot.
- If any shim is subject to serious corrosion, replace it with a new one.
- Always replace shims and shim cover as a set when replacing brake pads.
- Keep the rotor clean of brake fluid.
- Burnish the brake pads and disc rotor mutually contacting surfaces after refinishing or replacing rotors, after replacing pads, or if a soft pedal occurs at very low mileage. Refer to [BR-32. "Brake Burnishing Procedure"](#) .

Removal and Installation of Brake Pad

NFS000K2

REMOVAL

1. Remove tires from vehicle with a power tool.
2. Remove sliding pin bold (one on top).
3. Hang cylinder body with a wire, and remove pads, shims, shim cover and pad retainers from torque member.

INSTALLATION

1. Apply PBC (Poly Butyl Cuprysil) grease or silicone-based grease to the rear of the pad and to both sides of the shim, and install the inner shim and shim cover to the inner pad, and the outer shim to the outer pad.
2. Install the pad retainer and pad assemblies to the torque member.
3. Push the piston in so that the pad is firmly installed, and install cylinder body to torque member.

CAUTION:

When replacing pads with new ones, press in piston until pads can be installed. In this case, carefully monitor brake fluid level in reservoir tank because brake fluid will return to master cylinder reservoir tank.

NOTE:

Use a disc brake piston tool (commercial service tool) to easily press piston.

4. Install the sliding pin bolt (one on top) and tighten to the specified torque. Refer to [BR-27. "Components"](#) .
5. Secure disc rotor with wheel nuts. Depress brake pedal a few times until it gets a responsive touch.
6. Check brake for drag.
7. Install tires to vehicle.

Removal and Installation of Caliper Assembly

NFS000K3

REMOVAL

1. Remove tires from vehicle with a power tool.
2. Fasten disc rotor using wheel nut.
3. Drain brake fluid. Refer to [BR-9. "Drain and Refill"](#) .
4. Remove union bolt and then remove brake hose from caliper assembly.
5. Remove torque member mounting bolts, and remove caliper assembly.

CAUTION:

Do not drop brake pad.

6. Remove disc rotor.

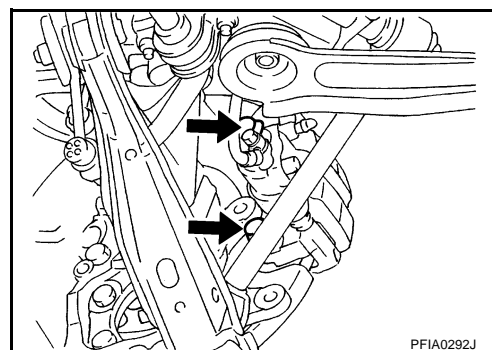

PF1A0292J

REAR DISC BRAKE

CAUTION:

Put matching marks on wheel hub assembly and disc rotor, if it necessary to remove disc rotor.

INSTALLATION

CAUTION:

- Refill with new brake fluid "DOT 3".
- Never reuse drained brake fluid.

1. Install disc rotor.

CAUTION:

Matching marks of disc rotor and wheel hub put at the time of removal when reusing disc rotor.

2. Install caliper assembly to the vehicle, and tighten torque member mounting bolts to the specified torque. Refer to [BR-27, "Components"](#).

CAUTION:

Before installing caliper assembly to the vehicle, wipe off oil and grease on washer seats on steering knuckle and mounting surface of caliper assembly.

3. Install L shape pin of brake hose to caliper assembly and tighten union bolts to the specified torque. Refer to [BR-27, "Components"](#).

CAUTION:

- Do not reuse the copper washer for union bolts.
- Securely attach brake hose to protrusion on caliper assembly.

4. Insert new brake fluid and bleed air. Refer to [BR-10, "Bleeding Brake System"](#).
5. Check brake for drag.
6. Install tires to vehicle.

Disassembly and Assembly of Caliper Assembly

NFS000K4

NOTE:

Do not remove torque member, pads, shims, shim cover and pad retainers when disassembling and assembling cylinder body.

DISASSEMBLY

1. Remove the slide pin bolt, and then remove cylinder body from torque member.

CAUTION:

Do not drop pads, shims, shim cover and pad retainer from torque member.

2. Remove sliding pin boot from torque member.
3. As shown in the figure, using a flat-bladed screwdriver, remove the retaining ring from the cylinder body.

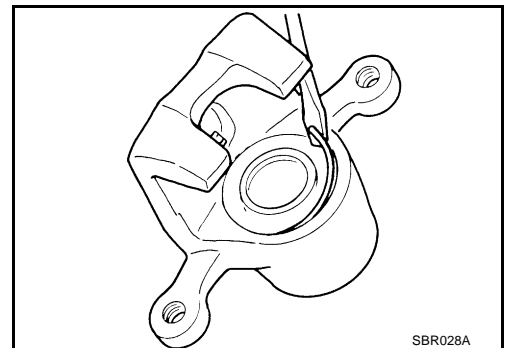

SBR028A

REAR DISC BRAKE

- Place a wooden block as shown in the figure, and blow air from union bolt mounting hole to remove pistons and piston boots.

CAUTION:

Do not get fingers caught in the piston.

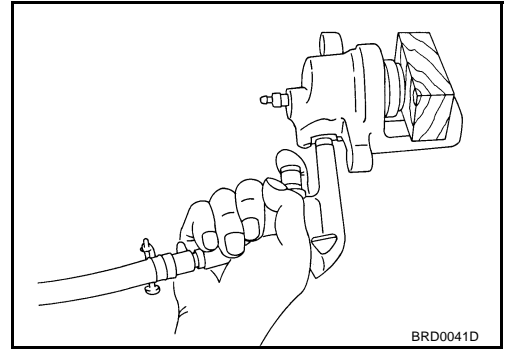

- Using a flat-bladed screwdriver, remove piston seals from cylinder body.

CAUTION:

Be careful not to damage cylinder inner wall.

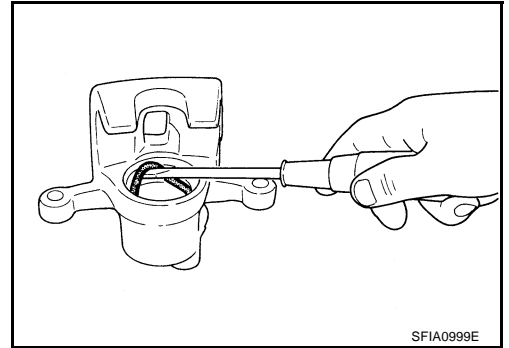

INSPECTION AFTER DISASSEMBLY

Cylinder Body

CAUTION:

Use new brake fluid to clean. Never use mineral oils such as gasoline or kerosene.

- Check inner wall of cylinder for corrosion, wear, and damage. If a malfunction is detected, replace cylinder body.
- Minor flaws caused by corrosion or a foreign material can be removed by polishing a surface of inner wall with a fine sandpaper. Replace the cylinder body, if a malfunction is detected.

Torque Member

Check for wear, cracks, and damage. If a malfunction is detected, replace the affected part.

Piston

CAUTION:

The piston sliding surface is plated. Do not polish with sandpaper.

Check piston surface for corrosion, wear, and damage. If a malfunction is detected, replace applicable part.

Sliding Pin Bolts and Sliding Pin Boots

Check sliding pin bolts and sliding pin boots for wear, damage, and cracks. If a malfunction is detected, replace applicable part.

ASSEMBLY

- Apply polyglycol ether based lubricant to the piston seal, and install them to the cylinder body.

CAUTION:

Do not reuse piston seal.

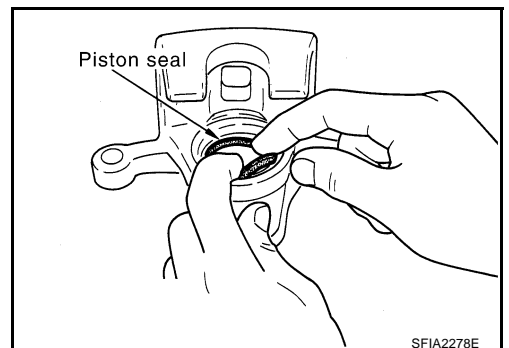

REAR DISC BRAKE

2. Apply rubber grease to piston boot. Cover the piston end with the piston boot, and install cylinder-slide lip on piston boot properly into the groove on cylinder body.

CAUTION:

Do not reuse the piston boot.

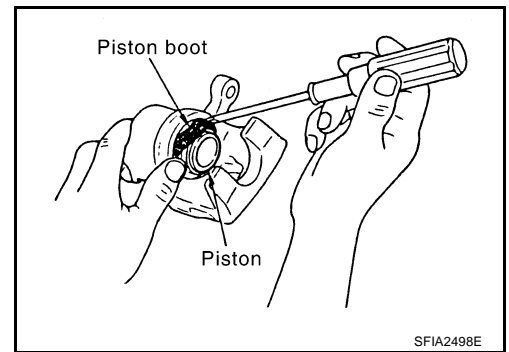

3. Apply brake fluid to the piston, and press piston into cylinder body by hand to assemble piston-side lip on piston boot properly into a groove on piston.

CAUTION:

Press piston evenly and change pressing point to prevent inner wall of cylinder from being rubbed.

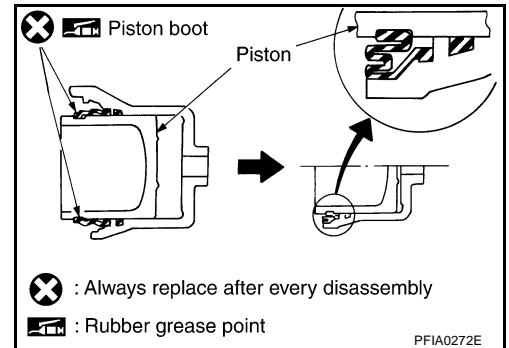

4. Fix piston boot with retaining ring.

CAUTION:

- **Make sure the boot is firmly in the cylinder body groove.**
- **Do not reuse the retaining ring.**

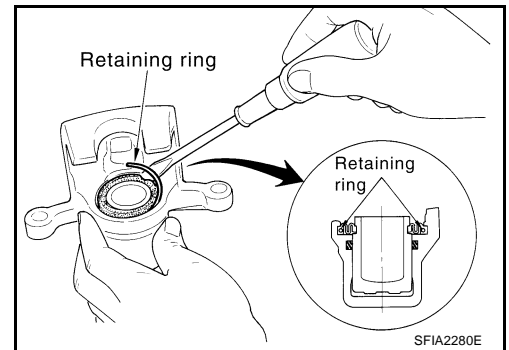

5. Install the sliding pin bolt and sliding pin boot to the torque member.
6. Apply PBC (Poly Butyl Cuprysil) grease or silicone- based grease to the rear of the pad and to both sides of the shim, and attach the inner shim and shim cover to the inner pad, and the outer shim to the outer pad.

7. Install the pad retainer and pad to the torque member.

CAUTION:

When attaching the pad retainer, attach it firmly so that it does not float up higher than the torque member, as shown in the figure.

8. After assembling shims and shim cover to pad, install it to the torque member.
9. Install cylinder body. Tighten sliding pin bolts to the specified torque. Refer to [BR-27, "Components"](#).

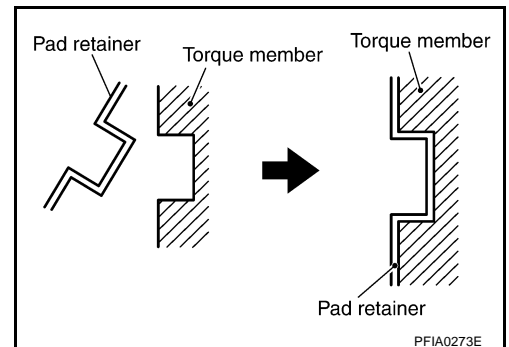

REAR DISC BRAKE

DISC ROTOR INSPECTION

Visual Inspection

Check surface of the disc rotor for uneven wear, cracks, and serious damage. If a malfunction detected, replace applicable part.

Runout Inspection

1. Using wheel nuts, secure disc rotor to the wheel hub. (2 or more positions)
2. Inspect runout using a dial gauge.

Measurement position:

At a point 10.0 mm (0.394 in) from outer edge of disc rotor

Runout limit (with it attached to the vehicle):

0.055 mm (0.0022 in) or less

NOTE:

Make sure that wheel bearing axial end play is within the specification before measuring runout. Refer to [RAX-6, "WHEEL BEARING INSPECTION"](#).

3. If runout is outside the limit, find the minimum runout point by shifting mounting positions of the disc rotor and wheel hub by one hole.

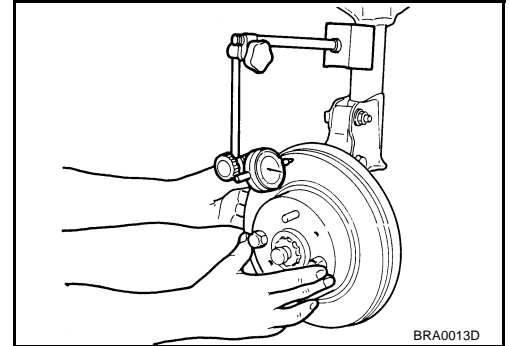

Thickness Inspection

Using a micrometer, check thickness of the disc rotor. If thickness is outside the standard, replace disc rotor.

Standard thickness : 16.0 mm (0.630 in)

Repair limit thickness : 14.0 mm (0.551 in)

Maximum uneven wear (measured at 8 positions)

: 0.015 mm (0.0006 in) or less

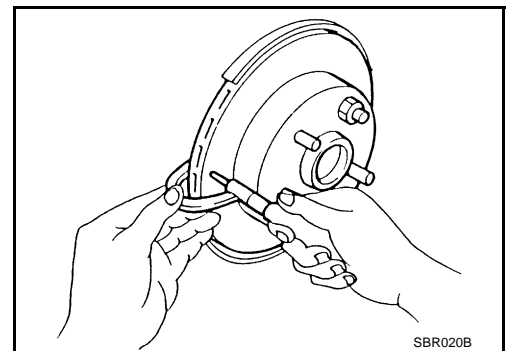

Brake Burnishing Procedure

Burnish the brake pad and disc rotor mutually contacting surfaces of disc rotor according to following procedure after refinishing or replacing rotors, after replacing pads, or if a soft pedal occurs at very low mileage.

CAUTION:

- **Be careful of vehicle speed because brake does not operate easily until pad and disc rotor are securely fitted.**
 - **Only perform this procedure under safe road and traffic conditions. Use extreme caution.**
1. Drive vehicle on straight, flat road.
 2. Depress brake pedal with the power to stop vehicle within 3 to 5 seconds until the vehicle stops.
 3. Drive without depressing brake for a few minutes to cool brake.
 4. Repeat steps 1 to 3 until pad and disc rotor are securely fitted.

NFS000TD

SERVICE DATA AND SPECIFICATIONS (SDS)

SERVICE DATA AND SPECIFICATIONS (SDS)

PFP:00030

General Specifications

NFS00060

Unit: mm (in)

Front brake	Cylinder bore diameter	45.0 (1.772) × 2
	Pad length × width × thickness	130 × 50 × 11.0 (5.12 × 1.97 × 0.433)
	Rotor outer diameter × thickness	320 × 28.0 (12.60 × 1.102)
Rear brake	Cylinder bore diameter	42.86 (1.6874)
	Pad length × width × thickness	83.0 × 31.9 × 8.5 (3.268 × 1.256 × 0.335)
	Rotor outer diameter × thickness	308 × 16.0 (12.13 × 0.630)
Master cylinder	Cylinder bore diameter	25.4 (1.0)
Control valve	Valve type	Electric brake force distribution
Brake booster	Diaphragm diameter	255 (10.04)
Recommended brake fluid		DOT 3

Brake Pedal

NFS00061

Brake pedal free height (from dash lower panel top surface)	M/T models	153.2 – 163.2 mm (6.03 – 6.43 in)
	A/T models	161.5 – 171.5 mm (6.36 – 6.75 in)
Brake pedal depressed height [under a force of 490 N (50 kg, 110 lb) with the engine running]	M/T models	90 mm (3.54 in) or more
	A/T models	95 mm (3.74 in) or more
Clearance between stopper rubber and the threaded end of stop lamp switch and ASCD cancel switch		0.74 – 1.96 mm (0.0291 – 0.0772 in)
Pedal play		3 – 11 mm (0.12 – 0.43 in)

Check Valve

NFS00062

Vacuum leakage [at vacuum of -66.7 kPa(-500 mmHg, -19.69 inHg)]	Within 1.3 kpa (10 mmHg, 0.39 inHg) of vacuum for 15 seconds
--	--

Brake Booster

NFS00063

Vacuum leakage [at vacuum of -66.7 kPa (-500 mmHg, -19.69 inHg)]	Within 3.3 kPa (25 mmHg, 0.98 inHg) of vacuum for 15 seconds
Output rod length	30.5 mm(1.201 in)
Input rod length	125 mm (4.92 in)

Front Disc Brake

NFS00064

Brake pad	Standard thickness	11.0 mm (0.433 in)
	Repair limit thickness	2.0 mm (0.079 in)
Disc rotor	Standard thickness	28.0 mm (1.102 in)
	Repair limit thickness	26.0 mm (1.024 in)
	Runout limit	0.035 mm (0.0014 in)

Rear Disc Brake

NFS00065

Brake pad	Standard thickness	8.5 mm (0.335 in)
	Repair limit thickness	2.0 mm (0.079 in)
Disc rotor	Standard thickness	16.0 mm (0.630 in)
	Repair limit thickness	14.0 mm (0.551 in)
	Runout limit	0.055 mm (0.0022 in)

SERVICE DATA AND SPECIFICATIONS (SDS)
